

EICO

369 / TV-FM Sweep and Post-Injection Marker Generator

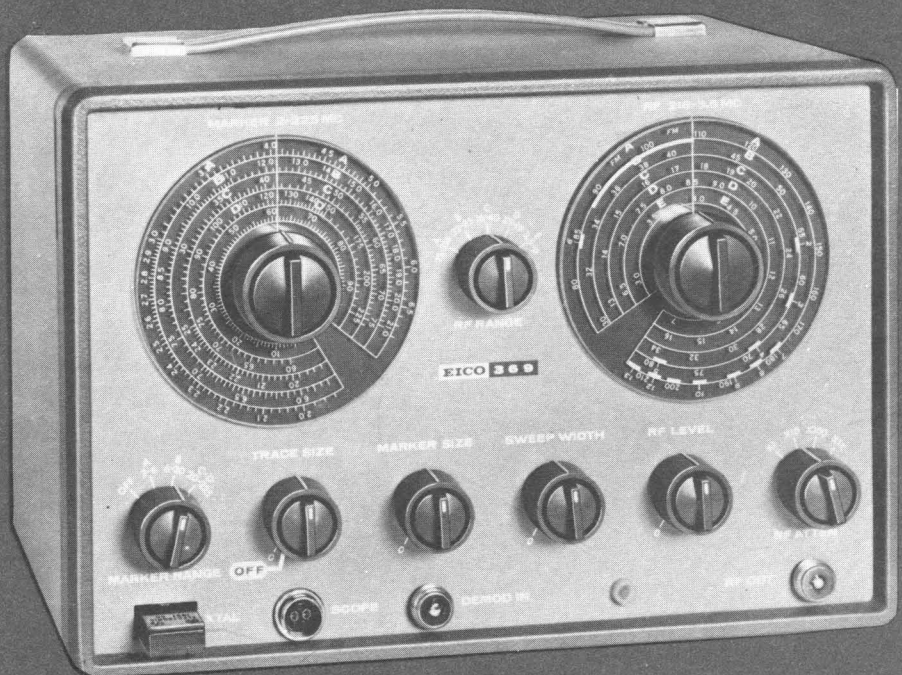

OPERATING MANUAL

GENERAL DESCRIPTION

The EICO Model 369 TV/FM Sweep & Post-Injection Marker Generator provides the greatest dependability, accuracy, and speed for service and factory alignment of color and black-and-white tv receivers and fm receivers.

With the EICO 369, circuit response is not affected by markers and markers are not affected by circuit response. The EICO 369 feeds only the required sweep signal to the input of the circuit being aligned or tested. At the output end of the circuit, a demodulator cable picks off the signal, and feeds the demodulated signal to a mixer stage inside the generator where the markers are added. Then this combined signal is fed to the oscilloscope. This means that circuitry under test of alignment is not affected by the marker signal, and that traps in the circuitry will not reduce or eliminate the marker.

The EICO 369 has a controllable inductor sweep circuit. This type of purely electronic sweep circuit has no mechanical parts to wear and give trouble later. The sweep generator is independent of the marker generator. It has five ranges: 3-7.5mc; 6-16mc; 16-42mc; 36-95mc and 75-220mc. All five ranges are fundamentals and tuning to the desired center frequency is simplified by a 6:1 vernier dial and a 350° scale. Output impedance is 50 ohms. Retrace blanking is obtained by both direct grid cut-off and indirect B+ cut-off (via the AGC chain) of the oscillator with a blanking tube that conducts during the negative excursion of the 60 cps sine sweep. A three-stage AGC circuit keeps the level of the swept signal constant over its entire frequency range, even when the widest sweep width of 20mc is being used. A phasing control at the rear of the EICO 369 adjusts permanently the horizontal sweep signal fed to the 'scope.

The marker generator in the EICO 369 has 4 ranges covering 2 - 225mc. The highest range, 60 - 225mc, is the third harmonic of the next lower range. All other ranges are fundamentals. Frequency setting is simplified by a 6:1 vernier dial and a 350° scale. For a rapid check of marker generator alignment, a 4.5mc crystal is supplied with each generator. When plugged into a front panel socket it automatically turns on a fixed frequency marker oscillator. The 4.5mc signal produced by this oscillator is mixed with the variable frequency marker. The 4.5mc crystal is used also for alignment of sound circuitry in tv receivers.

The demodulated wave form with post-injected marker is fed to the vertical input of the 'scope, and the horizontal sweep to the horizontal input of the 'scope, through a single, shielded, two-conductor cable. Separate level controls for trace size and marker size on the front panel can be used independently.

FEATURES

1. Entirely electronic sweep circuit (no moving parts, hum, or vibration) using controllable inductor, in which the oscillator coil inductance depends on the controlled excitation current in the primary windings of the unit. The controlled inductor provides a large and smoothly variable sweep width, and the sweep obtained is extremely linear and stable. The availability of a large sweep width renders operation of the instrument non-critical, since the band-pass region is easily located on the 'scope trace even when the tv set or generator are considerably off frequency. Once the band-pass waveform is located, it is only a matter of adjusting the sweep generator center frequency and the sweep width as required for the most satisfactory display.

2. Extremely flat sweep signal provided by the three-stage AGC circuit which automatically adjusts the oscillator for maximum output on each band with minimum amplitude variations. High output on all five bands permits "cold" alignment of all tuned circuits and filters.

3. The 60cps sine sweep fed to the horizontal input of the 'scope is obtained by bleeding and filtering a large voltage from the secondary winding of the power transformer to achieve both isolation from the line and low distortion. Positive action return trace blanking. Double pi line isolation filter.

4. Multiple marker system for easier alignment. A variable frequency marker oscillator covers from 2mc to 75mc on fundamentals in three ranges, and from 60mc to 225mc on harmonics of the highest fundamental range. (Note that the marker range includes the color burst frequency of 3.58mc). The fixed marker is a crystal-controlled oscillator employing a 4.5mc crystal supplied with the instrument. As the crystal plugs into a panel mount, other crystals may easily be substituted when desired. Variable and fixed markers are both fed to the post-injection mixer circuit. Note that when variable and fixed markers are mixed, pips appear on the 'scope trace at the fundamental and harmonic frequencies of both, and at the sum and difference frequencies. If the pips so obtained are not close enough for a particular job, a crystal of lower frequency can be used.

SPECIFICATIONS

Sweep Oscillator

	<u>Range</u>	<u>Center Frequency</u>	<u>Output</u>	<u>Regulation</u>
<u>Frequency Ranges & Output:</u>	A	75-220mc	.1V	±1db
	B	36-95mc	.2V	±1/2db
	C	16-42mc	.3V	±1/2db
	D	6-16mc	.3V	±1/2db
	E	3-7.5mc	.3V	±1/2db

Note 1: All frequency ranges are fundamental

Note 2: Three-stage AGC circuit

Note 3: 6:1 vernier tuning of center frequency sweep, 350 degrees scale

Output Impedance: 50Ω

Blanking: Negative excursion of power transformer sec. output applied through diode to cut off oscillator grid and osc. B+ through AGC circuit.

Output Attenuators: Four-step decade attenuator and continuously variable level adjustment

Sweep Width: Continuously variable up to 20mc depending on range. Minimum sweep width on all TV channels and IF frequencies 10mc.

Phasing: Narrow-range phasing control at rear of chassis permits permanent adjustment of horizontal deflection signal for accurate alignment.

Variable Frequency Marker Oscillator

	<u>Range</u>	<u>Frequency</u>
<u>Frequency Ranges:</u>	A	2-6mc
	B	6-20mc
	C	20-75mc
	D	60-225mc

Note 1: Range D is third harmonic of Range C

Note 2: 6:1 vernier tuning of variable marker frequency, 350 degrees scale

Fixed Frequency Marker Oscillator

Crystal-controlled oscillator using 4.5mc crystal included with instrument. Crystal socket on panel permits other crystals to be used. Insertion of crystal in socket automatically activates fixed frequency marker oscillator. Fixed marker is internally mixed with variable frequency marker.

Marker Post-Injection Circuit

Sweep signal only (independently attenuated) is fed to device under test via 50Ω shielded cable supplied. Demodulated output of device is returned via demodulator cable supplied (incorporating low-pass filter) through independent trace size attenuator to post-injection circuit. Variable and fixed markers (mixed) are also fed to post-injection circuit via independent marker size control. Demodulated signal and markers are mixed and amplified in post-injection circuit and fed to vertical input of 'scope via 'scope cable supplied. Horizontal deflection signal to 'scope is supplied via the same cable.

Tube Complement: 6BQ7A sweep oscillator and RF output cathode follower
12AT7 variable and crystal marker oscillator
12AX7 blanking diode and first AGC amplifier
6DR7 second AGC amplifier and AGC series regulator
12AU7 post-injection mixer and amplifier
6X4 full-wave rectifier
Selenium rectifier for increductor bias voltage

Cables: RF output cable - 50Ω termination
Demodulated Signal cable - incorporating low-pass RC filter
'Scope Cable - dual shielded cable carrying both vertical and horizontal 'scope input leads

Power Requirements: 105-125 VAC, 60 cps; 50 watts

Size (HWD): 8-1/2 x 12-1/2 x 7 inches

Weight: 16 lbs.

CIRCUIT DESCRIPTION

SWEEP OSCILLATOR

The sweep oscillator is of the Colpitts type, using half of a 6BQ7A tube (V2B). The coils are built into the controllable inductor unit (L5) and are connected in series. All coils are used on the lowest band and one more coil is shorted out on each successively higher band, until only the straps and switch remain to act as the coil on the highest band.

The coil cores are made of a special ferrous composition, and are located between and make contact with the laminated pole piece of the inductor core. A control winding (primary) on the inductor core controls the magnetic flux density in the inductor core and the cores of the signal coils. Thus when current is supplied to the control winding, the permeability of the special core materials is reduced. This in turn causes the inductance of the signal windings to decrease.

The low frequency edge of each swept band occurs at zero control current and the high frequency edge at maximum control current. The center frequency of each swept band depends on the setting of the tuning capacitor (C9).

The inductor control and the horizontal sweep voltage fed to the horizontal axis of the 'scope are both sinusoidal variations at 60 cps and are derived from the 117 volt, 60 cps line. Thus the sweep display on the scope exhibits a linear variation of frequency versus horizontal displacement from the low edge to the high edge of the swept band.

The magnitude of the inductor control current, which sets the sweep width (overall frequency variation), is controlled by a potentiometer (R41) connected across the 117 volt line in series with a limiting resistor (R37) which prevents the overloading of the controllable inductor. The inductor unit is connected to one end and to the arm of the potentiometer through a blocking capacitor (C26). Capacitor C25, which is in parallel with the inductor primary, has been chosen to resonate with the inductor at 60 cycles in order to increase the available range of control current and therefore the available range of sweep width.

Center frequency sweep is achieved through the use of a DC bias current through the control winding of the inductor unit. The DC voltage that develops the bias current is obtained by rectifying (CR1) and filtering (C27) the 117 volt, 60 cps line voltage. The DC bias current is controlled by series resistors (R39 and R40), which are selected on each band so that, at zero sweep width, the operating frequency is mid-way between the zero current and saturation current points of the inductor to assure excellent linearity on all bands. As the stated ranges of the sweep oscillator are all fundamental ranges, the user is assured of entirely adequate output on all bands.

The 60 cps horizontal sweep voltage fed to the 'scope must be controllable as to phase, and also be a true sine wave to ensure a linear display. R22 is the variable phase control, and the network #29756 performs the functions of filtering and attenuating the 60 cycle voltage obtained from the high voltage secondary of the power transformer T1. This voltage is taken from the secondary of the transformer to provide isolation from the line, and filtering is required to eliminate distortion introduced by the transformer.

The second half of the 6BQ7A tube V2A is connected as a cathode follower. The swept RF voltage is coupled from the grid circuit of the oscillator section to the grid of the cathode follower section. As a cathode follower exhibits a high input impedance, the loading effect on the oscillator is very slight. The cathode follower provides a low impedance output and is connected to the attenuator network,

BLANKING

If the swept RF output is not blanked during the negative excursion of the horizontal 60 cps sine sweep, the return trace (mirror image of the forward trace) will be superimposed on the forward trace and difficulty in interpreting the pattern will result. The important blanking function is achieved in the 369 by driving the oscillator grid highly negative to cut-off, and simultaneously feeding a portion of the negative grid blanking voltage to the AGC circuit which results in a reduced B+ voltage to the oscillator tube. A more detailed description of the blanking process follows.

Plate and grid of one-half of the 12AX7 blanking and AGC amplifier tube (V3A) are tied together and connected to the oscillator grid through isolating resistor R12. One side of the high voltage secondary winding of the power transformer is connected to the cathode of the blanking tube through a voltage dividing network consisting of resistors R13 and R18 and capacitor C31. Throughout the positive excursion of the voltage applied to the cathode, the plate is negative

with respect to the cathode and no current can flow. At this time, the oscillator operates with its own grid leak (R11) only. During the negative excursion of the voltage at the cathode, the grid and plate become effectively positive with respect to the cathode and the tube will conduct. As the plate follows the cathode, a high negative voltage is applied to the oscillator grid, thus cutting the oscillator tube off. Also, the negative voltage pulse is coupled to the grid of the second half of the 12AX7 tube (V3B), which is the 1st AGC amplifier, thus causing a positive pulse at the plate of this tube. The positive pulse is coupled to the grid of the first half of the 6DR7 end AGC amplifier (V4A), resulting in a large negative pulse at the plate of this tube. This negative pulse appears at the grid of the second half of the 6DR7 (V4B) acting as series regulator to cut this tube off, and consequently the B+ supply to the oscillator section of V2 is cut off. Therefore, the oscillator tube is cut off in two ways during the blanking period. L6 is an RF choke which prevents the oscillator RF output from getting back to the regulator circuit.

REGULATOR CIRCUIT

Automatic gain control of the RF output voltage is achieved by coupling part of the varying DC voltage developed at the oscillator grid to the control grid of the 1st AGC amplifier, one-half of the 12AX7 tube (V3A). To understand the operation, we utilize the well known fact that the negative voltage at the oscillator grid increases with the amplitude of the RF output. Supposing that instantaneously the RF output has increased, we can anticipate that the negative oscillator grid voltage will increase. By tracing the effect of this increase through the AGC chain, we can see the regulating action. The negative pulse results in a positive pulse at the plate of the 1st AGC amplifier, which is coupled to the control grid of the 6DR7 2nd AGC amplifier tube (V4A) and results in a negative pulse at the plate of this tube. This negative pulse is fed to the grid of the second half of the 6DR7 series regulator tube (V4B), which is in the path of the B+ voltage applied to the plate of the oscillator. The increase in the effective resistance of the regulator tube, as a result of the negative pulse on its control grid, provides the reduction in B+ voltage at the oscillator plate necessary to reduce the RF amplitude to the predetermined level. Similarly, an instantaneous drop in RF amplitude will produce effects opposite to those just described at each point in the AGC chain to increase the B+ voltage at the oscillator plate sufficiently to restore the RF amplitude to a predetermined level. Level control R17 (internal adjustment) is used to set the AGC circuit for maximum output on all bands with minimum amplitude variations.

MARKER OSCILLATOR, V5

One-half of the 12AT7 dual triode tube (V5B) is employed as a Colpitts variable frequency marker oscillator, and the other half (V5A) is used as a crystal marker oscillator. The variable marker oscillator covers the range from 2mc to 75mc in 3 fundamental bands and the range from 60mc to 225mc on the third harmonic of the highest fundamental band. The oscillator coils are slug-tuned so the oscillator can be trimmed for perfect tracking over the whole frequency range.

POST INJECTION MARKER CIRCUIT

The Model 369 employs a post-injection marker circuit in which the markers are added to the response curve after the demodulator circuit in the device under test. A swept RF sampling signal is fed to the grid of the mixer-amplifier tube (V1B), and the combined marker signals (variable and/or fixed) are fed to the cathode of the (V1B) tube. The beat signal (markers) are amplified in the plate circuit of V1B and fed through a Marker Size control to the second marker amplifier (V1A). The output of this amplifier is mixed in resistor R2 with the demodulated signal from the unit under test, which has been returned to the 369 through the demodulator cable. The combined signal is fed out through the 'scope cable to the vertical input of the oscilloscope. The demodulated trace is controlled by the Trace Size control.

POWER SUPPLY

A 6X4 full-wave rectifier tube (V6) is employed in the power supply, and the DC output is well-filtered by dual-section electrolytic C10 and resistor R16. Plate voltage for the rectifier and the required filament voltage for all tubes is supplied by power transformer T1, which also provides the voltages for the phasing and blanking circuits.

FUNCTION OF CONTROLS AND TERMINALS

RF RANGE switch – Permits selection from 5 fundamental sweep oscillator frequency ranges marked on panel.

RF 3-220Mc tuning control – Provides fine adjustment of sweep oscillator frequency. Approximate sweep center frequencies are all read on dial scale corresponding to the sweep range selected.

MARKER RANGE switch – Permits selection from 3 fundamental and 1 harmonic variable marker oscillator ranges marked on panel. At the MARKER OFF position, the variable marker oscillator is disabled. The crystal marker oscillator is operative at all positions, provided a crystal is inserted in the XTAL panel socket.

MARKER 2-225Mc tuning control – Provides a fine adjustment of marker oscillator frequency. Fundamental marker frequencies are read on dial scale corresponding to the sweep range selected. Range C (fundamental) and Range D (3rd harmonic) are both read at position C-D of the MARKER RANGE switch.

SWEEP WIDTH control – Provides adjustment of sweep width from zero to a maximum deviation depending on the selected center frequency.

MARKER SIZE control – Provides independent size adjustment of the markers obtained from the variable marker oscillator and/or crystal oscillator.

RF ATTENUATOR switch – Provides coarse amplitude adjustment of swept RF output in 20db steps.

RF LEVEL control – Provides fine adjustment of swept RF voltage amplitude.

TRACE SIZE CONTROL & ON-OFF switch – Permits adjustment of the amplitude of the demodulated signal. The ON-OFF power switch is actuated at the extreme counter-clockwise position to turn the instrument off.

RF OUTPUT connector – Output connection for swept RF output.

DEMOM IN connector – Input connection for demodulated signal.

SCOPE output jack – Take off terminal for the oscilloscope signals.

XTAL socket – Insertion of the 4.5mc crystal supplied with the instrument in this socket closes the crystal oscillator circuit and results in 4.5mc marker energy (and harmonics thereof) to be fed into the post-injection mixer. Broadband circuit permits other frequency crystals to be used if desired.

SCOPE cable – Dual cable providing a shielded vertical input cable and the horizontal 60 cycles phased signal cable.

OPERATION

The use of a sweep signal generator economizes on time and effort and also provides greater refinement of measurement in a very practical manner. For example, an adjustable frequency, adjustable output RF signal generator might be used to obtain output vs. input data for an IF amplifier at several discrete frequency points. This information can be plotted on a graph showing response vs. frequency to obtain the pass-band of the circuit. The procedure would have to be repeated after each circuit readjustment. While a plot for a narrow-band circuit would be laborious but possible, the time required for a broad-band circuit would make this procedure highly impractical.

A sweep signal generator in conjunction with a 'scope provides a simultaneous display of the response of a circuit at all frequencies within the swept band on the screen of the 'scope, in the form of a response vs. frequency curve. The immediate indication of changes caused by adjustments to the circuit under study expedites alignment work or circuit design enormously. Also, information is instantly obtained by sweep methods which might easily be missed using the point-by-point method. For example, regeneration effects and "suck-outs" may cause changes in the response curve over only a narrow range of frequencies. This effect might very easily be entirely within two adjacent discrete frequencies chosen for the point-by-point method. Obviously such effects will be missed, and a smooth response curve would be drawn which does not correspond in its entirety to the actual response.

Fig. 1 shows the Model 369, a broad band detector, and an oscilloscope interconnected. The resultant display on the 'scope screen is shown in Fig. 2. The pattern is a graph with abscissa (horizontal axis) proportional to frequency and the ordinate (vertical axis) proportional to the amplitude response of the detector circuit.

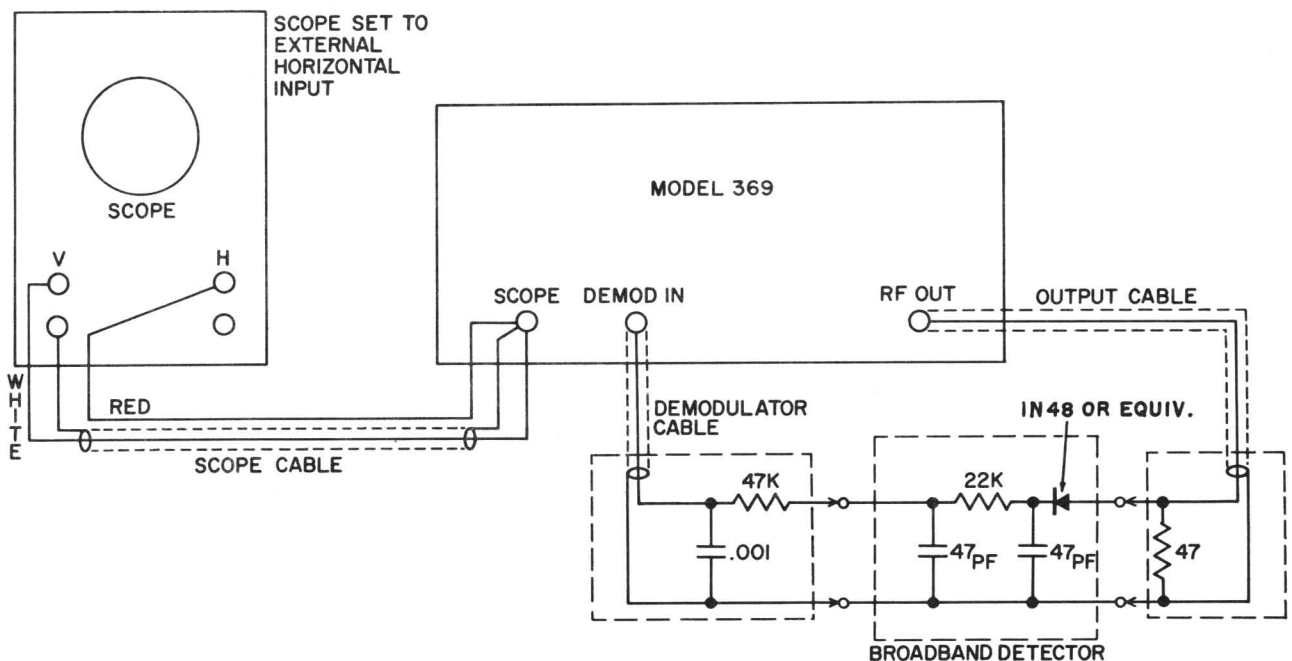

FIGURE 1

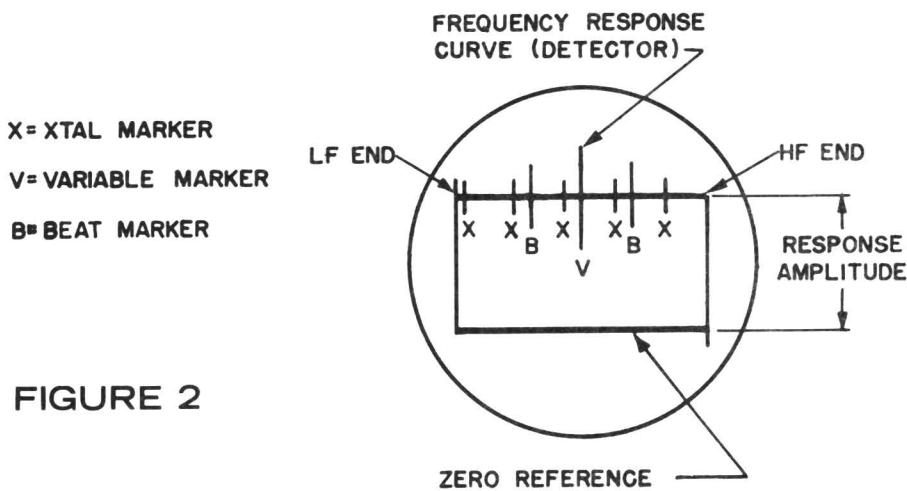

FIGURE 2

Of the two approximately parallel horizontal lines that appear on the screen, one is the reference line of zero input, signifying the blanking period that occurs during every other 1/120th of a second, and the other is the rectified RF output. The rectified RF output will be the upper trace if the detector provides a positive dc output (i. e., as shown in Fig. 2) and the 'scope beam is deflected upward by a positive voltage at the vertical input terminal that is not grounded. The left-hand end of the rectified RF output trace will represent the lower frequency edge of the swept band if the 60 cycle sine sweep is phased so that the start of the positive-going excursion of the 60 cps sine sweep (applied to the horizontal deflection plates of the 'scope) is synchronized with the start of the increasing-frequency excursion of the rectified swept RF band (applied to the vertical deflection plates of the 'scope), and the 'scope beam is deflected to the right by a positive voltage at the horizontal input terminal that is not grounded. It is not possible to interpose the low and high frequency edges of the swept band trace by use of the phasing control of the Model 369, since the latter provides a narrow range of adjustment for fine compensation of small phase shifts.

In this connection, note that tv receiver RF curves are shown deflecting downward, because, when RF response curves are observed, the 'scope is usually connected through an isolating resistor to the mixer grid circuit in the tuner, which goes increasingly negative as signal strength increases. As a result, these response curves deflect downward and are seen below the zero input reference trace. IF response curves are usually shown deflecting upward and are seen above the zero input reference trace. Of course, these curves may be upward or downward, depending on the connections to the rectifier or second detector.

Similarly, as regards to horizontal deflection, confusion will be avoided if the low frequency edge of RF response curves appear on the 'scope at the left side. With this connection, picture RF carriers will be to the left of associated sound RF carriers. Keep in mind that the low-frequency being placed on the left-hand side pertains to RF response curves only. When observing IF response curves, the opposite condition is obtained, and the low frequency is on the right-hand side because the heterodyning action causes a reversal of right and left so far as frequency direction is concerned. To avoid confusion on this subject, it is best to check the direction of frequency increase with an RF response curve obtained at the mixer grid, thereby establishing the left-hand side of the curve as the low-frequency side. The direction of frequency increase, on any response display, can always be determined by noting the direction of travel of the variable marker as its frequency is increased.

To interpret a response curve, facilities must exist for identifying frequencies along the abscissa. This is the function of the highly versatile marker circuits found in the Model 369. Single, dual, or multiple markers may be obtained as desired. High output levels on harmonics as well as fundamentals greatly increase the value of the marker facilities.

The marker appears on the RF response curve trace at a point along the frequency axis corresponding to its own frequency. This occurs because a portion of the marker oscillator output beats against the sweep oscillator output within the instrument. As the instantaneous frequency of the swept oscillator approaches the marker oscillator frequency, the beat frequency becomes visible on the 'scope. As the two frequencies near equivalence, the increasing response of the 'scope to the decreasing difference frequency causes the amplitude to increase correspondingly. The same phenomenon occurs in reverse when the swept oscillator frequency passes the marker oscillator frequency. Immediately adjacent to zero beat (frequency equivalence) the marker reaches its greatest amplitude, which serves to identify the frequency at the point on the RF response curve.

All of the specific uses of this instrument, interpretations of abnormal 'scope traces, and the variations in procedure appropriate to different types of receiver circuitry can not be covered in a brief instruction book. Many excellent books and magazine articles have appeared on the subject, and are easily obtainable. In any case, a detailed alignment procedure for each make and model of receiver is available as prepared by the manufacturer or from information supplied by the manufacturer. When aligning a receiver, it is imperative that you have access to the specific service and alignment notes for the particular model. The following description of operation, therefore, will be confined to general information on setting up the instrument for the specific alignment procedures given by the set manufacturers.

The Model 369 employs a center frequency sweep. This means that as the SWEEP WIDTH control is advanced clockwise, the sweep increases evenly on both sides of the center frequency read on the sweep oscillator dial. The sweep is blanked during half of the line cycle to provide a straight line zero input reference. The voltage response of the tuned circuit, at any frequency in the swept band, is proportional to the vertical distance from the corresponding frequency point on the response curve to the zero input reference line. To observe the response curve of a tuned circuit to be aligned with the Model 369, set the RF RANGE and RF 3-220mc controls to the nominal center frequency of the tuned circuit and advance the SWEEP WIDTH control clockwise until a satisfactory trace is obtained. If the left-hand edge (low frequency side) of the trace ends abruptly, instead of sloping down to a point on the zero input reference line, reduce the frequency setting of the RF 3-220mc dial until the start of the trace appears on the zero reference line. If the right-hand edge of the trace ends abruptly, increase the frequency setting of the RF 3-220mc dial. When both edges and abruptly, advance the SWEEP WIDTH control clockwise until both edges of the curve are on the zero reference line. See Fig. 3.



FIGURE 3

In connection with sweep width, it should be noted that the uppermost frequency of the sweep oscillator is not limited by the highest indicated frequency on the RF 3-220mc dial for the selected band, since the unit is capable of sweeping across bands. Furthermore, it is worth knowing that the maximum sweep width available on any band is obtained at a frequency setting near the high frequency end. This means that greater sweep width is available at the high end of band B than at the low end of band A at the same frequency.

To determine the bandwidth of a tuned circuit, the MARKER RANGE and MARKER 2-225mc controls are used to set the variable frequency marker pip to a point on the trace that is 30% down from the maximum voltage response on the slope of one side of the waveform. Having done so, the frequency on the marker dial is noted. Then the pip is set to the point on the trace that is 30% down from the maximum voltage on the slope on the other side of the waveform, and the frequency on the marker dial is noted again. The difference between the two frequencies is the bandwidth of the tuned circuit under test.

The outputs of both oscillators are mixed, so that the two oscillator frequencies, their harmonics, and the sum and difference of the fundamental frequencies and their harmonics, will all be present in the output. For example, if the 4.5mc crystal supplied is used, and the variable oscillator is set at 30mc, markers will be obtained 30mc, 34.5mc, 25.5mc, 39mc, 29mc; also at 22.5mc, 27mc, 31.5mc, and 36mc, which are direct harmonics of the crystal oscillator. Therefore, if the variable marker is set to one side of a broadband RF or IF response waveform, another marker will appear 4.5mc away on the opposite side of the waveform. Closer or further spacing of markers can be obtained by substituting crystals of lower or higher frequencies respectively.

Note that the markers produced by the higher harmonics of the 4.5mc crystal oscillator and the variable marker oscillator will be smaller in amplitude than the fundamental marker provided by the variable oscillator and the markers at the sum and difference frequencies of the fundamental variable and crystal marker frequencies (4.5mc on each side of the variable oscillator fundamental marker).

The crystal marker oscillator has many other uses. Using the 4.5mc crystal supplied, this oscillator can be used for alignment of the 4.5mc sound IF to be found in intercarrier sets. A 10.7mc or 5.35mc crystal can be used for FM alignment purposes, with the harmonics useful for FM RF alignment. In the same way, crystals having useful harmonics in the TV IF or RF regions may be used, if required.

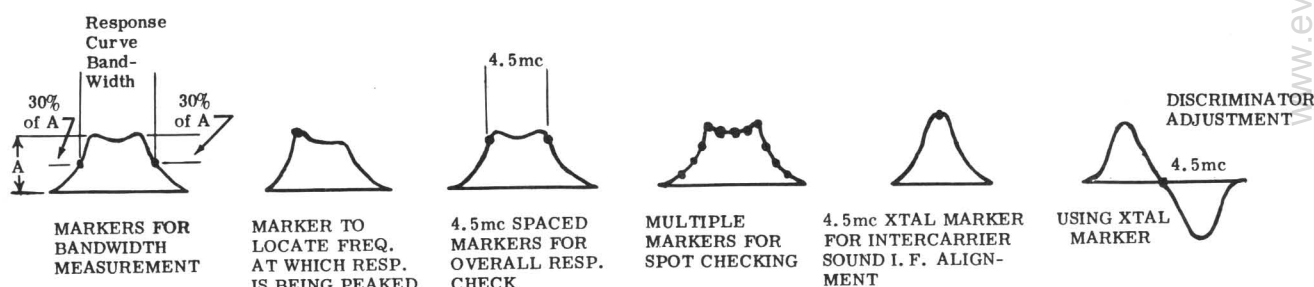

FIGURE 4

It is of course essential that markers be easily identified. To quickly determine which marker is the fundamental or harmonic of the variable oscillator, remove the crystal from the panel socket. The signal marker pip remaining will be the fundamental or harmonic of the variable oscillator. Restoring the crystal oscillator will permit identification of all the other markers. A fixed marker that remains when all markers have been removed can be assumed to be generated by the local oscillator of the set under test. A pip of this type can be eliminated by connecting a shorting jumper between oscillator grid and chassis.

RF LEVEL AND RF ATTEN CONTROLS

The RF LEVEL control provides continuous adjustment of the amplitude of the swept RF signal, whereas the RF ATTEN switch provides decade step attenuation. Start an alignment job with the RF ATTEN control set at 1K (least attenuation) and the RF LEVEL control set at approximately 5. When the response curve is obtained on the 'scope screen, increase or decrease the attenuation as required. It can not be overly stressed that the generator output (input to the circuit under test) should be kept as low as possible, no higher than is necessary for a good indication of the response on the 'scope screen. Use fully the gain provided by the oscilloscope to assist in this practice. The reason for this is that too much output will result in serious distortion of the response curve, resulting in misleading information, and therefore misalignment. To ensure that overloading has not distorted the response curve, reduce the setting of the RF LEVEL control while observing the waveform. If, at a reduced RF LEVEL control setting, the response curve changes shape, you can be sure the tuned circuit under test was being overloaded previously. Should the original RF LEVEL setting be near or below 1 on the dial, the RF ATTEN control should be turned counter-clockwise one position (greater attenuation), and then the RF LEVEL control reset.

TRACE SIZE CONTROL

The TRACE SIZE control attenuates the demodulated signal, which is in turn fed to the vertical amplifier of the oscilloscope. It is provided for the convenience of not having to re-adjust the 'scope's vertical gain control at every step in alignment or testing.

MARKER SIZE CONTROL

The MARKER SIZE control should be used to set the marker to an amplitude no greater than that required for easy observation. (Too great a marker amplitude will cause objectionable trace distortion.)

NOTE: The TRACE SIZE and MARKER SIZE controls are independent of each other.

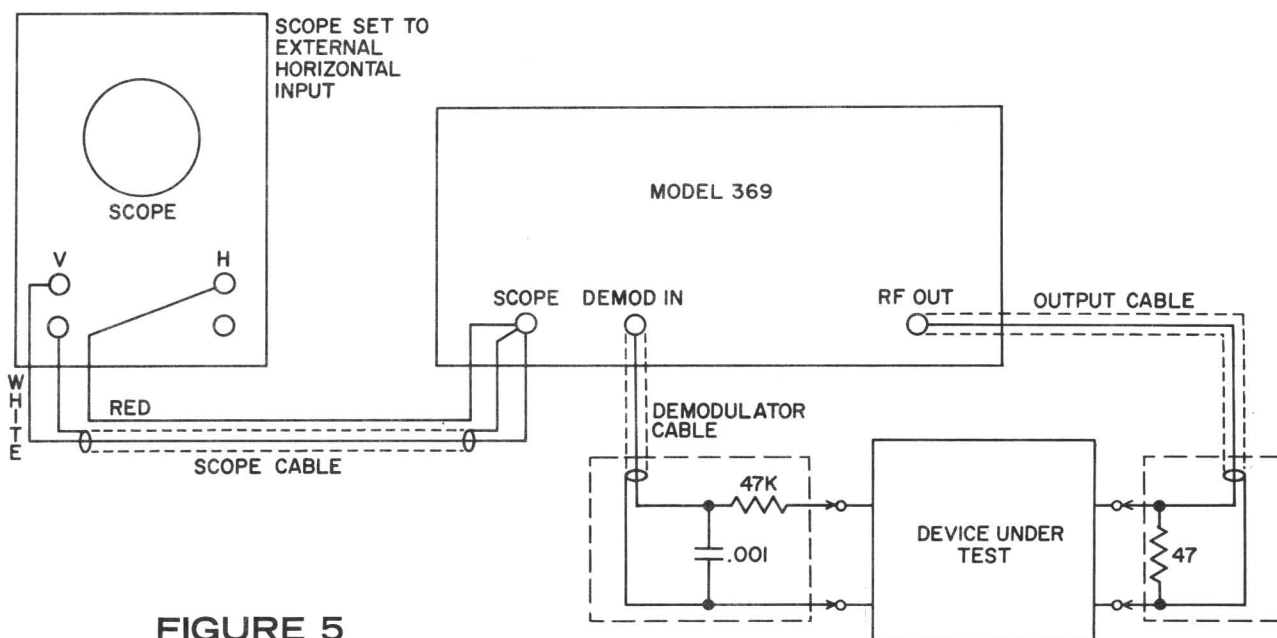

FIGURE 5

TV ALIGNMENT—GENERAL

Do not undertake re-alignment of a tv set unless there is evidence of misalignment. Many symptoms of incorrect alignment may also arise from other causes. Even an abnormal response curve is not certain evidence of misalignment and may sometimes be remedied by tube substitution. By connecting an oscilloscope and the Model 369 to a tv set as described below, gain checks may be made to locate a dead or weak stage. Tubes and other circuit components should be checked before making adjustments on tuned circuits.

It is unusual for RF re-alignment to be required unless the adjustments have been tampered with. Misalignment of the front end (RF, mixer, oscillator) is usually manifested by both picture and sound troubles, either on one channel, several channels, or all channels depending on the set design. Sound troubles only, on all channels, with picture and raster normal, is associated with sound section misalignment.

For all alignment except RF, it is required to render the local oscillator of the tv set inoperative. This may be done either by removing the oscillator tube or temporarily disconnecting the B+ lead going to its plate circuits. Also, render the AGC circuit inoperative by removing the AGC tube, if necessary, and apply a fixed negative dc potential to the AGC line as per manufacturer's instructions.

TRAP ALIGNMENT

In some tv receivers, adjacent channel sound and picture traps are provided in the early IF stages. These traps, if present, must be adjusted before IF alignment. Another type is the 4.5mc sound take-off trap, which is always located after the detector. This trap is more conveniently adjusted after IF alignment.

IF ALIGNMENT - GENERAL

There are two general types of picture IF amplifiers, the stagger-tuned type and the over-coupled type. The final response curve is the same in either case, but the alignment procedure is different. Note that if the trap adjustments are made after the IF alignment, the response curve will be destroyed. Keep in mind also that the correct bias must be applied to the IF tubes during the picture IF alignment (or on RF tubes during RF alignment) if the alignment is to be successful. The best procedure is to follow the manufacturer's instructions in this regard for the particular set being aligned.

IF ALIGNMENT - STAGGER-TUNED TYPE

To align stagger-tuned IF stages, feed the sweep generator output (from the RF OUT connector via the Output Cable) to the grid of the mixer tube through a small capacitor. Connect the Demodulator Cable (from the DEMOD IN connector) across the detector load resistor of the IF strip. Connect the Scope Cable to the V and H inputs of the oscilloscope. See Fig. 5 for a diagram of the connections. Refer to the set manufacturer's service notes during the alignment work.

Select the appropriate SWEEP RANGE and set the RF 3-220mc dial to the desired IF frequency. Adjust the SWEEP WIDTH control to obtain the entire frequency response curve. Reduce the sweep width if the response curve occupies too small a section of the trace and increase the sweep width if the response curve does not return to the zero input reference trace at both the left and right. Also readjust the RF 3-220mc dial setting, if necessary, to properly center the trace. Make sure that the response is not distorted due to overloading.

Select the appropriate MARKER RANGE position and then set the MARKER 2-225mc dial to the IF frequency of the first IF stage as given in the set manufacturer's service notes. Set the MARKER SIZE control to obtain a clearly visible pip. Adjust the first IF so that the marker coincides with the maximum on the trace. If recommended, the primary of the IF transformer preceding the stage being aligned should be shorted. The marker oscillator is then set at the frequency of the next stage and this stage is adjusted. It will be necessary to reduce the output of the generator as alignment proceeds, using the RF LEVEL and RF ATTEN controls. Do not reduce the 'scope vertical amplifier gain instead, but rather keep it at a maximum while holding the output from the generator to a minimum. After all the IF stages have been aligned in this manner, compare the overall response obtained with the curve recommended by the manufacturer in the service notes. The position on the curve of the sound and picture carriers can be checked with the dual markers. Small readjustments in the individual stages may be required to obtain the manufacturer's recommended curve.

NOTE: If the set has adjacent channel sound and picture traps, they should be adjusted before the IF alignment according to the following procedure. Using the crystal and/or variable marker facilities as required, obtain a marker at the nominal trap frequency and adjust the trap until a dip in the trace coincides with the marker pip. When the manufacturer specifies that a modulated signal be used for trap alignment, refer to the SPECIAL PROCEDURES section of the manual.

IF ALIGNMENT - OVER-COUPLED TYPE

To align over-coupled type IF stages, couple the sweep generator output (from the RF OUT connector via the Output Cable) to the grid of the final IF stage through a .001ufd capacitor. Connect the Demodulator Cable (from the DEMOD IN connector) across the detector load resistor of the IF strip. Connect the Scope Cable to the V and H inputs of the oscilloscope. (See Fig. 5). Then align the last IF stage as instructed in the set manufacturer's service notes. If recommended, shunt the primary of the transformer ahead of the control grid to which the signal is applied with a jumper or a 100-200uuf capacitor to prevent it from absorbing energy and causing a dip in the response curve. When alignment of the particular stage is completed, this shunt is removed. The proper trace to be obtained in each case will usually be found in the manufacturer's service notes and should be followed. Alignment proceeds stage by stage from the stage nearest the picture detector to the mixer tube. The overall response curve should be similar to the one shown in the manufacturer's instructions. Here too, the dual markers are used to locate the sound and picture carriers and to provide check points for determining whether the proper curve is being obtained.

NOTE: If the set has adjacent channel sound and picture traps, they should be adjusted before the IF alignment according to the following procedure. Using the crystal and/or variable marker facilities as required, obtain a marker at the nominal trap frequency and adjust the trap until a dip in the trace coincides with the marker pip. When the manufacturer specified that a modulated signal be used for trap alignment, refer to the SPECIAL PROCEDURES section of the manual.

SOUND IF ALIGNMENT

The common detector types found with tv sound IF systems are the discriminator, ratio detector, and gated-beam circuit. For the discriminator and ratio detector types, alignment procedures are similar except for the oscilloscope connection point. Adjustment of gated-beam detectors is usually performed using a transmitted tv signal according to procedures given in the manufacturer's service notes.

If the circuit uses a discriminator, connect the Demodulator Cable to the grid return of the last limiter tube, and adjust the generator's output for the lowest output that will give a satisfactory trace. Set the marker oscillator to the exact intermediate frequency of the sound IF strip, and perform adjustments maintaining a symmetrical wave-shape on each side of the marker. Then shift the Demodulator Cable to the volume control, or to the opposite side of the resistor going to the control, and adjust the discriminator transformer for the maximum amplitude and straightness of the slanted detecting curve. The adjustment is finished when the marker is at the center of the response curve. In intercarrier type sound systems, use the 4.5mc crystal oscillator to furnish the marker.

As for the ratio detector, note that in the output circuit of the two ratio detector diodes there are two capacitors, one connected to the plate of one diode and the other connected to the cathode of the other diode. Connect the Demodulator Cable to the junction of these two capacitors and ground. The i-f amplifiers and the detector transformer can then be aligned as described above for the case where a discriminator is employed.

VHF TUNER ALIGNMENT

Again it should be cautioned that oscillator and RF alignment should not be performed unless it is necessary. The general procedure is outlined below.

Restore the oscillator to operation, and feed the sweep generator output (from the RF OUT connector via the Output Cable) through an impedance matching device to the antenna input terminals. (For a 300 ohm antenna input, the impedance matching device will consist of 120 ohm resistors in series with both the "hot" and ground leads of the Output Cable.) Remove the first IF amplifier tube and shunt the grid resistor with another resistor (approximately 1000 Ω). Connect the DEMOD IN cable to the test point at the tap of the mixer grid load (always available in tuners). The vertical amplifier of the 'scope must have good sensitivity for an adequate size display of the RF response at this point. Set the channel selector of the tv set and the sweep generator to channel 13. Sweep this band adequately to display the entire bandwidth. With the marker tuned to the video and/or sound frequency of channel 13, determine whether these frequencies are within the response curve and are in the relatively flat region. Consult the service notes on the tv set for location of the proper alignment points on the tuner to correct the response curve if required. On other channels, it might be required to compress or expand turns of the individual coils to adjust for proper response.

ALIGNMENT OF INTERCARRIER SETS

Use fixed frequency methods for video IF strip alignment with a VTVM connected across the video detector. The output from either the variable or crystal oscillator may be used. If sweep techniques are prescribed, the previously described methods can be employed.

On completion of fixed frequency alignment, check the overall response with sweep generator and 'scope. Connect the generator to the mixer stage and the 'scope to the video detector and touch up the IF adjustment screws to obtain the recommended response curve.

Alignment of the sound IF strip is performed as described previously, except that the 4.5 mc crystal oscillator is used as the signal source or marker, depending on which alignment method is employed. When this is done, adjust the 4.5mc trap (if any) using the 4.5mc output of the crystal marker oscillator and a VTVM with an RF probe at the cathode or grid of the picture tube. For some sets, the DC probe of a VTVM will instead be connected to a point in the sound detector circuit. Follow the set manufacturer's instructions in all cases.

The tuner in an intercarrier set is aligned according to the same general methods described previously.

FM RECEIVER ALIGNMENT

The procedure for aligning an FM receiver is similar to sound IF alignment in tv receivers. The usual IF frequency is 10.7mc, although higher IF frequencies are used in some receivers. The variable marker oscillator will supply the required 10.7mc signal. If extremely accurate alignment is desired, the crystal oscillator may be employed, using a 10.7mc or 5.35mc crystal inserted in the crystal socket on the panel. In the latter case, the variable marker oscillator may be set to a frequency 100kc above or below the crystal oscillator frequency to obtain additional bandwidth markers. If the variable marker oscillator is used to provide the 10.7mc or other IF frequency, an external signal generator set to a frequency 100kc above or below the IF frequency may be used to provide additional bandwidth markers.

SPECIAL PROCEDURES

If it is essential that a modulated signal be used for adjustment of traps, detectors, etc., a separate signal generator having modulation facilities may be used. If such a generator is not available, an unmodulated signal can often be used together with a VTVM set for DC voltage measurement connected to the video or audio detector. When a modulated signal is used, a VTVM set for AC voltage measurement, or a 'scope, is usually connected to the grid or cathode of the picture tube. In either case, the trap will be set for a minimum indication. If a modulated signal is required for sound IF alignment in a TV or FM set, it may be possible to substitute the procedure described under SOUND IF ALIGNMENT. Follow the recommended procedure, however, if there is doubt as to the efficacy of this method.

ACCESSORY INSTRUMENTS

For routine servicing of both monochrome and color tv sets without undue difficulty, a stable, sensitive, and wide-band scope (essentially flat to at least 3.58mc) is a necessity. For sweep alignment, however, wide-band response is not required, since all that is required is faithful reproduction of a 60 cycle square wave. For this purpose, the 'scope should be flat from 6 to 600 cycles, or preferably 3 to 1200 cycles, and introduce very little phase shift over the range. A scope having DC (direct-coupled) vertical amplifiers is ideal for this purpose. The EICO Model 460 Oscilloscope has both 5mc bandwidth and DC vertical amplifiers and is required if color tv servicing is to be done as well as monochrome tv and FM servicing. For monochrome tv only and FM servicing, the EICO Model 427 and 430 'scopes with .5mc bandwidth, are excellent.

Three EICO probes are available to increase the usefulness of your oscilloscope. These types of probes are available: Oscilloscope Demodulator Probe Model PSD for signal tracing and waveform checks in the RF and IF sections of tv and radio receivers, and also for stage gain measurements in low impedance RF circuits; Oscilloscope Low Capacity Probe Model PLC for accurate reproduction of sync signal waveforms, and generally for tracing high frequency, wide-band waveforms in high impedance circuits, since this probe effectively reduces the capacitive loading of the oscilloscope by a factor of ten; Oscilloscope Direct Probe Model PD for use in low frequency or low impedance test circuits, and where it is desired to eliminate stray pick-up and signal re-radiation.

Another essential instrument for alignment work and routine tv servicing is a high input impedance VTVM, preferably of the type with true peak-to-peak response such as the EICO Models 232 and 249. Both these models have an impedance of 11 megohms. This impedance is sufficiently high to make loading effects negligible, and to give true voltage readings in the circuits under investigation. A high voltage probe and an RF probe are available as accessories for use with the VTVM.

For horizontal and vertical linearity adjustments on a properly operating or completely serviced tv receiver, use the EICO Model 352 Bar Generator. This instrument produces an adjustable number of evenly spaced vertical or horizontal bars when connected to the antenna input terminals of a tv receiver to facilitate rapid and accurate linearity adjustments. This service will help gain the good will of your customers.

Included in this section are instructions for mechanical adjustments, calibration, troubleshooting, and parts replacement. All adjustments and calibration procedures must be performed on completed kit instruments, in the order given, before they can be placed in use. The same procedures will serve for periodic re-adjustments in both kit and factory-wired instruments when required by component aging or replacement.

REMOVAL FROM CABINET

To remove the instrument from the cabinet, first disconnect it from the power line and remove the two screws at the cabinet rear. Then slide the chassis out of the front of the cabinet.

MECHANICAL ADJUSTMENTS

Both the MARKER 2-225mc and RF 3-220mc dials must be positioned so that the radial lines marking the low frequency end of all bands is brought exactly in front of the hairline on the panel when the variable capacitor plates are fully meshed. The procedure to make this adjustment is described below.

1. Turn the knob clockwise until the capacitor plates are fully meshed without forcing. **NOTE:** The knob can be turned slightly beyond this point with a little forcing, but doing this is undesirable because it would throw off the calibration. A sure way of avoiding this mistake is to watch the two thin adjacent gears on the capacitor shaft (both of which mesh with the thick brass gear on the driving shaft) while turning the knob clockwise. You are not forcing while the two thin adjacent gears move together; you are forcing when the gear nearest the capacitor frame is moved while the thin gear in front of it remains stationary. As forcing is possible only over a few degrees of rotation, you will have to observe closely.

2. Loosen the setscrews in the brass bushing which connects the ball drive to the variable capacitor shaft.

3. Position the dial (moving it clockwise) so that the radial line marking the low frequency end of all bands rests directly in front of the hairline on the panel. While the dial is in this position, retighten the setscrews on the bushing.

TEST SET-UP FOR CALIBRATION AND ADJUSTMENT

1. For the calibration and adjustment of the Model 369, it is necessary to make up a broadband detector. The broadband detector simulates a device with flat frequency response over the entire frequency spectrum of the Model 369. The components for the detector are easily obtainable and should be wired as shown in Fig. 6. (The broadband detector is shown schematically in Fig. 7.)

NOTE: In wiring the broadband detector, keep wires as short as possible to avoid resonances which will appear in the response curve on the 'scope. To minimize hum pickup, which distorts the response curve on the 'scope, it is most advisable to build the broadband detector into a shielding metal enclosure connected to ground.

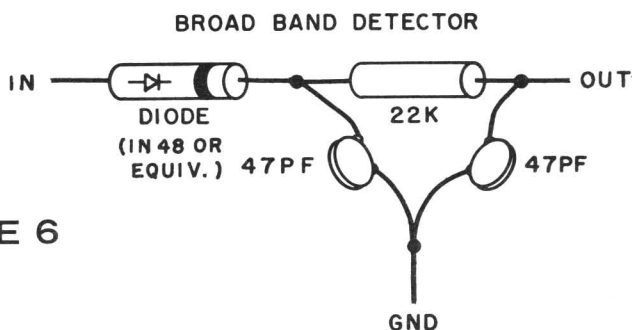

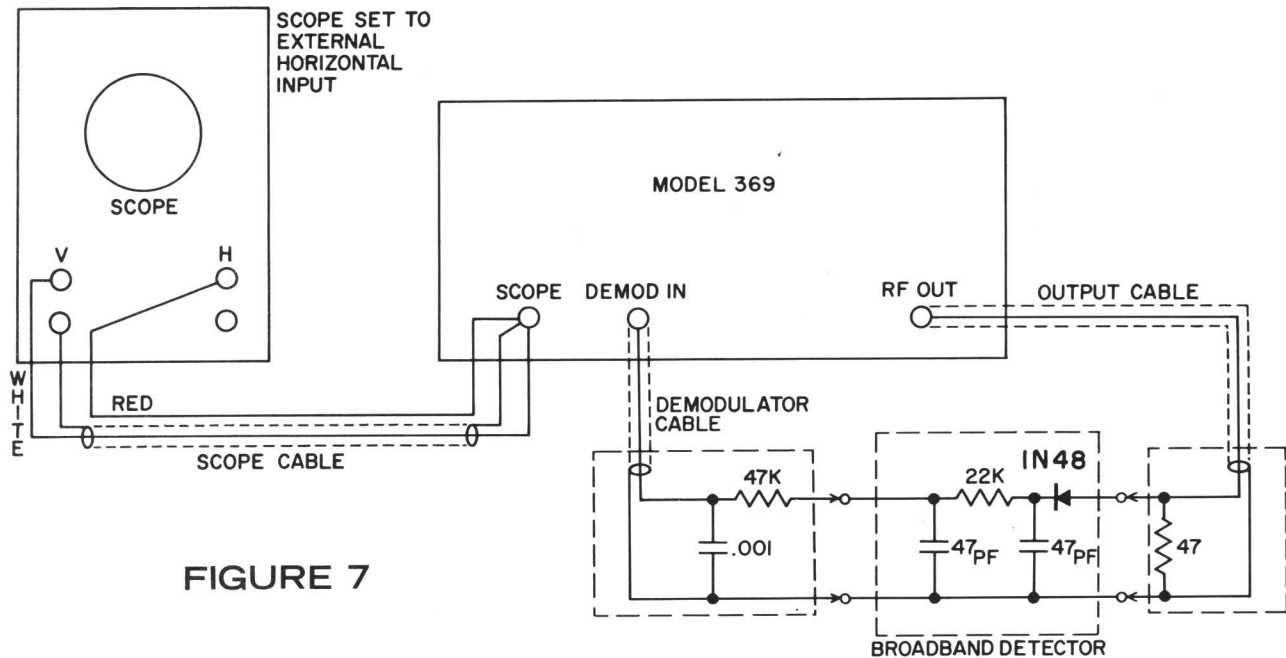

FIGURE 7

2. Connect the Model 369, the broadband detector, and an oscilloscope as shown in Fig. 7. This set-up is good for all calibration and adjustments.

3. Connect the line cord to the 117VAC, 60 cps line, and turn the TRACE SIZE control clockwise from the OFF position to turn the power on. The unit is now operating and ready for calibration and adjustment. Allow the unit to warm up for half an hour before proceeding.

ADJUSTMENT OF SWEEP OSCILLATOR

NOTE: The SWEEP 3-220mc dial is not calibrated accurately because the marker oscillators serve to provide accurate identification of frequencies along the response curve.

1. Set the RF LEVEL and RF ATTEN controls to the furthest clockwise position (maximum output). Set the RF RANGE selector to position E, and the SWEEP WIDTH control at zero. Set the 'scope controls for a horizontal deflection of 1/2 to 2/3 the screen diameter, and the TRACE and 'scope vertical gain controls for a convenient pattern height.

2. A rectangular shaped trace should result from the preceding operations, as shown in Fig. 8.

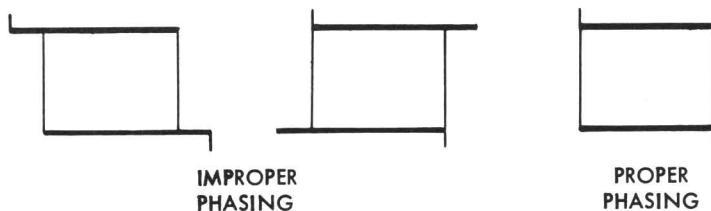

FIGURE 8

Note that the correct display consists of two bright, straight, and parallel horizontal lines connected by two light vertical lines at the extremities. A slight spike might be present at the extremities, caused by differentiation of the blanking pulse. This does not interfere with the operation of the unit. If the 'scope does not have good response below 60 cycles, the detected response line will be tilted. For this reason, it is preferable to use a 'scope with dc (direct-coupled) vertical amplifiers (such as the EICO Model 460 or Model 427). In the OPERATION section (page 5), information is given as to how to determine which of the horizontal lines is the detected sweep output, and which is the zero input reference; also, how to determine which is the high-frequency end, and which is the low-frequency end of the sweep.

If necessary, adjust the PHASE control located on the rear apron for correct phasing of the horizontal deflection voltage as shown in Fig. 8.

3. Now set the RF RANGE selector successively to each of the other ranges. At each position, wait for the AGC action to complete itself (finding the maximum output level with minimum amplitude variation). On each range the trace should consist of the same two straight horizontal parallel lines, although the vertical distance between the lines need not be the same on all ranges, and, in fact, will usually not be. On each range position, turn the RF 3-220mc dial through the full frequency range to determine whether there are any "dead" spots where the sweep oscillator does not function. The amplitude of the response curve will normally vary over any one sweep range, particularly on the two highest ranges. At one point at least, check the operation of the RF LEVEL and RF ATTEN controls by turning them fully counter-clockwise and then returning them to the furthest clockwise position.

4. Advance the SWEEP WIDTH control to maximum. The RF ATTEN should be set at X1K and the RF LEVEL at 10 (minimum attenuation). Rotate the AGC level adjust potentiometer R17 (on the chassis) maximum counter-clockwise. Set the RF RANGE selector at Range E, and turn the RF 3-220mc dial through the entire frequency range while observing the pattern on the 'scope. If a dip or break in response occurs, as shown in Fig. 9A, 9B, turn the AGC level control R17 clockwise just enough to bring the amplitude down to where the dip disappears, as shown in Fig. 9C. (Note that the ultimate effect of adjusting R17 is not evident instantaneously. Make the adjustment in small increments and allow time for AGC action). Then set the RF RANGE selector at Range D, and again turn the RF 3-220mc dial through the entire range while observing the pattern on the 'scope. If a dip or break occurs on this range, turn AGC level control R17 further clockwise until the dip disappears. Proceed successively to Range C and Range B, and turn R17 as far clockwise as is required to eliminate any dip in the output curve on every band. No further adjustment of the AGC level control should be attempted on Range A. (Note that adjustment of R17 can only correct dips or breaks in the output of the swept oscillator, not irregularities due to resonances or hum pickup in the broadband detector circuit. Therefore, be sure that the broadband detector is wired correctly as described previously, and preferably shielded by a grounded metal enclosure. In any case there will always be some residual hum pickup which will cause distortion of the response curve on the 'scope, particularly evident on the high end of Band A because of the reduced output level. Note that the response curves depicted in Fig. 9 are idealized and do not show the irregular tilt that would be introduced by hum pickup.

FIGURE 9

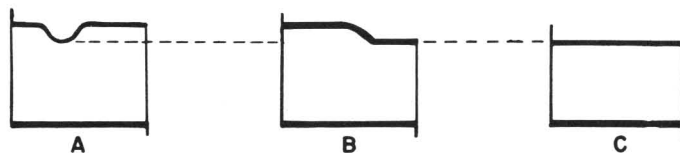

CALIBRATION OF MARKER GENERATOR

1. Insert the 4.5mc crystal in the XTAL socket on the panel and advance the MARKER SIZE control to 10 and the TRACE SIZE control to 0. Set RF RANGE switch to band A and the RF 3-220mc dial at 220mc. This will eliminate possible interference from the sweep generator in the marker calibration procedure.

2. Set the MARKER RANGE selector at position C-D and the MARKER 2-225mc dial to 22.5mc (5th harmonic of the crystal). Adjust the marker oscillator coil slug for Band C-D (see Fig. 10 for location) for zero beat between the crystal and variable marker oscillators. (The approach of zero beat will be indicated by an increased trace amplitude. Exactly at zero beat, the amplitude of the trace will drop to zero. Increased trace amplitude will be visible again on the other side of zero beat.) As there are strong crystal harmonics every 4.5mc, you can not be sure that the variable oscillator is zero beating against the selected harmonic without checking. For this reason, the coil slugs have been pre-set in production at approximately the correct position, so that the zero beat between the variable marker oscillator set to 22.5mc and the 5th harmonic of the 4.5mc crystal occurs when the coil slug is adjusted not more than a few turns either way from the pre-set position. To make certain that the coil slug adjustment is correct, it must be checked by setting the MARKER 2-225mc dial at 27mc (6th harmonic), 31.5mc (7th harmonic), and 36mc (8th harmonic), at all of which frequencies zero beat should occur again. If these checks do not confirm the correctness of the coil slug adjustment, reset the dial to 22.5mc and readjust the coil slug for zero beat at a different point. In all these adjustments, it may be necessary to re-adjust the MARKER SIZE control for a beat signal display of convenient amplitude on the 'scope.

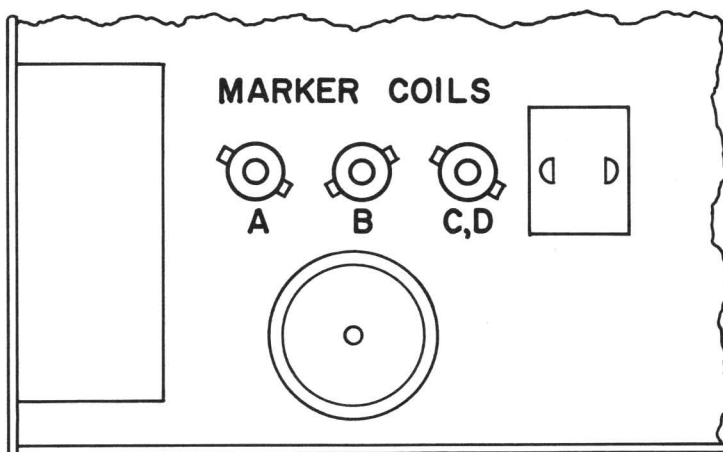

FIGURE 10

3. Set the MARKER RANGE selector at Range B. Set the MARKER 2-225mc dial at 9mc. Adjust the slug in the Band B coil for zero beat. To confirm the correctness of the coil adjustment, check for zero beat at dial settings of 13.5mc and 18mc on the Range B scale. Re-do the coil adjustment if confirmation is not obtained.

4. Set the MARKER RANGE selector at Range A. Set the MARKER 2-225mc dial at 2.25mc. Adjust the slug in the Range A coil for zero beat. To confirm the correctness of the coil adjustment, check for zero beat at a dial setting of 4.5mc. This completes the calibration of generator. Adjustment of the instrument is now completed.

TROUBLE-SHOOTING

The schematic diagram of the Model 369 plus the information given in the CIRCUIT DESCRIPTION section should aid in isolating the circuit in which the trouble is located. The next step is to localize the trouble in the particular section to the tube circuit involved and then to try a replacement tube. If the trouble is not eliminated, voltage and resistance checks should be made and compared with the data provided in the voltage and resistance chart (Fig. 11). Note that the sweep oscillator section consists of the oscillator, cathode follower, blanking, and AGC circuits, and that the voltages in these circuits are interdependent. Because of this voltage interdependence, first attempt to locate the defect by making wiring and cold resistance checks on each of these stages individually.

As an aid in localizing trouble, common symptoms together with their possible causes and remedies have been listed in groups corresponding to the major sections of the instrument (Fig. 13). Of course, all possible troubles could not be included in the chart and the make-up of the chart has been based on the assumption that the instrument has worked properly at some previous time. Keep in mind that in trouble-shooting, the main endeavor is to find and eliminate the source of the trouble. Recurrence of a trouble usually indicates that the effect, not the cause has been remedied.

RESISTANCE CHART

	V1 12AU7	V2 6BQ7A	V3 12AX7	V4 6DR7	V5 12AT7	V6 6X4
1	Above 330KΩ	Above 1M	20KΩ	Above 1M	INF.	170Ω
2	4.7K	100KΩ	20KΩ	Above 1M	22K	
3	680Ω	250Ω	15KΩ	Above 1M	470Ω	"N.S."
4	"N.S."	"N.S."	"N.S."	"N.S."	"N.S."	0
5	"N.S."	"N.S."	"N.S."	0	"N.S."	
6	Above 330KΩ	Above 1M	1.5MΩ	Above 1M	Above 1M	170Ω
7	100K	10KΩ	4.7MΩ	3M	47K	Above 300K
8	0	0	0	270Ω	470Ω	
9	0	—	0	Above 1M	0	

FIGURE 11A

REFERENCES FOR VOLTAGE & RESISTANCE CHART

- *Voltages will change with MARKER RANGE positions.
- **Voltages will vary with setting of AGC control, R17, and with RF RANGE and RF 3-220mc tuning dial positions.
Sweep Circuit Voltages: Across C27, 150VDC; across C25, 0 to 68VAC varies with Sweep Width setting, R41.
For this measurement use a blocking capacitor of at least .1uf. Unless otherwise noted, all voltage and resistance values may normally vary by ±10%.
- ***N.S. stands for "Not Significant".

CONTROL SETTINGS

TUNING KNOBS fully clockwise
 RF RANGE at E
 SWEEP WIDTH at 0
 RF LEVEL at 10
 RF ATTEN X1K
 MARKER SIZE at 10
 MARKER RANGE at A
 TRACE SIZE at 10
 XTAL IN

VOLTAGE CHART

	V1 12AU7	V2 6BQ7A	V3 12AX7	V4 6DR7	V5 12AT7	V6 6X4
1	14.4 VDC	160 VDC	-64VDC	350 VDC	140 to 170*	290 VAC
2	-.33 VDC	-12VDC	-64VDC	40 to 96VDC**	-3.5 to -9VDC*	NC
3	.4VDC	4VDC	148 AC	40 to 96VDC**	3.5VDC	6.3VAC
4	6.3VAC	6.3VAC	6.3VAC	6.3VAC	0	0
5	6.3VAC	0	6.3VAC	0	0	NC
6	14VDC	95 to 150 VDC**	24 to 40 VDC**	40 to 96 VDC**	120 VDC	290 VAC
7	-.4	-38 VDC**	-42 VDC	-.2 to -.7VDC**	-3 VDC	350 VDC
8	0	0	0	.22 to -.32VDC**	3.5 VDC	
9	0	0	0		6.3 VAC	

FIGURE 11B

FRONT OF UNIT

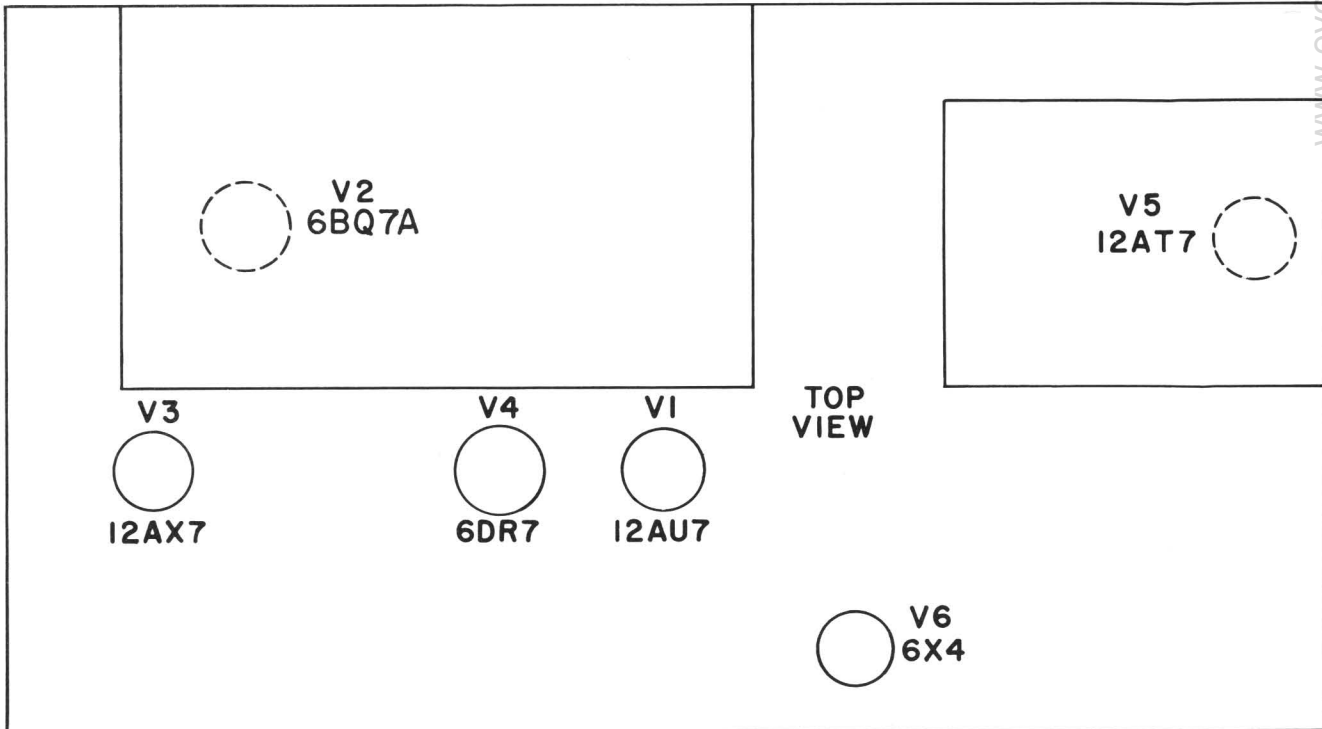

FIGURE 12 TUBE LAYOUT—TOP VIEW

TROUBLE-SHOOTING CHART

SYMPTOM	DEFECT	REMEDY
Pilot lamp I1 does not light.	I1 defective ON-OFF switch S4 defective. Line cord defective Transformer T1 defective. B+ short	Replace Replace Replace Replace Check for shorted filter electrolytic, tuning capacitor, B+ wiring.
Some or all tube filaments not lit.	Defective tube or tubes. Defective filament wiring. Transformer T1 defective.	Replace Repair Replace
No output from sweep osc.	Defective V2 AGC level control R17 mis-adjusted. Oscillator coil or coils of L5 open. Defective wiring	Replace Re-adjust Replace L5 Repair
Poor or no regulation (AGC action)	R17 misadjusted V3 or V4 defective R12, R15, R36 open C13, C24 defective Defective wiring to switch S3	Re-adjust Replace Replace Replace Repair
No blanking	Defective V3 R12, R22 open C11 shorted	Replace Replace Replace
No sweep	Control coil of L5 defective. C26 defective R39, R40, R41 open Defective CR1	Replace L5 Replace Replace Replace Replace
No variable markers	Defective V1, V5 L1, L2, L3, L4 open Defective R25, R26 (check if no negative voltage present at pin 2 of V5) Defective R4 C1, C2 open C3 shorted	Replace Replace Replace Replace Replace Replace
No crystal markers	Crystal defective PC3 defective C17 shorted	Replace Replace Replace
Trace Size control inoperative	R1 defective	Replace

FIGURE 13

PARTS LIST

SYM.#	STOCK#	DESCRIPTION	SYM#.	STOCK#	DESCRIPTION
<u>CAPACITORS</u>					
C1, 2	22556	disc, 68uuf, 500V	R8	10438	330Ω
C3	22550	disc, 600uuf, 500V	R9	10857	2200Ω, 1W
C4, 5, 6, 7, 15, 20	22533	disc, 47uuf	R10, 31, 43	10436	47Ω
C17	22551	disc, 22uuf	R11, 12	10400	10KΩ
C8, 11, 28	22515	disc, 500uuf	R13	10851	22KΩ, 1W
C9	29006	tuning, sweep	R14	10418	4.7MΩ
C10	24001	elect., 2 x 20ufd, 450V	R15	10407	1MΩ
C12	20501	tubular, 2ufd, 150V	R16	14309	7000Ω, 10W
C13	20056	tubular, 1ufd, 200V	R17	18017	potentiometer, 2MΩ
C14	22522	disc, 330uuf, 500V	R18	10849	47KΩ, 1W
C16	22503	disc, .01, 1500V	R20	10844	330KΩ, 1W
C22, 30,	22521	disc, .001ufd, 500V	R21	10446	270Ω
C18, 21	22023	tubular, 2uuf	R22	18112	potentiometer, 100KΩ
C19	29007	tuning, marker	R23, 32, 33, 34	10429	470Ω
C23, 29	22528	disc, 2 x .005ufd	R24, 42	10428	47KΩ
C24	22526	disc, .005ufd	R26	10424	22KΩ
C25	20067	tubular, .25ufd, 200V	R27	18115	potentiometer, 200Ω
C26	23010	elect., 10ufd, 150V	R28, 29, 30	10437	56Ω
C27	23015	elect., 50ufd, 150V	R36	10450	3900Ω
C31	20026	tubular, .047ufd, 600V	R37	10855	4700Ω, 1W
<u>COILS</u>					
L1	36011	variable	R38	10426	33KΩ
L2	36012	variable	R39	10956	10KΩ, 2W
L3	36013	variable	R40	10852	15KΩ, 1W
L4	35021	25uh, plain core	R41	18114	potentiometer, 10KΩ
L5	37010	controllable inductor	<u>SWITCHES</u>		
L6	35052	100uh, plain core - 3 pi	S1	60122	rotary, marker
L7, 8	35020	25uh, iron core	S2	60123	rotary, attenuator
<u>RESISTORS</u>					
(All resistors are 1/2 watt, 10% unless noted otherwise)					
R1	18111	potentiometer, 2MΩ, w/SPST	S3	60124	rotary, range
R2, 19, 35	10410	100KΩ	S4	18111	ON-OFF on R1
R3, 6	10412	330KΩ	<u>TUBES</u>		
R4	18113	potentiometer, 100KΩ	V1	90013	12AU7
R5	10406	680Ω	V2	90052	6BQ7A
R7, 25	10430	4700Ω	V3	90034	12AX7
			V4	90088	6DR7
			V5	90012	12AT7
			V6	90036	6X4

SYM. #	STOCK#	DESCRIPTION	SYM. #	STOCK#	DESCRIPTION
<u>TUBE SOCKETS</u>					
XV1, 3, 4, 5	97081	9 pin miniature		89526	sleeve, black (2)
XV2	97005	9 pin wafer		89564	nosepiece probe (2)
XV6	97022	7 pin miniature		89672	sleeve, small, black (1)
<u>TERMINAL STRIPS</u>				89679	bracket, handle mtg. (2)
TB1, 10	54004	2 post w/gnd.		89680	plate, handle mtg. (2)
TB2, 4, 8	54006	3 post, 2 right		89741	dial, plastic sweep (1)
TB3	54008	4 post		89742	dial, plastic marker (1)
TB5, 7, 14	54002	1 post right w/gnd.		89747	housing, probe demod. (1)
TB6	54000	1 post left	40000	89748	housing, probe RF out (1)
TB9, 13	54015	3 post, 2 left w/gnd.	40001	<u>HARDWARE</u>	
TB11	54060	3 post left	40007	nut, hex, #6-32	(20)
TB12	54005	2 post right w/gnd.	40016	nut, hex, 3/8"	(8)
TB15, 16	54016	3 post upright, left	40017	nut, hex, #4-40	(17)
<u>MISCELLANEOUS</u>			40022	nut, hex, 1/2"	(1)
CR1	93003	rectifier, 50mA	40045	nut, Tinnerman #8	(2)
F1	91002	fuse, 1 Amp	41003	nut, hex, #4-40	(5)
I1	97715	neon indicator	41069	nut, hex, #8-32	(4)
J1	50036	connector, female, 2-cond.	41089	screw, #8-32 x 3/8	(6)
J2, 4	50002	connector, male	41086	screw, set # 6-32 x 1/8	(4)
J3	97500	socket, crystal	41090	screw, #6-32 x 1/4, Fl. Hd.	(3)
P1	50037	connector, male, 2-cond.	41095	screw, #6-32 x 5/16	(35)
P2, 3	51000	connector, female	41125	screw, #6-32 x 3/16, Rd. Hd.	(1)
PC1	29757	printed circuit	41140	screw, #4-40 x 5/16	(16)
PC2	29756	printed circuit		screw, #2-56 x 1/4	(4)
PC3	29758	printed circuit		screw, #4-40 x 5/8, Rd. Hd.	(1)
T1	30002	transformer, power		screw, #6-32 x 1/4, self-tapping, Ph. Rd. Hd.	(10)
XF1	97805	fuseholder	42000	washer, lock, 3/8"	(9)
	46016	foot, plastic (4)	42001	washer, flat, 3/8"	(8)
	49000	crystal, 4.5mc (1)	42002	washer, lock, #6	(42)
	51502	clip, alligator (4)	42007	washer, lock, #4	(16)
	53036	knob, 1-1/16 dia. (7)	42008	washer, lock, #8	(4)
	53052	knob, 1-1/2 dia. (2)	42019	washer, rubber probe	(2)
	54512	board, probe (2)	42020	washer, fibre	(8)
	57004	line cord	42029	washer, rubber 1/2"	(1)
	58444	cable, 2-cond. one w/shield (1)	42511	retainer, neon indicator	(1)
66151		manual of instructions (1)	43000	lug, #6	(1)
66391		manual of construction (steps) (1)	43001	lug, pot., 3/8"	(3)
		manual of construction (figures) (1)	43005	lug, spade for probe	(3)
82101		strain relief, line cord (1)	44009	standoff	(8)
84000		drive, vernier (2)	47001	spring, spade for probe	(2)
87007		handle, plastic (1)	<u>SHEET METAL</u>		
89525		sleeve, red (2)	80096	panel, front	(1)
89320		label, nomenclature (1)	81251	chassis, main	(1)
			81252	chassis, sweep sub	(1)
			81253	chassis, marker sub	(1)
			81254	shield w/lugs	(1)
			81984	bracket, Xtal socket	(1)
			86007	frame	(1)
			88114	cabinet	(1)

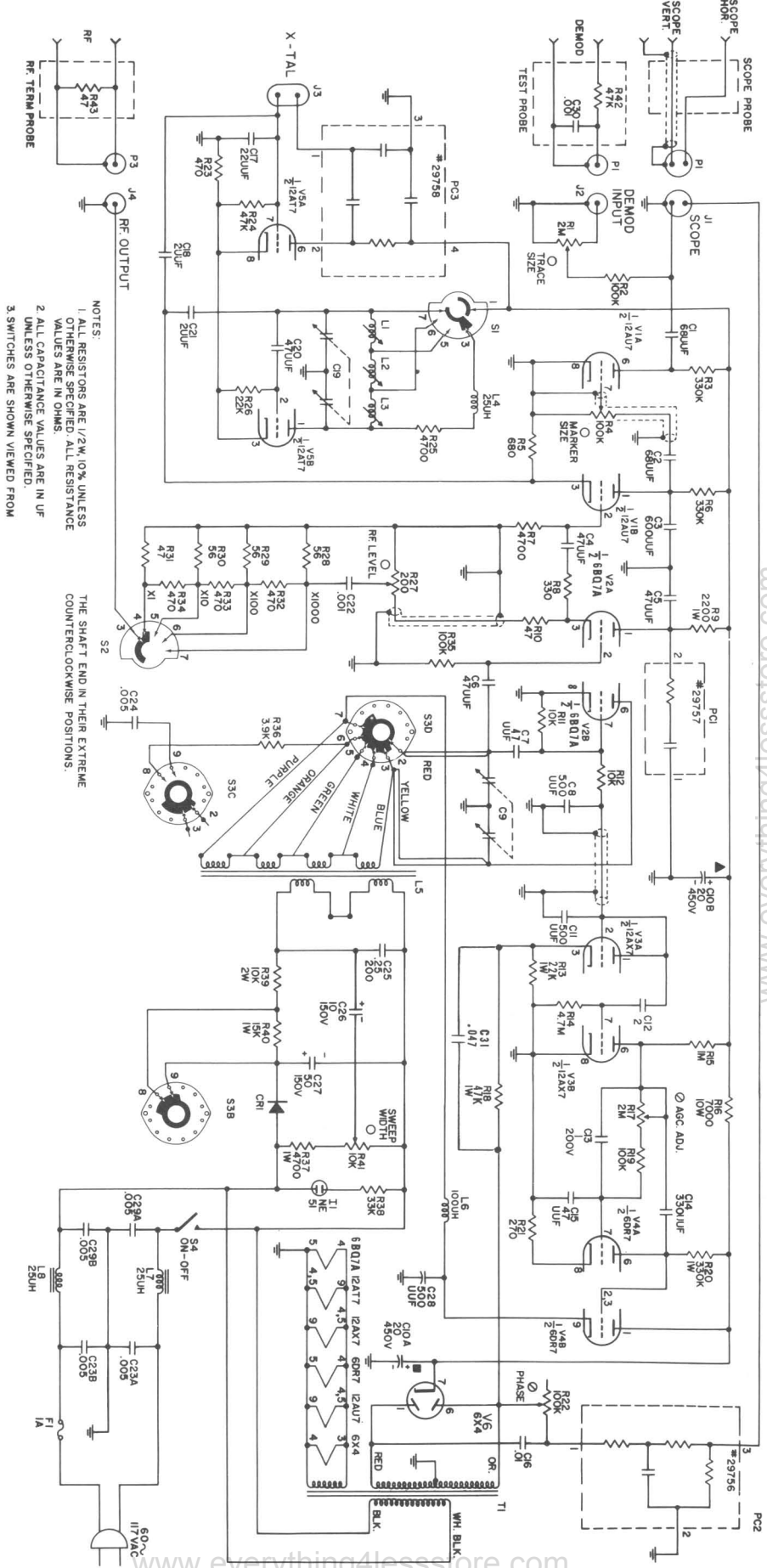

SCHEMATIC DIAGRAM

- NOTES:
- 1 ALL RESISTORS ARE 1/2W, 10% UNLESS OTHERWISE SPECIFIED. ALL RESISTANCE VALUES ARE IN OHMS.
 - 2 ALL CAPACITANCE VALUES ARE IN UF UNLESS OTHERWISE SPECIFIED.
 - 3 SWITCHES ARE SHOWN VIEWED FROM

THE SHAFT END IN THEIR EXTREME COUNTERCLOCKWISE POSITIONS.

EICO

Electronic Instrument Co., Inc.

EICO SERVICE BULLETIN

ESB No. 15
August 6, 1964

TO: All EICO Service Agencies
FROM: Henry Berlin
SUBJECT: Blowing of Fuses in Model 369 Sweep and Marker Generator

PROBLEM: Excessive current drain in 369, causing fuses to blow.

CAUSE: Shorting plates, or dust between plates, of rotor and stator sections of C9 and/or C19 tuning capacitors.

SOLUTION: Blow out dust with a blast of dry air or clean with a thin sheet of stiff paper.

Determine if plates are shorting by rotating tuning capacitors so plates are fully open (high frequency end). Then rotate slowly to close. If fuse blows or output falls off, check carefully for bent or warped plate and straighten. Use care not to bend plates unnecessarily or to create new shorts.

JUL 21 1966

EICO

Electronic Instrument Co., Inc.

EICO SERVICE BULLETIN

ESB No. 97
June 13, 1966

TO: All EICO Service Agencies
FROM: Henry Berlin
SUBJECT: Addenda IE 1630 and IE 1631 for Model 369 Sweep Generator

The modification called for in these addenda is the addition of a .001 mfd capacitor to across the filaments of the 6BQ7A.

This is designed to eliminate some cases of suck-out and is in addition to the suggestions made in the service notes in ESB-90.

Please place the bulletin and addenda in your manual.

www.everything4lesstore.com

EICO

Electronic Instrument Co., Inc.

EICO SERVICE BULLETIN

ESB No. 90

April 22, 1966

TO: All EICO Service Agencies
FROM: Henry Berlin
SUBJECT: Some service notes on Model 369

A) We sometimes run into cases in which incorrect harmonics have been used to calibrate the marker oscillator.

1. It is imperative that the tuning capacitor be fully meshed when the vertical line at the low frequency end of the dial coincides with the index line on the front panel.

2. Coils should be adjusted for zero beat at 4.5 mc. on Band A, 9 mc. on Band B, 40.5 mc. on Bands C and D. If a 5 mc. crystal is used, zero beat at 5, 10 and 40 mc. respectively.

3. Bend outer rotor plates of tuning capacitor outward if necessary for improved accuracy at the extreme low end of each band. After adjusting plates, recheck coil adjustments. We do not specify an accuracy for the marker oscillator. However, an accuracy of $\pm 3\%$ is frequently possible. The variable marker was intended for interpolation purposes, between harmonics generated by the crystal oscillator.

B) We do not expect a perfectly rectangular or flat trace from the 369. The corners may be slightly rounded and the trace may have "hills and valleys".

"Hills and valleys" should be reduced to a minimum with the AGC control. Sometimes "hills and valleys" are caused by standing waves on the RF output cable. To isolate this possibility, we would suggest using a short (6"-8") piece of 52 ohm coaxial cable terminated with a 47 ohm load resistor. If this eliminates or considerably reduces "hills and valleys", the problem has been pinned down to standing waves on the cable. Such standing waves should not affect the performance of the 369 in its normal application for receiver alignment.

C) In the event of "suck-out" (loss of output) on the high frequency ranges, as shown by exaggerated "hills and valleys":

1. Replace 6BQ7A - use a GE tube.
2. Ground 6BQ7A filament to the closest possible point on the chassis (leads must be very short); dress the leads per manual; use tinned copper braid to ground the far end of the tuning capacitor frame to the nearest 3-point tie strip.

EICO

Service Policy

PARTS REPLACEMENT

If it appears that a component is defective, and you desire a replacement, contact your EICO Distributor, the nearest EICO Authorized Service Agency or our Customer Service Department.

If you are claiming the right to a no-charge replacement under the terms and conditions of the warranty, it is required that you shall have sent in the registration card within 10 days of the date of purchase, and that you send back the defective part transportation prepaid. In claiming warranty service or parts, please send or show your original sales slip plus the IBM card from the carton. EICO or its authorized agency will make the necessary replacement at no charge for parts eligible under the terms and conditions of the warranty. In returning tubes, pack them very carefully to avoid breakage in shipment. Broken tubes will not be replaced. Please read the warranty on the subject of parts eligible for replacement.

Further information required on a part returned for a no-charge replacement under the terms and conditions of the warranty is as follows:

- a) Model number and serial number, if any, of unit. Also any code numbers in red under the words INSTRUCTION MANUAL on the cover of the book supplied with the unit or Revision number, such as Rev. 1, Rev. 2, etc.
- b) Stock number and description of part as given on the parts list. If the part is not listed (of itself) in the parts list, it means that the part is integral with a sub-assembly, which we consider replaceable only as an entity. Parts integral with a sub-assembly may be listed in the parts list, so identified, if we consider that some or all of the parts may be individually replaced in the field under appropriate circumstances. If your unit is out of warranty, you are generally advised to order a replacement sub-assembly.
- c) Describe as completely as possible the nature of the defect, or reason for requiring replacement.

REPAIR SERVICE

EICO maintains a national network of authorized service agencies, in addition to repair facilities at the factory, for in-warranty or out-of-warranty repair of EICO equipment. It is intended to serve those customers who are not sufficiently familiar with electronics to make use of the EICO Service Consultation facilities, or whose difficulties cannot be solved by correspondence.

For all out-of-warranty units repaired at the factory there is a minimum labor and handling fee. Charges for parts replaced are additional to the minimum fee.

For in-warranty completed kit units repaired at the factory there is a minimum labor and handling fee. There is no charge for a replaced defective part provided that the terms and conditions of the warranty for no charge replacement are not violated in the judgement of EICO.

For in-warranty factory-wired units, there is no charge for labor or parts if the unit complies with the terms and conditions of the warranty in the judgement of EICO. However, if the terms and conditions of the warranty are violated there will be a charge for labor plus parts.

In all cases, the unit must be sent to the factory or service agency transportation prepaid, and the unit will be returned to the customer transportation collect.

On kits, the services rendered for the minimum labor and handling fee by the factory are the correction of any minor wiring errors (not extensive corrections or rewiring), the labor involved in replacing defective parts, and any adjustments, alignment, or calibration procedures that would normally be performed on a factory-wired unit. Units not wired according to instructions, or modified in any way, or showing evidence of the use of acid core solder, will not be serviced and will be returned to the customer forthwith.

SEE SCHEDULE OF FACTORY SERVICE CHARGES

Units requiring extensive corrections or rewiring will incur an additional labor charge. An advance estimate will be submitted.

Please note: minimum labor and handling fees and service charges are subject to revision at any time.

LOCAL REPAIR FACILITIES

A list of authorized service stations is provided with your manual. The roster of stations may change from time to time, and if considerable time has elapsed since you purchased your unit, you are advised to contact the station you choose before sending the unit to them for repair. Use of a local service station will often result in faster service, and, usually, lower transportation costs.

It is necessary that you comply with the Shipping Instructions that follow when sending in a unit for service.

SHIPPING INSTRUCTIONS

You are strongly advised to retain the original shipping carton and inserts should reshipment be required for service or any other purpose. The carton may be collapsed for storage in as small a space as possible. In very many cases, the same carton is used for kit and factory-wired units so that the kit carton will serve for reshipment of the completed kit.

When sending a unit for service pack the unit very carefully, preferably in the original shipping carton with the original inserts. Be sure to place the bottom plate, cover, and supporting bracket, if any, on the unit before shipping.

If this is not possible, use a strong oversize carton, preferably wood, and using at least 3 inches of resilient packing material such as shredded paper or excelsior inserted between all sides of the unit and the carton. Seal the carton with strong gummed paper tape or strong twine or both. Attach a tag to the instrument on which is printed your name and address and brief reference to the trouble experienced. Affix "FRAGILE" or "HANDLE WITH CARE" labels to at least four sides of the carton or print these words large and clear with a bright color crayon. Ship prepaid.

Include your name and address on the outside of the carton. Return shipment will be made transportation charges collect. Note that a carrier cannot be held liable for damage in transit, if packing, IN HIS OPINION, is insufficient.

EICO THE EICO WARRANTY **EICO**

The Electronic Instrument Company, Inc., hereafter referred to as EICO, warrants that, for a period of 90 days from the date of purchase, any EICO kit will be free of defects in parts, and that any EICO factory-wired unit will be free of defects in parts and workmanship. For an EICO kit, EICO's obligation is limited to those parts which are returned transportation prepaid to the factory or authorized service agency without further damage, and in the judgement of EICO are either originally defective or have become defective in normal use. EICO's obligation does not include any labor required to locate trouble in or repair a kit. For an EICO factory-wired unit, EICO's obligation is limited to replacement or repair, at EICO's option, of those parts, sections, or entire units returned transportation prepaid to the factory or authorized service agency without further damage, and in the judgement of EICO are either originally defective or have become defective in normal use.

The warranty does not apply to any parts damaged in the course of handling, assembling, or wiring by the customer, or damaged due to abnormal usage or in violation of instructions or reasonable practice, or further damaged to a consequential degree in return shipment. Furthermore, the foregoing warranty is made only to the original customer, and is and shall be in lieu of all other warranties, whether expressed or implied, and of all other obligations or liabilities on the part of EICO, and in no event shall EICO be liable for any anticipated profits, consequential damages, loss of time, or other losses incurred by the customer in connection with the purchase or operation of EICO products or components thereof.

The registration card, which accompanies each EICO kit or factory-wired unit, must be filled in and returned to the company within 10 days after the date of purchase. This warranty applies only to registered units.

SCHEDULE OF FACTORY SERVICE CHARGES

(Consult your local EICO authorized service agency for THEIR charges.)

1. Same prices for wired units or completed kits.
2. Charges are based on the schedule of minimum charges above.
3. All labor charges are calculated at \$7.50 per hour. For example, if the minimum labor and handling fee is \$15.00, this covers up to 2 hours. Any labor time (in this example only) required over 2 hours is charged for at \$7.50 per hour.
4. Above prices are for labor only. Parts are additional.
5. ESTIMATES: An estimate for repairs will be given before repairs are made where repairs will exceed stated minimum charges. If you choose not to have your unit repaired, a charge of \$3.00 for estimating time will be made.
6. All prices are subject to change without notice.

CRA & CRU	...	\$ 3.50	488	\$ 5.00
Probes	3.50	495	5.00
AF4	7.50	526	5.00
RA6	5.00	536	5.00
HF12	7.50	540	5.00
HF14	5.00	555	5.00
HF20	10.00	556	5.00
HF22	5.00	565	5.00
HF30	5.00	566	5.00
HF32	9.50	567	5.00
HF35	5.00	584	5.00
ST40	15.00	610	5.00
HF50	5.00	612	5.00
HF52	10.00	615	5.00
HF60	5.00	625	6.00
HF61	6.00	628	7.00
HF61A	6.00	630	5.00
HF65	6.50	632	7.00
HF65A	6.50	636	5.00
ST70	15.00	666	10.00
HF81	13.50	667	10.00
ST84	10.00	680	6.00
HF85	8.00	706	5.00
HF86	9.00	710	5.00
HF87	9.00	711	7.00
HF89	9.00	712	10.00
HFT90	7.50	715	5.00
HFT92	9.00	717	7.50
HFT94	7.50	720	13.50
ST96	13.50	722	9.00
ST97	13.50	723	10.00
MX99	7.50	730	10.00
RP100	30.00	740	9.00
Playback Amp only	7.50	751	11.00
Power Supply only	7.50	752	11.00
Record Amp only	7.50	753	25.00
Head Alignment		760	9.00
only	10.00	761	9.00
145	5.00	762	9.00
145A	5.00	770	12.00
147	5.00	771-2	12.00
214	6.00	777	20.00
221	6.00	779, A	17.00
222	7.00	791	5.00
232	6.00	803	5.00
235	6.50	888	6.00
249	6.00	902	25.00
250	7.00	944	5.00
255	7.00	950	5.00
260/261	7.00	955	6.00
315	6.00	965	15.00
320	5.00	1020	5.00
322	5.00	1030	10.00
324	5.00	1040	7.50
342	15.00	1050	5.00
352	5.00	1055	5.00
360	5.00	1060	5.00
368	12.50	1064	6.00
369	12.50	1073	5.00
377	6.00	1078	5.00
378	7.00	1100	5.00
380	16.00	1120	5.00
425	6.00	1140	5.00
427	12.50	1171	5.00
430	12.50	1180	5.00
435	15.00	2036	13.50
460	15.00	2050	13.50
470	15.00	2080	13.50
			2200	10.00
			2400	20.00
			2510	12.00
			2536	17.50
			2715/16	10.00
			3070	12.00
			3200	12.00
			3566	25.00
			3570	26.25
			4000	20.00
			7923	19.00

AUTHORIZED WARRANTY SERVICE AGENCIES

ALABAMA

Birmingham
Nelco Service Co.
2900 - 4th Ave. S.

Mobile
Universal Electronics & Instr. Svce.
3058 Brookline Dr. W.

Montgomery
Audio Service Center
319 Fleming Rd.
(Hi-Fi Only)
G & T Electronics
18 Davis Dr.
(CB Only)

ARIZONA

Phoenix
ABC-2-Way Radio Comm.
1844 E. Indian School Rd.
(CB Only)

Tucson
Park Music Shop
1702 E. Speedway

CALIFORNIA

Anaheim
United Sound & TV Co.
2010 W. Lincoln Ave.

Barstow
Roy's Communications Svce.
615 E. Main St.

Los Angeles
Electronic Instruments Service
8921 S. Vermont Ave.
United Sound & TV Co.
5036 Venice Blvd.

Orange
Electro Tech Svce. Co.
417 S. Main St.

San Diego
Lewton's Radio & TV
4251 University Ave.
(High Fidelity Only)

San Francisco
California Sound Engineers
475 Barneveld Ave.
(Hi-Fi, CB & Ham Only)
Guaranteed Electronics Repair
5822 Mission St.

COLORADO

Colorado Springs
Clyde N. Still
2630 W. Kiowa St.

Denver
A. B. & K. Service, Inc.
1459 South Pearl St.

CONNECTICUT

Groton
Francis Electronics, Inc.
565 Long Hill Rd.

CONNECTICUT (cont'd)

Hartford
Herbert Electronics
1081 Capitol Ave.

New Haven
Baltimore Electronics
546 Whalley Ave.
(Hi-Fi Only)

Norwich
La Course Radio-Electric Svce.
184 Franklin St.

DISTRICT OF COLUMBIA

Bethesda
American Technical Services
4925 Bethesda Ave.

FLORIDA

Miami
Spire Audio-Visual Co.
24 N. W. 36th St.

North Miami Beach
Southeastern Communications, Inc.
2055 N. E. 151st St.

Orlando
Electronics Service Labs.
1024 N. Mills

Tampa
Maurice Wood
1949 W. Buffalo

Sylvania Service Center
1602 Florida Ave.

GEORGIA

Atlanta
S. A. Sparks Communication Svce.
1052 Memorial Drive S. E.

IDAHO

Twin Falls
TV Tuner Service
P. O. Box 793

ILLINOIS

Chicago
Banks Electronics
5107 W. Division St.

Electronic Engineers, Inc.
1639 W. Evergreen (1300 N.)

Oak Park

B. & S. Electronics
6326 W. Roosevelt Rd.

Peoria Heights

Put's Radio-Sales
737 E. Marietta
(CB Only)

IOWA

Cedar Rapids
Gene's Radio & TV
503-8th Ave. S. E.

Sioux City
Mar-Bon, Inc.
Route 2, Box 138
(CB & Ham Only)

KENTUCKY

Louisville
Maury's Fluorescent & Appl. Svce.
962 South 3rd St.

A & T Two-Way Radio
2339 Rockford Lane
(CB Only)

LOUISIANA

New Orleans
Transistor Electronics Svce. Co.
Room 5, Bldg. 17
Foreign Trade Zone
Foot of Napoleon Ave.
(Phone: 899-9505)

Shreveport

Audio & Instrument Assoc.
5511 Sussex Street

MAINE

Portland
Bartlett Radio Co.
181 Brackett St.

MARYLAND

Baltimore
Clayton Electronics, Inc.
5940 York Rd.

Bethesda

American Technical Services
4925 Bethesda Avenue

MASSACHUSETTS

Boston
Park Armature Co.
1218-30 Columbus Ave.

Worcester

Audio-Visual Associates
8 Boylston St.

MICHIGAN

East Detroit
Sealand Electronics, Inc.
23043 Gratiot

Lincoln Park

Lincoln Park Sound Svce.
2884 Fort Street

MISSOURI
St. Louis
Scherrer Instruments
5449 Delmar Blvd.

A. A. Kelley Radio & Elect. Svce.
4181 Manchester

NEBRASKA
Lincoln
Electronics Associates
2238 "O" St.

Omaha
Hi-Pix Stereo Service
3427 S. 42nd St.

NEW HAMPSHIRE
Manchester
Roland Demers Svce. Co.
436 Maple St.
Wholesale Electronics Corp.
40 Bridge St.

NEW JERSEY
Riverside
Dixey-Bonas TV
52 Scott St.

Singac
Hosica Laboratories
715 Main St.

NEW MEXICO
Albuquerque
The Audio Clinic
1510 Eubank Blvd., N. E.

NEW YORK
Albany
Baker Electronics
514 Second St.

Binghamton
Ross' Radio & TV Service
116 Main St.

Hastings on the Hudson
(Westchester County)
Central TV & HI-FI Service
543 Warburton Ave.

Huntington Station
Suffolk Sound Repair, Inc.
1671 New York Ave.
(Hi-Fi & Test Eqpt. Only)

Mineola
Ethical Electronic Service
468 Jericho Turnpike

NEW YORK CITY

Manhattan
Winters' Radio Laboratory
11 Warren St.

Brooklyn
G. M. T. V.
252 Prospect Park West

Queens
Electronic Servicenter
65-37 Queens Blvd.
Woodside
Great Northern Tronics, Inc.
145-04 Jamaica Ave.

NEW YORK CITY (cont'd)
Syracuse
Radio & Electronic Svce.
401 N. Townsend St. at Willow

Syracuse Communications, Inc.
2180 Erie Blvd. East
(CB & Ham Only)

Vestal
Compton Industries, Inc.
333 Vestal P'kway East

West Hempstead
Audotronic, Inc.
96 Hempstead Turnpike
(Hi-Fi & Test Equip. Only)

NORTH CAROLINA
Charlotte
Tryon Repair Service
3125 Tuckaseegee Rd.

Raleigh
Speed Instrument Co.
3028 E. Rothgeb Dr.

O H I O
Cleveland
Electronic Instrument Labs. Corp.
3617 Detroit Ave.
(Instr. & Test Eqpt. Only)

Dayton
Audio Labs.
3470 Salem Avenue

East Cleveland
Whitlow Electronic Corp.
2150 Noble Road

Toledo
Don's Electronics
1682 Belmont Ave.
(Hi-Fi & Tape Recorders Only)

OREGON
Portland
Mote's Communications
2927 S. E. 21st Ave.
(CB & Ham Only)

PENNSYLVANIA
Harrisburg
H. L. Crossley
549 S. 19th Street
(CB & Ham Only)

Havertown
Michael's TV & Radio Service
1127 West Chester Pike

Philadelphia
Electronic Servicenter
13 S. 21st St.

Sunshine Scientific Inst.
1810 Grant Ave.
(Inst. & Test Eqpt. Only)

Transistor Eqpt. Service Ctr.
2212 Glendale St.
Woodlyn
(Suburban Philadelphia)

Altron Electronics Co.
1309 Jefferson Ave.

PENNSYLVANIA (continued)
Pittsburgh
John's Radio & TV Svce.
917 Freeland Street

RHODE ISLAND
Pawtucket
Unique Radio Co.
736 Central Ave.

SOUTH CAROLINA
Charleston Heights
Custom Audio Lab.
2202 Meeting St.
(Hi-Fi & CB Only)

Greenville
Cantrell Whsl. Prod., Inc.
2570 N. Pleasantburg Dr.
(CB Only)

TENNESSEE
Chattanooga
Edwin Bohr/ Electronics
5880 Dayton Blvd.
(Instr. & Test Eqpt. Only)

TEXAS
El Paso
Test Equipment Co.
5319 Harlan Dr.
Ft. Worth
Knight's TV & Audio
1127 S. Main

La Feria
La Feria Radio & TV Service
Lubbock

Edwards Communications Svce., Inc.
1821 Avenue M
(CB Only)

Texas City
Ham's Communication Svce.
3001 Somerset Ave.

U T A H
Bountiful
Anderton Electronic Lab.
129 E. 1800 South
Provo

Brickey Electronics
1408 North 1750 West
Salt Lake City
Radio Electronics TV Svce.
1876 E. 2990 South

VIRGINIA
Arlington
Washington Electronic Service Co.
4112 Wilson Blvd.

Hampton
Central Electronics
4327 Kecoughtan Rd.
Virginia Beach
Hi-Fi Clinic
242 First Colonial Rd.

WASHINGTON
Seattle
Ron Merritt Co.
1320 Prospect St.

C A N A D A
Toronto, Ontario
John R. Tilton, Ltd.
51 McCormack St.

Weston, Ontario
EICO Canada, Ltd.
20 Millwick Drive

www.everything4lessstore.com

www.everything4lessstore.com

EICO—LEADER IN CREATIVE ELECTRONICS

For over 23 years, EICO has been designing and manufacturing electronic products and is now the world's largest producer of electronic kits and factory wired equipment marketed exclusively through dealers and distributors throughout the world.

Whatever your electronics interest, there's a wide range of versatile, professional EICO products for you to choose from, and each designed to provide you with the most pleasure and quality performance for your money.

The fact that more than 3 million EICO products are in use throughout the world attests to their quality and performance. EICO kits are so popular because they represent the best value and are available for inspection and immediate over-the-counter delivery at more than 2500 EICO dealers and distributors.

Should you have any questions about the selection or applications of any EICO product, you may at any time consult by mail with our technical correspondence staff. There's no charge for this service.

For your added convenience — EICO has set up a network of 200 service stations to make available to you on a local neighborhood basis the same high-quality technical service competence and replacement parts you get from our factory, should you ever need them.

The EICO Catalog is available to you Free for the asking. The catalog describes Eico's complete line of 200 "Best Buys" in Electronics. Cortina® Stereo Components, EICOCRAFT® Solid State electronic projects, Citizens Band 2-Way Radios, Automotive electronics, Amateur Radio equipment, Visutronic® Educational Training Aids, TRUVOHM® professional Multimeters and the famous EICO line of Test Instruments for home, shop, factory, laboratory and school.

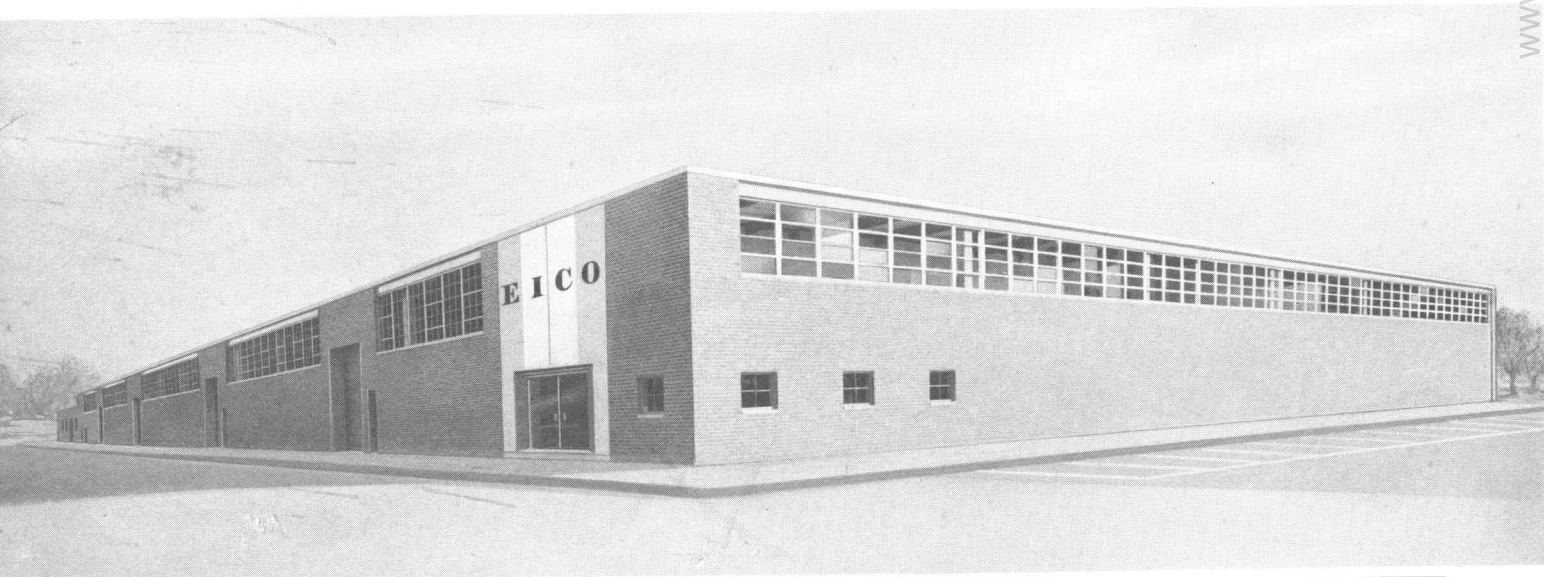

EICO Electronic Instrument Co., Inc., 283 Malta Street, Brooklyn, N. Y. 11207



MODEL 369-1 OPERATING MANUAL ADDENDUM

Please make the following additions to your Operating Manual:

Parts List:

Add C32 22521 disc .001ufd, 10% Z5U

Schematic:

Add a .001ufd, C32 Capacitor across pins 4 and 5 of Tube 6BQ7A

I.E. 1631 EICO Electronic Instrument Co., Inc., 131-01 39th Ave.,
Flushing, N.Y.

OPERATING MANUAL REVISIONS

Please make the following changes in your Operating Manual:

Wherever noted, change Tube V2, FCC88/6DJ8 to 6BQ7A.

Page 16 Test Set-Up For Calibration and Adjustment. Add the following to the note:

To minimize hum pick-up, which distorts the response curve on the 'scope, it is most advisable to build the broadband detector into a shielding metal enclosure connected to ground.

Page 16, Fig. 6: The diode should be 1N48 or equivalent.

Page 17, Step 1: Change "counter-clockwise" in the first sentence to read: "clockwise".

Page 18, No. 4. The following replaces what was previously printed.

4. Advance the SWEEP WIDTH control to maximum. The RF ATTEN should be set at X1K and the RF LEVEL at 10 (minimum attenuation). Rotate the AGC level adjust potentiometer R17 (on the chassis) maximum counter-clockwise. Set the RF RANGE selector at Range E, and turn the RF 3-220mc dial through the entire frequency range while observing the pattern on the 'scope. If a dip or break in response occurs, as shown in Fig. 9A, 9B, turn the AGC level control R17 clockwise just enough to bring the amplitude down to where the dip disappears, as shown in Fig. 9C. (Note that the ultimate effect of adjusting R17 is not evident instantaneously. Make the adjustment in small increments and allow time for AGC action). Then set the RF RANGE selector at Range D, and again turn the RF 3-220mc dial through the entire range while observing the pattern on the 'scope. If a dip or break occurs on this range, turn AGC level control R17 further clockwise until the dip disappears. Proceed successively to Range C and Range B, and turn R17 as far clockwise as is required to eliminate any dip in the output curve on every band. No further adjustment of the AGC level control should be attempted on Range A. (Note that adjustment of R17 can only correct dips or breaks in the output of the swept oscillator, not irregularities due to resonances or hum pick-up in the broadband detector circuit. Therefore, be sure that the broadband detector is wired correctly as described previously, and preferably shielded by a grounded metal enclosure. In any case there will always be some residual hum, pickup which will cause distortion of the response curve on the 'scope, particularly evident on the high end of Band A because of the reduced output level. Note that the response curves depicted in Fig. 9 are idealized and do not show the irregular tilt that would be introduced by hum pickup.

Page 19, Nos. 3 and 4. The following replaces what was previously printed:

3. Set the MARKER RANGE selector at Range B. Set the MARKER 2-225 mc dial at 9mc. Adjust the slug in the Band B coil for zero beat. To confirm the correctness of the coil adjustment, check for zero beat at dial settings of 13.5mc and 18mc on the Range B scale. Re-do the coil adjustment if confirmation is not obtained.

4. Set the MARKER RANGE selector at Range A. Set the MARKER 2-225mc dial at 2.25mc. Adjust the slug in the Range A coil for zero beat. To confirm the correctness of the coil adjustment, check for zero beat at a dial setting of 4.5mc. This completes the calibration of generator. Adjustment of the instrument is now completed.

Page 26, Parts List: Change C7 from a 22uuf disc cap., to a 47uuf disc, cap., Stock No. 22533

Add the following to the Parts List:

C31 20026 cap., tubular, .047uuf, 600V
 Change the Sym. # on R13 to R18
 " " " R18 to R13
 Change tube V2 (90083) 6DJ8/ECC88 to (90052) 6BQ7A

Page 27 Parts List, Miscellaneous: plastic foot (46016) is duplicated, delete one.

Page 27 Parts List, Hardware: Change 3/8 lockwasher (42000) from 7 to 8.
 Change #6 lockwasher (42002) from 40 to 42.
 Change 97025 to 97081
 Change 97024 to 97022

Add the following hardware to your Parts List:

#6-32 x 1/4	setscrew (41061)	Amt.	4
#6-32 x 3/16	round head screw (41089)	"	1
#2-56 x 1/4	screw (41095)	"	4
fibre washer	(42020)	"	8
#6 lug	(43000)	"	1
standoff	(44009)	"	8

Page 28, Schematic Diagram: Change V2 from 6DJ8 to 6BQ7A
 Change C7 from 22uuf to 47uuf
 Change R13 from 47K to 22K
 Change R18 from 22K to 47K
 Add .047 tubular cap. C31 - parallel with R18
 Change C12 from 2uuf to 2uf

KIT ASSEMBLY MANUAL REVISIONS

Page 13, Fig. 5, Step 5: The color code for R11 is brown, black, orange, silver instead of yellow, violet, red, silver

Page 13, Fig. 5, Step 7: Change C7 from 22uuf to 47uuf

Page 15, Fig. 8, Step 2: Change the second sentence to read:

"Connect from XV5-2 (C) to XV5-8 (C)".

Page 15, Fig. 8, Step 5: Change XV5-8 (S2) to read XV5-8 (S3).

- Page 16, Step 8: Secure S2 with one 3/8" flatwasher and one 3/8" hex nut.
 Page 17, Step 4: Change the color of the wire from yellow to orange.
 Page 17, Step 5: Change the color of the wire from orange to yellow.
 Page 18, Step 25: Change the length of the wire from 2-3/4" to 3-1/4".
 Page 19, Step 20: Change the length of the wire from 10" to 9".
 Page 19, Step 24: Change the length of the wire from 1" to 1-1/2".
 Page 20, Step 29: Change the length of the wire from 1" to 1-1/2".
 Page 21, Step 11: Change 47K resistor (yellow, violet, orange, silver) R13 to 22KΩ resistor (red, red, orange, silver) R13.
 Page 21, Step 12: Change the 22KΩ resistor (red, red, orange, silver) R18 to 47KΩ resistor (yellow, violet, orange, silver) R18. Connect from TB7-2 (C) to TB8-1 (C).
 Page 21, Add the following step to Fig. 12:

19. () Cut both leads on a .047ufd, 400V tubular capacitor, C31 to 3/4". Connect from TB7-2 (C) to TB8-1 (S4).

- Page 21, Step 1: Change the color of the black/yellow lead to black/white.
 Page 22, Step 11: Change the disc, cap., from C30 to C23.
 Page 22, Step 21: Use the following step in place of Step 21:

"Connect a 9-1/2" piece of orange wire from XV6-6 (S3) to TB7-2 (S3).

- Page 24, Fig. 16: Figure 16 is the "Wiring of the RF OUTPUT cable".
 Page 24, Fig. 16, Step 3: Change resistor R45 to R43.
 Page 25, Fig. 17: Figure 17 is the "Wiring of the DEMOD cable".
 Page 26, Fig. 17, Step 3: Change resistor R44 to R42.
 Page 26, Fig. 17, Step 4: Change capacitor, C17 to C30.

Please make the following changes in your Assembly Figures:

- Fig. 5, Step 7: Change the 22uuf capacitor to 47uuf.
 Fig. 8, Step 2: Show the 22KΩ resistor connected from XV5-2 to XV5-8. Cross out lug "V" and correct lug "X" to read lug "W".
 Fig. 10: Change the color of the lead going to S1-6 from yellow to orange and the color of the lead going to S1-7 from orange to yellow.
 Fig. 12, Step 11: Change the 47KΩ resistor to 22KΩ.
 Fig. 12, Step 12: Change the 22KΩ resistor to 47KΩ.
 Fig. 12: Add step 19:

19. () Draw a .047ufd tubular capacitor connected from TE7-2 to TB8-1.

- Fig. 13: Change the color of the black/yellow lead connected to TE9-4 to black/white.
 Fig. 15: Change the color of the red lead connected to P1-1 to white and the color of the white lead connected to P1-2 to red.

The following instructions apply only if your kit is supplied with threaded-bushing type potentiometer, R17, in place of the snap-in type called for in the manual.

Please make the following changes in the Operating Manual Parts List:

Change quantity of 40001 3/8 hex nut from 8 to 9.

Change quantity of 42000 3/8 lockwasher from 9 to 10.

Please make the following changes in your Assembly Manual:

Page 8, Fig. 1, Step 16, change step as follows:

16 () Orient the lugs on the (18017) 2M POTENTIOMETER, R17, so that they are facing the rear apron of the chassis. Place a 3/8 lockwasher between the potentiometer and the chassis. Secure with a 3/8 hex nut.

On Construction Figure 1, Step 16, draw a 3/8 lockwasher between the potentiometer and the chassis. (A 3/8 hex nut secures it to the chassis).