

1692
RLC Digibridge®
Instruction Manual

Form 1692-0120-00/C2

©QuadTech, Inc., 1993
5 Clock Tower Place, 210 East
Maynard, Massachusetts, U.S.A. 01754
October, 2000

Telephone	978-461-2100
Sales	800-253-1230
Facimile	978-461-4295
Website	www.quadtech.com

The material in this manual is for informational purposes only and is subject to change, without notice. QuadTech assumes no responsibility for any error or for consequential damages that may result from the misinterpretation of any procedures in this publication.

Contents

Specifications
Warranty
Introduction -Section 1
Installation -Section 2
Operation -Section 3
Theory -Section 4
Service and Maintenance -Section 5
Parts Lists and Diagrams -Section 6



Product will be marked with this symbol (ISO#3684) when it is necessary for the user to refer to the instruction manual in order to prevent injury or equipment damage.



Product marked with this symbol (IEC417) indicates presence of direct current.

Instruction Manual Changes

These two supplementary pages contain information of improvements or modifications not documented in the current manual. All references to GenRad in the manual now apply to QuadTech, Inc.

Page iv -Table of Contents (Parts Lists and Diagrams -Section 6)

Power supply assembly, board layout and schematic (pages 6-13 & 6-14) replaced by Power supply assembly part number 700011.

Page ix -Specifications (Environment, Power Requirements & Weight)

Power should be 90 -250V AC, 50 -60 Hz. Voltage switching is automatic and no longer selected by rear panel switch. 60 watts maximum.

Weight should be 10 lbs. (4.5 kg) net, 15 lbs. (6.8 kg) shipping.

Environment reads, Altitude <2000m, Installation Category 1, Pollution Degree 1



Page 1-2 -Paragraph 1.2.1,1692 RLC Digibridge

Voltage switching is automatic and no longer selected by rear panel switch.

Page 1-7 -Figure 1-2, Rear Controls and Connectors

Rear view should show new power supply assembly (PN 700011) without line voltage switch.

Page 1-8 - Table 1-2, Rear Connectors and Controls

- Ref No. 1 -  External bias connector receives cable 1658-2450 (not supplied with instruments shipped after July 97, available on request). Fuse is 2/10A, 250V, 3AG Type, Fast Blow. Replace only with the same type and rating.
- Ref No. 3 - Air filter has been deleted.
- Ref No. 5 -  Fuse is 6/10A, 250V, 3AG Type, Slow Blow. Replace only with the same type and rating. To replace, remove fuse drawer by pressing up on release tab.
- Ref No. 6 - Line-voltage switch has been deleted, power input is from 90 - 250V AC.

Page 1-10 - Table 1-3, Accessories and Options

- A quantity of two spare fuses are supplied, 6/10A, 250V, 3AG Type, Slow Blow (QuadTech part number 5330-1100)
- Bias cable 1658-2450 with built-in fuse (not supplied with instruments shipped after July 97, available on request). A quantity of one spare fuse is supplied, 2/10A, 250V, 3AG Type, Fast Blow (QuadTech part number 5330-3200)

Page 2-1 - Safety Inspection



Before operating the instrument inspect the power inlet module on the rear of the unit to ensure that the **properly rated fuse is in place**, otherwise damage to unit is possible. Fuse is 6/10A, 250V, 3AG Type, Slow Blow.

The 1692 is shipped with a standard U.S. power cord, QuadTech PN 4200-0300 (with Belden SPH-386 socket or equivalent, and 3 wire plug conforming to IEC 320) or an approved international cord set. Make sure the instrument is only used with these or other approved international cord sets, which ensures the instrument is provided with connection to protective earth ground.

Instruction Manual Changes (continued)

In all installations the instrument should be positioned with consideration for ample air flow to the side and rear panel ventilation holes. An open space around the instrument of at least 3 inches (75mm) is recommend. The suuounding environment should be free from excessive dust to prevent contamination of electronic circuits.

WARNING

If this instrument is used in a manner not specified in this manual protection to the operator and equipment may be impaired.

Page 2-2 -Power-Line Connection

Power line switch for 115V or 230V operation has been removed, switching is automatic for voltages between 90 -250V AC.

Figure 2-2 does not apply. Only certified line cords which comply with IEC 227 or IEC 245 should be used.

Page 2-3 - Paragraph 2.6.2, External Bias

- Bias cable 1658-2450, (not supplied with instruments shipped after July 97, available on request).

Page 3-1 -Paragraph 3.1.2 Startup, step a

Power line switch for 115V or 230V operation has been removed, switching is automatic.

Page 5-3 -Paragraph 5.3, Repair and Replacement of Circuit Boards

Contacts for QuadTech are:	Sales	800-253-1230
	Technical Assistance	978-461-2100

Page 5-4 -Table 5-1, Caution Note

Power line switch for 115V or 230V operation has been removed, switching is automatic.

Page 5-8 -Figure 5-1, Rear and Bottom View

Rear view should show new power supply assembly (PN 700011) without line voltage switch.

Page 5-10 -Figure 5-3, Power Supply Assembly

Power Supply Assembly shown, PN 1689-2005, has been replaced by Power Supply Assembly- PN 700011

Page 5-12 -Paragraph 5.5.1, ~ Disassembly of 1692 Digibridge, step h and i

Delete step h, there is no longer a protective cover. CAUTION note does not apply, the fan has been removed.

Step i, the 700011 power supply is secured by only 4 screws rather than 5.

Page 5-13 -Figure 5-6, Removal of Power Supply Assembly

Power Supply Assembly shown, PN 1689-2005, has been replaced by Power Supply Assembly, PN 700011.

Instruction Manual Changes (continued)

Page 5-17 -Instrument Cleaning Instructions

Monthly (more or less depending on usage) the built-in test fixture should be cleaned with a soft brush and isopropyl alcohol. Avoid getting excess alcohol on instrument paint surfaces, otherwise damage to the finish can result. For additional instrument cleaning instructions refer to paragraph 5.6.1 (Care of the Test Fixture) and paragraph 5.6.3 (Care of the Display Panel).

Page 5-18 -Paragraph 5.6.2, Cleaning the Air Filter

Delete paragraph, air filter has been removed.

Page 5-25 -Paragraph 5.7.4, Power Supply

Trouble analysis procedure does not apply to the new Power Supply Assembly, PN 700011.

Page 6-2 -Figure 6-2, Rear View

Rear view should show new power supply assembly (PN 700011) without line voltage switch.

Page 6-3 -Mechanical Parts List, Rear

Items 4 through 7 (power connector, fuse extractor post, line voltage switch and cover) deleted on new power supply assembly.

Page 6-13 & Page 6-14 -Parts Lists and Diagrams

Power Supply Assembly shown, PN 1689-2005, has been replaced by Power Supply Assembly, PN 700011. The 700011 Assembly must be repaired by module exchange.

Table of Contents

SPECIFICATIONSv

WARRANTYxi

INTRODUCTION - SECTION 1

1.1 Purpose	1-1
1.2 General Description	1-2
1.2.1 1692 RLC Digibridge	1-2
1.2.2 Interface Options	1-2
1.2.3 References	1-2
1.3 Controls, Indicators, Connectors	1-2
1.4 Accessories	1-9
Condensed Operating Instructions	1-12

INSTALLATION - SECTION 2

2.1 Unpacking and Inspection	2-1
2.2 Dimensions	2-1
2.3 Power-Line Connection	2-2
2.4 Line-Voltage Regulation	2-3
2.5 Test-Fixture Connections	2-3
2.6 Bias Voltage for the DUT	2-3
2.6.1 Internal Bias	2-3
2.6.2 External Bias	2-3
2.7 Handler Interface (Optional)	2-4
2.7.1 Interface via IEEE-488 Bus	2-4
2.7.2 Timing	2-6
2.8 IEEE-488 Interface (Option)	2-8
2.8.1 Purpose	2-8
2.8.2 Interface Functions	2-9
2.8.3 Signal Identification	2-10
2.8.4 Codes and Addresses	2-11
2.9 Environment	2-14

OPERATION - SECTION 3

3.1 Basic Procedure	3-1
3.1.1 General	3-1
3.1.2 Startup	3-1
3.1.3 Zeroing	3-2
3.1.4 Routine Measurement	3-3
3.2 Connecting the DUT	3-4
3.2.1 General	3-4
3.2.2 Using Integral Test Fixture	3-5
3.2.3 Using Test Fixture Adaptors	3-6
3.2.4 1689-9600/-9605 Remote TF	3-8
3.2.5 1688-9600 Extender Cable	3-9

3.2.6 1657-9600 Extender Cable	3-10
3.2.7 Effects Cable/Fixture Cap.	3-10
3.2.8 The 1689-9603 Tweezers	3-11
3.2.9 1689-9606 Kelvin Clip Cable	3-12
3.3 Measurement Parameters, etc.	3-13
3.3.1 Parameters R/Q, L/Q, C/D, C/R	3-13
3.3.2 Equivalent Circuits	3-14
3.3.3 Results Displayed	3-16
3.3.4 Units, Multipliers	3-18
3.4 Principal Test Conditions	3-20
3.4.1 Test Frequency	3-20
3.4.2 Test Voltage	3-20
3.4.3 Constant-Voltage Source	3-21
3.4.4 Other Conditions	3-21
3.5 Measurement Time/Meas Ranges	3-22
3.5.1 General	3-22
3.5.2 Measure Rate Selection	3-22
3.5.3 Measure Mode/Display Select	3-22
3.5.4 Ranges, Range Changing, etc.	3-23
3.5.5 Time Required..Averaging	3-24
3.5.6 Time Required..IEEE-488	3-25
3.6 Accuracy, The Limits of Errors	3-25
3.6.1 General	3-25
3.6.2 Averaging-Improve Accuracy	3-26
3.6.3 Accuracy Enhancement, etc.	3-26
3.6.4 Accuracy-Holding Range	3-27
3.7 Bias For The DUT	3-27
3.7.1 Internal Bias	3-27
3.7.2 External Bias	3-28
3.8 Bin Sorting & GO/NO-GO Results	3-30
3.8.1 Introduction to Binning	3-30
3.8.2 Sorting Methods	3-30
3.8.3 Limit Entry Procedure	3-31
3.8.4 Verification Nominal/Limit	3-34
3.8.5 Limit Meas/Bin Assignments	3-35
3.8.6 Summary on Limit Entries	3-35
3.9 Keyboard Lock, Function Map, etc.	3-37
3.9.1 Keyboard Lock	3-37
3.9.2 Function Map	3-38
3.9.3 Summary of Interrogations	3-38
3.10 Operation With A Handler	3-39

3.11	Data Output/Progrmm'g-IEEE-488	3-40
3.11.1	IEEE-488 Interface Unused	3-40
3.11.2	Talk-Only Use	3-40
3.11.3	Talk/Listen Use	3-45
3.11.4	Data Output in Binary Frmt	3-51
3.12	Sample IEEE Programs	3-54
3.12.1	Programming Hints	3-54
3.12.2	Hewlett Packard HP85	3-54
3.12.3	Capital Equip'mt.PC-488	3-54
3.12.4	Nat'l Instru'mts GPIB-PCII	3-55
3.13	Self Checks & Failure Displays	3-55
3.13.1	Power-Up Self Check	3-55
3.13.2	Failure Display/Sig.Overld	3-56
3.13.3	Failure Display/Meas Cycle	3-56
3.13.4	Failure Display/LC Resn'ce	3-57

THEORY - SECTION 4

4.1	Introduction	4-1
4.1.1	General	4-1
4.1.2	Brief Description	4-1
4.1.3	Block Diagram	4-2
4.2	Principal Functions	4-4
4.2.1	Elementary Measurement Crt.	4-4
4.2.2	Frequency & Time Source	4-5
4.2.3	Sine-Wave Generation	4-6
4.2.4	Dual-Slope Intg.Det/Conv.	4-6

SERVICE - SECTION 5

5.1	Customer Service	5-3
5.2	Instrument Return	5-3
5.2.1	Return Material	5-3
5.2.2	Packaging	5-3
5.3	Repair/Replacement-Circuit Bds.	5-3
5.4	Performance Verification	5-3
5.4.1	General	5-3
5.4.2	Performance Verif.Procedure	5-4
5.5	Disassembly and Access	5-8
5.5.1	Disassembly	5-9
5.5.2	Access	5-15
5.5.3	IEEE/Handler Int. Options	5-16
5.5.4	Removal Multiple-Pin Pkgs.	5-17
5.6	Periodic Maintenance	5-17
5.6.1	Care of the Test Fixture	5-17
5.6.2	Cleaning the Air Filter	5-18
5.6.3	Care of the Display Panel	5-19
5.7	Trouble Analysis	5-19
5.7.1	General	5-19
5.7.2	Power-Up Self Check, etc.	5-21
5.7.3	Battery & Fuse Replace'mt	5-24
5.7.4	Power Supply	5-25
5.7.5	Sinewave Generator Checks	5-26
5.7.6	Front End Amplifiers/SWs	5-27

5.8	Accuracy Verification	5-28
5.8.1	General	5-28
5.8.2	Capacitance Meas-Sm/Med C	5-29
5.8.3	Capacitance Meas-Lg.C,Rng4	5-33
5.8.4	Resistance Meas.Accuracy.	5-36
5.8.5	D-Measurement Accuracy.	5-37
5.8.6	Inductance Meas.Accuracy.	5-39
5.8.7	Limit Comparison Bins	5-41
5.9	Recalibration	5-43
5.9.1	Preparation	5-43
5.9.2	Zeroing/Select-DQ in PFM	5-43
5.9.3	Recalibration for Range 4	5-44
5.9.4	Recalibration for Range 3	5-45
5.9.5	Recalibration for Range 2	5-46
5.9.6	Recalibration for Range 1	5-47
5.10	Internal Settings	5-48
5.10.1	Address IEEE-488 Interface	5-48
5.10.2	Making +5Volts Available	5-49

PARTS LISTS AND DIAGRAMS - SECTION 6

6.1	General	6-1
6.2	Reference Designations	6-1
6.3	Diagrams	6-3
	Figure 6-1 Front View	6-2
	Figure 6-2 Rear View	6-2
	Federal Supply Code for Mfg.	6-4
	Figure 6-3 Main Bd.,sch.sht1	6-5
	Figure 6-4 Main Bd.,layout sht1	6-6
	Figure 6-5 Main Bd.,layout sht2	6-7
	Figure 6-6 Main Bd.,sch.sht2	6-8
	Figure 6-7 Main Bd.,sch.sht3	6-9
	Figure 6-8 Main Bd.,sch.sht4	6-10
	Figure 6-9 Main Bd.,sch.sht5	6-11
	Figure 6-10 Main Bd.,sch.sht6	6-12
	Figure 6-11 Main Bd.,sch.sht7	6-12
	Figure 6-12 Power Supply,assy	6-13
	Figure 6-13 Power Supply,layout	6-14
	Figure 6-14 Power Supply,sch.	6-14
	Figure 6-15 Display Bd.,layout	6-15
	Figure 6-16 Display Bd.,sch.sht1	6-16
	Figure 6-17 Display Bd.,sch.sht2	6-17
	Figure 6-18 Interface OpBd.layout	6-18
	Figure 6-19 Interface OpBd.sch.	6-19
	Figure 6-20 Keyboard Mod.assy	6-20
	Figure 6-21 Keyboard Ind.,detail	6-20
	Figure 6-22 Keyboard,sch.	6-21

Specifications

MEASUREMENT PARAMETERS AND MODES

Series or parallel R and Q, L and Q or C and D or C and R selected by the EQUIVALENT CIRCUIT key and the R/Q, L/Q, C/D and C/R keys. Continuous, triggered (single) or averaged (choice of 1 to 10) measurements selected by the MEASURE MODE key. The START button initiates triggered or averaged measurements. Parameter selection is initially made automatically based on the DUT being measuring. Automatic selection is inhibited once a specific parameter key has been selected by the operator.

DISPLAYS: LED-TYPE NUMERICAL

When the MEASURE function has been selected, either VALUE, RLC, % or BIN NO. may be displayed. The VALUE display provides five digits for measured R, L or C value and four digits for D, Q or R, with automatically positioned decimal points, units of measurement and minus signs when appropriate. The RLC display indicates the difference between the measured R, L or C and a nominal value entered by the user with appropriate units (ohms, uF etc.). The R, L, or C difference display has five digits with a simultaneous four digit direct reading display of D, Q, or R with automatically positioned decimal points and minus signs when appropriate. The % display indicates the % deviation of the measured R, L or C value the stored nominal value. The display is five digits with a maximum resolution of one part per million with minus sign when appropriate. A four digit direct reading display of D, Q or R is simultaneously provided. The BIN NO. display provides a single digit bin assignment number based on the measured value and user entered bin limits. When the ENTER function has been selected the display will indicate either the nominal RLC value or bin limits, entered or recalled by the user.

MEASUREMENT RATES

Approximately 2, 4 and 8 measurements/second for the three keyboard MEASURE RATE selections SLOW, MEDIUM and FAST.

TEST FREQUENCIES

There are five test frequencies, 100Hz, 120Hz, 1kHz, 10kHz, and 100kHz selected by the SHIFT and FREQUENCY keyboard buttons. Frequency accuracy is .01%

APPLIED VOLTAGES

Ac test signals of 0.3 V or 1.0 V rms maximum selected by the SHIFT and VOLTAGE keyboard buttons. A CONSTANT VOLTAGE mode can be selected which provides a low source impedance (25 ohms) in order to maintain a constant ac test level over a wider impedance range. Internal dc bias is 2 V. External dc bias of up to 60 V may be applied.

CHARGED CAPACITOR PROTECTION

The instrument is protected from damage due to the connection of charged capacitors with up to 1 joule of stored energy.

CALIBRATIONS

An OPEN circuit zero calibration can be performed to remove the effects of stray capacitance and conductance shunting the internal test fixture or any other fixture or cable connection. A similar SHORT circuit zero calibration can be performed to remove the effects of resistance and inductance in series in the test connections. New zero calibrations should be made to obtain best accuracy whenever the test frequency or the fixture geometry is changed. A complete recalibration of the internal standards for each measurement range may be performed by using the optional 1689-9604 Calibration Kit.

RLC AND DQ RANGES

The table below gives the overall display ranges for the two quantities measured at the same time.

Parameters	RLC Ranges	DQR Ranges
R and Q	.00001 ohm to 99999 Mohm	.0001 to 9999
L and Q	.00001 mH to 99999 H	.0001 to 9999
C and D	.00001 pF to 99999 mF	.0001 to 9999
C and R	.00001 nF to 99999 mF	.0001 ohm to 9999 kohms

Measurement range is automatically set by the unit for best accuracy and resolution. Automatic ranging can be inhibited by the keyboard's RANGE HOLD key.

RLC AND DQ ACCURACY

The table below gives the RLC and DQ accuracy for measurements made at the SLOW rate. The RLC accuracy given is valid when the phase angle of the component measured is low (Q of $R < 0.1$, Q of $L > 10$ or D of $C < 0.1$). Additional factors are given below the table for other conditions. Each RLC accuracy expression has three terms: the basic accuracy (0.1% of reading), an added fixed error which dominates when measuring very low values and an added % error term which dominates when measuring very high values.

The DQ error is fixed (i.e., not a percent), and the expression given holds over the RLC ranges where the added low value or high value RLC error terms are negligible. These accuracy specifications assume that an OPEN and SHORT zeroing calibrations have been made at the selected test frequency.

RLC Accuracy

Parameters & Freq	Basic Accuracy	Extreme Low end	Range Terms High End	DQ Accuracy
R & Q, 100Hz 120Hz and 1kHz	+-0.05%	+ 1 mohm	+ R/20 Mohm %	$.0003(1 + Q^2)$
R & Q, 10kHz	+-0.1%	+ 1 mohm	+ R/10 Mohm %	$.0005(1 + Q^2)$
R & Q, 100kHz	+-0.2%	+ 5 mohm	+ R/500kohm %	$.001(1 + Q^2)$
L & Q, 100 & 120Hz	+-0.05%	+ 1.0 uH	+ L/20kH %	$.0003(1 + Q^2)$
L & Q, 1kHz	+-0.05%	+ 0.1 uH	+ L/2kH %	$.0003(1 + Q^2)$
L & Q, 10kHz	+-0.1%	+ 0.02 uH	+ L/50H %	$.0005(1 + Q^2)$
L & Q, 100kHz	+-0.2%	+ 0.02 uH	+ L/1H %	$.001(1 + Q^2)$
C & D, 100 & 120Hz	+-0.05%	+ 2 pF	+ C/20mF %	$.0003(1 + D^2)$
C & D, 1kHz	+-0.05%	+ 0.1 pF	+ C/2mF %	$.0003(1 + D^2)$
C & D, 10kHz	+-0.1%	+ 0.01pF	+ C/50uF %	$.0005(1 + D^2)$
C & D, 100kHz	+-0.2%	+ 0.02pF	+ C/1uF %	$.001(1 + D^2)$
C & R	C accuracy is the same as given above.			
	R accuracy is the same as given above plus one count.			

MEASUREMENT RATE FACTOR

Multiply both RLC and DQ accuracy specifications by the following based on selected measurement speed:

SLOW: 1 MEDIUM: 2 FAST: 5

HIGH D AND LOW Q EFFECTS ON RLC ACCURACY

Multiply the above RLC accuracy specifications as follows:

If Q of R is > 0.1 , multiply the R accuracy by $(1 + Q)$
 If Q of L is < 10 , multiply the L accuracy by $(1 + 1/Q)$
 If D of C is > 0.1 , multiply the C accuracy by $(1 + D)$

where D and Q are absolute values (minus sign removed).

CONSTANT VOLTAGE FACTOR

Multiply the basic RLC and DQR accuracies given above by 2 when the CONSTANT VOLTAGE mode is used.

DQ ACCURACY AT EXTREME RLC RANGE

When a High End or Low End RLC error term is not small in comparison to the basic RLC accuracies given above, multiply the above D or Q accuracies by the RLC accuracy (in percent) divided by the basic RLC accuracy (the first term in the accuracy formulas).

SORTING

10 Bins: 8 pairs of RLC limits, one DQ limit, one fail bin. GO/NO-GO lights.

DUT CONNECTIONS

There is a built-in test fixture which will accept most common axial and radial leaded components. Four-terminal (Kelvin) connections are made to the DUT.

KEYBOARD LOCK

The keyboard can be locked to prevent inadvertent changes to test conditions and sorting routines.

PARAMETER STORAGE

All keyboard settings and programmed nominal values and bin limits can be stored in non-volatile memory for automatic reentry upon power up.

SELF-CHECK DIAGNOSTICS

Self-tests are performed during power-up to verify proper operation and validity of calibration. Coded error signals on the display notify the operator if a problem is encountered.

INTERFACE OPTION

IEEE-488 Bus: All keyboard functions are programmable from the bus except for external bias control and internal standard recalibration. All RLC, DQ and bin data are available as output to the bus. Output data format is ASCII or Binary. The following functions, per IEEE-488, have been implemented:

- AH1 Acceptor Handshake (Listener)
- SH1 Source Handshake (Talker)
- T5 Talker with normal and talk only modes (switch selectable) .
- L4 Listener
- SR1 Service Request
- RL2 Remote/Local
- PP0 No Parallel Poll
- DC1 Device Clear
- DT1 Device Trigger
- C0 No controller functions

Handler Outputs: Sorting results; Bins 0 thru 9 (10 lines)
 ACQ OVER; (1 line) indicates end of data acquisition (component can be moved without affecting measurement results)
 EOT; (1 line) indicates end of test and that valid bin numbers for sorting are available.

Outputs are active low (open collector drivers rated at 30 V ~x. Each will sink 16 mA at 0.4 V. External power and pull-up resistors are required).

Handler Inputs: Start; (1 line) To initiate measurement.
 Input is active low ($0V < V_l < 0.4V$) and ($+2.5V < V_h < +5V$)

ENVIRONMENT

Operating; 0 to 50 degrees C, < 85% RH
Double specifications below 15 and above 35 degrees C.
Storage; -40 to +74 degrees C

ACCESSORIES SUPPLIED

Power cord, axial-lead adaptors, bias cable and instruction manual.

ACCESSORIES AVAILABLE

IEEE/Handler Interface, 1658-9620 (see above)
BNC Adaptor, 1689-9601
Extender Cable with alligator clips and banana jacks, 1657-9600
Extender Cable with Kelvin Clips, 1689-9606
Extender Cable with 874 connectors, 1688-9600
Extender Cable BNC to ENO, 1689-9602
SMD Tweezers, 1689-9603
Remote Test Fixtures, 1689-9600 or 1689-9605
Calibration Kit, 1689-9604

POWER REQUIREMENTS

90 to 125 V or 180 to 250 Vac, 50 to 60 Hz.
Voltage selected by rear panel switch. 50 W maximum.

MECHANICAL DIMENSIONS (W x H x D)

14.8" x 4.4" x 13.5" (375 x 112 x 343 mm)

WEIGHT

13 lbs (5.9 kg) net, 18 lbs (8.2 kg) shipping

Warranty



QuadTech warrants that Products are free from defects in material and workmanship and, when properly used, will perform in accordance with QuadTech's applicable published specifications. If within one (1) year after original shipment it is found not to meet this standard, it will be repaired, or at the option of QuadTech, replaced at no charge when returned to a QuadTech service facility.

Changes in the Product not approved by QuadTech shall void this warranty.

QuadTech shall not be liable for any indirect, special or consequential damages, even if notice has been given of the possibility of such damages.

This warranty is in lieu of all other warranties, expressed or implied, including, but not limited to any implied warranty or merchantability or fitness for a particular purpose.

SERVICE POLICY

QuadTech policy is to maintain product repair capability for a period of five (5) years after original shipment and to make this capability available at the then prevailing schedule of charges.

Introduction – Section 1

1.1	PURPOSE	1-1
1.2	GENERAL DESCRIPTION	1-2
1.3	CONTROLS, INDICATORS, AND CONNECTORS	1-2
1.4	ACCESSORIES	1-9
	CONDENSED OPERATING INSTRUCTIONS.	1-12

1.1 PURPOSE

The 1692 RLC Digibridge is a microprocessor- controlled, automatic, programmable RLC measuring instrument that provides accurate measurement, convenience, speed, and reliability at low cost. Limit comparison, binning, and internal bias are provided; both test frequency (five) and voltage level (two) are selectable. With an interface option, each Digibridge tester can communicate with other equipment and respond to remote control.

The versatile, built-in test fixture, lighted keyboard, and informative display panel make the Digibridge tester convenient to use. Measurement results are clearly shown with decimal points and units, which are automatically presented to assure correctness. Display resolution is 5 full digits for R, L, and C (4 full digits for D, Q, Rs with Cs, and Rp with Cp). Notice that Rs is also known as ESR (equivalent series resistance).

The basic accuracy is 0.05%. Long-term accuracy and reliability are assured by the measurement system, which makes these accurate analog measurements over many decades of impedance without any critical internal adjustments. Calibration to account for any change of test-fixture parameters is semiautomatic; the operator needs to provide only open-circuit and short-circuit conditions in the procedure. The Digibridge tester normally autoranges and automatically identifies the principal measurement parameter.

The test fixture, with a pair of plug-in adaptors (supplied), receives any common component part (axial-lead or radial-lead), so easily that insertion of the device under test (DUT) is a one-hand operation. True 4-terminal connections are made automatically. Extender cables are available for measurements at a moderate distance from the instrument. Refer to paragraph 1.4, ACCESSORIES. Limit comparisons facilitate sorting into 8 GO and 2 NO-GO bins.

Selectable test conditions include:

5 Test frequencies (100 Hz, 120 Hz, 1kHz, 10 kHz, and 100 kHz)

Test voltages (0.3 V or 1.0 V).

Measurement speeds up to 8 per second.

Multi-measurement routines with automatic averaging of 1 to 10 measurements.

Displays: measured values, percentages, differences, GO/NO-GO, binning

Automatic output of value, bin number, bin summary and other results via IEEE-488 bus when this option is used.

Bias can be applied to capacitors being measured, either by programming the selection of an internal supply (2 V) or by sliding a switch to connect an external voltage source (up to 60 V).

The IEEE/Handler option provides full "talker/listener" and "talker only" capabilities consistent with the standard IEEE-488 bus. (Refer to the IEEE Standard 488-1978, Standard Digital Interface for Programmable Instrumentation. See para 2.8, in Section 2.) A separate connector also interfaces with component handling and sorting equipment.

1.2 GENERAL DESCRIPTION

1.2.1 1692 RLC Digibridge

Convenience is enhanced by the arrangement of test fixture and controls on the front ledge, with all controls for manual operation arranged on a lighted keyboard. Above and behind them, the display panel is inclined and recessed to enhance visibility of digital readouts and indicators. These indicators and those at the keyboard serve to inform and guide the operator in manipulating the simple controls, or to indicate that remote control is in effect.

The 1692 instrument stands on a table or bench top. The sturdy metal cabinet is durably finished, in keeping with the long-life circuitry inside. Glass-epoxy circuit boards interconnect and support high-quality components to assure years of dependable performance.

Adaptability to any common ac power line is assured by the removable power cord and the convenient linevoltage switch. Safety is enhanced by the fused, isolating power transformer and the 3-wire connection.

1.2.2 Interface Options

The IEEE/Handler interface option adds I/O capabilities to the instrument, enabling it to control and respond to parts handling/sorting equipment. Also (via separate connector) this option can be connected in a measurement system using the IEEE-488 bus. Either "talker/listener" or "talker only" roles can be performed by the Digibridge, by switch selection.

1.2.3 References

Electrical and physical characteristics are listed in Specifications at the front of this manual. Interface connections and instrument dimensions are given in Installation, Section 2. Controls are described below in Section 1; their use, in Operation, Section 3. A functional description is given in Theory, Section 4.

1.3 CONTROLS, INDICATORS, AND CONNECTORS

Figure 1-1 shows the controls and indicators on the front of the 1692 instrument. Table 1-1 identifies them with descriptions and functions.

Similarly, Figure 1-2 shows the controls and connectors on the rear of the 1692 and Table 1-2 identifies them.

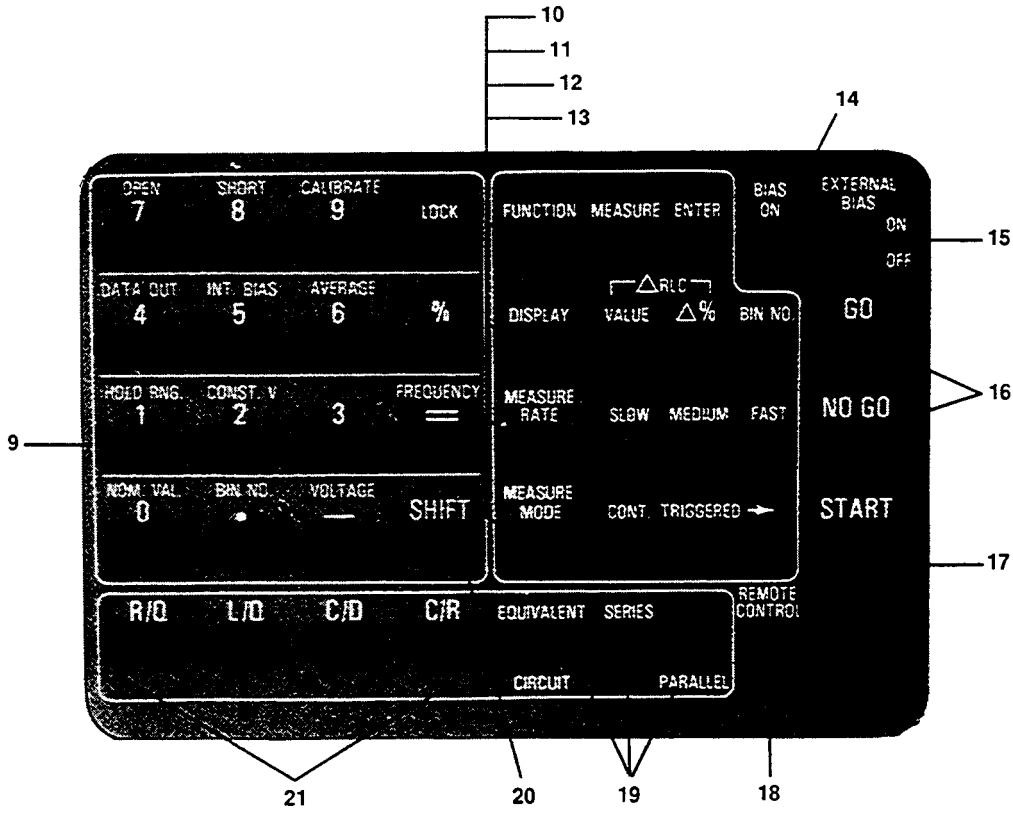
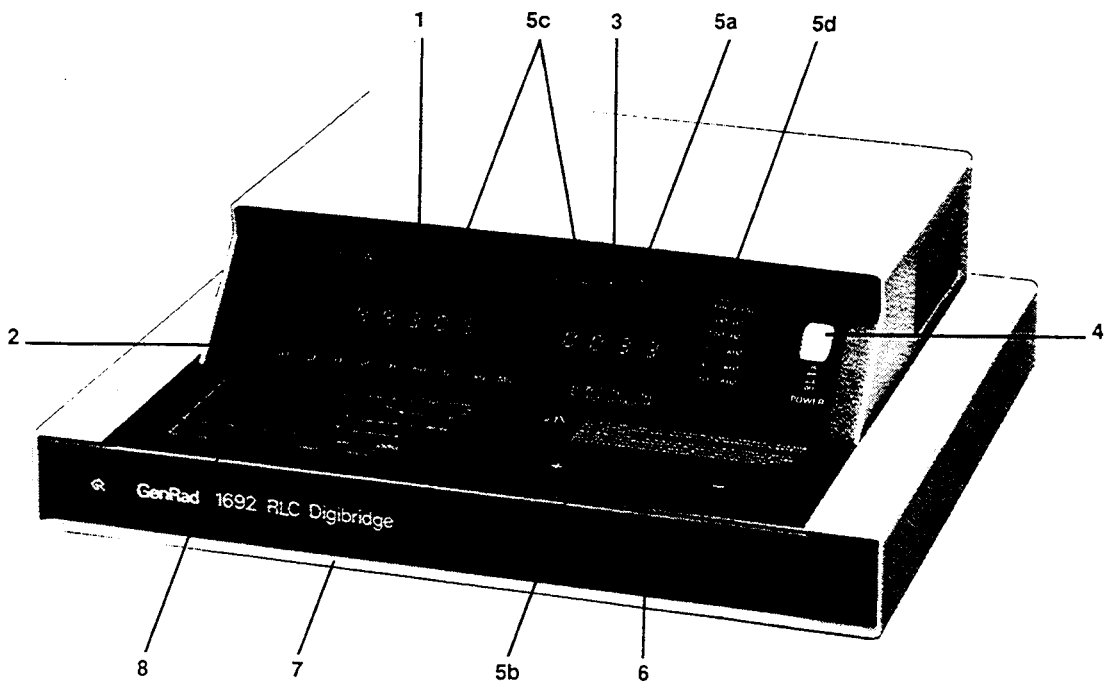

Figure 1-1. Front controls and displ;JYs. Upper illustration: 1692 RLC Digibridge.
Lower illustration: keyboard detail.

Table 1-1
FRONT CONTROLS AND INDICATORS

Fig. 1-1
Ref No.

Name	Description	Function
1 RLC display	Digital display, 5 numerals with decimal points and negative sign (-) when applicable	Display of principal measured value. If function is MEASURE and display selection is VALUE, number indicates R, L, or C. If display selection is delta% or delta RLC indicates percentage difference or value difference (respectively) of R, L, or C compared to stored nominal value. If display selection is BIN NO., indicates bin assignment of measured DUT. If function is ENTER, displays are indications of programmed entries or status in calibration sequences.
2 Units and multipliers	Light-spot (LED) indicators	Indicates measurement units associated with RLC display and secondary display if it is R.
3 QDR display	Digital display, 4 numerals with decimal points and negative sign (-) when applicable	If function is MEASURE, display of secondary measured value or (if display is BIN NO.) blank. If function is ENTER, RLC and QDR displays together indicate programmed entries or status in calibration sequences.
4 POWER switch	Pushbutton (push again to release)	Switches the Digibridge ON (button in) and OFF (button out). OFF position breaks both sides of power circuit.
5 a). Other display-panel indicators	Light-spot (LED) indicators	RANGE HELD indicates that autoranging is disabled.
5 b).	Light-spot (LED) indicators	CONST VOLT indicates that measurement source resistance is fixed at a low value or voltage level is selected for 1 V or 0.3 volts.

Table 1-1 (continued)
FRONT CONTROLS AND INDICATORS

Fig. 1-1

Ref No.	Name	Description	Function
5	c).	Light-spot (LED) indicators	Indicates display parameter selected, RLC measurement, bin assignment, delta% or delta RLC for principal display or QDR for secondary display.
5	d).	Light-spot (LED) indicators	Indicates test frequency selected, 100 Hz thru 100 kHz.
6	Test fixture	Pair of special connectors; each makes dual contact with inserted wire	Receives radial-lead DUT, making 4-terminal connection automatically. Adaptors (supplied) make similar connection with axial-lead DUT. Extension cables (5-terminal) are available.
			Handy reference information for basic operation: zeroing, making measurements, programming test conditions, limit entry, and bin sorting.
7	Reference card	Captive pull-out card	Manual programming and control. Refer to items 10 through 21 for more detail.
8	Keyboard	Group of keys, indicators, and 2 other switches	Multipurpose input of programming instructions, selections, and data. Dual purposes of keys are indicated by color: White labels apply normally. Yellow labels apply immediately after you press and release the [SHIFT] key.
9	Programming keys	Set of 16 keys, labeled with white and yellow	Make selection by pressing key repeatedly until the desired condition is indicated at right of the key.
			Selection of function. MEASURE enables measurements and some routines that cannot be done in ENTER, such as "zero" calibrations, keyboard lock or unlock, and part of full recalibration. ENTER enables programming of averaging, nominal value, and binning instructions.
10 thru 13, 19, and 21 (See below.)		Each key has associated LED indicators	
10	[FUNCTION] key	Indicators MEASURE and ENTER.	

Table 1-1 (continued)
FRONT CONTROLS AND INDICATORS

Fig. 1-1
Ref No.

Name	Description	Function
		(Either function allows selection of hold range, constant voltage, internal bias, parameter, equivalent circuit, measure mode, measure rate, and display.
11 [DISPLAY] key	Indicators: VALUE, delta%, BIN NO.	Selection of displays for MEASURE function; refer to items 1, 2, and 3 for description of displays. Two indicators are lit simultaneously for deltaRLC. This key has no effect on ENTER-function displays.
12 [MEASURE RATE] key	Indicators: SLOW, MED, FAST.	Selection of measurement speed as indicated. Speed is also affected by many other choices described in paragraph 3.5. Use SLOW for better accuracy; use FAST for speed. Mode selection: CONT, continuously repeating measurements; TRIGGERED, single measurement initiated by START button or input signal.
13 [MEASURE MODE] key	Indicators: CONT, TRIGGERED	Indicates that internal bias is on, or the EXTERNAL BIAS switch is ON.
14 BIAS ON indicator	LED indicator	To connect and disconnect the external bias circuit (rear connector, cable supplied) .
15 EXTERNAL BIAS switch	Slide switch, 2 positions: ON, OFF	GO means measured value is acceptable, based on the limits previously stored. (See paragraph 3.8.) NO-GO means RLC or QPR value or both are unacceptable. Indicator remains lighted during next measurement .
16 GO/NO-GO indicators	Pair of LED indicators	Starts measurement sequence (aborting any measurement that may be in process). Normally used in 1RIGGERED measure mode.
17 START button	Pushbutton switch.	

Table 1-1 (continued)
FRONT CONTROLS AND INDICATORS

Fig. 1-1

Ref No.	Name	Description	Function
18	REMOTE OONTROL indicator	LED indicator	Indicates when remote control is established by external command. (Functions only if the IEEE/Handler interface option is installed.)
19	EQUIVALENT CIRCUIT key	Indicators: SERIES and PARALLEL	Selection of equivalent circuit. Measured principal R, L, C and secondary R values (not D or Q) depend on this selection.
20	SHIFT key	Key labeled SHIFT	Pressing this shifts the role of any key labeled with both white and yellow FROM the white TO the other label. Do NOT hold the [SHIFT] key down; press it first, then the other key.
21	Parameter keys	Set of 4 keys, labeled: R/Q, L/Q, C/D, and C/R.	Selection of principal measurement parameter --R, L, or C --with secondary parameter Q, D, or R. Repeated pushing of anyone parameter key changes range in sequence 1 234 1 ...and hence measurement units.

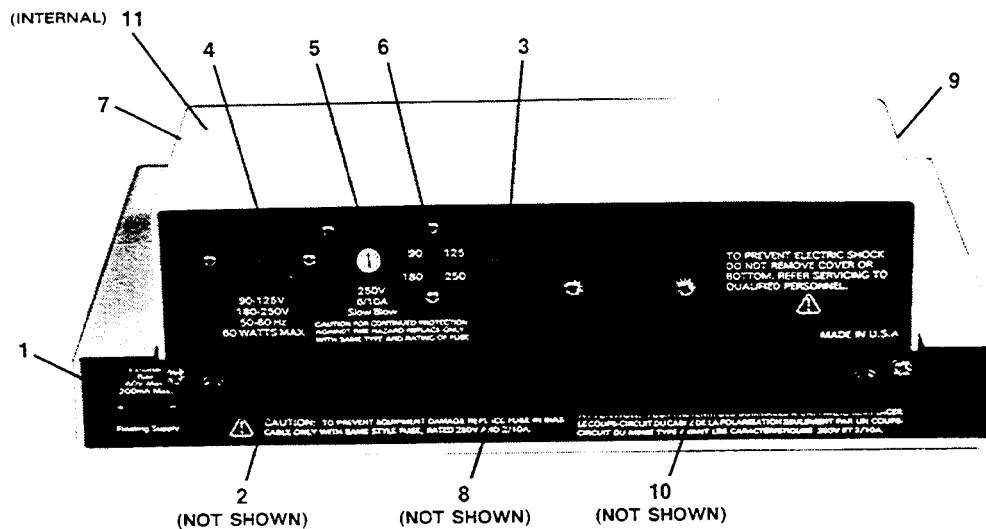

Figure 1-2. Rear controls and connectors, 1692 Digibridge.

Table 1-2
REAR CONNECTORS AND CONTROLS

Fig. 1-2

Ref No.	Name	Description	Function
1	EXTERNAL BIAS connector	Connector, 2 pins, labeled 60 V max, 200 mA max, + - .	Receives cable (1658-2450, supplied) for external bias supply. Observe the voltage and current limits and polarity.
2	TALK switch*	Toggle switch.	Selection of mode for IEEE-488 interface: TALK/LISTEN or TALK ONLY, as labeled.
3	Air filter	Porous plastic sponge	To prevent dirt from entering inlet vent.
4	Power connector	Shrouded 3-wire labeled plug, conforming to International Electrotechnical Commission 320.	Ac power input. Use appropriate power cord, with Belden SPH-386 socket or equivalent. The GenRad 4200-0300 power cord (supplied) is rated for 125 V.
5	Fuse (labeled 250 V, 1/2 A, SLOW BLOW)	Fuse in extraction post holder	Short circuit protection. Use Bussman type MDL or equivalent fuse, 1/2 A, 250 V rating.
6	Line-voltage switch	Slide switch. Upper position: 90 to 125 V; lower position, 180 to 250 V.	Adapts power supply to line-voltage ranges, as indicated. To operate, use a small screw driver, not a sharp object.
7	Vent	Air passage	Ventilation
8	HANDLER INTERFACE connector*	Socket, 24-pin; receives Amphenol "Microribbon" plug P/N 57-30240 (or equiv).	Connections to component handler (outputs are bin numbers and status; input is a "start" signal).
9	Vent	Air passage	Ventilation
10	IEEE-488 INTERFACE connector*	Socket, 24-pin. Receives IEEE-488 interface cable. (See para 2.8).	Input/output connections according to IEEE Std 488-1978. Functions: complete remote control. Output of selected results, with or without controller.

Table 1-2 (continued)
REAR CONNECTORS AND CONTROLS

Fig. 1-2

Ref.No.	Name	Description	Function
11	Fuse (1/4 amp)	Plug-in type, sub-miniature, quick setting. Manufacturers Part No. 273.250 by LITTLEFUSE, Inc., 800 E. Northwest Hwy., Des Plaines, IL 60016	Protects instrument circuitry from damage by charged capacitors

* TALK switch and 24-pin connectors are supplied with the interface option only.

1.4 ACCESSORIES

GenRad makes several accessories that enhance the usefulness of each Digibridge. The axial-lead adaptors (provided) convert the test fixture to a configuration well suited for axial-lead components. A choice of extender cables facilitates making connection to a parts handler or to any DUT that does not readily fit the test fixture. Extender cables are available with your choice of banana plugs, BNC, or type 874 connectors. Each cable branches into 4 parts, for true 4-terminal connections (and guard) to the device being measured, without appreciable reduction in measurement accuracy. A remote test fixture is available to receive hand-inserted components at a distance from the Digibridge.

Other useful accessories are offered. Refer to Tables 1-3, 1-4 and inquire at the nearest Digibridge Technical Support Center. (Refer to the back of this manual.)

NOTE

The GenRad line of Digibridge test fixtures, adaptors, and other accessories does continue to be improved and expanded. Inquire periodically at your local GenRad sales office for the latest information.

Table 1-3
ACCESSORIES AND OPTIONS FOR 1692 RLC DIGIBRIDGE

Quantity	Description	Part Number
1 supplied	Power cord, 200 cm (6.5 ft) long, 3-wire, AWG No. 18, with molded connector bodies. One end, with Belden SPH-386 socket, fits instrument. Other end conforms to ANSI standard C73.11-1966 (125 V max).	4200-0300
2 supplied	Test-fixture adaptors, for axial-lead parts. Replacements available: set of 4 adaptors.	1657-5995
1 supplied	Bias cable, with built-in fuse, to connect external bias supply and switching circuit.	1658-2450
1 recommended	IEEE-488/handler interface option retrofit (plug-in).	1658-9620
1 recommended	Tweezers, for handling and measuring chip components with terminals on opposite faces. BNC connectors; 127-cm (50-inch) cable. Use with adaptor 1689-9601.	1689-9603
1 recommended	Kelvin Clip Cable, for testing low impedance devices that have large or non-standard termination, such as electrolytic capacitors and inductors. BNC connectors; 120 cm (50 inch) cable. Use with adaptor 1689-9601.	1689-9606
1 recommended	Extender cable for connection to arts handler, large or remote DUT, custom test fixture, etc. Length 100 cm (40 in.). One end fits test fixture of Digibridge; other end terminates in 5 stackable banana plugs.	1657-9600
1 recommended	Test-fixture adaptor, for BNC cable.	1689-9601
1 recommended	BNC cable assembly, 4 color coded cables with known "stray" parameters, 90 cm (36 in.) long.	1689-9602
1 recommended	Remote test fixture (like the fixture on the Digibridge, adaptable in many ways), with BNC connectors. (Use 1689-9601 adaptor and 1689-9602 cable.)	1689-9600

Table 1-3 (continued)
ACCESSORIES AND OPTIONS FOR 1692 RLC DIGIBRIDGE

Quantity	Description	Part Number
1 recommended	Remote test fixture (like the 1689-9600); also has START bar, GO/NO-GO lights, which function only if the Digibridge has an interface option. Use 1689-9601 adaptor and 1689-9602 cable (as well as the 1689-2400 cable, included with this fixture).	1689-9605
1 available	Extender cable for connection to standards, large or remote DUT, custom test fixture, dielectric measurement cell, etc. Length 30 cm (12 in.). One end fits test fixture of Digibridge other end terminates in four type 874 coaxial connectors.	1688-9600
1 recommended	Calibration kit, contains six Kelvin-connected references (four precision resistances, open, and short), that plug into the built-in or 1689-9600/9605 test fixture.	1689-9604

1 GENERAL INFORMATION

The 1692 RLC Digibridge® is a microprocessor-controlled, automatic RLC meter. It measures impedance of the device under test (DUT) and displays its parameters: *R*, *L* or *C* and *D*, *Q* or *R*. A front-panel keyboard is used to select and program measurement and test conditions. A test signal of 0.3 V or 1.0 V at 100 Hz, 120 Hz, 1 kHz, 10 kHz or 100 kHz is applied to the device under test. (Default conditions are 1 V, 1 kHz.) Capacitors under test can be biased with 2 V (internal d.c.) or up to 60 V (external source). Consult the instruction manual for details about operation, accuracy, specifications, and service.

2 START-UP

- Set line-voltage switch (rear panel) to power-line voltage.
- If the Digibridge includes an optional IEEE-488 interface, set TALK switch (rear panel) to TALK ONLY (unless instructions are to be received through the IEEE-488 bus).
- Switch EXTERNAL BIAS OFF (front panel).
- Connect power cord to source of proper voltage.
- Press POWER button "in". Self-check codes will show briefly.
- Wait until keyboard lights indicate MEASURE, VALUE, SLOW, SERIES. If a fault is detected, measurements are blocked and an error code remains displayed. (See manual, paragraph 3.13.) If keyboard lights remain dark, keyboard is locked. To unlock it, see manual paragraph 3.9. To switch power off, press POWER button and release.

3 ZEROING

Before measurement, zero the Digibridge as follows:

- Open Circuit.* The MEASURE keyboard light should be lit. Press [MEASURE MODE] key to select TRIGGERED mode. If any test-fixture adaptors are to be used, install and position them for use. Be sure that test fixture is open circuited. Press keys: [C/D] [1] [6] [9] [2] [=] [SHIFT] [OPEN]. Keep hands and objects at least 10 cm (4 in.) from test fixture. Press START button. Wait for GO light.
- Short Circuit.* Short the fixture with a clean copper wire (AWG 18 to 30). Press [1] [6] [9] [2] [=] [SHIFT] [SHORT]. Press START button. Wait for GO light.

Note: For best accuracy, repeat this procedure every day and after any change of test-fixture adaptors.

4 MEASUREMENT

- Verify or select measurement conditions as follows (indicated by keyboard lights); press the adjacent key to change a selection.
 - Function: MEASURE ([FUNCTION] key)
 - Display: VALUE ([DISPLAY] key)
 - Measure rate: SLOW ([MEASURE RATE] key)
 - Measure mode: TRIGGERED ([MEASURE MODE] key)
 - Equivalent circuit: SERIES ([EQUIVALENT CIRCUIT] key)
- To measure *C* and *D* of a Capacitor (C Range .00001 pF to 99999 mF, D range .0001 to 9999): Press [C/D]. Place capacitor in test fixture. Press START. The RLC display shows *C* (series capacitance) and units (mF, μ F, pF); the DQR display shows *D* (dissipation factor). If RLC is negative, DUT is inductive.)
- To measure *C* and *R* of a Capacitor (C Range .00001 nF to 99999 mF, R range .0001 Ω to 9999 k Ω): Press [C/R]. Place capacitor in test fixture. Press START. The RLC display shows *C* (series capacitance) and units (mF, μ F, nF); the DQR display shows *R* (equivalent series resistance) and units (Ω , k Ω). (If RLC is negative, DUT is inductive.)
- To measure *L* and *Q* of an Inductor (L range .00001 mH to 99999 H, Q range .0001 to 9999): Press [L/Q]. Place inductor in test fixture. Press START. The RLC display shows *L* (series inductance) and units (mH, H); the DQR display shows *Q* (quality factor). (If RLC is negative, DUT is capacitive.)
- To measure *R* and *Q* of a Resistor (R range .00001 Ω to 99999 M Ω , Q range .0001 to 9999): Press [R/Q]. Place resistor in test fixture. Press START. The RLC display shows *R* (series resistance) and units (Ω , k Ω); the DQR display shows *Q* (quality factor). (If DQR is negative, DUT is capacitive; if not, DUT is inductive.)
- Special Displays. When a nominal value and bin limits have been programmed (see Limit Entry below), these displays can be selected with the [DISPLAY] key: "Δ%" shows the difference of measured RLC from nominal in percent of nominal value. "VALUE and Δ%", both lit, shows the difference from nominal in measurement units (μ F, mH, etc). "BIN NO" shows the assigned bin number.
- Other Parameters, Rates, Modes. To measure C/R, C/D, L/Q or R/Q parallel, press [EQUIVALENT CIRCUIT] to select

PARALLEL. To measure faster, press [MEASURE RATE] to select MEDIUM or FAST. To measure continuously, press [MEASURE MODE] to select CONT.

5 PROGRAMMABLE TEST CONDITIONS

(Accessible via ENTER function.)

- Press [FUNCTION] key to select ENTER function.
- Test frequency (normally 1 kHz) can be programmed by repeat keying of the [SHIFT] [FREQUENCY] keys until the appropriate indicator is lit.
- Test voltage (normally 1 V) can be programmed for 0.3 or 1.0 V by repeat keying of the [SHIFT] [VOLTAGE] keys until the appropriate indicator light is lit.
- Averaging. Results can be averages of 2 to 10 measurements. To program averaging of 5 measurements, press [5] [=] [SHIFT] [AVERAGE]. To cancel averaging, press [1] [=] [SHIFT] [AVERAGE].

Note: For step d to see present conditions, press [SHIFT] [AVERAGE].
- For internal 2-volt dc bias for capacitors, press [SHIFT] [INT BIAS]. To remove internal bias, repeat [SHIFT] [INT BIAS].
- To hold test voltage constant, press [SHIFT] [CONST V]. To cancel this selection, repeat [SHIFT] [CONST V].
- To hold a range: Measure a DUT in the range desired; or press one of the parameter keys ([R/Q] [L/Q] [C/D] [C/R]) repeatedly to step through the four ranges. When the desired range is indicated (by RLC unit indicator), press [SHIFT] [HOLD RNG]. To enable autoranging, repeat [SHIFT] [HOLD RNG].

Note: For steps e . . . g conditions are indicated by lights.

6 LIMIT ENTRY, GO/NO-GO TESTING, AND SORTING INTO BINS

- Press [DISPLAY] key to select VALUE. Press [FUNCTION] key to select ENTER.
- To enter a single DQR limit (always bin 0): press parameter key (such as [C/D]) appropriate to DUT. To change range and unit multipliers, press same key repeatedly. Enter max limit of *D*, *R* (series) or *Q* with *R*; enter min limit of *R* (parallel) or *Q* with *L*, as follows. (Keyed numbers appear on left-hand display.) Example, for *Q* limit of 85, press [8] [5] [=] [SHIFT] [BIN NO] [0]. Value now moves to right-hand display, confirming storage of limit.

Note: If you make a mistake, press parameter key again and repeat the entry.
- To enter RLC limits for bins 1-8, three methods are given:
 - Symmetrical percentage tolerances* (nested bins). Enter nominal value of DUTs to be sorted. (The value appears on the RLC display. Units were selected in step b.) Example, for nominal value 123.40, press [1] [2] [3] [.] [4] [=] [SHIFT] [NOM VAL]. Enter for bin 1 the narrowest percent tolerance to be sorted. Example, for a tolerance of $\pm 0.2\%$: press [.] [2] [%] [=] [SHIFT] [BIN NO] [1]. The numerical limits for RLC are computed and rounded-off values displayed (upper limit at left, lower at right). For bin 2, enter the next wider tolerance, similarly; then bins 3 . . . 8.
 - Various nominal values* (bucket sort). Plan for non-overlapping bins, each with a nominal value and limits defined by percent tolerance. For bin 1, enter nominal value and tolerance as described above. For each successive bin, similarly enter a new nominal value, then the tolerance and bin number. (Changing the nominal value does not affect limits already stored. Any DUT that qualifies for 2 overlapping bins is assigned to the lower bin.)
 - Unsymmetrical tolerances.* To enter unsymmetrical limits, for example +2% -5% in bin 6: press [2] [%] [-] [5] [%] [=] [SHIFT] [BIN NO] [6]. Two percentages of the same sign can be entered. Always enter the more positive tolerance first.
- You can close any bin that has been opened (steps b, c). For RLC bins, follow this example for bin 8: press [0] [=] [SHIFT] [BIN NO] [8]. To disable DQR sorting, close bin 0 thus: for *D*, *R* (series) or *Q*-with *R*, press [9] [9] [9] [9] [=] [SHIFT] [BIN NO] [0]; for *R* (parallel) or *Q* with *L*, press [0] [=] [SHIFT] [BIN NO] [0].
- To enable GO/NO-GO lights after opening at least one bin, leave "nominal value" at any non-zero value. To disable GO/NO-GO and all bin sorting, press [0] [=] [SHIFT] [NOM VAL].

Note: To see present numerical limits for bin 3 and nominal value, press [SHIFT] [BIN NO] [3], and [SHIFT] [NOM VAL].
- To measure DUT with bin sorting: Press [FUNCTION] to select MEASURE, and [DISPLAY] to select BIN NO. Insert DUT. Press START. Observe GO/NO-GO and bin-number results. NO-GO indicates either DQR failure (bin 0) or RLC failure (bin 9). See manual, paragraph 3.8.

Installation – Section 2

2.1 UNPACKING AND INSPECTION	2-1
2.2 DIMENSIONS	2-1
2.3 POWER-LINE CONNECTION	2-2
2.4 LINE-VOLTAGE REGULATION	2-3
2.5 TEST-FIXTURE CONNECTIONS	2-3
2.6 BIAS VOLTAGE FOR THE DUT	2-3
2.7 HANDLER INTERFACE (OPTION)	2-4
2.8 IEEE-488 INTERFACE (OPTION)	2-8
2.9 ENVIRONMENT	2-14

2.1 UNPACKING AND INSPECTION

If the shipping carton is damaged, ask that the carrier's agent be present when the instrument is unpacked. Inspect the instrument for damage (scratches, dents, broken parts, etc.). If the instrument is damaged or fails to meet specifications, notify the carrier and the nearest GenRad field office. (See list at back of this manual.) Retain the shipping carton and the padding material for the carrier's inspection.

2.2 DIMENSIONS

Figure 2-1.

The instrument is supplied in a bench configuration, i.e., in a cabinet with resilient feet for placement on a table. The overall dimensions are given in Figure 2-1.

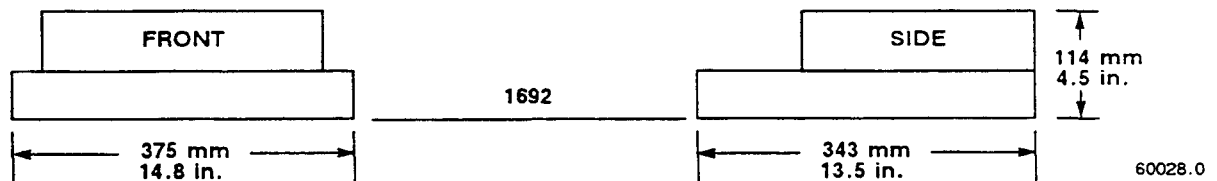

Figure 2-1. Overall dimensions of the Digibridge tester.

2.3 POWER-LINE CONNECTION

Figure 2-2.

The power transformer primary windings can be switched, by means of the line voltage switch on the rear panel, to accommodate ac line voltages in either of 2 ranges, as labeled, at a frequency of 50 or 60 Hz, nominal.

Making sure that the power cord is disconnected, use a small screwdriver to set this switch to match the measured voltage of your power line.

If your line voltage is in the lower range, connect the 3-wire power cable (P/N 4200-0300) to the power connector on the rear panel (Figure 1-2) and then to the power line.

The instrument is fitted with a power connector that is in conformance with the International Electrotechnical Commission publication 320. The 3 flat contacts are surrounded by a cylindrical plastic shroud that reduces the possibility of electrical shock whenever the power cord is being unplugged from the instrument. In addition, the center ground pin is longer, which means that it mates first and disconnects last, for user protection. This panel connector is a standard 3-pin grounding-type receptacle, the design of which has been accepted world wide for electronic instrumentation. The connector is rated for 250 V at 6 A. The receptacle accepts power cords fitted with the Belden type SPH-386 connector.

The associated power cord for use with that receptacle, for line voltages up to 125 V, is GenRad part no. 4200-0300. It is a 200-cm (6.5 ft), 3-wire, 18-gage cable with connector bodies molded integrally with the jacket. The connector at the power-line end conforms to the "Standard for Grounding Type Attachment Plug Caps and Receptacles", ANSI C73.11-1966, which specifies limits of 125 V and 15 A. This power cord is listed by Underwriters Laboratories, Inc., for 125 V, 10 A.

If your power line voltage is in the higher range (up to 250 V), be sure to use a power cord that is approved for 250 V. The end that connects to the Digibridge tester should have a connector of the type that is on the power cord supplied; the other end, an approved connector to mate with your standard receptacle. A typical configuration for a 250-V, 15-A plug is illustrated in Figure 2-2.

If the fuse must be replaced, be sure to use a "slow blow" fuse of the current and voltage ratings shown on the rear panel, regardless of the line voltage.

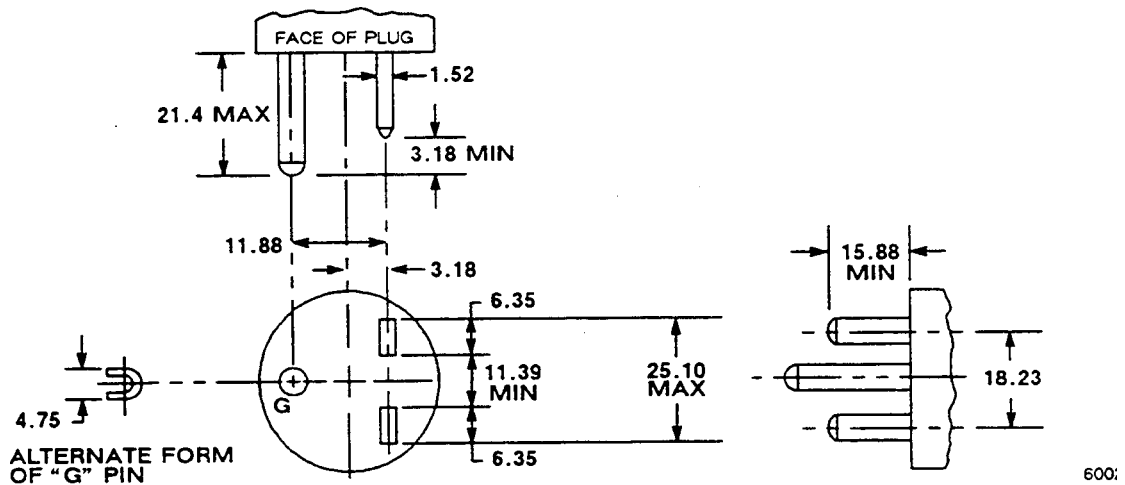

Figure 2-2. Configuration of 250-V 15-A plug. Dimensions in mm. This is listed as NEMA 6-15P. Use for example Hubbell plug number 5666.

2.4 LINE-VOLTAGE REGULATION

The accuracy of measurements accomplished with precision electronic test equipment operated from ac line sources can often be seriously degraded by fluctuations in primary input power. Line-voltage variations of +/-15% are commonly encountered, even in laboratory environments. Although most modern electronic instruments incorporate some degree of regulation, possible power-source problems should be considered for every instrumentation setup. The use of line-voltage regulators between power lines and the test equipment is recommended as the only sure way to rule out the effects on measurement data of variations in line voltage.

2.5 TEST-FIXTURE CONNECTIONS

Because an unusually versatile test fixture is provided on the front shelf of the instrument, external test fixture connections are generally NOT required. Simply plug the device to be measured (DUT) into the test fixture, with or without its adaptors. For details, refer to paragraph 3.2.

Accessory extender cables are available to connect to a DUT that is multiterminal, physically large, or otherwise unsuited for the built-in test fixture. Extender cables are needed, similarly, to connect from the Digibridge test fixture to the DUT socket in a mechanical parts handler. Cables and adaptors are listed in Table 1-3. Connection details are given in paragraph 3.2.

NOTE

The GenRad line of Digibridge test fixtures, adaptors, and other accessories does continue to be improved and expanded. Inquire periodically at your local GenRad sales office for the latest information.

2.6 BIAS VOLTAGE FOR THE DUT

2.6.1 Internal Bias

No external connections are required for the internal 2-volt bias. The circuit is self contained.

2.6.2 External Bias

External bias can be provided by connecting a suitable current-limited, floating dc voltage source, as follows.

Be sure that the voltage is never more than 60 V, max.

A current limiting voltage supply is recommended; set the limit at 200 mA, max.

Be sure that the bias supply is floating; DO NOT connect either lead to ground.

A well-filtered supply is recommended. Bias-supply hum can affect some measurements, particularly if test frequency is the power frequency.

Generally the external circuit must include switching for both application of bias after each DUT is in the test fixture and discharge before it is removed.

Connect the external bias voltage supply and switching circuit, using the 1658-2450 cable, supplied, via the rear-panel EXTERNAL BIAS connector.

Observe polarity marking on the rear panel; connect the supply accordingly.

2.7 HANDLER INTERFACE (OPTIONAL)

2.7.1 Interface via IEEE-488 Bus / Handler Interface Option (1658-9620)

If you have the 1658-9620 interface option, connect from the HANDLER INTERFACE on the rear panel to a handler, printer, or other suitable peripheral equipment as follows. (The presence of the 24-pin connectors shown in Figure 1-3 verifies that you have one of the interface options). Refer to Table 1-2 for the appropriate connector to use in making a cable. Refer to Table 2-1 for the key to signal names, functions, and pin numbers.

Connect the bin control lines to the handler. See Table 2-1. Notice that the 1658-9620 IEEE-488 Bus / Handler Interface Option card provides outputs for automatic sorting into 10 bins. (Refer to paragraph 3.8.)

As indicated in the Specifications at the front of this manual, the output signals come from open-collector drivers that pull each signal line to a low voltage when that signal is active and let it float when inactive. Each external circuit must be powered by a positive voltage, up to 30 V (max), with sufficient impedance (pull-up resistors) to limit the active-signal (logic low) current to 16 mA (max).

CAUTION

Provide protection from voltage spikes over 30 V.

The cautionary note above means typically that each relay or other inductive load requires a clamping diode (rectifier) across it (cathode connected to the power-supply end of the load).

The input signal is also active low and also requires a positive-voltage external circuit, which must pull the signal line down below 0.4 V, but not less than 0.0 V, i.e., not negative. The logic-low current is 0.4 mA (max). For the inactive state (logic high), the external circuit must pull the signal line above +2.5 V, but not above +5 V.

NOTE

The "end of test" signal EOT is provided by the Digibridge only while binning is enabled, by having a non-zero "nominal value" in memory. Refer to paragraph 3.8 for details.

Table 2-1
HANDLER INTERFACE KEY

Signal Name	1692-* Pin No.	Function (All signals "active low")
DC CONNECTIONS:		
----	5, 6, 7	Ground connection.
----	10	DC bus (+5 V) available; see note **
INPUT:		
START	1	Initiates measurement (single or avg).
OUTPUTS:		
EOT	18	"End of test"; bin signals are valid.***
ACQ OVER	22	"Data acquisition over"; DUT removal OK.
BIN 0	15	No-go because of D or Q limit.
BIN 1	17	Go, bin 1.
BIN 2	19	Go, bin 2.
BIN 3	21	Go, bin 3.
BIN 4	23	Go, bin 4.
BIN 5	14	Go, bin 5.
BIN 6	16	Go, bin 6.
BIN 7	20	Go, bin 7.
BIN 8	24	Go, bin 8.
BIN 9	13	No-go because of RLC limit.

* Interface plug-in options: 1658-9620.

** Low-power dc bus (+5 V) available for systems use, commonly for opto-couplers. CAUTION: limit the load to 25 mA, max.

*** EOT is enabled if binning is enabled (by having a non-zero nominal value).

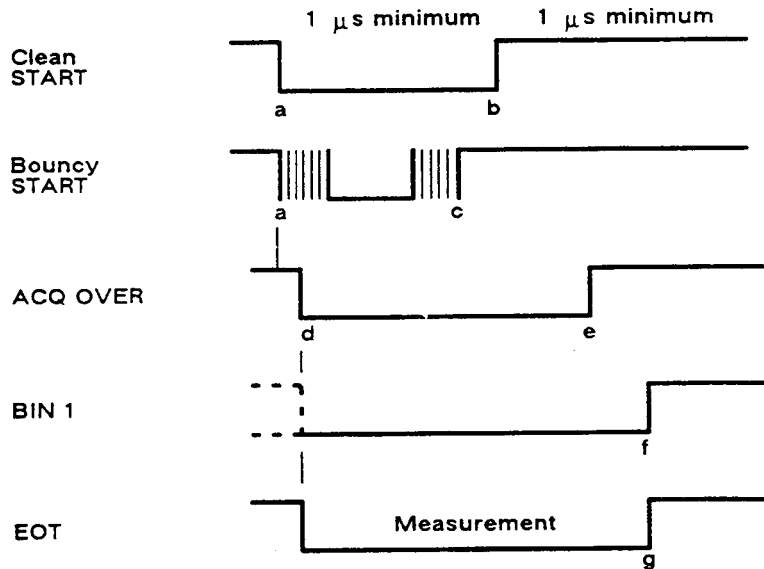

60045.0

Figure 2-3. Handler interface timing diagram. External circuit must keep a-b > 1 μ s, and (if START is not "debounced") a-c < [the settling time or programmed delay]. For single measurements, the DUT can be disconnected after e. The selected BIN line goes low at f; the other BIN lines stay high. For AVERAGE measurement routines, AOQ OVER goes low (e) at the end of the last measurement.

2.7.2 Timing

Figure 2-3.

Refer to the accompanying figure for timing guidelines. Notice that START must have a duration of 1 μ s (minimum) in each state (high and low). If START is provided by a mechanical switch without debounce circuitry, the Digibridge will make many false starts; if START does not settle down (low) within the default settling time after the first transition to high, the measurement time may increase substantially.

Measurement starts at time d, which is essentially the same as time b or c; measurement is completed at g. (The START signals are expanded for clarity.) Interval a-e, during which the DUT must remain connected for data acquisition, is considerably shorter than the total measurement time a-g. The DUT can be changed after e ("indexing on ACQ", to save time) or after g ("indexing on EOT", for a simpler test setup), as explained below.

After the calculation interval e-f, measurement results are available for sorting, i.e., one of the BIN lines goes low. A few micro-seconds later, EOT goes low (can be used to set a latch holding the bin assignment). ACQ OVER, the selected BIN line, and EOT then stays low until the next start command.

The time required for measurement depends on test condition, and operating selections. Interval a-e can be less than 15 ms; the cycle a-g can be less than 40 ms; refer to paragraph 3.5 for details.

Set up the handler either of two ways: indexing on EOT or indexing on ACQ, as follows. The handler must supply a signal (here called "start next measurement") when it has completed connection of the DUT to the test fixture.

Indexing on EOT. Set up the handler to respond to the EOT signal from the Digibridge, which occurs at the "end of test", when the bin assignment is available for sorting. Set up the Digibridge to receive its START signal from the handler's "start next measurement" signal. This setup is simpler than the one below.

NOTE

The Digibridge requires that a non-zero value be entered for "nominal value" to enable generation of the EOT signal and indication by the GO/NO-GO lights; see paragraphs 3.8.3,3.8.4.

Indexing on ACQ. Set up the handler to respond to the ACQ OVER signal from the Digibridge, which occurs when the "data acquisition" is complete. The handler can then remove the DUT from the test fixture and replace it with another DUT, while the Digibridge is calculating the result.

In addition, set up an interface that provides a START signal to the Digibridge by logical combination of the, EOT signal from the Digibridge AND the "start next measurement" signal from the handler. Indexing on ACQ results in higher measurement rate than indexing on EOT.

Be sure the TALK switch is set to TALK ONLY, if the IEEE-488 bus is not used.

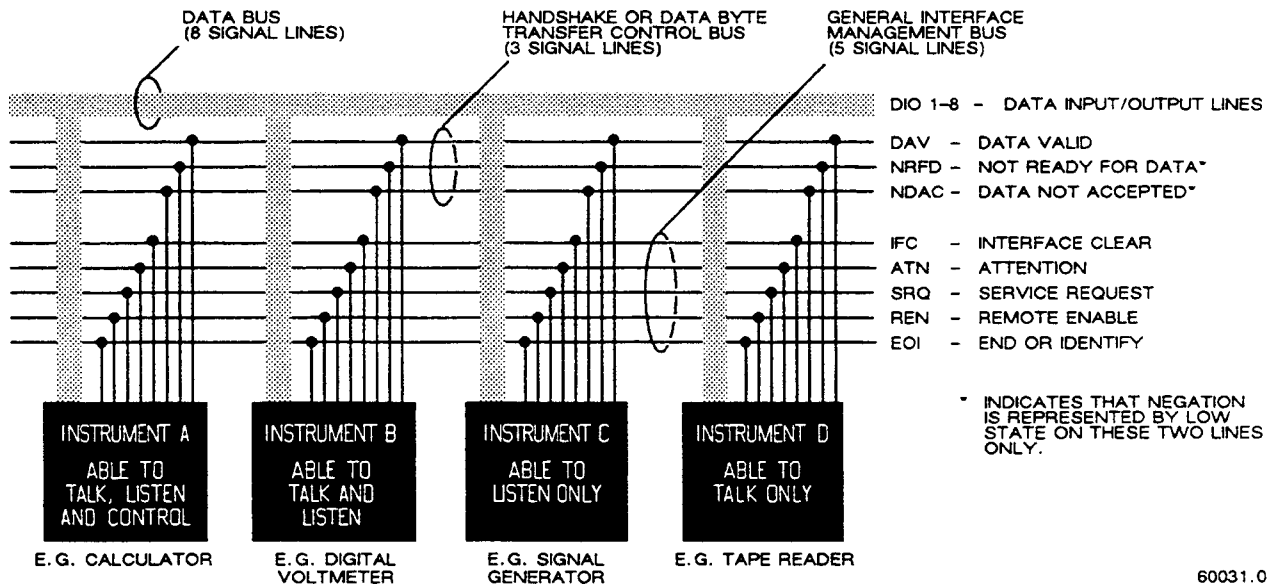

Figure 2-4. Block diagram of a generalized system interconnected by the 16-signal line bus specified in the IEEE Standard 488. Reprinted from *Electronics*, November 14, 1974; copyright McGraw-Hill, Inc., 1974.

2.8 IEEE-488 INTERFACE (OPTION)

2.8.1 Purpose

Figure 2-4.

If you have the 1658-9620 interface option, you can connect this instrument to a printer or into a system (containing a number of devices such as instruments, apparatus, peripheral devices, and generally a controller or computer) in which each component meets IEEE Standard 488-1978, Standard Digital Interface for Programmable Instrumentation. A complete understanding of this Standard (about 80 pages) is necessary to understand in detail the purposes of the signals at the IEEE-488 INTERFACE connector on the rear panel of this instrument.

NOTE

For copies of the Standard, order "IEEE Std 488-1978, IEEE Standard Digital Interface for Programmable Instrumentation", from IEEE Service Center, Department PB-8, 445 Hoes Lane, Piscataway, N. J. 08854.

To make connection to a single device like a printer, use a IEEE-488 cable, which fits the rear-panel connector labeled IEEE-488 INTERFACE. For larger systems, each device is connected to a system bus, in parallel, usually by the use of several stack able cables. Refer to the figure for a diagram of a hypothetical system. A full set of connections is 24 (16 signals plus shield and ground returns), as tabulated below and also in the Standard. Suitable cables, stack able at each end, are available from Component Manufacturing Service, Inc., West Bridgewater, MA 02379, U.S.A. (Their part number 2024/1 is for a 1-meter-long cable.)

This instrument will function as either a TALK/LISTEN or a TALK ONLY device in the system, depending on the position of the TALK switch. "TALK/LISTEN" denotes full programmability and is suited for use in a system that has a controller or computer to manage the data now. The "handshake" routine assures that the active talker proceeds slowly enough for the slowest listener that is active, but is not limited by any inactive (unaddressed) listener. TALK ONLY is suited to a simpler system --e.g. Digibridge and printer --with no controller and no other talker. Either mode provides measurement results to the active listeners in the system.

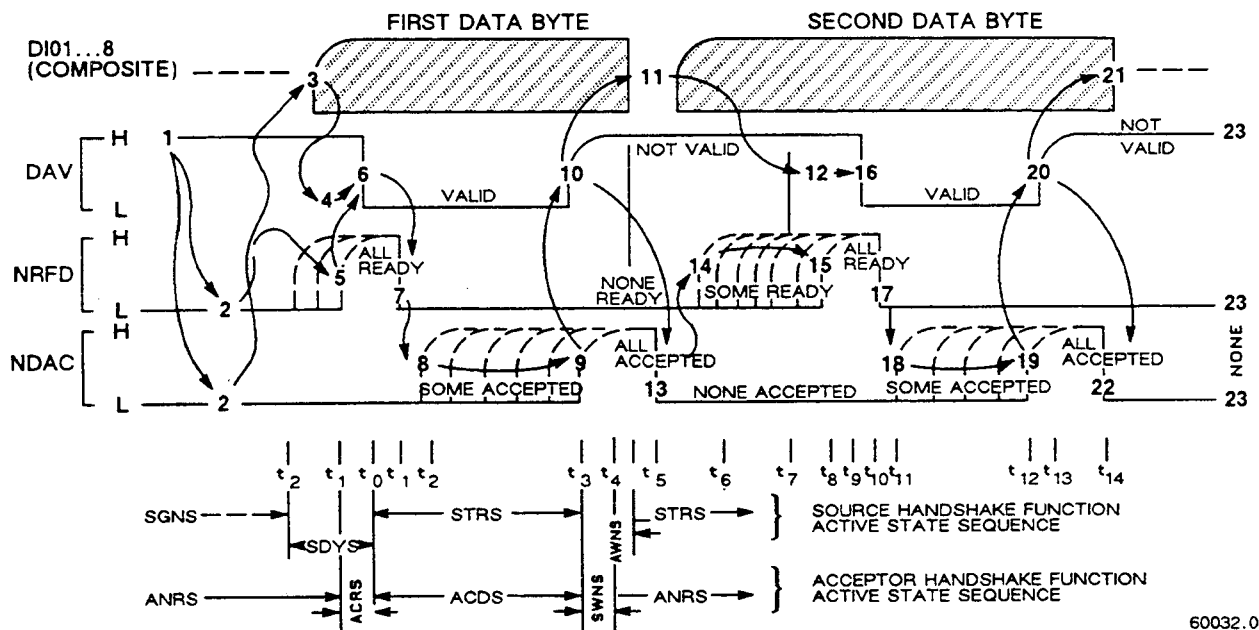

60032.0

Figure 2-5. The handshake process, illustrated by timing diagrams of the pertinent signals for a system with one talker and several listeners. For details, refer to the standard.

2.8.2 Interlace Functions

Figure 2-5.

The following functions are implemented. Refer to the Standard for an explanation of the function subsets, represented by the identifications below. For example, T5 represents the most complete set of talker capabilities, whereas PP0 means the absence of a capability.

- SH1, source handshake (talker)
- AH1, acceptor handshake (listener)
- T5, talker (full capability, serial poll)
- L4, listener (but not listen-only)
- SR1, request by device for service from controller
- RL2, remote control (no local lockout, no return-to-local switch)
- PP0, no parallel poll
- DC0, no device clear
- DT1, device trigger (typically starts measurement)
- C0, no controller functions.

The handshake cycle is the process whereby digital signals effect the transfer of each data byte by means of status and control signals. The cycle assures, for example, that the data byte has settled and all listeners are ready before the talker signals "data valid". Similarly, it assures that all listeners have accepted the byte before the talker signals "data not valid" and makes the transition to another byte. Three signal lines are involved, in addition to the 8 that convey the byte itself. Refer to the accompanying figure.

2.8.3 Signal Identification

Refer to Table 2-2 for a key to signal names, functions, and pin numbers. Further explanation is found in the Standard. The first three signals listed take part in the "handshake" routine, used for any multiline message via the data bus; the next five are used to manage the flow of information; the last eight constitute the multiline message data bus.

Table 2-2
IEEE-488 INTERFACE KEY

Pin No.	Signal Name	Function or Significance
6	DAV	Low state: "data is available" and valid on the DI01...DI08 lines.
7	NRFD	Low state: at least 1 listener on the bus is "not ready for data."
8	NDAC	Low state: at least 1 listener on the bus is "not done accepting data."
11	ATN	"Attention", specifies 1 of 2 uses for the DI01...DI08 lines, as follows. Low state: controller command messages. High state: data bytes from the talker device.
9	IFC	"Interface clear." Low state: returns portion of interface system to a known quiescent state.
10	SRQ	"Service request." Low: a talker or listener signals (to the controller) need for attention in the midst of the current sequence of events.
17	REN	"Remote enable." Low state: enables each device to enter remote mode when addressed to listen; (Remote-control commands are conveyed while ATN is high.) High state: all devices revert to local control.

Table 2-2 (continued)
IEEE-488 INTERFACE KEY

Pin No.	Signal Name	Function or Significance
5	EOI	"End or Identify." "END" if ATN is in high state, then, low state of EOI indicates end of a multiple-byte data transfer sequence.* "IDY" if ATN is in low state; then, low state of EOI activates a parallel poll.**
1	DI01	The 8-line data bus, which conveys interface messages (ATN low state) or device-dependent messages (ATN high state), such as remote-control commands from the controller or from a talker device.
2	DI02	
3	DI03	
4	DI04	
13	DI05	
14	DI06	
15	DI07	
16	DI08	

* "END" is typically sent concurrently with the delimiter "linefeed" character that terminates the string(s) of data output from the Digibridge (1, 2, or 3 lines; see para 2.8.4).

** IDY is not implemented in this Digibridge.

2.8.4 Codes and Addresses

General- The device-dependent messages, such as instrument programming commands and measurement data (which the digital interface exists to facilitate), have to be coded in a way that is compatible between talkers and listeners. They have to use the same language. Addresses have to be assigned, except in the case of a single "talker only" with one or more "listeners" always listening. The Standard sets ground rules for these codes and addresses.

In this instrument, codes for input and output data have been chosen in accordance with the rules. The address (for both talker and listener functions) is user selectable, as explained below.

Instrument Program Commands. The set of commands used in remote programming is an input data code 1 which the instrument will respond as a "talker/listener", after being set to a remote code and addressed to listen to device-dependent command strings. The set includes all of the keyboard functions except switching external bias ON/OFF and full recalibration, which are not remotely programmable.

Refer to paragraph 3.11.3 for a table of the commands used in programming

Address. The initial setting of address, provided by the factory, is binary 00011. Consequently, the talk address command (MTA) is C in ASCII code and, similarly, the listen-address command (MLA) is #- If a different address pair is desired, set it manually using the following procedure.

WARNING

Because of shock hazard and presence of electronic devices subject to damage by static electricity (conveyed by hands or tools), disassembly is strictly a "service" procedure.

a. Take the Digibridge to a qualified electronic technician who has the necessary equipment for minor disassembly and adjustment. Remove the interface option assembly, as described in the 1692 Digibridge Service instructions. (There is no need to remove the top cover first.)

b. Set the switches in "DIP" switch assembly S2 to the desired address, which is a 5-bit binary number. (See below.)

c. Replace the interface option assembly in its former place.

Notice that S2 is located at the end of the interface option board, about 3 cm (1 in.) from the TALK switch S1. If S2 is covered, lift the cover off, exposing the "DIP" switch, which has 6 tiny switches, numbered 1 thru 6. To enter logical 1 's, depress the side of each switch nearest the end of the board (switch open). To enter logical 0's, depress the other side of the switch (switch closed). The address is read from 5 to 1 (not using 6). Thus, for example, to set up the address 00011, enter 0's at positions 5, 4, 3; enter 1 's at positions 2, 1. (This makes the talk address "C" and the listen address "#".) Strictly speaking, the address includes more; S2 determines only the device-dependent bits of the address. You cannot choose talk and listen addresses separately, only as a pair. The list of possible pairs is shown in Table 2-3.

Table 2-3
ADDRESS PAIRS AND SETTINGS FOR SWITCH S2

Talk address		Listen address		Switch setting*
Symbol	Binary	Symbol	Binary	5 4 3 2 1
@	1 000 000	(space)	0 100 000	0 0 0 0 0
A	1 000 001	!	0 100 001	0 0 0 0 1
B	1 000 010	"	0 100 010	0 0 0 1 0
C	1 000 011	#	0 100 011	0 0 0 1 1
D	1 000 100	\$	0 100 100	0 0 1 0 0
E	1 000 101	%	0 100 101	0 0 1 0 1
F	1 000 110	&	0 100 110	0 0 1 1 0
G	1 000 111	'	0 100 111	0 0 1 1 1
H	1 001 000	(0 101 000	0 1 0 0 0
I	1 001 001)	0 101 001	0 1 0 0 1
J	1 001 010	*	0 101 010	0 1 0 1 0
K	1 001 011	+	0 101 011	0 1 0 1 1
L	1 001 100	,	0 101 100	0 1 1 0 0
M	1 001 101	-	0 101 101	0 1 1 0 1
N	1 001 110	.	0 101 110	0 1 1 1 0
O	1 001 111	/	0 101 111	0 1 1 1 1
P	1 010 000	0	0 110 000	1 0 0 0 0
Q	1 010 001	1	0 110 001	1 0 0 0 1
R	1 010 010	2	0 110 010	1 0 0 1 0
S	1 010 011	3	0 110 011	1 0 0 1 1
T	1 010 100	4	0 110 100	1 0 1 0 0
U	1 010 101	5	0 110 101	1 0 1 0 1
V	1 010 110	6	0 110 110	1 0 1 1 0
W	1 010 111	7	0 110 111	1 0 1 1 1
X	1 011 000	8	0 111 000	1 1 0 0 0
Y	1 011 001	9	0 111 001	1 1 0 0 1
Z	1 011 010	:	0 111 010	1 1 0 1 0
[1 011 011	;	0 111 011	1 1 0 1 1
\	1 011 100	<	0 111 100	1 1 1 0 0
]	1 011 101	=	0 111 101	1 1 1 0 1
^	1 011 110	>	0 111 110	1 1 1 1 0

Do NOT set the switch to 11111, because a talk address of "-" would be confused with an "un talk" command, and a listen address of "?", with an "un listen" command. (ASCII code for "-" is 1 011 111 and for "?" is 0 111 111.)

In the above example, the remote message codes MLA and MTA are X0100011 and XI000011, respectively. Thus the listen address and the talk address are distinguished, although they contain the same set of device dependent bits, which you set into S2.

Data Output. Data (results of measurements) are provided on the DI01...DI07 lines as serial strings of characters. Each character is a byte, coded according to the 7-bit ASCII code, as explained above. The alphanumeric characters used are appropriate to the data, for convenience in reading printouts. The character strings are always provided in the same sequence as that tabulated in paragraph 3.11.3; for example: RLC value, QDR value, bin number --if all 3 were selected (by the X7 command). The carriage-return and line-feed characters at the end of each string provide a printer (for example) with the basic commands to print each string on a separate line.

For example, if the measurement was 0.54321 uF (1 kHz, range 4 held), the character string for RLC value is:

U(space)C(space)uF(2 spaces)0.54321(CR)(LF).

If the D measurement was .001, the character string for QD value is:

(2 spaces)D(5 spaces)00.0010(CR)(LF).

If the measurement falls into bin 9, the character string for bin number is:

F(space)BIN(2 spaces)9(CR)(LF).

The character string for RLC value has the length of 17 characters; for QD value, 17 characters; for bin number, 10 characters -including spaces, carriage-return, and line-feed characters. Refer to the format tables in paragraph 3.11.2 for details.

2.9 ENVIRONMENT

The Digibridge can be operated in nearly any environment that is comfortable for the operator. Keep the instrument and all connections to the parts under test away from electromagnetic fields that may interfere with measurements.

Refer to the Specifications at the front of this manual for temperature and humidity tolerances. To safeguard the instrument during storage or shipment, use protective packaging. Service personnel refer to Section 5

When the Digibridge is mounted in a rack or other enclosed location, make sure that the ambient temperature **inside the rack** does not exceed the limits specified under "Environment" in the Specifications at the front of this manual, and that air can circulate freely past all air inlet and outlet vents.

Operation – Section 3

3.1	BASIC PROCEDURE.....	3-1
3.2	CONNECTING THE DUT	3-4
3.3	MEASUREMENT PARAMETERS, RESULTS DISPLAYS, OUTPUTS	3-13
3.4	PRINCIPAL TEST CONDITIONS	3-20
3.5	MEASUREMENT TIME AND MEASUREMENT RANGES.....	3-22
3.6	ACCURACY	3-25
3.7	BIAS FOR THE DUT	3-27
3.8	BIN SORTING AND GO/NO-GO RESULTS.....	3-30
3.9	KEYBOARD LOCK, FUNCTION MAP AND INTERROGATIONS	3- 37
3.10	OPERATION WITH A HANDLER.	3-39
3.11	DATA OUTPUT AND/OR PROGRAMMING VIA IEEE-488 BUS	3-40
3.12	SAMPLE IEEE PROGRAMS	3-54
3.13	SELF CHECKS AND FAILURE DISPLAYS (ERROR OODES)	3-55

3.1 BASIC PROCEDURE

3.1.1 General

For initial familiarization with the Digibridge RLC tester, follow this procedure carefully. After that, use this paragraph as a ready reference and refer to later paragraphs in this section for details. Condensed operating instructions are provided near the front of this manual.

One can also refer to the Condensed Operating Instructions, found stored in a pocket under the instrument. Reach under the front edge and pull the card forward as far as it slides easily. After use, slide it back in the pocket for protection.

3.1.2 Startup

CAUTION

Set the line voltage switch properly (rear panel) before connecting the power cord.

This is the regular startup procedure.

a. After the line-voltage switch has been set to the position that corresponds to your power-line voltage (which must be in either range: 90 to 125 V or 180 to 250 V ac, nominally 50 or 60 Hz), then connect the power cord as explained below.

Temperature. If the Digibridge tester has been very cold, warm it up in a dry environment, allowing time for the interior to reach 0 degrees C or above, before applying power. Otherwise, the instrument may be damaged by thermal shock.

Power Cord. Connect the power cord to the rear-panel connector, and then to your power receptacle.

b. If the Digibridge tester includes an optional IEEE-488 interface, set TALK switch (rear panel) to TALK ONLY (unless instructions are to be received through the IEEE-488 bus).

c. Switch EXTERNAL BLA..S OFF (front panel).

d. Press the POWER button "in", so that it stays in the depressed position. Self-check codes will show briefly, indicating that the instrument is automatically executing a power-up routine that includes self checks.

(To turn the instrument off, push and release the POWER button and leave it in the "out" position.)

e. Wait until keyboard lights indicate MEASURE, VALUE, SLOW, CONT (or TRIGGERED), SERIES. If they do not, there are two possible explanations: self-check fault and keyboard lock. If a fault is detected in the self-check, measurements are blocked and an error code remains displayed. Under some conditions, the block to operation can be bypassed. (See paragraph 3.13.) If the keyboard is locked, all of those keyboard indicators remain unlit except MEASURE and/or REMOTE CONTROL ---and all previously programmed test conditions, limits, etc are reestablished. To unlock it, see paragraph 3.9.

3.1.3 Zeroing

Before measurement, zero the Digibridge as follows. In this process, the instrument automatically measures stray parameters and retains the data, which it uses to correct measurements so that results represent parameters of the DUT alone, without (for example) test-fixture or adaptor capacitance.

a. Conditions.

SLOW measure rate, RANGE HELD indicator NOT lit.

b. Open Circuit.

Press [FUNCTION] key (if necessary) to select MEASURE function.

Press [MEASURE MODE] key (if necessary) to select TRIGGERED mode.

If any test-fixture adaptors are to be used, install and position them for use. (See paragraph 3.2).

Be sure that the test fixture is open circuited.

If you want this "zero" process to echo a display of 00000, press the [C/D] key. However doing so will disable automatic parameter selection. (See paragraph 3.1.4, step b.).

Press these keys deliberately: [1] [6] [9] [2] [=] [SHIFT] [OPEN].

Note: the GO indicator being lit and two zeros confirm the previous step.

Watch the GO indicator on the keyboard; not one on any remote test fixture.

Keep hands and objects at least 10 cm (4 in.) from test fixture.

Press the START button. The GO indication disappears.

Wait for the GO indicator to be lit again.

c. Short Circuit.

Short the fixture with a clean copper wire (AWG 18 to 30), length 5 to 8 cm.

Press these keys: [1] [6] [9] [2] [=] [SHIFT] [SHORT].

Note: the GO indicator being lit and two fives confirm the previous step.

Press the START button. The GO indication disappears.

Wait for the GO indicator to be lit again.

Remove the short circuit.

NOTE: For best accuracy, repeat this procedure daily and after changing test-
fixture adaptors or frequency.

3.1.4 Routine Measurement

a. Verify or select measurement conditions as follows (indicated by keyboard lights); press the adjacent key to change a selection.

Function: MEASURE ([FUNCTION] key), a necessary selection

Display: VALUE ([DISPLAY] key), for normal RLC/QDR results

Measure rate: SLOW ([MEASURE RATE] key), for best accuracy

Measure mode: TRIGGERED ([MEASURE MODE] key), optional

Equivalent circuit: SERIES ([EQUIVALENT CIRCUIT] key) --see paragraph 3.3.

If you are in doubt about how to connect the device to be tested with the Digibridge, refer to paragraph 3.2, below.

b. To measure *any passive component* (without knowing whether it is essentially a resistor, inductor, or capacitor), use "automatic parameter selection". This feature is provided at power-up only and remains enabled as long as you do NOT select any particular parameter. (Automatic parameter selection can be disabled by pressing any of the four parameter keys: R/Q, L/Q, C/D, or C/R. Once disabled, this feature can be enabled again only on a power-up.)

Place DUT in test fixture. Press START. (See note below.) The RLC display and units indicator show the principal measured value and the basic parameter, thus identifying the DUT. The QDR display shows the measured Q if the principal units are ohms or henries; the measured D or R if they are farads.

NOTE

Use either the Digibridge START button or the start bar on the 1689-
9605 Remote Test Fixture if it is being used.

In steps c, d, e, f, the parameters to be measured are specified by the user.

c. To measure *C and D of a Capacitor* (C Range .00001 pF to 99999 mF, D range .0001 to 9999): Press [C /D]. Place capacitor in test fixture. Press START. The RLC display shows Cs (series capacitance) and units (mF, uF, nF, pF); the QDR display shows D (dissipation factor). {If RLC is negative, DUT is inductive.}

d. To measure *C and R of a Capacitor* (C Range .00001 nF to 99999 mF, R range .0001 ohm to 9999 kilohms): Press [C/R]. Place capacitor in test fixture. Press START. The RLC display shows Cs (series capacitance) and units (mF, uF, nF); the QDR display shows Rs (equivalent series resistance) and units (ohms, kilohms). {If RLC is negative, DUT is inductive.}

e. To measure *L and Q of an Inductor* (L range .00001 mH to 99999 H, Q range .0001 to 9999): Press [L/Q]. Place inductor in test fixture. Press START. The RLC display shows Ls (series inductance) and units (mH, H); the QDR display shows Q (quality factor). {If RLC is negative, DUT is capacitive.}

f. To measure *R and Q of a Resistor* (R range .00001 ohm to 99999 Mohms, Q range .0001 to 9999): Press [R/Q]. Place resistor in test fixture. Press START. The RLC display shows Rs (series resistance) and units (ohms, kilohms; Mohms); the QDR display shows Q (quality factor). {If QDR is negative, DUT is capacitive; if not, DUT is inductive.}

NOTE: This procedure is basic; there are many alternatives described later. You can select and program for other parameters, equivalent circuits, types of results displayed, test conditions, measurement rate, and bin sorting, etc.

3.2 CONNECTING THE DUT

3.2.1 General

WARNING

Charged capacitors can be dangerous, even lethal. Never handle their terminals if they have been charged to more than **60 V**. Routine discharging procedures may not be perfectly dependable.

Connect the "device under test" (DUT), whose parameters are to be measured, as follows.

NOTE

Clean the leads of the DUT if they are noticeably dirty, even though the test-fixture contacts will usually bite through a film of wax to provide adequate connections.

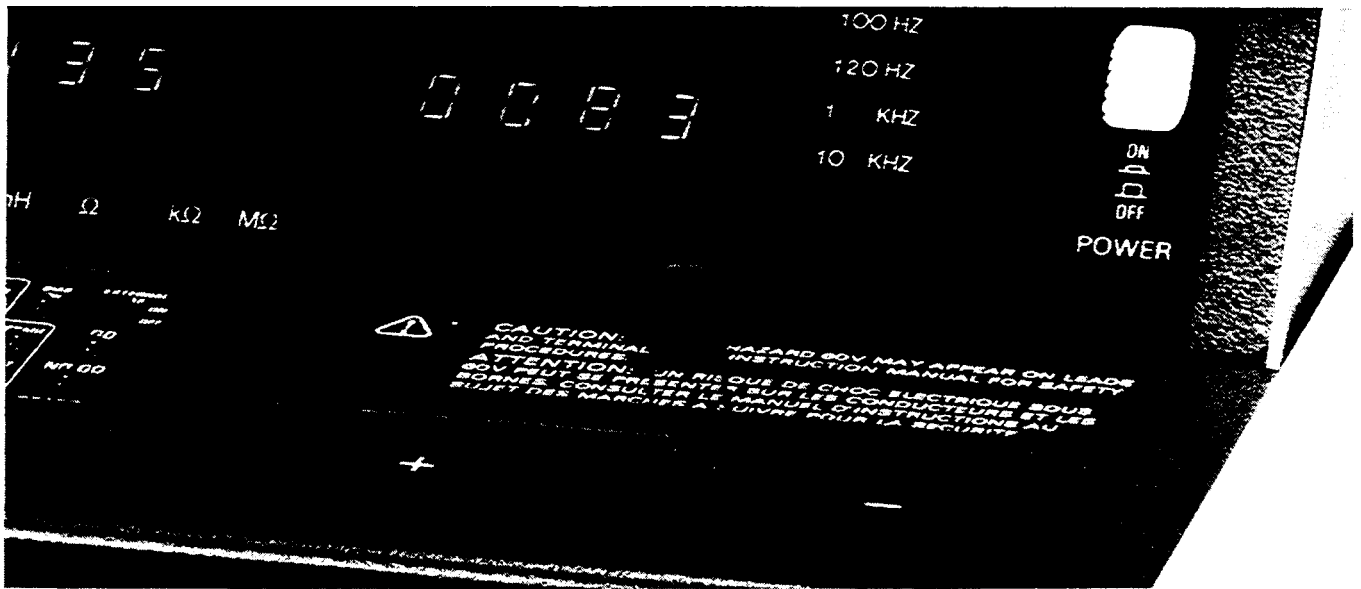

Figure 3-1. A radial-lead DUT is inserted into a Digibridge test fixture.

3.2.2 Using the Integral Test Fixture on the 1692 Digibridge for Radial-Lead DUTs

Figure 3-1.

NOTE

For use of a similar *remote* test fixture, refer to paragraph 3.2.4.

If the DUT is a radial-lead component or has parallel leads at one side, insert them into the Digibridge test fixture slots as described below.

The test fixture provided on the front ledge of the 1692 Digibridge provides convenient, reliable, guarded 4-terminal connection to any common radial-lead or (with adaptors that are provided) an axial-lead component part.

The slots in the test fixture accommodate wires with diameters from 0.25 mm (.01 in., AWG 30) to 1 mm (.04 in., AWG 18), spaced from 4 to 98 mm apart (0.16 to 3.9 in.) or equivalent strip conductors. Each "radial" wire must be at least 4 mm long (0.16 in.). The divider between the test slots contains a shield, at guard potential, with its edge semi-exposed. The tapped holes (6-32 thread) at the left and right ends of the test fixture are also grounded, to connect the shields of extender cables.

NOTE

If any adaptor(s), described below, are in place, remove them before attempting to insert a radial-lead DUT.

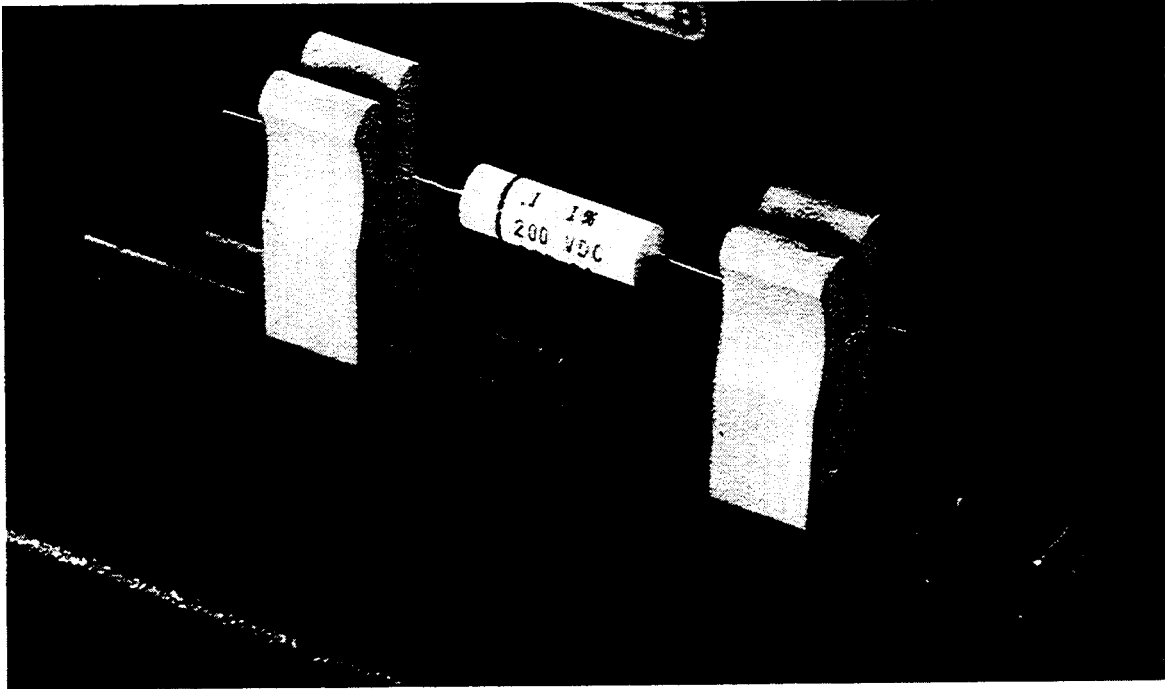

Figure 3-2. Use of adaptors (supplied) for connection of an axial-lead DUT to a Digibridge test fixture.

3.2.3 Using the Test-Fixture Adaptors for Axial-Lead DUTs

Figure 3-2.

If the DUT is an axial-lead component or has leads at opposite ends, insert the leads into the test fixture adaptor's slots as shown in Figure 3-2 and described below. NOTE: This description applies to the built-in test fixture of the 1692 Digibridge and also to remote test fixtures 1689-9600 and 1689-9605.

Install the test-fixture adaptors, supplied, as shown; put one in each slot of the test fixture, by pushing vertically downward. Slide the adaptors together or apart so the body of the DUT will fit easily between them.

Notice that the contacts inside the adaptor are off center; be sure to orient the adaptors so the contacts are close to the body of the DUT, especially if it has short or fragile leads.

The adaptors accommodate wires with diameters up to 1.5 mm (.06 in., AWG 15). The body of the DUT that will fit between these adaptors can be 80 mm long and 44 mm diameter (3.1 x 1.7 in.) maximum. Each "axial" wire must be at least 3 mm long (0.12 in.). The overall length of the DUT, including the axial wires must be at least 22 mm (0.866 in.).

Insert the DUT so that one lead makes connection on the left side of the test fixture, the other lead on the right side. Insertion and removal are smooth, easy operations and connections are reliable if leads are reasonably clean and straight. Press the DUT down so that the leads enter the slots in the adaptors as far as they go easily.

Be sure to remove any obvious dirt from leads before inserting them. The test-fixture contacts will wipe through a film of wax, but can become clogged and ineffectual if dirty leads are inserted repeatedly.

Be sure to insert only one thing into each half of the test fixture, at any one time. (If any object is inserted into the same slot with a DUT lead, it will probably NOT make true "Kelvin" connections.)

NOTE

For a DUT with very short leads, it is important to orient each adaptor so that its internal contacts (which are off center) are close to the DUT. To remove each adaptor, lift with a gentle tilt left or right (never forward or back).



Figure 3-3. Remote test fixture (1689-9605), connected to a Digibridge tester.

3.2.4 The 1689-9600 or -9605 Remote Test Fixture (with -9602 BNC Cable) Figure 3-3.

Connection of the DUT at a remote test fixture normally requires:

- Remote Test Fixture 1689-9600, 1689-9605, or equivalent special fixture.
- BNC Cable Assembly 1689-9602 --(Cable 4 BNC to 4 BNC)
- BNC Adaptor 1689-9601 ----- (connects 1692 built-in test fixture into 4 BNC connectors)

This remote test fixture functions like the one supplied on the 1692 Digibridge. True "Kelvin" connections are made at the points of contact with the DUT leads. The recommended cable should be used (rather than any randomly chosen BNC patch cords) because the known cable parameters enable you to make corrections for best accuracy. Install the remote test fixture as follows.

- a. Remove any adaptors, cables, etc, if present, from the DUT port of the instrument.
- b. Plug the BNC adaptor (1689-9601) into the integral test fixture, with the BNC connectors facing forward. Lock the connection with the 2 captive thumb screws. (The screws must be seated to complete the ground connection.)
- c. Connect the BNC cable assembly 1689-9602 to the Digibridge and to the remote test fixture as indicated in Table 3-1. Note that red designates leads that may be "hot". (When bias is applied, they carry dc negative voltage with respect to ground.)

Table 3-1
REMOTE TEST FIXTURE CONNECTIONS VIA BNC CABLE

Test-Circuit Function	Bias Polarity	BNC Connector at Digibridge	Color Code on 1689-9602 Cable	Connection at 1689-9600/-9605 Test Fixture*
IL (current, low)	+	Left	Black	I+,Left
PL (potential, low)	+	Left-center	Black/white	P+,Left-center
PH (potential, high)	-	Right-center	Red/white	P-,Right-center
IH (current, high)	-	Right	Red	I-,Right

* Left and right are defined with the fixture oriented for reading the legend.

d. For the 1689-9605 remote test fixture ---in order to activate the "Start" bar and the GO/NO-GO lights -connect the 1689-2400 Remote Tester Cable (supplied with the fixture) as follows. Connect one end to the HANDLER INTERFACE connector behind the instrument. Connect the other end to a similar connector behind the fixture.

e. Before making measurements, be sure to repeat the zeroing procedure (open circuit and short circuit), as described in paragraph 3.1.3.

NOTE: User provided cables and/or remote test fixtures can be used, particularly if the DUT is to be handled automatically. (See paragraph 3.10 about handlers.) For notes on cable and fixture capacitance and zeroing, see paragraph 3.2.7, below.

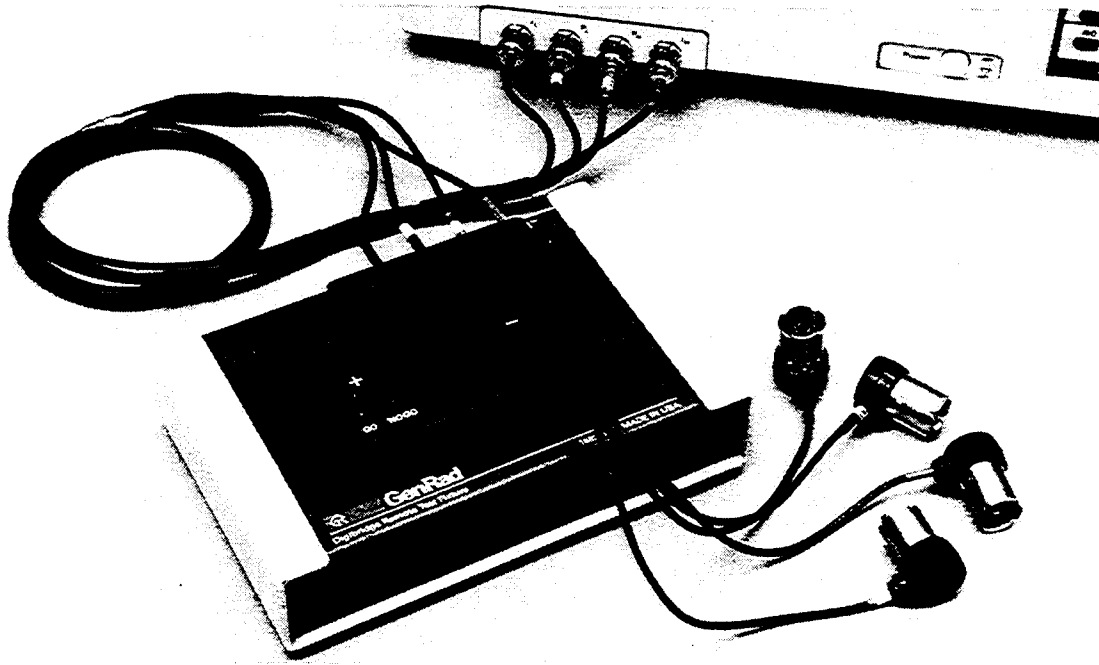

Figure 3-4. The type 874 extender cable is shown plugged into a Digibridge remote test fixture. Notice that the two thumb screws must be hand tightened for the guard connection (shields of cable).

3.2.5 The 1688-9600 Extender Cable ("Type 874" Connectors)

Figure 3-4.

The accessory extender cable 1688-9600 can be used to connect a DUT that is multiterminal, physically large, or otherwise unsuited for the built-in test fixture. This low-capacitance cable is used, for example, to connect type-874 equipped impedance standards or a special test fixture. The cable tips are type 874 coaxial connectors, which mate with a broad line of components and adaptors. Make connections as follows.

- a. Remove the adaptors, if present, from the Digibridge test fixture
- b. Plug the single-connector end of the extender cable into the test fixture so that its blades enter both slots and the cable lies away from the display panel (or away from the BNC connectors of the remote test fixture). Lock the connector with the two captive thumb screws.
- c. Using the type 874 connectors, connect to the DUT with careful attention to the following color code.

IL (current, low)	Black/black	Connect to first (+) main terminal of DUT.
PL (potential, low)	Black/white	Connect to first main terminal of DUT.
PH (potential, high)	Red/white	Connect to second (-) main terminal of DUT.
IH (current, high)	Red/red	Connect to second main terminal of DUT.
Guard (shield or gnd)	Outer contacts	Connect to shield or case of DUT, if any, <i>only</i> if isolated from main terminals.

Notice that the 2 cables with red must connect to the same end of the DUT, through a coaxial tee if the DUT is a 2-terminal or 3-terminal device; the 2 cables labeled with black, connect to the other end, similarly. Connection of guard, via the outer portion of the coaxial connector, should be to the shield or case of the DUT, *but NOT to either of the two main terminals.*

3.2.6 The 1657-9600 Extender Cable (Banana Plugs) and BNC Cable with Banana Plug Adaptors

1657-9600 Extender Cable (Recommended for 1692 Digibridge) The accessory extender cable 1657-9600 is available to connect to DUTs that are multiterminal, physically large, or otherwise unsuited for the built-in test fixture. (Refer to Table 1-3.) This cable is particularly convenient for connecting multiterminal components with binding posts that accommodate banana plugs.

a. Remove the adaptors, if present, from the test fixture.

b. Plug the single-connector end of the extender cable into the Digibridge test fixture so that its blades enter both slots and the cable lies away from the display panel. Lock the connector with the two captive thumb screws.

c. Note the color coding of the five banana plugs. Be sure that the "low" terminals (both potential and current) connect to one end of the DUT and the "high" terminals to the other end. Connect guard to a shield if any, but not to either end of the DUT. Refer to the following tabulation.

IL (current, low)	Black	Connect to first (+) main terminal of DUT.
PL (potential, low)	Black/white	Connect to first main terminal of DUT.
PH (potential, high)	Red/white	Connect to second (-) main terminal of DUT.
IH (current, high)	Red	Connect to second main terminal of DUT.
Guard (shield or gnd)	Black/green	Connect to shield of DUT, if any, but <i>not</i> to either main terminal.

NOTE: The Kelvin junctions (IL & PL) and (PH & IH) can be made by using stackable banana plugs, for convenience ---so that only one connection is sufficient at each main terminal of the DUT. Then, to obtain best results, it is very important to locate the banana-plug hardware in final position while zeroing (paragraph 3.1.3).

NOTE

Avoid contact between outer conductors of BNC-to-banana adaptors. Otherwise, measurements with high test frequency are liable to have errors that result from the changing mutual inductances between shields of cable conductors.

3.2.7 The Effects of Cable and Fixture Capacitances

It is important to use very low-capacitance shielded wire for cables, not only for accuracy, but also to minimize resonance effects in the measurement of large inductance at high frequency.

The Capacitances that are Most Liable to Affect Accuracy. Any test fixture extension cable adds a bit of capacitance in parallel with the DUT (because shielding of the leads is imperfect) and more between each terminal and ground. The zeroing process (paragraph 3.1.3) will compensate fully for the capacitances between cables in any normal test setup.

However, capacitance between ground and the "low" connections at the DUT (C from ground to IL and C from ground to PL, in parallel, designated C_{sn}) can affect measurement accuracy of very-high-impedance DUTs at high frequencies.

Zeroing. Be sure to repeat either the entire power-up procedure or at least the open-circuit and short-circuit zeroing procedure after any change in test fixtures or their cable connections.



Figure 3-5. 1689-9603 tweezers connected to a Digibridge, with BNC adaptor.

3.2.8 The 1689-9603 Tweezers

Figure 3-5.

The 1689-9603 tweezers combine the two functions:

1. Tweezers for handling chip components, up to 0.5 in. (12 mm) thick.
2. Test fixture for measuring these components, if their terminals are on opposite faces.

With these tweezers, you can conveniently pick up a tiny chip component, measure it, and put it in a bin (or decide what else to do with it), all in one operation.

Installation on the 1692 Digibridge requires BNC Adaptor 1689-9601. Install the tweezers as follows:

- a. Remove any adaptors, cables, etc, if present, from the DUT port of the instrument.

b. Plug the 1689-9601 BNC adaptor into the integral test fixture, with the BNC connectors facing forward. Lock the connection with the 2 captive thumb screws, which must be seated to complete the ground connection.

c. Connect the BNC cables of the tweezer assembly to the Digibridge as indicated in Table 3-1. In this table, ignore the last column (about the remote test fixture). Note that red designates leads that may be "hot". (When bias is applied, they carry dc negative voltage with respect to ground.)

d. If dc bias is used (see paragraph 3.7), notice that the faces of the tweezers are labeled "+" and "-" to indicate bias polarity.

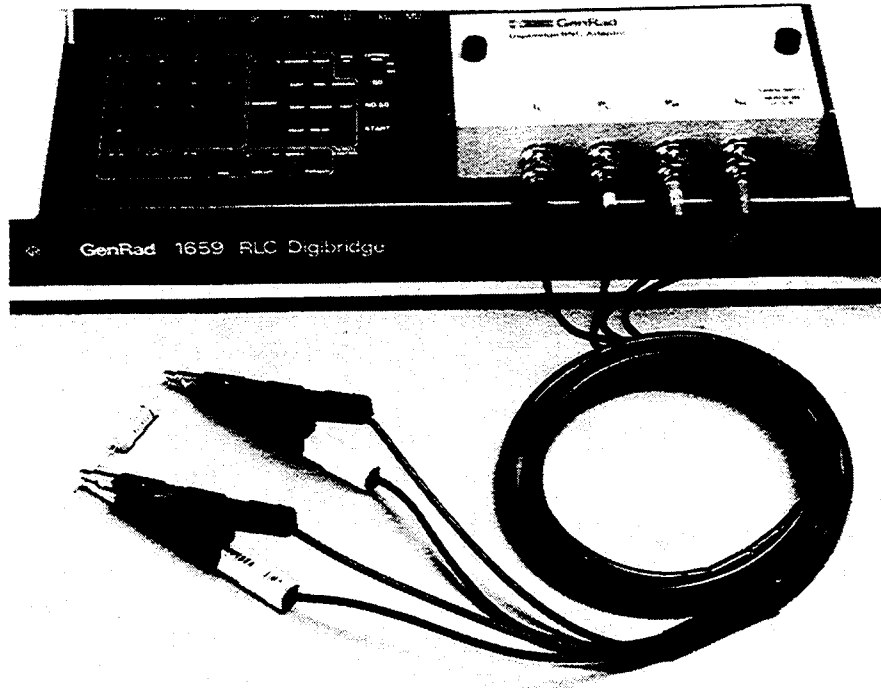

Figure 3-6. 1689-9606 Kelvin Clips connected to a Digibridge.

3.2.9 The 1689-9606 Kelvin Clip Cable

Figure 3-6.

The 1689-9606 Kelvin Clip Cable provides a means for easily making four terminal (Kelvin) connections to passive components. This cable is especially useful for testing low impedance devices or devices that have large non-standard terminations, such as electrolytic capacitors or inductors.

Installation on the 1692 Digibridge requires the 1689-9601 BNC Adaptor. Install Kelvin Clips as follows:

a. Remove any adaptors, cables, etc., if present, from the DUT port of the instrument.

b. Plug the 1689-9601 BNC adaptor into the integral test fixture, with the BNC connectors facing forward. Lock the connection with the 2 captive thumb screws, which must be seated to complete the ground connection.

c. Connect the BNC cables of the tweezer assembly to the Digibridge as indicated in Table 3-1. In this table, ignore the last column (about the remote test fixture). Note that red designates leads that may be "hot", (When bias is applied, they carry dc negative voltage with respect to ground.)

NOTE: Instructions supplied with the 1689-9606 may differ from Table 3-1. It is important to be aware that if DC BIAS is used that it is a negative voltage and that it is applied to the IH lead from the instrument.

3.3 MEASUREMENT PARAMETERS, RESULTS DISPLAYS, AND OUTPUTS

3.3.1 Parameters (R/Q, L/Q, C/D, C/R)

Automatic Selection. The Digibridge as powered up provides you with automatic selection of parameters (unless keyboard has been locked with a particular parameter selected).

This feature enables you to measure any passive component (without knowing whether it is essentially a resistor, inductor, or capacitor). It is provided at power-up and remains enabled as long as you do NOT select any particular parameter.

Automatic parameter selection can be disabled by pressing any of the four parameter keys: R/Q, L/Q, C/D, or C /R. Once disabled, this feature can be enabled again only on a power-up.

When selecting the parameter automatically, the Digibridge calculates Q: if $|Q| < 0.125$, R is selected; otherwise, for positive Q, L is selected; and for negative Q, C is selected. (The sign of Q is the same as the sign of the reactive component of impedance.)

Manual Selection To select the parameter to be measured:

- a. Press one of the 4 parameter keys:

[R/Q, L/Q, C/D, C/R]

- b. Use the [EQUIVALENT CIRCUIT] key to select SERIES or PARALLEL. Note: When you select SERIES equivalent circuit, the 4 parameter keys function as R_s/Q , L_s/Q , C_s/D , and C_s/R_s (s for series). When you select PARALLEL equivalent circuit, the 4 parameter keys function as R_p/Q , L_p/Q , C_p/D , and C_p/R_p (p for parallel).

Note: Equivalent circuits are discussed below, in paragraph 3.3.2.

For an inductor select L/Q; for a capacitor, C/D or C/R; for a resistor, R/Q. There will be an immediate confirmation on the display panel, where appropriate unit indicators will be lit. (However, do not attempt to select the unit multiplier.) The Digibridge will automatically switch to the appropriate multiplier -from mF to pF for example -, unless RANGE is HELD, when it makes a measurement. The result will be displayed in terms of the parameters and equivalent circuit that you select, (even if the DUT has the opposite kind of reactance --see below).

Note: Observing the results displays can be helpful in deciding whether you have made the best parameter selection. (See below.) Displays are discussed further in paragraph 3.3.3.

Negative RLC. If RLC is negative with an L or C value displayed, the DUT reactance is opposite to the selected parameter. As a rule, you should change parameter (usually select L instead of C or vice versa) so that a positive L or C value display can be obtained. However, the displayed negative value of L or C is mathematically correct and (without the minus sign) is in fact the value that will resonate with the DUT at the test frequency. Notice that the appearance of a device can be misleading. (For example, an inductor is capacitive if test frequency is above resonance; or a component part can be mislabeled or unlabeled.)

For more information about both the negative RLC and the negative QDR, see paragraph 3.3.3.

3.3.2 Equivalent Circuits -Series, Parallel

The results of R, L, or C measurements of many components depend on which of two equivalent circuits is chosen to represent it -series or parallel.

The more nearly "pure" the resistance or reactance, the more nearly identical are the "series" and "parallel" values of the principal parameter. However, if D is high or Q low, Cs differs substantially from Cp and Ls differs substantially from Lp; and these values are frequency dependent. Usually several measurements at frequencies near the desired evaluation will reveal that either series measurements are less frequency dependent than parallel, or the converse. The equivalent circuit that is less frequency dependent is the better model of the actual device.

We first give general rules for selection of measurement parameters, then some of the theory.

Making the Selection. The power-up selection is "series", confirmed by the SERIES indicator being lit, on the keyboard. To change the selection, press the [EQUIVALENT CIRCUIT] key.

Specifications. The manufacturer or principal user of the DUT probably specifies how to measure it. (Usually "series" is specified.) Refer also to the applicable MIL or EIA specifications. Select "parallel" or "series" and the test frequency according to the applicable specifications. If there are none known, be sure to specify with your results whether they are "parallel" or "series" and what the measurement frequency was.

Suggested Test Conditions.

- Capacitors less than 10 pF: Parallel, 10 kHz.
- Capacitors from 10 to 400 pF: Series or Parallel, 10 kHz.
- Capacitors from 400 pF to 1 uF: Series, 1 kHz.
- Capacitors greater than 1 uF: Series, 100 or 120 Hz.

Unless otherwise specified or for special reasons, always select "series" for capacitors and inductors. This has traditionally been standard practice. For very small capacitance, select a higher measurement frequency for best accuracy. (Refer to paragraph 3.6.) Conversely, for very large capacitance, select a lower measurement frequency for best accuracy.

- Inductors less than 10 uH: Series, 100 kHz.
- Inductors from 10 uH to 1 mH: Series, 10 kHz.
- Inductors from 1 mH to 1 H: Series, 1 kHz.
- Inductors greater than 1 H: Series, 100 or 120 Hz.

Select "series" as explained above. For very small inductance, select a higher measurement frequency for best accuracy. Conversely, for very large inductance, select a lower measurement frequency for best accuracy.

Resistors, below about 1 kilohm: Series, 1 kHz. Usually the specifications call for dc resistance, so select a low test frequency to minimize ac effects. Select "series" because the reactive component most likely to be present in a low resistance resistor is series inductance, which has no effect on the measurement of series R.

Larger Resistors, greater than 1 kilohm: Parallel, 100 or 120 Hz. As explained above, select a low test frequency. Select "parallel" because the reactive component most likely to be present in a high-resistance resistor is shunt capacitance, which has no effect on the measurement of parallel R. If the Q is less than 0.1, the measured Rp is probably very close to the dc resistance.

Theory --Series and Parallel Parameters. An impedance that is neither pure reactance nor a pure resistance can be represented at any specific frequency by either a series or a parallel combination of resistance and reactance. The values of resistance and reactance used in the equivalent circuit depend on whether a series or parallel combination is used. Keeping this concept in mind will be valuable in operation of the instrument and interpreting its measurements.

The equivalent circuits are shown in Figure 3-7, together with useful equations relating them. Notice that the Digibridge measures the equivalent series components R_s , L_s , or C_s , if you select SERIES EQUIVALENT CIRCUIT. It measures the parallel equivalent components R_p , L_p , or C_p if you select PARALLEL. D and Q have the same value regardless whether series or parallel equivalent circuit is calculated.

Resistance and Inductance

$$X = \omega L$$

$$Z = R_s + j\omega L_s \quad Z = \frac{j\omega L_p R_p}{R_p + j\omega L_p} \quad Z = \frac{R_p + jQ^2 \omega L_p}{R_p + j\omega L_p}$$

$$Q = \frac{1}{D} \quad Q = \frac{\omega L_s}{R_s} \quad Q = \frac{R_p}{\omega L_p}$$

$$L_s = \frac{Q^2}{1+Q^2} L_p \quad L_s = \frac{1}{1+D^2} L_p$$

$$L_p = \frac{1+Q^2}{Q^2} L_s \quad L_p = (1+D^2) R_s$$

$$R_s = \frac{\omega L_s}{Q} \quad R_p = Q\omega L_p \quad R_p = \frac{1}{G_p}$$

$$B_p = -\frac{1}{\omega L_p} \quad y = G_p - j\frac{1}{\omega C_p}$$

Resistance and Capacitance

$$X_s = -\frac{1}{\omega C_s}$$

$$Z = R_s - j\frac{1}{\omega C_s} \quad Z = \frac{R_p}{1 + j\omega R_p C_p} \quad Z = \frac{D^2 R_p + 1/(j\omega C_p)}{1 + D^2}$$

$$D = \frac{1}{Q} \quad D = \omega R_s C_s \quad D = \frac{1}{\omega R_p C_p}$$

$$C_s = (1+D)^2 C_p \quad C_p = \frac{1}{1+D^2} C_s$$

$$R_s = \frac{D^2}{1+D^2} R_p \quad R_p = \frac{1+D^2}{D^2} R_s$$

$$R_s = \frac{D}{\omega C_s} \quad R_p = \frac{1}{\omega C_p D} \quad R_p = \frac{1}{G_p}$$

$$B_p = \omega C_p \quad y = G_p + j\omega C_p$$

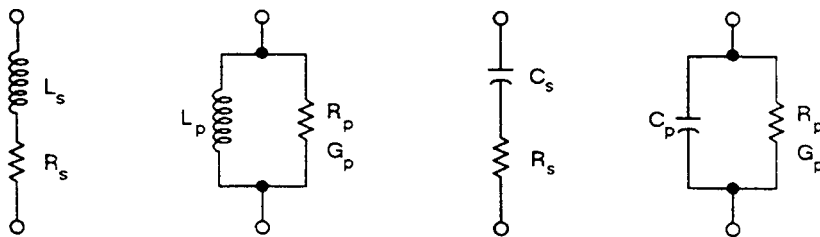

60046.0

Figure 3-7. Equivalent circuits and mathematical relationships for lossy inductors and capacitors.

ESR for Capacitors. The total loss of a capacitor can be expressed in several ways, including D and "ESR" , which stands for "equivalent series resistance" and which is designated "R.s" in the preceding paragraph. To obtain ESR, be sure that the SERIES indicator is lit; if you want ESR displayed simultaneously with Cs, push the [C/R] parameter key; if you want the 5-place resolution for ESR, push the [R/Q] key.

"Equivalent series resistance" is typically much larger than the actual "ohmic" series resistance of the wire leads and foils that are physically in series with the heart of a capacitor, because ESR includes also the effect of dielectric loss. ESR is related to D by the formula $ESR = R_s = \frac{D}{\omega C_s}$ (where ω represents "omega" = 2 pi times frequency).

Parallel Equivalent Circuits for Inductors. Even though it is customary to measure series inductance of inductors, there are situations in which the parallel equivalent circuit better represents the physical device. For small "air-core" inductors, the significant loss mechanism is usually "ohmic" or "copper loss" in the wire; and the series circuit is appropriate.

However, if there is an iron core, the significant loss mechanism may be "core loss" (caused by eddy currents and hysteresis); and the parallel equivalent circuit is appropriate, being a better model of the inductor. Whether this is true at any particular frequency should be determined by an understanding of the DUT, but probably it is so if the following is true: that measurements of L_p at two frequencies near the frequency of interest differ from each other less than do measurements of L_s at the same two frequencies.

3.3.3 Results Displayed

PRINCIPAL MEASUREMENT RESULTS

The principal Digibridge measurement will be presented on the left (RLC) part of the display panel in one of four ways; VALUE, deltaRLC, delta%, or BIN No., (only one way for any single measurement).

VALUE, Selected by the /DISPLA YJ Key. This measurement provides two displays: the principal one is RLC (resistance, inductance, or capacitance) and the secondary one is QDR (quality factor with R or L, either dissipation factor or resistance with C). The VALUE selection is the power-up default and one of the selections of the [DISPLAY] key.

Read the measurement on the main displays. The RLC display is the principal measurement, complete with decimal point and units which are indicated by the light spot in the lower part of the display panel. The light spot above the display identifies the measurement parameter (RLC, RLC, %, or BIN No.). The QDR display is Q if the selected parameter is R/Q or L/Q; it is D for C/D, or resistance (with units indicated) for C/R. The light spot above the display also identifies the measurement parameter (Q, D or R). Leading zeros before the decimal point are automatically eliminated in most cases by positioning of the decimal point. Otherwise, such zeroes are blanked out.

Negative RLC. If the RLC is negative with an L or C value displayed, the DUT reactance is opposite to the selected parameter. Generally, you should change parameter (usually select L instead of C or vice versa) so that a positive L or C value display can be obtained. See paragraph 3.3.1.

Delta Percent Displays, Selected by the [DISPLAY] Key. This presents the principal measurement (RLC) in terms of a percent difference above or below the nominal value last entered (i.e., a previously stored reference). Use this procedure.

- a. Select ENTER with the [FUNCTION] key.

b. Select appropriate parameter and units with [EQUIVALENT CIRCUIT] and [R/Q, L/Q, C/D or C/R] (Repeat keying will change unit multipliers.)

c. Enter the reference for delta percent by keying:

(Y)[=] [SHIFT] [NOM VALUE]

in which Y represents 1 to 6 numerical keys and (optionally) the decimal point key, depressed in sequence. Confirmation is shown (up to 5 digits) on the RLC display.

d. Select MEASURE with the [FUNCTION] key and delta% with the [DISPLAY] key.

e. Observe that the RLC display will now be in percent, not an electrical measurement unit. It is the difference of the measured principal value from the nominal value (the stored reference), expressed as a percent of the nominal value.

The secondary measurement result appears in the QDR display area, just as it would if the principal display were VALUE.

NOTE: If you wish to see the delta% display simultaneously with bin sorting (data output to handler or IEEE-488 bus), enter the bin limits first, as described in paragraph 3.8. Then (unless the last setting of nominal value happens to be the desired reference for percent difference) use the above procedure for setting up delta% displays.

Delta RLC Display, Selected by the [DISPLAY]Key. This selection is indicated by lighting BOTH indicators together: VALUE and delta%. The deltaRLC display is a difference from the stored nominal value, measured in the indicated electrical units, such as ohms, millihenries, or picofarads. The NEG RLC indicator is lit if the measured value is less than reference. The procedure for selecting deltaRLC displays is like the delta% procedure, above, except that the [DISPLAY] key is pressed repeatedly until *two* DISPLAY indicators (together labeled deltaRLC) are lit.

The secondary measurement result appears in the QDR display area, just as it would if the principal display were VALUE.

Bin No. Selected by using the [DISPLAY] key. When measurement is completed, the bin assignment will be shown on the left (RLC) display only, as a one-digit number, with the following significance:

- 0 = No-Go because of the secondary (QDR) limit
- 1 = Go, bin 1
- 2 = Go, bin 2
- ...Go, bin 3, 4, 5, 6, 7, or 8, as indicated.
- 9 = No-go by default (suits no other bin).

SECONDARY MEASUREMENT RESULTS

The secondary Digibridge measurement will be presented on the right (QDR) display panel, for each measurement if the DISPLAY selection is VALUE, delta%, or deltaRLC. There is no secondary display if the selection is BIN NO.

Negative QDR. A negative QDR has the following meanings.

Parameter Selection	+ QDR	-QDR
R/Q	DUT is inductive	DUT is capacitive
L/Q, C/D, or C/R	Q, D, or R is positive	Q, D, or R is negative (see below)

If the secondary measurement is negative -Q, D, or R as calculated by the Digibridge when selected parameter is L/Q, C/D, or C/R --then there are two likely possibilities. If the Q or D value (whichever is being displayed) is very small, a small (acceptable) calibration and/or measurement. error can lead to a negative result. (It should of course fall within the specified accuracy of the instrument.) Measurement error can be reduced by choice of measurement conditions, averaging, etc. Another possibility is that the DUT (as seen by the Digibridge) really does have a negative loss factor. This situation might occur when you are measuring certain kinds of multi-terminal networks or active devices.

NOTE

Improper connection of extender cables can cause a false indication of negative QDR.

GO/NO-GO INDICATORS

If comparison is enabled, by a non-zero entry for "nominal value", and limits in at least one bin, a GO or NOGO indication is provided at the keyboard, for every measurement. If you are using the 1689-9605 remote test fixture, a GO/NO-GO indication appears there also. (The display selection can be whatever you choose.) GO means the measurement falls in bin 1 through 8; NO-GO means bin 0 or 9.

3.3.4 Units, Multipliers

Units of R, L, and C are determined entirely by your selection of parameter. Units multipliers are fixed by parameter, range, and frequency, except that selection of delta% changes the RLC display to a percentage. See Table 3-2.

Units of D and Q are dimensionless and are expressed as a decimal ratio, without multiplier. To obtain D or Q in percent, from the regular display, move the decimal point two places to the right. For example, a regular display of D = .0045 is equivalent to 0.45%

Table 3-2
UNITS AND MULTIPLIERS FOR EACH RANGE

Parameter	100Hz, 120Hz, 1kHz				10kHz				100kHz			
	1	2	3	4	1	2	3	4	1	2	3	4
R	K[3]	K[3]	ohm	ohm	K[3]	K[3]	ohm	ohm	[1]	K[3]	ohm	ohm
L	H	H	mH	mH	H	mH	mH	mH	[1]	mH	mH	mH
C/D	pF	nF	nF	uF[4]	pF	nF	nF	nF[4]	[1]	pF	nF	nF[4]
C/R[2]	nF	nF	nF	uF[4]	nF	nF	nF	uF[4]	[1]	nF	nF	uF[4]

NOTES [1] Range 1 is not used, if frequency is above 20kHz.

[2] For C in nF, R is in kilohms. For C in uF, R is in ohms.

[3] Units can be in M for high values in this range. When ranging up the units will change from k to M at 2000 k. When ranging down, the units will change from M to k at .5 M.

[4] Units can be in mF for high values on this range. When ranging up, the units will change from uF to mF at 2000 uF. When ranging down, the units will change from mF to uF at .5 mF.

Decimal Point Position. The decimal point is automatically positioned for maximum resolution (i.e., so that the first significant digit or the first zero after the decimal point is in the first position in the display) with a few exceptions, as listed below. Of course, displays on low underrange or low extension of a held range may have a number of necessary zeros to right of the decimal point (and therefore reduced number of significant digits compared to the display area) because units and multipliers are fixed on anyone range. The above-mentioned exceptions are:

1. Delta% displays can resolve no less than 0.0001% (i.e., 1 ppm).
2. Hysteresis is provided to reduce flickering, as explained below.

If the first digit of the measurement is 9, the decimal point for any measured-value display is left unchanged from its previous position, provided that so doing places that 9 in either the first or second position in the display area. (Notice that a number like 09XXX has resolution almost as fine as a number like 10XXX.)

For example, if the measured value is 99.985 nF, the display is a full 5 digits if the previous measured-value display was 12.345, 99.984, or 99.999; but the display is rounded off to 099.98 nF if the previous measured-value display was 100.02 or 1234.5 nF. Hysteresis is provided on both measured-value displays (RLC and QDR).

Blanks in Measured- Value Displays. If a measurement exceeds the capability of the display (99999 for RLC display, 9999 for QDR), the display is blank. If a measurement is less than 1 right-hand digit, the display is all zeros. If any leading zero before the decimal point must occupy a position in the display, that zero is blanked out.

3.4 PRINCIPAL TEST CONDITIONS

3.4.1 Test Frequency

Power-up frequency is 1 kHz, unless the keyboard has been locked with some other choice. There are 4 other frequencies, available (100 Hz, 120 Hz, 10 kHz, and 100 kHz).

Selection. To change the test frequency, simply press the [SHIFT] key and then the [FREQUENCY] key. Repeat keying of the [SHIFT] [FREQUENCY] keys will change the frequency.

Indication. The light--spot LED on the right of the display panel will indicate the test frequency selected.

3.4.2 Test Voltage

The power-up test voltage is 1.0 volt rms, unless the keyboard has been locked with some other choice. There is one other selection available: (0.3 V).

Selection To change the test voltage, simply press the [SHIFT] key and then the [VOLTAGE] key. Repeat keying of the [SHIFT] [VOLTAGE] keys will change between the two test voltages.

Indication The light--spot LED on the bottom right of the display panel will indicate the test voltage selected.

The actual voltage across the DUT is never more than the source voltage, and depends on the DUT impedance and the source resistance of the Digibridge, for the range in use. The DUT voltage is close to the source voltage at the high-impedance end of each measurement range and lower at the low-impedance end. Normally, the smallest voltage across the DUT (if its impedance is 6.25 ohms or more) will be 20% of the source voltage; this is the case for resistors measured at the low end of each range. Refer to Table 3-3 for details. (This table is similar to the table of range constants in the specifications. However, the extreme limits are given here, on ranges 1 and 4.)

For example, what is the voltage across the DUT if it is a 1-uF capacitor. Assume the test frequency is 1 kHz, the test voltage is 1.0 V, the CONSTANT VOLTAGE indicator is NOT lit and the RANGE HELD indicator is NOT lit. The Digibridge will measure on range 3, with 1.0 V behind source resistance of 400 ohms. The DUT reactance is 159 ohms and the voltage across it is 370 m V.

For comparison, what is the voltage across the same DUT if you select CONSTANT VOLTAGE (see paragraph 3.4.3) or if range 4 is held. In either case, the source, 1.0 V, is behind 25 ohms. The voltage across the DUT is 988 mV.

**Table 3-3
AUTORANGING MEASUREMENT RANGES AND SOURCE RESISTANCES**

Range	Source Resistance	Principal Measured Parameter		
		----- Resistance	Capacitance	----- Inductance
1	97.4 kohms	max 99999 M	min .00001 pF	max 99999 H *
		mid 102 K	mid 1600 pF/f	mid 16 H/f
		min 25.6 K	max 6400 pF/f	min 4.1 H/f
2	6.4 kohms	max 25.6 K	min 6.4 nF/f	max 4100 mH/f
		mid 6.4 K	mid 25.3 nF/f	mid 1025 mH/f
		min 1.6 K	max 100. nF/f	min 256 mH/f
3	400 ohms	max 1600 ohms	min 100 nF/f	max 256 mH/f
		mid 400 ohms	mid 400 nF/f	mid 64 mH/f
		min 100 ohms	max 1600 nF/f	min 16 mH/f
4	25 ohms	max 100 ohms	min 1.6 uF/f	max 16 mH/f
		mid 25 ohms	mid 6.4 uF/f	mid 4 mH/f
		min .00001 ohm	max 99999 mF	min .00001 mH

* "K" is Kilohms; "M" is Megohms; "f" is equal to the test frequency in kHz.

3.4.3 Constant-Voltage Source

If it is important to measure the DUT at a particular test voltage, then select the constant-voltage feature as follows. Press:

[SHIFT] [CONSTANT VOLTAGE]

so that the CONSTANT VOLTAGE indicator is lit. The Digibridge now retains a source resistance of 25 ohms for all ranges. The voltage is constant for any DUT impedance significantly larger than 25 ohms. An example is given in the preceding paragraph. Choosing this feature causes a reduction in measurement accuracy by a factor of two.

(To disable the constant-voltage feature, press the same keys again.)

3.4.4 Other Conditions

Other test conditions are described in other parts of this manual. Averaging (selection of number of measurements to be averaged) -paragraph 3.6.2. Bias applied to the DUT (if it is a capacitor) -refer to paragraph 3.7.

3.5 MEASUREMENT TIME AND MEASUREMENT RANGES

3.5.1 General

Selection of MEASURE RATE (SLOW, MEDIUM, and FAST) obviously relates to measurement time, providing the user with an easily made choice. (The slower rates provide greater accuracy.)

In this paragraph, the many items that affect measurement time are explained. The measurement time (required to complete a measurement and display the results) depends not only on the selected measure rate, but also on the test conditions, choice of display, whether data is being sent out to other devices, etc. The best combination of conditions for any particular job should be selected recognizing their effects on speed and accuracy.

The minimum measurement time is about 125 ms (8 meas/sec). The corresponding conditions are: measure rate = fast, display selection = bin no., and no data output via IEEE-488 bus.

3.5.2 Measure Rate Selection at Keyboard

Choose one of 3 basic measurement rates with the [MEASURE RATE] key: SLOW, MEDIUM, or FAST. The measurement rates (continuous or triggered) are respectively about 2, 4, and 8 measurements per second, if the other test conditions are left at normal power-up defaults.

The tradeoff is speed vs. accuracy. The Digibridge will make a more precise and accurate measurement at a slower rate. For the above conditions, in very simplified terms, the basic accuracy is 0.05%, and the tradeoff is as follows:

- SLOW rate, 2 measurement per second, 0.05% accuracy (or better);
- MEDIUM rate, 4 measurements per second, 0.1% accuracy (or better);
- FAST rate, 8 measurements per second, 0.25% accuracy (or better).

For details on accuracy, refer to the specifications.

3.5.3 Measure Mode and Display Selection, Effects on Measurement Time

Measure Mode TRIGGERED. Selection of TRIGGERED results in a measurement rate the same as CONTINUOUS.

Measure Mode CONTINUOUS. Selection of CONTINUOUS results in a measurement rate discussed in paragraph 3.5.2 above. CONTINUOUS is also the power-up default mode. Notice that in continuous mode, the measurement being made when the DUT is connected to the Digibridge is erroneous.

Display Selection. The selection of BIN NO. display cuts 6 to 10 ms from the measurement time, compared to the other choice of display. Therefore, the BIN NO. choice is recommended for use with an automatic parts handler, if maximum throughput is desired and there is no need for the operator to observe values or percent differences.

More information about operation with a parts handler is given in paragraph 3.10.

3.5.4 Ranges, Range Changing, and Holding a Range to Save Time

RANGES and RANGE CHANGING

Descriptions of ranges, range extensions, and decimal point control are explained below.

Basic Ranges. The 4 basic ranges are numbered 1, 2, 3, 4, in order of decreasing impedance. Each basic range is approximately a factor of 16 wide. Refer to paragraph 3.4.2 for a table of ranges.

The word "upper" as used below refers to increasing measured value (which is the direction of increasing range number only if the principal measured parameter is capacitance). Similarly, the word "lower" as used below refers to decreasing measured value (which is the direction of decreasing range number only if the principal measured parameter is capacitance).

Extensions. Each of the 4 ranges goes beyond its basic range, with both upper and lower range extensions (also called overrange and underrange). Most of these extensions are seldom used because they overlap basic portions of other ranges and the Digibridge will automatically select the basic range unless you have selected "hold range" (see RANGE HELD indicator). Measurement units and multipliers in any range extension are the same as in the basic range. The fact that range definition depends on frequency causes a considerable variation in the width of range extensions. The lower limit is generally .00001, with all-zeros next; the upper limit is 99999, with all blanks next. Blanks in the measurement display are discussed below. In general, for any measurement within the specifications of the Digibridge, if a measurement can be displayed, it will be.

The only range extensions that are valid with autoranging are low underrange and high overrange, explained below.

Low Underrange. The "low" extension of the low range goes down to 1 count, with reduced accuracy. The smallest "1-count" increment in the display is the minimum measured value, given in the specifications in the front of this manual. Any measurement smaller than 1 count is displayed as all zeros.

High Overage. The "high" extension of the high range goes up to the maximum display (all 9's, with the decimal point at the right), and finally to blank, with reduced accuracy. The high overrange is used for the very large values of RLC that exceed the basic high range.

Autoranging. Autoranging is normal; it is inhibited only if you select RANGE HELD. There is a slight hysteresis in the changeover from range to range to eliminate a possible cause of display nickering.

Time Required to Change Range. The Digibridge must almost complete a measurement cycle in the previously established range before starting measurement in the range to which it changes. The Digibridge completes the data acquisition and a large part of the calculation process before "deciding" whether the present range is best for the measured value. Thus, measuring a lot of components that straddle a range boundary requires almost double the regular measurement time for every DUT that is on the opposite side of the boundary from its predecessor. (Note: if the Digibridge starts in range 1 to measure in range 4, four almost complete measurement cycles are required before the desired result appears.)

Therefore (at least in some measurement situations), maximum measurement speed requires range holding.

RANGE HOLDING

Why Hold a Range? The most important use of the range holding capability is to avoid range changes when the component is removed from the fixture when in the CONTINUOUS mode. With no component connected, the instrument will autorange to range 1. Thus, if range 1 is not selected when the component is in place, considerable time is lost by unnecessary autoranging. Another use of the range hold occurs when measuring components of the

same nominal value whose actual values spread across the boundary between two ranges. If allowed to autorange, the units and decimal point may change with range which may be confusing to the operator. There are other uses for holding a range, such as obtaining the correct bias current or getting better guard capability. When a range is held that is not the range that autoranging would select, the accuracy may be sacrificed.

To inhibit autoranging, select the "range held" mode (RANGE HELD indicator lit) as described below --three methods.

To Hold Present Range. If the present range (as indicated by the measurement display) is the desired one, press:

[SHIFT] [HOLD RANGE] to light the RANGE HELD indicator.

(To return to the normal autoranging feature, press the same keys again, making the RANGE HELD indicator unlit.)

To Hold the Range of a Sample DUT. One way to get into the desired range is to measure a DUT known to be in that range, thus:

Measure the DUT as usual.

Verify that the desired range is confirmed by the measurement display.

Press: [SHIFT] [HOLD RANGE] to light the RANGE HELD indicator.

(To return to the normal autoranging feature, press the same keys: [SHIFT] [HOLD RANGE] again, making the RANGE HELD indicator unlit.)

To Hold the Range selected by Use of a Parameter Key. Another way to get into the desired range is to use a parameter key, thus:

Select ENTER function with the [FUNCTION] key.

Press the appropriate parameter key (such as C /D) repeatedly, watching the units indicators. The range advances with each repetition, enabling you to determine the present range by the pattern of changes. Notice that there is *not* always a change of unit multiplier with each range change. (Refer to the table in paragraph 3.3.4.)

Press: [SHIFT] [HOLD RANGE] to light the RANGE HELD indicator.

(To return to the normal autoranging feature, press the two keys again, making the RANGE HELD indicator unlit.)

3.5.5 Time Required for Obtaining Averaging

Accuracy can be enhanced, at the cost of increased measurement time, by averaging. The time considerations and a brief instruction for selecting this method is given here.

Averaging. The measurement time is multiplied by the number of measurements (2 to 10), specified when averaging was programmed. To program the Digibridge to average, for example, 8 measurements, press:

[8] [=] [SHIFT] [AVERAGE] (See paragraph 3.6.3)

3.5.6 Time Required if IEEE-488 Output is Enabled

If data output is enabled, via IEEE-488 bus, additional time, about 2 ms to 12 ms, is required per measurement. This time requirement depends on the selected display and what data is being sent out, approximately as follows. (Refer to explanation of operation with the IEEE-488 interface, paragraph 3.12.)

Regular Output Data Format							CBF *
Output data: BIN	RLC	QDR	RLC, QDR	BIN, RLC	BIN, QDR	BIN, RLC, QDR	(any)
Display = BIN NO.	2	6	8	10	10	12	< 2 ms
Display = other	2	2	2	4	4	6	< 2 ms

* Compacted Binary Format. If the compacted binary format is selected, data output requires less than 2 ms.

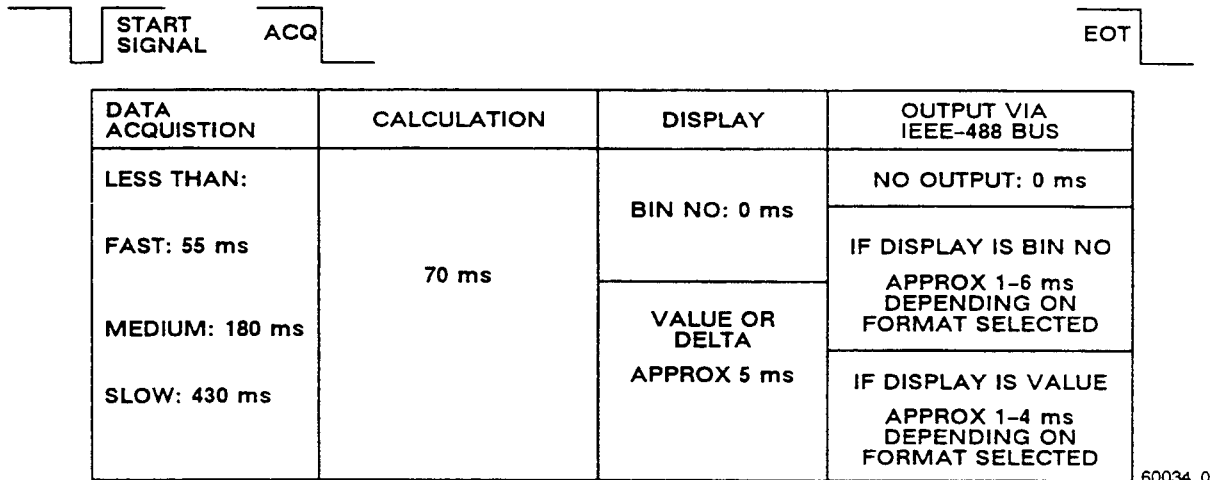

Figure 3-8. Summary of the components of measurement time used by the 1692 Digibridge and an indication of how the time per measurement depends on measurement conditions and system selections. The START signal can be received via START button, IEEE-488 bus, or handler interface. The ACQ (otherwise known as ACQ OVER) and EOT signals are sent via the handler interface.

3.6 ACCURACY, THE LIMITS OF ERRORS

3.6.1 General

Refer to the Specifications, at the front of this manual. The specifications apply at an ambient temperature of 23 degrees C (unless recalibration has been done at some other temperature), in low humidity, if the OPEN and SHORT zeroing procedures have been executed properly (paragraph 3.1). These specifications are valid when autoranging is used or the optimum range is set and held. When a non-optimum range is set and held, the accuracy may decrease, see paragraph 3.6.4.

Typical accuracy is described below, for convenience in obtaining a birds-eye view of the way it relates to the principal test conditions.

Refinement of the zeroing procedure to enhance accuracy for certain kinds of measurements is described in paragraph 3.6.3.

3.6.2 Averaging to Improve Accuracy

The accuracy of measuring each DUT can be enhanced automatically by the Digibridge if you program it to make several measurements and average them before reporting the final result. Thus, errors due to electrical noise and other effects that are just as likely to make the measurement too high as too low are largely canceled. (This is true regardless of the display selection, VALUE, BIN NO., etc.) Of course, the time required to complete a measurement with averaging set to 10 (for example) is 10 times as long as the time for a single measurement.

Averaging can be set to any integer between 2 and 10. To select 8 for example, select ENTER with the [FUNCTION] key, then press:

[8][=][SHIFT][AVERAGE]

Similarly, to inhibit averaging, select ENTER function and press:

[1][=][SHIFT][AVERAGE]

This is the default situation (no averaging).

Displays of averaged measurements depend on the measure mode.

1. If the measure mode is TRIGGERED, the display is repeatedly updated to be the running average, until the programmed number of measurements have been made; then the final average remains displayed until the next START command.
2. If the measure mode is CONTINUOUS, averaging proceeds without any change of display until the programmed number of measurements have been made; then the final average is displayed and remains until replaced by another final average.

3.6.3 Accuracy Enhancement for Large or Small Impedances at Particular Frequencies

Regular Zeroing at Test Frequency. When measuring very large or small values of impedance, the Digibridge will provide much better accuracy than the specifications, *if* the OPEN and SHORT zeroing procedure has been recently repeated with test frequency set to the actual test condition.

NOTES. Even better accuracy is possible if several measurements are averaged. See paragraph 3.6.2, above.

3.6.4 Accuracy When Holding a Non-Optimum Range.

The accuracy specifications are valid when the optimum range is used for any given impedance value. The optimum range is selected by the autoranging capability. If some other range is selected and held by the operator, the specified accuracy will be poorer. This accuracy may be calculated by multiplying the Extreme Range Terms in the accuracy specifications by the factors given in Table 3-4.

Table 3-4
Extreme Range Term Multiplying Factors

	Range 1	Range 2	Range 3	Range 4
Low End Terms				
R and L	5000	300	20	1
C	1	20	300	5000
Hight End Terms				
R and L	1	20	300	5000
C	5000	300	20	1

3.7 BIAS FOR THE DUT

NOTE

Keep the EXTERNAL BIAS switch OFF and the BIAS ON indicator unlit, for all measurements of inductors and resistors, and also for capacitors unless they are to be measured with dc bias applied.

3.7.1 Internal Bias

To measure capacitors with the internally available 2-volt dc bias voltage applied, use the following procedure. The FUNCTION should be :MEASURE.

- a. Press [SHIFT] [INT BIAS] keys so that the BIAS ON indicator is lit. NOTE: This indication, for internal bias, is somewhat dimmer than the other keyboard indicators.
- b. Observe correct polarity when inserting DUT into test fixture. Bias POSITIVE polarity is at the LEFT ("low" terminals) of the 1692 Digibridge built-in test fixture. Bias NEGATIVE polarity is at the RIGHT.
- c. For each DUT, in the CONTINUOUS or TRIGGERED measure mode, disregard the first displayed result and read the second. Notice enough of the subsequent results to verify that the DUT has stabilized. Use the stable result.

NOTE: There are two effects to be aware of in watching for stabilization of the DUT: voltage and capacitance. Besides charging to a "final" voltage, there is also the stabilization of capacitance value itself. For example, some aluminum electrolytic capacitors respond slowly to a change in applied voltage, therefore the DUT capacitance can be settling long after tthe voltage is essentially stable.

- d. Remove internal bias by pressing the [SHIFT] [INT BIAS] keys, so that the BIAS ON indicator is NOT lit.

NOTE

The BIAS ON indicator serves to indicate whether internal bias is connected or disconnected *only if the EXTERNAL BIAS is switched OFF*. (See below for external bias.)

Notice that repeating the same keyboard sequence will cyclically enable and disable internal bias. For best results, after removing bias and before making further measurements, allow at least 2 seconds for internal circuit discharge and settling.

3.7.2 External Bias

If bias is required at some other voltage than the 2- V internal bias, use external bias as described below. Also:

- Be sure that the voltage is never more than 60 V, max.
- A current limiting voltage supply is recommended; set the limit at 200 mA, max.
- Be sure that the bias supply is floating; DO NOT connect either lead to ground.
- Generally the external circuit must include switching for both application of bias after each DUT is in the test fixture and discharge before it is removed.
- A well-filtered supply is recommended. Bias-supply hum can affect some measurements.

Setup Procedure.

- a. Connect the external bias voltage supply and switching circuit, using the 1658-2450 cable, supplied, via the rear-panel EXTERNAL BIAS connector. Observe polarity marking on the rear panel; connect the supply accordingly.
- b. Set the external supply to limit current (< 200 mA).
- c. Set the external bias supply to the desired voltage (< 60 V).
- d. If the Digibridge power is off, switch its POWER ON and wait for completion of the self-check routine before the next step.
- e. Switch the EXTERNAL BIAS ON (switch is at right of keyboard) and verify that the BIAS ON indicator is lit -see below. (If polarity is inverted, the indicator will not be lit as brightly as normal.) If the bias cable fuse must be replaced, use a 200 mA fast-acting fuse.
- f. Switch the bias off using an external switch, so that the DUT can be inserted before bias is applied to it. Refer to the Operating Procedure below.

NOTE

The BIAS ON indicator serves to indicate *that the* EXTERNAL BIAS is switched ON, NOT NECESSARILY the presence of external bias. See below. Also: whenever the EXTERNAL BIAS switch IS ON, the Digibridge automatically selects CONSTANT VOLTAGE.

Indicator. When the EXTERNAL BIAS switch is ON, the BIAS ON indicator shines as long as the Digibridge POWER is ON. (The indicator brightness depends somewhat on the external bias voltage.) Also, when the EXTERNAL BIAS switch is ON, but the POWER is switched OFF, this indicator is lit by external bias voltages above about 3 V.

Effect on Power-Up. Be sure that the EXTERNAL BIAS switch is OFF before you switch the Digibridge POWER ON. This is generally necessary to permit the power-up self checks to pass.

Protection. The Digibridge is internally protected from damage from charged capacitors with stored energy up to 1 joule at any voltage up to 60 V.

CAUTION

If your test procedure includes charging capacitors to higher energy or higher voltage before or during connection to the Digibridge, EXTERNAL PRECAUTIONS MUST BE TAKEN TO PROTECT THE INSTRUMENT.

Operating Procedure.

- a. Select MEASURE function.
- b. Observe correct polarity when inserting DUT into test fixture. Bias POSITIVE polarity is at the LEFT ("low" terminals) of the 1692 Digibridge built-in test fixture. Bias NEGATIVE polarity is at the RIGHT.
- c. Use the external switches (user supplied) to remove bias from the test fixture, apply bias after the DUT is in place, remove bias after measurement, and short the DUT before its removal. A routine like this is generally recommended.

However, for occasional (non-production) measurements, if the capacitances being measured are less than 200 μF and the bias voltage less than 30 V, an optional procedure is to leave the external bias circuitry "on during measurements and to use the Digibridge EXTERNAL BIAS switch to apply bias to the DUT (ON) and to remove it and discharge the DUT (OFF).

- d. For each DUT, in the CONTINUOUS or TRIGGERED measure mode, disregard the first displayed result and read the second. Notice enough of the subsequent results to verify that the DUT has stabilized. Use the stable result.

NOTE: There are two effects to be aware of in watching for stabilization of the DUT: voltage and capacitance. Besides charging to a "final" voltage, there is also the stabilization of capacitance value itself. For example, some aluminum electrolytic capacitors respond slowly to a change in applied voltage, therefore the DUT capacitance can

be settling long after the voltage is essentially stable.

e. ASter biased measurements are completed, remove all bias by sliding the EXTERNAL BIAS switch OFF and if necessary pressing the [SHIFT] [INT BIAS] keys, so that the BIAS ON indicator is NOT lit.

3.8 BIN SORTING AND GO/NO-GO RESULTS

3.8.1 Introduction to Binning (Sorting Based on Limit Comparisons)

If a group of similar DUTs are to be measured, it is often convenient to use the limit-comparison capability of the Digibridge to categorize the parts. This can be done *in lieu of* or *in addition to* recording the measured value of each part. For example, the instrument can be used to sort a group of nominally 2.2-uF capacitors into bins of 2%, 5%, 10%, 20%, lossy rejects, and other rejects. Or it can assign DUTs to bins of (for example) a 5% series such as 1.8,2.0, 2.2, 2.4, 2.7 uF, etc. The bin assignments can be displayed, for guidance in hand sorting, or (with an interface option) output automatically to a handler for mechanized sorting.

Up to 8 regular bins are provided for categories of the principal measurement (RLC), in addition to a bin for rejects in the secondary measurement (QDR), and a bin for all other rejects; total = 10 bins.

NOTE: The 1658-9620 IEEE/handler interface option provides only eight "go" bin output signal lines. Thus, an automatic handler can sort into bins 1 through 8.

Manually entered limits are normally entered in pairs (defining the upper and lower limits of a bin), in the form of "nominal value" and "percent" above and below that nominal. If only one "percent" value is entered for a bin, the limit pair is symmetrical (such as +/- 2%). To set up a non-symmetrical pair of limits, two "percent" values must be entered, the higher one first. Any overlapping portion of 2 bins is automatically assigned to the lower-numbered bin.

For simple GO/NO-GO testing, set up a QDR limit and one regular bin. Entry of limits in additional bins will define additional GO conditions. Be sure the unused bins are closed. (Bins 0 thru 8 are initially zero, at power-up. This means that the default QDR limit is "all fail" for D, Rs, and Q with R; it is "all pass" for Rp or Q with L; and that bins 1 through 8 are initially closed.)

The test frequency can be selected after limits are entered, before any particular measurement.

3.8.2 Sorting Methods

Figures 3-9, 3-10.

The figures illustrate 2 basic methods of sorting: nested and sequential.

Nested bins (Figure 3-9) are the natural choice for sorting by tolerance around a single nominal value. The lower numbered bins must be narrower than the higher numbered ones. Symmetrical limit pairs are shown; but unsymmetrical ones are possible. (For example, range BE could be assigned to bin 3 and range AF to bin 4 by use of unsymmetrical limit pairs in these bins.)

Sequential bins (Figure 3-10), on the other hand, are the natural choice for sorting by nominal value. Any overlap is assigned to the lower numbered bin; any gap between bins defaults to bin 9. The usual method of entry uses a redefined nominal value for each bin, with a symmetrical pair of limits. If it is necessary to define bins without overlap or gaps, use a single nominal value and unsymmetrical limit pairs. It is possible to set up one or more tighter-tolerance bins within each member of a sequence.

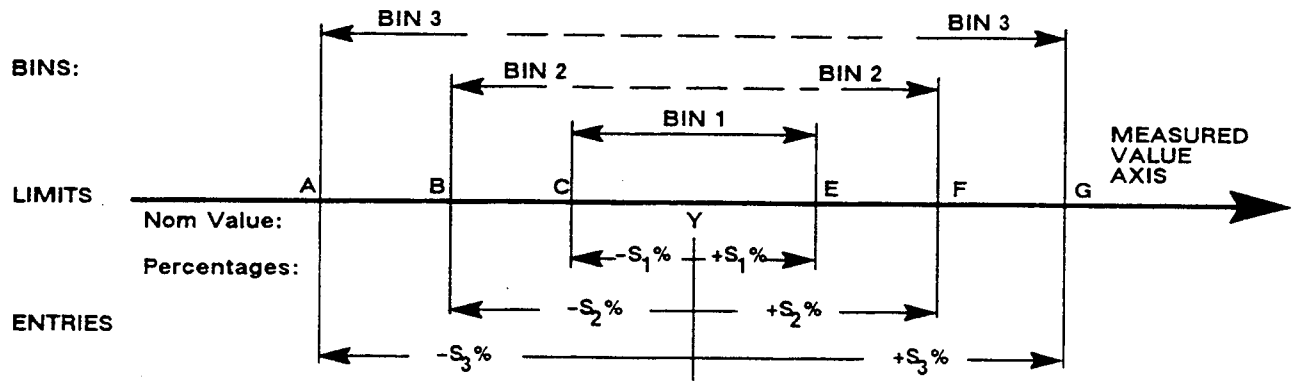

60035.0

Figure 3-9. Nested bins. A single nominal value Y is used and all limit pairs are symmetrical in this basic plan.

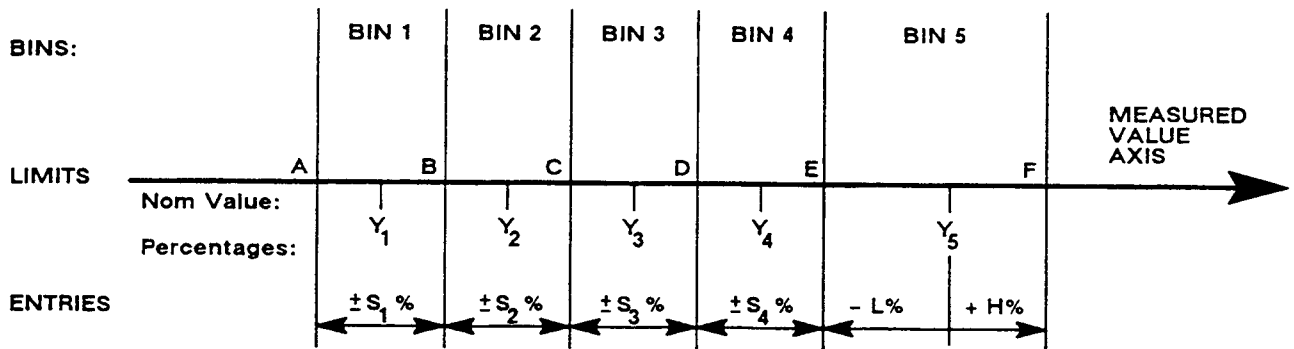

60036.0

Figure 3-10. Sequential bins. A different nominal value ($Y_1, Y_2, Y_3, Y_4,$ and Y_5) is entered for each bin and all limit pairs are symmetrical except for the unsymmetrical pair shown for example in bin 5.

Bucket sorting means sorting into bins that are not nested. The usual method is that mentioned above, sequential limits. However, there is no requirement that the bins be adjacent. Any of them can be defined with its own specific limits, which may be overlapping, adjacent, or isolated from any other bin.

3.8.3 Limit Entry Procedure

This procedure makes use of the limit entry keys (NOM VAL and BIN NO) at the left of the [SHIFT] key. These are labeled in yellow and apply only when the selected FUNCTION is ENTER.

QDR Limit Entering QDR limit is performed as follows:

- a. Press [DISPLAY] key to select VALUE.
Press [FUNCTION] key to select ENTER.

b. To enter a single QDR limit (always bin 0): press the parameter key (such as [L/Q]) appropriate to DUT. To change range and unit multipliers, press the same key repeatedly. (Refer to paragraph 3.3.4 for a table of units and multipliers, which indicates the sequence of multipliers that will appear.)

This entry can be a maximum limit or minimum limit depending on the parameter selection. Q is a maximum with R and a minimum with L. D is always a maximum. R is a maximum with C (series) and a minimum with C (parallel).

c. When keying a number in, it will be shown on the left-hand display. For example, to enter a Q limit of 85, press:

[8] [5] [=] [SHIFT] [BIN NO][0].

The value now moves to the right-hand display, confirming storage of the limit. Note: if you make a mistake, press the parameter key again and repeat the entry.

RLC Limits The following will describe (with examples) three common methods of sorting that are possible with the 1692 Digibridge.

Nested bins -Using the same nominal value with symmetrical or unsymmetrical limit pairs.

Sequential bins- Using a different nominal value with symmetrical or unsymmetrical limit pairs.

Sequential bins- Using the same nominal value with adjacent, but non-overlapping limits.

NOTE

If at any time during the entry of a limit the wrong key is depressed, another way to clear and start the entry again is:

With the [FUNCTION] key, select MEASURE momentarily and then ENTER again. From here begin the entry anew.

1. Nested bins. Enter the nominal value of DUTs to be sorted. (The value appears on the RLC displayUnits were selected in step b.) For example, to enter 123.40 as the nominal value, press

[1][2][3][.] [4][=] [SHIFT] [NOM VAL].

Enter for bin 1 the narrowest percent tolerance to be sorted. As an example, for a tolerance of +/-0.2%: press

[.] [2][%][=][SHIFT][BIN NO][1].

The numerical limits are automatically computed and rounded-off values appear on the Digibridge displays (upper limit at the left, lower at the right).

For bin 2, enter the next wider tolerance, similarly. (Use 1 digit for the bin number.) Repeat the procedure for bins 3, 4, 5, ...up to a maximum of 8 bins.

EXAMPLE: To enter a set of nested limits, operate the keyboard as described below for the example of inductors having $Q > 21$, $L_s = 33 \text{ mH} \pm 0.35\%$, $\pm 1\%$, $\pm S\%$, $\pm 7-9\%$. Note that the last set of limits ($\pm 7-9\%$), are unsymmetrical, whereas the others are symmetrical. In this case always enter the more positive tolerance first.

1. With [FUNCTION] key, select ENTER.
2. With [EQUIVALENT CIRCUIT] key, select SERIES.
3. With parameter key [L/Q], select RLC units: mH.
4. Enter Q limit thus: [2][1] [=][SHIFT] [BIN No.] [0].
5. Enter nominal RLC value: [3][3] [=] [SHIFT] [NOM VALUE].
6. Set bin 1 limits: [.] [3] [5] [%] [=] [SHIFT] [BIN No.] [1].
7. Set bin 2 limits: [1] [%] [=] [SHIFT] [BIN No.] [2].
8. Set bin 3 limits: [5] [%] [=] [SHIFT] [BIN No.] [3].
9. Set bin 4 limits: [7] [%] [-] [9] [%] [=] [SHIFT] [BIN No.] [4].
10. Close bin 5 (if open): [0] [%] [=] [SHIFT] [BIN No.] [5].
11. Close bins 6 through 8, similarly, if used before.

2. Sequential Bins (different nominal value). In this case a different nominal value is selected for each bin. The advantage of this method is that there is a straightforward definition of each bin in terms of percentages of the bins nominal value. The disadvantage is that overlaps or gaps in coverage among several bins are not obvious. (Remember that overlaps default to the lower-numbered bin; gaps default to bin 9.)

Example: For sorting capacitors into part of the standard 5% series, setting $D < .005$, and nominal values for the bins at $C_s = 0.91, 1.0, 1.1, 1.2, 1.3 \text{ uF}$.

1. With [FUNCTION] key, select ENTER.
2. With [EQUIVALENT CIRCUIT] key, select SERIES.
3. With parameter key [C/D], select units: uF.
4. Enter D limit: [.] [0] [0] [5] [=] [SHIFT] [BIN No.] [0].
5. Enter nominal C value: [.] [9] [1] [=] [SHIFT] [NOM VALUE].
6. Set bin 1 limits: [5] [%] [=] [SHIFT] [BIN No.] [1].
7. Redefine nominal: [1] [=] [SHIFT] [NOM VALUE].
8. Set bin 2 limits: [5] [%] [=] [SHIFT] [BIN No.] [2].
9. Redefine nominal: [1] [.] [1] [=] [SHIFT] [NOM VALUE].
10. Set bin 3 limits: [5] [%] [=] [SHIFT] [BIN No.] [3].
11. Redefine nominal: [1] [.] [2] [=] [SHIFT] [NOM VALUE].
12. Set bin 4 limits: [5] [%] [=] [SHIFT] [BIN No.] [4].
13. Redefine nominal: [1] [.] [3] [=] [SHIFT] [NOM VALUE].
14. Set bin 5 limits: [5] [%] [=] [SHIFT] [BIN No.] [5].
15. Close bin 6 (if open): [0] [%] [=] [SHIFT] [BIN No.] [6].
16. Close bins 7 and 8, similarly (if used before).

NOTE: Because there are overlaps, bin numbers affect the binning (if a DUT satisfies two bins, it goes into "the lower-numbered bin"); for example, 1.046 uF will go into the 1.00 uF bin (No.2) because it is numbered lower than the 1.1 uF bin (No.3).

3. Sequential Bin (same nominal value). In this case the same nominal value is selected for each bin. The advantage of this method is that all bin limits are related to the same nominal value, making it easy to define bins exactly adjacent to each other without overlaps or gaps. The disadvantage is that each bin is not readily defined in terms of its own nominal value.

Example: For sorting capacitors into six adjacent "1 %" bins from -3% to +3%, setting $D < .005$, and nominal value of the six bins at $C_s = 1.0 \text{ uF}$.

1. With [FUNCTION] key, select ENTER.
2. With [EQUIVALENT CIRCUIT] key, select SERIES.
3. With parameter key [C/D], select units: uF.
4. Enter D limit: [.] [0] [0] [5] [=] [SHIFT] [BIN No.] [0].
5. Enter nominal C value: [1] [=] [SHIFT] [NOM VALUE].
6. Set bin 1 limits: [-] [2] [%] [-] [3] [%] [=] [SHIFT] [BIN No.] [1].
7. Set bin 2 limits: [-] [1] [%] [-] [2] [%] [=] [SHIFT] [BIN No.] [2].
8. Set bin 3 limits: [0] [%] [-] [1] [%] [=] [SHIFT] [BIN No.] [3].
9. Set bin 4 limits: [1] [%] [0] [%] [=] [SHIFT] [BIN No.] [4].
10. Set bin 5 limits: [2] [%] [1] [%] [=] [SHIFT] [BIN No.] [5].
11. Set bin 6 limits: [3] [%] [2] [%] [=] [SHIFT] [BIN No.] [6].
12. Close bin 7 (if open): [0] [%] [=] [SHIFT] [BIN No.] [7].
13. Close bin 8, similarly (if used before).

NOTE: For any bin the less negative or more positive percentage must be entered first as shown clearly in steps 6 and 11. Because there are no overlaps, there will be no "default assignment to the lower-numbered bin". Binnumber sequence is immaterial.

3.8.4 Verification of Nominal and Limit Values

While the function is ENTER, the exact values entered into the Digibridge can be seen by either of 2 methods, as follows.

During the Entry Process. A confirming display is automatically provided immediately after the final keystroke of each entry step. For example, after the [NOM VALUE] keystroke, the entered value appears on the RLC display. After the [BIN NO] and number keystrokes, the actual limits of RLC value (not percentages) appear across the full display area: upper limit on the regular RLC display, lower limit (4 most significant digits) in the regular QDR display area. For bin 0, the QDR limit appears in the QDR area.

Upon Demand. To see the current "nominal value", depress the [SHIFT] [NOM VALUE] key (while the ENTER indicator is lit). To see the limits in any particular bin (or to verify that it has been cleared), depress [SHIFT] [BIN NO] and the desired number, similarly. Displays selected in this way are limited by the units that are shown on the panel. For example, if the bin-3 limits are 162 and 198 nF, but the display units are pF, when you press [BIN No.] [3], the display will go blank. Select either nF or uF (instead of pF) to obtain a display of these limits.

However, any "nominal values" previous to the current one are lost and cannot be displayed (unless entered again). Bin limits are not lost until replaced by new entries in the particular bin; but they are normally lost when POWER is switched OFF. To prevent loss, lock the keyboard; see paragraph 3.9.

For comments on how bin sorting information is displayed, see paragraph 3.3.3.

3.8.5 Limit Measurements and Bin Assignments

a. To measure a DUT with bin sorting:

Press the [FUNCTION] key to select MEASURE.

Press the [DISPLAY] key to select BIN NO.

Insert the DUT.

If the measure mode is TRIGGERED, press the START button.

Observe GO/NO-GO and bin-number results. GO indicates the DUT passed in bin 1, 2, 3 ...8. NO-GO indicates either QDR failure (bin 0) or RLC failure (bin 9). See also paragraph 3.1.4.

For continued operation of the Digibridge, in MEASURE function, using the limits entered above, you can select any desired display, such as VALUE, or BIN No., with the [DISPLAY] key. (If you have the interface option, the available output data are not limited to the display selection.) The GO/NO-GO lights will operate unless you inhibit comparisons. (See below.)

b. You can close any bin that has been opened (as in paragraph 3.8.3). For RLC bins, follow this example for bin 8, press:

[0] [=][SHIFT] [BIN NO][8].

To disable QDR sorting, close bin 0; thus, for D or Rs or Q with R, press:

[9] [9] [9][9] [=][SHIFT] [BIN NO] [0];

However, for Rp or Q with L, press:

[0] [=] [SHIFT] [BIN NO][0].

c. To enable GO/NO-GO lights after opening at least one bin, leave "nominal value" at any non-zero value. To disable GO/NO-GO and all bin sorting, press:

[0][=] [SHIFT] [NOM VAL].

3.8.6 Summary on Limit Entries

For additional detail, refer to the condensed instructions on the reference card under the Digibridge, and to the following notes.

Frequency. It is NOT necessary to select the test frequency first. Comparison results are valid even if the test frequency is changed later in the entry/measurement procedure.

Bin 0. The limit entered in bin 0 is always QDR. It is an upper or lower limit on the *secondary* measured value, depending on the parameter selection, as tabulated:

Rs/Q (upper)	L s /Q (lowe r)	Cs/D (upper)	Cs/Rs (upper)
Rp/Q (upper)	Lp /Q (lower)	Cp/D (upper)	Cp /Rp (lower) .

Unsymmetrical Limit Pairs. Enter 2 percentages for the bin. One or both may be + (unspecified sign) or -. Enter first the one that yields the larger absolute value of RLC.

Unused Bins. Initially, at power-up, bins 1 through 8 are closed so that unused ones can be ignored. Every unused bin that has previously been used (except 9) must be closed by entering 0%, as in the above examples. Once closed, it will stay closed until non-zero percent limits are inserted.

Allowable Limits. A maximum of 6 significant figures for nominal value and percent up to 99999.9.

NOTE

The two ranges (mF and Mohms) are display ranges only. When you try to enter a nominal value you are limited to uF or Kohms. The maximum nominal for uF is 99999.9 or 100 mF. Thus you cannot do a delta % or delta RLC for values larger than this, but you can do binning if you figure it out. Say you want to bin +/- 10% of 1 farad:

Enter 99999.9 as nominal value (100 mF) Enter 1000%800% = Bin 1 This will give you 1000% of 100 mF + 100 mF or 1100 mF for the high limit and 800% of 100 mF + 100 mF or 900 mF for the low limit. The same applies to Mohms.

Bin Order. Optional except for nested bins; be sure the narrower limit pairs go into lower numbered bins (because all overlap goes to the lower numbered bin).

Inhibiting Comparisons. To inhibit all comparisons, set nominal value to zero. (Then GO/NO-GO indicators stay off.) Subsequent setting of nominal value to any number except zero enables all comparisons as previously set up. To inhibit QDR comparisons, set bin 0 to the "all-pass" extreme, i.e., to 0000 for Rp, or Q with L; to 9999 for D or Rs or Q with R.

NOTE

When POWER is switched ON --if the keyboard is not locked --nominal value is initialized at zero. Therefore, all bin sorting is initially inhibited.

Changing Entries. Enter new value(s) --or a zero -to delete obsolete or erroneous nominal value or bin limits. Do not attempt to change or enter a single separate upper or lower limit in a bin, because any single percentage entered for a bin will be interpreted as a symmetrical pair of limits. Changing nominal value does not change any limits, but does determine the base for subsequent limit entries for specific bins. (After function is changed to :MEASURE, this nominal value will also serve as reference for delta percent measurements.)

RLC Unit Selection. In limit entry procedures, it is NOT necessary to select the range that the Digibridge will use in measuring. Just be sure that the number you enter for nominal value is suited to the units and unit multiplier indicated on the display panel. For example, nominal values of .033 H, and 33 mH are equivalent.

3.9 KEYBOARD LOCK, FUNCTION MAP, AND SUMMARY OF INTERROGATIONS

3.9.1 Keyboard Lock

Locking the keyboard provides security against unintentional or unauthorized change in the keyboard selectable test conditions, as well as preserving them during the time that POWER is switched OFF.

Indications of the unlocked or locked state are as follows:

Unlocked --several keyboard indicators lit.

Locked --NO keyboard indicators lit, except possibly MEASURE, BIAS ON and/or REMOTE CONTROL.

To lock the keyboard, first select MEASURE function. Then, press the following keys *deliberately*. The command sequence is the same to lock and to unlock:

[1][6] [9] [2][=] [LOCK]

NOTE

If the REMOTE CONTROL indicator is lit, the keyboard may have been deactivated by remote command, in which case the way to reactivate it is by remote command. Refer to paragraph 3.11.

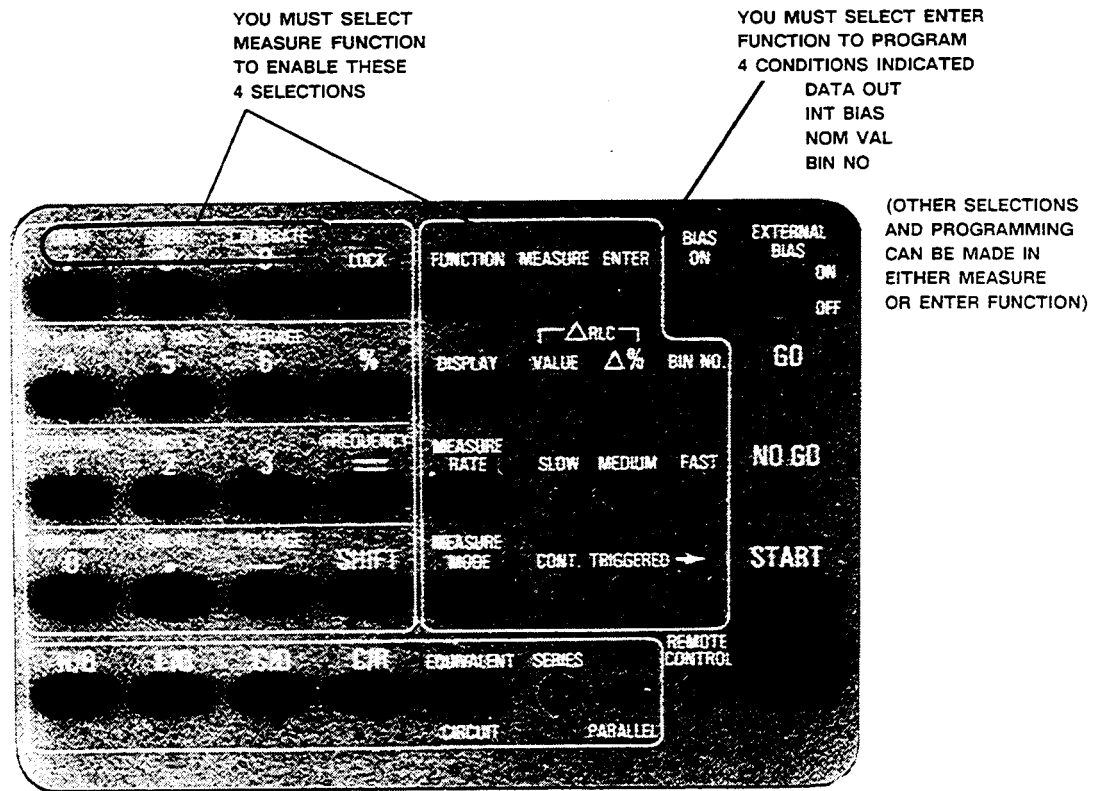

Figure 3-11. Map of keyboard, showing which programming entries can be made in MEASURE function and which ones in ENTER function.

3.9.2 Function Map

Figure 3-11.

The figure shows graphically (like a map of the keyboard) which programming keys are enabled in the MEASURE function and which ones in the ENTER function. Notice that five keys (HOLD RNG, CONST V, INT BIAS, FREQUENCY, and VOLTAGE) inside the square 16-key area and all of the keys outside of that square are enabled *regardless* of any selection by the [FUNCTION] key.

3.9.3 Summary of Interrogations

Certain status (and results) information is indicated automatically on the display panels. For example:

Indicators below RLC display	---	units of measurement.
Indicators above RLC display	---	parameter of measurement.
Indicators below DQR display	---	voltage status/level.
Indicators above DQR display	---	parameter of measurement.
	---	autoranging disabled.
Indicators to the right of DQR display	---	test frequency.
Measure indicator only lit	---	keyboard is locked.
Left display "0", right also "0", GO	---	open-circuit zeroing enabled.
Left display "5", right also "5", GO	---	short-circuit zeroing enabled.
Left display "6", right also "6", O	---	calibration enabled.
Left display "0 14", right "blank"	---	measurement signal overload.
Left display "22222", right "1111"	---	converter/detector malfunction.
Left display "22222", right "2222"	---	converter/detector malfunction.

The preceding three lines are explained in paragraph 3.13.3. Indicators on the keyboard provide important information, NOT summarized here.

The following interrogations will work only if you select ENTER function.

[SHIFT] [NOM VAL]	---	stored nominal value (appears displayed at left).
[SHIFT] [BIN NO] [1]	---	limits for bin 1 (both displayed, left and right).
[SHIFT] [AVERAGE]	---	number of measurements (or medians) averaged per result.
[SHIFT] [DATA OUT]	---	code for data output via IEEE-488.
[SHIFT] [LOCK] [CALIBRATE]	---	version number of Digibridge internal software (display format X.XX).
[SHIFT] [LOCK] [DATA OUT]	---	IEEE address (2 digit display) when IEEE option is installed.

3.10 OPERATION WITH A HANDLER

If you have the interface option (1658-9620 IEEE-488 BUS/HANDLER INTERFACE) and have made the system connections to a handler (paragraph 2.7), the Digibridge operating procedure is as follows.

a. Set up the handler either of two ways: indexing on EOT or indexing on ACQ, as explained below. The handler must supply a signal (here called "start next measurement") when it has completed connection of the DUT.

Indexing on EOT. Set up the handler to respond to the EOT signal from the Digibridge, which occurs at the "end of test", when the bin assignment is available for sorting. Set up the Digibridge to receive its START signal from the handler's "start next measurement" signal. This setup is simpler than the one below.

Indexing on ACQ. Set up the handler to respond to the ACQ signal from the Digibridge, which occurs after the "data acquisition" is complete. The handler can then remove the DUT from the test fixture and replace it with another DUT, while the Digibridge is calculating the result.

In addition, set up an interface that provides a START signal to the Digibridge by logical combination of the EOT signal from the Digibridge AND the "start next measurement" signal from the handler. Indexing on ACQ results in higher measurement rate than indexing on EOT.

b. Program the Digibridge for binning, as described in paragraph 3.8.

NOTE: Be sure to leave a non-zero number as "nominal value" in the Digibridge memory, to enable the GO /NO-GO indicators and the EOT signal.

c. If measured values are not needed, select BIN NO. with the [DISPLAY] key. This selection saves 6 to 10 ms for each measurement, compared to other displays.

However, if measured values are to be monitored visually, select VALUE with the [DISPLAY] key, or select the desired "delta" display. The displays are useful for incidental monitoring of measurements while the handler automatically sorts the parts being processed.

d. Select MEASURE function and TRIGGERED mode. This mode minimizes the time between insertion of the DUT into the test fixture and beginning of a valid measurement. Measurement starts when the Digibridge receives the START signal from the handler (or when the START button is pressed).

e. Select other measurement conditions as desired: EQUIVALENT CIRCUIT, RANGE HELD or autorange, MEASURE RATE, test FREQUENCY, test VOLTAGE, CONSTANT VOLTAGE or normal voltage, AVERAGE or regular, etc.

f. Enabling IEEE-488 output adds several milliseconds of calculation time to each measurement cycle: about 2 to 12 ms depending on the type of data. For measurement time considerations, refer to paragraph 3.5.

3.11 DATA OUTPUT AND/OR PROGRAMMING VIA IEEE-488 BUS

These considerations apply only if you have an interface option. (If you do, there will be interface connectors at the rear. See Figure 1-3.)

3.11.1 IEEE-488 Interface Unused

If there is no system connection to the IEEE-488 INTERFACE connector, be sure to keep the TALK switch set to TALK ONLY.

3.11.2 Talk-Only Use, for Data Output

This pertains to a relatively simple system, with the Digibridge outputting data to one or more "listen-only" (IEEE-488 compatible) devices such as a printer.

a. Set the TALK switch to TALK ONLY.

b. Program the Digibridge to send out results automatically after each measurement. The commands for this purpose can be executed only in ENTER function, as follows.

[1]	[=]	[SHIFT]	[DATA OUT]	(for bin numbers)
[2]	[=]	[SHIFT]	[DATA OUT]	(for QDR)
[3]	[=]	[SHIFT]	[DATA OUT]	(for QDR and bin numbers)
[4]	[=]	[SHIFT]	[DATA OUT]	(for RLC)
[5]	[=]	[SHIFT]	[DATA OUT]	(for RLC and bin numbers)
[6]	[=]	[SHIFT]	[DATA OUT]	(for RLC and QDR)
[7]	[=]	[SHIFT]	[DATA OUT]	(for RLC, QDR, and bin numbers)
[8]	[=]	[SHIFT]	[DATA OUT]	(no output on PASS, full data set on FAIL)
[9]	[=]	[SHIFT]	[DATA OUT]	(BIN data on PASS, full data set on FAIL)
[0]	[=]	[SHIFT]	[DATA OUT]	(for no data output via IEEE-488 bus)

Operate the Digibridge in the usual way (manually). The system may constrain operation in some way. For example, a slow printer will limit the measurement rate because it requires a certain time to print one value before it can accept the next.

Refer to Table 3-5 for examples of the interface message code for data transfer. This table shows typical codes, but does not repeat the entire ASCII code. (There is a more complete table, in paragraph 2.8.)

Output Formats for RLC, QDR, and BIN NO. Results. Refer to Tables 3-6 and 3-7 for the formats of the output data: RLC, QDR (for the most recent measurement). If output of results has been enabled, by DATA OUT as described above (or X1... X9 command; see paragraph 3.11.3, Table 3-10), the Digibridge sends data to the IEEE bus at the completion of each measurement sequence. The character string for RLC value has the length of 17 characters; for QDR value, 17 characters; for BIN NUMBER, 10 characters, including spaces, carriage return, and line feed characters.

NOTE

For a description of the compacted binary

dataoutput format (which saves time),
refer to paragraph 3.11.4.

Table 3-5
ABBREVIATED INTERFACE MESSAGE CODE FOR "TALK-ONLY" DATA TRANSFER

Character (ASCII)	Decimal Equiv	DI08	DI07	DI06	DI05	DI04	DI03	DI02	DI01
A	65	0	1	0	0	0	0	0	1
B	66	0	1	0	0	0	0	1	0
C	67	0	1	0	0	0	0	1	1
	-----		etc				-----		
1	49	0	0	1	1	0	0	0	1
2	50	0	0	1	1	0	0	1	0
3	51	0	0	1	1	0	0	1	1
	-----		etc				-----		

Table 3-6
DATA OUTPUT FORMAT FOR RLC VALUE, delta%, deltaRLC

Character Sequence	Purpose	Allowed Characters	Meaning
1	Status	(space) U O E I	Normal operation, measurement on a basic range Underrange held (reduced accuracy)* Overrange held (reduced accuracy)* End extension of range 1 or 4 (reduced accuracy)** Invalid measurement due to signal overload
2	Value or deltaRLC	(space) ^	Normal display ΔRLC Mode
3	Parameter	L C R	Inductance Capacitance Resistance
4	Normal	(space)	Normal mode (as described above)
5,6	Units	(space)H mH mF uF nF pF (space)% (space)O kO MO	Henries Millihenries millifarads Microfarads Nanofarads Picofarads Percent difference from nominal value Ohms Kilohms Megohms
7	Format	(space)	
8	Sign	(space) -	Positive R, L, C, Δ%, or ΔRLC Negative R, L, C, Δ%, or ΔRLC
9...15	Number	012345 6789. (space)	Measured number, right justified in format field; like the RLC display except the zero before the decimal point is explicitly provided and this number can be as long as seven characters. ***
16 17	Delimiter	(CR) (LF)	The standard "carriage return" and "line feed" characters; end of string.

--FOOTNOTES FOR TABLE 3-6 -

* Under range generally occurs when the measured impedance is lower than the normal low limit (for automatic range change) and there is a lower-impedance range. Overrange generally occurs when the measured impedance is higher than the normal high limit (for automatic range change) and there is a higher-impedance range. In either case, an appropriate range change will improve accuracy. If there is no appropriate range to change to, the status is "range end extension"; see below. Range limits are different if CONSTANT VOLTAGE has been selected; see paragraph 3.5.6.

** No possibility of changing range to improve accuracy. DUT impedance has reached a point where the accuracy HIGH Z or LOW Z terms may be significant. Refer to accuracy specifications in the front of this manual.

*** If the measurement is outside of the display range (display goes blank), 9999999 is output in this numeric field.

Table 3-7
QDR-VALUE DATA OUTPUT FORMAT

Character Sequence	Purpose	Allowed Characters	Meaning
1	Status	(space) 0 I	Normal operation Overrange of QDR display Invalid measurement due to signal overload
2	Format	(space)	
3	Parameter	Q D R	Quality factor Dissipation factor Resistance
4	Format	(space)	
5...7	Units	(2 spaces)0 (space)k0 (3 spaces)	Ohms Kilohms Dimensionless (for Q or D)
8	Sign	(space) -	Positive QDR value Negative QDR value
9....15	Number	012345 6789. (space) **	Measured number, right justified in format field; like the QDR display except the zero before the decimal point is explicitly provided and this number can be as long as six characters plus decimal point. *
16	Delimiter	(CR)	The standard "carriage return" and "line feed" characters; end of string.
17		(LF)	

* If measurement is overrange (display goes blank), 999999 is output in this field.

** Two leading zeros will precede the decimal point on values less than 1. Two spaces will precede the value on values greater than 1.

3.11.3 Talk/Listen Use, for Remote Programming and Data Transfers

Observe the REMOTE CONTROL indicator light. If it is lit, there is no opportunity for manual operation (except switching EXTERNAL BIAS ON and OFF and use of the START button if manual start is enabled.) The displays may be observed then, but their content is controlled by the system controller, via the IEEE-488 bus.

Details of test program preparation are beyond the scope of this manual. Refer to Table 3-11 for an example of message activity during a control sequence in which the controller says "start" and the Digibridge (after a measurement) says "C uF 1.2345".

Programming Guidelines. If the Digibridge is to be programmed (TALK switch set to TALK/LISTEN), keep the following suggestions in mind.

1. An "unlisten" command is required before measurement is possible.
2. If not addressed to talk, the Digibridge sends a service request (SRQ low) when it has data ready to send.
3. Then SRQ will not go false (high) until the Digibridge has been addressed to talk or has been serially polled. A typical program might include these features:
 - * Initial Setup: with ATN true, "untalk unlisten, my listen address (of Digibridge), my talk address (of CPU)"; then with ATN false, measurement conditions.
 - * Measurement Enabling Sequence, for example: untalk the Digibridge, send a GET, unlisten the Digibridge.
 - * After the CPU receives the SRQ, necessary enabling of data transfer: with ATN true, "untalk, unlisten, my listen address (of CPU), my talk address (of Digibridge)"; then ATN false.

Serial Poll --Status Byte --Table 9-9. When the bus is in the serial poll mode and the Digibridge is addressed to talk, the Digibridge responds with a status byte, which is encoded as shown in the table and sent on the data lines DI01 through DI08.

Table 3-8
INTERFACE MESSAGE CODE FOR REMOTE CONTROL

Message code*	Note **	ASCII Equiv	Decimal Equiv***	Sent concurrently with ATN line true:							
				DI08	DI07	DI06	DI05	DI04	DI03	DI02	DI01
MLA	Set	#	35	X	0	1	0	0	0	1	1
	Tot	(SP) to >	32 to 62	X	0	1	<MSB--device-address--LSB>				
MTA	Set	C	67	X	1	0	0	0	0	1	1
	Tot	@ to ^	64 to 94	X	1	0	<MSB--device-address--LSB>				
SPD	--	(EM)	25	X	0	0	1	1	0	0	1
SPE	--	(CAN)	24	X	0	0	1	1	0	0	0
UNL	--	?	63	X	0	1	1	1	1	1	1
UNT	--	--	95	X	1	0	1	1	1	1	1

Because the following messages are addressed commands, they will affect the Digibridge operation only while it is addressed to listen.****

GET	--	(BS)	8	X	0	0	0	1	0	0	0
GTL	--	(SOH)	1	X	0	0	0	0	0	0	1

*Mnemonic key to codes: :MLA = my listen address; MTA = my talk address; SPD = serial poll disable; SPE = serial poll enable; UNL = unlisten; UNT = untalk; GET = group execute trigger; GTL = go to local.

** Set =address setting as supplied by factory. Tot = total range of choice. See paragraph 2.8 for address changing procedure.

*** Decimal equivalent makes DI08 (which is immaterial) a zero. Logical 1 is low state (true), logical 0 is high state.

**** Digibridge is addressed to listen by MLA message containing its device address (see para. 2.8). It terminates this condition when it receives UNL command, which is necessary before it can make measurements or recognize its own keyboard.

Table 3-9
STATUS CODE

Line	Significance of a "1" (Low)	Significance of a "0" (High)
DI08	Remote.	Local.
DI07	Request for service, RQS. (This device asserted SRQ.)	No request by this Digibridge for service.
DI06	Recalibration required.	Normal operation.
DI05	Busy, measurement in process.	Measurement completed.
DI04	Limits were tested.	Limits were not tested.
DI03	RLC measured value is available.	RLC value is not available.
DI02	QDR measured value is available.	QDR value is not available.
DI01	Bin No. assignment is available.	Bin No. assignment is not available.

Instrument Program Commands. The set of commands used in remote programming is an input data code to which the instrument will respond as a "talker/listener", after being put into a remote-control mode via the bus (see Table 3-8) and addressed to listen to device-dependent command strings.

Refer to Table 3-10. The programming command set includes all of the keyboard functions except switching external bias ON/OFF and full recalibration, which are not remotely programmable. Keyboard functions are explained above, particularly in paragraphs 3.3, 3.4, 3.8, 3.9; and most of these commands are related to them in an obvious way.

Zero calibration by remote control is similar to the manual procedure. The "Z1" command is equivalent to manually keying

[1] [6] [9] [2][=] [SHIFT] [OPEN]

It is necessary to allow the Digibridge to reach range 1. (It must not be held on another range.) The test fixture must be physically open-circuited. Zero calibration is initiated by a "GO" command (equivalent to pressing START), which should not be followed by other commands until the Digibridge responds with "SRQ". (The purpose of the "Z0" command is to defeat the preceding "Z1" command, as you might wish to do if the "Z1" was sent by mistake.)

Limit entry commands are interpreted in relation to the previously established parameter; send the 'M' command first. Use the limit entry commands in the tabulated sequence, except that nominal value need not be repeated after once being entered.

Notice that f, n, h, and I in the table are "E-notation" numbers, containing any number of digits, with optional use of decimal point and optional use of power-of-ten multiplier. Do NOT omit the semicolon after each of these. (Refer to the table.) The letter n in the table is nominal value in base units (ohms, farads, or henries). For example, nominal value can be set to 543.21 pF by the command:

N543.21E-12;

Limits for bins 1 thru 8 are entered using percentages, referred to the current nominal value. For example, Bin No. 1 (designated 1) is set to +1.5%, -.05% by the command sequence:

B1H1.5;L-5E-2;

However, the limit for Bin Zero (the desired upper limit for D or Rs or Q with R, lower limit for Rp or Q with L) is entered as a value (dimensionless for D or Q, ohms for R). For example, Bin Zero is set to .001 (with parameter selection C/D) by the command:

B0H1E-3;

It is possible to average from 1 to 10 measurements. For example, 5 measurements can be averaged by the command sequence:

A5;

There are three types of commands: two-byte, three-byte, and floating-point, as described below. Each byte is coded according to the 7-bit ASCII code, using the DI01...DI07 lines. The most significant bit is DI07, as recommended by the Standard. (The eighth bit --DI08 --is ignored.) Thus, for example, the command for "MEASURE FUNCTION" is P0, having octal code 120 followed by 060. The two 7-bit binary bytes are therefore: 1 010 000 and 0 110 000.

Note: The ASCII code --"X3.4-1968, Code for Information Interchange" --is available from American National Standards Institute, 1430 Broadway, New York, N.Y. 10018. This code can be written out as follows. For the numerals 0, 1, 2 ...9, write the series of octal numbers 060, 061, 062 ...071; for the alphabet A, B, C... Z, write the series 101, 102, 103 ...132. (Refer also to the table in the paragraph about "Address", in 2.8.4.) The ASCII code conforms to the 7-bit code ISO 646 used internationally.

Two Byte and Three Byte Entries. These command entries, as shown in Table 3-10, are simple ASCII character sequences of two or three characters. The first character is a letter which designates the category of the entry. The following ASCII character -or two characters if this is a three-byte entry -are decimal digits (0 to 9) which convey information about the selection within the category. For example, the ASCII sequence *D2* means "in DISPLAY category, select VALUE." The command is like pressing the [DISPLAY] key to select VALUE.

NOTE

1. The 2-byte command **P2** is recommended as the first command in a remote programming sequence because it resets all selections to their power-up (default) conditions.
2. The 2-byte command **P3** returns the Digibridge to the diagnostic routine and local control (i.e., the equivalent to a power-down, power-up cycle).

Table 3-10
1 6 9 2 DIGIBRIDGE IEEE-488 PROGRAMMING COMMANDS

Program Category	Program Selection	Command Entry	Program Category	Program Selection	Command Entry		
DISPLAY:	Bin #	D0	NOM. VALUE:	n=Ohms, F, or H	Nn;		
	Delta%	D1		BIN NUMBER:	b=bin#	Bb	
	*VALUE	D2			BIN LIMITS:	High Limit	H%;
	Delta RLC	D3				Low Limit	L%;
MEAS RATE:	Fast	S0	RANGE:	Hold range	R0		
	Medium	S1		Hold range 1	R1		
	*Slow	S2		Hold range 2	R2		
AVERAGE:	a=# of meas.	Aa;		Hold range 3	R3		
	VOLTAGE:	*1 volt	V0	Hold range 4	R4		
		.3 volt	V1	*Auto range	R5		
		ZERO CAL:	Disable	Z0	INTERNAL BIAS:	*OFF	U0
Open	Z1		On	U1			
Short	Z2		MEASURE MODE:	*TRIGGERED		T0	
FUNCTION:	*MEASURE	P0		Continuous	T1		
	Enter	P1		DATA FORMAT:	*NORMAL	x0	
PARAMETER:	L/Q	M0	Compacted		x1		
	C/D	M1	INITIATION:		(START)	G0	
	C/R	M2		MANUAL START:	*ENABLE	W0	
	R/Q	M3			Disable	W1	
	*AUTO SEL.	M4	KEYBOARD LOCK:	*UNLOCK	K0		
DATA OUTPUT:	*NONE	X0		Lock	K1		
	Bin#	X1		FREQUENCY:	1 kHz	F0	
	QDR	X2			10 kHz	F1	
	QDR, Bin#	X3	100 kHz		F2		
	RLC	X4	100 Hz		F3		
	RLC, Bin#	X5	120 Hz	F4			
	RLC, QDR	X6	RESET:	Turn-On Conditions	P2		
	RLC, QDR, Bin#	X7		Diagnostics	P3		
	Pass/none, Fail/all	X8					
Pass/bin, Fail/all	X9						
EQUIV. OKT:	Parallel	C0					
	*SERIES	C1					

* Indicates Turn-On conditions.

Table 3-11
MESSAGE ACTIVITY ON IEEE-488 BUS DURING A SAMPLE EXAMPLE OF REMOTE CONTROL

Byte order	Message* line	ATN	Comment
1	(UNT)	true	Untalk all devices.
2	(UNL)	true	Unlisten all devices.
3**	(MLA 3)	true	Set Digibridge (address 3) to listen.
4	(MTA n)	true	Set controller (address n) to talk.
5	G	false	Typical device-dependent message: START. (See
6	0	false	Table 3-10 for "program commands".)
7	(UNL)	true	Unlisten Digibridge (must for measurement).
-	--	--	Digibridge makes measurement, asserts SRQ line to indicate completion.
8	(MLA n)	true	Set controller to listen.
9**	(MTA 3)	true	Set Digibridge to talk.
10	(space)		Typical data stream from Digibridge in
11	(space)		the format of Tables 3-6, 3-7 sent to
12	C		controller, which will execute some kind
13	(space)		of read command (specified by programmer)
14	u		according to destination (such as
15	F		a printer).
16	(space)		
17	(space)		
18	(space)		
19	1		
20	.		
21	2		
22	3		
23	4		
24	5		
25	(CR)		
26	(LF)		

*Message on DI01...DI08 lines is coded and interpreted differently depending on simultaneous state of ATN line (true = asserted = low, false = high). See Table 2-2.

**Bytes 3 and 4 can be programmed in a single command to controller; bytes 8 and 9 similarly. Notice that we refer to factory-set address as "3" by reading a 5-bit binary number (lines DI05...DI01).

3.11.4 Data Output in Compacted Binary Format

The compacted binary format for data output can be selected to save time. Selection must be made via IEEE-488 bus, not via the keyboard. The time saving is indicated by the fact that this format conveys a full set of test results in 8 binary bytes, compared to 44 binary bytes required by the regular format. Fewer characters are sent if you select less than complete results (such as bin number only, output only for FAIL, etc).

The data stream for one measurement consists of two to eight 8-bit bytes, depending on what output is programmed. The format is explained partly in truth Table 3-12, and partly in the text that follows.

NOTE

The 8 bits in each byte are 76543210, where 0 is LSB (least significant bit). The vertical line or space between bytes is for clarity only, not present in data.

The full eight bytes are sent only if RLC, QDR, and Bin information is needed (i.e., only if "status" bits 2,1,0 are logic 111. Otherwise, the data word is shortened, as follows.

If QDR data are NOT needed, the data format uses 5 bytes as follows.

If both QDR and BIN data are not needed, the "OTHER" byte is omitted.

Name :	STATUS	RLC, e	RLC, mantissa	OTHER	
Byte Number :	byte 1	byte 2	byte 3 byte 4	byte 5	
-----	-----	-----	-----	-----	

If RLC data are NOT needed, the data format uses 5 bytes as follows.

If both RLC and BIN data are not needed, the "OTHER" byte is omitted.

Name :	STATUS	QDR, e	QDR, mantissa	OTHER	
Byte Number :	byte 1	byte 2	byte 3 byte 4	byte 5	
-----	-----	-----	-----	-----	

If only BIN data are needed, the data format uses only 2 bytes, as follows.

If RLC, QDR, and BIN data are all NOT needed, no data output occurs.

Name :	STATUS	OTHER	
Byte Number :	byte 1	byte 2	
-----	-----	-----	

The *RLC,e* byte (except for bit 7) conveys the RLC exponent (2s complement).

The *RLC, mantissa* bytes (all 16 bits) convey the RLC mantissa (base 2).

The *QDR,e* byte (except for bit 7) conveys the QDR exponent (2s complement).

The *QDR, mantissa* bytes (all 16 bits) convey the QDR mantissa (base 2).

The binary exponent and mantissa define a binary floating-point number, as follows:

$$(\text{Sign}) (2^{(\text{exponent})}) * (\text{mantissa})$$

Table 3-12
TRUTH TABLE OF COMPACTED BINARY FORMAT FOR OUTPUT DATA

Name:	STATUS	RLC, e	RLC, mantissa	QDR, e	QDR, mantissa	OTHER
Byte Number:	byte 1	byte 2	byte 3 byte 4	byte 5	byte 6 byte 7	byte 8
	76543210	7		7		76543210
Normal meas'mt	00 *					
Overrange	01					
Underrange	10					
Invalid meas	11					
Range 1	00					
Range 2	01					
Range 3	10					
Range 4	11					
Bin number	001					
QDR	010					
QDR & bin no.	011					
RLC	100					
RLC & bin no.	101					
RLC, QDR, bin #	111					
RLC value is +		0				
RLC value is -		1				
QDR value is +				0		
QDR value is -				1		
Parameter L/Q						00
Parameter C/D						01
Parameter C/R						10
Parameter R/Q						11
Delta percent						01
Value (default)						10
Delta RLC						11
BIN 0						0000
BIN 1						0001
BIN 2						0010
BIN 3						0011
BIN 4						0100
(etc)						
(etc)						
BIN 9						1001

* Bit 3 of STATUS byte does not convey data.

The following examples illustrate how to obtain ordinary (base-10) numbers from the compacted binary data.

EXAMPLE 1. (Bytes are shown separated by spaces.)

STATUS	RLC, e	RLC, mantissa	QDR, e	QDR, mantissa	OTHER		
byte 1	byte 2	byte 3	byte 4	byte 5	byte 6	byte 7	byte 8
76543210	76543210	76543210	76543210	76543210	76543210	76543210	76543210
0001x111	01100101	11100001	00001001	01110101	10100000	00000000	01100111

The example-1 interpretation is as follows:

Byte 1: Normal measurement. Range 2. RLC, QDR, and bin number data are needed.

Byte 2, bit 7: Sign of C value is +.

Byte 2, other bits: C exponent is 1100101 in 2s complement notation, which is the same as a negative exponent of 011011 (i.e., -27, base 10).

NOTE 1: bit 6 is always 1 for a negative exponent, 0 for a positive exponent. Bytes 3, 4: C mantissa is .879044 (directly from the 16-bit binary number).

NOTE 2: In the mantissa, the first bit has the weight of 0.5, the next bit 0.25, the next bit 0.125, and each other bit half of the one before it, to the 16th bit.

Therefore, the C value is $(2 \text{ to the } -27\text{th power}) * (.879044) = (7.45058) * (10 \text{ to the } -9 \text{ power}) * (.879044) = 6.54939 * 10 \text{ e}(-9) \text{ farads} = 6.5494 \text{ nF}$. Bytes 5,6, and 7 (by the same method as bytes 2,3, and 4): $D = .0003$ Byte 8: Parameters are C/D. Data numbers are values (normal). Bin 7 assignment.

EXAMPLE 2. (Bytes are shown separated by spaces.)

STATUS	RLC, e	RLC, mantissa	
byte 1	byte 2	byte 3	byte 4
76543210	76543210	76543210	76543210
0010x010	00001010	10100011	00011100

The example-2 interpretation is as follows:

Byte 1: Normal measurement. Range 3. RLC data are needed.

Byte 2, bit 7: Sign of R value is +.

Byte 2, other bits: R exponent is 0001010 in 2s complement notation, which is the same as a positive exponent of 001010 (i.e., +10, base 10). (See NOTE 1, above.) Bytes 3, 4: R mantissa is .637146 (from the 16-bit binary number; see NOTE 2, above).

Therefore, the R value is $(2 \text{ to the } +10\text{th power}) * (.637146) = (1024) * (.637146) = 652.44 \text{ ohms}$.

3.12 SAMPLE IEEE PROGRAMS

Below are three sample IEEE-488 programs using three different IEEE controllers. These programs are intentionally very short and are intended as aids to demonstrate to the programmer how to operate a Digibridge using a typical controller. It is assumed that the Digibridge address is set to 3.

3.12.1 Programming Hints

- a. The initiation (start) command is "GO". That is the number 0, not the letter O.
- b. It is good practice to begin a new program with a "P2" command. This will reset all parameters to the known turn-on state. If "P2" is used later in the program, it will reset everything, including Nominal Value and any Bin Limits that may be set.
- c. An 'X' command must be sent to enable data output.
- d. The string "P2A10;M3X4Z2G0" should be sent for the Short Circuit Zero. A frequency other than 1 kHz can be sent, if needed.
- e. The string "P2A10;M1X4Z1G0" should be sent for the Open Circuit Zero. A frequency other than 1 kHz can be sent, if needed.
- f. All commands sent to the Digibridge must be followed by an UNL (unlisten) and then ATN (attention) must be unasserted. If the instrument is set to TALK, this should happen automatically.

3.12.2 Hewlett Packard HP85

```
100 REMOTE 703
110 OUTPUT 703; "P2X4G0"
120 ENTER 703; C$
130 DISP C$
140 LOCAL 703
150 SEND7; UNL @ RESUME 7
160 END
```

3.12.3 Capital Equipment Corp. PC-488 Card With the IBM-PC

```
100 DEFINT A-Z
110 DEF SEG=&HC000
120 INIT=0 : TRANSMIT=3 : ENTER=21
130 MY.ADDR=21 : SYSTEM.CONTROL=0
140 DIGIBRIDGE=3
150 CALL INIT (MY.ADDR, SYSTEM.CONTROL)
160 REN$="REN"
170 CALL TRANSMIT (REN$, STATUS)
180 M$="P2X4G0"
190 ST$="LISTEN 3 MTA DATA '"+M$+' ' UNL"
200 CALL TRANSMIT (ST$, STATUS)
210 R$=SPACE$(17)
220 CALL ENTER (R$, LENGTH, DIGIBRIDGE, STATUS)
230 PRINT " MEASUREMENT IS: ";R$
240 END
Ok
```

' PC-488 memory address
' PC-488 commands
' Initialize IEEE-488
' Address of Digibridge
, Enable remote control first
' Command for Digibridge
' Receive data
' Print result

3.12.4 National Instruments GPIB-PCII Card With the IBM-PC

```
100 '*****INITIALIZE BRIDGE*****
110 ADAP$="GPIB0" : DIGI$="DIGI":V%=1
120 CALL IBFIND (ADAP$,GPIB0%):CALL IBSIC (GPIB0%)
130 IF IBSTA% < 0 THEN GOTO 120
140 CALL IBGTS (GPIB0%,V%)
150 CALL IBFIND (DIGI$,DIGI%)
160 CLS '*****MEASURE AND DISPLAY DATA*****
170 C$=SPACE$(20):D$=SPACE$(20)
180 SET$="P2X6G0" ' bridge setup string
190 CALL IBWRT (DIGI%,SET$) ' send string to bridge
200 CALL IBRD (DIGI%,C$): CALL IBRD (DIGI%,D$) ' read measurement results
210 PRINT C$;D$ ' display results
220 CALL IBLOC (DIGI%) : CALL IBGTS (GPIB0%,V%) ' return to local control

230 END
Ok
```

3.13 SELF CHECKS AND FAILURE DISPLAYS (ERROR CODES)

3.13.1 Power-Up Self Check

Every time the instrument is switched ON or the line voltage reappears after an interruption, the Digibridge keeps itself busy for a short time going through an automatic self-check routine. The RLC and QDR displays indicate in code which check is being performed. It is possible to halt the diagnostic routine and hold the displayed code by pressing and holding the [SHIFT] key or other key. Normally these displays follow one another rapidly. However, if one of them persists, there has been a failure in the self check. The nature of the failure and the proper remedy for each are indicated below. Normal operation is inhibited in each of these cases.

NOTE

Operation can usually be enabled (in spite of failure messages other than 88888 or 33333) by pressing START button. This action is useful to enable measurements using a test fixture with very large capacitance or for certain transfer impedance measurements. But, it IS NOT RECOMMENDED unless you are well aware of what caused the self-check failure.

88888 8888. The random-access-memory read/write exercise was imperfect. Try power-up again; otherwise the remedy is beyond the operator's control; repair service is required.

77777 XXXX. The detector test was not completed satisfactorily. Be sure that the EXTERNAL BIAS switch is OFF; try power-up again. Otherwise the remedy is beyond the operator's control; repair service is required. (The QDR display provides some service information indicating in code which of 4 important digital signals is stuck, and whether high or low.)

66666 XXXX. The detector scale test failed. CPU will loop on failure. Switch POWER OFF and ON again. If these remedies are ineffective, repair service is required.

555 D XXXX. A signal-strength check failed. When D is 1..4, it indicates the range being checked (with voltage = 1.275 V). When D is 5, the range is 4, with voltage = .075 V. CPU will loop on failure. Be sure that the EXTERNAL BIAS switch is OFF and check to make sure that the charged capacitor protective fuse has not blown (Item 11, Figure 1-2). Recycle power OFF and ON to exit from loop.

444 E XXXX. A check on test frequency and waveform failed. For E of 1, 2, 3,4, 5,6, the frequency being checked is 6.06, 6.0, 1.2, 0.48, .0968, .0118 kHz, respectively. CPU will loop on failure; recycle power OFF and ON to exit from loop.

33333 XXXX. PROM data checksum test. XXXX = checksum, which must be zero to pass the test.

222 F XXXX. Calibration constants test. XXXX = normalized value of constant, which must be within the limits of 1.00000 +/- 0.78125 to pass the test. For F = 0, the constant is frequency correction factor. For F = 1, 2, 3, or 4, it is the conductance of range 1, 2, 3, or 4, respectively.

You can proceed from this power-up self-check failure (222 F XXXX) and operate the Digibridge. To do so, press the [C/D] key. Of course, the measured results are liable to be erroneous; you should then proceed to obtain service to repair the fault and/or recalibrate.

3.13.2 Failure Display due to Signal Overload

"014 " (*right display blank*) Occurrence of an unrecoverable signal overload during the last measurement. This means that a signal overload occurred during RANGE HELD or while measuring on Range 4. Otherwise (if a signal overload occurs on range 1, 2, or 3 and range is NOT held), this failure display is not shown; instead, the Digibridge will change to the next higher-numbered range and try again.

1. Transient voltage from charged capacitor.
2. Transient due to application of bias voltage.
3. Hardware failure.
4. LC resonance effect (measuring inductance).

3.13.3 Failure Display due to Abnormal Measurement Cycle

22222 xxxx. The Digibridge will abort the measurement and provide this display if there is (even once during a measurement) a converter/detector malfunction such that the integrator's conversion cannot be completed. There are two versions of this failure:

22222 2222. The cycle is "too long". Integrator voltage does not return to zero in reasonable time.

22222 1111. The cycle is "too short". Integrator voltage was already zero (or wrong polarity) when conversion began.

3.13.4 Failure Display due to LC Resonance

A display of "0 14" or 22222 1111 can occur, in place of the expected L and Q, because the inductor being measured resonates with measuring circuit capacitance. (Resonance can cause an overload of the converter/detector.) The Digibridge thus presents an easily noticed failure display rather than an invalid measurement result.

When Expected. This resonance effect can be expected when large values of inductance are being measured at high frequency. In particular, if the Digibridge is autoranging, this effect could be expected in range 1.

This resonance effect can also be expected under some conditions of high-frequency measurement with range 1 held but the inductance of the DUT appropriate for range 2. The effect is NOT expected with autoranging in ranges 2, 3, 4, unless stray capacitance is considerably large.

It is possible for valid measurement, with a slight reduction in accuracy, to be made under conditions very close to those that will trigger the LC resonance failure display. Such a measurement can be expected to meet accuracy specifications if it is displayed at all.

Recommended Procedure. If this LC-resonance failure display appears, in the course of otherwise normal measurements, the instrument is functioning normally. Valid measurements can usually be made by taking one or more of the following steps.

- a. Select low source impedance, by pressing [SHIFT] [CONST VOLTAGE] so that the CONSTANT VOLTAGE indicator lights up.
- b. Select a low-impedance range. For example, if measurement is normally in range 1, try holding range 2; or if range 1 has been held, select autorange.
- c. Reduce the measurement frequency.
- d. If cable and test fixture capacitance can be reduced, do so.
- e. If this resonance effect is not easily avoided, consider that the DUT may be self-resonant. If so, unqualified measurements of apparent inductance are misleading. Try a set of measurements of apparent inductance at different frequencies sufficiently low (or high) to avoid the resonance failure display.

NOTE: If the RLC reading is negative, with indicated units of mH or H, the measured reactance is capacitive, although the RLC display is a number of millihenries or henries.

Theory – Section 4

4.1 INTRODUCTION	4-1
4.2 PRINCIPAL FUNCTIONS	4-3

4.1 INTRODUCTION.

4.1.1 General.

This instrument uses an unusual method of measurement, which is quite different from those used in most previous impedance meters or bridges. A thorough understanding of this method will be helpful in unusual applications of the instrument. The following paragraph gives a brief overall description outlining the measurement technique to one familiar with impedance measurement methods. A more detailed description of operation, specific circuitry, and control signals is given later.

4.1.2 Brief Description of the 1692 Digibridge.

This Digibridge RLC tester uses a patented measurement technique, in which a microprocessor calculates the desired impedance parameters from a series of 6 or 8 voltage measurements (6 for FAST, 6 for MED, and 8 for SLOW measurement rates). These measurements include quadrature (90 degree) and inverse (180 degree) vector components of the voltages across the device under test Z_x (the DUT), and across a standard resistor R_s carrying the same current as the DUT. Each of these voltage measurements is meaningless by itself, because the reference signals have no particular phase relationship to the measured analog signals, and because the current through Z_x is not controlled. Each set of voltage measurements is made in rapid sequence with the same phase-sensitive detector and analog-to-digital converter. Therefore properly chosen differences between these measurements subtract out fixed offset errors, and ratios between them cancel out the value of the common current, the scale factor of the detector-converter, and the effect of the relative reference-to-signal phase angle.

The phase-sensitive detector uses 4 reference signals, precisely 90 degrees apart, that have exactly the same frequency as the test signal, but whose phase relationship to any of the analog voltages or currents (such as the current through Z_x and R_s) is incidental. Therefore, no precise analog phase shifter or waveform squaring circuit is required. Correct phase relationships are maintained by generating test signal and reference signals from the same high-frequency source.

Because of the measurement technique and circuitry, the only calibration adjustment in the Digibridge is the factory setting of the test-voltage-level reference. The only precision components in this instrument are four standard resistors and a quartz-crystal stabilized oscillator. There is no reactance standard. For example, C and D are calculated by the microprocessor from the set of voltage measurements, the predetermined frequency, and the calibrated R and Q of the applicable standard resistor.

In these calculations, the microprocessor automatically removes from the measured result the parameters of the test connection ("stray" capacitance and conductance and series resistance and inductance), if simple open-circuit and short-circuit "ZERO" calibration measurements have been performed by the operator. The values obtained during "ZERO" calibration are stored in Digibridge memory and retained during power-down and power-up.

The impedance of each internal standard resistor is similarly stored in memory for use by the microprocessor in the calculation of parameters being measured. (For this purpose, the Digibridge measures its own internal standard resistors against an external standard during factory calibration --and recalibration, if any.) Therefore, the impedances of the internal resistance standards are known at the calibration frequency (usually 1 kHz), and are computed by the microprocessor for other test frequencies.

The Digibridge also stores the frequency error of its crystal-referenced oscillator (actual vs nominal frequency, expressed in parts per million) so that the microprocessor uses a corrected frequency value in each calculation of capacitance or inductance from measured impedance. This frequency correction is programmed into the Digibridge during factory calibration --and recalibration, if any.

The microprocessor controls the measurement sequence, according to programs in the read-only memory, using stored operator selections that are made available through keyboard control or (if you have the interface option) by remote-control command. Selections include for example --parameters: R and Q, L and Q, C and D, or C and R; test voltage: 0.3 or 1.0 V; equivalent circuit: series or parallel; test rate: SLOW, MEDIUM, or FAST; frequency: 100 Hz, 120 Hz, 1 kHz, 10 kHz, and 100 kHz; and averaging: 1 or 10 measurements; etc.

The instrument normally autoranges to find the correct range; but operation can be restricted to any of the four ranges (1, 2, 3, 4), under keyboard control. Each range is 4 octaves wide (16:1), with reduced-accuracy extensions both above and below.

Leading zeroes before the decimal point are blanked out of the RLC and QDR displays.

4.1.3 Block Diagram.

Figure 4-1.

The block diagram shows the microprocessor in the upper center connected by data and address buses to digital circuitry including memories (RAM and ROM) and peripheral interface adaptors (PIAs).

Analog circuitry is shown in the lower part of the diagram, where Z_x is supplied with a test signal at frequency f from a sine-wave generator, driven by a crystal-controlled digital frequency divider circuit. The P/I signal selector and instrumentation amplifier supply an analog signal that represents 2 impedances alternately: the appropriate internal resistance standard, R_s , and the DUT, Z_x .

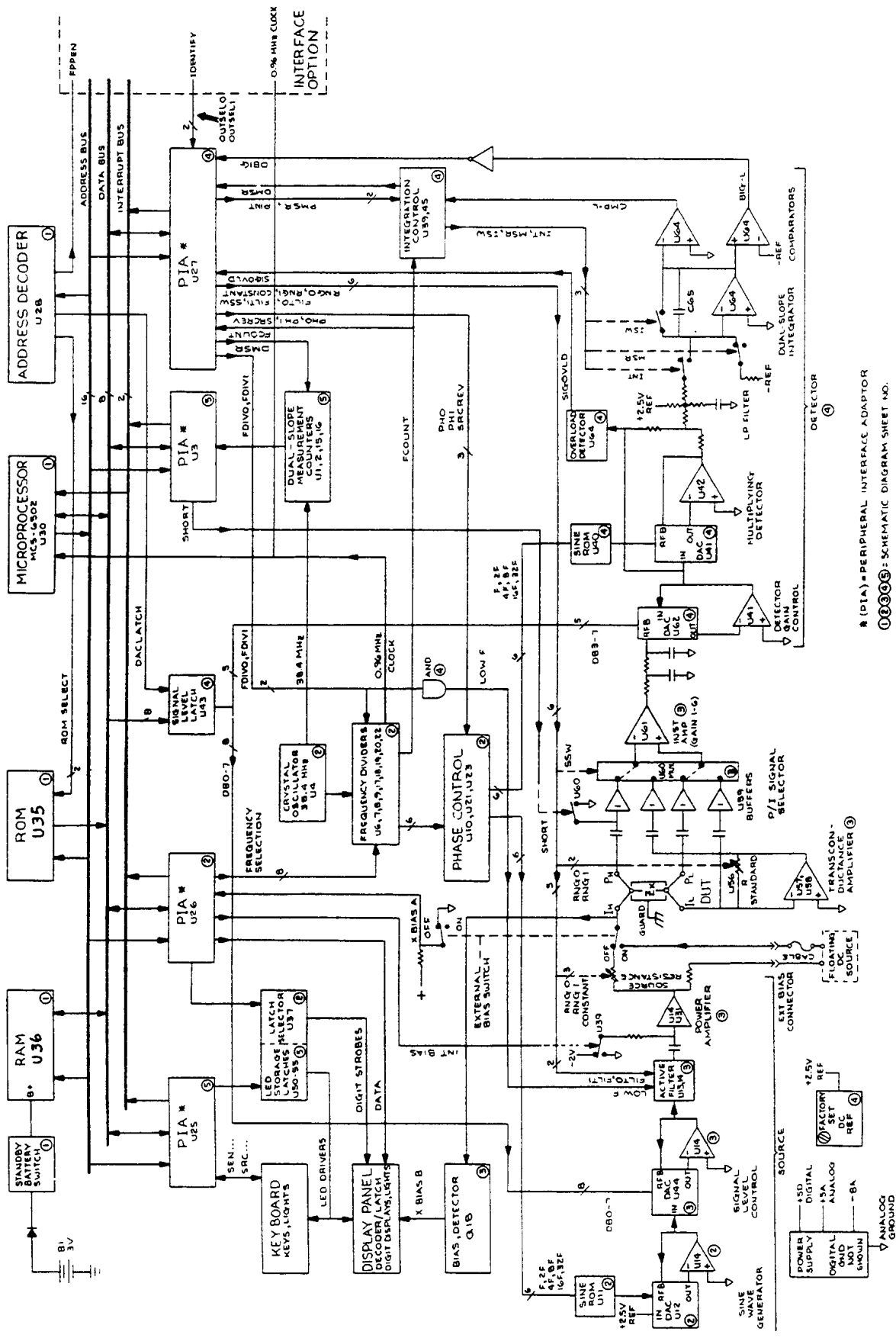
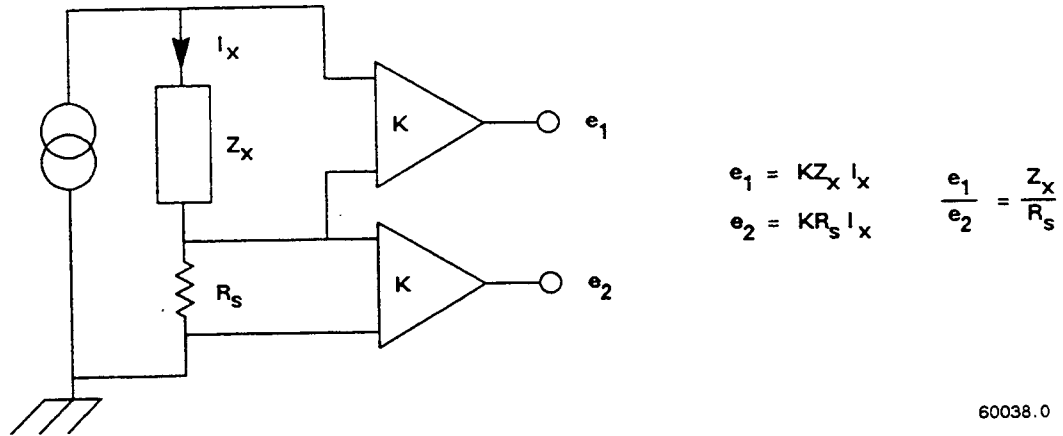

Figure 4-1. Block diagram of the 1692 RLC Digibridge.

The phase-sensitive (dual-slope) detector and measurement counters convert this analog signal into digital form. See circuit descriptions below.

From this information and criteria selected by the keyboard (or remote control), the microprocessor calculates the RLC and QD values for display, averaging, bin assignments, etc.



60038.0

Figure 4-2. Elementary measurement circuit.

4.2 PRINCIPAL FUNCTIONS.

4.2.1 Elementary Measurement Circuit.

Figure 4-2.

The measurement technique is illustrated by the accompanying simplified diagram, which can be correlated with the previous (block) diagram. A sine-wave generator drives current I_x through the DUT Z_x and standard resistor R_s in series. Two differential amplifiers with the same gain K produce voltages e_1 and e_2 . Simple algebra, some of which is shown in the figure, leads to the expression for the "unknown" impedance:

$$Z_x = R_s [e(1)/e(2)]$$

Notice that this ratio is complex. Two values (such as C and D or L and Q) are automatically calculated by the microprocessor from Z_x , frequency, and other information.

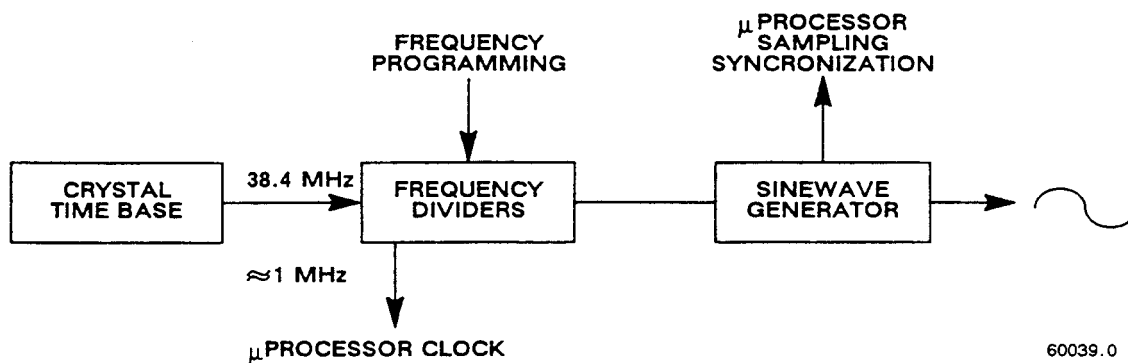

Figure 4-3. Frequency and timing source. Several clocks and synchronizing pulses as well as the measurement signal f are derived from the accurate time-base signal.

4.2.2 Frequency and Time Source.

Figure 4-3.

A necessary standard for accuracy is the frequency of the test signal; and equally important are the generation of multi-phase references for detection and clocks for the microprocessor. Frequency and timing requirements are implemented by derivation from a single very accurate oscillator, operating at 38.4 MHz. Digital dividers and logic circuitry provide the many clocks and triggers, as well as driving the sine-wave generator described below.

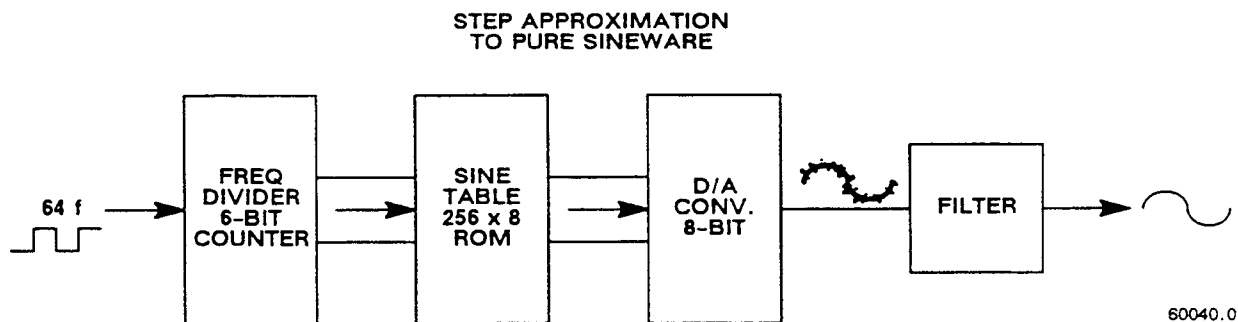

Figure 4-4. Sine wave generator. Given square waves at frequencies of $64 f$, $32 f$, $16 f$, $8 f$, $4 f$, $2 f$, and f , a ROM containing the mathematical sine function drives a D / A converter to form a finely stepped approximation to a sine wave at frequency f . The filter provides smoothing of the test signal.

4.2.3 Sine-Wave Generation.

Figure 4-4.

Source of the Test Signal. Starting with a digital signal at 64 times the selected test frequency, the sinewave generator provides the test signal that drives a small but essential current through the DUT. The sine wave is generated as follows.

Binary dividers count down from 64 f, providing signals at 32 f, 16 f, ...2f, f. This set of signals is used to address a read-only memory which contains a 64-step approximation to a sine function. The ROM output (as an 8-bit binary number) is converted by a D/A converter to a stepped approximation of a sine-wave, which is then smoothed by filtering before its use in the measurement of a DUT. The filter is switched appropriately, according to the selected test frequency.

Source of the Reference Sine Wave for the Multiplying Detector. Another sine-function ROM is addressed by the same digital signals (64 f through f) to produce another stepped approximation of a sine wave at 0 degrees. Suitable inversions of signals 2f and/or f serve to shift the phase of the output sine wave, under microprocessor control, by 90, 180, or 270 degrees.

4.2.4 The Dual-Slope Integrating Detector and Converter

(See Figure 4-1.)

Circuitry. The phase-sensitive detector/converter circuit consists of a multiplier whose dc output is measured by a dual-slope converter, providing the measurement in digital form. The multiplier is a multiplying D / A converter whose "reference" input is the test signal and whose digital controls are signals representing a stepwise approximation of a reference sine wave at the test frequency. The dc value of the multiplier output is proportional to the product of signal magnitude multiplied by the cosine of the phase angle between the test signal and the reference sine wave.

The dual-slope converter includes these three stages: dual-slope integrator, comparator, and counter (all controlled by the microprocessor through PIAs). In the dual-slope integrator, a capacitor is charged for a controlled integration time interval (sampling) at a rate proportional to the multiplier output voltage. This capacitor is then discharged at a fixed rate (the deintegration slope) to zero voltage, a condition that is sensed by a comparator. (See signal name "CMP-L" on the block diagram.) Thus, the integrator and comparator transform the sampled dc output from the multiplier into a precise interval of time. The dual-slope measurement counter is gated by this time interval, thus converting it into a digital number, which is a principal data input to the microprocessor.

If the integration time is relatively long, so that the integration capacitor voltage reaches a certain reference level, another comparator triggers the beginning of the return (deintegration) slope before sampling has been completed. (See signal name "BIG-L" on block diagram.) The detector is then sampling and converting simultaneously for a portion of the dual-slope conversion cycle.

Data Acquisition Time. Data acquisition time includes pauses for synchronization, and several integration/ deintegration cycles.

Data acquisition time is a complex, discontinuous function of test frequency, the selected measurement rate, and pauses for synchronization.

Service and Maintenance – Section 5

5.1	CUSTOMER SERVICE	5-3
5.2	INSTRUMENT RETURN.....	5-3
5.3	REPAIR AND REPLACEMENT OF CIRCUIT BOARDS	5-3
5.4	PERFORMANCE VERIFICATION	5-3
5.5	DISASSEMBLY AND ACCESS.....	5-8
5.6	PERIODIC MAINTENANCE.....	5-17
5.7	TROUBLE ANALYSIS	5-19
5.8	ACCURACY VERIFICATION	5-28
5.9	RECALIBRATION	5-43
5.10	INTERNAL SETTINGS	5-48

WARNING

These servicing instructions are for use by qualified personnel only. To avoid electrical shock, do not perform any servicing, other than that contained in the operating instructions, unless you are qualified to do so.

CAUTION

For continued protection against fire hazard, replace fuse only with same type and rating as shown on rear panel and in parts list.

Service personnel, observe the following precautions whenever you "handle a circuit board or integrated circuit in this instrument.

**HANDLING PRECAUTIONS
FOR ELECTRONIC DEVICES
SUBJECT TO DAMAGE BY STATIC ELECTRICITY**

Place instrument or system component to be serviced, spare parts in conductive (anti-static) envelopes or carriers, hand tools, etc., on a work surface defined as follows. The work surface, typically a bench top, must be conductive and reliably connected to earth ground through a safety resistance of approximately 250 kilohms to 500 kilohms. Also, for personnel safety, the surface must NOT be metal. (A resistivity of 30 to 300 kilohms per square is suggested.) Avoid placing tools or electrical parts on insulators, such as books, paper, rubber pads, plastic bags, or trays.

Ground the frame of any line-powered equipment, test instruments, lamps, drills, soldering irons, etc., directly to earth ground. Accordingly, (to avoid shorting out the safety resistance) be sure that grounded equipment has rubber feet or other means of insulation from the work surface. The instrument or system component being serviced should be similarly insulated while grounded through the power-cord ground wire, but must be connected to the work surface before, during, and after any disassembly or other procedure in which the line cord is disconnected.

Exclude any hand tools and other items that can generate a static charge. (Examples of forbidden items are non-conductive plunger-type solder suckers and rolls of tape.)

Ground yourself reliably, through a resistance, to the work surface; use, for example, a conductive strap or cable with a wrist cuff. The cuff must make electrical contact directly with your skin; do NOT wear it over clothing. (Resistance between skin contact and work surface through a commercially available personnel grounding device is typically in the range of 250 kilohms to 1 megohm.

If any circuit boards or IC packages are to be stored or transported, enclose them in conductive envelopes and/or carriers. Remove the items from such envelopes only with the above precautions; handle IC packages without touching the contact pins.

Avoid circumstances that are likely to produce static charges, such as wearing clothes of synthetic material, sitting on a plastic-covered or rubber-footed stool (particularly while wearing wool), combing your hair, or making extensive erasures. These circumstances are most significant when the air is dry .

When testing static-sensitive devices, be sure dc power is on before, during, and after application of test signals. Be sure all pertinent voltages have been switched off while boards or components are removed or inserted, whether hard wired or plugged in.

The symbol shown below may appear on circuit boards and/or schematic diagrams to call attention to static sensitive component parts. However, the absence of such a symbol does NOT assure the absence of static sensitive devices.



CERTIFICATION

Products provided by GenRad are thoroughly tested and calibrated to meet product specifications. A Record of Certification of conformance (which certifies that the product meets its specifications and that its calibration is traceable to appropriate national standards) is available upon request at the time of purchase.

5.1 CUSTOMER SERVICE

Our warranty (at the front of this manual) attests the quality of materials and workmanship in our products. If malfunction does occur, our service engineers are available for technical telephone assistance. If the difficulty cannot be eliminated by use of the following service instructions, please contact GenRad's Technical Assistance Center (see last page of this manual), giving full information of the trouble and of steps taken to remedy it. Describe the instrument by name, catalog number, serial number. (Refer to Digibridge rear panel.)

5.2 INSTRUMENT RETURN

5.2.1 Return Material

Before returning an instrument to GenRad for service, contact our nearest Service and Logistics Center for return shipping instructions (see last page).

5.2.2 Packaging

To safeguard your instrument during storage and shipment, please use packaging that is adequate to protect it from damage, i.e., equivalent to the original packaging. Any GenRad field office can advise. Contract packaging companies in many cities can provide dependable custom packaging on short notice. Mark the box "DELICATE INSTRUMENT".

5.3 REPAIR AND REPLACEMENT OF CIRCUIT BOARDS

This instruction manual contains sufficient information to guide an experienced and skillful electronic technician in fault analysis and the repair of some circuits in this instrument. Contact QuadTech's Technical Assistance Center if additional help is needed (see last page).

U.S.A.

SALES	800-253-1230
TECHNICAL ASSISTANCE CENTER	978-461-2100
SERVICE	978-461-2100

5.4 PERFORMANCE VERIFICATION

5.4.1 General

This procedure is recommended for verification that the Digibridge tester is performing normally. No other check is generally necessary because this procedure checks operation of nearly all of the circuitry. If the Digibridge passes this performance verification, it is safe to assume that the instrument is functional. (However, to insure *accuracy*, refer to paragraph 5.8, Accuracy Verification.)

All tests are done at 1 kHz, 1 volt NOT CONSTANT, and in SLOW measure rate so that basic bridge accuracy is realized. The accuracy of each verification is therefore $\pm .05\%$ plus the tolerance of the verifying DUT, which is discussed below. Table 5-1 lists the necessary resistors, capacitors, and inductors, which are inexpensive and readily obtained. The most accurate ones available should be used; tolerances listed are the "best" commonly catalogued. There are no calibrations and only one adjustment that could require resetting; and the internal standards are very stable. This procedure checks at least one point on each of the four measurement ranges.

Table 5-1
COMPONENTS RECOMMENDED FOR PERFORMANCE VERIFICATION

Component	Type *	Nominal Value	Tolerance
Resistors Metal Film	MIL-R-10509C (Style RN60)	49.9 ohms	+/- 0.1%
		499 ohms	+/- 0.1%
		4.99 kilohms	+/- 0.1%
		49.9 kilohms	+/- 0.1%
		499 kilohms	+/- 0.1%
Capacitors Metalized			
Polyester	GE: BA-19A106C	10 uF	+/- 5%
Polystyrene	Southern: 1PJ-334J	0.33 uF	+/- 0.5%
	Electronics 1PJ-333J	0.033 uF	+/- 0.5%
	Corp. 1PJ-332J	0.0033 uF	+/- 0.5%
Inductors	J.W.Miller		
Non-Ferrous	9220-28	1000 uH	+/- 5%
Ferrite Core	9250-107	100 mH	+/- 10%

* Equivalents may be substituted

CAUTION

Be sure that the voltage switch, rear panel, is correctly set for your power line (90 to 125 V -or- 180 to 250 V), that no components are connected to the test fixture, and that the EXTERNAL BIAS switch is OFF.

5.4.2 Performance Verification Procedure

a. After the line voltage switch has been set to correspond to the input line voltage, connect the line cord and switch the POWER ON.

The Digibridge then enters an automatic self-check routine and displays a sequence of codes. If one of these displays persists, a check failure has occurred and further checks or measurements are inhibited. (See paragraph 3.13.)

Normally, upon completion of the power-up self check, the following preset or default conditions are established, lighting a vertical line of indicators. (However, if the keyboard is locked, the locked-in conditions are re-established and most of the keyboard indicators are dark.) Normal:

[FUNCTION] -MEASURE
[DISPLAY] -VALUE
[MEASURE RATE] -SLOW
[MEASURE MODE] -CONT.
[EQUIVALENT CIRCUIT] -SERIES

NOTE: If interface option is installed, MEASURE MODE will indicate TRIGGERED and display blank.

The main panel displays and indicators (RLC and QDR) will normally come up with random, meaningless readings; ignore them.

b. However, if the keyboard is locked and the MEASURE indicator is lit, to unlock it, press:

[1][6][9][2] [=] LOCK

(If you have the interface option (1658-9620, it is possible that the FUNCTION is locked at ENTER. Then the use of remote control signals is required either to unlock the keyboard or to select the MEASURE function, which is a prerequisite for unlocking from the keyboard).

c. Confirm or select the following measurement conditions on the Digibridge:

```
[FUNCTION] -- ENTER (necessary for determining test frequency)
[DISPLAY]  -- VALUE
[MEASURE RATE] -- SLOW
[MEASURE MODE] -- TRIGGERED (necessary for zeroing)
[EQUIVALENT CIRCUIT] -- SERIES
EXTERNAL BIAS -- OFF (slide switch)
```

d. Verify that the test frequency is 1 kHz (the power-up default), the 1 kHz indicator (right side of display panel) should be lit. If any other frequency is observed, press: [SHIFT] [FREQUENCY] until the 1 kHz indicator is lit.

e. Verify that the test voltage is 1 volt, the 1V indicator should be lit. If the other voltage indicator is observed, press: [SHIFT][VOLTAGE] to light the 1V indicator.

f. Press the [FUNCTION] key to select MEASURE function.

g. If the Digibridge has an interface option (which has two 24-pin interface connectors on the rear panel), be sure that the TALK switch (rear panel) is set to TALK ONLY.

h. Zero the Digibridge as follows, before making measurements. (Make sure that the MEASURE and TRIGGERED keyboard indicators are lit.)

Test Fixture ---for the 1692 Digibridge. Install the axial-lead adaptors in the test fixture in position for

accepting the largest of the verifying DUTs in Table 5-1.

Open Circuit Zero.

Press the [C/D] key.

Press: [1][6][9][2][=][SHIFT][OPEN].

Keep hands and all objects at least 10 cm from fixture contacts.

Press START to initialize zeroing operation.

Wait until the GO indicator lights.

Short Circuit Zero. Short the fixture with a piece of copper wire, pressed into the test-fixture adaptors, where the DUT leads will go. Do not move the test fixture adaptors.

Press [1][6] [9] [2][=] [SHIFT] [SHORT].

Press START to initialize zeroing operation.

Wait until the GO indicator lights again.

(NOTE: For maximum accuracy, this zeroing procedure should be performed at the start of each day and every time the fixture configuration is changed.)

i. Press the [MEASURE MODE] key to select CONT. (continuous measurements).

j. Press [R/Q].

k. Insert, as DUT, the first resistor specified in Table 5-2.

1. Verify that the displays are within the extremes shown for check number 1 in Table 5-2, if the resistor is within the tolerance listed in Table 5-1.

NOTE ON TOLERANCES: Acceptable performance of the instrument is bracketed by the set of display "extremes" in Table 5-2. These are defined as the nominal (ideal) measurements plus-or-minus the sum of the instrument accuracy tolerances and the DUT accuracy tolerance (or slightly more). If the accuracy of your DUT is different from the recommendation, revise the acceptable "extremes" accordingly. Notice that this performance verification is NOT intended to prove the accuracy of the instrument.

NOTE ON INSIGNIFICANT FIGURES: The right-hand digit(s) of the display may be expected to nicker and change (with the automatically repeating measurements) if they are not significant for the specified accuracy of the instrument. (See further comment with step p below.)

m. Similarly, make the other checks indicated in Table 5-2, under the R/Q parameter (checks number 2, 3, 4, 5).

n. Press [C/D].

o. Insert as DUT the first capacitor specified in Table 5-2 (check number 6).

p. Verify that the displays are within the extremes shown for check number 6 in Table 5-2, if the capacitor is within the tolerance listed in Table 5-1.

q. Similarly make the other checks indicated in Table 5-2 under the C /D parameter (checks number 6, 7, 8, 9).

In check number 8, verify that the fifth digit is reasonably stable, as follows. (Notice that the fourth digit is the last significant one in the readout, for 0.02 percent accuracy.) In check number 8, the flickering of the fifth digit should stay typically between 2 counts. For example, if the display is 330.1X nF, the 'X' might flicker between 2 and 4. If, for example, 'X' is flickering between 9 and 11, it will of course cause a flickering of the preceding digit (330.19 and 330.21). In such a case, the correct readout is the larger 4-digit number (330.2) and the fifth digit is acceptably stable.

r. Press [L/Q].

s. Insert as DUT the first inductor specified in Table 5-2 (check number 10).

t. Verify that the displays are within the extremes shown for check number 10 in Table 5-2, if the inductor is within the tolerance specified by Table 5-1.

u. Similarly check the inductor specified in check number 11.

Table 5 -2
PERFORMANCE VERIFICATION

Check Number	Parameter	DUT	RLC Display Extremes	QDR Display Extremes
1	R/Q	49.9 ohms	49.825 to 49.975 ohms	*
2		499 ohms	498.25 to 499.75 ohms	
3		4.99 kilohms	4.9825 to 4.9975 Kohms	
4		49.9 kilohms	49.825 to 49.975 Kohms	*
5		499 kilohms	498.25 to 499.75 Kohms	
6	C/D	0.0033 uF	3281.8 to 3318.2 pF	.0000 to .0100
7		0.033 uF	32.818 to 33.182 nF	.0000 to .0100
8		0.33 uF	328.18 to 331.82 nF	.0000 to .0100
9		10 uF	9.495 to 10.505 uF	.0000 to .0300
10	L/Q	1000 uH	.9495 to 1.0505 mH	*
11		100 mH	89.95 to 110.05 mH	*

* The right hand display (QDR) can be expected to change frequently; accuracy of that display is not significant in these performance checks.

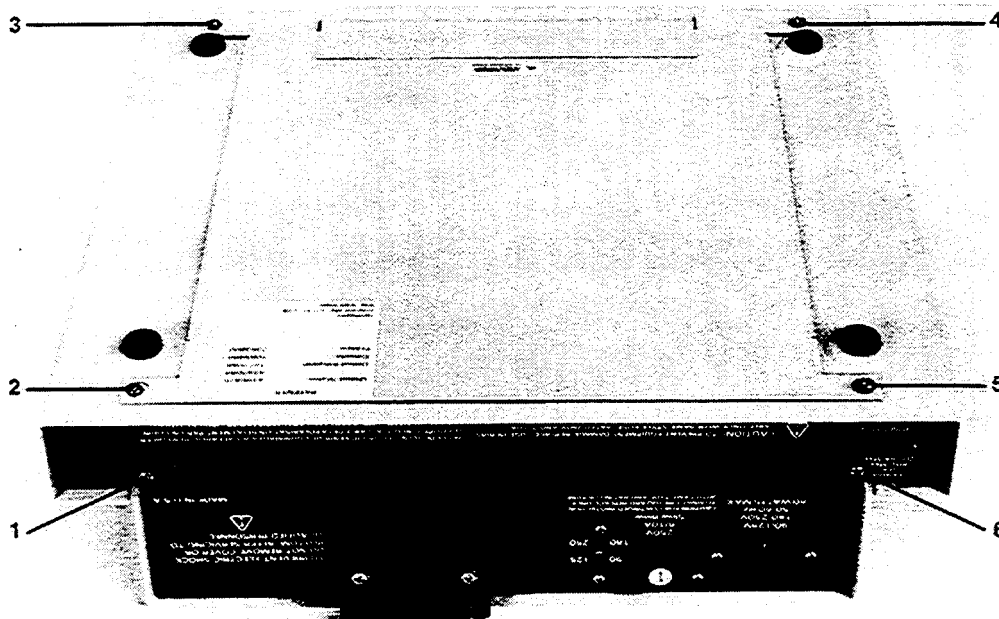

Figure 5-1. Rear and bottom view of the 1692 Digibridge, showing screw locations for disassembly: top-cover screws 1 and 6; bottom-shell screws 2, 3, 4, 5.

5.5 DISASSEMBLY AND ACCESS

WARNING

If disassembly or servicing is necessary, it should be performed only by qualified personnel familiar with the electrical shock hazards inherent to the high-voltage circuits inside the cabinet. Be sure that you never short or apply voltage to the battery BI. (See paragraph 5.7.3).

CAUTION

Observe precautions against damage by static electricity whenever you handle a circuit board or integrated circuit in this instrument. Refer to the beginning of Section 5.

5.5.1 Disassembly of 1692 Digibridge

Figures 5-1 through 5-9.

Use the following procedure for access to replaceable parts and contact points used in trouble analysis.

a. Disconnect the power cord.

b. Remove the top-cover screws from the rear panel of the main chassis. See Figure 5-1. (These screws are slightly outboard from the ones designated for interface option or cover plate. One of them is just to the right of the label EXTERNAL BIAS.) Slide the top cover forward about 6mm so that its front corners are unhooked. Lift it directly upward (Figure 5-2). Reassembly note: Install the cover without air filter, using the 2 screws, 13 mm long. Then stuff the air filter into position through the air intake opening; using your fingers, press the edges and corners of the filter into position.

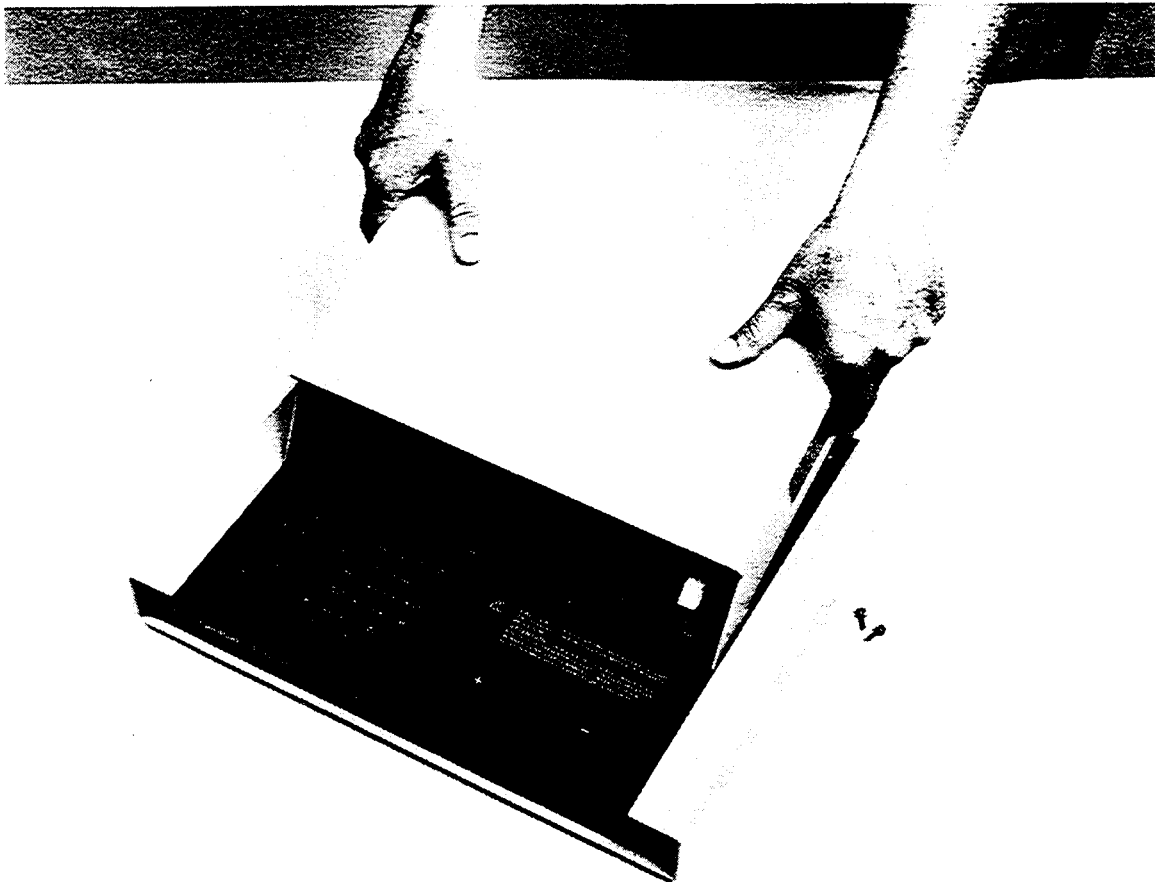

Figure 5-2. Removal of the top cover from 1692 Digibridge.

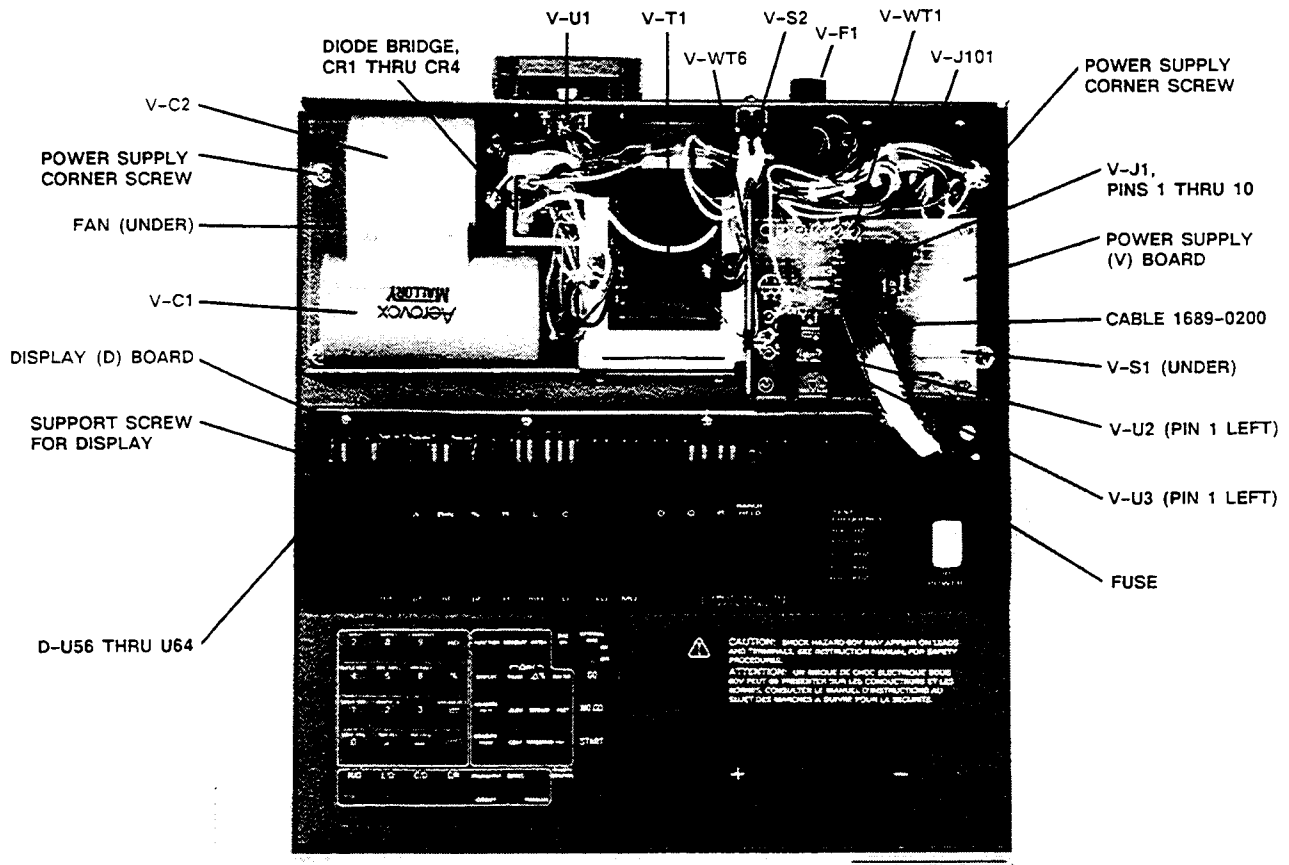

Figure 5-3. Power supply (V assembly) and display (or DB) board, shown in the 1692 Digibridge, with top cover off. The protective cover has been removed from above the power supply assembly.

c. Remove the interface option, if you have one, after removing the large screws with resilient washers in the rear panel. See Figure 1-2. (If the panel held by these screws is blank, leave it in place.) Reassembly note: align board edges carefully with connector and guide that are inside of instrument, while pushing interface option into position.

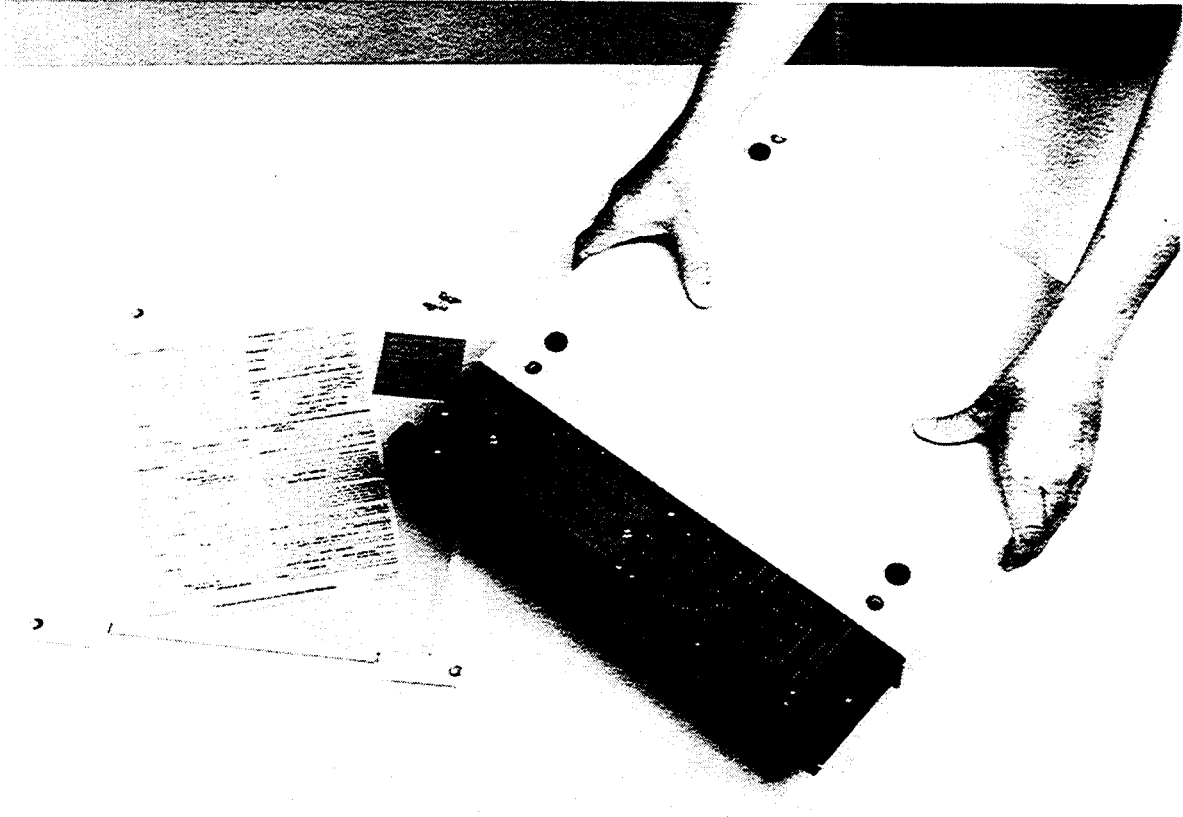

Figure 5-4. Removal of the bottom shell from the 1692 Digibridge. Notice that the top cover has been temporarily installed as a support.

d. Remove 4 screws from the bottom shell, one near each rubber foot (Figure 5-1). Lift the instruction card and its retaining pan free. Slide the bottom shell back (or forward), free of the main chassis (Figure 5-4). Reassembly notes: Be sure to enfold the pliable dirt seals at left and right sides of main chassis as you start to slide bottom shell onto main chassis; use 4 screws, 8 mm long.

NOTE

It may be advisable to provide "upside down" support by reinstalling the top cover temporarily.

The next step, removal of display board, is recommended before removal of the main circuit board.

e. Remove the 2 screws and washers (Figure 5-7, 2 screws at location D) from the bottom of the main board that holds the display board brackets.

f. Pull the board directly out of its socket in the main board. Keep the display board in its original (inclined) plane until it is completely free (Figure 5-5). Reassembly note: 2 screws, 6 mm long with washers.

g. Disconnect the ribbon cable (1689-0200) from main board (at connector J5). The cable can be removed from the power supply (J1) after removal of the protective cover as described below. Notice that the connectors are symmetrical; reversing either or both is permitted; and the cable is extra long, for convenience in servicing.

NOTE: The next two steps, removal of the power supply, are NOT related to the removal of the main board. Either can be left in place while the other is removed.

WARNING

Dangerous voltages are present on wires and terminals that will be exposed in the following steps. BE SURE THAT THE POWER CORD IS DISCONNECTED BEFORE PROCEEDING.

h. Remove the protective cover (with the warning label) from the upper right portion of the power supply (3 screws).

CAUTION

In reassembling, inspect carefully to be sure that none of the nearby wires touches the fan rotor or blades. Inspect by looking under the 1657-4720 board. To verify free rotation, blow on the fan and watch it spin.

i. Remove the five screws that fasten the bottom of the power supply to the main chassis. Four screws are at corners of power supply; the fifth is nearly hidden, between the transformer and the largest capacitor. Lift the power supply slightly and move it back carefully while disengaging the POWER pushbutton extension from its hole in the front panel (Figure 5-6). Reassembly note: 5 screws, 8 mm long.

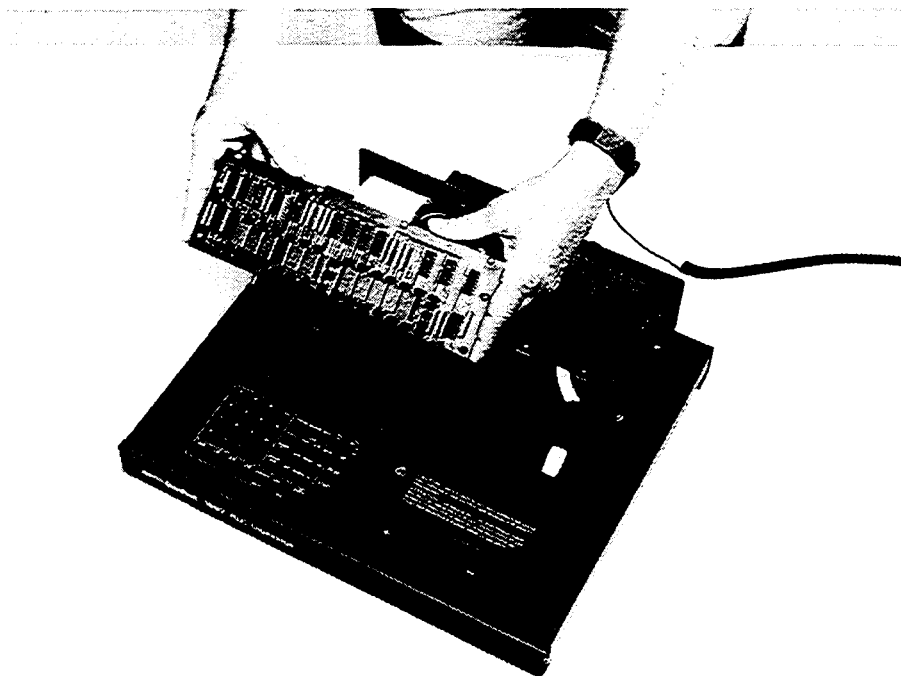

Figure 5-5. Removal of the display board from the 1692 Digibridge.



Figure 5-6. Removal of the power supply from the 1692 Digibridge. The ribbon cable must be disconnected first. The display board can be removed first or left in place, as shown here.

Before removing the main board, the ribbon cable must be disconnected first. Prior removal of the display board also is highly recommended. Because the board is partially enclosed by the main chassis, unusual care may be needed in removal. These motions are suggested: slide toward the rear, tilt as shown, and gently lift free.

j. Remove 11 screws from positions shown in Figure 5-7 as A and B, to free the main board. Lift slightly, and slide the board rearward so the keyboard can be lifted past the lip of the chassis. Tilt the front edge up about 6 cm (2 in.) before lifting the whole board out. Figure 5-8 shows how to tilt the main board to the best position for removal. Reassembly note: return washers to original positions; screws at A are 6 mm long, B screws are 8 mm long.

k. To remove the keyboard module, remove the 4 screws at E (Figure 5-7) and carefully pull the module directly away from the main board. Reassembly note: be very careful not to bend pins when plugging the keyboard-module connectors into their main-board sockets; use 4 screws, 6 mm long.

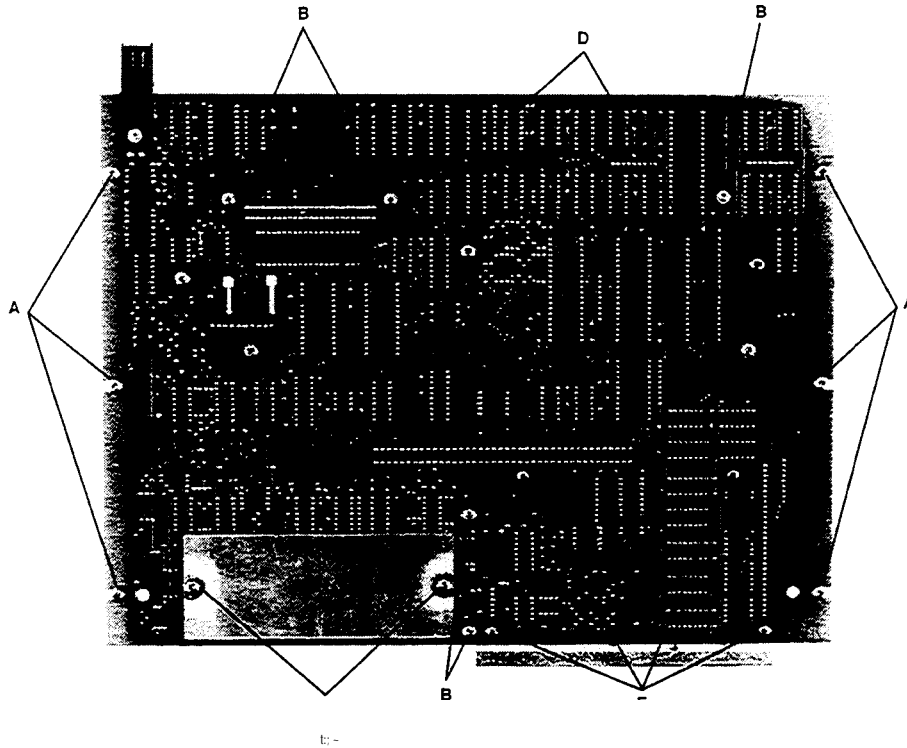

Figure 5-7. Locations of screws on the main board of the 1692 Digibridge, bottom view. Screws at A and B hold the board to the chassis. Screws at C hold a shield and (with 2 screws from the other side) the test fixture assembly -Screws at D hold brackets for the display board; and at E, the keyboard module.

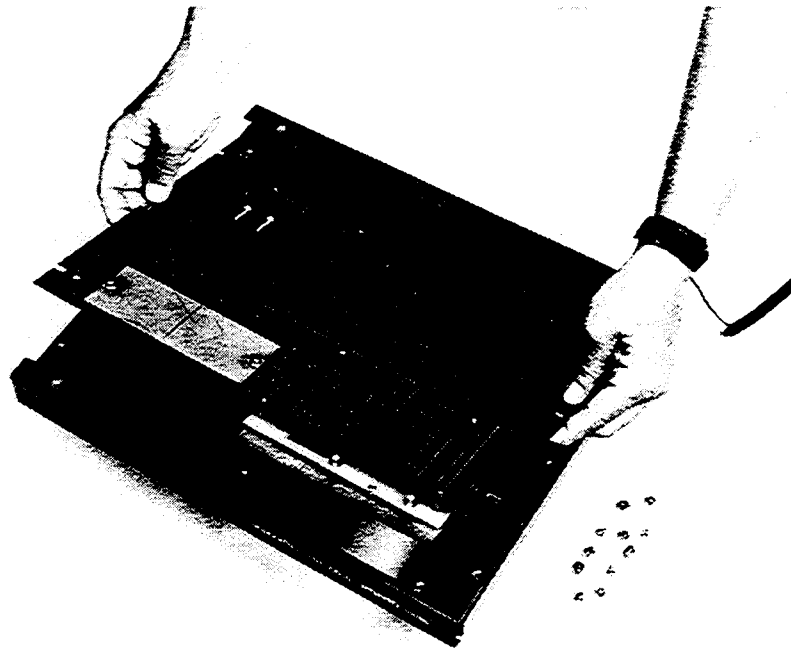

Figure 5-8. Removal of the main board from the 1692 Digibridge.

I. For access to the test-fixture contacts, remove the dross tray 1657-7700 (the plastic dirt catcher) by spreading it slightly and lifting it off. Then remove the guide block assembly 1689-2000 (includes dross tray) by removing 2 screws and associated washers, spacers and shield plate, on bottom of main board (see "C", Figure 5-7) and 2 test-fixture center shield screws (use hexagonal wrench 2.38 mm = .094 in.) from top of the main board. (See also Figure 5-9.)

Reassembly note: C screws are 13 mm long. Position the guide lock assembly for smooth entry of a radial-lead DUT before tightening screws. If an extension cable is available, its paddle boards can be used for a centering jig. Otherwise verify by eye, looking directly down on the board, through the slots in the guide block, to the contact gaps.

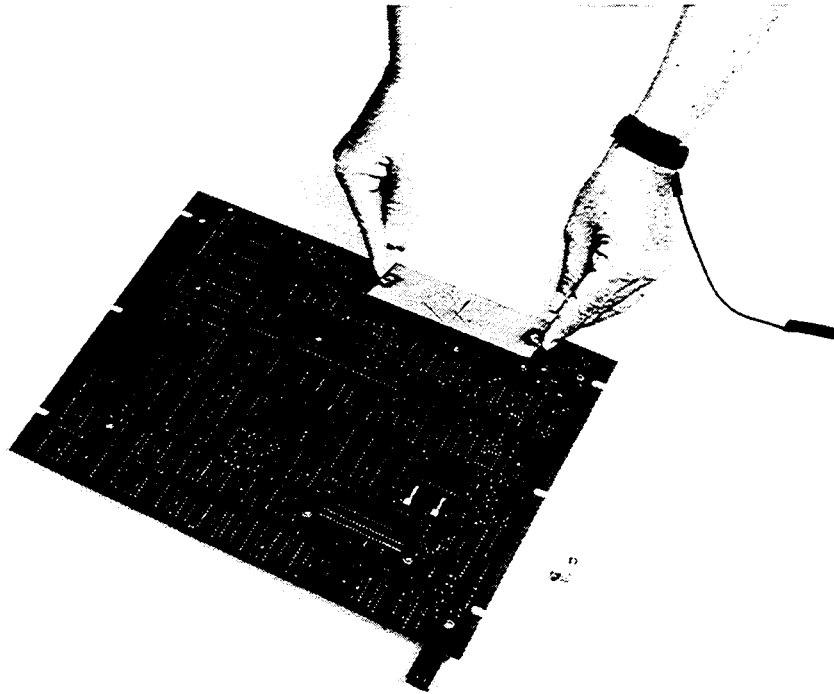

Figure 5-9. Removal of the shield from below the test fixture of the 1692 Digibridge. Notice the use of a personnel grounding strap.

5.5.2 Access

Mainboard. Locations of principal components for trouble analysis are shown in Section 6 layout diagram (Figure 6-4). The analog circuitry is placed along the front (forward of the display board connector) and along the front half of the right hand edge. However, most of this board supports digital circuitry.

Power Supply. For access to parts in the power supply, refer to Section 6.

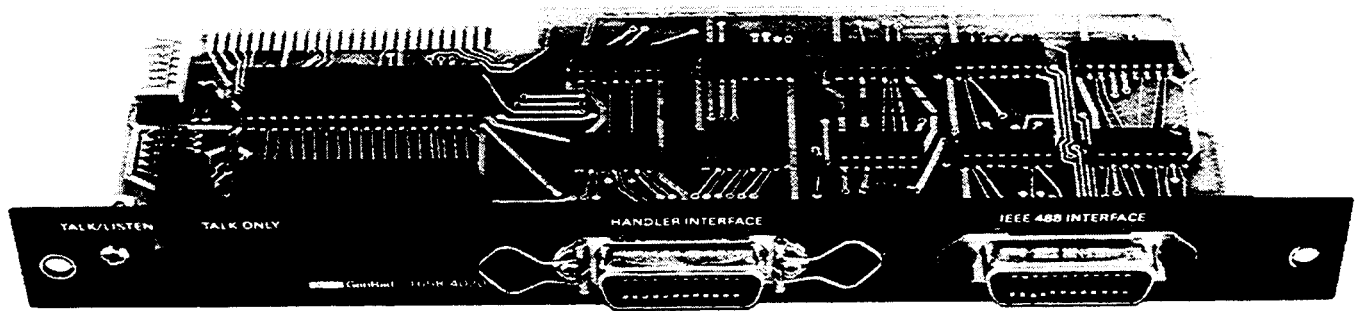

Figure 5-10. IEEE/handler interface option assembly 1658-9620, including the interface option board (IOB) 1658-4620.

5.5.3 IEEE/Handler Interface Options

Figure 5-10.

This Digibridge accepts the 1658-9620 option that provides both IEEE-488-bus and handler interfaces. Refer to the Specifications in the front of this manual and to Table 1-3 in Section 1.

Removal of Interface Board. The procedure is as follows:

- a. Switch POWER OFF and disconnect power cord from Digibridge.
- b. Place the instrument in the normal position (flat on table or in rack). Looking at the rear panel, remove the two screws that hold the interface-option's rear panel (or the blank cover plate) from the Digibridge. Refer to Figures 1-3 and 1-4, in Section 1.
- c. Withdraw the interface option (or the cover plate) horizontally, directly away from the front panel.

CAUTION

Observe precautions while handling the interface option. Because there are static-sensitive parts on the board, DO NOT TOUCH THE CIRCUITS or ICs. Refer to Section 5 of this manual, for recommended handling procedure.

Installation. Install or reinstall the interface option as follows.

a. Hold the interface option by its rear panel, so that the labels near the connectors read "right-side up". *Look through the opening into the instrument and observe the connector that will receive the interface option board '8 edge contacts.* Insert the board *horizontally* through the opening, with care to align the board-edge contacts with the mating connector inside.

b. Press the interface option fully into the Digibridge by hand, confirming that alignment is correct. Reinstall the screws that were removed in step b, above.

5.5.4 Removal of Multiple-Pin Packages

Use caution when removing a plug-in integrated-circuit or other multiple-pin part, not to bend pins nor stress the circuit board. Withdraw the part straight away from the board. Unless an IC is known NOT to be a static-sensitive type, place it immediately on a conductive pad (pins in the pad) or into a conductive envelope.

DO NOT attempt to remove a soldered-in IC package unless you have the proper equipment and skills to do so without damage.

5.6 PERIODIC MAINTENANCE

5.6.1 Care of the Test Fixture

For best results and minimum maintenance effort, the operator must remove any obvious dirt from leads of DUTs before inserting them into the test fixture. Its contacts will wipe through a film of wax, but they can become clogged and ineffectual if the operator is careless about cleanliness.

About once a year (more or less depending on usage) the test fixture and its axial-lead adaptors should be inspected and cleaned as follows:

a. Clean the contact surfaces and blades of the axial-lead adaptors with isopropyl alcohol. Rub with a cotton swab (Q-tip). Remove any remaining liquid alcohol by blowing with the breath and remove any remaining cotton fibers, with tweezers.

b. Expose the test-fixture contacts for cleaning as follows (depending on which test fixture is being cleaned).

Test Fixture Included On 1692 Digibridge.

Remove the MB board and expose the test-fixture contacts by removing its guide block assembly (part number 1689-2000), as described in paragraph 5.5.1 and repeated here for convenience. Remove the dross tray 1657-7700 (the plastic dirt catcher) by spreading it slightly and lifting it off. Carefully remove the guide block assembly (part no. 1689-2000, includes dross tray) by removing 2 screws and associated washers, spacers and shield plate, on bottom of main board (see "C", Figure 5-7) *and* 2 test-fixture center shield screws (use hexagonal wrench 2.38 mm = .094 in.) from top of the main board. (See also Figure 5-9.)

Reassembly note: C screws are 13 mm long. Position the guide block assembly for smooth entry of a radial-lead DUT before tightening screws. If an extension cable is available, its paddle boards can be used for a centering jig. Otherwise verify by eye, looking directly down on the board, through the slots in the guide block, to the contact gaps.

1689-9600 Test Fixture (the one without a START bar).

Remove the four rubber feet (one screw apiece) and slide the bottom housing off.

Remove the two hex socket head screws near the middle of the circuit board (top side; use hexagonal wrench 2.38 mm = .094 in).

Remove the two screws and associated washers near the right and left

Carefully remove the guide block assembly (part number 1689-2000).

Reassembly note: See above.

1689-9605 Test Fixture (the one with a START bar and GO/NO-GO lights).

Remove the four rubber feet (one screw apiece) and slide the base off.

Remove the two hex socket head screws near the rear, along the front-to-back midline of the circuit board (top side; use hexagonal wrench 2.38 mm = .094 in).

Remove the two screws and their washers, below the right and left ends of the test fixture guide block, taking care not to lose the spring under the START bar, which will become free.

Carefully remove the guide block assembly (not available as a replacement part), which includes the START bar, and which is tethered to the circuit board by a ground wire.

Reassembly note: See above.

c. Clean and check the 4 contact strips. Use a card wet with isopropyl alcohol for cleaning. Hold the board at an angle so that any drip falls away from the circuits.

If necessary for better access for cleaning, remove 2 front contacts (P/N 1689-1015). Use a hexagonal 2.38 mm, .094 in.) to remove 2 screws per contact. Reassembly note: gap between contacts should not be 24 mm (.009 in., or the thickness of 3 layers of typing paper); and contacts must press against each other by tiny dielectric spacers attached near each end of slot) so that a wire of 0.64 mm diameter (AWG 22, can be withdrawn from between them with a force of 1 (minimum) to 2 (maximum) newtons (100 to 200 mN). Tighten the hex-drive screws with a torque of 1.3 to 1.4 newton-meters (12 in-lb).

CAUTION

Because of alignment difficulty in reassembly,
DO NOT use the next step unnecessarily.

e. *If necessary*, remove the 2 remaining contacts as in the previous step. Reassembly note: align the contacts so that the surfaces that will press against the DUT leads are collinear (so that the guide block can be positioned with its slots matching the gaps in BOTH contact pairs); tighten hex-drive screws as specified above.

5.6.2 Cleaning the Air Filter

5.8.3 Care of the Display Panel

Use caution when cleaning the display window, not to scratch it nor to get cleaning substances into the instrument. Use soft cloth or absorbent cotton, moistened with a mild glass cleaner, such as "Windex" (Drackett Products Co., Cincinnati, Ohio). DO NOT use a paper towel; do NOT use enough liquid to drip or run.

If it should be necessary to place marks on the window, use paper-based masking tape (NOT any kind of marking pen, which could be abrasive or react chemically with the plastic). To minimize retention of any gummy residue, remove the tape within a few weeks.

5.7 TROUBLE ANALYSIS

5.7.1 General

CAUTION

Only well qualified and trained personnel should attempt trouble analysis. Be sure power is OFF during disassembly and setting up for tests. Carefully observe the HANDLING PRECAUTIONS given at the beginning of Section 5.

Resources. Refer to Section 4 for a good understanding of the theory of operation. The block diagrams and discussion there provide necessary background, which can generally save time in trouble analysis. Refer to Section 6 for hardware details: circuit layouts, schematic diagrams, and parts lists.

Abnormal digital signal levels. Most digital signal levels in this instrument are normally near zero (logic low), about +3.5 to +5 V (logic high), or rapidly switching between these states. Failure of a digital source often produces a dc voltage of about +2 V on a signal line. Use high-impedance probes in measuring. Use a scope as well as a voltmeter, because an average of 2 V may be normal for a digital signal that has a duty cycle near 50%.

Duplicated circuits and resistor networks. Some circuits, as in the display board for example, are duplicated several times. The ICs can usually be exchanged between a faulty circuit and a functional one, to identify a "bad" IC. Notice, also, that the resistor networks DB-Z2...DB-Z10 are simply compact packages of 220-ohm resistors. If one resistor is open, it is not necessary to replace the entire package. Use a 5% resistor.

Power-Up Self Check. Upon power-up, the Digibridge performs a self-check sequence as explained in paragraph 3.13. If a self-check failure occurs, the instrument display will indicate the nature of the failure. For more detail, refer to paragraph 5.7.2 below.

Telltale symptoms. Scan the following group of symptoms for a preliminary analysis of trouble and suggestions for more detailed procedures if applicable.

Display. A perpetually blank digit or decimal point may be caused by a fault in the directly associated circuit on the display board. (Refer to comments above.)

D Error. A large D error may be caused by faulty "protection" diodes in the analog front end. Check MB-CR30, CR31, CR32, CR33.

Reactance Error. If C or L measurements are not accurate, the test signal source may be at fault. In checking it, verify that the frequency is within +/- 0.01% of the specified nominal frequency. Refer to paragraph 3.4.1.

Keyboard Malfunction. If instrument passes its power-up self check and proceeds to measure BUT has no (or only a few) keyboard indicators lit, and the keys on the keyboard don't function normally: the fault is probably in the 30-wire cable connection between keyboard and main board. If the keyboard has been disconnected, check for misalignment of the connector that plugs directly into the keyboard. If only one key or indicator malfunctions, check that portion of the keyboard.

Test Signal. To check performance of the test-signal source, use a scope to look at the open-circuit signal at the I_h terminal of the test fixture (right front contact ---be sure there is no DUT). The signal on each range should be an un distorted sine wave at the selected frequency, approximately 2.82 V peak to peak.

Analog Front End and Detector. To check the entire analog front end, install any typical DUT in the test fixture, select the default test conditions (including CONT MEASURE MODE) by switching POWER OFF and ON. (The keyboard must not be locked.) Use an oscilloscope to look at the signal at the instrumentation amplifier output (MB-U61 pin 14). This waveform should switch back and forth between two 1-kHz sinewaves whose amplitudes are proportional to the voltages across the DUT and the internal standard resistor. If the DUT is an open circuit or a short circuit, this signal should switch back and forth between a very small and large signal. If these signal levels are incorrect or the signals are distorted, the problem is either in the sinewave generator or in the analog front end. Check this waveform with known "problem" test conditions. If this signal appears to be correct, use an oscilloscope to verify that the signal at MB-U64 pin 7 has the characteristic staircase/sawtooth waveform illustrated in Figure 5-11. If this is true (and if similarly normal waveform appears even when you select known "problem" test conditions), the fault is probably NOT in the analog detector.

Introduction to Detailed Analysis. The following trouble analysis procedures will serve as a guide for localizing a fault to a circuit area. In some cases, a specific component part can be isolated for replacement. In other cases, the problem can be narrowed down only to a circuit board.

Except for the short-cuts indicated above, follow the procedure strictly in the order given, doing the principal steps (a, b, c, d,...) until a failure is found. If so, do the secondary steps, if any are given at the point of failure (aa, ab, ac...).

NOTE

Reference designators, such as MB-U21, are frequently abbreviated in the following text, for example U21, because the context of the service procedure should leave no doubt as to which board is being serviced.

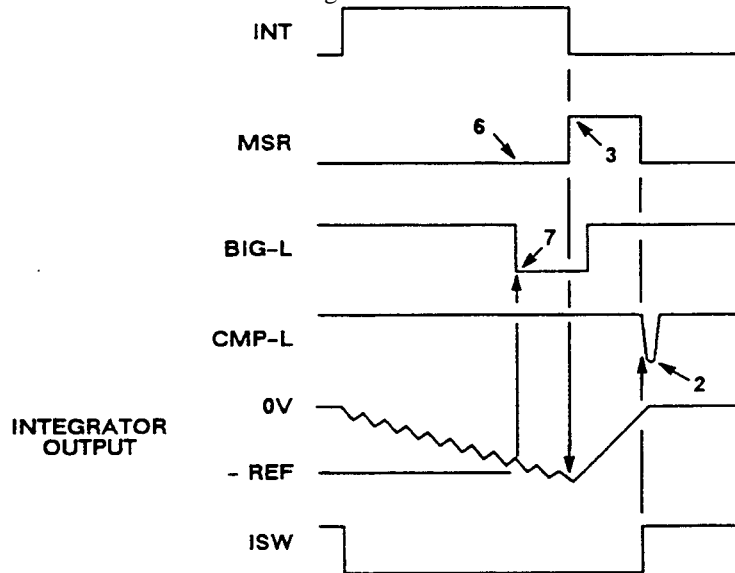

60041.0

Figure 5-11. Timing diagram for the detector portion of the power-up self-check, with keys to the crucial events that are checked. Labels 7 thru 1 correspond to tests identified with displays of 77777 7777 thru 77777 1111, respectively. When the instrument is making measurements, the waveforms are different in many details.

5.7.2 Power-Up Self Check and Certain Aborted Measurements

Figure 5-11.

The following outline of failure displays includes comments on some of the self check routines, significance of the displays, and some suggestions for appropriate service procedures.

GENERAL NOTES

For the most rigorous self check, in servicing, repeat the power-up self check several times, at least once with a short circuit as "DUT" in the test fixture and once with the test fixture empty (open circuit). A normally functional Digibridge should pass both ways.

Keen observation of the fleeting displays associated with the tests that pass, before the one that fails, are sometimes useful. Pressing any key, such as [SHIFT] will halt the self-test routine and hold the display until the key is released. Look for trends or tests that pass only marginally.

SELF-CHECK (FAILURE) DISPLAYS

88888 8888. RAM read/write exercise failure; Digibridge hangs up. PROCEDURE: Switch POWER OFF and ON to clear hangup and repeat self check. Check RAM circuitry and data and address buses.

77777 XXXX. Detector test failure; Digibridge hangs up. PROCEDURE: Switch POWER OFF and ON to clear hangup and repeat self check. Be sure that the EXTERNAL BIAS switch is OFF. Use scope to check waveforms on the main board as indicated below and in the accompanying figure.

77777 7777. DBIG (U27 pin 2) is stuck low. Integration failure. PROCEDURE: check integrator output (U64 pin 7). Its acquisition, i.e. integration slope (downward) should cross the level of -5.1 V; then BIG-L (U64 pin 14) should go low and DBIG high, signaling the microprocessor to start conversion, i.e. deintegration.

77777 6666. DMSR (U27 pin 8) is stuck high. Integration failure. PROCEDURE: check MSR (U45 pin 11). Both of these signals should be low during integration. Check the circuit back through D flip-flop U45 to PMSR at U27 pin 10.

77777 5555. FCOUNT is not toggling (U27 pins 9, 40). Check the circuit back to frequency multiplexer UI9 pin 9. Verify that all frequencies are present on the inputs to the multiplexer and that the control lines FDIV0 and FDIV1 are functioning (U19 pins 2, 14, respectively).

77777 3333. DMSR (U27 pin 8) is stuck low. Integration failure. PROCEDURE: Check MSR (U45 pin 11). Both of these signals should go high, starting the deintegration.

77777 2222. CMP-L (U64 pin 8) is stuck high. Deintegration failure. PROCEDURE: check that integrator output (U64 pin 7) rises to cross the 0- V level at the end of deintegration. CMP-L should go low at that crossing, and may remain low for only a brief pulse. The leading edge should cause DMSR to go low and ISW (U45 pin 6) should go high.

77777 1111. DBIG (U27 pin 2) is stuck high. Deintegration failure. PROCEDURE: verify that BIG-L goes high and DBIG goes low when integrator output becomes more positive than -5.1 V.

66666 XXXX. Stuck key or detector scale factor and zero bias test failure; the Digibridge will loop, automatically repeating the test and updating the display. XXXX is the magnitude of "zero" measurement, normalized to 1.

COMMENT: The "zero" measurement includes a sequence of five dual-slope conversions (measurements of voltage coming into the detector from the instrumentation amplifier). Frequency is 1 kHz; test signal level is 75 mV. The signal component is removed by averaging the results of two dual-slope conversions, sampled in opposite phases. The detector is supposed to be biased so that its "zero" output is essentially in the center of its operating range. For convenience, the CPU divides the "zero" measurement by its normal value and displays the result. Consequently, the ideal value for XXXX is 1.000. If it is less than 0.875 or more than 1.125, the test fails.

ANALYSIS PROCEDURE: Check the following circuits:

1. Zero (half-scale) bias current circuit (CR38, R116).

NOTE: R116 is a 10-kilohm potentiometer, which should be adjusted for 2.5 V measured at the cathode of CR38. These components are found about 93 mm (3 5/8 in.) from the right front corner, measured toward center of board.

2. Detector scale (integrator) current circuit (CR40, R119, U63).
3. Phase control circuit (U26, U27, U21, U23, U18, U22).
4. Detector switches (U63).

555 D XXXX. Signal strength check failure; the Digibridge will loop, automatically repeating the test and updating the display. The digit D indicates the range and voltage level used. (See below.) Test frequency is 1 kHz.

COMMENT: Possible cause is having EXTERNAL BIAS switch ON during power-up. The effect depends on what is connected to the EXTERNAL BIAS connector and what is in the test fixture. This switch must be OFF to assure normal power-up routines. Also, check to make sure that the charged capacitor protective fuse has not blown (Item 11, Figure 1-2), the effect is similar. The Digibridge separately squares the measurements of 4 component voltages, a quadrature pair across the DUT and a pair across the internal standard resistor. The squares are summed to represent the square of the applied voltage (essentially the open-circuit voltage from the HIGH terminals of the test fixture to ground). To normalize this result, it is divided by the square of the "zero" measurement. (See 66666 XXXX, above.) The ideal value for XXXX is about 0.64. If it is less than 0.250 or more than 1.000, this test fails.

ANALYSIS PROCEDURE: See below; depends on the failure display, which is coded to indicate test voltage (high or low) and range of the failed test.

555 5 0000. (Confirming symptoms: If you press START repeatedly until the instrument completes its self check, the BIAS ON indicator will be lit even though the EXTERNAL BIAS switch is OFF, no bias is applied, and INT BIAS has not been selected.) The fault is probably in the 6-wire connection between keyboard and main board. Check to be sure that the cable connector properly engages all 6 pins at the keyboard.

555 5 XXXX. Low voltage (75 m V rms), range 4. If XXXX is less than 0.250, check for a malfunction in the circuits that supply the test signal (U32, U31, U14, U13, U44 ...back to U4). Check the input signals and the gain through instrumentation amplifier U61.

However, if XXXX is greater than 1.000, check the test voltage and source resistance selector circuits (U32, controlled by U27 pins 6, 7); check filter selector U13, controlled by U27 pins 12, 13, as well as pins 14, 15, via U21 and U38. Also check for RAW SINE on D / A converter U44 pin 15.

555 4 XXXX. High voltage (1.275 V), range 4. Check test voltage selector circuit and instrumentation amplifier.

555 3 XXXX. High voltage (1.275 V), range 3. Check signal at Ih terminal with test fixture short circuited. Check signal at output of transconductance amplifier circuit (U58 pin 8) with test fixture short circuited.

555 2 XXXX. High voltage (1.275 V), range 2. (See previous suggestion.)

555 1 XXXX. High voltage (1.275 V), range 1. (See previous suggestion.)

444 E XXXX. Test frequency and waveform check failure; the Digibridge will loop, automatically repeating the test and updating the display. The digit E indicates the frequency used in the test. (See below.) High voltage test signal is used, on range 4.

COMMENT: Measurement, summing of squares, and normalization are exactly as described for 555 D XXXX. Also the failure limits for xx:xx are the same (0.250 and 1.000), except for tests 1 and 2, which have the limits: 0.125 and 1.000.

ANALYSIS PROCEDURE: Check for the generation of the proper frequency (indicated in code by failure display, see below) by U5, U6, U7, U8, U20, U17, U18, U19, U22. Check filter circuitry in signal source (U13) and detector (U62, U40, U41). Operation can usually be enabled, in spite of failure messages "444 1 XXXX" or "4442 XXXX", by pressing the START button.

444 6 XXXX. .0118 kHz.
444 5 XXXX. .0968 kHz.
444 4 XXXX. 0.480 kHz.
444 3 XXXX. 1.200 kHz.
444 2 XXXX. 6.000 kHz.
444 1 XXXX. 6.0606 kHz.

33333 XXXX. PROM data checksum failure. If the checksum XXXX is not 0000, check all digital circuitry, starting with the 6502 microprocessor U30. Any error on the address or data bus could cause a checksum error --- check ROM U35, check RAM U36; check all of the PIAs U3, U25, U26, U27. Look for address or data lines stuck at about 2 V or stuck low.

222 F XXXX. Calibration constants check failure; Digibridge hangs up, but will respond to keyboard inputs. The digit F is the range in question. COMMENT: Each check consists of a comparison between the stored calibration data for the range and the normal, expected values. The calibration can be expressed (essentially) as the conductance of the internal standard resistor. The Digibridge normalizes this conductance by dividing it by the nominal conductance of the standard, and displays the result, XXXX, which should be very close to 1.000. (See table giving source resistance for each range in paragraph 3.4.2.) If XXXX is less than 0.2187 or more than 1.781, this test fails. ANALYSIS PROCEDURE: depends upon display; see below.

NOTE: This is a non-catastrophic failure. If you press the [C/D] key, the Digibridge will proceed with the self-check routine. The instrument can be operated as usual, but results may be erroneous. To restore accuracy, recalibrate, as described in paragraph 5.9.

222 4 XXXX. Range 4 may be incorrectly calibrated. Refer to paragraph 5.9 for recalibration procedure. If calibration is accomplished correctly, but this failure display appears when POWER is cycled OFF and ON, check battery B1. (See Figure 6-4. Connect voltmeter only briefly.) If B1 voltage is less than 2.0 V, replace battery with a new one, as described in paragraph 5.7.3. If the problem is clearly associated with the loss of calibration when POWER is cycled OFF and ON, but the battery voltage is adequate, check the standby power circuit (Q9, Q10, CR9, CRI5). Only if necessary, replace the RAM, U36.

222 3 XXXX. Range 3. Be sure that recalibration has been done correctly. If necessary, check Rs standard switching circuitry as described above.

222 2 XXXX. Range 2. Same comment as for range 3.

222 1 XXXX. Range 1. Same comment as for range 3.

222 0 XXXX. Frequency correction factor. ANALYSIS PROCEDURE: Refer to 444 E XXXX.

5.7.3 Battery and Fuse Replacement

Battery. If, at power-up, there is a failure display of 222 4 XXXX and investigation shows the most likely cause to be low battery voltage, you probably should replace battery B1. (See power-up self check in paragraph 3.13 and above in 5.7; see part description in Table 1-3 and/or Section 6.) The procedure is as follows.

a. Remove the main board.

b. Find B1 at the right of center (see Figure 6-4). Cut its straps. Observe correct polarity, for replacement, + toward center of board.

WARNING

Wear safety glasses while doing any work on the battery. DO NOT short or apply voltage to the battery. Dispose of the old one in accordance with local regulations for disposal of hazardous materials. DO NOT incinerate.

c. Unsolder and remove the old battery with care not to overheat.

d. Install the replacement and secure with straps (like the originals) or lacing cord, to safeguard terminals from strain.

e. Solder the terminals with care and DO NOT overheat.

f. Perform complete calibration procedure. Refer to paragraph 5.9.

Fuse. If at power-up, there is a failure display of 555 5 XXXX (see Self Check paragraph 3.13.1 and Trouble Analysis paragraph 5.7.1) replacement of the capacitor discharge fuse may be necessary (see Table 1-2).

a. Remove the top cover from the Digibridge.

b. This fuse is located in a socket on the main board and behind the power switch. Unplug the fuse (using needle-nose pliers and replace.

5.7.4 Power Supply

NOTE

In the following procedure, do the principal steps (a, b, c, d, ...) as long as everything checks out normally. But if a failure is found, follow the secondary steps, if any are given at the point of failure (aa, ab, ac, ad ...).

Check the power supply (V assembly) if there is a massive failure (nothing works) or as a starting procedure in any thorough analysis. Refer to Figure 5-3.

NOTE

If a voltage regulator (U1, U2, or U3) must be replaced, be sure to spread silicone grease (like Dow Corning compound no. 5) on the surface toward the heat sink. For U1, coat both sides of the insulating washer.

a. Check the output voltages, using a digital voltmeter, with ground reference at V-J1, pin 9 (ribbon cable unplugged), as follows:

Pin 1 = +4.75 V to +5.25 V,
Pin 3 = +4.75 V to +5.25 V,
Pin 4 = -7.6 V to -8.4 V.

aa. If trouble is found at step a, check both analog and digital "+ 5 V" circuit: At outputs of UI and U2: + 5 V dc (regulated).

At WT1 (inputs of UI and U2): + 10.8 V dc, when primary voltage is 115 V rms, between terminals 1 and 2 of transformer T1.

Across input to diode bridge (yellow-to-yellow): 10 V rms.

ab. Check "-8 V" circuit: At output of V3: -8 V dc (regulated).

At input (center terminal) of U3: -13.8 V dc, when primary voltage is 115 V rms, between terminals 1 and 2 of transformer T1.

Across WT7 to WT8: 11.3 V rms.

ac. Check power-line circuit to primary of transformer V -T1.

b. Make a check similar to step a, with ribbon cable connected, ground reference at front edge of ME board (near the test fixture), probing MB-J5 from below the board, referring to Figure 6-4. (This checks for overload outside the power supply.)

5.7.5 Sinewave Generator Checks

Check the MB-board circuits that supply the test signals to the DUT, as follows.

a. Perform the zeroing procedure (both open circuit and short circuit), as described in paragraph 5.9.2 of the recalibration procedure.

b. Make the following test setup and keyboard selections.

[FUNCTION] -MEASURE
[DISPLAY] -VALUE
[:MEASURE RATE] -SLOW
[:MEASURE MODE] -CONT.
[EQUIVALENT CIRCUIT] -SERIES

c. Install a 10 kilohm resistor as the DUT.

d. Use an oscilloscope to verify that the signal at the right-hand end of the DUT in the test fixture is a sine wave, as follows. (For scope ground return, connect to the ground plane on the circuit board or via a 6-32 screw to the tapped hole in the left-hand end of the test fixture.)

Frequency: 1 kHz,
Amplitude: approx 1.8 Vpk-pk.

e. If no fault appears in steps a through d, skip to paragraph 5.7.6.

NOTE

The prefix "MB-" is omitted in the following text, wherever it is not necessary for clarity.

f. With an oscilloscope, observe and measure the signal at U32 pin 15. It must be a 1-kHz sinewave, approximately 2.8 V pk to pk.

g. With an oscilloscope, check at U31 pin 8, U14 pin 14, and U14 pin 8, for a 1-kHz sinewave, 2.8 Vpk-pk. If the test signal is missing, check backward, to the precision oscillator U4, then forward through dividers and sinewave generator, as shown on the main-board schematic sheet 2, in Section 6 of this manual.

5.7.6 Front End Amplifiers and Switches

Check the MB-board analog circuits that process the measurement signals from the test fixture to the point of A/D conversion, as follows.

a. Verify that there is a normal test signal at the test fixture. (See paragraph 5.7.5 step d, above.)

b. Check the range switching circuitry as follows. (Be sure that the RANGE HELD indicator is NOT lit.) Insert as DUT each of following resistors. With a scope connected to the right side of each DUT in turn, check for a 1-kHz sinewave with the level indicated below.

10 ohm -test signal should be 800 mVpk-pk (range 4)

1 kohm -test signal should be 2 Vpk-pk (range 3)

10 kohm -test signal should be 1.8 Vpk-pk (range 2)

1 Mohm -test signal should be 2.5 Vpk-pk (range 1)

If discrepancy is found in step b, check for 2.8 Vpk-pk at the appropriate signal source check point -as described in Table 5-5 -for the particular range in use.

c. Install a 1-kilohm resistor in the test fixture. Check the PH circuit at U59 pin 8, for a 1-kHz sinewave, 2.2 Vpk-pk. If there is a discrepancy in step c, but U59 pin 10 has a 2.2 Vpk-pk sinewave, then U59 is faulty.

d. Check the output of the IL circuit at U59 pin 14 for a 1-kHz sinewave, with the following selection of DUTs in turn:

10 ohm -signal level should be 1.8 Vpk-pk (range 4)

1 kohm -signal level should be 800 mVpk-pk (range 3)

10 kohm -signal level should be 1.2 Vpk-pk (range 2)

1 Mohm -signal level should be 250 mVpk-pk (range 1)

If a discrepancy is found in step d, check similarly at the R-Std signal check point --as described in Table 5-6. The signal should be the same as listed in step d above for U59 pin 14, for the particular DUT and range.

Table 5-5
SOURCE RESISTOR RANGE SWITCHING CHECKS

RNG1	Control Signals		Range	Nom Source Resistance	Signal Source Check Point
	RNG0	LSRC			
0	0	0	4	25 ohm	U32 pin 12
0	1	1	3	400 ohm	U32 pin 14
1	0	1	2	6.4 kohm	U32 pin 15
1	1	1	1	97.4 kohm	U32 pin 11

Table 5-6
DETECTOR (STANDARD) RESISTOR RANGE SWITCHING CHECKS

RNG1	Control Signals		Range	Nominal Standard Resistance	R-Std Signal Check Point
	RNG0	LSTD			
0	0	0	4	25 ohm	U56 pin 12
0	1	1	3	400 ohm	U56 pin 14
1	0	1	2	5.97 kohm	U56 pin 15
1	1	1	1	97.4 kohm	U56 pin 11

5.8 ACCURACY VERIFICATION

5.8.1 General

This procedure is a more rigorous alternative to the performance verification described above. Precision standards of impedance are required for this procedure, which checks the accuracy as well as the overall performance of the instrument. It will be controlled from the front panel, without disassembly. Table 5-7 lists the recommended standards and associated equipment. For the C accuracy checks, the standard is a precision decade capacitor.

Calibration of Standard. The acceptable RLC readout (min to max range) may have to be modified if the actual (calibrated) value of your standard or its accuracy (either or both) is different from the tabulated value(s).

For example, if your 10-pF standard is known to be 10.18 ± 0.25 pF, then compute the new tolerance as follows: Digibridge accuracy ± 0.02 percent. The limits are, therefore, 9.92 to 10.44 pF.

Verify that the instrument meets performance specifications as follows.

Table 5-7
EQUIPMENT FOR ACCURACY VERIFICATION

Name	Requirements	Recommended
Capacitor	Decade, 3-terminal, 1 pF to 1 uF, accuracy: +/- 0.05% +/- 0.5 pF	GenRad 1413-9700
Capacitor	Decade, 50 pF to 1.11115 uF, accuracy: +/- 0.5%	GenRad 1412
Extender cable	Adapt test fixture to type 874 connectors	GenRad 1688-9600
Adaptors (2 req'd)	Tee with type 874 connectors	Gilbert 0874-9910*
Extender cable	Adapt test fixture to binding posts and banana plugs	GenRad 1657-9600
Capacitor	Four-terminal, ratio type, 10 uF to 100 uF, accuracy: +/- 0.25%	GenRad 1417-9700
Capacitor	DC blocking, 500 uF, 10 V	GE 69F2214G2
Capacitor	Three-terminal, 1 uF, acc: +/- 0.02%, certified within +/- 0.03% including effects of aging since last certification	GenRad 1409-Y
Resistor	Decade, 3-terminal, 1 ohm to 1 Mohm, accuracy: +/- 0.01%	GenRad 1433-H
Inductors	Fixed, 2-terminal, 1 mH, +/- 0.1%	GenRad 1482-E
	100 mH, +/- 0.1%	GenRad 1482-L
	1 H, +/- 0.1%	GenRad 1482-P
	10 H, +/- 0.1%	GenRad 1482-T

*Gilbert Engineering Co., Inc., 5310 W. Camelback Rd, Glendale, AZ 85301

5.8.2 Capacitance Measurement Accuracy (Small and Medium C, Ranges 1, 2, 3)

Make the test setup and verify instrument performance as follows:

CAUTION

Be sure the line voltage switch, rear panel, is correctly set for your power line voltage.

a. After the line voltage switch has been set to correspond to the input line voltage, connect the power cord and switch POWER ON.

b. Connect the 1688-9600 extender cable (type 874 connectors) to the Digibridge test fixture, as described in paragraph 3.2.5. The screws must be hand tightened because they provide the ground (guard) connection.

c. Connect the "high" leads (red and red white) to one of the 874 Tee connectors. Connect the "low" leads (black and black/white) to the other 874 tee.

d. Before measurement, zero the Digibridge as follows. In this process, the Digibridge automatically measures stray parameters and retains the data, which it uses to correct measurements so that results represent parameters of the DUT alone, without (for example) test-fixture or adaptor capacitance.

Be sure that MEASURE RATE is SLOW and that the RANGE HELD indicator is NOT lit. DO NOT have test frequency programmed to other than 1 kHz.

Open Circuit.

Leave the two type 874 tees connected to the 1688-9600 extender cable,
but not connected to each other.

Press [FUNCTION] key (if necessary) to select MEASURE function.

Press [MEASURE MODE] key (if necessary) to select TRIGGERED mode.

Press these keys deliberately: [1] [6] [9] [2] [=] [SHIFT] [OPEN].

Confirm that the GO indicator is lit. Press the START button.

Keep hands and objects at least 10 cm (4 in.) from test fixture.

Wait for the GO indicator to be lit again, on the keyboard (not on any remote test fixture). (The RLC display should be .00000)

Short Circuit.

Connect the two type 874 tees together.

Press these keys deliberately: [1] [6] [9] [2] [=] [SHIFT] [SHORT].

Confirm that the GO indicator is lit. Press the START button.

Wait for the GO indicator to be lit again, on the keyboard (not on any remote test fixture).

Disconnect the two type 874 tees from each other.

e. Connect the type 874 tee with the red cables to the HIGH terminal of the 1413-9700 decade capacitor. Connect the other tee (black cables) to the LOW terminal of this capacitor.

f. Set the decade capacitor dials to 00000 pF.

.Press the C /D key.

.Press these keys deliberately: [1] [6] [9] [2] [=] [SHIFT] [OPEN].

.Confirm that the GO indicator is lit. Press the START button.

.Wait for the GO light. The RLC display should be .00000 pF.

.Press [MEASURE MODE] key to select CONT.

.Press [EQUIVALENT CIRCUIT] key to select SERIES.

g. Set the decade capacitor to 10 pF. If necessary, press the START button. Verify that the C and D measurements subsequently displayed on the Digibridge are within the limits given in the first line of Table 5-8.

h. Similarly, for each line in the table, set the capacitor and the Digibridge measurement rate, and verify that the resulting measurements are satisfactory.

i. Disconnect the 1688-9600 extender cable from the capacitor and the Digibridge.

NOTE

Whenever doing short-circuit or open-circuit zeroing, remember that the GO light to watch is the one on the keyboard (not on any remote test fixture, for example).

Table 5-8
CAPACITANCE ACCURACY CHECKS (RANGES 1 TO 3)

Capacitor Setting	Meas Rate	Digibridge Accuracy	Decade C Accuracy	RLC Display Min*	RLC Display Max*	QDR Display Max**
----- Range 1 -----						
10 pF	SLOW	1.05 %	5.05%	9.39	10.61	6100 ppm
100 pF	SLOW	.15%	.55%	99.300	100.70	2500 ppm
1500 pF	SLOW	.057%	.083%	1497.9	1502.1	700 ppm
1500 pF	MED	.113%	.083%	1497.1	1502.9	1002 ppm
1500 pF	FAST	.283%	.083%	1494.5	1505.5	1705 ppm
6400 pF	SLOW	.052%	.058%	6393.0	6407.0	500 ppm
----- Range 2 -----						
10 nF	SLOW	.051%	.055%	9.9884	10.011	200 ppm
25 nF	SLOW	.05%	.052%	24.975	25.025	200 ppm
25 nF	MED	.10%	.052%	24.962	25.038	500 ppm
25 nF	FAST	.25%	.052%	24.925	25.075	1200 ppm
100 nF	SLOW	.05%	.051%	99.900	100.10	200 ppm
----- Range 3 -----						
200 ppm	SLOW	.05%	.05%	199.80	200.20	200 ppm
400 nF	SLOW	.05%	.05%	399.60	400.40	200 ppm
400 nF	MED	.10%	.05%	399.40	400.60	500 ppm
400 nF	FAST	.25%	.05%	398.80	401.20	1200 ppm
1000 nF	SLOW	.05%	.05%	999.00	1001.0	200 ppm

*These ranges of acceptable displays are based on specified accuracy of decade capacitor, recently calibrated. If the capacitor values are known to higher accuracy by special calibration or lesser accuracy because of long-term drift, the acceptable RLC max and min criteria must be revised accordingly.

**Based on D values stated in GenRad documentation for the type 1413 decade capacitor. If capacitor D values are known more accurately, the acceptable QDR display criteria can be reduced accordingly.

Table 5-9
CAPACITANCE ACCURACY CHECKS (RANGE 4)

Capacitor Setting	Digibridge Accuracy	St'd C Accuracy	RLC Display (Uncorrected)		RLC Display Correction (See text)	Acceptable D	
			Min	Max		Min	Max
1 uF	--	--	(Used to determine K)			.0085	.0115
10 uF	.055%	.07%	9.987	10.013	+10K	.0085	.0115
100 uF	.10%	.07%	99.83	100.17	+100K	.0085	.0115

5.8.3. Capacitance Measurement Accuracy (Large C, Range 4)

This procedure follows after paragraph 5.8.2. (Leave the test frequency at 1 kHz, the measure rate SLOW, the selected parameter C/D, and the RANGE HELD indicator NOT lit.)

a. Connect the 1657-9600 extender cable (with banana plugs) to the Digibridge test fixture. Hand-tighten the screws, to provide the ground (guard) connection.

b. Connect the "high" leads (red and red/white) together. Separately connect the "low" leads (black and black white) together.

c. Before measurement, zero the Digibridge as follows:

Open Circuit.

Leave the high (red) banana plug stack disconnected from the low (black) stack

Press [FUNCTION] key (if necessary) to select MEASURE.

Press [MEASURE MODE] key (if necessary) to select TRIGGERED mode.

Press these keys deliberately: [1] [6] [9] [2] [=] [SHIFT] [OPEN].

Confirm that the GO indicator is lit.

Keep hands and objects at least 10 cm (4 in.) from test fixture.

Press the START button.

Wait for the GO indicator to be lit. The RLC display should be .00000 pF.

Short Circuit.

Connect the two banana plug stacks together; leave the guard (black/green) open.

Press these keys deliberately: [1] [6] [9] [2] [=] [SHIFT] [SHORT].

Confirm that the GO indicator is lit.

Press the START button.

Wait for the GO indicator to be lit. The RLC display should be .00000 ohms.

Press the [MEASURE MODE] key to select CONT.

d. Connect the three-terminal 1-uF capacitance standard (GR 1409- Y) as follows. This standard should be certified to an accuracy of +/- .03% including the effects of aging.

RED,	IH: capacitor H binding post
RED & WHITE	PH: stacked on the red banana plug
BLACK	IL: capacitor L binding post
BLACK & WHITE	PL: stacked on the black banana plug
BLACK & GREEN	G : capacitor G, NOT linked to L

e. Verify that the RLC display agrees with the certified value of the standard (corrected for temperature if appropriate) within +/- .0008 uF which is the sum of .03% for the standard and 0.05% for the Digibridge.

f. Calculate the difference D1, as follows, and retain it for future use

$$D1 = (\text{displayed measurement}) - (\text{value of standard}) \text{ uF}$$

g. Remove the 1-uF standard and connect the 4-terminal ratio-type capacitance standard (GR 1417) and the blocking capacitor (500 uF) as follows. Be sure that the dc blocking capacitor is fully discharged before connecting it. Notice that only the left-hand terminals of the standard are used.

RED,	IH: + end of blocking capacitor
-end of blocking cap:	CURRENT H terminal of capacitance standard
RED & WHITE,	PH: POTENTIAL H terminal of capacitance standard
BLACK	IL: CURRENT L terminal of capacitance standard
BLACK & WHITE,	PL: POTENTIAL L terminal of capacitance standard
BLACK & GREEN,	G : uninsulated terminal of capacitance standard

h. Set the dials on the capacitance standard thus:

CAPACITANCE: 1 uF
 TEST FREQUENCY: 1 kHz

NOTE

For detailed information on the GR 1417 4-Terminal Capacitance Standard, refer to its instruction manual.

i. Read the RLC display, which should be close to the nominal value of the standard: 1 uF.

j. Calculate the difference D2, as follows, and retain it for future use

$$D2 = (1.0000 \text{ uF}) - (\text{displayed measurement}) \quad \text{uF}$$

NOTE: The DQ display should show D = .0085 to .0115.

k. Calculate the calibration factor K as follows.

$$K = D1 + D2 \quad (\text{uF})$$

Example. Suppose that in step e, the display is 1.0013, and the value of the standard is 1.0006; then $D1 = +.0007$ uF. In step i, the nominal is 1.0000; suppose that the display is 1.0024; then $D2 = -.0024$ uF. The correction K would therefore be:

$$+.0007 - .0024 = -.0017 \text{ (uF).}$$

1. Reset the capacitance-standard dial to: CAPACITANCE = 10 uF.

m. Read the RLC display and correct it by adding 10K. (For example, if the display is 10.023 uF and if $K = -.0017$, the corrected measurement is 10.006 uF.) Verify that the corrected measurement is within the acceptable extremes for the 10-uF setting in Table 5-9.

n. Reset the capacitance-standard dial to: CAPACITANCE = 100 uF. Read the RLC display and correct it by adding 100K. As in step m, verify that the corrected measurement is within the acceptable extremes shown in Table 5-9.

Table 5-10
RESISTANCE ACCURACY CHECKS (at 1 kHz)

Standard Resistor Setting	Equivalent Circuit	Measure Rate	Typical Standard Accuracy*	Digibridge Accuracy	RLC Display Acceptable Extremes*
10.00 ohms	Series	SLOW	.03%	.06%	9.991 to 10.000
25.00 ohms	Series	SLOW	.018%	.054%	24.982 to 25.018
25.00 ohms	Series	MED	.018%	.108%	24.968 to 25.036
25.00 ohms	Series	FAST	.018%	.27%	24.928 to 25.072
90.00 ohms	Series	SLOW	.012%	.051%	89.943 to 90.050
200.0 ohms	Series	SLOW	.011%	.05%	199.88 to 200.12
400.0 ohms	Series	SLOW	.01%	.05%	399.76 to 400.24
400.0 ohms	Series	MED	.01%	.10%	399.56 to 400.44
400.0 ohms	Series	FAST	.01%	.25%	398.96 to 401.01
1500 ohms	Parallel	SLOW	.01%	.05%	1499.1 to 1500.9
2000 ohms	Parallel	SLOW	.01%	.05%	1998.8 to 2001.2
6400 ohms	Parallel	SLOW	.01%	.05%	6396.2 to 6403.8
6400 ohms	Parallel	MED	.01%	.10%	6393.0 to 6407.0
6400 ohms	Parallel	FAST	.01%	.25%	6383.4 to 6416.6
24 kilohms	Parallel	SLOW	.01%	.05%	23.986 to 24.014
30 kilohms	Parallel	SLOW	.01%	.05%	29.982 to 30.018
100 kilohms	Parallel	SLOW	.01%	.055%	99.93 to 100.07
100 kilohms	Parallel	MED	.01%	.11%	99.88 to 100.12
100 kilohms	Parallel	FAST	.01%	.275%	99.71 to 100.29

* If the calibrated value of the resistance standard is slightly different from the nominal value, or if the standard's accuracy is different from the typical accuracy, correct the "acceptable extremes" accordingly.

5.8.4 Resistance Measurement Accuracy

This procedure follows after paragraph 5.8.3. (Thus, test frequency = 1 kHz, measure rate = SLOW, range held indicator is NOT lit, and parameter C/D is specified.)

a. With the Digibridge still connected to the 1657-9600 extender cable, connect its banana plugs to the 1433-H Decade Resistor as follows:

- "high" leads (red and red/white) to the H binding post
- "low" leads (black and black/white) to the L binding post
- guard lead (black/green) to the G binding post.
- Disconnect** any link between the G and L binding posts.

- b. Set the decade resistor dials to 00000 ohms.

Press the [R/Q] key.

Press [MEASURE MODE] key to select TRIGGERED.

Press these keys deliberately: [1] [6] [9] [2] [=] [SHIFT] [SHORT].

Confirm that the GO indicator is lit. Press the START button.

Wait for the GO indicator to be lit again. The RLC display should be .00000 ohms.

Press [MEASURE MODE] key to select CONT.

- c. Refer to Table 5-10. Set the decade resistor dials to 0000010, as indicated in the first line of the table and verify that the RLC display is between the extremes listed. Repeat for each line of the table, setting the decade resistor dials, Digibridge equivalent circuit, and measurement rate, and verifying the results, as tabulated.

5.8.5 Inductance Measurement Accuracy

This procedure follows after paragraph 5.8.4. (Thus, test frequency=1 kHz, measure rate=SLOW, range held indicator is NOT lit, and parameter R/Q is specified.)

- a. Connect the 1657-9600 extender cable to the Digibridge test fixture. Hand tighten the screws, to provide ground (guard) connection.

- b. Connect the "high" leads (red and red/white) together and separately connect the "low" leads (black and black/white) together.

- c. Before measurement, zero the Digibridge as follows:

Open Circuit.

Keep the "high" banana-plug stack separated from the "low" stack.

Press [FUNCTION] key (if necessary) to select ~URE function.

Press [MEASURE MODE] key (if necessary) to select TRIGGERED mode.

Press these keys deliberately: [1] [6] [9] [2] [=] [SHIFT] [OPEN].

Confirm that the GO indicator is lit.

Keep hands and objects at least 10 cm (4 in.) from test fixture.

Press the START button.

Wait for the GO indicator to be lit again. The RLC display should be .00000 ohms

Short Circuit.

Connect the 2 banana plug stacks together, leave the guard (black/green) open.

Press these keys deliberately: [1] [6] [9] [2] [=] [SHIFT] [SHORT].

Confirm that the GO indicator is lit.

Press the START button.

Wait for the GO indicator to be lit again. The RLC display should be .00000 ohms

Press the [MEASURE MODE] key to select CONT.

Table 5-11
INDUCTANCE ACCURACY CHECKS (at 1 kHz)

Standard Inductor	Range	Measure Rate	Digibridge Accuracy	Typical Standard Accuracy	RLC Display* Acceptable Extremes	Expected Q**
1 mH	4	SLOW	.06%	0.1%	.9984 to 1.0016	7.5
		MED	.12%	0.1%	.9978 to 1.0022	---
		FAST	.30%	0.1%	.9960 to 1.0040	---
100 mH	3	SLOW	.05%	0.1%	99.85 to 100.15	7.5
		MED	.10%	0.1%	99.80 to 100.20	---
		FAST	.25%	0.1%	99.65 to 100.35	---
1 H	2	SLOW	.05%	0.1%	.9985 to 1.0015	10
		MED	.10%	0.1%	.9980 to 1.0020	---
		FAST	.25%	0.1%	.9965 to 1.0035	---
10 H	1	SLOW	.055%	0.1%	9.984 to 10.016	10
		MED	.11%	0.1%	9.979 to 10.021	---
		FAST	.275%	0.1%	9.962 to 10.038	---

* These ranges of acceptable displays are based on specific accuracy of decade inductors, recently calibrated. If the inductance values are known to higher accuracy by special calibration or lesser because of long-term drift, the "acceptable RLC extremes" must be revised accordingly.

** Based on Q of Type 1482 Standard Inductor, as stated in GenRad documentation. If inductor Q values are known more accurately, the Q can be checked to tighter tolerances.

d. Connect the banana plugs of the 1687-9600 extender cable to the 1-mH inductance standard (1482-E) as follows:

- "high" leads (red and red/white) to the LOW binding post
- "low" leads (black and black/white) to the HIGH binding post
- Guard lead (black/green) hanging free.
- Disconnect any link between ground and LOW binding posts.

e. Press the [L/Q] key to select inductance parameter. Press the [EQUIVALENT CIRCUIT] key (if necessary) to select SERIES.

f. Refer to Table 5-11 and verify that the RLC display is between the extremes listed for 1 mH, SLOW measurement rate (first line of table).

g. Similarly, with the other inductance standards (1 mH, 100 mH, 1 H, and 10 H), as indicated in the Standard Inductor column, and with the indicated measurement rate, verify that the RLC display is acceptable for each line of the table, for ranges 4, 3, 2, and 1.

5.8.6 D-Measurement Accuracy

Verify D-measurement accuracy with the following procedure. Dissipation-factor checks will be made using series equivalent circuit, with corresponding connections of resistance and capacitance standards.

This procedure follows after paragraph 5.8.5. (Thus, test frequency = 1 kHz, measure rate = SLOW, range held indicator is NOT lit, and parameter L/Q is specified.)

a. Connect the 1657-9600 extender cable to the Digibridge test fixture. Hand tighten the screws, to provide ground (guard) connection.

b. Connect the "high" leads (red and red/white) together and separately connect the "low" leads (black and black/white) together.

c. Press [SHIFT] [FREQUENCY] repeatedly to select 100 Hz.

d. Before measurement, zero the Digibridge as follows:

Open Circuit.

Keep the "high" banana-plug stack separated from the "low" stack.

Press [FUNCTION] key (if necessary) to select MEASURE function.

Press [MEASURE MODE] key (if necessary) to select TRIGGERED mode.

Press these keys deliberately: [1] [6] [9] [2] [=] [SHIFT] [OPEN].

Confirm that the GO indicator is lit.

Keep hands and objects at least 10 cm (4 in.) from test fixture.

Press the START button.

Wait for the GO indicator to be lit again. The RLC display should be .00000 pF.

Short Circuit.

Connect the 2 banana plug stacks together, leave the guard (black/green) open.

Press these keys deliberately: [1] [6] [9] [2] [=] [SHIFT] [SHORT].

Confirm that the GO indicator is lit.

Press the START button.

Wait for the GO indicator to be lit again. The RLC display should be .00000 ohms.

Press the [MEASURE MODE] key to select CONT.

e. Using the extender cable and plain bus wire, connect the decade R and C standards in series, as DUT to the Digibridge, as shown in Figure 5-12 and tabulated below.

RED, I+: stack on P+
 RED & WHITE, P+: resistor H
 BLACK, I-: stack on P
 BLACK & WHITE, P-: capacitor L
 BLACK & GREEN, G: resistor G, capacitor G
 (suitably connected together with a link and/or bus wire).

Also connect with a short jumper from resistor L to capacitor H.

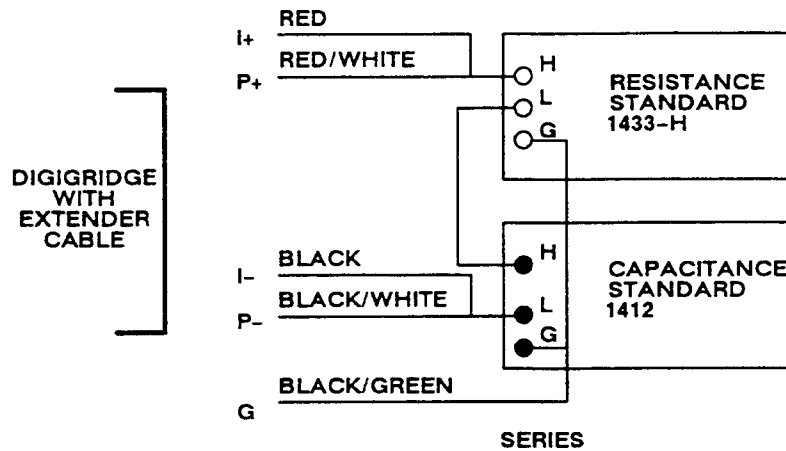

60042.0

Figure 5-12. Series connections of standards for D accuracy checks.

f. Confirm or select measurement conditions on the Digibridge thus:

DISPLAY	-VALUE
MEASURE RATE	-SLOW
EQUIVALENT CIRCUIT	-SERIES
FREQUENCY	-100 Hz
MEASURE MODE	-CONT
HOLD RANGE	-autorange
Parameter	-C/D
EXT BIAS	-OFF

g. Set the resistance and capacitance standards to the values given in line 1 of Table 5-12. Verify that the DQ display is within the range given, inclusive. Lock in this range on the 1692 by pressing [SHIFT] [HOLD RNG].

Table 5-12
SERIES CIRCUIT D-ACCURACY CHECK

Resistance Standard	Standard (100 Hz)	DQ Display
50 Ω	0.1592 μ F*	.0046 to .0054
100 Ω	same*	.0096 to .0104
500 Ω	same*	.0496 to .0504
1 k Ω	same*	.0996 to .1006
5 k Ω	same*	.4995 to .5005
10 k Ω	same*	.9994 to 1.001
50 k Ω	same*	4.992 to 5.008
90 k Ω	same*	8.975 to 9.025

* Set the capacitance standard to obtain, on the RLC readout, the tabulated capacitance.

h. Continue down the table, verifying each line. Because the capacitance in the series equivalent circuit is different from the decade capacitor setting when the series resistance is large, use the RLC readout to indicate capacitance in those lines of the table.

5.8.7 Limit Comparison Bins

Verify the Digibridge performance with regard to limit comparison and bin assignments as follows. The resistance standard 1433-H (Figure 5-12) or equivalent is required for this test.

a. Confirm or select measurement conditions on the Digibridge as listed:

FUNCTION	- ENTER
DISPLAY	- VALUE
MEASURE RATE	- SLOW
EQUIVALENT CIRCUIT	- SERIES
FREQUENCY	- 1 kHz (Select by repeatedly pressing [SHIFT] [FREQUENCY] if necessary.)
MEASURE MODE	- CONT
Range	- Select range 3 by repeatedly pressing R/Q for the first k Ω range and then press [SHIFT] [HOLD RNG] if necessary to hold.
EXT BIAS	- OFF

b. Connect the 1657-9600 extender cable from the Digibridge as follows:

"high" leads (red and red/white) to resistor H
 "low" leads (black and black/white) to resistor L
 "ground lead" (black/green) to resistor G

c. Refer to Table 5-13. After making the sequence of keystrokes (using the appropriate limit entry keys) shown under "Entry", verify that the Digibridge numerical displays are like the numbers tabulated in the same row of the table under "Displays". Make all entries as tabulated.

Table 5-13
ENTRY OF LIMITS

Entry	RLC Display	DQ Display
(none)	(blank)	(blank)
5 [=] [SHIFT] [NOM VALUE]	5.0000	(blank)
. [1] [=] [SHIFT] [BIN No.] [0]	(blank)	.1000
1 [%] [=] [SHIFT] [BIN No.] [1]	5.0500	4.950
2 [%] [=] [SHIFT] [BIN No.] [2]	5.1000	4.900
3 [%] [=] [SHIFT] [BIN No.] [3]	5.1500	4.850
4 [%] [=] [SHIFT] [BIN No.] [4]	5.2000	4.800
5 [%] [=] [SHIFT] [BIN No.] [5]	5.2500	4.750
6 [%] [=] [SHIFT] [BIN No.] [6]	5.3000	4.700
7 [%] [=] [SHIFT] [BIN No.] [7]	5.3500	4.650
8 [%] [=] [SHIFT] [BIN No.] [8]	5.4000	4.600

d. Select on the Digibridge:

FUNCTION	-MEASURE
DISPLAY	-BIN NO.

e. Refer to Table 5-14. For each setting of the resistance standard, verify that the DQ display is blank, the bin (RLC) display is a single digit as tabulated, and the GO/NO-GO lights work as tabulated.

Table 5-14
BIN ASSIGNMENT CHECK

Resistance Standard Set To	GO/NO-GO	Bin Display
5000 Ω	GO	1
5057 Ω	GO	2
5107 Ω	GO	3
5157 Ω	GO	4
5207 Ω	GO	5
5257 Ω	GO	6
5307 Ω	GO	7
5357 Ω	GO	8
5407 Ω	NO-GO	9
0000 Ω	NO-GO	0
5000 Ω	GO	1

NOTE

When the handler interface option is present, the bin signal lines can be checked with a scope (during the above procedure) to verify their logic "low" state. Refer to the interface option schematic in Section 6.

5.9 RECALIBRATION

5.9.1 Preparation

Introduction. This service procedure requires a set of external calibration resistors whose R and Q values are exactly known (see table in next paragraph). After recalibration, the Digibridge retains in RAM the corrections that the microprocessor needs to compensate for the small errors in the actual values of the internal standard resistor parameters. (Therefore, the Digibridge calculates its measurement results correctly, accomplishing by calculation the same result that would be obtained if the recalibration process actually trimmed the internal standards exactly to their nominal v.a.lues.)

Required Equipment. Refer to Table 5-15.

Table 5-15
EQUIPMENT FOR RECALIBRATION

GenRad No.	Description	Requirements
---	Temperature stabilized room	23 degrees C (73.4 F) recommended
1689-9604	Kit of four calibration resistors with nominal resistances of 24.9, 374 ohms; 5.97, 95.3 kilohms, and calibration "open" and "short".	R and Q values known at 1 kHz, R accuracy +/- .002%, calibration traceable to NBS; Q calibrated to +/- 25 ppm. *

* Refer to calibration certificate (Form No. 1689-8204) supplied with the kit.

Procedure.

- a. Remove any adaptor that may be in the test fixture. Inspect the Digibridge test fixture for cleanliness. If it is dirty or if it is scheduled for periodic cleaning soon, clean the test fixture as described in paragraph 5.6.
- b. Place all equipment including the Digibridge(s) to be recalibrated in the temperature stabilized room, normally at 23 degrees C.
- c. Switch Digibridge(s) ON and allow it to stabilize at room temperature for at least two hours. Leave the Digibridge test conditions at the defaults.

5.9.2 Zeroing

This zeroing procedure is like the routine procedure in Operation, Section 3. In this process, the Digibridge automatically measures stray parameters related to the test fixture and associated circuits and retains the data, which it uses in each recalibration step below to correct measurements so that results most accurately represent

parameters of the external calibration resistor alone.

Open Circuit.

- a. Press [FUNCTION] key (if necessary) to select MEASURE mode.
Press [MEASURE MODE] key (if necessary) to select TRIGGERED mode.
- b. Be sure that the test fixture is open circuited.
- c. Press these keys: [1] [6] [9] [2] [=] [SHIFT] [OPEN]. (A zero in each, left and right displays, and the GO indicator should be lit, confirming this step.)
- d. Keep hands and objects at least 10 cm (4 in.) from test fixture.
- e. Press the START button. The GO indication disappears.
- f. Wait for the GO indicator to be lit again (approximately 10 seconds).

Short Circuit.

- a. Short the fixture with a very low-resistance "short circuit".
- b. Press the keys: [1] [6] [9] [2] [=] [SHIFT] [SHORT]. (A 5 in each, left and right displays, and the GO indicator should be lit, confirming this step.) Keep away from test fixture, as in step d above.
- c. Press the START button. The GO indication disappears.
- d. Wait for the GO indicator to be lit again (approximately 10 seconds). The RLC display should be .00000 (ohms or mH).
- e. Disconnect the short circuit.

5.9.3 Recalibration for Range 4

- a. Connect the 24.9-ohm calibration resistor to the Digibridge test fixture.

b. Select ENTER with [FUNCTION] key and CONTINUOUS with [MEASURE MODE] key. To select range 4 first, sequence through all four ranges by depressing the R/Q key several times. Notice that the units LEDs will show 0 on two ranges (4 and 3) and k on the other two ranges (2 and 1). Stop on the first 0 range (i.e., as the units LED changes from kO to 0) this is range 4.

c. Enter the known parameters of the calibration resistor as in the following example, based on the values $R = 24.895$ ohms and $Q = 15$ ppm. (NOTES: The Digibridge will accept six digits for R, even though only five will be displayed. The Q is associated with "bin 0", and should be entered as an absolute value, 6 digits maximum and preceded with "-" if the known Q is negative. Although only 4 digits are shown, all 6 are used in the calibration.

Press [2] [4][.] [8][9] [5] [=] [SHIFT] [NOM VALUE]

NOTE: the calibration resistance value should appear in the left display.

Press [.] [0][0] [0][0] [1] [5] [=][SHIFT] [BIN NO][0]

NOTE: The calibration Q value (first 4 digits only, to the right of the decimal point) should appear in the right hand display.

d. Enable and execute the recalibration for this range as follows. (The following keystrokes are the same for any range.)

Select MEASURE with the [FUNCTION] key and TRIGGERED with [MEASURE MODE] key.

Press [1][6][9][2][=][1] [SHIFT] [CALIBRATE]

NOTE: The GO indicator being lit and a 6 in the left and a 6 in the right displays confirm that calibration is enabled.

Press START (The GO indicator remains unlit while calibration proceeds.) Keeping hands away from the test fixture, wait until the GO indicator is lit again. This completes recalibration of one range.

e. Check as follows that the Digibridge operates properly with the recalibration.

Select CONTINUOUS with the [MEASURE MODE] key. The Digibridge should measure the calibration resistor like any ordinary resistor and display its Rand Q values. The Q display should indicate . Also, the NO-GO indicator will probably be lit; this is normal.

f. Disconnect the calibration resistor from the test fixture.

5.9.4 Recalibration for Range 3

a. Connect the 374-ohm calibration resistor to the Digibridge test fixture.

b. Select ENTER with [FUNCTION] key and verify that measure mode is CONT. Press the R/Q key and sequence to the second 11 range (as discussed in paragraph 5.9.3) this is range 3.

c. Enter the known parameters of the calibration resistor as in the following example, based on the values R = 374.06 ohms and Q = 5 ppm. (NOTES: The Digibridge will accept six digits for R, even though only five will be displayed. The Q is associated with "bin 0", and should be entered as an absolute value again.

Press [3] [7] [4] [.] [0] [6] [=] [SHIFT] [NOM VALUE]

NOTE: the calibration resistance value should appear in the left display.

Press [.] [0] [0][0] [0] [0] [5] [=] [SHIFT] [BIN NO][0]

NOTE: The calibration Q value (first 4 digits only) should appear in the right hand display.

d. Enable and execute the recalibration for this range as follows. (The following keystrokes are the same for any range.)

Select MEASURE with the [FUNCTION] key and TRIGGERED with [MEASURE MODE] key.

Press [1][6][9][2][=][1][SHIFT][CALIBRATE]

NOTE: The GO indicator being lit and a 6 in the left and a 6 in the right displays confirm that calibration is enabled.

Press START (The GO indicator remains unlit while calibration proceeds.) Keeping hands away from the test fixture, wait until the GO indicator is lit again. This completes recalibration of one range.

e. Check as follows that the Digibridge operates properly with the recalibration.

Select CONTINUOUS with the [MEASURE MODE] key. The Digibridge should measure the calibration resistor like any ordinary resistor and display its R and Q values. The Q display should indicate . Also, the NO-GO indicator will probably be lit; this is normal.

f. Disconnect the calibration resistor from the test fixture.

5.9.5 Recalibration for Range 2

a. Connect the 5.97-kilohm calibration resistor to the Digibridge test fixture.

b. Select ENTER with [FUNCTION] key and verify that measure mode is CONT. Press the R/Q key and sequence to the first k range (as discussed in paragraph 5.9.3) this is range 2.

c. Enter the known parameters of the calibration resistor as in the following example, based on the values R = 5.9581 kilohms and Q = -22 ppm. (NOTES: The Digibridge will accept six digits for R, even though only five will be displayed. The Q is associated with "bin 0", and should be entered as an absolute value again.

Press [5][.][9][5][8][1][=][SHIFT][NOM VALUE]

NOTE: The calibration resistance value should appear in the left display.

Press [-][.][0][0][0][0][2][2][=][SHIFT][BIN NO][0]

NOTE: The calibration Q value (first 4 digits only) should appear in the right hand display.

d. Enable and execute the recalibration for this range as follows. (The following keystrokes are the same for any range.)

Select MEASURE with the [FUNCTION] key and TRIGGERED with [MEASURE MODE] key.

Press [1][6][9][2][=][1][SHIFT][CALIBRATE]

NOTE: The GO indicator being lit and a 6 in the left and a 6 in the right displays confirm that calibration is enabled.

Press START (The GO indicator remains unlit while calibration proceeds.) Keeping hands away from the test fixture, wait until the GO indicator is lit again. This completes recalibration of one range.

e. Check as follows that the Digibridge operates properly with the recalibration.

Select CONTINUOUS with the [MEASURE MODE] key.

The Digibridge should measure the calibration resistor like any ordinary resistor and display its R and Q values. The display should indicate . Also, the NO-GO indicator will probably be lit; this is normal.

f. Disconnect the calibration resistor from the test fixture.

5.9.6 Recalibration for Range 1

a. Connect the 95.3-kilohm calibration resistor to the Digibridge test fixture.

b. Select ENTER with [FUNCTION] key and verify that measure mode is CONT. Press the R/Q key and sequence to the second kΩ range (as discussed in paragraph 5.9.3) this is range 1.

c. Enter the known parameters of the calibration resistor as in the following example, based on the values R = 94.986 kilohms and Q = -280 ppm. (NOTES: The Digibridge will accept six digits for R, even though only five will be displayed. The Q is associated with "bin 0", and should be entered as an absolute value again.)

Press [9][4][.] [9] [8][6] [=] [SHIFT] [NOM VALUE]

NOTE: The calibration resistance value should appear in the left display.

Press [-][.] [0] [0][0] [2][8] [0] [=][SHIFT] [BIN NO] [0]

NOTE: The calibration Q value (first 4 digits only) should appear in the right-hand display.

d. Enable and execute the recalibration for this range as follows. (The following keystrokes are the same for any range.)

Select MEASURE with the [FUNCTION] key and TRIGGERED with [MEASURE MODE] key.
Press [~~ENTER~~] [SHIFT] [CAL] [RATE]

NOTE: The GO indicator being lit and a 6 in the left and a 6 in the right displays confirm that calibration is enabled.

Press START (The GO indicator remains unlit while calibration proceeds.) Keeping hands away from the test fixture, wait until the GO indicator is lit again. This completes recalibration of one range.

e. Check as follows that the Digibridge operates properly with the recalibration.

Select CONTINUOUS with the [:MEASURE MODE] key.

The Digibridge should measure the calibration resistor like any ordinary resistor and display its Rand Q values.

The Q display can be expected to "jump" a bit. Also, the NO-GO indicator will probably be lit; this is normal.

f. Disconnect the calibration resistor from the test fixture.

5.10 INTERNAL SETTINGS

5.10.1 Address for IEEE-488 Interface

Each device (instrument) in a system linked by an IEEE-488 bus must have its own address (except in the simple case of a single "talker only" with one or more "listeners" that are always listening). The initial setting of address, provided by the factory, in the interface option of this Digibridge, is 00011. If the requirements of a system installation make it necessary to change the Digibridge address, use the following procedure. Refer to paragraph 2.8.4 for further comments and a table of possible addresses.

a. Remove the interface option, after removing the 2 large screws with resilient washers in the rear panel. See Figure 1-2.

CAUTION

Observe the handling precautions given at the beginning of the Service Section.

b. Find S2 which is located at the end of the interface option board, about 3 cm (1 in.) from the TALK switch SI. If S2 is covered, lift the cover off, exposing the "DIP" switch, which has 2 rows of 6 tiny square pads with numbers 1 thru 6 between the rows. The five device-dependent bits of the address are set by this switch.

c. Set in the desired bits as follows. To enter logical 1's, depress pads nearest the end of the board. To enter logical 0's, depress pads on the other side of the "DIP" switch, the side marked with a + sign. The address is read from 5 to 1 (not using 6). Thus, for example, to set up the address 00011, enter 0's at positions 5, 4, 3; enter 1's at positions 2, 1. (This makes the talk address "C" and the listen address "#".)

NOTE: Strictly speaking, the address includes more; S2 determines only the device-dependent bits of the address. You cannot choose talk and listen addresses separately, only as a pair. The list of possible pairs is shown in Table 2-3. In the above example, the remote message codes MLA and MTA are X0100011 and X1000011, respectively. Thus the listen address and the talk address are distinguished, although they contain the same set of device-dependent bits, which are set into S2.

d. Replace the interface option assembly in its former place. Reassembly note: align board edges carefully with connector and guide that are inside of instrument, while pushing interface option into position.

5.10.2 Making +5 Volts Available via the Handler Interface Connector

A five-volt low-power dc bus is normally brought out via pin 10 of the handler interface connector. This bus is useful to supply voltage for opto-couplers in a handler. NOTE: Do NOT attempt to draw more than 25 mA. The bus is connected via a factory-installed jumper, which is accessible as follows.

a. Remove the interface option, after removing the 2 large screws with resilient washers in the rear panel. See Figure 1-2.

CAUTION

Observe the handling precautions given at the beginning of the Service Section.

b. Find wire tie points WT2 and WT3, on the circuit board, near the handler interface connector.

c. If the jumper is missing, connect a wire jumper between WT2 and WT3.

d. Replace the interface option assembly in its former place. Reassembly note: align board edges carefully with connector and guide that are inside of instrument, while pushing interface option into position.

Parts Lists and Diagrams – Section 6

6.1	GENERAL	6-1
6.2	REFERENCE DESIGNATIONS	6-1
6.3	DIAGRAMS	6-3
Figure 6-1.	Front View, showing mechanical parts	6-2
Figure 6-2.	Rear View, showing mechanical parts	6-2
Federal Supply Code for Manufacturers		6-4
Figure 6-3.	Main Board, schematic sheet 1, 1689-4702-SD	6-5
Figure 6-4.	Main Board, layout sheet 1 . . . 1689-4702	6-5
Figure 6-5.	Main Board, layout sheet 2 . . . 1689-4702	6-7
Figure 6-6.	Main Board, schematic sheet 2, 1689-4702-SD	6-8
Figure 6-7.	Main Board, schematic sheet 3, 1689-4702-SD	6-9
Figure 6-8.	Main Board, schematic sheet 4, 1689-4702-SD	6-10
Figure 6-9.	Main Board, schematic sheet 5, 1689-4702-SD	6-11
Figure 6-10.	Main Board, schematic sheet 6, 1689-4702-SD	6-12
Figure 6-11.	Main Board, schematic sheet 7, 1689-4702-SD	6-12
Figure 6-12.	Power Supply, assembly 1689-2005	6-13
Figure 6-13.	Power Supply Board, layout 1657-4720	6-14
Figure 6-14.	Power Supply, schematic 1689-2005-SD	6-14
Figure 6-15.	Display Board, layout 1689-4705	6-15
Figure 6-16.	Display Board, schematic, sh1 . . . 1689-4705-2D	6-16
Figure 6-17.	Display Board, schematic, sh2 . . . 1689-4705-2D	6-17
Figure 6-18.	Interface Option Board, layout, 1658-4720- ID	6-18
Figure 6-19.	Interface Option, schematic, 1658-4720-2DA	6-19
Figure 6-20.	Keyboard Module, assembly 1687-4200	6-20
Figure 6-21.	Keyboard Indicators, detail 1687-4710-2D	6-20
Figure 6-22.	Keyboard, schematic 1687-4710-2D	6-21

6.1 GENERAL

This section contains the parts lists, circuit board layout drawings, and schematic diagrams for the instrument. Refer to Section 4 for the functional block diagram and Section 5 for further details about part locations.

6.2 REFERENCE DESIGNATIONS

Each electrical component part on an assembly is identified on the equipment and drawings by means of a reference designator comprised of letters and numbers. Component parts on a circuit board or assembly are classified by the letter or letters of the reference designators (R for resistor, C for capacitor, etc) and individually identified by the numerical part of the reference designator (R1 for the first resistor, R2 for the second, etc). Some of the less obvious designator letters are: DS or CR for indicator light, Q for transistor, U for integrated-circuit device, WT for wire tie point, J or P for connector, and Z for network.

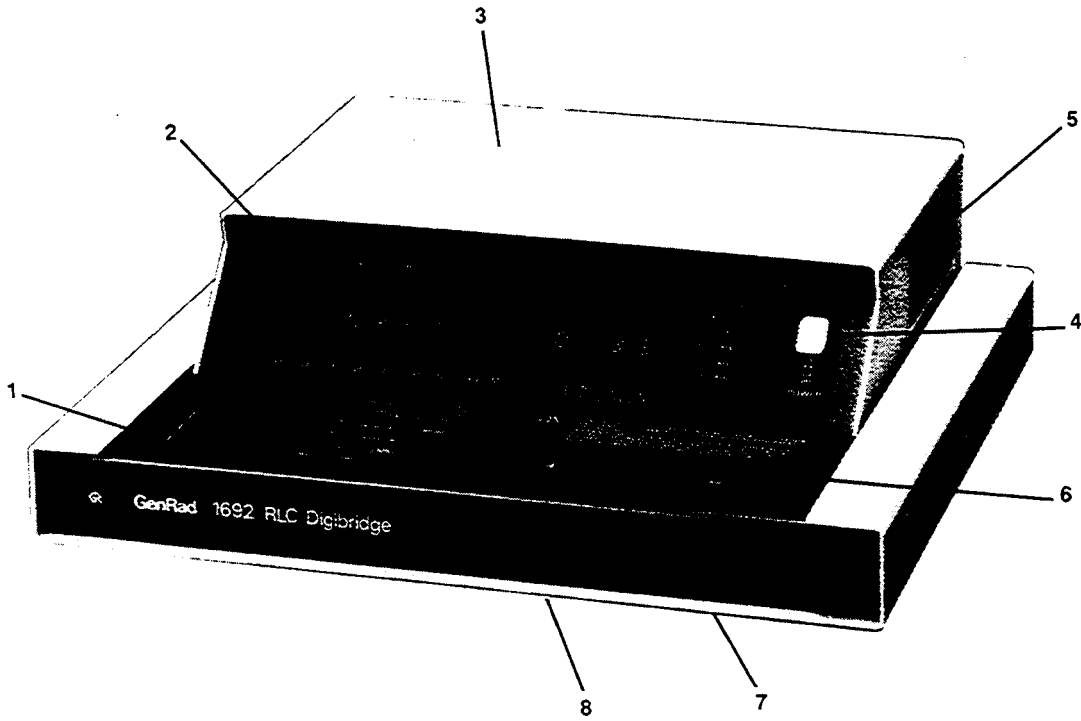

Figure 6-1. Front view of 1692, showing replaceable mechanical parts.

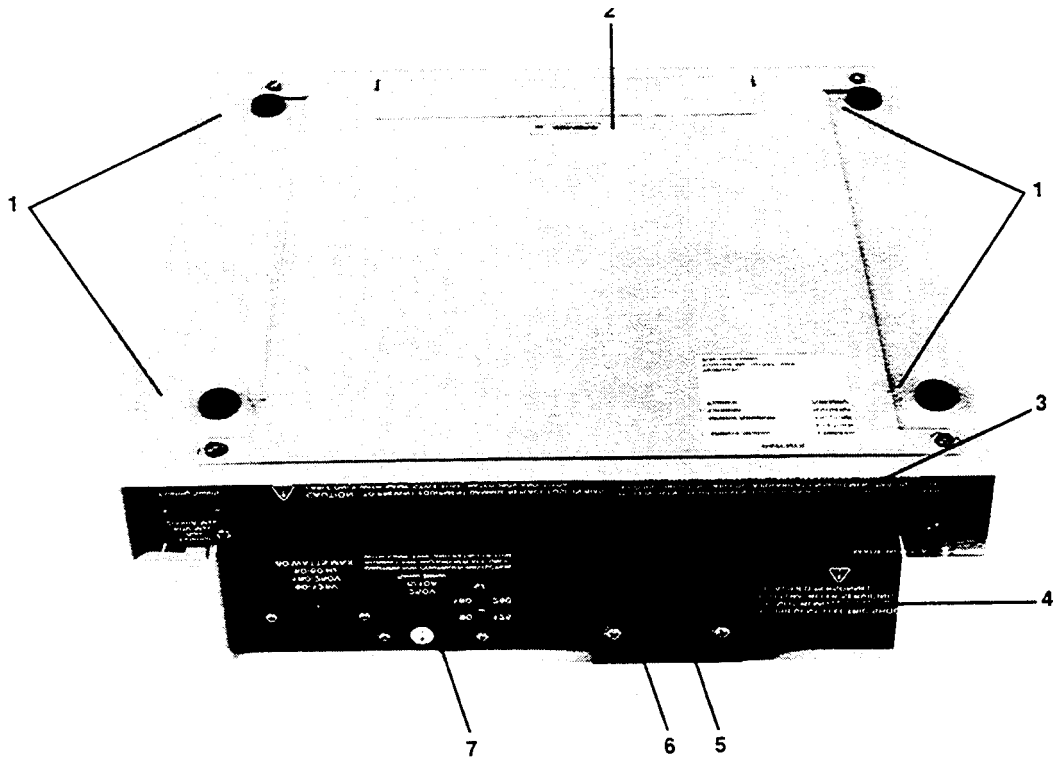

Figure 6-2. Rear view of 1692, showing replaceable mechanical parts.

MECHANICAL PARTS LIST FOR 1692 DIGIBRIDGE

FRONT (Figure 6-1)

Item	Description	GenRad Part	Mftr	Mftr Part No.
1	Keyboard top plate	1692-8040	24655	1692-8040
2	Display panel	1692-8000	24655	1692-8000
3	Top cover	1659-8003	24655	1659-8003
4	Switch actuator rod assembly	1659-8005	24655	1659-8005
5	Air filter (washable, dry type)	5155-1218	24655	5155-1218
6	Test fixture upper assembly (includes dross tray and and foamed plastic pad)	1689-2000 1657-7700 1657-7800	24655 24655 24655	1689-2000 1657-7700 1657-7800
-	Test fixture contacts (4 required; included on 1689-4702 board) each:	1689-1015	24655	1689-1015
7	Card Pan	1658-8200	24655	1658-8200
8	Instruction card	1692-0110	24655	1692-0110

REAR (Figure 6-2)

Item	Description	GenRad Part	Mftr	Mftr Part No.
1	Foot (4 required) each:	5260-2051	24655	5260-2051
2	Bottom shell (card pan not shown)	1657-8000	24655	1657-8000
3	IEEE/HANDLER interface option shown) Blank plate used if no option present:	1658-8040	24655	1658-8040
4	Power connector J101	4240-0250	82389	EAC-302
5	Fuse extractor post F1	5650-0100	75915	342-004
6	Line voltage switch S2	7910-0832	82389	11A-1266
7	Cover (over transistor U1)	1657-8120	24655	1657-8120

6.3 DIAGRAMS

In this section, the schematic diagrams are located on right-hand fold-out pages for convenience. The associated parts list, layout drawing, assembly view, etc. for each schematic diagram are located on the apron of the same page, the facing page, or otherwise nearby.

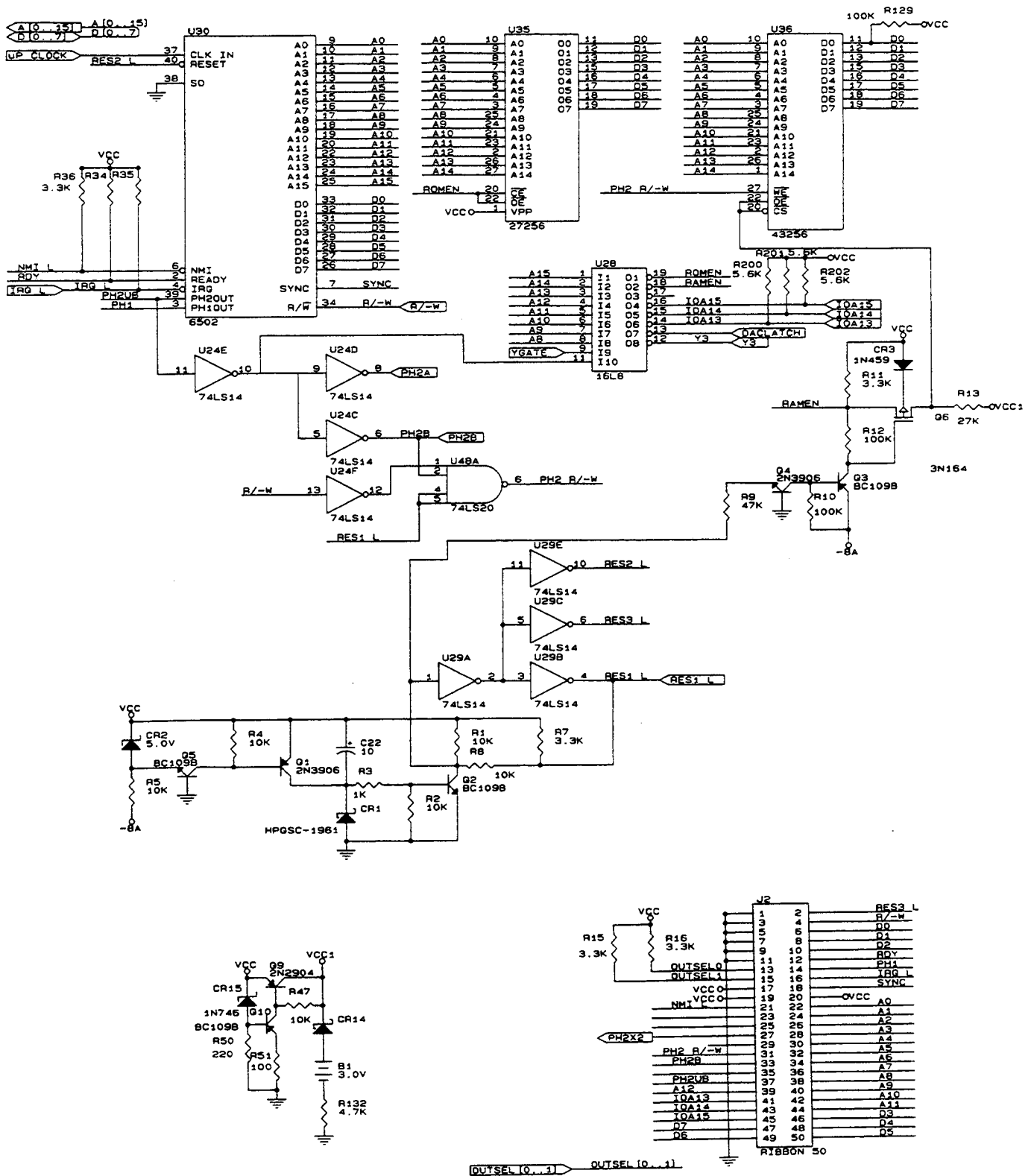
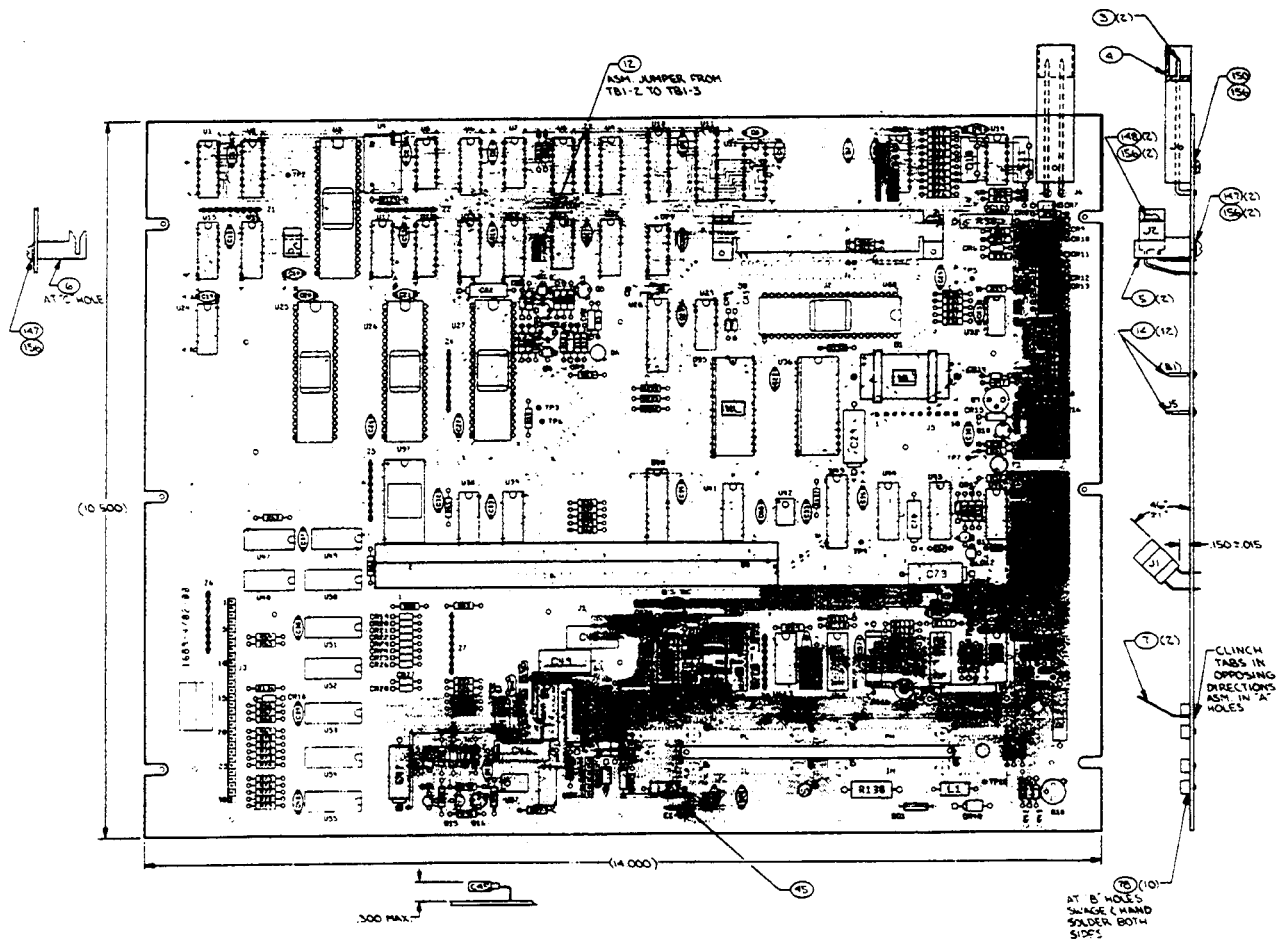

Figure 6-3. Main Board, schematic sheet 1, 1689-4702-SD



NOTES
1. BARE BOARD 1689-4702 REV. 01

2. BOARD VIEWED FROM COMPONENT SIDE (LAYER 1)

3. CIRCUITRY SHOWN REPRESENTS COMPONENT SIDE
CONTACT FINGERS, IF APPLICABLE, ARE TO BE
FREE OF SOLDER - ADIEM

S SQUARE PAD DENOTES THE FOLLOWING
POSITIVE TERMINALS OF CAPACITORS
ROTOR OF TRIP CAPACITORS
ARM OF POTENTIOMETERS
COLLECTOR OF TRANSISTORS
CATHODE END OF DIODES
PIN, OF OC'S, RELAYS, AND CONNECTORS

6. C-LEADS - ST BE A - OF 150
AWAY FROM EDGE OF BOARD

7. - BOW & TWIST N INCH/INCH'S 010
PER CSPC-0010-Q2

8. -IM- DENOTES B1 AND I,05 TO BE ASSEMBLED

AT TEXT LEVEL (IAB).

8. LAB MAY SELECT ANO-R VALUE FOR C71
AT TEXT LEVEL.

10. FOR MAX. C-NIT HEIGHT SEE
1688-G702-00-EL SHIT.2

Figure 6-4. Main Board, layout sheet 1, 1689-4702

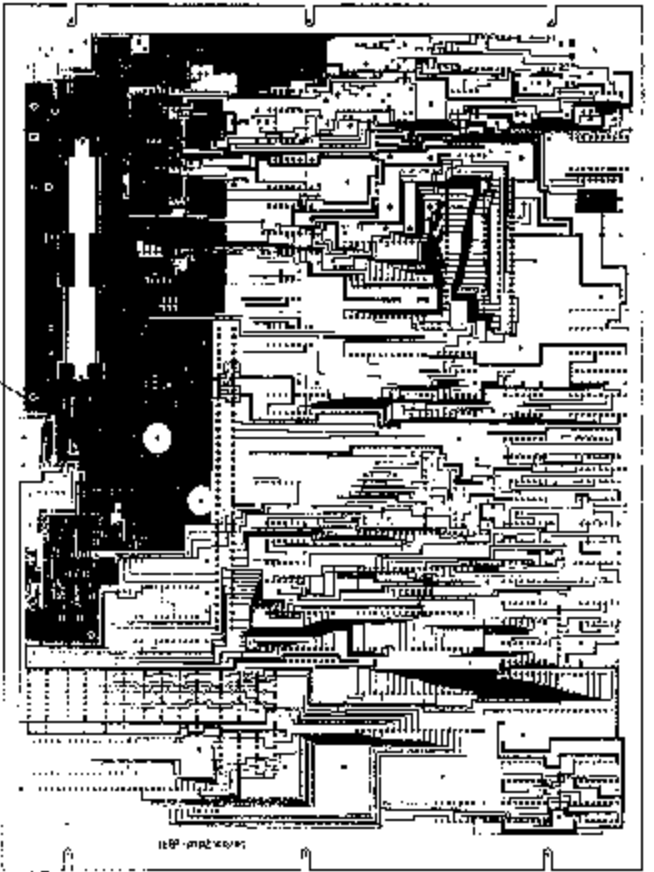

BOARD VIEWED FROM LAYER 2

Figure 8.5. Main Board, layout sheet 2, 1089-4102
PARTS LISTS AND DIAGRAMS 9-7

ELECTRICAL PARTS LIST

Item	Part Description	Part No.	Qty	Comp. Descr.
101	ANALOG AND CONTROL 3D	101-0100-00	1	
102	ANALOG AND CONTROL 3D	102-0100-00	1	
103	BASE TERMINAL	103-0100-00	1	
104	BASE TERMINAL	104-0100-00	1	
105	BASE TERMINAL	105-0100-00	1	
106	BASE TERMINAL	106-0100-00	1	
107	BASE TERMINAL	107-0100-00	1	
108	BASE TERMINAL	108-0100-00	1	
109	BASE TERMINAL	109-0100-00	1	
110	BASE TERMINAL	110-0100-00	1	
111	BASE TERMINAL	111-0100-00	1	
112	BASE TERMINAL	112-0100-00	1	
113	BASE TERMINAL	113-0100-00	1	
114	BASE TERMINAL	114-0100-00	1	
115	BASE TERMINAL	115-0100-00	1	
116	BASE TERMINAL	116-0100-00	1	
117	BASE TERMINAL	117-0100-00	1	
118	BASE TERMINAL	118-0100-00	1	
119	BASE TERMINAL	119-0100-00	1	
120	BASE TERMINAL	120-0100-00	1	
121	BASE TERMINAL	121-0100-00	1	
122	BASE TERMINAL	122-0100-00	1	
123	BASE TERMINAL	123-0100-00	1	
124	BASE TERMINAL	124-0100-00	1	
125	BASE TERMINAL	125-0100-00	1	
126	BASE TERMINAL	126-0100-00	1	
127	BASE TERMINAL	127-0100-00	1	
128	BASE TERMINAL	128-0100-00	1	
129	BASE TERMINAL	129-0100-00	1	
130	BASE TERMINAL	130-0100-00	1	
131	BASE TERMINAL	131-0100-00	1	
132	BASE TERMINAL	132-0100-00	1	
133	BASE TERMINAL	133-0100-00	1	
134	BASE TERMINAL	134-0100-00	1	
135	BASE TERMINAL	135-0100-00	1	
136	BASE TERMINAL	136-0100-00	1	
137	BASE TERMINAL	137-0100-00	1	
138	BASE TERMINAL	138-0100-00	1	
139	BASE TERMINAL	139-0100-00	1	
140	BASE TERMINAL	140-0100-00	1	
141	BASE TERMINAL	141-0100-00	1	
142	BASE TERMINAL	142-0100-00	1	
143	BASE TERMINAL	143-0100-00	1	
144	BASE TERMINAL	144-0100-00	1	
145	BASE TERMINAL	145-0100-00	1	
146	BASE TERMINAL	146-0100-00	1	
147	BASE TERMINAL	147-0100-00	1	
148	BASE TERMINAL	148-0100-00	1	
149	BASE TERMINAL	149-0100-00	1	
150	BASE TERMINAL	150-0100-00	1	
151	BASE TERMINAL	151-0100-00	1	
152	BASE TERMINAL	152-0100-00	1	
153	BASE TERMINAL	153-0100-00	1	
154	BASE TERMINAL	154-0100-00	1	
155	BASE TERMINAL	155-0100-00	1	
156	BASE TERMINAL	156-0100-00	1	
157	BASE TERMINAL	157-0100-00	1	
158	BASE TERMINAL	158-0100-00	1	
159	BASE TERMINAL	159-0100-00	1	
160	BASE TERMINAL	160-0100-00	1	
161	BASE TERMINAL	161-0100-00	1	
162	BASE TERMINAL	162-0100-00	1	
163	BASE TERMINAL	163-0100-00	1	
164	BASE TERMINAL	164-0100-00	1	
165	BASE TERMINAL	165-0100-00	1	
166	BASE TERMINAL	166-0100-00	1	
167	BASE TERMINAL	167-0100-00	1	
168	BASE TERMINAL	168-0100-00	1	
169	BASE TERMINAL	169-0100-00	1	
170	BASE TERMINAL	170-0100-00	1	
171	BASE TERMINAL	171-0100-00	1	
172	BASE TERMINAL	172-0100-00	1	
173	BASE TERMINAL	173-0100-00	1	
174	BASE TERMINAL	174-0100-00	1	
175	BASE TERMINAL	175-0100-00	1	
176	BASE TERMINAL	176-0100-00	1	
177	BASE TERMINAL	177-0100-00	1	
178	BASE TERMINAL	178-0100-00	1	
179	BASE TERMINAL	179-0100-00	1	
180	BASE TERMINAL	180-0100-00	1	
181	BASE TERMINAL	181-0100-00	1	
182	BASE TERMINAL	182-0100-00	1	
183	BASE TERMINAL	183-0100-00	1	
184	BASE TERMINAL	184-0100-00	1	
185	BASE TERMINAL	185-0100-00	1	
186	BASE TERMINAL	186-0100-00	1	
187	BASE TERMINAL	187-0100-00	1	
188	BASE TERMINAL	188-0100-00	1	
189	BASE TERMINAL	189-0100-00	1	
190	BASE TERMINAL	190-0100-00	1	
191	BASE TERMINAL	191-0100-00	1	
192	BASE TERMINAL	192-0100-00	1	
193	BASE TERMINAL	193-0100-00	1	
194	BASE TERMINAL	194-0100-00	1	
195	BASE TERMINAL	195-0100-00	1	
196	BASE TERMINAL	196-0100-00	1	
197	BASE TERMINAL	197-0100-00	1	
198	BASE TERMINAL	198-0100-00	1	
199	BASE TERMINAL	199-0100-00	1	
200	BASE TERMINAL	200-0100-00	1	

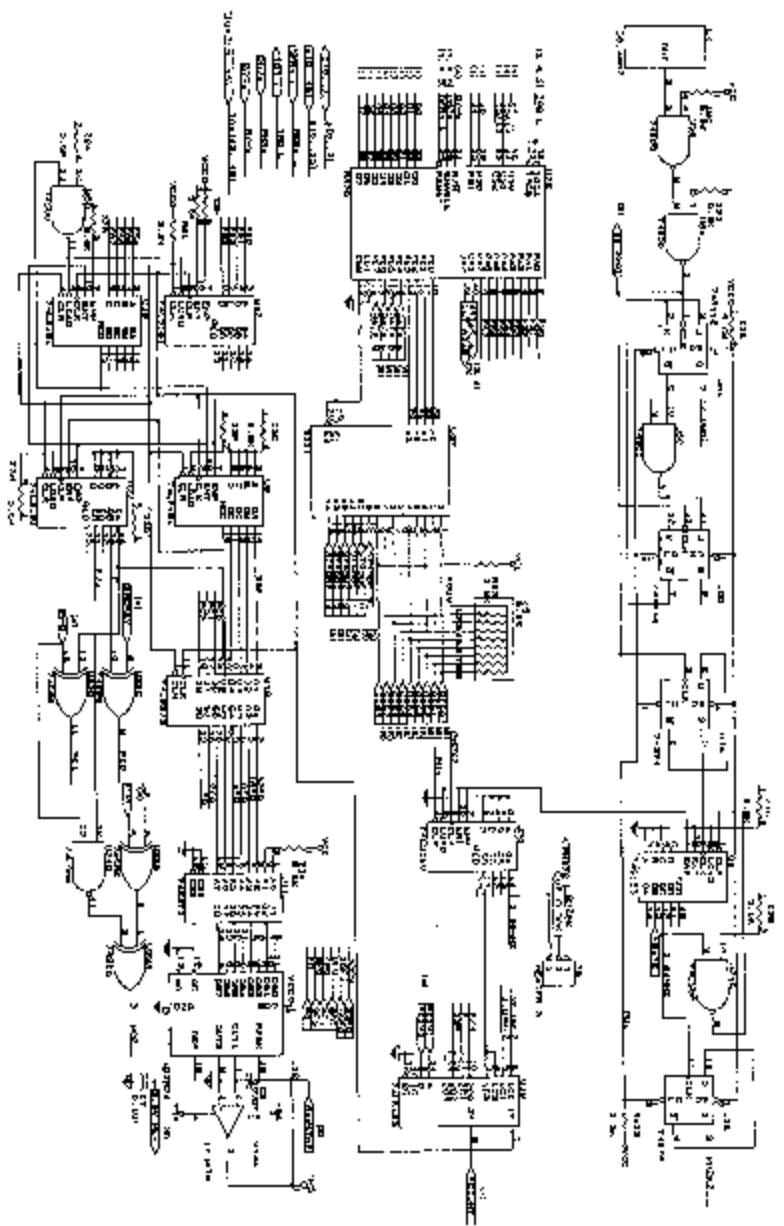

Figure 6-8. Main Board, schematic sheet 2, 1680-1702-8D
6-8 PARTS LIST AND DIAGRAMS

ELECTRICAL PARTS LISTS (CONT.)

Item Number	Item Description	Item No.	Comp. Subst.
70	Item Description		
71	Item Description		
72	Item Description		
73	Item Description		
74	Item Description		
75	Item Description		
76	Item Description		
77	Item Description		
78	Item Description		
79	Item Description		
80	Item Description		
81	Item Description		
82	Item Description		
83	Item Description		
84	Item Description		
85	Item Description		
86	Item Description		
87	Item Description		
88	Item Description		
89	Item Description		
90	Item Description		
91	Item Description		
92	Item Description		
93	Item Description		
94	Item Description		
95	Item Description		
96	Item Description		
97	Item Description		
98	Item Description		
99	Item Description		
100	Item Description		
101	Item Description		
102	Item Description		
103	Item Description		
104	Item Description		
105	Item Description		
106	Item Description		
107	Item Description		
108	Item Description		
109	Item Description		
110	Item Description		
111	Item Description		
112	Item Description		
113	Item Description		
114	Item Description		
115	Item Description		
116	Item Description		
117	Item Description		
118	Item Description		
119	Item Description		
120	Item Description		
121	Item Description		
122	Item Description		
123	Item Description		
124	Item Description		
125	Item Description		
126	Item Description		
127	Item Description		
128	Item Description		
129	Item Description		
130	Item Description		
131	Item Description		
132	Item Description		
133	Item Description		
134	Item Description		
135	Item Description		
136	Item Description		
137	Item Description		
138	Item Description		
139	Item Description		
140	Item Description		
141	Item Description		
142	Item Description		
143	Item Description		
144	Item Description		
145	Item Description		
146	Item Description		
147	Item Description		
148	Item Description		
149	Item Description		
150	Item Description		
151	Item Description		
152	Item Description		
153	Item Description		
154	Item Description		
155	Item Description		
156	Item Description		
157	Item Description		
158	Item Description		
159	Item Description		
160	Item Description		
161	Item Description		
162	Item Description		
163	Item Description		
164	Item Description		
165	Item Description		
166	Item Description		
167	Item Description		
168	Item Description		
169	Item Description		
170	Item Description		
171	Item Description		
172	Item Description		
173	Item Description		
174	Item Description		
175	Item Description		
176	Item Description		
177	Item Description		
178	Item Description		
179	Item Description		
180	Item Description		
181	Item Description		
182	Item Description		
183	Item Description		
184	Item Description		
185	Item Description		
186	Item Description		
187	Item Description		
188	Item Description		
189	Item Description		
190	Item Description		
191	Item Description		
192	Item Description		
193	Item Description		
194	Item Description		
195	Item Description		
196	Item Description		
197	Item Description		
198	Item Description		
199	Item Description		
200	Item Description		

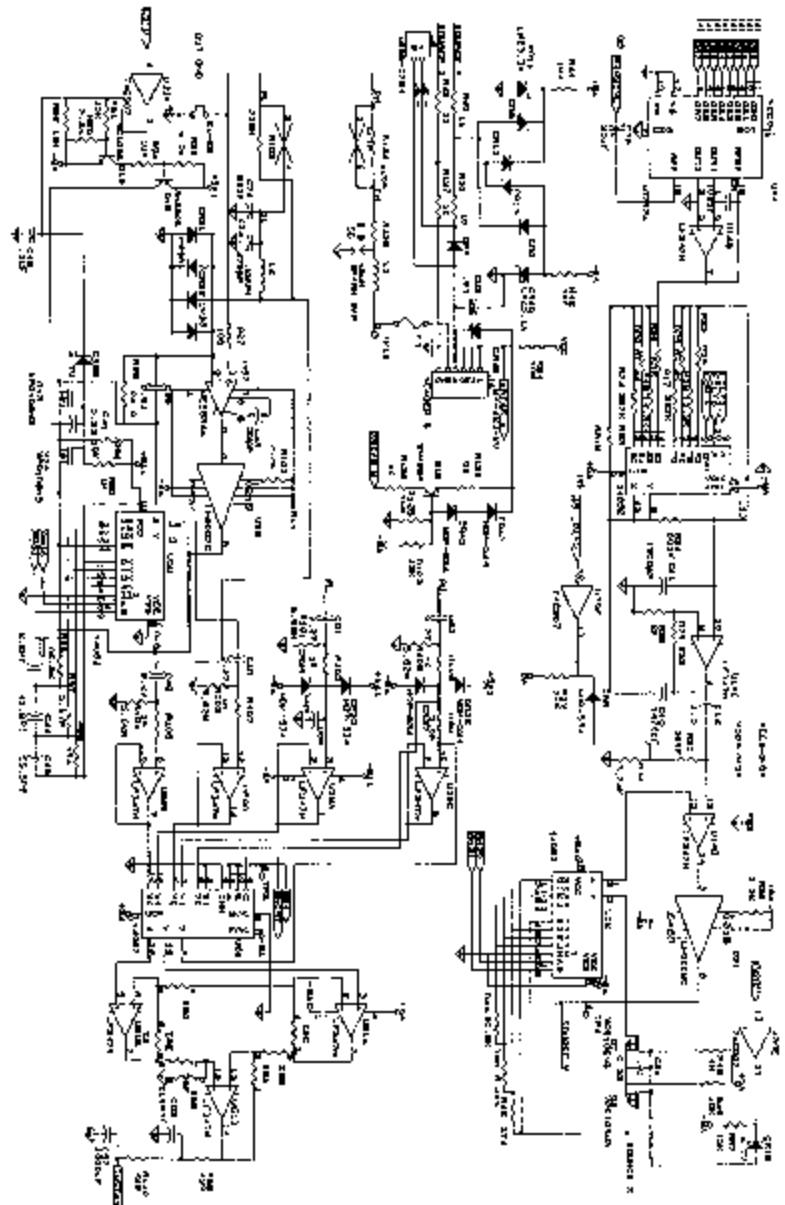

Figure 5-7. Main Board, electronic sheet 3, 108B-1702-2D
PARTS LISTS AND DIAGRAMS 6-8

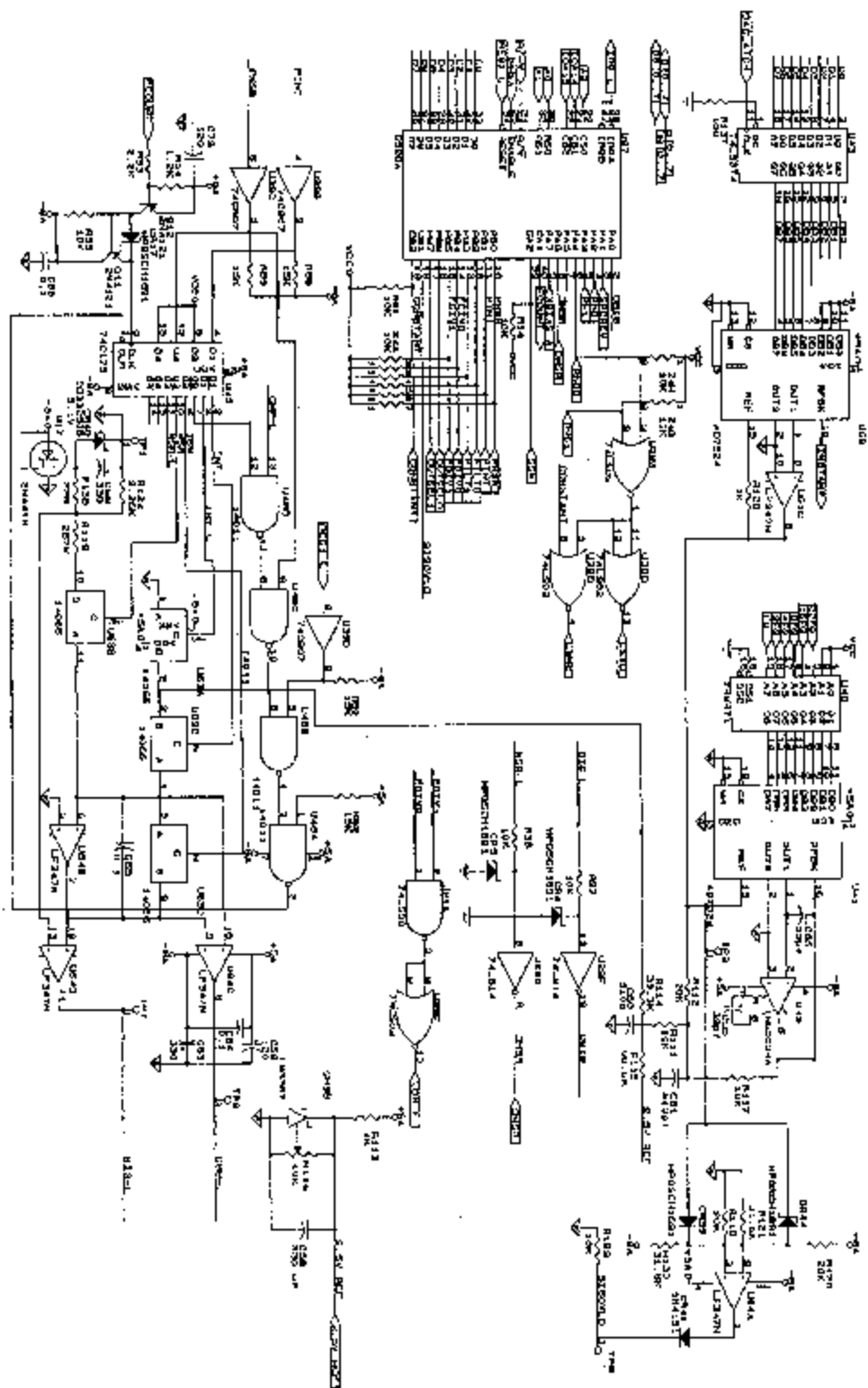

Figure 6-4. Main Board, schematic sheet 4, 1689-4702-SD
 6-10 PARTS LISTS AND DIAGRAMS

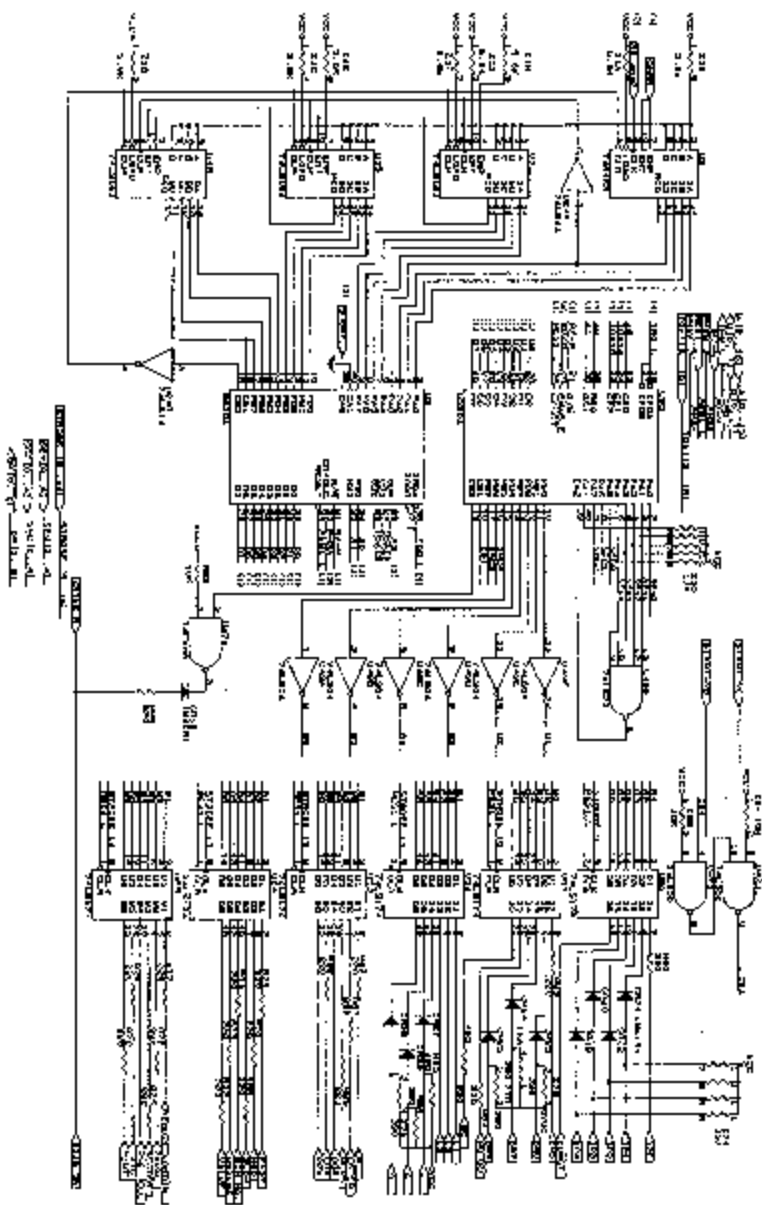

Figure 6-9. Main Board, schematic sheet 5, 1698-4702-SD

PARTS LISTS AND DIAGRAMS 6-11

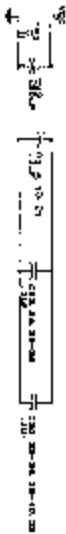
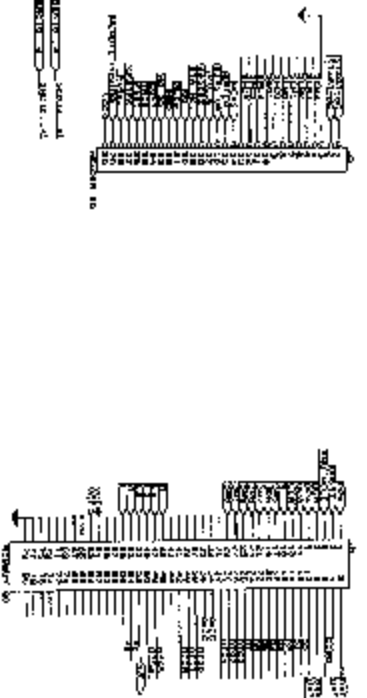
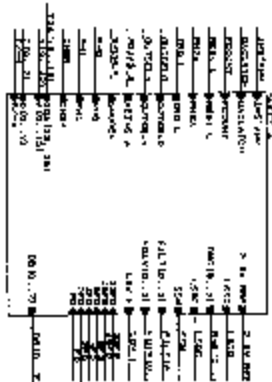
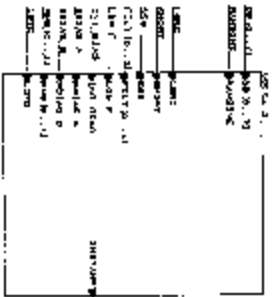
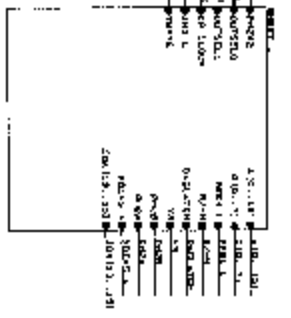

Figure 6-10. Main Board, schematic Sheet 6, 1888-4702-SD



ITEM NO.	DESCRIPTION	QTY	UNIT	REMARKS
1	POWER SUPPLY	1	PCB	
2	SWITCH	1	PCB	
3	RELAY	1	PCB	
4	LAMP	1	PCB	
5	RESISTOR	1	PCB	
6	CAPACITOR	1	PCB	
7	WIRE	1	PCB	
8	CONNECTOR	1	PCB	
9	INDICATOR LAMP	1	PCB	
10	RELAY	1	PCB	
11	SWITCH	1	PCB	
12	POWER SUPPLY	1	PCB	
13	RESISTOR	1	PCB	
14	CAPACITOR	1	PCB	
15	WIRE	1	PCB	
16	CONNECTOR	1	PCB	
17	INDICATOR LAMP	1	PCB	
18	RELAY	1	PCB	
19	SWITCH	1	PCB	
20	POWER SUPPLY	1	PCB	

Figure 6-11. Main Board, schematic sheet 7, 1888-4702-SD

6-12 PARTS LISTS AND DIAGRAMS

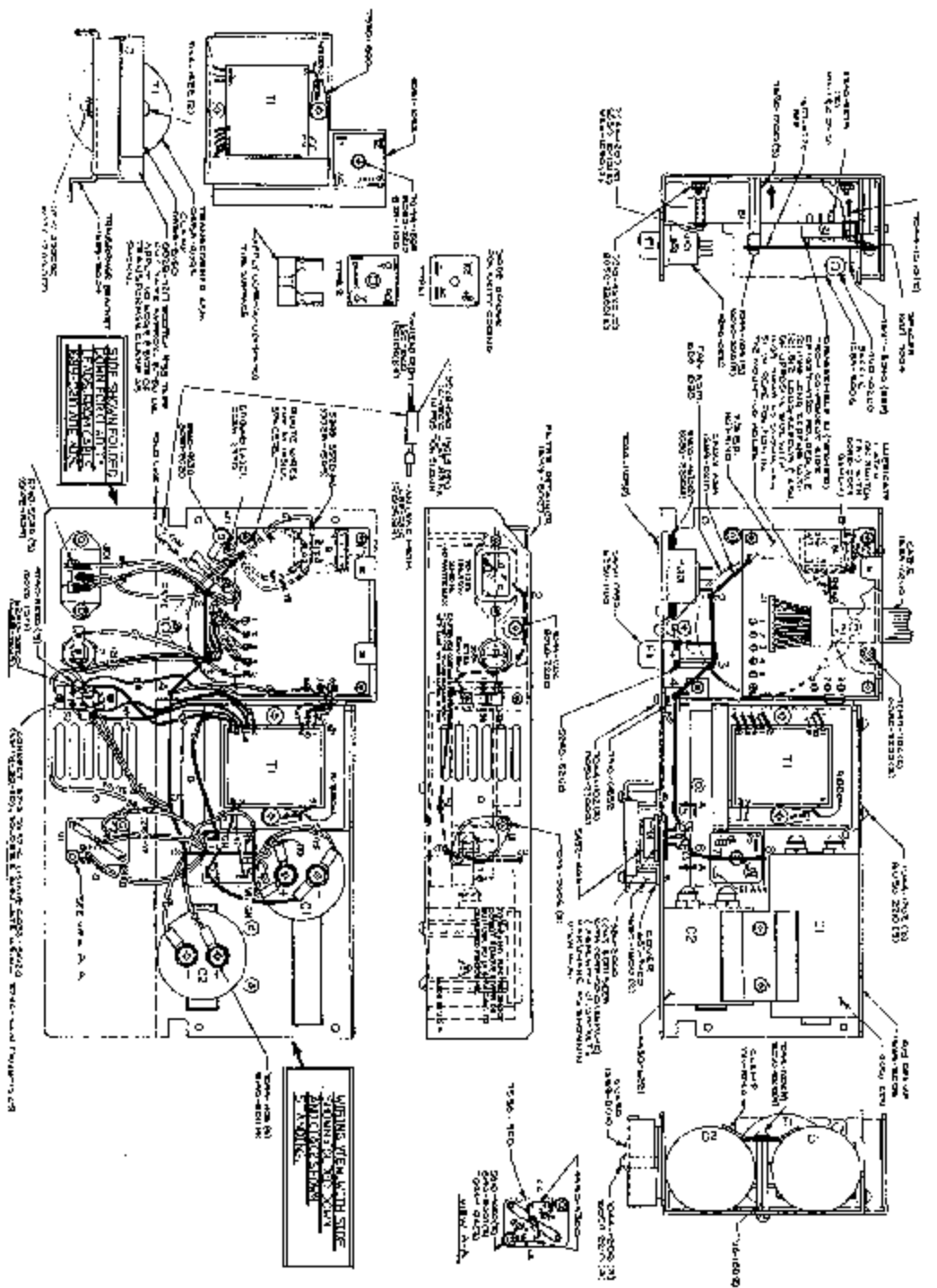
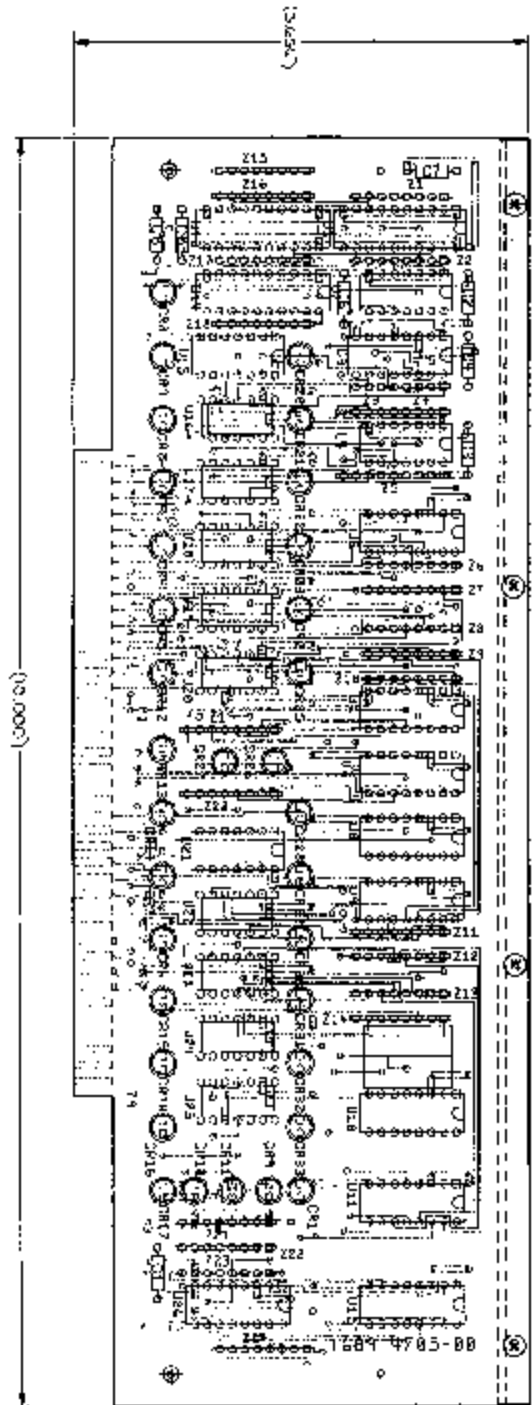

FIGURE 6-12. Power Supply, assembly, 1089-3005
 PARTS LISTS AND DIAGRAMS 6-13

ELECTRICAL PARTS LIST

Item Number: 1880-2705-00
 Description: ENHANCED DISPLAY BOARD

Item No.	Qty	Comp. Desc.
001	1	RES NET 8 1/2 IN ROM 2 JK 2448 2%
002	20	RES NET 8 1/2 IN ROM 2 JK 2448 2%
003	1	RES NET 8 1/2 IN ROM 2 JK 2448 2%
004	1	RES NET 8 1/2 IN ROM 2 JK 2448 2%
005	1	RES NET 8 1/2 IN ROM 2 JK 2448 2%
006	1	RES NET 8 1/2 IN ROM 2 JK 2448 2%
007	1	RES NET 8 1/2 IN ROM 2 JK 2448 2%
008	1	RES NET 8 1/2 IN ROM 2 JK 2448 2%
009	1	RES NET 8 1/2 IN ROM 2 JK 2448 2%
010	1	RES NET 8 1/2 IN ROM 2 JK 2448 2%
011	1	RES NET 8 1/2 IN ROM 2 JK 2448 2%
012	1	RES NET 8 1/2 IN ROM 2 JK 2448 2%
013	1	RES NET 8 1/2 IN ROM 2 JK 2448 2%
014	1	RES NET 8 1/2 IN ROM 2 JK 2448 2%
015	1	RES NET 8 1/2 IN ROM 2 JK 2448 2%
016	1	RES NET 8 1/2 IN ROM 2 JK 2448 2%
017	1	RES NET 8 1/2 IN ROM 2 JK 2448 2%
018	1	RES NET 8 1/2 IN ROM 2 JK 2448 2%
019	1	RES NET 8 1/2 IN ROM 2 JK 2448 2%
020	1	RES NET 8 1/2 IN ROM 2 JK 2448 2%
021	1	RES NET 8 1/2 IN ROM 2 JK 2448 2%
022	1	RES NET 8 1/2 IN ROM 2 JK 2448 2%
023	1	RES NET 8 1/2 IN ROM 2 JK 2448 2%
024	1	RES NET 8 1/2 IN ROM 2 JK 2448 2%
025	1	RES NET 8 1/2 IN ROM 2 JK 2448 2%
026	1	RES NET 8 1/2 IN ROM 2 JK 2448 2%
027	1	RES NET 8 1/2 IN ROM 2 JK 2448 2%
028	1	RES NET 8 1/2 IN ROM 2 JK 2448 2%
029	1	RES NET 8 1/2 IN ROM 2 JK 2448 2%
030	1	RES NET 8 1/2 IN ROM 2 JK 2448 2%
031	1	RES NET 8 1/2 IN ROM 2 JK 2448 2%
032	1	RES NET 8 1/2 IN ROM 2 JK 2448 2%
033	1	RES NET 8 1/2 IN ROM 2 JK 2448 2%
034	1	RES NET 8 1/2 IN ROM 2 JK 2448 2%
035	1	RES NET 8 1/2 IN ROM 2 JK 2448 2%
036	1	RES NET 8 1/2 IN ROM 2 JK 2448 2%
037	1	RES NET 8 1/2 IN ROM 2 JK 2448 2%
038	1	RES NET 8 1/2 IN ROM 2 JK 2448 2%
039	1	RES NET 8 1/2 IN ROM 2 JK 2448 2%
040	1	RES NET 8 1/2 IN ROM 2 JK 2448 2%
041	1	RES NET 8 1/2 IN ROM 2 JK 2448 2%
042	1	RES NET 8 1/2 IN ROM 2 JK 2448 2%
043	1	RES NET 8 1/2 IN ROM 2 JK 2448 2%
044	1	RES NET 8 1/2 IN ROM 2 JK 2448 2%
045	1	RES NET 8 1/2 IN ROM 2 JK 2448 2%
046	1	RES NET 8 1/2 IN ROM 2 JK 2448 2%
047	1	RES NET 8 1/2 IN ROM 2 JK 2448 2%
048	1	RES NET 8 1/2 IN ROM 2 JK 2448 2%
049	1	RES NET 8 1/2 IN ROM 2 JK 2448 2%
050	1	RES NET 8 1/2 IN ROM 2 JK 2448 2%
051	1	RES NET 8 1/2 IN ROM 2 JK 2448 2%
052	1	RES NET 8 1/2 IN ROM 2 JK 2448 2%
053	1	RES NET 8 1/2 IN ROM 2 JK 2448 2%
054	1	RES NET 8 1/2 IN ROM 2 JK 2448 2%
055	1	RES NET 8 1/2 IN ROM 2 JK 2448 2%
056	1	RES NET 8 1/2 IN ROM 2 JK 2448 2%
057	1	RES NET 8 1/2 IN ROM 2 JK 2448 2%
058	1	RES NET 8 1/2 IN ROM 2 JK 2448 2%
059	1	RES NET 8 1/2 IN ROM 2 JK 2448 2%
060	1	RES NET 8 1/2 IN ROM 2 JK 2448 2%
061	1	RES NET 8 1/2 IN ROM 2 JK 2448 2%
062	1	RES NET 8 1/2 IN ROM 2 JK 2448 2%
063	1	RES NET 8 1/2 IN ROM 2 JK 2448 2%
064	1	RES NET 8 1/2 IN ROM 2 JK 2448 2%
065	1	RES NET 8 1/2 IN ROM 2 JK 2448 2%
066	1	RES NET 8 1/2 IN ROM 2 JK 2448 2%
067	1	RES NET 8 1/2 IN ROM 2 JK 2448 2%
068	1	RES NET 8 1/2 IN ROM 2 JK 2448 2%
069	1	RES NET 8 1/2 IN ROM 2 JK 2448 2%
070	1	RES NET 8 1/2 IN ROM 2 JK 2448 2%
071	1	RES NET 8 1/2 IN ROM 2 JK 2448 2%
072	1	RES NET 8 1/2 IN ROM 2 JK 2448 2%
073	1	RES NET 8 1/2 IN ROM 2 JK 2448 2%
074	1	RES NET 8 1/2 IN ROM 2 JK 2448 2%
075	1	RES NET 8 1/2 IN ROM 2 JK 2448 2%
076	1	RES NET 8 1/2 IN ROM 2 JK 2448 2%
077	1	RES NET 8 1/2 IN ROM 2 JK 2448 2%
078	1	RES NET 8 1/2 IN ROM 2 JK 2448 2%
079	1	RES NET 8 1/2 IN ROM 2 JK 2448 2%
080	1	RES NET 8 1/2 IN ROM 2 JK 2448 2%
081	1	RES NET 8 1/2 IN ROM 2 JK 2448 2%
082	1	RES NET 8 1/2 IN ROM 2 JK 2448 2%
083	1	RES NET 8 1/2 IN ROM 2 JK 2448 2%
084	1	RES NET 8 1/2 IN ROM 2 JK 2448 2%
085	1	RES NET 8 1/2 IN ROM 2 JK 2448 2%
086	1	RES NET 8 1/2 IN ROM 2 JK 2448 2%
087	1	RES NET 8 1/2 IN ROM 2 JK 2448 2%
088	1	RES NET 8 1/2 IN ROM 2 JK 2448 2%
089	1	RES NET 8 1/2 IN ROM 2 JK 2448 2%
090	1	RES NET 8 1/2 IN ROM 2 JK 2448 2%
091	1	RES NET 8 1/2 IN ROM 2 JK 2448 2%
092	1	RES NET 8 1/2 IN ROM 2 JK 2448 2%
093	1	RES NET 8 1/2 IN ROM 2 JK 2448 2%
094	1	RES NET 8 1/2 IN ROM 2 JK 2448 2%
095	1	RES NET 8 1/2 IN ROM 2 JK 2448 2%
096	1	RES NET 8 1/2 IN ROM 2 JK 2448 2%
097	1	RES NET 8 1/2 IN ROM 2 JK 2448 2%
098	1	RES NET 8 1/2 IN ROM 2 JK 2448 2%
099	1	RES NET 8 1/2 IN ROM 2 JK 2448 2%
100	1	RES NET 8 1/2 IN ROM 2 JK 2448 2%



NOTES:

1. BASIC BOARD NO. 1880-0705-00 REV. 12
2. BOARD VIEW FROM COMPONENT SIDE
3. OCCULTARY SHOWN, REPRESENTS COMPONENT SIDE.
4. CONTACT POINTS, IN ALL SCALE, ARE TO BE FILED TO SOLDER AND ADHESIVE.
5. SQUARE PAD ■ DUE TO THE FOLLOWING:
 POSITIVE + END OF CAPACITORS
 HOT/UP - MINOR CAPACITORS
 ARM OF POTENTIOMETERS
 COLLECTOR OF TRANSISTERS
 CATHODE END OF DIODES
 PIN 41 OF 10'S BIT AYS AND CONNECTORS.
 7540-1074-00 AFTER WAVE SOLDERING.

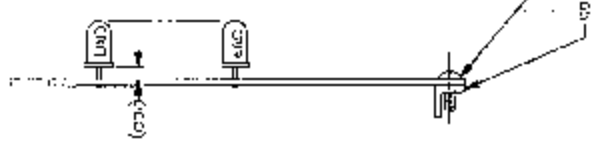

Figure 6-15. Display Board, layout, 1880-2705
 PARTS LISTS AND DIAGRAMS 6-15

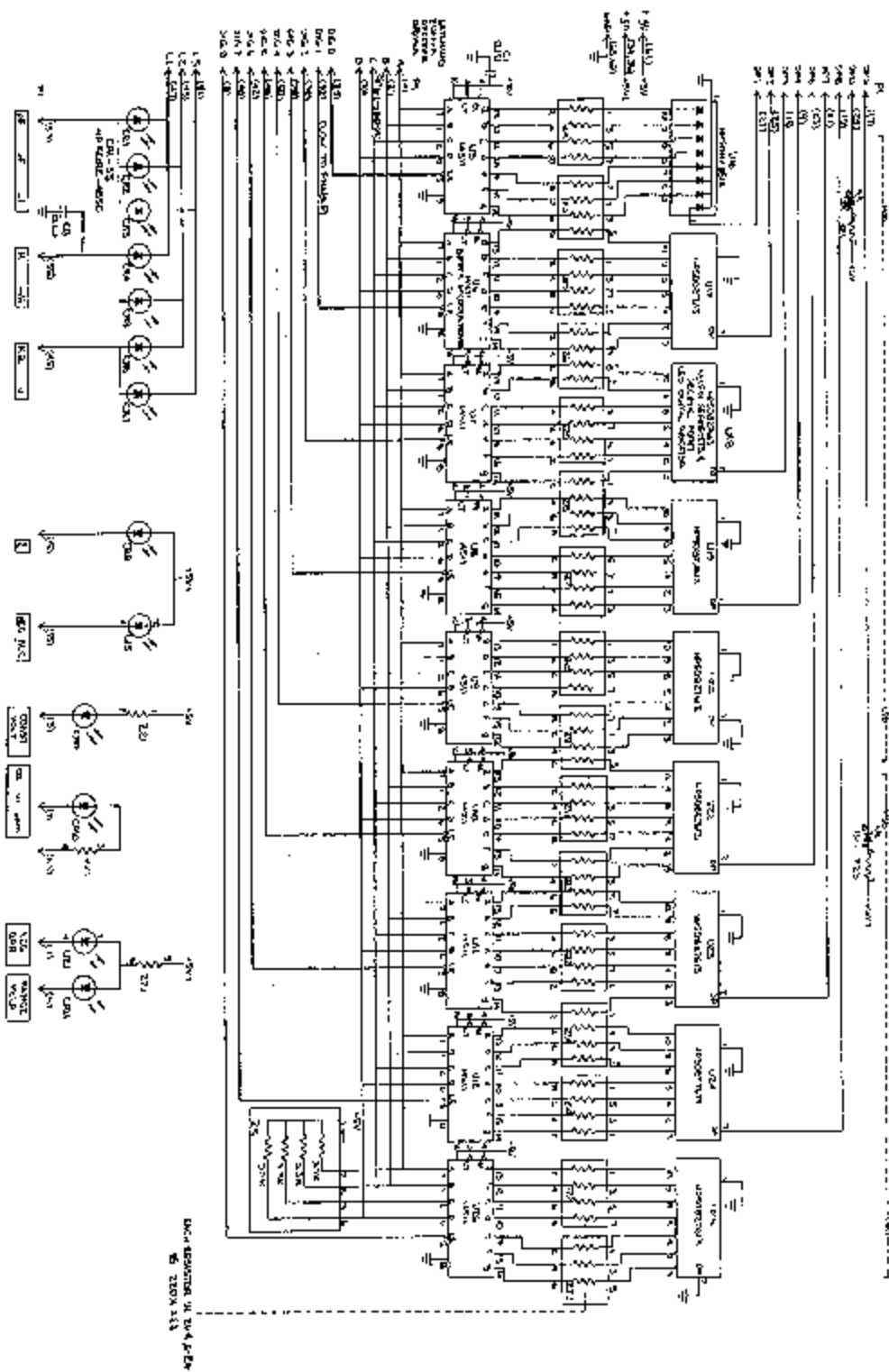

Figure 6-16. Display Board, schematic, sheet 1, 1888-4705-50

6-16 PARTS LISTS AND DIAGRAMS

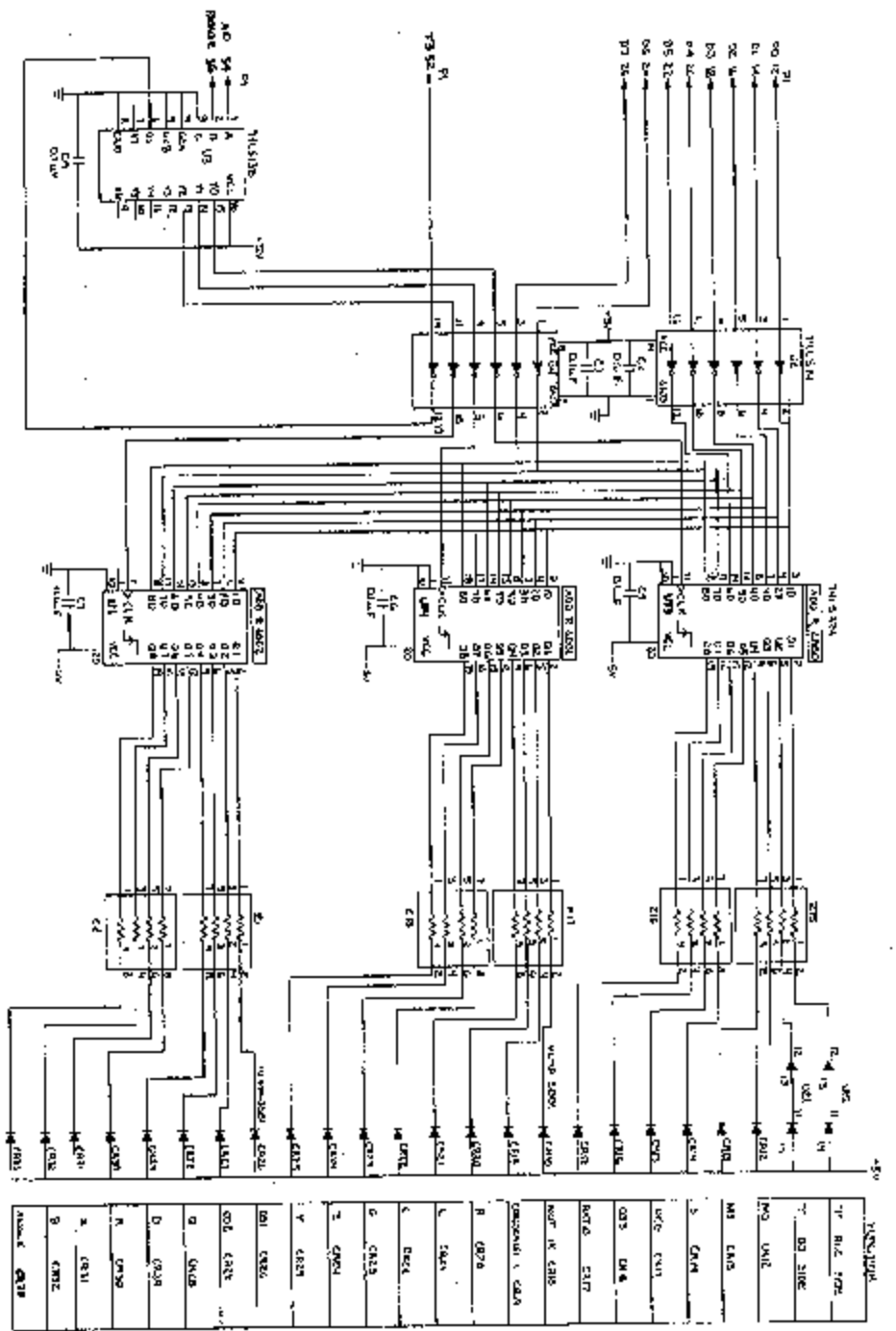

Figure 5-17. Display Board, schematic, sheet 2, 1089-1706-21
PARTS LISTS AND DIAGRAMS B-1

ELECTRICAL PARTS LISTS

INTERFACE OPTION ASM PN 168A-430

REVISED	DESCRIPTION	PART NO.	QTY	NOTE PART NUMBER
1	307M1 MICRO 800 24 COUNT	420-404	2	87-4520
2	307M1 PNL 307M1 COUNT MICRO 800	420-404	1	87-4520-2

NOTE: THE ASSEMBLY INCLUDES CIRCUIT BOARD 168A-130

ELECTRICAL PARTS LISTS

INTERFACE OPTION BOARD PN 168A-430

REVISED	DESCRIPTION	PART NO.	QTY	NOTE PART NUMBER
1	CAP 100K 1/2W 5% 100K	440-304	2	87-4520
2	CAP 100K 1/2W 5% 100K	440-304	2	87-4520
3	CAP 100K 1/2W 5% 100K	440-304	2	87-4520
4	CAP 100K 1/2W 5% 100K	440-304	2	87-4520
5	CAP 100K 1/2W 5% 100K	440-304	2	87-4520
6	CAP 100K 1/2W 5% 100K	440-304	2	87-4520
7	CAP 100K 1/2W 5% 100K	440-304	2	87-4520
8	CAP 100K 1/2W 5% 100K	440-304	2	87-4520
9	CAP 100K 1/2W 5% 100K	440-304	2	87-4520
10	CAP 100K 1/2W 5% 100K	440-304	2	87-4520
11	CAP 100K 1/2W 5% 100K	440-304	2	87-4520
12	CAP 100K 1/2W 5% 100K	440-304	2	87-4520
13	CAP 100K 1/2W 5% 100K	440-304	2	87-4520
14	CAP 100K 1/2W 5% 100K	440-304	2	87-4520
15	CAP 100K 1/2W 5% 100K	440-304	2	87-4520
16	CAP 100K 1/2W 5% 100K	440-304	2	87-4520
17	CAP 100K 1/2W 5% 100K	440-304	2	87-4520
18	CAP 100K 1/2W 5% 100K	440-304	2	87-4520
19	CAP 100K 1/2W 5% 100K	440-304	2	87-4520
20	CAP 100K 1/2W 5% 100K	440-304	2	87-4520
21	CAP 100K 1/2W 5% 100K	440-304	2	87-4520
22	CAP 100K 1/2W 5% 100K	440-304	2	87-4520
23	CAP 100K 1/2W 5% 100K	440-304	2	87-4520
24	CAP 100K 1/2W 5% 100K	440-304	2	87-4520
25	CAP 100K 1/2W 5% 100K	440-304	2	87-4520
26	CAP 100K 1/2W 5% 100K	440-304	2	87-4520
27	CAP 100K 1/2W 5% 100K	440-304	2	87-4520
28	CAP 100K 1/2W 5% 100K	440-304	2	87-4520
29	CAP 100K 1/2W 5% 100K	440-304	2	87-4520
30	CAP 100K 1/2W 5% 100K	440-304	2	87-4520
31	CAP 100K 1/2W 5% 100K	440-304	2	87-4520
32	CAP 100K 1/2W 5% 100K	440-304	2	87-4520
33	CAP 100K 1/2W 5% 100K	440-304	2	87-4520
34	CAP 100K 1/2W 5% 100K	440-304	2	87-4520
35	CAP 100K 1/2W 5% 100K	440-304	2	87-4520
36	CAP 100K 1/2W 5% 100K	440-304	2	87-4520
37	CAP 100K 1/2W 5% 100K	440-304	2	87-4520
38	CAP 100K 1/2W 5% 100K	440-304	2	87-4520
39	CAP 100K 1/2W 5% 100K	440-304	2	87-4520
40	CAP 100K 1/2W 5% 100K	440-304	2	87-4520
41	CAP 100K 1/2W 5% 100K	440-304	2	87-4520
42	CAP 100K 1/2W 5% 100K	440-304	2	87-4520
43	CAP 100K 1/2W 5% 100K	440-304	2	87-4520
44	CAP 100K 1/2W 5% 100K	440-304	2	87-4520
45	CAP 100K 1/2W 5% 100K	440-304	2	87-4520
46	CAP 100K 1/2W 5% 100K	440-304	2	87-4520
47	CAP 100K 1/2W 5% 100K	440-304	2	87-4520
48	CAP 100K 1/2W 5% 100K	440-304	2	87-4520
49	CAP 100K 1/2W 5% 100K	440-304	2	87-4520
50	CAP 100K 1/2W 5% 100K	440-304	2	87-4520
51	CAP 100K 1/2W 5% 100K	440-304	2	87-4520
52	CAP 100K 1/2W 5% 100K	440-304	2	87-4520
53	CAP 100K 1/2W 5% 100K	440-304	2	87-4520
54	CAP 100K 1/2W 5% 100K	440-304	2	87-4520
55	CAP 100K 1/2W 5% 100K	440-304	2	87-4520
56	CAP 100K 1/2W 5% 100K	440-304	2	87-4520
57	CAP 100K 1/2W 5% 100K	440-304	2	87-4520
58	CAP 100K 1/2W 5% 100K	440-304	2	87-4520
59	CAP 100K 1/2W 5% 100K	440-304	2	87-4520
60	CAP 100K 1/2W 5% 100K	440-304	2	87-4520
61	CAP 100K 1/2W 5% 100K	440-304	2	87-4520
62	CAP 100K 1/2W 5% 100K	440-304	2	87-4520
63	CAP 100K 1/2W 5% 100K	440-304	2	87-4520
64	CAP 100K 1/2W 5% 100K	440-304	2	87-4520
65	CAP 100K 1/2W 5% 100K	440-304	2	87-4520
66	CAP 100K 1/2W 5% 100K	440-304	2	87-4520
67	CAP 100K 1/2W 5% 100K	440-304	2	87-4520
68	CAP 100K 1/2W 5% 100K	440-304	2	87-4520
69	CAP 100K 1/2W 5% 100K	440-304	2	87-4520
70	CAP 100K 1/2W 5% 100K	440-304	2	87-4520
71	CAP 100K 1/2W 5% 100K	440-304	2	87-4520
72	CAP 100K 1/2W 5% 100K	440-304	2	87-4520
73	CAP 100K 1/2W 5% 100K	440-304	2	87-4520
74	CAP 100K 1/2W 5% 100K	440-304	2	87-4520
75	CAP 100K 1/2W 5% 100K	440-304	2	87-4520
76	CAP 100K 1/2W 5% 100K	440-304	2	87-4520
77	CAP 100K 1/2W 5% 100K	440-304	2	87-4520
78	CAP 100K 1/2W 5% 100K	440-304	2	87-4520
79	CAP 100K 1/2W 5% 100K	440-304	2	87-4520
80	CAP 100K 1/2W 5% 100K	440-304	2	87-4520
81	CAP 100K 1/2W 5% 100K	440-304	2	87-4520
82	CAP 100K 1/2W 5% 100K	440-304	2	87-4520
83	CAP 100K 1/2W 5% 100K	440-304	2	87-4520
84	CAP 100K 1/2W 5% 100K	440-304	2	87-4520
85	CAP 100K 1/2W 5% 100K	440-304	2	87-4520
86	CAP 100K 1/2W 5% 100K	440-304	2	87-4520
87	CAP 100K 1/2W 5% 100K	440-304	2	87-4520
88	CAP 100K 1/2W 5% 100K	440-304	2	87-4520
89	CAP 100K 1/2W 5% 100K	440-304	2	87-4520
90	CAP 100K 1/2W 5% 100K	440-304	2	87-4520
91	CAP 100K 1/2W 5% 100K	440-304	2	87-4520
92	CAP 100K 1/2W 5% 100K	440-304	2	87-4520
93	CAP 100K 1/2W 5% 100K	440-304	2	87-4520
94	CAP 100K 1/2W 5% 100K	440-304	2	87-4520
95	CAP 100K 1/2W 5% 100K	440-304	2	87-4520
96	CAP 100K 1/2W 5% 100K	440-304	2	87-4520
97	CAP 100K 1/2W 5% 100K	440-304	2	87-4520
98	CAP 100K 1/2W 5% 100K	440-304	2	87-4520
99	CAP 100K 1/2W 5% 100K	440-304	2	87-4520
100	CAP 100K 1/2W 5% 100K	440-304	2	87-4520

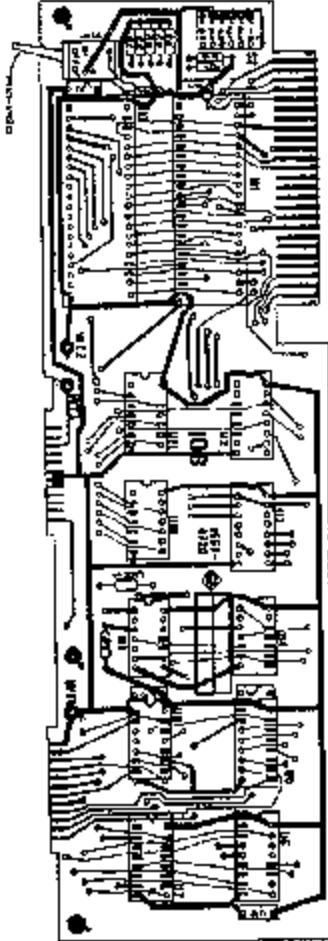



Figure 6-18. Interface Option Board, layout, 168A-430-1D
 6-18 PARTS LISTS AND DIAGRAMS

CAUTION 

THE FOLLOWING CIRCUITS ARE
 PROVIDED FOR INFORMATION
 PURPOSES ONLY. THEY ARE
 NOT TO BE USED FOR
 REPAIR TO CHINA 5800-PT1
 MODEL UNIT

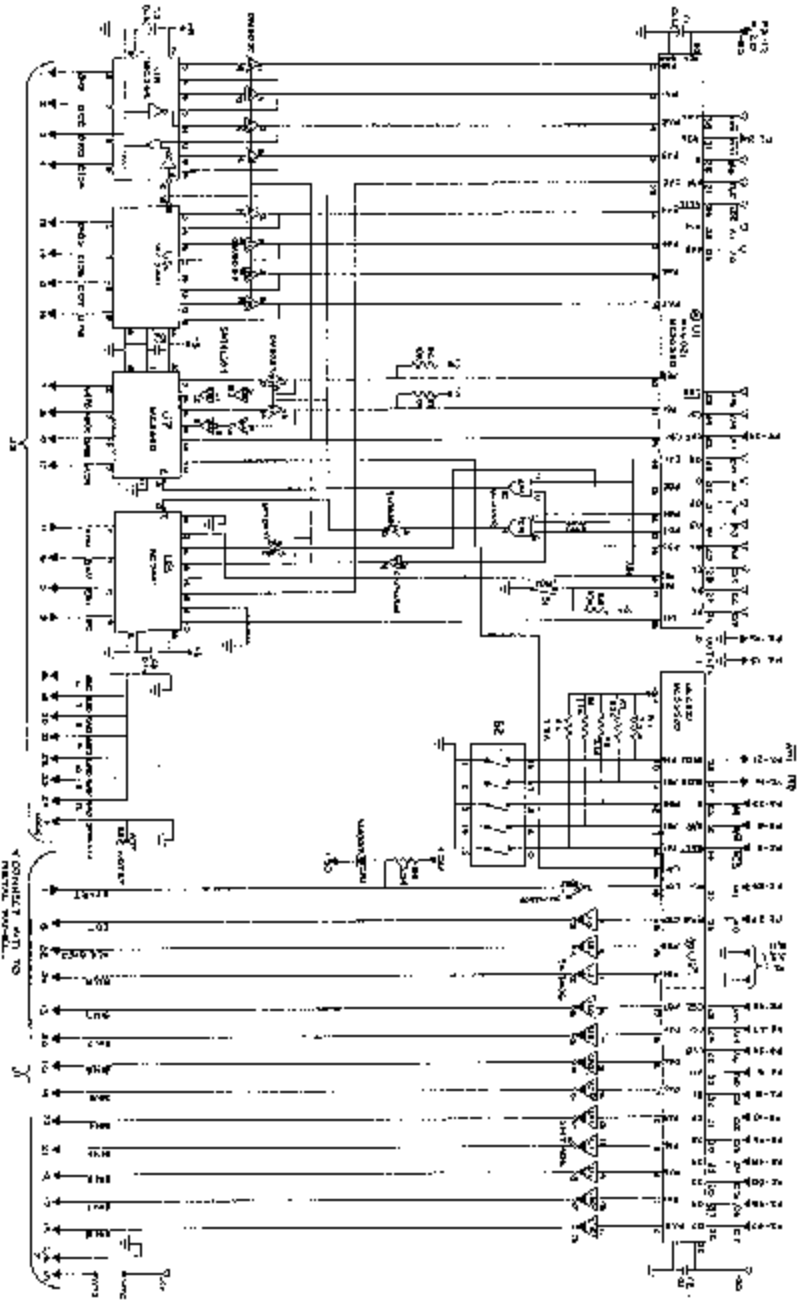

Figure 6-19. Interface Option, schematic, J624-472K-20A
 PARTS LISTS AND DIAGRAMS 6-19

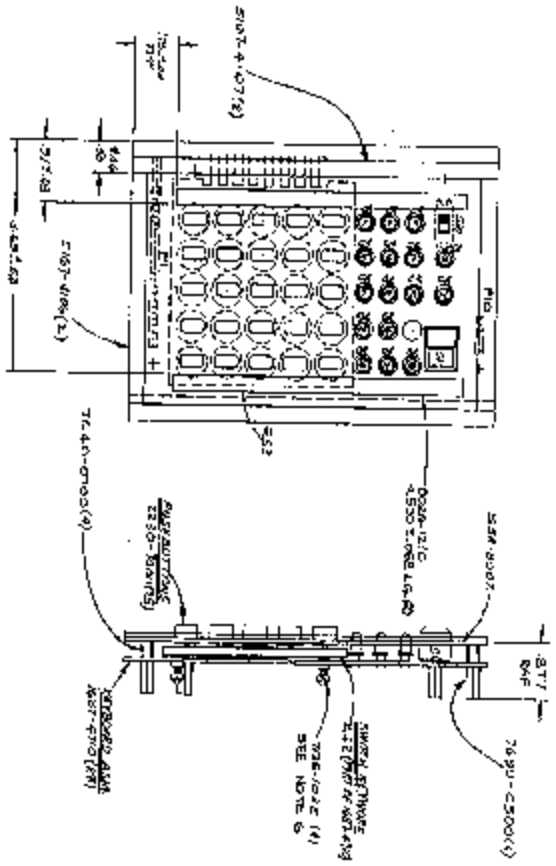

Figure 6-20. Keyboard Module, assembly, 1687-4200

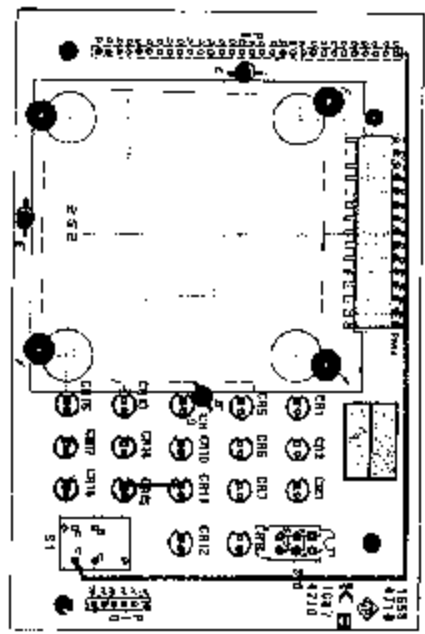

Figure 6-21. Keyboard Indicators, detail, 1687-4200-ID

ELECTRICAL PARTS LIST

REVISED DRAW NO.	DATE	DESCRIPTION	PART NO.	QTY	REMARKS
1	10/10/70	LED RED	808-104	2144	
2	10/10/70	LED RED	808-104	2144	
3	10/10/70	LED RED	808-104	2144	
4	10/10/70	LED RED	808-104	2144	
5	10/10/70	LED RED	808-104	2144	
6	10/10/70	LED RED	808-104	2144	
7	10/10/70	LED RED	808-104	2144	
8	10/10/70	LED RED	808-104	2144	
9	10/10/70	LED RED	808-104	2144	
10	10/10/70	LED RED	808-104	2144	
11	10/10/70	LED RED	808-104	2144	
12	10/10/70	LED RED	808-104	2144	
13	10/10/70	LED RED	808-104	2144	
14	10/10/70	LED RED	808-104	2144	
15	10/10/70	LED RED	808-104	2144	
16	10/10/70	LED RED	808-104	2144	
17	10/10/70	LED RED	808-104	2144	
18	10/10/70	LED RED	808-104	2144	
19	10/10/70	LED RED	808-104	2144	
20	10/10/70	LED RED	808-104	2144	
21	10/10/70	LED RED	808-104	2144	
22	10/10/70	LED RED	808-104	2144	
23	10/10/70	LED RED	808-104	2144	
24	10/10/70	LED RED	808-104	2144	
25	10/10/70	LED RED	808-104	2144	
26	10/10/70	LED RED	808-104	2144	
27	10/10/70	LED RED	808-104	2144	
28	10/10/70	LED RED	808-104	2144	

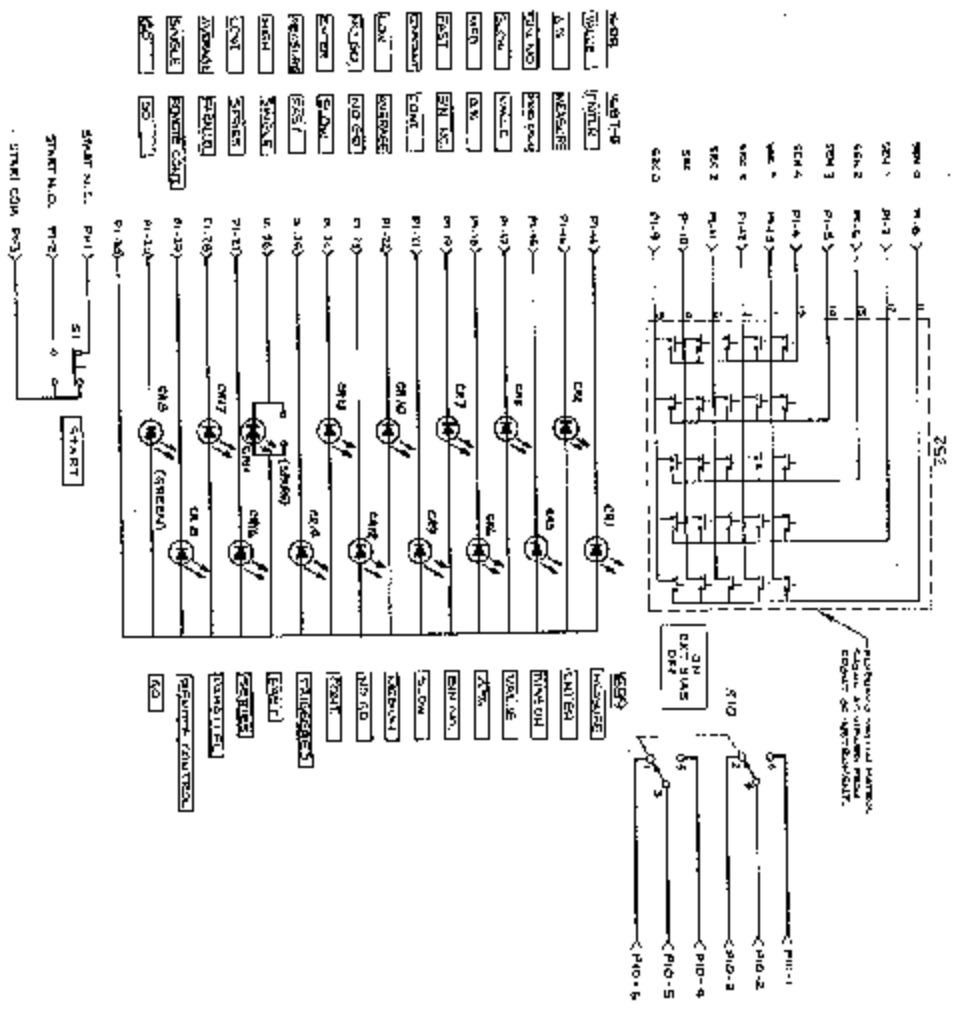

Figure 6-22 Keyboard, electrical, 1887-8710 2D
PARTS LISTS AND DIAGRAMS 6-21

GenRad

For more information or the location of your local GenRad sales office, arrange:

U.S.A. 1-800-GENRAD	Germany TEL: 069/431722 TEL: 069/431720	Asia Pacific Singapore TEL: 363-4400 TEL: 363-0344
Canada TEL: 416-490-69 TEL: 06-887-6266/6267	Italy TEL: 061 22221	All other Countries 120 Raffles Lane Singapore, 408760 TEL: 336-4400 TEL: 336-224
Mexico TEL: 06-562-0200	Switzerland TEL: 043 22 22 22	
United Kingdom London, W8 7AH TEL: 01-262 1111	Netherlands TEL: 2065 9985 N.L.	
France TEL: 01-4753 5111 F		

In Europe, after our commitment to continuous product improvement, the International Product Office is always available in U.S.A. 24 hrs.