

FOR SERVICE MANUALS
CONTACT:
MAURITRON TECHNICAL SERVICES
www.mauritron.co.uk
TEL: 01844 - 351694
FAX: 01844 - 352554

OS250 10MHz
DUAL TRACE
OSCILLOSCOPE 2076
Instruction / Manual

Contents

SECTION 1	Introduction	3	4.9	Power supplies	11
SECTION 2	Specification	4	4.10	Calibrator	12
			4.11	Blanking	12
			4.12	Tube network	12
SECTION 3	Operation	5	SECTION 5	Maintenance	13
3.1	Switching on	5	5.1	General	13
3.2	Obtaining a trace	5	5.2	Removal of sub-assemblies	13
3.3	Setting up the Y channels	5	5.3	Fault finding	13
3.4	Single trace operation	5	5.4	Setting up procedure	14
3.5	Dual trace operation	5	SECTION 6	Component Lists and Circuit Diagrams	17
3.6	Timebase and X expansion	5	SECTION 7	Guarantee and Service Facilities	29
3.7	X-Y mode	6			
3.8	Trigger	6			
3.9	Additional facilities	6			
SECTION 4	Circuit Description	8			
4.1	General	8			
4.2	The Y amplifiers	9	ILLUSTRATIONS		
4.3	The beam switch	10	Fig. 1	Block diagram	8
4.4	The trigger circuits	10	Fig. 2	Transformer tap connections	13
4.5	The timebase bistable and ramp generator	10	Fig. 3	Y amplifier circuit	19
4.6	Bright line circuit	11	Fig. 4	Timebase and X amplifier circuit	21
4.7	The X output amplifier	11	Fig. 5	Power supply circuit	23
4.8	X-Y mode	11	Fig. 6	Interconnection diagram	25
			Fig. 7	Top view	27
			Fig. 8	Bottom view	28

FOR SERVICE MANUALS
CONTACT:
MAURITRON TECHNICAL SERVICES
www.mauritron.co.uk
TEL: 01844 - 351694
FAX: 01844 - 352554

The Advance OS250 Oscilloscope is a 10 MHz dual trace instrument with a 10cm x 8cm display. It is designed for use in general purpose laboratory work, educational uses, TV and servicing applications.

It features two identical input channels with a maximum sensitivity of 5mV/cm and a bandwidth of DC to 10MHz. The two channels may be viewed separately, alternately

at fast timebase speeds, or chopped at a 250kHz rate at low timebase speeds.

Particular attention has been paid to trigger performance, and the system used includes a variable control with bright line operation in the absence of a signal, or when the trigger level is outside the range of the input signal.

FOR SERVICE MANUALS
CONTACT:
MAURITRON TECHNICAL SERVICES
www.mauritron.co.uk
TEL: 01844 - 351694
FAX: 01844 - 352554

DISPLAY

5 in flat faced c.r.t. giving 10 cm X 8 cm display E.H.T.—3.6 kV overall.

Phosphor—P31. Long persistence (P7) available as an option.

VERTICAL DEFLECTION

Two identical input channels, Y1 and Y2

Bandwidth (−3dB) DC—10MHz. (2Hz—10MHz on AC)

Sensitivity 5mV/cm to 20V/cm in 1-2-5 sequence.

Accuracy ±5%.

Input Impedance 1 MΩ/approx. 28 pF.

Input coupling DC—GND—AC.

Protection 400V DC or pk AC.

DISPLAY MODES

Single Trace Y1 or Y2.

Dual Trace chopped or alternate modes, automatically selected on timebase switch. Chop rate approx. 250kHz.

X-Y mode with Y1 input giving X deflection and Y2 input giving Y deflection.

Bandwidth DC to 500kHz <3° phase shift at 20kHz.

HORIZONTAL DEFLECTION

Timebase—1μs/cm to 0.5s/cm in 18 ranges (1-2-5) sequences.

Accuracy ±5%.

X Expansion—X10 pull switch gives fastest speed of 100 ns/cm. Accuracy ±5%

Variable control gives >2.5:1 reduction in sweep speed.

TRIGGER

Variable level control with option of bright line in absence of signal.

Trigger level control range

INTERNAL > 8cm

EXTERNAL > 20V

Source

Internal Y1 + or −

Y2 + or −

External + or −

External trigger input impedance, approx 100kΩ/10pF.

Coupling AC, AC fast, TV Frame.

Sensitivity

Internal 2mm approx. 40Hz—2MHz. } bright line on
External 1V approx. 40Hz—2MHz. } or off.

Internal 1cm approx. 8Hz—10MHz. } bright line off.
External 5V approx. 8Hz—10MHz. }

Internal 2cm pk/pk video on TVF

ADDITIONAL FACILITIES

Calibrator 1 V ± 2% square wave at supply frequency.

Ramp output 0-10V.

Z mod input AC coupled. 10V gives visible modulation (2 Hz to 10MHz). 70V gives full blanking.

SUPPLY

95-111V, 103-121V, 111-130V. } 45-440Hz
190-222V, 206-242V, 222-260V. }

Approx. 25VA.

OPERATING TEMPERATURE RANGE

0-50°C (15°C to 35°C for full accuracy, approx 2% degradation at 0°C and 50°C)

DIMENSIONS

18cm (7") X 29cm (11³/₈") X 42cm (16¹/₂")

Approx. 7 kg (15 lbs.).

ACCESSORIES

Connector BNC—BNC PL43

Connector BNC—clips PL44

OPTIONAL ACCESSORIES

Probe Kit PN 32824. A passive probe kit with X1 and X10 attenuations. With X10 attenuation input impedance is 10MΩ/13.5pF.

Viewing Hood PN A1/32264.

Trolley Type TR4 A general purpose oscilloscope trolley.

Protective Carrying Case PN 3247.

A strong carrying case which completely encloses the oscilloscope with three thicknesses of padded material covering the front panel.

Tube Option The OS250 may be ordered with a long persistence c.r.t. (P7 phosphor).

Rack Mount Kit PN 33389

Adaptor BNC—binding post PN 26234

3.1 SWITCHING ON

CAUTION The OS250 relies on convection cooling and must always be operated in a position such that external air circulation is not restricted.

1. Set the support/carrying handle to the required operating position. The handle is released by pulling both fixing bushes outward, and it can then be turned to lock in any one of 5 positions.
2. Check that the supply transformer taps are wired correctly for the supply and that the corresponding supply fuse is fitted (see section 5.1)
3. Turn the BRILL control clockwise beyond the OFF setting and ensure that the indicator lamp lights.

3.2 OBTAINING A TRACE

1. To obtain a trace
 - (a) Set the Y1 shift control to approximately mid setting
 - (b) Set the Y2 shift control to Y2 OFF.
 - (c) Set the X shift control to approximately mid setting.
 - (d) Set the TRIG level Control to normal position i.e. not pulled out for BRIGHT LINE OFF
 - (e) Set the TIME/CM switch to $5\mu\text{s}$
 - (f) Adjust the BRILL control to obtain a display of the required brightness.
 - (g) Centralise the display by adjusting the Y1 and X shift controls.
 - (h) Adjust the FOCUS control to obtain a sharply defined trace.

3.3 SETTING UP THE Y CHANNELS

1. Using one of the coaxial input signal leads (PL43 or PL44), connect a signal to the Y1 or Y2 input socket.
2. For
 - (a) Direct connection of the input signal, set the associated AC-Ground-DC input slide switch to DC.
 - (b) Capacitive coupling of the input signal through an internal $0.1\mu\text{F}$ 400V capacitor, set the slide switch to AC.

NOTE When examining low amplitude a.c. signals super-imposed on a high d.c. level, the slide switch should be set to AC and the sensitivity of the Y amplifier increased as in (4).

3. To locate the baseline, set the slide switch to the 'ground' setting. At this setting, the input signal is open circuit and the input of the amplifier is switched to ground.
4. To select the sensitivity, set the VOLTS/CM switch to the required range. To minimise pick up at sensitive settings, it is essential to ensure

that the ground lead connection is near to the signal point.

5. For vertical shift of the trace, adjust the Y shift controls (identified with vertical arrows).
6. Any trace movement under no signal conditions, when the setting of the VOLTS/CM switch is altered, can be minimised by adjustment of the BAL preset control.

NOTE This control will only need adjustment at infrequent intervals. Before adjusting the BAL preset control ensure that the input slide switch is set to the 'ground' setting.

3.4 SINGLE TRACE

1. For single trace operation on the Y1 channel, set
 - (a) The Y1 shift control beyond the Y1 OFF setting.
 - (b) The Y2 shift control to Y2 OFF.
2. For single trace operation on the Y2 channel, set
 - (a) The Y2 shift control beyond the Y2 Off setting.
 - (b) The Y1 shift control to Y1 OFF.

3.5 DUAL TRACE OPERATION

In the dual trace condition, the beam switching function is in operation and results in independent display of two signals simultaneously. Two modes of beam switching – chopped and alternate – are used, and automatically selected by the setting of the TIME/CM switch. At any fast setting from $1\mu\text{s}$ to 0.5ms , inclusive, the alternate switching mode is in operation. At slow settings from 1ms to 0.5s inclusive, the chopped switching mode is in operation.

For dual trace operation, set:

- (a) The Y1 shift control beyond the Y1 OFF position.
- (b) The Y2 shift control beyond the Y2 OFF position.

3.6 TIMEBASE AND X EXPANSION

The sweep speed of the internal timebase (i.e. the time scale of the horizontal axis) is determined by the setting of the TIME/CM switch. The setting of the switch automatically determines which mode of beam switching is used during dual trace operation. In addition to selection of the speed of the internal timebase, the switch has one further setting, X-Y, at which the internal timebase is inoperative.

1. To adjust the time scale of the horizontal axis:
 - (a) Set the TIME/CM switch to a suitable setting.
 - (b) If necessary, adjust the uncalibrated VARIABLE control.

NOTE The range of the VARIABLE control is approximately 3:1. Except at the CAL setting, the VARIABLE control is uncalibrated. At the CAL setting, the calibration corresponds to the setting of the TIME/CM switch.

2. For horizontal shift of the trace, adjust the X shift control (identified by horizontal arrow).
3. If close examination of any portion of the trace is required, operate the PULL X10 control. This facility is available at all settings except X-Y of the TIME/CM switch, and effectively increases the sweep length from 10cm to 100cm. Any portion of the increased sweep length may be selected for viewing on the display by use of the X shift control.

3.7 X - Y MODE

When the TIME/CM switch is set to X-Y, the Y1 input channel is switched to the X amplifier. Under this condition, an external signal applied to the X (Y1) socket is routed through the input attenuators in the Y1 channel, and the full range of the sensitivity may be utilised to obtain a calibrated horizontal deflection. Only single trace operation (Y2 channel) is possible. In this mode, the Y1 shift control is inoperative and X shift is effected by the X shift control. The X bandwidth is limited to 500 kHz and thus the relative phase shift between X and Y is significant only above 20 kHz.

3.8 TRIGGER

The timebase may be triggered from the positive or negative slope of the signal selected by the TRIG SELECT switch as follows:-

- (a) Y1 or Y2 signal (irrespective of which beam is displayed).
- (b) An external triggering source connected to the EXT TRIG socket.

When the LEVEL control is pulled out to select BRIGHT LINE OFF, the timebase will only trigger when the trigger signal reaches the selected level. When the LEVEL control is set outside the range of signal or when there is insufficient signal amplitude the timebase will not run and the screen will remain blank.

The more normal mode of operation is with the LEVEL control pushed in, when the timebase will free run in the absence of the correct trigger to display a bright line or unsynchronised display until the level control is adjusted and/or the amplitude of the trigger signal is increased. This free run action in the absence of correct trigger helps in finding the trace and leads to ease of operation. If the timebase is required to free run continuously, the LEVEL control should be set to either end of its rotation.

It is expected that the BRIGHT LINE OFF mode will be selected only when the instrument is to be used to display signals at low or high repetition rates.

- * The TRIG SELECT switch is used in conjunction with the ACF-AC-TVF slide switch. This switch connects different networks into the trigger amplifier circuit and is effective at all settings of the TRIG SELECT switch. The operating facilities available at the three settings of the slide switch are as follows:-

- AC Wideband trigger mode used for most signals.
- ACF A filter is switched into circuit to reject low frequencies. High frequency triggering may be effected from complex waveforms such as those with high ripple content or line triggering from a television video signal waveform.
- TVF A filter is switched into circuit to reject high frequencies. Its cut off is chosen to accept the frame synch of a TV video waveform and reject the line frequency component.

Summarising, triggering control is effected as follows.

1. Set the TRIG SELECT switch to select the required trigger signal and slope.
2. Set the ACF-AC-TVF switch to the required setting.
3. Adjust the LEVEL control so that the trace starts at the required point on the waveform.

3.9 ADDITIONAL FACILITIES

(a) Cal

This socket provides a d.c. coupled positive-going square wave of $1V \pm 2\%$ amplitude at line frequency for calibration checks. The square wave has a source impedance of $1k\Omega$ and a risetime of approximately $20\mu s$ suitable for probe compensation.

(b) Ramp

This socket on the front panel provides a d.c. coupled positive-going timing ramp of approximately 10V amplitude generated by the timebase. Source impedance is $18k\Omega$.

(c) Z Mod

The socket on the rear panel allows an a.c. coupled signal to modulate the brightness. Coupling is by an internal $0.02\mu F$ capacitor into $4.7M\Omega$. The input impedance at this socket is $100k\Omega$. (2Hz-10 MHz)

1. Sensitivity is approximately 10V pk-pk for visible modulation at normal brightness.
2. Full blanking requires a 70V negative-going pulse.

(d) Use of Optional Passive Probe

A X10 passive probe may be used to extend the voltage range and increase the input impedance of the Y amplifiers. The input resistance of a Y channel is $1M\Omega$, shunted by approximately $28pF$. The effect

* See OS250 TV Supplement.

tive capacity of the input lead must be added to this and the resultant impedance can often load the signal source. Therefore it is advisable to use a $10M\Omega$ X10 probe such as Advance PN32824. This reduces the input capacity and increases the input resistance, at the expense of a 10X reduction in sensitivity. The probe contains a shunt RC network in series with the input and forms an attenuator with the input RC of the Y channel. To obtain a flat frequency response it is necessary to adjust the capacitance of the probe to match the input capacity of the Y channel as follows:

1. Set the Y channel VOLTS/CM switch to 20mV, the TIME/CM switch to 1ms and TRIG INT POS from the appropriate channel.

2. Connect the probe to the CAL socket.
3. Adjust the probe compensation to obtain a level trace, i.e. flat top without overshoot or undershoot over the first few milliseconds of the 50Hz waveform.

(e) Camera

A camera may be fitted to the oscilloscope to record waveforms. This facility is particularly useful for the slow speed timebase settings. Suitable cameras utilising Polaroid or 35mm film may be obtained from D. Shackman & Sons, Polaroid Ltd., or Telford Products Ltd. Adaptors are available for attaching the camera to the oscilloscope. Other oscilloscope cameras may be used but suitable adaptors must be obtained and should be discussed with the camera manufacturer.

FOR SERVICE MANUALS
CONTACT:
MAURITRON TECHNICAL SERVICES
www.mauritron.co.uk
TEL: 01844 - 351694
FAX: 01844 - 352554

The OS250 block diagram is shown in Fig. 1. Inter connection of the printed circuit boards, controls, tube and associated components is shown in Fig. 6. Circuit diagrams are as follows:-

Fig. 3 Y1 and Y2 attenuators, pre-amplifiers, the main Y amplifier, beam switch and drive circuits.

Fig. 4 Timebase, X amplifier and trigger circuits.

Fig. 5 The power supply and tube network.

4.1 GENERAL

Referring to the block diagram (Fig.1) signals applied to the Y1 and Y2 input sockets pass into their respective attenuators and amplifiers. The VOLTS/CM switch controls the gain of the amplifier in the necessary 1 . 2 . 5 sequence to cover the ranges from 5mV/cm to 0.2V/cm. Above this a ÷ 100 attenuator is introduced before the amplifier.

The fast electronic beam switch selects either the Y1 or the Y2 signal to be amplified further and passed to the Y deflection plates of the c.r.t.

A sample of each signal is taken and passed to the trigger switch, where selection of Y1, Y2 or Ext trig source is made. The selected signal is amplified and passed to the Schmitt trigger, where it is converted into fast negative-going pulses. The hold off circuit acts as a gate which is normally open to allow a trigger pulse to set the timebase bistable. The boot-ramp generator then begins to generate its

linear ramp, which after passing through the X amplifier is applied to the cathode ray tube and drives the electron beam linearly across the tube face. A small portion of the signal from the ramp generator is fed back to the hold off circuit, shutting the gate to prevent any further pulses from the Schmitt trigger from reaching the timebase bistable during the ramp period. When the ramp has reached the necessary maximum level, the timebase bistable is reset, and the ramp is quickly returned to its quiescent state. A time constant in the hold off circuit now holds the gate closed to inhibit another ramp from being initiated for a short period, until the ramp timing capacitor is discharged fully. Thus a ramp is generated at a rate set by the TIME/CM switch when the trigger signal reaches a predetermined level. This ramp sweeps the beam across the c.r.t. face, returns and waits for the next trigger point to be reached. The timebase bistable is connected to a blanking amplifier whose function is to turn on the electron beam during the sweep and blank it off during the fly back and subsequent waiting period.

At fast sweep rates for a dual trace display, the TIME/CM switch automatically selects the alternate sweep mode of control for the beam switch. At the end of each sweep the signal from the time-base bistable reverses the state of the beam switch bistable, causing alternate displays of the Y1 and Y2 signal on successive sweeps of the timebase. At slow sweep rates, the chop mode is selected, when the chop

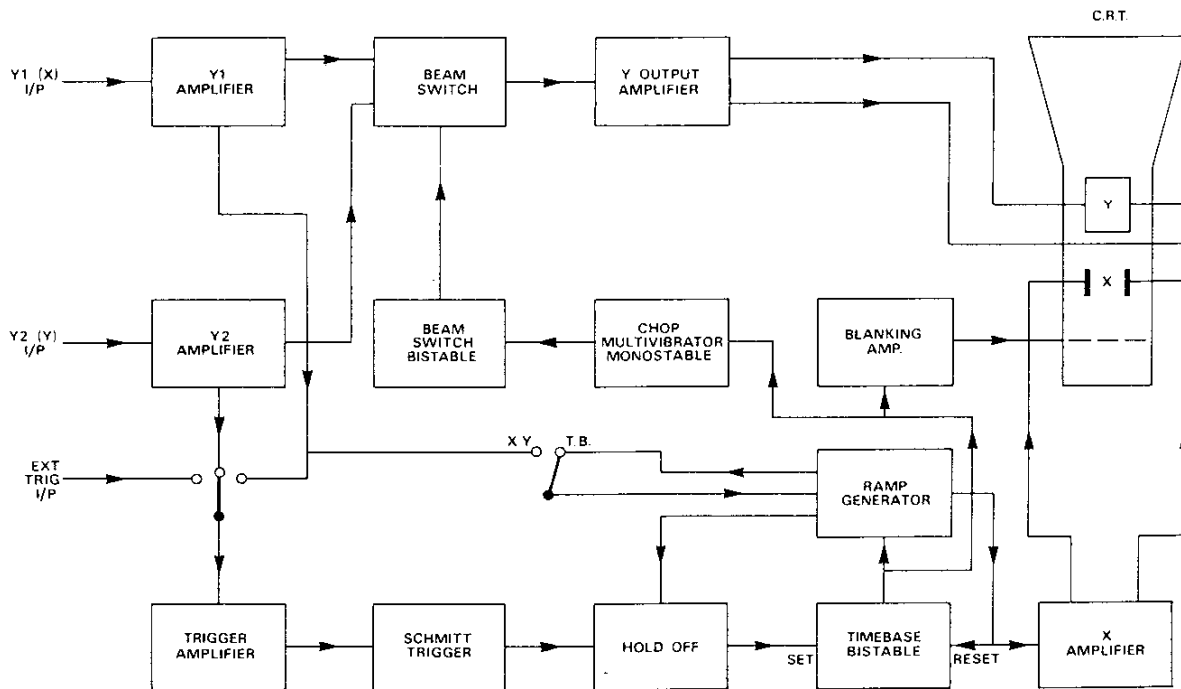

Fig. 1 Block diagram

multivibrator free runs independently, causing the beam to switch between Y1 and Y2 levels during the sweep. A signal from the multivibrator also blanks the trace during each switching transition. With Y1 or Y2 switched to the OFF position the beam switch bistable is locked to switch on the other channel.

In the X-Y mode, the signal from the Y1 amplifier, normally used for trigger, is passed via the ramp generator, which acts as a voltage follower, to drive the X plates while the beam switch selects Y2 to drive the Y plates. The beam blanking signal is not used.

4.2 THE Y AMPLIFIERS

The attenuator and pre-amplifier in the Y1 channel are identical to those in the Y2 channel. Accordingly, only the Y1 channel is described.

The input signal is applied to the front panel socket SKA and then to the 3 position slide switch S20, via R26. The switch selects AC or DC input coupling by including or by-passing C21 in the signal path. In the middle position of the switch, the input socket is disconnected, and the input of the attenuator is connected to ground through R27. The attenuator feeds into an impedance of $1M\Omega$ (R29). The $\div 100$ attenuation is determined by the potential divider action of R20 in series with the parallel combination of R29 and R201. High frequency compensation of the attenuator is achieved by the a.c. potential divider C202 and C203; C202 is set for the correct ratio. C201 is adjusted to maintain constant input capacitance between divided and undivided ranges. This attenuator is used on the six higher voltage ranges i.e. 0.5V/cm – 20V/cm, dividing them down to 5–200mV/cm. Further selection of input sensitivity is carried out by gain switching within the amplifier, and is described later. Diodes D201 and D202 in conjunction with R28 protect the input up to 400 volts peak.

The input stage consists of TR201 and TR202, a matched pair of field effect transistors. The current in TR202 is self biased such that the potential drop across R205 equals the gate/source potential. This same current flows in TR201, which operates as a source follower on the input signal. As R207 equals R205 the base potential of TR203 always equals the input voltage on the gate of TR201. The signal is passed via emitter follower TR203 to the gain switching stage.

The grounded emitter transistor TR204 forms a shunt feedback amplifier with gain determined by the ratio of the feedback resistor R211 to the input resistor R40 in parallel with the resistor selected by the range switch as shown in Table 1. R202 (BALance) sets the base of TR203 to null the potential across R40 etc.

The signal from the collector of TR204 is passed via R214 to the base of TR205 which in conjunction with TR206 forms a long tail pair amplifier, the gain of which

Table 1.

Switch Setting	Attenuation	Resistor Used	Amplifier Gain
5mV	$\div 1$	R40+R45	5
10mV	$\div 1$	R40+R44	2.5
20mV	$\div 1$	R40+R43	1.25
50mV	$\div 1$	R40+R42	0.5
100mV	$\div 1$	R40+R41	0.25
200mV	$\div 1$	R40 only	0.125
500mV	$\div 100$	R40+R45	5
1V	$\div 100$	R40+R44	2.5
2V	$\div 100$	R40+R43	1.25
5V	$\div 100$	R40+R42	0.5
10V	$\div 100$	R40+R41	0.25
20V	$\div 100$	R40+ only	0.125

is set by R217 and R223. The collector current of TR205 feeds into the trigger section of the timebase and 'X' amplifier circuit (fig.4). Potentiometer R52 provides a variable current via R219 into the collector circuit of TR206, to produce 'Y' shift. The bases of TR206 (Y1) and TR216 (Y2) are driven from the collector circuit of TR217 which being connected in a similar manner to TR204 and TR214 provides the correct bias and compensation for supply and temperature variations.

The beam switch, consists of diodes D203, D204, D206 and D207, with their associated drive circuitry and is described in detail in section 4.3. It selects the collector current of TR206 or of TR216 to pass through D205 and R223. The voltage developed across R223 consists of a fixed d.c. component, a variable d.c. component (Y shift) and the signal and is applied to the base of TR207, a common emitter amplifier. The emitter circuit includes potentiometer R222, to set the gain of the stage and hence the overall gain of the amplifier. The signal from the collector of TR207 is passed to the base of TR208, which with TR209, TR210 and TR211 forms the output cascode stage. TR208 and TR209, is a long-tail pair, which converts the input signal voltage to differential output current; its gain is determined by emitter resistors R234 and R236, with high frequency gain set by networks R232/C211/C212, R233/C213 and R236/C236. The collector currents of TR208 and TR209 flow into the emitters of the grounded base transistors TR210 and TR211 to develop the differential output voltage across the load resistors R230/R240 to drive the c.r.t. deflection plates. Inductors L201 and L202 are included to improve the high frequency response.

4.3 THE BEAM SWITCH

The cathode of D203 is supplied with a 6 volt positive-going square wave from the bistable TR218/TR219. When the waveform is "high", D203 is biased off and the collector current of TR206 passes through D204 into the output amplifier. During the low state of the waveform D203 conducts, passing this current to ground through TR219. As diodes D203 and D207 are fed with complimentary waveforms, when the current from TR206 passes to the output amplifier, that from TR216 is shunted to ground and vice-versa.

Bistable TR218/TR219 is switched with pulses from TR220/TR221, the chop multivibrator.

This emitter coupled circuit free runs at approx. 500kHz on TIME/CM settings from 0.5s to 1ms,† causing the bistable to operate the beam switch at 250kHz. In addition to driving the bistable, an output from the collector of TR221 is fed to the cathode of the c.r.t. to blank the trace during the beam switching transitions. The mark/space ratio of the multivibrator is approx. 1:4, causing the trace to be blanked for one fifth of each switching period.

At faster TIME/CM settings of 0.5ms†† to 1μs, the lower end of R292 is taken to -20V by a contact on the timebase switch biasing off TR221, and preventing oscillation. The circuit now acts as a monostable, triggered via C220 at the end of each sweep by pulses from the timebase bistable, each output pulse reversing the beam switch bistable and rapidly blanking the trace.

For single trace operation, the Y shift control on the channel not required is rotated fully anti-clockwise to operate the OFF switch. In this position, the switch S27 or S28 is closed, connecting the cathode of its associated diode to the negative line. This biases off the relevant transistor in the bistable. Thus when Y1 is turned off, S27 closes, biasing off TR218; TR219 turns on and sinks the current from Y1 channel to ground through D203. A reversal occurs when Y2 is turned off. In the X-Y mode, both shift controls are set to the on position; a contact on the TIME/CM switch in parallel with S27 is used to bias TR218 off, allowing Y2 signals only to reach the Y output stage.

* 4.4 THE TRIGGER CIRCUITS (Fig. 4)

The collector currents from TR205 and TR215 in the Y amplifier pass to the timebase printed circuit board into R108 and R109 respectively. In series with R108 is R110 shunted by C101, a collector load network used when X-Y mode is selected. External trigger signals appear across R107, and these, together with those across R108 and R109 pass to the trigger selector switch. The selected trigger signal is amplified by TR107 and passed to the coupling switch. Here, high pass, direct

and low pass networks provide the required ACF-AC-TVF filtering. Trigger level and slope selection operations are performed by long-tail pair amplifier TR101/TR102. The signal is applied to either input as determined by the slope selector switch, the other input being grounded via C121. The Trigger Level control, R10, provides a variable d.c. bias at both inputs, which the amplifier sums with the signal. The output at the collector of TR102, consisting of an alternating signal voltage superimposed on a d.c. level, passes to the Schmitt Trigger TR103/TR104, where fast negative edges are generated as the input signal crosses the circuit threshold.

4.5 THE TIMEBASE BISTABLE AND RAMP GENERATOR

The ramp generator comprises TR111, TR112 and TR113 as cascaded emitter follower stages, with bootstrap feedback action provided from the cathode of Zener diode D104. This feedback maintains constant voltage across the VARIABLE TIME control R11, R148, R147 and the timing resistor selected by the TIME/CM switch. This constant voltage drop, independent of actual voltage level produces a constant current to linearly charge the timing capacitor, also selected by the TIME/CM switch. The VARIABLE TIME control provides fine adjustment of the timing current, and hence sweep time, by varying the feedback voltage applied to the timing resistor.

In the quiescent condition of the timebase bistable, TR108 is on, TR109 is off and clamp transistor TR110, which shunts the timing capacitor, is saturated. A negative-going pulse from the Schmitt Trigger is coupled via C111 and D102 to turn off TR108. TR109 turns on, thus turning off TR110. The clamp is removed, allowing the timing capacitor to charge, producing the linear ramp. As the emitter of TR113 rises, a feedback voltage, via D105, R143 and R133 biases off D102 to prevent any further pulses reaching the bistable. Connected to the junction of R133/R143 is the HOLD OFF capacitor which now charges positive. When the ramp reaches its final amplitude, a rise of approximately 10V, feedback from the junction of R151/R149 is applied to the base of TR108, turning it on. The bistable reverts to its initial state allowing TR110 to turn on, rapidly discharging the timing capacitor and returning the ramp to its quiescent level. The hold off capacitor, which was charged to a positive voltage during the ramp, now slowly discharges through R143 and R153, until it is caught by D105. Only then is D102 biased for the next trigger pulse to initiate the next sweep.

An output is taken from the ramp generator via R155 to SKE, the RAMP OUT socket, on the front panel.

† 2ms. on OS250TV.

†† 1ms. on OS250TV.

* See OS250TV Supplement.

FOR SERVICE MANUALS
CONTACT:
MAURITRON TECHNICAL SERVICES

www.mauritron.co.uk

TEL: 01844 - 351694

FAX: 01844 - 352554

4.6 BRIGHT LINE CIRCUIT

When sufficient trigger signal is available, the square wave from the collector of TR104 passes through R127/C104, where restoration by D101 produces a negative going signal with respect to the negative rail. This negative signal on the base of TR105 is integrated by R124/C107 to produce a d.c. bias sufficient to hold off TR106. In this condition the circuit has no effect on timebase operation. However, when the triggering signal falls below the required level, the Schmitt trigger ceases to operate, removing the signal from D101. The voltage on the emitter of TR105 rises to approximately one volt above the negative line, turning on TR106. R177 is now effectively connected between the negative rail and the cathode of D102. It rapidly discharges the hold off capacitor below the normal quiescent level to a point where D102 conducts, turning TR108 off and initiating a sweep. At the end of the ramp, the charge on the hold off capacitor is again removed by R177/R143 and another ramp begins. These consecutive sweeps produce the bright line display. When the "PULL BRIGHT LINE OFF" control is operated, switch S10 closes, effectively shorting the base and emitter of TR106, holding it off; in this condition a ramp is only generated after the arrival of a trigger pulse.

4.7 THE X OUTPUT AMPLIFIER

The ramp or X-Y signal at the emitter of TR113 passes through R156 to the base of TR114, which with TR117 forms a long tail pair. Gain switching is carried out in the emitter circuit by selection of one of two resistance paths, with gains set by R169(X1) and R16 R162(X10). In timebase mode, the PULL X10 switch S11 can be operated in order to expand the trace length ten times. In the X-Y mode contacts on the TIME/CM switch, in parallel with S11, close to select this higher gain setting automatically. An X SHIFT voltage is produced at the base of TR117 by R12. The signals on the collectors of TR111 and TR117 are applied to the differential output amplifier, TR115 and TR116. Signals from the collectors of these two transistors drive the horizontal deflection plates of the c.r.t.

4.8 X-Y Mode

In this mode, signals are applied to both Y1 and Y2 input sockets; Y2 is routed through the beam switch to the Y deflection plates in the normal manner. Y1 is routed through the ramp generator, now acting as a high impedance unity gain buffer, and into the X output stage.

Signals entering Y1 channel pass through the attenuator and gain switching stage, as described previously. Current from TR105 passes to the X board, while that in TR206 is shunted to ground through D203. The current from TR205 develops a voltage across the series connection of

R110, R108. This voltage is level-shifted by R144/R146 to the base of TR111. In the X-Y mode, both timing resistors and capacitors are switched out of circuit, consequently TR111, TR112 and TR113 merely act as emitter followers which provide buffering between the level-shift resistors and the X output amplifier.

When this mode is selected, a contact on the TIME/CM S14(a) switch connects the cathodes of D106 and D107 to the negative line. The current drawn through D106 and R138 turns off TR108 and consequently TR110, and removes blanking. (See section 4.11)

Current through D107 controls the state of the beam switch bistable. (See section 4.3)

4.9 POWER SUPPLIES (Fig. 5)

All power supplies are derived from transformer T1. The primary winding can be connected to accept six supply voltage ranges, as shown in fig. 2, on the inside of the top cover.

The transformer secondary has four windings developing the following r.m.s. voltages; 6.3V, 44V (centre tapped), 140V and 1000V.

The 6.3V winding supplies the c.r.t. heater.

The 44V a.c. is rectified by MR32 and smoothed by C33/C34 to form the unstabilised +26V and -26V d.c. lines. These voltages are fed to series regulators to provide the stabilised +20V and -20V lines. As both regulators operate in an identical manner, only one will be described.

The base of series pass transistor, TR32, is fed from the output of the high gain error amplifier formed by TR305/TR306. This amplifier compares the zener reference voltage from D316 with the voltage at the junction of R310/311, a potential divider connected between the emitter of TR32 and ground. As this emitter supplies the +20V line, any fluctuations in the line voltage appear at the base of TR306 where they are amplified and inverted. This signal is then fed to the base of TR32 to correct the error, thus maintaining a constant output voltage. Resistor R309, in series with the collector of TR32, drops a voltage which is proportional to the output current. Under normal conditions, this voltage drop is less than that across R307, biasing off D310. As the output current rises above the safe maximum, D310 turns on, taking the current in R307 away from the emitter of TR305. This causes a drop in voltage at the collector of TR306 and hence on the base and emitter of TR32, limiting the current to a safe value.

The voltage from the 140V winding is rectified by MR31 and smoothed by C31 to form the unstabilised 170V line.

The 1000V winding energises both the -1.2kV and $+2.4\text{kV}$ supplies. Half wave rectification of the negative half cycle by D301 produces the negative line, while voltage doubling by D302/D303 produces the positive. Stabilisation of both lines against supply variation is achieved as follows. One end of the 1000V winding feeds the diodes mentioned above. The other end passes to ground through bridge rectifier MR301. The alternating current in the winding passes through the rectifier as direct current via R338 and TR301, developing a smooth direct voltage across C315. This voltage, controlled by the conduction of TR301, forms a threshold above which the alternating voltage applied to the bridge must rise before current can flow. As this threshold must be reached on both positive and negative excursions of the supply waveform, the overall effect is to take the middle out of the sine wave, thus reducing its voltage. This controlled voltage is rectified to produce the E.H.T. supplies. R322 feeds a negative current into the base of TR302, proportion to the peak value of the regulated waveform. This current is balanced by a reference current from the + line fed via R319 and SET E.H.T. potentiometer R320. The voltage at the summing point of the two currents appears at the emitter of TR302 and controls the current flow through D304, which in turn controls the conduction of TR301. As it is this conduction which controls the alternating voltage from which the feedback is derived, a closed loop circuit is formed. Variations in the magnitude of voltage across the 1000V winding either increases or decreases the voltage on the -1.2kV line. Feedback from this line is compared with a reference and the conduction of TR301 is varied accordingly to bring the line back to its correct voltage. As the $+2.4\text{kV}$ line is derived from the same stabilised source as the -1.2kV , it also remains constant.

4.10 CALIBRATOR (Fig. 5)

The $1\text{V} \pm 2\%$ square wave at the CAL 1V socket, SKD, is produced by TR307, on the power supply board. Current for the base of this transistor is supplied via R305 and D311. The anode of D312, is connected to the junction of these two components, its cathode being taken to one of the 22V windings. On positive excursions of the winding, D312 is biased off, and the current through R305, D311 saturates TR307. During negative excursions, D312 conducts, and the current in R305 passes through the transformer winding. In this condition

D311 and TR307 are turned off. The result is a square wave on the collector of TR307, at line frequency, with amplitude set by adjustment of R304.

4.11 BLANKING

The signal which blanks the c.r.t. when a sweep is not occurring is produced by TR308. The base of this transistor is fed via R135/C118 from the collector of TR108 in the timebase bistable. When TR108 is on, no current flows in R135, thus TR308 is off and its collector is at approximately 70V, as determined by R335, R336 and R337. This voltage is fed to the beam blanking plates of the c.r.t., pin 5, and blanks the trace. As TR108 turns off to initiate a sweep, the current in R135 turns TR308 on; its collector voltage falls to about 3V, where it is held by the action of the forward biased diode, D313. Under this condition c.r.t. blanking is removed. Blanking is not effected in the X-Y mode as TR108 in the timebase bistable is permanently off.

When dual trace operation is selected, a pulse is coupled via C314, from the collector of TR221 into the cathode of the c.r.t. in order to blank the trace during the switching transition.

Z Modulation

Signals applied to SKF on the rear panel pass via C313 to the grid of the c.r.t. where they produce trace intensity modulation.

4.12 TUBE NETWORK

The cathode of the c.r.t. draws current from the -1.2kV line through the BRILLIANCE control, R33. Clockwise rotation of this control decreases the grid potential, and hence varies the tube conduction from cut off to maximum. Electrons emitted from the cathode are focussed into a narrow beam by potentials on the focus and astigmatism electrodes. These potentials are approximately -850V and $+80\text{V}$, controlled by R34 and R332 respectively.

When a positive potential is applied to the blanking plates, the electron beam is deflected to one side of the tube, thus preventing the electrons striking the tube face. The geometry control R333 varies the potential on an electrostatic shield placed between the X and Y deflector plates to minimise interaction. After deflection by the X and Y plates, the electron beam is accelerated by the PDA potential of $+2.4\text{kV}$, to strike the phosphor coated tube face at high velocity, and produce a display.

FOR SERVICE MANUALS
CONTACT:
MAURITRON TECHNICAL SERVICES
www.mauritron.co.uk
TEL: 01844 - 351694
FAX: 01844 - 352554

5.1 GENERAL

Figs 7 and 8 show the internal location of sub assemblies and preset controls. Access to all preset controls and most other components is obtained by removing the top and bottom covers. Full access to all components can be achieved by removing the Y amplifier sub assembly or timebase and X amplifier sub-assembly. For detailed fault finding the instrument can be operated with either assembly out of the frame and with the interconnecting leads extended.

(a) Removal of Covers

Each cover is retained in position by four latch fasteners. Each fastener is released by turning it one quarter of a turn counter-clockwise.

(b) Transformer Tap connections

DISCONNECT THE INSTRUMENT FROM THE SUPPLY BEFORE ADJUSTING THE TRANSFORMER TAPS. The transformer tap connections for each of the normal supply voltages are shown in fig 2 below. This diagram is reproduced inside the top cover of the instrument. It will be seen that the two tapped primary windings are connected in series or parallel as necessary. The 'line' is the brown lead from the fuse and the 'neutral' is blue. Check that the correct fuse is fitted for the supply in use.

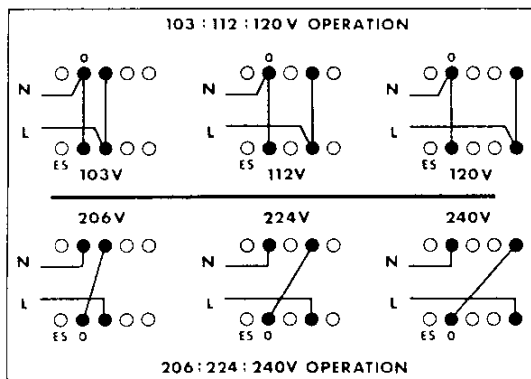

Fig. 2 Transformer tap connections

(c) Fuse Replacement

DISCONNECT THE INSTRUMENT FROM THE SUPPLY BEFORE CHANGING THE FUSE

The size 0 fuse is mounted on the rear panel, above the transformer. For 190-260V operation, a 200 mA slow blow fuse, Advance Part No. 24041 is required. For 95-130 volt operation, a 400mA slow blow fuse, Advance Part No. 32475 is required.

5.2 REMOVAL OF SUB-ASSEMBLIES

Removal procedures for each of the Printed Circuit Board assemblies are outlined below. However, almost all the components in the instrument, with the exception of those in the early stages of the Y amplifiers, are

accessible without recourse to board removal.

(a) Y Amplifier Sub-assembly.

1. Remove and identify the leads from pins 9,10, 11,12,13,16,17,21,23,25 and 29 on the above named assembly.
2. Remove and identify the leads from pins 5 and 41 on the time base board.
3. Remove the two screws holding the heat sink plate to the side bar of the instrument, and remove the screw from the rear of the assembly.
4. Remove the knobs from both Y1 and Y2 attenuator switches and shift controls.
5. Remove the fixing nuts from the attenuator controls.
6. The assembly can now be removed. With the assembly out of the instrument, the attenuator screens can be released by removal of the four fixing screws.

(b) * Timebase and X Amp Sub-assembly

1. Remove and identify leads from pins 21, 23 and 25 on Y amp board.
2. Remove and identify leads to pins 5,10,11,26, 33,41,43,44,45 and 46.
3. Remove two fixing screws at rear of assembly.
4. Remove the knobs from VARIABLE TIME, X SHIFT and TRIG LEVEL controls, from TIME/CM and TRIG SELECT switches.
5. Remove fixing nuts from TIME/CM and TRIG SELECT switches.
6. The assembly can now be removed.

(c) CRT Replacement

1. Remove the tube base connector.
2. Remove the P.D.A. cap.
3. Remove lead from pin 21 on power supply board.
4. Remove screw holding tube shield to the tube support clamp and the two screws from tube support clamp. Slacken the c.r.t. face mounting.
5. Slide the tube and tube shield back to clear the front panel mountings and remove the tube and shield from the instrument. The tube can then be withdrawn from the shield.
6. Replace the tube in the reverse order.

When the tube is replaced it may require rotation to align the trace with the graticule (see section 5.4d)

5.3 FAULT FINDING

Before any fault location is attempted, it is suggested that all supply line voltages are checked with respect to 0V. These are given in Table 2.

Table 2.

LINE	MEASURED VOLTAGE
+20V	+19 to +21V
-20V	-19 to -21V
+170V	+160 to +180V
PDA	> +1,900V use meter at least
*-1.2kV	-1,140 to -1,240V 20,000 Ω/V

*Measured at junction R322, R324

* See OS250TV Supplement.

NOTE: The power supply input voltage should be approximately at the centre of the range for which the transformer taps are connected.

Table 3, indicating voltages at various circuit locations, may be used as a general guide and servicing aid. The front panel controls should be set as follows.

- BRILL, X SHIFT, Y2 SHIFT—all at mid position.
- Y1 SHIFT—to Y1 OFF position
- Y1 and Y2 INPUT switches—to ground position.
- TRIG SELECT—to Y1 +ve.
- ACF,AC,TVF—to A.C.
- LEVEL—to mid position, BRIGHT LINE on.
- TIME/CM—to X-Y

Adjust X and Y2 shift controls to bring spot to centre of tube.

If a fault on a printed circuit board cannot be cleared it is recommended that the instrument is returned to the manufacturer for repair (See section 7). When faults have been cleared it is recommended that the setting up procedure is followed. Calibration adjustments should be made only after a 15 minute warm up period following switch on.

Table 3

LOCATION	TYPICAL VOLTAGE
Y Amplifier Sub-assembly	
Base TR203, TR222	0V.
Collector TR204,TR214,TR217	+7V
Pin 22	+3.6V
Pin 21	+3V
Collector TR207	+9.3V
Pins 9 and 10	+110V
Emitter TR221	12V
X Amplifier and Timebase Sub-assembly	
Collector TR107	+4V
Collector TR102	+13V
Collector TR106	-20V
Collector TR109	+0.1V
Emitter TR113	+5.5V
Emitter TR115,TR116	-6.8V
Pins 34, 37.	+92V
Power Supply Sub-assembly	
Emitter TR302	+0.5V
Collector TR308	+3.5V

5.4 SETTING UP PROCEDURE

(a) Test Equipment

1. Multirange Test Meter. 0-2.5kV with sensitivity >20kΩ/V
2. Variable Autotransformer output voltage 95-260V at 1A.
3. Sine/Square wave signal generator covering the range 10Hz-100kHz amplitude 20mV - 5V. Such as ADVANCE H1E or J3.
4. Source of voltage and time calibration signals such as a Bradley Oscilloscope calibrator
5. A T.V. video waveform Generator, such as Advance type SG73.

6. Square-wave Generator. 500kHz flat top square wave Generator with adjustable amplitude 0.2V to 1V into 50Ω, having a risetime of less than 5ns such as Advance SG21A.
7. R.f. Sinewave Generator. 500kHz to >10MHz with 50kHz reference frequency. Output amplitude 25mV to 5V pk to pk into 50ohms, 10V unterminated. Amplitude accuracy at 50kHz and 500kHz to 10MHz within 3%.
8. 50 ohms B.N.C. termination, such as Advance TP19.

Power Supply Voltages

- (b) With the transformer connected for 222 to 260V operation, connect the instrument to the A.C. supply via a variable autotransformer, and set the voltage to 240V ± 1%. If the supply transformer is not connected for 222 to 260V operation, the test should be carried out with the supply within 1% of the nominal voltage shown in fig. 2.

Check the voltages to chassis on the following pins on the power supply board :-

+20V	+19.0V min	+21.0V max
-20V	-19.0V min	-21.0V max
+170V	+160V min	+180V max
PDA	>+1900V	

Adjust R320 (EHT) to give 155V across C315. Unless the instrument is supplied from a known stable source, the supply voltage should be checked at the same time that the potential across C315 is measured. Measure the voltage from the junction of R322,R324 to chassis which should be between -1140 to -1240V. This voltage should not change by more than ± 9V when the supply voltage is varied from 222V to 260V.

(c) Astigmatism

Set the front panel controls as follows:- TIME/CM switch to X-Y, BRILLIANCE to mid position, X shift to mid position, Y1 and Y2 shifts to mid position and Y1 and Y2 VOLTS/CM switch to .2. Adjust X and Y2 shift to centre a spot on the screen. Adjust R332 (Astig) together with the BRILL and FOCUS controls to obtain a sharp round spot.

(d) Trace Rotation

Set the TIME/CM to 1ms/cm and bright line auto on. Rotate the c.r.t. to bring the trace exactly parallel with the horizontal graticule line. It may be necessary to slacken the c.r.t. face support screws to rotate the c.r.t.

(e) Geometry

Set the Y2 shift to off position, Y1 input switch to AC, Trigger Selector to Y1 and apply to Y1 input socket a 1kHz sinewave set to give approximately 8cm of Y deflection. Set the TIME/CM switch and level control so that approximately 10 cycles are displayed. Adjust R333 (Geom)

- for a compromise between horizontal and vertical pin-cushioning and barrelling effects. Reset the FOCUS, and if necessary readjust R332 (Astig).
- (f) **DC Balance**
Set the Y1 and Y2 input switches to ground. Adjust the Y1 and Y2 Bal controls to eliminate X and Y trace movement when Y1 and Y2 VOLTS/CM are switched from .2V/cm to 5mV/cm.
- (g) **Timebase Calibration**
Switch TIME/CM to 1ms/cm, variable time in CAL position. Apply 1ms markers to the Y1 input, adjusting Y sensitivity to give approximately 2 cm amplitude and triggering without bright line auto. Adjust R169 (X1 Gain) for 1 pulse/cm. Set X10 switch on, change markers to .1ms/cm and adjust R162 (X10 Gain) for 1 pulse/cm. Switch X10 off and set TIME/CM to 10 μ s/cm. Change markers to 10 μ s and adjust C10 for 1 pulse/cm. Check the timebase accuracy on all ranges to specification. Check that the variable time control reduces the speed by greater than 2.5:1. Ensure that the trace length is greater than 10cm on all ranges. With 10X mag. on apply time markers and check that the speed accuracy is within specification on all ranges ignoring the non-linearity on the first 5cm. of the 0.1 μ s/cm. range. Switch off the X10 mag.
- (h) **Y AMP Calibration**
Set both Y1 and Y2 attenuators to .2V/cm, both input switches to DC, and the TIME/CM to 5ms/cm. Apply 1V from a calibrator to Y1 and adjust R222 (Y Gain) for a 5cm display. Apply the same signal to Y2 input, trigger on Y2 and observe the deflection. Readjust R222 to equalise the errors from 5cm deflection between Y1 and Y2.
- (i) **Input Capacity and Attenuator Compensation**
Capacitors C25 and C27 are selected such that the input capacitance is approximately 28pF.
To set the attenuator compensation, set the Y1 VOLTS/CM switch to 0.5, the input coupling to D.C. and the TIME/CM to 0.5ms. Connect a low impedance 3V, 1kHz square wave signal to the input and adjust C202 for a square top to the display.
Repeat for Y2, adjusting C222.
To equalise the input capacitance on all ranges, set the Y1 VOLTS/CM switch to 0.2, the input coupling to DC and the TIME/CM to 0.5ms. Connect a 1kHz square wave signal either via a 10:1 probe or a 1M Ω series resistor connected in parallel with a 10 to 40pF trimmer capacitor, mounted close to the input socket. Set the input amplitude for approximately 6cm of display and adjust the probe compensation or the trimmer for a square top to the display. Set the Y1 VOLTS/CM switch to 0.5 and adjust C201 to regain the flat top to the display.
Repeat for Y2 adjusting C221.
- (j) **Internal Calibrator**
Set Y1 attenuator to .2V/cm then apply to Y1 input a 1V \pm 1% squarewave calibrator and note the exact deflection. Remove the 1v squarewave and apply the internal calibrator to Y1 input. Adjust R304 (Cal) to give the deflection previously noted.
- (k) * **Trigger Sensitivity**
Apply the CAL signal to the Y1 input, set to 5V/cm with the trigger set to Y1 and AC with BRIGHT LINE off. Rotation of the LEVEL control should give a stable display of the correct slope in both + and - positions. Check that timebase does not free run at any setting of the LEVEL control. Push the LEVEL control in. Rotation of the LEVEL control should show range with a stable display of the correct slope in both + and - positions but free running outside this range. Remove the calibrator from the Y1 input and set this input to GROUND. Check that the timebase free runs at all settings of the LEVEL control in both + and - positions.
Repeat for the Y2 channel.
- (l) **ACF AND TV Trigger**
Set Y2 attenuator to 1V/cm and select ACF. Two stable trigger points of opposite slope should be found in the level control. Switch to TV, Y2+ and apply to Y2 input a video waveform from a video waveform generator. Adjust Y2 attenuator to give 1 to 2cm display. Adjustment of the trig level control should give a stable display triggered from a video frame pulse. Remove the video input and return trig switch to A.C.
- (m) **EXT Trig**
With internal CAL signal applied to the Y2 input, the Y2 attenuator set to 5V/cm, and trig selector set to EXT, apply the CAL waveform also to the EXT trig socket via a 220k Ω resistor. Check that the instrument triggers correctly with the BRIGHT LINE both on and off.
- (n) **Pulse Response**
Switch the Y1 attenuator to 5mV/cm and set TIME/CM to 1 μ s/cm. Apply a 500 kHz fast risetime square wave signal to Y1 input using a 50 Ω termination at the input socket to prevent cable reflections. Adjust output from generator to give 6cm display. Adjust C211 to extend the

FOR SERVICE MANUALS

CONTACT:

MAURITRON TECHNICAL SERVICES

www.mauritron.co.uk

TEL: 01844 - 351694

FAX: 01844 - 352554

* See OS250 TV Supplement.

flat top towards the leading edge. Adjust C209 for a square corner. Apply the signal generator Y2 to check the squareness of corner, then readjust C211 and C209 as necessary for a compromise square corner between Y1 and Y2 amplifiers. Check that the pulse response is square on all ranges between 5mV/cm and .2V/cm, adjusting the generator for 5cm on each range, on both Y1 and Y2 allowing a maximum of 4% overshoot or undershoot.

(o) **Bandwidth**

Set Y1 attenuator to 5mV/cm and apply the output of a constant amplitude generator to the Y1 input. Set frequency to 50kHz and adjust generator output to give 6cm display. Increase the frequency until amplitude falls to 4.2cm. This frequency should be greater than 10MHz. Repeat for Y2 channel.

(p) **HF Trigger**

Switch off the BRIGHT LINE.
With the constant amplitude generator applied to the Y2 input and the TIME/CM set to

1 μ s/cm, X10, set the generator frequency to 10MHz and adjust the output to give 1cm display. It should be possible to obtain a clearly triggered waveform by adjustment of the level control. Repeat for the Y1 channel.

(q) **X-Y Operation**

Switch the TIME/CM to X-Y and both Y1 and Y2 attenuators to 200mV/cm. Apply a 4V signal to the Y1 input socket. The X deflection should be 8cm \pm 5%. Apply 50kHz from the Constant Amplitude Generator to the Y1 input and ground the Y2 input. Adjust the generator to give a 10cm horizontal line.

Increase frequency until the line reduces to 7cm. This frequency should be greater than 500kHz.

(r) **Z Mod**

Set the Y1 attenuator to 1V/cm and apply both to the Y1 input and to the Z mod socket a 10V 1kHz square wave. Check that blanking is operating at normal brilliance levels.

FOR SERVICE MANUALS
CONTACT:
MAURITRON TECHNICAL SERVICES
www.mauritron.co.uk
TEL: 01844 - 351694
FAX: 01844 - 352554

ABBREVIATIONS USED FOR COMPONENT DESCRIPTIONS

RESISTORS

CC	Carbon Composition	$\frac{1}{2}$ W	10%	unless otherwise stated
CF	Carbon Film	$\frac{1}{8}$ W	5%	unless otherwise stated
MO	Metal Oxide	$\frac{1}{2}$ W	2%	unless otherwise stated
MF	Metal Film	$\frac{1}{4}$ W	1%	unless otherwise stated
WW	Wire Wound	6W	5%	unless otherwise stated
CP	Control Potentiometer		20%	unless otherwise stated
PCP	Preset Potentiometer Type MPD, PC		20%	unless otherwise stated

CAPACITORS

CE(1)	Ceramic		+ 80%	
			- 25%	
CE(2)	Ceramic	500V	\pm 10%	unless otherwise stated
SM	Silver Mica			
PF	Plastic Film		\pm 10%	unless otherwise stated
PS	Polystyrene			
PE	Polyester		\pm 10%	unless otherwise stated
PC	Polycarbonate			
E	Electrolytic (aluminium)		+ 50%	
			- 10%	
T	Tantalum		+ 50%	
			- 10%	

FOR SERVICE MANUALS
 CONTACT:
MAURITRON TECHNICAL SERVICES
www.mauritron.co.uk
 TEL: 01844 - 351694
 FAX: 01844 - 352554

Component List and Illustrations

Section 6

Y AMPLIFIER

Ref	Value	Description	Tol %±	Part No.	Ref	Value	Description	Tol %±	Part No.
RESISTORS									
R 201	10k	MF	1	26338	R253	18k	CF		21811
R202	22k	CP		A4/32894	R254	470	CF		21797
R203	18k	CF		21811	R255	470	CF		21797
R204	470	CF		21797	R256	39k	CF		28728
R205	470	CF		21797	R257	470	CF		21797
R206	39k	CF		28728	R258	470	CF		21797
R207	470	CF		21797	R259	6k8	CF		21807
R208	470	CF		21797	R260	2k2	CF		21802
R209	6k8	CF		21807	R261	2k	MO		26731
R210	2k2	CF		21802	R262	18	CF		28709
R211	2k	MO		26731	R263	6k8	MO		28796
R212	18	CF		28709	R264	220	CF		21796
R213	6k8	MO		28796	R265	3k3	CF		21803
R214	220	CF		21796	R266	3k3	CF		21803
R215	3k3	CF		21803	R267	180	MO		26744
R216	3k3	CF		21803	R268	180k	CF		21822
R217	180	MO		26744	R269	12k	CF		21810
R218	180k	CF		21822	R270	10	CF		21793
R219	12k	CF		21810	R271	6k8	MO		28796
R220	10	CF		21793	R272	47	CF		28714
R221	47	CF		28714	R273	2k	MO		26731
R222	100	PCP		28520	R274	2k2	CF		21802
R223	330	CF		28721	R275	10	CF		21793
R224	12k	CF		21810	R276	22k	CF		21812
R225	56	CF		28715	R277	1k8	CF		28725
R226	3k3	CF	5	½W 18556	R278	2k7	CF		28726
R227	1k2	CF		21800	R279	1k8	CF		28725
R228	680	CF		28723	R280	15k	CF		28727
R229	10	CF		21793	R281	22k	CF		21812
R230	3k	MO	5	6W 33212	R282	22k	CF		21812
R231	47	CF		28714	R283	15k	CF		28727
R232	47	CF		28714	R284	22k	CF		21812
R233	22k	CF		21812	R285	1k	CF		21799
R234	120	CF		28718	R286	3.9k	CF		21804
R235	820	MO	5	4W 33212	R287	27k	CF		21813
R236	15k	CF		28727	R288	1k8	CF		28725
R237	180	CF		21795	R289	4k7	CF		21805
R238	47	CF		28714	R290	6k8	CF		21807
R239	10	CF		21793	R291	10k	CF		21809
R240	3k	MO	5	6W 33212	R292	27k	CF		21813
R241	1k2	CF		21800	CAPACITORS				
R242	2k7	CF		28726	C201	6pF	Trimmer		25750
R243	10	CF		21793	C202	6pF	Trimmer		25750
R244	560	CF		21798	C203				
R245	2k2	CF		21802	C204	.01µF	CE(2)	25	250V 22395
R246	2k2	CF		21802	C205	.01µF	CE(2)	25	250V 22395
R247	2k2	CF		21802	C206	39pF	CE(2)		22371
R248	2k2	CF		21802	C207	.01µF	CE(2)	25	250V 22395
R249	47	CF		28714	C208	39pF	CE(2)		22371
R250	10	CF		21793	C209	10/40pF	Trimmer		29483
R251	10k	MF	1	26338	C210	1000pF	CE(2)		22387
R252	22k	CP		A4/32894					

Component List and Illustrations

Section 6

Y AMPLIFIER (Cont.)

Ref	Value	Description	Tol %±	Part No.	Ref	Value	Description	Tol %±	Part No.
C211	10/40pF	Trimmer		29483	TR207		2N3904		24146
C212	220pF	PS	10	125V 11587	TR208		2N2369		23307
C213	270pF	CE(2)		22380	TR209		2N2369		23307
C214	68pF	CE(2)		22374	TR210		BF380		32902
C215	.1μF	CE(1)		30V 19647	TR211		BF380		32902
C216					TR212 }		AE23		A32957
C217	560pF	CE(2)		22384	TR213 }		Matched Pair		
C218	68pF	CE(2)		22374	TR214		2N3904		24146
C219	.01μF	CE(2)	25	250V 22395	TR215		2N3640		31781
C220	47pF	CE(2)		22372	TR216		2N3640		31781
C221	6pF	Trimmer		25750	TR217		2N3904		24146
C222	6pF	Trimmer		25750	TR218		2N2369		23307
C224	.01μF	CE(2)	25	250V 22395	TR219		2N2369		23307
C225	.01μF	CE(2)	25	250V 22395	TR220		BC212		29327
C226	47pF	CE(2)		22372	TR221		BC212		29327
C227	.01μF	CE(2)	25	250V 22395	TR222		2N3906		21533
C228	27pF	CE(2)		22369					
C229	27pF	CE(2)		22369	DIODES				
C230	.01μF	CE(2)	25	250V 22395	D201		IN3595		29330
C231	15pF	CE(2)		22366	D202		IN3595		29330
C232	15pF	CE(2)		22366	D203		IN4148		23802
C233					D204		IN4148		23802
C234	.01μF	CE(2)	25	250V 22395	D205		IN4148		23802
C235	.01μF	CE(2)	25	250V 22395	D206		IN4148		23802
C236	47pF	CE(2)		22372	D207		IN4148		23802
C237	39pF	CE(2)		22371	D208		IN4148		23802
C238	100pF	CE(2)		22376	D209		IN4148		23802
C239	.01μF	CE(2)	25	250V 22395	D210		IN4148		23802
C240	.01μF	CE(2)	25	250V 22395	D211		IN4148		23802
C241	.1μF	CE(1)		30V 19647	D212		IN4148		23802
C242	.1μF	CE(1)		30V 19647	D213		IN4148		23802
C243	.1μF	CE(1)		30V 19647	D214		IN4148		23802
C244	330pf	CE(2)		22381	D215		IN3595		29330
C245	0.1μF	CE(1)		30V 19647	D216		IN3595		29330
C246	68pF	CE(2)		22374					
					MISCELLANEOUS				
TRANSISTORS					L201	33μH			33204
TR201 }	AE23			A32957	L202	33μH			33204
TR202 }	Matched Pair				L203		Bead Ferrite		4442
TR203	2N3906			21533			FX1115		
TR204	2N3904			24146	L204		Bead Ferrite		4442
TR205	2N3640			31781			FX1115		
TR206	2N3640			31781					

FOR SERVICE MANUALS
CONTACT:
MAURITRON TECHNICAL SERVICES
www.mauritron.co.uk
TEL: 01844 - 351694
FAX: 01844 - 352554

RESISTORS	R26 R56 R21 R57	R27 R22	R20 R54 R28 R201 R20	R23 R55 R24 R251 R25	R20R R207 R257 R247 R203 R204 R246 R248 R209 R258 R202 R259 R255 R206 R253 R254 R252 R245 R259 R259	R40-45 R46-51	R212 R213 R211 R210 R202 R220 R260 R52 R261 R53 R262	R214 R216 R264 R266		
CAPACITORS	C40 C41	C25 C21 C27 C23	C201 C202 C221 C222	C22 C25 C24 C28	C341 C242	C204 C224	C205 C225	C340 C338		
MISC	SKA SKB	S20 S25	S21a F S22a F	S21a B S22a B	D201 D202 D215 D215	TR201 TR202 TR212 TR213	TR203 TR222	S215 S26b	TR204 TR214	S27 S28

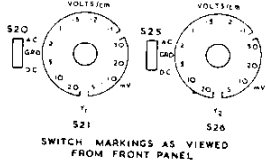
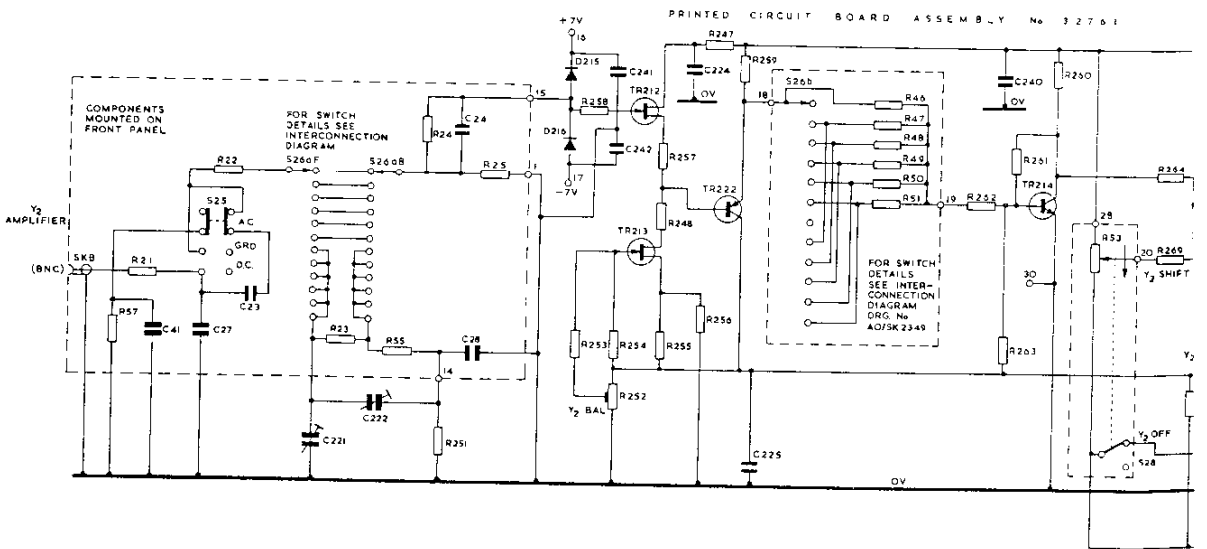
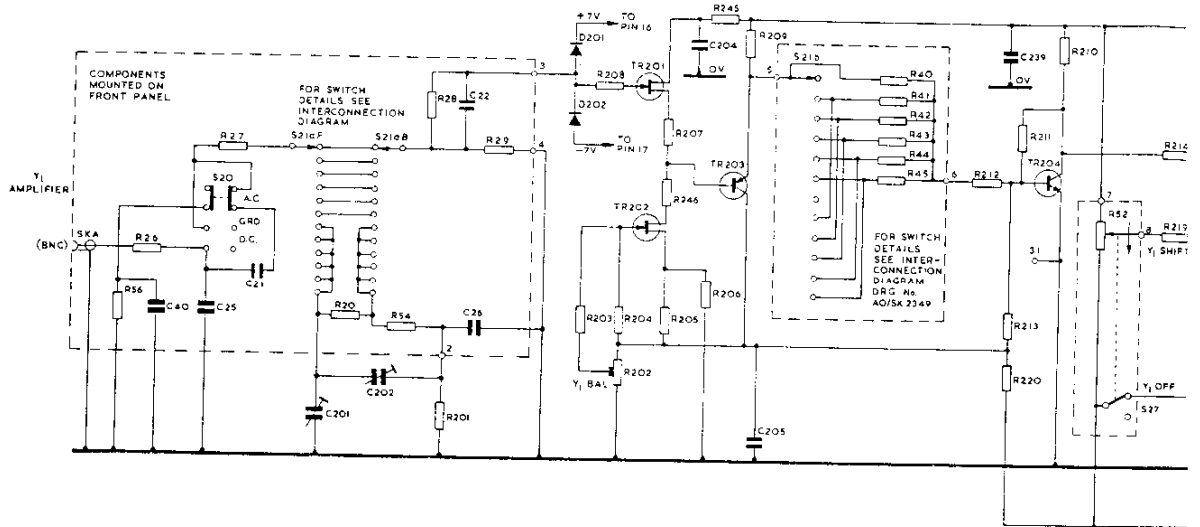

FOR SERVICE MANUALS
CONTACT:
MAURITRON TECHNICAL SERVICES
www.mauritron.co.uk
TEL: 01844 - 351694
FAX: 01844 - 352554

R20 R54 R98 R201 R29 R23 R55 R24 R251 R25	R209 R207 R267 R247 R258 R204 R246 R248 R206 R253 R254 R252 R245 R259 R256	R40-45 R40-51	R212 R213 R211 R210 R207 R220 R260 R52 R201 R53 R203 C239 C240	R214 R219 R204 R204 R214	R215 R217 R216 R205 R218 R266 R221 R274 R275 R244 R267 R272 R271	R229	R224 R228 R223 R277 R227 R225 R231 R276 R283 R225 R278 R249	R230 L2C R228 R229 R227 R222 C243 C238 C230 C237 C208 C234 C231 C232 C23
C21 C23	C201 C221 C202 C22 C24 C24 C28	D201 D202 D215 D216	C204 C234 C205 C235	S215 S265 S266	TR204 TR214 S27 S28	TR205 TR215 TR206 TR216	D203 D204 D204 D207	D205 D205 TR207 TR218 D210 D212 TR208 TR29 D208 D209
	S210F S200F S210B S250B				TR204 TR214 S27 S28	TR205 TR215 TR206 TR216	D203 D204 D207	D205 D205 TR207 TR218 D210 D212 TR208 TR29 D208 D209

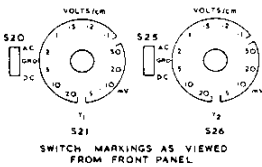
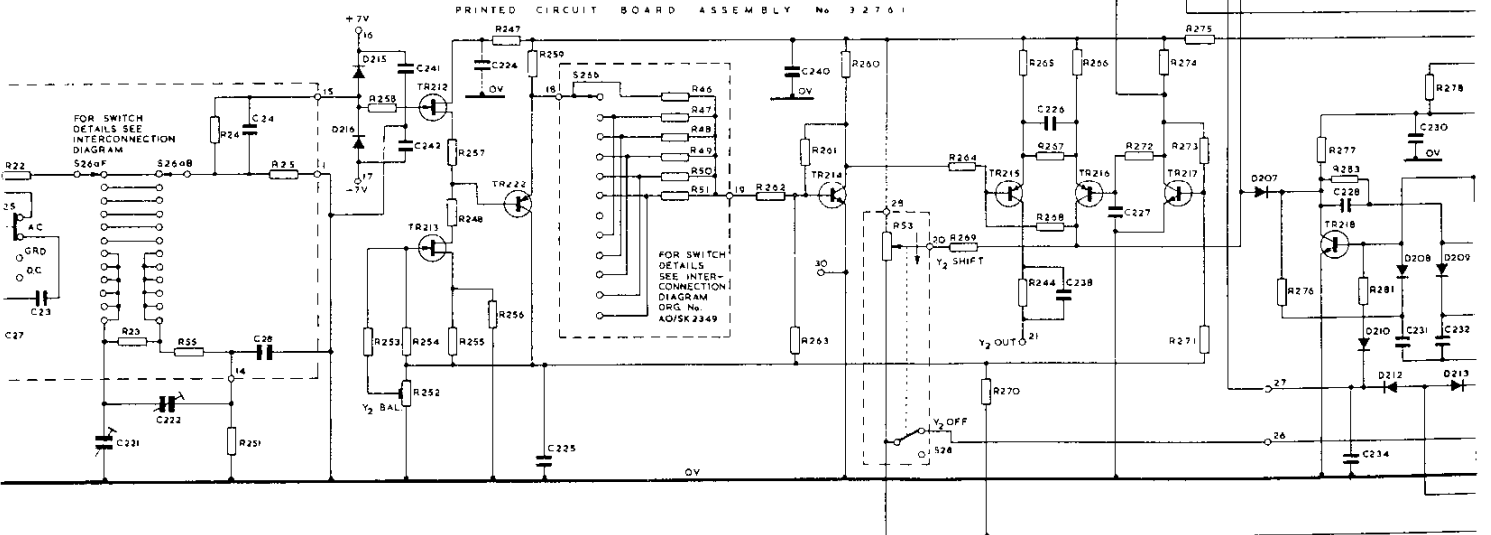
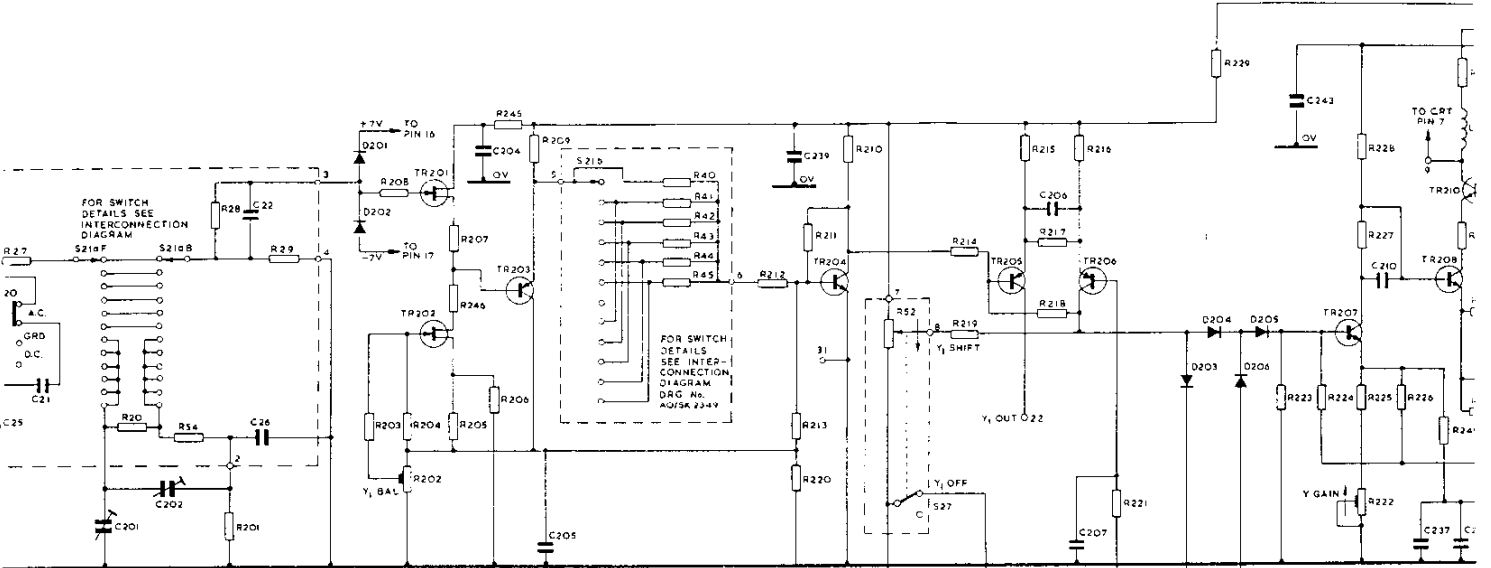

R210	R214	R215	R217	R218	R221	R274	R275	R279	R284	R288	R289	R291	R293
R260	R219	R265	R218	R266	R221	R272	R273	R277	R283	R287	R290	R292	
R52	R244	R269	R268				R271		R282	R285			
R53	R269	R270											
	C205	C207							C234	C235	C236	C211	C220
	C226	C227							C228	C230	C209	C212	C214
	C238								C234	C231	C232	C235	C246
S27	TR205	TR206		D204	D205			TR207	TR208	TR210	TR211	TR220	TR221
S28	TR215	TR216		D203	D206	D207		TR218	D210	D212	D208	D209	D211

NOTES
1. COMPONENTS CONTAINED WITHIN DOTTED LINES ARE NOT MOUNTED ON PRINTED CIRCUIT BOARD

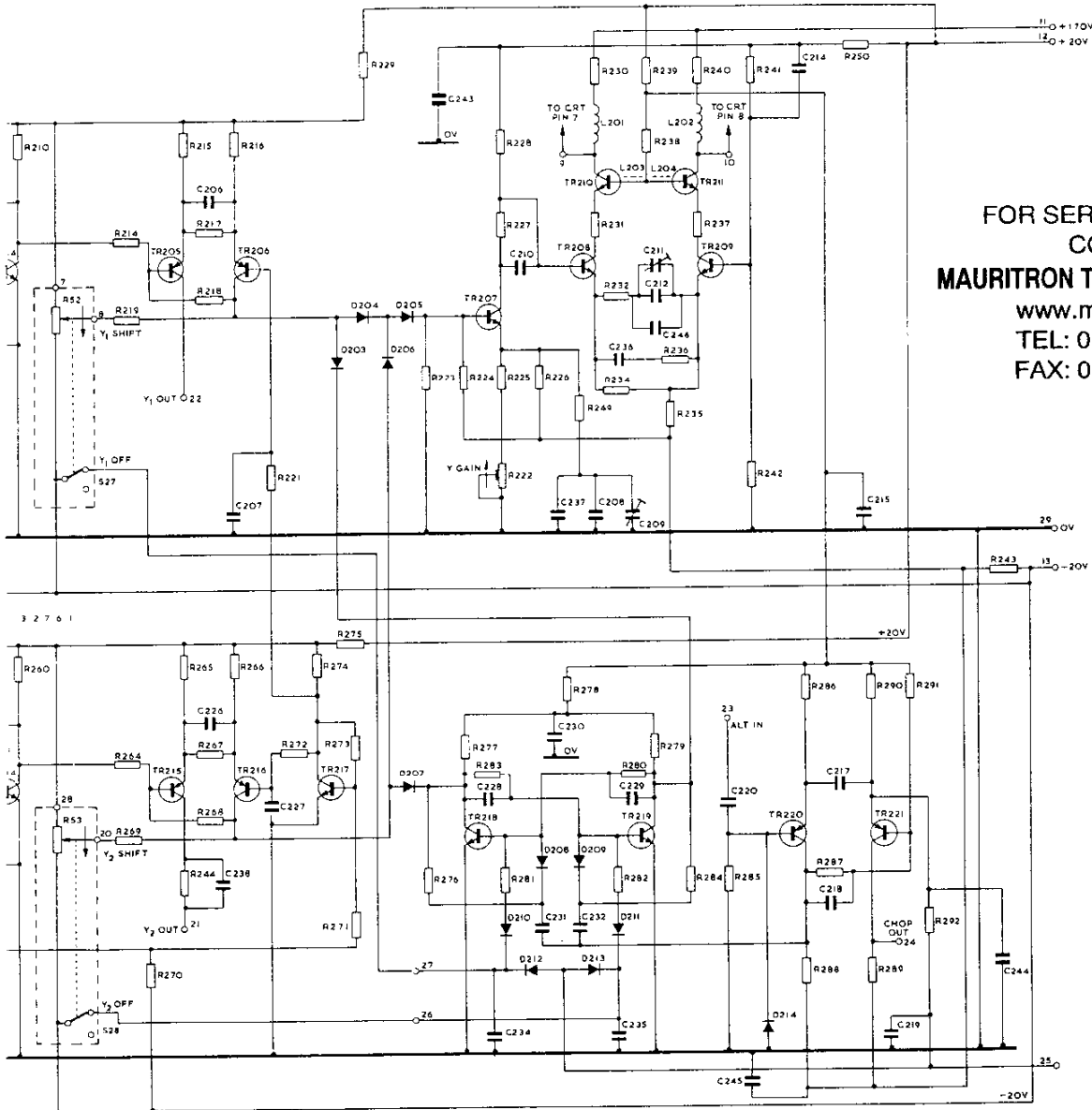

FOR SERVICE MANUALS
CONTACT:
MAURITRON TECHNICAL SERVICES
www.mauritron.co.uk
TEL: 01844 - 351694
FAX: 01844 - 352554

Fig. 3 Y Amplifier circuit

Component List and Illustrations

Section 6

TIMEBASE AND X AMPLIFIER

Ref	Value	Description	Tol %±	Part No.	Ref	Value	Description	Tol %±	Part No.
RESISTORS									
R101	22k	CF		21812	R155	18k	CF		21811
R102	22k	CF		21812	R156	100	CF		21794
R103	1k2	CF		21800	R157	56k	CF	5	1W 19058
R104	47	CF		28714	R158	270	CF		28720
R105	10	CF		21793	R159	2k7	CF		28726
R106	100k	CF	5	19061	R160	10k	MO	5	4W 29481
R107	560	CF		21798	R161	100	CF		21794
R108	220	CF		21796	R162	100	PCP		28520
R109	220	CF		21796	R163	2k	MO		26731
R110	620	MO		22485	R164	1k8	CF		28725
R111	10	CF		21793	R165				
R112	390	CF		28722	R166	1k5	CF		21801
R113	1k2	CF		21800	R167	100	CF		21794
R114	3k3	CF	5	18556	R168	10k	MO	5	4W 29481
R115	1k2	CF		21800	R169	1k	PCP		26870
R116	1k2	CF		21800	R170	2k	MO		26731
R117	10	CF		21793	R171	56k	CF	5	1W 19058
R118	47	CF		28714	R172	1k8	CF		28725
R119	100k	CF		21819	R173	100	CF		21794
R120	6k8	CF		21807	R174	1k8	CF		28725
R121	270	CF		28720	R175	1k8	CF		28725
R122	1k5	CF		21801	R176	10	CF		21793
R123	3k3	CF		21803	R177	10k	CF		21809
R124	1M	CF		31840	R178	27	CF		28711
R125	100	CF		21794	R179	270k	CF		32356
R126	4k7	CF		21805	R180				
R127	10k	CF		21809					
R128	2k2	CF		21802					
R129	120	CF		28718					
R130	1k	CF		21799					
R131	1k	CF		21799	CAPACITORS				
R132	2k7	CF		28726	C101	100pF	CE(2)		22376
R133	1k	CF		21799	C102	.01μF	CE(2)	25	250V 22395
R134	12k	CF		21810	C103	10μF	E		25V 32180
R135	18k	CF		21811	C104	.01μF	CE(2)	25	250V 22395
R136	3k9	CF		21804	C105	.01μF	CE(2)	25	250V 22395
R137	3k9	CF		21804	C106	33pF	CE(2)		22370
R138	10k	CF		21809	C107	.47μF	CE(1)		3V 33208
R139	47k	CF		21815	C108	33pF	CE(2)		22370
R140	47k	CF		21815	C109	27pF	CE(2)		22369
R141	100k	CF		21819	C110	.1μF	CE(1)		30V 19647
R142	10k	CF		21809	C111	27pF	CE(2)		22369
R143	1k	CF		21799	C112	22μF	E		25V 32181
R144	1k5	CF		21801	C113	.47μF	CE(1)		3V 33208
R145	100k	CF		21819	C114				
R146	15k	CF		28727	C117	27pF	CE(2)		22369
R147	2M2	CC		1180	C118	27pF	CE(2)		22369
R148	68k	CF		21816	C119	4700pF	CE(2)	25	500V 22393
R149	2k7	CF		28726	C120	.01μF	CE(2)	25	250V 22395
R150	100	CF		21794	C121	100pF	CE(2)		22376
R151	1k2	CF		21800	C122	27pF	CE(2)		22369
R152	56k	CF	5	19058					
R153	27k	CF		21813	C128	180pF	PS	5	125V 33343
R154	3k9	CF		21804	C129	10pF	CE(2)		22364

Component List and Illustrations

Section 6

TIMEBASE AND X AMPLIFIER (Cont.)

<i>Ref</i>	<i>Value</i>	<i>Description</i>	<i>Tol %±</i>	<i>Part No.</i>	<i>Ref</i>	<i>Value</i>	<i>Description</i>	<i>Tol %±</i>	<i>Part No.</i>
TRANSISTORS									
TR101		2N2369		23307	TR116		BF258		31490
TR102		2N2369		23307	TR117		BC212		29327
TR103		2N2369		23307					
TR104		2N2369		23307					
TR105		BC212		29327	DIODES				
TR106		BC182B		33205	D101		IN3595		29330
TR107		BC182B		33205	D102		IN4148		23802
TR108		2N2369		23307	D103		IN4148		23802
TR109		2N2369		23307	D104	8V2	ZENER	5	3798
TR110		2N2369		23307	D105		IN4148		23802
TR111		BC212		29327	D106		IN4148		23802
TR112		BC212		29327	D107		IN4148		23802
TR113		BC182B		33205	D108		IN4148		23802
TR114		BC212		29327	D109		IN4148		23802
TR115		BF258		31490	D110		IN4148		23802

FOR SERVICE MANUALS
CONTACT:
MAURITRON TECHNICAL SERVICES
www.mauritron.co.uk
TEL: 01844 - 351694
FAX: 01844 - 352554

RESIS	R106 R107	R104 R105 R108 R109	R111 R112 R113 R114 R115 R116 R117 R118 R119 R120	R118 R119 R121 R122 R123 R124 R125 R126	R130	R127 R102 R10	R124 R101	R13-18 R131	R177	R133	R135 R138 R142 R143	R136 R137	R139 R140 R141 R179	R146
CAP	C101 C107	C105 C103	C109	C102 C112 C113 C119 C106 C108 C121	C104 C111 C110	C14-16	C118 C117	C10-13 C120	C122					
MISC	S130F SKC	TR101 TR107	TR102 TR107	TR103 S12 S130B	TR104 D101	TR105 S10	TR106 D108 S140B D102 S140B D108 D107	TR108 TR109	D103					

FOR SERVICE MANUALS
CONTACT:
MAURITRON TECHNICAL SERVICES
www.mauritron.co.uk
TEL: 01844 - 351694
FAX: 01844 - 352554

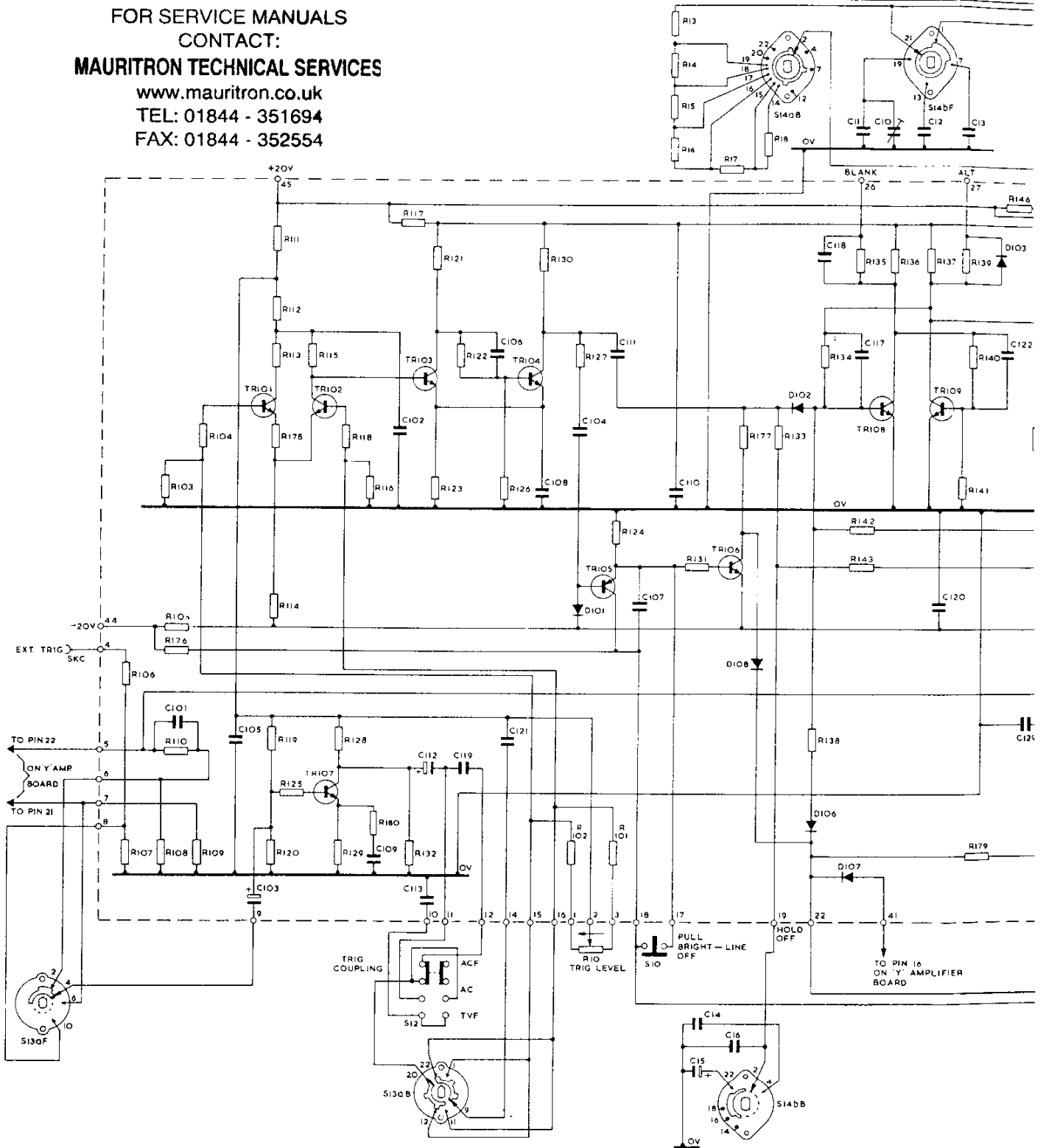

125	R118	R180	R117	R121		R130	R127	R124	R13-18	R177	R133	R134	R135	R136	R137	R139	R146		R144	R147	R150	R11	R152	R154	R155	F		
14	R115	R128	R116	R132	R122	R126		R102	R10		R131	R138	R142			R140	R145			R148	R151					R1		
19	R129															R141	R179				R149	R153				R156	R1	
120		C109	C102	C112	C119	C106	C108	C104	C11	C107		C118	C117		C10-13	C120		C122										
				C113	C121						C14-16							C129										
1102		TR103		TR104		TR105		TR106		TR108		TR109		TR110		TR111	TR112	TR113		D104		SKE		TR114				
07			S12			D101	S10				S140B									D105								
			S13aB								S145B																	

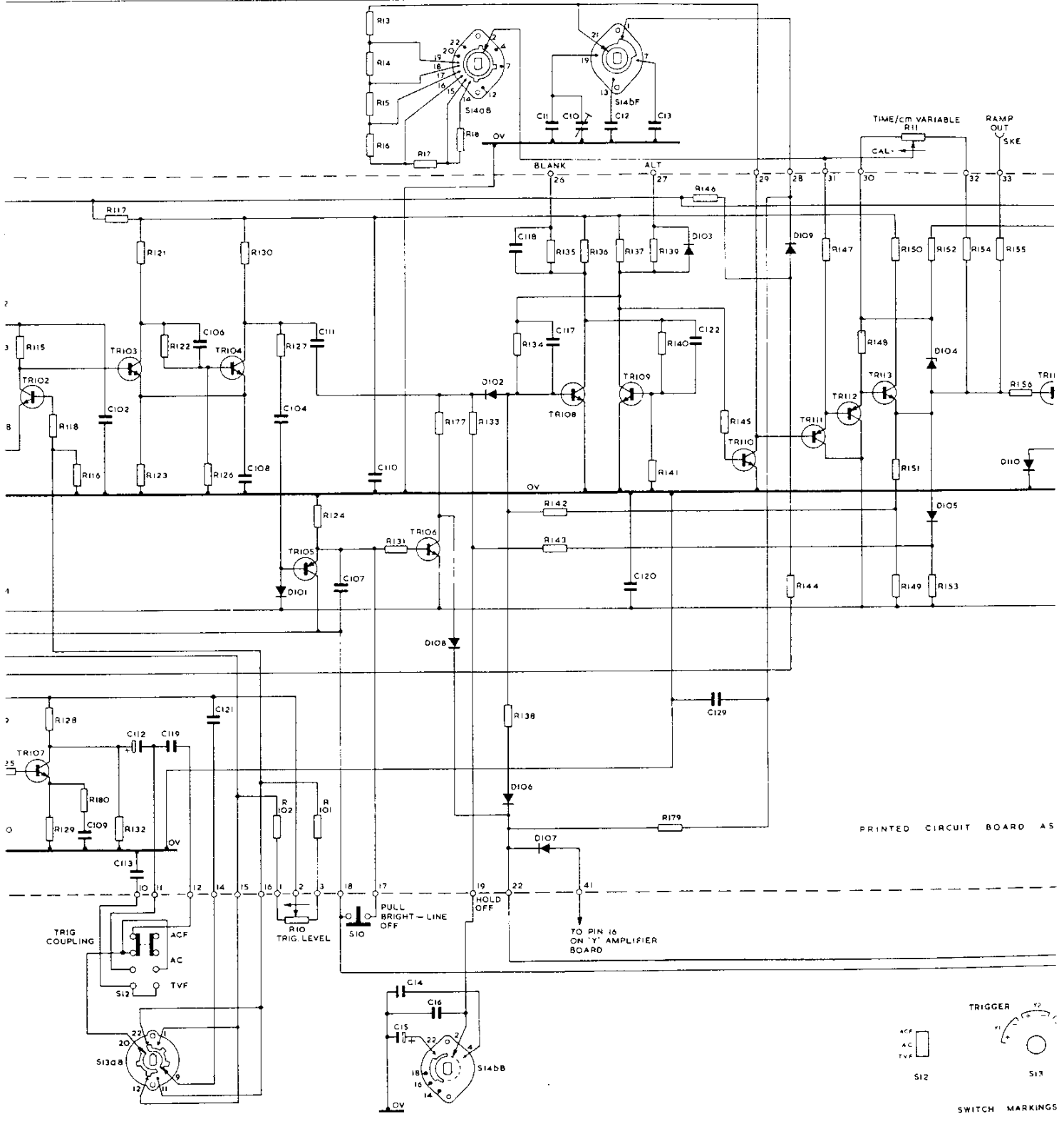

PRINTED CIRCUIT BOARD AS

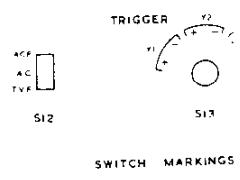

SWITCH MARKINGS

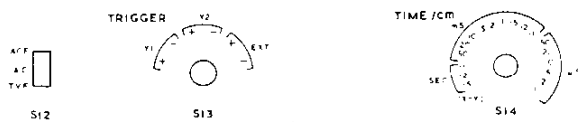
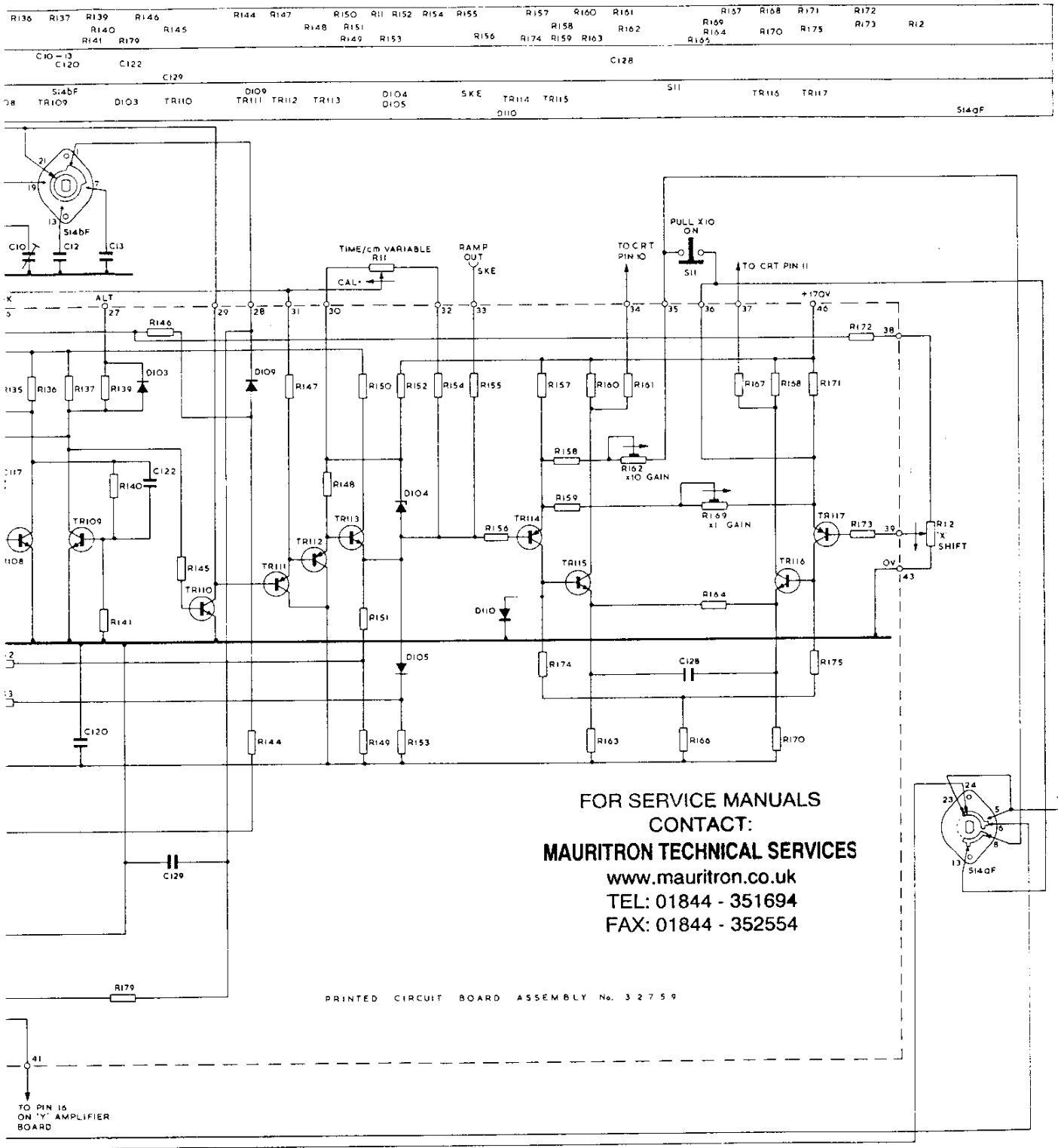

SWITCH MARKINGS AS VIEWED FROM FRONT PANEL

Fig. 4 Timebase and X amplifier circuit

Component List and Illustrations

Section 6

POWER SUPPLY

Ref	Value	Description	Tol %±	Part No.	Ref	Value	Description	Tol %±	Part No.
RESISTORS									
R301	5k6	CF		21806	C305	.01µF	CE(2)	25	1.5kV 23603
R302	1k	CF		21799	C306	5000pF	CE(1)		3kV 1514
R303	8k2	CF		21808	C307	5000pF	CE(1)		3kV 1514
R304	10k	PCP		28525	C308	5000pF	CE(1)		3kV 1514
R305	100k	CF		21819	C309	4µF	E		450V 23599
R306	47k	CF		21815	C310	4µF	E		450V 23599
R307	82	CF		28717	C311	4µF	E		450V 23599
R308					C312	4µF	E		450V 23599
R309	5R6	CF	5	½W 33210	C313	.02µF	CE(1)		1.5kV 25223
R310	2k2	CF		21802	C314	470pF	CE(2)	20	1.5kV 33207
R311	1k3	CF		33338	C315	4µF	E		450V 23599
R312	15k	CF		28727	C316	4.7µF	E		63V 32195
R313									
R314	5R6	CF	5	½W 33210	C317	.01µF	CE(2)	25	250V 22395
R315	82	CF		28717	C318/9	.01µF	CE(2)	25	250V 22395
R316	2k2	CF		21802					
R317	1k3	CF		33338	TRANSISTORS				
R318	47k	CF		21815	TR301		MPS U10		32924
R319	43k	MO		28813	TR302		BC 182B		33205
R320	10k	PCP		28525	TR303		BC 182B		33205
R321	1M5	CC		7016	TR304		BC212		29327
R322	3M3	CF	5	2W 29482	TR305		BC212		29327
R323	2M2	CC		1180	TR306		BC182B		33205
R324	47k	CC		2933	TR307		2N 2369		23307
R325					TR308		2N 5831		33209
R326	100k	CF		21819	MR301		WO4		29367
R327	47k	CF		21815					
R328	4M7	CC		597	DIODES				
R329	270k	CF		32356	D301		MR995A		32903
R330					D302		MR995A		32903
R331	1M5	CC		7016	D303		MR995A		32903
R332	220k	PCP		29363	D304		IN 4007		52337
R333	470k	PCP		28529	D305		IN 4148		23802
R334	100k	CF		21815	D306		IN 4148		23802
R335	27k	CF	5	2W 33211	D307		IN 4148		23802
R336	15k	CF	5	½W 18564	D308		IN 4148		23802
R337	22k	CF	5	½W 18566	D309		IN 4148		23802
R338	4k7	CC		3427	D310		IN 4148		23802
R339	2M2	CC		1180	D311		IN 4148		23802
R340					D312		IN 4148		23802
R341	2M2	CC		1180	D313		IN 4148		23802
R342	2M2	CC		1180	D314		IN 4148		23802
					D315	6V8	ZENER	5	4666
					D316	6V8	ZENER	5	4666
					D317		IN 4148		23802
CAPACITORS									
C301	4µF	E		450V 23599					
C302	4µF	E		450V 23599					
C303	4µF	E		450V 23599					
C304	4µF	E		450V 23599					

FOR SERVICE MANUALS
CONTACT:
MAURITRON TECHNICAL SERVICES
www.mauritron.co.uk
TEL: 01844 - 351694
FAX: 01844 - 352554

RESISTORS	R306 R318	R307 R315	R309 R314	R310 R311 R317 R316	R304 R303	R305 R337	R301 R342	R302 R341 R342 R339	R335 R336 R338
CAPACITORS				C317 C318	C305	C306 C307	C315 C308		C3
MISC	D308 D309 D306 D305	TR305 D316 D315 TR304	TR306 D310 TR303 D307		TR307 D311	D312	MR301 D302		R308 D313 TR301

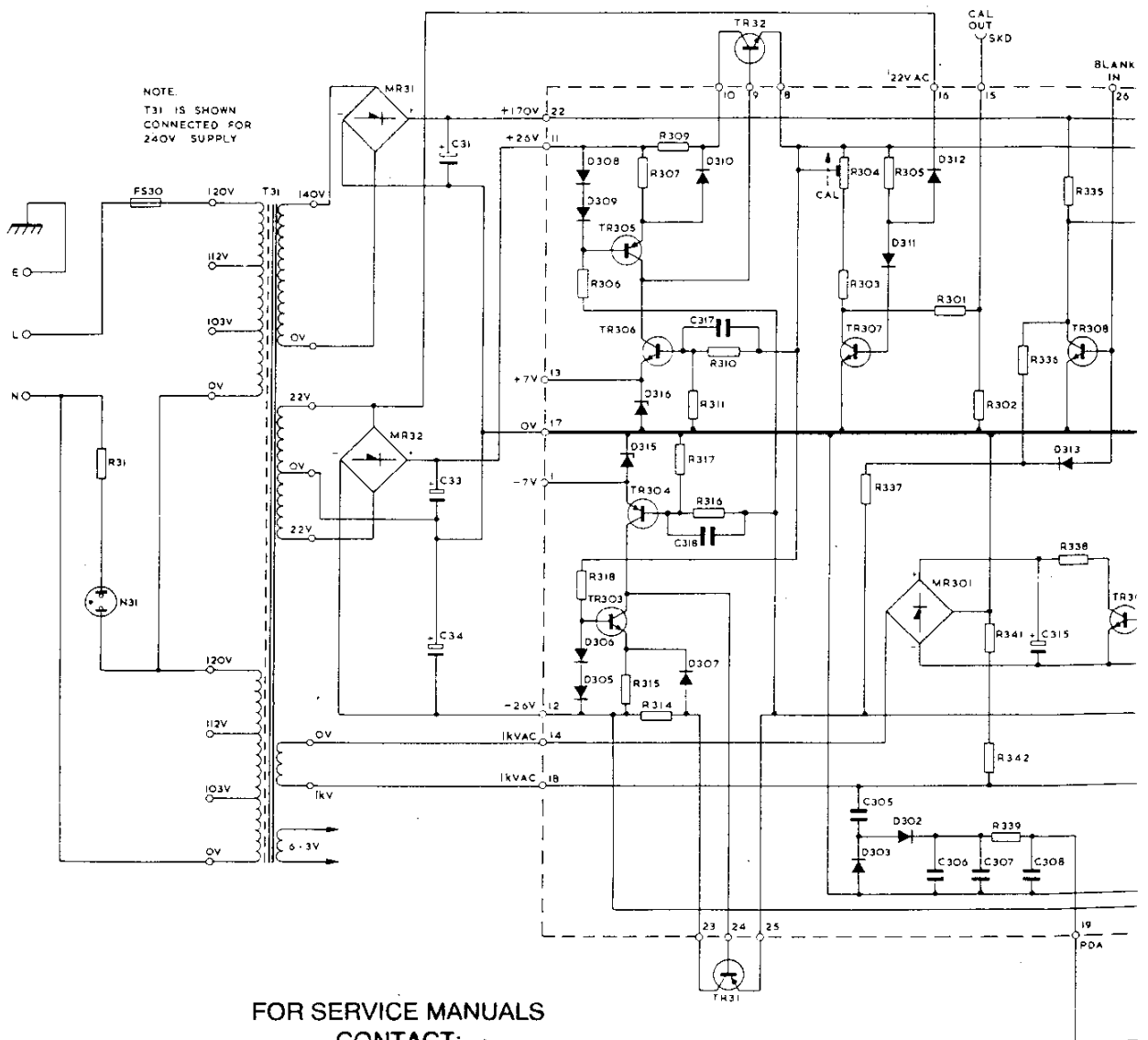

FOR SERVICE MANUALS
CONTACT:
MAURITRON TECHNICAL SERVICES
www.mauritron.co.uk
TEL: 01844 - 351694
FAX: 01844 - 352554

R306	R307	R309	R310	R304	R305	R301	R302	R335	R323	R332	R333	R320	R324	R331	R329
R318	R315	R314	R316	R303	R337	R341	R342	R338	R312	R321	R319	R322	R328	R325	R327
D308	TR305	TR306	D310	TR307	D311	D312	TR308	D304	TR302						
D309	D314	TR303	D310	MR301	D313	TR301	D304	D301							
D306	D315	TR303	D310	D303	D302										
D305	TR304	D307													

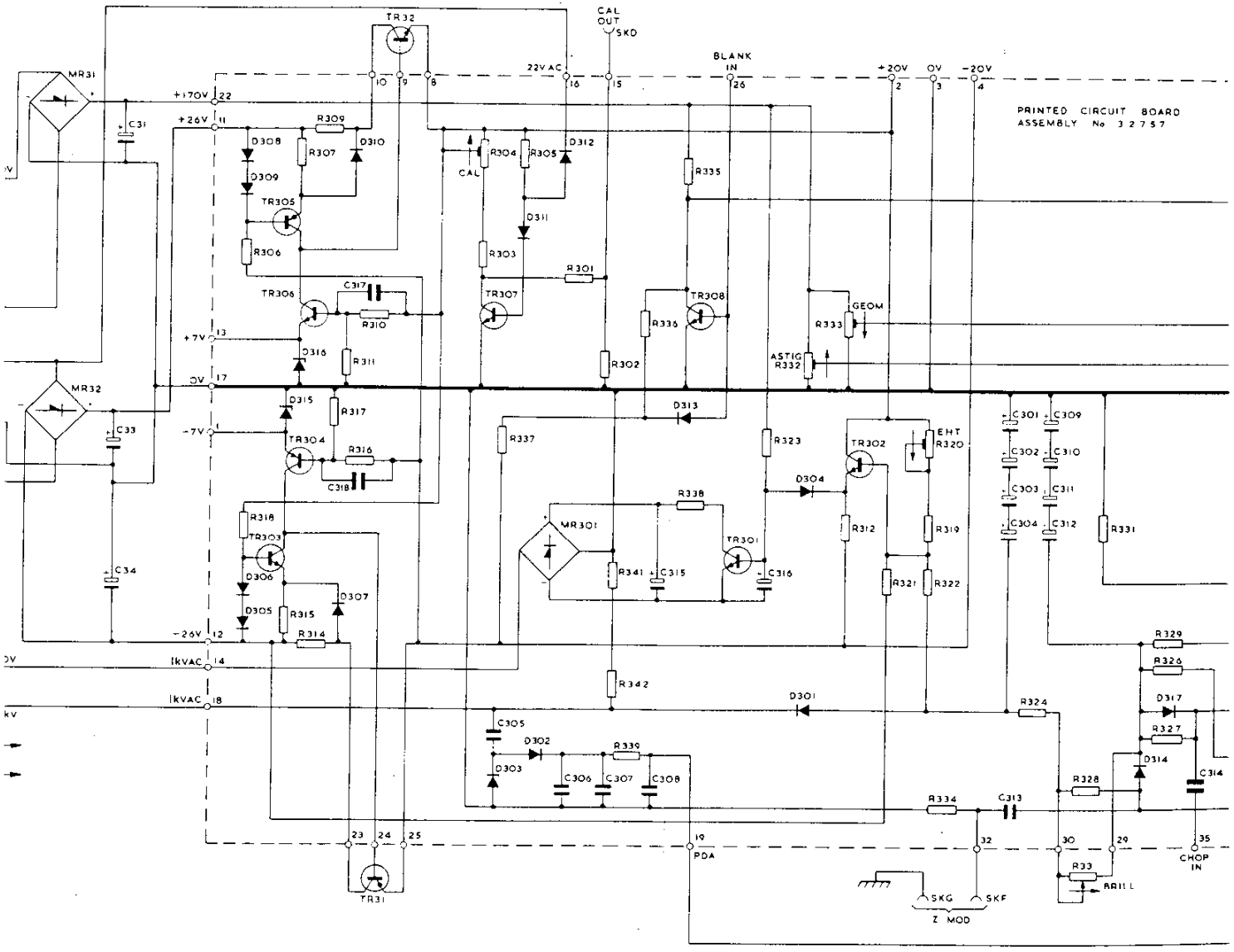

NOTE:

1. COMPONENTS NOT ENCLOSED WITHIN THE DOTTED AREA ARE CALLED FOR ON INTERCONNECTION DIAGRAM SK 2349

R302 R341 R342 R339	R335 R336 R338	R323 R332	R333 R312 R321	R320 R319 R322 R334	R324 R328	R331 R329 R326 R327
C315 C308	C316	C301-304	C309-312	C313	C314	
TR308 D313 TR301	D304 D301	TR302	D314 D317			

FOR SERVICE MANUALS
CONTACT:
MAURITRON TECHNICAL SERVICES
www.mauritron.co.uk
TEL: 01844 - 351694
FAX: 01844 - 352554

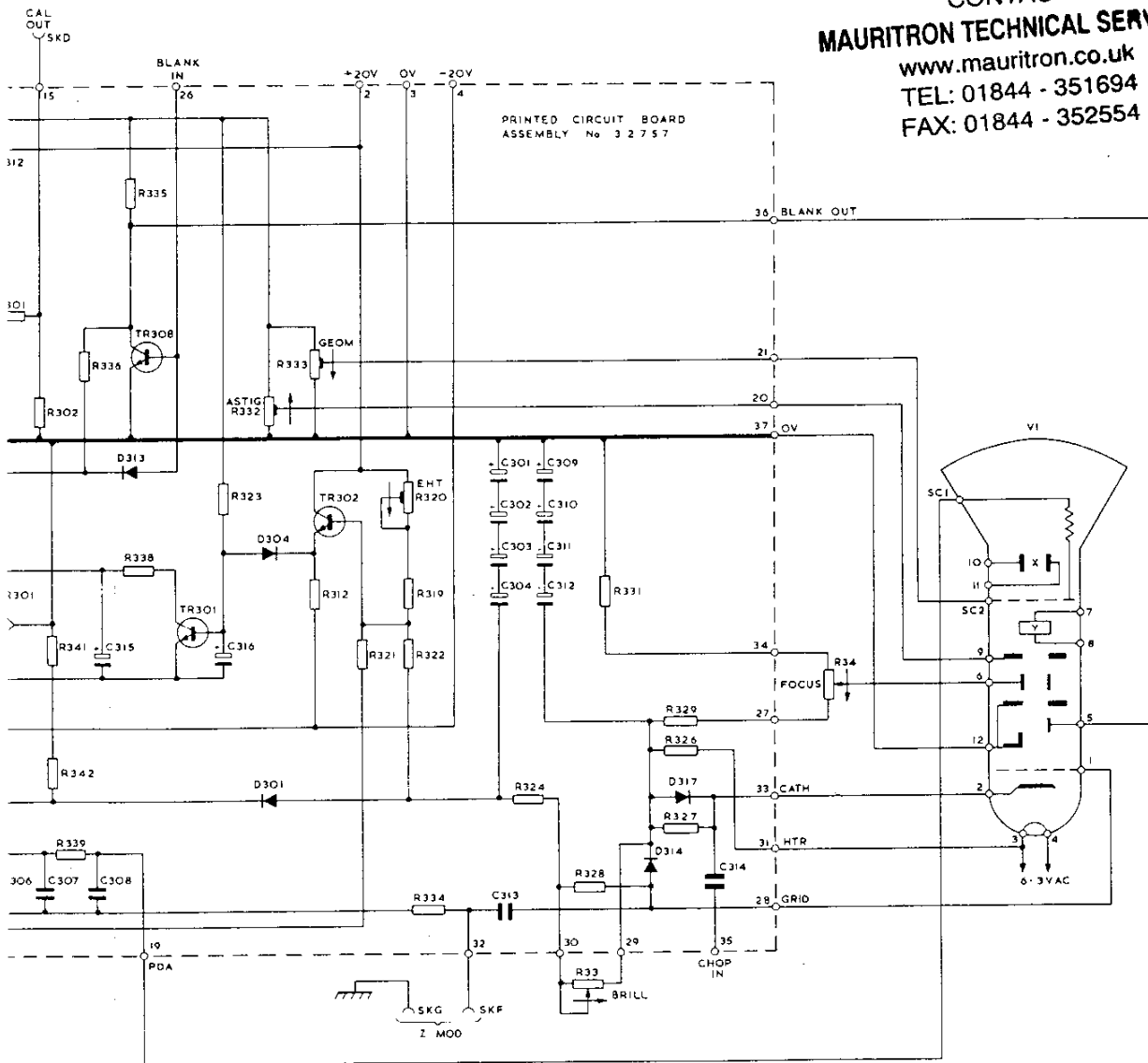

Fig. 5 Power supply circuit

Component List and Illustrations

Section 6

INTERCONNECTION

Ref	Value	Description	Tol %±	Part No.	Ref	Value	Description	Tol %±	Part No.
RESISTORS									
R10	100k	CP With S10		A4/32897	C26	470pF	PS	10	125V 11492
R11	10k	CP With S11		A4/32898	C27	8.2pF	CE(2)	1pF	500V 22363
R12	2k2	CP		A4/32896	C28	470pF	PS	10	125V 11492
R13	100k	MF	1	29476					
R14	100k	MF	1	29476	C31	100μF	E		275V 32906
R15	301k	MF	1	29477					
R16	499k	MF	1	26342	C33	1000μF	E		40V 32907
R17	1M	MF	1	26346	C34	1000μF	E		40V 32907
R18	3M01	MF	1	29478	C35	1000pF	CE(2)		22387
R20	990k	MF	1	26345	C40	5.6kpF	CE(2)		22394
R21	22	CF		28710	C41	5.6kpF	CE(2)		22394
R22	22	CF		28710	TRANSISTORS				
R23	990k	MF	1	26345	TR31		BD166		32901
R24	470k	CC		4906	TR32		BD165		32900
R25	1M	MF	1	26346					
R26	22	CF		28710	MR31		WO4		29367
R27	22	CF		28710	MR32		WO4		29367
R28	470k	CC		4906	SOCKETS				
R29	1M	MF	1	26346	SKA		50ΩBNC		1222
					SKB		50ΩBNC		1222
R31	68k	CF		21816	SKD		4mm Black		30097
					SKE		4mm Black		30097
R33	220k	CP With S30		A4/32899	SKF		4mm Black		29492
R34	1M	CP		A4/32893	SKG		4mm Black		29492
					SKH		4mm Black		29492
R40	16k	MF	1	29361	SWITCHES				
R41	15k8	MF	1	33291	S10		Part of R10		
R42	5k23	MF	1	33290	S11		Part of R11		
R43	1k72	MF	1	33289	S12				25869
R44	787	MF	1	33288	S13				32636
R45	360	MF	1	33287	S14				32634
R46	16k	MF	1	29361					
R47	15k8	MF	1	33291	S20				25869
R48	5k23	MF	1	33290	S21				32635
R49	1k72	MF	1	33289					
R50	787	MF	1	33288	S24				25869
R51	360	MF	1	33287	S25				32635
R52	22k	CP With S27		A4/32895	S26				
R53	22k	CP With S28		A4/32895	S27		Part of R52		
R54	22	CF		28710	S28		Part of R53		
R55	22	CF		28710					
R56/57	330k	CC		4408	S30		Part of R33		
CAPACITORS									
C10	6/25pF	Trimmer		23593	MISCELLANEOUS				
C11	68pF	SM	5	4513	V1		CRT D13-610 GH		32904
C12	.01μF	PS	1	24886			OR		
C13	1μF	PC	2	33206			CRT D13-610 GM		32905
C14	.047μF	CE(1)		30V 2793			Long Persistence		
C15	4.7μF	E		63V 32195	FS30		FUSE 220V Supply	200mA	24041
C16	1000pF	CE(2)		22387			OR		
							FUSE 110V Supply	400mA	32475
C21	.1μF	PE		400V 29495	T31		Transformer		A1/32637
C22	.01μF	CE(1)		500V 24902	N31		Indicator Neon Type Q		26586
C23	.1μF	PE		400V 29495					
C24	0.1μF	CE(1)		500V 24902					
C25	8.2pF	CE(2)	1pF	500V 22363					

	R57	R26	R27	R55	R25	R20	R4	R28	R43	R42	R46
RESIS	R13	R52	R24	R22	R55	R29	R54	R23	R44	R41	R4
	R14	R21							R45	R40	R47
	R15	R18	R10								R48
	R16	R7	R11								
CAP	C41		C21	C24	C40	C14	C28	C26	C22		
			C23	C27	C25	C15	C18				
			C11	C10	C12	C13	C15	C18			
MISC	SKA	SKC	S10	S28	S20	S216 F	S216 B	S216 B	S130 F	S216 B	S216 F
	SKB	SKE	S11	S140 B	S25	S216 F	S216 B	S216 B		S140 F	S216 F
			S12			S216 F	S216 B	S216 B			S216 B

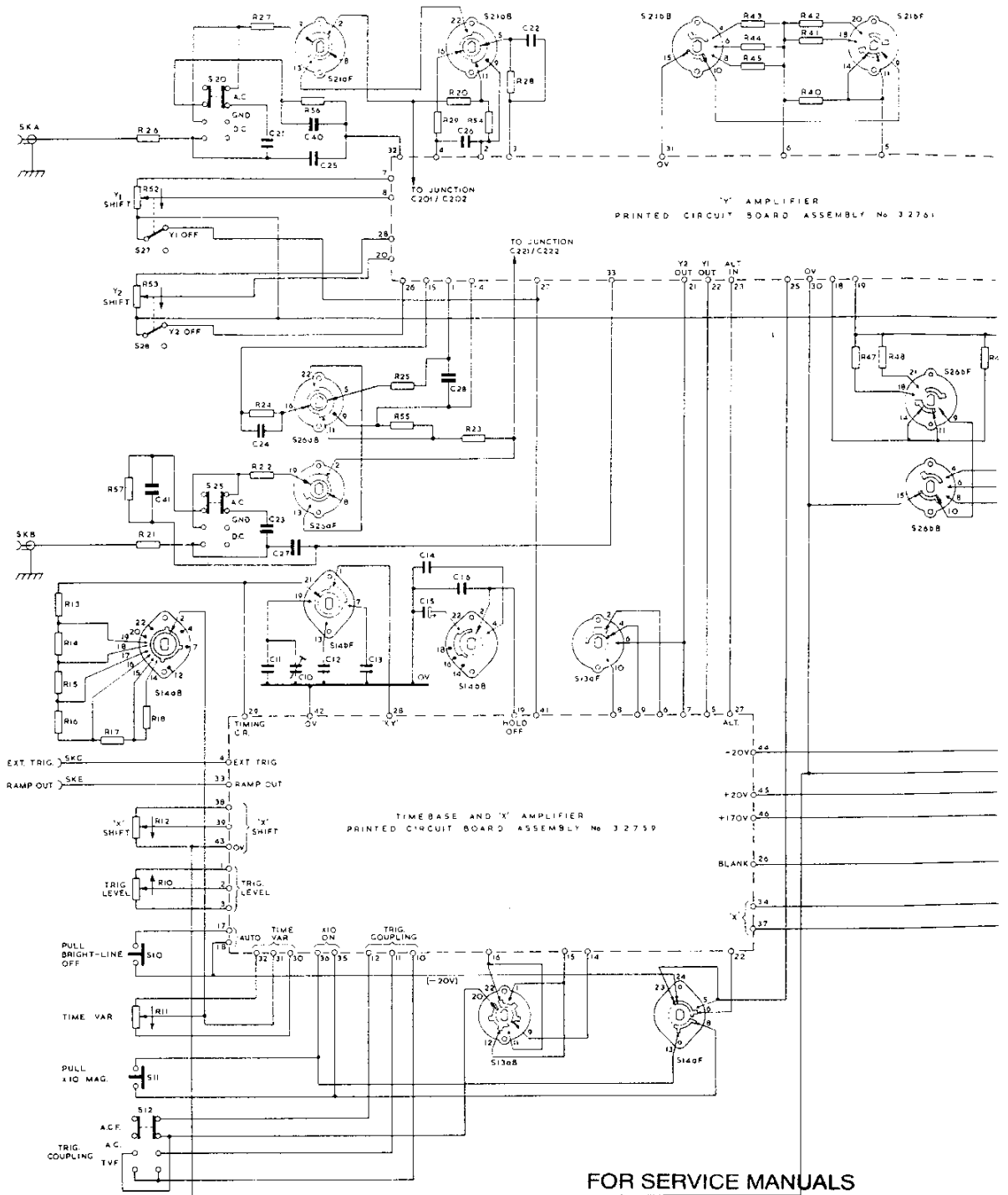

FOR SERVICE MANUALS
 CONTACT:
MAURITRON TECHNICAL SERVICES
 www.mauritron.co.uk
 TEL: 01844 - 351694
 FAX: 01844 - 352554

NOTE

R424	1k	CF	OS250 TV only	21799
R425	56k	CF	OS250 TV only	28729
S13	OS250 only			33995
	OS250 TV only			32634

R57	R26	R27	R56	R25	R20	R54	R28	R43	R42	R47	R48	R46	R50	R3
R13	R33	R24	R22	R55	R29	R54	R23	R44	R41			R49	R51	C
R14	R27							R45	R40					
R15	R18	R10												
R16	R17	R11												
C41	C21	C24	C40	C14	C28	C26	C22							
	C23	C27	C25	C15	C16									
	C11	C10	C17											
S27	S20	S210F	S210B	S130F	S210B	S140F	S210B	S205F	S205B					TR32
S11	S140B	S25	S200B	S140B	S130B									TR31
S12			S140F											SKG SKF

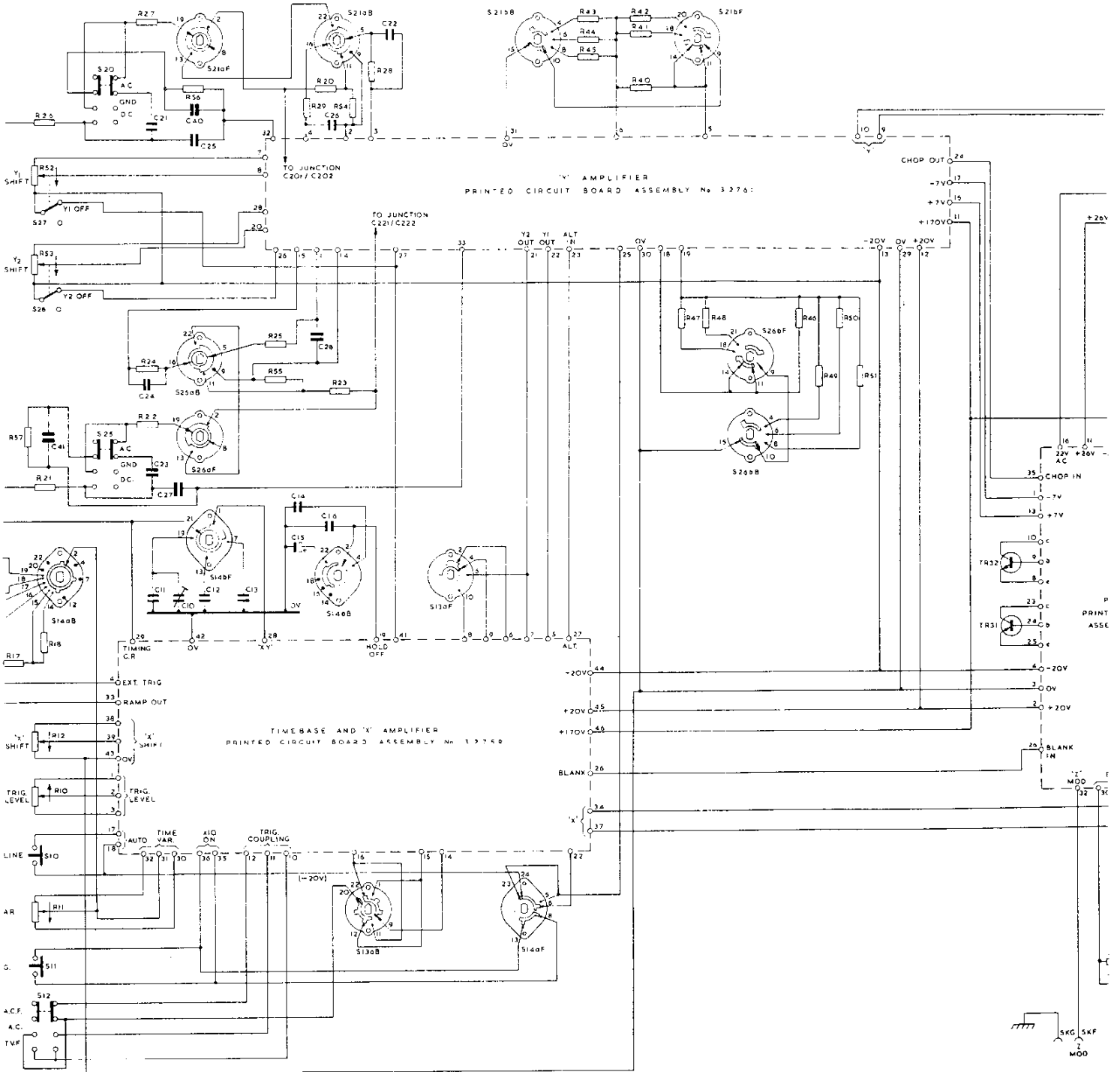

- 150 TV only 21799
- 150 TV only 28729
- 33995
- 32634

2	R47	R48	R46	R50	R38	R34	R31						
10			R49	R51	C34	C33	C31	C35					
5215F	526DF	526bB	TR32	TR31	SKG	SKF	MR32	MR31	VI	T1	F530	S30	N31

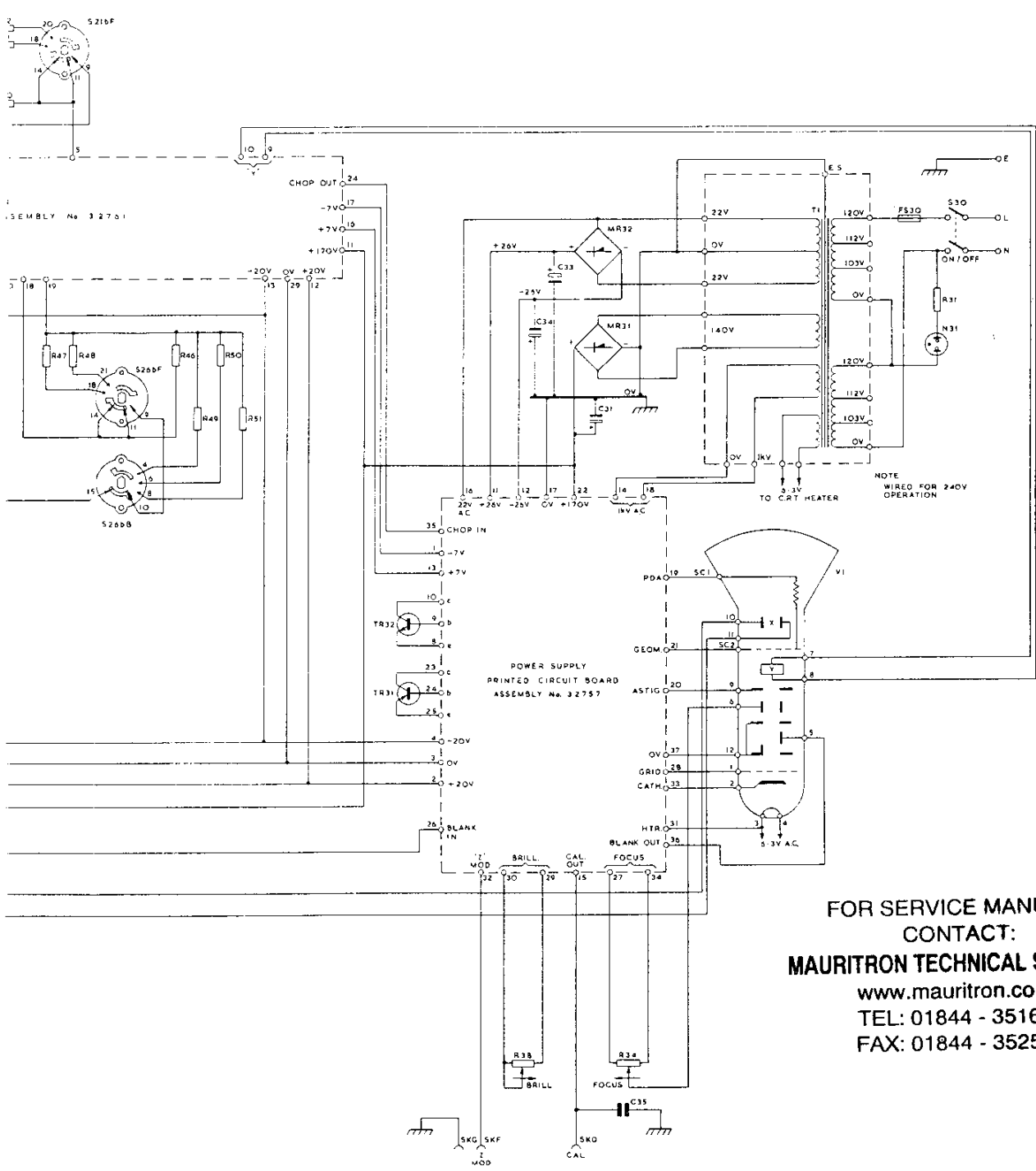

**FOR SERVICE MANUALS
CONTACT:
MAURITRON TECHNICAL SERVICES**
www.mauritron.co.uk
TEL: 01844 - 351694
FAX: 01844 - 352554

Fig. 6 Interconnection diagram

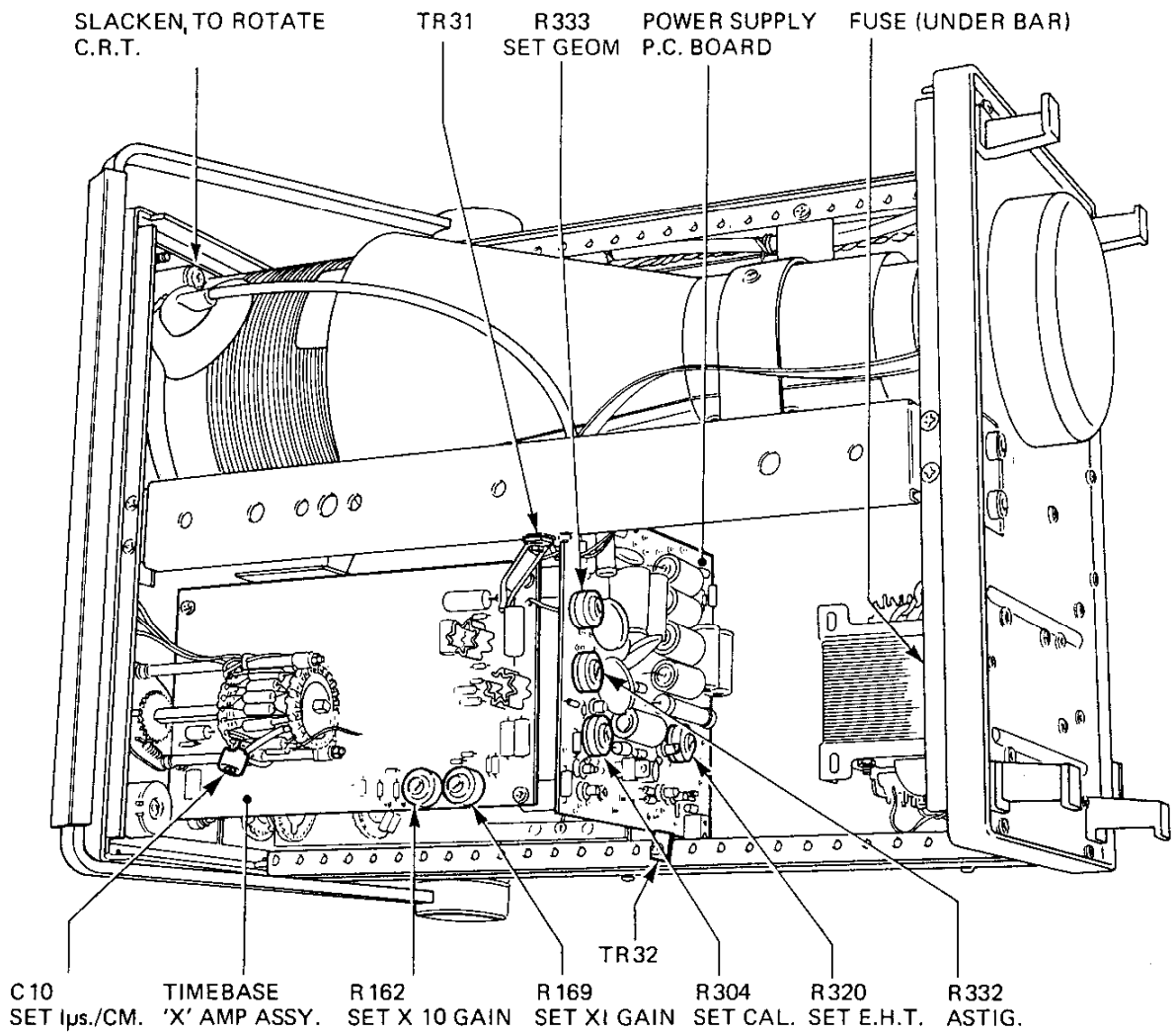

FOR SERVICE MANUALS
CONTACT:
MAURITRON TECHNICAL SERVICES
www.mauritron.co.uk
TEL: 01844 - 351694
FAX: 01844 - 352554

Fig. 7 Top view

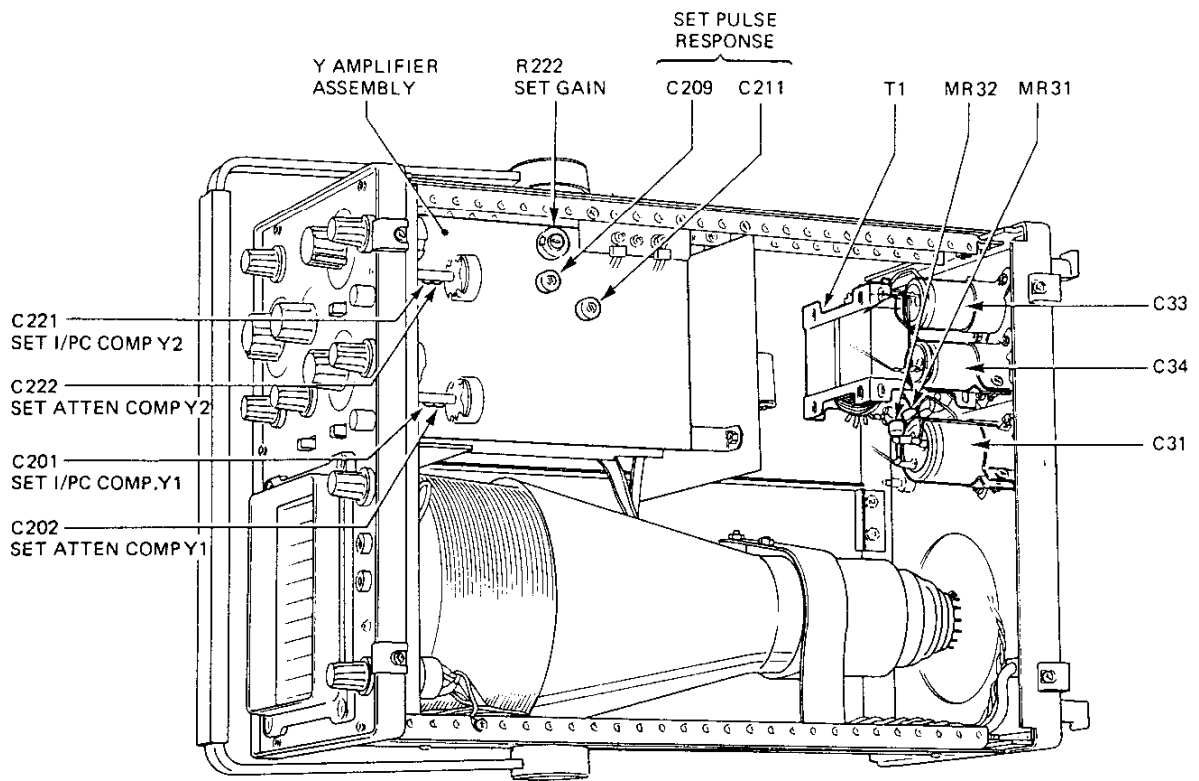

FOR SERVICE MANUALS
 CONTACT:
MAURITRON TECHNICAL SERVICES
 www.mauritron.co.uk
 TEL: 01844 - 351694
 FAX: 01844 - 352554

Fig. 8 Bottom view

This instrument is guaranteed for a period of one year from its delivery to the purchaser, covering the replacement of defective parts other than tubes, semiconductors and fuses. Tubes and semiconductors are subject to manufacturers' guarantee.

We maintain comprehensive after sales facilities and the instrument can, if necessary, be returned to our factory for servicing. The type and serial number of the instrument should always be quoted, together with full details of any fault and the service required. The Service Department can also provide maintenance and repair information by telephone or letter.

(Service Dept.)
Roebuck Road,
Hainault,
Essex.
Tel: 01-500-1000

Equipment returned to us for servicing must be adequately packed, preferably in the special box supplied, and shipped with transportation charges prepaid. We can accept no responsibility for instruments arriving damaged. Should the cause of failure during the guarantee period be due to misuse or abuse of the instrument, or if the guarantee has expired, the repair will be put in hand without delay and charged unless other instructions are received.

OUR SALES, SERVICE AND ENGINEERING DEPARTMENTS ARE READY TO ASSIST YOU AT ALL TIMES.

(Sales Dept.)
Raynham Road,
Bishops Stortford,
Herts.
Tel: 0279-55155

FOR SERVICE MANUALS
CONTACT:
MAURITRON TECHNICAL SERVICES
www.mauritron.co.uk
TEL: 01844 - 351694
FAX: 01844 - 352554