

QUICK REFERENCE GUIDE

# HP 8902A MEASURING RECEIVER

08902-90031



HEWLETT  
PACKARD

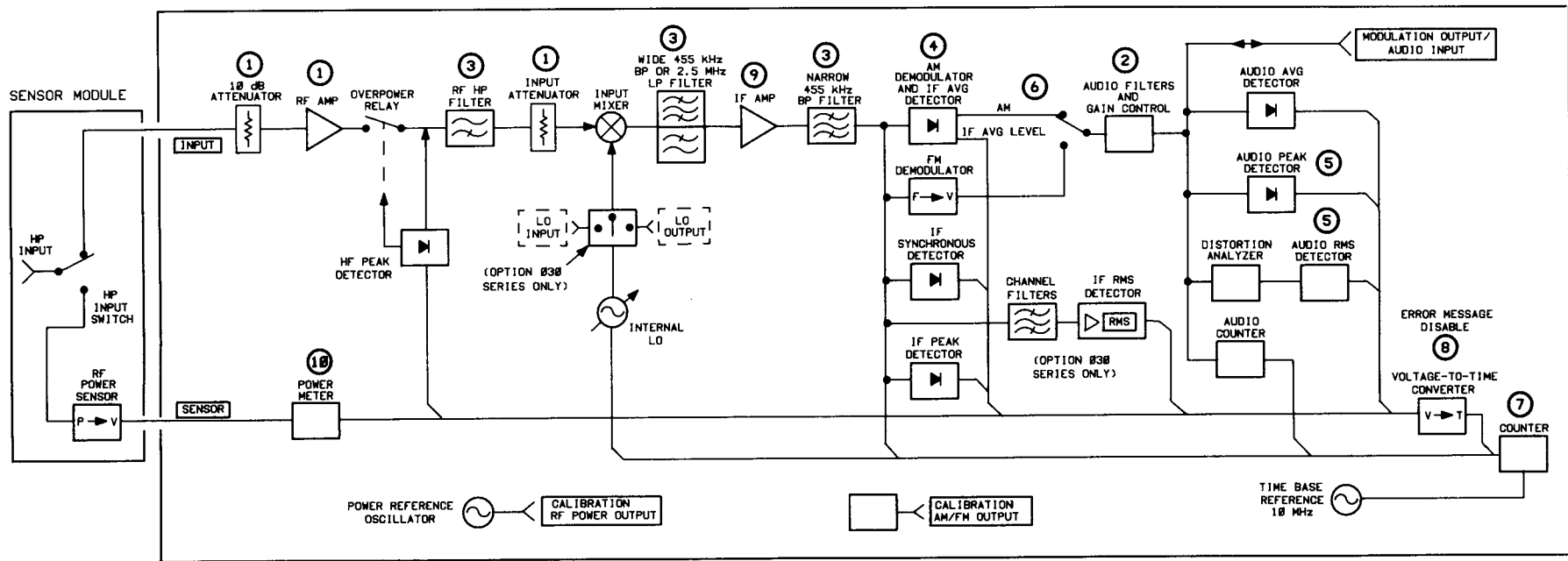

### 1. RF Input Attenuation and Gain

AUTO	RF Attenuation (dB)						RF Gain (dB)		AUTO*
	0	10	20	30	40	50	24	14	
1.0	1.1	1.2	1.3	1.4	1.5	1.6	1.7	1.8	1.9

\* Automatic selection 10 dB attenuator always inserted (Tuned RF Level only).

### 6. Automatic Level Control\*

Slow AM > 20 Hz	Fast AM > 1 kHz	Off
6.0	6.1	6.2

\* Except Tuned RF Level

## 2. Audio Range

Modulation	Auto	Detector			
		RMS	Pk, Ave, RMS		
AM (% pk)		4.0	40	100	100
FM (kHz, pk)*		0.4	4	40	400
ΦM (rad, pk)		0.4	4	40	400
	2.0	2.4	2.1 (2.4)	2.2	2.3

\* Divide-by-10 with 750 μs FM DE-EMPHASIS and PRE-DISPLAY.

## 3. RF and IF Filters

IF FREQ	Auto	455 kHz		1.5 MHz	
		Bandwidth			
Wide Filter		2.5 MHz	200 kHz		2.5 MHz
Narrow Filter		30 kHz Bandwidth		Narrow Filter Out	
RF HP Filter Out	3.0	3.6	3.5	3.1	3.2
RF HP Filter In		3.8	3.7	3.3	3.4

## 4. Tuned RF Level Detector Selection and Display Averaging

Detector	IF Synchronous				IF Average			
Measurement Averaging Time(s)	AUTO	10	1	0.1	AUTO	10	1	0.1
	4.0	4.1	4.2	4.3	4.4	4.5	4.6	4.7

## 5. Audio Detector Response

Audio Peak Detector Response and RMS Detector Digital Averaging Response:

Fast	Slow
5.0	5.1

## 7. RF Frequency Resolution

AUTO	10 Hz	100 Hz	1 kHz	1 Hz
7.0	7.1	7.2	7.3	7.4

## 8. Error Message Disable and Enable

Auto	Disable Errors							All Errors Enabled
	01	02	03	04	05	06	07	
8.0	8.1	8.2	8.3	8.4	8.5	8.6	8.7	8.8

## 9. IF Gain

IF Gain (dB)							
Auto	0	10	20	30	40	50	60
9.0	9.1	9.2	9.3	9.4	9.5	9.6	9.7

## 10. RF Power Range

Most Sensitive Range			⇒	Least Sensitive Range		
AUTO	#1	#2	#3	#4	#5	
10.0	10.1	10.2	10.3	10.4	10.5	

## 11. Previous Ratio

11.2 Display previous ratio reference.

### 12/13. Calibration FM, AM

	Display Peak FM	Display Peak AM
Computed	12.0	13.0
Residual	12.1	13.1
Measured	12.2	13.2

### 14. Limit

14.0 Disable

14.9 Display limit status: Lower limit status. Upper (0=disabled, 1=enabled).

	Lower Limit	Upper Limit
Set to Ratio		
Reference	14.1	14.2
Enable	14.3	14.4
Display	14.5	14.6
Display		
Measurement Code	14.7	14.8

### 15. Time Base Check

15.0 Displays Error 12 if Option 002 is installed and oven is cold. Displays 0 if Option 002 is installed and oven is warm, or if Option 002 is not installed.

15.1 Displays 0 if internal time base is being used. Displays 1 if external time base is being used.

### 16. Calibration Factors: AM,

### 17. Calibration Factors: FM

	AM Cal Factor	FM Cal Factor
Disable	16.0	17.0
Enable	16.1	17.1
Display	16.2	17.2

### 18. Tone-Burst Receiver

18.NN Configures instrument as a tone-burst receiver. A time delay of NN ms is inserted between detection of a carrier and unsquelching of the output at MODULATION OUTPUT/AUDIO INPUT. Range of NN is 1 to 99 ms. If NN is 0, delay is 99 ms.

## 21. HP-IB Address

**21.0** Displays HP-IB address in form AAAAAAA.TLS

AAAAAAA = binary address

T = 1 = talk only

L = 1 = listen only

S = 1 = requesting service

## 22. Service Request

**22.NN** A value of NN from 0 to 63 sums the weighted conditions below to set up a service request mask. The summed, weighted conditions are displayed when NN is 64.

1 Data Ready

2 HP-IB error (Cannot be disabled.)

4 Instrument error

8 Limit exceeded

16 Frequency Offset mode state change

32 Recal or Uncal

64 Read back SRQ mask

## 23. External LO (Option 030 Only)

**23.0** Return the LO to internal.

**23.1** Set the LO to external.

**23.2** Display LO status: (0 = Internal, 1 = External)

## 24. Selective Power Measurement (Option 030 Only)

**24.0** Sets the Measuring Receiver to the Selective Power Measurement Mode.

	Select	Establish 0 dB Ref.	Display Normalize Noise Meas.
Wide BW IF Filter (Adjacent-Channel, Cellular)	24.1	24.2	
Narrower BW IF Filter (Adjacent-Channel)	24.3	24.4	
Narrowest BW IF Filter (Single-Sideband Noise)	24.5	24.6	24.7

**24.8** Sets the value of the noise measurement BW.

**24.9** Display the value of the noise measurement BW.

## 25. External Attenuation (dB)

**25.2** Display attenuation value.

## 26. Set Reference

- 26.0 Exit attenuator measurement
- 26.1 Re-enter attenuator measurement

## 27. Frequency Offset Control

Frequency Offset Mode		External LO	
Exit	Re-enter	Display	Enter/Enable
27.0	27.1	27.2	27.3

## 29/30. Other Audio Measurement Modes

- 29.0 SINAD
- 30.0 EXT AUDIO RMS LEVEL

## 31. Tuned RF Level Noise Correction

- 31.0 Turn off noise correction.
- 31.1 Turn on noise correction.
- 31.2 Display noise correction status (1 = Off, 0 = On).

## 32. dB and Frequency Resolution

- 32.0 Normal measurement resolution (Power: 0.01 dB resolution)  
(Audio Frequencies from 100 to 250 kHz; 0.1 Hz resolution).
- 32.1 Increased measurement resolution (Power: 0.001 dB resolution)  
(Audio Frequencies from 100 to 250 kHz; 0.1 Hz resolution).
- 32.2 Display measurement resolution status. (0 = normal,  
1 = increased).

### 32.9 Tuned RF Level Measurements Using Track-Mode Tuning

1. Input a signal greater than  $-30$  dBm.
2. Select 32.9 SPCL.
3. If using an external LO, enter the external LO frequency in MHz.
4. Select MHz to enter the manual tune mode.
5. Step the signal generator down in amplitude and press the CALIBRATE key whenever the RECAL annunciator is displayed.

### **33/36. Other Measurement Modes**

- 33.0** LO FREQUENCY
- 34.0** IF FREQUENCY
- 35.0** RF LEVEL
- 36.0** PEAK TUNED RF LEVEL

### **37. Calibration Factors: RF Power**

- 37.0** Automatic Cal Factors
- 37.1** Manual Cal Factors
- 37.2** Display Status (0 = auto, 1 = held)
- 37.3** \*Enter frequency, cal factor
- 37.4** \*Display table size
- 37.5** \*Recall reference cal factor
- 37.6** \*Recall next frequency, cal factor
- 37.7** \*Clear Table

\* Two tables are available. The table being used is determined by the status of the Frequency Offset mode (Special Function 27).

### **38/39. Calibration Factors Tuned RF Level**

	<b>RF Power to Range 1</b>	<b>Range 1 to 2</b>	<b>Range 2 to 3</b>	<b>SET REF Reference</b>
Display	38.1	38.2	38.3	38.4
Enter	39.1	39.2	39.3	39.4

- 39.9** Clear all calibration factors.

## Frequency Offset (Special Function 27).

The Frequency Offset mode allows the Measuring Receiver to keep track of frequencies involved in the down-conversion process. This frequency offset process is used in conjunction with an external mixer and Local Oscillator (LO) to extend the frequency coverage above 1300 MHz.

**To enter the Frequency Offset mode:**

+

+ LO Frequency +

**To exit the Frequency Offset mode:**

+

**To re-enter the Frequency Offset mode with the same LO frequency:**

+

**To display the external LO frequency:**

+



*Operating Error Codes*

<b>Display Code</b>	<b>To Solve an Input Problem</b>	<b>To Solve an Operating Problem</b>
-- or 0 MHz	Adjust input signal level or change measurement sensitivity.	Decrease RF attenuation or gain.
----	Manually tune to input signal.	Re-check operating conditions being used.
-----	Check tuning.	Re-check special operating conditions being used.
01	Increase input signal level or decrease AM.	Press the MHz key to center IF signal in IF passband. If problem persists, signal may be drifting.
02	Increase RF input attenuation.	Decrease RF and/or IF gain setting.
03	Increase level of input signal.	Decrease selected RF input attenuation or increase IF gain. If Range Hold is being used, check range limits.
04	Decrease modulation level on input signal to within measurement range.	Increase range limit setting, Special Function 2.N.
05	Increase carrier level or decrease AM depth (<90%).	
06	Input level exceeds 7 Vrms (1W peak). Decrease level of input signal. If making a TRFL measurement, also press the CLEAR key.	Decrease selected RF or IF gain. If Range Hold is being used, check range limits.
07	Decrease modulation level on input signal. If making a TRFL measurement, decrease level of input signal and press CLEAR key.	Decrease selected RF or IF gain. If Range Hold is being used, check range limits.
08	Check connection to Calibrator. Check for Calibrator malfunction.	
09		Check internal time base for malfunction (Option 002 only).
10	Adjust frequency of input signal to within measurement range, or increase measurement range. If making a TRFL measurement, set the input level to between 0 and -20 dBm. Select the Frequency mode. When the instrument displays the frequency of the input signal, press the MHz key and re-enter the TRFL mode.	

*Operating Error Codes*

<b>Display Code</b>	<b>To Solve an Input Problem</b>	<b>To Solve an Operating Problem</b>
<b>11</b>	Select linear (Watts) units, or disregard error when there is no power present at sensor input.	Key in a different ratio reference.
<b>12</b>		Wait for oven to warm for highest accuracy.
<b>13</b>	Secure connection at SENSOR input.	
<b>14</b>		Remove power from power sensor input during zeroing process.
<b>15</b>		Verify that cal factors have been entered.
<b>16</b>	Increase audio signal level.	
<b>17</b>	Input signal level during reference measurement must be between 1.25V and 2.50V.	Check selected RF or IF gain level. (When making Ratio measurements, allow instrument to complete the reference measurement.)
<b>18</b>		Check sensor connection at RF POWER OUTPUT port.
<b>19</b>		Increase IF gain.
<b>20</b>		Re-enter frequency within measurement range. (In Ratio mode, a reference measurement of zero is invalid.)
<b>21</b>		Check compatibility of function(s) with selected measurement mode.
<b>22</b>		Check Special Function number and re-enter (prefix invalid).
<b>23</b>		Check Special Function number and re-enter (suffix invalid).
<b>24</b>		Invalid HP-IB code. Check function codes.
<b>25</b>		Check Special Function compatibility with measurement.
<b>26</b>		End of RF Power calibration table. (If displayed after first attempt to read table using 37.6 SPCL, the table is empty.)

*Operating Error Codes*

<b>Display Code</b>	<b>To Solve an Input Problem</b>	<b>To Solve an Operating Problem</b>
<b>30</b>		Change RF attenuation and gain or Range Hold setting.
<b>31</b>		Calibrate RF Power measurement.
<b>32</b>		Change IF gain or Range Hold setting.
<b>33</b>	Maintain stable frequency and level during calibration. Check SENSOR connection.	Check RF Power calibration.
<b>34</b>	Maintain stable frequency during TRFL calibration.	
<b>35</b>	Use a stable signal source for TRFL calibration.	

*Measuring Receiver Function to Code Summary*

Function	Code	Function	Code
<b>MEASUREMENTS</b>		<b>CALIBRATION</b>	
AM	M1	CALIBRATE Off	C0
FM	M2	CALIBRATE On	C1
ΦM	M3	% CAL FACTOR	CF
RF POWER	M4	SET REF	RF
FREQ	M5	ZERO	ZR
AUDIO FREQ	S1	SAVE CAL	SC
AUDIO DISTN	S2		
IF LEVEL	S3	<b>MANUAL OPERATIONS</b>	
TUNED RF LEVEL	S4	AUTO TUNING	AT
FREQ ERROR	S5	ENABLE ERRORS	B0
		DISABLE ERRORS	B1
<b>DETECTORS</b>		CLEAR (KEY)	CL
PEAK+	D1	BLUE KEY, CLEAR (KEY)	BC
PEAK-	D2	DISPLAY FREQ	FR
PEAK HOLD	D3	DISPLAY INCREMENT	FN
AVG (RMS Calibrated)	D4	INPUT FREQUENCY (Hz)	HZ
1 kHz DISTN	D5	↑ Hz	HU
400 Hz DISTN	D6	↓ Hz	HD
RMS	D8	TRACK Mode Off (Lock Mode)	K0
PEAK±/2	D9	TRACK Mode On	K1
		↑ kHz	KU
<b>DISPLAYS</b>		↓ kHz	KD
Display LOG Result	LG	MHz (INPUT FREQ)	MZ
Display LIN Result	LN	RECALL	RC
dB EXT ATTEN off	N0	STORE	TR
dB EXT ATTEN on	N1	SPECIAL FUNCTION	SP
RATIO Off	R0	SPECIAL, SPECIAL	SS
RATIO On	R1	mV Units	MV
PREVIOUS RATIO	R2	μV Units	UV
		V Units	VL
<b>FILTERS</b>		W Units	WT
HP (High-Pass) FILTERS Off	H0	<b>MISCELLANEOUS</b>	
50 Hz FILTER On	H1	MODULATION OUTPUT	A0
300 Hz FILTER On	H2	AUDIO INPUT	A1
LP (Low-Pass) FILTERS Off	L0	AUTOMATIC OPERATION	AU
3 kHz FILTER On	L1	Auto-Ranging (RANGE HOLD Off)	G0
15 kHz FILTER On	L2	RANGE HOLD	G1
>20 kHz FILTER On	L3	Identify Instrument	ID
		INSTR PRESET (same as DCL)	IP
<b>FM DE-EMPHASIS</b>		Trigger Off	T0
PRE-DISPLAY Off and		Hold	T1
FM DE-EMPHASIS Off	P0	Trigger Immediate	T2
PRE-DISPLAY On and		Trigger with Settling	T3
FM DE-EMPHASIS On	P1	Hexidecimal A	X0
25 μs DE-EMPHASIS	P2	Hexidecimal B	X1
50 μs DE-EMPHASIS	P3	Hexidecimal C	X2
75 μs DE-EMPHASIS	P4	Hexidecimal D	X3
750 μs DE-EMPHASIS	P5	Hexidecimal E	X4
		Hexidecimal F	X5

*Code to Measuring Receiver Function Summary*

Code	Function	Code	Function
A0	MODULATION OUTPUT	M1	AM
A1	AUDIO INPUT	M2	FM
AT	AUTO TUNING	M3	ΦM
AU	AUTOMATIC OPERATION	M4	RF POWER
B0	ENABLE ERRORS	M5	FREQ
B1	DISABLE ERRORS	MV	mV Units
BC	BLUE KEY, CLEAR (KEY)	MZ	MHz (INPUT FREQ)
C0	CALIBRATE Off	N0	dB EXT ATTEN Off
C1	CALIBRATE On	N1	dB EXT ATTEN On
CF	% CAL FACTOR	P0	PRE-DISPLAY Off and FM DE-EMPHASIS Off
CL	CLEAR (KEY)	P1	PRE-DISPLAY On and DE-EMPHASIS On
D1	PEAK+	P2	25 μs DE-EMPHASIS
D2	PEAK-	P3	50 μs DE-EMPHASIS
D3	PEAK HOLD	P4	75 μs DE-EMPHASIS
D4	AVG (RMS Calibrated)	P5	750 μs DE-EMPHASIS
D5	1 kHz DISTN	R0	RATIO Off
D6	400 Hz DISTN	R1	RATIO On
D8	RMS	R2	PREVIOUS RATIO
D9	PEAK±/2	RC	RECALL
FR	DISPLAY FREQ	RF	SET REF
FN	DISPLAY INCREMENT	S1	AUDIO FREQ
G0	Auto-Ranging (RANGE HOLD Off)	S2	AUDIO DISTN
G1	RANGE HOLD	S3	IF LEVEL
H0	HP (High-Pass) FILTERS Off	S4	TUNED RF LEVEL
H1	50 Hz FILTER On	S5	FREQ ERROR
H2	300 Hz FILTER On	SC	SAVE CAL
HU	↑ Hz	SP	SPECIAL FUNCTION
HD	↓ Hz	SS	SPECIAL, SPECIAL
HZ	INPUT FREQUENCY (Hz)	T0	Trigger Off
ID	Identify Instrument	T1	Hold
IP	INSTR PRESET (same as DCL)	T2	Trigger Immediate
K0	TRACK Mode Off (lock mode)	T3	Trigger with Settling
K1	TRACK Mode On	TR	STORE
KU	↑ kHz	UV	μV Units
KD	↓ kHz	VL	V Units
L0	LP (Low-Pass) FILTERS Off	WT	W Units
L1	3 kHz FILTER On	X0	Hexadecimal A
L2	15 kHz FILTER On	X1	Hexadecimal B
L3	>20 kHz FILTER On	X2	Hexadecimal C
LG	Display LOG Result	X3	Hexadecimal D
LN	Display LIN Result	X4	Hexadecimal E
		X5	Hexadecimal F
		ZR	ZERO

HP 8901A/02A Code Differences

HP 8901A	HP 8902A	Functions
A1 (or AU)	AU	AUTOMATIC OPERATION
F1 (or MZ)	MZ	MHz (INPUT FREQ)
F2 (or KU)	KU	↑ kHz
F3 (or KD)	KD	↓ kHz
F4 (or Z4 or SP)	SP	SPECIAL
F5 (or Z5 or SS)	SS	SPECIAL, SPECIAL
K1 (or CL)	CL	CLEAR
U1 (or D1)	D1	PEAK+
U2 (or D2)	D2	PEAK-
U3 (or D3)	D3	PEAK HOLD
U4 (or D4)	D4	Average Detector (RMS Calibrated)
Z1 (or HZ)	HZ	Hz INPUT FREQ
Z2 (or HU)	HU	↑ Hz
Z3 (or HD)	HD	↓ Hz
M4	35.0SP	Peak RF Level
S4	36.0SP	Peak Tuned RF Level
R1	LN, R1	% RATIO
R2	LG, R1	dB RATIO
4.0SP	AT, K0	Auto Tuning, low-noise lock mode
4.1SP	AT, K1	Auto Tuning, track mode
4.2SP	MZ, K0	Manual Tuning, low-noise lock mode
7.1SP	7.1SP	10 Hz frequency resolution
7.2SP	7.3SP	1000 Hz frequency resolution
9.0SP	G1	Hold Setting (RANGE HOLD)
10.0SP	34.0SP	IF Frequency
11.0SP	LN, R2	% PREVIOUS RATIO
11.1SP	LG, R2	dB PREVIOUS RATIO
11.3SP	use "-" key	Make Ratio Reference Negative
15.0SP	15.0SP	Oven Check (returns "0" if oven OK or not installed, rather than doing nothing as in the 8901A)
Status Byte	Status Byte	Status Byte Bits "Upper Limit" (weight 8) and "Lower Limit" (weight 16) are merged together into "Limit Reached" (weight 8)



## **Agilent Technologies**

Innovating the HP Way

June 8, 2000

Dear Customer,

As of November 1, 1999, four of Hewlett-Packard's businesses, test and measurement, semiconductor products, health care solutions, and chemical analysis became a new company, Agilent Technologies. Now, many of your Hewlett-Packard products and services are in the care of Agilent Technologies.

At Agilent Technologies, we are working diligently to make this transition as smooth as possible for you. However, as a result of this transition, the products and related documentation contained in this shipment may be labeled with either the Hewlett-Packard name and logo, the Agilent Technologies name and logo, or a combination of both. Information in this package may refer to Hewlett-Packard (HP), but applies to your Agilent Technologies product. Hewlett-Packard and Agilent branded products with the same model number are interchangeable.

Whatever logo you see, the information, products, and services come from the same reliable source.

If you have questions about Agilent Technologies products and services, please visit our website at <http://www.agilent.com>.

Sincerely,

Rebranding Team

# HP 8902A MEASURING RECEIVER

## Service Manual

### SERIAL NUMBERS

This manual provides complete information for instruments with serial-number prefixes:

2305A to 3018A and all *MAJOR* changes that apply to your instrument.

*rev.18JUN93*

For additional important information about serial numbers, refer to "INSTRUMENTS COVERED BY THIS MANUAL" in Section 1.

Fifth Edition

This material may be reproduced by or for the U.S. Government pursuant to the Copyright License under the clause at DFARS 52.227-7013 (APR 1988).

Copyright©HEWLETT-PACKARD COMPANY 1989  
EAST 24001 MISSION AVENUE, LIBERTY LAKE, WASHINGTON, 99019-9599

Service Manual HP Part 08902-90031

**Other Documents Available:**

Operation and Calibration Manual HP Part 08902-90029

Basic Operation and Application Guide HP Part 5953-8458

Quick Reference Guide HP Part 08902-90060

Microfiche Operation and Calibration Manual HP Part 08902-90030

Microfiche Service Manual HP Part 08902-90032

Printed in U.S.A. : July 1993





---

# **1 Regulatory Information**

(Updated March 1999)

## Safety Considerations

### GENERAL

This product and related documentation must be reviewed for familiarization with safety markings and instructions before operation.

This product has been designed and tested in accordance with *IEC Publication 1010*, "Safety Requirements for Electronic Measuring Apparatus," and has been supplied in a safe condition. This instruction documentation contains information and warnings which must be followed by the user to ensure safe operation and to maintain the product in a safe condition.

### SAFETY EARTH GROUND

A uninterruptible safety earth ground must be provided from the main power source to the product input wiring terminals, power cord, or supplied power cord set.

### SAFETY SYMBOLS



Indicates instrument damage can occur if indicated operating limits are exceeded.



Indicates hazardous voltages.



Indicates earth (ground) terminal

---

**WARNING**     **A WARNING note denotes a hazard. It calls attention to a procedure, practice, or the like, which, if not correctly performed or adhered to, could result in personal injury. Do not proceed beyond a WARNING sign until the indicated conditions are fully understood and met.**

---

---

**CAUTION**     A CAUTION note denotes a hazard. It calls attention to an operation procedure, practice, or the like, which, if not correctly performed or adhered to, could result in damage to or destruction of part or all of the product. Do not proceed beyond an CAUTION note until the indicated conditions are fully understood and met.

---

## Safety Considerations for this Instrument

---

### **WARNING**

**This product is a Safety Class I instrument (provided with a protective earthing ground incorporated in the power cord). The mains plug shall only be inserted in a socket outlet provided with a protective earth contact. Any interruption of the protective conductor inside or outside of the product is likely to make the product dangerous. Intentional interruption is prohibited.**

**Whenever it is likely that the protection has been impaired, the instrument must be made inoperative and be secured against any unintended operation.**

**If this instrument is to be energized via an auto transformer (for voltage reduction), make sure the common terminal is connected to the earth terminal of the power source.**

**If this product is not used as specified, the protection provided by the equipment could be impaired. This product must be used in a normal condition (in which all means for protection are intact) only.**

**No operator serviceable parts in this product. Refer servicing to qualified personnel. To prevent electrical shock, do not remove covers.**

**Servicing instructions are for use by qualified personnel only. To avoid electrical shock, do not perform any servicing unless you are qualified to do so.**

**The opening of covers or removal of parts is likely to expose dangerous voltages. Disconnect the product from all voltage sources while it is being opened.**

**The power cord is connected to internal capacitors that may remain live for 5 seconds after disconnecting the plug from its power supply.**

**For Continued protection against fire hazard, replace the line fuse(s) only with 250 V fuse(s) or the same current rating and type (for example, normal blow or time delay). Do not use repaired fuses or short circuited fuseholders.**

**Always use the three-prong ac power cord supplied with this product. Failure to ensure adequate earth grounding by not using this cord may cause product damage.**

**This product is designed for use in Installation Category II and Pollution Degree 2 per *IEC 1010* and *IEC 664* respectively. FOR INDOOR USE ONLY.**

**This product has autoranging line voltage input, be sure the supply voltage is within the specified range.**

**To prevent electrical shock, disconnect instrument from mains (line) before cleaning. Use a dry cloth or one slightly dampened with water to clean the external case parts. Do not attempt to clean internally.**

**Ventilation Requirements: When installing the product in a cabinet, the convection into and out of the product must not be restricted. The ambient temperature (outside the cabinet) must be less than the maximum operating temperature of the product by 4° C for every 100 watts dissipated in the cabinet. If the total power dissipated in the cabinet is greater than 800 watts, then forced convection must be used.**

---

### **Product Markings**

CE - the CE mark is a registered trademark of the European Community. A CE mark accompanied by a year indicated the year the design was proven.

CSA - the CSA mark is a registered trademark of the Canadian Standards Association.

## SAFETY CONSIDERATIONS

### GENERAL

This product and related documentation must be reviewed for familiarization with safety markings and instructions before operation.

This product is a Safety Class I instrument (provided with a protective earth terminal).

### BEFORE APPLYING POWER

Verify that the product is set to match the available line voltage and the correct fuse is installed.

### SAFETY EARTH GROUND

An uninterruptible safety earth ground must be provided from the main power source to the product input wiring terminals, power cord, or supplied power cord set.

### SAFETY SYMBOLS



Instruction manual symbol: the product will be marked with this symbol when it is necessary for the user to refer to the instruction manual (refer to Table of Contents).



Indicates hazardous voltages.



Indicates earth (ground) terminal.

### WARNING

The WARNING sign denotes a hazard. It calls attention to a procedure, practice, or the like, which, if not correctly performed or adhered to, could result in personal injury. Do not proceed beyond a WARNING sign until the indicated conditions are fully understood and met.

### CAUTION

The CAUTION sign denotes a hazard. It calls attention to an operating procedure, practice, or the like, which, if not correctly performed or adhered to, could result in damage to or destruction of part or all of the product. Do not proceed beyond a CAUTION sign until the indicated conditions are fully understood and met.

### WARNING

*Any interruption of the protective (grounding) conductor (inside or outside the instrument) or disconnecting the protective earth terminal will cause a potential shock hazard that could result in personal injury. (Grounding one conductor of a two conductor outlet is not sufficient protection).*

*Whenever it is likely that the protection has been impaired, the instrument must be made inoperative and be secured against any unintended operation.*

*If this instrument is to be energized via an autotransformer (for voltage reduction) make sure the common terminal is connected to the earth terminal of the power source.*

*Servicing instructions are for use by service-trained personnel only. To avoid dangerous electric shock, do not perform any servicing unless qualified to do so.*

*Adjustments described in the manual are performed with power supplied to the instrument while protective covers are removed. Energy available at many points may, if contacted, result in personal injury.*

*Capacitors inside the instrument may still be charged even if the instrument has been disconnected from its source of supply.*

*For continued protection against fire hazard, replace the line fuse(s) only with 250V fuse(s) of the same current rating and type (for example, normal blow, time delay, etc.). Do not use repaired fuses or short circuited fuseholders.*



**ATTENTION  
Static Sensitive  
Devices**

*This instrument was constructed in an ESD (electro-static discharge) protected environment. This is because most of the semiconductor devices used in this instrument are susceptible to damage by static discharge.*

*Depending on the magnitude of the charge, device substrates can be punctured or destroyed by contact or mere proximity of a static charge. The results can cause degradation of device performance, early failure, or immediate destruction.*

*These charges are generated in numerous ways such as simple contact, separation of materials, and normal motions of persons working with static sensitive devices.*

*When handling or servicing equipment containing static sensitive devices, adequate precautions must be taken to prevent device damage or destruction.*

*Only those who are thoroughly familiar with industry accepted techniques for handling static sensitive devices should attempt to service circuitry with these devices.*

*In all instances, measures must be taken to prevent static charge build-up on work surfaces and persons handling the devices.*

*For further information on ESD precautions, refer to "SPECIAL HANDLING CONSIDERATIONS FOR STATIC SENSITIVE DEVICES" in Section VIII Service Section.*

# VOLUME 1 TABLE OF CONTENTS

## SECTION 6 REPLACEABLE PARTS

Introduction To This Section . . . . .	6-1
Reference Designators and Abbreviations . . . . .	6-1
Replaceable Parts List . . . . .	6-1
Ordering Parts . . . . .	6-1
Replaceable Parts List Updating (Manual Updates) . . . . .	6-2
Mechanical and Chassis Part Locations and Reference Designations . . . . .	6-2
Recommended Spares List . . . . .	6-2

## SECTION 7 INSTRUMENT CHANGES

Introduction . . . . .	7-1
Introduction to This Section . . . . .	7-1
Modification for Invalid Error 06 Indication (2305A to 2535A) . . . . .	7-1
Firmware Change Summary (2305A to 2644A) . . . . .	7-2

## SECTION 8 SERVICE

Introduction to This Section . . . . .	8A-1
How This Section is Organized . . . . .	8A-1
Safety Considerations . . . . .	8A-2
Before Applying Power . . . . .	8A-2
Safety . . . . .	8A-2
Service Tools and Aids . . . . .	8A-3
Service Accessory Kit . . . . .	8A-3
Heat-Staking Tool . . . . .	8A-4
Assembly Locations . . . . .	8A-4
Parts and Cable Locations . . . . .	8A-5
Other Service Documents . . . . .	8A-5
Recommended Test Equipment and Accessories . . . . .	8A-5
General Troubleshooting . . . . .	8A-5
Operator Errors . . . . .	8A-5
Operation Out of Specification . . . . .	8A-5
Catastrophic Failures . . . . .	8A-6
Schematic Symbolology and Schematic Diagram Notes . . . . .	8A-10
Special Functions . . . . .	8B-1
General . . . . .	8B-1
Direct Control Special Functions (Prefix 0) . . . . .	8B-1
Service Special Functions (Prefix 40-99) . . . . .	8B-5

**SECTION 8**  
**SERVICE (cont'd)**

Error Messages . . . . .	8B-15
General . . . . .	8B-15
Error Message Catagories . . . . .	8B-15
Enabling Measurement Progress and Service Error Messages . . . . .	8B-15
Measurement Progress Error Messages (Errors 40 through 64) . . . . .	8B-15
Service Error Messages (Errors 65 through 89) . . . . .	8B-16
Power-Up Checks . . . . .	8B-18
Controller Test LEDs and Test Points . . . . .	8B-19
Signature Analysis . . . . .	8B-20
General Disassembly Procedures . . . . .	8C-1
Top Cover Removal . . . . .	8C-1
Bottom Cover Removal . . . . .	8C-1
Side Cover Removal . . . . .	8C-1
Information Tray Removal . . . . .	8C-1
Front Panel Disassembly Procedure . . . . .	8C-1
Front-Panel Assembly Removal . . . . .	8C-1
A1 Keyboard and Display Assembly Removal . . . . .	8C-2
Front Dress Panle and Display Window Removal . . . . .	8C-2
Replacement of Pushbutton Switches and Annunciator LEDs . . . . .	8C-2
Service Sheet BD1—Overall Block Diagram . . . . .	8D-1
Service Sheet BD2—RF Block Diagram . . . . .	8D-15
Service Sheet BD3—IF Block Diagram . . . . .	8D-27
Service Sheet BD4—Audio Block Diagram . . . . .	8D-41
Service Sheet BD5—Digital and Power Supply Block Diagram . . . . .	8D-51
Block Diagram Foldouts . . . . .	8E-1



## Section 6 REPLACEABLE PARTS

### 6-1. INTRODUCTION TO THIS SECTION

This section contains information for ordering parts. Table 6-1 lists reference designations, and Table 6-2 lists abbreviations that are used in the Replaceable Parts List. Table 6-3 lists all replaceable parts in the instrument. Table 6-4 contains the names and addresses that correspond to the manufacturer's code numbers listed in Table 6-3. Also included in this section are photographs and drawings to aid in identifying and ordering chassis mounted parts and mechanical parts.

### 6-2. REFERENCE DESIGNATIONS AND ABBREVIATIONS USED IN THIS MANUAL

Table 6-1 lists the reference designation letters for electrical parts in the instrument. The letter designations found in Table 6-1 are coupled with numeric designations to provide a unique reference designation for each part in the instrument. For example A16R1 is the reference designation of a particular resistor R1 on assembly A16.

Table 6-2 lists abbreviations used in the parts list and on schematics.

### 6-3. REPLACEABLE PARTS LIST

Table 6-3 is a list of replaceable parts and is organized as follows:

- a. Electrical assemblies and their components with reference designations in alphanumeric order.
- b. Chassis-Mounted parts with reference designations in alphanumeric order.
- c. Mechanical parts with reference designations in alphanumeric order.

For your convenience, the Replaceable Parts List is paginated so that each assembly listing can be removed from Section 6 and collated into Section 8 with its corresponding service information.

### Ordering Parts.

#### Instrument Serial Numbers.

Attached to the rear of the instrument is a serial-number plate. The first four digits and the letter are the instrument serial-number prefix. The last five digits (serial-number suffix) are unique to each instrument. When parts in the instrument are changed, the serial-number prefix of the instrument may also change. This means that sometimes a part will be listed more than once in the the replaceable parts list along with a serial-number prefix or range of serial-number prefixes. Find the serial-number prefix on the serial plate of your instrument and order the part listed under the corresponding prefix in the table. If no serial prefix information is listed, the part is compatible in instruments of all serial numbers.

### How to Order

To order a part in the Replaceable Parts List, call or write the nearest Hewlett-Packard Sales Office. Have the following information ready to speed the ordering process:

1. The Hewlett-Packard part number with the check digit. (The check digit will ensure accurate and timely processing of your order.)
2. The quantity required.
3. An approved purchase order number. (Sometimes required.)

### NOTE

*Within the USA, it is better to order directly from the HP Parts Center in Mountain View California. Ask your nearest HP office for information and forms for the "Direct Order System".*

### Manual Updating

This manual may be revised as needed to make corrections and to document hardware and firmware changes. The latest revision of the manual can be purchased from the following Hewlett-Packard locations:

Inside the U.S.A.: Call HP Parts Direct Ordering at 800-227-8164. They can also help determine if a new revision is available.

Outside the U.S.A.: Contact the local Hewlett-Packard Sales and Service Office for ordering information.

## 6-4. MECHANICAL AND CHASSIS PART LOCATIONS AND REFERENCE DESIGNATIONS

Most mechanical parts are identified in Figures 6-1 to 6-9. These figures are located at the end of this section. Major mechanical parts have reference designations that begin with the letters MP. To find the part number and description of a mechanical part, find the part in one of the photographs or drawings, and then look up the reference designation in Table 6-3. Mechanical hardware, such as screws, are listed under the part which they attach. For example, the screws that attach the fan (B1) to the rear panel are listed under B1.

## 6-5. RECOMMENDED SPARES LIST

Stocking spare parts for an instrument is often done to ensure quick return to service after a malfunction occurs. Hewlett-Packard has prepared a "Recommended Spares" list for this instrument. The contents of the list are based on failure reports and repair data. Quantities given are for one year of parts support. You can request a complimentary copy of the "Recommended Spares" list from your nearest Hewlett-Packard office.

When stocking parts to support more than one instrument or to support a variety of Hewlett-Packard instruments, it may be more economical to work from one consolidated list rather than simply adding together stocking quantities from the individual instrument lists. Hewlett-Packard will prepare consolidated "Recommended Spares" lists for any number or combination of instruments. Contact your nearest Hewlett-Packard office for details.

Table 6-1. Reference Designations

REFERENCE DESIGNATIONS			
A	assembly	E	miscellaneous electrical part
AT	attenuator; isolator; termination	F	fuse
B	fan; motor	FL	filter
BT	battery	H	hardware
C	capacitor	HY	circulator
CP	coupler	J	electrical connector (stationary portion); jack
CR	diode; diode thyristor; varactor	K	relay
DC	directional coupler	L	coil; inductor
DL	delay line	M	meter
DS	annunciator; signaling device (audible or visual); lamp; LED	MP	miscellaneous mechanical part
P	electrical connector (movable portion); plug	Q	transistor; SCR; triode thyristor; FET
R	resistor	RT	thermistor
S	switch	T	transformer
T	transformer	TB	terminal board
TC	thermocouple	TP	test point
U	integrated circuit; microcircuit	V	electron tube
VR	voltage regulator; breakdown diode	W	cable; transmission path; wire
X	socket	Y	crystal unit (piezo-electric or quartz)
Z	tuned cavity; tuned circuit		

Table 6-2. Abbreviations (1 of 2)

ABBREVIATIONS			
A	ampere	COEF	coefficient
ac	alternating current	COM	common
ACCESS	accessory	COMP	composition
ADJ	adjustment	COMPL	complete
A/D	analog-to-digital	CONN	connector
AF	audio frequency	CP	cadmium plate
AFC	automatic frequency control	CRT	cathode-ray tube
AGC	automatic gain control	CTL	complementary transistor logic
AL	aluminum	CW	continuous wave
ALC	automatic level control	cw	clockwise
AM	amplitude modulation	cm	centimeter
AMPL	amplifier	D/A	digital-to-analog
APC	automatic phase control	dB	decibel
ASSY	assembly	dBm	decibel referred to 1 mW
AUX	auxiliary	dc	direct current
avg	average	deg	degree (temperature interval or difference)
AWG	American wire gauge	...°	degree (plane angle)
BAL	balance	°C	degree Celsius (centigrade)
BCD	binary coded decimal	°F	degree Fahrenheit
BD	board	°K	degree Kelvin
BECU	beryllium copper	DEPC	deposited carbon
BFO	beat frequency oscillator	DET	detector
BH	binder head	diam	diameter
BKDN	breakdown	DIA	diameter (used in parts list)
BP	bandpass	DIFF AMPL	differential amplifier
BPF	bandpass filter	div	division
BRS	brass	DPDT	double-pole, double-throw
BWO	backward-wave oscillator	DR	drive
CAL	calibrate	DSB	double sideband
ccw	counter-clockwise	DTL	diode transistor logic
CER	ceramic	DVM	digital voltmeter
CHAN	channel	ECL	emitter coupled logic
cm	centimeter	EMF	electromotive force
CMO	cabinet mount only	EDP	electronic data processing
COAX	coaxial	ELECT	electrolytic
		ENCAP	encapsulated
		EXT	external
		F	farad
		FET	field-effect transistor
		F/F	flip-flop
		FH	flat head
		FIL H	filister head
		FM	frequency modulation
		FP	front panel
		FREQ	frequency
		FXD	fixed
		g	gram
		GE	germanium
		GHz	gigahertz
		GL	glass
		GRD	ground(ed)
		H	henry
		h	hour
		HET	heterodyne
		HEX	hexagonal
		HD	head
		HDW	hardware
		HF	high frequency
		HG	mercury
		HI	high
		HP	Hewlett-Packard
		HPF	high pass filter
		HR	hour (used in parts list)
		HV	high voltage
		Hz	Hertz
		IC	integrated circuit
		ID	inside diameter
		IF	intermediate frequency
		IMPG	impregnated
		in	incandescent
		INCL	include(s)
		INP	input
		INS	insulation
		INT	internal
		kg	kilogram
		KHz	kilohertz
		k	kilohm
		kV	kilovolt
		lb	pound
		LC	inductance-capacitance
		LED	light-emitting diode
		LF	low frequency
		LG	long
		LH	left hand
		LIM	limit
		LIN	linear taper (used in parts list)
		LK WASH	lock washer
		LO	low; local oscillator
		LOG	logarithmic taper (used in parts list)
		log	logarithm(ic)
		LPF	low pass filter
		LV	low voltage
		m	meter (distance)
		mA	milliampere
		MAX	maximum
		M	megohm
		MEG	meg (10 <sup>6</sup> ) (used in parts list)
		MET FLM	metal film
		MET OX	metallic oxide
		MF	medium frequency; microfarad (used in parts list)
		MFR	manufacturer
		mg	milligram
		MHz	megahertz
		mH	millihenry
		mho	mho
		min	minute (time)
		...'	minute (plane angle)
		MINAT	miniature
		mm	millimeter

NOTE

All abbreviations in the parts list will be in upper-case.

Table 6-2. Abbreviations (2 of 2)

MOD . . . . . modulator	OD . . . . . outside diameter	PWV . . . . . peak working voltage	TD . . . . . time delay
MOM . . . . . momentary	OH . . . . . oval head	RC . . . . . resistance-capacitance	TERM . . . . . terminal
MOS . . . . . metal-oxide semiconductor	OP AMPL . . . . . operational amplifier	RECT . . . . . rectifier	TFT . . . . . thin-film transistor
ms . . . . . millisecond	OPT . . . . . option	REF . . . . . reference	TGL . . . . . toggle
MTG . . . . . mounting	OSC . . . . . oscillator	REG . . . . . regulated	THD . . . . . thread
MTR . . . . . meter (indicating device)	OX . . . . . oxide	REPL . . . . . replaceable	THRU . . . . . through
mV . . . . . millivolt	oz . . . . . ounce	RF . . . . . radio frequency	TI . . . . . titanium
mVac . . . . . millivolt, ac	Ω . . . . . ohm	RFI . . . . . radio frequency interference	TOL . . . . . tolerance
mVdc . . . . . millivolt, dc	P . . . . . peak (used in parts list)	RH . . . . . round head; right hand	TRIM . . . . . trimmer
mVpk . . . . . millivolt, peak	PAM . . . . . pulse-amplitude modulation	RLC . . . . . resistance-inductance-capacitance	TSTR . . . . . transistor
mVp-p . . . . . millivolt, peak-to-peak	PC . . . . . printed circuit	RMO . . . . . rack mount only	TTL . . . . . transistor-transistor logic
mVrms . . . . . millivolt, rms	PCM . . . . . pulse-code modulation; pulse-count modulation	rms . . . . . root-mean-square	TV . . . . . television
mW . . . . . milliwatt	PDM . . . . . pulse-duration modulation	RND . . . . . round	TVI . . . . . television interference
MUX . . . . . multiplex	pF . . . . . picofarad	ROM . . . . . read-only memory	TWT . . . . . traveling wave tube
MY . . . . . mylar	PH BRZ . . . . . phosphor bronze	R&P . . . . . rack and panel	U . . . . . micro (10 <sup>-6</sup> ) (used in parts list)
μA . . . . . microampere	PHL . . . . . Phillips	RVV . . . . . reverse working voltage	UF . . . . . microfarad (used in parts list)
μF . . . . . microfarad	PIN . . . . . positive-intrinsic-negative	S . . . . . scattering parameter	UHF . . . . . ultrahigh frequency
μH . . . . . microhenry	PIV . . . . . peak inverse voltage	s . . . . . second (time)	UNDEF . . . . . undefined
μmho . . . . . micromho	pk . . . . . peak	" . . . . . second (plane angle)	UNREG . . . . . unregulated
μs . . . . . microsecond	PL . . . . . phase lock	S-B . . . . . slow-blow (fuse) (used in parts list)	V . . . . . volt
μV . . . . . microvolt	PLO . . . . . phase lock oscillator	SCR . . . . . silicon controlled rectifier; screw	VA . . . . . voltampere
μVac . . . . . microvolt, ac	PM . . . . . phase modulation	SE . . . . . selenium	Vac . . . . . volts, ac
μVdc . . . . . microvolt, dc	PNP . . . . . positive-negative-positive	SECT . . . . . sections	VAR . . . . . variable
μVpk . . . . . microvolt, peak	P/O . . . . . part of	SEMICON . . . . . semiconductor	VCO . . . . . voltage-controlled oscillator
μVp-p . . . . . microvolt, peak-to-peak	POLY . . . . . polystyrene	SHF . . . . . superhigh frequency	Vdc . . . . . volts, dc
μVrms . . . . . microvolt, rms	PORC . . . . . porcelain	SI . . . . . silicon	VDCW . . . . . volts, dc, working (used in parts list)
μW . . . . . microwatt	POS . . . . . positive; position(s) (used in parts list)	SIL . . . . . silver	V(F) . . . . . volts, filtered
nA . . . . . nanoampere	POSN . . . . . position	SL . . . . . slide	VFO . . . . . variable-frequency oscillator
NC . . . . . no connection	POT . . . . . potentiometer	SNR . . . . . signal-to-noise ratio	VHF . . . . . very-high frequency
N/C . . . . . normally closed	p-p . . . . . peak-to-peak	SPDT . . . . . single-pole, double-throw	Vpk . . . . . volts, peak
NE . . . . . neon	PP . . . . . peak-to-peak (used in parts list)	SPG . . . . . spring	Vp-p . . . . . volts, peak-to-peak
NEG . . . . . negative	PPM . . . . . pulse-position modulation	SR . . . . . split ring	Vrms . . . . . volts, rms
nF . . . . . nanofarad	PREAMPL . . . . . preamplifier	SPST . . . . . single-pole, single-throw	VSWR . . . . . voltage standing wave ratio
NI PL . . . . . nickel plate	PRF . . . . . pulse-repetition frequency	SS . . . . . Service Sheet	VTO . . . . . voltage-tune oscillator
N/O . . . . . normally open	PRR . . . . . pulse repetition rate	SSB . . . . . single sideband	VTVM . . . . . vacuum-tube voltmeter
NOM . . . . . nominal	ps . . . . . picosecond	SST . . . . . stainless steel	V(X) . . . . . volts, switched
NORM . . . . . normal	PT . . . . . point	STL . . . . . steel	W . . . . . watt
NPN . . . . . negative-positive-negative	PTM . . . . . pulse-time modulation	SQ . . . . . square	W/ . . . . . with
NPO . . . . . negative-positive zero (zero temperature coefficient)	PWM . . . . . pulse-width modulation	SWR . . . . . standing-wave ratio	WIV . . . . . working inverse voltage
NRFR . . . . . not recommended for field replacement		SYNC . . . . . synchronize	WW . . . . . wirewound
NSR . . . . . not separately replaceable		T . . . . . timed (slow-blow fuse)	W/O . . . . . without
ns . . . . . nanosecond		TA . . . . . tantalum	YIG . . . . . yttrium-iron-garnet
nW . . . . . nanowatt		TC . . . . . temperature compensating	Z <sub>0</sub> . . . . . characteristic impedance
OBD . . . . . order by description			

**NOTE**

All abbreviations in the parts list will be in upper-case.

**MULTIPLIERS**

Abbreviation	Prefix	Multiple
T	tera	10 <sup>12</sup>
G	giga	10 <sup>9</sup>
M	mega	10 <sup>6</sup>
k	kilo	10 <sup>3</sup>
da	deka	10
d	deci	10 <sup>-1</sup>
c	centi	10 <sup>-2</sup>
m	milli	10 <sup>-3</sup>
μ	micro	10 <sup>-6</sup>
n	nano	10 <sup>-9</sup>
p	pico	10 <sup>-12</sup>
f	femto	10 <sup>-15</sup>
a	atto	10 <sup>-18</sup>

Table 6-3. Replaceable Parts

Reference Designation	HP Part Number	C D	Qty.	Description	Mfr. Code	Mfr. Part Number
<b>A1</b>						
A1	08901-60143	0	1	KEYBOARD AND DISPLAY ASSEMBLY	28480	08901-60143
A1C1	0160-0228	6	5	CAPACITOR-FXD 22UF + -10% 15VDC TA	56289	150D226X9015B2
A1C2	0160-2291	5	1	CAPACITOR-FXD .18UF + -10% 80VDC POLYE	28480	0160-2291
A1C3	0160-0576	5	87	CAPACITOR-FXD .1UF + -20% 50VDC CER	28480	0160-0576
A1C4	0160-0576	5		CAPACITOR-FXD .1UF + -20% 50VDC CER	28480	0160-0576
A1C5	0160-0576	5		CAPACITOR-FXD .1UF + -20% 50VDC CER	28480	0160-0576
A1C6	0160-0576	5		CAPACITOR-FXD .1UF + -20% 50VDC CER	28480	0160-0576
A1C7	0160-0576	5		CAPACITOR-FXD .1UF + -20% 50VDC CER	28480	0160-0576
A1C8	0160-0576	5		CAPACITOR-FXD .1UF + -20% 50VDC CER	28480	0160-0576
A1C9	0160-0576	5		CAPACITOR-FXD .1UF + -20% 50VDC CER	28480	0160-0576
A1C10	0160-0576	5		CAPACITOR-FXD .1UF + -20% 50VDC CER	28480	0160-0576
A1C11	0160-0576	5		CAPACITOR-FXD .1UF + -20% 50VDC CER	28480	0160-0576
A1C12	0160-0576	5		CAPACITOR-FXD .1UF + -20% 50VDC CER	28480	0160-0576
A1C13	0160-0576	5		CAPACITOR-FXD .1UF + -20% 50VDC CER	28480	0160-0576
A1C14	0160-0576	5		CAPACITOR-FXD .1UF + -20% 50VDC CER	28480	0160-0576
A1C15	0160-0576	5		CAPACITOR-FXD .1UF + -20% 50VDC CER	28480	0160-0576
A1C16	0160-0576	5		CAPACITOR-FXD .1UF + -20% 50VDC CER	28480	0160-0576
A1C17	0160-0576	5		CAPACITOR-FXD .1UF + -20% 50VDC CER	28480	0160-0576
A1C18	0160-0576	5		CAPACITOR-FXD .1UF + -20% 50VDC CER	28480	0160-0576
A1C19	0160-0576	5		CAPACITOR-FXD .1UF + -20% 50VDC CER	28480	0160-0576
A1CR1	1901-1098	1	87	DIODE-SWITCHING 1N4150 50V 200MA 4NS	9N171	1N4150
A1CR2	1901-1098	1		DIODE-SWITCHING 1N4150 50V 200MA 4NS	9N171	1N4150
A1CR3	1901-1098	1		DIODE-SWITCHING 1N4150 50V 200MA 4NS	9N171	1N4150
A1CR4	1901-1098	1		DIODE-SWITCHING 1N4150 50V 200MA 4NS	9N171	1N4150
A1DS1	1990-0759	6	4	LED-LIGHT BAR MODULE LUM-INT = 3MCD	28480	HLMP-2620
	1200-1303	5	4	SOCKET-IC 16-CONT DIP DIP-SLDR	28480	1200-1303
A1DS2	1990-0759	6		LED-LIGHT BAR MODULE LUM-INT = 3MCD	28480	HLMP-2620
	1200-1303	5		SOCKET-IC 16-CONT DIP DIP-SLDR	28480	1200-1303
A1DS3	1990-1273	1	28	LED-LAMP-RED LUM-INT = 8.6MCD BVR = 5V	01542	QLMP-1613
A1DS4	1990-1273	1		LED-LAMP-RED LUM-INT = 8.6MCD BVR = 5V	01542	QLMP-1613
A1DS5	1990-1273	1		LED-LAMP-RED LUM-INT = 8.6MCD BVR = 5V	01542	QLMP-1613
A1DS6	1990-1273	1		LED-LAMP-RED LUM-INT = 8.6MCD BVR = 5V	01542	QLMP-1613
A1DS7	1990-1273	1		LED-LAMP-RED LUM-INT = 8.6MCD BVR = 5V	01542	QLMP-1613
A1DS8	1990-1273	1		LED-LAMP-RED LUM-INT = 8.6MCD BVR = 5V	01542	QLMP-1613
A1DS9	1990-1273	1		LED-LAMP-RED LUM-INT = 8.6MCD BVR = 5V	01542	QLMP-1613
A1DS10	1990-1273	1		LED-LAMP-RED LUM-INT = 8.6MCD BVR = 5V	01542	QLMP-1613
A1DS11	1990-1273	1		LED-LAMP-RED LUM-INT = 8.6MCD BVR = 5V	01542	QLMP-1613
A1DS12	1990-1273	1		LED-LAMP-RED LUM-INT = 8.6MCD BVR = 5V	01542	QLMP-1613
A1DS13	1990-1273	1		LED-LAMP-RED LUM-INT = 8.6MCD BVR = 5V	01542	QLMP-1613
A1DS14	1990-1273	1		LED-LAMP-RED LUM-INT = 8.6MCD BVR = 5V	01542	QLMP-1613
A1DS15	1990-1273	1		LED-LAMP-RED LUM-INT = 8.6MCD BVR = 5V	01542	QLMP-1613
A1DS16	1990-1273	1		LED-LAMP-RED LUM-INT = 8.6MCD BVR = 5V	01542	QLMP-1613
A1DS17	1990-1273	1		LED-LAMP-RED LUM-INT = 8.6MCD BVR = 5V	01542	QLMP-1613
A1DS18	1990-1273	1		LED-LAMP-RED LUM-INT = 8.6MCD BVR = 5V	01542	QLMP-1613
A1DS19	1990-0759	6		LED-LIGHT BAR MODULE LUM-INT = 3MCD	28480	HLMP-2620
	1200-1303	5		SOCKET-IC 16-CONT DIP DIP-SLDR	28480	1200-1303
A1DS20				NOT ASSIGNED		
A1DS21	1990-0759	6		LED-LIGHT BAR MODULE LUM-INT = 3MCD	28480	HLMP-2620
	1200-1303	5		SOCKET-IC 16-CONT DIP DIP-SLDR	28480	1200-1303
A1DS22	1990-1273	1		LED-LAMP-RED LUM-INT = 8.6MCD BVR = 5V	01542	QLMP-1613
A1DS23	1990-1273	1		LED-LAMP-RED LUM-INT = 8.6MCD BVR = 5V	01542	QLMP-1613

† Refer to Section 7 for update information.

\* Factory Selected Component (Refer to Section 5).

Δ Errata part change.

Table 6-3. Replaceable Parts

Reference Designation	HP Part Number	C D	Qty.	Description	Mfr. Code	Mfr. Part Number
A1DS24	1990-1273	1		LED-LAMP-RED LUM-INT = 8.6MCD BVR = 5V	01542	QLMP-1613
A1DS25	1990-1273	1		LED-LAMP-RED LUM-INT = 8.6MCD BVR = 5V	01542	QLMP-1613
A1DS26	1990-1273	1		LED-LAMP-RED LUM-INT = 8.6MCD BVR = 5V	01542	QLMP-1613
A1DS27	1990-1273	1		LED-LAMP-RED LUM-INT = 8.6MCD BVR = 5V	01542	QLMP-1613
A1DS28	1990-1273	1		LED-LAMP-RED LUM-INT = 8.6MCD BVR = 5V	01542	QLMP-1613
A1DS29	1990-1273	1		LED-LAMP-RED LUM-INT = 8.6MCD BVR = 5V	01542	QLMP-1613
A1DS30	1990-0699	3	2	LED-LIGHT BAR-RED MODULE LUM-INT = 7MCD	28480	1LM1-2350
	1200-0901	7	2	SOCKET-STRP 8-CONT W-WRAP	28480	1200-0901
<i>2305A TO 2914A</i>						
A1DS31†	1990-0670	0	5	LED-LAMP-YLW LUM-INT = 1MCD IF = 20MA-MAX	28480	1990-0670
A1DS32†	1990-0670	0		LED-LAMP-YLW LUM-INT = 1MCD IF = 20MA-MAX	28480	1990-0670
A1DS33†	1990-0670	0		LED-LAMP-YLW LUM-INT = 1MCD IF = 20MA-MAX	28480	1990-0670
A1DS34†	1990-0670	0		LED-LAMP-YLW LUM-INT = 1MCD IF = 20MA-MAX	28480	1990-0670
A1DS35†	1990-0670	0		LED-LAMP-YLW LUM-INT = 1MCD IF = 20MA-MAX	28480	1990-0670
A1DS36†	1990-0678	8	2	LED-LAMP-GRN LUM-INT = 800UCD IF = 30MA-MAX	28480	1990-0678
A1DS37†	1990-0950	3	5	LED-LAMP-RED LUM-INT = 1MCD IF = 13MA-MAX	28480	1990-0950
<i>2920A AND ABOVE</i>						
A1DS31†	1990-0487	7	5	LED-LAMP-YLW LUM-INT = 1MCD IF = 20MA-MAX	28480	1990-0487
A1DS32†	1990-0487	7		LED-LAMP-YLW LUM-INT = 1MCD IF = 20MA-MAX	28480	1990-0487
A1DS33†	1990-0487	7		LED-LAMP-YLW LUM-INT = 1MCD IF = 20MA-MAX	28480	1990-0487
A1DS34†	1990-0487	7		LED-LAMP-YLW LUM-INT = 1MCD IF = 20MA-MAX	28480	1990-0487
A1DS35†	1990-0487	7		LED-LAMP-YLW LUM-INT = 1MCD IF = 20MA-MAX	28480	1990-0487
A1DS36†	1990-0835	9	2	LED-LAMP-GRN LUM-INT = 6MCD IF = 30MA-MAX	28480	HLMP-1523
A1DS37†	1990-1273	1	5	LED-LAMP-RED LUM-INT = 8.6MCD BVR = 5V	01542	QLMP-1613
A1DS38	1990-1273	1		LED-LAMP-RED LUM-INT = 8.6MCD BVR = 5V	28480	1990-1273
A1DS39	1990-1273	1		LED-LAMP-RED LUM-INT = 8.6MCD BVR = 5V	28480	1990-1273
A1DS40	1990-1273	1		LED-LAMP-RED LUM-INT = 8.6MCD BVR = 5V	28480	1990-1273
A1DS41	1990-1273	1		LED-LAMP-RED LUM-INT = 8.6MCD BVR = 5V	28480	1990-1273
<i>2305A TO 2914A</i>						
A1DS42†	1990-0950	3		LED-LAMP-RED LUM-INT = 1MCD IF = 13MA-MAX	28480	1990-0950
A1DS43†	1990-0950	3		LED-LAMP-RED LUM-INT = 1MCD IF = 13MA = MAX	28480	1990-0950
A1DS44†	1990-0950	3		LED-LAMP-RED LUM-INT = 1MCD IF = 13MA = MAX	28480	1990-0950
A1DS45†	1990-0678	8		LED-LAMP-GRN LUM-INT = 800UCD IF = 30MA-MAX	28480	1990-0678
<i>2920A AND ABOVE</i>						
A1DS42†	1990-1273	1		LED-LAMP-RED LUM-INT = 8.6MCD BVR = 5V	01542	QLMP-1613
A1DS43†	1990-1273	1		LED-LAMP-RED LUM-INT = 8.6MCD BVR = 5V	01542	QLMP-1613
A1DS44†	1990-1273	1		LED-LAMP-RED LUM-INT = 8.6MCD BVR = 5V	01542	QLMP-1613
A1DS45†	1990-0835	9		LED-LAMP-GRN LUM-INT = 6MCD IF = 30MA = MAX	28480	HLMP-1523
A1DS46	1990-0699	3		LED-LIGHT BAR-RED MODULE LUM-INT = 7MCD	28480	1LM1-2350
	1200-0901	7		SOCKET-STRP 8-CONT W-WRAP	28480	1200-0901
A1J1	1251-5169	6	5	CONNECTOR 6-PIN M POST TYPE	28480	1251-5169
A1J2	1200-0507	9	2	SOCKET-IC 16-CONT DIP-SLDR	28480	1200-0507

† Refer to Section 7 for update information

\* Factory Selected Component (Refer to Section 5)

Δ Errata part change

Table 6-3. Replaceable Parts

Reference Designation	HP Part Number	C D	Qty.	Description	Mfr. Code	Mfr. Part Number
A1MP1	5041-0252	7	12	KEY CAP QUARTER GY-LIT	28480	5041-0252
A1MP2	5041-0943	3	1	KEY CAP HALF LOCAL	28480	5041-0943
A1MP3	5041-0252	7		KEY CAP QUARTER GY-LIT	28480	5041-0252
A1MP4	5041-0319	7	5	KEY CAP-HALF GRAY-LIT	28480	5041-0319
A1MP5	5041-0484	7	1	KEY CAP HALF YELLOW LED	28480	5041-0484
A1MP6	5041-0351	7	1	KAY CAP QUARTER	28480	5041-0351
A1MP7	5041-0252	7		KEY CAP QUARTER GY-LIT	28480	5041-0252
A1MP8	5041-0252	7		KEY CAP QUARTER GY-LIT	28480	5041-0252
A1MP9	5041-0319	7		KEY CAP-HALF GRAY-LIT	28480	5041-0319
A1MP10	5041-0386	8	5	KEY CAP FULL BK-LIT	28480	5041-0386
A1MP11	5041-0508	6	1	KEY CAP/HALF GR	28480	5041-0508
A1MP12	5041-0286	7	2	KEY CAP LT PIPE	28480	5041-0286
A1MP13	5041-0286	7		KEY CAP LT PIPE	28480	5041-0286
A1MP14	5041-0451	8	1	KEY CAP LT P/BLUE	28480	5041-0451
A1MP15	5041-0252	7		KEY CAP QUARTER GY-LIT	28480	5041-0252
A1MP16	5041-0252	7		KEY CAP QUARTER GY-LIT	28480	5041-0252
A1MP17	5041-0319	7		KEY CAP-HALF GRAY-LIT	28480	5041-0319
A1MP18	5041-0386	8		KEY CAP FULL BK-LIT	28480	5041-0386
A1MP19	5041-0835	2	1	KEY CAP/FULL 7 LT GY	28480	5041-0835
A1MP20	5041-0832	9	1	KEY CAP/FULL 4 LT GY	28480	5041-0832
A1MP21	5041-0829	4	1	KEY CAP/FULL 1 LT GY	28480	5041-0829
A1MP22	5041-0838	5	1	KEY CAP/FULL 0 LT GY	28480	5041-0838
A1MP23	5041-0252	7		KEY CAP QUARTER GY-LIT	28480	5041-0252
A1MP24	5041-0252	7		KEY CAP QUARTER GY-LIT	28480	5041-0252
A1MP25	5041-0319	7		KEY CAP-HALF GRAY-LIT	28480	5041-0319
A1MP26	5041-0386	8		KEY CAP FULL BK-LIT	28480	5041-0386
A1MP27	5041-0836	3	1	KEY CAP/FULL 8 LT GY	28480	5041-0836
A1MP28	5041-0833	0	1	KEY CAP/FULL 5 LT GY	28480	5041-0833
A1MP29	5041-0830	7	1	KEY CAP/FULL 2 LT GY	28480	5041-0830
A1MP30	5041-0839	6	1	KEY CAP/FULL GY DOT	28480	5041-0839
A1MP31	5041-0252	7		KEY CAP QUARTER GY-LIT	28480	5041-0252
A1MP32	5041-0252	7		KEY CAP QUARTER GY-LIT	28480	5041-0252
A1MP33	5041-0319	7		KEY CAP-HALF GRAY-LIT	28480	5041-0319
A1MP34	5041-0386	8		KEY CAP FULL BK-LIT	28480	5041-0386
A1MP35	5041-0837	4	1	KEY CAP/FULL 9 LT GY	28480	5041-0837
A1MP36	5041-0834	1	1	KEY CAP/FULL 6 LT GY	28480	5041-0834
A1MP37	5041-0831	8	1	KEY CAP/FULL 3 LT GY	28480	5041-0831
A1MP38	5041-1672	7	1	KEY CAP/FULL CLEAR	28480	5041-1672
A1MP39	5041-0252	7		KEY CAP QUARTER GY-LIT	28480	5041-0252
A1MP40	5041-0252	7		KEY CAP QUARTER GY-LIT	28480	5041-0252
A1MP41	5041-0310	8	1	KEY CAP HALF GY	28480	5041-0310
A1MP42	5041-0386	8		KEY CAP FULL BK-LIT	28480	5041-0386
A1MP43	5041-2753	7	1	KEY CAP-FULL MHZ	28480	5041-2753
A1MP44	5041-2750	4	1	KEY CAP-FULL KHZ UP	28480	5041-2750
A1MP45	5041-2751	5	1	KEY CAP-FULL KHZ DN	28480	5041-2751
A1MP46	5041-2752	6	1	KEY CAP-FULL SPCL	28480	5041-2752
A1R1	1810-0279	5	1	NETWORK-RES 10-SIP4.7K OHM X 9	01121	210A472
A1R2	1810-0207	9	1	NETWORK-RES 8-SIP22.0K OHM X 7	01121	208A223
A1R3	0757-0199	3	10	RESISTOR 21.5K 1% .125W F TC = 0 + -100	24546	C4-1/8-T0-2152-F
A1R4	0757-0123	3	2	RESISTOR 34.8K 1% .125W F TC = 0 + -100	28480	0757-0123
A1R5	0757-0461	2	4	RESISTOR 68.1K 1% .125W F TC = 0 + -100	24546	C4-1/8-T0-6812-F

† Refer to Section 7 for update information.

\* Factory Selected Component (Refer to Section 5)

Δ Errata part change

Table 6-3. Replaceable Parts

Reference Designation	HP Part Number	C D	Qty.	Description	Mfr. Code	Mfr. Part Number
A1R6	0757-0199	3		RESISTOR 21.5K 1% .125W F TC = 0 + -100	24546	C4-1/8-T0-2152-F
A1R7	0698-0082	7	18	RESISTOR 464 1% .125W F TC = 0 + -100	24546	C4-1/8-T0-4640-F
A1R8	0698-3453	2	1	RESISTOR 196K 1% .125W F TC = 0 + -100	24546	C4-1/8-T0-1963-F
A1R9	0757-0461	2		RESISTOR 68.1K 1% .125W F TC = 0 + -100	24546	C4-1/8-T0-6812-F
A1R10	0757-0461	2		RESISTOR 68.1K 1% .125W F TC = 0 + -100	24546	C4-1/8-T0-6812-F
A1R11	0757-0447	4	5	RESISTOR 16.2K 1% .125W F TC = 0 + -100	24546	C4-1/8-T0-1622-F
A1R12	1810-0402	6	10	NETWORK-RES 16-DIP330.0 OHM X 8	01121	316B331
A1R13	1810-0402	6		NETWORK-RES 16-DIP330.0 OHM X 8	01121	316B331
A1R14	1810-0402	6		NETWORK-RES 16-DIP330.0 OHM X 8	01121	316B331
A1R15	1810-0402	6		NETWORK-RES 16-DIP330.0 OHM X 8	01121	316B331
A1R16	1810-0402	6		NETWORK-RES 16-DIP330.0 OHM X 8	01121	316B331
A1R17	1810-0402	6		NETWORK-RES 16-DIP330.0 OHM X 8	01121	316B331
A1R18	1810-0402	6		NETWORK-RES 16-DIP330.0 OHM X 8	01121	316B331
A1R19	1810-0402	6		NETWORK-RES 16-DIP330.0 OHM X 8	01121	316B331
A1R20	1810-0402	6		NETWORK-RES 16-DIP330.0 OHM X 8	01121	316B331
A1R21	1810-0402	6		NETWORK-RES 16-DIP330.0 OHM X 8	01121	316B331
A1R22	1810-0370	7	7	NETWORK-RES 8-SIP220.0 OHM X 7	01121	208A221
A1R23	1810-0370	7		NETWORK-RES 8-SIP220.0 OHM X 7	01121	208A221
A1R24	1810-0370	7		NETWORK-RES 8-SIP220.0 OHM X 7	01121	208A221
A1R25	1810-0370	7		NETWORK-RES 8-SIP220.0 OHM X 7	01121	208A221
A1R26	1810-0370	7		NETWORK-RES 8-SIP220.0 OHM X 7	01121	208A221
A1R27	1810-0370	7		NETWORK-RES 8-SIP220.0 OHM X 7	01121	208A221
A1R28	0698-3438	3	10	RESISTOR 147 1% .125W F TC = 0 + -100	24546	C4-1/8-T0-147R-F
A1R29-R32				NOT ASSIGNED		
A1R33	0698-3438	3		RESISTOR 147 1% .125W F TC = 0 + -100	24546	C4-1/8-T0-147R-F
A1R34	1810-0370	7		NETWORK-RES 8-SIP220.0 OHM X 7	01121	208A221
A1S1	5060-9436	7	46	PUSHBUTTON SWITCH P.C. MOUNT	28480	5060-9436
A1S2	5060-9436	7		PUSHBUTTON SWITCH P.C. MOUNT	28480	5060-9436
A1S3	5060-9436	7		PUSHBUTTON SWITCH P.C. MOUNT	28480	5060-9436
A1S4	5060-9436	7		PUSHBUTTON SWITCH P.C. MOUNT	28480	5060-9436
A1S5	5060-9436	7		PUSHBUTTON SWITCH P.C. MOUNT	28480	5060-9436
A1S6	5060-9436	7		PUSHBUTTON SWITCH P.C. MOUNT	28480	5060-9436
A1S7	5060-9436	7		PUSHBUTTON SWITCH P.C. MOUNT	28480	5060-9436
A1S8	5060-9436	7		PUSHBUTTON SWITCH P.C. MOUNT	28480	5060-9436
A1S9	5060-9436	7		PUSHBUTTON SWITCH P.C. MOUNT	28480	5060-9436
A1S10	5060-9436	7		PUSHBUTTON SWITCH P.C. MOUNT	28480	5060-9436
A1S11	5060-9436	7		PUSHBUTTON SWITCH P.C. MOUNT	28480	5060-9436
A1S12	5060-9436	7		PUSHBUTTON SWITCH P.C. MOUNT	28480	5060-9436
A1S13	5060-9436	7		PUSHBUTTON SWITCH P.C. MOUNT	28480	5060-9436
A1S14	5060-9436	7		PUSHBUTTON SWITCH P.C. MOUNT	28480	5060-9436
A1S15	5060-9436	7		PUSHBUTTON SWITCH P.C. MOUNT	28480	5060-9436
A1S16	5060-9436	7		PUSHBUTTON SWITCH P.C. MOUNT	28480	5060-9436
A1S17	5060-9436	7		PUSHBUTTON SWITCH P.C. MOUNT	28480	5060-9436
A1S18	5060-9436	7		PUSHBUTTON SWITCH P.C. MOUNT	28480	5060-9436
A1S19	5060-9436	7		PUSHBUTTON SWITCH P.C. MOUNT	28480	5060-9436
A1S20	5060-9436	7		PUSHBUTTON SWITCH P.C. MOUNT	28480	5060-9436

† Refer to Section 7 for update information.

\* Factory Selected Component (Refer to Section 5).

Δ Errata part change.



Table 6-3. Replaceable Parts

Reference Designation	HP Part Number	C D	Qty.	Description	Mfr. Code	Mfr. Part Number
A1S21	5060-9436	7		PUSHBUTTON SWITCH P.C. MOUNT	28480	5060-9436
A1S22	5060-9436	7		PUSHBUTTON SWITCH P.C. MOUNT	28480	5060-9436
A1S23	5060-9436	7		PUSHBUTTON SWITCH P.C. MOUNT	28480	5060-9436
A1S24	5060-9436	7		PUSHBUTTON SWITCH P.C. MOUNT	28480	5060-9436
A1S25	5060-9436	7		PUSHBUTTON SWITCH P.C. MOUNT	28480	5060-9436
A1S26	5060-9436	7		PUSHBUTTON SWITCH P.C. MOUNT	28480	5060-9436
A1S27	5060-9436	7		PUSHBUTTON SWITCH P.C. MOUNT	28480	5060-9436
A1S28	5060-9436	7		PUSHBUTTON SWITCH P.C. MOUNT	28480	5060-9436
A1S29	5060-9436	7		PUSHBUTTON SWITCH P.C. MOUNT	28480	5060-9436
A1S30	5060-9436	7		PUSHBUTTON SWITCH P.C. MOUNT	28480	5060-9436
A1S31	5060-9436	7		PUSHBUTTON SWITCH P.C. MOUNT	28480	5060-9436
A1S32	5060-9436	7		PUSHBUTTON SWITCH P.C. MOUNT	28480	5060-9436
A1S33	5060-9436	7		PUSHBUTTON SWITCH P.C. MOUNT	28480	5060-9436
A1S34	5060-9436	7		PUSHBUTTON SWITCH P.C. MOUNT	28480	5060-9436
A1S35	5060-9436	7		PUSHBUTTON SWITCH P.C. MOUNT	28480	5060-9436
A1S36	5060-9436	7		PUSHBUTTON SWITCH P.C. MOUNT	28480	5060-9436
A1S37	5060-9436	7		PUSHBUTTON SWITCH P.C. MOUNT	28480	5060-9436
A1S38	5060-9436	7		PUSHBUTTON SWITCH P.C. MOUNT	28480	5060-9436
A1S39	5060-9436	7		PUSHBUTTON SWITCH P.C. MOUNT	28480	5060-9436
A1S40	5060-9436	7		PUSHBUTTON SWITCH P.C. MOUNT	28480	5060-9436
A1S41	5060-9436	7		PUSHBUTTON SWITCH P.C. MOUNT	28480	5060-9436
A1S42	5060-9436	7		PUSHBUTTON SWITCH P.C. MOUNT	28480	5060-9436
A1S43	5060-9436	7		PUSHBUTTON SWITCH P.C. MOUNT	28480	5060-9436
A1S44	5060-9436	7		PUSHBUTTON SWITCH P.C. MOUNT	28480	5060-9436
A1S45	5060-9436	7		PUSHBUTTON SWITCH P.C. MOUNT	28480	5060-9436
A1S46	5060-9436	7		PUSHBUTTON SWITCH P.C. MOUNT	28480	5060-9436
A1TP1	1251-0600	0	118	CONNECTOR-SGL CONT PIN 1.14-MM-BSC-SZ SQ	28480	1251-0600
A1TP2	1251-0600	0		CONNECTOR-SGL CONT PIN 1.14-MM-BSC-SZ SQ	28480	1251-0600
A1TP3	1251-0600	0		CONNECTOR-SGL CONT PIN 1.14-MM-BSC-SZ SQ	28480	1251-0600
A1TP4	1251-0600	0		CONNECTOR-SGL CONT PIN 1.14-MM-BSC-SZ SQ	28480	1251-0600
A1TP5	1251-0600	0		CONNECTOR-SGL CONT PIN 1.14-MM-BSC-SZ SQ	28480	1251-0600
A1U1	1820-1729	3	20	IC LCH TTL LS COM CLEAR 8-BIT	01295	SN74LS259N
A1U2	1820-2075	4	5	IC TRANSCEIVER TTL LS BUS OCTL	28480	1820-2075
A1U3	1990-0574	3	10	DISPLAY-NUM-SEG 1-CHAR .43-H	28480	5082-7651
A1U4	1200-0803	8	10	SOCKET-IC 14-CONT DIP DIP-SLDR	28480	1200-0803
A1U4	1990-0574	3		DISPLAY-NUM-SEG 1-CHAR .43-H	28480	5082-7651
A1U4	1200-0803	8		SOCKET-IC 14-CONT DIP DIP-SLDR	28480	1200-0803
A1U5	1990-0574	3		DISPLAY-NUM-SEG 1-CHAR .43-H	28480	5082-7651
A1U5	1200-0803	8		SOCKET-IC 14-CONT DIP DIP-SLDR	28480	1200-0803
A1U6	1990-0574	3		DISPLAY-NUM-SEG 1-CHAR .43-H	28480	5082-7651
A1U6	1200-0803	8		SOCKET-IC 14-CONT DIP DIP-SLDR	28480	1200-0803
A1U7	1990-0574	3		DISPLAY-NUM-SEG 1-CHAR .43-H	28480	5082-7651
A1U7	1200-0803	8		SOCKET-IC 14-CONT DIP DIP-SLDR	28480	1200-0803
A1U8	1990-0574	3		DISPLAY-NUM-SEG 1-CHAR .43-H	28480	5082-7651
A1U8	1200-0803	8		SOCKET-IC 14-CONT DIP DIP-SLDR	28480	1200-0803
A1U9	1990-0574	3		DISPLAY-NUM-SEG 1-CHAR .43-H	28480	5082-7651
A1U9	1200-0803	8		SOCKET-IC 14-CONT DIP DIP-SLDR	28480	1200-0803
A1U10	1990-0574	3		DISPLAY-NUM-SEG 1-CHAR .43-H	28480	5082-7651
A1U10	1200-0803	8		SOCKET-IC 14-CONT DIP DIP-SLDR	28480	1200-0803

[Refer to Section 7 for update information.]

\*Factory Selected Component (Refer to Section 5)

Δ Errata part change

Table 6-3. Replaceable Parts

Reference Designation	HP Part Number	C D	Qty.	Description	Mfr. Code	Mfr. Part Number
A1U11	1990-0574	3		DISPLAY-NUM-SEG 1-CHAR .43-H	28480	5082-7651
	1200-0803	8		SOCKET-IC 14-CONT DIP DIP-SLDR	28480	1200-0803
A1U12	1990-0574	3		DISPLAY-NUM-SEG 1-CHAR .43-H	28480	5082-7651
	1200-0803	8		SOCKET-IC 14-CONT DIP DIP-SLDR	28480	1200-0803
A1U13	1826-0412	1	3	IC COMPARATOR PRCN DUAL 8-DIP-P PKG	27014	LM393N
A1U14	1820-1144	6	2	IC GATE TTL LS NOR QUAD 2-INP	01295	SN74LS02N
A1U15	1820-2075	4		IC TRANSCEIVER TTL LS BUS OCTL	28480	1820-2075
A1U16	1820-1729	3		IC LCH TTL LS COM CLEAR 8-BIT	01295	SN74LS259N
A1U17	1820-2075	4		IC TRANSCEIVER TTL LS BUS OCTL	28480	1820-2075
A1U18	1820-2075	4		IC TRANSCEIVER TTL LS BUS OCTL	28480	1820-2075
A1U19	1820-1427	8	1	IC DCDR TTL LS 2-TO-4-LINE DUAL 2-INP	01295	SN74LS156N
A1U20	1820-1198	0	10	IC GATE TTL LS NAND QUAD 2-INP	01295	SN74LS03N
A1U21	1820-1198	0		IC GATE TTL LS NAND QUAD 2-INP	01295	SN74LS03N
A1U22	1820-1729	3		IC LCH TTL LS COM CLEAR 8-BIT	01295	SN74LS259N
A1U23	1820-1729	3		IC LCH TTL LS COM CLEAR 8-BIT	01295	SN74LS259N
A1U24	1820-1729	3		IC LCH TTL LS COM CLEAR 8-BIT	01295	SN74LS259N
A1U25	1820-1729	3		IC LCH TTL LS COM CLEAR 8-BIT	01295	SN74LS259N
A1U26	1820-1729	3		IC LCH TTL LS COM CLEAR 8-BIT	01295	SN74LS259N
A1U27	1820-1729	3		IC LCH TTL LS COM CLEAR 8-BIT	01295	SN74LS259N
A1U28	1820-1729	3		IC LCH TTL LS COM CLEAR 8-BIT	01295	SN74LS259N
A1U29	1820-1729	3		IC LCH TTL LS COM CLEAR 8-BIT	01295	SN74LS259N
A1U30	1820-1729	3		IC LCH TTL LS COM CLEAR 8-BIT	01295	SN74LS259N
A1U31	1820-1729	3		IC LCH TTL LS COM CLEAR 8-BIT	01295	SN74LS259N
A1U32	1820-1729	3		IC LCH TTL LS COM CLEAR 8-BIT	01295	SN74LS259N
A1U33	1820-1729	3		IC LCH TTL LS COM CLEAR 8-BIT	01295	SN74LS259N
A1U34	1820-1729	3		IC LCH TTL LS COM CLEAR 8-BIT	01295	SN74LS259N
A1U35	1820-1729	3		IC LCH TTL LS COM CLEAR 8-BIT	01295	SN74LS259N
A1U36	1820-1216	3	16	IC DCDR TTL LS 3-TO-8-LINE 3-INP	01295	SN74LS138N
A1U37	1820-1216	3		IC DCDR TTL LS 3-TO-8-LINE 3-INP	01295	SN74LS138N
A1U38	1820-1216	3		IC DCDR TTL LS 3-TO-8-LINE 3-INP	01295	SN74LS138N
A1U39	1820-1729	3		IC LCH TTL LS COM CLEAR 8-BIT	01295	SN74LS259N
A1U40	1820-1729	3		IC LCH TTL LS COM CLEAR 8-BIT	01295	SN74LS259N
A1U41	1820-2075	4		IC TRANSCEIVER TTL LS BUS OCTL	28480	1820-2075
A1W1	8150-0447	6	1	WIRE 24AWG BK 300V PVC 7X32 80C	28480	8150-0447
	0362-0227	1	1	CONNECTOR-SGL CONT SKT 1.14-MM-BSC-SZ	28480	0362-0227
A1W2	8159-0005	0		RESISTOR-ZERO OHMS 22 AWG LEAD DIA.	28480	8190-0005
A1W3	8159-0005	0		RESISTOR-ZERO OHMS 22 AWG LEAD DIA.	28480	8190-0005
A1W4	8159-0005	0		RESISTOR-ZERO OHMS 22 AWG LEAD DIA.	28480	8190-0005
A1W5	8159-0005	0		RESISTOR-ZERO OHMS 22 AWG LEAD DIA. 2	8480 8	190-0005

† Refer to Section 7 for update information

\* Factory Selected Component (Refer to Section 5)

Δ Errata part change

Table 6-3. Replaceable Parts

Reference Designation	HP Part Number	C D	Qty.	Description	Mfr. Code	Mfr. Part Number
<b>A2</b>						
A2	08901-60008	6	1	AUDIO FILTERS ASSEMBLY	28480	08901-60008
A2C1	0180-1746	5	35	CAPACITOR-FXD 15UF + -10% 20VDC TA	56289	150D156X9020B2
A2C2	0180-1746	5		CAPACITOR-FXD 15UF + -10% 20VDC TA	56289	150D156X9020B2
A2C3	0160-4650	4	2	CAPACITOR-FXD 1380PF + -1% 500VDC MICA	28480	0160-4650
A2C4	0160-4650	4		CAPACITOR-FXD 1380PF + -1% 500VDC MICA	28480	0160-4650
A2C5	0160-2055	9	28	CAPACITOR-FXD .01UF + 80-20% 100VDC CER	28480	0160-2055
A2C6	0160-2055	9		CAPACITOR-FXD .01UF + 80-20% 100VDC CER	28480	0160-2055
A2C7	0160-4648	0	2	CAPACITOR-FXD 1650PF + -1% 500VDC MICA	28480	0160-4648
A2C8	0160-4648	0		CAPACITOR-FXD 1650PF + -1% 500VDC MICA	28480	0160-4648
A2C9	0160-0134	1	2	CAPACITOR-FXD 220PF + -5% 300VDC MICA	28480	0160-0134
A2C10	0160-4649	1	1	CAPACITOR-FXD 214PF + -1% 500VDC MICA	28480	0160-4649
A2C11	0180-1714	7	2	CAPACITOR-FXD 330UF + -10% 6VDC TA	56289	150D337X9006S2
A2C12	0140-0229	3	1	CAPACITOR-FXD 380PF + -1% 300VDC MICA	72136	DM15F381F0300WV1C
A2C13	0180-2206	4	5	CAPACITOR-FXD 60UF + -10% 6VDC TA	56289	150D606X9006B2
A2C14	0140-0196	3	2	CAPACITOR-FXD 150PF + -5% 300VDC MICA	72136	DM15F151J0300WV1CR
A2C15	0180-2206	4		CAPACITOR-FXD 60UF + -10% 6VDC TA	56289	150D606X9006B2
A2C16	0180-2206	4		CAPACITOR-FXD 60UF + -10% 6VDC TA	56289	150D606X9006B2
A2C17	0140-0194	1	1	CAPACITOR-FXD 110PF + -5% 300VDC MICA	72136	DM15F111J0300WV1CR
A2C18				NOT ASSIGNED		
A2C19	0160-2055	9		CAPACITOR-FXD .01UF + 80-20% 100VDC CER	28480	0160-2055
A2C20	0180-2141	6	2	CAPACITOR-FXD 3.3UF + -10% 50VDC TA	56289	150D335X9050B2
A2C21	0160-4084	8	34	CAPACITOR-FXD .1UF + -20% 50VDC CER	28480	0160-4084
A2C22				NOT ASSIGNED		
A2C23	0160-2055	9		CAPACITOR-FXD .01UF + 80-20% 100VDC CER	28480	0160-2055
A2C24				NOT ASSIGNED		
A2C25	0180-1714	7		CAPACITOR-FXD 330UF + -10% 6VDC TA	56289	150D337X9006S2
A2C26	0160-4849	3	1	CAPACITOR-FXD 9100PF + -1% 100VDC	28480	0160-4849
A2C27	0160-2302	9	3	CAPACITOR-FXD 4000PF + -1% 100VDC MICA	28480	0160-2302
A2C28				NOT ASSIGNED		
A2C29 <sup>Δ</sup>	0160-6606	4	1	CAPACITOR-FXD .02UF + -1% 200VDC	28480	0160-6606
A2C30	0140-0154	3	1	CAPACITOR-FXD 1300PF + -5% 500VDC MICA	72136	DM20F132J0500WV1CR
A2C31	0160-4759	4	1	CAPACITOR-FXD 6800PF + -1% 200VDC	28480	0160-4759
A2C32	0160-3538	5	1	CAPACITOR-FXD 750PF + -5% 100VDC MICA	28480	0160-3538
A2C33	0160-3536	3	1	CAPACITOR-FXD 620PF + -5% 100VDC MICA	28480	0160-3536
A2C34	0140-0198	5	4	CAPACITOR-FXD 200PF + -5% 300VDC MICA	72136	DM15F201J0300WV1CR
A2C35				NOT ASSIGNED		
A2C36	0160-2055	9		CAPACITOR-FXD .01UF + 80-20% 100VDC CER	28480	0160-2055
A2C37	0160-2055	9		CAPACITOR-FXD .01UF + 80-20% 100VDC CER	28480	0160-2055
A2C38	0160-3068	6	1	CAPACITOR-FXD 1500PF + -5% 300VDC MICA	28480	0160-3068
A2CR1	1901-0040	1	34	DIODE-SWITCHING 30V 50MA 2NS DO-35	28480	1901-0040
A2CR2	1901-0040	1		DIODE-SWITCHING 30V 50MA 2NS DO-35	28480	1901-0040
A2J1	1250-1220	0	35	CONNECTOR-RF SMC M PC 50-OHM	28480	1250-1220
	2190-0124	4	40	WASHER-LK INTL T NO. 10 .195-IN-ID	28480	2190-0124
	2950-0078	9	41	NUT-HEX-DBL-CHAM 10-32-THD .067-IN-THK	28480	2950-0078
A2J2	1250-1220	0		CONNECTOR-RF SMC M PC 50-OHM	28480	1250-1220
	2190-0124	4		WASHER-LK INTL T NO. 10 .195-IN-ID	28480	2190-0124
	2950-0078	9		NUT-HEX-DBL-CHAM 10-32-THD .067-IN-THK	28480	2950-0078

† Refer to Section 7 for update information

\* Factory Selected Component (Refer to Section 5)

Δ Errata part change

Table 6-3. Replaceable Parts

Reference Designation	HP Part Number	C D	Qty.	Description	Mfr. Code	Mfr. Part Number
A2L1	9140-0137	1	6	INDUCTOR RF-CH-MLD 1MH 5% .2DX.45LG Q= 60	28480	9140-0137
A2L2	9140-0137	1		INDUCTOR RF-CH-MLD 1MH 5% .2DX.45LG Q= 60	28480	9140-0137
A2L3	9140-0293	0	2	INDUCTOR RF-CH-MLD 906UH 2% .2DX.45LG	28480	9140-0293
A2L4	9140-0293	0		INDUCTOR RF-CH-MLD 906UH 2% .2DX.45LG	28480	9140-0293
A2L5	9100-1653	4	1	INDUCTOR RF-CH-MLD 910UH 5% .2DX.45LG	28480	9100-1653
A2L6	9140-0291	8	1	INDUCTOR RF-CH-MLD 824UH 2% .2DX.45LG	28480	9140-0291
A2L7	9100-1645	4	1	INDUCTOR RF-CH-MLD 390UH 5% .2DX.45LG	28480	9100-1645
A2L8	9140-0292	9	1	INDUCTOR RF-CH-MLD 375UH 2% .2DX.45LG	28480	9140-0292
A2L9	9140-0280	5	1	INDUCTOR 13MH 2% .25DX.7LG	28480	9140-0280
A2L10	9100-1660	3	1	INDUCTOR RF-CH-MLD 2MH 5% .23DX.57LG	28480	9100-1660
A2L11	9140-0281	6	1	INDUCTOR 16MH 2% .25DX.7LG	28480	9140-0281
A2L12	9100-1654	5	1	INDUCTOR RF-CH-MLD 1.1MH 5% .23DX.57LG	28480	9100-1654
A2L13	9100-1651	2	1	INDUCTOR RF-CH-MLD 750UH 5% .2DX.45LG	28480	9100-1651
A2L14	9100-1648	7	1	INDUCTOR RF-CH-MLD 560UH 5% .2DX.45LG	28480	9100-1648
A2MP1	08901-00022	8	1	COVER AUD FILTER	28480	08901-00022
	2360-0113	2	36	SCREW-MACH 6-32 .25-IN-LG PAN-HD-POZI	00000	ORDER BY DESCRIPTION
A2MP2	08901-00014	8	1	ENCL SHLD DIVDR	28480	08901-00014
A2MP3	08901-00015	9	1	COVER ENCL SHLD	28480	08901-00015
A2MP4	08901-00050	2	1	SPACER #1	28480	08901-00050
A2MP5	08901-00051	3	1	SPACER #2	28480	08901-00051
A2MP6	08901-00052	4	1	SPACER #3	28480	08901-00052
A2MP7	08901-00053	5	1	SPACER #4	28480	08901-00053
A2Q1	1854-0295	7	4	TRANSISTOR-DUAL NPN PD = 400MW	28480	1854-0295
A2Q2	1854-0071	7	31	TRANSISTOR NPN SI PD = 300MW FT = 200MHZ	28480	1854-0071
A2Q3	1853-0007	7	21	TRANSISTOR PNP 2N3251 SI TO-18 PD = 360MW	04713	2N3251
A2Q4	1854-0477	7	14	TRANSISTOR NPN 2N2222A SI TO-18 PD = 500MW	04713	2N2222A
A2Q5	1854-0071	7		TRANSISTOR NPN SI PD = 300MW FT = 200MHZ	28480	1854-0071
A2Q6	1853-0012	4	3	TRANSISTOR PNP 2N2904A SI TO-39 PD = 600MW	01295	2N2904A
A2Q7	1854-0013	7	1	TRANSISTOR NPN 2N2218A SI TO-5 PD = 800MW	04713	2N2218A
<i>2305A TO 2449A</i>						
A2R1	0757-0442	9	77	RESISTOR 10K 1% .125W F TC = 0 + -100	24546	C4-1/8-T0-1002-F
A2R2	0757-0442	9		RESISTOR 10K 1% .125W F TC = 0 + -100	24546	C4-1/8-T0-1002-F
<i>2451A AND ABOVE</i>						
A2R1	0757-0290	5		RESISTOR 6.19K 1% .125W F TC = 0 + -100	24546	C4-1/8-T0-61
A2R2	0757-0290	5		RESISTOR 6.19K 1% .125W F TC = 0 + -100	24546	C4-1/8-T0-61F
A2R3	0699-0140	0	2	RESISTOR 524 .1% .1W F TC = 0 + -15	28480	0699-0140
A2R4	0699-0139	7	2	RESISTOR 660 .1% .1W F TC = 0 + -15	28480	0699-0139
A2R5	0698-8556	6	2	RESISTOR 1.62K .1% .125W F TC = 0 + -10	28480	0698-8556
A2R6	2100-3052	4	1	RESISTOR-TRMR 50 10% C SIDE-ADJ 17-TRN	02111	43P500
A2R7	0699-0140	0		RESISTOR 524 .1% .1W F TC = 0 + -15	28480	0699-0140
A2R8	0699-0144	4	2	RESISTOR 10K .01% .1W F TC = 0 + -5	28480	0699-0144
A2R9	0699-0145	5	4	RESISTOR 1.1174K .01% .1W F TC = 0 + -5	28480	0699-0145
A2R10	0698-3451	0	4	RESISTOR 133K 1% .125W F TC = 0 + -100	24546	C4-1/8-T0-1333-F
A2R11	0698-7219	6	2	RESISTOR 196 1% .05W F TC = 0 + -100	24546	C3-1/8-T0-196R-F
A2R12	0698-7244	7		RESISTOR 2.15K 1% .05W F TC = 0 + -100	24546	C3-1/8-T0-2151-F

†Refer to Section 7 for update information.

\*Factory Selected Component (Refer to Section 5)

Δ Errata part change.

Table 6-3. Replaceable Parts

Reference Designation	HP Part Number	C D	Qty.	Description	Mfr. Code	Mfr. Part Number
A2R13	0698-7244	7		RESISTOR 2.15K 1% .05W F TC = 0 + -100	24546	C3-1/8-T0-2151-F
A2R14	0698-7244	7		RESISTOR 2.15K 1% .05W F TC = 0 + -100	24546	C3-1/8-T0-2151-F
A2R15	0698-7244	7		RESISTOR 2.15K 1% .05W F TC = 0 + -100	24546	C3-1/8-T0-2151-F
A2R16	0698-3457	6	2	RESISTOR 316K 1% .125W F TC = 0 + -100	28480	0698-3457
A2R17	0698-7260	7	17	RESISTOR 10K 1% .05W F TC = 0 + -100	24546	C3-1/8-T0-1002-F
A2R18				NOT ASSIGNED		
A2R19	0698-8823	0	1	RESISTOR 8.25 1% .125W F TC = 0 + -100	28480	0698-8823
A2R20	0698-3451	0		RESISTOR 133K 1% .125W F TC = 0 + -100	24546	C4-1/8-T0-1333-F
A2R21				NOT ASSIGNED		
A2R22	0698-6414	1	5	RESISTOR 1K .1% .1W F TC = 0 + -5	28480	0698-6414
A2R23	0699-0176	2	1	RESISTOR 415 .1% .1W F TC = 0 + -15	28480	0699-0176
A2R24	0698-3444	1		RESISTOR 316 1% .125W F TC = 0 + -100	24546	C4-1/8-T0-316R-F
A2R25				NOT ASSIGNED		
A2R26	0757-0280	3	101	RESISTOR 1K 1% .125W F TC = 0 + -100	24546	C4-1/8-T0-1001-F
A2R27	0698-8475	8	7	RESISTOR 1.799K .1% .1W F TC = 0 + -5	28480	0698-8475
A2R28	0698-3430	5	10	RESISTOR 21.5 1% .125W F TC = 0 + -100	03888	PME55-1/8-T0-21R5-F
A2R29	0757-0280	3		RESISTOR 1K 1% .125W F TC = 0 + -100	24546	C4-1/8-T0-1001-F
A2R30	0698-8556	6		RESISTOR 1.62K .1% .125W F TC = 0 + -10	28480	0698-8556
A2R31	0699-0161	5	1	RESISTOR 580 .1% .1W F TC = 0 + -15	28480	0699-0161
A2R32	0699-0143	3	2	RESISTOR 825 .1% .1W F TC = 0 + -15	28480	0699-0143
A2R33	0757-0394	0	17	RESISTOR 51.1 1% .125W F TC = 0 + -100	24546	C4-1/8-T0-51R1-F
A2R34	0757-0180	2	1	RESISTOR 31.6 1% .125W F TC = 0 + -100	28480	0757-0180
A2R35	0757-0280	3		RESISTOR 1K 1% .125W F TC = 0 + -100	24546	C4-1/8-T0-1001-F
A2R36	0698-8475	8		RESISTOR 1.799K .1% .1W F TC = 0 + -5	28480	0698-8475
A2R37	0699-0144	4		RESISTOR 10K .01% .1W F TC = 0 + -5	28480	0699-0144
A2R38	0699-0145	5		RESISTOR 1.1174K .01% .1W F TC = 0 + -5	28480	0699-0145
A2R39	0757-0400	9	3	RESISTOR 90.9 1% .125W F TC = 0 + -100	24546	C4-1/8-T0-90R9-F
A2R40	2100-0552	3	3	RESISTOR-TRMR 50 10% C SIDE-ADJ 1-TRN	28480	2100-0552
A2R41	0699-0159	1	1	RESISTOR 860 .1% .1W F TC = 0 + -15	28480	0699-0159
A2R42	0698-8475	8		RESISTOR 1.799K .1% .1W F TC = 0 + -5	28480	0698-8475
A2R43	0698-3434	9	2	RESISTOR 34.8 1% .125W F TC = 0 + -100	24546	C4-1/8-T0-34R8-F
A2R44	2100-0552	3		RESISTOR-TRMR 50 10% C SIDE-ADJ 1-TRN	28480	2100-0552
A2R45	0699-0160	4	1	RESISTOR 940 .1% .1W F TC = 0 + -15	28480	0699-0160
A2R46	0698-3136	8	4	RESISTOR 17.8K 1% .125W F TC = 0 + -100	24546	C4-1/8-T0-1782-F
A2R47	0698-3243	8	2	RESISTOR 178K 1% .125W F TC = 0 + -100	24546	C4-1/8-T0-1783-F
A2R48	0698-6414	1		RESISTOR 1K .1% .1W F TC = 0 + -5	28480	0698-6414
A2R49	0699-0144	4		RESISTOR 10K .01% .1W F TC = 0 + -100	28480	0699-0144
A2R50	0757-0280	3		RESISTOR 1K 1% .125W F TC = 0 + -100	24546	C4-1/8-T0-1001-F
<i>2305A TO 2644A</i>						
A2R51	0757-0399	5	2	RESISTOR 82.5 1% .125W F TC = 0 + -100	24546	C4-1/8-T0-82R5-F
<i>2703A AND ABOVE</i>						
A2R51	0757-0399	0	1	RESISTOR 100 1% .125W F TC = 0 + -100	24546	C4-1/8-T0-101-F
A2RT1	0837-0027	6	2	THERMISTOR DISC 30-OHM TC = -3.9%/C-DEG	28480	0837-0027
A2RT2	0839-0011	2	1	THERMISTOR DISC 100-OHM TC = -3.8%/C-DEG	28480	0839-0011
A2RT3	0837-0027	6		THERMISTOR DISC 30-OHM TC = -3.9%/C-DEG	28480	0837-0027

† Refer to Section 7 for update information

\* Factory Selected Component (Refer to Section 5)

Δ Errata part change

*Table 6-3. Replaceable Parts*

Reference Designation	HP Part Number	C D	Qty.	Description	Mfr. Code	Mfr. Part Number
A2TP1	1251-0600	0		CONNECTOR-SGL CONT PIN 1.14-MM-BSC-SZ SQ	28480	1251-0600
A2TP2	1251-0600	0		CONNECTOR-SGL CONT PIN 1.14-MM-BSC-SZ SQ	28480	1251-0600
A2TP3	1251-0600	0		CONNECTOR-SGL CONT PIN 1.14-MM-BSC-SZ SQ	28480	1251-0600
A2TP4	1251-0600	0		CONNECTOR-SGL CONT PIN 1.14-MM-BSC-SZ SQ	28480	1251-0600
<i>2305A TO 2449A</i>						
A2U1	1826-0582	6	7	IC SWITCH ANLG QUAD 16-DIP-C PKG	27014	LF13201D
A2U2	1826-0582	6		IC SWITCH ANLG QUAD 16-DIP-C PKG	27014	LF13201D
<i>2451A AND ABOVE</i>						
A2U1	1826-0606	5		ANALOG SWITCH 4 SPST 16-CER DIP	17856	DG201BK
A2U2	1826-0606	5		ANALOG SWITCH 4 SPST 16-CER DIP	17856	DG201BK
A2U3	1826-0413	2	5	IC OP AMP LOW-BIAS-H-IMPD TO-99 PKG	34371	HA2-2605-5
<i>2305A TO 2449A</i>						
A2U4	1826-0582	6		IC SWITCH ANLG QUAD 16-DIP-C PKG	27014	LF13201D
<i>2451A AND ABOVE</i>						
A2U4	1826-0606	5		ANALOG SWITCH 4 SPST 16-CER DIP	17856	DG201BK
A2U5	1826-0109	3	1	IC OP AMP WB TO-99 PKG	34371	HA2-2625-B0593
A2W1	08901-20096	8	1	CABLE SEMI RIGID AM	28480	08901-20096
A2W2	08901-20095	7	1	CABLE SEMI RIGID FM	28480	08901-20095

{Refer to Section 7 for update information.

\*Factory Selected Component (Refer to Section 5).

Δ Errata part change.

Table 6-3. Replaceable Parts

Reference Designation	HP Part Number	C D	Qty.	Description	Mfr. Code	Mfr. Part Number
<b>A3</b>						
A3	08901-60009	7	1	AUDIO DE-EMPHASIS AND OUTPUT ASSEMBLY	28480	08901-60009
A3C1	0180-0058	0	9	CAPACITOR-FXD 50UF + 75-10% 25VDC AL	56289	30D506G025CC2
A3C2	0180-0058	0		CAPACITOR-FXD 50UF + 75-10% 25VDC AL	56289	30D506G025CC2
A3C3	0180-2929	8	9	CAPACITOR-FXD 68UF + .10% 10VDC TA	28480	0180-2929
<i>2305A TO 2515A</i>						
A3C4	0160-3858	2	2	CAPACITOR-FXD .039UF + -2% 200VDC	28480	0160-3858
<i>2519A AND ABOVE</i>						
A3C4	0160-5340	1		CAPACITOR-FXD .03UF + -1% 200VDC MPC	28480	0160-5340
A3C5	0160-4613	9	2	CAPACITOR-FXD .1UF + -1% 50VDC POLYSTY	28480	0160-4613
<i>2305A TO 2515A</i>						
A3C6	0160-3858	2		CAPACITOR-FXD .039UF + -2% 200VDC	28480	0160-3858
<i>2519A AND ABOVE</i>						
A3C6	0160-5340	1		CAPACITOR-FXD .03UF + -1% 200VDC MPC	28480	0160-5340
A3C7	0160-4613	9		CAPACITOR-FXD .1UF + -1% 50VDC POLYSTY	28480	0160-4613
A3C8	0160-2055	9		CAPACITOR-FXD .01UF + 80-20% 100VDC CER	28480	0160-2055
A3C9	0160-2055	9		CAPACITOR-FXD .01UF + 80-20% 100VDC CER	28480	0160-2055
A3C10	0160-3879	7	93	CAPACITOR-FXD .01UF + -20% 100VDC CER	28480	0160-3879
A3C11	0160-3879	7		CAPACITOR-FXD .01UF + -20% 100VDC CER	28480	0160-3879
A3C12	0160-3879	7		CAPACITOR-FXD .01UF + -20% 100VDC CER	28480	0160-3879
A3C13	0160-3879	7		CAPACITOR-FXD .01UF + -20% 100VDC CER	28480	0160-3879
A3C14	0160-3879	7		CAPACITOR-FXD .01UF + -20% 100VDC CER	28480	0160-3879
A3C15	0160-2055	9		CAPACITOR-FXD .01UF + 80-20% 100VDC CER	28480	0160-2055
A3C16	0160-3879	7		CAPACITOR-FXD .01UF + -20% 100VDC CER	28480	0160-3879
A3C17	0160-2055	9		CAPACITOR-FXD .01UF + 80-20% 100VDC CER	28480	0160-2055
A3C18	0160-3879	7		CAPACITOR-FXD .01UF + -20% 100VDC CER	28480	0160-3879
A3C19	0160-3879	7		CAPACITOR-FXD .01UF + -20% 100VDC CER	28480	0160-3879
A3C20	0160-3879	7		CAPACITOR-FXD .01UF + -20% 100VDC CER	28480	0160-3879
A3C21	0160-3879	7		CAPACITOR-FXD .01UF + -20% 100VDC CER	28480	0160-3879
A3C22	0160-3879	7		CAPACITOR-FXD .01UF + -20% 100VDC CER	28480	0160-3879
A3C23	0160-3879	7		CAPACITOR-FXD .01UF + -20% 100VDC CER	28480	0160-3879
A3C24 <sup>Δ</sup>	0160-6606	4		CAPACITOR-FXD .02UF + -1% 200VDC	28480	0160-6606
A3C25	0160-4317	0	1	CAPACITOR-FXD 1200PF + -1% 100VDC MICA	28480	0160-4317
A3C26	0140-0213	5	2	CAPACITOR-FXD 2000PF + -1% 300VDC MICA	72136	DM19F202F0300WV1CR
A3C27	0160-3879	7		CAPACITOR-FXD .01UF + -20% 100VDC CER	28480	0160-3879
A3C28	0160-3879	7		CAPACITOR-FXD .01UF + -20% 100VDC CER	28480	0160-3879
A3C29	0160-3879	7		CAPACITOR-FXD .01UF + -20% 100VDC CER	28480	0160-3879
A3C30	0160-3879	7		CAPACITOR-FXD .01UF + -20% 100VDC CER	28480	0160-3879
A3C31	0160-3879	7		CAPACITOR-FXD .01UF + -20% 100VDC CER	28480	0160-3879
A3C32	0160-3879	7		CAPACITOR-FXD .01UF + -20% 100VDC CER	28480	0160-3879
A3C33	0140-0213	5		CAPACITOR-FXD 2000PF + -1% 300VDC MICA	72136	DM19F202F0300WV1CR

†Refer to Section 7 for update information.

\*Factory Selected Component (Refer to Section 5)

Δ Errata part change

Table 6-3. Replaceable Parts

Reference Designation	HP Part Number	C D	Qty.	Description	Mfr. Code	Mfr. Part Number
A3C34 <sup>Δ</sup>	0160-6606	4		CAPACITOR-FXD .02UF + -1% 200VDC	28480	0160-6606
A3C35				NOT ASSIGNED		
A3C36	0140-0196	3		CAPACITOR-FXD 150PF + -5% 300VDC MICA	72136	DM15F151J0300WV1CR
A3C37	0160-4084	8		CAPACITOR-FXD .1UF + -20% 50VDC CER	28480	0160-4084
A3C38				NOT ASSIGNED		
A3C39	0160-3879	7		CAPACITOR-FXD .01UF + -20% 100VDC CER	28480	0160-3879
A3C40	0160-3879	7		CAPACITOR-FXD .01UF + -20% 100VDC CER	28480	0160-3879
A3C41	0160-3879	7		CAPACITOR-FXD .01UF + -20% 100VDC CER	28480	0160-3879
A3C42	0160-2204	0	3	CAPACITOR-FXD 100PF + -5% 300VDC MICA	28480	0160-2204
A3C43	0160-2201	7	1	CAPACITOR-FXD 51PF + -5% 300VDC MICA	28480	0160-2201
A3C44	0180-0291	3	9	CAPACITOR-FXD 1UF + -10% 35VDC TA	56289	150D105X9035A2
A3C45				NOT ASSIGNED		
A3C46				NOT ASSIGNED		
<i>2305A TO 2516A</i>						
A3C47	0160-3165	4	1	CAPACITOR-FXD .047UF + -2% 50VDC POLYE	28480	0160-3165
A3C48	0160-2302	9		CAPACITOR-FXD 4000PF + -1% 100VDC MICA	28480	0160-2302
<i>2519A AND ABOVE</i>						
A3C47	0160-5340	1		CAPACITOR-FXD .03UF + -1% 200VDC MPC	28480	0160-5340
A3C48	0160-4217	9		CAPACITOR-FXD 3900PF + -1% 500VDC MICA	28480	0160-4217
A3C49	0160-5201	3	2	CAPACITOR-FXD .01UF + -1% 200VDC	28480	0160-5201
A3C50	0160-3879	7		CAPACITOR-FXD .01UF + -20% 100VDC CER	28480	0160-3879
A3C51	0160-3879	7		CAPACITOR-FXD .01UF + -20% 100VDC CER	28480	0160-3879
A3C52	0160-5201	3		CAPACITOR-FXD .01UF + -1% 200VDC	28480	0160-5201
<i>2305A TO 2516A</i>						
A3C53	0160-2302	9		CAPACITOR-FXD 4000PF + -1% 100VDC MICA	28480	0160-2302
<i>2519A AND ABOVE</i>						
A3C53	0160-4217	9		CAPACITOR-FXD 3900PF + -1% 500VDC MICA	28480	0160-4217
A3C54				NOT ASSIGNED		
A3C55	0160-3879	7		CAPACITOR-FXD .01UF + -20% 100VDC CER	28480	0160-3879
A3C56	0160-3879	7		CAPACITOR-FXD .01UF + -20% 100VDC CER	28480	0160-3879
A3C57	0160-3879	7		CAPACITOR-FXD .01UF + -20% 100VDC CER	28480	0160-3879
A3C58	0180-0116	1	5	CAPACITOR-FXD 6.8UF + -10% 35VDC TA	56289	150D685X9035B2
A3C59	0160-3879	7		CAPACITOR-FXD .01UF + -20% 100VDC CER	28480	0160-3879
A3C60	0160-3879	7		CAPACITOR-FXD .01UF + -20% 100VDC CER	28480	0160-3879
A3C61	0160-3879	7		CAPACITOR-FXD .01UF + -20% 100VDC CER	28480	0160-3879
A3C62	0160-3879	7		CAPACITOR-FXD .01UF + -20% 100VDC CER	28480	0160-3879
A3C63				NOT ASSIGNED		
A3C64	0180-0228	6		CAPACITOR-FXD 22UF + -10% 15VDC TA	56289	150D226X9015B2
A3C65	0180-0228	6		CAPACITOR-FXD 22UF + -10% 15VDC TA	56289	150D226X9015B2
A3C66				NOT ASSIGNED		
A3C67				NOT ASSIGNED		
A3C68	0180-0058	0		CAPACITOR-FXD 50UF + 75-10% 25VDC AL	56289	30D506G025CC2

†Refer to Section 7 for update information

\*Factory Selected Component (Refer to Section 5)

Δ Errata part change



Table 6-3. Replaceable Parts

Reference Designation	HP Part Number	C D	Qty.	Description	Mfr. Code	Mfr. Part Number
A3C69	0180-0058	0		CAPACITOR-FXD 50UF + 75-10% 25VDC AL	56289	30D506G025CC2
A3C70	0160-0134	1		CAPACITOR-FXD 220PF + -5% 300VDC MICA	28480	0160-0134
A3C71				NOT ASSIGNED		
A3C72	0180-0116	1		CAPACITOR-FXD 6.8UF + -10% 35VDC TA	56289	150D685X9035B2
A3C73	0160-2055	9		CAPACITOR-FXD .01UF + 80-20% 100VDC CER	28480	0160-2055
A3C74	0160-2055	9		CAPACITOR-FXD .01UF + 80-20% 100VDC CER	28480	0160-2055
A3C75	0160-3879	7		CAPACITOR-FXD .01UF + -20% 100VDC CER	28480	0160-3879
A3C76	0180-0197	8	55	CAPACITOR-FXD 2.2UF + -10% 20VDC TA	56289	150D225X9020A2
A3C77	0180-0197	8		CAPACITOR-FXD 2.2UF + -10% 20VDC TA	56289	150D225X9020A2
A3CR1	1901-0040	1		DIODE-SWITCHING 30V 50MA 2NS DO-35	28480	1901-0040
A3CR2	1901-0040	1		DIODE-SWITCHING 30V 50MA 2NS DO-35	28480	1901-0040
A3CR3	1901-1098	1		DIODE-SWITCHING 1N4150 50V 200MA 4NS	9N171	1N4150
A3CR4	1901-0040	1		DIODE-SWITCHING 30V 50MA 2NS DO-35	28480	1901-0040
A3CR5	1901-0040	1		DIODE-SWITCHING 30V 50MA 2NS DO-35	28480	1901-0040
A3CR6	1901-0040	1		DIODE-SWITCHING 30V 50MA 2NS DO-35	28480	1901-0040
A3CR7	1901-0040	1		DIODE-SWITCHING 30V 50MA 2NS DO-35	28480	1901-0040
A3CR8				NOT ASSIGNED		
A3CR9	1901-1098	1		DIODE-SWITCHING 1N4150 200MA 4NS	9N171	1N4150
A3L1	9140-0137	1		INDUCTOR RF-CH-MLD 1MH 5% .2DX.45LG Q = 60	28480	9140-0137
A3L2	9100-1633	0	1	INDUCTOR RF-CH-MLD 68UH 5% .166DX.385LG	28480	9100-1633
A3L3	9140-0137	1		INDUCTOR RF-CH-MLD 1MH 5% .2DX.45LG Q = 60	28480	9140-0137
A3MP1	08901-00021	7	1	COVER AUD DE-EMP	28480	08901-00021
	2360-0113	2		SCREW-MACH 6-32 .25-IN-LG PAN-HD-POZI	00000	ORDER BY DESCRIPTION
A3Q1	1854-0477	7		TRANSISTOR NPN 2N2222A SI TO-18 PD = 500MW	04713	2N2222A
<i>2305A TO 2515A</i>						
A3R1	0698-7353	9	1	RESISTOR 19K 1% .125W F TC = 0 + -100	19701	MF4C1/8-T0-1902
<i>2519A AND ABOVE</i>						
A3R1	0698-6942	0		RESISTOR 25K .1% .125W F TC = 0 + -50	24546	C4-1/8-T0-2502-F
A3R2	0698-5091	8	1	RESISTOR 45K 1% .125W F TC = 0 + -100	24546	C4-1/8-T0-4502-F
A3R3	0757-0349	5	1	RESISTOR 22.6K 1% .125W F TC = 0 + -100	24546	C4-1/8-T0-2262-F
<i>2305A TO 2515A</i>						
A3R4	0698-6343	5	2	RESISTOR 9K .1% .125W F TC = 0 + -25	28480	0698-6343
<i>2519A AND ABOVE</i>						
A3R4	0698-8191	5		RESISTOR 12.5K .1% .125W F TC = 0 + -25	24546	C4-1/8-T0-1252-F
A3R5	0757-0280	3		RESISTOR 1K 1% .125W F TC = 0 + -100	24546	C4-1/8-T0-1001-F
A3R6				NOT ASSIGNED		
A3R7	0698-0085	0	16	RESISTOR 2.61K 1% .125W F TC = 0 + -100	24546	C4-1/8-T0-2611-F
A3R8	0698-3159	5	3	RESISTOR 26.1K 1% .125W F TC = 0 + -100	24546	C4-1/8-T0-2612-F
A3R9	0698-3161	9	4	RESISTOR 38.3K 1% .125W F TC = 0 + -100	24546	C4-1/8-T0-3832-F
A3R10				NOT ASSIGNED		
A3R11	0757-0441	8	11	RESISTOR 8.25K 1% .125W F TC = 0 + -100	24546	C4-1/8-T0-8251-F
A3R12	0757-0441	8		RESISTOR 8.25K 1% .125W F TC = 0 + -100	24546	C4-1/8-T0-8251-F
A3R13	0757-0438	3	40	RESISTOR 5.11K 1% .125W F TC = 0 + -100	24546	C4-1/8-T0-5111-F
A3R14	0757-0441	8		RESISTOR 8.25K 1% .125W F TC = 0 + -100	24546	C4-1/8-T0-8251-F

†Refer to Section 7 for update information

\*Factory Selected Component (Refer to Section 5)

Δ Errata part change

Table 6-3. Replaceable Parts

Reference Designation	HP Part Number	C D	Qty.	Description	Mfr. Code	Mfr. Part Number
A3R15				NOT ASSIGNED		
A3R16	0757-0442	9		RESISTOR 10K 1% .125W F TC = 0 + -100	24546	C4-1/8-T0-1002-F
A3R17	0757-0465	6	30	RESISTOR 100K 1% .125W F TC = 0 + -100	24546	C4-1/8-T0-1003-F
A3R18	0757-0438	3		RESISTOR 5.11K 1% .125W F TC = 0 + -100	24546	C4-1/8-T0-5111-F
A3R19	0757-0442	9		RESISTOR 10K 1% .125W F TC = 0 + -100	24546	C4-1/8-T0-1002-F
A3R20	0757-0438	3		RESISTOR 5.11K 1% .125W F TC = 0 + -100	24546	C4-1/8-T0-5111-F
A3R21	0683-2265	1	3	RESISTOR 22M 5% .25W FC TC = -900/ + 1200	01121	CB2265
A3R22	0757-0279	0	19	RESISTOR 3.16K 1% .125W F TC = 0 + -100	24546	C4-1/8-T0-3161-F
A3R23	0757-0438	3		RESISTOR 5.11K 1% .125W F TC = 0 + -100	24546	C4-1/8-T0-5111-F
A3R24				NOT ASSIGNED		
A3R25	0757-0442	9		RESISTOR 10K 1% .125W F TC = 0 + -100	24546	C4-1/8-T0-1002-F
A3R26	0698-7236	7		RESISTOR 1K 1% .05W F TC = 0 + -100	24546	C3-1/8-T0-1001-F
A3R27	2100-3273	1	2	RESISTOR-TRMR 2K 10% C SIDE-ADJ 1.TRN	28480	2100-3273
A3R28	0698-3156	2	7	RESISTOR 14.7K 1% .125W F TC = 0 + -100	24546	C4-1/8-T0-1472-F
<i>2305A TO 2515A</i>						
A3R29	0698-8046	9	1	RESISTOR 16K .1% .125W F TC = 0 + -25	19701	MF4C1/8-T9-1602
<i>2519A AND ABOVE</i>						
A3R29	0698-8942	0		RESISTOR 25K .1% .125W F TC = 0 + -50	24546	C4-1/8-T0-250
A3R30	0698-7264	1	1	RESISTOR 14.7K 1% .05W F TC = 0 + -100	24546	C3-1/8-T0-1472-F
A3R31	0698-8191	5	1	RESISTOR 12.5K .1% .125W F TC = 0 + -25	19701	MF4C1/8-T9-1252-B
A3R32	0698-7643	0	2	RESISTOR 6.25K .1% .125W F TC = 0 + -25	19701	MF4C1/8-T9-6251-B
A3R33	0699-0069	2	2	RESISTOR 2.15M 1% .125W F TC = 0 + -100	28480	0699-0069
A3R34	0698-8642	1	1	RESISTOR 56.2K .1% .125W F TC = 0 + -25	28480	0698-8642
A3R35	0698-8731	9	12	RESISTOR 4.8K .1% .1W F TC = 0 + -15	28480	0698-8731
<i>2305A TO 2515A</i>						
A3R36	0698-6614	3	1	RESISTOR 7.5K .1% .125W F TC = 0 + -25	28480	0698-6614
<i>2519A AND ABOVE</i>						
A3R36	0698-8307	5		RESISTOR 7.4K .25% .125W F TC = 0 + -50	28480	0698-8307
A3R37	0698-7643	0		RESISTOR 6.25K .1% .125W F TC = 0 + -25	19701	MF4C1/8-T9-6251-B
A3R38	0698-8731	9		RESISTOR 4.8K .1% .1W F TC = 0 + -15	28480	0698-8731
A3R39	0698-7251	6	6	RESISTOR 4.22K 1% .05W F TC = 0 + -100	24546	C3-1/8-T0-4221-F
A3R40	0698-7224	3	2	RESISTOR 316 1% .05W F TC = 0 + -100	24546	C3-1/8-T0-316R-F
A3R41	0698-3157	3	10	RESISTOR 19.6K 1% .125W F TC = 0 + -100	24546	C4-1/8-T0-1962-F
A3R42				NOT ASSIGNED		
A3R43	0698-8731	9		RESISTOR 4.8K .1% .1W F TC = 0 + -15	28480	0698-8731
A3R44	0698-8731	9		RESISTOR 4.8K .1% .1W F TC = 0 + -15	28480	0698-8731
A3R45	0698-8731	9		RESISTOR 4.8K .1% .1W F TC = 0 + -15	28480	0698-8731
A3R46	0698-8731	9		RESISTOR 4.8K .1% .1W F TC = 0 + -15	28480	0698-8731
A3R47	0698-8731	9		RESISTOR 4.8K .1% .1W F TC = 0 + -15	28480	0698-8731
A3R48	0757-1094	9		RESISTOR 1.47K 1% .125W F TC = 0 + -100	24546	C4-1/8-T0-1471-F
A3R49	0698-3159	5		RESISTOR 26.1K 1% .125W F TC = 0 + -100	24546	C4-1/8-T0-2612-F
A3R50	0698-8731	9		RESISTOR 4.8K .1% .1W F TC = 0 + -15	28480	0698-8731

[Refer to Section 7 for update information]

\* Factory Selected Component (Refer to Section 5)

Δ Errata part change

Table 6-3. Replaceable Parts

Reference Designation	HP Part Number	C D	Qty.	Description	Mfr. Code	Mfr. Part Number
A3R51 <sup>Δ</sup>	0698-6414	5		RESISTOR 1K .1% .1W F TC = 0 + -5	28480	0698-6414
A3R52	0757-0280	3		RESISTOR 1K 1% .125W F TC = 0 + -100	24546	C4-1/8-T0-1001-F
A3R53	0757-1094	9		RESISTOR 1.47K 1% .125W F TC = 0 + -100	24546	C4-1/8-T0-1471-F
A3R54	0698-3444	1		RESISTOR 316 1% .125W F TC = 0 + -100	24546	C4-1/8-T0-316R-F
A3R55 <sup>Δ</sup>	0698-6414	5		RESISTOR 1K .1% .1W F TC = 0 + -5	28480	0698-6414
A3R56	0757-0280	3		RESISTOR 1K 1% .125W F TC = 0 + -100	24546	C4-1/8-T0-1001-F
A3R57	0757-0439	4	8	RESISTOR 6.81K 1% .125W F TC = 0 + -100	24546	C4-1/8-T0-6811-F
A3R58				NOT ASSIGNED		
A3R59	0757-0401	0	51	RESISTOR 100 1% .125W F TC = 0 + -100	24546	C4-1/8-T0-101-F
A3R60	0757-0401	0		RESISTOR 100 1% .125W F TC = 0 + -100	24546	C4-1/8-T0-101-F
A3R61	0757-0442	9		RESISTOR 10K 1% .125W F TC = 0 + -100	24546	C4-1/8-T0-1002-F
A3R62	0757-0442	9		RESISTOR 10K 1% .125W F TC = 0 + -100	24546	C4-1/8-T0-1002-F
A3R63	0757-0280	3		RESISTOR 1K 1% .125W F TC = 0 + -100	24546	C4-1/8-T0-1001-F
A3R64	0757-0280	3		RESISTOR 1K 1% .125W F TC = 0 + -100	24546	C4-1/8-T0-1001-F
A3R65	0698-7272	1	1	RESISTOR 31.6K 1% .05W F TC = 0 + -100	24546	C3-1/8-T0-3162-F
A3TP1	1251-0600	0		CONNECTOR-SGL CONT PIN 1.14-MM-BSC-SZ SQ	28480	1251-0600
A3TP2	1251-0600	0		CONNECTOR-SGL CONT PIN 1.14-MM-BSC-SZ SQ	28480	1251-0600
A3TP3	1251-0600	0		CONNECTOR-SGL CONT PIN 1.14-MM-BSC-SZ SQ	28480	1251-0600
A3TP4	1251-0600	0		CONNECTOR-SGL CONT PIN 1.14-MM-BSC-SZ SQ	28480	1251-0600
A3TP5	1251-0600	0		CONNECTOR-SGL CONT PIN 1.14-MM-BSC-SZ SQ	28480	1251-0600
A3U1	1826-0413	2		IC OP AMP LOW-BIAS-H-IMPD TO-99 PKG	34371	HA2-2605-5
A3U2	1826-0413	2		IC OP AMP LOW-BIAS-H-IMPD TO-99 PKG	34371	HA2-2605-5
A3U3	1826-0413	2		IC OP AMP LOW-BIAS-H-IMPD TO-99 PKG	34371	HA2-2605-5
A3U4	1826-0753	3	5	IC OP AMP LOW-BIAS-H-IMPD QUAD 14-DIP-C	04713	MC34004BL
A3U5	1826-0371	1	6	IC OP AMP LOW-BIAS-H-IMPD TO-99 PKG	27014	LF256H
A3U6	1826-0059	2	10	IC OP AMP GP TO-99 PKG	01295	LM201AL
A3U7	1826-0783	9	6	IC OP AMP LOW-NOISE 8-DIP-C PKG	52063	XR5534ACN
A3U8	1826-0783	9		IC OP AMP LOW-NOISE 8-DIP-C PKG	52063	XR5534ACN
A3U9	1826-0753	3		IC OP AMP LOW-BIAS-H-IMPD QUAD 14-DIP-C	04713	MC34004BL
A3U10	1826-0783	9		IC OP AMP LOW-NOISE 8-DIP-C PKG	52063	XR5534ACN
A3U11	1826-0783	9		IC OP AMP LOW-NOISE 8-DIP-C PKG	52063	XR5534ACN
<i>2305A TO 2449A</i>						
A3U12	1826-0582	6		IC SWITCH ANLG QUAD 16-DIP-C PKG	27014	LF13201D
A3U13	1826-0582	6		IC SWITCH ANLG QUAD 16-DIP-C PKG	27014	LF13201D
A3U14	1826-0582	6		IC SWITCH ANLG QUAD 16-DIP-C PKG	27014	LF13201D
A3U15	1826-0582	6		IC SWITCH ANLG QUAD 16-DIP-C PKG	27014	LF13201D
<i>2451A AND ABOVE</i>						
A3U12	1826-0606	5		ANALOG SWITCH 4 SPST 16-CER DIP	17856	DG201BK
A3U13	1826-0606	5		ANALOG SWITCH 4 SPST 16-CER DIP	17856	DG201BK
A3U14	1826-0606	5		ANALOG SWITCH 4 SPST 16-CER DIP	17856	DG201BK
A3U15	1826-0606	5		ANALOG SWITCH 4 SPST 16-CER DIP	17856	DG201BK
A3U16	1820-1195	7	13	IC FF TTL LS D-TYPE POS-EDGE-TRIG COM	01295	SN74LS175N
A3U17	1820-1418	7	1	IC DCDR TTL LS BCD-TO-DEC 4-TO-10-LINE	01295	SN74LS42N
A3U18	1820-1195	7		IC FF TTL LS D-TYPE POS-EDGE-TRIG COM	01295	SN74LS175N
A3U19	1820-1195	7		IC FF TTL LS D-TYPE POS-EDGE-TRIG COM	01295	SN74LS175N
A3U20	1820-1216	3		IC DCDR TTL LS 3-TO-8-LINE 3-INP	01295	SN74LS138N

† Refer to Section 7 for update information.

\* Factory Selected Component (Refer to Section 5)

Δ Errata part change.

*Table 6-3. Replaceable Parts*

Reference Designation	HP Part Number	C D	Qty.	Description	Mfr. Code	Mfr. Part Number
A3U21	1820-1272	1	1	IC BFR TTL LS NOR QUAD 2-INP	01295	SN74LS33N
A3U22	1820-1112	8	5	IC FF TTL LS D-TYPE POS-EDGE-TRIG	01295	SN74LS74AN
A3U23	1820-1195	7		IC FF TTL LS D-TYPE POS-EDGE-TRIG COM	01295	SN74LS175N
A3VR1	1902-0041	4	10	DIODE-ZNR 5.11V 5% DO-35 PD = .4W	28480	1902-0041
A3VR2	1902-0048	1	2	DIODE-ZNR 6.81V 5% DO-35 PD = .4W	28480	1902-0048
A3VR3	1902-0048	1		DIODE-ZNR 6.81V 5% DO-35 PD = .4W	28480	1902-0048
A3VR4	1902-0041	4		DIODE-ZNR 5.11V 5% DO-35 PD = .4W	28480	1902-0041
A3VR5	1902-0041	4		DIODE-ZNR 5.11V 5% DO-35 PD = .4W	28480	1902-0041

† Refer to Section 7 for update information.

\* Factory Selected Component (Refer to Section 5).

Δ Errata part change.

Table 6-3. Replaceable Parts

Reference Designation	HP Part Number	C D	Qty.	Description	Mfr. Code	Mfr. Part Number
<b>A4</b>						
A4	08901-60184	9	1	FM DEMODULATOR ASSEMBLY	28480	08901-60184
A4C1	0160-4084	8		CAPACITOR-FXD .1UF + -20% 50VDC CER	28480	0160-4084
A4C2	0180-1746	5		CAPACITOR-FXD 15UF + -10% 20VDC TA	56289	150D156X9020B2
A4C3	0180-0197	8		CAPACITOR-FXD 2.2UF + -10% 20VDC TA	56289	150D225X9020A2
A4C4	0180-0197	8		CAPACITOR-FXD 2.2UF + -10% 20VDC TA	56289	150D225X9020A2
A4C5	0180-0197	8		CAPACITOR-FXD 2.2UF + -10% 20VDC TA	56289	150D225X9020A2
A4C6	0160-4492	2	3	CAPACITOR-FXD 18PF + -5% 200VDC CER 0 + -30	28480	0160-4492
A4C7	0160-4084	8		CAPACITOR-FXD .1UF + -20% 50VDC CER	28480	0160-4084
A4C8	0160-4084	8		CAPACITOR-FXD .1UF + -20% 50VDC CER	28480	0160-4084
A4C9	0160-4084	8		CAPACITOR-FXD .1UF + -20% 50VDC CER	28480	0160-4084
A4C10	0160-4492	2		CAPACITOR-FXD 18PF + -5% 200VDC CER 0 + -30	28480	0160-4492
A4C11	0180-0197	8		CAPACITOR-FXD 2.2UF + -10% 20VDC TA	56289	150D225X9020A2
A4C12	0180-0197	8		CAPACITOR-FXD 2.2UF + -10% 20VDC TA	56289	150D225X9020A2
A4C13	0160-4084	8		CAPACITOR-FXD .1UF + -20% 50VDC CER	28480	0160-4084
A4C14	0160-4084	8		CAPACITOR-FXD .1UF + -20% 50VDC CER	28480	0160-4084
A4C15	0160-4806	2	1	CAPACITOR-FXD 39PF + -5% 100VDC CER 0 + -30	28480	0160-4806
A4C16	0180-0197	8		CAPACITOR-FXD 2.2UF + -10% 20VDC TA	56289	150D225X9020A2
A4C17	0180-0197	8		CAPACITOR-FXD 2.2UF + -10% 20VDC TA	56289	150D225X9020A2
A4C18	0160-4832	4	32	CAPACITOR-FXD .01UF + -10% 100VDC CER	28480	0160-4832
A4C19	0180-0197	8		CAPACITOR-FXD 2.2UF + -10% 20VDC TA	56289	150D225X9020A2
A4C20	0160-4832	4		CAPACITOR-FXD .01UF + -10% 100VDC CER	28480	0160-4832
A4C21	0180-0094	4	9	CAPACITOR-FXD 100UF + 75-10% 25VDC AL	56289	30D107G025DD2
A4C22	0180-0197	8		CAPACITOR-FXD 2.2UF + -10% 20VDC TA	56289	150D225X9020A2
A4C23	0180-0094	4		CAPACITOR-FXD 100UF + 75-10% 25VDC AL	56289	30D107G025DD2
A4C24	0180-1746	5		CAPACITOR-FXD 15UF + -10% 20VDC TA	56289	150D156X9020B2
A4C25	0180-0094	4		CAPACITOR-FXD 100UF + 75-10% 25VDC AL	56289	30D107G025DD2
A4C26	0180-1746	5		CAPACITOR-FXD 15UF + -10% 20VDC TA	56289	150D156X9020B2
A4C27	0160-5699	3	3	CAPACITOR-FXD 20PF + -5% 100VDC CER 0 + -30	28480	0160-5699
A4C28	0160-5699	3		CAPACITOR-FXD 20PF + -5% 100VDC CER 0 + -30	28480	0160-5699
A4C29	0160-0162	5	1	CAPACITOR-FXD .022UF + -10% 200VDC POLYE	28480	0160-0162
A4C30	0160-0153	4	3	CAPACITOR-FXD 1000PF + -10% 200VDC POLYE	28480	0160-0153
A4C31	0160-4805	1	2	CAPACITOR-FXD 47PF + -5% 100VDC CER 0 + -30	28480	0160-4805
A4C32	0160-4808	4	1	CAPACITOR-FXD 470PF + -5% 100VDC CER	28480	0160-4808
A4C33	0160-5491	3	1	CAPACITOR-FXD 240PF + -5% 100VDC CER	28480	0160-5491
A4C34				NOT ASSIGNED		
A4C35	0160-4799	2	1	CAPACITOR-FXD 2.2PF + -.25PF 100VDC CER	28480	0160-4799
A4C36	0180-1746	5		CAPACITOR-FXD 15UF + -10% 20VDC TA	56289	150D156X9020B2
A4C37	0180-0197	8		CAPACITOR-FXD 2.2UF + -10% 20VDC TA	56289	150D225X9020A2
A4C38	0160-4801	7	3	CAPACITOR-FXD 100PF + -5% 100VDC CER	28480	0160-4801
A4C39	0160-3501	2	5	CAPACITOR-FXD 4UF + -10% 50VDC MET-POLYC	28480	0160-3501
A4C40				NOT ASSIGNED		
A4C41	0180-0197	8		CAPACITOR-FXD 2.2UF + -10% 20VDC TA	56289	150D225X9020A2
A4C42	0160-4812	0	5	CAPACITOR-FXD 220PF + -5% 100VDC CER	28480	0160-4812
A4C43	0160-4791	4	2	CAPACITOR-FXD 10PF + -5% 100VDC CER 0 + -30	28480	0160-4791
A4C44	0160-4795	8	2	CAPACITOR-FXD 4.7PF + .1PF 100VDC CER	28480	0160-4795
A4C45	0160-5719	8	1	CAPACITOR-FXD 620PF + -5% 100VDC CER	28480	0160-5719

† Refer to Section 7 for update information.

\* Factory Selected Component (Refer to Section 5)

Δ Errata part change

Table 6-3. Replaceable Parts

Reference Designation	HP Part Number	C D	Qty.	Description	Mfr. Code	Mfr. Part Number
A4C46	0160-4832	4		CAPACITOR-FXD .01UF + -10% 100VDC CER	28480	0160-4832
A4C47	0160-4822	2	6	CAPACITOR-FXD 1000PF + -5% 100VDC CER	28480	0160-4822
A4C48	0180-0197	8		CAPACITOR-FXD 2.2UF + -10% 20VDC TA	56289	150D225X9020A2
A4C49	0160-4832	4		CAPACITOR-FXD .01UF + -10% 100VDC CER	28480	0160-4832
A4C50	0160-4819	7	2	CAPACITOR-FXD 2200PF + -5% 100VDC CER	28480	0160-4819
A4C51	0160-4819	7		CAPACITOR-FXD 2200PF + -5% 100VDC CER	28480	0160-4819
A4CR1	1901-1098	1		DIODE-SWITCHING 1N4150 50V 200MA 4NS	9N171	1N4150
A4CR2	1901-1098	1		DIODE-SWITCHING 1N4150 50V 200MA 4NS	9N171	1N4150
A4CR3	1901-1098	1		DIODE-SWITCHING 1N4150 50V 200MA 4NS	9N171	1N4150
A4CR4	1901-1098	1		DIODE-SWITCHING 1N4150 50V 200MA 4NS	9N171	1N4150
A4CR5	1901-1098	1		DIODE-SWITCHING 1N4150 50V 200MA 4NS	9N171	1N4150
A4CR6	08901-80037	3	4	MATCH DIODE SET	28480	08901-80037
A4CR7	08901-80037	3		MATCH DIODE SET	28480	08901-80037
A4CR8	08901-80037	3		MATCH DIODE SET	28480	08901-80037
A4CR9	08901-80037	3		MATCH DIODE SET	28480	08901-80037
A4CR10	1901-0518	8	32	DIODE-SM SIG SCHOTTKY	28480	1901-0518
A4CR11	1901-0518	8		DIODE-SM SIG SCHOTTKY	28480	1901-0518
A4CR12	1901-0518	8		DIODE-SM SIG SCHOTTKY	28480	1901-0518
A4CR13	1901-0518	8		DIODE-SM SIG SCHOTTKY	28480	1901-0518
A4CR14	1901-1098	1		DIODE-SWITCHING 1N4150 50V 200MA 4NS	9N171	1N4150
A4CR15	1901-1098	1		DIODE-SWITCHING 1N4150 50V 200MA 4NS	9N171	1N4150
A4CR16	1901-1098	1		DIODE-SWITCHING 1N4150 50V 200MA 4NS	9N171	1N4150
A4DS1	1990-0325	2	2	LED-LAMP LUM-INT = 800UCD IF = 50MA-MAX	28480	5082-4403
A4DS2	1990-0325	2		LED-LAMP LUM-INT = 800UCD IF = 50MA-MAX	28480	5082-4403
A4J1	1250-1220	0		CONNECTOR-RF SMC M PC 50-OHM	28480	1250-1220
	2190-0124	4		WASHER-LK INTL T NO. 10 .195-IN-ID	28480	2190-0124
	2950-0078	9		NUT-HEX-DBL-CHAM 10-32-THD .067-IN-THK	28480	2950-0078
A4J2	1250-1220	0		CONNECTOR-RF SMC M PC 50-OHM	28480	1250-1220
	2190-0124	4		WASHER-LK INTL T NO. 10 .195-IN-ID	28480	2190-0124
	2950-0078	9		NUT-HEX-DBL-CHAM 10-32-THD .067-IN-THK	28480	2950-0078
A4J3	1250-1220	0		CONNECTOR-RF SMC M PC 50-OHM	28480	1250-1220
	2190-0124	4		WASHER-LK INTL T NO. 10 .195-IN-ID	28480	2190-0124
	2950-0078	9		NUT-HEX-DBL-CHAM 10-32-THD .067-IN-THK	28480	2950-0078
A4L1	9140-0098	3	2	INDUCTOR RF-CH-MLD 2.2UH 10%	28480	9140-0098
A4L2	9140-0098	3		INDUCTOR RF-CH-MLD 2.2UH 10%	28480	9140-0098
A4L3	9100-2272	5	2	INDUCTOR RF-CH-MLD 47UH 10% .105DX.26LG	28480	9100-2272
A4L4	9100-2272	5		INDUCTOR RF-CH-MLD 47UH 10% .105DX.26LG	28480	9100-2272
A4MP1	08901-00020	6	1	COVER FM D MOD	28480	08901-00020
	2190-0008	3	19	WASHER-LK EXT T NO. 6 .141-IN-ID	28480	2190-0008
	2360-0113	2		SCREW-MACH 6-32 .25-IN-LG PAN-HD-POZI	00000	ORDER BY DESCRIPTION
A4Q1	1854-0210	6	4	TRANSISTOR NPN 2N2222 SI TO-18 PD = 500MW	04713	2N2222
A4Q2	1854-0071	7		TRANSISTOR NPN SI PD = 300MW FT = 200MHZ	28480	1854-0071
A4Q3	1853-0020	4	23	TRANSISTOR PNP SI PD = 300MW FT = 150MHZ	28480	1853-0020
A4Q4	1853-0020	4		TRANSISTOR PNP SI PD = 300MW FT = 150MHZ	28480	1853-0020
A4Q5	1854-0071	7		TRANSISTOR NPN SI PD = 300MW FT = 200MHZ	28480	1854-0071

† Refer to Section 7 for update information.

\* Factory Selected Component (Refer to Section 5)

Δ Errata part change

Table 6-3. Replaceable Parts

Reference Designation	HP Part Number	C D	Qty.	Description	Mfr. Code	Mfr. Part Number
A4Q6	1853-0007	7		TRANSISTOR PNP 2N3251 SI TO-18 PD = 360MW	04713	2N3251
A4Q7	1853-0020	4		TRANSISTOR PNP SI PD = 300MW FT = 150MHZ	28480	1853-0020
A4Q8	1853-0020	4		TRANSISTOR PNP SI PD = 300MW FT = 150MHZ	28480	1853-0020
A4Q9	1854-0071	7		TRANSISTOR NPN SI PD = 300MW FT = 200MHZ	28480	1854-0071
A4Q10	1853-0020	4		TRANSISTOR PNP SI PD = 300MW FT = 150MHZ	28480	1853-0020
A4Q11	1858-0032	8	5	TRANSISTOR ARRAY 14-PIN PLSTC DIP	3L585	CA3146E
A4Q12	1853-0007	7		TRANSISTOR PNP 2N3251 SI TO-18 PD = 360MW	04713	2N3251
A4Q13	1853-0007	7		TRANSISTOR PNP 2N3251 SI TO-18 PD = 360MW	04713	2N3251
A4Q14	1854-0210	6		TRANSISTOR NPN 2N2222 SI TO-18 PD = 500MW	04713	2N2222
A4Q15	1854-0210	6		TRANSISTOR NPN 2N2222 SI TO-18 PD = 500MW	04713	2N2222
A4Q16	1854-0071	7		TRANSISTOR NPN SI PD = 300MW FT = 200MHZ	28480	1854-0071
A4Q17	1853-0007	7		TRANSISTOR PNP 2N3251 SI TO-18 PD = 360MW	04713	2N3251
A4Q18	1854-0295	7		TRANSISTOR-DUAL NPN PD = 400MW	28480	1854-0295
A4Q19	1858-0032	8		TRANSISTOR ARRAY 14-PIN PLSTC DIP	3L585	CA3146E
A4Q20	1854-0071	7		TRANSISTOR NPN SI PD = 300MW FT = 200MHZ	28480	1854-0071
A4Q21	1855-0020	8	4	TRANSISTOR J-FET N-CHAN D-MODE TO-18 SI	28480	1855-0020
A4Q22	1855-0049	1	2	TRANSISTOR-JFET DUAL N-CHAN D-MODE SI	28480	1855-0049
A4Q23	1854-0637	1	6	TRANSISTOR NPN 2N2219A SI TO-5 PD = 800MW	01295	2N2219A
	1200-0173	5	19	INSULATOR-XSTR DAP-GL	28480	1200-0173
A4Q24	1854-0071	7		TRANSISTOR NPN SI PD = 300MW FT = 200MHZ	28480	1854-0071
A4Q25	1853-0007	7		TRANSISTOR PNP 2N3251 SI TO-18 PD = 360MW	04713	2N3251
A4Q26	1854-0637	1		TRANSISTOR NPN 2N2219A SI TO-5 PD = 800MW	01295	2N2219A
	1200-0173	5		INSULATOR-XSTR DAP-GL	28480	1200-0173
A4Q27	1854-0071	7		TRANSISTOR NPN SI PD = 300MW FT = 200MHZ	28480	1854-0071
A4Q28	1854-0637	1		TRANSISTOR NPN 2N2219A SI TO-5 PD = 800MW	01295	2N2219A
	1200-0173	5		INSULATOR-XSTR DAP-GL	28480	1200-0173
	1205-0361	3	2	HEAT SINK SGL TO-5/TO-39-CS	13103	2226C
A4Q29	1854-0071	7		TRANSISTOR NPN SI PD = 300MW FT = 200MHZ	28480	1854-0071
A4Q30	1858-0032	8		TRANSISTOR ARRAY 14-PIN PLSTC DIP	3L585	CA3146E
A4Q31	1854-0071	7		TRANSISTOR NPN SI PD = 300MW FT = 200MHZ	28480	1854-0071
A4Q32	1853-0020	4		TRANSISTOR PNP SI PD = 300MW FT = 150MHZ	28480	1853-0020
A4Q33	1854-0637	1		TRANSISTOR NPN 2N2219A SI TO-5 PD = 800MW	01295	2N2219A
	1200-0173	5		INSULATOR-XSTR DAP-GL	28480	1200-0173
	1205-0361	3		HEAT SINK SGL TO-5/TO-39-CS	13103	2226C
A4Q34	1854-0071	7		TRANSISTOR NPN SI PD = 300MW FT = 200MHZ	28480	1854-0071
A4Q35	1855-0020	8		TRANSISTOR J-FET N-CHAN D-MODE TO-18 SI	28480	1855-0020
A4R1	0757-0401	0		RESISTOR 100 1% .125W F TC = 0 + -100	24546	C4-1/8-T0-101-F
A4R2	0698-3430	5		RESISTOR 21.5 1% .125W F TC = 0 + -100	03888	PME55-1/8-T0-21R5-F
A4R3	0698-3155	1	22	RESISTOR 4.64K 1% .125W F TC = 0 + -100	24546	C4-1/8-T0-4641-F
A4R4	0757-0279	0		RESISTOR 3.16K 1% .125W F TC = 0 + -100	24546	C4-1/8-T0-3161-F
A4R5	0757-0279	0		RESISTOR 3.16K 1% .125W F TC = 0 + -100	24546	C4-1/8-T0-3161-F
A4R6	0757-1094	9		RESISTOR 1.47K 1% .125W F TC = 0 + -100	24546	C4-1/8-T0-1471-F
A4R7	0757-0280	3		RESISTOR 1K 1% .125W F TC = 0 + -100	24546	C4-1/8-T0-1001-F
A4R8	0698-3155	1		RESISTOR 4.64K 1% .125W F TC = 0 + -100	24546	C4-1/8-T0-4641-F
A4R9	0757-0280	3		RESISTOR 1K 1% .125W F TC = 0 + -100	24546	C4-1/8-T0-1001-F
A4R10	0757-0280	3		RESISTOR 1K 1% .125W F TC = 0 + -100	24546	C4-1/8-T0-1001-F
A4R11	0757-0280	3		RESISTOR 1K 1% .125W F TC = 0 + -100	24546	C4-1/8-T0-1001-F
A4R12	0698-3155	1		RESISTOR 4.64K 1% .125W F TC = 0 + -100	24546	C4-1/8-T0-4641-F
A4R13	0698-0082	7		RESISTOR 464 1% .125W F TC = 0 + -100	24546	C4-1/8-T0-4640-F
A4R14	0698-0082	7		RESISTOR 464 1% .125W F TC = 0 + -100	24546	C4-1/8-T0-4640-F
A4R15	0698-3155	1		RESISTOR 4.64K 1% .125W F TC = 0 + -100	24546	C4-1/8-T0-4641-F
A4R16	0698-3155	1		RESISTOR 4.64K 1% .125W F TC = 0 + -100	24546	C4-1/8-T0-4641-F

† Refer to Section 7 for update information.

\* Factory Selected Component (Refer to Section 5)

Δ Errata part change.

Table 6-3. Replaceable Parts

Reference Designation	HP Part Number	C D	Qty.	Description	Mfr. Code	Mfr. Part Number
A4R17	0757-0280	3		RESISTOR 1K 1% .125W F TC=0+-100	24546	C4-1/8-T0-1001-F
A4R18	0757-0279	0		RESISTOR 3.16K 1% .125W F TC=0+-100	24546	C4-1/8-T0-3161-F
A4R19	0757-0280	3		RESISTOR 1K 1% .125W F TC=0+-100	24546	C4-1/8-T0-1001-F
A4R20	0757-0280	3		RESISTOR 1K 1% .125W F TC=0+-100	24546	C4-1/8-T0-1001-F
A4R21	0757-0280	3		RESISTOR 1K 1% .125W F TC=0+-100	24546	C4-1/8-T0-1001-F
A4R22	0698-3155	1		RESISTOR 4.64K 1% .125W F TC=0+-100	24546	C4-1/8-T0-4641-F
A4R23	0698-3155	1		RESISTOR 4.64K 1% .125W F TC=0+-100	24546	C4-1/8-T0-4641-F
A4R24	0698-0082	7		RESISTOR 464 1% .125W F TC=0+-100	24546	C4-1/8-T0-4640-F
A4R25	0698-3155	1		RESISTOR 4.64K 1% .125W F TC=0+-100	24546	C4-1/8-T0-4641-F
A4R26	0698-3155	1		RESISTOR 4.64K 1% .125W F TC=0+-100	24546	C4-1/8-T0-4641-F
A4R27	0757-0280	3		RESISTOR 1K 1% .125W F TC=0+-100	24546	C4-1/8-T0-1001-F
A4R28	0757-0279	0		RESISTOR 3.16K 1% .125W F TC=0+-100	24546	C4-1/8-T0-3161-F
A4R29	0757-0280	3		RESISTOR 1K 1% .125W F TC=0+-100	24546	C4-1/8-T0-1001-F
A4R30	0757-0280	3		RESISTOR 1K 1% .125W F TC=0+-100	24546	C4-1/8-T0-1001-F
A4R31	0757-0280	3		RESISTOR 1K 1% .125W F TC=0+-100	24546	C4-1/8-T0-1001-F
A4R32	0698-3155	1		RESISTOR 4.64K 1% .125W F TC=0+-100	24546	C4-1/8-T0-4641-F
A4R33	0698-3155	1		RESISTOR 4.64K 1% .125W F TC=0+-100	24546	C4-1/8-T0-4641-F
A4R34	0698-3155	1		RESISTOR 4.64K 1% .125W F TC=0+-100	24546	C4-1/8-T0-4641-F
A4R35	0757-0280	3		RESISTOR 1K 1% .125W F TC=0+-100	24546	C4-1/8-T0-1001-F
A4R36	0698-3155	1		RESISTOR 4.64K 1% .125W F TC=0+-100	24546	C4-1/8-T0-4641-F
A4R37	0757-0199	3		RESISTOR 21.5K 1% .125W F TC=0+-100	24546	C4-1/8-T0-2152-F
A4R38	0698-0084	9	21	RESISTOR 2.15K 1% .125W F TC=0+-100	24546	C4-1/8-T0-2151-F
A4R39	0757-0465	6		RESISTOR 100K 1% .125W F TC=0+-100	24546	C4-1/8-T0-1003-F
A4R40	0757-0465	6		RESISTOR 100K 1% .125W F TC=0+-100	24546	C4-1/8-T0-1003-F
A4R41	0757-0280	3		RESISTOR 1K 1% .125W F TC=0+-100	24546	C4-1/8-T0-1001-F
A4R42	0698-0082	7		RESISTOR 464 1% .125W F TC=0+-100	24546	C4-1/8-T0-4640-F
A4R43				NOT ASSIGNED		
A4R44				NOT ASSIGNED		
A4R45	0757-0442	9		RESISTOR 10K 1% .125W F TC=0+-100	24546	C4-1/8-T0-1002-F
A4R46	0698-3160	8	7	RESISTOR 31.6K 1% .125W F TC=0+-100	24546	C4-1/8-T0-3162-F
A4R47	0757-0401	0		RESISTOR 100 1% .125W F TC=0+-100	24546	C4-1/8-T0-101-F
A4R48	0757-0403	2	5	RESISTOR 121 1% .125W F TC=0+-100	24546	C4-1/8-T0-121R-F
A4R49	0698-8833	2	1	RESISTOR 10K 1% .125W F TC=0+-10	28480	0698-8833
A4R50	2100-3273	1		RESISTOR-TRMR 2K 10% C SIDE-ADJ 1-TRN	28480	2100-3273
A4R51	0698-3904	8	1	RESISTOR 14.7K .1% .1W F TC=0+-10	28480	0698-3904
A4R52	0757-0442	9		RESISTOR 10K 1% .125W F TC=0+-100	24546	C4-1/8-T0-1002-F
A4R53	0757-0442	9		RESISTOR 10K 1% .125W F TC=0+-100	24546	C4-1/8-T0-1002-F
A4R54	0698-3441	8	13	RESISTOR 215 1% .125W F TC=0+-100	24546	C4-1/8-T0-215R-F
A4R55	0757-0442	9		RESISTOR 10K 1% .125W F TC=0+-100	24546	C4-1/8-T0-1002-F
A4R56	0698-3430	5		RESISTOR 21.5 1% .125W F TC=0+-100	03888	PME55-1/8-T0-21R5-F
A4R57	0698-3430	5		RESISTOR 21.5 1% .125W F TC=0+-100	03888	PME55-1/8-T0-21R5-F
A4R58	0698-3441	8		RESISTOR 215 1% .125W F TC=0+-100	24546	C4-1/8-T0-215R-F
A4R59	0698-0084	9		RESISTOR 2.15K 1% .125W F TC=0+-100	24546	C4-1/8-T0-2151-F
A4R60	0757-0400	9		RESISTOR 90.9 1% .125W F TC=0+-100	24546	C4-1/8-T0-90R9-F
A4R61	0757-0199	3		RESISTOR 21.5K 1% .125W F TC=0+-100	24546	C4-1/8-T0-2152-F
A4R62	0698-3441	8		RESISTOR 215 1% .125W F TC=0+-100	24546	C4-1/8-T0-215R-F
A4R63	0757-0346	2	16	RESISTOR 10 1% .125W F TC=0+-100	24546	C4-1/8-T0-10R0-F
A4R64	0698-3441	8		RESISTOR 215 1% .125W F TC=0+-100	24546	C4-1/8-T0-215R-F
A4R65	0698-3441	8		RESISTOR 215 1% .125W F TC=0+-100	24546	C4-1/8-T0-215R-F
A4R66	0698-3430	5		RESISTOR 21.5 1% .125W F TC=0+-100	03888	PME55-1/8-T0-21R5-F

†Refer to Section 7 for update information

\*Factory Selected Component (Refer to Section 5)

Δ Errata part change



Table 6-3. Replaceable Parts

Reference Designation	HP Part Number	C D	Qty.	Description	Mfr. Code	Mfr. Part Number
A4R67	0757-0442	9		RESISTOR 10K 1% .125W F TC = 0 + -100	24546	C4-1/8-T0-1002-F
A4R68	0757-0346	2		RESISTOR 10 1% .125W F TC = 0 + -100	24546	C4-1/8-T0-10R0-F
A4R69	0698-8731	9		RESISTOR 4.8K .1% .1W F TC = 0 + -15	28480	0698-8731
A4R70	0757-0280	3		RESISTOR 1K 1% .125W F TC = 0 + -100	24546	C4-1/8-T0-1001-F
A4R71	0698-8731	9		RESISTOR 4.8K .1% .1W F TC = 0 + -15	28480	0698-8731
A4R72	0698-3155	1		RESISTOR 4.64K 1% .125W F TC = 0 + -100	24546	C4-1/8-T0-4641-F
A4R73	0757-0280	3		RESISTOR 1K 1% .125W F TC = 0 + -100	24546	C4-1/8-T0-1001-F
A4R74	0698-0084	9		RESISTOR 2.15K 1% .125W F TC = 0 + -100	24546	C4-1/8-T0-2151-F
A4R75	0698-8821	8	2	RESISTOR 5.62 1% .125W F TC = 0 + -100	28480	0698-8821
A4R76	0757-0280	3		RESISTOR 1K 1% .125W F TC = 0 + -100	24546	C4-1/8-T0-1001-F
A4R77	0698-0082	7		RESISTOR 464 1% .125W F TC = 0 + -100	24546	C4-1/8-T0-4640-F
A4R78	0698-0084	9		RESISTOR 2.15K 1% .125W F TC = 0 + -100	24546	C4-1/8-T0-2151-F
A4R79	0757-0280	3		RESISTOR 1K 1% .125W F TC = 0 + -100	24546	C4-1/8-T0-1001-F
A4R80	0698-3432	7	5	RESISTOR 26.1 1% .125W F TC = 0 + -100	03888	PME55-1/8-T0-26R1-F
A4R81	0698-3432	7		RESISTOR 26.1 1% .125W F TC = 0 + -100	03888	PME55-1/8-T0-26R1-F
A4R82	0698-3160	8		RESISTOR 31.6K 1% .125W F TC = 0 + -100	24546	C4-1/8-T0-3162-F
A4R83	0698-0084	9		RESISTOR 2.15K 1% .125W F TC = 0 + -100	24546	C4-1/8-T0-2151-F
A4R84	0757-0442	9		RESISTOR 10K 1% .125W F TC = 0 + -100	24546	C4-1/8-T0-1002-F
A4R85	2100-3352	7	2	RESISTOR-TRMR 1K 10% C SIDE-ADJ 1-TRN	28480	2100-3352
A4R86	0698-3454	3	5	RESISTOR 215K 1% .125W F TC = 0 + -100	24546	C4-1/8-T0-2153-F
A4R87	0698-0083	8	14	RESISTOR 1.96K 1% .125W F TC = 0 + -100	24546	C4-1/8-T0-1961-F
A4R88	0757-0465	6		RESISTOR 100K 1% .125W F TC = 0 + -100	24546	C4-1/8-T0-1003-F
A4R89	0757-0279	0		RESISTOR 3.16K 1% .125W F TC = 0 + -100	24546	C4-1/8-T0-3161-F
A4R90	0757-0280	3		RESISTOR 1K 1% .125W F TC = 0 + -100	24546	C4-1/8-T0-1001-F
A4R91	0698-0082	7		RESISTOR 464 1% .125W F TC = 0 + -100	24546	C4-1/8-T0-4640-F
A4R92	0757-0279	0		RESISTOR 3.16K 1% .125W F TC = 0 + -100	24546	C4-1/8-T0-3161-F
A4R93	0698-8549	7	3	RESISTOR 2.1K .5% .1W F TC = 0 + -5	28480	0698-8549
A4R94	0757-0280	3		RESISTOR 1K 1% .125W F TC = 0 + -100	24546	C4-1/8-T0-1001-F
A4R95	0698-8731	9		RESISTOR 4.8K .1% .1W F TC = 0 + -15	28480	0698-8731
A4R96	0757-0280	3		RESISTOR 1K 1% .125W F TC = 0 + -100	24546	C4-1/8-T0-1001-F
A4R97	0698-3438	3		RESISTOR 147 1% .125W F TC = 0 + -100	24546	C4-1/8-T0-147R-F
A4R98	0757-0395	1	2	RESISTOR 56.2 1% .125W F TC = 0 + -100	24546	C4-1/8-T0-56R2-F
A4R99	0699-0139	7		RESISTOR 660 .1% .1W F TC = 0 + -15	28480	0699-0139
A4R100	0698-3155	1		RESISTOR 4.64K 1% .125W F TC = 0 + -100	24546	C4-1/8-T0-4641-F
A4R101	0698-8827	4	11	RESISTOR 1M 1% .125W F TC = 0 + -100	28480	0698-8827
A4R102	0757-0280	3		RESISTOR 1K 1% .125W F TC = 0 + -100	24546	C4-1/8-T0-1001-F
A4R103	0698-3160	8		RESISTOR 31.6K 1% .125W F TC = 0 + -100	24546	C4-1/8-T0-3162-F
A4R104	0757-0442	9		RESISTOR 10K 1% .125W F TC = 0 + -100	24546	C4-1/8-T0-1002-F
A4R105	0698-3155	1		RESISTOR 4.64K 1% .125W F TC = 0 + -100	24546	C4-1/8-T0-4641-F
A4R106	0698-3446	3	7	RESISTOR 383 1% .125W F TC = 0 + -100	24546	C4-1/8-T0-383R-F
A4TP1	1251-0600	0		CONNECTOR-SGL CONT PIN 1.14-MM-BSC-SZ SQ	28480	1251-0600
A4TP2	1251-0600	0		CONNECTOR-SGL CONT PIN 1.14-MM-BSC-SZ SQ	28480	1251-0600
A4TP3	1251-0600	0		CONNECTOR-SGL CONT PIN 1.14-MM-BSC-SZ SQ	28480	1251-0600
A4TP4	1251-0600	0		CONNECTOR-SGL CONT PIN 1.14-MM-BSC-SZ SQ	28480	1251-0600
A4TP5	1251-0600	0		CONNECTOR-SGL CONT PIN 1.14-MM-BSC-SZ SQ	28480	1251-0600
A4TP6	1251-0600	0		CONNECTOR-SGL CONT PIN 1.14-MM-BSC-SZ SQ	28480	1251-0600
A4VR1	1902-0680	7	9	DIODE-ZNR 1N827 6.2V 5% DO-7 PD = .4W	24046	1N827

† Refer to Section 7 for update information.

\* Factory selected Component (Refer to Section 5)

Δ Errata part change.

Table 6-3. Replaceable Parts

Reference Designation	HP Part Number	C D	Qty.	Description	Mfr. Code	Mfr. Part Number
<b>A5</b>						
<i>2305A TO 2528A</i>						
A5	08902-60005	4	1	VOLTMETER ASSEMBLY	28480	08902-60005
<i>2530A AND ABOVE</i>						
A5	08902-60101	1	1	VOLTMETER ASSEMBLY	28480	08902-60101
A5C1	0180-2929	8		CAPACITOR-FXD 68UF + -10% 10VDC TA	28480	0180-2929
A5C2	0180-1746	5		CAPACITOR-FXD 15UF + -10% 20VDC TA	56289	150D156X9020B2
A5C3	0180-1746	5		CAPACITOR-FXD 15UF + -10% 20VDC TA	56289	150D156X9020B2
A5C4	0180-1746	5		CAPACITOR-FXD 15UF + -10% 20VDC TA	56289	150D156X9020B2
A5C5	0160-3879	7		CAPACITOR-FXD .01UF + -20% 100VDC CER	28480	0160-3879
A5C6	0160-3879	7		CAPACITOR-FXD .01UF + -20% 100VDC CER	28480	0160-3879
A5C7	0180-1746	5		CAPACITOR-FXD 15UF + -10% 20VDC TA	56289	150D156X9020B2
A5C8	0180-0197	8		CAPACITOR-FXD 2.2UF + -10% 20VDC TA	56289	150D225X9020A2
A5C9	0180-0094	4		CAPACITOR-FXD 100UF + 75-10% 25VDC AL	56289	30D107G025DD2
A5C10	0180-0374	3	6	CAPACITOR-FXD 10UF + -10% 20VDC TA	56289	150D106X9020B2
A5C11	0160-4387	4	3	CAPACITOR-FXD 47PF + -5% 200VDC CER 0 + -30	28480	0160-4387
A5C12	0180-0374	3		CAPACITOR-FXD 10UF + -10% 20VDC TA	56289	150D106X9020B2
A5C13	0160-0576	5		CAPACITOR-FXD .1UF + -20% 50VDC CER	28480	0160-0576
A5C14	0180-1704	5	1	CAPACITOR-FXD 47UF + -10% 6VDC TA	56289	150D476X9006B2
A5C15	0180-0374	3		CAPACITOR-FXD 10UF + -10% 20VDC TA	56289	150D106X9020B2
A5C16	0160-3879	7		CAPACITOR-FXD .01UF + -20% 100VDC CER	28480	0160-3879
A5C17	0180-0374	3		CAPACITOR-FXD 10UF + -10% 20VDC TA	56289	150D106X9020B2
A5C18	0160-3501	2		CAPACITOR-FXD 4UF + -10% 50VDC MET-POLYC	28480	0160-3501
A5C19	0160-0970	3	1	CAPACITOR-FXD .47UF + -10% 80VDC POLYE	28480	0160-0970
A5C20	0160-0576	5		CAPACITOR-FXD .1UF + -20% 50VDC CER	28480	0160-0576
A5C21	0160-3878	6	44	CAPACITOR-FXD 1000PF + -20% 100VDC CER	28480	0160-3878
A5C22	0160-3402	2	4	CAPACITOR-FXD 1UF + -5% 50VDC MET-POLYC	28480	0160-3402
A5C23	0160-3501	2		CAPACITOR-FXD 4UF + -10% 50VDC MET-POLYC	28480	0160-3501
A5C24	0160-3501	2		CAPACITOR-FXD 4UF + -10% 50VDC MET-POLYC	28480	0160-3501
A5C25	0160-3402	2		CAPACITOR-FXD 1UF + -5% 50VDC MET-POLYC	28480	0160-3402
A5C26	0160-0576	5		CAPACITOR-FXD .1UF + -20% 50VDC CER	28480	0160-0576
A5C27	0160-0576	5		CAPACITOR-FXD .1UF + -20% 50VDC CER	28480	0160-0576
A5C28	0160-0576	5		CAPACITOR-FXD .1UF + -20% 50VDC CER	28480	0160-0576
A5C29	0180-2929	8		CAPACITOR-FXD 68UF + -10% 10VDC TA	28480	0180-2929
A5C30	0160-4807	3	4	CAPACITOR-FXD 33PF + -5% 100VDC CER 0 + -30	28480	0160-4807
A5C31	0160-4397	6	1	CAPACITOR-FXD .1UF + -1% 100VDC POLYSTY	28480	0160-4397
A5C32	0160-0576	5		CAPACITOR-FXD .1UF + -20% 50VDC CER	28480	0160-0576
A5C33	0160-0576	5		CAPACITOR-FXD .1UF + -20% 50VDC CER	28480	0160-0576
A5C34	0180-0197	8		CAPACITOR-FXD 2.2UF + -10% 20VDC TA	56289	150D225X9020A2
A5C35	0160-4805	1		CAPACITOR-FXD 47PF + -5% 100VDC CER 0 + -30	28480	0160-4805
A5CR1	1901-0040	1		DIODE-SWITCHING 30V 50MA 2NS DO-35	28480	1901-0040
A5CR2	1901-1098	1		DIODE-SWITCHING 1N4150 50V 200MA 4NS	9N171	1N4150
A5CR3	1901-1098	1		DIODE-SWITCHING 1N4150 50V 200MA 4NS	9N171	1N4150
A5CR4	1901-1098	1		DIODE-SWITCHING 1N4150 50V 200MA 4NS	9N171	1N4150
A5CR5	1901-0518	8		DIODE-SM SIG SCHOTTKY	28480	1901-0518

†Refer to Section 7 for update information.

\*Factory Selected Component (Refer to Section 5).

Δ Errata part change.

Table 6-3. Replaceable Parts

Reference Designation	HP Part Number	C D	Qty.	Description	Mfr. Code	Mfr. Part Number
A5CR6	1901-0040	1		DIODE-SWITCHING 30V 50MA 2NS DO-35	28480	1901-0040
A5CR7	1901-0040	1		DIODE-SWITCHING 30V 50MA 2NS DO-35	28480	1901-0040
A5CR8	1901-0518	8		DIODE-SM SIG SCHOTTKY	28480	1901-0518
A5CR9	1901-0040	1		DIODE-SWITCHING 30V 50MA 2NS DO-35	28480	1901-0040
A5CR10	1901-0040	1		DIODE-SWITCHING 30V 50MA 2NS DO-35	28480	1901-0040
A5CR11	1901-1098	1		DIODE-SWITCHING 1N4150 50V 200MA 4NS	9N171	1N4150
A5CR12	1901-0040	1		DIODE-SWITCHING 30V 50MA 2NS DO-35	28480	1901-0040
A5CR13	1901-0040	1		DIODE-SWITCHING 30V 50MA 2NS DO-35	28480	1901-0040
A5CR14	1901-0880	7		DIODE-GEN PRP 125MA DO-35	28480	1901-0880
A5CR15	1901-1098	1		DIODE-SWITCHING 1N4150 50V 200MA 4NS	9N171	1N4150
A5CR16	1901-1098	1		DIODE-SWITCHING 1N4150 50V 200MA 4NS	9N171	1N4150
A5L1	9140-0210	1	9	INDUCTOR RF-CH-MLD 100UH 5% .166DX.385LG	28480	9140-0210
A5MP1	08901-00019	3	1	COVER VOLT MTR	28480	08901-00019
	2190-0008	3		WASHER-LK EXT T NO. 6 .141-IN-ID	28480	2190-0008
	2360-0113	2		SCREW-MACH 6-32 .25-IN-LG PAN-HD-POZI	00000	ORDER BY DESCRIPTION
A5Q1	1854-0810	2	18	TRANSISTOR NPN SI PD = 625MW FT = 200MHZ	28480	1854-0810
A5Q2	1853-0020	4		TRANSISTOR PNP SI PD = 300MW FT = 150MHZ	28480	1853-0020
A5Q3	1854-0477	7		TRANSISTOR NPN 2N2222A SI TC-18 PD = 500MW	04713	2N2222A
A5Q4	1853-0020	4		TRANSISTOR PNP SI PD = 300MW FT = 150MHZ	28480	1853-0020
A5Q5	1855-0414	4	3	TRANSISTOR J-FET 2N4393 N-CHAN D-MODE	04713	2N4393
A5Q6	1853-0020	4		TRANSISTOR PNP SI PD = 300MW FT = 150MHZ	28480	1853-0020
A5Q7	1854-0810	2		TRANSISTOR NPN SI PD = 625MW FT = 200MHZ	28480	1854-0810
A5R1	1810-0126	1	1	NETWORK-RES 14-DIP10.0K OHM X 13	11236	760-1-R10K
A5R2	2100-3358	3	2	RESISTOR-TRMR 1M 20% C SIDE-ADJ 1-TRN	28480	2100-3358
A5R3	0698-8549	7		RESISTOR 2.1K .5% .1W F TC = 0 + -5	28480	0698-8549
2305A TO 2449A A5R4	0699-0074	9	2	RESISTOR 14.7M 1% .125W F TC = 0 + -150	28480	0699-0074
2451A AND ABOVE A5R4	0699-0073	8		RESISTOR 10M 1% .125W F TC = 0 + -150	28480	0699-0073
A5R5	0757-0288	1	3	RESISTOR 9.09K 1% .125W F TC = 0 + -100	19701	MF4C1/8-T0-9091-F
A5R6	0698-8549	7		RESISTOR 2.1K .5% .1W F TC = 0 + -5	28480	0698-8549
A5R7	0757-0280	3		RESISTOR 1K 1% .125W F TC = 0 + -100	24546	C4-1/8-T0-1001-F
A5R8	0698-8731	9		RESISTOR 4.8K .1% .1W F TC = 0 + -15	28480	0698-8731
A5R9	0757-0442	9		RESISTOR 10K 1% .125W F TC = 0 + -100	24546	C4-1/8-T0-1002-F
A5R10	0757-0416	7		RESISTOR 511 1% .125W F TC = 0 + -100	24546	C4-1/8-T0-511R-F
A5R11	0757-0401	0		RESISTOR 100 1% .125W F TC = 0 + -100	24546	C4-1/8-T0-101-F
A5R12	0757-0442	9		RESISTOR 10K 1% .125W F TC = 0 + -100	24546	C4-1/8-T0-1002-F
A5R13	0698-3154	0	12	RESISTOR 4.22K 1% .125W F TC = 0 + -100	24546	C4-1/8-T0-4221-F
A5R14	0698-3132	4	11	RESISTOR 261 1% .125W F TC = 0 + -100	24546	C4-1/8-T0-2610-F
2305A TO 2449A A5R15	0699-0074	9		RESISTOR 14.7M 1% .125W F TC = 0 + -150	28480	0699-0074
2451A AND ABOVE A5R15	0699-0073	8		RESISTOR 10M 1% .125W F TC = 0 + -150	28480	0699-0073

† Refer to Section 7 for update information

\* Factory Selected Component (Refer to Section 5)

Δ Errata part change.

Table 6-3. Replaceable Parts

Reference Designation	HP Part Number	C D	Qty.	Description	Mfr. Code	Mfr. Part Number
A5R16	0757-0416	7		RESISTOR 511 1% .125W F TC = 0 + -100	24546	C4-1/8-T0-511R-F
A5R17	0698-0083	8		RESISTOR 1.96K 1% .125W F TC = 0 + -100	24546	C4-1/8-T0-1961-F
A5R18	2100-3358	3		RESISTOR-TRMR 1M 20% C SIDE-ADJ 1-TRN	28480	2100-3358
A5R19	0757-0461	2		RESISTOR 68.1K 1% .125W F TC = 0 + -100	24546	C4-1/8-T0-6812-F
A5R20	0698-3150	6	7	RESISTOR 2.37K 1% .125W F TC = 0 + -100	24546	C4-1/8-T0-2371-F
A5R21	0757-0346	2		RESISTOR 10 1% .125W F TC = 0 + -100	24546	C4-1/8-T0-10R0-F
A5R22	0699-0222	9	1	RESISTOR 10.5K .1% .1W F TC = 0 + -15	28480	0699-0222
A5R23	2100-3351	6	1	RESISTOR-TRMR 500 10% C SIDE-ADJ 1-TRN	28480	2100-3351
A5R24	0757-1094	9		RESISTOR 1.47K 1% .125W F TC = 0 + -100	24546	C4-1/8-T0-1471-F
A5R25	0757-0442	9		RESISTOR 10K 1% .125W F TC = 0 + -100	24546	C4-1/8-T0-1002-F
A5R26	0757-0439	4		RESISTOR 6.81K 1% .125W F TC = 0 + -100	24546	C4-1/8-T0-6811-F
A5R27	0757-0442	9		RESISTOR 10K 1% .125W F TC = 0 + -100	24546	C4-1/8-T0-1002-F
A5R28	0757-0416	7		RESISTOR 511 1% .125W F TC = 0 + -100	24546	C4-1/8-T0-511R-F
A5R29	0757-0458	7	8	RESISTOR 51.1K 1% .125W F TC = 0 + -100	24546	C4-1/8-T0-5112-F
A5R30	0698-3430	5		RESISTOR 21.5 1% .125W F TC = 0 + -100	03888	PME55-1/8-T0-21R5-F
A5R31	0757-0280	3		RESISTOR 1K 1% .125W F TC = 0 + -100	24546	C4-1/8-T0-1001-F
A5R32	0757-0416	7		RESISTOR 511 1% .125W F TC = 0 + -100	24546	C4-1/8-T0-511R-F
A5R33	0698-6286	5	1	RESISTOR 100M 10% .25W FC TC = -900/+ 1200	01121	CB1071
A5R34	0757-0442	9		RESISTOR 10K 1% .125W F TC = 0 + -100	24546	C4-1/8-T0-1002-F
A5R35	0757-0465	6		RESISTOR 100K 1% .125W F TC = 0 + -100	24546	C4-1/8-T0-1003-F
A5R36	0757-0279	0		RESISTOR 3.16K 1% .125W F TC = 0 + -100	24546	C4-1/8-T0-3161-F
A5R37	0757-0458	7		RESISTOR 51.1K 1% .125W F TC = 0 + -100	24546	C4-1/8-T0-5112-F
A5R38	2100-3353	8	1	RESISTOR-TRMR 20K 10% C SIDE-ADJ 1-TRN	28480	2100-3353
<i>2306A TO 2449A</i>						
A5R39	0698-3457	6		RESISTOR 316K 1% .125W F TC = 0 + -100	28480	0698-3457
<i>2451A AND ABOVE</i>						
A5R39	0698-3454	3		RESISTOR 215K 1% .125W F TC = 0 + -100	24546	C4-1/8-T0-2153-F
A5R40	0757-0401	0		RESISTOR 100 1% .125W F TC = 0 + -100	24546	C4-1/8-T0-101-F
A5R41	0698-8827	4		RESISTOR 1M 1% .125W F TC = 0 + -100	28480	0698-8827
A5R42	0757-0280	3		RESISTOR 1K 1% .125W F TC = 0 + -100	24546	C4-1/8-T0-1001-F
A5R43	0757-0416	7		RESISTOR 511 1% .125W F TC = 0 + -100	24546	C4-1/8-T0-511R-F
A5R44	0757-0420	3	9	RESISTOR 750 1% .125W F TC = 0 + -100	24546	C4-1/8-T0-751-F
A5R45	0698-3152	8	8	RESISTOR 3.48K 1% .125W F TC = 0 + -100	24546	C4-1/8-T0-3481-F
A5R46	0698-6360	6	3	RESISTOR 10K .1% .125W F TC = 0 + -25	28480	0698-6360
A5R47	0698-0084	9		RESISTOR 2.15K 1% .125W F TC = 0 + -100	24546	C4-1/8-T0-2151-F
A5R48	0698-6360	6		RESISTOR 10K .1% .125W F TC = 0 + -25	28480	0698-6360
A5R49	0699-0847	4	3	RESISTOR 1.96K .1% .125W F TC = 0 + -50	28480	0699-0847
A5R50	0699-0847	4		RESISTOR 1.96K .1% .125W F TC = 0 + -50	28480	0699-0847
A5R51	0757-0442	9		RESISTOR 10K 1% .125W F TC = 0 + -100	24546	C4-1/8-T0-1002-F
A5R52	0698-6631	4	1	RESISTOR 2.5K .1% .125W F TC = 0 + -25	28480	0698-6631
A5R53	0757-0442	9		RESISTOR 10K 1% .125W F TC = 0 + -100	24546	C4-1/8-T0-1002-F
A5R54	0698-3156	2		RESISTOR 14.7K 1% .125W F TC = 0 + -100	24546	C4-1/8-T0-1472-F

† Refer to Section 7 for update information

\* Factory Selected Component (Refer to Section 5)

△ Errata part change

Table 6-3. Replaceable Parts

Reference Designation	HP Part Number	C D	Qty.	Description	Mfr. Code	Mfr. Part Number
A5R55	0698-6362	8	1	RESISTOR 1K .1% .125W F TC = 0 + -25	28480	0698-6362
A5R56	0699-0847	4		RESISTOR 1.96K .1% .125W F TC = 0 + -50	28480	0699-0847
A5R57	0757-0467	8	4	RESISTOR 121K 1% .125W F TC = 0 + -100	24546	C4-1/8-T0-1213-F
A5R58	0757-0463	4	3	RESISTOR 82.5K 1% .125W F TC = 0 + -100	24546	C4-1/8-T0-8252-F
A5R59	0698-3157	3		RESISTOR 19.6K 1% .125W F TC = 0 + -100	24546	C4-1/8-T0-1962-F
A5R60	0698-3157	3		RESISTOR 19.6K 1% .125W F TC = 0 + -100	24546	C4-1/8-T0-1962-F
A5R61	0698-3157	3		RESISTOR 19.6K 1% .125W F TC = 0 + -100	24546	C4-1/8-T0-1962-F
A5R62	0757-0467	8		RESISTOR 121K 1% .125W F TC = 0 + -100	24546	C4-1/8-T0-1213-F
A5R63	0698-3243	8		RESISTOR 178K 1% .125W F TC = 0 + -100	24546	C4-1/8-T0-1783-F
A5R64	0698-8827	4		RESISTOR 1M 1% .125W F TC = 0 + -100	28480	0698-8827
A5R65	0757-0420	3		RESISTOR 750 1% .125W F TC = 0 + -100	24546	C4-1/8-T0-751-F
A5R66	0757-0416	7		RESISTOR 511 1% .125W F TC = 0 + -100	24546	C4-1/8-T0-511R-F
A5R67	0757-0416	7		RESISTOR 511 1% .125W F TC = 0 + -100	24546	C4-1/8-T0-511R-F
A5R68	0698-3443	0	9	RESISTOR 287 1% .125W F TC = 0 + -100	24546	C4-1/8-T0-287R-F
A5R69	0698-3441	8		RESISTOR 215 1% .125W F TC = 0 + -100	24546	C4-1/8-T0-215R-F
A5R70	0757-0419	0	7	RESISTOR 681 1% .125W F TC = 0 + -100	24546	C4-1/8-T0-681R-F
A5R71	0757-0405	4	4	RESISTOR 162 1% .125W F TC = 0 + -100	24546	C4-1/8-T0-162R-F
A5R72	0757-0419	0		RESISTOR 681 1% .125W F TC = 0 + -100	24546	C4-1/8-T0-681R-F
A5R73	2100-3103	6	1	RESISTOR-TRMR 10K 10% C SIDE-ADJ 17-TRN	02111	43P103
A5R74	0699-0239	8	1	RESISTOR 59K .1% .1W F TC = 0 + -15	28480	0699-0239
A5R75	0757-0280	3		RESISTOR 1K 1% .125W F TC = 0 + -100	24546	C4-1/8-T0-1001-F
A5R76	0757-0280	3		RESISTOR 1K 1% .125W F TC = 0 + -100	24546	C4-1/8-T0-1001-F
A5R77	0757-0280	3		RESISTOR 1K 1% .125W F TC = 0 + -100	24546	C4-1/8-T0-1001-F
A5R78	0757-0416	7		RESISTOR 511 1% .125W F TC = 0 + -100	24546	C4-1/8-T0-511R-F
A5R79	0757-0465	6		RESISTOR 100K 1% .125W F TC = 0 + -100	24546	C4-1/8-T0-1003-F
A5R80	0757-0346	2		RESISTOR 10 1% .125W F TC = 0 + -100	24546	C4-1/8-T0-10R0-F
A5R81	0757-0280	3		RESISTOR 1K 1% .125W F TC = 0 + -100	24546	C4-1/8-T0-1001-F
A5TP1	1251-0600	0		CONNECTOR-SGL CONT PIN 1.14-MM-BSC-SZ SQ	28480	1251-0600
A5TP2	1251-0600	0		CONNECTOR-SGL CONT PIN 1.14-MM-BSC-SZ SQ	28480	1251-0600
A5TP3	1251-0600	0		CONNECTOR-SGL CONT PIN 1.14-MM-BSC-SZ SQ	28480	1251-0600
A5TP4	1251-0600	0		CONNECTOR-SGL CONT PIN 1.14-MM-BSC-SZ SQ	28480	1251-0600
A5TP5	1251-0600	0		CONNECTOR-SGL CONT PIN 1.14-MM-BSC-SZ SQ	28480	1251-0600
A5TP6	1251-0600	0		CONNECTOR-SGL CONT PIN 1.14-MM-BSC-SZ SQ	28480	1251-0600
A5TP7	1251-0600	0		CONNECTOR-SGL CONT PIN 1.14-MM-BSC-SZ SQ	28480	1251-0600
A5TP8	1251-0600	0		CONNECTOR-SGL CONT PIN 1.14-MM-BSC-SZ SQ	28480	1251-0600
A5U1	1826-1048	7	1	IC OP AMP PRCN 8-DIP-C PKG	28480	1826-1048
A5U2	1826-0969	3	1	RMS/DC 10-METAL BPLR	28480	1826-0969
A5U3	1826-0371	1		IC OP AMP LOW-BIAS-HMPD TO-99 PKG	27014	LF256H
A5U4	1826-0098	9	3	IC COMPARATOR PRCN TO-99 PKG	27014	LM211H
A5U5	1826-0098	9		IC COMPARATOR PRCN TO-99 PKG	27014	LM211H
A5U6	1826-0059	2		IC OP AMP GP TO-99 PKG	01295	LM201AL
A5U7	1826-0783	9		IC OP AMP LOW-NOISE 8-DIP-C PKG	52063	XR5534ACN
A5U8	1826-0371	1		IC OP AMP LOW-BIAS-HMPD TO-99 PKG	27014	LF256H
A5U9	1826-0180	0	2	IC TIMER TTL MONO/ASTBL	01295	NE555P
A5U10	1826-0605	4	3	IC MULTIPLXR 8-CHAN-ANLG 16-DIP-C PKG	17856	DG508BK
A5U11	1826-0605	4		IC MULTIPLXR 8-CHAN-ANLG 16-DIP-C PKG	17856	DG508BK
A5U12	1826-0605	4		IC MULTIPLXR 8-CHAN-ANLG 16-DIP-C PKG	17856	DG508BK
A5U13	1820-1195	7		IC FF TTL LS D-TYPE POS-EDGE-TRIG COM	01295	SN74LS175N
A5U14	1820-1211	8	1	IC GATE TTL LS EXCL-OR QUAD 2-INP	01295	SN74LS86N
A5U15	1820-1411	0	13	IC LCH TTL LS D-TYPE 4-BIT	01295	SN74LS75N

† Refer to Section 7 for update information.

\* Factory Selected Component (Refer to Section 5).

Δ Errata part change

*Table 6-3. Replaceable Parts*

Reference Designation	HP Part Number	C D	Qty.	Description	Mfr. Code	Mfr. Part Number
A5U16	1820-1198	0		IC GATE TTL LS NAND QUAD 2-INP	01295	SN74LS03N
A5U17	1826-0371	1		IC OP AMP LOW-BIAS-HIMPD TO-99 PKG	27014	LF256H
A5U18	1820-1216	3		IC DCDR TTL LS 3-TO-8-LINE 3-INP	01295	SN74LS138N
A5VR1	1902-0946	8	1	DIODE-ZNR 3.3V 5% DO-35 PD = .4W TC = -.039%	28480	1902-0946
A5VR2	1902-3082	9	1	DIODE-ZNR 4.64V 5% DO-35 PD = .4W	28480	1902-3082
A5VR3	1902-3024	9	1	DIODE-ZNR 2.87V 5% DO-7 PD = .4W TC = -.07%	28480	1902-3024
A5VR4	1902-0680	7		DIODE-ZNR 1N827 6.2V 5% DO-7 PD = .4W	24046	1N827
A5W1				NOT ASSIGNED		
2305A TO 2627A						
A5W2				NOT ASSIGNED		
2625A AND ABOVE						
A5W2	8159-0005	0		RESISTOR-ZERO OHMS 22 AWG LEAD DIA	28480	8159-0005

† Refer to Section 7 for update information

\* Factory Selected Component (Refer to Section 5)

Δ Errata part change

Table 6-3. Replaceable Parts

Reference Designation	HP Part Number	C D	Qty.	Description	Mfr. Code	Mfr. Part Number
<b>A6</b>						
A6	08901-60186	1	1	AM DEMODULATOR ASSEMBLY	28480	08901-60186
A6C1	0180-0058	0		CAPACITOR-FXD 50UF +75-10% 25VDC AL	56289	30D506G025CC2
A6C2	0180-0058	0		CAPACITOR-FXD 50UF +75-10% 25VDC AL	56289	30D506G025CC2
A6C3	0160-2208	4	1	CAPACITOR-FXD 330 + -5% 300VDC MICA	28480	0160-2208
A6C4	0160-2660	2	1	CAPACITOR-FXD 20PF + -2% 500VDC CER 0 + -30	28480	0160-2660
A6C5	0160-4635	5	1	CAPACITOR-FXD 212PF + -1% 100VDC MICA	28480	0160-4635
A6C6	0160-4795	8		CAPACITOR-FXD 4.7PF + -.5PF 100VDC CER	28480	0160-4795
A6C7	0160-4807	3		CAPACITOR-FXD 33PF + -5% 100VDC CER 0 + -30	28480	0160-4807
A6C8	0121-0105	4	3	CAPACITOR-V TRMR-CER 9-35PF 200V PC-MTG	52763	304324 9/35PF N650
A6C9	0160-4833	5	7	CAPACITOR-FXD .022UF + -10% 100VDC CER	28480	0160-4833
A6C10				NOT ASSIGNED		
A6C11	0180-0197	8		CAPACITOR-FXD 2.2UF + -10% 20VDC TA	56289	150D225X9020A2
A6C12				NOT ASSIGNED		
A6C13				NOT ASSIGNED		
A6C14	0160-4832	4		CAPACITOR-FXD .01UF + -10% 100VDC CER	28480	0160-4832
A6C15	0160-4835	7	19	CAPACITOR-FXD .1UF + -10% 50VDC CER	28480	0160-4835
A6C16	0160-4812	0		CAPACITOR-FXD 220PF + -5% 100VDC CER	28480	0160-4812
A6C17	0160-4832	4		CAPACITOR-FXD .01UF + -10% 100VDC CER	28480	0160-4832
A6C18	0160-4822	2		CAPACITOR-FXD 1000PF + -5% 100VDC CER	28480	0160-4822
A6C19	0160-4822	2		CAPACITOR-FXD 1000PF + -5% 100VDC CER	28480	0160-4822
A6C20	0160-4835	7		CAPACITOR-FXD .1UF + -10% 50VDC CER	28480	0160-4835
A6C21	0160-4833	5		CAPACITOR-FXD .022UF + -10% 100VDC CER	28480	0160-4833
A6C22	0160-4833	5		CAPACITOR-FXD .022UF + -10% 100VDC CER	28480	0160-4833
A6C23	0160-4812	0		CAPACITOR-FXD 220PF + -5% 100VDC CER	28480	0160-4812
A6C24	0180-0197	8		CAPACITOR-FXD 2.2UF + -10% 20VDC TA	56289	150D225X9020A2
A6C25	0180-1746	5		CAPACITOR-FXD 15UF + -10% 20VDC TA	56289	150D156X9020B2
A6C26	0160-4832	4		CAPACITOR-FXD .01UF + -10% 100VDC CER	28480	0160-4832
A6C27				NOT ASSIGNED		
A6C28				NOT ASSIGNED		
A6C29	0160-4807	3		CAPACITOR-FXD 33PF + -5% 100VDC CER 0 + -30	28480	0160-4807
A6C30	0160-4835	7		CAPACITOR-FXD .1UF + -10% 50VDC CER	28480	0160-4835
A6C31	0160-3501	2		CAPACITOR-FXD 4UF + -10% 50VDC MET-POLYC	28480	0160-3501
A6C32	0180-0197	8		CAPACITOR-FXD 2.2UF + -10% 20VDC TA	56289	150D225X9020A2
A6C33				NOT ASSIGNED		
A6C34	0180-0197	8		CAPACITOR-FXD 2.2UF + -10% 20VDC TA	56289	150D225X9020A2
A6C35				NOT ASSIGNED		
A6C36	0180-0228	6		CAPACITOR-FXD 22UF + -10% 15VDC TA	56289	150D226X9015B2
A6C37	0160-5528	7	1	CAPACITOR-FXD .22UF + -5% 100VDC	28480	0160-5528
A6C38	0180-1746	5		CAPACITOR-FXD 15UF + -10% 20VDC TA	56289	150D156X9020B2
A6C39	0180-0197	8		CAPACITOR-FXD 2.2UF + -10% 20VDC TA	56289	150D225X9020A2
A6C40	0160-3539	6	1	CAPACITOR-FXD 820PF + -5% 100VDC MICA	28480	0160-3539
A6C41	0180-1746	5		CAPACITOR-FXD 15UF + -10% 20VDC TA	56289	150D156X9020B2
A6C42	0160-4807	3		CAPACITOR-FXD 33PF + -5% 100VDC CER 0 + -30	28480	0160-4807
A6C43*	0160-2208	4	1	CAPACITOR-FXD 330PF + -5% 300VDC MICA	28480	0160-2208

† Refer to Section 7 for update information

\* Factory Selected Component (Refer to Section 5)

Δ Errata part change

Table 6-3. Replaceable Parts

Reference Designation	HP Part Number	C D	Qty.	Description	Mfr. Code	Mfr. Part Number
A6C44	0180-1746	5		CAPACITOR-FXD 15UF + -10% 20VDC TA	56289	150D156X9020B2
A6C45	0180-1746	5		CAPACITOR-FXD 15UF + -10% 20VDC TA	56289	150D156X9020B2
A6C46	0160-4835	7		CAPACITOR-FXD .1UF + -10% 50VDC CER	28480	0160-4835
A6C47	0180-2929	8		CAPACITOR-FXD 68UF + -10% 10VDC TA	28480	0180-2929
A6C48				NOT ASSIGNED		
A6C49				NOT ASSIGNED		
A6C50	0160-4822	2		CAPACITOR-FXD 1000PF + -5% 100VDC CER	28480	0160-4822
<i>2305A TO 2338A</i>						
A6C51*	0160-0340	1	1	CAPACITOR-FXD 600PF + -1% 300VDC MICA	28480	0160-0340
<i>2339A AND 2340A</i>						
A6C51*	0160-4678	6		CAPACITOR-FXD 560PF + -1% 100VDC MICA	28480	0160-4678
<i>2341A AND 2342A</i>						
A6C51*	0160-0340	1	1	CAPACITOR-FXD 600PF + -1% 300VDC MICA	28480	0160-0340
<i>2343A AND ABOVE</i>						
A6C51*	0160-4678	6		CAPACITOR-FXD 560PF + -1% 100VDC MICA	28480	0160-4678
A6C52	0180-2613	7	1	CAPACITOR-FXD 390UF + -10% 6VDC TA	56289	150D397X9006R2-DJB
A6C53	0180-1746	5		CAPACITOR-FXD 15UF + -10% 20VDC TA	56289	150D156X9020B2
A6C54	0160-4833	5		CAPACITOR-FXD .022UF + -10% 100VDC CER	28480	0160-4833
A6C55	0160-5469	5	27	CAPACITOR-FXD 1UF + -10% 50VDC CER	28480	0160-5469
A6C56	0160-4835	7		CAPACITOR-FXD .1UF + -10% 50VDC CER	28480	0160-4835
A6C57	0160-4833	5		CAPACITOR-FXD .022UF + -10% 100VDC CER	28480	0160-4833
A6C58	0160-4825	5	4	CAPACITOR-FXD 560PF + -5% 100VDC CER	28480	0160-4825
A6C59	0160-4825	5		CAPACITOR-FXD 560PF + -5% 100VDC CER	28480	0160-4825
A6C60	0160-4810	8	1	CAPACITOR-FXD 330PF + -5% 100VDC CER	28480	0160-4810
A6C61	0180-0197	8		CAPACITOR-FXD 2.2UF + -10% 20VDC TA	56289	150D225X9020A2
A6C62	0180-1746	5		CAPACITOR-FXD 15UF + -10% 20VDC TA	56289	150D156X9020B2
A6C63	0160-4812	0		CAPACITOR-FXD 220PF + -5% 100VDC CER	28480	0160-4812
A6C64	0160-4801	7		CAPACITOR-FXD 100PF + -5% 100VDC CER	28480	0160-4801
A6C65	0180-0376	5	2	CAPACITOR-FXD .47UF + -10% 35VDC TA	56289	150D474X9035A2
A6C66	0160-4822	2		CAPACITOR-FXD 1000PF + -5% 100VDC CER	28480	0160-4822
A6C67	0160-5714	3	1	CAPACITOR-FXD .68UF + -10% 100VDC CER	28480	0160-5714
A6C68	0160-4789	0	1	CAPACITOR-FXD 15PF + -5% 100VDC CER 0 + -30	28480	0160-4789
A6C69	0180-1746	5		CAPACITOR-FXD 15UF + -10% 20VDC TA	56289	150D156X9020B2
A6C70	0160-4509	2	1	CAPACITOR-FXD .033UF + -5% 50VDC	28480	0160-4509
A6CR1-CR4				NOT ASSIGNED		
A6CR5	1901-1098	1		DIODE-SWITCHING 1N4150 50V 200MA 4NS	9N171	1N4150
A6CR6	1901-1098	1		DIODE-SWITCHING 1N4150 50V 200MA 4NS	9N171	1N4150
A6CR7	1901-1098	1		DIODE-SWITCHING 1N4150 50V 200MA 4NS	9N171	1N4150
A6CR8	1901-1098	1		DIODE-SWITCHING 1N4150 50V 200MA 4NS	9N171	1N4150
A6CR9	1901-0539	3	5	DIODE-SM SIG SCHOTTKY	28480	1901-0539
A6CR10	1901-0539	3		DIODE-SM SIG SCHOTTKY	28480	1901-0539
A6CR11				NOT ASSIGNED		
A6CR12				NOT ASSIGNED		
A6CR13	1901-0518	8		DIODE-SM SIG SCHOTTKY	28480	1901-0518
A6CR14	1901-0518	8		DIODE-SM SIG SCHOTTKY	28480	1901-0518

† Refer to Section 7 for update information

\* Factory Selected Component (Refer to Section 5)

Δ Errata part change



Table 6-3. Replaceable Parts

Reference Designation	HP Part Number	C D	Qty.	Description	Mfr. Code	Mfr. Part Number
A6CR15	08901-80024	8	2	DET DIODES-MATCH	28480	08901-80024
A6CR16	08901-80024	8		DET DIODES-MATCH	28480	08901-80024
A6CR17	1901-0518	8		DIODE-SM SIG SCHOTTKY	28480	1901-0518
A6CR18	1901-1098	1		DIODE-SWITCHING 1N4150 50V 200MA 4NS	9N171	1N4150
A6CR19	1901-1098	1		DIODE-SWITCHING 1N4150 50V 200MA 4NS	9N171	1N4150
A6CR20	1901-0518	8		DIODE-SM SIG SCHOTTKY	28480	1901-0518
A6CR21	1901-0539	3		DIODE-SM SIG SCHOTTKY	28480	1901-0539
A6CR22	1901-0518	8		DIODE-SM SIG SCHOTTKY	28480	1901-0518
A6J1	1250-1220	0		CONNECTOR-RF SMC M PC 50-OHM	28480	1250-1220
	2190-0124	4		WASHER-LK INTL T NO. 10 .195-IN-ID	28480	2190-0124
	2950-0078	9		NUT-HEX-DBL-CHAM 10-32-THD .067-IN-THK	28480	2950-0078
A6J2	1250-1220	0		CONNECTOR-RF SMC M PC 50-OHM	28480	1250-1220
	2190-0124	4		WASHER-LK INTL T NO. 10 .195-IN-ID	28480	2190-0124
	2950-0078	9		NUT-HEX-DBL-CHAM 10-32-THD .067-IN-THK	28480	2950-0078
A6J3	1250-1220	0		CONNECTOR-RF SMC M PC 50-OHM	28480	1250-1220
	2190-0124	4		WASHER-LK INTL T NO. 10 .195-IN-ID	28480	2190-0124
	2950-0078	9		NUT-HEX-DBL-CHAM 10-32-THD .067-IN-THK	28480	2950-0078
A6J4	1250-1220	0		CONNECTOR-RF SMC M PC 50-OHM	28480	1250-1220
	2190-0124	4		WASHER-LK INTL T NO. 10 .195-IN-ID	28480	2190-0124
	2950-0078	9		NUT-HEX-DBL-CHAM 10-32-THD .067-IN-THK	28480	2950-0078
A6L1	9140-0210	1		INDUCTOR RF-CH-MLD 100UH 5% .166DX.385LG	28480	9140-0210
A6L2	9140-0210	1		INDUCTOR RF-CH-MLD 100UH 5% .166DX.385LG	28480	9140-0210
A6L3	9140-0271	4	1	INDUCTOR RF-CH-MLD 13.3UH 2%	28480	9140-0271
A6L4	9140-0272	5	1	INDUCTOR RF-CH-MLD 32UH 2% .166DX.385LG	28480	9140-0272
A6L5	9140-0273	6	1	INDUCTOR RF-CH-MLD 47.6UH 2%	28480	9140-0273
A6L6				NOT ASSIGNED		
A6L7	9100-1652	3	1	INDUCTOR RF-CH-MLD 820UH 5% .2DX.45LG	28480	9100-1652
A6L8*	9100-1633	0	1	INDUCTOR RF-CH-MLD 68UH 5% .166DX.385LG	28480	9100-1633
A6L9	9100-1666	9	1	INDUCTOR RF-CH-MLD 3.6MH 5% .23DX.57LG	28480	9100-1666
A6L10	9140-0131	5	4	INDUCTOR RF-CH-MLD 10MH 5% .25DX.75LG	28480	9140-0131
A6MP1	08901-00109	2	1	COVER AM DEMOD	28480	08901-00109
	2190-0008	3		WASHER-LK EXT T NO. 6 .141-IN-ID	28480	2190-0008
	2360-0113	2		SCREW-MACH 6-32 .25-IN-LG PAN-HD-POZI	00000	ORDER BY DESCRIPTION
A6Q1	1853-0007	7		TRANSISTOR PNP 2N3251 SI TO-18 PD = 360MW	04713	2N3251
A6Q2	1858-0010	2	1	TRANSISTOR ARRAY 14-PIN PLSTC DIP	04713	MPQ2906
A6Q3				NOT ASSIGNED		
A6Q4	1853-0007	7		TRANSISTOR PNP 2N3251 SI TO-18 PD = 360MW	04713	2N3251
A6Q5	1854-0404	0	13	TRANSISTOR NPN SI TO-18 PD = 360MW	28480	1854-0404
<i>2305A TO 2449A</i>						
A6Q6	1855-0420	2	8	TRANSISTOR J-FET 2N4391 N-CHAN D-MODE	01295	2N4391
<i>2451A AND ABOVE</i>						
A6Q6	1855-0265	3		TRANSISTOR J-FET N-CHAN D-MODE TO-18 SI	17856	VCR2N
A6Q7	1855-0421	3	1	TRANSISTOR J-FET 2N5114 P-CHAN D-MODE	17856	2N5114
A6Q8	1854-0404	0		TRANSISTOR NPN SI TO-18 PD = 360MW	28480	1854-0404
A6Q9	1854-0404	0		TRANSISTOR NPN SI TO-18 PD = 360MW	28480	1854-0404
A6Q10	1853-0281	9	8	TRANSISTOR PNP 2N2907A SI TO-18 PD = 400MW	04713	2N2907A
A6Q11	1853-0007	7		TRANSISTOR PNP 2N3251 SI TO-18 PD = 360MW	04713	2N3251

\*Refer to Section 7 for update information

\*Factory Selected Component (Refer to Section 5)

Δ Errata part change

Table 6-3. Replaceable Parts

Reference Designation	HP Part Number	C D	Qty.	Description	Mfr. Code	Mfr. Part Number
A6Q12	1854-0215	1	1	TRANSISTOR NPN SI PD = 350MW FT = 300MHZ	04713	2N3904
A6Q13	1853-0007	7		TRANSISTOR PNP 2N3251 SI TO-18 PD = 360MW	04713	2N3251
A6Q14	1854-0637	1		TRANSISTOR NPN 2N2219A SI TO-5 PD = 800MW	01295	2N2219A
A6Q15	1854-0404	0		TRANSISTOR NPN SI TO-18 PD = 360MW	28480	1854-0404
A6Q16	1854-0404	0		TRANSISTOR NPN SI TO-18 PD = 360MW	28480	1854-0404
A6Q17	1855-0597	4		TRANSISTOR J-FET P-CHAN D-MODETO-92 SI	28480	1855-0597
A6Q18	1853-0281	9		TRANSISTOR PNP 2N2907A SI TO-18 PD = 400MW	04713	2N2907A
A6Q19	1854-0477	7		TRANSISTOR NPN 2N2222A SI TO-18 PD = 500MW	04713	2N2222A
A6Q20	1853-0007	7		TRANSISTOR PNP 2N3251 SI TO-18 PD = 360MW	04713	2N3251
A6Q21	1854-0404	0		TRANSISTOR NPN SI TO-18 PD = 360MW	28480	1854-0404
A6Q22-Q28				NOT ASSIGNED		
A6Q29	1854-0477	7		TRANSISTOR NPN 2N2222A SI TO-18 PD = 500MW	04713	2N2222A
A6Q30	1854-0404	0		TRANSISTOR NPN SI TO-18 PD = 360MW	28480	1854-0404
A6Q31	1853-0281	9		TRANSISTOR PNP 2N2907A SI TO-18 PD = 400MW	04713	2N2907A
A6R1	0757-1108	6	1	RESISTOR 300 1% .125W F TC = 0 + -100	24546	C4-1/8-T0-301-F
A6R2	0698-3157	3		RESISTOR 19.6K 1% .125W F TC = 0 + -100	24546	C4-1/8-T0-1962-F
A6R3	0698-3446	3		RESISTOR 383 1% .125W F TC = 0 + -100	24546	C4-1/8-T0-383R-F
A6R4	0698-3447	4	6	RESISTOR 422 1% .125W F TC = 0 + -100	24546	C4-1/8-T0-422R-F
A6R5	0757-0401	0		RESISTOR 100 1% .125W F TC = 0 + -100	24546	C4-1/8-T0-101-F
A6R6	0757-0280	3		RESISTOR 1K 1% .125W F TC = 0 + -100	24546	C4-1/8-T0-1001-F
A6R7	0757-0280	3		RESISTOR 1K 1% .125W F TC = 0 + -100	24546	C4-1/8-T0-1001-F
A6R8	0757-0441	8		RESISTOR 8.25K 1% .125W F TC = 0 + -100	24546	C4-1/8-T0-8251-F
A6R9	0757-0442	9		RESISTOR 10K 1% .125W F TC = 0 + -100	24546	C4-1/8-T0-1002-F
A6R10	0757-0280	3		RESISTOR 1K 1% .125W F TC = 0 + -100	24546	C4-1/8-T0-1001-F
A6R11				NOT ASSIGNED		
A6R12				NOT ASSIGNED		
A6R13	0698-3160	8		RESISTOR 31.6K 1% .125W F TC = 0 + -100	24546	C4-1/8-T0-3162-F
A6R14	0757-0458	7		RESISTOR 51.1K 1% .125W F TC = 0 + -100	24546	C4-1/8-T0-5112-F
A6R15	0757-0458	7		RESISTOR 51.1K 1% .125W F TC = 0 + -100	24546	C4-1/8-T0-5112-F
A6R16	0757-0442	9		RESISTOR 10K 1% .125W F TC = 0 + -100	24546	C4-1/8-T0-1002-F
A6R17	0757-0438	3		RESISTOR 5.11K 1% .125W F TC = 0 + -100	24546	C4-1/8-T0-5111-F
A6R18	0757-0438	3		RESISTOR 5.11K 1% .125W F TC = 0 + -100	24546	C4-1/8-T0-5111-F
A6R19	0698-3445	2	9	RESISTOR 348 1% .125W F TC = 0 + -100	24546	C4-1/8-T0-348R-F
A6R20	0757-0441	8		RESISTOR 8.25K 1% .125W F TC = 0 + -100	24546	C4-1/8-T0-8251-F
A6R21	0757-0442	9		RESISTOR 10K 1% .125W F TC = 0 + -100	24546	C4-1/8-T0-1002-F
A6R22	0698-3150	6		RESISTOR 2.37K 1% .125W F TC = 0 + -100	24546	C4-1/8-T0-2371-F
A6R23	0757-0465	6		RESISTOR 100K 1% .125W F TC = 0 + -100	24546	C4-1/8-T0-1003-F
A6R24	0757-0465	6		RESISTOR 100K 1% .125W F TC = 0 + -100	24546	C4-1/8-T0-1003-F
A6R25	0698-3445	2		RESISTOR 348 1% .125W F TC = 0 + -100	24546	C4-1/8-T0-348R-F
A6R26	0757-0438	3		RESISTOR 5.11K 1% .125W F TC = 0 + -100	24546	C4-1/8-T0-5111-F
A6R27	0757-0465	6		RESISTOR 100K 1% .125W F TC = 0 + -100	24546	C4-1/8-T0-1003-F
A6R28	0757-0458	7		RESISTOR 51.1K 1% .125W F TC = 0 + -100	24546	C4-1/8-T0-5112-F
A6R29	0757-0458	7		RESISTOR 51.1K 1% .125W F TC = 0 + -100	24546	C4-1/8-T0-5112-F
A6R30	0698-3444	1		RESISTOR 316 1% .125W F TC = 0 + -100	24546	C4-1/8-T0-316R-F
A6R31	0698-3157	3		RESISTOR 19.6K 1% .125W F TC = 0 + -100	24546	C4-1/8-T0-1962-F
A6R32	0698-3157	3		RESISTOR 19.6K 1% .125W F TC = 0 + -100	24546	C4-1/8-T0-1962-F
A6R33	0757-0416	7		RESISTOR 511 1% .125W F TC = 0 + -100	24546	C4-1/8-T0-511R-F
A6R34	0698-3154	0		RESISTOR 4.22K 1% .125W F TC = 0 + -100	24546	C4-1/8-T0-4221-F
A6R35	0757-0338	2	4	RESISTOR 1K 1% .25W F TC = 0 + -100	24546	C5-1/4-T0-1001-F

† Refer to Section 7 for update information.

\* Factory Selected Component (Refer to Section 5).

Δ Errata part change.

Table 6-3. Replaceable Parts

Reference Designation	HP Part Number	C D	Qty.	Description	Mfr. Code	Mfr. Part Number
A6R36	0757-0401	0		RESISTOR 100 1% .125W F TC = 0 + -100	24546	C4-1/8-T0-101-F
A6R37	0757-0442	9		RESISTOR 10K 1% .125W F TC = 0 + -100	24546	C4-1/8-T0-1002-F
A6R38	0757-0438	3		RESISTOR 5.11K 1% .125W F TC = 0 + -100	24546	C4-1/8-T0-5111-F
A6R39	0757-0443	0	3	RESISTOR 11K 1% .125W F TC = 0 + -100	24546	C4-1/8-T0-1102-F
A6R40				NOT ASSIGNED		
A6R41	0698-3444	1		RESISTOR 316 1% .125W F TC = 0 + -100	24546	C4-1/8-T0-316R-F
A6R42	0757-0338	2		RESISTOR 1K 1% .25W F TC = 0 + -100	24546	C5-1/4-T0-1001-F
A6R43				NOT ASSIGNED		
A6R44	0757-0442	9		RESISTOR 10K 1% .125W F TC = 0 + -100	24546	C4-1/8-T0-1002-F
A6R45				NOT ASSIGNED		
A6R46	0757-0416	7		RESISTOR 511 1% .125W F TC = 0 + -100	24546	C4-1/8-T0-511R-F
A6R47				NOT ASSIGNED		
A6R48				NOT ASSIGNED		
A6R49	0757-0401	0		RESISTOR 100 1% .125W F TC = 0 + -100	24546	C4-1/8-T0-101-F
A6R50	0698-3152	8		RESISTOR 3.48K 1% .125W F TC = 0 + -100	24546	C4-1/8-T0-3481-F
A6R51	0698-4488	5	1	RESISTOR 26.7K 1% .125W F TC = 0 + -100	24546	C4-1/8-T0-2672-F
A6R52	0698-3152	8		RESISTOR 3.48K 1% .125W F TC = 0 + -100	24546	C4-1/8-T0-3481-F
A6R53				NOT ASSIGNED		
A6R54	0698-4472	7	1	RESISTOR 7.68K 1% .125W F TC = 0 + -100	24546	C4-1/8-T0-7681-F
A6R55	0698-3150	6		RESISTOR 2.37K 1% .125W F TC = 0 + -100	24546	C4-1/8-T0-2371-F
A6R56	0757-0401	0		RESISTOR 100 1% .125W F TC = 0 + -100	24546	C4-1/8-T0-101-F
A6R57	0757-0438	3		RESISTOR 5.11K 1% .125W F TC = 0 + -100	24546	C4-1/8-T0-5111-F
A6R58	0698-3432	7		RESISTOR 26.1 1% .125W F TC = 0 + -100	03888	PME55-1/8-T0-26R1-F
A6R59				NOT ASSIGNED		
A6R60	0699-0148	8	2	RESISTOR 31.6K .1% .1W F TC = 0 + -15	28480	0699-0148
A6R61	0757-0200	7	5	RESISTOR 5.62K 1% .125W F TC = 0 + -100	24546	C4-1/8-T0-5621-F
A6R62	0757-0416	7		RESISTOR 511 1% .125W F TC = 0 + -100	24546	C4-1/8-T0-511R-F
A6R63	0698-3152	8		RESISTOR 3.48K 1% .125W F TC = 0 + -100	24546	C4-1/8-T0-3481-F
A6R64	0757-0401	0		RESISTOR 100 1% .125W F TC = 0 + -100	24546	C4-1/8-T0-101-F
A6R65	2100-3207	1	2	RESISTOR-TRMR 5K 10% C SIDE-ADJ 1-TRN	28480	2100-3207
A6R66	0698-8955	9	1	RESISTOR 13.5K .1% .1W F TC = 0 + -10	28480	0698-8955
A6R67	0698-0082	7		RESISTOR 464 1% .125W F TC = 0 + -100	24546	C4-1/8-T0-4640-F
A6R68	0757-0419	0		RESISTOR 681 1% .125W F TC = 0 + -100	24546	C4-1/8-T0-681R-F
A6R69	0699-0149	9	1	RESISTOR 28.7K .1% .1W F TC = 0 + -15	28480	0699-0149
A6R70	0698-3447	4		RESISTOR 422 1% .125W F TC = 0 + -100	24546	C4-1/8-T0-422R-F
A6R71	0757-0346	2		RESISTOR 10 1% .125W F TC = 0 + -100	24546	C4-1/8-T0-10R0-F
A6R72	0699-0096	5	2	RESISTOR 12K .1% .1W F TC = 0 + -10	28480	0699-0096
A6R73	0698-4454	5	3	RESISTOR 523 1% .125W F TC = 0 + -100	24546	C4-1/8-T0-523R-F
A6R74	0698-4454	5		RESISTOR 523 1% .125W F TC = 0 + -100	24546	C4-1/8-T0-523R-F
A6R75	0690-8191	5		RESISTOR 12.5K 1% .125W F TC = 0 + -100	24546	C4-1/8-T0-1252-F
A6R76	0698-4454	5		RESISTOR 523 1% .125W F TC = 0 + -100	24546	C4-1/8-T0-523R-F
A6R77	0757-0444	1	4	RESISTOR 12.1K 1% .125W F TC = 0 + -100	24546	C4-1/8-T0-1212-F
A6R78	0757-0443	0		RESISTOR 11K 1% .125W F TC = 0 + -100	24546	C4-1/8-T0-1102-F
A6R79	0699-0148	8		RESISTOR 31.6K .1% .1W F TC = 0 + -15	28480	0699-0148
A6R80	0698-0082	7		RESISTOR 464 1% .125W F TC = 0 + -100	24546	C4-1/8-T0-4640-F
A6R81	0698-4626	3	1	RESISTOR 1.47K 1% .25W F TC = 0 + -100	24546	C5-1/4-T0-1471-F
A6R82	0698-3440	7	7	RESISTOR 196 1% .125W F TC = 0 + -100	24546	C4-1/8-T0-196R-F

† Refer to Section 7 for update information

\* Factory Selected Component (Refer to Section 5)

Δ Errata part change

Table 6-3. Replaceable Parts

Reference Designation	HP Part Number	C D	Qty.	Description	Mfr. Code	Mfr. Part Number
A6R83-R86				NOT ASSIGNED		
A6R87	0757-0442		9	RESISTOR 10K 1% .125W F TC = 0 + -100	24546	C4-1/8-T0-1002-F
A6R88	0699-0143		3	RESISTOR 825 .1% .1W F TC = 0 + -15	28480	0699-0143
A6R89	0757-0401		0	RESISTOR 100 1% .125W F TC = 0 + -100	24546	C4-1/8-T0-101-F
A6R90	0757-0447		4	RESISTOR 16.2K 1% .125W F TC = 0 + -100	24546	C4-1/8-T0-1622-F
A6R91	0757-0442		9	RESISTOR 10K 1% .125W F TC = 0 + -100	24546	C4-1/8-T0-1002-F
A6R92	0698-0082		7	RESISTOR 464 1% .125W F TC = 0 + -100	24546	C4-1/8-T0-4640-F
A6R93	0698-3440		7	RESISTOR 196 1% .125W F TC = 0 + -100	24546	C4-1/8-T0-196R-F
A6R94	0757-0338		2	RESISTOR 1K 1% .25W F TC = 0 + -100	24546	C5-1/4-T0-1001-F
A6R95	0757-0394		0	RESISTOR 51.1 1% .125W F TC = 0 + -100	24546	C4-1/8-T0-51R1-F
A6R96	0698-8979		7	RESISTOR 11.6K 1% .125W F TC = 0 + -100	28480	0698-8979
A6R97	0698-3153		9	RESISTOR 3.83K 1% .125W F TC = 0 + -100	24546	C4-1/8-T0-3831-F
A6R98	0757-0440		7	RESISTOR 7.5K 1% .125W F TC = 0 + -100	24546	C4-1/8-T0-7501-F
A6R99	0757-0401		0	RESISTOR 100 1% .125W F TC = 0 + -100	24546	C4-1/8-T0-101-F
A6R100	0698-3132		4	RESISTOR 261 1% .125W F TC = 0 + -100	24546	C4-1/8-T0-2610-F
A6R101	0757-1094		9	RESISTOR 1.47K 1% .125W F TC = 0 + -100	24546	C4-1/8-T0-1471-F
A6R102	0698-3432		7	RESISTOR 26.1 1% .125W F TC = 0 + -100	03888	PME55-1/8-T0-26R1-F
A6R103	0698-3152		8	RESISTOR 3.48K 1% .125W F TC = 0 + -100	24546	C4-1/8-T0-3481-F
A6R104	0698-3454		3	RESISTOR 215K 1% .125W F TC = 0 + -100	24546	C4-1/8-T0-2153-F
A6R105	0757-0199		3	RESISTOR 21.5K 1% .125W F TC = 0 + -100	24546	C4-1/8-T0-2152-F
A6R106				NOT ASSIGNED		
A6R107	0757-0199		3	RESISTOR 21.5K 1% .125W F TC = 0 + -100	24546	C4-1/8-T0-2152-F
A6R108	0757-0199		3	RESISTOR 21.5K 1% .125W F TC = 0 + -100	24546	C4-1/8-T0-2152-F
A6R109	0698-8825		2	RESISTOR 681K 1% .125W F TC = 0 + -100	28480	0698-8825
A6R110	0757-0416		7	RESISTOR 511 1% .125W F TC = 0 + -100	24546	C4-1/8-T0-511R-F
A6R111				NOT ASSIGNED		
A6R112	0698-8827		4	RESISTOR 1M 1% .125W F TC = 0 + -100	28480	0698-8827
A6R113	0683-2265		1	RESISTOR 22M 5% .25W FC TC = -900/+ 1200	01121	CB2265
A6R114	0757-0280		3	RESISTOR 1K 1% .125W F TC = 0 + -100	24546	C4-1/8-T0-1001-F
A6R115	0757-0442		9	RESISTOR 10K 1% .125W F TC = 0 + -100	24546	C4-1/8-T0-1002-F
A6R116				NOT ASSIGNED		
A6R117	0757-0438		3	RESISTOR 5.11K 1% .125W F TC = 0 + -100	24546	C4-1/8-T0-5111-F
A6R118	0698-3152		8	RESISTOR 3.48K 1% .125W F TC = 0 + -100	24546	C4-1/8-T0-3481-F
A6R119	0757-0465		6	RESISTOR 100K 1% .125W F TC = 0 + -100	24546	C4-1/8-T0-1003-F
A6R120	0757-0317		7	RESISTOR 1.33K 1% .125W F TC = 0 + -100	24546	C4-1/8-T0-1331-F
A6R121	0757-0442		9	RESISTOR 10K 1% .125W F TC = 0 + -100	24546	C4-1/8-T0-1002-F
A6R122	0757-0438		3	RESISTOR 5.11K 1% .125W F TC = 0 + -100	24546	C4-1/8-T0-5111-F
A6R123				NOT ASSIGNED		
A6R124	0698-3440		7	RESISTOR 196 1% .125W F TC = 0 + -100	24546	C4-1/8-T0-196R-F
A6R125	0683-2265		1	RESISTOR 22M 5% .25W FC TC = -900/+ 1200	01121	CB2265
A6R126	0698-3440		7	RESISTOR 196 1% .125W F TC = 0 + -100	24546	C4-1/8-T0-196R-F
A6R127				NOT ASSIGNED		
A6R128	0757-0401		0	RESISTOR 100 1% .125W F TC = 0 + -100	24546	C4-1/8-T0-101-F
A6R129	0698-3454		3	RESISTOR 215K 1% .125W F TC = 0 + -100	24546	C4-1/8-T0-2153-F
A6TP1	1251-0600		0	CONNECTOR-SGL CONT PIN 1.14-MM-BSC-SZ SQ	28480	1251-0600
A6TP2	1251-0600		0	CONNECTOR-SGL CONT PIN 1.14-MM-BSC-SZ SQ	28480	1251-0600

† Refer to Section 7 for update information.

\* Factory Selected Component (Refer to Section 5).

Δ Errata part change.

Table 6-3. Replaceable Parts

Reference Designation	HP Part Number	C D	Qty.	Description	Mfr. Code	Mfr. Part Number
A6U1	1826-0035	4	2	IC OP AMP LOW-DRIFT TO-99 PKG	27014	LM308AH
A6U2	1826-0989	7	4	IC OP AMP GP 8-DIP-C PKG	27014	LM307J
A6U3	1826-0035	4		IC OP AMP LOW-DRIFT TO-99 PKG	27014	LM308AH
A6U4	1826-0716	8	1	IC OP AMP LOW-NOISE DUAL 8-DIP-C PKG	18324	NE5532AFE
A6U5	1826-0606	5	10	IC SWITCH ANLG QUAD 16-DIP-C PKG	17856	DG201BK
A6U6	1826-0102	6	1	IC OP AMP LOW-BIAS-HIMPD TO-99 PKG	27014	LM312H
A6U7	1826-0065	0	1	IC COMPARATOR PRCN 8-DIP-P PKG	27014	LM311N
A6U8	1820-1411	0		IC LCH TTL LS D-TYPE 4-BIT	01295	SN74LS75N
A6U9	1820-1216	3		IC DCDR TTL LS 3-TO-8-LINE 3-INP	01295	SN74LS138N
A6U10	1820-1197	9	5	IC GATE TTL LS NAND QUAD 2-INP	01295	SN74LS00N
A6VR2	1902-0072	1	1	DIODE-ZNR 7.87V 2% DO-35 PD = .4W	28480	1902-0072
A6VR3	1902-0680	7		DIODE-ZNR 1N827 6.2V 5% DO-7 PD = .4W	24046	1N827
A6VR4	1902-3059	0	5	DIODE-ZNR 3.83V 5% DO-35 PD = .4W	28480	1902-3059

†Refer to Section 7 for update information.

\*Factory Selected Component (Refer to Section 5)

Δ Errata part change

Table 6-3. Replaceable Parts

Reference Designation	HP Part Number	C D	Qty.	Description	Mfr. Code	Mfr. Part Number
<b>A10</b>						
<i>2305A TO 2519A</i>						
A10	08901-60141	8	1	POWER SUPPLY REGULATORS ASSEMBLY	28480	08901-60141
<i>2522A AND ABOVE</i>						
A10	08901-60269	1		POWER SUPPLY REGULATORS ASSEMBLY	28480	08901-60269
A10C1	0180-0229	7	6	CAPACITOR-FXD 33UF + -10% 10VDC TA	56289	150D336X9010B2
A10C2	0160-4831	3	2	CAPACITOR-FXD 4700PF + -10% 100VDC CER	28480	0160-4831
A10C3	0160-4831	3		CAPACITOR-FXD 4700PF + -10% 100VDC CER	28480	0160-4831
A10C4	0160-5098	6	4	CAPACITOR-FXD .22UF + -10% 50VDC CER	16299	CAC05X7R224J050A
A10C5	0180-0374	3		CAPACITOR-FXD 10UF + -10% 20VDC TA	56289	150D106X9020B2
A10C6	0180-1794	3		CAPACITOR-FXD 22UF + -10% 35VDC TA	56289	150D226X9035R2
A10C7	0180-1794	3		CAPACITOR-FXD 22UF + -10% 35VDC TA	56289	150D226X9035R2
A10C8	0160-4832	4		CAPACITOR-FXD .01UF + -10% 100VDC CER	28480	0160-4832
A10C9	0180-1794	3	1	CAPACITOR-FXD 22UF + -10% 35VDC TA	56289	150D226X9035R2
<i>2305A TO 2717A</i>						
<i>A10C10</i>						
A10C10	0180-0116	1		CAPACITOR-FXD 6.8UF + -10% 35VDC TA	56289	150D685X9035B2
<i>2742A AND ABOVE</i>						
<i>A10C10</i>						
A10C10	0180-0097	7		CAPACITOR-FXD 47UF + -10% 35VDC TA	56289	150D476X903552
A10C11	0160-4812	0		CAPACITOR-FXD 220PF + -5% 100VDC CER	28480	0160-4812
A10C12	0180-0116	1		CAPACITOR-FXD 6.8UF + -10% 35VDC TA	56289	150D685X9035B2
A10C13	0160-4822	2		CAPACITOR-FXD 1000PF + -5% 100VDC CER	28480	0160-4822
A10C14	0160-4830	2	2	CAPACITOR-FXD 2200PF + -10% 100VDC CER	28480	0160-4830
A10C15	0160-4830	2		CAPACITOR-FXD 2200PF + -10% 100VDC CER	28480	0160-4830
A10C16	0180-2141	6		CAPACITOR-FXD 3.3UF + -10% 50VDC TA	56289	150D335X9050B2
A10C17	0160-5098	6		CAPACITOR-FXD .22UF + -10% 50VDC CER	16299	CAC05X7R224J050A
A10C18	0180-0229	7		CAPACITOR-FXD 33UF + -10% 10VDC TA	56289	150D336X9010B2
A10C19	0160-5098	6		CAPACITOR-FXD .22UF + -10% 50VDC CER	16299	CAC05X7R224J050A
A10C20	0180-0229	7		CAPACITOR-FXD 33UF + -10% 10VDC TA	56289	150D336X9010B2
A10CR1	1901-0050	3		DIODE-SWITCHING 80V 200MA 2NS DO-35	28480	1901-0050
A10CR2	1901-1098	1		DIODE-SWITCHING 1N4150 50V 200MA 4NS	9N171	1N4150
A10CR3	1901-0050	3		DIODE-SWITCHING 80V 200MA 2NS DO-35	28480	1901-0050
A10CR4	1901-1098	1		DIODE-SWITCHING 1N4150 50V 200MA 4NS	9N171	1N4150
A10CR5	1901-0028	5	7	DIODE-PWR RECT 400V 750MA DO-29	28480	1901-0028
A10CR6	1901-0028	5		DIODE-PWR RECT 400V 750MA DO-29	28480	1901-0028
A10CR7	1901-1098	1		DIODE-SWITCHING 1N4150 50V 200MA 4NS	9N171	1N4150
A10CR8	1901-1098	1		DIODE-SWITCHING 1N4150 50V 200MA 4NS	9N171	1N4150
A10CR9	1901-1098	1		DIODE-SWITCHING 1N4150 50V 200MA 4NS	9N171	1N4150
A10CR10	1901-0028	5		DIODE-PWR RECT 400V 750MA DO-29	28480	1901-0028
A10CR11	1901-1098	1		DIODE-SWITCHING 1N4150 50V 200MA 4NS	9N171	1N4150
A10CR12	1901-1098	1		DIODE-SWITCHING 1N4150 50V 200MA 4NS	9N171	1N4150
A10CR13	1901-0028	5		DIODE-PWR RECT 400V 750MA DO-29	28480	1901-0028
A10CR14	1901-1098	1		DIODE-SWITCHING 1N4150 50V 200MA 4NS	9N171	1N4150
A10CR15	1901-0028	5		DIODE-PWR RECT 400V 750MA DO-29	28480	1901-0028

†Refer to Section 7 for update information

\*Factory Selected Component (Refer to Section 5)

Δ Errata part change

Table 6-3. Replaceable Parts

Reference Designation	HP Part Number	C D	Qty.	Description	Mfr. Code	Mfr. Part Number
A10CR16	1901-0028	5		DIODE-PWR RECT 400V 750MA DO-29	28480	1901-0028
A10DS1	1990-0485	5	5	LED-LAMP LUM-INT = 800UCD IF = 30MA-MAX	28480	5082-4984
A10DS2	1990-0485	5		LED-LAMP LUM-INT = 800UCD IF = 30MA-MAX	28480	5082-4984
A10DS3	1990-0485	5		LED-LAMP LUM-INT = 800UCD IF = 30MA-MAX	28480	5082-4984
A10DS4	1990-0485	5		LED-LAMP LUM-INT = 800UCD IF = 30MA-MAX	28480	5082-4984
A10DS5	1990-0485	5		LED-LAMP LUM-INT = 800UCD IF = 30MA-MAX	28480	5082-4984
A10F1	2110-0083	6	3	FUSE 2.5A 250V NTD 1.25X.25 UL	28480	2110-0083
A10F2	2110-0036	9	1	FUSE 8A 125V NTD 1.25X.25 UL	75915	312008
A10F3	2110-0083	6		FUSE 2.5A 250V NTD 1.25X.25 UL	28480	2110-0083
A10F4	2110-0083	6		FUSE 2.5A 250V NTD 1.25X.25 UL	28480	2110-0083
	2110-0643	4		FUSEHOLDER-CLIP TYPE 15A 250 V	28480	2110-0643
A10J1	1251-5635	1	1	CONNECTOR 12-PIN M POST TYPE	28480	1251-5635
A10MP1	5001-0178	2	2	BRACKET-ANGLE	28480	5001-0178
	2190-0007	2	3	WASHER-LK INTL T NO. 6 .141-IN-ID	28480	2190-0007
	2360-0191	6	3	SCREW-MACH 6-32 .188-IN-LG PAN-HD-POZI	00000	ORDER BY DESCRIPTION
A10MP2	5001-0178	2		BRACKET-ANGLE	28480	5001-0178
	2190-0007	2		WASHER-LK INTL T NO. 6 .141-IN-ID	28480	2190-0007
	2360-0191	6		SCREW-MACH 6-32 .188-IN-LG PAN-HD-POZI	00000	ORDER BY DESCRIPTION
A10Q1	1884-0005	0	1	THYRISTOR-SCR VRRM = 50	04713	MCR649P-2
	0340-0875	9	1	INSULATOR-XSTR THRM-CNDCT	28480	0340-0875
	2190-0004	9	11	WASHER-LK INTL T NO. 4 .115-IN-ID	28480	2190-0004
	2200-0141	8	11	SCREW-MACH 4-40 .312-IN-LG PAN-HD-POZI	28480	2200-0141
A10Q2	1854-0798	5	1	TRANSISTOR NPN SI DARL PD = 1W	04713	MPS-U45
	2190-0004	9		WASHER-LK INTL T NO. 4 .115-IN-ID	28480	2190-0004
	08901-00137	6	1	HEAT SINK, PC	28480	08901-00137
	2200-0141	8		SCREW-MACH 4-40 .312-IN-LG PAN-HD-POZI	28480	2200-0141
A10Q3	1853-0281	9		TRANSISTOR PNP 2N2907A SI TO-18 PD = 400MW	04713	2N2907A
A10Q4	1884-0273	4	3	THYRISTOR-SCR 2N4101 TO-66	3L585	2N4101
	0340-0681	5	4	INSULATOR-XSTR THRM-CNDCT GRA	28480	0340-0681
	2190-0004	9		WASHER-LK INTL T NO. 4 .115-IN-ID	28480	2190-0004
	2200-0141	8		SCREW-MACH 4-40 .312-IN-LG PAN-HD-POZI	28480	2200-0141
A10Q5	1854-0477	7		TRANSISTOR NPN 2N2222A SI TO-18 PD = 500MW	04713	2N2222A
A10Q6	1884-0273	4		THYRISTOR-SCR 2N4101 TO-66	3L585	2N4101
	0340-0681	5		INSULATOR-XSTR THRM-CNDCT GRA	28480	0340-0681
	2190-0004	9		WASHER-LK INTL T NO. 4 .115-IN-ID	28480	2190-0004
	2200-0141	8		SCREW-MACH 4-40 .312-IN-LG PAN-HD-POZI	28480	2200-0141
A10Q7	1884-0273	4		THYRISTOR-SCR 2N4101 TO-66	3L585	2N4101
	0340-0681	5		INSULATOR-XSTR THRM-CNDCT GRA	28480	0340-0681
	2190-0004	9		WASHER-LK INTL T NO. 4 .115-IN-ID	28480	2190-0004
	2200-0141	8		SCREW-MACH 4-40 .312-IN-LG PAN-HD-POZI	28480	2200-0141
A10Q8	1884-0073	2	1	THYRISTOR-SCR TO-5 VRRM = 100	28480	1884-0073
	1200-0173	5		INSULATOR-XSTR DAP-GL	28480	1200-0173
A10Q9	1854-0474	4	3	TRANSISTOR NPN SI PD = 310MW FT = 100MHZ	04713	2N5551
A10Q10	1858-0008	8	2	TRANSISTOR ARRAY 14-PIN PLSTC DIP	04713	MHQ6001
A10Q11	1858-0008	8		TRANSISTOR ARRAY 14-PIN PLSTC DIP	04713	MHQ6001
A10Q12	1853-0414	0	1	TRANSISTOR PNP 2N6423 SI TO-66 PD = 35W	04713	2N6423
	0340-0681	5		INSULATOR-XSTR THRM-CNDCT GRA	28480	0340-0681
	2190-0004	9		WASHER-LK INTL T NO. 4 .115-IN-ID	28480	2190-0004
	2200-0141	8		SCREW-MACH 4-40 .312-IN-LG PAN-HD-POZI	28480	2200-0141

†Refer to Section 7 for update information.

\*Factory Selected Component (Refer to Section 5)

Δ Errata part change

Table 6-3. Replaceable Parts

Reference Designation	HP Part Number	C D	Qty.	Description	Mfr. Code	Mfr. Part Number
A10Q13	1854-0474		4	TRANSISTOR NPN SI PD = 310MW FT = 100MHZ	04713	2N5551
A10Q14	1854-0474		4	TRANSISTOR NPN SI PD = 310MW FT = 100MHZ	04713	2N5551
A10R1	0757-0438		3	RESISTOR 5.11K 1% .125W F TC = 0 + -100	24546	C4-1/8-T0-5111-F
A10R2	0698-0085		0	RESISTOR 2.61K 1% .125W F TC = 0 + -100	24546	C4-1/8-T0-2611-F
A10R3	0811-3290		7	RESISTOR .1 5% 2W PW TC = 0 + -800	28480	0811-3290
A10R4	0811-3293		0	RESISTOR .18 5% 2W PW TC = 0 + -800	28480	0811-3293
A10R5	0698-3132		4	RESISTOR 261 1% .125W F TC = 0 + -100	24546	C4-1/8-T0-2610-F
A10R6	0698-3132		4	RESISTOR 261 1% .125W F TC = 0 + -100	24546	C4-1/8-T0-2610-F
A10R7	0757-0289		2	RESISTOR 13.3K 1% .125W F TC = 0 + -100	19701	MF4C1/8-T0-1332-F
A10R8	0757-0280		3	RESISTOR 1K 1% .125W F TC = 0 + -100	24546	C4-1/8-T0-1001-F
A10R9	0757-0289		2	RESISTOR 13.3K 1% .125W F TC = 0 + -100	19701	MF4C1/8-T0-1332-F
A10R10	0757-0416		7	RESISTOR 511 1% .125W F TC = 0 + -100	24546	C4-1/8-T0-511R-F
A10R11	0757-0420		3	RESISTOR 750 1% .125W F TC = 0 + -100	24546	C4-1/8-T0-751-F
A10R12	0698-0085		0	RESISTOR 2.61K 1% .125W F TC = 0 + -100	24546	C4-1/8-T0-2611-F
A10R13	0757-0420		3	RESISTOR 750 1% .125W F TC = 0 + -100	24546	C4-1/8-T0-751-F
A10R14	0698-0085		0	RESISTOR 2.61K 1% .125W F TC = 0 + -100	24546	C4-1/8-T0-2611-F
A10R15	0757-0416		7	RESISTOR 511 1% .125W F TC = 0 + -100	24546	C4-1/8-T0-511R-F
A10R16	0757-0280		3	RESISTOR 1K 1% .125W F TC = 0 + -100	24546	C4-1/8-T0-1001-F
A10R17	0757-0438		3	RESISTOR 5.11K 1% .125W F TC = 0 + -100	24546	C4-1/8-T0-5111-F
A10R18	0757-0416		7	RESISTOR 511 1% .125W F TC = 0 + -100	24546	C4-1/8-T0-511R-F
A10R19	0757-0280		3	RESISTOR 1K 1% .125W F TC = 0 + -100	24546	C4-1/8-T0-1001-F
A10R20	0698-0085		0	RESISTOR 2.61K 1% .125W F TC = 0 + -100	24546	C4-1/8-T0-2611-F
A10R21	0698-0084		9	RESISTOR 2.15K 1% .125W F TC = 0 + -100	24546	C4-1/8-T0-2151-F
A10R22	0698-0084		9	RESISTOR 2.15K 1% .125W F TC = 0 + -100	24546	C4-1/8-T0-2151-F
A10R23	0698-0084		9	RESISTOR 2.15K 1% .125W F TC = 0 + -100	24546	C4-1/8-T0-2151-F
A10R24	2100-3350		5	RESISTOR-TRMR 200 10% C SIDE-ADJ 1-TRN	28480	2100-3350
A10R25	0757-1094		9	RESISTOR 1.47K 1% .125W F TC = 0 + -100	24546	C4-1/8-T0-1471-F
A10R26	0757-0346		2	RESISTOR 10 1% .125W F TC = 0 + -100	24546	C4-1/8-T0-10R0-F
A10R27	0698-3430		5	RESISTOR 21.5 1% .125W F TC = 0 + -100	03888	PME55-1/8-T0-21R5-F
A10R28	0757-0401		0	RESISTOR 100 1% .125W F TC = 0 + -100	24546	C4-1/8-T0-101-F
A10R29	0757-0401		0	RESISTOR 100 1% .125W F TC = 0 + -100	24546	C4-1/8-T0-101-F
A10R30	0757-0346		2	RESISTOR 10 1% .125W F TC = 0 + -100	24546	C4-1/8-T0-10R0-F
A10R31	0757-0442		9	RESISTOR 10K 1% .125W F TC = 0 + -100	24546	C4-1/8-T0-1002-F
A10R32	0698-3624		9	RESISTOR 150 5% 2W MO TC = 0 + -200	28480	0698-3624
A10R33	0757-0438		3	RESISTOR 5.11K 1% .125W F TC = 0 + -100	24546	C4-1/8-T0-5111-F
A10R34	0698-3601		2	RESISTOR 10 5% 2W MO TC = 0 + -200	27167	FP42-2-T00-10R0-J
A10R35	0757-0401		0	RESISTOR 100 1% .125W F TC = 0 + -100	24546	C4-1/8-T0-101-F
A10R36	0757-0444		1	RESISTOR 12.1K 1% .125W F TC = 0 + -100	24546	C4-1/8-T0-1212-F
A10R37	0757-0438		3	RESISTOR 5.11K 1% .125W F TC = 0 + -100	24546	C4-1/8-T0-5111-F
A10R38	0698-0084		9	RESISTOR 2.15K 1% .125W F TC = 0 + -100	24546	C4-1/8-T0-2151-F
A10R39	0757-0442		9	RESISTOR 10K 1% .125W F TC = 0 + -100	24546	C4-1/8-T0-1002-F
A10R40	0757-0442		9	RESISTOR 10K 1% .125W F TC = 0 + -100	24546	C4-1/8-T0-1002-F
A10R41	0698-3444		1	RESISTOR 316 1% .125W F TC = 0 + -100	24546	C4-1/8-T0-316R-F
A10R42	0698-3136		8	RESISTOR 17.8K 1% .125W F TC = 0 + -100	24546	C4-1/8-T0-1782-F
A10R43	0757-0442		9	RESISTOR 10K 1% .125W F TC = 0 + -100	24546	C4-1/8-T0-1002-F
A10R44	0757-0402		1	RESISTOR 110 1% .125W F TC = 0 + -100	24546	C4-1/8-T0-111-F
A10R45	0698-0084		9	RESISTOR 2.15K 1% .125W F TC = 0 + -100	24546	C4-1/8-T0-2151-F
A10R46	0757-0274		5	RESISTOR 1.21K 1% .125W F TC = 0 + -100	24546	C4-1/8-T0-1211-F

†Refer to Section 7 for update information.

\*Factory Selected Component (Refer to Section 5).

Δ Errata part change.



Table 6-3. Replaceable Parts

Reference Designation	HP Part Number	C D	Qty.	Description	Mfr. Code	Mfr. Part Number
A10R47	0698-0084	9		RESISTOR 2.15K 1% .125W F TC = 0 + -100	24546	C4-1/8-T0-2151-F
A10R48	0811-3293	0		RESISTOR .18 5% 2W PW TC = 0 + -800	28480	0811-3293
A10R49	8110-0180	0	1	RIBBON-RES .157-OHM/FT .0253X.0625	28480	8110-0180
<i>2305A TO 2618A</i>						
A10R60	0698-3154	0		RESISTOR 4.22K 1% .125W F TC = 0 + -100	24546	C4-1/8-T0-4221-F
<i>2618A AND ABOVE</i>						
A10R60	0698-5808	5		RESISTOR 4K 1% .125W F TC = 0 + -100	24546	C4-1/8-T0-4001-F
A10R51	0757-0416	7		RESISTOR 511 1% .125W F TC = 0 + -100	24546	C4-1/8-T0-511R-F
<i>2305A TO 2623A</i>						
A10R62	0757-0289	2		RESISTOR 13.3K 1% .125W F TC = 0 + -100	19701	MF4C1/8-T0-1332-F
<i>2623A AND ABOVE</i>						
A10R62	0698-3156	2		RESISTOR 14.7K 1% .125W F TC = 0 + -100	24546	C4-1/8-T0-1472-F
A10R53	0757-0444	1		RESISTOR 12.1K 1% .125W F TC = 0 + -100	24546	C4-1/8-T0-1212-F
<i>2305A TO 2618A</i>						
A10R64	0698-3154	0		RESISTOR 4.22K 1% .125W F TC = 0 + -100	24546	C4-1/8-T0-4221-F
<i>2618A AND ABOVE</i>						
A10R64	0698-5808	5		RESISTOR 4K 1% .125W F TC = 1 + -100	24546	C4-1/8-T0-4001-F
A10R55	0757-0442	9		RESISTOR 10K 1% .125W F TC = 0 + -100	24546	C4-1/8-T0-1002-F
A10R56	0757-0289	2		RESISTOR 13.3K 1% .125W F TC = 0 + -100	19701	MF4C1/8-T0-1332-F
A10R57	0698-0084	9		RESISTOR 2.15K 1% .125W F TC = 0 + -100	24546	C4-1/8-T0-2151-F
A10R58	0757-0280	3		RESISTOR 1K 1% .125W F TC = 0 + -100	24546	C4-1/8-T0-1001-F
A10R59	0698-3160	8		RESISTOR 31.6K 1% .125W F TC = 0 + -100	24546	C4-1/8-T0-3162-F
A10R60	0757-0274	5		RESISTOR 1.21K 1% .125W F TC = 0 + -100	24546	C4-1/8-T0-1211-F
A10R61	0757-0401	0		RESISTOR 100 1% .125W F TC = 0 + -100	24546	C4-1/8-T0-101-F
A10R62	0757-0401	0		RESISTOR 100 1% .125W F TC = 0 + -100	24546	C4-1/8-T0-101-F
A10TP2	1251-0600	0		CONNECTOR-SGL CONT PIN 1.14-MM-BSC-SZ SQ	28480	1251-0600
A10TP3	1251-0600	0		CONNECTOR-SGL CONT PIN 1.14-MM-BSC-SZ SQ	28480	1251-0600
A10TP4	1251-0600	0		CONNECTOR-SGL CONT PIN 1.14-MM-BSC-SZ SQ	28480	1251-0600
A10TP5	1251-0600	0		CONNECTOR-SGL CONT PIN 1.14-MM-BSC-SZ SQ	28480	1251-0600
A10TP6	1251-0600	0		CONNECTOR-SGL CONT PIN 1.14-MM-BSC-SZ SQ	28480	1251-0600
A10TP7	1251-0600	0		CONNECTOR-SGL CONT PIN 1.14-MM-BSC-SZ SQ	28480	1251-0600
A10U1	1826-0785	1		IC OP AMP LOW-BIAS-HIMPD DUAL 8-DIP-C	01295	TL072ACJG
A10U2	1826-0785	1		IC OP AMP LOW-BIAS-HIMPD DUAL 8-DIP-C	01295	TL072ACJG
A10VR1	1902-0680	7		DIODE-ZNR 1N827 6.2V 5% DO-7 PD = .4W	24046	1N827
A10VR2	1902-0968	4	1	DIODE-ZNR 27V 5% DO-35 PD = .4W TC = + .095%	28480	1902-0968
A10VR3	1902-3214	9	2	DIODE-ZNR 16.2V 2% DO-35 PD = .4W	28480	1902-3214
A10VR4	1902-3214	9		DIODE-ZNR 16.2V 2% DO-35 PD = .4W	28480	1902-3214
A10VR5	1902-0960	6	2	DIODE-ZNR 12V 5% DO-35 PD = .4W TC = + .077%	28480	1902-0960
A10VR6 <sup>Δ</sup>	1902-3182	0		DIODE-ZNR 12V 5% DO-35 PD = .4W TC = + .077%	28480	1902-3182
A10VR7	1902-3333	3	1	DIODE-ZNR 46.4V 5% DO-35 PD = .4W	28480	1902-3333
A10VR8	1902-0952	6	2	DIODE-ZNR 5.6V 5% DO-35 PD = .4W TC = + .046%	28480	1902-0952
A10VR9	1902-0952	6		DIODE-ZNR 5.6V 5% DO-35 PD = .4W TC = + .046%	28480	1902-0952
A10VR10	1902-3301	5	1	DIODE-ZNR 34.8V 5% DO-35 PD = .4W	28480	1902-3301
A10VR11	1902-0943	5	3	DIODE-ZNR 2.4V 5% DO-35 PD = .4W TC = -.037%	28480	1902-0943

† Refer to Section 7 for update information.

\* Factory Selected Component (Refer to Section 5).

Δ Errata part change.

Table 6-3. Replaceable Parts

Reference Designation	HP Part Number	C D	Qty.	Description	Mfr. Code	Mfr. Part Number
<b>A11</b>						
<i>2305A TO 2530A</i>						
A11	08901-60093	9	1	COUNTER ASSEMBLY (EXCEPT OPTION 002)	28480	08901-60093
A1J	08901-60018	8	1	COUNTER ASSEMBLY (OPTION 002 ONLY)	28480	08901-60018
<i>2535A AND ABOVE</i>						
A11	08902-60107	7	1	COUNTER ASSEMBLY (EXCEPT OPTION 002)	28480	08902-60107
A1I	08902-60106	6	1	COUNTER ASSEMBLY (OPTION 002 ONLY)	28480	08902-60106
<i>2305A TO 2530A</i>						
A11C1	0160-2055	9		CAPACITOR-FXD .01UF + 80-20% 100VDC CER	28480	0160-2055
<i>2535A AND ABOVE</i>						
A11C1	0160-4832	4		CAPACITOR-FXD .01UF + -10% 100VDC CER	28480	0160-4832
A11C2	0180-0229	7		CAPACITOR-FXD 33UF + -10% 10VDC TA	56289	150D336X9010B2
<i>2305A TO 2530A</i>						
A11C3	0160-2055	9		CAPACITOR-FXD .01UF + 80-20% 100VDC CER	28480	0160-2055
A11C4	0160-2055	9		CAPACITOR-FXD .01UF + 80-20% 100VDC CER	28480	0160-2055
A11C5	0160-2055	9		CAPACITOR-FXD .01UF + 80-20% 100VDC CER	28480	0160-2055
A11C6	0160-2055	9		CAPACITOR-FXD .01UF + 80-20% 100VDC CER	28480	0160-2055
<i>2535A AND ABOVE</i>						
A11C3	0160-4832	4		CAPACITOR-FXD .01UF + -10% 100VDC CER	28480	0160-4832
A11C4	0160-4832	4		CAPACITOR-FXD .01UF + -10% 100VDC CER	28480	0160-4832
A11C5	0160-4832	4		CAPACITOR-FXD .01UF + -10% 100VDC CER	28480	0160-4832
A11C6	0160-4832	4		CAPACITOR-FXD .01UF + -10% 100VDC CER	28480	0160-4832
A11C7	0180-0197	8		CAPACITOR-FXD 2.2UF + -10% 20VDC TA	56289	150D225X9020A2
A11C8	0180-0197	8		CAPACITOR-FXD 2.2UF + -10% 20VDC TA	56289	150D225X9020A2
A11C9	0180-0197	8		CAPACITOR-FXD 2.2UF + -10% 20VDC TA	56289	150D225X9020A2
<i>2305A TO 2530A</i>						
A11C10	0160-2055	9		CAPACITOR-FXD .01UF + 80-20% 100VDC CER	28480	0160-2055
A11C11	0160-2055	9		CAPACITOR-FXD .01UF + 80-20% 100VDC CER	28480	0160-2055
A11C12	0160-2055	9		CAPACITOR-FXD .01UF + 80-20% 100VDC CER	28480	0160-2055
A11C13	0160-2055	9		CAPACITOR-FXD .01UF + 80-20% 100VDC CER	28480	0160-2055
<i>2535A AND ABOVE</i>						
A11C10	0160-4832	4		CAPACITOR-FXD .01UF + -10% 100VDC CER	28480	0160-4832
A11C11	0160-4832	4		CAPACITOR-FXD .01UF + -10% 100VDC CER	28480	0160-4832
A11C12	0160-4832	4		CAPACITOR-FXD .01UF + -10% 100VDC CER	28480	0160-4832
A11C13	0160-4832	4		CAPACITOR-FXD .01UF + -10% 100VDC CER	28480	0160-4832

{Refer to Section 7 for update information

\*Factory Selected Component (Refer to Section 5)

Δ Errata part change

Table 6-3. Replaceable Parts

Reference Designation	HP Part Number	C D	Qty.	Description	Mfr. Code	Mfr. Part Number
A11C14	0121-0105	4		CAPACITOR-V TRMR-CER 9-35PF 200V PC-MTG	52763	304324 9/35PF N650
<i>2306A TO 2630A</i>						
A11C15	0160-0161	4	2	CAPACITOR-FXD .01UF +-10% 200VDC POLYE	28480	0160-0161
A11C16	0160-2055	9		CAPACITOR-FXD .01UF +80-20% 100VDC CER	28480	0160-2055
A11C17	0160-0572	1	10	CAPACITOR-FXD 2200PF +-20% 100VDC CER	28480	0160-0572
A11C18	0160-2055	9		CAPACITOR-FXD .01UF +80-20% 100VDC CER	28480	0160-2055
A11C19	0160-2055	9		CAPACITOR-FXD .01UF +80-20% 100VDC CER	28480	0160-2055
A11C20	0160-3874	2	1	CAPACITOR-FXD 10PF +-.5PF 200VDC CER	28480	0160-3874
A11C21	0160-2055	9		CAPACITOR-FXD .01UF +80-20% 100VDC CER	28480	0160-2055
<i>2636A AND ABOVE</i>						
A11C15	0160-4832	4		CAPACITOR-FXD .01UF +-10% 100VDC CER	28480	0160-4832
A11C16	0160-4832	4		CAPACITOR-FXD .01UF +-10% 100VDC CER	28480	0160-4832
A11C17	0160-4819	7		CAPACITOR-FXD 220PF +-5% 100VDC CER	28480	0160-4819
A11C18	0160-4832	4		CAPACITOR-FXD .01UF +-10% 100VDC CER	28480	0160-4832
A11C19	0160-4832	4		CAPACITOR-FXD .01UF +-10% 100VDC CER	28480	0160-4832
A11C20	0160-4791	4		CAPACITOR-FXD 10PF +-5% 100VDC CER 0 + -30	28480	0160-4791
A11C21	0160-4832	4		CAPACITOR-FXD .01UF +-10% 100VDC CER	28480	0160-4832
A11C22	0180-0197	8		CAPACITOR-FXD 2.2UF +-10% 20VDC TA	56289	150D225X9020A2
<i>2306A TO 2630A</i>						
A11C23	0160-2055	9		CAPACITOR-FXD .01UF +80-20% 100VDC CER	28480	0160-2055
A11C24	0160-0570	9	3	CAPACITOR-FXD 220PF +-20% 100VDC CER	20932	5024EM100RD221M
A11C25	0160-3879	7		CAPACITOR-FXD .01UF +-20% 100VDC CER	28480	0160-3879
A11C26	0140-0198	5		CAPACITOR-FXD 200PF +-5% 300VDC MICA	72136	DM15F201J0300WV1
A11C27	0160-3875	3	5	CAPACITOR-FXD 22PF +-5% 200VDC CER 0 + -30	28480	0160-3875
A11C28	0140-0198	5		CAPACITOR-FXD 200PF +-5% 300VDC MICA	72136	DM15F201J0300
A11C29	0160-0939	4	1	CAPACITOR-FXD 430PF +-5% 300VDC MICA	28480	0160-0939
A11C30	0160-2055	9		CAPACITOR-FXD .01UF +80-20% 100VDC CER	28480	0160-2055
<i>2636A AND ABOVE</i>						
A11C23	0160-4832	4		CAPACITOR-FXD .01UF +-10% 100VDC CER	28480	0160-4832
A11C24	0160-4812	0		CAPACITOR-FXD 220PF +-5% 100VDC CER	28480	0160-4812
A11C25	0160-4832	4		CAPACITOR-FXD .01UF +-10% 100VDC CER	28480	0160-4832
A11C26	0160-4812	0		CAPACITOR-FXD 220PF +-5% 100VDC CER	28480	0160-4812
A11C27	0160-4787	8		CAPACITOR-FXD 22PF +-5% 100VDC CER	28480	0160-4787
A11C28	0160-4812	0		CAPACITOR-FXD 220PF +-5% 100VDC CER	28480	0160-4812
A11C29	0160-4808	4		CAPACITOR-FXD 470PF +-5% 100VDC CER	28480	0160-4808
A11C30	0160-4832	4		CAPACITOR-FXD .01UF +-10% 100VDC CER	28480	0160-4832
A11CR1	1901-0179	7	18	DIODE-SWITCHING 15V 50MA 750PS DO-7	28480	1901-0179
A11CR2	1901-0179	7		DIODE-SWITCHING 15V 50MA 750PS DO-7	28480	1901-0179
A11CR3	1901-0535	9	9	DIODE-SM SIG SCHOTTKY	28480	1901-0535
A11CR4	1901-0535	9		DIODE-SM SIG SCHOTTKY	28480	1901-0535
A11CR5	1901-0535	9		DIODE-SM SIG SCHOTTKY	28480	1901-0535
A11CR6	1901-0535	9		DIODE-SM SIG SCHOTTKY	28480	1901-0535

† Refer to Section 7 for update information

\* Factory Selected Component (Refer to Section 5).

Δ Errata part change

Table 6-3. Replaceable Parts

Reference Designation	HP Part Number	C D	Qty.	Description	Mfr. Code	Mfr. Part Number
A11DS1	1990-0647	1	1	LED-LAMP LUM-INT = 12MCD IF = 20MA-MAX	28480	5082-4558
A11J1	1250-1220	0		CONNECTOR-RF SMC M PC 50-OHM	28480	1250-1220
	2190-0124	4		WASHER-LK INTL T NO. 10 .195-IN-ID	28480	2190-0124
	2950-0078	9		NUT-HEX-DBL-CHAM 10-32-THD .067-IN-THK	28480	2950-0078
A11J2	1250-1220	0		CONNECTOR-RF SMC M PC 50-OHM	28480	1250-1220
	2190-0124	4		WASHER-LK INTL T NO. 10 .195-IN-ID	28480	2190-0124
	2950-0078	9		NUT-HEX-DBL-CHAM 10-32-THD .067-IN-THK	28480	2950-0078
A11J3	1250-1220	0		CONNECTOR-RF SMC M PC 50-OHM	28480	1250-1220
	2190-0124	4		WASHER-LK INTL T NO. 10 .195-IN-ID	28480	2190-0124
	2950-0078	9		NUT-HEX-DBL-CHAM 10-32-THD .067-IN-THK	28480	2950-0078
A11J4	1250-1220	0		CONNECTOR-RF SMC M PC 50-OHM	28480	1250-1220
	2190-0124	4		WASHER-LK INTL T NO. 10 .195-IN-ID	28480	2190-0124
	2950-0078	9		NUT-HEX-DBL-CHAM 10-32-THD .067-IN-THK	28480	2950-0078
A11J5	1250-1220	0		CONNECTOR-RF SMC M PC 50-OHM	28480	1250-1220
	2190-0124	4		WASHER-LK INTL T NO. 10 .195-IN-ID	28480	2190-0124
	2950-0078	9		NUT-HEX-DBL-CHAM 10-32-THD .067-IN-THK	28480	2950-0078
A11J6	1250-1220	0		CONNECTOR-RF SMC M PC 50-OHM	28480	1250-1220
	2190-0124	4		WASHER-LK INTL T NO. 10 .195-IN-ID	28480	2190-0124
	2950-0078	9		NUT-HEX-DBL-CHAM 10-32-THD .067-IN-THK	28480	2950-0078
<b>2305A TO 2630A</b>						
<b>A11L1</b>				NOT ASSIGNED		
<b>2635A AND ABOVE</b>						
A11L1	9100-3922	4		INDUCTOR-FXD 120-1300HZ	28480	9100-3922
A11L2	9100-2248	5	1	INDUCTOR RF-CH-MLD 120NH 10% .105DX.26LG	28480	9100-2248
<b>2305A TO 2630A</b>						
<b>A11MP1</b>						
A11MP1	08901-00033	1	1	COVER COUNTER	28480	08901-00033
<b>2635A AND ABOVE</b>						
A11MP1	08902-00028	5	1	COVER, COUNTER	28480	08902-00028
	2360-0113	2		SCREW-MACH 6-32 .25-IN-LG PAN-HD-POZI	00000	ORDER BY DESCRIPTION
A11MP2	08901-00063	7	1	LABEL I D (EXCEPT OPT. 002)	28480	08901-00063
A11Q1	1853-0015	7	2	TRANSISTOR PNP SI PD = 200MW FT = 500MHZ	28480	1853-0015
A11Q2	1853-0015	7		TRANSISTOR PNP SI PD = 200MW FT = 500MHZ	28480	1853-0015
A11Q3	1853-0020	4		TRANSISTOR PNP SI PD = 300MW FT = 150MHZ	28480	1853-0020
A11Q4	1853-0020	4		TRANSISTOR PNP SI PD = 300MW FT = 150MHZ	28480	1853-0020
A11Q5	1854-0071	7		TRANSISTOR NPN SI PD = 300MW FT = 200MHZ	28480	1854-0071
A11R1	0757-0442	9		RESISTOR 10K 1% .125W F TC = 0 + -100	24546	C4-1/8-T0-1002-F
A11R2	0757-0442	9		RESISTOR 10K 1% .125W F TC = 0 + -100	24546	C4-1/8-T0-1002-F
A11R3	0698-8812	7	2	RESISTOR 1 1% .125W F TC = 0 + -100	28480	0698-8812
A11R4	0698-8816	1	1	RESISTOR 2.15 1% .125W F TC = 0 + -100	28480	0698-8816
A11R5	0757-0346	2		RESISTOR 10 1% .125W F TC = 0 + -100	24546	C4-1/8-T0-10R0-F
A11R6	0757-0416	7		RESISTOR 511 1% .125W F TC = 0 + -100	24546	C4-1/8-T0-511R-F
A11R7	0757-0442	9		RESISTOR 10K 1% .125W F TC = 0 + -100	24546	C4-1/8-T0-1002-F
A11R8	0757-0463	4		RESISTOR 82.5K 1% .125W F TC = 0 + -100	24546	C4-1/8-T0-8252-F
A11R9	0757-0416	7		RESISTOR 511 1% .125W F TC = 0 + -100	24546	C4-1/8-T0-511R-F
A11R10	0757-0465	6		RESISTOR 100K 1% .125W F TC = 0 + -100	24546	C4-1/8-T0-1003-F

† Refer to Section 7 for update information

\* Factory Selected Component (Refer to Section 5)

Δ Errata part change

Table 6-3. Replaceable Parts

Reference Designation	HP Part Number	C D	Qty.	Description	Mfr. Code	Mfr. Part Number
A11R11	0757-0394	0		RESISTOR 51.1 1% .125W F TC = 0 + -100	24546	C4-1/8-T0-51R1-F
A11R12	1810-0204	6	1	NETWORK-RES 8-SIP1.0K OHM X 7	01121	208A102
A11R13	0757-0397	3	15	RESISTOR 68.1 1% .125W F TC = 0 + -100	24546	C4-1/8-T0-68R1-F
A11R14	0757-0280	3		RESISTOR 1K 1% .125W F TC = 0 + -100	24546	C4-1/8-T0-1001-F
A11R15	0698-3445	2		RESISTOR 348 1% .125W F TC = 0 + -100	24546	C4-1/8-T0-348R-F
A11R16	0757-0280	3		RESISTOR 1K 1% .125W F TC = 0 + -100	24546	C4-1/8-T0-1001-F
A11R17	0757-0280	3		RESISTOR 1K 1% .125W F TC = 0 + -100	24546	C4-1/8-T0-1001-F
A11R18	0757-0280	3		RESISTOR 1K 1% .125W F TC = 0 + -100	24546	C4-1/8-T0-1001-F
A11R19	0698-3153	9		RESISTOR 3.83K 1% .125W F TC = 0 + -100	24546	C4-1/8-T0-3831-F
A11R20	0757-0438	3		RESISTOR 5.11K 1% .125W F TC = 0 + -100	24546	C4-1/8-T0-5111-F
A11R21	0757-0416	7		RESISTOR 511 1% .125W F TC = 0 + -100	24546	C4-1/8-T0-511R-F
A11R22	0757-0416	7		RESISTOR 511 1% .125W F TC = 0 + -100	24546	C4-1/8-T0-511R-F
A11R23	0757-0398	4	3	RESISTOR 75 1% .125W F TC = 0 + -100	24546	C4-1/8-T0-75R0-F
A11R24	0757-0280	3		RESISTOR 1K 1% .125W F TC = 0 + -100	24546	C4-1/8-T0-1001-F
A11R25	0757-0397	3		RESISTOR 68.1 1% .125W F TC = 0 + -100	24546	C4-1/8-T0-68R1-F
A11R26	0757-0438	3		RESISTOR 5.11K 1% .125W F TC = 0 + -100	24546	C4-1/8-T0-5111-F
A11R27	0698-3429	2	13	RESISTOR 19.6 1% .125W F TC = 0 + -100	03888	PME55-1/8-T0-19R6-F
A11R28	0698-3445	2		RESISTOR 348 1% .125W F TC = 0 + -100	24546	C4-1/8-T0-348R-F
A11R29	0698-3445	2		RESISTOR 348 1% .125W F TC = 0 + -100	24546	C4-1/8-T0-348R-F
A11R30	0757-0424	7	3	RESISTOR 1.1K 1% .125W F TC = 0 + -100	24546	C4-1/8-T0-1101-F
A11R31	0757-1000	7	1	RESISTOR 51.1 1% .5W F TC = 0 + -100	28480	0757-1000
A11R32	0757-0438	3		RESISTOR 5.11K 1% .125W F TC = 0 + -100	24546	C4-1/8-T0-5111-F
A11R33	0698-3432	7		RESISTOR 26.1 1% .125W F TC = 0 + -100	03888	PME55-1/8-T0-26R1-F
A11R34	0757-0401	0		RESISTOR 100 1% .125W F TC = 0 + -100	24546	C4-1/8-T0-101-F
A11R35	0757-0401	0		RESISTOR 100 1% .125W F TC = 0 + -100	24546	C4-1/8-T0-101-F
A11R36	0757-0280	3		RESISTOR 1K 1% .125W F TC = 0 + -100	24546	C4-1/8-T0-1001-F
A11R37	1810-0206	8	8	NETWORK-RES 8-SIP10.0K OHM X 7	01121	208A103
A11R38	0757-0465	6		RESISTOR 100K 1% .125W F TC = 0 + -100	24546	C4-1/8-T0-1003-F
A11R39	0757-0280	3		RESISTOR 1K 1% .125W F TC = 0 + -100	24546	C4-1/8-T0-1001-F
A11TP1	1251-0600	0		CONNECTOR-SGL CONT PIN 1.14-MM-BSC-SZ SQ	28480	1251-0600
A11TP2	1251-0600	0		CONNECTOR-SGL CONT PIN 1.14-MM-BSC-SZ SQ	28480	1251-0600
A11TP3	1251-0600	0		CONNECTOR-SGL CONT PIN 1.14-MM-BSC-SZ SQ	28480	1251-0600
A11TP4	1251-0600	0		CONNECTOR-SGL CONT PIN 1.14-MM-BSC-SZ SQ	28480	1251-0600
A11TP5	1251-0600	0		CONNECTOR-SGL CONT PIN 1.14-MM-BSC-SZ SQ	28480	1251-0600
A11TP6	1251-0600	0		CONNECTOR-SGL CONT PIN 1.14-MM-BSC-SZ SQ	28480	1251-0600
A11TP7	1251-0600	0		CONNECTOR-SGL CONT PIN 1.14-MM-BSC-SZ SQ	28480	1251-0600

†Refer to Section 7 for update information

\*Factory Selected Component (Refer to Section 5)

Δ Errata part change

Table 6-3. Replaceable Parts

Reference Designation	HP Part Number	C D	Qty.	Description	Mfr. Code	Mfr. Part Number
A11U1	1820-0817	8	4	IC FF ECL D-M/S DUAL	04713	MC10131P
A11U2	1820-0803	2	1	IC GATE ECL OR-NOR TPL	04713	MC10105P
A11U3	1820-1425	6	1	IC SCHMITT-TRIG TTL LS NAND QUAD 2-INP	01295	SN74LS132N
A11U4	1820-1416	5	2	IC SCHMITT-TRIG TTL LS INV HEX 1-INP	01295	SN74LS14N
A11U5	1820-1193	5	4	IC CNTR TTL LS BIN ASYNCHRO	01295	SN74LS197N
A11U6	1820-0693	8	2	IC FF TTL S D-TYPE POS-EDGE-TRIG	01295	SN74S74N
A11U7	1820-1217	4	1	IC MUXR/DATA-SEL TTL LS 8-TO-1-LINE	01295	SN74LS151N
A11U8	1820-1251	6	2	IC CNTR TTL LS DECD ASYNCHRO	01295	SN74LS196N
A11U9	1820-1193	5		IC CNTR TTL LS BIN ASYNCHRO	01295	SN74LS197N
A11U10	1820-1251	6		IC CNTR TTL LS DECD ASYNCHRO	01295	SN74LS196N
A11U11	1820-1193	5		IC CNTR TTL LS BIN ASYNCHRO	01295	SN74LS197N
A11U12	1820-1199	1	5	IC INV TTL LS HEX 1-INP	01295	SN74LS04N
A11U13	1820-1411	0		IC LCH TTL LS D-TYPE 4-BIT	01295	SN74LS75N
A11U14	1820-1198	0		IC GATE TTL LS NAND QUAD 2-INP	01295	SN74LS03N
A11U15	1200-0638	7	2	SOCKET-IC 14-CONT DIP DIP-SLDR	28480	1200-0638
	1820-1198	0		IC GATE TTL LS NAND QUAD 2-INP	01295	SN74LS03N
	1200-0638	7		SOCKET-IC 14-CONT DIP DIP-SLDR	28480	1200-0638
A11U16	1820-0693	8		IC FF TTL S D-TYPE POS-EDGE-TRIG	01295	SN74S74N
A11U17	1820-1240	3	1	IC DCDR TTL S 3-TO-8-LINE 3-INP	01295	SN74S138N
A11U18	1820-1197	9		IC GATE TTL LS NAND QUAD 2-INP	01295	SN74LS00N
A11U19	1820-1193	5		IC CNTR TTL LS BIN ASYNCHRO	01295	SN74LS197N
A11U20	1820-1197	9		IC GATE TTL LS NAND QUAD 2-INP	01295	SN74LS00N
A11U21	1820-0723	5	2	IC RCVR TTL LINE RCVR DUAL 2-INP	01295	SN75107AN
A11Y1	0410-0423	2	1	CRYSTAL-QUARTZ 10.000 MHZ (EXCEPT OPT. 002)	28480	0410-0423

† Refer to Section 7 for update information.

\* Factory Selected Component (Refer to Section 5)

Δ Errata part change

Table 6-3. Replaceable Parts

Reference Designation	HP Part Number	C D	Qty.	Description	Mfr. Code	Mfr. Part Number
<b>A13 08901-60244 – SERIAL PREFIX 2305A TO 2742A</b>						
A13	08901-60244	2	1	CONTROLLER ASSEMBLY	28480	08901-60244
A13BT1	1420-0322	2		BATTERY 2.8V .2A-HR LII PIN	28480	1420-0322
	08901-00195	6	1	BATTERY INSULATOR	28480	08901-00195
A13C1	0180-2111	0	3	CAPACITOR-FXD 33UF +-10% 35VDC TA	56289	150D336X9035SA
A13C2	0160-4832	4		CAPACITOR-FXD .01UF +-10% 100VDC CER	28480	0160-4832
A13C3	0160-4835	7		CAPACITOR-FXD .1UF +-10% 50VDC CER	28480	0160-4835
A13C4	0160-4835	7		CAPACITOR-FXD .1UF +-10% 50VDC CER	28480	0160-4835
A13C5	0180-0197	8		CAPACITOR-FXD 2.2UF +-10% 20VDC TA	56289	150D225X9020A2
A13C6	0160-4835	7		CAPACITOR-FXD .1UF +-10% 50VDC CER	28480	0160-4835
A13C7	0180-0197	8		CAPACITOR-FXD 2.2UF +-10% 20VDC TA	56289	150D225X9020A2
A13C8	0180-0100	3	2	CAPACITOR-FXD 4.7UF +-10% 35VDC TA	56289	150D475X9035B2
A13C9	0160-4832	4		CAPACITOR-FXD .01UF +-10% 100VDC CER	28480	0160-4832
A13C10	0160-4832	4		CAPACITOR-FXD .01UF +-10% 100VDC CER	28480	0160-4832
A13C11	0180-0197	8		CAPACITOR-FXD 2.2UF +-10% 20VDC TA	56289	150D225X9020A2
A13C12	0160-4832	4		CAPACITOR-FXD .01UF +-10% 100VDC CER	28480	0160-4832
A13C13	0180-0197	8		CAPACITOR-FXD 2.2UF +-10% 20VDC TA	56289	150D225X9020A2
A13C14	0160-4832	4		CAPACITOR-FXD .01UF +-10% 100VDC CER	28480	0160-4832
A13C15	0160-4832	4		CAPACITOR-FXD .01UF +-10% 100VDC CER	28480	0160-4832
A13C16	0160-4832	4		CAPACITOR-FXD .01UF +-10% 100VDC CER	28480	0160-4832
A13C17	0180-0197	8		CAPACITOR-FXD 2.2UF +-10% 20VDC TA	56289	150D225X9020A2
A13C18	0180-0291	3		CAPACITOR-FXD 1UF +-10% 35VDC TA	56289	150D105X9035A2
<i>2305A TO 2528A</i>						
A13C19	0160-4814	2	3	CAPACITOR-FXD 150PF +-5% 100VDC CER	28480	0160-4814
A13C20	0160-4814	2		CAPACITOR-FXD 150PF +-5% 100VDC CER	28480	0160-4814
<i>2530A TO 2625A</i>						
A13C19	0160-4805	1		CAPACITOR-FXD 47PF +-5% 100VDC CER 0 + -30	28480	0160-4805
A13C20	0160-4805	1		CAPACITOR-FXD 47PF +-5% 100VDC CER 0 + -30	28480	0160-4805
<i>2627A AND ABOVE</i>						
A13C19				NOT ASSIGNED		
A13C20				NOT ASSIGNED		
A13C21 <sup>Δ</sup>	0180-5098	6		CAPACITOR-FXD .22UF +-10% 50VDC TA	28480	0180-5098
A13C22				NOT ASSIGNED		
A13CR1	1901-0159	3	1	DIODE-PWR RECT 400V 750MA DO-41	28480	1901-0159
A13CR2	1901-1098	1		DIODE-SWITCHING 1N4150 50V 200MA 4NS	9N171	1N4150
A13CR3	1901-1098	1		DIODE-SWITCHING 1N4150 50V 200MA 4NS	9N171	1N4150
A13CR4	1901-0880	7		DIODE-GEN PRP 125MA DO-35	28480	1901-0880
A13CR5	1901-0880	7		DIODE-GEN PRP 125MA DO-35	28480	1901-0880
A13CR6	1901-1098	1		DIODE-SWITCHING 1N4150 50V 200MA 4NS	9N171	1N4150
A13CR7	1901-1098	1		DIODE-SWITCHING 1N4150 50V 200MA 4NS	9N171	1N4150

† Refer to Section 7 for update information

\* Factory Selected Component (Refer to Section 5)

Δ Errata part change

Table 6-3. Replaceable Parts

Reference Designation	HP Part Number	C D	Qty.	Description	Mfr. Code	Mfr. Part Number
<b>A13 08901-60244 -- SERIAL PREFIX 2305A TO 2742A</b>						
A13DS1	1990-0534	5	4	LED-LAMP LUM-INT = 2.2MCD IF = 20MA-MAX	28480	5082-4555
A13DS2	1990-0534	5		LED-LAMP LUM-INT = 2.2MCD IF = 20MA-MAX	28480	5082-4555
A13DS3	1990-0534	5		LED-LAMP LUM-INT = 2.2MCD IF = 20MA-MAX	28480	5082-4555
A13DS4	1990-0534	5		LED-LAMP LUM-INT = 2.2MCD IF = 20MA-MAX	28480	5082-4555
<i>2305A TO 2626A</i>						
A13L1	9140-0238	3	1	INDUCTOR RF-CH-MLD 82UH 5% .166DX.385LG	28480	9140-0238
<i>2627A AND ABOVE</i>						
A13L1				NOT ASSIGNED		
A13MP1	4040-0749	4	2	EXTR-PC BD BRN POLYC .062-BD-THKNS	28480	4040-0749
	1480-0116	8	4	PIN-ROLL .062-IN-DIA .25-IN-LG STL	28480	1480-0116
A13MP2	4040-0751	8	1	EXTR-PC BD ORN POLYC .062-BD-THKNS	28480	4040-0751
	1480-0116	8		PIN-ROLL .062-IN-DIA .25-IN-LG STL	28480	1480-0116
A13Q1	1853-0393	4	1	TRANSISTOR PNP SI TO-18 PD = 500MW	28480	1853-0393
A13Q2	1858-0032	8		TRANSISTOR ARRAY 14-PIN PLSTC DIP	3L585	CA3146E
A13Q3	1853-0459	3	8	TRANSISTOR PNP SI PD = 625MW FT = 200MHZ	28480	1853-0459
A13R1	0757-0280	3		RESISTOR 1K 1% .125W F TC = 0 + -100	24546	C4-1/8-T0-1001-F
A13R2	0757-0280	3		RESISTOR 1K 1% .125W F TC = 0 + -100	24546	C4-1/8-T0-1001-F
A13R3	1810-0206	8		NETWORK-RES 8-SIP10.0K OHM X 7	01121	208A103
A13R4	1810-0206	8		NETWORK-RES 8-SIP10.0K OHM X 7	01121	208A103
A13R5	1810-0206	8		NETWORK-RES 8-SIP10.0K OHM X 7	01121	208A103
A13R6	0698-3156	2		RESISTOR 14.7K 1% .125W F TC = 0 + -100	24546	C4-1/8-T0-1472-F
A13R7	0757-0279	0		RESISTOR 3.16K 1% .125W F TC = 0 + -100	24546	C4-1/8-T0-3161-F
A13R8	0757-0401	0		RESISTOR 100 1% .125W F TC = 0 + -100	24546	C4-1/8-T0-101-F
A13R9	0757-0442	9		RESISTOR 10K 1% .125W F TC = 0 + -100	24546	C4-1/8-T0-1002-F
A13R10	0757-0419	0		RESISTOR 681 1% .125W F TC = 0 + -100	24546	C4-1/8-T0-681R-F
<i>2305A TO 2535A</i>						
A13R11	0698-3454	3		RESISTOR 215K 1% .125W F TC = 0 + -100	24546	C4-1/8-T0-2153-F
<i>2540A AND ABOVE</i>						
A13R11	0757-0458	7		RESISTOR 51.1K 1% .125W F TC = 0 + -100	24546	C4-1/8-T0-5112-F
A13R12	2100-2522	1	1	RESISTOR-TRMR 10K 10% C SIDE-ADJ 1-TRN	30983	ET50X103
A13R13	0698-6624	5	3	RESISTOR 2K .1% .125W F TC = 0 + -25	28480	0698-6624
A13R14	0698-8827	4		RESISTOR 1M 1% .125W F TC = 0 + -100	28480	0698-8827
A13R15	0698-6624	5		RESISTOR 2K .1% .125W F TC = 0 + -25	28480	0698-6624
A13R16	0698-6624	5		RESISTOR 2K .1% .125W F TC = 0 + -25	28480	0698-6624
A13R17	0757-0442	9		RESISTOR 10K 1% .125W F TC = 0 + -100	24546	C4-1/8-T0-1002-F
A13R18	0698-6360	6		RESISTOR 10K .1% .125W F TC = 0 + -25	28480	0698-6360
A13R19	0698-6348	0	1	RESISTOR 3K .1% .125W F TC = 0 + -25	28480	0698-6348
A13R20	0757-0442	9		RESISTOR 10K 1% .125W F TC = 0 + -100	24546	C4-1/8-T0-1002-F
A13R21	0757-0459	8	2	RESISTOR 56.2K 1% .125W F TC = 0 + -100	24546	C4-1/8-T0-5622-F
A13R22	0757-0441	8		RESISTOR 8.25K 1% .125W F TC = 0 + -100	24546	C4-1/8-T0-8251-F
A13R23	0757-0439	4		RESISTOR 6.81K 1% .125W F TC = 0 + -100	24546	C4-1/8-T0-6811-F
A13R24	0698-3162	0	3	RESISTOR 46.4K 1% .125W F TC = 0 + -100	24546	C4-1/8-T0-4642-F
A13R25	0698-3161	9		RESISTOR 38.3K 1% .125W F TC = 0 + -100	24546	C4-1/8-T0-3832-F
A13R26	0757-0447	4		RESISTOR 16.2K 1% .125W F TC = 0 + -100	24546	C4-1/8-T0-1622-F

† Refer to Section 7 for update information.

\* Factory Selected Component (Refer to Section 5)

Δ Errata part change.



Table 6-3. Replaceable Parts

Reference Designation	HP Part Number	C D	Qty.	Description	Mfr. Code	Mfr. Part Number
<b>A13 08901-60244 – SERIAL PREFIX 2305A TO 2742A</b>						
A13R27	0757-0442	9		RESISTOR 10K 1% .125W F TC = 0 + -100	24546	C4-1/8-T0-1002-F
A13R28	0757-0418	9	3	RESISTOR 619 1% .125W F TC = 0 + -100	24546	C4-1/8-T0-619R-F
A13R29	1810-0229	5	1	NETWORK-RES 8-SIP330.0 OHM X 7	01121	208A331
A13R30	0757-0442	9		RESISTOR 10K 1% .125W F TC = 0 + -100	24546	C4-1/8-T0-1002-F
A13TP1	1251-0600	0		CONNECTOR-SGL CONT PIN 1.14-MM-BSC-SZ SQ	28480	1251-0600
A13TP2	1251-0600	0		CONNECTOR-SGL CONT PIN 1.14-MM-BSC-SZ SQ	28480	1251-0600
A13TP3	1251-0600	0		CONNECTOR-SGL CONT PIN 1.14-MM-BSC-SZ SQ	28480	1251-0600
A13TP4	1251-0600	0		CONNECTOR-SGL CONT PIN 1.14-MM-BSC-SZ SQ	28480	1251-0600
A13TP5	1251-0600	0		CONNECTOR-SGL CONT PIN 1.14-MM-BSC-SZ SQ	28480	1251-0600
A13TP6	1251-0600	0		CONNECTOR-SGL CONT PIN 1.14-MM-BSC-SZ SQ	28480	1251-0600
A13TP7	1251-0600	0		CONNECTOR-SGL CONT PIN 1.14-MM-BSC-SZ SQ	28480	1251-0600
A13TP8	1251-0600	0		CONNECTOR-SGL CONT PIN 1.14-MM-BSC-SZ SQ	28480	1251-0600
A13TP9	1251-0600	0		CONNECTOR-SGL CONT PIN 1.14-MM-BSC-SZ SQ	28480	1251-0600
A13TP10	1251-0600	0		CONNECTOR-SGL CONT PIN 1.14-MM-BSC-SZ SQ	28480	1251-0600
A13TP11	1251-0600	0		CONNECTOR-SGL CONT PIN 1.14-MM-BSC-SZ SQ	28480	1251-0600
A13TP12	1251-0600	0		CONNECTOR-SGL CONT PIN 1.14-MM-BSC-SZ SQ	28480	1251-0600
A13TP13	1251-0600	0		CONNECTOR-SGL CONT PIN 1.14-MM-BSC-SZ SQ	28480	1251-0600
A13TP14	1251-0600	0		CONNECTOR-SGL CONT PIN 1.14-MM-BSC-SZ SQ	28480	1251-0600
A13TP15	1251-0600	0		CONNECTOR-SGL CONT PIN 1.14-MM-BSC-SZ SQ	28480	1251-0600
A13U1	1818-1968	7	1	IC CMOS 16384 (16K) STAT RAM 250-NS 3-S	28480	1818-1968
	1200-0565	9	1	SOCKET-IC 24-CONT DIP-SLDR	28480	1200-0565
A13U2	1820-1199	1		IC INV TTL LS HEX 1-INP	01295	SN74LS04N
A13U3	1826-0759	9	1	IC COMPARATOR GP QUAD 14-DIP-C PKG	04713	LM339J
<i>2305A TO 2331A</i>						
A13U4	08902-80064	6	1	ROM #3	28480	08901-80064
	1200-0553	5	3	SOCKET-IC 28-CONT DIP-SLDR	28480	1200-0553
<i>2337A TO 2449A</i>						
A13U4	08902-80068	0		ROM #3	28480	08901-80068
	1200-0553	5	3	SOCKET-IC 28-CONT DIP-SLDR	28480	1200-0553
<i>2451A TO 2515A</i>						
A13U4	08902-80073	7		ROM #3	28480	08901-80073
	1200-0553	5	3	SOCKET-IC 28-CONT DIP-SLDR	28480	1200-0553
<i>2519A TO 2536A</i>						
A13U4	08902-80078	2		ROM #3	28480	08901-80078
	1200-0553	5	3	SOCKET-IC 28-CONT DIP-SLDR	28480	1200-0553
<i>2535A TO 2606A</i>						
A13U4	08902-80083	9		ROM #3	28480	08901-80083
	1200-0553	5	3	SOCKET-IC 28-CONT DIP-SLDR	28480	1200-0553
<i>2616A TO 2631A</i>						
A13U4	08902-80089	5		ROM #3	28480	08901-80089
	1200-0553	5	3	SOCKET-IC 28-CONT DIP-SLDR	28480	1200-0553
<i>2644A TO 2706A</i>						
A13U4	08902-80092	1		ROM #3	28480	08901-80092
	1200-0553	5	3	SOCKET-IC 28-CONT DIP-SLDR	28480	1200-0553
<i>2717A AND ABOVE</i>						
A13U4	08902-80107	8		ROM #3	28480	08901-80107
	1200-0553	5	3	SOCKET-IC 28-CONT DIP-SLDR	28480	1200-0553

† Refer to Section 7 for update information

\* Factory Selected Component (Refer to Section 5)

Δ Errata part change

Table 6-3. Replaceable Parts

Reference Designation	HP Part Number	C D	Qty.	Description	Mfr. Code	Mfr. Part Number
<b>A13 08901-60244 – SERIAL PREFIX 2305A TO 2742A</b>						
A13U5	1820-1281	2	1	IC DCDR TTL LS 2-TO-4-LINE DUAL 2-INP	01295	SN74LS139N
A13U6	1826-0275	4	1	IC 78L12A V RGLTR TO-92	04713	MC78L12ACP
<i>2305A TO 2331A</i>						
A13U7	08901-80063	5	1	ROM #2	28480	08901-80063
	1200-0553	5		SOCKET-IC 28-CONT DIP-SLDR	28480	1200-0553
<i>2337A TO 2449A</i>						
A13U7	08901-80067	9		ROM #2	28480	08901-80067
	1200-0553	5		SOCKET-IC 28-CONT DIP-SLDR	28480	1200-0553
<i>2451A TO 2515A</i>						
A13U7	08901-80072	6		ROM #2	28480	08901-80072
	1200-0553	5		SOCKET-IC 28-CONT DIP-SLDR	28480	1200-0553
<i>2519A TO 2530A</i>						
A13U7	08901-80077	1		ROM #2	28480	08901-80077
	1200-0553	5		SOCKET-IC 28-CONT DIP-SLDR	28480	1200-0553
<i>2535A TO 2606A</i>						
A13U7	08901-80082	8		ROM #2	28480	08901-80082
	1200-0553	5	3	SOCKET-IC 28-CONT DIP-SLDR	28480	1200-0553
<i>2616A TO 2625A</i>						
A13U7	08901-80088	4		ROM #2	28480	08901-80088
	1200-0553	5	3	SOCKET-IC 28-CONT DIP-SLDR	28480	1200-0553
<i>2644A TO 2706A</i>						
A13U7	08901-80091	0		ROM #2	28480	08901-80091
	1200-0553	5	3	SOCKET-IC 28-CONT DIP-SLDR	28480	1200-0553
<i>2717A AND ABOVE</i>						
A13U7	08901-80106	7		ROM #2	28480	08901-80106
	1200-0553	5	3	SOCKET-IC 28-CONT DIP-SLDR	28480	1200-0553
A13U8	1820-2027	6	1	IC-STATIC MEMORY INTERFACE	28480	1820-2027
	1200-0552	4	2	SOCKET-IC 40-CONT DIP-SLDR	28480	1200-0552
A13U9	1820-1928	4	1	IC-F8-MPU; CLK FREQ = 2 MHZ	28480	1820-1928
	1200-0552	4		SOCKET-IC 40-CONT DIP-SLDR	28480	1200-0552

† Refer to Section 7 for update information.

\* Factory Selected Component (Refer to Section 5)

Δ Errata part change

Table 6-3. Replaceable Parts

Reference Designation	HP Part Number	C D	Qty.	Description	Mfr. Code	Mfr. Part Number
<b>A13 08901-60244 – SERIAL PREFIX 2305A TO 2742A</b>						
<i>2305A TO 2331A</i>						
<i>A13U10</i>	08901-80062	4	1	ROM #1	28480	08901-80062
	1200-0553	5		SOCKET-IC 28-CONT DIP-SLDR	28480	1200-0553
<i>2337A TO 2449A</i>						
<i>A13U10</i>	08901-80066	8		ROM #1	28480	08901-80066
	1200-0553	5		SOCKET-IC 28-CONT DIP-SLDR	28480	1200-0553
<i>2451A TO 2516A</i>						
<i>A13U10</i>	08901-80071	5		ROM #1	28480	08901-80071
	1200-0553	5		SOCKET-IC 28-CONT DIP-SLDR	28480	1200-0553
<i>2519A TO 2523A</i>						
<i>A13U10</i>	08901-80076	0		ROM #1	28480	08901-80076
	1200-0553	5		SOCKET-IC 28-CONT DIP-SLDR	28480	1200-0553
<i>2528A TO 2530A</i>						
<i>A13U10</i>	08901-80084	0		ROM #1	28480	08901-80084
	1200-0553	5		SOCKET-IC 28-CONT DIP-SLDR	28480	1200-0553
<i>2535A TO 2606A</i>						
<i>A13U10</i>	08901-80081	7		ROM #1	28480	08901-80081
	1200-0553	5		SOCKET-IC 28-CONT DIP-SLDR	28480	1200-0553
<i>2616A TO 2625A</i>						
<i>A13U10</i>	08901-80087	3		ROM #1	28480	08901-80087
	1200-0553	5		SOCKET-IC 28-CONT DIP-SLDR	28480	1200-0553
<i>2644A TO 2706A</i>						
<i>A13U10</i>	08901-80090	9		ROM #1	28480	08901-80090
	1200-0553	5		SOCKET-IC 28-CONT DIP-SLDR	28480	1200-0553
<i>2717A AND ABOVE</i>						
<i>A13U10</i>	08901-80105	6		ROM #1	28480	08901-80105
	1200-0553	5		SOCKET-IC 28-CONT DIP-SLDR	28480	1200-0553
A13U11	1820-1216	3		IC DCDR TTL LS 3-TO-8-LINE 3-INP	01295	SN74LS138N
A13U12	1820-1917	1	1	IC BFR TTL LS LINE DRVR OCTL	01295	SN74LS240N
A13U13	1820-1287	8	1	IC BFR TTL LS NAND QUAD 2-INP	01295	SN74LS37N
A13VR1	1902-0777	3	1	DIODE-ZNR 1N825 6.2V 5% DO-7 PD = .4W	04713	1N825
A13W1	8159-0005	0	11	RESISTOR-ZERO OHMS 22 AWG LEAD DIA	28480	8159-0005
A13W2	8159-0005	0		RESISTOR-ZERO OHMS 22 AWG LEAD DIA	28480	8159-0005

† Refer to Section 7 for update information.

\* Factory Selected Component (Refer to Section 5)

Δ Errata part change

Table 6-3. Replaceable Parts

Reference Designation	HP Part Number	C D	Qty.	Description	Mfr. Code	Mfr. Part Number
<b>A13 08901-60196 – SERIAL PREFIX 2745A AND ABOVE</b>						
A13	08901-60196	4	1	CONTROLLER ASSEMBLY	28480	08901-60196
A13BT1	1420-0322	2		BATTERY 2.8V .2A-HR LVI PIN	28480	1420-0322
A13C1	0180-0116	1	1	CAPACITOR-FXD 6.8UF + -10% 35VDC TA	56289	150D685X9035B2
A13C2	0160-4832	4		CAPACITOR-FXD .01UF + -10% 100VDC CER	28480	0160-4832
A13C3	0160-4835	7		CAPACITOR-FXD .1UF + -10% 50VDC CER	28480	0160-4835
A13C4				NOT ASSIGNED		
A13C5	0180-0197	8		CAPACITOR-FXD 2.2UF + -10% 20VDC TA	56289	150D225X9020A2
A13C6	0160-4835	7		CAPACITOR-FXD .1UF + -10% 50VDC CER	28480	0160-4835
A13C7	0180-0197	8		CAPACITOR-FXD 2.2UF + -10% 20VDC TA	56289	150D225X9020A2
A13C8				NOT ASSIGNED		
A13C9				NOT ASSIGNED		
A13C10	0160-4832	4		CAPACITOR-FXD .01UF + -10% 100VDC CER	28480	0160-4832
A13C11	0160-4832	4		CAPACITOR-FXD .01UF + -10% 100VDC CER	28480	0160-4832
A13C12	0160-4832	4		CAPACITOR-FXD .01UF + -10% 100VDC CER	28480	0160-4832
A13C13	0180-0197	8		CAPACITOR-FXD 2.2UF + -10% 20VDC TA	56289	150D225X9020A2
A13C14	0160-4832	4		CAPACITOR-FXD .01UF + -10% 100VDC CER	28480	0160-4832
A13C15	0160-4832	4		CAPACITOR-FXD .01UF + -10% 100VDC CER	28480	0160-4832
A13C16	0160-4832	4		CAPACITOR-FXD .01UF + -10% 100VDC CER	28480	0160-4832
△ A13C17	0180-0100	3		CAPACITOR-FXD 4.7UF + -10% 35VDC TA	28480	0180-0100
A13C18	0180-0291	3		CAPACITOR-FXD 1UF + -10% 35VDC TA	56289	150D105X9035A2
A13C19				NOT ASSIGNED		
A13C20				NOT ASSIGNED		
A13C21	0180-0197	8		CAPACITOR-FXD 2.2UF + -10% 20VDC TA	56289	150D225X9020A2
A13C22	0160-4814	2	1	CAPACITOR-FXD 150PF + -5% 100VDC CER	28480	0160-4814
A13CR1	1901-0159	3	1	DIODE-PWR RECT 400V 750MA DO-41	28480	1901-0159
A13CR2	1901-1098	1		DIODE-SWITCHING 1N4150 50V 200MA 4NS	9N171	1N4150
A13CR3	1901-1098	1		DIODE-SWITCHING 1N4150 50V 200MA 4NS	9N171	1N4150
A13CR4	1901-0880	7		DIODE-GEN PRP 125MA DO-35	28480	1901-0880
A13CR5	1901-0880	7		DIODE-GEN PRP 125MA DO-35	28480	1901-0880
A13CR6	1901-1098	1		DIODE-SWITCHING 1N4150 50V 200MA 4NS	9N171	1N4150
A13CR7	1901-1098	1		DIODE-SWITCHING 1N4150 50V 200MA 4NS	9N171	1N4150
A13DS1	1990-1110	5	4	LED-LAMP LUM-INT = 1.51MCD IF = 20MA-MAX	28480	1990-1110
A13DS2	1990-1110	5		LED-LAMP LUM-INT = 1.5MCD IF = 20MA-MAX	28480	1901-1110
A13DS3	1990-1110	5		LED-LAMP LUM-INT = 1.5MCD IF = 20MA-MAX	28480	1990-1110
A13DS4	1990-1110	5		LED-LAMP LUM-INT = 1.5MCD IF = 20MA-MAX	28480	1990-1110
A13L1				NOT ASSIGNED		
A13MP1	4040-0749	4	2	EXTR-PC BD BRN POLYC .062-BD-THKNS	28480	4040-0749
	1480-0116	8	4	PIN-ROLL .062-IN-DIA .25-IN-LG STL	28480	1480-0116
A13MP2	4040-0751	8	1	EXTR-PC BD ORN POLYC .062-BD-THKNS	28480	4040-0751
	1480-0116	8		PIN-ROLL .062-IN-DIA .25-IN-LG STL	28480	1480-0116
A13Q1	1853-0393	4	1	TRANSISTOR PNP SI TO-18 PD = 500MW	28480	1853-0393
A13Q2	1858-0032	8		TRANSISTOR ARRAY 14-PIN PLSTC DIP	3L585	CA3146E
A13Q3	1853-0459	3	8	TRANSISTOR PNP SI PD = 625MW FT = 200MHZ	28480	1853-0459

†Refer to Section 7 for update information.

\*Factory Selected Component (Refer to Section 5)

△ Errata part change

Table 6-3. Replaceable Parts

Reference Designation	HP Part Number	C D	Qty.	Description	Mfr. Code	Mfr. Part Number
<b>A13 08901-60196 – SERIAL PREFIX 2745A AND ABOVE</b>						
A13R1	0757-0280	3		RESISTOR 1K 1% .125W F TC = 0 + -100	24546	C4-1/8-T0-1001-F
A13R2	0757-0280	3		RESISTOR 1K 1% .125W F TC = 0 + -100	24546	C4-1/8-T0-1001-F
A13R3				NOT ASSIGNED		
A13R4				NOT ASSIGNED		
A13R5				NOT ASSIGNED		
A13R6	0698-3156	2		RESISTOR 14.7K 1% .125W F TC = 0 + -100	24546	C4-1/8-T0-1472-F
A13R7	0757-0279	0		RESISTOR 3.16K 1% .125W F TC = 0 + -100	24546	C4-1/8-T0-3161-F
A13R8	0757-0401	0		RESISTOR 100 1% .125W F TC = 0 + -100	24546	C4-1/8-T0-101-F
A13R9	0757-0442	9		RESISTOR 10K 1% .125W F TC = 0 + -100	24546	C4-1/8-T0-1002-F
A13R10	0757-0419	0		RESISTOR 681 1% .125W F TC = 0 + -100	24546	C4-1/8-T0-681R-F
△ A13R11	0698-3454	3		RESISTOR 215K 1% .125W F TC = 0 + -100	24546	C4-1/8-T0-2153-F
A13R12	2100-2522	1	1	RESISTOR-TRMR 10K 10% C SIDE-ADJ 1-TRN	30983	ET50X103
A13R13	0698-6624	5	3	RESISTOR 2K .1% .125W F TC = 0 + -25	28480	0698-6624
A13R14	0698-8827	4		RESISTOR 1M 1% .125W F TC = 0 + -100	28480	0698-8827
A13R15	0698-6624	5		RESISTOR 2K .1% .125W F TC = 0 + -25	28480	0698-6624
A13R16	0698-6624	5		RESISTOR 2K .1% .125W F TC = 0 + -25	28480	0698-6624
A13R17	0757-0442	9		RESISTOR 10K 1% .125W F TC = 0 + -100	24546	C4-1/8-T0-1002-F
A13R18	0698-6360	6		RESISTOR 10K .1% .125W F TC = 0 + -25	28480	0698-6360
A13R19	0698-6348	0	1	RESISTOR 3K .1% .125W F TC = 0 + -25	28480	0698-6348
A13R20	0757-0442	9		RESISTOR 10K 1% .125W F TC = 0 + -100	24546	C4-1/8-T0-1002-F
A13R21	0757-0459	8	2	RESISTOR 56.2K 1% .125W F TC = 0 + -100	24546	C4-1/8-T0-5622-F
A13R22	0757-0441	8		RESISTOR 8.25K 1% .125W F TC = 0 + -100	24546	C4-1/8-T0-8251-F
A13R23	0757-0439	4		RESISTOR 6.81K 1% .125W F TC = 0 + -100	24546	C4-1/8-T0-6811-F
A13R24	0698-3162	0	3	RESISTOR 46.4K 1% .125W F TC = 0 + -100	24546	C4-1/8-T0-4642-F
A13R25	0698-3161	9		RESISTOR 38.3K 1% .125W F TC = 0 + -100	24546	C4-1/8-T0-3832-F
A13R26	0757-0447	4		RESISTOR 16.2K 1% .125W F TC = 0 + -100	24546	C4-1/8-T0-1622-F
A13R27	0757-0442	9		RESISTOR 10K 1% .125W F TC = 0 + -100	24546	C4-1/8-T0-1002-F
A13R28	0757-0418	9	3	RESISTOR 619 1% .125W F TC = 0 + -100	24546	C4-1/8-T0-619R-F
A13R29	1810-0229	5	1	NETWORK-RES 8-SIP330.0 OHM X 7	01121	208A331
A13R30	0757-0442	9		RESISTOR 10K 1% .125W F TC = 0 + -100	24546	C4-1/8-T0-1002-F
A13R31	1810-0286	4	1	NETWORK-RES 16-DIP 10.0K OHM X 15	01121	316A103
A13TP16	1251-5730	7	1	CONNECTOR 15-PIN M POST TYPE	28480	1251-5730
A13U1	1LJ6-0001	2	1	IC CMOS 16384 (16K) STAT RAM 250-NS 3-S	28480	1LJ6-0001
	1200-0541	9	1	SOCKET-IC 24-CONT DIP-SLDR	28480	1200-0541
A13U2	1820-1199	1		IC INV TTL LS HEX 1-INP	01295	SN74LS04N
A13U3	1826-0759	9	1	IC COMPARATOR GP QUAD 14-DIP-C PKG	04713	LM339J
A13U4				NOT ASSIGNED		
A13U5				NOT ASSIGNED		
A13U6	1826-0275	4	1	IC 78L12A V RGLTR TO-92	04713	MC78L12ACP
A13U7				NOT ASSIGNED		
A13U8	1820-2027	6	1	IC-STATIC MEMORY INTERFACE	28480	1820-2027
	1200-0654	4	2	SOCKET-IC 40-CONT DIP-SLDR	28480	1200-0654
A13U9	1820-1928	4	1	IC-F8-MPU; CLK FREQ = 2 MHZ	28480	1820-1928
	1200-0654	4		SOCKET-IC 40-CONT DIP-SLDR	28480	1200-0654
A13U10				NOT ASSIGNED		
A13U11	1820-1216	3		IC DCDR TTL LS 3-TO-8-LINE 3-INP	01295	SN74LS138N

† Refer to Section 7 for update information.

\* Factory Selected Component (Refer to Section 5).

△ Errata part change.

*Table 6-3. Replaceable Parts*

Reference Designation	HP Part Number	C D	Qty.	Description	Mfr. Code	Mfr. Part Number
<b>A13            08901-60196 – SERIAL PREFIX 2745A AND ABOVE</b>						
A13U12	1820-1917	1	1	IC BFR TTL LS LINE DRVR OCTL	01295	SN74LS240N
A13U13	1820-1287	8	1	IC BFR TTL LS NAND QUAD 2-INP	01295	SN74LS37N
<i>2314A TO 2960A</i>						
A13U14 <sup>Δ</sup>	08901-80111	4	1	ROM #1	28480	08901-80111
<i>3001A TO 3024A</i>						
A13U14	08901-80116	9	1	ROM #1	28480	08901-80116
<i>3028A ONLY</i>						
A13U14	08901-80117	0	1	ROM #1	28480	08901-80117
<i>3104A TO 3112A</i>						
A13U14	08901-80121		1	ROM #1	28480	08901-80121
<i>3116A AND ABOVE</i>						
A13U14	08901-80128	3	1	ROM #1	28480	08901-80128
	1200-0567	1	1	SOCKET-IC 28-CONT DIP DIP-SLDR	28480	1200-0567
A13VR1	1902-0777	3	1	DIODE-ZNR 1N825 6.2V 5% DO-7 PD = .4W	04713	1N825
A13W1	8159-0005	0	11	RESISTOR-ZERO OHMS 22 AWG LEAD DIA	28480	8159-0005
A13W2	8159-0005	0		RESISTOR-ZERO OHMS 22 AWG LEAD DIA	28480	8159-0005

†Refer to Section 7 for update information.

\*Factory Selected Component (Refer to Section 5).

Δ Errata part change.

Table 6-3. Replaceable Parts

Reference Designation	HP Part Number	C D	Qty.	Description	Mfr. Code	Mfr. Part Number
<b>A14</b>						
<i>2305A TO 2519A</i>						
A14	08901-60223	7	1	REMOTE INTERFACE ASSEMBLY	28480	08901-60223
<i>2522A AND ABOVE</i>						
A14	08901-60268	0		REMOTE INTERFACE ASSEMBLY	28480	08901-60268
A14C1	0180-0229	7		CAPACITOR-FXD 33UF +-10% 10VDC TA	56289	150D336X9010B2
A14C2	0180-0197	8		CAPACITOR-FXD 2.2UF +-10% 20VDC TA	56289	150D225X9020A2
A14C3	0160-4832	4		CAPACITOR-FXD .01UF +-10% 100VDC CER	28480	0160-4832
A14C4	0160-4832	4		CAPACITOR-FXD .01UF +-10% 100VDC CER	28480	0160-4832
A14C5	0160-4832	4		CAPACITOR-FXD .01UF +-10% 100VDC CER	28480	0160-4832
A14C6	0160-4832	4		CAPACITOR-FXD .01UF +-10% 100VDC CER	28480	0160-4832
A14C7	0160-4832	4		CAPACITOR-FXD .01UF +-10% 100VDC CER	28480	0160-4832
A14C8	0160-4832	4		CAPACITOR-FXD .01UF +-10% 100VDC CER	28480	0160-4832
A14C9	0160-4832	4		CAPACITOR-FXD .01UF +-10% 100VDC CER	28480	0160-4832
A14C10	0160-4832	4		CAPACITOR-FXD .01UF +-10% 100VDC CER	28480	0160-4832
A14C11	0160-4832	4		CAPACITOR-FXD .01UF +-10% 100VDC CER	28480	0160-4832
A14C12	0160-4833	5		CAPACITOR-FXD .022UF +-10% 100VDC CER	28480	0160-4833
A14C13	0160-4832	4		CAPACITOR-FXD .01UF +-10% 100VDC CER	28480	0160-4832
A14C14	0160-4832	4		CAPACITOR-FXD .01UF +-10% 100VDC CER	28480	0160-4832
A14C15	0160-4832	4		CAPACITOR-FXD .01UF +-10% 100VDC CER	28480	0160-4832
A14C16	0160-4832	4		CAPACITOR-FXD .01UF +-10% 100VDC CER	28480	0160-4832
A14C17	0160-4814	2		CAPACITOR-FXD 150PF +-5% 100VDC CER	28480	0160-4814
A14C18	0160-4833	5		CAPACITOR-FXD .022UF +-10% 100VDC CER	28480	0160-4833
A14CR1	1901-0518	8		DIODE-SM SIG SCHOTTKY	28480	1901-0518
A14J1	1251-5649	7	1	CONNECTOR 20-PIN M POST TYPE	28480	1251-5649
	1251-4460	8	2	CLIP-CABLE PLUG RTNG-DUAL INLINE 16 CONT	28480	1251-4460
A14MP1	4040-0749	4		EXTR-PC BD BRN POLYCO .062-BD-THKNS	28480	4040-0749
	1480-0116	8		PIN-ROLL .062-IN-DIA .25-IN-LG STL	28480	1480-0116
A14MP2	4040-0752	9	1	EXTR-PC BD YEL POLYCO .062-BD-THKNS	28480	4040-0752
	1480-0116	8		PIN-ROLL .062-IN-DIA .25-IN-LG STL	28480	1480-0116
A14R1	0698-3438	3		RESISTOR 147 1% .125W F TC = 0 + -100	24546	C4-1/8-T0-147R-F
A14R2	0698-3444	1		RESISTOR 316 1% .125W F TC = 0 + -100	24546	C4-1/8-T0-316R-F
A14R3	1810-0206	8		NETWORK-RES 8-SIP10.0K OHM X 7	01121	208A103
A14R4	1810-0206	8		NETWORK-RES 8-SIP10.0K OHM X 7	01121	208A103
<i>2522A TO 3001A</i>						
A14R5	0757-0280	3		RESISTOR 1K 1% .125W F TC = 0 + -100	24546	C4-1/8-T0-1001-F
<i>3018A AND ABOVE</i>						
A14R5	0698-0084	9		RESISTOR 2.15K 1% .125W F TC = 0 + -100	28480	0698-0084

† Refer to Section 7 for update information.

\* Factory Selected Component (Refer to Section 5)

Δ Errata part change

Table 6-3. Replaceable Parts

Reference Designation	HP Part Number	C D	Qty.	Description	Mfr. Code	Mfr. Part Number
A14R6	0757-0416	7		RESISTOR 511 1% .125W F TC = 0 + -100	24546	C4-1/8-TO-511R-F
A14R7	1810-0136	3	1	NETWORK-RES 10-SIP MULTI-VALUE	28480	1810-0136
A14R8	0698-0083	8		RESISTOR 1.96K 1% .125W F TC = 0 + -100	24546	C4-1/8-TO-1961-F
A14R9	0698-7224	3		RESISTOR 316 1% .05W F TC = 0 + -100	24546	C3-1/8-TO-316R-F
<i>2305A TO 2516A</i>						
A14R10				NOT ASSIGNED		
<i>2522A AND ABOVE</i>						
A14R10	0757-0442	9		RESISTOR 10K 1% .125W F TC = 0 + -100	24546	C4-1/8-1002-F
A14S1	3101-1973	7	1	SWITCH-SL 7-1A DIP-SLIDE-ASSY .1A 50VDC	28480	3101-1973
	1200-0485	2	1	SOCKET-IC 14-CONT DIP DIP-SLDR	28480	1200-0485
A14TP1	1251-0600	0		CONNECTOR-SGL CONT PIN 1.14-MM-BSC-SZ SQ	28480	1251-0600
A14TP2	1251-0600	0		CONNECTOR-SGL CONT PIN 1.14-MM-BSC-SZ SQ	28480	1251-0600
A14TP3	1251-0600	0		CONNECTOR-SGL CONT PIN 1.14-MM-BSC-SZ SQ	28480	1251-0600
A14TP4	1251-0600	0		CONNECTOR-SGL CONT PIN 1.14-MM-BSC-SZ SQ	28480	1251-0600
A14TP5	1251-0600	0		CONNECTOR-SGL CONT PIN 1.14-MM-BSC-SZ SQ	28480	1251-0600
A14TP6	1251-0600	0		CONNECTOR-SGL CONT PIN 1.14-MM-BSC-SZ SQ	28480	1251-0600
A14TP7	1251-0600	0		CONNECTOR-SGL CONT PIN 1.14-MM-BSC-SZ SQ	28480	1251-0600
A14TP8	1251-0600	0		CONNECTOR-SGL CONT PIN 1.14-MM-BSC-SZ SQ	28480	1251-0600
A14TP9	1251-0600	0		CONNECTOR-SGL CONT PIN 1.14-MM-BSC-SZ SQ	28480	1251-0600
A14U1	1820-1689	4	2	IC SER-XMTR/RVCVR TTL QUAD	28480	1820-1689
A14U2	1820-1198	0		IC GATE TTL LS NAND QUAD 2-INP	01295	SN74LS03N
A14U3	1820-1112	8		IC FF TTL LS D-TYPE POS-EDGE-TRIG	01295	SN74LS74AN
A14U4	1820-1416	5		IC SCHMITT-TRIG TTL LS INV HEX 1-INP	01295	SN74LS14N
A14U5	1820-1689	4		IC SER-XMTR/RVCVR TTL QUAD	28480	1820-1689
A14U6	1820-1198	0		IC GATE TTL LS NAND QUAD 2-INP	01295	SN74LS03N
A14U7	1820-1905	7	1	IC GATE TTL LS NOR DUAL 5-INP	07263	74LS260PC
<i>2305A TO 2519A</i>						
A14U8	1820-0706	4	1	IC COMPTR TTL MAGTD 5-BIT	07263	9324PC
<i>2522A AND ABOVE</i>						
A14U8	1820-2740	0		IC COMPTR TTL LS MAGTD 2-INP 8-BIT	01295	SN74LS688N
A14U9	1820-1198	0		IC GATE TTL LS NAND QUAD 2-INP	01295	SN74LS03N
A14U10	1820-1198	0		IC GATE TTL LS NAND QUAD 2-INP	01295	SN74LS03N
A14U11	1820-1216	3		IC DCDR TTL LS 3-TO-8-LINE 3-INP	01295	SN74LS138N
A14U12	1820-0621	2	1	IC BFR TTL NAND QUAD 2-INP	01295	SN7438N
A14U13	1820-2100	6	1	IC MICPROC-ACCESS NMOS DUAL 8-BIT	07263	3861EPC
	1200-0654	7	1	SOCKET-IC 40-CONT DIP DIP-SLDR	28480	1200-0654
A14U14				NOT ASSIGNED		
A14U15	1820-1112	8		IC FF TTL LS D-TYPE POS-EDGE-TRIG	01295	SN74LS74AN
A14U16	1820-1112	8		IC FF TTL LS D-TYPE POS-EDGE-TRIG	01295	SN74LS74AN
A14U17	08901-80004	4	1	PROM PROGRAMMED	28480	08901-80004
A14U18				NOT ASSIGNED		
A14U19	1820-0054	5	1	IC GATE TTL NAND QUAD 2-INP	01295	SN7400N
A14U20	1820-1199	1		IC INV TTL LS HEX 1-INP	01295	SN74LS04N
A14U21	1820-1200	5	3	IC INV TTL LS HEX	01295	SN74LS05N
A14U22	1820-1200	5		IC INV TTL LS HEX	01295	SN74LS05N
A14VR1	1902-3182	0	1	DIODE-ZNR 12.1V 5% DO-35 PD = .4W	28480	1902-3182

† Refer to Section 7 for update information.

\* Factory Selected Component (Refer to Section 5)

Δ Errata part change



Table 6-3. Replaceable Parts

Reference Designation	HP Part Number	C D	Qty.	Description	Mfr. Code	Mfr. Part Number
<b>A15 08902-60004 – SERIAL PREFIX 2305A TO 2702A</b>						
A15	08902-60004	3	1	RF INPUT CONTROL ASSEMBLY	28480	08902-60004
A15C1	0180-2208	6	1	CAPACITOR-FXD 220UF + -10% 10VDC TA	56289	150D227X9010S2
A15C2	0160-0576	5		CAPACITOR-FXD .1UF + -20% 50VDC CER	28480	0160-0576
A15CR1	1901-1098	1		DIODE-SWITCHING 1N4150 50V 200MA 4NS	9N171	1N4150
A15CR2	1901-1098	1		DIODE-SWITCHING 1N4150 50V 200MA 4NS	9N171	1N4150
A15CR3	1901-1098	1		DIODE-SWITCHING 1N4150 50V 200MA 4NS	9N171	1N4150
A15CR4	1901-1098	1		DIODE-SWITCHING 1N4150 50V 200MA 4NS	9N171	1N4150
A15CR5	1901-1098	1		DIODE-SWITCHING 1N4150 50V 200MA 4NS	9N171	1N4150
A15CR6	1901-1098	1		DIODE-SWITCHING 1N4150 50V 200MA 4NS	9N171	1N4150
A15CR7	1901-1098	1		DIODE-SWITCHING 1N4150 50V 200MA 4NS	9N171	1N4150
A15CR8	1901-1098	1		DIODE-SWITCHING 1N4150 50V 200MA 4NS	9N171	1N4150
A15CR9	1901-1098	1		DIODE-SWITCHING 1N4150 50V 200MA 4NS	9N171	1N4150
A15CR10	1901-1098	1		DIODE-SWITCHING 1N4150 50V 200MA 4NS	9N171	1N4150
A15J1	1251-4582	5	2	CONNECTOR 10-PIN M POST TYPE	28480	1251-4582
A15J2	1200-0508	0	1	SOCKET-IC 14-CONT DIP-SLDR	28480	1200-0508
A15MP1	08902-00002	5	1	COVER RF INPUT	28480	08902-00002
	2360-0113	2		SCREW-MACH 6-32 .25-IN-LG PAN-HD-POZI	00000	ORDER BY DESCRIPTION
	2190-0008	3		WASHER-LK EXT T NO. 6 .141-IN-ID	28480	2190-0008
A15Q1	1854-0668	8	4	TRANSISTOR NPN SI TO-18 PD = 500MW	28480	1854-0668
A15Q2	1854-0668	8		TRANSISTOR NPN SI TO-18 PD = 500MW	28480	1854-0668
A15Q3	1854-0668	8		TRANSISTOR NPN SI TO-18 PD = 500MW	28480	1854-0668
A15Q4	1854-0668	8		TRANSISTOR NPN SI TO-18 PD = 500MW	28480	1854-0668
A15R1	0757-0280	3		RESISTOR 1K 1% .125W F TC = 0 + -100	24546	C4-1/8-T0-1001-F
A15R2	0757-0280	3		RESISTOR 1K 1% .125W F TC = 0 + -100	24546	C4-1/8-T0-1001-F
A15R3	0757-0280	3		RESISTOR 1K 1% .125W F TC = 0 + -100	24546	C4-1/8-T0-1001-F
A15R4	0757-0467	8		RESISTOR 121K 1% .125W F TC = 0 + -100	24546	C4-1/8-T0-1213-F
A15R5	0757-0280	3		RESISTOR 1K 1% .125W F TC = 0 + -100	24546	C4-1/8-T0-1001-F
A15R6	0757-0280	3		RESISTOR 1K 1% .125W F TC = 0 + -100	24546	C4-1/8-T0-1001-F
A15R7	0757-0280	3		RESISTOR 1K 1% .125W F TC = 0 + -100	24546	C4-1/8-T0-1001-F
A15R8	0757-0280	3		RESISTOR 1K 1% .125W F TC = 0 + -100	24546	C4-1/8-T0-1001-F
A15R9	0757-0280	3		RESISTOR 1K 1% .125W F TC = 0 + -100	24546	C4-1/8-T0-1001-F
A15R10	0757-0280	3		RESISTOR 1K 1% .125W F TC = 0 + -100	24546	C4-1/8-T0-1001-F
A15R11	0757-0280	3		RESISTOR 1K 1% .125W F TC = 0 + -100	24546	C4-1/8-T0-1001-F
A15R12	0698-3443	0		RESISTOR 287 1% .125W F TC = 0 + -100	24546	C4-1/8-T0-287R-F
A15R13	0698-3443	0		RESISTOR 287 1% .125W F TC = 0 + -100	24546	C4-1/8-T0-287R-F
A15R14	0698-3443	0		RESISTOR 287 1% .125W F TC = 0 + -100	24546	C4-1/8-T0-287R-F
A15R15	0698-3443	0		RESISTOR 287 1% .125W F TC = 0 + -100	24546	C4-1/8-T0-287R-F
A15U1	1820-0535	7	8	IC DRVR TTL AND DUAL 2-INP	01295	SN75451BP
A15U2	1820-0535	7		IC DRVR TTL AND DUAL 2-INP	01295	SN75451BP
A15U3	1820-0535	7		IC DRVR TTL AND DUAL 2-INP	01295	SN75451BP
A15U4	1820-0535	7		IC DRVR TTL AND DUAL 2-INP	01295	SN75451BP
A15U5	1820-0535	7		IC DRVR TTL AND DUAL 2-INP	01295	SN75451BP
A15U6	1820-1197	9		IC GATE TTL LS NAND QUAD 2-INP	01295	SN74LS00N
A15U7	1820-1441	6	1	IC ADDR TTL LS BIN FULL ADDR 4-BIT	01295	SN74LS283N
A15U8	1820-1199	1		IC INV TTL LS HEX 1-INP	01295	SN74LS04N
A15U9	1820-0629	0	1	IC FF TTL S J-K NEG-EDGE-TRIG	01295	SN74S112N
A15U10	1820-1208	3	1	IC GATE TTL LS OR QUAD 2-INP	01295	SN74LS32N
A15U11	1820-1201	6	1	IC GATE TTL LS AND QUAD 2-INP	01295	SN74LS08N

† Refer to Section 7 for update information

\* Factory Selected Component (Refer to Section 5)

Δ Errata part change.

Table 6-3. Replaceable Parts

Reference Designation	HP Part Number	C D	Qty.	Description	Mfr. Code	Mfr. Part Number
<b>A15 08902-60065 – SERIAL PREFIX 2704A AND ABOVE</b>						
A15	08902-60065	6	1	RF INPUT CONTROL ASSEMBLY	28480	08902-60065
A15C1				NOT ASSIGNED		
A15C2	0160-4832	4		CAPACITOR-FXD .01UF + -10% 100VDC CER	28480	0160-4832
A15C3	0160-4832	4		CAPACITOR-FXD .01UF + -10% 100VDC CER	28480	0160-4832
A15C4	0160-4832	4		CAPACITOR-FXD .01UF + -10% 100VDC CER	28480	0160-4832
A15C5	0160-4832	4		CAPACITOR-FXD .01UF + -10% 100VDC CER	28480	0160-4832
A15C6	0160-4832	4		CAPACITOR-FXD .01UF + -10% 100VDC CER	28480	0160-4832
A15C7	0160-4832	4		CAPACITOR-FXD .01UF + -10% 100VDC CER	28480	0160-4832
A15C8	0160-4853	9		CAPACITOR-FXD 22PF + -2% 200VDC CER 0 + -30	28480	0160-4853
A15C9	0180-0291	3		CAPACITOR-FXD 1UF + -10% 35VDC TA	28480	150D105X9035A2
A15C10	0160-4853	9		CAPACITOR-FXD 22PF + -200VDC CER 0 + -30	28480	0160-4853
A15C11	0180-0116	1		CAPACITOR-FXD 6.8UF + -10% 35VDC TA	56289	150D685X9035B2
A15CR1-10				NOT ASSIGNED		
A15J1	1251-4582	5	2	CONNECTOR 10-PIN M POST TYPE	28480	1251-4582
A15J2				NOT ASSIGNED		
A15J3	1251-4498	2		CONNECTOR 7-PIN M POST TYPE	28480	1251-4498
A15L1				NOT ASSIGNED		
A15L2	9100-3922	4		INDUCTOR-FXD 120-1300HZ	28480	9100-3922
A15MP1	08902-00002	5		COVER RF INPUT	28480	08902-00002
	2360-0113	2		SCREW-MACH 6-32 .25-IN-LG PAN-HD-POZI	00000	ORDER BY DESCRIPTION
	2190-0008	3		WASHER-LK EXT T NO.6 .141-IN-ID	28480	2190-0008
A15Q1-4				NOT ASSIGNED		
A15R1				NOT ASSIGNED		
A15R2				NOT ASSIGNED		
A15R3	0757-0280	3		RESISTOR 1K 1% .125W F TC = 0 + -100	24546	C4-1/8-TO-1001-F
A15R4	0757-0467	8		RESISTOR 121K 1% .125W F TC = 0 + -100	24546	C4-1/8-TO-1213-F
A15R5	0757-0280	3		RESISTOR 1K 1% .125W F TC = 0 + -100	24546	C4-1/8-TO-1001-F
A15R6	0757-0280	3		RESISTOR 1K 1% .125W F TC = 0 + -100	24546	C4-1/8-TO-1001-F
A15R7-15				NOT ASSIGNED		
A15R16	0698-3449	6		RESISTOR 28.7K 1% .125W F TC = 0 + -100	24546	C4-1/8-TO-2872-F
A15R17 <sup>Δ</sup>	1757-0461	2		RESISTOR 68.1K 1% .125W F TC = 0 + -100	02995	SFR25H
A15R18	0757-0280	3		RESISTOR 1K 1% .125W F TC = 0 + -100	24546	C4-1/8-TO-1001-F
A15U1-5				NOT ASSIGNED		
A15U6	1820-1197	9		IC GATE TTL LS NAND QUAD 2-INP	01295	SN74LS00N
A15U7	1820-1441	6		IC ADDR TTL LS BIN FULL ADDR 4-BIT	01295	SN74LS283N
A15U8	1820-1199	1		IC INV TTL LS HEX 1-INP	01295	SN74LS04N
A15U9	1820-0629	0		IC FF TLL S J-K NEG-EDGE-TRIG	01295	SN74S112N
A15U10	1820-1208	3		IC GATE TTL LS OR QUAD 2-INP	01295	SN74LS32N
A15U11	1820-1201	6		IC GATE TTL LS AND QUAD 2-INP	01295	SN74LS08N
A15U12	1820-1201	6		IC GATE TTL LS AND QUAD 2-INP	01295	SN74LS08N
A15U13	1820-1201	6		IC GATE TTL LS AND QUAD 2-INP	01295	SN74LS09N
A15U14	1820-2111	9		IC DRVR TTL INV	01295	SN75R68N
A15U15	1820-1419	8		IC COMPTR TTL LS MACTD 4-BIT	01295	SN75LS85N
A15U16	1820-1445	0		IC LCH TTL LS 4-BIT	01295	SN74LS375N
A15U17 <sup>Δ</sup>	1820-3954	0		IC MV TTL LS MONOSTBL RETRIG DUAL	01698	SN74LS123N

<sup>†</sup>Refer to Section 7 for update information.

\*Factory Selected Component (Refer to Section 5).

<sup>Δ</sup> Errata part change

Table 6-3. Replaceable Parts

Reference Designation	HP Part Number	C D	Qty.	Description	Mfr. Code	Mfr. Part Number
<b>A16</b>						
<i>2305A TO 2540A</i>						
A16	08902-60002	1	1	RF DETECTOR ASSEMBLY	28480	08902-60002
<i>2546A AND ABOVE</i>						
A16	08902-60041	8	1	RF DETECTOR ASSEMBLY	28480	08902-60041
A16C1	0160-0576	5		CAPACITOR-FXD .1UF + -20% 50VDC CER	28480	0160-0576
A16C2	0160-0576	5		CAPACITOR-FXD .1UF + -20% 50VDC CER	28480	0160-0576
A16C3	0160-0576	5		CAPACITOR-FXD .1UF + -20% 50VDC CER	28480	0160-0576
A16C4	0160-5630	2	1	CAPACITOR-FXD .15UF + -10% 50VDC CER	28480	0160-5630
A16C5	0160-3879	7		CAPACITOR-FXD .01UF + -20% 100VDC CER	28480	0160-3879
A16C6	0160-3879	7		CAPACITOR-FXD .01UF + -20% 100VDC CER	28480	0160-3879
A16C7	0160-0576	5		CAPACITOR-FXD .1UF + -20% 50VDC CER	28480	0160-0576
A16C8	0180-0197	8		CAPACITOR-FXD 2.2UF + -10% 20VDC TA	56289	150D225X9020A2
A16C9	0180-2929	8		CAPACITOR-FXD 68UF + -10% 10VDC TA	28480	0180-2929
A16C10	0180-0197	8		CAPACITOR-FXD 2.2UF + -10% 20VDC TA	56289	150D225X9020A2
<i>2305A TO 2540A</i>						
A16C11	0160-4768	5	3	CAPACITOR-FXD 470PF + -5% 100VDC CER	28480	0160-4768
<i>2546A AND ABOVE</i>						
A16C11	0160-4543	4		CAPACITOR-FXD 470-F + -10% 100VDC CER	28480	0160-4543
A16C12	0180-0197	8		CAPACITOR-FXD 2.2UF + -10% 20VDC TA	56289	150D225X9020A2
A16C13	0160-4040	6	3	CAPACITOR-FXD 1000PF + -5% 100VDC CER	28480	0160-4040
A16C14	0180-0197	8		CAPACITOR-FXD 2.2UF + -10% 20VDC TA	56289	150D225X9020A2
A16C15	0160-4502	5	1	CAPACITOR-FXD 390PF + -5% 100VDC CER	28480	0160-4502
A16C16	0160-4768	5		CAPACITOR-FXD 470PF + -5% 100VDC CER	28480	0160-4768
A16C17	0180-2205	3	1	CAPACITOR-FXD .33UF + -10% 35VDC TA	56289	150D334X9035A2
A16C18	0160-4040	6		CAPACITOR-FXD 1000PF + -5% 100VDC CER	28480	0160-4040
A16C19	0160-4825	5		CAPACITOR-FXD 560PF + -5% 100VDC CER	28480	0160-4825
<i>2305A TO 2337A</i>						
A16C20	0160-3877	5	9	CAPACITOR-FXD 100PF + -20% 200VDC CER	28480	0160-3877
<i>2338A TO 2340A</i>						
A16C20	0160-4768	5		CAPACITOR-FXD 470PF + -5% 100VDC CER	28480	0160-4786
<i>2341A ONLY</i>						
A16C20	0160-3877	5	9	CAPACITOR-FXD 100PF + -20% 200VDC CER	28480	0160-3877
<i>2342A AND ABOVE</i>						
A16C20	0160-4768	5		CAPACITOR-FXD 470PF + -5% 100VDC CER	28480	0160-4786

†Refer to Section 7 for update information

\*Factory Selected Component (Refer to Section 5)

Δ Errata part change.

Table 6-3. Replaceable Parts

Reference Designation	HP Part Number	C D	Qty.	Description	Mfr. Code	Mfr. Part Number
A16C21	0160-4492	2		CAPACITOR-FXD 18PF + -5% 200VDC CER 0 + -30	28480	0160-4492
A16C22	0160-0576	5		CAPACITOR-FXD .1UF + -20% 50VDC CER	28480	0160-0576
A16C23	0160-0576	5		CAPACITOR-FXD .1UF + -20% 50VDC CER	28480	0160-0576
A16C24	0160-0576	5		CAPACITOR-FXD .1UF + -20% 50VDC CER	28480	0160-0576
A16C25	0180-0058	0		CAPACITOR-FXD 50UF + 75-10% 25VDC AL	56289	30D506G025CC2
A16C28	0180-0197	8		CAPACITOR-FXD 2.2UF + -10% 20VDC TA	56289	150D225X9020A2
A16C27	0160-3879	7		CAPACITOR-FXD .01UF + -20% 100VDC CER	28480	0160-3879
A16C28	0160-0576	5		CAPACITOR-FXD .1UF + -20% 50VDC CER	28480	0160-0576
A16C29	0160-0576	5		CAPACITOR-FXD .1UF + -20% 50VDC CER	28480	0160-0576
A16C30	0160-0576	5		CAPACITOR-FXD .1UF + -20% 50VDC CER	28480	0160-0576
A16CR1	1901-1098	1		DIODE-SWITCHING 1N4150 50V 200MA 4NS	9N171	1N4150
A16CR2	08901-80005	5		DIODES, MATCHED	28480	08901-80005
A16CR3	1901-0518	8		DIODE-SM SIG SCHOTTKY	28480	1901-0518
A16CR4	1901-1098	1		DIODE-SWITCHING 1N4150 50V 200MA 4NS	9N171	1N4150
A16CR5	1901-0518	8		DIODE-SM SIG SCHOTTKY	28480	1901-0518
A16CR6	1901-1098	1		DIODE-SWITCHING 1N4150 50V 200MA 4NS	9N171	1N4150
A16CR7	08901-80005	5		DIODES, MATCHED	28480	08901-80005
<i>2305A TO 2540A</i>						
<i>A16J1</i>						
	1250-1220	0		CONNECTOR-RF SMC M PC 50-OHM	28480	1250-1220
	2190-0124	4		WASHER-LK INTL T NO. 10 .195-IN-ID	28480	2190-0124
	2950-0078	9		NUT-HEX-DBL-CHAM 10-32-THD .067-IN-THK	28480	2950-0078
<i>A16J2</i>						
	1250-1220	0		CONNECTOR-RF SMC M PC 50-OHM	28480	1250-1220
	2190-0124	4		WASHER-LK INTL T NO. 10 .195-IN-ID	28480	2190-0124
	2950-0078	9		NUT-HEX-DBL-CHAM 10-32-THD .067-IN-THK	28480	2950-0078
<i>2546A AND ABOVE</i>						
<i>A16J1</i>						
	1250-1425	7		CONNECTOR-RF SMC M PC 50-OHM	28480	1250-1425
	2190-0124	4		WASHER-LK INTL T NO. 10 .195-IN-ID	28480	2190-0124
	2950-0078	9		NUT-HEX-DBL-CHAM 10-32-THD .067-IN-THK	28480	2950-0078
<i>A16J2</i>						
	1250-1425	7		CONNECTOR-RF SMC M PC 50-OHM	28480	1250-1425
	2190-0124	4		WASHER-LK INTL T NO. 10 .195-IN-ID	28480	2190-0124
	2950-0078	9		NUT-HEX-DBL-CHAM 10-32-THD .067-IN-THK	28480	2950-0078
<i>A16J2</i>						
	1250-1220	0		CONNECTOR-RF SMC M PC 50-OHM	28480	1250-1220
	2190-0124	4		WASHER-LK INTL T NO. 10 .195-IN-ID	28480	2190-0124
	2950-0078	9		NUT-HEX-DBL-CHAM 10-32-THD .067-IN-THK	28480	2950-0078
<i>2305A TO 3104A</i>						
<i>A16K1</i>						
	0490-1185	3	1	RELAY-REED 1A 500MA 100VDC 5VDC-COIL	28480	0490-1185
<i>3104A TO 3112A</i>						
<i>A16K1</i>						
	0490-1745	1	1	RELAY-REED 1A 500MA 100VDC 5VDC-COIL	28480	0490-1745
<i>A16K2</i>						
	0490-1158	0	1	RELAY 2C 5VDC-COIL 1A 28VDC	28480	0490-1158
<i>A16L1</i>						
	9100-3922	4	45	INDUCTOR-FIXED 120-1300 HZ	28480	9100-3922
<i>A16L2</i>						
	9100-3922	4		INDUCTOR-FIXED 120-1300 HZ	28480	9100-3922
<i>A16L3</i>						
	9100-3922	4		INDUCTOR-FIXED 120-1300 HZ	28480	9100-3922
<i>A16L4</i>						
	9100-3922	4		INDUCTOR-FIXED 120-1300 HZ	28480	9100-3922
<i>A16L5</i>						
	9100-3922	4		INDUCTOR-FIXED 120-1300 HZ	28480	9100-3922
<i>A16L6</i>						
	9100-3922	4		INDUCTOR-FIXED 120-1300 HZ	28480	9100-3922
<i>A16L7</i>						
	9100-2258	7	1	INDUCTOR RF-CH-MLD 1.2UH 10% .105DX.26LG	28480	9100-2258
<i>A16L8</i>						
	9140-0142	8	1	INDUCTOR RF-CH-MLD 2.2UH 10% .105DX.26LG	28480	9140-0142
<i>A16L9</i>						
	9100-2257	6	1	INDUCTOR RF-CH-MLD 820NH 10% .105DX.26LG	28480	9100-2257
<i>A16L10</i>						
	9100-2261	2	1	INDUCTOR RF-CH-MLD 2.7UH 10% .105DX.26LG	28480	9100-2261

†Refer to Section 7 for update information.

\*Factory Selected Component (Refer to Section 5).

Δ Errata part change.

Table 6-3. Replaceable Parts

Reference Designation	HP Part Number	C D	Qty.	Description	Mfr. Code	Mfr. Part Number
A16L11	9100-3922	4		INDUCTOR-FIXED 120-1300 HZ	28480	9100-3922
A16L12	9100-3922	4		INDUCTOR-FIXED 120-1300 HZ	28480	9100-3922
A16MP1	08902-00001	4	1	COVER RF DETECT	28480	08902-00001
	2190-0008	3		WASHER-LK EXT T NO. 6 .141-IN-ID	28480	2190-0008
	2360-0113	2		SCREW-MACH 6-32 .25-IN-LG PAN-HD-POZI	00000	ORDER BY DESCRIPTION
A16MP2	5001-0176	0	16	GROUND STRAP	28480	5001-0176
A16MP3	5001-0176	0		GROUND STRAP	28480	5001-0176
A16MP4	08662-00040	0	4	SHIELD COMP SMALL	28480	08662-00040
A16MP5	08662-00038	6	4	SHIELD CKT SM	28480	08662-00038
A16Q1	1853-0020	4		TRANSISTOR PNP SI PD = 300MW FT = 150MHZ	28480	1853-0020
A16Q2	1853-0020	4		TRANSISTOR PNP SI PD = 300MW FT = 150MHZ	28480	1853-0020
A16Q3	1854-0810	2		TRANSISTOR NPN SI PD = 625MW FT = 200MHZ	28480	1854-0810
A16R1	0698-3429	2		RESISTOR 19.6 1% .125W F TC = 0 + -100	03888	PME55-1/8-T0-19R6-F
A16R2	0698-3429	2		RESISTOR 19.6 1% .125W F TC = 0 + -100	03888	PME55-1/8-T0-19R6-F
A16R3	0699-1213	0	1	RESISTOR 61.59 1% .2W C TC = 0 + -200	28480	0699-1213
A16R4	0698-3615	8	1	RESISTOR 47 5% 2W MO TC = 0 + -200	27167	FP42-2-T00-47R0-J
A16R5	0698-7242	5		RESISTOR 1.78K 1% .05W F TC = 0 + -100	24546	C3-1/8-T0-1781-F
A16R6	0757-0123	3		RESISTOR 34.8K 1% .125W F TC = 0 + -100	28480	0757-0123
A16R7	0757-0422	5		RESISTOR 909 1% .125W F TC = 0 + -100	24546	C4-1/8-T0-909R-F
A16R8	0698-3454	3		RESISTOR 215K 1% .125W F TC = 0 + -100	24546	C4-1/8-T0-2153-F
A16R9	0757-0465	6		RESISTOR 100K 1% .125W F TC = 0 + -100	24546	C4-1/8-T0-1003-F
<i>2305A TO 2522A</i>						
A16R10	0698-8961	7	1	RESISTOR 909K 1% .125W F TC = 0 + -100	28480	0698-8961
<i>2523A AND ABOVE</i>						
A16R10	0698-8827	4		RESISTOR 1M 1% .125W F TC = 0 + -100	28480	0698-8827
<i>2305A TO 2436A</i>						
A16R11	0698-3451	0		RESISTOR 133K 1% .125W F TC = 0 + -100	24546	C4-1/8-T0-1333-F
<i>2449A AND ABOVE</i>						
A16R11	0757-0470	3		RESISTOR 162K 1% .125W F TC = 0 + -100	24546	C4-1/8-T0-1623-F
A16R12	0757-0394	0		RESISTOR 51.1 1% .125W F TC = 0 + -100	24546	C4-1/8-T0-51R1-F
A16R13	0757-0442	9		RESISTOR 10K 1% .125W F TC = 0 + -100	24546	C4-1/8-T0-1002-F
A16R14	0757-0428	1	3	RESISTOR 1.62K 1% .125W F TC = 0 + -100	24546	C4-1/8-T0-1621-F
<i>2305A TO 2331A</i>						
A16R15	0698-3152	8		RESISTOR 3.48K 1% .125W F TC = 0 + -100	24546	C4-1/8-T0-3481-F
<i>2337A TO 2523A</i>						
A16R15	0698-3151	7		RESISTOR 2.87K A% .125W F TC = 0 + -100 2	4546 C	4-1/8-T0-2871-F
<i>2528A AND ABOVE</i>						
A16R15	0698-3152	8		RESISTOR 3.48K 1% .125W F TC = 0 + -100	24546	C4-1/8-T0-3481-F

†Refer to Section 7 for update information

\*Factory Selected Component (Refer to Section 5)

Δ Errata part change

Table 6-3. Replaceable Parts

Reference Designation	HP Part Number	C D	Qty.	Description	Mfr. Code	Mfr. Part Number
A16R16	0757-0441	8		RESISTOR 8.25K 1% .125W F TC = 0 + -100	24546	C4-1/8-T0-8251-F
A16R17	0757-0442	9		RESISTOR 10K 1% .125W F TC = 0 + -100	24546	C4-1/8-T0-1002-F
A16R18	0699-0071	6	3	RESISTOR 4.64M 1% .125W F TC = 0 + -100	28480	0699-0071
A16R19	0699-0071	6		RESISTOR 4.64M 1% .125W F TC = 0 + -100	28480	0699-0071
A16R20	0757-0465	6		RESISTOR 100K 1% .125W F TC = 0 + -100	24546	C4-1/8-T0-1003-F
A16R21	0757-0428	1		RESISTOR 1.62K 1% .125W F TC = 0 + -100	24546	C4-1/8-T0-1621-F
A16R22	0757-0401	0		RESISTOR 100 1% .125W F TC = 0 + -100	24546	C4-1/8-T0-101-F
A16R23	0698-3443	0		RESISTOR 287 1% .125W F TC = 0 + -100	24546	C4-1/8-T0-287R-F
A16R24	0757-0279	0		RESISTOR 3.16K 1% .125W F TC = 0 + -100	24546	C4-1/8-T0-3161-F
A16R25	0698-3266	5	1	RESISTOR 237K 1% .125W F TC = 0 + -100	24546	C4-1/8-T0-2373-F
A16R26	0699-0071	6		RESISTOR 4.64M 1% .125W F TC = 0 + -100	28480	0699-0071
A16R27	2100-3161	6	1	RESISTOR-TRMR 20K 10% C SIDE-ADJ 17-TRN	02111	43P203
A16R28	0757-0416	7		RESISTOR 511 1% .125W F TC = 0 + -100	24546	C4-1/8-T0-511R-F
A16R29	0757-0439	4		RESISTOR 6.81K 1% .125W F TC = 0 + -100	24546	C4-1/8-T0-6811-F
A16R30	0698-3158	4	7	RESISTOR 23.7K 1% .125W F TC = 0 + -100	24546	C4-1/8-T0-2372-F
A16R31	0757-0442	9		RESISTOR 10K 1% .125W F TC = 0 + -100	24546	C4-1/8-T0-1002-F
A16R32 <sup>Δ</sup>	0757-0180	2		RESISTOR 31.6 1% .125W F TC = 0 + -100	24546	C4-1/8-T0-3162-F
A16R33 <sup>Δ</sup>	2100-2061	3	1	RESISTOR-TRMR 200 10% C TOP-ADJ 1-TRN	73138	82PR200
A16R34	0757-0401	0		RESISTOR 100 1% .125W F TC = 0 + -100	24546	C4-1/8-T0-101-F
A16TP1	1251-0600	0		CONNECTOR-SGL CONT PIN 1.14-MM-BSC-SZ SQ	28480	1251-0600
A16TP2	1251-0600	0		CONNECTOR-SGL CONT PIN 1.14-MM-BSC-SZ SQ	28480	1251-0600
A16TP3	1251-0600	0		CONNECTOR-SGL CONT PIN 1.14-MM-BSC-SZ SQ	28480	1251-0600
A16TP4	1251-0600	0		CONNECTOR-SGL CONT PIN 1.14-MM-BSC-SZ SQ	28480	1251-0600
A16TP5	1251-0600	0		CONNECTOR-SGL CONT PIN 1.14-MM-BSC-SZ SQ	28480	1251-0600
A16U1	1826-0740	8	2	IC SWITCH ANLG DUAL 16-DIP-C PKG	32293	IH5043CDE
A16U2	1826-0098	9		IC COMPARATOR PRCN TO-99 PKG	27014	LM211H
A16U3	1826-0191	3	3	IC COMPARATOR GP DUAL TO-100 PKG	27014	LM319H
A16U4	1826-1048	7	1	IC OP AMP PRCN 8-DIP-C PKG	28480	1826-1048
A16U5	1826-0740	8		IC SWITCH ANLG DUAL 16-DIP-C PKG	32293	IH5043CDE
A16U6	1820-0535	7		IC DRVR TTL AND DUAL 2-INP	01295	SN75451BP
2305A TO 2540A A16U7				NOT ASSIGNED		
2546A AND ABOVE A16U7	1820-1416	5		IC SCHMITT-TRIG TTL LS INV HEX 1-INP	01295	SN74LS14N
A16W1	8159-0005	0		RESISTOR-ZERO OHMS 22 AWG LEAD DIA	28480	8159-0005
A16W2	8159-0005	0		RESISTOR-ZERO OHMS 22 AWG LEAD DIA	28480	8159-0005

<sup>†</sup>Refer to Section 7 for update information.

\*Factory Selected Component (Refer to Section 5)

<sup>Δ</sup> Errata part change

Table 6-3. Replaceable Parts

Reference Designation	HP Part Number	C D	Qty.	Description	Mfr. Code	Mfr. Part Number
<b>A17 08901-60145 – SERIAL PREFIX 2305A TO 2530A</b>						
A17	08901-60145	2	1	INPUT MIXER ASSEMBLY	28480	08901-60145
A17C1	0160-3879	7		CAPACITOR-FXD .01UF +-20% 100VDC CER	28480	0160-3879
A17C2	0160-4084	8		CAPACITOR-FXD .1UF +-20% 50VDC CER	28480	0160-4084
A17C3	0160-3873	1	4	CAPACITOR-FXD 4.7PF +- .5PF 200VDC CER	28480	0160-3873
A17C4	0160-3879	7		CAPACITOR-FXD .01UF +-20% 100VDC CER	28480	0160-3879
A17C5	0160-3879	7		CAPACITOR-FXD .01UF +-20% 100VDC CER	28480	0160-3879
A17C6	0160-3879	7		CAPACITOR-FXD .01UF +-20% 100VDC CER	28480	0160-3879
A17C7	0160-3879	7		CAPACITOR-FXD .01UF +-20% 100VDC CER	28480	0160-3879
A17C8	0180-0197	8		CAPACITOR-FXD 2.2UF +-10% 20VDC TA	56289	150D225X9020A2
A17C9	0160-3879	7		CAPACITOR-FXD .01UF +-20% 100VDC CER	28480	0160-3879
A17C10	0160-3879	7		CAPACITOR-FXD .01UF +-20% 100VDC CER	28480	0160-3879
A17C11	0160-4084	8		CAPACITOR-FXD .1UF +-20% 50VDC CER	28480	0160-4084
A17C12	0160-4084	8		CAPACITOR-FXD .1UF +-20% 50VDC CER	28480	0160-4084
A17C13	0160-4497	7	1	CAPACITOR-FXD 82PF +-5% 200VDC CER 0 +30	28480	0160-4497
A17C14	0160-4652	6	1	CAPACITOR-FXD 960PF +-1% 500VDC MICA	00853	RDM19F961F5C
A17C15	0160-4647	9	1	CAPACITOR-FXD 154PF +-1% 500VDC MICA	28480	0160-4647
A17C16	0160-4084	8		CAPACITOR-FXD .1UF +-20% 50VDC CER	28480	0160-4084
A17C17	0160-4646	8	1	CAPACITOR-FXD 444PF +-1% 500VDC MICA	28480	0160-4646
A17C18	0160-4084	8		CAPACITOR-FXD .1UF +-20% 50VDC CER	28480	0160-4084
A17C19	0160-4387	4		CAPACITOR-FXD 47PF +-5% 200VDC CER 0 +30	28480	0160-4387
A17C20	0160-4641	3	1	CAPACITOR-FXD 3520PF +-1% 50VDC	28480	0160-4641
A17C21	0160-4084	8		CAPACITOR-FXD .1UF +-20% 50VDC CER	28480	0160-4084
A17C22	0160-4651	5	1	CAPACITOR-FXD 817PF +-1% 500VDC MICA	00853	RDM19F(817)F5C
A17C23	0160-4084	8		CAPACITOR-FXD .1UF +-20% 50VDC CER	28480	0160-4084
A17C24	0180-0376	5		CAPACITOR-FXD .47UF +-10% 35VDC TA	56289	150D474X9035A2
A17C25	0160-4387	4		CAPACITOR-FXD 47PF +-5% 200VDC CER 0 +30	28480	0160-4387
A17C26	0160-4084	8		CAPACITOR-FXD .1UF +-20% 50VDC CER	28480	0160-4084
A17C27	08901-00064	8	1	STRAP/CAPACITOR	28480	08901-00064
<i>2305A TO 2326A</i>						
<i>A17C28</i> NOT ASSIGNED						
<i>2328A TO 2530A</i>						
<i>A17C28</i>	0160-5491	3		CAPACITOR-FXD 240PF +-5% 100VDC CER	28480	0160-5491
A17CR1	1901-1098	1		DIODE-SWITCHING 1N4150 50V 200MA 4NS	9N171	1N4150
A17CR2	1901-1098	1		DIODE-SWITCHING 1N4150 50V 200MA 4NS	9N171	1N4150
A17CR3	1901-1098	1		DIODE-SWITCHING 1N4150 50V 200MA 4NS	9N171	1N4150
A17CR4	1901-1098	1		DIODE-SWITCHING 1N4150 50V 200MA 4NS	9N171	1N4150
A17CR5	1901-1098	1		DIODE-SWITCHING 1N4150 50V 200MA 4NS	9N171	1N4150
A17CR6	1901-1098	1		DIODE-SWITCHING 1N4150 50V 200MA 4NS	9N171	1N4150
A17DS1	1990-0524	3	1	LED-LAMP LUM-INT = 1MCD IF = 20MA-MAX BVR = 5V	28480	5082-4550
A17J1	1250-1220	0		CONNECTOR-RF SMC M PC 50-OHM	28480	1250-1220
	2190-0124	4		WASHER-LK INTL T NO. 10 .195-IN-ID	28480	2190-0124
	2950-0078	9		NUT-HEX-DBL-CHAM 10-32-THD .067-IN-THK	28480	2950-0078
A17J2	1250-1220	0		CONNECTOR-RF SMC M PC 50-OHM	28480	1250-1220
	2190-0124	4		WASHER-LK INTL T NO. 10 .195-IN-ID	28480	2190-0124
	2950-0078	9		NUT-HEX-DBL-CHAM 10-32-THD .067-IN-THK	28480	2950-0078

†Refer to Section 7 for update information

\*Factory Selected Component (Refer to Section 5)

Δ Errata part change

Table 6-3. Replaceable Parts

Reference Designation	HP Part Number	C D	Qty.	Description	Mfr. Code	Mfr. Part Number
<b>A17 08901-60145 – SERIAL PREFIX 2305A TO 2530A</b>						
A17J3	1250-1220	0		CONNECTOR-RF SMC M PC 50-OHM	28480	1250-1220
	2190-0124	4		WASHER-LK INTL T NO. 10 .195-IN-ID	28480	2190-0124
	2950-0078	9		NUT-HEX-DBL-CHAM 10-32-THD .067-IN-THK	28480	2950-0078
A17L1	9100-3922	4		INDUCTOR-FIXED 120-1300 HZ	28480	9100-3922
A17L2	9100-3922	4		INDUCTOR-FIXED 120-1300 HZ	28480	9100-3922
A17L3	9100-3922	4		INDUCTOR-FIXED 120-1300 HZ	28480	9100-3922
A17L4	9100-3922	4		INDUCTOR-FIXED 120-1300 HZ	28480	9100-3922
A17L5	9100-4434	5	1	INDUCTOR RF-CH-MLD 240UH 2% .166DX.385LG	28480	9100-4434
<i>2305A TO 2326A</i>						
A17L6	9140-0302	2		INDUCTOR RF-CH-MLD 21.9UH 2%	28480	9140-0302
<i>2328A TO 2530A</i>						
A17L6	9100-1621	6		INDUCTOR RF-CH-MLD 18UH 10% .166DX.385LG	28480	9100-1621
A17L7	9140-0131	5		INDUCTOR RF-CH-MLD 10MH 5% .25DX.75LG	28480	9140-0131
<i>2305A TO 2403A</i>						
A17L8	08901-80002	2	1	INDUCR VARIABLE	28480	08901-80002
<i>2405A TO 2530A</i>						
A17L8	9140-0840	3		COIL-VAR 6.1UH-19.1UH Q=27 PC-MTG	28480	9140-0840
A17L9	9140-0131	5		INDUCTOR RF-CH-MLD 10MH 5% .25DX.75LG	28480	9140-0131
A17L10	9100-1626	1	1	INDUCTOR RF-CH-MLD 36UH 5% .166DX.385LG	28480	9100-1626
<i>2305A TO 2403A</i>						
A17L11	08901-80001	1	1	INDUCR VARIABLE	28480	08901-80001
<i>2405A TO 2530A</i>						
A17L11	9140-0841	4		COIL-VAR 18UH-56.3UH Q=20 PC-MTG	28480	9140-0841
A17L12	9140-0303	3	1	INDUCTOR RF-CH-MLD 89.3UH 2%	28480	9140-0303
A17L13	9140-0131	5		INDUCTOR RF-CH-MLD 10MH 5% .25DX.75LG	28480	9140-0131
<i>2305A TO 2326A</i>						
A17L14				NOT ASSIGNED		
<i>2328A TO 2530A</i>						
A17L14	9100-1621	6		INDUCTOR RF-CH-MLD 18UH 10% .166DX.385LG	28480	9100-1621
A17MP1	08901-00030	8	1	COVER MIXER	28480	08901-00030
	2360-0113	2		SCREW-MACH 6-32 .25-IN-LG PAN-HD-POZI	00000	ORDER BY DESCRIPTION
	2190-0008	3		WASHER-LK EXT T NO. 6 .141-IN-ID	28480	2190-0008
A17MP2	5001-0176	0		GROUND STRAP	28480	5001-0176
A17MP3	5001-0176	0		GROUND STRAP	28480	5001-0176
A17MP4	0363-0159	0	1	RFI STRIP-FINGERS BE-CU ZINC PLATED	28480	0363-0159

†Refer to Section 7 for update information.

\*Factory Selected Component (Refer to Section 5).

Δ Errata part change



Table 6-3. Replaceable Parts

Reference Designation	HP Part Number	C D	Qty.	Description	Mfr. Code	Mfr. Part Number
<b>A17 08901-60145 – SERIAL PREFIX 2305A TO 2530A</b>						
<i>2305A TO 2413A</i>						
A17MP5	08662-00040	0		SHIELD COMP SMALL	28480	08662-00040
A17MP6	08662-00038	6		SHIELD CKT SM	28480	08662-00038
<i>2414A TO 2530A</i>						
A17MP5				NOT ASSIGNED		
A17MP6				NOT ASSIGNED		
A17Q1	1853-0281	9		TRANSISTOR PNP 2N2907A SI TO-18 PD = 400MW	04713	2N2907A
A17Q2	1853-0281	9		TRANSISTOR PNP 2N2907A SI TO-18 PD = 400MW	04713	2N2907A
A17Q3	1853-0281	9		TRANSISTOR PNP 2N2907A SI TO-18 PD = 400MW	04713	2N2907A
A17Q4	1854-0632	6	1	TRANSISTOR NPN SI PD = 180MW FT = 4GHZ	25403	BFR-91
A17Q5	1853-0020	4		TRANSISTOR PNP SI PD = 300MW FT = 150MHZ	28480	1853-0020
A17Q6	1854-0720	3	1	TRANSISTOR NPN SI PD = 500MW FT = 4GHZ	28480	1854-0720
A17Q7	1853-0020	4		TRANSISTOR PNP SI PD = 300MW FT = 150MHZ	28480	1853-0020
A17Q8	1854-0071	7		TRANSISTOR NPN SI PD = 300MW FT = 200MHZ	28480	1854-0071
A17R1	0757-0442	9		RESISTOR 10K 1% .125W F TC = 0+ -100	24546	C4-1/8-T0-1002-F
A17R2	0757-0200	7		RESISTOR 5.62K 1% .125W F TC = 0+ -100	24546	C4-1/8-T0-5621-F
A17R3	0757-0346	2		RESISTOR 10 1% .125W F TC = 0+ -100	24546	C4-1/8-T0-10R0-F
A17R4	0698-8821	8		RESISTOR 5.62 1% .125W F TC = 0+ -100	28480	0698-8821
A17R5	0757-0280	3		RESISTOR 1K 1% .125W F TC = 0+ -100	24546	C4-1/8-T0-1001-F
A17R6	0698-0087	2	1	RESISTOR 316 1% .25W F TC = 0+ -100	24546	C5-1/4-T0-3160-F
A17R7	0698-0085	0		RESISTOR 2.61K 1% .125W F TC = 0+ -100	24546	C4-1/8-T0-2611-F
A17R8	0699-0135	3	2	RESISTOR 71.2 1% .25W F TC = 0+ -100	28480	0699-0135
A17R9	0699-0135	3		RESISTOR 71.2 1% .25W F TC = 0+ -100	28480	0699-0135
A17R10	0698-7204	9	5	RESISTOR 46.4 1% .05W F TC = 0+ -100	24546	C3-1/8-T0-46R4-F
A17R11	0698-7220	9	4	RESISTOR 215 1% .05W F TC = 0+ -100	24546	C3-1/8-T0-215R-F
A17R12	0698-7204	9		RESISTOR 46.4 1% .05W F TC = 0+ -100	24546	C3-1/8-T0-46R4-F
A17R13	0757-0467	8		RESISTOR 121K 1% .125W F TC = 0+ -100	24546	C4-1/8-T0-1213-F
A17R14	0698-3157	3		RESISTOR 19.6K 1% .125W F TC = 0+ -100	24546	C4-1/8-T0-1962-F
A17R15	0757-0280	3		RESISTOR 1K 1% .125W F TC = 0+ -100	24546	C4-1/8-T0-1001-F
A17R16	0699-0392	4	1	RESISTOR 34.8 1% .125W F TC = 0+ -100	28480	0699-0392
A17R17	0757-0439	4		RESISTOR 6.81K 1% .125W F TC = 0+ -100	24546	C4-1/8-T0-6811-F
A17R18	0757-0441	8		RESISTOR 8.25K 1% .125W F TC = 0+ -100	24546	C4-1/8-T0-8251-F
A17R19	0698-7204	9		RESISTOR 46.4 1% .05W F TC = 0+ -100	24546	C3-1/8-T0-46R4-F
A17R20	0757-0799	9	1	RESISTOR 121 1% .5W F TC = 0+ -100	28480	0757-0799
A17R21	0698-0085	0		RESISTOR 2.61K 1% .125W F TC = 0+ -100	24546	C4-1/8-T0-2611-F
A17R22	0698-7205	0	8	RESISTOR 51.1 1% .05W F TC = 0+ -100	24546	C3-1/8-T0-51R1-F
A17R23	0698-7205	0		RESISTOR 51.1 1% .05W F TC = 0+ -100	24546	C3-1/8-T0-51R1-F
A17R24	0698-7216	3	3	RESISTOR 147 1% .05W F TC = 0+ -100	24546	C3-1/8-T0-147R-F
A17R25	0698-3154	0		RESISTOR 4.22K 1% .125W F TC = 0+ -100	24546	C4-1/8-T0-4221-F
A17R26	0757-0438	3		RESISTOR 5.11K 1% .125W F TC = 0+ -100	24546	C4-1/8-T0-5111-F
A17R27	0698-7205	0		RESISTOR 51.1 1% .05W F TC = 0+ -100	24546	C3-1/8-T0-51R1-F
A17R28	0757-0278	9	3	RESISTOR 1.78K 1% .125W F TC = 0+ -100	24546	C4-1/8-T0-1781-F
A17R29	0757-0278	9		RESISTOR 1.78K 1% .125W F TC = 0+ -100	24546	C4-1/8-T0-1781-F
A17R30	0757-0401	0		RESISTOR 100 1% .125W F TC = 0+ -100	24546	C4-1/8-T0-101-F

{Refer to Section 7 for update information.

\*Factory Selected Component (Refer to Section 5)

Δ Errata part change

Table 6-3. Replaceable Parts

Reference Designation	HP Part Number	C D	Qty.	Description	Mfr. Code	Mfr. Part Number
<b>A17</b>	<b>08901-60145 – SERIAL PREFIX 2305A TO 2530A</b>					
A17R31	0757-0401	0		RESISTOR 100 1% .125W F TC = 0 + -100	24546	C4-1/8-T0-101-F
A17R32	0757-0346	2		RESISTOR 10 1% .125W F TC = 0 + -100	24546	C4-1/8-T0-10R0-F
A17R33	0757-0403	2		RESISTOR 121 1% .125W F TC = 0 + -100	24546	C4-1/8-T0-121R-F
A17R34	0757-0465	6		RESISTOR 100K 1% .125W F TC = 0 + -100	24546	C4-1/8-T0-1003-F
A17R35	0757-0401	0		RESISTOR 100 1% .125W F TC = 0 + -100	24546	C4-1/8-T0-101-F
A17R36	0757-0401	0		RESISTOR 100 1% .125W F TC = 0 + -100	24546	C4-1/8-T0-101-F
A17R37	0757-0465	6		RESISTOR 100K 1% .125W F TC = 0 + -100	24546	C4-1/8-T0-1003-F
A17R38	0757-0403	2		RESISTOR 121 1% .125W F TC = 0 + -100	24546	C4-1/8-T0-121R-F
A17R39	0757-0401	0		RESISTOR 100 1% .125W F TC = 0 + -100	24546	C4-1/8-T0-101-F
A17R40	0757-0403	2		RESISTOR 121 1% .125W F TC = 0 + -100	24546	C4-1/8-T0-121R-F
A17R41	0757-0465	6		RESISTOR 100K 1% .125W F TC = 0 + -100	24546	C4-1/8-T0-1003-F
A17R42	0757-0401	0		RESISTOR 100 1% .125W F TC = 0 + -100	24546	C4-1/8-T0-101-F
A17T1	08901-80031	7	1	TRANSFORMER ENCP	28480	08901-80031
A17U1	08901-67001	3	1	MIXER CIRCUIT	28480	08901-67001
	0340-0850	0	2	INSULATOR-XSTR TFE	28480	0340-0850
	1251-1556	7	24	CONNECTOR-SGL CONT SKT .018-IN-BSC-SZ	28480	1251-1556
A17U2	1826-0412	1		IC COMPARATOR PRCN DUAL 8-DIP-P PKG	27014	LM393N

†Refer to Section 7 for update information

\*Factory Selected Component (Refer to Section 5)

Δ Errata part change.

Table 6-3. Replaceable Parts

Reference Designation	HP Part Number	C D	Qty.	Description	Mfr. Code	Mfr. Part Number
<b>A17</b>	<b>08902-60104 – SERIAL PREFIX 2535A AND ABOVE</b>					
A17	08902-60104	4	1	INPUT MIXER ASSEMBLY	28480	08902-60104
A17C1	0160-3879	7	8	CAPACITOR-FXD .01UF + -20% 100VDC CER	28480	0160-3879
A17C2	0160-3879	7		CAPACITOR-FXD .01UF + -20% 100VDC CER	28480	0160-3879
A17C3	0160-3873	1	1	CAPACITOR-FXD 4.7PF + -.5PF 200VDC CER	28480	0160-3873
A17C4	0160-3879	7		CAPACITOR-FXD .01UF + -20% 100VDC CER	28480	0160-3879
A17C5	0160-3879	7		CAPACITOR-FXD .01UF + -20% 100VDC CER	28480	0160-3879
A17C6	0160-3879	7		CAPACITOR-FXD .01UF + -20% 100VDC CER	28480	0160-3879
A17C7	0160-3879	7		CAPACITOR-FXD .01UF + -20% 100VDC CER	28480	0160-3879
A17C8	0180-0197	8	2	CAPACITOR-FXD 2.2UF + -10% 20VDC TA	56289	150D225X9020A2
A17C9	0160-3879	7		CAPACITOR-FXD .01UF + -20% 100VDC CER	28480	0160-3879
A17C10	0160-3879	7		CAPACITOR-FXD .01UF + -20% 100VDC CER	28480	0160-3879
A17C11	0160-5469	5	5	CAPACITOR-FXD 1UF + -10% 50VDC CER	28480	0160-5469
A17C12	0160-4835	7	5	CAPACITOR-FXD .1UF + -10% 50VDC CER	28480	0160-4835
A17C13	0160-4812	0	1	CAPACITOR-FXD 220PF + -5% 100VDC CER	28480	0160-4812
A17C14	0160-4652	6	1	CAPACITOR-FXD 960PF + -1% 500VDC MICA	00853	RDM19F961F5C
A17C15	0160-4647	9	1	CAPACITOR-FXD 154PF + -1% 500VDC MICA	28480	0160-4647
A17C16	0180-2929	8	1	CAPACITOR-FXD 68UF + -10% 10VDC TA	28480	0180-2929
A17C17	0160-4646	8	1	CAPACITOR-FXD 444PF + -1% 500VDC MICA	28480	0160-4646
A17C18	0160-4835	7		CAPACITOR-FXD .1UF + -10% 50VDC CER	28480	0160-4835
A17C19	0160-4814	2	1	CAPACITOR-FXD 150PF + -5% 100VDC CER	28480	0160-4814
A17C20	0160-4641	3	1	CAPACITOR-FXD 3520PF + -1% 50VDC	28480	0160-4641
A17C21	0160-4835	7		CAPACITOR-FXD .1UF + -10% 50VDC CER	28480	0160-4835
A17C22	0160-4651	5	1	CAPACITOR-FXD 817PF + -1% 500VDC MICA	00853	RDM19F(817)F5C
A17C23	0160-0576	5	2	CAPACITOR-FXD .1UF + -20% 50VDC CER	28480	0160-0576
A17C24	0160-4535	4		CAPACITOR-FXD 1UF + -10% 50VDC CER	28480	0160-4535
A17C25	0160-4801	7	1	CAPACITOR-FXD 100PF + -5% 100VDC CER	28480	0160-4801
A17C26	0160-0576	5		CAPACITOR-FXD .1UF + -20% 50VDC CER	28480	0160-0576
A17C27	08901-00064	8	1	STRAP/CAPACITOR	28480	08901-00064
A17C28	0160-4512	7	2	CAPACITOR-FXD 120PF + -5% 200VDC CER	28480	0160-4512
A17C29	0160-5469	5		CAPACITOR-FXD 1UF + -10% 50VDC CER	28480	0160-5469
A17C30	0160-4535	4		CAPACITOR-FXD 1UF + -10% 50VDC CER	28480	0160-4535
A17C31	0160-4835	7		CAPACITOR-FXD .1UF + -10% 50VDC CER	28480	0160-4835
A17C32	0160-4822	2	1	CAPACITOR-FXD 1000PF + -5% 100VDC CER	28480	0160-4822
A17C33	0180-0197	8		CAPACITOR-FXD 2.2UF + -10% 20VDC TA	56289	150D225X9020A2
A17C34	0160-4835	7		CAPACITOR-FXD .1UF + -10% 50VDC CER	28480	0160-4835
A17C35	0160-4512	7		CAPACITOR-FXD 120PF + -5% 200VDC CER	28480	0160-4512
A17C36	0160-4535	4		CAPACITOR-FXD 1UF + -10% 50VDC CER	28480	0160-4535
A17CR1 <sup>Δ</sup>	1901-0179	7		DIODE-SWITCHING 15V 50MA 750PS DO-7	28480	1901-0179
A17CR2 <sup>Δ</sup>	1901-0179	7		DIODE-SWITCHING 15V 50MA 750PS DO-7	28480	1901-0179
A17CR3	1901-1098	1		DIODE-SWITCHING 1N4150 50V 200MA 4NS	9N171	1N4150
A17CR4	1901-1098	1		DIODE-SWITCHING 1N4150 50V 200MA 4NS	9N171	1N4150
A17CR5	1901-1098	1		DIODE-SWITCHING 1N4150 50V 200MA 4NS	9N171	1N4150
A17CR6	1901-0518	8	2	DIODE-SM SIG SCHOTTKY	28480	1901-0518
A17CR7	1901-0518	8		DIODE-SM SIG SCHOTTKY	28480	1901-0518

† Refer to Section 7 for update information.

\* Factory Selected Component (Refer to Section 5).

Δ Errata part change.

Table 6-3. Replaceable Parts

Reference Designation	HP Part Number	C D	Qty.	Description	Mfr. Code	Mfr. Part Number
<b>A17 08902-60104 – SERIAL PREFIX 2535A AND ABOVE</b>						
A17CR8	1901-1098	1		DIODE-SWITCHING 1N4150 50V 200MA 4NS	9N171	1N4150
A17CR9	1901-1098	1		DIODE-SWITCHING 1N4150 50V 200MA 4NS	9N171	1N4150
A17DS1	1990-0524	3	1	LED-LAMP LUM-INT = 1MCD IF = 20MA-MAX BVR = 5V	28480	5082-4550
A17E1	9170-0847	3	1	CORE-SHIELDING BEAD	02114	56-590-65/3B PARYLENE
A17J1	1250-1425	7	2	CONNECTOR-RF SMC M SGL-HOLE-RR 50-OHM	28480	1250-1425
A17J2	1250-1220	0	2	CONNECTOR-RF SMC M PC 50-OHM	28480	1250-1220
	2190-0124	4	2	WASHER-LK INTL T NO. 10 .195-IN-ID	28480	2190-0124
	2950-0078	9	2	NUT-HEX-DBL-CHAM 10-32-THD .067-IN-THK	28480	2950-0078
A17J3	1250-1220	0		CONNECTOR-RF SMC M PC 50-OHM	28480	1250-1220
	2190-0124	4		WASHER-LK INTL T NO. 10 .195-IN-ID	28480	2190-0124
	2950-0078	9		NUT-HEX-DBL-CHAM 10-32-THD .067-IN-THK	28480	2950-0078
A17J4	1250-1425	7		CONNECTOR-RF SMC M SGL-HOLE-RR 50-OHM	28480	1250-1425
A17L1	9100-3922	4	4	INDUCTOR-FIXED 120-1300 HZ	28480	9100-3922
A17L2	9100-3922	4		INDUCTOR-FIXED 120-1300 HZ	28480	9100-3922
A17L3	9100-3922	4		INDUCTOR-FIXED 120-1300 HZ	28480	9100-3922
A17L4	9100-3922	4		INDUCTOR-FIXED 120-1300 HZ	28480	9100-3922
A17L5	9100-4434	5	1	INDUCTOR 240UH 2% .165DX.385LF Q = 65	28480	9100-4434
A17L6	9100-3313	7	1	INDUCTOR RF-CH-MLD 22UH 5% .166DX.385LG	28480	9100-3313
A17L7	9100-1625	0	1	INDUCTOR RF-CH-MLD 33UH 5% .166DX.385LG	28480	9100-1625
A17L8	9140-0840	3	1	COIL-VAR 18UH-56.3UH Q = 20 PC-MTG	28480	9140-0840
A17L10	9100-1626	1	1	INDUCTOR RF-CH-MLD 36UH 5% .166DX.385LG	28480	9100-1626
A17L11	9140-0841	4	1	COIL-VAR 6.1UH-19.1UH Q = 20 PC-MTG	28480	9140-0841
A17L12	9140-0303	3	2	INDUCTOR RF-CH-MLD 89.3UH 2%	28480	9140-0303
A17L14	9140-0454	5	1	INDUCTOR RF-CH-MLD 18UH 5% .166DX.385LG	28480	9140-0454
A17MP1	08902-00026	3	1	COVER-MIXER	28480	08902-00026
	2360-0113	2	1	SCREW-MACH 6-32 .25-IN-LG PAN-HD-POZI	00000	ORDER BY DESCRIPTION
A17MP2	5001-0176	0	2	GROUND STRAP	28480	5001-0176
A17MP3	0363-0159	0	1	RFI STRIP-FINGERS BE-CU ZINC PLATED	28480	0363-0159
A17Q1	1853-0281	9	4	TRANSISTOR PNP 2N2907A SI TO-18 PD = 400MW	04713	2N2907A
A17Q2	1853-0314	9	2	TRANSISTOR PNP 2N2905A SI TO-39 PD = 600MW	04713	2N2905A
A17Q3	1854-0404	0	1	TRANSISTOR NPN SI TO-18 PD = 360MW	28480	1854-0404
A17Q4	1854-0632	6	1	TRANSISTOR NPN SI PD = 180MW FT = 4GHZ	25403	BFR-91
A17Q5	1853-0020	4	2	TRANSISTOR PNP SI PD = 300MW FT = 150MHZ	28480	1853-0020
A17Q6	1854-0720	3	1	TRANSISTOR NPN SI PD = 500MW FT = 4GHZ	28480	1854-0720
A17Q7	1853-0020	4		TRANSISTOR PNP SI PD = 300MW FT = 150MHZ	28480	1853-0020
A17Q8	1853-0281	9		TRANSISTOR PNP 2N2907A SI TO-18 PD = 400MW	04713	2N2907A
A17Q9	1853-0281	9		TRANSISTOR PNP 2N2907A SI TO-18 PD = 400MW	04713	2N2907A
A17Q10	1853-0314	9		TRANSISTOR PNP 2N2905A SI TO-39 PD = 600MW	04713	2N2905A
A17Q11	1854-0610	0	1	TRANSISTOR NPN SI TO-46 FT = 800MHZ	28480	1854-0610
A17Q12	1858-0008	8	1	TRANSISTOR ARRAY 14-PIN PLSTC DIP	04713	MHQ6001
A17Q13	1853-0281	9		TRANSISTOR PNP 2N2907A SI TO-18 PD = 400MW	04713	2N2907A
A17R1	0757-0442	9	1	RESISTOR 10K 1% .125W F TC = 0 + -100	24546	C4-1/8-T0-1002-F
A17R2	0757-0200	7	1	RESISTOR 5.62K 1% .125W F TC = 0 + -100	24546	C4-1/8-T0-5621-F
A17R3	0698-3154	0	5	RESISTOR 4.22K 1% .125W F TC = 0 + -100	24546	C4-1/8-T0-4221-F
A17R4	0698-8821	8	3	RESISTOR 5.62 1% .125W F TC = 0 + -100	28480	0698-8821
A17R5	0698-8821	8		RESISTOR 5.62 1% .125W F TC = 0 + -100	28480	0698-8821

† Refer to Section 7 for update information.

\* Factory Selected Component (Refer to Section 5)

Δ Errata part change

Table 6-3. Replaceable Parts

Reference Designation	HP Part Number	C D	Qty.	Description	Mfr. Code	Mfr. Part Number
<b>A17 08902-60104 – SERIAL PREFIX 2535A AND ABOVE</b>						
A17R6	0698-0087	2	1	RESISTOR 316 1% .25W F TC = 0 + -100	24546	C5-1/4-TO-3160-F
A17R7	0698-0085	0	2	RESISTOR 2.61K 1% .125W F TC = 0 + -100	24546	C4-1/8-TO-2611-F
A17R8	0699-0135	3	2	RESISTOR 71.2 1% .25W F TC = 0 + -100	28480	0699-0135
A17R9	0699-0135	3		RESISTOR 71.2 1% .25W F TC = 0 + -100	28480	0699-0135
A17R10	0698-7204	9	3	RESISTOR 46.4 1% .05W F TC = 0 + -100	24546	C3-1/8-TO-46R4-F
A17R11	0698-7220	9	1	RESISTOR 215 1% .05W F TC = 0 + -100	24546	C3-1/8-TO-215R-F
A17R12	0698-7204	9		RESISTOR 46.4 1% .05W F TC = 0 + -100	24546	C3-1/8-TO-46R4-F
A17R13	0757-0421	4	1	RESISTOR 825 1% .125W F TC = 0 + -100	24546	C4-1/8-TO-825R-F
A17R14	0698-3154	0		RESISTOR 4.22K 1% .125W F TC = 0 + -100	24546	C4-1/8-TO-4221-F
A17R15	0757-0422	5	2	RESISTOR 909 1% .125W F TC = 0 + -100	24546	C4-1/8-TO-909R-F
A17R16	0699-0392	4	1	RESISTOR 34.8 1% .125W F TC = 0 + -100	28480	0699-0392
A17R17	0757-0439	4	1	RESISTOR 6.81K 1% .125W F TC = 0 + -100	24546	C4-1/8-TO-6811-F
A17R18	0757-0441	8	1	RESISTOR 8.25K 1% .125W F TC = 0 + -100	24546	C4-1/8-TO-8251-F
A17R19	0698-7204	9		RESISTOR 46.4 1% .05W F TC = 0 + -100	24546	C3-1/8-TO-46R4-F
A17R20	0757-0799	9	1	RESISTOR 121 1% .5W F TC = 0 + -100	28480	0757-0799
A17R21	0698-0085	0		RESISTOR 2.61K 1% .125W F TC = 0 + -100	24546	C4-1/8-TO-2611-F
A17R22	0698-7205	0	3	RESISTOR 51.1 1% .05W F TC = 0 + -100	24546	C3-1/8-TO-51R1-F
A17R23	0698-7205	0		RESISTOR 51.1 1% .05W F TC = 0 + -100	24546	C3-1/8-TO-51R1-F
A17R24	0698-7216	3	1	RESISTOR 147 1% .05W F TC = 0 + -100	24546	C3-1/8-TO-147R-F
A17R25	0698-3154	0		RESISTOR 4.22K 1% .125W F TC = 0 + -100	24546	C4-1/8-TO-4221-F
A17R26	0757-0274	5	1	RESISTOR 1.21K 1% .125W F TC = 0 + -100	24546	C4-1/8-TO-1211-F
A17R27	0698-7205	0		RESISTOR 51.1 1% .05W F TC = 0 + -100	24546	C3-1/8-TO-51R1-F
A17R28	0757-0278	9	1	RESISTOR 1.78K 1% .125W F TC = 0 + -100	24546	C4-1/8-TO-1781-F
A17R29	0757-0294	9	2	RESISTOR 17.8 1% .125W F TC = 0 + -100	19701	MF4C1/8-TO-17R8-F
A17R30	0698-3441	8	1	RESISTOR 215 1% .125W F TC = 0 + -100	24546	C4-1/8-TO-215R-F
A17R31	0698-3431	6	1	RESISTOR 23.7 1% .125W F TC = 0 + -100	03888	PME55-1/8-TO-23R7-F
A17R32	0757-0418	9	3	RESISTOR 619 1% .125W F TC = 0 + -100	24546	C4-1/8-TO-619R-F
A17R33	0698-3443	0	3	RESISTOR 287 1% .125W F TC = 0 + -100	24546	C4-1/8-TO-287R-F
A17R34	0698-3443	0		RESISTOR 287 1% .125W F TC = 0 + -100	24546	C4-1/8-TO-287R-F
A17R35	0698-3154	0		RESISTOR 4.22K 1% .125W F TC = 0 + -100	24546	C4-1/8-TO-4221-F
A17R36	0757-0294	9		RESISTOR 17.8 1% .125W F TC = 0 + -100	19701	MF4C1/8-TO-17R8-F
A17R37	0757-0394	0	2	RESISTOR 51.1 1% .125W F TC = 0 + -100	24546	C4-1/8-TO-51R1-F
A17R38	0757-0180	2	1	RESISTOR 31.6 1% .125W F TC = 0 + -100	28480	0757-0180
A17R39	0757-0394	0		RESISTOR 51.1 1% .125W F TC = 0 + -100	24546	C4-1/8-TO-51R1-F
A17R40	0757-0418	9		RESISTOR 619 1% .125W F TC = 0 + -100	24546	C4-1/8-TO-619R-F
A17R41	0698-3443	0		RESISTOR 287 1% .125W F TC = 0 + -100	24546	C4-1/8-TO-287R-F
A17R42	0757-0401	0	2	RESISTOR 100 1% .125W F TC = 0 + -100	24546	C4-1/8-TO-101-F
A17R43	0757-0401	0		RESISTOR 100 1% .125W F TC = 0 + -100	24546	C4-1/8-TO-101-F
A17R44	0757-0418	9		RESISTOR 619 1% .125W F TC = 0 + -100	24546	C4-1/8-TO-619R-F
A17R45	0698-4037	0	2	RESISTOR 46.4 1% .125W F TC = 0 + -100	24546	C4-1/8-TO-46R4-F
A17R46	0698-8821	8		RESISTOR 5.62 1% .125W F TC = 0 + -100	28480	0698-8821
A17R47	0698-4037	0		RESISTOR 46.4 1% .125W F TC = 0 + -100	24546	C4-1/8-TO-46R4-F
A17R48	0698-3438	3	1	RESISTOR 147 1% .125W F TC = 0 + -100	24546	C4-1/8-TO-147R-F
A17R49	0757-0422	5		RESISTOR 909 1% .125W F TC = 0 + -100	24546	C4-1/8-TO-909R-F
A17R50	0698-3154	0		RESISTOR 4.22K 1% .125W F TC = 0 + -100	24546	C4-1/8-TO-4221-F
A17T1	08901-80031	7	1	XFMR TORD14.OTRN	28480	08901-80031
A17U1	08901-67001	3	1	MIXER CIRCUIT	28480	08901-67001
	0340-1098	0	1	INSULATOR-XSTR TFE	28480	0340-1098
	1251-1556	7	12	CONNECTOR-SGL CONT SKT .018-IN-BSC-SZ	28480	1251-1556

† Refer to Section 7 for update information.

\* Factory Selected Component (Refer to Section 5.)

Δ Errata part change.

Table 6-3. Replaceable Parts

Reference Designation	HP Part Number	C D	Qty.	Description	Mfr. Code	Mfr. Part Number
<b>A18</b>						
A18	08901-60004	2	1	IF AMPLIFIER ASSEMBLY	28480	08901-60004
A18C1	0180-0094	4		CAPACITOR-FXD 100UF + 75-10% 25VDC AL	56289	30D107G025DD2
A18C2	0180-0094	4		CAPACITOR-FXD 100UF + 75-10% 25VDC AL	56289	30D107G025DD2
A18C3	0160-3459	9	45	CAPACITOR-FXD .02UF + -20% 100VDC CER	28480	0160-3459
A18C4	0180-2620	6	14	CAPACITOR-FXD 2.2UF + -10% 50VDC TA	25088	D2R2GS1B50K
A18C5	0180-2619	3	7	CAPACITOR-FXD 22UF + -10% 15VDC TA	25088	D22GS1B15K
A18C6	0160-0156	7	1	CAPACITOR-FXD 3900PF + -10% 200VDC POLYE	28480	0160-0156
A18C7	0160-2257	3	1	CAPACITOR-FXD 10PF + -5% 500VDC CER 0 + -60	28480	0160-2257
A18C8	0140-0198	5		CAPACITOR-FXD 200PF + -5% 300VDC MICA	72136	DM15F201J0300WV1CR
A18C9	0180-2620	6		CAPACITOR-FXD 2.2UF + -10% 50VDC TA	25088	D2R2GS1B50K
A18C10	0160-2242	6	2	CAPACITOR-FXD 2.4PF + -.25PF 500VDC CER	28480	0160-2242
A18C11	0180-2620	6		CAPACITOR-FXD 2.2UF + -10% 50VDC TA	25088	D2R2GS1B50K
A18C12	0180-2620	6		CAPACITOR-FXD 2.2UF + -10% 50VDC TA	25088	D2R2GS1B50K
A18C13 <sup>Δ</sup>	0160-6623	5		CAPACITOR-FXD .1UF + -20% 50VDC CER	28480	0160-6623
A18C14	0160-2266	4	1	CAPACITOR-FXD 24PF + -5% 500VDC CER 0 + -30	28480	0160-2266
A18C15	0160-2199	2	10	CAPACITOR-FXD 30PF + -5% 300VDC MICA	28480	0160-2199
A18C16	0160-2205	1	1	CAPACITOR-FXD 120PF + -5% 300VDC MICA	28480	0160-2205
A18C17	0180-1746	5		CAPACITOR-FXD 15UF + -10% 20VDC TA	56289	150D156X9020B2
A18C18	0160-2242	6		CAPACITOR-FXD 2.4PF + -.25PF 500VDC CER	28480	0160-2242
A18C19	0180-0197	8		CAPACITOR-FXD 2.2UF + -10% 20VDC TA	56289	150D225X9020A2
A18C20	0180-2620	6		CAPACITOR-FXD 2.2UF + -10% 50VDC TA	25088	D2R2GS1B50K
A18C21	0160-2265	3	1	CAPACITOR-FXD 22PF + -5% 500VDC CER 0 + -30	28480	0160-2265
A18CR1	1901-1098	1		DIODE-SWITCHING 1N4150 50V 200MA 4NS	9N171	1N4150
A18CR2	1901-1098	1		DIODE-SWITCHING 1N4150 50V 200MA 4NS	9N171	1N4150
A18CR3	1901-1098	1		DIODE-SWITCHING 1N4150 50V 200MA 4NS	9N171	1N4150
A18CR4	1901-0880	7		DIODE-GEN PRP 125MA D0-35	28480	1901-0880
A18CR5	1901-0880	7		DIODE-GEN PRP 125MA D0-35	28480	1901-0880
A18CR6	1901-0518	8		DIODE-SM SIG SCHOTTKY	28480	1901-0518
A18CR7	1901-0518	8		DIODE-SM SIG SCHOTTKY	28480	1901-0518
<i>2305A TO 2449A</i>						
<i>A18E1</i> NOT ASSIGNED						
<i>2451A AND ABOVE</i>						
<i>A18E1</i>	9170-0029	3		CORE-SHIELDING BEAD		
A18J1	1250-1205	1	6	CONNECTOR-RF SMC M SGL-HOLE-RR 50-OHM	28480	1250-1205
A18J2	1250-1205	1		CONNECTOR-RF SMC M SGL-HOLE-RR 50-OHM	28480	1250-1205
A18L1	9100-1628	3	1	INDUCTOR RF-CH-MLD 43UH 5% .166DX.385LG	28480	9100-1628
A18L2	9140-0237	2	1	INDUCTOR RF-CH-MLD 200UH 5% .166DX.385LG	28480	9140-0237
A18MP1	08901-00029	5	1	COVER IF AMPLIFIER	28480	08901-00029
	2190-0124	4		WASHER-LK INTL T NO. 10 .195-IN-ID	28480	2190-0124
	2950-0078	9		NUT-HEX-DBL-CHAM 10-32-THD .067-IN-THK	28480	2950-0078

<sup>1</sup>Refer to Section 7 for update information.

<sup>\*</sup>Factory Selected Component (Refer to Section 5)

<sup>Δ</sup> Errata part change.

Table 6-3. Replaceable Parts

Reference Designation	HP Part Number	C D	Qty.	Description	Mfr. Code	Mfr. Part Number
A18Q1	1854-0071	7		TRANSISTOR NPN SI PD = 300MW FT = 200MHZ	28480	1854-0071
A18Q2	1854-0071	7		TRANSISTOR NPN SI PD = 300MW FT = 200MHZ	28480	1854-0071
A18Q3	1853-0018	0	1	TRANSISTOR PNP SI TO-72 PD = 200MW FT = 1GHZ	28480	1853-0018
A18Q4	1854-0477	7		TRANSISTOR NPN 2N2222A SI TO-18 PD = 500MW	04713	2N2222A
A18Q5	1853-0007	7		TRANSISTOR PNP 2N3251 SI TO-18 PD = 360MW	04713	2N3251
A18Q6	1853-0007	7		TRANSISTOR PNP 2N3251 SI TO-18 PD = 360MW	04713	2N3251
A18Q7	1854-0610	0	5	TRANSISTOR NPN SI TO-46 FT = 800MHZ	28480	1854-0610
A18R1	0698-3429	2		RESISTOR 19.6 1% .125W F TC = 0 + -100	03888	PME55-1/8-T0-19R6-F
A18R2	0698-3429	2		RESISTOR 19.6 1% .125W F TC = 0 + -100	03888	PME55-1/8-T0-19R6-F
A18R3	0757-0438	3		RESISTOR 5.11K 1% .125W F TC = 0 + -100	24546	C4-1/8-T0-5111-F
A18R4	0698-3155	1		RESISTOR 4.64K 1% .125W F TC = 0 + -100	24546	C4-1/8-T0-4641-F
A18R5	0757-0278	9		RESISTOR 1.78K 1% .125W F TC = 0 + -100	24546	C4-1/8-T0-1781-F
A18R6	0698-3153	9		RESISTOR 3.83K 1% .125W F TC = 0 + -100	24546	C4-1/8-T0-3831-F
A18R7	0698-3434	9		RESISTOR 34.8 1% .125W F TC = 0 + -100	24546	C4-1/8-T0-34R8-F
A18R8	0757-0418	9		RESISTOR 619 1% .125W F TC = 0 + -100	24546	C4-1/8-T0-619R-F
A18R9	0757-0416	7		RESISTOR 511 1% .125W F TC = 0 + -100	24546	C4-1/8-T0-511R-F
A18R10	0757-0416	7		RESISTOR 511 1% .125W F TC = 0 + -100	24546	C4-1/8-T0-511R-F
A18R11	0698-3438	3		RESISTOR 147 1% .125W F TC = 0 + -100	24546	C4-1/8-T0-147R-F
A18R12	0757-0438	3		RESISTOR 5.11K 1% .125W F TC = 0 + -100	24546	C4-1/8-T0-5111-F
A18R13	0698-0083	8		RESISTOR 1.96K 1% .125W F TC = 0 + -100	24546	C4-1/8-T0-1961-F
A18R14	0757-0338	2		RESISTOR 1K 1% .25W F TC = 0 + -100	24546	C5-1/4-T0-1001-F
A18R15	0698-3429	2		RESISTOR 19.6 1% .125W F TC = 0 + -100	03888	PME55-1/8-T0-19R6-F
A18R16	0698-3446	3		RESISTOR 383 1% .125W F TC = 0 + -100	24546	C4-1/8-T0-383R-F
A18R17	0698-3446	3		RESISTOR 383 1% .125W F TC = 0 + -100	24546	C4-1/8-T0-383R-F
A18R18	0698-3445	2		RESISTOR 348 1% .125W F TC = 0 + -100	24546	C4-1/8-T0-348R-F
A18R19	2100-0552	3		RESISTOR-TRMR 50 10% C SIDE-ADJ 1-TRN	28480	2100-0552
A18R20	0698-3150	6		RESISTOR 2.37K 1% .125W F TC = 0 + -100	24546	C4-1/8-T0-2371-F
A18R21	0698-3444	1		RESISTOR 316 1% .125W F TC = 0 + -100	24546	C4-1/8-T0-316R-F
A18R22	0698-3440	7		RESISTOR 196 1% .125W F TC = 0 + -100	24546	C4-1/8-T0-196R-F
A18R23	2100-3351	6		RESISTOR-TRMR 500 10% C SIDE-ADJ 1-TRN	28480	2100-3351
A18R24	0757-0416	7		RESISTOR 511 1% .125W F TC = 0 + -100	24546	C4-1/8-T0-511R-F
A18R25	0757-0402	1		RESISTOR 110 1% .125W F TC = 0 + -100	24546	C4-1/8-T0-111-F
A18R26	0757-0395	1		RESISTOR 56.2 1% .125W F TC = 0 + -100	24546	C4-1/8-T0-56R2-F
A18R27	0757-0402	1		RESISTOR 110 1% .125W F TC = 0 + -100	24546	C4-1/8-T0-111-F
A18R28	0698-3151	7	6	RESISTOR 2.87K 1% .125W F TC = 0 + -100	24546	C4-1/8-T0-2871-F
A18R29	0698-3447	4		RESISTOR 422 1% .125W F TC = 0 + -100	24546	C4-1/8-T0-422R-F
A18R30	0757-0401	0		RESISTOR 100 1% .125W F TC = 0 + -100	24546	C4-1/8-T0-101-F
A18R31	0757-0422	5		RESISTOR 909 1% .125W F TC = 0 + -100	24546	C4-1/8-T0-909R-F
A18R32	0698-3431	6	4	RESISTOR 23.7 1% .125W F TC = 0 + -100	03888	PME55-1/8-T0-23R7-F
A18R33	0757-0401	0		RESISTOR 100 1% .125W F TC = 0 + -100	24546	C4-1/8-T0-101-F

† Refer to Section 7 for update information.

\* Factory Selected Component (Refer to Section 5).

Δ Errata part change.

Table 6-3. Replaceable Parts

Reference Designation	HP Part Number	C D	Qty.	Description	Mfr. Code	Mfr. Part Number
<b>A19 08901-60024, 08901-60274 – SERIAL PREFIX 2305A TO 2717A</b>						
<i>2305A TO 2618A</i>						
A19	08901-60024	6	1	LO DIVIDER ASSEMBLY	28480	08901-60024
<i>2621A AND ABOVE</i>						
A19	08901-60274	8	1	LO DIVIDER ASSEMBLY	28480	08901-60274
A19C1	0160-0570	9		CAPACITOR-FXD 220PF + -20% 100VDC CER	20932	5024EM100RD221M
A19C2	0160-3878	6		CAPACITOR-FXD 1000PF + -20% 100VDC CER	28480	0160-3878
A19C3	0160-3878	6		CAPACITOR-FXD 1000PF + -20% 100VDC CER	28480	0160-3878
A19C4	0160-3878	6		CAPACITOR-FXD 1000PF + -20% 100VDC CER	28480	0160-3878
A19C5	0160-3878	6		CAPACITOR-FXD 1000PF + -20% 100VDC CER	28480	0160-3878
A19C6	0160-3878	6		CAPACITOR-FXD 1000PF + -20% 100VDC CER	28480	0160-3878
A19C7	0160-3878	6		CAPACITOR-FXD 1000PF + -20% 100VDC CER	28480	0160-3878
A19C8	0160-3878	6		CAPACITOR-FXD 1000PF + -20% 100VDC CER	28480	0160-3878
A19C9	0160-3878	6		CAPACITOR-FXD 1000PF + -20% 100VDC CER	28480	0160-3878
A19C10	0180-0197	8		CAPACITOR-FXD 2.2UF + -10% 20VDC TA	56289	150D225X9020A2
A19C11	0160-4822	2		CAPACITOR-FXD 1000PF + -20% 100VDC CER	28480	0160-4822
A19C12	0180-0197	8		CAPACITOR-FXD 2.2UF + -10% 20VDC TA	56289	150D225X9020A2
A19C13	0160-4822	2		CAPACITOR-FXD 1000PF + -20% 100VDC CER	28480	0160-4822
A19C14	0160-4832	4		CAPACITOR-FXD .01UF + -20% 100VDC CER	28480	0160-4832
A19C15	0160-3878	6		CAPACITOR-FXD 1000PF + -20% 100VDC CER	28480	0160-3878
A19C16	0160-4830	2		CAPACITOR-FXD 2200PF + -20% 100VDC CER	28480	0160-4830
A19C17	0160-0576	5		CAPACITOR-FXD 1000PF + -20% 100VDC CER	28480	0160-0576
A19C18	0160-4832	4		CAPACITOR-FXD .01UF + -20% 100VDC CER	28480	0160-4832
A19C19				NOT ASSIGNED		
A19C20				NOT ASSIGNED		
A19C21	0160-4835	7		CAPACITOR-FXD .1UF + -20% 50VDC CER	28480	0160-4835
A19C22	0160-4835	7		CAPACITOR-FXD .1UF + -20% 50VDC CER	28480	0160-4835
A19C23	0160-4835	7		CAPACITOR-FXD .1UF + -20% 50VDC CER	28480	0160-4835
A19C24	0160-4835	7		CAPACITOR-FXD .1UF + -20% 50VDC CER	28480	0160-4835
A19C25	0160-4832	4		CAPACITOR-FXD .01UF + -20% 100VDC CER	28480	0160-4832
A19C26	0160-4835	7		CAPACITOR-FXD .1UF + -20% 50VDC CER	28480	0160-4835
A19C27	0160-4832	4		CAPACITOR-FXD .01UF + -20% 100VDC CER	28480	0160-4832
A19C28	0160-0572	1		CAPACITOR-FXD 2200PF + -20% 100VDC CER	28480	0160-0572
A19C29	0160-0690	4	2	CAPACITOR-FXD 1PF + -.5PF 100VDC CER	28480	0160-0690
A19C30	0160-4832	4		CAPACITOR-FXD .01UF + -20% 100VDC CER	28480	0160-4832
A19C31	0160-0572	1		CAPACITOR-FXD 2200PF + -20% 100VDC CER	28480	0160-0572
A19C32	0160-3877	5		CAPACITOR-FXD 100PF + -20% 200VDC CER	28480	0160-3877
A19C33	0160-3877	5		CAPACITOR-FXD 100PF + -20% 200VDC CER	28480	0160-3877
A19C34	0160-3879	7		CAPACITOR-FXD .01UF + -20% 100VDC CER	28480	0160-3879
A19C35	0160-3877	5		CAPACITOR-FXD 100PF + -20% 200VDC CER	28480	0160-3877
A19C36	0160-3877	5		CAPACITOR-FXD 100PF + -20% 200VDC CER	28480	0160-3877
A19C37	0160-0571	0	7	CAPACITOR-FXD 470PF + -20% 100VDC CER	28480	0160-0571

1 Refer to Section 7 for update information.

\*Factory Selected Component (Refer to Section 5)

Δ Errata part change



Table 6-3. Replaceable Parts

Reference Designation	HP Part Number	C D	Qty.	Description	Mfr. Code	Mfr. Part Number
<b>A19 08901-60024, 08901-60274 – SERIAL PREFIX 2305A TO 2717A</b>						
<i>2305A TO 2343A</i>						
A19C38	0160-3878	6		CAPACITOR-FXD 1000PF + -20% 100VDC CER	28480	0160-3878
<i>2345A AND ABOVE</i>						
A19C38	0160-4389	6		CAPACITOR-FXD 100PF + -5PF 200VDC CER	28480	0160-4389
A19C39	0160-0572	1		CAPACITOR-FXD 2200PF + -20% 100VDC CER	28480	0160-0572
A19C40	0160-4830	2		CAPACITOR-FXD 2200PF + -20% 100VDC CER	28480	0160-4830
A19C41	0160-4830	2		CAPACITOR-FXD 2200PF + -20% 100VDC CER	28480	0160-4830
A19C42	0160-0572	1		CAPACITOR-FXD 2200PF + -20% 100VDC CER	28480	0160-0572
A19C43*	0160-4491	1	1	CAPACITOR-FXD 8.2PF + -5% 200VDC CER	28480	0160-4491
A19C44	0160-3568	1	2	CAPACITOR-FXD 2.7PF + -5% 200VDC CER	51642	100-100-NP0-279J
A19C45	0160-4084	8		CAPACITOR-FXD .1UF + -20% 50VDC CER	28480	0160-4084
A19C46	0160-3568	1		CAPACITOR-FXD 2.7PF + -5% 200VDC CER	51642	100-100-NP0-279J
A19C47	0160-4822	2		CAPACITOR-FXD 1000PF + -20% 100VDC CER	28480	0160-4822
A19C48	0160-4822	2		CAPACITOR-FXD 1000PF + -20% 100VDC CER	28480	0160-4822
A19C49	0160-0690	4		CAPACITOR-FXD 1PF + -.5PF 100VDC CER	28480	0160-0690
A19C50	0160-4822	2		CAPACITOR-FXD 1000PF + -20% 100VDC CER	28480	0160-4822
A19C51	0160-4822	2		CAPACITOR-FXD 1000PF + -20% 100VDC CER	28480	0160-4822
A19C52	0160-4835	7		CAPACITOR-FXD .1UF + -20% 50VDC CER	28480	0160-4835
A19C53	0160-4084	8		CAPACITOR-FXD .1UF + -20% 50VDC CER	28480	0160-4084
A19C54	0160-4822	2		CAPACITOR-FXD 1000PF + -20% 100VDC CER	28480	0160-4822
A19C55	0160-4835	7		CAPACITOR-FXD .1UF + -20% 50VDC CER	28480	0160-4835
A19C56	0160-0571	0		CAPACITOR-FXD 470PF + -20% 100VDC CER	28480	0160-0571
A19C57	0160-4822	2		CAPACITOR-FXD 1000PF + -20% 100VDC CER	28480	0160-4822
A19C58	0160-4084	8		CAPACITOR-FXD .1UF + -20% 50VDC CER	28480	0160-4084
A19C59	0160-0571	0		CAPACITOR-FXD 470PF + -20% 100VDC CER	28480	0160-0571
A19C60	0160-4835	7		CAPACITOR-FXD .1UF + -20% 50VDC CER	28480	0160-4835
A19C61	0160-4835	7		CAPACITOR-FXD .1UF + -20% 50VDC CER	28480	0160-4835
A19C62	0180-1746	5		CAPACITOR-FXD 15UF + -10% 20VDC TA	56289	150D156X9020B2
A19C63	0160-3877	5		CAPACITOR-FXD 100PF + -20% 200VDC CER	28480	0160-3877
A19C64	0160-3878	6		CAPACITOR-FXD 1000PF + -20% 100VDC CER	28480	0160-3878
A19C65	0160-4835	7		CAPACITOR-FXD .1UF + -20% 50VDC CER	28480	0160-4835
A19C66	0160-3878	6		CAPACITOR-FXD 1000PF + -20% 100VDC CER	28480	0160-3878
A19C67	0160-4835	7		CAPACITOR-FXD .1UF + -20% 50VDC CER	28480	0160-4835
A19C68	0160-3878	6		CAPACITOR-FXD 1000PF + -20% 100VDC CER	28480	0160-3878
A19C69	0160-3878	6		CAPACITOR-FXD 1000PF + -20% 100VDC CER	28480	0160-3878
A19C70	0160-3878	6		CAPACITOR-FXD 1000PF + -20% 50VDC CER	28480	0160-3878
A19CR1	1901-0033	2	8	DIODE-GEN PRP 180V 200MA DO-7	28480	1901-0033
<i>2305A TO 2411A</i>						
A19CR2	0122-0072	6	4	DIODE-VVC 2.2PF 5% C3/C25-MIN = 4.5	04713	BB105B
A19CR3	0122-0072	6		DIODE-VVC 2.2PF 5% C3/C25-MIN = 4.5	04713	BB105B
A19CR4	0122-0072	6		DIODE-VVC 2.2PF 5% C3/C25-MIN = 4.5	04713	BB105B
A19CR5	0122-0072	6		DIODE-VVC 2.2PF 5% C3/C25-MIN = 4.5	04713	BB105B
<i>2412A AND ABOVE</i>						
A19CR2	0122-0161	4		DIODE-VVC 2.2PR 7% BVR = 30V	28480	0122-0161
A19CR3	0122-0161	4		DIODE-VVC 2.2PR 7% BVR = 30V	28480	0122-0161
A19CR4	0122-0161	4		DIODE-VVC 2.2PR 7% BVR = 30V	28480	0122-0161
A19CR5	0122-0161	4		DIODE-VVC 2.2PR 7% BVR = 30V	28480	0122-0161

† Refer to Section 7 for update information

\* Factory Selected Component (Refer to Section 5)

Δ Errata part change

Table 6-3. Replaceable Parts

Reference Designation	HP Part Number	C D	Qty.	Description	Mfr. Code	Mfr. Part Number
<b>A19 08901-60024, 08901-60274 – SERIAL PREFIX 2305A TO 2717A</b>						
A19CR6	1901-0033	2		DIODE-GEN PRP 180V 200MA DO-7	28480	1901-0033
A19CR7	1901-1097	0	2	DIODE-PIN	28480	1901-1097
A19CR8	1901-1097	0		DIODE-PIN	28480	1901-1097
A19CR9	1901-0639	4	1	DIODE-PIN	28480	5082-3080
A19CR10	1901-0033	2		DIODE-GEN PRP 180V 200MA DO-7	28480	1901-0033
A19E1	9170-0029	3	11	CORE-SHIELDING BEAD	28480	9170-0029
A19E2	9170-0029	3		CORE-SHIELDING BEAD	28480	9170-0029
A19J1	1250-1425	7		CONNECTOR-RF SMC M PC 50-OHM	28480	1250-1425
	2190-0124	4		WASHER-LK INTL T NO. 10 .195-IN-ID	28480	2190-0124
	2950-0078	9		NUT-HEX-DBL-CHAM 10-32-THD .067-IN-THK	28480	2950-0078
A19J2	1250-1425	7		CONNECTOR-RF SMC M PC 50-OHM	28480	1250-1425
	2190-0124	4		WASHER-LK INTL T NO. 10 .195-IN-ID	28480	2190-0124
	2950-0078	9		NUT-HEX-DBL-CHAM 10-32-THD .067-IN-THK	28480	2950-0078
A19J3	1250-1425	7		CONNECTOR-RF SMC M PC 50-OHM	28480	1250-1425
	2190-0124	4		WASHER-LK INTL T NO. 10 .195-IN-ID	28480	2190-0124
	2950-0078	9		NUT-HEX-DBL-CHAM 10-32-THD .067-IN-THK	28480	2950-0078
A19L1	9100-3922	4		INDUCTOR-FIXED 120-1300 HZ	28480	9100-3922
A19L2	9100-3922	4		INDUCTOR-FIXED 120-1300 HZ	28480	9100-3922
A19L3	9100-3922	4		INDUCTOR-FIXED 120-1300 HZ	28480	9100-3922
A19L4	9100-3922	4		INDUCTOR-FIXED 120-1300 HZ	28480	9100-3922
A19L5	9135-0068	6	2	INDUCTOR RF-CH-MLD 33NH 6% .102DX.26LG	28480	9135-0068
A19L6	9135-0073	3	3	INDUCTOR RF-CH-MLD 51NH 6% .102DX.26LG	28480	9135-0073
A19L7	9135-0068	6		INDUCTOR RF-CH-MLD 33NH 6% .102DX.26LG	28480	9135-0068
A19L8	9135-0073	3		INDUCTOR RF-CH-MLD 51NH 6% .102DX.26LG	28480	9135-0073
A19L9				PART OF ETCHED CIRCUIT BOARD		
A19L10	9100-3922	4		INDUCTOR-FIXED 120-1300 HZ	28480	9100-3922
A19L11	9100-3922	4		INDUCTOR-FIXED 120-1300 HZ	28480	9100-3922
A19L12	9100-3922	4		INDUCTOR-FIXED 120-1300 HZ	28480	9100-3922
A19L13	9140-0210	1		INDUCTOR RF-CH-MLD 100UH 5% .166DX.385LG	28480	9140-0210
A19L14	9135-0073	3		INDUCTOR RF-CH-MLD 51NH 6% .102DX.26LG	28480	9135-0073
A19L15				PART OF ETCHED CIRCUIT BOARD		
<b>2305A TO 2618A</b>						
A19MP1	08901-00028	4	1	COVER LO DIVIDER	28480	08901-00028
	2360-0113	2		SCREW-MACH 6-32 .25-IN-LG PAN-HD-POZI	00000	ORDER BY DESCRIPTION
<b>2621A AND ABOVE</b>						
A19MP1	08901-00166	1	1	COVER LO DIVIDER	28480	08901-00166
	2360-0113	2		SCREW-MACH 6-32 .25-IN-LG PAN-HD-POZI	00000	ORDER BY DESCRIPTION
A19MP2	5001-0176	0		GROUND STRAP	28480	5001-0176
A19MP3	5001-0176	0		GROUND STRAP	28480	5001-0176
A19MP4	08662-00041	1	1	SHIELD COMPONENT LGE	28480	08662-00041
A19MP5	08662-00039	7	1	SHIELD CKT LGE	28480	08662-00039

†Refer to Section 7 for update information.

\*Factory Selected Component (Refer to Section 5).

Δ Errata part change

Table 6-3. Replaceable Parts

Reference Designation	HP Part Number	C D	Qty.	Description	Mfr. Code	Mfr. Part Number
<b>A19 08901-60024, 08901-60274 – SERIAL PREFIX 2305A TO 2717A</b>						
A19Q1	1854-0477		7	TRANSISTOR NPN 2N2222A SI TC=18 PD=500MW	04713	2N2222A
A19Q2	1853-0020		4	TRANSISTOR PNP SI PD=300MW FT=150MHZ	28480	1853-0020
A19Q3	1853-0020		4	TRANSISTOR PNP SI PD=300MW FT=150MHZ	28480	1853-0020
A19Q4	1858-0032		8	TRANSISTOR ARRAY 14-PIN PLSTC DIP	3L585	CA3146E
A19R1	0698-7236		7	RESISTOR 1K 1% .05W F TC=0+-100	24546	C3-1/8-T0-1001-F
A19R2	0698-7227		6	RESISTOR 422 1% .05W F TC=0+-100	24546	C3-1/8-T0-422R-F
A19R3	0698-7227		6	RESISTOR 422 1% .05W F TC=0+-100	24546	C3-1/8-T0-422R-F
A19R4	0698-7227		6	RESISTOR 422 1% .05W F TC=0+-100	24546	C3-1/8-T0-422R-F
A19R5	0698-7227		6	RESISTOR 422 1% .05W F TC=0+-100	24546	C3-1/8-T0-422R-F
A19R6	0698-7232		3	RESISTOR 681 1% .05W F TC=0+-100	24546	C3-1/8-T0-681R-F
A19R7	0698-7232		3	RESISTOR 681 1% .05W F TC=0+-100	24546	C3-1/8-T0-681R-F
A19R8	0698-7232		3	RESISTOR 681 1% .05W F TC=0+-100	24546	C3-1/8-T0-681R-F
A19R9	0698-7232		3	RESISTOR 681 1% .05W F TC=0+-100	24546	C3-1/8-T0-681R-F
A19R10	0698-3437		2	RESISTOR 133 1% .125W F TC=0+-100	24546	C4-1/8-T0-133R-F
A19R11	0757-0402		1	RESISTOR 110 1% .125W F TC=0+-100	24546	C4-1/8-T0-111-F
A19R12	0757-0422		5	RESISTOR 909 1% .125W F TC=0+-100	24546	C4-1/8-T0-909R-F
A19R13	0757-0422		5	RESISTOR 909 1% .125W F TC=0+-100	24546	C4-1/8-T0-909R-F
A19R14	0757-0422		5	RESISTOR 909 1% .125W F TC=0+-100	24546	C4-1/8-T0-909R-F
A19R15	0757-0422		5	RESISTOR 909 1% .125W F TC=0+-100	24546	C4-1/8-T0-909R-F
A19R16	0757-0280		3	RESISTOR 1K 1% .5W .125W F TC=0+-100	28480	0757-0280
A19R17	0698-3151		7	RESISTOR 2.87K 1% .125W F TC=0+-100	24546	0698-3151
A19R18	0698-3132		4	RESISTOR 261 1% .125W F TC=0+-100	24546	C4-1/8-T0-2610-F
A19R19	0698-7201		6	RESISTOR 34.8 1% .05W F TC=0+-100	24546	C3-1/8-T0-34R8-F
A19R20	0757-0280		3	RESISTOR 1K 1% .125W F TC=0+-100	24546	C4-1/8-T0-1001-F
<i>2305A TO 2343A</i>						
A19R21	0698-7205		0	RESISTOR 51.1 1% .05W F TC=0+-100	24546	C3-1/8-T0-51R1-F
<i>2345A TO 2618A</i>						
A19R21	0698-7214		1	RESISTOR 121 1% .05W F TC=0+-100	24546	C3-1/8-T0-121R-F
<i>2621A AND ABOVE</i>						
A19R21	0698-7205		0	RESISTOR 51.1 1% .05W F TC=0+-100	24546	C3-1/8-51.1R-F
A19R22	0757-0440		7	RESISTOR 7.5K 1% .125W F TC=0+-100	24546	C4-1/8-T0-7501-F
A19R23	0757-0289		2	RESISTOR 13.3K 1% .125W F TC=0+-100	19701	MF4C1/8-T0-1332-F
A19R24	0757-0442		9	RESISTOR 10K 1% .125W F TC=0+-100	24546	C4-1/8-T0-1002-F
A19R25	0698-3158		4	RESISTOR 23.7K 1% .125W F TC=0+-100	24546	C4-1/8-T0-2372-F
A19R26	1810-0203		5	NETWORK-RES 8-SIP470.0 OHM X 7	01121	208A471
<i>2305A TO 2343A</i>						
A19R27	0698-7209		4	RESISTOR 75 1% .05W F TC=0+-100	24546	C3-1/8-T0-75R0-F
<i>2345A TO 2618A</i>						
A19R27	0698-7205		0	RESISTOR 51.1 1% .05W F TC=0+-100	24546	C3-1/8-51.1R-F
<i>2621A AND ABOVE</i>						
A19R27	0698-3132		4	RESISTOR 261 1% .125W F TC=0+-100	24546	C4-1/8-T0-2610-F

†Refer to Section 7 for update information.

\*Factory Selected Component (Refer to Section 5).

Δ Errata part change.

Table 6-3. Replaceable Parts

Reference Designation	HP Part Number	C D	Qty.	Description	Mfr. Code	Mfr. Part Number
<b>A19</b>	<b>08901-60024, 08901-60274 – SERIAL PREFIX 2305A TO 2717A</b>					
A19R28	1810-0203	5		NETWORK-RES 8-SIP470.0 OHM X 7	01121	208A471
A19R29	1810-0203	5		NETWORK-RES 8-SIP470.0 OHM X 7	01121	208A471
A19R30	0698-7205	0		RESISTOR 51.1 1% .05W F TC = 0 + -100	24546	C3-1/8-T0-51R1-F
A19R31	0698-7260	7		RESISTOR 10K 1% .05W F TC = 0 + -100	24546	C3-1/8-T0-1002-F
A19R32	0698-7260	7		RESISTOR 10K 1% .05W F TC = 0 + -100	24546	C3-1/8-T0-1002-F
A19R33	0757-0420	3		RESISTOR 750 1% .125W F TC = 0 + -100	24546	C4-1/8-T0-751-F
A19R34	0757-0420	3		RESISTOR 750 1% .12W F TC = 0 + -100	24546	C4-1/8-T0-751-F
A19R35	0698-7195	7	2	RESISTOR 19.6 1% .05W F TC = 0 + -100	24546	C3-1/8-T0-19R6-F
A19R36	0757-0276	7		RESISTOR 61.9 1% .125W F TC = 0 + -100	24546	C4-1/8-T0-6192-F
A19R37	0698-7236	7		RESISTOR 1K 1% .05W F TC = 0 + -100	24546	C3-1/8-T0-1001-F
A19R38	0698-3151	7		RESISTOR 2.87K 1% .125W F TC = 0 + -100	24546	C4-1/8-T0-2871-F
A19R39	0757-0276	7		RESISTOR 61.9 1% .125W F TC = 0 + -100	24546	C4-1/8-T0-6192-F
A19R40	0698-7229	8	7	RESISTOR 511 1% .05W F TC = 0 + -100	24546	C3-1/8-T0-511R-F
A19R41	2100-2413	9	1	RESISTOR-TRMR 200 10% C SIDE-ADJ 1-TRN	30983	ET50X201
A19R42	0757-0416	7		RESISTOR 511 1% .125W F TC = 0 + -100	24546	C4-1/8-T0-511R-F
A19R43	0757-0416	7		RESISTOR 511 1% .125W F TC = 0 + -100	24546	C4-1/8-T0-511R-F
A19R44	0757-0397	3		RESISTOR 68.1 1% .125W F TC = 0 + -100	24546	C4-1/8-T0-68R1-F
A19R45	0757-0397	3		RESISTOR 68.1 1% .125W F TC = 0 + -100	24546	C4-1/8-T0-68R1-F
A19R46	0698-7229	8		RESISTOR 511 1% .05W F TC = 0 + -100	24546	C3-1/8-T0-511R-F
A19R47	0757-0416	7		RESISTOR 511 1% .125W F TC = 0 + -100	24546	C4-1/8-T0-511R-F
A19R48	0757-0346	2		RESISTOR 10 1% .125W F TC = 0 + -100	24546	C4-1/8-T0-10R0-F
A19R49	0757-0416	7		RESISTOR 511 1% .125W F TC = 0 + -100	24546	C4-1/8-T0-511R-F
A19R50	0757-0416	7		RESISTOR 511 1% .125W F TC = 0 + -100	24546	C4-1/8-T0-511R-F
A19R51	0757-0397	3		RESISTOR 68.1 1% .125W F TC = 0 + -100	24546	C4-1/8-T0-68R1-F
A19R52	0757-0397	3		RESISTOR 68.1 1% .125W F TC = 0 + -100	24546	C4-1/8-T0-68R1-F
A19R53	0757-0397	3		RESISTOR 68.1 1% .125W F TC = 0 + -100	24546	C4-1/8-T0-68R1-F
A19R54	0757-0416	7		RESISTOR 511 1% .125W F TC = 0 + -100	24546	C4-1/8-T0-511R-F
A19R55	0757-0416	7		RESISTOR 511 1% .125W F TC = 0 + -100	24546	C4-1/8-T0-511R-F
A19R56	0757-0416	7		RESISTOR 511 1% .125W F TC = 0 + -100	24546	C4-1/8-T0-511R-F
A19R57	0698-3132	4		RESISTOR 261 1% .125W F TC = 0 + -100	24546	C4-1/8-T0-2610-F
A19R58	0698-3132	4		RESISTOR 261 1% .125W F TC = 0 + -100	24546	C4-1/8-T0-2610-F
A19R59	0698-3132	4		RESISTOR 261 1% .125W F TC = 0 + -100	24546	C4-1/8-T0-2610-F
A19R60	0757-0442	9		RESISTOR 10K 1% .125W F TC = 0 + -100	24546	C4-1/8-T0-1002-F
A19R61	0757-0422	5		RESISTOR 909 1% .125W F TC = 0 + -100	24546	C4-1/8-T0-909R-F
A19R62	0698-3158	4		RESISTOR 23.7K 1% .125W F TC = 0 + -100	24546	C4-1/8-T0-2372-F
A19R63*	0757-0398	4	3	RESISTOR 75 1% .125W F TC = 0 + -100	24546	C4-1/8-T0-75R0-F
A19R64	0757-0416	7		RESISTOR 511 1% .125W F TC = 0 + -100	24546	C4-1/8-T0-511R-F
A19R65				NOT ASSIGNED		
A19R66	0757-0465	6		RESISTOR 100K 1% .125W F TC = 0 + -100	24546	C4-1/8-T0-1003-F
A19R67	0757-0397	3		RESISTOR 68.1 1% .125W F TC = 0 + -100	24546	C4-1/8-T0-68R1-F
A19R68	0757-0397	3		RESISTOR 68.1 1% .125W F TC = 0 + -100	24546	C4-1/8-T0-68R1-F
A19R69	0698-3447	4		RESISTOR 422 1% .125W F TC = 0 + -100	24546	C4-1/8-T0-422R-F
A19R70	0757-0397	3		RESISTOR 68.1 1% .125W F TC = 0 + -100	24546	C4-1/8-T0-68R1-F
A19R71	0698-0083	8		RESISTOR 1.96K 1% .125W F TC = 0 + -100	24546	C4-1/8-T0-1961-F
A19R72*	0757-0422	5	11	RESISTOR 909 1% .125W F TC = 0 + -100	24546	C4-1/8-T0-909R-F

†Refer to Section 7 for update information.

\*Factory Selected Component (Refer to Section 5)

Δ Errata part change

Table 6-3. Replaceable Parts

Reference Designation	HP Part Number	C D	Qty.	Description	Mfr. Code	Mfr. Part Number
<b>A19</b>	<b>08901-60024, 08901-60274 – SERIAL PREFIX 2305A TO 2717A</b>					
A19R73				NOT ASSIGNED		
A19R74*	0757-0422	5		RESISTOR 909 1% .125W F TC = 0+ -100	24546	C4-1/8-T0-909R-F
A19R75	0757-0416	7		RESISTOR 511 1% .125W F TC = 0+ -100	24546	C4-1/8-T0-511R-F
A19R76	0698-3438	3		RESISTOR 147 1% .125W F TC = 0+ -100	24546	C4-1/8-T0-147R-F
A19R77	0698-3438	3		RESISTOR 147 1% .125W F TC = 0+ -100	24546	C4-1/8-T0-147R-F
A19R78	0698-3438	3		RESISTOR 147 1% .125W F TC = 0+ -100	24546	C4-1/8-T0-147R-F
A19R79	0757-0726	2	1	RESISTOR 511 1% .25W F TC = 0+ -100	24546	C5-1/4-T0-511R-F
A19R80	0698-3441	8		RESISTOR 215 1% .125W F TC = 0+ -100	24546	C4-1/8-T0-215R-F
A19R81	0698-3441	8		RESISTOR 215 1% .125W F TC = 0+ -100	24546	C4-1/8-T0-215R-F
A19R82	0698-3441	8		RESISTOR 215 1% .125W F TC = 0+ -100	24546	C4-1/8-T0-215R-F
A19R83	0757-0416	7		RESISTOR 511 1% .125W F TC = 0+ -100	24546	C4-1/8-T0-511R-F
A19R84	0757-0416	7		RESISTOR 511 1% .125W F TC = 0+ -100	24546	C4-1/8-T0-511R-F
A19R85	0757-0397	3		RESISTOR 68.1 1% .125W F TC = 0+ -100	24546	C4-1/8-T0-68R1-F
<i>2305A TO 2343A</i>						
A19R86	0698-7209	4		RESISTOR 75 1% .05W F TC = 0+ -100	24546	C3-1/8-T0-75R0-F
<i>2345A AND ABOVE</i>						
A19R86	0698-7205	0		RESISTOR 51.1 1% .05W F TC = 0+ -100	24546	C3-1/8-51.1R-F
A19R87	0698-7205	0		RESISTOR 51.1 1% .05W F TC = 0+ -100	24546	C3-1/8-51R1-F
A19R88	0698-7236	7		RESISTOR 1K 1% .05W F TC = 0+ -100	24546	C3-1/8-T0-1001-F
A19R89	0757-0280	3		RESISTOR 1K 1% .125W F TC = 0+ -100	24546	C4-1/8-T0-1001-F
A19R90	0698-7236	7		RESISTOR 1K 1% .05W F TC = 0+ -100	24546	C3-1/8-T0-1001-F
A19R91	0698-7247	0	5	RESISTOR 2.87K 1% .05W F TC = 0+ -100	24546	C3-1/8-T0-2871-F
A19R92	0698-3151	7		RESISTOR 2.87K 1% .125W F TC = 0+ -100	24546	C4-1/8-T0-2871-F
A19R93	0698-7247	0		RESISTOR 2.87K 1% .05W F TC = 0+ -100	24546	C3-1/8-T0-2871-F
A19R94	0698-7208	3	1	RESISTOR 68.1 1% .05W F TC = 0+ -100	24546	C3-1/8-T0-68R1-F
A19R95	0698-7229	8		RESISTOR 511 1% .05W F TC = 0+ -100	24546	C3-1/8-T0-511R-F
A19R96	0757-0397	3		RESISTOR 68.1 1% .125W F TC = 0+ -100	24546	C4-1/8-T0-68R1-F
A19R97	0757-0416	7		RESISTOR 511 1% .125W F TC = 0+ -100	24546	C4-1/8-T0-511R-F
A19R98	0698-7229	8		RESISTOR 511 1% .05W F TC = 0+ -100	24546	C3-1/8-T0-511R-F
A19R99	0698-3439	4	4	RESISTOR 178 1% .125W F TC = 0+ -100	24546	C4-1/8-T0-178R-F
A19R100	0757-0397	3		RESISTOR 68.1 1% .125W F TC = 0+ -100	24546	C4-1/8-T0-68R1-F
A19R101	0757-0397	3		RESISTOR 68.1 1% .125W F TC = 0+ -100	24546	C4-1/8-T0-68R1-F
A19R102	0698-3439	4		RESISTOR 178 1% .125W F TC = 0+ -100	24546	C4-1/8-T0-178R-F
A19R103	0698-3132	4		RESISTOR 261 1% .125W F TC = 0+ -100	24546	C4-1/8-T0-2610-F
A19R104	0757-0442	9		RESISTOR 10K 1% .125W F TC = 0+ -100	24546	C4-1/8-T0-1002-F
A19R105	0757-0442	9		RESISTOR 10K 1% .125W F TC = 0+ -100	24546	C4-1/8-T0-1002-F
A19R106	0698-7209	4		RESISTOR 75 1% .05W F TC = 0+ -100	24546	C3-1/8-T0-75R0-F
A19R107	0757-0397	3		RESISTOR 68.1 1% .125W F TC = 0+ -100	24546	C4-1/8-T0-68R1-F
A19R108	0698-7209	4		RESISTOR 75 1% .05W F TC = 0+ -100	24546	C3-1/8-T0-75R0-F
A19R109	0698-7229	8		RESISTOR 511 1% .05W F TC = 0+ -100	24546	C3-1/8-T0-511R-F
A19R110	0698-7236	7		RESISTOR 1K 1% .05W F TC = 0+ -100	24546	C3-1/8-T0-1001-F
A10R111	0698-3132	4		RESISTOR 261 1% .125W F TC = 0+ -100	28480	0698-3132
A19R112	0698-7205	0		RESISTOR 51.1 1% .05W F TC = 0+ -100	24546	C3-1/8-T0-51R1-F
A19R113	0698-3132	4		RESISTOR 261 1% .126W F TC = 0+ -100	24546	C4-1/8-T0-2610-F
A19R114	0698-3132	4		RESISTOR 261 1% .126W F TC = 0+ -100	24546	C4-1/8-T0-2610-F
A19R115	0698-3132	4		RESISTOR 261 1% .126W F TC = 0+ -100	24546	C4-1/8-T0-2610-F
A19R116	0698-3132	4		RESISTOR 261 1% .126W F TC = 0+ -100	24546	C4-1/8-T0-2610-F

\*Refer to Section 7 for update information

\*Factory Selected Component (Refer to Section 5)

Δ Errata part change

Table 6-3. Replaceable Parts

Reference Designation	HP Part Number	C D	Qty.	Description	Mfr. Code	Mfr. Part Number
<b>A19</b>	<b>08901-60024, 08901-60274 – SERIAL PREFIX 2305A TO 2717A</b>					
A19TP1	1251-0600	0		CONNECTOR-SGL CONT PIN 1.14-MM-BSC-SZ SQ	28480	1251-0600
A19TP2	1251-0600	0		CONNECTOR-SGL CONT PIN 1.14-MM-BSC-SZ SQ	28480	1251-0600
A19U1	1820-1225	4	1	IC FF ECL D-M/S DUAL	04713	MC10231P
A19U2	1826-0372	2	6	IC MISC 8-DIP-P PKG	28480	1826-0372
A19U3	1826-0013	8	2	IC OP AMP LOW-NOISE TO-99 PKG	06665	SSS741CJ
A19U4	08901-67002	4	1	FREQUENCY DUBLER	28480	08901-67002
	0340-0850	0		INSULATOR-XSTR TFE	28480	0340-0850
	1251-1556	7		CONNECTOR-SGL CONT SKT .018-IN-BSC-SZ	28480	1251-1556
A19U5	1826-0372	2		IC MISC 8-DIP-P PKG	28480	1826-0372
A19U6	1820-0817	8		IC FF ECL D-M/S DUAL	04713	MC10131P
A19U7	1820-1940	0	2	IC CNTR ECL BIN SYNCHRO POS-EDGE-TRIG	28480	1820-1940
A19U8	1820-1940	0		IC CNTR ECL BIN SYNCHRO POS-EDGE-TRIG	28480	1820-1940
A19U9	1820-0796	2	1	IC GATE ECL NOR QUAD 2-INP	04713	MC1662L
A19U10	1826-0372	2		IC MISC 8-DIP-P PKG	28480	1826-0372
A19U11	1826-0372	2		IC MISC 8-DIP-P PKG	28480	1826-0372
A19U12	1820-0817	8		IC FF ECL D-M/S DUAL	04713	MC10131P
A19U13	1820-1400	7	2	IC GATE ECL AND QUAD 2-INP	04713	MC10104P
A19U14	1820-1400	7		IC GATE ECL AND QUAD 2-INP	04713	MC10104P
A19U15	1820-0828	1	2	IC DCDR ECL BIN 3-TO-8-LINE 3-INP	04713	MC10162P
A19U16	1820-0802	1	2	IC GATE ECL NOR QUAD 2-INP	04713	MC10102P
A19U17	1820-0817	8		IC FF ECL D-M/S DUAL	04713	MC10131P
A19U18	1820-0828	1		IC DCDR ECL BIN 3-TO-8-LINE 3-INP	04713	MC10162P
A19U19	1820-0802	1		IC GATE ECL NOR QUAD 2-INP	04713	MC10102P
A19U20	1820-1052	5	1	IC XLTR ECL ECL-TO-TTL QUAD 2-INP	04713	MC10125L
A19VR1	1902-0943	5		DIODE-ZNR 2.4V 5% DO-35 PD = .4W TC = -.037%	28480	1902-0943
A19VR2	1902-0049	2	3	DIODE-ZNR 6.19V 5% DO-35 PD = .4W	28480	1902-0049
A19VR3	1902-0049	2		DIODE-ZNR 6.19V 5% DO-35 PD = .4W	28480	1902-0049
A19VR4	1902-0049	2		DIODE-ZNR 6.19V 5% DO-35 PD = .4W	28480	1902-0049
A19W1	8159-0005	0		RESISTOR-ZERO OHMS 22 AWG LEAD DIA	28480	8159-0005
A19W2	8159-0005	0		RESISTOR-ZERO OHMS 22 AWG LEAD DIA	28480	8159-0005
A19W3				NOT ASSIGNED		
A19W4	8159-0005	0		RESISTOR-ZERO OHMS 22 AWG LEAD DIA	28480	8159-0005

† Refer to Section 7 for update information.

\* Factory Selected Component (Refer to Section 5)

Δ Errata part change

Table 6-3. Replaceable Parts

Reference Designation	HP Part Number	C D	Qty.	Description	Mfr. Code	Mfr. Part Number
<b>A19</b>	<b>08902-60126</b>			<b>SERIAL PREFIX 2742A AND ABOVE</b>		
A19	08902-60126	0	1	LO DIVIDER ASSEMBLY	28480	08902-60126
A19C1	0160-0570	9		CAPACITOR-FXD 220PF + -20% 100VDC CER	20932	5024EM100RD221M
A19C2	0160-3878	6		CAPACITOR-FXD 1000PF + -20% 100VDC CER	28480	0160-3878
A19C3	0160-3878	6		CAPACITOR-FXD 1000PF + -20% 100VDC CER	28480	0160-3878
A19C4	0160-3878	6		CAPACITOR-FXD 1000PF + -20% 100VDC CER	28480	0160-3878
A19C5	0160-3878	6		CAPACITOR-FXD 1000PF + -20% 100VDC CER	28480	0160-3878
A19C6	0160-3878	6		CAPACITOR-FXD 1000PF + -20% 100VDC CER	28480	0160-3878
A19C7	0160-3878	6		CAPACITOR-FXD 1000PF + -20% 100VDC CER	28480	0160-3878
A19C8	0160-3878	6		CAPACITOR-FXD 1000PF + -20% 100VDC CER	28480	0160-3878
A19C9	0160-3878	6		CAPACITOR-FXD 1000PF + -20% 100VDC CER	28480	0160-3878
A19C10	0180-0197	8		CAPACITOR-FXD 2.2UF + -10% 20VDC TA	56289	150D225X9020A2
A19C11	0160-4822	2		CAPACITOR-FXD 1000PF + -20% 100VDC CER	28480	0160-4822
A19C12	0180-0197	8		CAPACITOR-FXD 2.2UF + -10% 20VDC TA	56289	150D225X9020A2
A19C13	0160-4822	2		CAPACITOR-FXD 1000PF + -20% 100VDC CER	28480	0160-4822
A19C14	0160-4832	4		CAPACITOR-FXD .01UF + -20% 100VDC CER	28480	0160-4832
A19C15	0160-3878	6		CAPACITOR-FXD 1000PF + -20% 100VDC CER	28480	0160-3878
A19C16	0160-4830	2		CAPACITOR-FXD 2200PF + -20% 100VDC CER	28480	0160-4830
A19C17	0160-4822	2		CAPACITOR-FXD 1000PF + -5% 100VDC CER	28480	0160-4822
A19C18	0160-4832	4		CAPACITOR-FXD .01UF + -20% 100VDC CER	28480	0160-4832
A19C19				NOT ASSIGNED		
A19C20				NOT ASSIGNED		
A19C21	0160-4835	7		CAPACITOR-FXD .1UF + -20% 50VDC CER	28480	0160-4835
A19C22	0160-4835	7		CAPACITOR-FXD .1UF + -20% 50VDC CER	28480	0160-4835
A19C23	0160-4835	7		CAPACITOR-FXD .1UF + -20% 50VDC CER	28480	0160-4835
A19C24	0160-4835	7		CAPACITOR-FXD .1UF + -20% 50VDC CER	28480	0160-4835
A19C25	0160-4832	4		CAPACITOR-FXD .01UF + -20% 100VDC CER	28480	0160-4832
A19C26	0160-4835	7		CAPACITOR-FXD .1UF + -20% 50VDC CER	28480	0160-4835
A19C27	0160-4832	4		CAPACITOR-FXD .01UF + -20% 100VDC CER	28480	0160-4832
A19C28				NOT ASSIGNED		
A19C29	0160-0690	4	2	CAPACITOR-FXD 1PF + -.5PF 100VDC CER	28480	0160-0690
A19C30	0160-4832	4		CAPACITOR-FXD .01UF + -20% 100VDC CER	28480	0160-4832
A19C31	0160-0572	1		CAPACITOR-FXD 2200PF + -20% 100VDC CER	28480	0160-0572
A19C32	0160-3877	5		CAPACITOR-FXD 100PF + -20% 200VDC CER	28480	0160-3877
A19C33	0160-3877	5		CAPACITOR-FXD 100PF + -20% 200VDC CER	28480	0160-3877
A19C34	0160-3879	7		CAPACITOR-FXD .01UF + -20% 100VDC CER	28480	0160-3879
A19C35	0160-3877	5		CAPACITOR-FXD 100PF + -20% 200VDC CER	28480	0160-3877
A19C36	0160-3877	5		CAPACITOR-FXD 100PF + -20% 200VDC CER	28480	0160-3877
A19C37	0160-0571	0	7	CAPACITOR-FXD 470PF + -20% 100VDC CER	28480	0160-0571
A19C38	0160-4389	6		CAPACITOR-FXD 100PF + -.5PF 200VDC CER	28480	0160-4389
A19C39	0160-4830	2		CAPACITOR-FXD 2200PF + -10% 100VDC CER	28480	0160-4830
A19C40	0160-4830	2		CAPACITOR-FXD 2200PF + -20% 100VDC CER	28480	0160-4830
A19C41	0160-4830	2		CAPACITOR-FXD 2200PF + -20% 100VDC CER	28480	0160-4830
A19C42	0160-0572	1		CAPACITOR-FXD 2200PF + -20% 100VDC CER	28480	0160-0572
A19C43*	0160-4491	1	1	CAPACITOR-FXD 8.2PF + -5% 200VDC CER	28480	0160-4491

\*Refer to Section 7 for update information.

\*Factory Selected Component (Refer to Section 5)

Δ Errata part change

Table 6-3. Replaceable Parts

Reference Designation	HP Part Number	C D	Qty.	Description	Mfr. Code	Mfr. Part Number
<b>A19 08902-60126 – SERIAL PREFIX 2742A AND ABOVE</b>						
A19C44	0160-3568	1	2	CAPACITOR-FXD 2.7PF + -5% 200VDC CER	51642	100-100-NP0-279J
A19C45	0160-4084	8		CAPACITOR-FXD .1UF + -20% 50VDC CER	28480	0160-4084
A19C46	0160-3568	1		CAPACITOR-FXD 2.7PF + -5% 200VDC CER	51642	100-100-NP0-279J
A19C47	0160-4822	2		CAPACITOR-FXD 1000PF + -20% 100VDC CER	28480	0160-4822
A19C48	0160-4822	2		CAPACITOR-FXD 1000PF + -20% 100VDC CER	28480	0160-4822
A19C49	0160-0690	4		CAPACITOR-FXD 1PF + -.5PF 100VDC CER	28480	0160-0690
A19C50	0160-4822	2		CAPACITOR-FXD 1000PF + -20% 100VDC CER	28480	0160-4822
A19C51	0160-4822	2		CAPACITOR-FXD 1000PF + -20% 100VDC CER	28480	0160-4822
A19C52	0160-4835	7		CAPACITOR-FXD .1UF + -20% 50VDC CER	28480	0160-4835
A19C53	0160-4084	8		CAPACITOR-FXD .1UF + -20% 50VDC CER	28480	0160-4084
A19C54	0160-4822	2		CAPACITOR-FXD 1000PF + -20% 100VDC CER	28480	0160-4822
A19C55	0160-4835	7		CAPACITOR-FXD .1UF + -20% 50VDC CER	28480	0160-4835
A19C56	0160-0571	0		CAPACITOR-FXD 470PF + -20% 100VDC CER	28480	0160-0571
A19C57	0160-4822	2		CAPACITOR-FXD 1000PF + -20% 100VDC CER	28480	0160-4822
A19C58	0160-4084	8		CAPACITOR-FXD .1UF + -20% 50VDC CER	28480	0160-4084
A19C59	0160-0571	0		CAPACITOR-FXD 470PF + -20% 100VDC CER	28480	0160-0571
A19C60	0160-4835	7		CAPACITOR-FXD .1UF + -20% 50VDC CER	28480	0160-4835
A19C61	0160-4835	7		CAPACITOR-FXD .1UF + -20% 50VDC CER	28480	0160-4835
A19C62	0160-1746	5		CAPACITOR-FXD 15UF + -10% 20VDC TA	56289	150D156X9020B2
A19C63	0160-3877	5		CAPACITOR-FXD 100PF + -20% 200VDC CER	28480	0160-3877
A19C64	0160-3878	6		CAPACITOR-FXD 1000PF + -20% 100VDC CER	28480	0160-3878
A19C65	0160-0576	5		CAPACITOR-FXD .1UF + -10% 100VDC CER	28480	0160-0576
A19C66				NOT ASSIGNED		
A19C67	0160-0576	5		CAPACITOR-FXD .1UF + -20% 50VDC CER	28480	0160-0576
A19C68				NOT ASSIGNED		
A19C69				NOT ASSIGNED		
A19C70				NOT ASSIGNED		
A19CR1	1901-0033	2	8	DIODE-GEN PRP 180V 200MA DO-7	28480	1901-0033
A19CR2	0122-0161	4		DIODE-VVC 2.2PR 7% BVR = 30V	28480	0122-0161
A19CR3	0122-0161	4		DIODE-VVC 2.2PR 7% BVR = 30V	28480	0122-0161
A19CR4	0122-0161	4		DIODE-VVC 2.2PR 7% BVR = 30V	28480	0122-0161
A19CR5	0122-0161	4		DIODE-VVC 2.2PR 7% BVR = 30V	28480	0122-0161
A19CR6	1901-0033	2		DIODE-GEN PRP 180V 200MA DO-7	28480	1901-0033
A19CR7	1901-1097	0	2	DIODE-PIN	28480	1901-1097
A19CR8	1901-1097	0		DIODE-PIN	28480	1901-1097
A19CR9	1901-0639	4	1	DIODE-PIN	28480	5082-3080
A19CR10	1901-0033	2		DIODE-GEN PRP 180V 200MA DO-7	28480	1901-0033
A19E1	9170-0029	3	11	CORE-SHIELDING BEAD	28480	9170-0029
A19E2	9170-0029	3		CORE-SHIELDING BEAD	28480	9170-0029
A19J1	1250-1425	7		CONNECTOR-RF SMC M PC 50-OHM	28480	1250-1425
	2190-0124	4		WASHER-LK INTL T NO. 10 .195-IN-ID	28480	2190-0124
	2950-0078	9		NUT-HEX-DBL-CHAM 10-32-THD .067-IN-THK	28480	2950-0078
A19J2	1250-1425	7		CONNECTOR-RF SMC M PC 50-OHM	28480	1250-1425
	2190-0124	4		WASHER-LK INTL T NO. 10 .195-IN-ID	28480	2190-0124
	2950-0078	9		NUT-HEX-DBL-CHAM 10-32-THD .067-IN-THK	28480	2950-0078
A19J3	1250-1425	7		CONNECTOR-RF SMC M PC 50-OHM	28480	1250-1425
	2190-0124	4		WASHER-LK INTL T NO. 10 .195-IN-ID	28480	2190-0124
	2950-0078	9		NUT-HEX-DBL-CHAM 10-32-THD .067-IN-THK	28480	2950-0078

† Refer to Section 7 for update information

\* Factory Selected Component (Refer to Section 5)

Δ Errata part change



Table 6-3. Replaceable Parts

Reference Designation	HP Part Number	C D	Qty.	Description	Mfr. Code	Mfr. Part Number
<b>A19 08902-60126 – SERIAL PREFIX 2742A AND ABOVE</b>						
A19L1	9100-3922	4		INDUCTOR-FIXED 120-1300 HZ	28480	9100-3922
A19L2	9100-3922	4		INDUCTOR-FIXED 120-1300 HZ	28480	9100-3922
A19L3	9100-3922	4		INDUCTOR-FIXED 120-1300 HZ	28480	9100-3922
A19L4	9100-3922	4		INDUCTOR-FIXED 120-1300 HZ	28480	9100-3922
A19L5	9135-0068	6	2	INDUCTOR RF-CH-MLD 33NH 6% .102DX.26LG	28480	9135-0068
A19L6	9135-0073	3	3	INDUCTOR RF-CH-MLD 51NH 6% .102DX.26LG	28480	9135-0073
A19L7	9135-0068	6		INDUCTOR RF-CH-MLD 33NH 6% .102DX.26LG	28480	9135-0068
A19L8	9135-0073	3		INDUCTOR RF-CH-MLD 51NH 6% .102DX.26LG	28480	9135-0073
A19L9				PART OF ETCHED CIRCUIT BOARD		
A19L10	9100-3922	4		INDUCTOR-FIXED 120-1300 HZ	28480	9100-3922
A19L11	9100-3922	4		INDUCTOR-FIXED 120-1300 HZ	28480	9100-3922
A19L12	9100-3922	4		INDUCTOR-FIXED 120-1300 HZ	28480	9100-3922
A19L13	9140-0210	1		INDUCTOR RF-CH-MLD 100UH 5% .166DX.385LG	28480	9140-0210
A19L14	9135-0073	3		INDUCTOR RF-CH-MLD 51NH 6% .102DX.26LG	28480	9135-0073
A19L15				PART OF ETCHED CIRCUIT BOARD		
A19MP1	08901-00166	1	1	COVER LO DIVIDER	28480	08901-00166
	2360-0113	2		SCREW-MACH 6-32 .25-IN-LG PAN-HD-POZI	00000	ORDER BY DESCRIPTION
A19MP2	5001-0176	0		GROUND STRAP	28480	5001-0176
A19MP3	5001-0176	0		GROUND STRAP	28480	5001-0176
A19MP4	08662-00041	1	1	SHIELD COMPONENT LGE	28480	08662-00041
A19MP5	08662-00039	7	1	SHIELD CKT LGE	28480	08662-00039
A19Q1	1854-0477	7		TRANSISTOR NPN 2N2222A SI TO-18 PD = 500MW	04713	2N2222A
A19Q2	1853-0020	4		TRANSISTOR PNP SI PD = 300MW FT = 150MHZ	28480	1853-0020
A19Q3	1853-0020	4		TRANSISTOR PNP SI PD = 300MW FT = 150MHZ	28480	1853-0020
A19Q4	1858-0032	8		TRANSISTOR ARRAY 14-PIN PLSTC DIP	3L585	CA3146E
A19R1	0698-7236	7		RESISTOR 1K 1% .05W F TC = 0 + -100	24546	C3-1/8-T0-1001-F
A19R2	0698-7227	6	9	RESISTOR 422 1% .05W F TC = 0 + -100	24546	C3-1/8-T0-422R-F
A19R3	0698-7227	6		RESISTOR 422 1% .05W F TC = 0 + -100	24546	C3-1/8-T0-422R-F
A19R4	0698-7227	6		RESISTOR 422 1% .05W F TC = 0 + -100	24546	C3-1/8-T0-422R-F
A19R5	0698-7227	6		RESISTOR 422 1% .05W F TC = 0 + -100	24546	C3-1/8-T0-422R-F
A19R6	0698-7232	3		RESISTOR 681 1% .05W F TC = 0 + -100	24546	C3-1/8-T0-681R-F
A19R7	0698-7232	3		RESISTOR 681 1% .05W F TC = 0 + -100	24546	C3-1/8-T0-681R-F
A19R8	0698-7232	3		RESISTOR 681 1% .05W F TC = 0 + -100	24546	C3-1/8-T0-681R-F
A19R9	0698-7232	3		RESISTOR 681 1% .05W F TC = 0 + -100	24546	C3-1/8-T0-681R-F
A19R10	0698-3437	2	1	RESISTOR 133 1% .125W F TC = 0 + -100	24546	C4-1/8-T0-133R-F
A19R11	0757-0402	1		RESISTOR 110 1% .125W F TC = 0 + -100	24546	C4-1/8-T0-111-F
A19R12	0757-0422	5		RESISTOR 909 1% .125W F TC = 0 + -100	24546	C4-1/8-T0-909R-F
A19R13	0757-0422	5		RESISTOR 909 1% .125W F TC = 0 + -100	24546	C4-1/8-T0-909R-F
A19R14	0757-0422	5		RESISTOR 909 1% .125W F TC = 0 + -100	24546	C4-1/8-T0-909R-F
A19R15	0757-0422	5		RESISTOR 909 1% .125W F TC = 0 + -100	24546	C4-1/8-T0-909R-F
A19R16	0757-0280	3		RESISTOR 1K 1% .5W .125W F TC = 0 + -100	28480	0757-0280
A19R17	0698-3151	7		RESISTOR 2.87K 1% .125W F TC = 0 + -100	24546	0698-3151
A19R18	0698-3132	4		RESISTOR 261 1% .125W F TC = 0 + -100	24546	C4-1/8-T0-2610-F
A19R19	0698-7201	6	1	RESISTOR 34.8 1% .05W F TC = 0 + -100	24546	C3-1/8-T0-34R8-F
A19R20	0757-0280	3		RESISTOR 1K 1% .125W F TC = 0 + -100	24546	C4-1/8-T0-1001-F
A19R21	0698-7205	0		RESISTOR 51.1 1% .05W F TC = 0 + -100	24546	C3-1/8-51.1R-F
A19R22	0757-0440	7		RESISTOR 7.5K 1% .125W F TC = 0 + -100	24546	C4-1/8-T0-7501-F
A19R23	0757-0289	2		RESISTOR 13.3K 1% .125W F TC = 0 + -100	19701	MF4C1/8-T0-1332-F
A19R24	0757-0442	9		RESISTOR 10K 1% .125W F TC = 0 + -100	24546	C4-1/8-T0-1002-F
A19R25	0698-3158	4		RESISTOR 23.7K 1% .125W F TC = 0 + -100	24546	C4-1/8-T0-2372-F

[Refer to Section 7 for update information.]

\*Factory Selected Component (Refer to Section 5)

Δ Errata part change.

Table 6-3. Replaceable Parts

Reference Designation	HP Part Number	C D	Qty.	Description	Mfr. Code	Mfr. Part Number
<b>A19 08902-60126 – SERIAL PREFIX 2742A AND ABOVE</b>						
A19R26	1810-0203	5	3	NETWORK-RES 8-SIP470.0 OHM X 7	01121	208A471
A19R27	0698-3132	4		RESISTOR 261 1% .125W F TC = 0 + -100	24546	C4-1/8-T0-2610-F
A19R28	1810-0203	5		NETWORK-RES 8-SIP470.0 OHM X 7	01121	208A471
A19R29	1810-0203	5		NETWORK-RES 8-SIP470.0 OHM X 7	01121	208A471
A19R30	0757-0394	0		RESISTOR 51.1 1% .125W F TC = 0 + -100	24546	C4-1/8-T0-51R1-F
A19R31	0698-7260	7		RESISTOR 10K 1% .05W F TC = 0 + -100	24546	C3-1/8-T0-1002-F
A19R32	0698-7260	7		RESISTOR 10K 1% .05W F TC = 0 + -100	24546	C3-1/8-T0-1002-F
<i>2306A TO 2751A</i>						
A19R33	0757-0420	3		RESISTOR 750 1% .125W F TC = 0 + -100	24546	C4-1/8-T0-751-F
<i>2834A AND ABOVE</i>						
A19R33	0698-3132	4		RESISTOR 261 1% .125W F TC = 0 + -100	24546	C4-1/8-T0-2610-F
A19R34	0757-0420	3		RESISTOR 750 1% .125W F TC = 0 + -100	24546	C3-1/8-T0-751-F
A19R35	0698-7195	7	2	RESISTOR 19.6 1% .05W F TC = 0 + -100	24546	C3-1/8-T0-19R6-F
A19R36	0757-0276	7		RESISTOR 61.9 1% .125W F TC = 0 + -100	24546	C4-1/8-T0-6192-F
A19R37	0757-0394	0		RESISTOR 51.1 1% .125W F TC = 0 + -100	24546	C4-1/8-T0-51R1-F
A19R38	0757-0394	0		RESISTOR 51.1 1% .125W F TC = 0 + -100	24546	0757-0394
A19R39	0757-0276	7		RESISTOR 61.9 1% .125W F TC = 0 + -100	24546	C4-1/8-T0-6192-F
A19R40	0757-0416	7		RESISTOR 511 1% .125W F TC = 0 + -100	24546	0757-0416
A19R41	2100-2413	9	1	RESISTOR-TRMR 200 10% C SIDE-ADJ 1-TRN	30983	ET50X201
A19R42	0757-0416	7		RESISTOR 511 1% .125W F TC = 0 + -100	24546	C4-1/8-T0-511R-F
A19R43	0757-0416	7		RESISTOR 511 1% .125W F TC = 0 + -100	24546	C4-1/8-T0-511R-F
A19R44	0757-0397	3		RESISTOR 68.1 1% .125W F TC = 0 + -100	24546	C4-1/8-T0-68R1-F
A19R45	0757-0397	3		RESISTOR 68.1 1% .125W F TC = 0 + -100	24546	C4-1/8-T0-68R1-F
A19R46	0757-0416	7		RESISTOR 511 1% .125W F TC = 0 + -100	24546	C4-1/8-T0-511R-F
A19R47	0757-0416	7		RESISTOR 511 1% .125W F TC = 0 + -100	24546	C4-1/8-T0-511R-F
A19R48	0757-0346	2		RESISTOR 10 1% .125W F TC = 0 + -100	24546	0757-0346
A19R49	0757-0416	7		RESISTOR 511 1% .125W F TC = 0 + -100	24546	C4-1/8-T0-511R-F
A19R50	0757-0416	7		RESISTOR 511 1% .125W F TC = 0 + -100	24546	C4-1/8-T0-511R-F
A19R51	0757-0397	3		RESISTOR 68.1 1% .125W F TC = 0 + -100	24546	C4-1/8-T0-68R1-F
A19R52	0757-0397	3		RESISTOR 68.1 1% .125W F TC = 0 + -100	24546	C4-1/8-T0-68R1-F
A19R53	0757-0397	3		RESISTOR 68.1 1% .125W F TC = 0 + -100	24546	C4-1/8-T0-68R1-F
A19R54	0757-0416	7		RESISTOR 511 1% .125W F TC = 0 + -100	24546	C4-1/8-T0-511R-F
A19R55	0757-0416	7		RESISTOR 511 1% .125W F TC = 0 + -100	24546	C4-1/8-T0-511R-F
A19R56	0757-0416	7		RESISTOR 511 1% .125W F TC = 0 + -100	24546	C4-1/8-T0-511R-F
A19R57	0698-3132	4		RESISTOR 261 1% .125W F TC = 0 + -100	24546	C4-1/8-T0-2610-F
A19R58	0698-3132	4		RESISTOR 261 1% .125W F TC = 0 + -100	24546	C4-1/8-T0-2610-F
A19R59	0698-3132	4		RESISTOR 261 1% .125W F TC = 0 + -100	24546	C4-1/8-T0-2610-F
A19R60	0757-0442	9		RESISTOR 10K 1% .125W F TC = 0 + -100	24546	C4-1/8-T0-1002-F
A19R61	0757-0422	5		RESISTOR 909 1% .125W F TC = 0 + -100	24546	C4-1/8-T0-909R-F
A19R62	0698-3158	4		RESISTOR 23.7K 1% .125W F TC = 0 + -100	24546	C4-1/8-T0-2372-F
A19R63*	0757-0398	4	3	RESISTOR 75 1% .125W F TC = 0 + -100	24546	C4-1/8-T0-75R0-F
A19R64	0757-0416	7		RESISTOR 511 1% .125W F TC = 0 + -100	24546	C4-1/8-T0-511R-F
A19R65				NOT ASSIGNED		
A19R66	0757-0465	6		RESISTOR 100K 1% .125W F TC = 0 + -100	24546	C4-1/8-T0-1003-F
A19R67	0757-0397	3		RESISTOR 68.1 1% .125W F TC = 0 + -100	24546	C4-1/8-T0-68R1-F
A19R68	0757-0397	3		RESISTOR 68.1 1% .125W F TC = 0 + -100	24546	C4-1/8-T0-68R1-F

† Refer to Section 7 for update information.

\* Factory Selected Component (Refer to Section 5)

Δ Errata part change

Table 6-3. Replaceable Parts

Reference Designation	HP Part Number	C D	Qty.	Description	Mfr. Code	Mfr. Part Number
<b>A19 08902-60126 – SERIAL PREFIX 2742A AND ABOVE</b>						
A19R69	0698-3447	4		RESISTOR 422 1% .125W F TC = 0 + -100	24546	C4-1/8-T0-422R-F
A19R70	0757-0397	3		RESISTOR 68.1 1% .125W F TC = 0 + -100	24546	C4-1/8-T0-68R1-F
A19R71	0698-0083	8		RESISTOR 1.96K 1% .125W F TC = 0 + -100	24546	C4-1/8-T0-1961-F
A19R72*	0757-0422	5	11	RESISTOR 909 1% .125W F TC = 0 + -100	24546	C4-1/8-T0-909R-F
A19R73				NOT ASSIGNED		
A19R74*	0757-0422	5		RESISTOR 909 1% .125W F TC = 0 + -100	24546	C4-1/8-T0-909R-F
A19R75	0757-0416	7		RESISTOR 511 1% .125W F TC = 0 + -100	24546	C4-1/8-T0-511R-F
A19R76	0698-3438	3		RESISTOR 147 1% .125W F TC = 0 + -100	24546	C4-1/8-T0-147R-F
A19R77	0698-3438	3		RESISTOR 147 1% .125W F TC = 0 + -100	24546	C4-1/8-T0-147R-F
A19R78	0698-3438	3		RESISTOR 147 1% .125W F TC = 0 + -100	24546	C4-1/8-T0-147R-F
A19R79	0757-0726	2	1	RESISTOR 511 1% .25W F TC = 0 + -100	24546	C5-1/4-T0-511R-F
A19R80	0698-3441	8		RESISTOR 215 1% .125W F TC = 0 + -100	24546	C4-1/8-T0-215R-F
A19R81	0698-3441	8		RESISTOR 215 1% .125W F TC = 0 + -100	24546	C4-1/8-T0-215R-F
A19R82	0698-3441	8		RESISTOR 215 1% .125W F TC = 0 + -100	24546	C4-1/8-T0-215R-F
A19R83	0757-0416	7		RESISTOR 511 1% .125W F TC = 0 + -100	24546	C4-1/8-T0-511R-F
A19R84	0757-0416	7		RESISTOR 511 1% .125W F TC = 0 + -100	24546	C4-1/8-T0-511R-F
A19R85	0757-0397	3		RESISTOR 68.1 1% .125W F TC = 0 + -100	24546	C4-1/8-T0-68R1-F
A19R86	0757-0394	0		RESISTOR 51.1 1% .125W F TC = 0 + -100	24546	C4-1/8-T0-51R1-F
A19R87	0757-0394	0		RESISTOR 51.1 1% .125W F TC = 0 + -100	24546	C4-1/8-T0-51R1-F
A19R88	0698-7236	7		RESISTOR 1K 1% .05W F TC = 0 + -100	24546	C3-1/8-T0-1001-F
A19R89	0757-0280	3		RESISTOR 1K 1% .125W F TC = 0 + -100	24546	C4-1/8-T0-1001-F
A19R90	0698-7236	7		RESISTOR 1K 1% .05W F TC = 0 + -100	24546	C3-1/8-T0-1001-F
A19R91	0698-7247	0	5	RESISTOR 2.87K 1% .05W F TC = 0 + -100	24546	C3-1/8-T0-2871-F
A19R92	0698-3151	7		RESISTOR 2.87K 1% .125W F TC = 0 + -100	24546	C4-1/8-T0-2871-F
A19R93	0698-7247	0		RESISTOR 2.87K 1% .05W F TC = 0 + -100	24546	C3-1/8-T0-2871-F
A19R94	0698-7208	3	1	RESISTOR 68.1 1% .05W F TC = 0 + -100	24546	C3-1/8-T0-68R1-F
A19R95	0698-7229	8		RESISTOR 511 1% .05W F TC = 0 + -100	24546	C3-1/8-T0-511R-F
A19R96	0757-0397	3		RESISTOR 68.1 1% .125W F TC = 0 + -100	24546	C4-1/8-T0-68R1-F
A19R97	0757-0416	7		RESISTOR 511 1% .125W F TC = 0 + -100	24546	C4-1/8-T0-511R-F
A19R98	0698-7229	8		RESISTOR 511 1% .05W F TC = 0 + -100	24546	C3-1/8-T0-511R-F
A19R99	0698-3439	4	4	RESISTOR 178 1% .125W F TC = 0 + -100	24546	C4-1/8-T0-178R-F
A19R100	0757-0397	3		RESISTOR 68.1 1% .125W F TC = 0 + -100	24546	C4-1/8-T0-68R1-F
A19R101	0757-0397	3		RESISTOR 68.1 1% .125W F TC = 0 + -100	24546	C4-1/8-T0-68R1-F
A19R102	0698-3439	4		RESISTOR 178 1% .125W F TC = 0 + -100	24546	C4-1/8-T0-178R-F
A19R103	0698-3132	4		RESISTOR 261 1% .125W F TC = 0 + -100	24546	C4-1/8-T0-2610-F
A19R104	0757-0442	9		RESISTOR 10K 1% .125W F TC = 0 + -100	24546	C4-1/8-T0-1002-F
A19R105	0757-0442	9		RESISTOR 10K 1% .125W F TC = 0 + -100	24546	C4-1/8-T0-1002-F
A19R106	0698-7209	4		RESISTOR 75 1% .05W F TC = 0 + -100	24546	C3-1/8-T0-75R0-F
A19R107	0757-0397	3		RESISTOR 68.1 1% .125W F TC = 0 + -100	24546	C4-1/8-T0-68R1-F
A19R108	0698-7209	4		RESISTOR 75 1% .05W F TC = 0 + -100	24546	C3-1/8-T0-75R0-F
A19R109	0698-7229	8		RESISTOR 511 1% .05W F TC = 0 + -100	24546	C3-1/8-T0-511R-F
A19R110	0698-7236	7		RESISTOR 1K 1% .05W F TC = 0 + -100	24546	C3-1/8-T0-1001-F
A10R111	0698-3132	4		RESISTOR 261 1% .125W F TC = 0 + -100	28480	0698-3132
A19R112	0698-7205	0		RESISTOR 51.1 1% .05W F TC = 0 + -100	24546	C3-1/8-T0-51R1-F
A19R113	0698-3132	4		RESISTOR 261 1% .126W F TC = 0 + -100	24546	C4-1/8-T0-2610-F
A19R114	0698-3132	4		RESISTOR 261 1% .126W F TC = 0 + -100	24546	C4-1/8-T0-2610-F

\*Refer to Section 7 for update information

\*Factory Selected Component (Refer to Section 5)

Δ Errata part change

Table 6-3. Replaceable Parts

Reference Designation	HP Part Number	C D	Qty.	Description	Mfr. Code	Mfr. Part Number
<b>A19 08902-60126 – SERIAL PREFIX 2742A AND ABOVE</b>						
A19R115	0698-3132	4		RESISTOR 261 1% .126W F TC = 0 + -100	24546	C4-1/8-TO-2610-F
A19R116	0698-3132	4		RESISTOR 261 1% .126W F TC = 0 + -100	24546	C4-1/8-TO-2610-F
A19TP1	1251-0600	0		CONNECTOR-SGL CONT PIN 1.14-MM-BSC-SZ SQ	28480	1251-0600
A19TP2	1251-0600	0		CONNECTOR-SGL CONT PIN 1.14-MM-BSC-SZ SQ	28480	1251-0600
A19U1	1820-1225	4	1	IC FF ECL D-M/S DUAL	04713	MC10231P
A19U2	1826-0372	2	6	IC MISC 8-DIP-P PKG	28480	1826-0372
A19U3	1826-0013	8	2	IC OP AMP LOW-NOISE TO-99 PKG	06665	SSS741CJ
A19U4	08901-67002	4	1	FREQUENCY DUBLER	28480	08901-67002
	0340-1098	0		INSULATOR-XSTR TFE	28480	0340-1098
	1251-1556	7		CONNECTOR-SGL CONT SKT .018-IN-BSC-SZ	28480	1251-1556
A19U5	1826-0372	2		IC MISC 8-DIP-P PKG	28480	1826-0372
A19U6	1820-0817	8		IC FF ECL D-M/S DUAL	04713	MC10131P
A19U7	1820-1940	0	2	IC CNTR ECL BIN SYNCHRO POS-EDGE-TRIG	28480	1820-1940
A19U8	1820-1940	0		IC CNTR ECL BIN SYNCHRO POS-EDGE-TRIG	28480	1820-1940
A19U9	1820-0796	2	1	IC GATE ECL NOR QUAD 2-INP	04713	MC1662L
A19U10	1826-0372	2		IC MISC 8-DIP-P PKG	28480	1826-0372
A19U11	1826-0372	2		IC MISC 8-DIP-P PKG	28480	1826-0372
A19U12	1820-0817	8		IC FF ECL D-M/S DUAL	04713	MC10131P
A19U13	1820-1400	7	2	IC GATE ECL AND QUAD 2-INP	04713	MC10104P
A19U14	1820-1400	7		IC GATE ECL AND QUAD 2-INP	04713	MC10104P
A19U15	1820-0828	1	2	IC DCDR ECL BIN 3-TO-8-LINE 3-INP	04713	MC10162P
A19U16	1820-0802	1	2	IC GATE ECL NOR QUAD 2-INP	04713	MC10102P
A19U17	1820-0817	8		IC FF ECL D-M/S DUAL	04713	MC10131P
A19U18	1820-0828	1		IC DCDR ECL BIN 3-TO-8-LINE 3-INP	04713	MC10162P
A19U19	1820-0802	1		IC GATE ECL NOR QUAD 2-INP	04713	MC10102P
A19U20	1820-1052	5	1	IC XLTR ECL ECL-TO-TTL QUAD 2-INP	04713	MC10125L
A19U21	1820-1225	4		IC FF ECL D-M/S DUAL	04713	MC10216P
A19VR1	1902-0943	5		DIODE-ZNR 2.4V 5% DO-35 PD = .4W TC = -.037%	28480	1902-0943
A19VR2	1902-0049	2	3	DIODE-ZNR 6.19V 5% DO-35 PD = .4W	28480	1902-0049
A19VR3	1902-0049	2		DIODE-ZNR 6.19V 5% DO-35 PD = .4W	28480	1902-0049
A19VR4	1902-0049	2		DIODE-ZNR 6.19V 5% DO-35 PD = .4W	28480	1902-0049
A19W1	8159-0005	0		RESISTOR-ZERO OHMS 22 AWG LEAD DIA	28480	8159-0005
A19W2	8159-0005	0		RESISTOR-ZERO OHMS 22 AWG LEAD DIA	28480	8159-0005
A19W3				NOT ASSIGNED		
A19W4	8159-0005	0		RESISTOR-ZERO OHMS 22 AWG LEAD DIA	28480	8159-0005

† Refer to Section 7 for update information.

\* Factory Selected Component (Refer to Section 5).

Δ Errata part change

Table 6-3. Replaceable Parts

Reference Designation	HP Part Number	C D	Qty.	Description	Mfr. Code	Mfr. Part Number
<b>A20 08901-60185 – SERIAL PREFIX 2305A TO 2530A</b>						
A20	08901-60185	0	1	LO CONTROL ASSEMBLY	28480	08901-60185
A20C1	0160-3878	6		CAPACITOR-FXD 1000PF +-20% 100VDC CER	28480	0160-3878
A20C2	0160-3878	6		CAPACITOR-FXD 1000PF +-20% 100VDC CER	28480	0160-3878
A20C3	0180-0374	3		CAPACITOR-FXD 10UF +-10% 20VDC TA	56289	150D106X9020B2
A20C4	0160-3878	6		CAPACITOR-FXD 1000PF +-20% 100VDC CER	28480	0160-3878
A20C5	0180-2853	7	2	CAPACITOR-FXD 10UF +-20% 100VDC TA	56289	109D106X0100C2
A20C6	0180-0490	4	1	CAPACITOR-FXD 68UF +-10% 6VDC TA	90201	TDC686K006WLF
A20C7	0160-2204	0		CAPACITOR-FXD 100PF +-5% 300VDC MICA	28480	0160-2204
A20C8	0160-3879	7		CAPACITOR-FXD .01UF +-20% 100VDC CER	28480	0160-3879
A20C9	0160-2204	0		CAPACITOR-FXD 100PF +-5% 300VDC MICA	28480	0160-2204
A20C10	0160-3879	7		CAPACITOR-FXD .01UF +-20% 100VDC CER	28480	0160-3879
A20C11	0160-3879	7		CAPACITOR-FXD .01UF +-20% 100VDC CER	28480	0160-3879
A20C12	0160-2199	2		CAPACITOR-FXD 30PF +-5% 300VDC MICA	28480	0160-2199
A20C13	0180-2853	6		CAPACITOR-FXD 2.2UF +-10% 50VDC TA	25088	D2R2GS1B50K
A20C14	0160-0153	4		CAPACITOR-FXD 1000PF +-10% 200VDC POLYE	28480	0160-0153
A20C15	0160-3879	7		CAPACITOR-FXD .01UF +-20% 100VDC CER	28480	0160-3879
A20C16	0160-3879	7		CAPACITOR-FXD .01UF +-20% 100VDC CER	28480	0160-3879
A20C17	0160-0161	4		CAPACITOR-FXD .01UF +-10% 200VDC POLYE	28480	0160-0161
A20C18	0180-2853	7		CAPACITOR-FXD 10UF +-20% 100VDC TA	56289	109D106X0100C2
A20C19	0160-3879	7		CAPACITOR-FXD .01UF +-20% 100VDC CER	28480	0160-3879
A20C20	0160-3879	7		CAPACITOR-FXD .01UF +-20% 100VDC CER	28480	0160-3879
A20C21	0160-3879	7		CAPACITOR-FXD .01UF +-20% 100VDC CER	28480	0160-3879
A20C22	0160-3878	6		CAPACITOR-FXD 1000PF +-20% 100VDC CER	28480	0160-3878
A20C23	0160-3878	6		CAPACITOR-FXD 1000PF +-20% 100VDC CER	28480	0160-3878
A20CR1	1901-0040	1		DIODE-SWITCHING 30V 50MA 2NS DO-35	28480	1901-0040
A20CR2	1901-0040	1		DIODE-SWITCHING 30V 50MA 2NS DO-35	28480	1901-0040
A20CR3	1901-1098	1		DIODE-SWITCHING 1N4150 50V 200MA 4NS	9N171	1N4150
A20CR4	1901-1098	1		DIODE-SWITCHING 1N4150 50V 200MA 4NS	9N171	1N4150
A20CR5	1901-0040	1		DIODE-SWITCHING 30V 50MA 2NS DO-35	28480	1901-0040
A20CR6	1901-0040	1		DIODE-SWITCHING 30V 50MA 2NS DO-35	28480	1901-0040
A20CR7	1901-0040	1		DIODE-SWITCHING 30V 50MA 2NS DO-35	28480	1901-0040
A20CR8	1901-0040	1		DIODE-SWITCHING 30V 50MA 2NS DO-35	28480	1901-0040
A20CR9	1901-0040	1		DIODE-SWITCHING 30V 50MA 2NS DO-35	28480	1901-0040
A20CR10	1901-0040	1		DIODE-SWITCHING 30V 50MA 2NS DO-35	28480	1901-0040
A20CR11	1901-0040	1		DIODE-SWITCHING 30V 50MA 2NS DO-35	28480	1901-0040
A20CR12	1901-0040	1		DIODE-SWITCHING 30V 50MA 2NS DO-35	28480	1901-0040
A20CR13	1901-0040	1		DIODE-SWITCHING 30V 50MA 2NS DO-35	28480	1901-0040
A20CR14	1901-0040	1		DIODE-SWITCHING 30V 50MA 2NS DO-35	28480	1901-0040
A20CR15	1901-0040	1		DIODE-SWITCHING 30V 50MA 2NS DO-35	28480	1901-0040
A20CR16	1901-0040	1		DIODE-SWITCHING 30V 50MA 2NS DO-35	28480	1901-0040
A20CR17	1901-0518	8		DIODE-SM SIG SCHOTTKY	28480	1901-0518
A20CR18	1901-0518	8		DIODE-SM SIG SCHOTTKY	28480	1901-0518
A20CR19	1901-0518	8		DIODE-SM SIG SCHOTTKY	28480	1901-0518
A20CR20	1901-0040	1		DIODE-SWITCHING 30V 50MA 2NS DO-35	28480	1901-0040
A20CR21	1901-0040	1		DIODE-SWITCHING 30V 50MA 2NS DO-35	28480	1901-0040
A20CR22	1901-0040	1		DIODE-SWITCHING 30V 50MA 2NS DO-35	28480	1901-0040
A20CR23	1901-0040	1		DIODE-SWITCHING 30V 50MA 2NS DO-35	28480	1901-0040
A20CR24	1901-0518	8		DIODE-SM SIG SCHOTTKY	28480	1901-0518
A20CR25	1901-0040	1		DIODE-SWITCHING 30V 50MA 2NS DO-35	28480	1901-0040

† Refer to Section 7 for update information.

\* Factory Selected Component (Refer to Section 5)

Δ Errata part change

Table 6-3. Replaceable Parts

Reference Designation	HP Part Number	C D	Qty.	Description	Mfr. Code	Mfr. Part Number
<b>A20 08901-60185 – SERIAL PREFIX 2305A TO 2530A</b>						
A20CR26	1901-0518	8		DIODE-SM SIG SCHOTTKY	28480	1901-0518
A20CR27	1901-0518	8		DIODE-SM SIG SCHOTTKY	28480	1901-0518
A20E1	9170-0847	3		CORE SHIELDING BEAD	28480	9170-0847
A20MP1	08901-00104	7	1	COVER LO CONT BD	28480	08901-00104
	2360-0113	2		SCREW-MACH 6-32 .25-IN-LG PAN-HD-POZI	00000	ORDER BY DESCRIPTION
A20Q1	1854-0477	7		TRANSISTOR NPN 2N2222A SI TO-18 PD = 500MW	04713	2N2222A
A20Q2	1853-0034	0	8	TRANSISTOR PNP SI TO-18 PD = 360MW	28480	1853-0034
A20Q3	1854-0477	7		TRANSISTOR NPN 2N2222A SI TO-18 PD = 500MW	04713	2N2222A
A20Q4	1853-0034	0		TRANSISTOR PNP SI TO-18 PD = 360MW	28480	1853-0034
A20Q5	1854-0247	9	8	TRANSISTOR NPN SI TO-39 PD = 1W FT = 800MHZ	28480	1854-0247
	1200-0173	5		INSULATOR-XSTR DAP-GL	28480	1200-0173
A20Q6	1854-0477	7		TRANSISTOR NPN 2N2222A SI TO-18 PD = 500MW	04713	2N2222A
A20Q7	1853-0034	0		TRANSISTOR PNP SI TO-18 PD = 360MW	28480	1853-0034
A20Q8	1854-0023	9	4	TRANSISTOR NPN SI TO-18 PD = 360MW	28480	1854-0023
A20Q9	1854-0023	9		TRANSISTOR NPN SI TO-18 PD = 360MW	28480	1854-0023
A20Q10	1855-0273	3	2	TRANSISTOR J-FET P-CHAN D-MODE TO-92 SI	28480	1855-0273
A20Q11	1855-0273	3		TRANSISTOR J-FET P-CHAN D-MODE TO-92 SI	28480	1855-0273
A20Q12	1854-0023	9		TRANSISTOR NPN SI TO-18 PD = 360MW	28480	1854-0023
A20Q13	1855-0420	2		TRANSISTOR J-FET 2N4391 N-CHAN D-MODE	01295	2N4391
A20Q14	1854-0404	0		TRANSISTOR NPN SI TO-18 PD = 360MW	28480	1854-0404
A20Q15	1854-0404	0		TRANSISTOR NPN SI TO-18 PD = 360MW	28480	1854-0404
A20Q16	1854-0404	0		TRANSISTOR NPN SI TO-18 PD = 360MW	28480	1854-0404
A20Q17				NOT ASSIGNED		
A20Q18	1855-0420	2		TRANSISTOR J-FET 2N4391 N-CHAN D-MODE	01295	2N4391
A20Q19	1853-0020	4		TRANSISTOR PNP SI PD = 300MW FT = 150MHZ	28480	1853-0020
A20Q20	1854-0022	8	4	TRANSISTOR NPN SI TO-39 PD = 700MW	07263	S17843
	1200-0173	5		INSULATOR-XSTR DAP-GL	28480	1200-0173
A20Q21	1853-0020	4		TRANSISTOR PNP SI PD = 300MW FT = 150MHZ	28480	1853-0020
A20Q22	1854-0022	8		TRANSISTOR NPN SI TO-39 PD = 700MW	07263	S17843
	1200-0173	5		INSULATOR-XSTR DAP-GL	28480	1200-0173
A20Q23	1853-0012	4		TRANSISTOR PNP 2N2904A SI TO-39 PD = 600MW	01295	2N2904A
	1200-0173	5		INSULATOR-XSTR DAP-GL	28480	1200-0173
A20Q24	1853-0594	7	1	TRANSISTOR-DUAL PNP 2N3808 TO-78	28480	1853-0594
A20Q25				NOT ASSIGNED		
A20Q26	1854-0022	8		TRANSISTOR NPN SI TO-39 PD = 700MW	07263	S17843
	1200-0173	5		INSULATOR-XSTR DAP-GL	28480	1200-0173
A20Q27	1854-0022	8		TRANSISTOR NPN SI TO-39 PD = 700MW	07263	S17843
	1200-0173	5		INSULATOR-XSTR DAP-GL	28480	1200-0173
A20Q28	1854-0404	0		TRANSISTOR NPN SI TO-18 PD = 360MW	28480	1854-0404
A20R1	2100-3274	2	2	RESISTOR-TRMR 10K 10% C SIDE-ADJ 1-TRN	28480	2100-3274
A20R2	0698-7275	4	2	RESISTOR 42.2K 1% .05W F TC = 0 + -100	24546	C3-1/8-T0-4222-F
A20R3	0698-7243	6	2	RESISTOR 1.96K 1% .05W F TC = 0 + -100	24546	C3-1/8-T0-1961-F
A20R4	0757-0280	3		RESISTOR 1K 1% .125W F TC = 0 + -100	24546	C4-1/8-T0-1001-F
A20R5	0698-7260	7		RESISTOR 10K 1% .05W F TC = 0 + -100	24546	C3-1/8-T0-1002-F
A20R6	0698-7258	3	3	RESISTOR 8.25K 1% .05W F TC = 0 + -100	24546	C3-1/8-T0-8251-F
A20R7	0698-7270	9	1	RESISTOR 26.1K 1% .05W F TC = 0 + -100	24546	C3-1/8-T0-2612-F
A20R8	0698-7236	7		RESISTOR 1K 1% .05W F TC = 0 + -100	24546	C3-1/8-T0-1001-F
A20R9	0698-7212	9	16	RESISTOR 100 1% .05W F TC = 0 + -100	24546	C3-1/8-T0-100R-F
A20R10	0757-0465	6		RESISTOR 100K 1% .125W F TC = 0 + -100	24546	C4-1/8-T0-1003-F
A20R11	0698-7260	7		RESISTOR 10K 1% .05W F TC = 0 + -100	24546	C3-1/8-T0-1002-F

† Refer to Section 7 for update information.

\* Factory Selected Component (Refer to Section 5).

Δ Errata part change

Table 6-3. Replaceable Parts

Reference Designation	HP Part Number	C D	Qty.	Description	Mfr. Code	Mfr. Part Number
<b>A20 08901-60185 – SERIAL PREFIX 2305A TO 2530A</b>						
A20R12	0698-7260	7		RESISTOR 10K 1% .05W F TC = 0 + -100	24546	C3-1/8-T0-1002-F
A20R13	0698-7260	7		RESISTOR 10K 1% .05W F TC = 0 + -100	24546	C3-1/8-T0-1002-F
A20R14	0698-7279	8	1	RESISTOR 61.9K 1% .05W F TC = 0 + -100	24546	C3-1/8-T0-6192-F
A20R15	0698-7260	7		RESISTOR 10K 1% .05W F TC = 0 + -100	24546	C3-1/8-T0-1002-F
A20R16				NOT ASSIGNED		
A20R17	0698-7236	7		RESISTOR 1K 1% .05W F TC = 0 + -100	24546	C3-1/8-T0-1001-F
A20R18	0698-7236	7		RESISTOR 1K 1% .05W F TC = 0 + -100	24546	C3-1/8-T0-1001-F
<i>2305A TO 2345A</i>						
A20R19	0698-7267	4	1	RESISTOR 19.6K 1% .05W F TC = 0 + -100	24546	C3-1/8-T0-1962-F
A20R20	0698-7259	4	3	RESISTOR 9.09K 1% .05W F TC = 0 + -100	24546	C3-1/8-T0-9091-F
A20R21	0698-7251	6		RESISTOR 4.22K 1% .05W F TC = 0 + -100	24546	C3-1/8-T0-4221-F
A20R22	0698-7240	3		RESISTOR 1.47K 1% .05W F TC = 0 + -100	24546	C3-1/8-T0-1471-F
A20R23	0698-7220	9		RESISTOR 215 1% .05W F TC = 0 + -100	24546	C3-1/8-T0-215R-F
A20R24	0757-0470	3	2	RESISTOR 162K 1% .125W F TC = 0 + -100	24546	C4-1/8-T0-1623-F
A20R25	0698-7282	3	1	RESISTOR 82.5K 1% .05W F TC = 0 + -100	24546	C3-1/8-T0-8252-F
A20R26	0698-7274	3	1	RESISTOR 38.3K 1% .05W F TC = 0 + -100	24546	C3-1/8-T0-3832-F
<i>2403A TO 2530A</i>						
A20R19	0698-7279	8		RESISTOR 61.9K 1% .05W F TC = 0 + -100	24546	C3-1/8-T0-6192-F
A20R20	0698-7271	0		RESISTOR 28.7K 1% .05W F TC = 0 + -100	24546	C3-1/8-T0-2872-F
A20R21	0698-7263	0		RESISTOR 13.3K 1% .05W F TC = 0 + -100	24546	C3-1/8-T0-1332-F
A20R22	0698-7255	0		RESISTOR 6.19K 1% .05W F TC = 0 + -100	24546	C3-1/8-T0-6191-F
A20R23	0698-7246	9		RESISTOR 2.61K 1% .05W F TC = 0 + -100	24546	C3-1/8-T0-2611-F
A20R24	0698-3260	9		RESISTOR 464K 1% .125W F TC = 0 + -100	24546	C4-1/8-T0-4643-F
A20R25	0698-3266	5		RESISTOR 237K 1% .125W F TC = 0 + -100	24546	C4-1/8-T0-2373-F
A20R26	0698-7286	7		RESISTOR 121K 1% .05W F TC = 0 + -100	24546	C3-1/8-T0-1213-F
A20R27	0698-7261	8	2	RESISTOR 11K 1% .05W F TC = 0 + -100	24546	C3-1/8-T0-1102-F
A20R28	0698-7253	8	5	RESISTOR 5.11K 1% .05W F TC = 0 + -100	24546	C3-1/8-T0-5111-F
A20R29	0698-7216	3		RESISTOR 147 1% .05W F TC = 0 + -100	24546	C3-1/8-T0-147R-F
A20R30	0698-7251	6		RESISTOR 4.22K 1% .05W F TC = 0 + -100	24546	C3-1/8-T0-4221-F
A20R31	0698-7259	4		RESISTOR 9.09K 1% .05W F TC = 0 + -100	24546	C3-1/8-T0-9091-F
A20R32	0698-7284	5	11	RESISTOR 100K 1% .05W F TC = 0 + -100	24546	C3-1/8-T0-1003-F
A20R33	0698-7236	7		RESISTOR 1K 1% .05W F TC = 0 + -100	24546	C3-1/8-T0-1001-F
A20R34	0698-7236	7		RESISTOR 1K 1% .05W F TC = 0 + -100	24546	C3-1/8-T0-1001-F
A20R35	0698-7236	7		RESISTOR 1K 1% .05W F TC = 0 + -100	24546	C3-1/8-T0-1001-F
A20R36	0698-7236	7		RESISTOR 1K 1% .05W F TC = 0 + -100	24546	C3-1/8-T0-1001-F
A20R37	0698-7288	9	5	RESISTOR 147K 1% .05W F TC = 0 + -100	24546	C3-1/8-T0-1473-F
A20R38	0698-7236	7		RESISTOR 1K 1% .05W F TC = 0 + -100	24546	C3-1/8-T0-1001-F
A20R39	0698-7284	5		RESISTOR 100K 1% .05W F TC = 0 + -100	24546	C3-1/8-T0-1003-F
A20R40	0698-7243	6		RESISTOR 1.96K 1% .05W F TC = 0 + -100	24546	C3-1/8-T0-1961-F
A20R41	0698-7260	7		RESISTOR 10K 1% .05W F TC = 0 + -100	24546	C3-1/8-T0-1002-F
A20R42	0698-7260	7		RESISTOR 10K 1% .05W F TC = 0 + -100	24546	C3-1/8-T0-1002-F
A20R43	0757-0279	0		RESISTOR 3.16K 1% .125W F TC = 0 + -100	24546	C4-1/8-T0-3161-F
A20R44	0698-7260	7		RESISTOR 10K 1% .05W F TC = 0 + -100	24546	C3-1/8-T0-1002-F
A20R45	0698-7288	9		RESISTOR 147K 1% .05W F TC = 0 + -100	24546	C3-1/8-T0-1473-F
A20R46	0698-7275	4		RESISTOR 42.2K 1% .05W F TC = 0 + -100	24546	C3-1/8-T0-4222-F

† Refer to Section 7 for update information

\* Factory Selected Component (Refer to Section 5)

Δ Errata part change

Table 6-3. Replaceable Parts

Reference Designation	HP Part Number	C D	Qty.	Description	Mfr. Code	Mfr. Part Number
<b>A20 08901-60185 – SERIAL PREFIX 2305A TO 2530A</b>						
A20R47	0757-0460	1	3	RESISTOR 61.9K 1% .125W F TC = 0 + -100	24546	C4-1/8-T0-6192-F
A20R48	0698-7260	7		RESISTOR 10K 1% .05W F TC = 0 + -100	24546	C3-1/8-T0-1002-F
A20R49	0698-7253	8		RESISTOR 5.11K 1% .05W F TC = 0 + -100	24546	C3-1/8-T0-5111-F
A20R50	0757-0290	5	2	RESISTOR 6.19K 1% .125W F TC = 0 + -100	19701	MF4C1/8-T0-6191-F
A20R51	0698-7260	7		RESISTOR 10K 1% .05W F TC = 0 + -100	24546	C3-1/8-T0-1002-F
A20R52	0698-7258	3		RESISTOR 8.25K 1% .05W F TC = 0 + -100	24546	C3-1/8-T0-8251-F
A20R53	0698-7253	8		RESISTOR 5.11K 1% .05W F TC = 0 + -100	24546	C3-1/8-T0-5111-F
A20R54				NOT ASSIGNED		
A20R55				NOT ASSIGNED		
A20R56	0698-7236	7		RESISTOR 1K 1% .05W F TC = 0 + -100	24546	C3-1/8-T0-1001-F
A20R57	0757-0462	3	1	RESISTOR 75K 1% .125W F TC = 0 + -100	24546	C4-1/8-T0-7502-F
A20R58	0757-0199	3		RESISTOR 21.5K 1% .125W F TC = 0 + -100	24546	C4-1/8-T0-2152-F
A20R59	0698-7236	7		RESISTOR 1K 1% .05W F TC = 0 + -100	24546	C3-1/8-T0-1001-F
A20R60	0698-7259	4		RESISTOR 9.09K 1% .05W F TC = 0 + -100	24546	C3-1/8-T0-9091-F
A20R61	0698-7236	7		RESISTOR 1K 1% .05W F TC = 0 + -100	24546	C3-1/8-T0-1001-F
A20R62	0698-8744	4	1	RESISTOR 2K .05% .1W F TC = 0 + -15	28480	0698-8744
A20R63	0698-7284	5		RESISTOR 100K 1% .05W F TC = 0 + -100	24546	C3-1/8-T0-1003-F
A20R64	0757-0401	0		RESISTOR 100 1% .125W F TC = 0 + -100	24546	C4-1/8-T0-101-F
A20R65	0699-0381	1	2	RESISTOR 40K .1% .1W F TC = 0 + -15	28480	0699-0381
A20R66	0699-0381	1		RESISTOR 40K .1% .1W F TC = 0 + -15	28480	0699-0381
A20R67	0757-0401	0		RESISTOR 100 1% .125W F TC = 0 + -100	24546	C4-1/8-T0-101-F
A20R68	0699-0118	2	3	RESISTOR 20K .1% .1W F TC = 0 + -5	28480	0699-0118
A20R69	0698-3444	1		RESISTOR 316 1% .125W F TC = 0 + -100	24546	C4-1/8-T0-316R-F
A20R70	0698-7260	7		RESISTOR 10K 1% .05W F TC = 0 + -100	24546	C3-1/8-T0-1002-F
A20R71	0698-7236	7		RESISTOR 1K 1% .05W F TC = 0 + -100	24546	C3-1/8-T0-1001-F
A20R72	0698-7257	2	2	RESISTOR 7.5K 1% .05W F TC = 0 + -100	24546	C3-1/8-T0-7501-F
A20R73	0698-7260	7		RESISTOR 10K 1% .05W F TC = 0 + -100	24546	C3-1/8-T0-1002-F
A20R74	0757-0158	4	1	RESISTOR 619 1% .5W F TC = 0 + -100	28480	0757-0158
A20R75	0698-7236	7		RESISTOR 1K 1% .05W F TC = 0 + -100	24546	C3-1/8-T0-1001-F
A20R76	0698-7260	7		RESISTOR 10K 1% .05W F TC = 0 + -100	24546	C3-1/8-T0-1002-F
A20R77	0698-7218	5	1	RESISTOR 178 1% .05W F TC = 0 + -100	24546	C3-1/8-T0-178R-F
A20R78	0698-7260	7		RESISTOR 10K 1% .05W F TC = 0 + -100	24546	C3-1/8-T0-1002-F
A20R79	0698-7236	7		RESISTOR 1K 1% .05W F TC = 0 + -100	24546	C3-1/8-T0-1001-F
A20R80	0698-7286	7	1	RESISTOR 121K 1% .05W F TC = 0 + -100	24546	C3-1/8-T0-1213-F
A20R81	0757-0280	3		RESISTOR 1K 1% .125W F TC = 0 + -100	24546	C4-1/8-T0-1001-F
A20R82	0757-0279	0		RESISTOR 3.16K 1% .125W F TC = 0 + -100	24546	C4-1/8-T0-3161-F
A20R83	0698-7288	9		RESISTOR 147K 1% .05W F TC = 0 + -100	24546	C3-1/8-T0-1473-F
A20R84	0698-7262	9	7	RESISTOR 12.1K 1% .05W F TC = 0 + -100	24546	C3-1/8-T0-1212-F
A20R85	0699-0069	2		RESISTOR 2.15M 1% .125W F TC = 0 + -100	28480	0699-0069
A20TP1	1251-0600	0		CONNECTOR-SGL CONT PIN 1.14-MM-BSC-SZ SQ	28480	1251-0600
A20TP2	1251-0600	0		CONNECTOR-SGL CONT PIN 1.14-MM-BSC-SZ SQ	28480	1251-0600
A20TP3	1251-0600	0		CONNECTOR-SGL CONT PIN 1.14-MM-BSC-SZ SQ	28480	1251-0600
A20TP4	1251-0600	0		CONNECTOR-SGL CONT PIN 1.14-MM-BSC-SZ SQ	28480	1251-0600
A20U1	1826-0989	7	4	IC OP AMP GP 8-DIP-C PKG	27014	LM307J
A20U2	1820-1547	3	1	IC MULTIPLXR 8-CHAN-ANLG 16-DIP-C PKG	04713	MC14051BCL
A20U3	1820-1198	0		IC GATE TTL LS NAND QUAD 2-INP	01295	SN74LS03N
A20U4	1826-0328	8	1	IC OP AMP GP DUAL 8-DIP-C PKG	07933	RV4558DE
A20U5	1826-0557	5	1	IC OP AMP GP QUAD 14-DIP-C PKG	27014	LM348J

†Refer to Section 7 for update information.

\*Factory Selected Component (Refer to Section 5)

Δ Errata part change



Table 6-3. Replaceable Parts

Reference Designation	HP Part Number	C D	Qty.	Description	Mfr. Code	Mfr. Part Number
<b>A20 08901-60185 – SERIAL PREFIX 2305A TO 2530A</b>						
A20U6	1820-1200	5		IC INV TTL LS HEX	01295	SN74LS05N
A20U7	1820-1411	0		IC LCH TTL LS D-TYPE 4-BIT	01295	SN74LS75N
A20U8	1820-1199	1		IC INV TTL LS HEX 1-INP	01295	SN74LS04N
A20U9	1820-1216	3		IC DCDR TTL LS 3-TO-8-LINE 3-INP	01295	SN74LS138N
A20U10	1826-0188	8	2	IC CONV 8-B-D/A 16-DIP-C PKG	04713	MC1408L-8
A20U11	1820-1216	3		IC DCDR TTL LS 3-TO-8-LINE 3-INP	01295	SN74LS138N
A20U12	1826-0188	8		IC CONV 8-B-D/A 16-DIP-C PKG	04713	MC1408L-8
A20U13	08901-80075	9	2	OPTO-ISOLATOR LED-PCNDCT IF = 40MA-MAX	28480	08901-80075
A20U14	08901-80075	9		OPTO-ISOLATOR LED-PCNDCT IF = 40MA-MAX	28480	08901-80075
A20U15	1820-1195	7		IC FF TTL LS D-TYPE POS-EDGE-TRIG COM	01295	SN74LS175N
A20U16	1820-1411	0		IC LCH TTL LS D-TYPE 4-BIT	01295	SN74LS75N
A20U17	1820-1411	0		IC LCH TTL LS D-TYPE 4-BIT	01295	SN74LS75N
A20U18	1820-1411	0		IC LCH TTL LS D-TYPE 4-BIT	01295	SN74LS75N
A20U19	1820-1411	0		IC LCH TTL LS D-TYPE 4-BIT	01295	SN74LS75N
A20U20	1820-1411	0		IC LCH TTL LS D-TYPE 4-BIT	01295	SN74LS75N
A20U21	1820-1411	0		IC LCH TTL LS D-TYPE 4-BIT	01295	SN74LS75N
A20U22	1820-1411	0		IC LCH TTL LS D-TYPE 4-BIT	01295	SN74LS75N
A20U23	1820-1197	9		IC GATE TTL LS NAND QUAD 2-INP	01295	SN74LS00N
A20VR1	1902-0041	4		DIODE-ZNR 5.11V 5% DO-35 PD = .4W	28480	1902-0041
A20VR2	1902-0064	1	4	DIODE-ZNR 7.5V 5% DO-35 PD = .4W TC = +.05%	28480	1902-0064
A20VR3	1902-0064	1		DIODE-ZNR 7.5V 5% DO-35 PD = .4W TC = +.05%	28480	1902-0064
A20VR4	1902-0064	1		DIODE-ZNR 7.5V 5% DO-35 PD = .4W TC = +.05%	28480	1902-0064
A20VR5	1902-0064	1		DIODE-ZNR 7.5V 5% DO-35 PD = .4W TC = +.05%	28480	1902-0064

† Refer to Section 7 for update information.

\* Factory Selected Component (Refer to Section 5)

Δ Errata part change

Table 6-3. Replaceable Parts

Reference Designation	HP Part Number	C D	Qty.	Description	Mfr. Code	Mfr. Part Number
<b>A20 08901-60262 – SERIAL PREFIX 2535A AND ABOVE</b>						
A20	08901-60262	4	1	LO CONTROL ASSEMBLY	28480	08901-60262
A20C1	0160-4835	7	3	CAPACITOR-FXD .1UF + -10% 50VDC CER	28480	0160-4835
A20C2	0160-4835	7		CAPACITOR-FXD .1UF + -10% 50VDC CER	28480	0160-4835
A20C3	0180-1746	5	2	CAPACITOR-FXD 15UF + -10% 20VDC TA	56289	150D156X9020B2
A20C4	0160-4835	7		CAPACITOR-FXD .1UF + -10% 50VDC CER	28480	0160-4835
A20C5	0180-1746	5		CAPACITOR-FXD 15UF + -10% 20VDC TA	56289	150D156X9020B2
A20C6	0180-0269	5	1	CAPACITOR-FXD 1UF + 50-10% 150VDC AL	56289	30D105G150BA2
A20C7	0160-4801	7	2	CAPACITOR-FXD 100PF + -5% 100VDC CER	28480	0160-4801
A20C8	0160-4832	4	8	CAPACITOR-FXD .01UF + -10% 100VDC CER	28480	0160-4832
A20C9	0160-4801	7		CAPACITOR-FXD 100PF + -5% 100VDC CER	28480	0160-4801
A20C10	0160-4832	4		CAPACITOR-FXD .01UF + -10% 100VDC CER	28480	0160-4832
A20C11	0160-4832	4		CAPACITOR-FXD .01UF + -10% 100VDC CER	28480	0160-4832
A20C12	0160-4807	3	1	CAPACITOR-FXD 33PF + -5% 100VDC CER 0 + -30	28480	0160-4807
A20C13	0180-0197	8	1	CAPACITOR-FXD 2.2UF + -10% 20VDC TA	56289	150D225X9020A2
A20C14	0160-4814	2	1	CAPACITOR-FXD 150PF + -5% 100VDC CER	28480	0160-4814
A20C15	0160-4832	4		CAPACITOR-FXD .01UF + -10% 100VDC CER	28480	0160-4832
A20C16	0160-4832	4		CAPACITOR-FXD .01UF + -10% 100VDC CER	28480	0160-4832
A20C17	0160-0161	4	1	CAPACITOR-FXD .01UF + -10% 200VDC POLYE	28480	0160-0161
A20C18	0160-3324	7	1	CAPACITOR-FXD 1UF + -5% 100VDC MET-POLYC	28480	0160-3324
A20C19	0160-4832	4		CAPACITOR-FXD .01UF + -10% 100VDC CER	28480	0160-4832
A20C20	0180-1997	8	1	CAPACITOR-FXD 20UF + 50-10% 150VDC AL	28480	0180-1997
A20C21	0160-4832	4		CAPACITOR-FXD .01UF + -10% 100VDC CER	28480	0160-4832
A20C22	0160-4822	2	2	CAPACITOR-FXD 1000PF + -5% 100VDC CER	28480	0160-4822
A20C23	0160-4822	2		CAPACITOR-FXD 1000PF + -5% 100VDC CER	28480	0160-4822
A20C24	0160-4832	4		CAPACITOR-FXD .01UF + -10% 100VDC CER	28480	0160-4832
A20CR1	1901-1085	6	2	DIODE-SM SIG SCHOTTKY	28480	1901-1085
A20CR2	1901-1085	6		DIODE-SM SIG SCHOTTKY	28480	1901-1085
A20CR3				NOT ASSIGNED		
A20CR4				NOT ASSIGNED		
A20CR5	1901-1098	1		DIODE-SWITCHING 1N4150 50V 200MA 4NS	9N171	1N4150
A20CR6	1901-1098	1		DIODE-SWITCHING 1N4150 50V 200MA 4NS	9N171	1N4150
A20CR7	1901-1098	1		DIODE-SWITCHING 1N4150 50V 200MA 4NS	9N171	1N4150
A20CR8	1901-1098	1		DIODE-SWITCHING 1N4150 50V 200MA 4NS	9N171	1N4150
A20CR9	1901-1098	1		DIODE-SWITCHING 1N4150 50V 200MA 4NS	9N171	1N4150
A20CR10	1901-0518	8	6	DIODE-SM SIG SCHOTTKY	28480	1901-0518
A20CR11	1901-0518	8		DIODE-SM SIG SCHOTTKY	28480	1901-0518
A20CR12	1901-1098	1		DIODE-SWITCHING 1N4150 50V 200MA 4NS	9N171	1N4150
A20CR13	1901-1098	1		DIODE-SWITCHING 1N4150 50V 200MA 4NS	9N171	1N4150
A20CR14	1901-1098	1		DIODE-SWITCHING 1N4150 50V 200MA 4NS	9N171	1N4150
A20CR15	1901-1098	1		DIODE-SWITCHING 1N4150 50V 200MA 4NS	9N171	1N4150
A20CR16	1901-1098	1		DIODE-SWITCHING 1N4150 50V 200MA 4NS	9N171	1N4150
A20CR17	1901-0518	8		DIODE-SM SIG SCHOTTKY	28480	1901-0518
A20CR18	1901-0518	8		DIODE-SM SIG SCHOTTKY	28480	1901-0518
A20CR19	1901-0518	8		DIODE-SM SIG SCHOTTKY	28480	1901-0518
A20CR20	1901-1098	1		DIODE-SWITCHING 1N4150 50V 200MA 4NS	9N171	1N4150

† Refer to Section 7 for update information.

\* Factory Selected Component (Refer to Section 5)

Δ Errata part change

Table 6-3. Replaceable Parts

Reference Designation	HP Part Number	C D	Qty.	Description	Mfr. Code	Mfr. Part Number
<b>A20 08901-60262 – SERIAL PREFIX 2535A AND ABOVE</b>						
<i>2306A TO 2746A</i>						
A20CR21				NOT ASSIGNED		
<i>2748A AND ABOVE</i>						
A20CR21	1901-0518	8		DIODE-SM SIG SCHOTTKY	28480	1901-0518
A20CR22	1901-1098	1		DIODE-SWITCHING 1N4150 50V 200MA 4NS	9N171	1N4150
A20CR23				NOT ASSIGNED		
A20CR24	1901-0518	8		DIODE-SM SIG SCHOTTKY	28480	1901-0518
A20CR25	1901-1098	1		DIODE-SWITCHING 1N4150 50V 200MA 4NS	9N171	1N4150
A20DS1				NOT ASSIGNED		
A20DS2				NOT ASSIGNED		
A20DS3	1990-0717	6	2	LED-LAMP LUM-INT = 800UCD IF = 30MA-MAX	28480	HLMP-1501
A20DS4	1990-0717	6		LED-LAMP LUM-INT = 800UCD IF = 30MA-MAX	28480	HLMP-1501
A20L1	9100-3922	4	3	INDUCTOR-FIXED 120-1300 HZ	28480	9100-3922
A20L2	9100-3922	4		INDUCTOR-FIXED 120-1300 HZ	28480	9100-3922
A20L3	9100-3922	4		INDUCTOR-FIXED 120-1300 HZ	28480	9100-3922
A20MP1	08901-00104	7	1	CVR LO CONT BD	28480	08901-00104
	2360-0113	2	2	SCREW-MACH 6-32 .25-IN-LG PAN-HD-POZI	00000	ORDER BY DESCRIPTION
A20Q1	1854-0477	7	5	TRANSISTOR NPN 2N2222A SI TO-18 PD = 500MW	04713	2N2222A
A20Q2	1853-0034	0	3	TRANSISTOR PNP SI TO-18 PD = 360MW	28480	1853-0034
A20Q3	1854-0477	7		TRANSISTOR NPN 2N2222A SI TO-18 PD = 500MW	04713	2N2222A
A20Q4	1853-0034	0		TRANSISTOR PNP SI TO-18 PD = 360MW	28480	1853-0034
A20Q5	1854-0378	7	1	TRANSISTOR NPN 2N5109 SI TO-39 PD = 800MW	3L585	2N5109
A20Q6	1854-0477	7		TRANSISTOR NPN 2N2222A SI TO-18 PD = 500MW	04713	2N2222A
A20Q7	1853-0034	0		TRANSISTOR PNP SI TO-18 PD = 360MW	28480	1853-0034
A20Q8	1853-0594	7	3	TRANSISTOR-DUAL PNP 2N3808 TO-78	28480	1853-0594
A20Q9	1855-0292	6	2	TRANSISTOR J-FET 2N5432 N-CHAN D-MODE	17856	2N5432
A20Q10	1855-0292	6		TRANSISTOR J-FET 2N5432 N-CHAN D-MODE	17856	2N5432
A20Q11	1855-0423	5	1	TRANSISTOR MOSFET N-CHAN E-MODE	17856	VN10KM
A20Q12	1854-0813	5	3	TRANSISTOR NPN 2N3501S SI TO-39 PD = 1W	28480	1854-0813
A20Q13	1853-0462	8	2	TRANSISTOR PNP 2N3635 SI TO-39 PD = 1W	28480	1853-0462
A20Q14				NOT ASSIGNED		
A20Q15				NOT ASSIGNED		
A20Q16	1854-0477	7		TRANSISTOR NPN 2N2222A SI TO-18 PD = 500MW	04713	2N2222A
A20Q17				NOT ASSIGNED		
A20Q18				NOT ASSIGNED		
A20Q19	1853-0594	7		TRANSISTOR-DUAL PNP 2N3808 TO-78	28480	1853-0594
A20Q20	1854-0474	4	3	TRANSISTOR NPN SI PD = 310MW FT = 100MHZ	04713	2N5551
A20Q21	1854-0474	4		TRANSISTOR NPN SI PD = 310MW FT = 100MHZ	04713	2N5551
A20Q22	1854-0813	5	3	TRANSISTOR NPN 2N3501S SI TO-39 PD = 1W	28480	1854-0813
A20Q23	1853-0462	8	2	TRANSISTOR PNP 2N3635 SI TO-39 PD = 1W	28480	1853-0462
A20Q24	1853-0594	7		TRANSISTOR-DUAL PNP 2N3808 TO-78	28480	1853-0594
A20Q25				NOT ASSIGNED		
A20Q26	1854-0813	5	3	TRANSISTOR NPN 2N3501S SI TO-39 PD = 1W	28480	1854-0813
A20Q27	1854-0474	4		TRANSISTOR NPN SI PD = 310MW FT = 100MHZ	04713	2N5551
A20Q28	1854-0477	7		TRANSISTOR NPN 2N2222A SI TO-18 PD = 500MW	04713	2N2222A

† Refer to Section 7 for update information

\* Factory Selected Component (Refer to Section 5)

Δ Errata part change

Table 6-3. Replaceable Parts

Reference Designation	HP Part Number	C D	Qty.	Description	Mfr. Code	Mfr. Part Number
<b>A20 08901-60262 – SERIAL PREFIX 2535A AND ABOVE</b>						
A20R1	2100-3161	6	1	RESISTOR-TMR 20K 10% C SIDE-ADJ 17-TRN	02111	43P203
A20R2	0757-0463	4	1	RESISTOR 82.5K 1% .125W F TC = 0 + -100	24546	C4-1/8-T0-8252-F
A20R3	0698-7284	5	2	RESISTOR 100K 1% .05W F TC = 0 + -100	24546	C3-1/8-T0-1003-F
A20R4	0698-7284	5		RESISTOR 100K 1% .05W F TC = 0 + -100	24546	C3-1/8-T0-1003-F
A20R5	0698-7260	7	4	RESISTOR 10K 1% .05W F TC = 0 + -100	24546	C3-1/8-T0-1002-F
A20R6	0699-0381	1	1	RESISTOR 40K .1% .1W F TC = 0 + -15	28480	0699-0381
A20R7	0699-0122	8	2	RESISTOR 4.8K .1% .125W F TC = 0 + -25	28480	0699-0122
A20R8	0699-0122	8		RESISTOR 4.8K .1% .125W F TC = 0 + -25	28480	0699-0122
A20R9	0698-6360	6	1	RESISTOR 10K .1% .125W F TC = 0 + -25	28480	0698-6360
A20R10	0698-8049	2	1	RESISTOR 64K .1% .125W F TC = 0 + -25	19701	MF4C1/8-T9-6402-B
A20R11	0757-0289	2	3	RESISTOR 13.3K 1% .125W F TC = 0 + -100	19701	MF4C1/8-T0-1332-F
A20R12	0698-3152	8	2	RESISTOR 3.48K 1% .125W F TC = 0 + -100	24546	C4-1/8-T0-3481-F
A20R13	0698-3154	0	4	RESISTOR 4.22K 1% .125W F TC = 0 + -100	24546	C4-1/8-T0-4221-F
A20R14	0698-8212	1	1	RESISTOR 6K .25% .125W F TC = 0 + -25	19701	MF4C1/4-T9-6001-C
A20R15	0698-7260	7		RESISTOR 10K 1% .05W F TC = 0 + -100	24546	C3-1/8-T0-1002-F
A20R16	1810-0204	6	1	NETWORK-RES 8-SIP1.0K OHM X 7	01121	208A102
A20R17	0698-7244	7	4	RESISTOR 2.15K 1% .05W F TC = 0 + -100	24546	C3-1/8-T0-2151-F
A20R18	0698-7244	7		RESISTOR 2.15K 1% .05W F TC = 0 + -100	24546	C3-1/8-T0-2151-F
A20R19	0698-7279	8	1	RESISTOR 61.9K 1% .05W F TC = 0 + -100	24546	C3-1/8-T0-6192-F
A20R20	0698-3449	6	1	RESISTOR 28.7K 1% .125W F TC = 0 + -100	24546	C4-1/8-T0-2872-F
A20R21	0757-0289	2		RESISTOR 13.3K 1% .125W F TC = 0 + -100	19701	MF4C1/8-T0-1332-F
A20R22	0757-0290	5	1	RESISTOR 6.19K 1% .125W F TC = 0 + -100	19701	MF4C1/8-T0-6191-F
A20R23	0698-0085	0	2	RESISTOR 2.61K 1% .125W F TC = 0 + -100	24546	C4-1/8-T0-2611-F
A20R24	0698-3260	9	1	RESISTOR 464K 1% .125W F TC = 0 + -100	28480	0698-3260
A20R25	0698-3266	5	1	RESISTOR 237K 1% .125W F TC = 0 + -100	24546	C4-1/8-T0-2373-F
A20R26	0698-7286	7	2	RESISTOR 121K 1% .05W F TC = 0 + -100	24546	C3-1/8-T0-1213-F
A20R27				NOT ASSIGNED		
A20R28				NOT ASSIGNED		
A20R29	0698-3438	3	1	RESISTOR 147 1% .125W F TC = 0 + -100	24546	C4-1/8-T0-147R-F
A20R30	0698-3154	0		RESISTOR 4.22K 1% .125W F TC = 0 + -100	24546	C4-1/8-T0-4221-F
A20R31	0698-7259	4	2	RESISTOR 9.09K 1% .05W F TC = 0 + -100	24546	C3-1/8-T0-9091-F
<i>2305A TO 2745A</i>						
A20R32	0698-7260	7		RESISTOR 10K 1% .05W F TC = 0 + -100	24546	C3-1/8-T0-1002-F
<i>2748A AND ABOVE</i>						
A20R32	0698-7259	4		RESISTOR 9.09K 1% .05W F TC = 0 + -100	24546	C3-1/8-T0-9091-F
A20R33	0698-7244	7		RESISTOR 2.15K 1% .05W F TC = 0 + -100	24546	C3-1/8-T0-2151-F
A20R34	0698-7244	7		RESISTOR 2.15K 1% .05W F TC = 0 + -100	24546	C3-1/8-T0-2151-F
<i>2305A TO 2745A</i>						
A20R35	0698-3154	0		RESISTOR 4.22K 1% .125W F TC = 0 + -100	24546	C4-1/8-T0-4221-F
<i>2748A AND ABOVE</i>						
A20R35	0698-3152	8		RESISTOR 3.48K 1% .125W F TC = 0 + -100	24546	C4-1/8-T0-3487-F

† Refer to Section 7 for update information.

\* Factory Selected Component (Refer to Section 5).

Δ Errata part change.

Table 6-3. Replaceable Parts

Reference Designation	HP Part Number	C D	Qty.	Description	Mfr. Code	Mfr. Part Number
<b>A20 08901-60262 – SERIAL PREFIX 2535A AND ABOVE</b>						
A20R36	0757-0289	2		RESISTOR 13.3K 1% .125W F TC = 0 + -100	19701	MF4C1/8-T0-1332-F
A20R37	1810-0206	8	1	NETWORK-RES 8-SIP10.0K OHM X 7	01121	208A103
A20R38				NOT ASSIGNED		
A20R39				NOT ASSIGNED		
A20R40	0698-0085	0		RESISTOR 2.61K 1% .125W F TC = 0 + -100	24546	C4-1/8-T0-2611-F
A20R41				NOT ASSIGNED		
A20R42	0757-0123	3	4	RESISTOR 34.8K 1% .125W F TC = 0 + -100	28480	0757-0123
A20R43	0698-7248	1	2	RESISTOR 3.16K 1% .05W F TC = 0 + -100	24546	C3-1/8-T0-3161-F
A20R44	0698-7260	7		RESISTOR 10K 1% .05W F TC = 0 + -100	24546	C3-1/8-T0-1002-F
A20R45	0698-3152	8		RESISTOR 3.48K 1% .125W F TC = 0 + -100	24546	C4-1/8-T0-3481-F
A20R46	0698-7276	5	1	RESISTOR 46.4K 1% .05W F TC = 0 + -100	24546	C3-1/8-T0-4642-F
A20R47	0698-3159	5		RESISTOR 26.1 1% .125W F TC = 0 + -100	28480	0698-3159
A20R48	0757-0123	3		RESISTOR 34.8K 1% .125W F TC = 0 + -100	28480	0757-0123
A20R49				NOT ASSIGNED		
A20R50				NOT ASSIGNED		
A20R51	0698-7261	8	1	RESISTOR 11K 1% .05W F TC = 0 + -100	24546	C3-1/8-T0-1102-F
A20R52	0698-7258	3	1	RESISTOR 8.25K 1% .05W F TC = 0 + -100	24546	C3-1/8-T0-8251-F
A20R53				NOT ASSIGNED		
A20R54				NOT ASSIGNED		
A20R55				NOT ASSIGNED		
A20R56	0698-7236	7	7	RESISTOR 1K 1% .05W F TC = 0 + -100	24546	C3-1/8-T0-1001-F
<i>2305A TO 2540A</i>						
A20R57	0757-0123	3		RESISTOR 34.8K 1% .125W F TC = 0 + -100	28480	0757-0123
<i>2540A AND ABOVE</i>						
A20R57	0757-0458	7	R	ESISTOR 51.1K 1% .125W F TC = 0 + -100	28480	C4-1/8-T0-5112-F
A20R58	0757-0199	3	1	RESISTOR 21.5K 1% .125W F TC = 0 + -100	24546	C4-1/8-T0-2152-F
A20R59	0698-7236	7		RESISTOR 1K 1% .05W F TC = 0 + -100	24546	C3-1/8-T0-1001-F
A20R60	0698-7259	4		RESISTOR 9.09K 1% .05W F TC = 0 + -100	24546	C3-1/8-T0-9091-F
A20R61	0698-7236	7		RESISTOR 1K 1% .05W F TC = 0 + -100	24546	C3-1/8-T0-1001-F
A20R60-R69				NOT ASSIGNED		
A20R70	0698-7236	7		RESISTOR 1K 1% .05W F TC = 0 + -100	24546	C3-1/8-T0-1001-F
A20R71	0698-3439	4	1	RESISTOR 178 1% .125W F TC = 0 + -100	24546	C4-1/8-T0-178R-F
A20R72	0698-7236	7		RESISTOR 1K 1% .05W F TC = 0 + -100	24546	C3-1/8-T0-1001-F
A20R73	0698-0082	7	1	RESISTOR 464 1% .125W F TC = 0 + -100	24546	C4-1/8-T0-4640-F
A20R74	0698-3154	0		RESISTOR 4.22K 1% .125W F TC = 0 + -100	24546	C4-1/8-T0-4221-F
A20R75	0698-7236	7		RESISTOR 1K 1% .05W F TC = 0 + -100	24546	C3-1/8-T0-1001-F
A20R76	0698-7236	7		RESISTOR 1K 1% .05W F TC = 0 + -100	24546	C3-1/8-T0-1001-F
A20R77	0698-7286	7		RESISTOR 121K 1% .05W F TC = 0 + -100	24546	C3-1/8-T0-1213-F
A20R78	0699-0069	2	1	RESISTOR 2.15M 1% .125W F TC = 0 + -100	28480	0699-0069
A20R79				NOT ASSIGNED		
A20R80				NOT ASSIGNED		
A20R81				NOT ASSIGNED		
A20R82	0698-7248	1		RESISTOR 3.16K 1% .05W F TC = 0 + -100	24546	C3-1/8-T0-3161-F

[Refer to Section 7 for update information

\*Factory Selected Component (Refer to Section 5)

Δ Errata part change

Table 6-3. Replaceable Parts

Reference Designation	HP Part Number	C D	Qty.	Description	Mfr. Code	Mfr. Part Number
<b>A20 08901-60262 – SERIAL PREFIX 2535A AND ABOVE</b>						
A20TP1	1251-0600	0	4	CONNECTOR-SGL CONT PIN 1.14-MM-BSC-SZ SQ	28480	1251-0600
A20TP2	1251-0600	0		CONNECTOR-SGL CONT PIN 1.14-MM-BSC-SZ SQ	28480	1251-0600
A20TP3	1251-0600	0		CONNECTOR-SGL CONT PIN 1.14-MM-BSC-SZ SQ	28480	1251-0600
A20TP4	1251-0600	0		CONNECTOR-SGL CONT PIN 1.14-MM-BSC-SZ SQ	28480	1251-0600
A20U1	1826-0989	7	4	IC OP AMP GP 8-DIP-C PKG	27014	LM307J
A20U2	1826-0605	4	1	IC MULTIPLEXR 8-CHAN-ANLG 16-DIP-C PKG	17856	DG508BK
A20U3	1820-1198	0	1	IC GATE TTL LS NAND QUAD 2-INP	01295	SN74LS03N
A20U4	1826-0990	0	1	IC OP AMP GP DUAL 8-DIP-C PKG	04713	MC1458U
A20U5	1826-0716	8	1	IC OP AMP LOW-NOISE DUAL 8-DIP-C PKG	18324	NE5532AFE
A20U6	1820-1199	1	2	IC INV TTL LS HEX 1-INP	01295	SN74LS04N
A20U7	1820-1195	7	3	IC FF TTL LS D-TYPE POS-EDGE-TRIG COM	01295	SN74LS175N
A20U8	1820-1199	1		IC INV TTL LS HEX 1-INP	01295	SN74LS04N
A20U9	1820-1216	3	2	IC DCDR TTL LS 3-TO-8-LINE 3-INP	01295	SN74LS138N
A20U10	1826-0188	8	2	IC CONV 8-B-D/A 16-DIP-C PKG	04713	MC1408L-8
A20U11	1820-1216	3		IC DCDR TTL LS 3-TO-8-LINE 3-INP	01295	SN74LS138N
A20U12	1826-0188	8		IC CONV 8-B-D/A 16-DIP-C PKG	04713	MC1408L-8
A20U13	1820-1195	7		IC FF TTL LS D-TYPE POS-EDGE-TRIG COM	01295	SN74LS175N
A20U14	1826-0606	5	2	IC SWITCH ANLG QUAD 16-DIP-C PKG	17856	DG201BK
A20U15	1820-1195	7		IC FF TTL LS D-TYPE POS-EDGE-TRIG COM	01295	SN74LS175N
A20U16	1820-1411	0	7	IC LCH TTL LS D-TYPE 4-BIT	01295	SN74LS75N
A20U17	1820-1411	0		IC LCH TTL LS D-TYPE 4-BIT	01295	SN74LS75N
A20U18	1820-1411	0		IC LCH TTL LS D-TYPE 4-BIT	01295	SN74LS75N
A20U19	1820-1411	0		IC LCH TTL LS D-TYPE 4-BIT	01295	SN74LS75N
A20U20	1820-1411	0		IC LCH TTL LS D-TYPE 4-BIT	01295	SN74LS75N
A20U21	1820-1411	0		IC LCH TTL LS D-TYPE 4-BIT	01295	SN74LS75N
A20U22	1820-1411	0		IC LCH TTL LS D-TYPE 4-BIT	01295	SN74LS75N
A20U23	1826-0606	5		IC SWITCH ANLG QUAD 16-DIP-C PKG	17856	DG201BK
A20VR1	1902-0955	9	1	DIODE-ZNR 7.5V 5% DO-35 PD = .4W TC = +.062%	28480	1902-0955
A20W1	8159-0005	0	1	RESISTOR-ZERO OHMS 22 AWG LEAD DIA	28480	8159-0005

{Refer to Section 7 for update information.

\*Factory Selected Component (Refer to Section 5).

Δ Errata part change

Table 6-3. Replaceable Parts

Reference Designation	HP Part Number	C D	Qty.	Description	Mfr. Code	Mfr. Part Number
<b>A21</b>						
A21	08901-60025	7	1	LOW FREQUENCY VCXO FILTER ASSEMBLY	28480	08901-60025
A21C1	0160-2028	6	3	CAPACITOR-FXD 2700PF + -5% 500VDC MICA	28480	0160-2028
A21C2	0160-2534	9	2	CAPACITOR-FXD 300PF + -1% 300VDC MICA	28480	0160-2534
A21C3	0160-2028	6		CAPACITOR-FXD 2700PF + -5% 500VDC MICA	28480	0160-2028
A21C4	0160-2028	6		CAPACITOR-FXD 2700PF + -5% 500VDC MICA	28480	0160-2028
A21C5	0160-2534	9		CAPACITOR-FXD 300PF + -1% 300VDC MICA	28480	0160-2534
A21J1	1250-1425	7		CONNECTOR-RF SMC M SGL-HOLE-RR 50-OHM	28480	1250-1425
	2190-0124	4		WASHER-LK INTL T NO. 10 .195-IN-ID	28480	2190-0124
	2950-0078	9		NUT-HEX-DBL-CHAM 10-32-THD .067-IN-THK	28480	2950-0078
A21J2	1250-1425	7		CONNECTOR-RF SMC M SGL-HOLE-RR 50-OHM	28480	1250-1425
	2190-0124	4		WASHER-LK INTL T NO. 10 .195-IN-ID	28480	2190-0124
	2950-0078	9		NUT-HEX-DBL-CHAM 10-32-THD .067-IN-THK	28480	2950-0078
A21L1	9140-0112	2	5	INDUCTOR RF-CH-MLD 4.7UH 10%	28480	9140-0112
A21L2	9140-0112	2		INDUCTOR RF-CH-MLD 4.7UH 10%	28480	9140-0112
A21MP1	08901-00025	1	1	COVER VCOX FILTER	28480	08901-00025
A21MP2	5001-0176	0		GROUND STRAP	28480	5001-0176
A21MP3	5001-0176	0		GROUND STRAP	28480	5001-0176
A21MP4	08901-00044	4	1	GASKT-VCOX FILTER	28480	08901-00044

†Refer to Section 7 for update information

\*Factory Selected Component (Refer to section 5)

Δ Errata part change

Table 6-3. Replaceable Parts

Reference Designation	HP Part Number	C D	Qty.	Description	Mfr. Code	Mfr. Part Number
<b>A22</b>						
A22	08901-60007	5	1	LOW FREQUENCY VCXO ASSEMBLY	28480	08901-60007
A22C1	0180-0094	4		CAPACITOR-FXD 100UF + 75-10% 25VDC AL	56289	30D107G025DD2
A22C2	0180-0197	8		CAPACITOR-FXD 2.2UF + -10% 20VDC TA	56289	150D225X9020A2
A22C3	0160-3459	9		CAPACITOR-FXD .02UF + -20% 100VDC CER	28480	0160-3459
A22C4	0180-0197	8		CAPACITOR-FXD 2.2UF + -10% 20VDC TA	56289	150D225X9020A2
A22C5	0160-3459	9		CAPACITOR-FXD .02UF + -20% 100VDC CER	28480	0160-3459
A22C6	0160-3459	9		CAPACITOR-FXD .02UF + -20% 100VDC CER	28480	0160-3459
A22C7	0160-3459	9		CAPACITOR-FXD .02UF + -20% 100VDC CER	28480	0160-3459
A22C8	0180-0197	8		CAPACITOR-FXD 2.2UF + -10% 20VDC TA	56289	150D225X9020A2
A22C9	0180-0197	8		CAPACITOR-FXD 2.2UF + -10% 20VDC TA	56289	150D225X9020A2
A22C10	0160-3459	9		CAPACITOR-FXD .02UF + -20% 100VDC CER	28480	0160-3459
A22C11	0160-3459	9		CAPACITOR-FXD .02UF + -20% 100VDC CER	28480	0160-3459
A22C12	0160-3456	6	2	CAPACITOR-FXD 1000PF + -10% 1KVDC CER	28480	0160-3456
A22C13	0160-3456	6		CAPACITOR-FXD 1000PF + -10% 1KVDC CER	28480	0160-3456
A22C14	0160-3459	9		CAPACITOR-FXD .02UF + -20% 100VDC CER	28480	0160-3459
A22C15	0160-4678	8	1	CAPACITOR-FXD 560PF + -1% 100VDC MICA	28480	0160-4678
A22C16	0160-4679	7	1	CAPACITOR-FXD 270PF + -1% 300VDC MICA	28480	0160-4679
A22C17	0160-4456	8	1	CAPACITOR-FXD 750PF + -1% 300VDC MICA	28480	0160-4456
A22C18	0160-2328	9	1	CAPACITOR-FXD 200PF + -1% 300VDC MICA	28480	0160-2328
A22C19	0160-3459	9		CAPACITOR-FXD .02UF + -20% 100VDC CER	28480	0160-3459
A22C20	0180-0197	8		CAPACITOR-FXD 2.2UF + -10% 20VDC TA	56289	150D225X9020A2
A22C21	0160-2032	2	1	CAPACITOR-FXD 510PF + -5% 500VDC MICA	28480	0160-2032
A22C22	0160-2030	0	1	CAPACITOR-FXD 1200PF + -5% 500VDC MICA	28480	0160-2030
A22C23	0160-3459	9		CAPACITOR-FXD .02UF + -20% 100VDC CER	28480	0160-3459
A22C24	0180-0197	8		CAPACITOR-FXD 2.2UF + -10% 20VDC TA	56289	150D225X9020A2
A22C25	0160-3459	9		CAPACITOR-FXD .02UF + -20% 100VDC CER	28480	0160-3459
A22C26	0180-0197	8		CAPACITOR-FXD 2.2UF + -10% 20VDC TA	56289	150D225X9020A2
A22C27	0180-0197	8		CAPACITOR-FXD 2.2UF + -10% 20VDC TA	56289	150D225X9020A2
A22C28	0160-4680	0	1	CAPACITOR-FXD 4000PF + -5% 100VDC MICA	28480	0160-4680
A22CR1	1901-0535	9		DIODE-SM SIG SCHOTTKY	28480	1901-0535
A22CR2	1901-0179	7		DIODE-SWITCHING 15V 50MA 750PS DO-7	28480	1901-0179
A22CR3	1901-0535	9		DIODE-SM SIG SCHOTTKY	28480	1901-0535
A22CR4	1901-0179	7		DIODE-SWITCHING 15V 50MA 750PS DO-7	28480	1901-0179
A22CR5	1901-0535	9		DIODE-SM SIG SCHOTTKY	28480	1901-0535
A22CR6	1901-0179	7		DIODE-SWITCHING 15V 50MA 750PS DO-7	28480	1901-0179
A22CR7	1901-0535	9		DIODE-SM SIG SCHOTTKY	28480	1901-0535
A22CR8	1901-0179	7		DIODE-SWITCHING 15V 50MA 750PS DO-7	28480	1901-0179
<i>2305A TO 2411A</i>						
A22CR9	0122-0065	7	9	DIODE-VVC 29PF 3%	28480	0122-0065
A22CR10	0122-0065	7		DIODE-VVC 29PF 3%	28480	0122-0065
A22CR11	0122-0065	7		DIODE-VVC 29PF 3%	28480	0122-0065
A22CR12	0122-0065	7		DIODE-VVC 29PF 3%	28480	0122-0065
<i>2412A AND ABOVE</i>						
A22CR9	0122-0162	5		DIODE VVC 29PF 10% BVR = 30V		
A22CR10	0122-0162	5		DIODE VVC 29PF 10% BVR = 30V		
A22CR11	0122-0162	5		DIODE VVC 29PF 10% BVR = 30V		
A22CR12	0122-0162	5		DIODE VVC 29PF 10% BVR = 30V		

†Refer to Section 7 for update information.

\*Factory Selected Component (Refer to Section 5)

Δ Errata part change



Table 6-3. Replaceable Parts

Reference Designation	HP Part Number	C D	Qty.	Description	Mfr. Code	Mfr. Part Number
A22CR13	1901-0179	7		DIODE-SWITCHING 15V 50MA 750PS DO-7	28480	1901-0179
A22CR14	1901-0179	7		DIODE-SWITCHING 15V 50MA 750PS DO-7	28480	1901-0179
A22CR15	1901-0179	7		DIODE-SWITCHING 15V 50MA 750PS DO-7	28480	1901-0179
A22CR16	1901-0179	7		DIODE-SWITCHING 15V 50MA 750PS DO-7	28480	1901-0179
A22E1	9170-0029	3		CORE-SHIELDING BEAD	28480	9170-0029
A22E2	9170-0029	3		CORE-SHIELDING BEAD	28480	9170-0029
A22J1	1250-1220	0		CONNECTOR-RF SMC M PC 50-OHM	28480	1250-1220
	2190-0124	4		WASHER-LK INTL T NO. 10 .195-IN-ID	28480	2190-0124
	2950-0078	9		NUT-HEX-DBL-CHAM 10-32-THD .067-IN-THK	28480	2950-0078
A22L1	9140-0112	2		INDUCTOR RF-CH-MLD 4.7UH 10%	28480	9140-0112
A22L2 <sup>Δ</sup>	9140-0264	5	3	INDUCTOR RF-CH-MLD 1.5UH 10%	28480	9140-0264
A22L3	9140-0325	9	1	INDUCTOR RF-CH-MLD 10UH 2% .312DX.969LG	06560	004414-012G
A22L4	9140-0112	2		INDUCTOR RF-CH-MLD 4.7UH 10%	28480	9140-0112
A22L5	9100-1615	8	1	INDUCTOR RF-CH-MLD 1.2UH 10%	28480	9100-1615
A22L6	9140-0324	8	1	INDUCTOR RF-CH-MLD 6.8UH 2% .312DX.969LG	06560	004414-010G
A22L7	9100-1616	9		INDUCTOR RF-CH-MLD 1.5UH 10%	28480	9100-1616
A22L8	9140-0180	4	1	INDUCTOR RF-CH-MLD 2.7UH 10%	28480	9140-0180
A22L9	9100-1616	9		INDUCTOR RF-CH-MLD 1.5UH 10%	28480	9100-1616
A22L10	9140-0112	2		INDUCTOR RF-CH-MLD 4.7UH 10%	28480	9140-0112
A22MP1	08901-00026	2	1	COVER LF VCXO	28480	08901-00026
	2360-0113	2		SCREW-MACH 6-32 .25-IN-LG PAN-HD-POZI	00000	ORDER BY DESCRIPTION
A22MP2	5001-0176	0		GROUND STRAP	28480	5001-0176
A22MP3	5001-0176	0		GROUND STRAP	28480	5001-0176
A22Q1	1854-0477	7		TRANSISTOR NPN 2N2222A SI TO-18 PD = 500MW	04713	2N2222A
A22Q2	1853-0012	4		TRANSISTOR PNP 2N2904A SI TO-39 PD = 600MW	01295	2N2904A
	1200-0173	5		INSULATOR-XSTR DAP-GL	28480	1200-0173
A22Q3	1854-0610	0		TRANSISTOR NPN SI TO-46 FT = 800MHZ	28480	1854-0610
A22Q4	1854-0610	0		TRANSISTOR NPN SI TO-46 FT = 800MHZ	28480	1854-0610
A22Q5	1854-0247	9		TRANSISTOR NPN SI TO-39 PD = 1W FT = 800MHZ	28480	1854-0247
A22Q6	1854-0247	9		TRANSISTOR NPN SI TO-39 PD = 1W FT = 800MHZ	28480	1854-0247
A22Q7	1854-0610	0		TRANSISTOR NPN SI TO-46 FT = 800MHZ	28480	1854-0610
A22Q8	1854-0610	0		TRANSISTOR NPN SI TO-46 FT = 800MHZ	28480	1854-0610
A22Q9	1853-0001	1	1	TRANSISTOR PNP SI TO-39 PD = 600MW	28480	1853-0001
	1200-0173	5		INSULATOR-XSTR DAP-GL	28480	1200-0173
A22R1	0757-0401	0		RESISTOR 100 1% .125W F TC = 0 + -100	24546	C4-1/8-T0-101-F
A22R2	0757-0401	0		RESISTOR 100 1% .125W F TC = 0 + -100	24546	C4-1/8-T0-101-F
A22R3	0757-0422	5		RESISTOR 909 1% .125W F TC = 0 + -100	24546	C4-1/8-T0-909R-F
A22R4	0757-0280	3		RESISTOR 1K 1% .125W F TC = 0 + -100	24546	C4-1/8-T0-1001-F
A22R5	0698-3155	1		RESISTOR 4.64K 1% .125W F TC = 0 + -100	24546	C4-1/8-T0-4641-F
A22R6	0757-0439	4		RESISTOR 6.81K 1% .125W F TC = 0 + -100	24546	C4-1/8-T0-6811-F
A22R7	0698-3430	5		RESISTOR 21.5 1% .125W F TC = 0 + -100	03888	PME55-1/8-T0-21R5-F
A22R8	0698-3155	1		RESISTOR 4.64K 1% .125W F TC = 0 + -100	24546	C4-1/8-T0-4641-F
A22R9	0757-0439	4		RESISTOR 6.81K 1% .125W F TC = 0 + -100	24546	C4-1/8-T0-6811-F
A22R10	0698-3430	5		RESISTOR 21.5 1% .125W F TC = 0 + -100	03888	PME55-1/8-T0-21R5-F

†Refer to Section 7 for update information.

\*Factory Selected Component (Refer to Section 5).

Δ Errata part change.

Table 6-3. Replaceable Parts

Reference Designation	HP Part Number	C D	Qty.	Description	Mfr. Code	Mfr. Part Number
A22R11	0698-0082	7		RESISTOR 464 1% .125W F TC = 0 + -100	24546	C4-1/8-T0-4640-F
A22R12	0698-0082	7		RESISTOR 464 1% .125W F TC = 0 + -100	24546	C4-1/8-T0-4640-F
A22R13	0698-0082	7		RESISTOR 464 1% .125W F TC = 0 + -100	24546	C4-1/8-T0-4640-F
A22R14	0698-0082	7		RESISTOR 464 1% .125W F TC = 0 + -100	24546	C4-1/8-T0-4640-F
A22R15	0698-8004	9	4	RESISTOR 200K .1% .1W F TC = 0 + -15	07716	MAR-1/10-T10-2003-B
A22R16	0698-8004	9		RESISTOR 200K .1% .1W F TC = 0 + -15	07716	MAR-1/10-T10-2003-B
A22R17	0698-3445	2		RESISTOR 348 1% .125W F TC = 0 + -100	24546	C4-1/8-T0-348R-F
A22R18	0757-0398	4		RESISTOR 75 1% .125W F TC = 0 + -100	24546	C4-1/8-T0-75R0-F
A22R19	0698-0082	7		RESISTOR 464 1% .125W F TC = 0 + -100	24546	C4-1/8-T0-4640-F
A22R20	0698-0082	7		RESISTOR 464 1% .125W F TC = 0 + -100	24546	C4-1/8-T0-4640-F
A22R21	0698-8004	9		RESISTOR 200K .1% .1W F TC = 0 + -15	07716	MAR-1/10-T10-2003-B
A22R22	0698-8004	9		RESISTOR 200K .1% .1W F TC = 0 + -15	07716	MAR-1/10-T10-2003-B
A22R23	0757-0400	9		RESISTOR 90.9 1% .125W F TC = 0 + -100	24546	C4-1/8-T0-90R9-F
A22R24	0698-0082	7		RESISTOR 464 1% .125W F TC = 0 + -100	24546	C4-1/8-T0-4640-F
A22R25	0698-3430	5		RESISTOR 21.5 1% .125W F TC = 0 + -100	03888	PME55-1/8-T0-21R5-F
A22R26	0757-0394	0		RESISTOR 51.1 1% .125W F TC = 0 + -100	24546	C4-1/8-T0-51R1-F
A22R27	0698-3435	0	1	RESISTOR 38.3 1% .125W F TC = 0 + -100	24546	C4-1/8-T0-38R3-F
A22R28	0757-0421	4	5	RESISTOR 825 1% .125W F TC = 0 + -100	24546	C4-1/8-T0-825R-F
A22R29	0757-0394	0		RESISTOR 51.1 1% .125W F TC = 0 + -100	24546	C4-1/8-T0-51R1-F
A22R30	0698-3156	2		RESISTOR 14.7K 1% .125W F TC = 0 + -100	24546	C4-1/8-T0-1472-F
A22R31	0698-3446	3		RESISTOR 383 1% .125W F TC = 0 + -100	24546	C4-1/8-T0-383R-F
A22R32	0757-0438	3		RESISTOR 5.11K 1% .125W F TC = 0 + -100	24546	C4-1/8-T0-5111-F
A22R33	0757-0403	2		RESISTOR 121 1% .125W F TC = 0 + -100	24546	C4-1/8-T0-121R-F
A22R34	0757-0346	2		RESISTOR 10 1% .125W F TC = 0 + -100	24546	C4-1/8-T0-10R0-F
A22R35	0757-0401	0		RESISTOR 100 1% .125W F TC = 0 + -100	24546	C4-1/8-T0-101-F
A22R36	0757-0346	2		RESISTOR 10 1% .125W F TC = 0 + -100	24546	C4-1/8-T0-10R0-F
A22R37	0757-0399	5		RESISTOR 82.5 1% .125W F TC = 0 + -100	24546	C4-1/8-T0-82R5-F
A22R38	0757-0289	2		RESISTOR 13.3K 1% .125W F TC = 0 + -100	19701	MF4C1/8-T0-1332-F
A22R39	0757-0438	3		RESISTOR 5.11K 1% .125W F TC = 0 + -100	24546	C4-1/8-T0-5111-F
A22T1	08660-60369	0	2	TRANSFORMER-RF GRN	28480	08660-60369
A22T2	08660-60369	0		TRANSFORMER-RF GRN	28480	08660-60369
A22TP1	1251-0600	0		CONNECTOR-SGL CONT PIN 1.14-MM-BSC-SZ SQ	28480	1251-0600
A22TP2	1251-0600	0		CONNECTOR-SGL CONT PIN 1.14-MM-BSC-SZ SQ	28480	1251-0600
<b>2305A TO 2546A</b>						
A22Y1	0410-1181	1	1	CRYSTAL-QUARTZ 9.26 MHZ HC-42/U-HLDR	28480	0410-1181
	1200-0758	2	2	SOCKET-XTAL 2-CONT HC-25/U DIP-SLDR	28480	1200-0758
A22Y2	0410-1182	2	1	CRYSTAL-QUARTZ 11.26 MHZ HC-42/U-HLDR	28480	0410-1182
	1200-0758	2		SOCKET-XTAL 2-CONT HC-25/U DIP-SLDR	28480	1200-0758
<b>2606A AND ABOVE</b>						
A22Y1	0410-1615	6		CRYSTAL-QUARTZ RESONATOR 9.26 MHZ	28480	0410-1615
	1400-0973	7		CLIP CMPNT .139D .154 DIA STL	28480	1400-0973
A22Y2	0410-1616	7		CRYSTAL-QUARTZ RESONATOR 11.26 MHZ	28480	0410-1616
	1400-0973	7		CLIP CMPNT .139D .154 DIA STL	28480	1400-0973

† Refer to Section 7 for update information

\* Factory Selected Component (Refer to Section 5)

Δ Errata part change

Table 6-3. Replaceable Parts

Reference Designation	HP Part Number	C D	Qty.	Description	Mfr. Code	Mfr. Part Number
<b>A23</b>						
A23	08901-60144	1	1	SAMPLER ASSEMBLY	28480	08901-60144
A23C1	0160-3878	6		CAPACITOR-FXD 1000PF + -20% 100VDC CER	28480	0160-3878
A23C2	0160-3878	6		CAPACITOR-FXD 1000PF + -20% 100VDC CER	28480	0160-3878
A23C3	0160-3878	6		CAPACITOR-FXD 1000PF + -20% 100VDC CER	28480	0160-3878
A23C4	0160-0571	0		CAPACITOR-FXD 470PF + -20% 100VDC CER	28480	0160-0571
A23C5	0160-3878	6		CAPACITOR-FXD 1000PF + -20% 100VDC CER	28480	0160-3878
A23C6	0180-2617	1	7	CAPACITOR-FXD 6.8UF + -10% 35VDC TA	25088	D6R8GS1B35K
A23C7	0160-4084	8		CAPACITOR-FXD .1UF + -20% 50VDC CER	28480	0160-4084
A23C8	0160-4084	8		CAPACITOR-FXD .1UF + -20% 50VDC CER	28480	0160-4084
A23C9	0160-4084	8		CAPACITOR-FXD .1UF + -20% 50VDC CER	28480	0160-4084
A23C10	0160-4084	8		CAPACITOR-FXD .1UF + -20% 50VDC CER	28480	0160-4084
A23C11	0180-2618	2	1	CAPACITOR-FXD 33UF + -10% 10VDC TA	25088	D33GS1B10K
A23C12	0180-2617	1		CAPACITOR-FXD 6.8UF + -10% 35VDC TA	25088	D6R8GS1B35K
A23C13	0180-2617	1		CAPACITOR-FXD 6.8UF + -10% 35VDC TA	25088	D6R8GS1B35K
A23C14	0160-4084	8		CAPACITOR-FXD .1UF + -20% 50VDC CER	28480	0160-4084
A23C15	0180-2617	1		CAPACITOR-FXD 6.8UF + -10% 35VDC TA	25088	D6R8GS1B35K
A23C16	0160-0570	9		CAPACITOR-FXD 220PF + -20% 100VDC CER	20932	5024EM100RD221M
A23C17	0160-3877	5		CAPACITOR-FXD 100PF + -20% 200VDC CER	28480	0160-3877
A23C18	0160-3876	4	6	CAPACITOR-FXD 47PF + -20% 200VDC CER	28480	0160-3876
A23C19	0160-3876	4		CAPACITOR-FXD 47PF + -20% 200VDC CER	28480	0160-3876
A23C20	0160-3873	1		CAPACITOR-FXD 4.7PF + -.5PF 200VDC CER	28480	0160-3873
A23C21	0160-3876	4		CAPACITOR-FXD 47PF + -20% 200VDC CER	28480	0160-3876
A23C22	0160-3876	4		CAPACITOR-FXD 47PF + -20% 200VDC CER	28480	0160-3876
A23C23	0160-3873	1		CAPACITOR-FXD 4.7PF + -.5PF 200VDC CER	28480	0160-3873
A23C24	0160-4084	8		CAPACITOR-FXD .1UF + -20% 50VDC CER	28480	0160-4084
A23C25	0160-3873	1		CAPACITOR-FXD 4.7PF + -.5PF 200VDC CER	28480	0160-3873
A23C26	0160-3875	3		CAPACITOR-FXD 22PF + -5% 200VDC CER 0 + -30	28480	0160-3875
A23C27	0180-1745	4	1	CAPACITOR-FXD 1.5UF + -10% 20VDC TA	56289	150D155X9020A2
A23C28	0160-3875	3		CAPACITOR-FXD 22PF + -5% 200VDC CER 0 + -30	28480	0160-3875
A23C29	0180-0291	3		CAPACITOR-FXD 1UF + -10% 35VDC TA	56289	150D105X9035A2
A23C30	0160-5699	3		CAPACITOR-FXD 20PF + -5% 100VDC CER 0 + -30	28480	0160-5699
A23C31	0180-0291	3		CAPACITOR-FXD 1UF + -10% 35VDC TA	56289	150D105X9035A2
A23C32	0180-2617	1		CAPACITOR-FXD 6.8UF + -10% 35VDC TA	25088	D6R8GS1B35K
A23C33	0180-0197	8		CAPACITOR-FXD 2.2UF + -10% 20VDC TA	56289	150D225X9020A2
A23C34	0180-0291	3		CAPACITOR-FXD 1UF + -10% 35VDC TA	56289	150D105X9035A2
A23C35	0180-0197	8		CAPACITOR-FXD 2.2UF + -10% 20VDC TA	56289	150D225X9020A2
A23C36	0180-2617	1		CAPACITOR-FXD 6.8UF + -10% 35VDC TA	25088	D6R8GS1B35K
A23C37	0160-4653	7	1	CAPACITOR-FXD .1UF + -5% 100VDC MET-POLYP	28480	0160-4653
A23C38	0180-0291	3		CAPACITOR-FXD 1UF + -10% 35VDC TA	56289	150D105X9035A2
A23C39	0180-0291	3		CAPACITOR-FXD 1UF + -10% 35VDC TA	56289	150D105X9035A2
A23C40	0160-3879	7		CAPACITOR-FXD .01UF + -20% 100VDC CER	28480	0160-3879
A23C41	0160-3879	7		CAPACITOR-FXD .01UF + -20% 100VDC CER	28480	0160-3879
A23C42	0160-3877	5		CAPACITOR-FXD 100PF + -20% 200VDC CER	28480	0160-3877
A23C43	0160-0571	0		CAPACITOR-FXD 470PF + -20% 100VDC CER	28480	0160-0571
A23C44	0160-0571	0		CAPACITOR-FXD 470PF + -20% 100VDC CER	28480	0160-0571

1 Refer to Section 7 for update information.

\* Factory Selected Component (Refer to Section 5).

Δ Errata part change

Table 6-3. Replaceable Parts

Reference Designation	HP Part Number	C D	Qty.	Description	Mfr. Code	Mfr. Part Number
A23C45 <sup>Δ</sup>	0160-3568	1	1	CAPACITOR-FXD 2.7PF + .25PF 200VDC CER	28480	0160-3568
A23CR1	1901-0033	2		DIODE-GEN PRP 180V 200MA DO-7	28480	1901-0033
A23CR2	1901-0033	2		DIODE-GEN PRP 180V 200MA DO-7	28480	1901-0033
A23CR3	1901-0189	9		DIODE-STEP RECOVERY	28480	1901-0189
A23CR4	1901-0518	8		DIODE-SM SIG SCHOTTKY	28480	1901-0518
A23CR5	1901-0518	8		DIODE-SM SIG SCHOTTKY	28480	1901-0518
A23CR6	1906-0098	9	4	DIODE-MATCHED 1V	28480	1906-0098
A23CR7	1906-0098	9		DIODE-MATCHED 1V	28480	1906-0098
A23CR8	1906-0098	9		DIODE-MATCHED 1V	28480	1906-0098
A23CR9	1906-0098	9		DIODE-MATCHED 1V	28480	1906-0098
A23CR10	1901-0033	2		DIODE-GEN PRP 180V 200MA DO-7	28480	1901-0033
A23CR11	1901-0033	2		DIODE-GEN PRP 180V 200MA DO-7	28480	1901-0033
A23CR12	1901-0033	2		DIODE-GEN PRP 180V 200MA DO-7	28480	1901-0033
A23CR13	1901-0033	2		DIODE-GEN PRP 180V 200MA DO-7	28480	1901-0033
A23CR14	1901-0033	2		DIODE-GEN PRP 180V 200MA DO-7	28480	1901-0033
A23CR15	1901-0518	8		DIODE-SM SIG SCHOTTKY	28480	1901-0518
A23DS1	1990-0326	3	3	LED-LAMP LUM-INT = 300UCD IF = 50MA-MAX	28480	5082-4444
A23DS2	1990-0326	3		LED-LAMP LUM-INT = 300UCD IF = 50MA-MAX	28480	5082-4444
A23E1	9170-0029	3		CORE-SHIELDING BEAD	28480	9170-0029
A23J1	1250-1220	0		CONNECTOR-RF SMC M PC 50-OHM	28480	1250-1220
	2190-0124	4		WASHER-LK INTL T NO. 10 .195-IN-ID	28480	2190-0124
	2950-0078	9		NUT-HEX-DBL-CHAM 10-32-THD .067-IN-THK	28480	2950-0078
A23J2	1250-1220	0		CONNECTOR-RF SMC M PC 50-OHM	28480	1250-1220
	2190-0124	4		WASHER-LK INTL T NO. 10 .195-IN-ID	28480	2190-0124
	2950-0078	9		NUT-HEX-DBL-CHAM 10-32-THD .067-IN-THK	28480	2950-0078
A23L1	9100-3922	4		INDUCTOR-FIXED 120-1300 HZ	28480	9100-3922
A23L2	9100-3922	4		INDUCTOR-FIXED 120-1300 HZ	28480	9100-3922
A23L3	9100-3922	4		INDUCTOR-FIXED 120-1300 HZ	28480	9100-3922
A23L4	9100-3922	4		INDUCTOR-FIXED 120-1300 HZ	28480	9100-3922
A23L5	9140-0210	1		INDUCTOR RF-CH-MLD 100UH 5% .166DX.385LG	28480	9140-0210
A23L6	9140-0210	1		INDUCTOR RF-CH-MLD 100UH 5% .166DX.385LG	28480	9140-0210
A23L7-L9				PART OF ETCHED CIRCUIT BOARD		
A23L10	9100-2250	9	2	INDUCTOR RF-CH-MLD 180NH 10% .105DX.26LG	28480	9100-2250
A23L11	9100-2250	9		INDUCTOR RF-CH-MLD 180NH 10% .105DX.26LG	28480	9100-2250
A23L12				PART OF ETCHED CIRCUIT BOARD		
A23L13				PART OF ETCHED CIRCUIT BOARD		
A23L14	9140-0144	0	3	INDUCTOR RF-CH-MLD 4.7UH 10% .105DX.26LG	28480	9140-0144
A23L15	9140-0144	0		INDUCTOR RF-CH-MLD 4.7UH 10% .105DX.26LG	28480	9140-0144
A23L16	9100-3922	4		INDUCTOR-FIXED 120-1300 HZ	28480	9100-3922
A23MP1	08901-00024	0	1	COVER SAMP	28480	08901-00024
	2360-0113	2		SCREW-MACH 6-32 .25-IN-LG PAN-HD-POZI	00000	ORDER BY DESCRIPTION
A23MP2	5001-0176	0		GROUND STRAP	28480	5001-0176
A23MP3	5001-0176	0		GROUND STRAP	28480	5001-0176

† Refer to Section 7 for update information.

\* Factory Selected Component (Refer to Section 5).

Δ Errata part change.

Table 6-3. Replaceable Parts

Reference Designation	HP Part Number	C D	Qty.	Description	Mfr. Code	Mfr. Part Number
<i>2306A TO 2413A</i>						
A23MP4	08662-00040	0		SHIELD COMP SMALL	28480	08662-00040
A23MP5	08662-00038	6		SHIELD CKT SM	28480	08662-00038
<i>2414A AND ABOVE</i>						
A23MP4				NOT ASSIGNED		
A23MP5				NOT ASSIGNED		
A23Q1	1854-0247	9		TRANSISTOR NPN SI TO-39 PD = 1W FT = 800MHZ	28480	1854-0247
A23Q2	1854-0247	9		TRANSISTOR NPN SI TO-39 PD = 1W FT = 800MHZ	28480	1854-0247
	1200-0173	5		INSULATOR-XSTR DAP-GL	28480	1200-0173
A23Q3	1854-0023	9		TRANSISTOR NPN SI TO-18 PD = 360MW	28480	1854-0023
A23Q4	1853-0007	7		TRANSISTOR PNP 2N3251 SI TO-18 PD = 360MW	04713	2N3251
A23Q5	1854-0210	6		TRANSISTOR NPN 2N2222 SI TO-18 PD = 500MW	04713	2N2222
A23Q6	1853-0281	9		TRANSISTOR PNP 2N2907A SI TO-18 PD = 400MW	04713	2N2907A
	1205-0037	0	1	HEAT SINK TO-18-CS	28480	1205-0037
A23Q7	1853-0038	4	1	TRANSISTOR PNP SI TO-39 PD = 1W FT = 100MHZ	28480	1853-0038
	1200-0173	5		INSULATOR-XSTR DAP-GL	28480	1200-0173
A23Q8	1853-0020	4		TRANSISTOR PNP SI PD = 300MW FT = 150MHZ	28480	1853-0020
A23Q9	1855-0049	1		TRANSISTOR-JFET DUAL N-CHAN D-MODE SI	28480	1855-0049
A23Q10	1853-0020	4		TRANSISTOR PNP SI PD = 300MW FT = 150MHZ	28480	1853-0020
A23Q11	1855-0420	2		TRANSISTOR J-FET 2N4391 N-CHAN D-MODE	01295	2N4391
A23Q12	1855-0420	2		TRANSISTOR J-FET 2N4391 N-CHAN D-MODE	01295	2N4391
A23R1	0757-0288	1		RESISTOR 9.09K 1% .125W F TC = 0 + -100	19701	MF4C1/8-T0-9091-F
A23R2	0757-0416	7		RESISTOR 511 1% .125W F TC = 0 + -100	24546	C4-1/8-T0-511R-F
A23R3	0698-3154	0		RESISTOR 4.22K 1% .125W F TC = 0 + -100	24546	C4-1/8-T0-4221-F
A23R4	0757-1094	9		RESISTOR 1.47K 1% .125W F TC = 0 + -100	24546	C4-1/8-T0-1471-F
A23R5	0757-0405	4		RESISTOR 162 1% .125W F TC = 0 + -100	24546	C4-1/8-T0-162R-F
A23R6	0757-0421	4		RESISTOR 825 1% .125W F TC = 0 + -100	24546	C4-1/8-T0-825R-F
A23R7	0757-0442	9		RESISTOR 10K 1% .125W F TC = 0 + -100	24546	C4-1/8-T0-1002-F
A23R8	0698-3440	7		RESISTOR 196 1% .125W F TC = 0 + -100	24546	C4-1/8-T0-196R-F
A23R9	0757-0346	2		RESISTOR 10 1% .125W F TC = 0 + -100	24546	C4-1/8-T0-10R0-F
A23R10	0757-0405	4		RESISTOR 162 1% .125W F TC = 0 + -100	24546	C4-1/8-T0-162R-F
A23R11	0757-0280	3		RESISTOR 1K 1% .125W F TC = 0 + -100	24546	C4-1/8-T0-1001-F
A23R12	0757-1094	9		RESISTOR 1.47K 1% .125W F TC = 0 + -100	24546	C4-1/8-T0-1471-F
A23R13	0757-0442	9		RESISTOR 10K 1% .125W F TC = 0 + -100	24546	C4-1/8-T0-1002-F
A23R14	0698-3136	8		RESISTOR 17.8K 1% .125W F TC = 0 + -100	24546	C4-1/8-T0-1782-F
A23R15	0698-3154	0		RESISTOR 4.22K 1% .125W F TC = 0 + -100	24546	C4-1/8-T0-4221-F
A23R16	0698-3631	8	1	RESISTOR 330 5% 2W MO TC = 0 + -200	28480	0698-3631
A23R17	0698-3399	5	1	RESISTOR 133 1% .5W F TC = 0 + -100	28480	0698-3399
A23R18	0757-0465	6		RESISTOR 100K 1% .125W F TC = 0 + -100	24546	C4-1/8-T0-1003-F
A23R19	0757-0394	0		RESISTOR 51.1 1% .125W F TC = 0 + -100	24546	C4-1/8-T0-51R1-F
A23R20	0757-0394	0		RESISTOR 51.1 1% .125W F TC = 0 + -100	24546	C4-1/8-T0-51R1-F
A23R21	0757-0441	8		RESISTOR 8.25K 1% .125W F TC = 0 + -100	24546	C4-1/8-T0-8251-F
A23R22	0698-8827	4		RESISTOR 1M 1% .125W F TC = 0 + -100	28480	0698-8827
A23R23	0698-7205	0		RESISTOR 51.1 1% .05W F TC = 0 + -100	24546	C3-1/8-T0-51R1-F
A23R24	0757-0441	8		RESISTOR 8.25K 1% .125W F TC = 0 + -100	24546	C4-1/8-T0-8251-F
A23R25	0698-8827	4		RESISTOR 1M 1% .125W F TC = 0 + -100	28480	0698-8827
A23R26	0698-8827	4		RESISTOR 1M 1% .125W F TC = 0 + -100	28480	0698-8827

Refer to Section 7 for update information

\*Factory Selected Component (Refer to Section 7)

Δ Errata part change

Table 6-3. Replaceable Parts

Reference Designation	HP Part Number	C D	Qty.	Description	Mfr. Code	Mfr. Part Number
A23R27	0757-0280	3		RESISTOR 1K 1% .125W F TC = 0 + -100	24546	C4-1/8-T0-1001-F
A23R28	0757-0280	3		RESISTOR 1K 1% .125W F TC = 0 + -100	24546	C4-1/8-T0-1001-F
A23R29	0757-0438	3		RESISTOR 5.11K 1% .125W F TC = 0 + -100	24546	C4-1/8-T0-5111-F
A23R30	0698-3151	7		RESISTOR 2.87K 1% .125W F TC = 0 + -100	24546	C4-1/8-T0-2871-F
A23R31	0698-3151	7		RESISTOR 2.87K 1% .125W F TC = 0 + -100	24546	C4-1/8-T0-2871-F
A23R32	0757-0442	9		RESISTOR 10K 1% .125W F TC = 0 + -100	24546	C4-1/8-T0-1002-F
A23R33	2100-2633	5	1	RESISTOR-TRMR 1K 10% C SIDE-ADJ 1-TRN	30983	ET50X102
A23R34	0757-0289	2		RESISTOR 13.3K 1% .125W F TC = 0 + -100	19701	MF4C1/8-T0-1332-F
A23R35	0757-0394	0		RESISTOR 51.1 1% .125W F TC = 0 + -100	24546	C4-1/8-T0-51R1-F
A23R36	0698-7212	9		RESISTOR 100 1% .05W F TC = 0 + -100	24546	C3-1/8-T0-100R-F
A23R37	0757-0394	0		RESISTOR 51.1 1% .125W F TC = 0 + -100	24546	C4-1/8-T0-51R1-F
A23R38	0757-0289	2		RESISTOR 13.3K 1% .125W F TC = 0 + -100	19701	MF4C1/8-T0-1332-F
A23R39	0757-0280	3		RESISTOR 1K 1% .125W F TC = 0 + -100	24546	C4-1/8-T0-1001-F
A23R40	0698-3162	0		RESISTOR 46.4K 1% .125W F TC = 0 + -100	24546	C4-1/8-T0-4642-F
A23R41	0757-1094	9		RESISTOR 1.47K 1% .125W F TC = 0 + -100	24546	C4-1/8-T0-1471-F
A23R42	0757-0401	0		RESISTOR 100 1% .125W F TC = 0 + -100	24546	C4-1/8-T0-101-F
A23R43	0757-0420	3		RESISTOR 750 1% .125W F TC = 0 + -100	24546	C4-1/8-T0-751-F
A23R44	0757-0394	0		RESISTOR 51.1 1% .125W F TC = 0 + -100	24546	C4-1/8-T0-51R1-F
A23R45	0757-0465	6		RESISTOR 100K 1% .125W F TC = 0 + -100	24546	C4-1/8-T0-1003-F
A23R46	0698-3260	9	3	RESISTOR 464K 1% .125W F TC = 0 + -100	28480	0698-3260
A23R47	0698-3260	9		RESISTOR 464K 1% .125W F TC = 0 + -100	28480	0698-3260
A23R48	0757-0274	5		RESISTOR 1.21K 1% .125W F TC = 0 + -100	24546	C4-1/8-T0-1211-F
A23R49	0698-3260	9		RESISTOR 464K 1% .125W F TC = 0 + -100	28480	0698-3260
A23R50	0757-0394	0		RESISTOR 51.1 1% .125W F TC = 0 + -100	24546	C4-1/8-T0-51R1-F
A23R51	0757-0274	5		RESISTOR 1.21K 1% .125W F TC = 0 + -100	24546	C4-1/8-T0-1211-F
A23R52	0757-0421	4		RESISTOR 825 1% .125W F TC = 0 + -100	24546	C4-1/8-T0-825R-F
A23R53	0757-0279	0		RESISTOR 3.16K 1% .125W F TC = 0 + -100	24546	C4-1/8-T0-3161-F
A23R54	2100-2521	0	1	RESISTOR-TRMR 2K 10% C SIDE-ADJ 1-TRN	30983	ET50X202
A23R55 <sup>Δ</sup>	0757-0278	9	49	RESISTOR 1.78K 1% .125W F TC = 0 + -100	28480	0757-0278
A23R56	0757-0442	9		RESISTOR 10K 1% .125W F TC = 0 + -100	24546	C4-1/8-T0-1002-F
A23R57	0757-0394	0		RESISTOR 51.1 1% .125W F TC = 0 + -100	24546	C4-1/8-T0-51R1-F
A23R58	0698-0082	7		RESISTOR 464 1% .125W F TC = 0 + -100	24546	C4-1/8-T0-4640-F
A23R59	0757-0379	1	1	RESISTOR 12.1 1% .125W F TC = 0 + -100	19701	MF4C1/8-T0-12R1-F
A23R60	0698-3441	8		RESISTOR 215 1% .125W F TC = 0 + -100	24546	C4-1/8-T0-215R-F
A23R61	0757-0416	7		RESISTOR 511 1% .125W F TC = 0 + -100	24546	C4-1/8-T0-511R-F
A23R62	0757-0416	7		RESISTOR 511 1% .125W F TC = 0 + -100	24546	C4-1/8-T0-511R-F
A23R63	0757-0280	3		RESISTOR 1K 1% .125W F TC = 0 + -100	24546	C4-1/8-T0-1001-F
A23T1	08901-80042	0	1	SAMPLER TRANS	28480	08901-80042
A23TP1	1251-0600	0		CONNECTOR-SGL CONT PIN 1.14-MM-BSC-SZ SQ	28480	1251-0600
A23U1	1826-0138	8	3	IC COMPARATOR GP QUAD 14-DIP-P PKG	01295	LM339N
A23U2	1826-0413	2		IC OP AMP LOW-BIAS-H-IMPDP T0-99 PKG	34371	HA2-2605-5
A23VR1	1902-0041	4		DIODE-ZNR 5.11V 5% DO-35 PD = .4W	28480	1902-0041
A23VR2	1902-0041	4		DIODE-ZNR 5.11V 5% DO-35 PD = .4W	28480	1902-0041
A23VR3	1902-0041	4		DIODE-ZNR 5.11V 5% DO-35 PD = .4W	28480	1902-0041
A23VR4	1902-0554	4	2	DIODE-ZNR 10V 5% PD = 1W IR = 10UA	28480	1902-0554
A23VR5	1902-0554	4		DIODE-ZNR 10V 5% PD = 1W IR = 10UA	28480	1902-0554
A23W1	8159-0005	0		RESISTOR-ZERO OHMS 22 AWG LEAD DIA	28480	8159-0005

†Refer to Section 7 for update information

\*Factory Selected Component (Refer to Section 5)

Δ Equates part change

Table 6-3. Replaceable Parts

Reference Designation	HP Part Number	C D	Qty.	Description	Mfr. Code	Mfr. Part Number
<b>A24</b>						
A24	08901-60021	3	1	HIGH FREQUENCY VCO ASSEMBLY	28480	08901-60021
A24C1	0160-0571	0		CAPACITOR-FXD 470PF + -20% 100VDC CER	28480	0160-0571
A24C2	0160-3877	5		CAPACITOR-FXD 100PF + -20% 200VDC CER	28480	0160-3877
A24C3	0160-0575	4	12	CAPACITOR-FXD .047UF + -20% 50VDC CER	28480	0160-0575
A24C4	0160-3878	6		CAPACITOR-FXD 1000PF + -20% 100VDC CER	28480	0160-3878
A24C5	0160-3878	6		CAPACITOR-FXD 1000PF + -20% 100VDC CER	28480	0160-3878
A24C6	0160-0575	4		CAPACITOR-FXD .047UF + -20% 50VDC CER	28480	0160-0575
A24C7	0180-1746	5		CAPACITOR-FXD 15UF + -10% 20VDC TA	56289	150D156X9020B2
A24C8	0180-1746	5		CAPACITOR-FXD 15UF + -10% 20VDC TA	56289	150D156X9020B2
A24C9	0160-0573	2	2	CAPACITOR-FXD 4700PF + -20% 100VDC CER	28480	0160-0573
A24C10	0160-3531	8		CAPACITOR-FXD 2UF + -5% 50VDC MET-POLYC	28480	0160-3531
A24C11	0180-0229	7		CAPACITOR-FXD 33UF + -10% 10VDC TA	56289	150D336X9010B2
A24C12 <sup>Δ</sup>	0160-5951	0	1	CAPACITOR-FXD 390PF + -5% 50VDC CER 0 + -30	28480	0160-5951
A24C13	0160-3879	7		CAPACITOR-FXD .01UF + -20% 100VDC CER	28480	0160-3879
	4330-0145	9	2	INSULATOR-BEAD GLASS	28480	4330-0145
A24C14	0160-5034	0	1	CAPACITOR-FXD 120PF + -2% 50VDC CER 0 + -30	95275	VJ0805A121GH
A24C15	0160-3878	6		CAPACITOR-FXD 1000PF + -20% 100VDC CER	28480	0160-3878
A24C16				NOT ASSIGNED		
A24C17	0160-4304	5	1	CAPACITOR-FXD 10PF + -10% 100VDC CER	51959	0805C100K3T
A24C18	0160-4103	2	1	CAPACITOR-FXD 220PF + -5% 100VDC CER	72982	8121-M100-COG-221J
A24C19	0160-3878	6		CAPACITOR-FXD 1000PF + -20% 100VDC CER	28480	0160-3878
A24C20	0160-3878	6		CAPACITOR-FXD 1000PF + -20% 100VDC CER	28480	0160-3878
A24C21	0160-3878	6		CAPACITOR-FXD 1000PF + -20% 100VDC CER	28480	0160-3878
A24C22	0160-3878	6		CAPACITOR-FXD 1000PF + -20% 100VDC CER	28480	0160-3878
A24C23	0160-3878	6		CAPACITOR-FXD 1000PF + -20% 100VDC CER	28480	0160-3878
A24C24	0160-3878	6		CAPACITOR-FXD 1000PF + -20% 100VDC CER	28480	0160-3878
A24C25	0160-3878	6		CAPACITOR-FXD 1000PF + -20% 100VDC CER	28480	0160-3878
A24C26	0160-3878	6		CAPACITOR-FXD 1000PF + -20% 100VDC CER	28480	0160-3878
A24C27	0160-3878	6		CAPACITOR-FXD 1000PF + -20% 100VDC CER	28480	0160-3878
A24C28	0160-3878	6		CAPACITOR-FXD 1000PF + -20% 100VDC CER	28480	0160-3878
A24C29	0160-3878	6		CAPACITOR-FXD 1000PF + -20% 100VDC CER	28480	0160-3878
A24C30				NOT ASSIGNED		
A24C31	0160-3876	4		CAPACITOR-FXD 47PF + -20% 200VDC CER	28480	0160-3876
A24C32	0160-3875	3		CAPACITOR-FXD 22PF + -5% 200VDC CER 0 + -30	28480	0160-3875
A24C33	0160-3876	4		CAPACITOR-FXD 47PF + -20% 200VDC CER	28480	0160-3876
A24C34	0160-3879	7		CAPACITOR-FXD .01UF + -20% 100VDC CER	28480	0160-3879
A24C35	0160-3879	7		CAPACITOR-FXD .01UF + -20% 100VDC CER	28480	0160-3879
A24C36	0160-3879	7		CAPACITOR-FXD .01UF + -20% 100VDC CER	28480	0160-3879
A24CR1	1901-0880	7		DIODE-GEN PRP 125MA D0-35	28480	1901-0880
A24CR2	1901-0880	7		DIODE-GEN PRP 125MA D0-35	28480	1901-0880

<sup>†</sup> Refer to Section 7 for update information.

<sup>\*</sup> Factory Selected Component (Refer to Section 5).

<sup>Δ</sup> Errata part change.

Table 6-3. Replaceable Parts

Reference Designation	HP Part Number	C D	Qty.	Description	Mfr. Code	Mfr. Part Number
<i>2306A TO 2411A</i>						
A24CR3	0122-0326	3	2	DIODE-VVC 43PF 5% C3/C25-MIN = 5 BVR = 30V	28480	0122-0326
A24CR4	0122-0326	3		DIODE-VVC 43PF 5% C3/C25-MIN = 5 BVR = 30V	28480	0122-0326
<i>2412A AND ABOVE</i>						
A24CR3 <sup>Δ</sup>	0122-0173	8		DIODE VVC 29PF 7% BVR = 30V	28480	0122-0173
A24CR4 <sup>Δ</sup>	0122-0173	8		DIODE VVC 29PF 7% BVR = 30V	28480	0122-0173
A24CR5	1901-0880	7		DIODE-GEN PRP 125MA D0-3528480 1901-0880		
A24CR6	1901-0880	7		DIODE-GEN PRP 125MA D0-35	28480	1901-0880
<i>2305A TO 2411A</i>						
A24E1-E4				NOT ASSIGNED		
<i>2412A AND ABOVE</i>						
A24E1	4330-0145	9		INSULATOR-BEAD GLASS	28480	4330-0145
A24E2	4330-0145	9		INSULATOR-BEAD GLASS	28480	4330-0145
A24E3	4330-0145	9		INSULATOR-BEAD GLASS	28480	4330-0145
A24E4	4330-0145	9		INSULATOR-BEAD GLASS	28480	4330-0145
A24J1	1250-1205	1		CONNECTOR-RF SMC M SGL-HOLE-RR 50-OHM	28480	1250-1205
	2190-0124	4		WASHER-LK INTL T NO. 10 .195-IN-ID	28480	2190-0124
	2950-0078	9		NUT-HEX-DBL-CHAM 10-32-THD .067-IN-THK	28480	2950-0078
A24J2	1250-1205	1		CONNECTOR-RF SMC M SGL-HOLE-RR 50-OHM	28480	1250-1205
	2190-0124	4		WASHER-LK INTL T NO. 10 .195-IN-ID	28480	2190-0124
	2950-0078	9		NUT-HEX-DBL-CHAM 10-32-THD .067-IN-THK	28480	2950-0078
A24L1	9100-3922	4		INDUCTOR-FIXED 120-1300 HZ	28480	9100-3922
A24L2	9100-3922	4		INDUCTOR-FIXED 120-1300 HZ	28480	9100-3922
A24L3	9100-3922	4		INDUCTOR-FIXED 120-1300 HZ	28480	9100-3922
A24L4	9100-3922	4		INDUCTOR-FIXED 120-1300 HZ	28480	9100-3922
A24L5	9100-3922	4		INDUCTOR-FIXED 120-1300 HZ	28480	9100-3922
A24L6	9100-2251	0	2	INDUCTOR RF-CH-MLD 220NH 10% .105DX.26LG	28480	9100-2251
A24L7	08901-00068	2	1	INDUCTOR	28480	08901-00068
A24L8	9100-2251	0		INDUCTOR RF-CH-MLD 220NH 10% .105DX.26LG	28480	9100-2251
A24L9				PART OF ETCHED CIRCUIT BOARD		
A24L10				PART OF ETCHED CIRCUIT BOARD		
A24MP1	08901-00023	9	1	COVER HF VCO	28480	08901-00023
A24MP2	5001-0176	0		GROUND STRAP	28480	5001-0176
A24MP3	5001-0176	0		GROUND STRAP	28480	5001-0176
A24MP4	08662-00040	0		SHLD COMP SMALL	28480	08662-00040
A24MP5	08662-00038	6		SHIELD CKT SM	28480	08662-00038
A24MP6	08901-00043	3	1	GASKT-HF VCO	28480	08901-00043
A24Q1	1854-0247	9		TRANSISTOR NPN SI TO-39 PD = 1W FT = 800MHZ	28480	1854-0247
	0340-0834	0	1	INSULATOR-XSTR POLYI	28480	0340-0834
A24Q2	1855-0020	8		TRANSISTOR J-FET N-CHAN D-MODE TO-18 SI	28480	1855-0020
A24Q3	1855-0020	8		TRANSISTOR J-FET N-CHAN D-MODE TO-18 SI	28480	1855-0020
A24Q4	1853-0007	7		TRANSISTOR PNP 2N3251 SI TO-18 PD = 360MW	04713	2N3251
A24Q5	1853-0007	7		TRANSISTOR PNP 2N3251 SI TO-18 PD = 360MW	04713	2N3251
A24Q6	1854-0404	0		TRANSISTOR NPN SI TO-18 PD = 360MW	28480	1854-0404
A24Q7	1854-0404	0		TRANSISTOR NPN SI TO-18 PD = 360MW	28480	1854-0404

† Refer to Section 7 for update information.

\* Factory Selected Component (Refer to Section 5).

Δ Errata part change



Table 6-3. Replaceable Parts

Reference Designation	HP Part Number	C D	Qty.	Description	Mfr. Code	Mfr. Part Number
A24Q8	1853-0007	7		TRANSISTOR PNP 2N3251 SI TO-18 PD = 360MW	04713	2N3251
A24R1	0698-7236	7		RESISTOR 1K 1% .05W F TC = 0 + -100	24546	C3-1/8-T0-1001-F
A24R2	0757-0280	3		RESISTOR 1K 1% .125W F TC = 0 + -100	24546	C4-1/8-T0-1001-F
A24R3	0698-3449	6	2	RESISTOR 28.7K 1% .125W F TC = 0 + -100	24546	C4-1/8-T0-2872-F
A24R4	0757-0199	3		RESISTOR 21.5K 1% .125W F TC = 0 + -100	24546	C4-1/8-T0-2152-F
A24R5	0757-0416	7		RESISTOR 511 1% .125W F TC = 0 + -100	24546	C4-1/8-T0-511R-F
A24R6	0757-0274	5		RESISTOR 1.21K 1% .125W F TC = 0 + -100	24546	C4-1/8-T0-1211-F
A24R7	0698-3157	3		RESISTOR 19.6K 1% .125W F TC = 0 + -100	24546	C4-1/8-T0-1962-F
A24R8	0757-0402	1		RESISTOR 110 1% .125W F TC = 0 + -100	24546	C4-1/8-T0-111-F
A24R9	0757-0442	9		RESISTOR 10K 1% .125W F TC = 0 + -100	24546	C4-1/8-T0-1002-F
A24R10	0698-3155	1		RESISTOR 4.64K 1% .125W F TC = 0 + -100	24546	C4-1/8-T0-4641-F
A24R11	0698-3151	7		RESISTOR 2.87K 1% .125W F TC = 0 + -100	24546	C4-1/8-T0-2871-F
A24R12	0757-0401	0		RESISTOR 100 1% .125W F TC = 0 + -100	24546	C4-1/8-T0-101-F
A24R13	0757-0401	0		RESISTOR 100 1% .125W F TC = 0 + -100	24546	C4-1/8-T0-101-F
A24R14	0757-0405	4		RESISTOR 162 1% .125W F TC = 0 + -100	24546	C4-1/8-T0-162R-F
A24R15	0698-8827	4		RESISTOR 1M 1% .125W F TC = 0 + -100	28480	0698-8827
A24R16				NOT ASSIGNED		
A24R17	0698-0083	8		RESISTOR 1.96K 1% .125W F TC = 0 + -100	24546	C4-1/8-T0-1961-F
A24R18	0698-0083	8		RESISTOR 1.96K 1% .125W F TC = 0 + -100	24546	C4-1/8-T0-1961-F
A24R19	0698-3405	4	1	RESISTOR 422 1% .5W F TC = 0 + -100	28480	0698-3405
A24R20	0698-7195	7		RESISTOR 19.6 1% .05W F TC = 0 + -100	24546	C3-1/8-T0-19R6-F
A24R21	0757-0402	1		RESISTOR 110 1% .125W F TC = 0 + -100	24546	C4-1/8-T0-111-F
A24R22	0757-0402	1		RESISTOR 110 1% .125W F TC = 0 + -100	24546	C4-1/8-T0-111-F
A24R23	0698-7219	6		RESISTOR 196 1% .05W F TC = 0 + -100	24546	C3-1/8-T0-196R-F
A24R24	0698-7206	1	1	RESISTOR 56.2 1% .05W F TC = 0 + -100	24546	C3-1/8-T0-56R2-F
A24R25	0698-7222	1	1	RESISTOR 261 1% .05W F TC = 0 + -100	24546	C3-1/8-T0-261R-F
A24R26	0698-8827	4		RESISTOR 1M 1% .125W F TC = 0 + -100	28480	0698-8827
A24R27	0698-7199	1	1	RESISTOR 28.7 1% .05W F TC = 0 + -100	24546	C3-1/8-T0-28R7-F
A24TP1	1251-0600	0		CONNECTOR-SGL CONT PIN 1.14-MM-BSC-SZ SQ	28480	1251-0600
A24TP2	1251-0600	0		CONNECTOR-SGL CONT PIN 1.14-MM-BSC-SZ SQ	28480	1251-0600
A24TP3	1251-0600	0		CONNECTOR-SGL CONT PIN 1.14-MM-BSC-SZ SQ	28480	1251-0600
A24U1	1826-0372	2		IC MISC 8-DIP-P PKG	28480	1826-0372
A24U2	1826-0372	2		IC MISC 8-DIP-P PKG	28480	1826-0372
A24U3	1826-0785	1		IC OP AMP LOW-BIAS-H-IMPED DUAL 8-DIP-C	01295	TL072ACJG

† Refer to Section 7 for update information

\* Factory Selected Component (Refer to Section 5)

Δ Errata part change

Table 6-3. Replaceable Parts

Reference Designation	HP Part Number	C D	Qty.	Description	Mfr. Code	Mfr. Part Number
<b>A25</b>						
2503A TO 2530A A25	08901-60137	2	1	AUDIO MOTHER BOARD ASSEMBLY	28480	08901-60137
2536A TO 2621A A25	08902-60103	3	1	AUDIO MOTHER BOARD ASSEMBLY	28480	08902-60103
2631A AND ABOVE A25	08902-60116	8	1	AUDIO MOTHERBOARD ASSEMBLY	28480	08902-60103
A25C1	0160-2055	9		CAPACITOR-FXD .01UF +80-20% 100VDC CER	28480	0160-2055
A25C2	0160-3466	8	1	CAPACITOR-FXD 100PF + -10% 1KVDC CER	28480	0160-3466
A25J1	1250-0836	2	1	CONNECTOR-RF SMC M PC 50-OHM	28480	1250-0836
A25J2	1251-8417	2	4	CONN-POST TYPE .100-PIN-SPCG 16-CONT	28480	1251-8417
A25J3	1251-8417	2		CONN-POST TYPE .100-PIN-SPCG 16-CONT	28480	1251-8417
A25J4	1251-5169	6		CONNECTOR 6-PIN M POST TYPE	28480	1251-5169
A25J5	1251-5643	1	1	CONNECTOR 4-PIN M POST TYPE	28480	1251-5643
A25R1	0698-3443	0		RESISTOR 287 1% .125W F TC = 0 + -100	24546	C4-1/8-T0-287R-F
A25R2	0757-0280	3		RESISTOR 1K 1% .125W F TC = 0 + -100	24546	C4-1/8-T0-1001-F
A25XA1				NOT ASSIGNED		
A25XA2	1251-2035	9	8	CONNECTOR-PC EDGE 15-CONT/ROW 2-ROWS	28480	1251-2035
A25XA3	1251-2035	9		CONNECTOR-PC EDGE 15-CONT/ROW 2-ROWS	28480	1251-2035
A25XA4	1251-2035	9		CONNECTOR-PC EDGE 15-CONT/ROW 2-ROWS	28480	1251-2035
A25XA5	1251-1365	6	6	CONNECTOR-PC EDGE 22-CONT/ROW 2-ROWS	28480	1251-1365
A25XA6	1251-2035	9		CONNECTOR-PC EDGE 15-CONT/ROW 2-ROWS	28480	1251-2035
A25XA7	1251-2035	9		CONNECTOR-PC EDGE 15-CONT/ROW 2-ROWS	28480	1251-2035
A25XA8	1251-2035	9		CONNECTOR-PC EDGE 15-CONT/ROW 2-ROWS	28480	1251-2035
A25XA9-XA49				NOT ASSIGNED		
A25XA50	1251-1365	6		CONNECTOR-PC EDGE 22-CONT/ROW 2-ROWS	28480	1251-1365
A25XA51	1251-1365	6		CONNECTOR-PC EDGE 22-CONT/ROW 2-ROWS	28480	1251-1365
A25XA52	1251-1365	6		CONNECTOR-PC EDGE 22-CONT/ROW 2-ROWS	28480	1251-1365
A25XA53	1251-1365	6		CONNECTOR-PC EDGE 22-CONT/ROW 2-ROWS	28480	1251-1365

ⓘ Refer to Section 7 for update information

\* Factory Selected Component (Refer to Section 5)

Δ Errata part change

Table 6-3. Replaceable Parts

Reference Designation	HP Part Number	C D	Qty.	Description	Mfr. Code	Mfr. Part Number
<b>A26</b>						
A26	08901-60142	9	1	POWER SUPPLY MOTHER BOARD ASSEMBLY	28480	08901-60142
A26C1	0160-0889	3	1	CAPACITOR-FXD .33UF + -10% 80VDC POLYE	28480	0160-0889
A26C2	0160-0168	1	1	CAPACITOR-FXD .1UF + -10% 200VDC POLYE	28480	0160-0168
A26C3	0180-3017	7	1	CAPACITOR-FXD .045F + 75-10% 25VDC AL	28480	0180-3017
	2190-0034	5	10	WASHER-LK HLCL NO. 10 .194-IN-ID	28480	2190-0034
	2680-0099	1	8	SCREW-MACH 10-32 .375-IN-LG PAN-HD-POZI	00000	ORDER BY DESCRIPTION
A26C4	0180-0480	2	1	CAPACITOR-FXD 4500UF + 75-10% 25VDC AL	00853	500452U025AA2A
	2190-0034	5		WASHER-LK HLCL NO. 10 .194-IN-ID	28480	2190-0034
	2680-0099	1		SCREW-MACH 10-32 .375-IN-LG PAN-HD-POZI	00000	ORDER BY DESCRIPTION
A26C5	0160-4065	5	2	CAPACITOR-FXD .1UF + -20% 250VAC(RMS)	28480	0160-4065
A26C6	0180-3110	1	1	CAPACITOR-FXD .013F + 75-10% 40VDC AL	28480	0180-3110
	2190-0034	5		WASHER-LK HLCL NO. 10 .194-IN-ID	28480	2190-0034
	2680-0099	1		SCREW-MACH 10-32 .375-IN-LG PAN-HD-POZI	00000	ORDER BY DESCRIPTION
A26C7	0180-0677	9	1	CAPACITOR-FXD 5800UF + 75-10% 40VDC AL	28480	0180-0677
	2190-0034	5		WASHER-LK HLCL NO. 10 .194-IN-ID	28480	2190-0034
	2680-0099	1		SCREW-MACH 10-32 .375-IN-LG PAN-HD-POZI	00000	ORDER BY DESCRIPTION
A26C8	0180-1797	6	1	CAPACITOR-FXD 50UF + 50-10% 150VDC AL	56289	39D506F150FJ4
A26C9	0180-2207	5	1	CAPACITOR-FXD 100UF + -10% 10VDC TA	56289	150D107X9010R2
A26C10	0160-3968	5		CAPACITOR-FXD .47UF + -10% 250VAC (RMS)	28480	0160-3968
A26CR1	1901-0662	3	6	DIODE-PWR RECT 100V 6A	04713	MR751
A26CR2	1901-0662	3		DIODE-PWR RECT 100V 6A	04713	MR751
A26CR3	1901-1098	1		DIODE-SWITCHING 1N4150 50V 200MA 4NS	9N171	1N4150
A26CR4	1901-0662	3		DIODE-PWR RECT 100V 6A	04713	MR751
A26CR5	1901-0662	3		DIODE-PWR RECT 100V 6A	04713	MR751
A26CR6	1901-0662	3		DIODE-PWR RECT 100V 6A	04713	MR751
A26CR7	1901-0662	3		DIODE-PWR RECT 100V 6A	04713	MR751
A26CR8	1901-0028	5		DIODE-PWR RECT 400V 750MA DO-29	28480	1901-0028
A26F1	2110-0331	7	1	FUSE .3A 250V .25X.27	28480	2110-0331
	1251-8305	8	4	CABLE CLAMP-RECT CONN	28480	1251-8305
	1251-8308	1		CONNECTOR-SGL CONN SKT .054-IN-BSC-SZ	28480	1251-8308
A26J1	1251-3412	8	1	CONNECTOR 6-PIN M POST TYPE	28480	1251-3412
A26J2	1252-1762	9		CONNECTOR 6-PIN HDR POST TYPE	28480	1252-1762
A26J3	1252-1762	9		CONNECTOR 6-PIN HDR POST TYPE	28480	1252-1762
A26J4				NOT ASSIGNED		
A26J5	1251-5636	2	1	CONNECTOR 11-PIN M POST TYPE	28480	1251-5636
A26J6	1251-8041	9	1	CONN-POST TYPE .156-PIN-SPCG 8-CONT	28480	1251-8041
A26K1	0490-0618	5	1	RELAY 2C 24VDC-COIL 5A 115VAC	28480	0490-0618
A26MP1	08901-20049	1	1	SHIELD/HI VOLTAGE	28480	08901-20049
	0361-0207	5	1	RIVET-BLIND DR-PIN RNDH .125DIA	00000	ORDER BY DESCRIPTION
	2190-0008	3		WASHER-LK EXT T NO. 6 .141-IN-ID	28480	2190-0008
	2360-0119	8	1	SCREW-MACH 6-32 .438-IN-LG PAN-HD-POZI	00000	ORDER BY DESCRIPTION
	3050-0003	3	2	WASHER-FL NM NO. 6 .141-IN-ID .375-IN-OD	28480	3050-0003
	3050-0227	3	2	WASHER-FL MTLN NO. 6 .149-IN-ID	28480	3050-0227
	7120-4163	7	1	LABEL-WARNING .5-IN-WD 1-IN-LG AL	28480	7120-4163

† Refer to Section 7 for update information

\* Factory Selected Component (Refer to Section 5)

Δ Errata part change

Table 6-3. Replaceable Parts

Reference Designation	HP Part Number	C D	Qty.	Description	Mfr. Code	Mfr. Part Number
A26Q1	1884-0276	7	1	THYRISTOR-TRIAC TO-220AB	28480	1884-0276
	2190-0004	9		WASHER-LK INT LT NO.4 .115-IN-ID	00000	ORDER BY DESCRIPTION
	2200-0141	8		SCREW-MACH 4-40 .312-IN-LG PAN-HD-POZI	00000	ORDER BY DESCRIPTION
A26R1	0757-0401	0		RESISTOR 100 1% .125W F TC = 0+ -100	24546	C4-1/8-T0-101-F
A26R2	0757-0280	3		RESISTOR 1K 1% .125W F TC = 0+ -100	24546	C4-1/8-T0-1001-F
A26R3	0757-0280	3		RESISTOR 1K 1% .125W F TC = 0+ -100	24546	C4-1/8-T0-1001-F
A26R4	0698-0085	0		RESISTOR 2.61K 1% .125W F TC = 0+ -100	24546	C4-1/8-T0-2611-F
A26R5	0698-0085	0		RESISTOR 2.61K 1% .125W F TC = 0+ -100	24546	C4-1/8-T0-2611-F
A26R6	0757-0465	6		RESISTOR 100K 1% .125W F TC = 0+ -100	24546	C4-1/8-T0-1003-F
A26VR1	1902-3381	1	2	DIODE-ZNR 68.1V 5% DO-7 PD = .4W TC = +.079%	28480	1902-3381
A26VR2	1902-3381	1		DIODE-ZNR 68.1V 5% DO-7 PD = .4W TC = +.079%	28480	1902-3381
A26XA1-XA9				NOT ASSIGNED		
A26XA10	1251-1365	6		CONNECTOR-PC EDGE 22-CONT/ROW 2-ROWS	28480	1251-1365

† Refer to Section 7 for update information.

\* Factory Selected Component (Refer to Section 5).

Δ Errata part change.

Table 6-3. Replaceable Parts

Reference Designation	HP Part Number	C D	Qty.	Description	Mfr. Code	Mfr. Part Number
<b>A27 08901-60140 – SERIAL PREFIX 2305A TO 2530A</b>						
A27	08901-60140	7	1	DIGITAL MOTHER BOARD ASSEMBLY	28480	08901-60140
A27C1	0160-4801	7	28	CAPACITOR-FXD 100PF +-5PF 100VDC CER	28480	0160-4801
A27C2	0160-4801	7		CAPACITOR-FXD 100PF +-5PF 100VDC CER	28480	0160-4801
A27C3	0160-4801	7		CAPACITOR-FXD 100PF +-5PF 100VDC CER	28480	0160-4801
A27C4	0160-4801	7		CAPACITOR-FXD 100PF +-5PF 100VDC CER	28480	0160-4801
A27C5	0160-4801	7		CAPACITOR-FXD 100PF +-5PF 100VDC CER	28480	0160-4801
A27C6	0160-4801	7		CAPACITOR-FXD 100PF +-5PF 100VDC CER	28480	0160-4801
A27C7	0160-4801	7		CAPACITOR-FXD 100PF +-5PF 100VDC CER	28480	0160-4801
A27C8	0160-4801	7		CAPACITOR-FXD 100PF +-5PF 100VDC CER	28480	0160-4801
A27C9	0160-4801	7		CAPACITOR-FXD 100PF +-5PF 100VDC CER	28480	0160-4801
A27C10	0160-4801	7		CAPACITOR-FXD 100PF +-5PF 100VDC CER	28480	0160-4801
A27C11	0160-4801	7		CAPACITOR-FXD 100PF +-5PF 100VDC CER	28480	0160-4801
A27C12	0160-4801	7		CAPACITOR-FXD 100PF +-5PF 100VDC CER	28480	0160-4801
A27C13	0160-4801	7		CAPACITOR-FXD 100PF +-5PF 100VDC CER	28480	0160-4801
A27C14	0160-4801	7		CAPACITOR-FXD 100PF +-5PF 100VDC CER	28480	0160-4801
A27C15	0160-4801	7		CAPACITOR-FXD 100PF +-5PF 100VDC CER	28480	0160-4801
A27C16	0160-4801	7		CAPACITOR-FXD 100PF +-5PF 100VDC CER	28480	0160-4801
A27C17	0160-4801	7		CAPACITOR-FXD 100PF +-5PF 100VDC CER	28480	0160-4801
2314A TO 2628A						
A27C18	0160-4389	6		CAPACITOR-FXD 100PR +-5PF 200VDC CER	28480	0160-4389
2635A AND ABOVE						
A27C18				NOT ASSIGNED		
A27C19	0160-4801	7		CAPACITOR-FXD 100PF +-5PF 100VDC CER	28480	0160-4801
A27C20	0160-4801	7		CAPACITOR-FXD 100PF +-5PF 100VDC CER	28480	0160-4801
A27C21				NOT ASSIGNED		
A27C22				NOT ASSIGNED		
A27C23				NOT ASSIGNED		
A27C24				NOT ASSIGNED		
A27J1	1251-7998	3	2	CONN POST HDR 16	28480	1251-7998
A27J2	1251-7998	3		CONN POST HDR 16	28480	1251-7998
A27J3	1200-0507	9		SOCKET-IC 16-CONT DIP-SLDR	28480	1200-0507
	1251-4460	8		CLIP-CABLE PLUG RTNG-DUAL INLINE 16 CONT	28480	1251-4460
A27J4	1252-1762	9		CONNECTOR 6-PIN HDR POST TYPE	28480	1252-1792
A27XA1-XA10				NOT ASSIGNED		
A27XA11A	1251-1365	6	5	CONNECTOR-PC EDGE 22-CONT/ROW 2-ROWS	28480	1251-1365
A27XA12A	1251-1365	6		CONNECTOR-PC EDGE 22-CONT/ROW 2-ROWS	28480	1251-1365
A27XA12B	1251-2035	9	3	CONNECTOR-PC EDGE 15-CONT/ROW 2-ROWS	28480	1251-2035
A27XA13A	1251-1365	6		CONNECTOR-PC EDGE 22-CONT/ROW 2-ROWS	28480	1251-1365
A27XA13B	1251-2035	9		CONNECTOR-PC EDGE 15-CONT/ROW 2-ROWS	28480	1251-2035
A27XA14A	1251-1365	6		CONNECTOR-PC EDGE 22-CONT/ROW 2-ROWS	28480	1251-1365
A27XA14B	1251-2035	9		CONNECTOR-PC EDGE 15-CONT/ROW 2-ROWS	28480	1251-2035

† Refer to Section 7 for update information

\* Factory Selected Component (Refer to Section 5)

Δ Errata part change

Table 6-3. Replaceable Parts

Reference Designation	HP Part Number	C D	Qty.	Description	Mfr. Code	Mfr. Part Number
<b>A27</b>	<b>08902-60102 – SERIAL PREFIX 2535A AND ABOVE</b>					
A27	08902-60102	2	1	DIGITAL MOTHER BOARD ASSEMBLY	28480	08902-60102
A27C1	0160-4801	7	28	CAPACITOR-FXD 100PF +.5PF 100VDC CER	28480	0160-4801
A27C2	0160-4801	7		CAPACITOR-FXD 100PF +.5PF 100VDC CER	28480	0160-4801
A27C3	0160-4801	7		CAPACITOR-FXD 100PF +.5PF 100VDC CER	28480	0160-4801
A27C4	0160-4801	7		CAPACITOR-FXD 100PF +.5PF 100VDC CER	28480	0160-4801
A27C5	0160-4801	7		CAPACITOR-FXD 100PF +.5PF 100VDC CER	28480	0160-4801
A27C6	0160-4801	7		CAPACITOR-FXD 100PF +.5PF 100VDC CER	28480	0160-4801
A27C7	0160-4801	7		CAPACITOR-FXD 100PF +.5PF 100VDC CER	28480	0160-4801
A27C8	0160-4801	7		CAPACITOR-FXD 100PF +.5PF 100VDC CER	28480	0160-4801
2305A TO 2626A A27C9 2627A AND ABOVE A27C9	0160-4801	7		CAPACITOR-FXD 100PF +.5PF 100VDC CER  NOT ASSIGNED	28480	0160-4801
A27C10	0160-4801	7		CAPACITOR-FXD 100PF +.5PF 100VDC CER	28480	0160-4801
A27C11	0160-4801	7		CAPACITOR-FXD 100PF +.5PF 100VDC CER	28480	0160-4801
A27C12	0160-4801	7		CAPACITOR-FXD 100PF +.5PF 100VDC CER	28480	0160-4801
A27C13	0160-4801	7		CAPACITOR-FXD 100PF +.5PF 100VDC CER	28480	0160-4801
A27C14	0160-4801	7		CAPACITOR-FXD 100PF +.5PF 100VDC CER	28480	0160-4801
A27C15	0160-4801	7		CAPACITOR-FXD 100PF +.5PF 100VDC CER	28480	0160-4801
A27C16	0160-4801	7		CAPACITOR-FXD 100PF +.5PF 100VDC CER	28480	0160-4801
A27C17	0160-4801	7		CAPACITOR-FXD 100PF +.5PF 100VDC CER	28480	0160-4801
A27C18	0160-4801	7		CAPACITOR-FXD 100PF +.5PF 100VDC CER	28480	0160-4801
A27C19	0160-4801	7		CAPACITOR-FXD 100PF +.5PF 100VDC CER	28480	0160-4801
A27C20	0160-4801	7		CAPACITOR-FXD 100PF +.5PF 100VDC CER	28480	0160-4801
A27J1	1251-8417	3	2	CONN POST HDR 16	28480	1251-8417
A27J2	1251-8417	3		CONN POST HDR 16	28480	1251-8417
A27J3	1200-0507	9		SOCKET-IC 16-CONT DIP-SLDR	28480	1200-0507
	1251-4460	8		CLIP-CABLE PLUG RTNG-DUAL INLINE 16 CONT	28480	1251-4460
A27J4	1252-1762	9		CONNECTOR 6-PIN HDR POST TYPE	28480	1252-1762
A27XA1-XA10				NOT ASSIGNED		
A27XA11A	1251-1365	6	5	CONNECTOR-PC EDGE 22-CONT/ROW 2-ROWS	28480	1251-1365
A27XA12A	1251-2035	9	3	CONNECTOR-PC EDGE 15-CONT/ROW 2-ROWS	28480	1251-2035
A27XA12B	1251-2035	9	3	CONNECTOR-PC EDGE 15-CONT/ROW 2-ROWS	28480	1251-2035
A27XA13A	1251-1365	6		CONNECTOR-PC EDGE 22-CONT/ROW 2-ROWS	28480	1251-1365
A27XA13B	1251-2035	9		CONNECTOR-PC EDGE 15-CONT/ROW 2-ROWS	28480	1251-2035
A27XA14A	1251-1365	6		CONNECTOR-PC EDGE 22-CONT/ROW 2-ROWS	28480	1251-1365
A27XA14B	1251-2035	9		CONNECTOR-PC EDGE 15-CONT/ROW 2-ROWS	28480	1251-2035

† Refer to Section 7 for update information

\* Factory Selected Component (Refer to Section 5).

Δ Errata part change

Table 6-3. Replaceable Parts

Reference Designation	HP Part Number	C D	Qty.	Description	Mfr. Code	Mfr. Part Number
<b>A28</b>						
A28	08902-60007	6	1	RF MOTHERBOARD ASSEMBLY	28480	08902-60007
A28C1	0160-0576	5		CAPACITOR-FXD .1UF + -20% 50VDC CER	28480	0160-0576
A28C2	0160-0576	5		CAPACITOR-FXD .1UF + -20% 50VDC CER	28480	0160-0576
A28C3	0160-0576	5		CAPACITOR-FXD .1UF + -20% 50VDC CER	28480	0160-0576
A28C4	0160-0576	5		CAPACITOR-FXD .1UF + -20% 50VDC CER	28480	0160-0576
A28C5	0160-0576	5		CAPACITOR-FXD .1UF + -20% 50VDC CER	28480	0160-0576
A28C6	0160-0576	5		CAPACITOR-FXD .1UF + -20% 50VDC CER	28480	0160-0576
A28C7	0160-0576	5		CAPACITOR-FXD .1UF + -20% 50VDC CER	28480	0160-0576
A28J1	1251-4966	9	1	CONNECTOR 8-PIN M POST TYPE	28480	1251-4966
A28J2	1251-8417	2		CONN-POST TYPE .100-PIN-SPCG 16-CONT	28480	1251-8417
A28J3	1251-8417	2		CONN-POST TYPE .100-PIN-SPCG 16-CONT	28480	1251-8417
A28L1	9100-3922	4		INDUCTOR-FIXED 120-1300 HZ	28480	9100-3922
A28L2	9100-3922	4		INDUCTOR-FIXED 120-1300 HZ	28480	9100-3922
A28L3	9100-3922	4		INDUCTOR-FIXED 120-1300 HZ	28480	9100-3922
A28L4	9100-3922	4		INDUCTOR-FIXED 120-1300 HZ	28480	9100-3922
A28L5	9100-3922	4		INDUCTOR-FIXED 120-1300 HZ	28480	9100-3922
A28L6	9100-3922	4		INDUCTOR-FIXED 120-1300 HZ	28480	9100-3922
A28L7	9100-3922	4		INDUCTOR-FIXED 120-1300 HZ	28480	9100-3922
A28XA1-XA14				NOT ASSIGNED		
A28XA15	1251-2035	9		CONNECTOR-PC EDGE 15-CONT/ROW 2-ROWS	28480	1251-2035
A28XA16	1251-0472	4	7	CONNECTOR-PC EDGE 6-CONT/ROW 2-ROWS	28480	1251-0472
A28XA17	1251-0472	4		CONNECTOR-PC EDGE 6-CONT/ROW 2-ROWS	28480	1251-0472
A28XA18	1251-0472	4		CONNECTOR-PC EDGE 6-CONT/ROW 2-ROWS	28480	1251-0472
A28XA19	1251-2035	9		CONNECTOR-PC EDGE 15-CONT/ROW 2-ROWS	28480	1251-2035
A28XA20	1251-1365	6		CONNECTOR-PC EDGE 22-CONT/ROW 2-ROWS	28480	1251-1365
A28XA21	1251-0472	4		CONNECTOR-PC EDGE 6-CONT/ROW 2-ROWS	28480	1251-0472
A28XA22	1251-0472	4		CONNECTOR-PC EDGE 6-CONT/ROW 2-ROWS	28480	1251-0472
A28XA23	1251-0472	4		CONNECTOR-PC EDGE 6-CONT/ROW 2-ROWS	28480	1251-0472
A28XA24	1251-0472	4		CONNECTOR-PC EDGE 6-CONT/ROW 2-ROWS	28480	1251-0472

†Refer to Section 7 for update information

\*Factory Selected Component (Refer to Section 5)

Δ Errata part change

Table 6-3. Replaceable Parts

Reference Designation	HP Part Number	C D	Qty.	Description	Mfr. Code	Mfr. Part Number
<b>A29</b>						
A29	08901-60181	6	1	SERIES REGULATOR HEAT SINK ASSEMBLY	28480	08901-60181
A29MP1	1400-0017	0	1	CLAMP-CABLE .312-DIA .375-WD NYL	28480	1400-0017
	2190-0006	1	1	WASHER-LK HLCL NO. 6 .141-IN-ID	28480	2190-0006
	2360-0127	8	1	SCREW-MACH 6-32 .875-IN-LG PAN-HD-POZI	00000	ORDER BY DESCRIPTION
	2420-0002	6	1	NUT-HEX-DBL-CHAM 6-32-THD .109-IN-THK	28480	2420-0002
	3050-0227	3		WASHER-FL MTLCL NO. 6 .149-IN-ID	28480	3050-0227
A29MP2	08901-20218	6	1	HEATSINK	28480	08901-20218
	2200-0107	6	4	SCREW-MACH 4-40 .375-IN-LG PAN-HD-POZI	00000	ORDER BY DESCRIPTION
A29Q1	1853-0344	5	1	TRANSISTOR PNP 2N5876 SI TO-3 PD = 150W	04713	2N5876
	0340-1119	6	4	INSULATOR-COVER NYLON	28480	0340-1119
	2360-0125	6	4	SCREW-MACH 6-32 .750-IN-LG PAN-HD-POZI	00000	ORDER BY DESCRIPTION
	5001-5501	5	4	TRANS SPACER TO3	28480	5001-5501
A29Q2	1853-0411	7	1	TRANSISTOR PNP 2N6050 SI DARL TO-3	28480	1853-0411
	0340-1119	6		INSULATOR-COVER NYLON	28480	0340-1119
	2360-0125	6		SCREW-MACH 6-32 .750-IN-LG PAN-HD-POZI	00000	ORDER BY DESCRIPTION
	5001-5501	5		TRANS SPACER TO3	28480	5001-5501
A29Q3	1854-0669	9	1	TRANSISTOR NPN 2N6057 SI TO-3 PD = 150W	04713	2N6057
	0340-1119	6		INSULATOR-COVER NYLON	28480	0340-1119
	2360-0125	6		SCREW-MACH 6-32 .750-IN-LG PAN-HD-POZI	00000	ORDER BY DESCRIPTION
	5001-5501	5		TRANS SPACER TO3	28480	5001-5501
A29Q4	1854-0743	0	1	TRANSISTOR NPN 2N5878 SI TO-3 PD = 150W	01295	2N5878
	0340-1119	6		INSULATOR-COVER NYLON	28480	0340-1119
	2360-0125	6		SCREW-MACH 6-32 .750-IN-LG PAN-HD-POZI	00000	ORDER BY DESCRIPTION
	5001-5501	5		TRANS SPACER TO3	28480	5001-5501
A29W1	08901-60233	9	1	HEATSINK CABLE 01B	28480	08901-60233

†Refer to Section 7 for update information.

\*Factory Selected Component (Refer to Section 5).

△ Errata part change.



*Table 6-3. Replaceable Parts*

Reference Designation	HP Part Number	C D	Qty.	Description	Mfr. Code	Mfr. Part Number
<b>A30</b>						
A30	0960-0443	1	1	LINE MODULE-FILTERED	28480	0960-0443
A30C1	0160-4065	5		CAPACITOR-FXD .1UF + -20% 250VAC(RMS)	28480	0160-4065
A30TB1	5020-8122	2		LINE VOLTAGE SELECTOR CARD	28480	5020-8122

†Refer to Section 7 for update information.

\*Factory Selected Component (Refer to Section 5)

Δ Errata part change.

*Table 6-3. Replaceable Parts*

Reference Designation	HP Part Number	C D	Qty.	Description	Mfr. Code	Mfr. Part Number
<b>A31</b>						
A31	08901-60242	0	1	REMOTE INTERFACE CONNECTOR ASSEMBLY	28480	08901-60242
A31J1	1251-3283	1	1	CONNECTOR 24-PIN F MICRORIBBON	28480	1251-3283
A31J2	1251-5240	4	1	CONNECTOR 20-PIN M POST TYPE	28480	1251-5240
A31MP1	0380-0644	4	2	STANDOFF-HEX .327-IN-LG 6-32THD	00000	ORDER BY DESCRIPTION
	2190-0034	5		WASHER-LK HLCL NO. 10 .194-IN-ID	28480	2190-0034
A31MP2	1530-1098	4	2	CLEVIS 0.070-IN W SLT: 0.454-IN PIN CTR	00000	ORDER BY DESCRIPTION
	2190-0019	6	2	WASHER-LK HLCL NO. 4 .115-IN-ID	28480	2190-0019
	2200-0109	8	2	SCREW-MACH 4-40 .438-IN-LG PAN-HD-POZI	00000	ORDER BY DESCRIPTION
	2260-0002	6	2	NUT-HEX-DBL-CHAM 4-40-THD .062-IN-THK	28480	2260-0002

† Refer to Section 7 for update information.

\* Factory Selected Component (Refer to Section 5).

Δ Errata part change.

Table 6-3. Replaceable Parts

Reference Designation	HP Part Number	C D	Qty.	Description	Mfr. Code	Mfr. Part Number
<b>A32</b>						
A32	08901-60227	1	1	POWER REFERENCE OSCILLATOR ASSEMBLY	28480	08901-60227
	08901-00194	5	1	P.C. SHIELD	28480	08901-00194
A32C1	0160-3879	7		CAPACITOR-FXD .01UF + -20% 100VDC CER	28480	0160-3879
A32C2	0160-3036	8	2	CAPACITOR-FDTHRU 5000PF + 80 -20% 200V	28480	0160-3036
	2190-0009	4	2	WASHER-LK INTL T NO. 8 .168-IN-ID	28480	2190-0009
A32C3	2580-0002	4	2	NUT-HEX-DBL-CHAM 8-32-THD .085-IN-THK	28480	2580-0002
	0160-3036	8		CAPACITOR-FDTHRU 5000PF + 80 -20% 200V	28480	0160-3036
	2190-0009	4		WASHER-LK INTL T NO. 8 .168-IN-ID	28480	2190-0009
	2580-0002	4		NUT-HEX-DBL-CHAM 8-32-THD .085-IN-THK	28480	2580-0002
A32C4	0160-3879	7		CAPACITOR-FXD .01UF + -20% 100VDC CER	28480	0160-3879
A32C5	0160-3879	7		CAPACITOR-FXD .01UF + -20% 100VDC CER	28480	0160-3879
A32C6	0160-2027	5	1	CAPACITOR-FXD 300PF + -5% 500VDC MICA	28480	0160-2027
A32C7	0160-3070	0	1	CAPACITOR-FXD 100PF + -5% 300VDC MICA	28480	0160-3070
A32C8	0160-0100	3		CAPACITOR-FXD 4.7UF + -10% 35VDC TA	56289	150D475X9035B2
A32C9	0160-2255	1	1	CAPACITOR-FXD 8.2PF + -.25PF 500VDC CER	28480	0160-2255
	4330-0145	9		INSULATOR-BEAD GLASS	28480	4330-0145
A32C10	0160-3878	6		CAPACITOR-FXD 1000PF + -20% 100VDC CER	28480	0160-3878
A32C11	0160-0179	4	1	CAPACITOR-FXD 33PF + -5% 300VDC MICA	28480	0160-0179
A32C12	0160-3879	7		CAPACITOR-FXD .01UF + -20% 100VDC CER	28480	0160-3879
A32C13	0160-4006	4	1	CAPACITOR-FXD 36PF + -5% 300VDC GL	28480	0160-4006
A32C14	0160-4007	5	1	CAPACITOR-FXD 200PF + -5% 300VDC GL	28480	0160-4007
A32CR1	1901-0518	8		DIODE-SM SIG SCHOTTKY	28480	1901-0518
A32CR2	1901-0518	8		DIODE-SM SIG SCHOTTKY	28480	1901-0518
A32CR3	0122-0299	9	1	DIODE-VVC 82PF 5% C2/C20-MIN = 2 BVR = 20V	28480	0122-0299
A32J1	1250-1220	0		CONNECTOR-RF SMC M PC 50-OHM	28480	1250-1220
	2190-0124	4		WASHER-LK INTL T NO. 10 .195-IN-ID	28480	2190-0124
	2950-0078	9		NUT-HEX-DBL-CHAM 10-32-THD .067-IN-THK	28480	2950-0078
A32L1	08901-80043	1	1	COIL VARIABLE	28480	08901-80043
A32L2	9140-0144	0		INDUCTOR RF-CH-MLD 4.7UH 10% .105DX.26LG	28480	9140-0144
A32L3	08901-80044	2	1	COIL 3 1/2 TURNS	28480	08901-80044
A32MP1	08901-20232	4	1	OSC COVER	28480	08901-20232
A32Q1	1854-0247	9		TRANSISTOR NPN SI TO-39 PD = 1W FT = 800MHZ	28480	1854-0247
	1200-0173	5		INSULATOR-XSTR DAP-GL	28480	1200-0173
A32Q2	1854-0071	7		TRANSISTOR NPN SI PD = 300MW FT = 200MHZ	28480	1854-0071
A32R1	0757-0442	9		RESISTOR 10K 1% .125W F TC = 0 + -100	24546	C4-1/8-T0-1002-F
A32R2*	0757-1094	9	10	RESISTOR 1.47K 1% .125W F TC = 0 + -100	24546	C4-1/8-T0-1471-F
A32R3	0811-3234	9	1	RESISTOR 10K 1% .05W PWW TC = 0 + -10	20940	140-1/20-1002-F
A32R4	2100-3154	7	1	RESISTOR-TRMR 1K 10% C SIDE-ADJ 17-TRN	02111	43P102
A32R5*	0811-3381	7	1	RESISTOR 7.1K 1% .05W PWW TC = 0 + -10	28480	0811-3381

†Refer to Section 7 for update information.

\*Factory Selected Component (Refer to Section 5).

Δ Errata part change

*Table 6-3. Replaceable Parts*

Reference Designation	HP Part Number	C D	Qty.	Description	Mfr. Code	Mfr. Part Number
A32R6	0757-0440	7		RESISTOR 7.5K 1% .125W F TC = 0 + -100	24546	C4-1/8-T0-7501-F
A32R7	0698-7284	5		RESISTOR 100K 1% .05W F TC = 0 + -100	24546	C3-1/8-T0-1003-F
A32R8	0757-0465	6		RESISTOR 100K 1% .125W F TC = 0 + -100	24546	C4-1/8-T0-1003-F
A32R9	0698-7284	5		RESISTOR 100K 1% .05W F TC = 0 + -100	24546	C3-1/8-T0-1003-F
A32R10	0757-0280	3		RESISTOR 1K 1% .125W F TC = 0 + -100	24546	C4-1/8-T0-1001-F
A32R11	0757-0280	3		RESISTOR 1K 1% .125W F TC = 0 + -100	24546	C4-1/8-T0-1001-F
A32R12	0757-0442	9		RESISTOR 10K 1% .125W F TC = 0 + -100	24546	C4-1/8-T0-1002-F
A32R14	0757-0398	4		RESISTOR 75 1% .125W F TC = 0 + -100	24546	C4-1/8-T0-75R0-F
A32R15	0757-0317	7		RESISTOR 1.33K 1% .125W F TC = 0 + -100	24546	C4-1/8-T0-1331-F
A32R16	0698-6364	0	1	RESISTOR 50 .1% .125W F TC = 0 + -25	28480	0698-6364
A32U1	1826-0013	8		IC OP AMP LOW-NOISE TO-99 PKG	06665	SSS741CJ
A32U2	1826-1227	8	1	IC OP AMP GP 8-DIP-C PKG	27014	LM301AJ
A32VR1	1902-0680	7		DIODE-ZNR 1N827 6.2V 5% DO-7 PD = .4W	24046	1N827
A32VR2*	1902-0956	0	1	DIODE-ZNR 8.2V 5% DO-35 PD = .4W TC = + .065%	28480	1902-0956

†Refer to Section 7 for update information.

\*Factory Selected Component (Refer to Section 5)

Δ Errata part change

Table 6-3. Replaceable Parts

Reference Designation	HP Part Number	C D	Qty.	Description	Mfr. Code	Mfr. Part Number
<b>A50</b>						
A50	08901-60220	4	1	AM CALIBRATOR ASSEMBLY	28480	08901-60220
A50C1	0160-3459	9		CAPACITOR-FXD .02UF + -20% 100VDC CER	28480	0160-3459
A50C2	0180-0058	0		CAPACITOR-FXD 50UF + 75-10% 25VDC AL	56289	30D506G025CC2
A50C3	0180-0058	0		CAPACITOR-FXD 50UF + 75-10% 25VDC AL	56289	30D506G025CC2
A50C4	0180-2617	1		CAPACITOR-FXD 6.8UF + -10% 35VDC TA	25088	D6R8GS1B35K
A50C5	0160-3459	9		CAPACITOR-FXD .02UF + -20% 100VDC CER	28480	0160-3459
A50C6	0180-2619	3		CAPACITOR-FXD 22UF + -10% 15VDC TA	25088	D22GS1B15K
A50C7	0160-3459	9		CAPACITOR-FXD .02UF + -20% 100VDC CER	28480	0160-3459
A50C8	0160-3459	9		CAPACITOR-FXD .02UF + -20% 100VDC CER	28480	0160-3459
A50C9	0160-0207	9	1	CAPACITOR-FXD .01UF + -5% 200VDC POLYE	28480	0160-0207
A50C10	0180-2619	3		CAPACITOR-FXD 22UF + -10% 15VDC TA	25088	D22GS1B15K
A50C11	0180-2620	6		CAPACITOR-FXD 2.2UF + -10% 50VDC TA	25088	D2R2GS1B50K
A50C12	0160-3459	9		CAPACITOR-FXD .02UF + -20% 100VDC CER	28480	0160-3459
A50C13	0160-3459	9		CAPACITOR-FXD .02UF + -20% 100VDC CER	28480	0160-3459
A50C14	0180-2619	3		CAPACITOR-FXD 22UF + -10% 15VDC TA	25088	D22GS1B15K
A50C15	0180-2619	3		CAPACITOR-FXD 22UF + -10% 15VDC TA	25088	D22GS1B15K
A50C16	0160-2199	2		CAPACITOR-FXD 30PF + -5% 300VDC MICA	28480	0160-2199
A50C17	0160-3459	9		CAPACITOR-FXD .02UF + -20% 100VDC CER	28480	0160-3459
A50C18	0160-3459	9		CAPACITOR-FXD .02UF + -20% 100VDC CER	28480	0160-3459
A50C19	0160-3459	9		CAPACITOR-FXD .02UF + -20% 100VDC CER	28480	0160-3459
A50C20	0160-3459	9		CAPACITOR-FXD .02UF + -20% 100VDC CER	28480	0160-3459
A50C21				NOT ASSIGNED		
A50C22	0160-3454	4	1	CAPACITOR-FXD 220PF + -10% 1KVDC CER	28480	0160-3454
A50C23	0160-3459	9		CAPACITOR-FXD .02UF + -20% 100VDC CER	28480	0160-3459
A50C24	0160-3459	9		CAPACITOR-FXD .02UF + -20% 100VDC CER	28480	0160-3459
A50C25	0160-3459	9		CAPACITOR-FXD .02UF + -20% 100VDC CER	28480	0160-3459
A50C26	0160-3459	9		CAPACITOR-FXD .02UF + -20% 100VDC CER	28480	0160-3459
A50C27	0180-2620	6		CAPACITOR-FXD 2.2UF + -10% 50VDC TA	25088	D2R2GS1B50K
A50C28	0160-3691	1	1	CAPACITOR-FXD 75PF + -1% 100VDC MICA	28480	0160-3691
A50C29	0180-2619	3		CAPACITOR-FXD 22UF + -10% 15VDC TA	25088	D22GS1B15K
A50C30	0160-2199	2		CAPACITOR-FXD 30PF + -5% 300VDC MICA	28480	0160-2199
A50C31	0160-3459	9		CAPACITOR-FXD .02UF + -20% 100VDC CER	28480	0160-3459
A50C32	0160-3459	9		CAPACITOR-FXD .02UF + -20% 100VDC CER	28480	0160-3459
A50C33	0160-3459	9		CAPACITOR-FXD .02UF + -20% 100VDC CER	28480	0160-3459
A50C34	0160-2414	4	1	CAPACITOR-FXD .022UF + -5% 200VDC POLYE	28480	0160-2414
A50C35	0180-2620	6		CAPACITOR-FXD 2.2UF + -10% 50VDC TA	25088	D2R2GS1B50K
A50C36	0160-3459	9		CAPACITOR-FXD .02UF + -20% 100VDC CER	28480	0160-3459
A50C37	0180-2620	6		CAPACITOR-FXD 2.2UF + -10% 50VDC TA	25088	D2R2GS1B50K
A50C38	0160-3459	9		CAPACITOR-FXD .02UF + -20% 100VDC CER	28480	0160-3459
A50C39	0180-2619	3		CAPACITOR-FXD 22UF + -10% 15VDC TA	25088	D22GS1B15K
A50C40	0160-3459	9		CAPACITOR-FXD .02UF + -20% 100VDC CER	28480	0160-3459
A50C41	0180-2620	6		CAPACITOR-FXD 2.2UF + -10% 50VDC TA	25088	D2R2GS1B50K
A50C42	0160-2199	2		CAPACITOR-FXD 30PF + -5% 300VDC MICA	28480	0160-2199
A50C43	0180-2620	6		CAPACITOR-FXD 2.2UF + -10% 50VDC TA	25088	D2R2GS1B50K
A50C44	0160-0127	2	1	CAPACITOR-FXD 1UF + -20% 25VDC CER	28480	0160-0127
A50C45	0160-4084	8		CAPACITOR-FXD .1UF + -20% 50VDC CER	28480	0160-4084

†Refer to Section 7 for update information.

\*Factory Selected Component (Refer to Section 5).

Δ Errata part change

Table 6-3. Replaceable Parts

Reference Designation	HP Part Number	C D	Qty.	Description	Mfr. Code	Mfr. Part Number
A50C46	0160-3459	9		CAPACITOR-FXD .02UF + -20% 100VDC CER	28480	0160-3459
A50C47	0160-0153	4		CAPACITOR-FXD 1000PF + -10% 200VDC POLYE	28480	0160-0153
A50C48	0160-3459	9		CAPACITOR-FXD .02UF + -20% 100VDC CER	28480	0160-3459
A50C49	0160-2199	2		CAPACITOR-FXD 30PF + -5% 300VDC MICA	28480	0160-2199
A50C50	0160-2199	2		CAPACITOR-FXD 30PF + -5% 300VDC MICA	28480	0160-2199
A50C51	0180-2620	6		CAPACITOR-FXD 2.2UF + -10% 50VDC TA	25088	D2R2GS1B50K
A50C52	0160-3459	9		CAPACITOR-FXD .02UF + -20% 100VDC CER	28480	0160-3459
A50C53	0180-2620	6		CAPACITOR-FXD 2.2UF + -10% 50VDC TA	25088	D2R2GS1B50K
A50C54	0160-3459	9		CAPACITOR-FXD .02UF + -20% 100VDC CER	28480	0160-3459
A50CR1	1901-0179	7		DIODE-SWITCHING 15V 50MA 750PS DO-7	28480	1901-0179
A50CR2	1901-0179	7		DIODE-SWITCHING 15V 50MA 750PS DO-7	28480	1901-0179
A50CR3	1901-0179	7		DIODE-SWITCHING 15V 50MA 750PS DO-7	28480	1901-0179
A50CR4	1901-0179	7		DIODE-SWITCHING 15V 50MA 750PS DO-7	28480	1901-0179
A50CR5	1901-0179	7		DIODE-SWITCHING 15V 50MA 750PS DO-7	28480	1901-0179
A50CR6	1901-0179	7		DIODE-SWITCHING 15V 50MA 750PS DO-7	28480	1901-0179
A50CR7	1901-0179	7		DIODE-SWITCHING 15V 50MA 750PS DO-7	28480	1901-0179
A50CR8	1901-0179	7		DIODE-SWITCHING 15V 50MA 750PS DO-7	28480	1901-0179
A50CR9	1901-1098	1		DIODE-SWITCHING 1N4150 50V 200MA 4NS	9N171	1N4150
A50CR10	1901-1098	1		DIODE-SWITCHING 1N4150 50V 200MA 4NS	9N171	1N4150
A50CR11	1901-0535	9		DIODE-SM SIG SCHOTTKY	28480	1901-0535
A50CR12	1901-1098	1		DIODE-SWITCHING 1N4150 50V 200MA 4NS	9N171	1N4150
A50E1	9170-0847	3	4	CORE-SHIELDING BEAD	02114	56-590-65/3B PARYLENE
A50E2	9170-0847	3		CORE-SHIELDING BEAD	02114	56-590-65/3B PARYLENE
A50J1	1250-1220	0		CONNECTOR-RF SMC M PC 50-OHM	28480	1250-1220
	2190-0124	4		WASHER-LK INTL T NO. 10 .195-IN-ID	28480	2190-0124
	2950-0078	9		NUT-HEX-DBL-CHAM 10-32-THD .067-IN-THK	28480	2950-0078
A50J2	1250-1220	0		CONNECTOR-RF SMC M PC 50-OHM	28480	1250-1220
	2190-0124	4		WASHER-LK INTL T NO. 10 .195-IN-ID	28480	2190-0124
	2950-0078	9		NUT-HEX-DBL-CHAM 10-32-THD .067-IN-THK	28480	2950-0078
A50L1	9100-1635	2	9	INDUCTOR RF-CH-MLD 91UH 5% .166DX.385LG	28480	9100-1635
A50L2	9100-1635	2		INDUCTOR RF-CH-MLD 91UH 5% .166DX.385LG	28480	9100-1635
A50L3	9100-1635	2		INDUCTOR RF-CH-MLD 91UH 5% .166DX.385LG	28480	9100-1635
A50L4	9100-1635	2		INDUCTOR RF-CH-MLD 91UH 5% .166DX.385LG	28480	9100-1635
A50L5	9100-1637	4	2	INDUCTOR RF-CH-MLD 120UH 5% .166DX.385LG	28480	9100-1637
A50L6	9100-1637	4		INDUCTOR RF-CH-MLD 120UH 5% .166DX.385LG	28480	9100-1637
A50L7	9100-3913	3	1	INDUCTOR RF-CH-MLD 3.3UH 5% .166DX.385LG	28480	9100-3913
A50L8	9140-0179	1	1	INDUCTOR RF-CH-MLD 22UH 10% .166DX.385LG	28480	9140-0179
A50MP1	08901-00129	6	1	COVER AM CAL	28480	08901-00129
	2360-0113	2		SCREW-MACH 6-32 .25-IN-LG PAN-HD-POZI	00000	ORDER BY DESCRIPTION
A50MP2	08901-00114	9	1	LABEL AM CAL	28480	08901-00114
A50Q1	1858-0032	8	1	TRANSISTOR ARRAY 14-PIN PLSTC DIP	28480	1858-0032
A50Q2	1854-0345	8	3	TRANSISTOR NPN 2N5179 SI TO-72 PD = 200MW	04713	2N5179
A50Q3	1854-0345	8		TRANSISTOR NPN 2N5179 SI TO-72 PD = 200MW	04713	2N5179
A50Q4	1854-0345	8		TRANSISTOR NPN 2N5179 SI TO-72 PD = 200MW	04713	2N5179
A50Q5	1854-0295	7		TRANSISTOR-DUAL NPN PD = 400MW	28480	1854-0295
A50Q6	1854-0019	3	2	TRANSISTOR NPN SI TO-18 PD = 360MW	28480	1854-0019

†Refer to Section 7 for update information.

\*Factory Selected Component (Refer to Section 5)

Δ Errata part change

Table 6-3. Replaceable Parts

Reference Designation	HP Part Number	C D	Qty.	Description	Mfr. Code	Mfr. Part Number
A50Q7	1854-0019	3		TRANSISTOR NPN SI TO-18 PD = 360MW	28480	1854-0019
A50Q8	1854-0071	7		TRANSISTOR NPN SI PD = 300MW FT = 200MHZ	28480	1854-0071
A50Q9	1854-0071	7		TRANSISTOR NPN SI PD = 300MW FT = 200MHZ	28480	1854-0071
A50Q10	1854-0071	7		TRANSISTOR NPN SI PD = 300MW FT = 200MHZ	28480	1854-0071
A50Q11	1854-0071	7		TRANSISTOR NPN SI PD = 300MW FT = 200MHZ	28480	1854-0071
A50Q12	1854-0071	7		TRANSISTOR NPN SI PD = 300MW FT = 200MHZ	28480	1854-0071
A50Q13	1854-0071	7		TRANSISTOR NPN SI PD = 300MW FT = 200MHZ	28480	1854-0071
A50Q14	1853-0020	4		TRANSISTOR PNP SI PD = 300MW FT = 150MHZ	28480	1853-0020
A50Q15	1854-0071	7		TRANSISTOR NPN SI PD = 300MW FT = 200MHZ	28480	1854-0071
A50Q16	1853-0034	0		TRANSISTOR PNP SI TO-18 PD = 360MW	28480	1853-0034
A50Q17	1854-0477	7		TRANSISTOR NPN 2N2222A SI TO-18 PD = 500MW	04713	2N2222A
A50Q18	1854-0071	7		TRANSISTOR NPN SI PD = 300MW FT = 200MHZ	28480	1854-0071
A50Q19	1853-0034	0		TRANSISTOR PNP SI TO-18 PD = 360MW	28480	1853-0034
A50Q20	1854-0477	7		TRANSISTOR NPN 2N2222A SI TO-18 PD = 500MW	04713	2N2222A
A50Q21	1854-0071	7		TRANSISTOR NPN SI PD = 300MW FT = 200MHZ	28480	1854-0071
A50Q22	1853-0020	4		TRANSISTOR PNP SI PD = 300MW FT = 150MHZ	28480	1853-0020
A50Q23	1854-0071	7		TRANSISTOR NPN SI PD = 300MW FT = 200MHZ	28480	1854-0071
A50R1	0757-0346	2		RESISTOR 10 1% .125W F TC = 0 + -100	24546	C4-1/8-T0-10R0-F
A50R2	0757-0416	7		RESISTOR 511 1% .125W F TC = 0 + -100	24546	C4-1/8-T0-511R-F
A50R3	0757-0401	0		RESISTOR 100 1% .125W F TC = 0 + -100	24546	C4-1/8-T0-101-F
A50R4	0698-3444	1		RESISTOR 316 1% .125W F TC = 0 + -100	24546	C4-1/8-T0-316R-F
A50R5	0757-0438	3		RESISTOR 5.11K 1% .125W F TC = 0 + -100	24546	C4-1/8-T0-5111-F
A50R6	0698-0083	8		RESISTOR 1.96K 1% .125W F TC = 0 + -100	24546	C4-1/8-T0-1961-F
A50R7	0698-3152	8		RESISTOR 3.48K 1% .125W F TC = 0 + -100	24546	C4-1/8-T0-3481-F
A50R8	0698-5466	1	1	RESISTOR 5.7K 1% .125W F TC = 0 + -100	24546	C4-1/8-T0-5701-F
A50R9	0698-3153	9		RESISTOR 3.83K 1% .125W F TC = 0 + -100	24546	C4-1/8-T0-3831-F
A50R10	0698-3150	6		RESISTOR 2.37K 1% .125W F TC = 0 + -100	24546	C4-1/8-T0-2371-F
A50R11	0757-0438	3		RESISTOR 5.11K 1% .125W F TC = 0 + -100	24546	C4-1/8-T0-5111-F
A50R12	0698-3132	4		RESISTOR 261 1% .125W F TC = 0 + -100	24546	C4-1/8-T0-2610-F
A50R13	0698-0084	9		RESISTOR 2.15K 1% .125W F TC = 0 + -100	24546	C4-1/8-T0-2151-F
A50R14	0757-0280	3		RESISTOR 1K 1% .125W F TC = 0 + -100	24546	C4-1/8-T0-1001-F
A50R15	0698-0084	9		RESISTOR 2.15K 1% .125W F TC = 0 + -100	24546	C4-1/8-T0-2151-F
A50R16	0698-3441	8		RESISTOR 215 1% .125W F TC = 0 + -100	24546	C4-1/8-T0-215R-F
A50R17	0698-0084	9		RESISTOR 2.15K 1% .125W F TC = 0 + -100	24546	C4-1/8-T0-2151-F
A50R18	0698-3158	4		RESISTOR 23.7K 1% .125W F TC = 0 + -100	24546	C4-1/8-T0-2372-F
A50R19	0698-3158	4		RESISTOR 23.7K 1% .125W F TC = 0 + -100	24546	C4-1/8-T0-2372-F
A50R20	0698-4439	6	2	RESISTOR 3.24K 1% .125W F TC = 0 + -100	24546	C4-1/8-T0-3241-F
A50R21	0698-4439	6		RESISTOR 3.24K 1% .125W F TC = 0 + -100	24546	C4-1/8-T0-3241-F
A50R22	0757-0442	9		RESISTOR 10K 1% .125W F TC = 0 + -100	24546	C4-1/8-T0-1002-F
A50R23	0757-0447	4		RESISTOR 16.2K 1% .125W F TC = 0 + -100	24546	C4-1/8-T0-1622-F
A50R24	0757-0280	3		RESISTOR 1K 1% .125W F TC = 0 + -100	24546	C4-1/8-T0-1001-F
A50R25	0698-0083	8		RESISTOR 1.96K 1% .125W F TC = 0 + -100	24546	C4-1/8-T0-1961-F
A50R26	0698-0083	8		RESISTOR 1.96K 1% .125W F TC = 0 + -100	24546	C4-1/8-T0-1961-F
A50R27	0698-0083	8		RESISTOR 1.96K 1% .125W F TC = 0 + -100	24546	C4-1/8-T0-1961-F
A50R28	0698-0083	8		RESISTOR 1.96K 1% .125W F TC = 0 + -100	24546	C4-1/8-T0-1961-F
A50R29	0757-0465	6		RESISTOR 100K 1% .125W F TC = 0 + -100	24546	C4-1/8-T0-1003-F
A50R30	0698-3431	6		RESISTOR 23.7 1% .125W F TC = 0 + -100	03888	PME55-1/8-T0-23R7-F

† Refer to Section 7 for update information.

\* Factory Selected Component (Refer to Section 5)

Δ Errata part change

Table 6-3. Replaceable Parts

Reference Designation	HP Part Number	C D	Qty.	Description	Mfr. Code	Mfr. Part Number
A50R31	0698-3438	3		RESISTOR 147 1% .125W F TC = 0 + -100	24546	C4-1/8-T0-147R-F
A50R32	0698-3444	1		RESISTOR 316 1% .125W F TC = 0 + -100	24546	C4-1/8-T0-316R-F
A50R33	0698-3431	6		RESISTOR 23.7 1% .125W F TC = 0 + -100	03888	PME55-1/8-T0-237R-F
A50R34	0698-3438	3		RESISTOR 147 1% .125W F TC = 0 + -100	24546	C4-1/8-T0-147R-F
A50R35	0698-3444	1		RESISTOR 316 1% .125W F TC = 0 + -100	24546	C4-1/8-T0-316R-F
A50R36	0698-0085	0		RESISTOR 2.61K 1% .125W F TC = 0 + -100	24546	C4-1/8-T0-2611-F
A50R37	0757-0465	6		RESISTOR 100K 1% .125W F TC = 0 + -100	24546	C4-1/8-T0-1003-F
A50R38	0698-0084	9		RESISTOR 2.15K 1% .125W F TC = 0 + -100	24546	C4-1/8-T0-2151-F
A50R39	2100-3207	1		RESISTOR-TRMR 5K 10% C SIDE-ADJ 1-TRN	28480	2100-3207
A50R40	0757-0279	0		RESISTOR 3.16K 1% .125W F TC = 0 + -100	24546	C4-1/8-T0-3161-F
A50R41	0757-0465	6		RESISTOR 100K 1% .125W F TC = 0 + -100	24546	C4-1/8-T0-1003-F
A50R42	0757-0401	0		RESISTOR 100 1% .125W F TC = 0 + -100	24546	C4-1/8-T0-101-F
A50R43	0757-0401	0		RESISTOR 100 1% .125W F TC = 0 + -100	24546	C4-1/8-T0-101-F
A50R44	0757-0421	4		RESISTOR 825 1% .125W F TC = 0 + -100	24546	C4-1/8-T0-825R-F
A50R45	2100-3349	2	2	RESISTOR-TRMR 100 10% C SIDE-ADJ 1-TRN	28480	2100-3349
A50R46	0698-3442	9	4	RESISTOR 237 1% .125W F TC = 0 + -100	24546	C4-1/8-T0-237R-F
A50R47	0698-3447	4		RESISTOR 422 1% .125W F TC = 0 + -100	24546	C4-1/8-T0-422R-F
A50R48	0757-0401	0		RESISTOR 100 1% .125W F TC = 0 + -100	24546	C4-1/8-T0-101-F
A50R49	0757-0401	0		RESISTOR 100 1% .125W F TC = 0 + -100	24546	C4-1/8-T0-101-F
A50R50	0757-0438	3		RESISTOR 5.11K 1% .125W F TC = 0 + -100	24546	C4-1/8-T0-5111-F
A50R51	0757-0394	0		RESISTOR 51.1 1% .125W F TC = 0 + -100	24546	C4-1/8-T0-51R1-F
A50R52	0757-0394	0		RESISTOR 51.1 1% .125W F TC = 0 + -100	24546	C4-1/8-T0-51R1-F
A50R53	0757-0438	3		RESISTOR 5.11K 1% .125W F TC = 0 + -100	24546	C4-1/8-T0-5111-F
A50R54	0757-0419	0		RESISTOR 681 1% .125W F TC = 0 + -100	24546	C4-1/8-T0-681R-F
A50R55	0757-0438	3		RESISTOR 5.11K 1% .125W F TC = 0 + -100	24546	C4-1/8-T0-5111-F
A50R56	0698-0085	0		RESISTOR 2.61K 1% .125W F TC = 0 + -100	24546	C4-1/8-T0-2611-F
A50R57	0757-0419	0		RESISTOR 681 1% .125W F TC = 0 + -100	24546	C4-1/8-T0-681R-F
A50R58	0757-0438	3		RESISTOR 5.11K 1% .125W F TC = 0 + -100	24546	C4-1/8-T0-5111-F
A50R59	0698-0085	0		RESISTOR 2.61K 1% .125W F TC = 0 + -100	24546	C4-1/8-T0-2611-F
A50R60	0698-3153	9		RESISTOR 3.83K 1% .125W F TC = 0 + -100	24546	C4-1/8-T0-3831-F
A50R61	0757-0394	0		RESISTOR 51.1 1% .125W F TC = 0 + -100	24546	C4-1/8-T0-51R1-F
A50R62	0757-0394	0		RESISTOR 51.1 1% .125W F TC = 0 + -100	24546	C4-1/8-T0-51R1-F
A50R63	0757-0440	7		RESISTOR 7.5K 1% .125W F TC = 0 + -100	24546	C4-1/8-T0-7501-F
A50R64	0757-0440	7		RESISTOR 7.5K 1% .125W F TC = 0 + -100	24546	C4-1/8-T0-7501-F
A50R65	0757-0416	7		RESISTOR 511 1% .125W F TC = 0 + -100	24546	C4-1/8-T0-511R-F
A50R66	0698-4190	6	1	RESISTOR 50 .25% .125W F TC = 0 + -100	03888	PME55-1/8-T0-50R0-C
A50R67	0698-3488	3	1	RESISTOR 442 1% .125W F TC = 0 + -100	24546	C4-1/8-T0-422R-F
A50R68	0757-0428	1		RESISTOR 1.62K 1% .125W F TC = 0 + -100	24546	C4-1/8-T0-1621-F
A50R69	0698-6235	4	1	RESISTOR 96.25 .5% .125W F TC = 0 + -100	24546	C4-1/8-T0-96R25-D
A50R70	0757-0439	4		RESISTOR 6.81K 1% .125W F TC = 0 + -100	24546	C4-1/8-T0-6811-F
A50R71	0698-7982	0	1	RESISTOR 71.16 .1% .25W F TC = 0 + -50	19701	MF52C1/4-T2-71R16-B
A50R72	0757-0280	3		RESISTOR 1K 1% .125W F TC = 0 + -100	24546	C4-1/8-T0-1001-F
A50R73	0757-0419	0		RESISTOR 681 1% .125W F TC = 0 + -100	24546	C4-1/8-T0-681R-F
A50R74	0698-3445	2		RESISTOR 348 1% .125W F TC = 0 + -100	24546	C4-1/8-T0-348R-F
A50R75	0757-0401	0		RESISTOR 100 1% .125W F TC = 0 + -100	24546	C4-1/8-T0-101-F
A50R76	0757-0416	7		RESISTOR 511 1% .125W F TC = 0 + -100	24546	C4-1/8-T0-511R-F
A50R77	0698-7981	9	1	RESISTOR 96.25 .1% .25W F TC = 0 + -50	19701	MF52C1/4-T2-96R25-B
A50R78	0757-0424	7		RESISTOR 1.1K 1% .125W F TC = 0 + -100	24546	C4-1/8-T0-1101-F
A50R79	0698-3442	9		RESISTOR 237 1% .125W F TC = 0 + -100	24546	C4-1/8-T0-237R-F
A50R80	0757-0401	0		RESISTOR 100 1% .125W F TC = 0 + -100	24546	C4-1/8-T0-101-F

†Refer to Section 7 for update information.

\*Factory Selected Component (Refer to Section 5).

Δ Errata part change.



Table 6-3. Replaceable Parts

Reference Designation	HP Part Number	C D	Qty.	Description	Mfr. Code	Mfr. Part Number
A50R81	0698-3442	9		RESISTOR 237 1% .125W F TC = 0+ -100	24546	C4-1/8-T0-237R-F
A50R82	0757-0442	9		RESISTOR 10K 1% .125W F TC = 0+ -100	24546	C4-1/8-T0-1002-F
A50R83	0757-0438	3		RESISTOR 5.11K 1% .125W F TC = 0+ -100	24546	C4-1/8-T0-5111-F
A50R84	0757-0440	7		RESISTOR 7.5K 1% .125W F TC = 0+ -100	24546	C4-1/8-T0-7501-F
A50R85	0757-0438	3		RESISTOR 5.11K 1% .125W F TC = 0+ -100	24546	C4-1/8-T0-5111-F
A50R86	0757-0438	3		RESISTOR 5.11K 1% .125W F TC = 0+ -100	24546	C4-1/8-T0-5111-F
A50R87	0757-0200	7		RESISTOR 5.62K 1% .125W F TC = 0+ -100	24546	C4-1/8-T0-5621-F
A50R88	0698-3444	1		RESISTOR 316 1% .125W F TC = 0+ -100	24546	C4-1/8-T0-316R-F
A50R89	0698-3444	1		RESISTOR 316 1% .125W F TC = 0+ -100	24546	C4-1/8-T0-316R-F
A50R90	0698-3441	8		RESISTOR 215 1% .125W F TC = 0+ -100	24546	C4-1/8-T0-215R-F
A50R91	0757-0402	1		RESISTOR 110 1% .125W F TC = 0+ -100	24546	C4-1/8-T0-111-F
A50R92	0757-0416	7		RESISTOR 511 1% .125W F TC = 0+ -100	24546	C4-1/8-T0-511R-F
A50R93	0757-0280	3		RESISTOR 1K 1% .125W F TC = 0+ -100	24546	C4-1/8-T0-1001-F
A50R94	0757-0279	0		RESISTOR 3.16K 1% .125W F TC = 0+ -100	24546	C4-1/8-T0-3161-F
A50R95	0757-0421	4		RESISTOR 825 1% .125W F TC = 0+ -100	24546	C4-1/8-T0-825R-F
A50R96	0698-6343	5		RESISTOR 9K .1% .125W F TC = 0+ -25	28480	0698-6343
A50R97	0757-0442	9		RESISTOR 10K 1% .125W F TC = 0+ -100	24546	C4-1/8-T0-1002-F
A50R98	0698-3491	8	1	RESISTOR 1K .1% .125W F TC = 0+ -50	28480	0698-3491
A50R99	0698-3449	6		RESISTOR 28.7K 1% .125W F TC = 0+ -100	24546	C4-1/8-T0-2872-F
A50R100	0757-0280	3		RESISTOR 1K 1% .125W F TC = 0+ -100	24546	C4-1/8-T0-1001-F
A50R101	0698-4158	6	1	RESISTOR 100K .1% .125W F TC = 0+ -50	28480	0698-4158
A50R102	0757-0438	3		RESISTOR 5.11K 1% .125W F TC = 0+ -100	24546	C4-1/8-T0-5111-F
A50R103	0757-0280	3		RESISTOR 1K 1% .125W F TC = 0+ -100	24546	C4-1/8-T0-1001-F
A50R104	0757-0438	3		RESISTOR 5.11K 1% .125W F TC = 0+ -100	24546	C4-1/8-T0-5111-F
A50R105	0757-0280	3		RESISTOR 1K 1% .125W F TC = 0+ -100	24546	C4-1/8-T0-1001-F
A50R106	0757-0280	3		RESISTOR 1K 1% .125W F TC = 0+ -100	24546	C4-1/8-T0-1001-F
A50R107	0757-0442	9		RESISTOR 10K 1% .125W F TC = 0+ -100	24546	C4-1/8-T0-1002-F
A50R108	0757-0442	9		RESISTOR 10K 1% .125W F TC = 0+ -100	24546	C4-1/8-T0-1002-F
A50R109	0698-3441	8		RESISTOR 215 1% .125W F TC = 0+ -100	24546	C4-1/8-T0-215R-F
A50TP1	1251-0600	0		CONNECTOR-SGL CONT PIN 1.14-MM-BSC-SZ SQ	28480	1251-0600
A50TP2	1251-0600	0		CONNECTOR-SGL CONT PIN 1.14-MM-BSC-SZ SQ	28480	1251-0600
A50TP3	1251-0600	0		CONNECTOR-SGL CONT PIN 1.14-MM-BSC-SZ SQ	28480	1251-0600
A50U1	1826-0059	2		IC OP AMP GP TO-99 PKG	01295	LM201AL
A50U2	1826-0059	2		IC OP AMP GP TO-99 PKG	01295	LM201AL
A50U3	1826-0059	2		IC OP AMP GP TO-99 PKG	01295	LM201AL
A50U4	1826-0059	2		IC OP AMP GP TO-99 PKG	01295	LM201AL
A50U5	1826-0059	2		IC OP AMP GP TO-99 PKG	01295	LM201AL
A50U6	1826-0180	0		IC TIMER TTL MONO/ASTBL	01295	NE555P
A50U7	1820-1963	7	2	IC FF CMOS D-TYPE POS-EDGE-TRIG DUAL	3L585	CD4013BAE
A50U8	1826-0138	8		IC COMPARATOR GP QUAD 14-DIP-P PKG	01295	LM339N
A50U9	1820-1411	0		IC LCH TTL LS D-TYPE 4-BIT	01295	SN74LS75N
A50U10	1820-1216	3		IC DCDR TTL LS 3-TO-8-LINE 3-INP	01295	SN74LS138N
A50VR1	1902-0680	7		DIODE-ZNR 1N827 6.2V 5% DO-7 PD = .4W	24046	1N827
A50VR2	1902-3059	0		DIODE-ZNR 3.83V 5% DO-35 PD = .4W	28480	1902-3059
A50VR3	1902-3104	6	3	DIODE-ZNR 5.62V 5% DO-35 PD = .4W	28480	1902-3104

†Refer to Section 7 for update information.

\*Factory Selected Component (Refer to Section 5)

△ Errata part change

Table 6-3. Replaceable Parts

Reference Designation	HP Part Number	C D	Qty.	Description	Mfr. Code	Mfr. Part Number
<b>A51</b>						
A51	08901-60013	3	1	FM CALIBRATOR ASSEMBLY	28480	08901-60013
A51C1	0160-3459	9		CAPACITOR-FXD .02UF + -20% 100VDC CER	28480	0160-3459
A51C2	0160-3459	9		CAPACITOR-FXD .02UF + -20% 100VDC CER	28480	0160-3459
A51C3	0160-3459	9		CAPACITOR-FXD .02UF + -20% 100VDC CER	28480	0160-3459
A51C4	0160-3459	9		CAPACITOR-FXD .02UF + -20% 100VDC CER	28480	0160-3459
A51C5	0180-2206	4		CAPACITOR-FXD 60UF + -10% 6VDC TA	56289	150D606X9006B2
A51C6	0160-2199	2		CAPACITOR-FXD 30PF + -5% 300VDC MICA	28480	0160-2199
A51C7	0160-3459	9		CAPACITOR-FXD .02UF + -20% 100VDC CER	28480	0160-3459
A51C8	0160-3459	9		CAPACITOR-FXD .02UF + -20% 100VDC CER	28480	0160-3459
A51C9	0160-2199	2		CAPACITOR-FXD 30PF + -5% 300VDC MICA	28480	0160-2199
A51C10				NOT ASSIGNED		
A51C11	0160-2207	3	1	CAPACITOR-FXD 300PF + -5% 300VDC MICA	28480	0160-2207
A51C12	0160-2199	2		CAPACITOR-FXD 30PF + -5% 300VDC MICA	28480	0160-2199
A51C13	0180-2206	4		CAPACITOR-FXD 60UF + -10% 6VDC TA	56289	150D606X9006B2
A51C14	0160-4040	6		CAPACITOR-FXD 1000PF + -5% 100VDC CER	28480	0160-4040
A51C15	0180-0228	6		CAPACITOR-FXD 22UF + -10% 15VDC TA	56289	150D226X9015B2
A51C16	0140-0205	5	1	CAPACITOR-FXD 62PF + -5% 300VDC MICA	72136	DM15E620J0300WV1CF
A51C17	0160-3535	2	1	CAPACITOR-FXD 560PF + -5% 300VDC MICA	28480	0160-3535
A51C18	0180-0197	8		CAPACITOR-FXD 2.2UF + -10% 20VDC TA	56289	150D225X9020A2
A51C19	0160-0574	3	2	CAPACITOR-FXD .022UF + -20% 100VDC CER	28480	0160-0574
A51C20	0121-0436	4	1	CAPACITOR-V TRMR-AIR 2.6-23.5PF 350V	74970	189-0509-125
A51C21	0160-0574	3		CAPACITOR-FXD .022UF + -20% 100VDC CER	28480	0160-0574
A51C22	0160-3459	9		CAPACITOR-FXD .02UF + -20% 100VDC CER	28480	0160-3459
A51C23	0160-3459	9		CAPACITOR-FXD .02UF + -20% 100VDC CER	28480	0160-3459
A51C24	0160-3459	9		CAPACITOR-FXD .02UF + -20% 100VDC CER	28480	0160-3459
A51C25	0160-3459	9		CAPACITOR-FXD .02UF + -20% 100VDC CER	28480	0160-3459
A51CR1	1901-1098	1		DIODE-SWITCHING 1N4150 50V 200MA 4NS	9N171	1N4150
A51CR2	1901-1098	1		DIODE-SWITCHING 1N4150 50V 200MA 4NS	9N171	1N4150
<i>2305A TO 2411A</i>						
A51CR3	0122-0065	7		DIODE-VVC 29PF 3%	28480	0122-0065
<i>2412A AND ABOVE</i>						
A51CR3	0122-0173	8		DIODE-VVC 29PF 10% C3/C25-MIN = 5 BVR = 30V	25403	BB809SELECTED
A51CR4	1901-1098	1		DIODE-SWITCHING 1N4150 50V 200MA 4NS	9N171	1N4150
<i>2305A TO 2411A</i>						
A51CR6	0122-0065	7		DIODE-VVC 29PF 3%	28480	0122-0065
A51CR6	0122-0065	7		DIODE-VVC 29PF 3%	28480	0122-0065
<i>2412A AND ABOVE</i>						
A51CR6	0122-0173	8		DIODE-VVC 29PF 10% C3/C25-MIN = 5 BVR = 30V	25403	BB809SELECTED
A51CR6	0122-0173	8		DIODE-VVC 29PF 10% C3/C25-MIN = 5 BVR=30V	25403	0122-0173

†Refer to Section 7 for update information.

\*Factory Selected Component (Refer to Section 5)

△ Errata part change.

Table 6-3. Replaceable Parts

Reference Designation	HP Part Number	C D	Qty.	Description	Mfr. Code	Mfr. Part Number
A51CR7	1901-1098	1		DIODE-SWITCHING 1N4150 50V 200MA 4NS	9N171	1N4150
A51CR8	1901-1098	1		DIODE-SWITCHING 1N4150 50V 200MA 4NS	9N171	1N4150
A51E1	9170-0847	3		CORE-SHIELDING BEAD	02114	56-590-65/3B PARYLENE
A51E2	9170-0847	3		CORE-SHIELDING BEAD	02114	56-590-65/3B PARYLENE
A51J1	1250-1220	0		CONNECTOR-RF SMC M PC 50-OHM	28480	1250-1220
	2190-0124	4		WASHER-LK INTL T NO. 10 .195-IN-ID	28480	2190-0124
	2950-0078	9		NUT-HEX-DBL-CHAM 10-32-THD .067-IN-THK	28480	2950-0078
A51J2	1250-1220	0		CONNECTOR-RF SMC M PC 50-OHM	28480	1250-1220
	2190-0124	4		WASHER-LK INTL T NO. 10 .195-IN-ID	28480	2190-0124
	2950-0078	9		NUT-HEX-DBL-CHAM 10-32-THD .067-IN-THK	28480	2950-0078
A51L1	9100-1635	2		INDUCTOR RF-CH-MLD 91UH 5% .166DX.385LG	28480	9100-1635
A51L2	9100-1635	2		INDUCTOR RF-CH-MLD 91UH 5% .166DX.385LG	28480	9100-1635
A51L3	9100-1635	2		INDUCTOR RF-CH-MLD 91UH 5% .166DX.385LG	28480	9100-1635
A51L4	9100-1635	2		INDUCTOR RF-CH-MLD 91UH 5% .166DX.385LG	28480	9100-1635
A51L5	9100-1635	2		INDUCTOR RF-CH-MLD 91UH 5% .166DX.385LG	28480	9100-1635
A51L6	9140-0310	2	1	INDUCTOR RF-CH-MLD 390NH 5% .105DX.26LG	28480	9140-0310
A51L7	9140-0309	9	1	INDUCTOR RF-CH-MLD 1.8UH 5% .105DX.26LG	28480	9140-0309
A51MP1	08901-00040	0	1	COVER-FM CAL	28480	08901-00040
	2360-0113	2		SCREW-MACH 6-32 .25-IN-LG PAN-HD-POZI	00000	ORDER BY DESCRIPTION
A51Q1	1853-0034	0		TRANSISTOR PNP SI TO-18 PD = 360MW	28480	1853-0034
A51Q2	1854-0071	7		TRANSISTOR NPN SI PD = 300MW FT = 200MHZ	28480	1854-0071
A51Q3	1853-0007	7		TRANSISTOR PNP 2N3251 SI TO-18 PD = 360MW	04713	2N3251
A51Q4	1853-0007	7		TRANSISTOR PNP 2N3251 SI TO-18 PD = 360MW	04713	2N3251
A51Q5	1853-0034	0		TRANSISTOR PNP SI TO-18 PD = 360MW	28480	1853-0034
A51Q6	1853-0034	0		TRANSISTOR PNP SI TO-18 PD = 360MW	28480	1853-0034
A51Q7	1854-0247	9		TRANSISTOR NPN SI TO-39 PD = 1W FT = 800MHZ	28480	1854-0247
	1200-0173	5		INSULATOR-XSTR DAP-GL	28480	1200-0173
A51Q8	1854-0071	7		TRANSISTOR NPN SI PD = 300MW FT = 200MHZ	28480	1854-0071
A51Q9	1854-0295	7		TRANSISTOR-DUAL NPN PD = 400MW	28480	1854-0295
A51Q10	1854-0071	7		TRANSISTOR NPN SI PD = 300MW FT = 200MHZ	28480	1854-0071
A51Q11	1854-0071	7		TRANSISTOR NPN SI PD = 300MW FT = 200MHZ	28480	1854-0071
A51Q12	1853-0007	7		TRANSISTOR PNP 2N3251 SI TO-18 PD = 360MW	04713	2N3251
A51Q13	1853-0007	7		TRANSISTOR PNP 2N3251 SI TO-18 PD = 360MW	04713	2N3251
A51R1	0757-0401	0		RESISTOR 100 1% .125W F TC = 0 + -100	24546	C4-1/8-T0-101-F
A51R2	0757-0443	0		RESISTOR 11K 1% .125W F TC = 0 + -100	24546	C4-1/8-T0-1102-F
A51R3	0698-3154	0		RESISTOR 4.22K 1% .125W F TC = 0 + -100	24546	C4-1/8-T0-4221-F
A51R4	0698-3153	9		RESISTOR 3.83K 1% .125W F TC = 0 + -100	24546	C4-1/8-T0-3831-F
A51R5	0757-0442	9		RESISTOR 10K 1% .125W F TC = 0 + -100	24546	C4-1/8-T0-1002-F
A51R6	0698-3447	4		RESISTOR 422 1% .125W F TC = 0 + -100	24546	C4-1/8-T0-422R-F
A51R7	0698-6502	8	3	RESISTOR 3.32K .25% .125W F TC = 0 + -50	28480	0698-6502
A51R8	0698-6502	8		RESISTOR 3.32K .25% .125W F TC = 0 + -50	28480	0698-6502
A51R9	0757-0442	9		RESISTOR 10K 1% .125W F TC = 0 + -100	24546	C4-1/8-T0-1002-F
A51R10	0698-3153	9		RESISTOR 3.83K 1% .125W F TC = 0 + -100	24546	C4-1/8-T0-3831-F
A51R11	0698-8068	5	2	RESISTOR 4.99K .25% .125W F TC = 0 + -25	19701	MF4C1/8-T9-4991-C

† Refer to Section 7 for update information.

\* Factory Selected Component (Refer to Section 5).

Δ Errata part change

Table 6-3. Replaceable Parts

Reference Designation	HP Part Number	C D	Qty.	Description	Mfr. Code	Mfr. Part Number
A51R12	2100-3349	2		RESISTOR-TRMR 100 10% C SIDE-ADJ 1-TRN	28480	2100-3349
A51R13	0698-8068	5		RESISTOR 4.99K .25% .125W F TC = 0 + -25	19701	MF4C1/8-T9-4991-C
A51R14	0698-8024	3	1	RESISTOR 3.09K .25% .125W F TC = 0 + -50	19701	MF4C1/8-T2-3091-C
A51R15	0698-3155	1		RESISTOR 4.64K 1% .125W F TC = 0 + -100	24546	C4-1/8-T0-4641-F
A51R16	0757-0442	9		RESISTOR 10K 1% .125W F TC = 0 + -100	24546	C4-1/8-T0-1002-F
A51R17	0698-3155	1		RESISTOR 4.64K 1% .125W F TC = 0 + -100	24546	C4-1/8-T0-4641-F
A51R18	0757-0442	9		RESISTOR 10K 1% .125W F TC = 0 + -100	24546	C4-1/8-T0-1002-F
A51R19	0757-0464	5	1	RESISTOR 90.9K 1% .125W F TC = 0 + -100	24546	C4-1/8-T0-9092-F
A51R20	0757-0416	7		RESISTOR 511 1% .125W F TC = 0 + -100	24546	C4-1/8-T0-511R-F
A51R21	0698-7215	2	1	RESISTOR 133 1% .05W F TC = 0 + -100	24546	C3-1/8-T0-133R-F
A51R22	0698-7839	6	1	RESISTOR 222 .5% .125W F TC = 0 + -50	19701	MF4C1/8-T2-222R-D
A51R23	0698-5439	8	2	RESISTOR 1K .25% .125W F TC = 0 + -50	28480	0698-5439
A51R24 <sup>Δ</sup>	0698-3159	5	1	RESISTOR 26.1K 1% .125W F TC = 0 + -50	28480	0698-3159
A51R25				NOT ASSIGNED		
A51R26	0698-5439	8		RESISTOR 1K .25% .125W F TC = 0 + -50	28480	0698-5439
A51R27	0698-3152	8		RESISTOR 3.48K 1% .125W F TC = 0 + -100	24546	C4-1/8-T0-3481-F
A51R28	0698-3440	7		RESISTOR 196 1% .125W F TC = 0 + -100	24546	C4-1/8-T0-196R-F
A51R29	0698-3154	0		RESISTOR 4.22K 1% .125W F TC = 0 + -100	24546	C4-1/8-T0-4221-F
A51R30	0698-3157	3		RESISTOR 19.6K 1% .125W F TC = 0 + -100	24546	C4-1/8-T0-1962-F
A51R31	0698-0085	0		RESISTOR 2.61K 1% .125W F TC = 0 + -100	24546	C4-1/8-T0-2611-F
A51R32*	0757-0288	1		RESISTOR 9.09K 1% .125W F TC = 0 + -100	19701	MF4C1/8-T0-9091-F
A51R33	0757-0447	4		RESISTOR 16.2K 1% .125W F TC = 0 + -100	24546	C4-1/8-T0-1622-F
A51R34*	0698-3154	0		RESISTOR 4.22K 1% .125W F TC = 0 + -100	24546	C4-1/8-T0-4221-F
A51R35	0757-0401	0		RESISTOR 100 1% .125W F TC = 0 + -100	24546	C4-1/8-T0-101-F
A51R36	0757-0441	8		RESISTOR 8.25K 1% .125W F TC = 0 + -100	24546	C4-1/8-T0-8251-F
A51R37	0698-7205	0		RESISTOR 51.1 1% .05W F TC = 0 + -100	24546	C3-1/8-T0-511R-F
A51R38	0698-7212	9		RESISTOR 100 1% .05W F TC = 0 + -100	24546	C3-1/8-T0-100R-F
A51R39	0757-0420	3		RESISTOR 750 1% .125W F TC = 0 + -100	24546	C4-1/8-T0-751-F
A51R40	0698-7212	9		RESISTOR 100 1% .05W F TC = 0 + -100	24546	C3-1/8-T0-100R-F
A51R41	0757-0416	7		RESISTOR 511 1% .125W F TC = 0 + -100	24546	C4-1/8-T0-511R-F
A51R42	0757-0420	3		RESISTOR 750 1% .125W F TC = 0 + -100	24546	C4-1/8-T0-751-F
A51R43	0698-3132	4		RESISTOR 261 1% .125W F TC = 0 + -100	24546	C4-1/8-T0-2610-F
A51R44	0698-7212	9		RESISTOR 100 1% .05W F TC = 0 + -100	24546	C3-1/8-T0-100R-F
A51R45	0757-0438	3		RESISTOR 5.11K 1% .125W F TC = 0 + -100	24546	C4-1/8-T0-5111-F
A51R46	0757-0438	3		RESISTOR 5.11K 1% .125W F TC = 0 + -100	24546	C4-1/8-T0-5111-F
A51TP1	1251-0600	0		CONNECTOR-SGL CONT PIN 1.14-MM-BSC-SZ SQ	28480	1251-0600
A51TP2	1251-0600	0		CONNECTOR-SGL CONT PIN 1.14-MM-BSC-SZ SQ	28480	1251-0600
A51TP3	1251-0600	0		CONNECTOR-SGL CONT PIN 1.14-MM-BSC-SZ SQ	28480	1251-0600
A51U1	1826-0059	2		IC OP AMP GP TO-99 PKG	01295	LM201AL
A51U2	1826-0059	2		IC OP AMP GP TO-99 PKG	01295	LM201AL
A51U3	1826-0059	2		IC OP AMP GP TO-99 PKG	01295	LM201AL
A51U4	1826-0371	1		IC OP AMP LOW-BIAS-H-IMPD TO-99 PKG	27014	LF256H
A51U5	1820-1963	7		IC FF CMOS D-TYPE POS-EDGE-TRIG DUAL	3L585	CD4013BAE

† Refer to Section 7 for update information.

\* Factory Selected Component (Refer to Section 5).

Δ Errata part change

*Table 6-3. Replaceable Parts*

Reference Designation	HP Part Number	C D	Qty.	Description	Mfr. Code	Mfr. Part Number
A51U6	1826-0138		8	IC COMPARATOR GP QUAD 14-DIP-P PKG	01295	LM339N
A51U7	1820-1216		3	IC DCDR TTL LS 3-TO-8-LINE 3-INP	01295	SN74LS138N
A51U8	1820-1411		0	IC LCH TTL LS D-TYPE 4-BIT	01295	SN74LS75N
A51U9	1820-0723		5	IC RCVR TTL LINE RCVR DUAL 2-INP	01295	SN75107AN
A51VR1	1902-3059		0	DIODE-ZNR 3.83V 5% DO-35 PD = .4W	28480	1902-3059
A51VR2	1902-0680		7	DIODE-ZNR 1N827 6.2V 5% DO-7 PD = .4W	24046	1N827
A51VR3	1902-3104		6	DIODE-ZNR 5.62V 5% DO-35 PD = .4W	28480	1902-3104
A51VR4	1902-3104		6	DIODE-ZNR 5.62V 5% DO-35 PD = .4W	28480	1902-3104
A51VR5	1902-3059		0	DIODE-ZNR 3.83V 5% DO-35 PD = .4W	28480	1902-3059
A51VR6	1902-3059		0	DIODE-ZNR 3.83V 5% DO-35 PD = .4W	28480	1902-3059

†Refer to Section 7 for update information

\*Factory Selected Component (Refer to Section 5)

Δ Errata part change

Table 6-3. Replaceable Parts

Reference Designation	HP Part Number	C D	Qty.	Description	Mfr. Code	Mfr. Part Number
<b>A52</b>						
A52	08901-60131	6	1	AUDIO COUNTER/DISTORTION ANALYZER ASSY	28480	08901-60131
A52C1	0180-2929	8		CAPACITOR-FXD 68UF + -10% 10VDC TA	28480	0180-2929
A52C2	0180-0291	3		CAPACITOR-FXD 1UF + -10% 35VDC TA	56289	150D105X9035A2
A52C3	0180-0291	3		CAPACITOR-FXD 1UF + -10% 35VDC TA	56289	150D105X9035A2
A52C4	0160-3879	7		CAPACITOR-FXD .01UF + -20% 100VDC CER	28480	0160-3879
A52C5	0160-5098	6		CAPACITOR-FXD .22UF + -10% 50VDC CER	16299	CAC05X7R224J050A
A52C6	0160-3879	7		CAPACITOR-FXD .01UF + -20% 100VDC CER	28480	0160-3879
A52C7	0160-3879	7		CAPACITOR-FXD .01UF + -20% 100VDC CER	28480	0160-3879
A52C8	0160-3879	7		CAPACITOR-FXD .01UF + -20% 100VDC CER	28480	0160-3879
A52C9	0160-4797	0	1	CAPACITOR-FXD 3.3PF + -.25PF 100VDC CER	28480	0160-4797
A52C10	0160-3879	7		CAPACITOR-FXD .01UF + -20% 100VDC CER	28480	0160-3879
A52C11	0160-0576	5		CAPACITOR-FXD .1UF + -20% 50VDC CER	28480	0160-0576
A52C12	0160-0576	5		CAPACITOR-FXD .1UF + -20% 50VDC CER	28480	0160-0576
A52C13	0180-1746	5		CAPACITOR-FXD 15UF + -10% 20VDC TA	56289	150D156X9020B2
A52C14	0160-4267	9	6	CAPACITOR-FXD .02UF + -1% 200VDC	28480	0160-4267
A52C15	0160-5340	1	6	CAPACITOR-FXD .03UF + -1% 200VDC	28480	0160-5340
A52C16	0160-5340	1		CAPACITOR-FXD .03UF + -1% 200VDC	28480	0160-5340
A52C17	0160-4267	9		CAPACITOR-FXD .02UF + -1% 200VDC	28480	0160-4267
A52C18	0160-4768	5		CAPACITOR-FXD 470PF + -5% 100VDC CER	28480	0160-4768
A52C19	0160-0576	5		CAPACITOR-FXD .1UF + -20% 50VDC CER	28480	0160-0576
A52C20	0160-0576	5		CAPACITOR-FXD .1UF + -20% 50VDC CER	28480	0160-0576
A52C21	0160-0576	5		CAPACITOR-FXD .1UF + -20% 50VDC CER	28480	0160-0576
A52C22	0160-4267	9		CAPACITOR-FXD .02UF + -1% 200VDC	28480	0160-4267
A52C23	0160-5340	1		CAPACITOR-FXD .03UF + -1% 200VDC	28480	0160-5340
A52C24	0160-5340	1		CAPACITOR-FXD .03UF + -1% 200VDC	28480	0160-5340
A52C25	0160-4267	9		CAPACITOR-FXD .02UF + -1% 200VDC	28480	0160-4267
A52C26	0180-1746	5		CAPACITOR-FXD 15UF + -10% 20VDC TA	56289	150D156X9020B2
A52C27	0160-4267	9		CAPACITOR-FXD .02UF + -1% 200VDC	28480	0160-4267
A52C28	0160-5340	1		CAPACITOR-FXD .03UF + -1% 200VDC	28480	0160-5340
A52C29	0160-5340	1		CAPACITOR-FXD .03UF + -1% 200VDC	28480	0160-5340
A52C30	0160-4267	9		CAPACITOR-FXD .02UF + -1% 200VDC	28480	0160-4267
A52C31	0180-1746	5		CAPACITOR-FXD 15UF + -10% 20VDC TA	56289	150D156X9020B2
A52C32	0180-1746	5		CAPACITOR-FXD 15UF + -10% 20VDC TA	56289	150D156X9020B2
A52C33	0160-0576	5		CAPACITOR-FXD .1UF + -20% 50VDC CER	28480	0160-0576
A52C34	0160-3674	0	2	CAPACITOR-FXD .47UF + -5% 100VDC	28480	0160-3674
A52C35	0180-1746	5		CAPACITOR-FXD 15UF + -10% 20VDC TA	56289	150D156X9020B2
A52C36	0160-5036	2	3	CAPACITOR-FXD .27UF + -2% 100VDC	28480	0160-5036
A52C37	0160-5036	2		CAPACITOR-FXD .27UF + -2% 100VDC	28480	0160-5036
A52C38	0160-0576	5		CAPACITOR-FXD .1UF + -20% 50VDC CER	28480	0160-0576
A52C39	0160-0576	5		CAPACITOR-FXD .1UF + -20% 50VDC CER	28480	0160-0576
A52C40	0160-5036	2		CAPACITOR-FXD .27UF + -2% 100VDC	28480	0160-5036
A52C41	0160-3879	7		CAPACITOR-FXD .01UF + -20% 100VDC CER	28480	0160-3879
A52C42	0160-4801	7		CAPACITOR-FXD 100PF + -5% 100VDC CER	28480	0160-4801
A52C43	0160-4832	4		CAPACITOR-FXD .01UF + -10% 100VDC CER	28480	0160-4832
A52C44	0160-4832	4		CAPACITOR-FXD .01UF + -10% 100VDC CER	28480	0160-4832
A52C45	0160-4832	4		CAPACITOR-FXD .01UF + -10% 100VDC CER	28480	0160-4832

†Refer to Section 7 for update information.

\*Factory Selected Component (Refer to Section 5)

Δ Errata part change

Table 6-3. Replaceable Parts

Reference Designation	HP Part Number	C D	Qty.	Description	Mfr. Code	Mfr. Part Number
A52C46	0160-4832	4		CAPACITOR-FXD .01UF + -10% 100VDC CER	28480	0160-4832
A52C47	0160-4787	8	1	CAPACITOR-FXD 22PF + -5% 100VDC CER 0 + -30	28480	0160-4787
A52CR1	1901-1098	1		DIODE-SWITCHING 1N4150 50V 200MA 4NS	9N171	1N4150
A52CR2	1901-1098	1		DIODE-SWITCHING 1N4150 50V 200MA 4NS	9N171	1N4150
A52CR3				NOT ASSIGNED		
A52CR4	1901-1098	1		DIODE-SWITCHING 1N4150 50V 200MA 4NS	9N171	1N4150
A52CR5	1901-1098	1		DIODE-SWITCHING 1N4150 50V 200MA 4NS	9N171	1N4150
A52CR6	1901-1098	1		DIODE-SWITCHING 1N4150 50V 200MA 4NS	9N171	1N4150
A52CR7	1901-1098	1		DIODE-SWITCHING 1N4150 50V 200MA 4NS	9N171	1N4150
A52CR8	1901-1098	1		DIODE-SWITCHING 1N4150 50V 200MA 4NS	9N171	1N4150
A52J1	1250-1425	7	2	CONNECTOR-RF SMC M SGL-HOLE-RR 50-OHM	28480	1250-1425
A52J2	1250-1425	7		CONNECTOR-RF SMC M SGL-HOLE-RR 50-OHM	28480	1250-1425
A52L1	9100-3562	8	1	INDUCTOR RF-CH-MLD 4.7UH 5% .166DX.385LG	28480	9100-3562
A52L2	9140-0210	1		INDUCTOR RF-CH-MLD 100UH 5% .166DX.385LG	28480	9140-0210
A52L3	9140-0210	1		INDUCTOR RF-CH-MLD 100UH 5% .166DX.385LG	28480	9140-0210
A52MP1	08901-00074	0	1	CVR AUDIO MEAS	28480	08901-00074
	2190-0008	3		WASHER-LK EXT T NO. 6 .141-IN-ID	28480	2190-0008
A52R1	0698-8822	9	2	RESISTOR 6.81 1% .125W F TC = 0 + -100	28480	0698-8822
A52R2	0698-8822	9		RESISTOR 6.81 1% .125W F TC = 0 + -100	28480	0698-8822
A52R3	0699-0790	6	2	RESISTOR 100K .1% .1W F TC = 0 + -15	28480	0699-0790
A52R4	0757-0280	3		RESISTOR 1K 1% .125W F TC = 0 + -100	24546	C4-1/8-T0-1001-F
A52R5	0757-0280	3		RESISTOR 1K 1% .125W F TC = 0 + -100	24546	C4-1/8-T0-1001-F
A52R6	0699-0790	6		RESISTOR 100K .1% .1W F TC = 0 + -15	28480	0699-0790
A52R7	1810-0206	8		NETWORK-RES 8-SIP10.0K OHM X 7	01121	208A103
A52R8	0757-0280	3		RESISTOR 1K 1% .125W F TC = 0 + -100	24546	C4-1/8-T0-1001-F
A52R9	0699-0778	0	1	RESISTOR 3.717K .1% .1W F TC = 0 + -15	28480	0699-0778
A52R10	0699-0785	9	1	RESISTOR 24.14K .1% .1W F TC = 0 + -15	28480	0699-0785
A52R11	0699-0780	4	4	RESISTOR 4.64K .1% .1W F TC = 0 + -15	28480	0699-0780
A52R12	0699-0777	9	1	RESISTOR 3.622K .1% .1W F TC = 0 + -15	28480	0699-0777
A52R13	0699-0789	3	1	RESISTOR 72.42K .1% .1W F TC = 0 + -15	28480	0699-0789
A52R14	0757-0280	3		RESISTOR 1K 1% .125W F TC = 0 + -100	24546	C4-1/8-T0-1001-F
A52R15				NOT ASSIGNED		
A52R16	0757-0458	7		RESISTOR 51.1K 1% .125W F TC = 0 + -100	24546	C4-1/8-T0-5112-F
A52R17	0699-0782	6	1	RESISTOR 14.16K .1% .1W F TC = 0 + -15	28480	0699-0782
A52R18	0699-0780	4		RESISTOR 4.64K .1% .1W F TC = 0 + -15	28480	0699-0780
A52R19				NOT ASSIGNED		
A52R20	0699-0784	8	1	RESISTOR 17.55K .1% .1W F TC = 0 + -15	28480	0699-0784
A52R21				NOT ASSIGNED		
A52R22	0699-0776	8	1	RESISTOR 2.712K .1% .1W F TC = 0 + -15	28480	0699-0776
A52R23	0699-0780	4		RESISTOR 4.64K .1% .1W F TC = 0 + -15	28480	0699-0780
A52R24	0699-0788	2	1	RESISTOR 54.3K .1% .1W F TC = 0 + -15	28480	0699-0788
A52R25	0699-0787	1	1	RESISTOR 49.25K .1% .1W F TC = 0 + -15	28480	0699-0787
A52R26	0699-0786	0	1	RESISTOR 28.12K .1% .1W F TC = 0 + -15	28480	0699-0786
A52R27	0757-0279	0		RESISTOR 3.16K 1% .125W F TC = 0 + -100	24546	C4-1/8-T0-3161-F
A52R28	0699-0791	7	1	RESISTOR 103.2K .1% .1W F TC = 0 + -15	28480	0699-0791
A52R29	0699-0057	8	3	RESISTOR 9K .1% .1W F TC = 0 + -5	28480	0699-0057
A52R30	0698-6414	1		RESISTOR 1K .1% .1W F TC = 0 + -5	28480	0698-6414

†Refer to Section 7 for update information.

\*Factory Selected Component (Refer to Section 5).

Δ Errata part change

Table 6-3. Replaceable Parts

Reference Designation	HP Part Number	C D	Qty.	Description	Mfr. Code	Mfr. Part Number
A52R31	0699-0779	1	1	RESISTOR 4.523K .1% .1W F TC=0+-15	28480	0699-0779
A52R32	0699-0780	4		RESISTOR 4.64K .1% .1W F TC=0+-15	28480	0699-0780
A52R33	0698-6414	1		RESISTOR 1K .1% .1W F TC=0+-5	28480	0698-6414
A52R34	0699-0781	5	1	RESISTOR 7.18K .1% .1W F TC=0+-15	28480	0699-0781
A52R35	0699-0057	8		RESISTOR 9K .1% .1W F TC=0+-5	28480	0699-0057
A52R36	0699-0783	7	1	RESISTOR 14K .1% .1W F TC=0+-15	28480	0699-0783
A52R37	0757-0280	3		RESISTOR 1K 1% .125W F TC=0+-100	24546	C4-1/8-T0-1001-F
A52R38	2100-3352	7		RESISTOR-TRMR 1K 10% C SIDE-ADJ 1-TRN	28480	2100-3352
A52R39	0699-0057	8		RESISTOR 9K .1% .1W F TC=0+-5	28480	0699-0057
A52R40	0698-6414	1		RESISTOR 1K .1% .1W F TC=0+-5	28480	0698-6414
A52R41	0757-0420	3		RESISTOR 750 1% .125W F TC=0+-100	24546	C4-1/8-T0-751-F
A52R42	0698-3158	4		RESISTOR 23.7K 1% .125W F TC=0+-100	24546	C4-1/8-T0-2372-F
A52R43	0757-0280	3		RESISTOR 1K 1% .125W F TC=0+-100	24546	C4-1/8-T0-1001-F
A52R44	2100-3274	2		RESISTOR-TRMR 10K 10% C SIDE-ADJ 1-TRN	28480	2100-3274
A52R45	0698-8827	4		RESISTOR 1M 1% .125W F TC=0+-100	28480	0698-8827
A52R46	0757-0420	3		RESISTOR 750 1% .125W F TC=0+-100	24546	C4-1/8-T0-751-F
A52R47	2100-3354	9	1	RESISTOR-TRMR 50K 10% C SIDE-ADJ 1-TRN	28480	2100-3354
A52R48	0757-0458	7		RESISTOR 51.1K 1% .125W F TC=0+-100	24546	C4-1/8-T0-5112-F
A52R49	0698-3161	9		RESISTOR 38.3K 1% .125W F TC=0+-100	24546	C4-1/8-T0-3832-F
<i>2306A ONLY</i>						
<i>A62R60</i>	0698-3161	9		RESISTOR 38.3K 1% .125W F TC=0+-100	24546	C4-1/8-T0-3832-F
<i>2326A AND ABOVE</i>						
<i>A2R60</i>				NOT ASSIGNED		
A52R51	0698-3450	9	10	RESISTOR 42.2K 1% .125W F TC=0+-100	24546	C4-1/8-T0-4222-F
A52R52	0757-0280	3		RESISTOR 1K 1% .125W F TC=0+-100	24546	C4-1/8-T0-1001-F
A52R53	0698-3136	8		RESISTOR 17.8K 1% .125W F TC=0+-100	24546	C4-1/8-T0-1782-F
A52R54	0698-3444	1		RESISTOR 316 1% .125W F TC=0+-100	24546	C4-1/8-T0-316R-F
A52R55	0757-0465	6		RESISTOR 100K 1% .125W F TC=0+-100	24546	C4-1/8-T0-1003-F
A52R56	0698-3443	0		RESISTOR 287 1% .125W F TC=0+-100	24546	C4-1/8-T0-287R-F
A52R57	0698-3444	1		RESISTOR 316 1% .125W F TC=0+-100	24546	C4-1/8-T0-316R-F
A52R58	0757-0199	3		RESISTOR 21.5K 1% .125W F TC=0+-100	24546	C4-1/8-T0-2152-F
A52R59	0757-0290	5		RESISTOR 6.19K 1% .125W F TC=0+-100	19701	MF4C1/8-T0-6191-F
A52R60	0757-0418	9		RESISTOR 619 1% .125W F TC=0+-100	24546	C4-1/8-T0-619R-F
A52TP1	1251-0600	0		CONNECTOR-SGL CONT PIN 1.14-MM-BSC-SZ SQ	28480	1251-0600
A52TP2	1251-0600	0		CONNECTOR-SGL CONT PIN 1.14-MM-BSC-SZ SQ	28480	1251-0600
A52TP3	1251-0600	0		CONNECTOR-SGL CONT PIN 1.14-MM-BSC-SZ SQ	28480	1251-0600
A52TP4	1251-0600	0		CONNECTOR-SGL CONT PIN 1.14-MM-BSC-SZ SQ	28480	1251-0600
A52TP5	1251-0600	0		CONNECTOR-SGL CONT PIN 1.14-MM-BSC-SZ SQ	28480	1251-0600
A52U1	1826-0421	2	1	IC CONV RMS/DC 14-DIP-C PKG	24355	AD536AJ
A52U2	1826-0606	5		IC SWITCH ANLG QUAD 16-DIP-C PKG	17856	DG201BK
A52U3	1826-0753	3		IC OP AMP LOW-BIAS-HIMPD QUAD 14-DIP-C	04713	MC34004BL
A52U4	1826-0753	3		IC OP AMP LOW-BIAS-HIMPD QUAD 14-DIP-C	04713	MC34004BL
A52U5	1826-1012	8		ANALOG SWITCH 4 SPST 16-PIN	17856	DG201BP
A52U6	1826-1012	8		ANALOG SWITCH 4 SPST 16-PIN	17856	DG201BP
A52U7	1820-1216	3		IC DCDR TTL LS 3-T0-8-LINE 3-INP	01295	SN74LS138N
A52U8	1820-2096	9	2	IC CNTR TTL LS BIN DUAL 4-BIT	01295	SN74LS93N
A52U9	1820-1144	6		IC GATE TTL LS NOR QUAD 2-INP	01295	SN74LS02N
A52U10	1820-1417	6	1	IC GATE TTL LS NAND QUAD 2-INP	01295	SN74LS26N

†Refer to Section 7 for update information.

\*Factory Selected Component (Refer to Section 5)

Δ Errata part change.



*Table 6-3. Replaceable Parts*

Reference Designation	HP Part Number	C D	Qty.	Description	Mfr. Code	Mfr. Part Number
A52U11	1820-1445	0	1	IC LCH TTL LS 4-BIT	01295	SN74LS375N
A52U12	1820-1112	8		IC FF TTL LS D-TYPE POS-EDGE-TRIG	01295	SN74LS74AN
A52U13	1826-0191	3		IC COMPARATOR GP DUAL TO-100 PKG	27014	LM319H
A52U14	1820-1195	7		IC FF TTL LS D-TYPE POS-EDGE-TRIG COM	01295	SN74LS175N
A52U15	1820-1195	7		IC FF TTL LS D-TYPE POS-EDGE-TRIG COM	01295	SN74LS175N
A52U16	1820-2096	9		IC CNTR TTL LS BIN DUAL 4-BIT	01295	SN74LS393N
A52U17	1826-0785	1	1	IC OP AMP LOW-BIAS-H-IMP DUAL 8-DIP-C	01295	TL072ACJG
A52U18	1826-0783	9		IC OP AMP LOW-NOISE 8-DIP-C PKG	52063	XR5534ACN
A52U19	1826-0606	5		IC SWITCH ANLG QUAD 16-DIP-C PKG	17856	DG201BK
A52VR1	1902-0961	7	2	DIODE-ZNR 13V 5% DO-35 PD = .4W TC = +.082%	28480	1902-0961
A52VR2	1902-0961	7		DIODE-ZNR 13V 5% DO-35 PD = .4W TC = +.082%	28480	1902-0961
A52W1	8159-0005	0		RESISTOR-ZERO OHMS 22 AWG LEAD DIA	28480	8159-0005
A52W2	8159-0005	0		RESISTOR-ZERO OHMS 22 AWG LEAD DIA	28480	8159-0005
<i>2306A ONLY</i>						
A52W3				NOT ASSIGNED		
<i>2326A AND ABOVE</i>						
A52W3	8159-0005	0		RESISTOR-ZERO OHMS 22AWG LEAD DIA	28480	8159-0005

† Refer to Section 7 for update information.

\* Factory Selected Component (Refer to Section 5).

Δ Errata part change

Table 6-3. Replaceable Parts

Reference Designation	HP Part Number	C D	Qty.	Description	Mfr. Code	Mfr. Part Number
<b>A53</b>						
A53	08901-60130	5	1	POWER METER ASSEMBLY	28480	08901-60130
A53C1	0180-2111	0		CAPACITOR-FXD 33UF + -10% 35VDC TA	56289	150D336X9035SA
A53C2	0180-1746	5		CAPACITOR-FXD 15UF + -10% 20VDC TA	56289	150D156X9020B2
A53C3	0180-1746	5		CAPACITOR-FXD 15UF + -10% 20VDC TA	56289	150D156X9020B2
A53C4	0180-1746	5		CAPACITOR-FXD 15UF + -10% 20VDC TA	56289	150D156X9020B2
A53C5	0180-2929	8		CAPACITOR-FXD 68UF + -10% 10VDC TA	28480	0180-2929
A53C6	0160-4389	6		CAPACITOR-FXD 100PF + -5PF 200VDC CER	28480	0160-4389
A53C7	0160-4389	6		CAPACITOR-FXD 100PF + -5PF 200VDC CER	28480	0160-4389
A53C8	0160-0575	4		CAPACITOR-FXD .047UF + -20% 50VDC CER	28480	0160-0575
A53C9	0160-0575	4		CAPACITOR-FXD .047UF + -20% 50VDC CER	28480	0160-0575
A53C10	0160-4624	2	3	CAPACITOR-FXD 8200PF + -5% 50VDC CER	28480	0160-4624
A53C11	0160-0575	4		CAPACITOR-FXD .047UF + -20% 50VDC CER	28480	0160-0575
A53C12	0160-0575	4		CAPACITOR-FXD .047UF + -20% 50VDC CER	28480	0160-0575
A53C13	0180-2929	8		CAPACITOR-FXD 68UF + -10% 10VDC TA	28480	0180-2929
A53C14	0160-2290	4	3	CAPACITOR-FXD .15UF + -10% 80VDC POLYE	28480	0160-2290
A53C15	0160-4389	6		CAPACITOR-FXD 100PF + -5PF 200VDC CER	28480	0160-4389
A53C16	0160-0575	4		CAPACITOR-FXD .047UF + -20% 50VDC CER	28480	0160-0575
A53C17	0160-0575	4		CAPACITOR-FXD .047UF + -20% 50VDC CER	28480	0160-0575
A53C18	0160-4624	2		CAPACITOR-FXD 8200PF + -5% 50VDC CER	28480	0160-4624
A53C19	0160-2290	4		CAPACITOR-FXD .15UF + -10% 80VDC POLYE	28480	0160-2290
A53C20	0160-4389	6		CAPACITOR-FXD 100PF + -5PF 200VDC CER	28480	0160-4389
A53C21	0160-4624	2		CAPACITOR-FXD 8200PF + -5% 50VDC CER	28480	0160-4624
A53C22	0160-2290	4		CAPACITOR-FXD .15UF + -10% 80VDC POLYE	28480	0160-2290
A53C23	0160-4389	6		CAPACITOR-FXD 100PF + -5PF 200VDC CER	28480	0160-4389
A53C24	0180-1746	5		CAPACITOR-FXD 15UF + -10% 20VDC TA	56289	150D156X9020B2
A53C25	0160-0575	4		CAPACITOR-FXD .047UF + -20% 50VDC CER	28480	0160-0575
A53C26	0160-0575	4		CAPACITOR-FXD .047UF + -20% 50VDC CER	28480	0160-0575
A53C27	0160-0157	8	1	CAPACITOR-FXD 4700PF + -10% 200VDC POLYE	28480	0160-0157
A53C28	0180-2111	0		CAPACITOR-FXD 33UF + -10% 35VDC TA	56289	150D336X9035SA
A53C29	0160-4389	6		CAPACITOR-FXD 100PF + -5PF 200VDC CER	28480	0160-4389
A53C30	0160-4389	6		CAPACITOR-FXD 100PF + -5PF 200VDC CER	28480	0160-4389
A53C31	0160-0575	4		CAPACITOR-FXD .047UF + -20% 50VDC CER	28480	0160-0575
A53C32	0160-0575	4		CAPACITOR-FXD .047UF + -20% 50VDC CER	28480	0160-0575
A53C33	0160-5546	9	2	CAPACITOR-FXD .039UF + -5% 100VDC	28480	0160-5546
A53C34	0160-5546	9		CAPACITOR-FXD .039UF + -5% 100VDC	28480	0160-5546
A53C35	0180-1746	5		CAPACITOR-FXD 15UF + -10% 20VDC TA	56289	150D156X9020B2
A53C36	0160-3879	7		CAPACITOR-FXD .01UF + -20% 100VDC CER	28480	0160-3879
A53C37	0160-3879	7		CAPACITOR-FXD .01UF + -20% 100VDC CER	28480	0160-3879
A53C38	0160-3879	7		CAPACITOR-FXD .01UF + -20% 100VDC CER	28480	0160-3879
A53C39	0160-3879	7		CAPACITOR-FXD .01UF + -20% 100VDC CER	28480	0160-3879
A53C40	0160-3879	7		CAPACITOR-FXD .01UF + -20% 100VDC CER	28480	0160-3879
A53C41	0160-5370	7	1	CAPACITOR-FXD 2.2UF + -5% 50VDC MET-POLYE	28480	0160-5370
A53C42	0160-3879	7		CAPACITOR-FXD .01UF + -20% 100VDC CER	28480	0160-3879
A53C43	0160-3879	7		CAPACITOR-FXD .01UF + -20% 100VDC CER	28480	0160-3879
A53C44	0180-3674	0		CAPACITOR-FXD .47UF + -5% 100VDC	28480	0160-3674
A53C45	0160-3879	7		CAPACITOR-FXD .01UF + -20% 100VDC CER	28480	0160-3879

{Refer to Section 7 for update information

\*Factory Selected Component (Refer to Section 5).

Δ Errata part change.

Table 6-3. Replaceable Parts

Reference Designation	HP Part Number	C D	Qty.	Description	Mfr. Code	Mfr. Part Number
A53C46	0160-3879	7		CAPACITOR-FXD .01UF + -20% 100VDC CER	28480	0160-3879
A53C47	0160-3879	7		CAPACITOR-FXD .01UF + -20% 100VDC CER	28480	0160-3879
A53C48	0160-3324	7	1	CAPACITOR-FXD 1UF + -5% 100VDC MET-POLYC	28480	0160-3324
A53C49	0180-0197	8		CAPACITOR-FXD 2.2UF + -10% 20VDC TA	56289	150D225X9020A2
A53C50	0180-0197	8		CAPACITOR-FXD 2.2UF + -10% 20VDC TA	56289	150D225X9020A2
A53C51	0160-3879	7		CAPACITOR-FXD .01UF + -20% 100VDC CER	28480	0160-3879
A53C52	0180-1746	5		CAPACITOR-FXD 15UF + -10% 20VDC TA	56289	150D156X9020B2
A53C53	0160-3879	7		CAPACITOR-FXD .01UF + -20% 100VDC CER	28480	0160-3879
A53CR1	1901-0895	4	2	DIODE-SM SIG SCHOTTKY	28480	1901-0895
A53CR2	1901-0895	4		DIODE-SM SIG SCHOTTKY	28480	1901-0895
A53CR3	1901-1098	1		DIODE-SWITCHING 1N4150 50V 200MA 4NS	9N171	1N4150
A53CR4	1901-1098	1		DIODE-SWITCHING 1N4150 50V 200MA 4NS	9N171	1N4150
A53CR5	1901-1098	1		DIODE-SWITCHING 1N4150 50V 200MA 4NS	9N171	1N4150
A53K1	0490-1063	6	2	RELAY-REED 2A 500MA 50VDC 5VDC-COIL 10VA	28480	0490-1063
A53K2	0490-1063	6		RELAY-REED 2A 500MA 50VDC 5VDC-COIL 10VA	28480	0490-1063
A53MP1	08901-00075	1	1	COVER, RF POWER	28480	08901-00075
	2190-0008	3		WASHER-LK EXT T NO. 6 .141-IN-ID	28480	2190-0008
	2360-0113	2		SCREW-MACH 6-32 .25-IN-LG PAN-HD-POZI	00000	ORDER BY DESCRIPTION
A53Q1				NOT ASSIGNED		
A53Q2	1854-0810	2		TRANSISTOR NPN SI PD = 625MW FT = 200MHZ	28480	1854-0810
A53Q3	1854-0837	1		TRANSISTOR NPN 2N2219A SI TO-5 PD = 800MW	01295	2N2219A
	1200-0173	5		INSULATOR-XSTR DAP-GL	28480	1200-0173
A53Q4	1855-0414	4		TRANSISTOR J-FET 2N4393 N-CHAN D-MODE	04713	2N4393
A53Q5	1853-0459	3		TRANSISTOR PNP SI PD = 625MW FT = 200MHZ	28480	1853-0459
A53Q6	1854-0810	2		TRANSISTOR NPN SI PD = 625MW FT = 200MHZ	28480	1854-0810
A53Q7	1853-0459	3		TRANSISTOR PNP SI PD = 625MW FT = 200MHZ	28480	1853-0459
A53Q8	1853-0459	3		TRANSISTOR PNP SI PD = 625MW FT = 200MHZ	28480	1853-0459
A53Q9	1853-0459	3		TRANSISTOR PNP SI PD = 625MW FT = 200MHZ	28480	1853-0459
A53Q10	1854-0810	2		TRANSISTOR NPN SI PD = 625MW FT = 200MHZ	28480	1854-0810
A53Q11	1854-0810	2		TRANSISTOR NPN SI PD = 625MW FT = 200MHZ	28480	1854-0810
A53Q12	1854-0810	2		TRANSISTOR NPN SI PD = 625MW FT = 200MHZ	28480	1854-0810
A53Q13	1853-0459	3		TRANSISTOR PNP SI PD = 625MW FT = 200MHZ	28480	1853-0459
A53Q14	1853-0459	3		TRANSISTOR PNP SI PD = 625MW FT = 200MHZ	28480	1853-0459
A53Q15	1853-0459	3		TRANSISTOR PNP SI PD = 625MW FT = 200MHZ	28480	1853-0459
A53R1	0699-0075	0	1	RESISTOR 21.5M 1% .125W F TC = 0 + -150	28480	0699-0075
A53R2	0698-3450	9		RESISTOR 42.2K 1% .125W F TC = 0 + -100	24546	C4-1/8-T0-4222-F
A53R3	0698-3159	5		RESISTOR 26.1K 1% .125W F TC = 0 + -100	24546	C4-1/8-T0-2612-F
A53R4	0698-3450	9		RESISTOR 42.2K 1% .125W F TC = 0 + -100	24546	C4-1/8-T0-4222-F
A53R5	0698-3156	2		RESISTOR 14.7K 1% .125W F TC = 0 + -100	24546	C4-1/8-T0-1472-F
A53R6	0757-0459	8		RESISTOR 56.2K 1% .125W F TC = 0 + -100	24546	C4-1/8-T0-5622-F
A53R7	0698-3431	6		RESISTOR 23.7 1% .125W F TC = 0 + -100	03888	PME55-1/8-T0-23R7-F
A53R8	0757-0280	3		RESISTOR 1K 1% .125W F TC = 0 + -100	24546	C4-1/8-T0-1001-F
A53R9	0757-0444	1		RESISTOR 12.1K 1% .125W F TC = 0 + -100	24546	C4-1/8-T0-1212-F
A53R10	0757-0442	9		RESISTOR 10K 1% .125W F TC = 0 + -100	24546	C4-1/8-T0-1002-F
A53R11	0757-0463	4		RESISTOR 82.5K 1% .125W F TC = 0 + -100	24546	C4-1/8-T0-8252-F
A53R12	0757-0346	2		RESISTOR 10 1% .125W F TC = 0 + -100	24546	C4-1/8-T0-10R0-F
A53R13	2100-2655	1	2	RESISTOR-TRMR 100K 10% C TOP-ADJ 1-TRN	73138	82PR100K
A53R14	0698-3160	8		RESISTOR 31.6K 1% .125W F TC = 0 + -100	24546	C4-1/8-T0-3162-F
A53R15	0698-3451	0		RESISTOR 133K 1% .125W F TC = 0 + -100	24546	C4-1/8-T0-1333-F
A53R16	2100-2655	1		RESISTOR-TRMR 100K 10% C TOP-ADJ 1-TRN	73138	82PR100K

†Refer to Section 7 for update information.

\*Factory Selected Component (Refer to Section 5).

△ Errata part change.

Table 6-3. Replaceable Parts

Reference Designation	HP Part Number	C D	Qty.	Description	Mfr. Code	Mfr. Part Number
A53R17	0698-0083	8		RESISTOR 1.96K 1% .125W F TC = 0 + -100	24546	C4-1/8-T0-1961-F
A53R18	0698-0084	9		RESISTOR 2.15K 1% .125W F TC = 0 + -100	24546	C4-1/8-T0-2151-F
A53R19	0811-3351	1	1	RESISTOR 11K .025% .05W PWW TC = 0 + -10	28480	0811-3351
A53R20	0811-3348	6	2	RESISTOR 111.11 .025% .05W PWW TC = 0 + -10	28480	0811-3348
A53R21	0698-3450	9		RESISTOR 42.2K 1% .125W F TC = 0 + -100	24546	C4-1/8-T0-4222-F
A53R22	0757-0438	3		RESISTOR 5.11K 1% .125W F TC = 0 + -100	24546	C4-1/8-T0-5111-F
A53R23	0698-3150	6		RESISTOR 2.37K 1% .125W F TC = 0 + -100	24546	C4-1/8-T0-2371-F
A53R24	0811-3350	0	1	RESISTOR 10K .025% .05W PWW TC = 0 + -10	28480	0811-3350
A53R25	0811-3349	7	1	RESISTOR 1K .025% .05W PWW TC = 0 + -10	28480	0811-3349
A53R26	0811-3348	6		RESISTOR 111.11 .025% .05W PWW TC = 0 + -10	28480	0811-3348
A53R27	0757-0289	2		RESISTOR 13.3K 1% .125W F TC = 0 + -100	19701	MF4C1/8-T0-1332-F
A53R28	0698-3450	9		RESISTOR 42.2K 1% .125W F TC = 0 + -100	24546	C4-1/8-T0-4222-F
A53R29	0698-0084	9		RESISTOR 2.15K 1% .125W F TC = 0 + -100	24546	C4-1/8-T0-2151-F
A53R30	0698-3150	6		RESISTOR 2.37K 1% .125W F TC = 0 + -100	24546	C4-1/8-T0-2371-F
A53R31	0698-3450	9		RESISTOR 42.2K 1% .125W F TC = 0 + -100	24546	C4-1/8-T0-4222-F
A53R32	0757-0442	9		RESISTOR 10K 1% .125W F TC = 0 + -100	24546	C4-1/8-T0-1002-F
A53R33	0757-0442	9		RESISTOR 10K 1% .125W F TC = 0 + -100	24546	C4-1/8-T0-1002-F
A53R34	0698-3154	0		RESISTOR 4.22K 1% .125W F TC = 0 + -100	24546	C4-1/8-T0-4221-F
A53R35	0757-0200	7		RESISTOR 5.62K 1% .125W F TC = 0 + -100	24546	C4-1/8-T0-5621-F
A53R36	0757-0442	9		RESISTOR 10K 1% .125W F TC = 0 + -100	24546	C4-1/8-T0-1002-F
A53R37	0757-0465	6		RESISTOR 100K 1% .125W F TC = 0 + -100	24546	C4-1/8-T0-1003-F
A53R38	0757-0460	1		RESISTOR 61.9K 1% .125W F TC = 0 + -100	24546	C4-1/8-T0-6192-F
A53R39	0757-0279	0		RESISTOR 3.16K 1% .125W F TC = 0 + -100	24546	C4-1/8-T0-3161-F
A53R40	2100-2514	1	1	RESISTOR-TRMR 20K 10% C SIDE-ADJ 1-TRN	30983	ET50W203
A53R41	0757-0442	9		RESISTOR 10K 1% .125W F TC = 0 + -100	24546	C4-1/8-T0-1002-F
A53R42	0757-0465	6		RESISTOR 100K 1% .125W F TC = 0 + -100	24546	C4-1/8-T0-1003-F
A53R43	0757-0460	1		RESISTOR 61.9K 1% .125W F TC = 0 + -100	24546	C4-1/8-T0-6192-F
A53R44	0698-3154	0		RESISTOR 4.22K 1% .125W F TC = 0 + -100	24546	C4-1/8-T0-4221-F
A53R45	0757-0200	7		RESISTOR 5.62K 1% .125W F TC = 0 + -100	24546	C4-1/8-T0-5621-F
A53R46	0757-0442	9		RESISTOR 10K 1% .125W F TC = 0 + -100	24546	C4-1/8-T0-1002-F
A53R47	0757-0280	3		RESISTOR 1K 1% .125W F TC = 0 + -100	24546	C4-1/8-T0-1001-F
A53R48	0757-0422	5		RESISTOR 909 1% .125W F TC = 0 + -100	24546	C4-1/8-T0-909R-F
A53R49	0757-0465	6		RESISTOR 100K 1% .125W F TC = 0 + -100	24546	C4-1/8-T0-1003-F
A53R50	0698-0085	0		RESISTOR 2.61K 1% .125W F TC = 0 + -100	24546	C4-1/8-T0-2611-F
A53R51	0698-3446	3		RESISTOR 383 1% .125W F TC = 0 + -100	24546	C4-1/8-T0-383R-F
A53R52	0698-0085	0		RESISTOR 2.61K 1% .125W F TC = 0 + -100	24546	C4-1/8-T0-2611-F
A53R53	0698-0084	9		RESISTOR 2.15K 1% .125W F TC = 0 + -100	24546	C4-1/8-T0-2151-F
A53R54	0698-3152	8		RESISTOR 3.48K 1% .125W F TC = 0 + -100	24546	C4-1/8-T0-3481-F
A53R55	0698-3459	8	1	RESISTOR 383K 1% .125W F TC = 0 + -100	28480	0698-3459
A53R56	0698-8638	5	1	RESISTOR 3.16K .1% .125W F TC = 0 + -25	28480	0698-8638
A53R57	0757-0279	0		RESISTOR 3.16K 1% .125W F TC = 0 + -100	24546	C4-1/8-T0-3161-F
A53R58	0698-3160	8		RESISTOR 31.6K 1% .125W F TC = 0 + -100	24546	C4-1/8-T0-3162-F
A53R59	0698-0083	8		RESISTOR 1.96K 1% .125W F TC = 0 + -100	24546	C4-1/8-T0-1961-F
A53R60	0698-3443	0		RESISTOR 287 1% .125W F TC = 0 + -100	24546	C4-1/8-T0-287R-F
A53R61	0698-3156	2		RESISTOR 14.7K 1% .125W F TC = 0 + -100	24546	C4-1/8-T0-1472-F
A53R62	0757-0280	3		RESISTOR 1K 1% .125W F TC = 0 + -100	24546	C4-1/8-T0-1001-F
A53R63	0757-0470	3		RESISTOR 162K 1% .125W F TC = 0 + -100	24546	C4-1/8-T0-1623-F
A53R64	0698-3444	1		RESISTOR 316 1% .125W F TC = 0 + -100	24546	C4-1/8-T0-316R-F
A53R65	0811-1557	5	1	RESISTOR 15 5% 3W PW TC = 0 + -20	28480	0811-1557
A53R66	0698-3444	1		RESISTOR 316 1% .125W F TC = 0 + -100	24546	C4-1/8-T0-316R-F

[Refer to Section 7 for update information.]

\*Factory Selected Component (Refer to Section 5).

Δ Errata part change

Table 6-3. Replaceable Parts

Reference Designation	HP Part Number	C D	Qty.	Description	Mfr. Code	Mfr. Part Number
A53R67	0699-0842	9	1	RESISTOR 6.19K 1% .125W F TC=0+-25	28480	0699-0842
A53R68	0698-3156	2		RESISTOR 14.7K 1% .125W F TC=0+-100	24546	C4-1/8-T0-1472-F
A53R69	0698-3158	4		RESISTOR 23.7K 1% .125W F TC=0+-100	24546	C4-1/8-T0-2372-F
A53R70	0698-3450	9		RESISTOR 42.2K 1% .125W F TC=0+-100	24546	C4-1/8-T0-4222-F
A53R71	0757-0442	9		RESISTOR 10K 1% .125W F TC=0+-100	24546	C4-1/8-T0-1002-F
A53R72	0757-0442	9		RESISTOR 10K 1% .125W F TC=0+-100	24546	C4-1/8-T0-1002-F
A53R73	0698-3450	9		RESISTOR 42.2K 1% .125W F TC=0+-100	24546	C4-1/8-T0-4222-F
A53R74	0698-3450	9		RESISTOR 42.2K 1% .125W F TC=0+-100	24546	C4-1/8-T0-4222-F
A53R75	0698-3406	5	1	RESISTOR 1.33K 1% .5W F TC=0+-100	28480	0698-3406
A53R76	0698-3450	9		RESISTOR 42.2K 1% .125W F TC=0+-100	24546	C4-1/8-T0-4222-F
<i>2305A TO 2413A</i>						
A63R77	0698-3391	7	1	RESISTOR 21.5 1% .5W F TC=0+-100	28480	0698-3391
<i>2414A AND ABOVE</i>						
A63R77	0698-3388	2		RESISTOR 14.7 1% .5W F TC=0+-100	28480	0698-3388
A53R78	0698-0085	0		RESISTOR 2.61K 1% .125W F TC=0+-100	24546	C4-1/8-T0-2611-F
A53TP1	1251-0600	0		CONNECTOR-SGL CONT PIN 1.14-MM-BSC-SZ SQ	28480	1251-0600
A53TP2	1251-0600	0		CONNECTOR-SGL CONT PIN 1.14-MM-BSC-SZ SQ	28480	1251-0600
A53TP3	1251-0600	0		CONNECTOR-SGL CONT PIN 1.14-MM-BSC-SZ SQ	28480	1251-0600
A53TP4	1251-0600	0		CONNECTOR-SGL CONT PIN 1.14-MM-BSC-SZ SQ	28480	1251-0600
A53TP5	1251-0600	0		CONNECTOR-SGL CONT PIN 1.14-MM-BSC-SZ SQ	28480	1251-0600
A53TP6	1251-0600	0		CONNECTOR-SGL CONT PIN 1.14-MM-BSC-SZ SQ	28480	1251-0600
A53TP7	1251-0600	0		CONNECTOR-SGL CONT PIN 1.14-MM-BSC-SZ SQ	28480	1251-0600
A53U1 <sup>Δ</sup>	1826-0990	0	1	IC OP AMP GP DUAL TO-99 PKG	28480	1826-0990
A53U2	1826-0990	0	1	IC OP AMP GP DUAL 8-DIP-C PKG	04713	MC1458U
A53U3	1826-0989	7	4	IC OP AMP GP 8-DIP-C PKG	27014	LM307J
A53U4	1826-0606	5		IC SWITCH ANLG QUAD 16-DIP-C PKG	17856	DG201BK
A53U5	1820-1195	7		IC FF TTL LS D-TYPE POS-EDGE-TRIG COM	01295	SN74LS175N
A53U6	1820-1195	7		IC FF TTL LS D-TYPE POS-EDGE-TRIG COM	01295	SN74LS175N
A53U7	1826-0043	4		IC OP AMP GP TO-99 PKG	3L585	CA307T
A53U8	1826-0606	5		IC SWITCH ANLG QUAD 16-DIP-C PKG	17856	DG201BK
A53U9	1820-1195	7		IC FF TTL LS D-TYPE POS-EDGE-TRIG COM	01295	SN74LS175N
A53U10	1820-1934	2	1	IC CONV 8-B/D/A 16-DIP-C PKG	06665	DAC-08EQ
A53U11	1820-1729	3		IC LCH TTL LS COM CLEAR 8-BIT	01295	SN74LS259N
A53U12	1820-1216	3		IC DCDR TTL LS 3-TO-8-LINE 3-INP	01295	SN74LS138N
A53U13	1826-0371	1		IC OP AMP LOW-BIAS-HIMPD TO-99 PKG	27014	LF256H
A53U14	1820-0535	7		IC DRVR TTL AND DUAL 2-INP	01295	SN75451BP
A53U15	1820-0535	7		IC DRVR TTL AND DUAL 2-INP	01295	SN75451BP
A53U16	1820-1422	3	1	IC MV TTL LS MONOSTBL RETRIG	01295	SN74LS122N
A53U17	1826-1048	1		IC OP AMP PRCN 8-DIP-C PKG	06665	OP-07CZ
A53VR1	1902-3002	3	2	DIODE-ZNR 2.37V 5% DO-7 PD=.4W TC=-.074%	28480	1902-3002
A53VR2	1902-3002	3		DIODE-ZNR 2.37V 5% DO-7 PD=.4W TC=-.074%	28480	1902-3002
A53VR3	1902-0680	7		DIODE-ZNR 1N827 6.2V 5% DO-7 PD=.4W	24046	1N827
A53VR4	1902-0947	9	1	DIODE-ZNR 3.6V 5% DO-35 PD=.4W TC=-.036%	28480	1902-0947
A53VR5	1902-0680	7		DIODE-ZNR 1N827 6.2V 5% DO-7 PD=.4W	24046	1N827

†Refer to Section 7 for update information.

\*Factory Selected Component (Refer to Section 5).

Δ Errata part change.

Table 6-3. Replaceable Parts

Reference Designation	HP Part Number	C D	Qty.	Description	Mfr. Code	Mfr. Part Number
<b>A54</b>						
<i>2305A TO 2339A</i>						
<i>A54</i>						
THE RECOMMENDED REPLACEMENT FOR ALL INSTRUMENTS IS 08902-60031						
<i>2340A AND ABOVE</i>						
<i>A54</i>	08902-60031		6	IF SYNCHRONOUS DETECTOR ASSEMBLY	28480	08902-60031
A54C1	0160-0576		5	CAPACITOR-FXD .1UF + -20% 50VDC CER	28480	0160-0576
A54C2	0160-0576		5	CAPACITOR-FXD .1UF + -20% 50VDC CER	28480	0160-0576
A54C3	0160-0576		5	CAPACITOR-FXD .1UF + -20% 50VDC CER	28480	0160-0576
<i>2305A TO 2412A</i>						
<i>A54C4</i>						
	0160-0576		5	CAPACITOR-FXD .1UF + -20% 50VDC CER	28480	0160-0576
<i>2413A AND ABOVE</i>						
<i>A54C4</i>	0160-4084		8	CAPACITOR-FXD .1UF + -20% 50VDC CER	28480	0160-4084
A54C5	0160-0576		5	CAPACITOR-FXD .1UF + -20% 50VDC CER	28480	0160-0576
A54C6	0160-0576		5	CAPACITOR-FXD .1UF + -20% 50VDC CER	28480	0160-0576
A54C7	0160-4535		4	CAPACITOR-FXD 1UF + -10% 50VDC CER	28480	0160-4535
A54C8	0160-4535		4	CAPACITOR-FXD 1UF + -10% 50VDC CER	28480	0160-4535
A54C9	0160-5469		5	CAPACITOR-FXD 1UF + -10% 50VDC CER	28480	0160-5469
A54C10	0160-4535		4	CAPACITOR-FXD 1UF + -10% 50VDC CER	28480	0160-4535
A54C11	0160-0576		5	CAPACITOR-FXD .1UF + -20% 50VDC CER	28480	0160-0576
A54C12	0160-3879		7	CAPACITOR-FXD .01UF + -20% 100VDC CER	28480	0160-3879
A54C13	0160-0576		5	CAPACITOR-FXD .1UF + -20% 50VDC CER	28480	0160-0576
A54C14	0160-3879		7	CAPACITOR-FXD .01UF + -20% 100VDC CER	28480	0160-3879
A54C15	0160-5339		8	2 CAPACITOR-FXD 8UF + -10% 50VDC MET-POLYC	28480	0160-5339
A54C16	0160-0576		5	CAPACITOR-FXD .1UF + -20% 50VDC CER	28480	0160-0576
A54C17	0160-0576		5	CAPACITOR-FXD .1UF + -20% 50VDC CER	28480	0160-0576
A54C18	0160-5339		8	CAPACITOR-FXD 8UF + -10% 50VDC MET-POLYC	28480	0160-5339
A54C19	0160-4389		6	CAPACITOR-FXD 100PF + -5PF 200VDC CER	28480	0160-4389
A54C20	0160-0576		5	CAPACITOR-FXD .1UF + -20% 50VDC CER	28480	0160-0576
A54C21	0160-3879		7	CAPACITOR-FXD .01UF + -20% 100VDC CER	28480	0160-3879
A54C22	0160-0576		5	CAPACITOR-FXD .1UF + -20% 50VDC CER	28480	0160-0576
A54C23	0160-4535		4	CAPACITOR-FXD 1UF + -10% 50VDC CER	28480	0160-4535
A54C24	0160-0576		5	CAPACITOR-FXD .1UF + -20% 50VDC CER	28480	0160-0576
A54C25	0160-0576		5	CAPACITOR-FXD .1UF + -20% 50VDC CER	28480	0160-0576
A54C26	0160-0576		5	CAPACITOR-FXD .1UF + -20% 50VDC CER	28480	0160-0576
A54C27	0160-5757		4	1 CAPACITOR-FXD 96PF + -1% 100VDC CER	28480	0160-5757
A54C28	0160-0576		5	CAPACITOR-FXD .1UF + -20% 50VDC CER	28480	0160-0576
A54C29	0160-5758		5	1 CAPACITOR-FXD 120PF + -1% 100VDC + 100 + -20	28480	0160-5758
A54C30	0160-3879		7	CAPACITOR-FXD .01UF + -20% 100VDC CER	28480	0160-3879
A54C31	0160-0576		5	CAPACITOR-FXD .1UF + -20% 50VDC CER	28480	0160-0576
A54C32	0160-0576		5	CAPACITOR-FXD .1UF + -20% 50VDC CER	28480	0160-0576
A54C33	0160-4535		4	CAPACITOR-FXD 1UF + -10% 50VDC CER	28480	0160-4535
A54C34	0160-4535		4	CAPACITOR-FXD 1UF + -10% 50VDC CER	28480	0160-4535

†Refer to Section 7 for update information

\*Factory Selected Component (Refer to Section 5)

Δ Errata part change

Table 6-3. Replaceable Parts

Reference Designation	HP Part Number	C D	Qty.	Description	Mfr. Code	Mfr. Part Number
A54C35	0160-0576	5		CAPACITOR-FXD .1UF + -20% 50VDC CER	28480	0160-0576
A54C36	0160-5469	5		CAPACITOR-FXD 1UF + -10% 50VDC CER	28480	0160-5469
A54C37	0160-4535	4		CAPACITOR-FXD 1UF + -10% 50VDC CER	28480	0160-4535
A54C38	0160-4535	4		CAPACITOR-FXD 1UF + -10% 50VDC CER	28480	0160-4535
A54C39	0160-0576	5		CAPACITOR-FXD .1UF + -20% 50VDC CER	28480	0160-0576
A54C40	0160-3879	7		CAPACITOR-FXD .01UF + -20% 100VDC CER	28480	0160-3879
A54C41	0160-0576	5		CAPACITOR-FXD .1UF + -20% 50VDC CER	28480	0160-0576
A54C42	0160-3879	7		CAPACITOR-FXD .01UF + -20% 100VDC CER	28480	0160-3879
A54C43	0160-3402	2		CAPACITOR-FXD 1UF + -5% 50VDC MET-POLYLC	28480	0160-3402
A54C44	0160-0576	5		CAPACITOR-FXD .1UF + -20% 50VDC CER	28480	0160-0576
A54C45	0160-0576	5		CAPACITOR-FXD .1UF + -20% 50VDC CER	28480	0160-0576
A54C46	0160-4535	4		CAPACITOR-FXD 1UF + -10% 50VDC CER	28480	0160-4535
A54C47	0160-0576	5		CAPACITOR-FXD .1UF + -20% 50VDC CER	28480	0160-0576
A54C48	0160-0576	5		CAPACITOR-FXD .1UF + -20% 50VDC CER	28480	0160-0576
A54C49	0160-0576	5		CAPACITOR-FXD .1UF + -20% 50VDC CER	28480	0160-0576
A54CR1	1901-0518	8		DIODE-SM SIG SCHOTTKY	28480	1901-0518
A54CR2	1901-0880	7		DIODE-GEN PRP 125MA D0-35	28480	1901-0880
A54CR3	1901-1098	1		DIODE-SWITCHING 1N4150 50V 200MA 4NS	9N171	1N4150
<i>2305A TO 2411A</i>						
A64CR4	0122-0065	7		DIODE-VVC 29PF 3%	28480	0122-0065
A64CR5	0122-0065	7		DIODE-VVC 29PF 3%	28480	0122-0065
<i>2412A AND ABOVE</i>						
A64CR4	0122-0162	5		DIODE VVC 29PF 10% BVR = 30V		
A64CR5	0122-0162	5		DIODE VVC 29PF 10% BVR = 30V		
A54CR6	1901-1098	1		DIODE-SWITCHING 1N4150 50V 200MA 4NS	9N171	1N4150
A54CR7	1901-1098	1		DIODE-SWITCHING 1N4150 50V 200MA 4NS	9N171	1N4150
A54CR8	1901-1098	1		DIODE-SWITCHING 1N4150 50V 200MA 4NS	9N171	1N4150
A54CR9	1901-0518	8		DIODE-SM SIG SCHOTTKY	28480	1901-0518
A54CR10	1901-0518	8		DIODE-SM SIG SCHOTTKY	28480	1901-0518
A54CR11	1901-1098	1		DIODE-SWITCHING 1N4150 50V 200MA 4NS	9N171	1N4150
A54CR12	1901-1098	1		DIODE-SWITCHING 1N4150 50V 200MA 4NS	9N171	1N4150
A54DS1	1990-0719	8	1	LED-LAMP LUM-INT = 1MCD IF = 20MA-MAX BVR = 5V	28480	HLMP-13015
A54DS2	1990-0326	3		LED-LAMP LUM-INT = 300UCD IF = 50MA-MAX	28480	5082-4444
A54E1	9170-0029	3		CORE-SHIELDING BEAD	28480	9170-0029
A54E2				NOT ASSIGNED		
A54E3				NOT ASSIGNED		
A54E4	9170-0029	3		CORE-SHIELDING BEAD	28480	9170-0029
A54E5	9170-0029	3		CORE-SHIELDING BEAD	28480	9170-0029
A54E6	9170-0029	3		CORE-SHIELDING BEAD	28480	9170-0029
A54J1	1250-1425	7		CONNECTOR-RF SMC M SGL-HOLE-RR 50-OHM	28480	1250-1425
A54J2	1250-1425	7		CONNECTOR-RF SMC M SGL-HOLE-RR 50-OHM	28480	1250-1425
A54L1	9140-0137	1		INDUCTOR RF-CH-MLD 1MH 5% .2DX.45LG Q = 60	28480	9140-0137
A54L2	9140-0137	1		INDUCTOR RF-CH-MLD 1MH 5% .2DX.45LG Q = 60	28480	9140-0137
A54L3	08902-80002	3	2	INDUCTOR 1MHY	28480	08902-80002
A54L4	08902-80002	3		INDUCTOR 1MHY	28480	08902-80002

† Refer to Section 7 for update information.

\* Factory Selected Component (Refer to Section 5).

Δ Errata part change

Table 6-3. Replaceable Parts

Reference Designation	HP Part Number	C D	Qty.	Description	Mfr. Code	Mfr. Part Number
A54MP1	08902-00011	6	1	COVER-TRKG DTECT	28480	08902-00011
	2190-0008	3		WASHER-LK EXT T NO. 6 .141-IN-ID	28480	2190-0008
	2360-0113	2		SCREW-MACH 6-32 .25-IN-LG PAN-HD-POZI	00000	ORDER BY DESCRIPTION
A54MP2	5001-0176	0	GROUND STRAP	28480	5001-0176	
A54MP3	5001-0176	0	GROUND STRAP	28480	5001-0176	
A54Q1	1854-0810	2		TRANSISTOR NPN SI PD = 625MW FT = 200MHZ	28480	1854-0810
A54Q2	1854-0810	2		TRANSISTOR NPN SI PD = 625MW FT = 200MHZ	28480	1854-0810
A54Q3	1854-0810	2		TRANSISTOR NPN SI PD = 625MW FT = 200MHZ	28480	1854-0810
A54Q4	1854-0810	2		TRANSISTOR NPN SI PD = 625MW FT = 200MHZ	28480	1854-0810
A54Q5	1858-0049	7	1	TRANSISTOR ARRAY 16-PIN PLSTC DIP	28480	1858-0049
A54Q6	1854-0810	2		TRANSISTOR NPN SI PD = 625MW FT = 200MHZ	28480	1854-0810
A54Q7	1855-0414	4		TRANSISTOR J-FET 2N4393 N-CHAN D-MODE	04713	2N4393
A54Q8	1854-0810	2		TRANSISTOR NPN SI PD = 625MW FT = 200MHZ	28480	1854-0810
A54Q9	1854-0810	2		TRANSISTOR NPN SI PD = 625MW FT = 200MHZ	28480	1854-0810
A54R1	0698-7204	9		RESISTOR 46.4 1% .05W F TC = 0 + -100	24546	C3-1/8-T0-46R4-F
A54R2	0698-7236	7		RESISTOR 1K 1% .05W F TC = 0 + -100	24546	C3-1/8-T0-1001-F
A54R3	0698-7212	9		RESISTOR 100 1% .05W F TC = 0 + -100	24546	C3-1/8-T0-100R-F
A54R4	1810-0206	8		NETWORK-RES 8-SIP10.0K OHM X 7	01121	208A103
A54R5	0698-7247	0		RESISTOR 2.87K 1% .05W F TC = 0 + -100	24546	C3-1/8-T0-2871-F
A54R6	0698-7223	2		RESISTOR 750 1% .05W F TC = 0 + -100	24546	C3-1/8-T0-750R-F
A54R7	0698-7255	0	5	RESISTOR 6.19K 1% .05W F TC = 0 + -100	24546	C3-1/8-T0-6191-F
A54R8	0698-7227	6		RESISTOR 422 1% .05W F TC = 0 + -100	24546	C3-1/8-T0-422R-F
A54R9	0698-7245	8	5	RESISTOR 2.37K 1% .05W F TC = 0 + -100	24546	C3-1/8-T0-2371-F
A54R10	0698-7229	8		RESISTOR 511 1% .05W F TC = 0 + -100	24546	C3-1/8-T0-511R-F
A54R11	0698-7212	9		RESISTOR 100 1% .05W F TC = 0 + -100	24546	C3-1/8-T0-100R-F
A54R12	0698-7251	6		RESISTOR 4.22K 1% .05W F TC = 0 + -100	24546	C3-1/8-T0-4221-F
A54R13	0698-7216	3		RESISTOR 147 1% .05W F TC = 0 + -100	24546	C3-1/8-T0-147R-F
A54R14	0698-7262	9		RESISTOR 12.1K 1% .05W F TC = 0 + -100	24546	C3-1/8-T0-1212-F
A54R15	0698-7255	0		RESISTOR 6.19K 1% .05W F TC = 0 + -100	24546	C3-1/8-T0-6191-F
A54R16	0698-8475	8		RESISTOR 1.799K .1% .1W F TC = 0 + -5	28480	0698-8475
A54R17	2100-3756	5	2	RESISTOR-TRMR 20 10% C SIDE-ADJ 17-TRN	28480	2100-3756
A54R18	0698-8475	8		RESISTOR 1.799K .1% .1W F TC = 0 + -5	28480	0698-8475
A54R19	0698-7284	5		RESISTOR 100K 1% .05W F TC = 0 + -100	24546	C3-1/8-T0-1003-F
A54R20	0698-7284	5		RESISTOR 100K 1% .05W F TC = 0 + -100	24546	C3-1/8-T0-1003-F
A54R21	0699-0068	1	1	RESISTOR 1.47M 1% .125W F TC = 0 + -100	28480	0699-0068
A54R22	0698-7268	5	5	RESISTOR 21.5K 1% .05W F TC = 0 + -100	24546	C3-1/8-T0-2152-F
A54R23	0698-7245	8		RESISTOR 2.37K 1% .05W F TC = 0 + -100	24546	C3-1/8-T0-2371-F
A54R24*	0698-7240	3	5	RESISTOR 1.47K 1% .05W F TC = 0 + -100	24546	C3-1/8-T0-1471-F
A54R25*	0699-1502	0	1	RESISTOR 5.5M 1% .125W F TC = 0 + -150	28480	0699-1502
A54R26	0698-7268	5		RESISTOR 21.5K 1% .05W F TC = 0 + -100	24546	C3-1/8-T0-2152-F
A54R27	0698-7244	7		RESISTOR 2.15K 1% .05W F TC = 0 + -100	24546	C3-1/8-T0-2151-F
A54R28	0698-7262	9		RESISTOR 12.1K 1% .05W F TC = 0 + -100	24546	C3-1/8-T0-1212-F
A54R29	0699-0073	8	1	RESISTOR 10M 1% .125W F TC = 0 + -150	28480	0699-0073
A54R30	0698-7288	9		RESISTOR 147K 1% .05W F TC = 0 + -100	24546	C3-1/8-T0-1473-F
A54R31	0698-7268	5		RESISTOR 21.5K 1% .05W F TC = 0 + -100	24546	C3-1/8-T0-2152-F
A54R32	0698-7261	8		RESISTOR 11K 1% .05W F TC = 0 + -100	24546	C3-1/8-T0-1102-F
A54R33	0698-7227	6		RESISTOR 422 1% .05W F TC = 0 + -100	24546	C3-1/8-T0-422R-F
A54R34	0698-7247	0		RESISTOR 2.87K 1% .05W F TC = 0 + -100	24546	C3-1/8-T0-2871-F
A54R35	0698-7258	3		RESISTOR 8.25K 1% .05W F TC = 0 + -100	24546	C3-1/8-T0-8251-F

\* Refer to Section 7 for update information.

\* Factory Selected Component (Refer to Section 5).

△ Errata part change.



Table 6-3. Replaceable Parts

Reference Designation	HP Part Number	C D	Qty.	Description	Mfr. Code	Mfr. Part Number
A54R36	0698-7236	7		RESISTOR 1K 1% .05W F TC = 0 + -100	24546	C3-1/8-T0-1001-F
A54R37	0698-7262	9		RESISTOR 12.1K 1% .05W F TC = 0 + -100	24546	C3-1/8-T0-1212-F
A54R38	0698-7247	0		RESISTOR 2.87K 1% .05W F TC = 0 + -100	24546	C3-1/8-T0-2871-F
A54R39	0698-7236	7		RESISTOR 1K 1% .05W F TC = 0 + -100	24546	C3-1/8-T0-1001-F
A54R40	0698-7232	3		RESISTOR 681 1% .05W F TC = 0 + -100	24546	C3-1/8-T0-681R-F
A54R41	0698-7247	0		RESISTOR 2.87K 1% .05W F TC = 0 + -100	24546	C3-1/8-T0-2871-F
A54R42	0698-7247	0		RESISTOR 2.87K 1% .05W F TC = 0 + -100	24546	C3-1/8-T0-2871-F
A54R43	0698-7245	8		RESISTOR 2.37K 1% .05W F TC = 0 + -100	24546	C3-1/8-T0-2371-F
A54R44	0698-7212	9		RESISTOR 100 1% .05W F TC = 0 + -100	24546	C3-1/8-T0-100R-F
A54R45	0698-7268	5		RESISTOR 21.5K 1% .05W F TC = 0 + -100	24546	C3-1/8-T0-2152-F
A54R46	0699-0843	0	2	RESISTOR 2.87K .1% .125W F TC = 0 + -25	28480	0699-0843
A54R47	0698-7254	9	1	RESISTOR 5.62K 1% .05W F TC = 0 + -100	24546	C3-1/8-T0-5621-F
A54R48	0698-7227	6		RESISTOR 422 1% .05W F TC = 0 + -100	24546	C3-1/8-T0-422R-F
A54R49	0698-7249	2		RESISTOR 3.48K 1% .05W F TC = 0 + -100	24546	C3-1/8-T0-3481-F
A54R50	0699-0843	0		RESISTOR 2.87K .1% .125W F TC = 0 + -25	28480	0699-0843
A54R51	0698-7212	9		RESISTOR 100 1% .05W F TC = 0 + -100	24546	C3-1/8-T0-100R-F
A54R52	0698-7268	5		RESISTOR 21.5K 1% .05W F TC = 0 + -100	24546	C3-1/8-T0-2152-F
A54R53	0698-7247	0		RESISTOR 2.87K 1% .05W F TC = 0 + -100	24546	C3-1/8-T0-2871-F
A54R54	0698-7245	8		RESISTOR 2.37K 1% .05W F TC = 0 + -100	24546	C3-1/8-T0-2371-F
A54R55	0698-7257	2		RESISTOR 7.5K 1% .05W F TC = 0 + -100	24546	C3-1/8-T0-7501-F
A54R56	0698-7262	9		RESISTOR 12.1K 1% .05W F TC = 0 + -100	24546	C3-1/8-T0-1212-F
A54R57	0698-7212	9		RESISTOR 100 1% .05W F TC = 0 + -100	24546	C3-1/8-T0-100R-F
A54R58	0698-7255	0		RESISTOR 6.19K 1% .05W F TC = 0 + -100	24546	C3-1/8-T0-6191-F
A54R59	0698-7227	6		RESISTOR 422 1% .05W F TC = 0 + -100	24546	C3-1/8-T0-422R-F
A54R60	0698-7236	7		RESISTOR 1K 1% .05W F TC = 0 + -100	24546	C3-1/8-T0-1001-F
A54R61	0698-7255	0		RESISTOR 6.19K 1% .05W F TC = 0 + -100	24546	C3-1/8-T0-6191-F
A54R62	0698-7236	7		RESISTOR 1K 1% .05W F TC = 0 + -100	24546	C3-1/8-T0-1001-F
A54R63	0698-7245	8		RESISTOR 2.37K 1% .05W F TC = 0 + -100	24546	C3-1/8-T0-2371-F
A54R64	0698-7229	8		RESISTOR 511 1% .05W F TC = 0 + -100	24546	C3-1/8-T0-511R-F
A54R65	0698-7212	9		RESISTOR 100 1% .05W F TC = 0 + -100	24546	C3-1/8-T0-100R-F
A54R66	0698-7288	9		RESISTOR 147K 1% .05W F TC = 0 + -100	24546	C3-1/8-T0-1473-F
A54R67	0698-7249	2		RESISTOR 3.48K 1% .05W F TC = 0 + -100	24546	C3-1/8-T0-3481-F
A54R68	0698-7223	2	1	RESISTOR 287 1% .05W F TC = 0 + -100	24546	C3-1/8-T0-287R-F
A54R69	0698-3445	2		RESISTOR 348 1% .125W F TC = 0 + -100	24546	C4-1/8-T0-348R-F
A54R70	0698-7236	7		RESISTOR 1K 1% .05W F TC = 0 + -100	24546	C3-1/8-T0-1001-F
A54R71	0698-7262	9		RESISTOR 12.1K 1% .05W F TC = 0 + -100	24546	C3-1/8-T0-1212-F
A54R72	0698-7251	6		RESISTOR 4.22K 1% .05W F TC = 0 + -100	24546	C3-1/8-T0-4221-F
A54R73	0698-7241	4	1	RESISTOR 1.62K 1% .05W F TC = 0 + -100	24546	C3-1/8-T0-1621-F
A54R74	0698-8475	8		RESISTOR 1.799K .1% .1W F TC = 0 + -5	28480	0698-8475
A54R75	0698-7284	5		RESISTOR 100K 1% .05W F TC = 0 + -100	24546	C3-1/8-T0-1003-F
A54R76	2100-3756	5		RESISTOR-TRMR 20 10% C SIDE-ADJ 17-TRN	28480	2100-3756
A54R77	0698-8475	8		RESISTOR 1.799K .1% .1W F TC = 0 + -5	28480	0698-8475
A54R78	0698-7212	9		RESISTOR 100 1% .05W F TC = 0 + -100	24546	C3-1/8-T0-100R-F
A54R79	0698-7212	9		RESISTOR 100 1% .05W F TC = 0 + -100	24546	C3-1/8-T0-100R-F
A54R80	0699-0118	2		RESISTOR 20K .1% .1W F TC = 0 + -5	28480	0699-0118
A54R81	0699-0118	2		RESISTOR 20K .1% .1W F TC = 0 + -5	28480	0699-0118
A54R82	0698-7262	9		RESISTOR 12.1K 1% .05W F TC = 0 + -100	24546	C3-1/8-T0-1212-F
A54R83	0698-7236	7		RESISTOR 1K 1% .05W F TC = 0 + -100	24546	C3-1/8-T0-1001-F
A54R84	0698-8824	1	1	RESISTOR 562K 1% .125W F TC = 0 + -100	28480	0698-8824
A54R85	0698-8812	7		RESISTOR 1 1% .125W F TC = 0 + -100	28480	0698-8812

†Refer to Section 7 for update information.

\*Factory Selected Component (Refer to Section 5)

Δ Errata part change.

Table 6-3. Replaceable Parts

Reference Designation	HP Part Number	C D	Qty.	Description	Mfr. Code	Mfr. Part Number
A54R86	0698-7247	0		RESISTOR 2.87K 1% .05W F TC = 0 + -100	24546	C3-1/8-TO-2871-F
A54R87	0698-7244	7		RESISTOR 2.15K 1% .05W F TC = 0 + -100	24546	C3-1/8-TO-2151-F
A54TP1	1251-0600	0		CONNECTOR-SGL CONT PIN 1.14-MM-BSC-SZ SQ	28480	1251-0600
A54TP2	1251-0600	0		CONNECTOR-SGL CONT PIN 1.14-MM-BSC-SZ SQ	28480	1251-0600
A54TP3	1251-0600	0		CONNECTOR-SGL CONT PIN 1.14-MM-BSC-SZ SQ	28480	1251-0600
A54TP5	1251-0600	0		CONNECTOR-SGL CONT PIN 1.14-MM-BSC-SZ SQ	28480	1251-0600
A54U1	1826-1048	7	1	IC OP AMP PRCN 8-DIP-C PKG	28480	1826-1048
A54U2	1820-0427	6	2	IC MODULATOR TO-100 PKG	04713	MC1496G
A54U3	1820-0427	6		IC MODULATOR TO-100 PKG	04713	MC1496G
A54U4	1826-1048	7		IC OP AMP PRCN 8-DIP-C PKG	28480	1826-1048
A54U5	1826-0753	3		IC OP AMP LOW-BIAS-HIMPD QUAD 14-DIP-C	04713	MC34004BL
A54U6	1826-0606	5		IC SWITCH ANLG QUAD 16-DIP-C PKG	17856	DG201BK
A54U7	1826-0752	2	1	IC CONV 12-B-D/A 16-DIP-C PKG	24355	AD7542BD
A54U8	1826-0191	3		IC COMPARATOR GP DUAL TO-100 PKG	27014	LM319H
A54U9	1820-1729	3		IC LCH TTL LS COM CLEAR 8-BIT	01295	SN74LS259N

†Refer to Section 7 for update information

\*Factory Selected Component (Refer to Section 5)

Δ Errata part change

Table 6-3. Replaceable Parts

Reference Designation	HP Part Number	C D	Qty.	Description	Mfr. Code	Mfr. Part Number
<b>A55</b>						
<i>2305A TO 2530A</i>						
A55	08902-60003	2	1	IF AMPLIFIER/FILTER ASSEMBLY	28480	08902-60003
<i>2535A AND ABOVE</i>						
A55	08902-60105	5	1	IF AMPLIFIER/FILTER ASSEMBLY	28480	08902-60105
A55C1	0160-0576	5		CAPACITOR-FXD .1UF + -20% 50VDC CER	28480	0160-0576
A55C2	0180-0094	4		CAPACITOR-FXD 100UF + 75-10% 25VDC AL	56289	30D107G025DD2
A55C3	0180-0094	4		CAPACITOR-FXD 100UF + 75-10% 25VDC AL	56289	30D107G025DD2
A55C4	0160-0576	5		CAPACITOR-FXD .1UF + -20% 50VDC CER	28480	0160-0576
A55C5	0180-2929	8		CAPACITOR-FXD 68UF + -10% 10VDC TA	28480	0180-2929
A55C6	0160-0576	5		CAPACITOR-FXD .1UF + -20% 50VDC CER	28480	0160-0576
A55C7	0160-4535	4		CAPACITOR-FXD 1UF + -10% 50VDC CER	28480	0160-4535
A55C8	0160-4535	4		CAPACITOR-FXD 1UF + -10% 50VDC CER	28480	0160-4535
<i>2305A TO 2530A</i>						
<i>A55C9</i>						
NOT ASSIGNED						
<i>2535A AND ABOVE</i>						
A55C9	0160-4535	4		CAPACITOR-FXD 1UF + -10% 50VDC CER	28480	0160-4535
A55C10	0160-0576	5		CAPACITOR-FXD .1UF + -20% 50VDC CER	28480	0160-0576
A55C11	0160-4535	4		CAPACITOR-FXD 1UF + -10% 50VDC CER	28480	0160-4535
A55C12	0160-4535	4		CAPACITOR-FXD 1UF + -10% 50VDC CER	28480	0160-4535
A55C13	0160-4535	4		CAPACITOR-FXD 1UF + -10% 50VDC CER	28480	0160-4535
A55C14	0160-0576	5		CAPACITOR-FXD .1UF + -20% 50VDC CER	28480	0160-0576
A55C15	0160-4535	4		CAPACITOR-FXD 1UF + -10% 50VDC CER	28480	0160-4535
A55C16	0160-4535	4		CAPACITOR-FXD 1UF + -10% 50VDC CER	28480	0160-4535
A55C17	0160-5469	5		CAPACITOR-FXD 1UF + -10% 50VDC CER	28480	0160-5469
A55C18	0160-5469	5		CAPACITOR-FXD 1UF + -10% 50VDC CER	28480	0160-5469
A55C19	0160-4386	3		CAPACITOR-FXD 33PF + -5% 200VDC CER 0 + -30	28480	0160-4386
A55C20	0160-0576	5		CAPACITOR-FXD .1UF + -20% 50VDC CER	28480	0160-0576
A55C21 <sup>Δ</sup>	0160-5719	8	4	CAPACITOR-FXD 620PF + -5% 100VDC CER	28480	0160-5719
A55C22	0160-4896	0	1	CAPACITOR-FXD 47PF + -2% 200VDC CER 0 + -30	28480	0160-4896
A55C23	0160-4825	5		CAPACITOR-FXD 560PF + -5% 100VDC CER	28480	0160-4825
A55C24	0121-0105	4		CAPACITOR-V TRMR-CER 9-35PF 200V PC-MTG	52763	304324 9/35PF N650
A55C25	0160-0573	2		CAPACITOR-FXD 4700PF + -20% 100VDC CER	28480	0160-0573
A55C26	0160-4887	9	1	CAPACITOR-FXD 25PF + -2% 200VDC CER 0 + -30	28480	0160-4887
A55C27 <sup>Δ</sup>	0160-5719	8	4	CAPACITOR-FXD 620PF + -5% 100VDC CER	28480	0160-5719
A55C28	0160-4781	2	1	CAPACITOR-FXD 27PF + -2% 200VDC CER 0 + -30	28480	0160-4781

<sup>1</sup>Refer to Section 7 for update information.

<sup>\*</sup>Factory Selected Component (Refer to Section 5).

<sup>Δ</sup> Errata part change.

*Table 6-3. Replaceable Parts*

Reference Designation	HP Part Number	C D	Qty.	Description	Mfr. Code	Mfr. Part Number
A55C29 <sup>Δ</sup>	0160-5719	8	4	CAPACITOR-FXD 620PF + -5% 100VDC CER	28480	0160-5719
A55C30	0160-4535	4		CAPACITOR-FXD 1UF + -10% 50VDC CER	28480	0160-4535
A55C31	0160-4535	4		CAPACITOR-FXD 1UF + -10% 50VDC CER	28480	0160-4535
A55C32	0160-4535	4		CAPACITOR-FXD 1UF + -10% 50VDC CER	28480	0160-4535
A55C33	0160-4782	3	1	CAPACITOR-FXD 33PF + -2% 200VDC CER 0 + -30	28480	0160-4782
A55C34	0160-4535	4		CAPACITOR-FXD 1UF + -10% 50VDC CER	28480	0160-4535
<i>2305A TO 2530A</i>						
A55C35	0160-4383	0	1	CAPACITOR-FXD 6.8PF + -.5PF 200VDC CER	20932	5024E0200RD689D
<i>2535A AND ABOVE</i>						
A55C35				NOT ASSIGNED		
A55C36 <sup>Δ</sup>	0160-5719	8	4	CAPACITOR-FXD 620PF + -5% 100VDC CER	28480	0160-5719
A55C37	0160-5469	5		CAPACITOR-FXD 1UF + -10% 50VDC CER	28480	0160-5469
A55C38	0160-4791	4		CAPACITOR-FXD 10PF + -5% 100VDC CER 0 + -30	28480	0160-4791
A55C39	0160-4535	4		CAPACITOR-FXD 1UF + -10% 50VDC CER	28480	0160-4535
A55CR1	1901-0518	8		DIODE-SM SIG SCHOTTKY	28480	1901-0518
A55CR2	1901-0518	8		DIODE-SM SIG SCHOTTKY	28480	1901-0518
A55CR3	1901-0518	8		DIODE-SM SIG SCHOTTKY	28480	1901-0518
A55CR4	1901-0518	8		DIODE-SM SIG SCHOTTKY	28480	1901-0518
<i>2305A TO 2530A</i>						
A55J1	1250-1220	0		CONNECTOR-RF SMC M PC 50-OHM	28480	1250-1220
	2190-0124	4		WASHER-LK INTL T NO. 10 .195-IN-ID	28480	2190-0124
	2950-0078	9		NUT-HEX-DBL-CHAM 10-32-THD .067-IN-THK	28480	2950-0078
A55J2	1250-1220	0		CONNECTOR-RF SMC M PC 50-OHM	28480	1250-1220
	2190-0124	4		WASHER-LK INTL T NO. 10 .195-IN-ID	28480	2190-0124
	2950-0078	9		NUT-HEX-DBL-CHAM 10-32-THD .067-IN-THK	28480	2950-0078
<i>2535A AND ABOVE</i>						
A55J1	1250-1425	7		CONNECTOR-RF SMC M SGL-HOLE-RR 50 OHM	28480	1250-1425
	2190-0124	4		WASHER-LK INTL T NO. 10 .195-IN-ID	28480	2190-0124
	2950-0078	9		NUT-HEX-DBL-CHAM 10-32-THD .067-IN-THK	28480	2950-0078
A55J2	1250-1425	7		CONNECTOR-RF SMC M SGL-HOLE-RR 50 OHM	28480	1250-1425
	2190-0124	4		WASHER-LK INTL T NO. 10 .195-IN-ID	28480	2190-0124
	2950-0078	9		NUT-HEX-DBL-CHAM 10-32-THD .067-IN-THK	28480	2950-0078
A55L1	9100-1629	4	2	INDUCTOR RF-CH-MLD 47UH 5% .166DX.385LG	28480	9100-1629
A55L2	9100-1629	4		INDUCTOR RF-CH-MLD 47UH 5% .166DX.385LG	28480	9100-1629
A55L3	08902-80001	2	5	INDUCTOR 180UH	28480	08902-80001
A55L4	08902-80001	2		INDUCTOR 180UH	28480	08902-80001
A55L5	08902-80001	2		INDUCTOR 180UH	28480	08902-80001
A55L6	08902-80001	2		INDUCTOR 180UH	28480	08902-80001
A55L7	08902-80001	2		INDUCTOR 180UH	28480	08902-80001
A55MP1	08902-00014	9	1	COVER IF AMP FTR	28480	08902-00014
	2190-0008	3		WASHER-LK EXT T NO. 6 .141-IN-ID	28480	2190-0008
	2360-0113	2		SCREW-MACH 6-32 .25-IN-LG PAN-HD-POZI	00000	ORDER BY DESCRIPTION
A55MP2	08902-00012	7	1	SHIELD CAN	28480	08902-00012
A55MP3	2200-0171	4	2	SCREW-MACH 4-40 .750-IN-LG 82 DEG	00000	ORDER BY DESCRIPTION

† Refer to Section 7 for update information.

\* Factory Selected Component (Refer to Section 5)

Δ Errata part change

Table 6-3. Replaceable Parts

Reference Designation	HP Part Number	C D	Qty.	Description	Mfr. Code	Mfr. Part Number
A55Q1	1854-0810	2		TRANSISTOR NPN SI PD = 625MW FT = 200MHZ	28480	1854-0810
A55Q2	1853-0430	0	4	TRANSISTOR PNP 2N4959 SI TO-72 PD = 200MW	04713	2N4959
<i>2305A TO 2530A</i>						
A55Q3	1855-0420	2		TRANSISTOR J-FET 2N4391 N-CHAN D-MODE	01295	2N4391
<i>2535A AND ABOVE</i>						
A55Q3	1855-0292	6		TRANSISTOR J-FET 2N5432 N-CHAN D-MODE	17856	2N5432
A55Q4	1853-0430	0		TRANSISTOR PNP 2N4959 SI TO-72 PD = 200MW	04713	2N4959
A55Q5	1854-0810	2		TRANSISTOR NPN SI PD = 625MW FT = 200MHZ	28480	1854-0810
A55Q6	1855-0420	2		TRANSISTOR J-FET 2N4391 N-CHAN D-MODE	01295	2N4391
A55Q7	1855-0420	2		TRANSISTOR J-FET 2N4391 N-CHAN D-MODE	01295	2N4391
A55Q8	1854-0810	2		TRANSISTOR NPN SI PD = 625MW FT = 200MHZ	28480	1854-0810
A55Q9	1853-0430	0		TRANSISTOR PNP 2N4959 SI TO-72 PD = 200MW	04713	2N4959
A55Q10	1853-0430	0		TRANSISTOR PNP 2N4959 SI TO-72 PD = 200MW	04713	2N4959
A55Q11	1854-0810	2		TRANSISTOR NPN SI PD = 625MW FT = 200MHZ	28480	1854-0810
A55R1	0699-0678	9	2	RESISTOR 900 .01% .1W F TC = 0 + -5	28480	0699-0678
A55R2	0699-0681	4	3	RESISTOR 100 .01% .1W F TC = 0 + -5	28480	0699-0681
A55R3	0698-7203	8	2	RESISTOR 42.2 1% .05W F TC = 0 + -100	24546	C3-1/8-TO-42R2-F
A55R4	0698-4593	3	1	RESISTOR 464 1% .25W F TC = 0 + -100	24546	C5-1/4-TO-464R-F
A55R5	0698-7205	0		RESISTOR 51.1 1% .05W F TC = 0 + -100	24546	C3-1/8-TO-51R1-F
A55R6	0698-7244	7		RESISTOR 2.15K 1% .05W F TC = 0 + -100	24546	C3-1/8-TO-2151-F
A55R7	0698-3442	2		RESISTOR 237 1% .125W F TC = 0 + -100	24546	C4-1/8-TO-237R-F
A55R8	0698-3429	9		RESISTOR 19.6 1% .125W F TC = 0 + -100	03888	PME55-1/8-TO-19R6-F
A55R9	0699-0678	9		RESISTOR 900 .01% .1W F TC = 0 + -5	28480	0699-0678
A55R10	0699-0681	4		RESISTOR 100 .01% .1W F TC = 0 + -5	28480	0699-0681
A55R11	0698-7210	7	1	RESISTOR 82.5 1% .05W F TC = 0 + -100	24546	C3-1/8-TO-82R5-F
A55R12	0757-0274	5		RESISTOR 1.21K 1% .125W F TC = 0 + -100	24546	C4-1/8-TO-1211-F
A55R13	0698-7204	9		RESISTOR 46.4 1% .05W F TC = 0 + -100	24546	C3-1/8-TO-46R4-F
A55R14	0698-7244	7		RESISTOR 2.15K 1% .05W F TC = 0 + -100	24546	C3-1/8-TO-2151-F
A55R15	0698-7227	6		RESISTOR 422 1% .05W F TC = 0 + -100	24546	C3-1/8-TO-422R-F
A55R16	0698-3429	2		RESISTOR 19.6 1% .125W F TC = 0 + -100	03888	PME55-1/8-TO-19R6-F
A55R17	0698-0084	9		RESISTOR 2.15K 1% .125W F TC = 0 + -100	24546	C4-1/8-TO-2151-F
A55R18	0698-3429	2		RESISTOR 19.6 1% .125W F TC = 0 + -100	03888	PME55-1/8-TO-19R6-F
<i>2305A TO 2338A</i>						
A55R19	0699-0679	0	1	RESISTOR 683.8 .01% .1W F TC = 0 + -5	28480	0699-0679
A55R20	0699-0680	3		RESISTOR 216.2 .01% .1W F TC = 0 + -5	28480	0699-0680
<i>2339A AND 2340A</i>						
A55R19	0698-1149	3		RESISTOR 683.7 + -0.01% .1W F TC = 0 + -5	28480	0698-1149
A55R20	0699-1150	6		RESISTOR 216.4 + -0.01% .1W F TC = 0 + -5	28480	0698-1150
<i>2341A AND 2342A</i>						
A55R19	0699-0679	0	1	RESISTOR 683.8 .01% .1W F TC = 0 + -5	28480	0699-0679
A55R20	0699-0680	3	1	RESISTOR 216.2 .01% .1W F TC = 0 + -5	28480	0699-0680
<i>2343A AND ABOVE</i>						
A55R19	0699-1149	3		RESISTOR 683.7 + -0.01% .1W F TC = 0 + -5	28480	0699-1149
A55R20	0699-1150	6		RESISTOR 216.4 + -0.01% .1W F TC = 0 + -5	28480	0698-1150

† Refer to Section 7 for update information

\* Factory Selected Component (Refer to Section 5)

Δ Errata part change

Table 6-3. Replaceable Parts

Reference Designation	HP Part Number	C D	Qty.	Description	Mfr. Code	Mfr. Part Number
A55R21	0699-0681	4		RESISTOR 100 .01% .1W F TC = 0 + -5	28480	0699-0681
A55R22	0698-7220	9		RESISTOR 215 1% .05W F TC = 0 + -100	24546	C3-1/8-T0-215R-F
A55R23	0698-7214	1	1	RESISTOR 121 1% .05W F TC = 0 + -100	24546	C3-1/8-T0-121R-F
A55R24	0698-7203	8		RESISTOR 42.2 1% .05W F TC = 0 + -100	24546	C3-1/8-T0-42R2-F
A55R25	0698-7233	4	1	RESISTOR 750 1% .05W F TC = 0 + -100	24546	C3-1/8-T0-750R-F
A55R26	0698-7253	8		RESISTOR 5.11K 1% .05W F TC = 0 + -100	24546	C3-1/8-T0-5111-F
A55R27	0698-7244	7		RESISTOR 2.15K 1% .05W F TC = 0 + -100	24546	C3-1/8-T0-2151-F
A55R28	0698-3429	2		RESISTOR 19.6 1% .125W F TC = 0 + -100	03888	PME55-1/8-T0-19R6-F
A55R29	0757-0733	1	2	RESISTOR 1.1K 1% .25W F TC = 0 + -100	28480	0757-0733
A55R30	0698-7212	9		RESISTOR 100 1% .05W F TC = 0 + -100	24546	C3-1/8-T0-100R-F
A55R31	0698-3429	2		RESISTOR 19.6 1% .125W F TC = 0 + -100	03888	PME55-1/8-T0-19R6-F
A55R32	0698-7242	5		RESISTOR 1.78K 1% .05W F TC = 0 + -100	24546	C3-1/8-T0-1781-F
A55R33	2100-0545	4	1	RESISTOR-TRMR 1K 10% C SIDE-ADJ 17-TRN	32997	3292X-1-102
A55R34	0698-7237	8	1	RESISTOR 1.1K 1% .05W F TC = 0 + -100	24546	C3-1/8-T0-1101-F
A55R35	0698-7284	5		RESISTOR 100K 1% .05W F TC = 0 + -100	24546	C3-1/8-T0-1003-F
A55R36	0698-7253	8		RESISTOR 5.11K 1% .05W F TC = 0 + -100	24546	C3-1/8-T0-5111-F
A55R37	0698-7284	5		RESISTOR 100K 1% .05W F TC = 0 + -100	24546	C3-1/8-T0-1003-F
A55R38	2100-3732	7	1	RESISTOR-TRMR 500 10% C SIDE-ADJ 17-TRN	28480	2100-3732
<i>2305A TO 2630A</i>						
A55R39	0698-7212	9		RESISTOR 100 1% .05W F TC = 0 + -100	24546	C3-1/8-T0-100R-F
<i>2635A AND ABOVE</i>						
A55R39	0698-7225	4	1	RESISTOR 348 1% .05W F TC = 0 + -100	24546	C3-1/8-T0-348R-F
A55R40	0698-7240	3		RESISTOR 1.47K 1% .05W F TC = 0 + -100	24546	C3-1/8-T0-1471-F
A55R41	0757-0424	7		RESISTOR 1.1K 1% .125W F TC = 0 + -100	24546	C4-1/8-T0-1101-F
<i>2305A TO 2630A</i>						
A55R42	0698-7225	4	1	RESISTOR 348 1% .05W F TC = 0 + -100	24546	C3-1/8-T0-348R-F
<i>2635A AND ABOVE</i>						
A55R42	0698-7233	4		RESISTOR 750 1% .05W F TC = 0 + -100	24546	C3-1/8-T0-750R-F
A55R43	0698-3429	2		RESISTOR 19.6 1% .125W F TC = 0 + -100	03888	PME55-1/8-T0-19R6-F
A55R44	0698-7220	9		RESISTOR 215 1% .05W F TC = 0 + -100	24546	C3-1/8-T0-215R-F
A55R45	0698-3429	2		RESISTOR 19.6 1% .125W F TC = 0 + -100	03888	PME55-1/8-T0-19R6-F
A55R46	0757-0733	1		RESISTOR 1.1K 1% .25W F TC = 0 + -100	28480	0757-0733
A55R47	0698-7255	0		RESISTOR 6.19K 1% .05W F TC = 0 + -100	24546	C3-1/8-T0-6191-F
A55R48	2100-3759	8	1	RESISTOR-TRMR 2K 10% C SIDE-ADJ 17-TRN	28480	2100-3759
A55R49	0698-7212	9		RESISTOR 100 1% .05W F TC = 0 + -100	24546	C3-1/8-T0-100R-F
A55R50	0698-7284	5		RESISTOR 100K 1% .05W F TC = 0 + -100	24546	C3-1/8-T0-1003-F
<i>2305A TO 2630A</i>						
A55R51				NOT ASSIGNED		
<i>2635A AND ABOVE</i>						
A55R51	0698-7204	9		RESISTOR 46.4 1% .05W F TC = 0 + -100	24546	C3-1/8-T0-46R4-F

† Refer to Section 7 for update information.

\* Factory Selected Component (Refer to Section 5).

Δ Errata part change

*Table 6-3. Replaceable Parts*

Reference Designation	HP Part Number	C D	Qty.	Description	Mfr. Code	Mfr. Part Number
A55TP1	1251-0600	0		CONNECTOR-SGL CONT PIN 1.14-MM-BSC-SZ SQ	28480	1251-0600
A55TP2	1251-0600	0		CONNECTOR-SGL CONT PIN 1.14-MM-BSC-SZ SQ	28480	1251-0600
A55TP3	1251-0600	0		CONNECTOR-SGL CONT PIN 1.14-MM-BSC-SZ SQ	28480	1251-0600
A55TP4	1251-0600	0		CONNECTOR-SGL CONT PIN 1.14-MM-BSC-SZ SQ	28480	1251-0600
A55TP5	1251-0600	0		CONNECTOR-SGL CONT PIN 1.14-MM-BSC-SZ SQ	28480	1251-0600
A55TP6	1251-0600	0		CONNECTOR-SGL CONT PIN 1.14-MM-BSC-SZ SQ	28480	1251-0600
A55TP7	1251-0600	0		CONNECTOR-SGL CONT PIN 1.14-MM-BSC-SZ SQ	28480	1251-0600
A55TP8	1251-0600	0		CONNECTOR-SGL CONT PIN 1.14-MM-BSC-SZ SQ	28480	1251-0600
A55U1	1826-1020	9	2	IC SWITCH ANLG 2 SPST 10 -METAL	17856	DG200ABA
A55U2	1826-0606	5		IC SWITCH ANLG QUAD 16-DIP-C PKG	17856	DG201BK
A55U3	1826-0606	5		IC SWITCH ANLG QUAD 16-DIP-C PKG	17856	DG201BK
A55U4	1826-1020	9		IC SWITCH ANLG 2 SPST 10 -METAL	17856	DG200ABA
A55U5	1820-1216	3		IC DCDR TTL LS 3-TO-8-LINE 3-INP	01295	SN74LS138N
A55U6	1820-1195	7		IC FF TTL LS D-TYPE POS-EDGE-TRIG COM	01295	SN74LS175N
A55U7	1820-1195	7		IC FF TTL LS D-TYPE POS-EDGE-TRIG COM	01295	SN74LS175N
A55W1	8159-0005	0		RESISTOR-ZERO OHMS 22 AWG LEAD DIA	28480	8159-0005

†Refer to Section 7 for update information.

\*Factory Selected Component (Refer to Section 5)

Δ Errata part change

Table 6-3. Replaceable Parts

Reference Designation	HP Part Number	C D	Qty.	Description	Mfr. Code	Mfr. Part Number
<b>A70 08902-60006 – SERIAL PREFIX 2305A TO 2702A</b>						
A70	08902-60006	5	1	AMPLIFIER/SWITCH INTERCONNECT ASSY	28480	08902-60006
A70C1	0160-4835	7		CAPACITOR-FXD .1UF +-10% 50VDC CER	28480	0160-4835
A70C2	0160-4835	7		CAPACITOR-FXD .1UF +-10% 50VDC CER	28480	0160-4835
A70C3	0180-0116	1		CAPACITOR-FXD 6.8UF+-10% 35VDC TA	56289	150D685X9035B2
A70C4	0160-4835	7		CAPACITOR-FXD .1UF +-10% 50VDC CER	28480	0160-4835
A70C5	0160-4835	7		CAPACITOR-FXD .1UF +-10% 50VDC CER	28480	0160-4835
A70C6	0160-4835	7		CAPACITOR-FXD .1UF +-10% 50VDC CER	28480	0160-4835
A70C7	0160-4835	7		CAPACITOR-FXD .1UF +-10% 50VDC CER	28480	0160-4835
A70C8	0160-4835	7		CAPACITOR-FXD .1UF +-10% 50VDC CER	28480	0160-4835
A70C9	0160-4835	7		CAPACITOR-FXD .1UF +-10% 50VDC CER	28480	0160-4835
A70C10	0160-4835	7		CAPACITOR-FXD .1UF +-10% 50VDC CER	28480	0160-4835
A70C11	0160-4835	7		CAPACITOR-FXD .1UF +-10% 50VDC CER	28480	0160-4835
A70C12	0160-4835	7		CAPACITOR-FXD .1UF +-10% 50VDC CER	28480	0160-4835
A70DS1	1990-0718	7	1	LED-LAMP LUM-INT = 1MCD IF = 20MA-MAX BVR = 5V	28480	HLMP-1401
A70DS2	1990-0717	6	1	LED-LAMP LUM-INT = 800UCD IF = 30MA-MAX	28480	HLMP-1501
A70J1	1251-4582	5		CONNECTOR 10-PIN M POST TYPE	28480	1251-4582
A70J2				NOT ASSIGNED		
A70J3				NOT ASSIGNED		
A70L1	9100-3922	4		INDUCTOR-FIXED 120-1300 HZ	28480	9100-3922
A70L2	9100-3922	4		INDUCTOR-FIXED 120-1300 HZ	28480	9100-3922
A70L3	9140-0210	1		INDUCTOR RF-CH-MLD 100UH 5% .166DX.385LG	28480	9140-0210
A70L4	9100-3922	4		INDUCTOR-FIXED 120-1300 HZ	28480	9100-3922
A70L5	9100-3922	4		INDUCTOR-FIXED 120-1300 HZ	28480	9100-3922
A70L6	9100-3922	4		INDUCTOR-FIXED 120-1300 HZ	28480	9100-3922
A70L7	9100-3922	4		INDUCTOR-FIXED 120-1300 HZ	28480	9100-3922
A70L8	9100-3922	4		INDUCTOR-FIXED 120-1300 HZ	28480	9100-3922
A70L9	9100-3922	4		INDUCTOR-FIXED 120-1300 HZ	28480	9100-3922
A70L10	9100-3922	4		INDUCTOR-FIXED 120-1300 HZ	28480	9100-3922
A70R1	0698-3439	4		RESISTOR 178 1% .125W F TC = 0+ -100	24546	C4-1/8-T0-178R-F
A70R2	0698-3439	4		RESISTOR 178 1% .125W F TC = 0+ -100	24546	C4-1/8-T0-178R-F
A70R3	0757-0442	9		RESISTOR 10K 1% .125W F TC = 0+ -100	24546	C4-1/8-T0-1002-F
A70R4	0698-3162	0		RESISTOR 46.4K 1% .125W F TC = 0+ -100	24546	C4-1/8-T0-4642-F
A70R5	0757-0442	9		RESISTOR 10K 1% .125W F TC = 0+ -100	24546	C4-1/8-T0-1002-F
A70R6	0757-0416	7		RESISTOR 511 1% .125W F TC = 0+ -100	24546	C4-1/8-T0-511R-F
A70U1	1826-0412	1		IC COMPARATOR PRCN DUAL 8-DIP-P PKG	27014	LM393N

†Refer to Section 7 for update information.

\*Factory Selected Component (Refer to Section 5).

Δ Errata part change



Table 6-3. Replaceable Parts

Reference Designation	HP Part Number	C D	Qty.	Description	Mfr. Code	Mfr. Part Number
<b>A70 08902-60064 – SERIAL PREFIX 2704A AND ABOVE</b>						
A70	08902-60064	5		AMPLIFIER/SWITCH INTERCONNECT ASSY	28480	08902-60064
A70C1	0160-4835	7		CAPACITOR-FXD .1UF +-10% 50VDC CER	28480	0160-4835
A70C2	0160-4835	7		CAPACITOR-FXD .1UF +-10% 50VDC CER	28480	0160-4835
A70C3	0180-0116	1		CAPACITOR-FXD 6.8UF +-10% 35VDC TA	56289	150D685X9035B2
A70C4	0160-4835	7		CAPACITOR-FXD .1UF +-10% 50VDC CER	28480	0160-4835
A70C5	0160-4835	7		CAPACITOR-FXD .1UF +-10% 50VDC CER	28480	0160-4835
A70C6	0160-4835	7		CAPACITOR-FXD .1UF +-10% 50VDC CER	28480	0160-4835
A70C7	0160-4835	7		CAPACITOR-FXD .1UF +-10% 50VDC CER	28480	0160-4835
A70C8	0180-0116	1		CAPACITOR-FXD 6.8UF +-10% 35VDC TA	56289	150D685X9035B2
A70C9	0160-4835	7		CAPACITOR-FXD .1UF +-10% 50VDC CER	28480	0160-4835
A70C10	0160-4835	7		CAPACITOR-FXD .1UF +-10% 50VDC CER	28480	0160-4835
A70C11	0160-4835	7		CAPACITOR-FXD .1UF +-10% 50VDC CER	28480	0160-4835
A70C12	0160-4835	7		CAPACITOR-FXD .1UF +-10% 50VDC CER	28480	0160-4835
A70J1	1251-4582	5		CONNECTOR 10-PIN M POST TYPE	28480	1251-4582
A70J2				NOT ASSIGNED		
A70J3				NOT ASSIGNED		
A70J4	1251-4498	2		CONNECTOR 7-PIN M POST TYPE	28480	1251-4498
A70L1	9100-3922	4		INDUCTOR-FIXED 120-1300 HZ	28480	9100-3922
A70L2				NOT ASSIGNED		
A70L3	9140-0210	1		INDUCTOR RF-CH-MLD 100UH 5% .166DX.385LG	28480	9140-0210
A70L4-9				NOT ASSIGNED		
A70L10	9100-3922	4		INDUCTOR-FIXED 120-1300 HZ	28480	9100-3922
A70R1				NOT ASSIGNED		
A70R2				NOT ASSIGNED		
A70R3	0757-0442	9		RESISTOR 10K 1% .125W F TC = 0 +-100	24546	C4-1/8-T0-1002-F
A70R4	0698-3162	0		RESISTOR 46.4K 1% .125W F TC = 0 +-100	24546	C4-1/8-T0-4642-F
A70R5	0757-0442	9		RESISTOR 10K 1% .125W F TC = 0 +-100	24546	C4-1/8-T0-1002-F
A70R6	0757-0416	7		RESISTOR 511 1% .125W F TC = 0 +-100	24546	C4-1/8-T0-511R-F
A70U1	1826-0412	1		IC COMPARATOR PRCN DUAL 8-DIP-P PKG	27014	LM393N
A70U2	1820-2111	9		IC DRVR TTL INV	01295	SN75468N

†Refer to Section 7 for update information.

\*Factory Selected Component (Refer to Section 5)

Δ Errata part change

Table 6-3. Replaceable Parts

Reference Designation	HP Part Number	C D	Qty.	Description	Mfr. Code	Mfr. Part Number
<b>A71</b>						
A71	08902-60109	9	1	IF AMPLIFIER/DETECTOR ASSEMBLY (OPTION 030 ONLY)	28480	08902-60109
A71C1	0180-0116	1	4	CAPACITOR-FXD 6.8UF + -10% 35VDC TA	56289	150D685X9035B2
A71C2	0180-0197	8	1	CAPACITOR-FXD 2.2UF + -10% 20VDC TA	56289	150D225X9020A2
A71C3	0180-0116	1		CAPACITOR-FXD 6.8UF + -10% 35VDC TA	56289	150D685X9035B2
A71C4	0160-4832	4	14	CAPACITOR-FXD .01UF + -10% 100VDC CER	28480	0160-4832
A71C5	0160-4835	7		CAPACITOR-FXD .1UF + -10% 50VDC CER	28480	0160-4835
A71C6	0160-4835	7		CAPACITOR-FXD .1UF + -10% 50VDC CER	28480	0160-4835
A71C7	0160-4832	4		CAPACITOR-FXD .01UF + -10% 100VDC CER	28480	0160-4832
A71C8	0160-4797	0	6	CAPACITOR-FXD 3.3PF + -.25PF 100VDC CER	28480	0160-4797
A71C9	0160-4835	7		CAPACITOR-FXD .1UF + -10% 50VDC CER	28480	0160-4835
A71C10	0160-4835	7		CAPACITOR-FXD .1UF + -10% 50VDC CER	28480	0160-4835
A71C11	0160-4832	4		CAPACITOR-FXD .01UF + -10% 100VDC CER	28480	0160-4832
A71C12	0160-4835	7		CAPACITOR-FXD .1UF + -10% 50VDC CER	28480	0160-4835
A71C13	0160-4835	7		CAPACITOR-FXD .1UF + -10% 50VDC CER	28480	0160-4835
A71C14	0160-4832	4		CAPACITOR-FXD .01UF + -10% 100VDC CER	28480	0160-4832
A71C15	0160-4797	0		CAPACITOR-FXD 3.3PF + -.25PF 100VDC CER	28480	0160-4797
A71C16	0160-4835	7		CAPACITOR-FXD .1UF + -10% 50VDC CER	28480	0160-4835
A71C17	0160-4835	7		CAPACITOR-FXD .1UF + -10% 50VDC CER	28480	0160-4835
A71C18	0160-4832	4		CAPACITOR-FXD .01UF + -10% 100VDC CER	28480	0160-4832
A71C19	0160-4832	4		CAPACITOR-FXD .01UF + -10% 100VDC CER	28480	0160-4832
A71C20	0160-4797	0		CAPACITOR-FXD 3.3PF + -.25PF 100VDC CER	28480	0160-4797
A71C21	0160-4835	7		CAPACITOR-FXD .1UF + -10% 50VDC CER	28480	0160-4835
A71C22	0160-4835	7		CAPACITOR-FXD .1UF + -10% 50VDC CER	28480	0160-4835
A71C23	0160-4832	4		CAPACITOR-FXD .01UF + -10% 100VDC CER	28480	0160-4832
A71C24	0160-4832	4		CAPACITOR-FXD .01UF + -10% 100VDC CER	28480	0160-4832
A71C25	0160-4789	0	1	CAPACITOR-FXD 15PF + -5% 100VDC CER 0 + -30	28480	0160-4789
A71C26	0160-4835	7		CAPACITOR-FXD .1UF + -10% 50VDC CER	28480	0160-4835
A71C27	0160-4835	7		CAPACITOR-FXD .1UF + -10% 50VDC CER	28480	0160-4835
A71C28	0160-5550	5	1	CAPACITOR-FXD .1UF + -5% 100VDC MET-POLY C	28480	0160-5550
A71C29	0160-4832	4		CAPACITOR-FXD .01UF + -10% 100VDC CER	28480	0160-4832
A71CR1	1901-0518	8	6	DIODE-SM SIG SCHOTTKY	28480	1901-0518
A71CR2	1901-0518	8		DIODE-SM SIG SCHOTTKY	28480	1901-0518
A71CR3	1901-0518	8		DIODE-SM SIG SCHOTTKY	28480	1901-0518
A71CR4	1901-0518	8		DIODE-SM SIG SCHOTTKY	28480	1901-0518
A71CR5	1901-0518	8		DIODE-SM SIG SCHOTTKY	28480	1901-0518
A71FL1 <sup>Δ</sup>	9135-0268	8		FILTER-CERAMIC BANDPASS; 455KHZ CENTER	28480	9135-0268
A71FL2 <sup>Δ</sup>	9135-0267	7		FILTER-CERAMIC BANDPASS; 455KHZ CENTER	28480	9135-0267
A71J1	1250-1425	7		CONNECTOR-RF SMC M SGL-HOLE-RR 50-OHM	28480	1250-1425
	2190-0124	4		WASHER-LK INTL T NO. 10 .195-IN-ID	28480	2190-0124
	2950-0078	9		NUT-HEX-DBL-CHAM 10-32-THD .067-IN-THK	28480	2950-0078
A71J2	1250-1425	7		CONNECTOR-RF SMC M SGL-HOLE-RR 50-OHM	28480	1250-1425
	2190-0124	4		WASHER-LK INTL T NO. 10 .195-IN-ID	28480	2190-0124
	2950-0078	9		NUT-HEX-DBL-CHAM 10-32-THD .067-IN-THK	28480	2950-0078

† Refer to Section 7 for update information

\* Factory Selected Component (Refer to Section 5)

Δ Errata part change.

Table 6-3. Replaceable Parts

Reference Designation	HP Part Number	C D	Qty.	Description	Mfr. Code	Mfr. Part Number
A71L1	9100-1642	1	2	INDUCTOR RF-CH-MLD 270UH 5% .2DX.45LG	28480	9100-1642
A71L2	9100-1642	1		INDUCTOR RF-CH-MLD 270UH 5% .2DX.45LG	28480	9100-1642
A71MP1	08902-00034	3	1	BOARD COVER, IF AMP/DET	28480	08902-00034
A71Q1	1853-0459	3	7	TRANSISTOR PNP SI PD = 625MW FT = 200MHZ	28480	1853-0459
A71Q2	1854-0404	0	9	TRANSISTOR NPN SI TO-18 PD = 360MW	28480	1854-0404
A71Q3	1853-0459	3		TRANSISTOR PNP SI PD = 625MW FT = 200MHZ	28480	1853-0459
A71Q4	1854-0404	0		TRANSISTOR NPN SI TO-18 PD = 360MW	28480	1854-0404
A71Q5	1854-0404	0		TRANSISTOR NPN SI TO-18 PD = 360MW	28480	1854-0404
A71Q6	1853-0459	3		TRANSISTOR PNP SI PD = 625MW FT = 200MHZ	28480	1853-0459
A71Q7	1855-0235	7	1	TRANSISTOR J-FET N-CHAN D-MODE TO-52 SI	28480	1855-0235
A71Q8	1853-0459	3		TRANSISTOR PNP SI PD = 625MW FT = 200MHZ	28480	1853-0459
A71Q9	1854-0404	0		TRANSISTOR NPN SI TO-18 PD = 360MW	28480	1854-0404
A71Q10	1854-0404	0		TRANSISTOR NPN SI TO-18 PD = 360MW	28480	1854-0404
A71Q11	1855-0420	2	3	TRANSISTOR J-FET 2N4391 N-CHAN D-MODE	01295	2N4391
A71Q12	1855-0420	2		TRANSISTOR J-FET 2N4391 N-CHAN D-MODE	01295	2N4391
A71Q13	1854-0404	0		TRANSISTOR NPN SI TO-18 PD = 360MW	28480	1854-0404
A71Q14	1854-0404	0		TRANSISTOR NPN SI TO-18 PD = 360MW	28480	1854-0404
A71R1	0699-0678	9	4	RESISTOR 900 .01% .1W F TC = 0 + -5	28480	0699-0678
A71R2	0699-0681	4	4	RESISTOR 100 .01% .1W F TC = 0 + -5	28480	0699-0681
A71R3	0698-3441	8	18	RESISTOR 215 1% .125W F TC = 0 + -100	24546	C4-1/8-T0-215R-F
A71R4	0698-3441	8		RESISTOR 215 1% .125W F TC = 0 + -100	24546	C4-1/8-T0-215R-F
A71R5	0757-0274	5	14	RESISTOR 1.21K 1% .125W F TC = 0 + -100	24546	C4-1/8-T0-1211-F
A71R6	0698-3441	8		RESISTOR 215 1% .125W F TC = 0 + -100	24546	C4-1/8-T0-215R-F
A71R7	0698-0084	9		RESISTOR 2.15K 1% .125W F TC = 0 + -100	24546	C4-1/8-T0-2151-F
A71R8	0698-0082	7		RESISTOR 484 1% .125W F TC = 0 + -100	24546	C4-1/8-T0-4840-F
A71R9	0757-0274	5		RESISTOR 1.21K 1% .125W F TC = 0 + -100	24546	C4-1/8-T0-1211-F
A71R10	0698-3441	8		RESISTOR 215 1% .125W F TC = 0 + -100	24546	C4-1/8-T0-215R-F
A71R11	0699-0678	9		RESISTOR 900 .01% .1W F TC = 0 + -5	28480	0699-0678
A71R12	0699-0681	4		RESISTOR 100 .01% .1W F TC = 0 + -5	28480	0699-0681
A71R13	0698-3441	8		RESISTOR 215 1% .125W F TC = 0 + -100	24546	C4-1/8-T0-215R-F
A71R14	0698-3441	8		RESISTOR 215 1% .125W F TC = 0 + -100	24546	C4-1/8-T0-215R-F
A71R15	0757-0274	5		RESISTOR 1.21K 1% .125W F TC = 0 + -100	24546	C4-1/8-T0-1211-F
A71R16	0698-3441	8		RESISTOR 215 1% .125W F TC = 0 + -100	24546	C4-1/8-T0-215R-F
A71R17	0698-0084	9		RESISTOR 2.15K 1% .125W F TC = 0 + -100	24546	C4-1/8-T0-2151-F
A71R18	0698-0082	7		RESISTOR 484 1% .125W F TC = 0 + -100	24546	C4-1/8-T0-4840-F
A71R19	0757-0274	5		RESISTOR 1.21K 1% .125W F TC = 0 + -100	24546	C4-1/8-T0-1211-F
A71R20	0698-3441	8		RESISTOR 215 1% .125W F TC = 0 + -100	24546	C4-1/8-T0-215R-F
A71R21	0699-0678	9		RESISTOR 900 .01% .1W F TC = 0 + -5	28480	0699-0678
A71R22	0699-0681	4		RESISTOR 100 .01% .1W F TC = 0 + -5	28480	0699-0681
A71R23	0757-0274	5		RESISTOR 1.21K 1% .125W F TC = 0 + -100	24546	C4-1/8-T0-1211-F
A71R24	0698-3441	8		RESISTOR 215 1% .125W F TC = 0 + -100	24546	C4-1/8-T0-215R-F
A71R25	0757-0279	0	1	RESISTOR 3.16K 1% .125W F TC = 0 + -100	24546	C4-1/8-T0-3161-F
A71R26	0757-0394	0		RESISTOR 51.1 1% .125W F TC = 0 + -100	24546	C4-1/8-T0-51R1-F
A71R27	0698-0084	9		RESISTOR 2.15K 1% .125W F TC = 0 + -100	24546	C4-1/8-T0-2151-F
A71R28	0698-3441	8		RESISTOR 215 1% .125W F TC = 0 + -100	24546	C4-1/8-T0-215R-F
A71R29	0698-6317	3	1	RESISTOR 500 .1% .125W F TC = 0 + -25	03888	PME55-1/8-T9-500R-B
A71R30	0699-0825	8	1	RESISTOR 281.2 .1% .125W F TC = 0 + -25	28480	0699-0825

† Refer to Section 7 for update information

\* Factory Selected Component (Refer to Section 5)

Δ Errata part change.

Table 6-3. Replaceable Parts

Reference Designation	HP Part Number	C D	Qty.	Description	Mfr. Code	Mfr. Part Number
A71R31 <sup>Δ</sup>	0699-1655	4		RESISTOR 158.1 1% .125W F TC = 0 + -25	28480	0699-1655
A71R32 <sup>Δ</sup>	0699-1637	2		RESISTOR 203.2 1% .125W F TC = 0 + -25	28480	0699-1637
A71R33	0757-0274	5		RESISTOR 1.21K 1% .125W F TC = 0 + -100	24546	C4-1/8-T0-1211-F
A71R34	0757-0401	0	1	RESISTOR 100 1% .125W F TC = 0 + -100	24546	C4-1/8-T0-101-F
A71R35	0698-3154	0	3	RESISTOR 4.22K 1% .125W F TC = 0 + -100	24546	C4-1/8-T0-4221-F
A71R36	0757-0394	0		RESISTOR 51.1 1% .125W F TC = 0 + -100	24546	C4-1/8-T0-51R1-F
A71R37	0698-0084	9		RESISTOR 2.15K 1% .125W F TC = 0 + -100	24546	C4-1/8-T0-2151-F
A71R38	0698-3441	8		RESISTOR 215 1% .125W F TC = 0 + -100	24546	C4-1/8-T0-215R-F
A71R39	0757-0444	1		RESISTOR 12.1K 1% .125W F TC = 0 + -100	24546	C4-1/8-T0-1212-F
A71R40	0757-0465	6	5	RESISTOR 100K 1% .125W F TC = 0 + -100	24546	C4-1/8-T0-1003-F
A71R41	0698-3154	0		RESISTOR 4.22K 1% .125W F TC = 0 + -100	24546	C4-1/8-T0-4221-F
A71R42	0698-0084	9		RESISTOR 2.15K 1% .125W F TC = 0 + -100	24546	C4-1/8-T0-2151-F
A71R43	0698-0084	9		RESISTOR 2.15K 1% .125W F TC = 0 + -100	24546	C4-1/8-T0-2151-F
A71R44	0757-0274	5		RESISTOR 1.21K 1% .125W F TC = 0 + -100	24546	C4-1/8-T0-1211-F
A71R45	0698-0084	9		RESISTOR 2.15K 1% .125W F TC = 0 + -100	24546	C4-1/8-T0-2151-F
A71R46	0698-0084	9		RESISTOR 2.15K 1% .125W F TC = 0 + -100	24546	C4-1/8-T0-2151-F
A71R47	0698-0082	7		RESISTOR 464 1% .125W F TC = 0 + -100	24546	C4-1/8-T0-4640-F
A71R48	0698-0084	9		RESISTOR 2.15K 1% .125W F TC = 0 + -100	24546	C4-1/8-T0-2151-F
A71R49	0757-0465	6		RESISTOR 100K 1% .125W F TC = 0 + -100	24546	C4-1/8-T0-1003-F
A71R50	0757-0465	6		RESISTOR 100K 1% .125W F TC = 0 + -100	24546	C4-1/8-T0-1003-F
A71R51	0698-3154	0		RESISTOR 4.22K 1% .125W F TC = 0 + -100	24546	C4-1/8-T0-4221-F
A71TP1	1251-0600	0	2	CONNECTOR-SGL CONT PIN 1.14-MM-BSC-SZ SQ	28480	1251-0600
A71TP2	1251-0600	0		CONNECTOR-SGL CONT PIN 1.14-MM-BSC-SZ SQ	28480	1251-0600
A71U1	1826-1020	9	5	ANALOG SWITCH 2 SPST 10-METAL	17856	DG200ABA
A71U2	1826-1020	9		ANALOG SWITCH 2 SPST 10-METAL	17856	DG200ABA
A71U3	1826-1020	9		ANALOG SWITCH 2 SPST 10-METAL	17856	DG200ABA
A71U4	1826-0606	5	1	IC SWITCH ANLG QUAD 16-DIP-C PKG	17856	DG201BK
A71U5	1826-1020	9		ANALOG SWITCH 2 SPST 10-METAL	17856	DG200ABA
A71U6 <sup>Δ</sup>	1826-1314	4		RMS DC 14-CERDIP BPLR	28480	1826-1314
A71U7	1820-1195	7	3	IC FF TTL LS D-TYPE POS-EDGE-TRIG COM	01295	SN74LS175N
A71U8	1820-1195	7		IC FF TTL LS D-TYPE POS-EDGE-TRIG COM	01295	SN74LS175N

†Refer to Section 7 for update information

\*Factory Selected Component (Refer to Section 5)

Δ Errata part change

Table 6-3. Replaceable Parts

Reference Designation	HP Part Number	C D	Qty.	Description	Mfr. Code	Mfr. Part Number
<b>A72</b>						
A72	08902-60108	8	1	IF CHANNEL FILTER ASSEMBLY (OPTION 030 ONLY) (DOES NOT INCLUDE FL1,FL2,R5,R6,R9&R10)	28480	08902-60108
A72C1	0180-0116	1		CAPACITOR-FXD 6.8UF + -10% 35VDC TA	56289	150D685X9035B2
A72C2	0180-0116	1		CAPACITOR-FXD 6.8UF + -10% 35VDC TA	56289	150D685X9035B2
A72C3	0180-2929	8	1	CAPACITOR-FXD 68UF + -10% 10VDC TA	28480	0180-2929
A72C4	0160-4535	4		CAPACITOR-FXD 1UF + -10% 50VDC CER	28480	0160-4535
A72C5	0160-4835	7		CAPACITOR-FXD .1UF + -10% 50VDC CER	28480	0160-4835
A72C6	0160-4835	7		CAPACITOR-FXD .1UF + -10% 50VDC CER	28480	0160-4835
A72C7	0160-5469	5		CAPACITOR-FXD 1UF + -10% 50VDC CER	28480	0160-5469
A72C8	0160-4835	7		CAPACITOR-FXD .1UF + -10% 50VDC CER	28480	0160-4835
A72C9	0160-5469	5		CAPACITOR-FXD 1UF + -10% 50VDC CER	28480	0160-5469
A72C10	0160-4832	4		CAPACITOR-FXD .01UF + -10% 100VDC CER	28480	0160-4832
A72C11	0160-4835	7		CAPACITOR-FXD .1UF + -10% 50VDC CER	28480	0160-4835
A72C12	0160-4832	4		CAPACITOR-FXD .01UF + -10% 100VDC CER	28480	0160-4832
A72C13	0160-4832	4		CAPACITOR-FXD .01UF + -10% 100VDC CER	28480	0160-4832
A72C14	0160-4535	4		CAPACITOR-FXD 1UF + -10% 50VDC CER	28480	0160-4535
A72C15	0160-4832	4		CAPACITOR-FXD .01UF + -10% 100VDC CER	28480	0160-4832
A72C16	0160-4797	0		CAPACITOR-FXD 3.3PF + -.25PF 100VDC CER	28480	0160-4797
A72C17	0160-4535	4		CAPACITOR-FXD 1UF + -10% 50VDC CER	28480	0160-4535
A72C18	0160-4832	4		CAPACITOR-FXD .01UF + -10% 100VDC CER	28480	0160-4832
A72C19	0160-4835	7		CAPACITOR-FXD .1UF + -10% 50VDC CER	28480	0160-4835
A72C20	0160-4835	7		CAPACITOR-FXD .1UF + -10% 50VDC CER	28480	0160-4835
A72C21	0160-4535	4		CAPACITOR-FXD 1UF + -10% 50VDC CER	28480	0160-4535
A72C22 <sup>Δ</sup>	0160-4535	4		CAPACITOR-FXD 1UF + -10% 50VDC CER	28480	0160-4535
A72C23	0160-4797	0		CAPACITOR-FXD 3.3PF + -.25PF 100VDC CER	28480	0160-4797
A72C24	0160-4797	0		CAPACITOR-FXD 3.3PF + -.25PF 100VDC CER	28480	0160-4797
A72CR1	1901-1098	1		DIODE-SWITCHING 1N4150 50V 200MA 4NS	9N171	1N4150
A72CR2	1901-1098	1		DIODE-SWITCHING 1N4150 50V 200MA 4NS	9N171	1N4150
A72CR3	1901-1098	1		DIODE-SWITCHING 1N4150 50V 200MA 4NS	9N171	1N4150
A72CR4	1901-1098	1		DIODE-SWITCHING 1N4150 50V 200MA 4NS	9N171	1N4150
A72CR5	1901-1098	1		DIODE-SWITCHING 1N4150 50V 200MA 4NS	9N171	1N4150
A72CR6	1901-1098	1		DIODE-SWITCHING 1N4150 50V 200MA 4NS	9N171	1N4150
A72CR7	1901-0518	8		DIODE-SM SIG SCHOTTKY	28480	1901-0518
A72DS1	1990-0717	6	1	LED-LAMP LUM-INT = 800UCD IF = 30MA-MAX	28480	HLMP-1501
A72E1	9170-0847	3	2	CORE-SHIELDING BEAD	02114	56-590-65/3B
A72E2	9170-0847	3		CORE-SHIELDING BEAD	02114	56-590-65/3B

† Refer to Section 7 for update information.

\* Factory Selected Component (Refer to Section 5)

Δ Errata part change

Table 6-3. Replaceable Parts

Reference Designation	HP Part Number	C D	Qty.	Description	Mfr. Code	Mfr. Part Number
*****NOTE***** FOR INFORMATION ABOUT SELECTING FILTERS FL1-FL2, SEE SERVICE SHEET 33, NOTE 2						
A72FL1	08901-80079	3		OPTION 032 12.5 KHZ FILTER WHEN FILTER OPTIONS INSTALLED ARE 032 AND 037.	28480	08901-80079
A72FL1	08901-80080	6		OPTION 033 25 KHZ FILTER WHEN FILTER OPTIONS INSTALLED ARE 033 AND 032 OR 033 AND 037	28480	08901-80080
A72FL1	08901-80085	1		OPTION 035 30 KHZ FILTER WHEN FILTER OPTIONS INSTALLED ARE 035 AND 032, 035 AND 033, OR 035, AND 037	28480	08901-80085
A72FL2	08901-80079	3		OPTION 032 12.5 KHZ FILTER WHEN FILTER OPTIONS INSTALLED ARE 032 AND 037.	28480	08901-80079
A72FL2	08901-80080	6		OPTION 033 25 KHZ FILTER WHEN FILTER OPTIONS INSTALLED ARE 033 AND 032 OR 033 AND 037	28480	08901-80080
A72FL2	08901-80086	2		OPTION 035 30 KHZ FILTER WHEN FILTER OPTIONS INSTALLED ARE 035 AND 032, 035 AND 033, OR 035, AND 037	28480	08901-80086
A72J1	1250-1425	7		CONNECTOR-RF SMC M SGL-HOLE-RR 50-OHM	28480	1250-1425
	2190-0124	4		WASHER-LK INTL T NO. 10 .195-IN-ID	28480	2190-0124
	2950-0078	9		NUT-HEX-DBL-CHAM 10-32-THD .067-IN-THK	28480	2950-0078
A72J2	1250-1425	7		CONNECTOR-RF SMC M SGL-HOLE-RR 50-OHM	28480	1250-1425
	2190-0124	4		WASHER-LK INTL T NO. 10 .195-IN-ID	28480	2190-0124
	2950-0078	9		NUT-HEX-DBL-CHAM 10-32-THD .067-IN-THK	28480	2950-0078
A72J3	1251-4700	9	1	CONNECTOR 3-PIN M POST TYPE	28480	1251-4700
A72L1	9140-0137	1		INDUCTOR RF-CH-MLD 1MH 5% .2DX.45LG Q = 60	28480	9140-0137
A72L2	9140-0137	1		INDUCTOR RF-CH-MLD 1MH 5% .2DX.45LG Q = 60	28480	9140-0137
A72L3	9140-0137	1		INDUCTOR RF-CH-MLD 1MH 5% .2DX.45LG Q = 60	28480	9140-0137
A72MP1	08902-00033	2	1	BOARD COVER, IF CHAN FLTR	28480	08902-00033
A72Q1	1855-0421	3	1	TRANSISTOR J-FET 2N5114 P-CHAN D-MODE	17856	2N5114
A72Q2	1855-0420	2		TRANSISTOR J-FET 2N4391 N-CHAN D-MODE	01295	2N4391
A72Q3	1854-0668	8	2	TRANSISTOR NPN SI TO-18 PD = 500MW	28480	1854-0668
A72Q4	1854-0668	8		TRANSISTOR NPN SI TO-18 PD = 500MW	28480	1854-0668
A72Q5	1853-0430	0	1	TRANSISTOR PNP 2N4959 SI TO-72 PD = 200MW	04713	2N4959
	9170-0847	3		CORE-SHIELDING BEAD	02114	56-590-65/3B
A72Q6	1854-0345	8	1	TRANSISTOR NPN 2N5179 SI TO-72 PD = 200MW	04713	2N5179
A72Q7	1853-0459	3		TRANSISTOR PNP SI PD = 625MW FT = 200MHZ	28480	1853-0459
A72Q8	1854-0404	0		TRANSISTOR NPN SI TO-18 PD = 360MW	28480	1854-0404
A72Q9	1854-0404	0		TRANSISTOR NPN SI TO-18 PD = 360MW	28480	1854-0404
A72Q10	1853-0459	3		TRANSISTOR PNP SI PD = 625MW FT = 200MHZ	28480	1853-0459
A72Q11	1854-0404	0		TRANSISTOR NPN SI TO-18 PD = 360MW	28480	1854-0404
A72Q12	1853-0459	3		TRANSISTOR PNP SI PD = 625MW FT = 200MHZ	28480	1853-0459

†Refer to Section 7 for update information

\*Factory Selected Component (Refer to Section 5)

Δ Errata part change

Table 6-3. Replaceable Parts

Reference Designation	HP Part Number	C D	Qty.	Description	Mfr. Code	Mfr. Part Number
A72R1	0757-0465	6		RESISTOR 100K 1% .125W F TC=0+-100	24546	C4-1/8-T0-1003-F
A72R2	0757-0465	6		RESISTOR 100K 1% .125W F TC=0+-100	24546	C4-1/8-T0-1003-F
A72R3	0757-0274	5		RESISTOR 1.21K 1% .125W F TC=0+-100	24546	C4-1/8-T0-1211-F
A72R4	0757-0274	5		RESISTOR 1.21K 1% .125W F TC=0+-100	24546	C4-1/8-T0-1211-F
A72R5*				NOT SEPARATELY REPLACEABLE P/O A72FL1		
A72R6*				FACTORY SELECTED FOR FILTER OPTIONS NOT SEPARATELY REPLACEABLE P/O FL2 FACTORY SELECTED FOR FILTER OPTIONS		F
A72R7	0757-0400	9	3	RESISTOR 90.9 1% .125W F TC=0+-100	24546	C4-1/8-T0-90R9-F
A72R8	0698-3443	0		RESISTOR 287 1% .125W F TC=0+-100	24546	C4-1/8-T0-287R-F
A72R9*				NOT SEPARATELY REPLACEABLE P/O FL1 FACTORY SELECTED FOR FILTER OPTIONS		F
A72R10*				NOT SEPARATELY REPLACEABLE P/O FL2 FACTORY SELECTED FOR FILTER OPTIONS		F
A72R11	0757-0274	5		RESISTOR 1.21K 1% .125W F TC=0+-100	24546	C4-1/8-T0-1211-F
A72R12	0757-0405	4		RESISTOR 162 1% .125W F TC=0+-100	24546	C4-1/8-T0-162R-F
A72R13	0698-3443	0		RESISTOR 287 1% .125W F TC=0+-100	24546	C4-1/8-T0-287R-F
A72R14	0757-0274	5		RESISTOR 1.21K 1% .125W F TC=0+-100	24546	C4-1/8-T0-1211-F
A72R15	0757-0405	4		RESISTOR 162 1% .125W F TC=0+-100	24546	C4-1/8-T0-162R-F
A72R16	0698-0082	7		RESISTOR 464 1% .125W F TC=0+-100	24546	C4-1/8-T0-4640-F
A72R17	0698-3443	0		RESISTOR 287 1% .125W F TC=0+-100	24546	C4-1/8-T0-287R-F
A72R18	0698-3443	0		RESISTOR 287 1% .125W F TC=0+-100	24546	C4-1/8-T0-287R-F
A72R19	0757-1094	9		RESISTOR 1.47K 1% .125W F TC=0+-100	24546	C4-1/8-T0-1471-F
A72R20	0698-3443	0		RESISTOR 287 1% .125W F TC=0+-100	24546	C4-1/8-T0-287R-F
A72R21	0757-1094	9		RESISTOR 1.47K 1% .125W F TC=0+-100	24546	C4-1/8-T0-1471-F
A72R22	0698-3441	8		RESISTOR 215 1% .125W F TC=0+-100	24546	C4-1/8-T0-215R-F
A72R23	0698-3441	8		RESISTOR 215 1% .125W F TC=0+-100	24546	C4-1/8-T0-215R-F
A72R24	0699-0678	9		RESISTOR 900 .01% .1W F TC=0+-5	28480	0699-0678
A72R25	0699-0681	4		RESISTOR 100 .01% .1W F TC=0+-5	28480	0699-0681
A72R26	0757-0274	5		RESISTOR 1.21K 1% .125W F TC=0+-100	24546	C4-1/8-T0-1211-F
A72R27	0698-3441	8		RESISTOR 215 1% .125W F TC=0+-100	24546	C4-1/8-T0-215R-F
A72R28	0698-0084	9		RESISTOR 2.15K 1% .125W F TC=0+-100	24546	C4-1/8-T0-2151-F
A72R29	0698-0082	7		RESISTOR 464 1% .125W F TC=0+-100	24546	C4-1/8-T0-4640-F
A72R30	0757-0274	5		RESISTOR 1.21K 1% .125W F TC=0+-100	24546	C4-1/8-T0-1211-F
A72R31	0698-3441	8		RESISTOR 215 1% .125W F TC=0+-100	24546	C4-1/8-T0-215R-F
A72R32	0698-0084	9		RESISTOR 2.15K 1% .125W F TC=0+-100	24546	C4-1/8-T0-2151-F
A72R33	0698-0084	9		RESISTOR 2.15K 1% .125W F TC=0+-100	24546	C4-1/8-T0-2151-F
A72R34	0757-0274	5		RESISTOR 1.21K 1% .125W F TC=0+-100	24546	C4-1/8-T0-1211-F
A72R35	0698-3443	0		RESISTOR 287 1% .125W F TC=0+-100	24546	C4-1/8-T0-287R-F
A72R36	0698-3443	0		RESISTOR 287 1% .125W F TC=0+-100	24546	C4-1/8-T0-287R-F
A72R37	0698-3443	0		RESISTOR 287 1% .125W F TC=0+-100	24546	C4-1/8-T0-287R-F
A72R38	0757-0400	9		RESISTOR 90.9 1% .125W F TC=0+-100	24546	C4-1/8-T0-90R9-F
A72R39	0757-0400	9		RESISTOR 90.9 1% .125W F TC=0+-100	24546	C4-1/8-T0-90R9-F
A72R40	0757-0280	3	2	RESISTOR 1K 1% .125W F TC=0+-100	24546	C4-1/8-T0-1001-F
A72R41	0757-0280	3		RESISTOR 1K 1% .125W F TC=0+-100	24546	C4-1/8-T0-1001-F
A72R42	0698-0084	9		RESISTOR 2.15K 1% .125W F TC=0+-100	24546	C4-1/8-T0-2151-F
A72R43	0698-0084	9		RESISTOR 2.15K 1% .125W F TC=0+-100	24546	C4-1/8-T0-2151-F
A72R44	0698-3441	8		RESISTOR 215 1% .125W F TC=0+-100	24546	C4-1/8-T0-215R-F
A72T1	08901-80070	4	1	TRANSFORMER/FLTR	28480	08901-80070
A72U1	1826-0154	8		IC SWITCH ANLG DUAL TO-100 PKG	17856	DG200BA
A72U2	1820-0535	7	1	IC DRVR TTL AND DUAL 2-INP	01295	SN75451BP
A72U3	1820-1216	3	1	IC DCDR TTL LS 3-TO-8-LINE 3-INP	01295	SN74LS138N
A72U4	1820-1195	7		IC FF TTL LS D-TYPE POS-EDGE-TRIG COM	01295	SN74LS175N
A72U5	1826-0989	7	4	IC OP AMP GP 8-DIP-C PKG	27014	LM307J

† Refer to Section 7 for update information

\* Factory Selected Component (Refer to Section 5)

Δ Errata part change.

Table 6-3. Replaceable Parts

Reference Designation	HP Part Number	C D	Qty.	Description	Mfr. Code	Mfr. Part Number
<b>MISCELLANEOUS PARTS</b>						
<b>2305A TO 2702A</b>						
AT1	08902-60035	0	1	INPUT ATTENUATOR ASSY	28480	08902-60035
AT1	08902-60044	1		INPUT ATTENUATOR ASSY, RESTORED (REQUIRES EXCHANGE)	28480	08902-60044
	2380-0115	4	1	SCREW-MACH 6-32 .312-IN-LG PAN-HD-POZI	00000	ORDER BY DESCRIPTION
<b>2704A ONLY</b>						
AT1	08642-60962	7	1	INPUT ATTENUATOR 70dB	28480	08642-60962
<b>2706A AND ABOVE</b>						
AT1	08642-60291	5	1	INPUT ATTENUATOR 70dB	28480	08642-60291
<b>2305A TO 2702A</b>						
AT2	11722-60005	3	1	10 DB ATTENUATOR	28480	11722-60005
2704A AND ABOVE				REPLACED BY U3		
AT2						
<b>2305A TO 2339A</b>						
B1	08901-60094	0	1	FAN ASSEMBLY, 115V-50/60HZ (EXCEPT OPTION 004)	28480	08901-60095
	86701-00017	3		SHIELDING DISK	28480	86701-00017
	1520-0067	4	5	SHOCK MOUNT .44-EFF-HGT .31-OD (FOR FAN IN REAR PANEL)	28480	1520-0067
	0400-0009	9		GROMMET-RND .125-IN-HD .25-IN-GRV-OD	28480	0400-0009
	1251-3201	3		CONNECTOR 3-PIN F POST TYPE	28480	1251-3201
	1251-4283	3		CONTACT-CONN U/W-POST-TYPE FEM CAP	28480	1251-4283
<b>2340A ONLY</b>						
B1	08901-60247	5		FAN ASSEMBLY 115V-50/60HZ (EXCEPT OPTION 004)	28480	08901-60247
	0624-0216	4		SCREW-TPG 8-32 .375-IN-LG PAN-HD-POZI	28480	0624-0216
	3160-0300	6		FINGERGARD	28480	3160-0300
	86701-00017	3		SHIELDING DISK	28480	86701-00017
	1520-0067	4	5	SHOCK MOUNT .44-EFF-HGT .31-OD (FOR FAN IN REAR PANEL)	28480	1520-0067
<b>2341A TO 2343A</b>						
B1	08901-60094	0	1	FAN ASSEMBLY, 115V-50/60HZ (EXCEPT OPTION 004)	28480	08901-60095
	86701-00017	3		SHIELDING DISK	28480	86701-00017
	1520-0067	4	5	SHOCK MOUNT .44-EFF-HGT .31-OD (FOR FAN IN REAR PANEL)	28480	1520-0067
	0400-0009	9		GROMMET-RND .125-IN-HD .25-IN-GRV-OD	28480	0400-0009
	1251-3201	3		CONNECTOR 3-PIN F POST TYPE	28480	1251-3201
	1251-4283	3		CONTACT-CONN U/W-POST-TYPE FEM CAP	28480	1251-4283

†Refer to Section 7 for update information.

\*Factory Selected Component (Refer to Section 5).

△ Errata part change.



Table 6-3. Replaceable Parts

Reference Designation	HP Part Number	C D	Qty.	Description	Mfr. Code	Mfr. Part Number
<b>MISCELLANEOUS PARTS</b>						
<i>2345A AND ABOVE</i>						
<i>B1</i>	08901-60306	7		FAN ASSEMBLY 115V-50/60HZ (EXCEPT OPTION 004)	28480	08901-60306
	0624-0216	4		SCREW-TPG 8-32 .375-IN-LG PAN-HD-POZI	28480	0624-0216
	3160-0300	6		FINGERGUARD	28480	3160-0300
	86701-00017	3		SHIELDING DISK	28480	86701-00017
	1520-0067	4	5	SHOCK MOUNT .44-EFF-HGT .31-OD (FOR FAN IN REAR PANEL)	28480	1520-0067
<i>B1</i>	08901-60307	8	1	FAN ASSEMBLY, 115V 48/480-HZ (OPTION 004 ONLY)	28480	08901-60307
	0400-0009	9		GROMMET-RND .125-IN-ID .25-IN-GRV-OD	28480	0400-0009
	1251-3201	3		CONNECTOR 3-PIN F POST TYPE	28480	1251-3201
	1251-3897	3	3	CONTACT-CONN UMW-POST-TYPE FEM CRP	28480	1251-3897
	1520-0067	4		SHOCK MOUNT .44-EFF-HGT .31-OD	28480	1520-0067
	86701-00017	3		FAN SHIELD	28480	86701-00017
<i>C10</i>	0160-3968	5	1	CAPACITOR-FXD .47UF + -10PF 250VAC(RMS) (OPTION 004 ONLY)	28480	0160-3968
<i>CR1</i>	1906-0231	2	1	DIODE-CT-RECT 200V 15A	28480	1906-0231
	1200-0043	8	1	INSULATOR-XSTR ALUMINUM	28480	1200-0043
	2200-0107	6	6	SCREW-MACH 4-40 .375-IN-LG PAN-HD-POZI	00000	ORDER BY DESCRIPTION
<i>F1</i>	2110-0083	6	1	FUSE 2.5A 250V NTD 1.25X.25 UL (FOR 115V OPERATION)	28480	2110-0083
<i>F1</i>	2110-0043	8	1	FUSE 1.5A 250V NTD 1.25X.25 UL (FOR 230V OPERATION)	28480	2110-0043
<i>J1</i>	08662-60304	5	2	CONN ASSEMBLY RF INPUT (EXCEPT OPTION 001)	28480	08662-60304
	2190-0104	0	2	WASHER-LK INTL T 7/16 IN .439-IN-ID	28480	2190-0104
	2950-0132	6	2	NUT-HEX-DBL-CHAM 7/16-28-THD .094-IN-THK	00000	ORDER BY DESCRIPTION
	08731-210	2	2	LOCKING NUT	28480	08731-210
<i>J2</i>				MODULATION OUTPUT/AUDIO INPUT P/O W9 NSR (J2 APPEARS ON THE REAR PANEL OF OPTION 001 INSTRUMENTS)		
<i>J3</i>	1250-1811	5	6	ADAPTER-COAX STR F-N F-SMA CALIBRATION OUTPUT, AM/FM (EXCEPT OPTION 001) (INCLUDES ATTACHING HARDWARE)	28480	1250-1811
<i>2305A TO 2328A</i>						
<i>J4</i>	1250-1811	5		ADAPTER-COAX STR F-N F-SMA CALIBRATION OUTPUT, RF POWER (EXCEPT OPTION 001) (INCLUDES ATTACHING HARDWARE)	28480	1250-1811
<i>2329A AND ABOVE</i>						
<i>J4</i>	1250-1895	5		ADAPTER-COAX STR F-N F-SMA CALIBRATION OUTPUT, RF POWER (EXCEPT OPTION 001)	28480	1251-1895

⊠ Refer to Section 7 for update information

\* Factory Selected Component (Refer to Section 5)

△ Errata part change

Table 6-3. Replaceable Parts

Reference Designation	HP Part Number	C D	Qty.	Description	Mfr. Code	Mfr. Part Number
<b>MISCELLANEOUS PARTS</b>						
J5	1250-0083	1	4	CONNECTOR-RF BNC FEM SGL-HOLE-FR 50-OHM OUTPUT, AM	28480	1250-0083
	2190-0016	3	7	WASHER-LK INTL T 3/8 IN .377-IN-ID	28480	2190-0016
	2950-0001	8	7	NUT-HEX-DBL-CHAM 3/8-32-THD .094-IN-THK	00000	ORDER BY DESCRIPTION
J6	1250-0083	1		CONNECTOR-RF BNC FEM SGL-HOLE-FR 50-OHM OUTPUT, FM	28480	1250-0083
	2190-0016	3		WASHER-LK INTL T 3/8 IN .377-IN-ID	28480	2190-0016
	2950-0001	8		NUT-HEX-DBL-CHAM 3/8-32-THD .094-IN-THK	00000	ORDER BY DESCRIPTION
J7	1250-0083	1		CONNECTOR-RF BNC FEM SGL-HOLE-FR 50-OHM OUTPUT, RECORDER	28480	1250-0083
	2190-0016	3		WASHER-LK INTL T 3/8 IN .377-IN-ID	28480	2190-0016
	2950-0001	8		NUT-HEX-DBL-CHAM 3/8-32-THD .094-IN-THK	00000	ORDER BY DESCRIPTION
J8				OUTPUT, IF P/O W26 NSR		
J9				TIME BASE 10 MHZ OUTPUT P/O W22 NSR (OPTION 002 ONLY)		
J10				TIME BASE 10 MHZ INPUT P/O W23 NSR (OPTION 002 ONLY)		
J11	1250-1811	5		ADAPTER-COAX STR F-N F-SMA AM/FM CAL OUTPUT, REAR (OPTION 001 ONLY) (INCLUDES ATTACHING HARDWARE)	28480	1250-1811
<i>2305A TO 2328A</i> J12	1250-1811	5		ADAPTER-COAX STR F-N F-SMA CALIBRATION OUTPUT, RF POWER (OPTION 001 ONLY) (INCLUDES ATTACHING HARDWARE)	28480	1250-1811
<i>2329A AND ABOVE</i> J12	1250-1895	5		ADAPTER-COAX STR F-N F-SMA CALIBRATION OUTPUT, RF POWER (OPTION 001 ONLY)	28480	1251-1895
J13	1250-1811	5		ADAPTER-COAX STR F-N F-SMA LO OUTPUT, REAR (OPTIONS 003 AND 030 ONLY) (INCLUDES ATTACHING HARDWARE)	28480	1250-1811
J14	1250-1811	5		ADAPTER-COAX STR F-N F-SMA LO INPUT, REAR (OPTIONS 003 AND 030 ONLY) (INCLUDES ATTACHING HARDWARE)	28480	1250-1811
J15	08662-60304	5		CONN ASSY RF INPUT, REAR (OPTION 001 ONLY)	28480	08662-60304
	2190-0104	0		WASHER-LK INTL T 7/16 IN .439-IN-ID	28480	2190-0104
	2950-0132	6		NUT-HEX-DBL-CHAM 7/16-28-THD .094-IN-THK	00000	ORDER BY DESCRIPTION
	08731-210	2		LOCKING NUT	28480	08731-210

†Refer to Section 7 for update information

\*Factory Selected Component (Refer to Section 5)

Δ Errata part change

Table 6-3. Replaceable Parts

Reference Designation	HP Part Number	C D	Qty.	Description	Mfr. Code	Mfr. Part Number
<b>MISCELLANEOUS PARTS</b>						
J16	1510-0091	3	2	BINDING POST SGL SGL-TUR JGK RED "RF SWITCH 1"	28480	1510-0091
	2190-0016	3		WASHER-LK INTL T 3/8 IN .377-IN-HD	28480	2190-0016
	2950-0001	8		NUT-HEX-DBL-CHAM 3/8-32-THD .094-IN-THK	00000	ORDER BY DESCRIPTION
J17	1510-0091	3	2	BINDING POST SGL SGL-TUR JGK RED "RF SWITCH 2"	28480	1510-0091
	2190-0016	3		WASHER-LK INTL T 3/8 IN .377-IN-HD	28480	2190-0016
	2950-0001	8	1	NUT-HEX-DBL-CHAM 3/8-32-THD .094-IN-THK	00000	ORDER BY DESCRIPTION
J18	1510-0091	3		BINDING POST SGL SGL-TUR JGK RED RF SWITCH GROUND	28480	1510-0091
	2190-0016	3		WASHER-LK INTL T 3/8 IN .377-IN-HD	28480	2190-0016
	2950-0001	8		NUT-HEX-DBL-CHAM 3/8-32-THD .094-IN-THK	00000	ORDER BY DESCRIPTION
J19	1250-0083	1		CONNECTOR-RF BNC FEM SGL-HOLE-FR 50-OHM FREQ OFFSET TTL OUT	28480	1250-0083
	2190-0016	3		WASHER-LK INTL T 3/8 IN .377-IN-HD	28480	2190-0016
	2950-0001	8		NUT-HEX-DBL-CHAM 3/8-32-THD .094-IN-THK	00000	ORDER BY DESCRIPTION
<b>2305A TO 2505A</b>						
MP1	5020-8805	8	1	FRONT FRAME	28480	5020-8805
	2360-0114	3	6	SCREW-MACH 6-32 .25-IN-LG 82 DEG	00000	ORDER BY DESCRIPTION
MP2	5020-8837	6	4	CORNER STRUT	28480	5020-8837
	2360-0115	4	28	SCREW-MACH 6-32 .312-IN-LG PAN-HD-POZI	00000	ORDER BY DESCRIPTION
	2360-0119	8	1	SCREW-MACH 6-32 .438-IN-LG PAN-HD-POZI	00000	ORDER BY DESCRIPTION
	2510-0192	6	16	SCREW-MACH 8-32 .25-IN-LG 100 DEG (MP2 TO MP1, MP16)	00000	ORDER BY DESCRIPTION
<b>2515A AND ABOVE</b>						
MP1	5021-5805	4	1	FRONT FRAME	28480	5021-5805
	2360-0114	3	6	SCREW-MACH 6-32 .25-IN-LG 82 DEG	00000	ORDER BY DESCRIPTION
MP2	5021-5837	2	4	CORNER STRUT	28480	5021-5837
	2360-0115	4	28	SCREW-MACH 6-32 .312-IN-LG PAN-HD-POZI	00000	ORDER BY DESCRIPTION
	2360-0119	8	1	SCREW-MACH 6-32 .438-IN-LG PAN-HD-POZI	00000	ORDER BY DESCRIPTION
	0515-1331	5	16	SCREW-METRIC SPECIALTY M4 X 0.7 THD;6 (MP2 TO MP1, MP16)	28480	0515-1331
MP3	5041-8802	9	1	TRIM, TOP	28480	5041-8802
MP4	5062-3704	4	2	STRAP HANDLE 18 IN.	28480	5062-3704
MP5	5062-3735	1	1	COVER-TOP ASSY	28480	5062-3735
	0510-0043	4	2	RETAINER-RING E-R EXT .141-IN-DIA STL	28480	0510-0043
	0510-1171	1	2	RETAINER-PUSH ON RND EXT .265-IN-DIA STL	28480	0510-1171
MP6	5062-3747	5	1	COV-BOTTOM ASSY	28480	5062-3747
	0510-0043	4		RETAINER-RING E-R EXT .141-IN-DIA STL	28480	0510-0043
	0510-1171	1		RETAINER-PUSH ON RND EXT .265-IN-DIA STL	28480	0510-1171
MP7	08902-00066	1	2	SIDE COVER	28480	08902-00066
MP8	08902-00065	0	1	WINDOW PANEL	28480	08902-00065
MP9	5041-8819	8	2	STRAP, HANDLE, CAP-FRONT	28480	5041-8819
	0515-1239	2		SCREW-MACH M3 X 0.8 12MM-LG	00000	ORDER BY DESCRIPTION
MP10	5041-8820	1	2	STRAP, HANDLE, CAP-REAR	28480	5041-8820
	0515-1239	2		SCREW-MACH M3 X 0.8 12MM-LG	00000	ORDER BY DESCRIPTION
MP11	5041-8801	8	4	FOOT(STANDARD)	28480	5041-8801
MP12	5001-0540	2	2	TRIM, SIDE	28480	5001-0540
MP13	1460-1345	5	2	TILT STAND SST	28480	1460-1345

†Refer to Section 7 for update information.

\*Factory Selected Component (Refer to Section 5)

Δ Errata part change.

Table 6-3. Replaceable Parts

Reference Designation	HP Part Number	C	D	Qty.	Description	Mfr. Code	Mfr. Part Number
<b>MISCELLANEOUS PARTS</b>							
<i>2305A TO 2912A</i>							
<i>MP14</i>	08901-00097	7		1	FRONT PANEL (EXCEPT OPT 001)	28480	08901-00097
<i>MP14</i>	08901-00107	0		1	FRONT PANEL (OPT 001 ONLY)	28480	08901-00107
<i>2914A TO 3018A</i>							
<i>MP14</i>	08901-00200	4		1	FRONT PANEL (EXCEPT OPT 001)	28480	08901-00200
<i>MP14</i>	08901-00201	5		1	FRONT PANEL (OPT 001 ONLY)	28480	08901-00201
	0510-1148	2		3	RETAINER-PUSH ON KB-TO-SHFT EXT	28480	0510-1148
<i>3024A AND ABOVE</i>							
<i>MP14</i>	08901-00200	4		1	FRONT PANEL	28480	08901-00200
	6960-0150	3		3	HOLE PLUG .500D	28480	6960-0150
	6960-0148	9		1	HOLE PLUG .688D	28480	6960-0148
	6960-0154	7		1	HOLE PLUG .812D	28480	6960-0154
<i>2305A TO 2912A</i>							
<i>MP15</i>	08901-00100	3		1	FRONT SUB-PANEL	28480	08901-00100
	5040-6928	4			STRIP DIVIDER	28480	5040-6928
	2190-0003	8		11	WASHER-LK HLCL NO. 4 .115-IN-ID	28480	2190-0003
	2200-0149	6		11	SCREW-MACH 4-40 .625-IN-LG PAN-HD-POZI	00000	ORDER BY DESCRIPTION
	3050-0105	6		7	WASHER-FL MTLCL NO. 4 .125-IN-ID	28480	3050-0105
<i>2914A ONLY</i>							
<i>MP15</i>	08901-00209	3		1	FRONT SUB-PANEL	28480	08901-00209
	5040-6928	4			STRIP DIVIDER	28480	5040-6928
	2190-0003	8		11	WASHER-LK HLCL NO. 4 .115-IN-ID	28480	2190-0003
	2200-0149	6		11	SCREW-MACH 4-40 .625-IN-LG PAN-HD-POZI	00000	ORDER BY DESCRIPTION
	3050-0105	6		7	WASHER-FL MTLCL NO. 4 .125-IN-ID	28480	3050-0105
<i>2920A AND ABOVE</i>							
<i>MP15†</i>	08901-00209	3		1	FRONT SUB-PANEL	28480	08901-00209
	2190-0003	8		11	WASHER-LK HLCL NO. 4 .115-IN-ID	28480	2190-0003
	2200-0149	6		11	SCREW-MACH 4-40 .625-IN-LG PAN-HD-POZI	00000	ORDER BY DESCRIPTION
	3050-0105	6		7	WASHER-FL MTLCL NO. 4 .125-IN-ID	28480	3050-0105
	0380-1230	6		4	SPACER-RND .45-IN-LG .147-IN-ID (SEE SECTION 7)	00000	ORDER BY DESCRIPTION
	5041-3616	3		11	LIGHT PIPE (SEE SECTION 7)	28480	5041-3616
<i>2305A TO 2339A</i>							
<i>MP16</i>	08901-20230	2		1	REAR PANEL	28480	08901-20230
<i>2340A ONLY</i>							
<i>MP16</i>	08901-20233	5			REAR PANEL	28480	08901-20233
<i>2341A TO 2343A</i>							
<i>MP16</i>	08901-20230	2		1	REAR PANEL	28480	08901-20230
<i>2345A TO 2505A</i>							
<i>MP16</i>	08901-20233	5			REAR PANEL	28480	08901-20233
<i>2515A AND ABOVE</i>							
<i>MP16</i>	08901-20272	2		1	REAR PANEL	28480	08901-20272

†Refer to Section 7 for update information.

\*Factory Selected Component (Refer to Section 5).

Δ Errata part change

Table 6-3. Replaceable Parts

Reference Designation	HP Part Number	C D	Qty.	Description	Mfr. Code	Mfr. Part Number
<b>MISCELLANEOUS PARTS</b>						
<i>2305A TO 2451A</i>						
<i>MP17</i>	08901-00078	4	1	CENTER STRUT	28480	08901-00078
	0624-0100	5	111	SCREW-TPG 4-40 .5-IN-LG PAN-HD-POZI STL	28480	0624-0100
	2200-0107	6	8	SCREW-MACH 4-40 .375-IN-LG PAN-HD-POZI	00000	ORDER BY DESCRIPTION
	2360-0116	5	4	SCREW-MACH 6-32 .312-IN-LG 82 DEG	00000	ORDER BY DESCRIPTION
	2360-0117	6	14	SCREW-MACH 6-32 .375-IN-LG PAN-HD-POZI	00000	ORDER BY DESCRIPTION
<i>2505A TO 2621A</i>						
<i>MP17</i>	08901-00078	4	1	CENTER STRUT	28480	08901-00078
	0624-0653	3		SCREW 440X1/2 TAPTITE T-10 PNTX	00000	ORDER BY DESCRIPTION
	2200-0107	6	8	SCREW-MACH 4-40 .375-IN-LG PAN-HD-POZI	00000	ORDER BY DESCRIPTION
	2360-0116	5	4	SCREW-MACH 6-32 .312-IN-LG 82 DEG	00000	ORDER BY DESCRIPTION
	2360-0117	6	14	SCREW-MACH 6-32 .375-IN-LG PAN-HD-POZI	00000	ORDER BY DESCRIPTION
<i>2631A AND ABOVE</i>						
<i>MP17</i>	08901-00171	8	1	CENTER STRUT	28480	08901-00171
	0624-0653	3		SCREW 440X1/2 TAPTITE T-10 PNTX	00000	ORDER BY DESCRIPTION
	2200-0107	6	8	SCREW-MACH 4-40 .375-IN-LG PAN-HD-POZI	00000	ORDER BY DESCRIPTION
	2360-0116	5	4	SCREW-MACH 6-32 .312-IN-LG 82 DEG	00000	ORDER BY DESCRIPTION
	2360-0117	6	14	SCREW-MACH 6-32 .375-IN-LG PAN-HD-POZI	00000	ORDER BY DESCRIPTION
<i>MP18</i>	5041-8821	2	4	FOOT, REAR	28480	5040-8821
	0515-1232	5		SCREW-MACH M3.5 X 0.6 8MM-LG PAN-HD	00000	ORDER BY DESCRIPTION
<i>2305A TO 2621A</i>						
<i>MP19</i>	08901-00076	2	1	SUPPORT BRACKET AUD TOP	28480	08901-00076
	2360-0115	4		SCREW-MACH 6-32 .312-IN-LG PAN-HD-POZI	00000	ORDER BY DESCRIPTION
	08662-20028	6	10	HOLE PLUG	28480	08662-20028
<i>2631A AND ABOVE</i>						
<i>MP19</i>	08901-00169	4	1	SUPPORT BRACKET AUD TOP	28480	08901-00169
	2360-0115	4		SCREW-MACH 6-32 .312-IN-LG PAN-HD-POZI	00000	ORDER BY DESCRIPTION
	08662-20028	6	10	HOLE PLUG	28480	08662-20028
<i>MP20</i>	08901-00009	1	1	POWER SUPPLY SUPPORT BRACKET	28480	08901-00009
	2360-0115	4		SCREW-MACH 6-32 .312-IN-LG PAN-HD-POZI	00000	ORDER BY DESCRIPTION
	2360-0117	6		SCREW-MACH 6-32 .375-IN-LG PAN-HD-POZI	00000	ORDER BY DESCRIPTION
<i>MP20</i>	08901-00108	1	1	POWER SUPPLY SUPPORT BRACKET (OPT 002 ONLY)	28480	08901-00108
	2360-0115	4		SCREW-MACH 6-32 .312-IN-LG PAN-HD-POZI	00000	ORDER BY DESCRIPTION
	2360-0117	6		SCREW-MACH 6-32 .375-IN-LG PAN-HD-POZI	00000	ORDER BY DESCRIPTION
<i>MP21</i>	08901-00047	7	1	SUPPORT BRACKET DIGTL	28480	08901-00047
<i>MP22</i>	08901-20159	4	1	WIRE DUCT	28480	08901-20159
	2190-0006	1	4	WASHER-LK HLCL NO. 6 .141-IN-HD	28480	2190-0006
	2360-0197	2	4	SCREW-MACH 6-32 .375-IN-LG PAN-HD-POZI	28480	2360-0197
	3050-0227	3	4	WASHER-FL MTLC NO. 6 .149-IN-ID	28480	3050-0227

† Refer to Section 7 for update information.

\* Factory Selected Component (Refer to Section 5)

Δ Errata part change.

Table 6-3. Replaceable Parts

Reference Designation	HP Part Number	C D	Qty.	Description	Mfr. Code	Mfr. Part Number
<b>MISCELLANEOUS PARTS</b>						
2305A TO 2621A MP23	08901-00035	3	1	GASKET (BETWEEN EXTRUSION AND A27)	28480	08901-00035
2631A AND ABOVE MP23				NOT ASSIGNED		
2305A TO 2530A MP24	08901-00088	6	1	PC BD GUIDE	28480	08901-00088
	2360-0115	4		SCREW-MACH 6-32 .312-IN-LG PAN-HD-POZI	00000	ORDER BY DESCRIPTION
	08662-20028	6		HOLE PLUG	28480	08662-20028
2535A AND ABOVE MP24	08902-00023	0	1	PC BD GUIDE	28480	08902-00023
	2360-0115	4		SCREW-MACH 6-32 .312-IN-LG PAN-HD-POZI	00000	ORDER BY DESCRIPTION
	08662-20028	6		HOLE PLUG	28480	08662-20028
MP25	08901-80007	7	4	SHOCK MOUNT	28480	08901-80007
MP26				NOT ASSIGNED		
MP27	5061-2033	8	1	INFORMATION TRAY	28480	5061-2033
MP28	08901-00046	6	1	FAN COVER	28480	08901-00046
MP29	08902-00015	0	1	SPACER RF AMP (BETWEEN U1 AND A70)	28480	08902-00015
	2200-0105	4	4	SCREW-MACH 4-40 .312-IN-LG PAN-HD-POZI	00000	ORDER BY DESCRIPTION
MP30	08901-20160	7	1	WIRE DUCT COVER	28480	08901-20160
MP31	08901-00140	1	1	REAR WIRE DUCT SUPPORT	28480	08901-00140
2305A TO 2702A MP32	08902-00018	3	1	BRACKET, AMP (S1, S2)	28480	08902-00018
	2200-0151	0	4	SCREW-MACH 4-40 .75-IN-LG PAN-HD-POZI (ATTACH S1, S2 TO MP32)	00000	ORDER BY DESCRIPTION
	2190-0003	8		WASHER-LK HLCL NO. 4 .115-IN-ID	28480	2190-0003
	2200-0105	4	4	SCREW-MACH 4-40 .312-IN-LG PAN-HD-POZI (ATTACH A70 TO MP32)	00000	ORDER BY DESCRIPTION
	2360-0115	4		SCREW-MACH 6-32 .312-IN-LG PAN-HD-POZI (ATTACH MP32 TO MP33 AND MP17)	00000	ORDER BY DESCRIPTION
2704A AND ABOVE MP32	08902-00062	7		DECK AMPLIFIER	28480	08902-00062
	2200-0151	0	4	SCREW-MACH 4-40 .75-IN-LG PAN-HD-POZI (ATTACH U3 TO MP32)	00000	ORDER BY DESCRIPTION
	2190-0003	8		WASHER-LK HLCL NO. 4 .115-IN-ID	28480	2190-0003
	2200-0105	4	2	SCREW-MACH 4-40 .312-IN-LG PAN-HD-POZI (ATTACH A70 TO MP32)	00000	ORDER BY DESCRIPTION
	2360-0115	4		SCREW-MACH 6-32 .312-IN-LG PAN-HD-POZI (ATTACH MP32 TO MP33 AND MP17)	00000	ORDER BY DESCRIPTION
2305A TO 2702A MP33	08902-00016	1	1	DECK AMPLIFIER	28480	08902-00016
	2360-0115	4		SCREW-MACH 6-32 .312-IN-LG PAN-HD-POZI	00000	ORDER BY DESCRIPTION
2704A AND ABOVE MP33	08902-00063	8		BRACKET ATTENUATOR	28480	08902-00063
	2360-0115	4		SCREW-MACH 6-32 .312-IN-LG PAN-HD-POZI (ATTACH MP33 TO CHASSIS)	00000	ORDER BY DESCRIPTION

† Refer to Section 7 for update information.

\* Factory Selected Component (Refer to Section 5)

Δ Errata part change

Table 6-3. Replaceable Parts

Reference Designation	HP Part Number	C D	Qty.	Description	Mfr. Code	Mfr. Part Number
<b>MISCELLANEOUS PARTS</b>						
2305A TO 2530A MP34	1600-0692	1	3	STAMPING-BE-CU CLIP WINDOW RETAINING	28480	1600-0692
2535A AND ABOVE MP34				NOT ASSIGNED		
MP35	08902-00019	4	1	ATTENUATOR MOUNTING BRACKET	28480	08902-00019
	2200-0105	4		SCREW-MACH 4-40 .312-IN-LG PAN-HD-POZI	00000	ORDER BY DESCRIPTION
MP36	08901-00086	4	1	SHOCK MOUNT BRACKET, FRONT	28480	08901-00086
	0400-0010	2	4	GROMMET-RND .25-IN-ID .375-IN-GRV-OD	28480	0400-0010
	2190-0017	4	4	WASHER-LK HLCL NO. 8 .168-IN-ID	28480	2190-0017
	2580-0002	4	2	NUT-HEX-DBL-CHAM 8-32-THD .085-IN-THK	28480	2580-0002
MP37	08901-00079	5	1	SHOCK MOUNT BRACKET, REAR	28480	08901-00079
	0400-0010	2		GROMMET-RND .25-IN-ID .375-IN-GRV-OD	28480	0400-0010
	2190-0017	4		WASHER-LK HLCL NO. 8 .168-IN-ID	28480	2190-0017
	2580-0002	4		NUT-HEX-DBL-CHAM 8-32-THD .085-IN-THK	28480	2580-0002
2305A TO 2451A MP38	08902-20020	9	1	EXTRUSION ASSY LO	28480	08902-20020
	0403-0005	1	3	BUMPER FOOT-SCR .5-IN-MAX-OD.188-IN-THK	28480	0403-0005
	0624-0100	5		SCREW-TPG 4-40 .5-IN-LG PAN-HD-POZI STL	28480	0624-0100
	2190-0756	8	3	WASHER-FL MTLCL NO. 5 .13-IN-ID .25-IN-OD	28480	2190-0756
2505A AND ABOVE MP38	08902-20037	8	1	EXTRUSION ASSY LO	28480	08902-20020
	0403-0005	1	3	BUMPER FOOT-SCR .5-IN-MAX-OD.188-IN-THK	28480	0403-0005
	0624-0653	3		SCREW 440X1/2 TAPTITE T-10 PNTX	00000	ORDER BY DESCRIPTION
	2190-0756	8	3	WASHER-FL MTLCL NO. 5 .13-IN-ID .25-IN-OD	28480	2190-0756
MP39	08901-00099	9	1	SCREEN, RFI	28480	08901-00099
	2200-0567	2		SCREW-MACH 4-40 .125-IN-LG PNA-HD-POZI	00000	ORDER BY DESCRIPTION
MP40	08901-20164	1	1	FRONT WINDOW	28480	08901-20164
	0460-1297	5		STAMPING-BE-CU CLIP WINDOW RETAINING	28480	1600-0692
MP41	08902-00008	1	1	GASKET, EXTRUSION	28480	08902-00008
2305A TO 2461A MP42	08901-20219	7	1	EXTRUSION ASSY, AUD FRONT	28480	08901-20219
	0624-0100	5		SCREW-TPG 4-40 .5-IN-LG PAN-HD-POZI STL	28480	0624-0100
2505A TO 2621A MP42	08901-20219	7	1	EXTRUSION ASSY, AUD FRONT	28480	08901-20219
	0624-0653	3		SCREW 440X1/2 TAPTITE T-10 PNTX	00000	ORDER BY DESCRIPTION
2631A AND ABOVE MP42	08901-20278	8	1	EXTRUSION ASSY, AUD FRONT	28480	08901-20278
	0624-0653	3		SCREW 440X1/2 TAPTITE T-10 PNTX	00000	ORDER BY DESCRIPTION

† Refer to Section 7 for update information

\* Factory Selected Component (Refer to Section 5)

Δ Errata part change.

Table 6-3. Replaceable Parts

Reference Designation	HP Part Number	C D	Qty.	Description	Mfr. Code	Mfr. Part Number
<b>MISCELLANEOUS PARTS</b>						
2305A TO 2451A MP43	08901-20161	8	1	EXTRUSION ASSY, AUD REAR	28480	08901-20161
	0624-0100	5		SCREW-TPG 4-40 .5-IN-LG PAN-HD-POZI STL	28480	0624-0100
2505A TO 2530A MP43	08901-20161	8	1	EXTRUSION ASSY, AUD REAR	28480	08901-20161
	0624-0653	3		SCREW 440X1/2 TAPTITE T-10 PNTX	00000	ORDER BY DESCRIPTION
2535A TO 2621A MP43	08901-20259	5	1	EXTRUSION ASSY, AUD REAR	28480	08901-20259
	0624-0653	3		SCREW 440X1/2 TAPTITE T-10 PNTX	00000	ORDER BY DESCRIPTION
2631A AND ABOVE MP43	08901-20279	9	1	EXTRUSION ASSY, AUD REAR	28480	08901-20279
	0624-0653	3		SCREW 440X1/2 TAPTITE T-10 PNTX	00000	ORDER BY DESCRIPTION
2305A TO 2530A MP44	08901-20155	0	1	EXTRUSION ASSY, DIGTL	28480	08901-20155
2535A AND ABOVE MP44	08902-20054	9	1	EXTRUSION ASSY, DIGTL	28480	08901-20032
MP45				NOT ASSIGNED		
2305A TO 2530A MP46	08901-00121	8	1	OSCILLATOR MOUNTING PLATE	28480	08901-00121
	0360-0272	2	1	TERMINAL-SLDR LUG LK-MTG FOR#4-SCR	28480	0360-0272
	2200-0119	0	3	SCREW-MACH 4-40 1-IN-LG PAN-HD-POZI	00000	ORDER BY DESCRIPTION
2535A AND ABOVE MP46	08902-00025	2	1	OSCILLATOR MOUNTING PLATE	28480	08902-00025
	0360-0272	2	1	TERMINAL-SLDR LUG LK-MTG FOR#4-SCR	28480	0360-0272
	2200-0119	0	3	SCREW-MACH 4-40 1-IN-LG PAN-HD-POZI	00000	ORDER BY DESCRIPTION
MP47	08901-20165	2	1	DISPLAY BD SHIELD	28480	08901-20165
	2190-0003	8		WASHER-LK HLCL NO. 4 .115-IN-ID	28480	2190-0003
	2200-0149	6		SCREW-MACH 4-40 .625-IN-LG PAN-HD-POZI	00000	ORDER BY DESCRIPTION
	3050-0105	6		WASHER-FL MTLG NO. 4 .125-IN-ID	28480	3050-0105
MP48	08901-00102	5	1	DISPLAY BOARD INSULATOR	28480	08901-00102
	2200-0149	6		SCREW-MACH 4-40 .625-IN-LG PAN-HD-POZI	00000	ORDER BY DESCRIPTION
MP49	6960-0002	4	6	PLUG-HOLE DOME-HD FOR .5-D-HOLE STL	28480	6960-0002
MP50	6960-0046	6	1	PLUG-HOLE FL-HD FOR .688-D-HOLE BRS	28480	6960-0046
MP51	6960-0013	7	1	PLUG-HOLE DOME-HD FOR .812-D-HOLE STL	28480	6960-0013

† Refer to Section 7 for update information

\* Factory Selected Component (Refer to Section 5)

Δ Errata part change



Table 6-3. Replaceable Parts

Reference Designation	HP Part Number	C D	Qty.	Description	Mfr. Code	Mfr. Part Number
<b>MISCELLANEOUS PARTS</b>						
<i>2305A TO 2621A</i>						
<i>MP52</i>	08901-00090	0	1	DUCT SUPPORT	28480	08901-00090
	2190-0018	5	2	WASHER-LK HLCL NO. 6 .141-IN-ID	28480	2190-0018
	3030-0139	4	2	SCREW-SKT HD CAP 6-32 .375-IN-LG SST	00000	ORDER BY DESCRIPTION
	08662-20028	6		HOLE PLUG	28480	08662-20028
<i>2631A AND ABOVE</i>						
<i>MP52</i>	08901-00172	9	1	DUCT SUPPORT	28480	08901-00172
	2190-0018	5	2	WASHER-LK HLCL NO. 6 .141-IN-ID	28480	2190-0018
	3030-0139	4	2	SCREW-SKT HD CAP 6-32 .375-IN-LG SST	00000	ORDER BY DESCRIPTION
	08662-20028	6		HOLE PLUG	28480	08662-20028
MP53	08901-00089	7	1	RTNR DIGTL	28480	08901-00089
MP54	08901-20231	3	1	CENTER STRUT BRACE	28480	08901-20231
<i>2305A TO 2621A</i>						
<i>MP55</i>	08901-00077	3	1	SUPPORT BRACKET, AUD BOTTOM	28480	08901-00077
<i>2631A AND ABOVE</i>						
<i>MP55</i>	08901-00170	7	1	SUPPORT BRACKET, AUD BOTTOM	28480	08901-00170
MP56	7120-1254	1	1	NAMEPLATE .312-IN-WD .54-IN-LG AL	28480	7120-1254
MP57	7120-1927	5	1	LABEL-BLANK .625-IN-WD 1.5-IN-LG AL	28480	7120-1927
MP58				NOT ASSIGNED		
MP59	7120-4296	7	1	LABEL-WARNING .688-IN-WD 1.5-IN-LG AL	28480	7120-4296
<i>2305A TO 2605A</i>						
<i>MP60</i>	7120-5911	5	1	LABEL-WARNING 1-IN-WD 7-IN-LG PPR	28480	7120-5911
<i>2515A AND ABOVE</i>						
<i>MP60</i>	7120-8607	2	1	LABEL...THIS INSTRUMENT USES METRIC...	28480	7120-8607
MP61	7120-8053	2	1	LABEL-WARNING 15.1-MM-WD 45.6-MM-LG	28480	7120-8053
MP62	7120-8138	4	1	LABEL-WARNING 6-MM-WD 51-MM-LG VINYL	28480	7120-8138
MP63				NOT ASSIGNED		
<i>2305A TO 2748A</i>						
<i>MP64</i>	08901-00116	1	1	BOTTOM COVER INSULATOR	28480	08901-00116
<i>2751A AND ABOVE</i>						
<i>MP64</i>	08901-00193	4	1	BOTTOM COVER INSULATOR	28480	08901-00193
<i>2305A TO 2621A</i>						
<i>MP65</i>	08901-00127	4	1	BAFFLE AIR REAR LEFT	28480	08901-00127
	2360-0115	4		SCREW-MACH 6-32 .312-IN-LG PAN-HD-POZI	00000	ORDER BY DESCRIPTION
<i>2631A AND ABOVE</i>						
<i>MP65</i>	08901-00173	0	1	BAFFLE AIR REAR LEFT	28480	08901-00173
	2360-0115	4		SCREW-MACH 6-32 .312-IN-LG PAN-HD-POZI	00000	ORDER BY DESCRIPTION

† Refer to Section 7 for update information

\* Factory Selected Component (Refer to Section 5)

Δ Errata part change

Table 6-3. Replaceable Parts

Reference Designation	HP Part Number	C D	Qty.	Description	Mfr. Code	Mfr. Part Number
<b>MISCELLANEOUS PARTS</b>						
MP66	08901-00126	3	1	BAFFLE AIR FRONT RIGHT	28480	08901-00126
	2360-0115	4		SCREW-MACH 6-32 .312-IN-LG PAN-HD-POZI	00000	ORDER BY DESCRIPTION
MP67	08901-00125	2	1	REAR AIR BAFFLE	28480	08901-00125
	2200-0103	2	2	SCREW-MACH 4-40 .25-IN-LG PAN-HD-POZI	28480	2200-0103
<i>2305A TO 2621A</i>						
MP68	08901-00213	0	1	AIR DUCT COVER	28480	08901-00123
<i>2631A AND ABOVE</i>						
MP68	08901-00177	4	1	AIR DUCT COVER	28480	08901-00177
MP69	08902-20025	4	1	INPUT SWITCH COVER	28480	08902-20025
<i>2305A TO 2451A</i>						
MP70	0624-0100		5	SCREW-TPG 4-40 .5-IN-LG PAN-HD-POZI STL (ATTACH MOTHERBOARDS TO FRAME)	28480	0624-0100
<i>2505A AND ABOVE</i>						
MP70	0624-0653		3	SCREW 440X1/2 TAPTITE T-10 PNTX	00000	ORDER BY DESCRIPTION
MP71	8160-0072	4		RFI ROUND STRIP MNL-MSH .062-IN-OD	28480	8160-0072
MP72	7120-7032	5	1	LABEL-INFORMATION .325-IN-WD 1.75-IN-LG	28480	7120-7032
MP73	08902-90026	2	1	SPECIAL FUNCTION INFORMATION CARD	28480	08902-90026
MP74	08902-90027	3	1	OPERATING INFORMATION CARD	28480	08902-90027
MP75	5020-8806	9	1	REAR FRAME	28480	5020-8806
MP76	7121-4617	8	1	VOLTAGE INFORMATION LABEL	28480	7121-4617
<i>2305A TO 2406A</i>						
<i>MP77-MP80</i>						
<i>2411A AND ABOVE</i>						
MP77	08902-60032	7		GROUND STRAP	28480	08902-60032
MP78	08902-60032	7		GROUND STRAP	28480	08902-60032
MP79	08902-60032	7		GROUND STRAP	28480	08902-60032
MP80 <sup>Δ</sup>	08901-00214	0	2	SPACER (BETWEEN T1 AND MP16)	28480	08901-00214
MP81	5040-6888	5	4	LIGHT PIPES	28480	5040-6888
MP82	0380-0003	9	4	SPACER-RND .125-IN-LG .18-IN-HD	00000	ORDER BY DESCRIPTION
MP83	08901-00157	0	1	COVER, EXTRUSION (EXCEPT OPTION 030)	28480	08901-00157
MP84	08902-00024	1	1	MOUNTING PLATE - S4 (OPTION 030 ONLY)	28480	08902-00024
	2360-0113	2		SCREW-MACH 6-32 .25-IN-LG PAN-HD-POZI	00000	ORDER BY DESCRIPTION
	2190-0003	8		WASHER-LK HLCL NO. 4 .115-IN-HD	28480	2190-0003
<i>2305A TO 2702A</i>						
<i>MP85</i>						
<i>MP86</i>						
<i>2704A AND ABOVE</i>						
MP85	2200-0107	6	6	SCREW-MACH 4-40 .625-IN-LG 82 DEG	00000	2200-01700
MP86	2200-0105	4		SCREW-MACH 4-40 .312-IN-LG PAN-HD-POZI	00000 O	ORDER BY DESCRIPTION

<sup>†</sup> Refer to Section 7 for update information

<sup>\*</sup> Factory Selected Component (Refer to Section 5)

<sup>Δ</sup> Errata part change

Table 6-3. Replaceable Parts

Reference Designation	HP Part Number	C D	Qty.	Description	Mfr. Code	Mfr. Part Number
<b>MISCELLANEOUS PARTS</b>						
MP87 <sup>Δ</sup>	08901-00211	7	1	BD RETAINING BRACKET (FOR RETAINING A13 AND A14)	28480	08901-00211
	0380-0003	9	5	SPACER .125L.1811D	28480	0380-0003
	2360-0115	4	1	SCREW-MACHINE 6-32 .312PNPD	28480	2360-0115
	2190-0006	1	1	LOCK WASHER .1411D	28480	2190-0006
<b>2305A TO 2702A</b>						
S1	08902-60024	7	2	COAX SWITCH	28480	08902-60024
S2	08902-60024	7		COAX SWITCH	28480	08902-60024
<b>2704A AND ABOVE</b>						
S1				REPLACED BY U3		
S2				REPLACED BY U3		
<b>2305A TO 2912A</b>						
S3	3101-2080	9	1	SWITCH-RKR BASIC DPDT 3A 250VAC SLDR-LUG	28480	3101-2080
	5041-1418	9	1	ROCKER	28480	5041-1418
	2200-0164	5	2	SCREW-MACH 4-40 .188-IN-LG UNCT 82 DEG	00000	ORDER BY DESCRIPTION
<b>2914A AND ABOVE</b>						
S3	3101-2915	9	1	SWITCH-RKR PRI-SW SPDT 5A 120VAC	02392	U11 J50 ZQE WHITE
	08902-00017	2	1	LABEL-RF SWITCH	28480	08902-00017
	2200-0115	6		SCREW-MACH 4-40 .75-IN-LG PAN-HD-POZI	00000	ORDER BY DESCRIPTION
T1	9100-4255	8	1	TRANSFORMER-POWER 100/120/220/240V	28480	9100-4255
	7100-1283	4		TRANSFORMER COVER	28480	7100-1283
	2190-0034	5	6	WASHER-LK HLCL NO. 10 .194-IN-ID	28480	2190-0034
	2680-0131	2	2	SCREW-MACH 10-32 2.25-IN-LG PAN-HD-POZI	00000	ORDER BY DESCRIPTION
	2680-0132	3	4	SCREW-MACH 10-32 2.5-IN-LG PAN-HD-POZI	00000	ORDER BY DESCRIPTION
	2740-0002	4	2	NUT-HEX-DBL-CHAM 10-32-THD .125-IN-THK	00000	ORDER BY DESCRIPTION
	3050-0006	6	2	WASHER-SHLDR NO. 10 .2-IN-ID .5-IN-OD	28480	3050-0006
	3050-0226	2	4	WASHER-FL MTLN NO. 10 .203-IN-ID	28480	3050-0226
	1400-0249	0	6	CABLE TIE .062-.625-DIA .091-WD NYL	28480	1400-0249
	08901-00140	1	1	BRACKET	28480	08901-00140
U1	08902-67001	4	1	RF AMP	28480	08902-67001
	2200-0107	6		SCREW-MACH 4-40 .375-IN-LG PAN-HD-POZI	00000	ORDER BY DESCRIPTION
U2	5086-7283	2	1	LIMITER	28480	5086-7283
<b>2306A TO 2702A</b>						
U3				NOT ASSIGNED		
<b>2704A AND ABOVE</b>						
U3	08902-60121	9	1	ATTENUATOR/SWITCH	28480	08902-60121
	08902-80020	5	1	LABEL	28480	08902-80020

1 Refer to Section 7 for update information.

\*Factory Selected Component (Refer to Section 5).

Δ Errata part change.

Table 6-3. Replaceable Parts

Reference Designation	HP Part Number	C D	Qty.	Description	Mfr. Code	Mfr. Part Number
<b>MISCELLANEOUS PARTS</b>						
Y1	0960-0529	4	1	OSCILLATOR-CRYSTAL OVENIZED; 10MHZ; 1	28480	0960-0529
	2190-0006	1		WASHER-LK HLCL NO. 6 .141-IN-ID	28480	2190-0006
	2360-0203	1	4	SCREW-MACH 6-32 .625-IN-LG PAN-HD-POZI	00000	ORDER BY DESCRIPTION
	3050-0227	3		WASHER-FL MTLCL NO. 6 .149-IN-ID	28480	3050-0227
	0380-1181	6		SPACER-PRESS-IN 0.250-IN-LG; 0.180-IN	28480	0380-1181
W1	08902-20008	3	1	SEMI-RIGID COAX CABLE ASSY RF INPUT (J1) - W3 (EXCEPT OPTION 001)	28480	08902-20008
2305A TO 2702A W2	08902-20030	1	1	COAX CABLE ASSY (6) REAR PANEL RF INPUT (J15)W3	28480	08902-20030
2704A AND ABOVE W2	08902-20120	0	1	SEMI-RIGID COAX CABLE ASSY (OPT #001) REAR PANEL RF INPUT (J15)W3	28480	08902-20120
2305A TO 2702A W3 2704A AND ABOVE W3	08902-20009	4	1	SEMI-RIGID COAX CABLE ASSY  NOT ASSIGNED, REPLACED BY W61. RF INPUT CABLE (W1) - U3	28480	08902-20009
2305A TO 2702A W4	08902-20011	8	1	SEMI-RIGID COAX CABLE ASSY 10 DB PAD	28480	08902-20011
W6	08902-20010	7	1	SEMI-RIGID COAX CABLE ASSY SWITCH 1-2	28480	08902-20010
2704A AND ABOVE W4 W5				NOT ASSIGNED NOT ASSIGNED		
2305A TO 2702A W6	08902-20012	9	1	SEMI-RIGID COAX CABLE ASSY AMP IN	28480	08902-20012
2704A AND ABOVE W6				NOT ASSIGNED, REPLACED BY W62.		
2305A TO 2702A W7	08902-20013	0	1	SEMI-RIGID COAX CABLE ASSY AMP OUT	28480	08902-20013
2704A AND ABOVE W7				NOT ASSIGNED, REPLACED BY W63.		

†Refer to Section 7 for update information.

\*Factory Selected Component (Refer to Section 5).

Δ Errata part change

Table 6-3. Replaceable Parts

Reference Designation	HP Part Number	C D	Qty.	Description	Mfr. Code	Mfr. Part Number
<b>MISCELLANEOUS PARTS</b>						
W8	08902-20070 <sup>Δ</sup>	2	1	COAX CABLE ASSY - SEMI-RIGID A16J1 - U3, PORT 1.	28480	08902-20070
2305A TO 2312A W9	08901-60165	6	1	COAX CABLE ASSY (1) A52J2 - MODULATION OUT/AUDIO IN ALL INSTRUMENTS INCL OPT 001	28480	08901-60165
2413A AND ABOVE W9	08901-60165	6	1	COAX CABLE ASSY (1) A52J2 - MODULATION OUT/AUDIO IN (EXCEPT OPTION 001)	28480	08901-60165
W10	08901-60166	7	1	COAX CABLE ASSY (9) A50J2 TO CALIBRATION OUTPUT, AM/FM (EXCEPT OPTION 001)	28480	08901-60166
W11	08901-60178	1	1	COAX CABLE ASSY (98) CALIBRATION OUTPUT, RF POWER ALL INSTRUMENTS INCL OPT 001	28480	08901-60178
W12	08901-60166	7	1	COAX CABLE ASSY (9) CALIBRATION OUTPUT, AM/FM (OPTION 001 ONLY)	28480	08901-60166
W13	08901-60225	9	1	WIRING HARNESS A1J1 - A26J1	28480	08901-60225
W14	08901-60175	8	1	RIBBON CABLE ASSY A1J2 - A27J3	28480	08901-60175
W15	08902-60025	8	1	RIBBON CABLE ASSY A15J1 - A70J1	28480	08902-60025
W16	08901-60053	1	1	COAX CABLE ASSY (935) A2J1 - A6J1	28480	08901-60053
W17	08901-60056	4	1	COAX CABLE ASSY (947) A2J2 - A4J3	28480	08901-60056
W18	08901-60154	3	1	COAX CABLE ASSY (3) A11J1 - A19J1	28480	08901-60154
W19	08901-60064	4	1	COAX CABLE ASSY (934) A11J2 - A51J2	28480	08901-60064
W20	08901-60055	3	1	COAX CABLE ASSY (94) A11J3 - A4J2	28480	08901-60055
W21	08901-60169	0	1	COAX CABLE ASSY (4) A11J4 - Y1J1 (OPTION 002 ONLY)	28480	08901-60169
	1400-0510	8	5	CLAMP-CABLE .15-DIA .62-WD NYL	28480	1400-0510
W22	08901-60163	4	1	COAX CABLE ASSY (2) A11J5 - REAR TIME BASE OUTPUT (OPTION 002 ONLY)	28480	08901-60163
W23	08901-60161	2	1	COAX CABLE ASSY (5) A11J6 - REAR TIME BASE INPUT	28480	08901-60161

†Refer to Section 7 for update information.

\*Factory Selected Component (Refer to Section 5).

Δ Errata part change

Table 6-3. Replaceable Parts

Reference Designation	HP Part Number	C D	Qty.	Description	Mfr. Code	Mfr. Part Number
<b>MISCELLANEOUS PARTS</b>						
W24	08901-60054	2	1	COAX CABLE ASSY (926) A4J1 - A6J3	28480	08901-60054
W25	08902-60016	7	1	COAX CABLE ASSY (97) A6J2 - A54J1	28480	08902-60016
W26	08901-60162	3	1	COAX CABLE ASSY (902) A6J4 - OUTPUT IF	28480	08901-60162
W27	08901-60243	1	1	RIBBON CABLE ASSY A14J1 - A31J2	28480	08901-60243
W28	08901-60076	8	1	COAX CABLE ASSY (92) A50J1 - A51J1	28480	08901-60076
W29	08901-60157	6	1	COAX CABLE ASSY (941) A52J1 - A25J1	28480	08901-60157
W30	08902-60017	8	1	COAX CABLE ASSY (951) A54J2 - A55J1	28480	08902-60017
W31	08902-60015	6	1	OPTION 030 ONLY COAX CABLE ASSY (957) A18J1 - A55J2	28480	08902-60015
W32	08901-60078	0	1	COAX CABLE ASSY (7) A17J3 - A19J3	28480	08901-60078
W33	08901-60168	9	1	(EXCEPT OPTION 003 OR 030) COAX CABLE ASSY (927) A17J3 - REAR LO INPUT (OPTION 003 ONLY)	28480	08901-60168
W34	08901-60167	8	1	COAX CABLE ASSY (90) A19J3 - REAR LO OUTPUT (OPT 003 ONLY)	28480	08901-60167
W35	08901-20083	3	1	SEMI-RIGID COAX CABLE ASSY REAR PANEL J13 TO J14 (OPT 003 ONLY)	28480	08901-20083
W36	08901-60057	5	1	COAX CABLE ASSY (91) A21J2 - A23J1	28480	08901-60057
W37	08902-60020	3	1	COAX CABLE ASSY (934) A17J2 - AT1J2	28480	08902-60020
W38	08901-60063	3	1	COAX CABLE ASSY (916) A21J1 - A22J1	28480	08901-60063
W39	08901-60058	6	1	COAX CABLE ASSY (93) A23J2 - A24J2	28480	08901-60058
2314A TO 2636A W40 2742A AND ABOVE W40	08901-60060	0	1	COAX CABLE ASSY (905)  NOT ASSIGNED A17J1 - A18J2	28480	08901-60060
W41	08901-60179	2	1	WIRE HARNESS ASSY - RF POWER (EXCEPT OPT 001)	28480	08901-60179
W42	08901-60241	9	1	WIRE HARNESS ASSY - RF POWER (OPT 001 ONLY)	28480	08901-60241
W43	08902-60019	0	1	COAX CABLE ASSY (95) A16J2 - AT1J1	28480	08902-60019

†Refer to Section 7 for update information.

\*Factory Selected Component (Refer to Section 5.)

Δ Errata part change.

Table 6-3. Replaceable Parts

Reference Designation	HP Part Number	C D	Qty.	Description	Mfr. Code	Mfr. Part Number
<b>MISCELLANEOUS PARTS</b>						
W44	08901-60059	7	1	COAX CABLE ASSY (956) A19J2 - A24J1	28480	08901-60059
W45	08901-60296	4	1	WIRING HARNESS - DIGTL A26J3 - A27J4	28480	08901-60072
	1252-0073	3		CONTACT-CONN U/W-POST-TYPE FEM CRP	28480	1252-0073
	1252-1763	0		CONNECTOR 6-CONT HDR POST TYPE	28480	1252-1763
	1400-0510	8		CLAMP-CABLE .15-DIA .62-WD NYL	28480	1400-0510
2305A TO 2530A W46	08901-60230	6	1	RIBBON CABLE ASSY A25J2 - A27J2	28480	08901-60230
	1400-1151	5	2	CLAMP-CABLE .625-WD NYL	28480	1400-1151
2536A AND ABOVE W46	08902-60039	4	1	RIBBON CABLE ASSY A25J2 - A27J2	28480	08902-60039
W47	08901-60231	7	2	RIBBON CABLE ASSY A27J1 - A28J3	28480	08901-60231
	1400-1511	1	1	CABLE CLAMP	28480	1400-1511
W48	08901-60231	7		RIBBON CABLE ASSY A25J3 - A28J2	28480	08901-60231
	1400-1151	5		CLAMP-CABLE .625-WD NYL	28480	1400-1151
W49	08901-60071	3	1	WIRING HARNESS - AUDIO A25J4 - A26J2	28480	08901-60071
	1251-3275	1		CONNECTOR 6-PIN F POST TYPE	28480	1251-3275
	1251-3897	3		CONTACT-CONN U/W-POST-TYPE FEM CRP	28480	1251-3897
W50	08901-60232	8	1	WIRING HARNESS A26J6 - A28J1	28480	08901-60232
	1251-3275	1		CONNECTOR 6-PIN F POST TYPE	28480	1251-3275
	1251-3897	3		CONTACT-CONN U/W-POST-TYPE FEM CRP	28480	1251-3897
W51	08901-60176	9	1	WIRING HARNESS A25J5 - AM OUTPUT, FM OUTPUT, RECORDER OUTPUT AND FREQ OFFSET TTL OUT	28480	08901-60176
	1400-0510	8		CLAMP-CABLE .15-DIA .62-WD NYL	28480	1400-0510
W52	8120-1378	1		CABLE ASSY 18AWG 3-CNDCT JGK-JKT	28480	8120-1378
2305A TO 2412A W53				NOT ASSIGNED		
2413A AND ABOVE W53	08901-60258	8		COAX CABLE ASSEMBLY (1) A52J2 - MODULATION OUT/AUDIO IN (OPTION 001 ONLY)	28480	08901-60258
W54 <sup>Δ</sup>	08902-60133	9	1	CABLE ASSEMBLY: A19J3 TO S4J5 (156) OPTION 030 ONLY	28480	08902-60133
W55	08902-60019	0	1	CABLE ASSEMBLY: A17J3 TO S4J4 (95) OPTION 030 ONLY	28480	08902-60019
W56	08902-60051	0	1	CABLE ASSEMBLY: A17J4 TO A72J2 (8)	28480	08902-60051

<sup>†</sup>Refer to Section 7 for update information.

\*Factory Selected Component (Refer to Section 5)

<sup>Δ</sup> Errata part change.

Table 6-3. Replaceable Parts

Reference Designation	HP Part Number	C D	Qty.	Description	Mfr. Code	Mfr. Part Number
<b>MISCELLANEOUS PARTS</b>						
W57	08901-60078	0	1	CABLE ASSEMBLY: A72J1 TO A71J2 (7) OPTION 030 ONLY	28480	08901-60078
W58	08901-60255	5	1	WIRING HARNESS: A72J3 TO S4 BRN-"1", RED-"C+", ORN-"2" (OPTION 030 ONLY)	28480	08901-60255
W59	08902-60036	1	1	CABLE ASSEMBLY SEMI-RIGID: REAR PANEL J14 TO S4J3; OPTION 030 ONLY	28480	08902-60036
W60	08902-60037	2	1	CABLE ASSEMBLY SEMI-RIGID: REAR PANEL J13 TO S4J2; OPTION 030 ONLY	28480	08902-60037
2305A TO 2702A						
W61				NOT ASSIGNED		
W62				NOT ASSIGNED		
W63				NOT ASSIGNED		
2704A AND ABOVE						
W61 <sup>Δ</sup>	08902-20066	3	1	SEMI-RIGID COAX CABLE ASSY (OPT. 001 ONLY) RF INPUT CABLE (W1-U3, PORT 4)	28480	08902-20066
W61 <sup>Δ</sup>	08902-20117	5	1	SEMI-RIGID COAX CABLE ASSY (STD ONLY) RF INPUT CABLE (W1-U3, PORT 4)	28480	08902-20117
W62	08902-20118	6	1	SEMI-RIGID COAX CABLE ASSY	28480	08902-20118
W63	08902-20119	7	1	SEMI-RIGID COAX CABLE ASSY (U1 TO U3 PORT 2)	28480	08902-20119

†Refer to Section 7 for update information.

\*Factory Selected Component (Refer to Section 5).

Δ Errata part change.



Table 6-4. Code List of Manufacturers

Mfr. Code	Manufacturer Name	Address	Zip Code
50545	NIPPON ELECTRIC CO	TOKYO, JP	
00000	ANY SATISFACTORY SUPPLIER		
00853	SANGAMO ELEC CO S CAROLINA DIV	PICKENS, SC	29671
01121	ALLEN-BRADLEY CO	MILWAUKEE, WI	53204
01295	TEXAS INSTR INC SEMICOND CMPNT DIV	DALLAS, TX	75222
02111	SPECTROL ELECTRONICS CORP	CITY OF IND, CA	91745
02114	FERROXCUBE CORP	SAUGERTIES, NY	12477
03508	GE CO SEMICONDUCTOR PROD DEPT	AUBURN, NY	13201
03888	K D I PYROFILM CORP	WHIPPANY, NJ	07981
03911	CLAIREX CORP	MT VERNON, NY	10050
04713	MOTOROLA SEMICONDUCTOR PRODUCTS.	PHOENIX, AZ	85008
06560	JEFFERS ELECTRONICS INC	NOGALES, AZ	85621
06665	PRECISION MONOLITHICS INC	SANTA CLARA, CA	95050
07263	FAIRCHILD SEMICONDUCTOR DIV	MOUNTAIN VIEW, CA	94040
07716	TRW INC BURLINGTON DIV	BURLINGTON, IA	52601
07933	RAYTHEON CO SEMICONDUCTOR DIV HQ	MOUNTAIN VIEW, CA	94040
11236	CTS OF BERNE INC	BERNE, IN	46711
13103	THERMALLOY CO	DALLAS, TX	75234
16299	CORNING GLASS WKS COMPONENT DIV	RALEIGH, NC	27604
17856	SILICONIX INC	SANTA CLARA, CA	95054
18324	SIGNETICS CORP	SUNNYVALE, CA	94086
19701	MEPCO/ELECTRA CORP	MINERAL WELLS, TX	76067
20932	EMCON DIV ITW	SAN DIEGO, CA	92129
20940	MICRO-OHM CORP	EL MONTE, CA	91731
24046	TRANSITRON ELECTRONIC CORP	WAKEFIELD, MA	01880
24355	ANALOG DEVICES INC	NORWOOD, MA	02062
24546	CORNING GLASS WORKS (BRADFORD)	BRADFORD, PA	16701
25088	SIEMENS CORP	ISELIN, NJ	08830
25403	N.V. PHILIPS-ELCOMA DEPARTMENT	EINDHOVEN, HL	02876
27014	NATIONAL SEMICONDUCTOR CORP	SANTA CLARA, CA	95051
27167	CORNING GLASS WORKS (WILMINGTON)	WILMINGTON, NC	28401
28480	HEWLETT-PACKARD CO CORPORATE HQ	PALO ALTO, CA	94304
31585	RCA CORP SOLID STATE DIV	SOMERVILLE, NJ	
30983	MEPCO/ELECTRA CORP	SAN DIEGO, CA	92121
32293	INTERSIL INC	CUPERTINO, CA	95014
32997	BURNS INC TRIMPOT PROD DIV	RIVERSIDE, CA	92507
34335	ADVANCED MICRO DEVICES INC	SUNNYVALE, CA	94086
34371	HARRIS SEMICON DIV HARRIS INTERTYPE	MELBOURNE, FL	32901
34649	INTEL CORP	MOUNTAIN VIEW, CA	95051
51642	CENTRE ENGINEERING INC	STATE COLLEGE, PA	16801
52063	EXAR INTEGRATED SYSTEMS INC	SUNNYVALE, CA	94086
52763	STETTNER ELECTRONICS INC	CHATTANOOGA, TN	13035
56289	SPRAGUE ELECTRIC CO	NORTH ADAMS, MA	01247
72136	ELECTRO MOTIVE CORP	FLORENCE, SC	06226
72982	ERIE TECHNOLOGICAL PRODUCTS INC	ERIE, PA	16512
73138	BECKMAN INSTRUMENTS INC HELIPOT DIV	FULLERTON, CA	92634
74970	JOHNSON E F CO	WASECA, MN	56093
75915	LITTELFUSE INC	DES PLAINES, IL	60016
90201	MALLORY CAPACITOR CO	INDIANAPOLIS, IN	46206
95275	VITRAMON INC	BRIDGEPORT, CT	06601

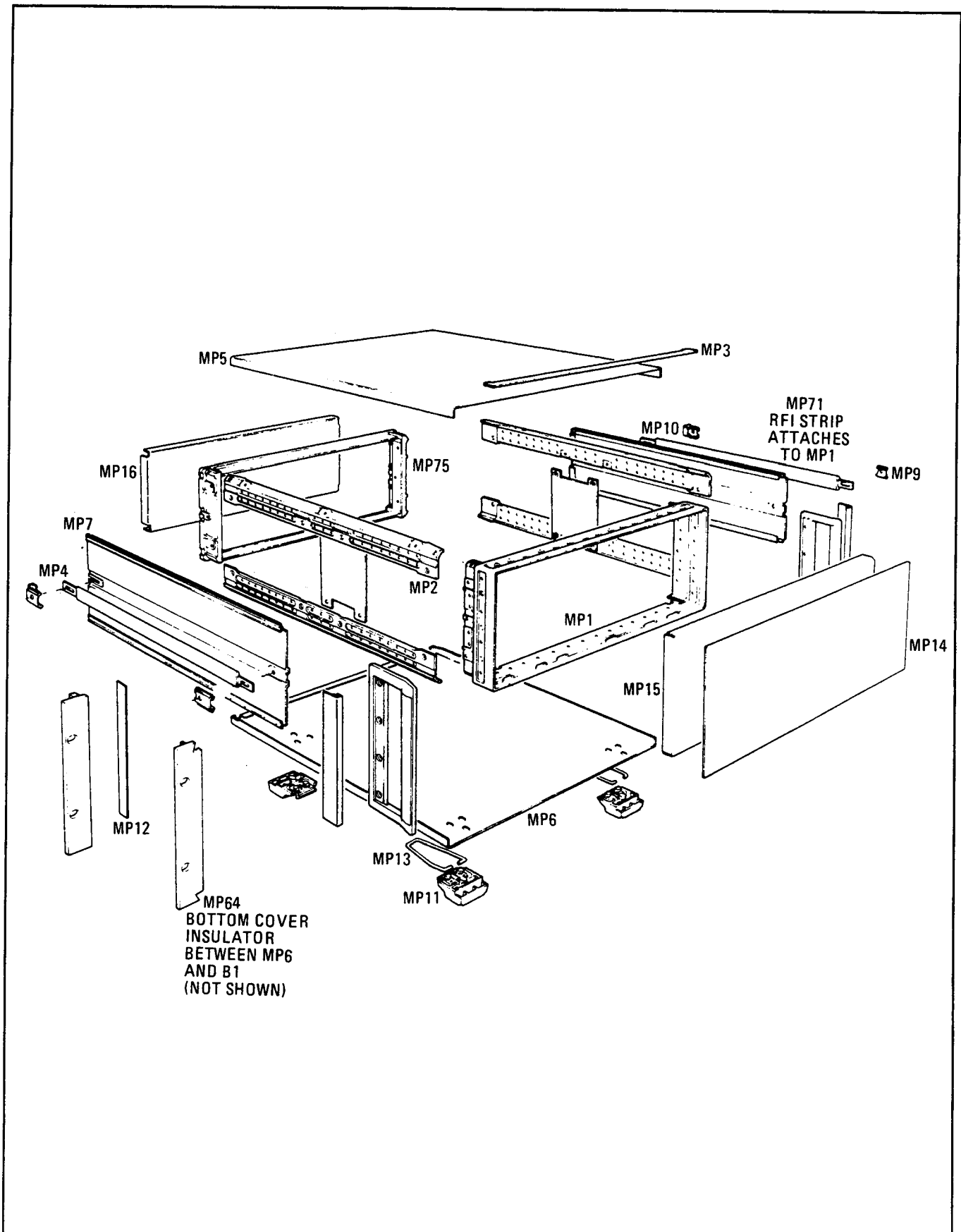

Figure 6-1. Cabinet Parts

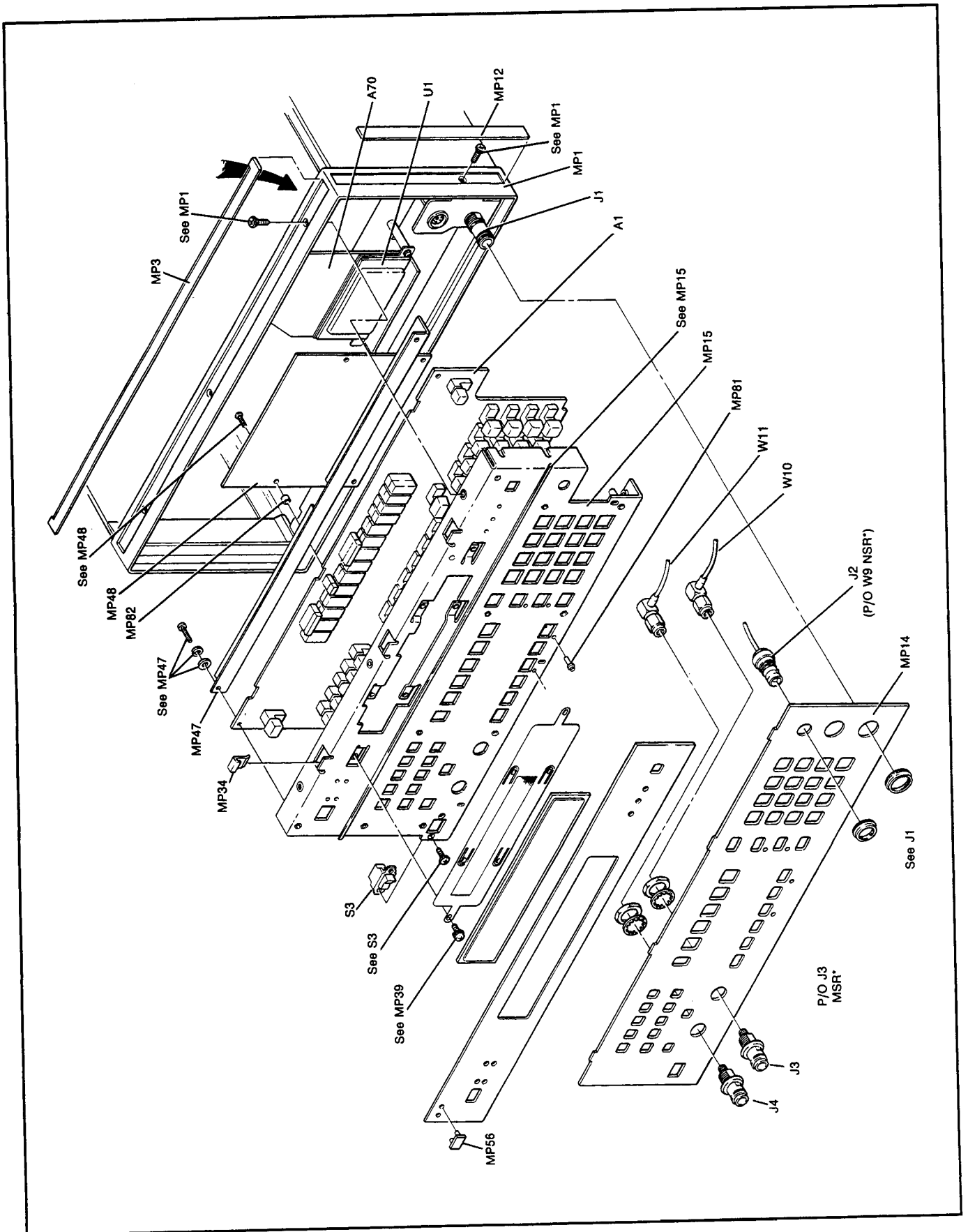

Figure 6-2. Exploded View of the Front Panel (1 of 2)

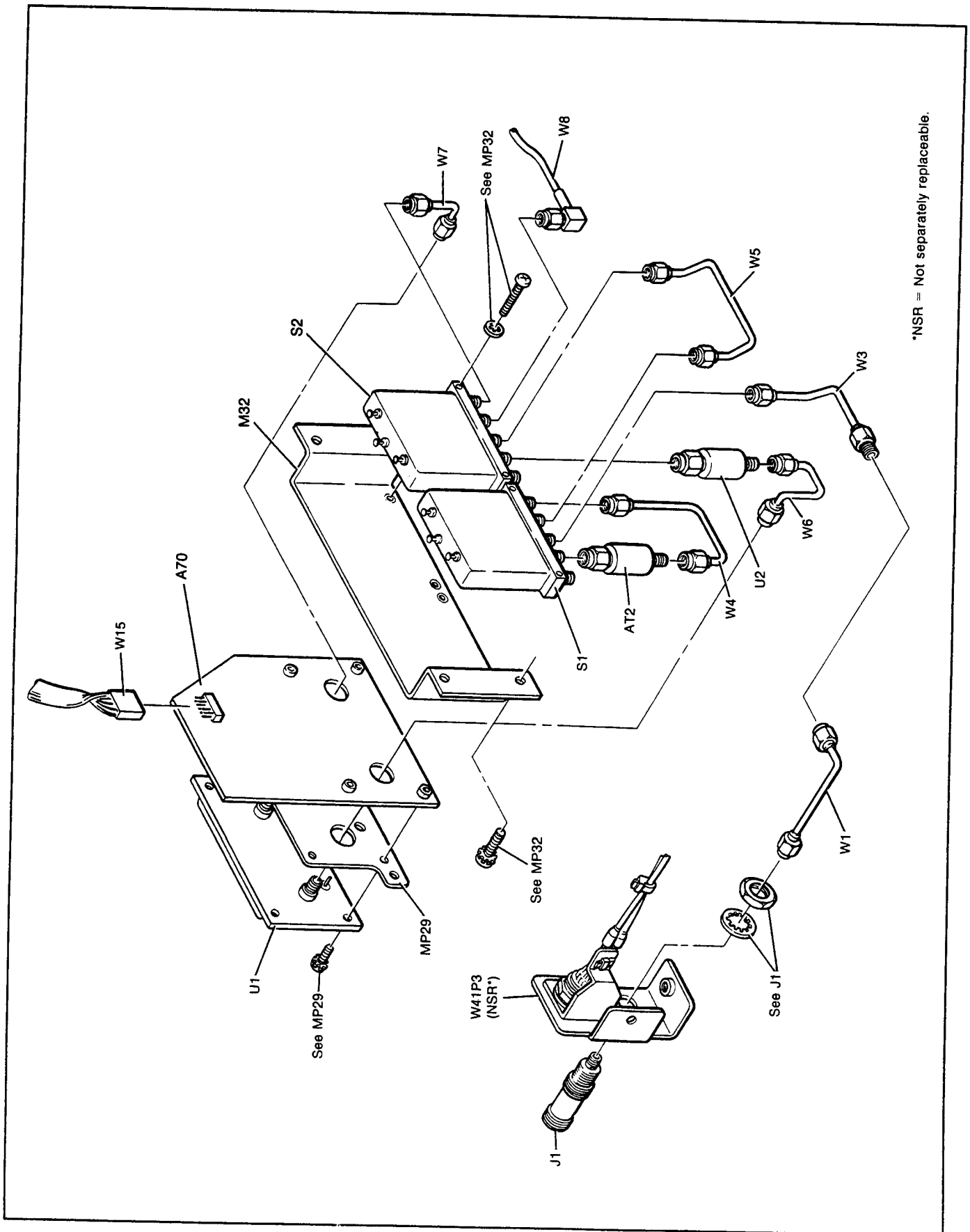

Figure 6-2. Exploded View of the Front Panel (2 of 2)(2305A to 2702A).

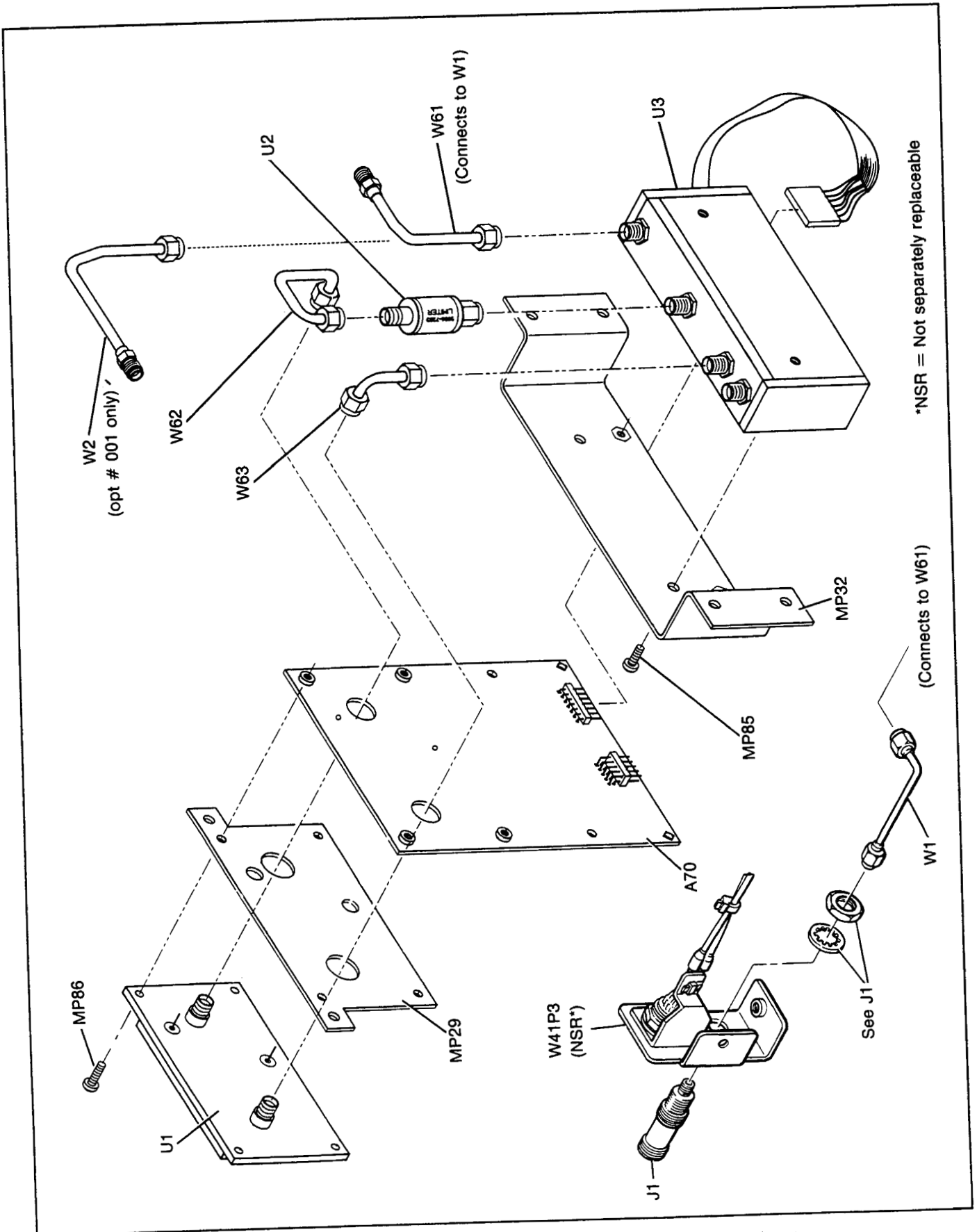

Figure 6-2. Exploded View of the Front Panel (2 of 2)(2704A and above).

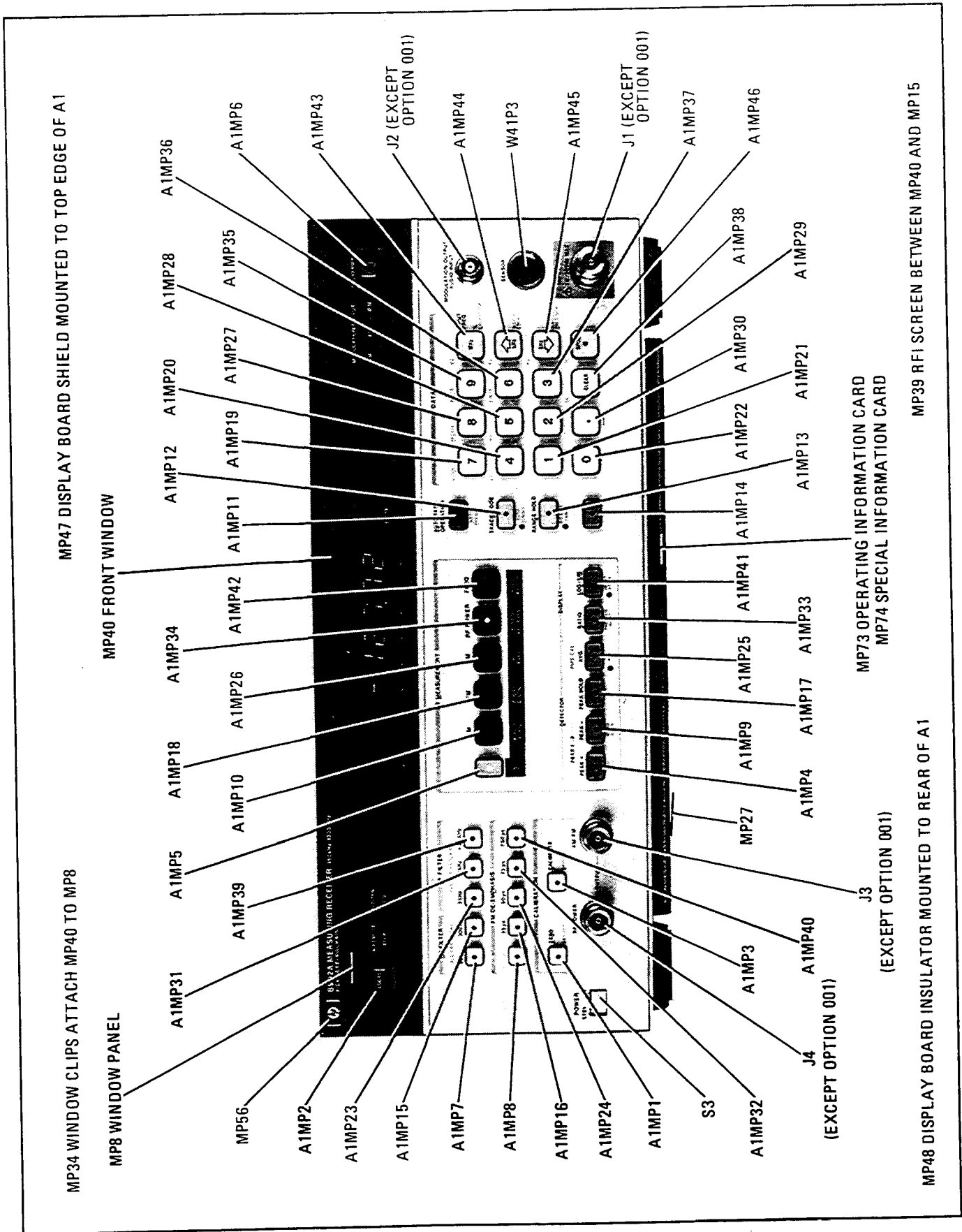

Figure 6-3. Parts Identification (Front View)

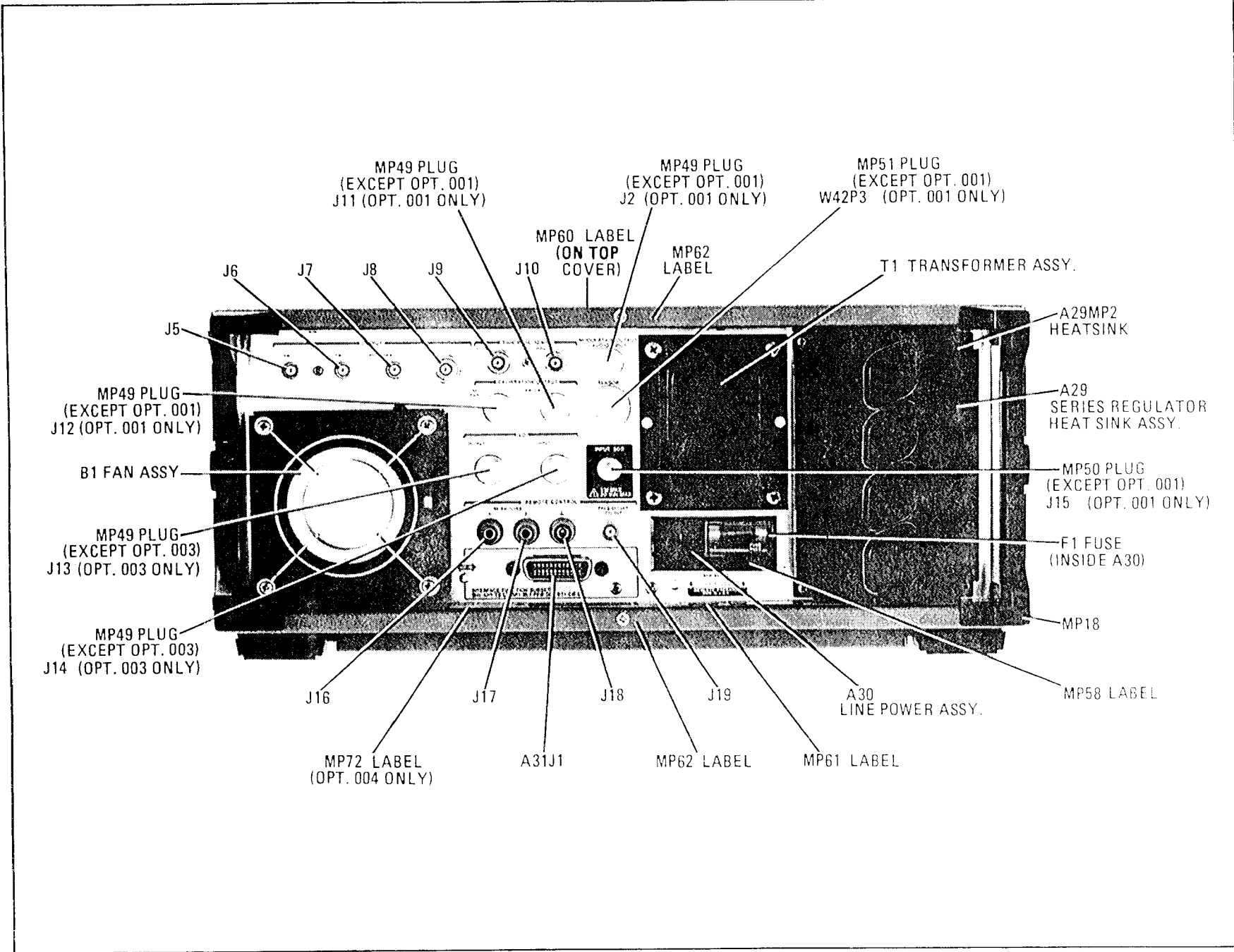

Figure 6-4. Parts Identification (Rear View)

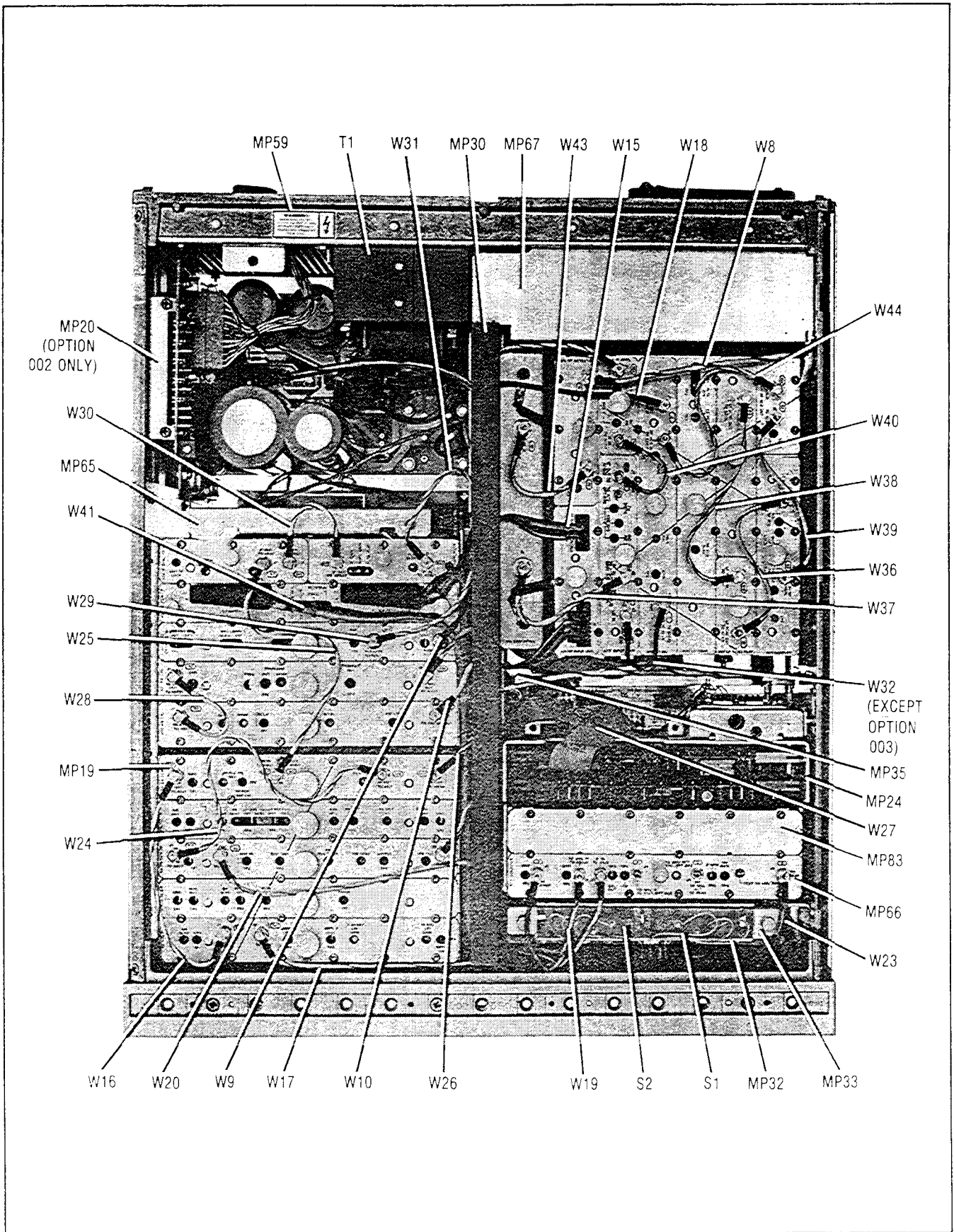

Figure 6-5. Parts and Cable Identification (Top View)



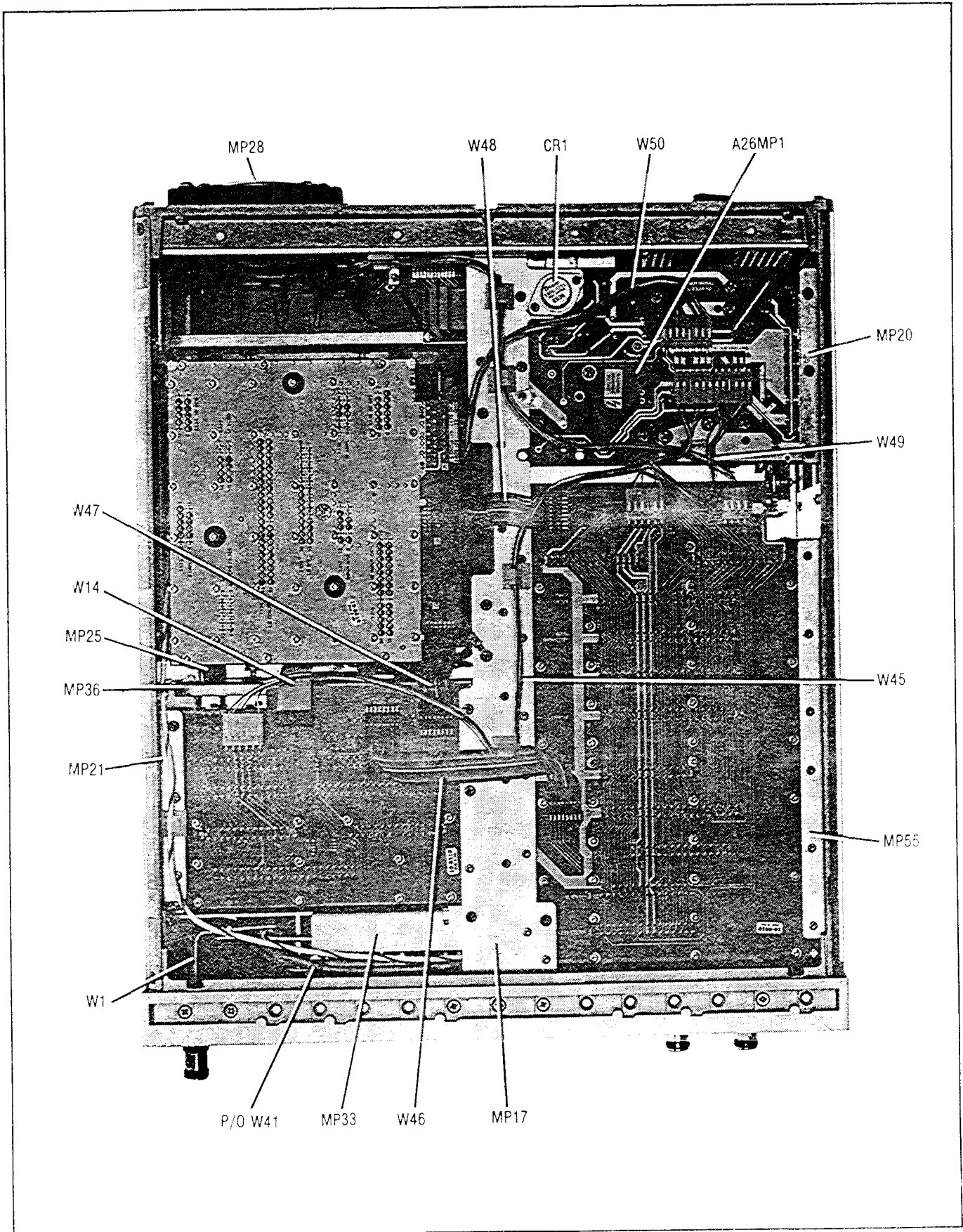

Figure 6-6. Parts and Cable Identification (Bottom View)

## Section 7 INSTRUMENT CHANGES

### 7-1. INTRODUCTION TO THIS SECTION

This section contains instrument modification recommendations and procedures that could improve the performance and reliability of your instrument. Refer to *Instruments Covered by This Manual*, paragraph 1-5 in Section 1 for important information about serial number coverage.

### 7-2. MODIFICATION FOR INVALID ERROR 06 INDICATION (2305A TO 2523A)

#### Description

These instruments may indicate Error 06 (instrument overpower) under normal operating conditions. Three independent sources for this problem have been identified: (1) microphonic chatter of contacts in the +15V power supply relay (A26K1), (2) drift in the input RF peak detector circuits, and (3) switching transients in the RF input attenuator.

#### Procedure

For instruments of any serial prefix, check the +15V power supply relay by tapping gently on the relay with a wooden or plastic instrument. See A26K1 on Service Sheet 31. If Error 06 appears as a result, replace or clean the contacts of the relay.

For instruments with serial prefix 2305A to 2523A, check the following components and replace them with the recommended parts if they are different. See Service Sheets 4 and 24 and also *Firmware Change Summary*, Change 9 below.

Reference Designator	Value or Type	Part Number
A13U10 <sup>(1)</sup>	EPROM	08901-80081
A13U7 <sup>(1)</sup>	EPROM	08901-80082
A13U4 <sup>(1)</sup>	EPROM	08901-80083
A16R10 <sup>(2)</sup>	1 M $\Omega$	0698-8827
A16R11 <sup>(2)</sup>	162 k $\Omega$	0757-0470
A16R15 <sup>(2)</sup>	3.48 k $\Omega$	0698-3152
A16C20 <sup>(2)</sup>	470 pF	0160-4768
A16U2 <sup>(3)</sup>	LM 211	1826-0098

<sup>(1)</sup> This revises firmware to date code 304.1985 (use 42.0 SPCL).  
<sup>(2)</sup> Some of the passive component changes on the A16 RF Detector Assembly may already be installed in some instruments.  
<sup>(3)</sup> This change replaces A16U2 with the same part from a different manufacturer.

## 7-3. FIRMWARE CHANGE SUMMARY (2305A TO 2644A)

### Description

The instrument has undergone several changes in firmware. This article summarizes the changes and should be helpful in deciding whether to update firmware to a more recent edition.

The firmware is changed whenever anomalies are found in the instrument's operation which can be corrected by altering the Controller's program. Firmware is also changed to add new features which may be only changes in the program or which may also result from instrument hardware changes.

Since the program resides in the ROMs (the firmware), the ROMs are altered each time the program is changed. At that time the new ROMs are given new part numbers and the software (the program) date is changed. (To display the software date, key in Special Function 42.0.) Always update firmware with the latest edition, which is backward compatible. (See Service Sheet 24 for ROM identification.)

### Summary of Software Editions

#### 1. Software date code: 167.1983 (2305A to 2331A)

ROM part numbers:

ROM 1, 08901-80062  
ROM 2, 08901-80063  
ROM 3, 08901-80064

This is a preliminary edition of software which should be replaced by the most recent edition.

#### 2. Software date code: 272.1983 (2337A to 2449A)

ROM part numbers:

ROM 1, 08901-80066  
ROM 2, 08901-80067  
ROM 3, 08901-80068

This is the first edition of software in production instruments.

#### 3. Software date code: 115.1984 (2451A to 2515A)

ROM part numbers:

ROM 1, 08901-80071  
ROM 2, 08901-80072  
ROM 3, 08901-80073

*Change 1* adds a few function settings not stored by the Store/Recall feature. Previously, when the settings were recalled, the functions were set to their current settings instead of the stored settings. The unstored functions were: (1) manually selected Tuned RF Level filtering (Special Function 4), (2) power sensor calibration factor table entry when entry is in progress, (3) the last calibrated power sensor type, (4) the HP-IB SRQ mask, and (5) the HP-IB Status Byte.

*Change 2* eliminates a potential HP-IB bus hang-up in Tuned RF Level. During an HP-IB trigger immediate (T2) or trigger with settling (T3) measurement, HP-IB handshaking is inhibited until the measurement is completed. Except for the Interface Clear bus command, the HP-IB temporarily hangs up. Since most measurements are short, bus use is restored quickly. If the signal is lost during a measurement, "--" is displayed and Error 96 is issued over HP-IB. (This is normal HP-IB operation.) In Tuned RF Level, however, if the signal is lost, the instrument searches for it indefinitely and hangs up the HP-IB indefinitely. With newer software if signal is lost in Tuned RF Level, the instrument now displays "--" (and Error 96 over HP-IB) after 20s.

*Change 3* eliminates an invalid condition in the Set Reference mode in Tuned RF Level where it was possible to reference to the power sensor.

*Change 4* increases RF Power measurement resolution by a factor of 10 to allow the instrument's power meter to be similar to other power meters. 1 mW now reads 1000.0  $\mu$ W instead of 1.000 mW.

*Change 5* adds Special Functions 23 and 24 which are used with Option Series 030, Selective Power measurements. New hardware and firmware *Change 17* (below) must also be added to implement this feature. Compatibility with all other measurements is maintained.

**4. Software date code: 119.1985 (2519A to 2523A)**

ROM part numbers:

ROM 1, 08901-80076  
ROM 2, 08901-80077  
ROM 3, 08901-80078

*Change 6* eliminates the loading effects of the input RF peak detector when calibrating Tuned RF Level for range 2 to range 1. The RF peak detector sets input attenuation in other measurement modes. The new firmware turns off the detector after attenuator is set which eliminates a potential 0.7 dB error.

*Change 7* increases digital averaging to reduce display bounce during noisy SINAD measurements (Special Function 5.1).

*Change 8* adds two special functions to enter and retrieve the Set Reference calibration factor in Tuned RF Level. To read the current Set Reference calibration factor, key in 38.4 SPCL while in Tuned RF Level. The calibration factor is displayed with a maximum of 8 digits and a resolution of 0.01%. To enter a Set Reference calibration factor, key in 39.4 SPCL then enter the calibration factor and press blue key and % CAL FACTOR (the MHZ key).

**5. Software date code: 234.1985 (2528A to 2530A)**

ROM part numbers:

ROM 1, 08901-80084  
ROM 2, 08901-80077  
ROM 3, 08901-80078

*Change 9* eliminates a false Error 06 which is sometimes generated by an attenuator switching transient during instrument preset. Only ROM 1 was changed.

**6. Software date code: 304.1985 (2535A to 2606A)**

ROM part numbers:

ROM 1, 08901-80081  
ROM 2, 08901-80082  
ROM 3, 08901-80083

*Change 10* adds track tune mode in Tuned RF Level measurements. Several hardware changes are also required to add this feature, but the new firmware is compatible with all instruments.

*Change 11* adds Special Function 31 which corrects for the noise floor when using the average detector in Tuned RF Level on the lowest range. Special Function 31.0 disables the noise floor correction. Special Function 31.1 enables the noise floor correction. Special Function 31.2 displays the noise-floor correction status.

*Change 12* adds Special Function 32 which alters several default conditions for specialized applications. Special Function 32.0 sets the "normal" defaults. Special Function 32.1 sets the "special" defaults (RF power resolution 0.001 dB and minimum audio frequency resolution 0.1 Hz). Special Function 32.2 displays the status of this special function.

*Change 13* adds Special Function 7.4 to increase the display resolution of RF frequency to 0.1 Hz below 10 MHz and 1 Hz above 10 MHz.

*Change 15* extends the frequency offset mode range to 200 GHz.

*Change 16* adds Special Function 47 which displays certain instrument configuration details for troubleshooting purposes. After keying in 47.0 SPCL the display will be of the form

<Tracking Synchronous Detector >, <New Opt. Series 030 ><Old Opt. Series 030 >

where 1 is yes and 0 is no. The new Option Series 030 refers to instruments with serial prefix 2535A and above; old refers to older versions of the HP 8901B Modulation Analyzer (which shares the firmware).

*Change 17* adds hardware identification of certain instrument configuration details needed for Option Series 030 measurements. (Refer also to Change 16 above.)

*Change 18* adds Special Functions 49.C to read the Option Series 030 IF RMS Detector.

*Change 19* increases the averaging time in Tuned RF Level for instruments when Special Function 32.1 is in effect. (See also Change 12.)

7. **Description (2621A and Above)** The A19 L.O. Divider Assembly has been changed to part number 08901-60274 for improved performance and reliability. The Top cover (A19MP1) has been changed to 08901-00166 to fit the new A19 L.O. Divider Assembly.
8. **Software date code: 70.1986 (2616A to 2631A)**

ROM part numbers:

ROM 1, 08901-80087  
 ROM 2, 08901-80088  
 ROM 3, 08901-80089

*Change 20* updates the original firmware released for the Option 030 and E04 for more efficient operation. The new firmware is compatible with all instruments.

9. **Software date code: 149.1986 (2644A to 2706A)**

ROM part numbers:

ROM 1, 08901-80090  
 ROM 2, 08901-80091  
 ROM 3, 08901-80092

*Change 21* allows for displaying the previously entered frequency when displaying RF Power Calibration Factors.

*Change 22* prevents the instrument from generating a 10 dB error when in Tuned RF Level range to range calibration. This would happen only on very rare occasions when the voltmeter was at a particular level.

*Change 23* adds increased "ERROR 01" limits up to  $\pm 100$  kHz for the testing of drifting signal generators (when in Track Mode).

10. **Software date code: 351.1986 (2717A and Above)**

ROM part numbers:

ROM 1, 08901-80105  
 ROM 2, 08901-80106  
 ROM 3, 08902-80107

*Change 24* updates the firmware to increase averaging (special function 32.1) and to reduce settling time when making power meter measurements.

**7-4. CABINET PARTS COLOR CHANGE**

*(2912A and above)*

**NOTE**

*Serial prefix 2912A changes the color of the instrument covers and accessories. The old color cover and accessories are no longer available. If your instrument has serial prefixes 2911A and below, and you must replace one of these parts, we recommend that you order the full set of covers and accessories. Affected cabinet parts are MP3-12, MP14, MP18, (see Table 6-3).*

**7-5. LEDS A1DS31-37, A1DS42-45**

*(2305A to 2914A)*

If the serial prefix of your instrument falls within 2305A to 2914A and you must replace A1DS31-37 or A1DS42-45 you must also order a new spacer and light pipe listed under MP15 (2920A and above) in the miscellaneous replaceable parts list.

**CAUTION**

*Do not unplug any boards in the Measuring Receiver unless the instrument is unplugged or switched to STBY (standby). Some boards contain devices which can be damaged if the board is removed when the power is on. Use conductive foam when removing MOS devices from sockets. Use care when unplugging ICs from high-grip sockets.*

**8-4. SERVICE TOOLS, AIDS, AND INFORMATION****Service Accessory Kit**

The Service Accessory Kit (HP 08901-60287) contains extender boards, extender cables, and other items needed for servicing the Measuring Receiver. The extender boards have a height that matches the assembly extrusions and, for 12 pin connectors, improves the mechanical stability of the extended assembly. The kit contains a special Digital Test/Extender Board (HP 08901-60081) which facilitates troubleshooting of the A13 Controller and A14 Remote Interface Assemblies (see Figure 8A-1).

The kit also contains a special conductive polyurethane foam pad (HP 4208-0094) that is required for the protection of MOS devices as cautioned in paragraph 8-3.

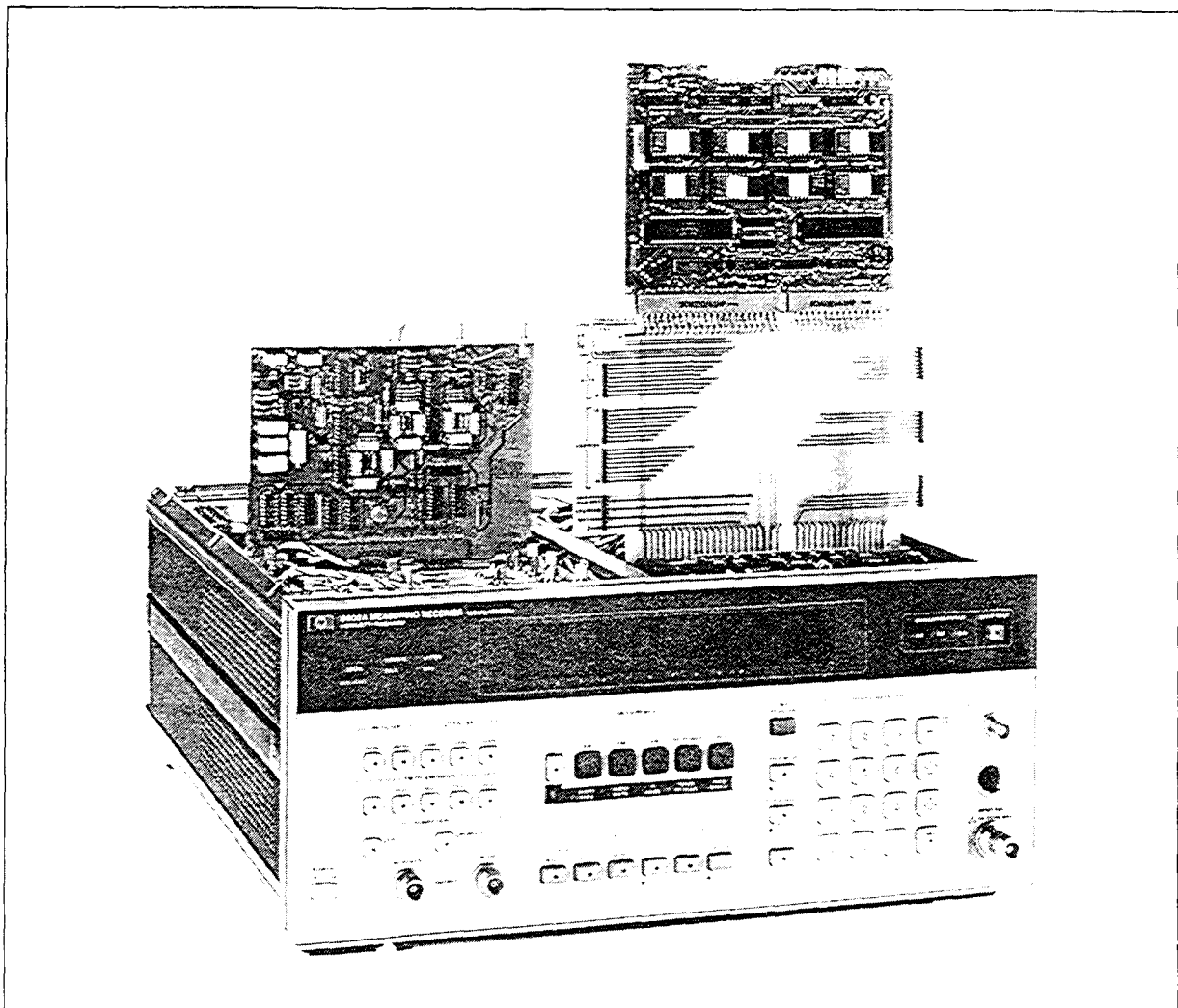

*Figure 8A-1. Assemblies on Extender Boards*

## Heat-Staking Tool

The front-panel pushbutton switches have small plastic pins protruding from the back. These tabs fit through holes in the front-panel printed-circuit board (assembly A1) and are melted down to hold the switch in place. This process is known as heat staking. The heat-staking tool is a standard soldering iron with a special tip attached (see Figure 8A-2). The special tip may be ordered as HP part number 5020-8160.

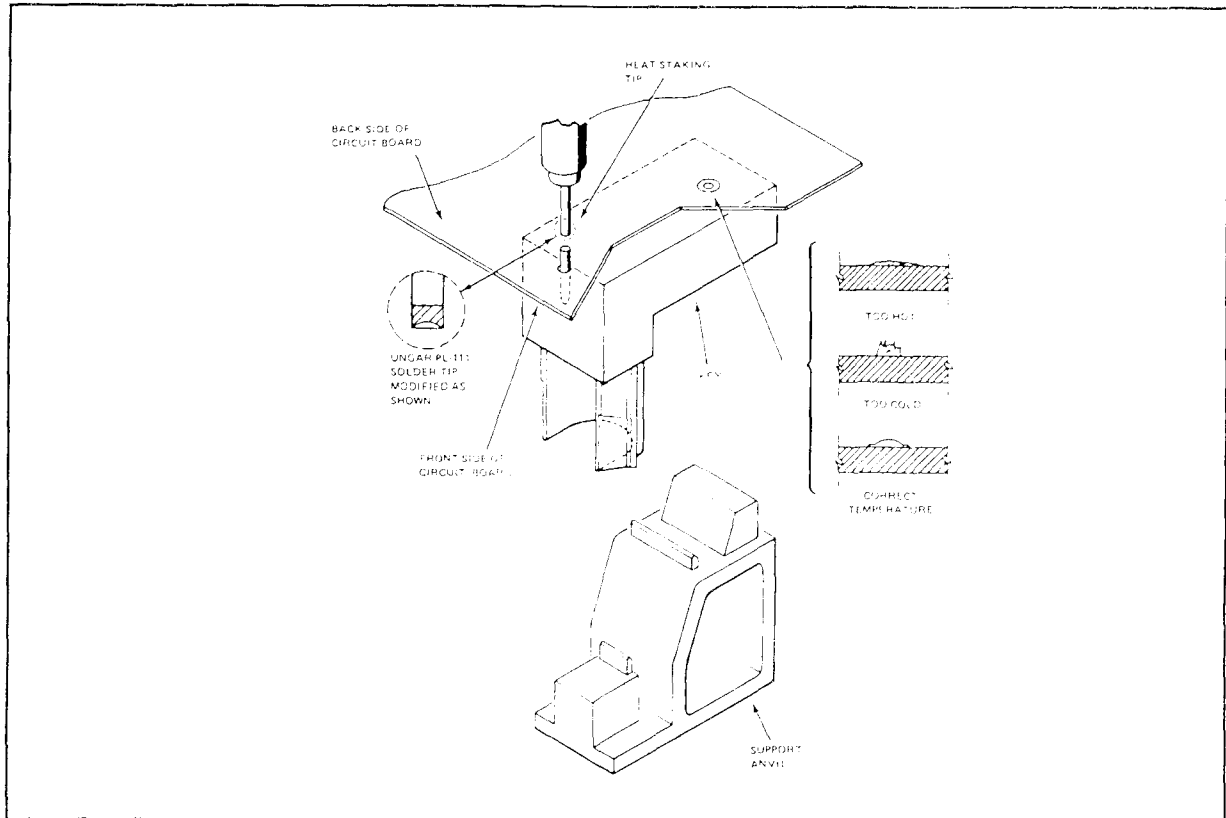

Figure 8A-2. Heat-Staking Tip

## Assembly Locations

Assemblies in the Measuring Receiver are numbered sequentially from front to back, left to right, and top to bottom as shown in Figures 8A-3 and 8A-3a. However, to facilitate the direct use of assemblies from other HP 8901 or 8902 series instruments, the sequence in the Audio Section of the instrument is interrupted after A6. Assemblies A50 to A55 replace assemblies A7 to A9. Assemblies A13 and A14 have color-coded board extractors. (For example, assembly A13 has a brown left extractor and orange right extractor. Thus, the color code of A13 is 13.) Assembly A1 is part of the front-panel assembly of the instrument. Instruments with serial prefixes **2535A and above** have slots for assemblies A71 and A72 sandwiched between A11 and A13. Switch S4 is behind A14. Assemblies A71 and A72 and switch S4 enable the HP 8902A to be fitted with Option Series 030 Selective Power Measurements.



## **Section 8 SERVICE**

### **8-1. INTRODUCTION TO THIS SECTION**

This section contains information for troubleshooting and repairing the Measuring Receiver. Included are troubleshooting tests, block and schematic diagrams, and principles of operation.

### **8-2. HOW THE SECTION IS ORGANIZED**

Section 8 is contained in this and two other volumes as:

#### **Volume 2**

- General Service Information:
  - Safety Considerations
  - Service Tools and Aids
  - General Troubleshooting Information
  - Assembly and Service Sheet Cross Reference Index
  - Assembly Locations
  - Schematic Diagram Notes
- Service Aids:
  - Special Functions
  - Error Messages
  - Power-Up Checks
  - Controller Test LEDs and Test Points
  - Signature Analysis
- Disassembly (for the front panel)
- Block Diagram (BD) Theory and Troubleshooting
  - The circuit descriptions and troubleshooting procedures for all the block diagrams.
- BD1 through BD5 Block Diagrams
  - Block Diagrams (foldouts) for the Measuring Receiver.

#### **Volume 3**

- Schematic Diagram Theory and Troubleshooting
  - Circuit descriptions and troubleshooting procedures for Service Sheets (SS) 1 through 34.

#### **Volume 4**

- SS1 through SS35 Schematic Diagrams
  - Schematic Diagrams (foldouts) and Component Locator Diagrams for the Measuring Receiver.
- SSA Summary
  - Service Special Functions and Error Message Summary.
- SSB and SSC Summary
  - Direct Control Special Function Summary.

## 8-3. SAFETY CONSIDERATIONS

### Before Applying Power

Verify that the instrument is set to match the available line voltage and that the correct fuse is installed. An uninterrupted safety earth ground must be provided from the main power source to the instrument input wiring terminals, power cord, or supplied power cord set. In addition, verify that a common ground exists between the Measuring Receiver and all test equipment.

### Safety

Pay attention to WARNINGS and CAUTIONS. They must be followed both for your protection and to avoid damage to the equipment.

#### **WARNING**

*Maintenance described herein is performed with power supplied to the instrument and with the protective covers removed. Such maintenance should be performed only by service-trained personnel who are aware of the hazards involved (for example, fire and electrical shock). When maintenance can be performed without power supplied, the power should be removed.*

*Any interruption of the protective (grounding) conductor (inside or outside the instrument) or disconnection of the protective earth terminal will create a potential shock hazard that could result in personal injury. Grounding one conductor of a two conductor outlet is not sufficient. Whenever it is likely that the protection has been impaired, the instrument must be made inoperative (that is, secured against unintended operation).*

*If this instrument is to be energized via an autotransformer, make sure that the autotransformer's common terminal is connected to the earth terminal of the power source.*

*Capacitors inside the instrument can still be charged even if the instrument is disconnected from its source of supply.*

*Make sure that only 250 volt fuses with the required rated current and of the specified type (normal blow, time delay, etc.) are used for replacement. Do not use repaired fuses or short-circuited fuseholders. To do so could create a shock or fire hazard.*

*A13BT1 is a Lithium battery. The following procedure is recommended for its disposal:*

*Discharge A13BT1 by soldering a 50 k $\Omega$  resistor across both battery terminals. Complete discharge will occur after one year, at 25°C.*

*Under Resource Conservation Recovery Act (RCRA) regulations, the completely discharged battery is considered "nonhazardous." However, the user must be responsible for individual state regulations for battery disposal.*

## Parts and Cable Locations

The locations of individual components mounted on printed-circuit boards or other assemblies are shown adjacent to the schematic diagram on the appropriate service sheet. The part reference designator is the assembly designator plus the part designator. For example, A6R9 is resistor R9 on the A6 assembly. For specific component descriptions and ordering information, refer to Table 6-3, *Replaceable Parts*, in Section 6. Chassis and frame parts, as well as mechanical parts and cables, are identified on Figures 6-1 through 6-6.

Major mechanical parts have reference designations that begin with the letters MP. Other mechanical parts, such as screws, are listed in the replaceable-parts list below the part to which they fasten. To find the part number and description of a mechanical part, find the part in one of the figures in Section 6 or Section 8. The part in the figure will be labeled with its reference designator. Look up that reference designator in the *Replaceable Parts* table. If the part is a fastener, such as a screw, nut, or washer, look to the figure for the part to which it fastens. Then, look up the fastened part in the parts list. Just below it are the part numbers and a description of the desired hardware.

## Component Replacement Procedures

The A3, A4, A6, A13, A14, A15, A21, A26, A31, A52, A53, A54 and A70 printed circuit board assemblies are manufactured using a Hot Air Leveled (HAL) process. The printed circuit board traces, pads and plated-through holes (PTH) are copper. While the process has several advantages over conventional processes, the printed circuit boards are more susceptible to broken traces, lifted pads and damage to the plated-through holes. Therefore, additional care must be taken when replacing components on HAL printed circuit boards.

Listed below are soldering considerations that apply to all printed circuit boards:

- The temperature of the soldering iron tip and time the tip is in contact with the printed circuit board.
- The size and shape of the soldering iron tip.
- The pressure of the soldering iron tip on the pad.
- The operator's skill.

When replacing components on HAL printed circuit boards the following steps should also be taken.

1. Use a temperature controlled soldering iron set at a temperature of 600°F (315°C).

Extensive tests were made by Hewlett-Packard using commercial brands of soldering irons. As a result of these tests, the recommended soldering iron was the HEXACON THERM-O-TRAC STATION #1000 with the FINGER GRIP SLEEVE 21 A-5 and solder tip #J 301X. During soldering, the tip temperature of the HEXACON THERM-O-TRAC STATION remained very stable.

2. Cut out the body of the component to be removed. (Leave leads as long as possible for easier removal.)
3. Apply heat to the lead only, add solder as required, slide tip down to the pad and remove solder with solder sucker.

### CAUTION

*Tip pressure on the pad is most critical and is totally operator dependent. Excessive tip pressure will damage or destroy the board. Do not use tin desoldering braid or solder wicking techniques on Hot Air Leveled boards.*

The melting point of solder in the plated through hole (PTH) is reached in 2.5 seconds at tip temperature of 600° to 750° F (315° to 400° C). The *recommended* time for heat to be applied is 3 seconds.

Keep the solder sucker clean and do not let the tip of the solder sucker hit the pad when removing solder. Breaking the lead loose can damage the PTH. If the lead is attached to the PTH after the solder has been removed, reheat the lead to remove it.

4. When soldering or desoldering multilead components, do not consecutively apply heat to adjacent leads. Distribute heat by skipping leads or crossing to opposite side of device.

### Other Service Documents

Service Notes, Manual Updates, and other service literature are available through Hewlett-Packard. For further information about Manual Updates, refer to Volume 1, paragraph 1-6.

### Recommended Test Equipment and Accessories

Test equipment and test accessories required to maintain the Measuring Receiver are listed in Tables 1-3 and 1-4. Equipment other than that listed may be used if it meets the listed critical specifications.

## 8-1. GENERAL TROUBLESHOOTING

Instrument problems usually fall into three general categories: operator errors, operation out of specification, and catastrophic failures. The troubleshooting strategy is different for each category.

### Operator Errors

Apparent failures sometimes can result from using the instrument outside of its range. Usually, the instrument can sense the condition and will display an error message. At other times it cannot; for example when it attempts to measure signals with frequencies higher than 1300 MHz. Consult the *Specifications* table (Table 1-1) and the *Detailed Operating Instructions* in Section 3 for more operation limitations.

### Operation Out of Specification

The specifications are listed in Volume 1, Table 1-1. Performance tests that can be used to verify the specifications are found in Volume 1, Section 4. If instrument performance is only slightly out of limits, it can sometimes be corrected by an adjustment. The procedures for adjustments are in Volume 1, Section 5. References listed for each adjustment indicate which service sheet to consult when the adjustment procedure fails. In general, however, it is also a good practice to perform the troubleshooting checks on Service Sheet BD1, since they take only a few minutes and reveal much information.

## Catastrophic Failures

Begin troubleshooting catastrophic failures by performing the troubleshooting checks on Service Sheet BD1. The simple procedures there take only a few minutes and will quickly differentiate a control (digital) problem from a hardware (analog) problem. The checks give cross-references to the detailed block diagrams (Service Sheets BD2 to BD5) which then direct you to the necessary schematic.

The troubleshooting information found on all service sheets consists of a series of performance checks. The purpose of the checks is not to identify which circuit or component has failed but rather to verify whether the assembly or circuit is operating correctly. Information on the possible cause of failure is given in the form of hints whenever they can be given reliably. The limits given in the troubleshooting checks are rather loose to facilitate the use of general-purpose equipment (usually an oscilloscope). If a slightly out-of-tolerance condition is suspected, the test can usually be run more rigorously paying greater attention to measurement accuracy.

Troubleshooting on the block diagram level normally utilizes User and Service Special Functions, while troubleshooting on the schematic level often utilizes Direct Control Special Functions. Direct Control Special Functions will require some study of their operation before using them for the first time.

**Table 8A-1. Assembly and Service Sheet Cross Reference Index**

<b>Reference Designator</b>	<b>Assembly Name</b>	<b>Schematic Service Sheet Number</b>	<b>Block Diagram</b>
A1	Keyboard and Display	25, 26, 27	5
A2	Audio Filters	12	4
A3	Audio De-emphasis and Output	13	4
A4	FM Demodulator	10, 11	3
A5	Voltmeter	14, 15	4
A6	AM Demodulator	8, 9	3
A7-A9	(Not Assigned)		
A10	Power Supply Regulators	31, 32	5
A11	Counter	22, 23	5
A12	(Not Assigned)		
A13	Controller	24	5
A14	Remote Interface	28	5
A15	RF Input Control	4	2
A16	RF Detector	4	2
A17	Input Mixer	5	2
A18	IF Amplifier	5	2
A19	LO Divider	17	2
A20	LO Control	20, 21	2
A21	Low Frequency VCXO Filter	19	2
A22	Low Frequency VCXO	19	2
A23	Sampler	18	2
A24	High Frequency VCO	18	2
A25	Audio Motherboard		
A26	Power Supply Motherboard	31, 32	5
A27	Digital Motherboard		
A28	RF Motherboard		
A29	Series Regulator Heat Sink	31, 32	5
A30	Line Power	31	5
A31	Remote Interface Connector	28	5
A32	Power Reference Oscillator	3	2
A33-A49	(Not Assigned)		
A50	AM Calibrator	30	3
A51	FM Calibrator	29	3
A52	Audio Counter/Distortion Analyzer	16	4
A53	Power Meter	1, 2	2
A54	IF Synchronous Detector	7	3
A55	IF Amplifier/Filter	6	3
A56-A69	(Not Assigned)		
A70	Amplifier/Switch Interconnect	4	2
A71	IF Channel Filter (Option Series 030)	33	3
A72	IF Amplifier/Detector (Option Series 030)	34	3

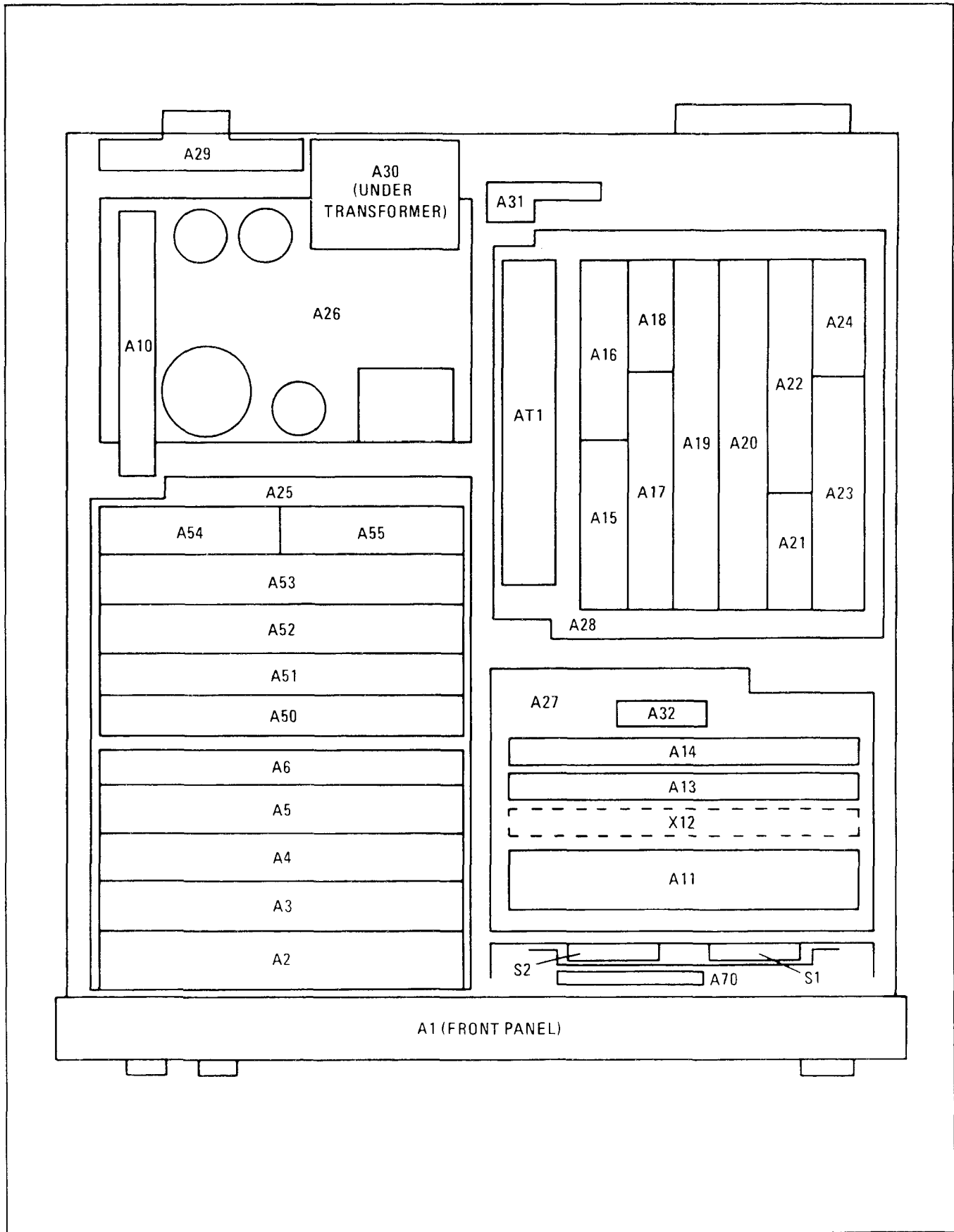
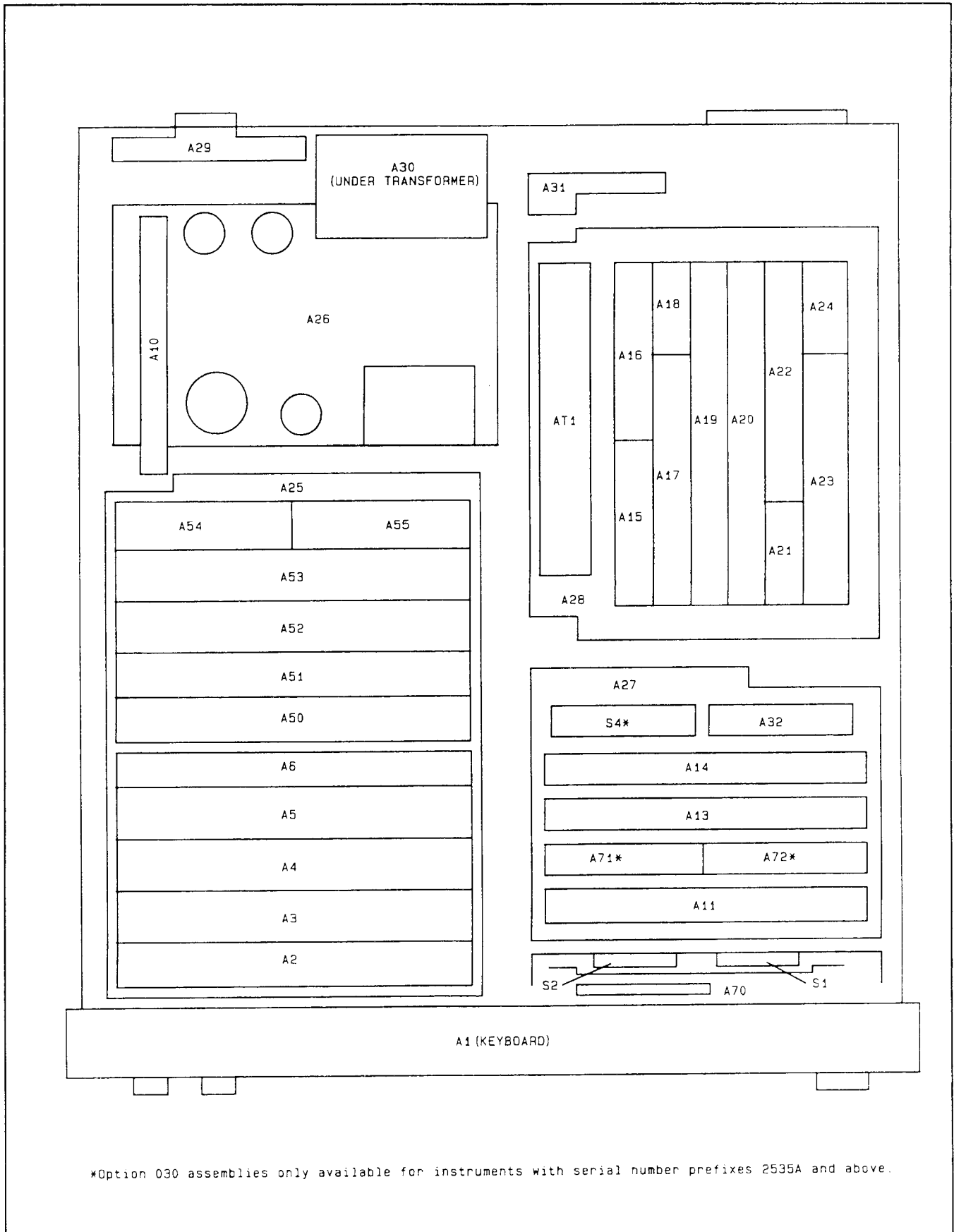

Figure 8A-3. Assembly Locations (2305A to 2530A)



\*Option 030 assemblies only available for instruments with serial number prefixes 2535A and above.

Figure 8A-3a. Assembly Locations (2535A and Above)



### 8-6. SCHEMATIC SYMBOLOGY AND SCHEMATIC DIAGRAM NOTES

Table 8A-6 summarizes the symbology used in presenting many devices found in the instrument. The logic symbols used in this manual are based on the Institute of Electrical and Electronic Engineers (IEEE) in IEEE-STD 91-1984, *Graphic Symbols for Logic Functions*. This publication may be purchased from:

Institute of Electrical and Electronic Engineers  
 345 East 47th Street  
 New York, NY 10017

Table 8-6. Schematic Diagram Notes (1 of 11)

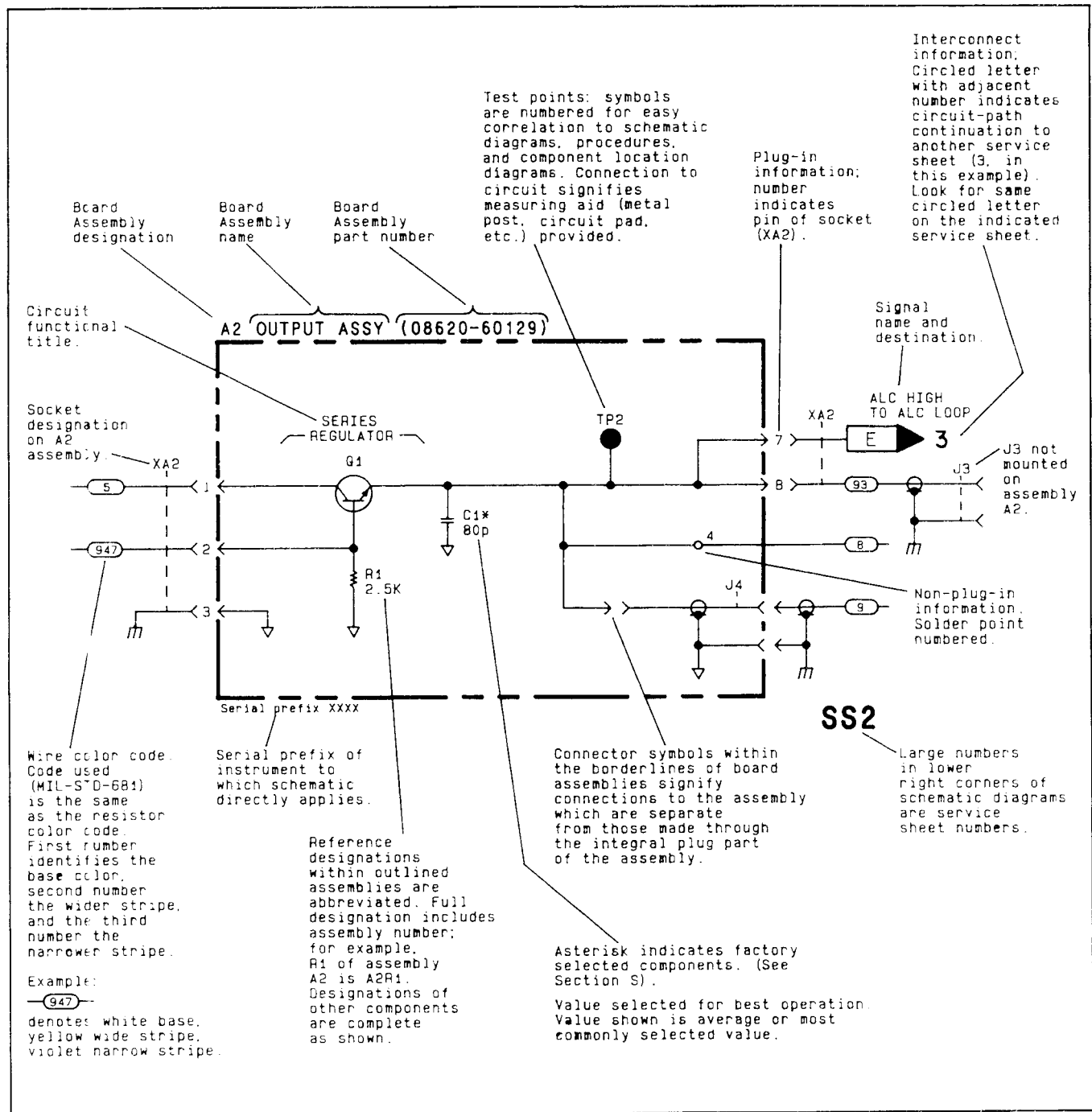

Table 8-6. Schematic Diagram Notes (2 of 11)

Values for all components are marked in units of farads, henries, and ohms unless otherwise specified.















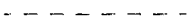

*	Asterisk denotes a factory-selected value. Value shown is typical. See Section V.
	Tool-aided adjustment.
	Encloses front-panel designation.
	Encloses rear-panel designation.
	Circuit assembly borderline.
	Other assembly borderline.
	Heavy line with arrows indicates path and direction of main signal.
	Heavy dashed line with arrows indicates path and direction of main feedback.
	Indicates stripline (i.e., RF transmission line above ground).
	Wiper moves toward cw with clockwise rotation of control (as viewed from shaft or knob).
TP1 	Numbered Test Point measurement aid provided.
	Encloses wire or cable color code. Code used is the same as the resistor color code. First number identifies the base color, second number identifies the wider stripe, and the third number identifies the narrower stripe, e.g.,  denotes white base, yellow wide stripe, violet narrow stripe.
	A direct conducting connection to earth, or a conducting connection to a structure that has a similar function (e.g., the frame of an air, sea, or land vehicle).
	A conducting connection to a chassis or frame.
	Common connections. All like-designation points are connected.
	Letter = off-page connection. Number = Service Sheet number for off-page connection. In the example, signal flow is continued on Service Sheet 12, at the point marked
	Number (only) = on-page connection.

Table 8-6. Schematic Diagram Notes (3 of 11)

	<p>Indicates multiple paths represented by only one line. Letters or names identify individual paths. Numbers indicate number of paths represented by the line.</p>
	<p>Coaxial or shielded cable.</p>
	<p>Ferrite bead. (Increases the self-inductance of the conductor passing through the bead.)</p>
	<p>Relay. Contact moves in direction of arrow when energized.</p>
	<p>Indicates a pushbutton switch with a momentary (ON) position.</p>
	<p>Feedthrough capacitor. (Acts as a feedthrough terminal when mounted on a chassis or a frame.)</p>
	<p>Indicates a PIN diode.</p>
	<p>Indicates a current regulation diode.</p>
	<p>Indicates a voltage regulation diode.</p>
	<p>Indicates a capacitive (varactor) diode.</p>
	<p>Indicates a Schottky (hot-carrier) diode.</p>
	<p>Light-emitting diode.</p>
	<p>Multiple transistors in a single package—physical location of the pins is shown in package outline on schematic.</p>
	<p>Identification of logic families as shown (in this case, ECL).</p>

Table 8-6. Schematic Diagram Notes (4 of 11)

**DIGITAL SYMBOLOGY REFERENCE INFORMATION**

**Input and Output Indicators**

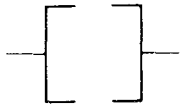

Implied Indicator—Absence of polarity indicator (see below) implies that the active state is a relative high voltage level. Absence of negation indicator (see below) implies that the active state is a relative high voltage level at the input or output.

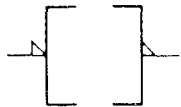

Polarity Indicator—The active state is a relatively low voltage level.



Dynamic Indicator—The active state is a transition from a relative low to a relative high voltage level.



Inhibit Input—Input that, when active, inhibits (blocks) the active state outputs of a digital device.

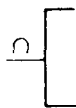

Analog Input—Input that is a continuous signal function (e.g., a sine wave).

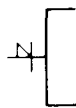

Polarity Indicator used with Inhibit Indicator—Indicates that the relatively low level signal inhibits (blocks) the active state outputs of a digital device.



Output Delay—Binary output changes state only after the referenced input (m) returns to its inactive state (m should be replaced by appropriate dependency or function symbols).

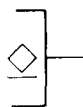

Open Collector Output.

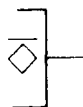

Open Emitter Output.

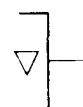

Three-state Output—Indicates outputs can have a high impedance (disconnect) state in addition to the normal binary logic states.

Table 8-6. Schematic Diagram Notes (5 of 11)

**DIGITAL SYMBOLOGY REFERENCE INFORMATION**

**Combinational Logic Symbols and Functions**



$\Sigma$	Summing Junction—Outputs added together at a common point.
&	AND—All inputs must be active for the output to be active.
$\geq 1$	OR—One or more inputs being active will cause the output to be active.
$\geq m$	Logic Threshold— <i>m</i> or more inputs being active will cause the output to be active (replace <i>m</i> with a number).
$\neq 1$	EXCLUSIVE OR—Output will be active when one (and only one) input is active.
$\neq m$	<i>m</i> and only <i>m</i> —Output will be active when <i>m</i> (and only <i>m</i> ) inputs are active (replace <i>m</i> with a number).
$\equiv$	Logic Identity—Output will be active only when all or none of the inputs are active (i.e., when all inputs are identical, output will be active).
	Amplifier—The output will be active only when the input is active (can be used with polarity or logic indicator at input or output to signify inversion).
X/Y	Signal Level Converter—Input level(s) are different than output level(s).
	Bilateral Switch—Binary controlled switch which acts as an on/off switch to analog or binary signals flowing in both directions. Dependency notation should be used to indicate affecting/affected inputs and outputs. Note: amplifier symbol (with dependency notation) should be read to indicate unilateral switching.
X→Y	Coder—Input code (X) is converted to output code (Y) per weighted values or a table.
(Functional Labels)	The following labels are to be used as necessary to ensure rapid identification of device function.
MUX	Multiplexer—The output is dependent only on the selected input.
DEMUX	Demultiplexer—Only the selected output is a function of the input.
CPU	Central Processing Unit

Table 8-6.Schematic Diagram Notes (6 of 11)

**DIGITAL SYMBOLOGY REFERENCE INFORMATION**

**Sequential Logic Functions**



Monostable—Single shot multivibrator. Output becomes active when the input becomes active. Output remains active (even if the input becomes inactive) for a period of time that is characteristic of the device and/or circuit.



Oscillator—The output is a uniform repetitive signal which alternates between the high and low state values. If an input is shown, then the output will be active if and only if the input is in the active state.

FF

Flip-Flop—Binary element with two stable states, set and reset. When the flip-flop is set, its outputs will be in their active states. When the flip-flop is reset, its outputs will be in their inactive states.

T

Toggle Input—When active, causes the flip-flop to change states.

S

Set Input—When active, causes the flip-flop to set.

R

Reset Input—When active, causes the flip-flop to reset.

J

J Input—Analogous to set input.

K

K Input—Analogous to reset input.

D

Data Input—Always enabled by another input (generally a C input—see Dependency Notation). When the D input is dependency-enabled, a high level at D will set the flip-flop; a low level will reset the flip-flop. Note: strictly speaking, D inputs have no active or inactive states—they are just enabled or disabled.

-m

Count-Up Input—When active, increments the contents (count) of a counter by "m" counts (m is replaced with a number).

-m

Count-Down Input—When active, decrements the contents (count) of a counter by "m" counts (m is replaced with a number).

->m

Shift Right (Down) Input—When active, causes the contents of a shift register to shift to the right or down "m" places (m is replaced with a number).

+ m

Shift Left (Up) Input—When active, causes the contents of a shift register to shift to the left or up "m" places (m is replaced with a number).

**NOTE**

*For the four functions shown above, if m is one, it is omitted.*

(Functional Labels)

The following functional labels are to be used as necessary in symbol build-ups to ensure rapid identification of device function.

mCNTR

Counter—Array of flip-flops connected to form a counter with modules m (m is replaced with a number that indicates the number of states: 5 CNTR, 10 CNTR, etc.).

Table 8-6. Schematic Diagram Notes (7 of 11)

**DIGITAL SYMBOLOGY REFERENCE INFORMATION****Sequential Logic Functions (Cont'd)**

REG	Register—Array of unconnected flip-flops that form a simple register or latch.
SREG	Shift Register—Array of flip-flops that form a register with internal connections that permit shifting the contents from flip-flop to flip-flop.
ROM	Read Only Memory—Addressable memory with read-out capability only.
RAM	Random Access Memory—Addressable memory with read-in and read-out capability.

**Dependency Notation**

Cm	Control Dependency—Binary affecting input used where more than a simple AND relationship exists between the C input and the affected inputs and outputs (used only with D-type flip-flops).
Gm	Gate (AND) Dependency—Binary affecting input with an AND relationship to those inputs or outputs labeled with the same identifier. The m is replaced with a number or letter (the identifier).
Vm	OR Dependency—Binary affecting input with an OR relationship to those inputs or outputs labeled with the same identifier. The m is replaced with a number or the letter (the identifier).
mAm	Address Dependency—Binary affecting inputs of affected outputs. The m prefix is replaced with a number that differentiates between several address inputs, indicates dependency, or indicates demultiplexing of address inputs and outputs. The m suffix indicates the number of cells that can be addressed.
ENm	Enable Dependency—Binary affecting input which, when active enables all outputs. When inactive open-collector and open-emitter outputs are off, and three-state outputs are at an external high impedance state.  When the enable input affects only certain inputs and outputs, they will be numbered to indicate the logic connection.
Xm	Transmission Dependency—Binary affecting input which bidirectionally connects dependent inputs and outputs.
Mm	Mode Dependency—Binary affecting input used to indicate that the effects of particular inputs and outputs of an element depend on the mode in which the element is operating. The m is replaced with a number or letter (the identifier).
Zm	Interconnection Dependency—Indicates the existence of internal logic connections between inputs, outputs, internal inputs, and/or internal outputs. The m is replaced with a number (the identifier).
,	Comma—AND Function.
/	Slant—OR Function.

**NOTE**

*The identifier (m) is omitted if it is one—that is, when there is only one dependency relationship of that kind in a particular device. When this is done, the dependency indicator itself (G, C, EN, or V) is used to prefix or suffix the affected (dependent) input or output.*

Table 8-6. Schematic Diagram Notes (8 of 11)

DIGITAL SYMBOLOGY REFERENCE INFORMATION	
	<p><b>Miscellaneous</b></p> <p>Schmitt Trigger—Input characterized by hysteresis; one threshold for positive going signals and a second threshold for negative going signals.</p>
Active	<p>Active State—A binary physical or logical state that corresponds to the true state of an input, an output, or a function. The opposite of the inactive state.</p>



Table 8-6. Schematic Diagram Notes (9 of 11)

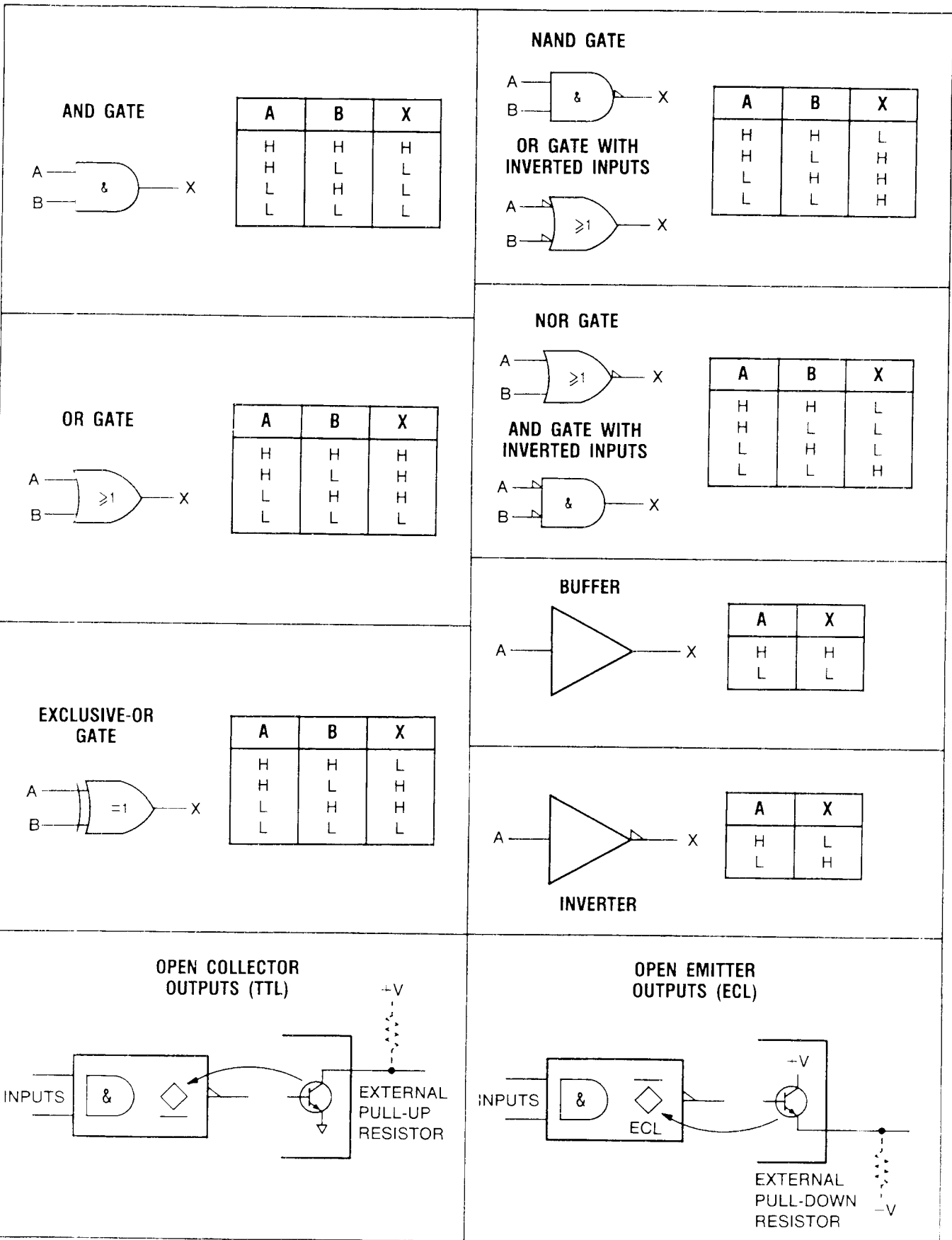

Table 8-6. Schematic Diagram Notes (10 of 11)

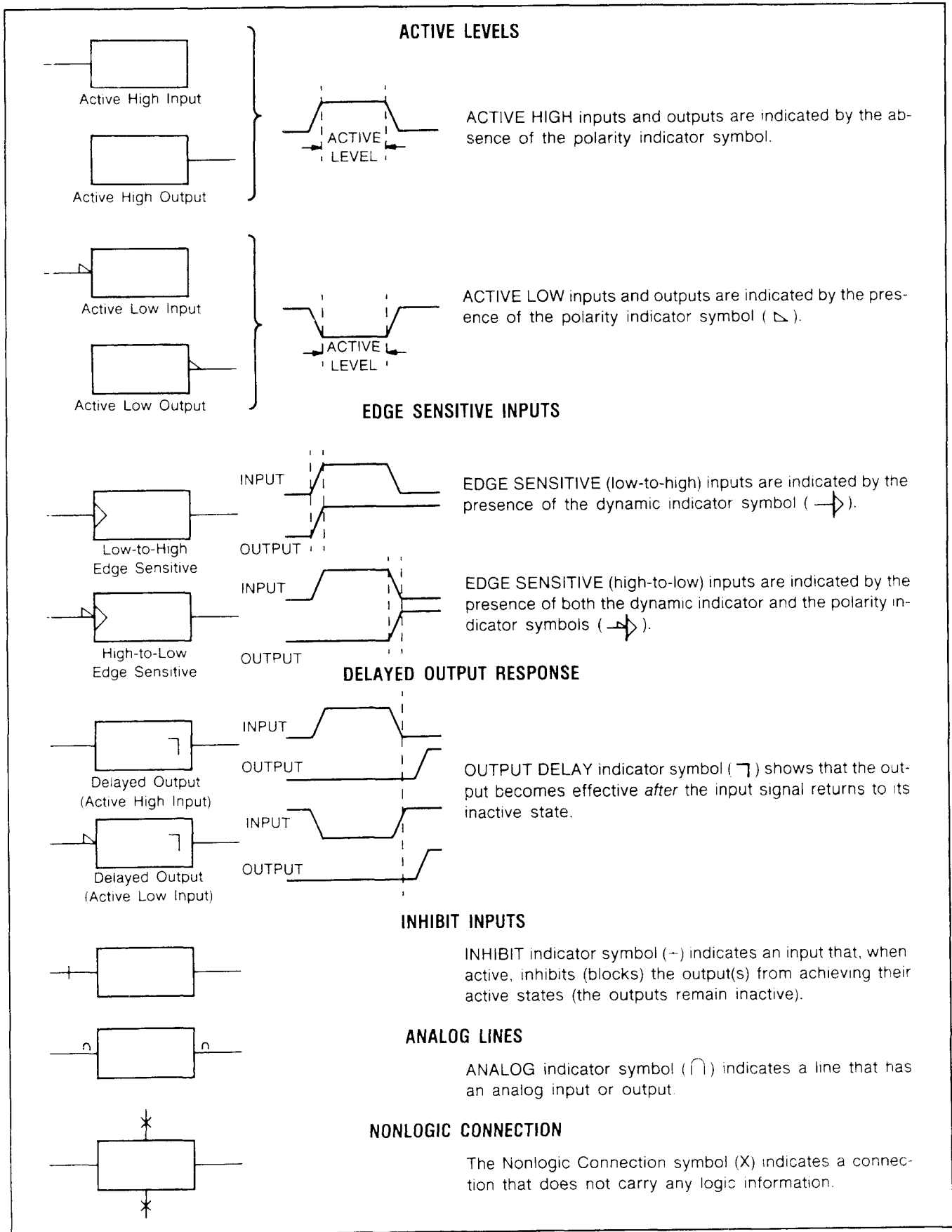
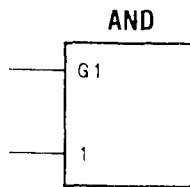
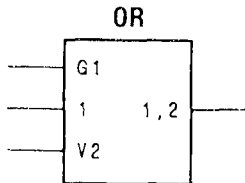

Table 8-6. Schematic Diagram Notes (11 of 11)



The input that controls or gates other inputs is labeled with a C or a G, followed by an identifying number. The controlled or gated input or output is labeled with the same number. In this example, 1 is controlled by G1.



When a V input is active, the output will be in its active state. With the V input inactive, the device functions as if the V input doesn't exist.

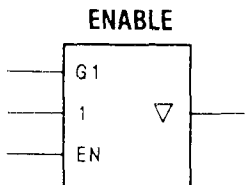

When the EN input is active, the output is enabled to function normally. When the EN input is inactive, the three-state output ( ▽ ), in this case, becomes a high impedance, effectively removing that device from the circuit.

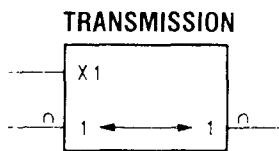

When the X1 input is active, the associated input-output pair are bi-directionally connected together. When X1 is inactive, the connection is broken.

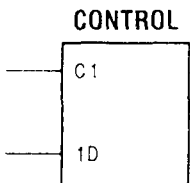

When the controlled or gated input or output already has a functional label (D is used here), that label will be prefixed by the identifying number.

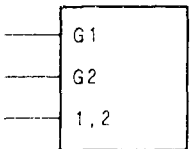

If the input or output is affected by more than one gate or control input, then the identifying numbers of each gate or control input will appear separated by commas.

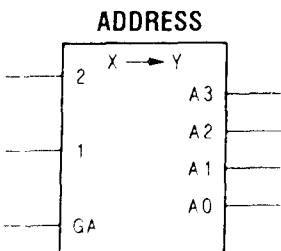

When GA is active, the active address line (0 through 3) is the decoded value of the 1 and 2 binary inputs. When the controlled address lines have a functional value, that value will be prefixed by the identifying letter.

## 8-7. SPECIAL FUNCTIONS

### General

Special Functions extend user control of the instrument beyond that normally available from the front panel. They are intended for the user who has a thorough understanding of the instrument and the service technician who needs arbitrary control of the instrument functions. During normal use, the Measuring Receiver safeguards itself against invalid measurements. Safeguards come in the form of automatic tuning and ranging, overpower protection, squelch, modulation output blanking, and error messages. When Special Functions are used, some of these safeguards are removed, and thus there is a degree of risk that the measurement may be invalid. However, there is no risk of damage to the instrument.

To enter a Special Function, enter the Special Function code (usually a prefix, decimal, and suffix), then press the SPCL key. The Special Function code will appear on the display as it is being entered. If a mistake is made during entry of the Special Function code, press the CLEAR key and start over. When a Special Function is entered, the light in the SPCL key will usually go on (if it is not already on). The readout on the display will depend on the Special Function entered. The readout may be a measured quantity, an instrument setting, a special code, or, in some cases, the display is unaltered. Special Functions can be entered from the HP-IB by issuing the Special Function code followed by the code SP or sp.

The Special Functions are grouped by prefix range as follows:

- 0: Direct Control Special Functions.** These functions are used for service. They halt the functioning of the Controller and configure the instrument hardware as dictated by the suffix. All software safeguards are relinquished.
- 1-39: User Special Functions.** These functions are used during normal instrument operation when a special configuration, measurement, or information is required. Many of the instrument safeguards remain implemented. More information on User Special Functions can be found under *Special Functions* in the *Detailed Operating Instructions* in Section 3 and on the Operating Information pull-out cards.
- 40-99: Service Special Functions.** These functions are used to assist in troubleshooting an instrument fault. The functions available are quite diverse and include special internal measurements, software control, and special service tests and configurations. Safeguards are generally relinquished.

### Direct Control Special Functions (Prefix 0)

Communication between the instrument's Controller and its hardware is via the Instrument Bus. During normal instrument operation, the Instrument Bus carries measurement results, status information, and commands (which control hardware). The Direct Control Special Functions halt the bus activity and send out commands as determined by the code suffix. One command is sent for each Special Function entry. A summary of the Direct Control Special Functions and codes is contained in Service Sheets A and B.

**Direct Control Special Function Code Format.** The Direct Control Special Function code is in the form *0.esd*, where 0 is the prefix (which may be omitted) and *esd* represents a three-digit hexadecimal number. The significance of *esd* (which stands for enable, select, and data) is discussed in the Principles of Operation for Service Sheet BD5. Specific Direct Control Special Function codes are used in the troubleshooting section of the individual service sheets.

As the Direct Control code is entered, the code will appear on the display. Pressing the SPCL key initiates the Special Function. The display will then be in the form *00rrrr.www*, where each digit represents a binary bit (0 or 1). The *rrrr* is the *d* (data) read back from the Instrument Bus. The *www* is the *d* (data) written to the bus. Thus *rrrr* and *www* are normally the binary form of the hexadecimal value for *d*. Exceptions to this are Special Functions *0.5sd* and *0.6sd*, which control the display itself.

The hexadecimal characters A, B, C, D, E, and F are displayed on entry as A, b, C, d, E, and F, and they are entered from the keyboard as Shift 0, Shift 1, Shift 2, etc., or from the HP-IB as X0, X1, X2, etc. Table 8B-1 summarizes the hexadecimal entry and readback for Direct Control Special Functions.

**Table 8B-1. Hexadecimal Information for Direct Control Special Functions**

Hexadecimal Character	Decimal Equivalent	Binary Equivalent	Keystroke Entry	HP-IB Code Entry	Display On Entry
0	0	0000	0	0	0
1	1	0001	1	1	1
2	2	0010	2	2	2
3	3	0011	3	3	3
4	4	0100	4	4	4
5	5	0101	5	5	5
6	6	0110	6	6	6
7	7	0111	7	7	7
8	8	1000	8	8	8
9	9	1001	9	9	9
A	10	1010	S (Shift) 0	X0	A
B	11	1011	S (Shift) 1	X1	b
C	12	1100	S (Shift) 2	X2	C
D	13	1101	S (Shift) 3	X3	d
E	14	1110	S (Shift) 4	X4	E
F	15	1111	S (Shift) 5	X5	F

**Direct Control Special Function Applications.** Direct Control Special Functions are most often used to provide manual control of various switches or digital-to-analog devices in the hardware. The following examples illustrate how to use Direct Control Special Functions:

**Example 1**

In the path of the demodulated audio signal is a set of selectable, active high-pass filters which are located on the A3 Audio De-emphasis and Output Assembly. A simplified diagram of the filters is shown in Figure 8B-1. The filters and through path are selected by analog switches U12A, U12B, and U12C. Table 8B-2, which is associated with the troubleshooting of the filters, lists the Direct Control Special Functions normally used to control the switches.

**Table 8B-2. Audio High-Pass Filter and FM Pre-Display De-Emphasis Direct Control Special Functions**

Check	Direct Control Special Function	
	Pre-Display On	Pre-Display Off
Thru Path	0.141	0.149
50 Hz HPF	0.142	0.14A
300 Hz HPF	0.144	0.14C

To insert the 50 Hz High-Pass Filter, key in 0.142 SPCL or .142 SPCL. The display will show 000010.0010, indicating that the Controller received  $d = 2$  from the keyboard (or HP-IB), issued it to the Instrument Bus, and read it back. If the circuitry on the assembly is working properly, switch U12A will close and the audio signal will pass through the 50 Hz High-Pass Filter.

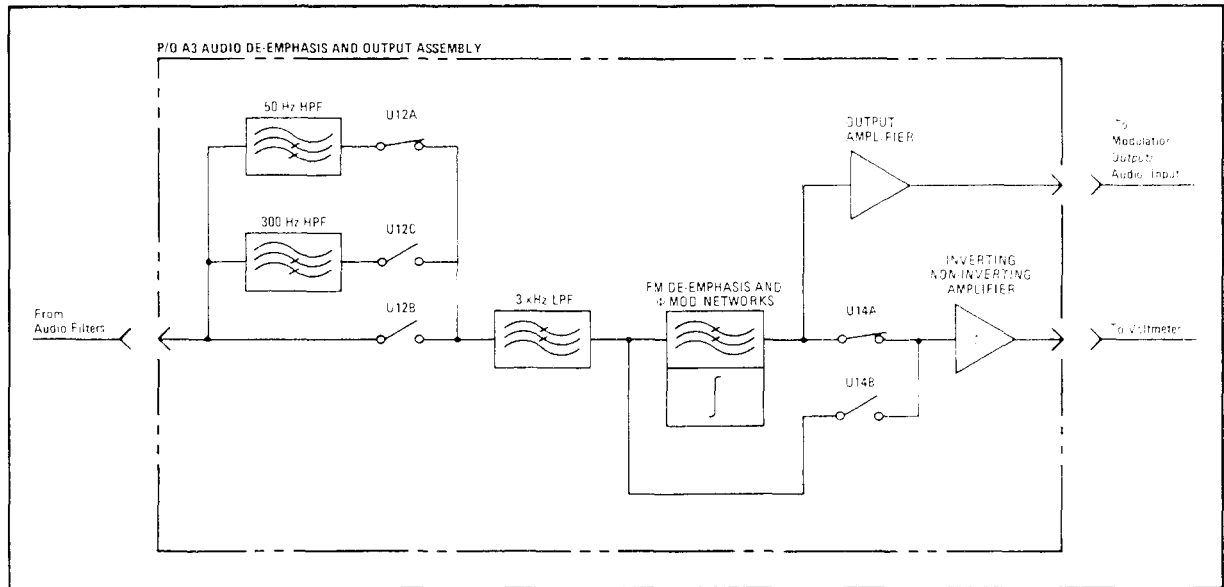

**Figure 8B-1.** Example Showing High-Pass Filter Switching

Notice that the display no longer shows a measurement result. No annunciators are lighted (except those related to HP-IB, if the Special Function is entered via HP-IB), and only the SPCL key is lighted. If any key other than a number key, S (Shift) key, or the LCL key is pressed, the instrument hardware will revert back to the measurement mode it was in before the Direct Control Special Function was entered. Thus, in this example, unless the 50 Hz High-Pass Filter had been previously selected with the front-panel key, it would be removed from the audio path, when any other key is pressed. (However, note that there are some Service Special Functions that will maintain the requested configurations even if another key is pressed.)

Table 8B-2 indicates that 0.14A will also select the 50 Hz High-Pass Filter. Any Direct Control Special Function of the form 0.14*d* also controls the pre-display filter on/off switches U14A and U14B. For pre-display on (0.142), U14A is closed. For pre-display off (0.14A), U14B is closed. As it turns out, 0.14*d* codes other than those shown in the table will also affect the high-pass filters. For example, 0.147 will close U12A, U12B, and U12C, simultaneously (with U14A also closed). This fact is ascertained from the service sheet schematic.

### Example 2

A second example from the A3 assembly illustrates data readback when using the Direct Control Special Function. One of the means of detecting an overrange of the audio circuits is by the Audio Overvoltage Detector. The detector is on the audio input line before any active (and hence, distortable) filters (see Figure 8B-2). The audio input line is the same as in the previous example. The Audio Overvoltage Detector senses the peak signal level on the line and U9 compares it against a reference. If the detected level rises above the reference, the output of U9 goes low and resets flip-flop U19D. Other flip-flops (not shown) are also reset and open the audio path ahead of the detector (without intervention of the Controller). U21D and U21C, when enabled, invert the output of U19D twice. The output of U21C is across the least-significant bit of the readback data line of the Instrument Bus. In the normal measurement cycle, the Controller reads the status of the Audio Overvoltage Detector (by enabling U21D and reading the output of U21C) and displays an error if U9 has tripped.

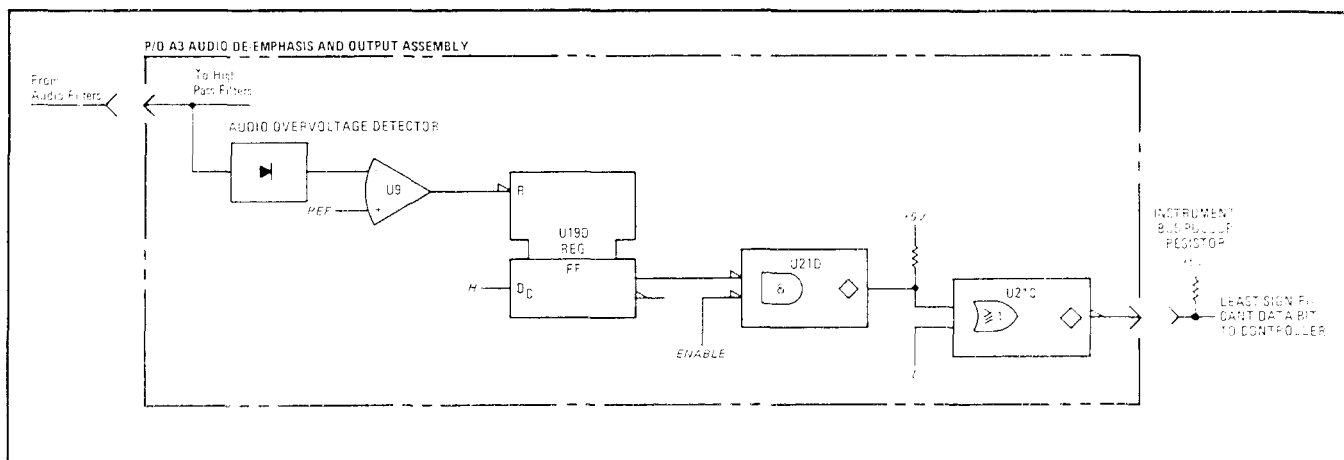

**Figure 8B-2.** Example Showing Audio Overvoltage Detector Readback

At this point in the discussion, a more detailed description of the Instrument Bus is needed. Data ( $d$ ) is read out from the I/O port of the Controller to the Instrument Bus through buffers (TTL inverters). However, data is read back to the I/O port directly, bypassing the buffers. An I/O port outputs a low by actively pulling the line to ground. It outputs a high by allowing the output to be passively pulled up by an external pull-up resistor. When a Controller I/O port inputs data from other circuits of the Measuring Receiver, these circuits must operate against the passive pull-up resistor.

Readback devices that are read out to the data lines, such as U12C, are similarly configured. U21C has an open-collector TTL output. When not outputting data, its output device is off, pulling it to a high-impedance (inactive) state. When it outputs data, a low is produced by switching the output device to ground. A high is produced by switching the device off and allowing the output to be passively pulled up. The readback lines are low true (that is,  $r = 1$  when the line is low).

When U12D is disabled (enable is high), its output is low. Therefore, U21C is high (inactive) and has no effect on the data line. U12D is enabled by Direct Control Special Function 0.15 $d$ . The value of  $d$  is arbitrary to enable U21D, but the least-significant bit must be 0 (that is,  $d$  must be even) to switch off the output device of the I/O data port.

To clarify this concept, suppose that U19D has not been reset. If Direct Control Special Function 0.152 is entered, the display will show 000010.0010. (0.15 $d$  also controls FM squelch. Using 0.152 deactivates squelch.) The four digits following the decimal are 0010 because  $d = 2$  was received by the Controller from the keyboard and issued to the Instrument Bus. The set flip-flop (U19D) puts a high on the input of U21D and an inactive high on the least-significant data line. This is read by the Controller as  $r = 0$  and thus is the same as the bit issued. The other three data readback lines are unaffected by the readback command and remain 001. Therefore, the  $d$  read back is 0010.

If U19D is reset, U21D puts a low on the least-significant data bit ( $r = 1$ ), and the data read back is 0011. The display is therefore 000011.0010. (Note that  $rrrr$  is different from  $www$ .) If  $d$  is keyed as a hexadecimal F, the display is 001111.1111 regardless of the state of U21D. This is because all output devices on the data I/O port of the Controller are on (logical 1).

One final note, after a Direct Control Special Function is entered, it is periodically issued to the Instrument Bus. If a fault causes  $rrrr$  to indicate a malfunction, the display will begin to read correctly as soon as the fault is removed.

## Service Special Functions (Prefix 40-99)

The Service Special Functions are used to perform a variety of tasks related to service. The functions are cataloged below. A suffix N indicates that a parameter other than 0 may be required to complete the Special Function code. Information within pointed brackets appears on the Measuring Receiver's display. See Table 8B-1 for entry of hexadecimal suffixes (A, B, C, D, E, and F).

**40.0 Controller Reset.** Initializes the Controller to its power-up state and is equivalent to switching the POWER switch to STBY and back to ON. Because this function affects the HP-IB hardware, it is unavailable from HP-IB (causes Error 24). See *Default Conditions and Power-Up Sequence* in Section 3.

**41.0 Controller Clear.** Initializes the Controller to its power-up state but bypasses the operational checks and is equivalent to pressing the blue key and INSTR PRESET (Instrument Preset) or giving the device clear command via HP-IB. Leaves HP-IB hardware unaffected but clears any service request message (SRQ) being issued by the Measuring Receiver, sets the service request condition to its power-up state, and clears all bits in the status byte. See *Default Conditions and Power-Up Sequence* in Section 3.

**42.0 Display Software Date.** Displays the date of the software in the form <day of year>.<year>. The display times out after 5s.

**43.N Measurement Progress and Service Error Message Display Control.** Measurement Progress Error Messages are Errors 40 through 64. Service Error Messages are Errors 65 through 89. Refer to *Error Messages*, paragraph 8-8.

N=0 Disables display of Service Error Messages (65 to 89).

N=1 Enables display of Service Error Messages (65 to 89). Cleared by the AUTOMATIC OPERATION key.

N=2 Enables display of Service Error Messages (65 to 89). Not cleared by the AUTOMATIC OPERATION key.

N=40 to N=89 Enables measurement to pause on the Measurement Progress and Service Error Message determined by N. See *Error Messages*, paragraph 8-8.

N=140 to N=189 Enables measurement to halt on the Measurement Progress and Service Error Message determined by N. See *Error Messages*, paragraph 8-8.

**44.N Tuned-Flag Control.** After successfully completing the tuning sequence during a tuned RF measurement, a tuned-flag is set. As the measurement sequence progresses, various status indicators are checked. If there is any indication that tuning may now be invalid (such as the input signal having drifted), the tuned-flag is cleared. The action taken after this depends upon the measurement mode. This Special Function permits manual setting and clearing of the tuned-flag.

N=0 Clears the internal tuned-flag. May initiate tuning.

N=1 Sets the internal tuned-flag.



**45.N AM and FM Calibrator and RF Power Reference Control.** See Service Sheets 30 (AM Calibrator), 29 (FM Calibrator), and 3 (RF Power Reference).

N	AM Calibrator		FM Calibrator Frequency	RF Power Reference
	Channel A	Channel B		
0	Off	Off	Low	Off
1	On	Off	Low	Off
2	Off	On	Low	Off
3	On	On	Low	Off
4	Switching 33% AM		Low	Off
5	Switching 100% AM		Low	Off
6	On	Off	High	Off
7	Off	On	High	Off
8	On	On	High	Off
9	Switching 33% AM		High	Off
10	Switching 100% AM		High	Off
11	On	Off	Switching	Off
12	Off	On	Switching	Off
13	On	On	Switching	Off
14	Switching 33% AM		Switching	Off
15	Switching 100% AM		Switching	Off
16	Off	Off	Low	On
17	On	Off	Low	On
18	Off	On	Low	On
19	On	On	Low	On
20	Switching 33% AM		Low	On
21	Switching 100% AM		Low	On
22	On	Off	High	On
23	Off	On	High	On
24	On	On	High	On
25	Switching 33% AM		High	On
26	Switching 100% AM		High	On
27	On	Off	Switching	On
28	Off	On	Switching	On
29	On	On	Switching	On
30	Switching 33% AM		Switching	On
31	Switching 100% AM		Switching	On

**46.N Count Internal Signals.** The Counter counts the internal signal selected by N for 100 ms and displays the count. This is equivalent to measuring the frequency of the signal with 10 Hz resolution for most signals. See Service Sheets 22 and 23.

N=1 Intermediate Frequency. See Service Sheet 10.

N=2 Voltage-to-Time Converter. 10 000 counts equal 1V, but includes a 0.6V offset. See Service Sheet 15 or Special Functions 49 and 50.

N=3 FM Calibrator. See Service Sheet 29.

N=4 High Frequency VCO Divided by 8. This is the 40 to 80 MHz signal proportional to the LO frequency. See Service Sheet 17.

N=8 Selected Time Base Reference. The display should read  $1000000 \pm 1$ . See Service Sheet 22.

N=9 External Time Base Reference. The display should read  $1000000 \pm 1$  when an external reference is connected. See Service Sheet 22.

N=A Internal Time Base Reference. The display should read  $1000000 \pm 1$  when no external reference is connected. See Service Sheet 22.

N=B Audio Counter Input or IF Synchronous Detector VCO. If the Audio Frequency measurement mode has been selected, the frequency of the signal at the input of Audio Counter is displayed. (The frequency is measured with the Counter in the A11 Counter Assembly. The Audio Counter in the A52 Audio Counter/Distortion Assembly is not exercised except for its Schmitt trigger input.) See Service Sheet 16. If the Tuned RF Level measurement mode has been selected, the frequency of the VCO of the IF Synchronous Detector (and hence the frequency of the IF) is read. See Service Sheet 7 and Special Function 48.2 (which is similar).

**47.0 Instrument Configuration Display (2535A and Above).** Displays certain instrument configuration details in the following form

<Tracking Synchronous Detector>.<New Opt. Series 030>< Old Opt. Series 030>

where 1 is yes and 0 is no. The new Option Series 030 refers to instruments with serial prefix 2535A and above; old refers to older versions of the HP 8901B Modulation Analyzer (which shares the firmware).

**48.N IF Synchronous Detector Control.** See Service Sheet 7.

#### NOTE

*Frequencies are displayed with 10 Hz resolution.*

N=0 Displays the dc output voltage (in volts).

N=1 Disconnects the input to the Synchronous Detector and displays the output offset voltage (in volts).

N=2 Disables VCO sweep and displays the VCO frequency.

N=3 Enables VCO fast sweep up and displays the VCO frequency.

N=4 Enables VCO fast sweep down and displays the VCO frequency.

N=5 Enables VCO slow sweep up and displays the VCO frequency.

N=6 Enables VCO slow sweep down and displays the VCO frequency.

N=7 Pretunes the VCO and displays the VCO frequency.

N=8 Disables the VCO and displays the VCO frequency (which should be 0 or 1 since the VCO is disabled).

N=9 Displays lock status. <0> indicates unlocked. <1> indicates locked.

**49.N Display Internal Voltages.** The Voltmeter measures and displays the internal voltage (in volts) selected by N. This special function also controls the rear-panel RECORDER output as explained in the following note.

N=0 Ground. See Service Sheet 15.

N=1 RF Peak Detector Ground. See Service Sheet 4.

N=2 RF Peak Detector  $\div 3$ . See Service Sheets 4 and 15.

N=3 RF Peak Detector. See Service Sheet 4.

N=4  $\times 10$  AM Calibrator. See Service Sheet 30.

N=5  $\times 1$  AM Calibrator. See Service Sheet 30.

N=6 Audio Range Detector. See Service Sheet 13.

N=7 RMS-to-DC Converter. See Service Sheet 16.

- N=8 Ground. See Service Sheet 15.
- N=9 Audio Average Detector. See Service Sheet 14.
- N=A Audio Peak Detector. See Service Sheet 14.
- N=B IF Average Detector. See Service Sheet 8.
- N=C IF RMS Detector (Option Series 030) (*2535A and Above*). See Service Sheet 34.
- N=D IF Peak Detector. See Service Sheet 9.
- N=E ALC Current. See Service Sheet 8.
- N=F RF Average Power or Sensor Identifier. To read average power, precede with Special Function 0.212. To read sensor identifier, precede with Special Function 0.211. See Service Sheet 2.

#### NOTE

*The suffix N can also be two digits, XY. The displayed result is equivalent to the display of 49.X SPCL minus the display of 49.Y SPCL. For example, 49.9 SPCL or 49.90 SPCL gives a display of the level from the RF Peak Detector with respect to ground. 49.91 SPCL gives a display of the level from the RF Peak Detector with respect to the level from the RF Peak Detector ground.*

*The rear-panel RECORDER output is connected to the output of the Voltmeter's selector switch (see Service Sheet 15). During normal operation, the selector is constantly being switched between the various inputs. Each voltage measurement also includes a separate measurement of ground. The displayed result is derived from the difference between the selected voltage and ground readings.*

*The switching at the RECORDER output can be halted by keying in Special Function 49.XY with X equal to 0 or 8 and Y equal to the desired input. The dc level at the RECORDER output is constant and equal to the selected input; the displayed measurement result is equal to the result using Special Function 49.Y. This feature is useful for troubleshooting the Voltmeter and for improving the accuracy of the RF Power and Tuned RF Level measurements (see Recorder Output in Section 9).*

**50.N Display Internal Voltages.** The Voltmeter measures and displays the internal voltage (in volts) selected by N. See also the previous note.

- N=0 Ground. See Service Sheet 15.
- N=1 -15V Supply. The display should read between 2.7200 and 3.000. See Service Sheet 15.
- N=2 -5V Supply. The display should read between 2.7300 and 3.1500. See Service Sheet 15.
- N=3 +5V Supply. The display should read between 2.8500 and 3.3200. See Service Sheet 15.
- N=4 +15V Supply. The display should read between 2.8500 and 3.1500. See Service Sheet 15.
- N=5 +40V Supply. The display should read between 2.9800 and 3.2900. See Service Sheets 15 and 20.
- N=6 IF Synchronous Detector without DC-to-RMS Converter. See Service Sheets 7 and 15.
- N=7 IF Synchronous Detector with DC-to-RMS Converter. See Service Sheets 7 and 15.

**52.N Read-Only Memory Verification.** The Controller displays the checksum of the read-only memory (ROM) specified by N. When specifying a ROM, use N=1 through 3. The display is in the form <actual checksum>.<expected checksum>. An initial zero (or zeros) will be blanked. Thus, for example, 24.024 would be a valid checksum, 24.124 would be invalid. The display times out after approximately 5s. See Service Sheet 24.

**53.N IF Synchronous Detector Test.** The Controller sequences the IF Synchronous Detector through groups of tests specified by N and returns a fault code corresponding to the test that failed. For N=1 to N=4, four tests are performed for each group. If all tests in the group pass, 0 will be displayed. If any tests fail, the fault codes appear on the display in the positions indicated. (The digit positions are numbered under the display window.) All leading zeros in the display are blanked. For example, in the group defined by N=1, if the VCO pretunes too high (Fault 3), the failure will result in the display “ 300” (five leading zeros blanked). The tests are continuously sequenced, and the display will be updated as the fault is corrected. When multiple faults are displayed, troubleshoot the lowest-numbered fault first. Most of the tests can be done manually using Special Function 48. (Some tests make use of the AM Calibrator.) For all tests, see Service Sheet 7.

N=0 Performs all tests in the groups listed for N=1 through N=4 (below). Displays the number of the first test that failed. If no test fails, a zero is displayed. Run this test with a cable connected between the CALIBRATION AM/FM OUTPUT and INPUT. The test takes approximately 15s to complete.

N=1 Tests the presence and pretune frequency of the VCO. The VCO is pretuned and its frequency measured by the Counter. No signal should be connected to the instrument's INPUT.

*Fault 1.* VCO signal not present. If the VCO frequency is less than 100 Hz, 1 will be displayed in digit position 2. (This error will be generated if the IF Synchronous Detector Assembly is not present.)

*Fault 2.* VCO pretune frequency too low. If the VCO frequency is less than 456.5 kHz, 2 will be displayed in digit position 4.

*Fault 3.* VCO pretune frequency too high. If the VCO frequency is more than 457.5 kHz, 3 will be displayed in digit position 6.

*Fault 4.* Undefined.

N=2 Tests the direction and speed of the VCO sweep. The VCO sweep configurations are checked by counting the VCO frequency after a timed interval. No signal should be connected to the instrument's INPUT.

*Fault 5.* VCO will not fast sweep up. If the VCO frequency has not increased by at least 2 kHz after a 670 ms interval, 5 will be displayed in digit position 2.

*Fault 6.* VCO will not slow sweep down. If the VCO frequency has not decreased by at least 2 kHz after a 4s interval, 6 will be displayed in digit position 4.

*Fault 7.* VCO fast sweep too fast or too slow. If the VCO frequency has changed at a rate less than 4 or greater than 9 kHz/s, 7 will be displayed in digit position 6.

*Fault 8.* VCO slow sweep too fast or too slow. If the VCO frequency has changed at a rate less than 800 or greater than 1200 Hz/s, 8 will be displayed in digit position 8.

N=3 Tests the sweep limits of the VCO. The VCO is pretuned and allowed sweep to its limits and the VCO frequency is checked by the Counter. No signal should be connected to the instrument's INPUT.

*Fault 9.* VCO lower sweep limit too high or too low. If the lower limit of the VCO is less than 439 or greater than 449 kHz, 9 will be displayed in digit position 2.

*Fault 10.* VCO upper sweep limit too high or too low. If the upper limit of the VCO is less than 462 or greater than 469 kHz, 10 will be displayed in digit positions 3 and 4.

*Fault 11.* Undefined.

*Fault 12.* Undefined.

N=4 Tests the ability of the VCO to lock and tests the output and linearity of the Synchronous Detector. A signal of known level (the signal from the AM Calibrator, which can be stepped by 6 dB) is measured by the IF Synchronous Detector (the Tuned RF Level measurement).

Lock status is checked and the output of the Synchronous Detector is checked at two different signal levels and with no signal. Connect a cable between the instrument's CALIBRATE AM/FM OUTPUT and INPUT.

*Fault 13.* Phase Detector does not lock. Lock status is checked. If the status is "unlocked", 13 will be displayed in digit positions 1 and 2.

*Fault 14.* Synchronous Detector output too high or too low. If the output of the Synchronous Detector, with the AM Calibrator at maximum level, is less than 0.977 or greater than 1.949V, 14 will be displayed in digit positions 3 and 4.

*Fault 15.* Synchronous Detector offset too high. If the output of the Synchronous Detector, with its input shut off, is greater than 10 mV, 15 will be displayed in digit positions 5 and 6.

*Fault 16.* Synchronous Detector linearity too low. If the output of the Synchronous Detector drops more 6.2 or less than 5.8 dB when the AM Calibrator level drops 6 dB, 16 will be displayed in digit positions 7 and 8.

**54.N Local Oscillator Test.** The Controller sequences the local oscillator (LO) through groups of tests specified by N and returns a fault code corresponding to the tests that failed. For N=1 to N=5, four tests are performed for each group. If all tests in the group pass, 0 will be displayed. If any tests fail, the test numbers appear on the display in the positions indicated. (The digit positions are numbered under the display window.) All leading zeros in the display are blanked. For example, in the group defined by N=1, a simultaneous time base (Test 2) and HF VCO or Divider (Test 4) failure will result in the display " 20004" (three leading zeros blanked). The tests are continuously sequenced, and the display will be updated as the fault is corrected. The tests are most easily visualized by referring to Figures 8D-1 through 8D-4.

N=0 Performs all tests in the group listed for N=1 through N=5 (below). Displays the number of the first test that failed. If no test fails, 0 is displayed.

#### NOTE

*If the display is not zero, it is important that all other tests be checked (N=1 through N=5). Some LO faults cause more than one test to fail. For example, if the HF VCO ÷8 output fails, the following tests will fail:*

*N=1, Test 4,  
N=2, Tests 5, 6, and 7,  
N=3, Tests 9 and 10,  
N=4, Tests 17 and 18.*

*This is because a frequency measurement of the LO is made in these particular tests. If the +40V Supply fails, the following tests will fail:*

*N=2, Tests 5 and 6,  
N=3, Tests 9 and 10,  
N=4, Tests 17 and 18.*

*Begin troubleshooting at the lowest-numbered test.*

*This test is run automatically at power-up. Results are not displayed, but a pass-fail indication is made on internal LEDs. (See Power-up Check, paragraph 8-9.)*

#### Counter Tests

N=1 Test 1. Undefined.

N=1 Test 2. Time Base Test. See Service Sheets 22 and 23.

Tests the 6.25 kHz TTL time base signal to determine if it toggles within a reasonable length of time. The Controller looks at A11U15D's output for 260  $\mu$ s. At least one transition (high-to-low or low-to-high) of the clock should occur during this time. If no clock transition occurs, 2 will be displayed in digit position 3. However, if a transition is detected, a second (verification) check is made by the Controller.

N=1 Test 3. Counter Test. See Service Sheet 23.

Counts the selected Time Base, which should be exactly 1000000. If the result is not 1000000, 3 will be displayed in digit position 6.

N=1 Test 4. HF VCO and Divider Output. See Service Sheets 17 and 18.

Connects the DAC output to the HF VCO and counts the LO frequency to determine if it is within certain limits. The Controller turns off the Sweep-Up and Sweep-Down Current Sources and LF VCXO tune filter, allowing the HF VCO to free run. The Controller then outputs the approximate center frequency code to the tuning DAC and checks if the HF VCO output is between 250 and 800 MHz. If the frequency is not within these limits, 4 will be displayed in digit position 8.

#### DAC and HF VCO Range Tests

N=2 Test 5. HF VCO Top of Range Test. See Service Sheet 18.

Tests the DAC's ability to drive the HF VCO to the top of its frequency range. The DAC is programmed to output the highest tune voltage. If the HF VCO does not tune to between 655 and 800 MHz, 5 will be displayed in digit position 2.

N=2 Test 6. HF VCO Bottom of Range Test. See Service Sheet 18.

Tests the DAC's ability to drive the HF VCO to the bottom of its frequency range. The DAC is programmed by the Controller to output the lowest tune voltage. If the HF VCO does not tune to between 280 and 310 MHz, 6 will be displayed in digit position 4.

#### NOTE

*Test 6 is not always conclusive. The test may not always detect a failure of the VCO to tune to the bottom of the band. If the VCO does fail to tune to the bottom of its band, the instrument will not tune to certain frequencies in the track mode.*

N=2 Test 7. HF VCO Mid-Range Test. See Service Sheet 18.

Tests the DAC's ability to control the HF VCO near the center of its frequency range. The DAC is programmed by the Controller to output a tune voltage near the center of the range. If the HF VCO does not tune to between 454 and 575 MHz, 7 will be displayed in digit position 6.

N=2 Test 8. Undefined.

#### DAC and HF VCO Incremental Range Tests

N=3 Test 9. Gain Test For Most Significant DAC. See Service Sheet 20.

Tests the gain of the most significant DAC. The Controller sends a hexadecimal 55 to the most-significant DAC (MSDAC) and a hexadecimal AA to the least-significant DAC (LSDAC). The Controller then counts the frequency of the HF VCO. The MSDAC is then changed to AA. The Controller again counts the frequency of the HF VCO and then computes the difference between the first and second frequencies. This difference should fall between 139 and 285 MHz. If it does not, 9 will be displayed in digit position 2.

N=3 Test 10. Gain Test For Least Significant DAC. See Service Sheet 20.

Tests the gain of the least significant DAC. The Controller sends a hexadecimal AA to the most-significant DAC (MSDAC) and a hexadecimal 55 to the least-significant DAC (LSDAC). The Controller then counts the frequency of the HF VCO. The LSDAC is then changed to AA. The Controller again counts the output of the HF VCO and then computes the difference between the first and second frequencies. This difference should fall between 1.95 and 4.5 MHz. If it does not, 10 will be displayed in digit positions 3 and 4.

N=3 Test 11. Undefined.

N=3 Test 12. Undefined.

#### **LF VCXO Lock Acquisition Tests**

N=4 Test 13. Phase Lock Loop Acquisition. See Service Sheets 18 and 20.

Tests the HF VCO's ability to lock to the LF VCXO. The Controller turns off the Sweep Current Sources and the LF VCXO tune filter. It then programs the DAC to output a tune voltage which causes the HF VCO to operate near the center of its frequency range. The Controller rapidly switches the DAC output to the LF VCXO (with the DAC still programmed to midrange). The sampler loop is then closed and the output of the HF VCO is counted. If the HF VCO is operating properly, it will drift until it locks to a harmonic of the LF VCXO (via the sampler). If the HF VCO frequency has moved more than 2 MHz, it has failed to lock to a harmonic of the LF VCXO, and 13 will be displayed in digit positions 1 and 2.

N=4 Test 14. Phase Lock Loop Stability. See Service Sheet 20.

Tests the ability of the HF VCO to follow step changes in the LF VCXO. The Controller sends the DAC a code which forces the LF VCXO to the bottom of its frequency range. The frequency of the HF VCO is counted. The DAC is then instructed to quickly slew the LF VCXO to the top of its frequency range and then back down to the bottom again. When the DAC output voltage reaches minimum, the HF VCO is again counted. The frequency change of the HF VCO should be less than 100 kHz. If it is not, 14 will be displayed in digit positions 3 and 4.

N=4 Test 15. Undefined.

N=4 Test 16. Undefined.

#### **LF VCXO Lock Range Tests**

N=5 Test 17. LF VCXO Range Test. See Service Sheets 19 and 20.

Tests to see if the DAC moves the LF VCXO within the proper frequency limits. Since the LF VCXO frequency cannot be measured directly, an indirect process is used. The Controller sends a hexadecimal 00 to the DAC, which drives the LF VCXO to its minimum frequency. This frequency change causes a proportional change in the HF VCO frequency, which is measured by the Counter. The Controller then sends a hexadecimal FF to the DAC, driving the LF VCXO to its highest frequency. The HF VCO output is again counted. The difference between the highest and lowest frequencies from the HF VCO should be between 2.95 and 5.5 MHz. If the frequency difference does not fall within this range, 17 will be displayed in digit positions 1 and 2.

N=5 Test 18. Gain of the LF VCXO Drive. See Service Sheets 19 and 20.

Tests the gain of the LF VCXO. This is the hardest test in this series for the instrument to pass. The Controller sends a hexadecimal 55 to the most-significant DAC (MSDAC) and a hexadecimal AA to the least-significant DAC (LSDAC) and then counts the frequency of the HF VCO. The Controller then changes the MSDAC to a hexadecimal AA and the LSDAC to a hexadecimal 55, and again counts the frequency of the HF VCO. The difference between the first and second frequencies should be within the range of 1.05 and 2.4 MHz. If it is not, 18 will be displayed in digit positions 3 and 4.

N=5 Test 19. Undefined.

N=5 Test 20. Undefined.

**55.0 Sweep Doubler Band.** Sweeps the LO slowly back and forth across the doubler band. See Service Sheet 17.

**56.0 Sweep Bands 4 through 8.** Sweeps the LO slowly and sequentially across bands 4 through 8. See Service Sheet 17.

**57.0 Sweep Bands DBLR through 3.** Sweeps the LO slowly and sequentially across bands DBLR through 3. See Service Sheet 17.

**60.0 Key Scan.** The keyboard is scanned and a key code is displayed and output to the HP-IB. The key codes are shown in Figure 8B-3.

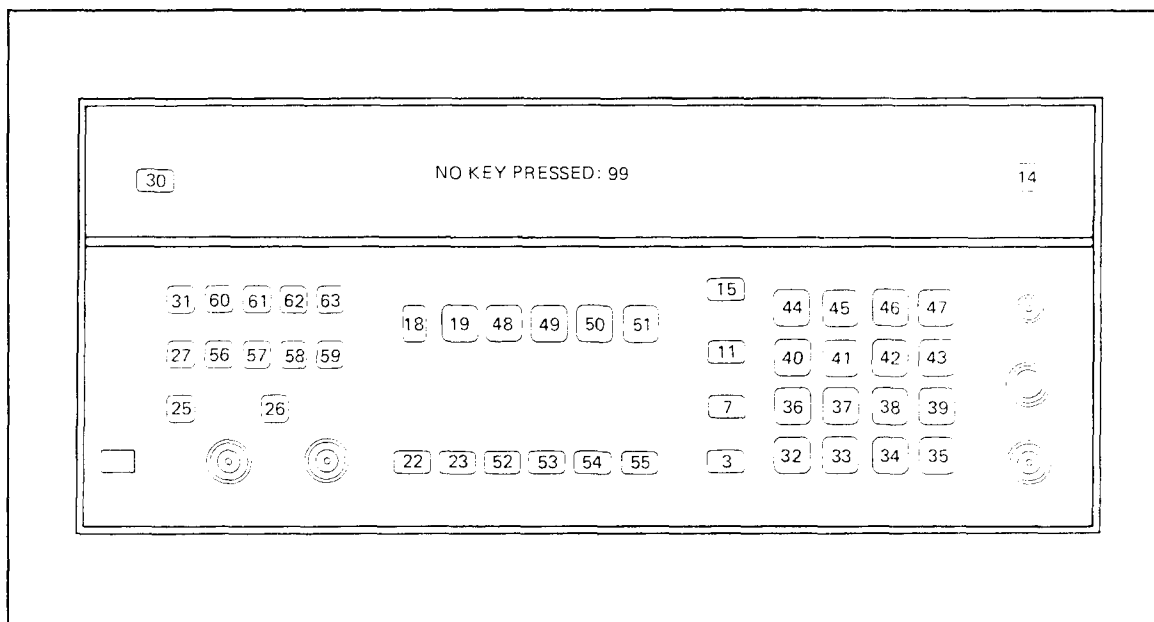

**Figure 8B-3.** Key Codes for Key Scan (Service Special Function 60)

To use the Key Scan Special Function, remove the instrument top cover. Key in 60.0 SPCL then jumper A13TP3 (INT) to A13TP1 (GND) on the A13 Controller Assembly. Press the front-panel keys and observe the display. If two or more keys are pressed simultaneously, the display shows the code corresponding to the first one found in its normal scan. See Service Sheet 25.

Two simple programs for displaying the key codes on a computing controller are shown in Table 8B-3. Removal of the top and bottom covers is unnecessary. The Measuring Receiver is assumed to have HP-IB address 14.

**Table 8B-3.** Key Scan Programs

HP 9825A (HPL)	HP 85A (BASIC)
0: rem 714; llo 7	10 REMOTE 714
1: wrt 714, "60.0SP"	20 LOCAL LOCKOUT 7
2: red 714, A	30 OUTPUT 714; "60.0SP"
3: dsp A	40 ENTER 714
4: jmp -2	50 DISP A
5: end	60 GOTO 40
	70 END



**61.N Display HP-IB Status.** Displays the status of the HP-IB lines selected by N. The display is in binary. See Service Sheet 28 for troubleshooting and a complete list of HP-IB mnemonics.

**NOTE**

*Information within pointed brackets appears on the Measuring Receiver's display.*

- N=0 <Addressed to Talk>.<Addressed to Listen>. This function reads back and displays the present state of the Talk and Listen Address flip-flops (A14U16A and B). For example, if the display shows 1.0, the Measuring Receiver is addressed to talk (and unaddressed to listen). This means the Talk Address flip-flop is set (and the Listen Address flip-flop is reset).
- N=1 <DAV>.<RFD><DAC>. This function reads back and displays the present state of the three bus handshake lines. <DAV> reflects the state of the Data Valid bus handshake line as being driven by the Measuring Receiver (1=being driven; 0=not being driven). Thus, when in Listen Only, this display will always show 0 for <DAV>. The <RFD> and <DAC> always track the bus lines Ready For Data and Data Accepted. For example, 1 for <RFD> means line Ready For Data is true (high).
- N=2 <ATN>.<REN>. This function reads back and displays the present state of the ATN (Attention) bus control line and the state of the Remote Enable Flip-Flop. A 1 for either <ATN> or <REN> indicates ATN is true (low at the bus) or that the Remote Enable Flip-Flop is set.
- N=3 <SPM>.<SRQ>. This function reads back and displays the state of the Serial-Poll flip-flop and the state of the SRQ bus-control line as being driven by the Measuring Receiver is in serial-poll mode (SPM) or that it is presently driving the SRQ bus control line.
- N=4 PIO Port A. This function inputs and displays (without modifying) the data at PIO port A (A14U13). Leading zeros are blanked. The following table interprets the display.

*PIO Port A*

<b>A14U13 Pin</b>	2	37	36	31	30	25	24	19
<b>Display Digit</b>	1	2	3	4	5	6	7	8
<b>Mnemonic</b>	IO8	IO7	IO6	IO5	IO4	IO3	IO2	IO1
1 = True								

- N=5 PIO Port B. This function is similar to the function above except PIO port B is displayed. The display is interpreted as shown in the table below.

*PIO Port B*

<b>A14U13 Pin</b>	1	38	35	32	29	26	23	20
<b>Display Digit</b>	1	2	3	4	5	6	7	8
<b>Mnemonic</b>	ATN	ARD	AAD	SRQ	RNL	ATT	ATL	SDV
1 = True								

## 8-8. ERROR MESSAGES

### General

The instrument generates error messages to indicate operating problems, incorrect keyboard entries, or service-related problems. The error message is cleared when the error condition is removed.

### Error Message Categories

**Errors 01 through 19, 30 through 39, and 90 through 99.** These are Operating Error Messages, which indicate that not all conditions have been met to assure a calibrated measurement. Operating Error Messages can usually be cleared by readjustment of the front-panel controls. The Error Disable Special Function 8 can be used to selectively disable certain error messages. More information on Operating Error Messages and error message disabling can be found under *Error Message Summary* and *Error Disable* in Section 3 and on the *Operating Information* pull-out card.

**Errors 20 through 29.** These are Entry Error Messages, which indicate that an invalid key sequence or keyboard entry has been made. These errors require that a new keyboard entry or function selection be made. More information on Entry Error Messages can be found under *Error Message Summary* in Section 3 and on the *Operating Information* pull-out card.

**Errors 40 through 64.** These are Measurement Progress Error Messages which indicate if a given segment of the measurement cycle has been traversed. These messages are not normally enabled.

**Errors 65 through 89.** These are Service Error Messages which provide additional service-related information and are discussed below. Service Error Messages do not necessarily infer that the instrument has a problem but may indicate a normal phenomenon under the particular circumstances. These messages are not normally enabled.

### Enabling Measurement Progress and Service Error Messages

Service Error Messages (Errors 40 through 89) are not normally displayed. When a service-related problem is suspected, enable the display Measurement Progress and Service Error Messages by keying in Special Function 43.N with N determined as follows:

N=0 Disables display of Service Error Messages 65 through 89.

N=1 Enables display of Service Error Messages 65 through 89. Cleared by AUTOMATIC OPERATION key.

N=2 Enables display of Service Error Messages 65 through 89. Not cleared by AUTOMATIC OPERATION key.

N=40 through N=89 and N=140 through N=189. Enables measurement to pause or halt on Measurement Progress and Service Error Message indicated by N. See the following paragraphs for details.

### Measurement Progress Error Messages (Errors 40 through 64)

These Service Error Messages are used to check the progress of a measurement. Refer to Table 8B-4, *Measurement Progress Error Codes* and Figure 8D-5, *Measuring Receiver Software Supervisor Flow Chart*. To see if the measurement progresses through a particular segment of the flow chart, enable the error code corresponding to the segment in either of the two following ways:

1. To cause the measurement to pause momentarily (approximately  $\frac{1}{2}$  second) and display the error code when the segment is encountered and then to continue on, key in 43.N SPCL, where the suffix N is the error code of the segment.
2. To cause the measurement to halt and display the error code when the segment is encountered, key in 43.N SPCL, where N is the error code of the segment plus 100. Press CLEAR to exit.

**Table 8B-4. Measurement Progress Error Codes**

Error Code	Flow Chart Segment
44	Non-Measurement Display
46	Measurement Display
48	Set Up Hardware
50	Frequency Tuning
52	Signal Leveling
54	Audio Ranging
56	Measure
58	Manipulate
60	Exit Manipulate

### Service Error Messages (Errors 65 through 89)

These Service Error Messages are quite diverse and are enabled in three ways.

1. Special Function 43.1 enables the Service Error Messages and allows the AUTOMATIC OPERATION key to clear them.
2. Special Function 43.2 enables the Service Error Messages but does not allow AUTOMATIC OPERATION to clear them.
3. Special Function 43.N enables the measurement to pause or halt when the Service Error Message specified by N or 100 minus N is encountered. The two alternatives are as follows:
  - a. To cause the measurement to pause (approximately  $\frac{1}{2}$  second) when a specified Service Error Message occurs, key in 43.N SPCL, where N is the Service Error Message code. After pausing and displaying the Service Error Message code, the measurement will continue on.
  - b. To cause the measurement to halt when a specified Service Error Message occurs, key in 43.N SPCL, where N is the specified Service Error Message code plus 100. Once the measurement is halted, pressing any key will terminate the halt feature unless testpoint TEST A on the A13 Controller Assembly is grounded. If the testpoint is grounded, pressing any key allows the measurement to proceed until the error is encountered again (permitting single-stepping of the measurement cycle). Press the AUTOMATIC OPERATION key rapidly twice in succession to exit this function.

The Service Error Messages are as follows:

**Error 67. Tuned RF Level Ranging.** The instrument has attempted to change ranges and found the signal either too high or too low after ranging. This may be due to improper switching of the RF Amplifier or attenuator, or it may be due to a fault on the IF Amplifier/Filter Assembly. See Service Sheets 4 and 6.

**Error 68. RF Amplifier Overpower.** Overpower status of the RF Amplifier was checked and found to be overpowered. See Service Sheet 4.

**Error 69. IF Synchronous Detector Fails to Lock.** Lock status of the IF Synchronous Detector was checked and found to be unlocked. Measuring a signal with significant drift or residual FM may cause this error. See Service Sheet 7.

**Error 70. Phase Lock Loop Step-Down.** The LO phase lock loop has stepped to a lower harmonic of the LF VCXO in an attempt to tune the LO to the required frequency. Stepping down once is occasionally necessary during normal tuning. See Service Sheet BD2 and *Service Special Function 54* in paragraph 8-7.

**Error 71. Phase Lock Loop Step-Up.** This error message is the same as Error 70 except that the loop has stepped to a higher harmonic.

**Error 72. Audio Overload.** The Audio Overvoltage Detector has tripped. This may have been due to the nature of the audio signal (for example, a high-frequency audio signal which overrides the circuits preceding a low-pass filter) or due to a problem in the audio circuits. See Service Sheet BD4.

**Error 73. No IF Signal Found after Finding an RF Input.** An RF input signal has been sensed by the Peak RF Level Detector but no IF signal has been sensed by the IF Level Detector. See Service Sheets 4 and 9.

**Error 74. FM Calibrator Underdeviation.** The frequency deviation of the FM Calibrator is less than 30 kHz. See Service Sheet 29.

**Error 75. FM Calibrator Overdeviation.** The frequency deviation of the FM Calibrator is greater than 38 kHz. See Service Sheet 29.

**Error 76. AM Calibrator Modulators Unequal.** The difference between the  $\times 10$  AM Cal signal for the two channels is greater than 0.6V. See Service Sheet 30.

**Error 77. AM Calibrator Channel B Out of Range.** The AM Cal level from Channel B is not within the range of +1.8 to +2.2V. An unterminated CALIBRATION AM/FM OUTPUT will cause this error. See Service Sheet 30.

**Error 78. Key Not Found.** A key closure was not found after a keyboard interrupt (except when a keyboard entry is in progress). See Service Sheet 25.

**Error 79. Audio Autorange Rangeback.** The audio autorange routine has found the audio signal level is too high, has changed to a less sensitive range, and has immediately found the signal is too low. The routine does not then range back, but instead displays Error 79 and remains on the low-sensitivity range for the rest of the measurement cycle. The error signifies that the routine would normally have ranged back but did not actually do it. This may have been due to the nature of the audio signal (for example, the voice signal) or due to a problem in the audio gain stages or detection circuits. See Service Sheet BD4.

**Error 80. Audio Settling Timeout.** First-time measurement results are not output to the display until the measurement result has settled or until one second has elapsed, whichever is first. Settling is determined by comparing successive measurements. This error message indicates that a one-second timeout has occurred. This may be due to the nature of the signal or an instability in the audio circuits. See Service Sheet BD4.

**Error 81. LO Tuning Adjusted to Center Signal in IF Passband.** This error message only occurs in automatic tuning, low-noise lock. If the signal in the IF drifts out of the acceptable pass-band limits (see the spectrum diagram in *RF Frequency Tuning* in Section 3) but is still acceptable, the LO frequency will be adjusted to center the signal in the IF passband. When this occurs, Error 81 will be displayed. In certain situations it is possible to trick the Controller into making this tuning adjustment when the signal is properly tuned; for example, when the IF signal has an excessively high AM depth (greater than 99% at normal RF signal levels) which cannot be accurately counted during the trough. Also note that if tuning adjustments are necessary three times in a row (without any intervening measurement), then the full auto-tuning sequence will be initiated, searching the entire spectrum for a signal.

**Error 82. Unable to Make Audio Count.** The audio count routine utilizes the main Counter in its frequency count sequence. The Controller initializes the Counter, which then waits for a “stop count” signal from the Audio Counter. If this “stop count” signal does not occur within 100 ms the audio count routine will time out. See Service Sheets 16 and 23.

**Error 89. Software Error.** Perform the Read Only Memory Verification. See *Service Special Function 52.N* in paragraph 8-7.

## 8-9. POWER-UP CHECKS

When the Measuring Receiver is first turned on (or if 40.0 SPCL is entered), the instrument goes through a series of operational checks. If a check fails, an error code is displayed for two seconds on the four internal TEST LEDs on the A13 Controller Assembly. The sequence then continues on to the next check.

Except for the check of the front-panel LED annunciators, no indication of the power-up sequence or its results is given on the front-panel display. The principal advantage to using the Power-Up Checks is that the keyboard and display need not be operational.

To use the Power-Up Checks, remove the top cover, remove any jumpers that may be on the four TEST test points (A, B, C, and D) on the A13 Controller Assembly, remove any signal at the INPUT and switch POWER to STBY for five seconds (to discharge the supplies) and back to ON. Observe the four TEST LEDs on the top of the Controller Assembly as the instrument powers up. The LEDs should light in the following sequence:

1. Indeterminate for about  $\frac{1}{4}$  second.
2. ( ) ( ) ( ) (1) for about 2 seconds.
3. ( ) ( ) (2) ( ) for about  $\frac{1}{4}$  second.
4. ( ) (4) ( ) ( ) for about  $\frac{1}{4}$  second.
5. (8)(4)(2)(1) for about 10 seconds.
6. ( ) ( ) ( ) (1), with (1) blinking indefinitely until a key is pressed.

The Power-Up Checks proper begin at step 2 and are carried out in the following order:

1. **Front-Panel Annunciator Check.** All front-panel LEDs and display segments and decimal points are lighted and remain so throughout the tests that follow and for a few seconds afterwards. Failure of one or more LEDs or display segments to light indicates that the respective components or drive circuits have failed. See Service Sheets 26 and 27.
2. **Read Only Memory Check.** The checksum of each of the read only memories (ROMs) is read and compared against a stored reference (stored in ROM 1). This is similar to issuing a series of 52.N SPCL commands (see *Service Special Functions*, paragraph 8-7). When a wrong checksum is found, the four TEST LEDs blink ( ) ( ) (2) (1) (that is, a binary 3). The check then continues on to the next ROM. See Service Sheets BD5 and 24. If no faulty ROM is found, a steady ( ) ( ) ( ) (1) appears for about 2 seconds.
3. **Random Access Memory Check.** Data is written into and retrieved from the random access memory (RAM). During the test, ( ) ( ) (2) ( ) is output to the TEST LEDs for about second. If the data read back differs from the data entered, the failure is indicated by outputting the same code for an additional 2 seconds. See Service Sheet 24.
4. **Instrument Bus Parity Check.** A parity check of the data lines of the Instrument Bus is made. A failure is indicated by ( ) ( ) (2) (1) on the TEST LEDs for about 2 seconds. See Service Sheets BD5, 15, and 24.
5. **Local Oscillator Check.** The Local Oscillator (LO) is given a series of tests similar to issuing the 54.0 SPCL command (see *Service Special Functions*, paragraph 8-7). During the test, ( ) (4) ( ) ( ) is output to the TEST LEDs for about second. A failure is indicated by outputting the same code for an additional 2 seconds. See Service Sheet BD2.
6. **Keyboard Check.** The keyboard is scanned to see if any keys are down. If a key is down, error code ( ) (4) ( ) (1) is output to the TEST LEDs for 2 seconds. See Service Sheets BD5 and 25.

## 8-10. CONTROLLER TEST LEDS AND TEST POINTS

Near the top edge of the A13 Controller Assembly are located four testpoints and four associated LED annunciators labeled TEST which are used primarily for troubleshooting the instrument. The LED annunciators are labeled (from left to right) 8, 4, 2, and 1 and are associated with test points A, B, C, and D respectively.

The label on the annunciators is sometimes used to represent a binary weighting. They function in the following ways:

1. At instrument power-up the TEST annunciators light in a certain sequence that indicates proper functioning of several vital areas of the instrument. A failure in any of the areas is indicated on the annunciators. For details see *Power-Up Checks* in paragraph 8-9.
2. After power-up, annunciator 1 toggles once for each measurement cycle.
3. After power-up, annunciator 2 toggles once for each keyboard interrupt (that is, each time a key is pressed).
4. After power-up, annunciator 4 toggles once for each HP-IB interrupt.
5. After power-up, annunciator 8 lights when the tracking circuit of the IF Synchronous Detector is sweeping and blinks briefly when the sweep changes direction. See Service Sheet 7.

Grounding of certain of the TEST testpoints alters instrument operation in the following ways:

1. Grounding testpoint A is used to alter the measurement halt function of Special Function 43.N. See *Service Error Messages* in paragraph 8-8.
2. Grounding testpoint B causes some of the power-up sequence to be bypassed and thus shortens the turn-on time of the instrument. The power-up checks are now invalid.
3. Grounding testpoint C initiates the Counter signature analysis troubleshooting routine. See Service Sheet 23.
4. Grounding testpoint D initiates the Keyboard signature analysis troubleshooting routine. The signature analyzer's start and stop leads are then connected to testpoint A and the probe is connected to testpoint B. See Service Sheet 25.

Whenever a testpoint is grounded, the associated annunciator is extinguished.

## 8-11. SIGNATURE ANALYSIS

Signature analysis is a simple method of verifying the operation of digital circuitry. When properly used, signature analysis can detect extremely subtle hardware faults. Signatures must identically match those given in the signature tables. If everything is working correctly, signatures will all match exactly. If they don't match, by even one digit, something is wrong.

The Counter, Controller, and Keyboard and Display Assemblies are designed for troubleshooting with signature analysis. Signature Analysis is a method of digital signal tracing using test routines programmed in the Measuring Receiver's ROM. With the Measuring Receiver's Controller executing the signature analysis routine, the signature analyzer's test probe is used to check nodes in the circuit under test. The signature analyzer converts the signals at the node into a four-digit "signature", which it displays. This signature is then compared to the signature in the troubleshooting checks adjacent to the appropriate schematic. These two signatures must be identical.

Signature analysis can be speeded up if the following considerations are kept in mind:

1. Make sure that every step is performed as described in the set-up procedure. That is, make sure that the clock, start, and stop connections and triggering are correct.
2. Double-check that the signatures are being taken at the correct node.
3. Make sure that the signature analyzer probe is making good contact with the pin being checked. Oxidation on pins can cause invalid signatures due to poor contact.
4. When you think you have found a bad signature, double check to make sure.
5. When checking a node, check that the unstable-signature indicator is not blinking.

## 8-12. GENERAL DISASSEMBLY PROCEDURES

### Top Cover Removal

1. Remove the two top plastic standoffs on the rear panel by removing the Pozidriv screws from each standoff.
2. Unscrew the Pozidriv screw at the middle of the rear edge of the top cover. This is a captive screw and will cause the top cover to push away from the frame.
3. Lift the top cover off the instrument.

### Bottom Cover Removal

1. Turn the instrument upside down.
2. Remove the two top plastic standoffs on the rear panel by removing the Pozidriv screws from each standoff.
3. Unscrew the Pozidriv screw at the middle of the rear edge of the bottom cover. This is a captive screw and will cause the bottom cover to push away from the frame.
4. Lift the bottom cover off the instrument.

### Side Cover Removal

1. Remove the two screws holding each side panel strap handle in place (there is one screw at either end of each strap handle).
2. Remove the strap handle caps and the strap handles.
3. Slide the side panel towards the rear of the instrument and then pull it off.

### Information Card Tray Removal

1. Turn the instrument upside down.
2. Remove two plastic feet from one side of the bottom cover.
3. Rotate the information card tray away from the remaining two plastic feet and remove.

## 8-13. FRONT-PANEL DISASSEMBLY PROCEDURE

### Front-Panel Assembly Removal

1. Remove the information card tray (refer to Information Card Tray Removal).
2. Remove the knurled nuts on the RF input (Type-N) and the modulation output/audio input (BNC) connectors.
3. Pry up the plastic trim strip on the top of the instrument's front frame with a small screwdriver.
4. Remove the three screws in the channel covered by the trim strip.
5. Remove the two outside screws and the center screw from the channel on the bottom of the front frame.
6. Pull the front-panel assembly outwards.
7. To completely separate the front panel from the instrument, disconnect the ribbon cable connectors and the RF cables.



## A1 Keyboard and Display Assembly Removal

1. Remove the front-panel assembly from the instrument (refer to Front-Panel Assembly Removal Procedure).
2. To separate the A1 Keyboard and Display Assembly from the front-dress panel MP14 and sub-panel MP15, first remove the Keyboard and Display insulator MP48 by unscrewing the four pan-head screws, and removing the washers and spacers which hold it in place.
3. Remove the six remaining screws and washers which fasten the A1 assembly to the sub-panel.
4. Disconnect the front panel LINE switch S3 jumpers at the A1 assembly.
5. Separate the A1 assembly from the front-dress panel and sub-panel.

## Front-Dress Panel and Display Window Removal

1. Remove the front-panel assembly from the instrument (refer to Front-Panel Assembly Removal Procedure).
2. To remove the front display window MP40, remove the three retaining clips and slide the screen straight up (towards the top edge of the front sub-panel).
3. To remove the front-dress panel MP14, remove the front-panel jacks (if present) and slide the dress panel downward (toward the bottom edge of the front panel). The bottom edge of the front dress panel will have to be pulled out slightly to allow for clearance of the LINE switch.

## Replacement Of Pushbutton Switches And Annunciator Leds

### Key Cap Replacement

1. To replace a front-panel pushbutton key cap, pull it off and snap on a new one. You will have to either remove the Keyboard from the Front Panel Assembly (refer to Front Panel Disassembly Procedure) or carefully use a pair of pliers to remove the keycap.

#### NOTE

*Watch the angular position of the key cap as you snap it in place, since eight different positions for installation are possible.*

### Key Cap Led Replacement

Many of the front-panel pushbutton key caps have molded-in clear lenses which are illuminated by miniature LEDs located in the center portion of the switch at the circuit board. During production of the instrument, the LEDs are first soldered in place and then the switch is slid down around them and heat staked in place. If replacement of the LED becomes necessary (due to burnout), it can be replaced without having to remove the switch. To replace a key cap LED, use the following procedure:

1. Remove the pushbutton key cap (refer to Key Cap Replacement Procedure).
2. Place the Modulation Analyzer on a table top. Lower the front panel so that it is facing downward (refer to the Front-Panel Disassembly Procedure). Unsolder the LED leads on the circuit side of the printed circuit board as you pull the LED down through the middle of the switch stem with a pair of small tweezers.
3. Insert a new LED (one with long leads). Make sure the polarity is right. Pull the leads through the circuit board and solder.
4. Clip off the excess LED lead length on the circuit side of the keyboard.
5. Put the front panel in place. Snap on the key cap. With the instrument power on, test the switch function to make sure that the LED works.

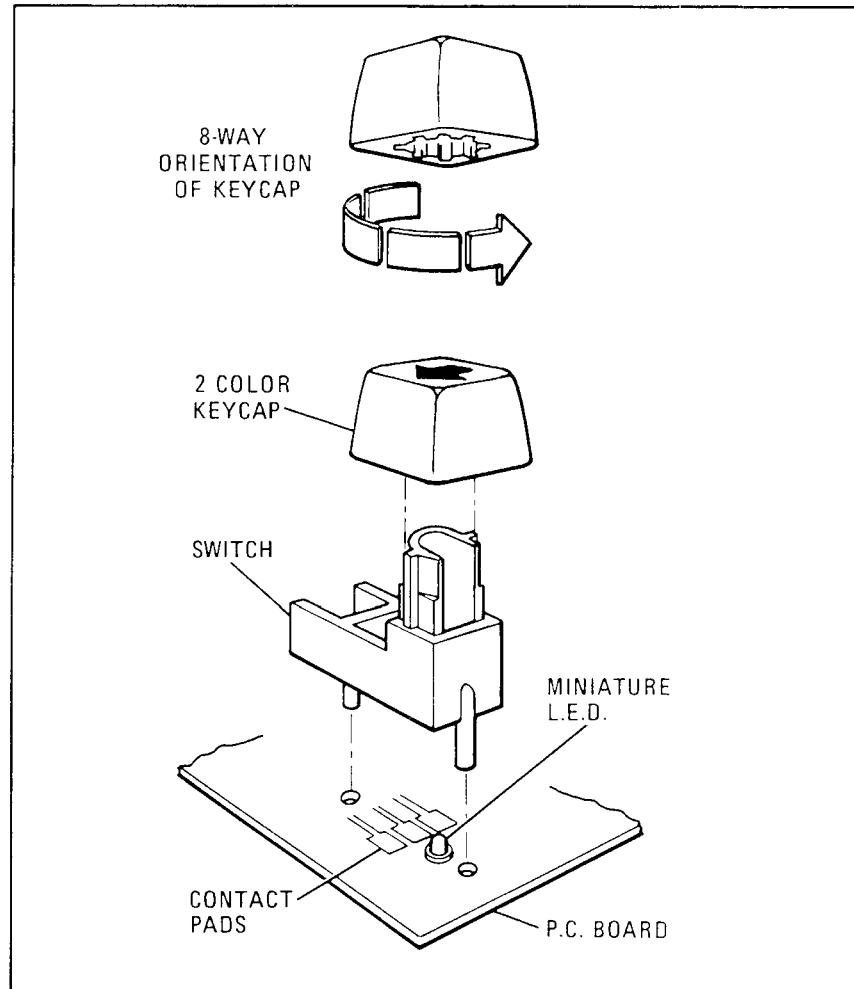

*Figure 8C-1. Front-Panel Pushbutton Switch Assembly*

## Switch Replacement

The front-panel switches have a very high cycle life. However, if one becomes faulty and needs replacement, follow the procedure outlined below:

1. Remove the pushbutton key cap. You will have to pull hard. Use your free hand to hold the board down as you pull.
2. Lower the front panel (refer to the Front-Panel Disassembly Procedure).
3. Remove the switch by chipping away the melted plastic tabs at the circuit of the keyboard which hold the switch in place.
4. To assure long life and reliable electrical performance, the circuit board contact traces (which are found underneath the switch) should be clean and free of surface imperfections. Clean the switch contact pads before installing a new switch. Make sure the LEDs are not tilted and that there is no excess solder around the leads.
5. For reliable operation, any method of assembly must assure that the switch is mounted tightly against the pc board. To facilitate the heat staking operation, specially molded support anvils (HP 5040-6881) can be ordered.

**NOTE**

*The following operation should be done in a well ventilated area. If the heat staking tip is too hot, the plastic will vaporize and emit fumes. These fumes, however, are non-toxic.*

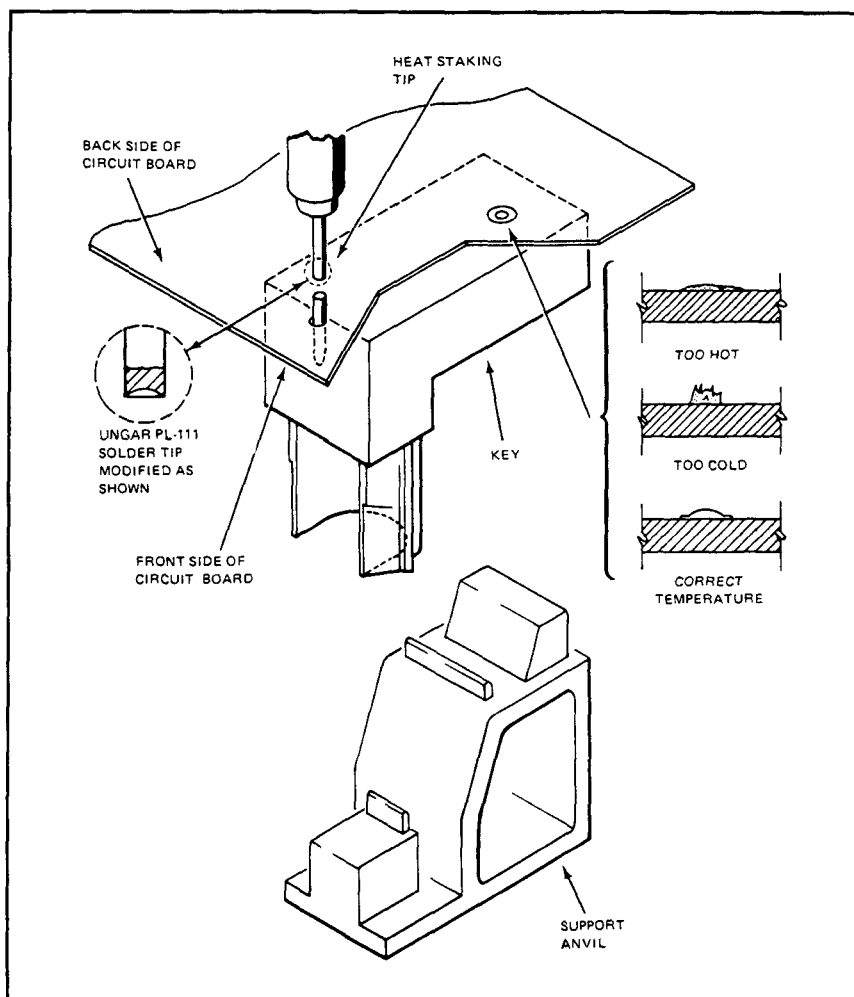

**Figure 8C-2.** Typical Assembly for Heat Staking Operation

- To assure proper switch assembly, verify that the switch is pushed firmly against the circuit board and, with the hot (440°C or 825°F) staking tip, push down on each of the posts (2) of the switch. Each post should take about one second to stake. With the proper cycle, the post should turn a darker color and, in about ten seconds, return to its original bright red color. The correctly staked post should have a smooth round "rivet" like top.

**CAUTION**

*Do not disturb the assembly for at least 10 seconds after heat staking.*

*If not enough heat is applied, the plastic will tend to stick to the tip of the iron.*

*If too much heat is applied, the plastic will fume profusely, the "rivet" will be irregularly shaped, and the plastic will be permanently discolored.*

*If the staking tool is worn or flaked, it will cause a misshaped rivet and/or a contamination deposit on the surface.*

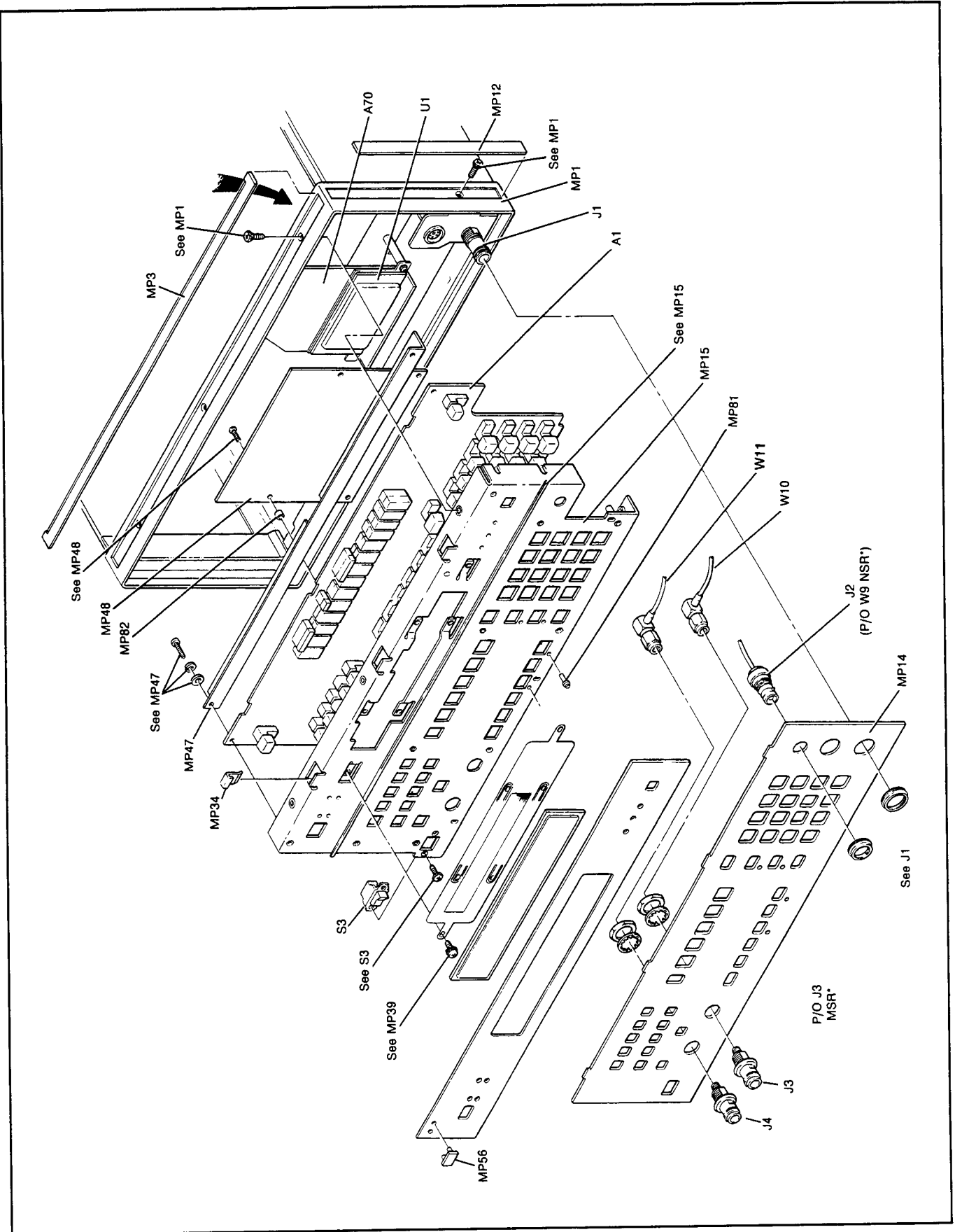

Figure 8C-3. Illustrated Parts Breakdown of the Front Panel (1 of 2)

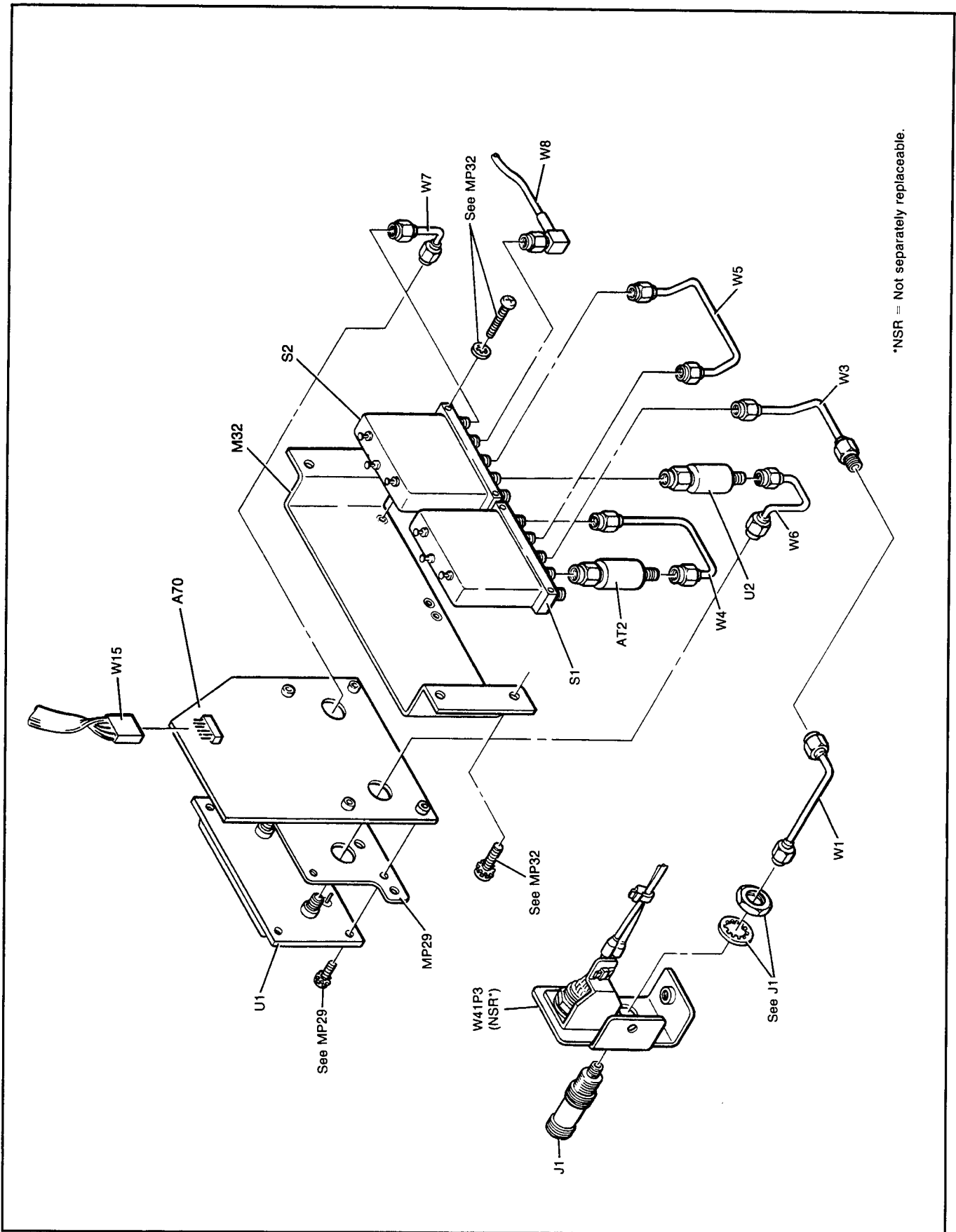

Figure 8C-3. Illustrated Parts Breakdown of the Front Panel (2 of 2)

# SERVICE SHEET BD1

## Block

- Overall Instrument

## Principles of Operation

### NOTE

*The following discussions cover the principles of operation of the Measuring Receiver. Each discussion is based on and referenced to a service sheet. An introductory-level discussion of the principles of operation can be found in Section 1 of the Operation and Calibration Manual under the title, Principles of Operation for Simplified Block Diagram.*

## General

The Measuring Receiver is a general-purpose, tuned, signal-measuring instrument. The Overall Block Diagram breaks up the instrument's functions so they correspond to those of a receiver: RF Block, IF Block, and Audio Block. The Digital Block (using the receiver analogy) roughly corresponds to the human operator. Each of the functional blocks is shown in greater detail in Service Sheets BD2 through BD5.

## Sensor Module

During normal operation, the RF input signal is applied to an external Sensor Module such as the HP 11722A. The Input Switch in the Sensor Module routes the RF signal to the Power Sensor when the RF Power measurement mode is selected or during the calibration portion of the Tuned RF Level measurement. The Power Sensor converts the RF input signal to a chopped dc voltage which is proportional to the average power level of the signal. For other measurement modes, the switch routes the input signal to the INPUT connector of the Measuring Receiver. The Sensor Module also contains a resistor which provides a means for the Measuring Receiver to identify the type of Power Sensor in the Sensor Module.

## Power Meter

The Power Sensor and Power Meter amplify the dc voltage from the Power Sensor's transducer so the voltage can be measured by the Voltmeter in the Audio Block. To minimize the effect of dc drift in the amplifiers (which may even exceed the dc voltage from the transducer itself), the transducer's output is converted to an ac voltage by a chopper in the Power Sensor. The chopper drive comes from the 220 Hz Multivibrator. The resultant ac signal is ac coupled to the narrow-band Input Amplifier, and the gain of this amplifier is autoranged by the Controller. The amplified ac signal is converted back to dc by the Synchronous Detector, which full-wave rectifies the ac signal by rechopping it in phase. Noise on the resultant dc signal is filtered by the Noise Filters to stabilize the displayed reading. The heaviest filtering is done on the most sensitive ranges and results in an increase in the measurement response time. Before an RF power measurement is initiated, the switch at the output of the Power Meter connects the Sensor Identifier Resistor circuit to the Voltmeter. The voltage across the resistor indicates the type of Power Sensor present.

The Zeroing DAC is set by the Controller to cancel any dc offset of the Power Sensor when no input is applied. In the zeroing sequence, the RF Input to the Power Sensor is switched out, a power reading is taken, and the Zeroing DAC is automatically adjusted for a zero reading. (In actual implementation, the Zeroing DAC is adjusted for a pre-determined offset voltage reading. The offset is subtracted out

in subsequent power measurements by the Controller. The Voltmeter then operates in its most linear region.)

Calibration of the Power Sensor is verified by connecting the Sensor Module to the CALIBRATION RF POWER OUTPUT connector, which outputs a calibrated 1 mW signal from the 50 MHz Power Reference Oscillator. If desired, a calibration factor can be stored and used to correct subsequent power readings as explained in the *Detailed Operating Instructions* in Section 3.

## RF Input

For all measurements which use the Input Mixer, the 10 dB Attenuator and the Input Attenuator are set by the Controller to provide the Input Mixer with an optimum input level. The Controller receives signal level information from the RF Peak and IF Peak Detectors and, for some measurements, the IF Synchronous and AM and IF Average and Detectors (in the IF Block). Because of its low input SWR, the 10 dB Attenuator is switched in whenever input attenuation is required. The RF Amplifier replaces the 10 dB Attenuator in the Tuned RF Level measurement mode when the RF input signal is low.

An Overpower Detector in the RF Amplifier senses RF overloads (approximately 0 dBm or more) and sets the switches at the input and output of the RF Amplifier to the bypass mode without intervention of the Controller. This detector does not degrade the input SWR of the RF Amplifier. The RF Limiter ahead of the RF Amplifier adds additional protection to the amplifier.

Next in the signal path is the overpower protection and power-level detection circuitry. The RF Peak Detector senses the signal level and the measured voltage is used to set the proper input attenuation. If the power at the front-panel input exceeds 1W, the measured voltage is also used to trip the Overpower Protection relay. When the 10 dB Attenuator is in, the overpower level reference is reduced to 0.1W, which corresponds to 1W at the input.

The 5.25 MHz High-Pass Filter is manually selectable. Since the IF generally responds to signals up to 2.5 MHz, the filter eliminates any low frequencies which may be present on the input. For input signals 150 kHz to 10 MHz, the filter should be switched out.

## Input Mixer and IF

The Input Mixer down-converts the RF input to the intermediate frequency (IF). The IF frequency is normally the frequency of the LO minus the frequency of the RF signal.

Except for the Tuned RF Level measurement mode, the IF is centered at 1.5 MHz for input signals 10 to 1300 MHz. (However, an IF of 455 kHz can be manually selected.) For signals between 2.5 MHz and 10 MHz or for the Tuned RF Level measurement mode, the IF is 455 kHz. Below 2.5 MHz, the signal is passed directly into the IF without being down converted (unless the 455 kHz IF has been manually selected).

The First IF Amplifier is a low-noise, 33 dB amplifier. When the 1.5 MHz IF is selected, the frequency response is determined by the 2.5 MHz Low-Pass Filter. When the 455 kHz IF is selected, the 455 kHz Bandpass IF Filter preceding the First IF Amplifier determines the IF response. In addition, in the Tuned RF Level measurement mode, the 455 kHz Bandpass Filter following the Second IF Amplifier is selected and determines the IF frequency response.

The IF signal is sent to the Third IF Amplifier and then to the 2.5 MHz Low-Pass Filter where it is buffered and sent to both the rear-panel IF OUTPUT connector and to the FM Demodulator circuitry. The IF Peak Detectors sense the presence of the IF signal (and thus the input RF signal) during an automatic signal search (via the IF Present and Stop Sweep lines). The Voltmeter measures detected IF level (via the IF Peak Level line) to help determine the setting of input attenuation.

## Low Level IF

The Tuned RF Level measurement uses an IF substitution technique. The signal is down-converted to a 455 kHz IF, amplified, detected by the IF Synchronous Detector, and then measured by the Voltmeter. Since the level range of the input signal is much greater than the linear range of the IF Synchronous Detector, the gain of the Second IF Amplifier is selected (in 10 dB increments) to bring the IF level into the range of the detector. The high step-to-step accuracy of the Second IF Amplifier is due to the tight tolerances of the gain-determining components and because the operating frequency is fixed and relatively low (455 kHz).

Although the relative accuracy of the IF detection scheme is excellent, source SWR and variations in the instrument's input circuits and mixer make a direct measurement of absolute power less accurate. An initial, operator-initiated calibration, however, removes most of the front-end error. During calibration, the operator applies a CW input signal (either from the signal source itself or from another source at the same frequency) at a level within the range of the Power Sensor being used. The instrument then measures the signal level at the Power Sensor with the Power Meter, switches the signal (via the Input Switch in the Sensor Module) to the Measuring Receiver's INPUT, and measures the power level with the IF Synchronous Detector. The two power-level measurements are compared and, using the Power Sensor reading as the reference, a calibration factor is computed and applied to successive Tuned RF Level measurements made at that frequency.

As the signal level is decreased, the Second IF Amplifier may run out of range, making it necessary to readjust the RF gain by inserting the RF Amplifier, adjusting the Input Attenuator, and recalibrating the IF. To recalibrate, the signal level is detected by the IF Synchronous Detector both before and after the RF gain is readjusted. (The IF gain is also readjusted as required by the IF Synchronous Detector.) Since the RF input level remains constant during recalibration, any difference between the two readings of the IF Synchronous Detector represents an error which the Controller uses to correct the calibration factor for that RF range. Further decreases in RF level may necessitate one further recalibration.

A narrow (30 kHz wide), 455 kHz Bandpass Filter improves the sensitivity of the measurement at very low levels where the signal-to-noise ratio is poor. Furthermore, the IF Synchronous Detector is able to track the signal over a 10 kHz range by phase locking a 455 kHz voltage-controlled oscillator (VCO, not shown) to the IF signal. The phaselock loop has a very narrow bandwidth (150 Hz), which further increases the detector's sensitivity. The VCO frequency is monitored by the Controller via the Counter to determine if the IF frequency has drifted out of limit, since at low levels, the normal IF input to the counter is very noisy. The frequency measurement also makes it possible to determine the frequency of the RF input signal at very low levels. The status of the phaselock loop is monitored by measuring the output of the detector. If no signal is sensed, the Controller initiates a search routine to sweep the VCO through the bandwidth of the IF.

The Third IF Amplifier provides additional IF gain for the signal during a signal search. After the IF Synchronous Detector locks onto the signal, the IF gain is switched back to normal to maintain IF calibration.

Tuned RF Level measurements can also be made with the AM and IF Average Detector. The wider bandwidth of this detector tolerates noisier signals but is less sensitive than the IF Synchronous Detector. Calibration is the same as for the IF Synchronous Detector.

## Selective Power Options (Option Series 030) (2535A and Above)

The Selective Power Options (Option Series 030) add a set of selectable bandpass filters and a programmable IF amplifier to enable the instrument to make accurate adjacent-channel power and single-sideband noise measurements on transmitters and signal generators. For these measurements, the instrument is first tuned to the incoming signal using the 455 kHz IF. The IF level is then measured with the IF RMS Detector after the IF is bandpass filtered and amplified. Next, the RF frequency is offset (as required by the specific test), and the IF level is again measured. The ratio of the two IF level measurements is the relative adjacent-channel power or single-sideband noise. (Refer to *Selective Power Measurements* in the *Detailed Operating Instructions* in Section 3.)



Two bandpass filters in series define the measurement bandwidth. The First Channel Filters are one of two pairs of IF filters. The Option Series 030 specifies the pairs of channel filters installed in the instrument. The pair of Second Channel Filters have bandwidths of 30 kHz (for adjacent channel power measurements) or 2.5 kHz (for single-sideband noise measurements). Filter selection is listed in Table 8D-1. The measurement bandwidth indicated in the table is the total bandwidth of the selected filters. In addition to determining the total measurement bandwidth, the second filter pair remove broadband noise generated by the preceding IF amplifiers. The Programmable IF Amplifier, governed by the Controller, keeps the IF signal within the linear range of the IF RMS Detector and increase the dynamic measurement range to 95 dB.

**Table 8D-1. Option Series 030 Filter Selection**

Option Number	Typical Measurement Application	Typical Channel Spacing	Measurement Bandwidth
032	Adjacent Channel Power	12.5 kHz	8.5 kHz
033	Adjacent Channel Power	20 or 25 kHz	16 kHz
035	Adjacent Channel Power	60 kHz	30 kHz
037	SSB Noise	—	2.5 kHz

At frequencies above 300 MHz, a low-noise, external LO is recommended for best performance. The LO is conveniently switched by the LO Input Switch. (This feature is not allowed in combination with Option 003, rear-panel LO connections.)

## AM Demodulator

The AM Demodulator is an automatic leveling control (ALC) loop with a relatively slow response time. The IF signal is amplified and detected by the AM and IF Average Detector, and the dc component of the detected signal is compared to a stable, dc reference. If the dc voltage is different from the reference, the difference is amplified by the ALC Feedback Amplifier which drives the Current-Variable Amplifier to force the detected voltage to equal the reference.

Since the AM on the IF carrier is too fast for the ALC loop to respond to, the ALC loop produces an ac voltage in the detector which is proportional to the AM. The ALC Bandwidth and Defeat line can be used either to completely defeat the ALC action or to speed up the ALC response time in response to variations in IF level (at the sacrifice of accuracy at low AM rates).

After demodulation, the recovered AM is filtered and processed by the Audio Circuits. The unfiltered AM from the AM and IF Average Detector (containing both ac and dc components) is sent to the rear-panel AM OUTPUT connector. The dc component from the detector is measured by the Voltmeter (1) to determine setting of the RF input attenuators when the ALC loop is switched off, (2) to determine the IF Level in the IF Level measurement mode (where it is compared to the ALC reference), (3) to determine the IF gain required for the Tuned RF Level measurement, and (4) as the alternate IF detector for the Tuned RF Level measurement mode.

## FM Demodulator

The FM Demodulator consists of IF Limiters and an FM Discriminator (frequency-to-voltage converter). The limiter-amplifier provides 66 dB of gain and limits the output voltage swing to approximately 1 V<sub>pp</sub> to reduce the influence of AM and noise on FM measurements. The signal from the limiters also drives a Counter input for measuring the IF frequency (except for the Tuned RF Level measurement where the IF Synchronous Detector is used). The FM Discriminator produces a voltage linearly proportional to the IF frequency, and the FM variations in the IF frequency appear as an ac component on the output. The ac component is amplified, filtered, and then processed by the Audio Circuits. The output from the FM Discriminator (with both ac and dc components) is sent to the rear-panel FM OUTPUT connector. The filtered dc component is used to tune the LO in the track-tune mode.

## Audio Circuits

The signal from the AM or FM Demodulators is filtered by a 260 kHz Low-Pass Filter. Before the audio signal is measured or sent to the MODULATION OUTPUT/AUDIO INPUT connector, it is processed further by various filters, amplifiers, and attenuators. For FM, the audio may also be de-emphasized. For  $\Phi$ M the signal is integrated. Factors which control the audio processing are: measurement mode, selected features, audio level, input frequency, and any selected special functions. Table 8D-2 summarizes the types of signal processing.

*Table 8D-2. Types of Audio Signal Processing*

Type of Processing	Selections Available
High-Pass Filters	<20 Hz (through path) 50 Hz 300 Hz
Low-Pass Filters	3 kHz 15 kHz >20 kHz (low ringing) >200 kHz (260 kHz LPF)
FM De-emphasis Networks	25 $\mu$ s 50 $\mu$ s 75 $\mu$ s 750 $\mu$ s None
FM De-emphasis Selection	Pre-display On Pre-display Off
Signal Polarity	Inverting Non-inverting
Relative Gain	0 dB 20 dB 40 dB

The Audio Range Detectors are used to determine the audio gain (the Audio Range Level line) and to sense audio overloading (the Audio Overvoltage Status line).

## Voltmeter

The demodulated signal is detected by both the Audio Average Detector and the Audio Peak Detector. The detector outputs are two of several Voltmeter inputs switched by the Input Selector. The Voltmeter consists of a Voltage-to-Time Converter whose output is applied to the Counter. The Voltage-to-Time Converter produces a Stop-Count pulse with an interval between pulses proportional to the dc input voltage. The pulse gates the Counter, which counts the 10 MHz time base reference. The count accumulated during the gate interval is proportional to the input voltage.

Other inputs into the Voltmeter include:

- RF Peak Level
- IF Peak Level
- IF Average Level (normally equal to the ALC reference)
- Audio Range Level
- RF Average Power Level
- AM Calibration
- Tuned RF Level (from the IF Synchronous Detector and including the level through an rms-to-dc converter, which corrects for noise errors on low-level signals)

- Audio Distortion (from an audio rms-to-dc converter)
- Various service-related voltages not shown.

The output from the Input Selector is always present at the rear-panel RECORDER OUTPUT connector. Normally, the output is constantly switching between inputs, but by means of special functions any of the measurement results can be selected and held. This feature is especially useful for making precise RF power measurements.

### Audio Distortion Analyzer

The input to the Distortion Analyzer is selected by the Output Switch. The input can be either the internal demodulated RF signal or an audio signal input to the front-panel MODULATION OUTPUT/AUDIO INPUT connector. The distortion measurement is limited to audio signals with a frequency of 400 Hz or 1 kHz.

The distortion measurement consists of measuring the rms level of the total audio signal then remeasuring the signal after it passes through a notch filter that removes the fundamental of the signal—leaving the distortion components, hum, and noise. Both measurements use the RMS-to-DC Converter to obtain true rms measurements. The dc level from the RMS-to-DC Converter is measured by the Voltmeter. The Post-Notch Amplifier and the Audio Amplifier optimize the signal level into the RMS-to-DC Converter. The Controller computes the distortion as the ratio of the output of the Notch Filter to its input (with corrections made to account for amplifier gain). (In the SINAD measurement mode, the reciprocal of distortion is computed.)

### Audio Counter

The input to the Audio Counter is selected by the Output Switch. As with the Audio Distortion Analyzer, the input can be either the internally demodulated RF signal or an audio signal input to the front-panel MODULATION OUTPUT/AUDIO INPUT connector.

The audio signal is first conditioned by the Schmitt Trigger to make it compatible with the digital circuits it drives. When a frequency count is to be made, the Controller, after clearing both the Counter and Audio Counter and after opening the Audio Switch, arms the Counter Control Logic. The first signal pulse from the Schmitt Trigger causes the Counter Control Logic to close the Audio Switch and the Counter Gate switch (in the main Counter). The number of cycles of the audio signal are counted by the Audio Counter. The number of time-base reference pulses are counted by the main Counter. After a fixed period of time, the Controller readies the count to stop. The next signal pulse from the Schmitt Trigger causes the two switches to open. The counts in the two counters are then read back, and the audio frequency is computed and displayed.

### Local Oscillator

The heart of the LO is a 320 to 650 MHz High-Frequency, Voltage-Controlled Oscillator (HF VCO). After passing through the programmable LO Divider, the HF VCO signal becomes the LO drive to the Input Mixer. The LO Divider is programmed to divide the HF VCO by powers of two from  $2^{-1}$  to  $2^8$ , (that is, from a times 2 divide by 256). Thus the LO can tune from 1300 MHz to 1.25 MHz in ten octave ranges. A fixed divide-by-eight output from the LO Dividers is the LO (HF VCO÷8) input to the Counter.

There are four tuning modes:

- manual tuning and low noise,
- automatic tuning and low noise,
- automatic tuning and signal tracking,
- manual tuning and signal tracking.

**Manual Tuning and Low Noise.** Consider the sequence followed for manual tuning. When a frequency is entered from the Keyboard, the LO is configured as in Figure 8D-1. The Digital-to-Analog Converter (DAC) is connected to the HF VCO tune input as shown. Knowing the desired frequency, the Controller



Next, the LO is configured as a phase-lock-loop as shown in Figure 8D-2. The DAC is now connected to the tune input of a highly stable, Low-Frequency, Voltage-Controlled, Crystal Oscillator (LF VCXO). The LF VCXO drives the Sampler at a nominal (but tunable) 2 MHz rate. The other input to the Sampler is the HF VCO. The Sampler drives the HF VCO tune line through the Tune Integrator and Amplifier. The HF VCO is thus phase locked to a harmonic of the LF VCXO, which greatly improves the noise and frequency stability of the HF VCO.

Before closing the phase-lock-loop, the DAC is set near the low end of its range. When the loop is first locked, the LO frequency is slightly low, but after an iterative sequence of counting the HF VCO and tuning the LF VCXO by the DAC, the LO is brought to within 500 Hz of the desired frequency. During the process of fine tuning the LO, the DAC may reach the end of its tuning range. If this happens, the Controller will break the lock loop, set the DAC to the other end of its range, and lock will be re-established to a different harmonic of the LF VCXO.

**Automatic Tuning and Low Noise.** The automatic tune mode is similar to the manual tune mode except the LO is first swept from the top to the bottom of each octave range by the Sweep Current Source. See Figure 8D-3. If the LO sweeps past a signal at the INPUT, the down-converted signal appears in the IF and is detected by the IF Detectors. The signal on the Stop Sweep line immediately turns off the Sweep Current Source. With no input to the Tune Integrator and Amplifier, the HF VCO will remain approximately tuned to the input signal, and the frequency of the LO (and thus the input) can be determined by the Controller. Once the signal has been found after a sweep of all octaves, it is found four more times by sweeping just the octave where it was first found and two octaves above it. This is necessary in case the signal has AM which was in a deep trough when the fundamental of the LO passed through and was out of the trough when the strong third harmonic of the LO passed through.

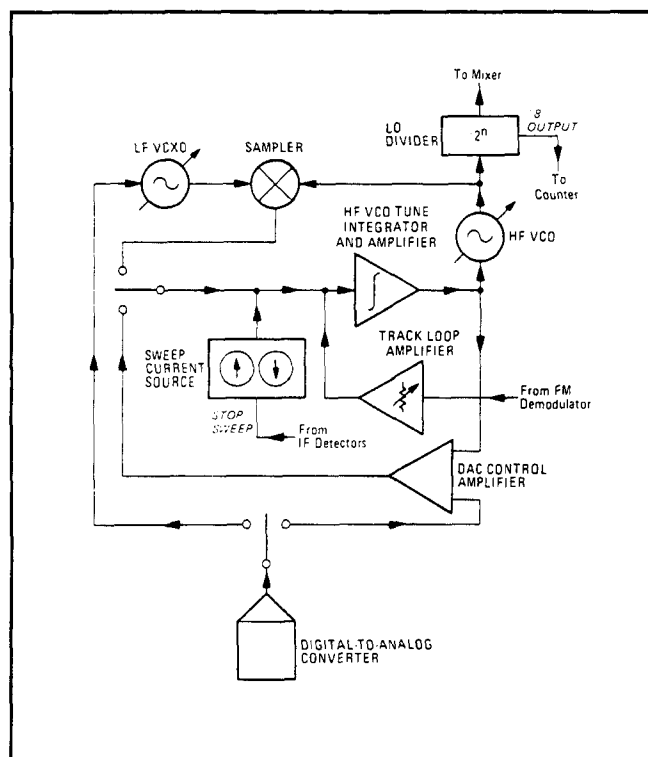
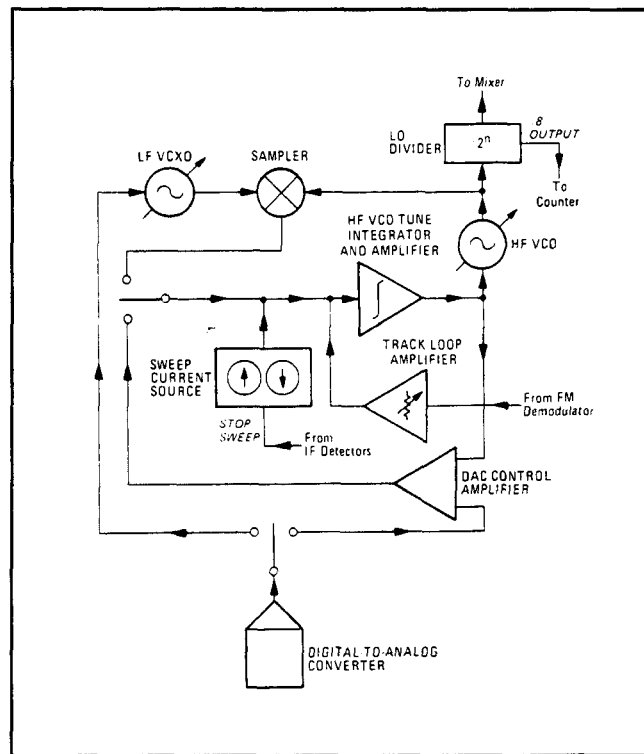

*Figure 8D-3. LO Configuration: HF VCO Sweep*

Having now found an input signal, the Controller manipulates the LO through a series of tuning sequences to search for the fundamental of the input that was found. Once the fundamental of the input signal is identified, the LO is tuned to approximately 1.5 MHz above that signal. The Controller then accurately counts the LO and the IF and thus determines the frequency of the input signal. (Signal frequency = LO frequency - intermediate frequency.)

At this point the LO is configured as in Figure 8D-1, and the tuning continues as in the manual tune mode using the computed frequency in place of a keyboard-entered frequency.

**Automatic Tuning and Signal Tracking.** In the track mode an automatic signal search is performed as described above. When a signal is found, the the LO is configured as in Figure 8D-4. Here, a dc voltage from the FM Demodulator is fed back to the HF VCO tune line to form a frequency lock loop. If the frequency of the input signal changes, the HF VCO is tuned to follow it. The gain of the loop depends on the octave number of the LO Divider. This gain variation is compensated for by adjusting the gain of the Track Loop Amplifier in the tune line.



*Figure 8D-4. LO Configuration: Track*

**Manual Tuning and Signal Tracking.** In the manual track tune mode the LO is first tuned as in the manual tune mode discussed above. The LO is then configured as in Figure 8D-4. Manual track tuning permits the tracking of a moving signal in the presence of stronger signals. Track tuning has a slightly higher residual FM level than low-noise tuning.

## Counter

Operation of the Counter is conventional. The input signal to the Counter is gated by a train of periodic time base pulses via the Time Base 6.25 kHz line. The period of the pulse train pulses is accurately known. While the Counter is gated, the Counter increments one count for each input cycle. When the time base disables the Counter, the accumulated count is transferred to storage registers (in this case, the Controller), and the Counter is cleared. When the time base again gates the Counter, the count sequence repeats. The stored count is then processed by the Controller (it is multiplied by an appropriate scale factor) and transferred to the display or used internally by the Controller. The Controller itself also forms the final stages of the Counter and keeps track of the number of time base pulses that occur while the Counter is gated.

The time base is derived from a 10 MHz reference. The reference can be either internal or external. Switching to external is done automatically when an external reference is applied to the rear-panel TIME BASE 10 MHz INPUT connector. The Time Base Dividers divide the 10 MHz reference by

1600. The output from the dividers becomes the Counter gate. A 2 MHz output (from a divide-by-five) is used as the Controller clock.

The Input Selector selects one of several possible inputs to the Counter. When the Voltmeter function is selected, the 10 MHz reference, gated by the Stop Count switch, is counted. The Stop Count switch closes when the Controller initiates a Ramp Gate pulse; it remains closed until opened by the Voltage-to-Time Converter. When the audio frequency function is selected, the 10 MHz reference is counted as for the Voltmeter function. The Stop Count switch, however, is now controlled by the Counter Control Logic of the Audio Counter.

## AM and FM Calibrators

The FM Calibrator consists of a 10.1 MHz VCO which toggles between two frequencies at a 10 kHz rate. Selecting the FM Calibration mode initiates a sequence of measurement cycles. During a measurement cycle, the VCO is measured by the Counter at the upper frequency and then measured at the lower frequency. The Controller then computes the deviation (one-half the difference between the two frequencies). The Controller then allows the FM Source to toggle at its 10 kHz rate. When the signal from the CALIBRATION AM/FM OUTPUT is connected to the INPUT of the Measuring Receiver (either directly, or through a Sensor Module), the FM on the calibrator signal is measured, and the FM calibration factor (the ratio of the measured FM to the computed FM) is displayed.

The AM Calibrator receives its input from the output of the 10.1 MHz VCO of the FM Calibrator, which is not toggled during AM calibration. This signal is limited and applied to the Amplitude Modulator. The AM Source toggles the modulator at a 10 kHz rate between a nominal level and twice that level to produce 33% AM.

To enhance the accuracy of the calibrator, measurements are made at the output of the modulator with the Amplifier/Detector while the AM Source is off. From these measurements the actual AM depth is computed. As with the FM Calibrator, the AM Calibrator output, when measured by the instrument, displays the AM calibration factor.

## Power Supplies

The instrument is run from five regulated supplies: +40V, +15V, -15V, +5V, and -5V. The +15V supply continues to power the high-stability, time base reference (Option 002) when POWER is switched to STBY.

## Controller and Remote Interface

The Controller plays a key role in governing the instrument operation. The Microprocessor in the Controller outputs information to configure the instrument, reads back and processes measurement results, reads back vital status information to prevent invalid measurements, and services interrupts from the Keyboard or Remote Interface. Information from the Input/Output (I/O) port of the Microprocessor is carried to the rest of the instrument by the Instrument Bus. Typically, the data on the Instrument Bus is decoded and latched at the various assemblies, then the decoded information is distributed to the appropriate circuit.

Information within the Controller itself is handled by three main buses: the ROM Control (ROMC) Bus (which coordinates the various devices which make up the Controller), the Address Bus (which addresses ROM and RAM), and the Data Bus (which carries information to or from ROM and RAM). Since the Remote Interface also contains Controller devices, these buses are also distributed to it. A battery backup to the RAM devices makes the memory non-volatile; that is, the instrument remembers key values even with the power switched off.

The Remote Interface receives inputs from the external interface bus (HP-IB), processes the information, and interrupts the Controller in a manner similar to the Keyboard. The Remote Interface also processes the measurement information and outputs it on the HP-IB if requested and is designed to make operation from an external computing controller as similar as possible to operation from the front panel.

## Instrument Software Supervisor Flowchart

The instrument's software is structured in a form called the supervisor. See Figure 8D-5. It is a loop that is continuously traversed, with measurements made near the end, after checks for proper frequency tuning, proper RF and IF level, and correct audio range. Arithmetic manipulation (for example, for the ratio function) follows the measurement, and the program then loops back up to the display.

The frequency, level, and audio blocks verify that the instrument is adjusted to make an accurate measurement. A measurement is not made until all of the tests are passed in immediate succession. If a test is not passed, corrective action is taken. The decision after that block forces the program back to the top of the supervisor, bypassing the measurement for that loop.

The software interface with the hardware makes use of two concepts called software state and hardware state. The software state is stored in 38 bytes of RAM and totally describes the state of the instrument. On power-up, the initialization procedure loads the software state from ROM. Keyboard and HP-IB entry routines modify only the software state and do not affect the hardware immediately. The setup block in the supervisor is where the hardware state is made to conform with the software state. Setup is not the only place where hardware is affected; the frequency tuning, leveling, audio ranging, and measurement blocks manipulate the hardware as well.

In a normal, stable measurement cycle, the program takes the measurement display branch at the top of the supervisor and so avoids the time overhead associated with the setup block. However, if the program loops back before taking a measurement, or if an error condition exists, the non-measurement display branch will be traversed, thus lighting an appropriate display and going through the setup block.

The Keyboard and HP-IB interrupt the flow around the loop, forcing the Microprocessor to execute a short program and then return to the loop as shown in the diagram. Since the supervisor can be interrupted at any point but always returns to a single location, Keyboard and HP-IB interrupts must abort the current measurement and start a new measurement cycle.

The Keyboard and HP-IB can be thought of as a medium through which the user requests a certain instrument setup. It is important to note that the actual instrument setup is guaranteed to conform to the Keyboard request only at the moment a measurement is taken. The Controller may change the instrument hardware at other times to optimize its tuning, leveling, and ranging functions. For example, in troubleshooting, 3.1 SPCL may be keyed in to check if the 455 kHz IF filter is being selected properly. If there is no RF input signal and the instrument is trying to auto-tune, it would be discovered that both IF filters (wide 455 kHz and 1.5 MHz) are being used. The proper test would have been to use a Direct Control Special Function (0.031 SPCL).

The microprocessor-based Controller interacts closely with the hardware of the instrument. Many circuits are used by the Controller for different functions at different times. Thus, a specific failure in one circuit can show up as a collection of symptoms that superficially seem unrelated. For example, a failure of the squelch detector in the FM Demodulator can result in frequency errors when tuning to an RF signal with large amounts of AM. The appearance of several symptoms can often be used as an advantage since they provide many avenues to pursue when tracking down a problem.

A distinct difference exists between special functions used for service (that is, Direct Control Special Functions and Service Special Functions) and those used for normal instrument operation. When service special functions are used, normal instrument functions are suspended. When the special function mode is left to resume normal measurements, all effects of these special functions on hardware are lost (with some exceptions such as AM or FM calibration and enabling of service errors). (Refer to paragraph 8-7 for details.) As an example, a Direct Control Special Function can be used to activate a particular Input Attenuator to check its operation. But once normal measurements are resumed, the attenuator setting will revert back to what it was before the Direct Control Special Function was invoked.



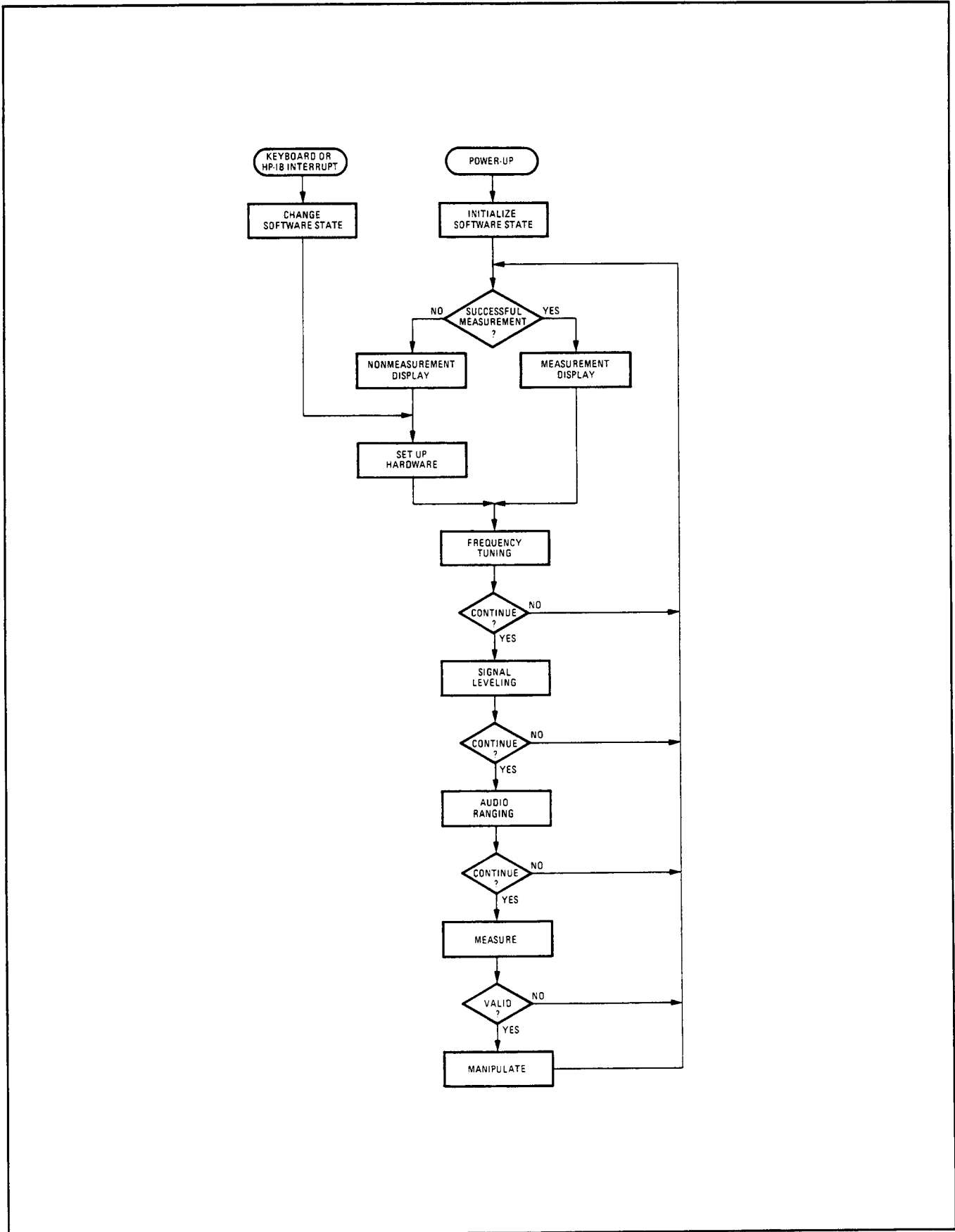

Figure 8D-5. Measuring Receiver Software Supervisor Flow Chart

## Troubleshooting

### General

The troubleshooting checks that follow are a starting place for locating an instrument fault. They are easy to perform and give much key information in a short amount of time. In most instances they can differentiate between an instrument hardware failure and a Controller or software problem. The checks should be done in order.

#### √1 Line Check

**Procedure:** Remove instrument top cover (three screws) and switch POWER to ON.

**Normal Indication:**

1. The fan runs indicating power is present on the power transformer secondaries.
2. The five green LEDs on the A10 Power Supply Regulators Assembly are lighted indicating that the supplies are nominally operating.

**If Indication Abnormal:**

1. Check the rear-panel line fuse and line voltage selector. Check Mains wiring. (See Service Sheet 31.)
2. Check the individual regulators. (See Service Sheet BD5.)

#### √2 Power-Up Checks

**Procedure:** If there are any jumpers on the TEST test points on the A13 Controller Assembly, remove them. Switch POWER to STBY for five seconds and back to ON. Note the sequencing of the four TEST LEDs on the top of the Controller Assembly as the instrument powers up.

**Normal Indication:** The four TEST LEDs light in the following sequence:

1. Indeterminate for about  $\frac{1}{4}$  second.
2. ( ) ( ) ( ) (1) for about 2 seconds. This indicates the start of the power-up routines and the run of the Read Only Memory Check.
3. ( ) ( ) (2) ( ) for about  $\frac{1}{4}$  second. This indicates the start of the power-up routines and the run of the Random Access Memory Check.
4. ( ) (4) ( ) ( ) for about  $\frac{1}{4}$  second. This indicates the running of the Local Oscillator Check.
5. (8) (4) (2) (1) for about 10 seconds. This indicates that all power-up checks passed and that a visual front-panel check can be made. (See √3 below.)
6. ( ) ( ) ( ) (1), with (1) blinking indefinitely until a key is pressed. The behavior of the LED (1) is also affected by the presence of an input signal.

Any other sequence indicates a failure of the check. Passing this check indicates that the Controller is functioning properly and that there is no catastrophic failure in the following circuits:

Read Only Memory,  
Random Access Memory,  
Instrument Bus,  
Local Oscillator (tuning only),  
Keyboard (only that no key is down).

**If Indication Abnormal:** If the TEST LEDs come on and remain in the random state of step 1 above, unplug the A14 Remote Interface Assembly and try again. If still faulty, check the Controller Kernel. (See Service Sheet BD5.)

If other indications appear in or after step 2 above, consult *Power-Up Checks*, paragraph 8-9, which discusses the individual checks, documents the error indications, and cross references to the service sheets.

### √3 Front-Panel LED Check

**Procedure:** Disconnect any connection to the INPUT connector. Switch POWER to STBY and back to ON.

**Normal Indication:** After less than one second, all front-panel LEDs and display segments and decimal points should light for about 10 seconds. The display should blank for one second, then show "--" with the MHz annunciator. The FREQ key, the AUTO TUNING, and the FM MODULATION OUTPUT annunciators should all light. This indicates that the Controller is able to output to the front-panel LED and display latches which are all operative.

**If Indication Abnormal:** If one or more LEDs or display segments fail, check the respective components and drive circuits. (See Service Sheets 26 and 27.) Also check the CPU I/O port. (See Service Sheet BD5.)

### √4 Measurement Error Check

**Procedure:** Key in 43.1 SPCL to enable Service Errors. Make the measurement in which the fault appears.

**Normal Indication:** As the Special Function code is entered, 43.1 should appear in the display. This indicates that the Controller responds to keyboard interrupts. After pressing the SPCL key, measurements should proceed as normal.

**If Indication Abnormal:** If the keys have no effect, check the Keyboard interrupt. (See Service Sheet 25.) If the keystrokes produce an erroneous display, check the Keyboard. (See Service Sheet BD5.) If the measurement is improper or error messages appear in the display, consult the error message tables (see *Error Messages* in the *Detailed Operating Instructions* of the *Operation and Calibration Manual*, or see *Error Messages*, paragraph 8-8, or see *Error Codes* in the *Operating Information* pullout card) or consult the block diagram service sheet that documents the section of the instrument that appears to have the fault. (See Service Sheets BD2 through BD5.)

#### NOTE

*For problems that are exclusive to the HP-IB, see Service Sheet BD5.*

## SERVICE SHEET BD2

### Block

- RF

### Principles of Operation

#### General

The RF Block Diagram documents the Power Meter, Power Reference Oscillator, RF Input, IF Amplifier, and Local Oscillator. The diagram also shows a typical Sensor Module connected to the Measuring Receiver's INPUT and SENSOR connectors.

#### Sensor Module

The Measuring Receiver is designed to be used with an external module containing a Power Sensor, RF switch, and interconnecting cable. The Sensor Module permits direct connection of either the Power Sensor or the RF INPUT to the RF source being measured. The direct connection to the Power Sensor minimizes power measurement errors that result from insertion and mismatch losses in interconnecting cables and connectors. The instrument's Controller switches the RF signal between the input to the Power Sensor and the front-panel RF INPUT depending on the measurement being made. This internal switching eliminates the need for manual reconnection and shortens measurement time.

The RF Power Sensing Element in the Power Sensor converts the absorbed RF power to a dc voltage proportional to the average power level. The element may be a thermocouple or a diode. Because the voltage from the RF Power Sensing Element is very small, dc amplifiers, which are subject to drift, are unsuitable for the first stages of amplification. Instead, the voltage is converted to a 220 Hz ac signal by the Chopper and then ac coupled into the AC Amplifier. The AC Amplifier is actually integrated in the first stage of Amplifier 1 in the A53 Power Meter Assembly.

The Power Meter circuitry in the Measuring Receiver is designed to work with a wide variety of power sensors with varying frequency and sensitivity ranges. The power sensors contain a Sensor Identifier Resistor which is unique for each type. The particular sensor is identified by driving the resistor with a known current and measuring the voltage across it. If no Power Sensor is connected, the instrument makes RF level measurements using the RF Peak Detector in the A16 RF Detector Assembly. (Refer to *RF Level, Special Function 35* in the *Detailed Operating Instructions of the Operation and Calibration Manual*.)

#### Power Meter Assembly (A53)

The Power Meter Assembly contains circuitry for amplifying and detecting the small ac signal from the external Power Sensor and for controlling the external input switch and Power Reference Oscillator. AC Amplifiers 1 and 2 and Attenuators 1 and 2 accurately amplify the chopped dc voltage from the external RF Power Sensing Element. (The AC Amplifier in the Power Sensor forms the first stage of Amplifier 1.) The amplifiers have a bandpass response tuned to 220 Hz to minimize noise. Table 8D-3 lists the attenuation for the power meter ranges. (The ranges are not listed in terms of absolute power because the sensitivity of the power sensors varies with type. Also, the attenuation in dB is the voltage attenuation; a step of 20 dB of attenuation corresponds to a 10 dB step in power level.) Special Function 10 controls selection of the attenuators.

**Table 8D-3. Power Meter Attenuator Selection**

Power Meter Range	Attenuator 1 (dB)	Attenuator 2 (dB)
1 (most sensitive)	0	0
2	0	20
3	0	40
4	40	20
5 (least sensitive)	40	40

The amplified ac signal, which is proportional to the input power, is converted to dc by the Synchronous Detector. The Synchronous Detector is a unity-gain amplifier which alternates between a non-inverting configuration and an inverting configuration at a 220 Hz rate. The 220 Hz drive signal is synchronized with the signal that drives the Chopper in the Power Sensor. Since the phase shift between the signal from the Power Sensor Chopper and the input of the Synchronous Detector is zero, the ac signal is full-wave rectified and has a dc component proportional to the output of the RF Power Sensing Element of the Power Sensor. After filtering by the Noise Filters, the dc voltage representing the recovered power level of the input signal is measured by the Voltmeter. The 220 Hz drive signal for the Power Sensor Chopper and for the Synchronous Detector is generated by the 220 Hz Multivibrator.

The Ground Regulator is a unity-gain, non-inverting amplifier which assures minimum voltage difference between the Sensor Ground and the Power Meter Assembly ground. High current flow through the ground return of the interconnecting cable causes the voltage difference, especially if the cable is quite long.

The Zeroing Control Digital-to-Analog Converter (DAC) compensates for the small dc offset voltage generated by the Power Sensing Element when no RF is present. To zero the sensor, the Controller switches the Input Switch of the Sensor Module away from the Power Sensor and measures the output from the Power Meter. If the output does not correspond to 0W power, the Zeroing Control DAC is programmed to inject a current into the RF Power Sensing Element to cancel the offset. (To keep the Synchronous Detector in its most-linear range, the voltage corresponding to 0W input power is offset slightly above 0 Vdc. The offset voltage is subtracted out by the Controller when actual power measurements are made.) The DAC remains set until re-zeroing is requested.

The Sensor Module Switch Control and Switch Drive One-Shot control switching of the Input Switch in the external Sensor Module. The circuitry is designed to drive latching-type RF switches which may or may not have automatic drive disconnect. The Power Reference Oscillator Control switches on the 50 MHz Oscillator when requested. To enable the assembly of a user-built sensor module, the switching voltages are made available at the rear-panel REMOTE CONTROL RF SWITCH connectors.

The rear-panel FREQ OFFSET TTL OUT connector outputs a dc voltage that indicates the state of the Frequency Offset Mode and whether the entered LO frequency is above or below 18 GHz. This feature is useful for controlling external microwave down converters, such as the HP 11793A, whose output is fed to the input of the Measuring Receiver. Special Function 27 controls the Frequency Offset Mode. Table 8D-4 shows the status of the FREQ OFFSET TTL OUT voltage.

**Table 8D-4. Status of FREQ OFFSET TTL OUT Connector**

State of Frequency Offset Mode	Entered LO Frequency (GHz)	Nominal Voltage (Vdc) at FREQ OFFSET TTL OUT
Not Offset	Any	0
Offset	0	0
Offset	$0 < \text{frequency} \leq 18$	+5
Offset	$18 < \text{frequency} \leq 40.7$	+3

## Power Reference Oscillator Assembly (A32)

Since the Power Meter uses an open-loop measurement technique (as opposed to a dc substitution technique), an independent power reference is required to calibrate (that is, determine the sensitivity of) the external Power Sensor. The Power Reference Oscillator produces a 50 MHz RF signal which is set, during calibration of the reference, to deliver 1 mW to a 50 $\Omega$  load. The output of the oscillator is accurately controlled by the Automatic Leveling Control (ALC) Loop. A Level Detector at the output of the oscillator senses the peak RF level. The level is compared to a stable, dc reference by the Level Error Amplifier. The error is amplified and fed back to the level-control circuitry in the oscillator to correct the error.

## RF Input Circuits (A15, A70, AT2, S1, S2, U1, U2)

The RF input circuits, along with the RF Detector Assembly (A16) and the Input Attenuator (AT1), amplify or attenuate the RF input signal to an optimum level for the Input Mixer. The RF input circuits are configured in three basic ways for three types of RF measurements:

- (1) When measuring RF power with an external Power Sensor, the RF input circuits are not used; they remain in their previous state. Instead, the RF signal is routed to the Power Sensor.
- (2) When measuring RF peak level (Special Function 35), the RF Switches (S1 and S2) are set to the through paths and the Input Attenuator (AT1) is set to 50 dB.
- (3) When making any tuned RF measurement (for example, frequency or AM), the RF input signal is routed through the two RF Switches (S1 and S2), the RF Detector Assembly (A16), the Input Attenuator (AT1), and into the Input Mixer Assembly (A17). Normally, the 10 dB Attenuator (AT2) is switched in whenever 10 dB attenuation or more is required. The RF Amplifier (U1) is normally switched in only on the lowest level ranges of the Tuned RF Level measurement mode. (Note that during the initial, high-level calibration in the Tuned RF Level measurement mode, the RF input is switched momentarily to the Power Sensor in the Sensor Module.)

The 10 dB Attenuator is placed immediately after the INPUT connector to maintain a low and constant input SWR even though the devices that follow are switched. Special Function 1 controls the RF attenuation and gain. When making Tuned RF Level measurements, Special Function 1.9 leaves the 10 dB Attenuator in on all ranges, improving the input SWR but sacrificing sensitivity.

The RF Amplifier (U1) improves the sensitivity of the instrument when measuring low-level signals in the Tuned RF Level measurement mode. The amplifier has a 455 kHz notch filter (not shown) to reject noise at 455 kHz which would otherwise pass directly into the IF and add to the down-converted signal being measured. The Limiter (U2) protects the RF Amplifier in the event of an input overload. Further protection is provided by the RF Amplifier itself. Overloads cause the bias of the amplifier to shift enough to be sensed by the RF Amplifier Overpower Detector. When an overload is sensed, the Overpower Latch trips and sets RF Switch S2 to the through path.

The two RF Switches are controlled via the Switch Drivers of the A15 RF Input Control Assembly. The AT1 Input Attenuator and AT2 10 dB Attenuator are also controlled by the Switch Drivers. The Attenuator Decoding switches in AT2 whenever 10 dB or more attenuation is requested by the Controller. (Exceptions are for Special Functions 1.9 and 35.)

The Overpower Latch switches out the RF Amplifier when an overload occurs and outputs the status of the RF Amplifier to inform the Controller that the amplifier has been switched out (presumably due to an overload condition).

CAUTION

*The overload protection for the RF Amplifier offers only limited protection. The protection is somewhat less than that provided for the A16 RF Detector Assembly. Be careful not to overdrive the input when measuring tuned RF level. Signal levels should remain below 0 dBm when the RF Amplifier is in use.*

### RF Detector Assembly (A16)

The RF level is sensed by the RF Peak Detector. The output of the detector is buffered by the Detector Amplifier and Detector Output Amplifier and then sent to the Voltmeter. The Controller uses data from the RF Peak Detector when automatically setting the Input Attenuator (AT1) and the 10 dB Attenuator (AT2), and when making a Peak RF Level measurement. (Refer to Special Function 35 in the *Detailed Operating Instructions of the Operation and Calibration Manual*.) The Detector Output Amplifier sensitivity is increased when the 10 dB Attenuator (AT2) is switched in. (When Special Function 35 is used, the 10 dB Attenuator (AT2) is not switched in and the Input Attenuator (AT1) is set to 50 dB.)

The Detector On/Off Switch shuts off the RF Peak Detector when not needed to prevent the slight clipping of the RF signal which can occur at high signal levels. The trip voltage of this switch is reduced when the 10 dB Attenuator is in. An overpower condition at the input will override the Detector On/Off Switch.

The Overpower Detector compares the detected RF level with a reference. If the peak RF level (including AM envelope peaks) exceeds 1W, the Overpower Protection relay is opened (de-activated) and latched. Pressing any key will reset the relay. The Detector Attenuator reduces the detected voltage when the 10 dB Attenuator (AT2) is not in.

Note that the Overpower Output/Detector Control line is bidirectional. It is an input line that both controls the Detector On/Off Switch and momentarily discharges the Detector Amplifier before a measurement is taken from the detector. Discharging the amplifier assures an up-to-the-moment reading of peak RF level should the level have decreased just prior to the measurement.

If the instrument is tuned to a frequency greater than 10 MHz, the 5.25 MHz High-Pass Filter can be switched in to eliminate low-frequency signals on the input (which can pass directly into the IF). Special Function 3 controls the selection of the 5.25 MHz High-Pass Filter (as well as the IF filter).

### Input Attenuator (AT1)

The Input Attenuator has a range of 0 to 70 dB in 10 dB steps. The three individual pads are each switched in by a solenoid. When thrown, the switches latch and disconnect the drive current to the solenoids. Special Function 1 controls the attenuation of the Input Attenuator.

### Input Mixer Assembly (A17)

The Input Mixer Assembly converts the RF input signal to the IF. Part of the IF filtering is included in this assembly. In the automatic tuning mode, the Local Oscillator (LO) is tuned so that the LO frequency minus the signal frequency equals the IF. Using manual tuning, it is also possible to tune the LO so that the IF responds to the image; that is, when the signal frequency minus LO frequency equals the IF. In this case, the phase of the FM and  $\Phi$ M is inverted.

The Input Mixer has two modes of operation. (1) For input signals in the range 2.5 to 1300 MHz, the Input Mixer down converts the input signal to the 1.5 MHz or the 455 kHz IF. (2) For signals below 2.5 MHz, the Input Mixer passes the signal directly into the IF. (Down conversion can be extended below 2.5 MHz using the 455 kHz IF and manual tuning.) The normal operating signal level is less than -16 dBm for AM and -6 dBm for FM and  $\Phi$ M.

The LO signal for the Input Mixer comes from the LO Dividers through the LO Amplifier.

***(The next two paragraphs apply to 2305A to 2530A.)***

The IF frequency response for most measurements is determined by the IF Filters and the IF amplifier in the A18 IF Amplifier Assembly. The 455 kHz Wide Bandpass Filter in the A17 Input Mixer Assembly determines the response of the 455 kHz IF except in the case of the Tuned RF Level measurement. The 455 kHz Wide Bandpass Filter is switched in automatically for input signals in the range of 2.5 to 10 MHz. (In tuned RF level, the much-narrower 455 kHz Narrow Bandpass Filter in the A55 IF Amplifier/Filter Assembly determines the frequency response.) When the 455 kHz IF is chosen, the 455 KHZ IF annunciator lights.

Automatic IF filter selection provides the optimum IF frequency and IF filter selection for each measurement mode. The frequency response of the IF filter is determined by the RF input blocking capacitors (not shown), the 4 MHz Low-Pass Filter, and (principally) the 2.5 MHz Low-Pass Filter in the A6 AM Demodulator Assembly (in Service Sheet BD3). Special Function 3 controls the IF frequency selection (as well as the 5.25 MHz High-Pass Filter in the RF Input Assembly).

***(The next three paragraphs apply to 2535A and above.)***

The IF frequency response for most measurements is determined by the IF filters and the IF amplifiers here and in the A18 IF Amplifier Assembly. The 455 kHz Wide Bandpass Filter in the A17 Input Mixer Assembly determines the response of the 455 kHz IF except in the case of the Tuned RF Level and the Selective Power measurements. The 455 kHz Wide Bandpass Filter is switched in automatically for input signals in the range of 2.5 to 10 MHz. (In tuned RF level, the much-narrower 455 kHz Narrow Bandpass Filter in the A55 IF Amplifier/Filter Assembly determines the frequency response. In the Selective Power measurement mode, the narrower channel filters in the A72 Channel Filter and A71 IF Amplifier/Detector Assemblies determine the frequency response.) When the 455 kHz IF is chosen, the 455 KHZ IF annunciator lights.

Automatic IF filter selection provides the optimum IF frequency and IF filter selection for each measurement mode. The frequency response of the IF filter is determined by the RF input blocking capacitors (not shown), 4 MHz Low-Pass Filters 1 and 2, and (principally) the 2.5 MHz Low-Pass Filter in the A6 AM Demodulator Assembly (in Service Sheet BD3). Special Function 3 controls the IF frequency selection (as well as the 5.25 MHz High-Pass Filter in the RF Input Assembly).

The First and Second IF Amplifiers function as buffers and provide the same IF gain for the assembly as in older instrument configurations.

## **IF Amplifier Assembly (A18)**

The IF Amplifier increases the signal from the Input Mixer Assembly to a level suitable to drive the AM and FM Demodulators. The IF strip is designed for low noise, linear phase shift vs. frequency (that is, constant group delay) to minimize FM distortion, and for flat frequency response to minimize incidental AM (that is, AM occurring as the result of FM).

## **Local Oscillator**

The Local Oscillator consists of the LO Divider Assembly (A19), LO Control Assembly (A20), Low Frequency VCXO Filter Assembly (A21), Low Frequency VCXO Assembly (A22), Sampler Assembly (A23), and High Frequency VCO Assembly (A24). The overall operation and different tuning modes of the LO are described in the *Principles of Operation* for Service Sheet BD1.

## **High Frequency VCO Assembly (A24)**

The High-Frequency, Voltage-Controlled Oscillator (HF VCO) has a nominal frequency range of 320 to 650 MHz. The output is buffered by two Output Buffer Amplifiers. One output drives the LO Divider, the other drives the Sampler. The tune input to the HF VCO has a switchable lead-lag network (Tune Voltage Filter) to reduce phase noise. The network is switched out while the LO is tuning and is switched in when tuned.



## LO Divider Assembly (A19)

The signal from the HF VCO, after passing through the LO Divider Assembly, is the LO drive to the Input Mixer. The LO Divider Assembly has one Doubler stage (640 to 1300 MHz LO range), one through path (320 to 640 MHz range), and eight LO Dividers (1.25 to 325 MHz ranges). Each divider is a high-speed, divide-by-two device. The Divider Output Gates enable and cascade the appropriate dividers for the range selected. The first three dividers are always enabled. The 40 to 81.25 MHz output of the third divider is the LO (HF VCO÷8) input to the Counter.

To prevent mistuning on the doubler range (which can result from spurious LO signals) the input to the Doubler is filtered by a tunable, Doubler Input Filter. The filter primarily suppresses the third harmonic of the HF VCO which becomes the  $\frac{3}{2}$  harmonic of the doubled signal. The Doubler High-Pass Filter following the Doubler suppresses feedthrough of the fundamental frequency (the  $\frac{1}{2}$  harmonic).

## Low Frequency VCXO and Filter Assemblies (A22 and A21)

The Low-Frequency, Voltage-Controlled, Crystal Oscillator (VCXO) is a highly stable, tunable, reference oscillator to which the HF VCO is locked in the low-noise tune modes. It consists of two tunable crystal oscillators (nominally 9.26 and 11.26 MHz) mixed together to produce a 2 MHz output. The two oscillators can each be tuned approximately 6.25 kHz in opposition for a total tuning range of 2 MHz  $\pm$ 6.25 kHz. This tuning scheme allows a broad tuning range while retaining the high stability of the individual oscillators. The 2 MHz Low-Pass Filter and 2 MHz Bandpass Filter (A21) reject unwanted mixing products which appear as spurious AM and FM residual tones. Careful selection of the crystal frequencies minimizes the output of spurious mixing products.

## Sampler Assembly (A23)

The Sampler is the phase detector of the phase lock loop. The tunable 2 MHz signal from the LF VCXO (A21) drives the Sampling Bridge through the 2 MHz Limiter and Impulse Generator. The output of the impulse generator is a train of extremely short-duration pulses with the repetition rate of the 2 MHz signal. The two pulses momentarily turn on the diodes (that is, close the switch) of the Sampling Bridge and pass the signal from the HF VCO (A24). The output from the Sampling Bridge is thus the HF VCO sampled at a 2 MHz rate. If the two signals are harmonically coherent, the output is a dc voltage with a level determined by the phase and amplitude of the HF VCO. The action of the phase lock loop tunes the HF VCO to drive the voltage to zero. If the relationship is not strictly harmonic (that is, phase lock is broken), the output is a beat note with a frequency equal to the difference between the HF VCO and the nearest harmonic of the LF VCXO. The output of the Sampling Bridge, which is the phase error voltage, is smoothed and buffered by the Sampler Amplifier.

The tune voltage for the HF VCO is supplied by the HF VCO Tune Integrator and Amplifier. The tune integrator has several sources of input: the Sampler Amplifier, the Track Loop Amplifier, the Sweep Up Current Source, the Sweep Down Current Source, and the DAC Control Amplifier. Only one input is active at a time. If one of the sweep current sources is active, the tune integrator sweeps the HF VCO. If the input is one of the amplifier outputs, the HF VCO Tune Integrator and Amplifier is configured as part of a feedback loop.

The grounding switch at the input of the HF VCO Tune Integrator and Amplifier is open only when the Sampler Amplifier is connected to its input. When the amplifier is not connected, the switch is closed to keep signals at the Sampler Amplifier output from coupling into the tune integrator. The Out-of-Lock Detector at the Sampler Amplifier output senses the presence of ripple and lights the OUT OF LOCK annunciator to indicate lock has broken. A BW Control line also lights the annunciator when the Tune Voltage Filter (in the HF VCO Assembly) has not been turned on. This line also controls the bandwidth of the HF VCO Tune Integrator and Amplifier. The bandwidth is narrowed in the low-noise phase lock and the track modes (that is, whenever the instrument is properly tuned).

The No-HF-VCO Detector lights the NO HF VCO annunciator if the amplitude of the signal from the HF VCO is too low. The 700 MHz Low-Pass Filter in the Sampling Bridge input line filters out harmonics of the HF VCO to assure proper sampler gain.

## LO Control Assembly (A20)

The LO Control Assembly contains the digital decoders and latches for the entire RF Section (that is, the section housing assemblies A15 through A24) and the low-frequency analog circuits that control and tune the LO.

The Digital-to-Analog Converters (DACs) drive either the LF VCXO (through the LF VCXO Tune Amplifier) or the HF VCO (through the DAC Control Amplifier and HF VCO Tune Integrator and Amplifier). The DAC outputs a current proportional to the weighting of the bits of its digital input. The amplifiers following the DAC convert the current into a tune voltage.

The LF VCXO Tune Filter filters the tune line of the LF VCXO to reduce phase noise in the low-noise phase lock mode. The filtering is necessary because the tune-line input is external to the phase lock loop.

The Sweep Down Current Source sweeps the HF VCO when the Controller searches for the input signal. The Sweep Up Current Source is the retrace for the sweep.

The Track Loop Amplifier is used only in the track tune modes. Its input is the dc output from the FM Demodulator which is proportional to the IF center frequency. If the input signal changes frequency, the HF VCO is tuned via the Track Loop Amplifier and HF VCO Tune Integrator and Amplifier (in A23) to keep the IF at a nominal 1.5 MHz. (Track tuning is not permitted with the 455 kHz IF (**2305A to 2530A**)). Thus the track mode is the only tuning mode where the LO "locks" to the input signal (that is, a frequency lock loop is formed). The Track Loop Amplifier has a different gain for each LO range. This compensates for the change in LO tuning sensitivity caused by the LO Dividers.

## Troubleshooting

### General

Procedures for checking the RF Section of the instrument are given below. The blocks or points to check are marked on the block diagram by a hexagon with a check mark and a number inside, for example,  $\checkmark 3$ . Before performing any check, perform all the checks on Service Sheet BD1.

**CAUTION**

*Tighten SMA connectors to 0.8 to 1.1 N·m (7 to 10 in·lb). Tighten SMC connectors to 0.6 N·m (5 in·lb). Hand tightening of connectors is insufficient. Hand-tightened connectors can work loose and cause reduced performance or malfunctions.*

### Equipment

Oscilloscope .....	HP 1740A
Power Supply .....	HP 6215A
Signal Generator .....	HP 8640B
Spectrum Analyzer .....	HP 8559A/182T
Voltmeter .....	HP 3455A

### $\checkmark 1$ Front End Check

1. Set the signal generator to 11 MHz CW at -30 dBm. Connect its RF output to the input of an ac coupled oscilloscope.
2. Switch the input impedance of the oscilloscope to 50Ω or terminate the input in 50Ω using a tee. Set the oscilloscope to observe the RF input waveform. Adjust the vertical sensitivity for a waveform amplitude of 4 divisions peak-to-peak.
3. Connect the oscilloscope's input to the end of W8 where it connects to A16J1 (RF IN) on the A16 RF Detector Assembly. Connect the signal generator's output to the Measuring Receiver's INPUT.
4. Press the blue key, then press INSTR PRESET (the AUTOMATIC OPERATION key) to preset the instrument. Key in the special functions listed in Table 8D-5. For each setting, the waveform amplitude should be within the limits indicated. If out of limits, see Service Sheet 4 and check the RF Switches, 10 dB Attenuator, the Limiter and RF Amplifier, and the Amplifier/Switch Interconnect Assembly.

*Hint:* If faulty, also check the status of the PAD and AMP annunciators on the Amplifier/Switch Interconnect Assembly.

**Table 8D-5. Levels at W8,  $\checkmark 1$  Step 4**

Special Function	Gain (dB)	Oscilloscope Display Limits (div pk-pk)		Annunciator Status	
		Minimum	Maximum	PAD	AMP
1.1	0	3.9	4.1	Off	Off
1.2	-10	1.2	1.4	On	Off
1.7*	+24	5.7	7.0	Off	On
1.8*	+14	1.8	2.2	On	On

\* Reduce the oscilloscope's vertical gain by 10.

5. Key in 1.7 SPCL. Slowly increase the signal generator's level to +3 dBm and observe the AMP annunciator. The AMP annunciator should remain on until the signal generator level is between

-1 and +1 dBm. If faulty, see Service Sheet 4 and check the RF Amplifier and the RF Amplifier Overpower Detector.

6. Reduce the signal generator level.

**√2 Input Attenuator and 5.25 MHz High-Pass Filter Check**

1. Set the signal generator to 5.25 MHz CW at -33 dBm. Connect its RF output to the input of an ac coupled oscilloscope.
2. Switch the input impedance of the oscilloscope to 50Ω or terminate the input in 50Ω using a tee. Set the oscilloscope to observe the RF input waveform. Adjust the signal generator's level for a waveform of 15 mVpp.
3. Connect the oscilloscope's input to AT1J2 (RF OUT) on the Measuring Receiver. Connect the signal generator's output to A16J1 (RF IN).
4. Press the blue key, then press INSTR PRESET (the AUTOMATIC OPERATION key) to preset the instrument. Key in the Special Functions listed in Table 8D-6 to set the input attenuation. (Special Function 35.0 is used to set the input attenuation to 50 dB.) Also set the signal generator level in 10 dB steps as listed. For each setting, the 5.25 MHz signal should appear within the limits indicated. If out of limits, see Service Sheet 4 and check the Input Attenuator.

**Table 8D-6. Levels at AT1J2, √2 Step 4**

Special Function	Attenuation (dB)	Signal Generator Level (dBm)	Oscilloscope Display Limits (mVpp)	
			Minimum	Maximum
1.1	0	-33	13	17
1.3	10	-23	13	17
1.4	20	-13	13	17
1.5	30	-3	13	17
1.6	40	+7	13	17
35.0	50	+17	13	17

5. Key in 3.4 SPCL to insert the 5.25 MHz High-Pass Filter. The signal on the oscilloscope display should drop to between 8 and 12 mVpp. If out of limits, see Service Sheet 4 and check the High-Pass Filter.

**√3 Overpower Protection Check**

1. Press the blue key, then press INSTR PRESET (the AUTOMATIC OPERATION key) to preset the instrument.
2. Set the power supply to 20 Vdc. Touch the +20V lead to the Measuring Receiver's INPUT (the minus side should be at ground). The display should show Error 06. If faulty, see Service Sheet 4 and check the Overpower Protection.

**NOTE**

*If step 2 is repeated, it is necessary to first perform step 3 in order to discharge the input dc blocking capacitor. Also, disconnect the supply from the INPUT before setting the voltage to 20 Vdc.*

3. Set the supply to zero (without turning it off) and while still connected to the INPUT, press CLEAR. Error 06 should go away. If it doesn't, see Service Sheet 4 and check the Overpower Protection.

### √4 RF Detector Check

1. Press the blue key, then press INSTR PRESET (the AUTOMATIC OPERATION key) to preset the instrument. Connect the CALIBRATION RF POWER OUTPUT to A16J1 (RF IN).
2. Key in 45.16 SPCL to turn on the RF power calibrator. Key in 35.0 SPCL to measure RF level with the RF peak level. The display should read between 0.6 and 1.6 mW. If faulty, see Service Sheet 4 and check detector circuits.
3. Key in 49.3 SPCL to read the voltage from the RF peak detector. Note the voltage reading.

Voltmeter Reading \_\_\_\_\_ Vdc

4. Key in FREQ, 1.6 SPCL, 0.024 SPCL, and 49.3 SPCL to read the RF peak detector on its most sensitive range. The display should read between 2.5 and 3.8 times the level noted in step 3. If faulty, see Service Sheet 4 and check the detector circuits.

### √5 Local Oscillator Tuning Check

1. Key in 54.0 SPCL. If the display shows other than 0, see *Special Function 54.N*, paragraph 8-7.

### √6 Local Oscillator Level Check

1. Set RF spectrum analyzer to measure a 0 dBm, 0 to 1400 MHz signal. Connect its input to the end of the cable connected to A17J3 (LO IN).
2. Key in 57.0 SPCL to cause the LO to sweep sequentially across bands DBLR through 3. The LO signal should sweep slowly from above 1300 to below 40 MHz. The sweep will occur over five bands. As the low end of a band is reached, the sweep will stop, jump up slightly in frequency, then continue to sweep. Throughout the sweep, the LO should maintain an amplitude of at least 0 dBm. If it does not, see Service Sheet 17 and check the dividers and gates associated with the bad band.

#### NOTE

*The sweep can be halted by pressing the SPCL key. If the power level is marginal at a particular frequency, halt the sweep at the frequency and make a more precise measurement with a power meter.*

3. Set the spectrum analyzer to view a 0 to 40 MHz signal.
4. Key in 56.0 SPCL to cause the LO to sweep sequentially across bands 4 through 8. The LO signal should sweep slowly from above 40 to below 1.25 MHz in the manner described in step 2 above. If the amplitude is not at least 0 dBm, see Service Sheet 17 and check the dividers and gates associated with the bad band.

#### NOTE

*The low-frequency bands can also be viewed on an oscilloscope. The oscilloscope should have a 50Ω termination. The signal should be a squarewave with an amplitude of 0.5 Vpp or greater.*

## √7 Track Mode Check

### NOTE

*This check assumes that √5 Local Oscillator Tuning Check and √6 Local Oscillator Level Check give positive results, but that track-mode tuning is suspected to be faulty.*

1. Set signal generator to approximately 20 MHz CW at 0 dBm. Connect its RF output to the Measuring Receiver's INPUT.
2. Connect high-impedance, dc coupled oscilloscope to the rear-panel FM OUTPUT.
3. Press the blue key, then press INSTR PRESET (the AUTOMATIC OPERATION key) to preset the instrument. After the Measuring Receiver is tuned, press MHz, then S (Shift) FREQ ERROR. The oscilloscope should show -1 to +1 Vdc. If it does not, see Service Sheet 11 and begin by checking the Charge-Count Discriminator.
4. Adjust the oscilloscope to vertically center the trace. Adjust the signal generator's frequency until the displayed frequency error is 500 kHz. The oscilloscope display should move down to between -3.2 and -2.8V. If faulty, see Service Sheet 11 and check the Charge-Count Discriminator.
5. Adjust the signal generator's frequency until the displayed frequency error is -500 kHz. The oscilloscope display should move up to between 2.8 to 3.2V. If faulty, see Service Sheet 11 and check the Charge-Count Discriminator.
6. Adjust the signal generator's frequency until the displayed frequency error is 0.0 kHz. Key in 3.1 SPCL to set the IF to 455 kHz. The oscilloscope display should move down to between -8 to -6V. If faulty, see Service Sheet 11 and check the Charge-Count Discriminator. If not faulty, see Service Sheet 20 and check the Track Loop Amplifier.

## √8 Input Mixer and IF Check

### NOTE

*This check assumes that √5 Local Oscillator Tuning Check and √6 Local Oscillator Level Check give positive results.*

1. Set signal generator to approximately 20 MHz CW at 0 dBm. Connect its RF output to the Measuring Receiver's INPUT.
2. Connect an ac coupled oscilloscope to rear-panel IF OUTPUT. Switch the input impedance of the oscilloscope to 50Ω or terminate the input in 50Ω using a tee.
3. Press the blue key, then press INSTR PRESET (the AUTOMATIC OPERATION key) to preset the instrument. Key in 1.3 SPCL to set the attenuation range to 20 dB. The waveform should be a sinewave 80 to 126 mVpp with a period of between 645 and 690 ns (that is, nominally 1.5 MHz). If faulty, see Service Sheets BD3, 5, and check the Input Mixer, IF Filters, IF Amplifiers, and FM IF Buffer.
4. Key in 3.1 SPCL to set the IF to 455 kHz. The waveform should be a sine wave 67 to 106 mVpp with a period of 2.19 to 2.21 μs (that is, nominally 455 kHz). If faulty, see Service Sheet 5 and check the 455 kHz Wide Bandpass Filter (**2305A to 2530A**) and in addition the First and Second IF Amplifiers (**2535A and Above**).

**√9 Power Meter Check**

1. Perform *Performance Test 8—Power Meter* in Section 4. If the *Zero Set* test fails, see Service Sheet 2 and check the *Zeroing DAC*. If the *Range-to-Range Error* test fails, see Service Sheets 1 and 2 and check the *Attenuators, Amplifiers, Synchronous Detector, and Noise Filter*. If the *Accuracy within a Range* test fails, see Service Sheet 1 and check the *Synchronous Detector*.

**√10 Power Reference Oscillator Check**

1. Perform *Performance Test 6 or 7—Power Reference* in Section 4. (Either of the two procedures can be followed.) If faulty, see Service Sheet 3.

**√11 Sensor Module Switch Control Check**

1. With no power sensor or sensor module connected to the *SENSOR* connector, connect a high-impedance, dc coupled oscilloscope to pin A of the *SENSOR* connector. (See Service Sheet 1 for the location of pin A.)
2. Set the oscilloscope sweep to 20 ms per division and vertical sensitivity to 10V per division.
3. Alternately press *RF POWER* and *FREQ*. Each time a new key is pressed, the signal on the oscilloscope display should drop to  $-15\text{V}$  for approximately 30 ms, then return to 0V. If faulty, see Service Sheet 2 and check the *Sensor Module Switch Control*.
4. Connect an ohmmeter to pin B of the *SENSOR* connector. Press *FREQ*, then press *RF POWER*. The resistance should be less than  $5\Omega$  for each setting. If faulty, see Service Sheet 2 and check the *Sensor Module Switch Control*.

## SERVICE SHEET BD3

### Block

- IF

### Principles of Operation

#### General

The IF Block Diagram documents the circuits that further amplify, filter, level detect, and demodulate the IF signal. The diagram also documents the AM and FM calibrators.

#### IF Amplifier/Filter Assembly (A55)

When the instrument is in the Tuned RF Level measurement mode, the amplifiers and attenuators in the A55 IF Amplifier/Filter Assembly provide highly accurate 10 dB steps of gain over a 60 dB range. The maximum overall gain of the three amplifier stages is fixed at approximately 60 dB. Attenuators 1, 2, and 3 are programed as indicated in Table 8D-7. Normally, gain stepping is used only in the Tuned RF Level measurement mode. For other tuned measurements (such as AM, FM, or frequency), the IF gain is held constant at its minimum of 0 dB (60 dB of gain minus 60 dB of attenuation). Special Function 9 controls the IF gain.

*Table 8D-7. IF Attenuator Selection (Attenuation and Gain in dB)*

Atten 1	Atten 2	Atten 3	Total Attenuation	Overall Gain
20	20	20	60	0
20	20	10	50	10
0	20	20	40	20
0	20	10	30	30
0	0	20	20	40
0	0	10	10	50
0	0	0	0	60

In the Tuned RF Level measurement mode, the frequency response for the 455 kHz IF is determined primarily by the 455 kHz Narrow Bandpass Filter. When this filter is not used, the IF signal bypasses the filter and is routed through a 6 dB attenuator (which matches the filter's passband insertion loss). Special Function 3 controls the IF frequency and bandpass selection.

The Programmable IF Gain Buffer is normally set for a gain of 6 dB. In the Tuned RF Level measurement mode, the gain of this amplifier is momentarily increased to maximize the sensitivity of the IF Synchronous Detector while the detector's VCO is swept in search of an IF signal.

#### IF Synchronous Detector Assembly (A54)

The IF Synchronous Detector, which is used in the Tuned RF Level measurement mode, enables the Measuring Receiver to measure the amplitude of extremely low-level signals.

Because low signal levels are typically being measured, the IF Synchronous Detector is designed to automatically lock to the 455 kHz IF signal and track it. The IF signal is fed into a Synchronous Detector. At the same time, in the Phase Detector, the signal from a Voltage Controlled Oscillator (VCO) is locked to the IF signal. (The VCO functions as an interpolation oscillator.) The Synchronous Detector mixes the low-level IF signal with the high-level VCO signal which has been synchronized with the IF signal. The 90° phase shift between the VCO drive signals to the two detectors causes the output of the Synchronous Detector (after low-pass filtering) to be a dc voltage proportional to the



average level of the input signal. Because the noise bandwidth of the loop is narrow (approximately 200 Hz), the measurement is relatively undisturbed by the presence of random noise. Amplitude noise is reduced by filtering on the dc output (see the Voltmeter on Service Sheet BD4). Phase noise is reduced by the Integrator in the VCO tune line of the phase lock loop.

The waveforms of Figure 8D-6 will help visualize the action of the IF Synchronous Detector. The first figure shows the detector when phase locked. In order to work properly, the two VCO signals driving the high-level inputs of the Phase Detector and Synchronous Detector must be in quadrature (that is, 90° out of phase) with each other. This phase relationship is obtained by shifting the phase of the VCO signal driving the Phase Detector by +45° and the phase of the VCO driving the Synchronous Detector by -45°. The drive signals to the two high-level ports of the detectors should be considered as switching functions which chop the input signal, rather than as drive voltages.

When the loop is locked, the dc value of the output of the Phase Detector is 0V. If either the IF signal or the VCO drifts, a dc voltage (which represents the phase difference of the two signals) is developed. (See the second set of waveforms.) The Integrator amplifies and filters the phase error voltage and tunes the VCO to correct the error.

When the loop is locked, the Synchronous Detector fullwave rectifies the input signal. The dc level of this signal (obtained by low-pass filtering) is proportional to the average level of the IF signal. Note that if the loop is not locked, as when the IF or LO frequency drifts out of range, the level of the output of the Synchronous Detector drifts back and forth and forms a beat frequency signal.

Total loss of IF signal is sensed by comparing the Synchronous Detector's output to a reference with the Out-of-Lock-Detector. Loss of VCO signal is sensed by the No-VCO Detector. Either condition causes the OUT OF LOCK annunciator to light. The Controller reads the LOCK STATUS line to determine whether the IF Synchronous Detector is locked. The Controller can also determine the VCO frequency by counting it via the Counter Buffer.

Whenever a loss of IF signal is sensed, the Controller enables the Pretune circuit to set the VCO to 457 kHz, then manipulates the Sweep Control logic (containing fast and slow, up and down sweep current sources) to sweep the VCO in an effort to find an IF input signal. When an IF signal within the capture range is found (by noting the presence of a dc output from the IF Synchronous Detector), the sweep routine is stopped. The capture range is about ±10 kHz.

## Channel Filter Assembly (A72, Option Series 030)

The A72 Channel Filter Assembly and A71 IF Amplifier/Detector Assembly are used only in the Selective Power measurement mode. The assemblies are installed only in Option Series 030 (the Selective Power Option) (**2535A and above only**) as defined in Table 8D-1. The Adjacent-Channel Power measurement is controlled by Special Function 24.

The 455 kHz IF signal is routed through an IF Step-Up Transformer to one of two channel filter paths. The channel filter path is determined by Special Function 24: First Channel 1 Filter (the "wide" filter) is selected by Special Functions 24.1 and 24.2; First Channel 2 Filter (the "narrow" filter) is selected by Special Functions 24.3, 24.4, 24.5, and 24.6. Four filters are available (specified by the option number) and two filter options must be chosen. Of the two filter options, the wider-bandwidth filter becomes First Channel 1 Filter; the narrower-bandwidth filter becomes First Channel 2 Filter. (Again, refer to Table 8D-1.) The total IF measurement bandwidth is the series combination of the First Channel Filters and the Second Channel Filters in the A71 IF Amplifier/Detector Assembly.

Each channel has an input channel buffer (0 dB gain) and an output channel amplifier (6 dB gain). The channel output has a selectable gain of 0 or 20 dB (the Channel Output Attenuator followed by the Channel Output Amplifier).

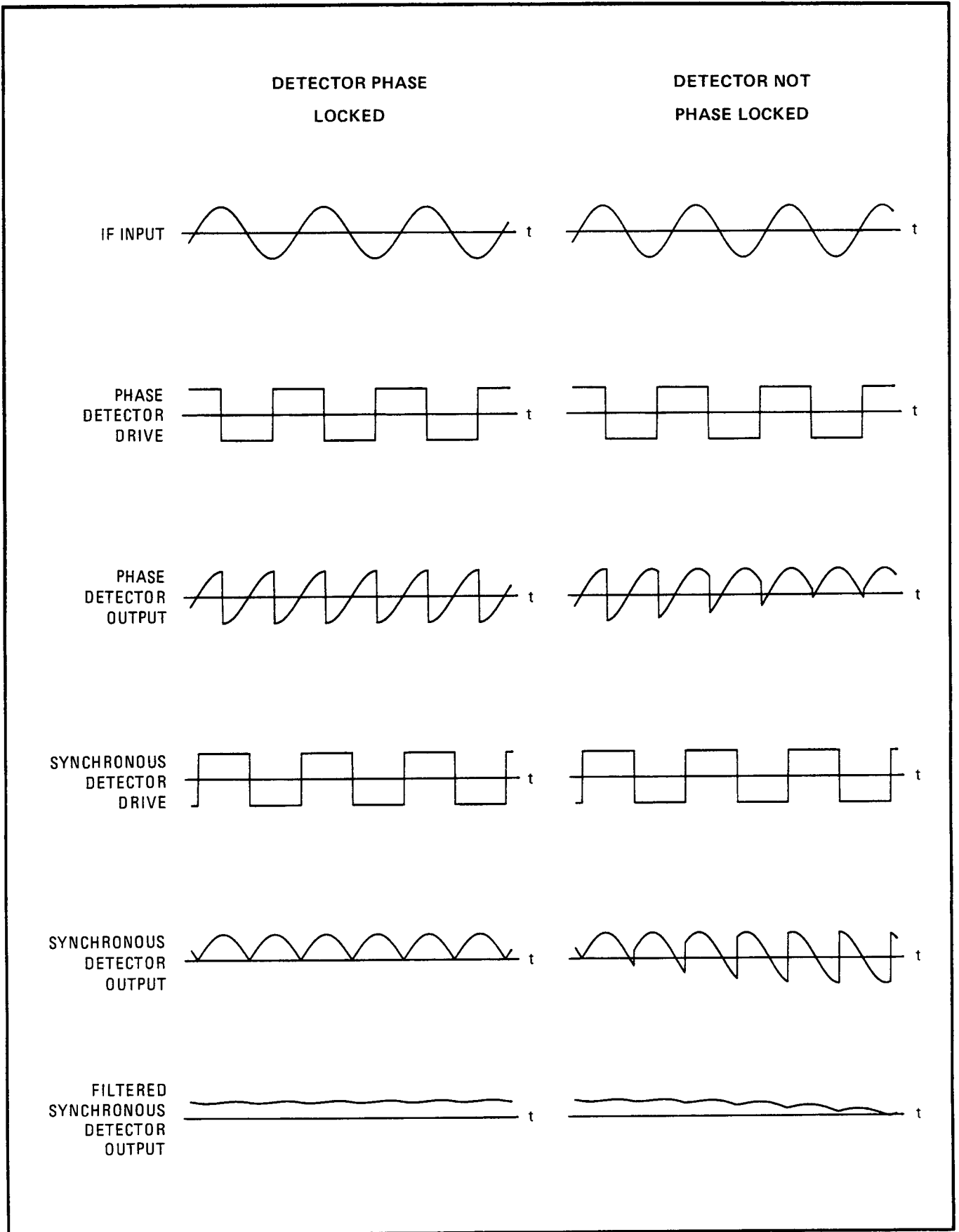

**Figure 8D-6.** IF Synchronous Detector Waveforms

## IF Amplifier/Detector Assembly (A71, Option Series 030)

The 455 kHz IF signal from the A72 Channel Filter Assembly is further amplified and filtered by the A71 IF Amplifier/Detector Assembly, which also converts the IF level to a dc voltage which is then measured by the Voltmeter.

The IF gain is determined by the combination of selectable Attenuators 1 through 4 and fixed-gain Amplifiers 1 through 3. Attenuators 1 through 3 have 0 and 20 dB steps. Attenuator 4 has 5 dB steps from 0 to 15 dB.

The Second Channel 1 Filter is always a 33 kHz wide bandpass filter. It is selected by Special Functions 24.1, 24.2, 24.3, or 24.4. The Second Channel 2 Filter is always a 2.5 kHz wide bandpass filter and has the same nominal bandwidth as the Option 037 filter in the A72 Channel Filter Assembly. It is selected by Special Function 24.5 or 24.6 for SSB noise measurements. The Channel Output Amplifier has 33 dB gain. The IF RMS Detector converts the 455 kHz level to its dc rms level equivalent.

## AM Demodulator Assembly (A6)

The down-converted signal from the IF Amplifier is filtered by a 2.5 MHz Low-Pass Filter. The AM IF Buffer drives the AM Demodulator. The FM IF Buffer drives the FM Demodulator and rear-panel IF OUTPUT connector.

The AM is demodulated by means of a precision, half-wave rectifier in an automatic level control (ALC) circuit. The buffered IF signal is amplified by a Current-Variable Amplifier then rectified (detected) by the AM and IF Average Level Detector. The detected signal, after carrier filtering, represents the carrier level (dc component) plus AM (ac component). The ac component accurately represents the AM only if the dc component is known or set to a known level. The detected signal is filtered and amplified by the Level Amplifier and Carrier Filter. The signal is then compared to a constant ALC Reference by the BW Control and Level Comparison Amplifier. The output of this amplifier is the carrier level error. The error voltage is amplified by the Resistor Drive Amplifier which sets the current input to the Current-Variable Amplifier. Current-variable resistors in the amplifier adjust the amplifier gain to cause the dc component of the carrier to equal the ALC Reference.

The amount of filtering in the Bandwidth Control and Level Comparison Amplifier determines the minimum AM rate which can be accurately demodulated. An ALC Bandwidth Control line sets the ALC loop for a fast or slow response. The feedback loop may also be defeated by the ALC Defeat line. Special Function 6 controls the ALC loop.

The second output of the AM and IF Average Level Detector is buffered by the AM Output Buffer. One output of the buffer is fed to the rear-panel AM OUTPUT connector. The other output is fed to the audio circuits for filtering and audio processing.

The output of the FM IF Buffer is detected by two detectors. The IF Peak Detector output is read by the Voltmeter. It is used in the automatic tuning routine and for making Tuned RF Level measurements using the IF Peak Detector. (Refer to the *Peak Tuned RF Level* detailed operating instruction in the *Operation and Calibration Manual*, Special Function 36. This measurement should not be confused with the two much more accurate and sensitive Tuned RF Level measurements initiated by the TUNED RF LEVEL key or Special Function 4 explained in the next paragraph.) The IF Present Detector is used to stop the LO sweep during a signal search (independent of the Controller).

The Voltmeter also receives IF level information from the output of the Level Amplifier and Carrier Filter. The IF level is measured after completion of tuning to confirm that the AM ALC loop is operating within range. The IF level is also measured for two other IF level measurements: IF Level and Average Tuned RF Level.

The IF Level measurement mode (invoked by pressing the S (shift) and IF LEVEL keys) compares the level from the Level Amplifier and Carrier Filter with the ALC reference and displays the ratio of the two (normally 100% unless the IF signal is too low or Special Function 6.2 is used). The Average Tuned RF Level measurement mode (invoked by Special Function 4) is similar to Tuned RF Level except that the IF level is measured by the Level Amplifier and Carrier Filter (with ALC off) instead

of the IF Synchronous Detector. The initial calibration and recalibration are the same as for the Tuned RF Level measurement mode.

The voltage from the Resistor Drive Amplifier is an indication of the ALC current driving the input resistor circuit. It is used for setting the AT1 Step Attenuator and AT2 10 dB Attenuator (see Service Sheet BD2) when the ALC is on. (When the ALC is off, the Input Attenuator is set using the IF Peak Detector for FM or the level read on the IF AVG Level line for AM.)

### FM Demodulator (A4)

The signal from the FM IF Buffer drives the FM IF Limiters. The limiters strip AM and noise off the IF to minimize demodulation of AM by the FM Demodulator (called incidental FM). The three stages each have 22 dB of gain. The output of the limiters is a squarewave which drives a Precision Limiter. This limiter clamps the upper and lower levels of the squarewave to highly-stable references required by the Charge-Count Discriminator. For each cycle of the IF signal, the discriminator passes a fixed quantity of charge through the feedback resistor of an amplifier. The voltage developed at the amplifier's output is proportional to the amount of charge delivered per unit of time. Fluctuations in IF frequency (FM) produce fluctuations in the voltage at the output of the discriminator. The demodulated FM passes through the FM Output Amplifier and on to the audio circuits for further filtering and audio processing.

The Squelch Switch grounds the output of the discriminator whenever the IF level detected by the Squelch Detector is insufficient. This squelch action attenuates the large noisy output that results when discriminating only noise and speeds recovery of the audio circuits from tuning-induced transients. The Controller also activates squelch during certain other measurement modes.

The signal from the FM IF Limiters also drives the Counter via the Counter IF Buffer.

### FM Calibrator Assembly (A51)

The heart of the FM Calibrator is a 10.1 MHz VCO. A 10 kHz trapezoidal wave is applied to the tune line of the VCO, which generates FM. During the calibration measurement, the VCO input is switched to the upper frequency,  $f_U$ , and the frequency is measured by the Counter. Then the VCO input is switched to the lower frequency,  $f_L$ , and the frequency is again measured. The Controller calculates the peak deviation as

$$FM = \frac{f_U - f_L}{2}.$$

A measurement of residual FM is also made on the unmodulated VCO and entered into the calculation of the FM calibration factor. The FM signal is then measured, and the calibration factor is calculated and shown on the display. The sensitivity of the VCO and tune voltage are designed to give approximately 34 kHz peak deviation.

To prevent ringing of the demodulated signal in the audio circuits, the modulation signal is given a slow risetime by the Trapezoid Generator—a soft limiter which receives its input from the Triangle Generator. The Triangle Generator and Mode Control comparator together form a relaxation oscillator. The output from the Mode Control comparator switches between a positive and negative output current.

The Triangle Generator (an integrator) generates a negative or positive ramp depending on its input. When its output reaches the Mode Control reference, the comparator output switches to initiate a ramp in the opposite direction.

Special Function 12 controls the FM Calibrator and permits its use with another Measuring Receiver or modulation analyzer.

### AM Calibrator Assembly (A50)

The RF input to the AM Calibrator is the unmodulated 10.1 MHz from the FM Calibrator. The signal passes through a Limiter to the inputs of two similar Amplifiers (A and B) and through to two similar Modulators (A and B). Current Source B switches Modulator B on and off while Current Source A latches Modulator A on. The outputs from the two Modulators are summed in the Summing Amplifier, and the summed signal appears (after attenuation) at the CALIBRATION AM/FM OUTPUT connector. If both signal paths are identical, the output from the calibrator is periodically toggling between a specific RF level and twice that level. This produces 33.33% AM.

Rather than relying of the two signal paths being identical, the AM is computed by careful, static measurement of the signal levels from the Modulators during a calibration sequence. First, Modulator

A is switched off and the voltage from the Amplifier/Detector is measured with Modulator B on, via the  $\times 1$  DC Amplifier ( $V_B$ ). This voltage is also measured via the  $\times 10$  DC Amplifier ( $V_{10B}$ ). Then Modulator B is switched off, Modulator A switched on, and the level is measured via the  $\times 10$  DC Amplifier ( $V_{10A}$ ). AM is then calculated by the formula

$$\%AM = \frac{100\%}{3 - \frac{2}{10} \frac{V_{10A} - V_{10B}}{V_B}}$$

For near-identical modulators the formula can be written in the form

$$\%AM = \frac{100\%}{3 - \epsilon}$$

where  $\epsilon$  is a small error term which need not be determined with great accuracy. Note that if Modulators A and B are identical,  $\epsilon$  approaches zero, and the formula reduces to  $100\%/3$  or  $33.33\%$ .

A measurement of residual AM is also made on the unmodulated RF and entered into the calculation of the AM calibration factor. The AM signal is then measured and the calibration factor is calculated and shown on the display.

To prevent ringing of the demodulated signal in the audio circuits, the modulation squarewave is given a slow risetime by the Current Sources. Special Function 13 controls the AM Calibrator and permits its use with another Measuring Receiver or modulation analyzer.

## Troubleshooting

### General

Procedures for checking the IF Section of the instrument are given below. The blocks or points to check are marked on the block diagram by a hexagon with a check mark and a number inside, for example,  $\sqrt{3}$ . Before performing any check, perform all the checks on Service Sheet BD1.

**CAUTION**

*Tighten SMC connectors to 0.6 N·m (5 in·lb). Hand tightening of connectors is insufficient. Hand-tightened connectors can work loose and cause reduced performance or malfunctions.*

### Equipment

Audio Synthesizer..... HP 3336C  
 Oscilloscope ..... HP 1740A  
 Signal Generator..... HP 8640B

#### $\sqrt{1}$ IF Amplifier/Filter Check

1. Set the signal generator or audio synthesizer to between 454 and 456 kHz CW at  $-7$  dBm. Connect its RF output to A55J2 (IF IN) on the Measuring Receiver.
2. Connect a high-impedance, ac coupled oscilloscope to A55J1 (IF OUT).
3. Press the blue key, then press INSTR PRESET (the AUTOMATIC OPERATION key) to preset the instrument. Key in 9.1 SPCL to set the relative IF gain to 0 dB. The 455 kHz waveform on the oscilloscope should have an amplitude between 500 and 700 mVpp. If faulty, see Service Sheet 6 and begin by checking the Second IF Amplifier.

*Hint:* The amplifier gain is adjustable. See *Adjustment 23—Narrow 455 kHz IF Filter* in Section 5.

4. Adjust the signal generator's level for a waveform of 600 mVpp. Key in the Special Functions listed in Table 8D-8 to set the IF gain. Also set the signal generator level in 10 dB steps as listed. For each setting the 455 kHz signal should appear within the limits indicated. If out of limits, see Service Sheet 6 and begin by checking the Second IF Amplifier.

**Table 8D-8. Signal Level at A55J1,  $\sqrt{1}$  Step 4**

Special Function	Gain (dB)	Signal Generator Level (dBm)	Oscilloscope Display Limits (mVpp)	
			Minimum	Maximum
9.1	0	$-7$	580	620
9.2	10	$-17$	580	620
9.3	20	$-27$	580	620
9.4	30	$-37$	580	620
9.5	40	$-47$	580	620
9.6	50	$-57$	580	620
9.7	60	$-67$	580	620

5. Set the signal generator's level to  $-7$  dBm.
6. On the Measuring Receiver, key in 9.1 SPCL. Key in 100 MHz to stop the automatic signal search. Key in 3.5 SPCL to insert the 455 kHz Narrow Bandpass Filter. The signal on the oscilloscope

should be between 580 and 620 mVpp. If faulty, see Service Sheet 6 and check the 455 kHz Narrow Bandpass Filter.

7. Tune the signal generator to 430 and 480 kHz. In each case the level on the oscilloscope should drop below 100 mVpp. If faulty, see Service Sheet 6 and check the 455 kHz Narrow Bandpass Filter.

*Hint:* The filter response is adjustable. See *Adjustment 23—Narrow 455 kHz IF Filter* in Section 5.

8. On the Measuring Receiver, key in 0.2 S (Shift) 36 SPCL to remove the narrow IF filter and to set the Programmable IF Gain Buffer to maximum gain. The level on the oscilloscope should increase to more than 2 Vpp. If faulty, see Service Sheet 6 and check the Programmable IF Gain Buffer.

*Hint:* This buffer is used in the Tuned RF Level measurement mode while searching for a signal within the 30 kHz IF bandwidth.

### √2 IF Synchronous Detector Check

1. Perform all tests of Special Function 53.N, *IF Synchronous Detector Tests*, paragraph 8-7.

### √3 FM IF Buffer Check

1. Perform the Input Mixer and IF Check on Service Sheet BD2.

### √4 IF Detector Check

#### NOTE

*This check assumes that the √3 FM IF Buffer Check gives positive results.*

1. Set the signal generator to 20 MHz CW at 0 dBm. Connect its RF output to the Measuring Receiver's INPUT.
2. Connect an ac coupled oscilloscope to rear-panel IF OUTPUT. Switch the input impedance of the oscilloscope to  $50\Omega$  or terminate the input in  $50\Omega$  using a tee.
3. Press the blue key, then press INSTR PRESET (the AUTOMATIC OPERATION key) to preset the instrument. Key in 20 MHz. If Error 01 appears, press MHz again. Key in 1.3 SPCL to set the attenuation range to 20 dB. Adjust the signal generator level for a 100 mVpp waveform on the oscilloscope.
4. Key in 49. S (Shift) 3 SPCL. This causes the IF level to be displayed. The display should read between 0.85 and 0.95. If it does not, see Service Sheet 9 and check the IF Peak Detector.
5. Switch signal generator's RF off.
6. Press CLEAR to clear the IF Present Latch. Key in 0.0 S (Shift) 4 SPCL. The display now reads the IF Present status. The display should read 000000.0000. If faulty, see Service Sheet 9 and check the IF Present Detector.
7. Switch the signal generator's RF on. The display should read 000001.0000 indicating that IF has been detected. If faulty, see Service Sheet 9 and check the IF Present Detector.



**NOTE**

*To repeat steps 5 through 7, it is necessary to press CLEAR first to clear the IF Present Latch.*

**√5 AM Demodulator Check****NOTE**

*This check assumes that the √3 IF FM Buffer Check gives positive results.*

1. Set the signal generator to approximately 20 MHz CW at 0 dBm. Connect its RF output to the Measuring Receiver's INPUT.
2. Press the blue key, then press INSTR PRESET (the AUTOMATIC OPERATION key) to preset the instrument. Press AM. Key in 49. S (Shift) 1 SPCL. This causes the average IF level (which the ALC loop is supposed to hold constant) to be displayed. The display should read between 2.096 and 2.104. If only slightly out of limits, perform the *Adjustment 8—ALC Reference* in Section 5; otherwise, see Service Sheet 8.
3. Connect a high-impedance, ac coupled oscilloscope to rear-panel AM OUTPUT.
4. Modulate the signal generator with 50% AM at a 400 Hz rate. The oscilloscope should show the demodulated AM with an ac amplitude of 750 to 850 mVpp. If faulty, see Service Sheet 8.
5. Key in 6.1 SPCL to set the ALC response time to fast. The amplitude should drop between 40 and 120 mVpp. If faulty, see Service Sheet 8 and check the Bandwidth Control and Level Comparison Amplifier.

**√6 FM Demodulator Check****NOTE**

*This check assumes that the √3 FM IF Buffer Check gives positive results.*

1. Set the signal generator to approximately 20 MHz CW at 0 dBm. Connect its RF output to the Measuring Receiver's INPUT.
2. Press the blue key, then press INSTR PRESET (the AUTOMATIC OPERATION key) to preset the instrument. Press FM. Allow the instrument to tune then press MHz. Pressing the MHz key sets tuning to manual.
3. Connect a high-impedance, dc coupled oscilloscope to A4J2 (IF OUT). The waveform should be TTL pulses with a period of approximately 670 ns. If faulty, see Service Sheet 10 and check the IF Limiters.
4. Reconnect the cable to A4J2. Connect the ac coupled oscilloscope to the rear-panel FM OUTPUT.
5. Modulate the signal generator with 100 kHz peak deviation FM at a 1 kHz rate. The oscilloscope should show the demodulated FM with an ac amplitude of 1.0 to 1.4 Vpp. If faulty, see Service Sheet 11 and check the Charge-Count Discriminator.

**NOTE**

*A slight fuzziness on the waveform is normal. It is the doubled 1.5 MHz IF carrier.*

6. Connect the oscilloscope to A4TP5 (FM OUT). The waveform should be 3.6 to 4.4 Vpp. If faulty, see Service Sheet 11 and check the FM Output Amplifier and Squelch.

**NOTE**

*This waveform will have even more of the doubled 1.5 MHz carrier on it.*

**√7 FM Calibrator Check**

1. Connect a high-impedance, ac coupled oscilloscope (with 10:1 divider probe) to A51TP2 (TRAPEZOID OUT).
2. Press FM and CALIBRATE. The waveform should be trapezoidal with round edges and an ac amplitude of 300 to 340 mVpp and period of 90 to 110  $\mu$ s. (Ignore Error 08 in the display.) If faulty, see Service Sheet 29 and check the trapezoid generation circuits.
3. Key in 12.1 SPCL and 46.3 SPCL. This sets the FM Calibrator to CW and causes the display to show its frequency. The display should read between 1009000 and 1011000. If only slightly out of limits, perform the *Adjustment 9—FM Calibrator* in Section 5. Otherwise, see Service Sheet 29 and check the 10.1 MHz VCO.
4. Key in 12.0 SPCL. This causes the display to read the computed peak deviation. The display should read between 31 and 37 kHz. If only slightly out of limits, perform *Adjustment 9—FM Calibrator*. Otherwise, see Service Sheet 29 and check the 10.1 MHz VCO.
5. Key in 12.1 SPCL. Connect the ac coupled oscilloscope to the CALIBRATION AM/FM OUTPUT. Switch the input impedance of the oscilloscope to 50 $\Omega$  or terminate the input in 50 $\Omega$  using a tee. The waveform should be approximately sinusoidal and have an ac amplitude of 35 to 45 mVpp. If faulty, see Service Sheet 29 and check the Output Amplifier. If it is good, see Service Sheet 30 and check the RF path through the AM Calibrator.

**√8 AM Calibrator Check**

1. Connect an ac coupled oscilloscope to the CALIBRATION AM/FM OUTPUT. Switch the input impedance of the oscilloscope to 50 $\Omega$  or terminate the input in 50 $\Omega$  using a tee.
2. Key in 13.1 SPCL to set the AM Calibrator to CW. The waveform should be approximately sinusoidal with an ac amplitude of 35 to 45 mVpp. If faulty, see Service Sheet 30 and check the RF path beginning at the input of the FM Calibrator.
3. Key in 13.0. This causes the display to show the AM depth. The display should show between 33.0 and 33.7%. If faulty, see Service Sheet 30 and begin by checking the Modulators.
4. Press AM then CALIBRATE. The waveform should show the carrier with AM. The AM envelope should be a rounded squarewave with a period of 90 to 110  $\mu$ s. The amplitude of the peak should be twice that of the trough. If faulty, see Service Sheet 30 and check the 10 kHz Modulation Oscillator.

### √9 Channel Filter Check (Option Series 030)

1. Set the signal generator or audio synthesizer to between 454 and 456 kHz CW at  $-10$  dBm (70.7 mVrms into  $50\Omega$ ). Connect its RF output to A72J2 (IF IN) on the Measuring Receiver.
2. Connect a high-impedance, ac coupled oscilloscope to A72J1 (IF OUT).
3. Press the blue key, then press INSTR PRESET (the AUTOMATIC OPERATION key) to preset the instrument. Key in 0.3D0 SPCL to switch in the Channel Output Attenuator and select channel 1. Fine tune the signal source to peak the signal on the oscilloscope. (Filter passband ripple can be as high as 2 dB. Find the highest peak of the ripple.) The 455 kHz waveform on the oscilloscope should have an amplitude between 640 and 1000 mVpp. If faulty, see Service Sheet 33 and check the circuits of channel 1.
4. Set the oscilloscope gain for a display of 6 divisions peak-to-peak. Key in 0.3D1 SPCL to switch out the Channel Output Attenuator. Decrease the oscilloscope's vertical gain by a factor of 10. The waveform should be between 5.9 and 6.1 divisions peak-to-peak. If faulty, see Service Sheet 33 and check the Channel Output Attenuator.
5. Increase the signal source frequency until the waveform drops to 3 divisions peak-to-peak. Record the signal source's frequency.
6. Decrease the signal source frequency until the waveform rises to 6 divisions peak-to-peak then drops to 3 divisions peak-to-peak. Note the signal source's frequency. The difference between this frequency and the frequency in step 5 should be as indicated in Table 8D-9. (The filter bandwidth depends on the option installed.) If faulty, see Service Sheet 33 and check the First Channel 1 Filter.

**Table 8D-9. Bandwidth of First Channel 1 Filter, √9 Step 6**

Option Combination	Frequency Difference Limits (kHz)	
	Minimum	Maximum
032 and 035 033 and 035 035 and 037	25.0	35.0
032 and 033 033 and 037	12.4	16.9
032 and 037	6.4	10.4

7. Key in 0.3D3 SPCL to select channel 2. Set the signal source frequency to 455 kHz then fine tune the source to peak the signal on the oscilloscope. (Filter passband ripple can be as high as 2 dB. Find the highest peak of the ripple.) The 455 kHz waveform on the oscilloscope should have an amplitude between 4 and 7 divisions peak-to-peak. If faulty, see Service Sheet 33 and check the circuits of channel 2.
8. Set the oscilloscope gain for a display of 6 divisions peak-to-peak. Increase the signal source frequency until the waveform drops to 3 divisions peak-to-peak. Record the signal source's frequency.
9. Decrease the signal source frequency until the waveform rises to 6 divisions peak-to-peak then drops to 3 divisions peak-to-peak. Note the signal source's frequency. The difference between this frequency and the frequency in step 8 should be as indicated in Table 8D-10. If faulty, see Service Sheet 33 and check the First Channel 2 Filter.

**Table 8D-10. Bandwidth of First Channel 2 Filter, (√9) Step 9**

Option Combination	Frequency Difference Limits (kHz)	
	Minimum	Maximum
032 and 037 033 and 037 035 and 037	3.0	7.0
032 and 033 032 and 035	6.4	10.4
033 and 035	12.4	16.9

- Key in 23.1 to switch the LO to external. The EXT LO indicator on A72 should go on and the LO input switch should make an audible click. If faulty, see Service Sheet 33 and check the LO Input Switch (S4) Control.

**(√10) IF Amplifier/Detector Check (Option Series 030)**

- Set the signal generator or audio synthesizer to between 454 and 456 kHz CW at -70 dBm (70.7 μVrms into 50Ω). Connect its RF output to A71J2 (IF IN) on the Measuring Receiver.
- Connect a high-impedance, ac coupled oscilloscope to A71J1 (TEST JACK).
- Press the blue key, then press INSTR PRESET (the AUTOMATIC OPERATION key) to preset the instrument. Key in 0.397 SPCL and 0.3E7 SPCL to switch in maximum IF gain and select the Second Channel 1 Filter. Fine tune the signal source to peak the signal on the oscilloscope. (Filter passband ripple can be as high as 2 dB. Find the highest peak of the ripple.) The 455 kHz waveform on the oscilloscope should have an amplitude between 1 and 2 Vpp. If faulty, see Service Sheet 34 and check the circuits of channel 1.
- Key in 49.C SPCL to read the IF with the IF RMS Detector. Calculate

$$\text{reading of step 3} \times 1.63.$$

The Measuring Receiver's display should read within 10% of the calculated value. If faulty, see Service Sheet 34 and check the IF RMS Detector.

- Set the signal source level for a Measuring Receiver display of 2.00.
- Key in the Direct Control Special Functions listed in Table 8-11 followed each time by 49.C SPCL. For each setting, the Measuring Receiver's display should be as indicated. If faulty, see Service Sheet 34 and check the corresponding attenuator.

**Table 8D-11. Attenuation Stepping, (√10) Step 6**

Direct Control Special Function	Attenuator	Display Limits	
		Minimum	Maximum
0.396	1	0.12	0.22
0.395	2	0.18	0.22
0.393	3	0.18	0.22
0.397, 0.3EB	4, 5 dB	1.02	1.24
0.3ED	4, 10 dB	0.57	0.70
0.3EE	4, 15 dB	0.32	0.39

- Key in 0.3E7 SPCL and 49.C SPCL. Increase the signal source frequency until the display drops to 1.0. Record the signal source's frequency.

8. Decrease the signal source frequency until the display rises to 2.0 then drops to 1.0. Note the signal source's frequency. The difference between this frequency and the frequency in step 7 should be between 33 and 55 kHz. If faulty, see Service Sheet 34 and check the Second Channel 1 Filter.
9. Key in 0.39F SPCL to select channel 2. Key in 49.C SPCL. Set the signal source frequency to 455 kHz then fine tune the source to peak the signal on the Measuring Receiver's display. (Filter passband ripple can be as high as 2 dB. Find the highest peak of the ripple.) The display should read between 1.5 and 2.5. If faulty, see Service Sheet 34 and check Second Channel 2 Filter.
10. Set the signal source level for a Measuring Receiver display of 2.00.
11. Increase the signal source frequency until the display drops to 1.0. Record the signal source's frequency.
12. Decrease the signal source frequency until the display rises to 2.0 then drops to 1.0. Note the signal source's frequency. The difference between this frequency and the frequency in step 11 should be between 3 and 7 kHz. If faulty, see Service Sheet 34 and check the Second Channel 2 Filter.
13. Key in 0.3F0 SPCL to read back the Option Series 030 Installed Indicator. The Measuring Receiver should display 000001.0000. If faulty, see Service Sheet 34 and check the Option Series 030 Installed Indicator.

# SERVICE SHEET BD4

## Block

- Audio

## Principles of Operation

### General

The Audio Block Diagram documents the audio circuits which process the demodulated IF signal and convert the audio signal to dc for measurement by an internal digital voltmeter. The audio circuits include amplifiers, filters, attenuators, switches, ac to dc converters, an integrator, a counter, a distortion analyzer, etc.

### Audio Filters Assembly (A2)

The residual IF carrier on the demodulated AM or FM is filtered by the 260 kHz Low-Pass Filter in each path. These filters determine the audio bandwidth when LP FILTER is set to >200 kHz. 20 dB Attenuator 1 partially determines the audio gain in the FM and  $\Phi$ M modes.

The demodulated signal passes through Amplifier 1, which has a gain of 8.9 dB, and when selected, the 15 kHz or >20 kHz Low-Pass Filter further filters the signal. The 15 kHz Low-Pass Filter is automatically selected for the 455 kHz IF. The >20 kHz Low-Pass Filter can also be selected. The 6 dB Attenuator in the through-path matches the 6 dB loss through the two filters.

Amplifier 2 has 13.7 dB of gain. 20 dB Attenuator 2 gives further audio-range control. Amplifier 3 has 20 dB of gain. Amplifiers 1, 2, and 3 distribute the audio gain for optimum noise reduction and distortion. Special Function 2 controls the overall audio gain. Table 8D-12 lists the modulation ranges and the associated attenuation. (The ranges in the table apply only for the PEAK+, PEAK-, and AVG audio detectors.)

*Table 8D-12. Attenuation vs. Modulation Range*

Modulation Range			20 dB Attenuator	
AM Depth (%)	FM Deviation (kHz)*	$\Phi$ M Deviation (rad)	1	2
40	4	4	out	out
100	40	40	out	in
100	400	400	in	in

\* With 750  $\mu$ s FM DE-EMPHASIS and PRE-DISPLAY selected the FM ranges are 0.4, 4, and 40 kHz.

### Audio De-emphasis and Output Assembly (A3)

The Audio De-emphasis and Output Assembly contains audio filters, FM de-emphasis networks, a  $\Phi$ M integrator, audio output amplifiers, and two audio level detectors.

The 50 and 300 Hz High-Pass and 3 kHz Low-Pass Filters are active filters selected from the front panel. The four FM de-emphasis networks are single-pole, low-pass filters with time constants of 750, 75, 50, and 25  $\mu$ s. The 750  $\mu$ s network also adds 20 dB of gain.

The phase deviation of the RF input signal is recovered by integrating the demodulated FM with the Phase Modulation Integrator. In mathematical terms, the instantaneous phase deviation is the integral of the instantaneous frequency deviation.

The audio output path to the Voltmeter (A5) is through the Inverting/Non-Inverting Amplifier. The amplifier usually has a gain of  $-1$ , but when PEAK+ is selected or, for FM and  $\Phi$ M, when the input signal is down converted by the Input Mixer (A17), the gain is  $+1$ . By using PRE-DISPLAY, the input to the amplifier can be selected to include the FM de-emphasis networks.

The Absolute Peak Detector, the Audio Overvoltage Detector, and the Voltmeter together sense the audio signal level to determine the audio range. The Audio Overvoltage Detector compares the audio voltage to a reference. If the audio level is too high, the Audio Overvoltage Detector reacts quickly to set the audio gain to minimum and to set a status flag which can be read by the Controller. The output of the Absolute Peak Detector (which detects the greater of the positive and negative peaks) is read by the Voltmeter.

If automatic ranging has been selected, the Controller reduces the audio gain depending on the following conditions governed by the Controller: (1) the magnitude of the positive or negative peak of the audio signal or (2) the voltage read from the Audio Peak Detector of the A5 Voltmeter Assembly. Most often the audio autoranging is determined by the voltage read from the Audio Peak Detector. However, situations arise where the predominant component of the audio signal is filtered out by one of the active filters in the audio chain (for example, a 10 kHz signal into the 3 kHz Low-Pass Filter). Having the Absolute Peak Detector ahead of the active filters prevents such situations from overdriving the audio circuits.

The front-panel MODULATION OUTPUT/AUDIO INPUT is driven by an inverting Output Amplifier via the A52 Audio Counter/Distortion Analyzer Assembly. The output of this connector is always affected by audio filtering and FM de-emphasis, when selected.

### **Voltmeter Assembly (A5)**

The Voltmeter consists of an average detector, a peak detector, and a voltage-to-time converter.

The Audio Average Detector consists of a precision Half-Wave Rectifier and a Summer and Filter. The summer amplifier adds the input signal, weighted by a factor of one, to the inverted and half-wave-rectified input, weighted by a factor of two. The resultant sum is a full-wave-rectified output. After filtering, the output dc voltage is equal to the signal's rectified average.

The Audio Peak Detector captures the positive, ac peak. The Sample-and-Hold Switch controls the transfer of the detector's output to the Voltage-to-Time Converter (via the Buffer Amplifier) and also controls the discharging of the Audio Peak Detector. Special Function 5 controls the discharge rate.

The voltage is actually measured by the Voltage-to-Time Converter. The Input Selectors select one of many dc inputs into the converter. The output of the selectors is a reference input to a Comparator. The Comparator's other input is a linear ramp. As the ramp (initiated by the Counter) rises, the Counter counts the time base reference (10 MHz). When the ramp voltage equals the level of the Comparator's other input, the Comparator signals the Counter to stop counting. The accumulated count represents the dc voltage. Ground is measured separately and subtracted from the Voltmeter measurement.

The True RMS-to-DC Converter improves the accuracy of the Tuned RF Level measurement at low levels by converting the sum of the dc level and noise on the signal from the IF Synchronous Detector (see Service Sheet BD3) to a dc level which represents the signal's true rms value. At low levels, this compensates for the effect of noise on the IF Synchronous Detector. The Voltmeter, by its nature, averages out this noise, whereas a true rms converter doesn't. Special Functions 49 and 50 allow direct access and display of the Voltmeter readings.

### **Audio Counter/Distortion Analyzer (A52)**

Inputs to the Audio Counter/Distortion Analyzer come from either the internal audio circuits via the Output Amplifiers in the A3 Audio De-emphasis and Output Assembly or from the external MODULATION OUTPUT/AUDIO INPUT as determined by the Internal/External Source Switch.

The distortion (plus noise) on a 400 Hz or 1 kHz audio signal is measured by comparing the level of the input signal with the level of that same signal which has had the fundamental removed by a

notch filter. The distortion measurement result (which also includes noise) is the ratio of the signal, with fundamental removed, to the unfiltered signal. In both measurements, the signal level is measured by the RMS-to-DC Converter which is then read by the Voltmeter. The voltage from the RMS-to-DC Converter can be measured and displayed by means of Special Function 30, which automatically switches the Input/Output Switch to the external, audio input position.

Since the notch-filter frequency is fixed at either 1 kHz or 400 Hz, the signal being measured should be within  $\pm 5\%$  of the selected frequency. Amplifier 1 and Amplifier 2, which together have an overall gain of 0, 20, or 40 dB, are programmed to provide an optimum level to the RMS-to-DC Converter. The voltage measured when the Notch Select Switch is set to include the Notch Filters is the numerator in the distortion calculation. The voltage measured when the Notch Select Switch is set to bypass the Notch Filters is the denominator in the distortion calculation. Since the signal minus its fundamental is often noisy, the signal to the Voltmeter is filtered by an active Ripple Filter to smooth the voltage readings. Special Function 29 puts the instrument in the SINAD measurement mode. The SINAD measurement is the same as the Audio Distortion measurement except that the reciprocal of the distortion measurement is displayed.

To calculate the frequency of an internal or external audio signal, the Controller counts signals from both the Audio Counter and the main Counter (on Service Sheet BD5). First, the analog audio signal is conditioned by the Schmitt Trigger to make it compatible with the digital circuits that follow. To begin the count, the Controller resets Counter Stages 1–4. At this time, Count/Pulse Switch 2 is set to receive the output from Counter Stage 2 and the Output Switch is closed. Count/Pulse Switch 1 is readied but not closed until the next pulse from the Schmitt Trigger triggers the Counter Gate Control and sets Count/Pulse Switch 1 to receive pulses from the Schmitt Trigger. The Counter Stages 1–4 now begin counting pulses from the Schmitt Trigger. Overflows from Stage 4 (every 65 536 counts) are counted by the Controller via the Output Switch and Instrument Bus.

Coincident with the closing of Count/Pulse Switch 1, the Voltmeter/Audio Gate (on Service Sheet BD5) closes and the main Counter begins counting the 10 MHz time base reference. After 100 ms, the Controller enables the Counter Gate Control to respond to the next pulse from the Schmitt Trigger. When the pulse arrives, it triggers the Counter Gate Control to open Count/Pulse Switch 1 and the Voltmeter/Audio Gate via the Stop Count Buffer. If no pulse is received from the Schmitt Trigger after a fixed time, the count sequence is aborted.

The count from Audio Counter Stages 1–4 is read back in two steps. First, the Controller reads back the count of Stages 3 and 4 by sending a series of pulses into Stage 3 via Count/Pulse Switch 2, looking for the overflow from Stage 4. By knowing the number of pulses sent to Stage 3, the Controller can calculate the accumulated count. Next, the Controller sends 255 pulses to Stages 3 and 4 to fill them, sets Count/Pulse Switch 2 to the output of Stage 2, and sends a series of pulses to Stage 1 via Count/Pulse Switch 1 while looking for an overflow from Stage 4. Again, by knowing the number of pulses sent to Stage 1, the Controller can calculate the accumulated count from Stages 1 and 2. The count from the main Counter is also read back by the Controller. Knowing the counts of the Audio and main Counters (including overflows), the Controller calculates and displays the signal frequency.



## Troubleshooting

### General

Procedures for checking the Audio Section of the instrument are given below. The blocks or points to check are marked on the block diagram by a hexagon with a check mark and a number inside, for example,  $\sqrt{3}$ . Before performing any check, perform all the checks on Service Sheet BD1.

**CAUTION**

*Tighten SMC connectors to 0.6 N·m (5 in·lb). Hand tightening of connectors is insufficient. Hand-tightened connectors can work loose and cause reduced performance or malfunctions.*

### Equipment

Audio Synthesizer .....	HP 3336C
Oscilloscope .....	HP 1740A
Signal Generator .....	HP 8640B

#### $\sqrt{1}$ Audio Filters and Gain Check

1. Set the audio synthesizer to 1 kHz at -17 dBm. (The synthesizer output impedance should be 50Ω.) Connect its output to A2J1 (AM IN).

**CAUTION**

*If the Measuring Receiver is to be turned off, disconnect the audio synthesizer first to prevent damage to the CMOS switches the large signal present.*

2. Connect a high-impedance, ac coupled oscilloscope (with 10:1 divider probe) to A2TP4 (AMPL 3 OUT).
3. Set the signal generator to approximately 20 MHz CW at 0 dBm. Connect its RF output to the Measuring Receiver's INPUT.
4. Press the blue key, then press INSTR PRESET (the AUTOMATIC OPERATION key) to preset the instrument. Press AM. Key in 2.1 SPCL to set the audio gain to maximum. The oscilloscope should show the 1 kHz sinusoidal waveform with an ac amplitude of 2.4 to 2.8 Vpp. If faulty, see Service Sheet 12 and check the audio path beginning at the 260 kHz Low-Pass Filter at the AM output.
5. Increase the synthesizer frequency to 260 kHz without altering the amplitude. The waveform should have an ac amplitude of 1.2 to 1.6 Vpp. If faulty, see Service Sheet 12 and check the 260 kHz Low-Pass Filter at the AM output as well as checking to see if the 15 kHz or >20 kHz are in the circuit. (They should be out.)

**NOTE**

*This is not a valid measurement of the filter bandwidth since the source impedance is incorrect. It will, however, show up a severe problem. For a more precise test of bandwidth, see Service Sheet 12 or perform Performance Test 4—Audio Filters in Section 4.*

6. Set the synthesizer level to  $-27$  dBm and frequency to 1 kHz. Connect its output to A2J2 (FM IN). Press FM. The waveform should have an ac amplitude of 3.0 to 3.6 Vpp. If faulty, see Service Sheet 12 and check the 260 kHz Low-Pass Filter at the FM output.
7. Increase the synthesizer frequency to 260 kHz. The waveform should have an ac amplitude of 1.1 to 1.5 Vpp. If faulty, see Service Sheet 12 and check the 260 kHz Low-Pass Filter at the FM output.

**NOTE**

*See previous note.*

8. Set the synthesizer level to  $-17$  dBm and frequency to 1 kHz. Key in 2.2 SPCL to reduce the audio gain by 20 dB. The waveform should have an ac amplitude of 950 to 1150 mVpp. If faulty, see Service Sheet 12 and check 20 dB Attenuator 1.
9. Key in 2.3 SPCL to reduce the audio gain another 20 dB. The waveform should have an ac amplitude of 95 to 115 mVpp. If faulty, see Service Sheet 12 and check 20 dB Attenuator 2.
10. Key in 2.2 SPCL. Set the synthesizer frequency to 110 kHz. Set LP FILTER to  $>20$  kHz. The waveform should have an ac amplitude of 400 to 600 mVpp. If faulty, see Service Sheet 12 and check the  $>20$  kHz Low-Pass Filter.
11. Set the synthesizer frequency to 15 kHz. Set LP FILTER to 15 kHz. The waveform should have an amplitude of 600 to 900 mVpp. If faulty, see Service Sheet 12 and check the 15 kHz Low-Pass Filter.

## **√2 Audio Filters and De-emphasis Check**

**NOTE**

*This check assumes that **√1** Audio Filters and Gain Check gives positive results.*

1. Set the audio synthesizer to 1 kHz at  $-17$  dBm. (The synthesizer output impedance should be  $50\Omega$ .) Connect its output to A2J2 (FM IN).
2. Connect a high-impedance, ac coupled oscilloscope (with 10:1 divider probe) to A3TP3 (DE-EM OUT).
3. Set the signal generator to approximately 20 MHz CW at 0 dBm. Connect its RF output to the Measuring Receiver's INPUT.
4. Press the blue key, then press INSTR PRESET (the AUTOMATIC OPERATION key) to preset the instrument. Press FM. Key in 2.2 SPCL to set the audio gain to an intermediate range. The oscilloscope should show a sinusoidal waveform with an ac amplitude of 1.9 to 2.3 Vpp. If faulty, see Service Sheet 13 and check the audio path beginning at the high-pass filters.
5. Set the synthesizer frequency to 300 Hz. Set HP FILTER to 300 Hz. The waveform should have an ac amplitude of 1.3 to 1.7 Vpp. If faulty, see Service Sheet 13 and check the 300 Hz High-Pass Filter.

6. Set the synthesizer frequency to 50 Hz. Set HP FILTER to 50 Hz. The waveform should have an ac amplitude of 1.3 to 1.7 Vpp. If faulty, see Service Sheet 13 and check the 50 Hz High-Pass Filter.
7. Set the synthesizer frequency to 3 kHz. Set HP FILTER off and the LP FILTER to 3 kHz. The waveform should have an ac amplitude of 1.2 to 1.8 Vpp. If faulty, see Service Sheet 13 and check the 3 kHz Low-Pass Filter.
8. Set the LP FILTER off and FM DE-EMPHASIS to PRE-DISPLAY. Set the synthesizer frequency and FM DE-EMPHASIS as listed in Table 8D-13. For each setting, the ac amplitude of the waveform should be as indicated. If faulty, see Service Sheet 13 and check the appropriate de-emphasis filter.

**Table 8D-13.** Amplitude at A3TP3,  $\sqrt{2}$  Step 8

Synthesizer Frequency (Hz)	FM DE-EMPHASIS ( $\mu$ s)	Waveform Amplitude Limits (Vpp)	
		Minimum	Maximum
6366	25	1.3	1.7
3183	50	1.3	1.7
2122	75	1.3	1.7
212.2	750*	1.3	1.7

\* Key in 2.3 SPCL to reduce the gain by 20 dB.

9. Key in 2.2 SPCL. Switch PRE-DISPLAY off. The waveform should have an ac amplitude of 1.9 to 2.3 Vpp. If faulty, see Service Sheet 13 and check the Pre-Display Switching.
10. Set the synthesizer frequency to 1 kHz. Press  $\Phi$ M. The waveform should have an ac amplitude of 1.9 to 2.3 Vpp. If faulty, see Service Sheet 13 and check the Phase Modulation Integrator.
11. Press PEAK-. The waveform should not noticeably change amplitude. If faulty, see Service Sheet 13 and check the Inverting/Non-Inverting Amplifier.
12. Press FM. Switch off all FM DE-EMPHASIS. Connect the oscilloscope to MODULATION OUTPUT/AUDIO INPUT. The waveform should have an ac amplitude of 1.9 to 2.3 Vpp. If faulty, see Service Sheet 13 and check the Output Amplifiers.
13. Key in 49.6 SPCL. This causes the output of the audio range detector to be displayed. The display should read 0.4 to 0.6. If faulty, see Service Sheet 13 and check the Absolute Peak Detector.
14. Key in 0.15 SPCL. The display now shows the audio overvoltage status. The display should read 000000.0000. If faulty, see Service Sheet 13 and check the Audio Overvoltage Detector.
15. Increase the synthesizer level to +10 dBm. The display should read 000001.0000 indicating that an audio overload has been detected. If faulty, see Service Sheet 13 and check the Audio Overvoltage Detector.

#### NOTE

*To repeat steps 13 and 14, it is necessary to press CLEAR first to clear the audio overvoltage latch.*

### √3 Audio Average and Peak Detector Check

#### NOTE

*This check assumes that √2 Audio Filters and De-emphasis Check gives positive results.*

1. Set the audio synthesizer to 1 kHz at -17 dBm. (The synthesizer output impedance should be 50Ω.) Connect its output to A2J2 (FM IN).
2. Connect a high-impedance, ac coupled oscilloscope (with 10:1 divider probe) to A3TP3 (DE-EM OUT).
3. Set the signal generator to approximately 20 MHz CW at 0 dBm. Connect its RF output to the Measuring Receiver's INPUT.
4. Press the blue key, then press INSTR PRESET (the AUTOMATIC OPERATION key) to preset the instrument. Press FM. Key in 2.2 SPCL to set the audio gain to an intermediate range. Fine adjust the synthesizer level for an ac waveform of 2 Vpp.
5. Connect a dc coupled oscilloscope to A5TP4 (AVG OUT). (Check the dc reference of the oscilloscope.) The level on the oscilloscope should be 660 to 760 mVdc. If faulty, see Service Sheet 14 and check the Average Detector.
6. Connect oscilloscope to rear-panel RECORDER OUTPUT. Key in 49.0 S (Shift) 0 SPCL to switch the output of the Audio Peak Detector to the RECORDER OUTPUT. The level on the oscilloscope should be 0.9 to 1.1 Vdc. If faulty, see Service Sheet 14 and check the Audio Peak Detector. Also check the Input Selectors to the Voltage-to-Time Converter; see Service Sheet 15.
7. Remove then reconnect the synthesizer output. The waveform should drop and rise (in a step-like manner) in less than one second. If faulty, see Service Sheet 13 and check the Sample-and-Hold Switch.
8. Key in 5.1 SPCL to set the Audio Peak Detector time constant to slow. Again key in 49.0 S 0 SPCL. Repeat step 7 above. The decay and rise time should be about two seconds.

### √4 Voltage-to-Time Converter Check

1. Key in 50.3 SPCL. This causes the +5V supply to be displayed. The display should read 2.85 to 3.15. If faulty, see Service Sheet 15 and begin troubleshooting with the Voltage-to-Time Converter.
2. Check the Input Selectors by keying in the Service Special Functions listed for 49.N and 50.N. Consult *Service Special Functions* in *Special Functions*, paragraph 8-7, for more information. If any reading seems faulty when the input is known to be good, see Service Sheet 15 and check the Input Selectors.

### √5 Parity Check

1. Perform the Power-Up Checks on Service Sheet BD1.

### √6 Distortion Analyzer Check

1. Set the audio synthesizer to 1 kHz at 1 Vrms (into a high impedance). Connect its output to A52J1 (AUDIO IN).
2. Connect an ac coupled, high-impedance oscilloscope to the MODULATION OUTPUT/AUDIO INPUT.
3. Press the blue key, then press INSTR PRESET (the AUTOMATIC OPERATION key) to preset the instrument. The 1 kHz audio signal should be displayed with an amplitude between 2.6 and 3.0 Vpp. If faulty, see Service Sheet 16 and check the Internal/External Source Switch.

4. Readjust the level from the synthesizer for a display of 3 Vpp. Key in 30.0 SPCL to set the instrument to measure External Audio RMS Level. The 1 kHz signal should disappear. If faulty, see Service Sheet 16 and check the Internal/External Source Switch.
5. Connect the oscilloscope to A52TP4 (BUF OUT). Connect the synthesizer to the MODULATION OUTPUT/AUDIO INPUT. The 1 kHz audio signal should be displayed with an amplitude between 2.8 and 3.2 Vpp. If faulty, see Service Sheet 16 and check the Audio Input Buffer.
6. Connect the oscilloscope to A52TP2 (AMPL 1 OUT). Key in 2.3 SPCL to assure that the 20 dB attenuator of Amplifier 1 is in. The amplitude of the displayed audio signal should be between 2.8 and 3.2 Vpp. If faulty, see Service Sheet 16 and check Amplifier 1 and the Notch Select Switch.
7. Reduce the amplitude of the signal from the synthesizer by 10 (that is, -20 dB). Key in 2.4 SPCL to bypass the 20 dB attenuator. The amplitude of the displayed audio signal should be between 2.8 and 3.2 Vpp. If faulty, see Service Sheet 16 and check Amplifier 1.
8. DC couple the oscilloscope and connect it to A52TP1 (RMS OUT). The oscilloscope should display a voltage between 0.9 and 1.2 Vdc. If faulty, see Service Sheet 16 and check the RMS-to-DC Converter and the Ripple Filter.
9. AC couple the oscilloscope and connect it to A52TP3 (NOTCH FLTR OUT). Key in 0.2 S (Shift) 0 S 4 SPCL to keep the Notch Select Switch in the through position, keep the gain of Amplifier 1 at 20 dB, switch in the 400 Hz Notch Filter, and set the gain of Amplifier 2 to 20 dB. The amplitude of the displayed audio signal should be between 2.7 and 3.3 Vpp. If faulty, see Service Sheet 16 and check the Notch Filters and Amplifier 2.
10. Key in 0.2 S 0 S 0 SPCL to reduce the gain of Amplifier 2 by 20 dB. The amplitude of the displayed audio signal should be between 270 and 330 mVpp. If faulty, see Service Sheet 16 and check Amplifier 2.
11. Key in 0.2 S 0 6 SPCL to switch in the 1 kHz Notch Filter and increase the gain of Amplifier 2 by 20 dB. The 1 kHz audio signal should disappear into the noise. If faulty, see Service Sheet 16 and check the Notch Filter.
12. Set the synthesizer frequency to 400 Hz. Key in 0.2 S 0 S 4 SPCL to insert the 400 Hz Notch Filter. The 400 Hz audio signal should disappear into the noise. If faulty, see Service Sheet 16 and check the Notch Filter.
13. Connect the oscilloscope again to A52TP2. Key in 0.2 S 0 5 SPCL to set the Notch Filter to 1 kHz, keep the gain of Amplifier 2 at 20 dB, set the gain of Amplifier 1 to 0 dB, and set the Notch Select Switch to the notch filter position. The 400 Hz audio signal should have an amplitude between 2.7 and 3.3 Vpp. If faulty, see Service Sheet 17 and check the Notch Select Switch.

### Audio Counter Check

1. Set the audio synthesizer to 1 kHz at 1 Vrms (into a high impedance). Connect its output to the MODULATION OUTPUT/AUDIO INPUT.
2. Connect an ac coupled, high-impedance oscilloscope to A52TP4 (BUF OUT).
3. Press the blue key, then press INSTR PRESET (the AUTOMATIC OPERATION key) to preset the instrument. Press S (Shift) AUDIO FREQ. Press AUDIO INPUT. The 1 kHz audio signal should be displayed on the oscilloscope with an amplitude between 2.6 and 3.0 Vpp. If faulty, perform .

4. Set the synthesizer to 100 mVrms (into a high impedance) and set the frequency as shown in Table 8D-14. For each setting, the displayed frequency should be within the limits indicated. If faulty, see Service Sheet 16 and begin by checking the Counter Buffer and Schmitt Trigger.

**Table 8D-14.** *Displayed Frequency,  $\sqrt{7}$  Step 4*

Synthesizer Frequency (Hz)	Displayed Count (kHz)	
	Minimum	Maximum
1 000	0.99998	1.00002
20	0.0199800	0.0200200
250 000	249.997	250.003

## SERVICE SHEET BD5

### Blocks

- Digital
- Power Supply

### Principles of Operation

#### General

The Digital and Power Supply Block Diagram documents the Controller, Counter, Keyboard and Display, Remote Interface (HP-IB), and the Power Supply.

#### Counter Assembly (A11)

The Counter consists of a 10 MHz Reference Oscillator, Time Base Dividers, Input Selector, four counter stages, and counter control circuits. The input to Stages 2 through 4 is selected by the Input Selector switch. When the LO frequency is counted, counter Stage 1 is enabled and fed into Stage 2. The input to Stage 1 is the High Frequency VCO signal divided by eight (HF VCO  $\div$ 8). When the Voltmeter or Audio Counter input is selected, the Selected 10 MHz Time Base Reference (from the Time Base Select Switch), gated by the Voltmeter/Audio Gate (the VOLTMETER/AUDIO line), is the input to Stage 2. Other signals which can be counted are the IF, the 10.1 MHz VCO of the FM Calibrator (the CALIBRATED FM 2 line), three 10 MHz Time Base References (Internal, External, or Selected), and the 455 kHz VCO from the IF Synchronous Detector (the 455 kHz VCO line). Counting of the Internal and External Time Base Reference is useful as a Counter self-check. Special Function 46 controls the Input Selector.

The Counter counts in binary. Stage 1 is a divide-by-eight, and Stages 2 through 4 are divide-by-sixteens. Additional stages of counting are contained in the Microprocessor (in A13), which counts the output carries from Stage 4 via the Counter Output and Time Base Gate.

At the end of a count sequence, the Time Base disables the Counter via the Counter Gate Control. The Counter Transfer Logic then transfers the count of the individual stages in parallel to the Controller (A13) via the Counter Output and Time Base Gate. First, the output from Stage 4 is transferred. Then the output from Stage 3 is loaded into Stage 4, and the output from Stage 4 is again transferred. The transfer process is again repeated with Stage 2 loading into Stage 4 via Stage 3, and transferring. Finally, Stage 1 is loaded into Stage 4 via Stages 2 and 3, and transferred. (The output from Stage 1 is used only when counting the LO frequency.)

To make a voltage measurement, the Voltage-to-Time Converter (in the A5 Voltmeter Assembly of Service Sheet BD4) generates a pulse whose time interval is proportional to its dc input voltage. During this time interval, the Counter counts the Selected 10 MHz Time Base Reference (via the VOLTMETER/AUDIO line). The count thus accumulated is proportional to the input voltage. The count is initiated when the Counter Gate Control enables the Input Selector and the Voltage-to-Time Converter (via the Ramp Gate). The Voltage-to-Time Converter then closes the Voltmeter/Audio Gate (via the Stop Count line) and the Selected Time Base Reference passes into Counter Stage 2. When the time interval ends, the Voltmeter/Audio Gate is opened. The Controller disables the Counter and transfers the accumulated count to the Controller.

The Audio Counter also makes use of the Stop Count line to control the counting of the Selected Time Base Reference during the count sequence. (See the discussion of the Audio Counter in Block Diagram BD4.)

The Selected Time Base Reference is either the standard 10 MHz Reference Oscillator, the Option 002 10 MHz High-Stability, Crystal Oscillator, or an external input from the rear-panel TIME BASE 10 MHz INPUT connector. For Option 002, the crystal from the 10 MHz Reference Oscillator is removed

and the oscillator's circuitry is driven by the High-Stability, Crystal Oscillator. In either case, when an external reference is applied, a detector senses the signal and throws the Time Base Select Switch to the external position. This switching is done in such a way as to minimize the interruption of the reference, since (after it is divided by five) it is also the Controller clock.

The Time Base Dividers divide the 10 MHz reference by 1600. During a frequency count, Controller synchronizes itself to the 6.25 kHz Time Base signal (via the Counter Output and Time Base Gate). Since the Controller controls the enable period of the Counter (via the Counter Gate Control), the Time Base signal ultimately determines the Counter accuracy. (The Counter is enabled for more than one period of the 6.25 kHz Time Base signal. The number of periods is counted by the Microprocessor via the Counter Output and Time Base Gate.)

## **Controller Assembly (A13) and Memory Assembly (A12)**

The Controller consists of the Central Processing Unit (CPU), Static Memory Interface (SMI), Read-Only Memory (ROM), CPU External Register (or random-access memory, RAM), Memory Select Decoders, and input/output interface circuitry. The CPU and SMI form the Microprocessor. When the Controller interfaces with the HP-IB via the A14 Remote Interface Assembly, the Microprocessor also includes the Peripheral Input/Output (PIO in A14).

The Controller's program is stored in ROM. To retrieve information from ROM, the SMI, under control of the CPU, outputs the appropriate address on the Address Bus. Two of the sixteen address bits are decoded by the Memory Select Decoders to enable one of the ROMs. The fourteen other address bits address the individual ROMs. The enabled ROM then outputs eight bits of data onto the Data Bus from the location corresponding to the input address. ROM information may be either a program instruction or data. In a similar manner, temporary information is written to or read from RAM. The RAM is addressed by eight of the eleven address bits; it inputs or outputs eight data bits.

The RAM is non-volatile, that is, it is not erased when the instrument is powered down or unplugged. When either the +12V or +5V Power Supply voltage drops, the +12V and +5V Power Supply Drop Detector disables the RAM (which prevents data access for read or write operations), and the Battery supplies power to the RAM and associated circuits.

The CPU interprets bytes from the ROM as data or instructions depending on the context of the program. If the byte is an instruction, the outcome depends on the nature of the instruction. A simple instruction (such as add or shift) is executed immediately, and the instruction in the next address is fetched. More complex instructions fetch additional data or instructions from following addresses and, in the case of jumps and subroutine calls, cause program execution to move to another location in memory.

When a front-panel key is pressed, an interrupt is generated. The interrupt causes program execution to jump to a specified address where the interrupt service subroutine is located. The subroutine interrogates the Keyboard to determine which key was pressed and then takes the appropriate action. HP-IB codes and commands interrupt the Microprocessor in a similar way.

The CPU communicates with the SMI and PIO through the ROM Control (ROMC) lines and the Data Bus. The CPU manipulates data (arithmetic and logic computations) and contains the clocking and control circuitry. The clock is normally derived from the Counter's Time Base Reference; however, if the clock fails (to an open circuit) or if the Counter Assembly is unplugged, a clock (internal to the CPU) will continue to generate clock pulses. The SMI interfaces with the external ROM and RAM.

The CPU also contains bidirectional input/output (I/O) ports to communicate with the instrument's hardware via the Instrument Bus. Four I/O bits are reserved for servicing of the Controller. Four LEDs driven from the port indicate errors encountered during power-up verification tests, measurement cycles, and Keyboard and HP-IB interrupts. Four test points on the port can be used to initiate troubleshooting routines which use signature analysis. See *Controller Test LEDs and Test Points*, paragraph 8-10.



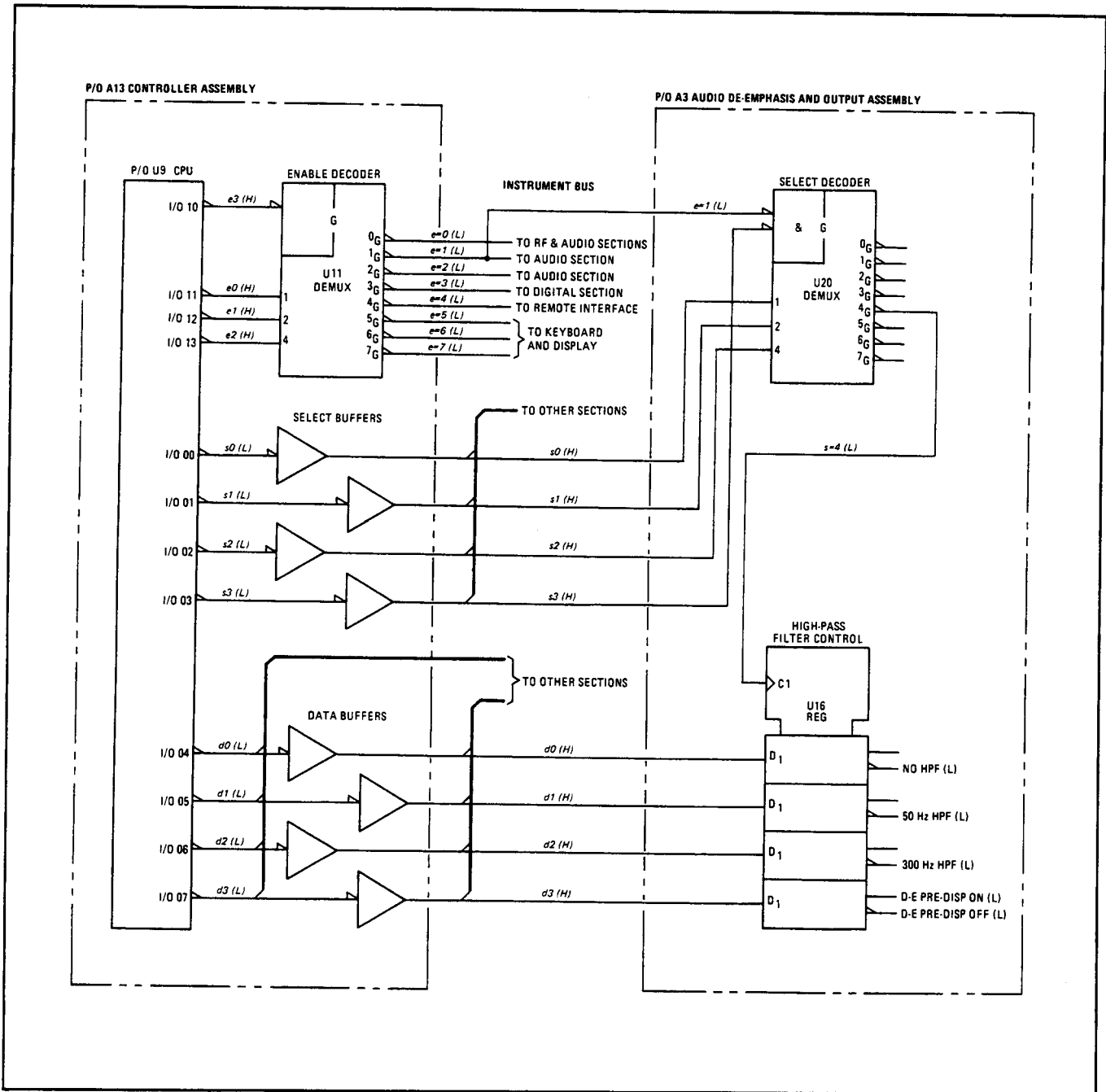

Figure 8D-7. Example Showing Instrument Bus Hookup

### Instrument Bus

Figure 8D-7 shows a typical hookup on the Instrument Bus. The Instrument Bus lines are broken down into three groups: enable (e), select (s), and data (d). The enable code (e0 to e3) comes from I/O lines 10 through 13 of the CPU (A13U9).

Three of the enable lines (e0, e1, and e2) are decoded by the Enable Decoder (A13U11) to activate one of eight unique enable lines (e=0 to e=7). The fourth line (e3) enables the decoder itself. The enable lines run to various instrument sections. Typically, each line is dedicated to a specific section or operational function; for example, enable line e=1 controls audio-related functions in the Audio Section.

The select (s0 to s3) and data (d0 to d3) lines come from I/O ports 00 to 07. The eight lines run in parallel to all sections of the instrument where they are decoded on the assemblies. (In the RF Section one assembly, the A20 LO Control Assembly, decodes the Instrument Bus for the entire section.) Up to 16 data codes for each of the 16 select codes are possible for each active enable line. The select code typically selects a functional category on an assembly, and the data code selects the specific function or configuration. On a given assembly, the select codes are decoded only while the corresponding enable line is active. The data codes are, in turn, decoded and latched only when triggered by the decoded select line. The latched data drive the digital-to-analog devices which control the instrument hardware.

On the schematic diagrams the lines leaving the I/O ports of the CPU are labeled with a mnemonic such as s2(L) for I/O line 02. The "s" indicates a select code, "2" indicates that it is the third, least-significant bit of the undecoded select code, and "(L)" indicates that the line is true (1) when the logic level is low. All bit-position numbering begins with 0. The select codes go out on the Instrument Bus through Select Buffers, which are simple inverters. Thus s2(L) goes out on the bus as s2(H). Decoded codes are labeled as e=1(L) for example. The "e" indicates an enable code, "=" indicates decoding, "1" indicates a decoded hexadecimal 1 (binary 0001), and "(L)" indicates the logic level corresponding to a true. The mnemonic "e=1" corresponds to  $e3e2e1e0 = 0001$ . Data codes are also buffered. However, unbuffered data lines are also connected to the Instrument Bus for reading back data to the I/O ports.

Figure 8D-7 illustrates how the 50 Hz High-Pass Filter is selected. The filter (not shown) is activated when the output line of the High-Pass Filter Control (A3U16) labeled 50 Hz HPF(L) goes low. Register U16 is simply a latch; it does not decode the data. To activate the 50 Hz High-Pass Filter, the CPU sends out the binary enable code 0001 (hexadecimal 1), select code 0100 (hexadecimal 4), and data code 0010 (hexadecimal 2). The Enable Decoder activates the line e=1(L). The decoder was enabled because e3(H) was low. Since s3(H) is low, and since e=1(L) is also low, the Select Decoder (A3U20) is enabled. The three least-significant bits of the select code are decoded and activate the s=4(L) line out of the decoder. This line clocks the data into the High-Pass Filter Control latch. Since the d1(H) line is high, the 50 Hz HPF(L) line goes low. This selects the 50 Hz High-Pass Filter.

There is a direct relationship between the codes output on the Instrument Bus and the Direct Control Special Functions discussed in paragraph 8-7. The enable, select, and data codes, combined into a hexadecimal number "esd", create the Direct Control suffix. In the example used in the previous paragraph, the suffix is 142 (corresponding to Direct Control code 0.142). Instrument control can be visualized as a series of Direct Control Special Functions issued under program control.

The example above decoded only three of the four select code bits and used the data bits directly (or inverted them). Notice that if the code  $esd = 147$  were issued, the through path (NO HPF), 50 Hz High-Pass Filter, 300 Hz High-Pass Filter, and De-emphasis Pre-Display On switches would all be activated. On some assemblies the data codes may be decoded and select codes above 7 may be used. On other assemblies certain select codes are used to enable readback devices which read back status or measurement data onto the unbuffered data lines. This is discussed in more detail in connection with Direct Control Special Functions in Service Aids.

## Keyboard and Display Assembly (A1)

The Keyboard and Display Assembly is both an input peripheral and an output peripheral to the Controller. The pressing of a key is sensed by the Keystroke Detector. The detector interrupts the Microprocessor which then enters an interrupt service routine. The routine causes the key rows and columns to be scanned sequentially via the Key Row and Column Scanner to ascertain which key is down. This scan is accomplished by driving the rows in sequence with the select decoder and reading the state of the columns with the data-readback lines. If no key closure is found (due, perhaps, to key bounce), the scan repeats. If no key closure is found after 50 ms, the Microprocessor leaves the key-service routine and returns to the measurement being made prior to the key interrupt (starting at the beginning of the measurement cycle).

Lighting of the key and annunciator lights, display digits, and decimal points is by a straightforward decoding of the Instrument Bus. Note that the lights in the keys do not light as a direct result of a key closure. Instead the Microprocessor, having recognized a key closure, sends the command out on the Instrument Bus to light the key light.

## Remote Interface Assembly (A14)

The Remote Interface Assembly interfaces the Controller with the Hewlett-Packard Interface Bus (HP-IB). It performs necessary handshake operations, interprets the HP-IB control lines, and is both an input and output peripheral to the Controller.

The Remote Interface Assembly consists of Handshake Logic, HP-IB Input/Output Transceivers, Interface Control Logic, Address Decoder, part of the Microprocessor, and Instrument Bus interface circuits.

As an input peripheral, the Remote Interface accepts a byte from the HP-IB data lines under control of the bus handshake lines. It then interprets the data byte and the bus-control lines to see if the byte is an address (talk or listen), a command, or a data byte. When a byte is processed, one of three things happens: (1) the byte is ignored, (2) the byte is processed in hardware (for example, some bus commands), or (3) the byte causes a Microprocessor interrupt (for example, codes received while addressed to listen). The Microprocessor treats an HP-IB interrupt as it would an interrupt from the Keyboard. However, the HP-IB interrupt service routine first checks whether the byte is a command (for example, Device Clear), address, or data (for example, "M1"). If the byte is an address or command, it is processed. If the byte is data, the routine first checks whether the instrument is in remote. If it is, the incoming byte is processed as program code. If not, the byte is ignored. After processing a byte, Microprocessor tells the Remote Interface what to do next (for example, input another byte, set a status latch, or prepare to output a byte).

As an output peripheral, the Remote Interface takes a byte of status or measurement data from the Microprocessor and processes it over the HP-IB. It does this only after determining that the Measuring Receiver has been addressed to talk. The require-service message (SRQ) is also output via the Remote Interface.

The Handshake Logic controls the asynchronous transfer of bytes over the HP-IB. The bytes are transferred without interrupting the Microprocessor in two cases: when the byte is data but the Measuring Receiver is not addressed to listen, or when the byte is not an interrupting bus command. The Handshake Logic also provides the means for the Microprocessor to complete the handshake if the byte is an interrupting type.

When the Measuring Receiver is accepting bytes, the Handshake Logic (1) monitors the Microprocessor and HP-IB and signals the HP-IB talker or bus controller when the Measuring Receiver is ready to receive, (2) tells the Microprocessor when valid data is on the HP-IB, and (3) tells the HP-IB talker when the Microprocessor has accepted the data. When the Measuring Receiver is outputting data or status bytes, the Handshake Logic (1) tells the Microprocessor when the HP-IB listener is ready to receive, (2) provides the Microprocessor with logic to tell the listener when data is valid, and (3) tells the Microprocessor when the listener has accepted data.

The HP-IB Input/Output transceiver acts as an HP-IB buffer and send/receive switch. It is controlled by the Interface Control Logic.

The Interface Control Logic, together with the Address Decoder, determines the talk or listen status of the interface and whether or not the Microprocessor should be interrupted. The ROM in the Interface Control Logic is addressed by two of the HP-IB data lines, the Address Decoder, and one of the HP-IB control lines (Attention, ATN). The ROM contains the control information for the Interface Control Logic and the Microprocessor.

If the Measuring Receiver's listen address is recognized by the Address Decoder, the Microprocessor attempts to set the Remote Enable Flip-Flop. If the HP-IB Remote Enable (REN) control line is true, the flip-flop is set (if not already set), and the Microprocessor sets a status bit in memory. Each time the Microprocessor performs any remote-dependent operation, it checks both the status bit and the flip-flop output (Remote Enable Latch, RNL). Both must be set for the instrument to remain in remote. If REN goes false at any time, the Remote Enable Flip-Flop is cleared, and the instrument is no longer in remote.

The Address Decoder compares the address set by the Address Switches with the five least-significant I/O bytes to determine if the instrument is being addressed. The Interface Control Logic looks at the

output of the Address Decoder and the next two input bits to determine if it is a talk or listen address and if the instrument should respond to it. The result of this determination modifies the address to the ROM in the Interface Control Logic.

The Address Readback outputs the address from the Address Switches to the Instrument Bus data lines when Special Function 21 (HP-IB Address) is selected. The Controller reads the HP-IB address from the Address Switches. (See *HP-IB Address* in the *Detailed Operating Instructions* in the *Operation and Calibration Manual*.)

The HP-IB input/output is directly handled by a portion of the Microprocessor that resides in the Remote Interface Assembly—the Peripheral Input/Output (PIO). The PIO is a device that routes the HP-IB data to and from the CPU and the HP-IB. It provides a communication link between the CPU and the Remote Interface hardware, and provides the means for interrupting the CPU. One of the two, eight-bit PIO output ports connects to the HP-IB data lines. The other output port connects to the Handshake Logic and Interface Control Logic.

#### NOTE

*For purposes of troubleshooting the Controller, the Remote Interface Assembly may be unplugged. Provision has been made to allow the instrument to work with only the loss of HP-IB operation.*

Although the Remote Interface Assembly receives data and operating information from the PIO, it is primarily through the Instrument Bus that it is controlled. (Commands such as SRQ that need rapid processing come from the PIO.) A Select Decoder decodes the select lines when enabled by code  $e=4$ . The decoded select lines enable or disable parts of the Remote Interface Assembly. Special Function 61 provides a means of reading back HP-IB status information to the front-panel display.

### Power Supply Assemblies (A10 and A26)

The five regulated power supplies are: +15V, -15V, +40V, +5V, and -5V. Each supply has its own secondary winding on the Line Transformer and all supplies except the +40V Supply have their own full-wave rectifier. The latter four supplies are referenced from the +15V supply. Each supply is a series regulator type. When the instrument is switched to STBY, the +15V supply remains on and supplies current only to the High-Stability, Crystal Oscillator (Option 002). In STBY, the other supplies become referenced to 0V and thereby shut themselves off. The supply switching is via the ON/STBY Relay. The fan is also switched by the relay.

## TROUBLESHOOTING

### General

Procedures for checking the Digital and Power Supply Sections of the instrument are given below. The blocks or points to check are marked on the block diagram by a hexagon with a check mark and a number inside, for example,  $\sqrt{3}$ . Before performing any check, perform all the checks on Service Sheet BD1.

#### CAUTION

*Tighten SMC connectors to 0.6 N·m (5 in·lb). Hand tightening connectors is insufficient. Hand-tightened connectors can work loose and cause reduced performance or malfunctions.*

### Equipment

Digital Test/Extender Board .....	HP 08901-60081
Oscilloscope .....	HP 1740A
Signature Analyzer .....	HP 5005A
Voltmeter .....	HP 3455A

#### $\sqrt{1}$ Time Base Reference Check

1. Disconnect any input to the rear-panel TIME BASE 10 MHz INPUT.
2. Connect high-impedance, dc coupled oscilloscope to A11J5 (INT 10 MHZ OUT). The waveform should be a TTL square wave with a period of 100 ns. If faulty, see Service Sheet 22 and check the 10 MHz Time Base Reference Oscillator.
3. Check A11TP4 (TB) with an oscilloscope. The waveform should be TTL pulses with a period of 160  $\mu$ s. If faulty, see Service Sheet 22 and check the Time Base Divider.

#### $\sqrt{2}$ Counter Check

##### NOTE

*This check assumes that the  $\sqrt{1}$  Time Base Reference Check give positive results. For Option 002, disconnecting the cable from the time base reference halts the Controller.*

1. Connect a jumper cable between A11J5 (INT 10 MHZ OUT) and A11J1 ( $\div 8$  IN). Key in 46.4 SPCL. This switches the Counter to measure the HF VCO divided by 8. The display should read 1000000 $\pm$ 1. If faulty, see Service Sheet 23.
2. Disconnect the jumper from A11J1 and connect it to A11J3 (IF IN). Key in 46.1 SPCL. This switches the Counter to measure the IF. The display should read 1000000 $\pm$ 1. If faulty, see Service Sheet 23 and check the Input Selector.
3. Disconnect the jumper from A11J3 and connect it to A11J2 (10 MHZ IN). Key in 46.3 SPCL. This switches the Counter to measure the output of the FM Calibrator. The display should read 1000000 $\pm$ 1. If faulty, see Service Sheet 23 and check the Input Selector.
4. Remove the jumper cable. Short A11TP1 (GND) to A11TP6 (VM GATE). Key in 46.1 SPCL. This switches the Counter to measure the 10 MHz time base reference via the Voltage-to-Time Converter input. The display should read 1000000 $\pm$ 1. If faulty, see Service Sheet 23 and check the Input Selector and Voltmeter Gate logic.

**√3 Controller Kernel Check**

**CAUTION**

*MOS and CMOS ICs can be damaged by static charges and circuit transients. Do not remove the A13 Controller Assembly or the A14 Remote Interface Assembly from the instrument while power is applied. Discharge the board and replacement IC to the same potential. (Use a conductive foam pad such as provided in the Service Accessory Kit HP 08901-60089.) When unplugging ICs, place the board on a conductive pad. When the IC is unplugged, insert it into the foam also.*

*A13 also contains a soldered-in battery. To prevent shorting out the battery, do not lay the board on a metal surface.*

*Several ICs on these assemblies are held in high-grip sockets. Both the socket and the device can be damaged if an attempt is made to remove the device with an IC extraction tool. The recommended procedure is to first ground the tip of a small blade-type screwdriver, then slide the tip between the IC and the socket and slowly pry up the IC one pair of pins at a time.*

1. Switch POWER to STBY. Extend the A13 Controller Assembly with the Digital Test/Extender Board. Switch POWER to ON.
2. Check A13TP12 (+12V) with dc voltmeter. The voltage should be between +11.4 and +12.6 Vdc. If faulty, see Service Sheet 24 and check the +12V Regulator.
3. Short A13TP9 (RESET) to A13TP10 (+5V). This resets the Controller and forces a short write (instruction) cycle. Connect a high-impedance, dc coupled oscilloscope to A13TP4 (WRT) or the WRT test point on the extender board. The waveform should be TTL pulses with a period of 2  $\mu$ s. If faulty, see Service Sheet 24 and check the clock and  $\Phi$  lines and the Power-On Reset circuit.
4. Set the ROMC switches on extender board to GND. This forces the SMI to step through its addresses. On the extender board, connect the signature analyzer clipleads as follows:

Clock .....	WRT
Start .....	ADDRESS 15
Stop .....	ADDRESS 15
Ground .....	GND

5. Set the signature analyzer's start, stop, and clock to trigger as follows:

Start .....	Falling Edge
Stop .....	Falling Edge
Clock .....	Rising Edge

6. Check the test points on the extender board with the signature analyzer probe as listed in Table 8D-15. If all signatures are bad except GND, see Service Sheet 24 and replace the SMI. If only one ADDRESS line is faulty, see Service Sheet 24 and check the SMI and the address line.
7. Check the RAM WRT and CPU READ test points on the extender board with an oscilloscope. RAM WRT should be a TTL high, CPU READ should be a TTL square wave with a period of 2  $\mu$ s. If faulty, see Service Sheet 24 and check the SMI and the load on the first two lines.
8. Switch POWER to STBY. Remove A13U1 (CPU External Register or RAM) from its socket.

**Table 8D-15. Address Line Signatures, (√3) Step 6**

Test Point	Signature	Test Point	Signature
+5V*	0001	ADDRESS 8	HC89
GND	0000	ADDRESS 7	52F8
ADDRESS 15	755U	ADDRESS 6	UPFH
ADDRESS 14	3827	ADDRESS 5	0AFA
ADDRESS 13	3C96	ADDRESS 4	5H21
ADDRESS 12	HAP7	ADDRESS 3	7F7F
ADDRESS 11	1293	ADDRESS 2	CCCC
ADDRESS 10	HPP0	ADDRESS 1	5555
ADDRESS 9	2H70	ADDRESS 0	UUUU

\* Test point on Controller Assembly A13TP10 (+5V).

- Switch POWER to ON. Check the CONTROL BUS test points on the extender board with the signature analyzer probe as listed in Tables 8-16a through 8-16f. If signatures are faulty, see Service Sheet 24 and check the Decoders and ROMs.

**NOTE**

*The signatures below are valid only for the firmware with the specified ROM part numbers. Consult Section 7, Instrument Changes, or the Manual Changes Packet for signatures corresponding to other firmware part numbers.*

**Table 8D-16a. Data Line Signatures, (√3) Step 9 (2305A to 2331A)**

Test Point	Signature*	Test Point	Signature*
DATA 0	Replace with latest parts.	DATA 4	Replace with latest parts.
DATA 1		DATA 5	
DATA 2		DATA 6	
DATA 3		DATA 7	

*Valid ROM part numbers:	ROM Number	Part Number
	1	08901-80062
	2	08901-80063
	3	08901-80064

**Table 8D-16b. Data Line Signatures, (√3) Step 9 (2337A to 2449A)**

Test Point	Signature*	Test Point	Signature*
DATA 0	4F0C	DATA 4	3FH0
DATA 1	2C60	DATA 5	48FC
DATA 2	10H0	DATA 6	9H29
DATA 3	C14U	DATA 7	89CU

*Valid ROM part numbers:	ROM Number	Part Number
	1	08901-80066
	2	08901-80067
	3	08901-80068

**Table 8D-16c. Data Line Signatures,  $\langle J_3 \rangle$  Step 9 (2451A to 2515A)**

Test Point	Signature*	Test Point	Signature*
DATA 0	AA89	DATA 4	43HA
DATA 1	P326	DATA 5	H133
DATA 2	F2CC	DATA 6	2H0U
DATA 3	8A55	DATA 7	5A6A
*Valid ROM part numbers:			
	<b>ROM Number</b>	<b>Part Number</b>	
	1	08901-80071	
	2	08901-80072	
	3	08901-80073	

**Table 8D-16d. Data Line Signatures,  $\langle J_3 \rangle$  Step 9 (2519A to 2523A)**

Test Point	Signature*	Test Point	Signature*
DATA 0	04C0	DATA 4	8344
DATA 1	H656	DATA 5	F017
DATA 2	UA85	DATA 6	60H7
DATA 3	A0U6	DATA 7	5U3F
*Valid ROM part numbers:			
	<b>ROM Number</b>	<b>Part Number</b>	
	1	08901-80076	
	2	08901-80077	
	3	08901-80078	

**Table 8D-16e. Data Line Signatures,  $\langle J_3 \rangle$  Step 9 (2528A and 2546A)**

Test Point	Signature*	Test Point	Signature*
DATA 0	4454	DATA 4	HC6U
DATA 1	P20F	DATA 5	1862
DATA 2	UCHA	DATA 6	8066
DATA 3	H5PF	DATA 7	8A44
*Valid ROM part numbers:			
	<b>ROM Number</b>	<b>Part Number</b>	
	1	08901-80084	
	2	08901-80077	
	3	08901-80078	

**Table 8D-16f. Data Line Signatures,  $\langle J_3 \rangle$  Step 9 (2550A to 2706A)**

Test Point	Signature*	Test Point	Signature*
DATA 0	00C2	DATA 4	4742
DATA 1	9904	DATA 5	U1UH
DATA 2	0731	DATA 6	U02U
DATA 3	CC13	DATA 7	82UF
*Valid ROM part numbers:			
	<b>ROM Number</b>	<b>Part Number</b>	
	1	08901-80081	
	2	08901-80082	
	3	08901-80083	



*Table 8D-16g. Data Line Signatures,  Step 9 (2717A and Above)*

Test Point	Signature*	Test Point	Signature*
DATA 0	AU23	DATA 4	7A46
DATA 1	F8A4	DATA 5	H187
DATA 2	56H1	DATA 6	252P
DATA 3	F364	DATA 7	4FU3
*Valid ROM part numbers:			
	<b>ROM Number</b>	<b>Part Number</b>	
	1	08901-80105	
	2	08901-80106	
	3	08902-80107	

**√4 CPU External Register (RAM) Check**

1. Perform the Power-Up Checks on Service Sheet BD1.

**√5 CPU I/O Port Check**

1. If the Digital Test/Extender Boards is not already extending A12 or A13, plug it into the empty slot in the Digital Section.

**NOTE**

*Check that the ROMC switches on the extender board are in the OPEN position.*

2. Key in 0.2 SPCL. Check the INSTRUMENT BUS test points on the extender board with an oscilloscope or signature analyzer probe (used as a logic probe) as listed in Table 8D-17. If faulty, see Service Sheet 24 and check the CPU and I/O port decoders and buffers.

**Table 8D-17. Instrument Bus Data, √4 Step 2**

Test Point	Measured Signal
ENABLE 2	Low-Going TTL Pulses, Period ≈60 ms
SELECT 0 to 3	TTL Low
DATA (H) 0 to 3	TTL Low
DATA (L) 0 to 3	TTL High

3. Key in 0.2 S (Shift) 5 S 5 SPCL. Recheck the test points listed in Table 8D-18. If faulty, see Service Sheet 24 and check the CPU and I/O port decoders and buffers.

**Table 8D-18. Instrument Bus Data, √4 Step 3**

Test Point	Measured Signal
SELECT 0 to 3	TTL High
DATA (H) 0 to 3	TTL High
DATA (L) 0 to 3	TTL Low

4. Key in the Special Functions listed in Table 8D-19. For each entry, the indicated ENABLE test point on the extender board should show low-going TTL pulses with a period of approximately 60 ms. All other ENABLE test points should be TTL highs. If faulty, see Service Sheet 24 and check the Enable Decoder and CPU.

**Table 8D-19. Instrument Bus Data, √4 Step 4**

Special Function	Test Point
0.0	ENABLE 0
0.1	ENABLE 1
0.3	ENABLE 3
0.4	ENABLE 4
0.5	ENABLE 5
0.6	ENABLE 6
0.7	ENABLE 7

### √6 Keyboard Key Check

1. Key in 60.0 SPCL. As the Special Function code is entered, 60.0 should appear in the display. This indicates that the Controller responds to keyboard interrupts. If faulty, see √7 and √8. While the SPCL key is down, 35 should appear in the display. After releasing the SPCL key, 99 should appear in the display. If another number appears, continue on.
2. Jumper A13TP3 (INT) to A13TP15 (GND). This defeats the keyboard interrupt.
3. Press the keys one at a time and compare the display with the key codes shown in Figure 8D-8. If a code other than 99 appears in the display with no key pressed, the key corresponding to the displayed key code is probably stuck down; see Service Sheet 25. If a wrong code appears for one or more keys, check the corresponding key and decoder; see Service Sheet 25.

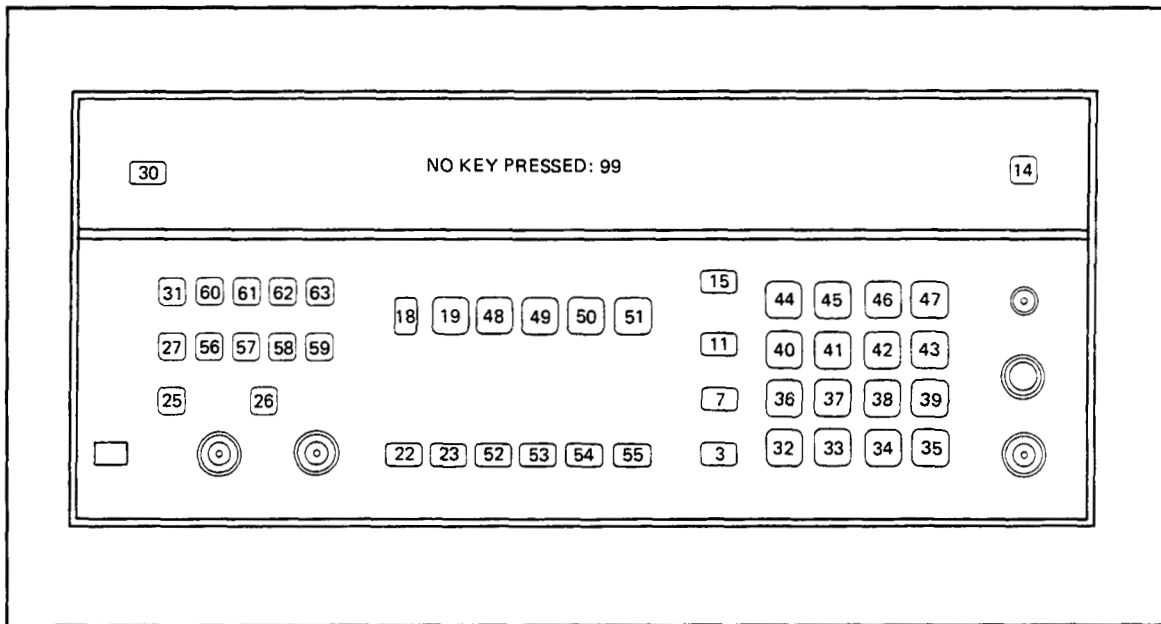

Figure 8D-8. Key Codes for Key Scan

### √7 Keyboard Interrupt Check

1. Connect high-impedance, dc coupled oscilloscope to A13TP3 (INT). The voltage should read a TTL high. Pressing any key should result in a TTL low which should remain low for 40 to 60 ms after the key is released. If faulty, see Service Sheet 25 and check the Keystroke Detector.

### √8 Front-Panel LED Check

1. Perform the Front-Panel LED Check on Service Sheets 26 and 27.

### √9 HP-IB Check

1. See Service Sheet 28.

### √10 Nonvolatile Memory Backup Check

1. Measure A13TP13 (BATT) with a dc voltmeter. The voltages should be between 2.7 and 2.9 Vdc. Repeat the measurement with POWER set to STBY. The voltage should not change. If faulty, see Service Sheet 24 and check the Nonvolatile Memory Supply.

*Hint:* The switching point between the normal and backup memory is adjustable. See *Adjustment 22—Battery Backup* in Section 5.

**√11 Power Supply Check**

1. Check test points A10TP2 through TP7 with a dc voltmeter. The voltages should be within the limits shown on Block Diagram 5. If a short on the supply is suspected, continue with step 2. If a regulator is suspected, see Service Sheets 31 and 32.

**NOTE**

*The supplies are interdependent. Often a short on one supply will shut down another. All supplies are dependent on the +15V Supply.*

*The switched +15V Supply line is normally grounded when the instrument is in standby. The +15V Supply (unswitched) LED should remain lighted when the POWER is set to STBY.*

2. Remove the plugs connected to A26J6 (RF SECTION), A26J3 (DIGITAL SECTION), and A26J2 (AUDIO SECTION) one at a time and observe the five power supply LEDs. (The plugs are located on the circuit side of the A26 Power Supply Motherboard.) An extinguished LED will light when the short is removed from the supply. The assemblies in the faulty section can then be removed one at a time until the one with the short is discovered.
3. Remove the plug connected to A26J1 (KEYBOARD). (This plug is on the component side.) Jumper pins 2 and 6 of A26J1 (where the green and black wires of W13 normally connect) to turn the instrument on. If the short is on the A1 Keyboard and Display Assembly, the extinguished LED will light. If the short still persists, see Service Sheets 31 and 32 and check the faulty regulator.

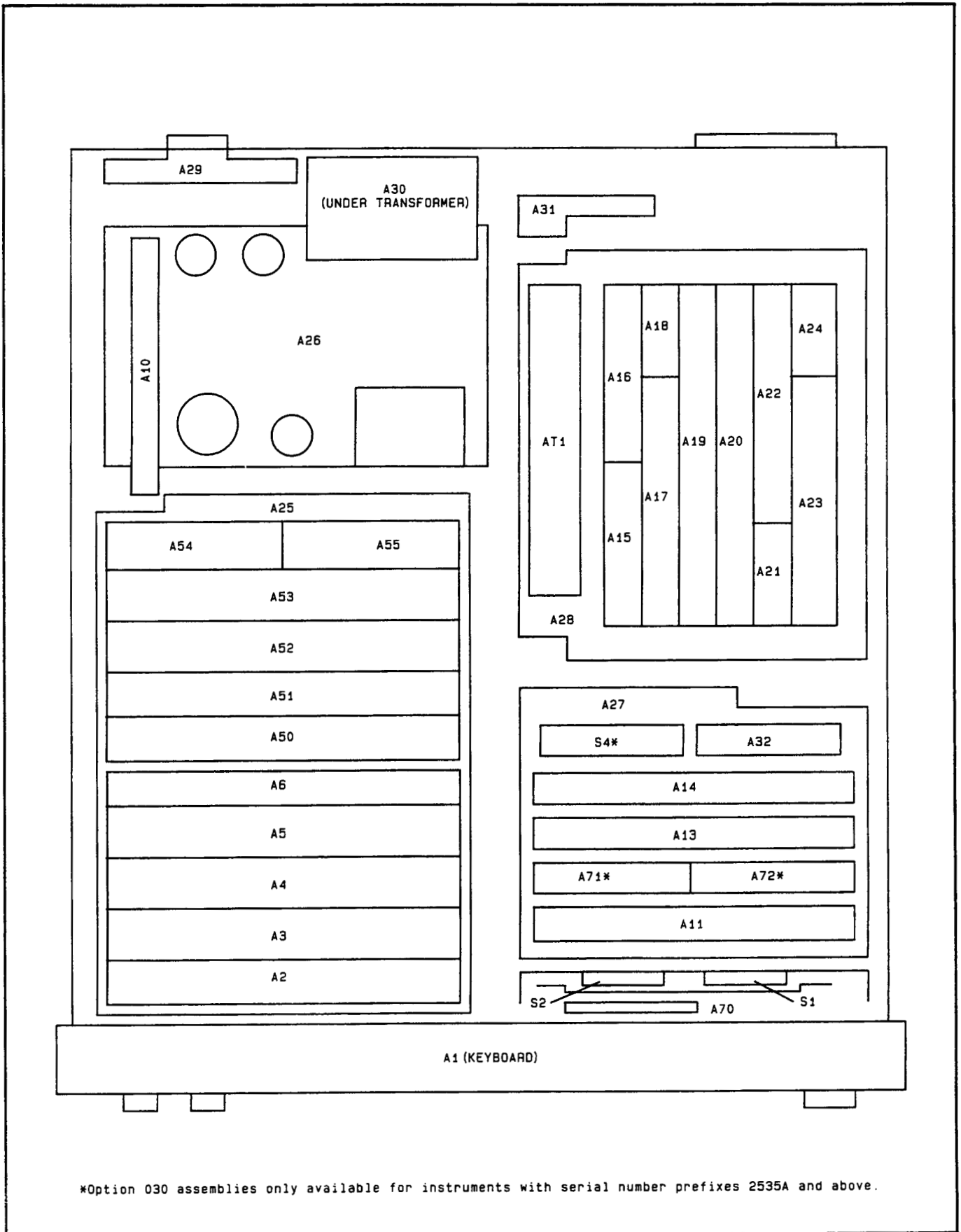

\*Option 030 assemblies only available for instruments with serial number prefixes 2535A and above.

Block Diagram Assembly Locations

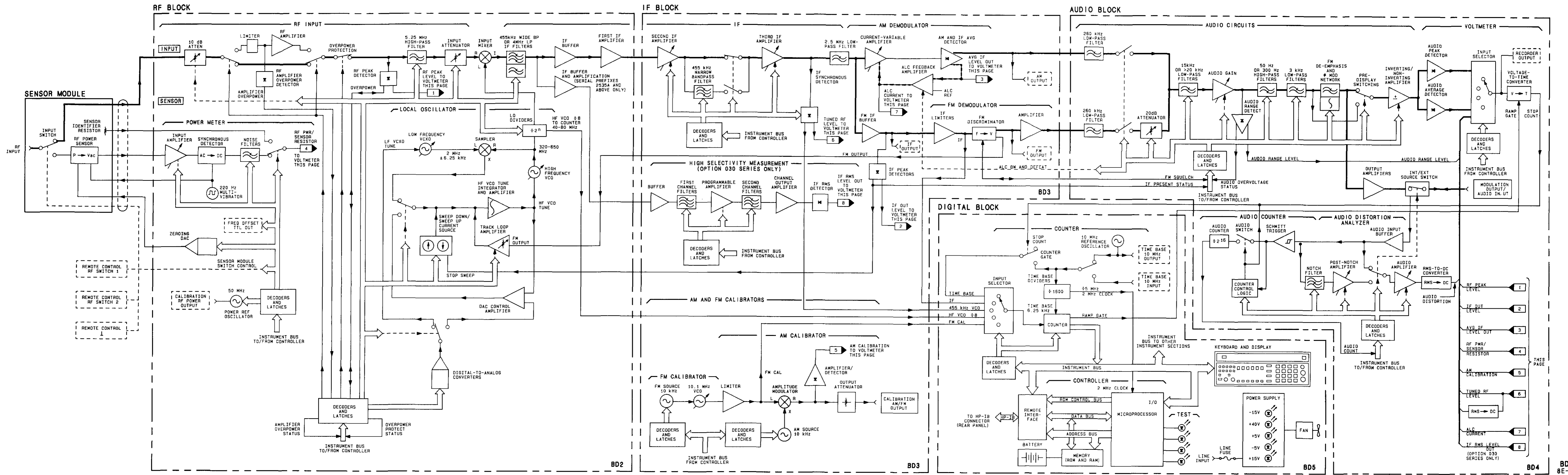

BD2

BD3

BD5

BD4

BD1

8E-3

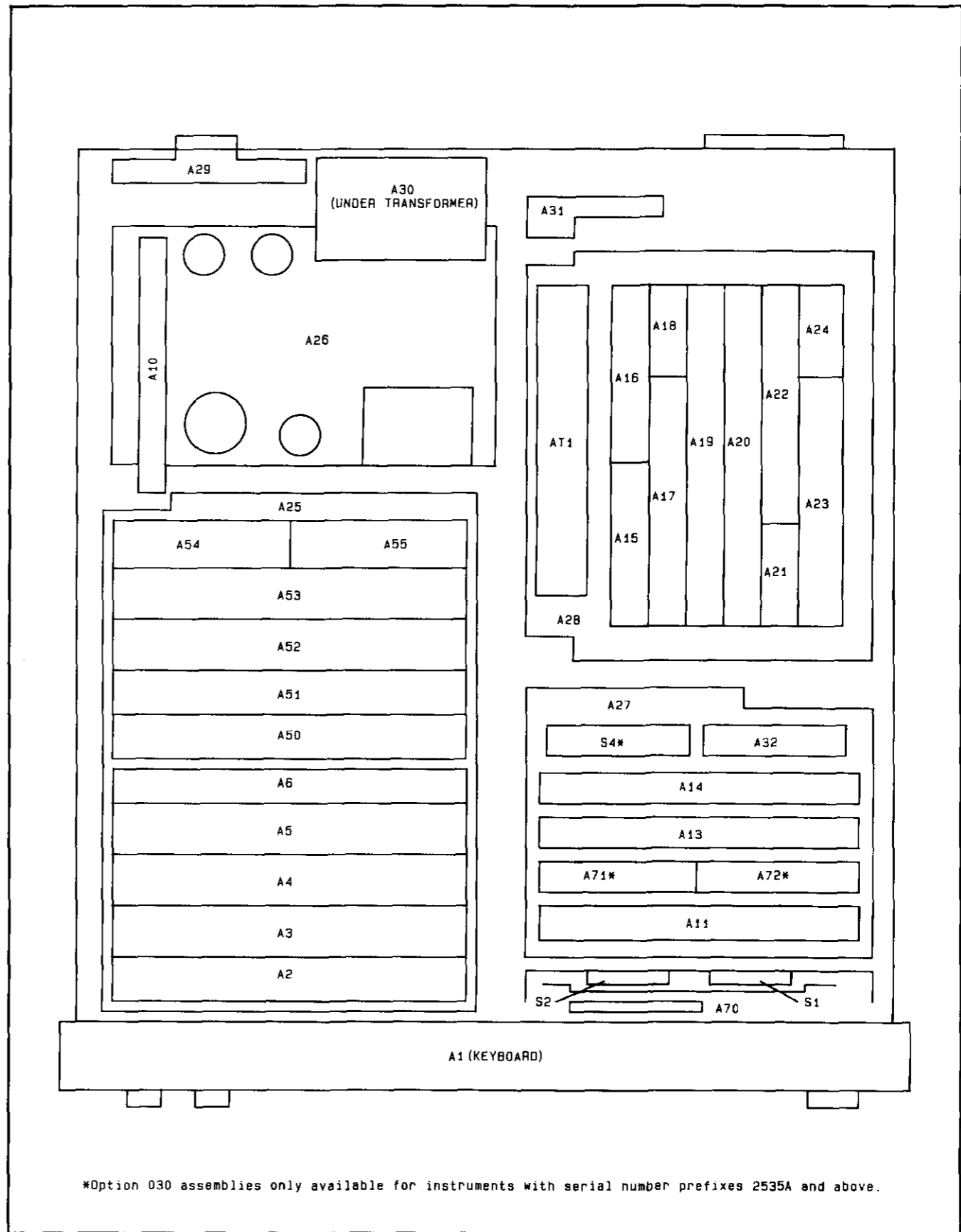

\*Option 030 assemblies only available for instruments with serial number prefixes 2535A and above.

OVERALL BLOCK DIAGRAM

**BD 1**

Block Diagram Assembly Locations

SEE REVERSE SIDE

## CHANGES

**Serial Prefix 2704A**

On the schematic:

- Replace the appropriate portion of the block diagram with the partial on page 8E-4.3.



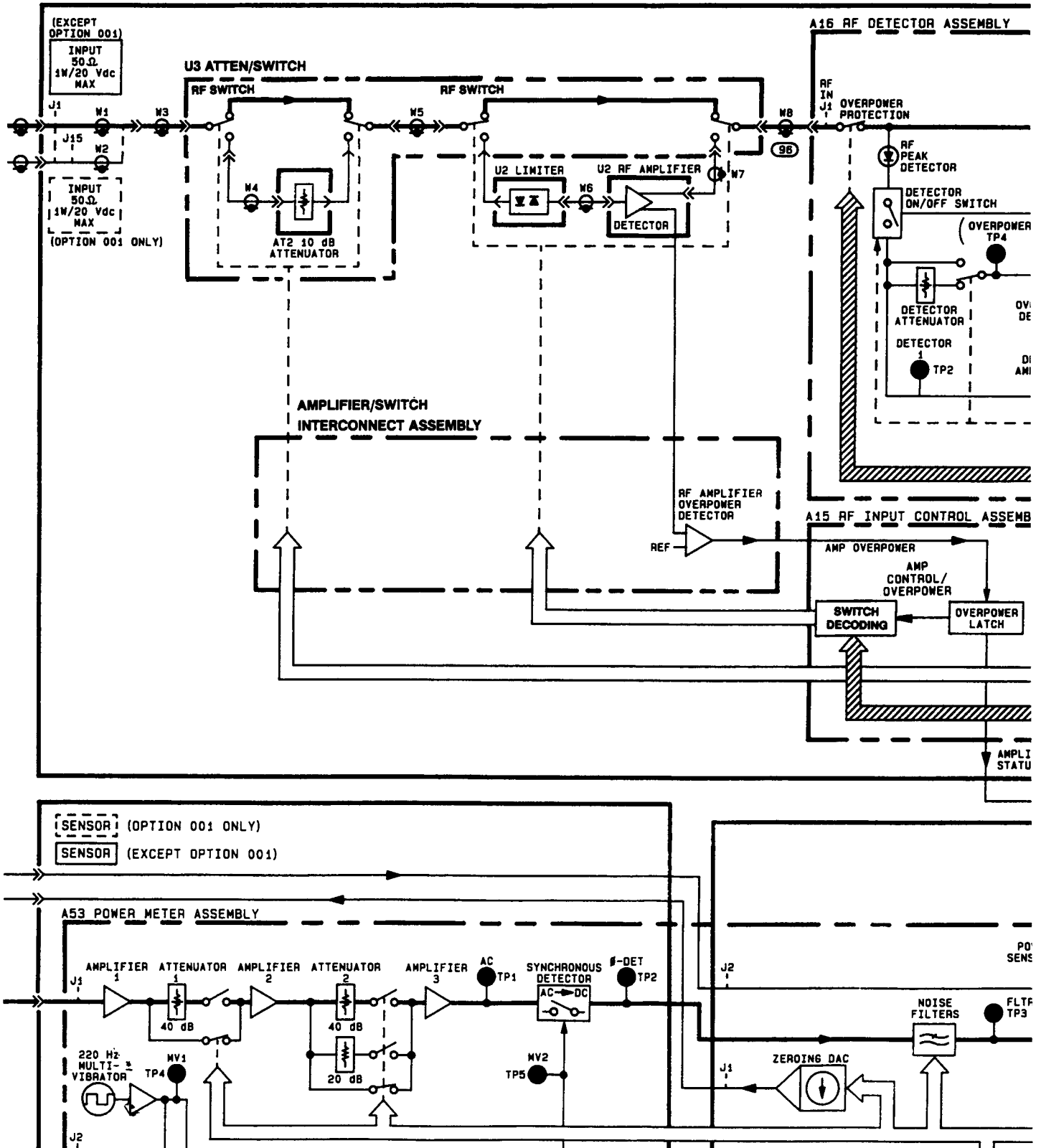

CHANGES TO FIGURE 8E-5 (2704A AND ABOVE)

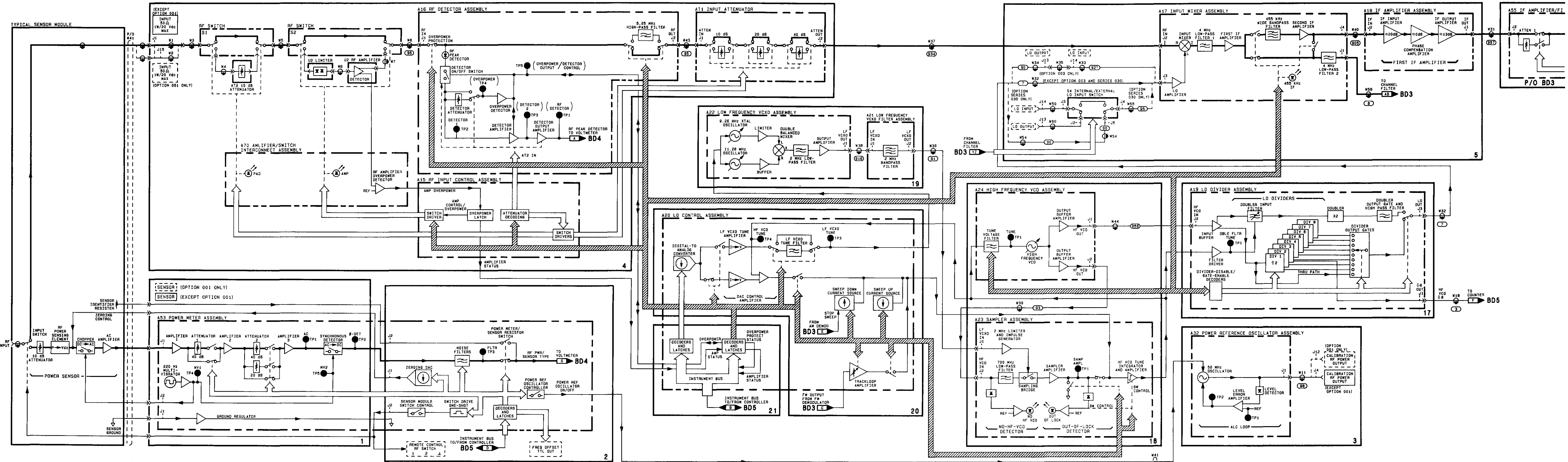

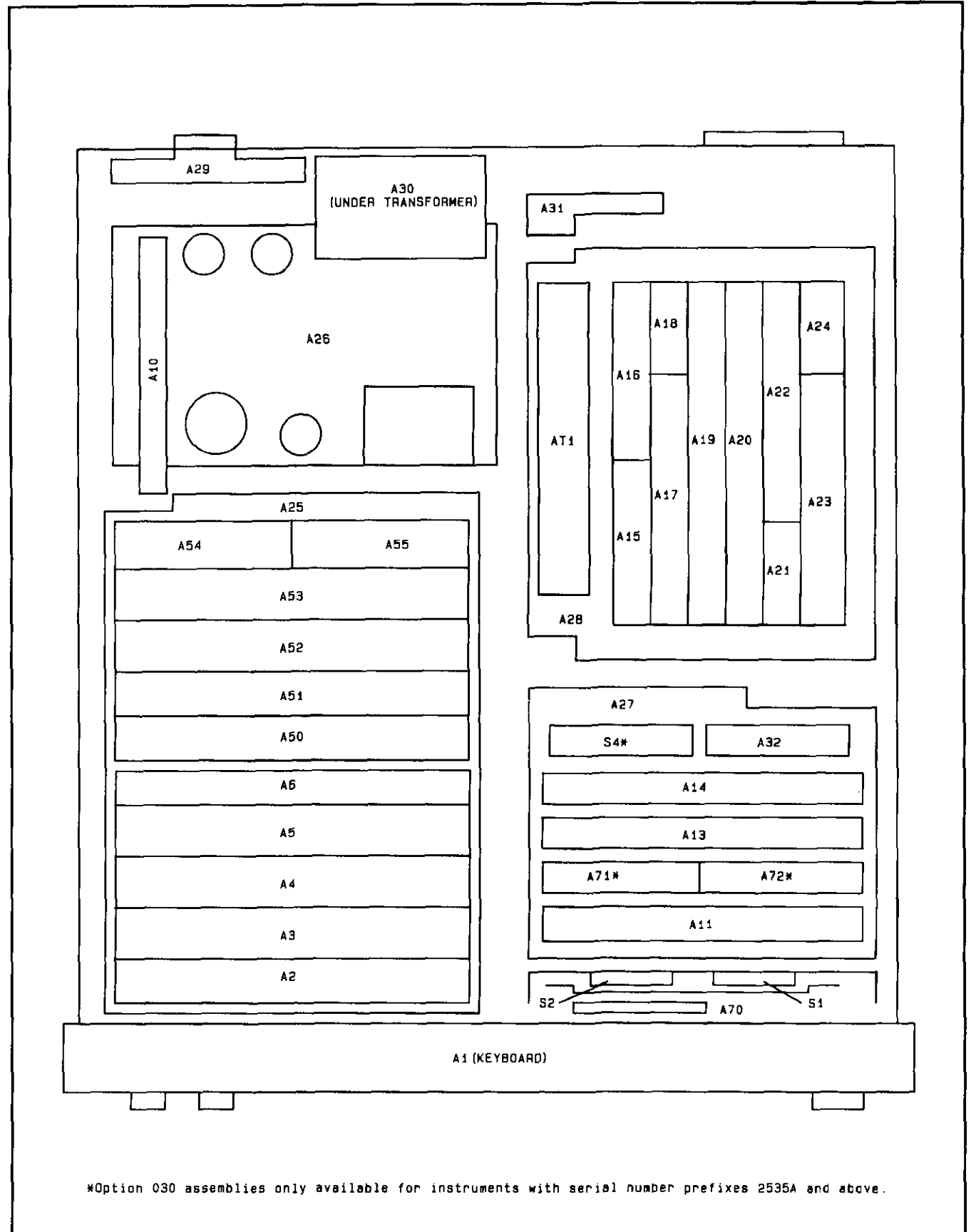

RF SECTION **BD2**

SEE REVERSE SIDE

Block Diagram Assembly Locations

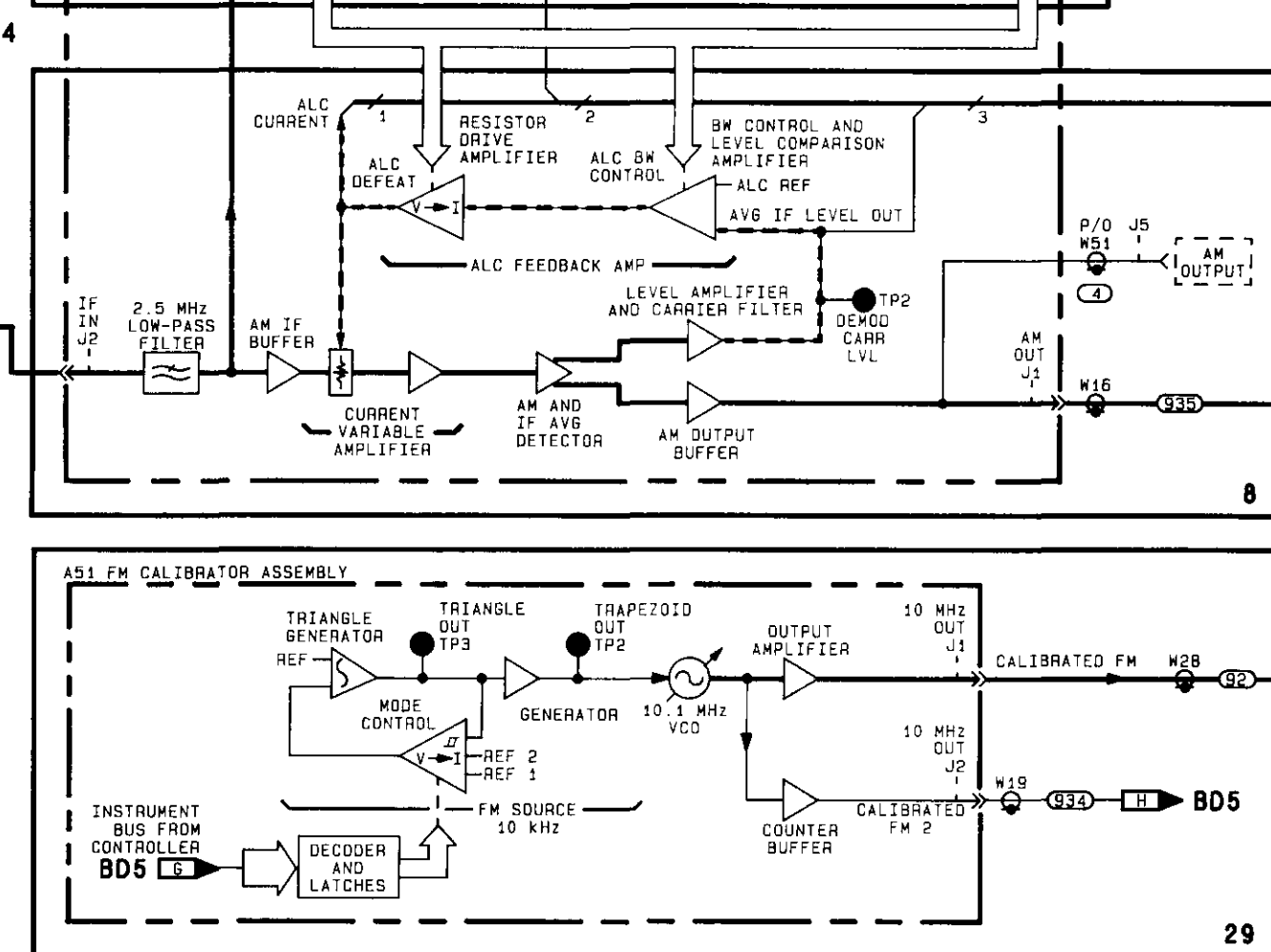
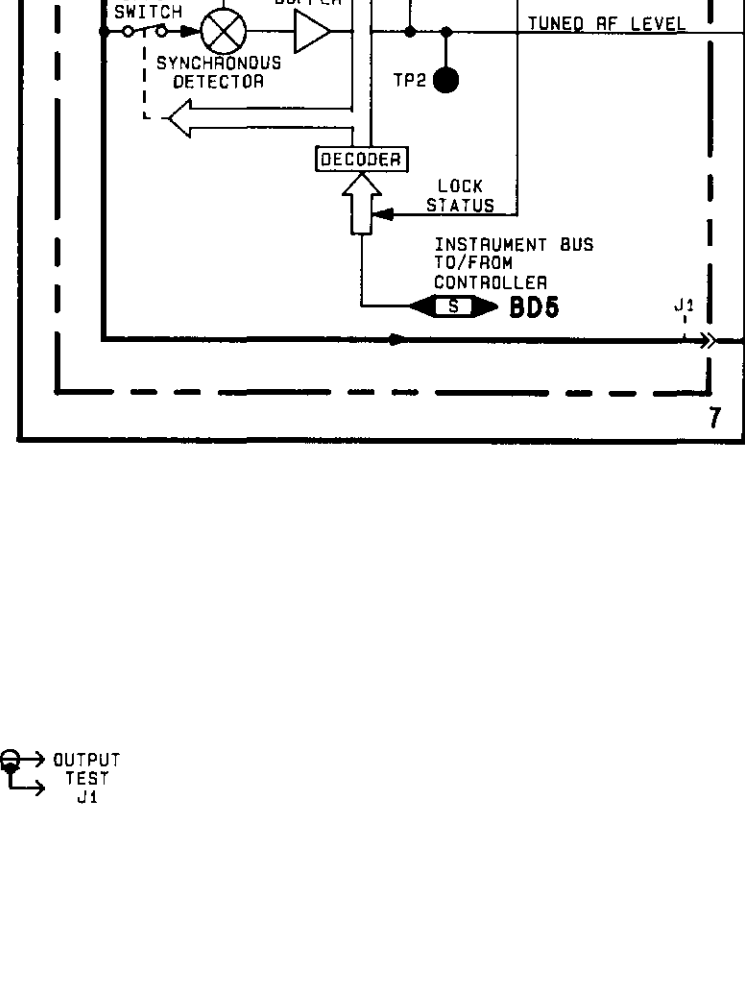
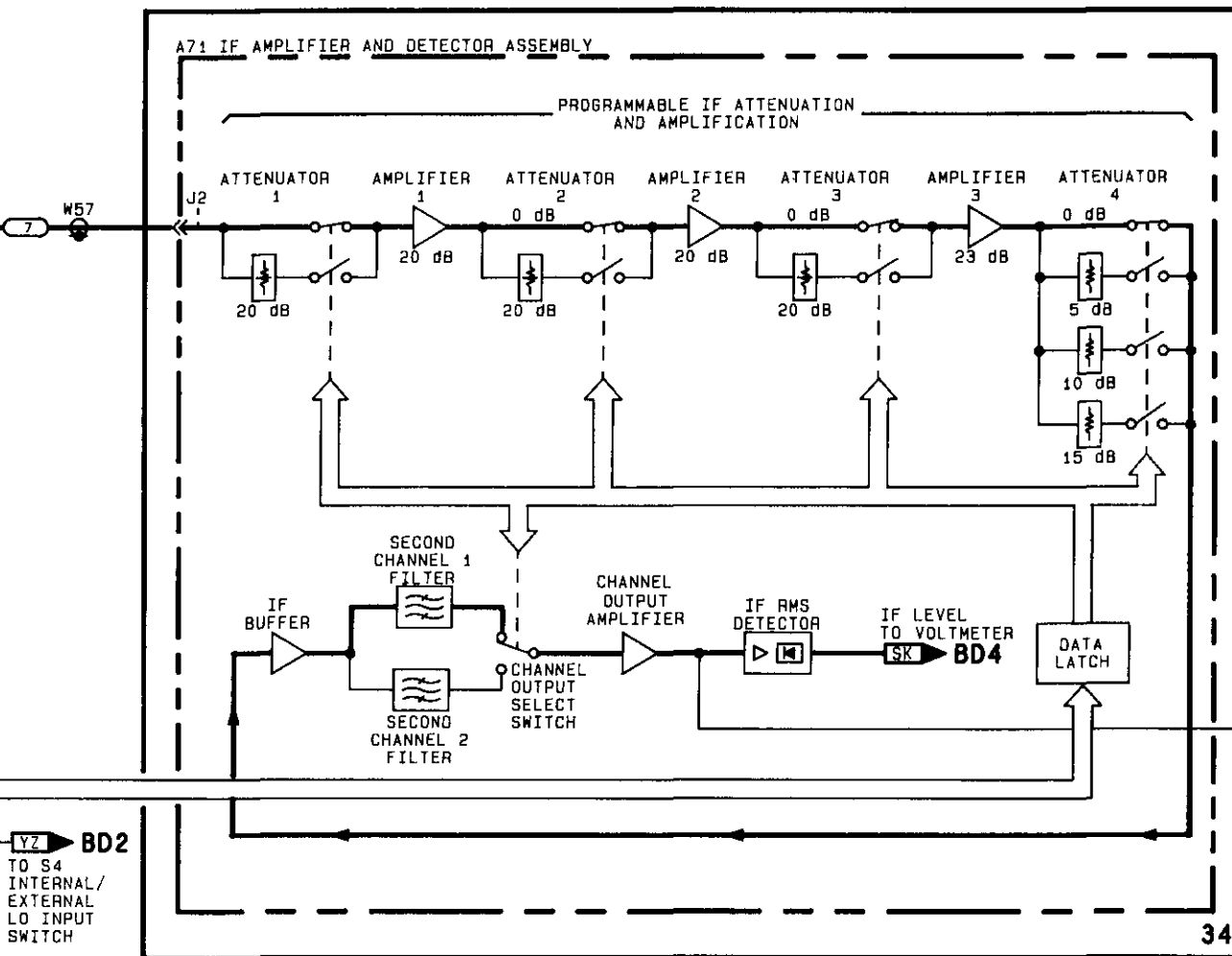
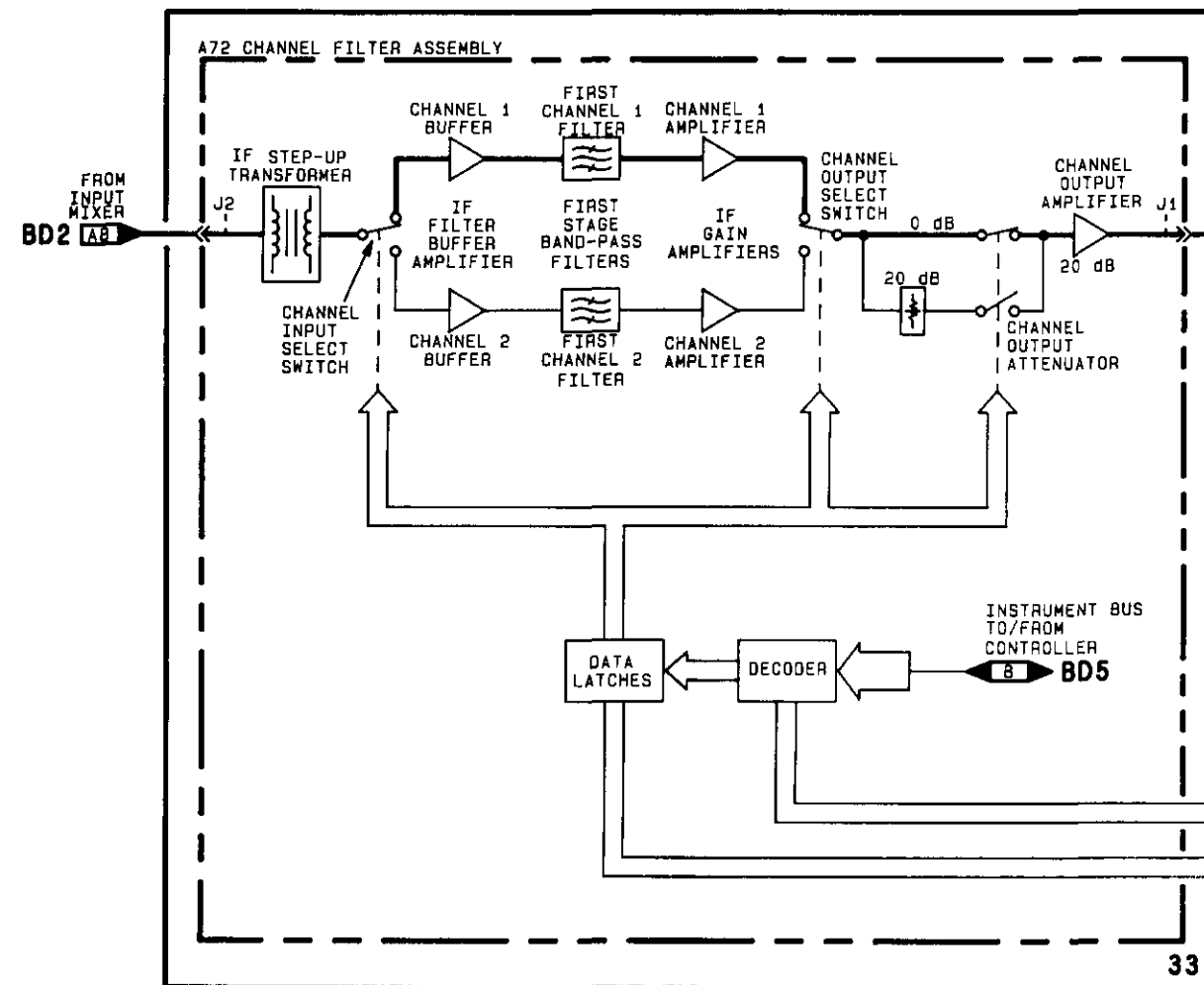
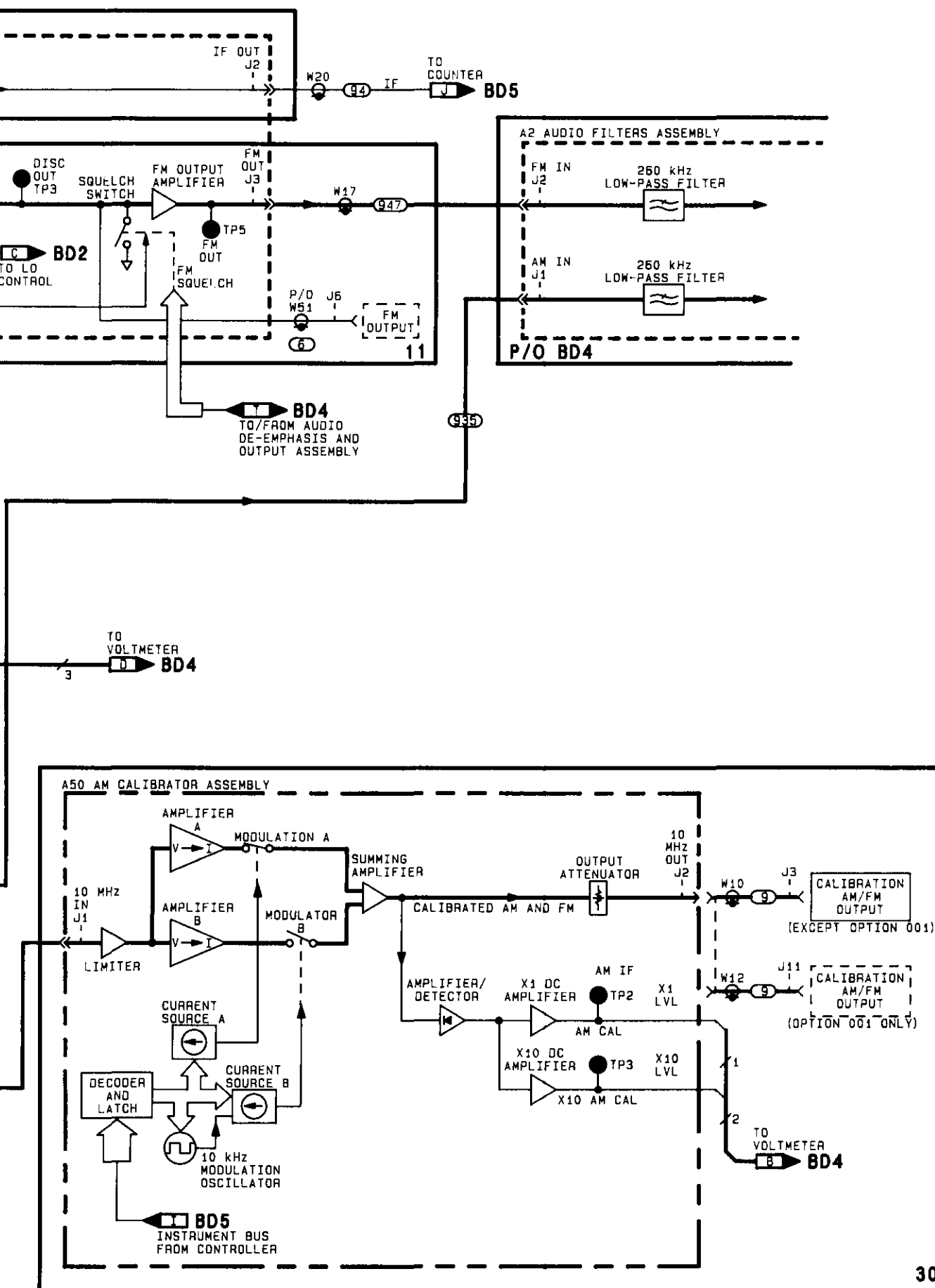
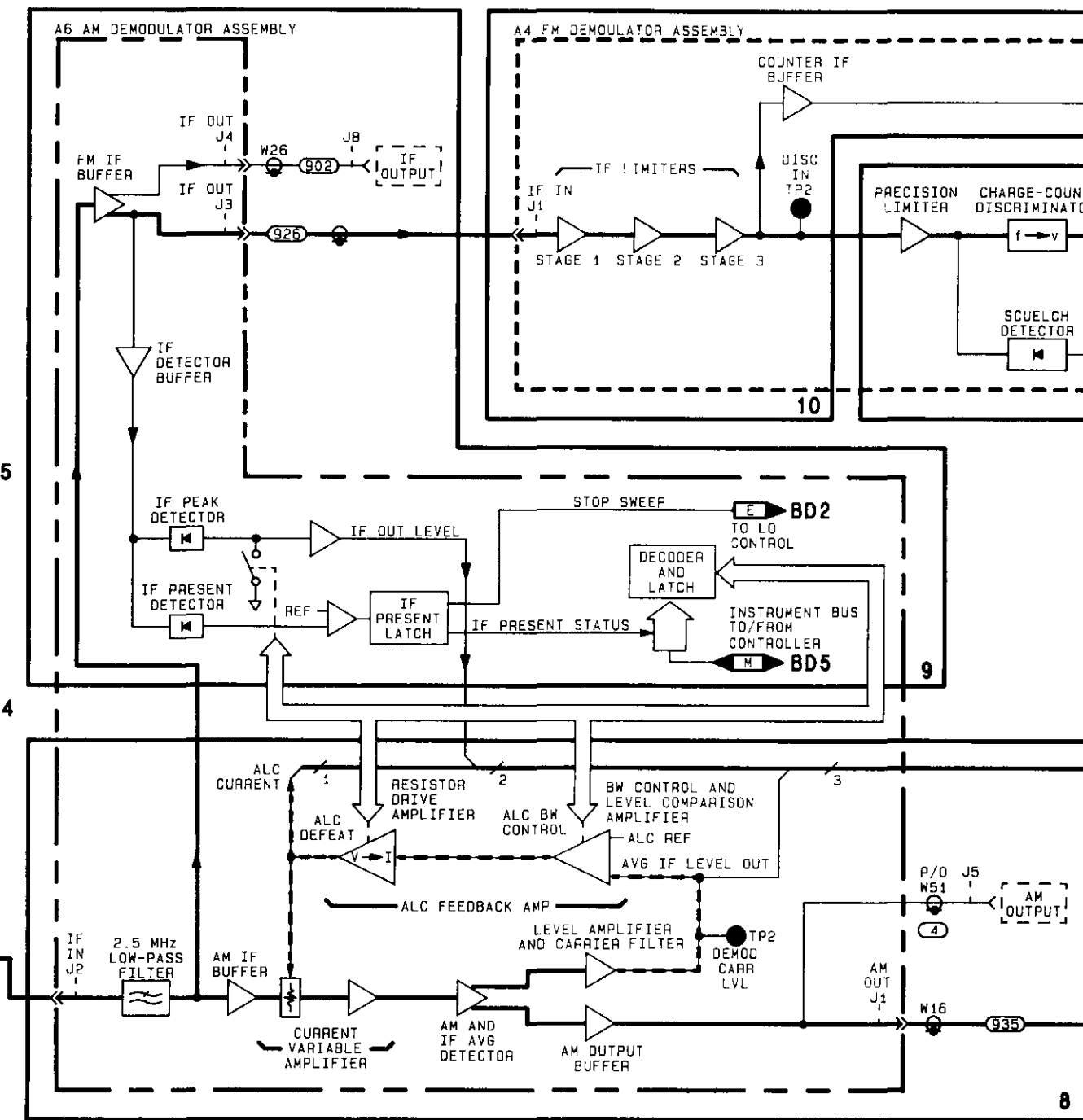
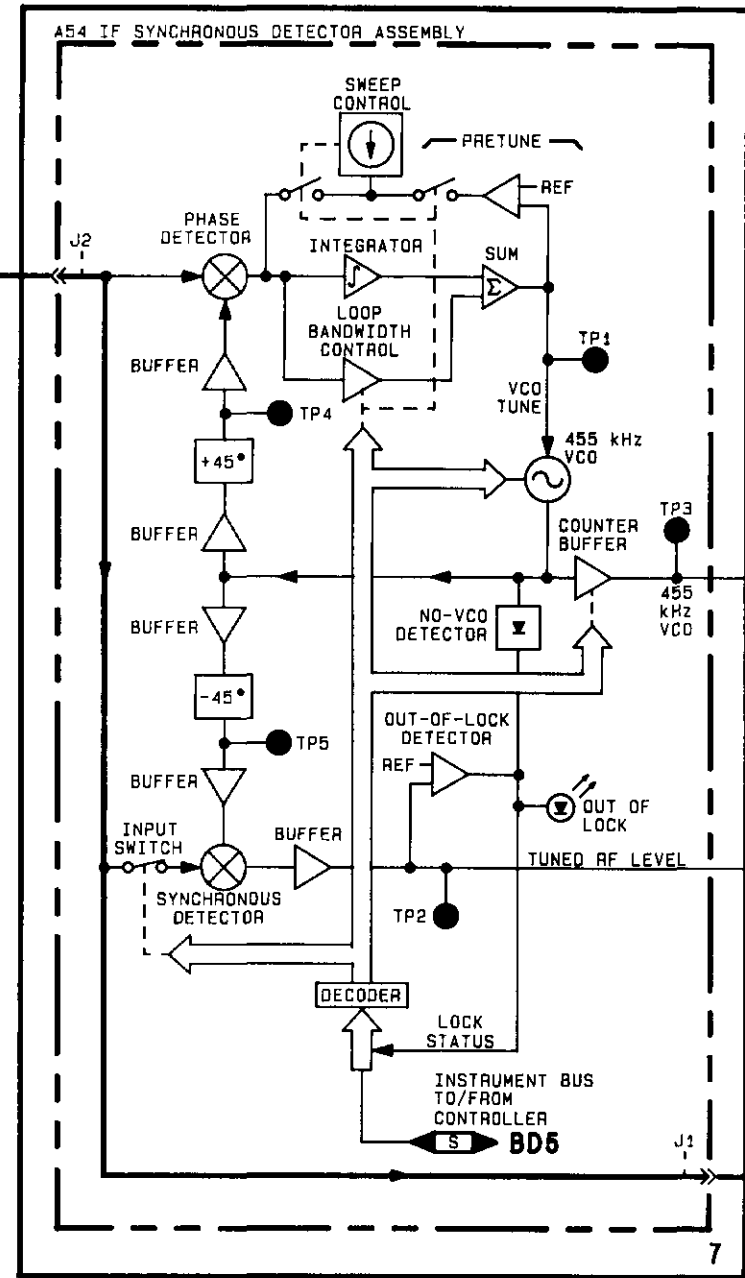
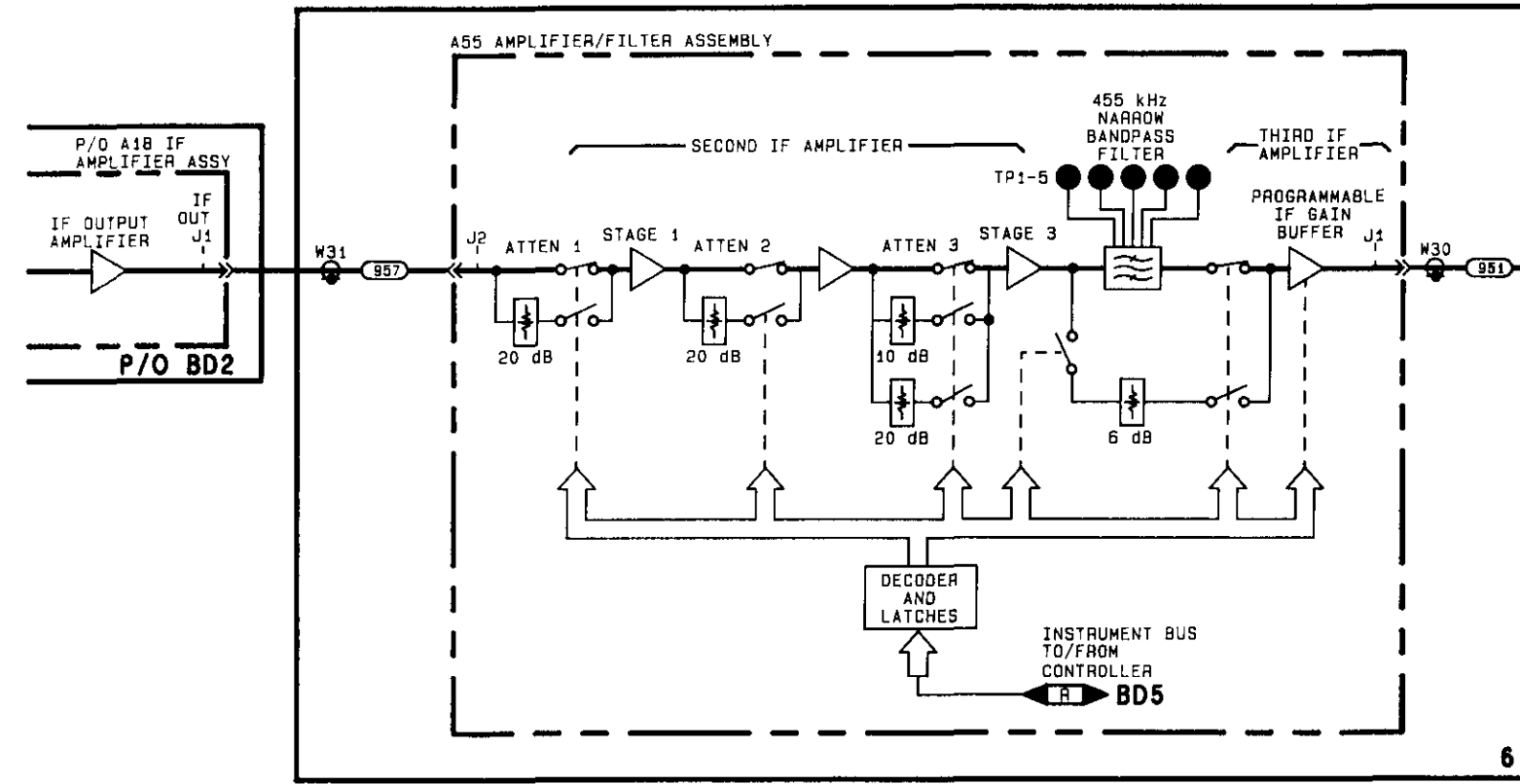

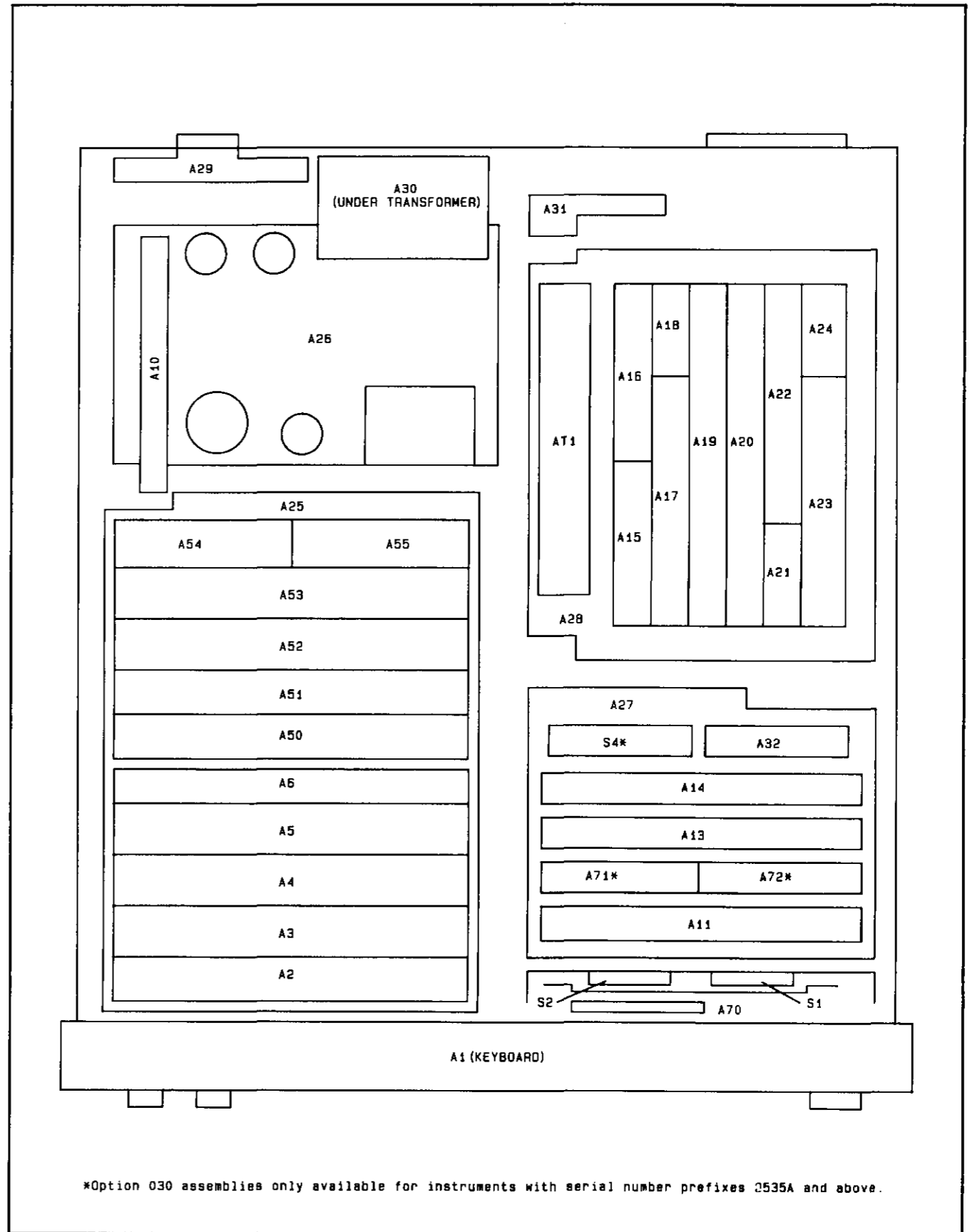

\*Option 030 assemblies only available for instruments with serial number prefixes 2535A and above.

IF SECTION **BD3**  
SEE REVERSE SIDE

Block Diagram Assembly Locations

## CHANGES

2413A and above

On the block diagram:

- W9 - In the lower, right portion of the block diagram, change the OPTION 001 ONLY cable from W9 to W53.

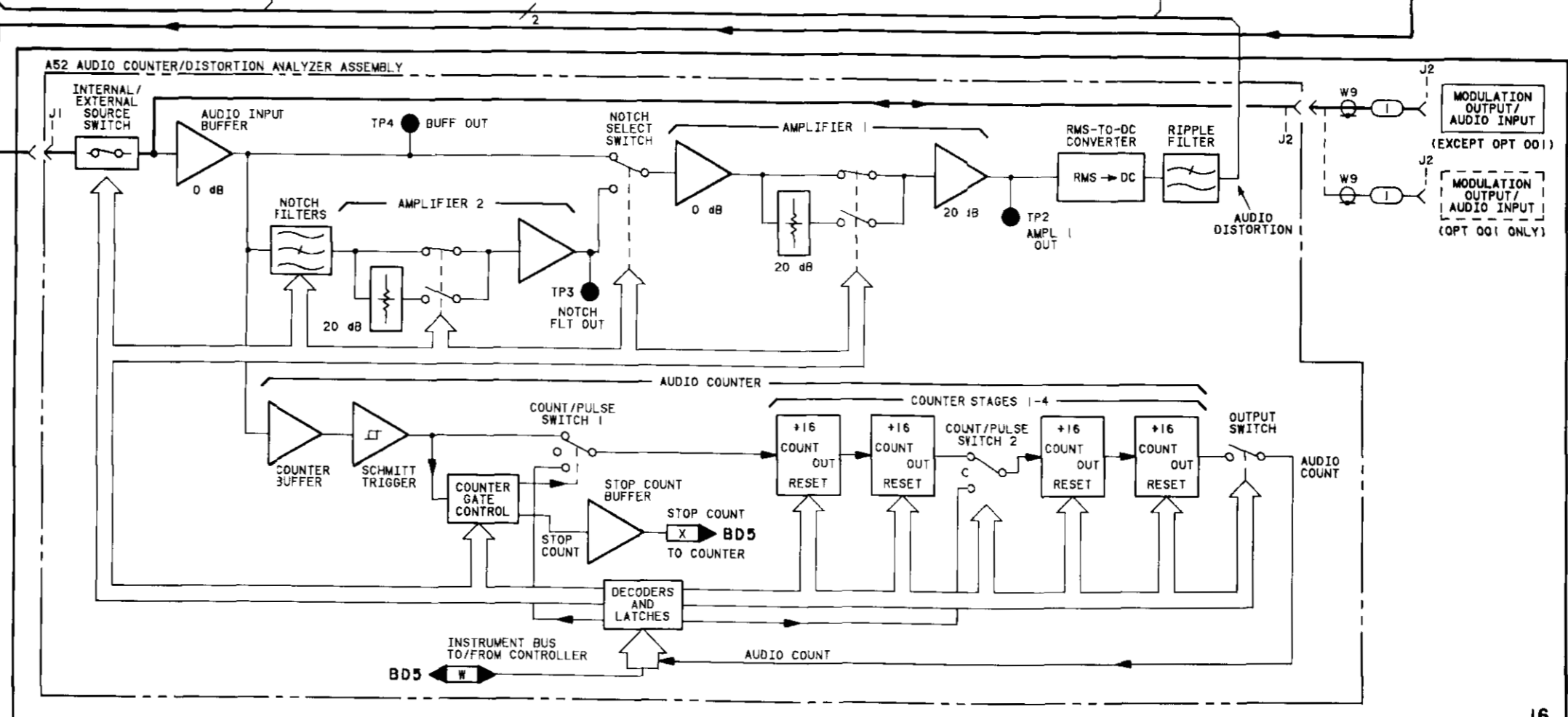
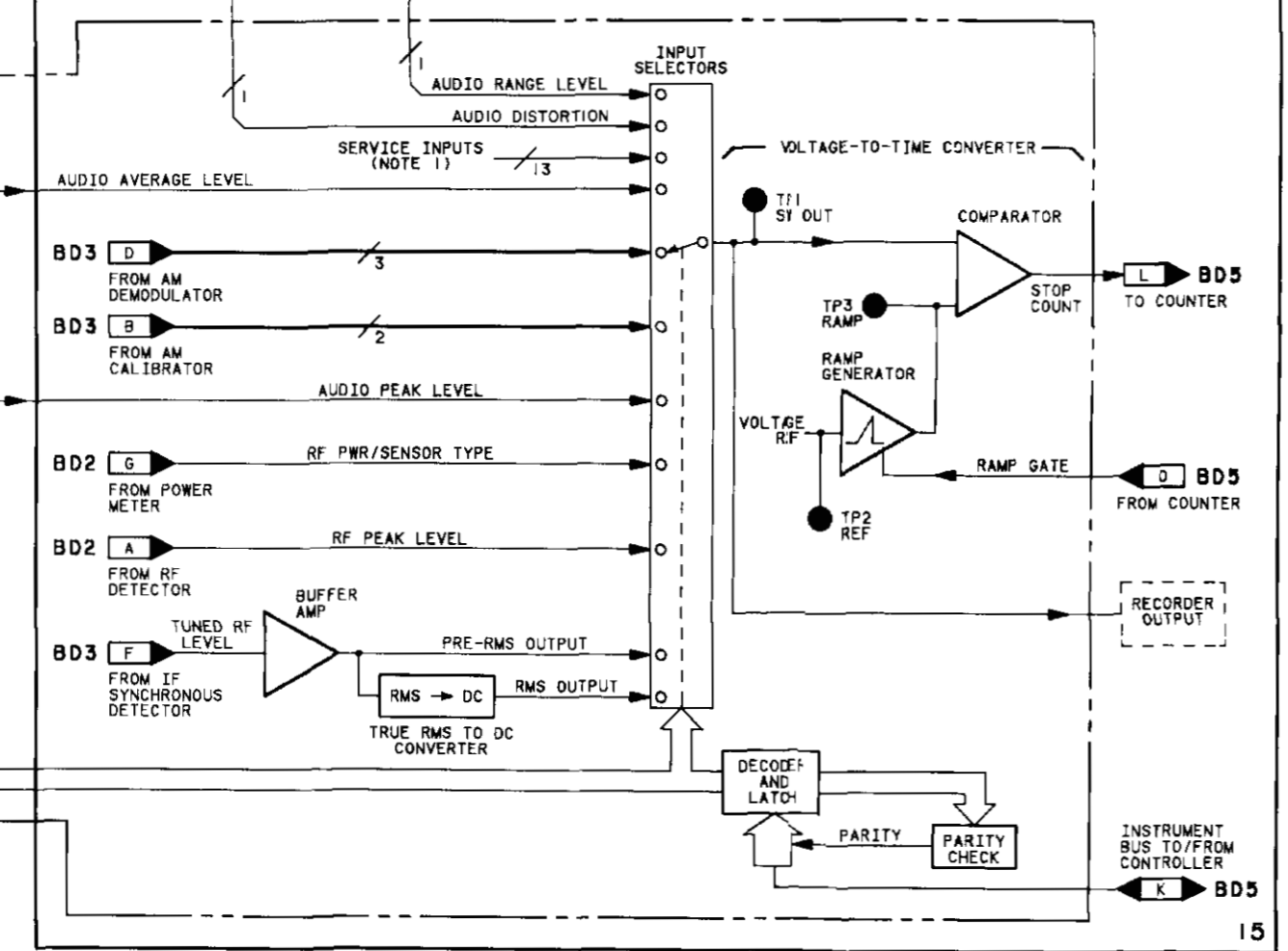
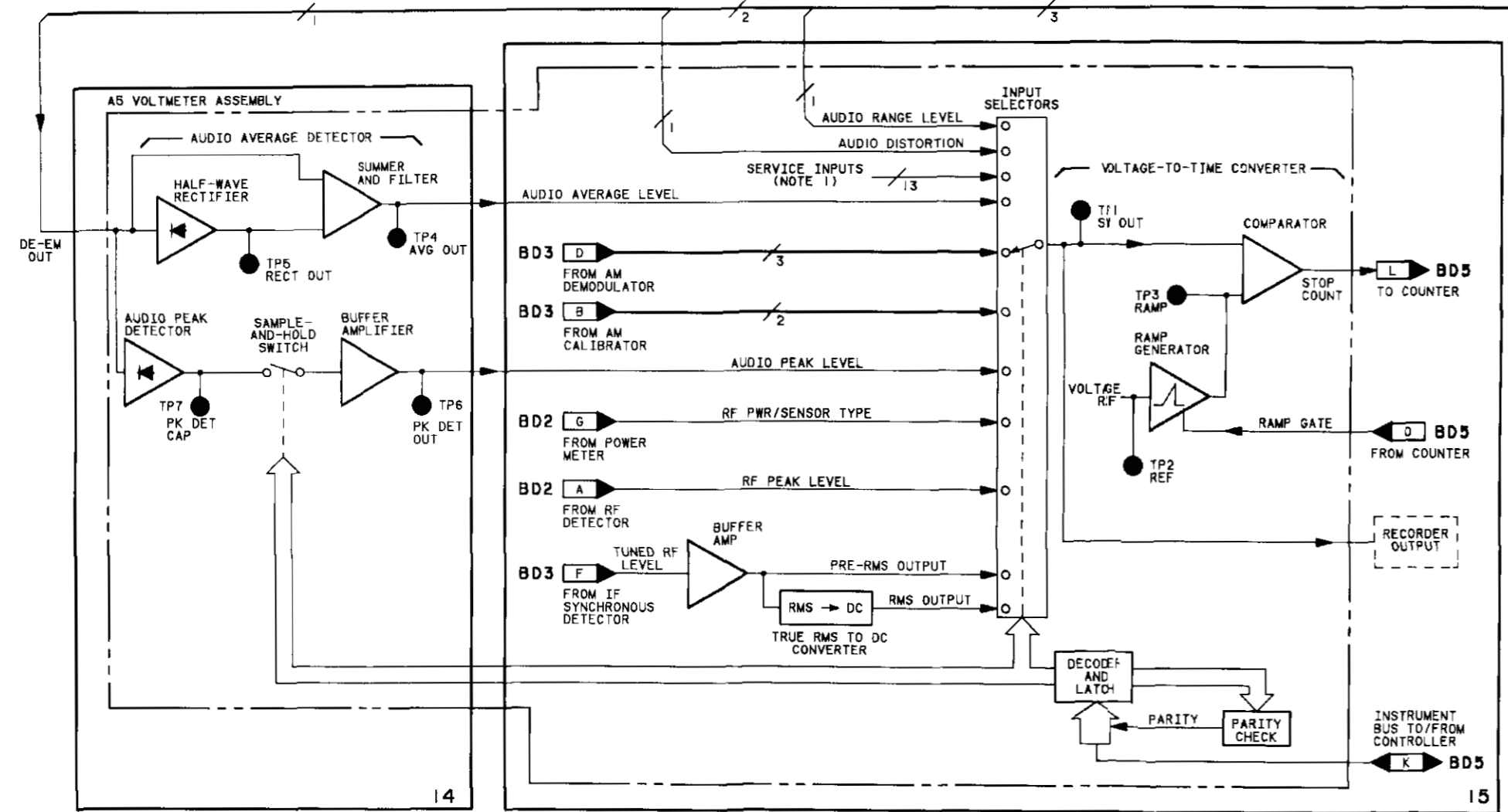
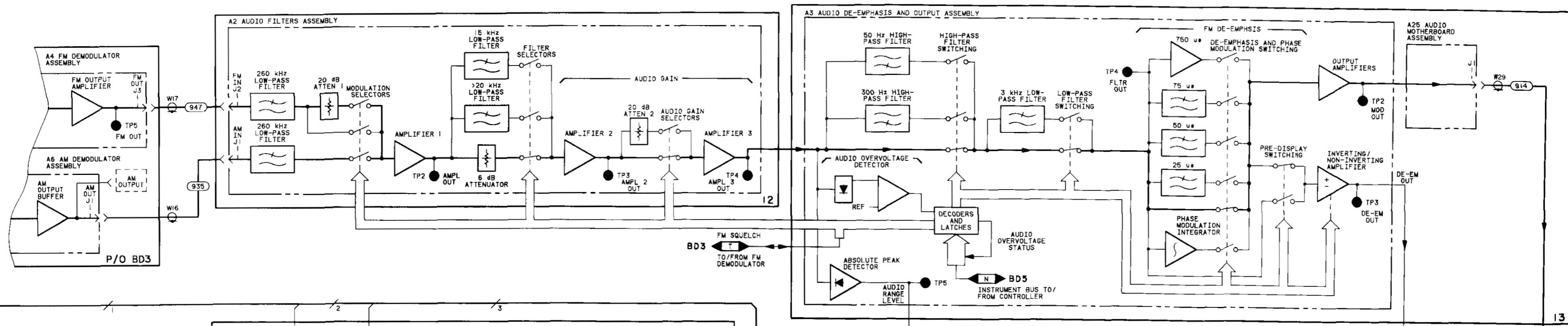

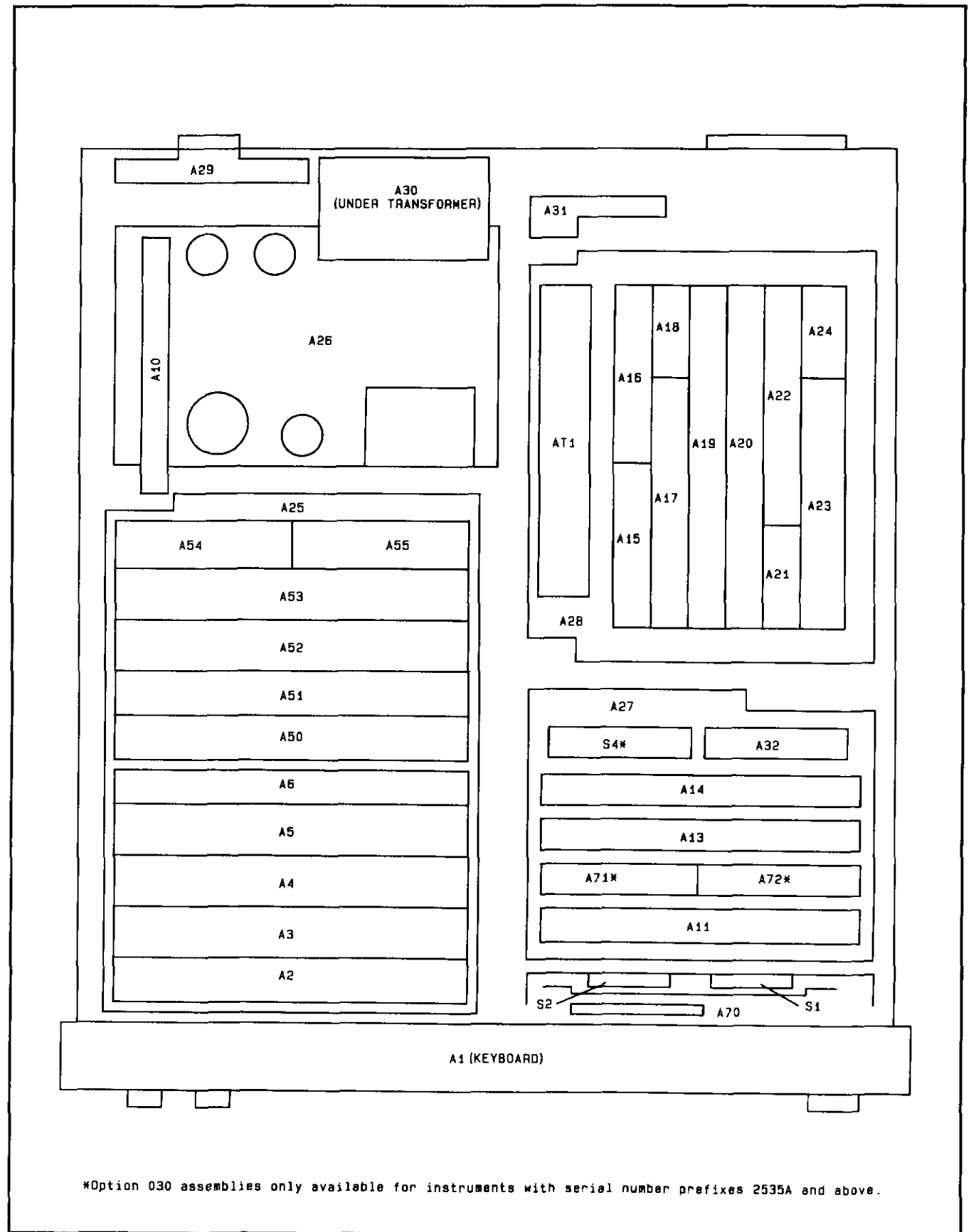

\*Option 030 assemblies only available for instruments with serial number prefixes 2535A and above.

SEE REVERSE SIDE

AUDIO SECTION **BD4**

Block Diagram Assembly Locations



**CHANGES**

<b>All serial prefixes</b>	<p>On the Component Locator:</p> <ul style="list-style-type: none"><li>• <u>BD3 callout X</u> - In the upper left hand corner of the schematic, change BD3 callout X to BD4 callout X.</li></ul>
----------------------------	--

