

This literature was published years prior to the establishment of Agilent Technologies as a company independent from Hewlett-Packard and describes products or services now available through Agilent. It may also refer to products/services no longer supported by Agilent. We regret any inconvenience caused by obsolete information. For the latest information on Agilent's test and measurement products go to:

www.agilent.com/find/products

Or in the US, call Agilent Technologies at 1-800-452-4844 (8am-8pm EST)



Agilent Technologies

Understanding Frequency Counter Specifications

Application Note 200-4

Electronic Counters Series

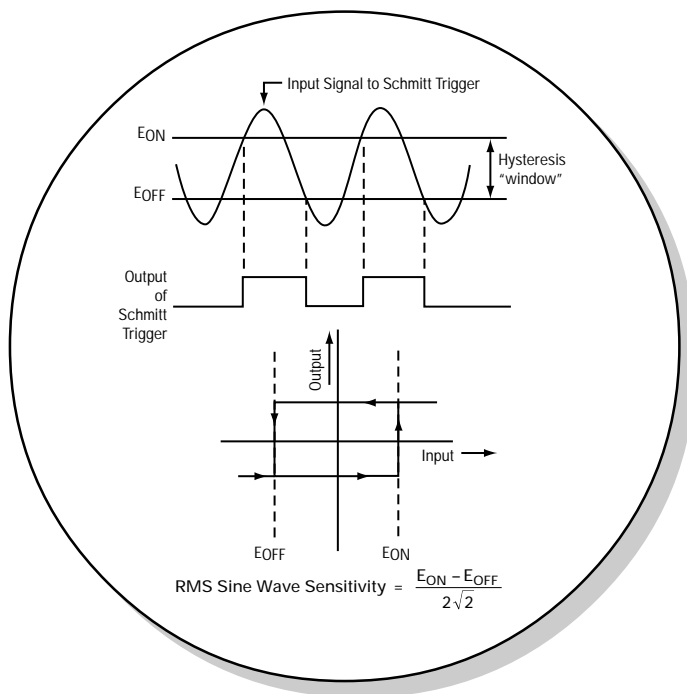

Table of Contents

Introduction	3
Input Characteristics	5
Operating Mode Specifications	11
Appendix A. Time Interval Averaging	29
Appendix B. RMS Specifications	34
Appendix C. Effects of Wideband Noise	35
Appendix D. Measurement of Counter Contributed Noise	36
Appendix E. HP 5315A/B LSD Displayed and Resolution	37

Introduction

If you've ever been confused by a frequency counter data sheet or unsure of the meaning of a particular specification, this application note is for you. In it, we'll define terms, work through examples, and explain how certain parameters can be tested.

First, however, we should review the purpose of a data sheet. The primary objective, of course, is to give you, the user, the information you need to make a buying decision — will the instrument solve your problem and is the performance worth the price? The instrument's performance is set forth in the specification section of the data sheet. *Specifications describe the instrument's warranted performance over the operating temperature range (usually 0°C to 50°C).* Specifications should be:

1. Technically accurate
2. Useable in a practical way
3. Testable

It goes without saying that a specification must be technically accurate. However, it may be that a technically accurate description of a parameter is so complex as to make the specification unuseable. In this case, a conservative simplified specification will be given. In addition to accuracy, specifications should be useable. For example, all the error terms in an accuracy specification should have identical units (i.e., Hz, or seconds). Finally, specifications should be testable. The user must be able to verify that the instrument is operating according to its warranted performance.

Performance parameters which are not warranted are indicated by giving TYPICAL or NOMINAL values. These supplemental characteristics are intended to provide useful application information. This is usually done for parameters which are of secondary importance and where verification on each and every instrument may be difficult and time consuming (which would add substantially to the manufacturing cost and therefore selling price).

Specifications for electronic frequency counters are usually divided into three sections: Input Characteristics, Operating Mode Characteristics, and General. The Input Characteristics section describes the

counter's input signal conditioning: input amplifier performance and conditioning circuitry such as coupling selection, trigger level control, and impedance selection. The Operating Mode Characteristics section specifies how the counter performs in each of its operating modes or functions such as Frequency, Period, Time Interval, and Totalize. Range, Least Significant Digit Displayed (LSD Displayed), Resolution, and Accuracy are usually specified. The General section specifies the performance of the timebase and instrument features such as auxiliary inputs and outputs (e.g., markers, trigger level lights, arming inputs, timebase inputs and outputs), Check mode, sample rates and gate time selection.

The next sections cover Input Characteristics specifications and Operating Mode specifications. Well known specifications such as coupling and input impedance are not covered. Refer to application note 200 "Fundamentals of Electronic Frequency Counters" for a discussion of these parameters. The examples in the next sections are drawn mainly from the HP 5315A/B 100 MHz/100 ns Universal Counter, the HP 5314A 100 MHz/100 ns Universal Counter, and the HP 5370A Universal Time Interval Counter.

Input Characteristics

Specification

Range

Definition

Range of frequency over which input amplifier sensitivity is specified. If input coupling is selectable, then ac and dc must be specified separately.

Example

dc COUPLED dc to 100 MHz
ac COUPLED 30 Hz to 100 MHz

Although the specification states that the input amplifier has a range from dc to 100 MHz, it does not mean that measurements in all operating modes can be made over this range. Consult the individual RANGE specifications under the appropriate OPERATING MODE specification. For example, with the HP 5315A/B, the minimum frequency which can be measured in Frequency mode is 0.1 Hz.

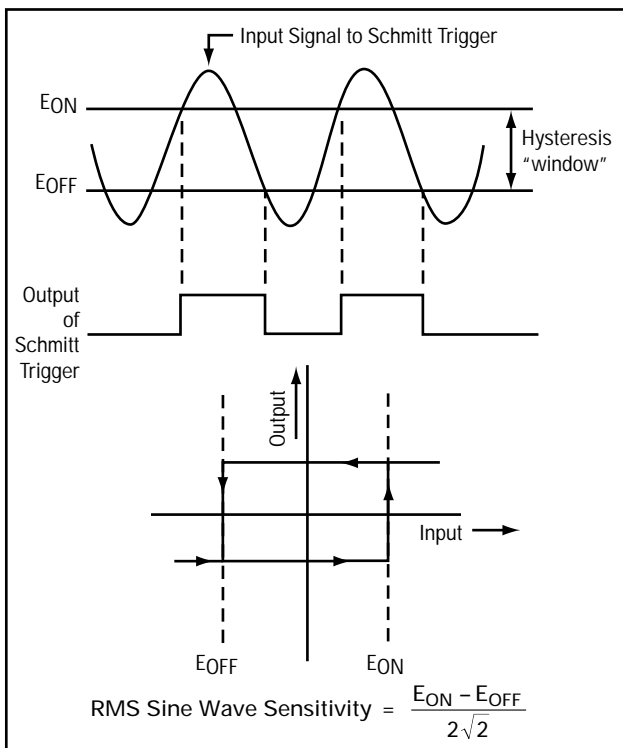

Figure 1. Counter sensitivity and hysteresis.

Specification

Sensitivity

Definition

Lowest amplitude signal at a particular frequency which the counter will count. Assumes that the trigger level (if available) has been optimally set for a value equal to the midpoint of the input signal.

Sensitivity is actually a measure of the amount of hysteresis in the input comparator and may vary with frequency. Because of this, the sensitivity specification may be split into two or more frequency ranges.

Hysteresis is used to describe the dead zone of a Schmitt Trigger (or voltage comparator). Referring to Figure 1, you see that when the input is above E_{ON} , the output goes high. When the input voltage falls below E_{OFF} , the output drops low. If you graph the input-output function, it resembles the familiar hysteresis loop between magnetizing force and magnetic flux in a magnetic material.

In order for the counter to count, the input must pass through both limits. The p-p minimum countable signal, defined as the counter's input amplifier sensitivity, is equal to $E_{ON} - E_{OFF}$. The rms sine wave

$$\text{sensitivity} = \frac{E_{ON} - E_{OFF}}{2\sqrt{2}}$$

The input waveform must cross both hysteresis limits to generate a count. This imposes a limit on the "useful" sensitivity of counter inputs. In the upper waveforms of Figure 2, the noise is not of sufficient amplitude to cross both limits. No extra counts are

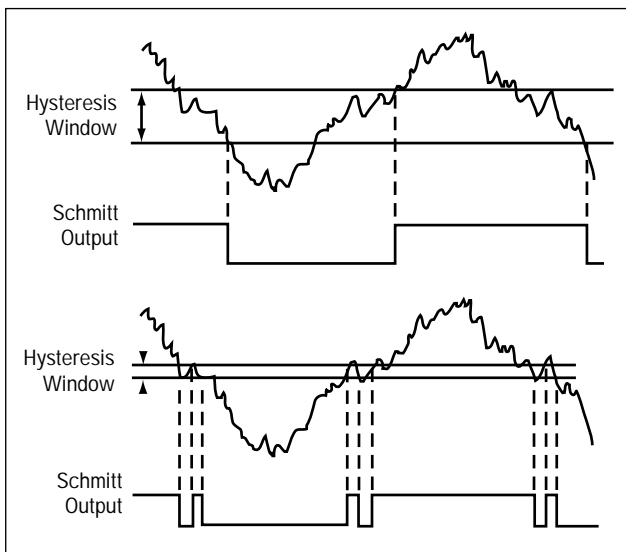

Figure 2. Noise induced counting.

generated and the frequency measurement is made without error (not the case, however, for reciprocal counters measuring frequency — trigger error causes measurement inaccuracies). The lower waveforms show a more sensitive counter input. In this case, the noise does cross both hysteresis limits and erroneous counts are generated.

Since the counter input does not respond to the rms value of the waveform but only the peak-to-peak value, the sensitivity specification should be volts peak-to-peak with a minimum pulse width. Since many applications involve measuring the frequency of a sine wave signal, the specification is also given in terms of volts rms sine wave. (Note, however, that a different waveform with the same rms voltage may not trigger the counter — the counter responds only to peak-to-peak.)

Example (HP 5315A/B)

10 mV rms sine wave to 10 MHz

(By looking at the RANGE specification, you see that in dc coupling the counter will count a 10 mV rms sine wave at any frequency between dc and 10 MHz and in ac coupling, it will count a 10 mV rms sine wave at any frequency between 30 Hz and 10 MHz).

25 mV rms sine wave to 100 MHz

(For frequencies between 10 MHz and 100 MHz, regardless of ac or dc coupling, the counter will count a 25 mV rms sine wave).

75 mV peak-to-peak pulse at minimum pulse width of 5 ns.

Specification

Signal Operating Range

Definition

If the signal peaks extend beyond the specified signal operating range, one or more operating modes may give incorrect results; for example, frequency miscounting or time interval inaccuracies.

Example (HP 5370A)

-2.5 V to +1 V

Specification

Dynamic Range

Definition

The minimum to maximum allowable peak-to-peak signal range, centered on the middle of the trigger level range. If the input signal exceeds this range, then the input amplifier may saturate, causing

transitions of the input to be missed. The dynamic range is limited by the range over which the differential input of the amplifier can swing without saturation.

For some input amplifiers, the dynamic range puts a further restriction on the allowable signal peaks as specified by the signal operating range. The signal peaks must always stay within the signal operating range specification and the peak-peak value must stay within the maximum dynamic range specification.

Example (HP 5370A)

- 50 × 1: 100 mV to 1 V p-p pulse**
- 50 × 10: 1 V to 7 V p-p pulse**
- 1 M × 1: 100 mV to 1 V p-p pulse**
- 1 M × 10: 1 V to 10 V p-p pulse**

The following condition is allowable for the HP 5370A.

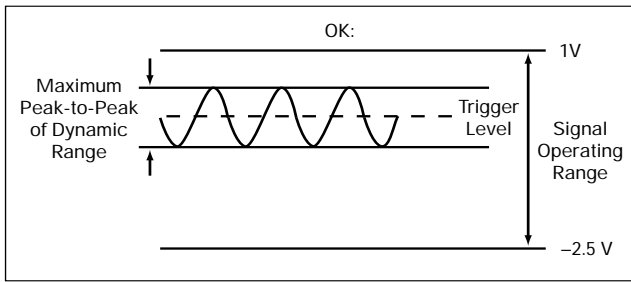

Figure 3. Valid input signal for the HP 5370A.

Neither of the following conditions is allowable for the HP 5370A.

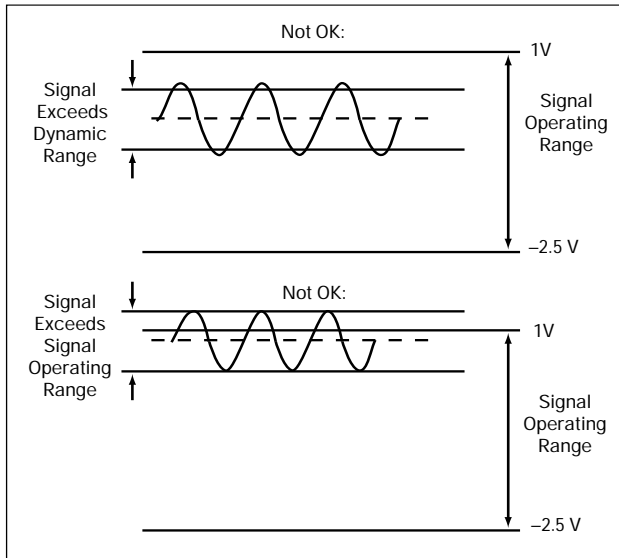

Figure 4. Invalid input signals for the HP 5370A.

Specification

Trigger Level

Definition

For instruments with a trigger level control, the range over which trigger level may be varied should be indicated. Trigger level is usually the voltage at the center of the hysteresis band and physically is the dc voltage applied to one input of the input comparator.

For instruments with a readout of trigger level (a dc signal or voltmeter reading), the settability of the trigger level should be indicated as well as the accuracy. The settability specification indicates to what tolerance trigger level may be set and the accuracy specification indicates the worst case difference between the indicated trigger level and the actual trigger point.

Specification

Damage Level

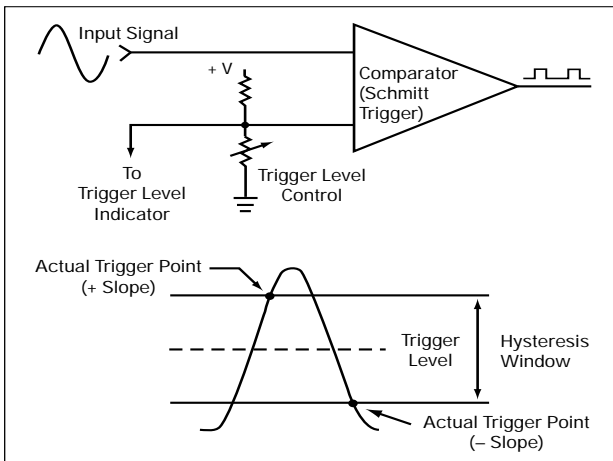

Figure 5. Trigger level and actual trigger point.

Definition

Maximum input the counter can withstand without input failure. The value may vary with attenuator setting and coupling selected.

Example (HP 5315A/B)

ac and dc $\times 1$:

dc to 2.4 kHz	250 V (dc + ac rms)
2.4 kHz to 100 kHz	$(6 \times 10^5 \text{ V rms Hz})/\text{FREQ}$
>100 kHz	6 V rms

ac and dc $\times 2$:

dc to 28 kHz	500 V (dc + ac peak)
28 kHz to 100 kHz	$(1 \times 10^7 \text{ V rms Hz})/\text{FREQ}$
>100 kHz	100 V rms

For signals less than 2.4 kHz, the dc + ac rms voltage peak may not exceed the value 250. For example, a 100 V rms 1 kHz signal could be accompanied by a dc level as high as 150 volts without damage.

$$\left(360 + \frac{280}{2} = 500 \text{ V} \right)$$

For signals in the range of 2.4 kHz to 100 kHz, the rms voltage times the frequency must be less than $6 \times 10^5 \text{ V rms} \times \text{Hz}$. A 10 kHz signal, therefore, could be at a level as high as 60 V rms:

$$\left(\frac{6 \times 10^5 \text{ rmsV} \times \text{Hz}}{10^4 \text{ Hz}} = 60 \text{ Vrms} \right)$$

To find the maximum rms voltage which can be applied to the counter input without damage, divide the specified volt rms \times Hz product by the frequency; i.e., in the case of the HP 5315A/B in the $\times 1$ attenuator position:

$$\frac{6 \times 10^5 \text{ Vrms} \times \text{Hz}}{\text{Freq (Hz)}}$$

For each operating mode of the counter, Range, LSD Displayed, Resolution, and Accuracy are specified. Each of these terms will be defined in detail with examples.

Operating Mode Specifications

Specification

Range

Definition

The minimum value of the input which can be measured and displayed by the counter up to the maximum value of the input.

Examples (HP 5315A/B)

Frequency Range: 0.1 Hz to 100 MHz

Time Interval Range: 100 ns to 10⁵ s

Since the HP 5315A counts a 10 MHz clock (100 ns period), the smallest single shot time interval which will permit the counter to accumulate at least one count during the time interval is 100 ns. The maximum time interval is what can be measured before the counter overflows.

Time Interval Average Range: 0 ns to 10⁵ s

Since the time interval average operating mode accumulates counts during a large number of successive time intervals, it is not required that at least one count be accumulated during each time interval. If only one count were accumulated during 200 time intervals, the time interval average would be computed as

$$\frac{100\text{ns}}{200} = 0.5\text{ns.}$$

Specification

LSD Displayed

Definition

The LSD Displayed is the value of the rightmost or least significant digit in the counter's display. The LSD Displayed may vary with gate time and magnitude of the measured quantity. (For example, the LSD Displayed by a reciprocal counter varies with gate time and frequency.)

For a digital instrument like a counter, output readings are discrete (quantized) even though the inputs are continuous. Even for the case where the input quantity is perfectly stable, the counter's readings may fluctuate. This fluctuation is due to quantization error (± 1 count error).

The value of the LSD Displayed often is the same as the quantization error which represents the smallest non-zero change which may be observed on the display. Because of this, resolution and accuracy statements often specify quantization error as \pm LSD Displayed.

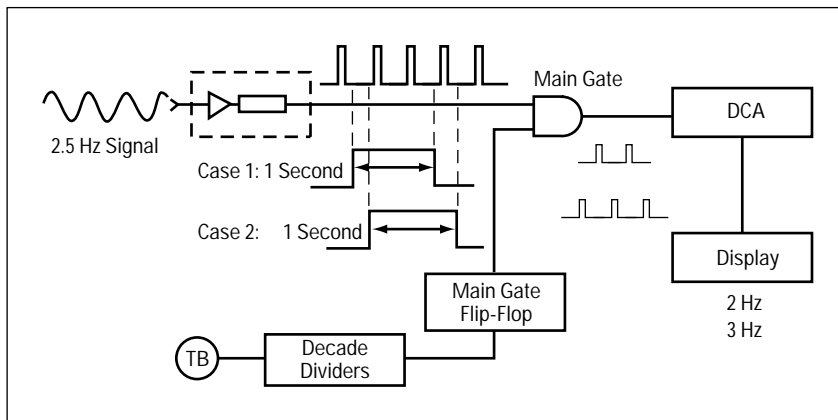

Figure 6. ± 1 count error.

Quantization error arises because the counter can't count a fraction of a pulse — a pulse is either present during the gate time or it isn't. The counter can't detect that a pulse was present just after the gate closed. Additionally, since the opening of the counter's main gate is not synchronized to the input signal, the quantization error may be in either direction. Consider a 2.5 Hz signal as shown in the figure. In case 1, the counter's gate is open for 1 second and accumulates 2 counts — the display will show 2 Hz. In case 2, the same length gate accumulates 3 counts for a display of 3 Hz.

Although we say ± 1 count, we do not mean that a particular measurement can vary by both + and - one count. The measurement can vary by one count at most. The reason that you have to say ± 1 count is that from a single measurement, you don't know a priori which way the next measurement will jump or if it will jump at all. So the specification has to include both possibilities.

Examples (HP 5314A)

Frequency LSD Displayed:

Direct Count 0.1 Hz, 1 Hz, 10 Hz Switch Selectable
Prescaled 10 Hz, 100 Hz, 1 kHz Switch Selectable

For direct count, the number of cycles of the input are totaled during the gate time. For a 1 second gate time, each count represents 1 Hz (the LSD Displayed). For a 10 second gate time, each count represents 0.1 Hz.

For a prescaled input, the number of counts accumulated during the gate time is reduced by the prescale factor over what would be accumulated by a direct count counter. Consequently, for a 1 second gate, each count represents N Hz where N is the prescale division factor. In the HP 5314A, the counter prescales by 10.

(HP 5315A/B)

Frequency LSD Displayed

10 Hz to 1 nHz depending upon gate time and input signal. At least 7 digits displayed per second of gate time.

In the definition section of the HP 5315A/B data sheet, you read:

$$\text{LSD} = \frac{2.5 \times 10^{-7}}{\text{Gate Time}} \times \text{Freq} \quad \text{If Freq} < 10 \text{ MHz}$$

$$\text{LSD} = \frac{2.5}{\text{Gate Time}} \quad \text{If Freq} \geq 10 \text{ MHz}$$

All above calculations should be rounded to the nearest decade.

For the HP 5315A/B there are no decade steps of gate time since the gate time is continuously variable. Additionally, since it is a reciprocal counter for frequencies below 10 MHz, the LSD Displayed depends upon the input frequency. Simply stated, you can be assured of at least 7 digits per second of gate time which means that for a 1 second gate time and a 10 kHz input frequency, the LSD displayed will be at least 0.01 Hz:

7th digit
↓
10000.00

(In actual fact, the HP 5315A/B will display 0.001 Hz for this example.) For 0.1 seconds, you'll get at least 6 digits. For fractional gate times, round off to the nearest decade (e.g., 0.5 seconds and below rounds to 0.1 seconds and above 0.5 seconds rounds to 1 second).

As an example, let's compute the LSD Displayed for a 300 kHz input measured with a 0.5 second gate time:

$$\frac{2.5 \times 10^{-7}}{0.5} \times 300 \times 10^3 = 0.15 \text{ Hz.}$$

Rounding to the nearest decade gives LSD = 0.1 Hz. This will be the value of the least significant digit in the counter's display. Of course, the user doesn't have to figure this out in practice — all he has to do is look at the counter's display.

The reason for the unusual LSD Displayed specification is that the HP 5315A/B is a reciprocal counter with a *continuously variable gate time* for frequencies below 10 MHz and a conventional counter with a *continuously variable gate time* for frequencies above 10 MHz.

For frequencies below 10 MHz, the counter synchronizes on the input signal which means that the counting begins synchronously with the input. Two internal counters then begin accumulating counts. One counter counts 10 MHz clock pulses from the internal timebase and a second counter accumulates input events. This counting continues during the selected gate time. The microprocessor then computes frequency by computing

$$\frac{\text{EVENTS}}{\text{TIME}}$$

(or computes period by dividing $\frac{\text{TIME}}{\text{EVENTS}}$.)

Unlike a conventional counter which simply displays the contents of the decade counting assemblies, the HP 5315A must compute the number of significant digits in the resultant of the division EVENTS/TIME. In the microprocessor algorithm, it was decided to truncate digits such that

$$\frac{\text{LSD Displayed}}{\text{FREQ}}$$

will always be less than 5×10^{-8} . Rounding the quantity

$$\left(\frac{2.5 \times 10^{-7}}{\text{Gate Time}} \times \text{Freq} \right)$$

to the nearest decade meets this requirement.

Period LSD Displayed:

100 ns to 1 fs (femtosecond: 10^{-15} second) depending upon gate time and input signal.

In the definition section of the HP 5315A/B data sheet, the following explanation is given:

$$\text{LSD} = \frac{2.5 \times 10^{-7}}{\text{Gate Time}} \times \text{Per} \quad \text{for Per} > 100 \text{ ns}$$

$$\text{LSD} = \frac{2.5}{\text{Gate Time}} \times \text{Per}^2 \quad \text{for Per} \leq 100 \text{ ns}$$

All above calculations should be rounded to the nearest decade.

As an example, a 50 ns period measured with a 50 millisecond gate time would have an LSD equal to:

$$\frac{2.5}{50 \times 10^{-3}} \left(50 \times 10^{-9} \right)^2 = 1.25 \times 10^{-3}$$

Rounding to the nearest decade gives 0.1 ps as the LSD Displayed.

Time Interval Average LSD Displayed

100 ns to 10 ps depending upon gate time and input signal.

In the definition section of the HP 5315A/B data sheet, the following is given:

	LSD
1 to 25 intervals	100 ns
25 to 2500 intervals	10 ns
2500 to 250,000 intervals	1 ns
250,000 to 25,000,000 intervals	100 ps
> 25,000,000 intervals	10 ps

To compute the number of time intervals averaged, N, multiply the gate time by the frequency (time interval repetition rate). For example, if a time interval average measurement is made on a 1 μ s time interval at a 200 kHz repetition rate and you select a 2 second gate time,

$$N = 2 \times 200 \times 10^3 = 400 \times 10^3.$$

In this case, the LSD Displayed by the counter would be 100 picoseconds.

The measurement time required to make the measurement is simply the gate time which is 2 seconds.

Prior to the microprocessor controlled HP 5315A/B, time interval averaging counters displayed more digits than you could believe when in time interval average function. This is because ± 1 count error is improved only by \sqrt{N} but the displayed number of digits increases by N. The microprocessor of the HP 5315A/B solves the problem by only displaying the digits you can believe. The HP 5315A/B decides to display the LSD which results, in the worst case, in a one sigma confidence level, meaning that for a stable input time interval, approximately 68% of the readings will vary by less than the LSD displayed. In most cases, however, the confidence level is much higher and may be as high as 10σ .

Time interval averaging is a statistical process. Consequently, the counter performs an average and displays the result which is an estimate of the actual time interval. The more time intervals averaged, the better the estimate. Even if the input time interval is perfectly stable, time interval average measurements made on the time interval will vary from measurement to measurement. As the number of averages in each time interval average measurement is increased, the variation between measurements is decreased. A measure of the variation is σ , the standard deviation.

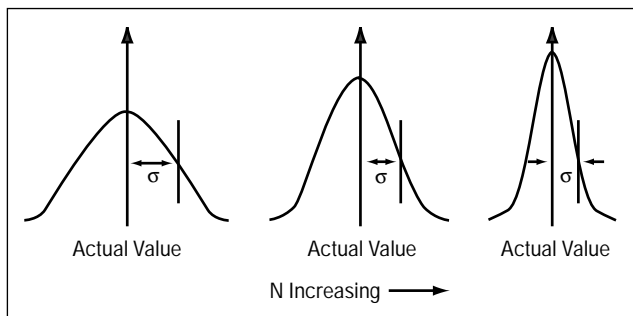

Figure 7.
Histogram plot of time interval average measurements. σ decreases as N, the number of time intervals in each average reading, is increased.

For time interval averaging, in the worst case,

$$2\sigma = \frac{T_{\text{clock}}}{\sqrt{N}}$$

where T_{clock} = period of counted clock and N = number of independent time intervals averaged. For a normal distribution, $\pm 2\sigma$ includes 95% of all the readings. The HP 5315A/B decides to display the LSD which results, in the worst case, in a one sigma confidence level.

$$\sigma = \frac{T_{\text{clock}}}{2\sqrt{N}} = \frac{100 \text{ ns}}{2\sqrt{N}}$$

When $N = 25$, $\sigma = \frac{100 \text{ ns}}{2 \times 5} = 10 \text{ ns}$.

When $N = 2500$, $\sigma = \frac{100 \text{ ns}}{2 \times 50} = 1 \text{ ns}$.

So in each range, the LSD Displayed is the worst case σ . Over most of the range, the LSD is significantly better than $\pm 1\sigma$. For example, in the 25 to 2500 interval range, 10 ns is the LSD Displayed.

For $N = 25$, $10 \text{ ns} = 1\sigma$ (68% confidence)
 but for $N = 100$, $10 \text{ ns} = 2\sigma$ (95% confidence)
 and for $N = 2500$, $10 \text{ ns} = 10\sigma$ (~100% confidence)

See appendix A for more on time interval averaging.

Specification

Resolution

Definition

In optics and in many other fields, resolution of a measuring device is determined by the minimum distance between two lines which are brought closer and closer together until two lines can no longer be observed in the output as shown in Figure 8. Resolution is defined at the point where the two lines are just close enough to cause the output to look like one line.

For a frequency counter, resolution can be defined similarly. If two stable frequencies are alternately measured by the counter and slowly brought closer together in frequency as shown in Figure 9, there will come a point at which two distinct frequencies cannot be distinguished due to randomness in the readings. Random readings are due to quantization error and trigger error (for reciprocal counters).

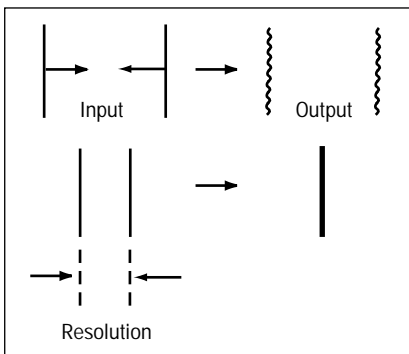

Figure 8. Resolution — optical system.

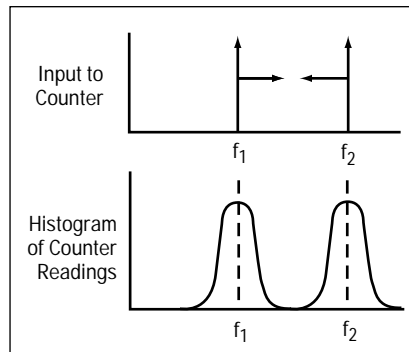

Figure 9. Resolution — frequency measurements.

Resolution is the maximum deviation (or may be expressed as rms deviation if random noise is resolution limiting) between successive measurements under constant environmental and constant input conditions and over periods of time short enough that the time base aging is insignificant. Practically speaking, it represents the smallest change in the input quantity which can be observed in the measurement result.

Of course, resolution can never be better than the LSD Displayed. Sometimes, the resolution is equal to the LSD Displayed. Often, the resolution is not as good as the LSD Displayed because of jitter and trigger error which are random noise induced errors.

Since resolution is often limited by noise (noise on the input signal or noise from the counter), resolution is sometimes specified as rms (1σ) deviation about the average value or will have rms terms as part of the specification. See appendix B for a discussion of how to interpret an rms resolution or accuracy specification.

Examples (HP 5314A)

Frequency Resolution: \pm LSD

\pm LSD is the ± 1 count quantization error of a traditional frequency counter. If the LSD is 1 Hz, then changes in the input frequency greater than 1 Hz will be observable in the measurements.

Period Resolution

$$\pm \text{LSD} \pm 1.4 \times \frac{\text{Trigger Error}}{N}$$

For the HP 5314A, the PERIOD LSD is selectable from 10 ns to 0.1 ns (100 ns/N for N = 1 to 1000 where N equals the number of periods in the period average measurement).

For period measurements, the input signal controls the opening and closing of the main gate. Since the input signal is controlling the opening and closing of the gate, even a small amount of noise on the input can cause the gate to open and close either too early or too late, causing the counter to accumulate either too few or too many counts.

Consider an input signal passing through the hysteresis window of a counter (Figure 10). In the absence of noise, the counter's gate would open at point A. Consider a noise spike with sufficient amplitude to cross the upper hysteresis limit at point B, thus causing the counter to start gating too soon. The rms trigger error associated with a single trigger is equal to:

$$\frac{\sqrt{X^2 + e_n^2}}{\text{input slew rate at trigger point}}$$

where X = effective rms noise of the counter's input channel
 (= 80 μ V rms for the HP 5314A and HP 5315A/B.)

e_n = rms noise voltage of input signal measured over a bandwidth equal to the counter's bandwidth. (See appendix C for a discussion of how noise can affect wide band counter inputs.)

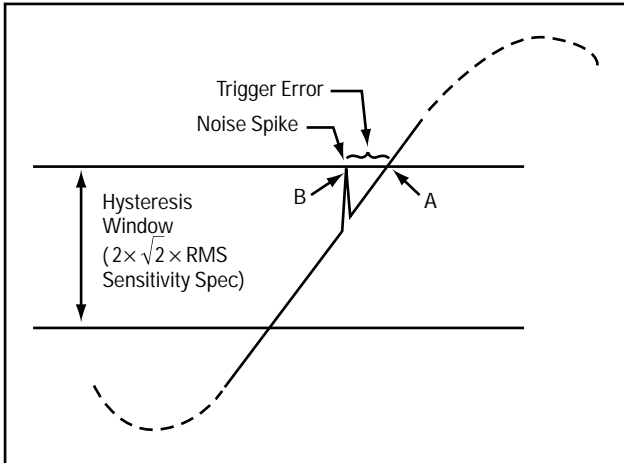

Figure 10. Trigger error.

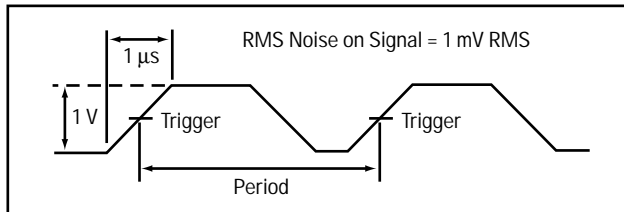

Figure 11. Trigger error example.

Since for period measurements, trigger error occurs at the beginning and end of the measurement and the noise adds on an rms basis, the rms trigger error for period measurements (and frequency measurements made by a reciprocal counter) is:

$$\frac{1.4 \times \sqrt{X^2 + e_n^2}}{\text{input slew rate at trigger point}} \text{seconds rms}$$

The effective rms noise contributed to the total noise by the counter's input circuitry has never before been specified and in many instances has been negligible. However, as sophisticated applications for counters increase, it is apparent that this noise contribution should be specified. Not all counter inputs are equally quiet and for some applications, this is important. In appendix D, how the effective counter input noise is measured is presented.

If the HP 5314A were used to measure the period of the waveforms in figures 10 and 11, the rms trigger error would be

$$\frac{\sqrt{80 \mu\text{V}^2 + 1 \text{mV}^2}}{\text{input slew rate at trigger point}} = \frac{1 \text{mV}}{1 \text{V}/\mu\text{s}} = 1 \text{ ns rms.}$$

Since there is trigger error associated with both the start and stop input, the total trigger error for the measurement equals $1.4 \times 1 \text{ ns}$ (trigger errors add on an rms basis) = 1.4 ns rms. If the LSD were 0.1 ns, then

the quantization is negligible and the resolution for the measurement would be ± 1.4 ns rms. This means if M period average measurements were made under the above conditions, there would be a variation of results. If the standard deviation of the M measurements were computed, it would be around 1.4 ns rms, meaning that approximately 68% of the M measurements were within ± 1.4 ns of the actual period.

As a second example, let's compute the HP 5314A's resolution for a period measurement on a 1 V rms sine wave at a frequency around 10 kHz. The noise on the signal is approximately 10 mV rms.

If A = the rms amplitude of the sine wave, then the signal may be described by the equation

$$S = A \sqrt{2} \sin 2\pi ft$$

$$\frac{dS}{dt} = A \sqrt{2} 2\pi f \cos 2\pi ft$$

Assuming triggering at the midpoint of the sine wave where the slope is maximum,

$$\left. \frac{dS}{dt} \right|_{\text{MAX}} = 2\sqrt{2} A \pi f$$

Figure 12 is a plot of slew rate versus frequency for various values of sine wave signal amplitude in volts rms. For our example, 1 V rms at 10 kHz has a slew rate of 90×10^3 V/S (assuming triggering at the midpoint — if the counter is set to trigger closer to the peaks of the sine wave, the slope is decreased greatly and trigger error will be much greater).

Figure 13 plots trigger error versus slew rate for various values of rms noise on the input signal. The lowest curve is for no noise on the input signal and is due only to the 80 μ V rms noise contributed by the counter's input. According to Figure 13, for a slew rate of 90×10^3 and noise equal 10 mV rms, the trigger error is approximately 1×10^{-7} seconds or 100 ns rms. Total trigger error is $100 \text{ ns rms} \times 1.4 = 140 \text{ ns rms}$.

For an LSD of 10 ns, the quantization error is negligible so the rms resolution is ± 140 ns rms. In general, the resolution specification will consist of some errors expressed in peak-to-peak (p-p) and other errors expressed in rms. Usually, either the (p-p) errors or the (rms) errors will predominate, allowing the smaller error to be neglected. For those cases where the (p-p) errors and rms errors are nearly equal, multiply the (rms) error by three to approximate a peak-to-peak value. This will allow the errors to be added on a linear basis without the difficulty of interpreting an addition of rms and peak-to-peak terms.

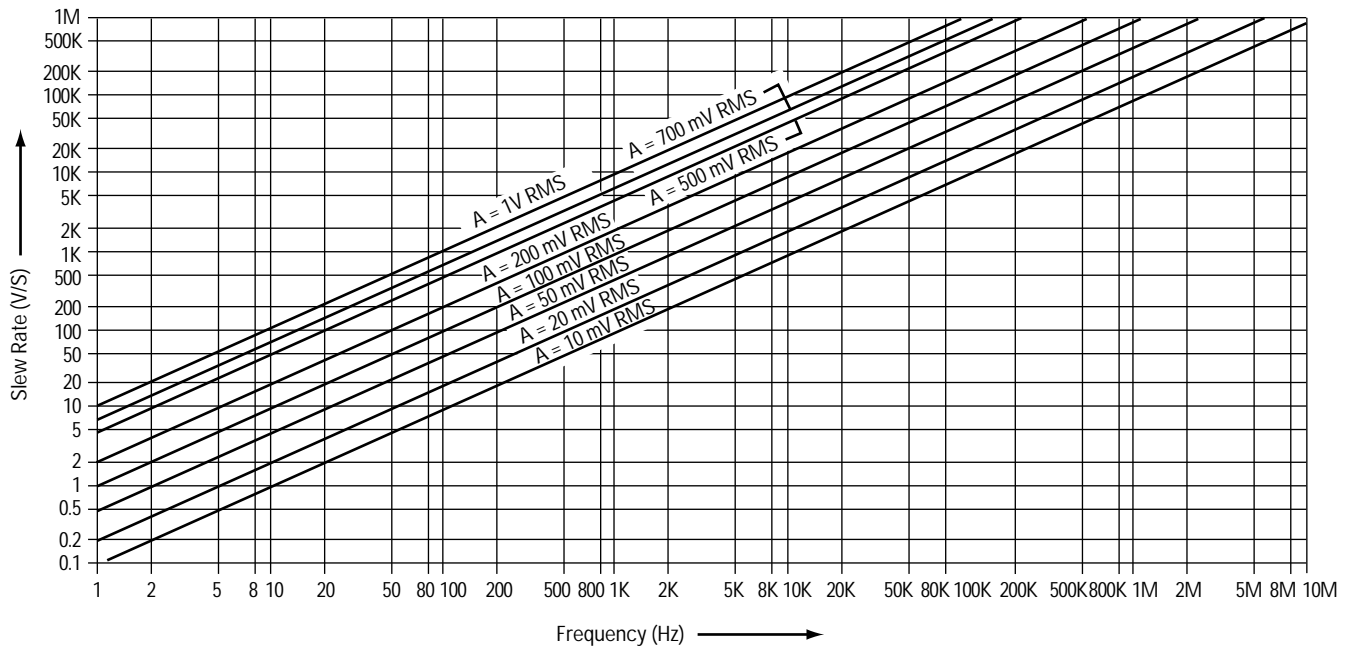

Figure 12. Slew rate vs frequency

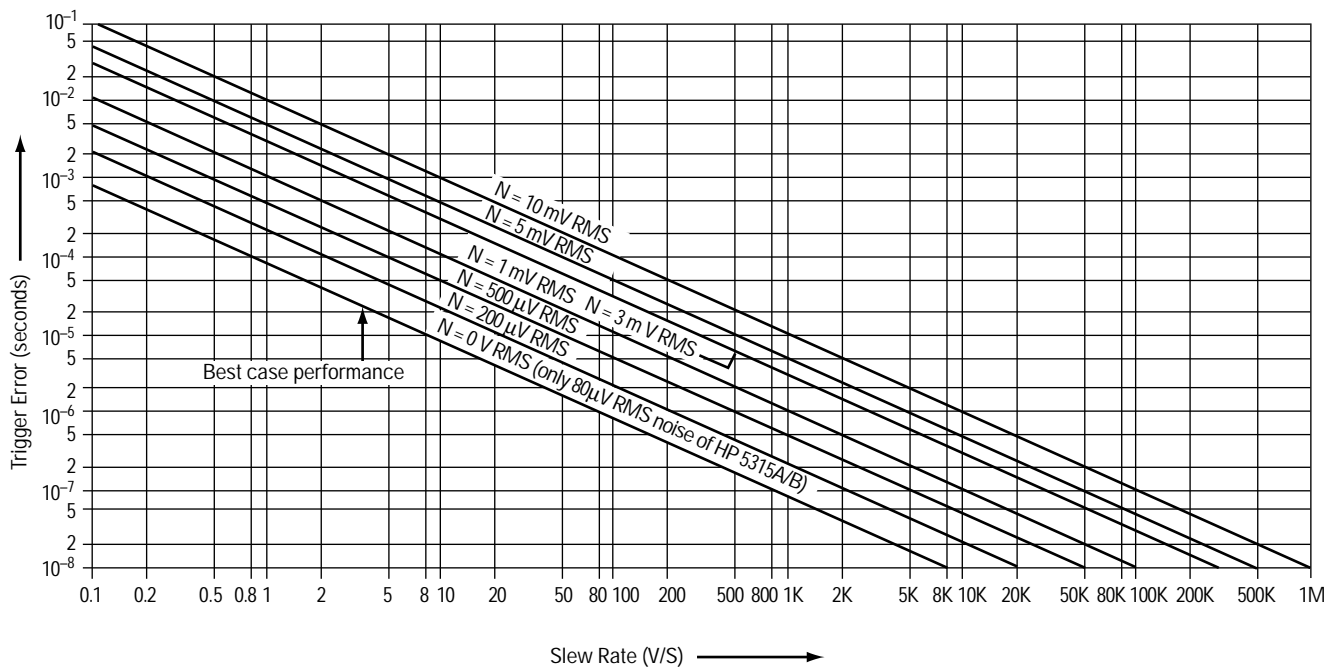

Figure 13. Trigger error vs slew rate

Example (HP 5315A/B)
Frequency Resolution:

$$\pm \text{LSD}^1 \frac{\pm 1.4 \times \text{trigger error}}{\text{Gate Time}} \times \text{Freq}$$

¹ due to arithmetic truncation, quantization error will be ± 1 or ± 2 counts of the LSD as follows :

$$\pm 2 \text{ counts of LSD if } \frac{\text{LSD}}{\text{FREQ}} < 1 \times 10^{-7} \text{ for Freq} < 10 \text{ MHz}$$

$$\pm 2 \text{ counts of LSD if } \frac{\text{LSD}}{\text{FREQ}} < \frac{1}{\text{Gate Time} \times \text{Freq}} \text{ for Freq} \geq 10 \text{ MHz}$$

± 1 count of LSD for all other cases

In the definition section, trigger error is defined as:

$$\frac{\sqrt{(80 \mu\text{V})^2 + e_n^2}}{\text{input slew rate at trigger point}}$$

and e_n = **rms noise on input signal for a 100 MHz bandwidth.**

The quantization error will be either ± 1 or ± 2 counts of the LSD. This is a direct result of the decision in the microprocessor algorithm to truncate digits whenever

$$\frac{\text{LSD Displayed}}{\text{FREQ}}$$

is less than 5×10^{-8} . Since the HP 5315A/B counts a 10 MHz timebase for frequencies less than 10 MHz, the quantization error can never be less than

$$\frac{\pm 1}{10 \text{ MHz}} = \pm 1 \times 10^{-7}.$$

So, whenever

$$\frac{\text{LSD Displayed}}{\text{FREQ}}$$

is less than 1×10^{-7} (but greater than $\pm 5 \times 10^{-8}$), the quantization error is specified as ± 2 counts of the LSD Displayed.

Refer to appendix E for more discussion of HP 5315A/B operation with respect to LSD Displayed and Resolution.

Let's compute the resolution achievable when measuring a 100 mV rms 20 kHz sine wave with a 2 second gate time. The LSD Displayed will be 0.001 Hz (just look at the counter). The quantization error will be ± 0.002 Hz since

$$\frac{\text{LSD}}{\text{FREQ}} = \frac{0.001}{2 \times 10^4} = 0.5 \times 10^{-7}$$

which is less than 1×10^{-7} . For a rms noise level on the signal of 1 mV rms, and referring to Figure 12 and Figure 13, the trigger error is seen to be $\sim 4 \times 10^{-8}$ s.

$$\text{Re resolution} = \pm 0.002 \text{ Hz} \pm \frac{1.4(4 \times 10^{-8})}{2} \times 2 \times 10^4 \cong \pm 0.002 \text{ Hz.}$$

HP 5315A/B
Best Case Resolution for 1 Second Gate

	100 Hz	1 kHz	10 kHz	100 kHz	1 MHz	10 MHz	100 MHz
50 mV rms	$\pm 260 \mu\text{Hz}$	$\pm 350 \mu\text{Hz}$	$\pm 0.0012 \text{ Hz}$	$\pm 0.01 \text{ Hz}$	$\pm 0.1 \text{ Hz}$	$\pm 1 \text{ Hz}$	$\pm 1 \text{ Hz}$
100 mV rms	$\pm 135 \mu\text{Hz}$	$\pm 225 \mu\text{Hz}$	$\pm 0.0011 \text{ Hz}$	$\pm 0.01 \text{ Hz}$	$\pm 0.1 \text{ Hz}$	$\pm 1 \text{ Hz}$	$\pm 1 \text{ Hz}$
500 mV rms	$\pm 35 \mu\text{Hz}$	$\pm 125 \mu\text{Hz}$	$\pm 0.001 \text{ Hz}$	$\pm 0.01 \text{ Hz}$	$\pm 0.1 \text{ Hz}$	$\pm 1 \text{ Hz}$	$\pm 1 \text{ Hz}$
1 mV rms	$\pm 23 \mu\text{Hz}$	$\pm 113 \mu\text{Hz}$	$\pm 0.001 \text{ Hz}$	$\pm 0.01 \text{ Hz}$	$\pm 0.1 \text{ Hz}$	$\pm 1 \text{ Hz}$	$\pm 1 \text{ Hz}$

The above chart gives frequency resolution versus input sine wave rms amplitude, i.e.,

$$\text{Resolution} = \pm 0.002 \text{ Hz} \pm \frac{1.4 \times \text{trigger error}}{\text{gate time}} \times \text{Freq.}$$

It is best case since the trigger noise is assumed to only come from the counter (i.e., 80 μV) and not from the input signal source.

Example (HP 5315A/B)

Time Interval Average Resolution:

$$\pm \text{LSD} \pm \frac{\text{Start Trigger Error}}{\sqrt{N}} \pm \frac{\text{Stop Trigger Error}}{\sqrt{N}}$$

Where $N = \text{Gate Time} \times \text{Freq}$

To be technically accurate, the start and stop trigger error could be added on a root mean square basis. For simplicity, they're added linearly which understates the actual resolution by $\sqrt{2}$.

As an example, we'll compute the resolution for a time interval measurement on the following:

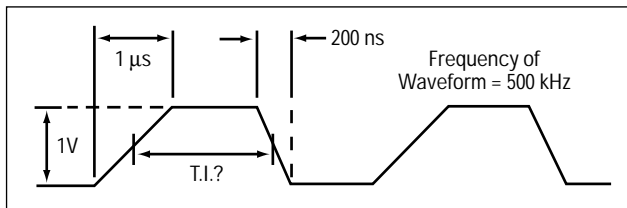

Figure 14. Trigger error example.

If you select a gate time of 1 second, then $N = 1 \text{ s} \times 500 \times 10^3 = 500 \times 10^3$. So the LSD = 100 ps.

$$\text{Start trigger error} = \frac{80 \mu\text{V}}{1 \text{ V}/1 \mu\text{s}} = 80 \times 10^{-12} \text{ s rms}$$

$$\text{Stop trigger error} = \frac{80 \mu\text{V}}{1 \text{ V}/200 \text{ ns}} = 16 \times 10^{-12} \text{ s rms}$$

$$\text{Resolution} = \pm 100 \text{ ps} \pm \frac{80 \text{ ps}}{\sqrt{50 \times 10^4}} \pm \frac{16 \text{ ps}}{\sqrt{50 \times 10^4}} \cong \pm 100 \text{ ps}$$

Specification

Accuracy

Definition

Accuracy may be defined as the closeness of a measurement to the true value as fixed by a universally accepted standard. The measure of accuracy, however, is in terms of its complementary notion, that is, deviation from true value, or limit of error, so that high accuracy has a low deviation and low accuracy has a high deviation.

The plot in Figure 15 shows successive measurement readings for two cases. In case 1, the readings are fairly consistent and repeatable. In case 2, the readings are more spread out. This could be due to noise or

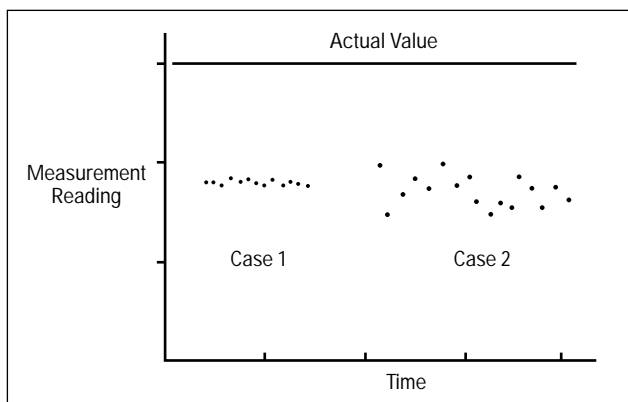
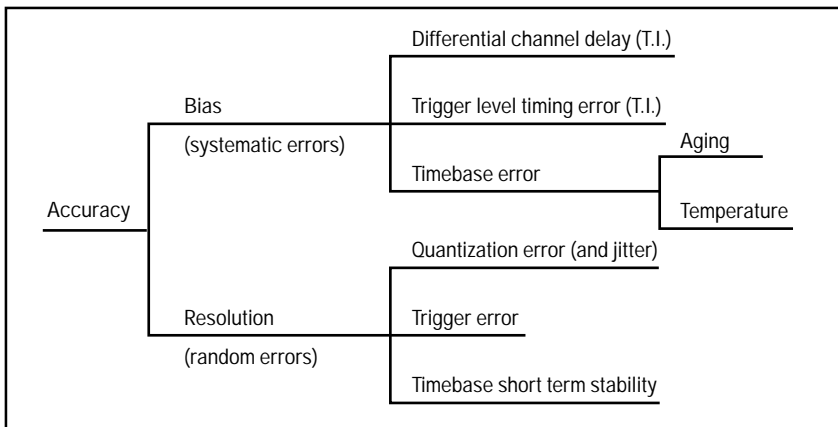

Figure 15. Accuracy

the operator's inability to consistently read an analog dial. Intuitively, you feel that case 1 is better than case 2. If it's not more accurate, at least it's more repeatable and this is useful if you're concerned with measuring differences between devices.

Notice that both cases are offset from the actual value. The important thing is that this offset is a systematic error which can be removed by calibration. The random errors of case 2 cannot be calibrated out.



The above chart shows universal counter accuracy as having two components: bias and resolution. Resolution may be limited by quantization error (or jitter as in the case of the HP 5370A Universal Time Interval Counter), trigger error (period, TI and frequency for reciprocal counters) and sometimes the short term stability of the timebase. Bias is the sum of all systematic errors and may be reduced or entirely removed by calibration. In many operating modes, timebase error is the dominant systematic error. For time interval measurements, differential channel delay and trigger level timing error are often the dominant systematic errors.

Except for time interval measurements, accuracy is specified as resolution plus timebase error. Timebase error is the maximum fractional frequency change in the timebase frequency due to all error sources (e.g., aging, temperature, line voltage). The actual error in a particular measurement may be found by multiplying the total $\Delta f/f$ of the timebase (or $\Delta t/t$ which equals $\Delta f/f$) by the measured quantity.

Example

- Aging Rate:** $<3 \times 10^{-7}/\text{month}$
- Temperature** $<5 \times 10^{-6}$ 0 to 50°C
- Line Voltage:** $<1 \times 10^{-7}$, $\pm 10\%$ variation

The total fractional frequency change in oscillator frequency is the sum of all effects. If the counter has not been calibrated for a year, the total $\Delta f/f$ due to aging is $3 \times 10^{-7}/\text{month} \times 12 \text{ month} = 3.6 \times 10^{-6}$. For worst case temperature variations, $\Delta f/f$ due to temperature is 5×10^{-6} .

Including worst case line voltage variation, the total $\Delta f/f$ due to all sources is 8.7×10^{-6} . The worst case frequency change in the 10 MHz oscillator would be $8.7 \times 10^{-6} \times 10^{-7} = 87$ Hz.

If measuring a 2 MHz frequency, the timebase error would cause an error of $\pm 8.7 \times 10^{-6} \times 106 = \pm 17$ Hz.

If measuring a 100 μ s time interval, the timebase error would cause an error of $\pm 8.7 \times 10^{-6} \times 10^{-4} = \pm 0.87$ ns $\cong \pm 1$ ns.

Example (HP 5370A) Opt 001

Aging Rate: $< 5 \times 10^{-10}$ /day

Short Term: $< 1 \times 10^{-11}$ for 1 s average

Temperature: $< 7 \times 10^{-9}$, 0°C to 50°C

Line Voltage: $< 1 \times 10^{-10}$, $\pm 10\%$ change

What is the timebase error in the measurement of a 5 MHz signal using the HP 5370A Opt. 001? The HP 5370A hasn't been calibrated for 1 month and the temperature change from when it was calibrated to now is 5°C at most.

$$\left. \frac{\Delta f}{f} \right|_{\text{aging}} = \pm 5 \times 10^{-10} / \text{day} \times 30 \text{ days} = \pm 1.5 \times 10^{-8}$$

$$\left. \frac{\Delta f}{f} \right|_{\text{temperature}} = \pm 7 \times 10^{-9} \times \frac{5^\circ}{50^\circ} = \pm 7 \times 10^{-10}$$

(For oven oscillators only, the temperature specification may be taken as essentially linear so that if the actual temperature change is only a tenth of the specification temperature change, then the $\Delta f/f$ variation will be a tenth of the specified $\Delta f/f$. However, RTX0's and TCXO's are definitely nonlinear.)

$$\left. \frac{\Delta f}{f} \right|_{\text{line voltage}} = \pm 1 \times 10^{-10}$$

$$\left. \frac{\Delta f}{f} \right|_{\text{total}} = \pm 1.5 \times 10^{-8} \pm 7 \times 10^{-10} \pm 1 \times 10^{-10} = \pm 1.6 \times 10^{-8}$$

$$\Delta f_{\text{error}} = f \times 1.6 \times 10^{-8} = \pm 5 \times 10^6 \times 1.6 \times 10^{-8} = \pm 0.08 \text{ Hz}$$

For time interval measurements, two additional errors are present: differential channel delay and trigger level timing error. Differential channel delay is the difference in delay between the start channel and the stop channel. For example, in the HP 5315A/B, this delay difference is specified as ± 4 ns maximum.

Trigger level timing error is the time error (in seconds) due to error in the trigger level readout (see Figures 16 and 17). If there is no readout of trigger level, then this error cannot be specified.

Unlike trigger error, trigger level timing error is a systematic error. The major component of the trigger level error comes from the fact that the actual trigger level is not a measurable level. The only dc level which can be measured is the output generated by the trigger level control which sets the level on one side of the comparator.

This voltage represents the center of the hysteresis band.

In the absence of a specification, the trigger level error may be estimated at $\pm 1/2$ hysteresis band. The hysteresis band is equal to the peak-to-peak pulse sensitivity.

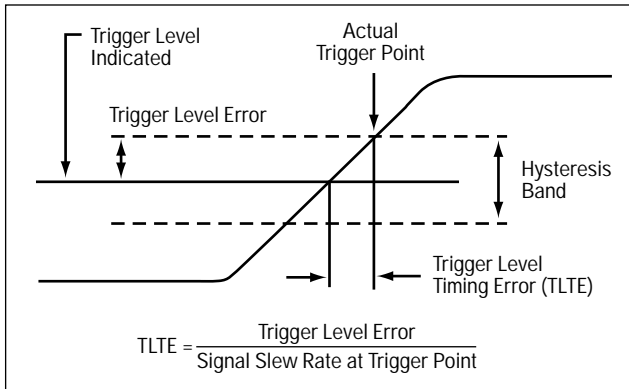

Figure 16. Trigger level timing error.

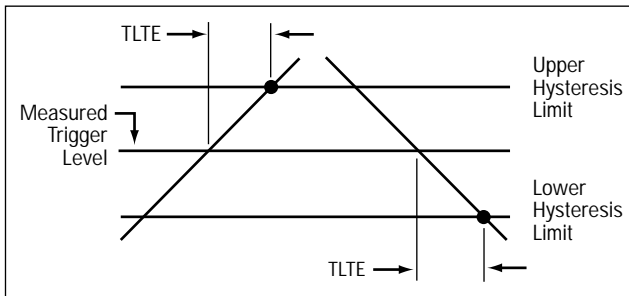

Figure 17. Trigger level timing error.

Specification

Time Interval Average Minimum Dead Time

Definition

Minimum time between a previous time interval's STOP and the current time interval's START.

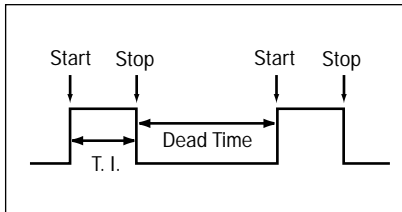

Figure 18. Dead time.

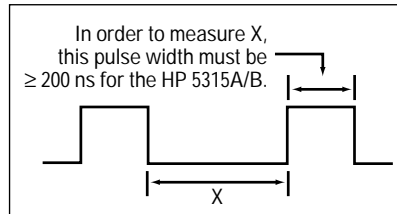

Figure 19. Dead time example.

Example (HP 5315A/B)

Minimum Dead Time: 200 ns

This puts an upper limit of 5 MHz on the highest time interval repetition rate in time interval averaging for the HP 5315A/B.

Appendix A. Time Interval Averaging

Time interval averaging reduces the ± 1 count quantization error as well as a trigger error.

Since time interval averaging is a statistical process and is based on laws of probability, the precision and accuracy of a time interval average measurement are best discerned by examining the statistics of the quantization error. In Figure A-1, consider the time interval, τ , to be made up of an integer number of clock pulses, Q , plus a fraction of a clock pulse, F . Any time interval may be thus represented. The quantization error can only take on two values. It can be $F \cdot T_{\text{clock}}$, which it takes on with a probability of $(1 - F)$ or it can be $(F - 1) T_{\text{clock}}$ which it takes on with a probability of F . If you work through the algebra, you'll find that the mean or expected value of the quantization error is 0 and the standard deviation is equal to $T_{\text{clock}} \sqrt{F(1 - F)}$

Derivation:

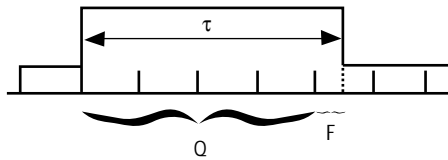

Figure A-1. $T = Q$ (integer clock periods) + F (Fractional clock period).

$$\begin{aligned} \text{Time Interval} &= T_{\text{clock}} (Q + F) \\ Q &= \text{Integer} \\ F &= \text{Fraction} \end{aligned}$$

Error can only take two values:

$$\begin{aligned} E &= F T_{\text{clock}} \text{ with probability } (1 - F) \\ &= (F - 1) T_{\text{clock}} \text{ with probability } F \end{aligned}$$

$$\begin{aligned} \mu_E &= F T_{\text{clock}} (1 - F) + (F - 1) T_{\text{clock}} F \\ &= F T_{\text{clock}} - F^2 T_{\text{clock}} + T_{\text{clock}} F^2 - T_{\text{clock}} F = 0 \end{aligned}$$

$$\begin{aligned} \sigma_E &= E(x^2) - E(x)^2 \\ &= F^2 T_{\text{clock}}^2 (1 - F) + (F - 1)^2 T_{\text{clock}}^2 F \\ &= F^2 T_{\text{clock}}^2 - F^3 T_{\text{clock}}^2 + F^3 T_{\text{clock}}^2 - 2 F^2 T_{\text{clock}}^2 + F T_{\text{clock}}^2 \\ &= F T_{\text{clock}}^2 (1 - F) \\ \sigma_E &= T_{\text{clock}} \sqrt{F(1 - F)} \end{aligned}$$

If we average N independent measurements, then by using the law of averages and identically distributed random variables, we get the following results.

$$\mu_{\bar{E}} = \frac{\sum \mu_E}{N} = 0$$

$$\sigma_{\bar{E}}^2 = \frac{\sigma_E^2}{N} = \frac{T_{\text{clock}}^2 F (1 - F)}{N}$$

$$\sigma_{\bar{E}} = \frac{T_{\text{clock}} \sqrt{F (1 - F)}}{\sqrt{N}}$$

The mean of the average quantization error is 0 (this means that the expected value of the average is the true time interval) and the variance of the average quantization error is just the variance of the original distribution divided by N . Thus, the standard deviation is divided by \sqrt{N} and the expression for the standard deviation of the average quantization error becomes

$$\frac{T_{\text{clock}} \sqrt{F(1-F)}}{\sqrt{N}}$$

If we consider $\sigma_{\bar{E}}$ to be a measure of the resolution, then this says that the resolution depends not only on the period of the clock and the number of time intervals averaged, but also the time interval itself (i.e., F).

Figure A-2 shows a normalized plot of the standard deviation of the error versus fractional clock pulse portion of the time interval and shows that the maximum sigma occurs when $F = 1/2$ (i.e., when the time interval is equal to $n + 1/2$ clock periods).

For this worst case, the quantization error of the time interval average measurement is equal to $1/2$ the period of the clock divided by the square root of N , the number of time intervals averaged.

This means that, in the worst case, out of a number of time interval average measurements, 95% (if N large) of the measurements will fall within

$$\pm \frac{T_{\text{clock}}}{\sqrt{N}} (= \pm 2\sigma_{\bar{E}})$$

of the actual time interval (in the absence of other errors).

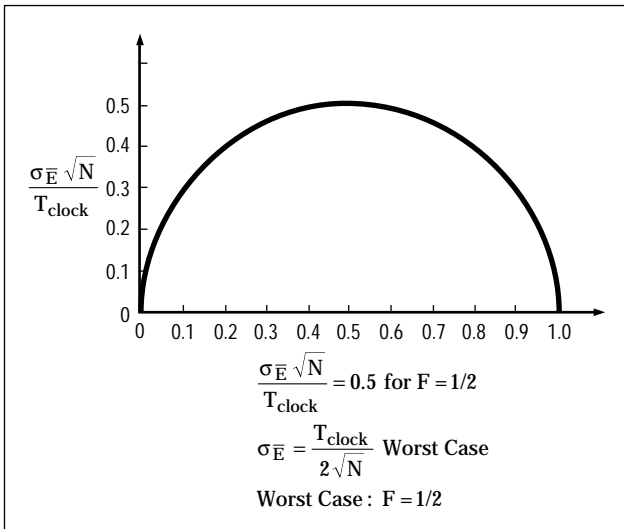

Figure A-2. σ_E versus fractional clock period.

The typical data sheet specifies that the error in a time interval average measurement is ± 1 count (clock) divided by the square root of N , the number of time intervals in the average. You see immediately that this specification is precisely twice the standard deviation of the worst case quantization error.

What does this all mean? It means that the specification of ± 1 count error for a time interval average measurement is not really the maximum possible value of the error. For a normal distribution, it does mean, however, that 95% of the readings on a given time interval will fall within $\pm T_{\text{clock}} / \sqrt{N}$. However, there is also the 5% of the readings which fall outside the two sigma worst case limits. You can see in Figure A-3 that as you increase the number of time intervals averaged, the spread of the distribution shrinks.

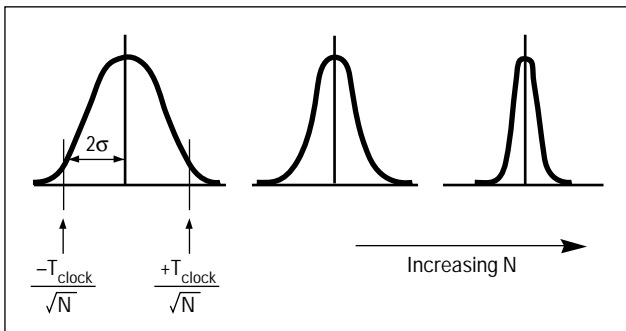

Figure A-3. Decreasing σ with increasing N .

For N small, the distribution of the counter's reading is not normal — it has a beta probability distribution. However, for large N , the distribution of the time interval average reading may be approximated by the normal distribution.

Figure A-4 shows some histogram plots on some time interval average measurements using the HP 5345A counter. The HP 5345A was connected to a desktop calculator which was also equipped with a plotter. The counter took a number of time interval average measurements. The resulting histogram plots show the probability distribution of the time interval average readings. The calculator program also computed the mean and standard deviation of the readings and plotted the mean and one sigma tick marks on the graph.

This first graph shows the histogram for 200 time intervals in the average measurement. The sigma was found to be 0.52 nanoseconds. You'll notice that this distribution is not normal but looks like a beta probability distribution. (In each case, the counter took a total of 100 time interval average measurements.)

The second graph is for a 100 fold increase in the number of time intervals in the average measurement. (The scale on the x axis has been expanded to 0.1 ns/division.) For a 100 fold increase, you'd expect the $\sqrt{100}$ or a 10 time decrease in the standard deviation. Notice that the sigma is now 0.056 nanoseconds. This distribution, with $N = 20,000$ appears approximately normal.

The third graph is for another 100 fold increase in the number of samples. The sigma has decreased to 0.0077 nanoseconds, a factor of 8 (not quite 10).

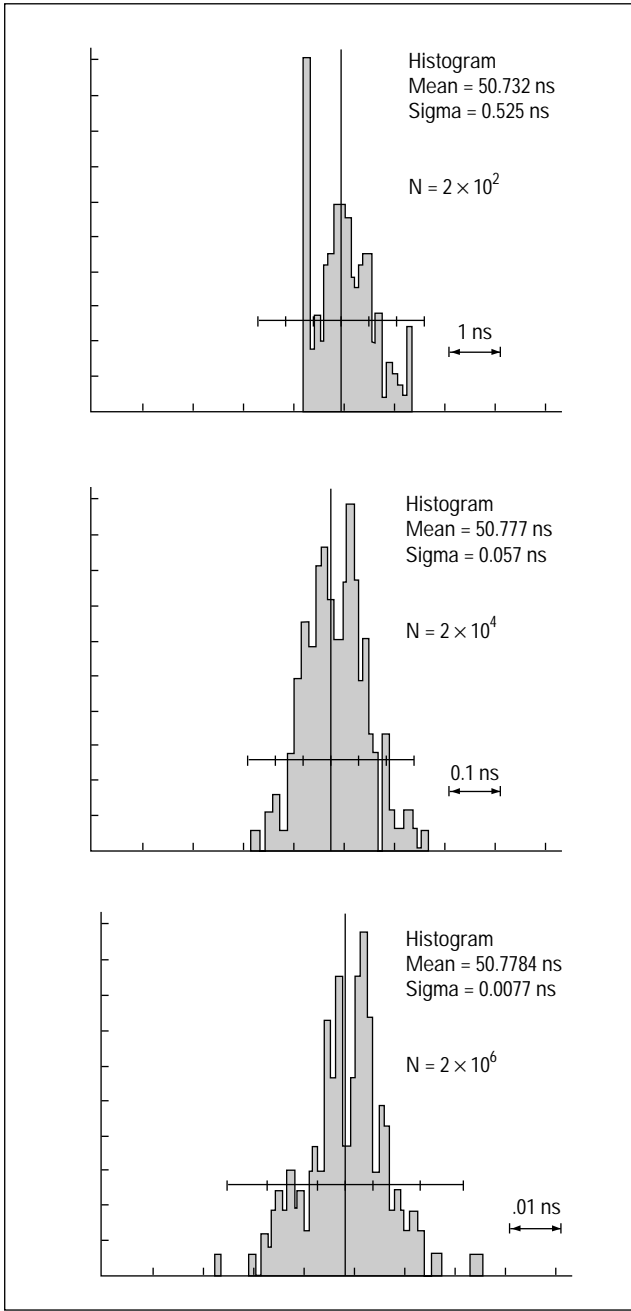

Figure A-4.
Histogram plots
with increasing N.

Appendix B. RMS Specifications

In the specification for resolution and accuracy, random errors are specified in terms of their rms value. Although one generally thinks of an accuracy statement as being a statement of the maximum possible error in the measurement, random noise errors are best specified on an rms basis instead of a peak basis. This is most easily demonstrated by examining the graph in Figure B-1 which is a plot of the expected maximum (peak) value in a sample (expressed in standard deviations away from the mean) as a function of sample size. As can be seen, the most probable peak value which will be observed in a sample depends on sample size and σ . For a sample size of 10, one would expect the peak value to equal 1.5σ or one and a half times the rms value. But, for a sample size of 1000, you will probably observe a peak value which is over 3σ or over three times the rms value. One cannot specify a peak value, then, unless a sample size is also specified.

As an example, consider making time interval average measurements on a stable $10 \mu\text{s}$ input time interval and the counter is set up such that the resolution is 125 ns rms. According to Figure B-1, if you take 10 time interval average measurements, the most probable maximum time interval observed would be $10.188 \mu\text{s}$ and the minimum $9.812 \mu\text{s}$ ($10 \mu\text{s} \pm 1.5 \sigma$). However, if you take 1000 samples, the maximum time interval observed is likely to be $10.388 \mu\text{s}$ and the minimum $9.612 \mu\text{s}$ ($10 \mu\text{s} \pm 3.1 \sigma$). However, the rms specification means that for any number of samples, you have a 68% confidence level that the actual time interval is somewhere between $9.875 \mu\text{s}$ and $10.125 \mu\text{s}$ ($10 \mu\text{s} \pm \sigma$). For higher confidence, use 2σ so that for our example, you could say with 95% confidence that the actual time interval is between $9.75 \mu\text{s}$ to $10.25 \mu\text{s}$ ($10 \mu\text{s} \pm 2 \sigma$).

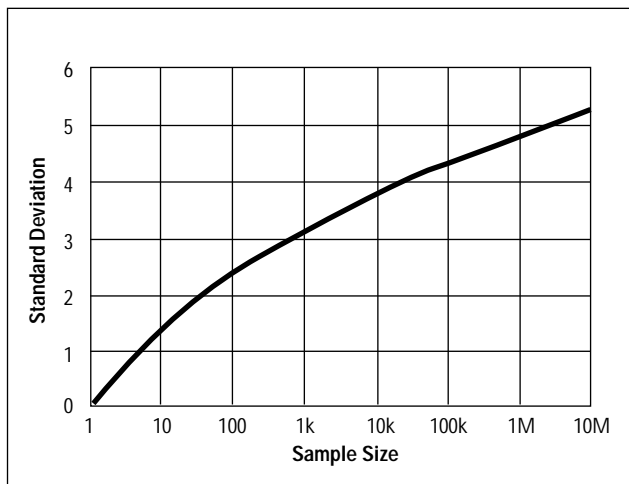

Figure B-1. The most probable maximum value within a Gaussian zero-mean sample.

Appendix C. Effects of Wideband Noise

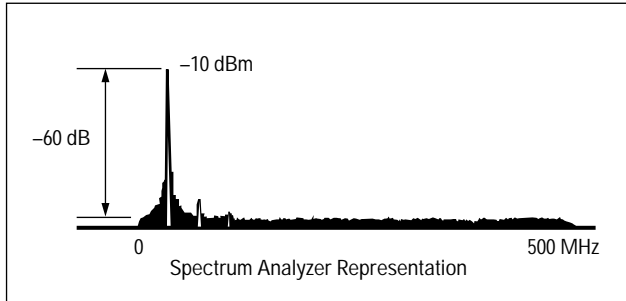

Figure C-1.
Spectrum analyzer
representation of
signal plus
wideband noise.

How do you determine the noise contributed by the signal source over the counter's bandwidth? One possible approach is to measure the signal of interest plus noise on a spectrum analyzer with a certain IF bandwidth and then calculate the noise over the counter's bandwidth.

Consider measuring a 10 MHz signal with a counter having a 500 MHz bandwidth. Let's say that you look at your 10 MHz signal on a spectrum analyzer with a IF bandwidth of 10 kHz and it shows the noise from the 10 MHz source to be flat and 60 dB below the fundamental, or at -70 dBm. -70 dBm into 50 is approximately $70 \mu\text{V rms}$. Obviously, you say, noise is no problem. You hook up the 10 MHz source to your counter and the counter display gives random readings. Why? Since the frequency counter is a time domain measuring instrument while the spectrum analyzer is frequency domain, the counter input sees the integral of all the spectral components over its bandwidth.

If the spectrum analyzer's 3 dB IF BW is 10 kHz, the equivalent random noise bandwidth is 12 kHz (1.2×10 kHz). Correcting the -70 dBm by 2.5 dB because of detector characteristic and logarithmic scaling, we can say that we have -67.5 dBm/12 kHz. To find the noise in a 500 MHz bandwidth, add

$$10 \log \frac{500 \text{ MHz}}{12 \text{ kHz}} = 46.2 \text{ dB.}$$

So, the noise in 500 MHz is $-67.5 + 46.2 = -21.3$ dBm which is equivalent to 19 mV rms. This causes a high level of trigger error and is responsible for the random readings. For high sensitivity counters, this level of noise could cause erratic counting.

(To learn more about noise measurements using spectrum analyzers, get a copy of Hewlett-Packard Application Note 150-4.)

Appendix D. Measurement of Counter Contributed Noise

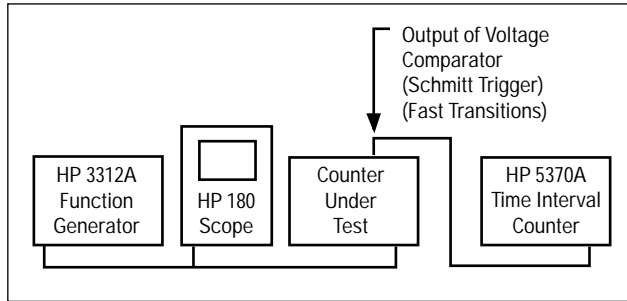

Figure D-1.
Measurement setup for measuring counter contribution noise.

Set the HP 3312A for a 100 mV peak-to-peak triangle wave with a period of 200 ms (1V/S slew rate) and apply this to the counter input. The output of the “counter under test’s” Schmitt trigger (voltage comparator) is fed to the HP 5370A which is measuring period. If the counter under test has a marker output (buffered comparator output), use the marker output. Otherwise, a scope probe can be used to pick up the comparator output.

Put the HP 5370A in PERIOD mode displaying STD DEV with a sample size of 1000. The equivalent single channel counter noise is equal to

$$\frac{\text{STD DEV}}{\sqrt{2}} (\text{seconds rms}) \times \text{slew rate (VOLTS/SEC)}$$

Make the test at other slew rates and check for maximum.

Appendix E. HP 5315A/B LSD Displayed and Resolution

If you assume a 1 second measurement time, you can see from the following chart what would happen if the HP 5315A/B counter were to display a constant number of digits:

Input Frequency	8 Digit Display (H z)	Least Significant Digit LSD	$\frac{\text{LSD}}{\text{FREQ}}$
100 kHz	100,000.00	0.01 Hz	1×10^{-7}
200 kHz	200,000.00	0.01 Hz	5×10^{-8}
300 kHz	300,000.00	0.01 Hz	3×10^{-8}
400 kHz	400,000.00	0.01 Hz	2.5×10^{-8}
500 kHz	500,000.00	0.01 Hz	2×10^{-8}
600 kHz	600,000.00	0.01 Hz	1.7×10^{-8}
700 kHz	700,000.00	0.01 Hz	1.4×10^{-8}
800 kHz	800,000.00	0.01 Hz	1.3×10^{-8}
900 kHz	900,000.00	0.01 Hz	1.1×10^{-8}

Due to the time base, the best the counter can resolve is 1 part in 10^7 per second (1 count in 10 MHz). From the chart above, it is apparent that the resolution limit would be exceeded above 100 kHz with a 1 second gate. When does the microprocessor decide to cut off the last digit as meaningless? As it turns out, the designer of the HP 5315A programmed the processor to truncate the last digit if the displayed resolution exceeds 5×10^{-8} . This insures that the last digit is never worse than ± 2 counts and can, in fact, be much better than ± 1 count. The actual behavior of the HP 5315A/B for a 1 second gate time is shown in the following chart:

Input Frequency	Actual Display	Significant Digit	$\frac{\text{Least LSD}}{\text{FREQ}}$
100 kHz	100,000.00	0.01 Hz	1×10^{-7}
200 kHz	200,000.00	0.01 Hz	5×10^{-8}
300 kHz	300,000.0	0.1 Hz	3×10^{-7}
400 kHz	400,000.0	0.1 Hz	2.5×10^{-7}
500 kHz	500,000.0	0.1 Hz	2×10^{-7}
600 kHz	600,000.0	0.1 Hz	1.7×10^{-7}
700 kHz	700,000.0	0.1 Hz	1.4×10^{-7}
800 kHz	800,000.0	0.1 Hz	1.3×10^{-7}
900 kHz	900,000.0	0.1 Hz	1.1×10^{-7}

Notice that at 300 kHz the displayed resolution overstates the actual error by a factor of 3. However, for simplicity in the specifications, it

was decided to conservatively specify accuracy and resolution limits at ± 1 count whenever the ratio of the LSD to Displayed reading is greater than 1×10^{-7} .

Above 10 MHz, the situation changes only slightly. The counter now synchronizes on the timebase, counts the number of events during the gate time, and calculates

$$\frac{\text{EVENTS}}{\text{TIME}} \text{ or } \frac{\text{TIME}}{\text{EVENTS}}.$$

in this case, the resolution limit is identical to a conventional counter:

$$\pm \frac{1}{\text{Gate Time}}$$

Let's see what a similar chart would look like if you measure a 100 MHz signal with gate times from 0.1 s to 0.9 s (remember the gate time of the HP 5315A/B is continuously variable):

Gate Time	Display	LSD	$\frac{1}{\text{Gate Time}}$	Specified Quantization Error
0.1	100 000 00	10 Hz	10 Hz	± 1 LSD
0.2	100 000 00	10 Hz	5.0 Hz	± 1 LSD
0.3	100 000 00	10 Hz	3.3 Hz	± 1 LSD
0.4	100 000 00	10 Hz	2.5 Hz	± 1 LSD
0.5	100 000 000	1 Hz	2.0 Hz	± 2 LSD
0.6	100 000 000	1 Hz	1.7 Hz	± 2 LSD
0.7	100 000 000	1 Hz	1.4 Hz	± 2 LSD
0.8	100 000 000	1 Hz	1.3 Hz	± 2 LSD
0.9	100 000 000	1 Hz	1.1 Hz	± 2 LSD

Again, for reasons of simplicity, the resolution and accuracy specification above 10 MHz conservatively indicates ± 2 count whenever the LSD Displayed is less than

$$\frac{1}{\text{Gate Time}}.$$

For more information about Hewlett-Packard Test and Measurement products, applications, services, and for a current sales office listing, visit our web site, <http://www.hp.com/go/tmdir>. You can also contact one of the following centers and ask for a test and measurement sales representative.

United States:

Hewlett-Packard Company
Test and Measurement Call Center
P.O. Box 4026
Englewood, CO 80155-4026
1 800 452 4844

Canada:

Hewlett-Packard Canada Ltd.
5150 Spectrum Way
Mississauga, Ontario
L4W 5G1
(905) 206 4725

Europe:

Hewlett-Packard
European Marketing Centre
P.O. Box 999
1180 AZ Amstelveen
The Netherlands
(31 20) 547 9900

Japan:

Hewlett-Packard Japan Ltd.
Measurement Assistance Center
9-1, Takakura-Cho, Hachioji-Shi,
Tokyo 192, Japan
(81) 426 56 7832
(81) 426 56 7840 Fax

Latin America:

Hewlett-Packard
Latin American Region Headquarters
5200 Blue Lagoon Drive
9th Floor
Miami, Florida 33126
U.S.A.
(305) 267 4245/4220

Australia/New Zealand:

Hewlett-Packard Australia Ltd.
31-41 Joseph Street
Blackburn, Victoria 3130
Australia
1 800 629 485

Asia Pacific:

Hewlett-Packard Asia Pacific Ltd.
17-21/F Shell Tower, Time Square,
1 Matherson Street, Causeway Bay,
Hong Kong
(852) 2599 7777
(852) 2506 9285