

**Spectrum Analyzer Series**  
**APPLICATION NOTE 150-8**

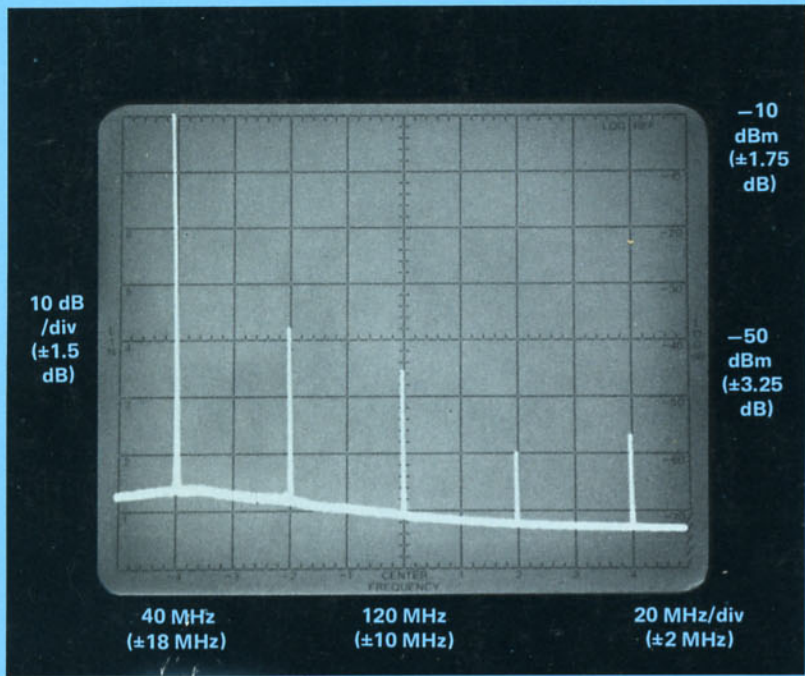

**SPECTRUM ANALYSIS....**  
**Accuracy Improvement**

**APPLICATION NOTE 150-8**

**SPECTRUM ANALYSIS ...**  
**Accuracy Improvement**

**Printed March 1976**

HEWLETT  PACKARD

## INTRODUCTION

The accuracy of amplitude and frequency measurements depends upon the equipment used and procedure followed. This note will describe those factors affecting spectrum analyzer accuracy and explain how they interact to determine "worst case" measurement accuracy. When this background is understood, the reader will be able to analyze his measurement and decide what procedure to follow for the desired degree of accuracy. In addition, the reader will appreciate what capabilities and features to keep in mind when evaluating and comparing spectrum analyzers.

It is assumed that the reader is familiar with the controls and operation of a spectrum analyzer. For a review of the subject refer to Hewlett-Packard Application Note 150, "Spectrum Analyzer Basics."

AN 150-8 discusses techniques for measuring amplitude and frequency in general situations. Certain types of signals (such as pulsed RF, noise, and EMI) require specialized measurement procedures that introduce additional sources of uncertainty. Although these special cases will not be covered here, the reader is referred to these other Hewlett-Packard application notes for details:

AN 150-2 Pulsed RF

AN 150-4 Noise Measurements

AN 63E EMI Measurements

## TABLE OF CONTENTS

<b>CHAPTER 1 — Amplitude Accuracy</b> . . . . .	1
Standard Measurement Procedures . . . . .	1
Factors . . . . .	2
Interaction . . . . .	3
Determining Overall Spectrum Analyzer Amplitude Measurement Accuracy	4
Amplitude Measurements in Voltage . . . . .	4
<b>CHAPTER 2 — Frequency Accuracy</b> . . . . .	6
Standard Measurement Procedures . . . . .	6
Factors . . . . .	7
Interaction . . . . .	8
Determining Overall Spectrum Analyzer Amplitude Measurement Accuracy	8
<b>CHAPTER 3 — Spectrum Analyzer Performance Considerations Relevant to Accurate Measurement</b> . . . . .	9
<b>CHAPTER 4 — Conclusion</b> . . . . .	10
<b>APPENDIX A — Special Cases</b> . . . . .	12
Swept Measurements: Amplitude . . . . .	12
Accuracy Factors . . . . .	13
Swept Measurements: Frequency . . . . .	14
Accuracy Factors . . . . .	14
Low Level Signals . . . . .	15
Closely Spaced Signals . . . . .	16
<b>APPENDIX B — Enhancing Accuracy</b> . . . . .	17
Enhancing Amplitude Accuracy . . . . .	17
Calibration Accuracy . . . . .	17
Comparison Accuracy . . . . .	18
RF Substitution . . . . .	18
IF Substitution . . . . .	18
Voltage Measurements . . . . .	19
Enhancing Frequency Accuracy . . . . .	19
Direct Measurement . . . . .	19
Tracking Generator . . . . .	19
Counting the LO's . . . . .	20
Relative Measurement . . . . .	22
<b>APPENDIX C — Accuracy Related Specifications</b> . . . . .	24

## CHAPTER 1 Amplitude Accuracy

Depending upon the measurement procedure being followed, various parts of a spectrum analyzer's design may influence its amplitude accuracy. The generalized block diagram, Figure 1, shows the parts of an analyzer de-

sign subject to uncertainty and the controls that influence amplitude measurement accuracy. Before the specific factors that contribute to accuracy are detailed, the standard measurement procedures will be described.

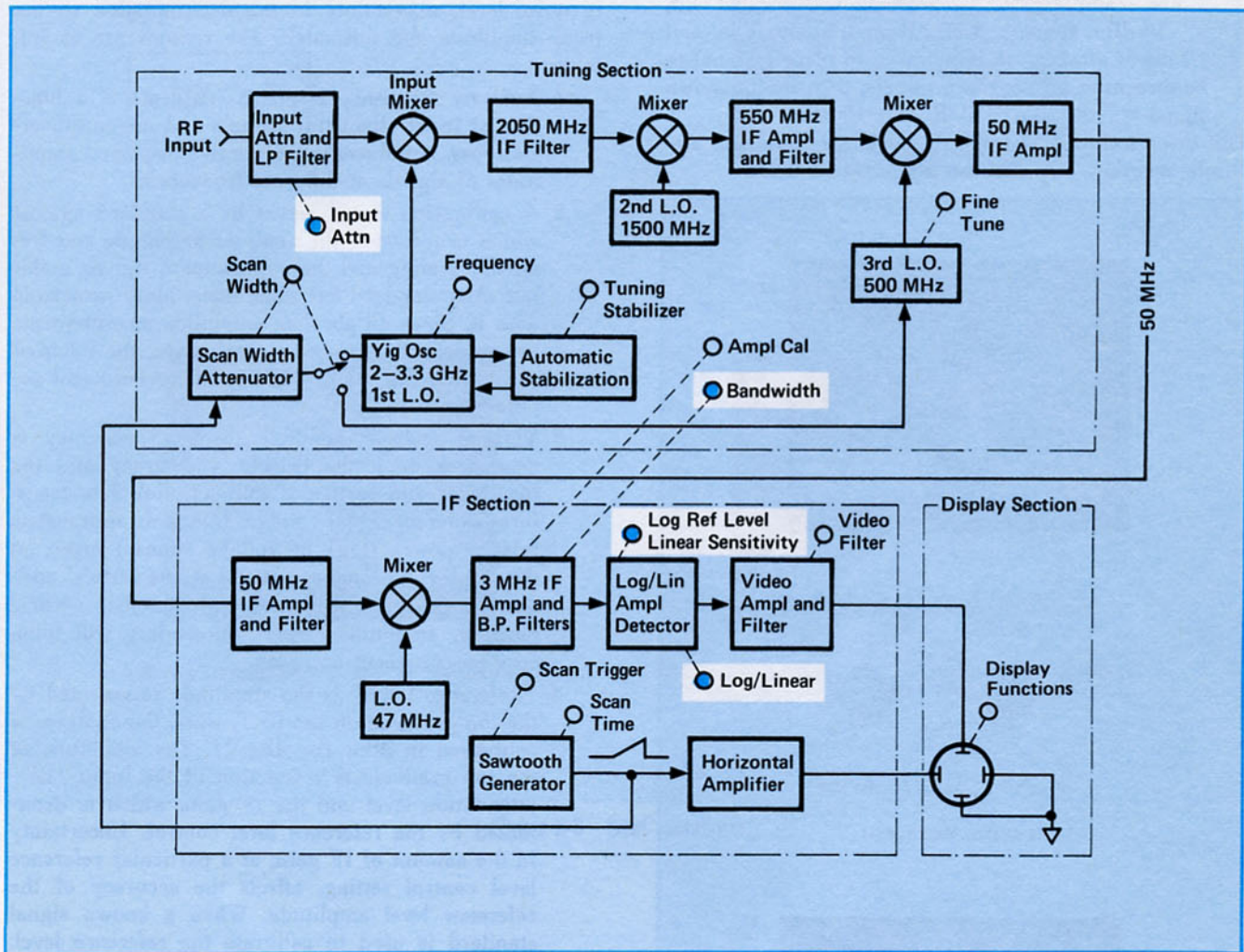

**Figure 1** Controls affecting amplitude accuracy

### Standard Measurement Procedures

Some time prior to the measurement, the top graticule or "reference level" line of the analyzer CRT is calibrated using the analyzer's internal calibration signal. The signal to be measured is later connected to the analyzer input and its amplitude is determined in one of the following ways:

1. **Relative measurement technique:**

The number of divisions between the top graticule and the signal peak is multiplied by the vertical scale factor and then subtracted from the reference level control settings. Figure 2a shows an example of this technique.

2. **IF substitution technique:**

The reference level control is adjusted to place the signal peak at the top graticule line. Signal amplitude is read directly from the reference level control settings. This technique requires a wide range of reference level control (70 dB) as well as a calibrated

vernier. Figure 2b applies this method to the previous example.

3. **RF substitution technique:**

An attenuator is used to match the unknown signal level to the calibration level. The attenuator may be a part of the analyzer or external to it. If the attenuator is built in, then the reference level of the analyzer should change automatically and compensate for the level of input attenuation to maintain absolute calibration. The attenuator must be variable over a wide range and have a calibrated vernier to make accurate substitutions. Since high frequency RF substitution is generally not as accurate as IF substitution, Hewlett-Packard encourages the use of the latter technique and does not include an RF attenuator vernier in its spectrum analyzer designs. If the internal attenuator is used, a known signal level is connected to the analyzer and a known amount of input attenuation is inserted. The standard

procedure for calibrating a particular CRT level is followed. The signal to be measured is then connected and input attenuation is added or deleted until the displayed signal level is placed at the calibration level. The unknown signal level equals: The calibration level – (or +) the decrease (or increase) in attenuation between calibration and measurement.

For example, if the top graticule is calibrated with a  $-30$  dBm signal and  $30$  dB input attenuation, and  $10$  dB of attenuation is removed to place a signal to be measured on the top graticule, then the unknown signal =  $-30$  dBm  $-10$  dB or  $-40$  dBm.

With these techniques in mind, the factors affecting amplitude accuracy will now be discussed in detail.

## Factors

The factors affecting the accuracy of amplitude measurements on a spectrum analyzer are: analyzer frequency response (flatness), calibrator accuracy, vertical scale accuracy, reference level/linear sensitivity control accuracy, resolution bandwidth behavior, per division scaling behavior, input attenuator accuracy, signal level relative to noise level, uncertainty in the determination of the trace amplitude and mismatch. The reasons are as follows:

1. Analyzer frequency response (flatness) is a function of input attenuator flatness and mixer conversion loss. It influences the relative displayed amplitudes of signals at different frequencies.
2. A calibration signal serves as a standard against which to reference the analyzer amplitude and frequency scaling and thereby compare signals under test. Any standard has some uncertainty associated with it. Since all absolute amplitude measurements are made with respect to a reference, the inherent calibration uncertainty is part of measurement accuracy.
3. Vertical scale, "amplitude display," accuracy is dependent upon the detector's accuracy and the log/linear and vertical amplifiers' ability to transform different signal voltages into their appropriate relative power (log) or voltage (linear) levels on the display. So long as a signal at one vertical position is measured with respect to another vertical position, amplitude display uncertainty will influence measurement accuracy.
4. "Reference Level" is the amplitude represented by the top graticule on the CRT, when the analyzer is calibrated in dBm (or dBmV). The amplitude of the top graticule is a function of the input (RF) attenuation level and the IF gain, which is determined by the reference level control. Uncertainty in the amount of IF gain, at a particular reference level control setting, affects the accuracy of the reference level amplitude. When a known signal standard is used to calibrate the reference level, calibrator uncertainty is substituted for reference level control uncertainty. Any subsequent change in the reference level control (IF gain) will introduce reference level control uncertainty into the measurement. On those spectrum analyzer models that can be calibrated in linear voltage, the knob that controls IF gain becomes a "linear sensitivity" control, where "linear sensitivity" refers to the amplitude per division scaling from the bottom graticule. The same uncertainty factors apply as described above.
5. The various available bandwidths of a spectrum analyzer have uncertainty associated with their relative insertion loss characteristics. As a result, if a signal is measured using different bandwidths, the measured amplitudes may differ. Whenever the bandwidth setting is changed between calibration and measurement, the calibration accuracy is degraded and measurement accuracy is compromised.
6. Similarly, changing the per division scaling factor (log/linear) introduces uncertainty associated with

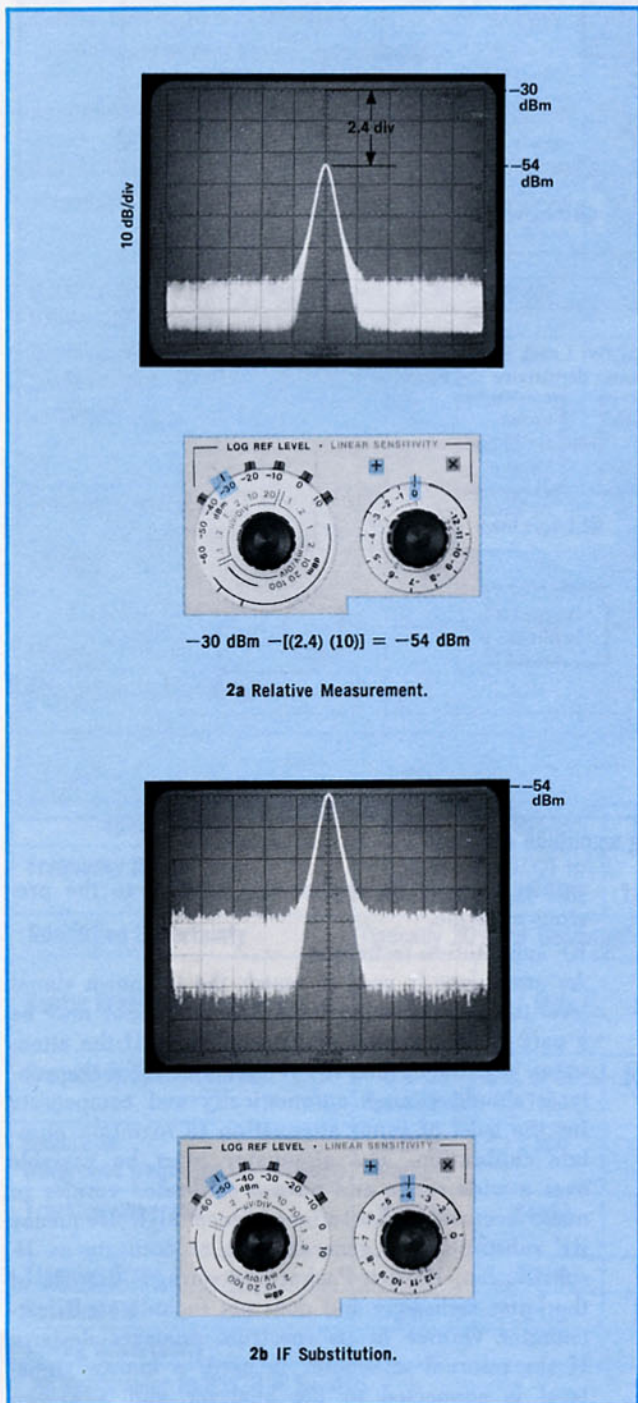

Figure 2 Standard measurement procedures

the relative calibration characteristics of the log/linear amplifiers.

7. The amount of the input attenuation has inherent uncertainty which reduces reference level accuracy if the attenuator is changed between reference level calibration and the measurement.
8. The amplitude displayed at any point on a spectrum analyzer CRT is the sum of all signal energy present in the IF passband. Therefore, the displayed amplitude of a signal is actually signal plus noise. Depending upon the signal level relative to the noise level, the inaccuracy in assuming that the "displayed" amplitude equals the "signal" amplitude may be small or large (see page 15).

If the displayed signal level was 3 dB above the displayed noise level, then interpreting the "displayed" amplitude to be the "signal" amplitude would result in 1.2 dB error (1.8 dB in linear). If the displayed signal level was 6 dB above the displayed noise level, the error would be 0.15 dB (0.5 dB in linear). For signals that appear 9 dB or more above the noise, the error becomes negligible.

The same concept applies when one signal falls on the skirt of a second signal (see page 16), or if distortion products coming from a device under test are coincident with analyzer harmonic or intermodulation distortion. In these cases, the displayed amplitude is a function of *all* the signal energy and noise present in the passband.

9. The "true" amplitude of a trace on the CRT is measured with respect to the center of the beam. Because the trace has a finite width (approximately 0.1 division) there is uncertainty in the determination of the "center" of the trace (0.03 division). This uncertainty affects the measurement of the number of divisions between the center of the trace and the reference level (RF substitution), or the placement of the center of the trace on the reference level (IF substitution). With 10 dB/division vertical scaling, this uncertainty amounts to 0.3 dB.
10. Impedance mismatch can be a significant source of error when making power measurements. If the impedance of the analyzer is not matched to the impedance of the signal source (or any device connected to it), reflections may arise that reduce the signal power transferred to the analyzer. When this occurs, signal power will not be measured accurately.

The general expression used to calculate mismatch error limits in dB is  $20 \log_{10} (1 \pm |\rho_{\text{analyzer}} \times \rho_{\text{source}}|)$ . However, when this expression is applied to a spectrum analyzer, the error will be overstated by  $\pm 0.24$  dB; this is because the frequency response (flatness) uncertainty spec of the analyzer included  $\pm 0.24$  dB of mismatch error (the flatness spec is measured using a leveled source with a  $\rho = 0.09$ ). Consequently, the amount of mismatch error calculated by the above expression should be reduced by 0.24 dB to determine the "actual" mismatch error limits.

Since impedances can be matched relatively accurately at low frequencies, mismatch error does not contribute much measurement uncertainty. At

high frequencies, however, mismatch can reduce power measurement accuracy significantly.

This note is not intended to describe how to minimize mismatch; however, as a general rule, at least 10 dB or more of padding between the source and analyzer will improve the match substantially. The reader should refer to HP Application Note 56, "Microwave Mismatch Error Analysis," for a more detailed discussion of the subject.

Depending upon the measurement procedure followed, various of these previously described factors will interact to yield a total measurement uncertainty.

### Interaction

All the factors that affect amplitude accuracy are potential sources of uncertainty and may or may not reduce measurement accuracy depending upon the method followed. Uncertainty due to noise being measured along with the signal is a function of their relative amplitudes. Uncertainty in the designation of the trace amplitude is a function of the vertical scale factor used. Calibration uncertainty is unavoidable, but may be decreased. Mismatch uncertainty is always present to some degree, but can be reduced using special techniques. Flatness uncertainty is important whenever the calibration frequency is different from the test frequency. Some form of "comparison" inaccuracy is always present though the amount can be minimized by careful attention to methodology. The other factors only contribute uncertainty if their associated control settings are changed.

Three of the factors can be classified as relating to the "comparison" of the signal under test to a calibrated reference. One of these "comparison factors" is present in each of the three standard measurement procedures previously discussed. Contingent upon the procedure followed, any one source or a combination may contribute uncertainty.

1. Measuring signal level with respect to the calibrated reference level and CRT scale without changing the reference level or attenuator controls, introduces only amplitude display (vertical scale) uncertainty. This is the "relative measurement technique."
2. Changing the reference level control (IF gain) to place the signal peak at exactly the same vertical level on the CRT scale as the calibrated standard, without changing the attenuator setting, introduces only reference level control uncertainty. This is the "IF substitution technique."
3. Changing the signal level, by adding or deleting "input attenuation," so that it matches the calibration level (leaving the reference level control unchanged) introduces only attenuation uncertainty. This is the "RF substitution technique."

If a combination of these techniques is followed, a number of sources of uncertainty will be present simultaneously and "comparison uncertainty" will be increased significantly. What comparison method to use, to minimize uncertainty, depends on the specifications of the equipment. Typically, amplitude display uncertainty is relatively large. At low frequencies "RF substitution" promises good accuracy, while at higher frequencies "IF substitution" is most accurate.

## Determining Overall Spectrum Analyzer Amplitude Measurement Accuracy

The analysis of total measurement accuracy can be summarized as follows:

Accuracy =

- CALIBRATOR uncertainty (abbreviated CAL).
  - + FREQUENCY RESPONSE (flatness) uncertainty (FR) — if calibration is not done at the same frequency as the signal under test.
  - + Uncertainty resulting from noise power being measured along with signal power (NL).
  - + Uncertainty in the determination of the trace amplitude (TA).
- Depending upon whether the following controls are changed between calibration and test:
- + LOG REFERENCE LEVEL CONTROL (linear sensitivity) uncertainty (LRLC).
  - + LOG REFERENCE LEVEL VERNIER (linear sensitivity) uncertainty (LRLV).
  - + AMPLITUDE DISPLAY uncertainty (AD).
  - + ATTENUATOR uncertainty (AT).
  - + Uncertainty resulting from SWITCHING BETWEEN BANDWIDTHS (SBBW).
  - + Uncertainty in LOG REFERENCE LEVEL resulting from switching between scale factors (LRL).
  - + Mismatch error (MISMATCH).

Worst Case Accuracy =  $\pm | (CAL) + (FR) + (NL) + (TA) + (LRLC + LRLV + AD + AT) + (SBBW + LRL) + (MISMATCH) |$ .

It should be noted that the probability of the *worst* case occurring is very small. In some applications a more meaningful parameter for error analysis is to identify the limits within which there is a 95.5% probability that total measurement error will occur.

One method to determine those limits is to apply Monte Carlo techniques to simulate a number of measurements and then statistically analyze the results.

An example will clarify the use of the accuracy expression:

If Hewlett-Packard models 8554B Tuning Section (100 kHz to 1250 MHz) and 8552B IF Section were used to measure the amplitude of a -25 dBm signal at 1000 MHz, the following uncertainty specifications would be found in the data sheet for the log mode of operation:

- CAL =  $\pm 0.3$  dB.
- FR =  $\pm 1.0$  dB.
- LRLC =  $\pm 0.2$  dB.
- LRLV =  $\pm 0.25$  dB.
- AD =  $\pm 1.5$  dB.
- AT =  $\pm 1.0$  dB.
- SBBW =  $\pm 0.5$  dB.
- LRL =  $\pm 0.6$  dB.

With vertical scaling of 10 dB/div, TA = 0.3 dB. Noise level in a 10 kHz bandwidth = -105 dBm; the signal is 80 dB above the noise level so NL  $\approx$  0 dB. Reflection coefficient = 0.30 (VSWR = 1.85); if the reflection coefficient of the signal source is 0.20 (VSWR = 1.5), then the maximum mismatch

error limits  $\pm (|20 \log_{10} (1 \pm \rho_1 \rho_2)| - 0.24)$ , MISMATCH), are  $\pm 0.30$  dB.

If all the controls that affect amplitude accuracy were changed in the process of measuring the signal's amplitude then all sources of error may be present and worst case uncertainty would equal:  $\pm 5.95$  dB. (See Table 1.)

If the "relative measurement technique" was followed leaving all other controls unchanged, worst case uncertainty would equal  $\pm 3.40$  dB.

If "IF substitution" was used to measure signal amplitude, leaving all other controls unchanged, uncertainty would equal  $\pm 2.35$  dB. (Accuracy could be further improved to  $\pm 2.11$  dB if 2 dB/div vertical scaling were used.)

The limits, within which there is 95.5% probability that total measurement error will occur, for the three techniques respectively are: 2.85 dB, 2.54 dB, 1.67 dB. (See Table 1.)

	All Controls Used	Relative Measurement	IF Substitution	
			10 dB/Div	2 dB/Div
CAL	0.3	0.3	0.3	0.3
FR	1.0	1.0	1.0	1.0
NL	0.0	0.0	0.0	0.0
TA	0.3	0.3	0.3	0.06
LRLC	0.2	—	0.2	0.2
LRLV	0.25	—	0.25	0.25
AD	1.5	1.5	—	—
AT	1.0	—	—	—
SBBW	0.5	—	—	—
LRL	0.6	—	—	—
MISMATCH	0.3	0.3	0.3	0.3
<b>Total Worst Case</b>				
<b>Accuracy</b>	$\pm 5.95$ dB	$\pm 3.40$ dB	$\pm 2.35$ dB	$\pm 2.11$ dB
<b>95.5% Probability</b>	$\pm 2.85$ dB	$\pm 2.54$ dB	$\pm 1.67$ dB	$\pm 1.61$ dB

**Table 1**  
Error Comparison for a Typical Amplitude Measurement Using Various Measurement Techniques

It should be obvious from this example that careful attention to methodology can reduce worst case uncertainty appreciably (in this case from  $\pm 5.95$  dB to  $\pm 2.35$  dB). Simply leaving the bandwidth and scale factor control unchanged avoids  $\pm 1.1$  dB of uncertainty. The "Relative measurement technique" causes  $\pm 1.5$  dB of "comparison" uncertainty in contrast to  $\pm 0.45$  dB for "IF" substitution. "IF substitution" yields the best accuracy that can be achieved with this equipment.

## Amplitude Measurements in Voltage

Signal levels may also be measured in voltage using a linear display (and then converted to dBm). The vertical axis of the CRT is scaled in mV/division from the *bottom* graticule. A signal's amplitude is measured by multiplying the number of divisions between the bottom graticule and

the signal peak by a scale factor which is selected using a "linear sensitivity" control and vernier multiplier. See Figure 3.

The factors affecting the accuracy of this technique are essentially the same as described previously for measuring amplitudes in dBm, with the following differences:

1. Although "trace amplitude" uncertainty (TA) remains 0.03 division, its magnitude in dB is a function of the number of divisions of deflection caused by the signal response. A signal response eight divisions high has uncertainty of  $\pm 0.03$  dB, compared to  $\pm 0.27$  dB for a one division deflection. For greatest accuracy, the deflection should be as large as possible.
2. In a similar way, Amplitude Display uncertainty (AD), which is interpreted as "linearity uncertainty" in the linear mode, is a function of the size of the signal deflection. Linearity is typically specified as a percentage of full screen deflection (which translates into a fixed number of divisions).
3. "Linear sensitivity control and vernier accuracy" (LSC and LSV) replace Log Reference Control and Vernier accuracy. Because the vernier multiplier introduces its own uncertainty if it is not in the X1 position, it is recommended that X1 be used for the sake of accuracy and simplicity.
4. Uncertainty resulting from switching between log scale factors (LRL) does not apply.

$$\text{Worst Case Accuracy} = \pm |(\text{CAL}) + (\text{FR}) + (\text{NL}) + (\text{TA}) + (\text{LSC} + \text{LSV} + \text{AD} + \text{AT}) + (\text{SBBW}) + (\text{MISMATCH})|$$

Returning to the previous signal level measurement example using Hewlett-Packard Models 8554B and 8552B, in the linear mode: TA =  $\pm 0.04$  dB (0.03 div of a 6.3 div deflection at 2 mV/div), AD =  $\pm 0.30$  dB (0.224 div of 6.3 div deflection), LSC =  $\pm 0.2$  dB (LSV = 0 dB at X1); total worst case uncertainty equals  $\pm 2.14$  dB. This compares to  $\pm 2.35$  dB and 2.11 dB for IF substitution using 10 dB/div and 2 dB/div scaling.

Depending on the size of the signal deflection: the "comparison accuracy" of a linear measurement (which ranges from  $\pm 0.2$  dB for an 8 div deflection to  $\pm 1.93$  dB for a 1 div deflection) may be greater or less than the  $\pm 0.45$  dB of an IF substitution measurement; similarly, "trace amplitude uncertainty" in linear ranges from  $\pm 0.03$  to  $\pm 0.27$  dB compared to  $\pm 0.06$  dB for 2 dB/div. For signal deflections greater than 6.78 divisions (when the linear sensitivity vernier is X1) measurements in linear

are more accurate than IF substitution on a 2 dB/div log display.

It should be noted that if linear sensitivity is determined by dividing the voltage of the reference level (top graticule) by the number of vertical divisions, several other considerations become relevant. The magnitude of the signal measurement error due to reference level uncertainty becomes a function of the size of the signal deflection, and linearity uncertainty is calculated over the display range between the reference level and the peak of the signal response.

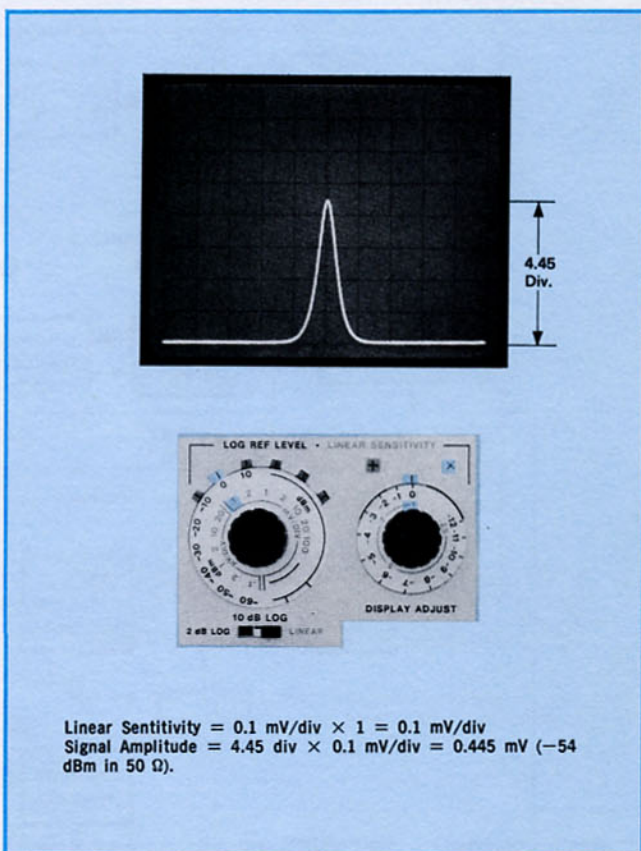

Figure 3 Signal voltage measurement

Supplementary equipment and special techniques can be used to further improve the accuracy of amplitude measurements. Enhancing amplitude accuracy is a subject of Appendix B, page 17.

Swept amplitude measurements (insertion loss, return loss), low level signal measurements, and closely spaced signal measurements require special analysis. Appendix A discusses these special cases in detail.



## CHAPTER 2

### Frequency Accuracy

The block diagram in Figure 4 shows how those controls that influence frequency accuracy affect the operation of an analyzer. (Refer to AN 150 for a discussion of spectrum analyzer basics.) What controls are used to

make a frequency measurement depends upon the procedure followed. Standard measurement procedures are the subjects of the next section.

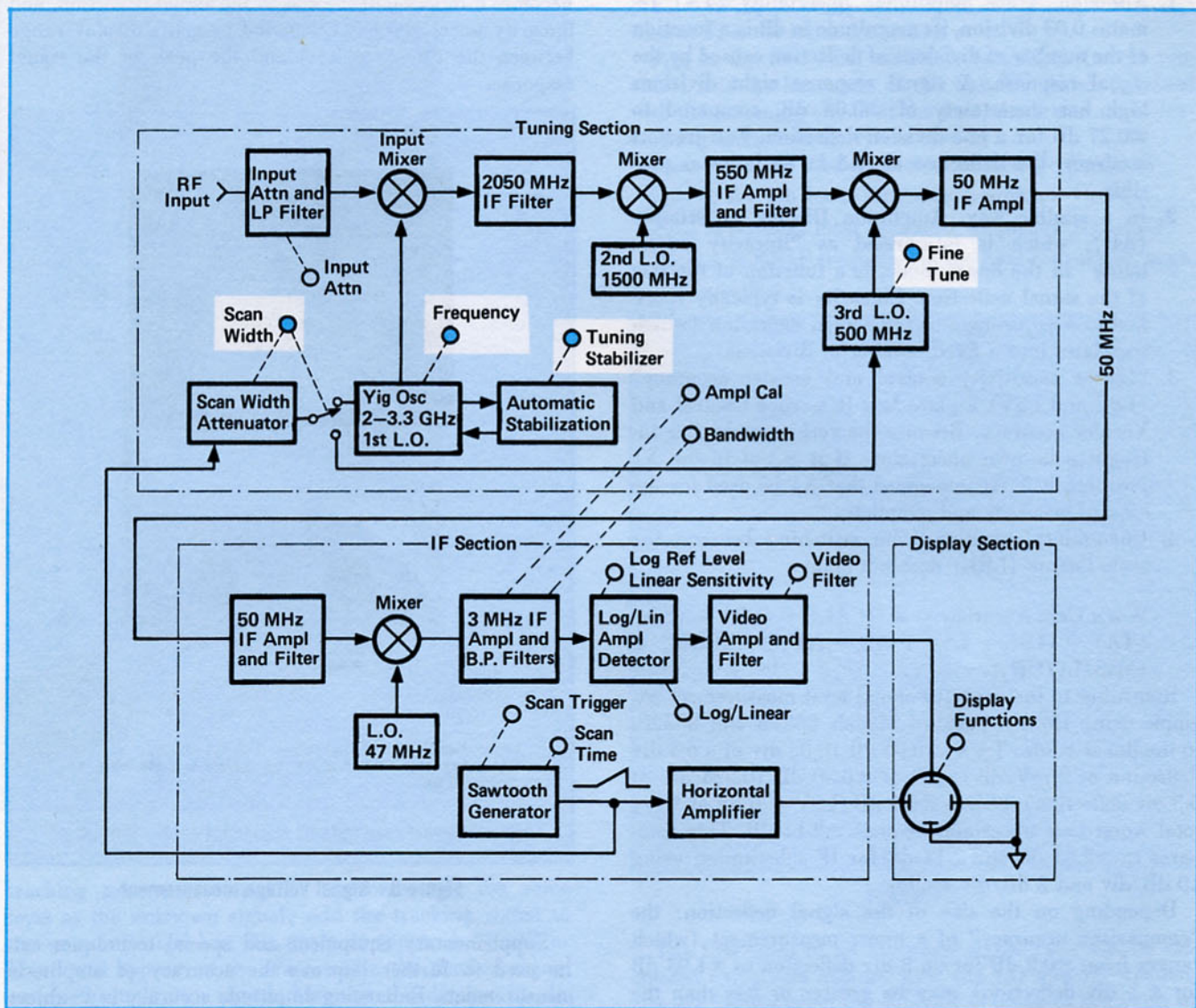

Figure 4 Controls affecting frequency accuracy

### Standard Measurement Procedures

The frequency of an unknown signal can be measured on a spectrum analyzer in two basic ways:

#### 1. Relative measurement technique:

The number of divisions between a known signal frequency and the unknown signal peak is multiplied by the frequency span per division (scanwidth) and then added to or subtracted from the known signal frequency. (Figure 5a presents an example of this technique.) The known signal frequency may be the analyzer "LO feedthrough" (which represents 0 Hz), the internal calibration signal, or any other signal

source whose frequency is known to a relatively high degree of accuracy.

#### 2. Absolute measurement technique:

The unknown signal is "tuned" to the center of the CRT using the analyzer course and fine tune controls, and the display center frequency is read off a frequency dial or built-in digital readout. Figure 5b shows an example of the technique.

Several potential sources of uncertainty exist which may combine to constrain total measurement accuracy. The procedure followed determines which of these factors are relevant to the measurement.

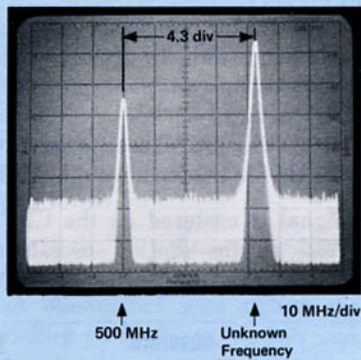

500 MHz      10 MHz/div  
Unknown Frequency



$$\begin{aligned} \text{Unknown frequency} &= 500 \text{ MHz} + 4.3 (10 \text{ MHz}) \\ &= 543 \text{ MHz} \end{aligned}$$

5a "Relative" measurement technique.

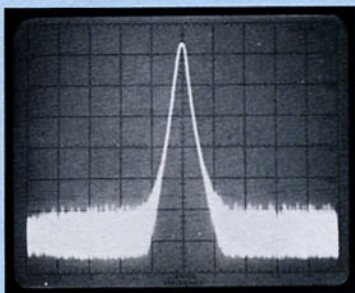
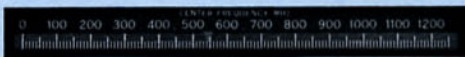

543 MHz

Tune unknown signal to center of CRT.

5b "Absolute" measurement technique.

Figure 5 Frequency measurement techniques

## Factors

The factors affecting the accuracy of frequency measurements on a spectrum analyzer are resolution uncertainty, frequency dial (or digital readout) uncertainty, frequency span accuracy, and reference frequency uncertainty. The reasons are as follows:

1. The uncertainty surrounding the designation of one particular point as the "peak" of a displayed signal is defined as "resolution uncertainty." Resolution (IF) bandwidth is the window through which an analyzer looks at frequencies present at its input. It

is the shape of this IF filter which is traced out on the display that represents the "signal." Since points whose frequencies are close to the center frequency also appear on the curvature at the peak of the trace, it is difficult to determine the "center" frequency. (See Figure 6.) The uncertainty in defining a signal peak is important when measuring frequency because it limits the ability of a user to tune an unknown signal to the center of the CRT or to determine the distance between a reference point and the displayed signal. Resolution uncertainty is typically less than 30% of the bandwidth setting with 10 dB/division vertical scaling (20% for 2 dB/division and 10% for linear scaling). When measuring the distance between two signals, resolution uncertainty is two times that of a lone signal.

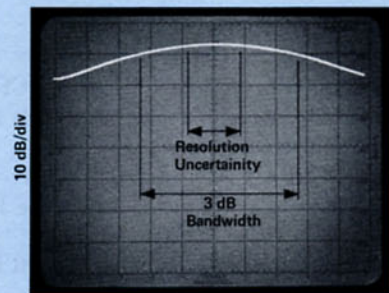

$$\text{Resolution Uncertainty} = 30\% \text{ Bandwidth Setting (with 10 dB/div vertical scaling)}$$

Figure 6 Resolution uncertainty

2. Frequency dial uncertainty refers to how accurately the dial (or digital readout) reflects the display center frequency. The input signal frequency is deduced from the swept LO (mechanically in the case of a dial and electronically for a digital readout). Uncertainty is caused by limited dial/display resolution and error in the deduction process. It limits a user's ability to determine the center frequency from the analyzer dial with a high degree of accuracy. This source of uncertainty is particularly important when the "absolute measurement technique" is being employed.
3. Frequency span per division (scanwidth) determines the horizontal scaling of the analyzer. It is controlled by attenuating the sawtooth that drives the first LO. Uncertainty in the attenuation and non-linearity of the oscillator and horizontal amplifier limits horizontal scaling accuracy. Frequency span error becomes important when a signal under test is compared to a reference signal.

4. A calibration signal serves as the standard against which unknown signals are compared. Since any frequency standard has uncertainty associated with it, reference frequency uncertainty is a part of any relative measurement.

Total measurement uncertainty will depend upon how these factors interact during the measurement procedure.

#### Interaction

The accuracy of an "absolute measurement" is limited by the uncertainty surrounding the resolution of the signal peak and the accuracy of the frequency dial. In a "relative measurement," twice as much resolution uncertainty exists since two signal peaks must be resolved; reference frequency uncertainty and scanwidth accuracy further contribute to total measurement uncertainty.

#### Determining Overall Spectrum Analyzer Frequency Measurement Accuracy

Total measurement accuracy can be analyzed as follows:

Accuracy =

- resolution uncertainty (RU).
- + CENTER FREQUENCY ACCURACY (CFA)—if a signal is tuned to the display center and its frequency read off the dial or digital display.
- + FREQUENCY SPAN ACCURACY (FSA)—if a signal is compared to a reference using the horizontal scaling.
- + REFERENCE FREQUENCY UNCERTAINTY (REF)—if applicable.

Worst Case Accuracy =  $\pm |RU + CFA + FSA + REF|$ .

The following example will show how the accuracy expression can be used to compare the two standard measurement techniques.

If Hewlett-Packard models 8554B Tuning Section (100 kHz to 1250 MHz) and 8552B IF Section were

used to measure the frequency of a 1000 MHz signal, the following specifications and accuracy parameters would apply:

RU =  $\pm 300$  Hz for one signal (30% of assumed 1 kHz bandwidth, 10 dB/div vertical scaling);  $\pm 600$  Hz for two.

CFA =  $\pm 10$  MHz.

FSA =  $\pm 10\%$  of 1000 MHz separation (100 MHz).

REF =  $\pm 0$  Hz for LO feedthrough (0 Hz).

If the test signal is centered on the CRT and its frequency is read off the dial ("absolute measurement technique"), accuracy = 10 MHz. (See Table 2.)

	Absolute Technique	Relative Technique
RU	300 Hz	600 Hz
CFA	10 MHz	—
FSA	—	100 MHz
REF	—	0 Hz
<b>Total Worst Case Accuracy</b>	<b><math>\pm 10</math> MHz</b>	<b><math>\pm 100</math> MHz</b>

**Table 2**  
Error Comparison for a Typical Frequency Measurement Using Various Measurement Techniques

If the "relative measurement technique" is used and the LO feedthrough is used as a reference, then accuracy = 100 MHz.

In this example the "absolute measurement technique" is more accurate. However, if the separation between the reference signal and the signal under test is small, the relative technique has the potential for great accuracy. Supplementary equipment and special techniques can be used to further improve the accuracy of frequency measurements. Enhancing frequency accuracy is a topic of Appendix B, page 19.

## CHAPTER 3

### Spectrum Analyzer Performance Considerations Relevant to Accurate Measurements

Potential amplitude and frequency accuracy are meaningful only if the signal under test can be discriminated from other signals. An analyzer must generate very little noise if it is to have the sensitivity to detect low level signals (Figure 7). A wide dynamic range (low level spurious and residual responses) is necessary to measure small signals in the presence of large ones (Figure 8). Analyzer stability (phase lock capability), resolution bandwidth, and IF shape factor (60 dB bandwidth/3 dB bandwidth) are important determinants of an analyzer's ability to discriminate among closely spaced signals (Figure 9). Refer to Application Note 150 for a detailed

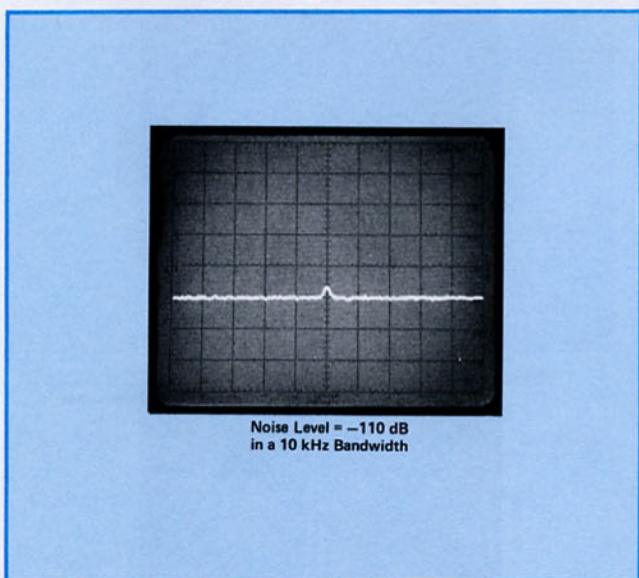

Figure 7 Low Level Signal Detection

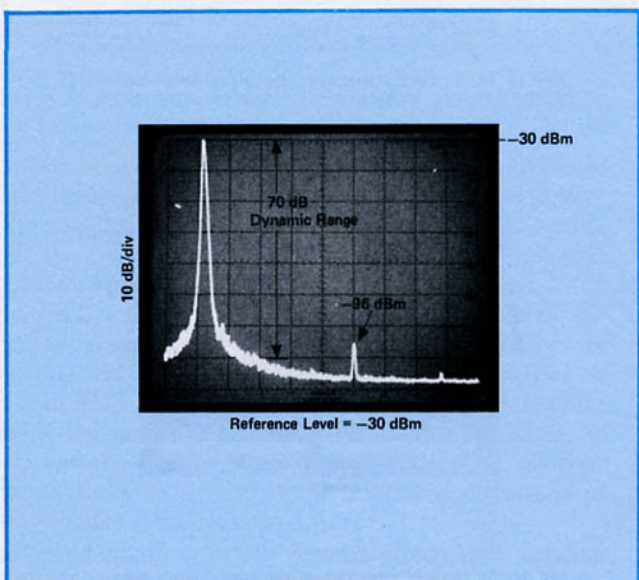

Figure 8 Measurement of small signals in the presence of large ones

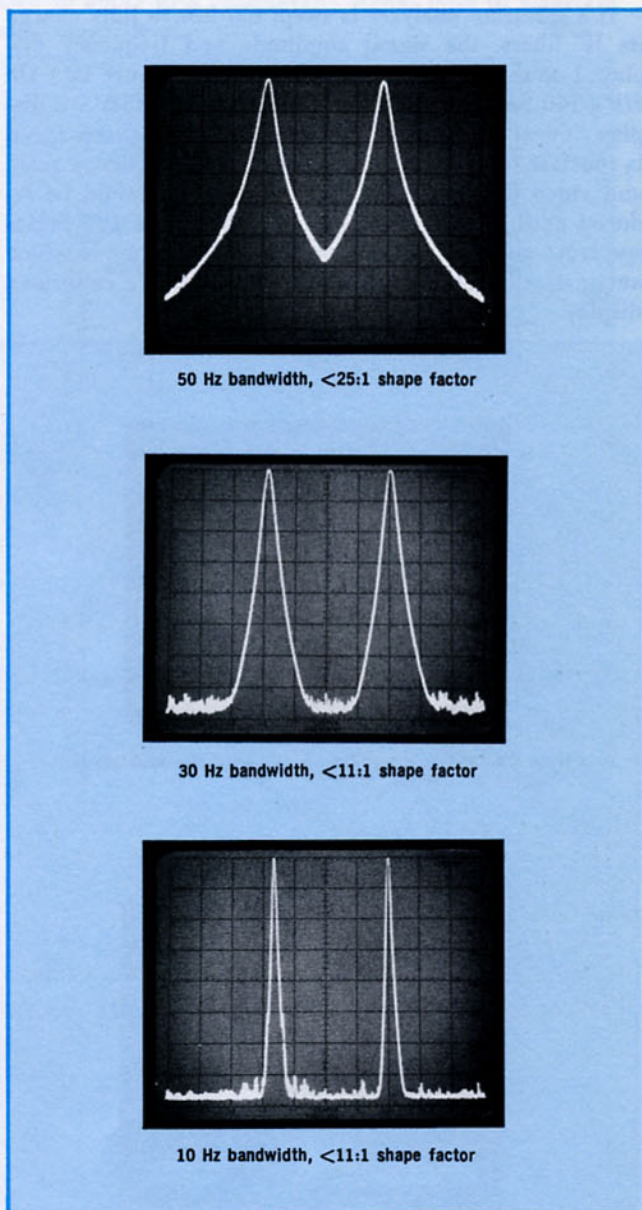

Figure 9 Effect of bandwidth and shape factor on signal discrimination

discussion of analyzer design concepts.

Since specifications are meaningful only in the context of their definitions, care should be taken to compare instruments on an equal basis.

The reader should be aware that if the graticule is not etched on the face of the CRT, parallax occurs. As a result, an observer's perception of the position of a point on the CRT in relation to the graticule may be in error (perhaps to the extent of  $\pm 0.1$  division). This uncertainty will affect both amplitude and frequency measurement accuracy. Hewlett-Packard utilizes parallax-free internal graticules to eliminate this source of error.

## CHAPTER 4 Conclusion

Errors can result from improper technique.

If a spectrum analyzer is swept too fast to fully charge its IF filters, the signal amplitude and frequency displayed on the CRT will be incorrect. (See Figure 10.) On HP's 140 Series spectrum analyzers and the 3580A a display "uncal" light alerts the user when the sweep speed is too fast for the resolution bandwidth, frequency scan, and video filter settings. The sweep speed should be reduced until the warning light goes off. HP's 180 Series spectrum analyzers feature an "auto" sweep mode which automatically sets the sweep speed to insure a calibrated display.

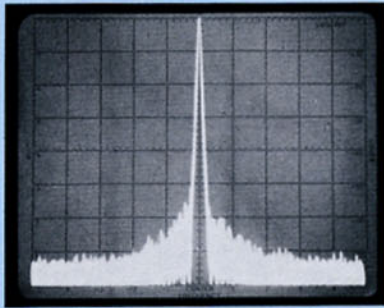

When the "display uncal" light is off, a signal's amplitude and frequency are displayed correctly.

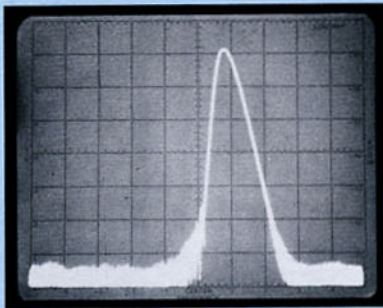

The same signal when the spectrum analyzer is swept too fast. Notice the decrease in amplitude and shift in frequency. The "display uncal" light warns that the signal is displayed incorrectly.



**Figure 10** Effect of sweeping too fast on signal display

In the case of swept measurements (refer to AN 150-3) the spectrum analyzer sweep speed must also be slow enough to accommodate the response time of the device under test. Sweep speed should be decreased until the position of the swept response ceases to change.

If the signal level at the analyzer's input mixer is too large, "gain compression" may occur. When this happens, the signal level out of the mixer is no longer proportional to the input level so the resultant measured signal level is incorrect. To insure that gain compression does not occur, the signal level at the input mixer should be decreased by 10 dB (increase input attenuation by 10 dB); if the displayed signal also decreases by 10 dB, the measured amplitude is correct. (See Figure 11.)

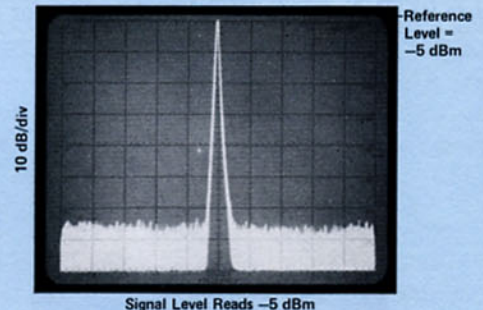

**11a**

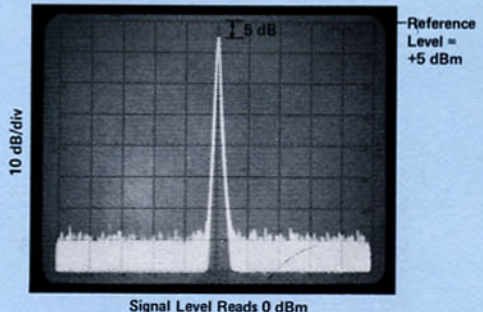

**11b**

Add 10 dB of input attenuation; the signal level changes by 5 dB, therefore, gain compression was occurring in 10a.

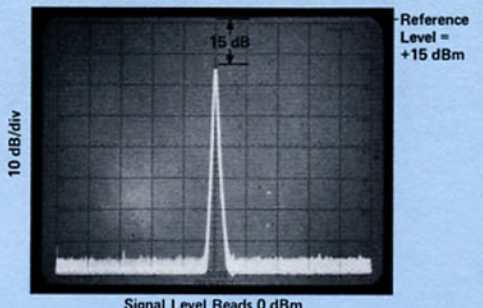

**11c**

Add 10 dB more of attenuation; the signal level changes by 10 dB, therefore, gain compression was not occurring in 10b.

**Figure 11** Gain compression recognition

Furthermore, spurious responses (analyzer intermodulation or harmonic distortion) or residual responses (internally generated signals) may be present on the display. To the extent that such responses are interpreted as coming from the input, or fall coincident with signals from the input, erroneous measurements would be made. Spurious responses can be recognized by decreasing the signal level at the mixer by 10 dB (by adding RF attenuation), and noting whether the signal of interest changes by more than 10 dB. (See Figure 12.) Residual responses

may be identified by disconnecting the source and noting any signals that remain on display. (See Figure 13.)

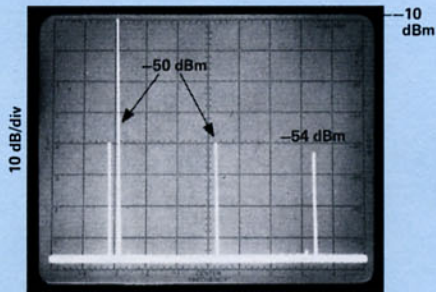

12a

A signal measurement situation with 4 "signals" present on the display.

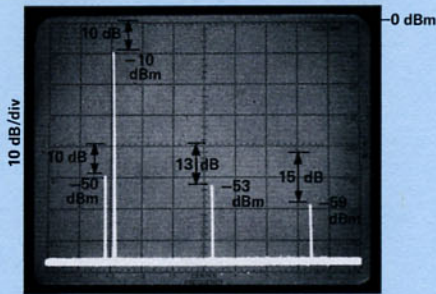

12b

When 10 dB of attenuation is inserted, the first and second signals shift down by 10 dB, indicating they are "real." However, the third signal shifted by 13 dB while the fourth signal shifted down by 15 dB — indicating they are "spurious."

Figure 12 Spurious response recognition

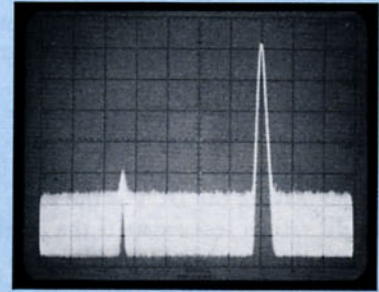

13a Two signals present on CRT.

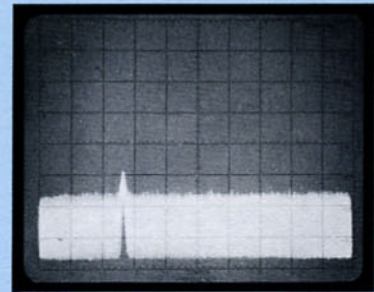

13b When the source is disconnected, the residual response remains.

Figure 13 Residual response recognition

Measurement accuracy depends on the ability of the user to exploit the full potential of his instrumentation. This note has attempted to describe procedures that will allow him to do this.

## APPENDIX A Special Cases

### Swept Measurements: Amplitude

Chapter 1 referred to the measurement of discrete signal amplitudes, but a spectrum analyzer can also be combined with a tracking generator to make swept measurements of insertion loss and return loss (refer to Hewlett-Packard Application Note 150-3 for details). This section of the note will be devoted to the accuracy factors relevant to swept measurements.

Insertion loss and return loss of a device under test (DUT) are measured with respect to a reference signal level. Zero dB insertion loss exists, by definition, if the level of the signal leaving the DUT is the same as the level entering. Zero dB return loss exists if the level of the signal reflected from the terminated DUT equals the level of the signal incident on the device. Figure A-1 schematically describes the measurement. One way to calibrate the spectrum analyzer/tracking generator measurement system is to position the reference signal at the top graticule line of the CRT by varying the generated signal level or the reference level of the analyzer.

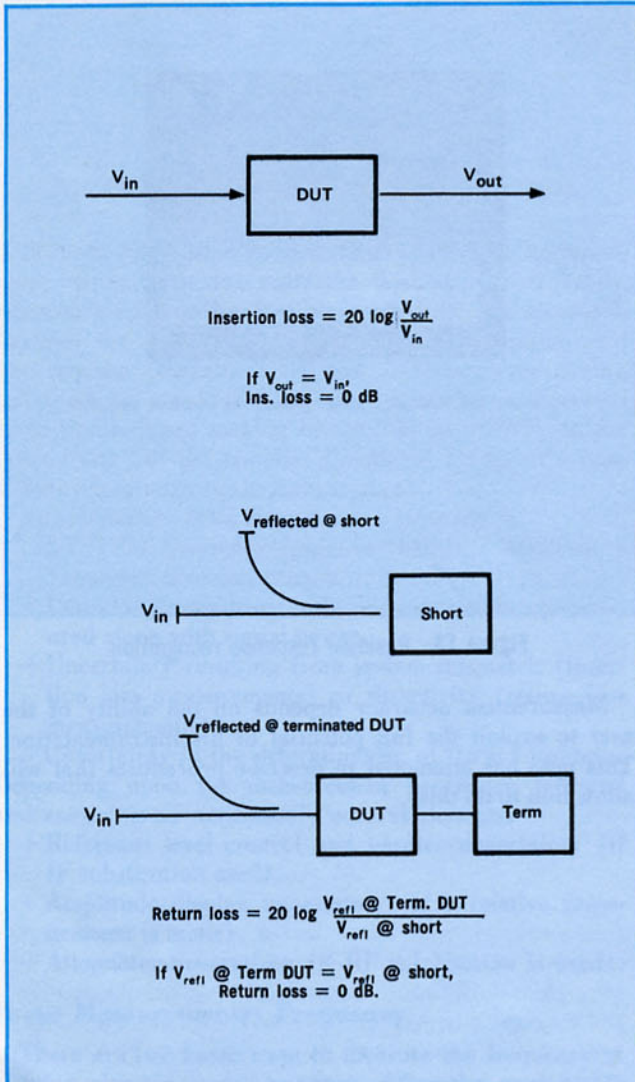

Figure A-1 Swept measurement techniques

To make an insertion loss measurement, the tracking generator output should be connected directly to the analyzer using the same cables that will be used to connect the DUT, and the signal level positioned at the top graticule to calibrate the reference level for 0 dB insertion loss. The tracking signal should then be input the DUT and the spectrum analyzer connected to the output to display the swept response. (See Figure A-2.)

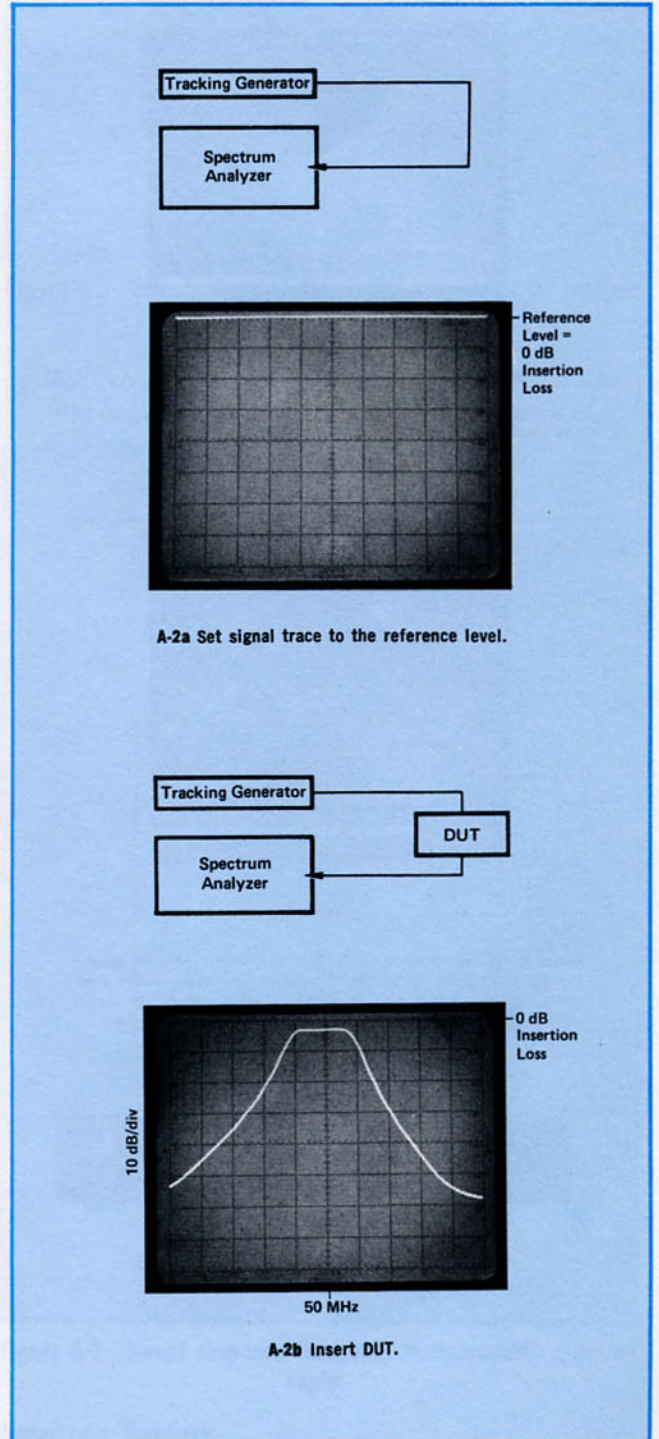
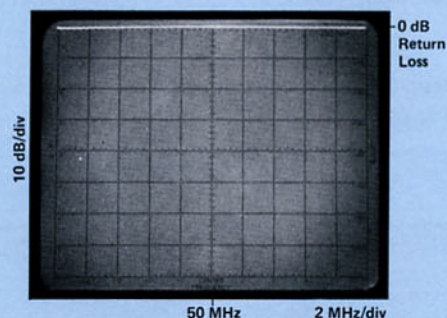
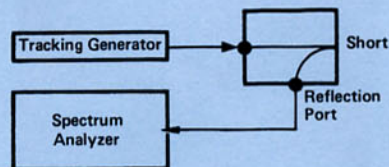

Figure A-2 Insertion loss measurement

To make a return loss measurement, the spectrum analyzer should be connected to the reflection port of a directional bridge and the tracking signal input the source port. The load port should be shorted and the resulting signal trace positioned at the top graticule to calibrate the reference level for 0 dB return loss. The terminated DUT should then be connected to the load port of the bridge to display the swept response. (See Figure A3.)

The actual measurement of insertion loss or return loss of a DUT at any frequency is made using the "relative measurement," "IF substitution," or "RF substitution" techniques already described.



A-3a Set signal trace to the reference level.

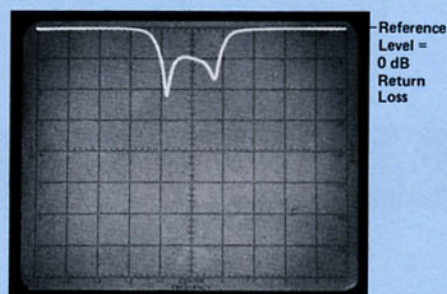
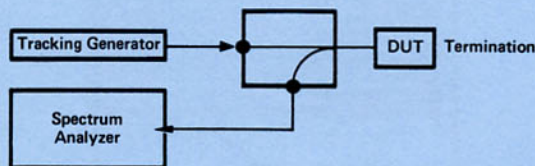

A-3b Insert terminated DUT.

Figure A-3 Return loss measurement

## Accuracy Factors

The same accuracy factors (flatness, trace amplitude, reference level uncertainty, amplitude display accuracy, attenuator accuracy, signal level relative to noise level, and mismatch) apply as before. Calibrator uncertainty no longer exists since 0 dB insertion or return loss is defined as the reference signal level.

The tracking generator has its own sources of uncertainty that must be considered along with those arising from other sources to determine total measurement accuracy. The frequency response (flatness) uncertainty of the tracking signal and any directional bridge/coupler should be added to that of the analyzer to ascertain system flatness uncertainty.

The flatness uncertainty of the entire swept measurement test system may be calibrated out of the measurement through the use of an X-Y recorder.

A graph can be accurately scaled by using precision attenuators to vary the position of the calibration trace. To avoid flatness uncertainty, the response of the DUT is measured with respect to the calibrated scale. (See Figure A-4.) While this technique eliminates flatness uncertainty it also introduces recorder linearity as a new source of uncertainty which must be evaluated as part of amplitude measurement accuracy.

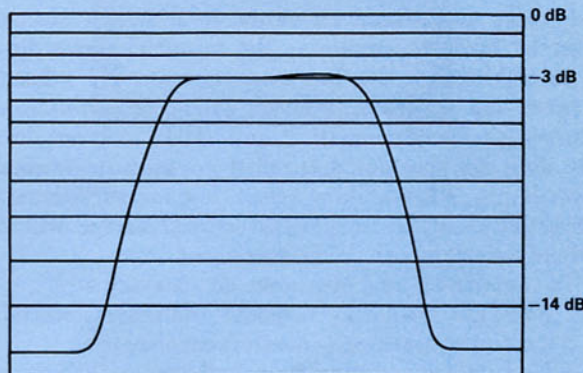

Figure A-4 Using an X-Y recorder to avoid system flatness uncertainty

A problem may occur if the analyzer is calibrated with respect to the output level *setting* on the tracking generator (assuming output level is calibrated); if tracking error exists, the analyzer will not be correctly calibrated with respect to the trace (Figure A-5). (A detailed discussion of this point can be found in AN 150-3 page 11). For this reason, the calibration procedure outlined previously is recommended.



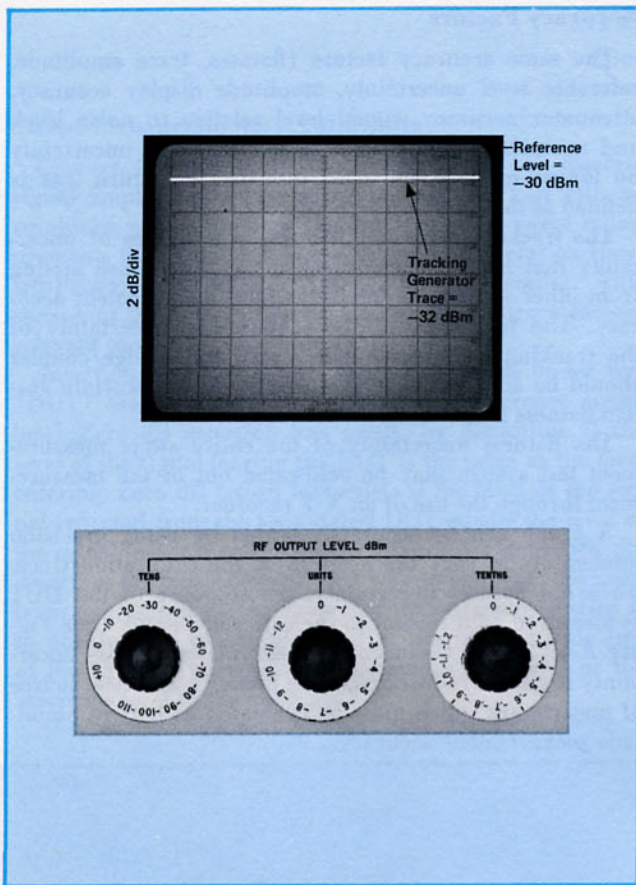

Figure A-5 Tracking error effect on trace amplitude

A more global analysis of the total system mismatch must be made to determine the mismatch error limits, when making insertion loss measurements. The mismatch between the generator/analyzer during calibration and between the generator/DUT and DUT/analyzer during test must be considered together to evaluate mismatch error limits. When making return loss measurements, the “directivity” of the coupler/directional bridge will contribute uncertainty to the measurement.

To summarize, total measurement accuracy =  
 SYSTEM frequency response (flatness) uncertainty  
 (analyzer, tracking generator, coupler).

- + Uncertainty resulting from noise power being measured along with signal power.
- + Uncertainty resulting from system mismatch (insertion loss measurements) or directivity (return loss measurements).

+ Uncertainty in the determination of trace amplitude. Depending upon the measurement procedure followed and assuming no unnecessary control changes:

- + Reference level control and vernier uncertainty (if IF substitution used).
- + Amplitude display uncertainty (if a relative measurement is made).
- + Attenuator uncertainty (if RF substitution is used).

### Swept Measurements: Frequency

There are two basic ways to measure the frequency at a point along a swept response. After the analyzer is tuned to the point in question, the frequency can be read off the frequency dial (digital display) (Figure A-6) or a

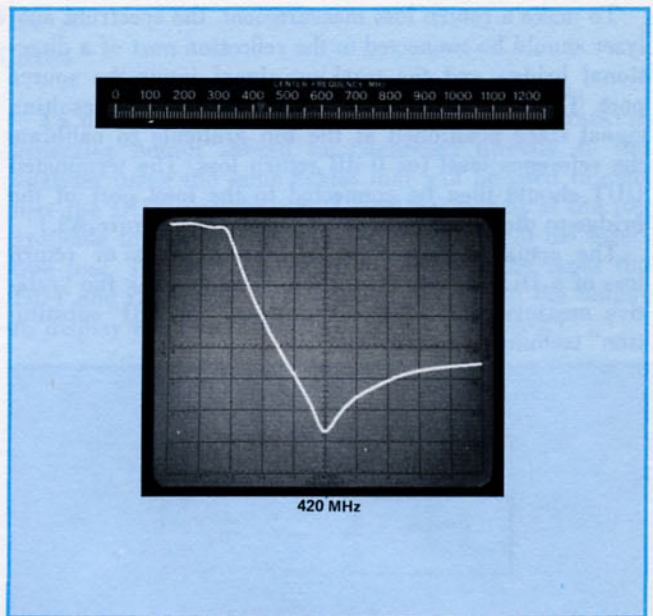

Figure A-6 Swept response frequency measurement: analyzer frequency dial

counter can measure the frequency of the tracking signal (Figure A-7).

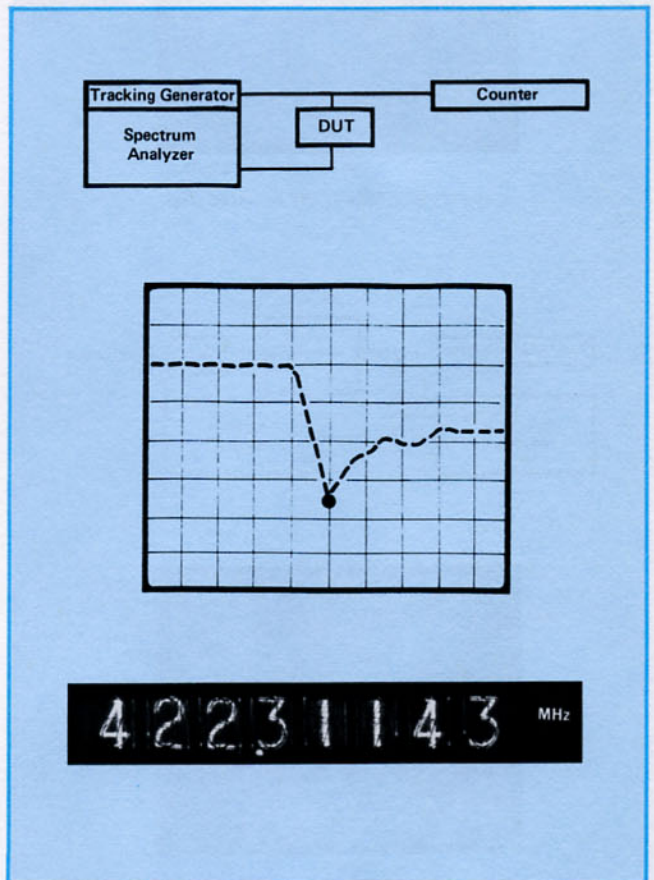
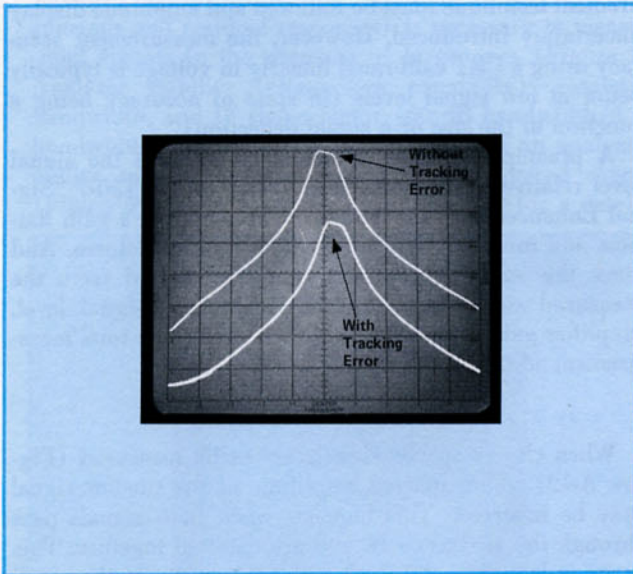

Figure A-7 Swept response frequency measurement: tracking signal

### Accuracy Factors

The accuracy with which a user is able to measure the frequency at a particular point is influenced by several

factors: his ability to tune to the point in question, tracking error, center frequency accuracy, tracking generator residual FM, and counter accuracy. The uncertainty associated with the tuning process can be called "tuning uncertainty," and is typically 5% of the scanwidth per division setting. Tracking error between the tracking generator and spectrum analyzer causes a shift in the horizontal position of the swept response trace relative to the frequency dial of the analyzer (Figure A-8).



**Figure A-8** Tracking error effect on trace frequency

If the frequency dial (digital display) of the analyzer is used to measure frequency, accuracy equals:

- tuning uncertainty.
- + tracking error.
- + center frequency accuracy.

If a counter is used to measure the tracking signal, tracking error does not contribute to measurement uncertainty. (See HP Application Note 150-3.) Accuracy equals:

- tuning uncertainty.
- + tracking generator residual FM.
- + counter accuracy.

### Low Level Signals

It has been noted that the signal amplitude displayed on the analyzer is the sum of the signal plus noise present in the passband. For signals close to the analyzer's noise level, the inaccuracy in assuming that the "displayed" amplitude equals the "true" amplitude is significant.

In reality, the displayed amplitude is the sum of the signal plus the noise detected by the analyzer. The noise level detected and displayed on a spectrum analyzer is not true RMS noise, but something less. This is because noise is log shaped prior to detection (if a log display is used) and the detector is an average responding envelope detector. Refer to AN 150-4 for a detailed discussion of random noise measurements.

When a small signal is present along with random noise, the response of the detector to the signal plus noise energy is affected by the analyzer's behavior to random noise. The net effect is a displayed signal level which is less than the signal plus true RMS noise present

in the passband, but larger than the actual signal level alone.

Figures A-9 and A-10 are nomographs based on empirical data that allow a user to determine what "correction" factor to apply to a "displayed" signal level to ascertain "true" signal level.

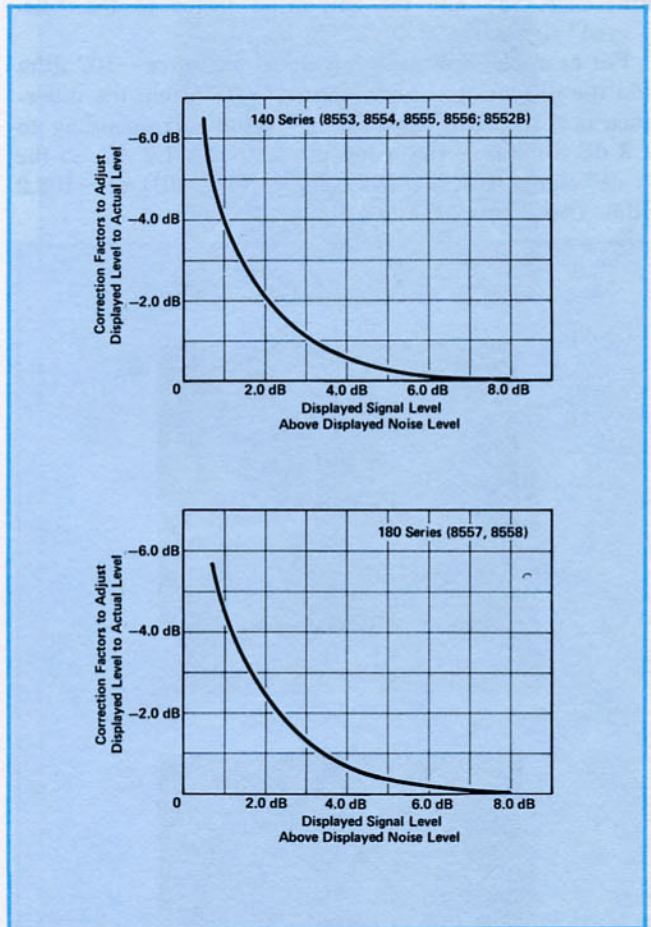

**Figure A-9** Low level signal measurement correction factors log mode

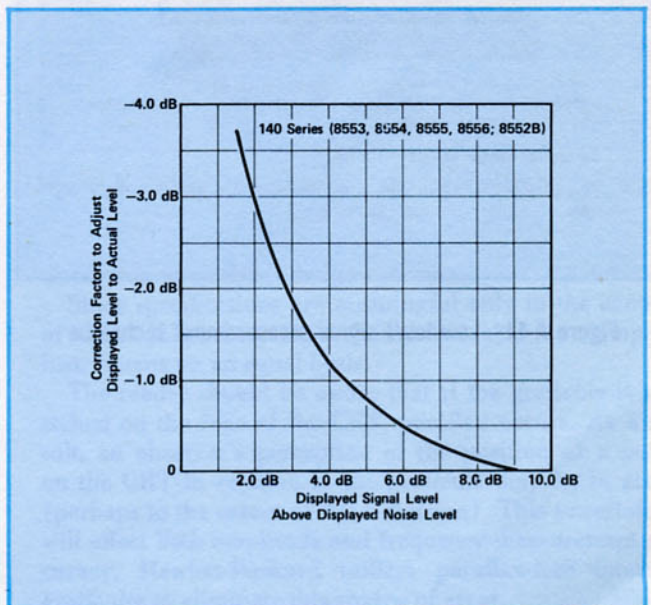

**Figure A-10** Low level signal measurement correction factors linear mode

The proper measurement technique should be as follows: (1) Note the difference in dB between the displayed signal level and the displayed noise level (noise level should be measured with the signal removed and maximum video filtering); (2) look on the nomograph to find out what "correction" factor corresponds to this difference, (3) add the correction factor to the "displayed" signal level.

For example, if a displayed signal measures  $-102$  dBm and the displayed noise measured  $-105$  dBm, the difference is  $3$  dB. The "correction" factor corresponding to a  $3$  dB difference (on a log display) is  $-1.2$  dB, so the "true" signal level is  $-102$  dBm +  $(-1.2$  dB) or  $-103.2$  dBm. (See Figure A-11.)

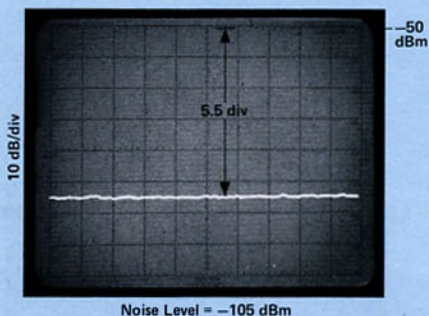
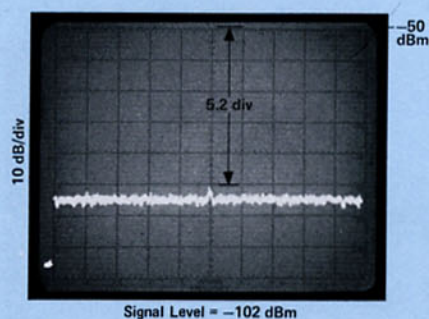

Difference between signal level and noise level =  $-102$  dBm -  $(-105$  dBm) =  $+3$  dB.

Correction factor equals  $-1.2$  dB.

"True" signal level equals  $-102$  dBm +  $(-1.2$  dB) =  $-103.2$  dBm.

When measuring low level signals, the noise level of the analyzer should be as low as possible. Since noise is bandwidth dependent, the measurement should be made with as narrow a bandwidth as possible. Video filtering should be used to average noise variations.

For greatest accuracy, low level signals should be measured on a display that is calibrated linearly in voltage. Because of limited IF gain, small signals cannot be raised to the reference level of a log display; the relative measurement technique must be followed and amplitude display uncertainty introduced. However, the measurement accuracy using a CRT calibrated linearly in voltage is typically better at low signal levels (in spite of accuracy being a function of the size of a signal deflection).

A preamplifier may be useful to increase the signal level relative to the noise level (refer to AN 150-7 "Signal Enhancement" for details). The amplifier's gain flatness and mismatch will reduce total system flatness. And since the amplifier's gain must be subtracted from the measured signal level to determine "true" signal level, amplifier gain uncertainty will further degrade total measurement accuracy.

### Closely Spaced Signals

When closely spaced signals are being measured (Figure A-12), the displayed amplitude of the smaller signal may be incorrect. This happens when both signals pass through the analyzer's IF and are detected together. This error is less than  $\pm 0.5$  dB and only occurs if the small signal is less than  $10$  dB above the larger signal's skirt.

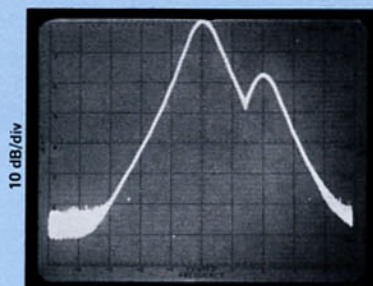

Figure A-11 Low level signal measurement technique

Figure A-12 Measuring closely spaced signal

## APPENDIX B

### Enhancing Accuracy

#### Enhancing Amplitude Accuracy

Supplementary instrumentation and specialized measurement techniques may be useful in improving the accuracy of the calibration procedure and amplitude comparison process. Techniques are also available to reduce mismatch error (refer to AN-56).

It should be noted that any piece of equipment attached between a signal source and the analyzer input (such as a preselector, or attenuator) may reduce the available sensitivity depending on its insertion loss and mismatch loss. Furthermore, the frequency response characteristics of the insertion loss/gain and mismatch loss will introduce additional flatness uncertainty into the measurement.

#### Calibration Accuracy

Calibration accuracy can be improved in the following ways:

1. A signal source/precision power meter or low frequency signal/true RMS voltmeter can be used to calibrate the reference level (top graticule) by substituting a more accurately known standard for a less accurate one. Such a procedure reduces "calibrator uncertainty."
2. If a signal source having the same frequency as the signal under test is used to calibrate the reference level, analyzer "frequency response (flatness) uncertainty" can be avoided.

Both improvements can be realized and measurement accuracy substantially improved if a signal generator/

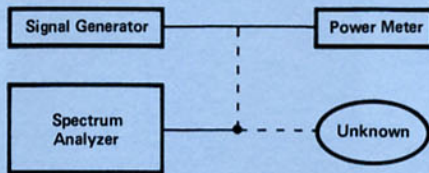

1. Make a rough measurement to determine unknown signal's frequency.
2. Tune Signal Generator/Power Meter to this frequency.
3. Use known external reference signal amplitude to calibrate the analyzer reference level (B-1a).
4. Input unknown signal (B-1b).
5. Change reference level control and vernier to match the signal's level to the reference level (B-1c).

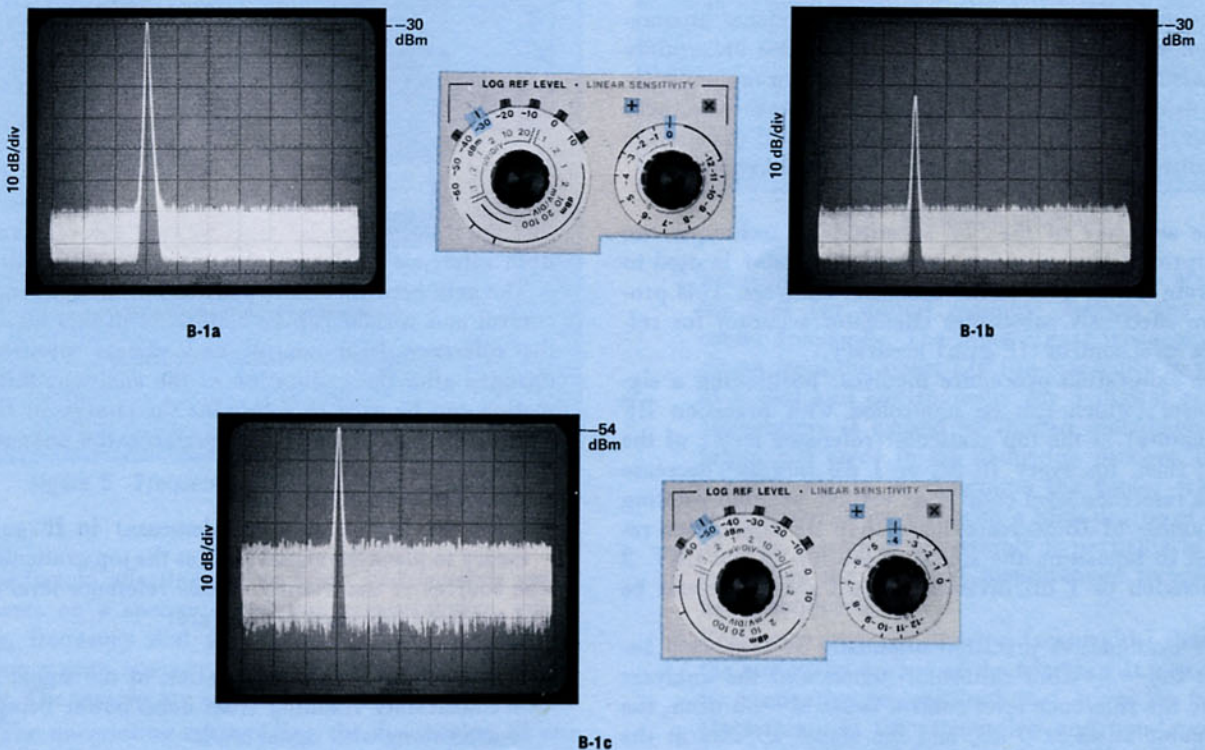

Figure B-1 Procedure to reduce calibration uncertainty

precision power meter is tuned to the frequency of the signal under test and then used to calibrate the reference level. (See Figure B-1.)

It was previously shown, in the example using Hewlett-Packard models 8554B Tuning Section and 8552B IF Section to measure an unknown signal's amplitude, that a crude measurement procedure resulted in worst case measurement accuracy of  $\pm 5.95$  dB whereas a careful "IF substitution" measurement yielded a worst case accuracy of  $\pm 2.35$  dB.

Continuing with that same example, if Hewlett-Packard models 8640B Signal Generator, 435A Power Meter and 8481A Power Sensor were tuned to the frequency of the signal to be measured and used to calibrate the reference level, calibrator uncertainty (CAL) would be  $\pm 0.30$  dB, flatness uncertainty (FR) would be 0 dB, and the resulting total worst case measurement accuracy would equal  $\pm 1.35$  dB.

## Comparison Accuracy

### RF Substitution

The accuracy of the comparison process used to measure a signal's amplitude may possibly be improved if a precision external attenuator with vernier is used to do RF substitution.

In this technique, attenuation is used to match the unknown signal level to a known calibration level. The smaller of the two signals is used to establish a reference position on the CRT while the larger signal is attenuated until it is positioned at this reference point. The unknown signal level then equals the calibrator level plus/or minus the attenuator setting (plus if the signal to be measured is attenuated, minus if the calibrator is attenuated). (See Figure B-2.)

The use of an external attenuator introduces attenuation uncertainty as well as additional flatness uncertainty and mismatch error. The extent of the accuracy improvement using this technique depends upon how these sources of uncertainty compare to the reference level uncertainty and mismatch error present in doing IF substitution.

### IF Substitution

The accuracy of the "IF substitution" technique can be improved if a precision external attenuator is used to calibrate the IF gain of the spectrum analyzer. This procedure effectively substitutes attenuator accuracy for reference level control (IF gain) accuracy.

The calibration procedure involves: positioning a signal level (which can be controlled with precision RF attenuators) at the top graticule (reference level) of the CRT; then, for every 10 dB or 1 dB increase/decrease in the reference level control or vernier position—noting the number of dB decrease/increase in RF attenuation required to reposition the signal at the top of the CRT. 2 dB/division or 1 dB/division vertical scaling should be used.

For example: A precision attenuator is connected between the  $-30$  dBm calibrator signal and the analyzer input; the reference level control is set at  $-30$  dBm, the attenuator is set at 0 dB, and the signal appears at the top graticule of the CRT. If the reference level control is decreased 10 dB to  $-40$  dBm and the RF attenuation needed to keep the signal at the top graticule (2 dB per division vertical scaling) is 9.95 dB, then it can be said

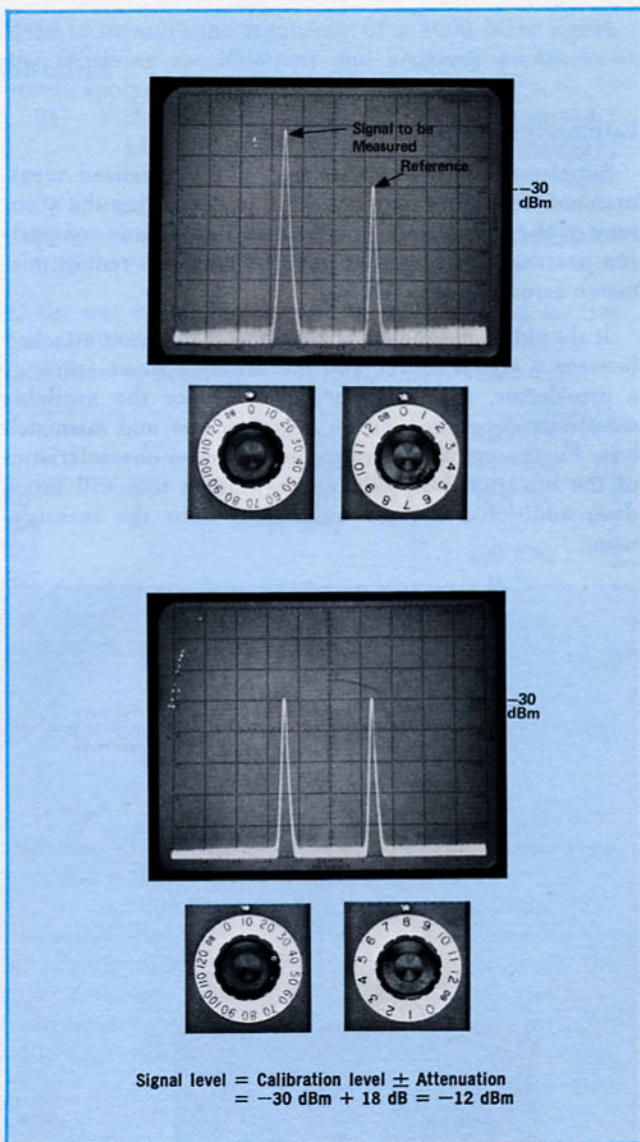

Figure B-2 RF substitution

that the difference in IF gain between the  $-30$  and  $-40$  dBm reference level control positions is 9.95 dB.

The gain between all the positions of the reference level control and vernier can be calibrated in this way. When the reference level control and vernier positions are changed after the calibration of the analyzer, this information can be used to determine the change in IF gain. For an "IF substitution" measurement, the unknown signal amplitude would equal:

Analyzer calibration level

-(or +) the increase (or decrease) in IF gain necessary to place the signal peak at the top graticule.

The sources of uncertainty in this reference level control and vernier calibration process are:

Attenuator accuracy

+ Uncertainty in the designation of the signal peak

+ Uncertainty resulting from noise power being measured along with signal level.

When signal levels are well above the noise level and 1 or 2 dB/division vertical scaling is used, the calibration accuracy is primarily a function of the attenuator accuracy.

### Voltage Measurement

An analogous technique, to the one described for calibrating IF gain, can be used to improve the calibration of the linear sensitivity control on a spectrum analyzer. As linear sensitivity is changed from setting to setting, the attenuation of a reference signal is changed to maintain the signal's vertical position on the CRT. The difference in attenuator settings is then used to determine the change in linear sensitivity.

### Enhancing Frequency Accuracy

Ancillary instrumentation can be used to enhance frequency accuracy in two ways:

1. By "directly" measuring the frequency of any point on the display.
2. By decreasing the uncertainty in a relative measurement due to frequency span error.

### Direct Measurement

It is possible to "directly" measure the frequency of any point on a CRT trace much more accurately than tuning the point to the center of the display and reading the center frequency off a frequency dial (or digital read-out.) Direct measurement is accomplished either by counting a tracking signal which is tuned to the same frequency as the point of interest or by counting the analyzer's LO frequency at the point of interest and then deducing the point's frequency.

### Tracking Generator

A tracking generator produces a signal of the same frequency as its related spectrum analyzer is tuned to receive. When a tracking generator is connected to a spectrum analyzer, the frequency of the large amplitude tracking signal, if the analyzer is tuned to the signal under test, can be measured with a counter. The counter may be a part of the tracking generator or external to it. (Refer to Hewlett-Packard Application Note 150-3 for a detailed discussion of tracking generator operation.)

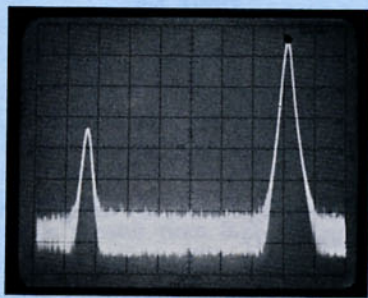

3137261 MHz

Tune marker to peak of signal to be measured, read frequency on counter.

Figure B-3 Measuring frequency with a tracking generator: tunable marker

Those models that incorporate counters measure the frequency at a tunable marker point which is generated on the analyzer CRT (Figure B-3). If the tracking generator is connected to an external counter, the spectrum analyzer/tracking generator must be manually scanned to the point on the CRT to be measured, and then the tuned tracking generator output frequency is counted (Figure B-4).

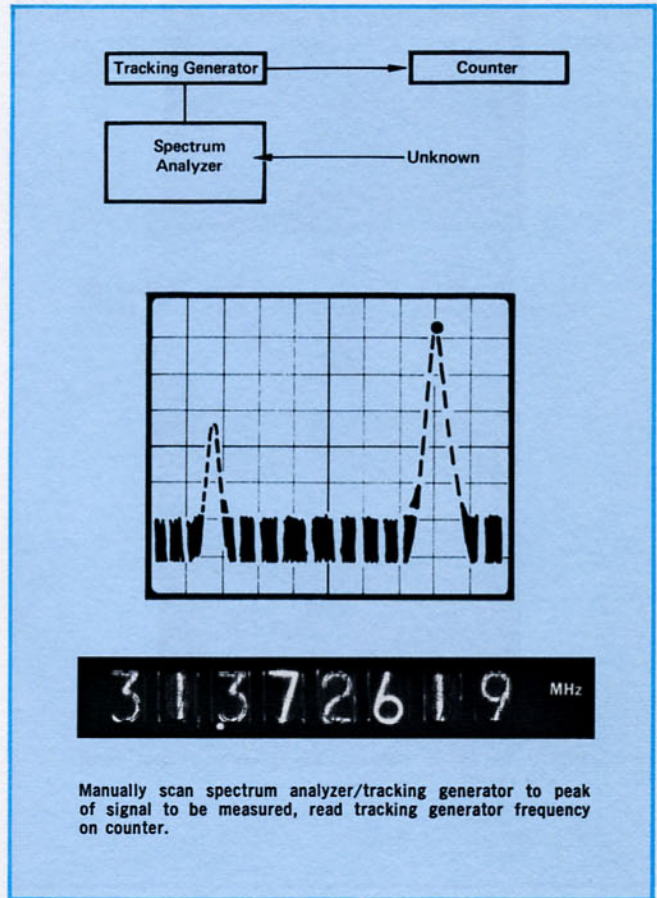

Figure B-4 Measuring frequency with a tracking generator: manual scan

When a tracking generator is used to measure an unknown signal's frequency, the following sources of uncertainty are present: resolution uncertainty, residual FM of the tracking signal, counter accuracy, and tracking error. Resolution uncertainty as described earlier, refers to the ability of the user to tune to a signal peak. Residual FM in the tracking signal degrades the frequency resolving capability of the counter. Counter accuracy limits the potential accuracy of the measurement. Tracking error is a difference between the tracking signal frequency and the frequency of the point where the analyzer is tuned. To summarize, total frequency measurement accuracy (when using a tracking generator) =

- resolution uncertainty.
- + residual FM of the tracking signal.
- + counter accuracy.
- + tracking error (if applicable).

Depending upon how the tracking generator is designed, tracking error may be insignificant (a few Hz) or significant (a few kHz). If tracking error is important, it can be avoided using a "beat frequency technique." The

beat technique also eliminates resolution uncertainty. To make a measurement using the beat technique (Figure B-5): center the unknown signal on the display; set the

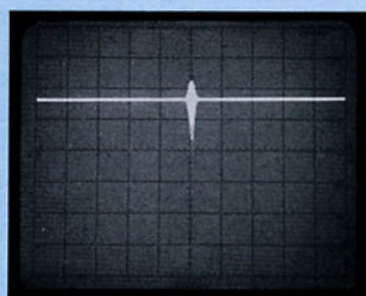

Add the unknown signal and a tracking signal of about the same amplitude at the analyzer's input. Observe the beat.

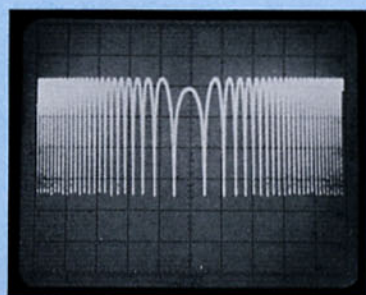

Magnify the display, manually tune to center of beat, count tracking generator frequency.

Figure B-5 Beat technique to eliminate tracking error

tracking generator output to approximately the same level as the unknown signal; add the tracking signal to the unknown signal at the analyzer input. A "beat" or bump will appear on the trace where the tracked signal equals the unknown signal. Magnify the display by decreasing scanwidth and bandwidth; manually, tune the spectrum analyzer/tracking generator output to the middle of the beat. At this point, measure the tracking signal frequency with a counter.

Hewlett-Packard Model 8443A Tracking Generator has a "restore signal" mode of operation that automatically generates a tracking signal of exactly the same frequency as the unknown signal on whose skirt its marker is tuned. In this mode, resolution uncertainty and tracking error do not exist. (Refer to AN 150-3 for details.)

#### Counting the LO's

Another method for measuring the frequency of any point on the display is to count the spectrum analyzer's LO frequency when it is manually scanned to a point of interest, and then calculate the frequency at that point. This procedure avoids the need for a tracking generator and is especially valuable at high frequencies above the

range of tracking generators (Hewlett-Packard tracking generators operate up to 1300 MHz). However, this "indirect" method is complicated because it requires numerical manipulation in order to deduce the frequency of an incoming signal.

The general operating equation for a spectrum analyzer with  $m$  conversion stages is as follows:

$$F_s = nF_{LO1} \pm (F_{LO2} + \dots + F_{LOl} + F_{LOm} + F_{IFfinal})$$

where:  $F_s$  is the input frequency.

$F_{LO1}$  is the first local oscillator frequency (swept tunable),  $n$  is the harmonic of the first LO which is mixed with the incoming signal at the first conversion stage (except for microwave analyzers,  $n = 1$ ).

$F_{LO2}$  is the 2nd local oscillator frequency (fixed).

$F_{LOl}$  is the  $l$ th local oscillator frequency (fixed).

$F_{LOm}$  is the  $m$ th local oscillator frequency (tunable).

$F_{IFfinal}$  is the IF frequency of the final conversion stage.

(See Figure B-6.)

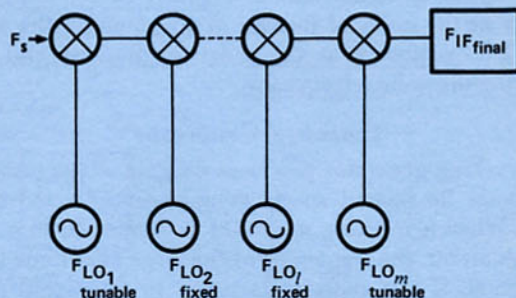

Figure B-6

The frequency of an incoming signal ( $F_s$ ) can be calculated using this expression if the LO and IF frequencies are known when the analyzer is tuned to the point of the signal.  $F_{IFfinal}$  is specified, and all the LO frequencies can be counted.

The total measurement accuracy using this technique = resolution uncertainty

+  $nLO_1$ : residual FM  
 + drift (in the time interval between the counting of  $LO_1$  and the counting of the last LO)  
 + counter accuracy  
 ( $nLO_1$  accuracy equals  $n$  times  $LO_1$  fundamental accuracy)

etc.

+  $LO_m$ : residual FM  
 + drift  
 + counter accuracy  
 +  $F_{IFfinal}$  uncertainty.

If all the LO's are counted simultaneously, drift can be disregarded.

An alternative approach to this technique exists that is less complex, but also less accurate. The terms of the operating equation for a spectrum analyzer can be re-grouped according to whether the frequencies are tunable or fixed:

$$F_s = (nF_{LO1} - F_{LOm}) - (F_{LO2} + \dots + F_{LOl}) \pm (F_{IFfinal})$$

tunable LO
fixed LO
fixed IF  
frequencies
frequencies
frequency

The above expression can be further generalized as follows:

$$F_s = nF_{LO1} - F_{LOm} - F_{fixed}$$

where  $F_{fixed} = (F_{LO2} + \dots + F_{LOl}) \pm (F_{final})$

If  $F_{fixed}$  is known, and  $F_{LO1}$  and  $F_{LOm}$  are counted, then  $F_s$  can be calculated using the above expression.

To measure  $F_{fixed}$ , a known reference signal (typically the calibrator signal) is input, the analyzer is manually scanned to the signal peak, and  $LO_1$  and  $LO_m$  are counted. The expression  $F_{fixed} = nF_{LO1} - F_{LOm} - F_{Ref}$  is then used to calculate  $F_{fixed}$ . The amplitude of the reference signal should not be so large that it pulls the frequency of the fixed LO's.

Once  $F_{fixed}$  is known, the frequency of an unknown signal is determined by manually scanning the analyzer to the unknown signal peak, counting  $LO_1$  and  $LO_m$  and applying the expression  $F_s = nF_{LO1} - F_{LOm} - F_{fixed}$ . (See Figure B-7.)

This technique involves two separate measurements,

one to calculate  $F_{fixed}$  and one to calculate  $F_s$ .

The accuracy of the  $F_{fixed}$  measurement =

Resolution uncertainty (in tuning to the reference signal)

+ reference frequency uncertainty

+  $nLO_1$ : residual FM

+ drift (in the time interval between the counting of  $LO_1$  and  $LO_m$ )

+ counter accuracy.

+  $LO_m$ : residual FM

+ drift

+ counter accuracy.

As in the previous technique, drift can be disregarded if  $LO_1$  and  $LO_m$  are counted simultaneously.

The total accuracy of the  $F_s$  measurement =

The accuracy of  $F_{fixed}$

+ resolution uncertainty (in tuning to  $F_s$ ).

+  $nLO_1$ : residual FM

+ drift

+ counter accuracy.

+  $LO_m$ : residual FM

+ drift

+ counter accuracy.

+ drift in  $LO_2$  (in the time interval between the calculation of  $F_{fixed}$  and the calculation of  $F_s$ ).

etc.

+ drift in  $LO_l$ .

The last drift terms must be included to account for a change in  $F_{fixed}$  due to fixed LO drift in the time interval between the two measurements.

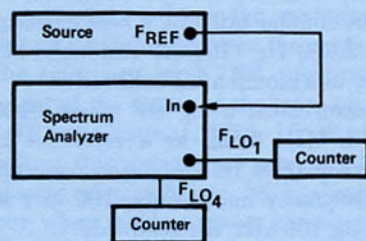

$$F_{fixed} = F_{LO1} - F_{LO4} - F_{ref.}$$

$$= 3050 - 47 - 1000 \text{ MHz}$$

$$= 2003 \text{ MHz}$$

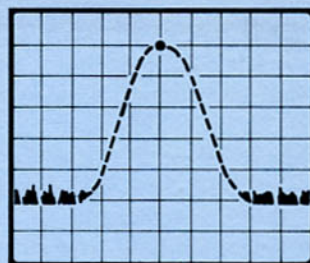

1000 MHz  
Reference Signal

B-7a Manually Tune Analyzer to peak of Reference Signal using narrow BW and scan width. Count  $F_{LO1}$  and  $F_{LO4}$ .

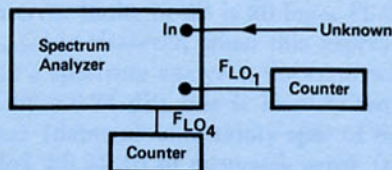

$$F_{unknown} = F_{LO1} - F_{LO4} - F_{fixed}$$

$$= 2550 - 47 - 2003 \text{ MHz}$$

$$F_{unknown} = 500 \text{ MHz}$$

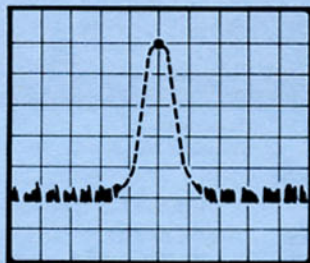

Unknown signal

B-7b Manually Tune Analyzer to peak of unknown signal. Count  $F_{LO1}$   $F_{LO4}$ .

Figure B-7 Measuring frequency by counting LO's



## Relative Measurement

Supplementary instrumentation can also increase the accuracy of the "relative measurement technique." Substantial improvement is possible if a high accuracy reference signal, near in frequency to the signal under test, is used as a standard of comparison. This reduces the frequency span necessary to simultaneously display the two signals on the CRT, and consequently the degree of frequency span uncertainty in the measurement.

A precision comb generator is an effective standard because it produces many reference signals, or "teeth," some of which will be close to the signal to be measured (Figure B-8). External triggering and modulation will generate any desired reference signal spacing so that the user can interpolate to a high degree of accuracy—even at microwave frequencies. Alternatively, an external calibrated signal frequency or signal generator/counter could be used as a standard.

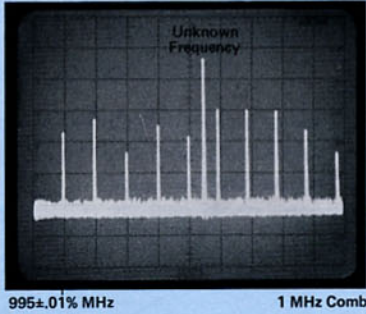

B-8a

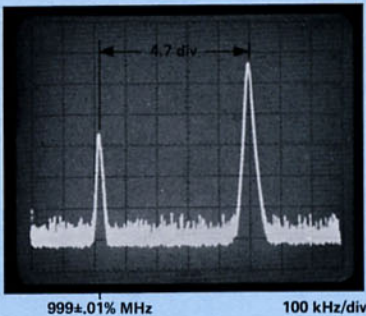

B-8b

Unknown frequency = 999 MHz + 4.7 × 100 kHz = 999.47 MHz

In the case of a comb generator, reference frequency uncertainty would equal the comb frequency accuracy. Reference frequency uncertainty of a signal generator/counter would equal the residual FM of the generator plus counter accuracy. As described in detail previously, total relative measurement accuracy equals the sum of resolution, reference frequency, and frequency span uncertainties.

That part of total measurement uncertainty resulting from frequency span and resolution uncertainties may be totally eliminated by "beating" a calibrated reference frequency with the signal under test. This can be done by connecting the output of a signal generator/counter to the spectrum analyzer input along with the unknown signal, and tuning the generator so that the two signals are indistinguishable from one another on the CRT at a narrow scanwidth and bandwidth. If the power level out of the signal generator is approximately the same as the unknown signal's level, an easily discernible "beat" will occur between the two signals when the generated source frequency exactly equals the unknown frequency (Figure B-9). The only uncertainty derives from how accurately the generated signal can be counted.

Total measurement accuracy =  
residual FM of generator.  
+ counter accuracy.

The previous example of measuring an unknown (1000 MHz) signal frequency with Hewlett-Packard models 8554B tuning section and 8552B IF section demonstrated that the analyzer's frequency dial yielded  $\pm 10$  MHz accuracy while a relative measurement with "LO feed-through" as a reference resulted in  $\pm 100$  MHz accuracy.

Continuing with that same example, measuring the signal's frequency with HP models 8444A tracking generator and 5340A counter utilizing a beat technique yields an accuracy of  $\pm 500$  Hz (200 Hz residual FM, 300 Hz counter accuracy one month after calibration).

A relative measurement using HP model 8406A comb generator with 1 MHz comb as a reference results in  $\pm 200$  kHz accuracy (600 Hz resolution uncertainty, 100 kHz reference frequency uncertainty, 100 kHz scanwidth accuracy assuming 100 kHz/div scanwidth).

Employing a beat technique in a relative measurement with HP model 8660B synthesizer and 86602A RF section yields an accuracy of  $\pm 1$  kHz (frequency accuracy one month after calibration).

Figure B-8 Relative technique using a comb generator

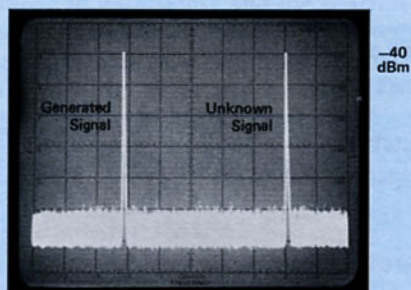
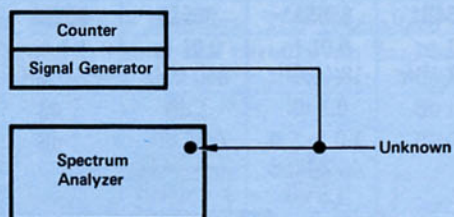

B-9a

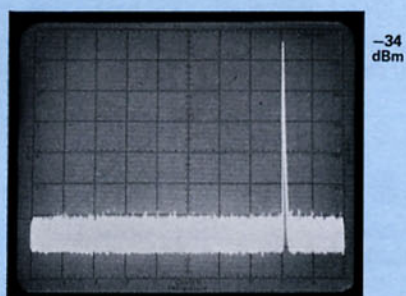

B-9b Tune generated signal to equal the unknown signal.

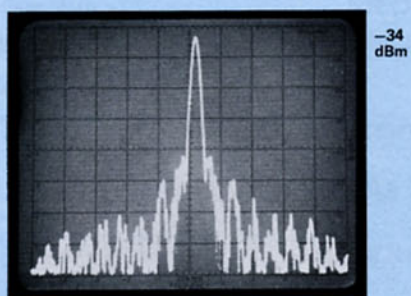

B-9c Magnify the display and tune generated signal to exactly "beat" with unknown signal. Count generated signal.

Figure B-9 Beat technique

## APPENDIX C

### Accuracy Related Specifications

#### Amplitude

Specifications (Log display mode)	8556A*	8553B*	8554B*	8555A*	8557A	8558A	3580A
Frequency Range	0.02 to 300 kHz	0.001 to 110 MHz	0.1 to 1250 MHz	0.01 to 18(40)GHz	0.01 to 350 MHz	0.1 to 1500 MHz	5 Hz to 50 kHz
Calibrator Uncertainty	0.3 dB	0.3 dB	0.3 dB	0.3 dB	1 dB	1 dB	0.15 dB
Frequency Response Uncertainty	0.2 dB	0.5 dB	1.0 dB	1.0 to 2.0 dB 8445B 1.5 dB	0.75 dB	1 dB	0.5 dB
Amplitude Trace Determination Uncertainty	0.03 div	0.03 div	0.03 div	0.03 div	0.03 div	0.03 div	0.03 div
Log Reference Level Control Uncertainty (Linear Sensitivity Uncertainty)	0.2 dB (0.2 dB)	0.2 dB (0.2 dB)	0.2 dB (0.2 dB)	0.2 dB (0.2 dB)	0.5 dB	0.5 dB	1.0 dB (3% ref. lev.)
Log Reference Level Vernier Uncertainty	0.1 or 0.25 dB	0.1 or 0.25 dB	0.1 or 0.25 dB	0.1 or 0.25 dB			—
Amplitude Display Uncertainty (Linear Uncertainty)	0.25 dB/dB ≤1.5 dB (0.22 div.)	0.25 dB/dB ≤1.5 dB (0.22 div.)	0.25 dB/dB ≤1.5 dB (0.22 div.)	0.25 dB/dB ≤1.5 dB (0.22 div.)	0.1 dB/dB ≤1.5 dB (3% typ.)	0.1 dB/dB ≤1.5 dB (3% typ.)	2.0 dB (2%)
Attenuator Uncertainty	Input Level 0.2 dB	0.2 dB	0.6 dB/step ≤1.0 dB	0.6 dB flatness	0.5 dB/10 dB step ≤1.0 dB	0.5 dB/10 dB step ≤1.0 dB	0.3 dB
Uncertainty from Switching Between Bandwidths	1.5 dB	1.5 dB	0.5 dB	0.5 dB	1.0 dB	1.0 dB	1.0 dB
Uncertainty in Reference Level Switching Scale Factors	0.6 dB	0.6 dB	0.6 dB	0.6 dB	1.0 dB	1.0 dB	N/A
$\rho$ (VSWR) Typical into 50 $\Omega$	— 1 M $\Omega$ imped.	0.13(1.3)	0.2(1.5)	0.13(1.3) 8445B 0.33(2.0)	0.27(1.7)	0.2(1.5)	— 1 M $\Omega$ imped.
Tracking Generator	Built In	8443A	8444A	8444A	—	8444A Option 058	Built In
$\rho$ (VSWR)	— 600 $\Omega$ out-put imped.	0.09(1.2)	0.33(2.0)	0.33(2.0)	—	0.33(2.0)	— 600 $\Omega$
Flatness	±0.25 dB	±0.5 dB	±0.5 dB	±0.5 dB	—	±0.5 dB	±3.0%
Attenuator Uncertainty	—	±0.2 or ±0.1 dB	—	—	—	—	—

#### Frequency

Specifications	8556A*	8553B*	8554B*	8555A*	8557A	8558B	3580A
Frequency Range	0.02 to 300 kHz	0.001 to 110 MHz	0.1 to 1250 MHz	0.01 to 18(40) GHz	0.01 to 350 MHz	0.1 to 1500 MHz	5 Hz to 50 kHz
Resolution Uncertainty	Typically 30% of bandwidth setting 10 dB/div scaling, 20% (2 dB/DIV and 1 dB/DIV) 10% linear						
Center Frequency Accuracy	3 kHz	1 MHz	10 MHz	n X 15 MHz, 8445B 003 0.2%	3 MHz +10% Freq. Span Per Div	1 MHz + 20% _or_ 5 MHz + 20%	100 Hz
Frequency Span Accuracy	3% of Separation	3% or 10% Sep.	10% Sep.	10% Sep.	10% Sep.	10% Sep.	2% Sep.
Calibrator (reference frequency uncertainty)	0.01% Markers	3 kHz	3 kHz	3 kHz	50 kHz	50 kHz	—
Tracking Generator	Built-In	8443A	8444A	8444A	—	8444A Option 058	Built-In
Tracking Error	3 Hz	10 Hz	10 kHz	10 kHz	—	10 kHz	2.5 Hz
Residual FM	1 Hz	1 Hz	200 Hz	200 Hz	—	1 kHz	Negl.
Tuning Uncertainty	Typically 5% Frequency Span Per Division						

\* All specs refer to 8552B IF Section.

