

The 2026Q is designed to work with a radio test set to provide a fully integrated radio receiver test solution for cellular and PCS systems



- **Two tone interference generation for AMPS/CDMA receiver testing in accordance with IS-97-A/IS-98-A**
- **Option for providing GSM signals for receiver and amplifier testing**
- **Combiner output frequency range from 800 MHz to 2.0 GHz**
- **Provides single calibrated point of reference for the transceiver under test**
- **Excellent phase noise and spectral purity**
- **Elimination of additional RF combining or signal conditioning**
- **High internal isolation of returned signals**
- **Includes two independent, fully featured RF signal generators 10 kHz to 2.4 GHz**
- **Very low levels of internally generated intermodulation products**
- **Single unit solution for CDMA interference testing**

The 2026Q is a derivative of the popular 2026 MultiSource RF signal generator. It has been designed to work directly with a CDMA radio test set to produce a fully integrated radio receiver test solution for CDMA cellular and PCS systems in accordance with IS-97-A/IS-98-A.

Calibrated and Combined Signal Path

It is designed to produce a fully calibrated combined RF output containing any mix of internally generated interference signals from its two RF sources, together with a calibrated signal path for a radio test set transmit output. A return path from the transceiver back to the radio test set receiver input is also provided through the instrument as illustrated in figure 1.

This allows a CDMA receiver to be tested for sensitivity in the presence of single or dual tone interference. The interfering signals are combined without the need for any RF switching mechanism that would otherwise affect the test result.

Option 116 allows the 2026Q to provide GSM modulated signals for receiver or amplifier testing with low floor noise characteristics.

High Isolation

2026Q is configured to ensure high levels of isolation between each of the transmit and receive paths between the radio test set, the interfering signal sources and the transceiver under test.

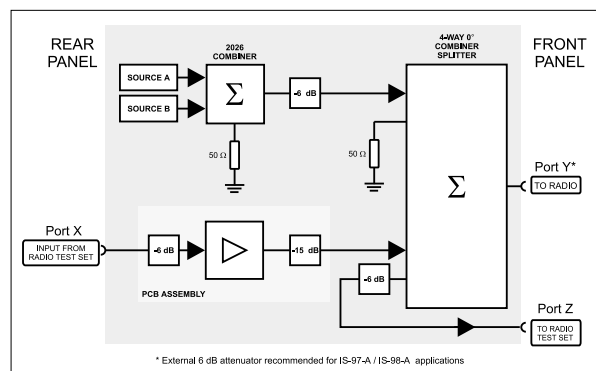

Figure 1 : 2026Q configured for radio testing with a test set

Path loss test data is supplied with each instrument for the frequency bands 865 MHz - 895 MHz, 1750 MHz - 1990 MHz. Drift influences within these bands is minimal ensuring a level accuracy of better than ± 0.75 dB. The

frequency response across each of these bands is flat to within ± 0.1 dB, thus minimizing the need for additional system calibration.

Independent Signal Generators

Each of the RF generators contained within 2026Q may be used independently, routed to their individual RF connectors. In this mode, each generator covers the full frequency range 10 kHz to 2.4 GHz with an output power of between -137 dBm and +24 dBm. Each source may be independently modulated either from an internal or external source(s). Modulation modes include AM, FM, PM, Pulse and 2/4 level FSK. The standard 2026 specification applies when used in this mode.

Excellent Spectral Purity

Very low phase noise and spurious responses are achieved making them ideal for CDMA handset interference tests and other general purpose applications. The 2026Q has a low residual FM of typically 3 Hz and typical sideband noise of -121 dBc/Hz at 20 kHz offset from 1 GHz.

The excellent noise floor performance is more than adequate for mobile handset and base station testing.

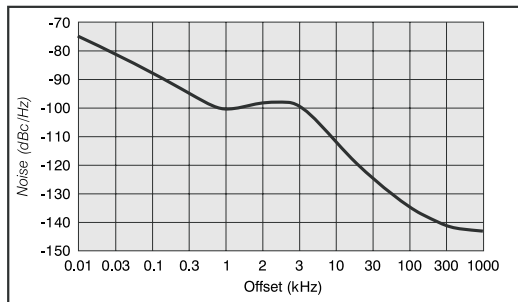

Typical SSB Phase Noise at 1 GHz

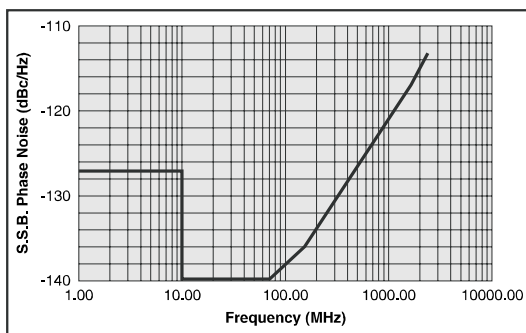

Typical Phase Noise at 20 kHz offset

Flexible Source Routing

Each of the signal sources can either be routed to a separate output connector or switched to the input of an RF combiner network before being fed to the combiner output connector. The combiner routing is set up quickly and effectively using the Combiner Set Up menu.

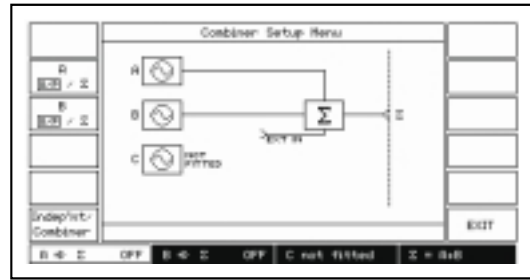

Setting up the source and combiner routing

The flexibility of the signal routing allows the 2026Q to accept an external input from another signal generator, such as the 2050 Digital and Vector Generator producing CDMA modulation or a radio test set.

Automatic Source Coupling

The two internal generators can have their frequency and level 'coupled'. In the case of RF level this coupling can be any fixed offset enabling control of a single parameter to manifest a change in both sources. For RF frequency this coupling can be both a fixed frequency offset or a harmonically related offset and again allow simple programming and control of the instrument.

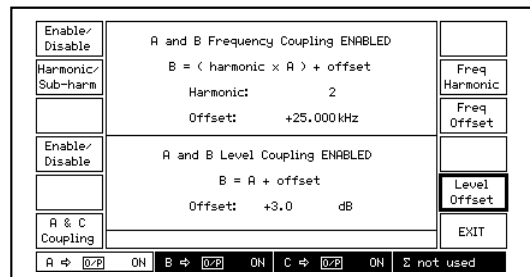

Setting up coupling

Sweep

The 2026Q allows either of the independent RF sources to be frequency swept with user defined start, stop, and step values to reduce the amount of operator time or GPIB overhead. By enabling the coupling facility, sweeping one source will simultaneously sweep the other internal RF source to allow automated swept measurements on frequency conversion devices to be made.

High RF Output

Each of the RF signal generators is able to deliver up to +24 dBm at their output, making them ideal for testing components such as mixers and amplifiers etc.

Comprehensive Modulation

Each signal source is capable of being independently modulated from its own fully programmable modulation source to ensure maximum flexibility. The internal modulation sources are each capable of generating sine, triangle or square wave signals.

Amplitude, frequency and phase modulated carriers can be generated from the internal modulation sources or from the

independent external inputs.

The frequency modulation system provides excellent performance in the DC coupled mode with very low carrier frequency error and stability ensuring that the generator can accurately test receivers sensitive to small frequency errors.

Programming

A GPIB interface is fitted so that all standard signal generator functions are controllable over the bus. The protocol and syntax of GPIB commands has been designed in accordance with IEEE 488.2 standard to facilitate the generation of ATE programs.

A RS-232 interface is fitted as standard with a common command set to GPIB commands. RS-232 control is particularly suitable for use with simple external controllers or RF modems when the instrument is being used in a remote location.

Low Cost of Ownership

An electronic trip protects the individual source outputs against the accidental application of reverse power.

Careful attention to the thermal design and the use of well-proven signal generator modules gives high reliability and calibration validity.

The use of flash memory and software download via the RS-232 interface means the 2026Q can be upgraded with its covers fitted.

Option 116 - GSM Modulation

Option 116 is available to allow 2026A/B to emulate GSM signals using FM techniques which achieves superior noise floor performance than solutions using IQ systems. The facility is ideal for testing GSM receiver selectivity and for testing the linearity of high performance multi-carrier power amplifiers.

Specification

General Description

The 2026Q CDMA Interferer MultiSource Generator is a purpose built instrument for testing CDMA hand-set and base station equipment. It features two synthesized RF signal generators with both independent and combined RF outputs. The combined RF output provides a path to and from the radio under test and an appropriate CDMA radio test set. Each signal source covers the frequency range 10 kHz to 2.4 GHz, whilst the combined path covers the range 800 MHz to 2.0 GHz.

Carrier Frequency

Independent source frequency range

10 kHz to 2.4 GHz with a resolution of 1 Hz

Combined output frequency range

800 MHz to 2.0 GHz with a resolution of 1 Hz

Accuracy

As frequency standard

RF Output

Range

Individual outputs
-137 dBm to +24 dBm⁽¹⁾

Combiner outputs
-37 dBm to -3 dBm⁽¹⁾

Maximum output is reduced by 5 dB when pulse modulation is selected and/or by up to 6 dB when AM is selected dependent upon AM depth.

Resolution

0.1 dB or 3 digits for linear units

Accuracy (Individual RF outputs)

(over temp range 17 to 27°C)

RF Level	-127 dBm to +6 dBm	> +6 dBm to +24 dBm ⁽²⁾	Temp Stability
Up to 1.2 GHz	±0.8 dB	±1.0 dB	< ±0.02 dB/°C
Above 1.2 GHz	±1.6 dB	±2.0 dB	< ±0.04 dB/°C

Accuracy (Combined RF output)

(over temp range 17 to 27°C and level range -20 dBm to -35 dBm)

RF Frequency range	Level Accuracy
865 MHz - 895 MHz	±0.75 dB
1750 MHz - 1990 MHz	±0.75 dB

Attenuator hold

Inhibits operation of the step attenuator from the level at which the key is enabled. Useable for a level reduction of at least 10 dB. Typical accuracy ±3 dB.

VSWR

Individual outputs
For output levels less than -5 dBm, output VSWR is less than 1.5:1 for carrier frequencies up to 1.2 GHz and less than 1.7:1 for carrier frequencies up to 2.4 GHz.

Path Loss

	865 MHz to 895 MHz	1750 MHz to 1990 MHz
(X → Y)*	14 dB typ.	15 dB typ.
(Y → Z)	13.5 dB typ.	13.5 dB typ.
(Y → X)	>40 dB	> 40 dB

* -measured values are supplied with each instrument with a frequency response of <± 0.1 dB across the frequency bands 865 MHz to 895 MHz, 1750 MHz to 1780 MHz and 1930 MHz to 1990 MHz. Measurement uncertainty of ± 0.25 dB applies.

Options are available providing lower path loss figures - please contact your IFR sales office for further details.

VSWR (refer to Figure 1)

	865 MHz to 895 MHz	1750 MHz to 1990 MHz
Port X	<1.2:1	<1.35:1
Port Y	<1.6:1*	<1.6:1*
Port Z	<1.35:1	<1.35:1

*Typically <1.25:1

Maximum	Safe Power (matched)
Port X	+19 dBm
Port Y	+33 dBm
Port Z	+33 dBm

RF Output connector

50 Ω type N connector to MIL 390123D.

Output protection

Individual outputs

Protected from a source of reverse power up to 50 W from 50 Ω or 25 W from a source VSWR of 5:1. Protection circuit can be reset from the front panel or via the GPIB interface.

Combined output

No reverse power protection.

Spectral Purity**Harmonics**

Individual outputs:

Typically better than -30 dBc for RF level up to +6 dBm, typically better than -25 dBc for RF levels up to +18 dBm (+14 dBm above 1.2 GHz).

Combined output:

Typically better than -30 dBc for RF level up to -36 dBm, typically better than -25 dBc for RF levels up to -13 dBm.

Non-Harmonics

Better than -70 dBc to 1 GHz, better than -64 dBc above 1 GHz, better than -60 dBc above 2 GHz.

Isolation

Better than 80 dB between individual outputs in use.
Better than 60 dB from a used individual output and the combiner output.

Intermodulation

<-80 dBc at an RF output level of -22 dBm on the combiner, across the range 800 MHz to 2.0 GHz. Intermodulation levels reduce with reducing RF Level.

Residual FM (FM off)

Less than 4.5 Hz RMS deviation in a 300 Hz to 3.4 kHz un-weighted bandwidth at 1 GHz. Typically <1 Hz at 249 MHz, <3 Hz at 1001 MHz.

Radio Connections

Refer to Figure 1

SSB phase noise

Better than -124 dBc/Hz at 20 kHz offset from a carrier frequency of 470 MHz, typically -121 dBc/Hz at 20 kHz offset from a carrier frequency of 1 GHz.

Carrier Leakage

Less than 0.5 μ V PD at the carrier frequency in a two turn 25 mm diameter loop, 25 mm from the surface of the signal generator.

Modulation Capability

FM, AM or phase modulation can be applied to the carriers generated by each signal source from independent internal or external modulation sources.

The internal modulation sources are capable of generating two simultaneous signals into any one of the modulation channels. Each internal and external modulation source can be simultaneously enabled to produce combined amplitude and frequency (or phase) modulation.

Pulse modulation can be applied to each of the carriers from external pulse sources. The pulse modulation can be used in combination with the other forms of modulation.

2 level or 4 level FSK modulation can be applied to each carrier using data from an external source.

Frequency Modulation**Deviation**

0 to 100 kHz

Resolution

3 digits or 1 Hz

Accuracy at 1 kHz

\pm 5%

Bandwidth (1 dB)

DC to 100 kHz (DC coupled)

10 Hz to 100 kHz (AC coupled)

20 Hz to 100 kHz (AC coupled with ALC)

Group delay

Less than 5 μ s to 100 kHz

Carrier frequency offset (DC coupled)

Less than 1% of the set frequency deviation

Distortion

Less than 1% at 1 kHz rate for deviations up to 100 kHz

Typically \leq 0.3% at 1 kHz rate for deviations up to 10 kHz

Less than 3% at 1 kHz rate and deviations upto 100 kHz for carrier frequencies below 50 MHz

Modulation source

Internal modulation oscillator or external via front panel BNC

FSK**Modes**

2 level or 4 level FSK

Data source

External data input via a 25 way rear panel D Type connector

Frequency shift

Variable up to ± 100 kHz

Accuracy

As FM deviation accuracy

Timing jitter

± 3.2 μ s

Filter

8th order Bessel, -3 dB at 3.9 kHz

Phase Modulation

Deviation

0 to 10 radians

Resolution

3 digits or 0.01 radians

Accuracy at 1 kHz

$\pm 5\%$ of indicated deviation excluding residual phase modulation

3 dB Bandwidth

100 Hz to 10 kHz

Distortion

Less than 3% at 10 radians at 1 kHz modulation rate. Typically <0.5% for deviations up to 1 radian at 1 kHz

Modulation source

Internal LF generator or external via front panel BNC.

Amplitude Modulation

For carrier frequencies <500 MHz, useable to 1.5 GHz on the individual outputs

Range

0 to 99.9%

Resolution

0.1%

Accuracy⁽³⁾

$\pm 5\%$ of set depth at 1 kHz rate

1 dB Bandwidth

DC to 30 kHz (DC coupled)

10 Hz to 30 kHz (AC coupled)

20 Hz to 30 kHz (AC coupled with ALC)

Distortion⁽³⁾

<1.5% at 1 kHz rate for modulation depths up to 30%

<2.5% at 1 kHz rate for modulation depths up to 80%

Modulation source

Internal LF generator or external, via front panel BNC

PM on AM

Typically 0.1 radians at 30% depth at 470 MHz

Pulse Modulation

Frequency range

32 MHz to 2.4 GHz, useable to 10 MHz

RF level range

Maximum guaranteed output is reduced by 5 dB when pulse modulation is selected

RF level accuracy

When pulse modulation is enabled, adds ± 0.5 dB to the RF level accuracy specification

Control

Pulse input is on a front panel BNC with 10 k Ω nominal input impedance

A logic 0 (0 V to 1 V) turns the carrier off, a logic 1 (3.5 V to 5 V) turns the carrier on

Maximum input is ± 15 V

On/off ratio

Better than 45 dB below 1.2 GHz, better than 40 dB above 1.2 GHz

Rise and fall times

Less than 10 μ s

Overshoot

<1 dB

Modulation Oscillator

The internal modulation oscillator for each signal source is capable of generating one or two modulation tones simultaneously in one modulation channel.

Frequency range

0.01 Hz to 20 kHz with a resolution of 0.01 Hz

Frequency accuracy

As frequency standard

Distortion

Less than 0.1% THD at 1 kHz

Waveforms

Sine wave to 20 kHz and a triangular or square wave to 3 kHz

Square wave jitter

<6.4 μ s on any edge

Audio Output

The modulation oscillator signal from each source is available on the front panel Modulation Input/Output BNC connector at a nominal level of 2 V RMS EMF from a 600 Ω source impedance.

External Modulation

Input on the front panel Modulation Input/Output connector. The modulation is calibrated with 1.414 V peak (1 V RMS sine wave) applied. Input impedance is 100 k Ω nominal. Maximum safe input

±15 V.

MODULATION ALC

The external modulation input can be levelled by a peak levelling ALC system over the input voltage range of 0.75 V to 1.25 V RMS sine wave. High and low indicators in the display indicate when the input is outside levelling range.

Sweep Mode

The carrier frequency of one source can be swept. To enable more than one source to be swept the coupling facility must be invoked.

Control parameters

Start/stop values of carrier frequency, frequency step size and time per step.

Step time

50 ms to 10 s per step

Trigger

A trigger input is available on a rear panel BNC connector and can be used in single, continuous, start/stop or single step mode.

Frequency Standard (OCXO)

Frequency

10 MHz

Ageing rate

±2.5 in 10^7 per year, ±5 in 10^9 per day after 2 months continuous use.

Temperature Stability

Better than ±5 in 10^8 over the temperature range 0 to 50°C.

Warm up time

Within 2 in 10^7 of final frequency 10 minutes after switch on at a temperature of 20°C.

External input/output

Rear panel BNC connector accepts an external input of 1 MHz or 10 MHz at a level of 220 mV RMS to 1.8 V RMS into 1 kΩ. Rear panel BNC connector provides an output of 10 MHz at a nominal level of 2 V pk-pk into 50 Ω.

General

GPIB INTERFACE

All signal source parameters except the supply switch are remotely programmable.

Designed in accordance with IEEE 488.2.

RS-232

All signal source parameters except the supply switch are remotely programmable.
Connector is 9 way D type, baud rate 300 to 9600 bits per second. Handshake hardware is DTR, RTS, CTS and DSR and software is XON and XOFF. Electrical interface is to EIA-232-D.

ELECTROMAGNETIC COMPATIBILITY

Conforms with the protection requirements of Council Directive 89/336/EEC. Complies with the limits specified in the following standards:

IEC/EN61326-1 : 1997, RF Emission Class B, Immunity Table 1, Performance Criteria B

SAFETY

Conforms with the requirements of EEC Council Directive 73/23/EEC and Standard IEC/EN 61010-1 : 1993

RATED RANGE OF USE

(Over which full specification is met unless otherwise indicated.)

Temperature 0 to 55°C, Humidity up to 93% at 40°C
Altitude up to 3050 m (10,000 ft)

CONDITIONS OF STORAGE AND TRANSPORT

Temperature -40 to +71°C, Humidity up to 93% at 40°C
Altitude up to 4600 m (15,000 ft)

POWER REQUIREMENTS

AC Supply

90 to 132 V or 188 to 255 V, 47 Hz to 63 Hz, 250 VA maximum

CALIBRATION INTERVAL

2 years

DIMENSIONS AND WEIGHT

(over projections but excluding front panel handles)

Height	Width	Depth	Weight
177 mm	419 mm	488 mm	<17kg

Options

OPTION 116 - GSM MODULATION

Option 116 is available on 2026Q and 2026A/B signal generators.

Baseband source

Data rate

270.833333 kHz (13 MHz/48).

Data rate accuracy

As 10 MHz frequency standard.

Filter

Gaussian filter approximated by eight-pole RC network.

Number of outputs

3

Data pattern

($2^{15} - 1$) PRBS sequence.

The outputs are separated in time to ensure that they are not correlated.

ACCURACY

FM deviation

Typically better than 2% when used as described.

SPECTRAL CHARACTERISTIC

Wideband noise

For an output of +10 dBm on the individual output typically -83 dBc measured in a 100 kHz bandwidth relative to the modulated signal measured in a 30 kHz bandwidth at 6 MHz offset, in accordance

with ETSI-defined measurement methods on wideband noise.

- (1) Level uncalibrated above +20 dBm for frequencies >1.2 GHz (-7 dBm at combiner output)
- (2) Level accuracy is unspecified below 100 kHz for levels >+6 dBm
- (3) For RF output levels not exceeding +10 dBm (-22 dBm at combiner output)

Versions and Accessories

When ordering please quote the full ordering number information.

Ordering Numbers

Versions

2026Q CDMA Interferer MultiSource Generator

Options

Option 116 GSM PRBS modulation

Supplied with

AC power supply lead
46882/361 Operating Manual
46880/087 Service Manual

Optional Accessories

46884/293 Rack mounting kit, depths from 480 mm to 680 mm
46884/294 Rack mounting kit, depths from 680 mm to 840 mm
46884/931 Rack mounting kit containing front panel brackets only
46662/614 Soft carrying case
43129/189 1.5 m GPIB lead
46884/650 RS-232 Cable 9 way female to a 9 way female 1.5 m
46884/649 RS-232 Cable 9 way female to a 25 way female 1.5 m

CHINA

Tel: [+86] (10) 6467 2823
Fax: [+86] (10) 6467 2821

FRANCE

Tel: [+33] 1 60 79 96 00
Fax: [+33] 1 60 77 69 22

GERMANY

Tel: [+49] (8131) 29260
Fax: [+49] (8131) 2926130

HONG KONG

Tel: [+852] 2832 7988
Fax: [+852] 2834 5364

LATIN AMERICA

Tel: [+1] (972) 899 5150
Fax: [+1] (972) 899 5154

SPAIN

Tel: [+34] (91) 640 11 34
Fax: [+34] (91) 640 06 40

UNITED KINGDOM

Tel: [+44] (0) 1438 742200
Toll Free: [+44] (0800) 282 388 (UK only)
Fax: [+44] (0) 1438 727601

USA

Tel: [+1] (316) 522 4981
Toll Free: [+1] (800) 835 2352 (US only)
Fax: [+1] (316) 522 1360

email ***info@ifrsys.com***

web ***www.ifrsys.com***

As we are always seeking to improve our products, the information in this document gives only a general indication of the product capacity, performance and suitability, none of which shall form part of any contract. We reserve the right to make design changes without notice. All trademarks are acknowledged. Parent company IFR Systems, Inc. © IFR 2001.

Part No. 46891/004
Issue 4
03/2001