

# Model 228A Voltage/Current Source

Instruction Manual



Contains Operating and Servicing Information

**KEITHLEY**

# WARRANTY

Keithley Instruments, Inc. warrants this product to be free from defects in material and workmanship for a period of 1 year from date of shipment.

Keithley Instruments, Inc. warrants the following items for 90 days from the date of shipment: probes, cables, rechargeable batteries, diskettes, and documentation.

During the warranty period, we will, at our option, either repair or replace any product that proves to be defective.

To exercise this warranty, write or call your local Keithley representative, or contact Keithley headquarters in Cleveland, Ohio. You will be given prompt assistance and return instructions. Send the product, transportation prepaid, to the indicated service facility. Repairs will be made and the product returned, transportation prepaid. Repaired or replaced products are warranted for the balance of the original warranty period, or at least 90 days.

## LIMITATION OF WARRANTY

This warranty does not apply to defects resulting from product modification without Keithley's express written consent, or misuse of any product or part. This warranty also does not apply to fuses, software, non-rechargeable batteries, damage from battery leakage, or problems arising from normal wear or failure to follow instructions.

THIS WARRANTY IS IN LIEU OF ALL OTHER WARRANTIES, EXPRESSED OR IMPLIED, INCLUDING ANY IMPLIED WARRANTY OF MERCHANTABILITY OR FITNESS FOR A PARTICULAR USE. THE REMEDIES PROVIDED HEREIN ARE BUYER'S SOLE AND EXCLUSIVE REMEDIES.

NEITHER KEITHLEY INSTRUMENTS, INC. NOR ANY OF ITS EMPLOYEES SHALL BE LIABLE FOR ANY DIRECT, INDIRECT, SPECIAL, INCIDENTAL OR CONSEQUENTIAL DAMAGES ARISING OUT OF THE USE OF ITS INSTRUMENTS AND SOFTWARE EVEN IF KEITHLEY INSTRUMENTS, INC., HAS BEEN ADVISED IN ADVANCE OF THE POSSIBILITY OF SUCH DAMAGES. SUCH EXCLUDED DAMAGES SHALL INCLUDE, BUT ARE NOT LIMITED TO: COSTS OF REMOVAL AND INSTALLATION, LOSSES SUSTAINED AS THE RESULT OF INJURY TO ANY PERSON, OR DAMAGE TO PROPERTY.

# KEITHLEY

Keithley Instruments, Inc. • 28775 Aurora Road • Cleveland, OH 44139 • 216-248-0400 • Fax: 216-248-6168 • <http://www.keithley.com>

CHINA:	Keithley Instruments China • Yuan Chen Xin Building, Room 705 • 12 Yumin Road, Dewai, Madian • Beijing 100029 • 8610-62022886 • Fax: 8610-62022892
FRANCE:	Keithley Instruments SARL • BP 60 • 3 Allée des Garays • 91122 Palaiseau Cédex • 33-1-60-11-51-55 • Fax: 33-1-60-11-77-26
GERMANY:	Keithley Instruments GmbH • Landsberger Strasse 65 • D-82110 Germering, Munich • 49-89-8493070 • Fax: 49-89-84930759
GREAT BRITAIN:	Keithley Instruments, Ltd. • The Minster • 58 Portman Road • Reading, Berkshire RG30 1EA • 44-118-9575666 • Fax: 44-118-9596469
ITALY:	Keithley Instruments SRL • Viale S. Gimignano 38 • 20146 Milano • 39-2-48303008 • Fax: 39-2-48302274
NETHERLANDS:	Keithley Instruments BV • Avelingen West 49 • 4202 MS Gorinchem • 31-(0)183-635333 • Fax: 31-(0)183-630821
SWITZERLAND:	Keithley Instruments SA • Kriesbachstrasse 4 • 8600 Dübendorf • 41-1-8219444 • Fax: 41-1-8203081
TAIWAN:	Keithley Instruments Taiwan • IFL., 1, Min Yu First Street • Hsinchu, Taiwan, R.O.C. • 886-35-778462 • Fax: 886-35-778455

# Model 228A Voltage/Current Source Instruction Manual

All references to the Model 228 apply also to the Model 228A.

© 1988, Keithley Instruments, Inc.  
Test Instrumentation Group  
All rights reserved.  
Cleveland, Ohio, U.S.A.  
April 1991, Fourth Printing  
Document Number: 228A-901-01 Rev. D



# Safety Precautions

---

The following safety precautions should be observed before using this product and any associated instrumentation. Although some instruments and accessories would normally be used with non-hazardous voltages, there are situations where hazardous conditions may be present.

This product is intended for use by qualified personnel who recognize shock hazards and are familiar with the safety precautions required to avoid possible injury. Read the operating information carefully before using the product.

The types of product users are:

**Responsible body** is the individual or group responsible for the use and maintenance of equipment, and for ensuring that operators are adequately trained.

**Operators** use the product for its intended function. They must be trained in electrical safety procedures and proper use of the instrument. They must be protected from electric shock and contact with hazardous live circuits.

**Maintenance personnel** perform routine procedures on the product to keep it operating, for example, setting the line voltage or replacing consumable materials. Maintenance procedures are described in the manual. The procedures explicitly state if the operator may perform them. Otherwise, they should be performed only by service personnel.

**Service personnel** are trained to work on live circuits, and perform safe installations and repairs of products. Only properly trained service personnel may perform installation and service procedures.

Exercise extreme caution when a shock hazard is present. Lethal voltage may be present on cable connector jacks or test fixtures. The American National Standards Institute (ANSI) states that a shock hazard exists when voltage levels greater than 30V RMS, 42.4V peak, or 60VDC are present. **A good safety practice is to expect that hazardous voltage is present in any unknown circuit before measuring.**

Users of this product must be protected from electric shock at all times. The responsible body must ensure that users are prevented access and/or insulated from every connection point. In some cases, connections must be exposed to potential human contact. Product users in these circumstances must be trained to protect themselves from the risk of electric shock. If the circuit is capable of operating at or above 1000 volts, **no conductive part of the circuit may be exposed.**

As described in the International Electrotechnical Commission (IEC) Standard IEC 664, digital multimeter measuring circuits (e.g., Keithley Models 175A, 199, 2000, 2001, 2002, and 2010) measuring circuits are Installation Category II. All other instruments' signal terminals are Installation Category I and must not be connected to mains.

Do not connect switching cards directly to unlimited power circuits. They are intended to be used with impedance limited sources. NEVER connect switching cards directly to AC mains. When connecting sources to switching cards, install protective devices to limit fault current and voltage to the card.

Before operating an instrument, make sure the line cord is connected to a properly grounded power receptacle. Inspect the connecting cables, test leads, and jumpers for possible wear, cracks, or breaks before each use.

For maximum safety, do not touch the product, test cables, or any other instruments while power is applied to the circuit under test. ALWAYS remove power from the entire test system and discharge any capacitors before: connecting or disconnecting cables or jumpers, installing or removing switching cards, or making internal changes, such as installing or removing jumpers.

Do not touch any object that could provide a current path to the common side of the circuit under test or power line (earth) ground. Always make measurements with dry hands while standing on a dry, insulated surface capable of withstanding the voltage being measured.

Do not exceed the maximum signal levels of the instruments and accessories, as defined in the specifications and operating information, and as shown on the instrument or test fixture panels, or switching card.

When fuses are used in a product, replace with same type and rating for continued protection against fire hazard.

Chassis connections must only be used as shield connections for measuring circuits, NOT as safety earth ground connections.

If you are using a test fixture, keep the lid closed while power is applied to the device under test. Safe operation requires the use of a lid interlock.

If a  screw is present, connect it to safety earth ground using the wire recommended in the user documentation.

The  symbol on an instrument indicates that the user should refer to the operating instructions located in the manual.

The  symbol on an instrument shows that it can source or measure 1000 volts or more, including the combined effect of normal and common mode voltages. Use standard safety precautions to avoid personal contact with these voltages.

The **WARNING** heading in a manual explains dangers that might result in personal injury or death. Always read the associated information very carefully before performing the indicated procedure.

The **CAUTION** heading in a manual explains hazards that could damage the instrument. Such damage may invalidate the warranty.

Instrumentation and accessories shall not be connected to humans.

Before performing any maintenance, disconnect the line cord and all test cables.

To maintain protection from electric shock and fire, replacement components in mains circuits, including the power transformer, test leads, and input jacks, must be purchased from Keithley Instruments. Standard fuses, with applicable national safety approvals, may be used if the rating and type are the same. Other components that are not safety related may be purchased from other suppliers as long as they are equivalent to the original component. (Note that selected parts should be purchased only through Keithley Instruments to maintain accuracy and functionality of the product.) If you are unsure about the applicability of a replacement component, call a Keithley Instruments office for information.

To clean the instrument, use a damp cloth or mild, water based cleaner. Clean the exterior of the instrument only. Do not apply cleaner directly to the instrument or allow liquids to enter or spill on the instrument.

---

## Model 228A Errata

Page 3-32

At the bottom of the page, add the following caution to avoid output transients that could cause damage to external circuitry.

### **CAUTION**

**An output transient a few milliseconds in duration may occur when placing the Model 228 in OPERATE while it is in the process of a single or continuous memory control cycle. This transient can be as high as full scale of the range it is currently on and may cause damage to external circuitry. To avoid this potentially damaging transient, always make sure the Model 228 is in OPERATE before starting the memory control cycle. If a memory control cycle is already started, it can be stopped by pressing the MEMORY CONTROL button.**





# SPECIFICATIONS

## AS A CONSTANT VOLTAGE SOURCE

RANGE	OUTPUT		COMPLIANCE (Source or Sink)			
	MAXI-MUM	RESOLUTION	ACCURACY* (1 YEAR) 18°-28°C	MAXI-MUM	RESOLUTION	ACCURACY (1 YEAR) 18°-28°C
100V	±101.0V	100mV	±(0.1%+0.1 V)	±1.010 A	1mA	±(0.1% + 4mA) ±0.1010A 100 μA ±(0.1%+400 μA)
10V	±10.10V	10mV	±(0.1% + 10mV)	±10.10 A	10mA	±(0.5% + 40mA) ±1.010 A 1mA ±(0.1% + 4mA) ±0.1010A 100 μA ±(0.1%+400 μA)
1V	±1.010V	1mV	±(0.1%+1.0mV)	±10.10 A	10mA	±(0.5% + 40mA) ±1.010 A 1mA ±(0.1% + 4mA) ±0.1010A 100 μA ±(0.1%+400 μA)

\*Above 0.4% range.

TEMPERATURE COEFFICIENT (0°-18°C & 28°-50°C): ±(0.1× applicable accuracy specification)/°C.

NOISE:	RANGE	0.1-300Hz	0.1-300kHz	0.1-20MHz
	100V	5.0mV p-p	15mV p-p	25mV p-p typ.
	10V	2.0mV p-p	15mV p-p	25mV p-p typ.
	1V	0.7mV p-p	15mV p-p	25mV p-p typ.

OUTPUT RESISTANCE (max.): 100V Range: 10mΩ. 10V Range: 100 μΩ. 1V Range: 100 μΩ.

OUTPUT INDUCTANCE: 100μH typical.

SENSING: Rear panel switch selectable REMOTE and LOCAL sensing.

REMOTE SENSING: Corrects for up to 0.5V drop per output lead. Maximum 5Ω per sense lead for rated accuracy. Maximum 0.5Ω per sense lead for rated output resistance.

## AS A CONSTANT CURRENT SOURCE

RANGE	OUTPUT (1 YR., 18°-28°C)		COMPLIANCE (Source or Sink)			
	MAXI-MUM	RESOLUTION	ACCURACY* (1 YEAR) 18°-28°C	MAXI-MUM	RESOLUTION	ACCURACY (1 YEAR) 18°-28°C
10 A	±10.10 A	10mA	±(0.5% + 10mA)	±10.10V	10mV	±(0.1% + 40mV) ±1.010V 1mV ±(0.1% + 4mV)
1 A	±1.010 A	1mA	±(0.1%+1.0mA)	±101.0V	100mV	±(0.1%+400mV) ±10.10V 10mV ±(0.1% + 40mV) ±1.010V 1mV ±(0.1% + 4mV)
0.1A	±0.1010A	100 μA	±(0.1%+0.1mA)	±101.0V	100mV	±(0.1%+400mV) ±10.10V 10mV ±(0.1% + 40mV) ±1.010V 1mV ±(0.1% + 4mV)

\*Above 0.4% of range.

TEMPERATURE COEFFICIENT (0°-18°C & 28°-50°C): ±(0.1× applicable accuracy specification)/°C.

NOISE:	RANGE	0.1-300Hz	0.1-300kHz	0.1-20MHz
	10 A	25 mA p-p	25mA p-p	25mA p-p typ.
	1 A	5 mA p-p	5mA p-p	10mA p-p typ.
	0.1A	0.5mA p-p	2mA p-p	3mA p-p typ.

OUTPUT RESISTANCE (min.): 10A Range: 10<sup>4</sup>Ω. 1A Range: 10<sup>5</sup>Ω. 0.1A Range: 10<sup>6</sup>Ω.

OUTPUT CAPACITANCE: 0.2μF typical.

OUTPUT LOAD: Must be non-inductive.

## CURRENT MONITOR OUTPUT

SCALE FACTOR: 1V = 100% of range.

ACCURACY: Same as constant current mode.

BANDWIDTH: 5kHz typical.

OUTPUT RESISTANCE: 10kΩ.

## EXTERNAL MODULATION

INPUT RESISTANCE: 6.8kΩ.

SENSITIVITY: -10V increases magnitude of programmed output by 100% of full scale; +10V decreases magnitude of programmed output by 100% of full scale.

ACCURACY: 2% typical, dc to 60Hz.

MAXIMUM MODULATION: Modulation and programmed setting should not cause operation exceeding the range of zero to 101% of full scale.

MODULATION FREQUENCY: 600Hz bandwidth.

## IEEE-488 BUS IMPLEMENTATION (IEEE-488-1978)

MULTILINE COMMANDS: DCL, LLO, SDC, GET, GTL, UNT, UNL, SPE, SPD.

UNILINE COMMANDS: IFC, REN, EOI, SRQ, ATN.

INTERFACE FUNCTIONS: SH1, AH1, T6, TE0, L4, LE0, SR1, RL1, PP0, DC1, DT1, C0, E1.

PROGRAMMABLE PARAMETERS: Output (operate or standby), Range, Voltage, Current, Trigger Mode, Sink, Modulation (Voltage or Current), Display Mode, Output Prefix (data format on readback), SRQ Mask, EOI, Terminator Characters, Status, Self Test, Memory Location (100 point memory), Dwell Time.

## GENERAL

DISPLAY: Dual 3½-digit LED (0.5 in.) indicate programmed values in Standby and output values in Operate.

READBACK ACCURACY: Same as output accuracy.

FRONT PANEL PROGRAMS: COPY, SINK, IEEE address, MOD V, MOD I, TEST, RESET.

LOAD TRANSIENT RECOVERY TIME: With a resistive load the output will recover 90% of any load changes within 1ms after end of changes, provided the changes do not cause transfer to another control mode.

STANDBY: Programs output to 0V, 0A without changing ranges or polarity.

LINE REGULATION: Less than 0.01% output change for ac power line changes within specified limits.

PROGRAM MEMORY (battery backed up): Stores up to 100 output settings. Range of Dwell Times: 10ms to 1000s. Accuracy of Dwell Times: ±(0.05%+2ms).

BATTERY BACKUP: Rechargeable 3.6V nickel-cadmium. 1 month retention of data with unit turned off.

TRIGGER: IN and OUT TTL-compatible.

PROGRAMMING RESPONSE TIME: Less than 100ms on fixed range (typical).

MAXIMUM COMMON MODE VOLTAGE (output or output common to chassis): 100V dc.

OUTPUT CONNECTIONS: Quick disconnect card with screw terminals for output, modulation, current monitor, and external sense. BNC (chassis isolated) connectors for TRIGGER IN/OUT.

SELF TEST: Analog and digital circuits tested at power-on. Power supplies, temperatures, and output continuously monitored.

WARMUP: 10 minutes to rated accuracy.

POWER: 105-125 or 210-250 V ac (internally switch selectable), 50 or 60Hz, 500 VA maximum.

COOLING: Internal fan for forced air cooling.

ENVIRONMENT: Operating: 0° to 50°C, less than 80% non-condensing RH below 35°C. Storage: -25° to 70°C.

DIMENSIONS, WEIGHT: 133mm high × 435mm wide × 448mm deep (5¼ in. × 17¼ in. × 17¼ in.). Net weight 10.9kg (24 lbs.).

## ACCESSORIES AVAILABLE:

Model 2288: Fixed Rack Mounting Kit

Model 2289: Slide Rack Mounting Kit

Model 7008-3: IEEE-488 Cable (3 ft.)

Model 7008-6: IEEE-488 Cable (6 ft.)



# TABLE OF CONTENTS

## SECTION 1—GENERAL INFORMATION

1.1	Introduction . . . . .	1-1
1.2	Features . . . . .	1-1
1.3	Using the Instruction Manual . . . . .	1-2
1.4	Warranty Information . . . . .	1-2
1.5	Manual Addenda . . . . .	1-2
1.6	Safety Symbols and Terms . . . . .	1-2
1.7	Specifications . . . . .	1-2
1.8	Unpacking and Inspection . . . . .	1-2
1.9	Accessories . . . . .	1-3

## SECTION 2—SAFETY AND GENERAL OPERATION

2.1	Safety Precautions . . . . .	2-1
2.2	General Operating Procedure . . . . .	2-1
2.3	Standby Mode Notes . . . . .	2-3

## SECTION 3—FRONT PANEL OPERATION

3.1	Introduction . . . . .	3-1
3.2	Preparation For Use . . . . .	3-1
3.2.1	Line Voltage Selection . . . . .	
3.2.2	Fuse Checks . . . . .	3-1
3.3	Power Up . . . . .	3-1
3.4	Warm Up . . . . .	3-2
3.5	Environmental Conditions . . . . .	3-2
3.6	Operating Instructions . . . . .	3-2
3.7	Front Panel Description . . . . .	3-7
3.8	Rear Panel Description . . . . .	3-14
3.9	Quick Disconnect Board . . . . .	3-16
3.10	Remote and Local Sensing . . . . .	3-18
3.11	Front Panel Programs . . . . .	3-18
3.11.1	Program 1 Copy . . . . .	3-18
3.11.2	Program 2 Sink . . . . .	3-19
3.11.3	Program 3 IEEE . . . . .	3-19
3.11.4	Program 4 MOD V (Modulate Output Voltage) . . . . .	3-20
3.11.5	Program 5 MOD I (Modulate Output Current) . . . . .	3-20
3.11.6	Program 6 Test (Diagnostic Self Test) . . . . .	3-21
3.11.7	Program 9 Reset . . . . .	3-21
3.12	Loads . . . . .	3-21
3.12.1	Load Line Description . . . . .	3-22
3.12.2	Resistive Loads . . . . .	3-24
3.12.3	Reactive Loads . . . . .	3-24
3.12.4	Inductive Loads . . . . .	3-24
3.12.5	Capacitance Loads . . . . .	3-26
3.12.6	Load Regulation . . . . .	3-26
3.13	Operating Examples . . . . .	3-27
3.13.1	Example 1: 10.00V, 10.00A Output . . . . .	3-27
3.13.2	Example 2: 100V, 1A Output . . . . .	3-28

3.13.3	Example 3: 1V, 10A, 1sec; 10V, 10A 2sec; and 100V, 1A, 3sec Output in the Continuous Memory Control Mode	3-30
3.13.4	Example 4: Model 228 as an Active Load (Current Sink)	3-33
3.13.5	Example 5: Operation as Source and Sink	3-35
3.13.6	Example 6: Fabricating Output Waveforms	3-35
3.13.7	Example 7: Using the External Trigger (Input and Output)	3-26
3.13.8	Example 8: Floating Operation (Extended Compliance)	3-27
3.14	Applications	3-37
3.14.1	Low Resistance Measurements	3-37
3.14.2	Battery Tests	3-38
3.14.3	External Modulation	3-39
3.14.4	Ramp Generation	3-40
3.14.5	Power Semiconductor Testing	3-41

## SECTION 4—IEEE BUS OPERATION

4.1	Introduction	4-1
4.1.1	Software Considerations	4-1
4.1.2	Interface BASIC Programming Statements	4-1
4.1.3	Interface Function Codes	4-2
4.1.4	Model 228 Interface Commands	4-3
4.2	IEEE-488 Bus Lines	4-4
4.2.1	Bus Management Lines	4-4
4.2.2	Handshake Lines	4-5
4.2.3	Data Lines	4-5
4.3	System Set Up Procedure	4-5
4.4	Bus Commands	4-6
4.4.1	Uniline Commands	4-7
4.4.2	Universal Commands	4-7
4.4.3	Addressed Commands	4-8
4.5	Device-Dependent Commands	4-10
4.5.1	Display Mode (D)	4-14
4.5.2	Memory Control (P)	4-16
4.5.3	Prefix (G)	4-17
4.5.4	SRQ Request Mode (M)	4-19
4.5.5	Trigger Modes	4-21
4.5.6	Programmable Terminator (Y)	4-21
4.5.7	Inputs (I, V, W and B)	4-22
4.5.8	Function (F)	4-24
4.5.9	Range (R)	4-24
4.5.10	External Modulation (A, C)	4-26
4.5.11	Sink Mode (S)	4-26
4.5.12	Status Word (U)	4-26
4.5.13	Self Test (J)	4-28
4.5.14	EOI and Bus Hold-Off Modes (K)	4-28
4.6	Front Panel Error Messages	4-29
4.6.1	IDDC Error	4-30
4.6.2	IDDCO Error	4-30
4.6.3	No Remote Error	4-30
4.7	Response Times	4-31

## SECTION 5—PERFORMANCE VERIFICATION

5.1	Introduction	5-1
5.2	Environmental Conditions	5-1

5.3	Recommended Test Equipment . . . . .	5-1
5.4	Initial Conditions . . . . .	5-1
5.5	Performance Verification Procedure . . . . .	5-1
5.5.1	Voltage Mode Verification (1V, 10V and 100V) . . . . .	5-1
5.5.2	Output Current Verification . . . . .	5-2

## SECTION 6—THEORY OF OPERATION

6.1	Introduction . . . . .	6-1
6.2	Power Supply . . . . .	6-1
6.2.1	Linear Power Supply . . . . .	6-1
6.2.2	Switching Power Supply . . . . .	6-2
6.3	Analog Control . . . . .	6-2
6.4	Digital Board . . . . .	6-6
6.5	Display Board . . . . .	6-6

## SECTION 7—MAINTENANCE

7.1	Introduction . . . . .	7-1
7.2	Fuse Replacement . . . . .	7-1
7.3	Line Voltage Selection . . . . .	7-1
7.4	Disassembly . . . . .	7-2
7.4.1	Removing the Top and Bottom Covers . . . . .	7-2
7.4.2	Remove the Rear Panel . . . . .	7-3
7.4.3	Digital Board, Mother Board and Power Supply Board Access . . . . .	7-3
7.4.4	Heat Sink Assembly and Fan Access . . . . .	7-3
7.5	Troubleshooting . . . . .	7-10
7.5.1	Recommended Test Equipment . . . . .	7-10
7.5.2	Digital Self Test . . . . .	7-10
7.5.3	Troubleshooting . . . . .	7-10
7.6	Calibration . . . . .	7-13
7.6.1	Recommended Test Equipment . . . . .	7-13
7.6.2	Environmental Conditions . . . . .	7-13
7.6.3	Warm Up . . . . .	7-13
7.6.4	Top Cover Removal . . . . .	7-13
7.6.5	+15V Supply Adjustment . . . . .	7-14
7.6.6	Test Setup . . . . .	7-14
7.6.7	+1V Reference Adjustment . . . . .	7-14
7.6.8	Current Calibration . . . . .	7-14
7.7	Special Handling of Static Sensitive Devices . . . . .	7-15

## SECTION 8—REPLACEABLE PARTS

8.1	Introduction . . . . .	8-1
8.2	Replaceable Parts . . . . .	8-1
8.3	Ordering Information . . . . .	8-1
8.4	Factory Service . . . . .	8-1
8.5	Schematic Diagram and Component Location Drawings . . . . .	8-1

# LIST OF ILLUSTRATIONS

3-1	Graph of Operation .....	3-2
3-2	Model 228 Front Panel .....	3-5
3-3	Model 228 Rear Panel .....	3-5
3-4	Quick Disconnect Board .....	3-17
3-5	Quick Disconnect Board Installation .....	3-17
3-6	Graph of Operation for External Modulation .....	3-20
3-7	Load Line (Positive Line Shown) .....	3-23
3-8	Resistive Load Connections .....	3-24
3-9	Limiting Inductive Reaction Voltage .....	3-25
3-10	Inductive Load Connections .....	3-26
3-11	Capacitive Load Connections .....	3-26
3-12	Model 228 Recommended Operating Limits .....	3-26
3-13	Model 228 As An Active Load .....	3-26
3-14	Output Waveform .....	3-36
3-15	External Trigger Connections .....	3-37
3-16	Connections for Floating Operation .....	3-37
3-17	Low Resistive Measurements .....	3-38
3-18	Battery Life Test .....	3-39
3-19	Data Logging Configuration .....	3-39
3-20	Power Supply Protection Circuit .....	3-39
3-21	Connections for External Modulation .....	3-40
3-22	Typical Modulated Output .....	3-40
3-23	Ramp Generation .....	3-40
3-24	Ramp Characteristics .....	3-41
3-25	Power Transistor Test Set Up .....	3-41
3-26	Power Transistor $I_C/V_{CE}$ Curves .....	3-42
3-27	Automated Test Set Up .....	3-42
3-28	FET Test Set Up .....	3-42
3-29	FET Curves .....	3-42
3-30	Automated Test Set Up for FETs .....	3-43
4-1	Bus Structure .....	4-4
4-2	Handshake Sequence .....	4-5
4-3	Contact Assignments .....	4-6
4-4	Typical Bus Connector .....	4-6
4-5	General Format of SRQ Byte and Mask .....	4-19
4-6	Format of SRQ Byte .....	4-19
4-7	Error Status Word .....	4-27
4-8	Status Word Format .....	4-27
4-9	IEEE Display Error Message .....	4-29
5-1	Output Voltage Configuration .....	5-2
5-2	Output Current Configuration .....	5-2
6-1	Model 228 Block Diagram .....	6-1
6-2	Analog Control .....	6-3
6-3	Voltage Sensing .....	6-3
6-4	Current Sensing .....	6-4
6-5	Output Amplifier .....	6-4
6-6	A/D Converter .....	6-5
6-7	Display and Keyboard .....	6-5

7-1	Top and Bottom Cover Removal .....	7-4
7-2A	Rear Panel Removal .....	7-5
7-2B	Wiring Input .....	7-6
7-3	Model 228 Exploded View .....	7-7
7-4	Detail of Connectors .....	7-9
7-5	Heat Sink Assembly (Exploded View) .....	7-11
7-6	Calibration Setup .....	7-17
8-1	Mother Board, Component Location Drawing, Dwg. No. 228-100 .....	8-6
8-2	Mother Board, Schematic Diagram, Dwg. No. 228-106 .....	8-7
8-3	Display Board, Component Location Drawing, Dwg. No. 228-110 .....	8-15
8-4	Display Board, Schematic Diagram, Dwg. No. 228-116 .....	8-17
8-5	Power Supply Board, Component Location Drawing, Dwg. No. 228-150 .....	8-22
8-6	Power Supply Board, Schematic Drawing, Dwg. No. 228-156 .....	8-23
8-7	Digital Board, Component Location Drawing, Dwg. No. 228-140 .....	8-27
8-8	Digital Board, Schematic Drawing, Dwg. No. 228-146 .....	8-29

# LIST OF TABLES

3-1	Line Voltage Setting .....	3-1
3-2	Front Panel Controls .....	3-3
3-3	Rear Panel Description .....	3-4
3-4	Front Panel Messages .....	3-8
3-5	Front Panel Messages and Prompts .....	3-8
3-6	Error Messages (Either Display)* .....	3-8
3-7	Power Up Default Conditions .....	3-10
3-8	Summary of Front Panel Programs .....	3-18
3-9	Maximum Inductive Reaction Voltage .....	3-26
4-1	HP-85 and IBM BASIC Statements .....	4-2
4-2	Model 228 Interface Function Codes .....	4-3
4-3	IEEE Command Groups .....	4-3
4-4	IEEE Contact Designations .....	4-6
4-5	DCL and SDC Default Conditions .....	4-8
4-6	Device-Dependent Commands .....	4-11
4-7	Device-Dependent Commands Not Available to the Front Panel .....	4-13
4-8	Hierarchy of Command Execution .....	4-14
4-9	SRQ Mask Commands .....	4-19
4-10	Input Command Summary .....	4-22
4-11	Range Commands .....	4-24
4-12	Hold OFF Times .....	4-29
4-13	Response Times .....	4-31
4-14	Response Times (Other Control Changes) .....	4-31
5-1	Recommended Test Equipment .....	5-1
5-2	Output Voltage Verification .....	5-2
5-3	Output Current Verification .....	5-2
7-1	Fuse Replacement .....	7-1
7-2	Low Voltage Operation, Part Changes .....	7-2
7-3	Line Voltage Selection .....	7-2
7-4	Recommended Test Equipment .....	7-10
7-5	Power Supply Checks .....	7-11
7-6	Analog Circuitry Checks .....	7-11
7-7	Digital Circuitry Checks .....	7-12
7-8	Display Board Checks .....	7-13
7-9	Recommended Calibration Equipment .....	7-13
7-10	Model 228 Static Sensitive Devices .....	7-15
8-1	Mother Board Parts List .....	8-2
8-2	Display Board Parts List .....	8-13
8-3	Power Supply Parts List .....	8-19
8-4	Digital Board Parts List .....	8-25
8-5	Mechanical Parts List .....	8-31



# SECTION 1

## GENERAL INFORMATION

### 1.1 INTRODUCTION

The Model 228 Voltage/Current Source is both a constant voltage and constant current source with front panel and IEEE operation. The Model 228 can be used as a constant voltage source or a constant current source. It has four quadrant operation. This means that the voltage or current sources can operate as a source or a sink in either positive or negative polarities. Full power capability of 100W may be obtained in any quadrant.

Parameter entry is done in one of two ways. Either using the data keypad to enter the desired value into the display or using the display modify function. The display modify function allows the user to modify either display by selecting a digit of the display and incrementing or decrementing that digit with the appropriate keys. With the carry, borrow and autorepeat capability, front panel operation is flexible and easy to program. The user selects the range with the decimal point.

The Model 228 has a 100 point data memory that allows the user to store up to 100 unique values of current, voltage and dwell time for future use. Once a particular level is stored in the data memory, the user need not reprogram that level.

The output terminals are located on a quick disconnect board that inserts into the rear panel of the mainframe. The output is disconnected from the quick disconnect board when it is removed from the mainframe.

### 1.2 FEATURES

The Model 228 includes the following features:

- Six ranges that allow a wide variety of voltage/current values.
- Seven front panel programs. The programs include:
  - Program 1 Copy for duplicating memory location information.
  - Program 2 Sink for sink only operation.
  - Program 3 IEEE for changing IEEE primary address.
  - Program 4 MOD V for modulating output voltage.
  - Program 5 MOD I for modulating output current.
  - Program 6 Test for Model 228 self test.
  - Program 9 Reset for resetting the Model 228 to factory set values. See paragraph 3.13.7

- Dual displays for easy reference of the instrument's status. The left display has two display modes (voltage and memory step). The right display also has two display modes (amps and seconds).
- Two methods of modifying the source or sink value: Data entry from the data keypad, and increment or decrement of displayed value using the decade keys.
- 100 point data memory to store up to 100 unique values of voltage, current and dwell time. Each location also includes: sink mode status and voltage current modulation status. All information stored in a memory location is battery backed up. This means that if the instrument is powered down, the stored information (voltage, current and dwell time parameters) remains in a particular location until changed by the user.
- OPERATE/STANDBY switch that places the output in either the operate mode (displayed value is present at output) or in the standby mode (output is programmed to approximately zero).
- Compliance status is easy to read on the front panel compliance graph. The graph shows the user at a glance how the Model 228 is operating (source or sink polarity and voltage or current compliance).
- IEEE-488 bus operation is standard. This enables the Model 228 to be incorporated into a system that uses programmed control over the IEEE-488 bus.
- Single step, single cycle and continuous memory modes control the sequence between data points in the 100 point data memory. The program mode may be controlled in one of three ways; using the front panel START/STOP key, the external trigger pulse or by commands over the IEEE-488 bus.
- Output terminals are located on the quick disconnect board for optimum safety. The output terminals, the sense terminals, current monitor terminals and the external modulation terminals are also located on the quick disconnect board. Several quick disconnect boards may be wired with their own unique wiring configuration. When one configuration is required, simply insert into the mainframe. In this way, cumbersome rewiring of one board is avoided.
- Remote and Local Sensing. This allows the user to sense at the output terminals or at the load or source. Remote sensing compensates for the effects of the I•R lead drop by maintaining regulation at the load instead of at the output terminals of the Model 228.
- Four Quadrant Operation. This means that the voltage or current outputs can operate as a source or a load in either positive or negative polarities. The front panel compliance graph shows the user where the Model 228 is operating (source or sink).

- Output Modulation. This feature allows the output signal to be modulated from an external AC signal source. Voltage or current may be modulated.
- Bipolar Output. This means that the polarity of the output may be reversed by using front panel controls instead of reversing the wires.
- Most of the front panel keys autorepeat if held in.

### 1.3 USING THE INSTRUCTION MANUAL

This manual contains information necessary for operating, programming and servicing the Model 228 Voltage/Current Source and is divided into the following sections:

1. Section 2 contains safety instructions and a general operating procedure.
2. Section 3 contains front and rear panel descriptions, a general operating procedure and specific operating examples showing how to use the Model 228.
3. Section 4 contains information pertaining to the IEEE-488 bus, including primary address selection, device-dependent command programming, bus connection and several sample programs.
4. Section 5 includes a procedure to verify the performance of the Model 228.
5. Section 6 contains theory of operation with detailed schematics and block diagrams. This section facilitates understanding of the individual circuits of the Model 228.
6. Section 7 contains servicing information for the Model 228. Calibration, troubleshooting, line voltage selection, fuse replacement and static sensitive device information is contained in this section.
7. Section 8 gives replaceable parts information.

### 1.4 WARRANTY INFORMATION

Warranty information may be found inside the front cover of this manual. Should it become necessary to exercise the warranty, contact your nearest Keithley representative or the factory to determine the course of action. Keithley Instruments maintains service facilities in the United States, United Kingdom and throughout Europe. Addresses of these facilities may be found inside the front cover of this manual. Information concerning the application, operation or service of your instrument may be directed to the application engineer at any of these locations.

### 1.5 MANUAL ADDENDA

Information concerning improvements or changes to the instrument which occur after the printing of this manual may be found on an addendum sheet included with this manual. Be sure to review these changes before attempting to operate the instrument.

If an additional manual is required, order the manual package (Keithley Part Number 228-901-00). The manual package includes an instruction manual and all pertinent addenda.

### 1.6 SAFETY SYMBOLS AND TERMS

The following safety symbols and terms are used in this manual or found on the Model 228:

The symbol  on the instrument indicates that the user should refer to the operating instructions in this manual.

The symbol  on the instrument indicates that a lethal potential may be present at the output terminals. Standard safety practices should be observed when such potentials are encountered.

The **WARNING** heading used in this manual explains dangers that could result in personal injury or death.

The **CAUTION** heading used in this manual explains hazards that could damage the instrument.

### 1.7 SPECIFICATIONS

Detailed Model 228 specifications may be found immediately preceding this section of the manual.

### 1.8 UNPACKING AND INSPECTION

The Model 228 Voltage/Current Source was carefully inspected, both electrically and mechanically before shipment. Upon receiving the Model 228, carefully unpack all items from the shipping containers and check for any obvious signs for physical damage that may have occurred during ship-

ment. Report any damage to the shipping agent immediately. Retain the original packing materials in case reshipment becomes necessary. The following items are included with every Model 228 order:

Model 228 Voltage/Current Source

Model 228 Instruction Manual, Reference and Program Instructions and the Instruction Label.

Quick Disconnect Board

Additional accessories as ordered.

## 1.9 ACCESSORIES

**Model 2286 Quick Disconnect Board** — The quick disconnect board contains output, sense, external modulation and current monitor terminals. The quick disconnect board inserts into the rear panel of the Model 228 mainframe. When the board is in place, the terminals are connected to the actual potentials (if in the operate mode). Removing the board from the mainframe disconnects the terminals from the output. This is a safety feature designed so the user should not have to come into contact with a dangerous potential.

With all of the terminals on the board, many configurations could be wired. To avoid cumbersome and time consuming rewiring for each configuration, several quick disconnect boards could be wired for each unique configuration. One quick disconnect board is supplied with each Model 228.

**Model 2288 Fixed Rack Mount**— The Model 2288 is a fixed or stationary rack mounting kit that mounts the Model 228 in a standard 19 inch rack.

**Model 2289 Slide Rack Mount**— The Model 2289 is a sliding rack mount kit. It enables one Model 228 to be rack mounted with the added feature of sliding the instrument for fast access.

**Model 7008-3**—The Model 7008-3 is a 1 meter (3 feet) IEEE-488 cable. The cable has 24 stranded wire conductors and is terminated on each end with standard IEEE-488 connectors.

**Model 7008-6**—The Model 7008-6 is a 2 meter (6 feet) IEEE-488 cable. The cable has 24 stranded wire conductors and is terminated on each end with standard IEEE-488 connectors.



# SECTION 2

## SAFETY AND GENERAL OPERATION

### 2.1 SAFETY PRECAUTIONS

Safety information such as warnings and cautions are located throughout this manual. The information is placed in the appropriate places in the manual where a hazard may exist. The warnings refer to a potentially dangerous situation where personal injury or even death may occur. The cautions refer to a potentially hazardous situation where the instrument may be damaged. Take the time to read and most of all understand these warnings and cautions.

The following safety information is provided as a general safety practice before, during and after operation of the Model 228.

1. Do not operate the instrument with the top cover and/or bottom cover removed. Lethal potentials are present throughout the mainframe. The covers must also be in place to allow proper air flow through the instrument. Proper air flow is required to cool the instrument during operation. If proper cooling is impeded the instrument may overheat.
2. Never assume the output is at a safe potential while the AC line is connected.
3. The Model 228 is capable of producing several times its current rating for short periods of time (msec). Keep this in mind when choosing a load. Brief bursts of high current are still enough to damage other instrumentation and cause serious injury.
4. Using the Model 228 to sink power from an external source requires some precautions that are outlined as follows:
  - A. A temporary loss of line voltage resets the Model 228 output to a high impedance state. Therefore, a user supplied voltage limiting circuit may be required to control the external source. A zener diode placed across the output is recommended.
  - B. When the voltage polarity of an external source opposes the programmed polarity of the Model 228, voltage has priority.

where:

$$V_S = \text{Source Voltage (} V_{\text{SOURCE}} \text{)}$$

$$I_S = \text{Source Current (} I_{\text{SOURCE}} \text{)}$$

$$R_L = \text{Load Resistance}$$

when:

$$\frac{V_S + V_{228}}{R_L} \text{ is greater than the current setting of the Model 228.}$$

The standby mode programs the Model 228 for approximately 0.0V, 0.0A.

$$\frac{V_S + V_{228}}{R_L} = \frac{V_S + 0}{R_L} \text{ is greater than zero.}$$

Therefore,  $I_S = V_S/R_L$  up to the limits of the output fuse. The output fuse is factory rated at 20A. In some circuit applications it may be necessary to limit the current with a resistor or select a lower rated output fuse. The output fuse must have a minimum voltage rating of 250V.

- C. When the voltage polarity of an external source matches the programmed polarity of the Model 228, current has priority.

when:

$$V_S - I_S R_L \text{ is greater than the voltage setting of Model 228.}$$

5. Before operation, ground the instrument through a properly earth grounded receptacle. Failure to ground the instrument may result in severe injury or even death in the event of a short circuit or malfunction.
6. After extensive use of the Model 228, set the instrument to standby and allow it to cool down for a few minutes before turning off the power to the instrument.
7. Never come into contact with the output connections while the instrument is turned on.
8. Observe proper polarity when operating in the sink mode. A reversed polarity may allow the instrument to operate at a current limit of the output fuse.
9. Use cables for the output that have appropriate current and insulation rating. For example, if 10V at 10A is to be produced or dissipated then the cables must be rated for that amount. Also, use insulated lugs for connections on the quick disconnect board.
10. Do not leave the instrument unattended when it is in the operate mode. Always place the instrument in standby after the measurement or test is completed.
11. Always set up the test circuit while the power is turned off. Do not come into contact with any part of the test circuit while power is on.

### 2.2 GENERAL OPERATING PROCEDURE

This is a general operating procedure to familiarize the user with front panel operation of the Model 228. There are several operating parameters involved with Model 228 operation. These parameters are taken into account in this procedure. Of course, every detail of Model 228 operation is not

covered in the general procedure. Section 3 includes several specific examples of Model 228 operation.

**NOTE**

Most of the front panel keys auto-repeat if held in. Refer to the operation notes at the end of this procedure.

1. Turn on the Model 228 and allow 10 minutes for warm up.

**NOTE**

To achieve rated accuracy, run Program 6 immediately after the 10-minute warm-up period.

2. Select the desired memory location. There are two methods for selecting memory locations. This procedure covers both methods.

**NOTE**

The unit powers up to memory location 1. This need not be changed if memory control is not being used.

Method 1: Select Memory Location

- A. Press the VOLTS/MEMORY STEP key if not in the memory step display. The present memory location is displayed on the left display.
- B. Press the SELECT key to select the display to be modified (left or right). The selected display is indicated by the flashing bright digit.
- C. Press the left or right key (indicated by the left and right arrows) to select the digit that is to be modified. The selected digit is indicated by the flashing bright digit.
- D. Press the increment or decrement keys (indicated by the up and down arrows) to modify the selected digit for the desired memory location.

Method 2: Select Memory Location

- A. Press the VOLTS/MEMORY key to select MEMORY STEP. The present memory location is displayed on the left display.
  - B. Press the SELECT key to select the left display. The selected display is indicated by the flashing bright digit.
  - C. Enter the desired memory location number using the DATA keys.
  - D. Press ENTER.
3. Program the desired source. There are two methods for programming the source. The source may be voltage or current.

Method 1: Program the Source

- A. Press either the VOLTS/MEMORY STEP key to display the source voltage on the left display, or the AMPS/DWELL TIME key to display the source current on the right display.
- B. Press the SELECT key to select the display to be modified. The left display is for voltage and the right

display is for current. The selected display is indicated by the flashing bright digit.

- C. Press the left or right key to select which digit is to be modified. The selected digit is indicated by the flashing bright digit.
- D. Press the increment or decrement key to modify the selected digit and source value. The output value is updated continuously along with the display when using the increment or decrement keys.

Method 2: Program the Source

- A. Press the VOLTS/MEMORY STEP key to display the source voltage, or the AMPS/DWELL TIME key to display the source current.
  - B. Press the SELECT key to select the left display; the left display for voltage or the right display for current. The selected display is indicated by the flashing bright digit.
  - C. Enter the desired source value on the display using the DATA key.
  - D. Press ENTER.
4. Program the desired dwell time. This may be done by one of two methods.

Method 1: Program Dwell Time

- A. Press the AMPS/DWELL TIME key if dwell time is not displayed. The present dwell time is displayed on the right display.
- B. Press the SELECT key to select the left display. The selected display is indicated by the flashing bright digit.
- C. Press the left or right key to select the digit to be modified. The selected digit is indicated by the flashing bright digit.
- D. Press the increment or decrement key (indicated by the up and down arrows) to modify the selected digit and dwell time. The value is updated continuously along with the display when using the increment or decrement keys.

Method 2: Program Dwell Time

- A. Press the AMPS/DWELL TIME key if not in the dwell time mode. The present dwell time is displayed on the right display.
  - B. Press the SELECT key to select the left display. The selected digit is indicated by the flashing bright digit.
  - C. Enter the desired dwell time using the DATA keys.
  - D. Press ENTER.
5. Select the desired memory control mode (single step, single cycle or continuous).
  6. Connect appropriate load.
  7. Select remote or local sensing (rear panel switch).
  8. Program the instrument to the operate mode by pressing the OPERATE/STANDBY key.
  9. If applicable, press the START/STOP key to start the selected memory control mode.

## Notes

- Using the increment or decrement keys to either exceed the maximum value for that range or change sign, briefly displays an error message and the last key pressed is ignored. Refer to Tables 3-4, 3-5 and 3-6 for front panel messages.
- Using the increment and decrement keys to adjust the most significant digit does not change the range. The range error message is displayed for about one second and the instrument remains at the previous setting.
- During the edit mode, if no activity has happened on the front panel for approximately 20 seconds or if the ENTER key is pressed, the edit mode is cancelled and the display returns to normal intensity.
- For the current function the output load must be, in general, non-inductive. A small amount of inductance in the load can be tolerated if the inductive reactive voltage  $L \frac{di}{dt}$  is limited to the maximum compliance voltage of the range. Table 3-9 lists the maximum inductive reaction voltage for each current range. Refer to paragraph 3.12.3
- Operation of the Model 228 as a power sink produces heat. The Model 228 employs a fan for forced air cooling. Do not block the airflow of the fan. The instrument may overheat and go into the thermal shut down mode.
- When using the DATA keypad to modify the displayed data, the actual value is not entered until the ENTER button is pressed.
- In the operate mode (OPERATE LED on), the actual voltage and current are monitored and displayed. For example, if 5V, 5A are programmed and the load is drawing 2.3A, then 5V, 2.3A is displayed.
- All of the front panel keys (except PROGRAM, CANCEL, OPERATE and LOCAL) autorepeat if held in.
- In the immediate mode (which uses DECADE keys and output is updated along with the display), the ENTER key need not be pressed. After approximately 20 seconds the Model 228 cancels the edit mode and returns to the previous operating mode. The new data remains.
- The STANDBY LED is of amber color to distinguish it from the OPERATE LED which is red.
- If the internal operating temperature reaches over 100°C, the Model 228 displays an error message as shown in Tables 3-4, 3-5 and 3-6. At this point the instrument locks up and displays the error message. The Model 228 must be turned off and allowed to cool down before continuing operation.
- The Model 228 when first turned on, goes through a power up sequence that is described in Section 3.
- The Model 228 has a bipolar output. This means that the polarity of the output may be reversed without having to reverse the output leads.
- All of the information programmed into the memory locations is battery backed up. This means that if the instrument is powered down, the information programmed in the memory locations is not lost. The information remains in the memory location until changed by the user.
- Tables 3-4, 3-5 and 3-6 contain a complete list of front panel messages and their definition. Included are error and instrument status messages.
- The user selects the range with the absolute location of the decimal point. 1.000V selects the 1V range, 1V output. 1.00V selects the 10V range, 1V output. 001.V selects the 100V range, 1V output.
- Increment and decrement keys do not change the range or polarity. These functions increase/decrease the magnitude of both positive and negative limits.
- After power on, the current range select relays remain open until the operate key is pressed the first time. This effectively open-circuits the output and may cause transients on the output during auto cal and the first time operate is selected.

### CAUTION

**The MONITOR and MODULATION terminals remain connected to the Model 228's internal circuitry; therefore, large voltages or currents may exist between OUT+ and these terminals during calibration.**

- While in the standby mode, the output remains programmed the same as when first programmed to standby. Therefore range changes, source/sink status, (etc.) take affect when operate is selected.
- The front panel compliance graph may show multiple LEDs. As an example; when current is zero, +0 and -0 are approximately the same magnitude so two LEDs will show.
- If the measured output current exceeds 200% of range, the output is disconnected and the Model 228 is placed in the standby mode. Normal operation returns by pressing the OPERATE key.

## 2.3 GENERAL OPERATION NOTES

- Using the increment or decrement keys to either exceed the maximum value for that range or change sign, causes the Model 228 to briefly display an error message. The last key pressed is ignored. Refer to Tables 3-4, 3-5 and 3-6 for front panel messages.
- Using the increment or decrement key to adjust the most significant digit does not change the range. The range error message is displayed for about one second; and the instrument remains at the maximum display for that range or zero, whichever is programmed.
- During the edit mode, if no activity has happened on the front panel for approximately 20 seconds, or if the ENTER key is pressed, the edit mode is cancelled. The display returns to normal intensity.
- For the current function, the output load must be, in general non-inductive. A small amount of inductance in the load can be tolerated if the inductive reactive voltage,

$L \frac{di}{dt}$ , is limited to the maximum compliance voltage of the range. Table 3-4 lists the maximum inductive reaction voltage for each current range.

5. Operation of the Model 228 as a power sink produces heat. The Model 228 employs a fan for forced air cooling. Do not block the airflow of the fan. The instrument may overheat and go into the thermal lock up mode.
6. When using the DATA keypad to modify the displayed data, the actual value is not entered until the ENTER button is pressed.
7. In the operate mode (OPERATE LED on), the actual voltage and current are monitored and can be displayed. For example, if 5V, 5A are programmed and the load is drawing 2.3A, then 5V, 2.3A is displayed.
8. All of the front panel keys (except PROGRAM, CANCEL, OPERATE and LOCAL) autorepeat if held in.
9. In the immediate mode (using DECADE keys and the output is updated along with the display) the ENTER key need not be pressed. After approximately 20 seconds, the Model 228 cancels the edit mode and returns to the previous operating mode. The new data remains.
10. The STANDBY LED is of amber color to distinguish it from the OPERATE LED which is red.
11. If the internal operating temperature reaches over 100°C, the Model 228 displays an error message as shown in Table 3-4. At this point, the instrument locks up with the error message displayed. The Model 228 must be turned off and allowed to cool down before continuing operation.
12. The Model 228 goes through an autocalibration cycle when the instrument is powered on. Refer to the maintenance section for complete details.
13. The Model 228 has a bipolar output. This means that the polarity of the output may be reversed without having to reverse the output leads.
14. All of the information programmed into the memory locations is battery backed up. This means that if the instrument is powered down, the information programmed in the memory locations is not lost. The information remains in the memory locations until changed by the user.
15. Tables 3-5, 3-6 and 3-7, contain a complete list of front panel messages and their definition. The messages include: error messages and instrument status messages.

## 2.4 STANDBY MODE NOTES

The following situations depict when the Model 228 output is electrically disconnected (via internal relays) from the instrument.

1. Power is off.
2. During the auto calibration cycle. Upon power up, until the end of the calibration cycle and during a portion of front panel Program 6.
3. Within a few line cycles for low or missing line voltage. If the microprocessor is reset, the normal power up sequence occurs. If the microprocessor is not reset, the next time the A/D is triggered (approximately six times a second) or when the output is changed.

In the standby mode the Model 228 output is still active. The standby mode has the same effect as programming the output for the following conditions:

1. 0V +four counts (on the same voltage range and same polarity).
2. 0A +four counts (on the same current range and same polarity).
3. MOD V off.
4. MOD I off.

The output is NOT disconnected. Programming the output for the new values, ranges polarity, sink mode or modulation does NOT change the output until the Model 228 is placed in the operate mode.

### Notes

1. Since the output is still active, the quick disconnect card should be removed from the mainframe BEFORE any wiring changes are to be made.
2. The Model 228 looks like a short or an open circuit to an external source. This depends on whether the voltage polarities oppose or match before the Model 228 is placed in standby. Polarity changes do not affect the output until the Model 228 is placed in the operate mode.
3. Large reactive loads are not immediately discharged by placing the Model 228 in the standby mode. This is because the 0V setting does not change the current through an inductor and the 0A setting does not change the voltage across a capacitor. In reality, capacitors and inductors discharge at approximately 0.4% of range when the Model 228 is in the standby mode.



# SECTION 3 FRONT PANEL OPERATION

## 3.1 INTRODUCTION

Information in this section concerns front panel operation of the Model 228 and is divided into four categories: operating instructions, operating examples, front panel programs and applications. Operating instructions include using the Model 228 to source or sink, voltage or current, in the positive or negative direction. Operating examples cover many aspects of Model 228 operation. The front panel programs section describes each program and gives a few examples of Model 228 uses.

## 3.2 PREPARATION FOR USE

The following steps must be performed to prepare the Model 228 for operation. These steps can be performed quickly and will ensure proper line voltage and fuse selection.

### 3.2.1 Line Voltage Selection

The Model 228 may be operated from either 105V-125V or 210V-250V, 50Hz or 60Hz power source. The instrument was shipped from the factory set for an operating voltage that is marked on the rear panel. The operating voltage of the instrument is internally selectable. Refer to Section 7 Maintenance, for information on setting the line voltage.

#### CAUTION

**Do not attempt to operate the instrument on a supply voltage outside the indicated range. Damage to the instrument may occur.**

### 3.2.2 Fuse Checks

It is important to check each of the three fuses for proper rating before applying power to the Model 228. If the line voltage was recently changed, the linear supply fuse (LINE FUSE 1) and the switching supply fuse (LINE FUSE 2) must also be changed to accommodate the new line voltage. The output fuse (OUTPUT FUSE) should also be checked for proper rating. Refer to Section 7 Maintenance, for information on proper fuse rating.

#### CAUTION

**Check all three fuses for appropriate rating. The fuse ratings are listed in Tables 7-1 and 7-2, and they are also shown on the rear panel. Incorrect rating may cause damage to the instrument in case of short circuit or malfunction.**

## 3.3 POWER UP

Plug the Model 228 into the proper power source. (see Table 3-1.) For fuse replacement of line switch (S102) setting, refer to Section 7 Maintenance.

#### WARNING

**Ground the instrument through a properly earth grounded receptacle before operating. Failure to ground the instrument may result in severe injury or death in the event of a short circuit or malfunction.**

**Table 3-1. Line Voltage Setting**

Input Voltage	Switch Setting (SW302)	Fuse 1	Fuse 2
90V – 110V*	115V	6.3A, 250V	1A, 250V
105V – 125V	115V	5A, 250V	3/4A, 250V
180V – 220V*	230V	3.15A, 250V	0.5A, 250V
210V – 250V	230V	2.5A, 250V	3/8A, 250V

\*Operation at these input voltages requires power supply modifications. Refer to the maintenance section of this manual for more information.

Turn the instrument on. The Model 228 runs through a power up sequence that is described as follows:

1. Immediately after turning on the Model 228 via the front panel POWER switch, both displays indicate the following for several seconds:

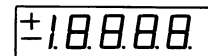
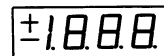

- A. This is a display test. The operator can note inoperative display segments by comparing the Model 228's display with the above figure.
- B. In addition, all LEDs are turned on for the same period of time. The LEDs include: VOLTS, MEM STEP, AMPS, SECONDS, STANDBY, OPERATE, STOP,

START, SINGLE MODULATE I, MODULATE V and SINK ONLY. All of these LEDs light simultaneously if operating properly.

- C. While the display test is running, the Model 228 is performing a digital self test on the RAM circuitry and cyclic redundancy check (CRC) on the ROM circuitry. If there is a problem, the Model 228 displays an error message. For further information, refer to Section 7 Maintenance.

If the Model 228 did not pass the RAM test the following is displayed.

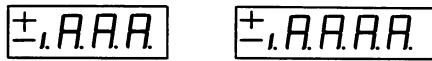

If the Model 228 did not pass the ROM test the following is displayed.



- 2. The Model 228 displays the software revision level. The following is an example of software revision A1.



- 3. Next, the Model 228 displays the present primary address. The following is an example of primary address set to 11.



### 3.4 WARM UP

In order to achieve rated accuracy, the Model 228 requires ten minutes for warm up.

#### NOTE

To achieve rated accuracy, run Program 6 immediately after the 10-minute warm-up period.

### 3.5 ENVIRONMENTAL CONDITIONS

Operate the Model 228 in an environment with an ambient temperature within the range of 0°C to 50°C, up to 35°C at 80% non-condensing relative humidity. Environmental conditions for storage are from -25°C to 70°C.

### 3.6 OPERATING INSTRUCTIONS

The following instructions show how to operate the Model 228 using the front panel controls. In order to operate the Model 228, the user must understand the front and rear panel controls. It is important to read and follow the safety precautions and warnings before operating the instrument. A brief description of the front panel controls is provided in Table 3-2. A more detailed description of the front panel controls is contained in paragraph 3.7. A brief description of the rear panel terminals and controls is provided in Table 3-3. A more detailed description of the rear panel controls is contained in paragraph 3.8. Figure 3-2 shows the front panel of the Model 228. Figure 3-3 shows the rear panel of the Model 228. A graph of operation is contained in Figure 1.

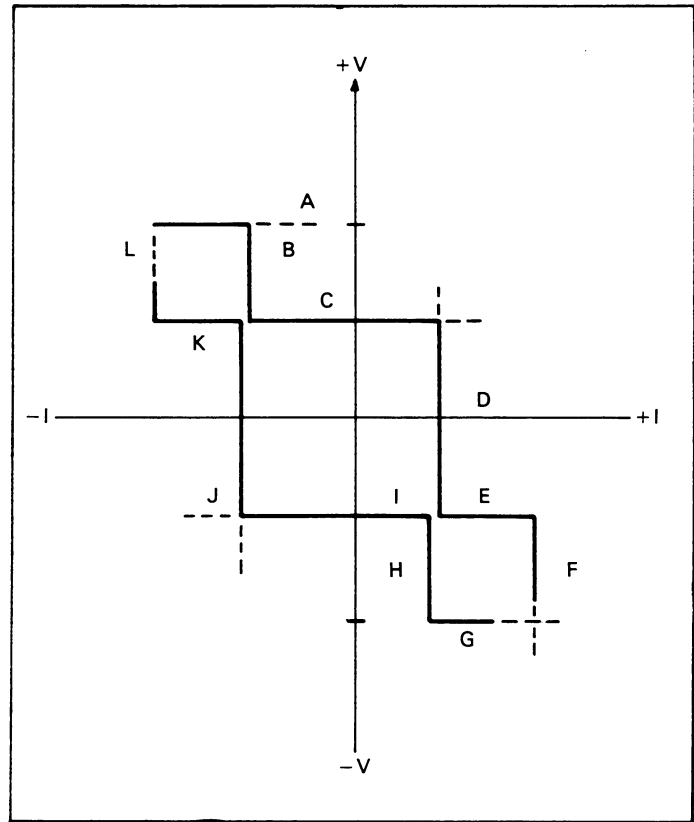

- |                                    |                                    |
|------------------------------------|------------------------------------|
| A = +115V (DESTRUCTIVE LIMIT)      | G = -115 (DESTRUCTIVE LIMIT)       |
| B = - CURRENT LIMIT (+ PROGRAMMED) | H = + CURRENT LIMIT (- PROGRAMMED) |
| C = + VOLTAGE LIMIT (+ PROGRAMMED) | I = - VOLTAGE LIMIT (- PROGRAMMED) |
| D = + CURRENT LIMIT (+ PROGRAMMED) | J = - CURRENT LIMIT (- PROGRAMMED) |
| E = - VOLTAGE LIMIT (+ PROGRAMMED) | K = + VOLTAGE LIMIT (- PROGRAMMED) |
| F = 20A FUSE                       | L = 20A FUSE                       |

Figure 3-1. Graph of Operation

**Table 3-2. Front Panel Controls**

Control	Description
POWER ON/OFF	Turns the unit on or off.
OPERATE/STANDBY	Places the output in either standby or operate. Standby programs the output terminals for 0V, 0A. Operate places the programmed value (voltage or current) on the output terminals.
VOLTS/MEMORY STEP	Places the left display (viewed from the front panel) in either the volts display mode or the memory step mode.
AMPS/DWELL TIME	Places the left display (viewed from the front panel) in either the amps display mode or the dwell time display mode.
DISPLAY MODIFY GROUP	
SELECT	Determines which display (left or right) to modify.
DECADE	The DECADE keys (left, right, up and down) modify the selected display. The left and right keys (indicated by the left and right arrows) select which digit is to be modified. The increment and decrement keys (indicated by the up and down arrows) increment or decrement the value of the selected (bright) digit and therefore the displayed value by one unit each time the key is pressed. The output tracks the increment or decrement of the displayed value.
ENTER	The ENTER key places the displayed data into the present memory location.
DATA	The DATA keys enter the desired value on the display. ENTER must be pressed to update the value to the output. The DATA keys also activate the desired front panel program. Refer to paragraph 3.11 for front panel programs.
MEMORY CONTROL GROUP	
START/STOP	The START/STOP key enables or disables the memory control functions.
SINGLE STEP	Selects the SINGLE STEP memory control function which allows the user to step through the programmed memory locations one at a time. Each successive key pressed advances the unit to the next memory location. The memory control mode must be activated in order for single step to operate.
SINGLE CYCLE	Selects the single cycle memory control function which allows the user to run through one complete cycle of the programmed memory location. The memory control mode must be activated in order for Single Cycle to operate.
CONTINUOUS	Selects the CONTINUOUS memory function which allows the user to run through the programmed memory locations continuously. The memory control mode must be activated in order for CONTINUOUS to operate.
PROGRAM CONTROL GROUP	
PROGRAM	The PROGRAM key is used as the first step in activating the front panel programs.
CANCEL	The CANCEL key has two functions. In the program mode, the CANCEL key takes the instrument out of the program mode. During entry of new data, the CANCEL key terminates editing. The instrument is then returned to the previous operating mode.
LOCAL	The LOCAL key enables front panel operation. In the remote mode (over IEEE-488 bus), pressing the LOCAL key enables front panel operation and takes the Model 228 out of the remote mode.

**Table 3-3. Rear Panel Description**

Connections/Controls	Description
OUTPUT CONNECTOR	The output connections are located on a card that is inserted into the Model 228 mainframe. When the connector is removed from the mainframe the output connections are disengaged from the actual output potentials.
SENSE	The sense connectors are located on a card that is inserted into the Model 228 mainframe. The sense lines are used to sense the output at the output connector (Local) or sense the output at the load (Remote).
CURRENT MONITOR	This connection supplies a voltage proportional to the output current for use with oscilloscopes or DMMs.
TRIGGER IN	The TRIGGER IN connector accepts a TTL level negative going pulse of greater than 10 $\mu$ sec to initiate the selected memory mode.
TRIGGER OUT	The TRIGGER OUT connector outputs a TTL level negative going pulse of greater than 10 $\mu$ sec at the end of each programmed dwell time.
EXTERNAL MODULATION	This connector allows the output (voltage or current) to be externally modulated.
FUSE 1	This is the line power fuse for the linear power supply on the analog board. The fuse is rated as shown in Tables 7-1 and 7-2. If this fuse is blown the Model 228 will not power up.
FUSE 2	This is the switching supply fuse. It is rated as shown in Tables 7-1 and 7-2. If this fuse is blown there is no output present.
FUSE 3	This is the output fuse. The fuse is rated at 20A.
IEEE-488 Connector	This connector is used to connect the instrument to the IEEE-488 bus. The IEEE interface functions are marked above the connector.
LINE RECEPTACLE	The line receptacle connects to a three wire line cord which provides connections to the line voltage.

### 3.7 FRONT PANEL DESCRIPTION

#### OPERATION GROUP

**POWER ON/OFF**—The ON/OFF switch operates on the push-push principle. Depressing this switch turns the instrument on. Once the instrument is on, pressing (releasing) this switch turns the instrument off. When the Model 228 is turned on, the output is programmed to about 0V, 0A and the programmed settings are displayed. Note that the Model 228 does not change range polarity or sink status while in the standby modes, and external modulation is disabled.

**OPERATE/STANDBY**—The OPERATE/STANDBY key is an alternate action control (toggle) which places the Model 228 in either the operate mode or the standby mode. In the operate mode, the OPERATE LED is turned on and the programmed source value is present on the output terminals. In the standby mode, the STANDBY LED is turned on the output is programmed to approximately zero and the displayed value remains the same.

In the standby mode the Model 228 is still active. The standby mode has the same effect as programming the output for the following conditions:

1. 0V +four counts (on the same voltage range and polarity).
2. 0A +four counts (on the same current range and same polarity).
3. MOD V off.
4. MOD I off.

The output is NOT disconnected. Programming the output for a new value, range polarity, sink mode or modulation, does not change the output until the Model 228 is placed in the operate mode.

#### Notes

1. Since the output is still active the quick disconnect board should be removed from the mainframe before any wiring changes are to be made.
2. The Model 228 looks like a short or an open circuit to an external source. This depends on whether the voltage polarities oppose or match before the Model 228 is placed in standby. Polarity changes do not affect the output until the Model 228 is placed in the operate mode.
3. Large reactive loads are not discharged immediately after placing the Model 228 in the standby mode. This is because the 0V setting does not change the current through an inductor and the 0A setting does not change the voltage across a capacitor. In general, capacitors and inductors discharge at approximately 0.4% of range when the Model 228 is in the standby mode.

**VOLTS/MEMORY STEP**—The VOLTS/MEMORY STEP key is an alternate action control which places the left display in either the volts display mode or the memory step mode. In the volts display mode, the voltage for the present memory location (step) is displayed on the left display. In the memory step mode, the present memory location is displayed on the left display. This key allows the user to view either the present memory location or the voltage at the present memory location. There are 100 memory locations (steps). Each memory location contains five parameters (Voltage, Current, Dwell Time, Modulation on or off and Sink Mode on or off). These parameters are defined (programmed) by the user. This means that each memory location may have its own unique values.

**AMPS/DWELL TIME**—The AMPS/DWELL TIME key is an alternate action control which places the right display in either the amps display mode or the dwell time display mode. In the amps display mode, the current for the present memory location is displayed on the right display. In the dwell time display mode, the dwell time for the present memory location is displayed on the right display. This key allows the user to view either the dwell time for the present memory location or the current for the present memory location. The dwell time ranges from 10msec to 1000sec.

#### DISPLAY MODIFY GROUP (EDIT)

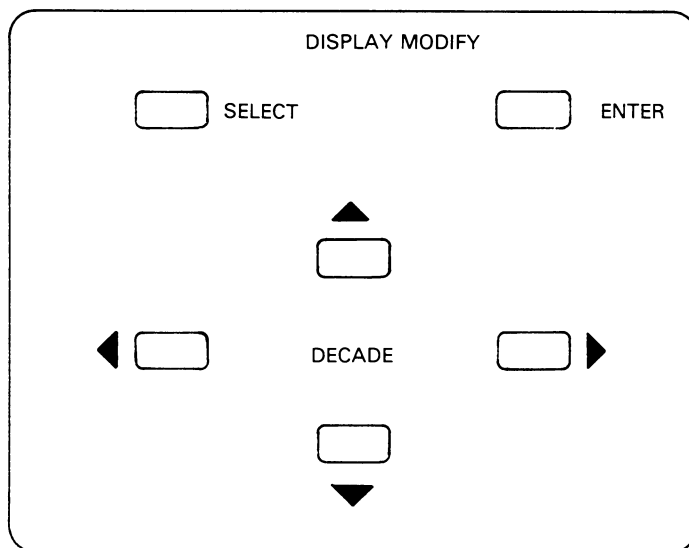

**SELECT**—The SELECT key determines which display (left or right) can be configured. Pressing the SELECT key once selects the previously selected display for modification. Subsequent key presses toggle the edit mode between displays. Use the SELECT key before modifying the volts, memory step, amps or dwell time functions.

**DECADE**—The DECADE keys (right, left, up and down) modify the selected display. The left and right keys (indicated

by left and right arrows) select which digit on the display is to be modified. These keys wrap the cursor around to the opposite end (most significant) digit if attempting to go beyond the left most or right most (least significant) digit. The modify digit is indicated by the "bright flashing" digit on the display. The left and right keys autorepeat if held in. That is, the left key when pressed and held in keeps advancing to the next digit to the left. The same is true for the right key except, of course, it advances to the right.

The increment and decrement keys (indicated by the up and down arrows) increment and decrement the modify (bright) digit and therefore the displayed value. The modify digit is modified by one unit each time the increment or decrement

key is pressed. The increment/decrement keys are autorepeating. That is, pressing and holding in the increment key increments the display continually until the range limit is reached or the key is released. The same is true for the decrement key.

The increment key has the mathematical carry capability. This means that if the modify digit is a 9, pressing the increment key once sets the modify digit to 0 and the next significant digit is increased by one. If the display is at the maximum (1010), pressing the increment key causes an error message to be displayed for approximately one second. Refer to Tables 3-4, 3-5 and 3-6 for front panel messages and Table 3-7 for the power up default conditions. The display then returns to the previous condition.

**Table 3-4. Front Panel Messages**

Message Left Display	Message Right Display	Comments
buF	Err	Bad data was copied from the memory buffers.
+5	Err	+5V analog supply is outside of a $\pm 50\%$ range.
-5	Err	-5V analog supply is outside of a $\pm 50\%$ range.
+15	Err	+15V analog supply is outside of a $\pm 50\%$ range.
-15	Err	-15V analog supply is outside of a $\pm 50\%$ range.
+115	Err	+115V analog supply is outside of a $\pm 50\%$ range.
-115	Err	-115V analog supply is outside of a $\pm 50\%$ range.
-50°	Err	Temperature sensor is not operating properly.
+90°	Err	Heat sink temperature has increased past 90°C. Turn sink mode on.
+100°	Err	Temperature exceeds 100°C. The Model 228 turns off the switching supply and locks up the front panel. Turn off power and let it cool down.
CAL	Err1	Calibration error. Autocalibration cannot be performed. Voltage DAC (Digital to Analog Converter) gain is out of cal range.
CAL	Err2	Calibration error. Auto calibration cannot be performed. Voltage DAC (Digital to Analog Converter) offset is out of cal range.
CAL	Err3	Calibration error. Auto calibration cannot be performed. Current DAC (Digital to Analog Converters) gain is out of cal range.
CAL	Err4	Calibration error. Auto calibration cannot be performed. Current DAC (Digital to Analog Converter) offset is out of cal range.
no	AdFb	No data transmits across the opto-isolators.
Ad	Err	A/D error. The A/D does not read the 1V reference and ground properly.
no	Pro	No program exists. Illegal program number attempted.
IEEE	Err	IEEE address error. An attempt to enter an illegal IEEE address was made. The range of IEEE addresses is 0-31.
buF	End	Buffer end. The end of memory locations is reached. Maximum of 100 locations.
	IddC	Illegal Device-Dependent Command
	IddCo	Illegal Device-Dependent Command Option
no	rn	No remote. The instrument was not in remote when programmed.

**Table 3-5. Front Panel Messages and Prompts**

Message Left Display	Message Right Display	Comments
IEEE	11	IEEE address. Address 11 shown. Front panel Program 3 activated or power up sequence.
rEU	A	Software revision level. Revision A shown.
Pro	?	Prompt to enter the number of the desired front panel program.
CAL	20	Calibration. The Model 228 is going through the autocalibration sequence. The Model 228 counts down from 20 to 0 during this sequence. This sequence may be bypassed by pressing the CANCEL key. However, the previous cal will be valid.
U	on	External modulate V program is on.
U	off	External modulate V program is off.
I	on	External modulate I program is on.
I	off	External modulate I program is off.
SIn	on	Sink program on.
SIn	oFF	Sink program off.
CoP	002	Copy program enabled. Contents of memory location 1 duplicated into memory location 2.

**Table 3-6. Error Messages (Either Display)\***

Message	Comments
oFL	Overflow. Attempt to output beyond the present range. Reading exceeds 1999 on any range.
rnG	Range. Attempt to program beyond the present range. Illegal range combination.
Err	Error. Exceeded 1010 limit or attempt to program below zero.

\*NOTE: These messages appear on the display where the error occurred.

**Table 3-7. Power Up Default Conditions**

Mode	Value	Status
Display	D0	Left Display = Volts, Right Display = Amps. Left Display ready for edit.
Function	F0	Standby (output programmed to +4 counts on present range)
Data Format	G0	Prefix of buffer location contents.
EOI	K0	Send EOI.
SRQ	M0	Disabled
Program Mode	P0	Single Step Mode.
Range	R0	Autorange
Trigger	T6	Stop on X
Terminator	CR LF	Carriage Return Line Feed
Buffer Location	BO01	Location #1
Voltage	V	Dependent on previously programmed values of memory location 1.
Current	I	Dependent on previously programmed values of memory location 1.
Dwell Time	W	Dependent on previously programmed values of memory location 1.
Sink Mode	S	Dependent on previously programmed values of memory location 1.
External Modulation	A	Dependent on previously programmed values of memory location 1.
	C	Dependent on previously programmed values of memory location 1.
Program 1	Copy	Disabled
Program 2	Sink	Dependent on previously programmed values of memory location 1.
Program 3	IEEE	Not affected
Program 4	Mod V	Dependent on previously programmed values of memory location 1.
Program 5	Mod I	Dependent on previously programmed values of memory location 1.
Program 6	Test	J1 if passed; in status byte J2 if failed; in status byte
Program 9	Reset	Disabled

The decrement key has the mathematical borrow capability. This means that if the modify digit is 0, pressing the decrement key sets the modify digit to 9 and the next significant digit is decreased by one unit. If the display is 0000, pressing the decrement key causes an error message to be displayed for approximately one second. The display then returns to the previous condition.

Using the increment and decrement keys to change the sign of the displayed value causes an error message to be displayed for approximately one second. The display then returns to the previous condition.

The DECADE keys operate in the immediate mode. In the immediate mode, the output value is updated as the display is

updated. For example: If 95.0V is displayed and present on the output, selecting the 5 digit and pressing the increment key increases the display to 96.0V. At the same time, the output is also changed to 96.0V.

ENTER—The ENTER key loads the displayed data into the present memory location. Pressing the ENTER key after modifying the displayed data, loads the new data into the present memory location. The display then reverts to normal intensity and the display modifying operation (edit) is terminated. The DATA keys do not affect the output until the ENTER key is pressed.



## DATA GROUP

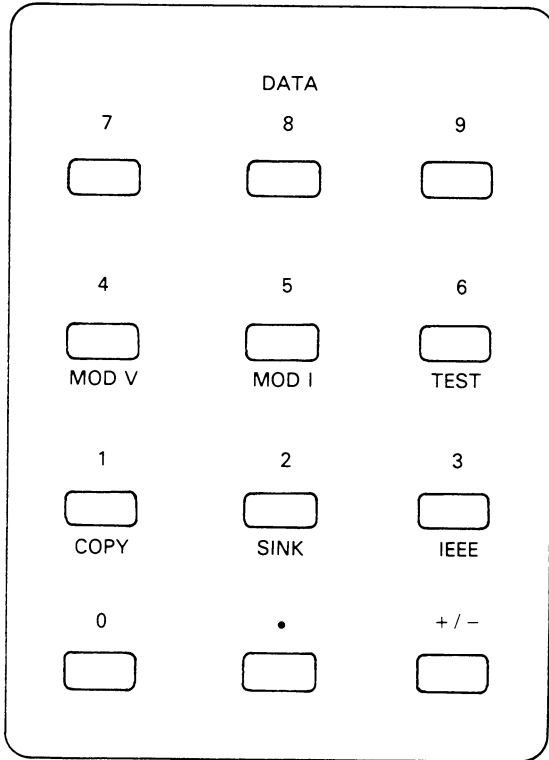

**DATA**—The DATA keys have dual functions. In the enter mode, these keys enter the desired number on the display. In the program mode, the keys activate the desired program. The front panel programs are described in paragraph 3.11. Entering data on the display using the DATA keys always start with the left most (most significant) digit on the display.

## MEMORY CONTROL GROUP

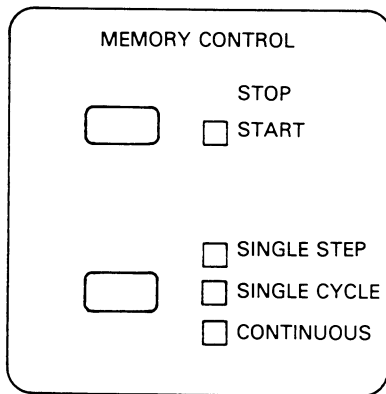

**START/STOP**—The START/STOP key serves three functions that are described as follows:

1. When the START/STOP key is pressed, the selected memory control mode (Single Step, Single Cycle or Continuous) is started.
2. Pressing the START/STOP key while the memory control mode is running stops the memory control mode at the present memory location.
3. In the single step memory control mode, pressing the START/STOP key advances the instrument to the next programmed memory location.

The START/STOP LED is turned on while the single cycle and continuous memory control mode is going through its cycle. In the single step memory control mode, the START/STOP LED is turned off for the duration of the programmed dwell time of the memory location.

When the Model 228 is in the standby mode (OPERATE LED is turned off) and either the single cycle or continuous memory control mode, the START/STOP key continues to control the buffer with no output present on output terminals. For example: The continuous mode keeps going on its cycle even though the Model 228 is in the standby mode (STANDBY LED on).

**SINGLE STEP**—In the single step mode (SINGLE STEP LED is on), the memory location is advanced by one step each time the START/STOP key is pressed or the proper external trigger pulse is received. The voltage, current and dwell time may be different for each memory location. That is, the user defines these parameters for each memory location.

At the completion of the programmed dwell time a pulse is sent out via the external trigger output connector. The START/STOP LED is turned off at this time. The pulse is a negative going TTL level pulse with a duration of greater than  $10\mu\text{sec}$ . The pulse could be used to trigger another instrument into its special function (e.g. chart recorder, DMM, etc).

Pressing the SINGLE STEP key when in the last programmed memory location and the single step mode causes the Model 228 to revert to memory location 1.

A zero dwell time for any memory location causes the Model 228 to jump to memory location 1.

**SINGLE CYCLE**—In the single cycle mode (SINGLE CYCLE LED is on), and upon actuation of the START/STOP key or upon receiving a proper external trigger pulse, the Model 228 advances to the next memory location. After the duration of the dwell time for the memory location the Model 228 advances to the next memory location. START/STOP LED is turned on. This cycle continues advancing through the programmed memory location until the last programmed location is reached or stops at last memory location before zero dwell time. Pressing the START/STOP key jumps the Model 228 to memory location 1.

The voltage, current and dwell time parameters may be different for each memory location. That is, the user defines these three parameters.

At the completion of each programmed dwell time, the Model 228 outputs a negative going TTL level pulse of greater than  $10\mu\text{sec}$  in duration. The pulse appears at the external trigger output connector on the rear panel. This pulse could be used to trigger another instrument into operation (e.g. DMM, controller, etc.)

**CONTINUOUS**—In the continuous mode (CONTINUOUS LED is on) and upon actuation of the START/STOP key or after the proper external trigger pulse is received, the Model 228 advances to the next programmed memory location. After the duration of the present memory location the Model 228 advances to the next programmed memory location and remains there for its programmed dwell time. This cycle continues until the last programmed memory location is reached or a memory location with a zero dwell time is reached. At this point the Model 228 jumps to memory location 1. The cycle then repeats and continues repeating until it is stopped.

The voltage, current and dwell time parameters may be different for each memory location. That is, the user defines these three parameters. Just like the single step and single cycle modes, in the continuous mode a negative going TTL level pulse of greater than  $10\mu\text{sec}$  appears at the external trigger output connector upon completion of each programmed dwell time. This pulse could be used to trigger another instrument into its function in the system (e.g. start measurement cycle on DMM, inform a controller that the dwell time is ended, etc.). A zero dwell time for any memory location reverts the Model 228 to memory location 1.

## ADDITIONAL TEST SEQUENCES

As previously discussed, a test sequence cycle is terminated by the first memory location that has a dwell time of 0 seconds. In the single step mode, the test sequence can be stopped at the last programmed memory location of the sequence. In the single cycle mode, the cycle always stops at the last programmed memory step location. Stopping the test sequence at the last programmed memory steps makes it possible to use other programmed test sequences.

The instrument must be in the single step or single cycle mode to use more than one test sequence. At the end of the first test sequence, (last memory step location of the sequence displayed), advance the display (using the DISPLAY MODIFY keys) to the memory step location immediately before the first programmed memory location of the next test sequence. This second test sequence will then start when the START button is pressed.

Example—The following example will illustrate how to use two test sequences:

1. Program memory locations 1 through 9 so that they have some dwell time. This represents the first test sequence.
2. Program memory location 10 for a dwell time of 0 seconds. This step will terminate the first test sequence.
3. Program memory locations 11 through 19 so that they also have some dwell time. This represents the second test sequence.
4. Place the instrument in the single cycle mode.
5. Press the START button. The instrument will cycle once through the first test sequence and stop at the last memory location of that sequence.
6. Using the DISPLAY MODIFY buttons, advance the display to memory location 10.
7. Press the START button. The instrument will cycle once through the second test sequence.

Note: If the single step mode is used on the above example, stop the cycle of the first test sequence at memory step location 9.

In the continuous mode, the instrument continually cycles from the first programmed memory step to the last programmed memory step. Since the instrument will not stop at the last programmed memory location, only one test sequence can be used in the continuous mode.

## PROGRAM GROUP

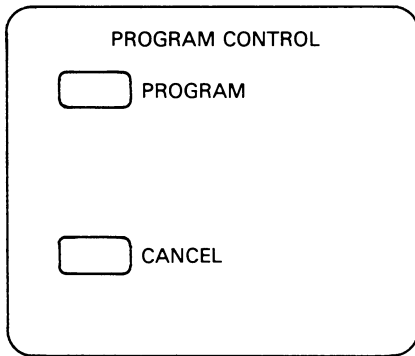

**PROGRAM**—The PROGRAM key is used as the first step in activating the front panel address.

**CANCEL**—The CANCEL key has two levels of operation and they are described as follows:

1. Pressing the CANCEL key when a front panel program is running terminates the program mode and reverts the Model 228 to the previous mode of operation.
2. Pressing the CANCEL key during the entry of data in any of the programs, reverts the new data to the previous data, terminates the program and then terminates the program mode. The instrument is then reverted to the previous mode of operation.

**COMPLIANCE Graph**—The COMPLIANCE graph indicates the state of the output. Refer to the front panel and/or following Figure. By noting the front panel COMPLIANCE graph four parameters concerning the output are known.

1. The polarity of the voltage.
2. The polarity of the current.
3. The controlling function (Voltage or Current).
4. Operation as a sink or source.

For example: If the LED just above the +I (+I<sub>SOURCE</sub>) symbol is turned on, then four parameters are known.

1. The polarity of the voltage is positive.
2. The polarity of the current is positive.
3. The controlling function is current.
4. The instrument is operating as a source.

The reason that the current is the controlling function is that the line for that LED goes through the +I axis the current is constant and the voltage is the parameter that varies. For line intersecting the voltage axis it is the voltage that is the controlling function and the current is the parameter that varies.

As another example consider that the LED just to the right of the  $-V(-V_{\text{SINK}})$  symbol is turned on. As in the previous example, four parameters are known by noting the COMPLIANCE graph.

1. The polarity of the voltage is negative
2. The polarity of the current is positive.
3. Voltage is the controlling function.
4. The instrument is operating as an active load (current sink).

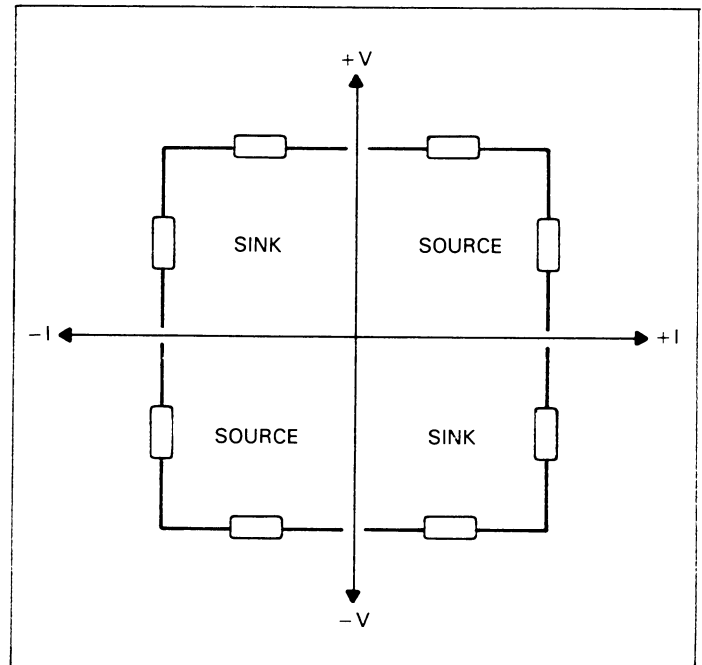

## STATUS GROUP

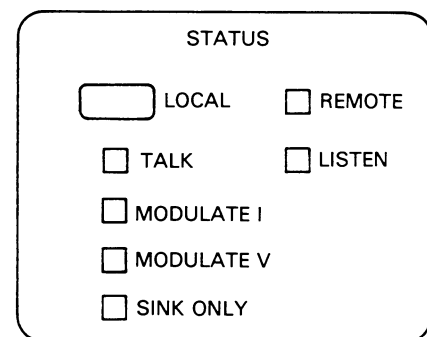

**LOCAL**—In the remote mode (IEEE-488 bus operation) of operation all front panel controls except LOCAL and POWER ON/OFF are disabled. Pressing the LOCAL key takes the Model 228 out of the remote mode and enables all of the front panel controls.

**REMOTE LED**—When the REMOTE LED is on, the Model 228 is in the remote mode of operation (IEEE-488 bus operation). When the REMOTE LED is off, the Model 228 is in the local mode of operation. Refer to Section 4 for more information concerning IEEE-488 bus operation.

**TALK LED**—When the TALK LED is on, the Model 228 is in the talk mode. Refer to Section 4 for more information concerning IEEE-bus operation.

**LISTEN LED**—When the LISTEN LED is on, the Model 228 is in the listen mode. Refer to Section 4 for more information concerning IEEE-488 bus operation.

**MODULATE I**—When the MODULATE I LED is on, external current modulation is enabled. An external AC signal can be superimposed on the output current through the external modulation connector on the rear panel. This assumes that current is the controlling function. Current is the controlling function when the Model 228 voltage (V) setting is greater than the product of the Model 228 current (I) setting and the user load.

**MODULATE V**—When the MODULATE V LED is on, the Model 228 is in the voltage modulation mode. An external AC signal up to the specified limits may be superimposed on the output voltage through the quick disconnect board on the rear panel. This assumes that voltage is the controlling function. Voltage is the controlling function when the Model 228 voltage (V) setting is less than the product of the Model 228 current (I) setting and the user load.

**SINK ONLY**—When the SINK ONLY LED is on, the Model 228 is in the sink mode of operation. Take note of the front panel COMPLIANCE graph. The COMPLIANCE graph indicates which quadrant of sink mode the Model 228 is operating.

**VOLTS/MEMORY STEP Display**—The left display (viewed from the front panel) is used exclusively for the volts and the memory step modes. The display is a 3½ digit ±1999 count LED display. The VOLTS LED and the MEMORY STEP LED are located next to the display. These LEDs indicate which mode is activated (volts or memory step).

**AMPS/DWELL TIME Display**—The right display (viewed from the front panel) is used exclusively for the amps and the dwell time modes. The display is a 3½ digit ±1999 count LED display. The AMPS LED and the DWELL TIME LED are located next to the display. These LEDs indicate which mode is activated (amps or dwell time).

### 3.8 REAR PANEL DESCRIPTION

#### OUTPUT CONNECTOR GROUP

**Output Connector**—The output connector (OUT+ and OUT- terminals) are located on the quick disconnect board. This board fits into the Model 228 mainframe. The output is disconnected when the quick disconnect board is removed from the mainframe. The output terminals are screw type terminals that accept up to #16 AWG wire. Only insulated lugs should be used to connect to the output terminals on the quick disconnect board. An example of an insulated lug is Keithley part number LU-99-2.

#### CAUTION

**Care should be taken to avoid shorting the terminals on the quick disconnect board. Instrument damage may occur.**

**Sense Terminals**—The sense terminals are located on the quick disconnect board. The sense terminals are used in the volts mode. When a load is connected to the Model 228, there is an IR lead drop between the load and the Model 228. In some situations the IR lead drop is negligible and not need be taken into consideration. This is where local sensing may be used. In other situations the IR lead drop may cause an error in the actual voltage delivered. In this case the Model 228 could be configured for remote sensing.

Remote sensing compensates for the IR lead drop by maintaining regulation at the load instead of at the output terminals of the Model 228.

When using remote sensing, the output sense +(S+) terminal must be connected to OUT+ and the output sense -(S-) terminal must be connected to OUT- at the load.

#### DISPLAYS

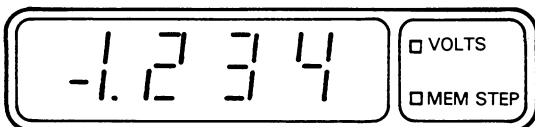

LEFT DISPLAY

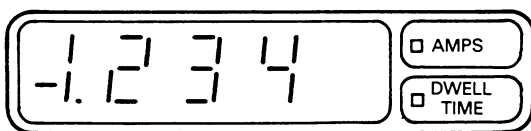

RIGHT DISPLAY

### CAUTION

Take care to connect the sense terminals to the load with the proper polarity. Improper polarity may result in damage to the instrument and the load.

Current Monitor Terminals—The Model 228 monitors the output current internally and provides a voltage proportional to the output current for the user.

### TRIGGER GROUP

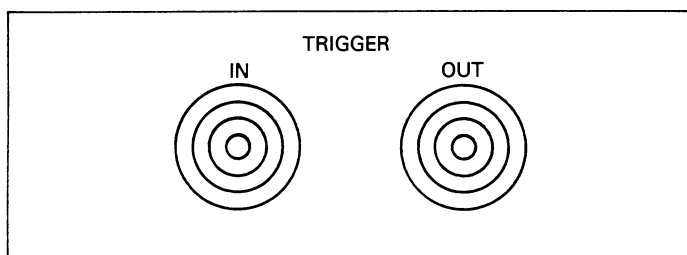

TRIGGER IN—The TRIGGER IN connector is a female BNC connector that accepts a TTL level negative going pulse of greater than  $10\mu\text{sec}$  that when received starts the selected memory control mode (Single Step, Single Cycle or Continuous). In the single step mode, one pulse is required for each memory location. In the single cycle mode, one pulse required for each cycle of the programmed memory locations. In the continuous mode, one pulse is required to start the cycle.

TRIGGER OUT—The TRIGGER OUT connector is a female BNC connector that outputs a TTL level negative going pulse of greater than  $10\mu\text{sec}$  at the end of the programmed dwell time. This pulse appears at the end of the dwell time for each programmed memory location.

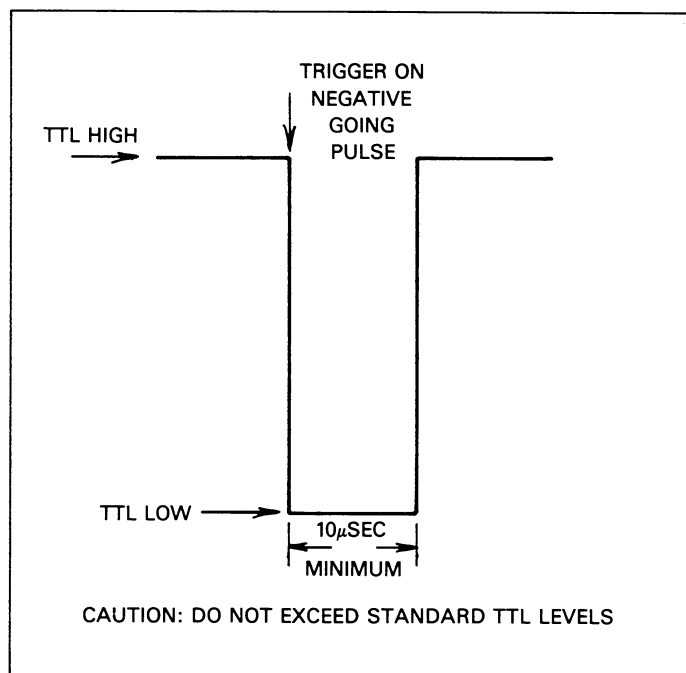

External Modulation Terminals—The external modulation terminals consists of two screw terminals that are located on the quick disconnect board. External modulation allows the user to modulate the output voltage or current. With an AC signal (up to specified limits). The limits are given in the instrument specifications that precede Section 1 and Figure 3-6. Modulation input is a voltage across a  $6.8k$  impedance. The front panel MODULATE I and MODULATE V LEDs indicate whether the output current or output voltage is being modulated.

When using the external modulation, use shielded cables. Connect the shield to output LO. This action shields any extraneous noise from being introduced into the signal.

AC LINE—The AC LINE connector mates with a three wire line cord which provides connections to line voltage. For correct line voltage setting refer to paragraph 7.3.

**WARNING**

**Ground the instrument through a properly earth grounded receptacle before operation. Failure to ground the instrument may result in severe injury or death in the event of a short circuit or malfunction.**

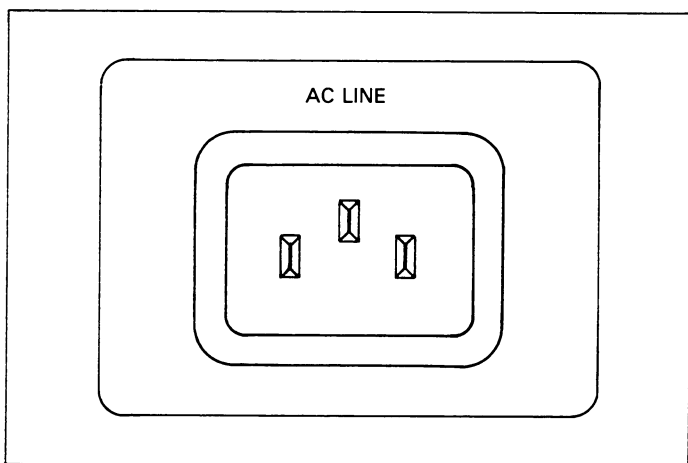

Fuses—There are three fuses that are located on the rear panel. Each fuse protects a different circuit of the Model 228.

F1—Fuse 1 is the linear power supply fuse. The fuse is a SLO-BLO fuse and is rated at 3/4A for 90V-125V operation and 3/8A for 180V-250V operation.

F2—Fuse 2 is the line power fuse for the switching power supply on the analog board. The fuse is a normal blow fuse rated at 5A for 90V-125V operation and 2.5A for 190V-250V

operation. This fuse protects the line and the Model 228 linear power supply.

F3—Fuse 3 is the output fuse. The fuse is rated at 20A, 250V, normal blow. If this fuse is blown there is no output present on the output connectors except through the sense connection.

**CAUTION**

**Do not install a fuse with a higher rating than specified. Instrument damage may occur.**

### 3.9 QUICK DISCONNECT BOARD

Instead of the more common terminals used on other sources for output connections, the Model 228 output connector, along with the sense, modulation and current monitor terminals, are located on the quick disconnect board. This board fits through the rear panel into the Model 228 mainframe. The output, sense, current monitor and external modulation cables are connected to the terminals on the board of the Model 228. The card is plugged into the appropriate slot in the rear panel. When the card is removed from the mainframe, the output, sense, current monitor and external modulation terminals are disconnected from the mainframe connections. As a result, the user should never have to come in contact with a live output. Figure 3-4 shows the quick disconnect board and the location of each terminal.

Several quick disconnect boards could be used, each with a unique configuration. In that way, when a particular configuration is required, it is simply plugged into the Model 228. Thus, redundant rewiring of just one quick disconnect board is avoided. Figure 3-5 shows how to install the quick disconnect board into the Model 228 mainframe. The Keithley part number of the quick disconnect board is Model 2286. One quick disconnect board is supplied with each Model 228.

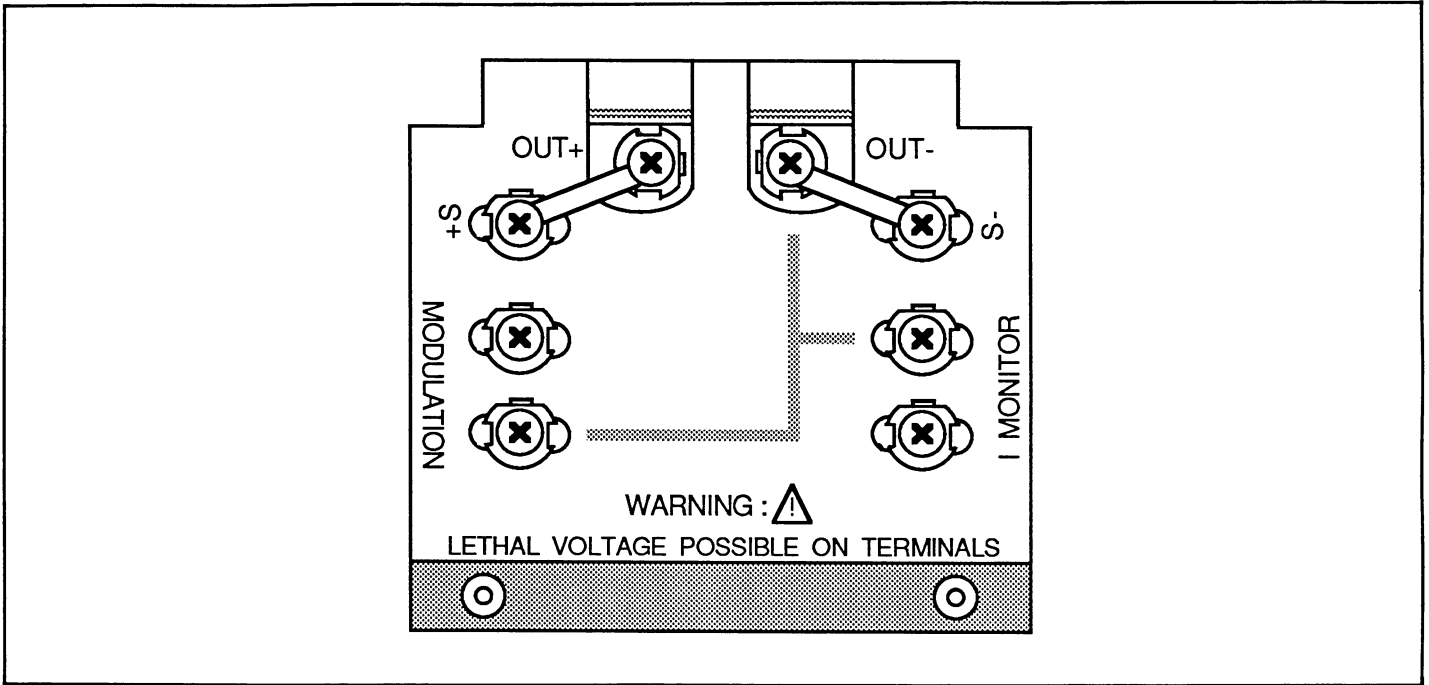

Figure 3-4. Quick Disconnect Board

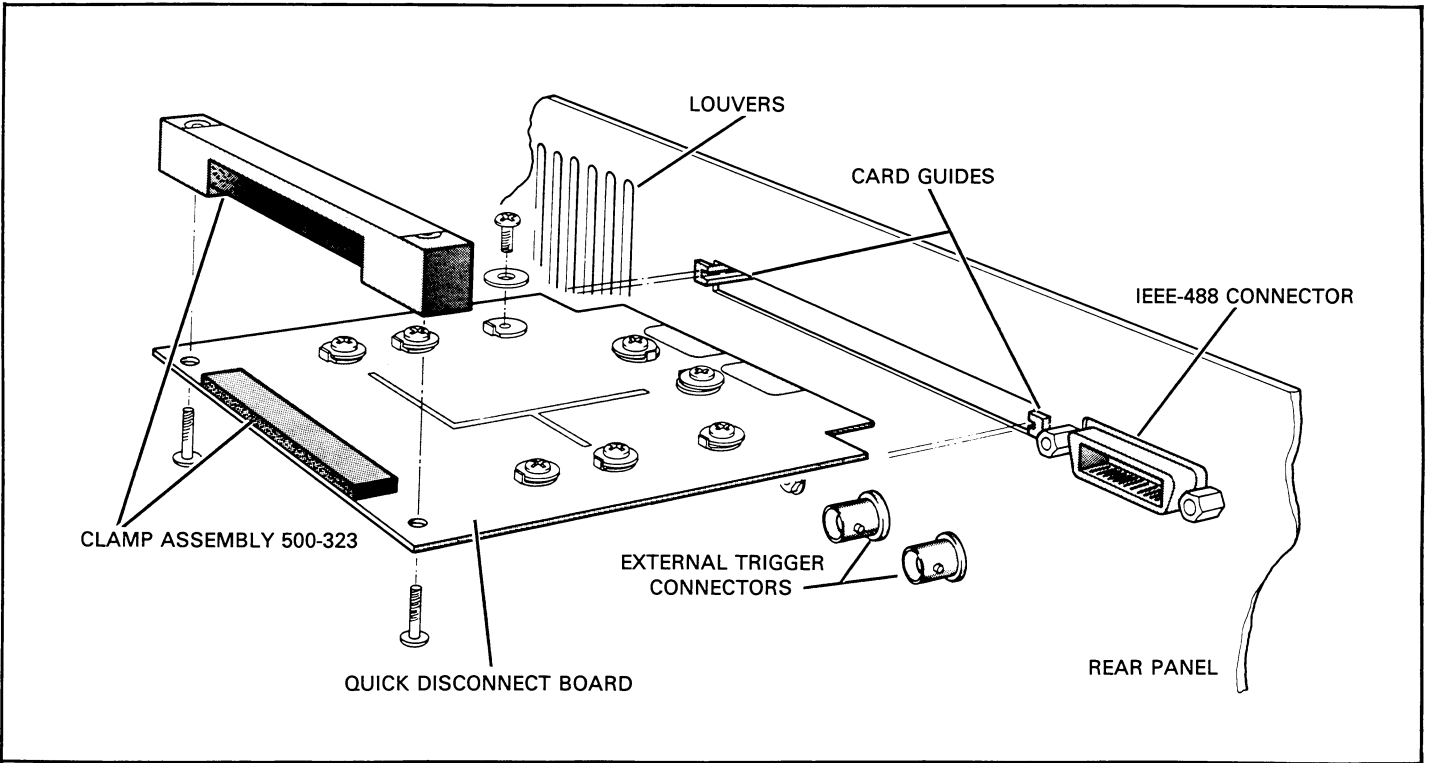

Figure 3-5. Quick Disconnect Board Installation

### 3.10 REMOTE/LOCAL SENSING

The sense (S+ and S-) terminals are located on the quick disconnect board. The sense terminals are used in the volts mode. When a load is connected to the Model 228, there is an IR lead drop between the load and the Model 228. In some situations the IR lead drop is negligible and does not need to be taken into consideration. This is where local sensing may be used.

To configure the quick disconnect board for local sensing, install the two shorting links as shown in Figure 3-4. The links connect the sense (S) terminals directly to the output (OUT) terminals. The load can then be connected to the two output (OUT) terminals.

In more sensitive applications, the IR lead drop may cause an intolerable error in the actual voltage delivered to the load. In this case, the Model 228 could be configured for remote sensing. Remote sensing compensates for the IR lead drop by maintaining regulation at the load instead of at the output terminals of the Model 228. To configure the quick disconnect board for remote sensing, remove the two shorting links. For remote sensing, connect OUT+ and S+ to the positive side of the load, and connect OUT- and S- to the negative side of the load.

#### CAUTION

**Take care to connect the sense terminals (S+ and S-) to the load with the proper polarity. Connect S+ to the positive terminal and S- to the negative terminal. Improper polarity may result in damage to the instrument.**

### 3.11 FRONT PANEL PROGRAMS

This section contains instructions necessary for operating the seven front panel programs of the Model 228. The programs are activated by pressing the PROGRAM key along with the DATA key that represents the desired program. The programs do a number of various tasks which are summarized in Table 3-8.

Program Notes:

1. Each program is entered by pressing the PROGRAM key followed by the desired program number.
2. After the PROGRAM key is pressed the Model 228 displays the following on the right display.

PRO?

As you have noticed, the question mark is flashing. This is a prompt for the user to enter the desired program number (refer to Table 3-7). After entering the program number, the Model 228 goes into the program selected.

3. Data is entered on the right display by pressing the desired number key. As each digit is entered, the cursor moves one place to the right until the last digit (least significant) is reached. Then it is wrapped around to the first digit on the left (most significant) of the display.
4. Only as many significant digits as necessary need to be entered. The Model 228 completes the constant with trailing zeroes where necessary.
5. Invalid key presses are ignored. If an invalid key is pressed, the flashing digit (cursor) remains at the present digit.
6. If an incorrect digit is entered, the complete constant must be re-entered. The new value may be entered by cycling the cursor around to the most significant digit. To do this, repeatedly press any one of the number keys.
7. If too many digits are entered Err is displayed and the program is terminated.
8. Once all the digits of the desired constant are shown on the display, the constant is entered into the program by pressing the ENTER key. This applies only to Programs 1 and 3.

**Table 3-8. Summary of Front Panel Programs**

Program	Operation
1	Copy
2	Sink
3	IEEE (Set IEEE primary address)
4	Mod V (Voltage Modulation)
5	Mod I (Current Modulation)
6	Test (Diagnostic Self Test)
9	Reset (Factory Conditions)

#### 3.11.1 Program 1 Copy

Program 1 is used to duplicate the voltage, current, dwell time data, sink only mode and modulation status of one memory location into the next memory location. This program is useful in an application when one to four of the five parameters required are constant. The variable parameter(s) is (are) the only one that needs to be changed for each memory location. For example: Plotting the IV characteristics of a diode is an example where the current could be set at a certain level and the dwell time be constant. The voltage could be programmed to increase 0.1V in each successive memory location. Program 1 could duplicate the current and dwell time data in each programmed memory location. Only the voltage would have to be changed for each programmed memory location.

#### NOTE

For this example the sink mode and modulation status are off.



In this case the voltage, current and dwell time parameters are programmed in the first memory location and Program 1 is activated. All the data is duplicated into the next memory location. The next step is to change the voltage of the programmed memory locations to the desired level. The memory control mode is selected and the START/STOP key is pressed. The Model 228 outputs the parameters in each memory location at the programmed rate (dwell time).

Using Program 1 saves many programming steps. Use the following procedure to duplicate the current and dwell time of memory location 1 to memory locations 2 through 10.

**Required Parameters:**

500mA Current Limit  
One Second Dwell Time  
0.1V to 1V in 0.1V steps

1. Turn on the Model 228 and allow ten minutes for warm up.
2. Select memory location 1.
3. Program 0.1V for memory location 1.
4. Program 500mA for memory location 1.
5. Program a one second dwell time for memory location 1.
6. Press PROGRAM,1. Duplicates data from one location into the next location.
7. Repeat step 6 for every location up to location 10.
8. Reprogram the voltage for each memory location. (0.2V in location 2, 0.3V in location 3, etc.)
9. Press AMPS/SECONDS. Selects the current for display.
10. Press OPERATE/STANDBY.
11. Select SINGLE CYCLE. Press START/STOP.

After the START/STOP key is pressed the Model 228 outputs the programmed parameters in one second intervals. All of the memory locations are covered and the cycle stops after memory location 10. By noting the left display (for each memory location), the current level is known. The voltage level is also known. The IV graph could be plotted with this information. Program 1 saves the user from programming all three parameters for each memory location.

### 3.11.2 Program 2 Sink

Use Program 2 when the Model 228 is to be used as a high power load above 50W. By noting the front panel, the state of the output is known. The front panel COMPLIANCE graph shows when the Model 228 is operating in the sink mode (active load). In the sink mode the Model 228 acts as a load and dissipates power instead of sourcing. The connected external source and 228 setting indicates that the Model 228 is in the sink mode.

If the Model 228 is operating near the maximum dissipation limit (100W), and this is causing the internal temperature to exceed 90°C, the sink only program (Program 2) activates as indicated by the flashing SINK ONLY LED. In this mode the sourcing capability is reduced. Return to normal operation by pressing PRO, 2.

For example: Consider charging and discharging a battery. While charging, the Model 228 sources power. When discharging, the Model 228 sinks power. In the sink mode the Model 228 is an accurate and stable load. When operating the Model 228 as an active load ensure that the recommended operating limits of Figure 3-12 are not exceeded.

Press the following keys to enable the sink only program: PROGRAM, 2.

The sink program allows the instrument to decrease its high power supply and still operate as an active load. With the supply reduced, the Model can dissipate full power continuously at 50°C ambient temperature with no derating.

### 3.11.3 Program 3 IEEE

Program 3 is used to set the primary address of the Model 228 for IEEE-488 bus operation. The primary address of the Model 228 is set to 11 at the factory, but it may be set to any value between 0 and 31 (as long as address conflicts are avoided) via front panel Program 3. This is a convenient feature that eliminates the cumbersome rear panel switches that are generally used in other instruments to set primary address. Note that the primary address of the instrument must agree with the address specified in the controller's programming language. Program 3 is the only way to change the Model 228's primary address. The programmed primary address is briefly displayed as part of the power up cycle, the self test sequence and Program 9 sequence.

**NOTE**

If other instrumentation is connected to the bus, be sure that each device has a different primary address. If this precaution is not observed, erratic bus operation may result.

To initiate Program 3 and change the primary address to 22, press the following keys:

1. Press PROGRAM (Selects program mode and displays Pro?).
2. Press 3 (selects Program 3 and displays the following).

Where:

IEEE = IEEE indicator

11 = Primary Address

3. Press 2,2,ENTER. This step loads the number 22 onto the display. Pressing the ENTER key programs the primary address 22 and reverts the Model 228 to the previous operating mode.
4. Press PROGRAM,3. This step shows the user that the primary address has indeed changed to 22.
5. Now that you know how, change the primary address back to 11.
  - A. Press PROGRAM,3.
  - B. Press 1,1,ENTER.

### 3.11.4 Program 4 MOD V (Modulate Output Voltage)

This program is used to allow an AC signal to be superimposed on the output. The modulation signal is applied to the rear panel external modulation terminals on the quick disconnect board. Program 4 is activated and then the front panel MODULATE V LED turns on. Figure 3-6 shows a graph of operation for the external modulation feature. When Program 4 is activated Program 5 is disabled.

Use the following procedure to activate Program 4.

1. Connect the external signal source to the external modulation connector on the quick disconnect board.
2. Press Program, 4. This step activates Program 4 and turns on the front panel MODULATE V LED.
3. Program the Model 228 for the desired output.
4. Set the Model 228 to the operate mode.
5. The modulate output is now present on the output connectors.

#### NOTE

Use shielded cables when using external modulation. The shield should be connected to output LO. Shielded cables help in reducing extraneous noise.

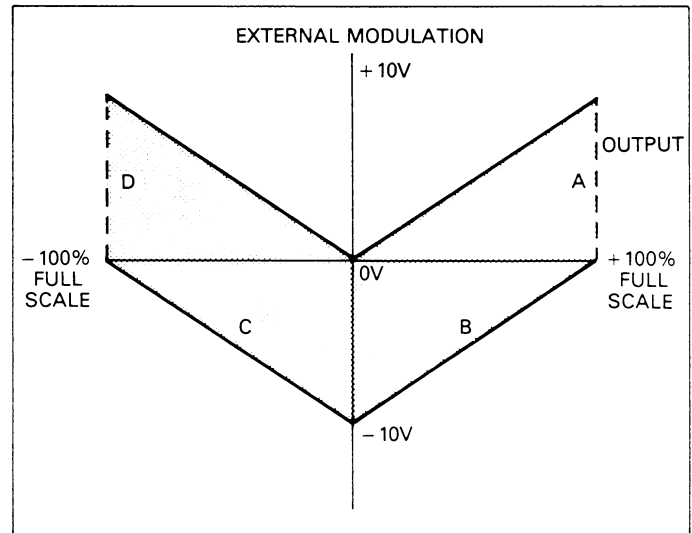

AREAS B and C INCREASE THE MAGNITUDE OF THE OUTPUT SETTING  
AREAS A and D DECREASE THE MAGNITUDE OF THE OUTPUT SETTING

Figure 3-6. Graph of Operation for External Modulation

### 3.11.5 Program 5 MOD I (Modulate Output Current)

Program 5 is used to allow an AC signal to be superimposed on the output. The modulation signal is applied to the external modulation terminals on the quick disconnect board. Program 5 is activated and then the front panel MODULATE I LED turns on. Figure 3-6 shows a graph of operation for the external modulation feature. When Program 5 is activated, Program 4 is disabled.

Use the following procedure to activate Program 5.

1. Connect the external signal source to the external modulation terminals.
2. Press PROGRAM, 5. This step activates Program 5 and turns on the front panel MODULATE I LED.
3. Program the Model 228 for the desired output.
4. Set the Model 228 to the operate mode.
5. The modulation signal is now present on the output signal.

### NOTE

Use shielded cables when externally modulating the output of the Model 228. The shield should be connected to output LO. Shielded cables help in reducing extraneous noise.

### 3.11.6 Program 6 Test (Diagnostic Self Test)

Program 6 is used to run a test on the ROM, RAM circuitry, perform auto cal sequence and tests the front panel LEDs. This test is also performed in the power up sequence. If it is desired to run the self test without using the IEEE-488 bus, Program 6 can be used. Use the following procedure to activate Program 6.

1. Press PROGRAM. Selects the program mode.
2. Press 6. Initiates the Program 6 test sequence.

Once step 2 is completed the Model 228 performs the following sequence:

The Model 228 turns on all the segments in the display and also turns on the rest of the front panel LEDs (e.g. LOCAL, REMOTE, SINGLE CYCLE, VOLTS, etc). The display segments are shown as follows:



This is a display test, the operator can note inoperative display segments by comparing the display with the above figure. All the LEDs should turn on if operating correctly. While the LEDs are on, the Model 228 is performing a cyclic redundancy check (CRC) of the ROM circuitry. A digital self test of the RAM circuitry is also being performed at this time. If the digital self test reveals a problem with the RAM circuitry the Model 228 displays the following.

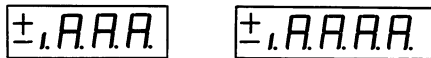

If the CRC reveals a problem with the ROM circuitry the Model 228 displays the following.

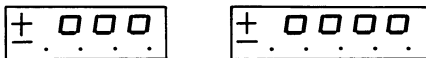

If all tests pass, the Model 228 displays the following:

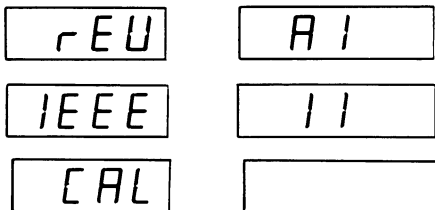

After the CAL cycle message, the Model 228 reverts to the previously shown display. For example, if the Model 228 was displaying +1.234V then that is the display it reverts to after the CAL 00 message.

### 3.11.7 Program 9 Reset

Program 9 is used to reset the Model 228 to the factory conditions. These conditions are the same as the device clear (DCL) command with one exception. The exception is that all of the programmed memory locations are cleared of all previous data. To activate Program 9 use the following procedure:

The sequence for Program 9 is the same sequence as upon power up.

1. Press PROGRAM, 9. Selects Program 9.
2. All digits and LEDs are turned for a few seconds.
3. The Model 228 displays the software revision level.
4. The Model 228 displays the primary address.
5. The Model 228 reverts to the VOLTS and AMPS display and memory location 1.

Once the VOLTS and AMPS display show zero, the Model 228 is reset to the factory on conditions.

### 3.12 LOADS

The Model 228 is capable of delivering power to a load or sinking (dissipating) power. Either mode depends on the programming of the instrument. If the actual voltage and current have the same polarity (both positive or both negative), the Model 228 is operating in the source mode. The front panel COMPLIANCE graph displays the state of the Model 228 (source or sink).

In the source mode, the Model 228 must have a device in which to deliver the programmed power. This device is generally known as the "load." The load stores or dissipates the Model 228 output power. The load must be rated to handle the programmed output power of the Model 228. If the load is not properly rated, damage may result. There are three categories of loads: resistive, capacitive and inductive. These different loads all have their own unique parameters. Each type of load contains in some small amount each of these parameters. In general, however, loads are considered to be mostly one parameter, either resistive, capacitive or inductive. Each type of load is described in the following paragraphs.

The Model 228 is a constant voltage/constant current source. The load determines which parameter is constant, either voltage or current. For example, if the load is of high impedance, the voltage is controlled with the impedance determining the amount of current. If the load is of low impedance, the current is controlled with the impedance determining the voltage. For example: If the Model 228 is programmed to 10V and 10A, a load of more than 1Ω controls the current, and a load of less than 1Ω controls the voltage.

$$I = 10V / 2\Omega = 5.00A \text{ (} 2\Omega \text{ load, current limits to 5A)}$$

$$V = 10A \times 0.5\Omega = 5.00V \text{ (} 0.5\Omega \text{ load, voltage limit of 5V)}$$

$R > \frac{V_{\text{SETTING}}}{I_{\text{SETTING}}}$  then, the Model 228 operates as a voltage source.

$R < \frac{V_{\text{SETTING}}}{I_{\text{SETTING}}}$  then, the Model 228 operates as a current source.

Where:

V = The voltage setting on the Model 228.

I = The current setting on the Model 228.

R = User load.

### 3.12.1 Load Line Description

The information contained in Figure 3-7 is a general description only. Refer to other sections of this manual for detailed information.

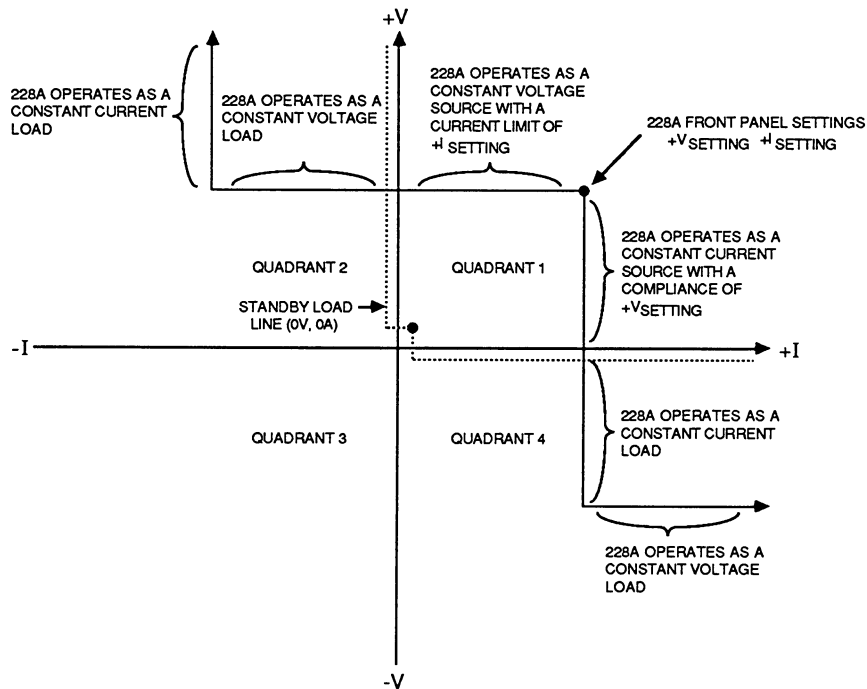

#### QUADRANT 1:

This quadrant is used for normal operation. The Model 228A will source positive voltage and current.

The Model 228A is sourcing power to a load.

Since  $V=I \times R$ , the combination of load  $R$  and the Model 228A settings will determine if the Model 228A is operating as a constant current or constant voltage source.

The Model 228A will maintain a constant voltage output as long as  $I_{SETTING} > V_{SETTING} / R_{LOAD}$ .

The Model 228A will maintain a constant current option as long as  $V_{SETTING} > I_{SETTING} \times R_{LOAD}$ .

Standby mode is a setting of 0 volts and 0 amps.

#### QUADRANT 2:

This quadrant is used for general constant voltage load or constant current load applications.

The Model 228A is dissipating (sinking) power from an external device.

The Model 228A will maintain a constant voltage across its terminals as long as the external device's current into the Model 228A is less than the Model 228A's current setting.

The Model 228A will operate as a constant current load as long as the external device's voltage is greater than the Model 228A voltage setting.

In standby mode, the Model 228A will appear to be an open circuit.

NOTE: For operating in this quadrant the polarity of the Model 228A's voltage setting and the polarity of the external device's voltage must be the same.

#### QUADRANT 3:

This quadrant is not on the positive load line shown above. If the Model 228A were set to  $-V$  and  $-I$  the Model 228A's load line would then cross this quadrant.

#### QUADRANT 4:

This quadrant is used for a constant voltage load on a current source.

The Model 228A is dissipating (sinking) power from an external device.

The Model 228A will maintain a constant voltage across its terminals as long as the external device's current is greater than or equal to the Model 228A's current setting.

In standby mode, the Model 228A will appear to be a short circuit.

NOTE: For operation in this quadrant the polarity of the Model 228A's voltage source and the polarity of the external device's voltage must be opposite. It is important to note that current is not limited while the Model 228A is operating in quadrant 4 and should not be used to discharge batteries. Excessive current may cause damage to the Model 228A and/or the external source. Quadrants 1 and 2 should normally be used to charge and discharge storage elements, such as batteries and capacitors.

Operating Note: For most applications, the Model 228A will be operated in quadrant 1 (source) or quadrant 2 (sink). To operate as a sink in quadrant 2, the polarity of the Model 228A and the external source must be the same. That is, external source positive must be connected to Model 228A positive. Whether the Model 228A operates as a source or as a sink depends on the voltage value of the external source and the programmed voltage of the Model 228A. If the voltage

of the external source is equal to or less than the programmed voltage of the Model 228A, then the Model 228A will operate as a source. Current will flow out of the Model 228A. Conversely, if the voltage of the external source exceeds the programmed voltage of the Model 228A, then the Model 228A will operate as an active sink. Current will flow into the Model 228A.

Figure 3-7. Load Line (Positive Line Shown)

### 3.12.2 Resistive Loads

Using a resistive load, the Model 228 is capable of delivering a constant voltage or constant current up to the programmed compliance. With a resistive load as shown in Figure 3-8, the voltage developed across the load resistance is defined as  $V_L = I_L \times R_L$ .

Where:

$V_L$  = The voltage developed across the load.

$I_L$  = The current through the load.

$R_L$  = The load resistance.

If the voltage is programmed to less than the voltage  $V_L$ , then the Model 228 is voltage controlled. If the current is programmed to less than the current  $I_L$ , then the Model 228 is current limited.

The power delivered to the resistive load must not exceed the power rating of the load. If excessive power is delivered to the load, damage may result. For example, if the load is a resistor and is rated at 10W, then the power must not exceed 10W. This means that if the Model 228 voltage is programmed for 10V, then the current must not be programmed for more than 1A ( $10V \times 1A = 10W$ ) or 10A and 1V ( $10A \times 1V = 10W$ ). In any case, the voltage/current combination must not exceed the limits of the load. Otherwise, the load may be damaged.

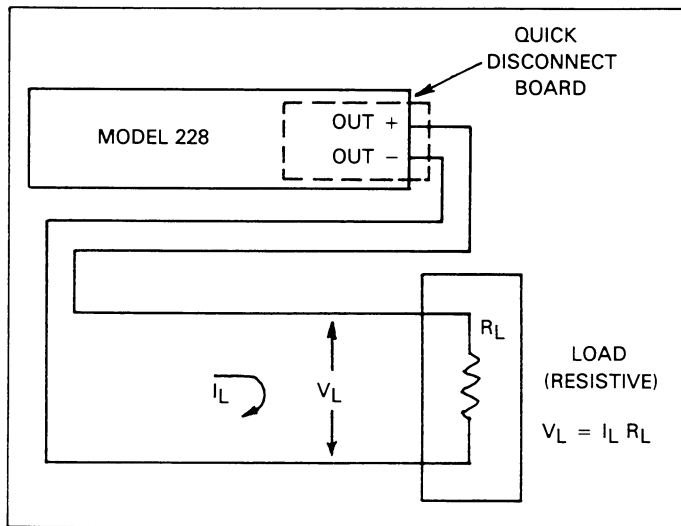

Figure 3-8. Resistive Load Connections

### 3.12.3 Reactive Loads

The Model 228 is stable for an exceptionally wide range of

capacitance and inductive loads. Reactive loads require certain considerations that are listed as follows:

1. The user must supply the necessary circuitry to limit the voltage across inductors. Voltage above 101% of the selected voltage range may damage the instrument. During power on, calibration, low or missing line power, the Model 228 disconnects the output with relays. This could cause uncontrolled arcing along the inductive circuit. Refer to Figure 3-9 for suggested clamp circuit.
2. Capacitors and inductors require proper discharging before touching any output wiring. This is because in the standby mode or when power failures occur, the reactive circuit could be left with a full charge.
3. Settling times are longer for large reactive loads, as a result overshoot and ringing may occur. Damping resistors could be used to improve the response. Refer to Figure 3-9 for damping resistor circuits.

### 3.12.4 Inductive Loads

In general, in the constant current mode the output load should be resistive. However, a small amount of inductance in the load can be tolerated, but only if the inductive reaction voltage,  $L \frac{di}{dt}$ , is limited to less than the maximum compliance voltage for each range. Figure 3-9 shows a suggested method of limiting the inductive reaction voltage. The zener diodes must be rated for each current range as listed in Table 3-9. An inductive load may not be obvious. Loads that contain wirewound resistors or relay coils, (etc.) are inductive and could produce damaging voltage spikes. Figure 3-10 shows inductive load connections.

#### CAUTION

**In the current function, if the output load connected to the Model 228 is inductive, limit the inductive reaction voltage to less than the maximum compliance voltage for that range. Otherwise, instrument damage may occur.**

Some examples of inductive loads include:

1. Relay Coils
2. Electric Motors
3. Wirewound Resistors
4. Transformers
5. Solenoids

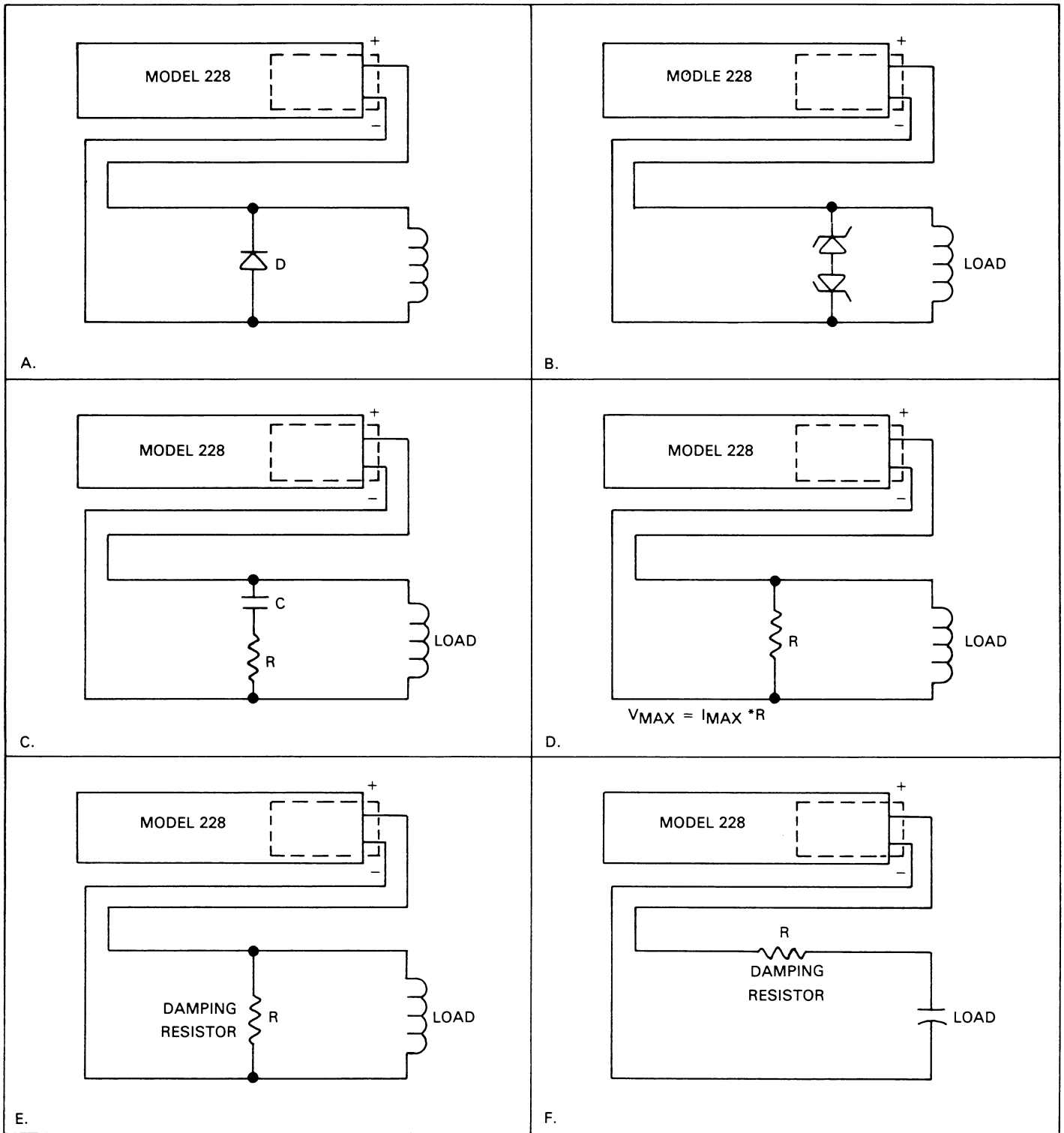

NOTE SETTLING TIMES INCREASE WITH NON RESISTIVE LOADS.

Figure 3-9. Limiting Inductive Reaction Voltage

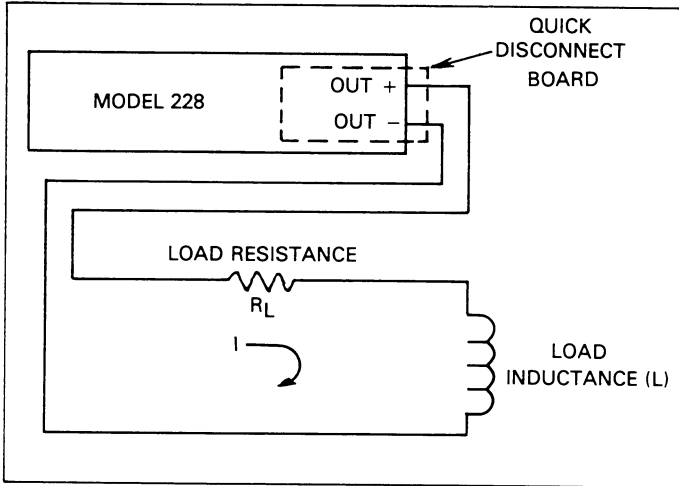

Figure 3-10. Inductive Load Connection

Table 3-9. Maximum Inductive Reaction Voltage

Range	Max $L \frac{di}{dt}$
10 A	10V
1 A	100V
100mA	100V

### 3.12.5 Capacitance Loads

When a capacitive load is connected to the Model 228 output, the Model 228 delivers a constant current until the voltage developed reaches the programmed compliance voltage, instrument voltage compliance limit or the working voltage of the load. The voltage charges to a maximum  $V_C$  with the following equation:

$$V_O = \frac{1}{C} \int I \frac{di}{dt} \text{ up to } V_C \text{ (maximum)}$$

Figure 3-11 shows the Model 228 connected to a capacitive load. If the Model 228 compliance voltage is changed to a smaller value than is charged on the capacitor, the capacitor starts discharging into the Model 228. For this period, the Model 228 is in the sink mode. Notice the front panel COMPLIANCE graph; it indicates the Model 228 is in the sink mode. When the capacitor charge voltage reaches the lower compliance voltage, the Model 228 returns to the source mode.

Some examples of capacitive loads include:

1. Capacitor
2. Power Supplies

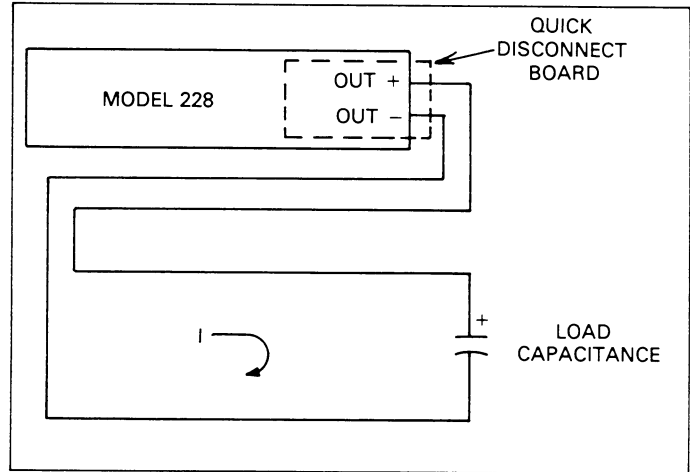
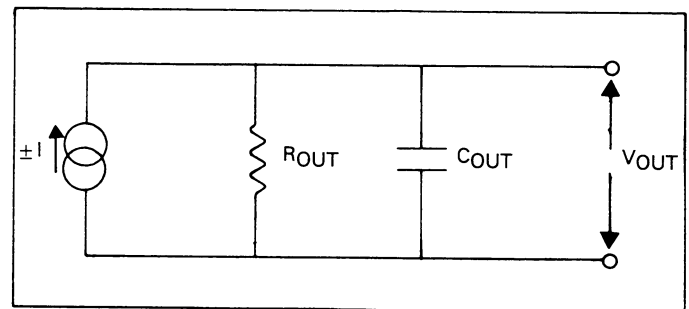

Figure 3-11. Capacitive Load Connections

### 3.12.6 Load Regulation

Load regulation is an important parameter that is to be considered when using the Model 228 as a current source or a voltage source. Load regulation may be computed by the following two methods:

1. As a Current Source:



$$\text{Load Regulation (Current Mode)} = \frac{\Delta V_{OUT}}{\frac{R_{OUT}}{I}} \times 100\%$$



2. As a Voltage Source:

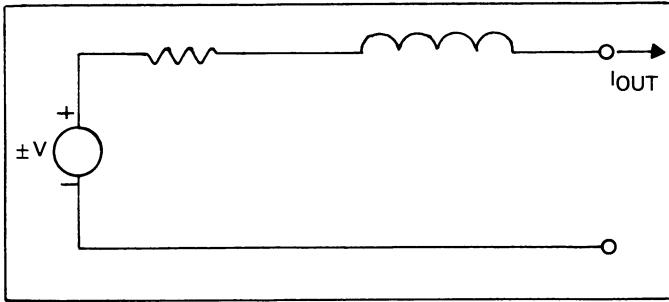

$$\text{Load Regulation (Voltage Mode)} = \frac{[\Delta I_{OUT} \cdot R_{OUT}]}{V} \times 100\%$$

As an example; consider the 1A range and 100V compliance. The  $R_{OUT}$  specification is  $10^5\Omega$ .

$$\text{Load Regulation} = \frac{[\Delta V_{OUT}]}{I} \times 100\% = \frac{[100V]}{1A} \times 100\% = 0.1\%$$

### 3.13 OPERATING EXAMPLES

The following examples give specific instructions on how to use the Model 228 in various configurations. These examples are written with the first time user in mind. However, refer to the front and rear panel control descriptions in Tables 3-2 and 3-3 before proceeding with these examples. Note all of the warning and cautions associated with these examples. Take the time to read them and, most of all, to understand them.

#### 3.13.1 Example 1: 10.00V, 10.00A Output

In this example, the Model 228 will be programmed for +10.00V and +10.00A. These values were chosen to keep the numbers simple ( $10V/10A = 1\Omega$ ). With these values, the user can concentrate on the front panel instead of a cumbersome number calculation. The 10V range has a maximum compliance current of 10A; conversely, the 10A range has a maximum compliance voltage of 10V. Refer to the specifications that precede Section 1. In this example, voltage and current are limited to 10.00V and 10.00A by the user; and in this case, the instrument limits these values. This information is stored in memory location 1.

This example does not step the user through the selection of a memory location. Memory location 1 is selected upon power up and that is sufficient for this example. Since there is just one memory location used in this example, programming the dwell time is not covered. Later examples explain the use of memory locations.

The Model 228 is a constant voltage/constant current (CV/CC) source. This means that the voltage and current are programmed into the instrument. The output of voltage or current depends on the load. If the load is of high impedance, the voltage is controlled with the impedance determining the amount of current drawn from the source. If the load is of low impedance, the current is controlled with the impedance determining the voltage. The maximum value of voltage or current (up to rated specifications) is defined by the user. The user defines these parameters when programming the voltage and current values. In this example:

If the load is less than  $1\Omega$ , the source controls current. The LED just above the + (+ $I_{SOURCE}$ ) on the front panel COMPLIANCE graph is on.

If the load is greater than  $1\Omega$ , the source controls voltage. The LED just to the right of the +V (+ $V_{SOURCE}$ ) on the front panel COMPLIANCE graph is on.

For example: A  $2\Omega$  load results in a current of 5A (voltage is controlled by the Model 228).

$$I = \frac{10V}{2\Omega} = 5.00A.$$

A  $0.5\Omega$  load results in a voltage of 2.5V (current is controlled by the Model 228).

$$V = 0.5\Omega \times 10A = 5.00V.$$

If  $R > \frac{V_{SETTING}}{I_{SETTING}}$  then, the Model 228 operates as a voltage source.

If  $R < \frac{V_{SETTING}}{I_{SETTING}}$  then, the Model 228 operates as a current source.

Where:

V = The voltage setting of the Model 228.

I = The current setting of the Model 228.

R = User Load

Also, in the operate mode, the display shows the actual parameter value. For example, if 10V and 10A are programmed and the load is drawing 7.5A, then 7.50A is displayed on the right display (right display must be in amps display mode).

To program the Model 228 for 10.00V, 10.00A, use the following procedure:

### CAUTION

This example outputs 100W. Make sure that the connected load is rated to at least 100W. Otherwise, damage to the load may occur.

1. Turn on the Model 228 and allow ten minutes for warm up.

### WARNING

Do not operate the instrument with the top cover and/or the bottom cover removed. Lethal potentials exist throughout the Model 228 mainframe. The covers must also be in place to allow proper airflow through the instrument. If proper airflow is impeded, the instrument may overheat.

### NOTE

Upon power up, memory location 1 is selected.

2. Program the desired voltage value. There are two methods to do this and both are given as follows:

#### Method 1: Program Desired Voltage Value

- A. Press the VOLTS/MEMORY STEP key to display volts (VOLTS LED on).
- B. Press the SELECT key until the left display is selected. The selected display is depicted by the flashing bright digit.

### NOTE

During the edit mode, if nothing happens on the front panel for approximately 20 seconds, the Model 228 cancels the edit mode and returns the display to the previous conditions.

- C. Press the left or right key to select the modify digit. The left and right keys are indicated by the arrows on the front panel. The modify digit is depicted by the flashing bright digit.
- D. Press the increment or decrement key to modify the voltage value. The output tracks the display when using the increment or decrement keys. The increment/decrement keys are indicated by the up/down arrows on the front panel.

#### Method 2: Program Desired Voltage Value

- A. Press the VOLTS/MEMORY STEP key to display volts (VOLTS LED on).
- B. Press the SELECT key until the left display is selected. The selected display is depicted by the flashing bright digit.

C. Press 1, 0, ., 0, 0.

D. Press ENTER.

3. Program the desired current value. Like the voltage value, this can be done in one of two methods. Both methods are given as follows:

#### Method 1: Program Desired Current Value

- A. Press the AMPS/DWELL TIME key to display current (AMPS LED on).
- B. Press the SELECT key until the display on the right is selected. The selected display is depicted by the flashing bright digit.
- C. Press the left or right keys (these keys are indicated by the arrows on the front panel) to select the modify digit. The modify digit is depicted by the flashing bright digit.
- D. Press the increment/decrement keys to modify the current value. The output tracks the display when using the increment/decrement keys.

#### Method 2: Program Desired Current Value

- A. Press the AMPS/DWELL TIME key to display current (AMPS LED on).
  - B. Press the SELECT key until the right display is selected. The selected display is depicted by the flashing bright digit.
  - C. Press 1, 0, ., 0, 0.
  - D. Press ENTER.
4. Connect the appropriate load. For this example, the load must be rated at least 100W.
  5. Press OPERATE/STANDBY to place the instrument in the operate mode. In the operate mode, the source value is present on the output terminals.

After step 5 is completed, the Model 228 outputs the voltage and current to the connected load. This simple example is designed to set the Model 228 to output a source value. The next example sets the Model 228 to output 100V, 1A.

### 3.13.2 Example 2: 100V, 1A Output

This example will program the Model 228 to output a value of 100V, 1A. The maximum current compliance of a 100V range is 1A; conversely, the 1A range has a maximum voltage compliance of 100V. Refer to the specifications that precede Section 1. Like Example 1, this example does not explain the use of memory locations which will be discussed later.

Again, the output value depends on the load. If the load is of high impedance, the value is voltage controlled. If the load is of low impedance, the value is current controlled. A comparison between the Model 228 and a battery is a simplified way of understanding the load of a voltage/current source. As an example, assume a battery is rated at 1.5V and 1A/hour. If the battery has a load of 1k $\Omega$ , the battery outputs

1.5mA at 1.5V. Therefore, the current output is limited by the load. The same is true for the Model 228. If the load is of high impedance, the load determines the current. If the load is of low impedance, the load determines the voltage.

#### NOTE

When voltage is controlled by the Model 228, the load determines the current by Ohm's law  $I = V/R$ . When current is controlled by the Model 228, the load determines the voltage by Ohm's law,  $V = I \cdot R$ .

This example is designed to allow the user to become familiar with the front panel operation of the Model 228. It illustrates some basic operating methods of the Model 228.

#### WARNING

**This procedure outputs a dangerous potential of 100V up to 1A. Take care not to come into contact with the live output, as personal injury or death may occur.**

#### CAUTION

**This example outputs 100W. Make sure the load is rated for at least 100W. Otherwise, damage to the load may occur.**

In the operate mode, the display shows the actual parameter value. For example, if 100V and 1A are programmed and the load is drawing 750mA, then .750A is displayed on the right display. The right display must be in the amps display mode in order to display the current.

The Model 228 operates as a voltage source when the following condition occurs:  $V < I \times R$ .

The Model 228 operates as a current source when the following condition occurs:  $V > I \times R$ .

Where:

V = The voltage setting of the Model 228.

I = The current setting of the Model 228.

R = User Load.

1. Turn on the Model 228 and allow ten minutes for warm up.

#### NOTE

Upon power up, memory location 1 is selected.

2. Program the desired source. There are two methods to do this. Both are given.

Method 1: Program Desired Source

- A. Press the VOLTS/MEMORY STEP key to display volts (VOLTS LED on).
- B. Press the SELECT key until the left display key is selected. The selected display is depicted by the flashing bright digit.
- C. Press the left or right key to select the modify digit. The left and right keys are indicated by the arrows on the front panel. The modify digit is depicted by the flashing bright digit.
- D. Press the increment or decrement key to modify the current source value. The output tracks the display when using the increment/decrement keys to modify the display. The increment/decrement keys are indicated by the up and down arrows on the front panel.

Method 2: Program Desired Source

- A. Press the VOLTS/MEMORY STEP key to display volts (VOLTS LED on).
  - B. Press the SELECT key until the right display is selected. The selected display is depicted by the flashing bright digit.
  - C. Press 1, 0, 0, ., 0.
  - D. Press ENTER.
3. Program the desired current value. This may be done by one of two methods. Both methods are given.

Method 1: Program Desired Current Value

- A. Press the AMPS/DWELL TIME key to display the current (AMPS LED on).
- B. Press the SELECT key until the right display is selected. The selected display is depicted by the flashing bright digit.
- C. Press the left or right key to select the modify digit. The left and right keys are indicated by arrows on the front panel. The modify digit is depicted by the flashing bright digit.
- D. Press the increment or decrement key to modify the current value. The output tracks the display when using the increment/decrement keys.

Method 2: Program Desired Current Value

- A. Press the AMPS/DWELL TIME key to display current (AMPS LED on).
  - B. Press the SELECT key until the right display is selected. The selected display is depicted by the flashing bright digit.
  - C. Press 1, ., 0, 0, 0.
  - D. Press ENTER.
4. Connect the appropriate load. The load must be rated for at least 100W.

#### NOTE

The output load must be non-inductive. A small amount of inductance in the load can be tolerated if the inductive reaction voltage,  $L \frac{di}{dt}$ , is limited to less than the compliance voltage of that range. Refer to paragraph 3.9.2.

5. Press the OPERATE/STANDBY key. This step places the 1.00A source current on the output terminals.

#### WARNING

**The completion of step 5 outputs a dangerous potential. Make sure the load is properly rated. Do not come into contact with the live output as personal injury or death may occur.**

After step 5 is completed, 100V at 1A is delivered to the output connector and therefore, is available to the load. The actual voltage drop and current output depends upon the value of the load. This simple example is designed to set the Model 228 to 100V at 1A to a predetermined load. In the next example, the user will set the Model 228 to output three separate source values in succession.

### 3.13.3 Example 3: 1V, 10A, 1sec; 10V, 10A 2sec; and 100V, 1A, 3sec Output in the Continuous Memory Control Mode

This example will set the Model 228 to output three separate source values in succession. This could be used to test certain parameters of a resistor. The higher voltage could be used to test the voltage coefficient of the resistor. The higher current could be used to test the power rating of the resistor. The accuracy could also be verified by using the Model 228 as an accurate voltage source. The parameters may vary for this type of application. The parameter values chosen represent several ranges of the Model 228.

In order to obtain the three source values, program the desired values into the memory locations. Each memory location contains five distinct parameters that make up the memory location: Voltage, Current, Dwell Time, Modulation (V or I) and Source or Sink mode. Each parameter must be programmed into each memory location.

After the source values are entered into the memory locations, the user must select the desired dwell time. The dwell time is the time spent on a specific memory location before

moving to the next location. After the dwell time is entered, the modulation mode must be entered. The modulation shows the user that Model 228 is in either current or voltage modulation. Then the last parameter (source or sink) must be entered. The order of programming these five parameters does not matter, as long as all five are programmed into the memory location.

This example may be used as a model for storing several (up to 100) source values. Up to 100 unique values may be stored in the Model 228. All of the information stored in the memory locations (Voltage, Current and Dwell Time, Source/Sink and Modulate V or I) is battery backed up. This means that if the instrument is powered down, the information is still valid. The stored parameters remain as is until they are changed by the user. Before beginning the example, read the following outline. The outline gives a short description of the example. The main parts of the example are sectioned off to show the complete example in a simplified form. The actual example follows this short outline.

1. Turn the instrument on.
2. Select memory location 1.
3. Program the desired voltage of memory location 1.
4. Program the desired current of memory location 1.
5. Program the desired dwell time of memory location 1.
6. Program either source or sink for memory location 1.
7. Program modulate V or I for memory location 1.
8. Select memory location 2.
9. Program the desired voltage of memory location 2.
10. Program the desired current of memory location 2.
11. Program the desired dwell time of memory location 2.
12. Program either source or sink for memory location 2.
13. Program modulate V or I.
14. Select memory location 3.
15. Program the desired voltage for memory location 3.
16. Program the desired current for memory location 3.
17. Program the desired dwell time of memory location 3.
18. Program either source or sink for memory location 3.
19. Program modulate V or I for memory location 3.
20. Select memory location 4.
21. Program the dwell time of memory location 4 to zero.
22. Select memory location 1.
23. Select the continuous memory control mode.
24. Connect appropriate load.
25. Select the operate mode.
26. Press the START/STOP key.

#### WARNING

**Memory location 3 contains a lethal potential of 100V and a current of up to 1A. Take**

**care not to come into contact with a live circuit that may cause personal injury or death.**

**NOTE**

There are two methods of programming values into the Model 228. Examples 1 and 2 explain in detail each method. In this example, data keys method is used.

1. Turn on the Model 228 and allow ten minutes for warm up.

**NOTE**

Upon power up, memory location 1 is selected.

2. Select memory location 1.
  - A. Press the VOLTS/MEMORY STEP key to display the present memory location (MEM STEP LED on).
  - B. Press the SELECT key until the left display is selected. The selected display is depicted by the flashing bright digit.
  - C. Press 1, ENTER.
3. Program the desired voltage value.
  - A. Press the VOLTS/MEMORY STEP key to display volts (VOLTS LED on).
  - B. Press the SELECT key until the left display is selected. The selected display is depicted by the flashing bright digit.
  - C. Press 1, ., 0, 0, 0, ENTER.
4. Program the desired current value.
  - A. Press the AMPS/DWELL TIME key to display current (AMPS LED on).
  - B. Press the SELECT key until the right display is selected. The selected display is depicted by the flashing bright digit.
  - C. Press 1, 0, ., 0, 0, ENTER.
5. Program the desired dwell time value.
  - A. Press the AMPS/DWELL TIME key to display the dwell time (SECONDS LED on).
  - B. Press the SELECT key until the right display is selected. The selected display is depicted by the flashing bright digit.
  - C. Press 1, ., 0, 0, 0, ENTER.
6. Program Modulation (V or I). Press Program 4 to modulate V or press Program 3 to modulate I. Notice that the appropriate LED turns on.
7. Program source or sink.
  - A. Press Program 2 to enable the sink mode. Notice that the appropriate SINK LED turns on.
  - B. If source mode is desired, turn off the sink program.

8. Select memory location 2.
  - A. Press the VOLTS/MEMORY STEP key to display the memory location (MEM STEP LED on).
  - B. Press the SELECT key until the left display is selected. The selected display is depicted by the flashing bright digit.
  - C. Press 2, ENTER.
9. Program the desired voltage value for memory location 2.
  - A. Press the VOLTS/MEMORY STEP key to display volts (VOLTS LED on).
  - B. Press the SELECT key until the left display is selected. The selected display is depicted by the flashing bright digit.
  - C. Press 1, 0, ., 0, 0, ENTER.
10. Program the desired current value for memory location 2.
  - A. Press the AMPS/DWELL TIME key to display the dwell time (AMPS LED on).
  - B. Press the SELECT key until the right display is selected. The selected display is depicted by the flashing bright digit.
  - C. Press 1, 0, ., 0, 0, ENTER.
11. Program the desired dwell time for memory location 2.
  - A. Press the AMPS/DWELL TIME key to display the dwell time (SECONDS LED on).
  - B. Press the SELECT key until the right display is selected. The selected display is depicted by the flashing bright digit.
  - C. Press 2, ., 0, 0, 0, ENTER.
12. Program modulate V or I. Press Program 4 to modulate V or press Program 5 to modulate I. Notice that the appropriate LED turns on.
13. Program source or sink.
  - A. Press Program 2 for sink mode. Notice that the SINK LED turns on.
  - B. If source mode is desired, turn off sink mode.
14. Select memory location 3.
  - A. Press the VOLTS/MEMORY STEP key to display the memory location (MEM STEP LED on).
  - B. Press the SELECT key until the left display is selected. The selected display is depicted by the flashing bright digit.
  - C. Press 3, ENTER.
15. Program the desired voltage value for memory location 3.
  - A. Press the VOLTS/MEMORY STEP key to display volts (VOLTS LED on).
  - B. Press the SELECT key until the right display is selected. The selected display is depicted by the flashing bright digit.
  - C. Press 1, 0, 0, ., 0, ENTER.
16. Program the desired current value of memory location 3.
  - A. Press the AMPS/DWELL TIME key to display the dwell time (AMPS LED on).
  - B. Press the SELECT key until the right display is

selected. The selected display is depicted by the flashing bright digit.

- C. Press 1, ., 0, 0, 0, ENTER.
17. Program the desired dwell time for memory location 3.
  - A. Press the AMPS/DWELL TIME key to display the dwell time (SECONDS LED on).
  - B. Press the SELECT key until the right display is selected. The selected display is depicted by the flashing bright digit.
  - C. Press 3, ., 0, 0, 0, ENTER.
18. Program modulate V or I. Press Program 4 to modulate V or press Program 5 to modulate I. Notice that the appropriate LED turns on.
19. Program source or sink.
  - A. Press Program 2 for sink mode. Notice that the SINK LED turns on.
  - B. If source mode is desired, turn off sink mode.
20. Select memory location 4.
  - A. Press the VOLTS/MEM STEP key to display the memory location (MEM STEP LED on).
  - B. Press the SELECT key to select the left display for modification.
  - C. Press 4, ENTER.
21. Program the dwell time to zero.
  - A. Press the AMPS/DWELL TIME key to display the dwell time on the right display (SECONDS LED on).
  - B. Press the SELECT key until the right display is selected. The selected display is depicted by the flashing bright digit.
  - C. Press 0, 0, . 0, 0, ENTER.
22. Select memory location 1.
23. Press the CONTINUOUS key. This step places the Model 228 in the continuous memory control mode.
24. Connect the appropriate load. The load must be rated at least 100W.
25. Press OPERATE/STANDBY to place the source value at the output terminals.

#### NOTE

Before placing the instrument in the operate mode, take the time to read and understand the safety precautions described in Section 2. These precautions are presented for user safety.

26. Press the STOP/START key to start the memory control mode.

#### WARNING

**Memory location 3 contains a lethal potential. Do not come into contact with the live output. Personal injury or death may occur.**

After step 26, the Model 228 continuously cycles through the programmed memory locations. Since the OPERATE LED is on, the source values are present at the output terminals.

The single step memory control mode allows the user to step through the programmed memory locations one at a time. Each time it is desired to advance to the next programmed memory location, the user need only press the START/STOP button. The START/STOP LED turns on for the duration of the programmed dwell time and then turns off. When the last programmed memory location is selected (memory location 3, in this example), pressing the START/STOP key reverts the instrument to memory location 1. This is true for the last programmed location as long as the next location has a zero dwell time.

The single cycle memory control mode allows the user to cycle through all the programmed memory locations one time. To start the single cycle mode, press the START/STOP key. Once the single cycle mode is activated, the Model 228 starts from the next programmed memory location and advances to each programmed memory location. The instrument remains at each memory location for the programmed dwell time and then advances to the next location. After the dwell time of the last programmed memory location, the START/STOP LED turns off and the single cycle mode is ended.

The continuous memory control mode allows the user to cycle through all of the programmed memory locations continuously. To start the continuous memory control mode, press the START/STOP key. To stop the continuous memory control mode, press the START/STOP key a second time. When the START/STOP key is pressed the second time, the continuous mode stopped at the present memory location. Once the continuous memory control mode is activated, the Model 228 advances to the next memory location. The instrument remains at this location for the programmed dwell time (dwell time can vary for each location) and then advances to the next memory location. The cycle continues up to and including the last programmed memory location (or memory location with a zero dwell time) and then reverts to memory location 1. At this point, the cycle starts over again and keeps repeating until the START/STOP key is pressed and the instrument is turned off or another memory control mode is activated.

#### Memory Control Mode Notes

1. The START/STOP key has three functions:
  - A. Start the memory control mode.
  - B. Stop the memory control mode.
  - C. Advance to the next memory location in the single step mode.

2. The single step mode allows the user to step through the programmed memory locations one at a time.
3. The single cycle mode allows the user to cycle through the programmed memory locations one at a time.
4. The continuous mode allows the user to cycle through the programmed memory locations continuously.
5. Dwell time is the time spent on one memory location.
6. An entry of zero for the dwell time for any memory location reverts the instrument to memory location 1. (20msec to 1000sec in 1msec steps. (1sec steps in 1000sec range).
7. Each memory location contains five distinct parameters:
  - A. Voltage
  - B. Current
  - C. Dwell Time
  - D. Modulate V or I
  - E. Source or Sink
8. There is a total of 100 memory locations.
9. The memory control mode may be started by one of three methods.
  - A. Pressing the START/STOP key.
  - B. Applying proper external trigger.
  - C. Sending the proper command over the IEEE-488 bus. This means that the PROGRAM command (P0, P1 or P2) is selected and the appropriate trigger command is implemented. For example, if the T0 (Start on TALK) mode is selected, and the instrument is addressed to talk, the selected memory control mode is initiated.
10. When the continuous or single cycle memory control modes are running, stopping the sequence halts the instrument at the present memory location. Continuing the sequence starts at the next memory location.

Examples 1, 2 and 3 all deal with the Model 228 programmed as a source. This means that the Model 228 outputs voltage and current. Observe the front panel COMPLIANCE graph and notice that the Model 228 is operating in the source mode (+V and +I LEDs are turned on one at a time). The source mode is depicted by the voltage and current having the same polarity. The polarity could be either positive or negative it does not matter as long as the polarity is the same for the voltage and the current, the instrument is operating in the source mode.

### 3.13.4 Example 4: Model 228 as an Active Load (Current Sink)

This next example deals with the Model 228 operating in the sink mode. In the sink mode of operation, power is delivered to the Model 228 by an external source.

As can be seen by the graph and/or Figure 3-12, when voltage and current both have the same sign (positive or negative), the Model 228 is in the source mode.

If the voltage or current have different polarity, then the Model 228 is in the sink mode. In the sink mode, the Model 228 accepts power (dissipates) instead of providing the power. Operating the Model 228 as an active load dissipates power up to the limits shown in Figure 3-12. Of course, the limits shown in Figure 3-12 must not be exceeded.

#### CAUTION

**When the Model 228 is used in the sink mode, that is, power is delivered to the Model 228 by an external power source. Care should be taken to limit the power delivered to the Model 228 as shown in Figure 3-12. If power dissipated within the Model 228 exceeds these limitations, overheating and damage to the instrument may occur. For example, if the external power source is capable of delivering greater than 1A, then the voltage across the Model 228 output terminals must be less than 100V ( $100V \times 1A = 100W$ ).**

#### WARNING

**During the sink mode of operation, the Model 228 and the external source must have the same voltage polarity in order for the current limiting to operate. Otherwise, the output fuse (20A) is the current limit.**

The COMPLIANCE graph on the front panel provides the user with the location of where the Model 228 is operating. By noting the front panel COMPLIANCE LEDs, four parameters concerning the output are known:

1. The polarity of the voltage.
2. The polarity of the current.
3. The controlling function (voltage or current).
4. The operating mode (sink or source).

For example: If the LED just above the +I (+ISOURCE) symbol is turned on, then:

1. The polarity of the voltage is positive because it is in the +V half.
2. The polarity of the current is positive because it is in the +I half.
3. The controlling function is current because the line for that LED goes through the +I axis, the current is constant and the voltage is the parameter that varies. For lines intersecting the voltage axis, the voltage is constant and the current is the parameter that varies.

4. The instrument is operating as a source because the voltage and the current both have the same polarity (positive). (The LED is in a "source" quadrant.)

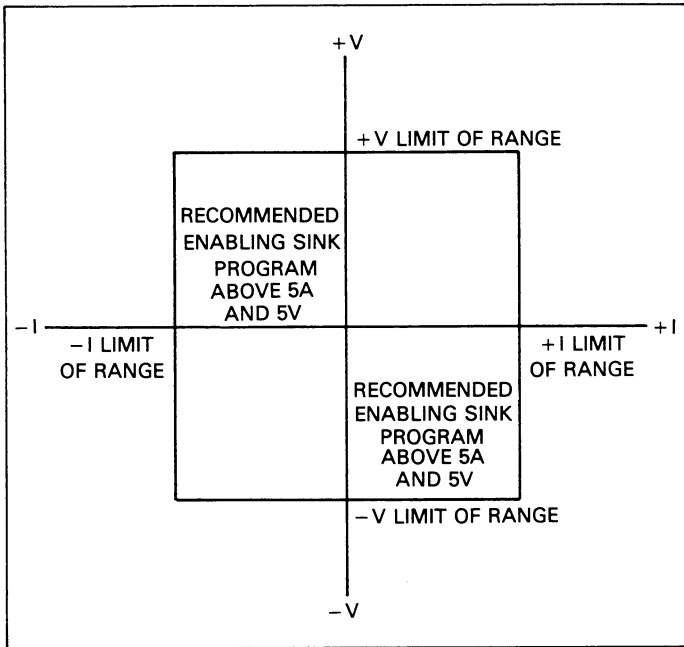

**Figure 3-12. Model 228 Recommended Operating Limits**

In this example, the Model 228A accepts (dissipates) power from the battery voltage. In the sink mode, the Model 228A is an active load that is both constant and accurate. The configuration is shown in Figure 3-13. Make sure the polarity of the connections are correct before placing the Model 228A in the operate mode.

Using the SINK program (front panel Program 2) reduces the internal power dissipation within the Model 228A. The sink only mode activates automatically if the internal temperature of the instrument reaches 90°C. Normally, this only occurs at high ambient temperatures and high power sink operation.

**NOTE**

The sink only mode is only useful on the 10A range, between 5V and 10V. The sink only program limits sourcing capability to approximately 1.5A and also limits sink capability when voltages are less than three volts.

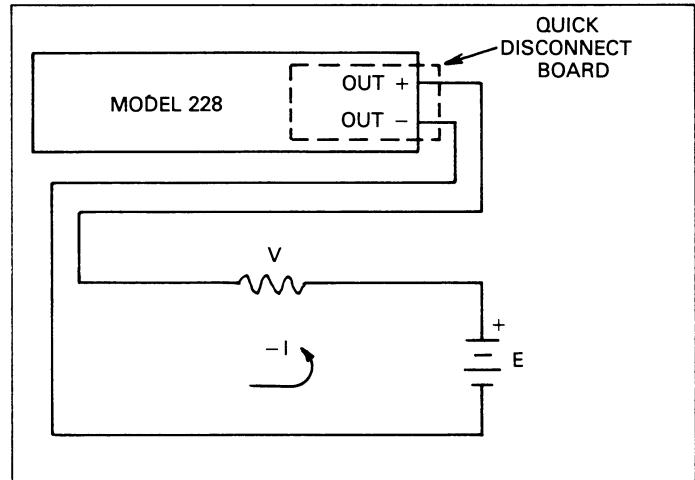

**Figure 3-13. Model 228 as an Active Load**

**NOTE**

The external source connected to the Model 228 output determines whether the Model 228 operates as an active load. In other words, the Model 228 operates as an active load whenever its output is connected to a voltage source that exceeds the programmed output voltage of the instrument.

The following procedure programs the Model 228 to sink 25V, 100mA = (2.5W).

1. Turn on the Model 228 and allow ten minutes for warm up.

**NOTE**

Upon power up, memory location 1 is selected.

2. Program the desired voltage value. In this example, the voltage must be positive.
  - A. Press the VOLTS/MEMORY key. This step displays the present voltage value on the left display.
  - B. Press the SELECT key. This step selects the left display for modification.
  - C. Press 2, 5, ., 0, 0, ENTER.
3. Program the desired current value. In this example, the current is programmed as positive. The external source determines whether the Model 228 acts as a source or an active load. Refer to Figure 3-12 and/or the front panel COMPLIANCE graph.
  - A. Press the AMPS/DWELL TIME key. This step displays the present current value on the right display.



### 3.13.5 Example 5: Operation as Source and Sink

To help illustrate the Model 228 source and sink characteristics, this example shows how the Model 228 can source a current to charge a capacitor and then when the capacitor is fully charged, the Model 228 will be programmed as an active load to accept the charge.

The voltage values of this example were chosen on the same range (100V, 100mA). The current values were chosen so that the capacitor would charge and discharge at a somewhat slow rate. In this way, the user could watch the display and see what was going on in the circuit. The dwell time was chosen so the Model 228 would remain at the memory locations long enough to see the capacitor charge and discharge.

Even though modulation is a parameter of memory location, it was not used in this example. Memory location 2 turned on the sink mode. This is not required for less than 50W dissipation. Also, note that while Program 2 is active, sourcing capabilities is reduced.

1. Connect a 10,000 $\mu$ F, 50V capacitor on the output terminals of the Model 228. Observe proper polarity when connecting the capacitor.
2. Charging the Capacitor (Operating as a Source). Program memory location 1 for the following parameters:
  - A. 50V
  - B. 25mA
  - C. 60 second Dwell Time
  - D. Turn off modulation.
  - E. Turn off sink mode.
3. Discharging the Capacitor (Operating as an Active Load). Program memory location 2 for the following parameters:
  - A. 20V
  - B. 25mA
  - C. 60 second Dwell Time
  - D. Turn off modulation.
  - E. Turn on sink mode.
4. Program the dwell time of memory location 3 to zero.
5. Set the Model 228 to the continuous program mode.
6. Set the Model 228 to the operate mode.
7. Press the START/STOP key.
8. Watch the front panel displays.

When the Model 228 is in memory location 1, the capacitor is charging. Note the voltage on the left display. It increases as the charge on the capacitor charges. The compliance graph shows the Model 228 is in current limit (LED just above the

+I is on). The capacitor is charging at the rate programmed. When the capacitor is charged to 50V, the amps display shows approximately zero current flowing (capacitor charged). The LED to the right and left of the +V symbol are on indicating that the capacitor is at the voltage level programmed.

When the Model 228 is in memory location 2, the capacitor is discharging. Note the voltage on the left display. It decreases as the capacitor discharges. As the capacitor discharges, the compliance graph shows the Model 228 in current limit (LED above the -I is on). When the capacitor is discharged to the 20V programmed level, the LED to the right and left of the +V symbol are on indicating that the capacitor is at the level programmed.

This simple example illustrates several operating modes of the Model 228. The following features and functions of the Model 228 are used in this example.

1. Programming a voltage value.
2. Programming a current value.
3. Programming memory control mode (continuous).
4. Programming the five parameters of a memory location: Voltage, Current, Dwell Time, Modulation, Source or Sink.
5. Operation as a source (memory location 1).
6. Operation as an active load (memory location 2).

### 3.13.6 Example 6: Fabricating Output Waveforms

The Model 228 is capable of fabricating output waveforms. With the 100 available memory locations, the Model 228 can fabricate waveforms with up to 100 individual steps. 100 steps of a waveform may not be necessary. A less complicated waveform could consist of just two memory locations. A square wave is an example of a two memory location waveform. The following is an example of programming the Model 228 to output a squarewave of +5V to 0V at 20Hz. To keep the example simple the current parameter for each of the two memory locations will be set to 100mA.

#### NOTE

To avoid confusion in this example, set all the parameters of memory location 3 to zero.

1. Turn on the Model 228 and allow ten minutes for warm up.
2. Press VOLTS/MEMORY STEP, SELECT. (Selects volts display and sets the left display for modification).

3. Press 5, ., 0, 0, ENTER. (Programs memory location 1 voltage for 5V).
4. Press AMPS/DWELL TIME, SELECT. (Selects amps display and sets the right display for modification).
5. Press ., 1, 0, 0, ENTER. (Programs memory location 1 current for 100mA).
6. Press AMPS/DWELL TIME, SELECT. (Selects dwell time display and sets the display for modification).
7. Press ., 0, 2, 5, ENTER. (Programs memory location 1 for 25msec dwell time).
8. Press VOLTS/MEMORY STEP, SELECT. (Selects memory step display and sets the display for modification).
9. Press 2, ENTER. (Selects memory location 2).
10. Press VOLTS/MEMORY STEP, SELECT. (Selects volts display and sets the display for modification).
11. Press 0, ., 0, 0, ENTER. (Programs memory location 2 for 0.0V)
12. Press AMPS/DWELL TIME, SELECT. (Selects amps display and sets the display for modification).
13. Press ., 1, 0, 0, ENTER. (Programs memory location 2 current for 100mA).
14. Press AMPS/DWELL TIME, SELECT. (Selects the dwell time display and sets the display for modification).
15. Press ., 0, 2, 5, ENTER. (Program memory location 2 dwell time to 25msec).
16. Connect load.
17. Press CONTINUOUS, OPERATE, START/STOP. (Selects the continuous memory control mode, enables the output and starts the continuous mode).

Upon completion of step 17, the Model 228 outputs a 5V to 0V, 20Hz square wave. Refer to Figure 3-14.

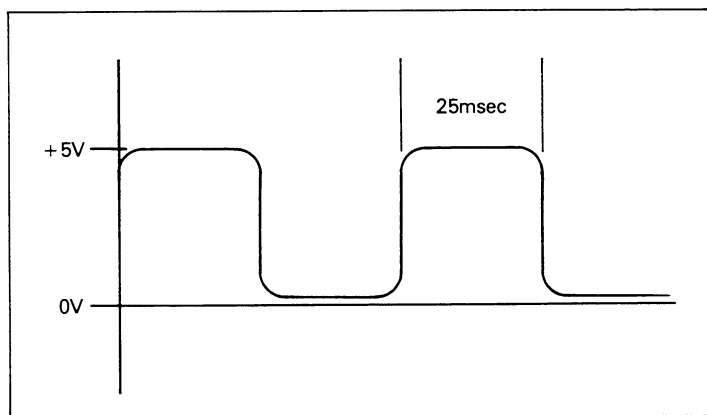

**Figure 3-14. Output Waveform**

### 3.13.7 Example 7: Using the External Trigger (Input and Output)

A TTL level negative going pulse of greater than  $10\mu\text{sec}$  applied at the rear panel external TRIGGER connector initiates the selected memory control mode (Single Step, Single Cycle or Continuous). The pulse starts the memory control mode in the same manner as the front panel START/STOP key. To output any programmed values, the memory control mode must be selected, the OPERATE key enabled and the proper external trigger pulse must be applied to the rear panel external TRIGGER input connector.

The external trigger output is a TTL level negative going greater than  $10\mu\text{sec}$  pulse that signifies the completion of a programmed dwell time. The pulse appears at the rear panel external trigger output connector at the end of the programmed dwell time in all three memory control modes (Single Step, Single Cycle and Continuous). For the single cycle and continuous memory control mode, there is an output pulse at the end of every programmed dwell time. For the single step mode, there is an output pulse at the end of the programmed dwell time for the one memory location. To go on to the next step, (memory location); and therefore output another pulse, another external trigger input pulse is required. Refer to paragraph 3.7 Memory Control Group.

As an example of using external input and output triggering, assume the Model 228 is to be used in conjunction with the Model 195A System DMM. The Model 228 can be programmed to output up to 100 voltage/current levels for given periods of time. As each output voltage/current is applied, the Model 228 triggers the Model 195A to take a reading. When the Model 195A completes its reading, it triggers the Model 228 to output the next programmed voltage/current value. The sequence repeats itself until all readings have been taken.

To use the Model 195A with the Model 228 perform the following steps:

1. Connect the Model 228 and the Model 195A as shown in Figure 3-15. Use suitable shielded cables with BNC connectors. The Model 195A voltmeter complete output should be connected to the Model 228 external trigger input. The Model 195A external trigger input should be connected to the Model 228 external trigger output.
2. Place the Model 195A in the external trigger mode.
3. Connect both the Model 228 and the Model 195A to the circuit under test.
4. Program the Model 228 with the desired output voltage, current and dwell time values (refer to paragraph 3.10, Examples 1, 2 and 3). Set the Model 195A to the ap-

appropriate function and range. If desired, enable the Model 195A data buffer for reading storage.

5. Select the Model 228 memory control mode. To illustrate this example, select the single step mode.
6. Place the Model 228 in the operate mode.
7. Press the START/STOP key on the Model 228 to output the first voltage/current value.
8. Press the Model 195A front panel trigger button. This starts the measurement cycle on the Model 195A.
9. After the Model 195A completes the reading, it triggers the Model 228 into the next memory location; and therefore, output the next voltage/current value.
10. Each instrument will trigger the other until the trigger cycle is stopped.

**CAUTION**

**Do not exceed 30V between the external trigger connectors (outer ring) and chassis ground or instrument damage may occur.**

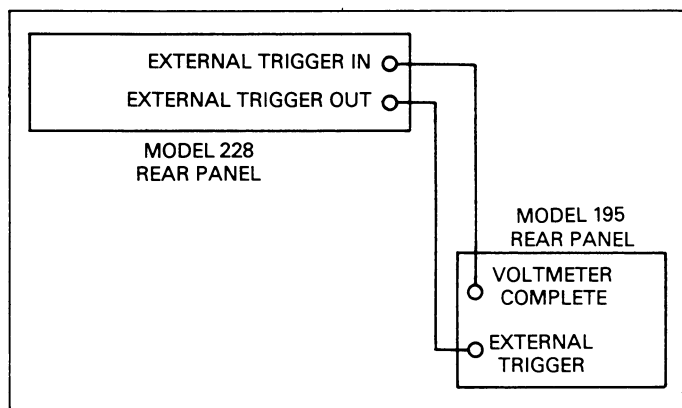

**Figure 3-15. External Trigger Connections**

**3.13.8 Example 8: Floating Operation (Extended Compliance)**

The Model 228 may be floated up to 101V off of chassis ground (earth ground). Floating the Model 228 off of earth ground increases the compliance voltage by that level. The maximum float voltage is 101V and the maximum compliance voltage is 100V. This increases the compliance level to 201V. This does not mean that the Model 228 will deliver 201V of compliance. 100V is from the Model 228 and 101V from the external supply. A second Model 228 is a good choice to use for the external supply. Before floating the Model 228 above earth ground with an external supply, always check for the proper circuit connections. Figure 3-16 shows the proper connections when floating the Model 228 above earth ground.

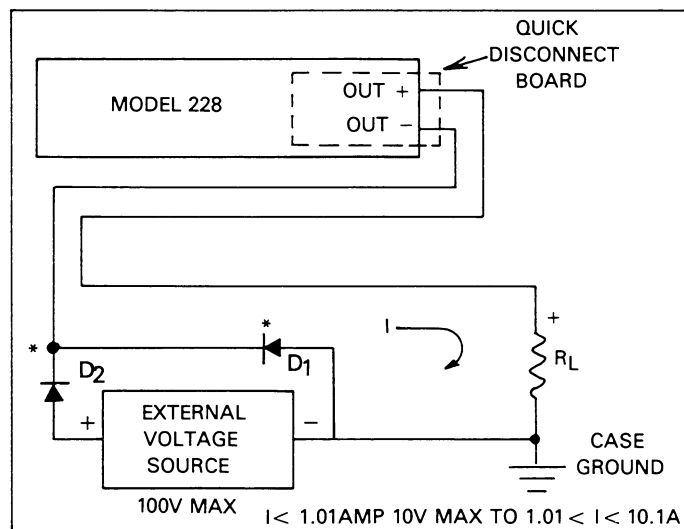

\*IF THE EXTERNAL VOLTAGE SOURCE IS NOT A MODEL 228, THE DIODES SHOWN (D<sub>1</sub> & D<sub>2</sub>) SHOULD BE USED TO PROTECT THE EXTERNAL SOURCE FROM SUCH ERRORS AS:

1. INCORRECT MODEL 228 PROGRAMMED POLARITY.
2. IMPROPER POWER ON SEQUENCE.
3. EXCESSIVE MODEL 228 PROGRAMMED VOLTAGE.

**Figure 3-16. Connection for Floating Operation**

**CAUTION**

**When an external voltage source is connected in series with the Model 228 output (as shown in Figure 3-16), care should be taken to observe the power limits specified in Figure 3-12. Also, the current MONITOR and MODULATION connectors are held within a few volts of the OUT – terminal by the Model 228.**

**3.14 APPLICATIONS**

The following applications allow the Model 228 to be used in several situations including: source current and an active load (current sink).

**3.14.1 Low Resistance Measurements**

Connectors, switch and relay contacts, printed circuit boards and other devices with  $\mu\Omega$  resistances can be measured with current, source and sensitive voltmeters, For example: Using 10A and 1mV range gives  $100\mu\Omega$  resolution ( $1\text{mV}/10\text{A}$ ) =  $100\mu\Omega$ . This resolution is obtainable without using an additional digital multimeter.

### NOTE

For this example remote sensing should be used.

The four terminal measurement eliminates the effects of test lead resistances. The Model 228 could be used to supply a current ( $I$ ) through the device under test (DUT). This develops a voltage ( $IR_{DUT}$ ) which could be read by the sensitive voltmeter. Using a 100mA current, the 10nV resolution of the Keithley Model 181 Nanovoltmeter corresponds to  $0.1\mu\Omega$ . Thermal EMFs, electrochemical and other effects add an extraneous DC voltage ( $V_{OFFSET}$ ) to the voltage developed by the current source. This offset may be eliminated by applying first a positive and then a negative current, both of the same magnitude ( $I$ ).

For positive current:  $V_{X+} = IR_{DUT} + V_{OFFSET}$

For negative current:  $V_{X-} = -IR_{DUT} + V_{OFFSET}$

The difference of these voltages is as follows:

$$(V_{X+} - V_{X-}) = (IR_{DUT} + V_{OFFSET}) - (-IR_{DUT} + V_{OFFSET}) = 2IR_{DUT}$$

or

$$R_{DUT} = \frac{(V_{X+} - V_{X-})}{2I}$$

The DUT can be installed in the Model 8003 Low Resistance Test Box, which employs Kelvin sensing and includes all interconnecting cables to Models 181 and 228.

The same measurement techniques can be applied to materials testing, where a metal under stress eventually microfractures, causing an increase in resistance. Small laboratory samples or even large airplane wings can be tested in this manner. Refer to Figure 3-17 for an example configuration.

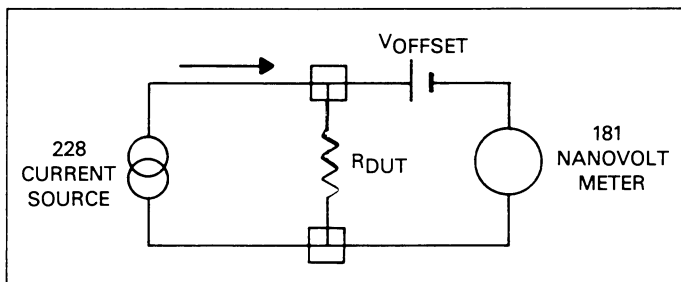

Figure 3-17. Low Resistance Measurements

### 3.14.2 Battery Tests

The Model 228 is capable of acting as a source or as an accurate and stable load. Testing the life of a battery requires such a load. The Model 228 could be set to dissipate power from the battery. The load conditions could be programmed over the IEEE-488 bus or from the front panel.

Figure 3-18 shows the configuration of the Model 228 sinking power from the battery. The battery in the figure is rated at 10V therefore the Model 228 should be programmed for a voltage less than 10V in order to operate in the sink mode. When the voltage of the Model 228 is less than the voltage of the battery, current is drawn from the battery into the Model 228. The COMPLIANCE graph shows that the instrument is operating in the sink mode. The voltage is positive but current is being drawn from the battery which shows up on the COMPLIANCE graph as negative current.

The battery could be discharged in this manner. A data logger would be useful to log the decline in battery voltage over a long period of time. The Keithley Model 197 DMM has a built-in 100 point data logger that would be ideal for this application. The data logger of the Model 197 has six selectable rates at which the data may be logged automatically. It also has a numerical trigger for manual data logging. The automatic rates range from three readings per second to one reading per hour. The Model 197 and the Model 228 would work in conjunction with each other to accomplish the battery test. Figure 3-19 shows the configuration of the Model 228, Model 197 and the battery for the test.

When using the Model 228 to test power supplies; most power supplies would be damaged if external voltages or currents are forced upon the, Figure 3-20 is a suggested protection circuit. The two diodes in Figure 3-20 protect most supplies in the event of the following errors.

1. Incorrect Model 228 polarity.
2. Improper power on sequence.
3. The Model 228 is programmed for excessive voltage.

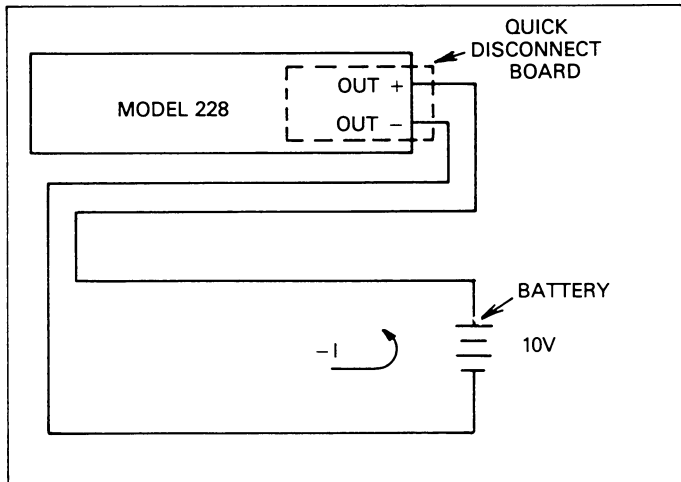

**Figure 3-18. Battery Life Test**

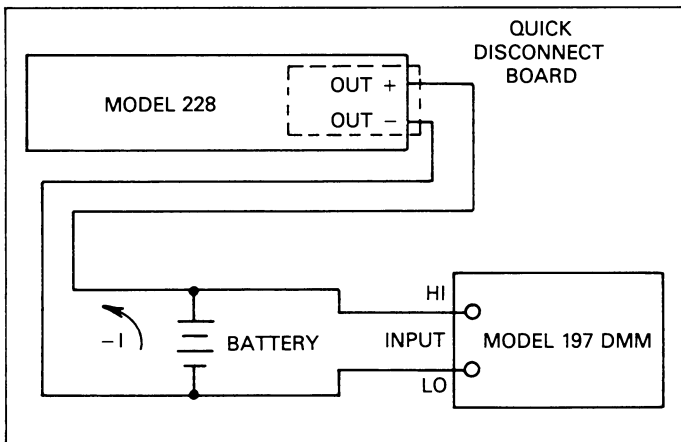

**Figure 3-19. Data Logging Configuration**

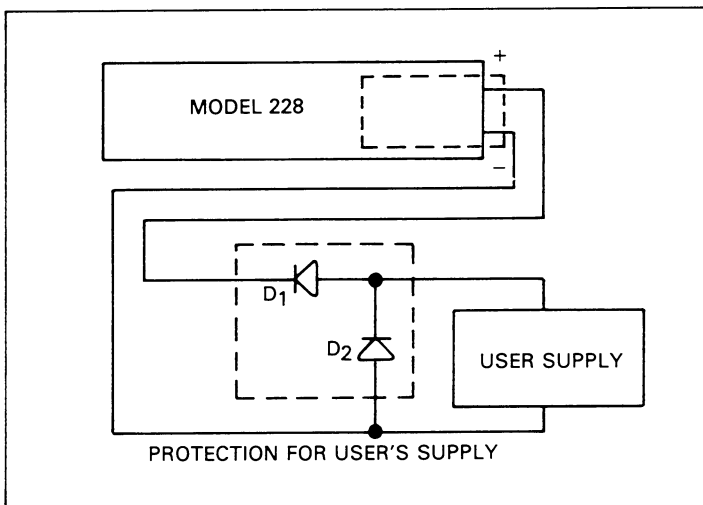

**Figure 3-20. Power Supply Protection Circuit**

### 3.14.3 External Modulation

The output of the Model 228 may be externally modulated. This means the user supplies a low frequency (DC to 600Hz) low voltage ( $\pm 10V$ ) signal that is superimposed on the output signal of the Model 228. This external AC signal is applied to the external modulation terminals on the quick disconnect board and therefore the output signal. The polarity of the modulation is determined by the programmed polarity of the output signal. The input resistance to the external modulate terminal is  $6.8k\Omega$ . The maximum modulation with the output programmed to zero is  $+0.0V$  to  $-10V$ . The maximum modulation with the output programmed to full scale is  $+10V$  to  $-0.0V$ .

The front panel MODULATE I and MODULATE V LEDs indicate which function is selected.

The external modulation feature could be used to add low frequency signals to the Model 228 output. An example could be performing power supply rejection tests without the burden of large transformer or additional power amplifiers. Figure 3-21 shows the configuration for using the external modulation feature. Figure 3-22 shows a typical modulated output.

where:

$$PSRR = \log_{10} \frac{V_i}{V_o}$$

#### NOTE

Use shielded cables when externally modulating the output of the Model 228. The shield should be connected to output LO. Shield cables help in reducing extraneous noise.

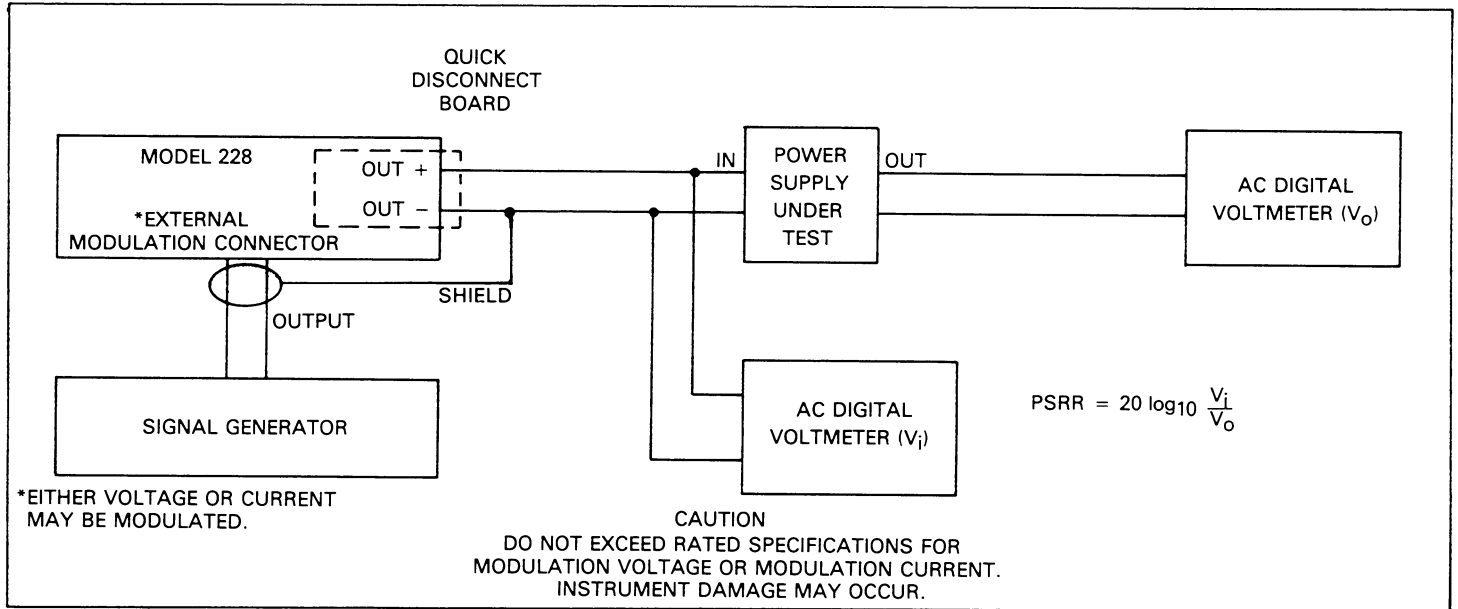

Figure 3-21. Connections for External Modulation

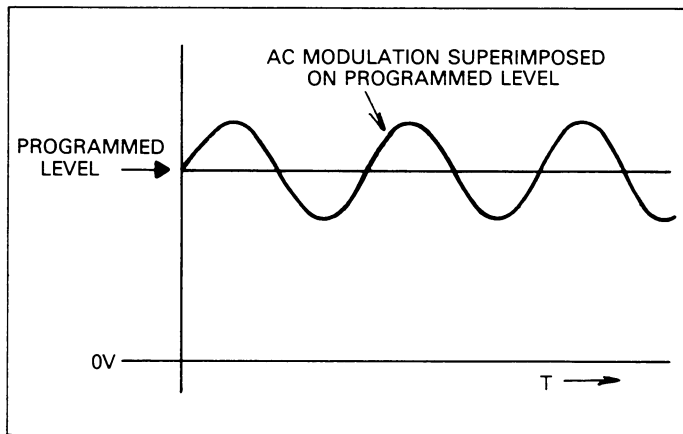

Figure 3-22. Typical Modulated Output

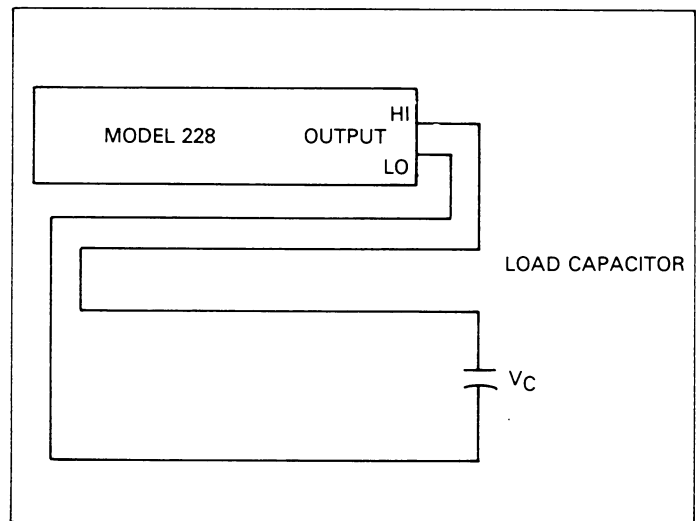
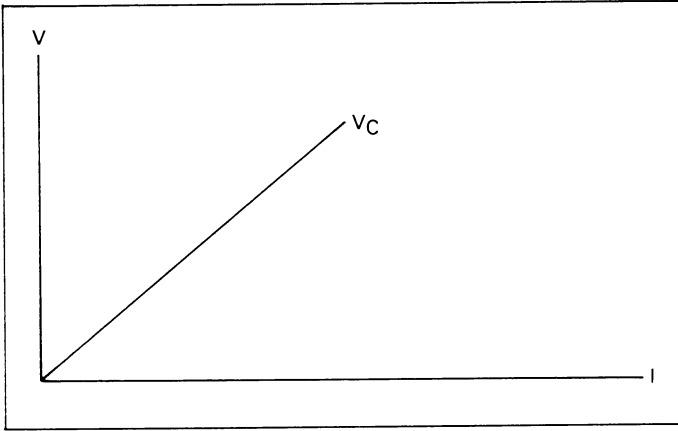

Figure 3-23. Ramp Generation

### 3.14.4 Ramp Generation

A very accurate ramp may be generated by charging a capacitor with the Model 228. The Model 228 charges the capacitor with a constant current up to the compliance limit of the Model 228 or the working voltage of the capacitor. Figure 3-23 shows the Model 228 connected to a capacitor. Figure 3-24 shows the ramp that is generated by the constant current being applied to the capacitor.



**Figure 3-24. Ramp Characteristics**

The ramp is generated as the capacitor charges. When the compliance limit of the Model 228 is reached or the capacitor is fully charged, the ramp levels out to the voltage level on the capacitor. The ramp could be used with a data logger (e.g. Keithley Model 197 DMM in data logger mode). The data logger could be used to store up to 100 data points of the ramp to verify the accuracy of the ramp.

### 3.14.5 Power Semiconductor Testing

The Model 228 is suitable for testing power semiconductors such as VMOS FETs, diodes, power Bipolar transistors, etc. Typical curves for the transistors may be obtained using one or two Model 228s. The Model 228 supplies up to 100W for these applications. Obtaining the curves for bipolar transistors involves two Model 228s. One Model 228 is connected between the base and emitter and another Model 228 is connected between the collector and the emitter. Figure 3-25 shows the configuration for obtaining the family of curves for a power transistor. The curves shown are the collector-emitter voltage versus collector current ( $V_{CE}$ ,  $I_C$  curves).

Most  $V_{CE}/I_C$  curves illustrated in data manuals show the maximum safe forward bias area. This area is self explanatory and should not be exceeded. Figure 3-26 shows typical a structure of  $V_{CE}/I_C$  curves. Also shown in Figure 3-26 is the maximum safe forward bias area.

For incoming inspection testing, manual testing may not be cost efficient. The configuration shown in Figure 3-25 may be connected to the IEEE-488 bus and a computer. The Model

228 has a built-in IEEE-488 interface that allows the test circuit to be incorporated into the measurement system. Figure 3-27 shows the configuration with the Model 228s connected to the computer over the bus.

With the system configuration, the computer may be programmed to control the testing automatically. The Model 228 responds to IEEE-488 protocol concerning commands and data. With the Keithley Model 8573 IEEE-488 interface the Model 228 may be controlled with the IBM PC or XT. The Model 8573 IEEE-488 is supplied with its own software boot disk and instruction manual. The instruction manual provides clear instructions for operating the Model 8573 with the IBM PC or XT.

Other transistor tests may be performed using the Model 228 and the configuration shown in Figure 3-25. Examples of these tests include:

1. DC Current Gain—The graph of DC current gain shows collector current ( $I_C$ ) versus  $h_{fe}$ .
2. "ON" Voltages—The graph of "ON" voltages shows the collector current ( $I_C$ ) versus the "ON" voltage of the transistor.
3. Collector Saturation Region—The collector saturation region graph shows base current ( $I_C$ ) versus collector emitter voltage ( $V_{CE}$ ).

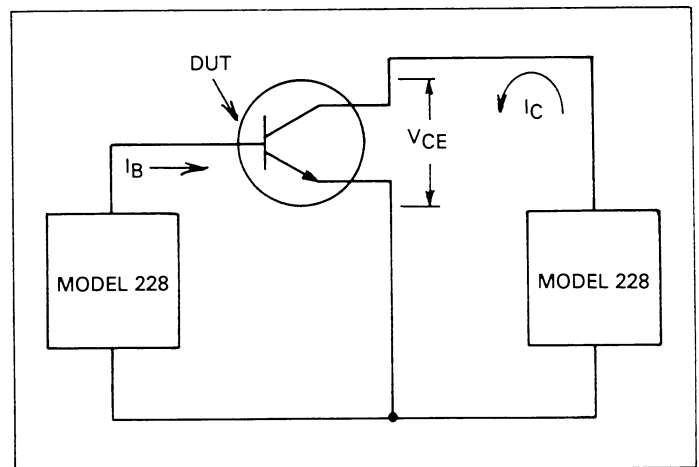

**Figure 3-25. Power Transistor Test Set Up**

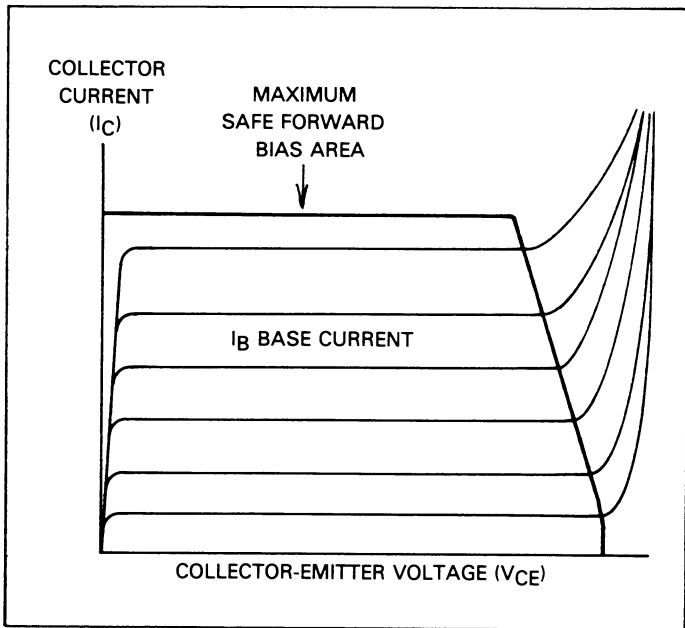

Figure 3-26. Power Transistor  $I_C/V_{CE}$  Curves

bipolar transistor. Figure 3-28 shows the configuration using a FET instead of a bipolar transistor. Figure 3-29 shows the family of curves for a FET instead of a bipolar transistor. Figure 3-30 shows the automated test set up with a FET instead of a bipolar transistor.

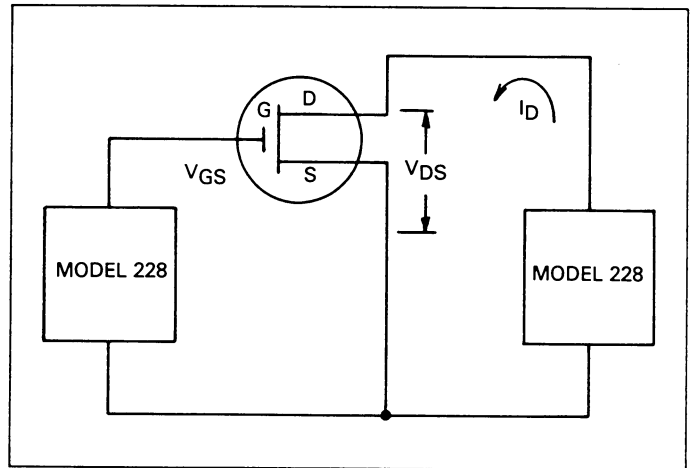

Figure 3-28. FET Test Set Up

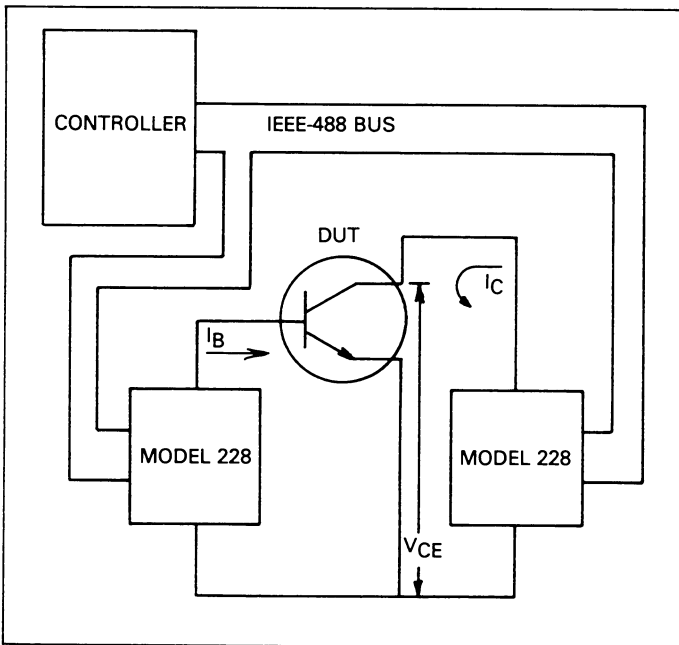

Figure 3-27. Automated Test Set Up

**NOTE**

Using the bipolar capability of the Model 228, both polarity transistors can be tested without rewiring.

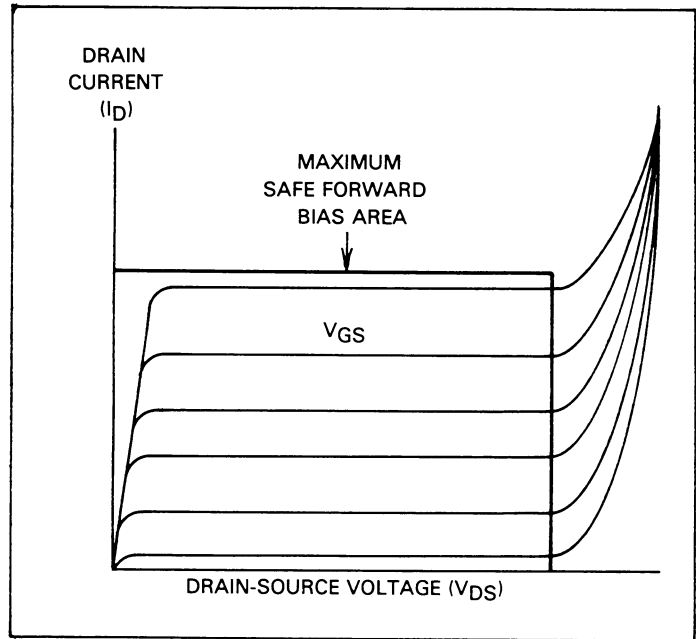
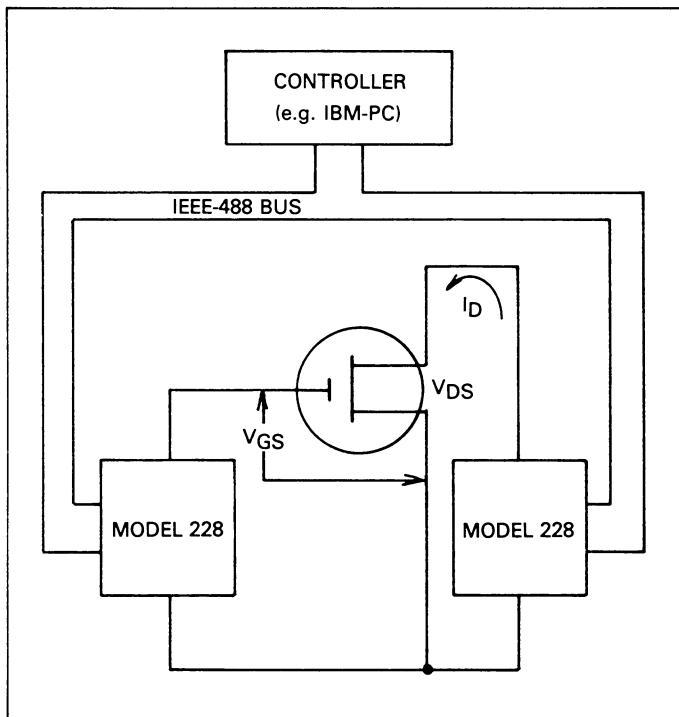

Figure 3-29. FET Curves

The test set up is shown in Figure 3-25, the curves shown in Figure 3-26 and the automated set up shown in Figure 3-27 could all apply to FETs as well as bipolar transistors. In Figure 3-25 the set up would be slightly different for a FET than for a





**Figure 3-30. Automated Test Set Up for FETs**

### 3.14.6 Compensation for Noise

#### OUTPUT NOISE

For most applications, electrical noise coming from the Model 228 is negligible. However, some Model 228 users may have some output noise questions when operating this instrument in extremely sensitive applications. The following information will help you determine possible sources of the noise, which noise frequency range your test application is sensitive to, and what you can do to isolate or reduce the noise.

Before you can isolate or reduce electrical noise effects in your application, you must determine what frequencies your test is most sensitive to.

- A good source of information is the specification sheet from the device under test.
- Add a "known" controlled noise source (such as a function generator) to the circuit and measure the circuit's sensitivity to it.
- Set up a "noise free" environment, then add one noise source at a time to determine which noise sources affect the test.

To check the circuit's noise sensitivity, try the following:

**COMMON MODE**—Connect a sine wave generator between the "earth" ground and circuit ground. Monitor any changes in the circuit's performance as frequency is swept to determine its noise sensitivity.

**NORMAL MODE**—Connect a sine wave generator in series with "safe" level (<30V) signal lines. Be careful not to violate grounding through the function generator (since many function generators connect one output terminal to "earth" ground). Isolate the function generator from high level (>30V) signals with a transformer. Check circuit performance as in common mode testing to determine noise sensitivity.

#### NOISE SOURCES

There are many possible sources of electrical noise both from the Model 228 and from external sources. The following characterizes noise sources within the Model 228:

- The Model 228's microprocessor is isolated from the output circuitry by opto-isolators. However, some microprocessor hash in the 25-100MHz range may appear on the output due to capacitive coupling within the Model 228. When viewed with a wideband oscilloscope, the noise may look much greater than low frequency noise. However, this is usually not a problem in experiments since it is mostly common mode and not seen across the load. The low common mode rejection ratio of most scopes at these frequencies impairs their ability to make accurate normal mode (across the load) noise measurements.
- There may be low level noise at the Model 228 power line frequency.
- There may also be some noise generated at 50kHz and harmonics of 50kHz due to the switching power supply.

Some noise sources in typical laboratory environments include:

- **Equipment with Microprocessors and/or Digital Circuitry:** This includes personal computers, peripherals, and test equipment. Noise from these sources is coupled through cables. Frequency components of this type of noise include multiples and subharmonics of internal clocks and hash from signal edges.
- **Computer Terminals:** Terminals may generate noise at 15kHz and harmonics of 15kHz. In addition, some 1MHz-100MHz microprocessor hash may be generated.

- Fluorescent Lighting: Noise can be generated at the harmonics of the power line frequency.
- DC motors: All frequencies can produce some amount of noise (white noise source).
- Broadcast Stations and Commercial Transmitters: Again, a continuous spectrum of noise is generated, most usually around 1MHz and above 50MHz.

## CHECKING FOR NOISE SOURCES

When characterizing electrical noise, a spectrum analyzer or an oscilloscope would be very helpful.

A spectrum analyzer is very useful when used with an antenna and "sniffer" probe. The analyzer provides relative amplitude and frequency information. Multiply the relative amplitude information with the circuit sensitivity at particular frequencies to determine the most significant problems.

If your oscilloscope has an adjustable bandwidth control, it may be used like a spectrum analyzer. Unfortunately, many oscilloscopes have a greater sensitivity-bandwidth product than most circuits. Note that spikes have less energy than a continuous waveform of the same peak amplitude.

## NOISE REDUCTION TECHNIQUES

The following suggestions are "rules of thumb" which may solve many commonly encountered problems.

### Low Frequency Noise Reduction Techniques (to 300Hz)

Low frequency noise is often the result of less than optimal shielding, grounding or circuit layout. Try these solutions:

- Run power lines and grounds for control circuitry separately from noise-selection circuitry.
- If you must ground one of the Model 228's leads, do it at the circuit under test. Only one "earth" connection is allowed for a system to avoid ground loops.
- Employ the "remote sense" capability of the Model 228.
- Use twisted-pair wire for the Model 228's output and sense leads.

### Medium Frequency Noise Reduction Techniques (300Hz-300kHz)

Lead inductance and capacitor equivalent series resistance become significant at medium frequencies. Try the following:

- Bypass the power supply at the circuit under test. Use polystyrene, mylar or ceramic capacitors.
- Shield the circuit. (A ground plane connected at only one point will do.)
- All wires over 6" long (including power supply line) should be shielded or of the "twisted-pair" type. Note--large diameter wire is usually less inductive than small diameter wire of the same length.

Remember--two pieces of equipment may not be at the same "ground" potential even if they are plugged into the same power outlet box.

### High Frequency Noise Reduction Techniques (300kHz-20MHz)

To reduce high frequency noise, try the following:

- Put the circuit under test in a conductive box (for full shielding effects).
- Make sure the leads on bypass capacitors are ¼" or less in length. This requires bringing conductors to capacitors, not vice versa.
- Use mica, glass, low-loss ceramic or polystyrene capacitors.
- Bypass all wires going in to or out of the circuit under test.
  - Ferrite beads are most useful when the DC and peak AC current does not exceed about 10mA.
  - Wire wrapped around a 10Ω or 100Ω carbon composition resistor and soldered to its leads makes a good low Q inductor capable of handling higher currents.
  - Capacitors that short noise to protective shields should have leads as short as possible (¼"). Feedthrough type capacitors are preferred.

- Use bulkhead connectors bolted to the shield for coaxial cables if possible.
- Line filters (electromagnetic interference suppressors) in a metal case work well at higher frequencies if bolted to the circuit shield. Be sure to use the proper current rating.
- Use twisted-pair wire for proper supply and sense lines. Noise coupled into the Model 228 through sense lines will appear on the output and degrade specified performance.
- Avoid using a large value capacitor in parallel with a small value capacitor since this can form a parallel resonant circuit.\* Otherwise, isolate the two capacitors with a damping resistor (10Ω carbon composition is a good starting value).

\* Large value capacitors appear inductive at high frequencies while the small value capacitor may still appear capacitive. The parallel combination will then have a higher impedance at some frequencies than either capacitor by itself.

### 3.14.7 Voltage/Current Transients

Under certain circumstances, the Model 228 will output voltage or current transients approximately 1msec in duration. It is important to be aware of these transients and be familiar with techniques to avoid them in situations where their presence is damaging, or at the very least, a nuisance.

The possibility of a transient occurring only exists when the Model 228 switches from current control to voltage control (voltage transient) or from voltage control to current control (current transient). In addition to obvious control changes caused by programmed voltage and current parameters in memory steps, control changes may also occur when going from standby to operate, changing polarity or changing ranges.

When the Model 228 is in standby, it is actually programmed to output 0.4% of the range it is on. For example, on the 100V, 1A range (R8), the instrument will be set to 0.4V and 4mA. The following table lists the standby settings for each range. The controlling function (voltage or current) in standby is determined by the load connected to the output. The table below shows the controlling function on each range for the various load conditions. For example, with a 50Ω load resistor and the 100V, 1V range (R8) selected, standby would put the output in current control.

#### Controlling Function in Standby

Range	Standby Settings	Controlling Function	
		Voltage	Current
R1; 1V, 100mA	4mV, 400μA	>10Ω	<10Ω
R2; 1V, 1A	4mV, 4mA	>1Ω	<1Ω
R3; 1V, 10A	4mV, 40mA	>0.1Ω	<0.1Ω
R4; 10V, 100mA	40mV, 400μA	>100Ω	<100Ω
R5; 10V, 1A	40mV, 4mA	>10Ω	<10Ω
R6; 10V, 10A	40mV, 40mA	>1kΩ	<1kΩ
R7; 100V, 100mA	400mV, 400μA	>10Ω	<10Ω
R8; 100V, 1A	400mV, 4mA	>100Ω	<100Ω

Being aware of the controlling function (voltage or current) in standby is important because the Model 228 internally goes into standby when changing polarity or ranges. When changing ranges, the instrument will first go into standby on the range it is presently at, then go into standby on the next programmed range, and finally go to the programmed settings of that range. Thus, three steps have to be considered to see if control changes occur when changing

ranges. When changing polarity, the instrument first goes into standby and then goes into the programmed settings. Thus, two steps have to be considered to see if a control change occurs when switching polarity.

Amplitude of the transient is determined by the programmed parameters of the memory step that caused the control change. If the control change is going from current to voltage control, maximum possible peak of the transient is the programmed current times the load resistor (Ohms law). If the control change is going from voltage to current control, the transient will approach the value of the programmed voltage setting.

**Example**—Assume a current to voltage control change will generate a transient. The settings at the voltage control step are 10V and 1A. The load is a resistor of 25Ω.

$$\text{Maximum Peak Transient} = 1\text{A} \times 25\Omega = 25\text{V}$$

In this example, the transient will exceed the 10V programmed voltage level by up to 15V. Note that if the voltage control step is programmed for 25V (or more), the transient will not occur. At 24V, the transient will be minimal (not more than 1V higher than the programmed voltage).

#### Controlling Transients

Not all control changes will generate a transient. With voltage in control, a transient will not occur in the next memory step if the voltage settings are the same. For example, going from a voltage controlled step set for 10V to a current controlled step also set for 10V will not result in a transient. With current in control, a transient will not occur in the next step if the current settings are the same. For example, going from a current controlled step set for 0.5A to a voltage controlled step also set for 0.5A will not result in a transient. Careful programming using these techniques should prevent most transients from occurring.

When a transient-generating control change cannot be avoided, an interim step can be added between the two steps to eliminate or at least minimize the transient.

#### Interim Step Programming

The purpose of the interim step is to induce the control change at settings that will generate a momentary transient at a level that will equal or approximate the actual voltage level of the preceding or following memory step.

**Voltage-to-Current Control Change**—In this situation, the momentary transient will approximate the programmed voltage setting of the current controlled step. The interim step should be programmed to a voltage setting that is identical to the voltage setting of the voltage control step or very close to the actual output voltage of the current control step. The interim step must control current and output the same voltage as the current control step. Thus, the current setting of the interim step must be identical to the current setting of the current control step.

**Example**—Assumptions: 10Ω load; 10V, 10A range for all steps; Model 228 programmed as follows:

Standby:	40mV	40mA	10Ω	(Voltage controlled)
Memory	1V	1A	10Ω	(Voltage controlled; 1V output)
Step 1:				
Memory	10V	0.2A	10Ω	(Current controlled; 2V output)
Step 2:				

This simple, single step test sequence is intended to output 1V at step 1 and 2V at step 2. However, a transient of up to 10V will be seen on the leading edge of step 2 (see the following waveform).

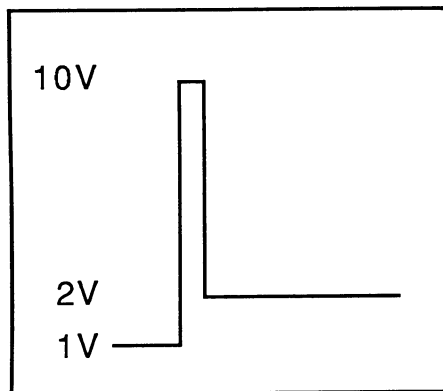

To effectively reduce the transient, the following interim step can be added between the two steps.

Standby:	40mV	40mA	10Ω	(Voltage controlled)
Memory	1V	1A	10Ω	(Voltage controlled; 1V output)
Step 1:				
Memory	2.01V	0.2A	10Ω	(Current controlled; 2V output)
Step 2:				
Memory	10V	0.2A	10Ω	(Current controlled; 2V output)
Step 3:				

The interim step (step 2) is programmed for a current setting identical to the current setting of step 3. The voltage setting of step 2 is high enough to put the step in current control, yet low enough to make the transient insignificant. The 2.01V transient is very close to the desired 2V output of step 3 (see the following waveform).

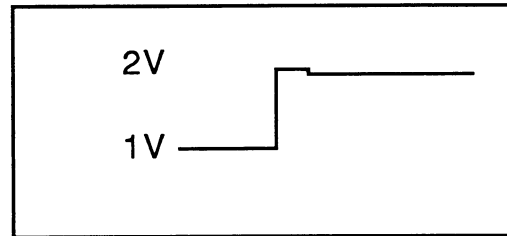

**Current-to-Voltage Control Change**—In this situation, the transient will approximate the product of the current setting of the voltage control step times the load resistance. The interim step should therefore be programmed to a current setting that is identical to the current setting of the current control step, or to a setting whose value times the load resistor will calculate very closely to the output voltage of the voltage control step. The interim step must control voltage and output the same voltage as the voltage control step. Thus, the voltage setting of the interim step must be identical to the voltage setting of the voltage control step.

**Example**—Assumptions: 0.5Ω load; 10V, 10A range for all steps; Programmed as follows:

Standby:	40mV	40mA	0.5Ω	(Current controlled)
Memory	2V	3A	0.5Ω	(Current controlled; 1.5V output)
Step 1:				
Memory	3V	10A	0.5Ω	(Voltage controlled; 3V output)
Step 2:				

This single step test sequence is intended to output 2V at step 1 and 3V at step 2. However, a transient of up to 5V will be seen at the leading edge of step 2 (see the following waveform).

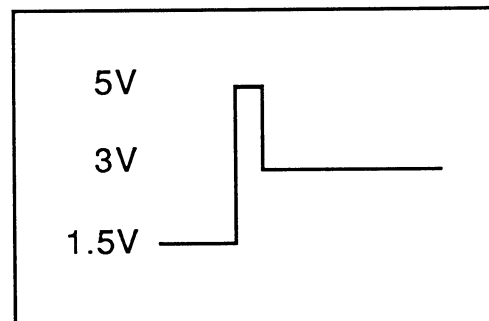

To effectively reduce the transient, the following interim step can be added between the two steps.

Standby:	40mV	40mA	0.5Ω	(Current controlled)
Memory	2V	3A	0.5Ω	(Current controlled;
Step 1:				1.5V output)
Memory	3V	6.01A	0.5Ω	(Voltage controlled; 3V
Step 2:				output)
Memory	3V	10A	0.5Ω	(Voltage controlled; 3V
Step 3:				output)

The interim step (step 2) is programmed for a voltage setting identical to the output voltage of step 3. The current setting of step 2 is high enough to put the step in voltage control, yet low enough to make the transient insignificant. The 3.005V transient is very close to the desired 3V output of step 3 (see the following waveform).

Use the following general rules to avoid, eliminate or minimize transients:

1. Avoid range changes in a test sequence. Use a range that will accommodate all step programming of the test sequence.
2. When programming, be aware of control changes. When in voltage control, programming the next step at the same voltage setting will prevent a transient from occurring. When in current control, programming the next step at the same current setting will prevent a transient from occurring.
3. Use interim programming between transient-generating test sequence steps.
4. A possible external solution to a transient is to install a zener diode across the load to clamp the voltage at an appropriate level.

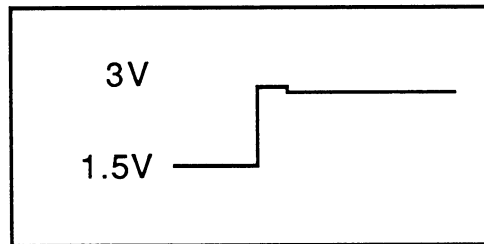



# SECTION 4

## IEEE BUS OPERATION

### 4.1 INTRODUCTION

This section contains information necessary to operate the Model 228 over the IEEE-488 bus. The Model 228 has a standard IEEE interface that allows the user to give commands and read data via an external device. Front panel Programs 2, 4, 5 and 6 may be activated over the bus.

A typical set up for controlled operation is shown in Figure 4-1. Generally, a system will contain one controller and a number of other instruments to which the commands are given. Device operation is categorized into three operators: controller, talker and listener. The controller does what its name implies; it controls the instruments on the bus. The talker sends data while a listener receives data. Depending on the type of instrument, any particular device can be a talker only, a listener only or both a talker and a listener.

Any given system can have only one active controller, but any number of talkers or listeners may be present up to the hardware limitations of the bus. Generally, the bus is limited to 15 devices, but this number may be reduced if higher than normal transfer rates are required or if longer than normal cables are used.

Only one device on the bus may be a talker at any given time while several devices can be commanded to listen. Before a device can be commanded to talk or listen it must be appropriately addressed. Devices are selected by their primary address. Usually, each device on the bus has its own primary address so that each device may be addressed individually. The primary address of the Model 228 is set at the factory to 11. The primary address may be changed by front panel Program 3. For more information concerning front panel programs refer to paragraph 3-11.

Once a device is addressed to talk or listen, the appropriate bus transactions take place. For example: if the Model 228 is addressed to talk, it places its data string on the bus one byte at a time. The controller reads the information and the appropriate software can be used to direct the information to the desired location.

### 4.1.1 Software Considerations

The most sophisticated computer in the world would be useless without the necessary software. This basic requirement is also true of the IEEE-488 bus, which requires the use of handler routines as described in this section.

Before a controller can be used with the IEEE-488 interface, the user must make certain that the appropriate handler software is present within the controller. With the HP-85 computer, for example, the HP-85 interface card must be used with an additional I/O ROM, which contains the necessary handler software. As another example, the IBM PC (use the Keithley Model 8573 IEEE-488 interface) also requires handler software. This handler software is on the disk that is provided with the Keithley Model 8573.

Other small computers that can be used as controllers have limited IEEE capability. The PET/CBM computer, for example, is incapable of sending multiline commands from BASIC, although these commands can be sent through machine language routines. The capabilities of other small computers depends on the particular interface being used. Often, little software "tricks" are required to achieve the desired results.

From the preceding discussion, the message is clear, make sure the proper software is being used with the interface. Often, the user may incorrectly suspect that a hardware problem is causing fault when it was the software that was causing the problem all along.

### 4.1.2 Interface BASIC Programming Statements

Many of the programming instructions covered in this section use examples written in Hewlett-Packard Model 85 BASIC and Keithley Model 8573 interface statements. These computers and interfaces were chosen for these examples because of their versatility in controlling the IEEE-488 bus. This section covers those HP-85 and Model 8573 statements that are essential to Model 228 operation.

A complete list of HP-85 BASIC and Model 8573 interface statements is shown in Table 4-1. HP-85 statements have one or three digit argument that must be specified as part of the statement. The first digit is the interface select code, which is set to 7 at the factory. The last two digits of those statements with a 3-digit argument specify primary address.

Those statements with a 3-digit argument listed in the table show a primary address of 11 (the default primary address of the Model 228). For a different address the last two digits need to be changed to the required value. For example, to send a GTL command to a device using a primary address of 11 the following statement would be used:

LOCAL 711.

Some of the statements have two forms; the exact configuration depends on the command to be sent over the bus. For example, CLEAR 7 sends a DCL command, while CLEAR 711 sends the DC command to device with a primary address of 11.

The Model 8573 statements, which are also listed in Table 4-1, are different than the HP-85 statements. Each of these statements use the IBM BASIC CALL statement, with a different variable passed as shown in the table. The command words, such as IBCLR (Interface Bus Clear) and IBSRE (Interface Bus Send Remote Enable), are BASIC variables. These variables must be initialized at the start of each BASIC program. These keywords should not be used for any other purpose in your BASIC program.

Before using the Model 8573 examples, the software must be configured with the following procedure. Note that the binary handler file called GPIB.COM and the system con-

figuration file called CONFIG.SYS must be present on the DOS boot disk (see the Model 8573 Instruction Manual).

1. Boot up the system in the usual manner and enter BASICA.
2. Place the Model 8573 software disk into the default drive and load the program called "DECL.BAS". Modify the program by changing the XXXXX values in lines 1 and 2 to 16000.
3. Add the following lines to the declaration file:  

```
7 NA$="GPIB0":CALL IBFIND(NA$,BRD0%)
8 NA$="DEV0":CALL IBFIND(NA$,M228%)
9 V%=11:CALL IBPAD(M228%,V%)
```
4. Now save the modified declaration file for future use. Remember that you must load and run this short program before using the Model 8573 programming examples throughout this section. Also, do not use the BASIC CLEAR or NEW commands after running this program.

### 4.1.3 Interface Function Codes

The interface codes are part of the IEEE-488-1978 standards. These codes define an instrument's ability to support various functions and should not be confused with programming commands found elsewhere in this section.

Table 4-2 lists the codes for the Model 228. These codes are also listed on the rear panel of the Model 228. The codes are located near the IEEE connector. The numeric value following each one or two letter codes defines the Model 228 capabilities as follows:

SH (Source Handshake Function)—The ability for the Model 228 to initiate the transfer of message/data on the data bus is

**Table 4-1. HP-85 and IBM BASIC Statements**

Action	HP-85 Statement	Model 8573 Statement
Transmit string to device 11.	OUTPUT 711;A\$	CALL IBWRT(M228%,CMD\$)
Obtain string from device 11.	ENTER 711;A\$	CALL IBRD (M228%,CMD\$)
Send GTL to device 11.	CALL LOCAL 711	CALL IBLOC(M228%)
Send SDC to device 11.	CLEAR 11	CALL IBCLR(M228%)
Send DCL to all devices.	CLEAR 7	CMD\$ = CHR\$(&H14):CALL IBCMD (BRD0%,CMD\$)
Send remote enable.	REMOTE 7	V% = 1:CALL IBSRE(BRD0%,V%)
Serial poll device 11.	SROLL(711)	CALL IBRSP(M228%,SB%)
Send local lockout.	LOCAL LOCKOUT 7	CMD\$ = CHR\$(&H11):CALL IBCMD (BRD0%,CMD\$)
Send GTL to device 11.	TRIGGER 711	CALL IBTRG(M228%)
Send IFC.	ABORTIO 7	CALL IBSIC(BRD0%)



provided by the SH function.

AH (Acceptor Handshake Function)—The ability for the Model 228 to guarantee proper reception of message data on the data bus is provided by the AH function.

T (Talker Function)—The ability for the Model 228 to send device-dependent data over the bus (to other devices) is provided by the T function. Model 228 talker capabilities exist only after it has been addressed to talk.

L (Listener Function)—The ability for the Model 228 to receive device-dependent data over the bus (from another device) is provided by the L functions. Listener function capabilities exist only after the Model 228 has been addressed to listen.

SR (Service Request Function)—The ability for the Model 228 to request service from the controller is provided by the SR function.

RL (Remote-Local Function)—The ability for the Model 228 to be placed in the remote or local mode is provided by the RL function.

PP (Parallel Poll Function)—The Model 228 does not have parallel polling capabilities.

DC (Device Clear Function)—The ability for the Model 228 to be cleared (initialized) is provided by the DC function.

DT (Device Trigger Function)—The ability for the Model 228 to have its basic operation is provided by the DT function.

C (Controller Function)—The Model 228 does not have controller capabilities.

TE (Extended Talker Capabilities)—The Model 228 does not have extended talker capabilities.

LE (Extended Listener Capabilities)—The Model 228 does not have extended listener capabilities.

#### 4.1.4 Model 228 Interface Commands

Interface commands controlling Model 228 operation are listed in Table 4-3. Not included in the table are device-dependent commands, which are covered in detail in paragraph 4-5.

**Table 4-2. Model 228 Interface Function Codes**

Code	Interface Function
SH1	Source Handshake Capability
AH1	Acceptor Handshake Capability
T6	Talker (Basic Talker, Serial Poll, Unaddressed To Talk On LAG)
L4	Listener (Basic Listener, Unaddressed To Listen On TAG)
SR1	Service Request Capability
RL1	Remote/Local Capability
PP0	No Parallel Poll Capability
DC1	Device Clear Capability
DT1	Device Trigger Capability
C0	No Controller Capability
E1	Open Collector Bus Drivers
TE0	No Extended Talker Capabilities
LE0	No Extended Listener Capabilities

**Table 4-3. IEEE Command Groups**

<b>HANDSHAKE COMMAND GROUP</b>	
	DAC = DATA ACCEPTED
	RFD = READY FOR DATA
	DAV = DATA VALID
<b>UNIVERSAL COMMAND GROUP</b>	
	ATN = ATTENTION
	DCL = DEVICE CLEAR
	IFC = INTERFACE CLEAR
	REN = REMOTE ENABLE
	SPD = SERIAL POLL DISABLE
	SPE = SERIAL POLL ENABLE
<b>ADDRESS COMMAND GROUP</b>	
LISTEN:	LAG = LISTEN ADDRESS GROUP
	MLA = MY LISTEN ADDRESS
	UNL = UNLISTEN
TALK:	TAG = TALK ADDRESS GROUP
	MTA = MY TALK ADDRESS
	UNT = UNTALK
	OTA = OTHER TALK ADDRESS
<b>ADDRESSED COMMAND GROUP</b>	
	ACG = ADDRESSED COMMAND GROUP
	GET = GROUP EXECUTE TRIGGER
	GTL = GO TO LOCAL
	SDC = SELECTIVE DEVICE CLEAR
<b>STATUS COMMAND GROUP</b>	
	RQS = REQUEST SERVICE
	SRQ = SERIAL POLL REQUEST
	STB = STATUS BYTE
	EOI = END

## 4.2 IEEE-488 BUS LINES

As shown in Figure 4-1, the signal lines on the IEEE-488 bus are divided into three groups; management, handshake and data lines. The management and handshake lines ensure that proper data transfer and bus operation take place while the data lines handle bus information. Each of the bus lines are low true with approximately zero volts as a logic 1.

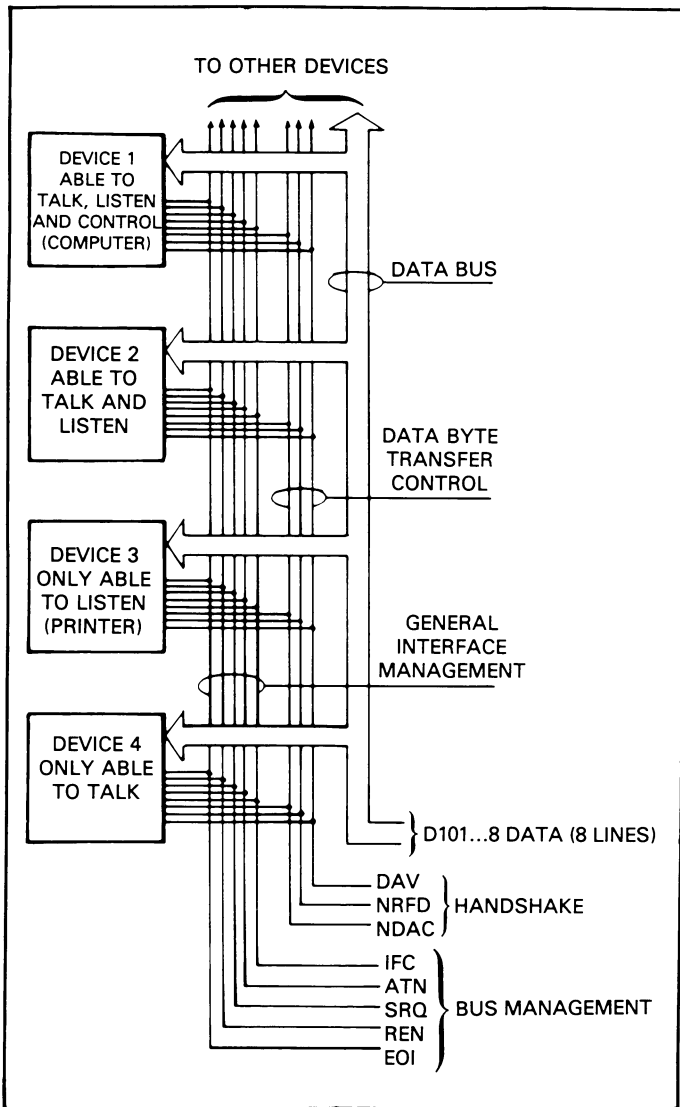

Figure 4-1. Bus Structure

### 4.2.1 Bus Management Lines

The bus management group consist of five signal lines that send certain single line bus commands and ensure an orderly transfer of data. The five signal lines are:

ATN (Attention)—The state of the ATN line determines whether information placed in the data bus by the controller is to be considered data or a command.

REN (Remote Enable)—Setting the REN line low (true) sends the REN command and sets up the instrument on the bus for remote operation. If REN is followed by the primary address of the Model 228, then it will be the only instrument to be placed in the remote mode.

**HP-85 Programming Example**—The REN line is set low (true) by the HP-85 when the following line is entered into the HP-85.

```
REMOTE 711 (END LINE)
```

When the END LINE key is pressed, the Model 228 is placed in the remote mode and the front panel REMOTE LED turns on.

**Model 8573 Programming Example**—The REN line is set low (true) by the IBM PC through the Model 8573 interface when the following is entered into the IBM PC.

```
V% = 1:CALL IBSRE(BRD0%,V%) (return)
CMD$="X":CALL IBWRT(M228%,CMD$) (return)
```

When the return key is pressed the second time, the Model 228 is placed in the remote mode and front panel REMOTE LED turns on.

IFC (Interface Clear)—The IFC command is sent by the controller to set the Model 228 to the talk and listen idle states. The instrument responds to the IFC command by turning off the front panel TALK or LISTEN LEDs if the instrument was previously in one of those modes. To send the IFC command, the controller only has to set the IFC line true.

**HP-85 Programming Example**—Before demonstrating the IFC command, turn on the front panel REMOTE and TALK LEDs by entering the following statement into the HP-85:

```
REMOTE 711 (END LINE)
ENTER 711;A$ (END LINE)
```

The front panel TALK and REMOTE LEDs should now be on. The IFC command may now be sent by entering the following statements into the HP-85:

```
ABORTIO 7 (END LINE)
CLEAR 7 (END LINE)
```

After the END LINE key is pressed the second time, the TALK LED turns off, indicating the Model 228 is in the talk idle state. Note that the remote mode is not cancelled.

**Model 8573 Programming Example**—Before demonstrating the IFC command, turn on the front panel REMOTE and TALK LEDs by entering the following statements into the IBM PC.

```
V% = 1:CALL IBSRE(BRD0%,V%) (return)
CMD$ = CHR$(&HA):CALL IBCMD(BRD0%,CMD$)
      (return)
```

The front panel TALK and REMOTE LEDs should now be on. The IFC command may now be sent by entering the following statement into the IBM PC:

```
CALL IBSIC(BRD0%) (return)
```

After the return key is pressed, the TALK LED turns off, indicating the Model 228 is in the talk idle state. Note that the remote mode is not cancelled.

EOI (End Or Identify)—The EOI is used to identify the last byte of multibyte transfer sequence.

SRQ (Service Request)—The SRQ line is set low (true) by a device when it requires service. SRQ may be identified by reading the status word.

### 4.2.2 Handshake Lines

The handshake group consists of three handshake lines which operate in an interlocked sequence. The interlocked sequence ensures reliable data transfer regardless of the transfer sequence. The rate of transfer is usually determined by the slowest device on the bus. The three handshake lines are:

1. DAV (Data Valid)
2. NRFD (Not Ready For Data)
3. NDAC (Not Data Accepted)

The DAV line is controlled by the source. The NRFD and NDAC lines are controlled by the accepting devices. The complete sequence is shown in Figure 4-2. This sequence handles information one byte at a time.

Once the data is on the bus, the source checks to see that NRFD is high. At the same time NDAC should be low from the previous transfer. Once the NRFD and NDAC lines are properly set, the source sets the DAV line low. The NRFD line goes low; the NDAC line goes high once all the devices

have accepted the data. Each device releases the NDAC line at its own rate, but the NDAC line will not go high until the slowest device on the bus has accepted the data.

After the NDAC line goes high, the source sets the DAV line high indicating that the data is no longer valid. At this point, the NDAC line goes low. The NRFD line is released by each device on the bus, but does not go high until the slowest device on the bus has released the line. The bus is now set to repeat the sequence with the next data byte.

The sequence just described is used to transfer both data and multiline commands. The state of the ATN line determines whether the data bus contains data or commands.

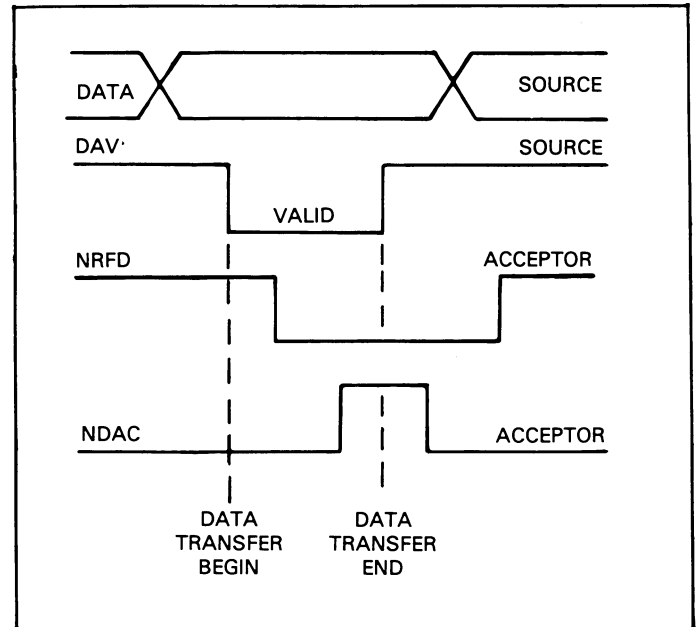

Figure 4-2. Handshake Sequence

### 4.2.3 Data Lines

The IEEE-488 bus uses eight data lines that transfer data one byte at a time. DIO1 through DIO8 (Data Input/Output) are the eight data lines used transmit both data and multiline commands and are bidirectional. The data lines operate with low true logic.

## 4.3 SYSTEM SET UP PROCEDURE

There are two primary set up steps that prepare the system for operation. The two steps are as follows:

1. Bus Connections—The Model 228 is connected to the bus via the rear panel connector. It is a standard IEEE bus connector. Maximum cable length for any device on the bus is 20 meters. The Keithley Models 7008-3 and 7008-6 are ideal for connecting instruments to the bus. Figures 4-3 and 4-4 show the connector pin assignments and the IEEE bus connector. The connector contact designations are listed in Table 4-4.

#### 4.4 BUS COMMANDS

The Model 228 may be given a number of special bus commands through the IEEE-488 interface. This section briefly describes the purpose of the bus commands which are grouped into the following three categories:

Uniline Commands—Sent by setting the associated bus line low.

Multiline Commands—General commands that are sent with the ATN line low.

Device-Dependent Commands—Special commands that depend on device configuration; sent with ATN high.

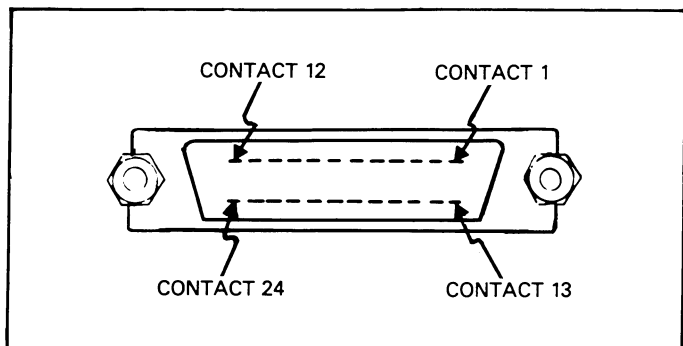

Figure 4-3. Contact Assignments

2. Primary Address Selection—The primary address of the Model 228 must be set to the appropriate value when using the Model 228 in the addressable mode. The primary address is selected by using front panel Program 3. For more information concerning the front panel programs refer to paragraph 3.11.

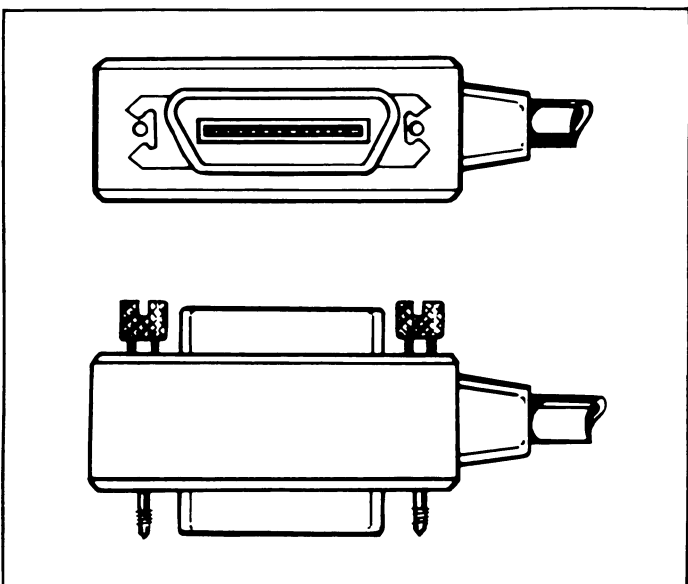

Figure 4-4. Typical Bus Connector

Table 4-4. IEEE Contact Designations

Contact Number	IEEE-488 Designation	Type
1	DIO1	Data
2	DIO2	Data
3	DIO3	Data
4	DIO4	Data
5	EOI (24)*	Management
6	DAV	Handshake
7	NRFD	Handshake
8	NDAC	Handshake
9	IFC	Management
10	SRQ	Management
11	ATN	Management
12	SHIELD**	Ground
13	DIO5	Data
14	DIO6	Data
15	DIO7	Data
16	DIO8	Data
17	REN (24)*	Management
18	Gnd, (6)*	Ground
19	Gnd, (7)*	Ground
20	Gnd, (8)*	Ground
21	Gnd, (9)*	Ground
22	Gnd, (10)*	Ground
23	Gnd, (11)*	Ground
24	Gnd, LOGIC	Ground

\*Number in parentheses refer to signal ground return of referenced contact number. EOI and REN signal lines return on contact 24.

\*\*The cable shield is normally connected to contact 12. This shield should be connected to ground only at the controller end to avoid ground loop problems.

## 4.4.1 Uniline Commands

As stated previously, uniline commands are sent by setting the associated bus line low (true). The five uniline (single line) commands are:

**ATN (Attention)**—The ATN are sent when the information on the data bus is an universal or addressed command. Universal and addressed commands are described in paragraphs 4.4.2 and 4.4.3. When the ATN line is high, the byte on the bus is considered to be data. The Model 228 responds to the appropriate universal and addressed commands when the ATN line is low and to the device-dependent commands when the ATN line is high, assuming it is properly addressed.

**REN (Remote Enable)**—The controller sends the command to all devices on the bus when remote operation is desired. The Model 228 responds by setting itself up for remote operation as indicated by the front panel REMOTE LED.

**EOI (End Or Identify)**—EOI is sent during the last byte of a multiline transfer by setting the EOI line low. In this way, the last byte is identified allowing variable length data words to be transmitted. The Model 228 implements this command when in the appropriate bus response mode as stated in paragraph 4.5.5.

**IFC (Interface Clear)**—The IFC command sets the bus to a known state by setting the IFC line low (true).

**SRQ (Service Request)**—The SRQ line is pulled low (true) by an external device thereby informing the controller the device requires service. The Model 228 implements this command in the appropriate bus response mode as stated in paragraph 4.5.5.

## 4.4.2 Universal Commands

The universal commands are sent when the ATN line is low (true). There are six universal commands and their effect on Model 228 operation is described as follows:

**DCL (Device Clear)**—The DCL command is used to clear the Model 228, thereby setting it to a known state. Program memory is cleared of all previously stored data when a DCL or SDC command is received. The buffer is set to location one.

**HP-85 Programming Example**—Using front panel controls, program a voltage of 5.00V, current of 100.0mA and a dwell time is 3.00 seconds into memory location 1. Now enter the following statements into the HP-85:

```
REMOTE 711 (END LINE)
CLEAR 7 (END LINE)
```

When the END LINE key is pressed after the CLEAR 7 statement, the Model 228 reverts to the power up default conditions which are listed in Table 4-5. This means that all the parameters of memory location 1 were set to the default conditions listed in Table 4-5. All the parameters in each memory location are battery backed up. Therefore, the programmed parameters are unchanged.

**Model 8573 Programming Example**—Using front panel controls, program a voltage of 5.00V, a current of 100.0mA and a dwell time of 3.00 seconds into memory location one. Now enter the following statement into the IBM PC:

```
CMD$ = CHR$(&HA):CALL IBCMD(BRD0%,CMD$)
      (return)
```

When the return key is pressed, the Model 228 reverts to the power up default conditions listed in Table 4-5. All the parameters in each memory location are battery backed up. Therefore, the programmed parameters are unchanged.

**SPE (Serial Poll Enable)**—The serial poll enable sequence is used to obtain the Model 228 status byte. Usually, the serial polling sequence is used to determine which of several devices has requested service over the SRQ line. The serial polling sequence is conducted as follows:

1. The controller sets the ATN line true.
2. The SPE command is placed on the bus by the controller.
3. The Model 228 is addressed to talk.
4. The controller sets the ATN line false.
5. The instrument then places its status byte on the bus to be read by the controller.
6. The controller then sets the ATN line low and places SPD on the bus to end the serial polling sequence.

**HP-85 Programming Example**—The HP-85 SPOLL statement automatically performs the serial polling sequence. To demonstrate serial polling, turn the instrument off then on and then enter the following statements into the HP-85:

```
REMOTE 711 (END LINE)
S=SPOLL (711) (END ELINE)
DISP S (END LINE)
```

When the END LINE key is pressed after the S=SPOLL statement, the controller performs the serial polling sequence. When the END LINE key is pressed after the DISP S statement the status byte value is shown on the CRT. The status byte has a value of zero (0) with this example because all the bits are set to zero (0).

**Table 4-5. DCL and SDC Default Conditions**

Mode	Value	Status
Display	D0	Left display = Volts, Right display = Amps, Left display ready for edit.
Function	F0	Standby. Output set to +4 counts on present range. Refer to paragraph 2.3.
Data Format	G0	Prefix of buffer location contents.
EOI	K0	Send EOI
SRQ	M0	SRQ Disabled
Program Mode	P0	Single Step Mode
Range	R0	Autorange
External Modulation	A & C	Dependent on previously programmed values of present memory location.
Trigger	T6	Stop on X
Terminator	CR LF	Carriage Return Line Feed
Sink Mode	S	Dependent on previously programmed values of present memory location.
Memory Location	B	Present memory location.
Voltage	V	Dependent on previously programmed values of present memory location.
Current	I	Dependent on previously programmed values of present memory location.
Dwell Time	W	Dependent on previously programmed values of present memory location.
Program 1	Copy	Disabled
Program 2	Sink	Dependent on previously programmed values of present memory location.
Program 3	IEEE	Not affected
Program 4	Mod V	Dependent on previously programmed values of present memory location.
Program 5	Mod I	Dependent on previously programmed values of present memory location.
Program 6	Test	Disabled
Program 9	Reset	Disabled

**Model 8573 Programming Example**—The IBM PC conducts a serial poll when the following statements are entered. To demonstrate serial polling, turn the instrument off then on and then enter the following statements into the IBM PC.

```
V% = 1:CALL IBSRE(BRD0%,V%) (return)
CALL IBSRP(M228%,SB%) (return)
PRINT SB% (return)
```

When the return key is pressed after the CALL IBSRP (M228%,SB%) statement, the controller performs the serial polling sequence. When the return key is pressed after the PRINT statement the status byte value is shown on the CRT. The status byte has a value of zero (0) with this example because all the bits are set to zero (0).

SPD (Serial Poll Disable)—The controller automatically sends the SPD command on the bus to end the serial polling sequence in SPE.

UNT (Untalk)—The controller sends the UNT command to clear the bus of any talkers.

UNL (Unlisten)—The controller sends the UNL command to clear the bus of any talkers.

### 4.4.3 Addressed Commands

Each of the addressed commands are sent to a specific device on the bus. Each device is selected on the basis of its primary address. The Model 228 responds to these commands only if the primary address of the command is the same as the primary address of the Model 228. All of the following commands are implemented by addressing the Model 228 to listen.

SDC (Selective Device Clear)—The SDC command performs the same function as the DCL command except that only the addressed device responds. The instrument returns to the set conditions listed in Table 4-5 when responding to an SDC command. The program memory of the addressed Model 228 is cleared of all previously stored data when an SDC command is received. In addition, the buffer and the display pointers are set to memory location 1.

**HP-85 Programming Example**—Using the front panel controls program a voltage of 7V, a current of 1.5A and a dwell time of 250msec for memory location 1. Now enter the following statements into the HP-85:

REMOTE 711 (END LINE)  
CLEAR 716 (END LINE)

Notice that when the END LINE key is pressed after the CLEAR 711 statement that the Model 228 did not respond to the SDC because the command was sent with the wrong primary address (16). Now enter the following statement into the HP-85:

CLEAR 711 (END LINE)

When the END LINE key is pressed after the CLEAR 711 statement, notice that the instrument returns to the power up default conditions listed in Table 4-5. Note that the program memory is cleared of previously stored data.

**Model 8573 Programming Example**—Using front panel controls program a voltage of 7V, a current of 1.5A and a dwell time of 250msec for memory location 1. Now enter the following statements into the IBM PC:

CALL IBCLR(M228%) (return)

When the return key is pressed, notice that the instrument returns to the power up default conditions listed in Table 4-5. Note also that the program memory is cleared of previously stored data.

GET (Group Execute Trigger)—The GET command is used to trigger devices to perform a specific action that depends on device configuration. Although GET is considered to be an addressed command, many devices respond to GET without being addressed. Using the GET command is only one of several methods that can be used to start or stop the Model 228 program operation.

**HP-85 Programming Example**—To help illustrate this example, first set the Model 228 to a known state, such as the default conditions. As in the previous example, to do this use the SDC command as follows:

REMOTE 711 (END LINE)  
CLEAR 711 (END LINE)

When the END LINE key is pressed after the CLEAR 711 statement, the Model 228 reverts to the default conditions listed in Table 4-5. Now enter the following statement into the HP-85 to place the instrument in the single cycle memory control mode (P1) and start on GET trigger mode.

OUTPUT 711;"P1T2X" (END LINE)

Where P1 is the command to set the instrument into the continuous mode and T2 is the command to set the instrument to the start on GET mode. Now the instrument may be triggered to start with the following statement:

TRIGGER 711 (END LINE)

After this statement is entered, the front panel START/STOP LED turns on indicating the instrument has been triggered. To stop the continuous mode, enter the following statements into the HP-85.

OUTPUT 711;"T3X" (END LINE)  
TRIGGER 711 (END LINE)

Where T3 is the command to set the instrument into the stop on GET mode. When the END LINE key is pressed after the OUTPUT 711;"T3X" statement, the continuous mode is stopped. When the END LINE key is pressed after the TRIGGER 711 statement the START/STOP LED turns off indicating the instrument has received the trigger.

The Model 228 also responds to the GET command without addressing. This command is sent with the following HP-85 statement:

TRIGGER 7

**Model 8573 Programming Example**—To help illustrate this example, first enter the following statements into the IBM PC.

V%=1:CALL IBSRE(BRD0%,V%) (return)  
CMD\$="T2P2X":CALL IBWRT(M228%,CMD\$) (return)

When the return key is pressed the first time the Model 228 reverts to the conditions listed in Table 4-5. When the return key is pressed the second time the Model 228 is placed in the start on get trigger mode and the continuous mode.

P2 is the command to set the instrument into the continuous mode and T2 is the command to set the instrument into the start on GET mode. Now the instrument may be triggered with the following statement:

CALL IBTRG(M228%) (return)

After this statement is entered, the front panel START/STOP LED turns on indicating the instrument has been triggered. To stop the continuous mode enter the following statement into the IBM PC:

CMD\$="T3X":CALL IBWRT(M228%,CMD\$) (return)

T3 is the command to set the instrument into the stop on GET mode. The next line provides the trigger required to stop the continuous mode. After the trigger has been received the front panel START/STOP LED turns off.

```
CALL IBTRG(M228%) (return)
```

GTL (Go To Local)—The GTL command is used to remove the instrument from the remote mode. The REN line MUST BE SET HI (FALSE) in order for the GTL command to restore operation of the locked out Model 228 front panel controls.

**HP-85 Programming Example**—To illustrate this example the Model 228 must first be placed in the remote and lockout modes. To place the instrument in these modes enter the following statements into the HP-85:

```
REMOTE 711 (END LINE)
LOCAL LOCKOUT 7 (END LINE)
```

When the END LINE key is pressed after the LOCAL LOCKOUT statement, the Model 228 is in the remote mode (REMOTE LED on) and the front panel controls are locked out (except ON/OFF and LOCAL). The GTL command sequence is automatically sent by the HP-85 with the following statement:

```
LOCAL 711 (END LINE)
```

Note that the REMOTE LED on the front panel control is restored. Setting the REN line false with the LOCAL 7 statement also takes instrument out of the remote mode.

**Model 8573 Programming Example**—To illustrate this example the Model 228 must, first be placed in the remote and local lockout modes. To place the instrument in these modes enter the following statements into the IBM PC:

```
V%=1:CALL IBSRE(BRD0%,V%) (return)
CMD$="X":CALL IBWRT(M228%,CMD$) (return)
```

When the return key is pressed after the CALL IBLOC(BD%) statement, the Model 228 is in the remote mode (REMOTE LED on). The GTL command sequence is automatically sent by the IBM PC with the following statement:

```
CALL IBLOC(M228%) (return)
```

After return key is pressed, the RMT indicator turns off and the instrument is returned to local operation.

## NOTE

The Model 228 may be placed in the local mode by pressing the LOCAL button on the front panel.

## 4.5 DEVICE-DEPENDENT COMMANDS

The device-dependent commands allow the user to send commands to the Model 228 that perform the same operations as the front panel controls (except for POWER ON/OFF). There are a number of commands that control parameters which are not available from the front panel and they are listed in Table 4-6. Each command is entered as an ASCII character followed by a specific parameter that is sent over the bus by the controller. The bus treats these commands as data in that the ATN line is high (false) when the commands are transmitted.

Several commands may be grouped together. Before a command or command string is executed, the ASCII character X must be sent. Commands sent without an X (execute) are retained within the command buffer until the execute character is received.

The condition of the status word with the Model 228 is affected by the device-dependent commands. The status word may be obtained from the unit by using commands covered in this section. Refer to paragraph 4.5.13 for status word information. Illegal commands do not change the mode of the Model 228, but the status byte condition changes as described in paragraph 4.5.5. Normal Model 228 commands are covered in the following paragraphs. All the device-dependent commands for the Model 228 are listed in Table 4-6. Table 4-7 lists the device-dependent commands that are not available to the front panel.

The Model 228 executes the programmed commands in the order listed in Table 4-8. This means that if a statement is entered into the HP-85 as follows:

```
OUTPUT 711;"P1W3.5D1X" (END LINE)
```

The Model 228 executes the commands in the following order according to Table 4-8.

1. Displays memory step (D1).
2. Selects the single cycle mode (P1).
3. Programs the dwell time to 3.5 seconds (W3.5).

With the Model 8573, the instrument executes the commands in the same order as did the HP-85.



There are two types of commands that make up the device-dependent commands listed in Table 4-8. They are as follows:

Independent Commands—Commands that do not interact

with each other.

Timer Commands—Commands that control the time and date.

**Table 4-6. Device-Dependent Commands**

Mode	Command	Notes
Display	D0	Left Display      Right Display VOLTS              AMPS
	D1	MEM STEP          AMPS
	D2	VOLTS              DWELL TIME
	D3	MEM STEP          DWELL TIME
	D4	Display Message Mode
Program	P0	Single Step Mode
	P1	Single Cycle Mode
	P2	Continuous Mode
Prefix	G0	Buffer location contents with prefix.
	G1	Buffer location contents without prefix.
	G2	Full buffer contents with prefix.
	G3	Full buffer contents without prefix.
	G4	Volts, amps readings with prefix.
G5	Volts, amps readings without prefix.	
SRQ	M0	Disabled
	M1	Error (IDDC, IDDCO or No Remote)
	M2	Ready
	M4	End of Buffer
	M8	End of Dwell Time
Trigger	T0	Start on TALK
	T1	Stop on TALK
	T2	Start on GET
	T3	Stop on GET
	T4	Start on X
	T5	Stop on X
	T6	Start on External Trigger
T7	Stop on External Trigger	
Terminator	Y(ASCII)	Any ASCII except capitals, numbers, + - / . or e
	Ym	One Terminator
	Y mn	Two Terminator
	Y(DEL)	None
Inputs	V	Voltage
	I	Current
	W	Dwell Time
	B	Memory Location
Function	F0	Standby (output set to +4 counts on present range). Refer to paragraph 2.3 for details concerning the standby mode.
	F1	Operate (output is present on terminals).

**Table 4-6. Device-Dependent Commands (Cont.)**

Mode	Command	Notes
Range	R0	Autorange
	R1	1V, 100mA
	R2	1V, 1A
	R3	1V, 10A
	R4	10V, 100mA
	R5	10V, 1A
	R6	10V, 10A
	R7	100V, 100mA
	R8	100V, 1A
External Mod	A0	Turn off Voltage Modulation
	A1	Turn on Voltage Modulation
	C0	Turn off Current Modulation
	C1	Turn on Current Modulation
Sink	S0	Turn off sink mode.
	S1	Turn on sink mode.
Status	U0	Send Status Word
	U1	Send Error Status word
Self Test	J0	Inactive 0; in statys byte. Passed 2; in status byte. Failed 1; in states byte.
EOI	K0	Send EOI, hold off bus until commands processed on X.
	K1	Send no EOI, hold off bus until commands processed on X.
	K2	Send EOI, do not hold off on X.
	K3	Send no EOI, do not hold off on X.
Execute	X	Execute other device-dependent commands.

**Table 4-7. Device-Dependent Commands Not Available to the Front Panel**

Mode	Command	Notes
Display	D4	Display Message Mode
Prefix	G0	Buffer location contents with prefix.
	G1	Buffer location contents without prefix.
	G2	Full buffer contents with prefix.
	G3	Full buffer contents without prefix.
	G4	Volts, amps readings with prefix.
	G5	Volts, amps readings without prefix.
EOI	K0	Send EOI, hold off bus until commands processed on X.
	K1	Send no EOI, hold off bus until commands processed on X.
	K2	Send EOI, do not hold off on X.
	K3	Send no EOI, do not hold off on X.
SRQ	M0	Disabled
	M1	Error (IDDC, IDDCO or No Remote)
	M2	Ready
	M4	End of Buffer
	M8	End of Dwell Time
Trigger	T0	Start on TALK
	T1	Stop on TALK
	T2	Start on GET
	T3	Stop on GET
	T4	Start on X
	T5	Stop on X
	T6	Start on External Trigger
	T7	Stop in External Trigger
Terminator	Y(ASCII)	Any ASCII except capitals, numbers, + - / . or e
	Yn	One terminator
	Ymn	Two terminator
	Y(DEL)	None
Status	U0	Send status word
	U1	Send error word
Execute	X	Execute other device-dependent commands.
Range	R0	Autorange
	R1	1V, 100mA
	R2	1V, 1A
	R3	1V, 10V
	R4	10V, 100mA
	R5	10V, 1A
	R6	10V, 10A
	R7	100V, 100mA
	R8	100V, 1A

**Table 4-8. Hierarchy of Command Execution**

Mode	Command
*Display	D0, D1, D2, D3 and D4
*Function	F0 and F1
*Prefix	G0, G1, G2, G3, G4 and G5
*EOI	K0, K1, K2 and K3
*SRQ	M0, M1, M2, M4 and M8
*Program	P0, P1 and P2
*External Modulation	A0, A1, C0 and C1
*Trigger	T0, T1, T2, T3, T4, T5, T6 and T7
*Terminator	Y(ASCII), Y(m), Y(mn) and Y(DEL)
*Status	U0 and U1
*Execute	X
*Self Test	J0
**Range	R0, R1, R2, R3, R4, R5, R6, R7 and R8
***Inputs	V, I, W and B

- \*Executed first
- \*\*Executed second
- \*\*\*Executed last

### 4.5.1 Display Mode (D)

The following five commands set the display for the volts, memory step, amps, dwell time or display message mode.

D0=The D0 command sets the Model 228 for the volts display and amps display mode. Volts is shown on the left display. Amps is shown on the right display. Refer to paragraph 3.7.

D1=The D1 command sets the Model 228 for the memory step and amps mode. The memory step is shown on the left display. Amps is shown on the right display. Refer to paragraph 3.7.

D2=The D2 command sets the Model 228 for the dwell time and volts display mode. Dwell time is shown on the right display. Volts is shown on the left display. Refer to paragraph 3.7.

D3=The D3 command sets the Model 228 for the dwell time display mode. The dwell time is shown on the right display. Refer to paragraph 3.7.

D4=The D4 command sets the Model 228 for the display message mode. The display message mode allows the user to display a customized message on the Model 228 front panel display.

**HP-85 Programming Example**—To display and transmit the present memory location with a prefix and display the data on the HP-85 CRT, enter the following statement into the HP-85:

PROGRAM	COMMENTS
5 DIM A\$[50]	Dimension A\$.
10 REMOTE 711 (END LINE)	Set the Model 228 to the remote mode.
20 CLEAR 7 (END LINE)	Clear the Model 228.
30 OUTPUT 711;"G0D1X" (END LINE)	Display present memory location on the Model 228 display and send memory location with prefix.
40 ENTER 711;A\$ (END LINE)	Obtain data string.
50 DISP A\$	Display data string.
60 END	

After typing in the program, press the RUN key on the HP-85 to run the program. After the RUN key is pressed the present memory location with the prefix is displayed on the HP-85 CRT as follows:

NDCV+1.000E-2, ODCI+0.000E+0, W+3.500E+0,  
B+1.000E+0

where:

DCV = 0.01V

Amps = .0000A

Memory Step = 1

Dwell Time = 3.5 seconds

N = function in control

O = function not in control

This program can be used for any of the prefix (G) commands.

**Model 8573 Programming Example**—To display and transmit the present memory location with a prefix and display the data on the IBM PC CRT, enter the following statements into the IBM PC.

```
V%=1:CALL IBSRE(BRD0%,V%) (return)
CMD$="G0D1X":CALL IBWRT(M228%,CMD$) (return)
RD$=SPACES(25):CALL IBRD(M228%,RD$) (return)
PRINT RD$ (return)
```

After the second statement, the Model 228 displays the present memory location on its front panel display and transmits the data string to the computer. After the fourth statement, the present memory location with the prefix is displayed on the computer CRT.

As another example we will illustrate the D4 (display message) mode. Read the following paragraphs and do the programming example.

The ASCII message is, of course, limited to the display of the seven segment LEDs on the front panels of the Model 228. Both front panel displays may be used to display the message.

The message may be controlled with the following commands:

D4aaaaaaX=The command is D4 while the letter "a" represents an ASCII character (up to seven characters may be sent).

D0, D1, D2 or D3=Takes the Model 228 out of the message display mode (D4) and into the display mode that is programmed.

**NOTE**

For the following notes, refer to the display numbering sequence shown.

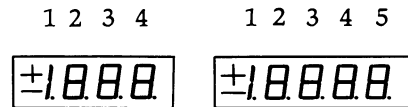

**Notes**

1. The first character on both displays must be a plus (+), minus (-), decimal point or the number 1. Otherwise it will be ignored.
2. Characters 2, 3 and 4 on the left display and 2, 3, 4 and 5 on the right display will accept any displayable ASCII character. Any character not displayed will appear as a "d" segment. A "d" segment is shown as follows:

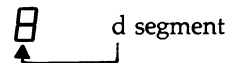

3. The maximum number of characters for the displays that can be sent is nine. The first four characters are shown on the left display. The last five characters are shown on the right display.
4. Depending on the program more than one message may be displayed.

**HP-85 Programming Example**—To display the message "For self test send J0," enter the following program into the HP-85:

PROGRAM	COMMENTS
10 REMOTE 711	Set for remote.
20 OUTPUT 711;"D4 FORSELF"	Display FORSELF.
30 WAIT 1000	Wait on second.
40 OUTPUT 711; "D4 TEST X"	Display TEST.
50 WAIT 1000	Wait one second.
60 OUTPUT 711; "D4 SENDX"	Display SEND.
70 WAIT 1000	Wait one second.
80 OUTPUT 711; "D4 J0X"	Display J0.
90 WAIT 5000	Wait 5 seconds.
100 GOTO 20	Repeat.
110 END	

**NOTE**

Make sure there is a space in the program between D4 and the message. Otherwise an erratic display will result.

When RUN key on the HP-85 is pressed the Model 228 displays the following message:

Display operation may be restored by entering the following statement into the HP-85:

OUTPUT 711;"D0X" (END LINE)

**Model 8573 Programming Example**—To display the message "HELLO," enter the following program into the IBM PC:

PROGRAM	COMMENTS
10 V%=1:CALL IBSRE (BRD0%,V%)	Set up for remote operation.
20 CMD\$="D4 HELLO":CALL IBWRT(M228%,CMD\$)	Display HELLO.

After the return key is pressed the second time the Model 228 displays HELLO. Display operation may be restored by entering the following statement into the IBM PC.

```
CMD$="D0X":CALL IBWRT(M228%,CMD$)
```

### 4.5.2 Memory Control Mode (P)

The following three commands set the Model 228 to single step cycle or continuous memory control mode.

P0=The P0 command sets the Model 228 to the single step memory control mode. The single step memory control mode allows the user to step through the programmed memory locations one at a time upon sending the P0 command. One location per P2 command.

P1=The P1 command sets the Model 228 to the single cycle memory control mode. The single cycle mode allows one complete cycle through the programmed channels.

P2=The P2 command sets the Model 228 to the continuous memory control mode. The continuous mode allows a continuous cycle through the programmed memory location.

**HP-85 Programming Example**—The following example illustrates the P1 (single cycle) memory control mode.

PROGRAM	COMMENTS
10 DIM A\$ [60]	
20 REMOTE 711	Set up for remote operation.
30 OUTPUT 711;"B1X" (END LINE)	Set memory location 001.
40 OUTPUT 711;"V5I1W1X" (END LINE)	Set 5V, 1A and 1 second dwell time in memory location 001.
50 OUTPUT 711;"B2X" (END LINE)	Set memory location 002.
60 OUTPUT 711;"V10IW2X" (END LINE)	Set 10V, 1A and 2 second dwell time in memory location 002.
70 OUTPUT 711;"B3X" (END LINE)	Set memory location 003.
80 OUTPUT 711;"V25I1W3X" (END LINE)	Set 25V, 1A and 3 second dwell time in memory location 003.
90 OUTPUT 711;"P1X" (END LINE)	Set single cycle mode.
100 OUTPUT 711;"D0G0X" (END LINE)	Set for volts display and buffer location with prefix sent.
110 OUTPUT 711;"T0X" (END LINE)	Set for start on talk.
120 ENTER 711;A\$ (END LINE)	Obtain start on talk.
130 DISP A\$	Display data string.
140 END	

After entering the program, press the HP-85 RUN key to run the program. After the RUN key is pressed, the Model 228 steps through memory locations 1, 2 and 3. The Model 228 also displays the programmed voltage for each of the memory locations. Since the program specifies the single cycle mode, the memory locations are stepped through only once. To do so continuously, program P2 in line 90 instead of P1. The HP-85 screen displays the full buffer contents for memory location 3. This is because the TALK statement (Line 120) tells the instrument to send its data string. Since the Model 228 is presently on memory location 3, that data is sent over the bus.

Memory Location 1 = Voltage, Current, Dwell Time, Modulation on or off, Sink on or off.

Memory Location 2 = Voltage, Current, Dwell Time, Modulation on or off, Sink on or off.

Memory Location 3 =  $NDCV + 2.500E + 1$ ,  $ODCI + 1.000E + 0$ ,  $W + 3.000E + 0$ ,  $B + 3.000E + 0$ .

**Model 8573 Programming Example**—The following program illustrates the single cycle memory control mode (P1) over the bus using the IBM PC and the Model 8573 IEEE-488 interface. Load the modified DECL.BAS file into the IBM computer (see Model 8573 Instruction Manual) and add the following lines.

PROGRAM	COMMENTS
10 NA\$="GPIB0":CALL IBFIND (NA\$, BRD0%)	Find the board descriptor.
20 NA\$="DEV0":CALL IBFIND (NA\$, M228%)	Find the instrument descriptor.
30 V% = 11:CALL IBPAD (M228%, V%)	Set primary address to 11
40 V% = 1:CALL IBSRE (BRD0%, V%)	Set remote enable.
50 CMD\$="B1X":CALL IBWRT (M228%, CMD\$)	Select memory location 1.
60 CMD\$="V5I1W1X":CALL IBWRT(M228%, CMD\$)	Set 5V, 1A and 1 second dwell time.
70 CMD\$="B2X":CALL IBWRT (M228%, CMD\$)	Select memory location 2
80 CMD\$="V5I1W2X":CALL (M228%, CMD\$)	Set 10V, 1A and 2 second dwell time.
90 CMD\$="B3X":CALL IBWRT (M228%, CMD\$)	Select memory location 3
100 CMD\$="V25I1W3X":CALL (M228%, CMD\$)	Set 25V, 1A and 3 second dwell time.
110 CMD\$="P0G0X":CALL IBWRT (M228%, CMD\$)	Selects buffer location and single cycle mode.
120 CMD\$="T0D0X":CALL IBWRT (M228%, CMD\$)	Select start on talk and volts display mode.
130 RD\$=SPACE(60):CALL IBRD (M228%, RD\$)	Obtain data string.
140 PRINT RD\$	Display data string.
150 V% = 0:CALL IBONL (BRD0%, V%)	Close the board file.
160 CALL IBONL(M228%, V%)	Close the instrument file.

To run the program press the F2 function key. After placing the instrument in remote (line 40), the program sets memory locations 1, 2 and 3 for various parameters. Lines 110 and 120 set the instrument for buffer location output, single cycle mode, start on talk trigger mode and volts display mode. Lines 130 and 140 obtain the data string and displays it on the IBM CRT. Lines 150 and 160 close the board and instrument file.

### 4.5.3 Prefix (G)

When addressed to talk, the instrument will send a data string containing information about the programmed current, voltage, dwell time and memory location. This data string can be sent with or without a prefix. The prefix (G) commands and their format are described as follows:

G0=Present Buffer Location Output. Sending the G0 command allows the data to be sent with a prefix as follows:

$NDCV \pm n.nnnE \pm n$ ,  $I \pm n.nnnE \pm n$ ,  $W \pm n.nnnE \pm n$ ,  $B + n.nnnE \pm n$

Voltage, Current, Dwell Time, Memory Location

G1=Present Buffer Location Output. Sending the G1 command allows the data to be sent without a prefix as follows:

$\pm n.nnnE \pm n$ ,  $\pm n.nnnE \pm n$ ,  $\pm n.nnnE \pm n$ ,  $\pm n.nnnE \pm n$

G2=Full Buffer Output. Sending the G2 command allows all of the data in all 100 buffer locations to be sent with a prefix. The format is as follows:

$NDCV \pm n.nnnE \pm n$ ,  $I \pm n.nnnE \pm n$ ,  $W \pm n.nnnE \pm n$ ,  $B + 1.000E + 2$

. . . . .

$NDCV \pm n.nnnE \pm n$ ,  $I \pm n.nnnE \pm n$ ,  $W \pm n.nnnE \pm n$ ,  $B + 1.00E + 2$

G3=Full Buffer Output. Sending the G3 command allows all of the data in all 100 buffer locations to be sent without a prefix. The format is as follows:

$\pm n.nnnE \pm n$ ,  $\pm n.nnnE \pm n$ ,  $\pm n.nnnE \pm n$ ,  $\pm n.nnnE \pm n$

. . . . .

$\pm n.nnnE \pm n$ ,  $\pm n.nnnE \pm n$ ,  $\pm n.nnnE \pm n$ ,  $+ 1.00E + 2$

G4=Present Voltage and Current Buffer Output. Sending the G4 command allows the voltage and current data that is present on the output to be sent with a prefix. The format is as follows:

$NDCV \pm n.nnnE \pm n$ ,  $I \pm n.nnnE \pm n$ ,  $W \pm n.nnnE \pm n$ ,  $B \pm n.nnnE \pm n$

G5=Present Voltage and Current Buffer Output. Sending the G5 command allows the voltage and current that is present on the output to be sent without a prefix. Also, present output mode values are sent (operate or standby). The format is as follows:

$\pm n.nnnE \pm n$ ,  $\pm n.nnnE \pm n$ ,  $\pm n.nnnE \pm n$ ,  $+n.nnnE \pm n$

**HP-85 Programming Example**—The following program sends the data string over the IEEE bus. In order to obtain the data string from the instrument, the controller must perform the following sequence:

1. Set ATN true.
2. Address the Model 228 to talk.
3. Set ATN false.
4. Input the data string one byte at a time.

**NOTE**

Press the END LINE key after each line is entered.

PROGRAM	COMMENTS
10 DIM A\$ [100]	Dimensions A\$ for 100 characters.
20 REMOTE 711	Set instrument up for remote operation.
30 CLEAR 7	Clear the instrument.
40 OUTPUT 711;"B1X"	Selects memory location 1.
50 OUTPUT 711;"V10I1W10X"	Set 10V, 1A and 10 second dwell time.
60 OUTPUT 711;"G0D0X"	Programs the volts display mode and the Buffer location with prefix mode.
70 ENTER 711; A\$	Obtain data string.
80 DISP A\$	Display data string.
90 END	

Once the program is entered, press the HP-85 RUN key to start the program. The data string appears on the HP-85 CRT. The Model 228 is programmed for 10V, 1A 10 second dwell time the prefix mode and the volts display mode. If no

prefix is desired in the data string, change line 60 to read as follows:

60 OUTPUT 711;"G1D0X"

The G1 command programs the instrument to drop the prefix from the data string.

**Model 8573 Programming Example**—The following program sends the data string over the IEEE bus. In order to obtain the data string from the instrument, the controller must perform the following sequence.

1. Set ATN true.
2. Address the Model 228 to talk.
3. Set ATN false.
4. Input the data string one byte at a time.

**NOTE**

Load the modified DECL.BAS file into the IBM computer (see the Model 8573 Instruction Manual) and add the following lines. Press the return key after each line is entered.

PROGRAM	COMMENTS
10 NA\$=" GPIB0":CALL IBFIND (NA\$,BRD0%)	Find the board descriptor.
20 NA\$=" DEV0":CALL IBFIND (NA\$,M228%)	Find the instrument descriptor.
30 V%=11:CALL IBPAD (M228%,V%)	Set primary address to 11.
40 V%=1:CALL IBSRE (BRD0%,V%)	Send remote enable
50 CMD\$="B1X":CALL IBWRT (M228%,CMD\$)	Select memory location 1.
60 CMD\$="V10I1W10X":CALL IBWRT(M228%,CMD\$)	Set 10V, 1A and 10 second dwell time.
70 CMD\$="G0D0X":CALL IBWRT M228%,CMD\$)	Set volts display mode and buffer output with prefix mode.
80 RD\$=SPACE\$(50):CALL (M228%,CMD\$)	Obtain data string.
90 PRINT RD\$	Display data String.
100 V%=0:CALL IBONL (BRD0%,V%)	Close board file.
110 CALL IBONL(M228%,V%)	Close instrument file.



Once the program is entered, press the F2 function key to run the program. The Model 228 is programmed for 10V, 1A, 10 second dwell time volts display mode and the buffer location output with prefix mode. If the prefix is not desired, change line 70 to:

```
70 CMD$="G1D0X":CALL
  IBWRT(M228%,CMD$)
```

The G1 command programs the instrument to drop the prefix from the data string.

### 4.5.4 SRQ Response Mode (M)

The bus response mode determines whether or not the Model 228 requests service from the controller through the SRQ line.

Table 4-9 lists the conditions that cause an SRQ. Note that the instrument can be programmed for one or more conditions simultaneously.

**Table 4-9. SRQ Mask Commands**

SRQ Command	End of Dwell Time	End of Buffer	Ready	IDDC, IDDCO No Remote
M0*				
M1				X
M2			X	
M3			X	X
M4		X		
M5		X		X
M6		X	X	
M7		X	X	X
M8	X			
M9	X			X
M10	X		X	
M11	X		X	X
M12	X	X		
M13	X	X		X
M14	X	X	X	
M15	X	X	X	X

\*M0 Disables SRQ.

**SRQ Mask**—The Model 228 uses an internal mask to determine which conditions cause an SRQ to be generated. Figure 4-5 shows the general format of this mask, which is made up of eight bits.

SRQ may be programmed by sending the ASCII letter "M" followed by a decimal number to set the appropriate bits in the mask. Note that the instrument may be programmed for more than one set of conditions simultaneously. To do so, simply add up the decimal bit values for the required SRQ conditions. For example, to enable SRQ under illegal device-dependent command option, send M1X. To disable SRQ, send M0X. This command clears all bits in the SRQ mask.

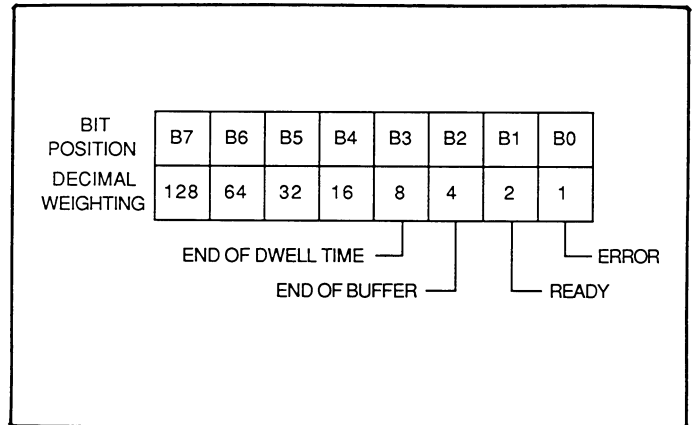

**Figure 4-5. Format of SRQ Mask**

Figure 4-6 shows the format of the SRQ mask byte. Bits within the mask can be controlled by sending the ASCII character "M" followed by a decimal number from 0 to 15.

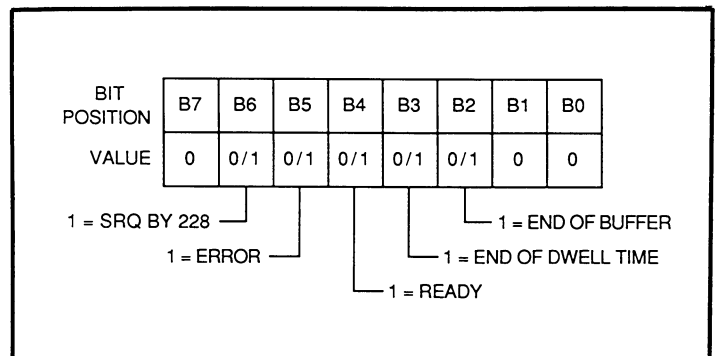

**Figure 4-6. Format of SRQ Status Byte**

**Status Byte Format**—The status byte format byte contains information relating to data and error conditions within the instrument. The general format of the status byte (which is obtained by the serial polling sequence) is shown in Figure 4-6. Note that the various bits correspond to the bits in the SRQ mask.

Bit 6 provides a means to determine if an SRQ was asserted by the Model 228. If this bit is set, service was requested by the instrument. Bit 5 flags a Model 228 error condition. If this bit was set, an illegal device-dependent command

(IDDC) or illegal device-dependent command option (IDDCO) was set, or the instrument was not in remote when programmed.

Bit 4 is set when the Model 228 is ready for operation. Bit 3 is set when the end of the present programmed dwell time is reached during program execution. Bit 2 is set if the end of the buffer (program memory) is encountered when running a program.

Note that the status byte should be read to clear the SRQ line once the instrument has generated an SRQ. All bits in the status byte are latched when the SRQ is generated. Bits are cleared when the status byte is read. Even with SRQ disabled, the status byte can be read to determine appropriate instrument conditions. In this case, bits 2, 3, 4 and 5 are continuously updated to reflect current instrument status; however, bit 5 (the error bit) latches and remains latched until the status byte is read, even if no SRQ occurs.

**HP-85 Programming Example**—Enter the following program into the HP-85:

**NOTE**

After each line is entered press the END LINE key.

PROGRAM	COMMENTS
10 REMOTE 711	Set up for remote operation.
20 OUTPUT 711;"M1X"	Program for SRQ on error
30 OUTPUT 711;"R9X"	Attempt to program illegal option.
40 S=SPOLL(711)	Conduct serial poll.
50 DISP"B7 B6 B5 B4 B3 B2 B1 B0"	Identify the bits.
60 FOR I=7 TO 0 STEP -1	Loop eight times.
70 DISP BIT (S,I);	Display each bit position.
80 NEXT I	
90 DISP	
100 END	

After the program is entered, press the HP-85 RUN key to run the program. The computer places the instrument in remote and then programs the SRQ mode of the instrument. Line 30 attempts to program an illegal option (R9), at which point the instrument generates an SRQ and sets the bus error bits in its status byte. The computer serial polls the instrument and displays the status byte bits in proper order on the CRT. In this example, the SRQ (B6) bit is set because of the attempt to program an illegal command option. Other bits may be set depending on instrument status.

**Model 8573 Programming Example**—

**NOTE**

Load the modified DECL.BAS file into the IBM computer (see the Model 8573 Instruction Manual) and add the following lines. Press the return key after each line is entered.

PROGRAM	COMMENTS
10 NA\$="GPIB0":CALL IBFIND (NA\$,BRD0%)	Find the board descriptor.
20 NA\$="DEV0":CALL IBFIND (NA\$,M228%)	Find the instrument descriptor.
30 V%=11:CALL IBPAD (M228%,V%)	Set primary address 11.
40 V%=1:CALL IBSRE (BRD0%,V%)	Send remote enable.
50 CMD\$="M1X":CALL IBWRT (M228%,CMD\$)	Program for SRQ on error.
60 CMD\$="R9X":CALL IBWRT (M228%,CMD\$)	Attempt to program illegal command option.
70 PRINT"B7 B6 B5 B4 B3 B2 B1 B0"	Identify the bits
80 MASK%=128	Defind bit mask.
90 CALL IBRSP(M228%,SB%)	Conduct serial poll.
100 FOR I =1 to 8	Loop eight times.
110 IF (SB% AND MASK%) =0 THEN PRINT "0"; ELSE PRINT "1 "	Mask off the bits and display them.
120 MASK%=MASK%/2	
130 NEXT I	
140 PRINT	
150 V%=0:CALL IBONL (BRD0%,V%)	Close the board file.
160 CALL IBONL(M228%,V%)	Close the instrument file.

After the program is entered, press the F2 function key to run the program. After placing the instrument in remote and setting SRQ (line 50), line 60 attempts to program the instrument into a range that does not exist (R9). At which point the instrument generates an SRQ and sets the error and SRQ bits in its status byte. Other bits may also be set depending on instrument status. Lines 70, 80 and 90 display the bit positions, set the mask value to the most significant bit and serial poll the instrument. Since the status byte is in decimal form, lines 100, 110, 120 and 130 are used to generate the binary equivalent of the status byte value.

## 4.5.5 Trigger Modes (T)

Triggering is used to tell the Model 228 to initiate the memory control mode sequence (single step, single cycle or continuous). The trigger stimulus may come from commands sent over the bus, through the external trigger input or by the front panel START/STOP key. Triggering may be used to either start the memory control mode sequence or stop the sequence. The trigger modes are as follows:

T0=Start on Talk. In the T0 mode, talk commands initiate the memory control mode sequence.

T1=Stop on Talk. In the T1 mode, talk commands stop the memory control mode sequence.

T2=Start on GET. In the T2 mode, a GET command (Group Execute Trigger) initiates the memory control mode sequence.

T3=Stop on GET. In the T3 mode, a GET command stops the memory control mode sequence.

T4=Start on X. In the T4 mode, an execute command initiates the memory control mode sequence.

T5=Stop on X. In the T5 mode, an execute command stops the memory control mode sequence.

T6=Start on External Trigger-In the T6 mode, an external trigger pulse initiates the memory control mode sequence.

T7=Stop on External Trigger-In the T7 mode, and external trigger pulse stops the memory control mode sequence.

**HP-85 Programming Example**—Set the instrument to its default conditions by entering the following statements into the HP-85:

```
REMOTE 711 (END LINE)
CLEAR 7 (END LINE)
```

The default conditions include the trigger mode to be set for the T6 mode. Enter the following statement to set the Model 228 to the T2 trigger mode.

```
OUTPUT;"T2X" (END LINE)
```

After the END LINE key is pressed, the Model 228 is placed in the T2 mode (Start on GET). When a GET command is sent by the controller to the Model 228, the instrument goes into the selected memory control mode. For example; if memory locations 1 through 25 are programmed for various values of voltage current and dwell time and the single cycle mode is selected, then when the GET command is received, the Model

228 steps through the programmed memory locations. To send a GET command, enter the following statement into the HP-85:

```
TRIGGER 711 (END LINE)
```

**Model 8573 Programming Example**—Set the Model 228 to the default conditions by entering the following statements into the IBM computer:

```
V% = 1:CALL IBSRE(BRD0%,V%) (return)
CALL IBCLR(M228%) (return)
```

The default conditions include the Model 228 set to the T6 trigger mode. To set the Model 228 to the T2 mode enter the following statement into the IBM computer:

```
CMD$="T2X":CALL IBWRT(M228%,CMD$) (return)
```

After the return key is pressed, the Model 228 is set to the T2 trigger mode (Start on GET). When a GET command is sent by the controller to the Model 228, the selected memory control mode is initiated. For example, if memory locations 1 through 25 are programmed for various values of voltage, current and dwell time and the single cycle memory control mode is selected, then when GET is received the Model 228 steps through the programmed memory locations. To send GET, enter the following statement into the IBM computer:

```
CALL IBTRG(M228%) (return)
```

## 4.5.6 Programmable Terminator (Y)

The Model 228 uses special terminator characters to mark the end of its data string. To allow a wide variety of controllers to be used, the terminator can be changed by sending the appropriate command over the bus. The default value is the commonly used carriage return, line feed (CR LF) sequence. The terminator assumes this default value upon power up, receiving DCL or SDC command.

The terminator may be programmed by sending the ASCII character Y followed by the desired terminator character. Any ASCII character except one of the following may be used:

1. All capital letters
2. All numbers
3. Blank
4. + - / , . and e.

Special command characters will program the instrument for special terminator sequences as follows:

1. Y(ASCII) any ASCII except preceding list.
2. Ymn = Two terminator characters.
3. Yn = One terminator character.
4. Y(DEL) = No terminator character.

**NOTE**

Most controllers use the CR or LF character to terminate their input sequences. Using a nonstandard terminator may cause the controller to hang up unless special programming is used.

**HP-85 Programming Example**—Enter the following statements into the HP-85. To reverse the default CR LF terminator sequence, type the following lines into the HP-85:

```
REMOTE 711 (END LINE)
OUTPUT 711;"Y";CHR$(10);CHR$(13);"X" (END LINE)
```

When the END LINE key is pressed the second time, the normal terminator sequence is reversed. The instrument terminates each data string or status word with a LF CR sequence.

**Model 8573 Programming Example**—Use the following statements to reverse the default terminator sequence.

```
V%=1:CALL IBSRE(BRD0%,V%) (return)
CMD$="Y"=CHR$(10)+CHR$(13)+"X":CALL IBWRT
(M228%,CMD$) (return)
```

The terminator sequence will be reversed when the second statement is executed.

**4.5.7 Inputs (I, V, W and B)**

The input commands control the current (I), voltage (V), dwell time (W) and the memory location (B). The input commands that affect Model 228 operation are as follows:

I=stores the current (I) value into the present memory location.

V=stores the voltage (V) value into the present memory location.

W=stores the dwell time (W) value into the present memory location.

B=selects the memory location.

A complete summary of input commands along with the format of each is shown in Table 4-10. The parameter of each command (except memory location) may be entered in direct or scientific notation as long as the allowable range for each command is not exceeded. Some examples of the various command formats are as follows:

Desired Result	Command Variations
1.5A Current	I1.5; I15E-1; I.15E+1
25V Voltage	V25; V2.5E+1; V250E-1
250msec Dwell Time	W250E-3; W.25; W25E-2

**Notes**

1. An IDDCO (Illegal Device-Dependent Command Option) error occurs if the input command parameter is outside of the legal range. A front panel error message indicates this error. The instrument may also be programmed to generate an SRQ if such an error occurs, as described in paragraph 4.5.4.
2. Dwell time accuracy is valid only if the IEEE bus is idle.
3. The input command for memory location truncates any valid variation. For example, if the command is B1.9; then the Model 228 truncates anything to the right of the decimal point. This means that the Model 228 selects memory location 1.

**Table 4-10. Input Command Summary**

Command	Controls	Allowable Range
Innnn	Current (I) Value	.0001A to 10.10A
Vnnn	Voltage (V) Value	.001V to 101.0V
Wnnn	Dwell Time (W) Value	.02sec to 1000sec
Bnnn	Memory Location (B)	1 to 101

**HP-85 Programming Example**—The following program sets up the Model 228 output according to the values entered from the HP-85 keyboard. Press the END LINE key after each line is entered.

PROGRAM	COMMENTS
10 REMOTE 711	Set for remote operation.
20 DISP"ENTER MEM STEP"	
30 INPUT B\$	
40 DISP" ENTER I"	Enter desired memory location (Example: location 1=B1)
50 INPUT I\$	
60 DISP"ENTER V"	Enter desired current. (Example: 2.5A = I2.5)
70 INPUT V\$	
80 DISP"ENTER W"	Enter desired voltage. (Example: 2.5V = V2.5)
85 INPUT W\$	
90 OUTPUT 711;"R0F0X", "B",B\$,"I",I\$,"V",V\$ "W",W\$,"X"	Output to IEEE bus, address 11.
100 GO TO 20	Repeat.
110 END	

After entering the program, press the HP-85 RUN key to start the program. The program prompts the operator for inputs at the appropriate points in the program. Each parameter of a memory location is entered. To stop the program press the PAUSE key.

**Model 8573 Programming Example**—The following program sends a command string to the Model 228 and displays the instrument data string on the IBM CRT.

#### NOTE

Load the modified DECL.BAS file into the IBM computer (see the Model 8573 Instruction Manual) and add the following lines.

PROGRAM	COMMENTS
10 NA\$="GPIB0":CALL IBFIND (NA\$,BRD0%)	Find the board descriptor.
20 NA\$="DEV0":CALL IBFIND (NA\$,M228%)	Find the instrument descriptor.
30 V%=11:CALL IBPAD (M228%,V%)	Set primary address to 11.
40 V%=1:CALL IBSRE (BRD0%,V%)	Send remote enable.
50 INPUT"COMMAND";CMD\$	Prompt for command string.
60 IF CMD\$="EXIT" THEN 140	See if program is to be stopped.
70 IF CMD\$="" THEN 50	If null command string go back and get another.
80 CALL IBWRT (M228%,RD\$)	Address Model 228 to listen and send command string.
90 RD\$=SPACE\$(50)	Assign reading input buffer.
100 CALL IBRD M228%,RD\$)	Address Model 228 to listen and input data string.
110 RD\$=LEFT\$ (RD\$,IBCNT%)	Trim string to proper size.
120 PRINT RD\$	Display reading on CRT.
130 GOTO 50	Repeat.
140 V%=0:CALL IBONL (BRD0%,V%)	Close the board file.
150 CALL IBONL (M228%,V%)	Close the instrument file.
160 END	

After entering the program press the F2 function key to run the program. The CRT prompts the operator for the desired commands and then displays the data string on the CRT.

## 4.5.8 Function (F)

The function commands control the actual output of the Model 228. These commands perform the same operation as the front panel OPERATE/STANDBY key. The output may be controlled by bus commands as follows:

F0 (Standby)=The output terminals are programmed to +4 counts on the present range. Refer to paragraph 2.2.1 for details concerning the standby mode.

F1 (Operate)=The output terminals are programmed to the present value of voltage and current.

**HP-85 Programming Example**—Using the front panel OPERATE/STANDBY key, place the instrument in the standby mode and enter the following statements into the HP-85:

```
REMOTE 711 (END LINE)
OUTPUT 711;"F1X" (END LINE)
```

When the END LINE key is pressed the second time, the front panel OPERATE LED turns on and the instrument is placed in the operate mode. Do not leave the instrument in the operate mode unattended. Always place the instrument in standby after the measurement or test is completed.

### WARNING

Do not come into contact with any live circuit that could cause personal injury or

death. Always turn the instrument to standby, let it cool down and then turn it off before coming into contact with the output terminals of the Model 228.

## 4.5.9 Range (R)

The range commands set the maximum allowable current that may be programmed into the instrument. Table 4-11 shows the range commands. Upon power up, or after a DCL or SDC, the R0 (AUTO) mode is enabled.

1. On a given range, the source parameter can be no larger than the range will allow.
2. If an under range command is given, a zero source value is stored.
3. If an overrange command is given, the instrument responds with a front panel IDDCO (Illegal Device-Dependent Command Option) error as described in paragraph 4.5.4.

**HP-85 Programming Example**—The following program sets the Model 228 to the 1V, 10A range and then gives an input command of 750mV. The program stops at this point and prompts the user to continue the program. Once the program is running again the controller sends an illegal device-dependent command option (5V) to the instrument. Then the program displays an IDDCO on the instrument as well as on the HP-85 CRT.

### NOTE

After entering each line press the END LINE key.

Table 4-11. Range Commands

Range Command	Range	Maximum Output	Minimum Step
R0	Auto		
R1	1V, 100mA	1V, 100mA	1mV, 10 $\mu$ A
R2	1V, 1A	1V, 1A	1mV, 100 $\mu$ A
R3	1V, 10A	1V, 10A	1mV, 1mA
R4	10V, 100mA	10V, 100mA	10mV, 10 $\mu$ A
R5	10V, 1A	10V, 1A	10mV, 100 $\mu$ A
R6	10V, 10A	10V, 10A	10mV, 1mA
R7	100V, 100mA	100V, 100mA	100mV, 10 $\mu$ A
R8	100V, 1A	100V, 1A	100mV, 100 $\mu$ A

PROGRAM	COMMENTS
10 REMOTE 711 @ CLEAR	Set up for remote operation and clear the screen.
20 CLEAR 711	Return to the default conditions
30 OUTPUT 711; "R3M1D0X"	Set the Model 228 to the 1V, 10A range turn on SRQ and display Volts, Amps.
40 OUTPUT 711;"V.75X"	Program the Model 228 to 750mV.
50 DISP" PRESS CONT"	
60 PAUSE	
70 OUTPUT 711;"V5X"	Attempt to program illegal voltage on this range.
80 S=SPOLL (711)	Conduct serial poll.
90 IF BIT(S,5) AND BIT(S,1) =1 THEN DISP"ILLEGAL COMMAND OPTION"	Check for IDDCO.
100 OUTPUT 711;"R0X"	Set to autorange.
110 END	

After entering the program, press the RUN key. The program sets the Model 228 to the 1V, 10A range and programs for a voltage of 750mV. Press the CONT key and observe that the instrument displays IDDCO. The IDDCO is also displayed on the CRT because the status byte was checked by the computer when the error IDDCO bits were set.

It is important to note that the commands in line 70 would be valid if the instrument were set to the proper range. This is taken care of automatically in the R0 mode, since the instrument changes to the appropriate range, depending on the commanded value. To demonstrate this point, change line 30 to OUTPUT 711; 'R0M1X' and run the program again. This time the commands in line 70 are accepted by the instrument since it remains in the autorange mode.

**Model 8573 Programming Example**—The following program sets the Model 228 to the 1V, 10A range and then gives an input command of 750mV. The program stops at this point and prompts the user to continue the program. Once the program is running again the controller sends an illegal command option (5V) to the instrument. Then the program displays an IDDCO on the instrument as well as on the CRT.

#### NOTE

Load the modified DECL.BAS file into the IBM computer (see the Model 8573 Instruction Manual) and add the following lines. After each line is entered press the return key.

PROGRAM	COMMENTS
10 NA\$="GPIB0":CALL IBFIND (NA\$,BRD0%)	Find the board descriptor.
20 NA\$="DEV0"CALL IBFIND (NA\$,M228%)	Find the instrument descriptor.
30 V%=11:CALL IBPAD (M228%,V%)	Set primary address to 11.
40 V%=1:CALL IBSRE (BRD0%,V%)	Set remote enable.
50 CALL IBCLR(M228%)	Set to default conditions.
60 CMD\$="R3M1XD0":CALL IBWRT(M228%,CMD\$)	Set to 1V, 10A range turn on SRQ and display Volts, Amps.
70 CMD\$="V.75X":CALL IBWRT (M228%,CMD\$)	Program the 750mV.
80 CMD\$="V5X":CALL IBWRT (M228%,CMD\$)	Attempt to program illegal voltage on this range.
90 CALL IBSRP (M228%,SB%)	Conduct serial poll.
100 PRINT SB%	Display data.
110 CMD\$="R0X":CALL IBWRT (M228%,CMD\$)	Set to autorange.
120 V%=.:CALL IBONL (BRD0%,V%)	Close board file.
130 CALL IBONL (M228%,V%)	Close instrument file.

After entering the program, press the F2 function key to run the program. The program sets the Model 228 to the 1V, 10A range and sets 750mV. Then the program attempts to set the instrument to 5V. This value is outside of the selected range and causes the IDDCO message to be displayed on the instrument. A serial poll is conducted and an SRQ reveals the IDDCO. The computer also displays the data.

It is important to note that the commands in line 80 would be valid if the instrument were set to the proper range. This is taken care of automatically in the R0 mode, since the instrument changes to the appropriate range depending on the commanded value. To demonstrate this point, change line 60 to:

```
60 CMD$="R3M1X":CALL      Run program.
   IBWRT(M228%,CMD$)
```

This time the commands in line 80 are accepted by the instrument since it remains in the autorange mode.

## 4.5.10 External Modulation (A, C)

The external modulation mode may be enabled or disabled over the bus. In external modulation, an external AC signal is applied to the external modulation connector and therefore the output. Current or voltage may be modulated as can be seen by the front panel LEDs (MODULATE V and MODULATE I). The commands for external modulation are as follows:

A0—Turn off voltage modulation.  
A1—Modulate voltage.

C0—Turn off current modulation.  
C1—Modulate current.

**HP-85 Programming Example**—To turn on the modulate current function enter the following lines into the HP-85:

```
REMOTE 711 (END LINE)
OUTPUT 711;"A1X" (END LINE)
```

After the END LINE key is pressed the second time, the Model 228 is placed in the modulate current mode.

**Model 8573 Programming Example**—To turn on the modulate current function enter the following lines into the IBM computer.

```
V% = 1:CALL IBSRE(BRD0%,V%) (return)
CMD$="A1X":CALL IBWRT(M228%,CMD$) (return)
```

After the return key is pressed the second time, the Model 228 is placed in the modulate current mode.

## 4.5.11 Sink Mode (S)

The Model 228 may be operated in the sink mode. That is, power is delivered to the Model 228. The sink program allows the instrument to decrease the high power supply and still operate as an active load. With the supply reduced, the Model 228 can dissipate full power continuously at 50°C with no derating. Refer to paragraph 3.13.4 for details concerning the sink mode. The commands to enable the sink mode are as follows:

S0=Disable sink mode.

S1=Enable sink mode.

**HP-85 Programming Example**—To enable the sink mode over the bus, enter the following statements into the HP-85:

```
REMOTE 711 (END LINE)
OUTPUT 711;"S1X" (END LINE)
```

After the END LINE key is pressed the second time, the Model 228 is placed in the sink mode. The front panel SINK ONLY LED turns on. The Model 228 high power supply is decreased and the instrument can dissipate full power continuously at 50°C with no derating.

**Model 8573 Programming Example**—To enable the sink mode over the bus, enter the following statements into the IBM computer:

```
V% = 1:CALL IBSRE(BRD0%,V%) (return)
CMD$="S1X":CALL IBWRT(M228%,CMD$) (return)
```

After the return key is pressed the second time, the Model 228 is placed in the sink mode. The front panel SINK ONLY LED turns on. The Model 228 high power supply is decreased and the instrument can dissipate full power continuously at 50°C with no derating.

## 4.5.12 Status Word (U)

The status word command allows access to information concerning various operating modes of the instrument. When the U0 command is given, the instrument outputs the status word the next time it is addressed to talk. The status word is sent instead of the normal data string. The status word is sent only once each time the U0 command is given. The command for the status word to be sent is as follows:

U0=Send Status Word. The format is the Model number (228) followed by five bytes representing the modes and functions of the Model 228. Information concerning all modes except for SRQ are one byte in length.

U1=Send Error Status Word. The format is the model number (228) followed by five bytes representing the various errors.

Figure 4-7 shows the general format of the error status word. The figure shows the errors of the word. Figure 4-8 shows the general format of the status word. The figure shows the default values. The letters correspond to modes programmed by the respective device-dependent commands.



Note that all returned values except for those associated with the terminator correspond to the programmed numeric values. For example, if the instrument is presently in the R3 range, the R byte in the status word will correspond to an ASCII 3.

**Notes**

1. The status word should not be confused with the SRQ status byte. The status word contains a number of bytes pertaining to the various operating modes of the instrument. The status byte is a single byte that is read by using the serial polling sequence and contains information on SRQ status and error or data conditions.
2. To make sure proper status is returned, the status word should be read immediately after sending the command. Otherwise, instrument status may change, resulting in erroneous status information.
3. The status word is sent only once each time the status command is given. Once the status is read, the instrument sends the normal data string the next time it addressed to talk.
4. The SRQ status information contains several bytes. These bytes assume the decimal value previously set by the SRQ mode command.

**HP-85 Programming Example**— To output the status word enter the following program into the HP-85:

**NOTE**

After each line is entered, press the END LINE key.

PROGRAM	COMMENTS
10 REMOTE 711	Set up for remote operation.
20 CLEAR 7	Clear the Model 228.
30 OUTPUT 711; "U0X"	Output status word.
40 ENTER 711; A\$	Obtain data string.
50 DISP A\$	Display data string.
60 END	End of program.

After the program is entered into the computer, press the HP-85 RUN key to run the program. After pressing the RUN key, the Model 228 outputs the status word. In this case, the status is transmitted to the controller with a prefix.

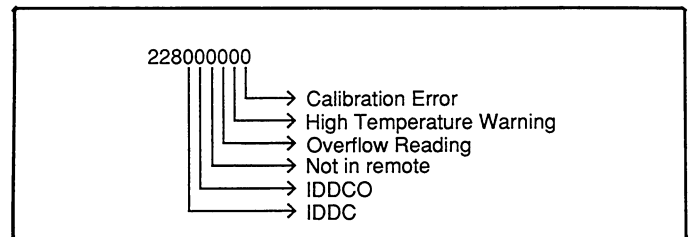

**Figure 4-7. Error Status Word**

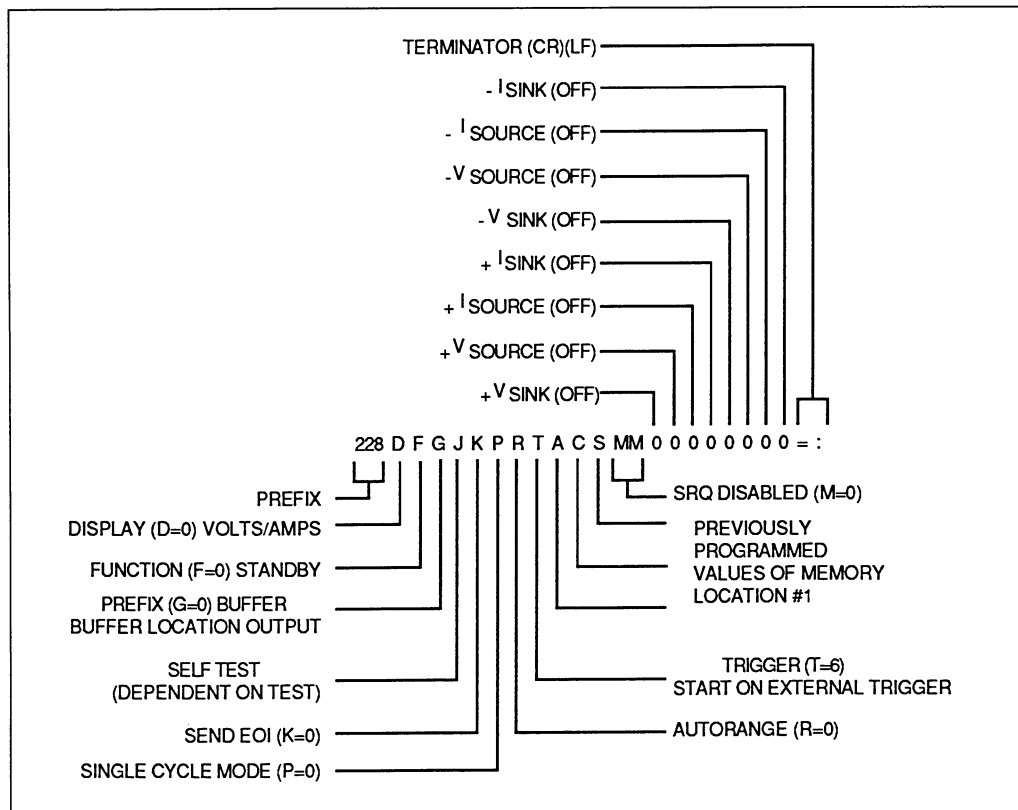

**Figure 4-8. Status Word Format**

**Model 8573 Programming Example**—To output the status word enter the following program into the IBM computer.

**NOTE**

Load the modified DECL.BAS file into the IBM computer (see the Model 8573 Instruction Manual) and add the following lines. After each line is entered press the return key.

PROGRAM	COMMENTS
10 NA\$="GPIB0":CALL IBFIND (NA\$,BRD0%)	Find the board descriptor.
20 NA\$="DEV0":CALL IBFIND (NA\$,M228%)	Find the instrument descriptor.
30 V%=11:CALL IBPAD (M228%,V%)	Set primary address to 11.
40 V%=1:CALL IBSRE (BRD0%,V%)	Send remote enable.
50 CMD\$="U0X":CALL IBWRT (M228%,CMD\$)	Output status word.
60 RD\$=SPACE(50):CALL IBRD (M228%,RD\$)	Obtain data string.
70 PRINT RD\$	Display data string.
80 V%=0:CALL IBONL (BRD0%,V%)	Close the board file.
90 CALL IBONL (M228%,V%)	Close the instrument file.

After the program is entered, press the F2 function key to run the program. After pressing the F2 key the Model 228 outputs the status word and it is displayed on the CRT.

Upon power up, or after the instrument receives a DCL or SDC command, the K0 mode is enabled.

**4.5.13 Self Test (J)**

The letter J is the command that programs the Model 228 to go through many of the testing routines that are automatically performed upon power up. When the J command is sent the following routines are performed:

1. All of the front panel LEDs turn on. This is a display test. The user can note inoperative display segments or individual LEDs by observing the front panel.
2. During the display test, the Model 228 performs a check on the RAM circuitry and a cyclic redundancy check (CRC) on the ROM circuitry. If a problem is found with either of these two tests, then the appropriate messages are displayed and the J byte in the status word is set.

3. After steps 1 and 2, the Model 228 displays the present software level.
4. After step 3, the Model 228 displays the present primary address.
5. After step 4, the Model 228 goes through the autocalibration cycle and displays the CAL message.
6. After step 6, the Model 228 is ready for operation.

**NOTE**

The self test (J) over the bus, performs the exact same sequence as Program 6. The messages are also the same. Refer to paragraph 3.11.6.

**4.5.14 EOI and Bus Hold-Off Modes (K)**

The K command controls whether the instrument sends the EOI command at the end of its data string; and whether busy activity is held off (through the NRFD line) until all commands sent to the instrument are internally processed once the instrument receives the X character. K command options include:

K0=Send EOI with last byte; hold off bus on X.

K1=Do not send EOI with last byte; hold off bus on X.

K2=Send EOI with last byte; do not hold off bus on X.

K3=Send no EOI with last byte; do not hold off bus on X.

The EOI line on the IEEE-488 bus provides a method to positively identify the last byte in a multi-byte transfer sequence. Keep in mind that some controllers rely on EOI to terminate their input sequences. In this case, suppressing EOI with the K command may cause the controller's input sequence to hang up unless other terminator sequences are used.

The bus hold off mode allows the instrument to temporarily hold up bus operation when it receives the X character until it processes all commands sent in the command string. Keep in mind that all bus operation will cease, not just activity associated with the Model 228. The advantage of this mode is that no bus commands will be missed while the instrument is processing commands previously received.

The hold off period depends on the commands being processed. Table 4-12 lists hold off times for a number of different commands. Since a NRFD hold off is employed, the handshake sequence for the X character is completed, and no bus hang up occurs under these conditions.

**HP-85 Programming Example**—To program the instrument for the K2 mode, enter the following statements into the HP-85:

```
REMOTE 711 (END LINE)
OUTPUT 711;"K2X" (END LINE)
```

When the second statement is executed, the instrument will be placed in the K2 mode. In this mode, EOI will still be transmitted at the end of the data string, but the bus hold-off mode will be disabled.

**Model 8573 Programming Example**—To place the instrument in the K2 mode, enter the following statements into the IBM computer:

```
V% = 1:CALL IBSRE(BRD0%,V%) (return)
CMD$="K2X":CALL IBWRT(M228%,CMD$) (return)
```

The Model 228 will be placed in the K2 mode when the second statement is executed. The EOI mode will be enabled, but the bus hold off will be disabled.

**Table 4-12. Hold Off Times**

Command	X Hold Off
V, I, B, W	46msec
All other device-dependent commands (A, C, D, etc.)	43msec

## 4.6 FRONT PANEL ERROR MESSAGES

The process of programming the Model 228 involves the proper use of syntax. Syntax is defined as the orderly systematic arrangement of programming commands or languages. The Model 228 must receive value commands with the proper syntax or the instrument goes through the following sequence.

1. Ignore the entire command string in which the invalid command appears.
2. Set appropriate bits in the status byte.
3. Generate an SRQ if programmed to do so.
4. Display an appropriate front panel error message.

Device-dependent commands are sent as a string of several ASCII characters. Some examples of valid command strings include:

F0X=Single command string.

F0M2P0R4X=Multiple command string.

R7 X=Space is ignored.

Some examples of invalid command strings are:

@0X=Invalid command; @ is not a command.

D6X=Invalid command option; 6 is not an option of the D command.

The numbers after the command are each interpreted as a decimal integer. For example:

T01.0X is interpreted as T1X

Figure 4-9 shows the front panel error messages used by the Model 228. The message in Figure 4-9A results from an illegal device-dependent command (IDDC), while the message in Figure 4-9B results from an illegal device-dependent command option (IDDCO). The no remote message in Figure 4-9C results from attempting to program the instrument when it is not in the remote mode.

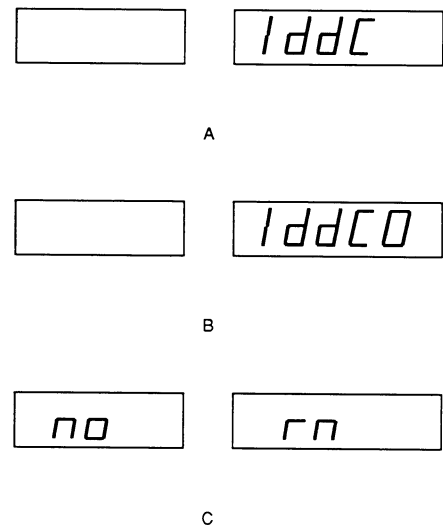

**Figure 4-9. IEEE Display Error Message**

## 4.6.1 IDDC Error

An IDDC error results when the Model 228 receives an invalid command such as \$X. This command is invalid because no such letter exists in the instrument's programming language.

**HP-85 Programming Example**—To demonstrate an IDDC error, enter the following statements into the HP-85:

```
REMOTE 711 (END LINE)
OUTPUT 711;"$X" (END LINE)
```

When the END LINE key is pressed the second time, the error message in Figure 4-8A is displayed on the Model 228 front panel for about one second. The instrument then returns to the previous mode.

**Model 8573 Programming Example**—To demonstrate an IDDC error, enter the following statements into the IBM computer:

```
V%=1:CALL IBSRE(BRD0%,V%) (return)
CMD$="Q2X":CALL IBWRT(M228%,CMD$) (return)
```

When the return key is pressed the second time, the error message in Figure 4-8A is displayed on the Model 228 front panel for about one second. The instrument then returns to the previous mode.

## 4.6.2 IDDCO Error

An illegal device-dependent command option (IDDCO) results when the Model 228 receives an invalid command such as D7X. This command option is invalid because no option of 7 exists for the command D.

**HP-85 Programming Example**—To demonstrate an IDDCO error, enter the following statements into the HP-85:

```
REMOTE 711 (END LINE)
OUTPUT 711;"R9X" (END LINE)
```

When the END LINE key is pressed the second time, the error message in Figure 4-8B is displayed for about one second. The instrument then returns to the previous mode.

## Model 8573 Programming Example—

```
V%=1:CALL IBSRE(BRD0%,V%) (return)
CMD$="R9X":CALL IBWRT(M228%,CMD$) (return)
```

When the return key is pressed the second time, the error in Figure 4-8B is displayed for about one second. The instrument then returns to the previous mode.

## 4.6.3 No Remote Error

A front panel no remote error message is displayed if the Model 228 is not in the remote mode when it receives a command over the bus. If an attempt is made to program the instrument when it is not in the remote mode, the no remote message in Figure 4-8C is displayed on the front panel for about one second.

**HP-85 Programming Example**—To make sure the instrument is not in the remote mode, enter the following into the HP-85:

```
LOCAL 7 (END LINE)
```

Now enter the following programming statement into the keyboard:

```
OUTPUT 711;"D1X" (END LINE)
```

When the statement is executed, the no remote error message in Figure 4-8C is displayed on the front of the instrument for about one second. The instrument then returns to the previous mode.

**Model 8573 Programming Example**—To make sure the instrument is not in the remote mode, enter the following into the IBM computer:

```
CALL IBLOC(M228%)
```

Now enter the following programming statement into the keyboard:

```
V%=1:CALL IBSRE(BRD0%,V%) (return)
```

When the statement is executed, the no remote error message in Figure 4-8C is displayed on the front panel of the instrument for about one second. The instrument then returns to the previous mode.

## 4.7 RESPONSE TIMES

A primary consideration is the length of time it takes to realize an SRQ and output change once a command string

is sent to the instrument. Table 4-13 shows the length of time it takes for an SRQ to occur and the output voltage to change when the voltage setting (V command) is changed over the bus. Table 4-14 shows SRQ and output voltage times for various other control changes.

**Table 4-13. Response Time (Voltage Changes)**

Range	Commands	SRQ on Ready	Vout
Auto	V0 to V5	49.4ms	55 ms
	V1 to V19	51.6ms	58 ms
	V-5 to V5	50 ms	106 ms
R1 (1V, 100mA)	V0 to V1	52 ms	58 ms
	V-1 to V1	51.5ms	107 ms
R2 (1V, 1A)	V0 to V1	50.8ms	58 ms
	V-1 to V1	51.5ms	107 ms
R3 (1V, 10A)	V0 to V1	51.4ms	58 ms
	V-1 to V1	51 ms	107 ms
R4 (10V, 100A)	V0 to V10	52.4ms	57.6ms
	V-10 to V10	53 ms	107 ms
R5 (10V, 1A)	V0 to V10	52.4ms	58.8ms
	V-10 to V10	52 ms	107 ms
R6 (10V, 10A)	V0 to V10	52.4ms	59.4ms
	V-10 to V10	52 ms	107 ms
R7 (100V, 100mA)	V0 to V20	53.6ms	59.4ms
	V-12 to V12	54 ms	108 ms
R8 (100V, 1A)	V0 to V20	52.2 s	59 ms
	V-12 to V12	53.5 s	108.5ms

**Table 4-14. Response Times (Other Control Changes)**

Commands	SRQ On Ready	Vout
V0I.1 to V5I1	65.5ms	71.5ms
V0F0 to V5F1	60 ms	72.5ms
V0R0 to V5R4	56 ms	63 ms
V0R4 to V5R8	58 ms	65 ms
R1V0 to R8V5	59 ms	66 ms
R1V0I.1	73 ms	80 ms
R8V5I1	73 ms	108 ms



# SECTION 5 PERFORMANCE VERIFICATION

## 5.1 INTRODUCTION

Performance verification may be performed upon receipt of the instrument to ensure that no damage or misadjustment has occurred during transit. Verification may also be performed whenever there is question of the instrument's accuracy.

### NOTE

For instruments that are still under warranty (less than 12 months since date of shipment), whose performance falls outside specifications at any point, contact your Keithley representative or the factory.

## 5.2 ENVIRONMENTAL CONDITIONS

Verification should be performed at an ambient temperature of 18°-28°C and less than 70% relative humidity, unless otherwise indicated.

## 5.3 RECOMMENDED TEST EQUIPMENT

Table 5-1 lists all the test equipment required for verification. If alternate equipment is used, the alternate equipment specifications must be at least as good as the specifications listed in Table 5-1.

**Table 5-1. Recommended Test Equipment**

Description	Specifications	Model	Mfg.
Digital Multimeter	100.00mV ±0.016% 1.0000V ±0.011% 10.000V ±0.015% 100.00V ±0.015%	197	Keithley
Load (Current Shunt)	1Ω ±0.01% 0.1Ω ±0.02% 0.01Ω ±0.02%	2575	Valhalla

## 5.4 INITIAL CONDITIONS

The Model 228 must be turned on and allowed ten minutes for warm up. If the instrument has been subjected to extremes of temperature, allow sufficient time for internal temperature to reach normal operating conditions as specified in paragraph 5.2. Typically, it takes one hour to stabilize a unit that is 10°C (18°F) out of the specified range.

## 5.5 PERFORMANCE VERIFICATION PROCEDURE

Use the following procedure to verify the accuracy of the Model 228. If the Model 228 is out of specification, check the test configuration. If the test configuration is properly set up, then check the test equipment's calibration date. If the test equipment is in calibration, proceed to Section 7 Maintenance, unless the Model 228 is under warranty.

### WARNING

**Verification should be performed by qualified personnel using accurate and reliable test equipment.**

### 5.5.1 Voltage Mode Verification (1V, 10V and 100V)

1. Connect the Model 228 and the Model 197 as shown in Figure 5-1.
2. Set the Model 197 to the 2VDC range.
3. Program the Model 228 to output 1.000V, 100mA.
4. Verify the reading on the Model 197 to be within the limits listed in Table 5-2.
5. Set the Model 228 to standby.
6. Set the Model 197 to the 20VDC range.
7. Program the Model 228 to output 10.00V, 100mA.
8. Verify the reading on the Model 197 to be within the limits listed in Table 5-2.
9. Set the Model 228 to standby.
10. Set the Model 197 to the 200VDC range.
11. Program the Model 228 to output 100.00V, 100mA.
12. Verify the reading to be within the limits listed in Table 5-2.
13. Set the Model 228 to standby.
14. Repeat steps 2 through 13 using negative output.

**Table 5-2. Output Voltage Verification**

Range	Model 228 Output	Model 197 Allowable Readings @18°C–28°C
1V	+ 1.000V, 100mA	+ .998 to + 1.002
10V	+ 10.00V, 100mA	+ 9.98 to + 10.02
100V	+ 100.0V, 100mA	+ 99.8 to + 100.2
1V	- 1.000V, 100mA	- .998 to - 1.002
10V	- 10.00V, 100mA	- 9.98 to - 10.02
100V	- 100.0V, 100mA	- 99.8 to - 100.2

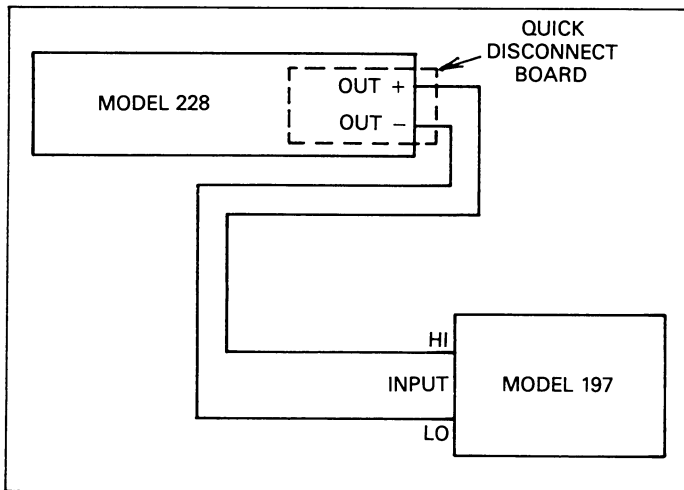

**Figure 5-1. Output Voltage Configuration**

**5.5.2 Output Current Verification**

1. Set up the configuration shown in Figure 5-2.
2. Set the Model 197 to the 200mVDC range.
3. Program the Model 228 to output 100mA, 1V.
4. Verify the reading on the Model 197 is within the limits listed in Table 5-3.
5. Set the Model 228 to standby.
6. Set the Model 197 to the 2VDC range.

7. Program the Model 288 to output 1.000A, 1V.
8. Verify the reading on the Model 197 is within the limits listed in Table 5-3.
9. Set the Model 228 to standby.
10. Set the Model 197 to the 20VDC range.
11. Program the Model 228 to output 10.00A, 10V.
12. Verify the reading on the Model 197 is within the limits listed in Table 5-3.
13. Set the Model 228 to standby.
14. Repeat steps 2 through 13 with negative output.

**Table 5-3. Output Current Verification**

Range	Model 228 Output	Model 197 Allowable Readings @ 18°C–28°C
100mA	+ .1000A, 1V	+ .0998 to + .1002
1 A	+ 1.000A, 1V	+ .998 to + 1.002
10 A	+ 10.00A, 10V	+ 9.94 to + 10.06
100mA	- .1000A, 1V	- .0998 to - .1002
1 A	- 1.000A, 1V	- .998 to - 1.002
10 A	- 10.00A, 10V	- 9.94 to - 10.06

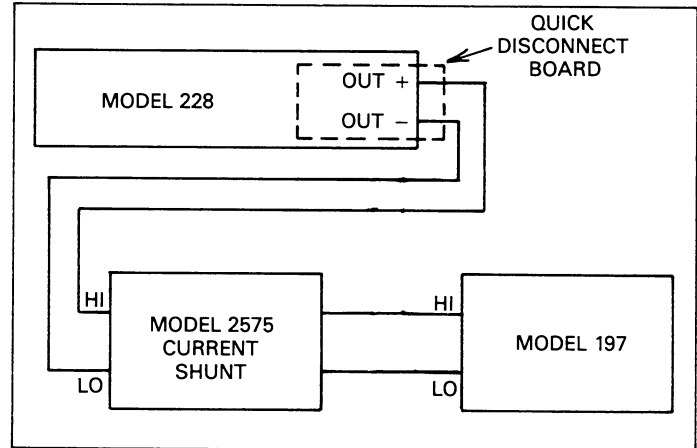

**Figure 5-2. Output Current Configuration**



# SECTION 6 THEORY OF OPERATION

## 6.1 INTRODUCTION

This section contains an overall functional description of the Model 228. The information is supported by simplified schematics and block diagrams to aid in understanding of this complex instrument. This section is divided into the following parts:

1. The switching power supply and linear power supply are described in paragraph 6.2.
2. The analog board and the A/D converter are described in paragraph 6.3.
3. The digital board is described in paragraph 6.4.
4. The display board is described in paragraph 6.5.

Detailed schematics and component layout drawings are located at the end of the instruction manual. Figure 6-1 is a block diagram of the Model 228.

## 6.2 POWER SUPPLY

The power supply is comprised of two power supplies: the switching power supply and the linear power supply. The switching circuitry of the switching power supply is powered by the linear supply and the linear supply is powered by the AC line. The switching power supply is designed for lower power consumption and to reduce the physical size of the transformers.

### 6.2.1 Linear Power Supply

The linear supply is comprised of T305, CR308, CR309, CR310, VR303, VR304 and associated resistors and capacitors. The AC line voltage is applied to the primary of T305 through S302 and S301. CR308 and CR309 rectify the signal of T305's secondary. VR303 and VR304 regulate

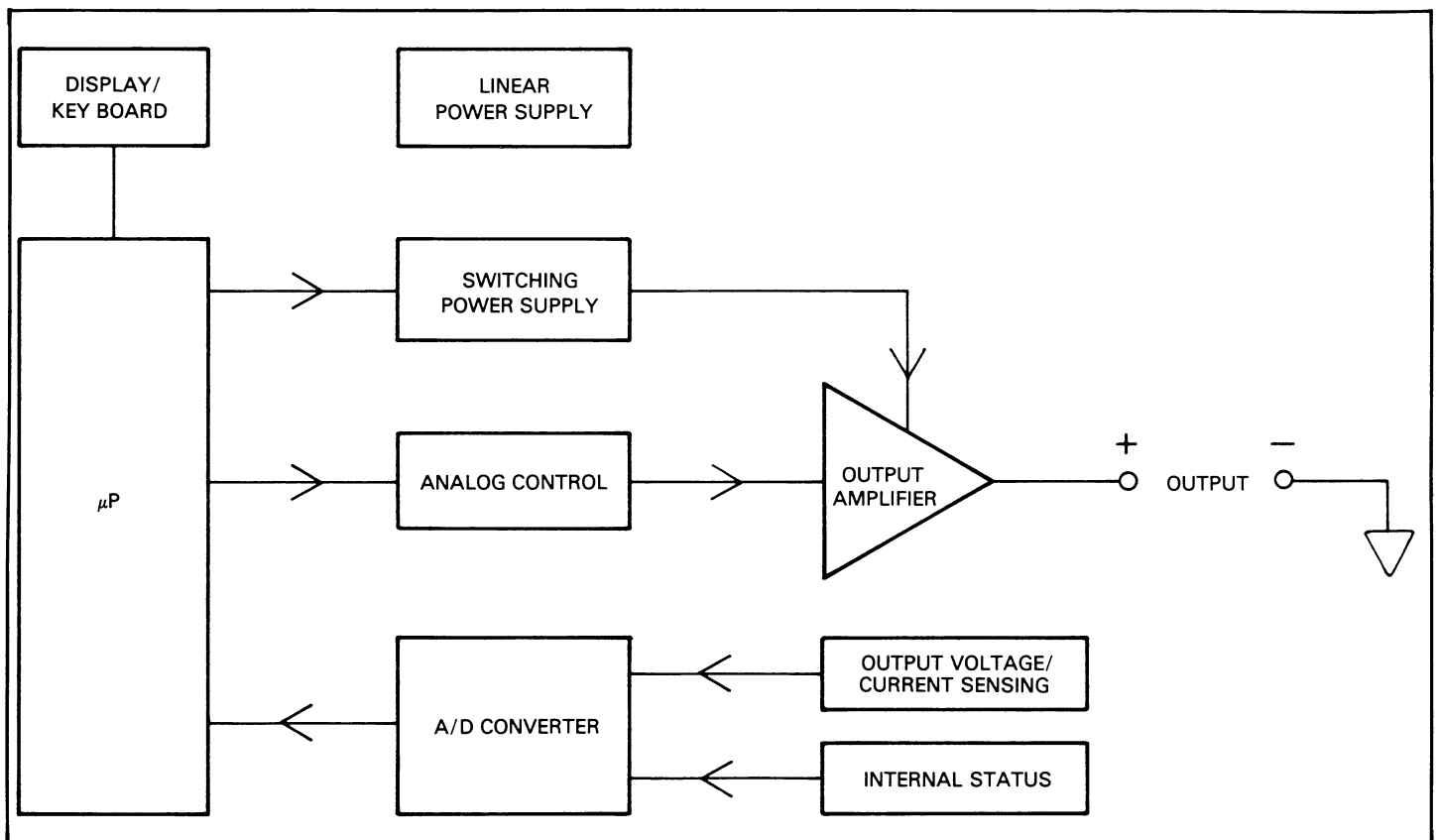

Figure 6-1. Model 228 Block Diagram

$\pm$  voltage for the positive and negative five volt supplies. Capacitors C334, C336, C335 and C343 filter the supplies. Capacitor C333 filters the +9V digital supply.

## 6.2.2 Switching Power Supply

The switching power supply is a push-pull type supply operating at a constant frequency of 50kHz with a variable duty cycle. The description of the switching power supply is divided into three sections; Primary DC supply, Switching Circuitry and Filtering.

### Primary DC Supply

The AC line voltage is applied to RT301 and CR301 through S301 and F301. CR301, C304, C305, C340 and C341 convert the AC line voltage into DC voltage. RT301, negative temperature coefficient thermistor, limits the turn on current. Inductors (chokes) L310 and L311 along with C304, C305, C340 and C341 form pie filters that attenuate 50kHz switching noise from getting into the power line.

A safety circuit (crowbar) comprised of Q301, VR301 and R304 open the line fuse (F302) if the improper line voltage is applied. R302 and R303 are used as bleeder resistors to discharge the 350V that is charged on C304, C305, C340 and C341 after power is turned off.

### Switching Circuit

U302 is the heart of the switching circuitry. U302 has an internal clock and reference. This component controls the 50kHz pulses that determine the amount of energy that is produced by the supply. The two outputs of U302 (pin 11 and pin 8) are buffered by U303 and U304 before driving T302. T302 in turn drives the power switching FETs Q302 and Q303. The +15V supply is sensed (R327, R329, R331 and U302) and held at 15V by varying the duty cycle of the power switching FETs, Q302 and Q303.

The soft start of the supply is controlled by C332 and R334. The supply is disabled by shorting C332 and Q304. The disable signal may come from one of two places; the analog board or the current sense circuit (T304, R312, R313, R314, R320, C317, C328, CR302 and U301). The signal disables the supply for a short time when the FET (Q302 and Q303) current is too high.

Q302 and Q303 are isolated from the secondary by T302 and act as switches. Only one FET is on at a time. This switches the voltage on T303 pin 2 (referenced to pin 11) between the

+175V and -175V. R309, R310, C306 and C308 limit the voltage spikes that are caused when current through T303 is abruptly turned off at 100,000 times a second.

### Filtering

The current on the secondary on transformer T303 is rectified and filtered before it is used by the Model 228 circuitry. The rectifiers are CR303-CR306 and CR315-CR318. R304, C309, R315, C318 limit the voltage spikes that are caused when current through T303 is abruptly turned off 100,000 times a second. C310, C311, C319 and C320 along with L301, L304, L306 and L308 comprise low pass filter which allows the outputs to be regulated.

L302, L303, L305, L307, L309, C314, C323, C324 and C315 attenuate the switching noise and ripple voltage on the output. R316, R317, R318 and R319 provide a minimum load to the power supply secondaries. The minimum load is required to prevent the supply from oscillating or losing regulation.

## 6.3 ANALOG CONTROL

U103A supplies a signal which drives the output in the polarity programmed by the operator. Comparators U106 through U109 supply a signal which balances the signal from U103A when the output approaches a programmed limit. The  $\pm$  voltage limits are set with a zero to +1.010V signal from the voltage DAC (Vdac) U110. The acronym DAC means Digital to Analog Converter. The  $\pm$  current limits are set with a zero to +1.010V signal from the current DAC (Idac) U111. The positive limits (U107 and U109) are sensed by comparing the (DAC voltage) with the (feedback voltage) and attempting to keep feedback voltage less than or equal to the DAC voltage. The negative limits (U106 and U108) are sensed by comparing the (DAC voltage + feedback voltage) with ground and attempting to keep (DAC voltage + feedback voltage) greater than or equal to zero or - (feedback voltage) less than or equal to (DAC voltage). Refer to Figures 6-3 and 6-4.

U112 scales the output voltage for -1.010V to +1.010V for the A/D converter and the voltage limit comparators U108 and U109.

U113 (X10 amplifier) scales the output current for -1.010V to +1.010V for the A/D converter and the current limit comparators U106 and U107. U115 senses which comparator (U106 through U109) is controlling the output for the microprocessor.

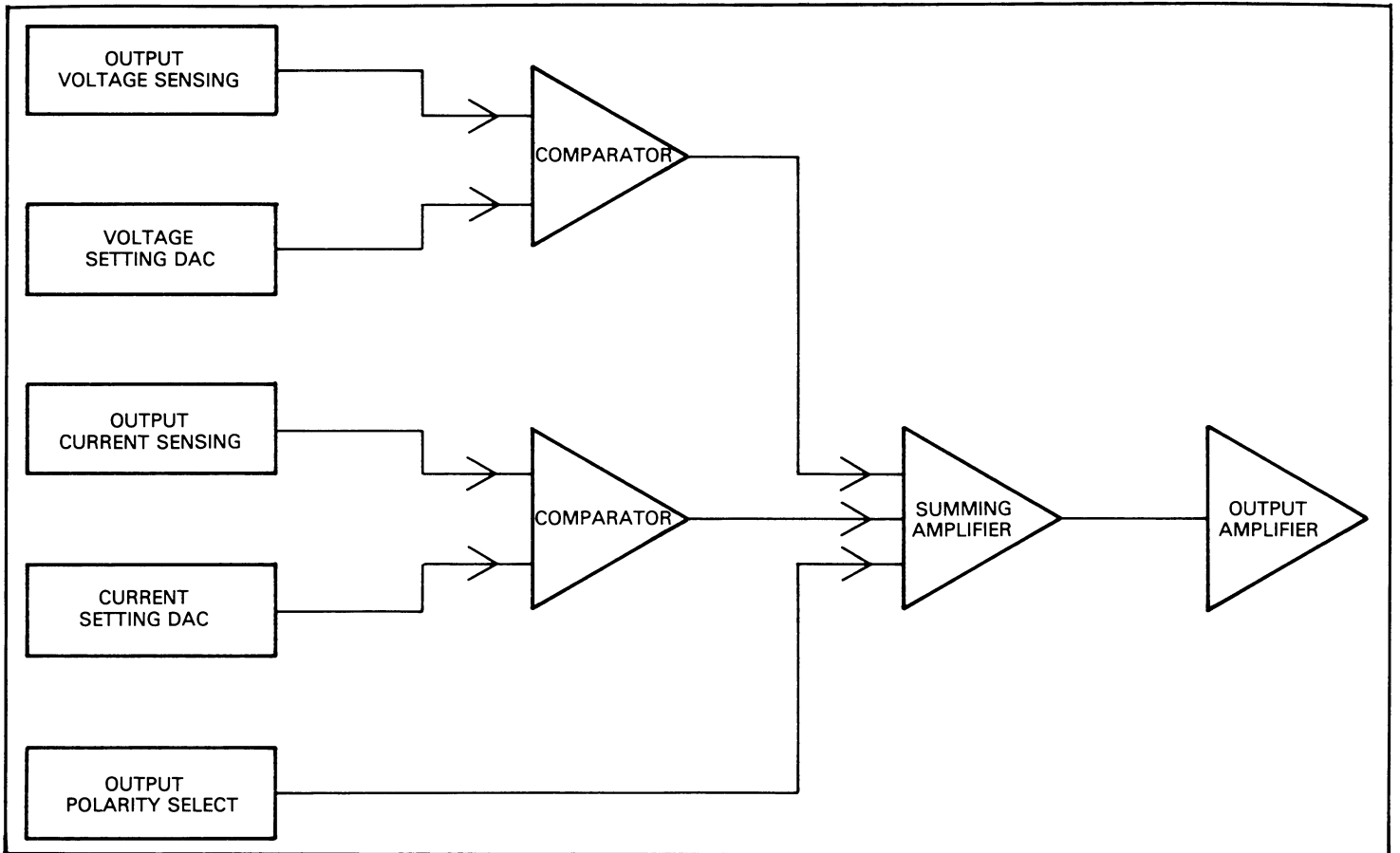

Figure 6-2. Analog Control

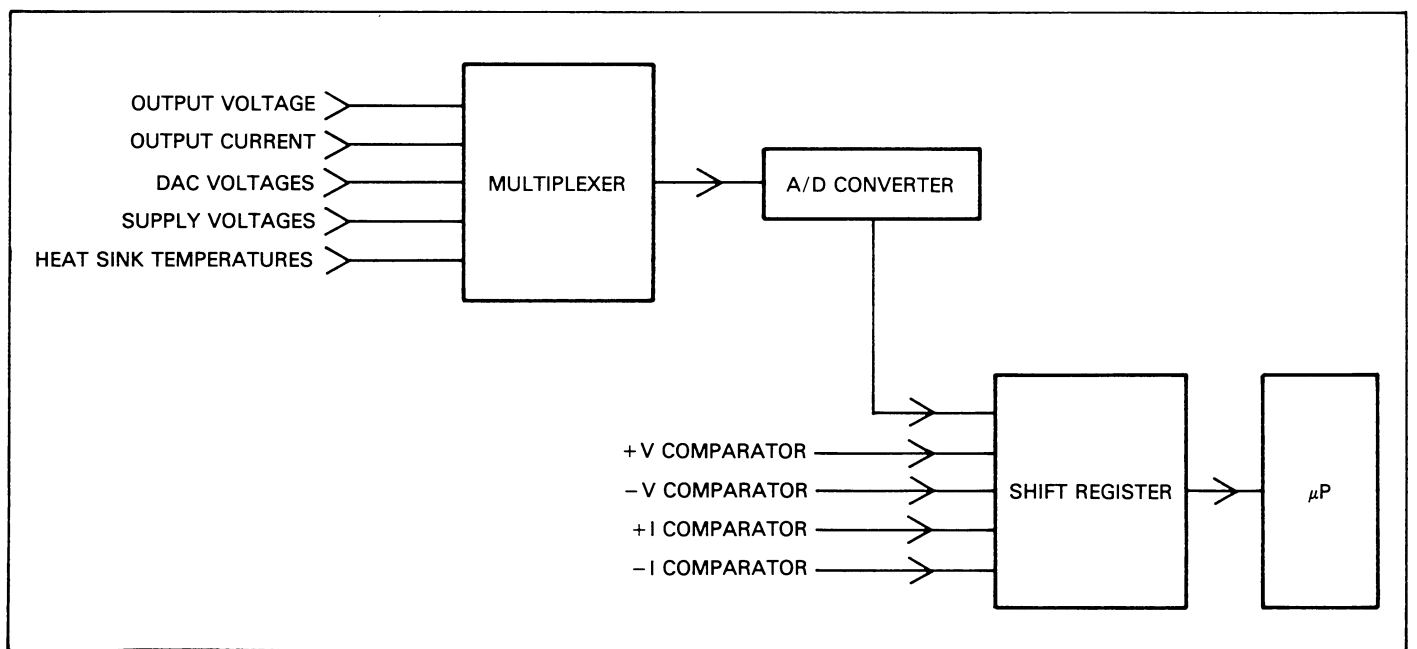
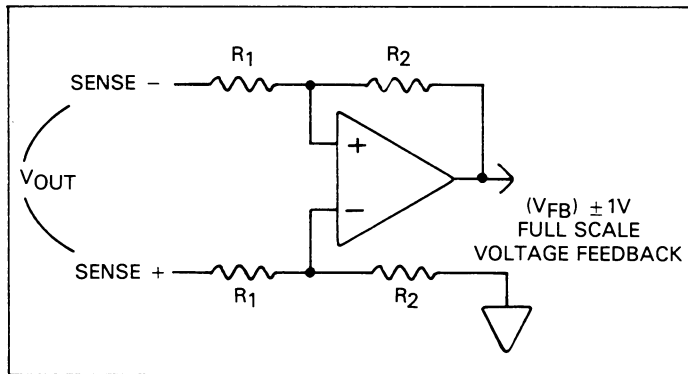

Figure 6-3. A/D Converter

$$V_{FB} = [(SENSE +) - (SENSE -)] \frac{R_2}{R_1} = V_{OUT} \frac{R_2}{R_1} = \frac{V_{OUT}}{1}, \frac{V_{OUT}}{10}, \frac{V_{OUT}}{100}$$



**Figure 6-4. Voltage Sensing**

The output amplifier is a two stage voltage amplifier and a three stage current amplifier (Refer to Figure 6-5). Overall voltage gain is set by R114/R109 at 18. R115 and C102 decrease the gain to 5 at higher frequencies to maintain control loop stability. R107, C101, R113 and C104 also aid stability from oscillation.

VR104 and VR105 limit the maximum current through Q110/Q111 and Q115/Q116 to prevent secondary breakdown when attempting to source more than about 1.5A while the instrument is programmed for sink only. CR116 and CR118 allow the output to source 10A at low voltages without shorting the higher voltage supplies when the output exceeds the low voltage supplies (base-collector diode of Q112 through Q114, Q117 and Q119).

CR117 and CR119 act much the same as CR116 and CR118 except when the Model 228 is programmed for sink only. Sink only removes the  $\pm 15V$  at 10A supplies from the output using relays K301 and K302. C103 and R153 improve stability from oscillation when very large capacitors load the output. This is done by bypassing the pole caused by the output resistance and load capacitor.

The A/D converter (U122) is a single chip  $4\frac{1}{2}$  digit A/D converter. The clock which is provided by U123 allows  $2\frac{1}{2}$  times the normal frequency for this chip to increase the conversion rate to about six per second. The one volt reference is provided from a 6.2V zener that is internal to the current DAC (U111). Refer to Figure 6-6.

Multiplexers U117 and U119 switch the input of the A/D converter to the signal to be measured. R162, R161, R127 and R128 divide the power supply sense voltage down to below the  $\pm 2V$  capability of the A/D converter.

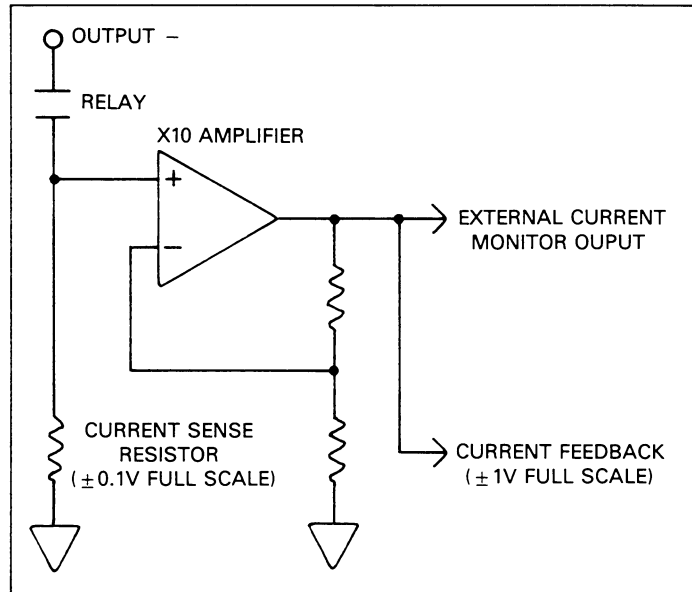

**Figure 6-5. Current Sensing**

CR120 and CR121 are temperature sensors that are mounted to the output amplifier heat sinks and provide  $1\mu A/^\circ\text{Kelvin}$ . With R151 and R158 ( $1k\Omega$  resistors),  $1mV/^\circ\text{Kelvin}$  ( $296mV$  at  $23^\circ\text{C}$ ) is available to the A/D converter. There are three temperatures that are of key importance to the Model 228:

$-50^\circ\text{C}$ —This temperature displayed on the front panel indicates the sensors are unplugged or broken.

$+90^\circ\text{C}$ —This temperature displayed on the front panel indicates that the instrument should switch to the sink only program to reduce output transistor temperature.

$+100^\circ\text{C}$ —This temperature message on the front panel indicates that the power supply should be disabled since this temperature should never be reached during normal operation.

Data is taken from the A/D converter by ANDing the "BUSY" and "CLOCK" signals. This provides 10,001 + (zero to 20,000 pulses) for zero volts to two volts.

The analog and digital section are isolated from each other by opto-isolators (U419 through U422) and also by separate power supplies. Data from analog circuits is shifted serially out of U409 into U114, U104, U103, U102 and U101 shift registers. When U114 pin 12 (Status Select) is low data from the A/D converter (pulses) pass through U120 (and U116G and U422) to U409 where they are counted. When status select is high, strobe pulses from U409 shift data from U120 into U409.

The A/D starts a conversion when its run/hold line is pulsed (signal from U114 pin 14). Normally, this happens six times per second. However, the A/D converter may be stopped during self test, IEEE-488 communications or when the output is being updated often (e.g. the memory function is used with very fast dwell times).

The analog reset circuitry is comprised of R164, CR115, C128 and U124. When line power is switched off or interrupted this circuitry detects the interruption. The switching power supply is temporarily turned off (U124B) and the output of the Model 228 is switched to an open circuit by disabling the current shunt relays (K104, K105 and K106). A flip-flop formed by U121B and U121C holds the reset condition until cleared by the microprocessor (pulse on the strobe line).

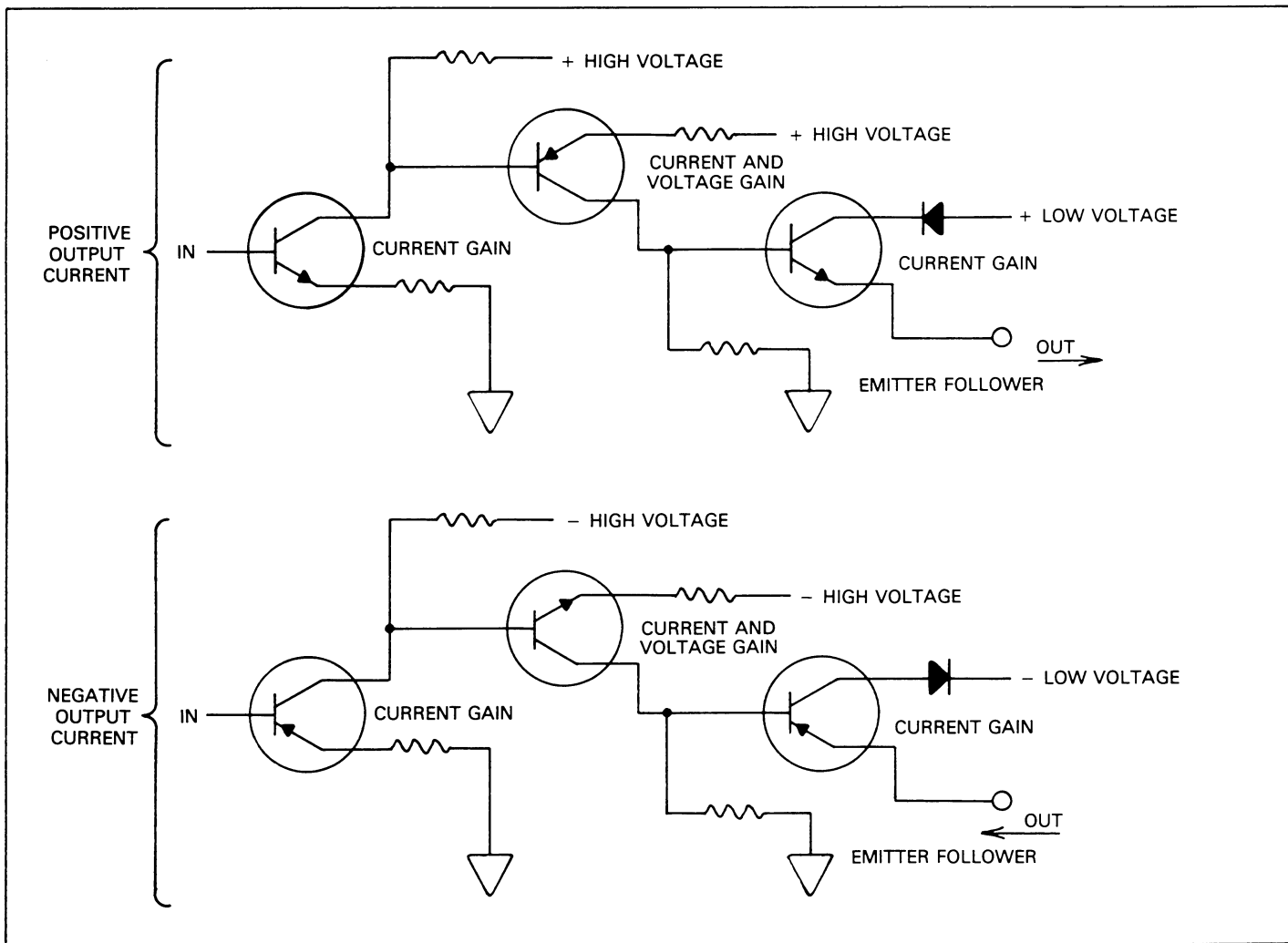

Figure 6-6. Output Amplifier

## 6.4 DIGITAL BOARD

The Model 228 is controlled by the internal microprocessor. This section briefly describes the operation of the various sections of the microprocessor and associated digital circuitry. For more complete circuit details refer to schematic 228-146 at the end of this manual.

The microcomputer centers around the 6809 high density N-MOS microprocessor (U410). It is an eight bit microprocessor with direct addressing up to 64k bytes of memory. Timing for the microprocessor is accomplished by the use of Y401; a 4MHz crystal. Internally this frequency is divided down by four to obtain a bus operating frequency of 1MHz.

The software for the microprocessor is stored in EPROMs U413 and U414. The software revision level is displayed in the power up sequence. U412 and U411 are CMOS Random Access Memory (RAM). Partial address decoding is used in this system. The function selected is determined by the state of A11, A12, A13, A14 and A15 address lines. These address lines determine which is selected by the decoders. The decoders are U403, U407, U404, and U102. Only one of the following devices (ROM, RAM, VIA, etc) will have access to the data bus at any one time.

The digital circuitry is optically isolated from the analog circuitry by U419 through U422 and the associated circuitry. The output signals consist of SHIFT, DATA, STROBE and STATUS. These signal lines permit serial communication to the analog circuitry.

The external trigger circuitry consists of U409, CR401, R401, R402 and R403. U409 is protected by the circuit formed by CR401, R401 through R403.

The battery back up circuitry turns on when power is turned off. The battery power is connected to all the RAM circuitry. This retains the data in the buffer locations when power is shut down. When power is lost, transistors Q402 and Q401 turn off and the battery voltage is routed through diode CR402 to the RAM circuitry.

U415, U416 and U408 comprise the IEEE-488 interface bus circuitry. U415 is the main interface chip. U408 and U416 are the bus transceivers.

U423 (on the digital board) detects loss of power and resets the microprocessor. This prevents writing to the battery backed up memory of U411 and U412.

## 6.5 DISPLAY BOARD

The display information is sent through display latch U417 (SE1 through SE7). The information is updated at a 1kHz rate. This means each digit is on for 1msec. Each update begins by presenting new segment information to display latch and sending a clock pulse on PA0. The clock pulse to U204 shifts a digit enable bit to the next digit to be enabled. Every 12 times the display is updated, a digit enable bit is generated at PA1 and goes to the data input of the shift register. U206 and U207 are the drivers for the LED segments of the display digits. The appropriate LEDs are also activated. Refer to the block diagram of Figure 6-7.

When each of the first 6 digits are selected, a row of switches are also selected. The row (S1 through S5) is then read by the microprocessor through U409 inputs PA3-PA7).

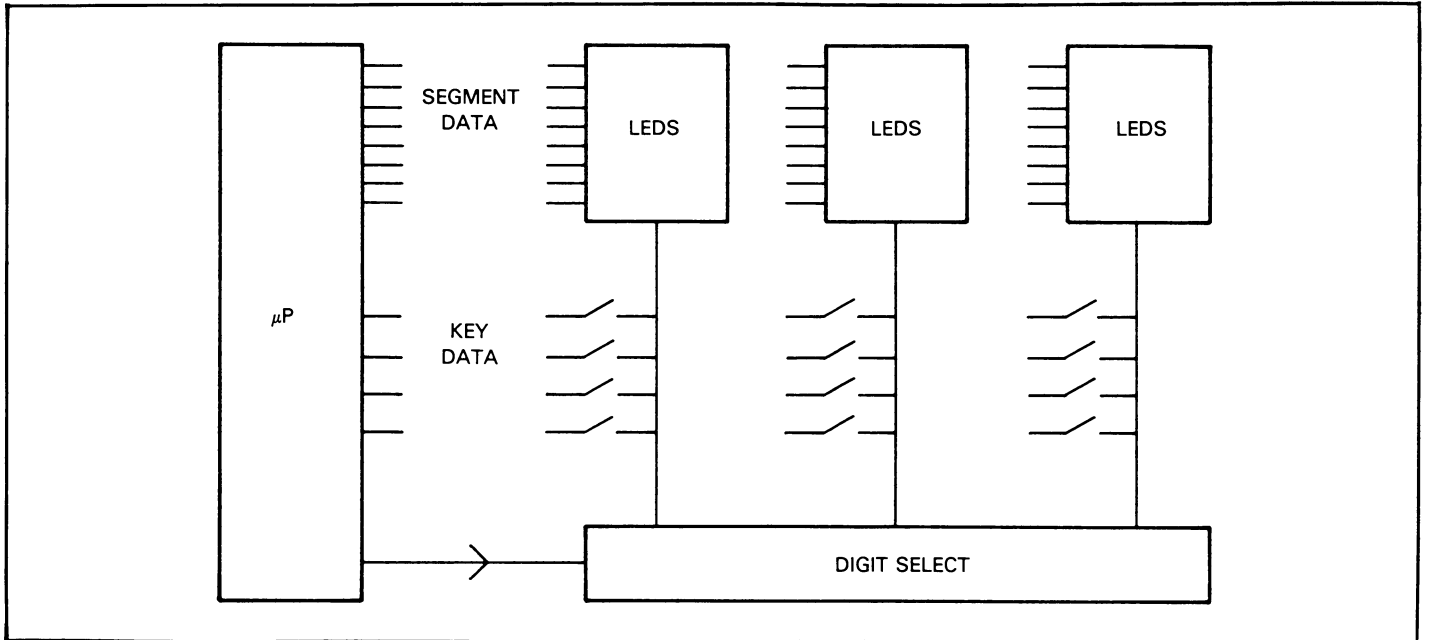

Figure 6-7. Display and Keyboard





# SECTION 7 MAINTENANCE

## 7.1 INTRODUCTION

This section contains information necessary to maintain the Model 228 Voltage/Current Source. Fuse replacement, line voltage setting, disassembly instructions, calibration procedures and troubleshooting information is contained in this section.

## 7.2 FUSE REPLACEMENT

For maximum safety the Model 228 incorporates three separate fuses. These fuses protect the user as well as the instrument. LINE FUSE 1 protects the linear power supply. LINE FUSE 2 protects the switching power supply. The OUTPUT FUSE protects the load and the Model 228. All the fuses are located on the rear panel and are user accessible. The fuses are clearly marked to avoid confusion. If more than one fuse needs to be checked or replaced, replace one fuse at a time. In this manner inadvertent switching of fuses is avoided. To replace a fuse use the following procedure:

### NOTE

The following procedure applies to each fuse.

### WARNING

**Turn off the Model 228, disconnect it from line power and all other equipment before replacing the fuse.**

1. Turn off the Model 228 and disconnect the line cord.
2. The fuse carrier is spring loaded. Using a flat blade screwdriver, push the fuse carrier in and rotate ¼ turn counterclockwise. The carrier and fuse will disengage from the instrument.
3. Remove the fuse from the carrier and replace per Tables 7-1 and 7-2.

### CAUTION

**Do not install a fuse with a higher rating than specified in Tables 7-1 and 7-2. Instrument damage may result.**

4. To install the fuse and carrier into the holder, reverse the procedure in step 2.

**Table 7-1. Fuse Replacement**

	Fuse Rating	3AG Size	5mm Size*
<b>90—110V</b>			
Line Fuse 1	6.3A, 250V	N.A.	FU-69
Line Fuse 2	1A, 250V	N.A.	FU-72
Output Fuse	20A, 250V	FU-47	FU-47**
<b>105—125V</b>			
Line Fuse 1	5A, 250V	FU-64	FU-65
Line Fuse 2	0.75A, 250V	FU-19	FU-52†
Output Fuse	20A, 250V	FU-47	FU-47**
<b>180—220V</b>			
Line Fuse 1	3.15A, 250V	N.A.	FU-70
Line Fuse 2	0.5A, 250V	N.A.	FU-71
Output Fuse	20A, 250V	FU-47	FU-47**
<b>210—250V</b>			
Line Fuse 1	2.5A, 250V	FU-66	FU-67
Line Fuse 2	.375A, 250V	FU-18	FU-53‡
Output Fuse	20A, 250V	FU-47	FU-47**

\*5mm size fuses require changing the fuse holder cap. Use Keithley Part No. FH-26 for 5mm fuses.

\*\*This fuse is 3AG size. No 5mm 20A, 250V fuse is currently available.

†This fuse is rated at 0.8A.

‡This fuse is rated at 0.4A.

## 7.3 LINE VOLTAGE SELECTION

The Model 228 operates from either 105V-125V or 210V-250V, 50Hz or 60Hz. The instrument was shipped from the factory set for an operating voltage that is marked on the rear panel. The operating voltage of the instrument is internally selectable using SW302. SW302 is located directly beneath the quick disconnect board. Set up the Model 228 to operate on the available AC line as follows:

### WARNING

**To prevent a shock hazard, always turn off the instrument and disconnect all test equipment from the Model 228 before removing the top or bottom cover.**

1. Remove the top cover. Refer to the disassembly instructions in paragraph 7.4. Refer to Figure 7-1.
2. Refer to Table 7-3 and set switch SW302 accordingly. SW302 is located directly beneath the quick disconnect board.
3. Install the proper fuse per paragraph 7.2

**NOTE**

Model 228 can operate on 90V—110V or 180V—220V. Table 7-2 lists all part changes for low voltage operation.

**Table 7-3. Line Voltage Selection**

Line Voltage	Line Frequency	Switch Setting SW302
90V—110V	50Hz—60Hz	115V
105V—125V	50Hz—60Hz	115V
180V—220V	50Hz—60Hz	230V
210V—250V	50Hz—60Hz	230V

**Table 7-2. Low Voltage Operation Part Changes**

Component	For 90V-110V Operation Change To	For 180V—220V Operation Change To
Fuse F301	FU-69, 6.3A, 250V	FU-70, 3.15A, 250V
Fuse F302	FU-72, 1A, 250V	FU-71, 0.5A, 250V
Thermistor RT301	CAL-R, #65560	CAL-R, #65560
Transformer T303	TR-215	TR-215
Transformer TR-216	TR-216	
MOSFET Q302	TG-182 (IRF343)	TG-182 (IRF343)
MOSFET Q303	TG-182 (IRF343)	TG-182 (IRF343)
Capacitor C306	C-64-680pF	C-64-680pF
Capacitor C308	C-64-680pF	C-64-680pF
Resistor R323	R-88-357	R-88-357
Resistor R321	R-76-24k	R-76-24k
Bridge Rectifier CR301	*RF-63	*RF-63

\*Electronic Devices Inc. #PY80 with heat sink.

**NOTE**

The line voltage setting of the instrument is marked on the rear panel. The preceding procedure may be used to confirm the factory setting or to set the instrument for operating on another voltage range. If the voltage range is changed, the box next to the selected line voltage should be appropriately marked as an external reminder of the setting. Use a water and petroleum resistant marking pen as described in IEC-348.

**7.4 DISASSEMBLY**

If it becomes necessary to disassemble the Model 228, use the following procedure. Also, refer to Figures 7-1 through 7-5. The following procedures allow only the parts that require disassembly to be disassembled. For example, if the digital board is to be removed, then refer to the procedure on removing the digital board. There are four basic methods to disassemble the Model 228. The methods consist of the following:

1. Removing the right side panel (viewed from the rear) to gain access to the mother board, digital board and power supply board.
2. Removing the left side panel (viewed from the rear) to gain access to the heat sink assembly and the fan.
3. Removing the rear panel to gain access to the components at the rear of the instrument.
4. Removing the top and bottom cover.

**7.4.1 Removing the Top and Bottom Covers**

**WARNING**

**To prevent a shock hazard, always turn the instrument off and disconnect it from line power before removing the top or bottom cover.**

1. Remove the top cover.
  - A. Remove the top two retaining screws located at the rear of the instrument.
  - B. Grasping the top cover at the rear of the instrument, carefully pull it out and away from the instrument. Refer to Figure 7-1.
2. Remove the bottom cover in the same manner as the top cover with one exception. The four feet on the bottom cover must be removed in order to remove the bottom cover.

## 7.4.2 Remove the Rear Panel

1. Remove the four retaining screws. Two on each side of the rear panel.
2. Disconnect the external trigger connector wires from the quick disconnects.
3. Remove the two screws that secure the IEEE-488 connector to the rear panel.
4. Disconnect the output fuse wires.
5. Carefully remove the rear panel.

## 7.4.3 Digital Board, Mother Board and Power Supply Board Access

The digital board, mother board and power supply board may be accessed through the right side panel (viewed from the rear). This procedure allows access to these boards without dismantling the entire instrument.

1. Remove the top and bottom cover. Refer to paragraph 7.4.1.
2. Remove the decorative strips from the side panel. Refer to Figure 7-3.
  - A. From inside the mainframe, place a thin blade screwdriver into one of the holes where the decorative strip is secured.
  - B. Carefully push outwards until the strip disengages from the fasteners.
  - C. Pull the strip away from the mainframe.
  - D. To install the strip, align the strip in the recessed part of the side panel and press the strip at the points of the fasteners.
3. Remove the eight screws that secure the side panel to the mainframe. Also, remove the two screws that secure the side panel to the rear panel.
4. Remove the side panel.
5. Remove the digital board.
  - A. Disconnect the display cable (P1006) from the digital board. Refer to Figure 7-2, 7-3 and 7-4.
  - B. Disconnect the analog-to-digital cable (P1007) from the mother board.
  - C. Disconnect the power supply cable (P1009) from the power supply board.
  - D. Disconnect the external trigger input and output cable (J1008) from the digital board.
  - E. Remove the three screws that secure the digital board to the top rails.
  - F. Remove the digital board through the open side panel.
6. Remove the mother board.
  - A. Remove the four screws that secure the mother board to the bottom rails.
  - B. Disconnect the appropriate wires.
  - C. Remove the mother board through the open side panel.
  - D. Remove the mother board shield by carefully lifting the shield off of the retaining clips. Be careful not to pinch or sever any wires when reinstalling the shield.
7. Remove the power supply board.
  - A. Remove the six screws that secure the power supply to the bottom rails.
  - B. Disconnect the appropriate wires.
  - C. Remove the power supply board from the mainframe.
  - D. Remove the power supply board shield by carefully lifting it off of the retaining clips. Be careful not to pinch or sever any wires when reinstalling the shield.

## 7.4.4 Heat Sink Assembly and Fan Access

1. Remove the top and bottom covers as described in paragraph 7.4.1
2. Remove the two decorative strips from the left side panel (viewed from the rear). Refer to Figures 7-2, 7-3, 7-4 and 7-5.
  - A. Place a thin blade screwdriver into one of the holes where the decorative strip is secured.
  - B. Carefully push outwards until the strip disengages from the fasteners.
  - C. Pull the strip away from the mainframe.
  - D. To install the strip, align in the recessed part of the side panel. Then press the strip at the points of the fasteners.
3. Remove the screws that secure the side panel to the mainframe. Also, remove the two screws that secure the side panel to the rear panel.
4. Remove the side panel.
5. Heat Sink Assembly Removal.
  - A. Remove the four screws that secure the heat sink assembly to the top rails.
  - B. Remove the four screws that secure the heat sink assembly to the bottom rails.
  - C. Disconnect all of the appropriate connectors and wires.
  - D. Remove the heat sink assembly through the open side panel.
6. Fan Removal.
  - A. Remove the two screws that secure the fan to the top rails.
  - B. Remove the two screws that secure the fan to the bottom rails.
  - C. Disconnect the power cable (J1011) from the mother board.
  - D. Remove the fan through the open side panel.
7. Remove the display board.
  - A. Remove the four screws that secure the front panel to the side panels.

- B. Pull the front panel away from the mainframe. The display cable and the power switch are not disconnected. Be careful not to pull the front panel to far away from the mainframe.
- C. Remove the screw that secures the display to the front panel.

- D. Remove the four set screws that secure the display board to the front panel.
- E. Separate the front panel and the display board.

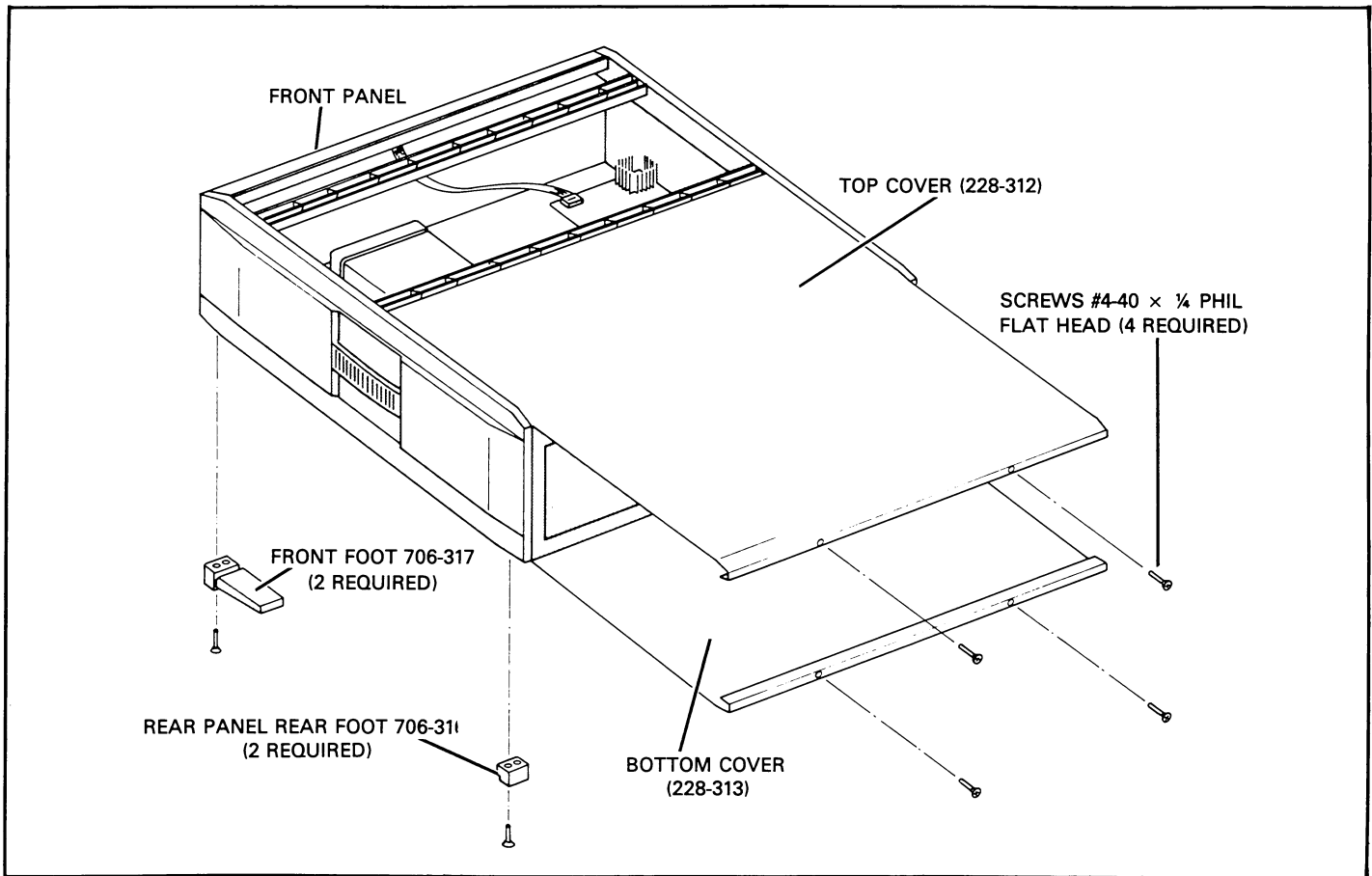

**Figure 7-1. Top and Bottom Cover Removal**

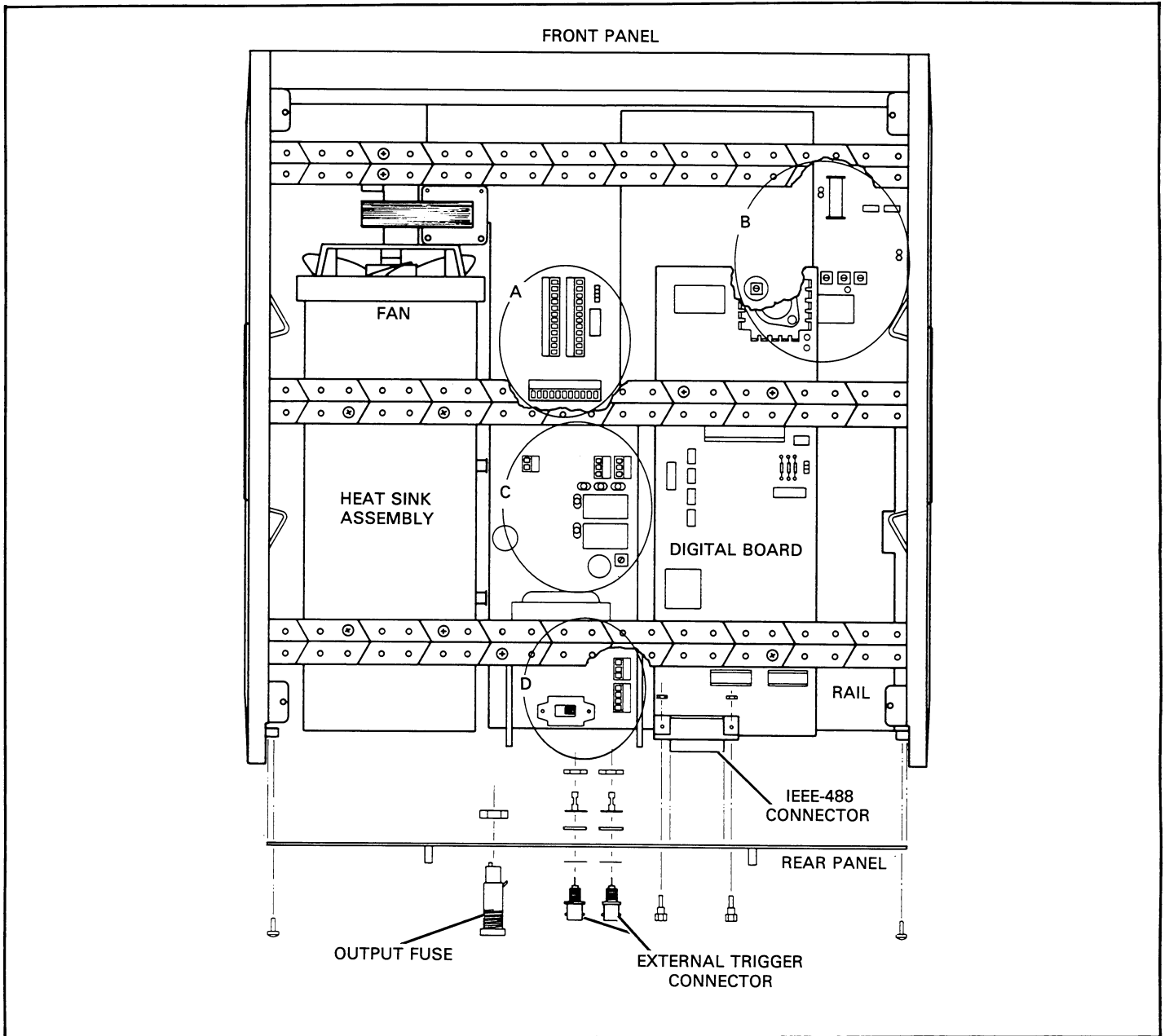

**Figure 7-2A. Rear Panel Removal**

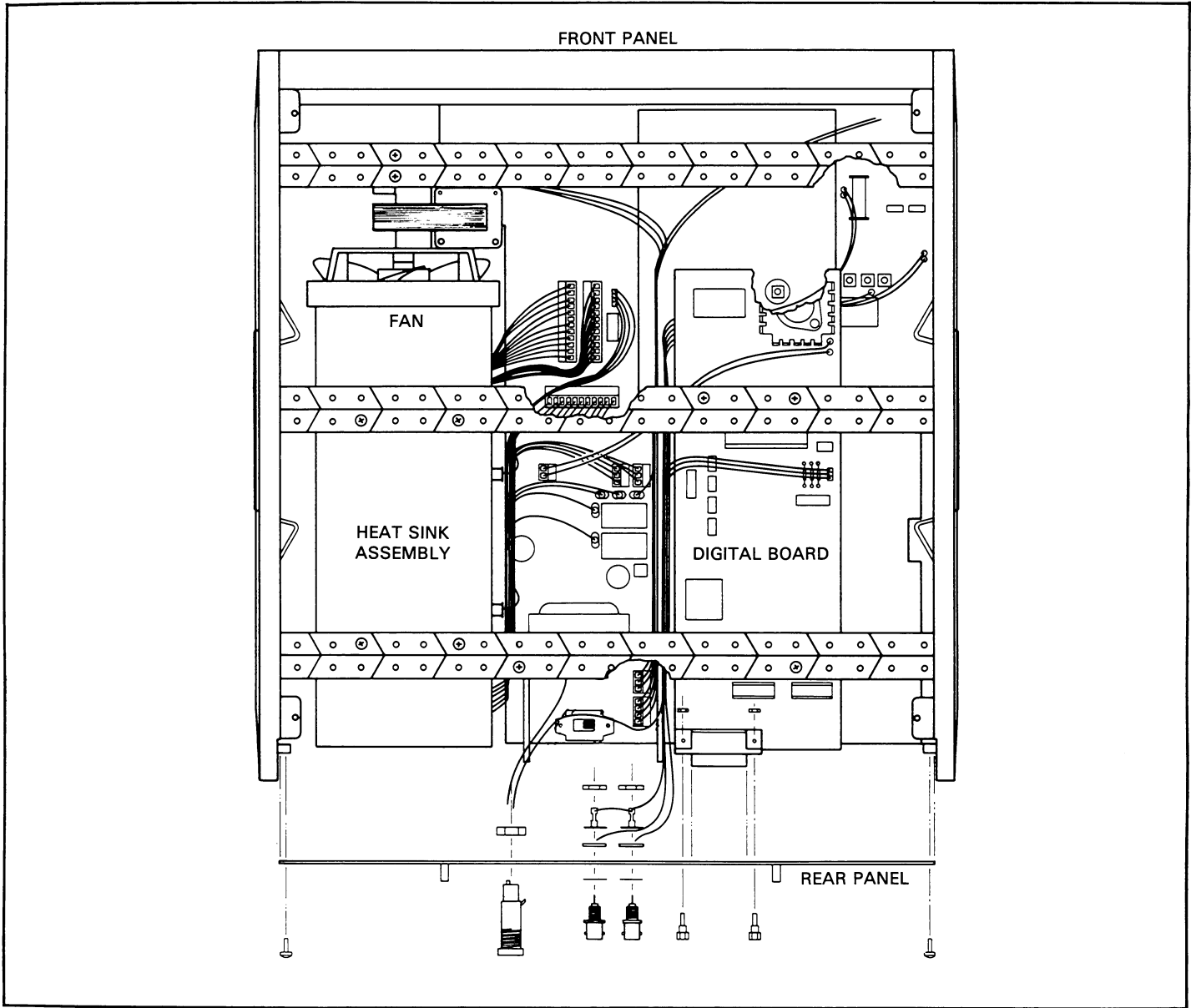

Figure 7-2B. Wiring Input

## 7.5 TROUBLESHOOTING

The troubleshooting instructions contained in this section are intended for qualified personnel that have a basic understanding of analog and digital circuitry. The individual should be experienced at using electronic test equipment as well as ordinary troubleshooting procedures. Also, the troubleshooter must be familiar with general safety practices when troubleshooting electronic equipment. The information presented here has been written to assist in isolating a defective circuit or circuit section; isolation of the specific component is left to the troubleshooter.

### WARNING

**Always wear safety glasses when troubleshooting the Model 228.**

### 7.5.1 Recommended Test Equipment

The recommended test equipment required to troubleshoot the Model 228 is listed in Table 7-4.

### 7.5.2 Digital Self Test

Upon power up or when front panel Program 6 is activated or when the J command is received over the bus, the Model 228

performs a digital self test. The self test consists of checking the RAM circuitry, a cyclic redundancy check (CRC) of the ROM circuitry, a LED test, autocalibration, the software revision level is displayed and the primary address is displayed. The LED test turns on all front panel LEDs for approximately five seconds. During this time the Model 228 performs the RAM and ROM tests. The sequence of the digital self test is as follows:

1. All the front panel LEDs turn on for approximately five seconds. The operator can note inoperative display segments.

### NOTE

Refer to the power up sequence in paragraph 3.3 for display messages.

2. Next, the Model 228 displays the software revision level.
3. Next, the Model 228 displays the present primary address.
4. After step 3 the Model 228 goes into the autocalibration sequence.

### 7.5.3 Troubleshooting

Refer to Table 7-5 for power supply checks. The power supply should always be the first item on the list of any troubleshooting. Refer to Table 7-6 for analog circuitry checks. Refer to Table 7-7 for digital circuitry checks and Table 7-8 for display board checks.

**Table 7-4. Recommended Test Equipment**

Item	Equipment	Use
1	Five function DMM with $\pm 0.03\%$ basic DC accuracy.	Power supply, DC Voltage continuity and logic level checks.
2	Dual trace, triggered sweep oscilloscope. DC to 10MHz bandwidth.	Waveform Checks
3	5 $\Omega$ resistor, 100W, 1%	Load Resistor

**Table 7-5. Power Supply Checks**

Step	Item/Component	Required Condition*	Remarks
1	F301, F302	Check for continuity	Power supply fuses
2	P1014, pin 6	+5VDC $\pm$ 5%	+5V supply
3	P1014, pin 5	-5VDC $\pm$ 5%	-5V supply
4	+15V pad	+15V $\pm$ 15%	+15V supply
5	-15V pad	-15V $\pm$ 15%	-15V supply
6	P1014, pin 11	+115V $\pm$ 15%	+115V supply
7	P1014, pin 10	-115V $\pm$ 15%	-115V supply
8	U302, pin 15	+5V	Reference
9	U302, pin 8	+1.5V	Pulse width voltage regulator output.
10	U302, pin 11	+1.5V	Pulse width voltage regulator output.
11	U303, pin 3	50kHz pulses	Driver output
12	U304, pin 3	50kHz pulses	Driver output

\*Referenced to power supply common.

**Table 7-6. Analog Circuitry Checks**

Step	Test Setup*	Item/Component	Required Condition	Remarks
1	A	U116 pins 14 and 16	<1V	Operate relay, and 0.1A and 1V range relays energized.
2	B	U116 pins 13 and 15	<1V	Operate relay, and 1A and 10V range relays energized.
3	C	U116 pin 12	<1V	Operate relay and 10A range relay energized.
4	D	U110 pin 15	+1.000V $\pm$ .004V	Output of voltage digital-to-analog converter.
5	D	U111 pin 15	+1.000V $\pm$ .004V	Output of current digital-to-analog converter.
6	E	U106, pin 6	-.6V to -8V	-I Limit
7	D	U107, pin 6	+.6V to +8V	+I Limit
8	F	U108, pin 6	-.6V to -8V	-V Limit
9	C	U109, pin 6	+.6V to +8V	+V Limit
10	D	U105B, pin 6	0V $\pm$ .1V	Summing Junction
11	G	U105B, pin 7	$\pm$ 0.45V	Summary amp output.
12	B	Junction of R108, R109 and R110	0.46V to 0.66V	Output of first stage of amp (current gain).
13	D	Junction of R114 and R122	0.4V to 1.6V	Output of second stage of amp (current and voltage gain).
14	B	Out + terminal	10V	Output second of last stage of amp (current gain).
15	D	U122, pin 10	Varying levels from -1.5V to +1.5V	Output of multiplexer.

\*Test Setups—All voltages measured with respect to shield clip next to K103, operate.

A—Program the Model 228 to output 1V and 0.1A with no load.

B—Program the Model 228 to output 10V and 1A with no load.

C—Program the Model 228 to output +10V and +10A with no load.

D—Program the Model 228 to output +1V and +0.1A to a 5 $\Omega$  load.

E—Program the Model 228 to output -1V and -0.1A to a 5 $\Omega$  load.

F—Program the Model 228 to output -10V, -10A with no load.

G—Program the Model 228 to output 0V, 0A with no load.



**Table 7-7. Digital Circuitry Checks**

Step	Test Setup*	Item/Component	Required Condition	Remarks
1	A	U411, U412, U413 and U414 (RAM & ROM)	Pass RAM and ROM Self Test on power up.	Display will lock up if failure occurs. See paragraph 7.5.2.
2	B	U401, pin 2	+5V $\pm$ 5%	Output of 5V regulator.
3	C	U409, pin 2 (PA0)	TTL level pulses every 1msec	VIA clock
4	C	U409, pin 3 (PA1)	TTL level pulses every 15msec	Shift Data
5	C	U409, pin 5 (PA3)	Switch data (+5 or 0V)	Data input to VIA
6	C	U409, pin 6 (PA4)	Switch data (+5V or 0V)	Data input to VIA
7	C	U409, pin 7 (PA5)	Switch data (+5V or 0V)	Data input to VIA
8	C	U409, pin 8 (PA6)	Switch data (+5V or 0V)	Data input to VIA
9	C	U409, pin 9 (PA7)	Switch data (+5V or 0V)	Data input to VIA
10	C	U409, pin 19	250kHz bursts six times/sec	VIA Data Line
11	C	U420, pin 6	250kHz bursts six times/sec	Data output.
12	C	U122, pin 21	250kHz bursts six times/sec	Output of A/D Converter
13	C	U123, pin 3	250kHz clock	250kHz clock
14	C	U422, pin 3	250kHz clock six times/sec	Input to Opto
15	C	U409, pin 15 and 16	250kHz bursts six times/sec	Analog Data to VIA
16	B	U410, pin 13	1kHz	IRQ Line
17	B	U410, pin 37	+5V $\pm$ 5%	Reset line
18	B	U415, pin 9	+5V signal pulsed 0V to +5V every 1msec.	INT Line
19	B	U415, pin 19	+5V (Logic "1")	RESET Line
20	B	U415, pin 18 ( $\Phi$ E)	1MHz square wave at 0V to +5V	Clock to U115
21	D	U415, pin 28	Should go false (+5) when command is sent.	ATN line
22	E	U415 pins 28 (ATN), 24 (NDAC), 25 (NRFD), 26 (DAV), and the data lines.	Refer to Figure 4-3 for required conditions.	Handshake Sequence

**\*Test Setups**

A—Turn Model 228 on.

B—Place the Model 228 in standby.

C—Program 228 to output 1V, 0.1A to a 10 $\Omega$  load.

D—Program the Model 228 into remote and send a device-dependent command over the bus.

E—Send data on multiline command over the bus.

**Table 7-8. Display Board Checks**

Step	Item/Component	Required Condition	Remarks
1	Display	Turn 228 on to run display test.	Verify that all display segments and LEDs are working.
2	P1006 pins 18, 20, 21 and 22	+5V $\pm$ 5% (referenced to digital common)	+5V supply
3	U204, pin 8		Clock
4	U204, pin 1		Shift data

## 7.6 CALIBRATION

Calibration of the Model 228 should be performed yearly (every 12 months) or whenever performance verification (Section 5) indicates that the Model 228 is out of specification. If any step in the calibration procedure cannot be performed, refer to paragraph 7.5 Troubleshooting or contact your Keithley representative or the factory.

The calibration procedure should be performed in the order that it is presented. That is, the +15V supply should be adjusted first, the +1V reference should be adjusted next and the current ranges should be calibrated last.

### WARNING

All service information is intended for qualified electronic maintenance personnel only.

### 7.6.1 Recommended Test Equipment

Recommended test equipment is listed in Table 7-9. Alternate test equipment may be used. However, the accuracy of the alternate test equipment must at least be equal to the specifications listed in Table 7-9.

**Table 7-9. Recommended Calibration Equipment**

Item	Description	Specification	Mfr.	Model
A	DMM (1)	2V $\pm$ 0.005%	Keithley	197
B	DMM (2)	200mV $\pm$ 0.007%	Keithley	197
C	Resistor	0.01 $\Omega$ $\pm$ 0.02%	Valhalla	2572

### 7.6.2 Environmental Conditions

Calibration should be performed under laboratory conditions having an ambient temperature of 23°C  $\pm$ 1°C and a relative humidity of less than 50%.

### 7.6.3 Warm Up

The Model 228 must be turned on and allowed ten minutes for warm up. If the instrument has been subjected to extremes of temperatures, allow sufficient time for internal temperatures to reach normal operating conditions. Typically, it takes one hour to stabilize a unit that is within 10°C (18°F) of the specified temperature range.

### 7.6.4 Top Cover Removal

To gain access to the power supply and the calibration adjustment pots, the top cover must be removed (refer to paragraph 7.4). Minimize the time the top cover is removed. When not making an adjustment, loosely place the top cover on the top of the instrument to help maintain the proper internal temperature.

### WARNING

To eliminate a shock hazard, turn the instrument off, remove the line cord and all leads connected to the instrument before removing the top cover.

### NOTE

Minimize the time the top cover is removed while calibrating the Model 228.

## 7.6.5 +15V Supply Adjustment

1. Set the Model 197 to the 100VDC range.
2. Connect the Model 197 to the positive side of CR312 and to the power supply low.
3. Adjust R329 (see Figures 7-2 and 7-4) for a +15.0V reading on the Model 197.

## 7.6.6 Test Setup

Set up the circuit shown in Figure 7-6 and perform the following procedures to adjust the +1V reference and calibrate the current ranges.

## 7.6.7 +1V Reference Adjustment

Perform the following procedure to calibrate the +1V Reference. Refer to Figures 7-2 and 7-4 for location of the calibration pot.

1. Make sure the Model 228 is in STANDBY.
2. Set DMM #1 to the 2VDC range and DMM #2 to the 200mVDC range.
3. Set the Model 2575 for 000.01Ω.
4. Program the Model 228 for +10.00V and +1.000A.
5. Set the Model 228 to OPERATE.
6. Adjust R159 (see Figures 7-2 and 7-4) until the amps display of the Model 228 agrees with the reading on DMM #1. For example, if the reading on DMM #1 is 1.00200V, then adjust the amps display to read 1.002A.
7. Select Program 6 (self test and autocal).
8. Repeat steps 5 and 6.
9. Place the Model 228 in STANDBY.

## 7.6.8 Current Calibration

Perform the following procedure to calibrate the current ranges of the Model 228. Refer to Figures 7-2 and 7-4 for location of the calibration pots.

1. With the Model 228 in standby, check that DMM #1 is still on the 1VDC range and DMM #2 is on the 200mVDC range.
2. Check that the Model 2575 is still set for 0.01Ω.
3. Select Program 6 (self test and autocal).
4. Program the Model 228 for +10.00V and +.1000A.
5. Set the Model 228 to OPERATE.
6. Adjust R175 (0.1A cal) until the output equals 0.100A ( $.1A \times .010\Omega = 1mV$  reading on the voltmeter).
7. Program the Model 228 for 10.00V, 1.000A.
8. Adjust R174 (1A cal) until the output equals 1.000A ( $1A \times .010\Omega = 10mV$  reading on the voltmeter).

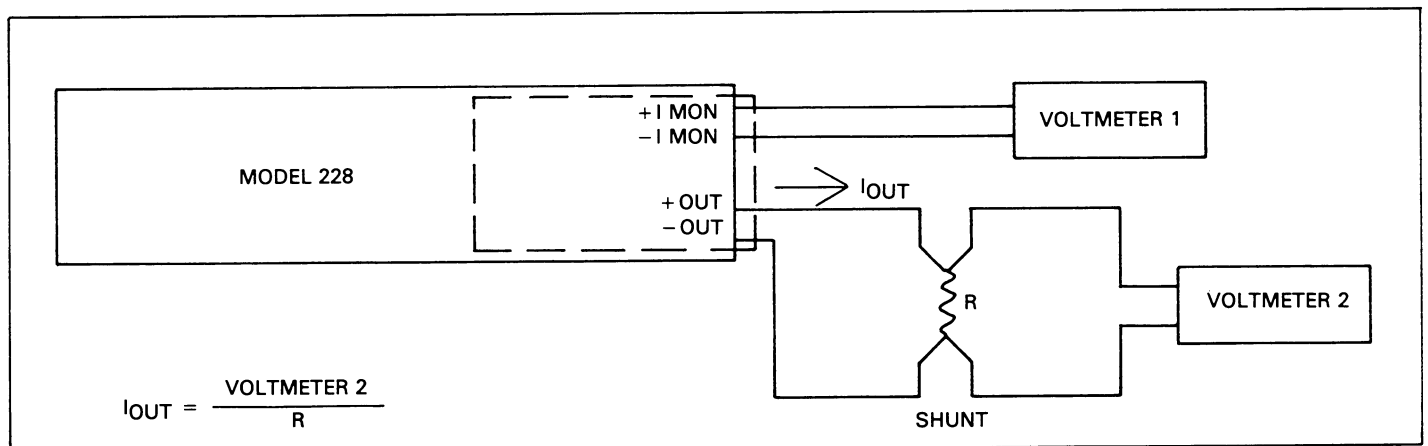

Figure 7-6. Calibration Setup

9. Program the Model 228 for 10.00V, 10.00A.
10. Adjust R173 (10A cal) until the output equals 10.00A (10A  $\times$  .01 $\Omega$  = 100mV reading on the voltmeter).
11. Place the Model 228 in the standby mode. Calibration is complete.

6. Use grounded tip soldering irons.
7. After devices are soldered or inserted into sockets they are protected and normal handling can resume.

## 7.7 SPECIAL HANDLING OF STATIC SENSITIVE DEVICES

MOS devices are designed to function at high impedance levels. Normal static charge can destroy these devices. Table 7-10 lists all the static sensitive devices of the Model 228. Steps 1 through 7 provide instruction on how to avoid damaging these devices.

1. Devices should be handled and transported in protective containers, antistatic tubes or conductive foam.
2. Use a properly grounded work bench and a grounding wriststrap.
3. Handle devices by the body only.
4. PC boards must be grounded to bench while inserting devices.
5. Use antistatic solder suckers.

**Table 7-10. Model 228 Static Sensitive Devices**

Circuit Designation	Keithley Part Number
U118	IC-108
U121	IC-102
U409	LSI-28
U410	LSI-38
U411	LSI-58
U412	LSI-58
U413	228-800-**
U414	228-800-**
U417	IC-397

\*\*Order same software as presently installed. Example if the software revision level is A1 then order 228-800-A1 for U413.

# SECTION 8 REPLACEABLE PARTS

## 8.1 INTRODUCTION

This section contains replacement parts information, schematic diagrams and component location drawings for the Model 228.

## 8.2 REPLACEABLE PARTS

Parts are listed alpha-numerically in order of their circuit designation. Table 8-1 contains parts list information for the mother board. Table 8-2 contains parts list information for the digital board. Table 8-3 contains parts list information for the power supply board. Table 8-4 contains parts list information for the display board. Table 8-5 contains a list of mechanical parts for the Model 228.

## 8.3 ORDERING INFORMATION

To place an order, or to obtain information concerning replacement parts, contact your Keithley representative or the factory. See the inside front cover of this manual for addresses. When ordering include the following information:

1. Instrument Model Number
2. Instrument Serial Number
3. Part Description
4. Circuit Designation (if applicable)
5. Keithley Part Number

If an additional instruction manual is required, order the manual package (Keithley Part Number 228-901-00). The

manual package includes an instruction manual and all pertinent addenda.

## 8.4 FACTORY SERVICE

If the instrument is to be returned to the factory for service, photo copy and complete the service form which follows this section and return it with the instrument.

## 8.5 SCHEMATIC DIAGRAMS AND COMPONENT LOCATION DRAWINGS

The component location drawings and schematic diagrams are presented as follows:

Figure 8-1. Mother Board, Component Location Drawing, Dwg. No. 228-100.

Figure 8-2. Mother Board, Schematic Diagram, Dwg. No. 228-106.

Figure 8-3. Display Board, Component Location Drawing, Dwg. No. 228-110.

Figure 8-4. Display Board, Schematic Diagram, Dwg. No. 228-116.

Figure 8-5. Power Supply Board, Component Location Drawing, Dwg. No. 228-150.

Figure 8-6. Power Supply Board, Schematic Diagram, Dwg. No. 228-156.

Figure 8-7. Digital Board, Component Location Drawing, Dwg. No. 228-140.

Figure 8-8. Digital Board, Schematic Diagram, Dwg. No. 228-146.

**Table 8-1. Mother Board Parts List**

<b>Circuit Desig.</b>	<b>Description</b>	<b>Keithley Part No.</b>
C101	Capacitor, 1 uF, 50V, Ceramic Film	C-237-1
C102	Capacitor, 0.1uF, 100V, Metalized Polypropylene	C-306-.1
C103	Capacitor, 1uF, 100V, Metalized Polyester	C-294-1
C104	Capacitor, 1uF, 50V, Ceramic Film	C-237-1
C105	Capacitor, 1uF, 50V, Ceramic Film	C-237-1
C106	Capacitor, 2200pF, 1000V, Ceramic Disc	C-64-680p
C107	Capacitor, 2200pF, 1000V, Ceramic Disc	C-64-680p
C108	Capacitor, 680pF, 1000V, Ceramic Disc	C-64-680p
C109	Capacitor, 680pF, 1000V, Ceramic Disc	C-64-680p
C110	Capacitor, 0.1uF, 100V, Metalized Polyester	C-305-.1
C111	Capacitor, 0.1uF, 100V, Metalized Polyester	C-305-.1
C112	Capacitor, 0.33uF, 50V, Ceramic Film	C-237-.33
C113	Capacitor, 10uF, 25V, Aluminum Electrolytic	C-314-10
C114	Capacitor, 10uF, 25V, Aluminum Electrolytic	C-314-10
C115	Capacitor, 1000p, 500V, Ceramic Disc	C-22-1000p
C116	Capacitor, 1000p, 500V, Ceramic Disc	C-22-1000p
C117	Capacitor, 0.1uF, 100V, Metalized Polyester	C-305-.1
C118	Capacitor, 0.1uF, 100V, Metalized Polyester	C-305-.1
C119	Capacitor, 1500pF, 1000V, Ceramic Disc	C-64-1500p
C120	Capacitor, 10uF, 25V, Aluminum Electrolytic	C-314-10
C121	Capacitor, 1uF, 50V, Metalized Polycarbonate	C-215-1
C122	Capacitor, 1uF, 50V, Metalized Polycarbonate	C-215-1
C123	Capacitor, 0.1uF, 50V, Metalized Polypropylene	C-269-.1
C124	Capacitor, 10uF, 25V, Aluminum Electrolytic	C-314-10
C125	Capacitor, 0.01uF, 500V, Ceramic Disc	C-22-.01
C126	Capacitor, 330pF, 1000V, Ceramic Disc	C-64-330p
C127	Capacitor, 0.1uF, 50V, Metalized Polypropylene	C-178-.1
C128	Capacitor, 0.47uF, 50V Ceramic Film	C-237-.47
C129	Capacitor, 0.01uF, 500V, Ceramic Disc	C-314-10
C130	Capacitor, 0.01uF, 500V, Ceramic Disc	C-314-10
C131	Capacitor, 1uF, 50V, Ceramic Film	C-237-1
C132	Capacitor, 0.22uF, 50V, Metalized Polycarbonate	C-201-.22
C133	Capacitor, 0.1uF, 50V, Metalized Polycarbonate	C-201-.1
C134	Capacitor, 4700pF, 1000V, Ceramic Disc	C-64-4700p
C135	Capacitor, 4700pF, 1000V, Ceramic Disc	C-64-4700p
C136	Capacitor, 1000pF, 1000V, Ceramic Disc	C-64-1000p
C137	Capacitor, 4700pF, 1000V, Ceramic Disc	C-64-4700p
C138	Capacitor, 4700pF, 1000V, Ceramic Disc	C-64-4700p
C139	Capacitor, 0.05uF, 1000V, Metalized Polyester	C-285-.05
C140	Capacitor, 0.01uF, 1000V, Ceramic Disc	C-64-.01
CR101	Silicon Diode, 1N914	RF-28
CR102	Silicon Diode, 1N914	RF-28
CR103	Silicon Diode, 1N914	RF-28
CR104	Silicon Diode, 1N914	RF-28
CR105	Silicon Diode, 1N914	RF-28
CR106	Silicon Diode, 1N914	RF-28
CR107	Silicon Diode, 1N914	RF-28
CR108	Silicon Diode, 1N914	RF-28
CR109	Silicon Diode, 1.5A, 400V, W04M	RF-46
CR110	Silicon Diode, 1N914	RF-28
CR111	Silicon Diode, 1N914	RF-28
CR112	Silicon Diode, 1N914	RF-28
CR113	Silicon Diode, 1.5A, 400V, W04M	RF-46
CR114	Silicon Diode, 1.5A, 400V, W04M	RF-46
CR115	Silicon Diode, 1N914	RF-28
CR118	High Current Rectifier, 12A, MR1124R	RF-28

Circuit Desig.	Description	Keithley Part No.
CR119	High Current Rectifier, 12A, MR1124R	RF-28
CR120	Temperature Sensor, AD590JH	RF-28
CR121	Temperature Sensor, AD590JH	RF-28
CR122	Diode, 10075	RF-28
CR123	Diode, 10075	RF-28
CR124	Diode, 10075	RF-28
CR125	Diode, 10075	RF-28
CR126	Diode, 10075	RF-28
CR127	Diode, 10075	RF-28
CR128	Diode, 10075	RF-28
K101	Relay	RL-73
K102	Relay	RL-73
K103	Relay	RL-73
K104	Relay	RL-89
K105	Relay	RL-89
K106	Relay	RL-89
L101	Choke	CH-29
Q101	Transistor, Power, Selected	228-603
Q102	Transistor, Power, Selected	228-602
Q103	JFET, P-Channel, J270	TG-166
Q104	JFET, P-Channel, J270	TG-166
Q105	JFET, P-Channel, J270	TG-166
Q106	JFET, P-Channel, J270	TG-166
Q107	JFET, P-Channel, J270	TG-166
Q108	JFET, P-Channel, J270	TG-166
Q109	JFET, P-Channel, J270	TG-166
Q110	Transistor, Power, 250W, PNP, MJ15025	228-602
Q111	Transistor, Power, 250W, PNP, MJ15025	228-602
Q112	Transistor, Power, 250W, NPN, MJ15024	TG-170
Q113	Transistor, Power, 250W, NPN, MJ15024	TG-170
Q114	Transistor, Power, 250W, NPN, MJ15024	TG-170
Q115	Transistor, Power, 250W, NPN, MJ15024	228-603
Q116	Transistor, Power, 250W, NPN, MJ15024	228-603
Q117	Transistor, Power, 250W, PNP, MJ15025	TG-171
Q118	Transistor, Power, 250W, PNP, MJ15025	TG-171
Q119	Transistor, Power, 250W, PNP, MJ15025	TG-171
Q120	JFET, P-Channel, J270	TG-166
Q121	Transistor, N-Channel MOSFET	TG-177
Q122	Transistor, N-Channel MOSFET	TG-177
Q123	Transistor, NPN, 2N3904	TG-47
R101	Resistor, 267, 1%, 1/2W, Metal Film	R-94-267
R102	Resistor, 2.94k, 1%, 1/8W, Metal Film	R-88-2.94k
R103	Resistor, 267, 1%, 1/2W, Metal Film	R-94-267
R104	Resistor, 2.94k, 1%, 1/8W, Metal Film	R-88-2.94k
R105	Resistor, 470, 10%, 2W, Carbon	R-3-470
R106	Resistor, 120, 5%, 1W, Fixed	R-328-120
R107	Resistor, 10, 5%, 1/4W, Composition	R-76-10
R108	Resistor, 39, 5%, 1/2W, Composition	R-19-39
R109	Resistor, 51, 5%, 1W, Fixed	R-328-51
R110	Resistor, 39, 5%, 1/2W, Composition	R-19-39
R111	Resistor, 470, 10%, 2W, Carbon	R-3-470
R112	Resistor, 120, 5%, 1W, Fixed	R-328-120
R113	Resistor, 10, 5%, 1/4W, Composition	R-76-10
R114	Resistor, 1k, 5%, 10W, Wirewound	R-325-1k
R115	Resistor, 220, 10%, 1/2W, Carbon	R-1-220
R116	Resistor, .45, 5%, 5W, Fixed	R-324-.45

Circuit Desig.	Description	Keithley Part No.
R117	Resistor, .45, 5%, 5W, Fixed	R-324-.45
R118	Resistor, .45, 5%, 5W, Fixed	R-324-.45
R119	Not Used	
R120	Not Used	
R121	Not Used	
R122	Resistor, 10, 10%, 2W, Carbon	R-3-10
R123	Resistor, 9, 5%, 5W, Wirewound	R-257-9
R124	Resistor, 9, 5%, 5W, Wirewound	R-257-9
R125	Resistor, 9, 5%, 5W, Wirewound	R-257-9
R126	Resistor, 9, 5%, 5W, Wirewound	R-257-9
R127	Resistor, 100k, 1%, 1/8W, Metal Film	R-88-100k
R128	Resistor, 100k, 1%, 1/8W, Metal Film	R-88-100k
R129	Resistor, 10k, 5%, 1/4W, Composition	R-76-10k
R130	Resistor, 1k, 5%, 1/4W, Composition	R-76-1k
R131	Resistor, 1k, 5%, 1/4W, Composition	R-76-1k
R132	Resistor, 4.7k, 5%, 1/4W, Composition	R-76-4.7k
R133	Resistor, 44k, .1%, 1/8W, Metal Film	R-179-44k
R134	Resistor, 44k, .1%, 1/8W, Metal Film	R-179-44k
R135	Thick Film Resistor Network	TF-183-2
R136	Resistor, 44k, .1%, 1/8W, Metal Film	R-179-44k
R137	Resistor, 44k, .1%, 1/8W, Metal Film	R-179-44k
R138	Thick Film Resistor Network	TF-183-2
R139	Thick Film Resistor Network	TF-178-2
R140	Resistor, 10k, 5%, 1/4W, Composition	R-76-1k
R141	Resistor, 10k, 5%	R-76-1k
R142	Resistor, 40.2k, 1%, 1/8W, Composition	R-88-40.2k
R143	Resistor, 681k, 0.1%, 1/10W, Composition	R-263-681
R144	Resistor, 6.81k, 1%, 1/8W, Composition	R-88-6.81k
R145	Resistor, 390, 5%, 1/4W, Composition	R-76-390
R146	Thick Film Resistor Network	TF-192
R147	Thick Film Resistor Network	TF-192
R148	Resistor, 390, 5%, 1/4W, Composition	R-76-390
R149	Resistor, 55.3k, 0.1%, 1/10W, Metal Film	R-263-55.3k
R150	Resistor, 11k, 0.1%, 1/10W, Metal Film	R-263-11k
R151	Resistor, 1k, 1%, 1/8W, Metal Film	R-88-1k
R152	Resistor, 1M, 1%, 1/8W, Metal Film	R-88-1M
R153	Resistor, 100, 1%, 1/8W, Metal Film	R-88-100
R154	Resistor, 10k, 10%, 1W, Carbon	R-2-10k
R155	Resistor, 10k, 10%, 1W, Carbon	R-2-10k
R156	Resistor, 681, 0.1%, 1/10W, Metal Film	R-263-681
R157	Resistor, 40.2k, 1%, 1/8W, Metal Film	R-88-40.2k
R158	Resistor, 1k, 1%, 1/8W, Metal Film	R-88-1k
R159	Potentiometer, 5k	RP-97-5k
R160	Resistor, 270k, 5%, 1/4W, Metal Film	R-76-270k
R161	Thick Film Resistor Network	TF-39
R162	Thick Film Resistor Network	TF-177-1
R163	Thick Film Resistor Network	TF-39
R164	Thick Film Resistor Network	TF-39
R165	Resistor, 4.32k, 1%, 1/8W, Metal Film	R-88-4.32k
R166	Resistor, 2.2M, 5%, 1/4W, Metal Film	R-76-2.2M
R167	Resistor, 36k, 5%, 1/4W, Metal Film	R-76-36k
R168	Resistor, 15k, 5%, 1/4W, Metal Film	R-76-15k
R169	Resistor, 56k, 5%, 1/4W, Composition	R-76-56k
R170	Resistor, 10k, 5%, 1/4W, Composition	R-76-10k
R171	Resistor, 8.95k, 0.1%, 1/10W, Metal Film	R-263-8.95k
R172	Resistor, 1.005k, 0.1%, 1/10W, Metal Film	R-263-1.005k
R173	Potentiometer, 200k	RP-97-200k
R174	Potentiometer, 200k	RP-97-200k
R175	Potentiometer, 200k	RP-97-200k
R176	Resistor, 10k, 5%, 1/4W, Composition	R-76-1k



Circuit Design.	Description	Keithley Part No.
R177	Resistor, 10k, 5%, 1/4W, Composition	R-76-1k
R178	Resistor, 1, .1%, 10W, Wirewound	R-231-1
R179	Resistor, 0.1, 0.1%, 7.5W, Wirewound	R-262-0.1
R180	Resistor, 0.01, .25%, 7.5W, Wirewound	R-274-0.01
R181	Resistor, 3.9k, 5%, 1/4W, Composition	R-76-3.9K
R182	Resistor, 10k, 5%, 1/4W, Composition	R-76-10k
R183	Resistor, 680, 5%, 1/4W, Composition	R-76-680
R184	Resistor, 6.8k, 5%, 1/4W, Composition	R-76-6.8k
R185	Resistor, 6.8k, 5%, 1/4W, Composition	R-76-6.8k
R186	Resistor, 7.5k, 5%, 1/4W, Composition	R-76-7.5K
R187	Potentiometer, 5k	RP-97-5K
U101	8 Stage Shift/Store Register, MC14094BCP	IC-251
U102	8 Stage Shift/Store Register, MC14094BCP	IC-251
U103	8 Stage Shift/Store Register, MC14094BCP	IC-251
U104	8 Stage Shift/Store Register, MC14094BCP	IC-251
U105	Wide Bandwidth Dual JFET Input Op Amp	IC-246
U106	JFET Op Amp, LF411	IC-453
U107	JFET Op Amp, LF411	IC-453
U108	JFET Op Amp, LF411	IC-453
U109	JFET Op Amp, LF411	IC-453
U110	D/A Converter, DAC80	IC-323
U111	D/A Converter, DAC80	IC-323
U112	Op Amp, 1052	IC-575
U113	Op Amp, 1052	IC-575
U114	8 Stage Shift/Store Register, MC14094BCP	IC-251
U115	Low Power, Low Offset Voltage Quad Comparator, LM339	IC-219
U116	High V, High I Darlington Trans. Array, ULN2003A	IC-206
U117	Analog Multiplexer, 4051	IC-277
U118	Quad 2-Input NOR Gate, 4001	IC-108
U119	Analog Multiplexer, 4051	IC-277
U120	8 Bit Parallel-to-Serial Converter, 74LS165	IC-237
U121	Quad 2-Input NAND Gate, 4011	IC-102
U122	A/D Converter, 4-1/2 digit, 7135	LSI-41
U123	Comparator, ICM7555	IC-400
U124	Low Power, Low Offset Voltage Quad Comparator, LM339	IC-219
VR101	Zener Diode, 6.2V, 106.4	DZ-60
VR102	Zener Diode, 6.2V, 106.4	DZ-60
VR103	Zener Diode, 18V, 1N720	DZ-35
VR104	Zener Diode, 6.8V, 1N5342	DZ-77
VR105	Zener Diode, 6.8V, 1N5342	DZ-77
VR106	Transistor, J505	TG-140
VR107	Current Regulator (CR200), CR200	TG-218
VR108	Diode, Low Voltage Reference	DZ-62
VR109	Diode, Low Voltage Reference	DZ-62
W301	Jumper	J-3
W401	Jumper Connector	CS-476
W402	Jumper Connector	CS-476
W403	Jumper Connector	CS-476

Item	Quantity	Description	Rev
A	1	POWER SUPPLY	17-100
B	1	SYSTEM BOARD	17-100
C	1	VIDEO BOARD	17-100
D	1	KEYBOARD	17-100
E	1	MOUSE	17-100
F	1	SOFTWARE	17-100
G	1	OPERATOR'S MANUAL	17-100
H	1	INSTALLATION MANUAL	17-100
I	1	OPERATOR'S MANUAL	17-100
J	1	INSTALLATION MANUAL	17-100
K	1	OPERATOR'S MANUAL	17-100
L	1	INSTALLATION MANUAL	17-100
M	1	OPERATOR'S MANUAL	17-100
N	1	INSTALLATION MANUAL	17-100
O	1	OPERATOR'S MANUAL	17-100
P	1	INSTALLATION MANUAL	17-100
Q	1	OPERATOR'S MANUAL	17-100
R	1	INSTALLATION MANUAL	17-100
S	1	OPERATOR'S MANUAL	17-100
T	1	INSTALLATION MANUAL	17-100
U	1	OPERATOR'S MANUAL	17-100
V	1	INSTALLATION MANUAL	17-100
W	1	OPERATOR'S MANUAL	17-100
X	1	INSTALLATION MANUAL	17-100

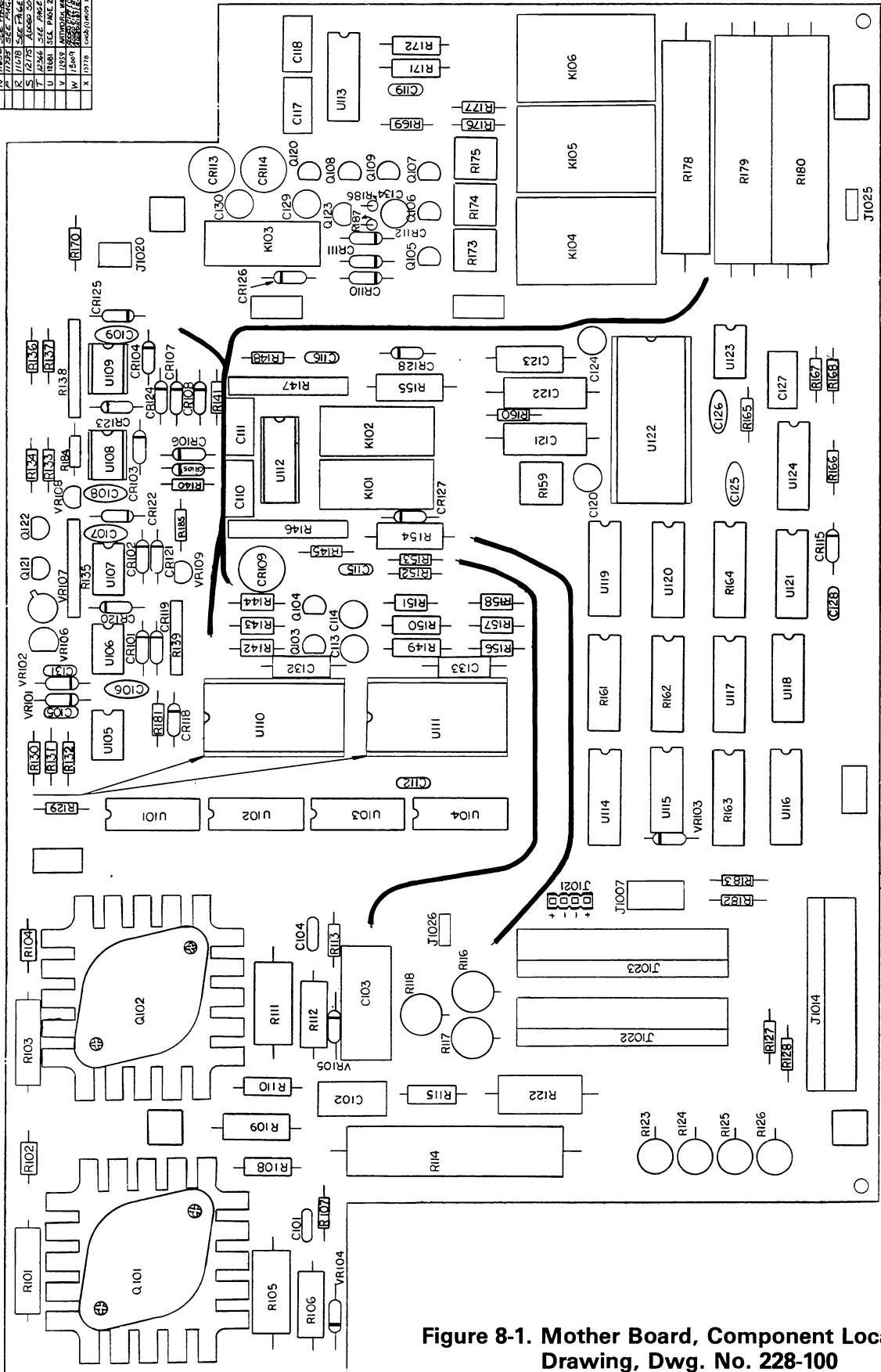

Figure 8-1. Mother Board, Component Location Drawing, Dwg. No. 228-100