

INSTRUCTION MANUAL  
FOR  
REGULATED POWER SUPPLIES

LQ-520 SERIES

This manual provides instructions intended for the operation of Lambda power supplies, and is not to be reproduced without the written consent of Lambda Electronics. All information contained herein applies to all LQ 520 series models unless otherwise specified.

LAMBDA ELECTRONICS

MAIN PLANT TELEPHONE: 516 MYrtle 4-4200

MELVILLE, L.I., N.Y.

IM-LQ 520

## TABLE OF CONTENTS

Section	Page
SPECIFICATIONS AND FEATURES . . . . .	1
OPERATING INSTRUCTIONS . . . . .	4
Controls, Instruments, and Fuses . . . . .	4
Ground Connections . . . . .	5
Basic Modes of Operation . . . . .	5
Supply — Load Connections . . . . .	5
Detailed Operating Procedures . . . . .	7
Operation After Protective Device Shutdown . . . . .	13
MAINTENANCE . . . . .	13
General . . . . .	13
Trouble Analysis . . . . .	13
Checking Transistors and Capacitors . . . . .	13
Printed Circuit Board Maintenance Techniques . . . . .	14
Complete Power Supply Calibration Procedures . . . . .	14
Adjustment of Voltage Calibration Control R102 . . . . .	14
Adjustment of Current Calibration Control R104 . . . . .	15
Adjustment of Meter Reference Calibration Control R204 . . . . .	15
Adjustment of Voltmeter Calibration Control, R213 . . . . .	16
Adjustment of Ammeter Calibration Control, R242 . . . . .	16
Performance Checks . . . . .	16
SERVICE . . . . .	17
PARTS ORDERING . . . . .	17
USE OF RACK ADAPTERS (Fig. 15)	
Installation of ½ Rack Units into LRA-1 (Fig. 15)	
Shipment of Units Mounted in LRA-1 (Fig. 15)	
Mounting Chassis Slides (Fig. 15)	
Using Blank Panels and Blank Chassis (Fig. 15)	

## SPECIFICATIONS AND FEATURES

Specifications apply for all models

**DC OUTPUT AND RATINGS** — Voltage and current regulated for line and load. Refer to the following tables.

Voltage Range . . . . .

TABLE I

VOLTAGE RANGE

MODEL	LQ 520	LQ 521	LQ 522	LQ 523	LQ 524
Voltage Range VDC*	0-10	0-20	0-40	0-60	0-120

Multi-Current Ranges . . . . . Current range must be chosen to suit the appropriate maximum ambient temperature.

\*With external programming; front panel voltage control allows adjustment over a range of 1%  $V_o$  max to  $V_o$  max.

TABLE II

MAX. CURRENT (AMPS)

MODEL	MAXIMUM CURRENT AT AMBIENT OF:			
	30°C	40°C	50°C	60°C
LQ 520	5.0	4.7	4.3	3.7
LQ 521	3.3	3.0	2.6	2.3
LQ 522	1.8	1.6	1.4	1.2
LQ 523	0.9	0.8	0.7	0.6
LQ 524	0.5	0.45	0.4	0.35

## REGULATED VOLTAGE OUTPUT

Regulation (line) . . . . .	0.005 percent plus 0.5 millivolt for input variations from 105-132 or 132-105 volts AC.
Regulation (load) . . . . .	0.005 percent plus 0.5 millivolt for load variations from no load to full load or full load to no load.
Remote Programming	
External Resistor . . . . .	Nominal 1000 ohms/volt output. (Refer to page 6 for details.)
Programming Voltage . . . . .	One-to-one voltage change.
Ripple and Noise . . . . .	150 microvolts rms; 1.0 millivolt peak-to-peak with either positive or negative terminal grounded.
Temperature Coefficient . . . . .	Output change in voltage less than $(0.005\% V_o + 10\mu V)/^{\circ}C$ (with external programming resistors).
Remote Sensing . . . . .	Provision is made for remote sensing to eliminate effect of power output lead resistance on DC regulation.
Series/Parallel operation . . . . .	Provision is made for auto series/auto parallel (master-slave) operation to permit tracking to a common reference.

## REGULATED CURRENT OUTPUT: AUTOMATIC CROSSOVER

Current range . . . . .	1% to full rated load current (refer to Table II).
Regulation (line) . . . . .	1 ma max for line variations from 105-132 or 132-105 volts AC.
Regulation (load) . . . . .	2.5 ma max for load changes from 0 to rated DC voltage or rated DC voltage to 0.

AC INPUT — 105-132 volts AC @ 47-440 Hz. For 47-53 Hz operation, derate output by 10%. For 63-440 Hz operation, consult factory. Input power: 180 watts maximum\*. Input current: 1.8A RMS maximum\*.

\*With output loaded to full current rating, maximum rated output voltage, input voltage 132 VAC at 60 Hz.

## OVERLOAD PROTECTION

Thermal . . . . .	Thermostat, resets automatically when over-temperature condition is eliminated.
Electrical	
External . . . . .	Adjustable, automatic, electronic current-limiting circuit, settable to 105 percent of rated current, limits output current to preset limit for protection of load and power supply when external overloads and direct shorts occur.
Internal . . . . .	“SLO-BLO”, 3A fuse F1 protects the AC input circuit. Overload of the supply does not cause fuse failure.

Fuse F2 provides protection against internal circuit failure in conjunction with overvoltage protector option.

**INPUT AND OUTPUT CONNECTIONS** — Heavy duty terminal block on rear of chassis with 5-foot, 3 wire detachable line cord for all models except V and V1 option units, which have an AC receptacle in place of the 3-wire line cord and the AC input terminals on the terminal block that are used for the AC input connection on standard AC input units; five-way binding posts provide for additional positive (+) ground, and negative (-) DC output connections on front panel.

**OVERSHOOT** — No overshoot of output voltage under conditions of power turn-on, power turn-off or power failure.

**OPERATING AMBIENT TEMPERATURE RANGE AND DUTY CYCLE** — Continuous duty from 0°C to 60°C ambient with corresponding load current ratings for all modes of operation.

**STORAGE TEMPERATURE** — (non-operating) -55°C to +85°C

**COOLING** — Convection cooled; no fans or blowers.

**METERING** — Digital panel meter monitors output voltage or load current as selected by METER SELECTION switch.

**FUNGUS** — All LQ series power supplies are fungus inert.

#### CONTROLS

- Power . . . . . Panel mounted switch for all units
- Meter Selector . . . . . Selects meter function. Either output voltage or current can be monitored; located on front panel of all models.
- DC Output . . . . . Coarse and fine voltage controls on LQ 520 and LQ 521 (single ten turn voltage control for LQ-522 thru LQ-524) and coarse current control permit adjustment of DC output; located on front panel of all models. Front panel voltage control allows adjustment over a range of 1%  $V_o$  max to  $V_o$  max.
- Binding posts (+) (-) (GND) . . . . . Five-way binding posts on front panel of all models.

#### PHYSICAL DATA

- Size . . . . . 5-3/16" H x 4-3/16" W x 15-1/2"D
- Weight . . . . . 14 lbs. net, 18 lbs. shipping
- Panel Finish . . . . . Charcoal brown (standard); special finishes available to customer specifications at moderate surcharge.

#### AC INPUT OPTION

V-V1 option. Standard LQ power supplies can be obtained for 187-242 VAC ("V") input or 205-265 VAC ("V1") input. See nameplate for AC input rating.

#### MOUNTING

- Laboratory bench, table top . . . . . Bumpers secured to the base of all units permit proper circulation of air through the unit. Removal of bumpers will restrict free-flow of air; avoid removing bumpers. Retractable bench rest on bottom of unit is provided as an aid in viewing output meters.
- Standard 19" Rack . . . . . All units can be used with rack adapters:  
LRA-1 (slide accommodation provided)  
LRA-2 (conventional mount)

## ACCESSORIES

- Rack Adapters . . . . . Rack adapter LRA-1, with or without chassis slides is available as well as rack adapter LRA-2 which is used for simple rack installations where chassis slides are not required. See figure 15.
- Blank Panels . . . . . Half-rack panels can be used with the Lambda rack adapters, see figure 15.
- Overvoltage Protector . . . . . Externally mounted. Overvoltage Protectors LHOV-4, LHOV-5, and LHOV-6 are available for use with LQ power supplies LQ520, LQ521, LQ522 and LQ523.
- Pot Cover . . . . . Lambda pot cover PC-1, consisting of a lock nut and a black anodized knurled knob, is tamper proof and fits standard potentiometer shaft threads.

## OPERATING INSTRUCTIONS

### CONTROLS, INSTRUMENTS, AND FUSES

Power ON-OFF Switch. The power ON-OFF switch, located on the front panel, controls application of input power to the supply. When the switch is in the ON position, the digital panel meter will be illuminated.

OUTPUT VOLTAGE Control. The OUTPUT VOLTAGE control is a dual control consisting of a coarse adjustment potentiometer, which varies the DC voltage over a range of 0.1-9, 0.2-19, volts as applicable, and a fine adjustment potentiometer, which varies the DC voltage over a one-volt range\*\*. Clockwise rotation results in increasing voltage. The total DC voltage output for voltage regulated operation is equal to the sum of each shaft setting; for current regulated operation the maximum voltage limit is equal to the sum of each shaft setting. The control is located on the front panel of all units.

\*\*On models LQ522 thru LQ524 the DC OUTPUT VOLTAGE control is a single ten turn control, which varies the DC voltage over a range of 1% Vomax to Vomax.

CURRENT LIMITER Control. The CURRENT LIMITER control varies the DC current over the rated current range. Clockwise rotation results in increasing current. The control is located on the front panel of all units.

Digital Panel Meter. A digital meter monitors output voltage or current over rated range. Display illuminates when ON-OFF switch is in "ON" position. Display flashes when meter is overloaded. Meter accuracy is 5% ± two counts.

METER SELECTOR Switch. Selects meter function. Either output voltage or load current can be monitored.

Fuses. Fuse F1, internally located, is a 3 ampere, 3AG "SLO-BLO" fuse which functions in the AC input circuit.

Fuse F2, internally located, provides protection against internal circuit failure. See schematic diagram for current ratings of pertinent F2 fuse.

Connection Terminals. Make all connections to the supply at the terminal block on the rear of the supply. DC output connections can also be made at the five-way binding posts located on the front panel. Apply input power through the line cord or directly to terminals 1 and 2 if the line cord is removed. Always connect the ungrounded (hot) power lead to terminal 1.

The supply positive terminal is brought out to terminal 6. The supply negative terminal is brought out to terminal 4. Recommended wiring of the power supply to the load and selection of wiring is shown in figures 1 through 10. Selection of proper wiring is made on the basis of load requirements. Make all performance checks and measurements of current or voltage at the rear output terminals. Connect measuring devices to sense terminals or use the shortest leads possible.

## GROUND CONNECTIONS

The Lambda power supply can be operated either with negative or positive output terminal grounded or with no terminal grounded. Both positive and negative ground connections are shown in the diagrams for all suggested output connections illustrated in this manual.

**NOTE:** When operating the supply with neither terminal grounded high impedance leakage resistance and capacitance paths can exist between the power supply circuitry and chassis ground.

## BASIC MODES OF OPERATION

This power supply is designed to operate as a constant voltage source or as a constant current source. Automatic crossover to either mode of operation occurs when load conditions change as follows:

**Constant Voltage.** The power supply will function as a constant voltage source while the load current does not equal the current value,  $I_{LIM}$ , set by the CURRENT LIMITER control. When current  $I_L = V/R_L = I_{LIM}$ , the supply will cross over automatically and will operate as a constant current source. Further decrease in value of load resistance  $R_L$  results in a decrease of voltage across the load while current remains regulated to  $I_{LIM}$ .

**Constant Current (Automatic Crossover).** The power supply will function as a constant current source while the load voltage  $V_L$  does not equal the voltage value set by the OUTPUT VOLTAGE control. When load voltage  $V_L$  equals the value set by the OUTPUT VOLTAGE control, the supply will automatically cross over and operate as a constant voltage source.

## SUPPLY — LOAD CONNECTIONS

**NOTE:** Refer to DETAILED OPERATING PROCEDURES for step-by-step instructions for operation of power supply.

## CONNECTIONS FOR OPERATION AS A CONSTANT VOLTAGE SOURCE

The output impedance and regulation of the power supply at the load may change when using the supply as a constant voltage source and connecting leads of practical length are used. To minimize the effect of the output leads on these characteristics, remote sensing is used. Recommended types of supply load connections with local or remote sensing are described in the following paragraphs.

Refer to figure 1 to determine voltage drop for particular cable length, wire size and current conditions. Lead lengths must be measured from supply terminals to load terminals as shown in figure 2.

**Two-Wire Connection, Figure 3.** The two-wire connection, with local sensing, is the connection suitable for application with relatively constant load where extremely close load regulation over full-rated current excursion is *not* required at the load.

**Four-Wire Connection, Figure 4.** The four-wire connection with remote sensing, provides complete compensation for the DC voltage drops in the connecting cables. A 2MF, 35V capacitor may be required to reduce noise, between terminals 3, 4, and 6, 7 whenever remote sensing is used. +S and -S sensing leads must be twisted together.

Programmed Voltage Connections, Using External Resistor, Figure 5. Discrete voltage steps can be programmed with a resistance voltage divider valued at 1000 ohms/volt output and a shorting-type switch as shown in figure 5. When continuous voltage variations are required, use variable resistor with the same 1000 ohms/volt ratio in place of the resistive voltage divider and shorting-type switch. Use a low temperature coefficient resistor to assure most stable operation. When resistively programming downward to voltages less than 1 volt, programming must be accomplished in two steps; first from original value to 1 volt, and then from 1 volt to final desired value.

As shown in figure 5, voltages can be programmed utilizing either local or remote sensing connections, as desired.

Programmed Voltage Connections Using Programming Voltage Figure 6. The power supply voltage output can be programmed with an externally connected programming power supply.

The output voltage of the programmed supply will maintain a one-to-one ratio with the voltage of the programming supply.

### CONNECTIONS FOR OPERATION AS A CONSTANT CURRENT SOURCE

Automatic Crossover Constant Current Connections, Figure 3. Figure 3 shows the connections which are used when operating the power supply as a constant current source with automatic crossover, using local setting of current control\*.

\*Setting control for output currents below rated limits can result in no output or no regulation.

In this mode of operation, when the load voltage increases to the limit of the OUTPUT VOLTAGE control setting, due to changing load resistance, the power supply crossover circuit will cause the unit to operate as a constant voltage supply.

### CONNECTIONS FOR SERIES OPERATION

The voltage capability of LQ power supplies can be extended by series operation of two LQ power supplies of equal\* voltage ratings. A maximum of 300 volts can be connected between either the +DC or -DC terminal and chassis ground, and a maximum voltage capability of 240 volts is possible for model LQ524.

\*For applications using supplies of unequal ratings, consult factory for details of operation.

The two units are shown connected for series operation in figures 7 and 8. Figure 7 shows the series connection diagram which would be suitable for use in all applications where exact one-to-one voltage tracking of the "master" (M) unit by the "slave" (S) unit is not required. The slight offset in tracking is easily compensated for by adjusting the OUTPUT VOLTAGE controls on the (S) unit.

Figure 8 shows the series connection diagram suitable for applications where exact one-to-one voltage tracking is required. In this series configuration, resistor RBAL permits the (S) unit to track the (M) unit on an exact one-to-one basis, thereby eliminating the possibility of an offset voltage existing between the two units.

Resistor RBAL should be a two-watt, 10 ohm/volt output, resistor. This value would permit wide-range compensation for manufacturing differences inherent in the components used in each unit. Resistors RS and RM function in the voltage sensing circuits of both units, enabling the (S) unit to reference its output voltage to that of the (M) unit. In figure 7, RM performs a similar function. Capacitor CS, used to eliminate stray AC pickup, is rated at 2.5 mfd, 250 V.

For either series mode of operation, select RS and RM on the basis of 1000 ohms per volt of (M) unit output voltage. RS must equal RM. Choose RS and RM to be low temperature coefficient resistors.



Diodes CR<sub>M</sub> and CR<sub>S</sub>, which protect the units against reverse voltage, must be capable of withstanding the maximum rated current of the (M) unit, and must have a reverse blocking voltage equal to 2.5 times the maximum rated output voltage.

Both methods permit operation for either constant voltage or constant current with automatic crossover to either mode of operation whenever the respective limiting operating current or voltage is reached. As shown in figures 7 and 8, each method permits connection for either local or remote sensing.

#### CONNECTIONS FOR PARALLEL OPERATION

The current capability of LQ power supplies can be extended by parallel operation of two LQ power supplies of equal\* voltage capacities. The two units are shown connected for parallel operation in figures 9 and 10. One power supply designated the "master" or (M) unit controls its own output as well as the output of the second power supply, designated the "slave" or (S) unit.

\*For applications using supplies of unequal voltage ratings, consult factory for details of operation.

Unit (S) operates to regulate its current to be equal to that of the (M) unit by comparing the current in its internal sampling resistor with that current sampled by the master internal sampling resistor.

Parallel connected units can be operated for constant voltage with local sensing, figure 9, or remote sensing, figure 10, as well as for constant current with automatic crossover, figure 9. When operating for constant voltage, the (M) unit can automatically cross over into constant current operation.

#### DETAILED OPERATING PROCEDURES

##### SAFETY NOTICE

**DANGEROUS VOLTAGES EXIST IN THIS EQUIPMENT. OBSERVE THE USUAL SAFETY PRECAUTIONS WHEN OPERATING OR SERVICING THE EQUIPMENT TO AVOID SHOCK OR INJURY.**

#### CONSTANT VOLTAGE OPERATION, ADJUSTABLE CURRENT LIMIT

1. Apply AC power to the supply but place power ON-OFF switch in OFF position.

**NOTE:** When shipped from the factory, the supply is ready for use as a constant current source with automatic crossover or as a local-sensing constant voltage source. Jumpers are connected at the factory as shown in figure 3. Take care to remove the appropriate jumpers for load requirements that need different supply-load connections. Refer to the appropriate connection diagram. When five way binding posts are used, do not remove barrier strip jumpers.

2. Determine load requirements, select wire size from figure 1 and 2, and choose desired type of supply-load connection from figure 3 and 4. Do not connect load.
3. Place power ON-OFF switch in ON position and check that digital panel meter illuminates.
4. Set CURRENT LIMITER control fully CW and adjust OUTPUT VOLTAGE control knobs to obtain desired voltage indication. When the current to the load must be limited to an intermediate value within the current rating of the supply, proceed as follows: a) place power ON-OFF switch in OFF position, b) connect jumper between +V and -V terminals, c) place power ON-OFF switch in ON position, place METER SELECTION switch in AMPS position, and adjust CURRENT LIMITER control to obtain the desired meter indication, d) place power ON-OFF switch in OFF position and remove jumper.
5. Connect supply to load as shown on selected connection diagram.

6. Place power ON-OFF switch in ON position and check that digital panel meter illuminates.
7. Check that digital panel meter indicates desired values; as required, adjust OUTPUT VOLTAGE control knobs and CURRENT LIMITER control to obtain correct meter indications.
8. Power supply is now in proper operation.

#### PROGRAMMED CONSTANT VOLTAGE OPERATION, ADJUSTABLE CURRENT LIMIT

1. Apply AC power to the supply, but place power ON-OFF switch in OFF position.

**NOTE:** When shipped from the factory, the supply is ready for use as a constant current source with automatic crossover or as a local-sensing constant voltage source. Jumpers are connected at the factory as shown in figure 3. Take care to remove the appropriate jumpers for load requirements that need different supply-load connections. Refer to the appropriate connection diagram. When the five way binding posts are used, do not remove barrier strip jumpers.

2. Determine load requirements, select wire size and length from figures 1 and 2, and choose desired type of supply load connections from figures 5 and 6. Refer to paragraph on Programmed Voltage Connections.
3. Connect supply terminals as shown on the selected connection diagram. As shown in figure 5, take care to use a shorting-type switch for the external programming control when several voltages are desired and the programming voltage method is not used. Do not connect load. Note that when resistively programming downward to voltages less than 1 volt, programming must be accomplished in two steps; first, from original value to 1 volt, and then from 1 volt to final desired value.
4. When current to the load must be limited to an intermediate value within the current rating of the supply, proceed as follows:
  - (a) Connect jumper between +V and -V terminals.
  - (b) Place power ON-OFF switch in ON position and adjust CURRENT LIMITER control to obtain the desired current limit meter indication.
  - (c) Place power ON-OFF switch in OFF position and remove jumper between +V and -V terminals.
5. Connect Supply to load as shown on the selected connection diagram.
6. Place power ON-OFF switch in ON position and check that digital panel meter illuminates.
7. Check that digital panel meter indicates desired values; as required, adjust CURRENT LIMITER knob and external programming voltage control to obtain correct meter indications.
8. Power supply is now operating properly.

#### CONSTANT CURRENT OPERATION WITH CROSSOVER, ADJUSTABLE VOLTAGE LIMIT

1. Apply AC power to the supply, but place ON-OFF switch in OFF position.

**NOTE:** When shipped from factory, the supply is ready for use as a constant current source with automatic crossover or as a local-sensing constant voltage source. Jumpers are connected at the factory as shown in figure 3. Take care to remove the appropriate jumpers for load requirements that need different supply-load connections. Refer to the appropriate connection diagram. When the five way binding posts are used, do not remove barrier strip jumpers.

2. Determine load requirements, select wire size from figures 1 and 2 and connect supply terminals as shown in figure 3. Do not connect load.
3. Adjust CURRENT LIMIT control to the desired output current as follows:
  - (a) Connect jumper between +V and -V terminals.
  - (b) Place power ON-OFF switch in ON position, METER SELECTION switch in AMPS position, and adjust CURRENT LIMITER control to obtain the desired load current as indicated on current meter.
  - (c) Place power ON-OFF switch in OFF position and remove jumper between +V and -V terminals.
4. Place power ON-OFF switch in ON position, METER SELECTION switch in VOLTS position, and adjust OUTPUT VOLTAGE control knobs to obtain the desired voltage limit point as indicated on voltage meter.
5. Place power ON-OFF switch in OFF position and connect load to the supply as shown in figure 3.
6. Place power ON-OFF switch in ON position and check that digital panel meter illuminates.
7. Check that digital panel meter indicates desired values; adjust OUTPUT VOLTAGE control knobs and CURRENT LIMITER control as required to obtain correct indications.
8. Power supply is now in proper operation.

**\*SERIES CONNECTION CONSTANT VOLTAGE OPERATION, WITH CURRENT LIMIT**

1. Apply AC power input to the "slave" (S) and "master" (M) units, and place power ON-OFF switches in OFF position.

NOTE: When shipped from the factory, the supply is ready for use as a constant current source with automatic crossover or as a local-sensing constant voltage source. Jumpers are connected at the factory as shown in figure 3. Take care to remove the appropriate jumpers for load requirements that need different supply-load connections. Refer to the appropriate connection diagram. When the five way binding posts are used, do not remove barrier strip jumpers.

2. Determine load requirements, select wire size from figures 1 and 2, and choose correct type of series supply-load connections from figures 7 and 8. Refer to paragraph on CONNECTIONS FOR SERIES OPERATION.
3. Connect power supply terminals as shown on the selected connection diagram. As required, select resistors  $R_{BAL}$ ,  $R_S$ , and  $R_M$  and diodes  $CR_S$  and  $CR_M$  in accordance with instructions contained in CONNECTIONS FOR SERIES OPERATION. Do not connect load.
4. \*\*Place power ON-OFF switches in ON position, place METER SELECTION switch in VOLTS position, and adjust OUTPUT VOLTAGE control knobs on the (M) unit to obtain the desired meter indication. Adjust (S) unit OUTPUT VOLTAGE controls until (S) unit voltage meter indication equals (M) unit voltage meter indication. This setting will be approximately one-half of the combined (M) and (S) unit output voltage. The (S) unit will track any change in (M) unit output voltage made with the (M) unit OUTPUT VOLTAGE control. Place power ON-OFF switch in OFF position.

\*Applies only to units of equal voltage and current capacities, when units of unequal ratings are series connected, consult factory.

\*\*This step does not apply to figure 8.

5. When current to the load must be limited to an intermediate value within the current rating of each supply, proceed as follows:
  - (a) Connect jumper between +V and -V terminals on the (M) unit.
  - (b) Place power ON-OFF switch in ON position, place meter selector switch in AMPS position, and adjust CURRENT LIMITER control on the (M) unit to the desired current limit point, as indicated on digital panel meter.
  - (c) Set CURRENT LIMITER control on (S) unit slightly above CURRENT LIMITER control setting on (M) unit.
  - (d) Place power ON-OFF switch in OFF position and remove jumpers between +V and -V terminals.
6. Connect supplies to load as shown on the selected connection diagram.
7. Place power ON-OFF switches in ON position and check that digital panel meter illuminates.
8. Check that digital panel meter indicates desired values; adjust OUTPUT VOLTAGE control knobs and CURRENT LIMITER control as required to obtain correct indications.
9. Power supplies are now in proper operation.

#### SERIES CONNECTION CONSTANT CURRENT OPERATION, WITH VOLTAGE LIMIT

1. Apply AC power input to the "slave" (S) and "master" (M) units and place power ON-OFF switches in OFF position.
 

NOTE: When shipped from the factory, the supply is ready for use as a constant current source with automatic crossover or as a local-sensing constant voltage source. Jumpers are connected at the factory as shown in figure 3. Take care to remove the appropriate jumpers for load requirements that need different supply-load connections. Refer to the appropriate connection diagram. When the five way binding posts are used, do not remove barrier strip jumpers.
2. Determine load requirements, select wire size from figures 1 and 2 and choose correct type of series supply-load connections from 7A and 8A. Refer to paragraph on CONNECTIONS FOR SERIES OPERATION.
3. Connect power supply terminals as shown on the selected connection diagram. As required, select resistors  $R_{BAL}$ ,  $R_S$ , and  $R_M$  and diodes  $CR_S$  and  $CR_M$  as instructed in CONNECTIONS FOR SERIES OPERATION. Do not connect load.
4. Place power ON-OFF switches in ON position, and METER SELECTION switch in VOLTS position.
5. Adjust (S) unit OUTPUT VOLTAGE controls until (S) unit voltage meter indication equals (M) unit voltage meter indication. The (S) unit will track any change in (M) unit output voltage made with the (M) unit OUTPUT VOLTAGE control.

6. When the voltage to the load must be limited to an intermediate value within the voltage rating of the series combination, proceed as follows:
  - (a) Place power ON-OFF switch of the (M) unit in ON position.
  - (b) Turn the (M) unit OUTPUT VOLTAGE control knobs until voltage meter indicates approximately one-half the total rating desired for the series combination.
  - (c) Place power ON-OFF switch in OFF position.
7. Adjust CURRENT LIMITER control for the desired load current as follows:
  - (a) Connect jumper between +V and -V terminal on (M) unit.
  - (b) Place power ON-OFF switch in ON position, METER SELECTION switch in AMPS position, and adjust CURRENT LIMITER control to the desired load current as indicated on (M) unit digital panel meter.
  - (c) Set CURRENT LIMITER control on (S) unit slightly above CURRENT LIMITER control setting on (M) unit.
  - (d) Place power ON-OFF switch in OFF position and remove jumpers between +V and -V terminals.
8. Connect supplies to load as shown on the selected connection diagram.
9. Place power ON-OFF switches in ON position and check that digital panel meter illuminates.
10. Check that digital panel meter indicates desired values; adjust OUTPUT VOLTAGE control knobs and CURRENT LIMITER control as required to obtain correct indications.
11. Power supplies are now in proper operation.

#### PARALLEL CONNECTION CONSTANT VOLTAGE OPERATION, WITH CURRENT LIMIT

1. Apply AC power input to the "slave" (S) and "master" (M) units and place power ON-OFF switches in OFF position.

NOTE: When shipped from the factory, the supply is ready for use as a constant current source with automatic crossover or as a local-sensing constant voltage source. Jumpers are connected at the factory as shown in figure 3. Take care to remove the appropriate jumpers for load requirements that need different supply-load connections. Refer to the appropriate connection diagram. When the five way binding posts are used, do not remove barrier strip jumpers.

2. Determine load requirements, select wire size from figures 1 and 2 and choose correct type of parallel supply-load connections from figures 9 and 10. Connect supply terminals as shown on the selected connection diagram, but do not connect load.
3. Place power ON-OFF switches of both (M) and (S) units in ON position, and METER SELECTION switch in VOLTS position.
4. Turn (M) and (S) unit CURRENT LIMITER controls fully CW.
5. Adjust (M) unit OUTPUT VOLTAGE control for the desired voltage as read on (M) unit digital panel meter.

6. Place power ON-OFF switches of both units in OFF position.
7. When current to the load must be limited to an intermediate value within the current rating of of each supply, proceed as follows:
  - (a) Connect supply to the load and place a jumper across load terminals.
  - (b) Place power ON-OFF switches in ON position, place METER SELECTION switches in AMPS position, and adjust (M) unit CURRENT LIMITER control for desired meter reading. The short circuit current will be the sum of (M) & (S) unit meter readings.
  - (c) Place power ON-OFF switches in OFF position and remove jumper across load.
8. Place power ON-OFF switches in ON position and check that digital panel meters illuminate.
9. Check that digital panel meter indicates desired values; adjust OUTPUT VOLTAGE control knobs and CURRENT LIMITER control as required to obtain correction indications.
10. Power supplies are now in proper operation.

#### PARALLEL CONNECTION CONSTANT CURRENT OPERATION, WITH VOLTAGE LIMIT

1. Apply AC power input to the "slave" (S) and "master" (M) units and place power ON-OFF switches in OFF position.

NOTE: When shipped from the factory, the supply is ready for use as a constant current source with automatic crossover or as a local-sensing constant voltage source. Jumpers are connected at the factory as shown in figure 3. Take care to remove the appropriate jumpers for load requirements that need different supply-load connections. Refer to the appropriate connection diagram. When the five way binding posts are used, do not remove barrier strip jumpers.

2. Determine load requirements, select wire size from figures 1 and 2, and choose type of parallel supply-load connections from figure 9. Connect supply terminals as shown on the selected connection diagram, but do not connect load.
3. Place power ON-OFF switches of both (M) and (S) units in ON position, and METER SELECTION switches in VOLTS position.
4. Turn (S) unit current limiter control fully CW.
5. Adjust (M) unit OUTPUT VOLTAGE control for the desired voltage limit point as read on (M) unit digital panel meter.
6. Place power ON-OFF switches of both units in OFF position.
7. Set the desired load current as follows:
  - (a) Connect supply to the load and place a jumper across load terminals.
  - (b) Place power ON-OFF switches in ON position, place METER SELECTION switches in AMPS position, and adjust (M) unit CURRENT LIMITER control for desired meter reading. The regulated current will be the sum of (M) and (S) unit meter readings.
  - (c) Place power ON-OFF switches in OFF position and remove jumper across load.

8. Place power ON-OFF switches in ON Position and check that digital panel meter illuminates.
9. Check that digital panel meter indicates desired values; adjust OUTPUT VOLTAGE control knobs and CURRENT LIMITER control as required to obtain correct indications.
10. Power supplies are now in proper operation.

#### OPERATION AFTER PROTECTIVE DEVICE SHUTDOWN

Thermostat Shutdown. The thermostat opens the input circuit only when the temperature of the transistor heat radiator exceeds a maximum safe value. The thermostat will automatically reset when the temperature of the radiator decreases to safe operating value. After eliminating the cause(s) for overheating and allowing time for the power supply to cool to a proper temperature, resume operation of the supply. Refer to appropriate operation paragraph in DETAILED OPERATING PROCEDURES.

Fuse Shutdown. Internal component failure is prevented by fuses which protect the components from damage caused by excessive currents. Fuses will blow when the maximum rated current value for the fuse is exceeded. Fatigue failure of fuses can occur when mechanical vibrations from the installation combine with thermally induced stresses to weaken the fuse metal. Many fuse failures are caused by a temporary condition, and replacing the blown fuse will make the fuse protected circuit operative.

### MAINTENANCE

#### GENERAL

This section describes trouble analysis routine, replacement procedures, calibration and test procedures that are useful for servicing the Lambda power supply. Refer to the section on SPECIFICATIONS AND FEATURES for the minimum performance standards.

#### TROUBLE ANALYSIS

Whenever trouble occurs, systematically check all fuses, primary power lines, external circuit elements, and external wiring for malfunction before troubleshooting the equipment. Failures and malfunctions often can be traced to simple causes such as improper jumper and supply-load connections or fuse failure due to metal fatigue.

Use the electrical schematic diagram and block diagram, figure 11, as an aid to locating trouble causes. The schematic diagram contains various circuit voltages that are averages for normal operation. Measure these voltages using the conditions for measurement specified on the schematic diagram. Use measuring probes carefully to avoid causing short circuits and damaging circuit components.

#### CHECKING TRANSISTORS AND CAPACITORS

Check transistors with an instrument that has a highly limited current capability. Observe proper polarity for PNP or NPN to avoid error in measurement. The forward transistor resistance is low but never zero; backward resistance is always higher than the forward resistance.

For good transistors, the forward resistance for any junction is always greater than zero.

Do not assume trouble is eliminated when only one part is replaced. This is especially true when one transistor fails, causing other transistors to fail. Replacing only one transistor and turning power on, before checking for additional defective components could damage the replaced component.

When soldering semi-conductor devices, wherever possible, hold the lead being soldered with a pair of pliers placed between the component and the solder joint to provide an effective heat sink.

NOTE: The leakage resistance obtained from a simple resistance check of a capacitor is not always an indication of a faulty capacitor. In all cases the capacitors are shunted with resistances, some of which have low values. Only a dead short is a true indication of a shorted capacitor.

#### PRINTED CIRCUIT BOARD MAINTENANCE TECHNIQUES

1. If foil is intact but not covered with solder, it is a good contact. Do not attempt to cover with solder.
2. Voltage measurements can be made from either side of the board. Use a needle-point probe to penetrate to the wiring whenever a protective coating is used on the wiring. A brass probe can be soldered to an alligator clip adapted to the measuring instrument.
3. Wherever possible, use a heat sink when soldering transistors.
4. Broken or damaged printed wiring is usually the result of an imperfection, strain, or careless soldering. To repair small breaks, tin a short piece of hook-up wire to bridge the break, and holding the wire in place, flow solder along the length of wire so that it becomes part of the circuitry.
5. When unsoldering components from the board, never pry or force loose the part; unsolder the component by using the wicking process described below:
  - (a) Select a 3/16 inch tinned copper braid for use as a wick; if braid is not available, select AWG No. 14 or No. 16 stranded wire with 1/2 inch insulation removed.
  - (b) Dip the wick in liquid rosin flux.
  - (c) Place the wick onto the soldered connection and apply soldering iron onto the wick.
  - (d) When sufficient amount of solder flows onto the wick, freeing the component, simultaneously remove iron and wick.

#### COMPLETE POWER SUPPLY CALIBRATION PROCEDURE

When the power supply is to be completely calibrated, the controls listed below must be calibrated in the order listed.

##### Control Calibration Order

R102  $V_0$  max adjust  
R104  $I_0$  max adjust  
R204 meter reference calibration  
R213 voltmeter calibration  
R242 ammeter calibration

#### ADJUSTMENT OF VOLTAGE CALIBRATION CONTROL R102

The adjustment procedure requires that the power supply is removed from associated equipment, is at an ambient temperature of 25-30°C and is operated at nominal line voltage, no load.



Whenever R101, R1 or IC101 are replaced, and voltage indications do not reflect maximum ratings, adjust R102 as follows:

1. Apply AC power to the supply and place power ON-OFF switch in OFF position.
2. Break seal on wiper of R102 from resistor housing.
3. Place power ON-OFF switch in ON position.
4. Turn OUTPUT VOLTAGE controls (R1) fully CW.
5. Connect a DVM (John Fluke Model 825A or equivalent) at supply output terminals to measure output voltage. Adjust R102 until maximum output voltage is reached (as indicated by DVM).
6. Place power ON-OFF switch in OFF position.
7. After adjustment is completed, remove AC power input to the supply and reseal the wiper of R102 to potentiometer housing.

#### ADJUSTMENT OF CURRENT CALIBRATION CONTROL R104

The adjustment procedure requires that the power supply is removed from associated equipment, is at an ambient temperature of 25-30°C and is operated at nominal line voltage.

Whenever R2, R3, R103, R104 and IC101 are replaced, and current indications do not reflect published ratings, adjust R104 as follows:

1. Apply AC power to the supply and place power ON-OFF switch in OFF position.
2. Break seal on wiper of R104 from resistor housing. Set R104 fully CCW.
3. Connect an ammeter between the +V and -V output terminals.
4. Turn CURRENT LIMITER control (R2) fully CW.
5. Place power ON-OFF switch in ON position.
6. Slowly adjust R104 CW to obtain 105% of maximum rated output current, as indicated by external ammeter. DO NOT TURN BEYOND THIS POINT.
7. Place power ON-OFF switch in OFF position.
8. After adjustment is completed, remove AC power input to the supply and reseal the wiper of R104 to potentiometer housing.

#### ADJUSTMENT OF METER REFERENCE CALIBRATION CONTROL, R204

The adjustment procedure requires that the power supply is removed from associated equipment, is at an ambient temperature of 25-30°C and is operated at nominal line voltage, with no load.

1. Apply AC power to the supply and place power ON-OFF switch in OFF position.
2. Break seal on wiper of R204 from resistor housing.
3. Connect a digital voltmeter, Data Technology Model 40 or equivalent, with plus lead to terminal TP2 and minus lead to terminal TP1.
4. Place power ON-OFF switch in ON position. Adjust R204 until digital voltmeter indicates 100 millivolts.
5. Place power ON-OFF switch in OFF position.
6. After adjustment is completed, remove AC power input to the supply and reseal the wiper of R204 to potentiometer housing.

## ADJUSTMENT OF VOLTMETER CALIBRATION CONTROL, R213

The adjustment procedure requires that the power supply is removed from associated equipment, is at an ambient temperature of 25-30°C and is operated at nominal line voltage, no load.

1. Apply AC power to the supply and place power ON-OFF switch in OFF position.
2. Break seal on wiper of R213 from resistor housing.
3. Connect a DVM (John Fluke Model 825A or equivalent) at rear output sensing terminals +S and -S to measure output voltage.
4. Place power ON-OFF switch in ON position.
5. Observing the DVM, adjust front panel voltage control for maximum rated output voltage.
6. Place METER SELECTION switch in Volts position.
7. Adjust R213 so that front panel meter reading is identical to external DVM reading.
8. Place power ON-OFF switch in OFF position.
9. After adjustment is completed, remove AC power to the supply and reseal the wiper of R213 to the potentiometer housing.

## ADJUSTMENT OF AMMETER CALIBRATION CONTROL, R242

The adjustment procedure requires that the power supply is removed from associated equipment, is at an ambient temperature of 25-30°C and is operated at nominal line voltage.

1. Apply AC power to the supply and place power ON-OFF switch in OFF position.
2. Break seal on wiper of R242
3. Connect an external ammeter between the +V and -V output terminals.
4. Place power ON-OFF switch in the ON position.
5. Observing the external ammeter, adjust the front panel CURRENT LIMITER control for maximum rated current.
6. Place METER SELECTION switch in AMPS position.
7. Adjust R242 so that front panel meter reading is identical to reading indicated by the external ammeter.
8. Place power ON-OFF switch in OFF position.
9. After adjustment is completed, remove AC power to the supply and reseal the wiper of R242 to the potentiometer housing.

## PERFORMANCE CHECKS

Checks With Constant Voltage Operation. Check the ripple and regulation of the power supply using the test connection diagram shown in figure 12. Use suggested test equipment or equivalent to obtain accurate results. Refer to SPECIFICATIONS AND FEATURES for minimum performance standards.

Set the differential meter, DC DVM (John Fluke Model 871A or equivalent) to the selected power supply operating voltage. Check the power supply load regulation accuracy while switching from the load to no load condition. Long load leads should be a twisted pair to minimize AC pick-up.

Use a Variac to vary the line voltage from 105-132 or 132-105 volts AC and check the power-supply line regulation accuracy on the differential meter.

Use a VTVM, Ballantine 320 or equivalent, to measure rms ripple voltage of the power supply DC output. Use oscilloscope to measure peak-to-peak ripple voltage of the power supply DC output.

**Checks With Constant Current Operation.** Check the ripple or regulation of the power supply using the test connection diagram shown in figure 13. Refer to SPECIFICATIONS AND FEATURES for minimum performance standards.

Check the power supply load regulation accuracy while switching from the short circuit to load condition. Measure the voltage across sensing resistor  $R_s$ . Use John Fluke Model 871A or equivalent for the DVM connected across  $R_s$ . For  $R_s$ , use a resistor having the same value as resistor R3 in the unit being tested. To obtain regulation figure substitute values obtained into regulation formula:

$$\frac{\Delta E}{R_s} = \text{Regulation in milliamperes,}$$

where  $\Delta E$  is the voltage change in millivolts and  $R_s$  is the resistance of the sensing resistor.

Use a Variac to vary the line voltage from 105-132 or 132-105 volts AC and check the power supply line regulation accuracy using the VTVM and the regulation formula:

$$\frac{\Delta E}{R_s}$$

### SERVICE

When additional instructions are required or repair service is desired, contact the nearest Lambda office where trained personnel and complete facilities are ready to assist you.

Please include the power supply model and serial number together with complete details of the problem. On receipt of this information Lambda will supply service data or advise shipping for factory repair service.

All repairs not covered by the warranty will be billed at cost and an estimate forwarded for approval before work is started.

### PARTS ORDERING

Standard components and special components used in the Lambda power supply can be obtained from the factory. In case of emergency, critical spare parts are available through any Lambda office.

The following information must be included when ordering parts:

1. Model number and serial number of power supply and purchase date.
2. Lambda part number.
3. Description of part together with circuit designation.
4. If part is not an electronic part, or is not listed, provide a description, function and location of part.

## PARTS LIST

The electrical parts located on Lambda models LQ-520 — LQ-524 are listed here. Parts common to a group of models are listed first. Unique parts of individual models within the group are listed separately, by model, immediately following the group common-parts listing.

### COMMON PARTS

#### MODELS LQ-520 — LQ-524

CIRC. DESIG.	DESCRIPTION	LAMBDA NO.
C6	Cap., mylar, 0.33 mf $\pm 10\%$ , 100 vdc	CGM-33-012
C7, C8	Cap., mylar, 0.01 mf $\pm 20\%$ , 80 vdc	CGL-10-008
C9	Cap., mica, 330 pf $\pm 5\%$ , 600 vdc	CCJ-33-001
C101	Cap., elect., 140 mf -10 +75%, 40 vdc	CBR-14-214
C102	Cap., elect., 100 mf -10 +75%, 40 vdc	CBR-10-108
C103	Cap., mylar, 470 pf $\pm 5\%$ , 200 vdc	CGJ-47-002
C105	Same as C103	
C107	Cap., elect., 390 mf -10 +75%, 15 vdc	CBR-39-212
C108, C109	Cap., elect., 40 mf (37 mf min, 75 mf min), 35 vdc	CBP-40-014
C113	Cap., elect., 2.7 mf $\pm 10\%$ , 35 vdc	CBN-27-033
C114	Cap., mylar, 0.1 mf $\pm 10\%$ , 80 vdc	CGM-10-006
C115	Cap., elect., 39 mf $\pm 10\%$ , 10 vdc	CBP-39-072
C119, C120	Cap., mica, $\pm 5\%$ , 100 pf, 500 vdc	CCJ-68-007
C201	Cap., mylar, 0.1 mf $\pm 10\%$ , 200 vdc	CAM-10-012
C202	Cap., mylar, 0.47 mf $\pm 10\%$ , 200 vdc	CGM-47-016
C203	Cap., mylar, 0.22 mf $\pm 10\%$ , 200 vdc	CGM-22-002
C204	Same as C119	
C205	Cap., mylar, 0.01 mf $\pm 10\%$ , 200 vdc	CGL-10-002
CR9	Rectifier	FBL-00-103
CR101 thru CR104	Rectifier	FBL-00-030
CR105	Rectifier	FBL-00-092
CR106	Same as CR101	
CR109	Same as CR101	
CR113 thru CR115	Same as CR101	
CR124	Rectifier	FBL-00-105
CR132	Rectifier, zener diode	FBM-Z-133
CR205	Rectifier, zener diode	FBM-Z-140
CR306, CR307	Rectifier	FBL-00-196
F1	Fuse, 3A, 125V, SLO-BLO	FFC-03-000
IC101	Integrated circuit	FBT-00-128
IC103	Integrated circuit	FBT-00-047
IC104	Integrated circuit	FBT-00-046
IC201	Integrated circuit	FBT-00-074
IC206	Integrated circuit	FBT-00-074
IC301 thru IC303	Integrated circuit	FBT-00-075
Q201	Transistor, PNP	FBN-L199
R2	Res., var., ww, 400 ohms $\pm 5\%$ , 2 w	DNR-40-061
R101	Res., film, 7,500 ohms $\pm 1\%$ , 1/8 w	DCS-75-145

### COMMON PARTS (Cont.)

#### MODELS LQ-520 — LQ-524 (Cont.)

CIRC. DESIG.	DESCRIPTION	LAMBDA NO.
R102	Res., var., cermet, 5,000 ohms $\pm 10\%$ , 3/4 w @ 75° C	DRS-50-034
R103	Res., film, 1,000 ohms $\pm 5\%$ , 1/2 w	DCS-10-019
R104	Res., var., cermet, 2,000 ohms $\pm 10\%$ , 1 w @ 25° C	DRS-20-012
R106	Res., comp., 100,000 ohms $\pm 10\%$ , 1/4 w	DCB-1041
R107	Res., comp., 120 ohms $\pm 10\%$ , 1/2 w	DEB-1211
R118	Res., comp., 330 ohms $\pm 10\%$ , 1/2 w	DEB-3311
R202	Res., film, 47,500 ohms $\pm 1\%$ , 1/2 w	DCT-47-040
R203	Res., film, 200,000 ohms $\pm 1\%$ , 1/4 w	DCV-20-028
R204	Res., var., cermet, 2,000 ohms $\pm 20\%$ , 1 w @ 25° C	DRS-20-012
R205	Res., comp., 1.2 megohms $\pm 10\%$ , 1/2 w	DEB-1251
R212	Res., film, 953,000 ohms $\pm 1\%$ , 1/2 w	DCV-95-042
R213	Res., var., cermet, 100,000 ohms $\pm 10\%$ , 1 w	DRV-10-019
R221	Res., comp., 820 ohms $\pm 10\%$ , 1/4 w	DCB-8211
R225	Res., comp., 1,000 ohms $\pm 10\%$ , 1/4 w	DCB-1021
R226	Res., comp., 330,000 ohms $\pm 10\%$ , 1/4 w	DCB-3341
R227	Res., comp., 51,000 ohms $\pm 5\%$ , 1/2 w	DEB-5135
R228	Res., comp., 68,000 ohms $\pm 10\%$ , 1/4 w	DCB-6831
R229	Same as R225	
R230	Res., film, 2,000 ohms $\pm 1\%$ , 1/4 w	DCS-20-067
R231	Res., film, 22,600 ohms $\pm 1\%$ , 1/2 w	DCT-24-105
R241	Res., film, 1,000 ohms $\pm 1\%$ , 1/4 w	DCS-10-055
R316	Res., comp., 270 ohms $\pm 10\%$ , 1/2 w	DEB-2711
R320	Same as R316	
R322, R323	Same as R316	
S1	Switch, toggle, ON-OFF	FDA-11-040
S301	Switch, slide, METFER SELECTOR	FDE-22-002

### UNIQUE PARTS

#### MODEL LQ-520

C1	Cap., elect., 5,500 mf -10 +100%, 30 vdc	CBS-55-091
C2	Cap., elect., 1,500 mf -10 +100%, 30 vdc	CBS-15-217
C3	Cap., mylar, 0.22 mf $\pm 10\%$ , 200 vdc	CGM-22-002
C5	Cap., elect., 3.9 mf $\pm 10\%$ , 50 vdc	CBN-39-041
C104	Cap., mica, 680 pf $\pm 10\%$ , 500 vdc	CCJ-68-006
CR1A, CR1B	Rectifier, dual, common anode	FBL-00-139
CR2A, CR2B	Rectifier, dual, common cathode	FBL-00-141
CR5	Rectifier	FBL-00-054

UNIQUE PARTS (Cont.)  
MODEL LQ-520 (Cont.)

<u>CIRC. DESIG.</u>	<u>DESCRIPTION</u>	<u>LAMBDA NO.</u>
CR110, CR111	Rectifier	FBL-00-030
F2	Fuse, 10A, 32V, NORM-BLO	FFB-10-000
Q1 thru Q4	Transistor, NPN	FBN-36220
Q5	Transistor, NPN	FBN-35469
Q101	Transistor, NPN	FBN-L109
R1	Res., var., ww, 400 ohms	DNT-10-076
R3	Res., ww, 0.12 ohm $\pm 5\%$ , 10 w	DFM-12-115
R4 thru R7	Res., ww, 0.39 ohm $\pm 5\%$ , 5 w	DFM-39-046
R10	Res., ww, 480 ohms $\pm 3\%$ , 5 w	DFR-48-080
R11	Res., film, 82 ohms $\pm 5\%$ , $\frac{1}{2}$ w	DCP-82-020
R115	Res., comp., 1,800 ohms $\pm 10\%$ , $\frac{1}{2}$ w	DEB-1821
R125	Res., comp., 470 ohms $\pm 10\%$ , $\frac{1}{2}$ w	DEB-4711
R211	Res., film, 1,000 ohms $\pm 10\%$ , $\frac{1}{4}$ w	DLS-10-055
R242	Res., var., cermet, 20,000 ohms $\pm 10\%$ , 1 w @ 25°C	DRT-20-051
S2	Thermostat	FKA-142-015
T1	Transformer	ABA-LQ520-1

MODEL LQ-521

C1	Cap., elect., 3,900 mf -10 +100%, 45 vdc	CBS-39-070
C2	Cap., elect., 860 mf -10 +75%, 50 vdc	CBR-86-200
C3	Cap., mylar, 0.22 mf $\pm 10\%$ , 200 vdc	CGM-22-002
C5	Cap., elect., 3.9 mf $\pm 10\%$ , 50 vdc	CBN-39-041
C104	Cap., mica, 680 pf $\pm 10\%$ , 500 vdc	CCJ-68-006
CR1A, CR1B, CR2A, CR2B	Rectifier, dual, common anode	FBL-00-139
CR5, CR6	Rectifier	FBL-00-054
CR110, CR111	Rectifier	FBL-00-030
F2	Fuse, 5A, 32V, NORM-BLO	FFB-05-000
Q1 thru Q4	Transistor, NPN	FBN-36220
Q5	Transistor, NPN	FBN-35469
Q101	Transistor, NPN	FBN-L109
R1	Res., var., ww, 20,000 ohms -0 +10%, 2 w	DNT-20-043
R3	Res., ww, 0.16 ohm $\pm 5\%$ , 5 w	DFM-16-105
R4 thru R7	Res., ww, 0.39 ohm $\pm 5\%$ , 5 w	DFM-39-046
R10	Res., ww, 700 ohms $\pm 5\%$ , 7 w	DFR-70-088
R11	Res., film, 182 ohms $\pm 1\%$ , $\frac{1}{2}$ w	DCR-18-108
R115	Res., comp., 4,300 ohms $\pm 5\%$ , $\frac{1}{2}$ w	DEB-4325
R125	Res., comp., 470 ohms $\pm 10\%$ , $\frac{1}{2}$ w	DEB-4711
R211	Res., film, 1,000 ohms $\pm 1\%$ , $\frac{1}{4}$ w	DCS-10-055
R242	Res., var., cermet, 20,000 ohms $\pm 10\%$ , 1 w @ 25°C	DRT-20-051
S2	Thermostat	FKA-142-015
T1	Transformer	ABA-LQ521-1

UNIQUE PARTS (Cont.)  
MODEL LQ-522

<u>CIRC. DESIG.</u>	<u>DESCRIPTION</u>	<u>LAMBDA NO.</u>
C1	Cap., elect., 1,100 mf -10 +100%, 75 vdc	CBS-11-015
C2	Cap., elect., 500 mf -10 +75%, 75 vdc	CBR-50-198
C3	Cap., mylar, 0.22 mf $\pm 10\%$ , 200 vdc	CGM-22-002
C5	Cap., elect., 5.6 mf -10 +50%, 250 vdc	CBN-56-026
C104	Cap., mica, 680 pf $\pm 10\%$ , 500 vdc	CCJ-68-006
CR5, CR6	Rectifier	FBL-00-054
CR110, CR111	Rectifier	FBL-00-030
CR126 thru CR131	Rectifier	FBL-00-047
F2	Fuse, 3A, 250V, NORM-BLO	FFB-03-000
Q1 thru Q4	Transistor, NPN	FBN-36487
Q5	Transistor, NPN	FBN-36488
Q101	Transistor, NPN	FBN-L108
R1	Res., var., ww, 40,000 ohms, 2 w @ 70°C	DNT-40-074
R3	Res., ww, 0.30 ohm $\pm 5\%$ , 3 w	DFM-30-053
R4 thru R7	Res., ww, 2.0 ohms $\pm 3\%$ , 3 w	DFN-20-009
R10	Res., ww, 900 ohms $\pm 5\%$ , 10 w	DFR-90-049
R11	Res., film, 390 ohms $\pm 2\%$ , $\frac{1}{2}$ w	DCR-39-046
R115	Res., comp., 13,000 ohms $\pm 5\%$ , $\frac{1}{2}$ w	DEB-1335
R125	Res., comp., 470 ohms $\pm 10\%$ , $\frac{1}{2}$ w	DEB-4711
R211	Res., film, 1,000 ohms $\pm 1\%$ , $\frac{1}{4}$ w	DCS-10-055
R240	Res., film, 22,600 ohms $\pm 1\%$ , $\frac{1}{2}$ w	DCT-23-098
R242	Res., var., cermet, 20,000 ohms $\pm 1\%$ , 1 w @ 25%	DRT-20-051
S2	Thermostat	FKA-142-015
T1	Transformer	ABA-LQ522-1

MODEL LQ-523

C1	Cap., elect., 800 mf -10 +100%, 110 vdc	CBR-80-023
C2	Cap., elect., 320 mf -10 +75%, 110 vdc	CBR-32-197
C3	Cap., mylar, 0.068 mf $\pm 10\%$ , 400 vdc	CGL-68-004
C5	Cap., elect., 5.6 mf -10 +50%, 250 vdc	CBN-56-026
C104	Cap., mica, 680 pf $\pm 10\%$ , 500 vdc	CCJ-68-006
CR110, CR111	Rectifier	FBL-00-030
CR126 thru CR131	Rectifier	FBL-00-065
F2	Fuse, 3A, 250V, NORM-BLO	FFB-03-000
Q1, Q2	Transistor, NPN	FBN-35902
Q5	Transistor, NPN	FBN-35903
Q101	Transistor, NPN	FBN-L108
R1	Res., var., ww, 60,000 ohms -0 +10%, 2 w @ 70°C	DNT-60-075

UNIQUE PARTS (Cont.)  
MODEL LQ-523 (Cont.)

<u>CIRC. DESIG.</u>	<u>DESCRIPTION</u>	<u>LAMBDA NO.</u>
R3	Res., ww, 0.66 ohm $\pm 2\%$ , 3 w	DFM-66-059
R4, R5	Res., ww, 3.0 ohms $\pm 3\%$ , 3 w	DFN-30-023
R10	Res., ww, 2,000 ohms $\pm 5\%$ , 10 w	DFS-20-037
R11	Res., ww, 562 ohms $\pm 1\%$ , $\frac{1}{2}$ w	DCR-56-099
R115	Res., comp., 27,000 ohms $\pm 10\%$ , $\frac{1}{2}$ w	DEB-2731
R125	Res., comp., 470 ohms $\pm 10\%$ , $\frac{1}{2}$ w	DEB-4711
R211	Res., film, 1,000 ohms $\pm 1\%$ , $\frac{1}{4}$ w	DCS-10-055
R240	Res., film, 40,200 ohms $\pm 1\%$ , $\frac{1}{2}$ w	DCT-40-058
R242	Res., var., cermet, 100,000 ohms $\pm 10\%$ , 1 w @ 25°C	DRV-10-019
S2	Thermostat	FKA-132-043
T1	Transformer	ABA-LQ523-1
<u>MODEL LQ-524</u>		
C1	Cap., elect., 400 mf -10 +75%, 200 vdc	CBR-40-032
C2	Cap., elect., 170 mf -10 +75%, 200 vdc	CBR-17-196
C3	Cap., mylar, 0.068 mf $\pm 10\%$	CGL-68-004
C5	Cap., elect., 3.3 mf -10 +50%, 250 vdc	CBN-33-027
C104	Cap., mica, 1,000 pf $\pm 5\%$ , 500 vdc	CCK-10-002
C106	Cap., elect., 560 mf -10 +75%, 7 vdc	CBR-56-213
C111,	Cap., mylar, 0.01 mf $\pm 10\%$ ,	CGL-10-002
C112	200 vdc	
CR110,	Rectifier	FBL-00-064
CR111		
CR117	Rectifier	FBL-00-030
thru		
CR119		

UNIQUE PARTS (Cont.)  
MODEL LQ-524 (Cont.)

<u>CIRC. DESIG.</u>	<u>DESCRIPTION</u>	<u>LAMBDA NO.</u>
CR126	Same as CR110	
thru		
CR129		
CR130	Rectifier	FBL-00-033
F2	Fuse, 1A, 250V, NORM-BLO	FFB-01-000
Q1, Q2	Transistor, NPN	FBN-35902
Q5, Q6	Transistor, NPN	FBN-35903
Q101,	Transistor, NPN	FBN-L115
Q102		
Q103	Transistor, NPN	FBN-L108
R1	Res., var., ww, 120,000 -0 +10%, 2 w @ 70°C	DNV-12-002
R3	Res., ww, 1.22 ohms $\pm 2\%$ , 3 w	DFN-12-078
R11	Res., film, 1,180 ohms $\pm 1\%$ , $\frac{1}{2}$ w	DCS-12-133
R113,	Res., film, 66,500 ohms $\pm 1\%$ ,	DCT-67-074
R114	$\frac{1}{4}$ w	
R116	Res., comp., 47,000 ohms $\pm 10\%$ ,	DHB-4731
R119,	Res., comp., 180 ohms $\pm 10\%$ , $\frac{1}{2}$ w	DEB-1811
R120		
R240	Res., film, 40,200 ohms $\pm 1\%$ , $\frac{1}{2}$ w	DCT-40-058
R242	Res., var., cermet, 100,000 ohms $\pm 10\%$ , 1 w @ 25°C	DRV-10-019
S2	Thermostat	FKA-132-043
T1	Transformer	ABA-LQ524-1

"V" AND "V1" OPTION

On LQ-520 - LQ-524 units with "V" or "V1" option: S1 becomes FDA-21-070; F1 becomes FFC-01-500 and F3, FFC-01-500, is added.

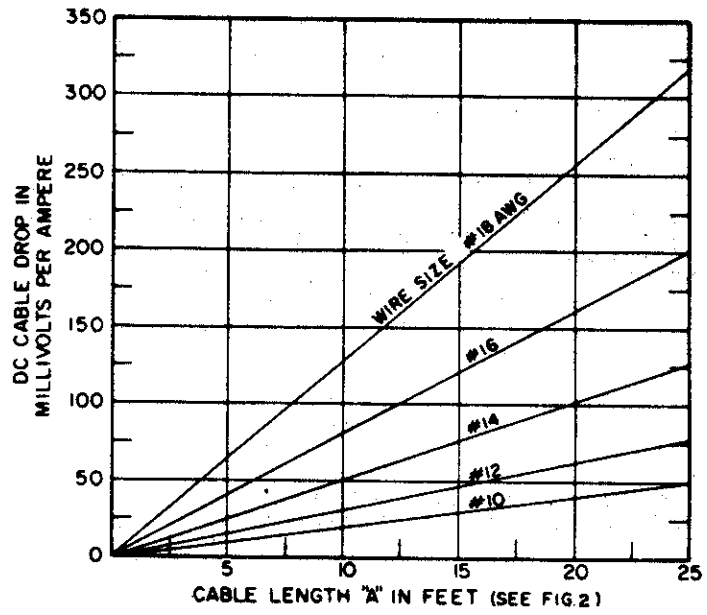

Figure 1. Cable Connection Chart

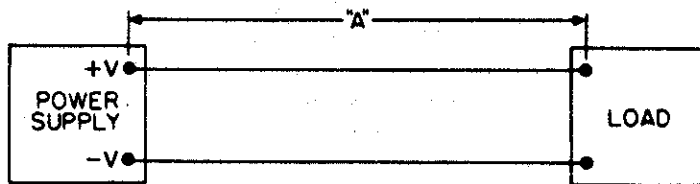
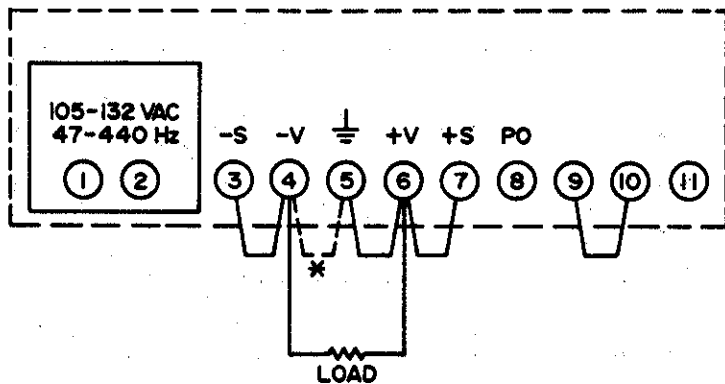
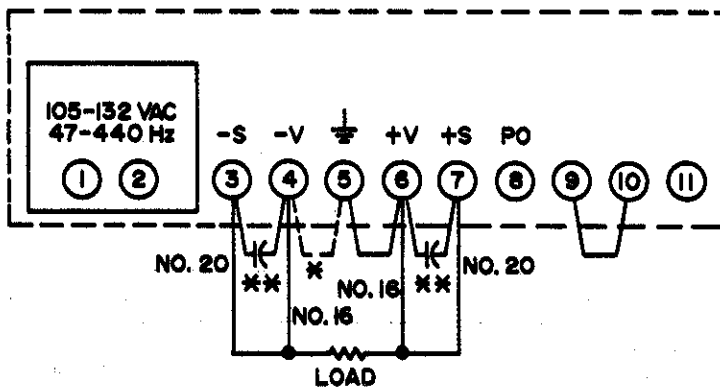

Figure 2. Cable Length "A" in Feet



**NOTE:**  
 \* FOR NEGATIVE GROUND, DISCONNECT JUMPER FROM TERMINALS 5 AND 6 AND RECONNECT TO TERMINALS 4 AND 5.

Figure 3. Local Sensing Connections



**NOTE:**  
 \* FOR NEGATIVE GROUND, DISCONNECT JUMPER FROM TERMINALS 5 AND 6 AND RECONNECT TO TERMINALS 4 AND 5.  
 \*\* 2MF, 35V, ELECT. MAY BE REQUIRED TO ELIMINATE NOISE PICK-UP.

Figure 4. Remote Sensing Connections



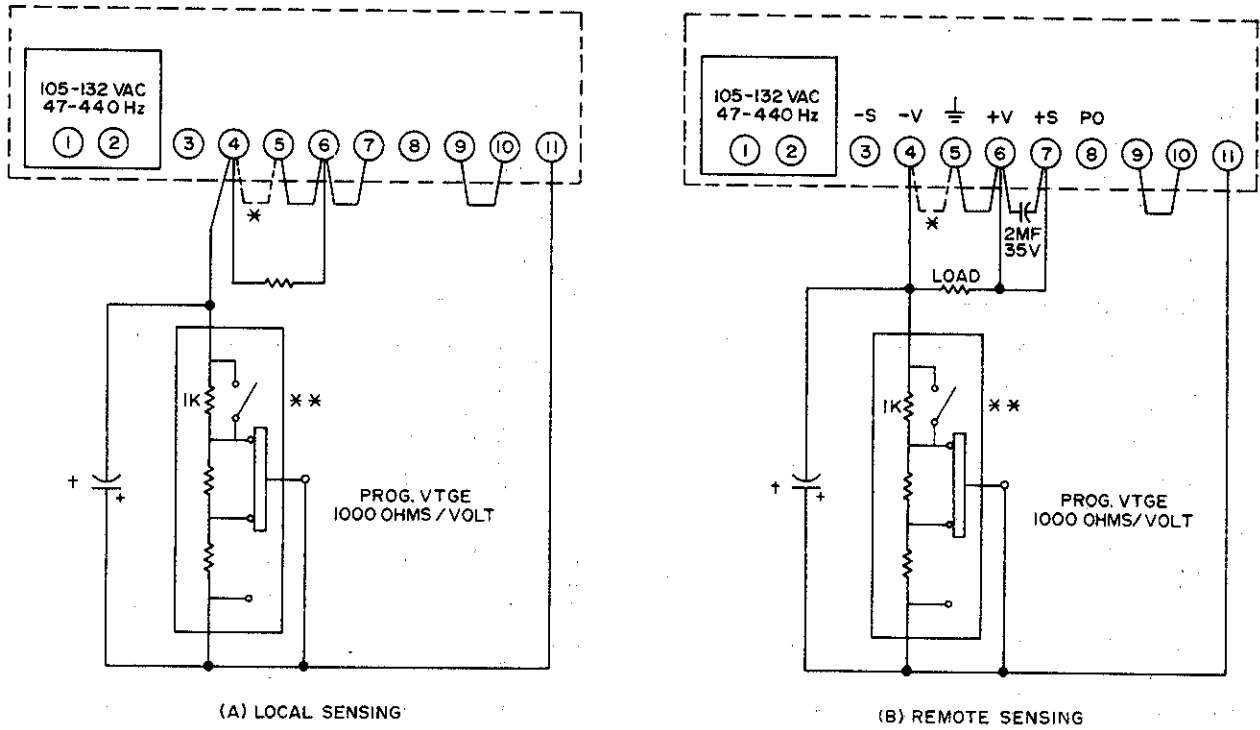

(A) LOCAL SENSING

(B) REMOTE SENSING

NOTES:  
 \* FOR NEGATIVE GROUND, DISCONNECT JUMPER FROM TERMINALS 5 AND 6 AND RECONNECT TO TERMINALS 4 AND 5.  
 \*\* 1K RESISTOR AND SWITCH REPRESENT A TYPICAL METHOD OF ACHIEVING THE PROGRAMMING SEQUENCE DESCRIBED ON PAGE 6.  
 † CAPACITOR TO BE IDENTICAL RATING AS C5 ON SCHEMATIC.

Figure 5. Programmed Voltage, with External Resistor

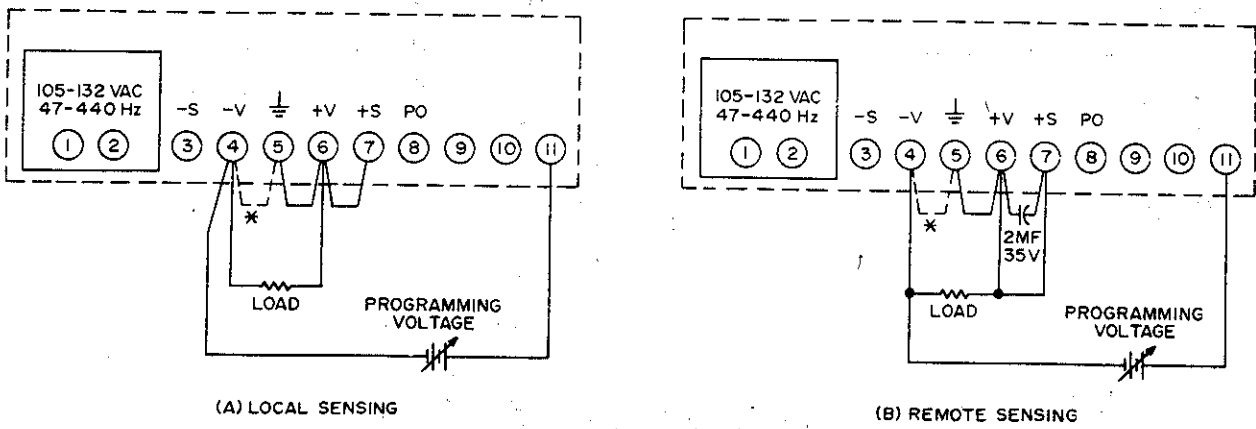

(A) LOCAL SENSING

(B) REMOTE SENSING

NOTE:  
 \* FOR NEGATIVE GROUND, DISCONNECT JUMPER FROM TERMINALS 5 AND 6 AND RECONNECT TO TERMINALS 4 AND 5.

Figure 6. Programmed Voltage, with External Programming Voltage Source

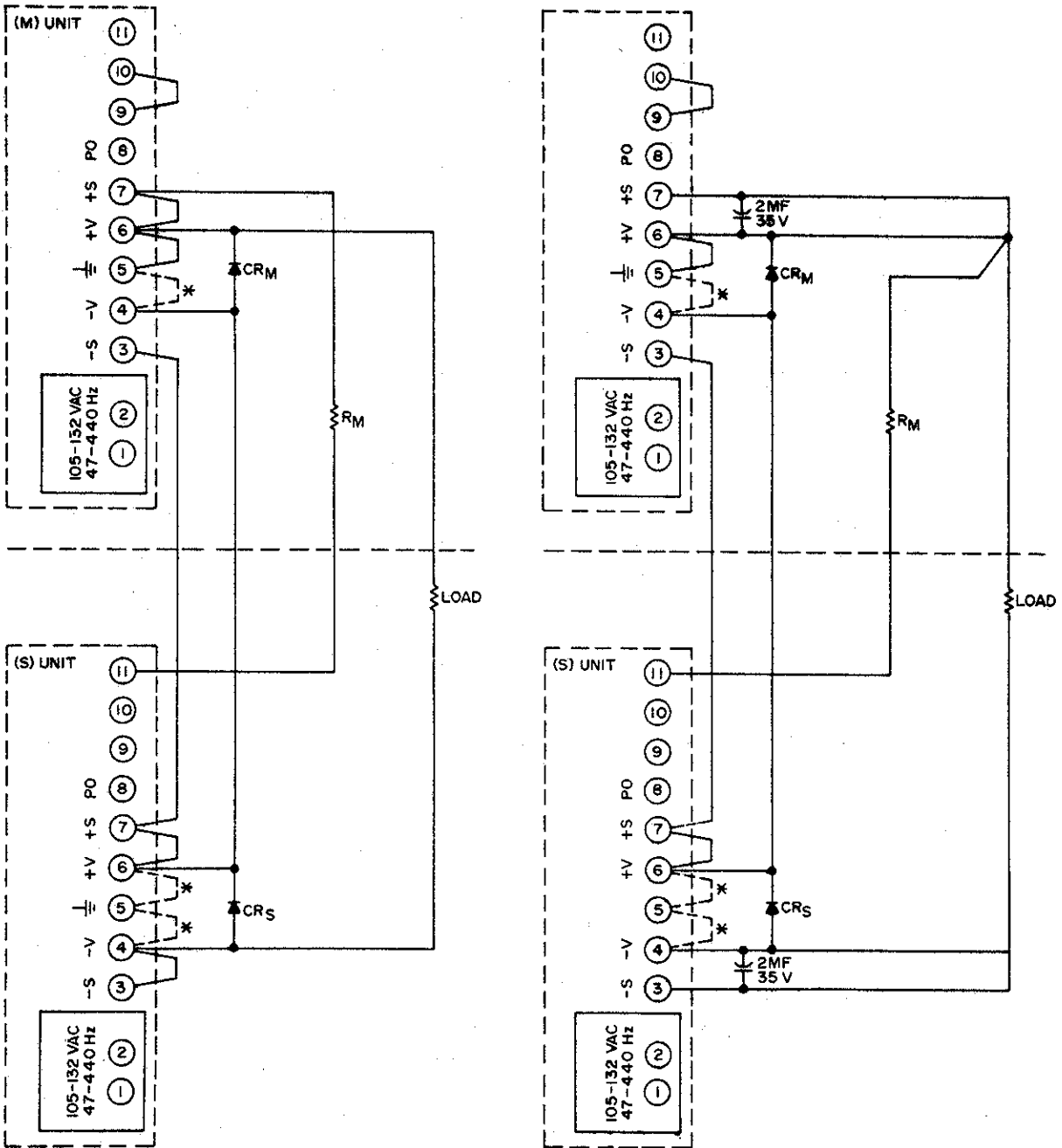

(A) LOCAL SENSING

(B) REMOTE SENSING

NOTE:

\* MAKE ONLY ONE GROUND CONNECTION FOR THE SERIES COMBINATION TO CHANGE GROUND AS SHOWN. REMOVE JUMPER FROM TERMINALS 5 AND 6 ON (M) UNIT AND CONNECT ANY ONE OF THE OTHER JUMPERS AS SHOWN IN DOTTED LINE.

Figure 7. Series Connection

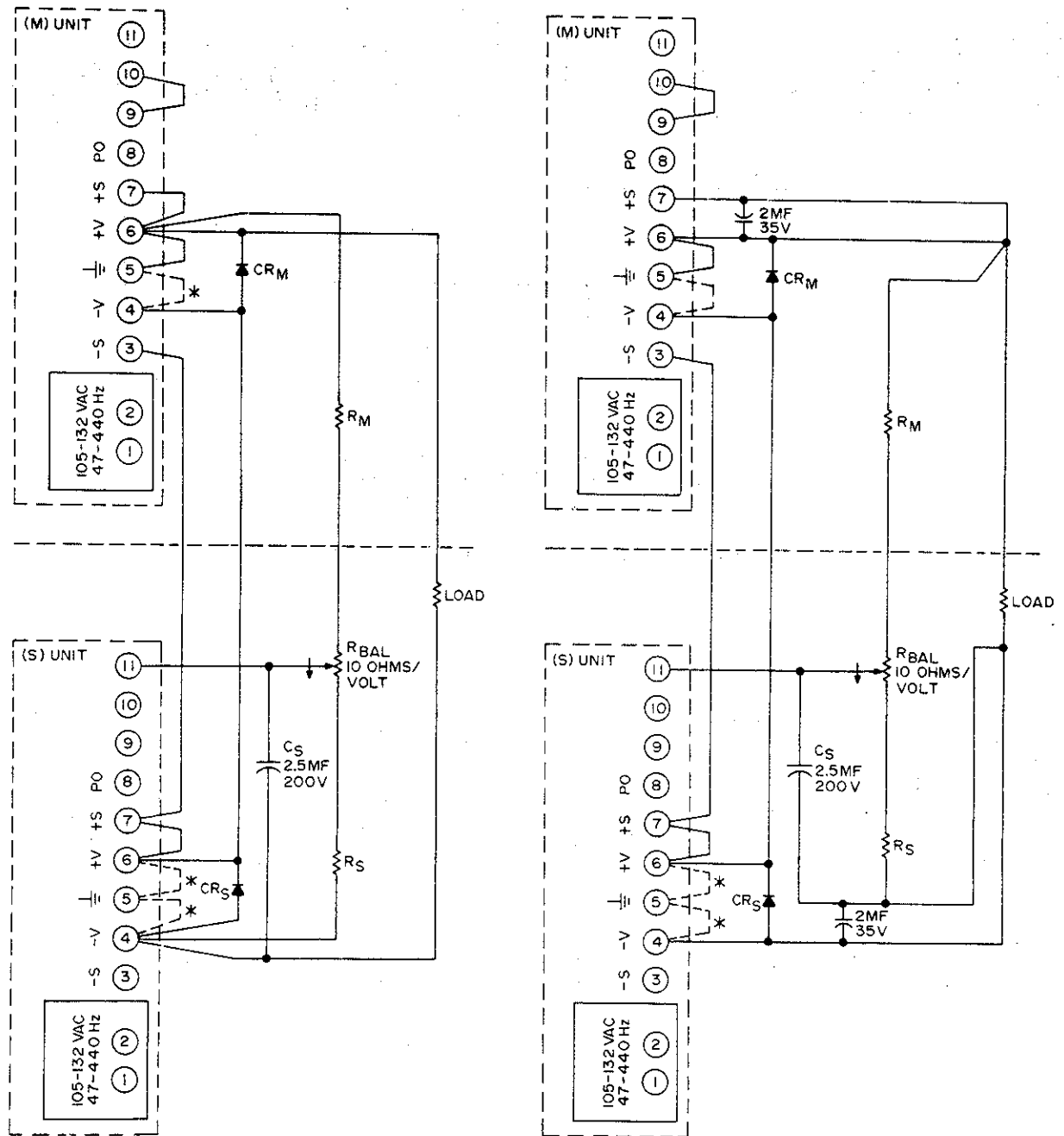

(A) LOCAL SENSING

(B) REMOTE SENSING

NOTE:

\* MAKE ONLY ONE GROUND CONNECTION FOR THE SERIES COMBINATION, TO CHANGE GROUND AS SHOWN, REMOVE JUMPER FROM TERMINALS 5 AND 6 ON (M) UNIT AND CONNECT ANY ONE OF THE OTHER JUMPERS AS SHOWN IN DOTTED LINE.

Figure 8. Typical Block Diagram

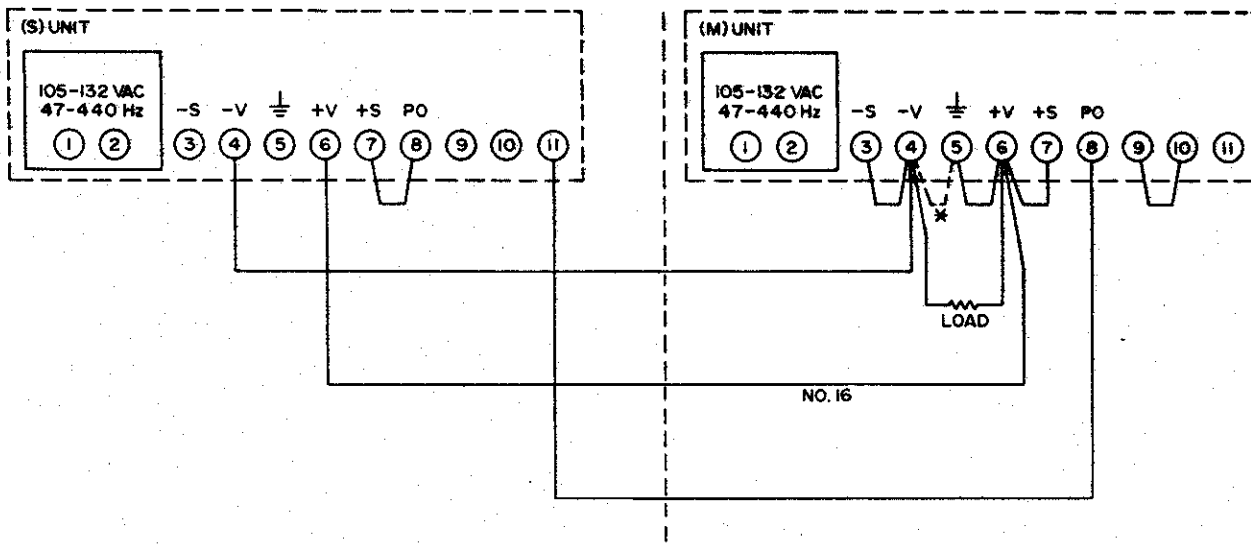

NOTE:  
 \* FOR NEGATIVE GROUND, DISCONNECT JUMPER FROM  
 TERMINALS 5 AND 6 AND RECONNECT TO TERMINALS  
 4 AND 5.

Figure 9. Parallel Connection, Local Sensing

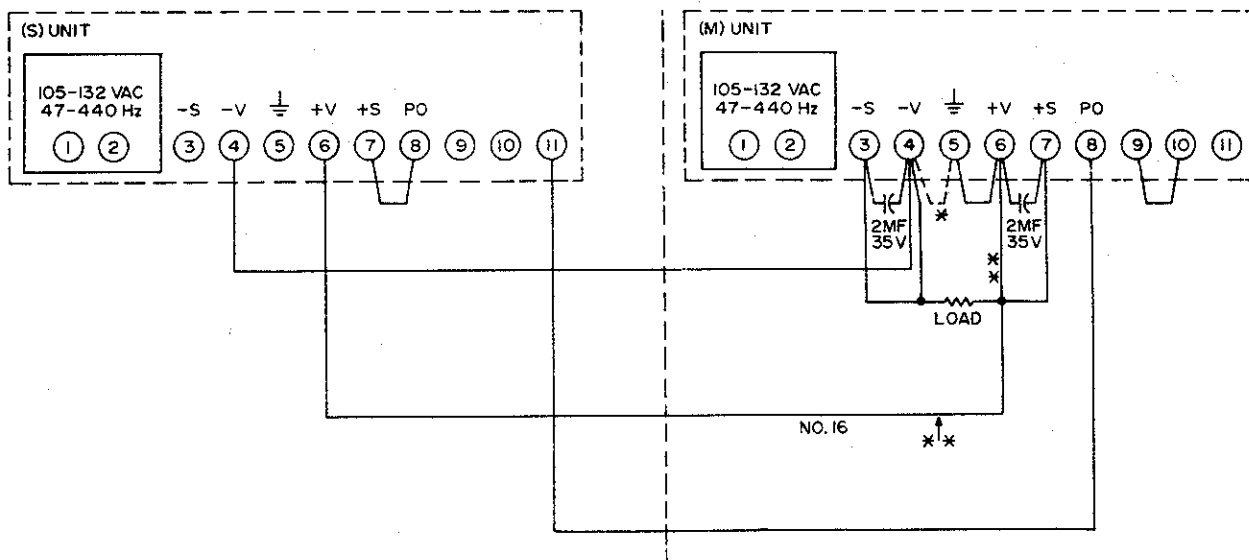

NOTE:  
 \* FOR NEGATIVE GROUND, DISCONNECT JUMPER FROM  
 TERMINALS 5 AND 6 AND RECONNECT TO TERMINALS  
 4 AND 5.  
 \*\* LEAD LENGTHS MUST BE EQUAL.

Figure 10. Outline Drawing

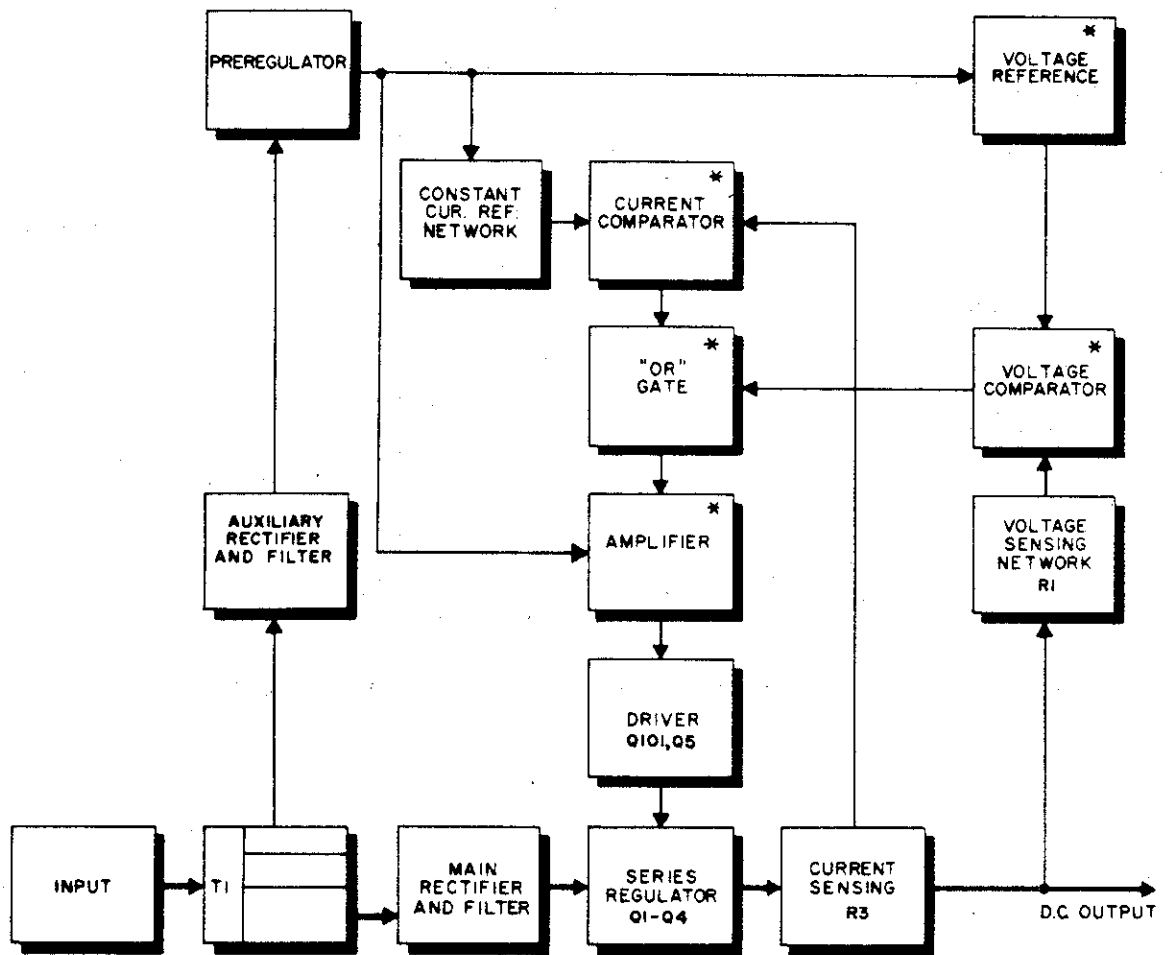

\* THIS CIRCUIT ELEMENT IS LOCATED IN IC101.

Figure 11. Component Location Diagram

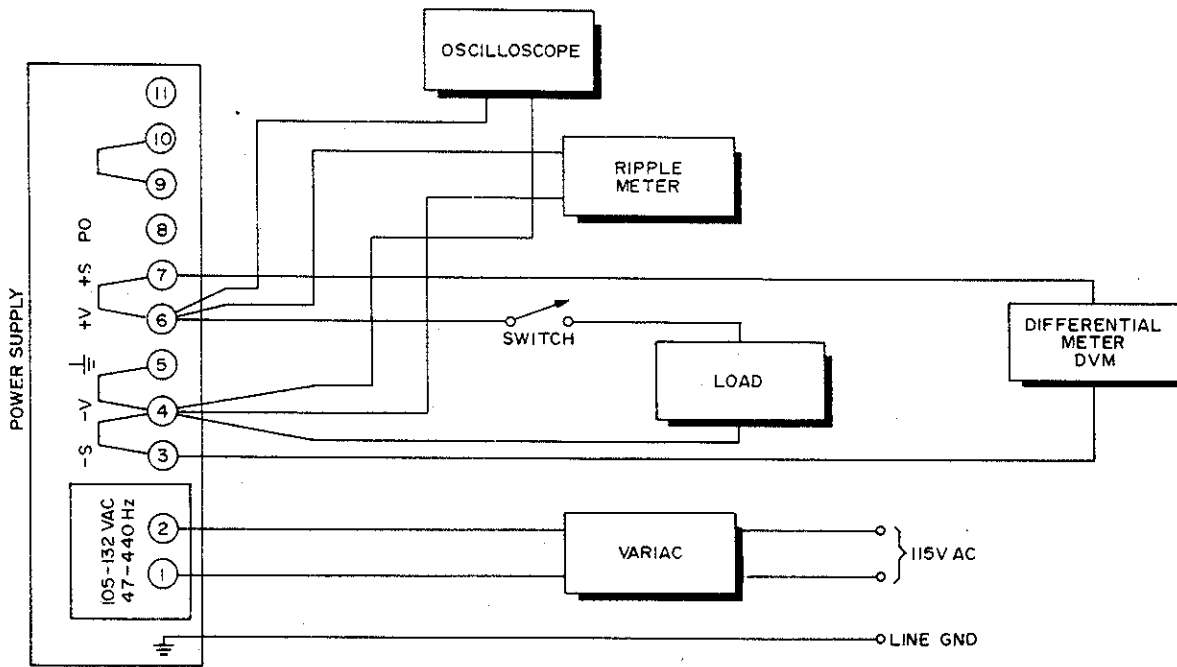

- NOTES:
1. REGULATION AND RIPPLE CHECK METERS MUST NOT BE GROUNDED THROUGH THREE-WIRE LINE CORD TO GROUND.
  2. PERFORM CHECKS WITH LOCAL SENSING CONNECTIONS ONLY.

Figure 12. Test Connections for Constant Voltage Performance Checks

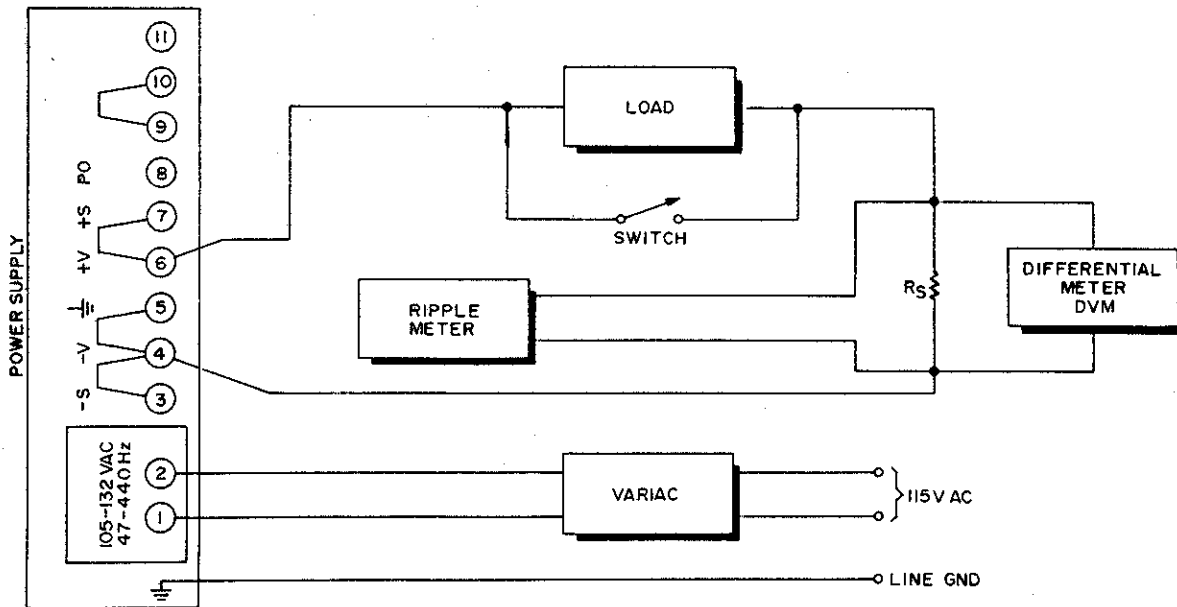

- NOTES:
1. REGULATION AND RIPPLE CHECK METERS MUST NOT BE GROUNDED THROUGH THREE-WIRE LINE CORD TO GROUND.
  2. PERFORM CHECKS WITH LOCAL SENSING CONNECTIONS ONLY.

Figure 13. Test Connections for Constant Current Performance Checks

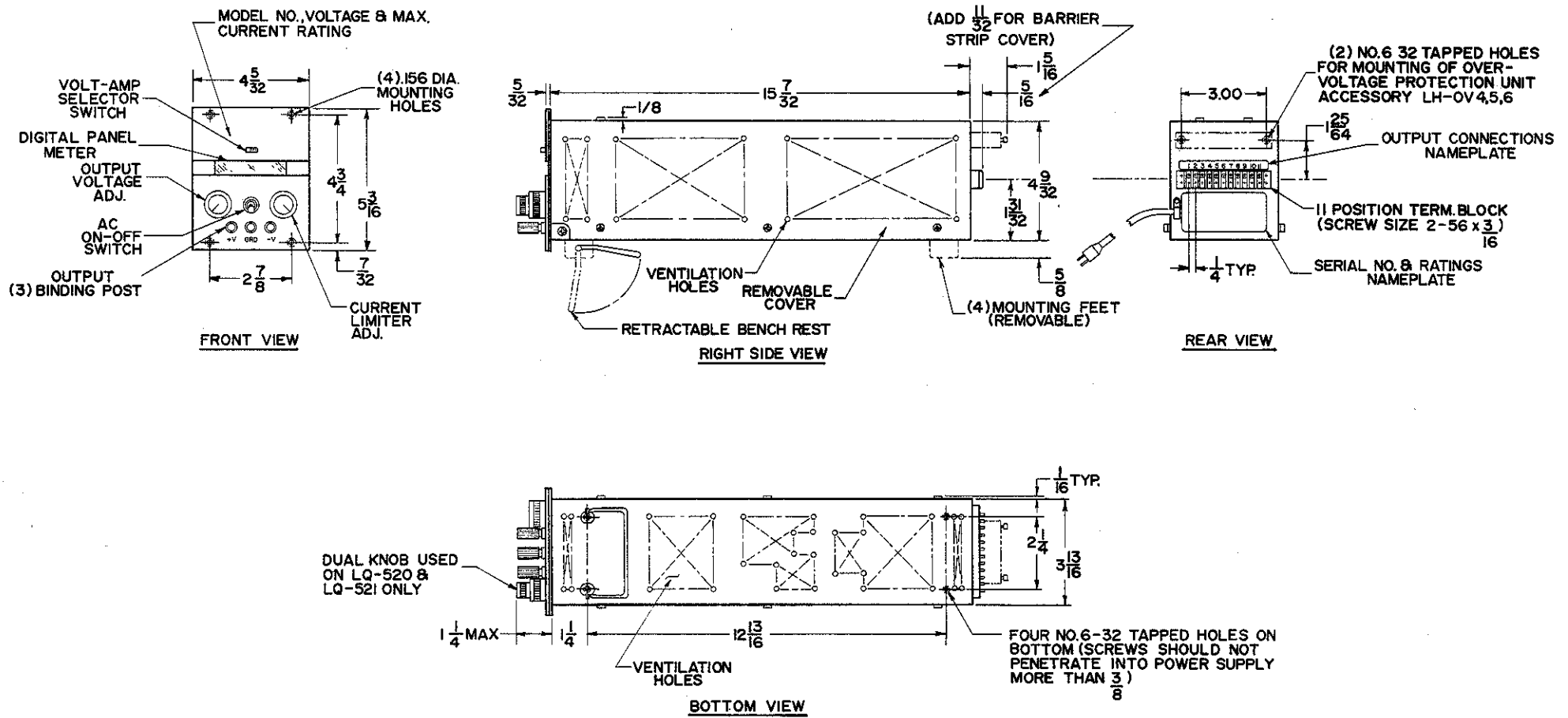

Figure 14. Outline Drawing

## GENERAL DESCRIPTION

Rack adapter LRA-1 is designed for use in equipment racks where ruggedized mounting of units is required. The adapter can be used with or without chassis slides.

Rack adapter LRA-2 is designed for simple applications of rack installation where chassis slides and ruggedized mounting of equipment are not required.

Both rack adapter LRA-1 and LRA-2 can be used to install 1/4-rack or 1/2-rack power supply units into equipment racks. Each adapter can accept various combinations of 1/4 and 1/2-rack units up to four 1/4-rack units or two 1/2-rack units.

### INSTALLATION OF 1/2 RACK UNITS INTO LRA-1

To install 1/2-rack power supply units, remove slide numbers 2 and 3 and/or 6 and 7, together with securing hardware and associated slide bar nut.

Using slide screws and slide bar nuts that were removed, store removed slides on the frame at the rear of the adapter where screw clearance holes are provided for securing each slide to the adapter.

### SHIPMENT OF UNITS MOUNTED IN LRA-1

To protect the unit against damage from shock and vibrations when transporting adapter with installed units, eight universal tie-down mounting holes, located in the adapter base, at the rear of the rack adapter, are used to secure 1/4-rack and/or 1/2-rack units into the rack adapter. Secure each unit using two 6-32 x 5/8 screws, two lock-washers and two spacers installed from the bottom side of the rack adapter. See detail A for typical securing hardware. Eight spacers are supplied with rack adapter LRA-1.

## RUGGEDIZED MOUNTING

When ruggedized mounting of units is required, follow the procedure described for SHIPMENT OF UNITS MOUNTED IN LRA-1. See detail A for typical securing hardware.

### MOUNTING CHASSIS SLIDES

Mount chassis slides using the following hardware. To assure unrestricted mounting of units into the adapter designated screw lengths must not be exceeded. Insert screws into designated holes and secure slide in position using long bar nut supplied with rack adapter LRA-1.

CHASSIS TRAK NO. CTS. -116:  
10-32 x 7/16 fl-hd (82°);  
use A holes.

LAMBDA NO. KHT-34-103 (1 PR)  
6-32 x 3/8 pan-hd;  
use B, C, and D holes.

GRANT PULLEY NO. 4435:  
6-32 x 5/15 fl-hd (100°);  
use B and D holes.

### USING BLANK PANELS

Blank front panels Model SB-20 and SB-40 are available for covering any 1/4-rack or 1/2-rack opening respectively. The blank panels can be used with rack adapter LRA-1 and LRA-2 whenever a 1/4-rack or 1/2-rack space in the adapter is not occupied by a unit. Secure each panel in position using four 6-32 x 3/8 pan-head screws supplied with the rack adapter.



REAR TIE-DOWN MOUNTING HOLES  
(FOR RUGGEDIZED MOUNTING  
SEE DETAIL "A")

FRAME REAR 17 (OVER CHASSIS)

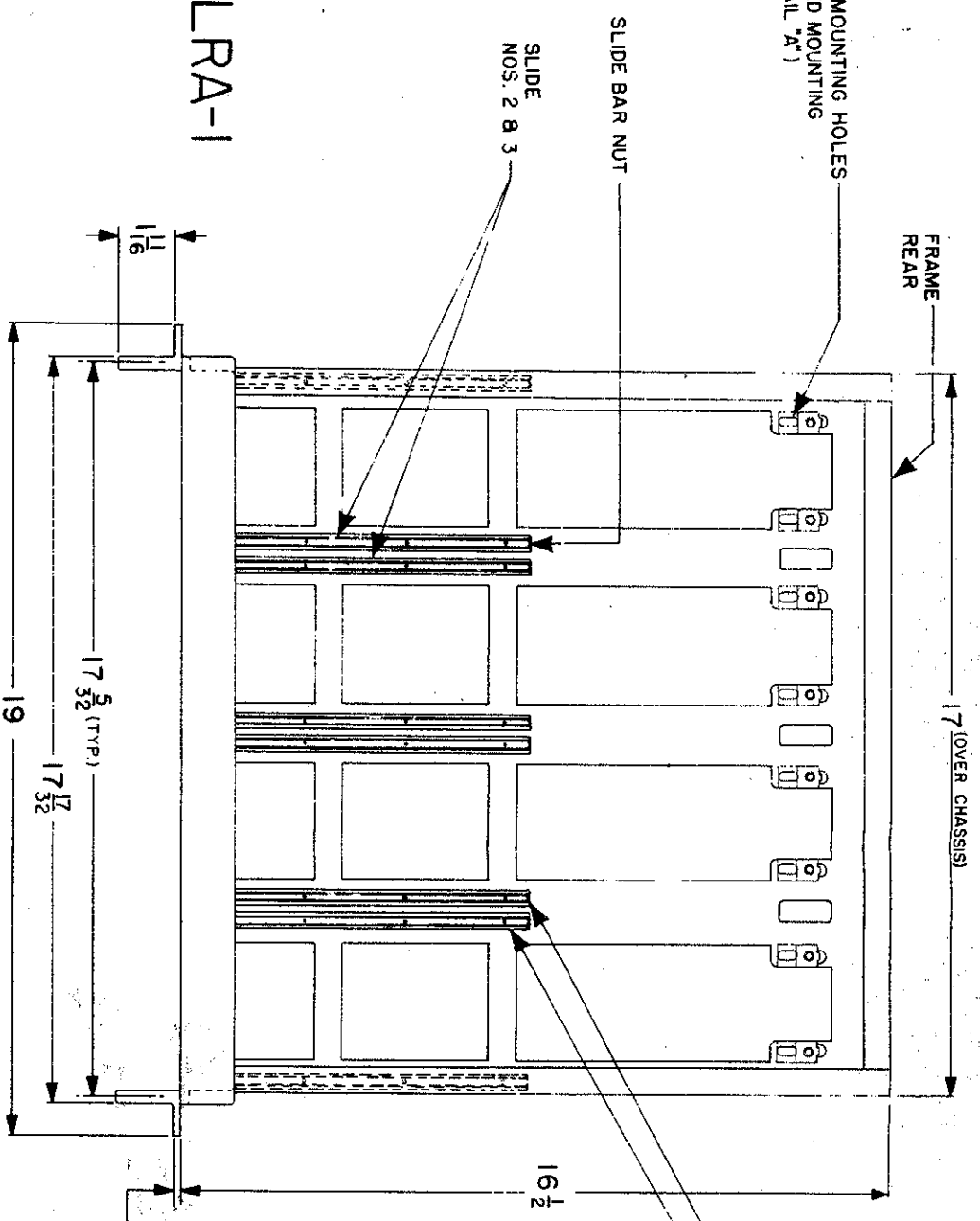

LRA-1

TABLE OF WEIGHTS

MODEL	NET (LBS)	SHIPPING (LBS)
LRA-1	12	18
LRA-2	3	4

MOUNTING HOLES PROVIDED FOR CHASSIS SLIDES: \_\_\_\_\_  
 "A" HOLES - CHASSIS TRAK, INC. NO. CTS-116  
 "B" "C" "A" "D" HOLES - LAMBDA SLIDES NO. KHT-34-003 (PAIR), LENGTH=16", TRAVEL=17"  
 "B" "A" "D" HOLES - GRANT PULLEY CO. NO. 4435 - LENGTH=16", TRAVEL=15  
 "A" HOLES ARE 1/4 DIA.  
 "B" SLOTS ARE 5/32 WIDE x 1/2 LONG  
 "C" "A" "D" SLOTS ARE 5/32 WIDE x 1/4 LONG

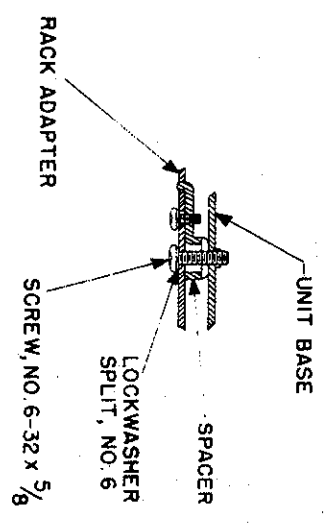

DETAIL A

LRA-2

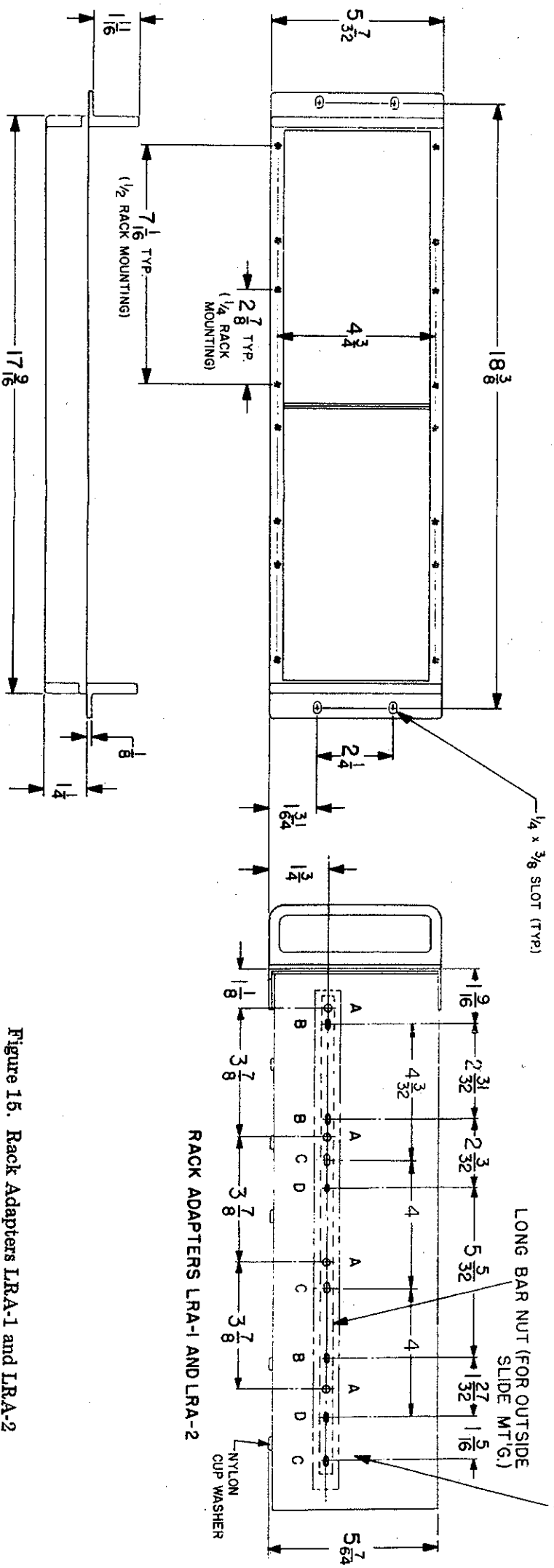

RACK ADAPTERS LRA-1 AND LRA-2

Figure 15. Rack Adapters LRA-1 and LRA-2

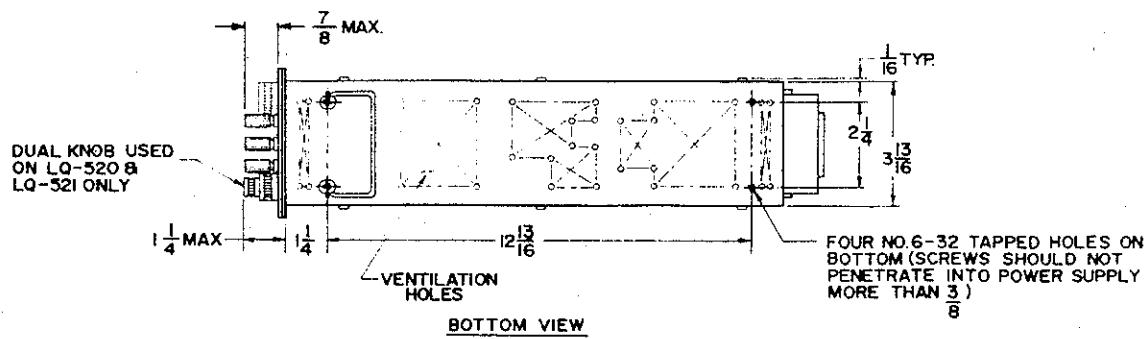
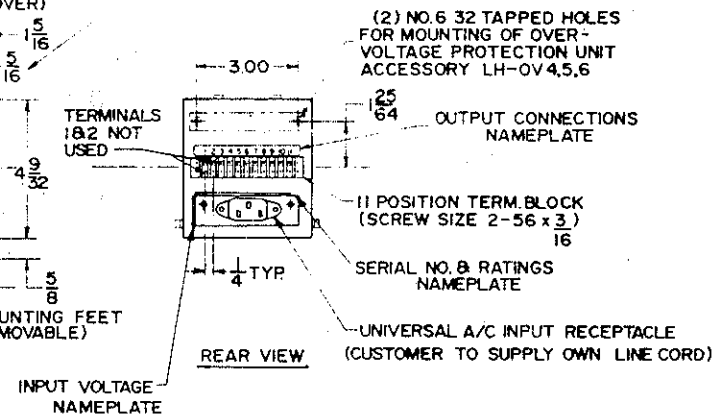
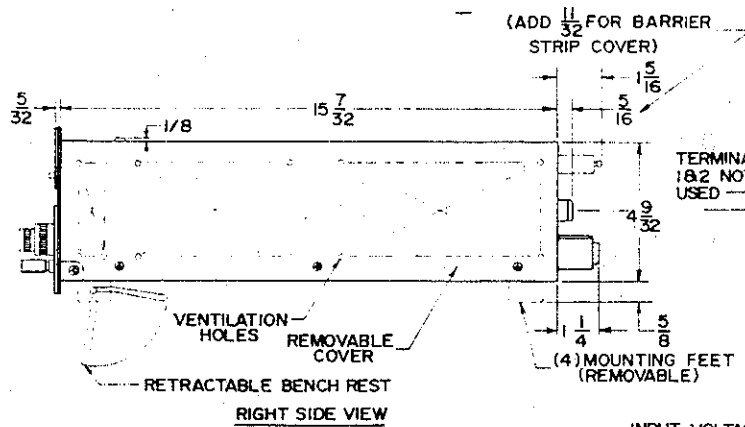
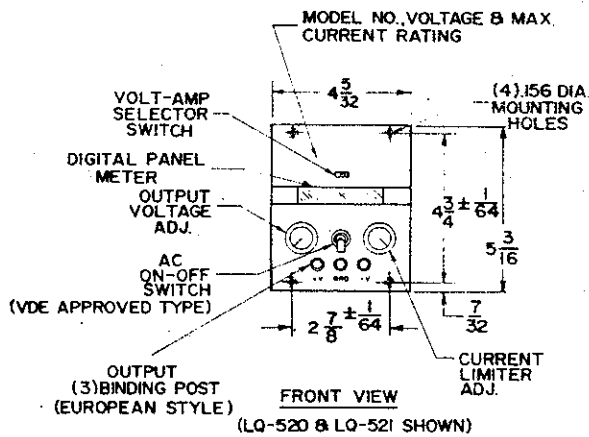

Outline Drawing For V and V1 Option Units

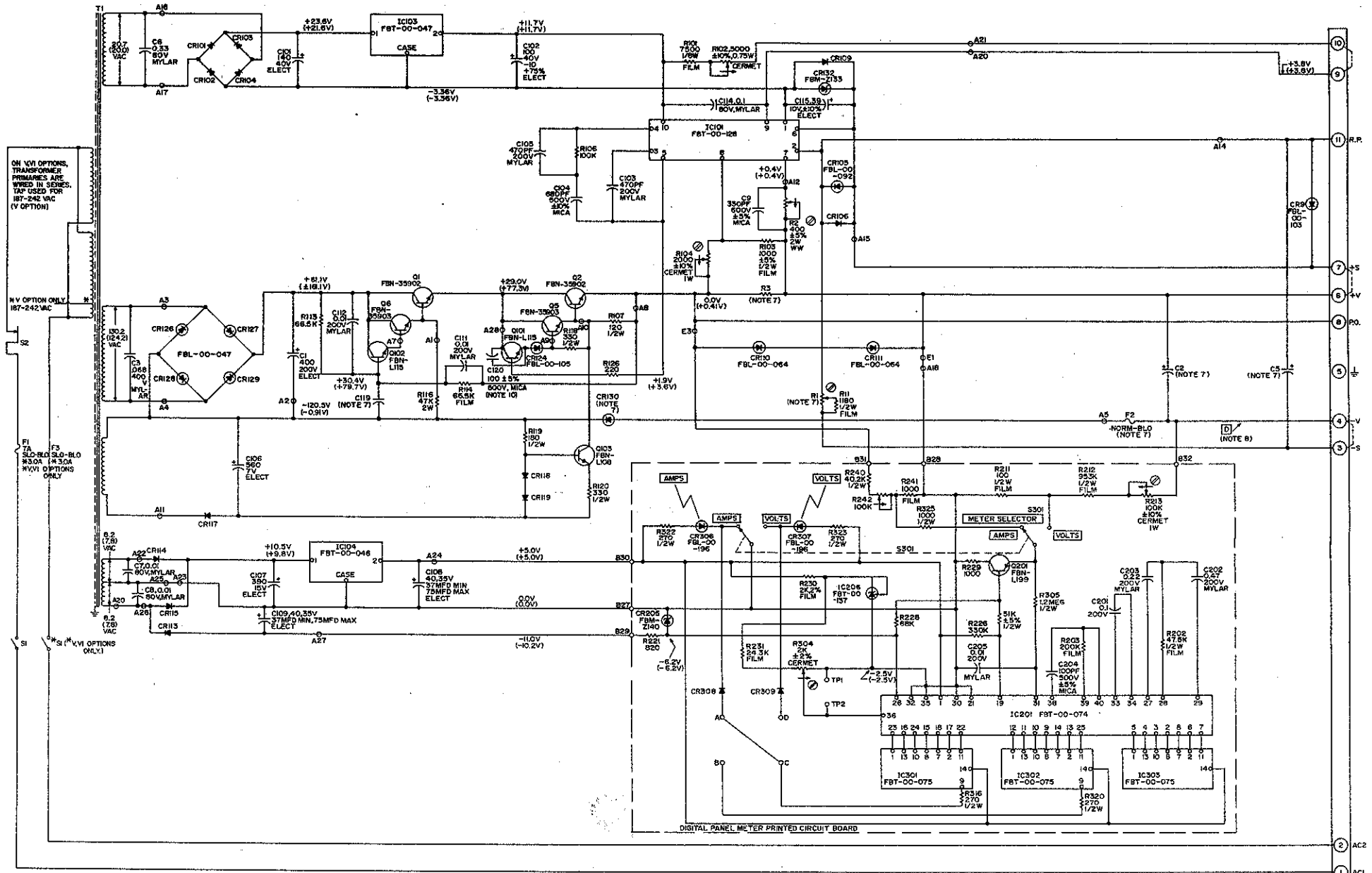

- NOTES
- RESISTORS ARE 1/4W COMP WITH VALUES IN OHMS UNLESS OTHERWISE NOTED.
  - CAPACITOR VALUES ARE IN MICROFARADS UNLESS OTHERWISE NOTED.
  - RESISTOR TOLERANCES: COMP ±10%, FILM ±1%, WIREWOUND ±5% UNLESS OTHERWISE NOTED.
  - CAPACITOR TOLERANCES: ELECTROLYTIC -10+100%, CERAMIC ±20%, MYLAR ±10% UNLESS OTHERWISE NOTED.
  - SYMBOLS:
    - INDICATES ACTUAL UNIT MARKING
    - INDICATES CLOCKWISE ROTATION OF SHAFT
    - SEE INSTRUCTION MANUAL
    - LAMBDA PART NO. FBL-00-030 USE IN 4002 DIODE FOR REPLACEMENT UNLESS OTHERWISE NOTED.

- INDICATES TERMINAL ON PRINTED WIRING BOARD OR TERMINAL BOARD.
- INDICATES ADJUSTMENT OR CALIBRATION CONTROL.
- DESIGNATIONS ARE LAMBDA PART NUMBERS.
- SEE TABLE 1 FOR COMPONENT VALUES.
- SEE TABLE 1 FOR VOLTAGE VALUES.
- CONDITIONS FOR CIRCUIT POINT MEASUREMENTS: CV AND CC.
- INPUT: 115VAC, 60Hz. INDICATED VOLTAGES ARE TYPICAL VALUES AND ARE DC UNLESS OTHERWISE NOTED.
- DC MEASUREMENTS TAKEN WITH 20,000 OHMS/VOLT VOLTMETER BETWEEN +S (TERM 7) AND INDICATED POINTS UNLESS NOTED OTHERWISE.
- CONSTANT VOLTAGE: READ NOS. NOT IN PARENTHESIS. OUTPUT: MAX RATED VOLTAGE, ZERO CURRENT.

- CONSTANT CURRENT: READ NOS. IN PARENTHESIS. OUTPUT: 0 VOLTS, MAX RATED CURRENT (SHORT CIRCUIT).
- NOT USED ON UNITS WITH SERIAL NO. PREFIXES A-E

FOR WIRING OF POWER SUPPLY TO LOAD REFER TO SUPPLY-TO-LOAD WIRING DIAGRAMS.

DOTTED CONNECTIONS SHOWN ON T811 INDICATE JUMBERS IN PLACE FOR LOCAL SENSING CONNECTION.

THIS SCHEMATIC APPLIES TO UNITS BEARING SERIAL NO. PREFIXES A-H.

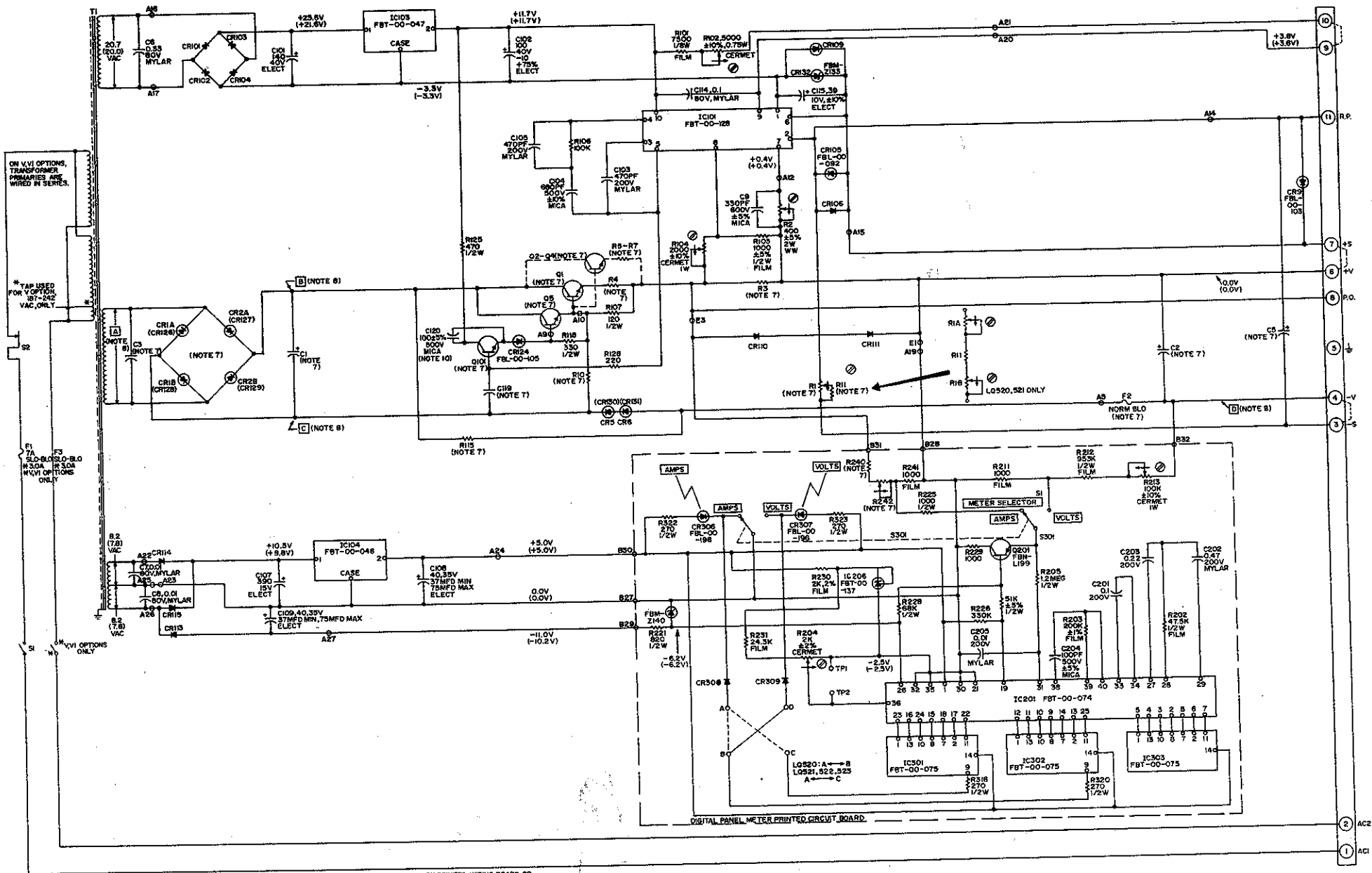

- NOTES
1. RESISTORS ARE 1/4W COMP WITH VALUES IN OHMS UNLESS OTHERWISE NOTED.
  2. CAPACITOR VALUES ARE IN MICROFARADS UNLESS OTHERWISE NOTED.
  3. RESISTOR TOLERANCES: COMP  $\pm 10\%$ , FILM  $\pm 1\%$ , WIREWOUND  $\pm 5\%$  UNLESS OTHERWISE NOTED.
  4. CAPACITOR TOLERANCES: ELECTROLYTIC  $\pm 10-100\%$ , CERAMIC  $\pm 20\%$ , MYLAR  $\pm 10\%$  UNLESS OTHERWISE NOTED.
  5. SYMBOLS:
    - INDICATES ACTUAL UNIT MARKING
    - INDICATES CLOCKWISE ROTATION OF SHAFT
    - SEE INSTRUCTION MANUAL
    - LAMBDA PART NO. F8L-00-030; USE IN 4002 DIODE FOR REPLACEMENT UNLESS OTHERWISE NOTED.

- O- INDICATES TERMINAL ON PRINTED WIRING BOARD OR TERMINAL BOARD.  
 ⊕ INDICATES ADJUSTMENT OR CALIBRATION CONTROL.  
 6. DESIGNATIONS ARE LAMBDA PART NUMBERS.  
 7. SEE TABLE I FOR COMPONENT VALUES.  
 8. SEE TABLE I FOR VOLTAGE VALUES.  
 9. CONDITIONS FOR CIRCUIT POINT MEASUREMENTS, CV AND CC.  
 INPUT: 115VAC, 60Hz;  
 INDICATED VOLTAGES ARE TYPICAL VALUES AND ARE DC UNLESS OTHERWISE NOTED. DC MEASUREMENTS TAKEN WITH 20,000 OHMS/VOLT VOLTMETER UNLESS OTHERWISE NOTED.  
 A. CONSTANT VOLTAGE  
 READ NOS. NOT IN PARENTHESIS  
 OUTPUT: MAX. RATED VOLTAGE, ZERO CURRENT.

- B. CONSTANT CURRENT  
 READ NOS. IN PARENTHESIS  
 OUTPUT: 0 VOLTS, MAX. RATED CURRENT (SHORT CIRCUIT).  
 \* NOT USED ON L0520  
 † NOT USED ON UNITS WITH SERIAL NO. PREFIXES A-F

FOR WIRING OF POWER SUPPLY TO LOAD REFER TO SUPPLY-TO-LOAD WIRING DIAGRAMS.

DOTTED CONNECTIONS SHOWN ON TB1 INDICATE JUMPERS IN PLACE FOR LOCAL SENSING CONNECTION.

THIS SCHEMATIC APPLIES TO UNITS BEARING SERIAL NO. PREFIXES A-H

SCHEMATIC DIAGRAM  
REGULATED POWER SUPPLY

L0520, L0521  
L0522, L0523

**LAMBDA**  
ELECTRONICS  
MELVILLE, NEW YORK  
DIVISION OF **TRACO** INSTRUMENTS INC.