

---

# LEADER TEST INSTRUMENTS

---

**SCHEMATHEEK**  
Beh. T. Hultermans  
Postbus 4228  
5004 EE Eindhoven

**MODEL LSG-10**

## SIGNAL GENERATOR

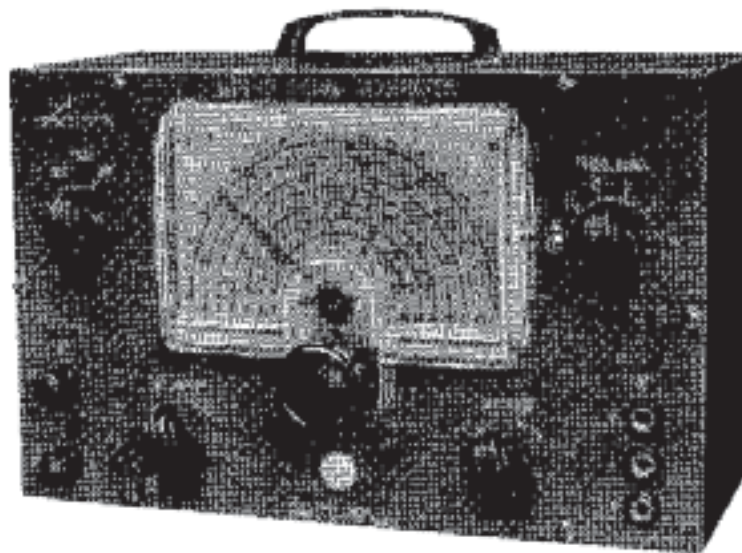

**OHMATSU ELECTRIC CO., LTD.**

850, TSUNASHIMA-CHO, KOHOKU-KU,  
YOKOHAMA, JAPAN.



Reworked by  
**PAØPGA**

This manual was downloaded from **BAMA's**  
boatanchor site <http://bama.sbc.edu>



# MODEL LSG-10 SIGNAL GENERATOR

The **LSG-10** is a compact and handy high quality instrument for the radio service bench, amateur constructor, and for instruction. It is light in weight, occupies small space, and is built for maximum service.

<b>SPECIFICATIONS :</b>	Frequency Range	120 KC to 260 MC
	and A	120 KC to 320 KC
	B	320 KC to 1000 KC
	C	1.0 MC to 3.2 MC
	D	3.2 MC to 11 MC
	E	11 MC to 38 MC
	F	37 MC to 130 MC
	Calibrated Harmonics	120 MC to 260 MC
R. F. Output	Over 100,000 microvolts	
R. F. Control	Variable with 2 taps	
Modulation Freq.	Approximately 400 cps	
A. F. Output	2 to 3 volts	
A. F. Input	Approximately 4 volts	
Tube Complement	R. F. Osc-Buffer	12BH7
	A. F. Osc-Amplifier	6AR5
Power Source	volts, 50/60 cps	12 watts
Size & Weight	$6\frac{1}{2}'' \times 10'' \times 4\frac{1}{2}''$	6 lb appr.
	(250 × 160 × 115 mm)	2.7 kg)

**DESCRIPTION :** **A.** Radio-Frequency Section. A 12BH7 is used as a combined radio frequency oscillator and buffer. One triode section is used as a Colpitts oscillator and the other triode is used for a buffer to isolate the load from the frequency determining portion. The output voltage is continuously variable with two taps, High and Low.



**B. Audio Section.** A 6AR5 is used as a 400 cycle generator. The output can be used either as an internal modulator or an audio source for external use. When frequencies other than 400 cycles are to be used for modulation, the tube becomes an amplifier.

The frequency calibration can be depended upon to 2%, directly from the scale. However, when a higher degree of accuracy is desired, the generator must be calibrated using a heterodyne frequency meter or other source of accurate frequencies, and calibrated using the logging scale on the dial.

The generator is designed for an \_\_\_\_\_ volts, 50/60 cps, and care should be taken that a DC source is not used.

**OPERATION :** Attach line plug to the \_\_\_\_\_ volt AC power line. Insert the plug of the center lead of the output cable into the "H" output jack and the shield plug into the "G" jack. The center lead and shield clips should be connected to the ANT and GND terminals respectively, of the receiver under test. Set the generator to the desired frequency by turning the center knob and "FREQ. BAND" switch. Set the "MOD" switch to "INT", and turn the AC switch (lower left) clockwise. A 400 cycle tone should be heard from the speaker of the receiver when the latter is tuned to the generator frequency. Suitable R. F. output can be obtained by adjusting the "R. F. FINE" knob, and also by changing the output tap to "L". The input to the receiver from the generator should be as low as possible to avoid overloading the tubes in the receiver. Excessive inputs cause two resonance points to appear and proper alignment or adjustments are impossible.

External modulating frequencies may be applied by turning the "MOD" knob to "EXT" and the audio input to the AF binding posts. For audio testing, the 400 cycle output is available at the same binding posts by turning the "MOD" switch to "INT", and the output may be varied by the AF IN/OUT control.



# SCHEMATIC WIRING DIAGRAM

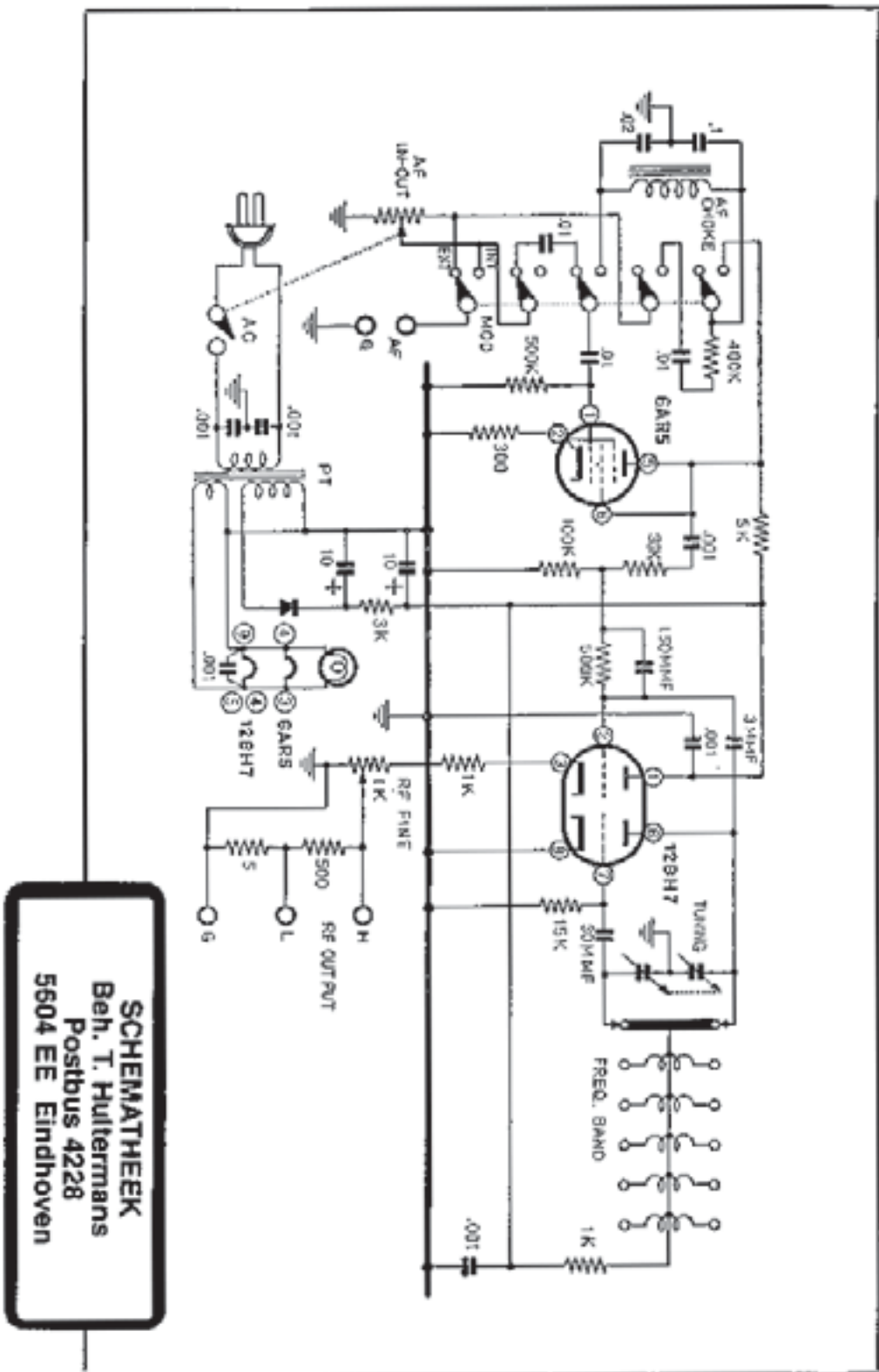



# K4XL's BAMA

This manual is provided free of charge from the "Boatanchor Manual Archive", as a service to the Boatanchor community. It was uploaded by someone who wanted to help you repair and maintain your equipment.

If you paid anyone other than **BAMA** for this manual, you paid someone who is making a profit from the free labor of others, without asking their permission

You may pass on copies of this manual to anyone who needs it. But do it without charge.

Thousands of files are available without charge from **BAMA**. Visit us at: <http://bama.sbc.edu>

**Real radio's have tubes!  
Keep them glowing !!**

**File credits:**

**T. Hultermans**

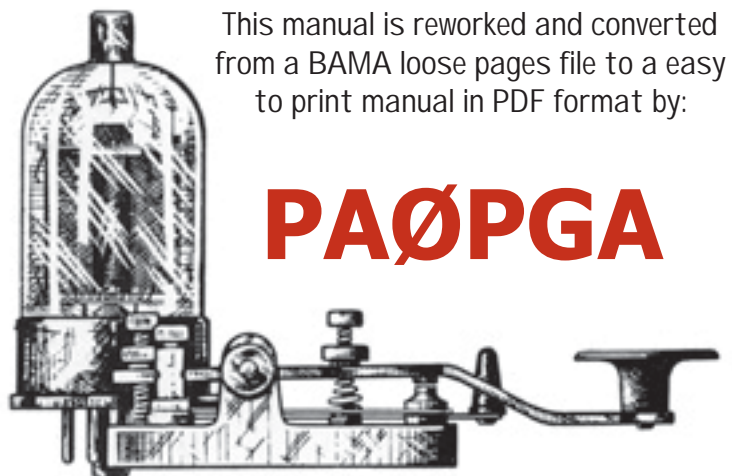

This manual is reworked and converted from a BAMA loose pages file to a easy to print manual in PDF format by:

**PAØPGA**



**Reworked by  
PAØPGA**

This manual was downloaded from **BAMA's** boatanchor site <http://bama.sbc.edu>

