

CT218

LEADING PARTICULARS

PURPOSE OF EQUIPMENT	A signal generator covering the range 85 kc/s to 30 Mc/s with facilities for FM, AM and CW. Provision is made for crystal check of the RF oscillator frequency.
OUTPUT VOLTAGE: normal	1 μ V to 100 mV in 1 dB steps at a source impedance of 75 ohms.
low output	0.1 μ V to 10 mV in 1 dB steps at a source impedance of 7.5 ohms.
high output	1 volt at low impedance.
AMPLITUDE MODULATION	Continuously variable 0-80 per cent.
FM DEVIATION:	<p style="text-align: right;">DEVIATION</p> 85 kc/s—394 kc/s NIL (no FM). 394 kc/s—850 kc/s 0—15 kc/s. 850 kc/s—1.83 Mc/s 0—30 kc/s. 1.83 Mc/s—30 Mc/s 0—90 kc/s.
INTERNAL MODULATION FREQUENCY	400, 1000, 1600 or 3000 c/s
EXTERNAL MODULATION INPUT	10 volts AF into 100,000 ohms.
OUTPUT IMPEDANCE	75 ohms and 7.5 ohms—resistive.
MONITORING FACILITIES:	Carrier level. Modulation depth or deviation. Carrier frequency (audible beats).
POWER SUPPLY	AC mains, 100-150V, 200-250V 45-100 c/s.
ACCESSORIES:	Mains connector, three core with M14 socket. Output connector, coaxial with terminating unit Plain output cable.
WEIGHT	90 lb. (124 lb. when fitted in steel case).
STORES REF.	10S/16780.

CHAPTER 1

GENERAL DESCRIPTION

LIST OF CONTENTS

	<i>Para.</i>		<i>Para.</i>
<i>Introduction</i>	1	<i>Frequency modulator</i>	11
<i>General description</i>	7	<i>Output monitoring</i>	13

LIST OF TABLES

	<i>Table</i>
<i>Valve functions</i>	1

LIST OF ILLUSTRATIONS

	<i>Fig.</i>		<i>Fig.</i>
<i>General view</i>	1	<i>Block diagram</i>	3
<i>Connectors and terminating unit</i>	2		

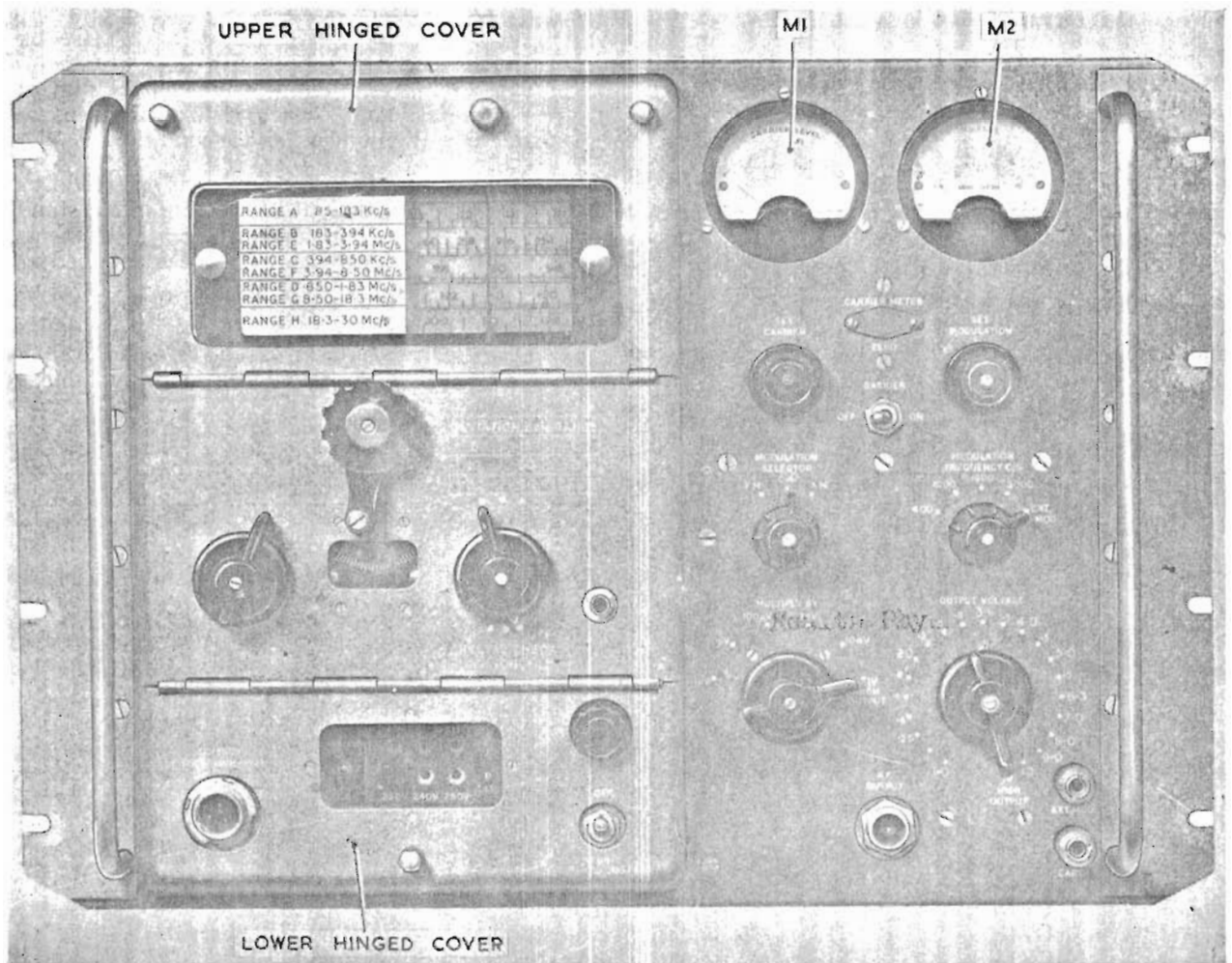

Fig. 1. General View

CHAPTER 2

OPERATING INSTRUCTIONS

LIST OF CONTENTS

	<i>Para.</i>		<i>Para.</i>
Mains voltage adjustment	1	Carrier meter zero	10
Mains voltage range	2	Modulation	12
Connection to mains	3	<i>External modulation</i>	15
Controls	4	<i>Frequency limits</i>	17
Tuning the instrument	5	RF output voltage	19
<i>Crystal check</i>	5		
<i>Setting the cursor</i>	8		

LIST OF TABLES

	<i>Table</i>		<i>Table</i>
Main beat frequencies	1	Limits for frequency modulation	3
Limits for amplitude modulation	2		

LIST OF ILLUSTRATIONS

	<i>Fig.</i>		<i>Fig.</i>
Front panel	1	Terminating unit—circuit	3
Output voltage diagram	2	Output voltage chart	4

Mains voltage adjustment

1. Before connecting to the AC mains supply, adjust the mains tap to the correct setting. This may be accomplished by opening the hinged cover at the bottom left-hand corner of the front panel (*fig. 1 of Chapter 1*), and fitting the smaller bakelite-headed thumbscrew (*fig. 1 of this Chapter*) in the appropriate position.

Mains voltage range

2. To change from the 200-250 V range to the 100-150 V range, withdraw the larger bakelite-headed thumbscrew (*fig. 1*), lift the panel so released and, having operated the switch (*fig. 1*), turn over the panel and secure it with the large thumbscrew. The smaller thumbscrew may then be inserted in the appropriate position. Having adjusted the mains tap (*para. 1*), the hinged cover must be closed before connecting to the supply. The fuses and the pilot lamp fitting are exposed when the hinged cover is opened, and renewal of these parts is then possible.

Connection to mains

3. The three-core mains lead is fitted with a Mk.4 socket which engages with the Mk.4 plug fitted on the instrument. The plug and socket are used in

the '5' position. Having connected the mains supply, switch on, note that the pilot lamp glows and the air circulator motor is heard to start up. Allow some 15 minutes for the valves to reach thermal stability.

Controls

4. *Fig. 1* shows the front panel of the instrument, the function of the controls may be listed as:

(1) Main tuning control (C49, C73 and RV3 ganged).

(2) FREQUENCY RANGE selector (SWA and SWK ganged).

Range A	: 85 kc/s — 183 kc/s (Scale 1)
B	183 kc/s — 394 kc/s (Scale 2)
C	394 kc/s — 850 kc/s (Scale 3)
D	850 kc/s — 1·83 Mc/s (Scale 4)
E	1·83 Mc/s — 3·94 Mc/s (Scale 2)
F	3·94 Mc/s — 8·50 Mc/s (Scale 3)
G	8·50 Mc/s — 18·3 Mc/s (Scale 4)
H	18·3 Mc/s — 30 Mc/s (Scale 5)

(These range figures are engraved on the scale escutcheon to the left of the scale window.)

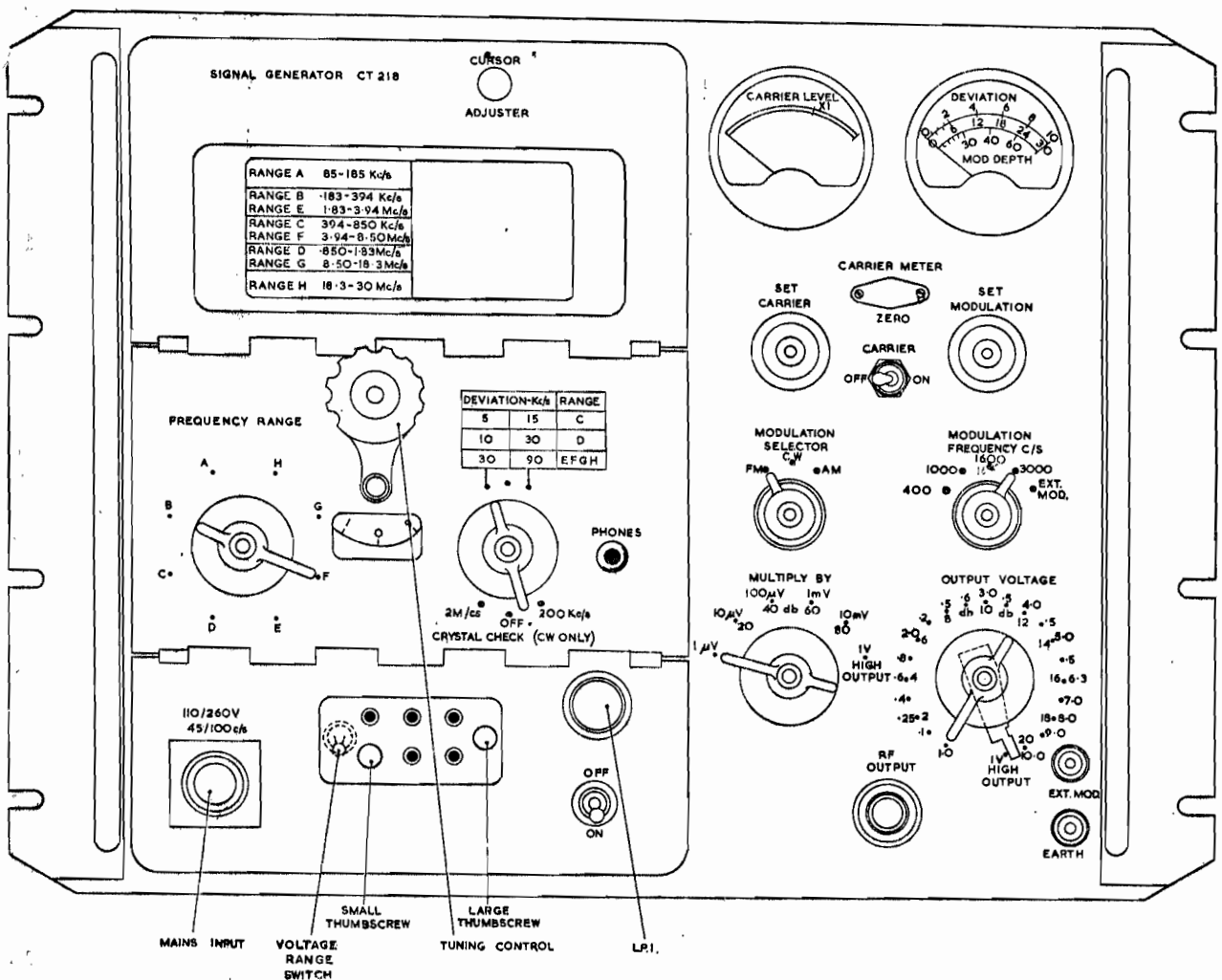

Fig. 1. Front Panel

- (3) CRYSTAL CHECK and DEVIATION KC/S (SWC) switches in either a 200 kc/s or a 2 Mc/s crystal on CW only, and sets the maximum deviation on FM, for a given range.
- (4) ON/OFF mains switch (SWG).
- (5) CARRIER METER ZERO (RV4) adjusts zero setting of pointer (screwdriver operated).
- (6) SET CARRIER control (RV1), sets carrier level so that 1 volt RMS appears across the 75-ohm output terminals with both attenuator controls turned fully clockwise. The correct setting of this control is indicated by $\times 1$ engraved on the scale of the meter M1.
- (7) SET MODULATION (RV5) sets the modulation amplitude, i.e. the modulation depth on AM and frequency deviation on FM. The meter M2 indicates the modulation amplitude (depth or deviation).
- (8) CARRIER OFF/ON (SWH). This removes the HT supply to the RF buffer amplifier and tuned output amplifier in the RF box.
- (9) MODULATION FREQUENCY C/S. (SWD) selects one of four audio frequencies from an internal oscillator or external modulation.
- (10) MULTIPLY BY (SWE). The coarse attenuator. The voltage reading on the fine attenuator is multiplied by the voltage reading on the coarse attenuator.
- (11) OUTPUT VOLTAGE (SWF). The fine attenuator. The voltage indicated by the knob is multiplied by the number on the coarse attenuator. The dB value indicated on the fine attenuator is added to the dB reading on the coarse attenuator (Reference level $1\mu V$).
- (12) CURSOR ADJUSTER. Moves the cursor across the scales, a pair of arrows on the escutcheon indicates the centre of the range of movement of the cursor.

Tuning the instrument

Crystal check

5. To set up a particular frequency it is first necessary to ensure that the scale markings accurately indicate the required frequency. Due to the mechanical and electrical factors involved it is desirable that correction to the normal scale settings should be made. Some instruments include a correction graph or calibration chart made during the original calibration of the particular model. The CT218 has an inbuilt calibration crystal oscillator enabling the RF oscillator frequency to be

monitored at particular frequencies throughout the range of the instrument.

6. The method of correction employed in the CT218 is movement of the scale cursor to indicate the correct scale reading of a crystal beat note. For scale settings in the region of the corrected position the inaccuracy of reading is negligible and the average setting may be expected to produce a frequency within $\frac{1}{4}$ per cent of the scale setting. A logging scale is provided to assist in interpolating or resetting to a particular frequency, e.g. in bandwidth measurements.

7. An inbuilt loudspeaker gives audible indication of the beats occurring between the RF oscillator and the crystal check oscillator. There are spots marked on the scale to indicate positions at which strong beat notes may be heard. An additional facility is the provision of a jack arranged for use with low-impedance telephones (600 ohms or lower) to enable the weaker harmonics to be readily identified.

Setting the cursor

8. The procedure to be followed when setting to a particular frequency is laid down in the following sub-paragraphs:

- (1) Switch to the required frequency range (SWA) (*para.* 4).
- (2) Set MODULATION SELECTOR (SWB) to CW.
- (3) Select the appropriate crystal, generally the 200 kc/s crystal for the lower ranges and the 2 Mc/s crystal on the higher ranges.
- (4) Tune on the frequency scale to the crystal harmonic nearest to the required frequency and adjust for zero beat in the phones or loudspeaker. A table of the main beat frequency positions on the scale is given in the following Table 1.
- (5) Move the cursor into alignment with the scale marking corresponding with the crystal harmonic frequency used. The SET CURSOR control knob must be pushed in to connect with the cursor mechanism.
- (6) With this cursor setting tune to the required frequency.
- (7) Turn off the CRYSTAL CHECK switch (SWC) (if CW is needed) or switch the MODULATION SELECTOR (SWB) to AM or FM as required.

9. A large number of additional beat notes will be heard other than those indicated in the Table and on the scales of the instrument. These will occur at points where the two oscillators bear some harmonic relationship. For example, with the RF oscillator tuned to 1.33 Mc/s, the third harmonic of this will beat with the second harmonic of the 2 Mc/s crystal oscillator. Further notes on the use of the crystal check are given in the Appendix to this Chapter.

Carrier meter zero

10. A small plate, marked CARRIER METER ZERO covers the control RV4. First turn off the CARRIER switch (SWH) and, after loosening the two securing screws, swivel the plate counter-clockwise to expose RV4 which may then be adjusted with a screwdriver to bring the meter indication to zero.

11. The carrier level may now be set by switching on the CARRIER switch and rotating the SET CARRIER control until the meter pointer is level with the $\times 1$ mark on the scale. The voltage applied to the attenuators is then 1 volt.

Modulation

12. The modulation frequency should next be selected or external modulation applied to the EXT. MOD. and EARTH terminals at the bottom right-hand corner of the instrument. The MODULATION SELECTOR should now be turned to give the required type of modulation, i.e. AM, CW or FM, and the SET MODULATION control will then adjust the mod. depth (on AM) or the deviation (on FM).

Note ...

On Frequency Range A the modulation frequency must not exceed 1 Kc/s

13. On FM there are two ranges of deviation available. The maximum deviation possible varies with the waveband in use and the limits are clearly marked on the panel above the CRYSTAL CHECK/DEVIATION control. In effect the DEVIATION selector is a $\times 3$ attenuator in the AF network, so that there is a factor of three times in the possible deviation range between the two positions of the switch. For example, on band C (the lowest band on which FM is available) there are two possible

TABLE 1
Main beat frequencies

Range	Position of crystal beat marking
A	100
B and E	200, 300, 400
C and F	400, 500, 600, 700, 800
D and G	0.9, 1.0, 1.1, 1.2, 1.3, 1.4, 1.5, 1.6, 1.7, 1.8, 1.9
H	18, 19, 20, 21, 22, 23, 24, 25, 26, 27, 28, 29, 30

settings for the condition '5 kc/s deviation', these are:

- (1) With the DEVIATION switch in the lower range and the SET MODULATION control turned well round to indicate 5 kc/s on the DEVIATION meter, i.e. 10 on the upper scale.
- (2) With the DEVIATION switch in the higher range, the SET MODULATION control may be turned to bring the meter pointer to read 10 on the lower deviation scale.

14. On AM the percentage modulation depth is read directly from the bottom scale of the meter.

External modulation

15. If modulating frequencies other than those available within the CT218 are required, an external source may be applied to the EXT. MOD. terminals at the lower right-hand corner of the panel.

16. For a maximum modulation the input needed is 10 volts, the input impedance being 100K.

Frequency limits

17. Certain frequency limits must be observed when external modulation is applied and the following Tables 2 and 3 should be consulted to avoid undue distortion in the output wave.

18. A suitable instrument for external modulation is the signal generator Type 65 (or 65A). A.P.2879AD gives a description of the signal generator Type 65 and A.P.2536C contains summaries of both instruments. The Admiralty oscillator G205 (W7252) or equivalent will also be suitable.

RF output voltage

19. The source voltage indicated on the engravings of the attenuator switches may be considered as being applied through the output impedance (75 ohms) of the instrument to the 75-ohm terminal of the terminating unit (fig. 2 of chap. 1). The arrangement is illustrated in fig. 2 of this Chapter which shows V_{ind} (the voltage indicated on the attenuators) in series with Z_o (the output impedance of 75 ohms). Thus the output voltage of the signal generator is the open-circuit voltage appearing at the terminals '75-ohm $\times 1$ ' and 'E' of the

terminating unit. A circuit of the terminating unit is given in fig. 3.

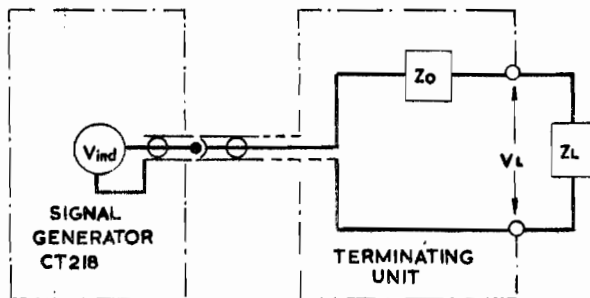

Fig. 2. Output Voltage Diagram

20. If the terminal voltage V_L of a load (Z_L of fig. 2) is to be known it may be calculated from the formula:

$$V_L = \frac{V_{ind} Z_L}{Z_o + Z_L}$$

where V_{ind} is the source voltage, Z_o is the impedance (resistive) marked against the output terminal (75 ohms or 7.5 ohms).

Z_L is the impedance of the load.

This formula is presented in graphical form in fig. 4. It may be seen by reference to fig. 4 that for a load impedance above a few thousand ohms the error in assuming V_L to be equal to V_{ind} is negligible.

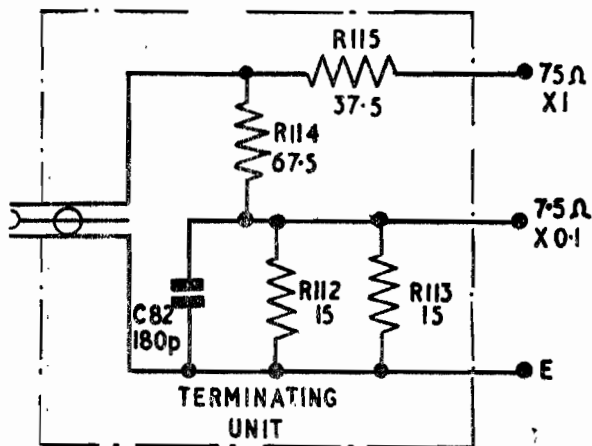

Fig. 3. Terminating Unit—Circuit

TABLE 2
Limits for amplitude modulation (10V input)

RF range	AF limits
A	50 c/s—1 kc/s
B	50 c/s—3 kc/s
C	50 c/s—6 kc/s
D, E, F, G, H	50 c/s—12 kc/s

TABLE 3
Limits for frequency modulation (10V input)

RF range	AF limits	Max. deviation
A	—	—
B	—	—
C	50 c/s—3 kc/s	15 kc/s
D	50 c/s—6 kc/s	30 kc/s
E, F, G, H	50 c/s—12 kc/s	90 kc/s

Note...

The nature of the modulator used for FM in the CT218 renders the instrument unsuitable for use with sawtooth or square-wave inputs, this limitation precludes the use of the instrument as a wobulator.

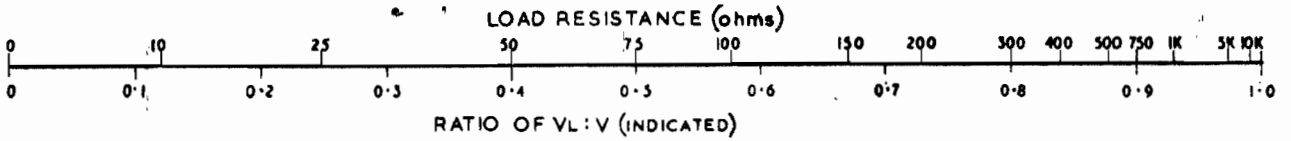

Fig. 4. Output Voltage Chart

21. The terminating unit has an output terminal marked '×0.1, 7.5 ohms' and the EMF at this point is one-tenth of that indicated by the attenuators, the corresponding dB readings are 20 dB down, i.e. 20 dB must be subtracted from the attenuator readings. Notes on the use of the 7.5-ohm terminal are given in the Appendix to this Chapter, which also includes more detailed notes on the connection of the CT218 to an external load having either balanced or unbalanced input.

22. If an extension to the length of the output cable is needed almost any type of coaxial cable may be used if the length added is less than about one-sixteenth of the wavelength in use. This amounts to approximately 18 in. at 30 Mc/s. If

low-loss 75-ohm cable is used in conjunction with the 75-ohm outlet any reasonable length of additional cable may be used. These requirements are to ensure that the output voltage is not altered by the presence of the additional cable.

23. In practice it is usual for a sequence of operations with a signal generator to specify particular settings of the attenuators without reference to the actual terminal voltage. The source EMF is the fundamental quantity considered acting in series with the output impedance selected. The settings are often quoted in dB and the input circuit is generally matched to the signal generator output by suitable resistors.

Revised by...

CHAPTER 3

CIRCUIT DESCRIPTION

LIST OF CONTENTS

	<i>Para.</i>		<i>Para.</i>
<i>Introduction</i>	1	<i>Crystal oscillator switching</i>	23
CIRCUIT DESCRIPTION			
<i>Power supply</i>	2	<i>AF amplifier</i>	27
<i>RF oscillator</i>	10	<i>AF oscillator</i>	28
<i>FM shunt coil</i>	11	<i>Modulation indicator AM</i>	30
<i>RF buffer amplifier</i>	13	<i>Modulation indicator FM</i>	34
<i>Output amplifier</i>	14	<i>Frequency modulation</i>	
<i>Amplitude modulation</i>	17	<i>The modulator</i>	37
<i>RF output</i>	18	<i>Function of the switch SWL</i>	44
<i>Crystal check oscillator</i>	20	<i>Adjustment of deviation</i>	47
		<i>AF drive to TR2</i>	50
		<i>Construction of TR2</i>	52

LIST OF TABLES

	<i>Table</i>		<i>Table</i>
<i>Valve functions</i>	1	<i>Location of Inductors</i>	5
<i>Function of RF filters</i>	2	<i>Location of Valves</i>	6
<i>Location of resistors</i>	3	<i>Location of switches</i>	7
<i>Location of Capacitors</i>	4	<i>Miscellaneous components</i>	8

LIST OF ILLUSTRATIONS

	<i>Fig.</i>		<i>Fig.</i>
<i>Simplified block diagram</i>	1	<i>Monitor meter circuits</i>	4
<i>Signal generator CT218—circuit</i>	2	<i>Frequency modulation circuit</i>	5
<i>Amplitude modulation circuit</i>	3		

Introduction

1. The circuit description which follows deals with the circuit in the sequence of power supply, generation and amplification, monitoring and

modulating the signal. Reference should be made to the block and circuit diagrams (figs. 1 and 2 respectively) in order to follow the sequence clearly. A list of the valve functions is given in Table 1.

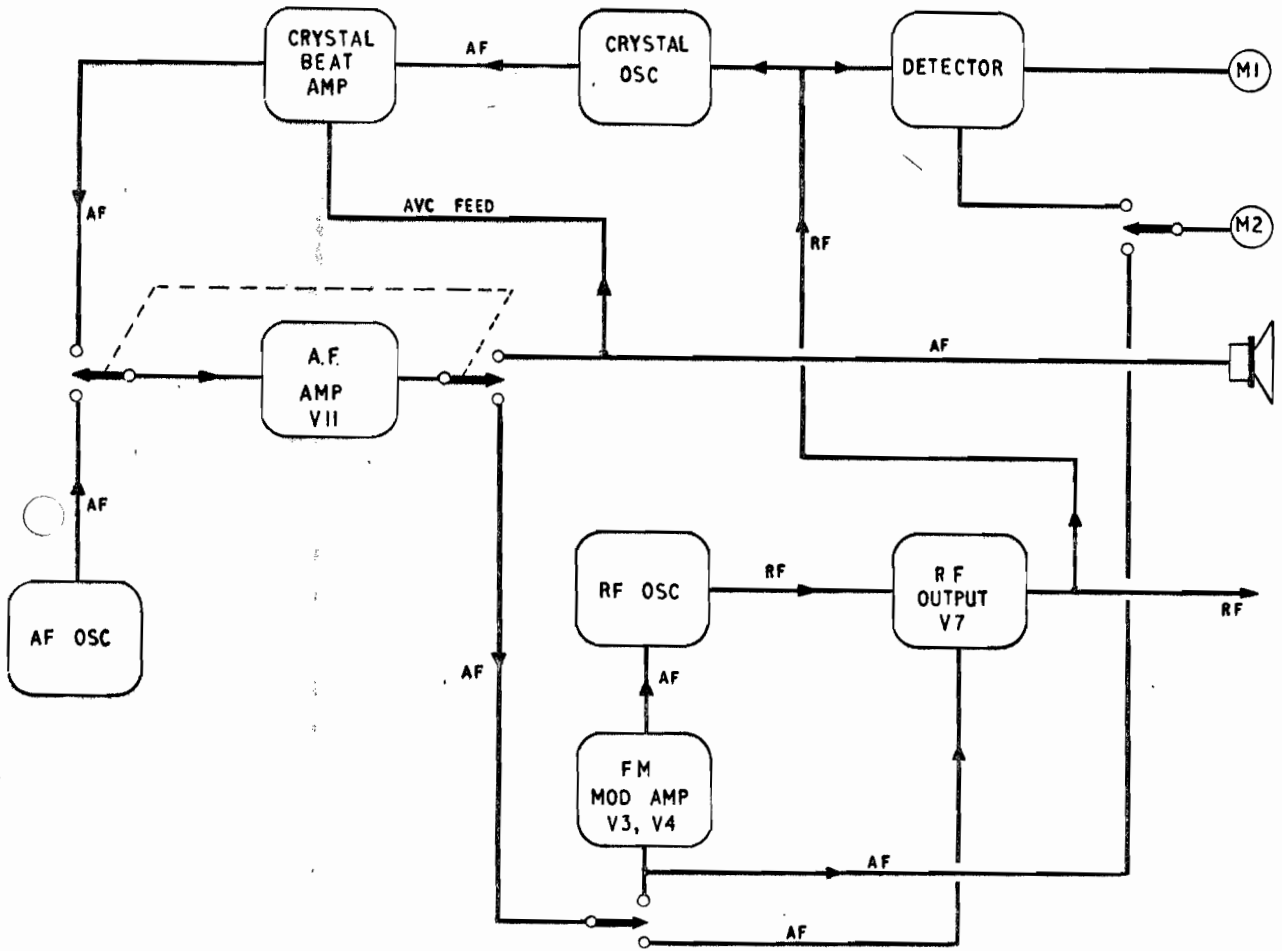

Fig. 1. Simplified Block Diagram

**TABLE 1
Valve functions**

Valve	Function
1	HT rectifier
2	HT stabilizer (supplying V5 screen-grid)
3	FM AF driver valve
4	FM modulation amplifier (cathode-follower)
5	RF oscillator
6	RF buffer amplifier
7	RF output
8	RF level detector diode
9	Carrier meter zero diode
10	AF oscillator
11	AF amplifier (modulation and loudspeaker)
12	AF amplifier (crystal check)
13	AGC diode for V12
14a	Crystal check oscillator (200 kc/s)
14b	Crystal check oscillator (2 Mc/s)
15	Modulation meter amplifier
16	Modulation meter amplifier
17	Modulation meter amplifier
18a	Modulation level diode
18b	Modulation meter zero diode
19	HT rectifier

CIRCUIT DESCRIPTION**Power supply.**

2. The AC input transformer TR1 of fig. 2 has two separate 100-volt primaries and these may be connected either in parallel or series (by means of the switch SWJ) for inputs of 100V or 200V. One of the primaries (B, fig. 2) has an additional winding tapped at intervals of 10 volts up to 50V. This gives the two ranges of 100-150V (with the two 100V primaries in parallel) and 200-250V (with the windings in series).

3. The air circulator motor has two field coils designated A and B, coil A is connected across primary A of the mains transformer and coil B across the 100-volt section of primary B. With SWJ in the 100-150V position the field coils are in parallel and when switched to the 200-250V position the coils are in series with an applied potential of 200V.

4. The transformer has three LT secondaries and one centre-tapped HT winding supplying power for the valves. Rectification is by two CV2235 valves (V1 and V19) in a full-wave circuit. A conventional HT filter is used consisting of L3, L4, C6, C5 and C7.

5. Stabilized HT is provided by V2 for the screen-grid of V5 (RF oscillator) to minimize frequency drift caused by changes in the HT supply.

6. Switch SWH (CARRIER ON-OFF) disconnects HT from the RF section of the instrument and substitutes a dummy load (R3, R4) to maintain a constant HT voltage when the carrier is switched off.

7. There are three separate HT feeds from the power section:

- (1) The supply to the AF sections and crystal oscillator
- (2) The switched supply to the RF unit
- (3) The stabilized feed to the RF oscillator screen-grid.

8. All connections through the screening box to and from the RF circuits are adequately filtered, the filters themselves being complete units fitted in screening cans and connections made with screened cable. In addition to the RF box filters, the mains input is also filtered to eliminate any possibility of RF pick-up from the mains. Details of the filters are listed in Table 2.

9. There are no common bias arrangements in the CT218, the valves being individually self or auto-biased according to the particular operating conditions.

RF oscillator

10. A CV138, V5, is used as a tuned anode, inductance-feedback oscillator. The 'bottom end' of the grid winding is connected to HT positive for convenience of switching but in other respects there is no significant difference between this and the usual oscillator. The output is taken from a point either on the grid coil or an additional output winding according to the range selected. The coil appropriate to the range is selected by rotating the turret (FREQUENCY RANGE switch) which is ganged to SWA and SWK.

FM shunt coil

11. On ranges C to H provision is made for frequency modulation, and the method adopted is inductance variation in the tuned circuit. Situated on the chassis of the RF unit close to the coil turret is the Ferrite modulator (TR2), and an RF coil in this device is shunted across the oscillator (V5) tuned circuit. The inductance of the modulator coil TR2 is varied by the application of an AF signal to the input winding of the modulator and this causes a variation in the total tuned circuit inductance. This gives rise to a frequency variation which provides the FM facility.

12. The oscillator tuning capacitor C49 is connected between V5 anode and chassis and thus has HT potential on the fixed vanes. The frame is clamped to the drive-shaft housing and the moving vanes are rotated by the worm-driven, throated gear wheel.

TABLE 2

Function of RF filters

Function	L number	Location
Anode circuit 2 Mc/s crystal oscillator V14a	7	1M
Anode circuit 200 kc/s crystal oscillator V14b	53	1L
Anode circuit tuned output stage V7	5	1B
Screen grid circuit tuned output stage V7	10	3K
Anode circuits V5, V6 and screen grid V6	6	1B
Screen grid circuit V5	9	2B
Anode and screened grid of circuits V3, V4	8	1B
Heater circuits V3, V4, V5 and V14	12	2B
Heater circuits V6 and V7	13	2B
Audio input to grid circuit V4	11	3B
Cathode circuit V8	47, 49	2N
Heater circuit V8	48, 50	2N

RF buffer amplifier (V6)

13. The RF output from the oscillator is fed through C48 to the CV2127 buffer valve. This stage is untuned, the low value of anode load (R42, 500 ohms) provides a gain relatively unaffected by

feed point of V7. The frame of the condenser is mounted on the main assembly but with insulating bushes to isolate the HT voltage present on the frame. An insulated coupling is used to gang the spindles of C49 and C73.

Amplitude modulation (fig. 3)

17. The output from the modulator valve V11 is applied to the screen-grid of V7 the CV2127 RF output valve. The HT supply of the screen-grid of V7 is variable by RV1, the CARRIER LEVEL control. The resulting RF voltage from (V7) may thus be adjusted in amplitude by RV1 and also amplitude-modulated by the AF voltages applied from either the AF oscillator V10 or an external AF supply connected to the EXT. MOD. terminals.

RF output

18. The RF power available at the selected secondary coil (shown as L46 in fig. 2) is passed directly to the output attenuators and the voltage across the coil is measured by the diode rectifier V8 and meter M1.

19. Associated with V8 is another diode V9 of the same type connected in reverse sense so that the standing current of V8 with no RF input is balanced. Adjustment of the balancing current produced in this manner is provided by RV4 situated on the front panel beneath a small cover plate. RV4 is marked CARRIER METER ZERO. The circuit of V8 and V9 is shown in functional form in fig. 4.

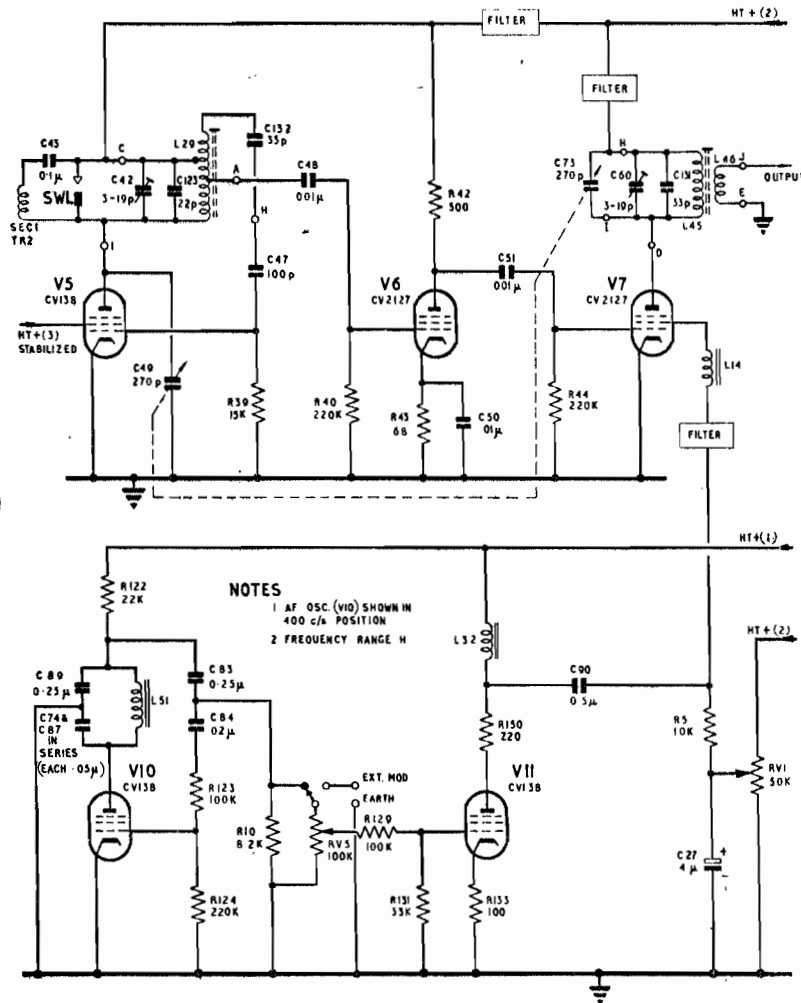

Fig. 3. Amplitude Modulation Circuit

frequency. The RF voltage developed across R42 is passed by C51 to the grid of the CV2127 RF output valve V7.

Output amplifier (V7)

14. This valve is connected as a class C, tuned anode amplifier, the appropriate coils being selected by rotating the turret ganged to the switch (SWA). Bias is provided by grid current charging C51.

15. The output is taken from a secondary winding on the appropriate anode coil and a resistance network is included where required on each range selected to maintain a constant output voltage throughout the tuning range.

16. The tuning condenser C73 is ganged to the RF oscillator (V5) tuning condenser C49, but the fixed vanes are, in this case, connected to the

Crystal check oscillator (fig. 2)

20. A CV858, V14, is connected into the circuit by switches SWBba, SWCab and SWCca. The purpose of the crystal oscillator is to provide a number of spot frequency points at which the calibration of the RF oscillator may be accurately checked. Two crystal oscillator triodes (V14a and V14b) are incorporated and either may be selected by SWC. V14a is a triode oscillator with the RF signal from V7 injected into the crystal oscillator grid circuit. Due to the non-linear action of the valve, mixing of the two signals occurs and a beat note is produced. When the frequency difference between the fundamentals or harmonics of the two RF waves is small an AF beat note results. The anode circuit of V14 has an RF load (L55-R18 or R147), an RF filter (L7 or L53), and an AF load (R138). The AF voltage developed across R138 is passed by C91 to V12, the crystal beat note amplifier. The output from this stage is fed to V11 which is used as an AF output valve with choke coupling to the speaker transformer TR3.

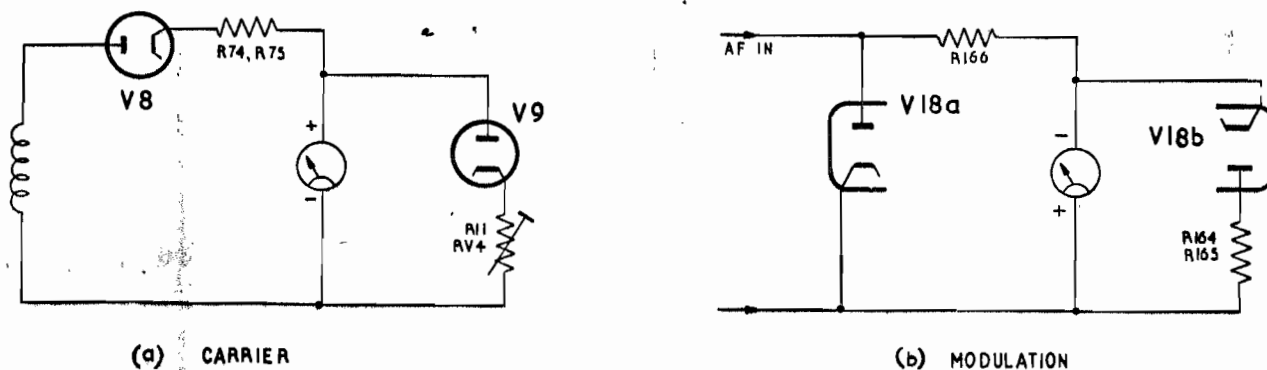

Fig. 4. Monitor Meter Circuits

21. The AF voltage appearing at the primary of the TR3 is rectified by the diode V13 and the negative DC from the anode of this diode is passed after decoupling by R140, C92, to the grid of V12 to provide AGC as a measure of compensation for the very wide range of amplitudes in the beat notes. AGC delay is provided by R144 and R141.

22. To give some impression of the range of amplitudes normally encountered it is to be observed that the 200 kc/s crystal will give audible beats with the carrier on the range H. This corresponds to a crystal harmonic higher than the 100th, the amplitude is thus very low, while a beat between the fundamental of the two oscillators has an amplitude of the order of volts.

Crystal oscillator switching

23. The crystal oscillator is only required for use when CW is in operation, as any form of modulation would interfere with the working of the mixer. Additionally, it may not always be necessary for the oscillator to be switched on when CW is being used.

24. Accordingly, there are two separate switches in the HT supply to V14, these are SWB(ba) (the MODULATION SELECTOR), and SWC (ab) (the CRYSTAL CHECK-DEVIATION switch).

25. In the crystal oscillator there are two separate triode oscillators operating at frequencies of 200 kc/s plus harmonics, and at 2 Mc/s plus harmonics. The required frequency is selected in SWC (ca) by switching the anode load resistor R138 to the selected triode in V14.

26. For convenience the CRYSTAL CHECK switch is mounted on the same control as the DEVIATION switch (SWC); this does not give rise to any difficulty as the FM circuit is out of action when using the crystal oscillator.

AF amplifier (V11)

27. The block diagram, fig. 1, shows that V11 is used as an AF output stage feeding the loudspeaker when the crystal oscillator is in use. When modulation of the carrier is required, V11 is connected as an amplifier which:

- (1) Amplitude-modulates the carrier at the screen-grid of V7.
- or
- (2) On FM feeds the FM modulator section V3, V4, TR2.

AF oscillator (V10)

28. The basic circuit is a Colpitts type as shown in fig. 3 with the output taken from a tapping on the grid condenser branch. The range switch controls the screen-grid feed and output tapping so that the voltage output is the same at all frequencies. This is shown in fig. 2.

29. The HT feed is supplied by R122 to one end of the anode inductance which is tapped. The tapplings in conjunction with C74 and C85 to 89 determines the frequency of oscillation.

Modulation indicator AM

30. Modulation is indicated by a valve-voltmeter (M2) which on AM indicates modulation depth by measuring the low frequency component present at the cathode circuit of V8, the RF detector diode.

31. The indicated modulation depth is only accurate if M1 is set to the correct reference level.

32. To make this point clear; modulation depth, depends on the ratio of AF to RF amplitude. From this it may be seen that if the RF level is altered while the AF level remains constant, the ratio is altered. This is another way of saying that the modulation depth is changed.

33. The modulation depth meter is calibrated directly in per cent at the particular RF level selected, that is when the meter M1 indicates $\times 1$.

Modulation indicator FM

34. The FM deviation is measured indirectly by metering the AF input to the modulator section V3, V4. Switch SWB (bc) connects the input of the valve-voltmeter to either the junction of R73, R76 (AM) or R168, R169 (FM). In the CW position of the switch the valve-voltmeter input is earthed.

35. After amplification by V15, V16 and the cathode-follower V17, the AF voltage is rectified by one diode section of V18 and the resulting DC is passed through the meter M2 to give an indication on the appropriate scale of the magnitude of the modulation. Negative feedback is applied over the three valves V15, V16 and V17 and the overall amplification is adjusted by the feedback control RV6, the setting of which is determined in the course of calibration.

36. The second section of V18 is a reverse-connected diode across the meter M2 and serves the same purpose as the diode V9 in the M1 circuit (para. 19). There is no variable control provided on V18, the resistor R165 being selected in the process of calibration.

Frequency modulation

The modulator (TR2)

37. The device used in the CT218 for frequency modulating the RF is known as a Ferrite (or magnetic) reactor and operates on the principle that variation of the permeability of the core of the coil varies the coil inductance.

38. The permeability of a dust-iron core depends on the ratio B/H, that is, the ratio of the flux density within the material to the strength of the magnetic field in which the material is situated.

39. The B/H (or hysteresis) curve of a ferromagnetic substance is not linear and thus as the field strength and the position of the working point on the curve is altered so the ratio B/H changes. As this ratio determines the incremental permeability of the coil core it is seen that the inductance of the coil varies as the magnetizing force changes.

40. The ferrite reactor TR2 used in the CT218 uses the steady magnetic bias of a permanent magnet with a superimposed AC field provided by the primary winding in which AF currents are flowing. In this way a minor hysteresis loop is traced at AF from a point on the B/H curve determined by the field of the biasing magnet.

41. In effect the incremental permeability and hence the inductance of the RF coil of the Ferrite reactor is varied at AF from a value determined by the permanent magnet field. As the RF coil forms

part of the tuned circuit inductance of the oscillator, the oscillator frequency will vary in accordance with the AF currents applied to the ferrite reactor.

42. The core is biased at such a point on the B/H curve that the AC field is small in comparison with the steady field and the shift in mean permeability is small enough to cause little practical error. The steady field, provided by the permanent magnet, is accurately adjusted in calibration to ensure the optimum working conditions. The total distortion introduced by the modulator is of the order of 5 per cent.

43. To prevent part of the oscillator valve anode current flowing through the RF winding of TR2 and causing unwanted changes in the permeability of the core, a series condenser C43, is included in the ferrite reactor circuit.

Function of the switch SWL

44. If the magnetic bias of the ferrite core of TR2 undergoes a sudden, temporary change, a permanent alteration in the permeability of the core may result due to the magnetic properties of the core. This will effect the frequency of RF oscillations as described in para. 41. As may be seen from the FM circuit diagram (fig. 5), on rotating the coil turret the HT feed to the oscillator valve V5 is broken temporarily and C43 will charge through TR2 secondary and V5. This would result in a change in permeability as mentioned above.

45. A pair of switch contacts SWL is connected across one reactor RF coil and these are actuated by rotation of the turret so that while the turret is between ranges the coil is short-circuited and there is thus no current surge through it as the anode current of the valve is interrupted.

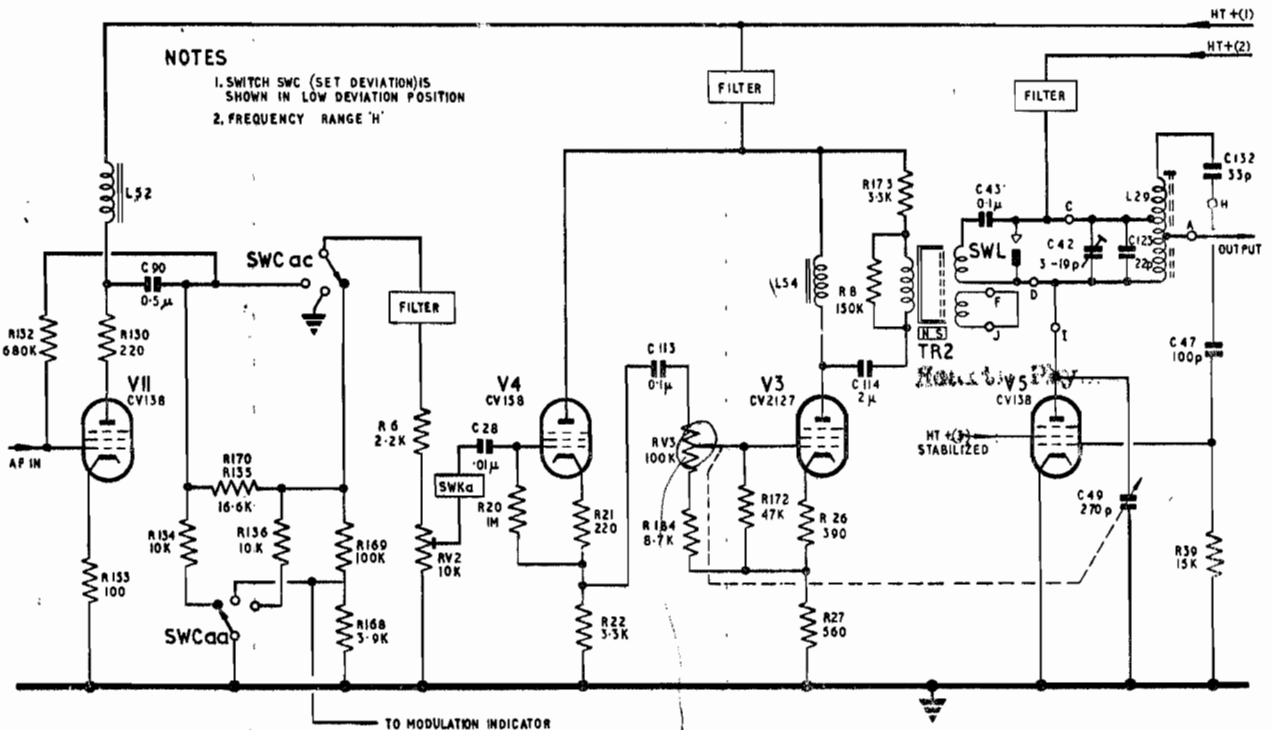

Fig. 5. Frequency Modulation Circuit

DIEN
CSPR. CONTROL

46. On ranges C and D the two RF coils in TR2 are connected in series but the switch contacts of SWL are only across the coil winding to which the HT feed is applied. However, there is no need for the second coil winding to be short-circuited during rotation of the range switch as rotation of this switch disconnects the second coil from the circuit. If a fault should develop causing failure of the contacts SWL to short-circuit the reactor coil during range changing, pronounced jumps in the frequency of the RF oscillator would occur.

Adjustment of deviation

47. As the method of modulation is variation of the total oscillator (V5) tuned circuit inductance it is to be noted that any alteration in the ratio of L/C in the tuned circuit, i.e. alteration of resonant frequency, will result in a different value of deviation for a given value of modulator input.

48. For this reason the input to the modulator (V3) must be adjusted over the tuning range of the instrument. The range switch SWA (fig. 2) is ganged to SWK which sets the maximum input to the modulator to the value required on each range. This is indicated on the FM breakdown circuit (fig. 5) by the box enclosing the letters SWKa and on the main circuit (fig. 2) it is shown in full. It is seen that the resistor selected by SWKa, in series with R171 (fig. 2) forms a potential divider giving the correct amount of deviation for the range selected.

49. As the deviation ratio would otherwise vary over the tuning sweep of any one range, a further correction is applied in the form of a variable potentiometer RV3 in the AF signal chain ganged to the main tuning condenser as shown in fig. 2 and 5. In this way the actual deviation is held to within 5 per cent of the indication deviation.

AF drive to TR2

50. To isolate the primary of the Ferrite reactor TR2 (fig. 5) from the DC component of the anode current of V3 a choke-capacitance coupling circuit is used comprising L54 and C114. The absence of cathode decoupling on V3 ensures a high anode impedance and constant current feed for the inductive primary of TR2.

51. To ensure level AF response a resistor R8 is shunted across the primary of TR2 to damp the internal resonance which occurs at the upper end of the AF range while a series resistor R173 is inserted to overcome a low frequency resonance between TR2 and C114.

Construction of TR2

52. A ferroxcube dust-iron core on which the RF coil is wound is mounted in the gap of a nickel-iron lamination stack. On the arms of the 'Ni-Fe' stack are mounted an AF winding and a small, accurately adjusted permanent magnet. The whole assembly is enclosed in a mumetal case to provide good shielding against stray magnetic fields. TR2 is

mounted on the RF chassis close to the oscillator section of the coil turret and the switch contacts SWL are inside the turret close to the leads from TR2.

TABLE 3
Location of resistors (fig. 2)

Circuit Ref.	Location	Circuit Ref.	Location
R1	B4	R58	D2
R2	A3	R59	D2
R3	B4	R60	D2
R4	B4	R61	D2
R5	J4	R62	D2
R6	C3	R63	C2
R7	F2	R64	O1
R8	G2	R65	O1
R9	—	R66	O1
R10	G5	R67	O1
R11	—	R68	O1
R12	—	R69	O2
R13	—	R70	O2
R14	C3	R71	O2
R15	—	R72	N6
R16	E2	R73	O5
R17	O5	R74	O5
R18	L2	R75	O5
R19	—	R76	O5
R20	E3	R77	H6
R21	E3	R78	P3
R22	E3	R79	P3
R23	K1	R80	P3
R24	J1	R81	P2
R25	H1	R82	P2
R26	G3	R83	P4
R27	G3	R84	P4
R28	H1	R85	P4
R29	G2	R86	P3
R30	B6	R87	P3
R31	B6	R88	P3
R32	F6	R89	P2
R33	F6	R90	P2
R34	—	R91	P2
R35	H6	R92	P2
R36	J6	R93	P4
R37	G6	R94	P4
R38	G6	R95	P3
R39	J3	R96	P3
R40	J3	R97	P3
R41	J1	R98	P3
R42	J2	R99	P3
R43	K3	R100	P2
R44	K3	R101	P2
R45	K2	R102	P2
R46	B5	R103	P2
R47	B5	R104	P4
R48	C6	R105	P4
R49	C6	R106	P3
R50	D6	R107	P3
R51	D6	R108	P3
R52	F6	R109	P2
R53	F6	R110	P2
R54	C6	R111	P6
R55	G6	R112	P1
R56	C6	R113	P1
R57	H6	R114	P1

Circuit Ref.	Location	Circuit Ref.	Location
R115	P1	R152	L6
R116	M4	R153	L6
R117	F6	R154	L6
R118	—	R155	L5
R119	—	R156	L6
R120	F4	R157	M5
R121	E4	R158	L6
R122	F4	R159	M6
R123	G4	R160	N6
R124	G5	R161	M6
R125	G5	R162	N6
R126	G4	R163	N6
R127	G4	R164	P6
R128	—	R165	P6
R129	H4	R166	O6
R130	H5	R167	O6
R131	H5	R168	K5
R132	J5	R169	K5
R133	J5	R170	J4
R134	J5	R171	E3
R135	J4	R172	F3
R136	K5	R173	G2
R137	M4	R174	D2
R138	M4	R175	D2
R139	M4	R176	D2
R140	L4	R177	D2
R141	K4	R178	C2
R142	L4	R179	E2
R143	M4	R180	F2
R144	K4	R181	F2
R145	M5	R182	F2
R146	H5	R183	F2
R147	M2	R184	F2
R148	L3	R185	D6
R149	M3	R186	D6
R150	J4	R187	J6
R151	K6	R188	J6

TABLE 4
Location of Capacitors (fig. 2)

Circuit Ref.	Location	Circuit Ref.	Location
C1	B5	C22	L3
C2	B5	C23	B3
C3	B5	C24	B2
C4	B5	C25	B3
C5	B5	C26	C3
C6	C4	C27	J4
C7	B5	C28	E2
C8	B1	C29	G2
C9	B1	C30	J1
C10	M2	C31	J1
C11	B2	C32	H1
C12	B2	C33	F2
C13	L3	C34	G3
C14	B3	C35	B6
C15	B2	C36	C6
C16	B3	C37	D6
C17	B1	C38	E6
C18	B1	C39	F6
C19	M2	C40	H6
C20	B2	C41	J6
C21	B2	C42	H2

Circuit Ref.	Location	Circuit Ref.	Location
C43	H2	C92	L5
C44	H1	C93	K5
C45	H3	C94	N4
C46	H3	C95	L4
C47	J2	C96	L1
C48	J2	C97	L1
C49	H3	C98	L2
C50	J3	C99	L1
C51	J2	C100	L3
C52	J1	C101	K6
C53	B5	C102	K6
C54	C6	C103	L6
C55	D6	C104	L6
C56	E6	C105	M6
C57	F6	C106	N6
C58	H6	C107	B3
C59	J6	C108	G5
C60	K2	C109	M4
C61	K2	C110	M2
C62	—	C111	L6
C63	K3	C112	J2
C64	N4	C113	E3
C65	J4	C114	G3
C66	L2	C115	L3
C67	—	C116	B6
C68	—	C117	C6
C69	—	C118	D6
C70	—	C119	E6
C71	—	C120	G6
C72	—	C121	H6
C73	K2	C122	J6
C74	F4	C123	H6
C75	N1	C124	B5
C76	N1	C125	C6
C77	N1	C126	D6
C78	N2	C127	E6
C79	N2	C128	G6
C80	N2	C129	H6
C81	N2	C130	J6
C82	P1	C131	K2
C83	G4	C132	H1
C84	G4	C133	L2
C85	F4	C134	M2
C86	F4	C135	M2
C87	F4	C136	N3
C88	F4	C137	M2
C89	F4	C138	M4
C90	J4	C139	N4
C91	M4	C140	K4

TABLE 5
Location of Inductors (fig. 2)

Circuit Ref.	Location	Circuit Ref.	Location
L1	B5	L10	K3
L2	B5	L11	B3
L3	B3	L12	B2
L4	B3	L13	B2
L5	B1	L14	K2
L6	B1	L15	B6
L7	M1	L16	B6
L8	B1	L17	C6
L9	B2	L18	C6

Circuit Ref.	Location	Circuit Ref.	Location
L19	D6	L38	E6
L20	D6	L39	G6
L21	E6	L40	G6
L22	E6	L41	H6
L23	G6	L42	H6
L24	G6	L43	J6
L25	H6	L44	J6
L26	H6	L45	K2
L27	J6	L46	K2
L28	J6	L47	N2
L29	H2	L48	N2
L30	H2	L49	N2
L31	B5	L50	N2
L32	B5	L51	G4
L33	C6	L52	J4
L34	C6	L53	L1
L35	D6	L54	G2
L36	D6	L55	L2
L37	E6	L56	L2

TABLE 6
Location of Valves (fig. 2)

Circuit Ref.	Location	Circuit Ref.	Location
V1	C4	V12	M4
V2	A4	V13	L4
V3	G2	V14a	L2
V4	E2	V14b	M2
V5	H2	V15	L6
V6	J2	V16	M6
V7	K2	V17	N6
V8	N1	V18a	O6
V9	O5	V18b	O6
V10	F5	V19	C4
V11	J4		

TABLE 7
Location of switches (fig. 2)

Circuit Ref.	Location	Circuit Ref.	Location
SWAa	E4	SWDca	F4
SWAb	D4	SWDda	F4
SWBaa	J4	SWDdb	E4
SWBab	H4	SWEb	O1
SWBac	J4	SWEd	O1
SWBba	G3	SWEf	O2
SWBbc	K6	SWEh	O2
SWCaa	K4	SWEk	O2
SWCab	H4	SWF	P3
SWCac	K4	SWG	C5
SWCca	M4	SWH	B3
SWDaa	G4	SWJ	D4
SWDab	G5	SWKa	D2
SWDba	E4	SWKb	F3
SWDbb	F4	SWL	H2

TABLE 8
Miscellaneous components (fig. 2)

Circuit Ref.	Location	Circuit Ref.	Location
TR1	C4	LP2	D5
TR2	G2	LP3	D5
TR3	K4	LP4	E5
XL1	L2	LP5	E5
XL2	M2	LP6	E5
MOTOR	D5	FS1	D5
LP1	D5	FS2	D5

REVISION: PLY.

Chapter 4

MECHANICAL DESCRIPTION

LIST OF CONTENTS

	<i>Para.</i>		<i>Para.</i>
<i>Introduction</i>	1	<i>The air circulator</i>	13
<i>Tuning mechanism</i>	2	<i>The FREQUENCY RANGE switch</i>	16
<i>Scale unit</i>	7	<i>The front panel assembly</i>	17
<i>Circuit layout and filtering</i>	10		

LIST OF ILLUSTRATIONS

	<i>Fig.</i>		<i>Fig.</i>
<i>Tuning drive mechanism</i>	1	<i>Underside of chassis</i>	5
<i>Scale drive unit</i>	2	<i>Chassis rear view</i>	6
<i>Front panel with top cover open</i>	3	<i>Side view of chassis</i>	7
<i>Interior view of chassis</i>	4	<i>FREQUENCY RANGE switch gearing</i>	8

Introduction

1. This chapter gives details of the mechanisms used for tuning and range switching and of the air circulator system. A brief description of the chassis assembly and layout is included. Circuit references given are the same throughout this volume and are based on the details in the main circuit diagram of fig. 2, Chap. 3, Part 1.

Tuning mechanism

2. An exploded view of the tuning mechanism is shown in fig. 1, and in fig. 4 the position of the tuning circuit elements (C49, C73 and RV3) on the chassis may be seen. The scale drive chassis is shown in fig. 2 and 3.

3. The following components are driven from the main tuning drive shaft (*refer to fig. 1 and key*):

- (1) RF oscillator and output tuning capacitors, C49 and C73.
- (2) Frequency modulation level corrector control, RV3.
- (3) Vernier scale.

4. The main oscillator circuit is tuned by the section C49 of the ganged condenser. The fixed vanes of C49 are connected to the anode circuit of the oscillator valve and thus carry HT potential. C73 is the tuning capacitor of the output stage and the fixed and moving plates have HT potential applied. For this reason the output section of the ganged condenser is insulated and a coupling disc provided between the spindles.

5. The variable resistor RV3 is also driven from the main shaft as shown in fig. 1. The speed of rotation of RV3 is the same as that of C49-C73. The lever L bears on a cam (*item 39 of fig. 1*) situated at the rear of the worm wheel driving RV3. At the extreme ends of the range (about 40 revolutions of the main shaft) the cam allows the lever L to engage the stop S by the tension of a spring. Damage to the main shaft of gearing is avoided by the provision of a friction clutch (*items 4 to 8 in fig. 1*) in the tuning head.

6. The spindles of the tuning capacitors are driven by a worm gear on the main shaft, this is item 20 of fig. 1; the worm engages with (21) a spring-loaded wheel which provides a minimum of backlash. The drive from the main shaft is applied to the spindle of the oscillator tuning condenser C49 which is in turn coupled by an insulated coupling disc to C73. This arrangement removes any backlash which may be introduced by the coupling disc from the oscillator section.

Scale unit

7. The scale unit (*shown in fig. 2*) is made accessible by unscrewing the two hexagon-headed captive screws S1 (*fig. 3*) situated above the tuning escutcheon and swinging down the hinged cover to the position shown in fig. 3. When the screw S2 (*fig. 3*) is released the whole scale unit may be swung out into the position shown in fig. 2. The unit swings about the spindle on which the guide roller spool RS1 (*fig. 3*) is mounted. This spool

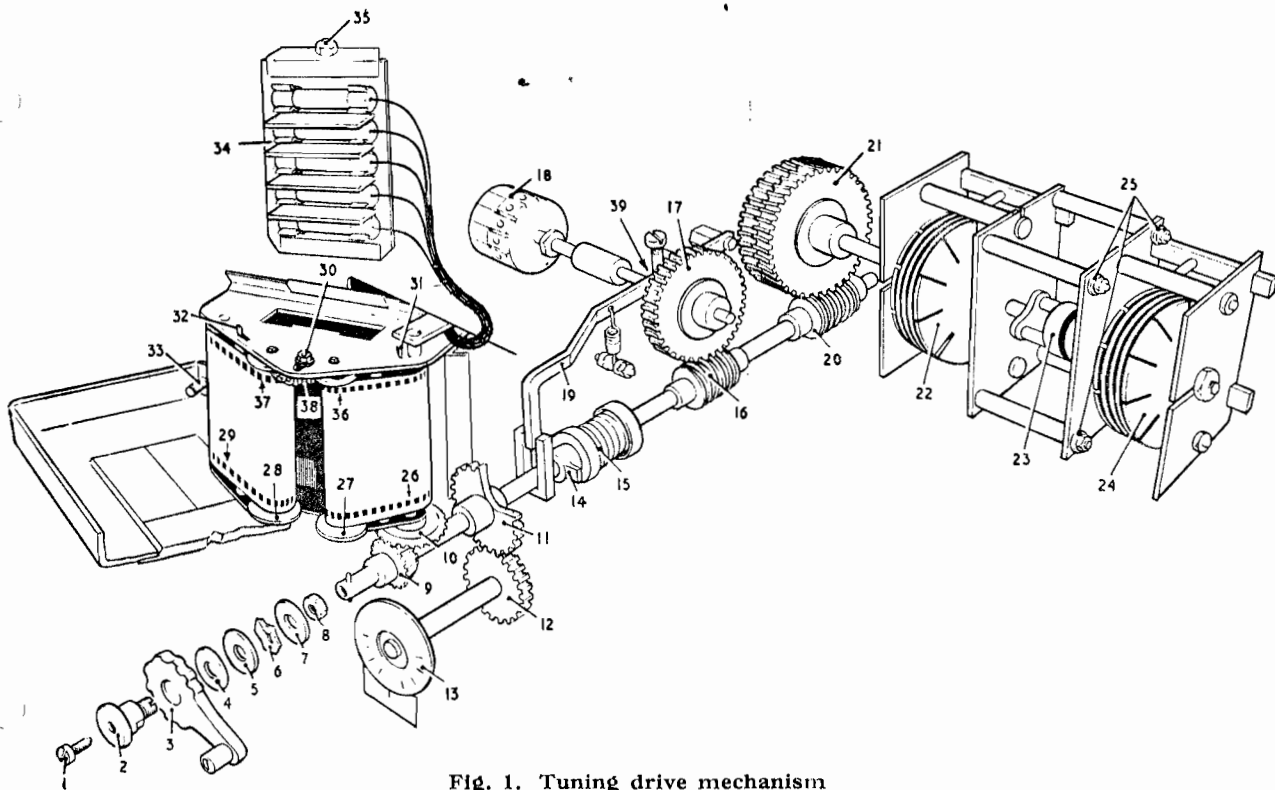

Fig. 1. Tuning drive mechanism

KEY TO FIG. 1

- 1 HANDLE FIXING SCREW
- 2 SHAFT DRIVING BUSH
- 3 TUNING HANDLE
- 4 CORK WASHER
- 5 FRICTION WASHER
- 6 SPRING WASHER
- 7 SPACING WASHER
- 8 RETAINING NUT
- 9 BEVEL WHEEL BW2
- 10 BEVEL WHEEL BW1
- 11 VERNIER GEAR
- 12 VERNIER GEAR
- 13 VERNIER SCALE
- 14 STOP 'S'
- 15 FLEXIBLE COUPLING
- 16 WORM DRIVE TO RV3
- 17 WORM WHEEL OF RV3
- 18 RV3
- 19 LEVER L
- 20 WORM DRIVE TO TUNING GANG
- 21 WORM WHEEL OF TUNING GANG
- 22 C49
- 23 GANG COUPLING (INSULATED)
- 24 C73
- 25 INSULATOR BUSHES
- 26 DRIVE ROLLER SPOOL RS1
- 27 ROLLER SPOOL RS4
- 28 ROLLER SPOOL RS3
- 29 ROLLER SPOOL RS2
- 30 IDLER GEAR SECURING NUT
- 31 RS4 PAWL
- 32 RS3 PAWL
- 33 CHASSIS CLAMPING SCREW S2
- 34 ILLUMINATING UNIT
- 35 ILLUMINATING UNIT SECURING SCREW
- 36 PINION GEAR OF RS4
- 37 PINION GEAR OF RS3
- 38 IDLER GEAR OF RS3-4
- 39 ROTATION LIMIT CAM

Radio Phy.

transmits the drive from the tuning drive shaft to the film as described in the following para.

8. The film is driven by the bevel wheel BW1 (fig. 1) on the main shaft engaging with the bevel wheel BW2 mounted on the spindle of the guide roller spool RS1, the spool RS1 is fitted at each end with teeth corresponding to the holes in the 70 mm. film scale and as RS1 is rotated the film is drawn along. The total length of the film is about 8 ft., and about 3 in. of film is presented to view through the window. The excess film is stored on two spring-loaded roller spools RS3 and RS4, and passes over the guide roller RS2. As the scale is moved, the film is wound from one storage roller on to the other. The spools RS3 and RS4 are connected through gears G1, G2 and G3, to each other so that as the drive spool RS1 pulls the film from one storage roller, the other roller is rotated by the gears and the film is thus drawn on to the second roller. Due to the spring-loading of the rollers an almost constant film tension is maintained at all scale positions.

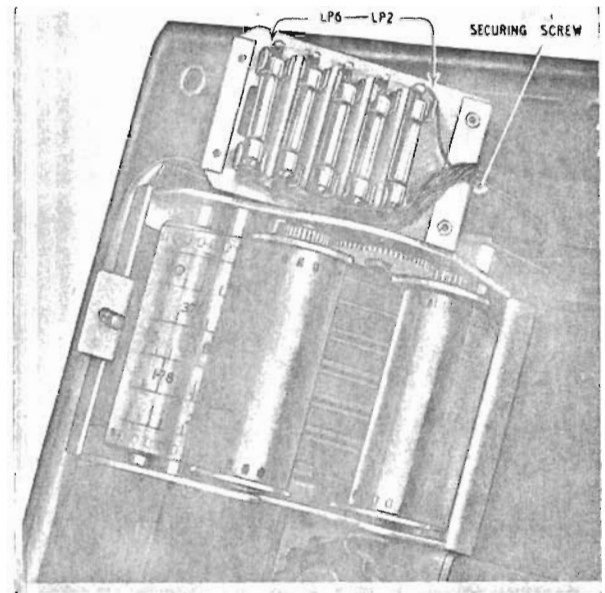

Fig. 2. Scale drive unit

9. The scale is illuminated by one of the five lamps shown in fig. 1 and 2. The five lamps (LP2-LP6) are carried in a holder which slides into a slot at the top of the scale unit chassis so that the lamps are immediately behind the scale. The lamp holder clips into a spring clip at the bottom of the slot and is held in position at the top of the scale chassis by a captive screw (35 on fig. 1). The appropriate lamp is selected by the section SWA of the FREQUENCY RANGE SWITCH, illuminating ranges A, B and E, C and F, D and G and H respectively.

Circuit layout and filtering (fig. 4)

10. The disposition of the circuits is arranged to provide the minimum of mutual interference and RF leakage. The chassis is divided into sections by metal screens and in addition all RF circuits are completely enclosed within a metal box (fig. 6). This metal box is removable for servicing and the edge of the box fits into spring contacts which may be seen around the edge of the front portion of the RF unit in fig. 4. These contacts ensure good connections for the screening of the RF unit.

11. The coil turret is housed in two separately screened compartments housed within the RF box. These are on the under side of the chassis and are not shown in the illustrations. The blower unit must be removed and the base of the screening cover must be unscrewed before the coil turret screens are accessible.

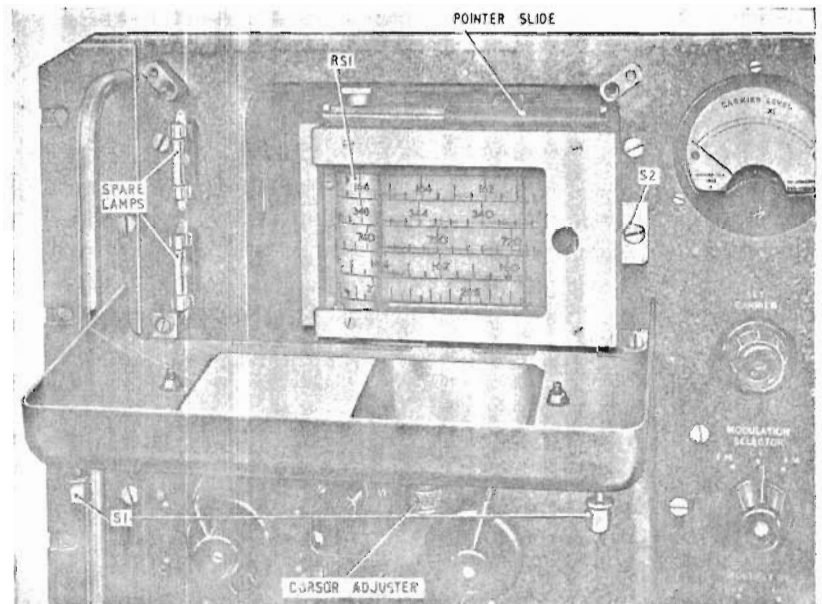

Fig. 3. Front panel with top cover open

12. The RF output feed is taken by coaxial cable via PL3-SK3 (fig. 5) to the attenuators (SWE and SWT) which may be seen at the top right-hand side of the chassis in fig. 5. The attenuators are fully enclosed units mounted on to the front panel of the instrument. The diode V8 (RF level detector) is situated within the screening case of the OUTPUT VOLTAGE control SWE. The filters in the heater and cathode circuits of V8 are also within the case of SWE and the leads from the attenuator SWE are to be seen in fig. 5.

The air circulator (fig. 5 and 7)

13. The centrifugal blower motor unit is mounted below the RF box and fitted to the instrument frame by three brackets. Air from the unit is

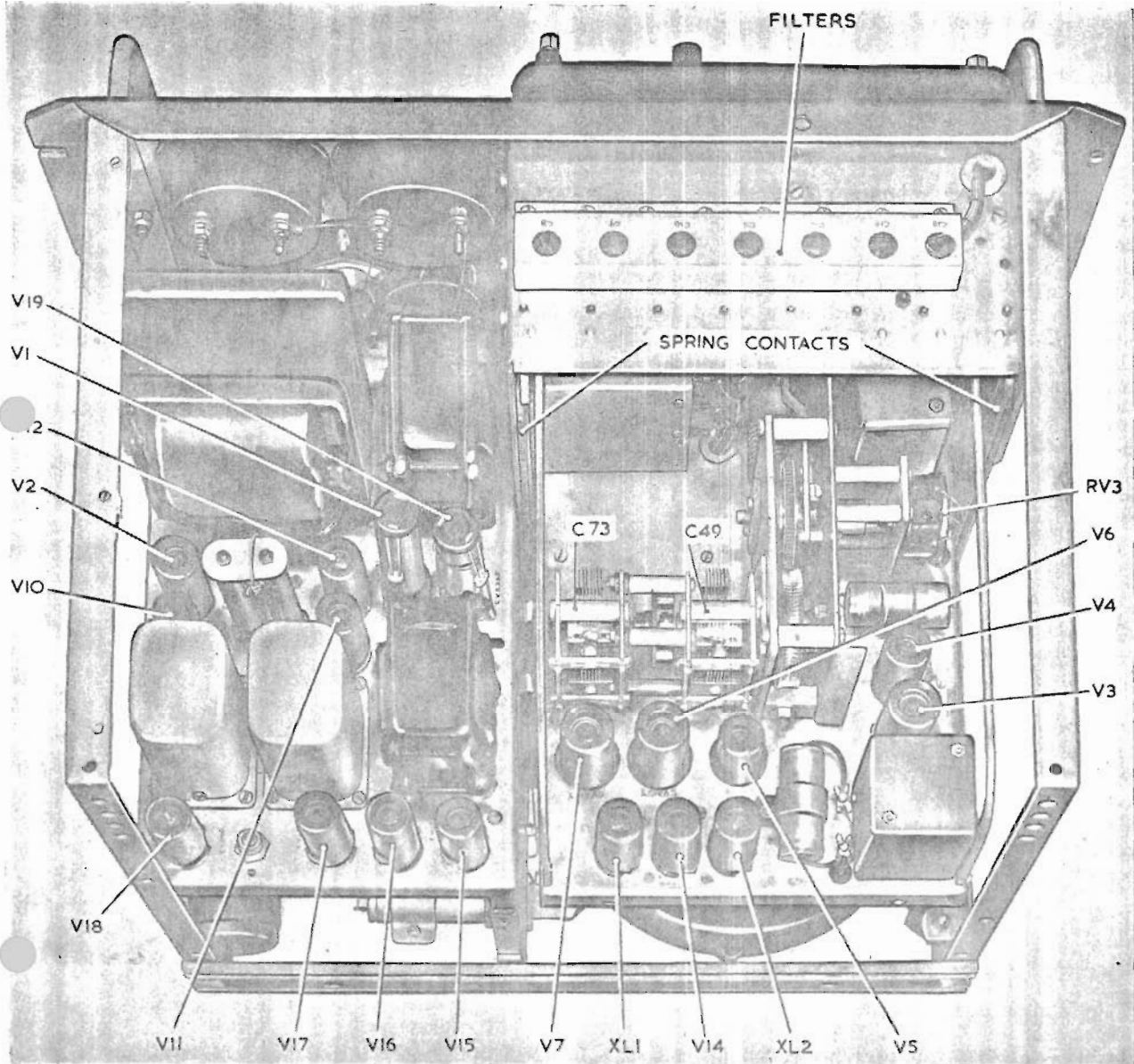

Fig. 4. Interior view of chassis

Radio Phy.

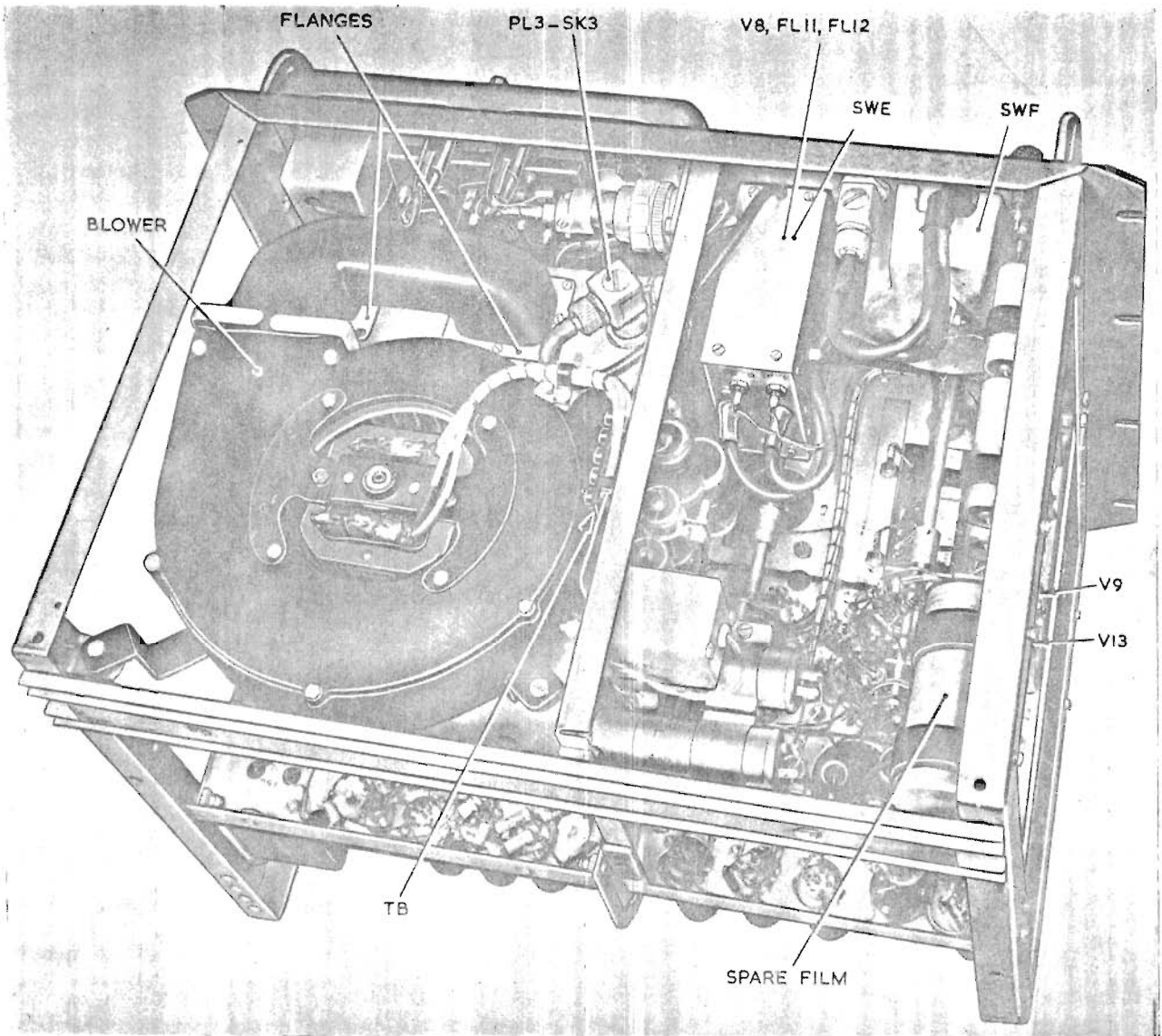

Fig. 5. Underside of chassis

Konrad Rhy

passed by a flexible plastic duct into the RF box from which it escapes through outlets in the top of the box (fig. 6). In fig. 5 the blower ducting is shown and it will be seen that there is a single entry clipped on to the blower unit and two outlets to the RF box which is provided with flanges on to which the ducting is pressed. At each end of the flanges is a metal grille to provide RF screening of the air inlets.

14. In operation, the air circulator prevents excessive temperature rise in the RF box by providing a draught of air through the instrument. Good ventilation must therefore be provided to allow the blower to function satisfactorily.

15. The CT218 is fully tropicalized but no attempt at sealing any part of the instrument has been made.

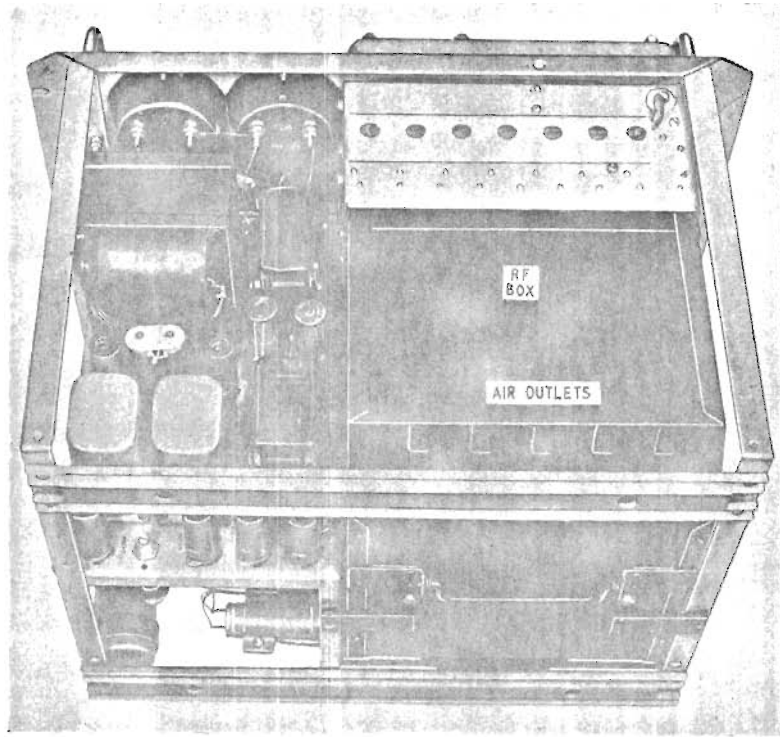

Fig. 6. Chassis rear view

The FREQUENCY RANGE switch (fig. 8)

16. Behind the front panel is the switch assembly of SWA (SWA, SWK and the coil turret being ganged to the FREQUENCY RANGE switch), and this selects the scale lamp appropriate to the range selected. The switch spindle passes into the RF box and a bevel gear

(shown in fig. 8) links the main spindle to the coil turret spindle on which is mounted the assembly of SWK (fig. 5, Chap. 3, Part 1). The coil turret is in two sections containing the RF oscillator and RF output coils and associated components including the ferrite reactor TR2, details of which appear in Chapter 3, Part 1.

The front panel assembly (fig. 3)

17. The front panel is assembled in two parts, one main plate forms the front of the instrument case and this is surmounted at the left by a raised sub-panel. On the main plate are mounted the meters, carrier and modulation controls, attenuators, RF output and AF input sockets. The sub-panel is hinged in two places to give access to the mains adjustment panel and film scale.

18. The sub-panel is secured to the main panel by four screws, accessible when the hinged portions are opened as in fig. 3. The monitor loudspeaker is mounted on the sub-panel and connected by a single wire to the supply point. This is the terminal block TB in fig. 5, which holds the motor connections. The loudspeaker circuit is completed via the chassis.

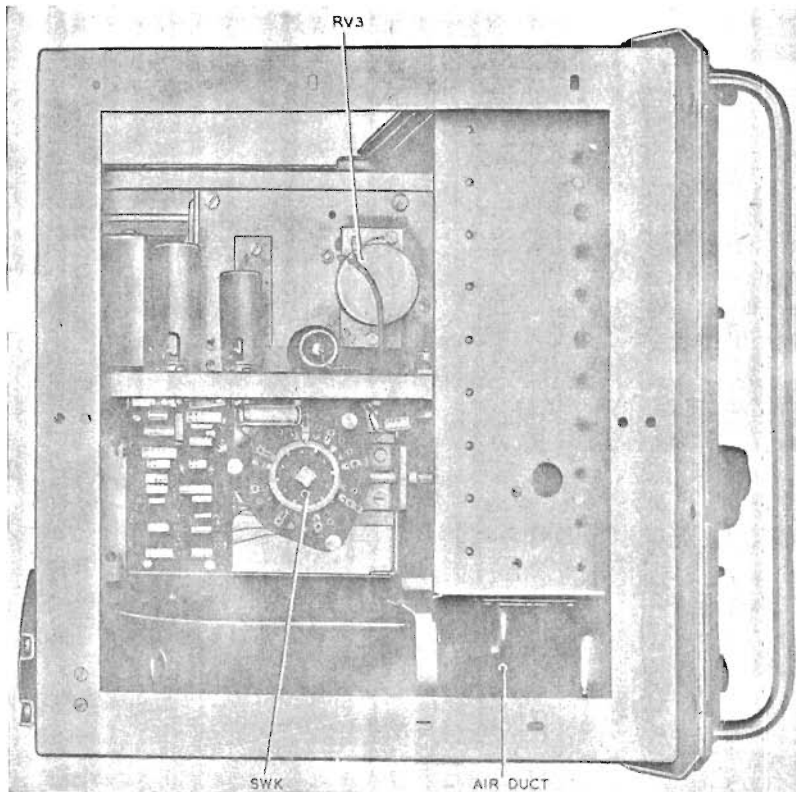

Fig. 7. Side view of chassis

19. On the upper hinged section of the sub-panel is mounted the CURSOR ADJUSTER control. A rubber on the spindle of this control may be brought

into contact with the pointer slide (which may be seen in fig. 3) when the hinged section is raised and screwed in position.

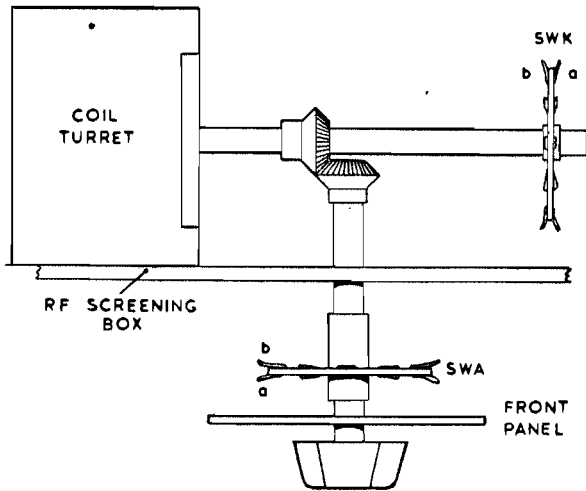

Fig. 8. FREQUENCY RANGE switch gearing

20. The spindles of the TUNING, FREQUENCY RANGE and DEVIATION controls are bushed into the main panel but not in the sub-panel. There are suitable holes in the sub-panel to accommodate the spindles.

21. The instrument is housed in a metal box which has provision for ventilation. The size of the case is such as to allow the complete instrument to be mounted in a standard rack.

22. Several of these signal generators are fitted in heavy steel cases as indicated in 'Leading Particulars'. These models are intended for Naval use. The chassis and front panel are identical to the chassis and panel of the standard model but no dust cover is provided, they are thus unsuitable for rack mounting.

Revised Page

CHAPTER 1

TESTING AND SERVICING

LIST OF CONTENTS

	<i>Para.</i>		<i>Para.</i>
<i>Introduction</i>	1	<i>Renewal of film scale</i> ...	8
<i>Fuses</i>	3	<i>Carrier meter zero</i>	11
<i>Panel and scale lamps</i>	6		

LIST OF ILLUSTRATIONS

	<i>Fig.</i>		<i>Fig.</i>
<i>Mains adjustment panel</i>	1	<i>Carrier meter zero control</i>	3
<i>Film scale sub-chassis</i>	2		

Introduction

1. The CT218 is an item of general purpose test gear, consequently major servicing is not carried out by Units. Maintenance action by Units is confined to minor servicing, including renewal of fuses, lamps and scale film. Valve renewal will not normally be undertaken except at advanced lines of servicing because of the need for subsequent recalibration. The only spares carried in the instrument are fuses, scale and panel lamps and film scale. Periodic tests of the RF frequency accuracy and output level may be made with the inbuilt monitors.

The use of the monitors has been described in Chap. 2 of Part 1.

2. Checks of output level, modulation frequencies, depth and deviation must be made with suitable external equipment. The frequency accuracy of the crystal oscillators may be checked by comparing the two oscillators one against the other. To do this, tune the instrument to produce a zero beat with the 2 Mc/s crystal, then switch in the 200 kc/s crystal and with the same setting of the main tuning control, check that the AF beat note is approximately the same as with the 2 Mc/s oscillator.

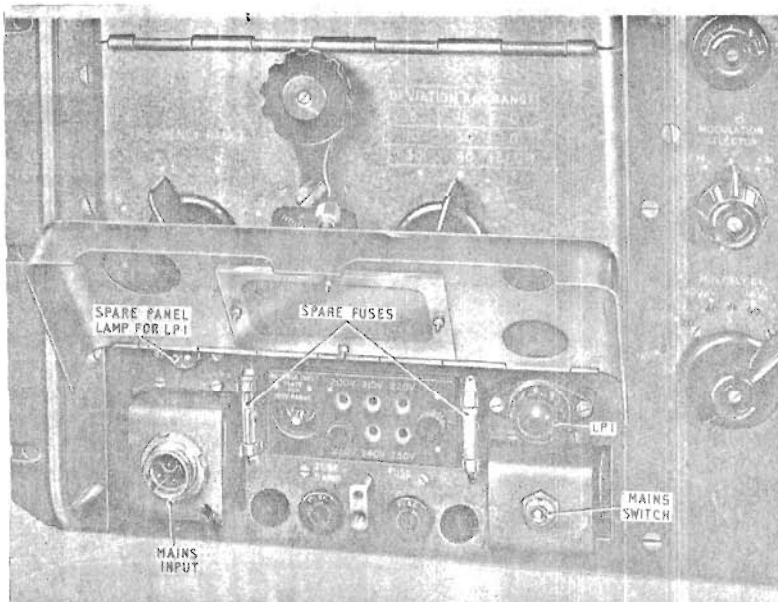

Fig. 1. Mains adjustment panel

Fuses (fig. 1)

3. If the instrument should fail to operate (i.e. no output indications, no lights and motor not running) the main fuses should be checked. Defective fuses should be renewed using the spares carried in the holders adjacent to the mains adjustment panel. The fuse rating is 5A. Access to the fuses is gained by first removing the mains input plug, then unscrewing the hexagon-headed screw at the bottom of the sub-panel and raising the cover. The active fuses are carried in screw-in holders below the mains adjustment panel.

4. If the instrument does not function after renewing the fuses, the usual procedure for the repair of test equipment should be followed.

5. At intervals, the instrument should be recalibrated as required by the standing orders relating to Signal Generators.

Important Note . . .

If the instrument operates but the blower motor fails to run, the instrument should be switched off as continued use would result in overheating. Normal servicing action should be taken.

Panel and scale lamps

6. A spare panel lamp is carried at the left-hand side of the mains adjustment panel, this should be used for renewal of the panel lamp LP1 if this should fail. If a scale lamp should fail to light when switching to the appropriate range it should be renewed, using one of the spares located at the left

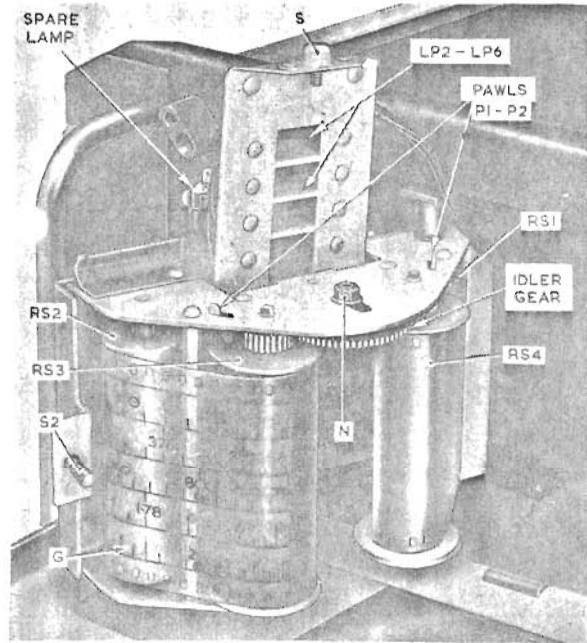

Fig. 2. Film scale sub-chassis

of the scale sub-chassis (shown in fig. 3, Chap. 4, Part 1). Access to the lamps is by opening the top section of the front sub-panel, releasing the film sub-chassis by undoing the screw at the right-hand side of the chassis and swinging the sub-chassis outwards to the position shown in fig. 2. The lamp carrier may be lifted out of its slide after releasing the screw (S of fig. 2) at the top of the lamp carrier.

7. The lamps are selected by the FREQUENCY RANGE switch (section SWA) in the following sequence:

Range	Lamp
A	LP2
B	LP3
C	LP4
D	LP5
E	LP3
F	LP4
G	LP5
H	LP6

The numbering of the lamps is shown in fig. 2 and these numbers are the same as those used on the main circuit diagram (fig. 5, Chap. 3, Part 1).

Renewal of film scale

8. The non-inflammable film scale is not likely to cause trouble but if damaged, it may be renewed as described in the following paragraphs. A spare scale and a tool (winding key) are carried in a canister situated below the chassis. The canister may be seen in fig. 5, Chap. 4, Part 1.

9. To remove the old film from the instrument (referring to fig. 2 of this Chapter):

- (1) Rotate the tuning handle fully clockwise until it engages with the stop.
- (2) Open the top hinged section of the front panel and undo the clamping screw S2 which secures the film drive sub-chassis (this screw is located at the extreme right-hand side of the sub-chassis).
- (3) Swivel the sub-chassis outwards to the position shown in fig. 2.
- (4) Loosen, but do not remove, the 4BA nut N clamping the idler gear at the top of the chassis and slide the gear outwards to disengage it. This will allow the springs in the spools to unwind.
- (5) Reclamp the idler gear in the 'free' position and ensure that the two pawls (P1 and P2) are disengaged.
- (6) Remove the film from the nearly empty spool and slide the film through the film gate then unwind it from the full spool.

10. Ensure that the new scale is in a roll measuring about 1½ in. outside diameter with the ends folded inwards and the low frequency characters at the outside of the roll. The new scale may then be fitted as follows:

- (1) Insert the folded end of the film in the slot of the left-hand spool RS3 and by rotating the spool carefully wind on all but about 14 in. of film.
- (2) Engage the pawl P1 in the pinion of its spool, thread the free end of film through the gate G until the marking LIMIT STOP appears near the centre of the window.
- (3) Ensure that the film is bedded squarely on the teeth of the sprockets RS1 and is located in the film guide. Tuck the folded end of film centrally in the slot of the right-hand spool RS4, then wind this spool to take up the slack in the film.
- (4) With the key referred to in para. 8, wind the spindle of the right-hand spool RS4 five complete turns clockwise and engage the pawl P2 in the pinion of this spool.
- (5) Place the key on the shaft of the other spool RS3 and, after disengaging the pawl P1, wind three turns counter-clockwise.
- (6) While still holding the key on the spindle of RS3, engage the idler gear and tighten the clamping nut N securely. Disengage the pawl P2 on the other spool.
- (7) Set the cursor to the centre of the window, rotate the tuning handle to the fully counter-clockwise stop and carefully slip the film over the sprocket teeth of RS1 to bring the LIMIT STOP line behind the cursor.

The instructions in sub-para. 7 should be repeated after returning the sub-chassis to its normal position and closing the front cover.

Carrier meter zero (fig. 3)

11. If the carrier meter does not indicate zero with the instrument switched ON and the CARRIER switch SWH in the OFF position, an adjustment to RV4, the CARRIER METER ZERO control should be made.

12. The procedure for adjustment of RV4 is:

- (1) With the instrument switched OFF, check that the CARRIER METER pointer is at zero. A correction may be made by adjustment of the screw on the meter case.
- (2) With the instrument switched ON allow a period of time for thermal stability to be reached.
- (3) Set the CARRIER switch to the OFF position.
- (4) Loosen the screws which secure the cover plate of RV4 and swivel the plate to the position shown in fig. 3.

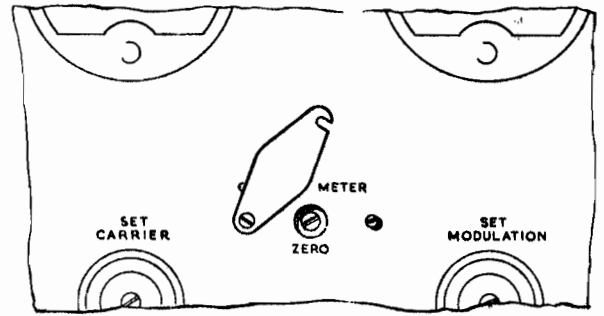

Fig. 3. Carrier meter zero control

- (5) With a small screw-driver, adjust the slotted control RV4 bringing the meter pointer to zero. Replace the cover and tighten the screws.

Return to Page.

APPENDIX

NOTES ON OUTPUT TERMINATIONS AND
USE OF CRYSTAL CHECK

LIST OF CONTENTS

	Para.		Para.
Normal output loading	1	Effect of output cable... ..	11
Special case of 75-ohm load	6	High output	12
Low output	7	Use of crystal check oscillator	19
Balanced input connection	10		

LIST OF TABLES

	Table		Table
RF of crystal check points	1	Crystal check points	2

LIST OF ILLUSTRATIONS

	Fig.		Fig.
Output conditions at CT218 panel socket	1	Alternative connection of 75-ohm load	4
Terminating unit	2	Connection to balanced load	5
Output conditions at terminating unit	3		

Normal output loading

1. The output impedance of the MULTIPLY BY and OUTPUT VOLTAGE attenuators is 75 ohms at all settings (they are out of circuit on the HIGH OUTPUT positions) and they are calibrated in terms of source EMF for a correct termination which is normally provided by the terminating unit when its terminals are open-circuit. This means that the

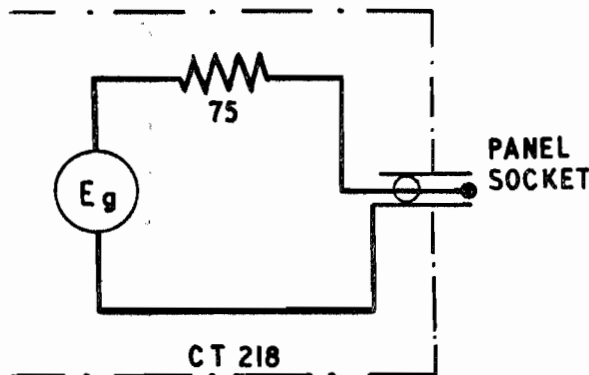

$E_g = 2 \times V \text{ (ind)}$

Fig. 1. Output conditions at CT218 panel socket

instrument may be considered as a voltage generator supplying an EMF of twice the voltage indicated on the attenuators, in series with the output impedance of 75 ohms. This is the condition existing at the RF Output panel socket. Fig. 1 represents the equivalent circuit at this point.

2. As stated in para. 1, the addition of the terminating unit (fig. 2) (or a 75-ohm load) will provide an output voltage equal to that indicated on the attenuators. This is because the load of 75 ohms (provided by the terminating unit) acts in series with the output impedance of 75 ohms, and therefore the fraction of the source EMF appearing across the load is 0.5 E_g (this is the indicated voltage).

3. Looking at the terminals of a 75-ohm resistive load applied to the panel socket (fig. 1) of the instrument we see a total circuit impedance (fig. 2) of 37.5 ohms (the parallel connection of the output and load impedances). To make the impedance at the output terminals of the terminating unit equal to 75 ohms, a resistor of 37.5 ohms (fig. 2) must be added in series with the combination of the output impedance (Z_o) and the load. At the 75-ohm terminal of the terminating unit, the open

circuit voltage is the voltage indicated on the attenuators, and the circuit impedance is 75 ohms. The equivalent circuit at this point (shown in fig. 3) is that of a voltage generator of EMF = $V(\text{ind})$ volts with an internal impedance of 75 ohms.

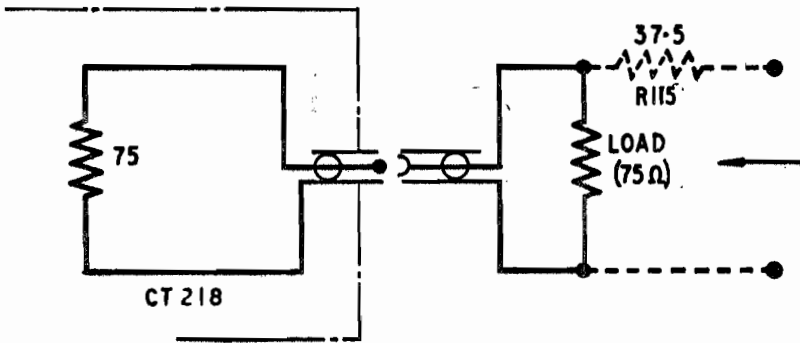

Fig. 2. Terminating unit

4. As mentioned in Chap. 2, the terminal voltage may be calculated if required by considering the source voltage indicated on the attenuators applied to the external load in series with the output impedance of the instrument (normally 75 ohms.) The chart of output voltage in Chap. 2 applies to the use of the 75-ohm terminal of the terminating unit. If for any reason the output from the panel socket is fed to a load it must be remembered that the source EMF is twice the indicated output voltage.

5. For all normal uses the terminating unit should be in circuit but for the special case of a receiver or amplifier having a 75-ohm input system it may be desirable to use a direct coaxial cable connection.

Special case of 75-ohm load

6. There are two methods in which a 75-ohm load may be connected to the CT218, the normal method is outlined in para. 4 using the terminating unit and dividing the voltage indicated on the attenuators by two to find the actual terminal PD. The alternative method is to use the unterminated output connection (fig. 1 of Chap. 1) between the panel socket and the equipment under test. In this case the actual voltage applied to the load is that indicated on the attenuators. This is because the EMF at this point

is twice the indicated voltage acting in series with 75 ohms. Thus there are two ranges of output voltage available, i.e. 0.5 μV to 50 mV (with terminating unit) and 1 μV to 100 mV (direct). These conditions are shown in fig. 4 of this Appendix.

Low output

7. The 7.5-ohm terminal shown in fig. 3 of Chap. 2 has two main uses:

- (1) to facilitate matching to loads less than 75 ohms;
- (2) to provide a range of source EMF down to 0.1 μV .

If, for example, a receiver having a 50-ohm input circuit is to be tested a 42.5-ohm resistor should be connected between the 7.5-ohm terminal and the receiver input connection, this will ensure that the receiver input is matched but a correction of -20 dB ($V_{\text{out}} = 0.1 \times V_{\text{in}}$) must be applied to

the attenuator readings. The load terminal voltage would be half this value.

Note ...

Without the additional resistor the receiver input circuit would be heavily damped by the 7.5-ohm shunt impedance and any reading taken would be incorrect.

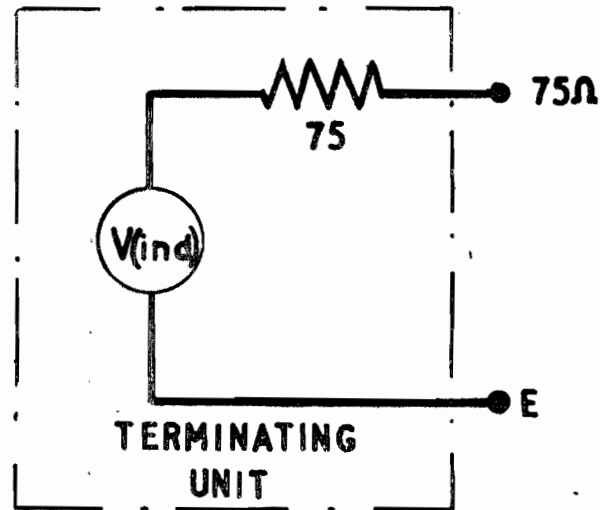

Fig. 3. Output conditions at terminating unit

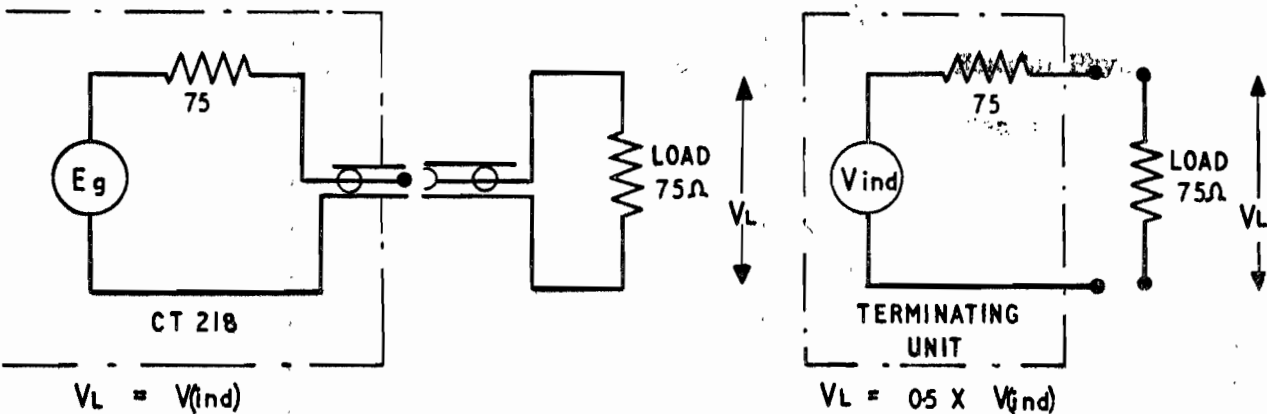

Fig. 4. Alternative connection of 75-ohm load

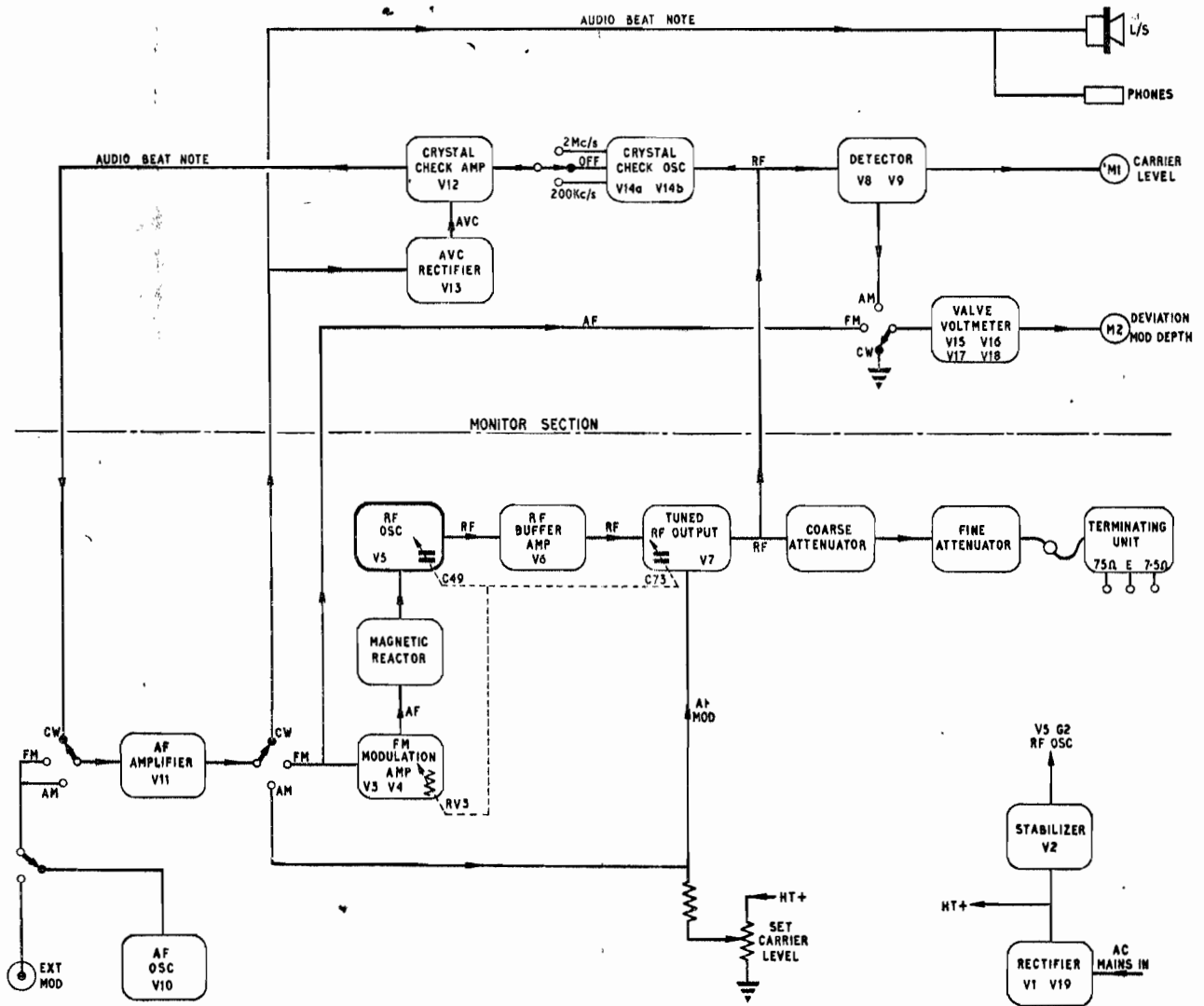

Fig. 3. Block Diagram

8. The interconnections of the valves are given in the accompanying block diagram (fig. 3) which also shows the functions of some of the principal controls.

9. By reference to fig. 3 it will be seen that the instrument may be considered as divided into two parts, the signal generator and the monitoring section.

10. The signal chain, commencing at the RF oscillator V5 continues through V6 and V7 to the attenuators with modulation applied either to V7 (AM) or the circuit associated with V5 (FM). The modulation chain commencing at V10, the AF oscillator, passes through V11 to the appropriate modulating section of the instrument.

Frequency modulator

11. The magnetic reactor used to produce FM is, in effect, an RF coil with a dust-iron core whose permeability is varied by the applied AF current.

12. The permeability variation causes a corresponding inductance variation in the coil. The coil forms part of the oscillator tuning inductance and a variation of coil inductance effects the frequency of oscillation. An AF current applied to the reactor thus causes frequency modulation of the RF oscillator. A more detailed discussion of the modulator is to be found in Chapter 2 of this publication.

Output monitoring

13. The monitoring section of the instrument is shown at the top half of the block diagram which also shows the functions of the valves. It is to be noted that the AF amplifier V11 is common to both sections as it is used as a modulation amplifier on both AM and FM and as a loudspeaker amplifier when the crystal check oscillator is in use. Delayed AGC is applied to the beat amplifier V12 to give some degree of volume level control since there is a very wide range of amplitude between different beats.

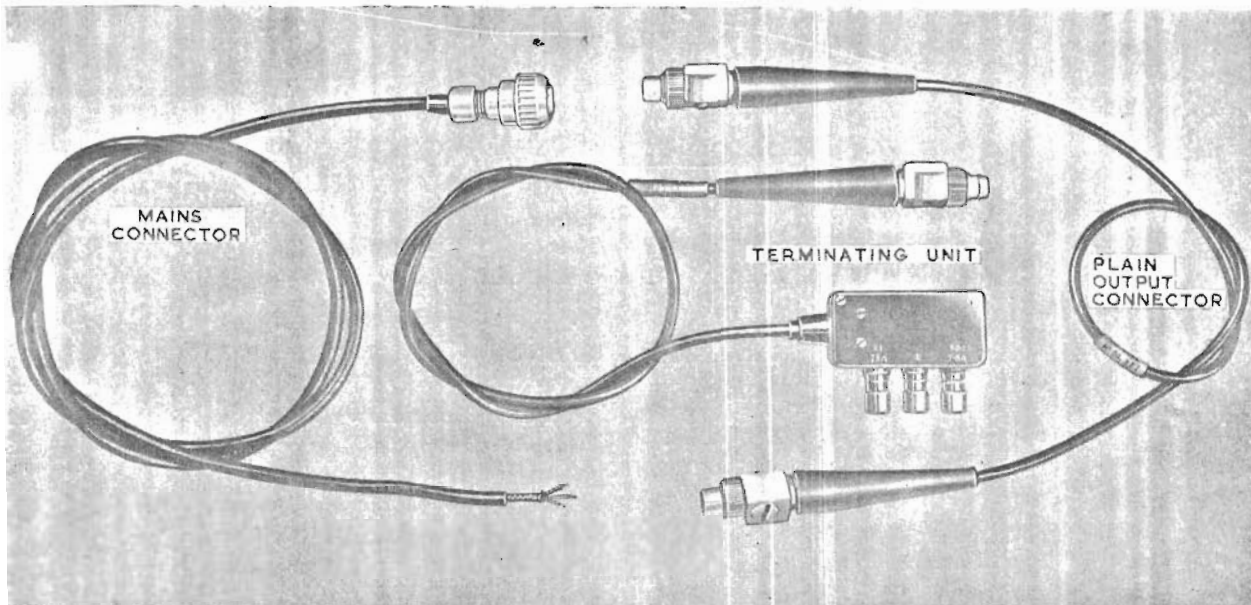

Fig. 2. Connectors and Terminating Unit

Introduction

1. The signal generator CT218 (figs. 1 and 2) is an instrument with facilities for FM, AM and CW. Four internal modulating frequencies are available with continuous control of amplitude. Provision is made for crystal check of the RF oscillator frequency at intervals of 200 kc/s and 2 Mc/s.

2. Attenuation of the RF output is provided in two stages, a coarse attenuator having 4 steps of 20 dB is followed by a fine attenuator which has 20 steps of 1 dB. These controls are designated MULTIPLY BY and OUTPUT VOLTAGE and are calibrated in terms of voltage as well as dB. The range covered by the two controls totals 100 dB (the reference level being 1 μ V), which corresponds to the voltage range 1 μ V to 100 mV.

3. The RF amplitude is set to a standard level of 1 volt on one panel meter (CARRIER LEVEL) while modulation is indicated on a second meter (MOD. DEPTH).

4. The power supply requirement is AC mains of 100–150 V or 200–250 V. To ensure selection of the correct voltage range to suit the AC supply used, an interlocking switch and engraved plate is provided on the voltage adjustment panel. This panel may be seen through the window beside the mains switch and pilot lamp (fig. 1).

5. An air circulator is built into the instrument to provide a measure of temperature control, particularly in the RF unit. The tropicalized finish ensures reliable operation under Service conditions.

6. The chassis of the instrument is enclosed by a dust-cover and is designed for fitting into a standard rack. A small number of these instruments, fitted in steel transit cases, has been supplied for Naval use.

General description

7. The instrument uses 19 valves and the functions of these are described in the following table:

TABLE 1
Valve functions

Valve type	Position	Function
CV2235	1	HT rectifier
CV287	2	HT stabilizer
CV2127	3	FM modulation amplifier
CV138	4	FM modulation amplifier cathode-follower
CV138	5	RF master oscillator
CV2127	6	RF buffer amplifier
CV2127	7	RF tuned output amplifier
CV469	8	Carrier level detector
CV469	9	Carrier level zero correction diode
CV138	10	AF oscillator
CV138	11	Modulation amplifier
CV131	12	Crystal check beat note amplifier
CV469	13	AGC diode for V12
CV858	14	Crystal oscillator (frequency check)
CV138	15	Modulation indicator amplifier
CV138	16	Modulation indicator amplifier
CV133	17	Modulation indicator amplifier (cathode-follower)
CV140	18	Modulation indicator rectifier
CV2235	19	HT rectifier

8. When using the 7.5-ohm terminal to provide a source of low EMF it is also necessary to add a resistor of suitable value (i.e. $R = Z_L - 7.5$ ohms) to ensure correct input loading and to make output voltage readings correspond with those taken with the 75-ohm output. (An example is given in para. 9.)

9. The following example on the use of the 7.5-ohm terminal will illustrate this point:

An equipment under test has an input impedance of 75 ohms, an operation has been carried out with the equipment connected to the 75-ohm terminal of the terminating unit. It is now required to make use of the $\times 0.1$, i.e. divide by ten, facility and the lead to the equipment is transferred to the 7.5-ohm terminal. The output voltage conditions may now be examined. In the first case the output terminal voltage was half the indicated voltage:

$$V_L = \frac{E_g \times 75}{75 + 75} = \frac{E_g}{2}$$

When the load was transferred to the 7.5-ohm terminal the voltage at the 75-ohm terminal became that indicated on the attenuators and it is one-tenth of this voltage which appears at the 7.5-ohm terminal. (The 75-ohm load at this point makes little difference to the output.) Therefore, the actual attenuation is only five times (14 dB) and not ten times (20 dB) under these conditions. The use of a 68-ohm series resistor (para. 8) in this case would correct both input loading and attenuation.

Balanced input connection (fig. 5)

10. It is not necessary to use a balancing transformer when connecting a signal generator to a balanced transformer input circuit. All that is required is the connection of one-half of the input coil of the equipment under test to the signal

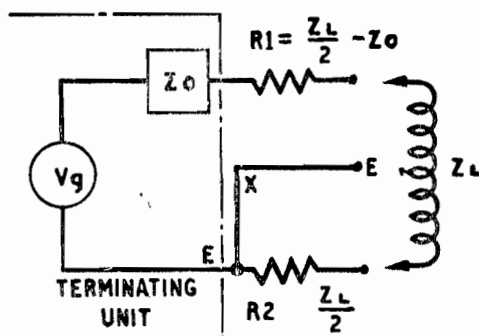

AS POINTS E ARE AT THE SAME RF POTENTIAL CONNECTION "X" MAY BE OMITTED

Fig. 5. Connection to balanced load

generator and the provision of an equivalent resistive load for the remaining half of the input coil. In this way the balancing system becomes aperiodic. The circuit arrangement is shown in fig. 5. The output voltage is one-half of that indicated by

applying the usual formula to the readings on the attenuators. In all other respects the preceding paras. apply. In fig. 5 the points marked 'E' are at the same potential and there is thus no need for the input coil centre-tap to be connected.

Effect of output cable

11. If for any reason it is necessary for the equipment under test to be situated out of reach of the CT218 leads, an extension lead may be used under the following conditions:

(1) The cable should be low-loss 75-ohm coaxial connected to the 75-ohm terminal of the terminating unit. The length is then unimportant, this may be appreciated by considering the impedance seen when looking towards the generator from the remote end of the cable. The cable impedance is 75 ohms and it is terminated at the generator in 75 ohms, so the remote end impedance is thus 75 ohms. As there has been *no change* in the circuit impedance there can be no change in the output voltage conditions and the voltage appearing at the remote end is the same as at the sending end. The termination requirements are then exactly the same as if there were only a short cable.

(2) If a cable of different impedance is used then resonance conditions may be encountered unless matched at the generator end and the limitation of length mentioned in Chap. 2 must be borne in mind.

High output

12. In the 1V HIGH OUTPUT positions of the attenuators the output impedance at the panel socket varies over a wide range and depends upon the carrier frequency in use. Because of this it is essential that the terminating unit is used in all tests involving the use of the high output facility.

13. If the terminating unit is not used, the terminal voltage at the end of a connecting cable may differ greatly from the voltage indicated on the CARRIER LEVEL meter (the actual voltage measured by the meter is 1 Volt at the set level 'X1' point). For example, 5 yds. of 75-ohm cable is used to connect the signal generator to a high impedance point in a receiver. Varying the signal generator frequency over the high ranges will cause some spurious output effects. Analysis shows at certain frequencies that the unterminated cable produces a terminal voltage at the receiver as large as 10 Volts although the panel meter indicates the correct level of 1 Volt. If the observations are repeated with the terminating unit in circuit, the results will be normal. This example emphasizes the need to use the terminating unit with the HIGH OUTPUT setting.

14. If the load applied to the 75-ohm terminal of the terminating unit is of the order of 10-4000 ohms, the terminal voltage will be less than 1 Volt due to the presence of the 37.5-ohm resistor in the terminating unit (R115 of fig. 2). The source EMF (1 Volt) is actually applied across the 75-ohm load of the terminating unit (R112, R113 and R114 of

fig. 3 of Chap. 2). With an external load the internal impedance from the point of view of terminal PD is 37.5 ohms, but from the point of view of matching to an external load the impedance varies with frequency over the range 50-90 ohms.

15. The actual terminal voltage for any value of external load may be obtained by applying the formula:

$$\text{Terminal voltage} = \frac{Z_L}{37.5 + Z_L} \text{ Volts.}$$

Where Z_L is the load impedance in ohms.

For loads in excess of 4000 ohms the correction to the terminal voltage is negligible and the terminal voltage is almost exactly 1 Volt.

16. It is to be noted that because the attenuators are out of circuit on the 1-Volt output setting, the input to the terminating unit is the voltage monitored on the panel meter, that is, 1 Volt.

17. If a long cable is needed in any test involving the use of the 1-Volt output facility it must be terminated at one end. The terminating unit achieves this and it may be fitted either at the generator end or at the remote end of the cable. Alternatively, a 75-ohm resistor may be connected at either end of the cable to provide a termination and avoid spurious effects as described in para. 13.

18. When using FM it is essential to avoid reactive and resonance effects in the connecting cable as these would give rise to amplitude modulation of the signal.

Use of crystal check oscillator

19. For ease of reading in this section of the Appendix, the phrase 'frequency of beat' will be used to denote the actual frequency of applied RF which produces a zero beat in the crystal check system of the CT218.

20. When setting up a particular frequency by using the weaker beats it is important that the true

'frequency of beat' be known. For example, it is often necessary in modern equipment to align RF circuits to within a few hundred cycles of a stated value and, as the scale correction (cursor adjustment) varies throughout the tuning range of the CT218, it is quite possible for a beat to occur at a point on the scale which seems to bear no relation to any anticipated 'frequency of beat'.

21. For example, on a particular CT218, a frequency of 160 kc/s is to be set up accurately. The 100 kc/s beat is identified and the cursor set. Tuning towards the 160 kc/s point, beats are observed at scale markings of 151.5 and 162. The actual frequencies of such beats may be determined in the following manner:

- (1) Write down a list of the first few crystal harmonic frequencies.
- (2) Write down a list of multiples of the scale readings where the beats occur. (This is done in Table 1 for the example quoted in this para.)
- (3) Where a scale multiple appears to be within the expected scale-setting error of a crystal harmonic, it will be correct to align the cursor to the scale marking at which a true beat occurs. To find the value of such a beat, divide the above crystal harmonic by the scale multiple factor corresponding.

The row of multiples in Table 1 contains the number 606 which is within the probable error of the value 600 in the crystal harmonic row. Correcting the 606 to 600 and dividing by the multiple factor (4) gives the true RF of 150 kc/s. In the second row, the number 810 occurs. This may be corrected to 800 and divided by its multiple factor (5) which gives 160 kc/s. Setting the cursor to this point on the scale allows the RF to be read directly from the scale. The main beat points on the lower frequency ranges are given in Table 2. Those marked with an asterisk are also marked by dots on the scale of the CT218.

TABLE 1
RF OF CRYSTAL CHECK POINTS

Crystal frequency Kc/s	Crystal harmonic Kc/s					
	200	400	600	800	1000	1200 (ch)
Scale reading Kc/s	Multiple (m) of scale reading					
	second	third	fourth	fifth	sixth	
Example (1) 151.5	303	454.5	606			(S)
Example (2) 162	324	486	648	810		(S)

When S (a scale reading or multiple thereof) is approximately equal to ch (a crystal harmonic), f (the actual frequency generated) is given by:

$$f = ch \div m$$

e.g. (from example 1) 606 \approx 600 and $f = 600 \div 4 = 150$ kc/s and the cursor should be set to this scale marking.

22. The CT218 may be used to check the frequency of an oscillator either by using the crystal check oscillator directly or by use of the crystal-checked RF produced by the CT218. Connect the output from the oscillator to be checked (e.g. by means of the plain connector) to the panel socket of the CT218. The CT218 attenuators should be set to HIGH OUTPUT and CRYSTAL CHECK on. The CARRIER LEVEL indicator may be set quite low and the oscillator under test or signal generator frequencies adjusted to give a beat. There are various possibilities:

- (1) a beat between signal generator and crystal oscillator;
- (2) a beat between signal generator and test oscillator;
- (3) a beat between crystal oscillator and test oscillator, including any harmonics of the three.

23. It is a simple matter to decide which applies by slight alteration of either the signal generator or oscillator tuning.

TABLE 2
CRYSTAL CHECK POINTS

Range A Kc/s	Range B Kc/s	Range C Kc/s
*100	*200	*400
114.2	233	450
120	250	533.3
125	266.6	550
133.3	*300	*600
142.8	333	640
150	350	666.6
160	360	*700
167.6	*400	*800
175		

An asterisk beside a beat frequency in this table indicates that the scale of the CT218 has a dot to mark this point.

Source: Phys...

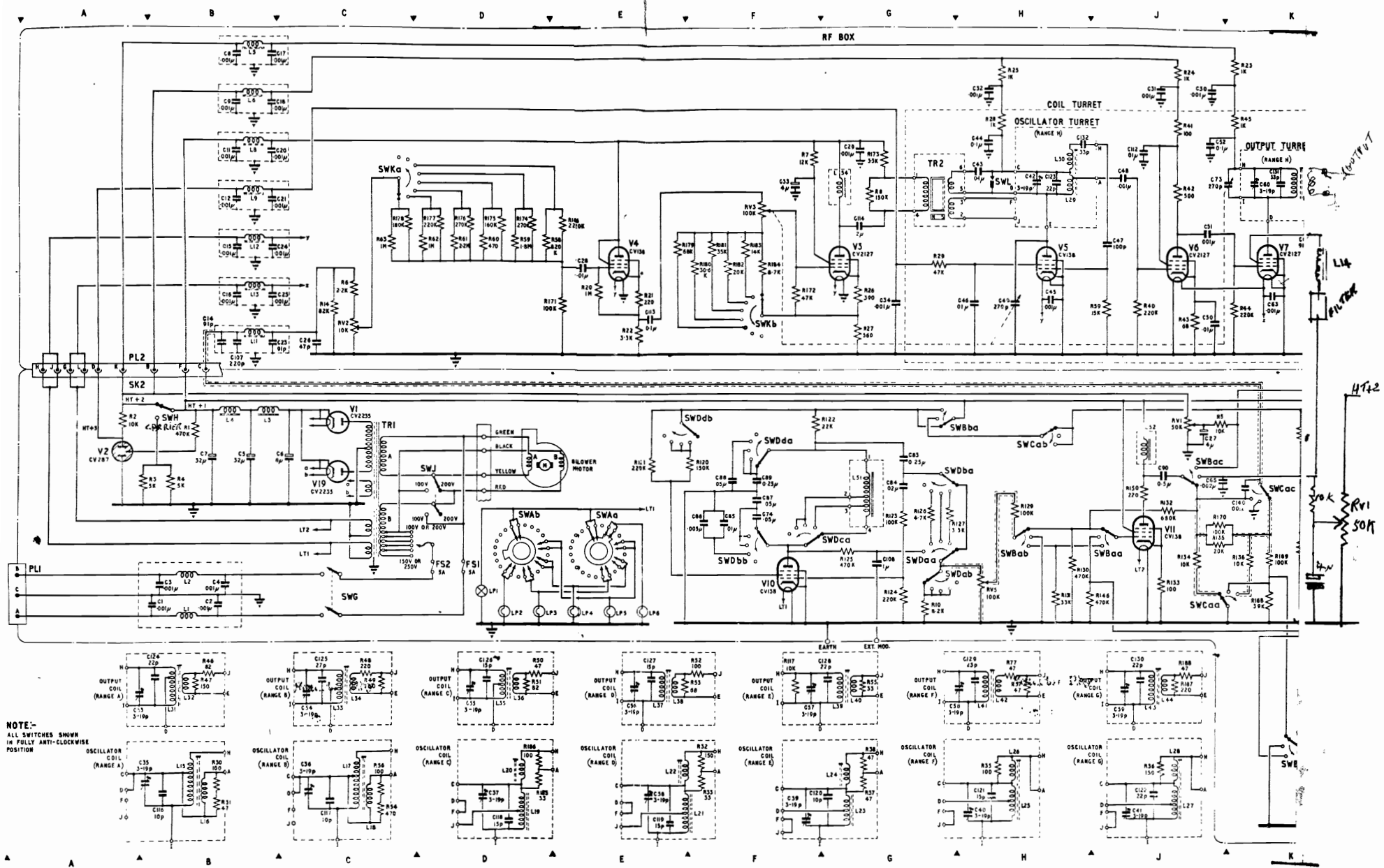

Signal generator CT218 - circuit

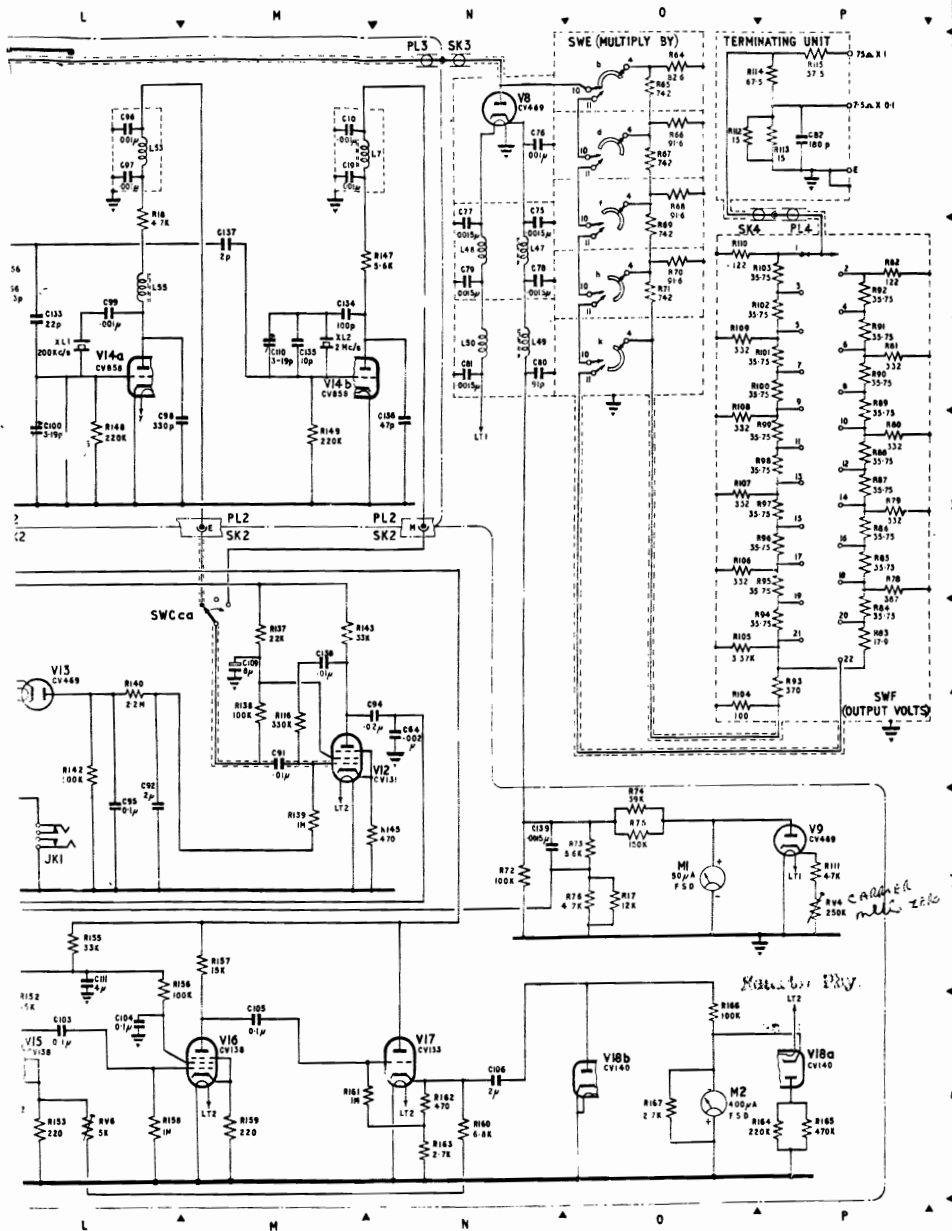

Fig. 2