

100 MHz Digital Storage Oscilloscopes PM3365A/67A/75/77

Service Manual

4822 872 05342
900303

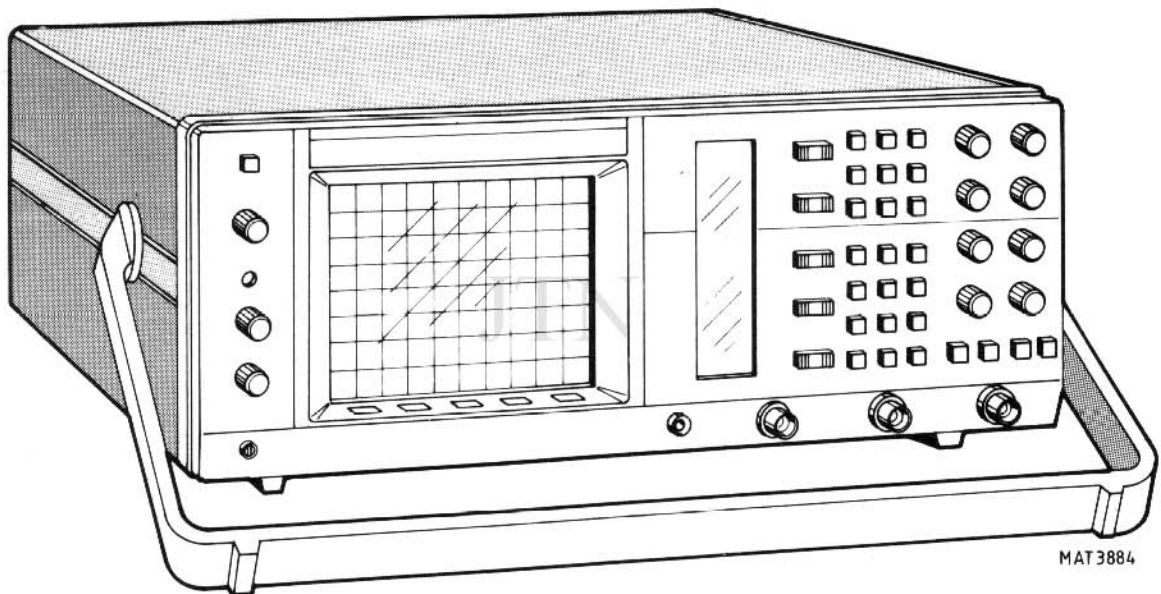

WARNING: These servicing instructions are for use by qualified personnel only. To avoid electric shock do not perform any servicing other than that contained in the Operating Instructions unless you are fully qualified to do so.



PHILIPS

IMPORTANT: In correspondence concerning this instrument please quote the typenumber and serial number as given on the type plate.

NOTE: The design of this instrument is subject to continuous development and improvement. Consequently, this instrument may incorporate minor changes in detail from the information contained in this manual.

JTN

Table of Contents

1 SAFETY INSTRUCTIONS	1 - 1
1.1 INTRODUCTION	1 - 1
1.2 SAFETY PRECAUTIONS	1 - 1
1.3 CAUTION AND WARNING STATEMENTS	1 - 1
1.4 SYMBOLS	1 - 1
1.5 IMPAIRED SAFETY-PROTECTION.....	1 - 2
1.6 GENERAL CLAUSES	1 - 2
2 CHARACTERISTICS	2 - 1
2.1 DISPLAY.....	2 - 3
2.2 VERTICAL DEFLECTION OR Y AXIS	2 - 3
2.3 HORIZONTAL DEFLECTION OR X AXIS	2 - 5
2.3.1 Time-base	2 - 5
2.3.2 X-deflection	2 - 6
2.3.3 EXT Input.....	2 - 6
2.4 TRIGGERING.....	2 - 6
2.5 SIGNAL ACQUISITION	2 - 7
2.6 CHANNELS A AND B.....	2 - 8
2.7 TIME BASE	2 - 9
2.8 TRIGGER.....	2 - 9
2.9 MEMORY.....	2 - 9
2.10 DISPLAY	2 - 10
2.11 CALCULATION FACILITIES	2 - 10

2.12 AUTO SETTING	2 - 10
2.13 CURSORS.....	2 - 10
2.14 POWER SUPPLY	2 - 11
2.15 SUNDRIES	2 - 11
2.16 ENVIRONMENTAL CHARACTERISTICS	2 - 12
2.17 SAFETY	2 - 14

3 INTRODUCTION TO CIRCUIT DESCRIPTION AND BLOCK DIAGRAM DESCRIPTION 3 - 1

3.1 INTRODUCTION TO CIRCUIT DESCRIPTION	3 - 1
3.1.1 General.....	3 - 1
3.1.2 Explanation of signal name set-up	3 - 1
3.1.3 Location of electrical parts	3 - 12
3.2 BLOCK DIAGRAM DESCRIPTION.....	3 - 13
3.2.1 Introduction.....	3 - 13
3.2.2 Attenuator unit (unit A1)	3 - 13
3.2.3 Pre-amplifier unit and adaptation unit (unit A2 and A16)	3 - 13
3.2.4 Time-base unit (unit A4)	3 - 20
3.2.5 XYZ unit (unit A3).....	3 - 21
3.2.6 Power supply unit	3 - 21
3.2.7 P ² CCD circuits and control logic (unit A17 and A18).....	3 - 22
3.2.8 ADC circuit (unit A15)	3 - 22
3.2.9 Signal processing unit (unit A13 and A14)	3 - 23
3.2.10 Y-DAC and X-DAC circuits (unit A15)	3 - 23
3.2.11 Microprocessor system (unit A12)	3 - 23

4 ATTENUATOR UNIT (A1) 4 - 1

4.1 VERTICAL ATTENUATORS.....	4 - 1
4.2 EXTERNAL INPUT	4 - 2

5 PRE-AMPLIFIER UNIT (A2)	5 - 1
5.1 VERTICAL PRE-AMPLIFIER.....	5 - 1
5.2 TB TRIGGER PRE-AMPLIFIER.....	5 - 2
5.3 PRE-AMPLIFIER CONTROL.....	5 - 3
6 XYZ-AMPLIFIER UNIT (A3)	6 - 1
6.1 INTRODUCTION.....	6 - 1
6.2 FINAL VERTICAL (Y) AMPLIFIER.....	6 - 1
6.3 FINAL HORIZONTAL (X) AMPLIFIER.....	6 - 1
6.4 FINAL BLANKING (Z) AMPLIFIER AND CRT.....	6 - 2
7 TIME-BASE UNIT (A4)	7 - 1
7.1 TRIGGER AMPLIFIER.....	7 - 1
7.2 TIMING CIRCUIT.....	7 - 2
7.3 SWEEP GENERATORS.....	7 - 4
7.4 DAC STAIR GENERATOR.....	7 - 6
7.5 DELAY D/A CONVERTER + COMPARATOR.....	7 - 6
7.5 X DEFL AMPLIFIER AND DISPLAY MODE SWITCH.....	7 - 7
7.6 Z-AMPLIFIER.....	7 - 7
7.8 TIMING DIAGRAM.....	7 - 8
8 CRT CONTROL UNIT (A5)	8 - 1

9 POWER SUPPLY UNIT (A6)	9 - 1
9.1 INPUT CIRCUIT	9 - 1
9.1 CONVERTER CIRCUIT	9 - 1
9.3 SECONDARY OUTPUT RECTIFIERS.....	9 - 3
9.4 HT SUPPLY	9 - 4
9.5 CALIBRATOR	9 - 4
10 FRONT UNIT (A7-A8)	10 - 1
10.1 KEY-MATRIX	10 - 1
10.2 FRONT CONTROLS AND INDICATOR.....	10 - 1
10.3 LCD DISPLAY CIRCUIT.....	10 - 1
11 MOTHERBOARD UNIT (A10)	11 - 1
12 OPTIONS (A11)	12 - 1
13 CPU UNIT (A12)	13 - 1
13.1 INTRODUCTION.....	13 - 1
13.2 MEMORY MAP	13 - 2
13.3 CIRCUIT DESCRIPTION	13 - 3
13.4 SIGNAL NAME LIST.....	13 - 6

14 DCL UNIT (A13)	14 - 1
14.1 ORGANISATION OF THE MEMORY	14 - 1
14.2 INTRODUCTION TO THE SAMPLE TRANSPORTS	14 - 1
14.3 SIGNAL ACQUISITION.....	14 - 2
14.4 COPYING SAMPLES TO DISPLAY MEMORY.....	14 - 3
14.5 DISPLAYING OF TRACE AND REGISTER.....	14 - 3
14.6 MICROPROCESSOR MANIPULATION.....	14 - 4
14.7 DISPLAYING OF TEXT AND CURSORS	14 - 4
14.8 CLEARING THE DISPLAY MEMORY	14 - 5
14.9 CLEARING THE ACQUISITION MEMORY.....	14 - 5
14.10 EXOR D307	14 - 6
14.11 CHIP SELECT	14 - 6
14.12 DOTS AND PLOTTER CONTROL.....	14 - 7
14.13 TIMING DIAGRAM.....	14 - 7
14.14 SIGNAL NAME LIST	14 - 8
15 ACL UNIT (A14)	15 - 1
15.1 TRIGGER CONTROL	15 - 1
15.2 CCD + ADC TIMING	15 - 2
15.3 AVERAGE AND INTERPOLATION CIRCUIT.....	15 - 2
15.4 DELAY COUNTER.....	15 - 3
15.5 ACQUISITION FLOW	15 - 3
15.6 SIGNAL NAME LIST.....	15 - 3

16 ADC DAC UNIT (A15)	16 - 1
16.1 ADC CIRCUIT	16 - 1
16.2 VERTICAL DAC CIRCUIT	16 - 2
16.3 HORIZONTAL DAC CIRCUIT	16 - 3
16.4 X POS SWITCH CIRCUIT	16 - 3
16.5 Z CONTROL	16 - 3
16.5.1 Plot mode	16 - 3
16.5.2 Dots mode	16 - 4
16.6 PLOT AND PENLIFT CIRCUIT	16 - 4
16.7 SIGNAL NAME LIST	16 - 5
17 ADAPTATION UNIT (A16)	17 - 1
17.1 VERTICAL DISPLAY MODE SWITCH	17 - 1
17.2 ANALOG MODE	17 - 1
17.3 DIGITAL SAMPLING MODE	17 - 2
17.4 DIGITAL REAL TIME MODE	17 - 3
17.4 SIGNAL NAME LIST	17 - 3
18 P²CCD UNIT (A18) - PM3365A/67A ONLY!	18 - 1
18.1 MINI CCD UNIT (A17)	18 - 1
18.1.1 Introduction	18 - 1
18.1.2 Input buffer	18 - 2
18.1.3 P ² CCD - OQ0204	18 - 2
18.1.4 Signal name list of the mini ccd unit	18 - 5
18.2 ACE (ADVANCED CUSTOMISED ECL)	18 - 5

JTN

18.3 CLOCK DRIVERS	18 - 6
18.4 MINI CCD DEFAULT CIRCUITS	18 - 6
18.5 P ² CCD OUTPUT	18 - 7
18.6 SIGNAL NAME LIST	18 - 8
19 P²CCD UNIT (A18) - PM3375/77 ONLYI	19 - 1
19.1 P ² CCDs	19 - 1
19.1.1 Introduction	19 - 1
19.1.2 Input buffer	19 - 2
19.1.3 P ² CCD - OQ0204	19 - 2
19.2 ACE (ADVANCED CUSTOMISED ECL)	19 - 4
19.3 FAST CLOCK OSCILLATORS	19 - 5
19.4 CLOCK DRIVERS	19 - 5
19.5 P ² CCD OUTPUT	19 - 6
19.5.1 Level shifter	19 - 6
19.5.2 Clamp Intergrate Hold circuit	19 - 6
19.5.3 Analog leakage correction	19 - 7
19.6 SIGNAL NAME LIST	19 - 8
20 PERFORMANCE TEST	20 - 1
20.1 GENERAL INFORMATION	20 - 1
20.2 RECOMMENDED TEST EQUIPMENT	20 - 2
20.3 TEST PROCEDURE	20 - 3
20.3.1 Preliminary settings	20 - 3
20.3.2 Power supply	20 - 3
20.3.3 Power consumption	20 - 4
20.3.4 Auto set	20 - 5
20.3.5 Orthogonality	20 - 6
20.3.6 Vertical deflection; deflection coefficients	20 - 7

20.3.7	Vertical deflection; variable gain control range	20 - 8
20.3.8	Vertical deflection; input coupling.....	20 - 8
20.3.9	Vertical deflection; frequency response in analog mode.....	20 - 9
20.3.10	Vertical deflection; frequency response in sampling mode.....	20 - 10
20.3.11	Vertical deflection; rise-time.....	20 - 11
20.3.12	Vertical deflection; noise.....	20 - 12
20.3.13	Vertical deflection; dynamic range at 10 MHz.....	20 - 12
20.3.14	Vertical deflection; position range	20 - 13
20.3.15	Vertical deflection; cross talk between A and B at 10 MHz	20 - 14
20.3.16	Vertical deflection; cross talk between A and B at 100 MHz.....	20 - 15
20.3.17	Vertical deflection; common mode rejection ratio.....	20 - 16
20.3.18	Vertical deflection; visual signal delay	20 - 17
20.3.19	Vertical deflection; base line jump	20 - 18
20.3.20	Horizontal deflection; X deflection	20 - 19
20.3.21	Horizontal deflection; time-base deflection coefficients	20 - 20
20.3.22	Horizontal deflection; variable control ratio (VAR TB).....	20 - 22
20.3.23	Horizontal deflection; TB magnifier balance.....	20 - 23
20.3.24	Horizontal deflection; X deflection coefficient via A.....	20 - 23
20.3.25	Horizontal deflection; X deflection coefficient via EXT	20 - 24
20.3.26	Horizontal deflection; frequency response 1	20 - 25
20.3.27	Horizontal deflection; frequency response 2.....	20 - 26
20.3.28	Maximum phase shift between hor. and vert.deflection	20 - 27
20.3.29	Triggering; sources and coupling	20 - 28
20.3.30	Triggering; slope selection and level control range.....	20 - 29
20.3.31	Triggering; trigger sensitivity via A and B.....	20 - 30
20.3.32	Triggering; trigger sensitivity via EXT.....	20 - 31
20.3.33	Triggering; trigger sensitivity TVL-TVF	20 - 32
20.3.34	Cursors; voltage cursor accuracy	20 - 32
20.3.35	Cursors; time cursor accuracy.....	20 - 33
20.3.36	Z-MOD sensitivity.....	20 - 34
20.3.37	CAL signal; frequency and output voltage	20 - 35

21 DISMANTLING THE INSTRUMENT	21 - 1
21.1 GENERAL INFORMATION	21 - 1
21.2 REMOVING THE TOP AND BOTTOM COVERS	21 - 1
21.3 ACCESS TO THE ADJUSTING ELEMENTS	21 - 1
22 CHECKING AND ADJUSTING	22 - 1
22.1 GENERAL INFORMATION	22 - 1
22.2 RECOMMENDED TEST AND CALIBRATION EQUIPMENT	22 - 5
22.3 SURVEY OF ADJUSTING ELEMENTS	22 - 6
22.4 CHECKING AND ADJUSTING PROCEDURE	22 - 12
22.4.1 Preparation	22 - 12
22.4.2 Power supply adjustment	22 - 12
22.4.3 CRT display adjustment	22 - 12
22.4.4 Gain and LF-sq.wave response EXT and A input	22 - 13
22.4.5 Gain and LF-sq.wave response channel A(B)	22 - 13
22.4.6 Offset channel A(B)	22 - 13
22.4.7 Triggering	22 - 14
22.4.8 Time-base sweep speeds	22 - 15
22.4.9 HF sq.wave response	22 - 15
22.4.10 P ² CCD-adjustment - PM3365A/67A only	22 - 16
22.4.11 P ² CCD-adjustment - PM3375/77 only	22 - 17
22.4.12 Display section adjustments	22 - 19
22.4.13 Horizontal S-mode	22 - 19
22.4.14 Gain and offset channel A (B) - PM3365A/67A only	22 - 20
22.4.16 Sample mode adjustments	22 - 22

23 CORRECTIVE MAINTENANCE	23 - 1
23.1 REPLACEMENTS	23 - 1
23.1.1 Standard parts	23 - 1
23.1.2 Special parts	23 - 1
23.1.3 Transistors and Integrated Circuits.....	23 - 1
23.2 STATIC SENSITIVE COMPONENTS	23 - 2
23.2.1 Introduction.....	23 - 2
23.2.2 Storage And Transport	23 - 3
23.2.3 Testing Or Handling	23 - 3
23.2.4 Mounting.....	23 - 4
23.2.5 Soldering	23 - 4
23.2.6 Static Charges	23 - 4
23.2.7 Transient Voltages	23 - 4
23.2.8 Voltage Surges	23 - 4
23.3 SOLDERING TECHNIQUES FOR SMD's	23 - 5
23.3.1 Introduction.....	23 - 5
23.3.2 Required Tools And Materials	23 - 7
23.3.3 General Hints For Smd Handling.....	23 - 7
23.3.4 Replacement Of Smds	23 - 8
23.4 REMOVING THE UNITS AND MECHANICAL PARTS	23 - 10
23.4.1 Attenuator unit (A1)	23 - 10
23.4.2 Pre-amplifier unit (A2) and Adaptation unit (A16).....	23 - 11
23.4.3 XYZ-amplifier unit (A3).....	23 - 11
23.4.4 Time-base unit (A4)	23 - 12
23.4.5 CRT control unit (A5)	23 - 12
23.4.6 Power supply unit (A6)	23 - 12
23.4.7 Front unit (A7) and LCD unit (A8).....	23 - 13
23.4.8 Digital unit (A10 ... A15).....	23 - 14
23.4.9 P ² CCD unit (A18) and mini CCD unit (A17).....	23 - 15
23.4.10 Removing the delay-line cable.....	23 - 15
23.4.11 Replacement of CRT	23 - 15
23.5 SOLDERING TECHNIQUES	23 - 16

23.6 INSTRUMENT REPACKING.....	23 - 16
23.7 TROUBLE SHOOTING	23 - 17
23.7.1 Introduction.....	23 - 17
23.7.2 Trouble-shooting techniques.....	23 - 17
23.7.3 Power-up routine.....	23 - 18
23.7.4 I ² C structure.....	23 - 19
23.7.5 Trouble-shooting the power supply	23 - 20
23.7.6 p.c.b. Interconnections.....	23 - 20
23.8 SPECIAL TOOLS	23 - 24
23.8.1 Trimming Kit SBC 317 - 4822 310 50095.....	23 - 24
23.8.2 p.c.b. Snapper - 5322 535 91942.....	23 - 24
23.8.3 Extension board - 5322 216 51211	23 - 25
23.9 RECALIBRATION AFTER REPAIR.....	23 - 25
24 SAFETY INSPECTION	24 - 1
24.1 GENERAL DIRECTIVES	24 - 1
24.2 SAFETY COMPONENTS.....	24 - 1
24.3 CHECKING THE PROTECTIVE EARTH CONNECTION.....	24 - 1
24.4 CHECKING THE INSULATION RESISTANCE.....	24 - 1
24.5 CHECKING THE LEAKAGE CURRENT	24 - 1
24.6 VOLTAGE TEST	24 - 1
25 PARTS LIST	25 - 1
25.1 MECHANICAL PARTS	25 - 1
25.1.1 Bezel assembly.....	25 - 1
25.1.2 Mechanical parts indicated in figure 25.2.....	25 - 2
25.1.3 Mechanical parts indicated in figure 25.3.....	25 - 6
25.1.4 Mechanical parts indicated in figure 25.4.....	25 - 6
25.2 UNITS (see figure 25.5)	25 - 6

25.3 CABLES AND CONNECTORS	25 - 7
25.3.1 Flatcables and connectors.....	25 - 7
25.3.2 P.c.b.-connectors (male headers).....	25 - 8
25.3.3 50 Ω cables and connectors.....	25 - 8
25.3.4 Miscellaneous cables	25 - 8
25.3.5 Miscellaneous sockets and connectors	25 - 9
25.4 ELECTRICAL PARTS	25 - 10
25.4.1 CAPACITORS	25 -
25.4.2 RESISTORS	25 -
25.4.3 COILS	25 -
25.4.4 SEMI-CONDUCTORS	25 -
25.4.5 INTEGRATED CIRCUITS.....	25 -
25.4.6 CATHODE RAY TUBE.....	25 -
25.4.7 MISCELLANEOUS.....	25 -

JTN

List of Figures

Figure 2.1 Dimensions of oscilloscope	2 - 2
Figure 2.2 Operating positions	2 - 2
Figure 2.3 Maximum input voltage versus frequency	2 - 4
Figure 3.1 Block diagram, analog part.....	3 - 7
Figure 3.2 Block diagram, digital part.....	3 - 17
Figure 4.1 Table of attenuator settings	4 - 1
Figure 4.2 Attenuator unit pcb	4 - 3
Figure 4.3 Circuit diagram of attenuator, ch. A-1	4 - 5
Figure 4.4 Circuit diagram of attenuator, ch. A-2	4 - 8
Figure 4.5 Attenuator unit pcb	4 - 9
Figure 4.6 Circuit diagram of attenuator, ch. B-1	4 - 11
Figure 4.7 Circuit diagram of attenuator, ch. B-2	4 - 12
Figure 4.8 Attenuator unit p.c.b.....	4 - 14
Figure 4.9 Circuit diagram of attenuator, EXT.....	4 - 16
Figure 5.1 The four stages of the vertical pre-amplifier.....	5 - 1
Figure 5.2 Pre-amplifier unit p.c.b.	5 - 6
Figure 5.3 Circuit diagram of pre-amplifier, channel switch.....	5 - 8
Figure 5.4 Circuit diagram of pre-amplifier, delay line driver.....	5 - 9
Figure 5.5 Pre-amplifier unit p.c.b.	5 - 11
Figure 5.6 Circuit diagram of pre-amplifier, MTB trigger switch.....	5 - 13
Figure 5.7 Circuit diagram of pre-amplifier, level circuit.....	5 - 15
Figure 5.8 Pre-amplifier unit p.c.b.	5 - 16
Figure 5.9 Circuit diagram of pre-amplifier, logic control.....	5 - 18
Figure 5.10 Circuit diagram of pre-amplifier, supply voltages.....	5 - 19
Figure 5.11 Pre-amplifier unit p.c.b.	5 - 21
Figure 6.1 XYZ amplifier p.c.b.	6 - 3
Figure 6.2 Circuit diagram of XYZ amplifiers, final Y amplifier	6 - 5
Figure 6.3 Circuit diagram of XYZ amplifier, final X amplifier	6 - 6
Figure 6.4 XYZ amplifier unit p.c.b.	6 - 8
Figure 6.5 Circuit diagram of XYZ amplifiers, Z amplifier	6 - 10
Figure 6.6 Circuit diagram of XYZ amplifier, CRT circuit	6 - 12

Figure 7.1 D4103 configuration	7 - 2
Figure 7.2 Simplified diagram of the time-base sweep generator.....	7 - 4
Figure 7.3 Digital sampling principal, trigger delay = 10 divisions.	7 - 6
Figure 7.4 Free-running sweep-timing diagram	7 - 8
Figure 7.5 Time-base unit p.c.b.....	7 - 9
Figure 7.6 Circuit diagram of time-base, trigger amplifier and TB control.....	7 - 12
Figure 7.7 Time-base unit p.c.b.....	7 - 13
Figure 7.8 Circuit diagram of time-base, sweep current control.....	7 - 16
Figure 7.9 Time-base unit p.c.b.....	7 - 17
Figure 7.10 Circuit diagram of time-base, time-base control.....	7 - 20
Figure 7.11 Time-base unit p.c.b.....	7 - 21
Figure 7.12 Circuit diagram of time-base, sweep circuit.....	7 - 24
Figure 7.13 Time-base unit p.c.b.....	7 - 25
Figure 7.14 Circuit diagram of time-base, hor. display mode switch.....	7 - 28
Figure 7.15 Time-base unit p.c.b.....	7 - 29
Figure 7.16 Circuit diagram of time-base, DAC stair gen. and comparator	7 - 32
Figure 7.17 Time-base unit p.c.b.....	7 - 33
Figure 7.18 Circuit diagram of time-base, Z pre-amplifier	7 - 36
Figure 7.19 Time-base unit p.c.b.....	7 - 37
Figure 7.20 Circuit diagram of time-base, horizontal pre-amplifier	7 - 40
Figure 7.21 Time-base unit p.c.b.....	7 - 41
Figure 7.22 Circuit diagram of time-base, supply voltages	7 - 44
Figure 8.1 Circuit diagram of CRT control	8 - 1
Figure 8.2 CRT control unit p.c.b.....	8 - 1
Figure 9.1 Collector-voltage and -current waveforms of V6018 (switching off) ..	9 - 2
Figure 9.2 Converter circuit.....	9 - 2
Figure 9.3 Timing diagram converter circuit.....	9 - 3
Figure 9.4 HT oscillator	9 - 4
Figure 9.5 Power supply unit p.c.b.	9 - 5
Figure 9.6 Circuit diagram of power supply, primary circuit.....	9 - 8
Figure 9.7 Power supply unit p.c.b.....	9 - 9
Figure 9.8 Circuit diagram of power supply, secondary circuit.....	9 - 12
Figure 9.9 Power supply unit p.c.b.....	9 - 13
Figure 9.10 Circuit diagram of power supply, EHT circuit and various	9 - 16

Figure 10.1 Circuit diagram of front unit, key matrix	10 - 3
Figure 10.2 Front unit p.c.b.....	10 - 5
Figure 10.3 Circuit diagram of front unit, front controls and probe indication....	10 - 6
Figure 10.4 LCD unit p.c.b.....	10 - 8
Figure 10.5 Circuit diagram of LCD unit	10 - 10
Figure 11.1 Motherboard unit p.c.b.....	11 - 1
Figure 13.1 I ² C bus structure.....	13 - 4
Figure 13.2 DTACK generator	13 - 5
Figure 13.3 Circuit diagram of CPU unit, part 1	13 - 9
Figure 13.4 CPU unit p.c.b.	13 - 11
Figure 13.5 Circuit diagram of CPU unit, part 2.....	13 - 12
Figure 14.1 Organisation of the memory.....	14 - 1
Figure 14.2 Display cycle controlled by SC0...4.....	14 - 2
Figure 14.3 Block diagram of signal acquisition.....	14 - 2
Figure 14.4 Block diagram of copying samples to display memory.....	14 - 3
Figure 14.5 Block diagram of trace/register display flow.....	14 - 3
Figure 14.6 Block diagram of text/cursors display flow	14 - 4
Figure 14.7 Block diagram of the clear function.....	14 - 5
Figure 14.8 Block-diagram of the clear function.....	14 - 5
Figure 14.9 Chip select circuit.....	14 - 6
Figure 14.10 Timing diagram for D314.....	14 - 7
Figure 14.11 Circuit diagram of DCL unit, acquisition memory.....	14 - 10
Figure 14.12 DCL unit p.c.b.	14 - 13
Figure 14.13 Circuit diagram of DCL unit, display memory.....	14 - 15
Figure 15.1 Timing diagram of the trigger control.....	15 - 1
Figure 15.2 Timing diagram CCD and ADC timing	15 - 2
Figure 15.3 ACL unit p.c.b.....	15 - 5
Figure 15.4 Circuit diagram of ACL unit, part 1.....	15 - 7
Figure 15.5 Circuit diagram of ACL unit, part 2.....	15 - 9
Figure 15.6 ACL unit p.c.b.....	15 - 10
Figure 15.7 Circuit diagram of ACL unit, part 3.....	15 - 12

Figure 16.1 Waveforms on N501	16 - 1
Figure 16.2 Waveform on D501	16 - 1
Figure 16.3 Waveform on deglitch circuit.....	16 - 2
Figure 16.4 Z control fot PLOT mode.....	16 - 3
Figure 16.5 Z control for DOTS mode	16 - 4
Figure 16.6 Z control for DOTS JOINED mode	16 - 4
Figure 16.7 Circuit diagram of ADC DAC unit, Y DAC circuit.....	16 - 7
Figure 16.8 ADC DAC unit p.c.b.	16 - 9
Figure 16.9 Circuit diagram of ADC DAC unit, X-DAC and ADC circuit	16 - 10
Figure 16.10 ADC DAC unit p.c.b.....	16 - 12
Figure 16.11 Circuit diagram of ADC DAC unit, part 3	16 - 14
Figure 17.1 Principle of track & hold amplifier.....	17 - 2
Figure 17.2 Adaptation unit p.c.b.....	17 - 4
Figure 17.3 Circuit diagram of adaptation unit, part 1.....	17 - 6
Figure 17.4 Circuit diagram of adaptation unit, part 2.....	17 - 8
Figure 17.5 Adaptation unit p.c.b.....	17 - 9
Figure 17.6 Circuit diagram of adaptation unit, part 3.....	17 - 11
Figure 17.7 Adaptation unit p.c.b.....	17 - 12
Figure 17.8 Circuit diagram of adaptation unit, part 4.....	17 - 14
Figure 18.1 Schematic diagram of a P ² CCD circuit	18 - 1
Figure 18.2 Sample and transport sequence.....	18 - 2
Figure 18.3 Output signal.....	18 - 3
Figure 18.4 Principle of the sample clock drivers.....	18 - 6
Figure 18.5 CIH circuit.....	18 - 7
Figure 18.6 Analog leakage correction	18 - 8
Figure 18.7 Mini CCD unit p.c.b.	18 - 10
Figure 18.8 Circuit diagram of mini CCD unit.....	18 - 12
Figure 18.9 P ² CCD unit p.c.b.....	18 - 13
Figure 18.10 Circuit diagram of P ² CCD: ACE.....	18 - 16
Figure 18.11 P ² CCD unit p.c.b.	18 - 17
Figure 18.12 Circuit diagram of P ² CCD: clock drivers	18 - 20
Figure 18.13 P ² CCD unit p.c.b.	18 - 21
Figure 18.14 Circuit diagram of P ² CCD: part 3	18 - 24
Figure 18.15 P ² CCD unit p.c.b.	18 - 25
Figure 18.16 Circuit diagram of P ² CCD: CIH circuit	18 - 28

Figure 19.1 Schematic diagram of a P ² CCD circuit	19 - 1
Figure 19.2 Sample and transport sequence.....	19 - 2
Figure 19.3 Output signal.....	19 - 3
Figure 19.4 Principle of the sample clock drivers.....	19 - 5
Figure 19.5 CIH circuit.....	19 - 6
Figure 19.6 Analog leakage correction	19 - 7
Figure 19.7 Part of P ² CCD unit, part 1	19 - 11
Figure 19.8 Circuit diagram of P ² CCD, oscillator circuit.....	19 - 14
Figure 19.9 Part of P ² CCD unit p.c.b., part 2	19 - 15
Figure 19.10 Circuit diagram of P ² CCD, ACE.....	19 - 18
Figure 19.11 Part of P ² CCD unit p.c.b., part 3	19 - 19
Figure 19.12 Circuit diagram of P ² CCD, clock drivers channel A.....	19 - 22
Figure 19.13 Part of P ² CCD unit p.c.b., part 4	19 - 23
Figure 19.14 Circuit diagram of P ² CCD, clock drivers channel B.....	19 - 26
Figure 19.15 Part of P ² CCD unit p.c.b., part 5	19 - 27
Figure 19.16 Circuit diagram of P ² CCD, input amplifiers.....	19 - 30
Figure 19.17 Part of P ² CCD unit p.c.b., part 6	19 - 31
Figure 19.18 Circuit diagram of P ² CCD, P ² CCD channel A.....	19 - 34
Figure 19.19 Part of P ² CCD unit p.c.b., part 7	19 - 35
Figure 19.20 Circuit diagram of P ² CCD, P ² CCD channel B.....	19 - 38
Figure 19.21 Part of P ² CCD unit p.c.b., part 8	19 - 39
Figure 19.22 Circuit diagram of P ² CCD, CIH circuit	19 - 42
Figure 19.23 Part of P ² CCD unit p.c.b., part 9.....	19 - 43
Figure 19.24 Circuit diagram of P ² CCD, power supplies and level shifter	19 - 46
Figure 20.1 SOFTSTART condition.....	20 - 3
Figure 20.2 Rise-time	20 - 9
Figure 20.3 Visual signal delay	20 - 16
Figure 20.4 X deflection	20 - 18
Figure 20.5 TB VAR range.....	20 - 21
Figure 20.6 Phase shift.....	20 - 26
Figure 21.1 Access to all parts for checking and adjusting	21 - 2
Figure 22.1 Adjusting elements	22 - 3
Figure 22.2 Square-wave response	22 - 16
Figure 22.3 Adjustment of DV = 300 mV	22 - 17
Figure 22.4 Adjustment of DV = 300 mV	22 - 18
Figure 22.5 DAC and text adjustments	22 - 19

Figure 23.1 Static sensitive symbol	23 - 2
Figure 23.2 Six clamping lips for XYZ-amplifier unit	23 - 11
Figure 23.3 Power supply unit outside the instrument	23 - 13
Figure 23.4 Measuring the front unit working condition.....	23 - 13
Figure 23.5 Measuring the digital unit in working condition	23 - 14
Figure 23.6 Removing the CRT	23 - 15
Figure 23.7 I ² C structure.....	23 - 19
Figure 23.8 p.c.b. Interconnections.....	23 - 22
Figure 23.9 Trimming tool kit	23 - 24
Figure 23.10 p.c.b. Snapper.....	23 - 24
Figure 25.1 Bezel assembly.....	25 - 1
Figure 25.2 Exploded view.....	25 - 3
Figure 25.3 Rear view	25 - 5
Figure 25.4 Inside view showing the parts in the CRT compartment	25 - 5
Figure 25.5 View of the units.....	25 - 5

JTN

SAFETY INSTRUCTIONS

JTN

1 SAFETY INSTRUCTIONS

Read these pages carefully before installation and use of the instrument.

1.1 INTRODUCTION

The following clauses contain information, cautions and warnings which must be followed to ensure safe operation and to retain the instrument in a safe condition. Adjustment, maintenance and repair of the instrument shall be carried out only by qualified personnel.

1.2 SAFETY PRECAUTIONS

For the correct and safe use of this instrument it is essential that both operating and servicing personnel follow generally-accepted safety procedures in addition to the safety precautions specified in this manual.

Specific warning and caution statements, where they apply, will be found throughout the manual.





Where necessary, the warning and caution statements and/or symbols are marked on the apparatus.

1.3 CAUTION AND WARNING STATEMENTS

CAUTION: Is used to indicate correct operating or maintenance procedures in order to prevent damage to or destruction of the equipment or other property.

WARNING: Calls attention to a potential danger that requires correct procedures or practices in order to prevent personal injury.

1.4 SYMBOLS

	High voltage ≥ 1000 V (red)
	Live part (black/yellow)
	Read the operating instructions
	Static sensitive components (black/yellow)
	Protective earth (grounding) terminal (black)

1.5 IMPAIRED SAFETY-PROTECTION

Whenever it is likely that safety-protection has been impaired, the instrument **must** be made inoperative and be secured against any unintended operation. The matter should then be referred to qualified technicians. Safety protection is likely to be impaired if, for example, the instrument fails to perform the intended measurements or shows visible damage.

1.6 GENERAL CLAUSES

WARNING: The opening of covers or removal of parts, except those to which access can be gained by hand, is likely to expose live parts and accessible terminals which can be dangerous to live.

- The instrument shall be disconnected from all voltage sources before it is opened.
- Bear in mind that capacitors inside the instrument can hold their charge even if the instrument has been separated from all voltage sources.

WARNING: Any interruption of the protective earth conductor inside or outside the instrument, or disconnection of the protective earth terminal, is likely to make the instrument dangerous. Intentional interruption is prohibited.

- Components which are important for the safety of the instrument may only be renewed by components obtained through your local Philips organisation. (See also section 23).
- After repair and maintenance in the primary circuit, safety inspection and tests, as mentioned in section 23 have to be performed.

CHARACTERISTICS

JTN

2 CHARACTERISTICS

A. Performance Characteristics

Properties expressed in numerical values with stated tolerance are guaranteed by PHILIPS. Specified non-tolerance numerical values indicate those that could be nominally expected from the mean of a range of identical instruments. This specification is valid after the instrument has warmed up for 30 minutes (reference temperature 23 °C). For definitions of terms, reference is made to IEC Publication 351-1.

B. Safety Characteristics

This apparatus has been designed and tested in accordance with Safety Class I requirements of IEC Publication 348, Safety requirements for Electronic Measuring Apparatus, UL 1244 and CSA 556B and has been supplied in a safe condition.

C. Initial Characteristics

Overall dimensions:

Width

Including handle:

Excluding handle:

JTN 387 mm
350 mm

Length

Including handle:

Excluding handle, excl. knobs:

Excluding handle, incl. knobs:

518,5 mm

443,5 mm

455,5 mm

Height

Including feet:

Excluding feet:

Excl. under-cabinet:

146,5 mm

134,5 mm

132,5 mm



Figure 2.1 Dimensions of oscilloscope

Mass: 9,5 kg

Operating positions:

- a. Horizontally on bottom feet
- b. Vertically on rear feet
- c. On the carrying handle in two sloping positions.

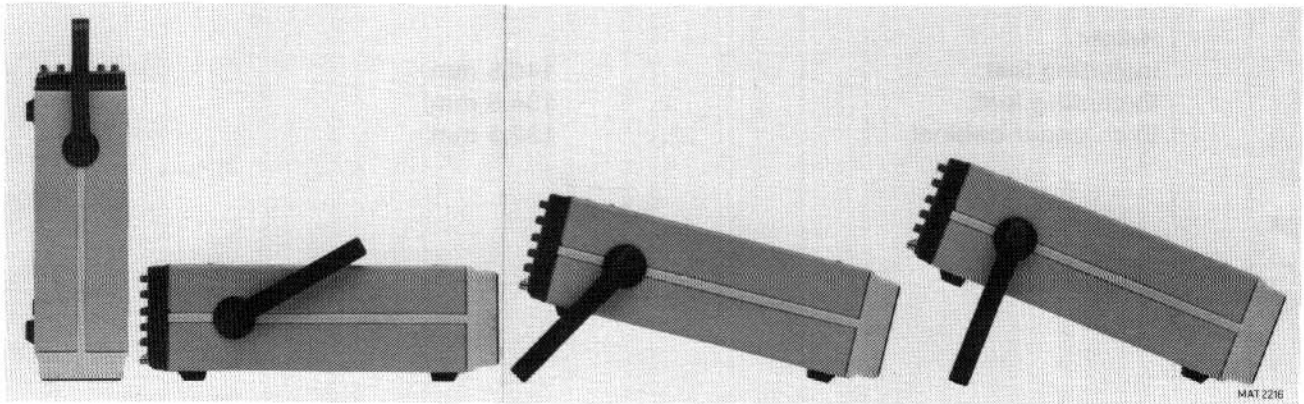

Figure 2.2 Operating positions

CHARACTERISTICS	SPECIFICATION	ADDITIONAL INFORMATION
2.1 DISPLAY		
* CRT		
Type number	PHILIPS D14-372	
Measuring area (h x w)	80 x 100 mm	8 x 10 div., 1 div. = 10 mm, 1 subdiv. (sd) = 2 mm
* Screen type		
Standard	GH (P31)	Standard persistence (7 ms)
Option	GM (P7)	Long persistence (30 ms)
* Total acceleration voltage	16 kV	
* Graticule:		
Engravings	Internal fixed	
Division lines	1 cm	Horizontal as well as vertical
Subdivisions	2 mm	Horizontal as well as vertical
Dotted lines	1,5 and 6,5 cm from top	Only horizontal
Percentages	0%, 10%, 90%, 100%	Left side only
* Orthogonality	90 ± 1°	Measured in zero point
* Illumination	Continuously variable	By means of potentiometer

2.2 VERTICAL DEFLECTION OR Y AXIS

* Auto set	Automatic setting according to input signal	
* Deflection modes and sources	Channel A and/or B or ADDED (A + B, A-B)	Channel B can be inverted. All combinations are possible in ALTERNATE as well as in CHOP mode
* Deflection coefficients	2 mV/div...10 V/div	In 1, 2, 5 sequence. If probe with range indicator is used, deflection coeff. is automatically calculated in display
* Variable adjustment range	1 : > 2,5	
* Error limit	± 3%	Only in calibrated position
* Input impedance Paralleled by	1 MΩ ± 2% 20 pF ± 2 pF	Measured below 1 MHz Measured below 1 MHz

CHARACTERISTICS	SPECIFICATION	ADDITIONAL INFORMATION
* Max. Input voltage	400 V (d.c. + a.c. peak)	Up to 125 kHz, for higher frequency see figure 2.3
Max. test voltage (rms)	500 V	Max. duration 60 s.

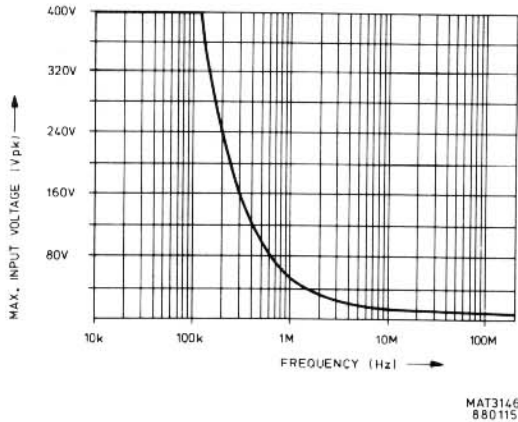

Figure 2.3 Maximum input voltage versus frequency

* Bandwidth		
20 mV/div...10 V/div	≥ 100 MHz	Input 6 div. sine-wave.
2 mV/div...10mV/div	≥ 75 MHz	Input 6 div sine-wave.
* Rise-time		
20 mV/div...10 V/div	< 3,5 ns	Calculated from $0,35/f$ at -3 dB
2 mV/div...10 mV/div	< 4,7 ns	Calculated from $0,35/f$ at -3 dB
* Noise		
20 mV/div...10 V/div	< 0,05 div	Tangentially measured. Pick up on open BNC excluded.
2 mV/div...10 mV/div	< 0,2 div	Tangentially measured. Pick up on open BNC excluded.
* Lower -3 dB point	≤ 10 Hz	In AC position, 6 div. sine-wave
* Dynamic range		
d.c. ...10 MHz	> 24 div	
* Min position range	± 8 div	
* Cross talk between channels		
At 10 MHz	1 : > 100	Both channels same attenuator setting. Input max. 8 div. sine-wave.
At 100 MHz	1 : > 50	2, 5 and 10 V are excluded.

CHARACTERISTICS	SPECIFICATION	ADDITIONAL INFORMATION
* Common Mode Rejection Ratio		Both channels same attenuator setting, vernier adjusted for best CMRR; measured with max. 8 div. (± 4 div) each channel
at 1 MHz	1 : 100	
at 50 MHz	1 : 10	
* Visible signal delay	> 13 ns	Max. intensity, measured from line start to trigger point.
* Base line jump: between attenuator steps 20 mV...10 V	< 0,2 div	
Additional jump between 10 mV and 20 mV	< 0,3 div	
Normal Invert jump	< 0,2 div	
ADD jump	< 0,6 div.	Only channel B When A and B are positioned in screen centre (20 mV...10V). Max. jump between any two positions of the variable potmeter
Variable jump	< 0,2 div	

2.3 HORIZONTAL DEFLECTION OR X AXIS

2.3.1 Time-base

* Time coefficient	0,5 s/div...50 ns/div	In 1, 2, 5 sequence (magn. off)
Error limit	± 3 %	Measured at -4... +4 div. from screen centre.
* Horizontal position range	Start of sweep and 10th div. can be shifted at least 0,5 div over screen centre	
* Variable control ratio	1 : > 2,5	
* Time-base magnifier	Expansion x10	Not valid in X-deflection.
Error limit	± 4 %	Measured at +4...-4 div. from screen centre. Excluding first 50 ns and last 50 ns.
* Horizontal magnifier balance	< 0,5 div	Shift start of sweep in x10 in mid-screen position, then switch to x1.
* Hold-Off		
Min to max hold-off time ratio	1 : > 10	Minimum hold-off time is related to time-base setting.

CHARACTERISTICS	SPECIFICATION	ADDITIONAL INFORMATION
2.3.2 X-deflection		
* Deflection coeff. Via channel A or B	2 mV/div...10 V/div	In 1, 2, 5 sequence + variable
Via EXT Input	100 mV/div	
* Error limit Via channel A or B	± 5%	
Via EXT input	± 5%	
* Bandwidth	DC... ≥ 2 MHz	DC coupled
* Phase shift between X and Y-deflection	< 3° DC...100 kHz	DC coupled
* Dynamic range	> 24 div DC...100 kHz	DC coupled
2.3.3 EXT input		
* Input impedance Paralleled by	1 MΩ ± 2% 20 pF ± 2 pF	Measured below 1 MHz Measured below 1 MHz
* Max. input voltage (d.c. + a.c. peak)	400 V	For derating with frequency see figure 2.3 Max. duration 60 s.
Max. test voltage (rms)	500 V	
* Lower -3 dB point	< 10Hz	AC coupled
2.4 TRIGGERING		
* Trig. mode AUTO (auto free run)	Bright line in absence of trigger signal	Auto free run starts 100 ms (typ.) after no trigger pulse.
TRIGGERED		Switches automatically to free run if one of the display channels is grounded.
SINGLE		In multi-channel mode (alternate) each channel is armed after reset; if sweep has already started, sweep is not finished. Not applicable in peak-to-peak coupling
* TRIGGER SOURCE	A, B, Composite (A/B), EXT, Line	In line, trigger source is always the mains. Line trigger amplitude depends on line input voltage. Approx. 6 div. at 220 V mains voltage and 50 Hz frequency.

CHARACTERISTICS	SPECIFICATION	ADDITIONAL INFORMATION
* TRIGGER COUPLING	Peak-to-peak (p-p), DC, TVL, TVF, TVF, LF, HF	
* LEVEL range Peak-to-peak:	Related to peak-to-peak value	p-p coupling is DC rejected
DC internal	> ± 8 div.	
DC external	> ± 800 mV	
TVL/TVF	Fixed level	
HF	50 kHz...100 MHz	
LF	DC...50 kHz	
* Trigger slope	+/-	Slope sign in LCD. For TVL/TVF use + or - to chose positive or negative video
* TRIGGER SENSITIVITY		
Internal		
DC...10 MHz	> 0,5 div.	Trig. coupling DC.
At 100 MHz	> 1,2 div.	Trig. coupling DC.
At 150 MHz	> 2,0 div.	Trig. coupling DC.
External		
DC...10 MHz	> 50 mV	Trig. coupling DC.
At 100 MHz	> 150 mV	Trig. coupling DC.
At 150 MHz	> 500 mV	Trig. coupling DC.
TVL/TVF internal	> 0,7 div.	Sync. pulse
TVL/TVF external	> 70 mV	Sync. pulse

2.5 SIGNAL ACQUISITION

* Sampling type at 50 s/div...0,5 μs/div. at 0,2 μs/div...20 ns/div.	Real time Equivalent time (Sequential sampling)	For PM3365A/67A For PM3365A/67A
at 50 s/div...0,2 μs/div. at 0,1 μs/div...20ns/div.	Real time Equivalent time (Sequential sampling)	For PM3375/77 For PM3375/77
* Maximum sample rate:		Sample rate depends on time/div setting
Real time	100 megasamples/s	For PM3365A/67A
Equivalent time	250 megasamples/s 2,5 gigasamples/s	For PM3375/77
* Vertical (voltage) resolution	8 bits	0,4% of full range of 10 divisions.
* Horizontal (time) resolution:		
In single channel acquisition		
at 50 s/div...5 ms/div	4096 samples/acquisition	1 Sample = 0,025% of full record.
at 2 ms/div...20 ns/div	512 samples/acquisition	1 Sample = 0,2% of full record.

CHARACTERISTICS	SPECIFICATION	ADDITIONAL INFORMATION
in dual channel acquisition at 50 s/div...5 ms/div	2048 samples/acquisition	1 Sample = 0,05% of full record.
at 2 ms/div...20 ns/div	512 samples/acquisition	1 Sample = 0,2 % of full record.
* Record length	10,2 x time/div	Display in unmagnified position.
* Acquisition time:		
real time	10,2 x time/div	exclusive delay time
at 5 ms/div...0,5 μ s/div	+ 30 ms...50 ms	exclusive delay time
at 0,5 s/div...5 ms/div	+ 50 ms...70 ms	
equivalent time	1024 x 20 μ s + 30 ms...50 ms	Depending on trigger frequency
* Sources	Channel A, Channel B	Channel B can be inverted before acquisition.
* Acquisition modes	1 Channel only 2 Channels	Full memory available for 1 channel Simultaneously sampled; 2 channels share memory.

JTN

2.6 CHANNELS A AND B

* Frequency response:		Z source = 25 Ω
Lower transition point of BW		
Input coupling in DC position	d.c.	
Input coupling in AC position	≤ 10 Hz	
Upper transition point of BW (amb 15...35°C)		
20 mV/div...10 V/div	≥ 100 MHz (-3 dB)	Deviation max. 3 MHz for ambient 0...40°C.
2 mV/div...10 mV/div	≥ 75 MHz (-3 dB)	Deviation max. 3 MHz for ambient 0...40°C.
* Max. base line instability: Jump (Ambient: 15...35°C):		Add 25% for ambient 0...40°C.
when switching to memory mode:	$\leq 0,3$ div	Add 0,5 div for 0,5 μ s/div and 1 μ s/div
when actuating INVertor switchd	$\leq 0,3$ div	
between any time/div positions	$\leq 0,5$ div	
Drift	$\leq 0,1$ div/h	Measured in 20 mV/div position
Temperature coef.	$\leq 0,05$ div/K	Measured in 20 mV/div position

CHARACTERISTICS	SPECIFICATION	ADDITIONAL INFORMATION
2.7 TIME BASE		
* Modes	Recurrent Single shot Multiple shot Roll Zoom	Up to 2 shots Will be stopped by trigger The part of the trace between the cursors will be magnified by doing a new acquisition with adopted trigger delay and time/div
* Time coefficients: In recurrent In single shot and multiple shot Error limit (Ambient: 15...35°C) In real time mode	0,5 s/div...20 ns/div 50 s/div...0,5 μ s/div 50 s/div...0,2 μ s/div $\pm 1 \%$	For PM3365A/67A For PM3375/77 Add 0,5 % for ambient 0...40°C
up to memory In equivalent time mode	$\pm 0,1\%$ $\pm 3\%$	
2.8 TRIGGER		
* Trigger delay range: In real time	-10... + 2500 div -10... + 5000 div	Selectable in divisions For PM3365A/67A For PM3375/77
In equivalent time Accuracy Fixed trigger delay in sampling mode	0... + 20 div $\pm 0,3$ div 100 ns \pm 10 ns	Selectable in divisions.
* Trigger level view Inaccuracy	$\leq 0,5$ div	Indication in LCD
2.9 MEMORY		
* Memory size: Registers Register depth: acquisition register Wordlength	4 4096 words 4096 words 8 bits	
* Functions	Clear Load Lock	Contents of acquisition are saved in register Memory system is locked. If lock is not active the signal is written into the acquisition memory.
*Front setting memory size	64 front settings	

CHARACTERISTICS	SPECIFICATION	ADDITIONAL INFORMATION
2.10 DISPLAY		
* Sources	Channel A, Channel B, Reference register, R1 or R2 or R3	In any combination
* Display expansion horizontal	1x...32x	Value of trigger delay setting in LCD is based on unmagnified display
* Display manipulations	dot join	Including digital interpolation at 20 ns/div...2 ms/div
* Display part range horizontal	full memory	The displayed part of the magnified memory can be chosen
2.11 CALCULATION FACILITIES		
* Functions	Frequency, Period, Pulse width, Rise or fall time, Peak-to-peak value, Root mean square value, Mean value, dV, dt Average Envelope	Between cursors indicated by markers
2.12 AUTO SETTING		
* Settling time	3 s (typical)	Auto set is done in analog mode.
2.13 CURSORS		
* Horizontal resolution: in single channel mode in dual channel mode	1 : 4096 1 : 2048	
at 2 ms/div...20 ns/div	1 : 512 1 : 1024	display in dots display in dot-join
* Vertical resolution	1 : 256	over 10 div
* Read out resolution	3 Digits	
* Voltage cursors: Error limit, amb. 15...35°C	± 3 %	Referred to input at BNC, error of probes etc. excluded. Add 3% for ambient 0...40°C.

CHARACTERISTICS	SPECIFICATION	ADDITIONAL INFORMATION
Cursor range	Displayed part of memory	Cursors can not pass each other. (X-position is ignored).

2.14 POWER SUPPLY

* Line input voltage a.c.:		One range
Nominal	100 V...240 V	
Limits of operation	90 V...250 V	
* Line frequency:		
Nominal	50 Hz...400 Hz	
Limits of operation	43 Hz...445 Hz	
* Safety requirements within specification of:		
IEC 348 CLASS I		
UL 1244		
VDE 0411		
CSA 556 B		
* Power consumption (AC source)		At nominal source voltage
Nominal	75 W 85W	For PM3365A/67A For PM3375/77

2.15 SUNDRIES

* Z-MODulation		TTL-compatible
ViH	$\geq 2,0$ V	Blanks display.
ViL	$\leq 0,8$ V	Max. intensity.
Minimum pulse width for blanking	25 ns	Analog control between ViH and ViL is possible.
* CAL output		To calibrate drop or tilt of probes. The output may be short-circuited to ground.
Output voltage	$1,2$ V \pm 1%	Rectangular output voltage.
Frequency	2 kHz	
* Data and settings retention:		When instrument is switched off or during mains failure. The oscilloscope settings and traces are saved.
Memory back-up voltage	2...3,5 V	At 25°C
Memory back-up current drain	Typical 25 μ A	
Recommended batteries		According to IEC285 (= Alkaline Manganese Penlight Battery)
type	LR 6	e.g. PHILIPS LR 6.
quantity	2 pcs	Delivered with the instrument.

CHARACTERISTICS	SPECIFICATION	ADDITIONAL INFORMATION
temperature rise of batteries	20 K	After warming-up period of instrument.
Retention time	typical 5 years	At 25°C, with recommended (fresh) batteries.
* Temperature range	0... +70°C	At -40...0°C settings retention is uncertain. It is advised to remove batteries from the instrument when it is stored during longer (24h) period below -30°C or above 60°C. WARNING: UNDER NO CIRCUMSTANCES BATTERIES SHOULD BE LEFT IN INSTRUMENT AT TEMPERATURES BEYOND THE RATED RANGE OF THE BATTERY SPECIFICATIONS!
* Analog plot output		
Connector	DIN plug 9 pin female	Register selectable
Functions	Memory dump	Horizontal and vertical
Sensitivity	1 V/full memory \pm 3%	Pen-up is software selectable (0 or 1). Open collector output; max. 12 V.
Pen lift	TTL compatible	Software selectable
Plot time per dot	20 ms...2000 ms	In dual channel operation; with more registers starting with the lowest number.
Plot sequence	Channel A first	

2.16 ENVIRONMENTAL CHARACTERISTICS

The environmental data mentioned in this manual are based on the results of the manufacturer's checking procedures. Details on these procedures and failure criteria are supplied on request by the PHILIPS/FLUKE organisation in your country, or by PHILIPS, INDUSTRIAL AND ELECTRO-ACOUSTIC SYSTEMS DIVISION, EINDHOVEN, THE NETHERLANDS.

* Meets environmental requirements of:	MIL-T-28800 C, type III, CLASS 5 Style D	Except for front cover.
* Temperature: operating temp. range within specification	10°C...40°C	MIL-T-28800 C par. 3.9.2.3. tested cf. par. 4.5.5.1.1.
Limits of operating temperature range	0°C...40°C	MIL-T-28800 C par. 3.9.3.3. tested cf. par. 4.5.5.1.1.
Non-operating (storage):	-40°C... +75°C	Cf. MIL-T-28800 C par. 3.9.2.3. tested cf. par. 4.5.5.1.1.

CHARACTERISTICS	SPECIFICATION	ADDITIONAL INFORMATION
* Max. humidity operating/non-operating	95% RH	10 ... 30 °C
* Max. altitude:		MIL-T-28800 C par. 3.9.3. tested, par. 4.5.5.2.
Operating	4,5 km (15000 feet)	Maximum (Operating temperature derated 3°C for each km, for each 3000 feet, above sea level).
Non-operating (storage)	12 km (40 000 feet)	
* Vibration (operating)		MIL-T-28800 C par. 3.9.4.1. tested, par. 4.5.5.3.1.
Freq. 5...15 Hz		
Sweep time	7 min.	
Excursion (p-p)	1,5 mm	
Max acceleration	7 m/s ² (0,7 x g)	at 15 Hz
Freq. 15...25 Hz		
Sweep time	3 min.	
Excursion (p-p)	1 mm	
Max acceleration	13 m/s ² (1,3 x g)	at 25 Hz
Freq. 25...55 Hz		
Sweep time	5 min.	
Excursion (p-p)	0,5 mm	
Max acceleration	30 m/s ² (3 x g)	at 55 Hz
Resonance dwell	10 min.	at each resonance freq. (or at 33 Hz if no resonance was found). Excursion, 9.7.1. to 9.7.2.
* Shock (operating)		MIL-T-28800 C par. 3.9.5.1. tested, par. 4.5.5.4.1.
Amount of shocks total	18	
each axis	6	3 in each direction
Shock wave-form	Half sine-wave	
Duration	11 ms	
Peak acceleration	300 m/s ² (30 x g)	
* Bench handling		MIL-T-28800 C par. 3.9.5.3. tested, cf. par. 4.5.5.4.3.
Meets requirements of	MIL-STD-810 method 516, proced. V	
* Salt atmosphere		MIL-T-28800 C par. 3.9.8.1. tested, par. 4.5.6.2.1.
Structural parts meet requirements of	MIL-STD-810 method 509, proced. I salt solution 20%	

CHARACTERISTICS	SPECIFICATION	ADDITIONAL INFORMATION
* EMI (Electronic Magnetic Interference) meets requirements of	MIL-STD-461 CLASS B CE03, CE07 CS01, CS02, CS06 RS02, RS03	Applicable requirements of part 7 No malfunction
* Magnetic radiated susceptibility Maximum deflection factor	2 mm/Gs	Tested conforming IEC 351-1 par 5.1.3.1 Measured with instrument in a homogeneous magnetic field (in any direction with respect to instrument) with a flux intensity (p-p value) of 1,42 mT (14,2 gauss) and of symmetrical sine-wave form with a frequency of 45 Hz...66 Hz

2.17 SAFETY

* Meets requirements of	IEC 348 CLASS I VDE 0411 UL 1244 CSA 556 B	Except for power cord, unless shipped with Universal European power plug. Except for power cord, unless shipped with North American power plug
-------------------------	---	---

**INTRODUCTION TO CIRCUIT
DESCRIPTION AND BLOCK
DIAGRAM DESCRIPTION**

JTN

3 INTRODUCTION TO CIRCUIT DESCRIPTION AND BLOCK DIAGRAM DESCRIPTION

3.1 INTRODUCTION TO CIRCUIT DESCRIPTION

3.1.1 General

The functioning of the circuits is described per printed-circuit board (p.c.b.). For every p.c.b. a separate chapter (4-19) is available containing the lay out of the p.c.b., the associated circuit diagram(s), the circuit description and a signal name list.

3.1.2 Explanation of signal name set-up

Signal name consists of two parts:

- a functional part of maximal 6 characters
- a realisation part of 2 characters

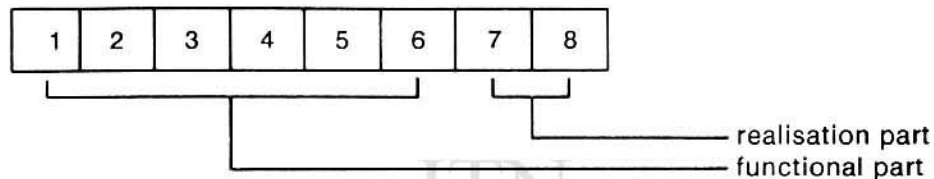

The realisation part is optional. If it is used then the functional parts should consist of 6 characters. If necessary dummies (minus sign) are used in the functional part, to make it 6 characters long.

The first character of the realisation part has the following meaning:

- H: active high signal
- L: active low signal
- X: irrelevant (e.g. counter outputs)

The second character of the realisation part is used to identify signal levels:

- A: analog
- C: CMOS 12 V or 15 V
- D: CMOS 5 V
- E: ECL -4,5 V or -5,2 V
- T: TTL 5 V or HCT

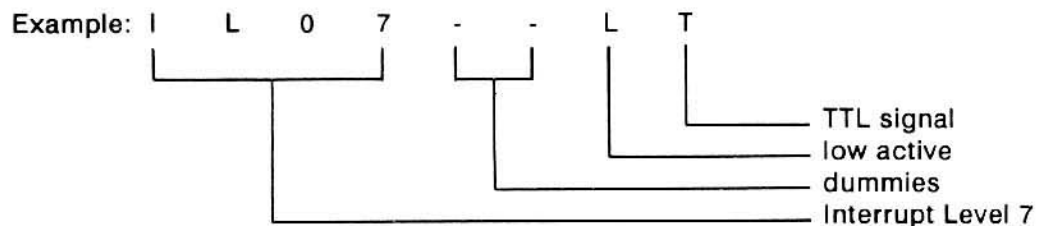

Sometimes the functional part can also be used for a serial number e.g. to indicate a buffered version of a signal.

Example: CHPT--01

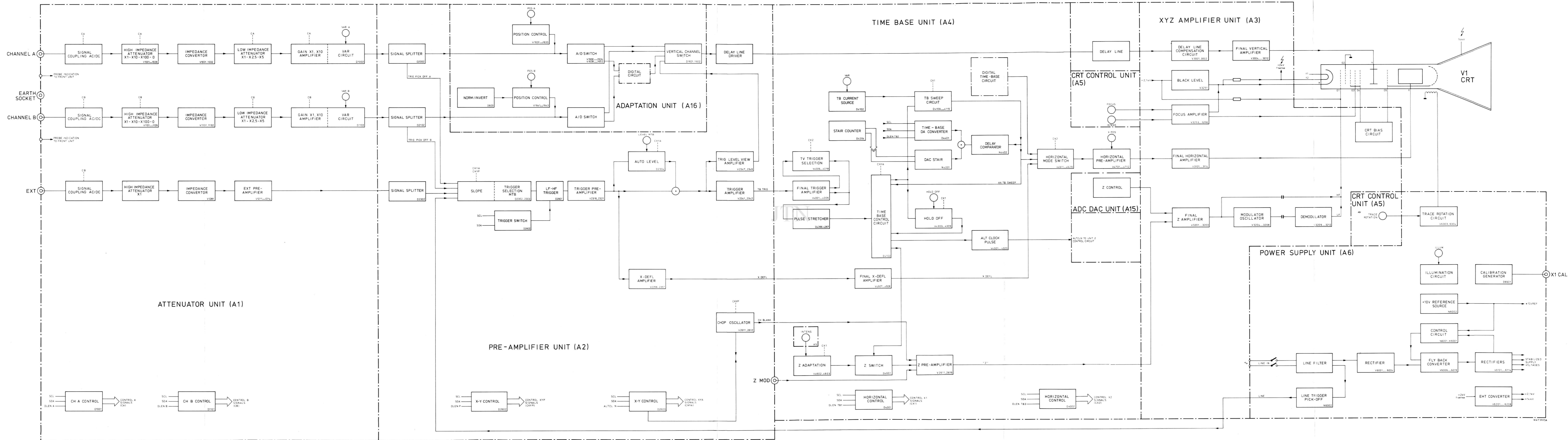
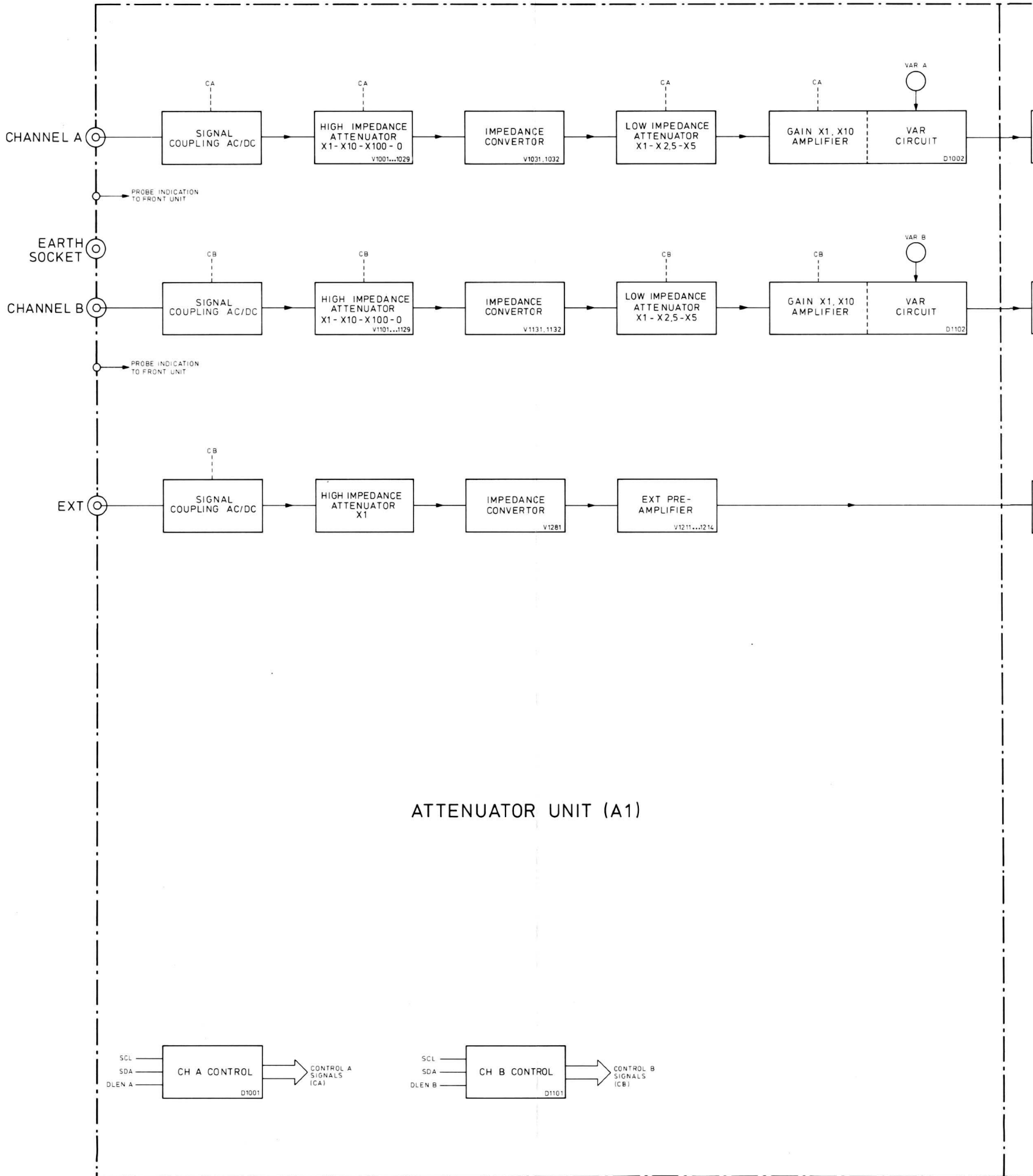
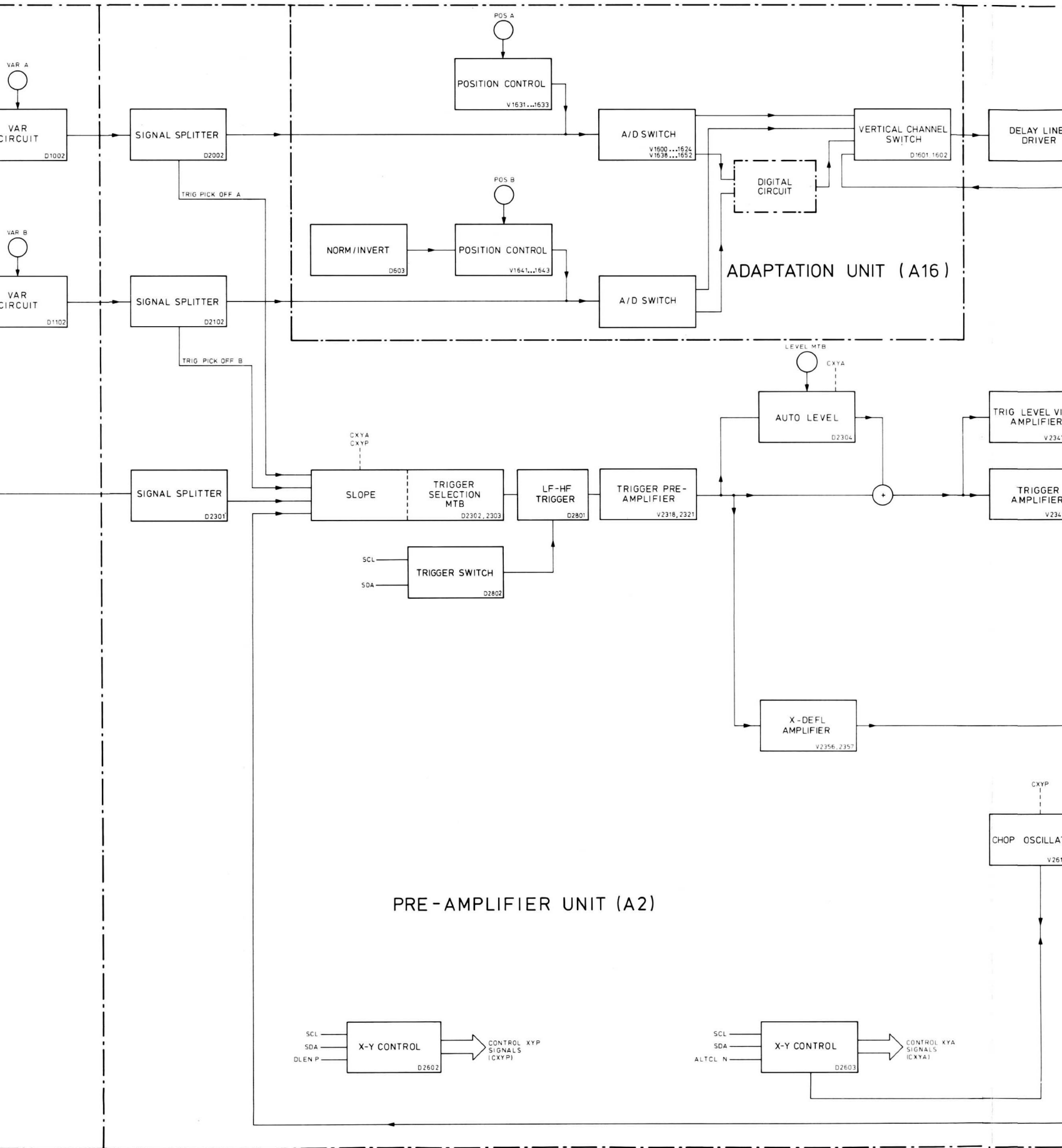

Figure 3.1 Block diagram, analog part



ATTENUATOR UNIT (A1)

Figure 3.1 Block diagram, analog part



TIME BASE UNIT (A4)

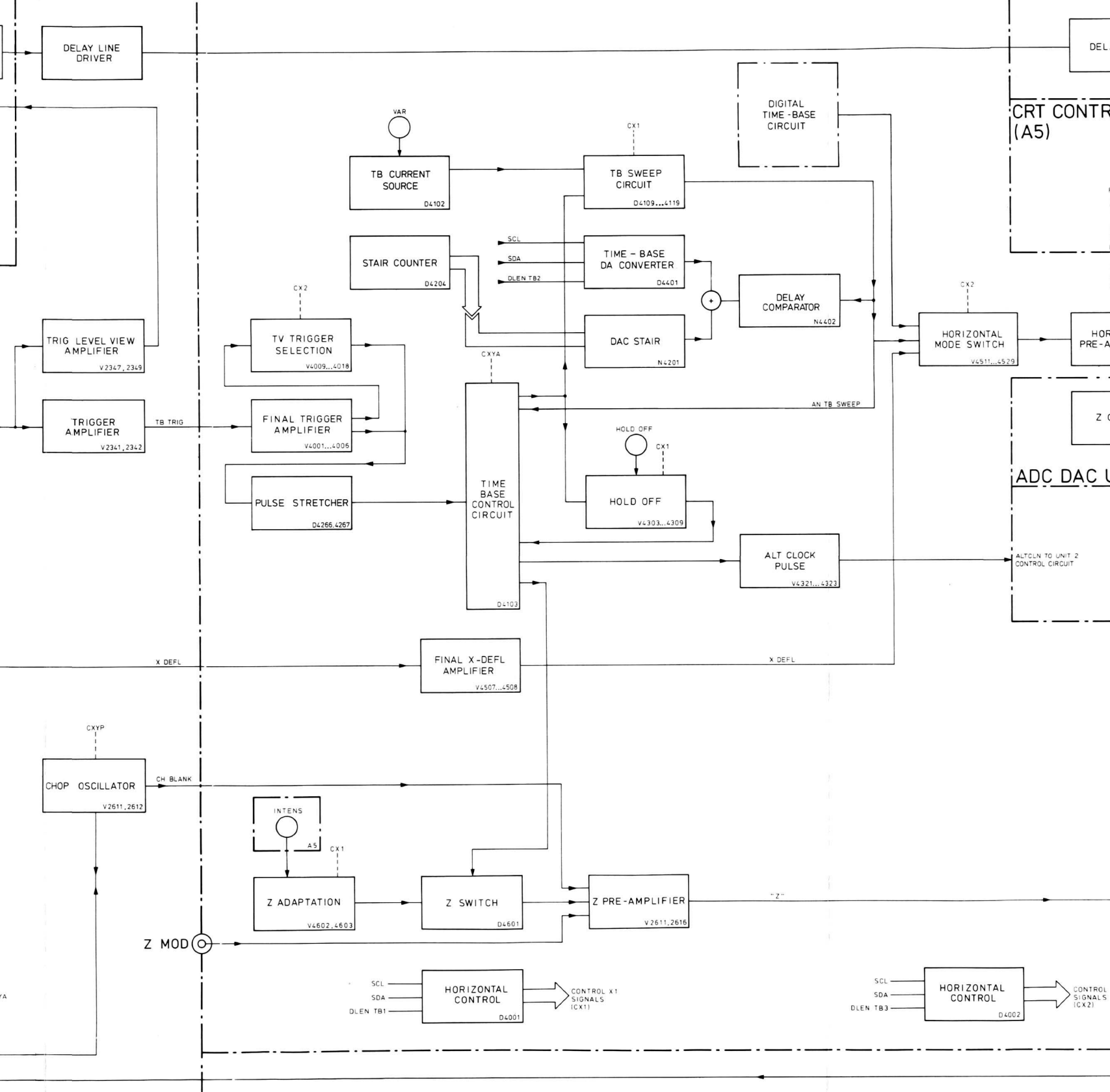

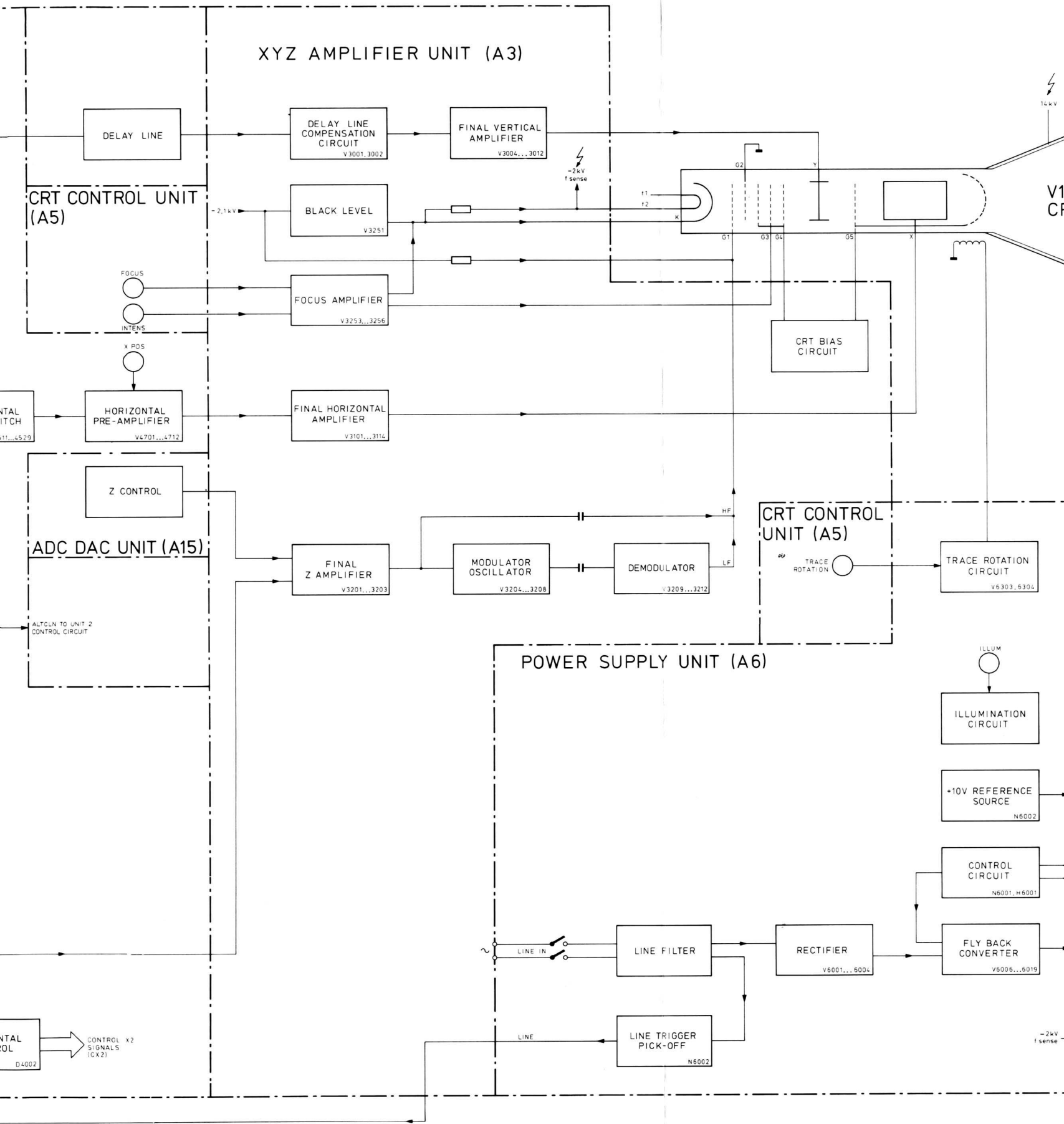

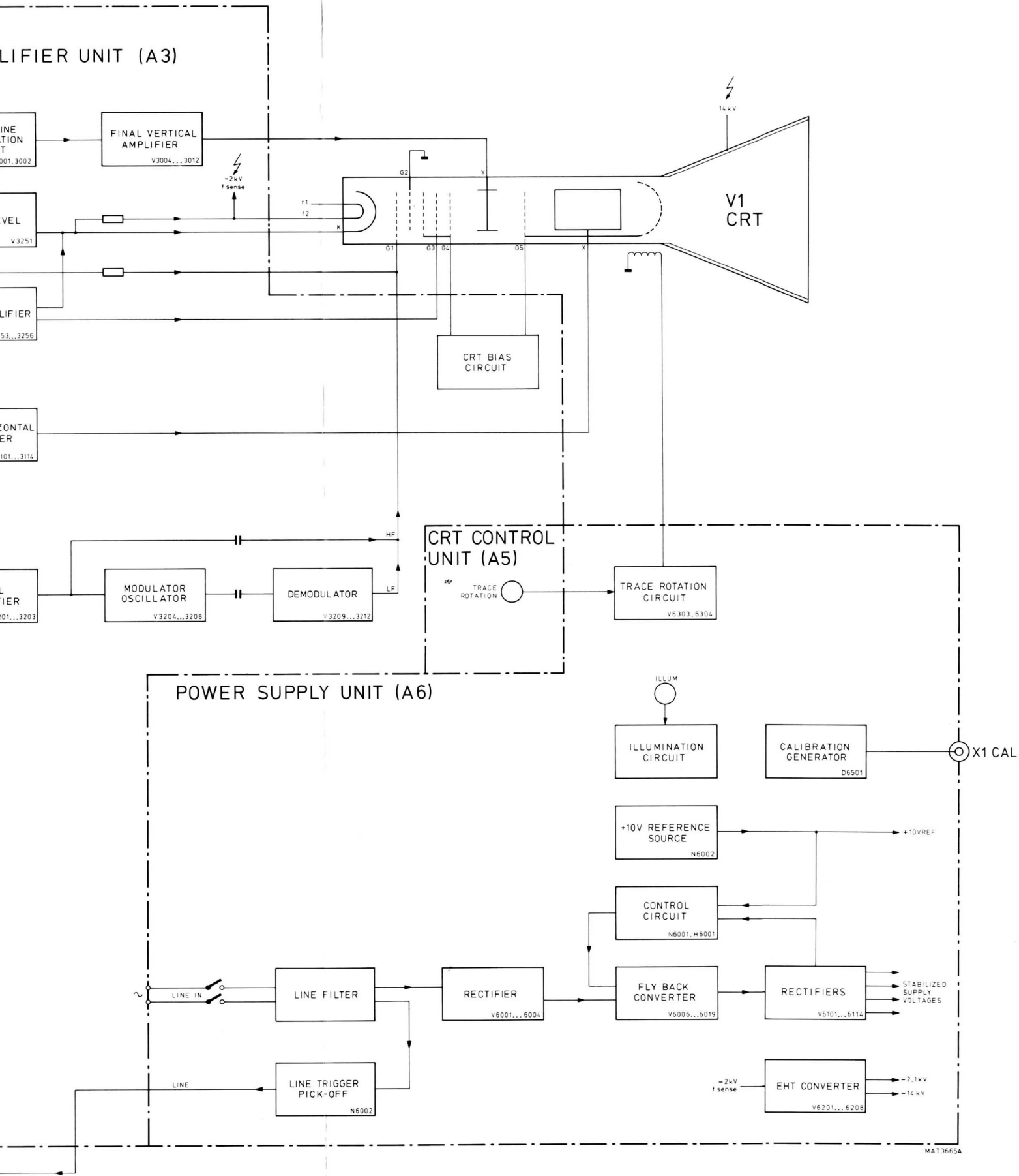

Signal name list:

The digital unit description in Chapters 12...19 contains a list with the signal names used in that unit given in alphabetical order.

After each name, a description is given and on which unit the signal is generated. Only if the signal is generated on the unit itself, are the other units on which the signal is used (signal destination(s)) mentioned, otherwise a minus sign is filled in. If the signal flows over more units in sequence, the path is indicated.

Some signals may have more signal sources, because the sources have open-collector output circuits, or 3-state output circuits. In this case the sources are mentioned, separated with a plus (+) sign. The unit where the signal is generated is always indicated as signal source.

A number of power supply lines and ground lines are not mentioned on the signal name lists because they appear in almost every unit.

3.1.3 Location of electrical parts

The item numbers of C....., R....., V....., N....., D.... and K.... have been divided into groups which relate to the circuit and the printed-circuit boards according to the following table:

<u>Item number</u>	<u>Unit no.</u>	<u>Printed-circuit board</u>
1000-1599	A1	Attenuator unit
2000-2999	A2	Pre-amplifier unit
3000-3999	A3	XYZ amplifier unit
4000-4999	A4	Time-base unit
5000-5099	A5	CRT control unit
6000-6999	A6	Power supply unit
7000-7999	A7	Front unit
8000-8999	A8	LCD unit
200- 299	A12	CPU unit
300- 399	A13	DCL unit
400- 499	A14	ACL unit
500- 599	A15	ADC DAC unit
1600-1799	A16	Adaptation unit
700- 799	A17	Mini CCD (PM3365A/67A only)
800- 999	A18	P ² CCD unit
5100-5999	A18	P ² CCD unit (PM3375/77 only)

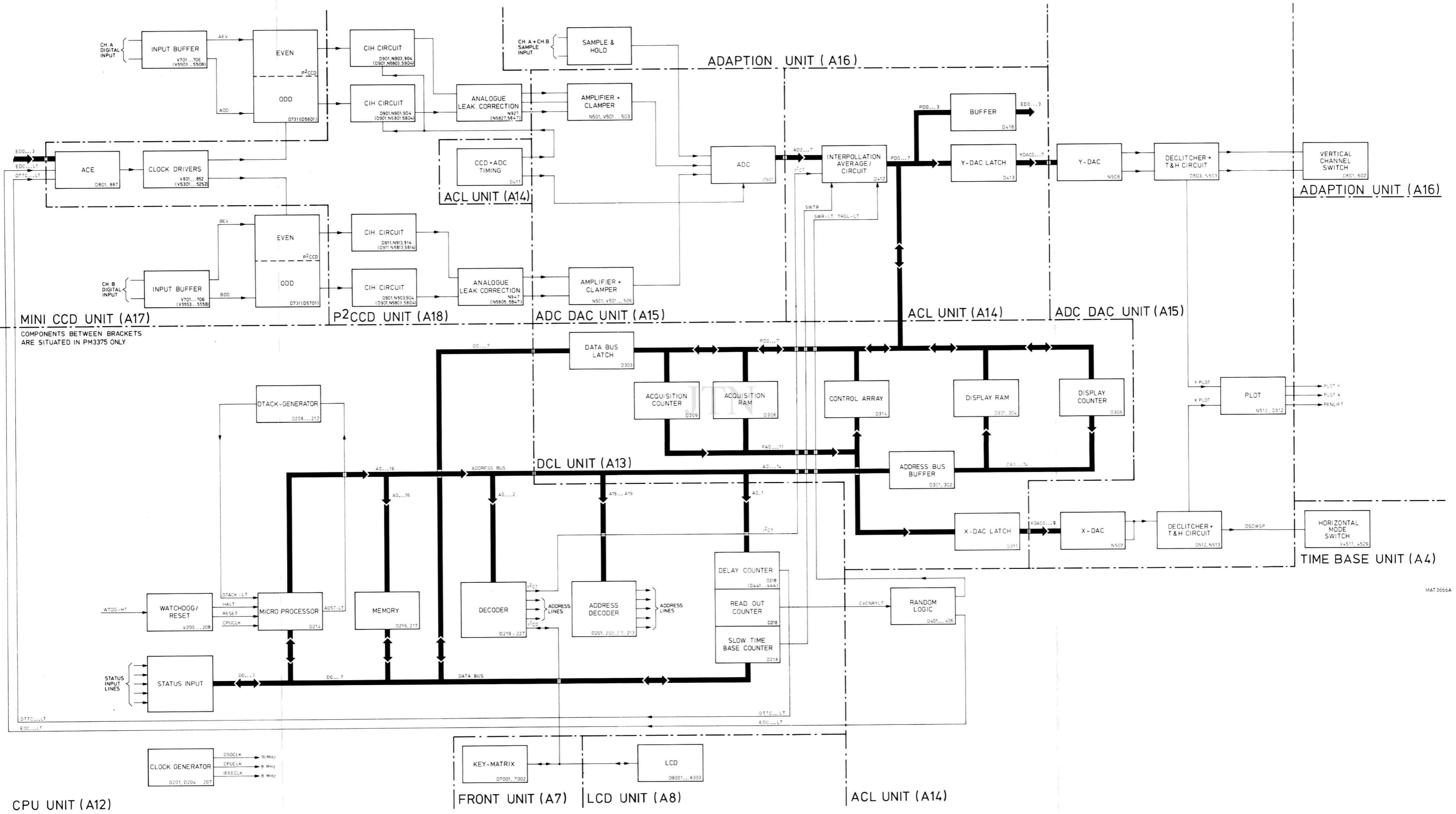

CPU UNIT (A12)

FRONT UNIT (A7)

LCD UNIT (A8)

ACL UNIT (A14)

Figure 3.2 Block diagram, digital part

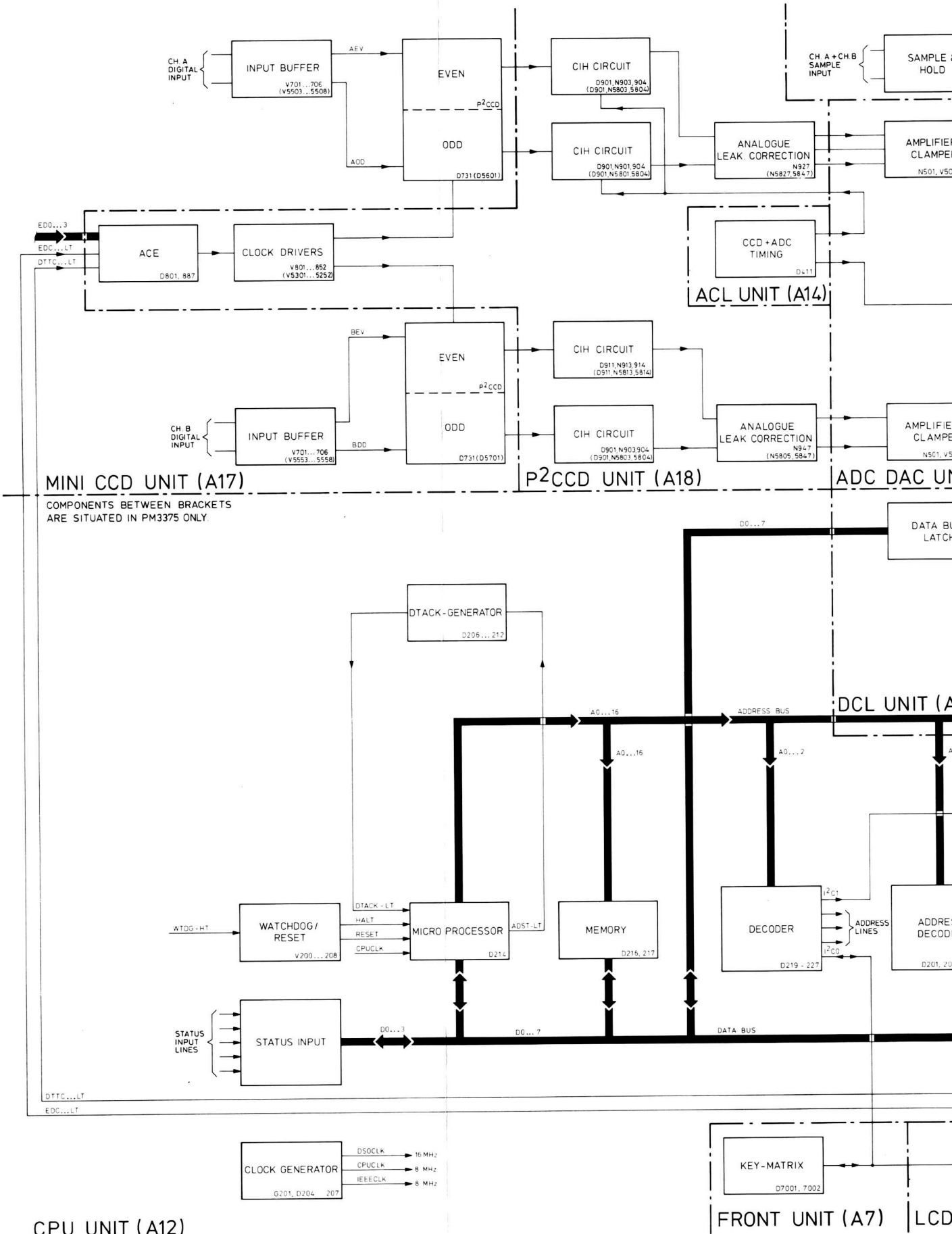
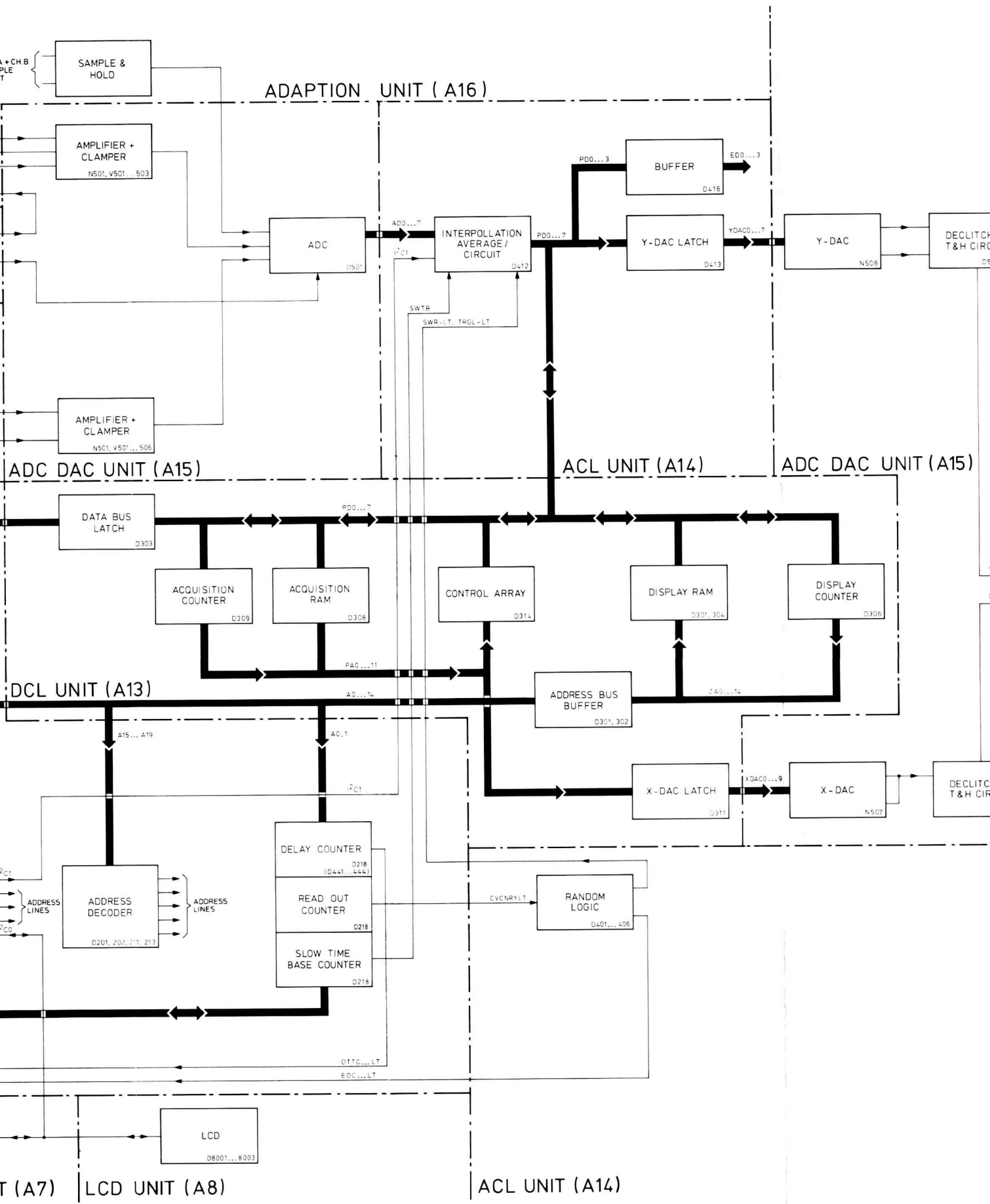

Figure 3.2 Block diagram, digital part



T (A7)

LCD UNIT (A8)

ACL UNIT (A14)

16)

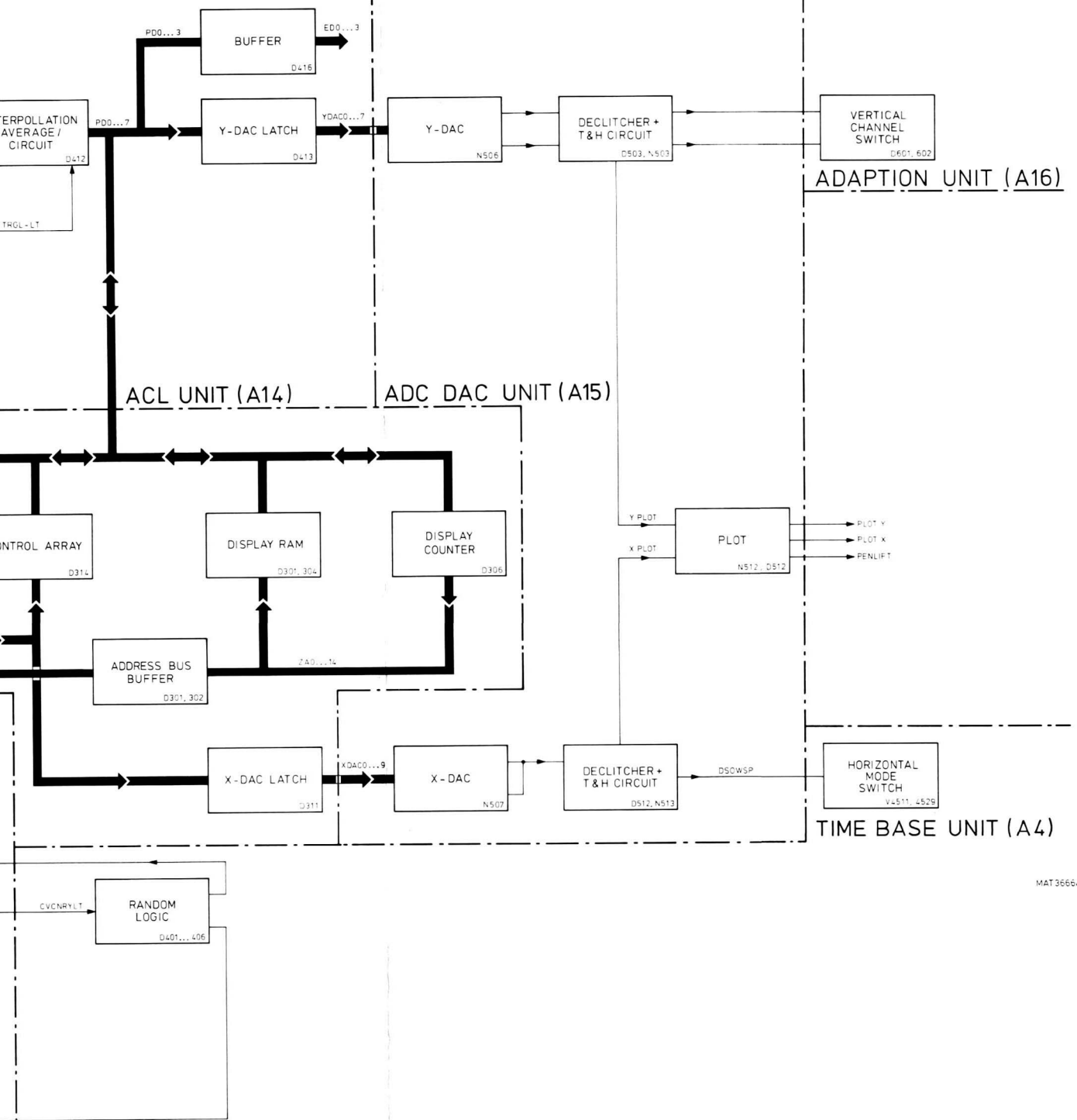

ADAPTION UNIT (A16)

ACL UNIT (A14)

ADC DAC UNIT (A15)

TIME BASE UNIT (A4)

ACL UNIT (A14)

On the adaptation unit, vertical shift of the displayed signal is achieved by the front-panel POSITION control. Switching between the real time path and the digital storage path is obtained in the A/D SWITCH block. The digital circuit is given in figure 3.2 and described separately. Next, the output of the VERTICAL CHANNEL SWITCH is routed via the DELAY LINE DRIVER to the DELAY LINE.

The TRIGGER LEVEL VIEW channel enables display of the time base triggerlevel and can be used to determine the trigger point of the signal.

*** Trigger circuit:**

The SLOPE/TRIGGER SELECTION block receives a trigger signal from one of the vertical channels A or B, from the EXT SIGNAL SPLITTER or from the LINE TRIGGER PICK-OFF. Inverting of the trigger signal is controlled by the CXYA signals INVAM and INVBM to obtain the slope function. Routed via the DC-LF-HF SELECTION and the TRIGGER PRE-AMPLIFIER block, the signal is split up into different paths:

- after summation of the LEVEL signal, direct to the TRIGGER AMPLIFIER
- to the AUTO LEVEL block. This block contains the different trigger facilities and levelling of the trigger signal is influenced by the front-panel LEVEL control. The output of this path is routed again to the summation point to influence the direct trigger signal.
- to the X-DEFL AMPLIFIER for X-deflection facility. This block incorporates a phase correction circuit for the X-Y display.

The TRIGGER AMPLIFIER feeds the trigger signal to the time-base unit. The trigger signal from the summation point is also routed via the TRIGGER LEVEL VIEW AMPLIFIER to the vertical CHANNEL SWITCH stage to display the trigger point.

*** Chopper oscillator circuit:**

A square-wave signal for chopper blanking and vertical switching is generated in the CHOP OSCILLATOR. For chopper blanking the signal is routed to the Z PRE-AMPLIFIER on the time-base unit.

3.2.4 Time-base unit (unit A4)

This unit incorporates the time-base (TB), the horizontal amplifier and the Z amplifier circuit. All functions are controlled by the CX1 and CX2 signals, generated by the HORIZONTAL CONTROL CIRCUIT blocks.

*** Time-base (TB):**

The trigger signal can be either directly routed to the TIME-BASE CONTROL CIRCUIT or first routed via the TV TRIGGER SELECTION for the TV trigger coupling. When in the AUTO mode, in the absence of trigger signals, the time base will be free running.

The CURRENT SOURCE applies the sawtooth charging current to the sweep circuit. This block generates the time base sawtooth signal, which is routed to the HORIZONTAL DISPLAY MODE SWITCH..

The HOLD OFF and the ALT CLOCK PULSE blocks are also under control of the TIME BASE CONTROL CIRCUIT. Hold off time is varied by the front-panel HOLD OFF control. The output of the HOLD OFF block is routed to the TIME-BASE CONTROL CIRCUIT again.

The ALTCLN-pulse is applied to the PRE-AMPLIFIER UNIT.

3.2.5 XYZ unit (unit A3)

This unit comprises the final amplifiers for the vertical (Y) and horizontal (X) deflection and for the blanking (Z) circuit. In addition to this, the CRT control circuits are also incorporated in the unit.

* Final vertical amplifier:

The output signal from the pre-amplifier unit is first routed via the DELAY LINE to give sufficient delay to ensure that the steep leading edges of fast signals are displayed and then fed to the DELAY LINE COMPENSATION. This block compensates the signal for distortion originating in the DELAY LINE before it is applied to the FINAL VERTICAL AMPLIFIER. The output of the FINAL VERTICAL AMPLIFIER feeds the vertical deflection plates of the CRT.

* Final horizontal amplifier:

The horizontal deflection signal is routed to the FINAL HORIZONTAL AMPLIFIER, the output of which feeds the horizontal deflection plates of the CRT.

* Blanking circuit:

The output signal from the Z PRE-AMPLIFIER of the time-base unit, that determines trace blanking or unblanking and modulation is routed to the FINAL Z-AMPLIFIER. After amplification the blanking signal is split into two paths:

- the h.f. signals are fed via a high voltage capacitor to grid G1 of the CRT.
- the l.f. signals are used to modulate the amplitude of an oscillator wave-form, which then passes via another high voltage capacitor and is demodulated in the DEMODULATOR block to retrieve the original signal.

Note that the original h.f. and l.f. signals are again recombined on the grid G1.

* CRT control circuits:

The FOCUS AMPLIFIER block is influenced by both front-panel FOCUS and INTENS controls to provide a focus that is independent of the intensity, and drives the focusing grid G3 of the CRT.

The -100 V BLACK LEVEL block provides the correct presetting of the cathode voltage.

The CRT BIAS gives a d.c. voltage to the grids G4 and G5 to provide an optional adjustment for geometry and astigmatism.

3.2.6 Power supply unit

The mains input voltage is filtered and then applied to the RECTIFIER block to obtain a d.c. voltage source. Another output of the LINE FILTER block is routed via the LINE TRIGGER PICK-OFF and serves as a MTB LINE trigger signal. The rectified mains source is routed to the FLYBACK CONVERTER, which generates the necessary voltages for the oscilloscope circuits. Each supply voltage is rectified in the RECTIFIERS block. The LOW-voltage supplies are stabilized by the CONTROL circuit to the converter. The +10 V REF supply serves as a low-voltage reference and is generated in the +10 V REFERENCE source block. This reference voltage is also fed to the different circuits on the power supply or in the oscilloscope.

The EHT CONVERTER generates the -14 kV for the post-accelerator anode of the CRT and the -2 kV for the cathode circuits.

*** Auxiliary circuits:**

The CALIBRATION GENERATOR generates the CAL voltage, which is applied to the output socket X1. The CAL voltage has a square-wave of 1,2 V p-p level with a frequency of 2 kHz.

The ILLUMINATION CIRCUIT determines the amount of current passed to the graticule illumination lamp of the CRT, controlled by the ILLUM control on the front-panel.

The TRACE ROTATION CIRCUIT determines the strength and sense of the current passed to the trace rotation coil around the neck of the CRT. The current is influenced by the front-panel screwdriver-operated TRACE ROT control.

3.2.7 P²CCD circuits and control logic (unit A17 and A18)

In the PM3365A, the P²CCD unit incorporates two mini CCD units (one for each channel), the P²CCD driver circuits and the P²CCD output circuits. The two mini CCD units are mounted as separate units on the main board.

In the PM3375 the two P²CCDs are situated on the main P²CCD unit A18.

The vertical channels A and B for the signals to be displayed are identical. Each channel comprises an INPUT BUFFER, P²CCD, odd and even CIH (Clamp Integrate Hold) circuit and the ANALOG LEAKAGE CORRECTION.

Signals derived from the A/D switch on the adaptation unit are passing the P²CCD circuits. These Profiled Peristaltic Charged Coupled Devices act as analog shift registers which are able to store signal samples in a rhythm that depends on the selected time base speed. This rhythm is generated by the ACE (Advanced Customised ECL) and via the CLOCK DRIVERS applied to the P²CCDs. For time-base speeds which cannot be handled by the ADC any more, the P²CCD devices are used for time conversions. This means that signal samples can be sampled by the P²CCDs in a high rhythm and later converted by an ADC circuit in a lower rhythm. This lower rhythm is generated by the READ OUT COUNTER. Each channel contains a P²CCD which contains in its turn two sections of 256 signal samples.

The P²CCD is fully controlled by the ACE which delivers control signals and which also controls the CLOCK DRIVERS.

The output of the P²CCDs are applied to fast CIH circuits. These circuits are able to hold the signal information for a time that is long enough for the track-and-hold circuit to take them over. The CIH circuit is controlled by the CCD and ADC TIMING.

The ANALOG LEAKAGE CORRECTION corrects the signals for leakage.

3.2.8 ADC circuit (unit A15)

The signal derived from the P²CCD unit must first be clamped into the correct input signal for the ADC. This ADC converts this signal to an 8-bit digital word and is able to perform conversion with a maximum speed of 50 kHz. This conversion is controlled by the CCD + ADC TIMING.

3.2.9 Signal processing unit (unit A13 and A14)

The signal processing circuit consists of an AVERAGE AND INTERPOLATION circuit, an ACQUISITION circuit and a DISPLAY circuit. It takes data from the ADC, performs calculation on it and sends the data to the Y-DAC latch or it reads/writes the data from/to the microprocessor. The address of the data is put into the X-DAC latch.

The AVERAGE AND INTERPOLATION circuit averages the differences between the odd and even channels and calculates also 512 linear interpolated points between each of the 512 samples. The output data is transferred to the Y-DAC latch or to the memories.

During time intervals of 500 ns each, the different data transports occur in the following sequence:

- data is written in the ACQUISITION MEMORY, addressed by the ACQUISITION COUNTER.
- data is copied to the bidirectional latch in the CONTROL ARRAY.
- data is written in the DISPLAY MEMORY, addressed by the DISPLAY COUNTER.
- data is written in the Y-DAC LATCH.

Finally, during the last time interval the microprocessor is connected to the DISPLAY RAM via the DATA BUS LATCH and ADDRESS BUS BUFFER. The data from the microprocessor can influence several functions such as text, plot, dots, etc.

3.2.10 Y-DAC and X-DAC circuits (unit A15)

The Y-DAC and X-DAC convert the 8-bit data and 13-bit address information into analog signals again. Glitches on the output of both DACs are removed by the DEGLITCHER. Next the signals are fed via a TRACK&HOLD circuit, dot-join circuit, VERTICAL CHANNEL SWITCH or HORIZONTAL MODE SWITCH to the analogue circuits.

3.2.11 Microprocessor system (unit A12)

The microprocessor system mainly consists of a powerful 68008 μ P, a RAM for data and a ROM containing the system software. The microprocessor is running at a frequency of 8 MHz provided by a CLOCK GENERATOR. This generator in its turn is driven by a 16 MHz crystal oscillator.

DECODERS decode a number of addresses resulting in the various address lines that are fed to the different circuits. Also the I2C busses are decoded.

A WATCHDOG/RESET circuit detects abnormal program sequences via an output port and resets the microprocessor via the RESET and HALT lines in order to restart the program again.

The STATUS input reads the different status information of the instrument for the microprocessor.

ATTENUATOR UNIT (A1)

JTN

4 ATTENUATOR UNIT (A1)

4.1 VERTICAL ATTENUATORS

The A and B channel attenuators are identical: therefore only channel is described.

All relay and FET switches are controlled by the microprocessor via the I²C bus. The TEA 1017 converts this serial DATA into the parallel control signals for all relay or FET switches. A list of the control lines for all attenuator settings is given in the table below.

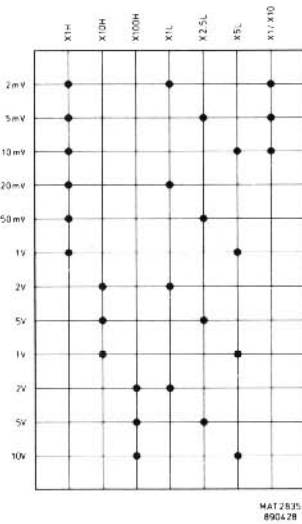

Figure 4.1 Table of attenuator settings

The channel A attenuator consists of in four stages:

High impedance attenuator with a separate path for the low frequency (lf) and the high frequency (hf) path for the signal. Each path is divided in three attenuator stages for the x1, x10 and x100 attenuation

The hf attenuators use adjustable capacitive dividers and are buffered by a junction FET buffer for each divider section. These buffers can be switched on by applying a positive control signal to the drain of the FET.

The lf attenuators use fixed resistor dividers. Only the x10 and x100 division path are switched on by means of a relay. Depending on the relay K1004 position, the input signal can either be dc-coupled (relay activated) or ac-coupled (relay not activated). Operational amplifier N1002 gives an additional inverting of the lf signal.

	HF RELAY	LF RELAY	FET	TRIMMER FOR L.F.L.F SQUARE WAVE	RESISTOR DIVIDER
x 1	--	K1003	V1013	C1018	R1001-R1026
x 10	K1007	K1002	V1008	C1014	R1001-R1026-R1027
X100	K1008	K1001	V1004	C1004	R1001-R1026-R1028

Note that the signal on the base of V1031 is a reconstituted version of the input signal again.

When grounded, relay R1006 is activated and the inverting input and output of N1001 are short-circuited. This means that the output pin 6 follows the non-inverting input pin 3.

The hf path is also connected to ground via FET V1001 and V1004.

All other relay- and FET switches are then switched-off.

The **impedance converter** serves as a non-inverting buffer circuit for the high impedance attenuator. For the l.f.-feedback the output signal of this stage is routed to the l.f. summation point N1002-2.

The **low impedance attenuator** reduces the gain by x1, x2.5 and x5, depending on which relay is activated.

	RELAY	RESISTOR DIVIDER
x1	K1011	--
x2.5	K1012	R1051 vs R1052, R1053 and R1054
x5	K1013	R1051, R1052 and R1053 vs R1054

The **continuous circuit (OQ0221)**, the differential input voltages of which are fed to pins 4 and 5.

This stage comprises the following functions:

- Continuously variable control (pin 11).
- Gain x1 (pin 2 and 3) with offset adjustment R1062 (R1162) and gain adjustment R1064 (R1164).
- Gain x10 (pin 6 and 7) with offset adjusting R1072 (R1172) and gain adjustment R1074 (R1174).
- x1/x10 control (pin 10) to select the 2, 5 and 10 mV/DIV settings.

The differential output current from pin 13 and pin 14 is routed via a common-base circuit V1036, V1037 and applied to the pre-amplifier unit.

4.2 EXTERNAL INPUT

The external input can be subdivided into four stages:

Input coupling, basically similar to the ch.A input coupling.

High impedance attenuator for the x1 attenuator only, where the l.f. square-wave can be adjusted with trimmer C1206.

Impedance converter, which converts the current from the high impedance attenuator into an asymmetrical output signal with a 80 mV/div. sensitivity.

Pre-amplifier. The output currents EXT- and EXT+ are applied to the pre-amplifier unit and serves as external trigger signal or as an external deflection signal.

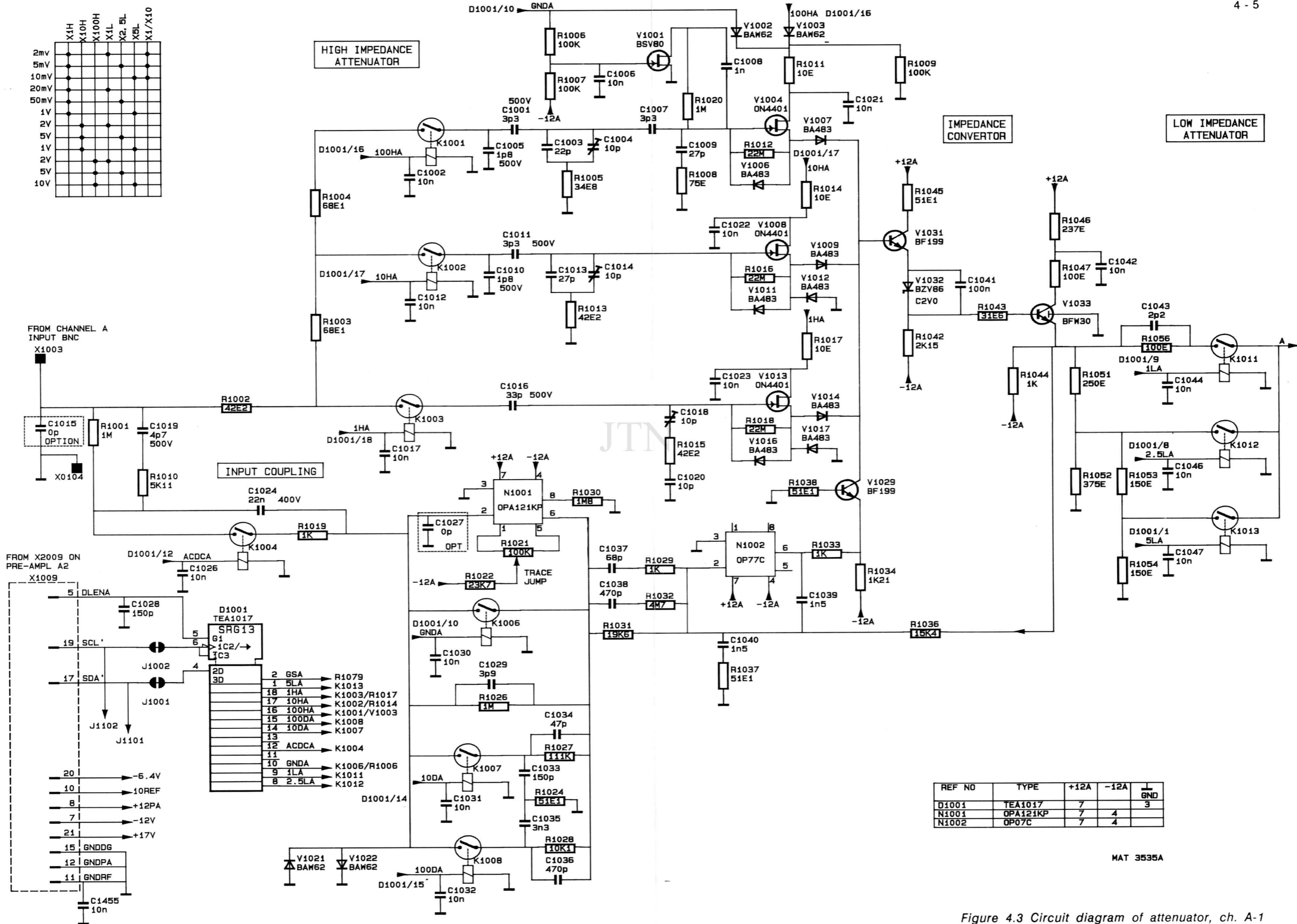

MAT 3535A

Figure 4.3 Circuit diagram of attenuator, ch. A-1

GAIN SWITCH
VAR CIRCUIT

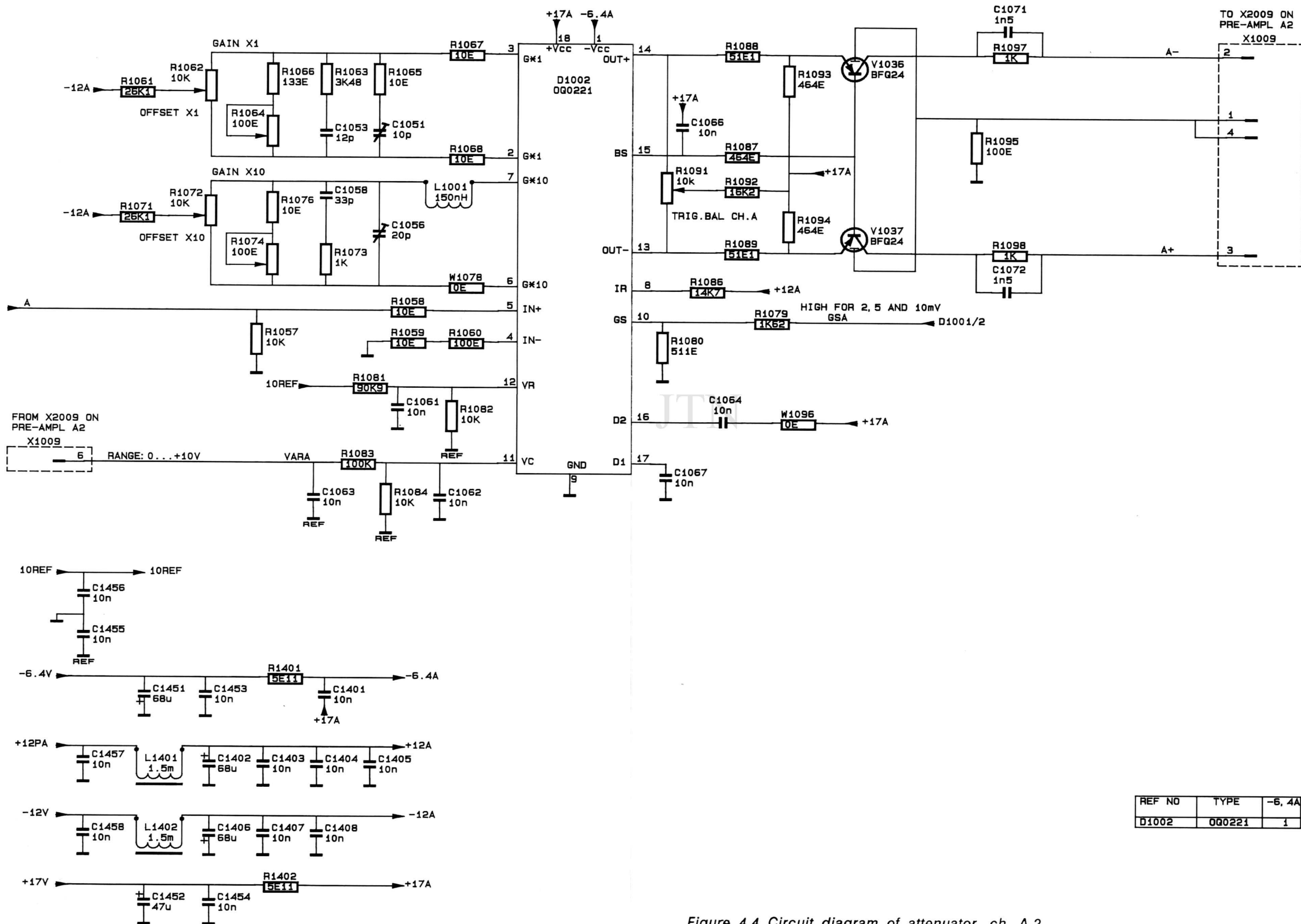
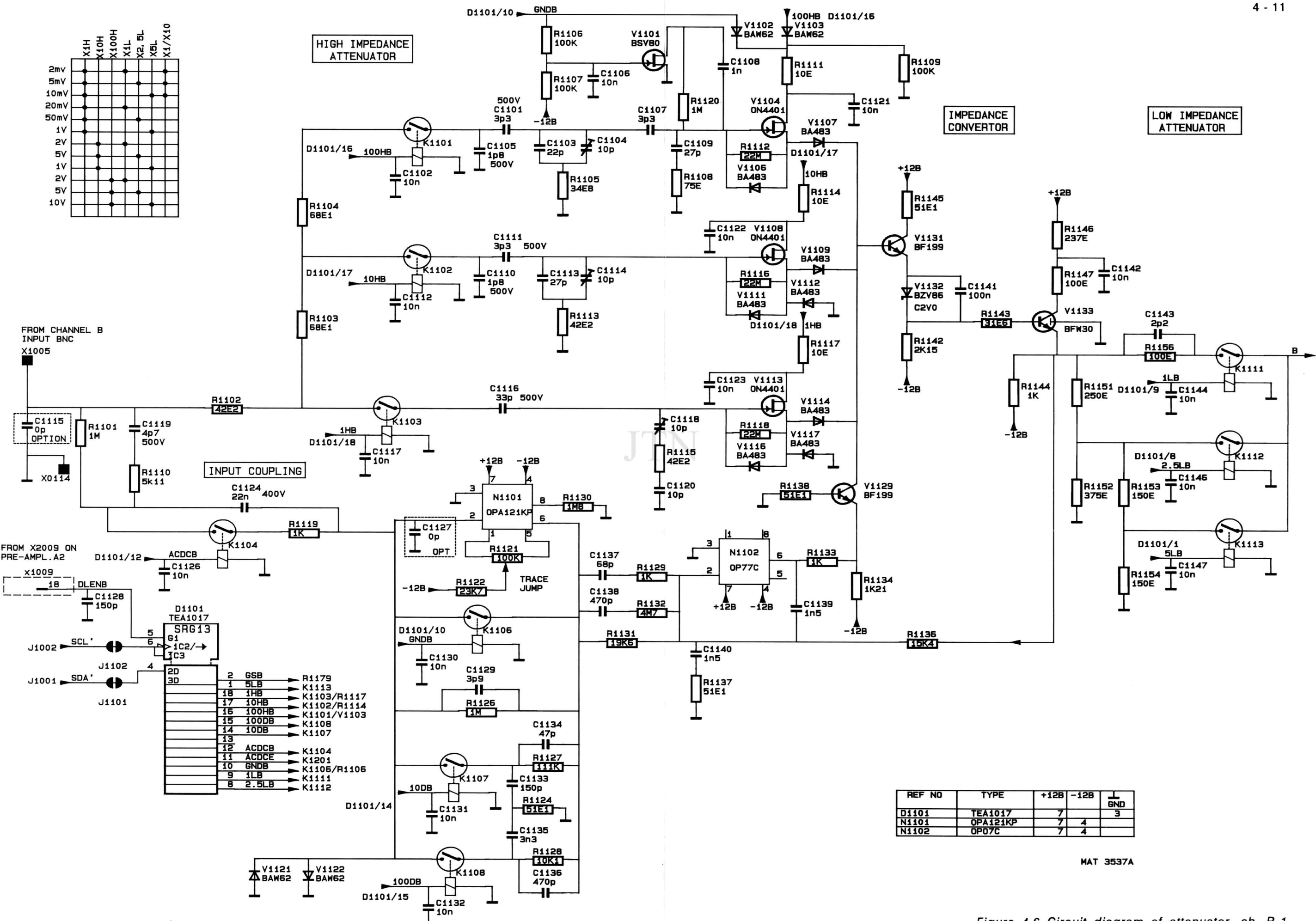

Figure 4.4 Circuit diagram of attenuator, ch. A-2



2mV	X1H
5mV	X10H
10mV	X100H
20mV	X1L
50mV	X2, 5L
1V	X5L
2V	X1/X10
5V	
10V	

REF NO	TYPE	+12B	-12B	GND
D1101	TEA1017	7	3	
N1101	OPA121KP	7	4	
N1102	OP07C	7	4	

MAT 3537A

Figure 4.6 Circuit diagram of attenuator, ch. B-1

GAIN SWITCH
VAR CIRCUIT

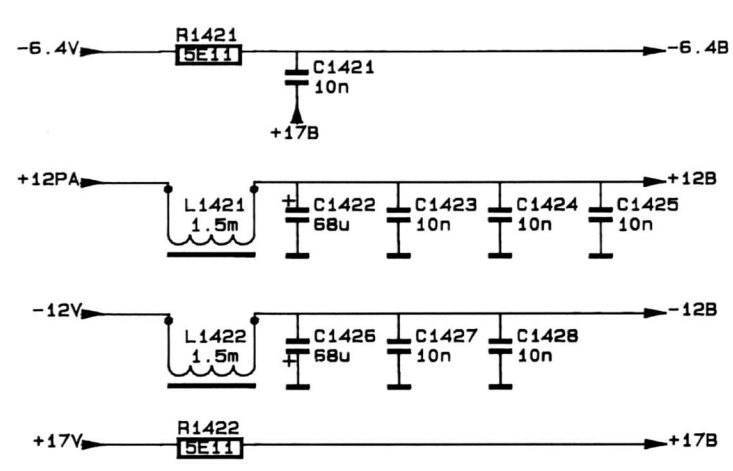
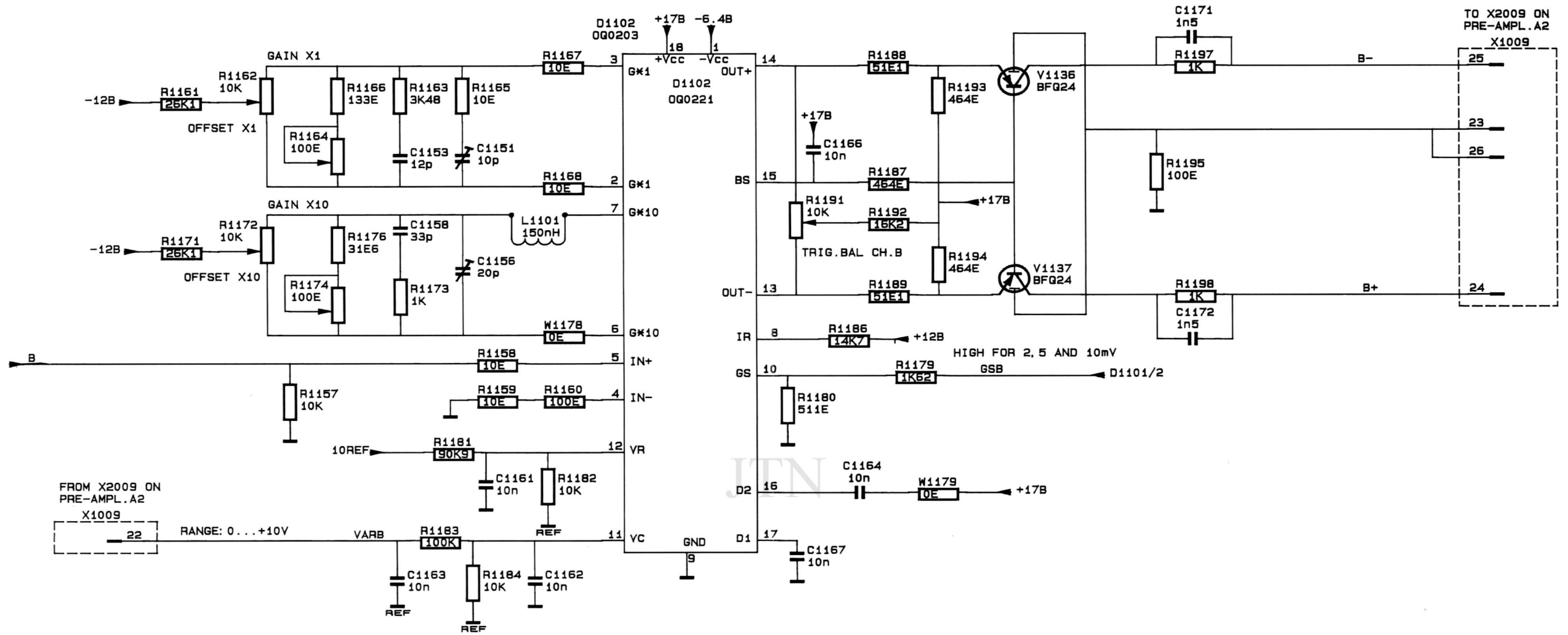

REF NO	TYPE	+17B	-6, 4B	B
D1102	OQ0221	18	1	9

MAT 3538A

Figure 4.7 Circuit diagram of attenuator, ch. B-2

TO X2009 ON PRE - AMPLIFIER (A2)

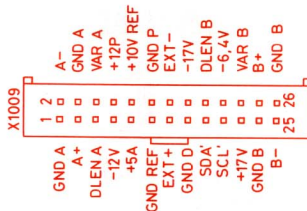

A1

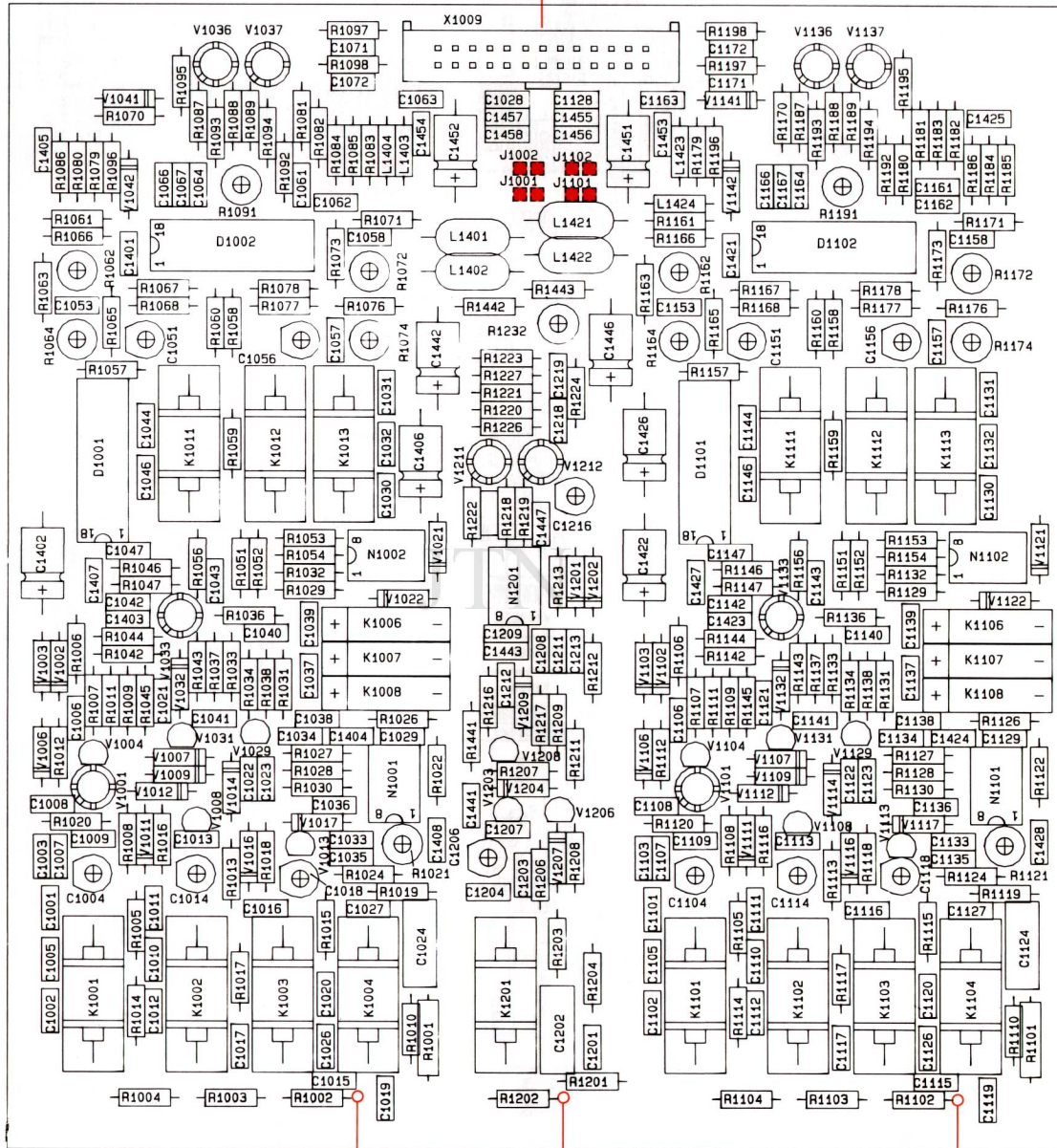

TOP VIEW



BF199

BF410
ON4401

BSV80

BFQ24
BFW30

FROM X1003
CH. A INPUT BNC

FROM X1004
EXT INPUT BNC

FROM X1005
CH. B INPUT BNC

SOLDERJOINTS:

- J1001 IF OPENED, SDA' TO D1001 IS INTERRUPTED
- J1002 IF OPENED, SCA' TO D1001 IS INTERRUPTED
- J1003 IF OPENED, SDA' TO D1101 IS INTERRUPTED
- J1004 IF OPENED, SCA' TO D1101 IS INTERRUPTED

TO BE USED IN POWER-UP ROUTINE IN CASE OF FAILURE

Figure 4.8 Attenuator unit p.c.b.

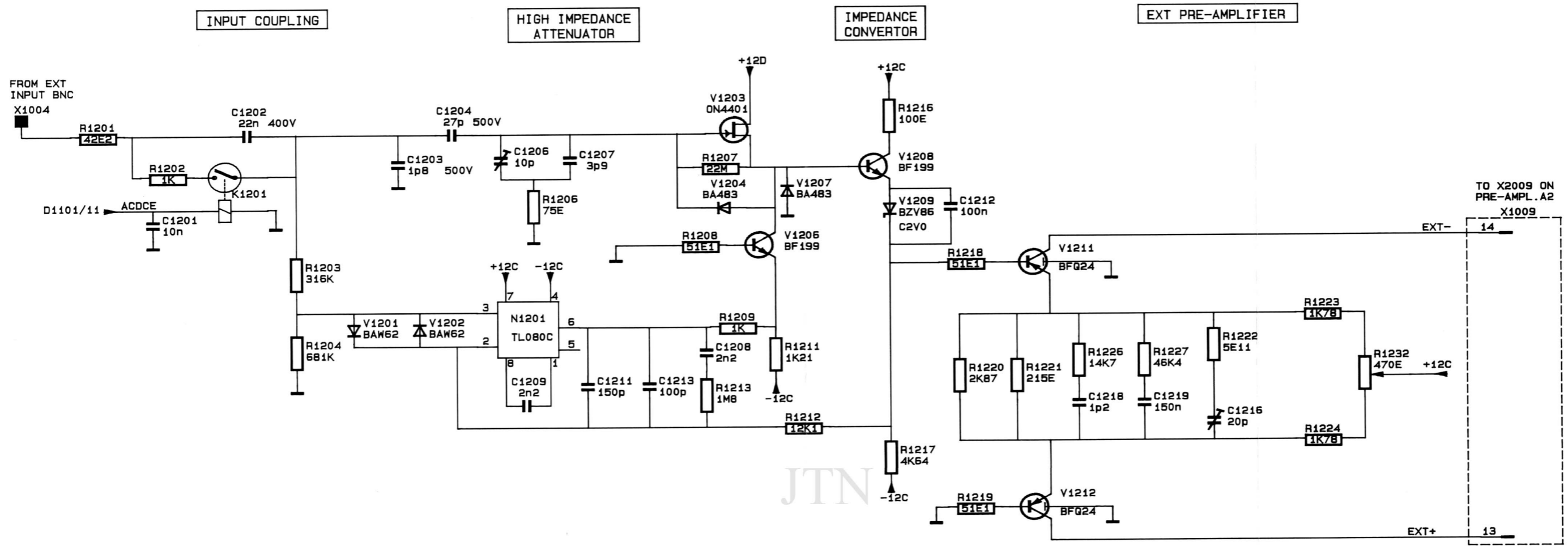

JTN

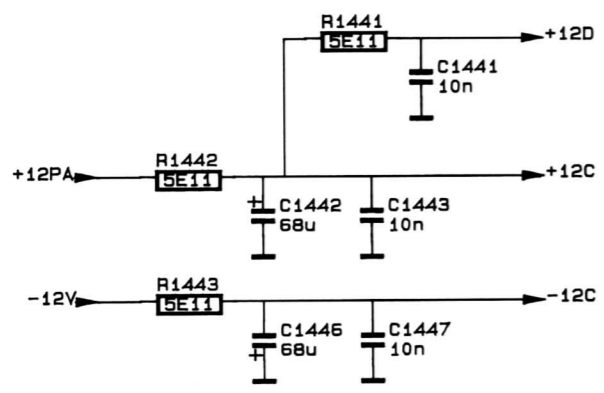

REF NO	TYPE	+12C	-12C
N1201	TL080	7	4

MAT 3539A

Figure 4.9 Circuit diagram of attenuator, EXT

PRE-AMPLIFIER UNIT (A2)

JTN

5 PRE-AMPLIFIER UNIT (A2)

The pre-amplifier unit consists of:

- Vertical pre-amplifier
- Trigger pre-amplifier
- Pre-amplifier control, incl. CHOPPER oscillator

All control pulses for this unit are generated by the pre-amplifier control circuit, via the I²C bus (see section 5.4).

5.1 VERTICAL PRE-AMPLIFIER

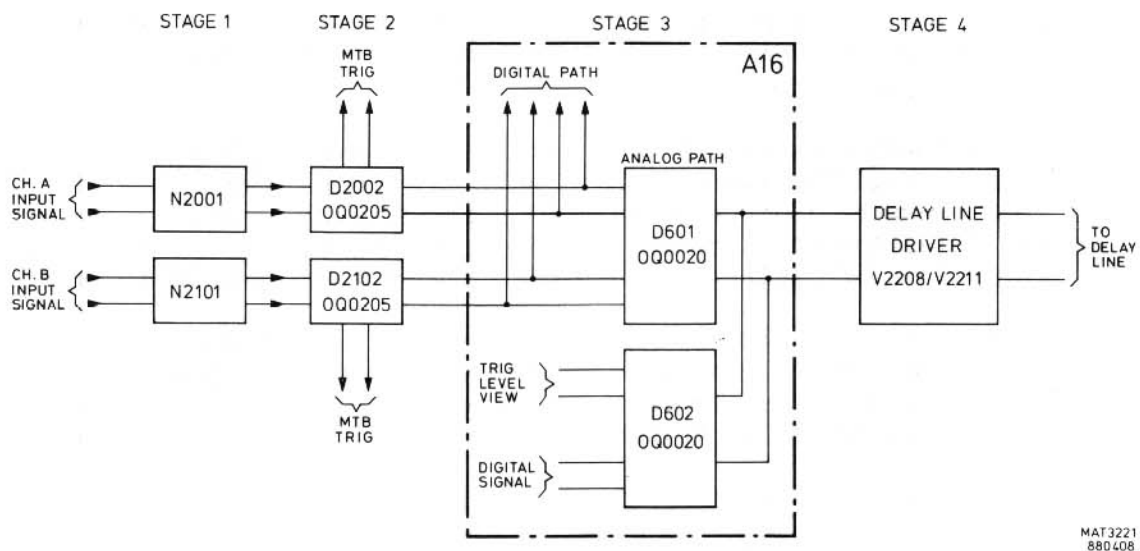

Figure 5.1 The four stages of the vertical pre-amplifier

The vertical pre-amplifier consists of four stages.

Stage 1; The channel A(B) pre-amplifier receives its input signal from the attenuator unit. This stage consists of series feedback amplifier N2001 (N2101) and has a signal amplification of 1,25x. The current output is fed to the signal splitter.

Stage 2; The signal splitter (Q0205) copies this signal into two identical differential output current signals for:

- Vertical channel (pin 7 and 10)
- TB triggering (pin 5 and 12), see section 5.2

Stage 3; Vertical channel switch (unit A16), see also description of A16, chapter 17.

This stage comprises the following functions:

- Vertical channel switch selection.
ch.A /ch.B analog, or ch.A /ch.B digital, or trigger level view.
- Position control.
POS A (R7006) for ch. A and POS B (R7008) for ch. B.
- Channel B normal/invert (high is INVERT).
The balance between normal/invert can be adjusted with R2212.

Stage 4; (V2208/V2211) serves as delay line driver where the output current of the vertical channel switch (A16) is converted into a voltage signal which is applied to the delay line. The current for this stage and for the vertical channel switch (A16) is fed via R2256 and R2263.

5.2 TB TRIGGER PRE-AMPLIFIER

Trigger possibilities are:

	Signal name	routed to	Selected by:		inverted by:	
			name	routed to	name	routed to
ch. A	TRAM +, TRAM-	D2302(3,4)	AM	D2302(10)	INVAM	D2302(2)
ch. B	TRBM +, TRBM-	D2302(5,6)	BM	D2302(11)	INVBM	D2302(7)
EXT	EXTM +, EXTM-	D2303(3,4)	EXTM	D2303(10)	INVAM	D2303(2)
line	LINE	D2303(5)	LNM	D2303(11)	INVAM	D2303(7)

D2150 serves as a signal splitter and receives its input signal from the attenuator unit. This input current signal is copied into a identical differential output current signal for the EXT TB signal (pin 6 and 11)

The symmetrical output currents from D2302 (13, 14) and D2303 (13, 14) are buffered by V2801 and V 2802 and then applied to the DC-LF-HF trigger circuit D2801. This device is controlled on pin 15 for LF, pin 10 for HF and pin 9 for DC trigger coupling. A +3,2 V to one of these three inputs selects one trigger coupling mode while the other two inputs are then +1,9 V. D2802 converts the data of the I²C bus to these control lines.

In LF mode, the signal from D2801 (13, 16) passes a low-pass filter formed by C2801, R2809 and R2811. All components with frequencies higher than 50 kHz are then rejected. In HF mode, the signal from D2801 (12, 17) passes a high-pass filter formed by C2802, C2803, R2811 and R2813. All components with frequencies lower than 50 kHz are now rejected.

In DC mode, the signal from D2801 (11, 18) is directly coupled.

The resulting currents TRMOD- and TRMOD+ are buffered by V2316 and V2319 and then converted into a symmetrical voltage by the shunt feedback circuit V2318 and V2321. Note that the sensitivity at the collectors of V2318 and V2321 is 110 mV/div (c.i. MTB- and MTB+).

At this point the signal path is divided into:

- an external deflection path, routed via the series feedback circuit V2356 and V2357, the X DEFL+ and X DEFL- signals are fed to the timebase unit A2. R2416, R2422 and C2350 gives phase correction for the X-Y display.
- a trigger path, fed to both V2333 and V2334, where depending on the current to the base, levelling of the trigger signal is obtained. Two separate series feedback circuits take care of voltage-to-current conversion:
 - * V2341 and V2342 for time-base triggering. The trigger output signal, TRIGM- and TRIGM+ are fed to the time-base unit A4.
 - * V2347 and V2349 for trigger level view. This symmetrical output can be balanced by potentiometer R2407 (LEVEL VIEW BAL). The TRIGV+ and TRIGV- signals are fed to D2202 (3-4).

Integrated circuit D2304 serves as an auto level circuit. The following functions are possible.

a. Peak-peak

In this case the amplitude of the trigger signal applied to D2304 (3,7) is measured by peak-peak detectors on D2304 (2,4,6,8). The output current from D2304 (14,15) is dependent on the peak-peak level and is adjustable with the LEVEL control R7012, connected to D2304(1).

b. Triggering

In this case the level range is 16 div. The level is adjustable with R7012 and the current variation on D2304 (14,15) can be varied between + or - 0,6mA.

c. TV triggering

The level control is made ineffective. In TV triggering, the LEVEL must be set to a fixed value. This is done by applying a high level current to pin 1 via diode V2326.

d. Auto

In auto the signal LEVEL ZERO is high and via diode V2325 the output level D2304 (15) is asymmetrical with output level D2304 (14). Thus the maximum signal amplitude is 2 Vp-p.

5.3 PRE-AMPLIFIER CONTROL

The pre-amplifier control converts the data from the I²C bus (SDA and SCL), derived from the microcomputer, into the control pulses for the pre-amplifier unit. To eliminate interference the SDA and SCL lines can be switched off via D2601.

This integrated circuit serves as a digital switch, controlled by the VERT IIC line. Logic high connects the outputs D2601(4,14,15) to the input "1" contact (switched on 3,13,1); logic low connects the outputs to the "2" contact (switched off 5,12,2) and gives SDA a logic low level and SCL a logic high level. When D2601 is switched on, the serial data information is converted into parallel control pulses via D2602 and D2603, provided that D2602 is enabled (D2602-5 is high). The control lines are active when the level of the line is high.

Output Q12-D2602(9) serves as a power up not line for D2603: when the oscilloscope is in the power-up routine, Q12 is high and resets D2603. After the power-up routine, Q12 goes low and enables D2603.

Integrated circuit D2603 relieves the microcomputer of a number of such functions as:

- trigger level view
- chop/alt
- trigger select
- time-base select (fed to time base unit A4)

Adaptation of this I.C. to the oscilloscope version is made by the AD0 and AD1 inputs D2603(15,16).

For this oscilloscope, AD0 must be HIGH and AD1 must be HIGH.

Timing for alternate and chopped mode is derived by the ALTCLN and CHOPCL pulses.

The chopper oscillator formed by V2611 and V2612 supplies a square wave voltage of 1,5 Vp-p with a frequency of 1 MHz.

This frequency is defined by two current loops:

- I1 is determined by: V2612(c-e), C2611, R2627 and R2625.
- I2 is determined by: V2611(c-e), C2611, R2628 and R2625.

The duty cycle ($I1/I1 + I2$) is 12% approx.

The square wave on the collector of V2612 serves as a chopper clock pulse for D2603 and gives a 500 kHz display for 2 channels CHOP, 333 kHz display for 3 channels CHOP and 250 kHz for 4 channels CHOP (A-B-TRIG VIEW-ADD).

Note that D2603(8) serves as the chopper switch, which is high when the CHOP softkey is depressed.

5-5, 5-10, 5-15, 5-20

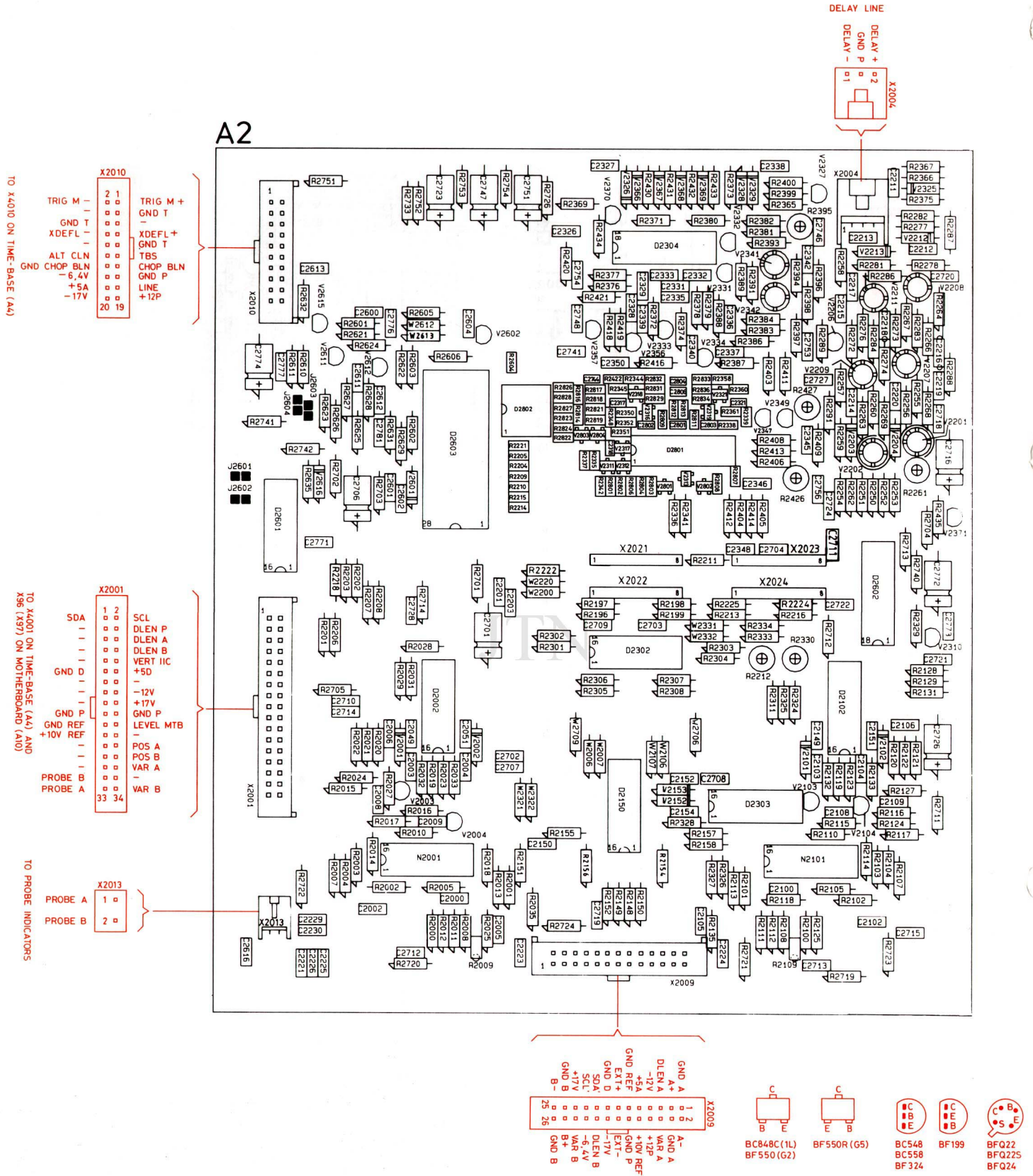

TO X1009 ON ATTENUATOR (A1)

MAT3547A

Figure 5.2 Pre-amplifier unit p.c.b.
 Figure 5.5 Pre-amplifier unit p.c.b.
 Figure 5.8 Pre-amplifier unit p.c.b.
 Figure 5.11 Pre-amplifier unit p.c.b.

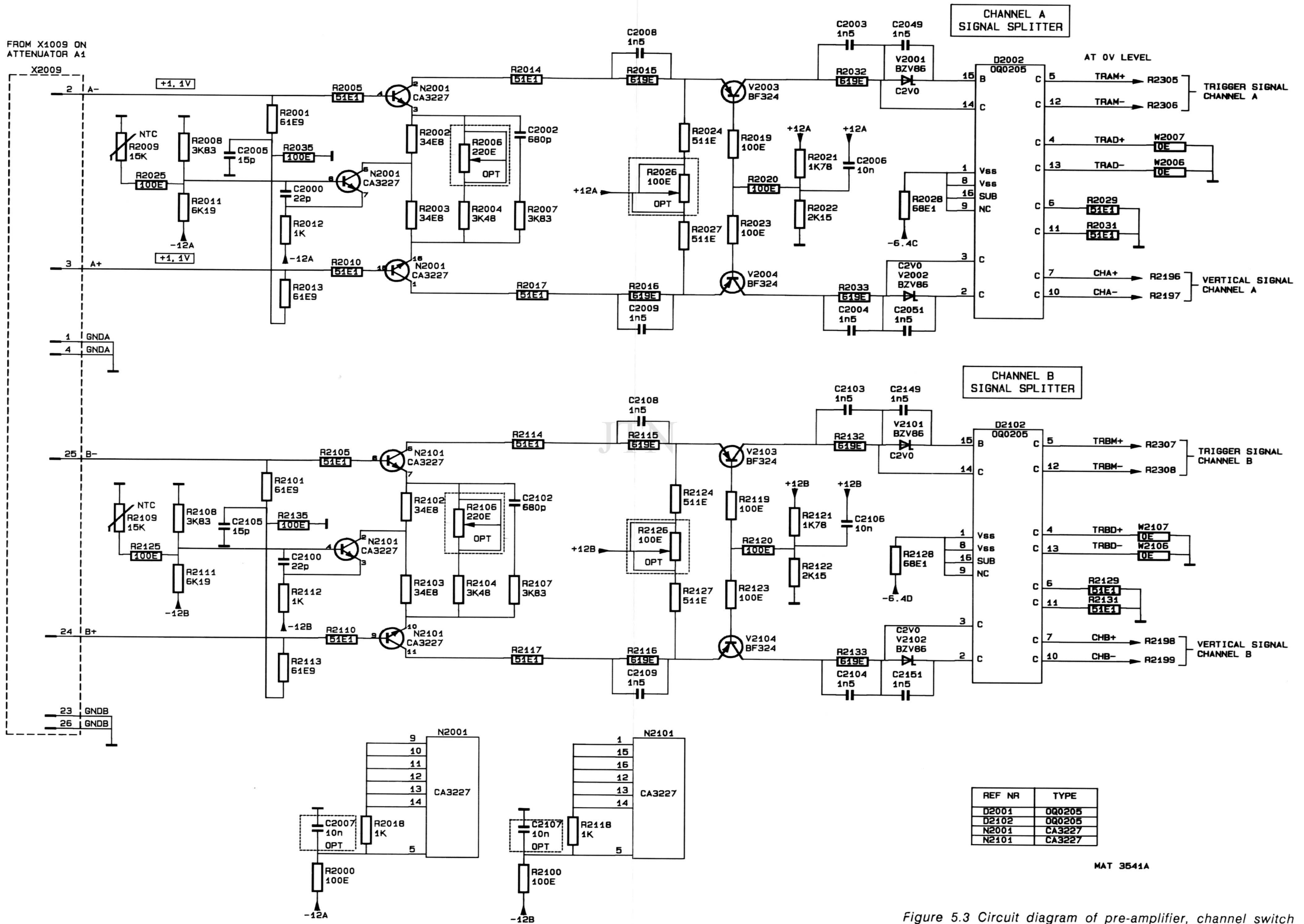

Figure 5.3 Circuit diagram of pre-amplifier, channel switch

X2021, X2022, X2023 AND X2024 ARE CONNECTED WITH A16: ADAPTION-UNIT

DELAY LINE DRIVER

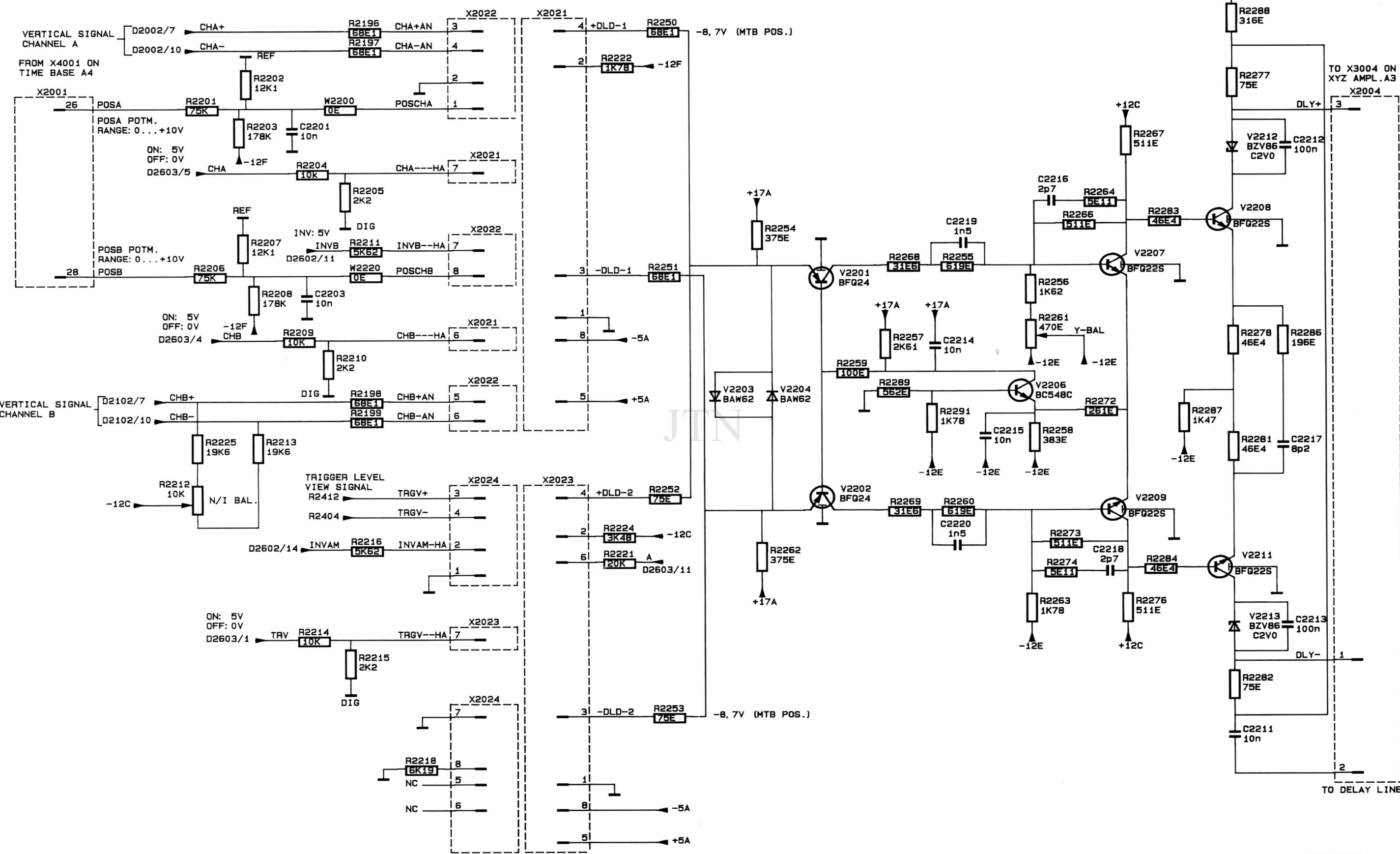
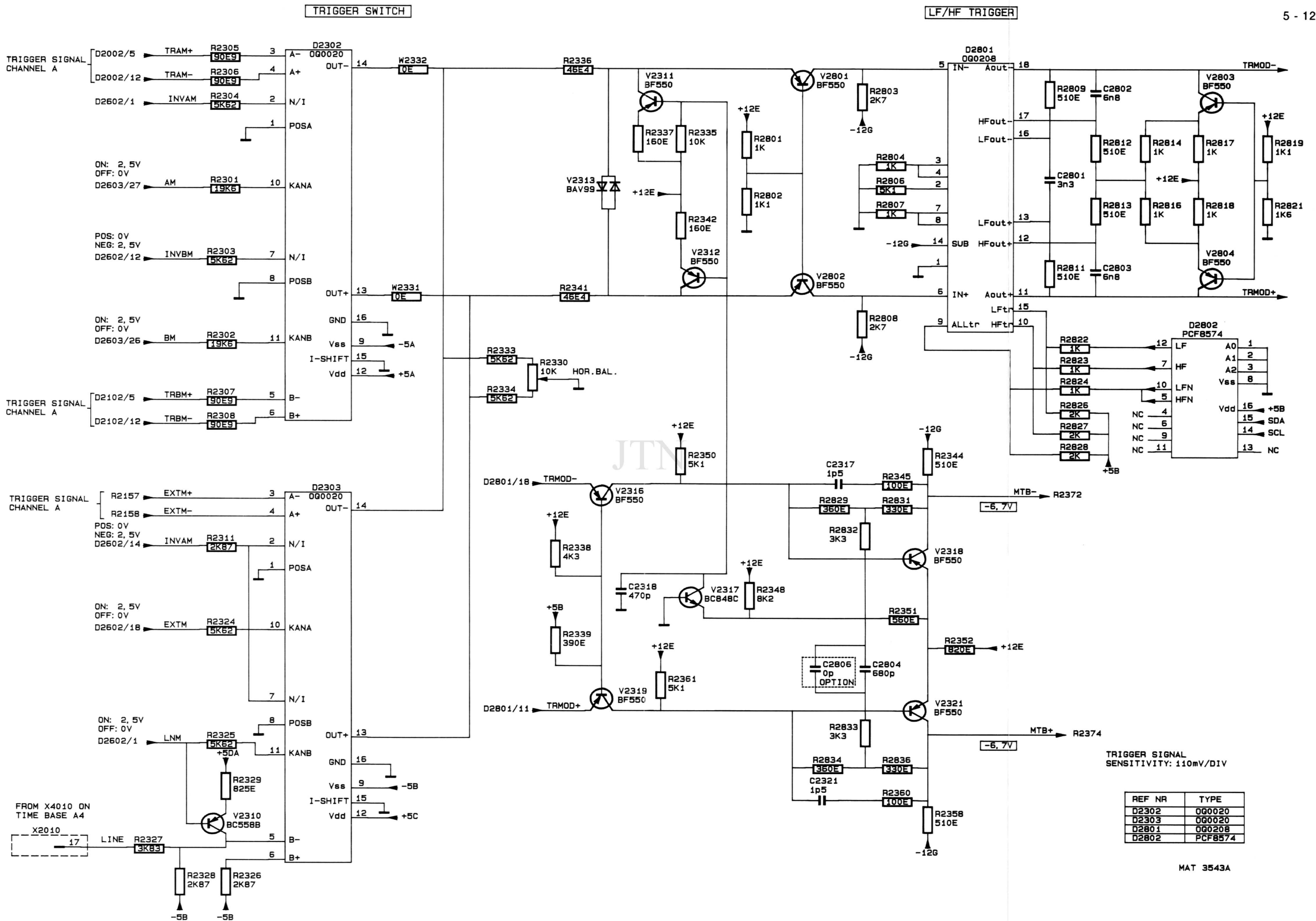

Figure 5.4 Circuit diagram of pre-amplifier, delay line driver



TRIGGER SIGNAL SENSITIVITY: 110mV/DIV

REF NR	TYPE
D2302	0G0020
D2303	0G0020
D2801	0G0208
D2802	PCF8574

MAT 3543A

Figure 5.6 Circuit diagram of pre-amplifier, MTB

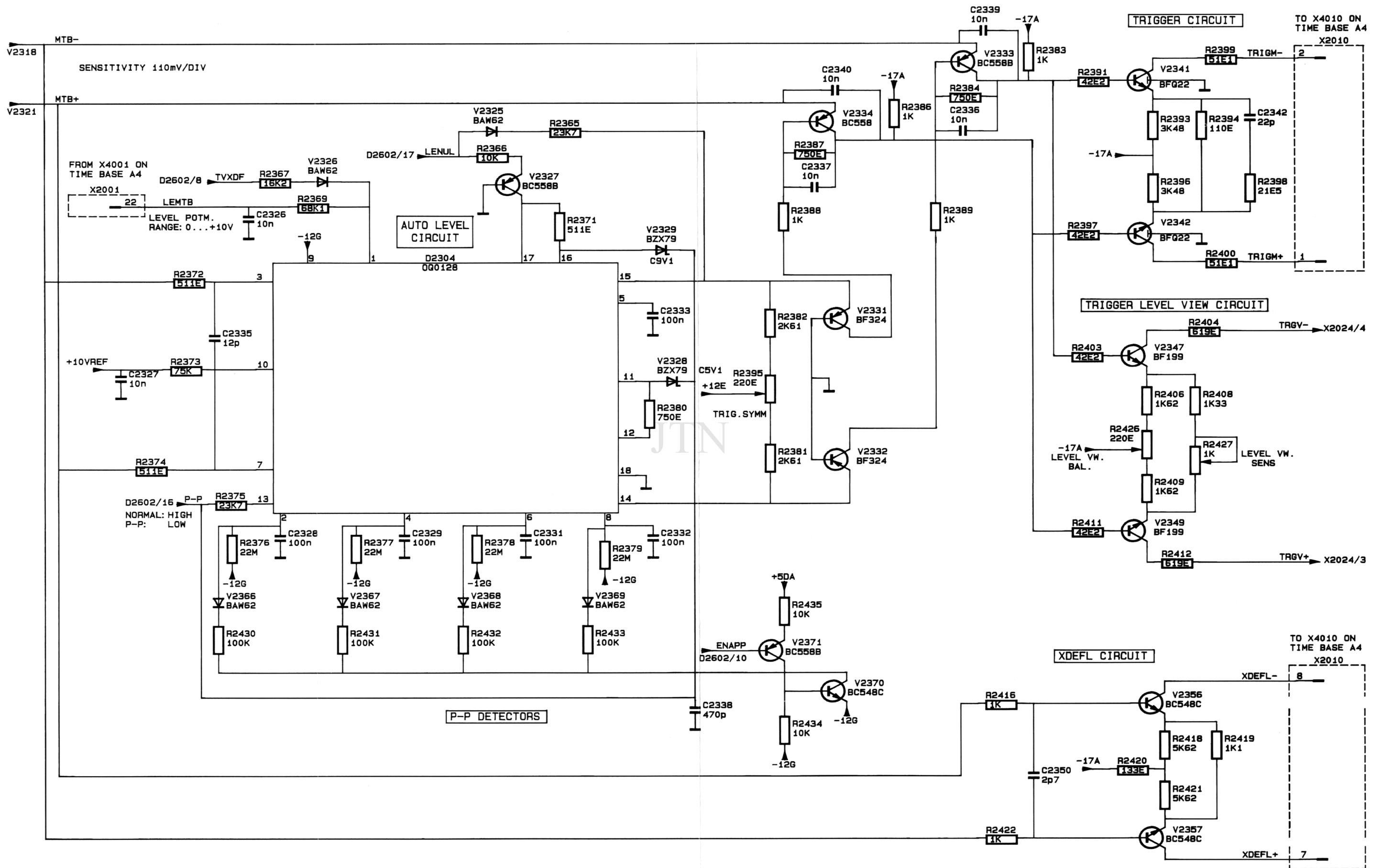

MAT 3544A

Figure 5.7 Circuit diagram of pre-amplifier, level circuit

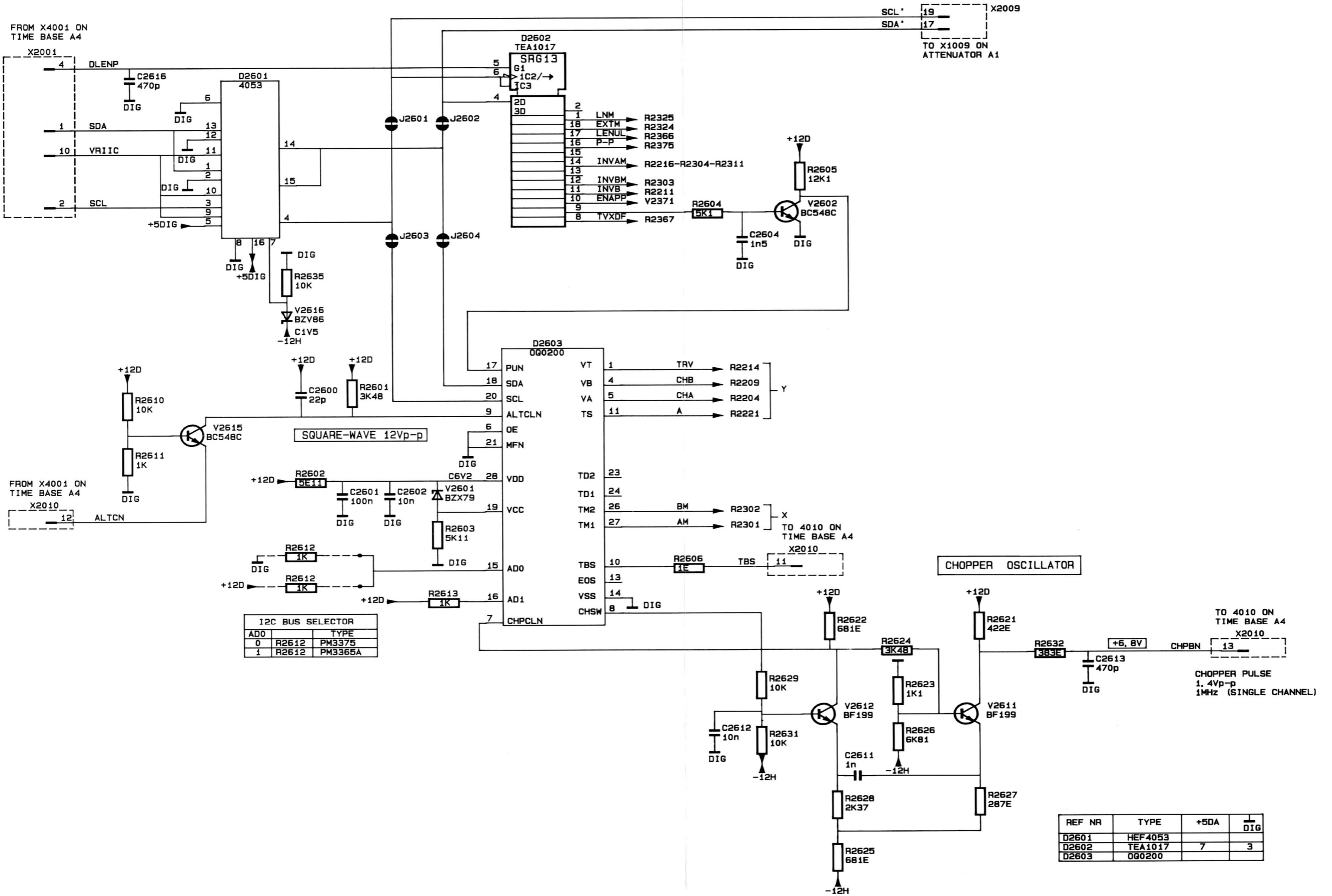

MAT 3545A

Figure 5.9 Circuit diagram of pre-amplifier, logic control

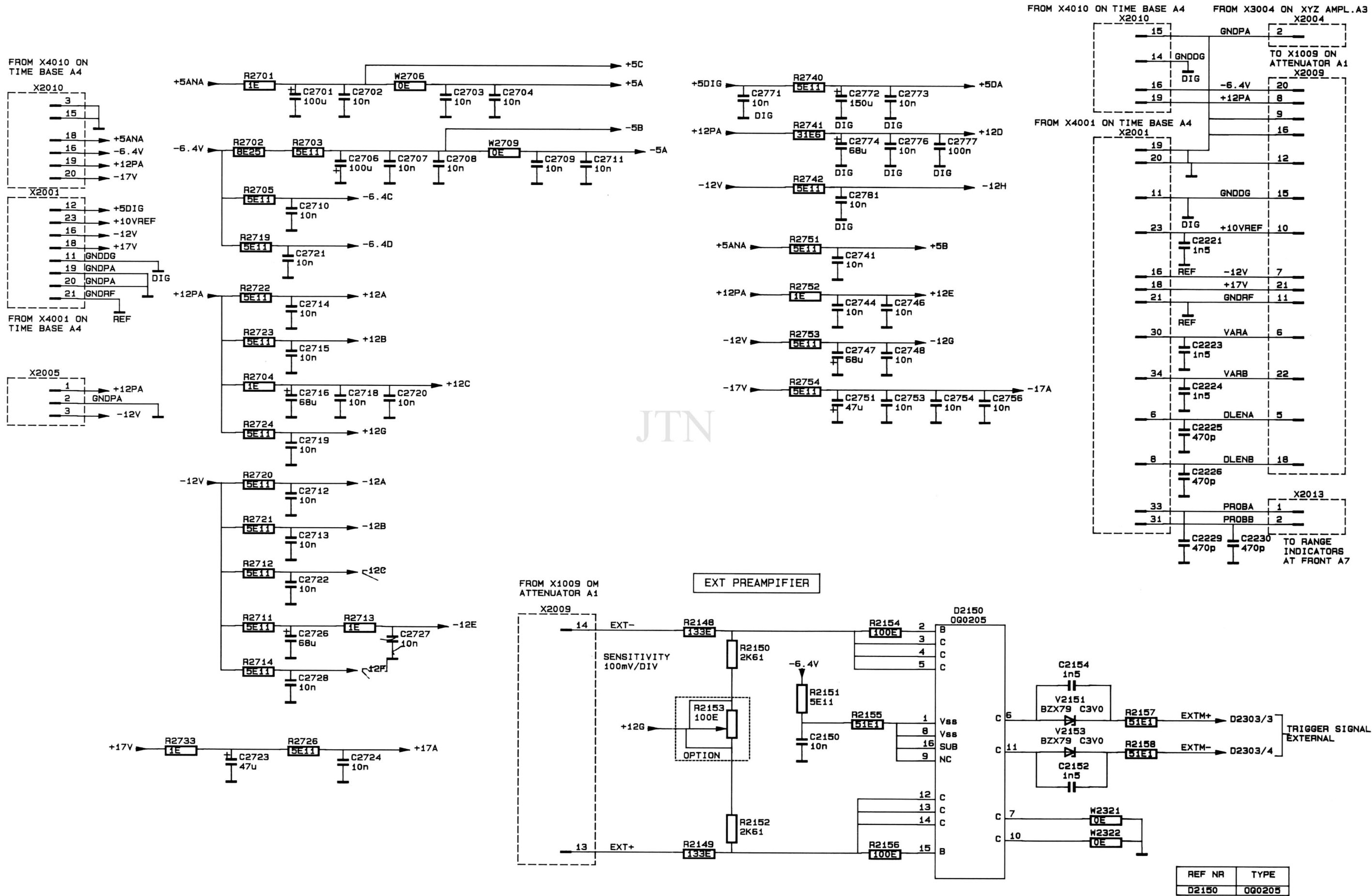

Figure 5.10 Circuit diagram of pre-amplifier, supply voltages

XYZ-AMPLIFIER UNIT (A3)

JTN

6 XYZ-AMPLIFIER UNIT (A3)

6.1 INTRODUCTION

Unit A3 incorporates two separate p.c.b.'s which are connected via X3001. One p.c.b. includes among other things the CRT socket and is connected at the rear of the CRT. The other p.c.b. comprising the proper final X and Z amplifiers is situated at the upper side of the CRT. For ease of description, unit A3 is described as one unit.

The XYZ-amplifier unit consists of:

- Final vertical (Y) amplifier.
- Final horizontal (X) amplifier.
- Final unblanking (Z) amplifier, incl. CRT.

6.2 FINAL VERTICAL (Y) AMPLIFIER.

The final Y-amplifier receives its signal from the delay line and supplies the correct vertical signal to the Y-deflection plates of the CRT. For this the signal is processed in four stages:

- V3001, V3002 as a series feedback amplifier, including a delay line compensation network and potentiometer R3007 controlling current source V3003 for correction of any unbalance in the Y-deflection plates of the CRT. These circuits are connected between the emitters of both transistors. In this stage the input voltage is converted into a current signal.
- V3004, V3006 as a shunt feedback amplifier, which gives a voltage signal to the next stage.
- V3008, V3009 as a series feedback amplifier, including a final RC-correction network and potentiometer R3038 for gain adjustment to compensate the different CRT sensitivities. V3007 supplies a constant current of 60 mA, i.e. 30 mA for each side. Note that the output again supplies a current signal.
- V3011, V3012 as a common-base amplifier for buffering the final Y- amplifier to the Y-deflection plates. The maximum amplitude on each deflection plate is:
 $30 \text{ mA} \times 665 \text{ E} = 20 \text{ V approx.}$

6.3 FINAL HORIZONTAL (X) AMPLIFIER

The input current for X-deflection is obtained from the time-base unit (ref: X- and X+) and processed in three stages, with circuits in the following configurations:

- V3101, V3102 as a common-base amplifier. The current "I" on the collector of both transistors determines the voltage across R3102 and R3116. This voltage is about 1,5 V p-p and feeds the next stage.
- V3103, V3106 as a series feedback amplifier, including a RC- correction network for optimum linearity of the trace and potentiometer R3118 for x1 amplifier adjustment, mounted between the emitters of both transistors. V3104 serves as current source.
- V3112, V3114 are connected as a shunt feedback amplifier, with resistors R3126 and R3134 as the feedback resistors. The transistor source are emitter followers V3109,

V3111. This circuit serves as the actual final amplifier, which converts the deflection current into the proper deflection voltage for the X-deflection plates of the CRT. Transistors V3108, V3116 supply the bias current for the circuit.

6.4 FINAL BLANKING (Z) AMPLIFIER AND CRT

The blanking current derived from the Z pre-amplifier of the time-base unit is routed via common base amplifier V3200 and emitter-follower V3201 to the shunt-feedback amplifier V3202. This stage is fed by current source V3203, which gives a constant current of 4 mA. The voltage on the collector of V3202 can vary between +5 V for unblanking and -35 V for fully blanking.

This Z-pulse may contain d.c., l.f. and h.f. components to be applied to grid G1 of the CRT. Since G1 is at a cathode potential of -2000 V, blocking capacitors are required between G1 and the Z-amplifier output. The h.f. component is directly routed via blocking capacitor C3211 to G1. However, the d.c. and l.f. components are blocked, so these components are first modulated on a 200 kHz carrier signal by V3207 and V3208 to pass blocking capacitor C3209. Then the signal is demodulated again by V3209 and V3211. Finally, the reconstituted d.c. and l.f. components are added to the h.f. component.

Transistor V3251 forms a nominal 70 V zener circuit which provides the voltage difference between the cathode and G1 of the CRT. This bias voltage ensures blanking when there is no input signal. For adaptation to each CRT, this voltage can be varied between about 40 V and 100 V by means of R3252 (BLACK LEVEL). Resistor R3254 maintains the filament at the same potential as the cathode.

Any ripple on the cathode voltage is fed-back via transistor V3213 to the input of the Final Z-amplifier and added to the blanking signal. This means that the differential voltage between G1 and the cathode of the CRT is always fixed. Because this differential voltage determines the intensity of the spot, as a result, the intensity is almost independent of the ripple.

The amplifier stage V3253, V3254 and V3256 provides amplification for the range of the FOCUS control. The range of 0... +10 V gives a final range on G3 of the CRT of -1350 V ... -1600 V.

Resistor R3257 connects the INTENS control to the focus adjustment to maintain a sharply defined trace at varying brightness.

For optimum presetting of the GEOMETRY, the voltage on G5 of the CRT is set to a fixed level of -30 V. The ASTIGMATISM can be varied by means of potentiometer R3267.

A3

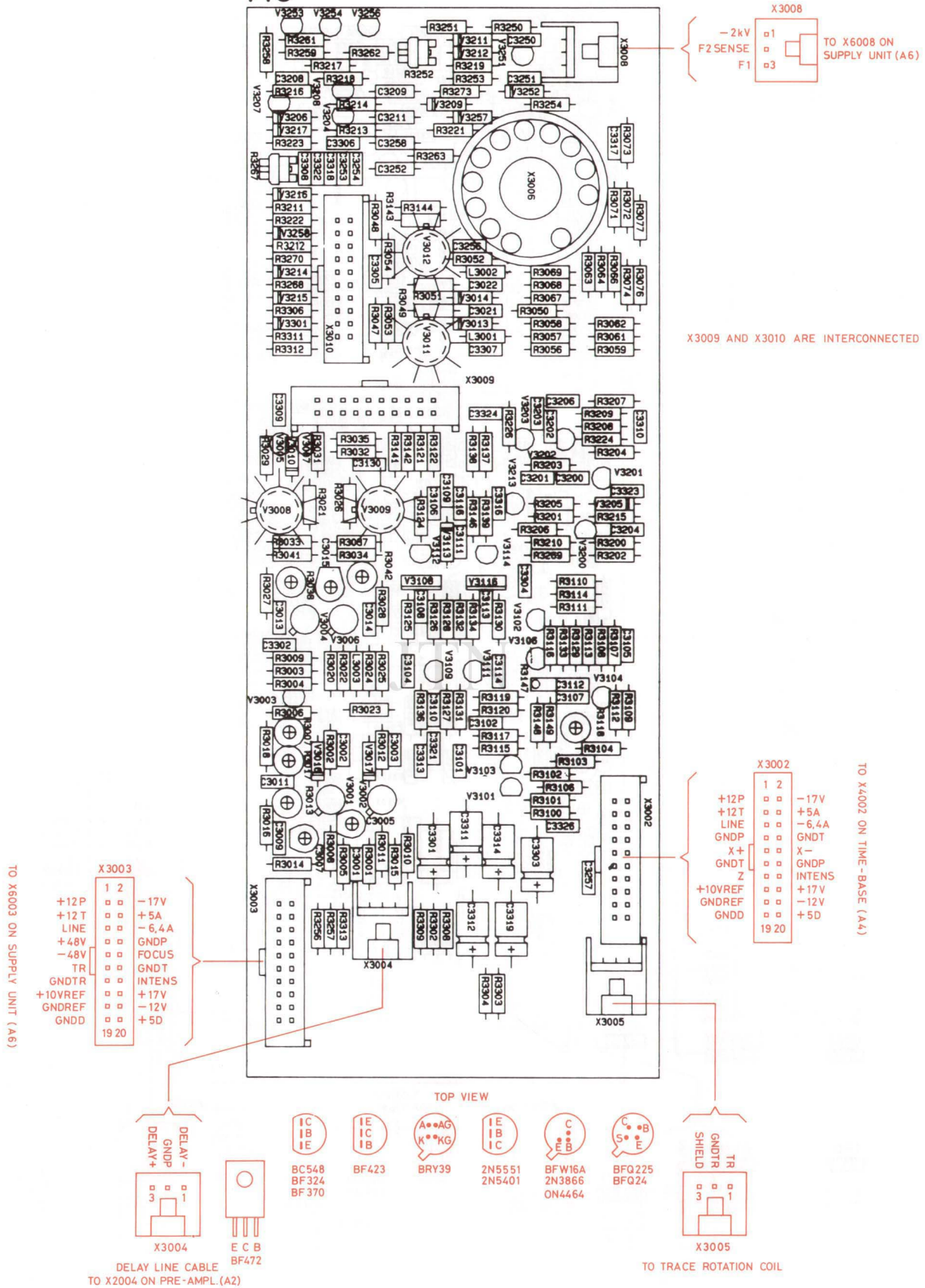

Figure 6.1 XYZ amplifier unit p.c.b.
Figure 6.4 XYZ amplifier unit p.c.b.

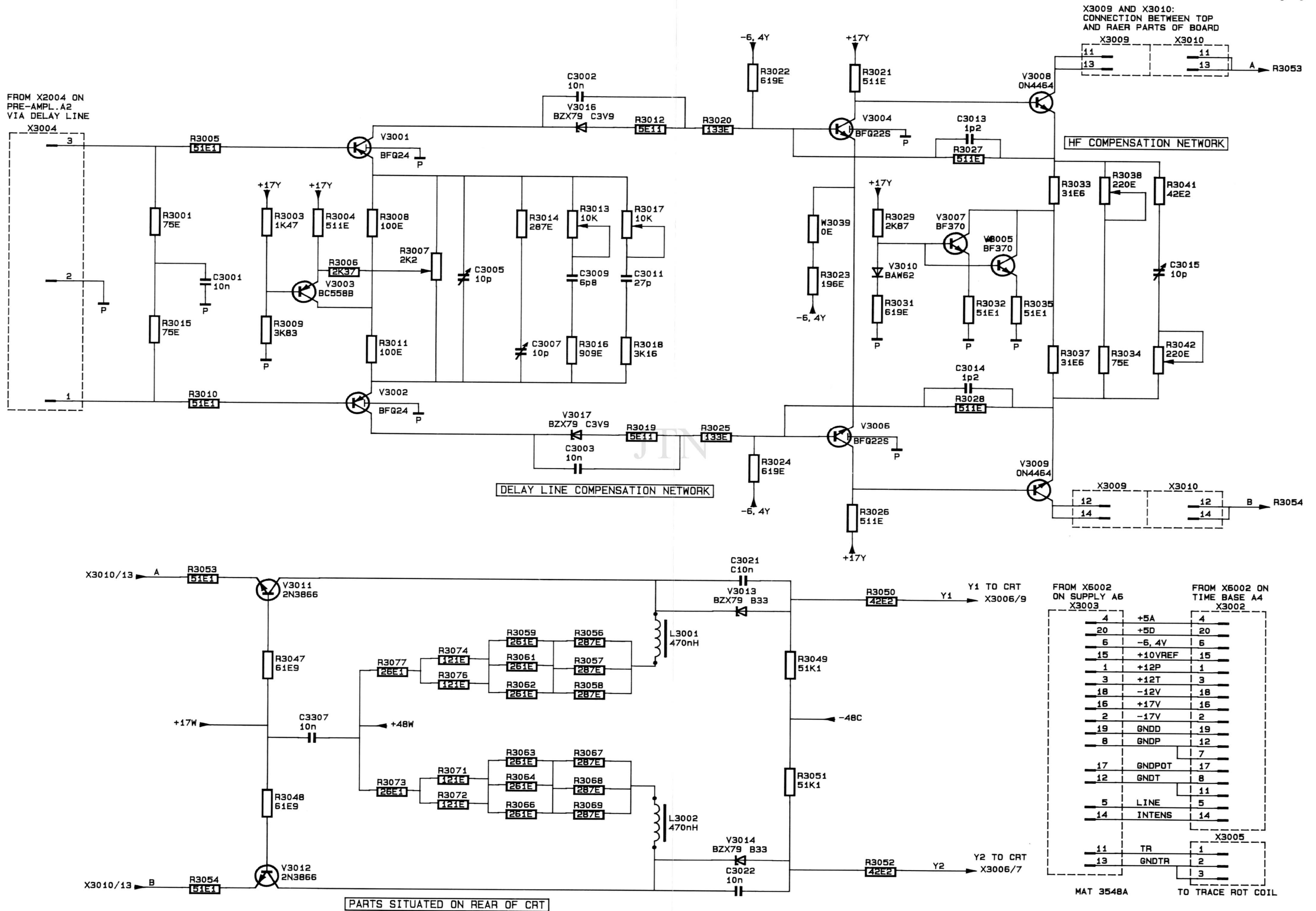

Figure 6.2 Circuit diagram of XYZ amplifiers, final Y amplifier

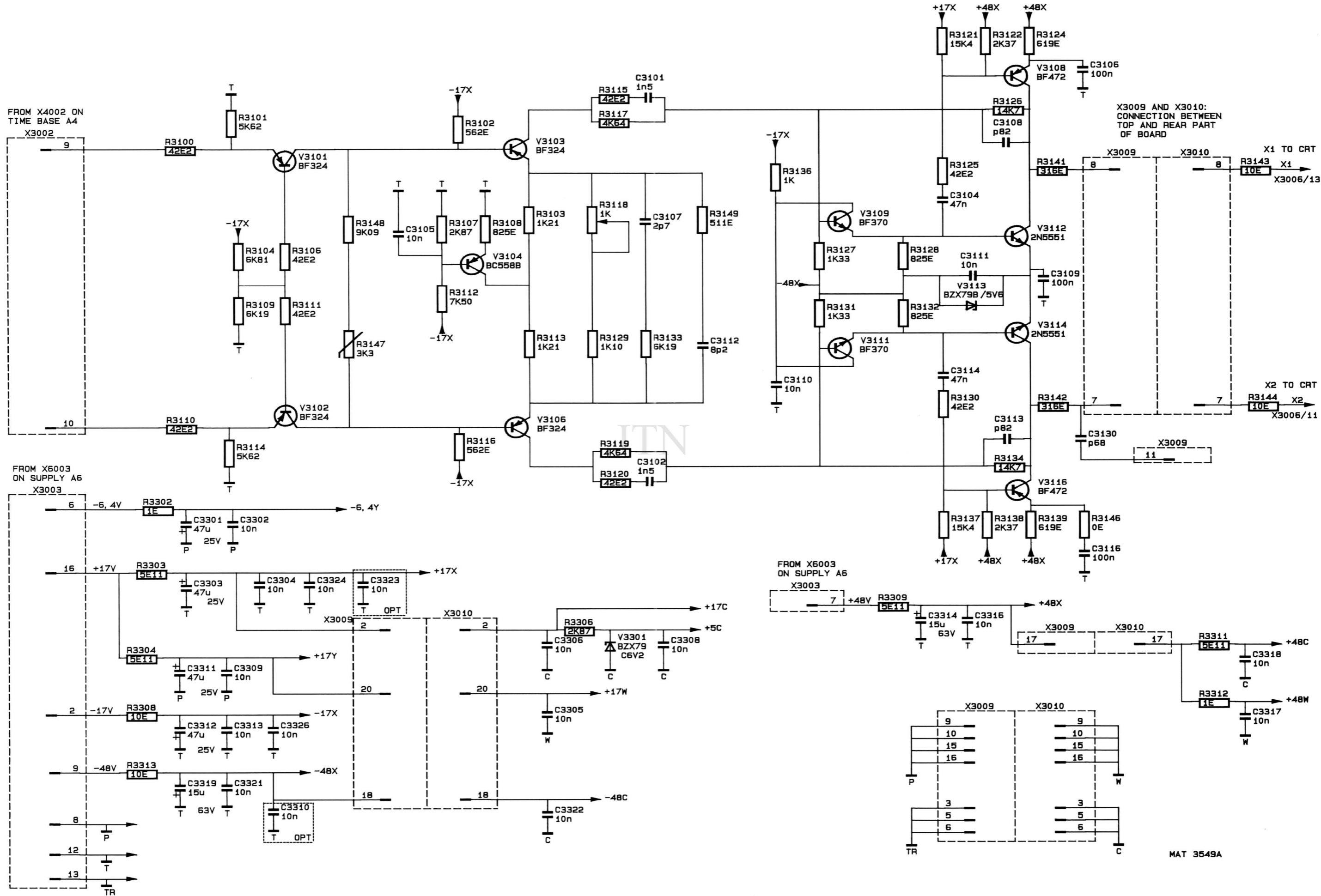

Figure 6.3 Circuit diagram of XYZ amplifier, final X amplifier

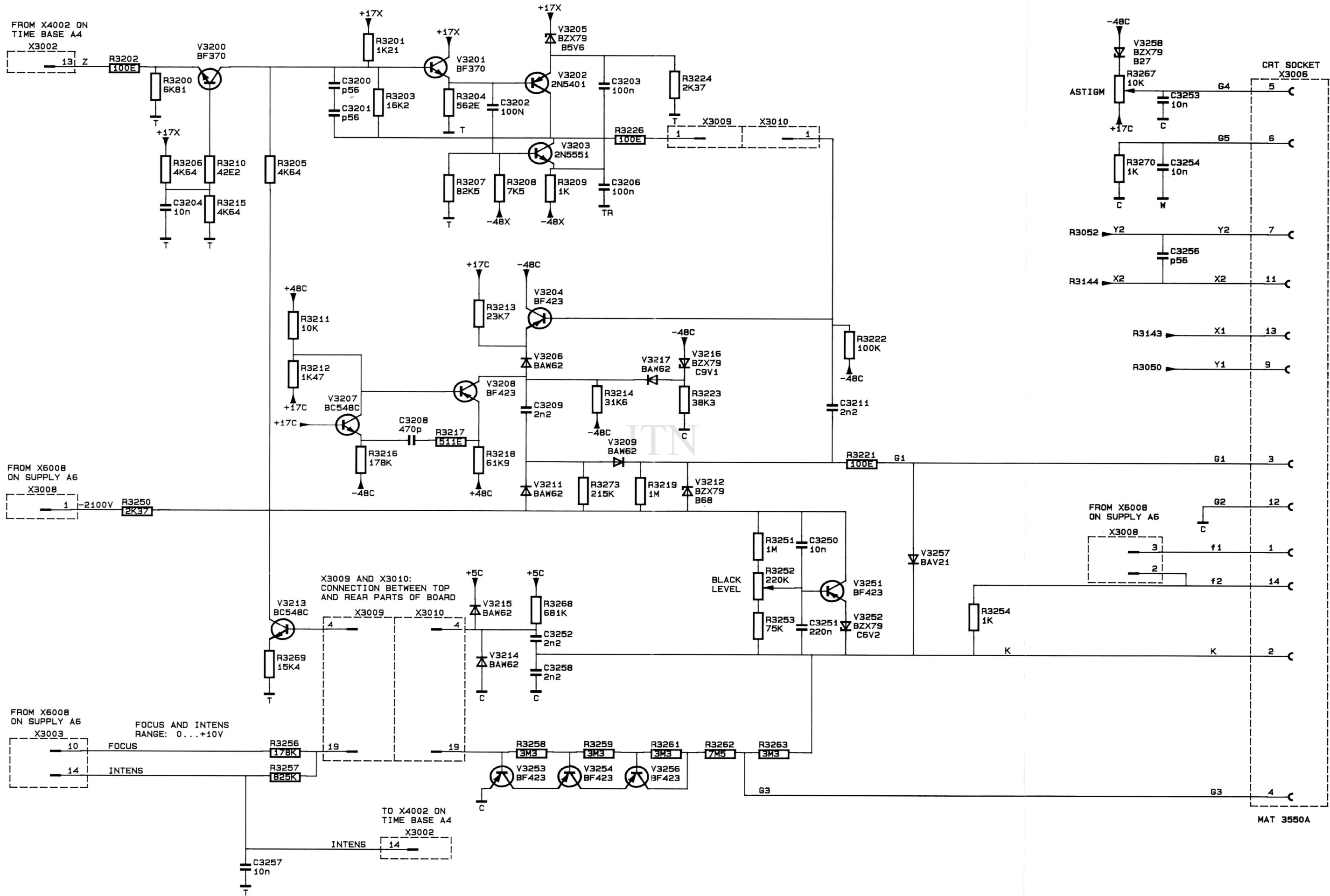
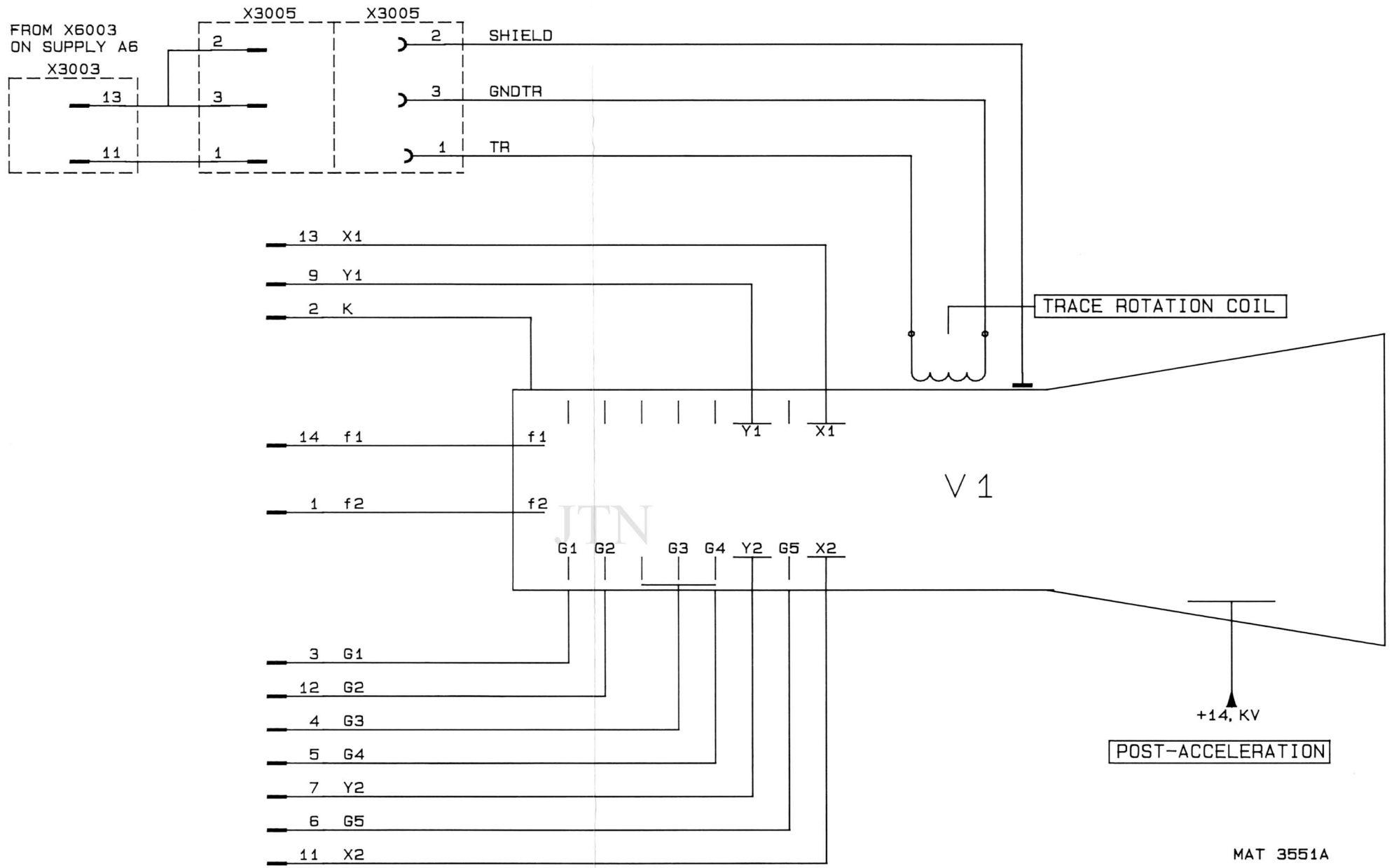

Figure 6.5 Circuit diagram of XYZ amplifiers, Z amplifier



MAT 3551A

Figure 6.6 Circuit diagram of XYZ amplifier, CRT circuit

TIME-BASE UNIT (A4)

JTN

7 TIME-BASE UNIT (A4)

The time-base unit consists of:

- Trigger amplifier
- Timing circuit
- Sweep generator
- DAC stair generator
- Delay D/A converter, incl. comparator
- X DEFL amplifier, incl. display mode switch
- Horizontal pre-amplifier
- Z amplifier

As a supplement, the timing diagram for several conditions of the time base is given in section 7.6.

All control pulses for this unit are generated by the time-base control circuit, via the I²C bus. Integrated circuits D4001 and D4002 convert this series DATA into the parallel control pulses, provided that DLEN TB1, and DLEN TB2 are HIGH.

7.1 TRIGGER AMPLIFIER

JTN

* TB triggering:

The symmetrical trigger current signals TRIGM+ and TRIGM- are derived from the pre-amplifier unit and converted into the asymmetrical trigger voltage via the summation amplifier V4004, the shunt feedback amplifier V4008 and the emitter follower V4009. The summation amplifier adds the base signal voltage of V4004 (caused by TRIGM-) and the collector signal current of V4001 (caused by TRIGM+).

* TV triggering:

When the signal TVMTB goes LOW, the normal trigger path is blocked via V4022 and the trigger signal is routed via the TV trigger stage V4011...V4023. Transistor V4012 serves to clip the synchronisation pulse and LINE/FRAME selection is obtained by V4021. If the signal TVF/LINE is high, TV frames are detected by C4004 ... C4007. A low control signal serves line detection by C4007.

* Pulse stretcher:

The trigger pulse is applied via the ECL-Schmitt trigger to the clock input of the dual ECL D-flip-flop D4267.

This flip-flop in combination with two Schmitt trigger circuits D4266 (9, 10, 6, 7) for delay Δt_1 and D4266 (12, 13, 14, 15) for delay Δt_2 form the pulse stretcher.

On receipt of a trigger pulse at the clock input of FF1, its inverted output goes low. After time Δt_1 , this output on D4266-6 is applied as a logic high signal, which sets FF2. Consequently, its inverted output goes low and the non-inverting output goes high. This results in a reset of FF1. After Δt_2 , FF2 is reset and, as a result, FF1 is enabled again. The output pulse (MTB TRIG signal) is then applied to the sense input of D4103.

Times Δt_1 and Δt_2 are chosen so that the pulse stretcher acts as a pulse-shaper at frequencies up to 2 kHz, as a divide-by-two circuit from 2 kHz to 10 kHz, and as a divider by n for frequencies above 10 kHz.

7.2 TIMING CIRCUIT (see figure 7.1)

The timing for the entire time-base circuit is obtained by D4103 together with its associated components.

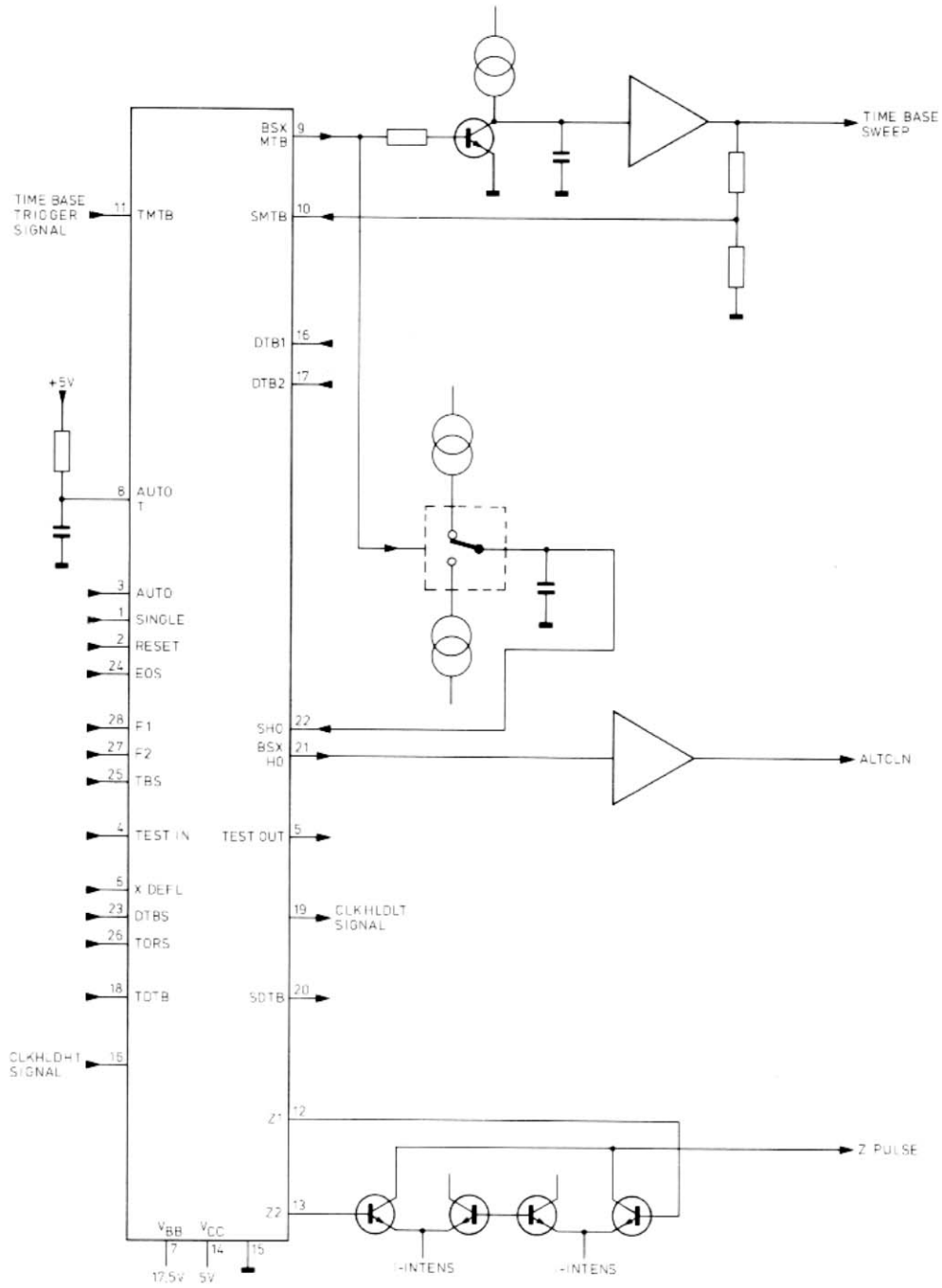

MAT3669
890428

Figure 7.1 D4103 configuration

D4103 has the following relevant pin connections:

Pin	Name	INPUT-OUTPUT	Description
1	SINGLE	TTL-input	Selects the single time-base mode.
2	RESET	TTL-input	Stops the sweep and starts the hold off sweep.
3	AUTO	TTL-input	Selects the AUTO trigger mode, the time-base is free-running after the last trigger pulse.
4	TESTIN	TTL-input	Selects the possibility to drive several functions (TESTOUT) in combination with SINGLE and RESET.
5	TESTOUT	TTL-output	--
6	X DEFL 1	TTL-input	Activates the Z1 and Z2 outputs.
7	Vbb	-	+ 1,5 V supply input.
8	AUTOTIME	input	RC-time determination (100 ms) for the AUTO trigger mode.
9	BSXMTB	TTL-output	Discharges the TB-sweep capacitor(s).
10	SMTB	SCHMITT-input	Determines the end of the TB-sweep.
11	TMTB	SCHMITT-input	Determines the start of the TB-sweep.
12	Z1	TTL-output	Determines the blanking of the CRT.
13	Z2	TTL-output	Determines the blanking of the CRT.
14	GND	-	Ground.
15	Vcc	-	+ 5 V supply input.
16	CLKHLDHT	SCHMITT-input	Determines the hold mode of the track & hold circuit.
17	DTB2	-	not used, connected to ground.
18	TDTB	-	not used, connected to ground.
19	CLKHLDLT	TTL-output	Determines the hold mode of the track & hold circuit.
20	SDTB	-	not used, connected to ground.
21	BSXHO	TTL-output	Determines the ALT clock pulse.
22	SHO	SCHMITT-input	Determines the end of the Hold-off sweep.
23	DTBS	-	not used; connected to +5Z.
24	EOS	-	not used; connected to +5Z.
25	TBSX	TTL-input	Determines the TB-unblanking (HIGH).
26	TORS	TTL-input	Determines the STARTS condition (LOW) or TRIG'D condition (HIGH) of the DTB.
27	F2	TTL-input }	Determines the time-base display mode (both LOW).
28	F1	TTL-input }	

NOTE: All SCHMITT-inputs are at + 2,5 V level.

7.3 SWEEP GENERATORS

The sweep generator is active in the analog time base modes and in the digital sampling time base modes. First the working principal of the sweep generator is described, then the function tables related to the mode (analog or digital sampling) are given. See figure 7.2.

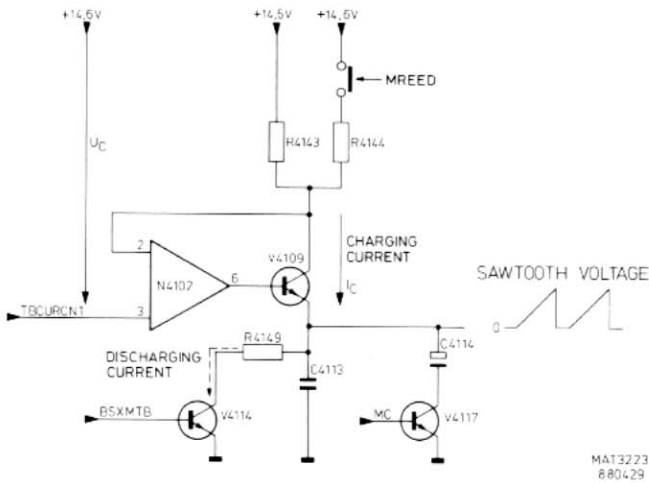

Figure 7.2 Simplified diagram of the time-base sweep generator

The signal TBCURCNT is a selectable d.c. voltage which controls the charging current:

$$I_c = \frac{U_c}{R4143 (+ R4144)}$$

The charging current and the charging capacitors C4113 (+ C4114) determines the sweep speed. The capacitors are discharged by V4114.

The sawtooth voltage on the charging capacitors is split up into two components (h.f. and l.f.) and buffered. The h.f. sweep components (up to 2 μ sec.) are routed via C4116 and V4118. The l.f. sweep components (0,5 sec ... 2 μ sec) are routed via N4103 and V4119.

Finally, the time-base sweep voltage is applied to the horizontal display mode switch and to the comparator circuit.

* Control signals for ANALOG TIME BASE MODES

The analog time-base modes are controlled by the following signals:

- MA0...MA2, for selecting a resistor divided voltage (R4118 ... R4124) with respect to +14,6 V.
 - MREED, for addition of R4144 to increase the charging current.
 - MC, for addition of C4114 to the charging capacitance C4113.
- C4114 is not in circuit for time-base settings 50 nsec ... 100 μ sec, calibration by R4107.
C4114 is in circuit for time-base settings 200 μ sec ... 0,5 sec, calibration by R4108.

The voltage TBCURCNT can be continuously varied by moving the VAR TB control R7009 from the cal position, so a sweep speed variation of 1 : 2,5 can be obtained.

Function table for the sweep generator in ANALOG time-base modes:

sweep speed	MA2	MA1	MA0	MREED	MC
50 ns/div.	1	1	1	0	0
.1 μ s/div.	0	1	0	0	0
.2	0	0	1	0	0
.5	0	0	0	0	0
1	0	1	1	0	0
2	1	0	0	1	0
5	1	1	1	1	0
10	0	1	0	1	0
20	0	0	1	1	0
50	0	0	0	1	0
.1 ms/div.	0	1	1	1	0
.2	1	0	0	0	1
.5	1	1	1	0	1
1	0	1	0	0	1
2	0	0	1	0	1
5	0	0	0	0	1
10	0	1	1	0	1
20	1	0	0	1	1
50	1	1	1	1	1
.1 s/div.	0	1	0	1	1
.2	0	0	1	1	1
.5	0	0	0	1	1

NOTE: When MREED is low, then RELAY is switched on.

*** Hold-off circuit:**

During the time-base sweep, capacitor C4304 is discharged. In the lower sweep speeds (lower than 10 μ s) capacitor C4302 is also discharged via V4306. After the sweep, the capacitor(s) are charged via current source V4304 until the voltage across C4304 reaches the +2,5 V level. This voltage is applied to D4103 as the SHO signal and determines if the time base can generate a new sweep.

Depending on the HOLD OFF control potentiometer R7011 adjustment, a part of the charging current leaks away via V4301 and thus continuously variation of the charging time (i.e. hold-off time) is obtained. When BSXMTB goes LOW, the time base starts to run again and at the same time C4304 (and C4302) are discharged again via V4309.

*** Control signals for DIGITAL SAMPLING TIME-BASE MODES**

In digital sampling time base modes, an analog sweep is generated to determine the sampling moment by comparing the analog sweep and a DAC stair signal. The analog sweep time is 3 times slower as the selected digital time base to obtain a trigger delay of 20 divisions, see also Section 7.5.

The digital sampling time base modes are controlled by the following signals:

- MA0...MA2, for code 101 digital sampling is selected.
- DA0...DA2, for selecting a resistor divided voltage (R4218 ... R4224) with respect to +14,6 V.
- MREED, for addition of R4144 to increase the charging current.
- MC, not active in digital sampling modes (= low).
- DC, active in digital sampling modes (= high).

The analog sweep speed for sampling modes can be calibrated in service menu 3.8 by potentiometer R4208.

Function table for the sweep generator in DIGITAL SAMPLING time-base modes:

sweep speed	DA2	DA1	DA0	MA2	MA1	MA0	MREED	MC
60 ns/div. (*)	0	1	0	1	0	1	0	0
.15 μ s/div.	0	0	1	1	0	1	0	0
.30 μ s/div	0	0	0	1	0	1	0	0
.60 μ s/div	0	1	1	1	0	1	0	0

(*) PM3365A/67A only

NOTE: Sweep time is 3 times slower as the selected digital time base.

7.4 DAC STAIR GENERATOR

The DAC stair generator, generates a staircase voltage to obtain the sampling moments for the sequential sampling mode. The generator consists a 9 bit Digital Analog Converter and a binary counter. The binary counter is controlled by the reset signal SRTACQHT (low = reset) and the clock signal SRTMTBLT (high to low = clock). The counter is enabled at the beginning of a sampling acquisition, and will count once every two sweeps until 2 times 512 sweeps. The binary code is applied to the DAC which converts the digital code into an analog voltage; the DACSTAIR signal. The DACSTAIR signal is routed to the comparator circuit. The gain of the DACSTAIR signal can be adjusted by potentiometer R4247. Further the active SRTMTBLT signal and the active CLKHLDLT signal determines the hold moment for the track & hold circuit (HOLD-LT = low).

7.5 DELAY D/A CONVERTER + COMPARATOR

The delay D/A converter provides a d.c. voltage indicating the selected trigger delay. A serial digital code (I²C-bus) is converted into a d.c. voltage "U_d" by D4401 and N4101. For a trigger delay of 0 divisions U_d = 0 V, for a trigger delay of 20 divisions U_d = 0,66 x U_{pp}. The d.c. voltage is added to the DACSTAIR signal (N4203) and applied to the comparator circuit (N4402).

The low to high edge of the output signal CLKHLDHT of the comparator circuit indicates the hold moment of the TRACK & HOLD circuit (on unit A16). The DACSTAIR signal is increased one step every two sweeps. On the first sweep a sample of channel A is taken, on the second sweep a sample of channel B is taken. Now the DACSTAIR signal is increased one step, so the hold moment of the samples is delayed 1/512 part of a screen. After 2 x 512 sweeps, a complete acquisition is done, and a full screen (A&B) is in memory.

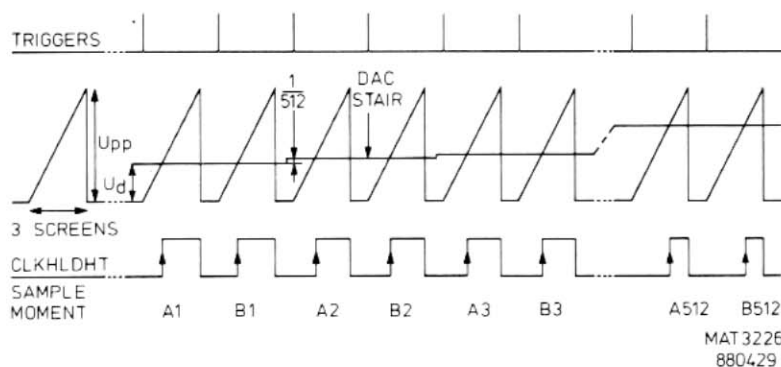

Figure 7.3 Digital sampling principal, trigger delay = 10 divisions.

7.5 X DEFL AMPLIFIER AND DISPLAY MODE SWITCH

* X DEFL amplifier:

The circuit for converting the symmetrical X DEFL+ and X DEFL- signals into the asymmetrical voltage, applied to the display mode switch is identical to the trigger input. However, this circuit can be switched-off by diodes V4500 and V4505, provided that the X DEFL signal is HIGH.

* Horizontal display mode switch:

The three deflection signals for real time-base, digital time-base or X deflection are switched to the horizontal pre-amplifier via diode switches. These switches are under control of the signals X DEFL and TBS. The output of the circuit is applied to R4701 on the horizontal pre-amplifier stage. The logic table is given below:

X DEFL	TBS	Output
1	*	X DEFL signal
0	0	Digital time base
0	1	Analog time base

7.6 Z-AMPLIFIER

* Z-switch:

The Z-switch N4601 is configured as two differential amplifiers with a common current output to R4625. The stage is supplied by a constant current source via pin 1 and pin 8. The inputs Z1 and Z2 are derived from the timer stage D4103 and determine the unblanking of the CRT. For this oscilloscope Z1 and Z2 must be HIGH for normal intensity of the time base signal. The amplitude of the Z-current can be varied by the front-panel INTENS control R5001. The slider of this control potentiometer drives the base pin 2 and pin 7 of both current sources.

To prevent burn-in of the CRT in the lower sweep speeds 0,5 sec...50 μ sec, signal ZB is LOW and reduces the voltage to pin 2 and pin 7.

Signal ZA is a software-controlled pulse to blank the trace when the AMPL/DIV switch is used.

* Z Pre-amplifier:

In normal condition, the fully current for CRT blanking derived from N4601 is routed via R4625, V4612 and R2628 to the XYZ Amplifier A3.

However, there are two conditions for additional blanking:

- In the chopped mode of the vertical channels the display is blanked during switching over between channels. This happens by connecting the CHOPBLN pulse to V4611. When this pulse is HIGH, transistor V4611 conducts and a part of the blanking current flows via V4611 e-c to the +5 kV rail.
- If a HIGH level is applied to the external Z MOD input on the rear panel, this signal causes conducting of V4616 so that a part of the blanking current flows via V4616 e-c to the +5 kV rail.

In digital mode, the blanking current is derived via X413 from the Z control circuit on unit A15.

7.8 TIMING DIAGRAM

The following figure gives the timing diagram for D4103 for a free running time base sweep.

SINGLE	0
RESET	0
AUTO	1
TEST IN	0
X DEFL	0
TORS	0
F1	0
F2	0
DTBS	0
EOS	1
TBS	1

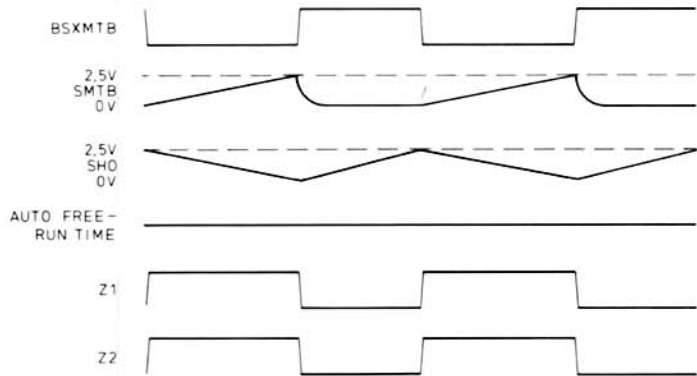

MAT2228
860210

Figure 7.4 Free-running sweep-timing diagram

JTN

A4

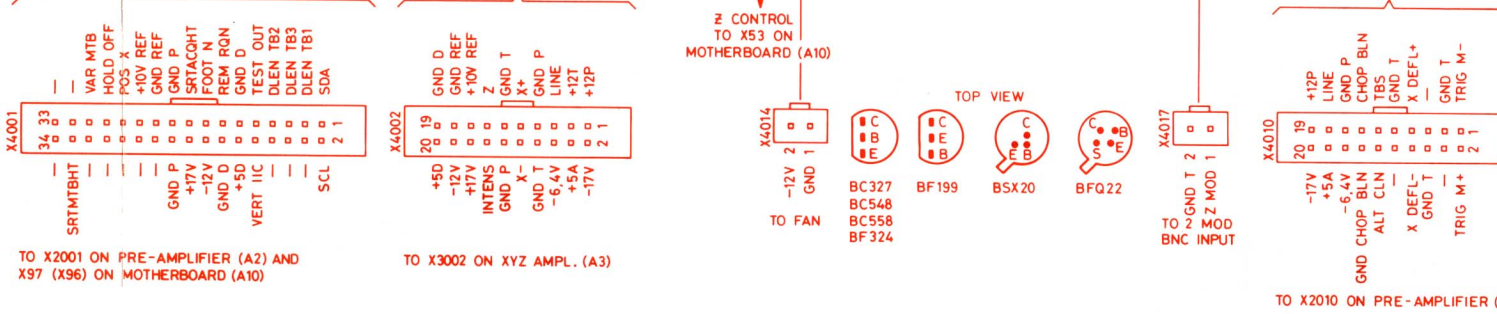
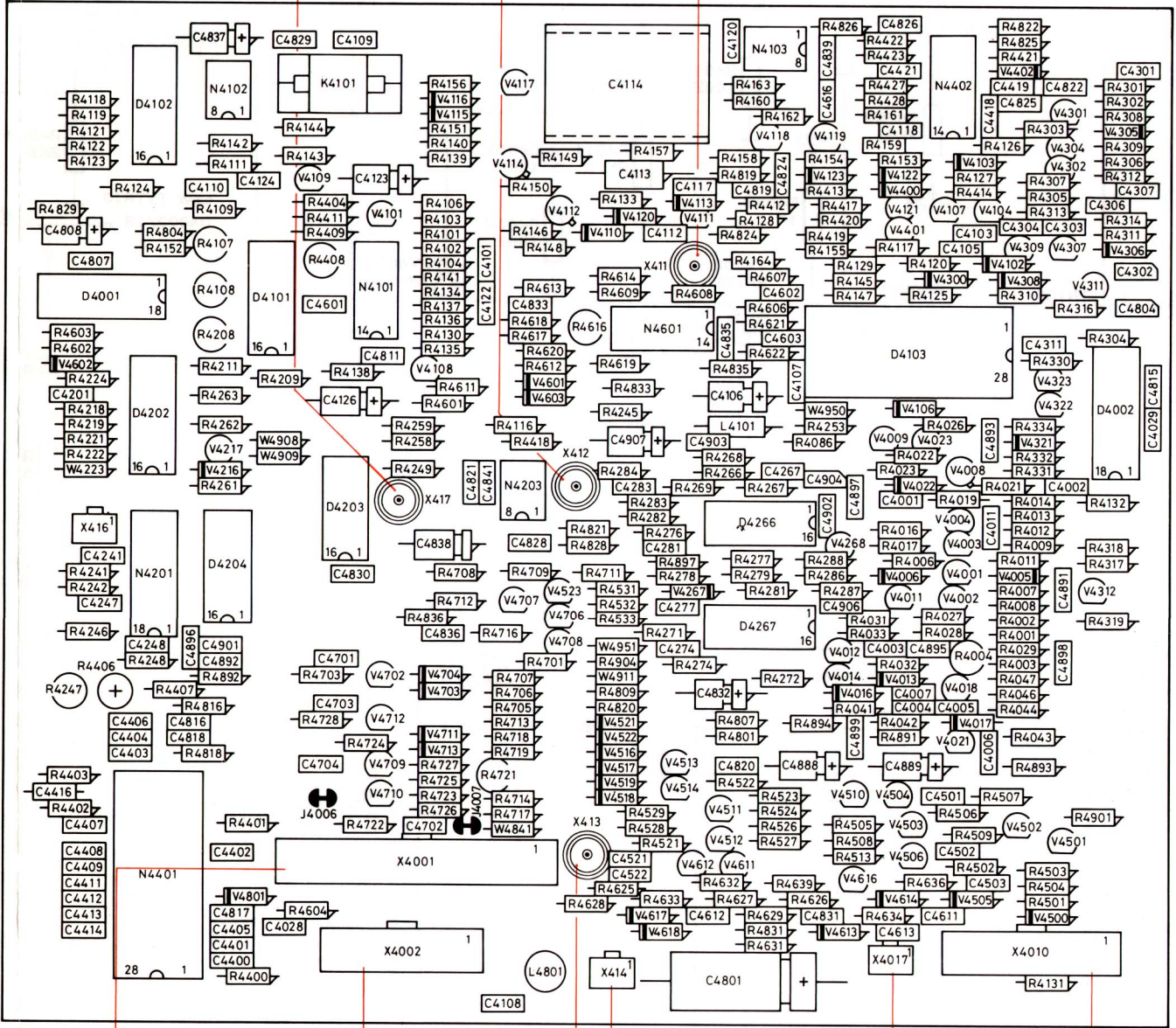

Figure 7-10, 7-14, 7-18, 7-22, 7-26, 7-30, 7-34, 7-38, 7-42
Time-base unit p.c.b.

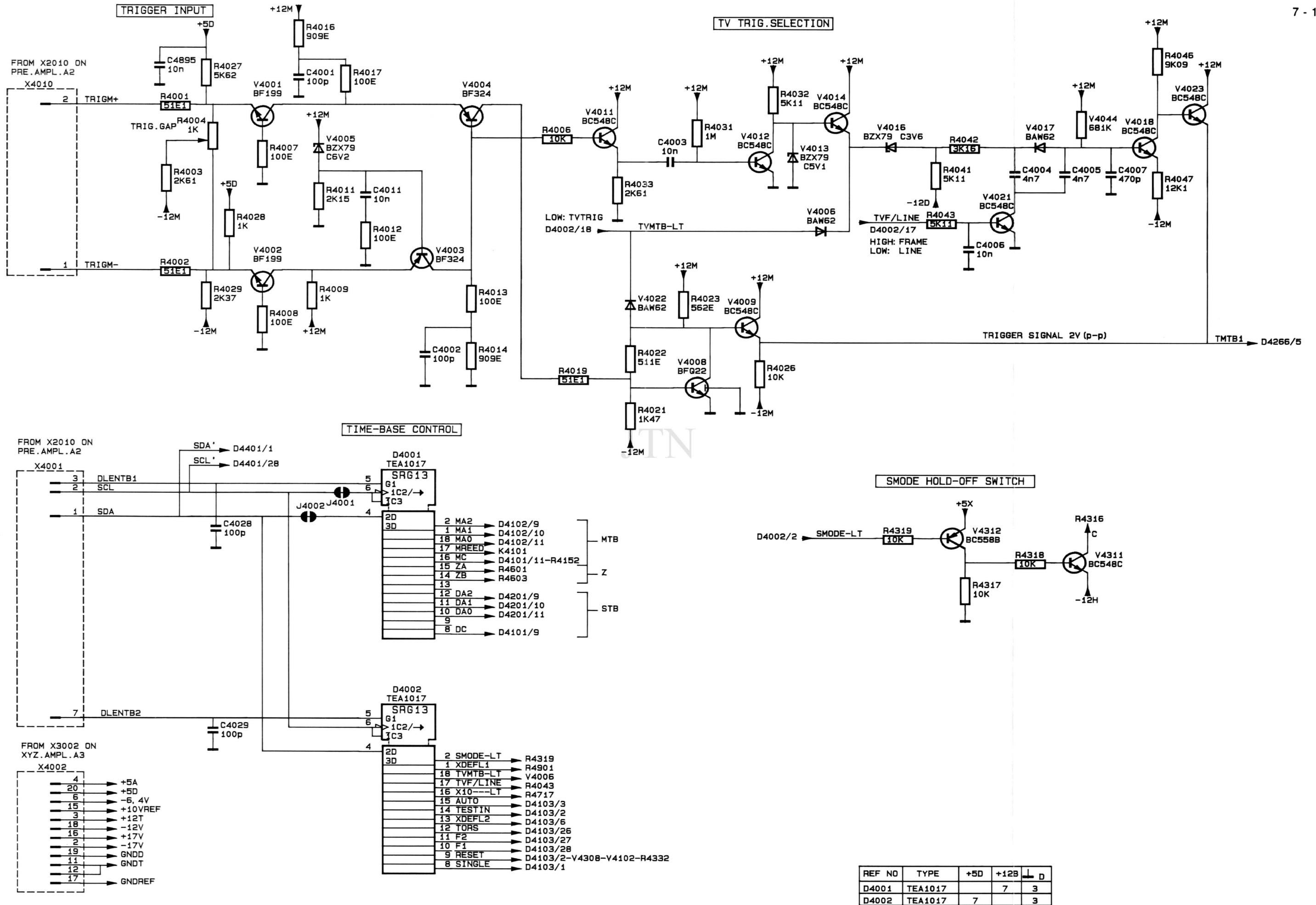

Figure 7.6 Circuit diagram of time-base, trigger amplifier and time-base control

REF NO	TYPE	+5D	+12B	D
D4001	TEA1017		7	3
D4002	TEA1017		7	3

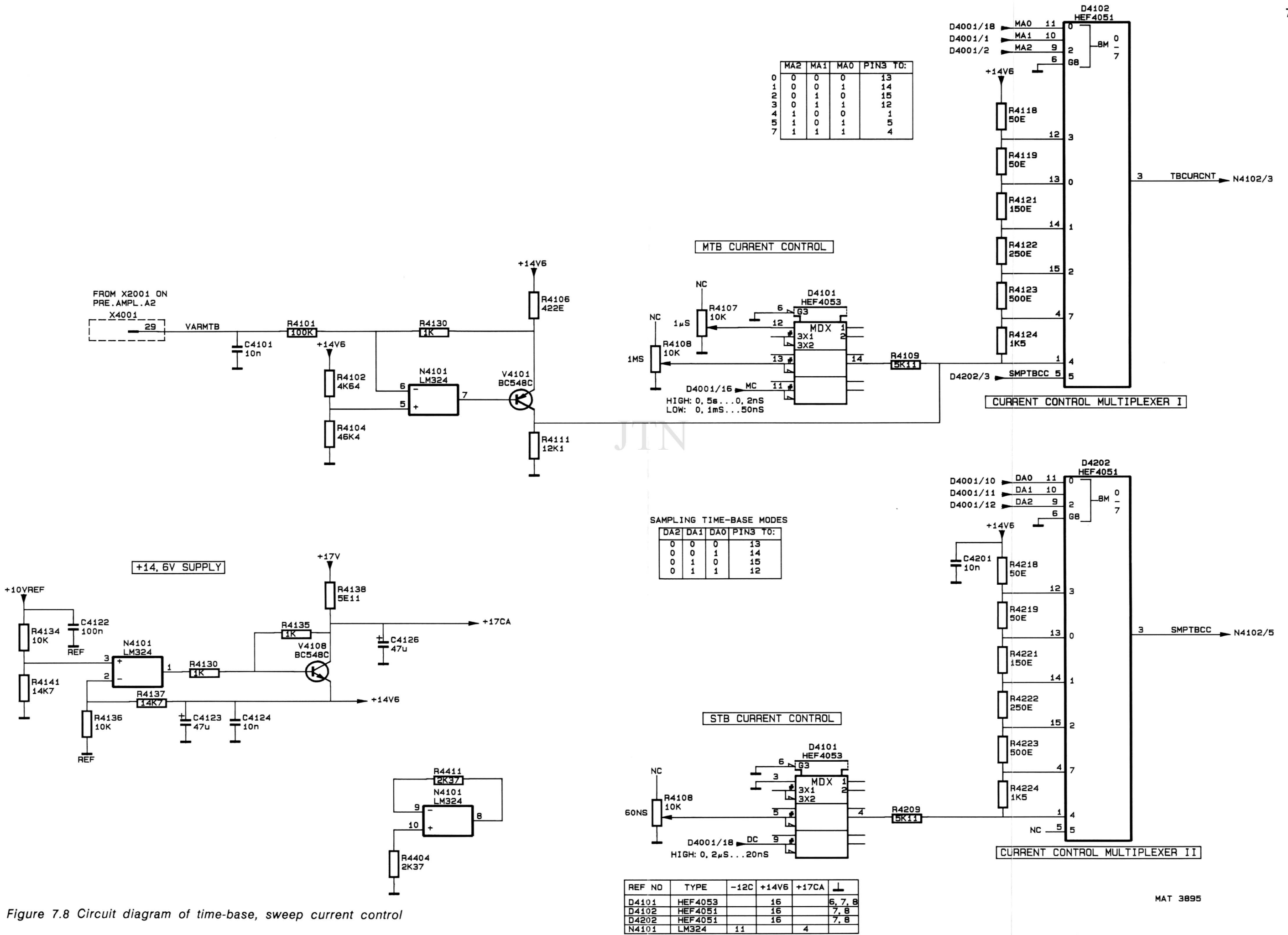
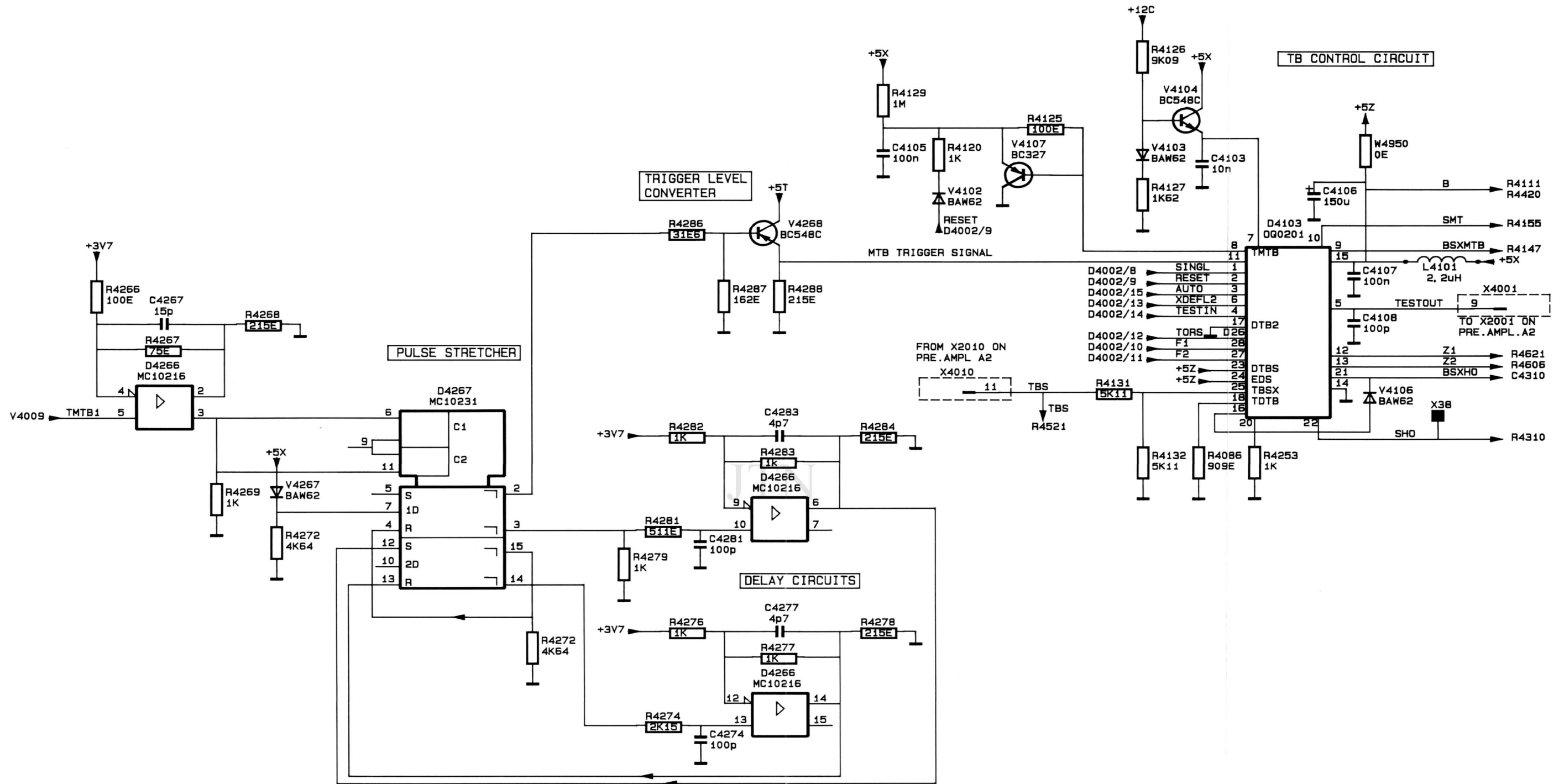

Figure 7.8 Circuit diagram of time-base, sweep current control



REF NO	TYPE	+5T	↓
D4101	0G0201		
D4266	MC10216	1, 16	8
D4267	MC10231	1, 16	8

MAT 3896

Figure 7.10 Circuit diagram of time-base, time-base control

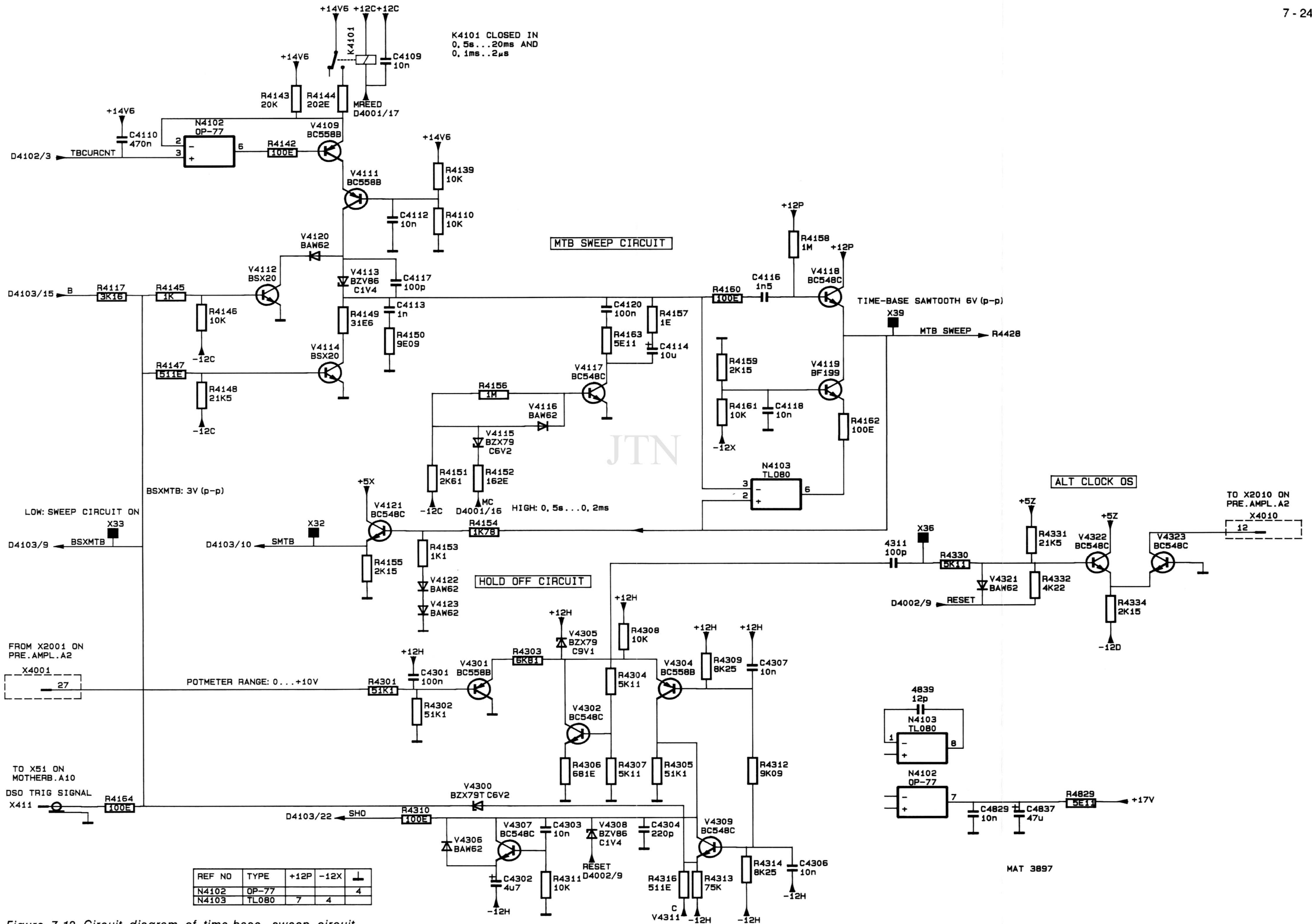
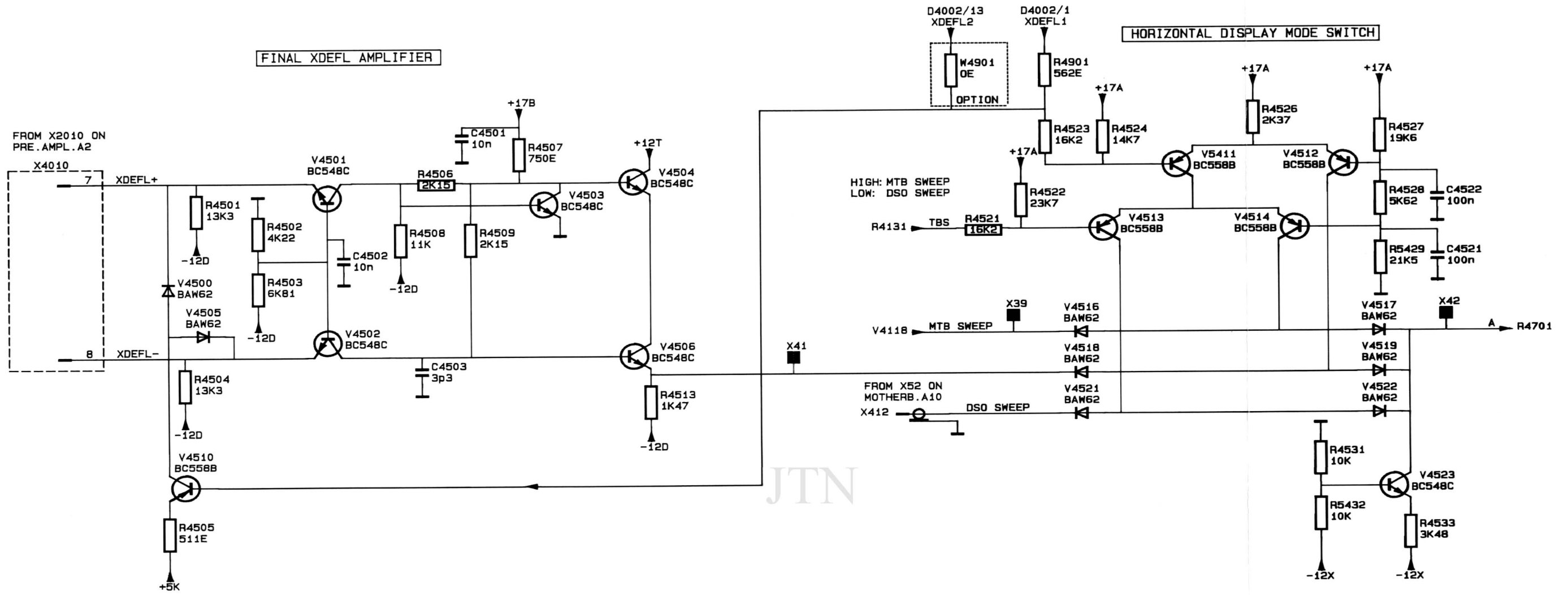

Figure 7.12 Circuit diagram of time-base, sweep circuit



JTN

MAT 3898

Figure 7.14 Circuit diagram of time-base, hor. display mode switch

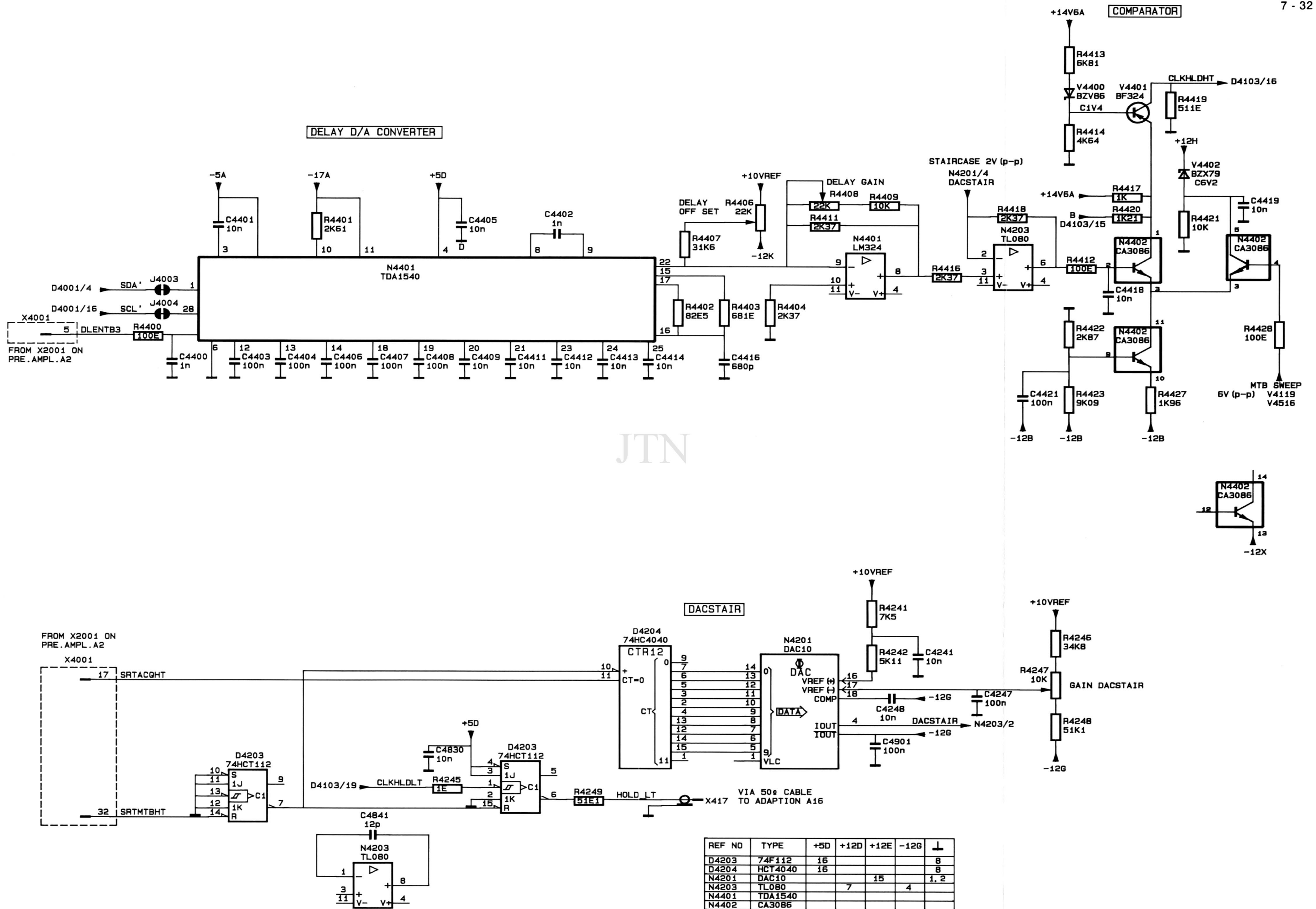
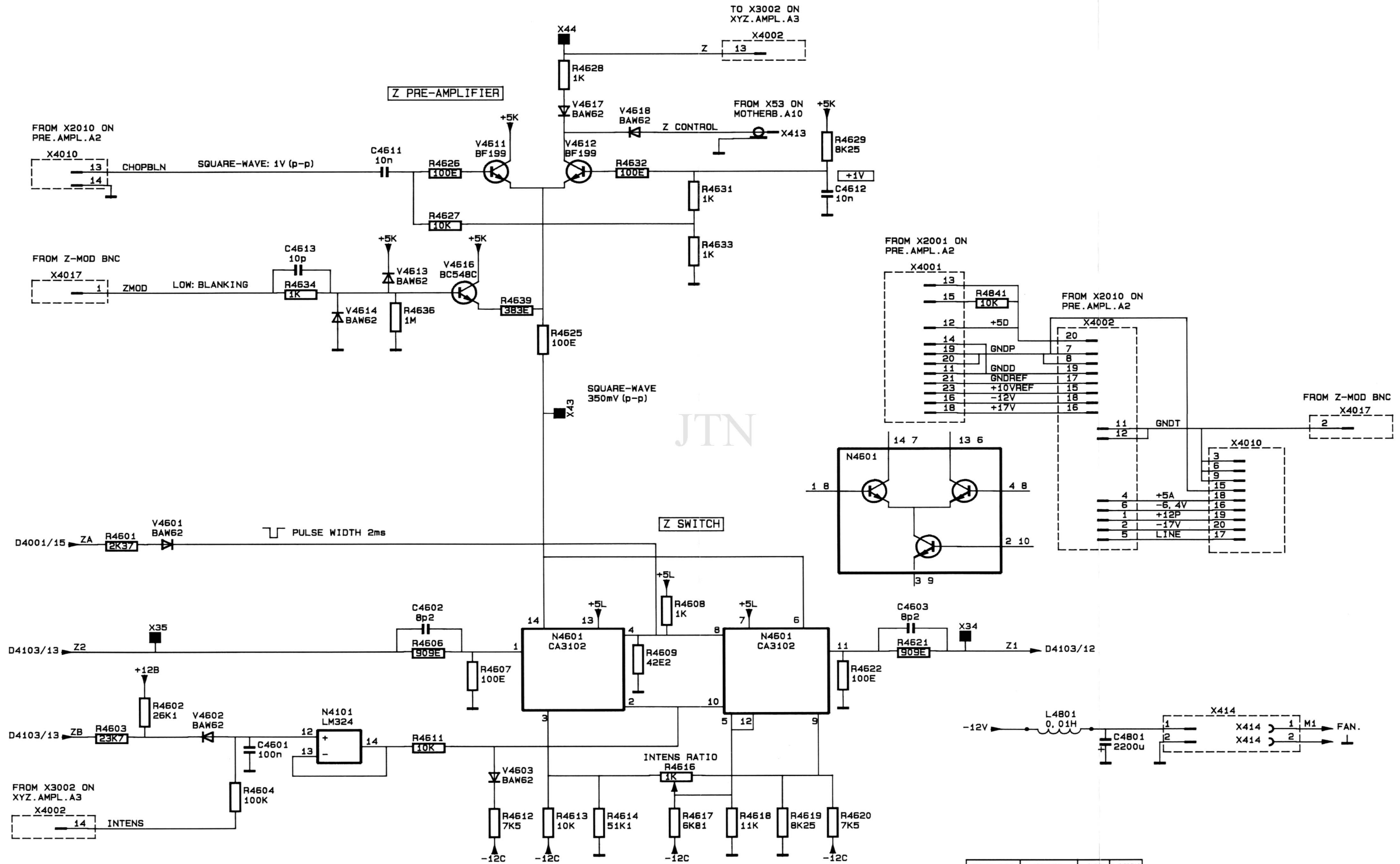

Figure 7.16 Circuit diagram of time-base, DAC stair generator and comparator



FROM X2001 ON PRE-AMPL. A2

13	R4841	10K
15		+5D
12		
14		
19		GNDD
20		
11		GNDD
21		GNDDREF
23		+10VREF
16		-12V
18		+17V

FROM X2010 ON PRE-AMPL. A2

20		7
7		8
19		19
17		15
18		18
16		16

FROM Z-MOD BNC X4017

11		GNDD
12		
3		
6		
9		
15		
18		
16		
19		
20		
17		

REF NO	TYPE	12C	+17CA
N4101	LM324	11	4
N4601	CA3102		

MAT 3900

Figure 7.18 Circuit diagram of time-base, Z pre-amplifier

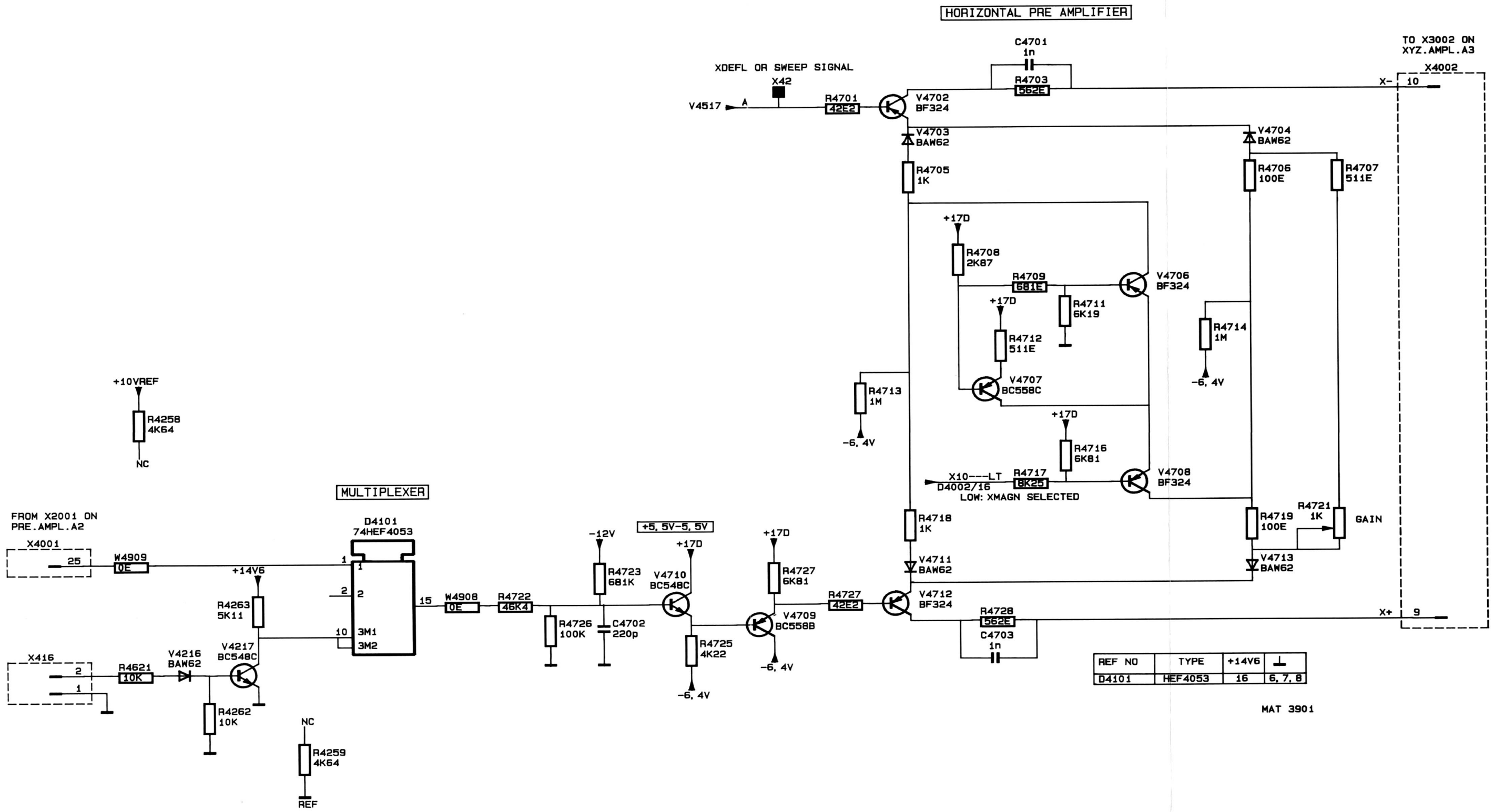
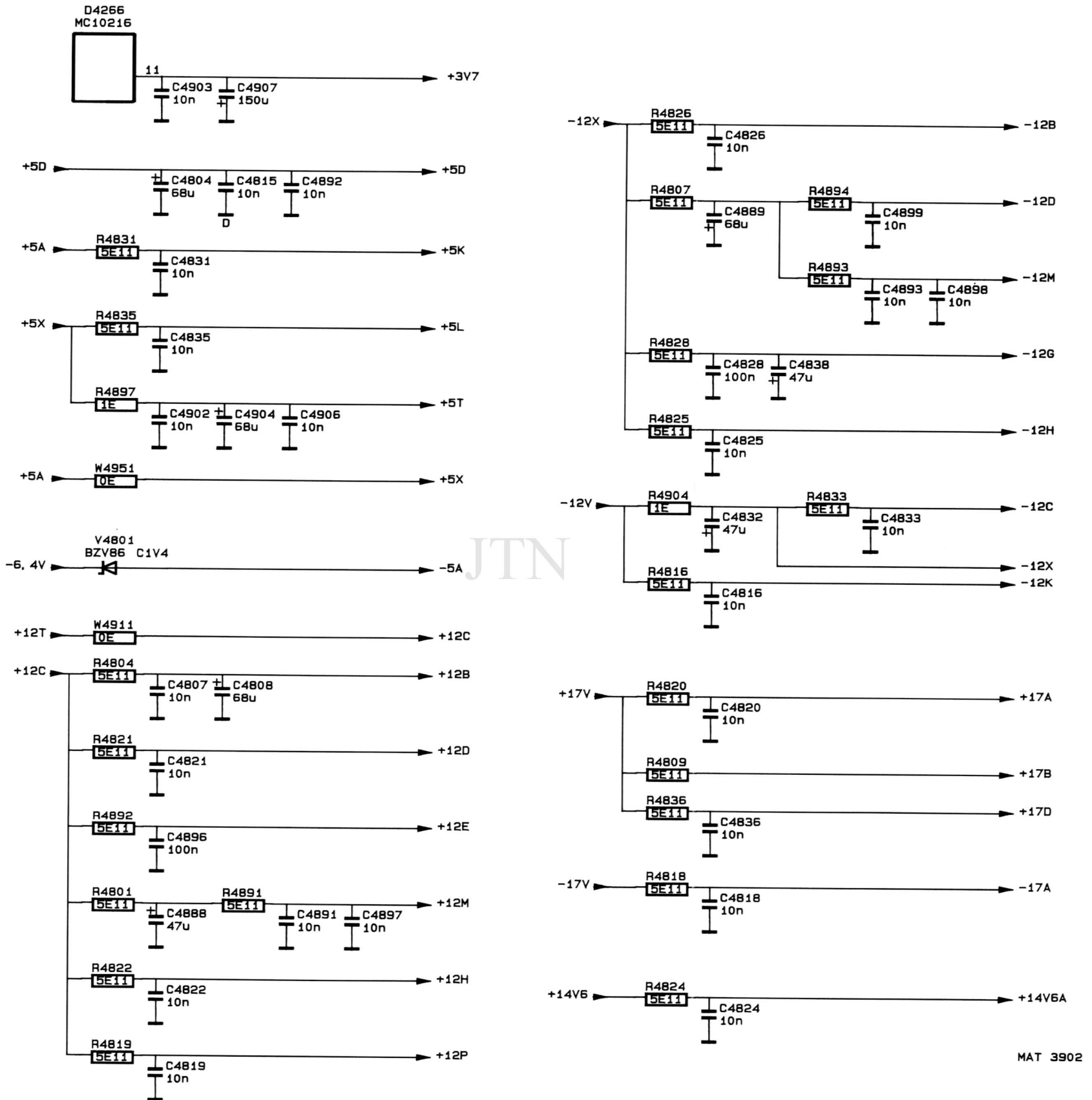

Figure 7.20 Circuit diagram of time-base, horizontal pre-amplifier



MAT 3902

Figure 7.22 Circuit diagram of time-base, supply voltages

CRT CONTROL UNIT (A5)

JTN

8 CRT CONTROL UNIT (A5)

This unit incorporates the potentiometers that control the CRT functions. These potentiometers are INTENS (R1), screwdriver operated control TRACE ROT (R2), FOCUS (R3) and ILLUM (R4).

The range of these potentiometers is between 0 V and + 10 V.

The way these potentiometers influences the associated circuit is described together with the description of the relevant circuit part.

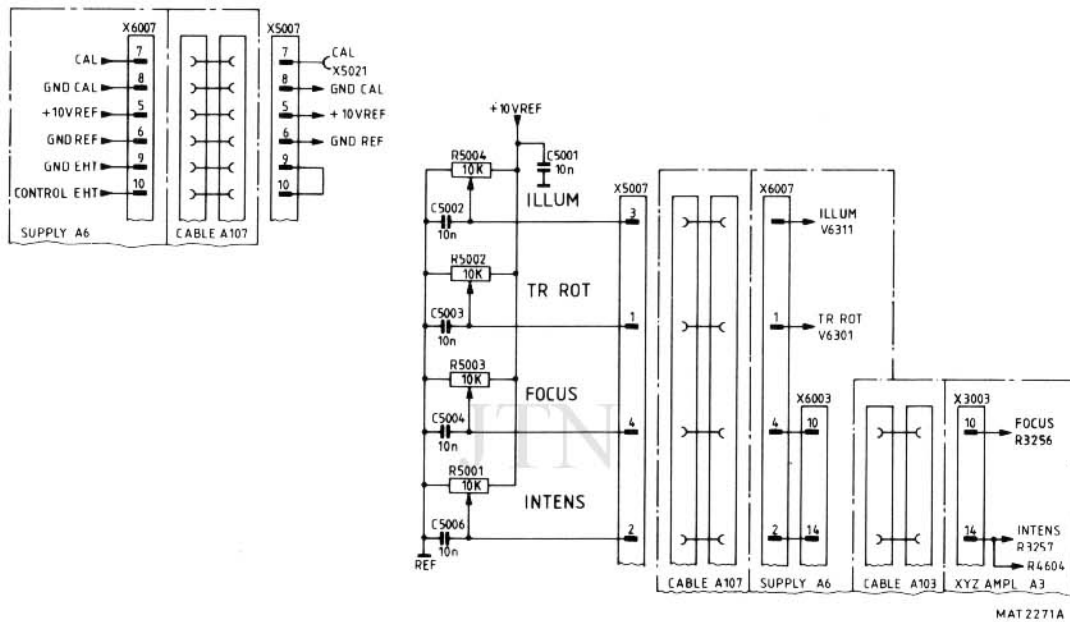

Figure 8.1 Circuit diagram of CRT control

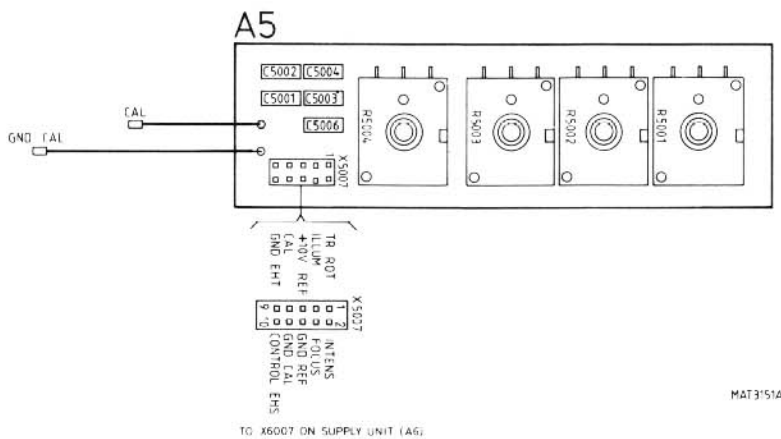

Figure 8.2 CRT control unit p.c.b.

POWER SUPPLY UNIT (A6)

JTN

9 POWER SUPPLY UNIT (A6)

Basically, the power supply unit consists of:

- input circuit
- converter circuit
- secondary output rectifiers
- HT supply
- CAL oscillator
- CRT control circuit

9.1 INPUT CIRCUIT

The instrument may be powered from a nominal mains voltage of 90 V...264 V a.c. The mains voltage is primary protected by a fuse of 1,6 AT, which is located on the rear of the instrument.

After rectification by the diode bridge V6001...V6004 a d.c. voltage is applied to the converter circuit.

This voltage is smoothed by capacitors C6007, C6008 and chokes L6000, L6001 and L6002.

Depending on the mains voltage, the rectified voltage is 120 V...370 V.

NOTE: All measurements in the primary circuit should be done with a floating oscilloscope. As reference voltage can be used measuring point X48.

A fixed part of the mains voltage serves as a LINE-trigger signal. The amplitude of the LINE trigger signal is $1/22 \times \text{MAINS}$.

NOTE: The LINE trigger signal is not present when a d.c. voltage serves as MAINS.

9.1 CONVERTER CIRCUIT

In this oscilloscope a flyback converter is used to generate the required voltages out of the LINE IN voltage. The combination of the transistors V6014 and V6018 functions as a switch in this flyback converter. The converter switching frequency depends on the amplitude of the LINE IN voltage (for 110 Vac: 30 kHz approx and for 220 Vac: 45 kHz approx).

Transistors V6014 and T6018 conduct on the forward stroke and charge transformer T6001. The thyristor V6013 fires when the voltage on the gate reaches the firing level (0,6 V approx). Consequently, V6018 blocks - V6014 blocks (flyback stroke). During this flyback stroke, the secondary windings of T6001 discharge via the diode rectifiers into smoothing capacitors. The NTC resistor R6009 provides temperature compensation for the firing point of the thyristor. During the flyback, capacitor C6009 charges again via the parh T6001-1, V6012, V6009, R6001, C6009 and T6001-2.

At the end of the flyback, when C6009 has been charged, the voltage over this capacitor is stabilized by a voltage stabilizer and is used to switch on again V6014 (and V6018). The voltage stabilizer consisting of V6009, R6006 and V6012 gives a square-wave signal to the gate of transistor V6014 with a maximum amplitude of 15 V.

The dv/dt limiter with L6004, L6006, V6017 and V6019 serves to slow down the increase of the collector voltage of V6018 (measuring point X46) when this transistor is switched off. (see figure 9.1).

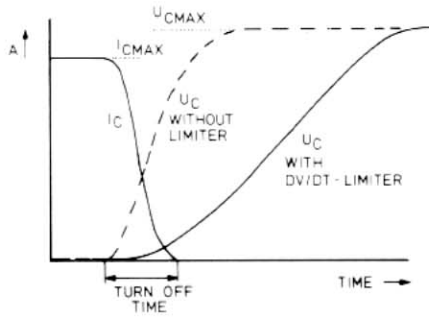

MAT3714
890825

Figure 9.1 Collector-voltage and -current waveforms of V6018 (switching off)

By slowing down the increase of U_c (i.e. limiting dV/dt), the product $P = U_c \cdot I_c$ of the collector voltage U_c and the collector current I_c , build up in the transistor while switching off, is limited.

The voltage control circuit [N6001(5-6-7) and associated components] feed back any variation in the -12 R voltage to the gate of V6013. For example: if the -12 V voltage is too low, more current is sent into H6001. Because of the extra current, V6013 fires earlier so that the output voltages decreases.

NOTE: The only function of diode V6021 is protection of R6017, R6018 and the circuit that controls the base of V6018. If the main fuse has blown, always check V6021, too!

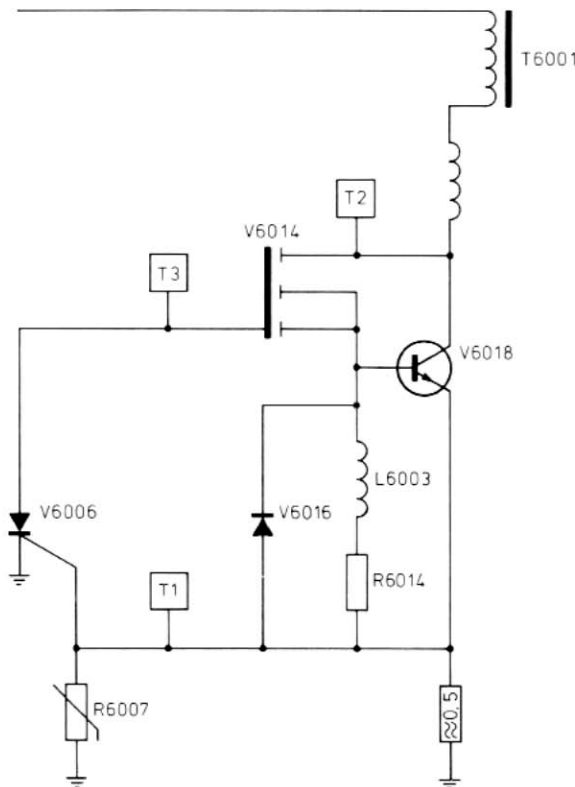

MAT2119
860214

Figure 9.2 Converter circuit

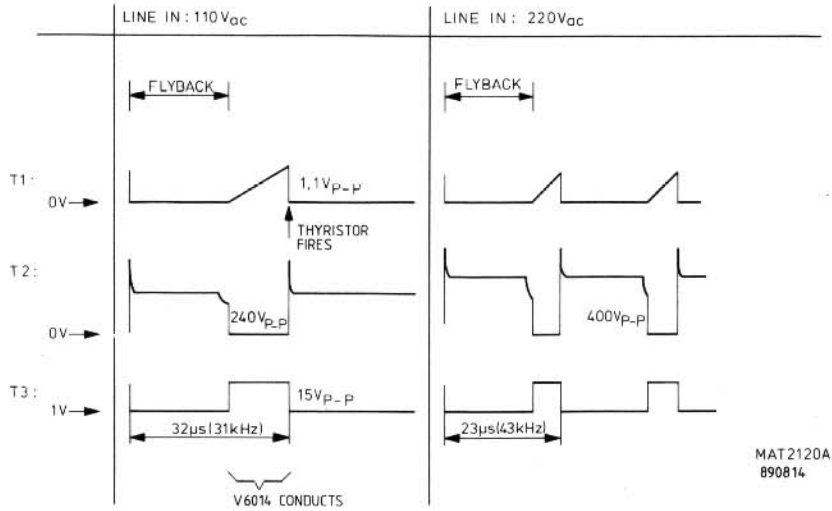

Figure 9.3 Timing diagram converter circuit

9.3 SECONDARY OUTPUT RECTIFIERS

The output voltages taken from the secondary windings of transformer T6001 are rectified by diodes and smoothed by capacitors in conventional circuits.

A "CROWBAR" circuit with transistor V6137 and V6112 protects the +5 V supply. When the +5 V level is too high, transistor V6137 (and V6112) conduct and the power supply goes into short circuit mode. (This results in a decrease of the converter switching frequency).

A voltage protection circuit using V6134, V6136 and V6112 protects against overloads protection. When the power supply is overloaded, these components conduct and the power supply goes into in the short-circuit mode.

9.4 HT SUPPLY

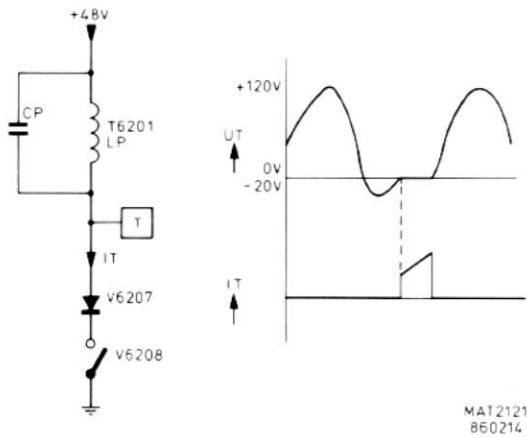

Figure 9.4 HT oscillator

The HT supply consists of an oscillator and a regulator circuit.

Transformer T6201 determines the frequency (50 kHz approx.) of the oscillator. The output signal voltage on the secondary winding of T6201 is rectified by diode V6207 and smoothed by C6211. The -2,1 kV is also converted to -14,5 kV in the HT multiplier D6201 and routed via connector X6030 to the post-acceleration anode of the CRT.

To regulate this HT voltage the -2 kV is fed to the input of OP-AMP N6002.

The output level of N6002 determines the energy to T6201, and thus the amplitude of the HT-voltage.

9.5 CALIBRATOR

The calibrator circuit consists of two analog switches D6501(8-9) and D6501(11-12) controlled by the active HIGH enable inputs 6 and 12 respectively, that are connected as an 2 kHz astable oscillator. Capacitor C6502 and resistor R6504 determine the 2 kHz frequency. The oscillator outputs, applied to enable inputs 5 and 13 of the second stage are in anti-phase with each other. Depending on the level of input 5 and 13, the CAL voltage will have a 1,2 V level or a 0 V level.

A6

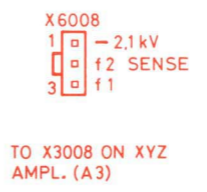
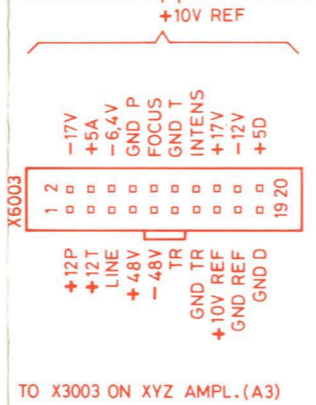
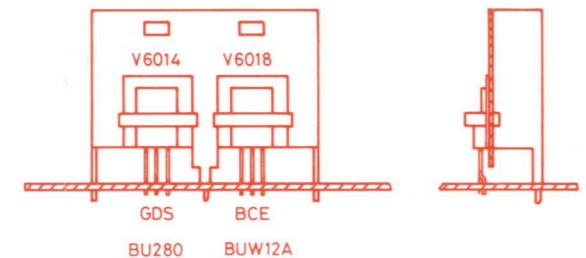
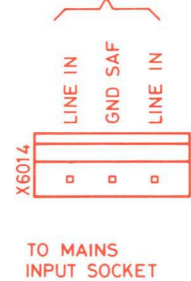
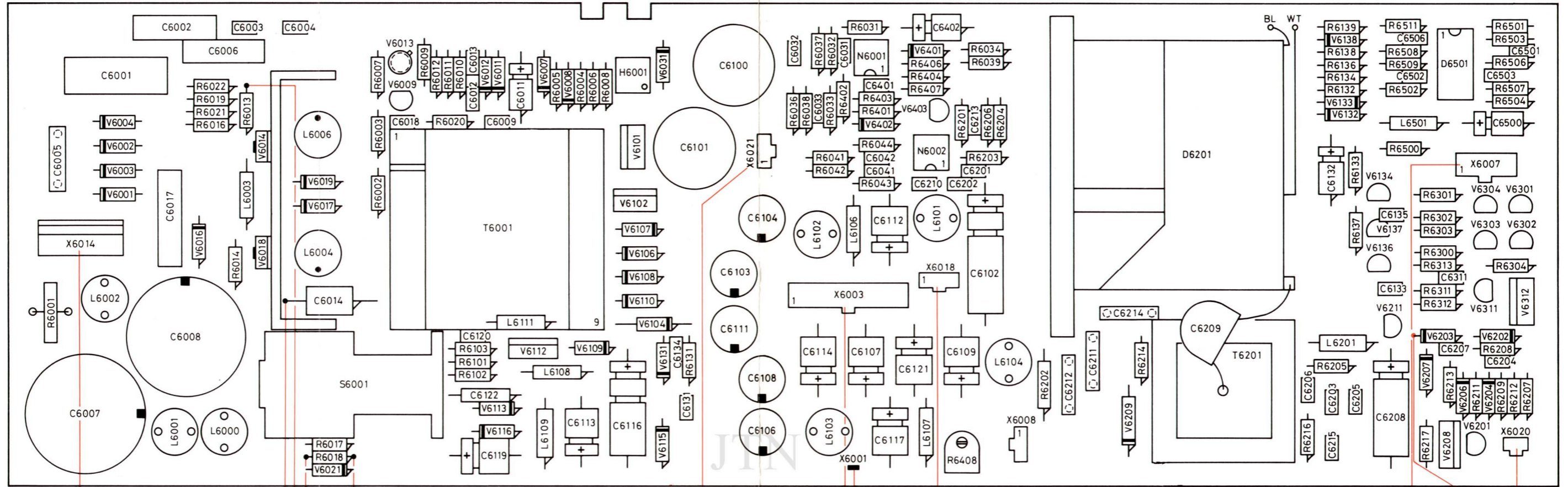

TOP VIEW

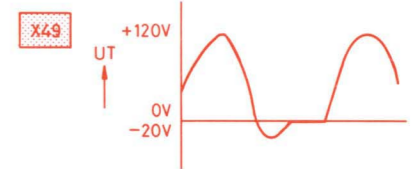
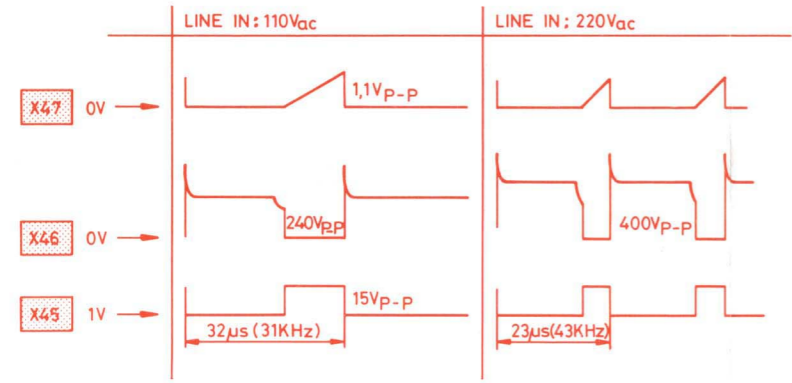
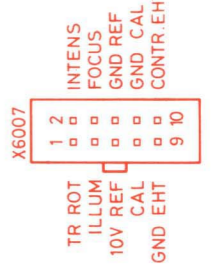
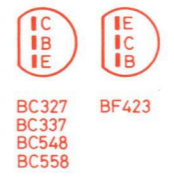
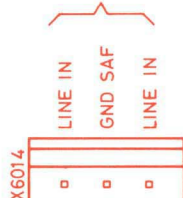
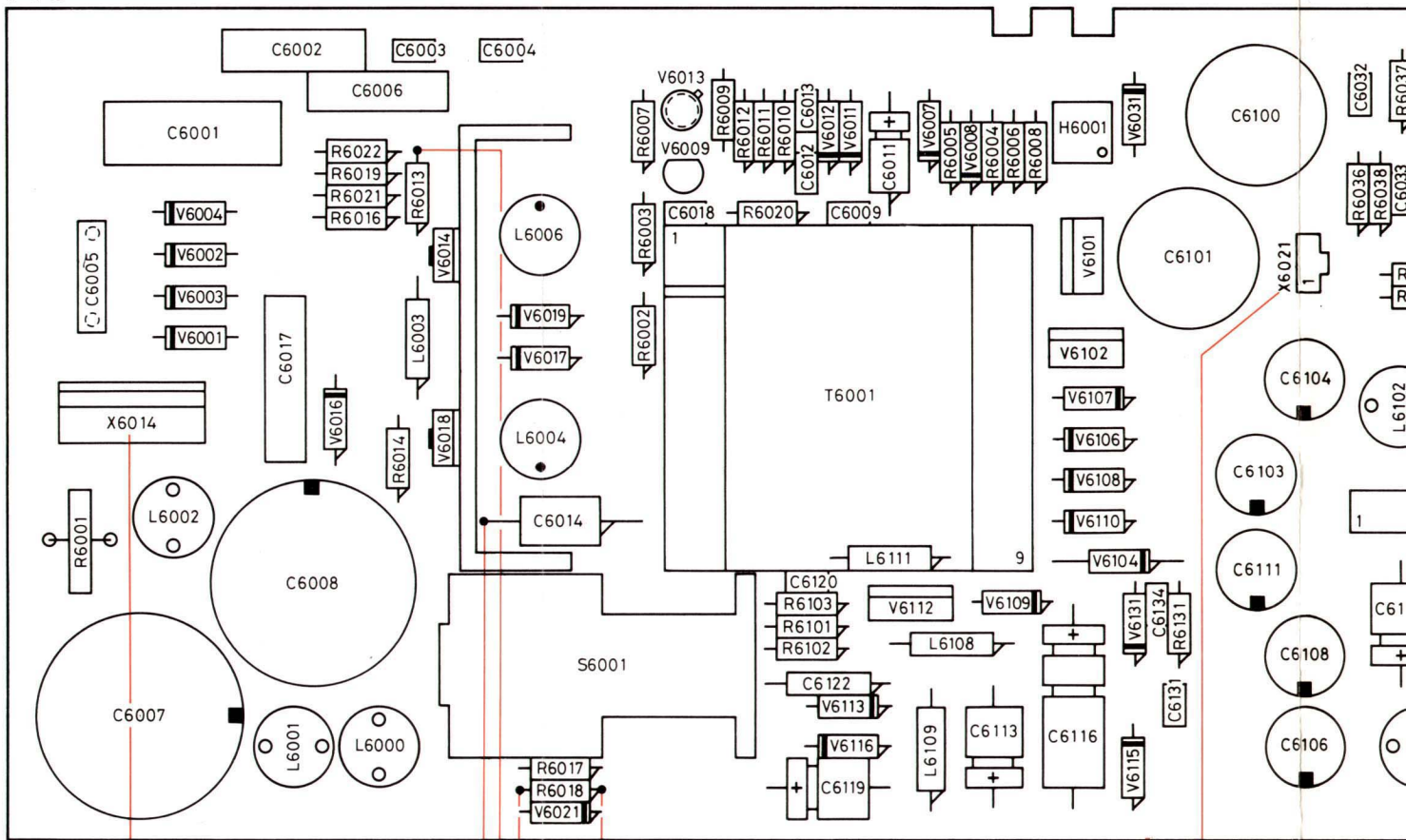
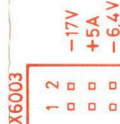
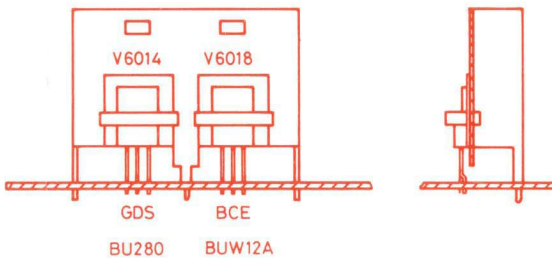

Figure 9.5 Power supply unit p.c.b.
 Figure 9.7 Power supply unit p.c.b.
 Figure 9.9 Power supply unit p.c.b.

A6



TO MAINS
INPUT SOCKET



TO X3003 O

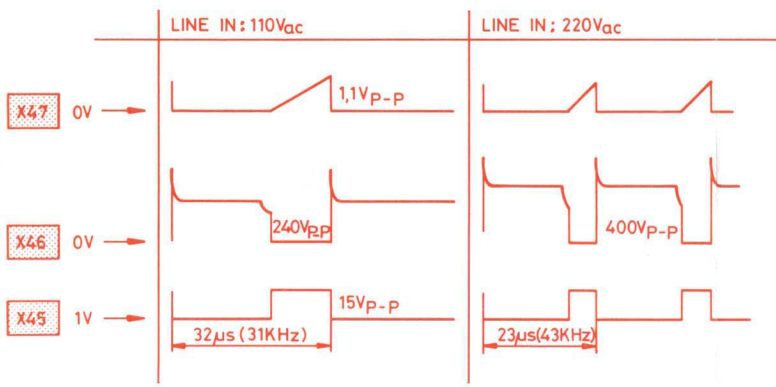

SIGNALS MEASURED, RELATED TO X48



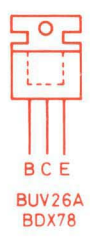
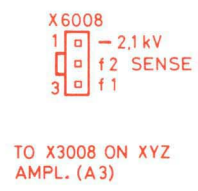
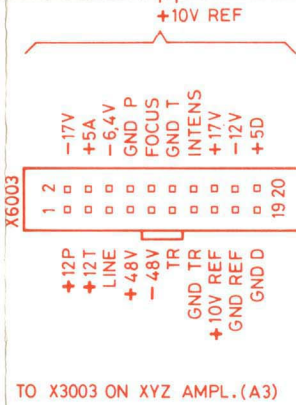
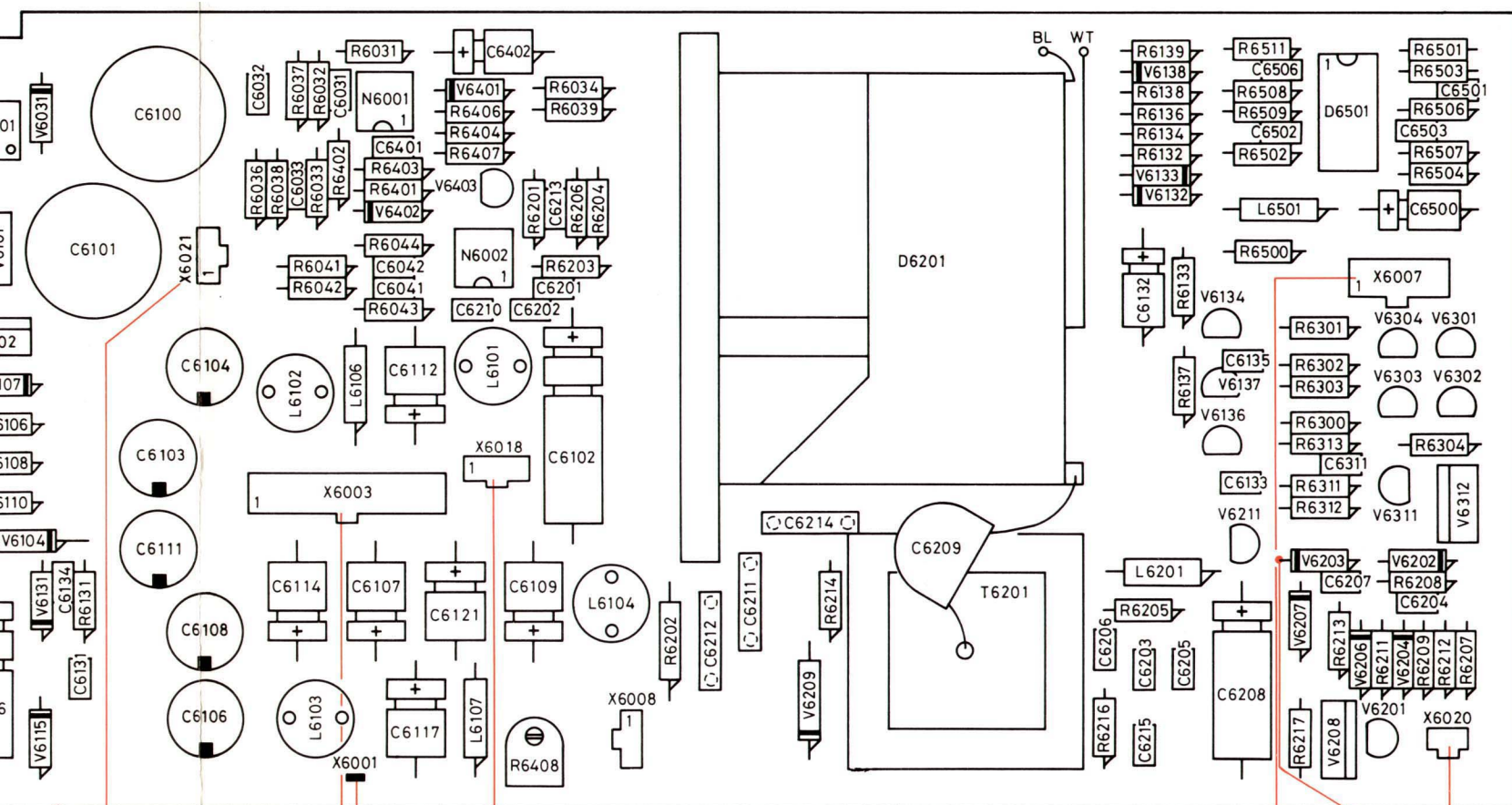

TOP VIEW

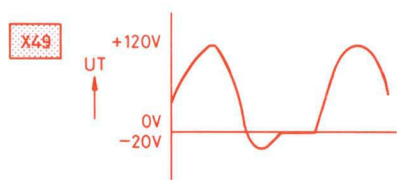
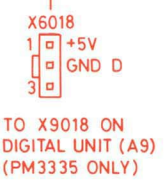
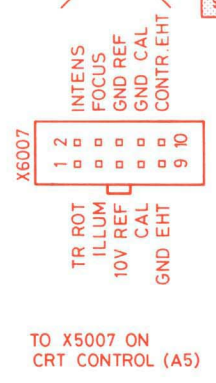
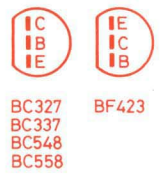

Figure 9.5 Power supply unit p.c.b.
 Figure 9.7 Power supply unit p.c.b.
 Figure 9.9 Power supply unit p.c.b.

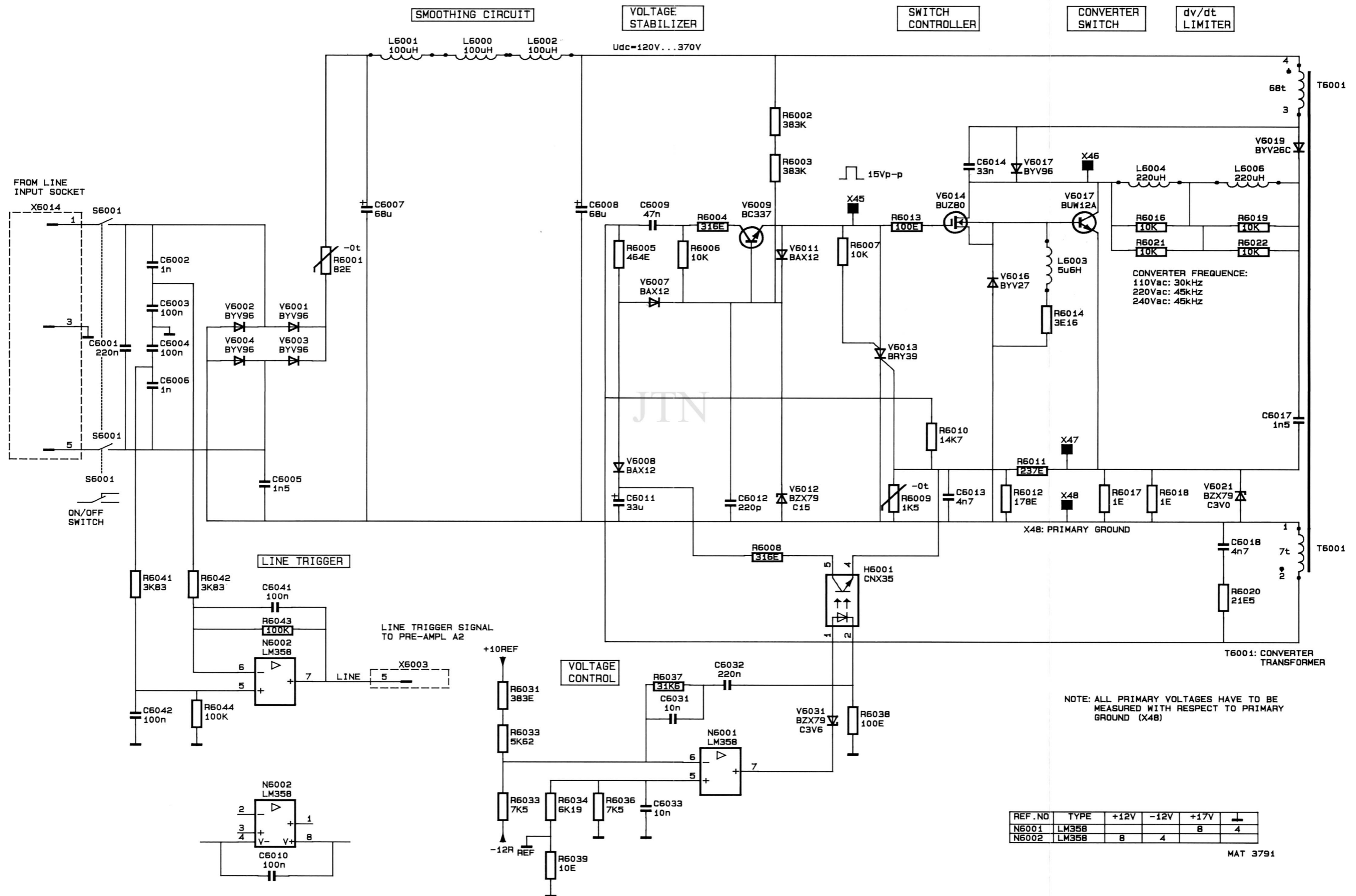

Figure 9.6 Circuit diagram of power supply, primary circuit

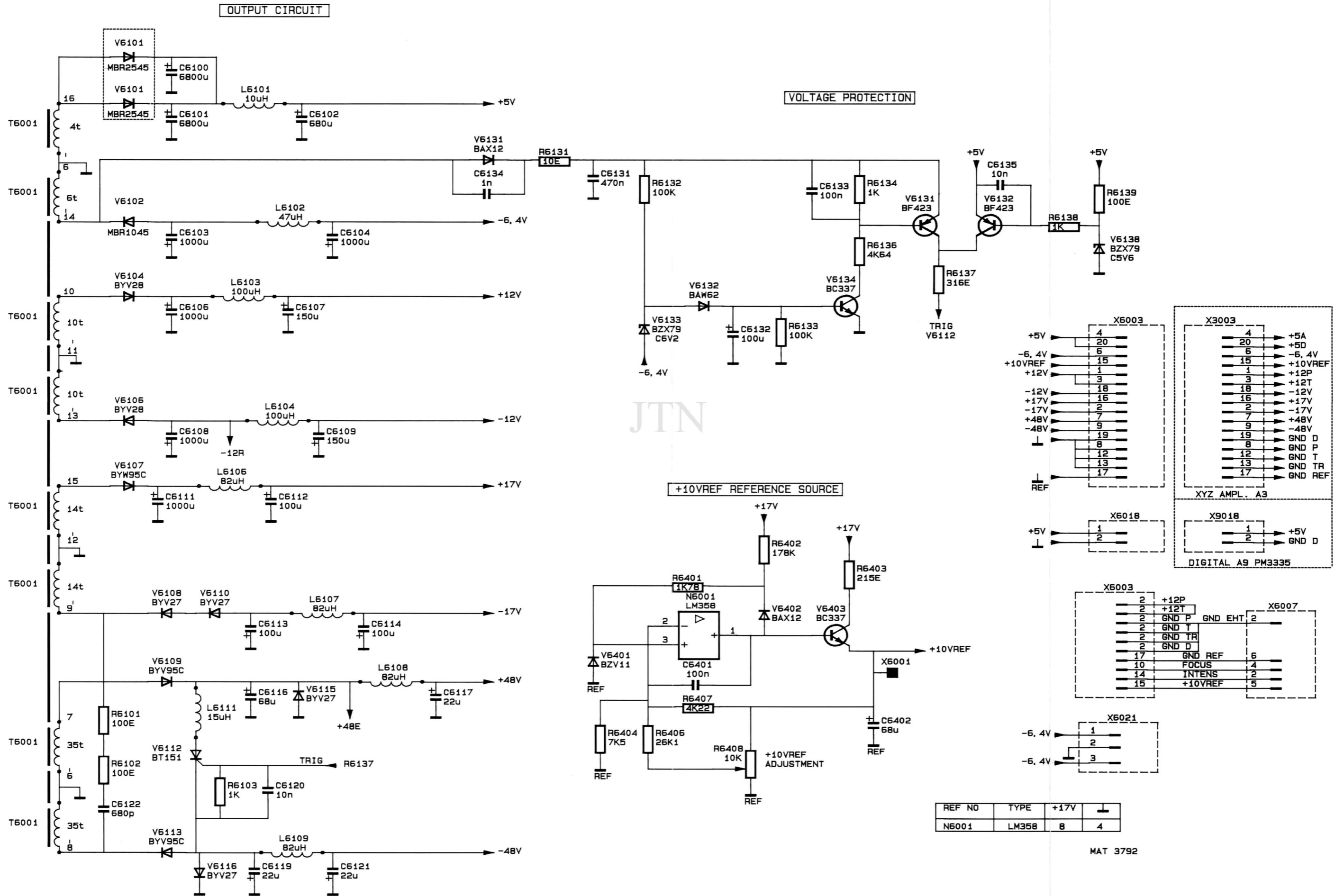

Figure 9.8 Circuit diagram of power supply, secondary circuit

REF NO	TYPE	+17V	⊥
N6001	LM358	8	4

MAT 3792

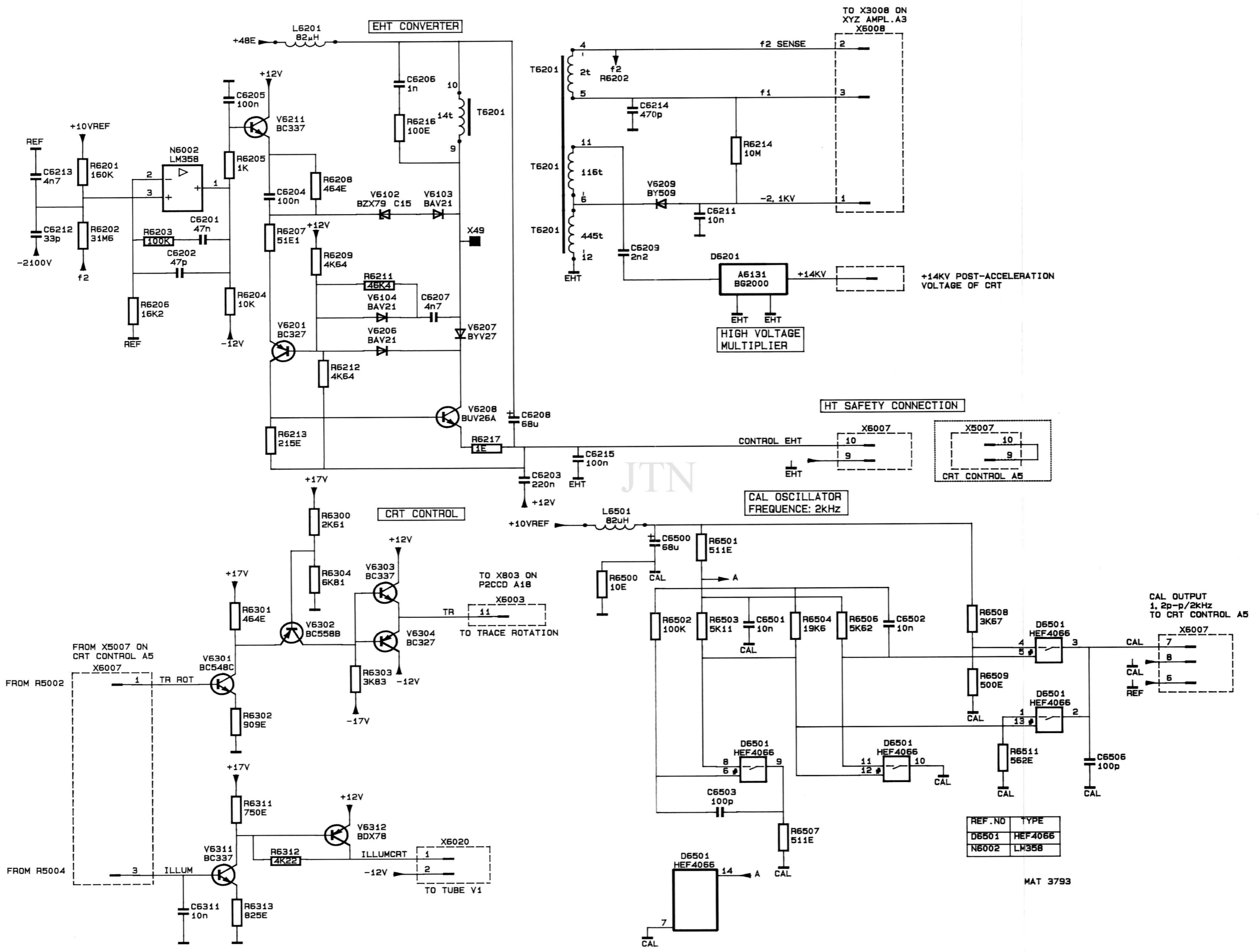

Figure 9.10 Circuit diagram of power supply, EHT circuit and various

REF. NO	TYPE
D6501	HEF4066
N6002	LM358

MAT 3793

FRONT UNIT (A7-A8)

10

JTN

10 FRONT UNIT (A7-A8)

The front unit consists of:

- the key-matrix
- the front controls and indicator
- the LCD display

10.1 KEY-MATRIX

The key matrix is connected to two remote 8 bit I/O ports. ROW 1...8 is applied to D7001 and COLUMN 1...8 is applied to D7002. Depending on the softkey which is depressed, a certain ROW and COLUMN will be influenced. This is read by the SDA0 line and thus by the microprocessor. The lines ROW 1, COL 1, COL 3, COL 5, COL 6 and COL 7 are also connected to the cursor unit A9 and read the cursor softkeys.

10.2 FRONT CONTROLS AND INDICATOR

The front-panel controls give a voltage between 0...10 V to the various circuits. To determine the UNCAL position of VAR A, VAR B or VAR DC, the dc voltages on the slider of the potentiometer are applied to comparator N7001. When the voltage level of the control is lower than 0,7 V, the I²C bus reads a logic high. Then the microprocessor adapts the LCD display to indicate the CAL status (e.g. no flashing " > " segment visible)

Integrated circuit D7004 (OQ0044) detects the kind of probe which is connected to the oscilloscope. Depending on the resistance between the probe indication input (pin 3 for channel A and pin 16 for channel B) and ground, the V/DIV reading of the LCD automatically increases according to the following table:

Pin 3 (16)	Pin 6 (17)	Pin 7 (12)	V/DIV attenuation
2k32	0	0	x10
6k98	1	0	x100
7k68	0	1	x1
10k	1	1	x1

10.3 LCD DISPLAY CIRCUIT

The LCD is driven by three drivers D8001, D8002 and D8003 (PCF8577). The temperature dependent supply voltage VCPCF is 4 V approx. at 25° C. When the temperature increases, this voltage decreases also. The single-pin built-in oscillator on pin 37 of D8001 provides the modulation frequency for the LCD segment driver outputs. Capacitor C7008 and resistor R7018 are connected to this pin to form the oscillator, with a frequency of 150 Hz approx. Pin 36 and pin 37 are used to determine the LCD driver address in the I²C bus.

The outputs pin 1...pin 32 directly drive the LCD.

Outputs BP1 and BP2 (pin 33 and pin 34) drive the COMMON pins of the LCD.

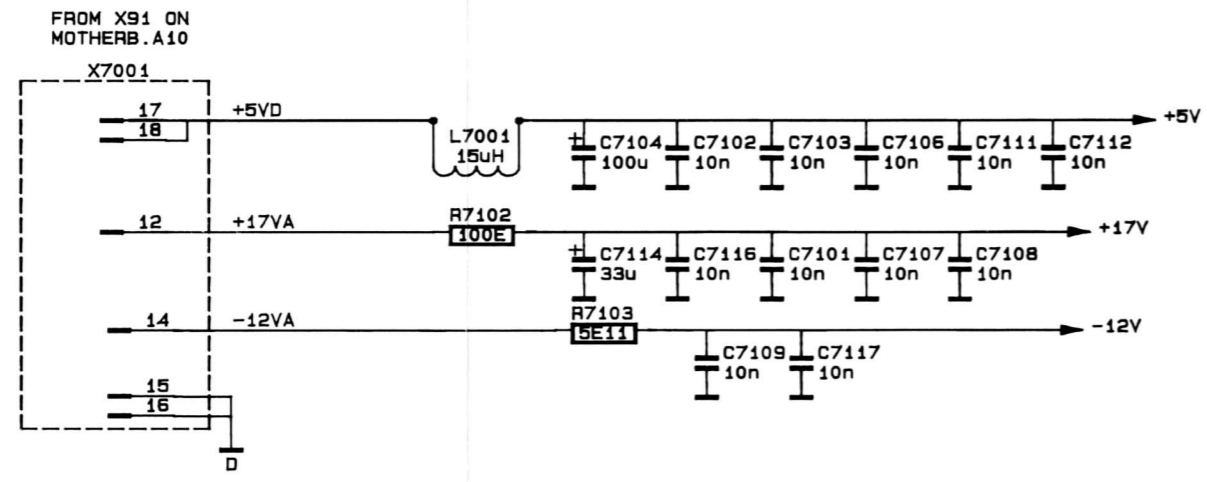
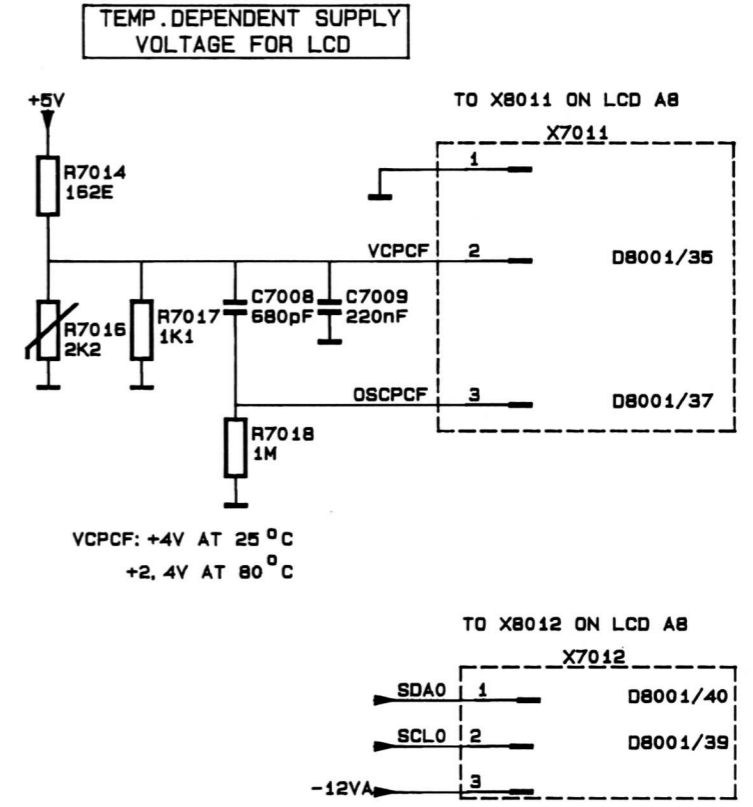
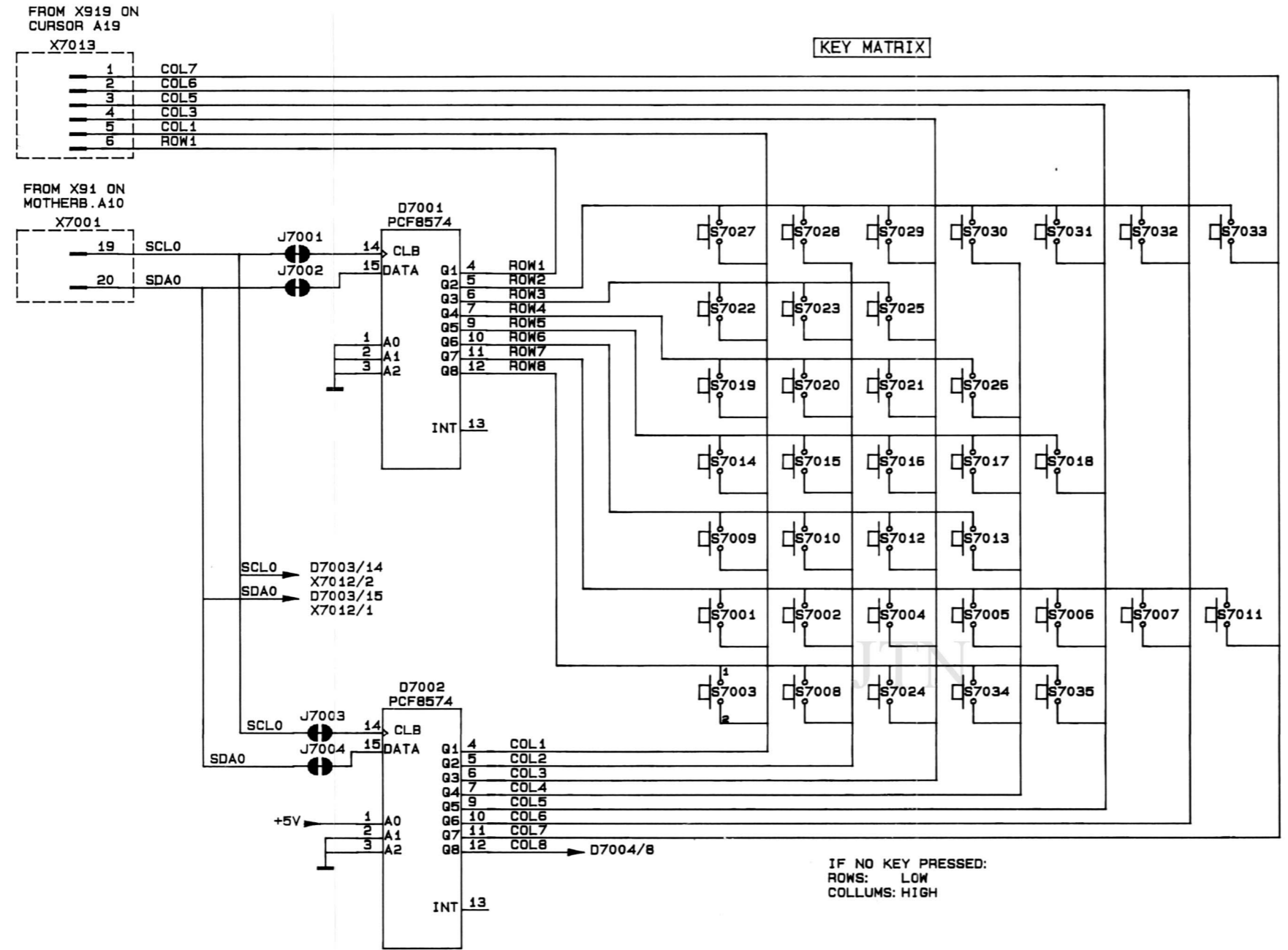

REF NO	TYPE	+5V	⊥
D7001	PCF8574	16	8
D7002	PCF8574	16	8

MAT 3559B

Figure 10.1 Circuit diagram of front unit, key matrix

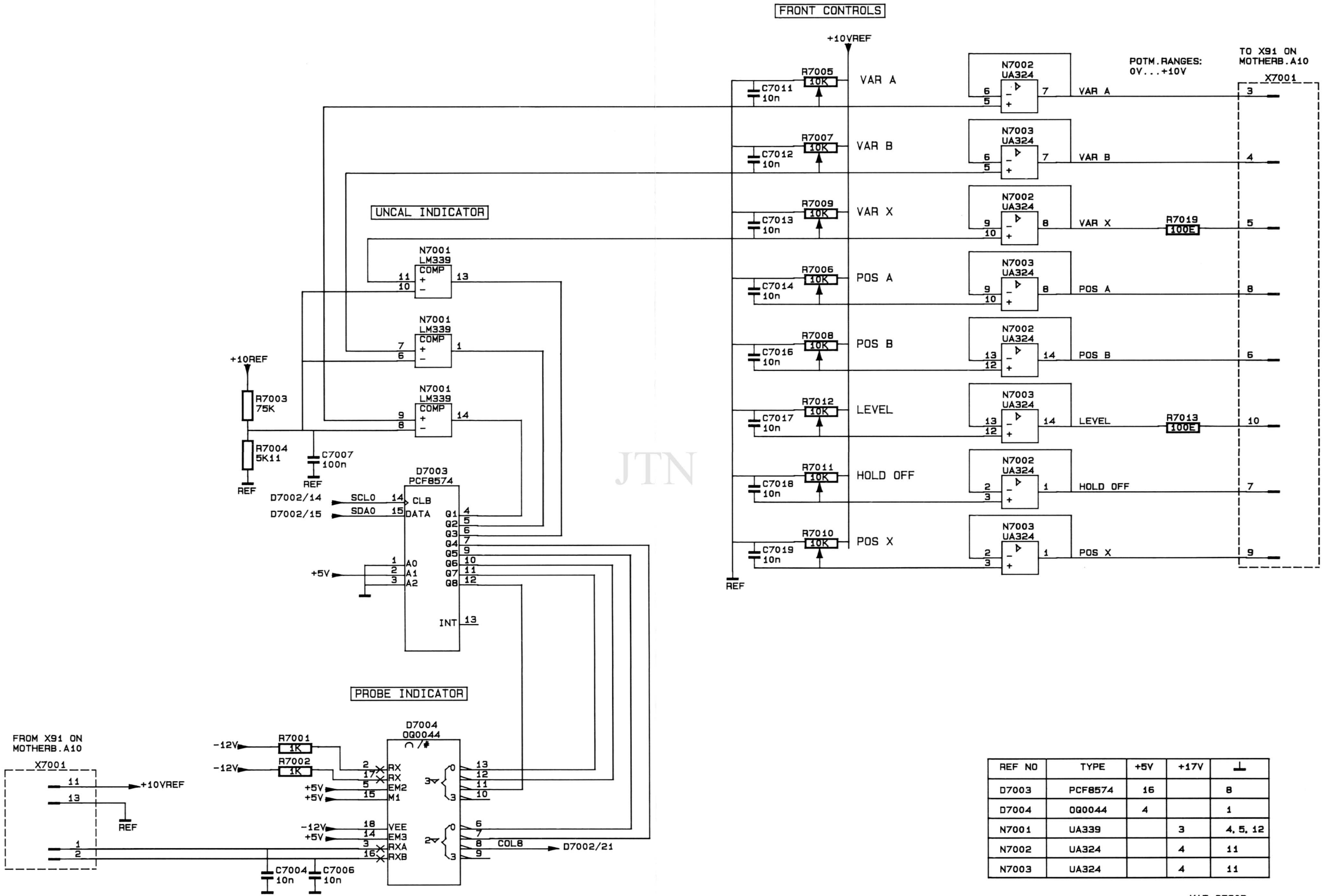

REF NO	TYPE	+5V	+17V	⊥
D7003	PCF8574	16		8
D7004	OQ0044	4		1
N7001	UA339		3	4, 5, 12
N7002	UA324		4	11
N7003	UA324		4	11

MAT 3560B

Figure 10.3 Circuit diagram of front unit, front controls and probe indication

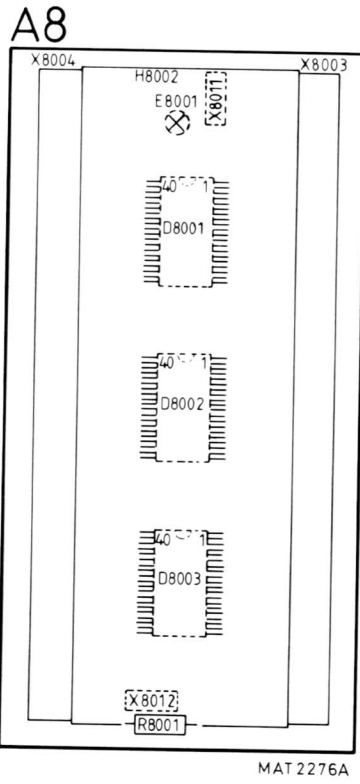
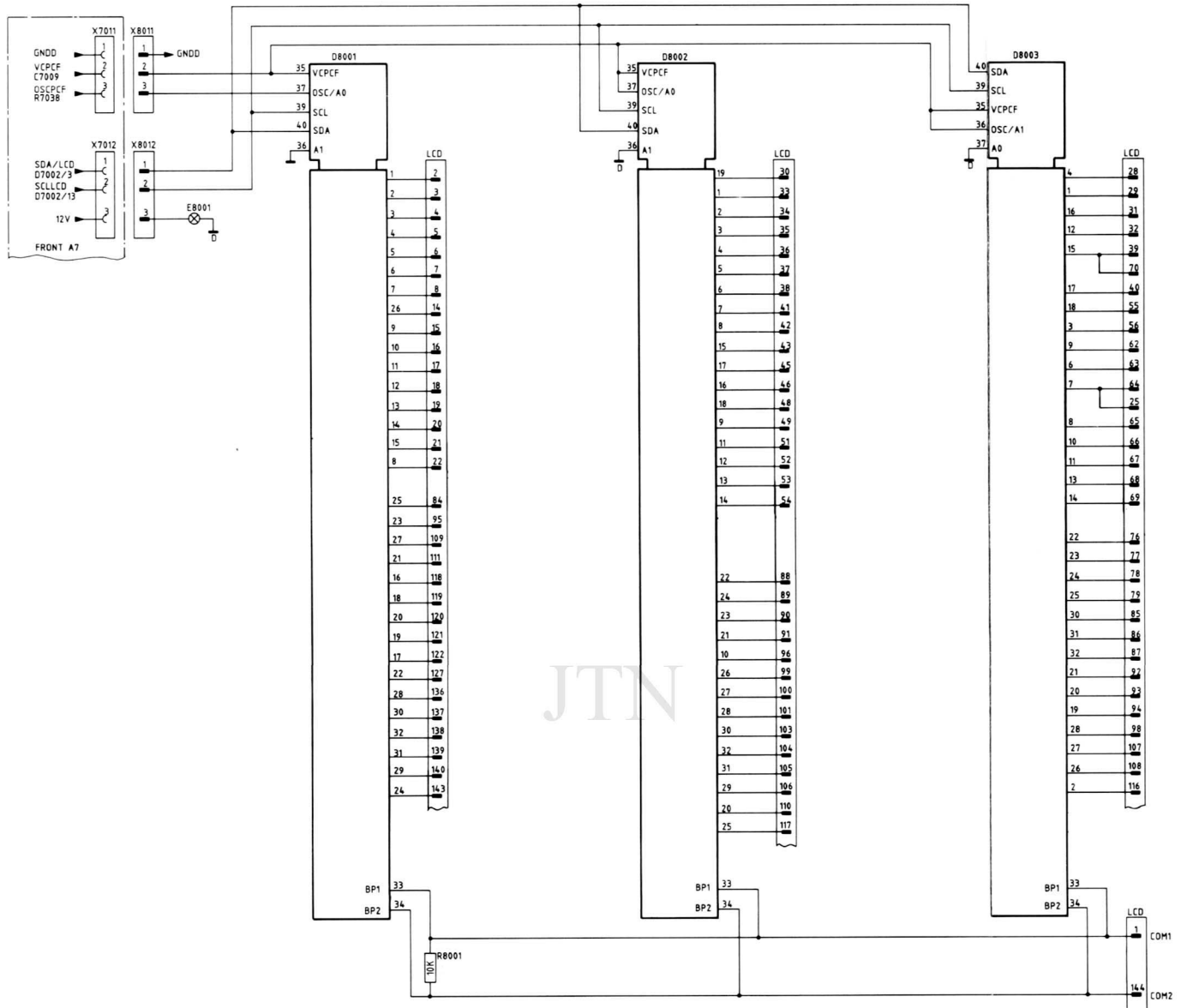

Figure 10.4 LCD unit p.c.b.

JTN



REF NO	TYPE	+
DB001	PCF8577	38
DB002	PCF8577	38
DB003	PCF8577	38

LCD				
PIN	COM1		COM2	
	DISPLAY	SEGMENT	DISPLAY	SEGMENT
144				COM2
143		x1		INV
142	NC		NC	
141	NC		NC	
140	1	a	1	f
139	1	g	1	e
138	1	c	1	d
137	1	b		P1
136		ALT		A
135	NC		NC	
134	NC		NC	
133	NC		NC	
132	NC		NC	
131	NC		NC	
130	NC		NC	
129	NC		NC	
128	NC		NC	
127		x2		INV
126	NC		NC	
125	NC		NC	
124	NC		NC	
123	NC		NC	
122	3	a	3	f
121	3	g	3	e
120	3	c	3	d
119	3	b		P2
118		TRIG D		NOT
117				TB
116		TRIG		AUTO
115	NC		NC	
114	NC		NC	
113	NC		NC	
112	NC		NC	
111		x4		x3
110	5	g	5	e
109	5	c	5	d
108	6	g	6	e
107	6	c	6	d
106	7	g	7	e
105	7	c	7	d
104		3		MAGN
103		2		4
102	NC		NC	
101		10		8
100		EXT		A
99		DC		P-P
98		y10,TV		y9
97				y7,y8
96		y4		y5,y6
95				DIGITAL MEMORY
94		y1		y2,y3
93	8	g	8	e
92	8	c	8	d
91	9	g	9	e
90	9	c	9	d
89	9	b		P6
88	10	g	10	e
87	10	c	10	d
86	10	b		P7
85	11	c	11	d
84		LOCK		REG
83	NC		NC	
82	NC		NC	
81	NC		NC	
80	NC		NC	
79		z2		z1
78		z3		z4
77		z6		z5
76				REMOTE
75	NC		NC	
74	NC		NC	
73	NC		NC	

LCD				
PIN	COM1		COM2	
	DISPLAY	SEGMENT	DISPLAY	SEGMENT
1		COM1		
2	2	a	2	f
3	2	b		
4	2	g	2	e
5	2	c	2	d
6		r		l
7		v		l
8		DC		AC
9	NC		NC	
10	NC		NC	
11	NC		NC	
12	NC		NC	
13	NC		NC	
14		CHOP		B
15		ADD		LEVEL VIEW
16	4	a	4	f
17	4	b		
18	4	g	4	e
19	4	c	4	d
20		r		l
21		v		l
22		DC		AC
23	NC		NC	
24	NC		NC	
25	NC		NC	
26	NC		NC	
27	NC		NC	
28		ARMED		
29		MULTI		X-DEFL
30		SINGLE		
31	5	a	5	f
32	5	b		P3
33	6	a	6	f
34	6	b		P4
35	7	a	7	f
36	7	b		
37		l		r
38		s		u
39		s		u
40		16		x9
41		x5		x8
42		x6		x7
43		LINE		DC
44	NC		NC	
45		B		AC
46		LF		HF
47	NC		NC	
48	8	a	8	f
49	8	b		P5
50	NC		NC	
51	9	a	9	f
52	10	a	10	f
53	11	a	11	f
54	11	b		
55	11	g	11	e
56		mV		DIV
57	NC		NC	
58	NC		NC	
59	NC		NC	
60	NC		NC	
61	NC		NC	
62		PLOT		ROLL
63		DOTS		STATUS
64		0,1/2,1,2,17,2,21		
65		z15		z16
66		z14		z13
67		z11		z12
68		z10		z9
69		z7		z8
70				MENU
71	NC		NC	
72	NC		NC	



MAT 3016
871016

Figure 10.5 Circuit diagram of LCD unit

MOTHERBOARD UNIT (A10)

11 MOTHERBOARD UNIT (A10)

A10

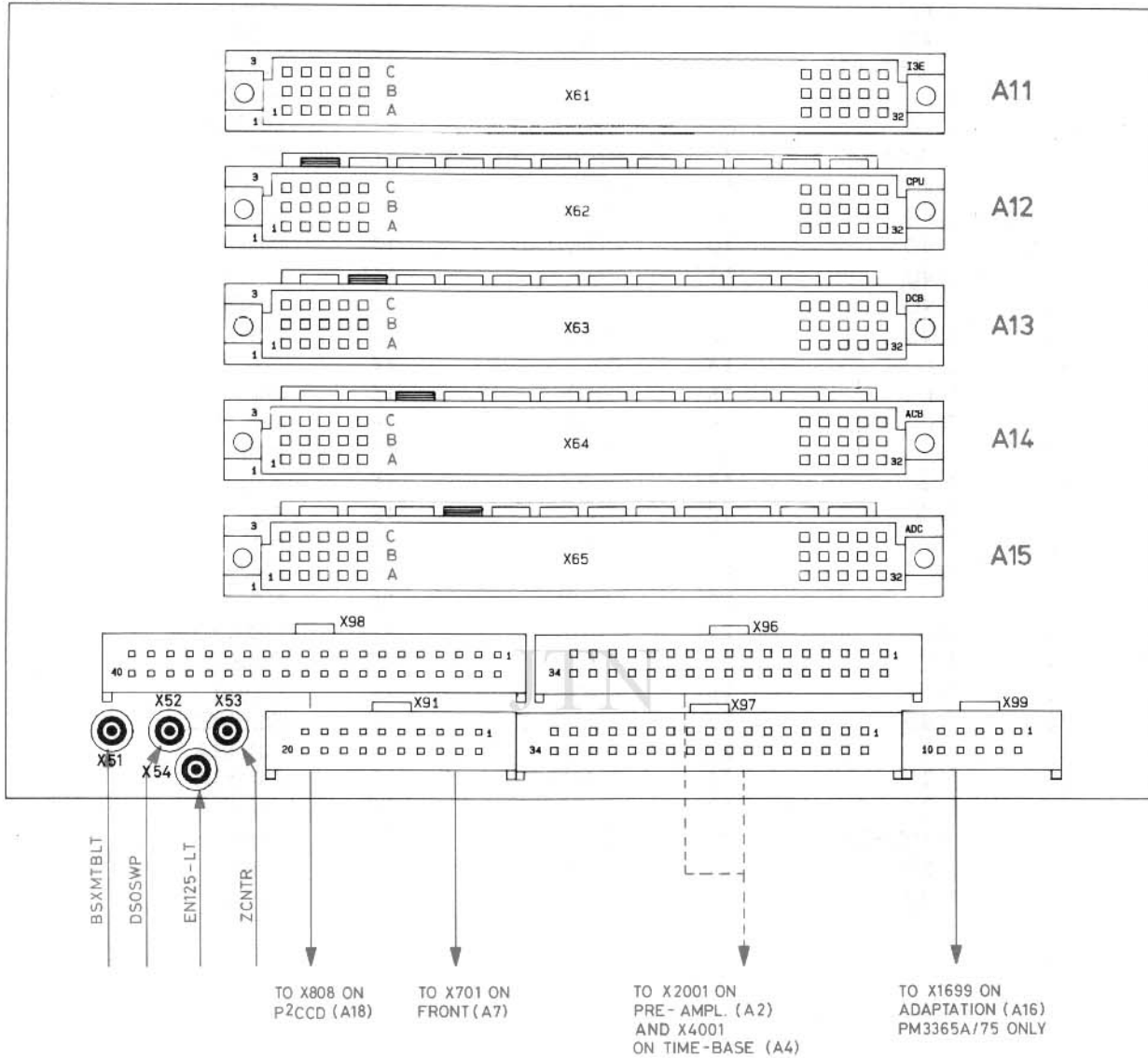

MAT3562A

Figure 11.1 Motherboard unit p.c.b.

A complete signal name list of all motherboard connectors is given on the next pages.

Attention: Flat cable A101 is connected to X97 if no option is installed in socket X61.
 Flat cable A101 is connected to X96 if an IEEE-488 or a RS232 option is installed in socket X61

- X61: Socket for A11, IEEE-488 or RS232 unit (optional)
- X62: Socket for A12, Central Processor (CPU) unit
- X63: Socket for A13, Digital Control Logic (DCL) unit
- X64: Socket for A14, Acquisition Control Logic (ACL) unit
- X65: Socket for A15, Analog to Digital and Digital to Analog Converter (ADC-DAC) unit

CONNECTOR PINNINGS X61

A		B		C	
1	-17V	1	GND	1	-6,4V
2	+12T	2	GND	2	GND
3	GND	3	GND	3	GND
4	RESET-HT	4	DGPTCSLT	4	IEEECSLT
5	NC	5	NC	5	ROM2CSLT
6	GND	6	WRITE-LT	6	DACCS-LT
7	RESET-LT	7	READ--LT	7	SDA0
8	GND	8	IEEECLK	8	SCL0
9	GND	9	GND	9	NC
10	GND	10	RDWR--HT	10	GND
11	GND	11	NC	11	GND
12	GND	12	NC	12	GND
13	GND	13	GND	13	GND
14	D0	14	D1	14	D2
15	D3	15	GND	15	D4
16	D5	16	GND	16	D6
17	D7	17	A16	17	A14
18	A15	18	A12	18	A10
19	A13	19	A8	19	A6
20	A11	20	A4	20	A2
21	A9	21	A0	21	GND
22	A7	22	VARB	22	VARX
23	A5	23	VARA	23	HOLDOFF
24	A3	24	POSB	24	POSXOUT
25	A1	25	POSA	25	LEVEL
26	GND	26	DPOSXOUT	26	DLEVEL
27	NC	27	DHOFF	27	DPOSA
28	NC	28	DVARX	28	DPOSB
29	NC	29	DVARB	29	DVARA
30	+10VREF	30	GNDREF	30	+17V
31	+5V	31	+5V	31	+5V
32	GND	32	GND	32	GND

CONNECTOR PINNINGS X62

A		B		C	
1	SCL	1	SRTTB-LT	1	RDADD-LT
2	RESET-HT	2	GND	2	GND
3	DCCLK	3	DTTC--LT	3	MEMON-LT
4	GND	4	DGPTCSLT	4	IEEECSLT
5	DELTRGHT	5	GND	5	ROM2CSLT
6	RSTACQLT	6	WRITE-LT	6	DACCS-LT
7	RESER-LT	7	READ--LT	7	SDA0
8	DSOCLK	8	IEEECLK	8	SCL0
9	DSPINTLT	9	TBSTNCHT	9	GND
10	SWR---HT	10	SWTBCLKT	10	DSOACKLT
11	ENCVCNHT	11	SWTBCLK	11	DSOCS-LT
12	CVCNRYLT	12	GND	12	DTST--LT
13	RDWR--HT	13	GND	13	GND
14	D0	14	D1	14	D2
15	D3	15	GND	15	D4
16	D5	16	NC	16	D6
17	D7	17	NC	17	A16
18	A15	18	NC	18	A14
19	A13	19	GND	19	A12
20	A11	20	GND	20	A10
21	A9	21	GND	21	A8
22	A7	22	GNDB	22	A6
23	A5	23	NC	23	A4
24	A3	24	NC	24	A2
25	A1	25	DLENY-HT	25	A0
26	DLENX-HT	26	GND	26	DLENB-HT
27	DLENA-HT	27	TESTO-HT	27	VERIICHT
28	DLENP-HT	28	DLENT2HT	28	DLENT1HT
29	SDA1	29	EDC---LT	29	SCL1
30	+10VREF	30	GNDREF	30	+17V
31	+5V	31	+5V	31	+5V
32	GND	32	GND	32	GND

CONNECTOR PINNINGS X63

A		B		C	
1	SCL	1	GND	1	RES5
2	RESET-HT	2	GND	2	BATT
3	TBWE--HT	3	DCWE--HT	3	STWE--HT
4	PENLFT	4	GND	4	MEMON-HT
5	PLOT--HT	5	DELTRGHT	5	DOTS--LT
6	ZON---LT	6	NC	6	SC0---HT
7	OSCON-LT	7	NC	7	RESET-LT
8	TCINN-HT	8	TRIGENHT	8	DSOCLK
9	INVA0-HT	9	DATEN-HT	9	DSPINTLT
10	MIDCLKHT	10	XYDLE-HT	10	DSOCS-LT
11	RES7	11	OLCLK	11	DSOCS-LT
12	WRSMP-HT	12	MDOE--LT	12	DTST--LT
13	RSTH--LT	13	POSXOFHT	13	RDWR--HT
14	GND	14	D1	14	D0
15	GND	15	D3	15	D2
16	PD0	16	PD1	16	D4
17	PD2	17	PD3	17	D5
18	PD4	18	PD5	18	D6
19	PD6	19	PD7	19	D7
20	XDAC0	20	SC1---HT	20	GND
21	XDAC1	21	GND	21	A16
22	XDAC2	22	A15	22	A14
23	XDAC3	23	A13	23	A12
24	XDAC4	24	A11	24	A10
25	XDAC5	25	A9	25	A8
26	XDAC6	26	A7	26	A6
27	XDAC7	27	A5	27	A4
28	XDAC8	28	A3	28	A2
29	XDAC9	29	A1	29	A0
30	RES1	30	RES2	30	GND
31	+5V	31	+5V	31	+5V
32	GND	32	GND	32	GND

CONNECTOR PINNINGS X64

A		B		C	
1	SCL	1	GND	1	RES5
2	RESET-HT	2	GND	2	MEMON-HT
3	CDRD--HT	3	TCEV--LT	3	SWCK
4	RSSW--HT	4	DISOD-HT	4	INTOD-HT
5	PLOT--HT	5	DELTRGHT	5	DOTS--LT
6	EDC---LT	6	RSTEV-LT	6	RSTOD-LT
7	BSXMTBLT	7	SC0---HT	7	DISEV-HT
8	OSCON-LT	8	TCINN-HT	8	TRIGENHT
9	RSTACQLT	9	INVA0-HT	9	DATEN-HT
10	DTUF--HT	10	MIDCLK	10	XYDLE-HT
11	SRTACQHT	11	RES7	11	OLCLK
12	CHB---LT	12	WRSMPT-HT	12	MDOE--LT
13	GND	13	RSTH--LT	13	GND
14	CHA---LT	14	SWR---HT	14	TBSYNCHT
15	NC	15	ENCVCNHT	15	SWTBCLK
16	STCONVLT	16	CVCNRYLT	16	SWTB
17	CHSEL1HT	17	CHSEL0HT	17	NC
18	AD1	18	AD0	18	SDA1
19	AD3	19	AD2	19	SCL1
20	AD5	20	AD4	20	SC1---HT
21	AD7	21	AD6	21	NC
22	YDAC0	22	ED0	22	PD0
23	YDAC1	23	ED1	23	PD1
24	YDAC2	24	ED2	24	PD2
25	YDAC3	25	ED3	25	PD3
26	YDAC4	26	HOLDB-LT	26	PD4
27	YDAC5	27	SRTTB-LT	27	PD5
28	YDAC6	28	SRTMTBHT	28	PD6
29	YDAC7	29	CCDENBHT	29	PD7
30	RES1	30	RES2	30	DLENX-HT
31	+5V	31	+5V	31	+5V
32	GND	32	GND	32	GND

CONNECTOR PINNINGS X65

A		B		C	
1	GND	1	+5A	1	-6,4V
2	GND	2	+5A	2	+5A
3	MEMON-HT	3	BATT	3	+12T
4	GNDP2	4	GNDP2	4	GNDP2
5	+YDAC	5	GNDP2	5	-YDAC
6	GNDP1	6	GNDP1	6	GNDP1
7	CHAEV	7	GNDP1	7	CHAOD
8	GND A	8	GND A	8	GND A
9	CHBEV	9	GND A	9	CHBOD
10	GND B	10	GND B	10	GND B
11	ZCNTR	11	GND B	11	DSOSWP
12	PLOT--HT	12	AIN4	12	DOTS--LT
13	ZON---LT	13	GND	13	SC0---HT
14	POXFHT	14	GND	14	PENLFT
15	POSX	15	+17V	15	STCONVLT
16	POSXOUT	16	GND	16	CHSEL1HT
17	AD1	17	GND	17	CHSEL0HT
18	AD3	18	GND	18	AD0
19	AD5	19	GND	19	AD2
20	AD7	20	GND	20	AD4
21	XDAC0	21	GND	21	AD6
22	XDAC1	22	GND	22	YDAC0
23	XDAC2	23	NC	23	YDAC1
24	XDAC3	24	NC	24	YDAC2
25	XDAC4	25	GND	25	YDAC3
26	XDAC5	26	GND	26	YDAC4
27	XDAC6	27	GND	27	YDAC5
28	XDAC7	28	GND	28	YDAC6
29	XDAC8	29	GND	29	YDAC7
30	XDAC9	30	+10VREF	30	-12V
31	+5V	31	+5V	31	+5V
32	GND	32	GND	32	GND

CONNECTOR PINNINGS X91

1	PRBA	2	PRBB
3	VARA	4	VARB
5	VARX	6	POSB
7	HOLDOFF	8	POSA
9	POSX	10	LEVEL
11	+10VREF	12	+17V
13	GND REF	14	-12V
15	GND	16	GND
17	+5V	18	+5V
19	SCL0	20	SDA0

CONNECTOR PINNINGS X96 and X97

1	SDA	2	SCL
3	DLEN TB1	4	DLEN P
5	DLEN TB3	6	DLEN A
7	DLEN TB2	8	DLEN B
9	TEST OUT	10	VERT IIC
11	GND D	12	+5D
13	REMRQN	14	GND D
15	FOOTN	16	-12V
17	SRTACQHT	18	+17V
19	GND P	20	GND P
21	GND REF	22	LEVEL MTB
23	+10VREF	24	--
25	POS X	26	POS A
27	HOLD OFF	28	POS B
29	VAR MTB	30	VAR A
31	PROBE B	32	SRTMTBHT
33	PROBE A	34	VAR B

CONNECTOR PINNINGS X98

1	GNDB	2	CHBEV
3	CHBOD	4	GND A
5	CHAOD	6	CHAEV
7	GNDP1	8	+YDAC
9	-YDAC	10	GNDP2
11	MEMON-HT	12	RSTOD-LT
13	DISEV-HT	14	RSTEV-LT
15	SWTB	16	DISOD-HT
17	INTEV-HT	18	INTOD-HT
19	SAMPLEHT	20	CDRD--HT
21	DCCLK	22	TCEV--LT
23	ED3	24	DTUF--LT
25	ED2	26	EDC--LT
27	ED1	28	DTTC--LT
29	ED0	30	RSSW--HT
31	DCWE--HT	32	SWCK
33	OSCON-LT	34	TBWE--HT
35	+12T	36	STWE--HT
37	+5A	38	-17V
39	-6,4V	40	GND

CONNECTOR PINNINGS X99

1	+17V	2	CCDENBHT
3	HOLDB-LT	4	GND
5	CHA---LT	6	+5V
7	CHB---LT	8	GND
9	ADCIN4	10	GNDP

50 OHM CONNECTORS

X51	BSXMTBLT
X52	DSOSWP
X53	ZCNTR
X54	EN125-LT (PM3355 and PM3375 only)

OPTIONS (A11)

JTN

12 OPTIONS (A11)

The optionslot on the Motherboard (connector X61) is reserved for optional expansions for this instrument.

Description of the option is given in separate manuals.

JTN

CPU UNIT (A12)

JTN

13 CPU UNIT (A12)

13.1 INTRODUCTION

This unit mainly consists of a powerful 68008 microprocessor configuration with PROM, address decoders, I/O buffers and a clock generator. The microprocessor runs at a clock frequency of 8 MHz. The microprocessor has an asynchronous bus structure with a 20-bit address bus and an 8-bit databus. Asynchronous means that the microprocessor waits for a "data acknowledge" signal before continuing. This enables the microprocessor to handle different access times in the circuit.

To provide specific serial data transfer possibilities, the microprocessor system also contains an I²C bus interface.

The I²C bus is for 2-way, 3-line communication between different ICs or modules. The three lines are a serial data line (SDA), a serial clock line (SCL) and ground. Both lines must be connected to a positive supply via a pull-up resistor when connected to the output stages of a device. Data transfer may be initiated only when the bus is not busy.

JTN

13.2 MEMORY MAP

Only a part of the complete address range is used, according to the following memory map. The map gives also the memory select signals, generated by device D201.

Address (hex)	Decoding	Signal	Connected to
00000 1FFFF	ROM1	ROM1CSLT	D216-24
20000 3FFFF	ROM2 (not used)	ROM2CSLT	--
40000 40000 48000 50000 5FFFF 58000	RDIC0-LT WRIIC-LT RDIC1-LT MFOUT-LT -- -- RSPLT-LT --	MFIOCSLT	D202-4
60000 7FFFF	RAM	RAMCS-LT	D217-20
80000 9FFFF	IEEE or RS232 (optional)	IEEECSLT	D116-8
A0000 BFFFF	TIMER	TMRCS-LT	D218-21
C0000 C0000 D0000 DFFFF	Digital control DAC	DCPTCSLT	D213-1 and D213-12
E0000 FFFF	various	DSOCS-LT	D314-7

The signal MFIOCSLT is decoded again by D202. When RDWR--HT is high, this determines the read status of the decoded signals; when it is low this determines the write status. The coding of MFIOCSLT is as follows:

Address range (Hex)	Read	Write
40000-47FFF	RDIC0-LT	WRIIC-LT
48000-4FFFF	RDIC1-LT	MFOUT-LT
50000-57FFF	--	--
58000-5FFFF	RSPLT-LT	--

The signal DCPTCSLT is decoded by D213 and, controlled by A16, gives the DACCS-LT and DGPTCS-LT signals.

The signal DSOCS-LT is applied to the DCL unit A13 and selects among other things the acquisition RAM or the display RAM.

13.3 CIRCUIT DESCRIPTION

The **MICROPROCESSOR** D214 is connected via the DATA bus D0...D7 to the **PROM** D216, to the **RAM** D217, to the **TIMER** D218 and to the DCL unit A13. D216 contains 128K x 8 Read Only Memory, while D217 contains 8K x 8 Random Access Memory. Both devices are addressed via the ADDRESS bus.

The **TIMER** D218 consists of three separate timers which are controlled by the microprocessor:

- GATE 0 forms the delay counter (not active!)
- GATE 1 forms the read-out counter
- GATE 2 forms the slow time base counter

After the timer has counted the value determined by the value on the data bus, the output becomes low.

ATTENTION: Because for this instrument (PM3365A/75) the delay counter is formed by D441, D442, D443 and D444 on unit A14, output signal DTTC--LT has been disabled by the removing of resistor R229. However, this board can also be used for servicing older instruments (PM3365) by means of inserting R229. Take notice that in these older instruments unit A14 must be of an older type, so without D441 ... 444.

The **C-BUS DECODER** decodes the DLEN signals for the various circuits at the time that the signal MFOUT-LT is low.

It gives the following decoding:

Address (Hex)	Signal
48000	DLENP-HT
48001	DLENT1-HT
48002	DLENT2-HT
48003	VERIIC-HT
48004	N.C.
48005	DLENB-HT
48006	DLENX-HT
48007	DLENA-HT

Note that for servicing, soldering joints are added in the p.c.b. tracks connecting the circuits. These can be used to localize a fault in the I²C bus by means of interrupting the bus connection. A description of the fault-find procedure is given in Section 23-5-4 of this manual.

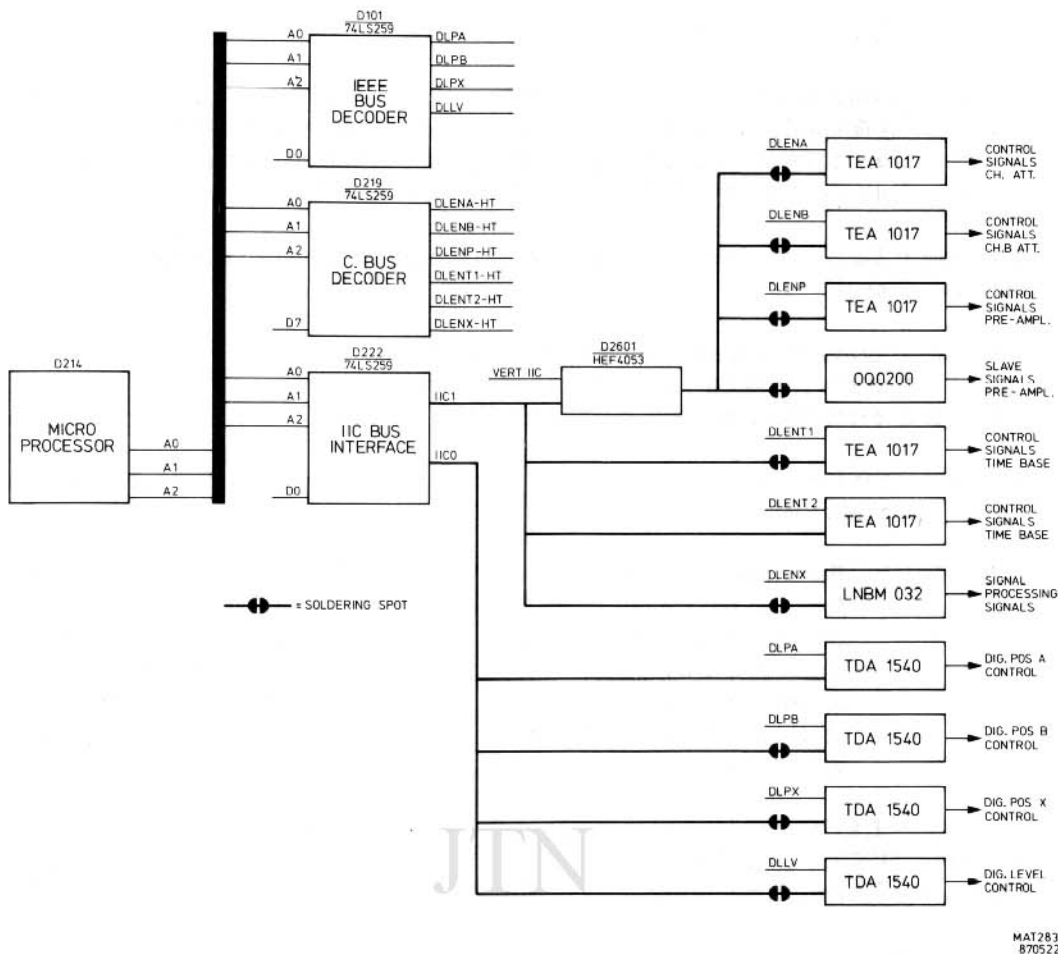

Figure 13.1 I²C bus structure

The I²C BUS INTERFACE D222 decodes the I²C bus and other signals at the time when WRIIC-LT is low. It gives the following decoding:

Address	Signal	Description
40000	SDA	Serial data
40001	SCL	Serial clock
40002	SEL0	Selection I ² C bus 0
40003	SEL1	Selection I ² C bus 1
40004	--	--
40005	RSNT-HT	Resets 20 ms timer D207
40006	WTDG-HT	Watchdog control
40007	MEMON-HT	Memory on signal

Next the signals SDA, SCL, SEL0 and SEL1 are decoded to the I²C 0 bus and I²C 1 bus by D223.

The STATUS INPUT device D221 serves as an input port to read the following status info:

- SWR---HT, sweep ready
- DELTRGLT, indication for delay trigger input
- SCL 1 ,
- SDA 1 , indication for I²C 1 bus
- SDA 0 ,
- SCL 0 , indication for I²C 0 bus
- TEST0-HT, indication for triggered mode
- EDC---HT, enable delay counter

When the enable inputs RDIC0-LT and RDIC1-LT become low, the status input is read and copied in the accumulator of the microprocessor via the data bus.

The **CLOCK GENERATOR** consists of a complete integrated oscillator of 16 MHz (G201) and a number of divider stages.

The table below gives the frequency of the generated signals.

Name	Frequency
DSOCLK	16 MHz
CPUCLK	8 MHz
IEEECLK	8 MHz
INTCLK	32 kHz

The **20 ms INTERRUPT** device D207 interrupts the microprocessor each 20 ms so that a new screen can be written.

The **DTACK GENERATOR** basically consists of D212, D209 and D211.

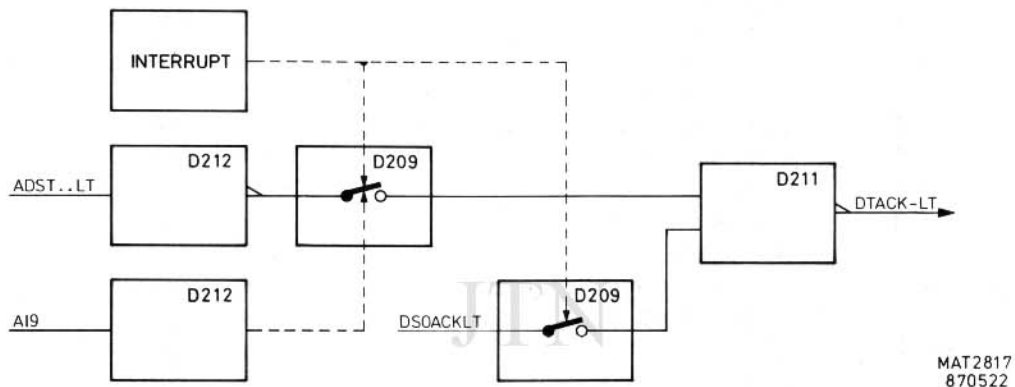

Figure 13.2 DTACK generator

The microprocessor generates the address strobe ADST--LT as a message that the address put on the address bus is valid. This signal is applied D212-3 and converted into the data acknowledge DTACK-LT signal. This signal indicates that the data is valid.

The DTACK-LT signal can be interrupted in two ways:

- display interrupt; this starts writing a new trace A, B, RA or RB. Now FC0, FC1 and FC2 are high with the result that a low level is applied to D209-13. This blocks the ADST path.
- 20 ms interrupt, this starts writing a new screen. When address line A19 is high, a low level is applied to D209-2 which also blocks the ADST path. Now DSOACKLT controls the DTACK-LT pulse via D211-3 or D206 takes care for a peripheral acknowledge.

The **MICROPROCESSOR RESET** circuit consists of the power-up reset and the watchdog circuit.

After switching-on, transistor V204 conducts so that the RESET-LT and HALT-LT signals are low, initiating the main program. After the supply voltages are within their specifications the signals are released and the microprocessor is ready for use.

The **WATCHDOG** is a facility to control the correct function of the software. In normal condition the WTDG--HT is low; this causes capacitor C201 to charge. But each 1,5 s the WTDG--HT is high for a short moment so that C201 is discharged again. When the WTDG--HT signal is not active low, C201 will charge until D203-13 is high so that D203-11 goes high. This results in V203 conducting so HALT-LT and RESET-LT become low, thus initiating the main program again.

13.4 SIGNAL NAME LIST

Signal name	Description	Signal source	Signal destination(s)
A0...16	Address bus	D214	D216 - D217 - D301 - D302
ADST-LT	Address strobe	D212	D214
CPUCLK	CPU clock	D204	D214
CVCNRYLT	Conversion counter ready	D218	D403 - D406
D0...7	Data bus	D214	D218 - D116 - D303
DACCS-LT	Digital analog conversion chip select	D213	D101
DCCLK	Delay counter clock	R886	D218
DELTRGHT	Delay trigger	D314	D221 - D402
DGPTCSLT	Digital pot.meter chip select	D213	D102
DLENA-HT	Data latch enable ch. A	D219	X9616 - X9716
DLENB-HT	Data latch enable ch. B	D219	X9618 - X9718
DLENP-HT	Data latch enable pre-amplifier	D219	X9614 - X9714
DLENT1HT	Data latch enable time-base 1	D219	X9613 - X9713
DLENT2HT	Data latch enable time-base 2	D219	X9617 - X9717
DLENX-HT	Data latch enable X	D219	D412
DSOACKLT	Digital storage osc. acknowledge	D314	D209
DSOCLK	Digital storage osc. clock	R226	D314
DSOCS-LT	Digital storage chip select	D201	D314
DSPLNTLT	Display interrupt	D314	D214 - R217
DTACK-LT	Data acknowledge	D211	D214
DTST-LT	Data strobe	D214	D201 - D202 - D206 D213 - D314 - D316
DTTC-LT	Delay trigger terminal count	D218	D801
EDC--LT	Enable delay counter	R401	D221 - D801
ENCVCNHT	Enable conversion counter	D406	D218
FC0...2	Functional code 0...2	D214	D209
HALT-LT	Halt	V207	D214
IACK-LT	Interrupt acknowledge	D212	D201 - D209 - D211
IEEECLK	IEEE clock	D204	D116
IEEECSLT	IEEE chip select	D201	D208
IPL20-LT	Interrupt priority level	D208	D214
MFIOCSLT	MF input/output chip select	D201	D202
MFOUT-LT	MF output enable	D202	D219
MEMON-HT	Memory on	D222	R601 - R602
RAMCS-LT	Ram chip select	D201	D217
RDIC0-LT	Read IIC bus 0	D202	D221
RDIC1-LT	Read IIC bus 1	D202	D221
RDWR-HT	Read/ Write	D303	D212 - D214 - D306 - D309
READ-LT	Read	D213	D218
REST--HT	Reset	N201	D116 - D314 - D318
RESET-LT	Reset	V208	R191 - D214 - D318
ROM1CS-LT	ROM 1 chip select	D201	D216
ROM2CS-LT	ROM 2 chip select	D201	--
RSNT-HT	Reset interrupt	D222	D207
RSTACQLT	Reset acquisition	D202	D402 - D403
SCL	Serial clock	D222	D223
SCL0	Serial clock 0	D221	D223 - N102 - D7001 - D7002

Signal name	Description	Signal source	Signal destination(s)
SCL1	Serial clock 1	D223	D221 - D412
SDA	Serial data	D222	D223
SDA0	Serial data 0	D221	D223 - N101 - D7001 - D7002
SDA1	Serial data 1	D223	D222 - D412
SEL0	Select 0	D222	D223
SEL1	Select 1	D222	D223
SRTTB-LT	Start time base	R232	D432 - D433
SWR---HT	Sweep ready	D403	D221
SWTB	Slow time base	D218	D412 - D801
SWTBCLK	Slow time base clock	D409	D218 - D411
TBSYNCHT	Time base synchronisation	D403	D218
TESTO-HT	Test out	D4103	D221
TMRCS-LT	Timer chip select	D201	D208 - D218
VERIICHT	Vertical IIC select	D219	D2601
VLPRADLT	Valid peripheral address	D212	D214
WRIIC-LT	Write IIC	D202	D222
WRITE-LT	Write	D213	D116 - D217 - D218
WTDG	Watchdog	D222	R200

JTN

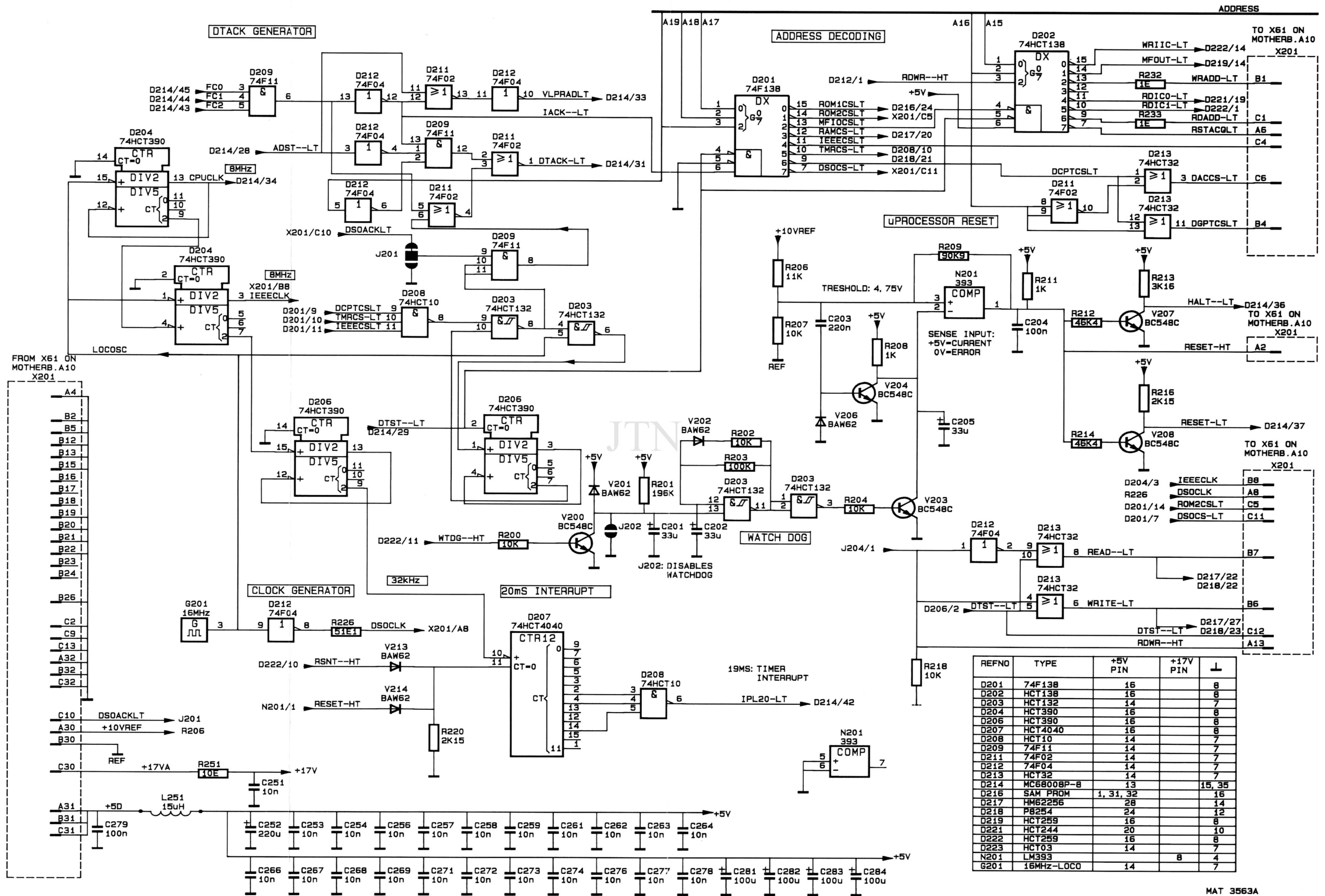

REFNO	TYPE	+5V PIN	+17V PIN	↓
D201	74F138	16		8
D202	HCT138	16		8
D203	HCT132	14		7
D204	HCT390	16		8
D206	HCT390	16		8
D207	HCT4040	16		8
D208	HCT10	14		7
D209	74F11	14		7
D211	74F02	14		7
D212	74F04	14		7
D213	HCT32	14		7
D214	MC6800BP-8	13		15, 35
D216	SAM PROM	1, 31, 32		16
D217	HM62256	28		14
D218	P8254	24		12
D219	HCT259	16		8
D221	HCT244	20		10
D222	HCT259	16		8
D223	HCT03	14		7
N201	LM393		8	4
G201	16MHz-LOCO	14		7

MAT 3563A

Figure 13.3 Circuit diagram of CPU unit, part 1

DCL UNIT (A13)

JIN

14 DCL UNIT (A13)

The DCL unit consists of:

- acquisition memory with associated components
- display memory with associated components
- control array
- dots + plotter control

14.1 ORGANISATION OF THE MEMORY

The memory consists of a 8k x 8 static RAM (Random Access Memory) D308, and a 32k x 8 static RAM D304.

D308 is called the acquisition memory.

D304 is called the display memory. This device is divided into:

- 4k byte trace memory
- 4k register back-up memory
- 4k text memory

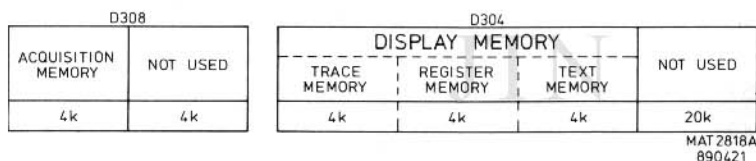

Figure 14.1 Organisation of the memory

Notice that the display memory is provided with a battery back-up circuit. When the instrument is switched-off, the RAM D304 keeps his supply voltage V_{bb} by means of an analog OR-gate V301-V302.

Addressing of the memories is achieved by two counters, COUNTER 1 (D309) and COUNTER 2 (D306), or by the microprocessor. Both counters are divided in three similar 12-bit counters selected by the OS0-pin 32 and OS1-pin 31 inputs. The TC output pin 9 detects an overflow of a counter. These signals are applied to the control array D314.

14.2 INTRODUCTION TO THE SAMPLE TRANSPORTS

The digital processor unit must generate the timing signals for the following sample-transports:

- Transport of signal samples from the ADC unit A15 to the acquisition memory.
- Transport of signal samples from the acquisition memory to the display (trace) memory.
- Transport of signal samples from the display (trace) memory to the CRT screen.
- Reading/writing of signal samples by the microprocessor from/to the display memory.

As well as the counters, the microprocessor is connected to the address bus ZA0 ...14. The microprocessor is buffered with a 14-bit tri-state buffer D301 and D302. The counters have access to the address bus sequentially. If a counter requires access to the address bus, this occurs in a certain time interval of 500 ns and is controlled by the signals SC0...SC4. SC2 and SC3 are inside the control array D314 and are not visible.

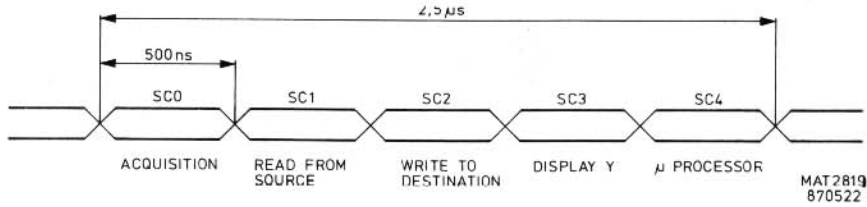

Figure 14.2 Display cycle controlled by SC0...4

The different sample transport are described separately in the next sections.

14.3 SIGNAL ACQUISITION

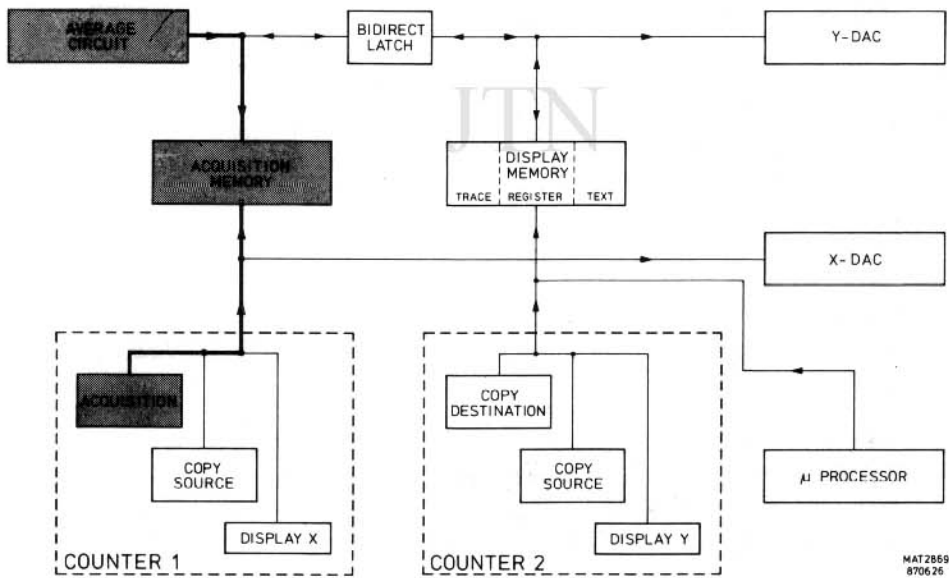

Figure 14.3 Block diagram of signal acquisition

During SC0 and if WRSMP is high the samples are taken from the average circuit on unit A14. These samples are put on the data bus PD0 ...7 and written in the acquisition memory D308. The addressing is obtained by the acquisition counter of D309.

14.4 COPYING SAMPLES TO DISPLAY MEMORY

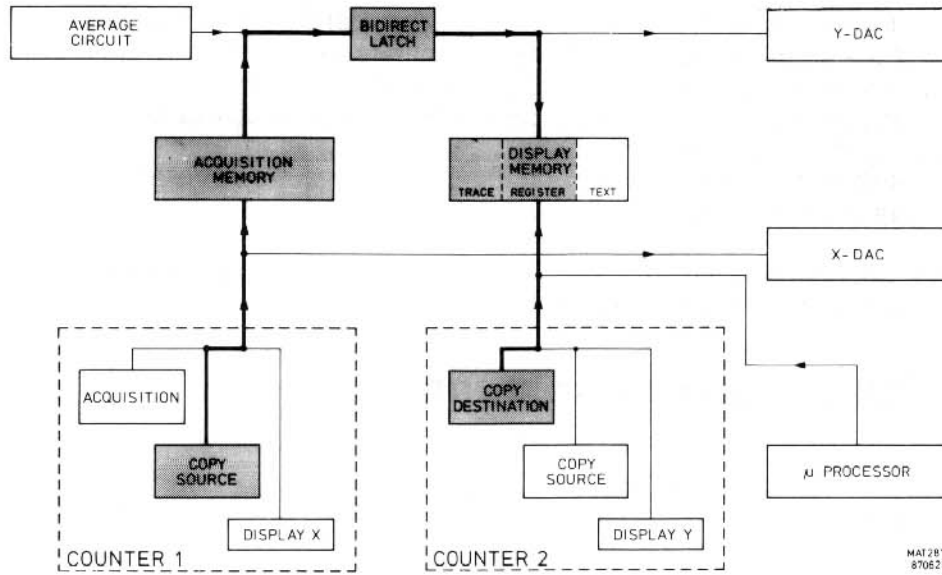

Figure 14.4 Block diagram of copying samples to display memory

During SC1 the data from the acquisition memory is read by counter 1 D309 and is written into the bidirectional latch of D314. Then during SC2 the copy destination counter of D306 reads the data from the latch and writes this data into the display memory D304.

14.5 DISPLAYING OF TRACE AND REGISTER

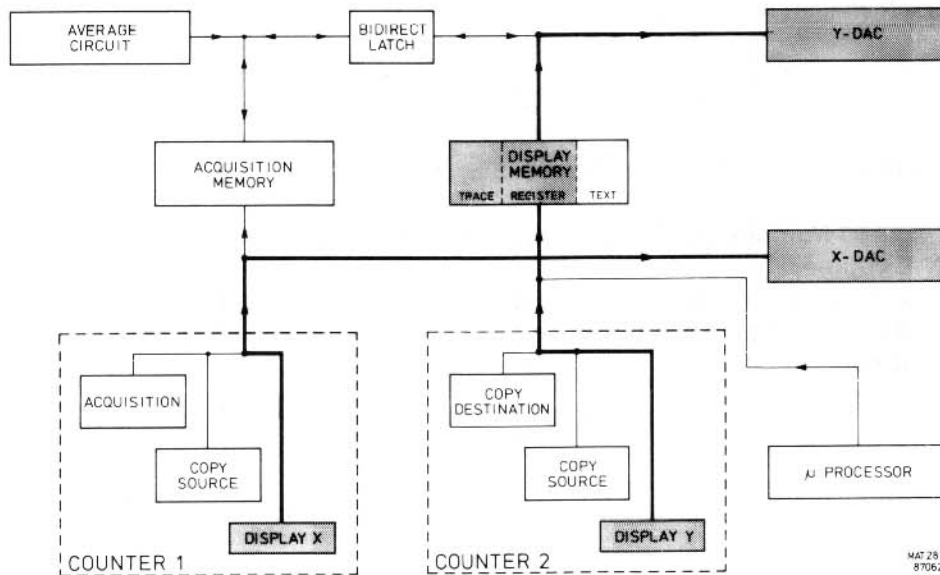

Figure 14.5 Block diagram of trace/register display flow

During SC3, the data from the display memory D304 is read by counter D306 and is written to the Y-DAC latch D413 on unit A14. The X address is determined by counter D309 and is latched in D311 and D312. These addresses are clocked by the signal XYDLE generated by D314.

14.6 MICROPROCESSOR MANIPULATION

During SC4 the signal DSOSEL-LT is low, provided that DCOCS-LT is also low. This means that the address lines A0...14 from the buffers D301 and D302 are enabled. At the same time the data from the microprocessor bus D0...7 is also enabled via D303. This data can influence all microprocessor controlled functions such as text, plot, dots, also addressed by the microprocessor.

During SC4 the signal TOE-LT applied to pin 8 of D309 and D306 is high because both counters are in their tri-state condition.

For PLOT, the time that the data is written to the Y-DAC and the address is written to the X-DAC is adjustable in the service menu.

14.7 DISPLAYING OF TEXT AND CURSORS

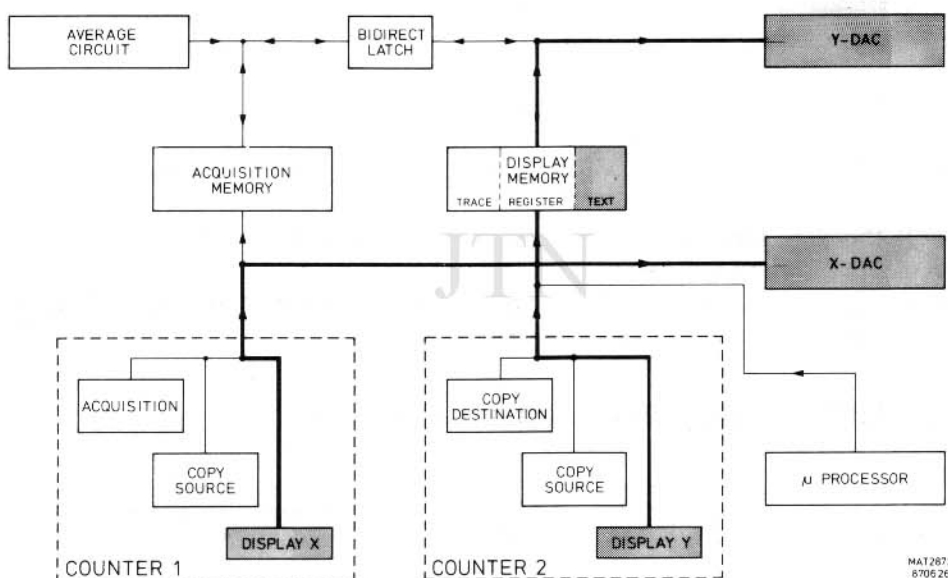

Figure 14.6 Block diagram of text/cursors display flow

The text is read from the display memory and addressed by the DISPLAY Y counter and DISPLAY X counter.

This text is displayed per vertical column. When the Y-DAC data has reached the control character \$FF, the display X counter receives a clock-pulse. This means that the next column is displayed.

14.8 CLEARING THE DISPLAY MEMORY

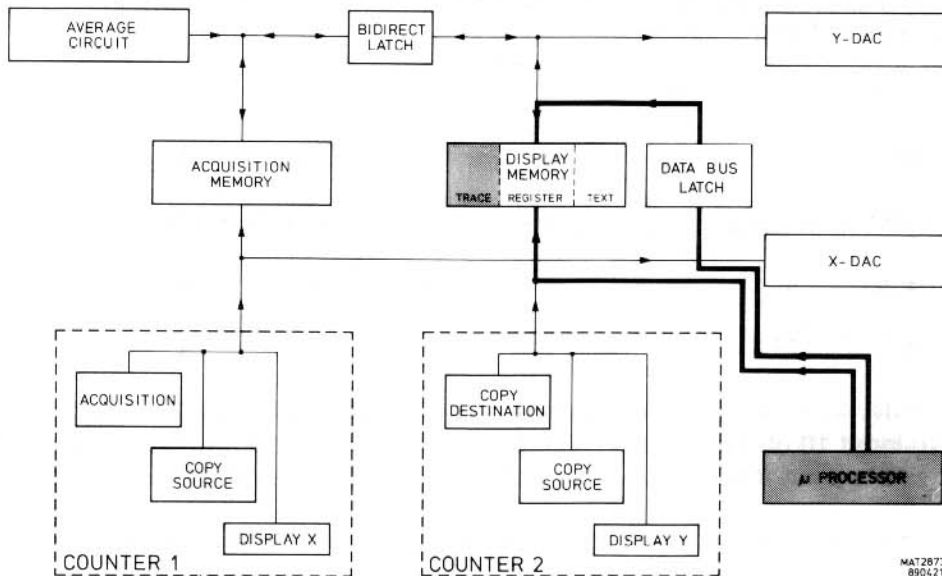

Figure 14.7 Block diagram of the clear function

When the clear function is active by means of the microprocessor, the display memory is written with \$80 (\$00) by the C.P.U. This means that the complete trace is cleared.

14.9 CLEARING THE ACQUISITION MEMORY

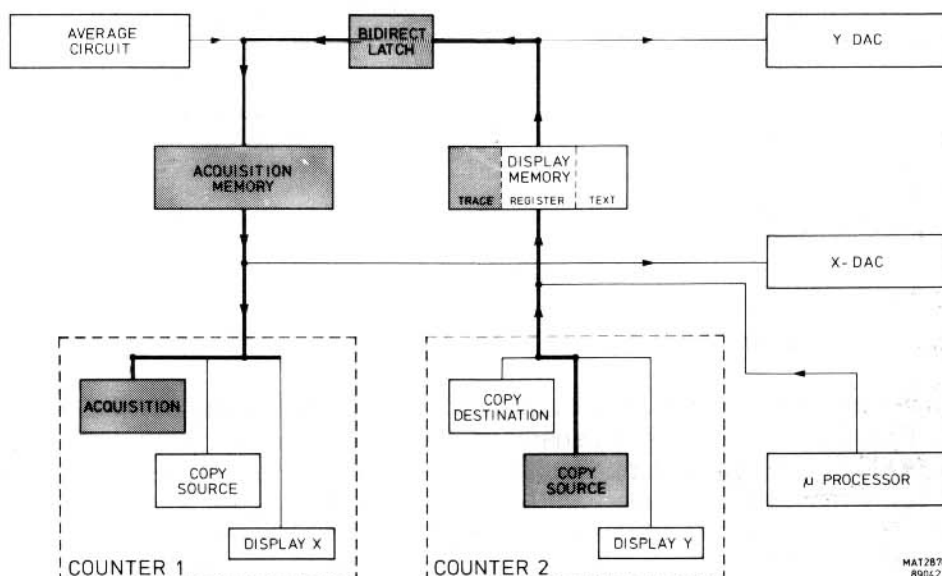

Figure 14.8 Block-diagram of the clear function

After the microprocessor has cleared the display memory, these samples are written into the bidirectional latch by means of the copy source counter of D306. Then the acquisition counter of D309 writes these samples from the latch into the acquisition memory.

14.10 EXOR D307

In P and D1 mode, the samples from the average circuit contain the samples from channels A and B and also the interpolated samples from channels A and B. This happens in the following sequence:

address	4095	0	1	2	3	4	5	6
sample	Ai	A	Bi	B	Ai	A	Bi	A

On behalf of the acquisition memory this sequence must be converted into:

address	4095	0	1	2	3	4	5	6
sample	Ai	Bi	A	B	Ai	Bi	A	B

The signal INVA0-HT is high for sample A and interpolated sample B. This signal is applied to input 10 of the exclusive OR-gate D307. The other input is connected to PA0. For address 0, input 9 is low; because of the high level of INVA0-HT the output pin 8 will be high.

For address 1, input 9 is high; because of the high level of INVA0-HT the output pin 8 will be low, etc.

Thus inverting of address line PA0 during sample A and interpolated sample B is obtained.

14.11 CHIP SELECT

JTN

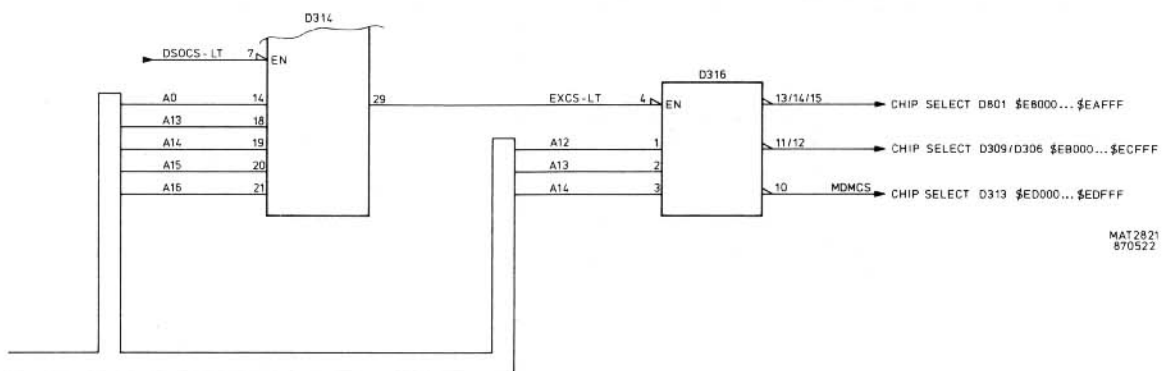

MAT2821
870522

Figure 14.9 Chip select circuit

The address lines A0 and A13...A16 are applied to the control array D314 and enabled by the signal DSOCS-LT. The resulting enable signal EXCS-LT is low for the addresses \$E8000...\$EFFFF. This signal is applied to the decoder device D316 as an active low enable input. When low, depending on the addressing of A12...14, a chip select output is active low. Three lines are used to select D801 on the P²CCD unit, two lines are used to select the two counters D306 or D309 and one line is used to select D313.

14.12 DOTS AND PLOTTER CONTROL

Addressed by BA0...BA2 which are simultaneously with A0...A2 the data on PD0 is applied to one of the six output lines. These static lines DOTS-LT, PLOT-HT, PENLIFT, POSXOF-HT, TRIGEN-HT and OSCON-LT in PM3365A (or EN100-LT and EN125-LT in PM3375) control several functions in the instrument such as among other things, the DOTS and plotter.

14.13 TIMING DIAGRAM

The following figure gives the timing diagram for the gate array D314 for the display cycle.

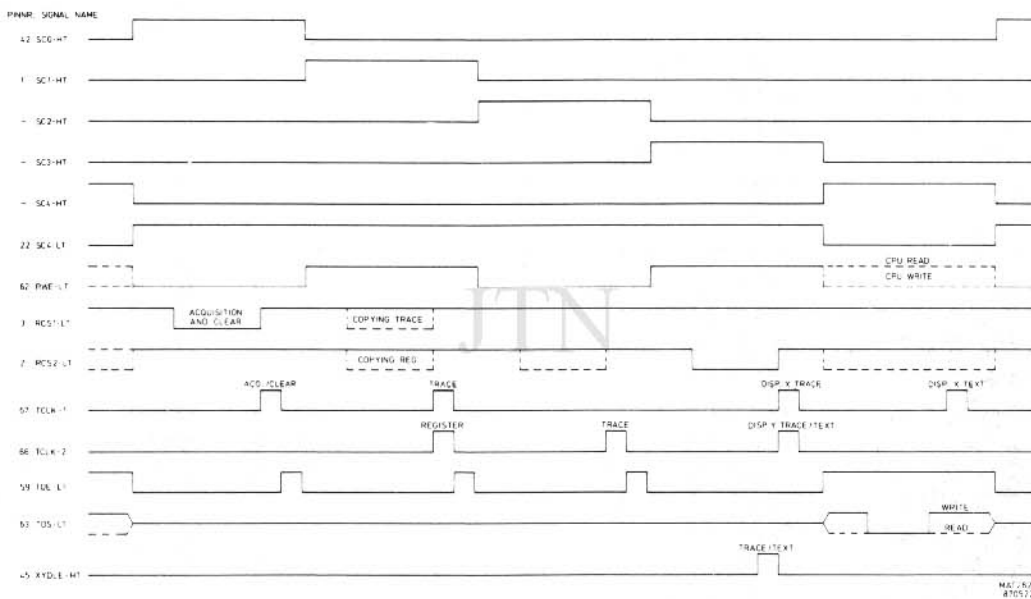

Figure 14.10 Timing diagram for D314

14.14 SIGNAL NAME LIST

Signal name	Description	Signal source	Signal destination(s)
A0...16	Address bus	D214	D216 - D217 - D301 - D303
BA0...2	Buffered address bus	D318	D306 - D307 - D313
D0...D7	Data bus	D216	D116 - D214 - D217 - D303
DATEN-HT	Data enable	D313	D416
DCWE--HT	Delay counter write	D316	D801
DLTRG-HT	Delay trigger	D402	D314 - D406
DOTS--LT	Control signal for dot join	D313	D503 - D505
DTST-LT	Data strobe	D214	D201 - D202 - D206 D213 - D314 - D316
DSOACK-LT	Digital storage osc. acknowledge	D314	D209
DSOSEL-LT	Digital storage osc.	D314	D303
DSOCS-LT	Digital storage osc.	D201	D314
DSPINTLT	Display interrupt	D314	D214
EN100-LT	Enable P-mode/100 MHz	D313	D407 - D801 - D5202 - R862 - R5128
EN125-LT	Enable P-mode/125 MHz	D313	D407 - D5202 - R5113
EXCSLT	External chip select	D314	D316
INVAO-HT	Invert address 0	D407	D307
MDMCS-LT	MDM chip select	D316	D313
MDOE-LT	MD output enable	D314	D412
MIDCLK	MID clock	D314	D409
OLCLK-PT	Output logic clock	D314	D401 - D409
OS1-HT	Output select 1	D314	D306 - D309
OSCON-LT	Enable P-mode/100 MHz	D313	D407 - D801 - R862
POXOF-HT	Control X POS	D313	R555
PD0...7	Buffered bidirectional tri-state data bus	D303	D309 - D413
PLOT--HT	Control signal plot	D313	D504 - D512
PENLIFT	Control signal penlift	D313	R614
RCS1-LT	RAM chip select 1	D314	D307
RCS2-LT	RAM chip select 2	D314	D318
RCS1B-LT	RAM chip select 1 buffered	D307	D308
RCS2B-LT	RAM chip select 2 buffered	D318	D304
RDWR-HT	Read/write	D214	D212 - D213
RESET-HT	Reset, high active	D318	D116 - R211 - R212 - R213 - D314
RESET-LT	Reset, low active	V208	R191 - D214 - D318
R/W	Read/ write	D303	D306 - D309 - D314
RWE-LT	RAM write	D314	D304 - D308
RSTHDS-LT		D314	D401
SC0--HT	State counter 0	D314	D407 - D408
SC1--HT	State counter 1	D314	D408
STWE-LT	Status write	D316	D801
TBWE-LT	Time base write	D316	D801
TC1	Terminal count 1	D309	D314
TC2	Terminal count 2	D306	D314

Note: Signal OSCON-LT and EN100-LT, generated by D313/10 are identical.

Signal name	Description	Signal source	Signal destination(s)
TCINN-PT	Terminal count in	D314	D404
TCS1-LT	Teller chip select 1	D316	D309
TCS2-LT	Tellerchip select 2	D316	D306
TCLK1	Teller clock 1	D314	D309
TCLK2	Teller clock 2	D314	D306
TDS-LT	Teller data strobe	D314	D306 - D309
TOE-LT	Teller output enable	D314	D306 - D309
TRIGENHT	Trigger enable	D313	D402 - D402 - D406
WRSMP-HT	Write sample	D412	D314
XDAC0...9	Data for X DAC	D311/D312	N507
XYDLE-HT	X DAC and Y DAC latch enable	D311	D302 - D304
ZA0...14	Buffered tri-state address bus	D306	D302 - D304
ZON---LT	Control intensity	D314	D504
PA0...12	Buffered tri-state data bus	D309	D308

JTN

A13

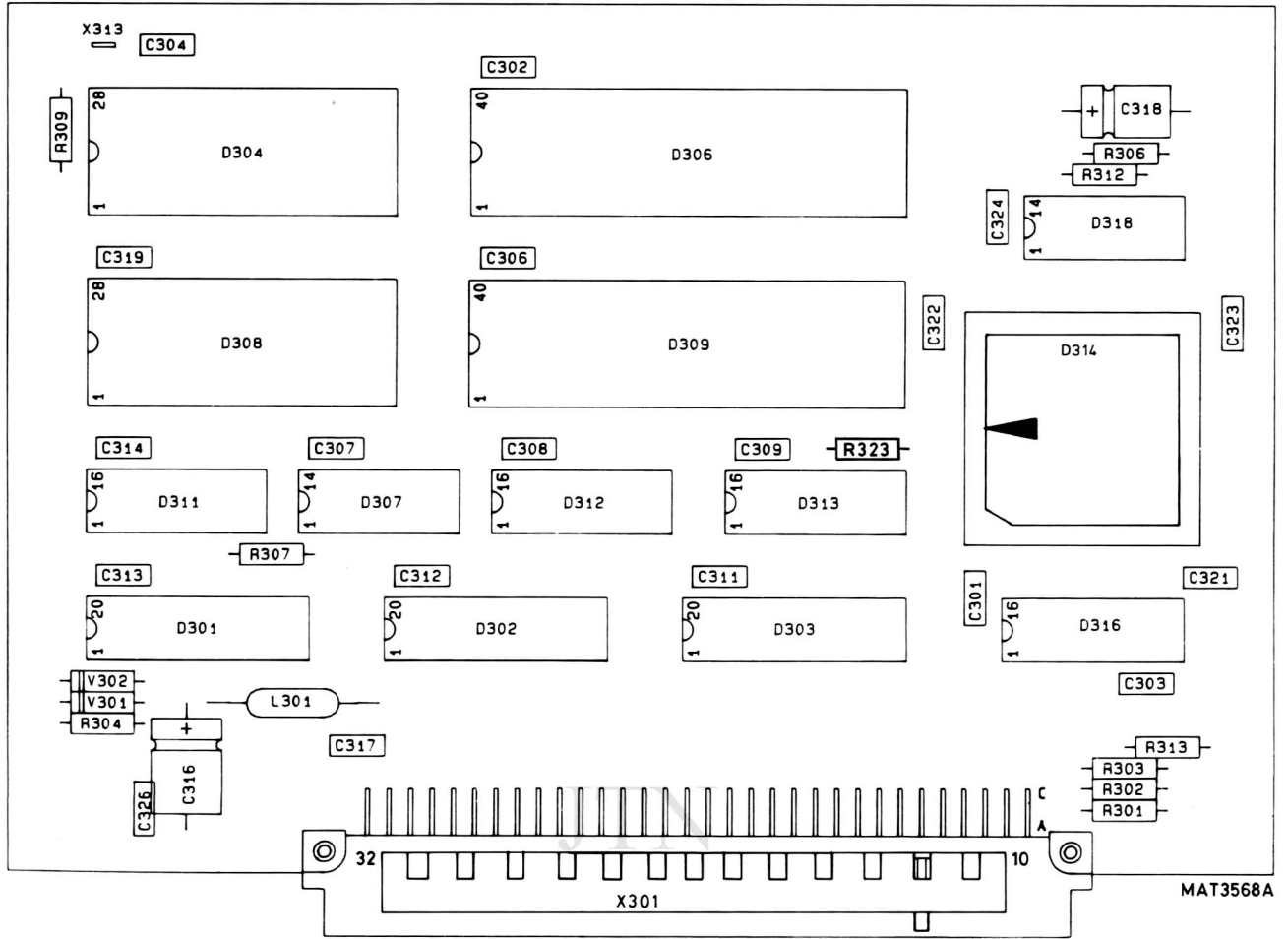

TEST PIN X313: BATTERY BACK-UP VOLTAGE V_{CC}

Figure 14.12 DCL unit p.c.b.

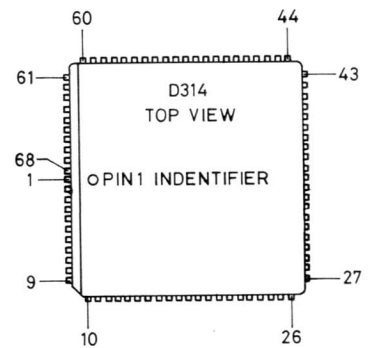

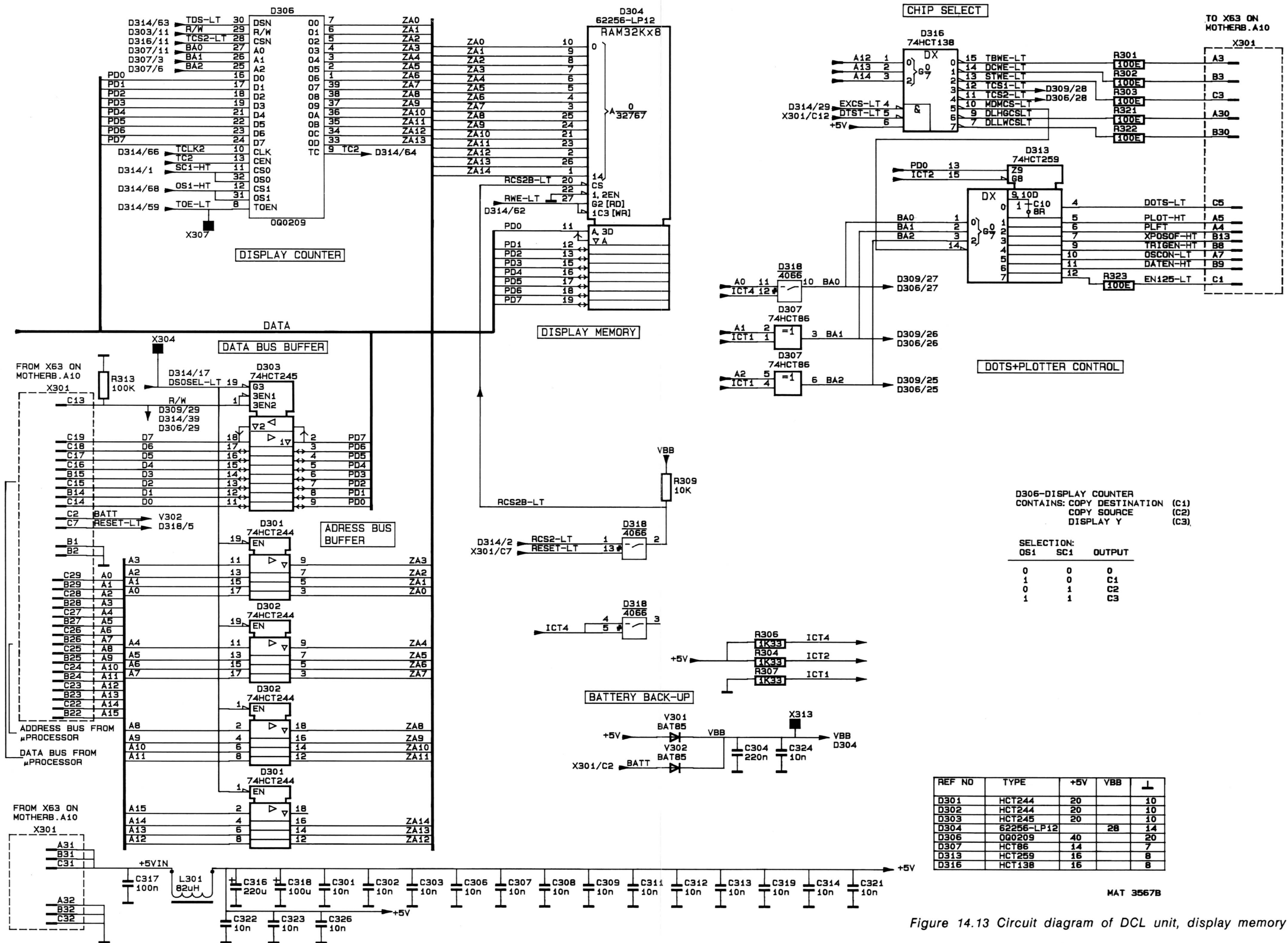

Figure 14.13 Circuit diagram of DCL unit, display memory

ACL UNIT (A14)

JTN

15 ACL UNIT (A14)

The ACL unit consists of:

- trigger control
- CCD + ADC timing
- average and interpolation circuit
- delay counter (PM3365A/75 only)

15.1 TRIGGER CONTROL

The trigger control determines the start of the acquisition.
A timing diagram of the trigger control is given in figure 15.1.

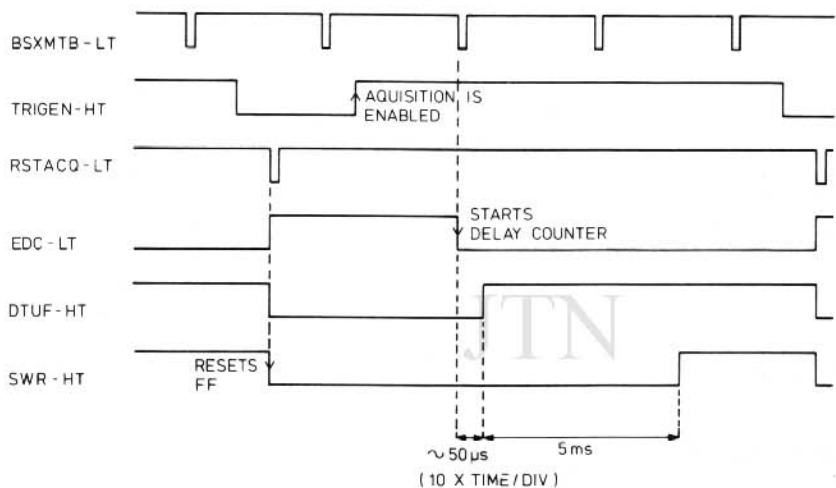

MAT2823B
890811

Figure 15.1 Timing diagram of the trigger control.

At the moment that TRIGEN-HT is low and RSTACQ-LT becomes low, flip-flops D403 and D404 are reset.

Now TCINN-HT, generated by the microprocessor, can go high after the acquisition counter has counted the pre-trigger value. Then TRIGEN-HT is high again so that the acquisition is enabled.

The high level of TCINN-HT clocks D404, as a result D404-9 is high and D404-2 is enabled waiting for a new trigger signal BSXMTB-LT. When this signal is low, then EDC-LT is low and starts the delay counter.

At the moment that the EDC has counted, signal DTUF-HT is high which enables D402 and therefore SWTB is clocked through.

15.2 CCD + ADC TIMING

The clock pulse OLCLK-HT is derived from D314. The pulse is 800 kHz for the P-mode and 640 kHz for the D-mode and is applied to the timer D409. Enabled by a high level on pin 10, this counter operates and the outputs Q0 (400/320 kHz), Q1 (200/160 kHz) and Q2 (100/80 kHz) are fed to D411. D408 serves for synchronisation between SC0 and WRSMP-HT.

The PAL (Programmable Array Logic) chip D411 generates several control pulses for the CCD logic.

The signals DISEV-HT, DISOD-HT, RSTOD, RESTEV, SAMPLE, INTOD and INTEV are fed to the P²CCD output circuit on unit A18. The signals STCONV-HT, CHSEL0-HT and CHSEL1-HT are fed to the ADC on unit A15.

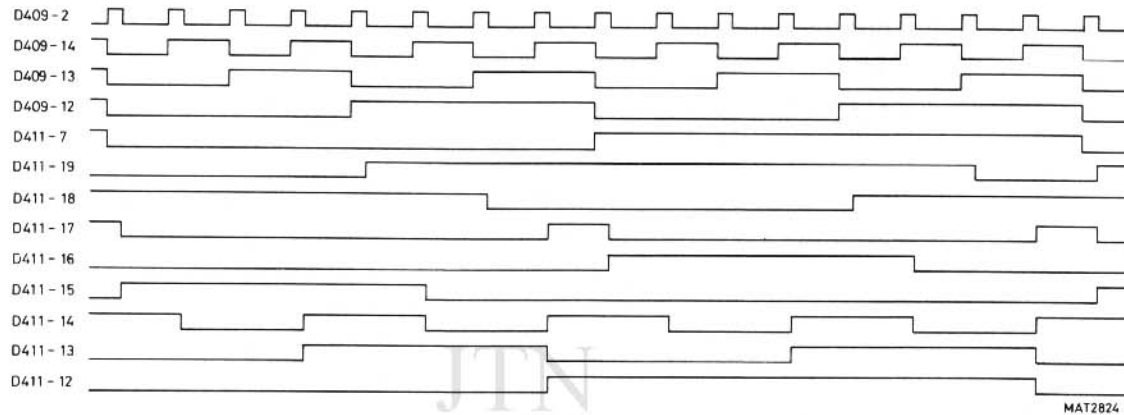

Figure 15.2 Timing diagram CCD and ADC timing

15.3 AVERAGE AND INTERPOLATION CIRCUIT

The ADC bus is generated on the ADCDAC unit A15. This bus is applied to the signal processor device D412.

The P²CCD is split up into two parts (EVEN and ODD channel) and the samples of the EVEN channel have another gain and offset than the ODD channel. D412 averages these differences according to the formula

$$A_m = \frac{A_n + (A_n - 1)}{2}$$

Next D412 calculates also 512 linear interpolated points between each of the 512 samples according to the formula

$$A_c = \frac{A_m + (A_n - 1)}{2}$$

These averaged and interpolated samples are written into the acquisition memory for signal manipulation, see chapter 14.

The output bus PD0... PD7 is applied to the memories on unit A13 for display manipulation and to the Y-DAC latch D413.

When XYDLE-HT is high, this device is enabled to receive the PD-bus and transfers it to the YDAC0... YDAC7 bus.

This bus is fed to the Y-DAC on the ADCDAC unit A15.

The four least-significant bits ED0... ED3 are applied to the P²CCD panel A18. These lines preset the ACE on this unit.

15.4 DELAY COUNTER

The total delay counter is formed by D441, D442, D443 and D444 on this unit and D801 on unit A18.

Signal DCCLK is received from the ACE D801 on unit A18 and is the clock for this counter. The trigger delay is determined by the value on the data bus PD0...3 and after the counter has counted this presetted value, the output DTTC-LT becomes low. This pulse is routed again to the ACE D801 on unit A18.

15.5 ACQUISITION FLOW

At the falling edge of signal BSXMTB-LT, D flipflop D404 is clocked. If the D-input is HIGH then EDC-LT is LOW (enable signal). This means that the sample clock (100 or 125 MHz) will clock the DELAY COUNTER.

Signal SWTB is the clock for the DELAY COUNTER, the frequency of this clock depends on the time-base position: 100 kHz ... 8 Hz.

The ACE on unit A18 is a 16x divider. So signal DCCLK will be 100 kHz/16 ... 8 Hz/16. This pulse is routed to the DELAY COUNTER D441 ... 444 and forms thus a total delay (D441 ... 444 is MSB and D801 is LSB). As a result the DTUF-HT from D801 indicates that the DELAY COUNTER is ready.

This means that now can be started with the acquisition of the samples for the screen (512, 2048 or 4096 samples).

The choice between the P²CCD (P-) mode and the DIRECT (D-) or ROLL (R-) mode is made by signal EN100-LT/EN125-LT for PM3375 (OSCON-LT for PM3365A). This signal controls the multiplexer, formed by the three NAND-gates of D406 on this unit.

- If LOW, then the P-mode is selected. Now signal CDRD-HT is switched to the output of the multiplexer.
- If HIGH, then the D- or R-mode is selected and the synchronized DTUF--HT (= DLTRG-HT) is connected to the output of the multiplexer.

The resulting signal ENCVNHT is then routed to the READ OUT counter (D218 on unit A12).

This counter generates the CVCNRYLT pulse, applied to flipflop D403 on this unit. Output SWR---HT of this flipflop indicates that all samples are taken in the ACQUISITION memory and that these samples has to be written into the DISPLAY memory on unit A 13.

15.6 SIGNAL NAME LIST

Signal name	Description	Signal source	Signal destination(s)
AD0...7	Data bus from ADC circuit	N505	D412
BSXMTB-LT		D4103	D401
CCDENBHT	CCD enable	R447	R1637
CDRD-HT	CCD read	R883	D404 - D411
CHSEL0HT	Channel select 0	D411	N505
CHSEL1HT	Channel select 1	D411	N505
CVCNRYLT	Conversion counter ready	D218	D403 - D406
DATEN-HT	Data enable	D313	D416
DLENX-HT	Data latch enable X	D219	D412

Signal name	Description	Signal source	Signal destination(s)
DMODE-HT	Direct mode	D412	D408
DMODE-LT	Direct mode	D412	D408
DISEV-HT	Discharge even	R403	D921 - D922
DISOD-HT	Discharge odd	R404	D921 - D922
DLTRG-HT	Delay trigger	D402	D314 - D406
DTUF-HT	Delay trigger underslow	R884	D402
ED0...3	Buffered data bus	R413...R417	D801
EDC--LT	Enable delay counter	R401	D221 - D801
EN100-LT	Enable P-mode/100 MHz	D313	D407 - D801 - D5202 - R862 - R5128
EN125-LT	Enable P-mode/125 MHz	D313	D407 - D5202 - R5113
ENCVCN-HT	Enable conversion counter	D406	D218
INVA-HT	Invert A	D412	D407
INVA0-HT	Invert address A0	D407	D307
INTEV-HT	Integrate even	R411	D911
INTOD	Integrate odd	R409	D901
MIDCLK	Mid clock	D314	D412
MDOE-LT	MD output enable	D314	D412
OLCLK-HT	Output logic clock	D314	D401 - D409
OSCON-LT	Enable P-mode/100 MHz	D313	D407 - D801 - R862
PD0...7	Buffered bidirectional tri-state data bus	D303	D413
RSTACKLT	Reset acquisition	D202	D402 - D403
RSTEV-LT	Reset even	R407	R751
RSTH-LT	Reset	D314	D401
RSTH-HT	Reset	D401	D412
RSTOD-LT	Reset odd	R406	R781
RSSW-HT	Reset slow clock	R407	D801
SDA1	Serial data 1	D223	R223 - D412
SC0--HT	State counter 0	D314	D407 - D408
SC1--HT	State counter 1	D314	D408
SCL1	Serial clock 1	D223	D412
SAMPLEHT	Sample clock CIH	R408	D411 - D922
SRTMTBHT	Start MTB	R449	D4203
SRTTB	Start time-base	D232	D432 - D433
STCONVHT	Start conversion	D411	N505
SWCK	Slow clock	R412	D801
SWTBCLK	Slow time base clock	D409	D218 - D411
SWR--HT	Sweep ready	D403	D221
SWR--LT	Sweep ready	D403	D412
SWTB	Slow time base	D218	D412 - D801
TBSYNCHT	Time base synchronisation	D403	D402 - D412
TBSYNCLT	Time base synchronisation	D403	D412
TCEV-LT	Transport clock even	882	D401 - D408 - D411
TCINN-HT	Terminal count in	D314	D404
TRGLTC		D403	D412
TRIGENHT	Trigger enable	D313	D403 - D404 - D406
WRSMP-HT	Write sample	D412	D314
XYDLE-HT	A DAC and Y DAC latch enable	D314	R427
YDAC0...7	Data bus for Y DAC	D413	N506

NOTE: Signal OSCON-LT and EN100-LT, generated by D313/10 on unit A13 are identical.

A14

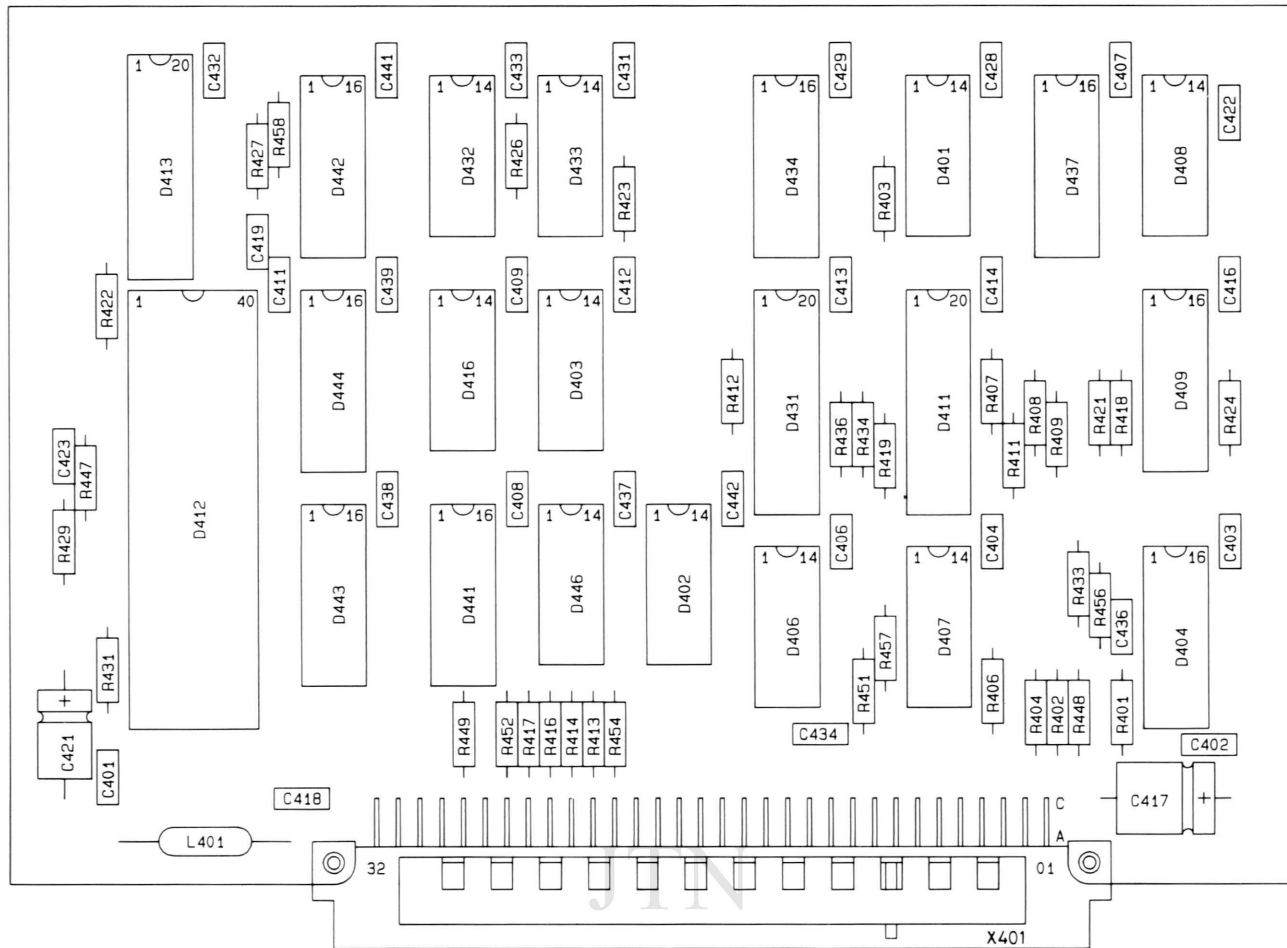

MAT3851

Figure 15.3 ACL unit p.c.b.
Figure 15.6 ACL unit p.c.b.

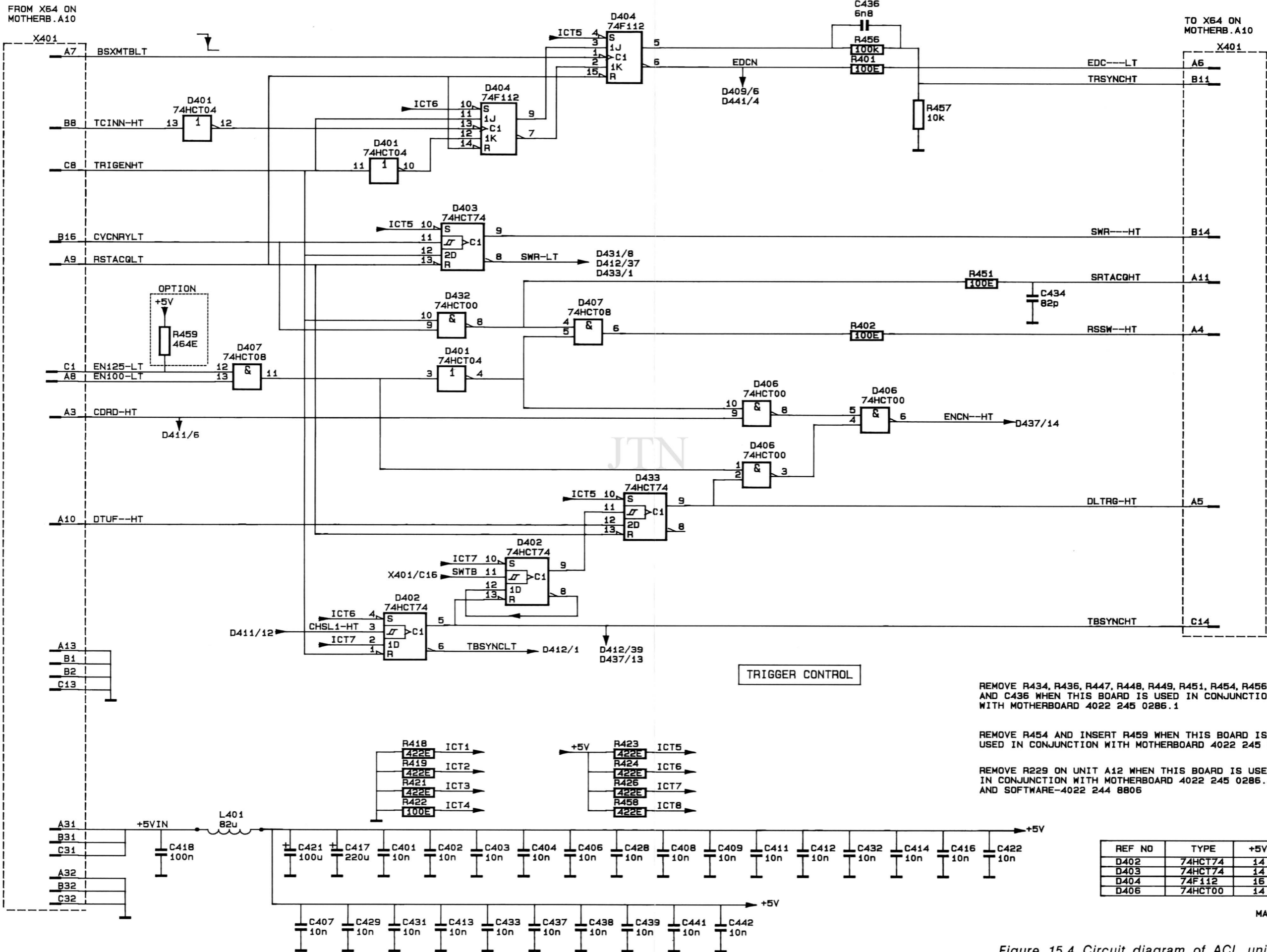

REMOVE R434, R436, R447, R448, R449, R451, R454, R456 AND C436 WHEN THIS BOARD IS USED IN CONJUNCTION WITH MOTHERBOARD 4022 245 0286.1

REMOVE R454 AND INSERT R459 WHEN THIS BOARD IS USED IN CONJUNCTION WITH MOTHERBOARD 4022 245 0286.3

REMOVE R229 ON UNIT A12 WHEN THIS BOARD IS USED IN CONJUNCTION WITH MOTHERBOARD 4022 245 0286.4 AND SOFTWARE-4022 244 8806

REF NO	TYPE	+5V	GND
D402	74HCT74	14	7
D403	74HCT74	14	7
D404	74F112	16	8
D406	74HCT00	14	7

MAT 3569A

Figure 15.4 Circuit diagram of ACL unit, part 1

NOTE: S-MODE COMPONENTS
ALSO PRESENT IN
PM3350A/55, BUT
NOT USED

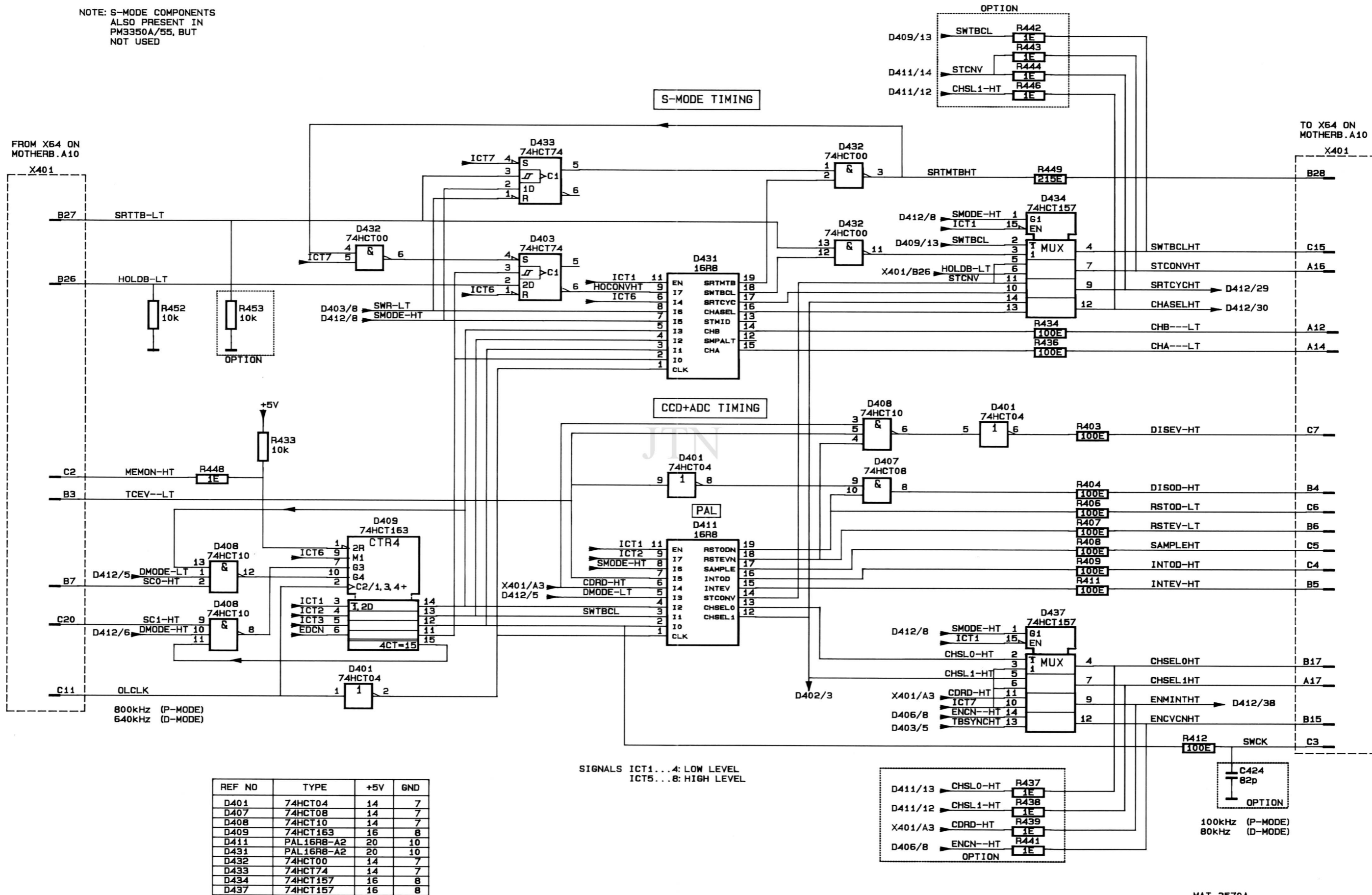

Figure 15.5 Circuit diagram of ACL unit, part 2

ADC DAC UNIT (A15)

JTN

16 ADC DAC UNIT (A15)

The ADC DAC unit consists of:

- ADC circuit
- vertical DAC circuit
- horizontal DAC circuit
- X POS switch circuit
- Z control circuit
- plot and penlift circuit

16.1 ADC CIRCUIT

The four signal samples CHAEV, CHAOD, CHBEV and CHBOD are derived from the P²CCD unit. The samples for each channel are first fed to differential amplifier N501. This device compares both input signals and gives the following results for a sine wave signal with 10 divisions amplitude.

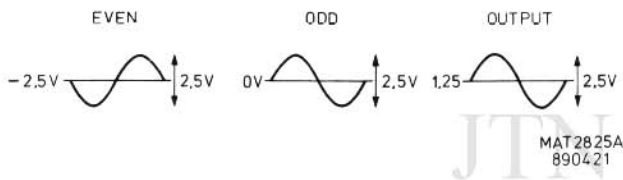

Figure 16.1 Waveforms on N501

The output signal is limited for an amplitude between -0,3 V... +3,0 V by the limiting diodes V501...V506 to protect the ADC input and then applied to the ADC N505.

This ADC, AD7824 is a high-speed-4-channel 8-bit analog-to-digital converter with a conversion time of 2,5 us per channel. Three channels are used for the AIN1, AIN3 and AIN4 signals. Next, it has two digital inputs A0 and A1 for channel selection.

CHS0	CHS1	Signal	Channel selected
0	0	AIN1	A
1	0	AIN3	B
0	1	--	--
1	1	AIN4	T&H OUTPUT

Conversion is started at the falling edge of the STCONVLT pulse while the data AD0...7 is present on the output at the rising edge of the STCONVLT pulse.

Figure 16.2 shows control signals in the P, D and R mode. For sampling mode ch. A or ch. B is selected by D1601 on the Adaptation unit A16.

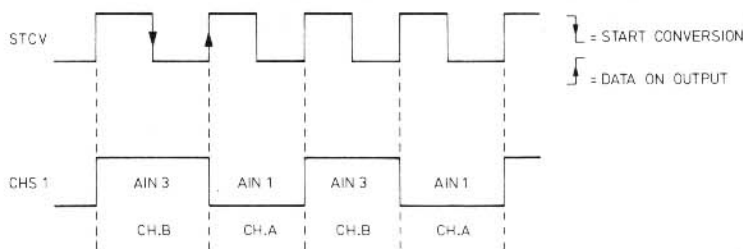

Figure 16.2 Waveform on D501

The value of the 8-bit data is determined by the input signal. AD0...7 is 0000 0000 (00H) for an input voltage of 0 V and 1111 1111 (FFH) for an input voltage of +2,5 V. This AD-bus is applied to the ACL unit A14 for signal acquisition.

16.2 VERTICAL DAC CIRCUIT

The 8-bit Y-DAC bus derived from the ACL unit A14 is applied to DAC N506. The 8-bit digital-to-analogue converter converts the value of YDAC0...7 into a differential current signal. The reference current is 2 mA. The differential current is converted into a differential voltage by V521 and V522.

During refreshment of the 8-bit data, glitches appear on the output current. These glitches are removed by D503.

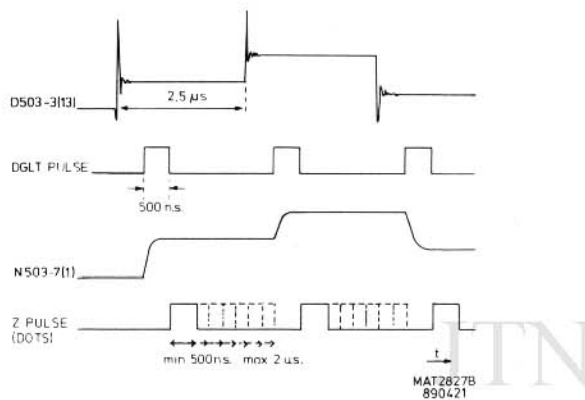

Figure 16.3 Waveform on deglitch circuit

Only when the DGLT pulse goes high, the hold capacitor C521 (C522) is charged to the value of the differential voltage. The charging time of C521-R532 (C522-R533) is much lower than the 500 ns of the DGLT pulse, so the hold capacitors will be fully charged. Because both capacitors are buffered by N503 they keep charged when DGLT is low for 2 μs until DGLT is high again. Then the capacitors will charge to the new value. Notice that DGLT is only high when the differential voltage on D503-3 (13) has become stable.

When DOT-JOIN is depressed, DOTS--LT is high. In this case, four integration capacitors C523...C527 are in circuit. The differential signal voltage is then loaded with these four capacitors. During the horizontal sweeps the Z pulse is constant high so the space between two dots is also intensified on the screen.

The + PLOT and - PLOT signals are fed to the plot and penlift circuit.

Next the differential voltage signal is again converted into the differential current signals +YDAC and -YDAC by V531 and V532. These signals are applied to the adaptation unit A16. Potentiometer R542 serves for gain adjustment for the text, offset is adjusted by potentiometer R550.

16.3 HORIZONTAL DAC CIRCUIT

This circuit is basically similar to the vertical DAC circuit. However, the symmetrical current output of 10-bit DAC N507-4 (2) is converted into an asymmetrical voltage by N511. The amplitude of the sawtooth on D512-3 is 2.5 V. This signal is applied to the input of the deglitch circuit.

N513 serves as an output buffer and gives the digital sawtooth sweep of 0 V ... 5 V. This sweep is applied to the time-base unit A4.

16.4 X POS SWITCH CIRCUIT

The front-panel X POS control or R553 is switched to the POSXOUT output via a diode switch V553 ... V557. This switch is under control of the signal POSXOFHT. When POSXOFHT is low, the front-panel control POS X is active and determines the X position of the signal on the screen. But, during the time that the text is written on the screen, POSXOFHT is high. This means that the X position of the text is fixed by means of R553.

16.5 Z CONTROL

The brightness on the screen is controlled by three signals:

- PLOT--HT, dims the brightness when the instrument is in plot action.
- DOTS--LT, dims the brightness when the screen is dot-joined.
- ZON---LT, switches off the intensity during the flyback of the digital sawtooth or between two dots.

These TTL signals are first fed to D504 which converts the amplitude to 12 V. Because pin 15 is connected to +5 V the device is always enabled.

16.5.1 Plot mode

During the plot action, the signals PLOT--HT and DOTS--LT are high. This means that a part of the current source on unit A4 is floating (mainly) through resistor R565 and R566 so that the brightness on the screen is dimmed. During the flyback between two traces, signal ZON---LT is high so that the trace is fully blanked.

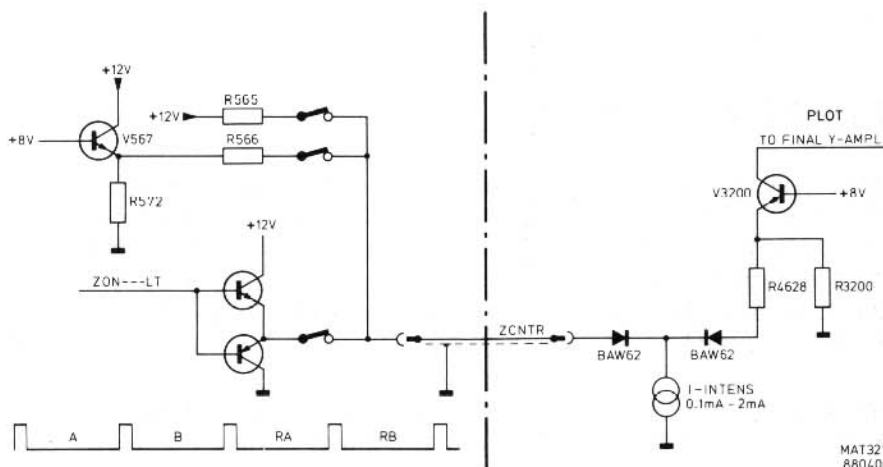

Figure 16.4 Z control for PLOT mode

16.5.2 Dots mode

In dots mode the signals PLOT--HT and DOTS--LT are low. This means that blanking is only controlled by the ZON---LT pulse. This pulse is high and thus the trace is blanked during the flyback and the time between the dots.

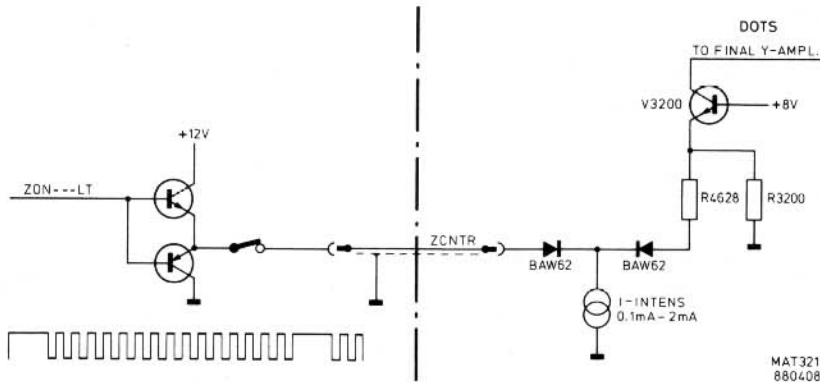

Figure 16.5 Z control for DOTS mode

When dots-joined is selected, the signal PLOT--HT is low and DOTS--LT is high. This means that when the trace is written the brightness is dimmed because a part of the current source on unit A4 is floating through resistor R566. During the flyback, signal ZON---LT is high so that the trace is fully blanked. Note that the period between two dots is not blanked now.

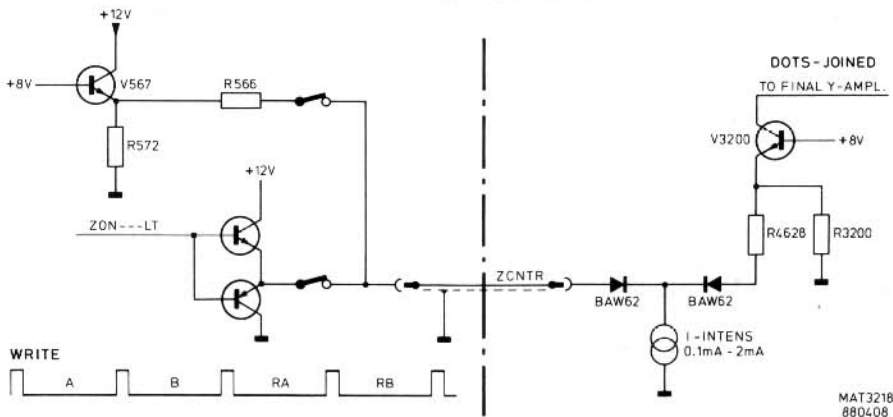

Figure 16.6 Z control for DOTS JOINED mode

16.6 PLOT AND PENLIFT CIRCUIT

This circuit generates the correct signals for an external plotter. The vertical + PLOT and - PLOT signals are derived from N503 and converted into an asymmetrical signal between 0...1 V by N512. The horizontal X PLOT signal is derived from N513 and also converted into a voltage signal between 0...1 V. Both voltage signals are applied to multiplexer D512. When PLOT--HT is high the signals are fed to the PLOT output socket at the rear of the instrument.

Selectable by the service menu, the PENLIFT signals can be active low or active high. This signal is fed via V611, V612 and V613 and applied as an open-collector output to the PLOT socket.

The signals PLOT--HT and PENLIFT are derived from D313 on the DCL circuit A13.

16.7 SIGNAL NAME LIST

Signal name	Description	Signal source	Signal destination(s)
AD0...7	Data bus from ADC circuit	N505	D412
BATT	Battery voltage	X501/B3	V302
CHAEV	Channel A even	R937	R501
CHAOD	Channel A odd	R927	R502
CHBEV	Channel B even	R957	R508
CHBOD	Channel B odd	R947	R509
CHSEL0	Channel select 0	D411	N505
CHSEL1	Channel select 1	D411	N505
DGLT	Degitch control	R584	D503 - D512
DSOSWP	Digital storage osc. sweep	N513	V4521
DOTS--LT	Control signal for dot join	D313	D503 - D504 - R596
PENLIFT	Penlift	D313	R614
PLOT--HT	Control signal for plot	D313	D504 - D512
PLOT-X	Plot X	R608	X505/1
PLOT-Y	Plot Y	R611	X505/3
+PLOT	Pos. plot	N503	R592
-PLOT	Neg. plot	N503	R591
POSX	X position	N7003	D113 - R560
POSXOFHT	Position off	D313	V555
POSXOUT	X position out	V554/V557	R4722
SC0--HT	State counter 0	D314	R584
STCONVHT	Start conversion	D411	N505
XDAC0...9	Data bus for X DAC	D311/D312	N507
XPLOT	X plot signal	N513	R587
YDAC0...7	Data bus for Y DAC	D413	N506
+YDAC	Pos. Y DAC out	V531	R1616
-YDAC	Neg. Y DAC out	V532	R1617
ZCNTR	Z control	D505	V4618
ZON---LT	Z on control	D314	D504

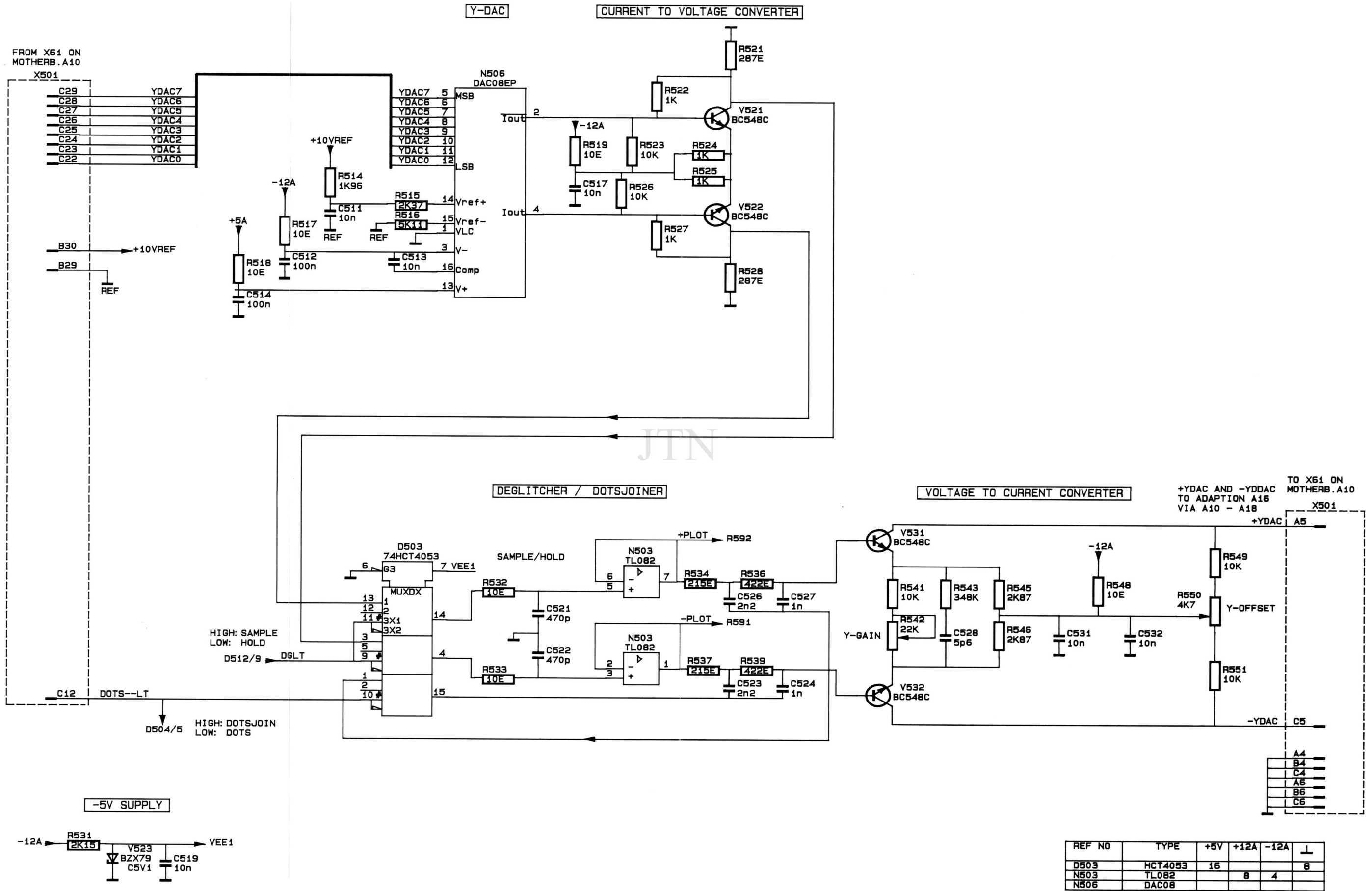

REF NO	TYPE	+5V	+12A	-12A	⊥
D503	HCT4053	16			8
N503	TL082		8	4	
N506	DAC08				

MAT 3573A

Figure 16.7 Circuit diagram of ADC DAC unit, Y DAC circuit

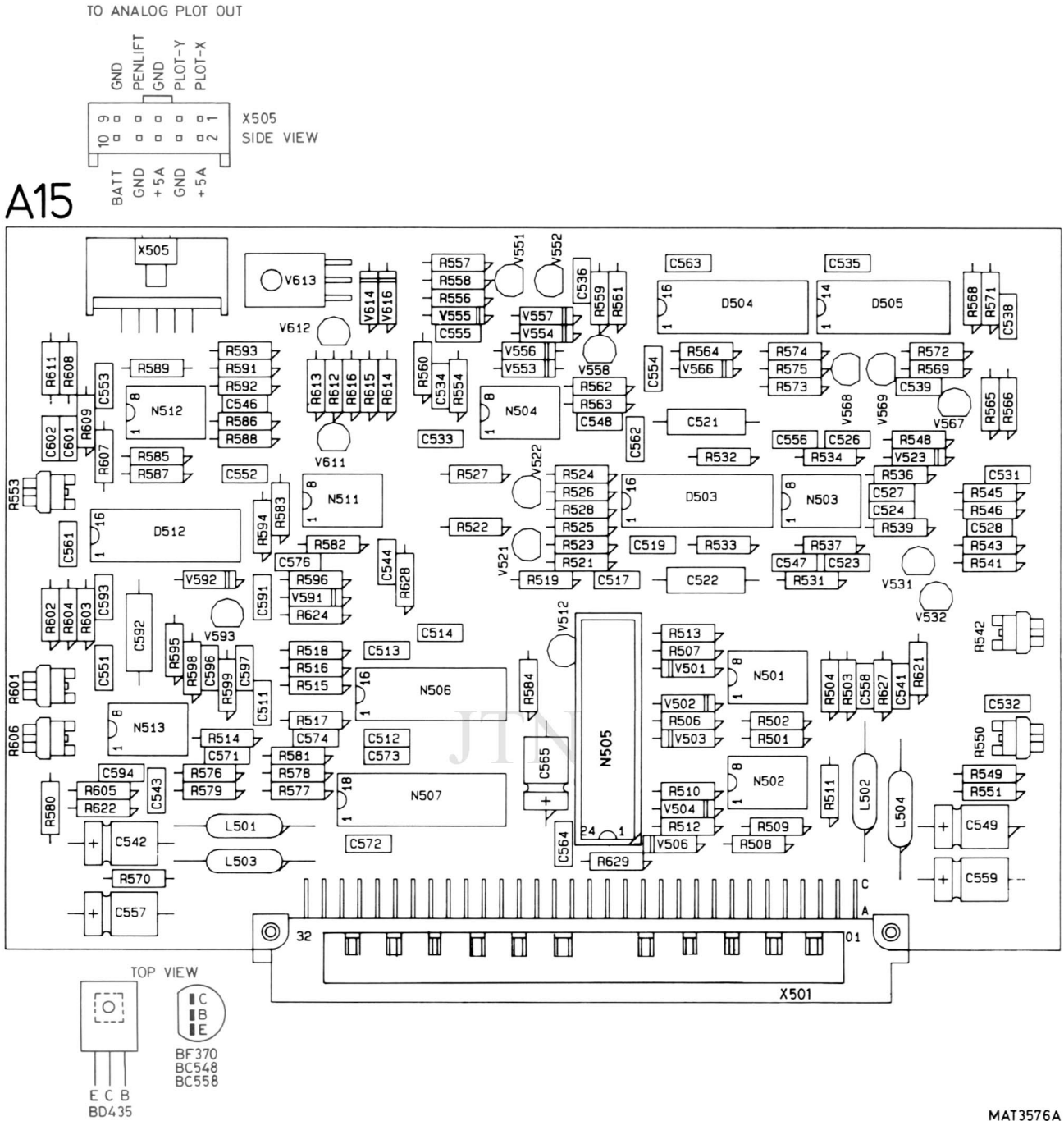
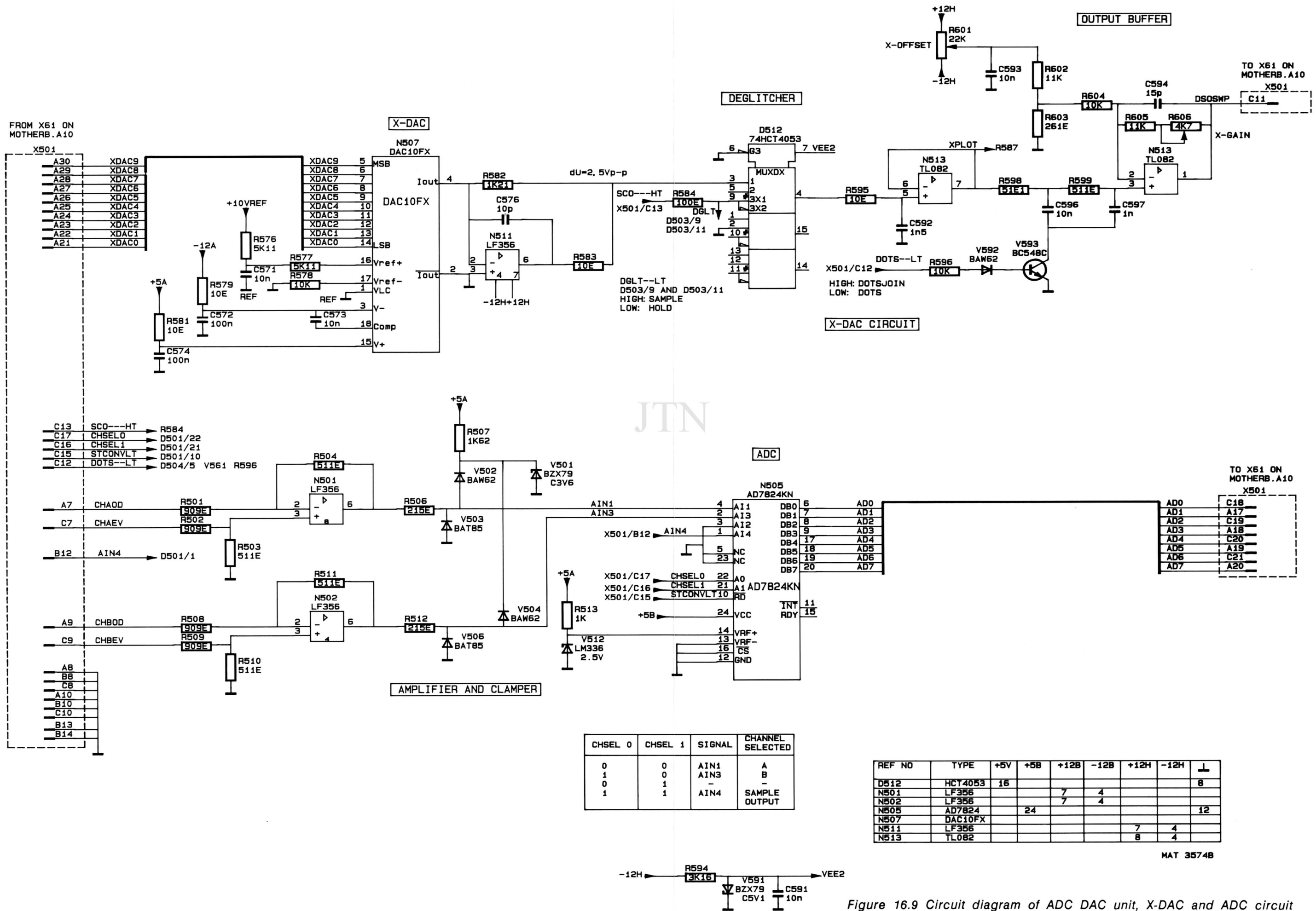

Figure 16.8 ADC DAC unit p.c.b.

Figure 16.10 ADC DAC unit p.c.b.



CHSEL 0	CHSEL 1	SIGNAL	CHANNEL SELECTED
0	0	AIN1	A
1	0	AIN3	B
0	1	-	-
1	1	AIN4	SAMPLE OUTPUT

REF NO	TYPE	+5V	+5B	+12B	-12B	+12H	-12H	L
D512	HCT4053	16						8
N501	LF356		7	4				
N502	LF356		7	4				
N505	AD7824		24					12
N507	DAC10FX					7	4	
N511	LF356					8	4	
N513	TL082							

MAT 3574B

Figure 16.9 Circuit diagram of ADC DAC unit, X-DAC and ADC circuit

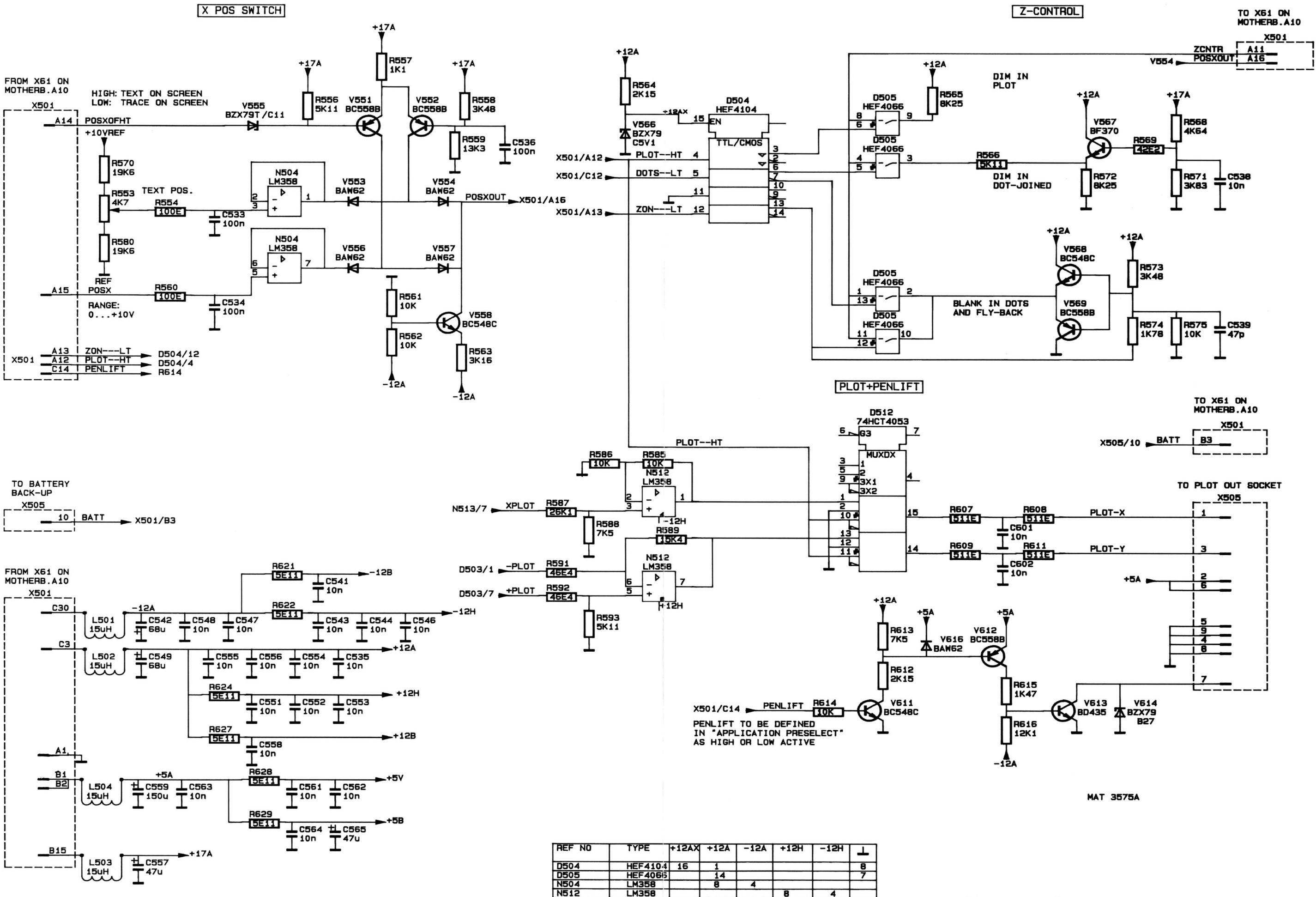

REF NO	TYPE	+12AX	+12A	-12A	+12H	-12H	⊥
D504	HEF4104	16	1				8
D505	HEF4066		14				7
N504	LM358		8	4			
N512	LM358				8	4	

Figure 16.11 Circuit diagram of ADC DAC unit, part 3

ADAPTATION UNIT (A16)

JTN

17 ADAPTATION UNIT (A16)

17.1 VERTICAL DISPLAY MODE SWITCH

The vertical display mode switch can operate in 3 modes:

- Analog mode
- Digital sampling mode
- Digital real time mode.

These modes can be selected by a diode switch and a relais. The diode switch is under control of signal CCDENBHA and select "digital real time mode" OR "analog/digital sampling mode". The relais is under control of signal MEMON-LA and select "analog mode" OR "digital sampling mode". The selection table is as follows:

signal/mode	dig. real time	dig. sampling	analog
CCDENBHA	+ 12 V	-12 V	- 12 V
MEMON-LA	0 V	0 V	+ 12 V

17.2 ANALOG MODE

Selection of the analog mode means that the current signals of channels A and B are directly coupled to the inputs of the analog vertical mode switch D1601. The current signals are influenced by a Y-POSITION control circuit. For channel A the Y-position control is obtained via the long-tailed pair amplifier V1631 and V1632. The channel B Y-POSITION control (V1641 and V1642) is identical, but also includes a multiplexer D1603 for normal/invert function.

The output current signals of the vertical channel switch D1601 are routed via the relais (MEMON-LA = +12 V) and the HF clamp circuit to the delay line driver on unit A2. The HF-clamp circuit is in this mode inactive, because both diodes in V1612 are off.

Another vertical channel switch (D1602) is connected to the delay line driver. D1602 selects between the trigger level view current signals (TRIGV +, TRIGV-) OR the analog current signals from the DAC (+YDAC, -YDAC).

The vertical channel switches are under control of the signals CHA---HA, CHB---HA, TRGV--HA and MEMON-HT on pin 10 and pin 11 of D1601 and D1602 according to the following selection table:

	D1601		D1062	
	pin 10	pin 11	pin 10	pin 11
CH A	1	0	0	0
CH B	0	1	0	0
CH A + CH B	1	1	0	0
TRIG LEVEL VIEW	0	0	1	0
DIGITAL	0	0	0	1

Furthermore channel B and trigger level view can be inverted:

- Invert channel B is obtained by signal INVB--HA (high).
The balance between normal/invert can be adjusted with R2212.
- Invert trigger level view is obtained by signal INVAM-HA (high).

17.3 DIGITAL SAMPLING MODE

Selection of the digital sampling mode means that the current signals of channel A and B are directly coupled to the inputs of the analog vertical channel switch D1601. The current signals are influenced by the Y-POSITION control circuit (see also 17.2). The channel selection of D1601 is under control of the signals CHA---LT and CHB---LT instead of the signals CHA---HA and CHB---HA which are inactive.

The output signals of the vertical channel switch D1601 are routed via the relays (MEMON-LA = 0 V) to the track & hold input circuit.

The output current D1601 floats via the two diodes in V1604 during the switch period (11 ms) of the relays contact, so no latch-up can occur. In all other situations these diodes are switched-off.

The track & hold input circuit converts the symmetrical current signals (+TANDH, -TANDH) into an a-symmetrical voltage signal (T&H + AN) by means of a common base stage, a series feedback stage, another common base stage and a current mirror. Gain, offset and HF-response can be adjusted and signal voltage can be measured on R1713, R1714 and R1749. The output signal T&H + AN (100 mV/div.) is fed to the track & hold circuit.

The track & hold circuit consists of a switchable long-tailed pair amplifier, a current mirror, a (hold) capacitor and a buffer output stage.

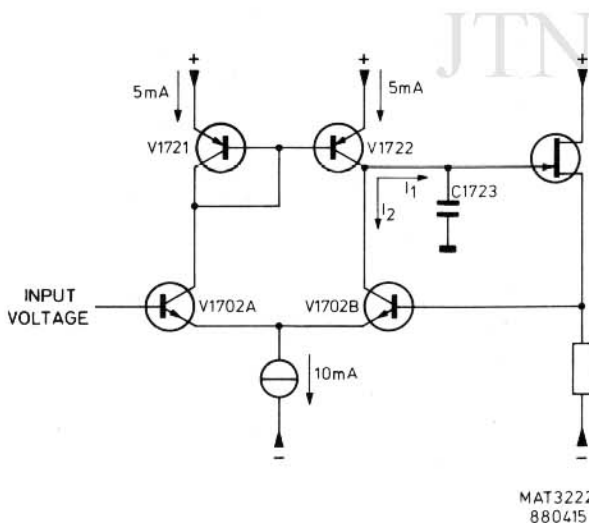

Figure 17.1 Principle of track & hold amplifier.

The principle of the track & hold amplifier in track mode is as follows:

- The capacitance is discharged.
- A positive input voltage makes V1702a conducting and V1702b blocking and causes a collector current in V1721.
- The collector current of V1721 is copied in the collector of V1722, while V1702b was blocked all the collector current of V1722 will charge the (hold) capacitor C1723 (I_1).
- The voltage on the output buffer and on the base of V1702b will rise until it reaches the original positive input voltage.
- No current is anymore charging the capacitor and both transistors (V1702a and V1702b) are conducting half the current of the current source.

In hold mode the current source is switched off V1702A and V1702B are blocking and the (hold) capacitor is isolated and holds its charge.

17.4 DIGITAL REAL TIME MODE

Selection of the digital real time mode means that the current signals of channels A and B are coupled to the common-base amplifier V1638, V1639, V1649 and V1651 (B-INVERT: V1648 and V1652), because control signal CCDENBHA is active (high). The current signals are influenced by the Y-POSITION control circuit (see also 17.2). The output currents of the common-base amplifiers are applied to the P²CCD unit A18, via four 50 Ω cables.

Next, MEMON-HT causes the selection of the vertical current signals -YDAC and +YDAC. These signals are routed via D1602 to the delay-line driver on unit A2.

In digital memory mode, selection can be made for trigger level view by applying a high level to D1602-10. This d.c. signal is received from the trigger level view pre-amplifier on unit A2.

17.4 SIGNAL NAME LIST

Signal name	Description	Signal source	Signal destination(s)
CCDENBHT	CCD enable	R447	R1627
ADCIN4	ADC input signal	R1786	N505
CCDENBHA	CCD enable	V1623	V1637 - R1674
CHA + AN	Ch. A analog input signal	R2196	V1636
CHA-AN	Ch. A analog input signal	R2197	V1634
CHB + AN	Ch. B analog input signal	R2198	V1644
CHB-AN	Ch. B analog input signal	R2199	V1646
CHA---HA	Ch. A selection, analog mode	R2204	D1601
CHA---LT	Ch. A selection, sampl. mode	R436	R1601
CHB---HA	Ch. B selection, analog mode	R2209	D1601
CHB---LT	Ch. B selection, sampl. mode	R434	R1603
+DLD-1	Delay line driver signal	V1613	R2250
-DLD-1	Delay line driver signal	V1614	R2251
+DLD-2	Delay line driver signal	R1626	R2252
-DLD-2	Delay line driver signal	R1624	R2253
HOLD--LT	Control signal for T&H		R1759 - R1791
INVAM-HA	Invert trigger level	R2216	D1602
INVB--HA	Invert channel B	R2201	D1601 - D1603
MEMON-HT	Digital memory on	D222	R1607 - R1614
POSCHA	Position channel A	W2200	R1631
POSCHB	Position channel B	W2200	R1651
+TANDH	Analog signal for T&H input	K1601	R1701
-TANDH	Analog signal for T&H input	K1601	R1702
T&H + AN	T&H analog input signal	R1749	R1764
TRGV--HA	Triggel level view selection	R2214	D1602
TRIGV +	Triggel level input signal	R2412	D1602
TRIGV-	Trigger level input signal	R2404	D1602
+YDAC	+ Y analog signal from DAC	V531	R1616
-YDAC	- Y analog signal from DAC	V532	R1617

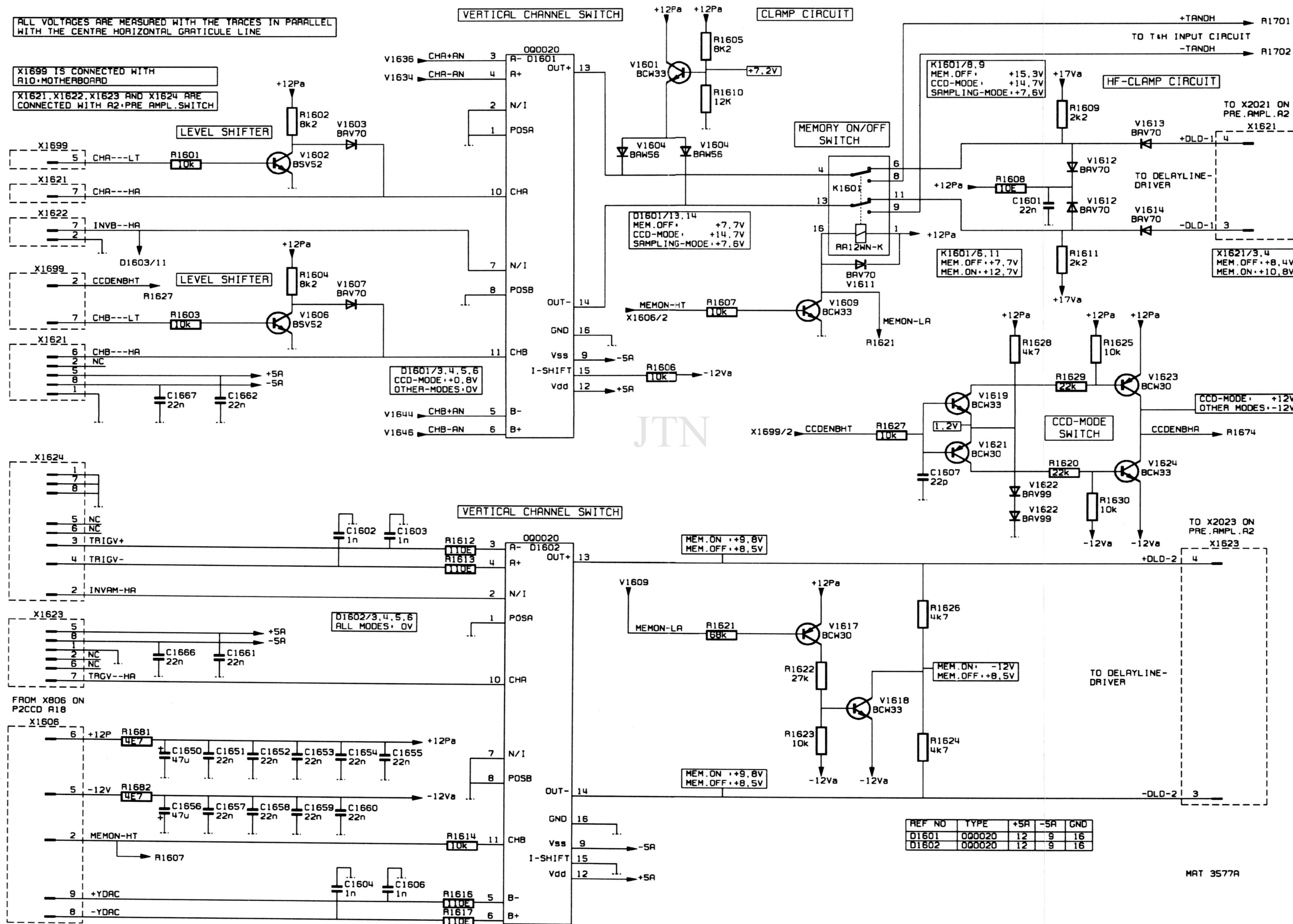

Figure 17.3 Circuit diagram of adaptation unit, part 1

ALL VOLTAGES ARE MEASURED WITH THE TRACES IN PARALLEL WITH THE CENTRE HORIZONTAL GRATICULE LINE.

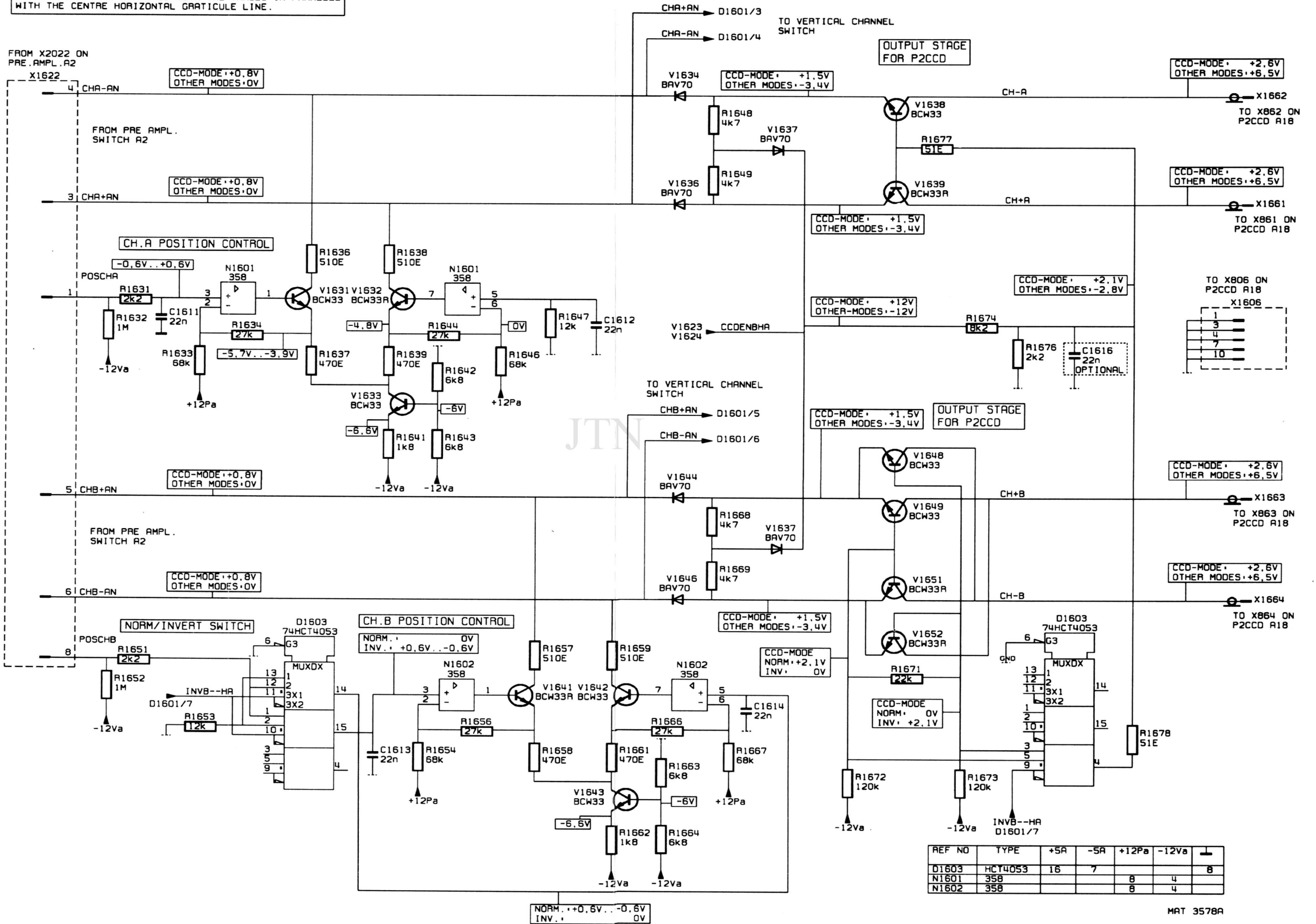
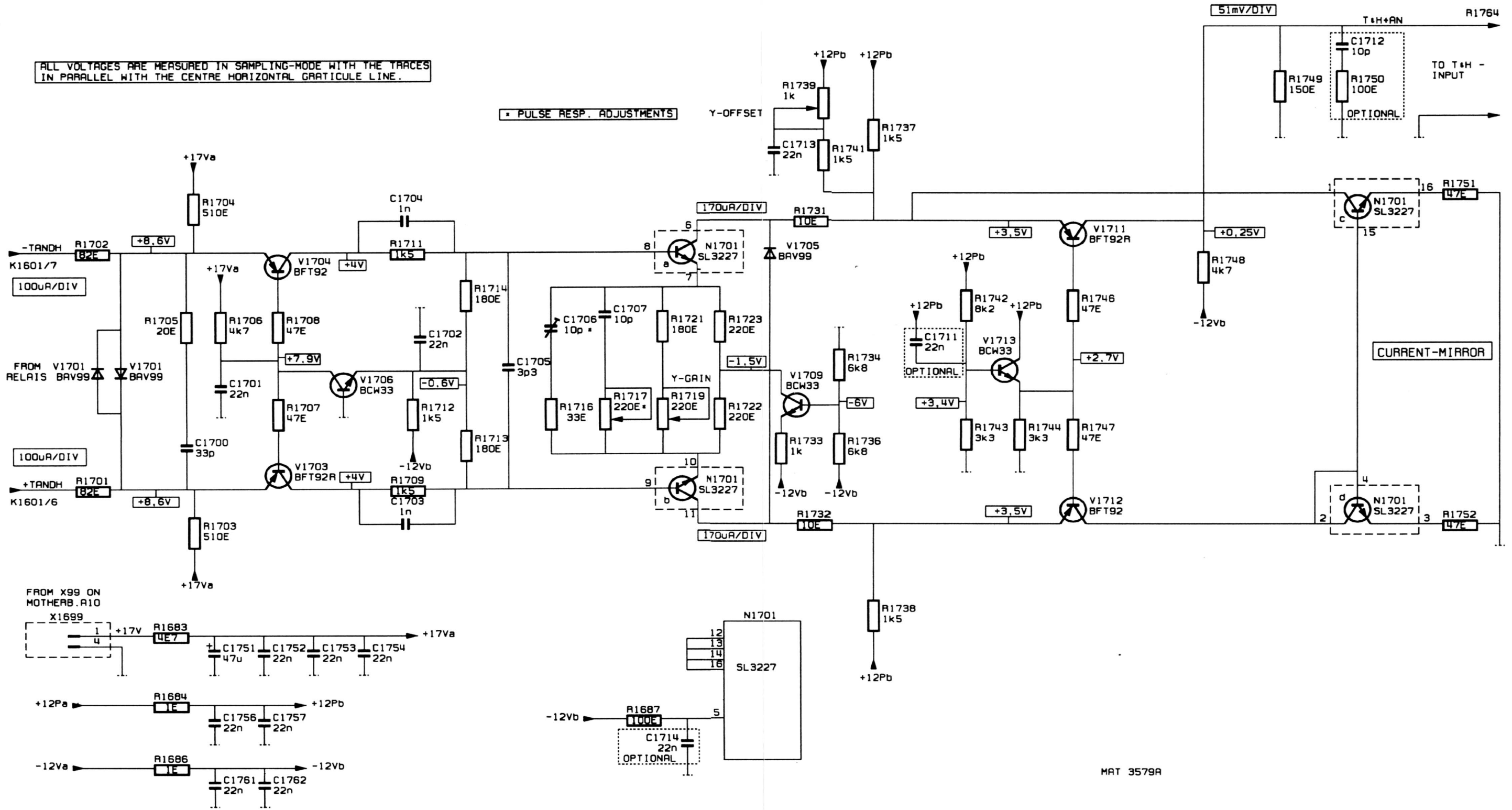

Figure 17.4 Circuit diagram of adaptation unit, part 2

ALL VOLTAGES ARE MEASURED IN SAMPLING-MODE WITH THE TRACES IN PARALLEL WITH THE CENTRE HORIZONTAL GRATICULE LINE.

PULSE RESP. ADJUSTMENTS



MAT 3579A

Figure 17.6 Circuit diagram of adaptation unit, part 3

ALL VOLTAGES ARE MEASURED IN SAMPLING-MODE WITH THE TRACES IN PARALLEL WITH THE CENTRE HORIZONTAL GRATICULE LINE.
 VOLTAGES MARKED WITH * ARE MEASURED IN TB TRIG MODE SINGLE AFTER PRESSING THE RESET BUTTON. IN THIS MODE THE T+H IS CONSTANT TRACKING THE INPUT SIGNAL.

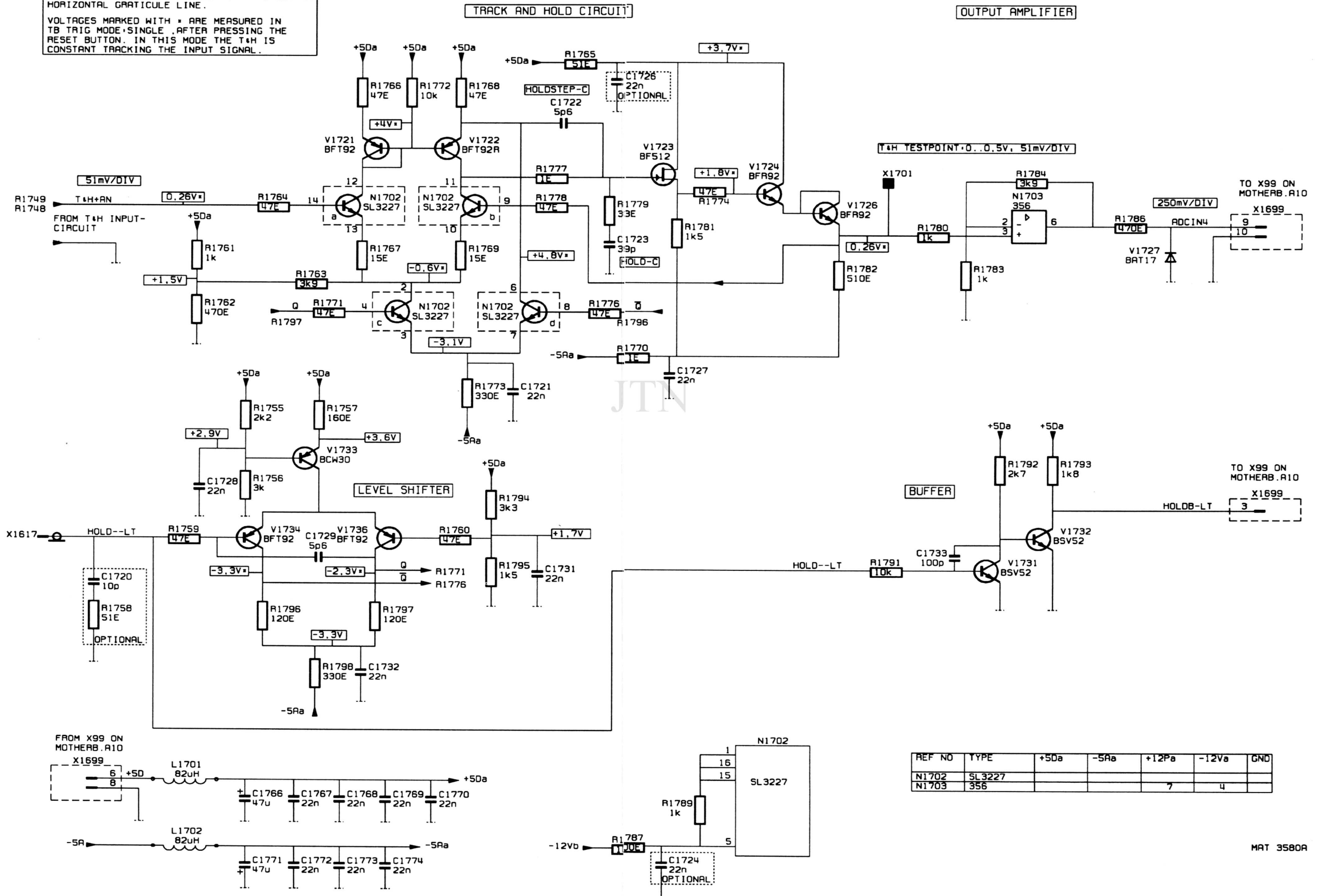

Figure 17.8 Circuit diagram of adaptation unit, part 4

P²CCD UNIT (A18) - PM3365A/67A ONLY!

JTN

18 P²CCD UNIT (A18) - PM3365A/67A ONLY!

The P²CCD unit consists of:

- Two separate mini CCD units which are mounted on this unit
- The ACE (Advanced Customised ECL) device with associated circuit
- The clock drivers circuits
- The Mini CCD default circuits
- The P²CCD output circuit

18.1 MINI CCD UNIT (A17)

18.1.1 Introduction

The P²CCDs for channels A and B are situated on the mini CCD units A17 which are mounted on this unit A18. The two units for ch. A and ch. B are identical.

WARNING: The P²CCD is a MOS device, which is highly sensitive to electrostatic discharges. It is not possible to replace it without causing damage, due to electrostatic discharges.

The P²CCD (Profiled Peristaltic Charge Coupled Device) - OQ0204 - which is basically an analog shift register, consists of an ODD-side and an EVEN-side. Each side consists of a sample gate of 256 stages, through which the samples can be shifted, and an output gate (see figure 18.1).

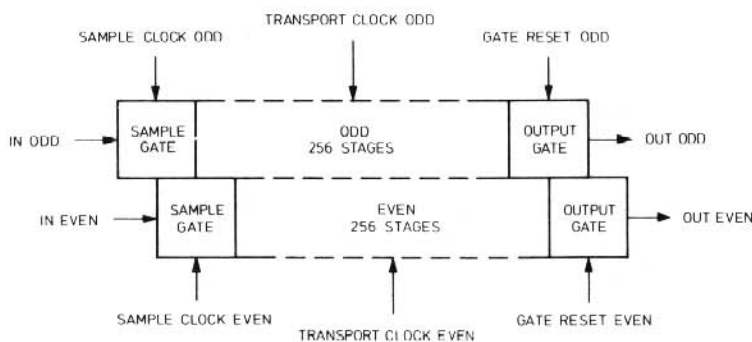

MAT 2506
861205

Figure 18.1 Schematic diagram of a P²CCD circuit

The clock signals of the ODD and the EVEN side are always in anti-phase (see figure 18.2).

- On the rising edge of the sample clock, a sample of the input signal is taken.
- On the falling edge of the sample clock, this sample is shifted to the first stage
- On the falling edge of the transport clock, all samples in all stages are shifted (transferred) one stage. The last sample is transferred to the output stage. The output stage is enabled when the gate reset signal is 0 V.

The P²CCD circuit applies the samples to the Clamp, Integrate and Hold circuit (CIH circuit), which takes over the samples. Then the gate reset signal is +12 V again, which resets the output capacitor.

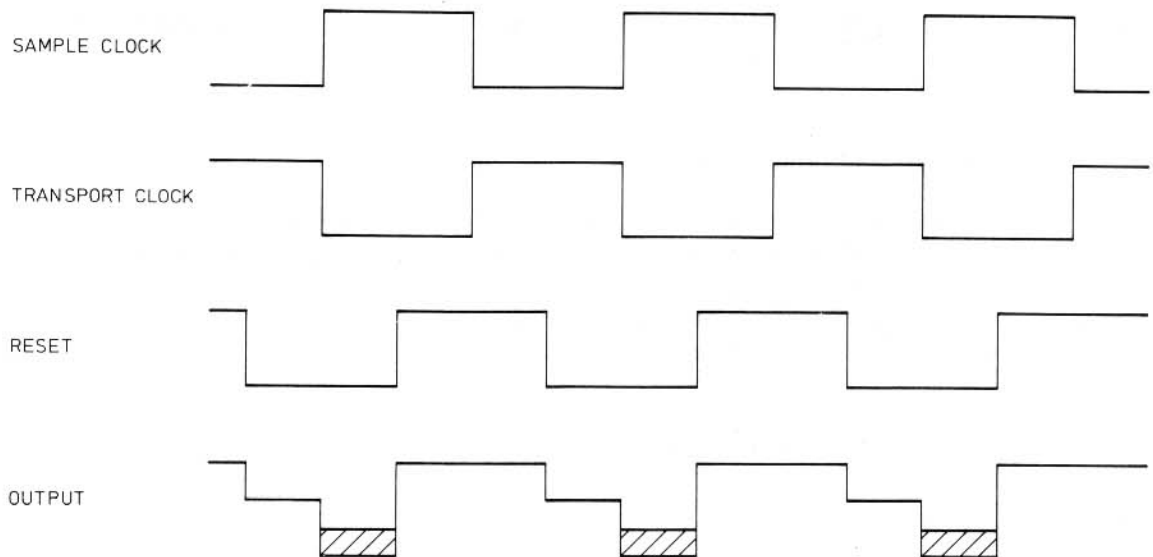

MAT2829
870515

Figure 18.2 Sample and transport sequence

18.1.2 Input buffer

The differential input current with a sensitivity of $100 \mu\text{A}/\text{DIV}$ is received via 50Ω cables from adaptation unit A16. This current is buffered by common-base amplifiers V701 and V702 and then applied to the shunt feedback amplifiers V703 and V704. This stage converts the input current into the voltage for the P²CCD. The d.c level of this signal is controlled by the DCIA (or DCIB) signal.

18.1.3 P²CCD - OQ0204

The P²CCD circuit OQ0204 has the following pin connectors.

Pin	Name	Description
1	INE	Same signal as SAMPLE CLOCK EVEN but d.c. shifted. This d.c. value can be varied by potentiometer R894 for ch: A or R892 for ch. B on unit A18.
2	G1E	d.c. barrier voltage level. This d.c. value can be varied by potentiometer R974 for ch. A or R977 for ch. B on unit A18.
3	G2E	Input signal, even. The input signal can be varied by potentiometer R966 for ch. A or R970 for ch. B on unit A18.
4	G3E	SAMPLE CLOCK EVEN, takes samples of the input signal.
5	G4E	Same signal as SAMPLE CLOCK EVEN but d.c. shifted.
6	CL1IN	TRANSPORT CLOCK EVEN, transfers the samples in all 256 even stages one stage further.
7	CL2IN	Same signal as TRANSPORT CLOCK EVEN but d.c. shifted
8	SUB	Default value of -2 V approx.
9	CL20	n.c.

Pin	Name	Description
10	CL10	n.c.
11	GSP	GATE SEPARATION. Default value of +4,8 V approx.
12	OUT EVEN	Output signal even.
13	DRSE	DRAIN RESET EVEN. Default value of +19,2 V approx.
14	GRE	GATE RESET EVEN signal. When 0 V, the even output is enabled, when +12 V, the even output is disabled.
15	GRO	GATE RESET ODD signal. When 0 V, the odd output is enabled, when +12 V, the odd output is disabled.
16	DRSO	DRAIN RESET ODD. Default value of +19,2 approx.
17	OUT ODD	Output signal odd.
18	DSFS	Supply voltage of +25 V.
19	CL30	n.c.
20	CL40	n.c.
21	SUB	Default value of -2 V approx.
22	CL40	Same signal as TRANSPORT CLOCK ODD but d.c. shifted.
23	CL30	TRANSPORT CLOCK ODD, transfers the samples in all 256 odd stages one stage further.
24	G40	Same signal as SAMPLE CLOCK ODD but d.c. shifted.
25	G30	SAMPLE CLOCK ODD, takes samples of the input signal.
26	G20	Input voltage, odd. The input signal can be varied by potentiometer R966 for ch. A or R970 for ch. B on unit A18.
27	G10	d.c. barrier voltage level. This d.c. value can be varied by potentiometer R974 for ch. A or R977 for ch. B on unit A18.
28	INO	Same signal as SAMPLE CLOCK ODD but d.c. shifted. This d.c. value can be varied by potentiometer R894 for ch. A or R892 for ch. B on unit A18.

The output signals are buffered by emitter-followers V736 for EVEN and V766 for ODD and then applied to multiplexers D901 and D911 on A18.

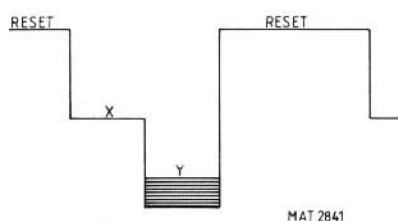

Figure 18.3 Output signal

While the output stage of the P²CCD is reset by the GRE signal (for even samples, or GRO for odd samples) its output voltage is about 19,2 V. This voltage is determined by a resistor divider network at the DRSE input (pin 13 of the P²CCD).

When the RESET is removed, the output drops to an undefined level X. On the falling edge of the transport clock, the sample leaves the output stage of the P²CCD. Now the output voltage drops to level Y. The voltage difference between level X and level Y represents the value of the sample.

This voltage difference is detected by the input of the CIH circuit (see section 18.5).

The following table gives a list of sample clock frequencies and the slower read-out frequencies for all time-base position (P = P²CCD-mode, D = Direct mode, R = Roll mode).

TIME/DIV	mode	sample clock freq.	read-out freq.
0,5 μ s	P	50 MHz	50 kHz
1 μ s	P	25 MHz	50 kHz
2 μ s	P	12,5 MHz	50 kHz
5 μ s	P	5 MHz	50 kHz
10 μ s	P	2,5 MHz	50 kHz
20 μ s	P	1,25 MHz	50 kHz
50 μ s	P	500 kHz	50 kHz
0,1 ms	P	250 kHz	50 kHz
0,2 ms	P	125 kHz	50 kHz
0,5 ms	D1	50 kHz	50 kHz
1 ms	D1	50 kHz	50 kHz
2 ms	D1	50 kHz	50 kHz
5 ms	D2	40 kHz	40 kHz
10 ms	D2	40 kHz	40 kHz
20 ms	D2	40 kHz	40 kHz
50 ms	D2	40 kHz	40 kHz
0,1 s	D2	40 kHz	40 kHz
0,2 s	D2	40 kHz	40 kHz
0,5 s	D2	40 kHz	40 kHz
1 s	R	40 kHz	40 kHz
2 s	R	40 kHz	40 kHz
5 s	R	40 kHz	40 kHz
10 s	R	40 kHz	40 kHz
20 s	R	40 kHz	40 kHz
50 s	R	40 kHz	40 kHz

Note: In P and D1 mode (time-base settings: 0,5 μ s/div...2 ms/div), the P²CCDs act as time converters: the read-in frequency is higher than the read-out frequency. In D2 and R mode (time-base settings: 5 ms/div...0,5s/div), the P²CCDs act as analog shift registers: the read-in frequency is the same as the read-out frequency.

Note: The P²CCD is not used for the sampling mode, c.i. TIME/DIV positions 0,2 μ s ... 20 ns.

18.1.4 Signal name list of the mini ccd unit

Signal name	Description	Signal source	Signal destination(s)
BARA	Barriär ch. A	R974	R770
BARB	Barriär ch. B	R977	R770
BIASA	Bias voltage ch. A	R894	N701
BIASB	Bias voltage ch. B	R892	N701
CH + A	Channel +A input	V616	R702
CH-A	Channel -A input	V617	R707
CH + B	Channel +B input	V622	R702
CH-B	Channel -B input	V621	R701
DCIA	DC level in ch. A	N921	R715
DCIB	DC level in ch. B	N922	R715
DCOA	DC level out ch. A	R717/R718	N921
DCOB	DC level out ch. B	R717/R718	N922
OUTAEV	Output ch. A even	V736	D911
OUTAOD	Output ch. A odd	V766	D901
OUTBEV	Output ch. B even	V736	D911
OUTBOD	Output ch. B odd	V766	D901
RSTEV-LT	Reset even	R407	R751
RSTOD-LT	Reset odd	R406	R781
SCEAM	Sample clock even ch. A	L806	D731
SCEBM	Sample clock even ch. B	L836	D731
SCOAM	Sample clock odd ch. A	L801	D731
SCOBM	Sample clock odd ch. B	L831	D731
TCEAM	Transport clock even ch. A	L822	D731
TCEBM	Transport clock even ch. B	L852	D731
TCOAM	Transport clock odd ch. A	L816	D731
TCOBM	Transport clock odd ch. B	L846	D731

18.2 ACE (ADVANCED CUSTOMISED ECL)

The CCD logic and fast time-base divider are integrated in an ECL-GATE-ARRAY D801. It contains various fast dividers to generate the sample and transport clock from the FCH and FCL signals in P-mode. It also contains the logic for the change over to the slow clock (SWCK) for the read out stroke in P-mode. In the Direct mode the sample and transport clocks are derived from SWTB.

In D-mode, the sample and transport clock has a clock-frequency of 50 kHz (D1 mode) or 40 kHz (D2 mode). These frequencies are derived from signal SWCK (100 kHz in D1 mode and 80 kHz in D2 mode).

In P-mode the delay counter indicates the moment when the P²CCD is read. The delay counter consists of a 4-bit presettable counter, internal in the ECL-GATE-ARRAY, and a 16-bit external counter D887.

The output lines are at ECL level (-0,9 V...-1,7 V). The output signals TCEV, CDRD, DTUF and DCC are buffered and converted into a TTL level.

The digital time-base generator in P-mode is driven by a 100 MHz crystal oscillator. The oscillator can be switched-on and -off by the signal OSCON-LT.

18.3 CLOCK DRIVERS

Each SAMPLE AND TRANSPORT clock driver consists of two transistors with a current source. To increase the bandwidth of the signal, a coil is added between the collector and the gate capacitance of the P²CCD; the sample clock drivers are buffered by a bridged T-network.

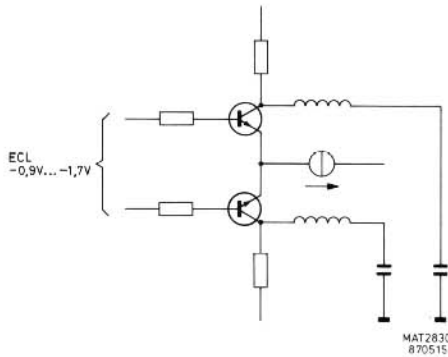

Figure 18.4 Principle of the sample clock drivers

The inputs are at ECL level (-0,9 V...-1,7 V) and are derived from the ACE. These are converted into a 0 ... 9 V signal for the sample clock drivers or 0...6 V signal for the transport clock drivers.

18.4 MINI CCD DEFAULT CIRCUITS

The default settings BIAS A (BIAS B) and +27 V for the P²CCD are obtained by resistor dividers or by a zener diode. The d.c. value of BIAS A (BIAS B) can be varied by potentiometer R894 (R892).

The level shifter D921 converts the TTL signals DISOD-HT, DISEV-HT, SPOD and SPEV into the same signals but at CMOS level (signal between 0... +12 V). The sample signal SAMPLEHT is split up into a sample Odd or sample Even signal by D922.

18.5 P²CCD OUTPUT

The P²CCD output circuit consists of 4 CIH (Clamp Integrate Hold) circuits, followed by the analog leakage correction.

Since channel A and B are identical (and the even and odd side of each channel are identical) only channel A odd side of the CIH is described.

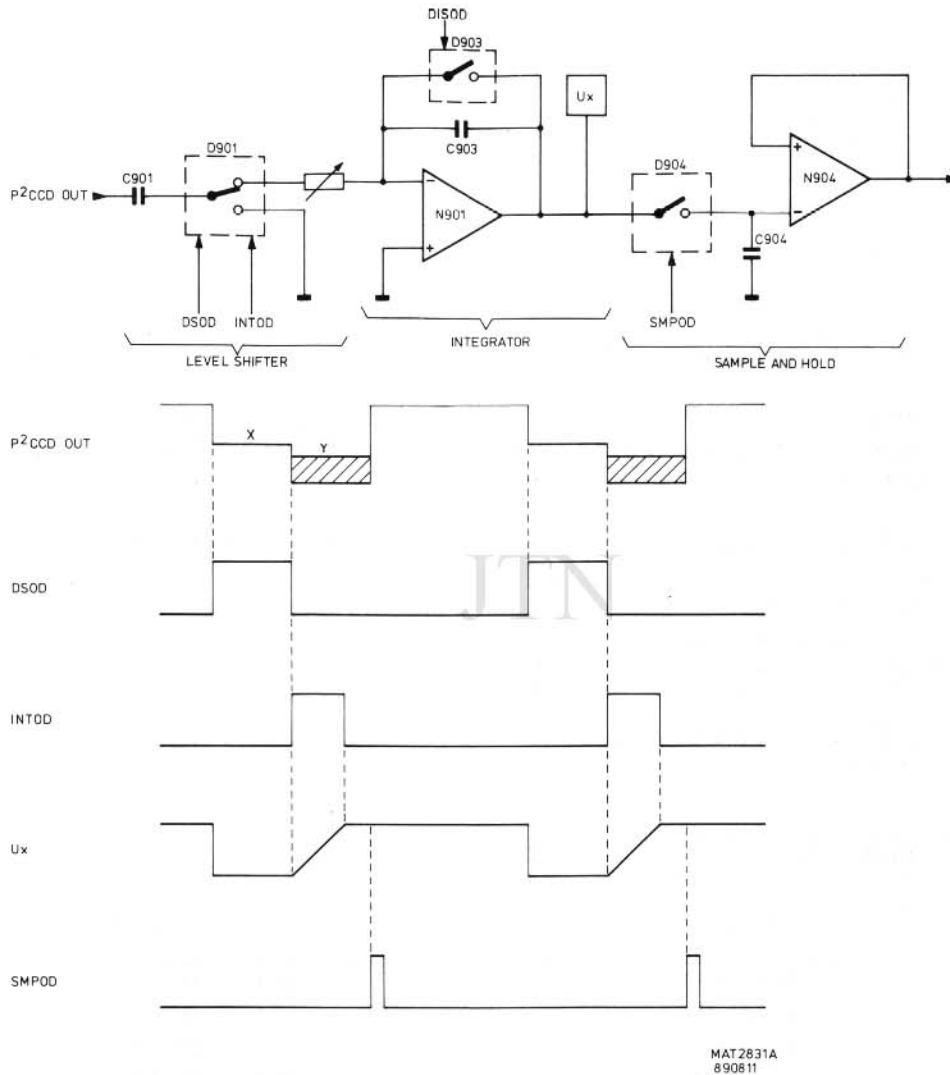

MAT2831A
890811

Figure 18.5 CIH circuit

The CIH receives its signal from the P²CCD.

The first stage is multiplexer D901, which serves as a level shifter. D901 detects the voltage difference between level X and Y which represents the value of the sample and sets the voltage reference level X to 0 V. When DSOD is high, capacitor C901 is clamped to ground and charged to the voltage X. Then, when INTOD is high, capacitor C901 passes this d.c. sample voltage Y-X to the next stage.

The second stage, integrator N901 has two functions: it filters and amplifies the sample voltage. During the time that INTOD is high the sample voltage is present and the output of N901 is rising linearly. Then when INTOD is low again, the output of N901 gives a constant voltage. Next, when DISOD is high capacitor C903 is short-circuited by D903 and is discharged so that it is ready for a new cycle. The output of this stage is buffered by a dual FET V903.

The third stage is the sample and hold circuit D904. The constant output voltage of the previous stage charges the hold capacitor C904 during the time that SMPOD is high. If SMPOD is low, the capacitor C904 is isolated from the second stage and holds its charge; the output voltage of N904 is now constant.

The outputs of the odd and even signals of ch. A (B) are applied to the analog leakage correction.

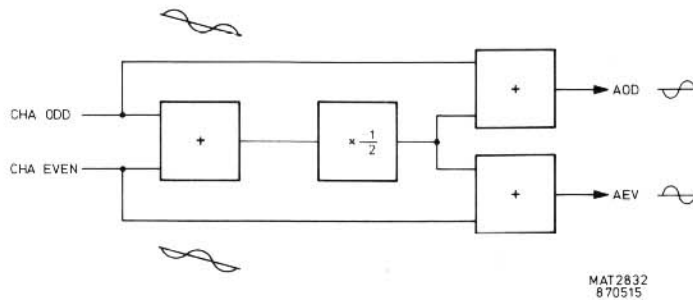

Figure 18.6 Analog leakage correction

The two samples CH.A ODD and CH.A EVEN contain the samples with a certain analog common leakage. The odd and even signals are in anti-phase while the leakage is in phase. The circuit can be split into three phases:

- Adding of both signals by R904 and R909. This results in a double leakage signal on N905-6.
- Amplification by $-1/2$ by N905. The result is a pure leakage signal on N905-7.
- Adding the pure leakage signal to the ch. A odd (or: ch. A even) signal by N927-2. This results in the AOD and AEV signals.

In this way, the final samples AOD and AEV are corrected for leakage. These samples are applied to the ADC circuit on unit A15.

18.6 SIGNAL NAME LIST

Signal name	Description	Signal source	Signal destination(s)
BARA	Barri�r ch. A	R974	R760 - R770
BARA	Barri�r ch. A	R974	R760 - R770
BARB	Barri�r ch. B	R977	R760 - R770
BIASA	Bias voltage ch. A	R894	N701
BIASB	Bias voltage ch. B	R892	N701
CDRD-HT	CCD read	R883	D406 - D411
CHAOD	Channel A odd signal	R927	R501
CHAEV	Channel A even signal	R937	R502
CHBOD	Channel B odd signal	R947	R508
CHBEV	Channel B even signal	R957	R509
DCCLK	Delay counter clock	R886	D218
DCIA	DC level in ch. A	N921	R715
DCIB	DC level in ch. B	N922	R715
DCOA	DC level out ch. A	R717/718R968	
DCOB	DC level out ch. B	R717/718R972	
DCWE-HT	Delay counter write	D316	D801
DISEV-HT	Discharge even (5V)	R403	D921 - D922
DISOD-HT	Discharge odd (5V)	R404	D921 - D922

Signal name	Description	Signal source	Signal destination(s)
DSEV-HT	Discharge even (12V)	D921	D903
DSOD-HT	Discharge odd (12V)	D921	D903
DTTC-LT	Delay trigger terminal count	D218	D801
DTUF-HT	Delay trigger underflow	R884	D402
ED0...3	Buffered data bus	R413...417	D801
EDC--LT	Enable delay counter	R401	D221 - D801
FCH	Fast clock high	R874	D801
FCL	Fast clock low	R875	D801
INTEV-HT	Integrate even	R411	D911
INTOD-HT	Integrate odd	R409	D901
OUTAEV	Output ch. A even	V736	D911
OUTAOD	Output ch A odd	V766	D901
OUTBEV	Output ch. A even	V736	D911
OUTBOD	Output ch. B odd	V766	D901
OSCON-LT	Enable P-mode/100 MHz	D313	D407 - D801 - R862
RSSW	Reset slow clock	R407	D801
SAMPLEHT	Sample clock	R408	D922
SCEA	Sample clock even ch. A	D801	R806
SCEAM	Sample clock even ch. A	L806	D731
SCEB	Sample clock even ch. B	D801	R836
SCEBM	Sample clock even ch. B	L836	D731
SCOA	Sample clock odd ch. A	D801	R801
SCOAM	Sample clock odd ch. A	L801	D731
SCOB	Sample cleck odd ch. B	D801	R831
SCOBM	Sample clock odd ch. B	L831	D731
SMPEV-HT	Sample even	D921	D914
SMPOD-HT	Sample odd	D921	D904
STWE-HT	Status write	D316	D801
SWCK	Slow clock	D412	D801
SWTB	Slow time base	D218	D801 - D412
TBWE-HT	Time base write	D316	D801
TCEA	Transport clock even ch. A	D801	R822
TCEAM	Transport clock even ch. A	L822	D731 - R747
TCEB	Transport clock even ch. B	D801	R852
TCEBM	Transport clock even ch. B	L852	D731 - R747
TCEV-LT	Transport clock even	R882	D401 - D408 - D411
TCOA	Transport clock odd ch. A	D801	R816
TCOAM	Transport clock odd ch. A	L816	D731 - R777
TCOB	Transport clock odd ch. B	D801	R846
TCOBM	Transport clock odd ch. B	L846	D731 - R777

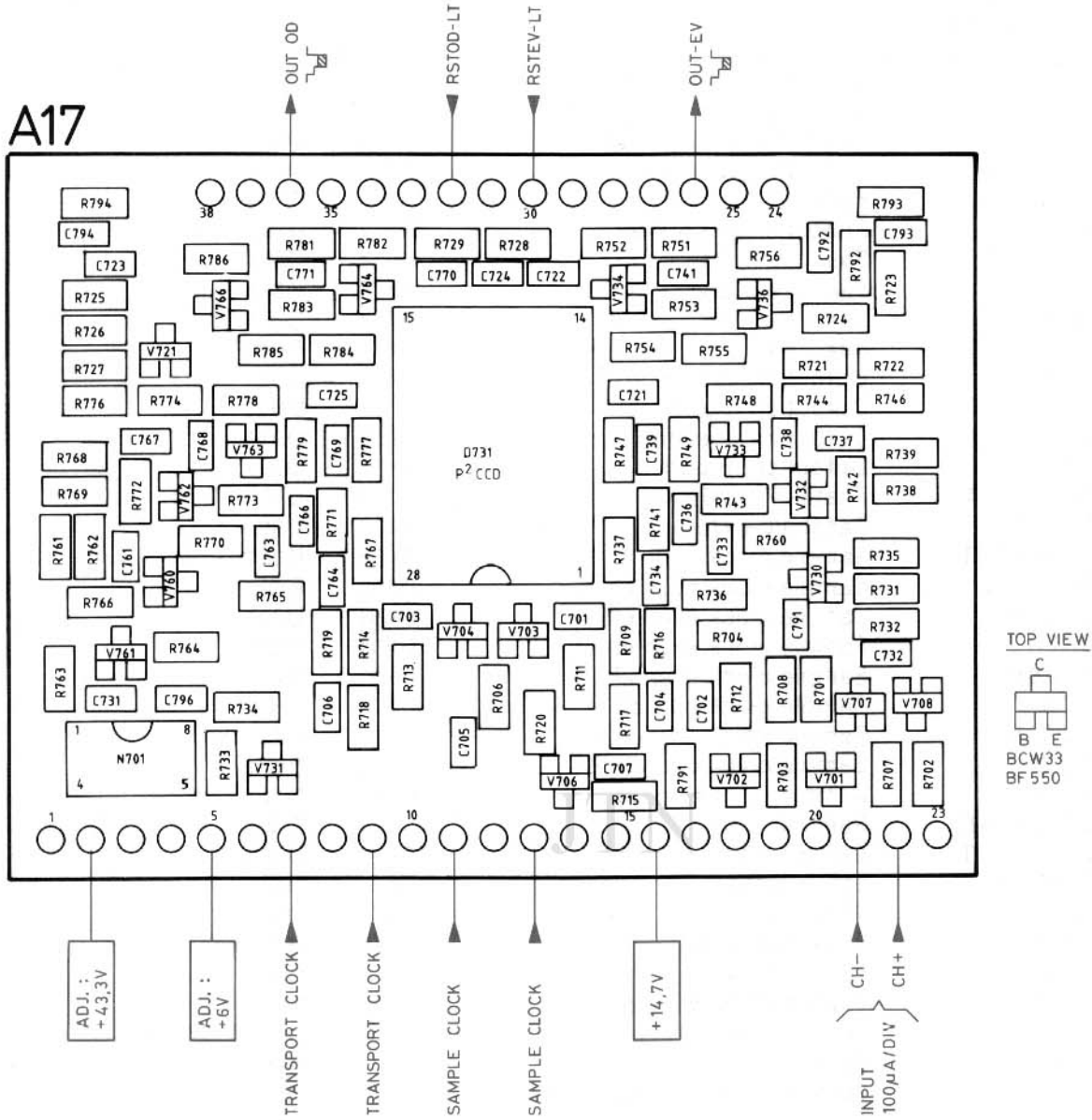

Figure 18.7 Mini CCD unit p.c.b.

MAT3583A

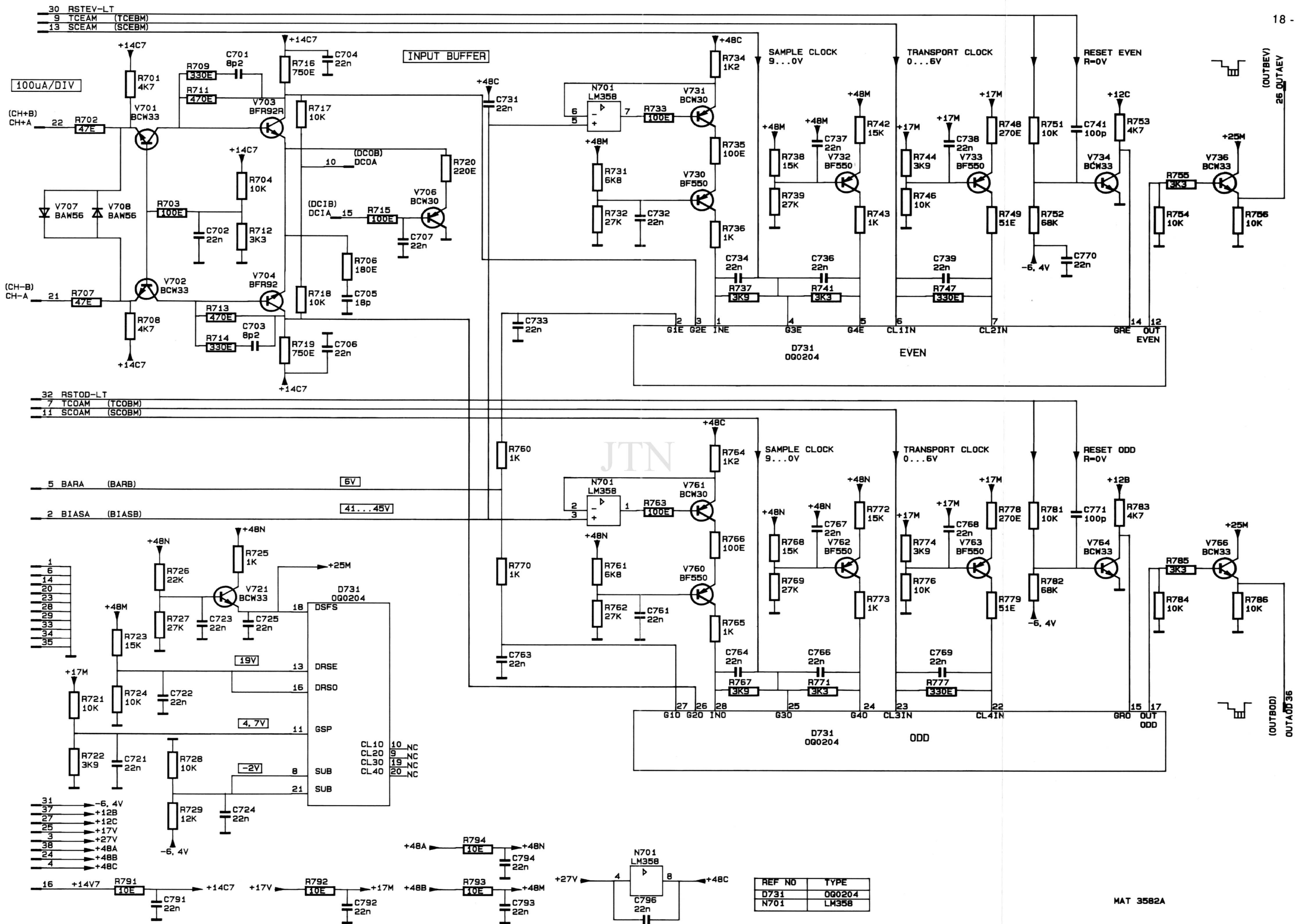
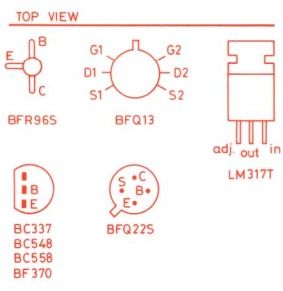
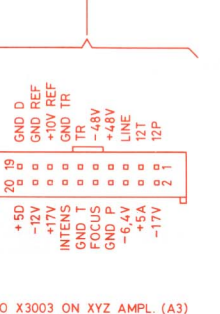
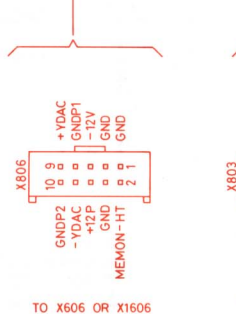
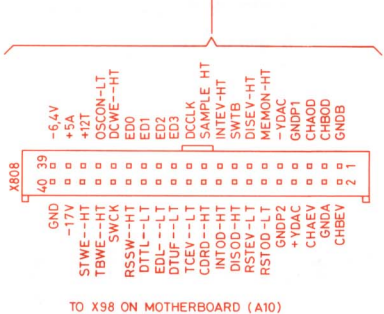
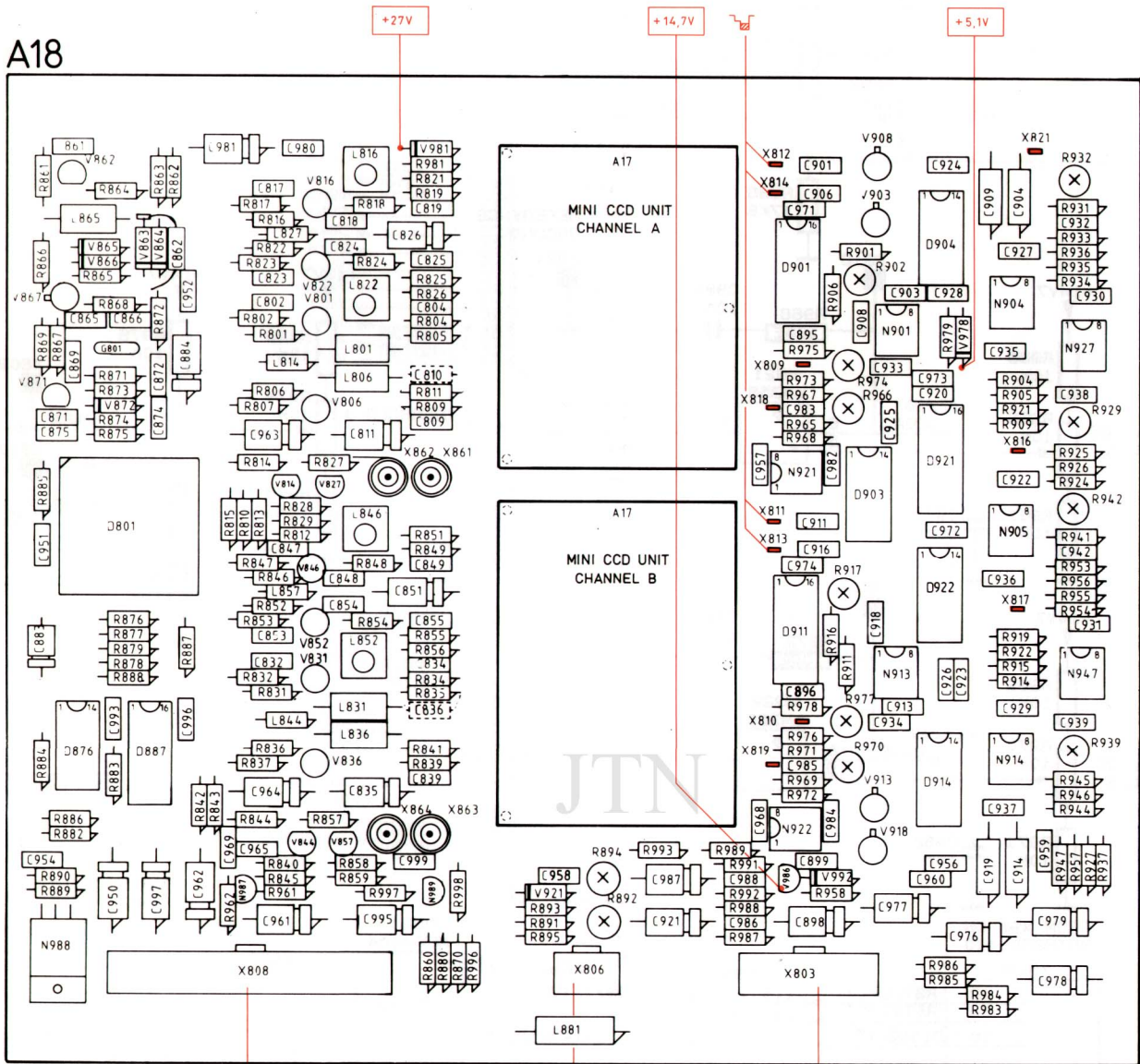

Figure 18.8 Circuit diagram of mini CCD unit

A18



TEST PIN	SIGNAL	ADJUSTING ELEMENT
X809	BAR (TRESHOLD) A	R974
X810	BAR (TRESHOLD) B	R977
X811	OUTAEV	R966
X812	OUTAOD	R966
X813	OUTBEV	R970
X814	OUTBOD	R970
X816	LEAKAGE A	R902
X817	LEAKAGE B	R917
X818	DC LEVEL A	R966
X819	DC LEVEL B	R970
X821	GND	--

ADJUSTING ELEMENTS:	
R892	BIAS B
R894	BIAS A
R902	LEAKAGE CORRECTION
R917	LEAKAGE CORRECTION
R929	GAIN A
R932	OFFSET A
R939	GAIN B
R942	OFFSET B
R966	DC LEVEL A
R970	DC LEVEL B
R974	TRESHOLD A
R977	TRESHOLD B

50 Ω CABLE CONNECTIONS:		
PIN:	SIGNAL:	DERIVED FROM:
X861	CH+A	X661 (PM3350A)
	CH+A	X1661 (PM3365A)
X862	CH-A	X662 (PM3350A)
	CH-A	X1662 (PM3365A)
X863	CH+B	X663 (PM3350A)
	CH+B	X1663 (PM3365A)
X864	CH-B	X664 (PM3350A)
	CH-B	X1664 (PM3365A)

Figure 18.9 P²CCD unit p.c.b.
 Figure 18.11 P²CCD unit p.c.b.
 Figure 18.13 P²CCD unit p.c.b.
 Figure 18.15 P²CCD unit p.c.b.

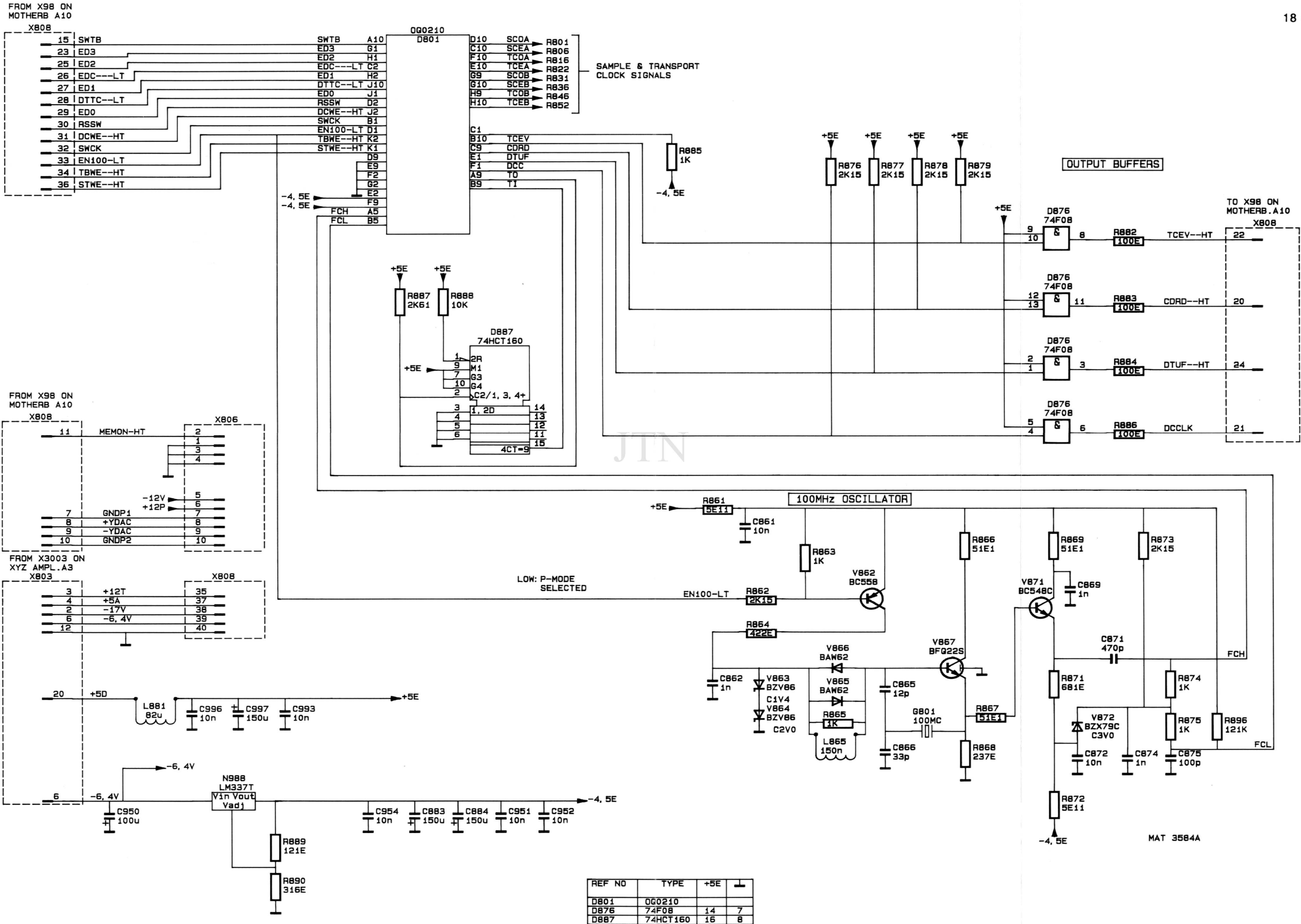

Figure 18.10 Circuit diagram of P²CCD: ACE

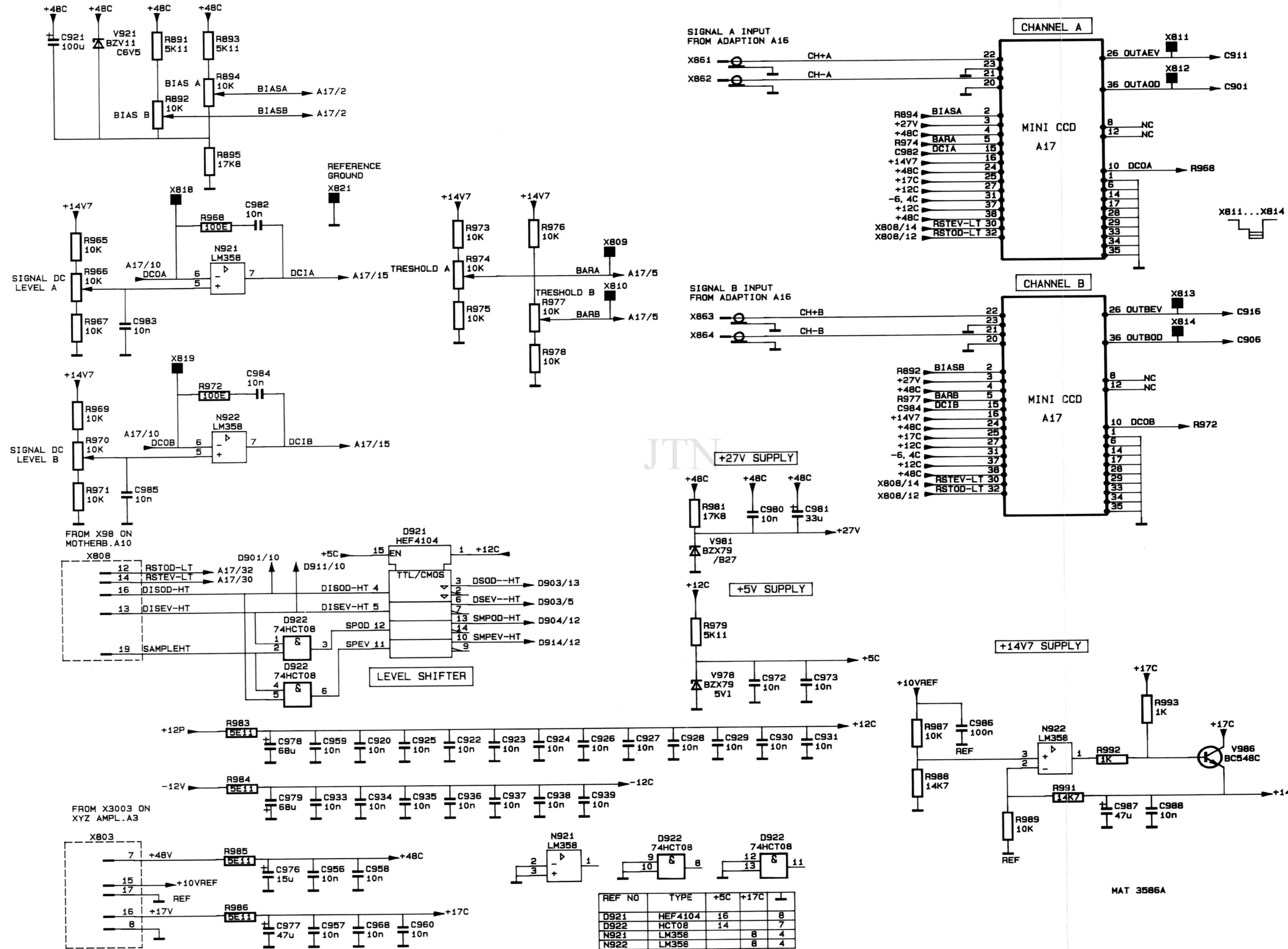

Figure 18.14 Circuit diagram of P²CCD: part 3

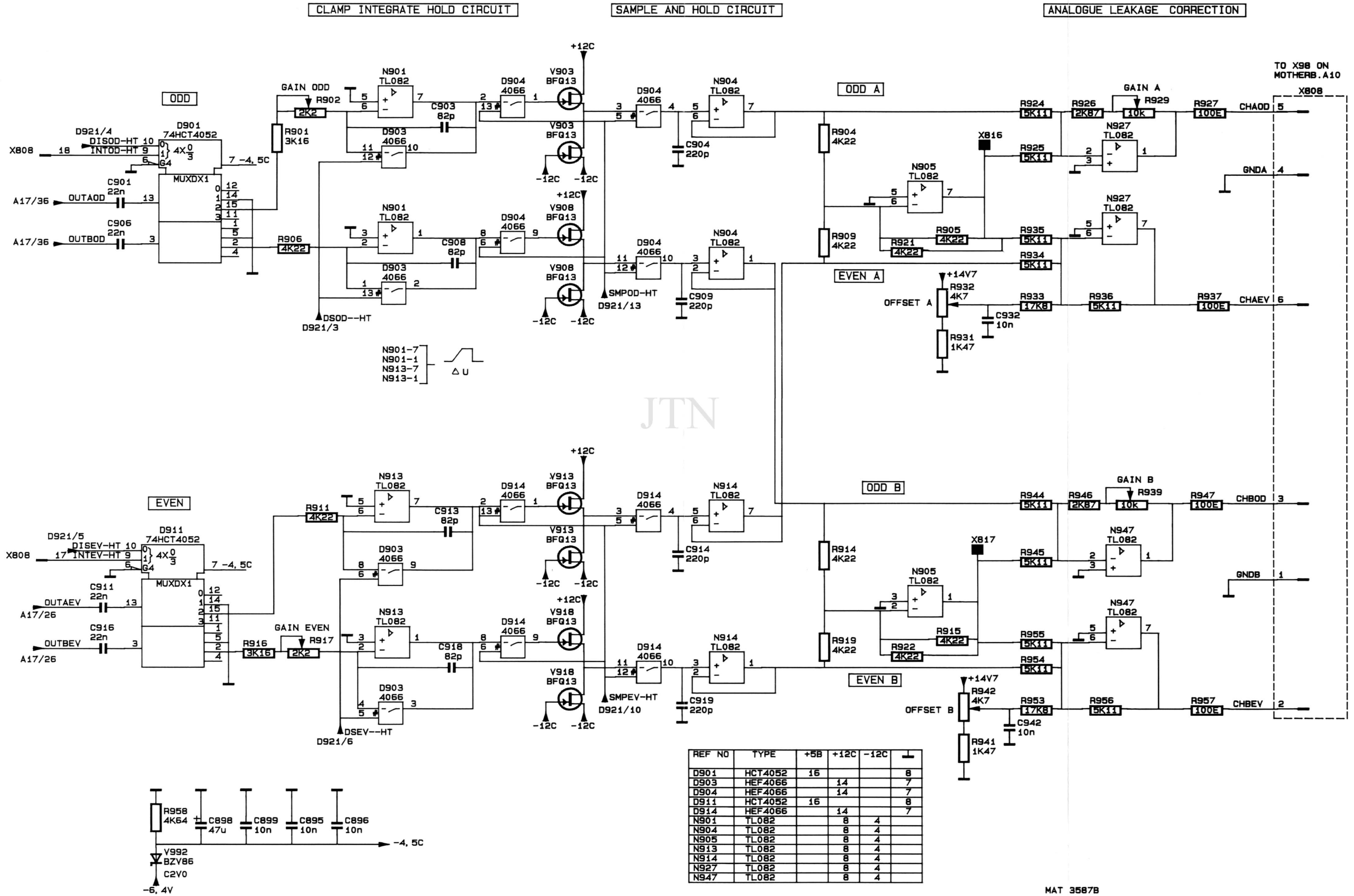

Figure 18.16 Circuit diagram of P²CCD: CIH circuit

P²CCD UNIT (A18) - PM3375/77 ONLY!

JIN

19 P²CCD UNIT (A18) - PM3375/77 ONLY!

The P²CCD unit consists of:

- The P²CCDs with associated circuits
- The ACE (Advanced Customised ECL) device with associated circuit
- The clock drivers circuits
- The CCD default circuits
- The P²CCD output circuit

19.1 P²CCDs

19.1.1 Introduction

The P²CCD (Profiled Peristaltic Charge Coupled Device) - OQ0204 - which is basically an analog shift register, consists of an ODD-side and an EVEN-side. Each side consists of a sample gate, 256 stages through which the samples can be shifted, and an output gate (see figure 19.1).

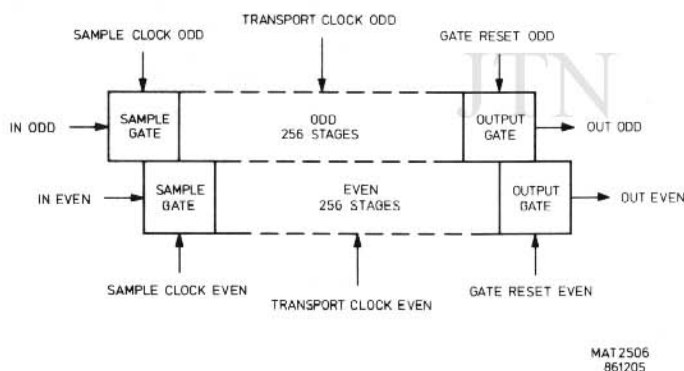

Figure 19.1 Schematic diagram of a P²CCD circuit

The clock signals of the ODD and the EVEN side are always in anti-phase (see figure 19.2).

- On the rising edge of the sample clock, a sample of the input signal is taken.
- On the falling edge of the sample clock, this sample is shifted to the first stage
- On the falling edge of the transport clock, all samples in all stages are shifted (transferred) one stage. The last sample is transferred to the output stage. The output stage is enabled when the gate reset signal is 0 V.

The P²CCD circuit applies the samples to the Clamp, Integrate and Hold circuit (CIH circuit), which takes over the samples. Then the gate reset signal is +12 V again, which resets the output capacitor.

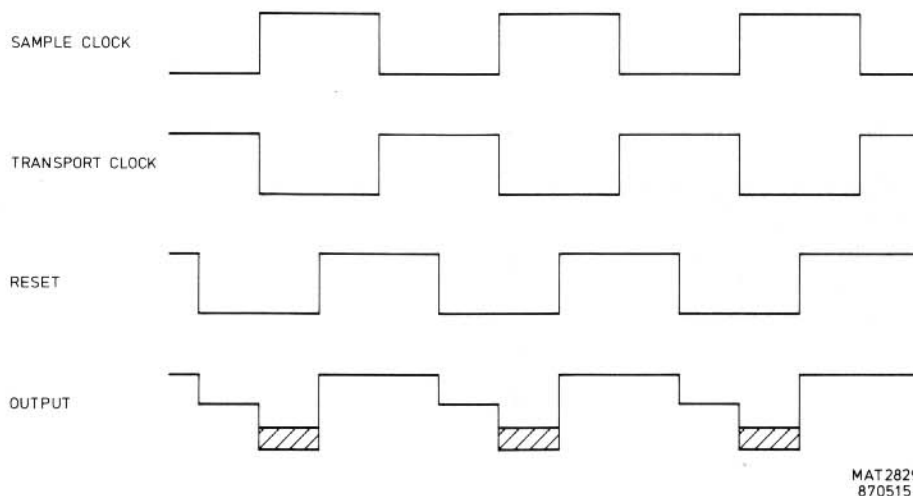

Figure 19.2 Sample and transport sequence

19.1.2 Input buffer

The differential input current with a sensitivity of $100 \mu\text{A}/\text{DIV}$ is received via 50Ω cables from adaptation unit A16. This current is buffered by common-base amplifiers V5504 and V5503 and then applied to the shunt feedback amplifiers V5506 and V5507. This stage converts the input current into the voltages CH + AA and CH-AA which serves as the input voltage for the P²CCD. The d.c. level of these signals is controlled by pot.meter R5527.

19.1.3 P²CCD - OQ0204

The P²CCD circuit OQ0204 has the following pin connectors.

Pin	Name	Description
1	INE	Same signal as SAMPLE CLOCK EVEN but d.c. shifted. The bias value of this signal can be varied by potentiometer R5604 for ch. A or R5602 for ch. B.
2	G1E	d.c. barrier voltage level. This d.c. value can be varied by potentiometer R5608 for ch. A or R5708 for ch. B.
3	G2E	Input signal, even. The input signal can be varied by potentiometer R5527 for ch. A or R5577 for ch. B.
4	G3E	SAMPLE CLOCK EVEN, takes samples of the input signal.
5	G4E	Same signal as SAMPLE CLOCK EVEN but d.c. shifted.
6	CL1IN	TRANSPORT CLOCK EVEN, transfers the samples in all 256 even stages one stage further.
7	CL2IN	Same signal as TRANSPORT CLOCK EVEN but time shifted
8	SUB	Default value of -3,9 V approx.
9	CL20	n.c.

Pin	Name	Description
10	CL10	n.c.
11	GSP	GATE SEPARATION. Default value of +3,0 V approx.
12	OUT EVEN	Output signal even.
13	DRSE	DRAIN RESET EVEN. Default value of +19,2 V approx.
14	GRE	GATE RESET EVEN signal. When 0 V, the even output is enabled, when +12 V, the even output is disabled.
15	GRO	GATE RESET ODD signal. When 0 V, the odd output is enabled, when +12 V, the odd output is disabled.
16	DRSO	DRAIN RESET ODD. Default value of +19,2 approx.
17	OUT ODD	Output signal odd.
18	DSFS	Supply voltage of +25 V.
19	CL30	n.c.
20	CL40	n.c.
21	SUB	Default value of -3,9 V approx.
22	CL4IN	Same signal as TRANSPORT CLOCK ODD but time shifted.
23	CL3IN	TRANSPORT CLOCK ODD, transfers the samples in all 256 odd stages one stage further.
24	G40	Same signal as SAMPLE CLOCK ODD but d.c. shifted.
25	G30	SAMPLE CLOCK ODD, takes samples of the input signal.
26	G20	Input voltage, odd. The input signal can be varied by potentiometer R5527 for ch. A or R5577 for ch. B.
27	G10	d.c. barrier voltage level. This d.c. value can be varied by potentiometer R5608 for ch. A or R5708 for ch. B.
28	INO	Same signal as SAMPLE CLOCK ODD but d.c. shifted. The bias value of this signal can be varied by potentiometer R5604 for ch. A or R5602 for ch. B.

The output signals are buffered by emitter-followers V5672 (V5772) for EVEN and V5671 (V5771) for ODD.

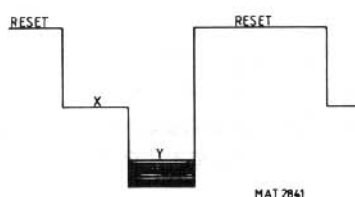

Figure 19.3 Output signal

While the output stage of the P²CCD is reset by the GRE signal (for even samples, or GRO for odd samples) its output voltage is about 19,2 V. This voltage is determined by a resistor divider network at the DRSE input (pin 13 of the P²CCD).

When the RESET is removed, the output drops to an undefined level X. On the falling edge of the transport clock, the sample leaves the output stage of the P²CCD. Now the output voltage drops to level Y. The voltage difference between level X and level Y represents the value of the sample.

This voltage difference is detected by the input of the CIH circuit (see section 19.5).

The following table gives a list of sample clock frequencies and the slower read-out frequencies for all time-base positions (P = P²CCD mode, D = Direct mode, R = Roll mode).

TIME/DIV	mode	sample clock freq.	read-out freq.
0,2 μ s	P	125 MHz	50 kHz
0,5 μ s	P	50 MHz	50 kHz
1 μ s	P	25 MHz	50 kHz
2 μ s	P	12,5 MHz	50 kHz
5 μ s	P	5 MHz	50 kHz
10 μ s	P	2,5 MHz	50 kHz
20 μ s	P	1,25 MHz	50 kHz
50 μ s	P	500 kHz	50 kHz
0,1 ms	P	250 kHz	50 kHz
0,2 ms	P	125 kHz	50 kHz
0,5 ms	D1	50 kHz	50 kHz
1 ms	D1	50 kHz	50 kHz
2 ms	D1	50 kHz	50 kHz
5 ms	D2	40 kHz	40 kHz
10 ms	D2	40 kHz	40 kHz
20 ms	D2	40 kHz	40 kHz
50 ms	D2	40 kHz	40 kHz
0,1 s	D2	40 kHz	40 kHz
0,2 s	D2	40 kHz	40 kHz
0,5 s	D2	40 kHz	40 kHz
1 s	R	40 kHz	40 kHz
2 s	R	40 kHz	40 kHz
5 s	R	40 kHz	40 kHz
10 s	R	40 kHz	40 kHz
20 s	R	40 kHz	40 kHz
50 s	R	40 kHz	40 kHz

Note: In P and D1 mode (time-base settings: 0,2 μ s/div...2 ms/div), the P²CCDs act as time converters: the read-in frequency is higher than the read-out frequency. In D2 and R mode (time-base settings: 5 ms/div...0,5s/div), the P²CCDs act as analog shift registers: the read-in frequency is the same as the read-out frequency. The P²CCD is not used for the sampling mode, c.i. TIME/DIV positions 0,1 μ s ... 20 ns.

19.2 ACE (ADVANCED CUSTOMISED ECL)

The CCD logic and fast time-base divider are integrated in an ECL-GATE-ARRAY D801. It contains various fast dividers to generate the sample and transport clock from the FCH and FCL signals in P-mode. It also contains the logic for the change over to the slow clock (SWCK) for the read out stroke in P-mode. In the Direct mode the sample and transport clocks are derived from SWTB.

In D-mode, the sample and transport clock has a clock-frequency of 50 kHz (D1 mode) or 40 kHz (D2 mode). These frequencies are derived from signal SWCK (100 kHz in D1 mode and 80 kHz in D2 mode).

In P-mode the delay counter indicates the moment when the P²CCD is read. The delay counter consists of a 4-bit presetable counter internal in the ECL-GATE-ARRAY and a 16-bit external counter D441 .. D446 (on unit A14).

The output lines are at ECL level (-0,9 V...-1,7 V).

The output signals TCEV, CDRD, DTUF and DCC are buffered and converted into a TTL level.

19.3 FAST CLOCK OSCILLATORS

The digital time-base generator in P-mode is driven by a 100 MHz or 125 MHz crystal oscillator. The 100 MHz oscillator is active in the time-base settings 0,2 ms ... 0,5 μ s, the 125 MHz oscillator is only active in time-base setting 0,2 μ s. The oscillators can be switched-on and -off by the signals EN100-LT and EN125-LT. Since both oscillators are identical, only the 100 MHz oscillator is described.

When EN100-LT is low, V5101 and thus zener V5102 are conducting. This causes a d.c. level of 3,6 V on the base of V5104 so that crystal G5101 starts to oscillate. The 100 MHz resonance circuit around this crystal is formed by L5101, C5103 and C5104. This signal is applied to the input of the frequency doubler.

The input transistor, V5121, is set in class C, so the 100 MHz (or 125 MHz) signal is distorted. The second harmonic is then filtered. This is done by the circuit formed by L5121 and C5123...5128. Note that trimmer C5128 is only in circuit when EN100-LT is low (200 MHz). Finally, the filtered signal with a frequency of 200 MHz or 250 MHz is buffered by V5131 and V5132 and applied to the ACE. The amplitude of this signal is 1 V(p-p). To keep the output amplitude constant, this signal is fed-back to the input of the frequency doubler via N5101.

19.4 CLOCK DRIVERS

Each SAMPLE AND TRANSPORT clock driver consists of two transistors with a current source. To increase the bandwidth of the signal, a coil is added between the collector and the gate capacitance of the PCCD; all clock drivers are buffered by a bridged T-network. For timing reasons in the transport gates, TCEAM2 and TCEOAM2 has to be delayed to transport clocks TCEAM1 and TCOAM1. This is done by using a 2 ns delay network (LC circuit) which is a part of the pcb.

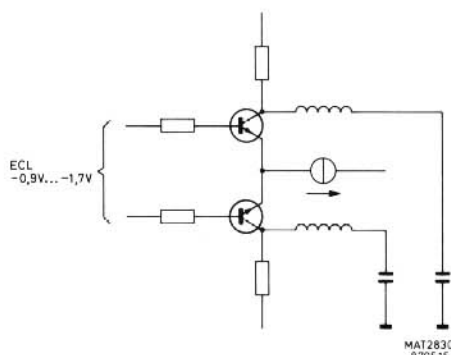

Figure 19.4 Principle of the sample clock drivers

The inputs are at ECL level (-0,9 V...-1,7 V) and are derived from the ACE. These are converted into a 0 ... 9 V signal for the sample clock drivers or 0...6 V signal for the transport clock drivers.

19.5 P²CCD OUTPUT

19.5.1 Level shifter

The level shifter D921 converts the TTL signals DISOD-HT, DISEV-HT, SPOD and SPEV into the same signals but at CMOS level (signal between 0... +12 V). The sample signal SAMPLEHT is split up into a sample Odd or sample Even signal by D922.

19.5.2 Clamp Intergrate Hold circuit

The P²CCD output circuit consists of 4 CIH (Clamp Intergrate Hold) circuits, followed by the analog leakage correction.

Since channel A and B are identical (and the even and odd side of each channel are identical) only channel A odd side of the CIH is described.

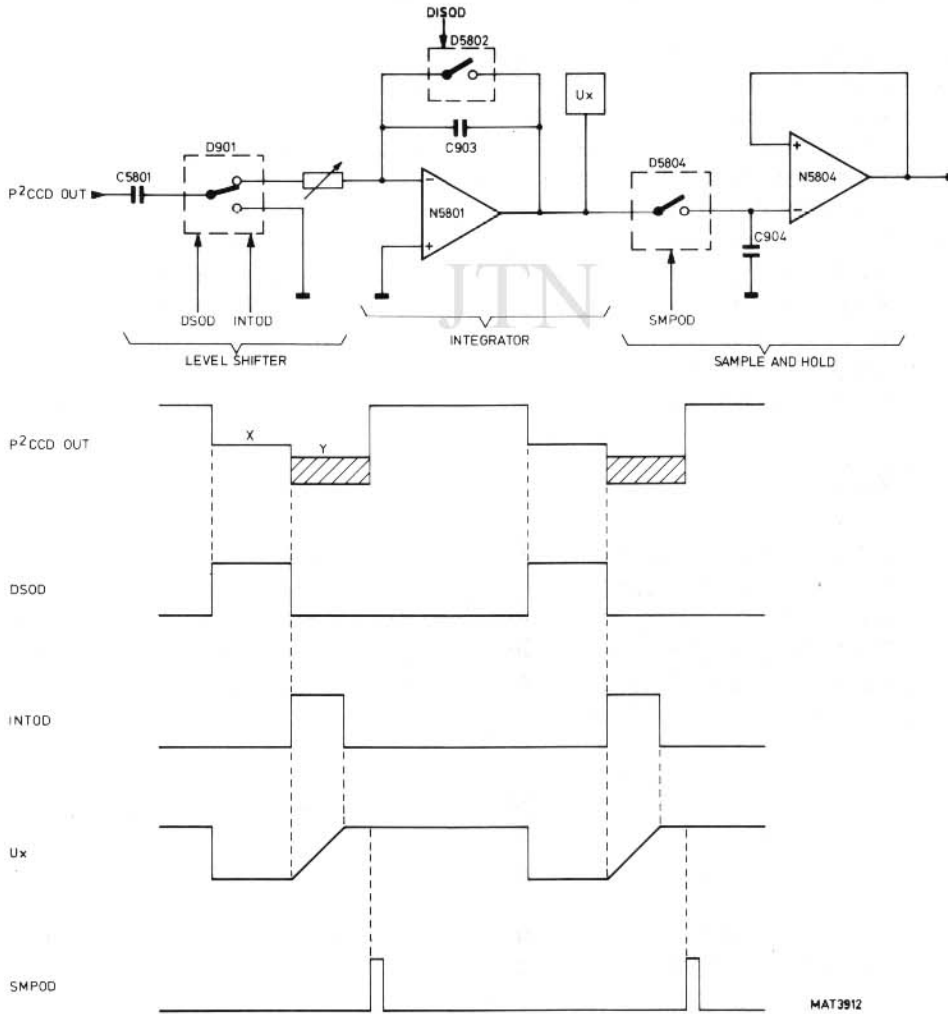

Figure 19.5 CIH circuit

The CIH receives its signal from the P²CCD.

The first stage is multiplexer D901, which serves as a level shifter. D901 detects the voltage difference between level X and Y which represents the value of the sample and sets the voltage reference level X to 0 V. When DSOD is high, capacitor C5801 is clamped to ground and charged to the voltage X. Then, when INTOD is high, capacitor C5801 passes this d.c. sample voltage Y-X to the next stage.

The second stage, integrator N5801 has two functions: it filters and amplifies the sample voltage. During the time that INTOD is high the sample voltage is present and the output of N5801 is rising linearly. Then when INTOD is low again, the output of N5801 gives a constant voltage. Next, when DISOD is high capacitor C5803 is short-circuited by D5803 and is discharged so that it is ready for a new cycle. The output of this stage is buffered by a dual FET V5803.

The third stage is the sample and hold circuit D5804. The constant output voltage of the previous stage charges the hold capacitor C5804 during the time that SMPOD is high. If SMPOD is low, the capacitor C5804 is isolated from the second stage and holds its charge; the output voltage of N5804 is now constant.

The outputs of the odd and even signals of ch. A (B) are applied to the analog leakage correction.

19.5.3 Analog leakage correction

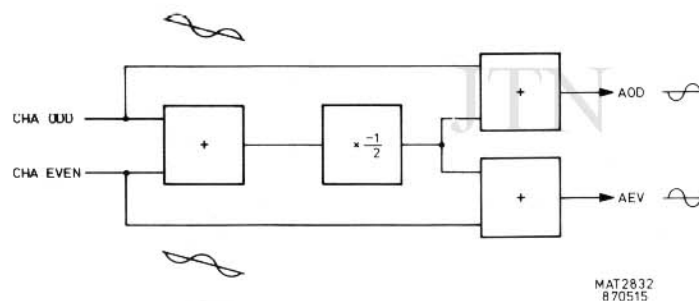

Figure 19.6 Analog leakage correction

The two samples CH.A ODD and CH.A EVEN contain the samples with a certain analog common leakage. The odd and even signals are in anti-phase while the leakage is in phase. The circuit can be split into three phases:

- Adding of both signals by R5804 and R5809. This results in a double leakage signal on N5827-2.
- Amplification by $-1/2$ by N5827. The result is a pure leakage signal on N5827-1.
- Adding the pure leakage signal to the ch. A odd (or: ch. A even) signal by N5847 (N5827). This results in the CHAOD and CHAEV signals.

In this way, the final samples CHAOD and CHAEV are corrected for leakage. These samples are applied to the ADC circuit on unit A15.

19.6 SIGNAL NAME LIST

Signal name	Description	Signal source	Signal destination(s)
BARA	Barriär ch. A	R974	R760 - R770
BARA	Barriär ch. A	R974	R760 - R770
BARB	Barriär ch. B	R977	R760 - R770
BIASA	Bias voltage ch. A	R894	N701
BIASB	Bias voltage ch. B	R892	N701
CDRD-HT	CCD read	R883	D406 - D411
CH + A	Channel +A input	V616	R702
CH-A	Channel -A input	V617	R707
CH + B	Channel +B input	V622	R702
CH-B	Channel -B input	V621	R701
CHAOD	Channel A odd signal	R927	R501
CHAEV	Channel A even signal	R937	R502
CHBOD	Channel B odd signal	R947	R508
CHBEV	Channel B even signal	R957	R509
DCCLK	Delay counter clock	R886	D218
DCIA	DC level in ch. A	N921	R715
DCIB	DC level in ch. B	N922	R715
DCOA	DC level out ch. A	R717/718	R968
DCOB	DC level out ch. B	R717/718	R972
DCWE-HT	Delay counter write	D316	D801
DISEV-HT	Discharge even (5V)	R403	D921 - D922
DISOD-HT	Discharge odd (5V)	R404	D921 - D922
DSEV-HT	Discharge even (12V)	D921	D903
DSOD-HT	Discharge odd (12V)	D921	D903
DTTC-LT	Delay trigger terminal count	D218	D801
DTUF-HT	Delay trigger underflow	R884	D402
ED0...3	Buffered data bus	R413...417	D801
EDC--LT	Enable delay counter	R401	D221 - D801
EN100-LT	Enable P-mode/100 MHz	D313	D407 - D801 - D5202 R862 - R5128
EN125-LT	Enable P-mode/125 MHz	D313	D407 - D5202 - R5113
FCH	Fast clock high	R874	D801
FCL	Fast clock low	R875	D801
INTEV-HT	Integrate even	R411	D911
INTOD-HT	Integrate odd	R409	D901
OUTAEV	Output ch. A even	V736	D911
OUTAOD	Output ch A odd	V766	D901
OUTBEV	Output ch. A even	V736	D911
OUTBOD	Output ch. B odd	V766	D901
RSSW	Reset slow clock	R407	D801
RSTEV-LT	Reset even	R407	R751
RSTOD-LT	Reset odd	R406	R781
SAMPLEHT	Sample clock	R408	D922
SCEA	Sample clock even ch. A	D801	R806
SCEAM	Sample clock even ch. A	L806	D731
SCEB	Sample clock even ch. B	D801	R836
SCEBM	Sample clock even ch. B	L836	D731
SCOA	Sample clock odd ch. A	D801	R801
SCOAM	Sample clock odd ch. A	L801	D731
SCOB	Sample cleck odd ch. B	D801	R831
SCOBM	Sample clock odd ch. B	L831	D731

Signal name	Description	Signal source:	Signal destination(s):
SMPEV-HT	Sample even	D921	D914
SMPOD-HT	Sample odd	D921	D904
STWE-HT	Status write	D316	D801
SWCK	Slow clock	D412	D801
SWTB	Slow time base	D218	D801 - D412
TBWE-HT	Time base write	D316	D801
TCEA	Transport clock even ch. A	D801	R822
TCEAM	Transport clock even ch. A	L822	D731 - R747
TCEB	Transport clock even ch. B	D801	R852
TCEBM	Transport clock even ch. B	L852	D731 - R747
TCEV-LT	Transport clock even	R882	D401 - D408 - D411
TCOA	Transport clock odd ch. A	D801	R816
TCOAM	Transport clock odd ch. A	L816	D731 - R777
TCOB	Transport clock odd ch. B	D801	R846
TCOBM	Transport clock odd ch. B	L846	D731 - R777

JTN

A18

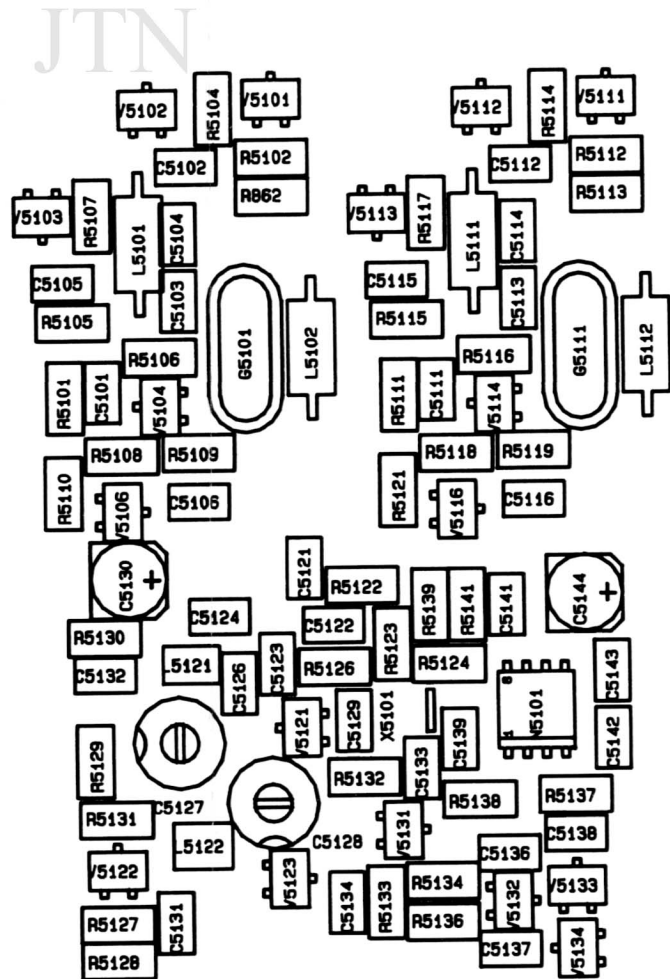
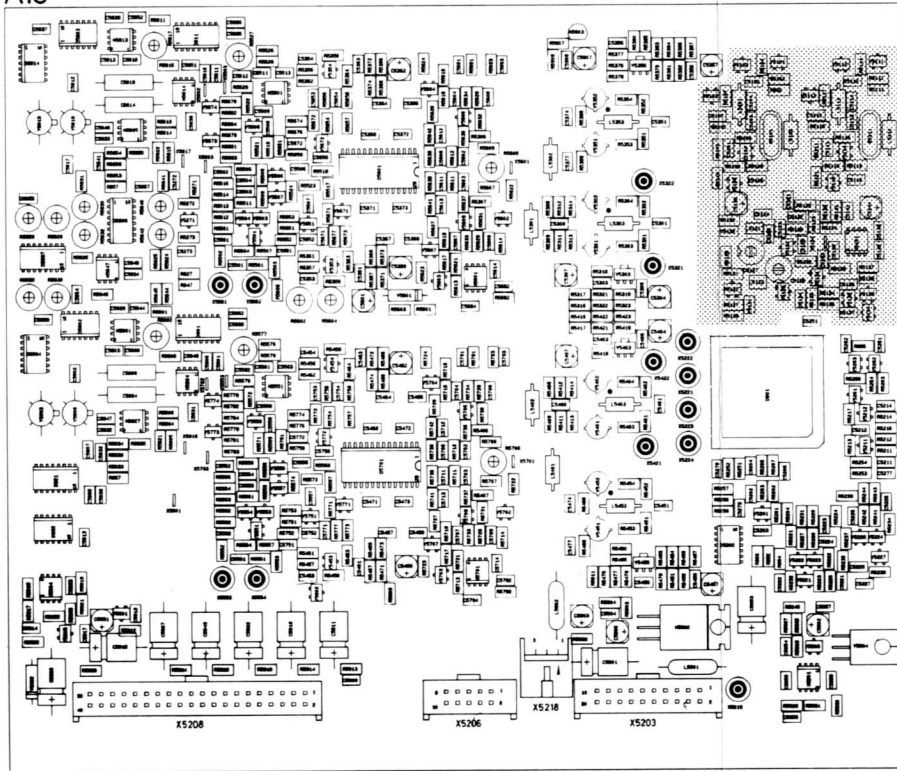
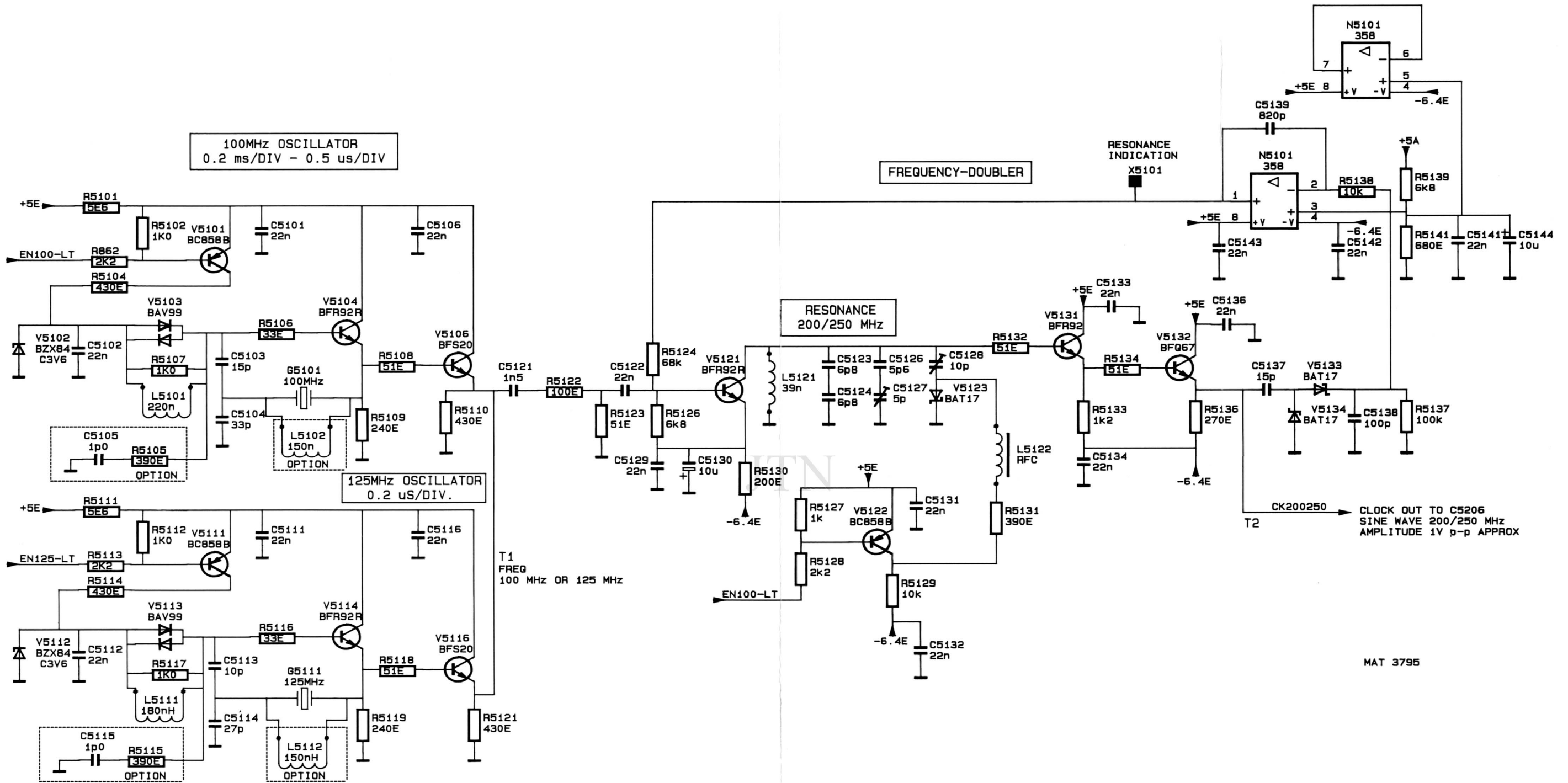

Figure 19.7 Part of P²CCD unit, part 1



MAT 3795

Figure 19-8 Circuit diagram of P²CCD, oscillator circuit

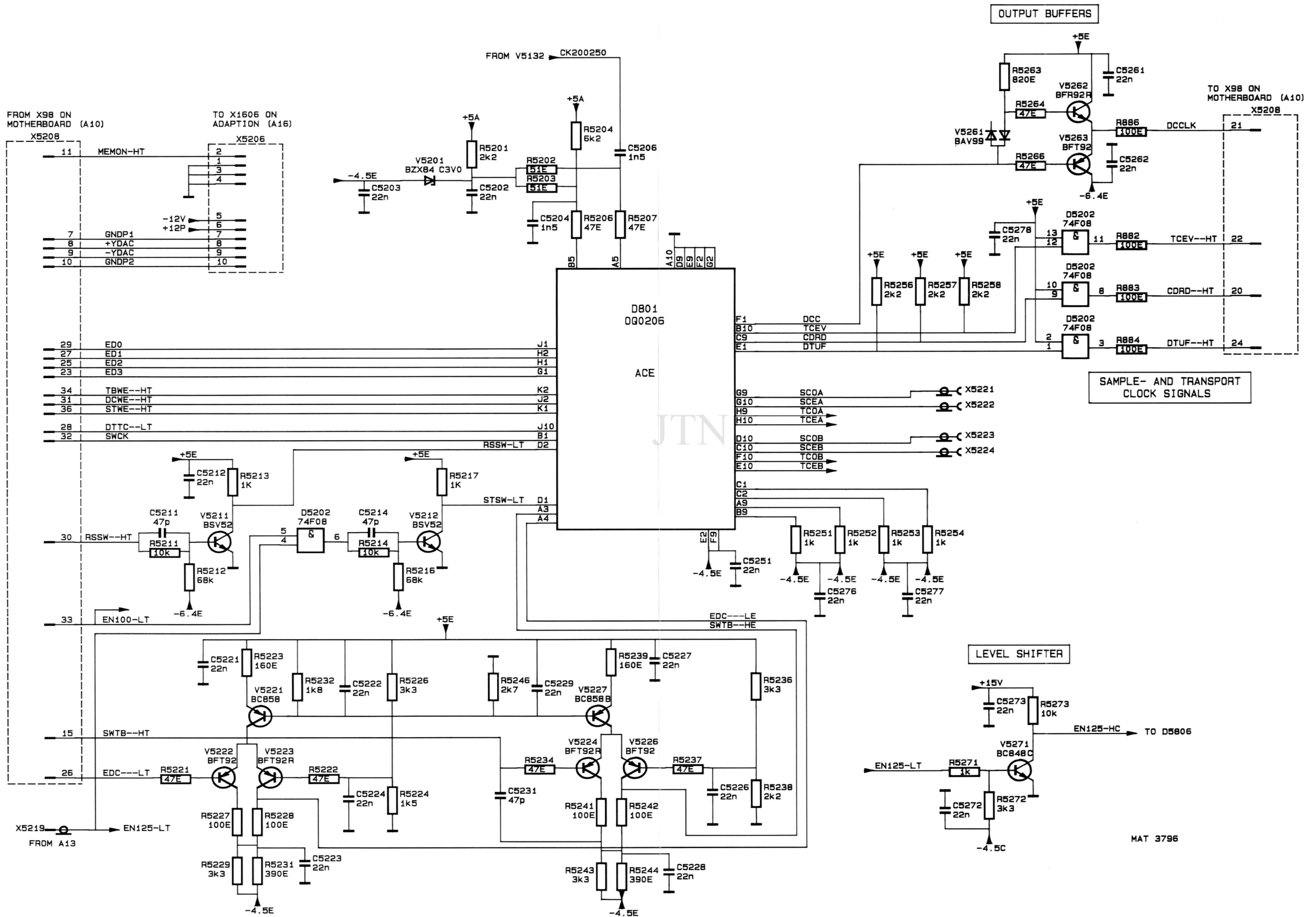
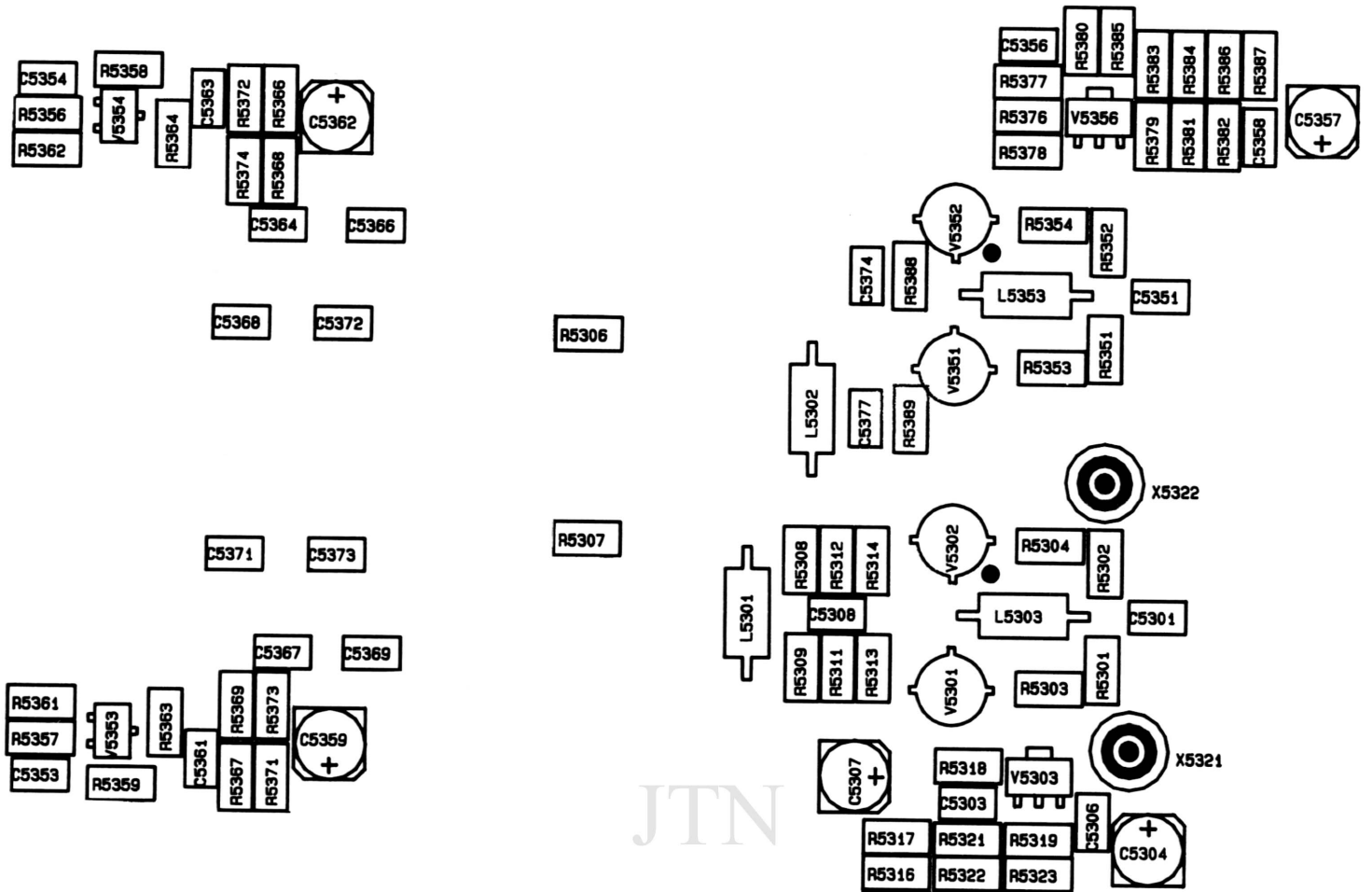

Figure 19.10 Circuit diagram of P²CCD, ACE

MAT 3796



JTN

A18

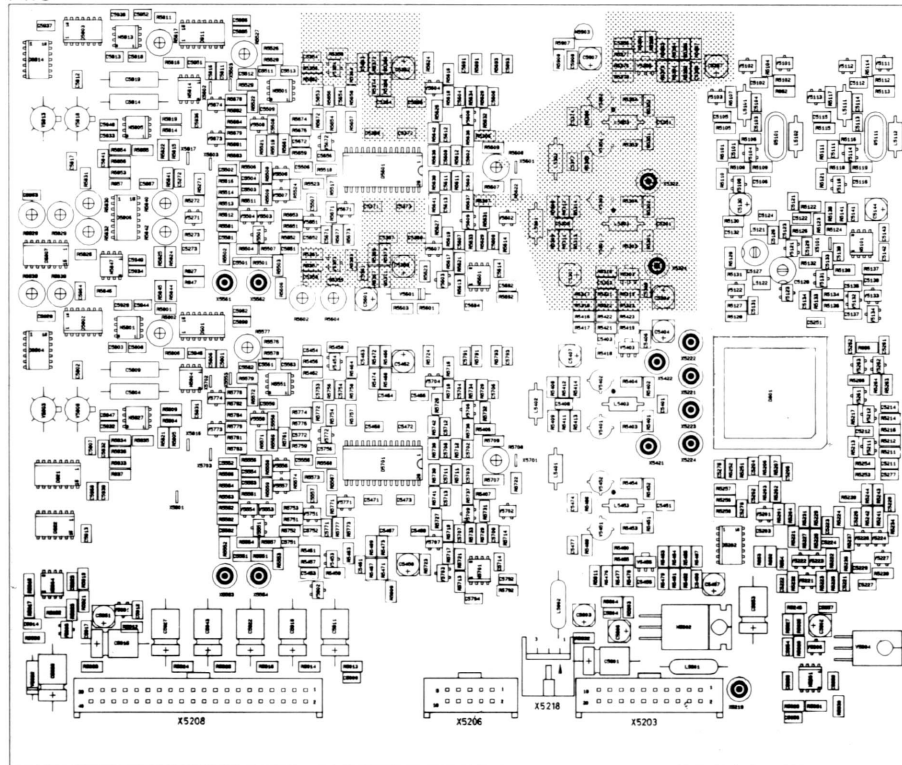

Figure 19.11 Part of P²CCD unit p.c.b., part 3

SAMPLE-DRIVER CHANNEL A

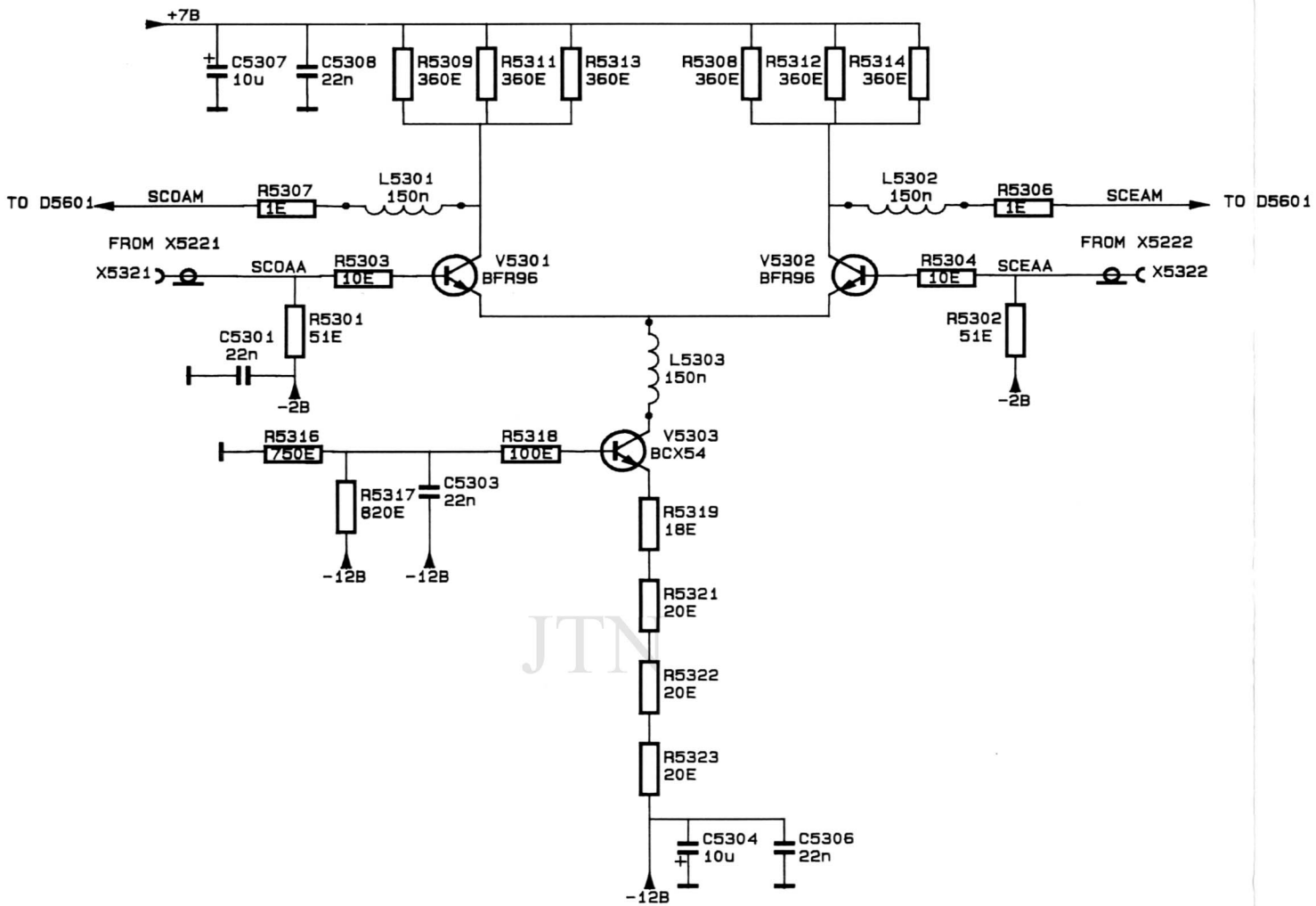
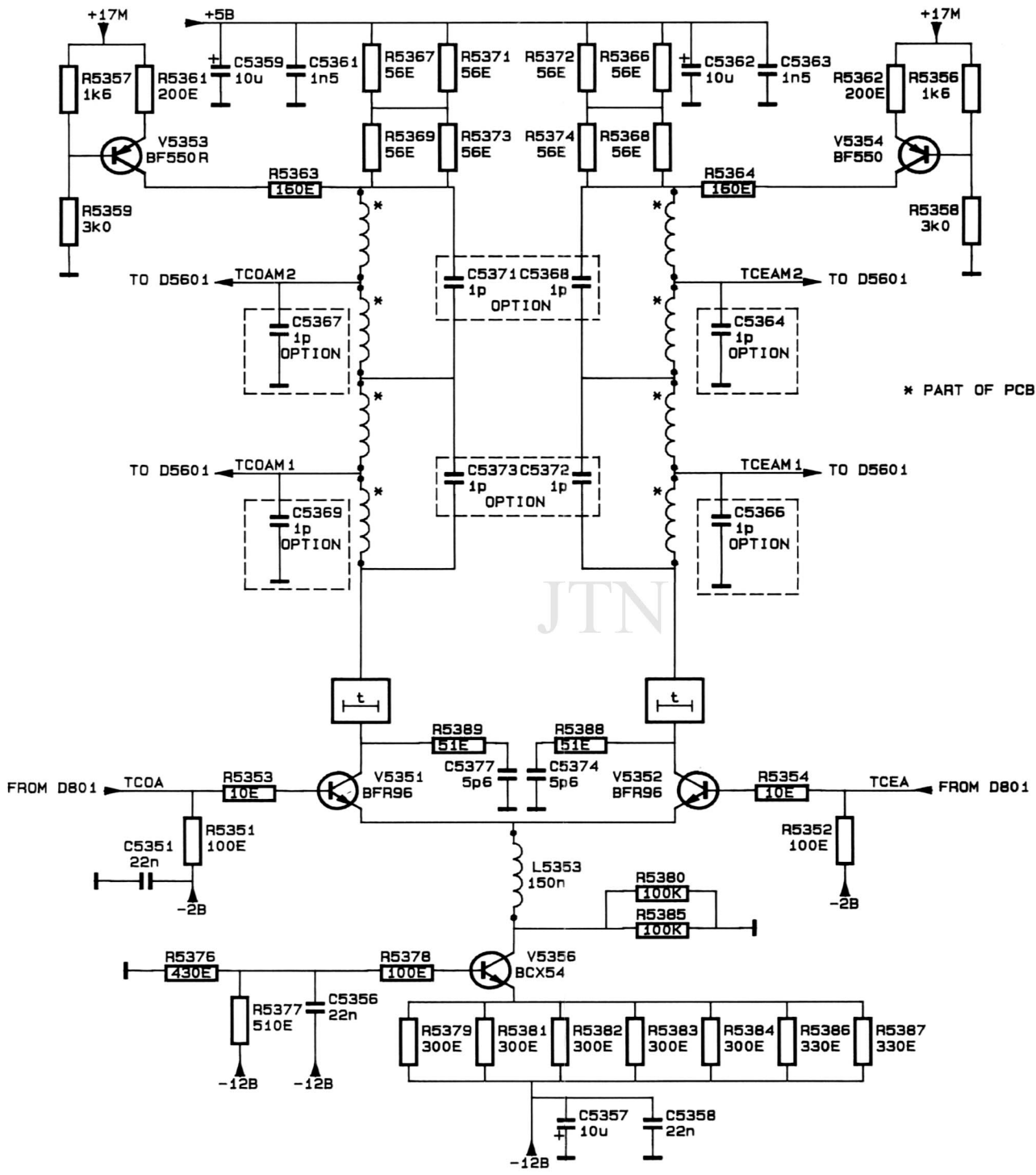

Figure 19-12 Circuit diagram of P²CCD, clock drivers channel A

TRANSPORT-DRIVER CHANNEL A



* PART OF PCB

A18

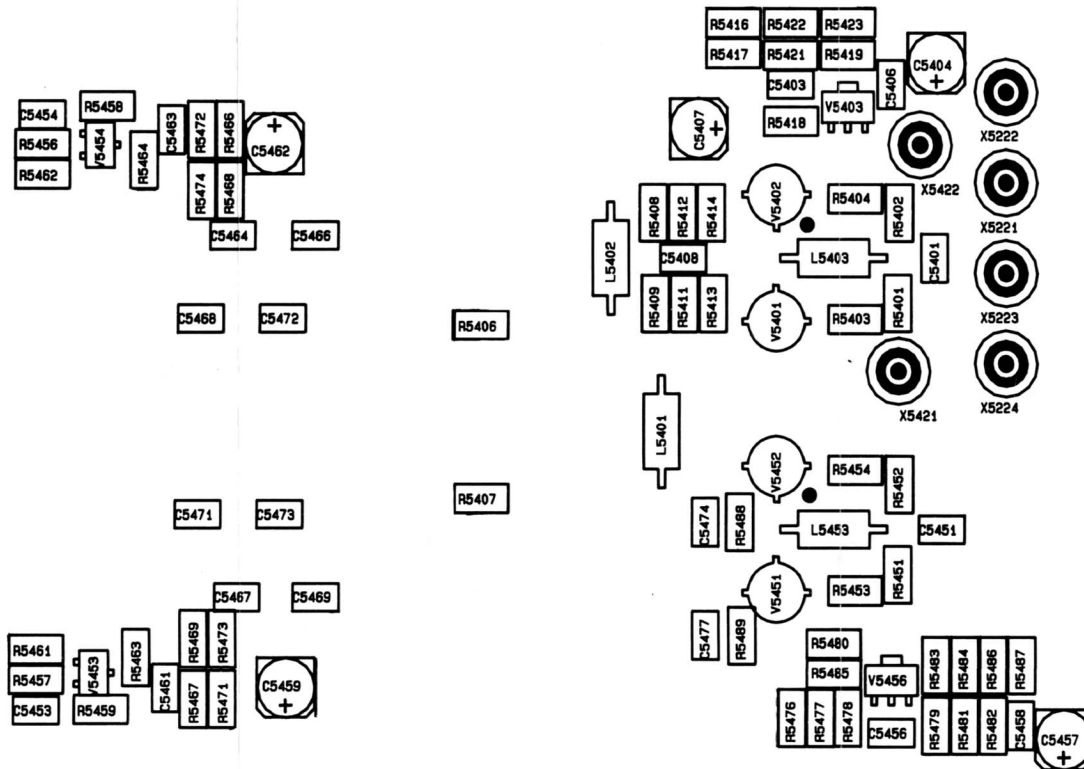
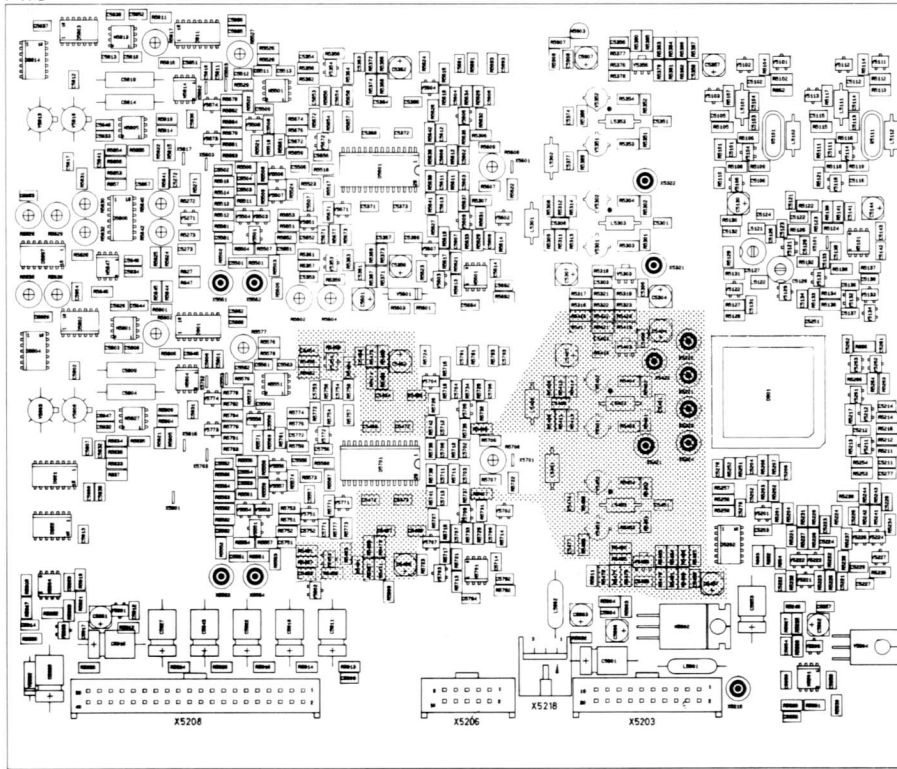

Figure 19.13 Part of P²CCD unit p.c.b., part 4

SAMPLE-DRIVER CHANNEL B

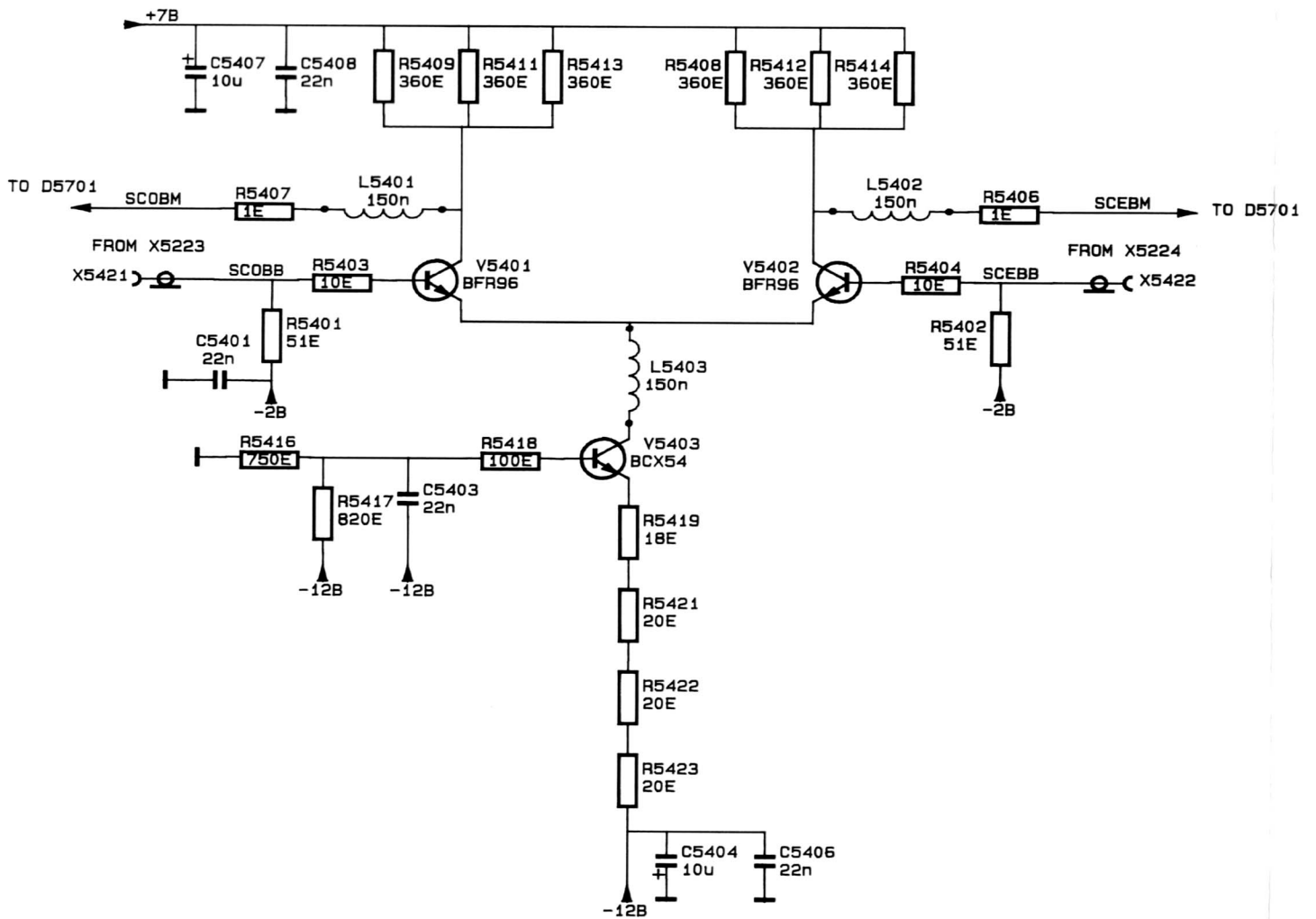
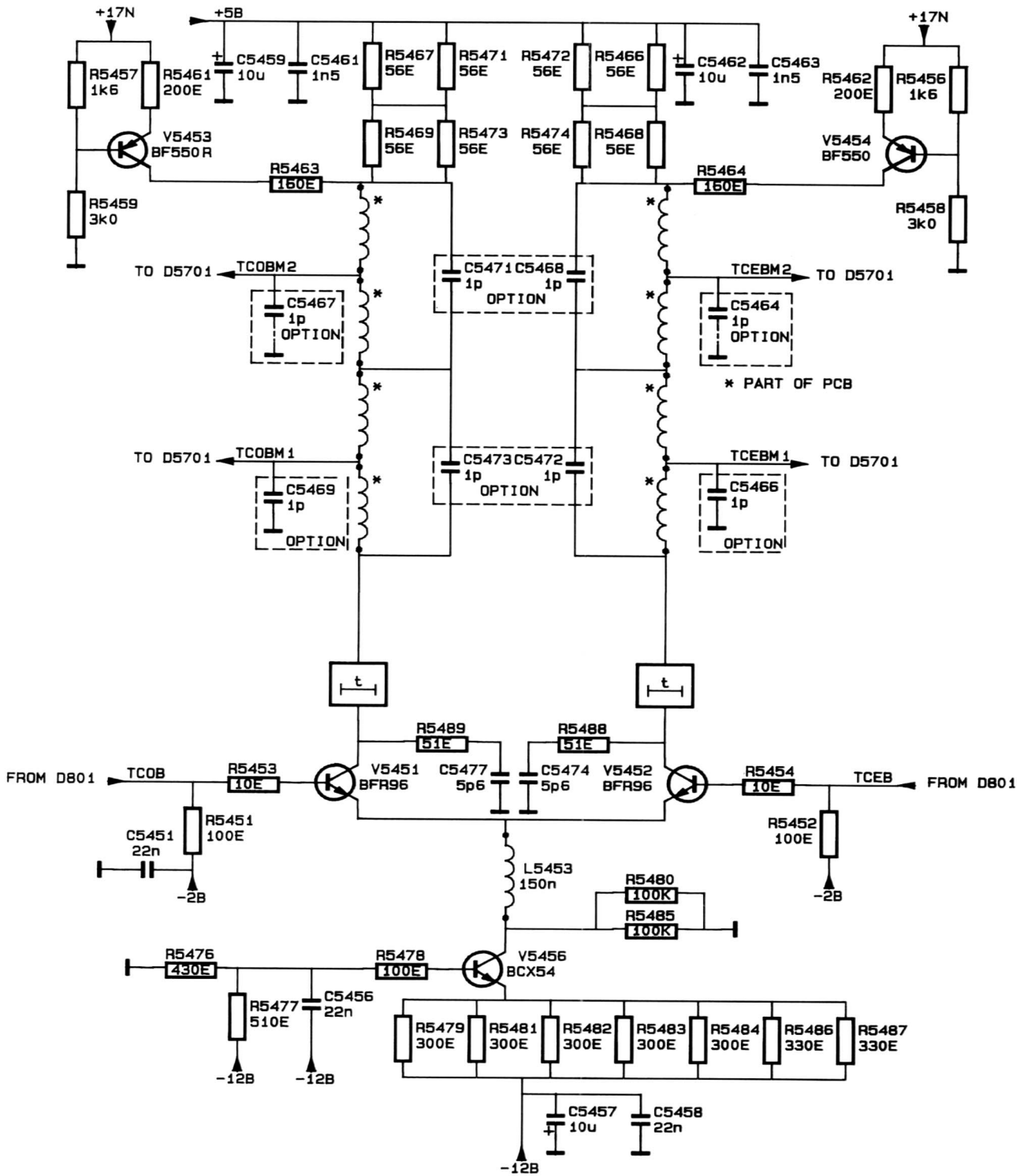
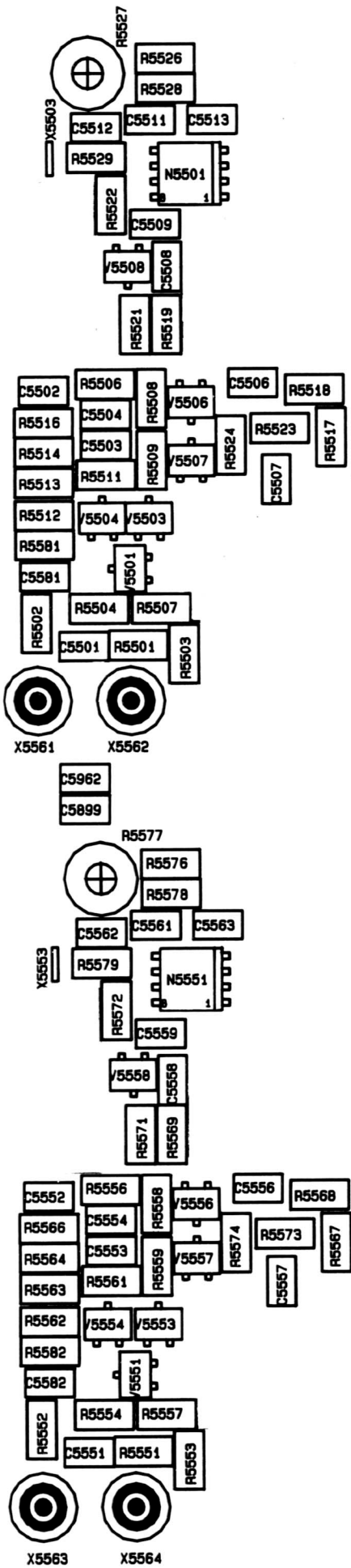

Figure 19.14 Circuit diagram of P²CCD, clock drivers channel B

TRANSPORT-DRIVER CHANNEL B





A18

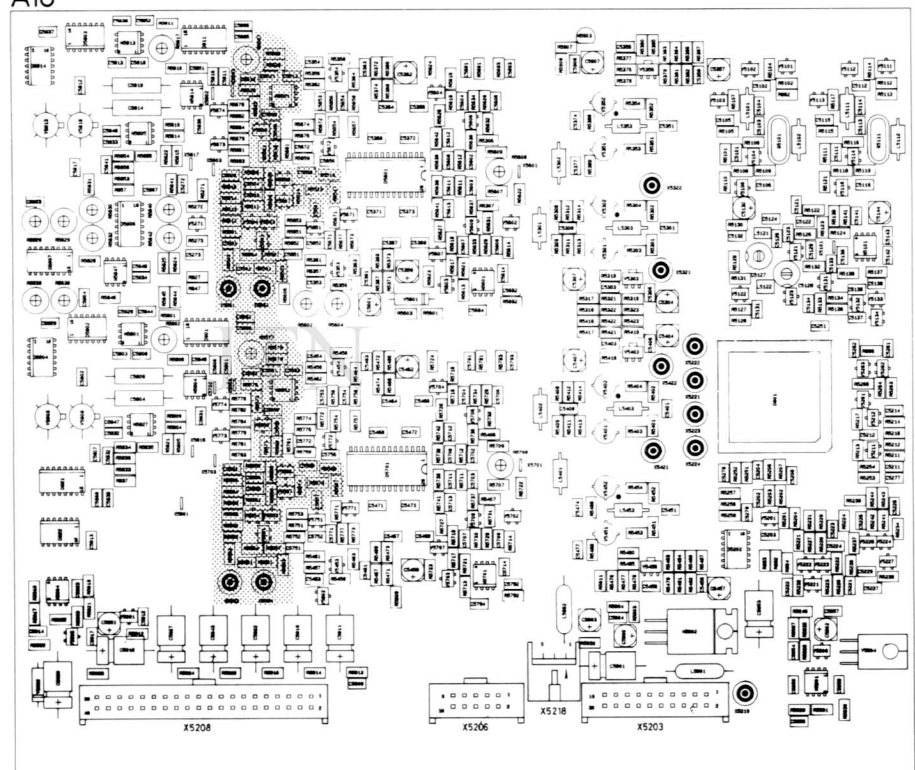

Figure 19.15 Part of P²CCD unit p.c.b., part 5

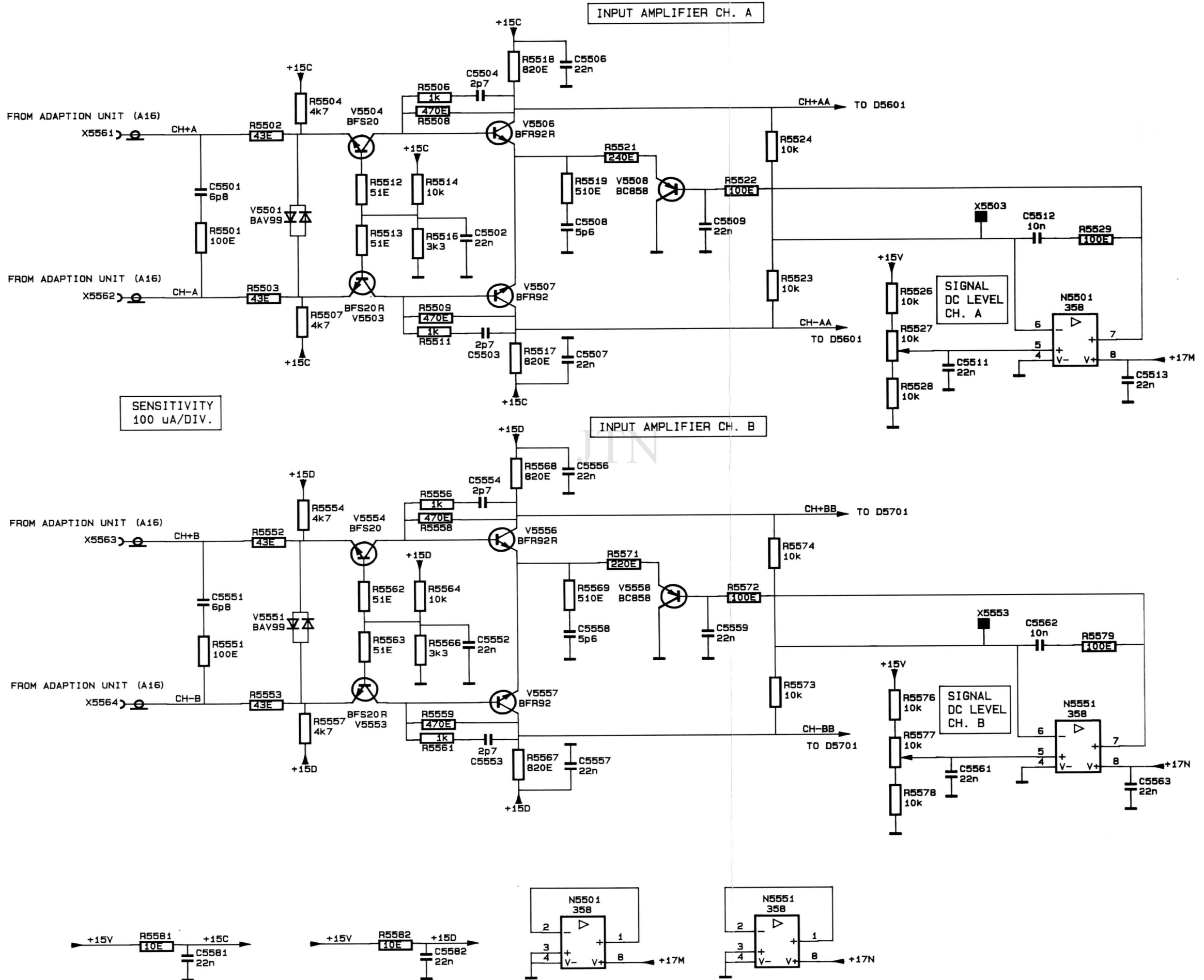
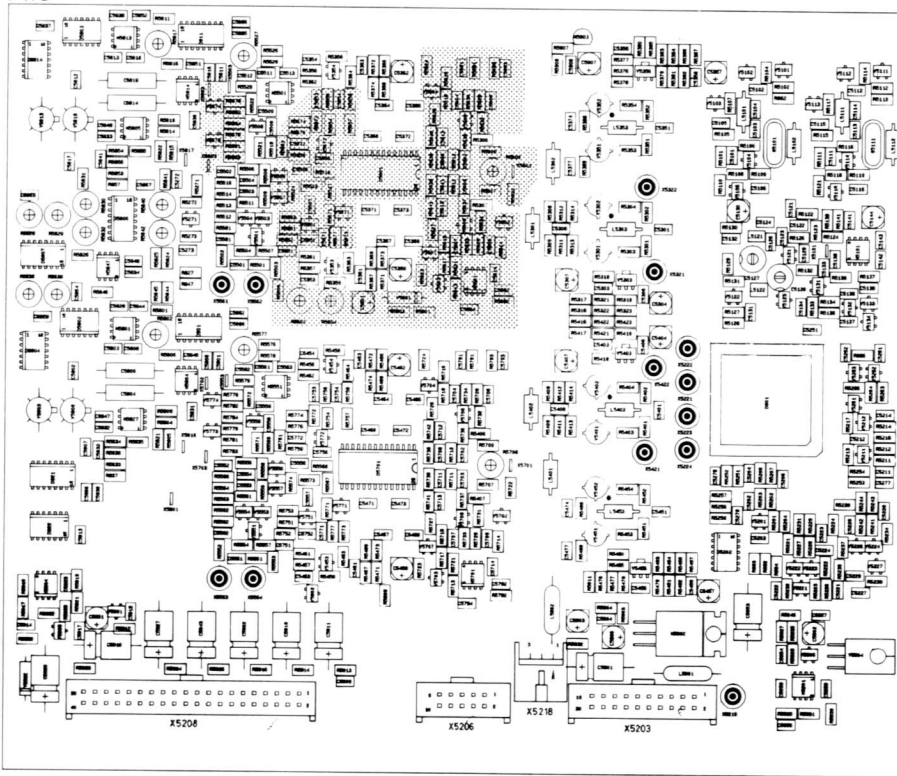

Figure 19.16 Circuit diagram of P²CCD, input amplifiers

A18



JTN

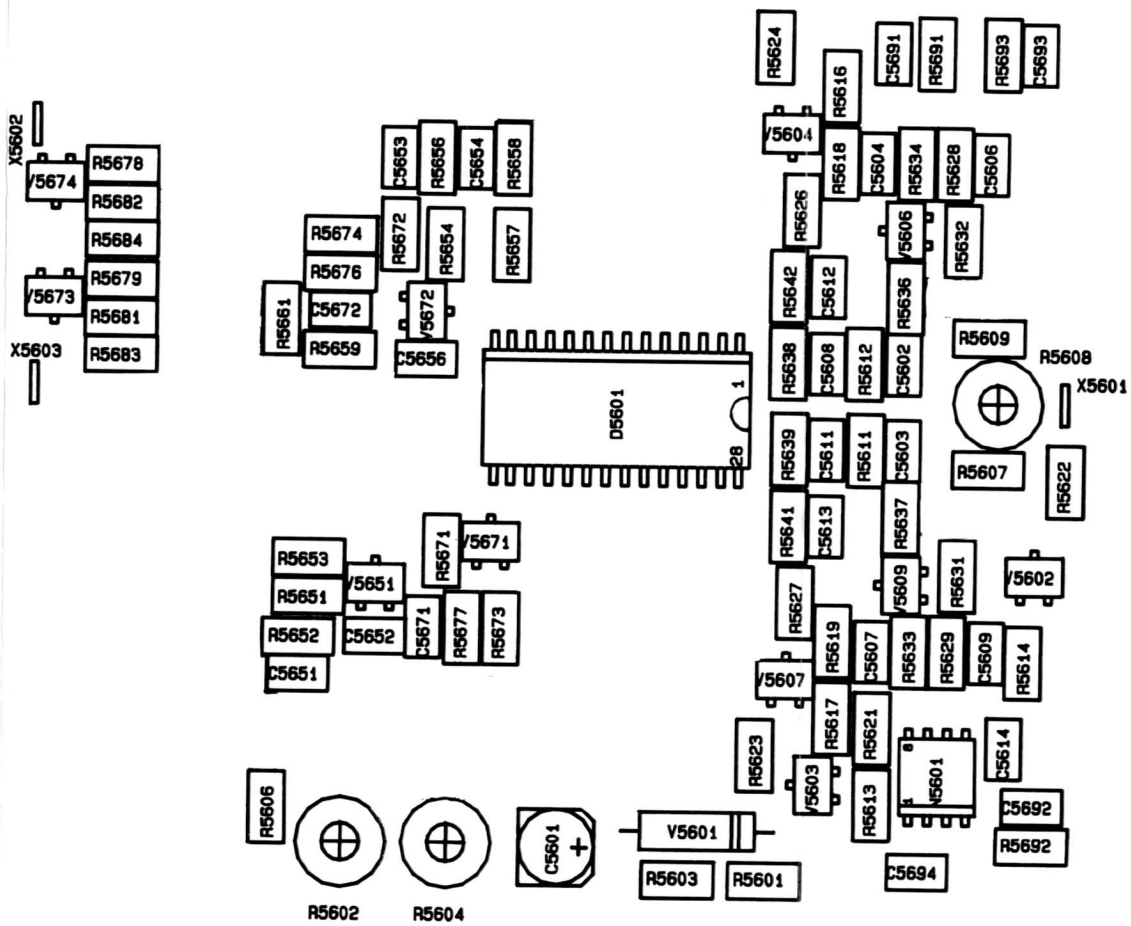

Figure 19.17 Part of P²CCD unit p.c.b., part 6

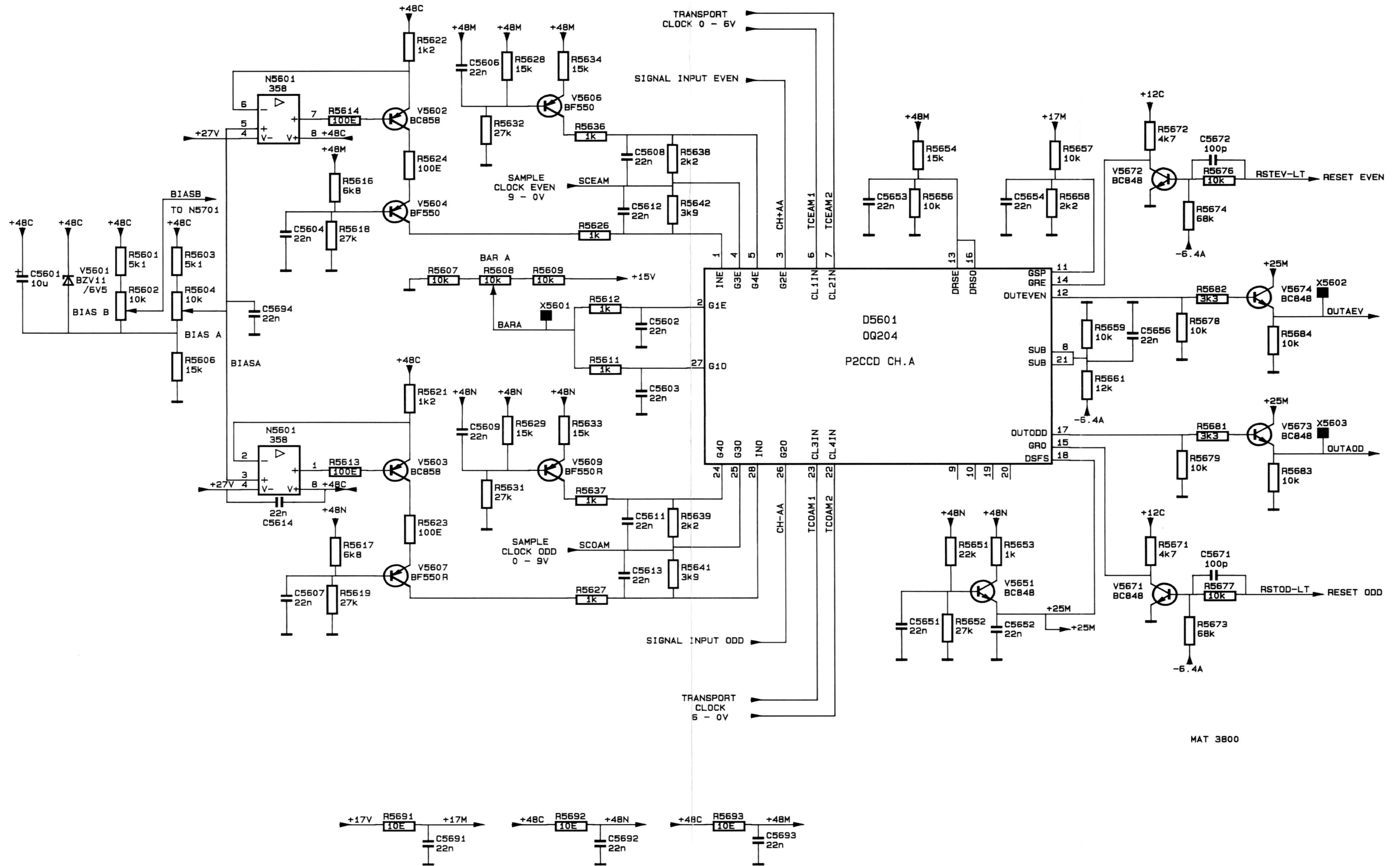

Figure 19.18 Circuit diagram of P²CCD, P²CCD channel A

A18

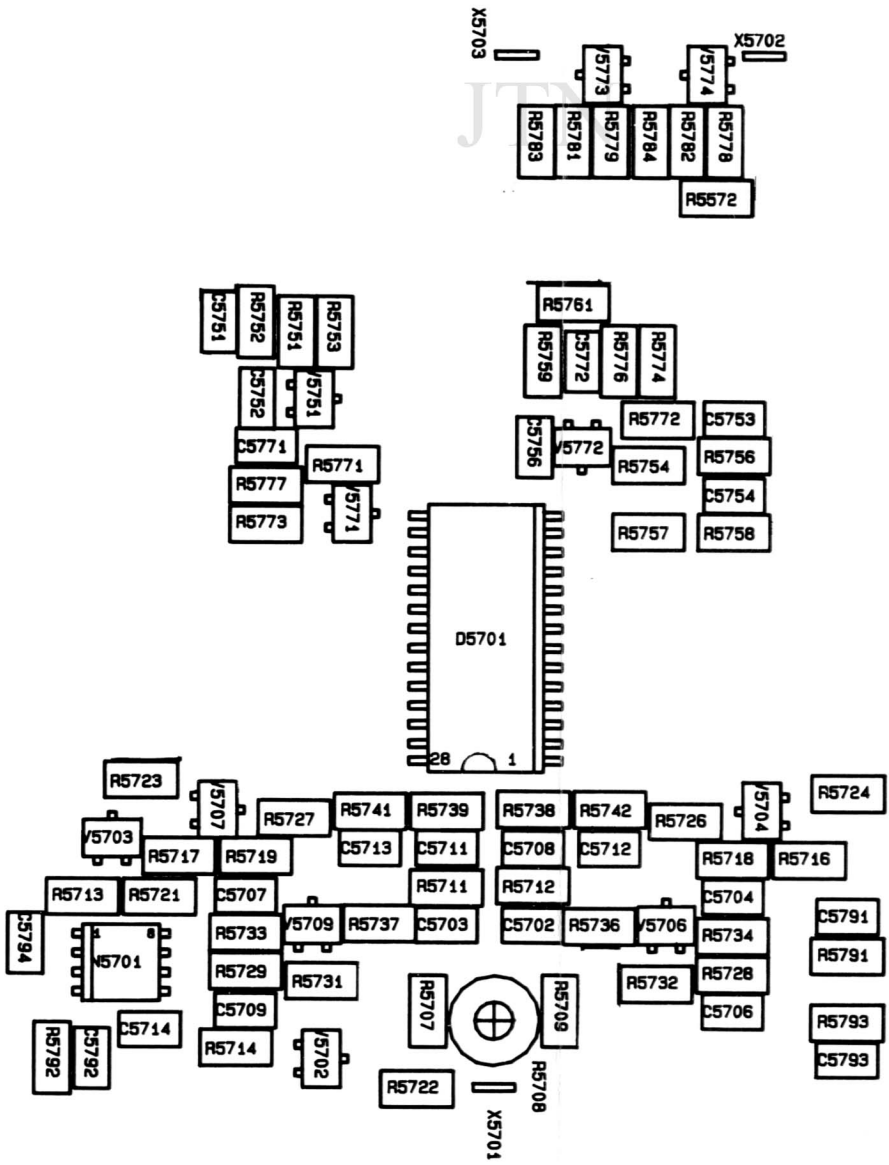
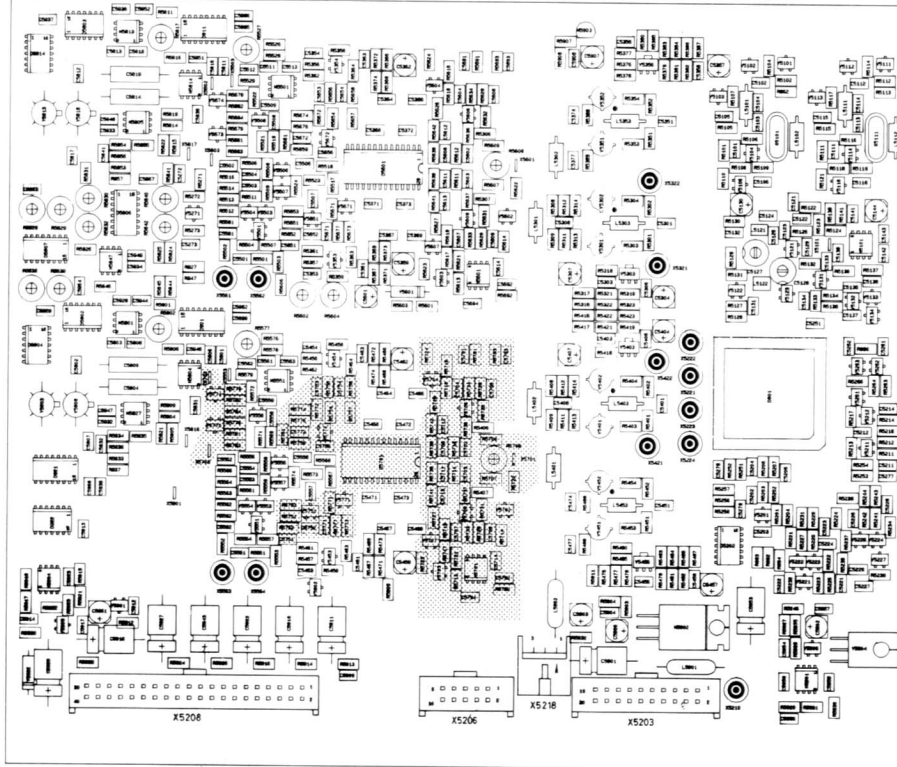
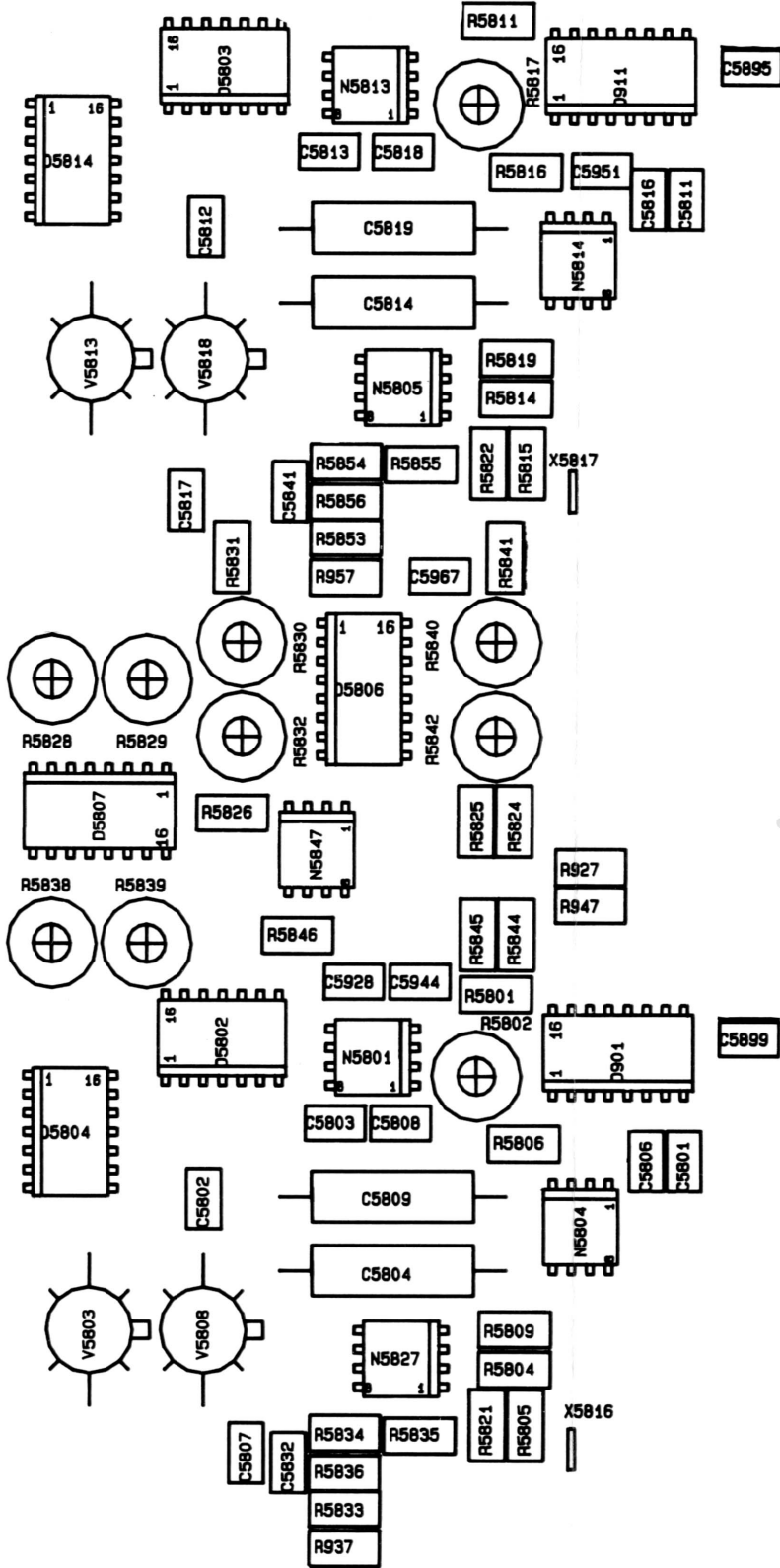
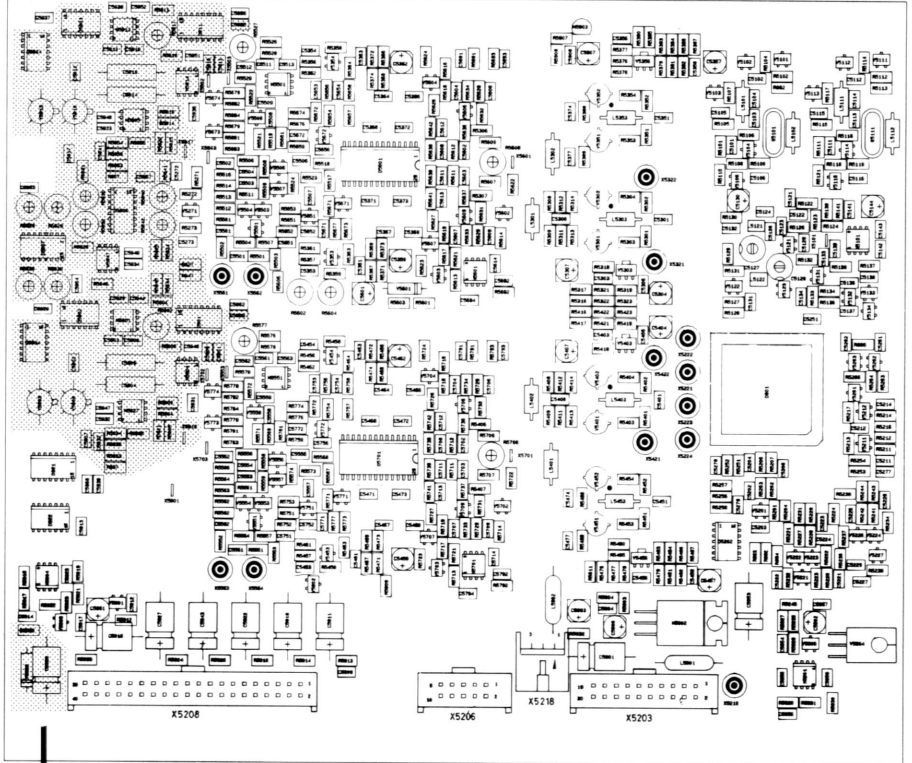

Figure 19.19 Part of P²CCD unit p.c.b., part 7



A18



JTN

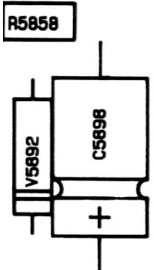
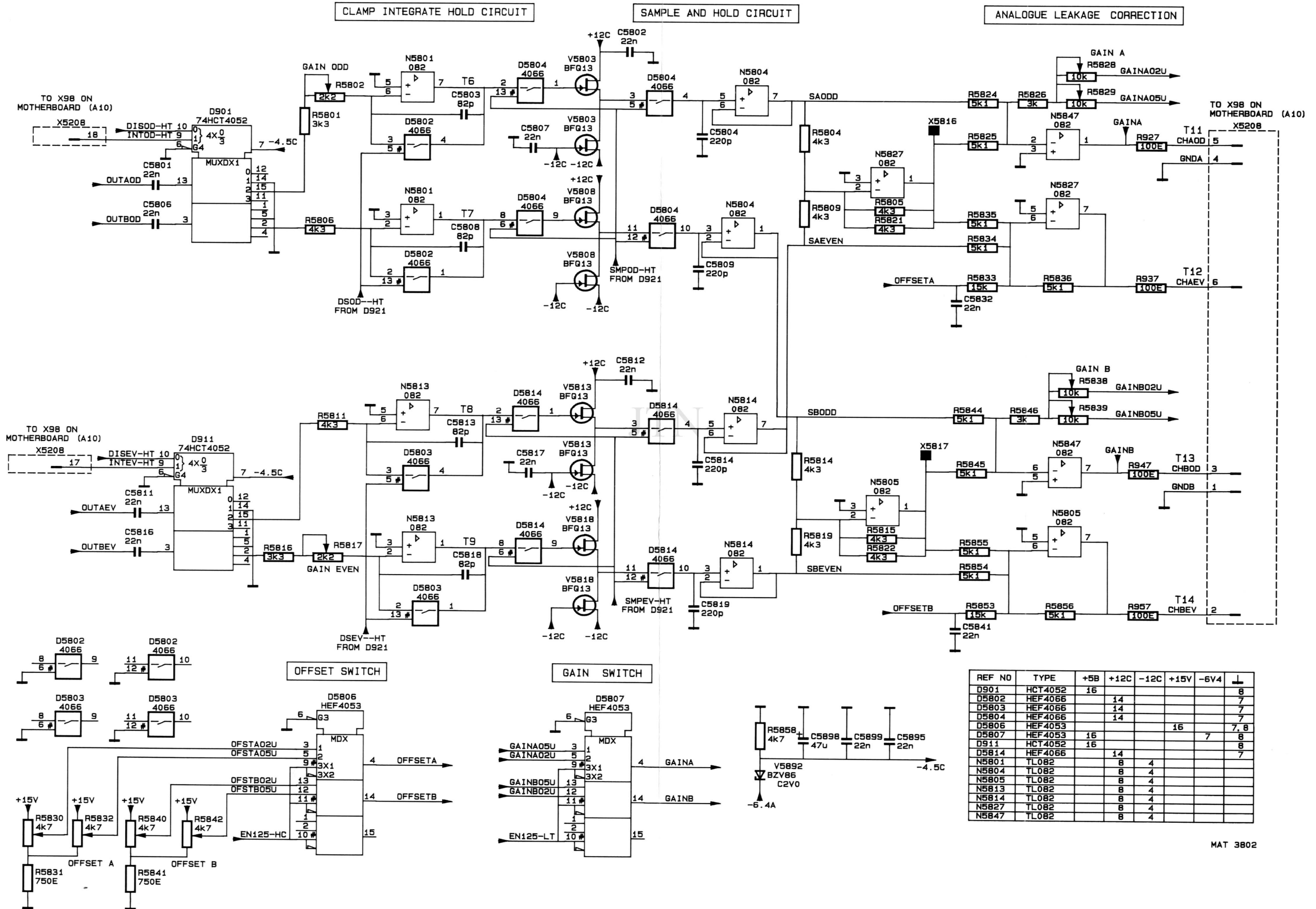

Figure 19.21 Part of P²CCD unit p.c.b., part 8



REF NO	TYPE	+5B	+12C	-12C	+15V	-6V4	⊥
D901	HCT4052	16					8
D5802	HEF4066		14				7
D5803	HEF4066		14				7
D5804	HEF4066		14				7
D5806	HEF4053				16		7, 8
D5807	HEF4053	16				7	8
D911	HCT4052	16					8
D5814	HEF4066		14				7
N5801	TL082		8	4			
N5804	TL082		8	4			
N5805	TL082		8	4			
N5813	TL082		8	4			
N5814	TL082		8	4			
N5827	TL082		8	4			
N5847	TL082		8	4			

MAT 3802

Figure 19.22 Circuit diagram of P²CCD, CIH circuit

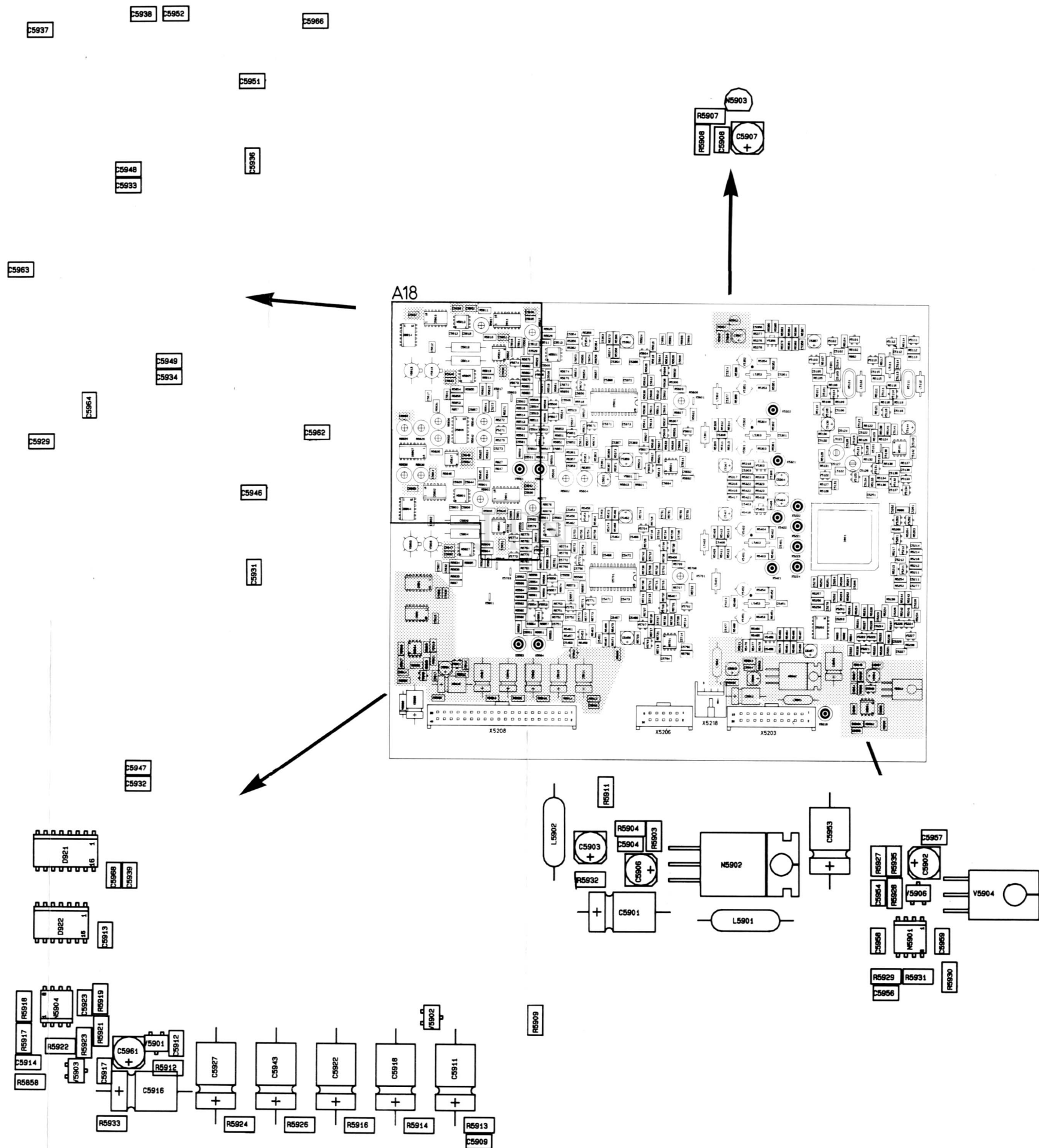

Figure 19.23 Part of P²CCD unit p.c.b., part 9

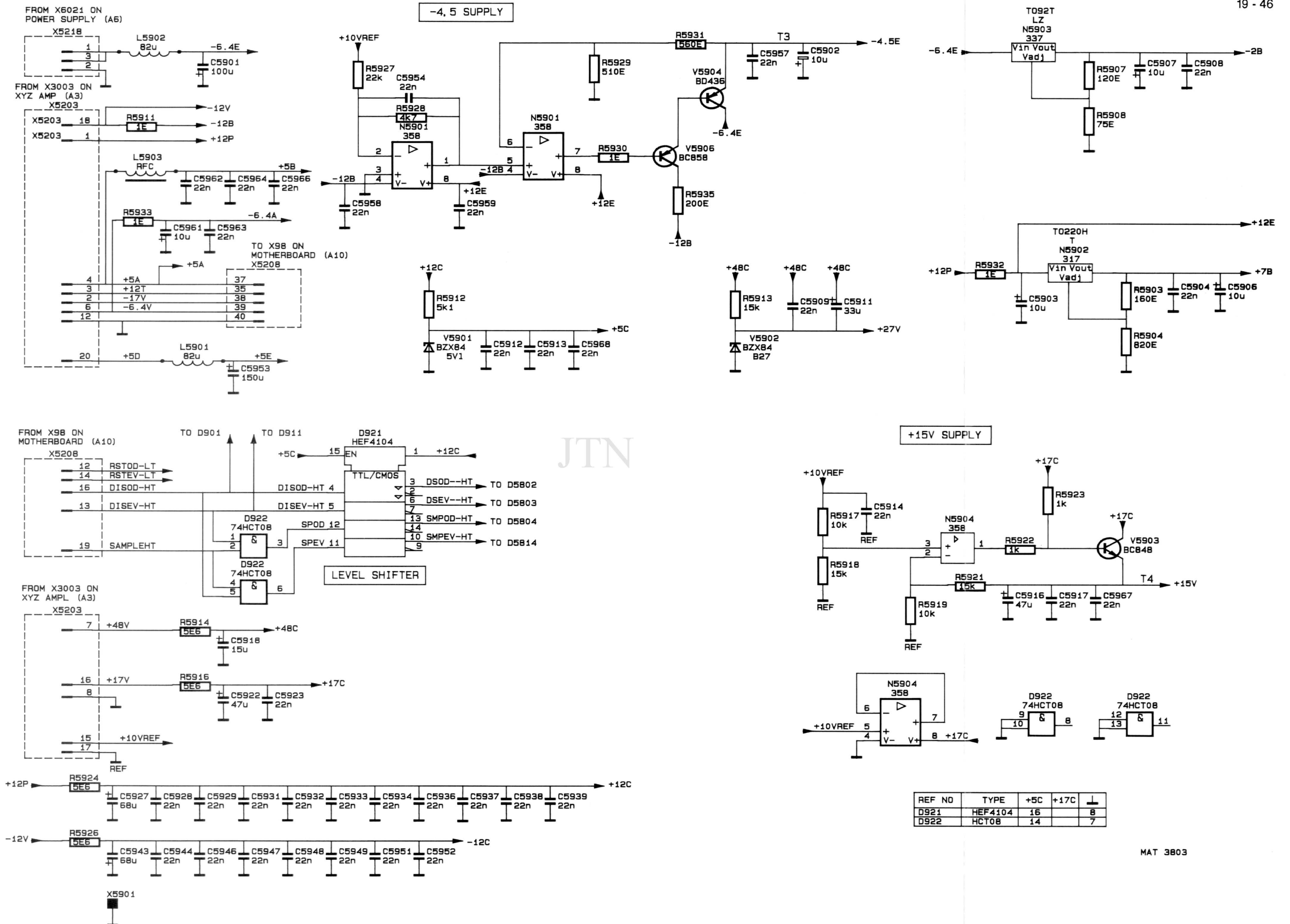
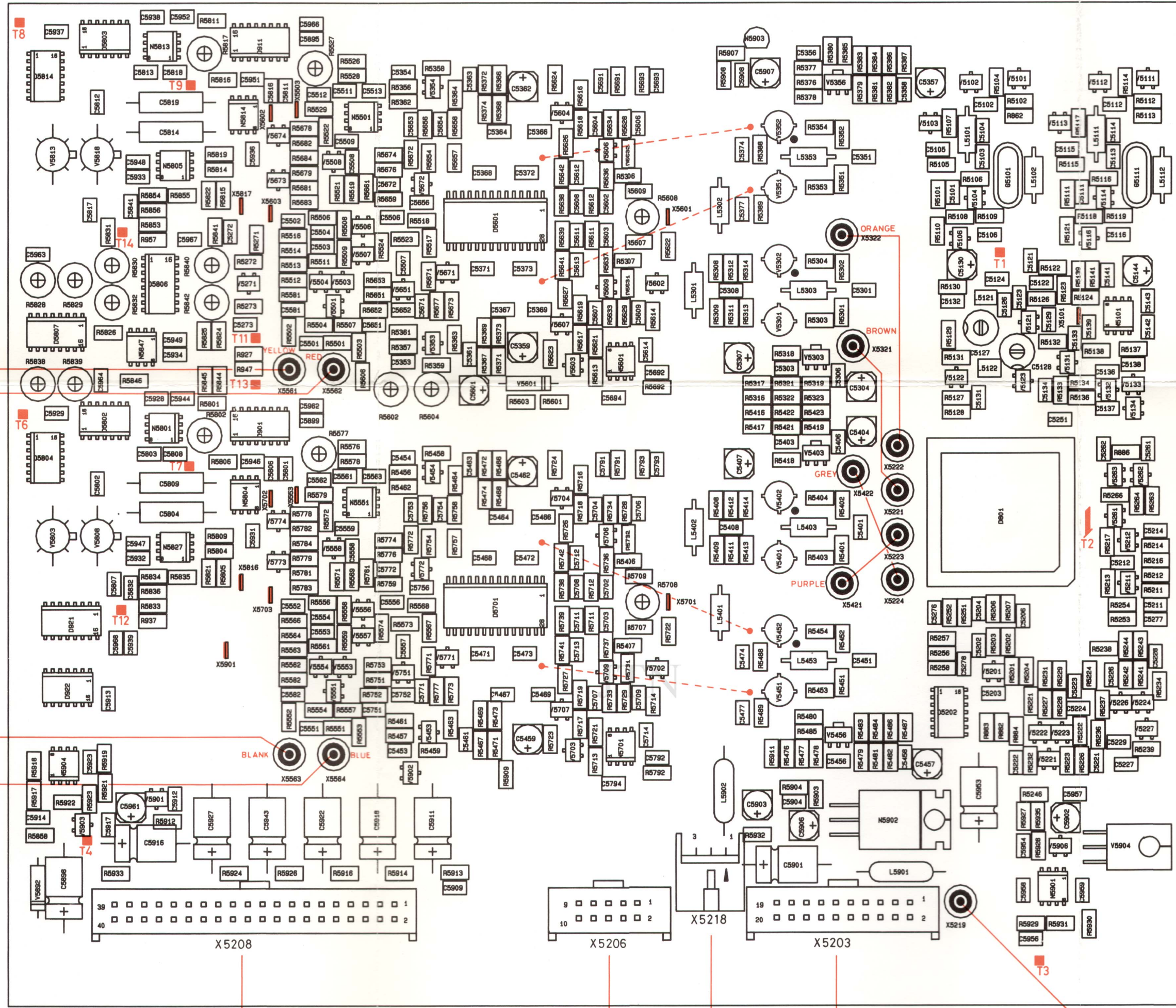

Figure 19.24 Circuit diagram of P²CCD, power supplies and level shifter

A18



- 50 Ω CABLE CONNECTIONS**
- X5561 FROM X 661 (PM3355)
FROM X1661 (PM3375)
 - X5562 FROM X 662 (PM3355)
FROM X1662 (PM3375)
 - X5563 FROM X 663 (PM3355)
FROM X1663 (PM3375)
 - X5564 FROM X 664 (PM3355)
FROM X1664 (PM3375)

TEST PIN	SIGNAL	ADJUSTING ELEMENT
X5101	RES. INDICATION	C5127/28
X5503	DC LEVEL A	R5527
X5553	DC LEVEL B	R5577
X5601	BAR A	R5608
X5701	BAR B	R5708
X5602	OUTAEV	R5604
X5603	OUTAOD	R5604
X5702	OUTBEV	R5602
X5703	OUTBOD	R5602
X5816	LEAKAGE A	R5802
X5818	LEAKAGE B	R5817
X5901	GND	

- ADJUSTING ELEMENTS:**
- C5127 RESONANCE 250 MHz
 - C5128 RESONANCE 200 MHz
 - R5527 DC LEVEL A
 - R5577 DC LEVEL B
 - R5604 BIAS A
 - R5602 BIAS B
 - R5608 BAR A
 - R5708 BAR B
 - R5817 GAIN EVEN
 - R5802 GAIN ODD
 - R5828 GAIN A 200 NS
 - R5829 GAIN A
 - R5838 GAIN B 200 NS
 - R5839 GAIN B
 - R5830 OFFSET A 200 NS
 - R5832 OFFSET A
 - R5840 OFFSET B 200 NS
 - R5842 OFFSET B

- TESTPADS:**
- T1 100 MHz OR 125 MHz
 - T2 CLOCK OUT CK200250 (1 Vp-p SINE-WAVE)
 - T3 -4,5V
 - T4 +15V
 - T6 } Ux
 - T7 } Ux
 - T8 } Ux
 - T9 } Ux
 - T11 CHAOD OUTPUT
 - T12 CHAEV OUTPUT
 - T13 CHBOD OUTPUT
 - T14 CHBEV OUTPUT

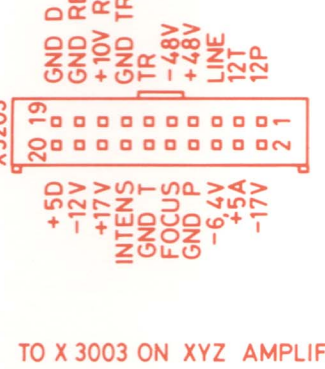
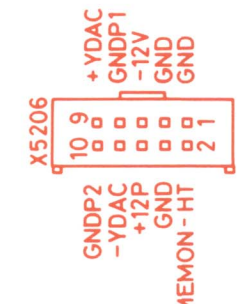
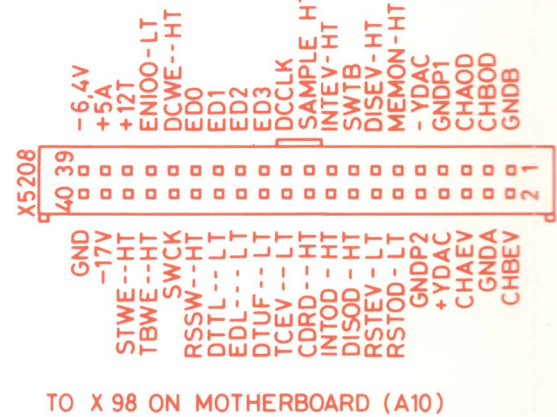
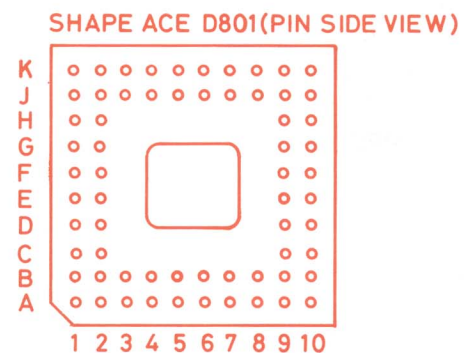
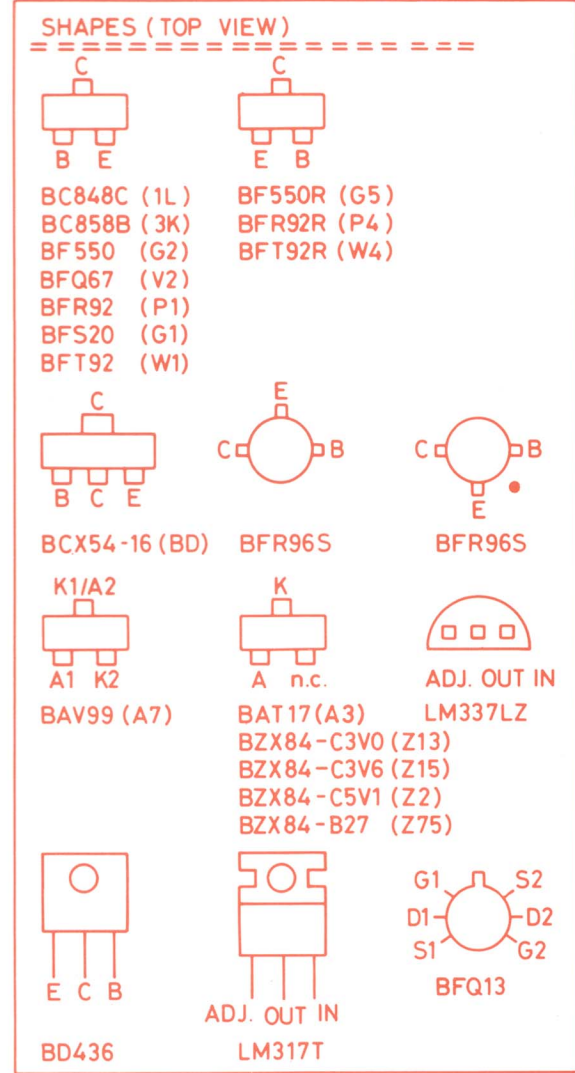

EN125-LT FROM X 54 ON MOTHERBOARD (A10)

Figure 19.25 P²CCD unit

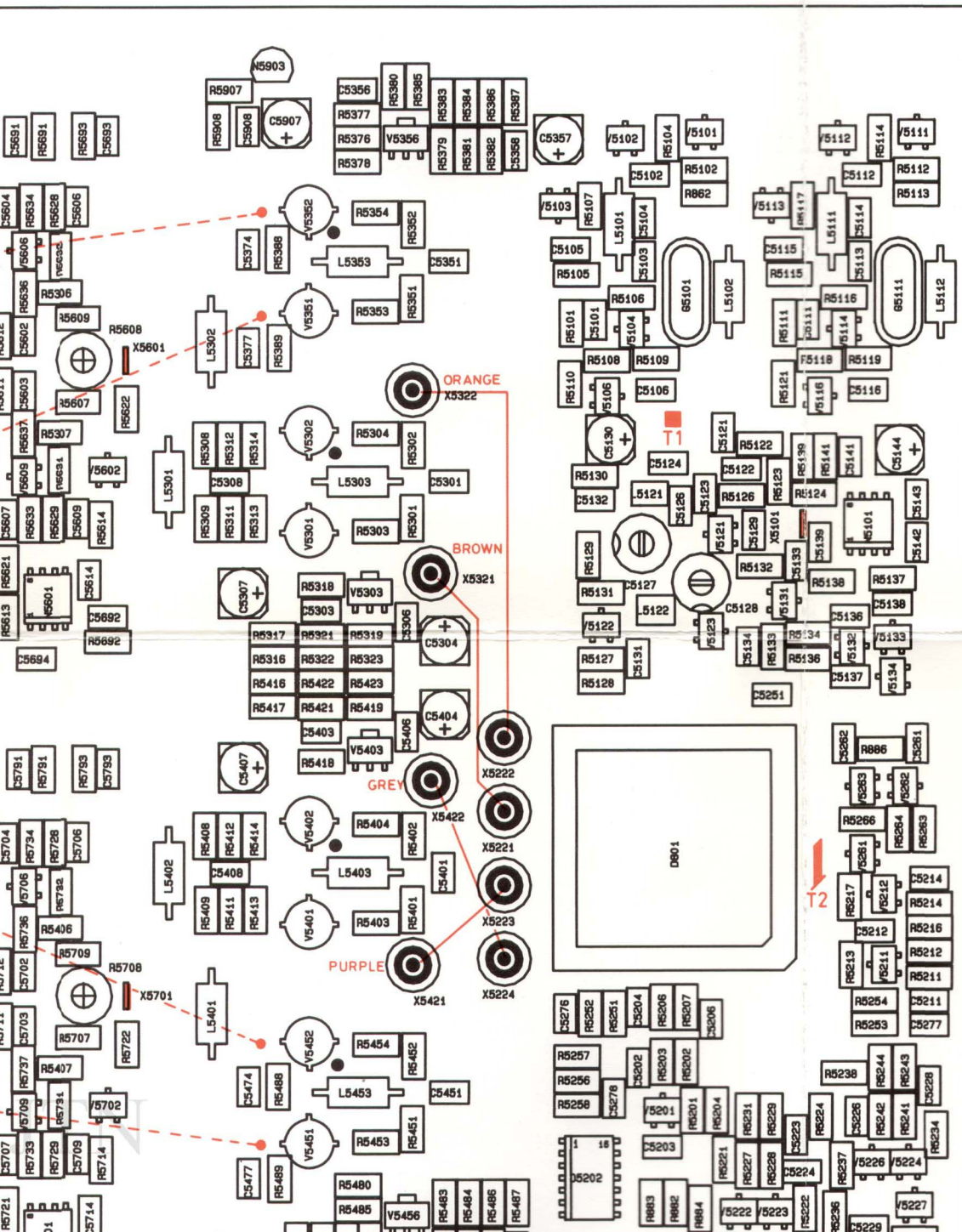

TEST PIN	SIGNAL	ADJUSTING ELEMENT
X5101	RES. INDICATION	C5127/28
X5503	DC LEVEL A	R5527
X5553	DC LEVEL B	R5577
X5601	BAR A	R5608
X5701	BAR B	R5708
X5602	OUTAEV	R5604
X5603	OUTAOD	R5604
X5702	OUTBEV	R5602
X5703	OUTBOD	R5602
X5816	LEAKAGE A	R5802
X5818	LEAKAGE B	R5817
X5901	GND	
ADJUSTING ELEMENTS:		
C5127	RESONANCE 250 MHZ	
C5128	RESONANCE 200 MHZ	
R5527	DC LEVEL A	
R5577	DC LEVEL B	
R5604	BIAS A	
R5602	BIAS B	
R5608	BAR A	
R5708	BAR B	
R5817	GAIN EVEN	
R5802	GAIN ODD	
R5828	GAIN A 200 NS	
R5829	GAIN A	
R5838	GAIN B 200 NS	
R5839	GAIN B	
R5830	OFFSET A 200 NS	
R5832	OFFSET A	
R5840	OFFSET B 200 NS	
R5842	OFFSET B	

TESTPADS :	
T1	100 MHZ OR 125 MHZ
T2	CLOCK OUT CK200250 (1 Vp-p SINE-WAVE)
T3	-4,5V
T4	+15V
T6	} 
T7	
T8	

CH + B

CH - B

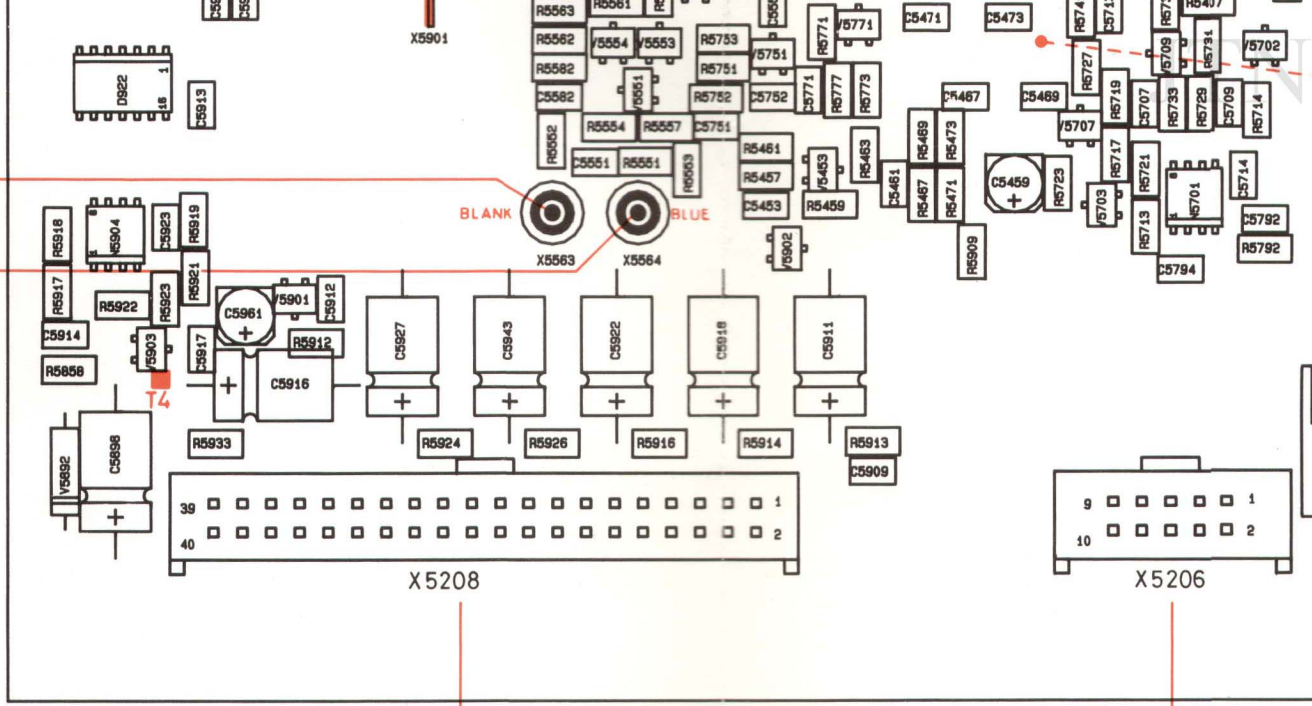

- 6.4V
 + 5A
 + 12T
 EN100-LT
 DCWE--HT
 ED0
 ED1
 ED2
 ED3
 DCCLK
 SAMPLE HT
 INTEV-HT
 SWTB
 DISEV-HT
 MEMON-HT
 - YDAC
 GNDP1
 CHAOD
 CHBOD
 GNDB

+ YDAC
 GNDP1
 - 12V
 GND
 GND



GND
 -17V
 STWE--HT
 TBWE--HT
 SWCK
 RSSW--HT
 DTLL--LT
 EDL--LT
 DTUF--LT
 TCEV--LT
 CDRD--HT
 INTOD--HT
 DISOD--HT
 RSTOD--LT
 GNDP2
 +YDAC
 CHAEV
 GNDA
 CHBEV

GNDP2
 -YDAC
 +12P
 GND
 MEMON-HT

TO X 98 ON MOTHERBOARD (A10)

TO X 1606 ON ADAPTATION (A10)

SHAPE ACE D801(PIN SIDE VIEW)

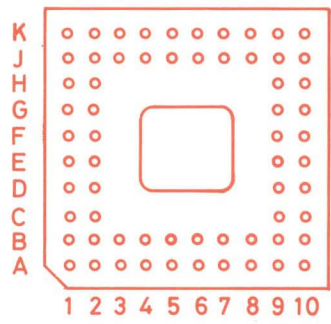

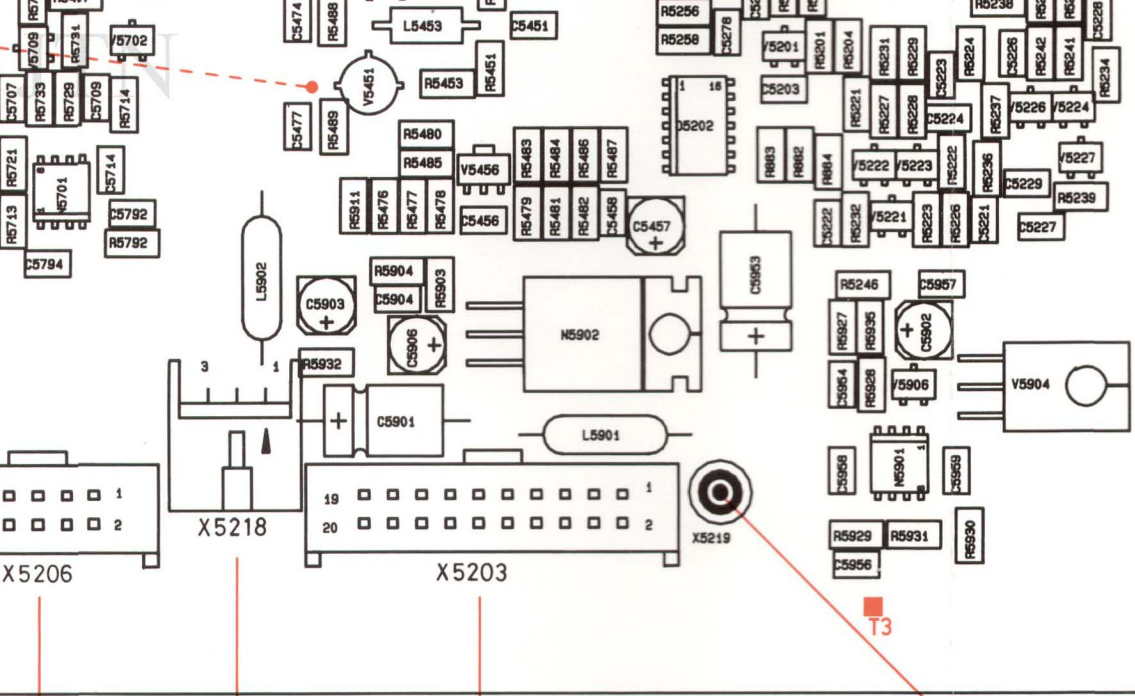

- T2 CLOCK OUT CK200250
(1 Vp-p SINE-WAVE)
- T3 -4,5V
- T4 +15V
- T6 } Ux
- T7 } Ux
- T8 } Ux
- T9 } Ux
- T11 CHAOD OUTPUT
- T12 CHAEV OUTPUT
- T13 CHBOD OUTPUT
- T14 CHBEV OUTPUT

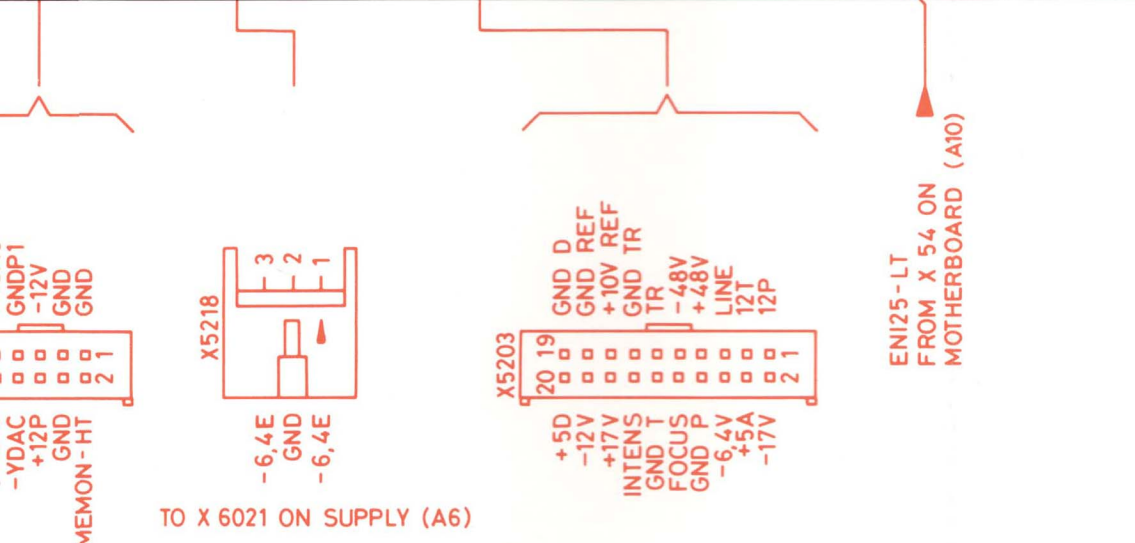

MEMON - HT
-YDAC
+12V
GND
GND
GND
MEMON - HT

TO X 6021 ON SUPPLY (A6)

X5203
19 20 1 2
GND D REF
GND REF
+10V REF
GND TR
-48V
+48V
LINE
12T
12P

TO X 3003 ON XYZ AMPLIFIER (A3)

ENI25-LT
FROM X 54 ON
MOTHERBOARD (A10)

SHAPES (TOP VIEW)

BC848C (1L)	BF550R (G5)	
BC858B (3K)	BFR92R (P4)	
BF550 (G2)	BFT92R (W4)	
BFQ67 (V2)		
BFR92 (P1)		
BFS20 (G1)		
BFT92 (W1)		
BCX54-16 (BD)	BFR96S	BFR96S
K1/A2	K	ADJ. OUT IN
BAV99 (A7)	BAT17 (A3)	LM337LZ
	BZX84-C3V0 (Z13)	
	BZX84-C3V6 (Z15)	
	BZX84-C5V1 (Z2)	
	BZX84-B27 (Z75)	
BD436	LM317T	BFQ13

MAT3794

Figure 19.25 P2CCD unit

PERFORMANCE TEST

JTN

20 PERFORMANCE TEST

20.1 GENERAL INFORMATION

WARNING: Before switching-on, ensure that the instrument has been installed in accordance with the Installation Instructions, outlined in Section 2 of the Operation Guide.

This procedure is intended to:

- Check the instrument's specification.
- Be used for incoming inspection to determine the acceptability of newly purchased instruments and/or recently recalibrated instruments.
- Check the necessity of recalibration after the specified recalibration intervals.

NOTE: The procedure does not check every facet of the instrument's calibration; rather, it is concerned primarily with those parts of the instrument which are essential to measurement accuracy and correct operation. Removing the instrument's covers is not necessary to perform this procedure. All tests are made from the outside of the instrument.

If the test is started within a short period after switching-on, bear in mind that steps may be out of specification, due to insufficient warming-up time.

Warming-up time under average conditions is 30 minutes.

The tests are made with a stable, well-focussed, low-intensity display. Unless otherwise noted, adjust the intensity and trigger-level controls as needed.

IMPORTANT NOTES

- Unless otherwise stated, set the 3 VAR controls into position CAL, the 3 POS controls and TRIG LEVEL into the centre position, HOLD OFF at MIN.
- The input voltage has to be supplied to the A-input; unless otherwise stated. Set the TIME/DIV switch to a suitable position; unless otherwise stated.
- Tolerances given are for the instrument under test and do not include test equipment error. Bear in mind that the test equipment is properly terminated.
- In some tests, channel B appears in parentheses after channel A, e.g. A(B). This indicates that the channel A test should be performed first, then the test for channel B.

20.2 RECOMMENDED TEST EQUIPMENT

Type of instrument	Required specification	Example of recommended instrument
Function generator	Freq: 1 MHz ... 10 MHz Sine-wave/square-wave Ampl: 0...20 V (pp) DC offset - 5 ... +5 V Rise-time \leq 30 ns Duty cycle 50 %	Philips PM 5134
Constant amplitude sine-wave generator	Freq: 50 kHz ... 150 MHz. Constant pp. amplitude of 120 mV and 3 V.	Tektronix SG 503
Square-wave calibration generator	For ampl. calibration: Freq: 1 kHz Ampl: 10 mV... 50 V For rise-time measurements: Freq: 1 MHz Ampl: 10 ... 500 mV Rise-time: \leq 1 ns	Tektronix PG 506
Time marker generator	Repetition rate: 0,5 s ... 5 ns	Tektronix TG 501
Digital multimeter	Wide voltage and current ranges.	Philips PM 2525 with AC, DC and resistance ranges. High-voltage probe. Required: 1 % accuracy, PM 9246
Variable voltage transformer (VARIAC)	Well insulated output voltage 90 ... 264 V (ac)	Philips order. number 2422 529 00005
Watt meter		NORMA type D 1150
TV pattern generator with video output		Philips PM 5518
Oscilloscope	The bandwidth must be the same or higher than the bandwidth of the instrument under test.	Philips PM 3065
50 Ω cables, 75 Ω cable, 50 Ω terminations, 75 Ω termination, 10:1 attenuator, T-piece, power splitter	Tektronix and Philips BNC types for fast rise-time square-wave, high freq. sine-wave and other applications.	TEK 012-0482-00 TEK 012-0074-00 TEK 011-0049-01 TEK 011-0055-01 TEK 011-0059-02 PHI PM 9067 PHI PM 9584/02
Trimming tools		Philips 800NTX (ord. kit number 4822 310 50095) or Bernstein nr. 1-250

20.3 TEST PROCEDURE

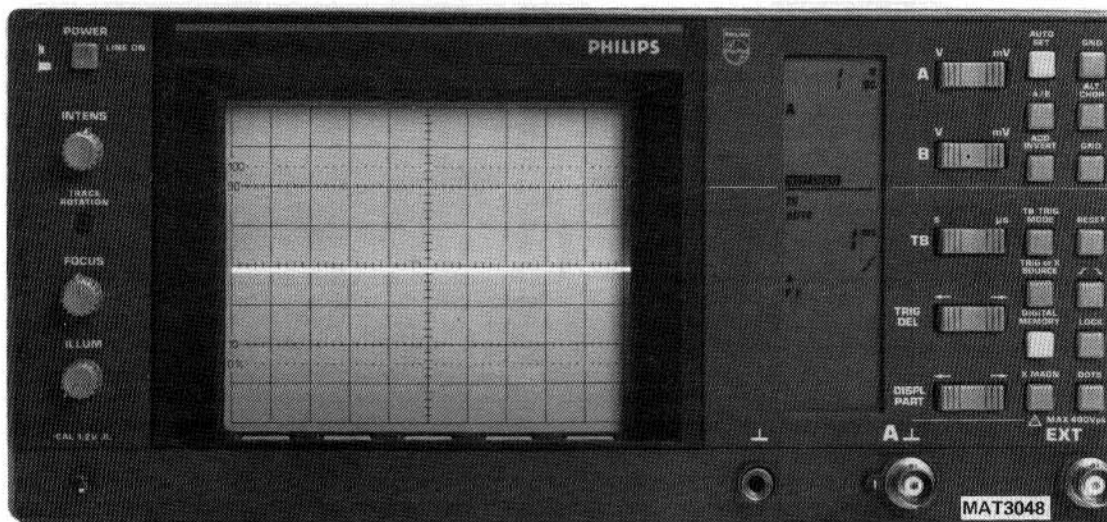

Figure 20.1 SOFTSTART condition.

20.3.1 Preliminary settings

test equipment:

None

*settings/procedure
and requirements:*

- 1 – Switch-on the oscilloscope under test.
- 2 – Check that all LCD segments on the frontpanel of the oscilloscope are on for approximately 1 second.
- 3 – Press pushbuttons MENU and AUTO SET in sequence.
- 4 – Check that the front controls of the oscilloscope are set in the softstart condition as indicated in figure 20.1.
- 5 – At the start of every test, the AUTO SET button must be pressed (after the input signal is applied).
- 6 – Press the AUTO SET button to leave the softstart condition.

20.3.2 Power supply

In this test the correct working of the power supply at all possible line voltages is tested.

test equipment:

Variable voltage transformer (VARIAC)

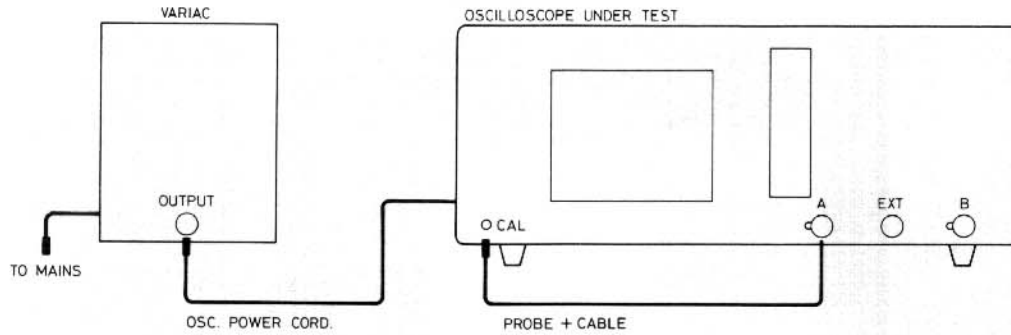
test set-up:MAT3827
900202**settings/procedure:**

- 1 – Adjust the input line voltage to the oscilloscope (output from VARIAC) to a desired value between 100 and 240 V (r.m.s.), frequency 50...400 Hz.
- 2 – Press POWER ON button of the oscilloscope.
- 3 – Apply the CAL signal provided on the front panel of the oscilloscope to input A, e.g. by means of a probe.
- 4 – Press the AUTO SET button.

requirements:

- 1 – Oscilloscope must start at any input voltage between 100 and 240 V.
- 2 – The instrument's performance does not change over the indicated voltage range; the displayed CAL signal is distortion-free and has equal intensity.

20.3.3 Power consumption

This test checks the power consumption of the oscilloscope.

test equipment:

- Variable voltage transformer (VARIAC)
- Watt meter

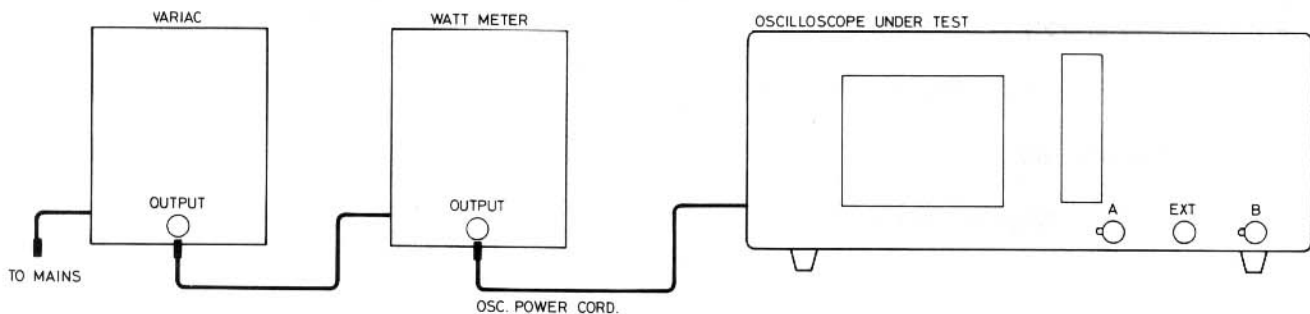
test set-up:MAT3828
900202

settings/procedure:

- 1 – Adjust the input voltage (output from VARIAC) to the oscilloscope to the nominal line voltage.
- 2 – Press POWER ON button of the oscilloscope.

requirements:

Power consumption is maximum :

- 75 W for PM3365A/PM3367A
- 85 W for PM3375/PM3377

20.3.4 Auto set

This test checks the correct working of the auto set function.

test equipment:

Constant amplitude sine-wave generator (SG 503)

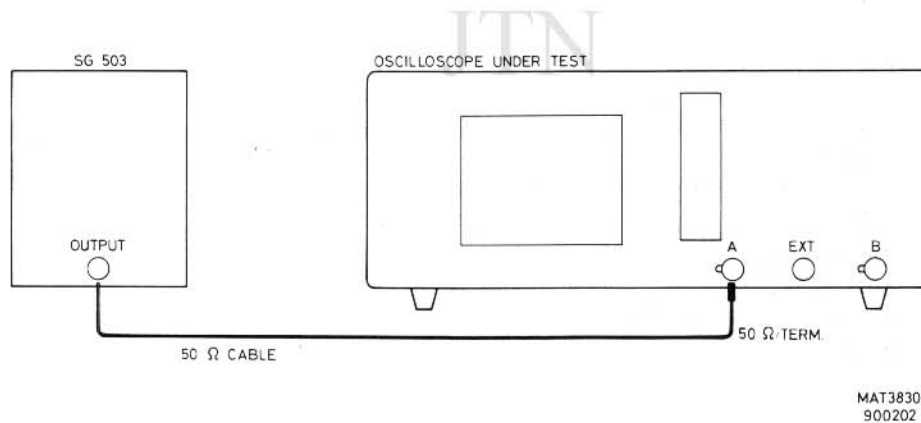
test set-up:*settings/procedure:*

- 1 – Set channels A and B to 20 mV/div; the other settings are not relevant.
- 2 – Apply a 90 MHz sine-wave signal of 60 mV (pp) to input A; use a 50 Ω termination.
- 3 – Press the AUTO SET button.

requirements:

Check that the display is stable and well-triggered.

Repeat settings/procedure for channel B.

20.3.5 Orthogonality

In this test the angle between the horizontal and vertical deflection plates, the so called orthogonality, is checked.

test equipment:

LF sine-wave generator (function generator, PM 5134)

test set-up:

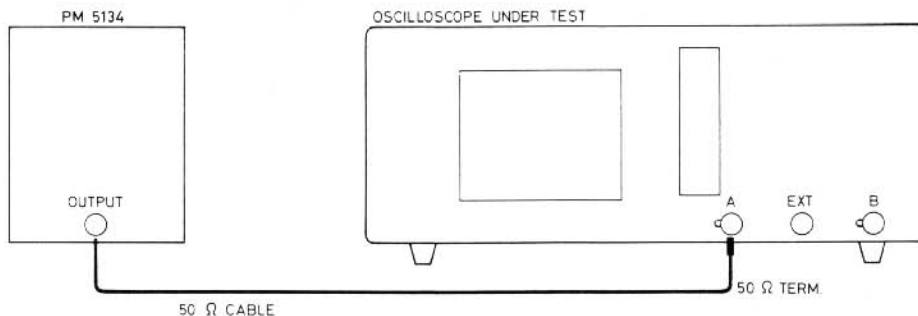

MAT3834
900202

JTN

settings/procedure:

- 1 – Apply a 50 Hz sine-wave signal of 8 V (pp) to input A; use a 50 Ω termination.
- 2 – Press the AUTO SET button and adjust the input signal to a trace-height of 8 div.
- 3 – Press the GND button and check that the straight line is exactly in parallel with the horizontal graticule lines. If not, readjust the trace rotation.
- 4 – Press the GND button again and check that the signal of 8 div is displayed.
- 5 – Press X DEFL.
- 6 – Press TRIG or X SOURCE and select B as trigger source.
- 7 – Shift the line to the centre of the screen with X POS.

requirements:

- 1 – Check that the vertical line is in parallel with the vertical graticule line in the centre of the screen.
- 2 – Verify that the angle with respect to the horizontal graticule lines is $90^\circ \pm 1^\circ$ as indicated in figure 4.2.

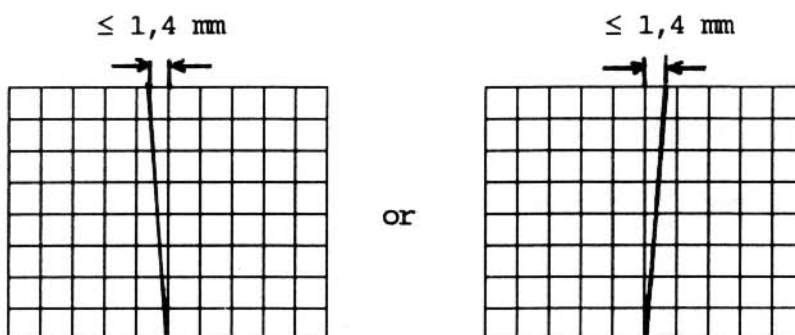

MAT 3913
900403

Figure 4.2. Orthogonality

20.3.6 Vertical deflection; deflection coefficients

The vertical deflection coefficients of both channels A and B are checked by means of a calibrated signal.

test equipment:

Square-wave calibration generator (PG 506)

test set-up:

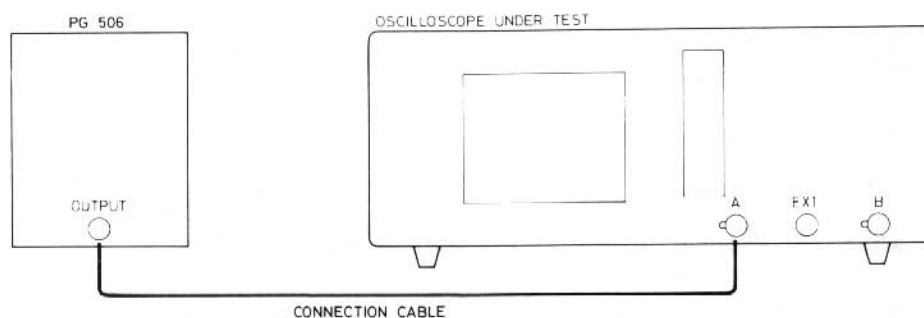

MAT3829
900202

settings/procedure:

- 1 - Apply a 1 kHz square-wave signal of 10 mV to input A.
Generator in position STD AMPL.
- 2 - Press the AUTO SET button.
- 3 - Set channel A to 2 mV/div and to DC.
- 4 - Change the input voltage and the setting of channel A according to the table below and check that the amplitude of the signal agrees with this table.

requirements:

Input voltage (pp)	A(B) setting	Requirements
10 mV	2 mV	4,85...5,15 div
20 mV	5 mV	3,88...4,12 div
50 mV	10 mV	4,85...5,15 div
0,1 V	20 mV	4,85...5,15 div
0,2 V	50 mV	3,88...4,12 div
0,5 V	0,1 V	4,85...5,15 div
1 V	0,2 V	4,85...5,15 div
2 V	0,5 V	3,88...4,12 div
5 V	1 V	4,85...5,15 div
10 V	2 V	4,85...5,15 div
20 V	5 V	3,88...4,12 div
50 V	10 V	4,85...5,15 div

Repeat settings/procedure for channel B.

20.3.7 Vertical deflection; variable gain control range (continuation of 20.3.6)

In this test the range of the vertical variable gain control is checked.

settings/procedure:

- 1 – Apply a square-wave signal of 5 V to input A and press AUTO SET.
- 2 – Set channel A to 1 V/div and to DC.
- 3 – Turn the VAR control of channel A fully counter clockwise.

requirements:

Verify that the displayed amplitude is not more than 2 div (ratio 1 : 2,5) and turn VAR back to CAL position.

Repeat settings/procedure for channel B.

20.3.8 Vertical deflection; input coupling (continuation of 20.3.7)

The function of the AC input capacitor is checked, as well as the grounding function of the coupling switch.

settings/procedure:

Turn the VAR control knob fully clockwise.

requirements:

Check for both channel A and B.

- 1 – Press the GND button and check that the signal disappears and that a straight line is displayed.
- 2 – Press the GND button again, then the AC/DC button and check that the signal shifts upwards when DC is pressed.

20.3.9 Vertical deflection; frequency response in analog mode

This test is performed to verify the analog vertical bandwidth.

test equipment:

Constant amplitude sine-wave generator (SG 503)

test set-up:

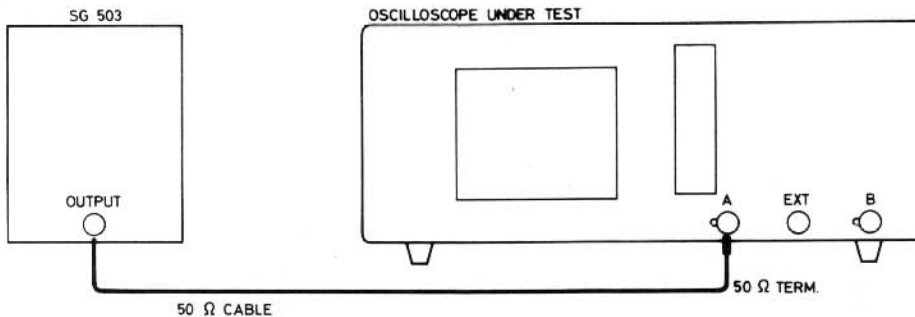

settings/procedure:

- 1 – Apply a 50 kHz sine-wave signal of 120 mV (pp) to input A and press the AUTO SET button; use a 50 Ω termination.
- 2 – Set channel A to 20 mV/div and VAR to CAL.
- 3 – Adjust the input signal to a trace-height of exactly 6 div.
- 4 – Increase the frequency up to 100 MHz (slowly) and verify that the vertical deflection is 4,2 div or more over the complete bandwidth range.
- 5 – Reduce the amplitude of the input signal to 12 mV and the frequency to 50 kHz.
- 6 – Set channel A to 2 mV/div and adjust the input signal to a trace-height of exactly 6 div.
- 7 – Increase the frequency up to 75 MHz (slowly) and check that the vertical deflection is 4,2 div or more over the complete bandwidth range.

requirements:

The vertical deflection must be 4,2 div or more.

Repeat settings/procedure for channel B.

20.3.10 Vertical deflection; frequency response in sampling mode

This test is performed to verify the vertical bandwidth in the sampling mode.

test equipment:

Constant amplitude sine-wave generator (SG 503)

test set-up:

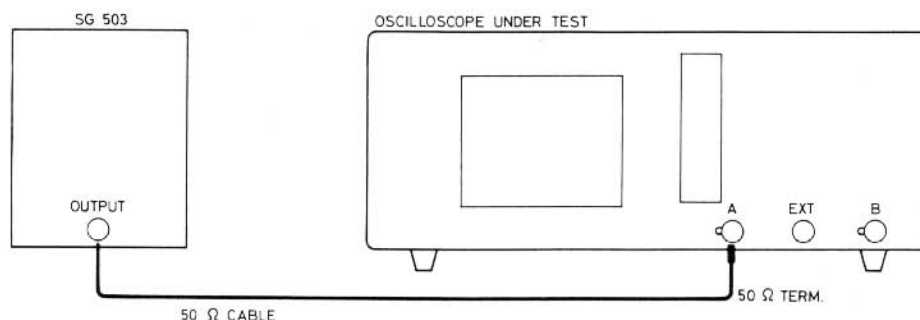

MAT3830
900202

settings/procedure:

- 1 – Press DIGITAL MEMORY.
- 2 – Apply a 50 kHz sine-wave signal of 120 mV (pp) to input A and press the AUTO SET button; use a 50 Ω termination.
- 3 – Set channel A to 20 mV/div and VAR to CAL.
- 4 – Adjust the input signal to a trace-height of exactly 6 div.
- 5 – Set TB to 20 ns/div.
- 6 – Set the frequency to 10 MHz and check that the vertical deflection is more than 4,2 div.
- 7 – Increase the frequency up to 100 MHz (slowly) and verify that the vertical deflection is 4,2 div or more over the complete bandwidth range.
- 8 – Reduce the amplitude of the input signal to 12 mV and the frequency to 50 kHz.
- 9 – Press the AUTO SET button.
- 10 – Set channel A to 2 mV/div and adjust the input signal to a trace-height of exactly 6 div.
- 11 – Set TB to 20 ns/div.
- 12 – Set the frequency to 10 MHz and check that the vertical deflection is more than 4,2 div.
- 13 – Increase the frequency up to 75 MHz (slowly) and check that the vertical deflection is 4,2 div or more over the complete bandwidth range.

requirements:

The vertical deflection must be 4,2 div or more.

Repeat settings/procedure for channel B.

20.3.11 Vertical deflection; rise-time

By means of a fast rise-time pulse the rise-time of the oscilloscope is checked.

test equipment:

Fast rise-time square-wave generator (PG 506)

test set-up:

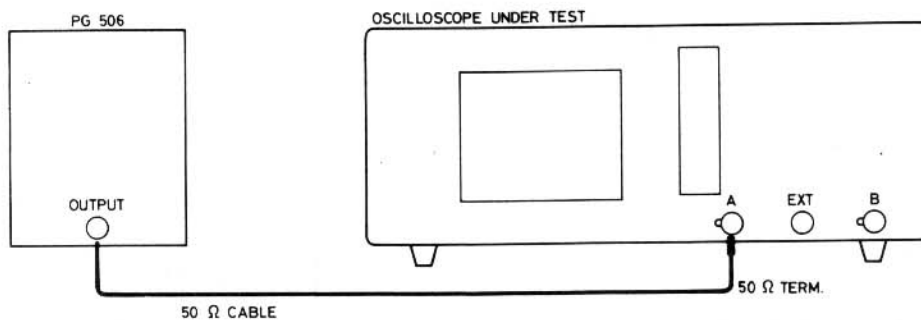

MAT3831
900202

settings/procedure:

- 1 - Apply a fast rise-time pulse, repetition frequency 1 MHz, to input A; use a 50 Ω termination. Generator in position FAST RISE.
- 2 - Set A to 100 mV/div.
- 3 - Press X MAGN.
- 4 - Set TB to 5 ns/div.
- 5 - Position the rising edge of the signal to the horizontal centre of the screen, by means of the X POS control.
- 6 - Adjust the trace-height exactly between the dotted lines 0 % and 100 % (5 div).

requirements:

$$\text{Important: } tr(\text{measured}) = \sqrt{tr(\text{input signal})^2 + tr(\text{oscilloscope})^2}$$

- 1 - Check the rise-time, measured between the 10 % and 90 % lines (4 div).
- 2 - The rise-time measured must be 3,5 ns (0,7 div) or less.

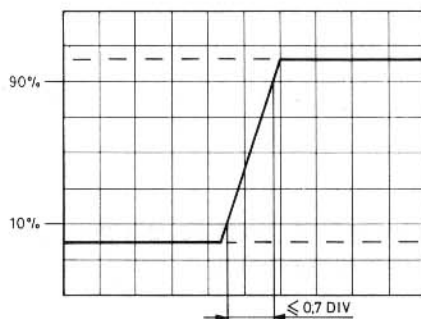

MAT3832
900202

Figure 20.3 Rise-time

20.3.12 Vertical deflection; noise

The noise, caused by the instrument's amplifiers, may not exceed a certain value. This value is checked by the following procedure.

test equipment:

LF square-wave generator (function generator, PM 5134)

test set-up:

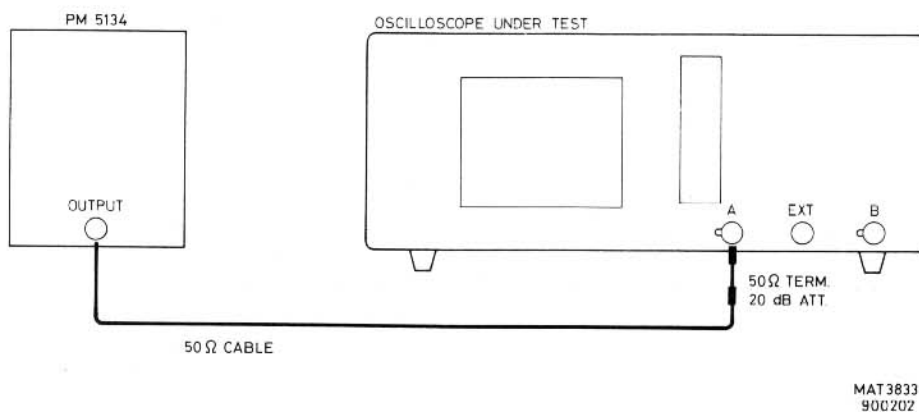

settings/procedure:

- 1 – Apply a 100 Hz square-wave signal of 100 mV to input A, via a 20 dB attenuator and a 50 Ω terminator (terminator to the oscilloscope input BNC).
- 2 – Press the AUTO SET button.
- 3 – Set channel A to 2 mV/div and coupling to DC.
- 4 – Set TB to 20 μs/div.
- 5 – Set TRIG SOURCE to B.
- 6 – While the oscilloscope is not triggered, the input signal is visible as two traces, separated by the peak to peak voltage of the signal.
- 7 – Decrease the input voltage from the generator so, that the two traces just meet each other and the dark area between the lines has just disappeared.
- 8 – Remove the 20 dB attenuator, not the 50 Ω termination, and measure the pp value of the square-wave voltage. (This value is equal to 10 times the noise of the trace)

requirements:

Ensure that the displayed square-wave is less than 2 div.

Repeat settings/procedure for channel B. (step 5, TRIG to A!)

20.3.13 Vertical deflection; dynamic range at 10 MHz

A certain overdrive of the oscilloscope must be allowed. In practice, a signal of 24 divisions must be displayed distortion-free at low frequencies.

test equipment:

Constant amplitude sine-wave generator (SG 503)

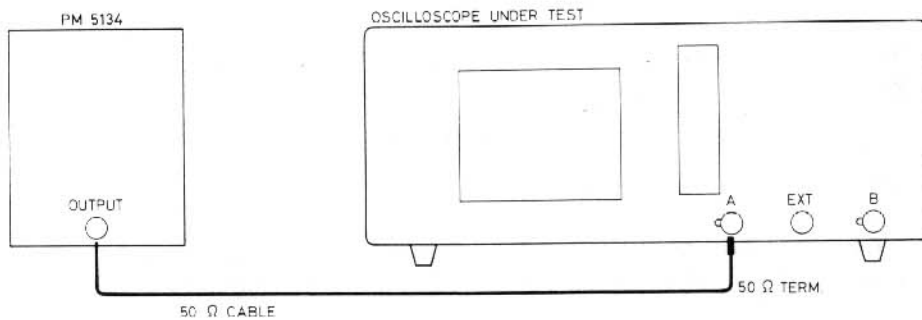
test set-up:MAT3834
900202**settings/procedure:**

- 1 - Apply a 10 MHz sine-wave signal of 2,4 V (pp) to input A; use a 50 Ω termination.
- 2 - Press the AUTO SET button and set A to 0,1 V/div.
- 3 - Shift the sine-wave vertically over the screen by means of the Y POS control.

requirements:

Verify that top and bottom of the sine-wave signal of 24 divisions can be displayed distortion-free.

Repeat settings/procedure for channel B.

20.3.14 Vertical deflection; position range

The range of the vertical shift is checked by means of a signal of 16 divisions.

test equipment:

LF sine-wave generator (function generator, PM 5134)

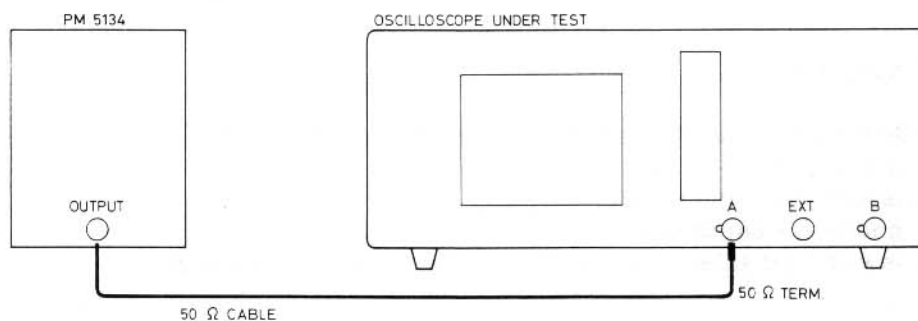
test set-up:MAT3834
900202

settings/procedure:

- 1 – Apply a 1 kHz sine-wave signal of 8 V (pp) to input A; use a 50 Ω termination.
- 2 – Press the AUTO SET button and set A to 0,5 V/div.

requirements:

Rotate the Y POS control of channel A fully clockwise and counter clockwise and check that the top and bottom of the signal can be positioned on the vertical centre of the screen.

Repeat settings/procedure for channel B.

20.3.15 Vertical deflection; cross talk between A and B at 10 MHz

Both channels A and B influence each other. A certain amount of interference is allowed, this is checked here.

test equipment:

Constant amplitude sine-wave generator (SG 503)

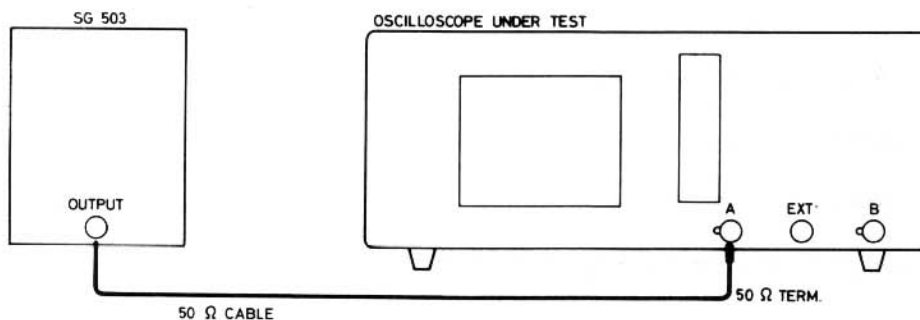
test set-up:

MAT3830
900202

settings/procedure:

- 1 – Apply a 10 MHz sine-wave signal of 4 V (pp) to input A; use a 50 Ω termination.
- 2 – Press the AUTO SET button.
- 3 – Press A/B (both channels displayed).
- 4 – Set channel A and B to 0,5 V/div.
- 5 – Press A/B, to display channel B and press GND of channel B.

requirements:

Verify that the trace-height of the channel without input signal is less than 0,08 div, (better than 1 : 100).

20.3.16 Vertical deflection; cross talk between A and B at 100 MHz

At higher frequencies the interference between the two channels is more. Now, the test is carried out at a high frequency.

test equipment:

Constant amplitude sine-wave generator (SG 503)

test set-up:

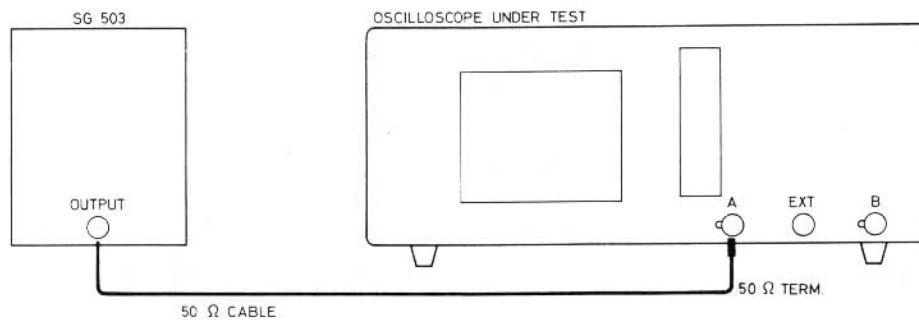

MAT3830
900202

settings/procedure:

- 1 - Apply a 100 MHz sine-wave signal of 4 V (pp) to input A; use a 50 Ω termination.
- 2 - Press the AUTO SET button.
- 3 - Press A/B (both channels displayed).
- 4 - Set channel A and B to 0,5 V/div.
- 5 - Press A/B, to display channel B and press GND of channel B.

requirements:

Verify that the trace-height of the channel without input signal is less than 0,16 div, (better than 1 : 50).

Repeat settings/procedure for channel B.

20.3.17 Vertical deflection; common mode rejection ratio

The common mode rejection ratio (CMRR) indicates the susceptibility to common mode signals, this is checked in this test.

test equipment:

- HF constant amplitude sine-wave generator (SG 503)
- Power splitter

test set-up:

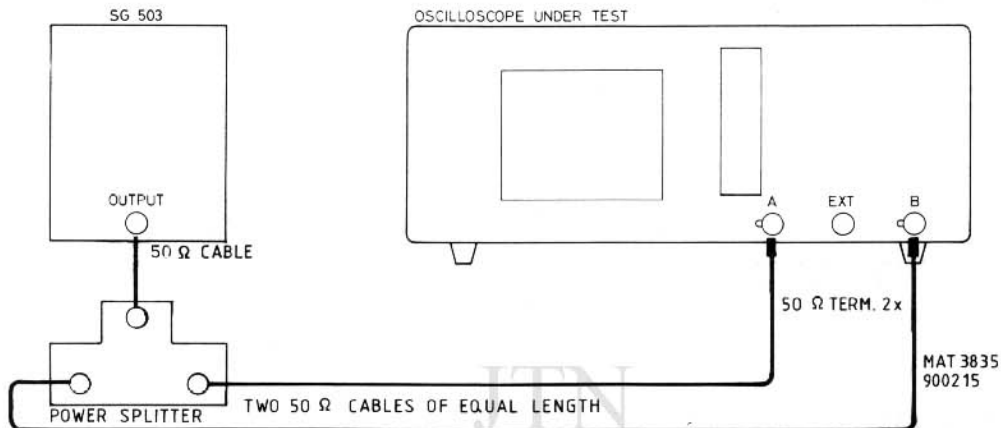

settings/procedure:

- 1 – Apply a 1 MHz sine-wave signal of 4 V (pp) to inputs A and B. Use a power splitter and two cables of equal length to A and B. Use 50 Ω terminations.
- 2 – Press the AUTO SET button.
- 3 – Set A and B to 0,5 V/div and adjust the input voltage to exactly 4 div.
- 4 – Set A and B to 0,2 V/div and input coupling to DC.
- 5 – Press ADD/INVERT 3 times (ADD and INVERT on).
- 6 – Adjust the VAR controls of A and B for minimum trace-height of the straight line.
- 7 – Press A/B 2 times, only the straight line is visible now.
- 8 – Readjust one of the VAR controls for minimum trace-height.

requirements:

Check that the trace-height of the A – B signal is less than 0,1 div.

Repeat settings/procedure with a 50 MHz sine-wave signal; now the trace-height of the A-B signal must be less than 1 div.

20.3.18 Vertical deflection; visual signal delay

It must be possible to observe the rising edge of a pulse. Therefore, a certain signal delay is introduced in the instrument. This delay is checked in this test.

test equipment:

Square-wave calibration generator (PG 506)

test set-up:

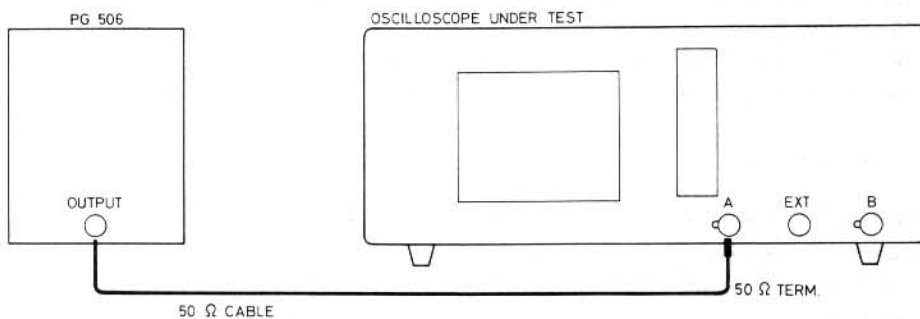

MAT3831
900202

JTN

settings/procedure:

- 1 – Apply a fast rise-time (≤ 1 ns) signal of 0,5 V, frequency 1 MHz, to input A; use a 50 Ω termination. Generator in position FAST RISE.
- 2 – Press the AUTO SET button and set A to 0,1 V/div.
- 3 – Set TB to 50 ns/div.
- 4 – Press X MAGN and turn X POS to display the rising edge.
- 5 – Turn INTENSITY fully clockwise.
- 6 – Set trigger coupling to DC.
- 7 – Adjust TRIG LEVEL for maximum visual signal delay.

requirements:

Verify that the visual signal delay is at least 13 ns (2,6 div).

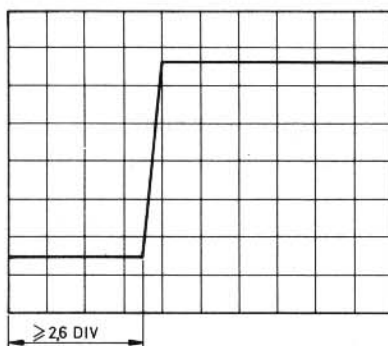

MAT3836

Figure 20.4 Visual signal delay

20.3.19 Vertical deflection; base line jump

Several adjustments of balance, offset and jump, are checked here.

test equipment:

None

*settings/procedure
and requirements:*

This test must be done in the service menu OFFS-A.

To enter this menu proceed as follows:

Press MENU and keep it pressed, then press AUTO SET, the LCD will show an asterisk (*).

Attenuator balance:

- 1 - Select OFFS-A of CRT function controls.
- 2 - Check LCD display: "3.0" flashing.
- 3 - The attenuator is switched between the 1-2-5 positions.
- 4 - Verify that both spots do not jump more than 0,2 div (1 subdiv).
If necessary, turn Y POS to show 2 spots.

VAR balance:

- 1 - Press mV of channel A UP-DOWN control.
- 2 - Check LCD display: "3.1" flashing.
- 3 - Rotate VAR control of channel A.
- 4 - Verify that spot A does not shift more than 0,2 div (1 subdiv).
- 5 - Reset VAR control back to CAL.
- 6 - Rotate VAR control of channel B.
- 7 - Verify that spot B does not shift more than 0,2 div (1 subdiv).
- 8 - Reset VAR control back to CAL.

x1/x10 attenuator offset:

- 1 - Press mV of channel A UP-DOWN control
- 2 - Check LCD display: "3.2" flashing.
- 3 - Verify that both spots do not jump more than 0,3 div (1,5 subdiv).

NORMAL-INVERT jump:

- 1 - Press mV of channel A UP-DOWN control 4 times.
- 2 - Check LCD display: "3.6" flashing.
- 3 - Verify that the spot does not jump more than 0,2 div (1 subdiv).
- 4 - Press AUTO SET 2 times to leave the service menu.

20.3.20 Horizontal deflection; X deflection

The correct working of the X-Y mode is tested.

test equipment:

LF sine-wave generator (function generator, PM 5134)

test set-up:

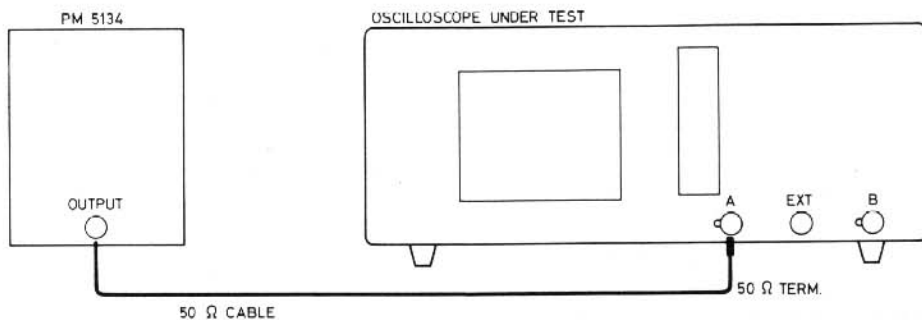

MAT3834
900202

settings/procedure:

- 1 - Apply a 2 kHz sine-wave signal of 800 mV (pp) to input A; use a 50 Ω termination.
- 2 - Press the AUTO SET button and set A to 0,1 V/div.
- 3 - Adjust the input signal to a trace-height of 8 div.
- 4 - Press X DEFL and check that only the X DEFL is on.

requirements:

Verify that a line with an angle of 45° is displayed.

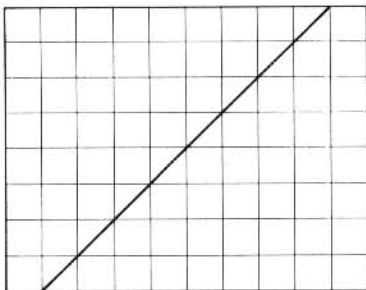

MAT3837
900202

Figure 20.5 X deflection

20.3.21 Horizontal deflection; time-base deflection coefficients

The deflection coefficients of the time-base generator are verified by means of a calibration signal.

test equipment:

Time marker generator (TG 501)

test set-up:

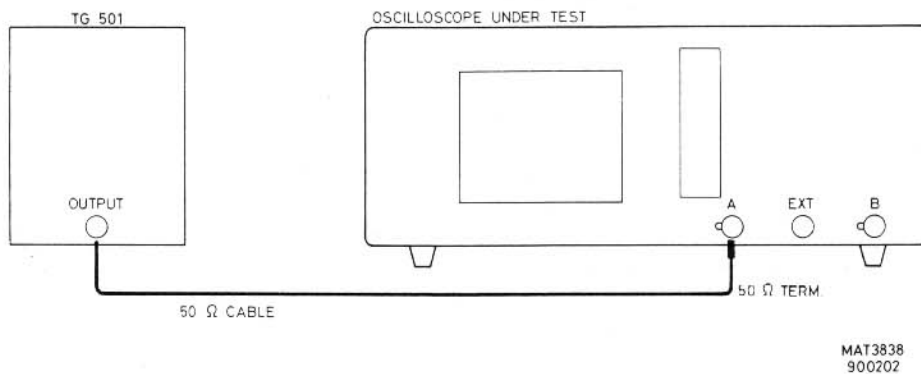

settings/procedure:

- 1 - Apply a 50 ns time marker signal to input A; use a 50 Ω termination.
- 2 - Press the AUTO SET button.
- 3 - Verify the deflection coefficients in TB x1 and TB x10 according to the table in requirements. Make use of the deflection error facility of the TG 501.

NOTE: - Error limits must be measured between the 2nd and 10th graticule line; there are 11 graticule lines.
 - In TB x10 measured on the central 10 div of the expanded TB of 100 div.

requirements:

Marker pulse at:		TB setting	Max. error at:	
TB x1	TB x10		TB x1	TB x10
50 ns	5 ns	50 ns	3 %	4 %
0,1 μ s	10 ns	0,1 μ s	3 %	4 %
0,2 μ s	20 ns	0,2 μ s	3 %	4 %
0,5 μ s	50 ns	0,5 μ s	3 %	4 %
1 μ s	0,1 μ s	1 μ s	3 %	4 %
2 μ s	0,2 μ s	2 μ s	3 %	4 %
5 μ s	0,5 μ s	5 μ s	3 %	4 %
10 μ s	1 μ s	10 μ s	3 %	4 %
20 μ s	2 μ s	20 μ s	3 %	4 %
50 μ s	5 μ s	50 μ s	3 %	4 %
0,1 ms	10 μ s	0,1 ms	3 %	4 %
0,2 ms	20 μ s	0,2 ms	3 %	4 %
0,5 ms	50 μ s	0,5 ms	3 %	4 %
1 ms	0,1 ms	1 ms	3 %	4 %
2 ms	0,2 ms	2ms	3 %	4 %
5 ms	0,5 ms	5 ms	3 %	4 %
10 ms	1 ms	10 ms	3 %	4 %
20 ms	2 ms	20 ms	3 %	4 %
50 ms	5 ms	50 ms	3 %	4 %
0,1 s	10 ms	0,1 s	3 %	4 %
0,2 s	20 ms	0,2 s	3 %	4 %
0,5 s	50 ms	0,5 s	3 %	4 %

JIN

20.3.22 Horizontal deflection; variable control ratio (VAR TB)

The horizontal deflection coefficients can be varied by a variable control. Here, the range of this control is checked.

test equipment:

Time marker generator (TG 501)

test set-up:

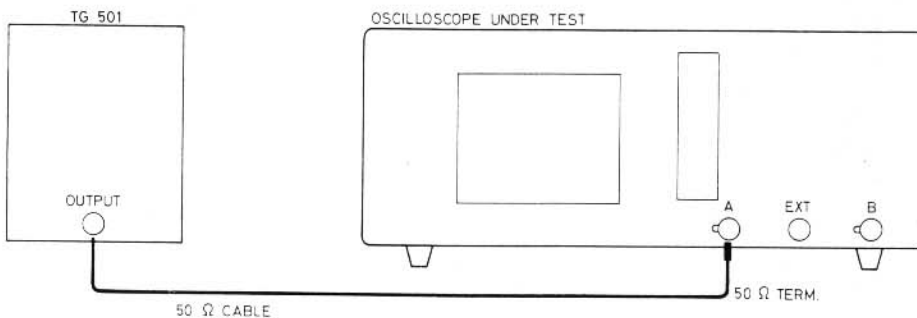

MAT3838
900202

JTN

settings/procedure:

- 1 – Apply a $1 \mu\text{s}$ time marker signal to input A; use a 50Ω termination.
- 2 – Press the AUTO SET button.
- 3 – Set TB to $0,2 \mu\text{s}/\text{div}$ and VAR to CAL; time marker on the first and sixth graticule line. (distance between markers 5 div)
- 4 – Turn the TB VAR fully counter clockwise.

requirements:

Verify that the second marker is placed between the second and third graticule line. This means that the VAR control overlaps the time-base steps $0,2$ to $0,5 \mu\text{s}$ (ratio $2,5 : 1$).

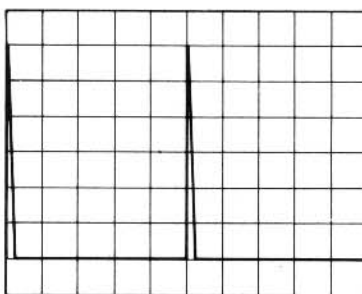

VAR IN CAL POSITION

MAT3839
900202

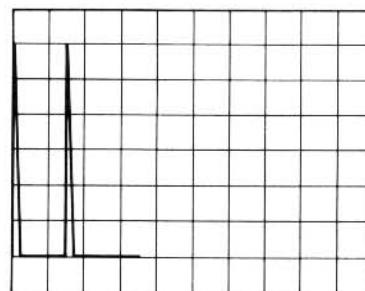

VAR FULLY COUNTER CLOCKWISE

MAT3840
900202

Figure 20.6 TB VAR range

20.3.23 Horizontal deflection; TB magnifier balance

The magnitude of the horizontal amplification can be increased by 10. When switching from x1 to x10 a certain shift can appear. The maximum allowed shift is checked here.

test equipment:

Time marker generator (TG 501)

test set-up:

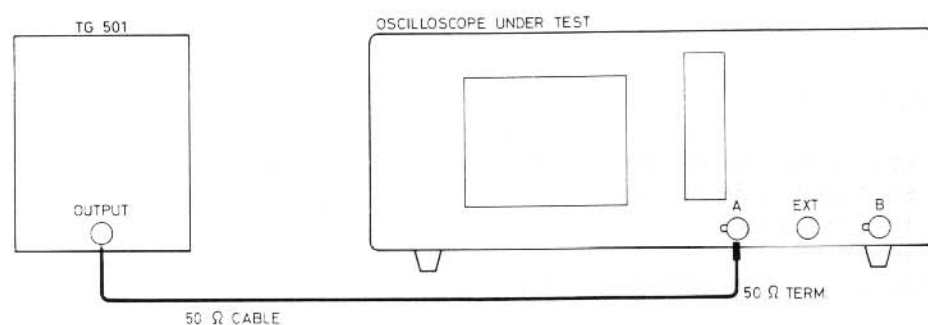

MAT3838
900202

settings/procedure:

- 1 – Apply a $1 \mu\text{s}$ time marker signal to input A; use a 50Ω termination.
- 2 – Set TB to $0,2 \mu\text{s}/\text{div}$ and VAR to CAL; time marker on the first and sixth graticule line.
- 3 – Set X MAGN on.
- 4 – Set the top of the second marker pulse exactly at the vertical centre of the graticule.
- 5 – Set X MAGN to off.

requirements:

Verify that the top of the second marker pulse is not shifted more than 0,5 div, when X MAGN is switched to off.

20.3.24 Horizontal deflection; X deflection coefficient via A

The amplification of the horizontal amplifier via the vertical amplifier is checked.

test equipment:

Sine-wave generator (function generator, PM 5134)

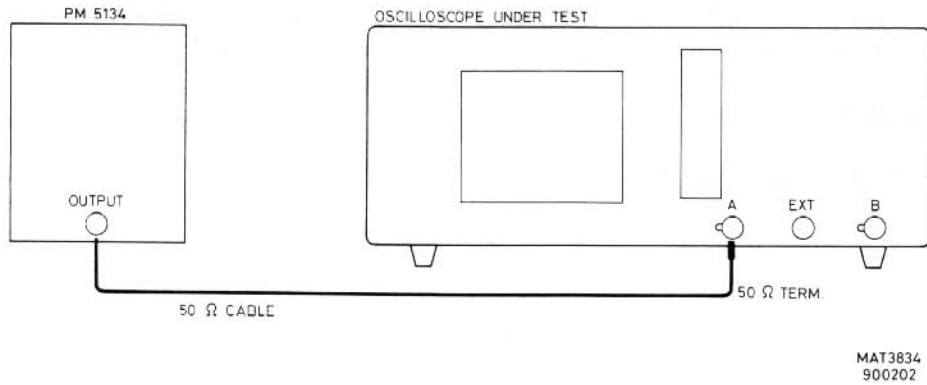
test set-up:**settings/procedure:**

- 1 – Apply a 2 kHz sine-wave signal of 800 mV (pp) to input A; use a 50 Ω termination.
- 2 – Press the AUTO SET button.
- 3 – Set for a trace-height of 4 div.
- 4 – Press X DEFL.
- 5 – Press A/B twice for only channel B display.

requirements:

Verify that a horizontal line of 3,8...4,2 div is displayed.

20.3.25 Horizontal deflection; X deflection coefficient via EXT

The amplification of the horizontal amplifier via the external input is checked.

test equipment:

Sine-wave generator (function generator, PM 5134)

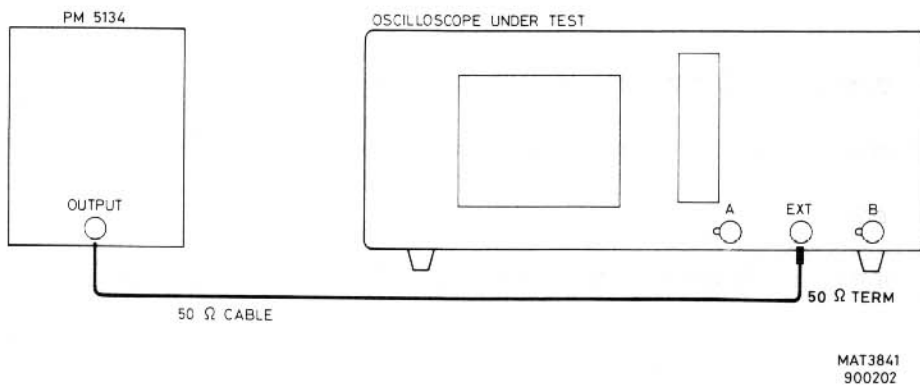
test set-up:

settings/procedure:

- 1 - Apply a 2 kHz sine-wave signal of 1 V (pp) to input EXT; use a 50 Ω termination.
- 2 - Select EXT with TRIG or X SOURCE.
- 3 - Press X DEFL.

requirements:

Verify that a horizontal line of 9,5...10,5 div is displayed.

20.3.26 Horizontal deflection; frequency response 1

In this test, the bandwidth of the horizontal amplifier is verified.

test equipment:

Constant amplitude sine-wave generator (SG 503).

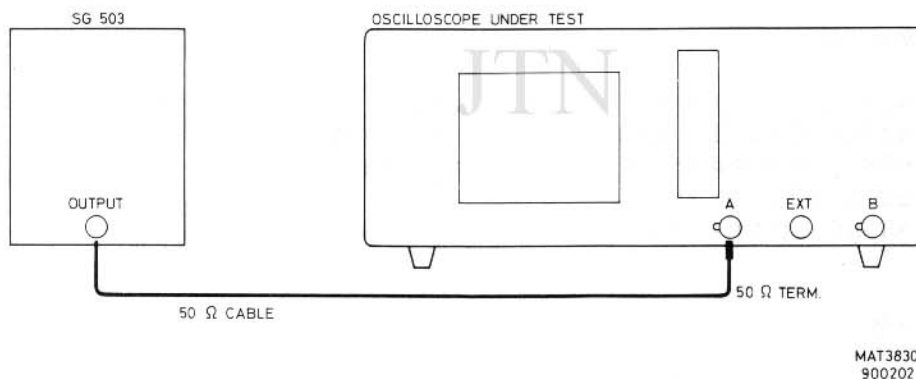
test set-up:*settings/procedure:*

- 1 - Apply a 50 kHz sine-wave signal of 30 mV (pp) to input A; use a 50 Ω termination.
- 2 - Press the AUTO SET button and set A to 5 mV/div.
- 3 - Press X DEFL.
- 4 - Press A/B twice for channel B as vertical deflection.
- 5 - Adjust the input voltage for exactly 6 div horizontal deflection.
- 6 - Increase the input frequency up to 2 MHz.

requirements:

Verify that the trace width is at least 4,2 div over the complete bandwidth range.

20.3.27 Horizontal deflection; frequency response 2

In this test, the function of the horizontal amplifier at low frequencies is checked.

test equipment:

LF sine-wave generator (function generator, PM 5134)

test set-up:

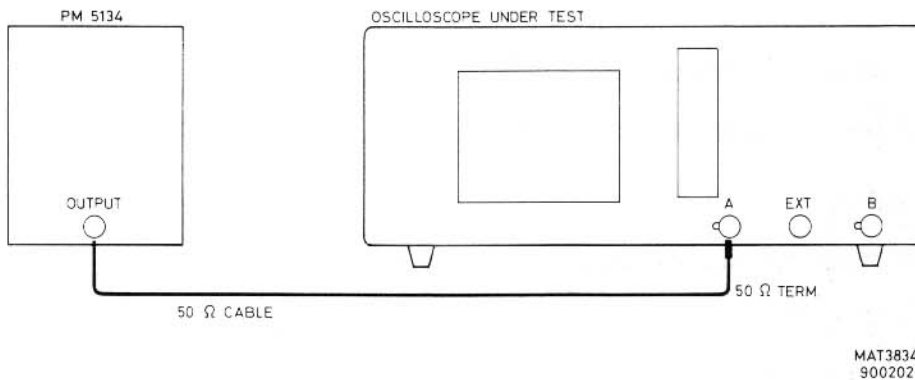

settings/procedure:

- 1 – Apply a 10 Hz sine-wave signal of 30 mV (pp) to input A; use a 50 Ω termination.
- 2 – Press the AUTO SET button and set A to 5 mV/div.
- 3 – Set the vertical deflection of A to exactly 6 div.
- 4 – Select X DEFL.
- 5 – Press A/B twice for channel B as vertical deflection.

requirements:

Ensure that the trace width is at least 4,2 div.

20.3.28 Maximum phase shift between horizontal and vertical deflection

There will be a certain phase shift between the horizontal and vertical amplifier. The value of this shift is measured here.

test equipment:

LF sine-wave generator (function generator, PM 5134)

test set-up:

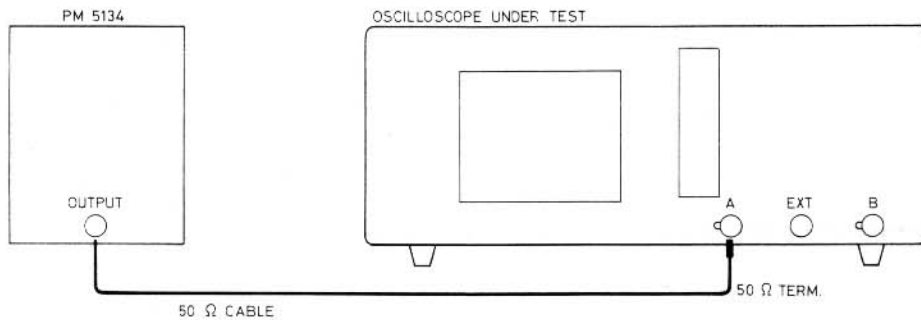

MAT3834
900202

settings/procedure:

- 1 - Apply a 2 kHz sine-wave signal of 1,2 V (pp) to channel A; use a 50 Ω termination.
- 2 - Press the AUTO SET button and set for a trace-height of exactly 6 div.
- 3 - Press X DEFL.
- 4 - Increase the input frequency to 100 kHz.

requirements:

Verify that the phase shift is less than 3°, (see figure 20.6).

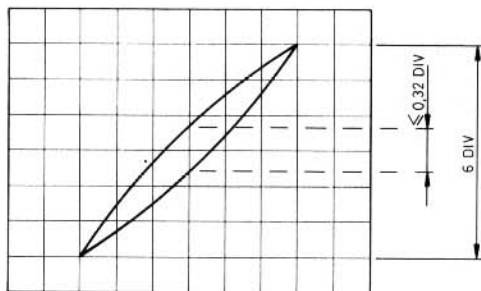

MAT3842
900202

Figure 20.7 Phase shift

20.3.29 Triggering; sources and coupling

In this test, the various trigger sources and coupling modes are tested.

test equipment:

Sine-wave generator (function generator, PM 5134)

test set-up:

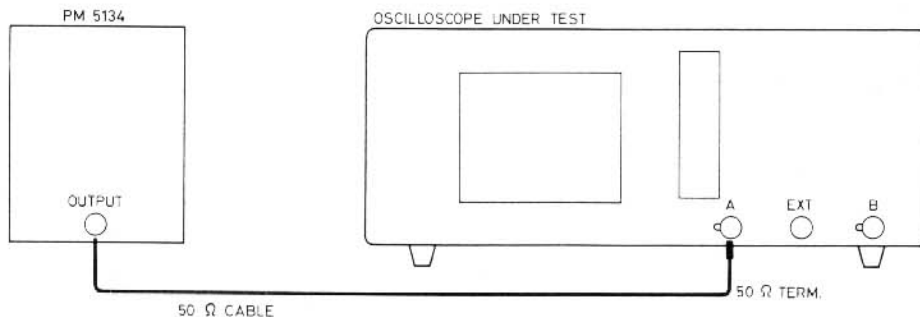

MAT3834
900202

JTN

*settings/procedure
and requirements:*

- 1 – Apply a 2 kHz sine-wave signal of 800 mV (pp) to input A; use a 50 Ω termination.
- 2 – Press AUTO SET and set the trace-height to 4 div.
- 3 – Press TRIG COUPL and select DC.
- 4 – Adjust TRIG LEVEL for a triggered signal.
- 5 – Check that a sine-wave signal of 4 div is displayed.
- 6 – Press TRIG COUPL and select p-p.
- 7 – Turn TRIG LEVEL and check that the signal is triggered over the complete range of this control.
- 8 – Connect the CAL signal to input B.
- 9 – Press A/B to display both channels.
- 10 – Set channel B to 0,2 V/div.
- 11 – Select B as trigger source with TRIG or X SOURCE, (A is not triggered, B is triggered now).
- 12 – Check that a square-wave of 6 div is displayed.
- 13 – Increase the input frequency to input A to 20 kHz (CAL signal to B).
- 14 – Press TRIG or X SOURCE 4 times, (A and B selected).
- 15 – Check that 2 well-triggered traces are displayed.

20.3.30 Triggering; slope selection and level control range

This test checks the range of the trigger level control and the correct working of the slope selection.

test equipment:

- LF sine-wave generator (function generator, PM 5134)
- T-piece

test set-up:

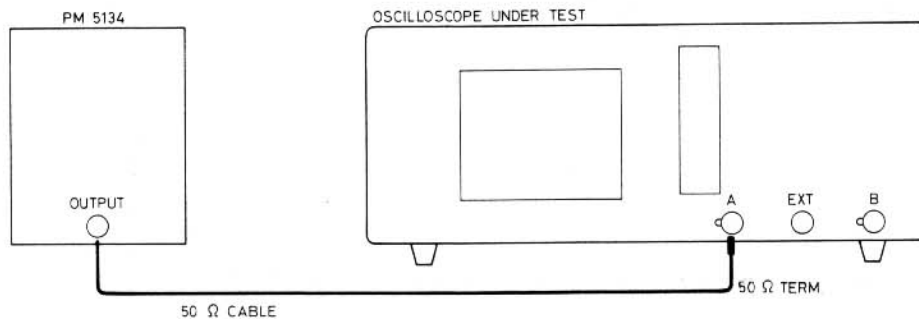

MAT3834
900202

*settings/procedure
and requirements:*

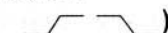
- 1 - Apply a 2 kHz sine-wave signal of 1,6 V (pp) to input A; use a 50 Ω termination.
- 2 - Set A to 0,2 V/div at DC input coupling.
- 3 - Set TRIG COUPL for p-p triggering.
- 4 - Turn TRIG LEVEL fully clockwise and fully counter clockwise.
- 5 - Check that the signal is well-triggered over the complete TRIG LEVEL range.
- 6 - Set the TRIG LEVEL control in its mid-position.
- 7 - The start of the signal display must be in the vertical centre.
- 8 - Press TB TRIG MODE.
- 9 - Press SLOPE. ()
- 10 - Check that the sine-wave signal is inverted and that it is triggered on the negative slope.
- 11 - Press SLOPE once again.
- 12 - Press TRIG COUPL for DC coupling.
- 13 - Set A to 100 mV/div (16 div trace-height).
- 14 - Turn the TRIG LEVEL.
- 15 - Verify that the LEVEL range is more than + 8 div and - 8 div and that the signal is triggered on the positive slope. Use Y POS control.

Repeat this procedure for channel B.

Repeat this procedure for the same signal to inputs A and EXT together, by means of a T-piece.

20.3.31 Triggering; trigger sensitivity via A and B

The trigger sensitivity depends on the amplitude and frequency of the trigger signal. In this test the sensitivity via the A and B inputs is checked.

test equipment:

Constant amplitude sine-wave generator (SG 503)

test set-up:

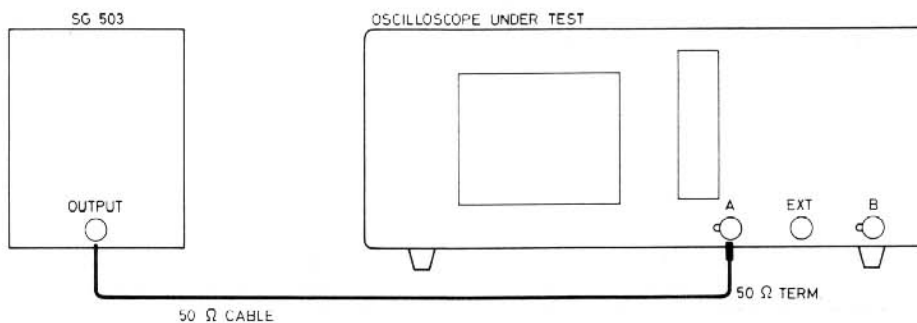

MAT3830
900202

JTN

*settings/procedure
and requirements:*

- 1 – Apply a 10 MHz sine-wave signal of 250 mV (pp) to input A; use a 50 Ω termination.
- 2 – Press AUTO SET and set A to 0,2 V/div.
- 3 – Set AC/DC coupling of A to DC.
- 4 – Press TB TRIG MODE for TRIG mode.
- 5 – Press TRIG COUPL for DC trigger coupling.
- 6 – Turn TRIG LEVEL for a well-triggered signal.
- 7 – Decrease the amplitude of the input signal.
- 8 – Verify that the signal is well-triggered at amplitudes of 0,5 div and more.
- 9 – Decrease the input frequency to 50 kHz.
- 10 – Verify that the signal stays well-triggered at amplitudes of 0,5 div and more.
- 11 – Increase the input frequency to 100 MHz.
- 12 – Increase the input voltage to 1,2 div.
- 13 – Turn TRIG LEVEL.
- 14 – Verify that the signal is well-triggered at amplitudes of 1,2 div and more.
- 15 – Increase the input frequency to 150 MHz.
- 16 – Increase the input voltage to 2 div.
- 17 – Verify that the signal is well-triggered at amplitudes of 2 div and more.

Repeat this procedure for channel B.

20.3.32 Triggering; trigger sensitivity via EXT

The trigger sensitivity depends on the amplitude and frequency of the trigger signal. In this test the sensitivity via the trigger input EXT is checked.

test equipment:

- Constant amplitude sine-wave generator (SG 503)
- T-piece

test set-up:

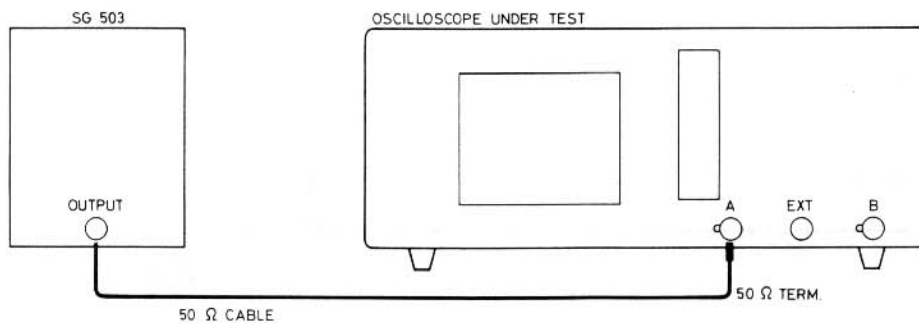

MAT3830
900202

*settings/procedure
and requirements:*

- 1 – Apply a 10 MHz sine-wave signal of 250 mV (pp) to input A; use a 50 Ω termination.
- 2 – Press AUTO SET and set A to 0,2 V/div.
- 3 – Set AC/DC coupling of A to DC and connect the input signal, by means of a T-piece, to inputs EXT and A together.
- 4 – Press TB TRIG MODE for TRIG mode.
- 5 – Press TRIG COUPL for DC trigger coupling.
- 6 – Turn TRIG LEVEL for a well-triggered signal.
- 7 – Decrease the amplitude of the input signal.
- 8 – Verify that the signal is well-triggered at amplitudes of 50 mV and more.
- 9 – Decrease the input frequency to 50 kHz.
- 10 – Verify that the signal stays well-triggered at amplitudes of 50 mV and more.
- 11 – Increase the input frequency to 100 MHz.
- 12 – Increase the input voltage to 250 mV.
- 13 – Turn TRIG LEVEL.
- 14 – Verify that the signal is well-triggered at amplitudes of 150 mV and more.
- 15 – Increase the input frequency to 150 MHz.
- 16 – Increase the input voltage to 1 V.
- 17 – Verify that the signal is well-triggered at amplitudes of 500 mV and more.

20.3.33 Triggering; trigger sensitivity TVL-TVF

This test checks the trigger sensitivity for television line- and frame signals.

test equipment:

TV pattern generator with video output (PM 5518)

test set-up:

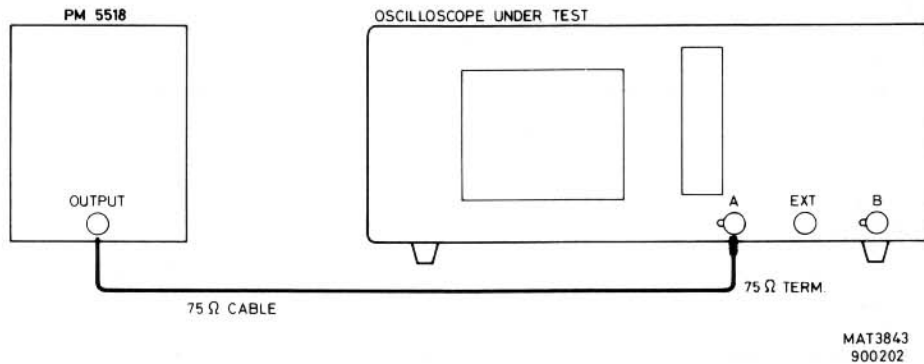

settings/procedure:

- 1 – Apply a video signal to Input A with an amplitude of 0,7 div sync pulse amplitude; use a 75 Ω termination.
- 2 – Press the AUTO SET button.
- 3 – Press TB TRIG mode for TRIG mode.
- 4 – Press AC/DC for DC input coupling.
- 5 – Press TRIG COUPL for TVL and TVF.

requirements:

Check for a stable triggering on the narrow TVL and the wide TVF pulse at sync amplitudes of 0,7 V.

Repeat settings/procedure for channel B.

20.3.34 Cursors; voltage cursor accuracy

In this test the accuracy of the voltage cursors is checked.

test equipment:

Square-wave calibration generator (PG 506)

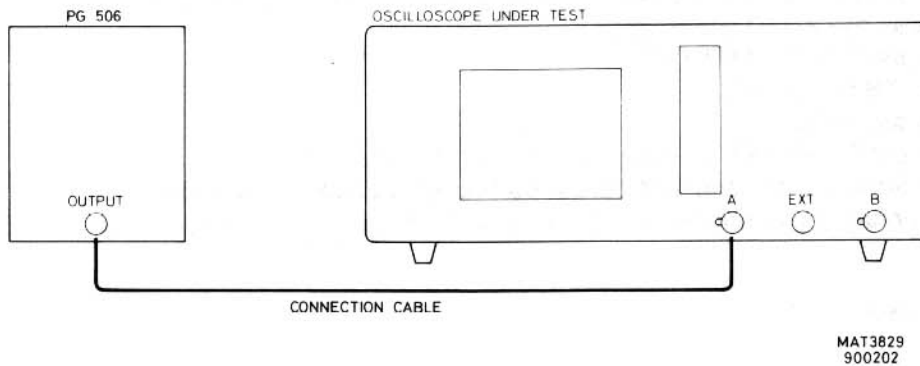
test set-up:**settings/procedure:**

- 1 – Apply a 1 kHz square-wave voltage of 1 V to the channel A input.
- 2 – Press the AUTO SET button.
- 3 – Set channel A to 0,2 V/div and to DC.
- 4 – Press DIGITAL MEMORY.
- 5 – Press LOCK.
- 6 – Select CURSORS by means of the CRT function controls.
- 7 – Position the 1st cursor in the horizontal mid of the top of the waveform.
- 8 – Position the 2nd cursor in the horizontal mid of the bottom of the waveform.

requirements:

Verify that the voltage cursor read-out at the top of the screen is 0,97...1,03 V.

20.3.35 Cursors; time cursor accuracy

In this test the accuracy of the time cursors is checked.

test equipment:

Time marker generator (TG 501)

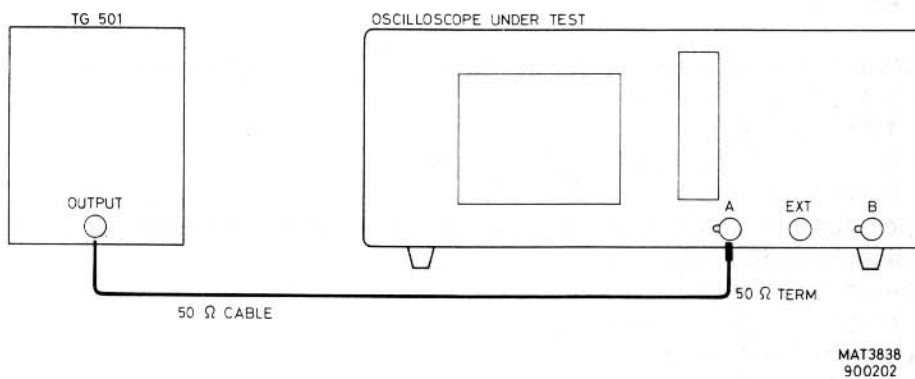
test set-up:

settings/procedure:

- 1 – Apply a 1 ms time marker signal to input A; use a 50 Ω termination.
- 2 – Press the AUTO SET button.
- 3 – Press DIGITAL MEMORY.
- 4 – Set TB to 1 ms/div.
- 5 – Press LOCK.
- 6 – Select CURSORS by means of the CRT function controls.
- 7 – Position the 1st and 2nd cursor so that they cover a distance of 8 time marker intervals; position the markers exactly to the top of the marker pulses.

requirements:

Check for a time cursor read-out of 7,99...8,01 ms.

20.3.36 Z-MOD sensitivity

This test checks the sensitivity of the Z modulation facility.

test equipment:

- Square-wave generator (function generator, PM 5134)
- T-piece

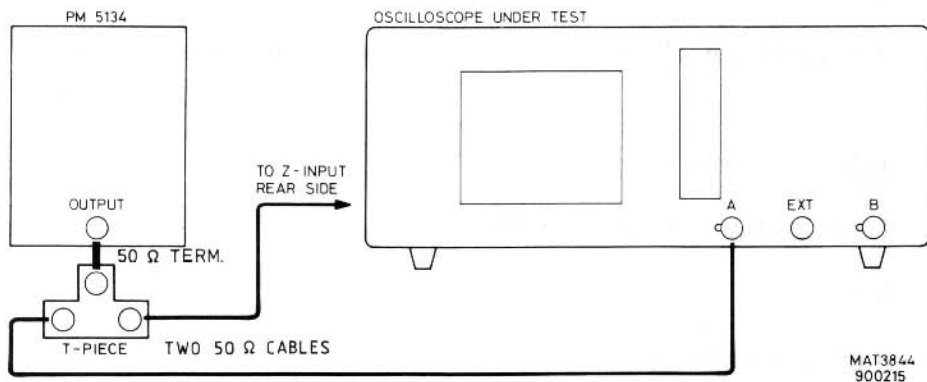
test set-up:*settings/procedure and requirements:*

- 1 – Apply a 1 kHz square-wave signal, duty cycle 50 %, amplitude 2,5 V, to input A.
- 2 – Press the AUTO SET button.
- 3 – Set TB to 0,5 ms/div.
- 4 – Set the trace of channel A in mid position.
- 5 – Apply the same signal by means of the T-piece to the Z-input (rear side).
- 6 – Check that only the bottom half of the square-wave signal is displayed. (500 μ s blanking and 500 μ s unblanking)
- 7 – Remove the Z-input.
- 8 – Decrease the input signal to 1 V.
- 9 – Reconnect the Z-input.
- 10 – Set A to 0,5 V/div.
- 11 – Check that the top half of the square-wave signal is visible with a lower intensity.
- 12 – Check that the top half of the signal is completely unblanked (visible with full intensity) at an input signal less than 0,8 V.

20.3.37 CAL signal; frequency and output voltage

The CAL signal is a calibration signal with fixed frequency and voltage. In this test, the values of frequency and voltage are checked.

test equipment:

None

test set-up:

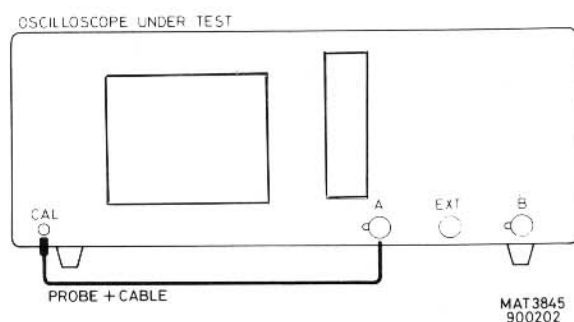

settings/procedure:

- 1 – Connect the CAL signal to input A and press the AUTO SET button.
- 2 – Press GND of channel A.
- 3 – Set the trace in the centre of the screen.
- 4 – Press GND of channel A again.
- 5 – Select DC of A input coupling.

requirements:

- 1 – Check that a positive going square-wave signal of 1,2 V (pp) is displayed, i.e. 2,4 div at 0,5 V/div.
- 2 – Check that the frequency of the displayed signal is about 2 kHz, i.e. 5 div at 0,1 ms/div.

DISMANTLING THE INSTRUMENT

JTN

21 DISMANTLING THE INSTRUMENT

21.1 GENERAL INFORMATION

This section provides the dismantling procedures required for the removal of components during repair operations.

All circuit boards removed from the instrument must be adequately protected against damage, and all normal precautions regarding the use of tools must be observed.

During the dismantling a careful note must be made of all disconnected leads so that they can be reconnected to their correct terminals during assembly.

CAUTION: Damage may result if:

- The instrument is switched-on when a circuit board has been removed.
- a circuit board is removed within one minute after switching-off the instrument.

21.2 REMOVING THE TOP AND BOTTOM COVERS

The instrument is protected by two covers: a top cover and a bottom cover. To remove these covers, proceed as follows:

- Slacken the two screws that secure both covers, located at the rear of the instrument.
- Gently push each cover backwards until it can be lifted.
- The covers can be removed by lifting them clear of the instrument.

21.3 ACCESS TO THE ADJUSTING ELEMENTS

After removing both covers (section 21.2), the P²CCD unit and the time base unit have to fix vertically in the chassis.

NOTE: *To avoid damage of the flatcables, the metal bracket that fixes the P²CCD unit have to be removed from the chassis first. Then you can easily fix the P²CCD unit vertically in the chassis.*

Next the digital unit (A10 ... A15) has to be removed out of the instrument. It can be placed beside the instrument using the metal cover as a bottom plate. The four already existing holes in the cover must be used to position the digital unit in this place.

If necessary, the power supply unit can be lifted out of the instrument. To do so, proceed as follows:

- Push both parts at the back of the extension shaft towards each otherso that the extension shaft can easily be loosened from the ON/OFF switch on the power supply unit.
- Remove the complete extension shaft.
- Push both lips that secure the power supply unit sideways and gentlylift this unit out of the instrument.
- Fix the power supply unit in the available p.c.b. guide fixing.

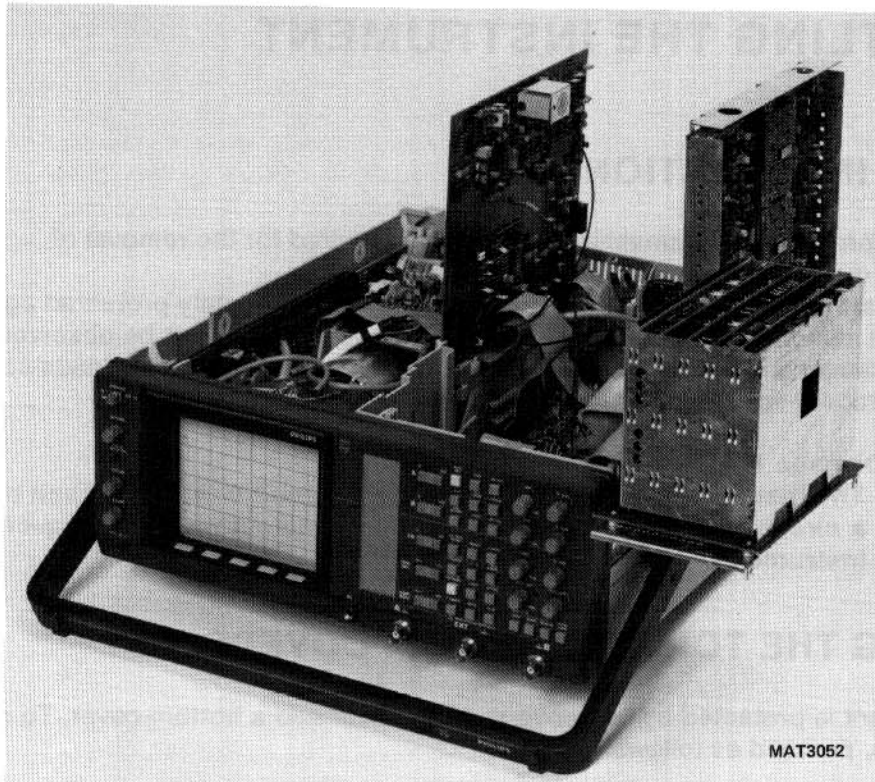

Figure 21.1 Access to all parts for checking and adjusting

NOTE: *For checking and adjusting the instrument it is not necessary to remove the bottom cover.*

CHECKING AND ADJUSTING

JIN

22 CHECKING AND ADJUSTING

22.1 GENERAL INFORMATION

The following information provides the complete checking and adjusting procedure for the instrument. As various control functions are interdependent, a certain order of adjustment is necessary.

The procedure is, therefore, presented in a sequence which is best suited to this order, cross-reference being made to any circuit which may affect a particular adjustment. Before any check or adjustment, the instrument must attain its normal operating temperature.

- Warming-up time under average conditions is 30 minutes.
- Where possible, instrument performance should be checked before any adjustment is made.
- All limits and tolerances given in this section are calibration guides, and should not be interpreted as instrument specifications unless they are also published in section 2.
- Tolerances given are for the instrument under test and do not include test equipment error.
- The most accurate display adjustments are made with a stable, well- focused low intensity display.
- All controls that are mentioned without item numbers are located on the outside of the instrument.

WARNING: The opening of covers or removal of parts, except those to which access can be gained by hand, is likely to expose live parts, and also accessible terminals may be live.
The instrument shall be disconnected from all voltage sources before any adjustment, replacement or maintenance and repair during which the instrument will be opened.
If afterwards any adjustment, maintenance or repair of the opened instrument under voltage is inevitable, it shall be carried out only by qualified person who is aware of the hazard involved.
Bear in mind that capacitors inside the instrument may still be charged even if the instrument has been separated from all voltage sources.

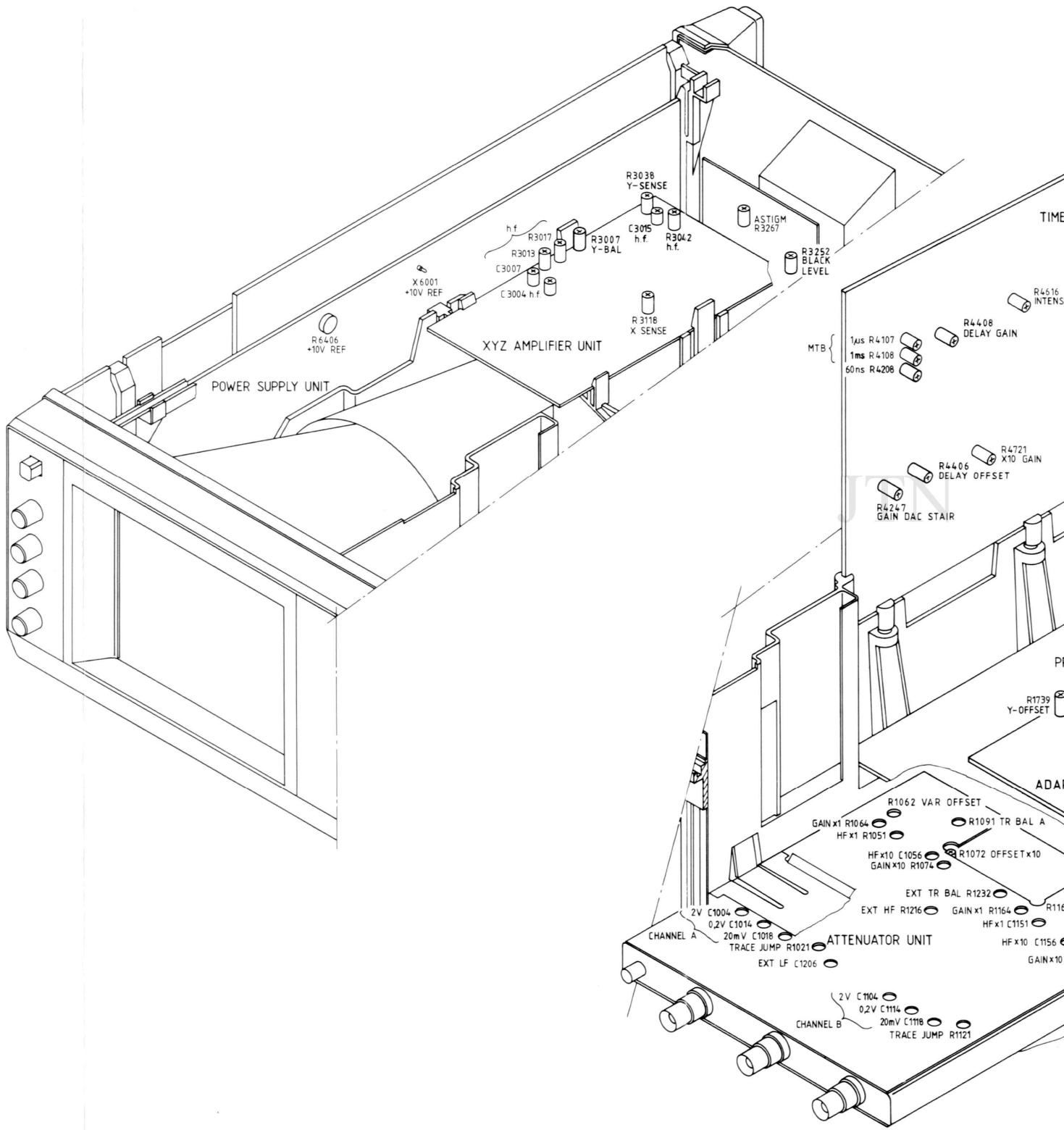

22.2 RECOMMENDED TEST AND CALIBRATION EQUIPMENT

Type of Instrument	Required specification	Example of recommended instrument
Function generator	Freq.: 1 MHz ... 10 MHz Sine-wave/Square-wave Ampl. 0...20 Vpp DC offset 0...± 5 V Rise-time ≤ 30 ns Duty cycle 50 %	Philips PM5134
Constant amplitude sine-wave generator	Freq.: 100 kHz ... 50 MHz Const. ampl. of 120 mVpp and 3 Vpp	Tektronix SG 503
Square-wave calibration generator	For ampl. calibration: Freq.: 1 kHz Ampl.: 10 mV ... 50 V For rise-time measurements: Freq.: 1 MHz Ampl.: 10 mV ... 500 mV Rise-time: ≤ 1 ns	Tektronox PG 506
Time-marker generator	Repetition rate: 0,5 s ... 0,05 μs	Tektronix TG 501
Digital multimeter	Wide voltage, current and resistance ranges. High-voltage probe required, accuracy 0,1% PM9246	Philips PM2524
Oscilloscope	The bandwidth must be the same or higher than the bandwidth of the instrument under test.	Philips PM3065
Variable mains transformer	Well-insulated output voltage 90...264 Vac	Philips ord.number 2422 529 00005
Moving-iron meter		
Dummy probe 2:1	1 MΩ ± 0,1 %//20 pF	
Cables, T-piece, 10:1 attenuator, terminations for the generators	General Radio types for fast rise-time square-wave and high freq. sine-wave. BNC-types for other applications	
Trimming tool kit		Philips 800NTX (ordering number 4822 310 50015)

22.3 SURVEY OF ADJUSTING ELEMENTS

Adjustment	Adjusting element(s)	Unit	Signal type, Generator, menu	Requirement
POWER SUPPLY (see section 22.4.2)				
+ 10 V supply	R6406 X6001	power supply	digital voltm.	10 V (\pm 10 mV)
CRT DISPLAY (see section 22.4.3)				
pre adjustment	R4616	time base	--	mid position
black level line parr.	R3252	CRT socket	--	INTENS 10 ⁰ from c.c.w. spot just not visible
TRACE ROTATION front		--	--	graticule
Astigmatism	R3267	CRT socket	function generator 1 kHz/6 div. sine wave	well defined trace
GAIN, LF S.Q. WAVE (see sections 22.4.4 and 22.4.5)				
EXT input	C1206	atten. unit	calibrated sq. wave: 0,5 V/ 1 kHz	dots at beginning and end of line
	R3118	XYZ ampl.	calibrated sq. wave: 0,5 V/ 1 kHz	5 div. horizontal
A input	R1064	atten. unit	calibrated sq. wave: 0,1 mV/ 1 kHz	5 div. vertical at A sens. 20 mV/div.
	C1018	atten. unit	calibrated sq. wave: 0,1 V/ 1 kHz	Straight pulse top at A sens. 20 mV/div
	R3038	XYZ ampl.	calibrated sq. wave: 0,1 mV/ 1 kHz	5 div. vertical at A sens 20 mV/div.
	R1074	atten. unit	calibrated sq. wave: 10 mV/ 1 kHz	5 div. vertical at A sens 2 mV/div.
	C1014	atten. unit	calibrated sq. wave: 1 V/ 1 kHz	Straight pulse top at A sens. 0,2 V/div.
	C1004	atten. unit	calibrated sq. wave: 10 V/ 1 kHz	Straight pulse top at A sens. 2 V/div.

Adjustment	Adjusting element(s)	Unit	Signal type, Generator, menu	Requirement
B Input	C1118	atten. unit	calibrated sq. wave: 0,1 V/ 1 kHz	Straight pulse top at B sens. 20 mV/div.
	R1164	atten. unit	calibrated sq. wave: 0,1 V/ 1 kHz	5 div. vertical at B sens 20 mV/div.
	R1174	atten. unit	calibrated sq. wave: 10 mV/ 1 kHz	5 div. vertical at B sens 2 mV/div.
	C1114	atten. unit	calibrated sq. wave: 1 V/ 1 kHz	Straight pulse top at A sens. 0,2 V/div.
	C1104	atten. unit	calibrated sq. wave: 10 V/ 1 kHz	Straight pulse top at A sens. 2 V/div.

OFFSET (see section 22.4.6)

Final Y ampl.	R3007	XYZ-ampl.	--	centre line
1-2-5 bal. A	R1021	atten. unit	serv.menu: 3.0	minimise jump
1-2-5 bal. B	R1121	atten. unit	serv.menu: 3.0	minimise jump
VAR balance A	R1062	atten. unit	serv.menu: 3.1	Turn VAR jump
VAR balance B	R1162	atten. unit	serv.menu: 3.1	Turn VAR jump
1-10 balance A	R1072	atten. unit	serv.menu: 3.2	VAR CAL jump
1-10 balance B	R1172	atten. unit	serv.menu: 3.2	VAR CAL jump
Trig.bal. A	R1091	atten. unit	serv.menu: 3.3	VAR CAL jump
Trig.bal. B	R1191	atten. unit	serv.menu: 3.4	VAR CAL jump
Trig.bal. EXT	R1232	atten. unit	serv.menu: 3.5	VAR CAL jump
Norm.Inv. bal.	R2212	preamplifier	serv.menu: 3.6	VAR CAL jump
Final Y ampl.	R2261	preamplifier	serv.menu: 3.7	Minimise jump with LEVEL. Centre line with R2261

TRIGGERING (see section 22.4.7)

trigg.symmetry	R4004	time base	sine-wave to A 0,4 V/1 kHz	well triggered display
LEVEL preset	R2427	preamplifier	sine-wave to A 8 V/1 kHz	LEVEL pos. such that line does not move when turning R2427.

Adjustment	Adjusting element(s)	Unit	Signal type, Generator, menu	Requirement
LEVEL VIEW balance	R2426	preamplifier	sine-wave to A 8 V/1 kHz	min. jump between LEVEL VIEW on/off.
LEVEL VIEW sensitivity	R2427	preamplifier	sine-wave to A 8 V/1 kHz	LEVEL 3 div. up or down. Min. jump between LEVEL VIEW on/off
TIME-BASE (see section 22.4.8)				
sweep speed: 1 ms/div.	R4108	time base	time markers: 1 ms	max. accuracy between 2nd and 10th graticule line
1 μ s/div.	R4107	time base	1 μ s	max. accuracy between 2nd and 10th graticule line
X MAGN and 0,1 ms/div.	R4721	time base	0,1 μ s	max. accuracy between 2nd and 10th graticule line
20 ns/div.	R4208	time base	20 ns serv menu: 3.8	max. accuracy between 2nd and 10th graticule line
HF SQ. WAVE (see section 22.4.9)				
pulse response A (B)	R3017	XYZ-ampl.	fast-rise sq. wave: 100 mV/ 100 kHz	Optimal pulse response
	R3013	XYZ-ampl.	100 mV/ 1 MHz	
	C3007	XYZ-ampl.	100 mV/ 1 MHz	
	C3005	XYZ-ampl.	100 mV/ 1 MHz	
	C1051/1151	attenuator	100 mV/ 1 MHz	
	C1056/1156	attenuator	100 mV/ 1 MHz	
P²CCD ADJUST (see section 22.4.10) PM3365A/67A only				DIGITAL MEMORY
Treshold A	R974, X809	P ² CCD unit	digital voltm.	6 V d.c
Treshold B	R977, X810	P ² CCD unit	digital voltm.	6 V d.c
Bias charge A	R894	P ² CCD unit	digital voltm.	43,3 V
Bias charge B	R892	P ² CCD unit	digital voltm.	43,3 V

Adjustment	Adjusting element(s)	Unit	Signal type, Generator, menu	Requirement
Signal DC level A	R966, X811 X812	P ² CCD unit	measuring oscilloscope	300 mV d.c.
Signal DC level B	R970, X813 X814	P ² CCD unit	measuring oscilloscope	300 mV d.c.
Leakage corr. A	R902, X816	P ² CCD unit	measuring oscilloscope	line
Leakage corr. B	R917, X817	P ² CCD unit	measuring oscilloscope	line
P²CCD ADJUST (see section 22.4.11) PM3375/77 only				DIGITAL MEMORY
Oscillator	C5127, 5128	P ² CCD unit	measuring	min. signal
Treshold A	R5608, X5601	P ² CCD unit	digital voltm.	6 V d.c.
	R5527, X5503	P ² CCD unit	digital voltm.	7 V d.c.
Treshold B	R5708, X5701	P ² CCD unit	digital voltm.	6 V d.c.
	R5577, X5553	P ² CCD unit	digital voltm.	7 V d.c.
Bias charge A	R5604 X5602/03	P ² CCD unit	measuring oscilloscope	300 mV d.c.
Bias charge B	R5602 X5702/03	P ² CCD unit	measuring oscilloscope	300 mV d.c.
Leakage corr. A	R5802, X5816	P ² CCD unit	measuring oscilloscope	line
Leakage corr. B	R5817, X5817	P ² CCD unit	measuring oscilloscope	line
DISPLAY SECTION (see section 22.4.12)			service menu DISPLAY	DIGITAL MEMORY on
Y-offset	R550	digital unit	step 1	display vertical mid
Y-gain	R542	digital unit	step 2	6 div. vertical
X-offset	R601	digital unit	step 3	display horizontal mid
X-gain	R606	digital unit	step 4	10 div. horizontal
Text position	R553	digital unit	step 5	text in horizontal mid

Adjustment	Adjusting element(s)	Unit	Signal type, Generator, menu	Requirement
HORIZONTAL S-MODE (see section 22.4.13)				DIGITAL MEMORY
Gain Dacstair	R4247	time base	time marker 20 ns	max. accuracy between 2nd and 10th graticule line
Delay gain	R4408	time base	time marker 20 ns	stable display
Delay offset	R4406	time base	fast-rise sq. wave 1 MHz	downgoing edge in centre of screen
GAIN - OFFSET (see section 22.4.14) PM3365A/67A only				
Offset A	R932	P ² CCD unit	--	Position 2,5 divisions downwards with DIGITAL MEMORY on
Gain A	R929	P ² CCD unit	calibrated sq. wave: 100 mV/ 1 kHz	A sens.: 20 mV/div 5 div. deflection
Offset A	R932	P ² CCD unit	--	Position vertical mid with DIGITAL MEMORY on
Offset B	R942	P ² CCD unit	--	Position 2,5 divisions downwards with DIGITAL MEMORY on
Gain B	R939	P ² CCD unit	calibrated sq. wave: 100 mV/ 1 kHz	B sens.: 20 mV/div 5 div. deflection
Offset B	R942	P ² CCD unit	--	Position vertical mid with DIGITAL MEMORY on
GAIN - OFFSET (see section 22.4.15) PM3375/77 only				
Offset A 200 μ s	R5832	P ² CCD unit	--	Position 2,5 divisions downwards with DIGITAL MEMORY on
Gain A 200 μ s	R5829	P ² CCD unit	calibrated sq. wave: 100 mV/ 1 kHz	A sens.: 20 mV/div 5 div. deflection
Offset A 200 μ s	R5832	P ² CCD unit	--	Position vertical mid with DIGITAL MEMORY on

Adjustment	Adjusting element(s)	Unit	Signal type, Generator, menu	Requirement
Offset B 200 μ s	R5842	P ² CCD unit	--	Position 2,5 divisions downwards with DIGITAL MEMORY on
Gain B 200 μ s	R5839	P ² CCD unit	calibrated sq. wave: 100 mV/1 kHz	B sens.: 20 mV/div 5 div. deflection
Offset B 200 μ s	R5842	P ² CCD unit	--	Position vertical mid with DIGITAL MEMORY on
Offset A 200 ns	R5830	P ² CCD unit	--	Position 2,5 divisions downwards with DIGITAL MEMORY on.
Gain A 200 ns	R5828	P ² CCD unit	calibrated sq. wave: 100 mV/1 MHz	A sens.: 20 mV/div 5 div. deflection
Offset A 200 ns	R5830	P ² CCD unit	--	Position vertical mid with DIGITAL MEMORU on.
Offset B 200 ns	R 5840	P ² CCD unit	--	Position 2,5 divisions downwards with DIGITAL MEMORY on.
GAIN B 200 ns	R5838	P ² CCD unit	calibrated sq. wave: 100 mV/1 MHz	B sens.: 20 mV/div 5 div. deflection
Offset B 200 ns	R5840	P ² CCD unit	--	Position vertical mid with DIGITAL MEMORY on.
SAMPLE MODE ADJUSTMENTS (see section 22.4.16)				DIGITAL MEMORY
Gain and offset	R1719	adapt unit	calibrated sq. wave 100 mV/1 MHz	A sens: 20 mV/div - 5 div deflection
Bal S-mode	R1739	adapt unit	--	minimum trace jump
pulse response	C1706	adapt unit	fast rise sq. wave 100 mV/1 MHz	optimal pulse response
	R1717	adapt unit	100 mV/1 MHz	

22.4 CHECKING AND ADJUSTING PROCEDURE

The adjusting elements and measuring points are given in figure 22.1.

NOTE: Use always an insulated adjustment tool.

22.4.1 Preparation

Before starting the checking and adjusting procedure, it is necessary to be aware of the following.

- Unless otherwise indicated, the time base must be triggered on the channel that is selected for vertical display and the trigger path is P-P coupled. The time base must function in the AUTO mode and its sweep speed must be adjusted to give good display of the phenomena of interest. The INTENS and FOCUS control must be adjusted to a well-defined trace display.
- Preliminary setting of the controls:
All VAR controls must be set in CAL position
All POS and LEVEL controls must be set in mid-position.
The HOLD OFF control must be set to MIN position.
- Take care to remove the input voltage after each section.
- All signal values are peak-to-peak values (pk-pk), unless otherwise indicated.

For better access to the adjusting elements on the time base unit and the power supply unit, proceed as indicated in section 21.3.

ATTENTION: Do not readjust potentiometer R2395, situated on the pre-amplifier unit A2. However, if this potentiometer is inadvertently turned, proceed as follows:

- Set R2395 in its mid-position.
- Readjust R4004 according to section 22.4.7.

22.4.2 Power supply adjustment

Adjustment on power supply unit A6.

- Connect the instrument to the mains voltage and switch on the oscilloscope.
- Connect a digital multimeter to connection point X6001 (+ 10V REF) on the power supply unit and the instrument's ground.
- Adjust R6406 so that the supply voltage is exactly + 10 V (tolerance: + or - 0,01 V).

22.4.3 CRT display adjustment

Black level:

- Press X DEFL key.
- Set the INTENS control to 10^0 from its left hand stop.
- Set R4616 in its mid position.
- Adjust R3252 so that the spot is just not visible.

Trace rotation:

- Press X DEFL key again for deflection via MTB.
- Adjust the front-panel TRACE ROTATION control so that the trace runs exactly in parallel with the horizontal graticule lines.

Astigmatism:

- Apply a 120 mV/1 kHz sine-wave signal to input A.
- Press AUTO SET key.
- Set the INTENS control for normal brightness.
- Adjust R3267 (and the FOCUS control) so that the trace is sharp and well-defined over the whole screen area.

22.4.4 Gain and LF-sq.wave response EXT and A input

Adjustments on attenuator unit A1, unless otherwise indicated.

Input EXT:

- Press MENU and then AUTO SET in sequence in order to reach the default setting.
- Press X DEFL.
- Select TRIG SOURCE "EXT".
- Select TRIG COUPL "DC".
- EXT input signal: calibrated sq.wave 0,5 V/1 kHz.
- Adjust C1206 for equal dots at beginning and end of horizontal line.
- Adjust R3118 on XYZ-amplifier A3 for 5 div. horizontal deflection (+ or -0,1 div.).

Input A:

- Select TRIG SOURCE "B".
- A Input signal: calibrated sq.wave 100 mV/1 kHz.
- Channel A sensitivity: 20 mV/div.
- Adjust R1064 for 5 div. vertical deflection (+ or - 0,1 div.).
- Remove the input signal.

22.4.5 Gain and LF-sq.wave response channel A(B)

Adjustments are located on attenuator unit A1, except R3038 that is located on XYZ-amplifier A3.

- Do the adjustments for channel A first. Then those mentioned between brackets for channel B.
- Press MENU and then AUTO SET in sequence in order to reach the default setting.
- Select TRIG SOURCE "A(B)".
- Adjust vertical gain to 5 div. (+ or - 0,1 div.) and pulse top as straight as possible (max. distortion + or - 0,075 div.). Use a calibrated sq.wave signal.

Input signal channel A(B)	Input sensitivity channel A(B)	Adjusting elements	
		sq.wave resp.	gain
0,1 V	20 mV/div.	C1018 (C1118)	R3038 (R1164)
10 mV	2 mV/div.	--	R1074 (R1174)
1 V	0,2 V/div.	C1014 (C1114)	--
10 V	2 V/div.	C1004 (C1104)	--

22.4.6 Offset channel A(B)**Y balance preset:**

- Short circuit pin 1 and pin 3 (c.i. both outside pins) of socket X3004 on unit A3 by means of a pair of tweezers.
- Adjust R3007 so that the line is in the centre of the screen.

Service menu:

- Y POS A (B) controls: mid-position.
- Press MENU and AUTO SET together in order to reach the service menu.
- Press CRT-softkey OFFS-A.
- The successive steps in the following adjustment procedure must be selected with the channel A UP-DOWN control for the input sensitivities.
- The adjustments are located on the attenuator unit; unless otherwise noted in last column of table.

Adjustment step	Adjustment point	Max instab.	
3.0 1-2-5 balance A(B)	R1021 (R1121)	0,1 div.	
3.1 VAR-balance A(B)	R1062 (R1162)	0,2 div.	Turn VAR A(B)
3.2 1-10 balance A(B)	R1072 (R1172)	0,2 div.	VAR A(B) in CAL
3.3 Trig. balance A	R1091	0,3 div.	
3.4 Trig. balance B	R1191	0,3 div.	
3.5 Trig. balance EXT	R1232	0,3 div.	
3.6 Norm/Inv. bal. B	R2212	0,1 div.	on pre amplifier
3.7 Y bal.	R2261	0,2 div.	on pre amplifier Minimise jump with TRIG LEVEL. Centre line with R2261.

- Press AUTO SET twice to leave the service menu.

22.4.7 Triggering

Adjustments on pre-amplifier unit A2 unless otherwise noted.

- Press MENU and then AUTO SET in sequence in order to reach the default setting..
- Channel A input signal: 0,4 V/1 kHz sine-wave.
- TRIGGER LEVEL: mid position.
- Trigger slope pushbutton must be continuously switched.
- Adjust R4004 (time-base A4) for a well triggered display.

- Channel A input signal: 8 V/1 kHz sine-wave.
- Select TRIGGER COUPL "DC".
- Press LEVEL VIEW.
- Put TRIG LEVEL in such a position that line does not move when turning R2427 between its utmost positions. Keep TRIG LEVEL in this position.

- Switch LEVEL VIEW off.
- Time base sweep speed: 50 ns/div.
- INTENS control: fully clockwise.
- Adjust R2426 for minimal trace jump (+ or - 0,4 div. max) when switching LEVEL VIEW on and off.

- Switch LEVEL VIEW on.
- Shift the line with TRIG LEVEL 3 div. upwards or downwards from its present situation (within graticule).
- Adjust R2427 for minimal trace jump (+ or - 0,2 div. max) when switching LEVEL VIEW on and off.
- Remove the input signal.

22.4.8 Time-base sweep speeds

Adjustments on time-base unit A4.

- Press MENU and then AUTO SET in sequence in order to reach the default setting.
- Select TRIG COUPL "DC".
- Channel A input signal: time marker pulse 1 ms.
- Adjust Y POS A, TRIG LEVEL and channel A input sensitivity for a well-readable display.
- Adjust R4108 so that 2nd and 10th marker pulse coincide with the corresponding graticule lines (max. deviation 0,16 div.). Use X POS for a correct horizontal position.

- Channel A input signal: time marker pulse 1 μ s.
- Time base sweep speed: 1 μ s/div.
- Adjust R4107 so that 2nd and 10th marker pulse coincide with corresponding graticule lines. Max. deviation 0,16 div.

- Channel A input signal: time marker pulse 0,1 ms.
- Press X MAGN.
- Time base sweep speed: 0,1 ms/div.
- Adjust R4721 so that 2nd and 10th marker pulse coincide with corresponding graticule lines. Use X POS for a correct horizontal position; the control must stay approximately in its mid position. Max. deviation 0,24 div.
- Turn X POS fully clockwise and fully counter clockwise and check that the marker pulse deviation does not exceed 0,24 div.

- Channel A input signal: time marker pulse 20 ns.
- Press MENU and AUTO SET together in order to reach the service menu.
- Press CRT-softkey OFFS-A.
- Press the channel A UP-DOWN control several times in order to reach step 3.8.
- Adjust R4208 so that the correct marker pulses coincide with 2nd and 10th graticule lines. Max. deviation 0,16 div.
Take notice that 3 marker pulses must be visible within one division
- Remove the input signal.

22.4.9 HF sq.wave response

Adjustments on XYZ-amplifier unit A3 and attenuator unit A1.

- Channel A input signal: fast rise time sq.wave 1 MHz/500 mV/rise time \leq 1ns via 50 Ω termination resistor.
- Press AUTO SET.
- Channel A input sensitivity: 100 mV/div.
- Time base sweep speed: 50 ns/div.
- Press TB MAGN to * 10.
- Preset C1051 in mid position.
- Preset R3042 clockwise.
- Preset C3015 for minimum overshoot.
- Press TB MAGN to * 1.
- Time base sweep speed: 0,5 μ s/div.
- Adjust the square-wave response with R3017.
- Time base sweep speed: 0,1 μ s/div upto 5 ns/div.
- Adjust the square-wave response with R3013, C3007, C3005, C3015 and R3042 for optimum rise-time and minimum overshoot.

- Press TB MAGN to * 10.
- Time base sweep speed: 5 ns/div.
- Adjust the square-wave response with C1051.
- Decrease the input voltage to 50 mV.
- Channel A input sensitivity: 10 mV/div.
- Adjust the square-wave response with C1056.

- Channel B input signal: fast rise time sq.wave 1 MHz/500 mV/rise time ≤ 1 ns via 50 Ω termination resistor.
- Press AUTO SET.
- Channel B input sensitivity: 100 mV/div.
- Time base sweep speed: 5 ns/div
- Adjust the square-wave response with C1151.
- Decrease the input voltage to 50 mV.
- Channel B input sensitivity: 10 mV/div.
- Adjust the square-wave response with C1156.

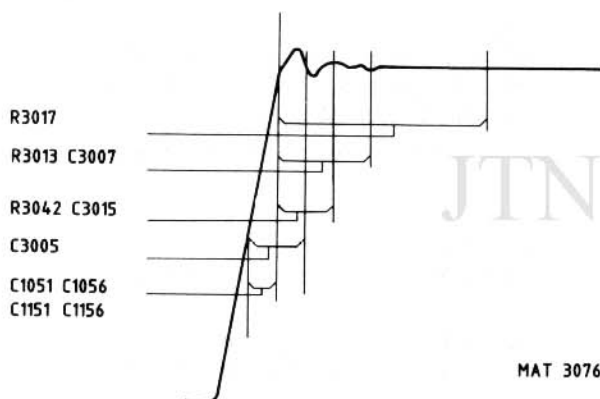

Figure 22.2 Square-wave response

- Check that the pulse via channel A or B has a rise-time of $\leq 3,5$ ns and that pulse aberrations are $\leq 0,2$ div. peak-to-peak. Tilt must not exceed + or - 0,1 div.

22.4.10 P²CCD-adjustment - PM3365A/67A only

Adjustments located on P²CCD-unit A18 in PM3365A/67A.

Threshold A (B):

- Press MENU and AUTO SET in order to reach the default setting.
- Select channel A and B for vertical display.
- Set A and B line in centre of screen by means of A POS and B POS.
Y POS A and B: must stay in mid position during the adjustments in this chapter.
- Switch DIGITAL MEMORY on.
- Adjust the d.c. voltage between measuring point X809 (X810) and X821 (= earth) to 6 V (+ or - 100 mV) with R974 (R977).

Bias charge A (B):

- Adjust the d.c. voltage between connector point 2 of A17 of ch. A (ch. B) and X821 (= earth) to 43,3 V (+ or - 0,1 V) with R894 (R892).

Linearity A (B):

- Press MENU and then AUTO SET.
- Select channel A and B for vertical display.
- Switch DIGITAL MEMORY on.
- Channel A and B sensitivity: 0,1 V/div.
- Connect a measuring oscilloscope with a.c. coupled input to measuring point X812 (X814) and X821 (= earth).
- Measuring oscilloscope: 200 mV/div - 1 ms/div.
- Channel A (B) input coupling: GND.
- Adjust R966 (R970) so that the the voltage "V" between the measuring points X811-X812 (X813-X814) and X821 (= earth) is 300 mV (+ or - 30 mV). Refer to figure 22.3. The values of X811-X812 (X813-X814) must be averaged to the 300 mV.
- Channel A (B) input signal: triangular 1 V/1 kHz.
- Switch GND off for A(B).
- Channel A (B) input coupling: DC.
- Check with the measuring oscilloscope that the triangular voltage is visible in the bottom level of the measured signal.
- Disconnect the input signal.

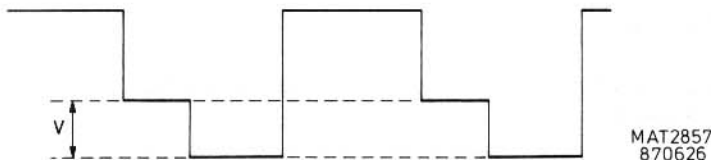

Figure 22.3 Adjustment of $\Delta V = 300 \text{ mV}$

Leakage correction:

- Channel A (B) input signal: square wave 800 mV/1 kHz.
- Time base speed: 200 $\mu\text{s}/\text{div}$.
- Connect a measuring oscilloscope with a.c. coupled input to measuring point X816 (X817) and X821 (= earth).
- Measuring oscilloscope: 100 mV/div - 1 ms/div.
- Adjust R902 (R917) so that the square wave signal has become a line.
- Remove input signal.
- Remove the measuring oscilloscope.

22.4.11 P²CCD-adjustment - PM3375/77 only

Adjustments located on P²CCD unit A18 in PM3375/77.

Oscillator:

- Press MENU and AUTO SET in sequence in order to reach the default setting.
- Switch DIGITAL MEMORY on.
- Connect a measuring oscilloscope with d.c. coupled input to measuring point X5101 and X5901 (= earth).
- Time base speed: 0,2 $\mu\text{s}/\text{div}$.
- Adjust C5127 so that the d.c.-value on the measuring oscilloscope is as small as possible.
- Time base speed: 0,5 $\mu\text{s}/\text{div}$.
- Adjust C5128 so that the d.c.-value on the measuring oscilloscope is as small as possible.
- Repeat the adjustments of C5127 and C5128 a couple of times since they are interdependent.
- Remove the measuring oscilloscope.

Threshold A (B):

- Switch DIGITAL MEMORY off.
- Select channel A and B for vertical display.
- Set A and B line in centre of screen by means of A POS and B POS .
A POS and B POS: must stay in mid-position during the adjustments in this chapter.
- Switch DIGITAL MEMORY on.
- Time base speed: 10 μ s/div.
- Adjust the d.c. voltage between measuring point X5601 (X5701) and X5901 (= earth) to 6 V (+ or- 100 mV) with R5608 (R5708).
- Adjust the d.c. voltage between measuring point X5503 (X5553) and X5901 (= earth) to 7 V (+ or- 100 mV) with R5527 (R5577).

Bias charge A and B:

- Press MENU and then AUTO SET in sequence in order to reach the default setting.
- Select channel A and B for vertical display.
- Switch DIGITAL MEMORY on.
- Channel A and B sensitivity: 0,1 V/div.
- Time base speed: 10 μ s/div.
- Channel A and B input coupling: GND.
- Connect a measuring oscilloscope with a.c. coupled input to measuring point X5602 (or X5603) and X5901 (= earth).
Measuring oscilloscope: 200 mV/div - 1 ms/div.
- Adjust R5604 so that the voltage "V" on the measuring oscilloscope is 300 mV (+ or- 30 mV). Refer to figure 22.4. The values of X5602 and X5603 must be averaged to the 300 mV.
- Channel A input signal: triangular 1 V/1 kHz.
- Switch GND off.
- Channel A input coupling: DC.
- Check with the measuring oscilloscope that the triangular voltage is visible in the bottom level of the measured signal.
- Disconnect the input signal.
- Remove the measuring oscilloscope.
- Connect a measuring oscilloscope with a.c. coupled input to measuring point X5702 (or X5703) and X5901 (= earth).
Measuring oscilloscope: 200 mV/div - 1 ms/div.
- Adjust R5602 so that the voltage "V" on the measuring oscilloscope is 300 mV (+ or- 30 mV). Refer to figure 22.4. The values of X5602 and X5603 must be averaged to the 300 mV.
- Channel B input signal: triangular 1 V/1 kHz.
- Switch GND off.
- Channel B input coupling: DC.
- Check with the measuring oscilloscope that the triangular voltage is visible in the bottom level of the measured signal.
- Disconnect the input signal.
- Remove the measuring oscilloscope.

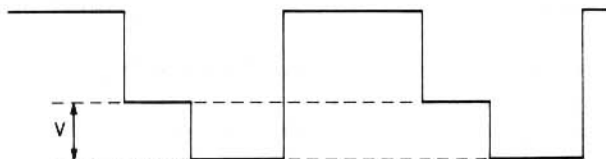

MAT2857
870626

Figure 22.4 Adjustment of $\Delta V = 300$ mV

Leakage correction:

- Channel A (B) input signal: square wave 800 mV/1 kHz.
- Time base speed: 200 μ s/div.
- Connect a measuring oscilloscope with a.c. coupled input to measuring point X5816 (X5817) and X5901 (= earth).
- Measuring oscilloscope: 100 mV/div - 1 ms/div.
- Adjust R5802 (R5817) so that the square wave signal has become a line.
- Remove the input signal.
- Remove the measuring oscilloscope.

22.4.12 Display section adjustments

All adjustments are located on the digital unit A15 or A16.

DAC and text adjustments:

- Press MENU and then AUTO SET in sequence in order to reach the default setting..
- Adjust X POS so that trace starts at first vertical graticule line.
- Press MENU and AUTO SET together in order to reach the Service menu.
- Press CRT softkey DISPLAY.
- The CRT now shows the picture as given in figure 22.5.
- Adjust INTENS and FOCUS for a good display.

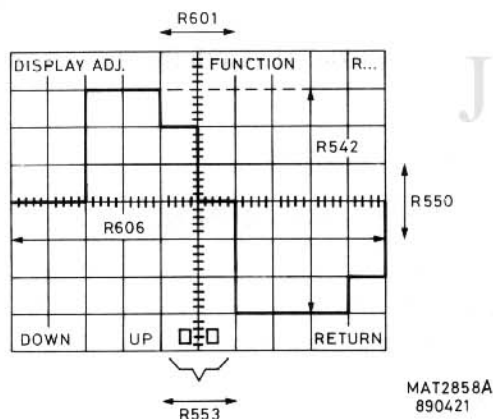

Figure 22.5 DAC and text adjustments

- Do the adjustments steps describe in the table:

Step	Adjustment	Requirement
1	R550, Y-offset	display in vertical mid (+ or - 0,07 div.)
2	R542, Y-gain	6 div. pk-to-pk, + or - 0,07 div.
3	R601, X-offset	display horizontal mid (+ or - 0,2 div.)
4	R606, X-gain	10 div. pk-to-pk, + or - 0,12 div.
5	R553, text pos.	text in horizontal mid, + or - 0,2 div.

- Press AUTO SET twice to leave the service menu.

22.4.13 Horizontal S-mode

All adjustments located on the time-base unit A4.

Gain Dacstair:

- Press MENU and then AUTO SET in sequence in order to reach the default setting.
- Preset R4406 fully clockwise.
- Channel A input signal: time marker pulse 20 ns.

- Channel A input sensitivity: 0,2 V/div.
- Switch DIGITAL MEMORY on.
- Time base sweep speed: 20 ns/div.
- Adjust R4247 so that 2nd and 10th marker pulse coincide with the corresponding graticule lines. Max. deviation 0,16 div.
- Change TRIGGER DELAY from 5 to 15 div and again back to 5 div.
- Adjust R4408 so that the trace does not move.
- Repeat this action several times until the trace gives a stable display.
Max. tolerance + or- 0,2 div.

Delay offset:

- Channel A input signal: fast rise time sq. wave 1 MHz/rise time ≤ 1 ns via 50 Ω termination resistor.
- Set TRIGGER DELAY to +15 div.
- Set X POS so that line starts at first vertical graticule line.
- Time base trigger slope: negative.
- Adjust R4406 so that the up-going edge is in the centre of the screen.
- Remove input signal.

22.4.14 Gain and offset channel A (B) - PM3365A/67A only

All adjustments located on P²CCD-unit A18 in PM3365A/67A.

For channel A:

- Press MENU and then AUTO SET in sequence in order to reach the default setting.
- Channel A sensitivity: 20 mV/div.
- Channel A coupling: GND.
- Adjust Y POS A 2,5 div. downwards from vertical mid.
- Switch DIGITAL MEMORY on.
- Position the trace 2,5 div. downwards from vertical mid with R932.
- Channel A coupling: switch GND off.
- Channel A input signal: calibrated sq.wave 100 mV/1 kHz.
- Adjust R929 to 5 div. vertical deflection (+ or - 0,1 div.).
- Channel A coupling: GND.
- Switch DIGITAL MEMORY off.
- Position the trace in vertical mid with Y POS A.
- Switch DIGITAL MEMORY on.
- Position the trace in vertical mid of screen with R932 (+ or - 0,2 div.).
- Remove input signal.

For channel B:

- Press MENU and then AUTO SET in sequence in order to reach the default setting.
- Vertical display and TRIG SOURCE: B.
- Channel B sensitivity: 20 mV/div.
- Channel B coupling: GND.
- Adjust Y POS B 2,5 div. downwards from vertical mid.
- Switch DIGITAL MEMORY on.
- Position the trace 2,5 div. downwards from vertical mid with R942.
- Channel B coupling: switch GND off.
- Channel B input signal: calibrated sq.wave 100 mV/1 kHz.
- Adjust R939 to 5 div. vertical deflection (+ or - 0,1 div.).
- Channel B coupling: GND.
- Switch DIGITAL MEMORY off.
- Position the trace in vertical mid with Y POS B.
- Switch DIGITAL MEMORY on.
- Position the trace in vertical mid of screen with R942 (+ or - 0,2 div.).
- Remove the input signal.

22.4.15 Gain and offset channel A(B) - PM3375/77 only

All adjustments located on P²CCD-unit A18 in PM3375/77

For channel A at 200 μ s:

- Press MENU and AUTO SET in sequence in order to reach the default setting.
- Channel A sensitivity: 20 mV/div.
- Channel A input coupling: GND.
- Time base speed: 200 μ s/div.
- Adjust Y POS A 2,5 div. downwards from vertical mid.
- Switch DIGITAL MEMORY on.
- Position the trace 2,5 div. downwards from vertical mid with R5832.

- Channel A coupling: switch GND off.
- Channel A input signal: calibrated sq. wave 100 mV/1 kHz
- Adjust R5829 to 5 div. vertical deflection (+ or- 0,1 div.).
- Channel A coupling: GND.
- Switch DIGITAL MEMORY off.
- Position the trace in vertical mid with Y POS A.
- Switch DIGITAL MEMORY on.
- Position the trace in vertical mid of screen with R5832. (+ or- 0,2 div.).
- Remove the input signal.

For channel B at 200 μ s:

- Press MENU and AUTO SET in sequence in order to reach the default setting.
- Vertical display and TRIG SOURCE: B
- Channel B sensitivity: 20 mV/div.
- Channel B input coupling: GND.
- Time base speed: 200 μ s/div.
- Adjust Y POS B 2,5 div. downwards from vertical mid.
- Switch DIGITAL MEMORY on.
- Position the trace 2,5 div. downwards from vertical mid with R5842.

- Channel B coupling: switch GND off.
- Channel B input signal: calibrated sq. wave 100 mV/1 kHz
- Adjust R5839 to 5 div. vertical deflection (+ or- 0,1 div.).
- Channel B coupling: GND.
- Switch DIGITAL MEMORY off.
- Position the trace in vertical mid with Y POS B.
- Switch DIGITAL MEMORY on.
- Position the trace in vertical mid of screen with R5842. (+ or- 0,2 div.).
- Remove the input signal.

For channel A at 0,2 μ s:

- Press MENU and AUTO SET in sequence in order to reach the default setting.
- Channel A sensitivity: 20 mV/div.
- Channel A input coupling: GND.
- Adjust Y POS A 2,5 div. downwards from vertical mid.
- Time base speed: 0,2 μ s/div.
- Switch DIGITAL MEMORY on.
- Position the trace 2,5 div. downwards from vertical mid with R5830.

- Channel A coupling: switch GND off.
- Channel A input signal: calibrated sq. wave 100 mV/1 MHz
- Adjust R5828 to 5 div. vertical deflection (+ or- 0,1 div.).
- Channel A coupling: GND.
- Switch DIGITAL MEMORY off.
- Position the trace in vertical mid.
- Switch DIGITAL MEMORY on.
- Position the trace in vertical mid of screen with R5830. (+ or- 0,2 div.).
- Remove the input signal.

For channel B at 0,2 μ s:

- Press MENU and AUTO SET in sequence in order to reach the default setting.
 - Vertical display and TRIG SOURCE: B
 - Channel B sensitivity: 20 mV/div.
 - Channel B input coupling: GND.
 - Adjust Y POS B 2,5 div. downwards from vertical mid.
 - Time base speed: 0,2 μ s/div.
 - Switch DIGITAL MEMORY on.
 - Position the trace 2,5 div. downwards from vertical mid with R5840.
-
- Channel B coupling: switch GND off.
 - Channel B input signal: calibrated sq. wave 100 mV/1 MHz
 - Adjust R5838 to 5 div. vertical deflection (+ or- 0,1 div.).
 - Channel B coupling: GND.
 - Switch DIGITAL MEMORY off.
 - Position the trace in vertical mid.
 - Switch DIGITAL MEMORY on.
 - Position the trace in vertical mid of screen with R5840. (+ or- 0,2 div.).
 - Remove the input signal.

22.4.16 Sample mode adjustments

All adjustments located on adaptation unit A16.

Gain and offset:

- Press MENU and then AUTO SET in order to reach the default setting.
- Switch DIGITAL MEMORY on.
- Channel A input signal: calibrated square-wave signal 1 MHz/100 mV.
- Channel A input sensitivity: 20 mV/div.
- Time base sweep speed: 0,2 μ s/div.
- Adjust R1719 for a vertical amplitude of 5 div. (+ or - 0,1 div.).
- Press GND for a grounded display.
- Adjust R1739 for a minimum trace jump when selecting DIGITAL MEMORY on and DIGITAL MEMORY off.

HF square-wave response:

- Channel A input signal: fast rise-time sq.wave 1 MHz/120 mV/rise time \leq 1 ns via 50 Ω termination resistor.
- Press GND again for a normal display.
- Switch DIGITAL MEMORY on.
- Time base sweep speed: 20 ns/div.
- Set TRIGGER DELAY to +15 div.
- Adjust the square-wave response with C1706 and R1717.

CORRECTIVE MAINTENANCE

JTN

23 CORRECTIVE MAINTENANCE

23.1 REPLACEMENTS

WARNING: The Extremely High Tension (EHT) cable is directly connected to the CRT. When the EHT cable to the post-acceleration anode is disconnected, the cable must be discharged by shorting the terminal to the instrument's earth.

23.1.1 Standard parts

Electrical and mechanical replacement parts can be obtained through your local PHILIPS/FLUKE organisation or representative. However, many of the standard electronic components can be obtained from other local suppliers. Before purchasing or ordering replacement parts, check the parts list for value, tolerance, rating and description.

NOTE: Physical size and shape of a component may affect the instrument's performance, particularly at high frequencies. Always use direct-replacement components, unless it is known that a substitute will not degrade the instrument's performance.

23.1.2 Special parts

In addition to the standard electronic components, some special components are used:

- Components, manufactured or selected by PHILIPS to meet specific performance requirements.
- Components which are important for the safety of the instrument.

ATTENTION: Both type of components may only be replaced by components obtained through your local PHILIPS/FLUKE organisation of representative.

23.1.3 Transistors and Integrated Circuits

- Return transistors and IC's to their original positions, if removed during routine maintenance.
- Do not renew or switch semi-conductor devices unnecessarily, as it may affect the calibration of the instrument.
- Any replacement component should be of the original type or a direct replacement. Bend the leads to fit the socket or pcb-holes and cut the leads to the same length as on the component being renewed. See also the Performance test in this Service manual.
- When a device has been renewed, check the operation of the part of the instrument that may be affected.
- When re-installing power-supply transistors, use silicon grease to increase the heat-transfer capabilities.

WARNING: Handle silicon grease with care. Avoid contact with the eyes. Wash hands thoroughly after use.

23.2 STATIC SENSITIVE COMPONENTS

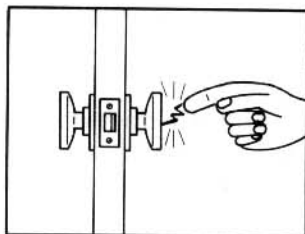

MAT3818

23.2.1 Introduction

The instrument in which the black/yellow "static sensitive components" symbol is present, contains electrical components that can be damaged by electrostatic discharge. This symbol can be found on every printed circuit board with static sensitive components. Though e.g. all our MOS integrated circuits incorporate protection against electrostatic discharge, they nevertheless can be damaged by accidental over-voltages.

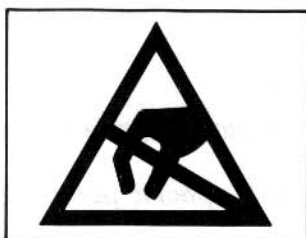

MAT3850

JTN

Figure 23.1 Static sensitive symbol

It is also possible that a delayed failure or "winding" effect may occur. When this happens the component will fail anywhere between two hours to six months later.

In storing and handling static sensitive components, the normal precautions for these devices are recommended. Handling and servicing static sensitive assemblies and components should be performed only at a static free workstation by qualified personnel.

CAUTION: Testing, handling and mounting call for special attention. Personnel, handling static sensitive devices, should normally be connected to ground via a high-ohmic resistor.

23.2.2 Storage And Transport

Store and transport the circuits in their original packing until required for use. Alternatively, you may make use of a conductive material or a special IC carrier that either short-circuits all leads or insulates them from external contact.

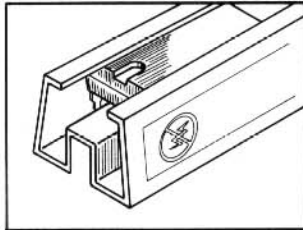

MAT 3819

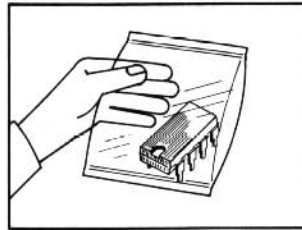

MAT 3820

Examples of suitable anti-static packing material.

23.2.3 Testing Or Handling

Minimise handling as much as possible and handle the devices by the body. Do not slide the devices over any surface. Work on a conductive surface (e.g. conductive table top) when testing the circuits or transferring them from one carrier to another. Electrically connect the person doing the testing or handling to the conductive surface, for example via a conductive bracelet and a conductive cord. Connect all testing and handling equipment to the same potential. Signals should not be applied to the same surface or the inputs while the device power supply is off. All unused input leads should be connected either to the supply voltage or to ground. When handling plug-in units, handle only by the non-conductive edges and never touch the open edge connector except at a static-free work station. Placing shorting strips on edge connectors helps to protect installed static sensitive devices.

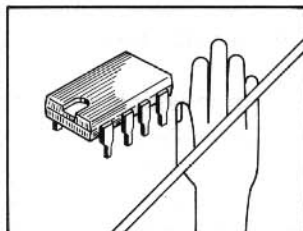

MAT 3821

Minimize handling

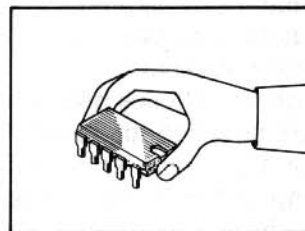

MAT 3822

Handle the devices by the body

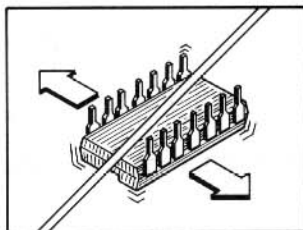

MAT 3823

Do not slide the devices over any surface

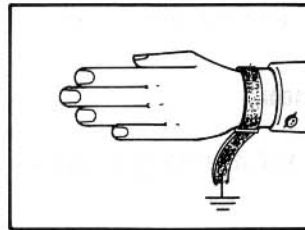

MAT 3824

Wear a conductive bracelet

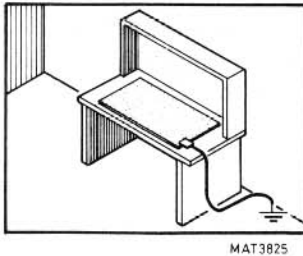

*Use a workbench with
conductive surface*

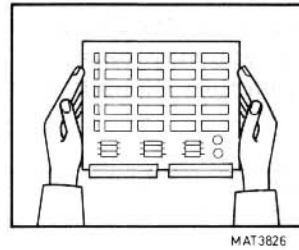

*Handle plug-in units only by the
non-conductive edges.*

23.2.4 Mounting

Mount static sensitive integrated circuits on printed circuit boards after all other components have been mounted. Take care that the circuits themselves, metal parts of the board, mounting tools and the person doing the mounting are kept at the same electric (ground) potential.

NOTE: If it is impossible to ground the printed-circuit board, the person mounting the circuits should touch the conductive parts of the board before bringing the static sensitive circuits into contact with it.

23.2.5 Soldering

Soldering iron tips, including those of low voltage irons, or soldering baths should also be kept at the same potential as the static sensitive circuits and the board.

23.2.6 Static Charges

Dress personnel in clothing of non-electrostatic material (no wool, silk or synthetic fibres). Avoid these materials in the working area.

After the static sensitive circuits have been mounted, the proper handling precautions should still be observed.

Until the sub-assemblies are inserted into the complete system in which the proper voltages are supplied, the board is not more than an extension of the leads of the devices mounted on the board. To prevent static charges from being transmitted through the board wiring to the device it is recommended that conductive clips or conductive tape is put on the circuit board terminals.

23.2.7 Transient Voltages

To prevent permanent damage due to transfer voltages, do not insert or remove static sensitive devices, or printed circuit boards with static sensitive devices, from test sockets or system with power on.

23.2.8 Voltage Surges

Beware of voltage surges due to switching electrical equipment ON or OFF, relays and d.c. lines.

23.3 SOLDERING TECHNIQUES FOR SMD's

23.3.1 Introduction

This section deals with the removal and replacement method for surface mounted devices (SMDs). It incorporates subjects such as:

- Required tools and materials
- Replacement of SMDs
- General hints for SMD handling

Surface-mounted components used in this instrument are:

- Chip components, such as resistors and capacitors
These components are packaged in rectangular ceramic leadless bodies.
For replacement, see Section 23.3.4.1.

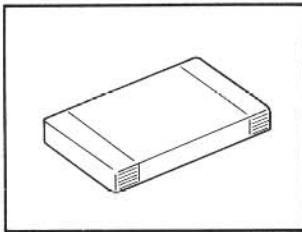

JTN

- Small outline transistor (SOT) packages, such as:
SOT 23, SOT 143 and SOT 223.
The leads are grouped with the collector on one side and the base-emitter leads on the opposite side, or for diode pairs (SOT 143) two by two leads which are grouped on both sides.
For replacement, see Section 23.3.4.1.

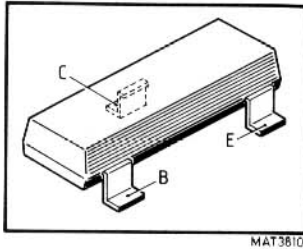

MAT3810

- Small outline integrated circuit (SOIC) packages, such as: SO 8, SO 14, SO 16, SO 16L, SO 20 and SO 28.
The device is rectangular with gull-wing shaped leads at two sides. Pin #1 is located on the far left as you face the beveled side.
For replacement, see Section 23.3.4.2

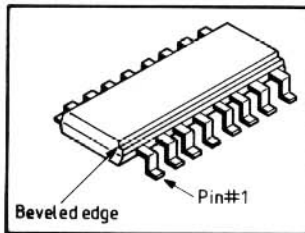

MAT3811

- Quad flatpack (QFP) packages, such as QFP 44 and QFP 80. The device is square with leads located on all four sides.
Pin #1 is identified by a 45° index corner. Continue the pin count in a counter-clockwise direction.
For replacement, see Section 23.3.4.2

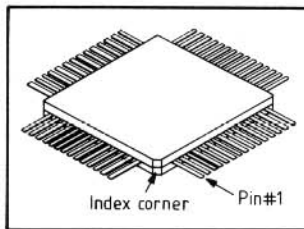

MAT3812

23.3.2 Required Tools And Materials

To ensure proper repair of the surface mounted devices, the following tools have been carefully selected and are therefore recommended.

- A hot-air solder tool: Leister Hot-Jet
- Nozzles for the different packages
- Micro Electronic Systems (MES) repair kit, containing dispenser, vacuum pipette and different caplettes
- Mini soldering iron station: WECP-COD3 (regulated transformer) and Weller MLR-20 (mini soldering iron)

The following materials are recommended:

- Soldering tin, dia 0,8 mm, SnPb 60/40 with a Resin Mildly Activated (RMA) flux.
Ordering code: 4822 390 80133
- Solder paste 026
- Non-corrosive and Resin Mildly Activated (RMA) flux- Colophony
Ordering code: 4822 390 50025
- Desolder braided wire; ordering code: 4822 321 40042
- Magnifying glass 3x ... 10x

23.3.3 General Hints For Smd Handling

23.3.3.1 Tools

The removal and attachment method of SMD components mainly employs convection heating. This involves the application of hot air to the solder joints. For removing, nozzles are available for different size and shaped components. This permits the heat to be placed directly on the leads.

There are always two adjustments on the hot-air solder tool, one for temperature (50 ... 500 °C) and the other for the air flow.

Next, a mini soldering iron can be used to prepare the solder pads before attachment and to do any touchup work.

NOTE: *The recommended Leister tools and Weller mini soldering iron can be ordered via your local dealer.*

23.3.3.2 Electrostatic discharging (ESD)

All integrated circuits and many semi-conductors are susceptible to ESD. Careless handling during repair can reduce life drastically. To prevent any failure which is caused by static damage, some precautions must be taken for:

- Transportation: use static shielding bags and containers
- Working area: use anti-static mat and wristband, connected to earth potential

A complete description of ESD handling is given in Section 23.2.

23.3.3.3 Fluxing and cleaning

For optimal soldering result, solder flux must be used to chemically clean the metals and the solder. The flux removes oxide from the metals and acts as a wetting agent. Because the use of flux can cause electrical leakage problems in high-ohmic circuits, it is important to use non-corrosive and Resin Mildly Activated (RMA) flux, such as Colophony.

The flux residue left over after attachment the SMD components must be removed. To assure proper cleaning of the board, this must be done IMMEDIATELY after repair. The longer the flux remains on the board, the harder it is to clean.

23.3.4 Replacement Of Smds

ATTENTION: *The methods given are based on the restriction that the components once removed must NOT be used again.*

23.3.4.1 Replacement of SMDs with two up to four connections

IMPORTANT: Before removing the component, observe very carefully its position in order to avoid that the new component is installed upside-down. This is especially important for capacitors and four-leads SOTs.

REMOVING:

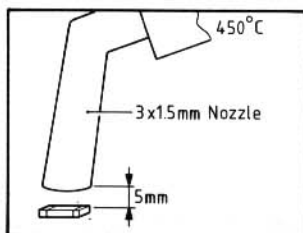

- Prepare the hot-air tool; attach a 3 x 1,5 mm oval tip nozzle, set the temperature of the hot gas to 450 °C and the air flow to "high".
- Hold the nozzle 5 mm above the component to be removed.
- Heat the component up equally for about 5 seconds.
- When the solder becomes molten, remove the component from the board using the vacuum pipette.

ATTENTION: *Be careful that the adjacent components are not damaged by the hot-air flow.*

- Remove the hot-air tool.
- Clean all pads with the braided wire.

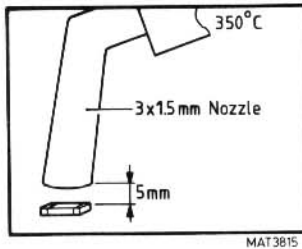
ATTACHING:

- Apply new solder paste in small dots to all soldering pads.
- Prepare the hot-air tool; use a 3 x 1,5 mm oval tip nozzle, set the temperature of the hot gas to 350 °C and the air flow to "low".
- Place the new component with a pair of tweezers on the sticky solder paste of the contact pads.
- Position the component well.
- Apply the heat from a distance of 5 mm in the direction of the solder paste.
- Allow even reflow of the solder, the soldering time per joint should be not more then about 10 seconds.
- Remove the hot-air tool.
- Clean the pcb very carefully; be sure to remove all flux residue.
- Inspect the solder joints and, if necessary, remove superfluous solder rests with the use of braided wire.

23.3.4.2 Replacement of SMDs with more connections

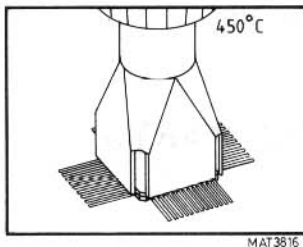
REMOVING:

- Prepare the hot-air tool; attach a correct nozzle, set the temperature of the hot gas to 450 °C and the air flow to "high".
- Hold the nozzle on the component to be removed.
- Heat all connections of the component equally up for about 10 seconds.
- When the solder becomes molten, remove the component from the board using the vacuum pipette. Use a small screwdriver to break the glue bond when necessary.

ATTENTION: *Be careful that the adjacent components are not damaged by the hot-air flow*

- Remove the hot-air tool.
- Clean all pads with the braided wire.

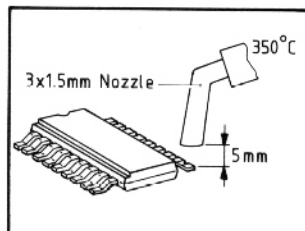
ATTACHING:

- Apply a certain amount of flux to the soldering pads.
- Apply new solder paste in a straight line to the soldering pads.
- Prepare the hot-air tool; attach a 3 x 1,5 mm oval tip nozzle, set the temperature of the hot gas to 350 °C and the air flow to "low".
- Place the new component with a pair of tweezers on the sticky solder paste of the contact pads. Use the pin #1 location for reference.

ATTENTION: *It is very helpful to use a magnifying glass having a magnification of 3 to 10 to check the correct position of all leads.*

- Fix the component with a small soldering tip by briefly heating soldering pads in two diagonally opposite corners.
- Apply the heat from a distance of 5 mm in the direction of the solder paste.
- Slowly move the nozzle over the row of solder joints.
- Allow even reflow of the solder, the soldering time per joint should be not more then about 10 seconds.
- Remove the hot-air tool.
- Clean the pcb very carefully; be sure to remove all flux residue.
- Inspect the solder joints for good connections or short-circuits and, if necessary, remove superfluous solder rests with the use of braided wire.

23.4 REMOVING THE UNITS AND MECHANICAL PARTS

NOTE: *For installation, reverse the sequence.*

23.4.1 Attenuator unit (A1)

- First remove the digital unit (see section 23.4.8).
- Push gently both clamping lips that secure the metal locking plate for the attenuator unit and remove the locking plate.
- Push the attenuator unit backwards for about 1 cm.
- Remove the front unit (see section 23.4.7).
- Remove the control knobs of the CRT control unit.
- Pull gently both clamping lips that secure the front profile gently backwards and loosen the front profile.

ATTENTION: *To avoid damage, ensure that the BNCs of the attenuator unit are behind the front profile before loosening the front profile.*

Now the attenuator unit can easily pulled out of the instrument after removing the connector with flat cable and the ground connector.

Dismantling the Attenuator unit:

- For access to the components of the unit, remove both upper and bottom covers.
- When removing the BNCs first unsolder the wire to the pcb and then unscrew the BNC-nut with a spanner of max. 5 mm thickness.

23.4.2 Pre-amplifier unit (A2) and Adaptation unit (A16)

- First remove the P²CCD unit (see section 23.4.9).
- Then remove the time-base unit (see section 23.4.4).
- Unlock the two p.c.b. supports
- The complete p.c.b. can be removed from the instrument after having removed all flat cables.

23.4.3 XYZ-amplifier unit (A3)

The XYZ amplifier unit incorporates two separate p.c.b.'s connected via a flat cable. One p.c.b. includes among other things the CRT socket and must be loosened first. For this, the CRT socket must be gently removed from the CRT.

Now the part situated above the CRT can be removed as follows:

- Remove all flat cables and the delay line cable plug.
- Pull all six clamping lips that secure the XYZ-amplifier unit p.c.b. outwards and take out the complete unit.

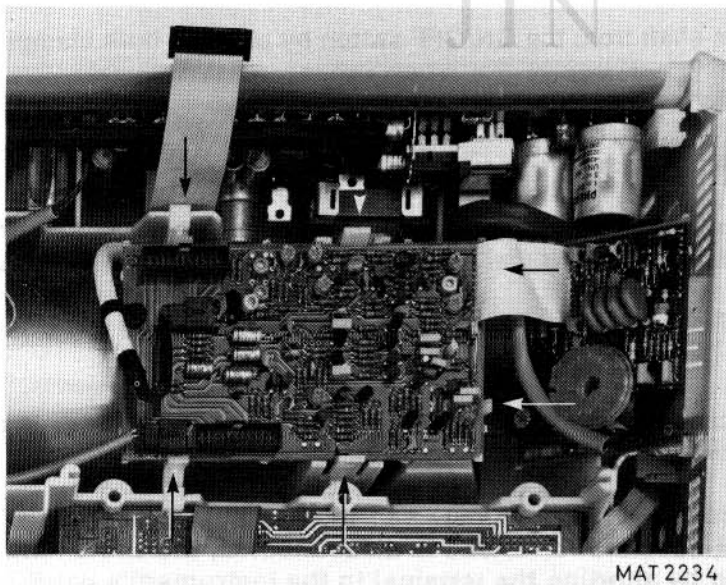

Figure 23.2 Six clamping lips for XYZ-amplifier unit

23.4.4 Time-base unit (A4)

- Remove the P²CCD unit (see section 23.4.9).
- Unlock the p.c.b. support with a special tool that fits the diameter of the p.c.b. support (see section 23.8.2).
- The complete p.c.b. can be taken out of the instrument after having removed all flat cables.

23.4.5 CRT control unit (A5)

- Remove the front unit (see section 23.4.7)
- Loosen the front profile (see section 23.4.1)
- Now the CRT control unit can be pulled out of the front profile after having removed the flat-cable and the CAL connector.

23.4.6 Power supply unit (A6)

WARNING: Inside the power supply pcb there are many parts that carry dangerous high voltages. Some of these voltages remain some time after disconnecting the instrument from the mains. Therefore, it is recommended to wait at least five minutes after having disconnected the instrument from the mains, before removing the p.c.b. If working on the power supply unit under live condition cannot be avoided, it must be done by a qualified technician who is aware of the dangers involved.

- Remove the extension shaft from the ON/OFF switch by pushing both clamps of the shaft together.
- Push both clamping lips that secure the power supply unit.
- Lift the power supply unit outside the instrument.
- Place the p.b.c. in the unit slider.

NOTE: After the mentioned actions, the power supply unit can be measured under working conditions, provided that all cables are still connected to the unit.

The flat cable to the CRT control unit can easily be removed now when removing this unit.

- Remove the two flat cables, the power supply cable, the two- and three-pole cable connectors and the EHT-connector from the CRT.

WARNING: The EHT cable is directly connected to the CRT. When the EHT cable to the post-acceleration anode is disconnected, the cable must be discharged by shorting the terminal to the instrument's earth.

- The power supply can now be taken out of the instrument.

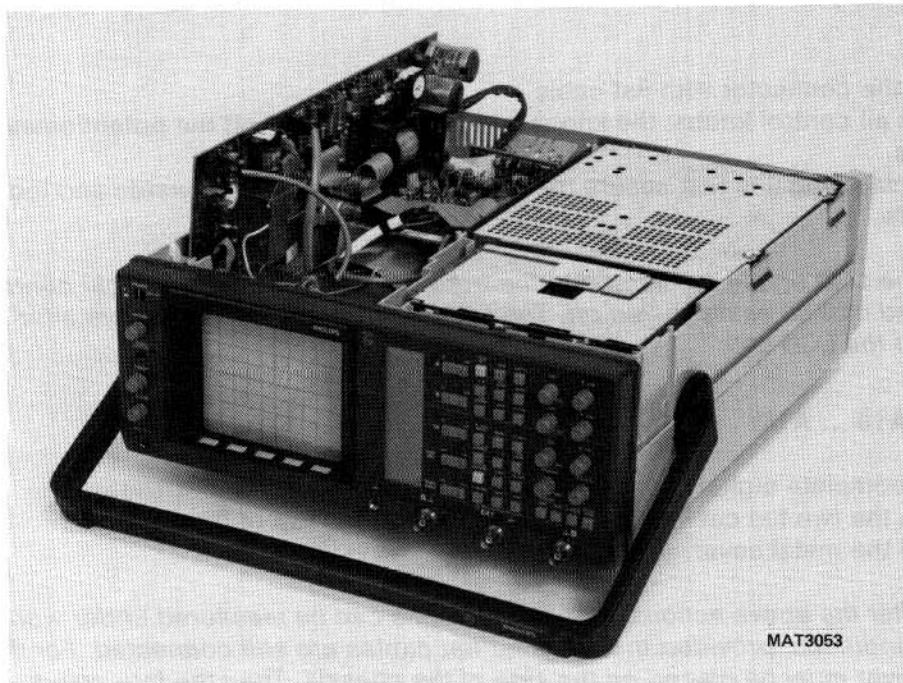

Figure 23.3 Power supply unit outside the instrument

23.4.7 Front unit (A7) and LCD unit (A8)

- Unscrew the two screws, located at the rear of the front unit.
- Now the complete unit assembly can be slid out of the front profile of the instrument.

NOTE: After the above actions, the front unit can be measured under working conditions, provided that the flat cable is still connected to the unit.



Figure 23.4 Measuring the front unit working condition

For accessibility to the component side of the front unit and LCD unit, proceed as follows:

- Unplug the connector with flat cable.
- Remove all control knobs; the knobs can be easily pulled off the potentiometer spindles.
- Pull all clamping lips that secure the front unit p.c.b. gently outwards and loosen the text plate.

NOTE: *The LCD unit is connected to the front unit by means of two 3-pin connectors and can be easily pulled off. The LCD display lamp is accessible after pulling off the LCD unit.*

23.4.8 Digital unit (A10 ... A15)

- Lift the complete digital unit outside the instrument.
- Remove the two flat cables that are connected at the top of the unit.
- Remove the metal cover.

NOTE: *After the above actions, all separate units can be measured under working conditions, provided that all other flat cables are still connected. For this the cover must be placed on the side of the chassis. Then the four stand-ups on unit A10 must be placed in the four already existing holes on the cover.*

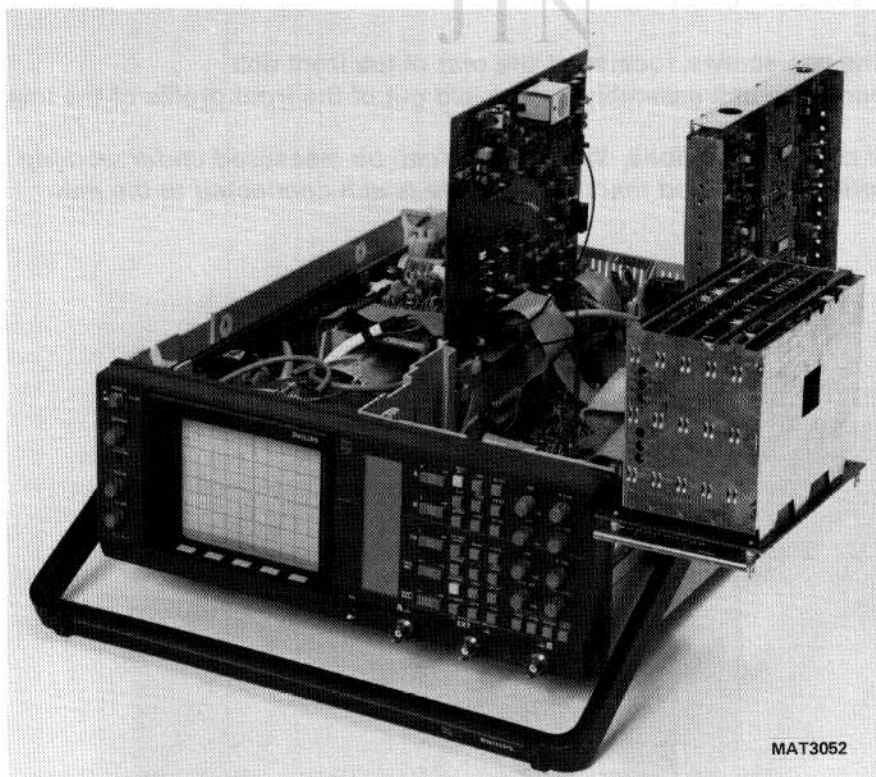

Figure 23.5 *Measuring the digital unit in working condition*

- Now each of the four (five when an option is also present) p.c.b.'s can be lifted out of the digital unit.

23.4.9 P²CCD unit (A18) and mini CCD unit (A17)

- Unscrew the two screws that fix the metal cover to the chassis and take-off the cover.
- The complete p.c.b. with metal under cover can be taken out of the instrument after removing all 50 Ω cables, all flat cables and the metal bracket on the chassis.
- Now the p.c.b. can be removed from the metal under-cover by unscrewing the four screws.
- The mini CCD units can easily be taken out of their sockets (PM3365A/67A only).

23.4.10 Removing the delay-line cable

The delay-line cable is a 54 cm cable that is connected to the amplifier unit and to the XYZ amplifier unit.

To remove the delay-line cable, proceed as follows:

- For access to the delay line cable, remove the time-base unit (see section 23.4.4) and the pre-amplifier unit (see section 23.4.2).
- Unlock the plastic clamps that fix the cable to the instrument's chassis and to the units.
- Remove the plug that connects the delay-line cable to the pre- amplifier unit.
- Unscrew the plastic clamp that fixes the cable to the XYZ-amplifier unit.
- Remove the plug that connects the delay-line cable to the XYZ- amplifier unit.

23.4.11 Replacement of CRT

IMPORTANT: It is strongly recommended to study of this chapter and the associated illustration (figure 23.6) before starting replacement.

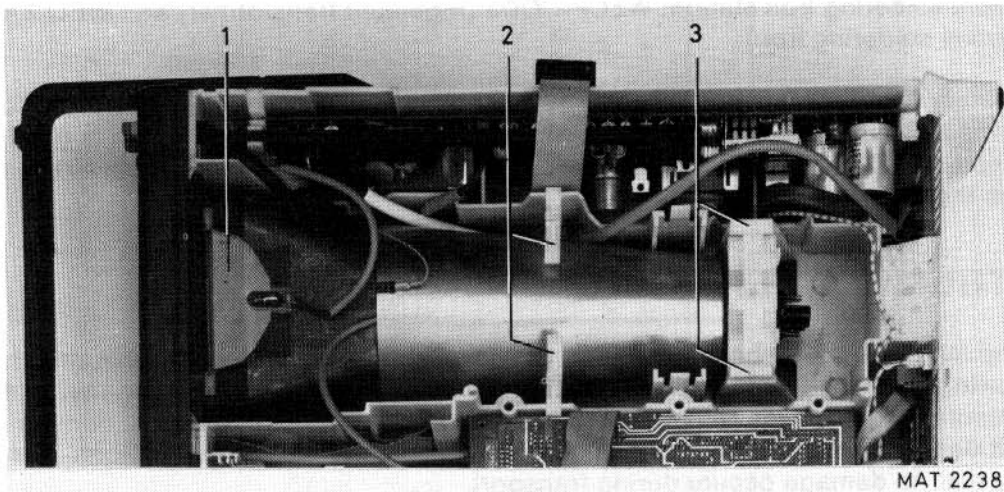

Figure 23.6 Removing the CRT

- Remove the XYZ-amplifier unit, see section 23.4.3.
- Remove the graticule lamp holder (1).
- Remove the bezel with the screen filter.
- Remove the two plastic pcb supports (2).
- Unlock the EHT-cable.

WARNING: Handle the CRT carefully. Rough handling or scratching can cause the CRT to implode.

- Push the two clamping lips that secure the CRT support (3) and gently lift the CRT, incl. metal shielding out of the instrument.

NOTE: Before re-assembling a new CRT, first remove its protective cover and place the CRT front rubber around the CRT-front.

23.5 SOLDERING TECHNIQUES

Working method:

- Carefully unsolder one after the other the soldering leads of the semi-conductor.
- Remove all superfluous soldering material. Use desolder braided wire; ordering code: 4822 321 40042.
- Check that the leads of the replacement part are clean and pre-tinned on the soldering place.
- Locate the replacement semi-conductor exactly on its place, and solder each lead to the relevant printed conductor on the circuit board.

NOTE: Bear in mind that the maximum permissible soldering time is 10 seconds during which the temperature of the leads must not exceed 250° C. The use of solder with a low melting point is therefore recommended.

Take care not to damage the plastic encapsulation of the semi-conductor (softening point of the plastic is 150° C).

ATTENTION: When you are soldering inside the instrument, it is essential to use a low-voltage soldering iron, the tip of which must be earthed to the mass of the oscilloscope.

A suitable soldering irons is:

- Mini soldering iron station: WECP-COD3 (regulated transformer) and WELLER MLR-20 (mini soldering iron).

Ordinary 60/40 solder with core and 35 to 40 W pencil type soldering iron can be used for the majority of the soldering. If a higher wattage-rating soldering iron is used on the etched circuit boards, excessive heat can cause the etched circuit wiring to separate from the board base material.

23.6 INSTRUMENT REPACKING

If the instrument is to be shipped to a Service Centre for service or repair, attach a tag showing the full address and the name of the individual at the users firm that can be contacted. The Service Centre needs the complete instrument, its serial number and a fault description. If the original packing is not available, repack the instrument in such a way that no damage occurs during transport.

23.7 TROUBLE SHOOTING

23.7.1 Introduction

The following information is provided to facilitate trouble shooting. Information contained in other sections of the manual should also be used to locate the defect. An understanding of the circuit is helpful in locating troubles, particularly where integrated circuits are used. Refer to the circuit description for this information.

23.7.2 Trouble-shooting techniques

If a fault appears, the following test sequence can be used to find the defective part:

- Check if the settings of the controls of the oscilloscope are correct.
- Check the equipment to which the oscilloscope is connected and the interconnection cables.
- Check if the oscilloscope is well-calibrated. If not, refer to section 22. "Checking and Adjusting".
- Visually check the part of the oscilloscope in which the fault is suspected. In this way, it is possible to find faults such as bad soldering connections, bad interconnection plugs and wires, damaged components or transistors and IC's that are not correctly plugged into their sockets.
- Location of the circuit part in which the fault is suspected: the symptom often indicates this part of the circuit. If the power supply is defective the symptom will appear in several circuit parts.

After having carried out the previous steps, individual components in the suspected circuit parts must be examined:

- Transistors and diodes.
Check the voltage between base and emitter (0,7 V approx. in conductive state) and the voltage between collector and emitter (0,2 V approx. in saturation) with a voltmeter or an oscilloscope. When removed from the p.c.b. it is possible to test the transistor with an ohmmeter since the base/collector junctions can be regarded as diodes. Like a normal diode, the resistance is very high in one direction and low in the other direction. When measuring take care that the current from the ohmmeter does not damage the component under test. Replace the suspected component by a new one if you are sure that the circuit is not in such condition that the new component will be damaged.
- Integrated circuits.
In circuit, testing can be done with an oscilloscope or voltmeter. A good knowledge of the circuit part under test is essential. Therefore, first read the circuit descriptions in sections 3...19.
- Capacitors.
Leakage can be traced with an ohmmeter adjusted to its highest resistance range. When testing take care of polarity and maximum allowed voltage. An open capacitor can be checked if the response for AC signals is observed. Also a capacitance meter can be used: compare the measured value with the value and tolerance indicated in the parts list.
- Resistors.
Can be checked with an ohmmeter after having unsoldered one side of the resistor from the p.c.b. Compare the measured value with the value and tolerance indicated in the parts list.

- Coils and transformers.
An ohmmeter can be used for tracing an open circuit. Shorted or partially shorted windings can be found by checking the waveform responses when HF signals are passed through the circuit. Also an inductance meter can be used.
- Data latches.
To measure on inputs and outputs of data latches a measuring oscilloscope can be triggered by the clock signal which is connected to the clock input of the data latch. This measurement can only be made in this way when there is an acceptable repetition time of the clock signal. A too low clock pulse repetition time results in a low intensity of the trace on the measuring oscilloscope screen.
The outputs can easily be checked by a voltmeter or oscilloscope.

23.7.3 Power-up routine

Every time the instrument is switched-on the following initialisation program is executed:

- Checking the CPU.
- Initialisation of the I²C bus (if correct, all relevant LCD segments light for about 1 sec).
- Back up test.
- Initialisation of the variables.
- Checking if service routine is required (if yes, the program will continue with the service routine).
- Checking the "WATCH-DOG" on A12 .
- Eventually initialisation of the option.

If during the program-run a circuit is found to be faulty, the program stops. It is recommended to switch-off and after a few seconds switch- on again. This will reset the micro-computer controlled system automatically. If the Instrument goes in the same faulty situation again, the following procedure indicates how to handle. If no failure is found, all relevant LCD-segments will be lighting for about one second. After this the normal program is executed.

PROCEDURE:

Check if the LCD is lighting for about one second. If not, close solder-joint J202 on unit A12 and measure on testpin X223. If a square-wave is measured with a 6 μ s high period and a 8 μ s low period then the μ Proc. RAM is defective or one or more address/data lines are short circuited. If the LCD has lighted for about one second and the program stops, close also solder-joint J202 and measure on testpin X223. If now a pulse is measured with a 5 μ s high period and a 15 μ s low period then the I²C bus is defective. On the SCL a clockpulse must be present when a softkey (e.g. AUTO SET) is depressed while the SDA gives the data information (looks like a random pulse).

If one of these signals is not present, you can localize on what unit the fault exists. This can be done by first unplug connector X1009, X2001 or X101 on resp. A1, A2 and A11. To localize what serial- parallel conversion IC is defective, you can disconnect the solder joint in the SDA and SCL print track lead to that IC. The following IC's can disconnected in this way: D1001, D1101, D2602, D2603, D4001, D4002, D4401, N103, N104 and N106 (see also figure 23.7).

When the Instrument restarts every time again, this means the WATCHDOG is initiating the main program (see also section 13.3), the watchdog can be disabled. This can be done by means of removing R204 on unit A12. When disabled, pin 36 and pin 37 of the microprocessor are set to a low level.

23.7.4 I²C structure

The I²C bus is for 2-way, 3-line communication between different ICs or modules. The three lines are a serial data line (SDA), a serial clock line (SCL) and ground. Both lines must be connected to a positivesupply via a pull-up resistor when connected to the output stages of a device. Data transfer may be initiated only when the bus is not busy.

The lines SDA and SCL are fed to the various circuits, where depending on the addressing, the serial information is converted into the different control signals (see figure 23.7).

Note that for servicing, solder joints are added in the p.c.b. tracks connecting the circuits. These can be used to localize a fault in the I²C bus by means of interrupting the bus connection.

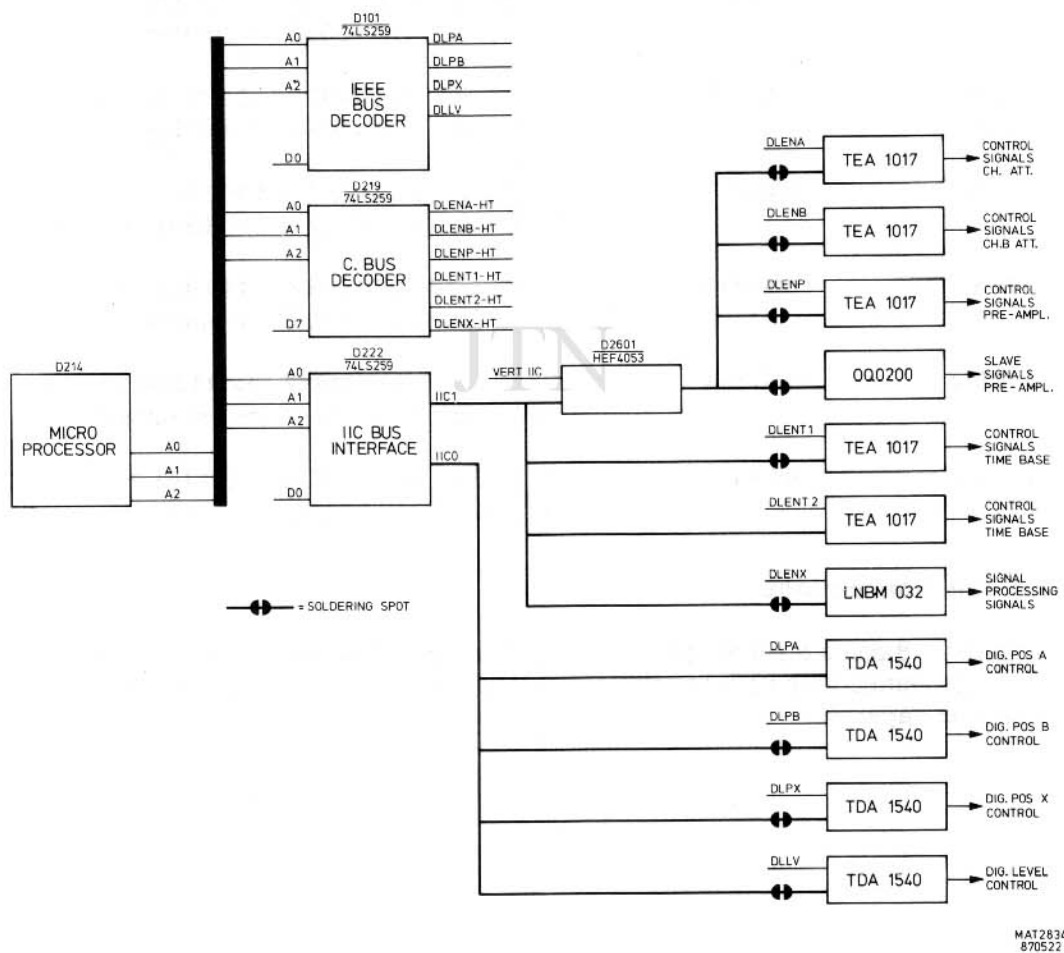

Figure 23.7 I²C structure

23.7.5 Trouble-shooting the power supply

To determine whether a certain fault condition is initiated by the power supply itself or by the connected oscilloscope circuits, a dummy load is listed in the table below. The table gives also an example of the resistor types that can be used to compose the dummy load. These resistors can be ordered at Concern Service.

Supply voltage	Output current	Dummy resistance and their service ordering numbers
+ 5 V	2,4 A	2,9E-12W: 3 x 10E (4822 112 21052) and 22E (4822 11221063) in parallel.
- 6,4 V	930 mA	6,9E-6W: 8,2E (4822 112 41052) and 47E (4822 110 23072) in parallel.
+ 12 V	720 mA	17,2E-8,7W: 33E (4822 112 41067) and 39E (4822 112 43069) in parallel.
- 12 V	500 mA	24,7E-6W: 39E (4822 112 41069) and 68E (4822 112 41076) in parallel.
+ 17 V	340 mA	51E-6W: 1E (4822 110 23027) in serial with 2 x 100E (4822 112 41081) in parallel.
- 17 V	100 mA	171E-1,7W: 270E (4822 110 43092) and 470E (4822 110 43098) in parallel.
+ 48 V	140 mA	341E-7W: 330E (4822 112 41094) in serial with 12E (4822 110 23056) in parallel.
+ 48 V	40 mA	1k22-2W: 2k2 (4822 110 23116) and 2k7 (4822 110 23118) in parallel.

23.7.6 p.c.b. Interconnections

Figure 23.8 gives a survey of all interconnections between the p.c.b.'s and to the CRT. All interconnections between the connectors on board level are given in the diagram on the next page.

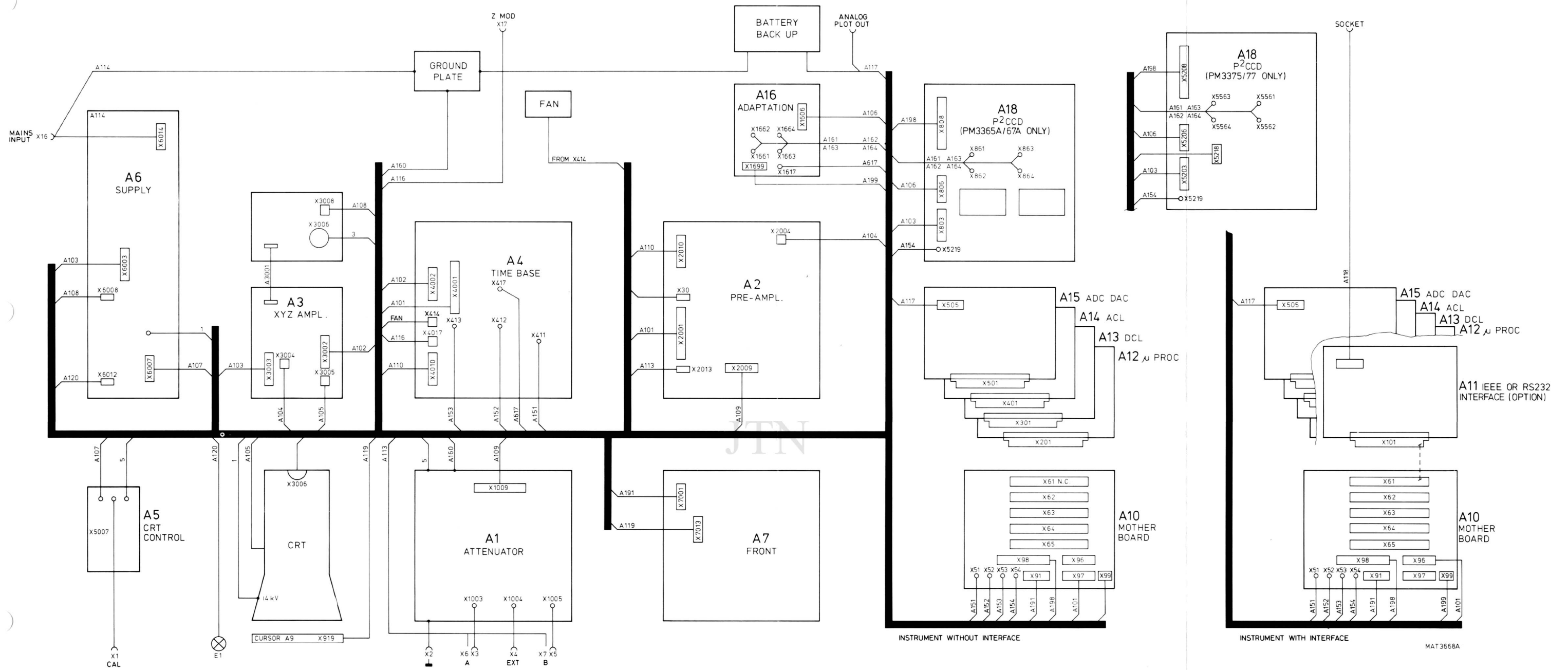

Figure 23.8 p.c.b. Interconnections

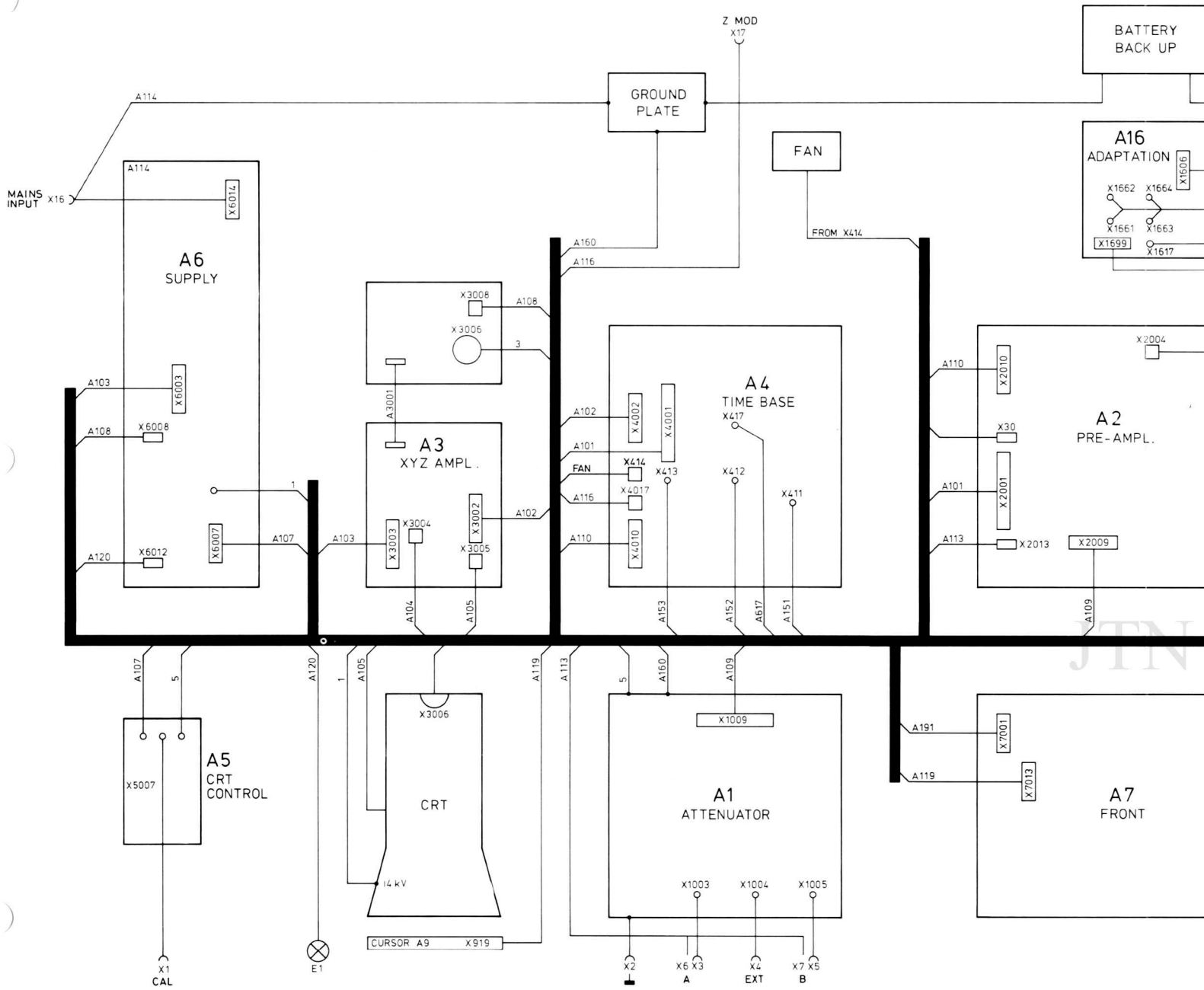

Figure 23.8 p.c.b. Interconnections

23.8 SPECIAL TOOLS

23.8.1 Trimming Kit SBC 317 - 4822 310 50095

The SBC 317 Trimming Kit (4822 310 50095) matches every current trimming requirement for all products. The set contains 27 items (22 different bits, plus 3 bit holders and 2 extension pieces). The insulated holders and extension pieces make it easy to reach into a chassis and make accurate adjustments, without wasting time or risking shocks. The SBC 317 Trimming Kit is packed in a flat transparent case. Several of the most commonly required bits are duplicated. In addition, a spare set of 8 bits is separately available as replacement (4822 310 50016).

The Trimming Kit contains the following parts:



Figure 23.9 Trimming tool kit

23.8.2 p.c.b. Snapper - 5322 535 91942

A special tool is available for removal of the p.c.b. from the p.c.b. supports. Information on how to use this tool is given in chapter 23.4. The ordering number of this tool is 5322 535 91942

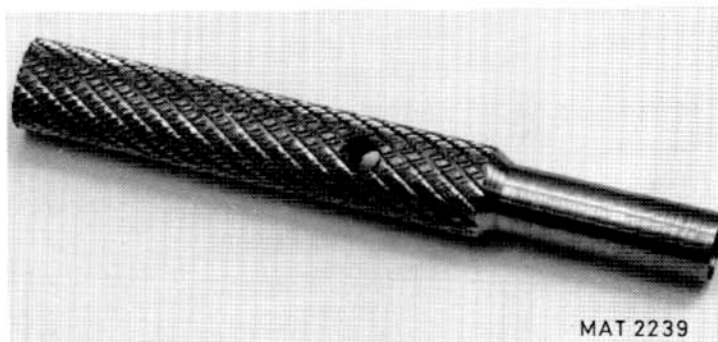

Figure 23.10 p.c.b. Snapper

23.8.3 Extension board - 5322 216 51211

For test and repair purposes the unit A11...A15 can be plugged in their connectors via an extension board. This board is available under codenumber 5322 216 51211.

23.9 RECALIBRATION AFTER REPAIR

After any electrical component has been renewed the calibration of its associated circuit should be checked, as well as the calibration of other closely-related circuits. Since the power supply affects all circuits, calibration of the entire instrument should be checked if work has been done in the power supply or if the transformer has been renewed.

JTN

SAFETY INSPECTION

JTN

24 SAFETY INSPECTION

24.1 GENERAL DIRECTIVES

- Take care that the creepage distances and clearances have not been reduced.
- Before soldering, the wires should be bent through the holes of solder tags, or wrapped around the tag in the form of an open U, or, wiring rigidity shall be maintained by cable clamps or cable lacing.
- Replace all insulating guards and -plates.

24.2 SAFETY COMPONENTS

Components in the primary circuit may only be renewed by components selected by PHILIPS, see also section 23.1.2.

24.3 CHECKING THE PROTECTIVE EARTH CONNECTION

The correct connection and condition is checked by visual control and by measuring the resistance between the protective lead connection at the plug and the cabinet/frame. The resistance shall not be more than 0,1 Ω . During measurement the mains cable should be removed from the mains. Resistance variations indicate a defect.

24.4 CHECKING THE INSULATION RESISTANCE

Measure the insulation resistance at $U = 500$ V dc between the mains connections and the protective lead connections. For this purpose, set the mains switch to ON. The insulation resistance shall not be less than 2 M Ω .

NOTE: 2 M Ω is a minimum requirement at 40° C and 95% Relative Humidity. Under normal conditions the insulation resistance should be much higher (10 ... 20 M Ω).

24.5 CHECKING THE LEAKAGE CURRENT

The leakage current shall be measured between each pole of the mains supply in turn, and all accessible conductive parts connected together (including the measuring earth terminal). The leakage current is not excessive if the measured currents from the mentioned parts does not exceed 0,5 mA rms.

24.6 VOLTAGE TEST

The instrument shall withstand, without electrical breakdown, the application of a test voltage between the supply circuit and accessible conductive parts that are likely to become energized. The test potential shall be 1500 V rms at supply-circuit frequency, applied for one second. The test shall be conducted when the instrument is fully assembled, and with the primary switch in the ON position.

During the test, both sides of the primary circuit of the instrument are connected together and to one terminal of the voltage test equipment; the other voltage test equipment terminal is connected to the accessible conductive parts.

PARTS LIST

JTN

25 PARTS LIST

(subject to alteration without notice)

25.1 MECHANICAL PARTS

At the time of printing this Service manual, the oscilloscopes are changed from the old "brown" colour into the new "grey" colour.

The parts lists below indicate the ordering codes for both coloured mechanical parts (brown and grey). Only the parts with changed colour are indicated in the "new" grey table of ordering codes.

25.1.1 Bezel assembly

Item	Qty	Ordering code (old) brown	Ordering code (new) grey	Description
1	1	5322 459 20503	5322 381 11119	Bezel
2	1	5322 414 20213	5322 414 60699	Button
3	1	5322 464 90484		Cover
4	1	5322 216 51209		Cursor unit A19
5	1	5322 480 30181		Contrast filter blue
6	1	5322 455 81095	5322 455 81125	Textfilm on bezel PM3365A
	1	5322 455 81101	5322 455 81126	Textfilm on bezel PM3367A
	1	5322 455 71039	5322 455 81128	Textfilm on bezel PM3375
	1	5322 455 71042	5322 455 81131	Textfilm on bezel PM3377

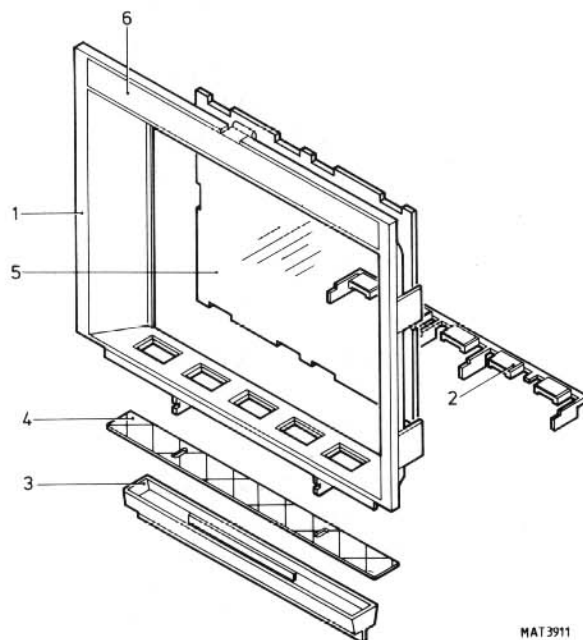

MAT3911

Figure 25.1 Bezel assembly

25.1.2 Mechanical parts indicated in figure 25.2

Item	Qty	Ordering code (old) brown	Ordering code (new) grey	Description
4	1	5322 268 14052		CAL socket
5	1	4822 530 70296		Clamping spring for CAL socket
6	11	5322 414 10018	5322 414 60697	Control knob with spring
7	1	5322 464 90252	5322 464 90659	Front frame
8	1	5322 455 81026	5322 455 81105	Textfilm CRT unit
9	1	5322 455 81096	5322 455 81104	Textfilm for handle PM3365A
9	1	5322 455 71038	5322 455 81104	Textfilm for handle PM3375
10	1	5322 498 50219	5322 498 50308	Handle assembly
10a	2	5322 498 70091		Handle arret
10b	2	5322 529 50203		Spring dowel for handle arret
11	1	5322 414 60142	5322 414 60698	Power-on knob, green-brown
12	2	5322 498 50268		Locking clip for handle
13	1	5322 535 80735		Extension part for power-on switch
14	1	5322 447 91499	5322 447 91801	Upper cabinet for PM3365A/67A
14	1	5322 447 91787	5322 447 91806	Upper cabinet for PM3375/77
15	2	5322 462 10265		P.c.b. guiding for A3
16	2	5322 462 10264		P.c.b. support for A6
17	1	5322 464 90486	5322 464 90661	Chassis
18	6	5322 462 30304		P.c.b. support
19	1	5322 464 90249	5322 447 91802	Bottom cabinet
20	2	5322 447 91487		Attenuator cover
21	1	5322 464 90664		Attenuator chassis
22	3	5322 506 21188		BNC spacer ring
23	3	5322 532 41006		BNC extension bush
24	3	5322 267 10004		BNC socket
25	1	5322 464 90254	5322 256 91632	Front unit frame
26	1	5322 455 81061	5322 455 81114	Textfilm for front unit
27	23	5322 276 11856	5322 276 20489	Softkey brown - grey
28	1	5322 276 12332	5322 276 20493	Softkey mushroom - dark mushroom
29	1	5322 276 11857	5322 276 20492	Softkey green - green
30	5	5322 277 10878	5322 276 20491	UP-DOWN key brown - grey
32	2	5322 492 63354		Range indication spring
33	1	5322 450 60952		LCD window
34	1	5322 256 60289	5322 256 91613	Battery back-up holder
35	1	5322 361 10326		FAN assembly
36	4	5322 462 30377		Panel support
37	4	4822 530 70296		Panel support clamp
38	1	5322 417 20154		Metal fastener for A18
39	2	5322 290 40257		Flat cable clamp
40	2	5322 532 11588		Rubber support
41	2	5322 256 64014		Battery holder
42	3	5322 462 71476	5322 462 41695	Plastic screw in upper cabinet
43	4	5322 462 50325	5322 462 41697	Bottom foot
--	3	5322 255 40054		Heatsink for V3011 and V3012
--	2	5322 401 10954		Delay line cable clamp
--	1	5322 492 70224		Clamping spring for A16
--	2	4822 492 63051		Mounting clip for V6014 and V6016
--	2	5322 255 41133		Isolation foil for V6014 and V6016

ATTENTION: In some versions of the PM3375/77, the P²CCD unit A18 has been fixed by means of nylon screws, M3x8. Total quantity per instrument is 7. Ordering number: 5322 502 24491.

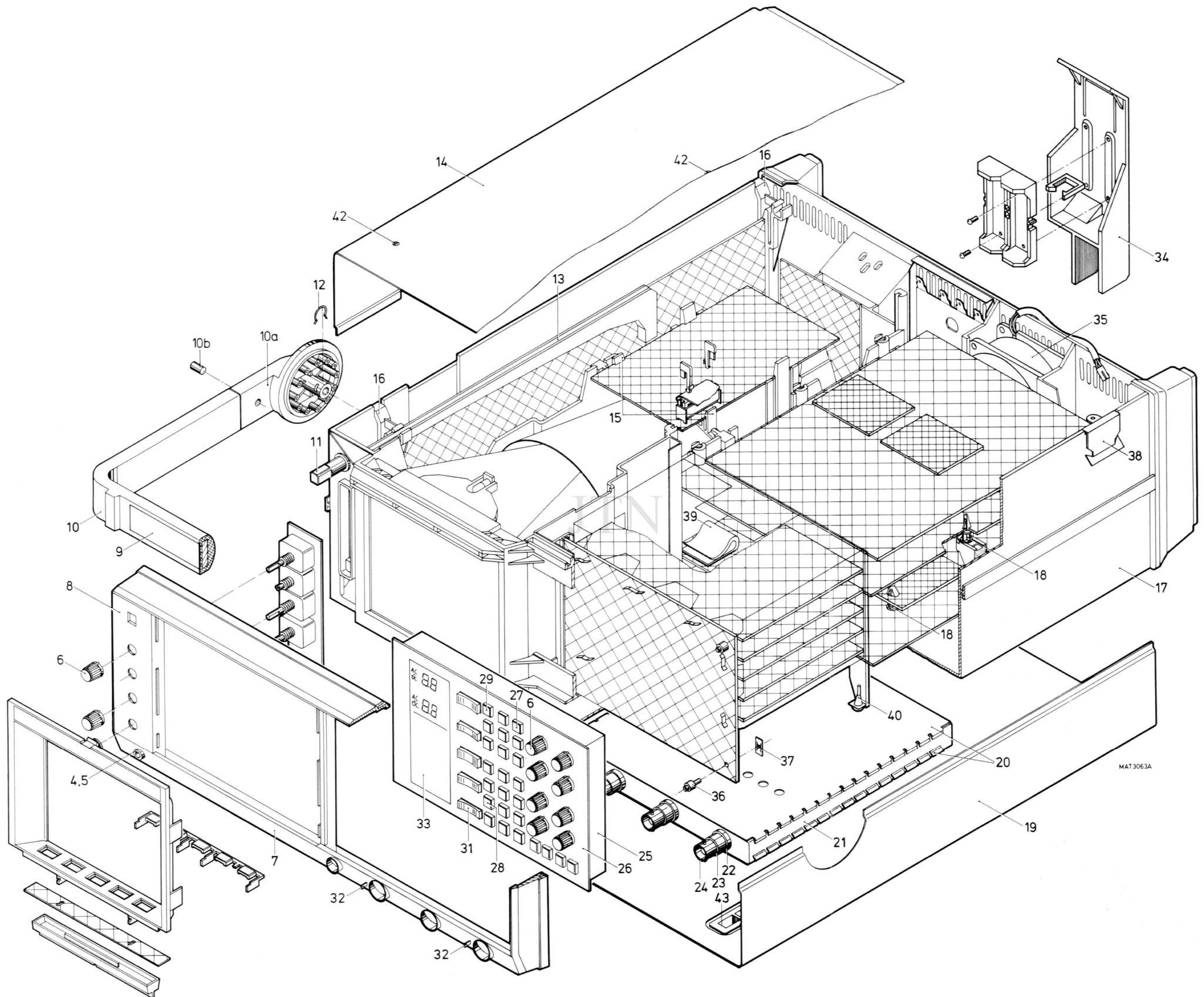

Figure 25.2 Exploded view

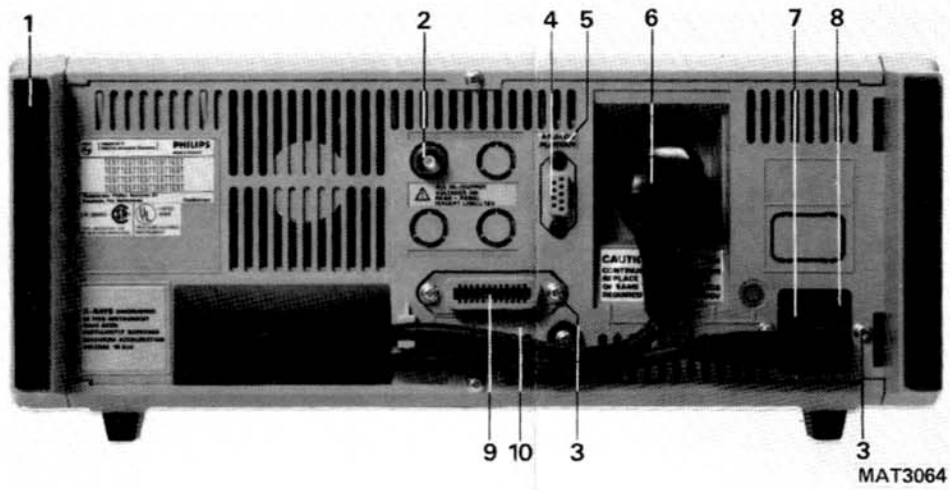

Figure 25.3 Rear view

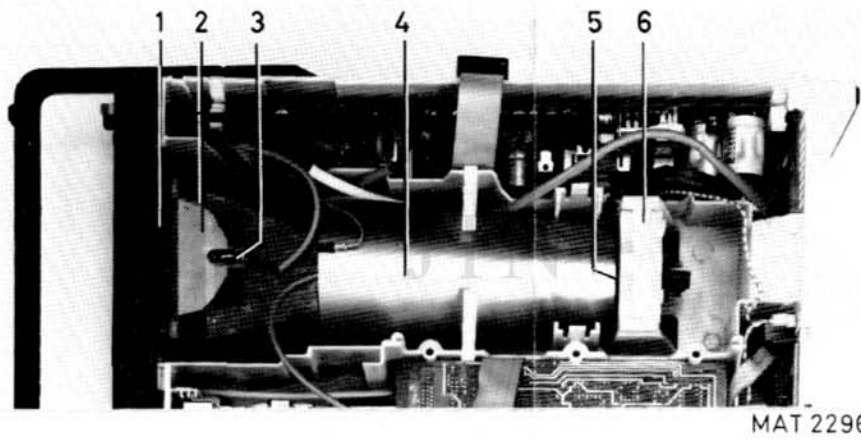

Figure 25.4 Inside view showing the parts in the CRT compartment

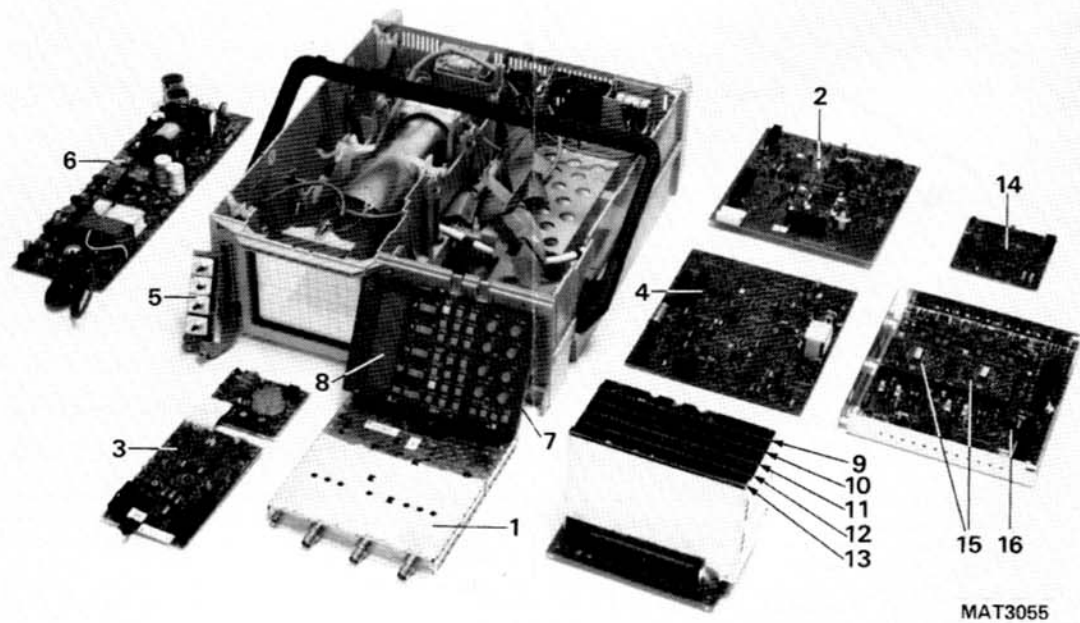

Figure 25.5 View of the units

25.1.3 Mechanical parts indicated in figure 25.3

Item	Qty	Ordering code (old) brown	Ordering code (new) grey	Description
1	2	5322 462 50324	5322 462 41696	Rear foot
2	1	5322 267 10004		BNC socket for Z-MOD
3	4	5322 502 12003		Screws for ANALOG PLOT OUT and Mains input sockets.
4	1	5233 321 22614		Analog plot out socket.
5	1	5322 455 81059		Analog plot out sticker
6	1	5322 321 21616		Line cable, European version
	1	5322 321 10446		Line cable, USA version
	1	5322 321 21617		Line cable, British version
	1	5322 321 21618		Line cable, Swiss version
	1	5322 321 21781		Line cable, Australean version
7	1	5322 219 81119		Mains input socket, incl. fuse holder
8	1	4822 253 30024		Fuse 1,6A (for mains input)

25.1.4 Mechanical parts indicated in figure 25.4

Item	Qty	Ordering code (old) brown	Ordering code (new) grey	Description
1	1	5322 460 60404		CRT front rubber
2	1	5322 462 40957		Light conductor for CRT
3	1	5322 134 40534		Lamp 28V-80mA
4	1	5322 466 30163		CRT shielding
5	1	5322 466 30164		CRT manchet, rubber
6	1	5322 462 10263		CRT support

25.2 UNITS (see figure 25.5)

Item	Unit	Ordering code (old) brown	Ordering code (new) grey	Description
1	A1	5322 214 90066		Attenuator unit
2	A2	5322 216 51256		Pre-amplifier unit
3	A3	5322 214 90068		XYZ-amplifier unit
4	A4	5322 216 51228		Time-base unit
5	A5	5322 216 51118		CRT-control unit
6	A6	5322 216 51195		Power supply unit
7	A7	5322 216 51197	5322 216 51262	Front unit
8	A8	5322 216 51207		LCD unit
18	A10	5322 216 51252		Motherboard unit
9	A11	5322 216 51198		IEEE-488 unit (optional)
9	A11	5322 216 51212		RS232-C unit (optional)
10	A12	5322 216 51199		CPU unit
11	A13	5322 216 51201		DCL unit
12	A14	5322 216 51202		ACL unit
13	A15	5322 216 51203		ADC-DAC unit
14	A16	5322 216 51229		Adaptation unit
15	A17	5322 216 51205		Mini CCD unit (PM3365A/67A only)
16	A18	5322 216 51206		P ² CCD unit (PM3365A/67A only)
16	A18	5322 216 51255		P ² CCD unit (PM3375/77 only)
17	A19	5322 216 51209		Cursor unit

25.3 CABLES AND CONNECTORS

25.3.1 Flatcables and connectors

For the flatcables used in this oscilloscope, the required version must be made by yourself with the following parts:

- Universal flatcable, 40 wires, length 60 cm 5322 323 50112

To get the required number of wires, the flat cable must be split by means of a pair of scissors or a knife.

The cable must be cut to the required length.

- Flatcable connectors

The connectors can be mounted on the flatcable by means of a pair of pliers or in a bench-vice.

ATTENTION: Check the position of the flatcable in the connector before pressing the connector together.

NOTE: The position of all cables and connectors is indicated on Figure 23.8 (p.c.b. interconnections)

The following connectors are available:

Type	Item	Ordering number
6 pole cable connector	X7019	5322 268 40301
10 pole cable connector	X505-X606-X806- X4016-X5007-X6007	5322 268 40234
20 pole cable connector	X91-X803-X2010- X3002-X3003-X4002 X4010-X6009-X7091	5322 268 40235
26 pole cable connector	X102-X1009-X2009	5322 267 70175
34 pole cable connector	X96(X97)-X2001-X4001	5322 268 40236
40 pole cable connector	X98-X808	5322 267 70227

The following AMP-connectors are available:

2 pole-single, without contact pins	5322 268 40232
3 pole-single, without contact pins	5322 268 40233
bus contact for AMP-cable connector, per piece:	5322 268 20152
5 pole connector for power-in:	5322 267 50452
bus contact for connector, per piece:	5322 268 24128

The flatcables are fixed onto the p.c.b. connectors by means of flatcable

connector clamps, per piece	5322 401 11156
-----------------------------	----------------

25.3.2 P.c.b.-connectors (male headers)

Type	Item	Ordering number
2 pole-single	X414-X416-X4017-X6020	5322 265 20275
2 pole-single 90° type	X2013	5322 265 20445
3 pole-single	X6008-X6021	5322 265 30434
3 pole single	X7011-X7012	5322 265 30396
3 pole-single	X8011-X8012	5322 267 40667
3 pole-single 90° type	X2004-X3004-X3005- X3008-X5218	5322 265 30433
5 pole-single	X6014	5322 265 40436
6 pole-single	X7013	5322 265 30591
8 pole-single	X2021-X2022-X2023 X2024	5322 267 50786
8 pole-single	X1621-X1622-X1623 X1624	5322 265 40483
10 pole-double	X99-X606-X806-X1699- X4016-X5007-X6007- X5206	5322 265 40485
10 pole-double 90° type	X505-X1606	5322 265 61212
20 pole-double	X91-X803-X2010- X3002-X3003-X3009- X3010-X4002-X4010- X5203-X6003-X7009	5322 265 51129
20 pole-double 90° type	X7001	5322 265 51286
26 pole-double	X102-X1009-X2009	5322 265 61071
34 pole-double	X96-X97-X2001-X4001	5322 265 61069
40 pole-double	X98-X808-X5208	5322 265 61211

25.3.3 50 Ω cables and connectors

The 50 Ω coax-cables are standerzided, so some cables are a little bit too long. The tules around the cable end might have the wrong colour, but if necessary it can be replaced by the original one.

- Cable, 30 cm long, 90° type 5322 321 22617
- Cable, 45 cm long 5322 321 22616

The 50 Ω coax-connector socket consists of two parts, bush and pin.

- Outer part (bush) 5322 268 24116
- Inner part (pin) 5322 268 14141

25.3.4 Miscellaneous cables

- Delay line cable, 54 cm long 5322 321 21595
- Flex jump cable, used for interconnection for A3 - 11 pole. 5322 290 60605

25.3.5 Miscellaneous sockets and connectors

CRT socket	5322 255 40502
p.c.b. socket, 96 pole, triple	5322 267 70167
p.c.b. connector, 96 pole, triple	5322 265 61188
Socket for D314	5322 255 40677
Socket for D801	5322 255 41124
Socket for D214, 48 pins	5322 255 40851
Socket for D216, 32 pins	5322 255 40829
p.c.b. socket, 8 pole (X1621, X1622, X1623, X1624)	5322 265 40483
p.c.b. socket, 8 pole (X2021, X2022, X2023, X2024)	5322 267 50786

JTN

25.4 ELECTRICAL PARTS

The item numbers of the electrical components have been divided into groups which relate to the circuits and the printed-circuit boards.

A survey of this numbering is given in the following table:

<u>Item number</u>	<u>Unit no</u>	<u>Printed-circuit board</u>
1000-1599	A1	Attenuator unit
2000-2999	A2	Pre-amplifier unit
3000-3999	A3	XYZ amplifier unit
4000-4999	A4	Time-base unit
5000-5099	A5	CRT control unit
6000-6999	A6	Power supply unit
7000-7999	A7	Front unit
8000-8999	A8	LCD unit
200- 299	A12	CPU unit
300- 399	A13	DCL unit
400- 499	A14	ACL unit
500- 599	A15	ADC DAC unit
1600-1799	A16	Adaptation unit
700- 799	A17	Mini CCD (PM3365A/67A only)
800- 999	A18	P ² CCD unit
5100-5999	A18	P ² CCD unit (PM3375/77 only)

POSNR	DESCRIPTION	ORDERING CODE	POSNR	DESCRIPTION	ORDERING CODE
C 0884	CAP. ELECTROLYT. -10+50% 150UF	4822 124 20672	C 1036	CAP. CERAMIC 10% 470PF	4822 122 30034
C 0895	CAP. CERAMIC -20+50% 10NF	4822 122 31414	C 1037	CAP. CERAMIC 2% 47PF	4822 122 31072
C 0896	CAP. CERAMIC -20+50% 10NF	4822 122 31414	C 1038	CAP. CERAMIC 10% 470PF	4822 122 30034
C 0898	CAP. ELECTROLYT. -10+50% 47UF	4822 124 20699	C 1039	CAP. CERAMIC 10% 1.5NF	4822 122 31169
C 0899	CAP. CERAMIC -20+50% 10NF	4822 122 31414	C 1040	CAP. CERAMIC 10% 1.5NF	4822 122 31169
C 0901	CAP. 100V 10% 22NF	4822 121 41856	C 1041	CAP. FOIL 63V 10% 100NF	5322 121 42492
C 0903	CAP. CERAMIC -20+50% 82PF	4822 122 31237	C 1042	CAP. CERAMIC -20+50% 10NF	4822 122 31414
C 0904	CAP. FOIL 220PF 1% 82PF 400V	4822 122 31237	C 1043	CAP. CERAMIC 0.25PF 2.2PF	4822 122 31036
C 0906	CAP. 100V 10% 22NF	4822 121 41856	C 1044	CAP. CERAMIC -20+50% 10NF	4822 122 31414
C 0908	CAP. CERAMIC 2% 82PF	4822 122 31237	C 1046	CAP. CERAMIC -20+50% 10NF	4822 122 31414
C 0909	CAP. FOIL 220PF 1% 400V	4822 121 51555	C 1047	CAP. CERAMIC -20+50% 10NF	4822 122 31414
C 0911	CAP. 100V 10% 22NF	4822 121 41856	C 1051	CAP. VARIABLE 7-10.0 PF MUR	5322 125 11013
C 0913	CAP. CERAMIC 2% 82PF	4822 122 31237	C 1053	CAP. CERAMIC 2% 12PF	4822 122 31056
C 0914	CAP. FOIL 220PF 1% 400V	4822 121 51555	C 1056	CAP. TRIMMER 2-20PF MUR	5322 125 50296
C 0916	CAP. 100V 10% 22NF	4822 121 41856	C 1058	CAP. CERAMIC 2% 33PF	5322 122 32072
C 0918	CAP. CERAMIC 2% 82PF 400V	4822 122 31237	C 1061	CAP. CERAMIC -20+50% 10NF	4822 122 31414
C 0919	CAP. FOIL 220PF 1% 400V	4822 121 51555	C 1062	CAP. CERAMIC -20+50% 10NF	4822 122 31414
C 0920	CAP. CERAMIC -20+50% 10NF	4822 122 31414	C 1063	CAP. CERAMIC -20+50% 10NF	4822 122 31414
C 0921	CAP. ELECTROLYT. -10+50% 100UF	4822 124 20679	C 1064	CAP. CERAMIC -20+50% 10NF	4822 122 31414
C 0922	CAP. CERAMIC -20+50% 10NF	4822 122 31414	C 1066	CAP. CERAMIC -20+50% 10NF	4822 122 31414
C 0923	CAP. CERAMIC -20+50% 10NF	4822 122 31414	C 1067	CAP. CERAMIC -20+50% 10NF	4822 122 31414
C 0924	CAP. CERAMIC -20+50% 10NF	4822 122 31414	C 1071	CAP. CERAMIC 10% 1.5NF	4822 122 31169
C 0925	CAP. CERAMIC -20+50% 10NF	4822 122 31414	C 1072	CAP. CERAMIC 10% 1.5NF	4822 122 31169
C 0926	CAP. CERAMIC -20+50% 10NF	4822 122 31414	C 1101	CAP. CERAMIC 0.25PF 3.3PF	5322 122 32549
C 0927	CAP. CERAMIC -20+50% 10NF	4822 122 31414	C 1102	CAP. CERAMIC -20+50% 10NF	4822 122 31414
C 0928	CAP. CERAMIC -20+50% 10NF	4822 122 31414	C 1103	CAP. CERAMIC 2% 22PF	5322 122 32417
C 0929	CAP. CERAMIC -20+50% 10NF	4822 122 31414	C 1104	CAP. VARIABLE 7-10.0 PF MUR	5322 125 11013
C 0930	CAP. CERAMIC -20+50% 10NF	4822 122 31414	C 1105	CAP. CERAMIC 0.25PF 1.8PF	4822 122 31185
C 0931	CAP. CERAMIC -20+50% 10NF	4822 122 31414	C 1106	CAP. CERAMIC -20+50% 10NF	4822 122 31414
C 0932	CAP. CERAMIC -20+50% 10NF	4822 122 31414	C 1107	CAP. CHIP 0.25PF 3.3PF	4822 122 31821
C 0933	CAP. CERAMIC -20+50% 10NF	4822 122 31414	C 1108	CAP. CERAMIC 10% 1NF	4822 122 30027
C 0934	CAP. CERAMIC -20+50% 10NF	4822 122 31414	C 1109	CAP. CERAMIC 2% 27PF	5322 122 32776
C 0935	CAP. CERAMIC -20+50% 10NF	4822 122 31414	C 1110	CAP. CERAMIC 0.25PF 1.8PF	4822 122 31185
C 0936	CAP. CERAMIC -20+50% 10NF	4822 122 31414	C 1111	CAP. CERAMIC 0.25PF 3.3PF	5322 122 32549
C 0937	CAP. CERAMIC -20+50% 10NF	4822 122 31414	C 1112	CAP. CERAMIC -20+50% 10NF	4822 122 31414
C 0938	CAP. CERAMIC -20+50% 10NF	4822 122 31414	C 1113	CAP. CERAMIC 2% 27PF	5322 122 32776
C 0939	CAP. CERAMIC -20+50% 10NF	4822 122 31414	C 1114	CAP. VARIABLE 7-10.0 PF MUR	5322 125 11013
C 0942	CAP. CERAMIC -20+50% 10NF	4822 122 31414	C 1116	CAP. CERAMIC 2% 33PF	5322 122 32551
C 0950	CAP. ELECTROLYT. -10+50% 100UF	4822 124 20679	C 1117	CAP. CERAMIC -20+50% 10NF	4822 122 31414
C 0951	CAP. CERAMIC -20+50% 10NF	4822 122 31414	C 1118	CAP. VARIABLE 7-10.0 PF MUR	5322 125 11013
C 0952	CAP. CERAMIC -20+50% 10NF	4822 122 31414	C 1119	CAP. CERAMIC 0.25PF 4.7PF	5322 122 33082
C 0954	CAP. CERAMIC -20+50% 10NF	4822 122 31414	C 1120	CAP. CERAMIC 2% 10PF	4822 122 32185
C 0956	CAP. CERAMIC -20+50% 10NF	4822 122 31414	C 1121	CAP. CERAMIC -20+50% 10NF	4822 122 31414
C 0957	CAP. CERAMIC -20+50% 10NF	4822 122 31414	C 1122	CAP. CERAMIC -20+50% 10NF	4822 122 31414
C 0958	CAP. CERAMIC -20+50% 10NF	4822 122 31414	C 1123	CAP. CERAMIC -20+50% 10NF	4822 122 31414
C 0959	CAP. CERAMIC -20+50% 10NF	4822 122 31414	C 1124	CAP. FOIL 400V 10% 22NF	5322 121 40308
C 0960	CAP. CERAMIC -20+50% 10NF	4822 122 31414	C 1126	CAP. CERAMIC -20+50% 10NF	4822 122 31414
C 0961	CAP. ELECTROLYT. -10+50% 100UF	4822 124 20679	C 1128	CAP. CERAMIC 2% 150PF	4822 122 31413
C 0962	CAP. ELECTROLYT. -10+50% 150UF	4822 124 20672	C 1129	CAP. CERAMIC 0.25PF 3.9PF	5322 122 36107
C 0963	CAP. ELECTROLYT. -10+50% 68UF	4822 124 20689	C 1130	CAP. CERAMIC -20+50% 10NF	4822 122 31414
C 0964	CAP. ELECTROLYT. -10+50% 68UF	4822 124 20689	C 1131	CAP. CERAMIC -20+50% 10NF	4822 122 31414
C 0965	CAP. CERAMIC -20+50% 10NF	4822 122 31414	C 1132	CAP. CERAMIC -20+50% 10NF	4822 122 31414
C 0968	CAP. CERAMIC -20+50% 10NF	4822 122 31414	C 1133	CAP. CERAMIC 2% 150PF	4822 122 31413
C 0969	CAP. CERAMIC -20+50% 10NF	4822 122 31414	C 1134	CAP. CERAMIC 2% 47PF	4822 122 31072
C 0971	CAP. CERAMIC -20+50% 10NF	4822 122 31414	C 1135	CAP. CERAMIC 10% 3.3NF	4822 122 30099
C 0972	CAP. CERAMIC -20+50% 10NF	4822 122 31414	C 1136	CAP. CERAMIC 10% 470PF	4822 122 30034
C 0973	CAP. CERAMIC -20+50% 10NF	4822 122 31414	C 1137	CAP. CERAMIC 2% 47PF	4822 122 31072
C 0974	CAP. CERAMIC -20+50% 10NF	4822 122 31414	C 1138	CAP. CERAMIC 10% 470PF	4822 122 30034
C 0976	CAP. ELECTROLYT. -10+50% 15UF	4822 124 20729	C 1139	CAP. CERAMIC 10% 1.5NF	4822 122 31169
C 0977	CAP. ELECTROLYT. -10+50% 47UF	4822 124 20699	C 1140	CAP. CERAMIC 10% 1.5NF	4822 122 31169
C 0978	CAP. ELECTROLYT. -10+50% 68UF	4822 124 20689	C 1141	CAP. FOIL 63V 10% 100NF	5322 121 42492
C 0979	CAP. ELECTROLYT. -10+50% 68UF	4822 124 20689	C 1142	CAP. CERAMIC -20+50% 10NF	4822 122 31414
C 0980	CAP. CERAMIC -20+50% 10NF	4822 122 31414	C 1143	CAP. CERAMIC 0.25PF 2.2PF	4822 122 31036
C 0981	CAP. ELECTROLYT. -10+50% 33UF	4822 124 20712	C 1144	CAP. CERAMIC -20+50% 10NF	4822 122 31414
C 0982	CAP. CERAMIC -20+50% 10NF	4822 122 31414	C 1146	CAP. CERAMIC -20+50% 10NF	4822 122 31414
C 0983	CAP. CERAMIC -20+50% 10NF	4822 122 31414	C 1147	CAP. CERAMIC -20+50% 10NF	4822 122 31414
C 0984	CAP. CERAMIC -20+50% 10NF	4822 122 31414	C 1151	CAP. VARIABLE 7-10.0 PF MUR	5322 125 11013
C 0985	CAP. CERAMIC -20+50% 10NF	4822 122 31414	C 1153	CAP. CERAMIC 2% 12PF	4822 122 31056
C 0986	CAP. FOIL 63V 10% 100NF	5322 121 42492	C 1156	CAP. TRIMMER 2-20PF MUR	5322 125 50296
C 0987	CAP. ELECTROLYT. -10+50% 47UF	4822 124 20699	C 1158	CAP. CERAMIC 2% 33PF	5322 122 32072
C 0988	CAP. CERAMIC -20+50% 10NF	4822 122 31414	C 1161	CAP. CERAMIC -20+50% 10NF	4822 122 31414
C 0993	CAP. CERAMIC -20+50% 10NF	4822 122 31414	C 1162	CAP. CERAMIC -20+50% 10NF	4822 122 31414
C 0995	CAP. ELECTROLYT. -10+50% 68UF	4822 124 20689	C 1163	CAP. CERAMIC -20+50% 10NF	4822 122 31414
C 0996	CAP. CERAMIC -20+50% 10NF	4822 122 31414	C 1164	CAP. CERAMIC -20+50% 10NF	4822 122 31414
C 0997	CAP. ELECTROLYT. -10+50% 150UF	4822 124 20672	C 1166	CAP. CERAMIC -20+50% 10NF	4822 122 31414
C 0999	CAP. CERAMIC -20+50% 10NF	4822 122 31414	C 1167	CAP. CERAMIC -20+50% 10NF	4822 122 31414
C 1001	CAP. CERAMIC 0.25PF 3.3PF	5322 122 32549	C 1171	CAP. CERAMIC 10% 1.5NF	4822 122 31169
C 1002	CAP. CERAMIC -20+50% 10NF	4822 122 31414	C 1172	CAP. CERAMIC 10% 1.5NF	4822 122 31169
C 1003	CAP. CERAMIC 2% 22PF	5322 122 32417	C 1201	CAP. CERAMIC -20+50% 10NF	4822 122 31414
C 1004	CAP. VARIABLE 7-10.0 PF MUR	5322 125 11013	C 1202	CAP. FOIL 400V 10% 22NF	5322 121 40308
C 1005	CAP. CERAMIC 0.25PF 1.8PF	4822 122 31185	C 1203	CAP. CERAMIC 0.25PF 1.8PF	4822 122 31185
C 1006	CAP. CERAMIC -20+50% 10NF	4822 122 31414	C 1204	CAP. CERAMIC 2% 27PF	5322 122 32776
C 1007	CAP. CHIP 0.25PF 3.3PF	4822 122 31821	C 1206	CAP. VARIABLE 7-10.0 PF MUR	5322 125 11013
C 1008	CAP. CERAMIC 10% 1NF	4822 122 30027	C 1207	CAP. CERAMIC 0.25PF 3.9PF	5322 122 36107
C 1009	CAP. CERAMIC 2% 27PF	5322 122 32776	C 1208	CAP. CERAMIC 10% 2.2NF	4822 122 30114
C 1010	CAP. CERAMIC 0.25PF 1.8PF	4822 122 31185	C 1209	CAP. CERAMIC 10% 2.2NF	4822 122 30114
C 1011	CAP. CERAMIC 0.25PF 3.3PF	5322 122 32549	C 1211	CAP. CERAMIC 2% 150PF	4822 122 31413
C 1012	CAP. CERAMIC -20+50% 10NF	4822 122 31414	C 1212	CAP. FOIL 63V 10% 100NF	5322 121 42492
C 1013	CAP. CERAMIC 2% 27PF	5322 122 32776	C 1213	CAP. CERAMIC 2% 100PF	4822 122 31316
C 1014	CAP. VARIABLE 7-10.0 PF MUR	5322 125 11013	C 1216	CAP. TRIMMER 2-20PF MUR	5322 125 50296
C 1016	CAP. CERAMIC 2% 33PF	5322 122 32551	C 1218	CAP. CERAMIC 0.25PF 1.2PF	5322 122 32312
C 1017	CAP. CERAMIC -20+50% 10NF	4822 122 31414	C 1219	CAP. CERAMIC 2% 150PF	4822 122 31413
C 1018	CAP. VARIABLE 7-10.0 PF MUR	5322 125 11013	C 1401	CAP. CERAMIC -20+50% 10NF	4822 122 31414
C 1019	CAP. CERAMIC 0.25PF 4.7PF	5322 122 33082	C 1402	CAP. ELECTROLYT. -10+50% 68UF	4822 124 20689
C 1020	CAP. CERAMIC 2% 10PF	4822 122 32185	C 1403	CAP. CERAMIC -20+50% 10NF	4822 122 31414
C 1021	CAP. CERAMIC -20+50% 10NF	4822 122 31414	C 1404	CAP. CERAMIC -20+50% 10NF	4822 122 31414
C 1022	CAP. CERAMIC -20+50% 10NF	4822 122 31414	C 1405	CAP. CERAMIC -20+50% 10NF	4822 122 31414
C 1023	CAP. CERAMIC -20+50% 10NF	4822 122 31414	C 1406	CAP. ELECTROLYT. -10+50% 68UF	4822 124 20689
C 1024	CAP. FOIL 400V 10% 22NF	5322 121 40308	C 1407	CAP. CERAMIC -20+50% 10NF	4822 122 31414
C 1026	CAP. CERAMIC -20+50% 10NF	4822 122 31414	C 1408	CAP. CERAMIC -20+50% 10NF	4822 122 31414
C 1028	CAP. CERAMIC 2% 150PF	4822 122 31413	C 1421	CAP. CERAMIC -20+50% 10NF	4822 122 31414
C 1029	CAP. CERAMIC 0.25PF 3.9PF	5322 122 34107	C 1422	CAP. ELECTROLYT. -10+50% 68UF	4822 124 20689
C 1030	CAP. CERAMIC -20+50% 10NF	4822 122 31414	C 1423	CAP. CERAMIC -20+50% 10NF	4822 122 31414
C 1031	CAP. CERAMIC -20+50% 10NF	4822 122 31414	C 1424	CAP. CERAMIC -20+50% 10NF	4822 122 31414
C 1032	CAP. CERAMIC -20+50% 10NF	4822 122 31414	C 1425	CAP. CERAMIC -20+50% 10NF	4822 122 31414
C 1033	CAP. CERAMIC 2% 150PF	4822 122 31413	C 1426	CAP. ELECTROLYT. -10+50% 68UF	4822 124 20689
C 1034	CAP. CERAMIC 2% 47PF	4822 122 31072	C 1427	CAP. CERAMIC -20+50% 10NF	4822 122 31414
C 1035	CAP. CERAMIC 10% 3.3NF	4822 122 30099	C 1441	CAP. CERAMIC -20+50% 10NF	4822 122 31414
			C 1442	CAP. ELECTROLYT. -10+50% 68UF	4822 124 20689

POSNR	DESCRIPTION	ORDERING CODE	POSNR	DESCRIPTION	ORDERING CODE
C 1443	CAP. CERAMIC -20+50% 10NF	4822 122 31414	C 2226	CAP. CERAMIC 10% 470PF	4822 122 30034
C 1444	CAP. ELECTROLYT. -10+50% 68UF	4822 124 20689	C 2229	CAP. CERAMIC 10% 470PF	4822 122 30034
C 1447	CAP. CERAMIC -20+50% 10NF	4822 122 31414	C 2230	CAP. CERAMIC 10% 470PF	4822 122 30034
C 1451	CAP. ELECTROLYT. -10+50% 68UF	4822 124 20689	C 2317	CAP. CHIP V 0.25PF 1.5PF	5322 126 10225
C 1452	CAP. ELECTROLYT. -10+50% 47UF	4822 124 20699	C 2318	CAP. CHIP V 5% 470PF	5322 122 32268
C 1453	CAP. CERAMIC -20+50% 10NF	4822 122 31414	C 2321	CAP. CHIP V 0.25PF 1.5PF	5322 126 10225
C 1454	CAP. CERAMIC -20+50% 10NF	4822 122 31414	C 2326	CAP. CERAMIC -20+50% 10NF	4822 122 31414
C 1455	CAP. CERAMIC -20+50% 10NF	4822 122 31414	C 2327	CAP. CERAMIC -20+50% 10NF	4822 122 31414
C 1456	CAP. CERAMIC -20+50% 10NF	4822 122 31414	C 2328	CAP. FOIL 63V 10% 100NF	5322 121 42492
C 1457	CAP. CERAMIC -20+50% 10NF	4822 122 31414	C 2329	CAP. FOIL 63V 10% 100NF	5322 121 42492
C 1458	CAP. CERAMIC -20+50% 10NF	4822 122 31414	C 2331	CAP. FOIL 63V 10% 100NF	5322 121 42492
C 1601	CAP. CHIP V 10% 22NF	5322 122 32654	C 2332	CAP. FOIL 63V 10% 100NF	5322 121 42492
C 1602	CAP. CHIP V 5% 1NF	5322 126 10511	C 2333	CAP. FOIL 63V 10% 100NF	5322 121 42492
C 1603	CAP. CHIP V 5% 1NF	5322 126 10511	C 2335	CAP. CERAMIC 2% 12PF	4822 122 31056
C 1604	CAP. CHIP V 5% 1NF	5322 126 10511	C 2336	CAP. CERAMIC -20+50% 10NF	4822 122 31414
C 1606	CAP. CHIP V 5% 1NF	5322 126 10511	C 2337	CAP. CERAMIC -20+50% 10NF	4822 122 31414
C 1607	CAP. CHIP V 5% 22PF	5322 122 32654	C 2338	CAP. CERAMIC -20+50% 10NF	4822 122 30034
C 1611	CAP. CHIP V 10% 22NF	5322 122 32654	C 2339	CAP. CERAMIC -20+50% 10NF	4822 122 31414
C 1612	CAP. CHIP V 10% 22NF	5322 122 32654	C 2340	CAP. CERAMIC -20+50% 10NF	4822 122 31414
C 1613	CAP. CHIP V 10% 22NF	5322 122 32654	C 2342	CAP. CERAMIC 2% 22PF	5322 122 32143
C 1614	CAP. CHIP V 10% 22NF	5322 122 32654	C 2350	CAP. CERAMIC 0.25PF 2.7PF	4822 122 31038
C 1650	CAP. ELECTROLYT. -10+50% 47UF	4822 124 20699	C 2600	CAP. CERAMIC 2% 22PF	5322 122 32143
C 1651	CAP. CHIP V 10% 22NF	5322 122 32654	C 2601	CAP. FOIL 63V 10% 100NF	5322 121 42492
C 1652	CAP. CHIP V 10% 22NF	5322 122 32654	C 2602	CAP. CERAMIC -20+50% 10NF	4822 122 31414
C 1653	CAP. CHIP V 10% 22NF	5322 122 32654	C 2604	CAP. CERAMIC 10% 1.5NF	4822 122 31169
C 1654	CAP. CHIP V 10% 22NF	5322 122 32654	C 2611	CAP. CERAMIC 10% 1NF	4822 122 30027
C 1655	CAP. CHIP V 10% 22NF	5322 122 32654	C 2612	CAP. CERAMIC -20+50% 10NF	4822 122 31414
C 1656	CAP. ELECTROLYT. -10+50% 47UF	4822 124 20699	C 2613	CAP. CERAMIC 10% 470PF	4822 122 30034
C 1657	CAP. CHIP V 10% 22NF	5322 122 32654	C 2616	CAP. CERAMIC 10% 470PF	4822 122 30034
C 1658	CAP. CHIP V 10% 22NF	5322 122 32654	C 2701	CAP. ELECTROLYT. -10+50% 100UF	4822 124 20679
C 1659	CAP. CHIP V 10% 22NF	5322 122 32654	C 2702	CAP. CERAMIC -20+50% 10NF	4822 122 31414
C 1660	CAP. CHIP V 10% 22NF	5322 122 32654	C 2703	CAP. CERAMIC -20+50% 10NF	4822 122 31414
C 1661	CAP. CHIP V 10% 22NF	5322 122 32654	C 2704	CAP. CERAMIC -20+50% 10NF	4822 122 31414
C 1662	CAP. CHIP V 10% 22NF	5322 122 32654	C 2706	CAP. ELECTROLYT. -10+50% 100UF	4822 124 20679
C 1666	CAP. CHIP V 10% 22NF	5322 122 32654	C 2707	CAP. CERAMIC -20+50% 10NF	4822 122 31414
C 1667	CAP. CHIP V 10% 22NF	5322 122 32654	C 2708	CAP. CERAMIC -20+50% 10NF	4822 122 31414
C 1700	CAP. CHIP V 5% 33PF	5322 122 32659	C 2709	CAP. CERAMIC -20+50% 10NF	4822 122 31414
C 1701	CAP. CHIP V 10% 22NF	5322 122 32654	C 2710	CAP. CERAMIC -20+50% 10NF	4822 122 31414
C 1702	CAP. CHIP V 10% 22NF	5322 122 32654	C 2711	CAP. CERAMIC -20+50% 10NF	4822 122 31414
C 1703	CAP. CHIP V 5% 1NF	5322 126 10511	C 2712	CAP. CERAMIC -20+50% 10NF	4822 122 31414
C 1704	CAP. CHIP V 5% 1NF	5322 126 10511	C 2713	CAP. CERAMIC -20+50% 10NF	4822 122 31414
C 1705	CAP. CHIP V 0.25PF 3.3PF	5322 122 32286	C 2714	CAP. CERAMIC -20+50% 10NF	4822 122 31414
C 1706	CAP. VARIABLE 7-10.0 PF MUR	5322 125 11013	C 2715	CAP. CERAMIC -20+50% 10NF	4822 122 31414
C 1707	CAP. VARIABLE 7-10.0 PF MUR	5322 125 11013	C 2716	CAP. ELECTROLYT. -10+50% 68UF	4822 124 20689
C 1713	CAP. CHIP V 10% 22NF	5322 122 32654	C 2718	CAP. CERAMIC -20+50% 10NF	4822 122 31414
C 1721	CAP. CHIP V 10% 22NF	5322 122 32654	C 2719	CAP. CERAMIC -20+50% 10NF	4822 122 31414
C 1722	CAP. CERAMIC V 0.5PF 5.6PF	5322 122 32967	C 2720	CAP. CERAMIC -20+50% 10NF	4822 122 31414
C 1723	CAP. CERAMIC V 5% 39PF	5322 122 32966	C 2721	CAP. CERAMIC -20+50% 10NF	4822 122 31414
C 1727	CAP. CHIP V 10% 22NF	5322 122 32654	C 2722	CAP. CERAMIC -20+50% 10NF	4822 122 31414
C 1728	CAP. CHIP V 10% 22NF	5322 122 32654	C 2723	CAP. ELECTROLYT. -10+50% 47UF	4822 124 20699
C 1729	CAP. CERAMIC V 0.5PF 5.6PF	5322 122 32967	C 2724	CAP. CERAMIC -20+50% 10NF	4822 122 31414
C 1731	CAP. CHIP V 10% 22NF	5322 122 32654	C 2726	CAP. ELECTROLYT. -10+50% 68UF	4822 124 20689
C 1732	CAP. CHIP V 10% 22NF	5322 122 32654	C 2727	CAP. CERAMIC -20+50% 10NF	4822 122 31414
C 1733	CAP. CHIP V 5% 100PF	5322 122 32531	C 2728	CAP. CERAMIC -20+50% 10NF	4822 122 31414
C 1751	CAP. ELECTROLYT. -10+50% 47UF	4822 124 20699	C 2741	CAP. CERAMIC -20+50% 10NF	4822 122 31414
C 1752	CAP. CHIP V 10% 22NF	5322 122 32654	C 2744	CAP. CHIP V 10% 10NF	5322 122 34098
C 1753	CAP. CHIP V 10% 22NF	5322 122 32654	C 2746	CAP. CERAMIC -20+50% 10NF	4822 122 31414
C 1754	CAP. CHIP V 10% 22NF	5322 122 32654	C 2747	CAP. ELECTROLYT. -10+50% 68UF	4822 124 20689
C 1756	CAP. CHIP V 10% 22NF	5322 122 32654	C 2748	CAP. CERAMIC -20+50% 10NF	4822 122 31414
C 1757	CAP. CHIP V 10% 22NF	5322 122 32654	C 2751	CAP. ELECTROLYT. -10+50% 47UF	4822 124 20699
C 1761	CAP. CHIP V 10% 22NF	5322 122 32654	C 2753	CAP. CERAMIC -20+50% 10NF	4822 122 31414
C 1762	CAP. CHIP V 10% 22NF	5322 122 32654	C 2754	CAP. CERAMIC -20+50% 10NF	4822 122 31414
C 1766	CAP. ELECTROLYT. -10+50% 47UF	4822 124 20699	C 2756	CAP. CERAMIC -20+50% 10NF	4822 122 31414
C 1767	CAP. CHIP V 10% 22NF	5322 122 32654	C 2771	CAP. CERAMIC -20+50% 10NF	4822 122 31414
C 1768	CAP. CHIP V 10% 22NF	5322 122 32654	C 2772	CAP. ELECTROLYT. -10+50% 150UF	4822 124 20672
C 1769	CAP. CHIP V 10% 22NF	5322 122 32654	C 2773	CAP. CERAMIC -20+50% 10NF	4822 122 31414
C 1770	CAP. CHIP V 10% 22NF	5322 122 32654	C 2774	CAP. ELECTROLYT. -10+50% 68UF	4822 124 20689
C 1771	CAP. ELECTROLYT. -10+50% 47UF	4822 124 20699	C 2776	CAP. CERAMIC -20+50% 10NF	4822 122 31414
C 1772	CAP. CHIP V 10% 22NF	5322 122 32654	C 2777	CAP. FOIL 63V 10% 100NF	5322 121 42492
C 1773	CAP. CHIP V 10% 22NF	5322 122 32654	C 2781	CAP. CERAMIC -20+50% 10NF	4822 122 31414
C 1774	CAP. CHIP V 10% 22NF	5322 122 32654	C 2801	CAP. CHIP V 10% 3.3NF	4822 122 33891
C 2000	CAP. CER*MI' 2% 22PF	5322 122 32143	C 2802	CAP. CHIP V 10% 6.8NF	5322 122 31866
C 2002	CAP. CERAMIC 10% 680PF	4822 122 30053	C 2803	CAP. CHIP V 10% 6.8NF	5322 122 31866
C 2003	CAP. CERAMIC 10% 1.5NF	4822 122 31169	C 2804	CAP. CHIP V 5% 680PF	4822 122 31775
C 2004	CAP. CERAMIC 10% 1.5NF	4822 122 31169	C 3001	CAP. CERAMIC -20+50% 10NF	4822 122 31414
C 2005	CAP. CHIP 2% 15PF	4822 122 31823	C 3002	CAP. CERAMIC -20+50% 10NF	4822 122 31414
C 2006	CAP. CERAMIC -20+50% 10NF	4822 122 31414	C 3003	CAP. CERAMIC -20+50% 10NF	4822 122 31414
C 2008	CAP. CERAMIC 10% 1.5NF	4822 122 31169	C 3005	CAP. VARIABLE 7-10.0 PF MUR	5322 125 11013
C 2009	CAP. CERAMIC 10% 1.5NF	4822 122 31169	C 3007	CAP. VARIABLE 7-10.0 PF MUR	5322 125 11013
C 2009	CAP. CERAMIC 10% 1.5NF	4822 122 31169	C 3009	CAP. CERAMIC 0.25PF 6.8PF	4822 122 31049
C 2051	CAP. CERAMIC 10% 1.5NF	4822 122 31169	C 3011	CAP. CERAMIC 2% 27PF	4822 122 30045
C 2100	CAP. CERAMIC 2% 22PF	5322 122 32143	C 3013	CAP. CERAMIC 0.25PF 1.2PF	5322 122 32312
C 2102	CAP. CERAMIC 10% 680PF	4822 122 30053	C 3014	CAP. CERAMIC 0.25PF 1.2PF	5322 122 32312
C 2103	CAP. CERAMIC 10% 1.5NF	4822 122 31169	C 3015	CAP. TRIMMER 1.8-10PF	5322 125 50049
C 2104	CAP. CERAMIC 10% 1.5NF	4822 122 31169	C 3021	CAP. CERAMIC -20+50% 10NF	4822 122 31414
C 2105	CAP. CHIP 2% 15PF	4822 122 31823	C 3022	CAP. CERAMIC -20+50% 10NF	4822 122 31414
C 2106	CAP. CERAMIC -20+50% 10NF	4822 122 31414	C 3101	CAP. CERAMIC 10% 1.5NF	4822 122 31169
C 2108	CAP. CERAMIC 10% 1.5NF	4822 122 31169	C 3102	CAP. CERAMIC 10% 1.5NF	4822 122 31169
C 2109	CAP. CERAMIC 10% 1.5NF	4822 122 31169	C 3104	CAP. FOIL 100V 10% 47NF	5322 121 42491
C 2149	CAP. CERAMIC 10% 1.5NF	4822 122 31169	C 3105	CAP. CERAMIC -20+50% 10NF	4822 122 31414
C 2150	CAP. CERAMIC -20+50% 10NF	4822 122 31414	C 3106	CAP. FOIL 63V 10% 100NF	5322 121 42492
C 2151	CAP. CERAMIC 10% 1.5NF	4822 122 31169	C 3107	CAP. CERAMIC 0.25PF 2.7PF	4822 122 31038
C 2152	CAP. CERAMIC 10% 1.5NF	4822 122 31169	C 3108	CAP. CERAMIC 0.25PF 0.82PF	4822 122 31214
C 2154	CAP. CERAMIC 10% 1.5NF	4822 122 31169	C 3109	CAP. FOIL 63V 10% 100NF	5322 121 42492
C 2201	CAP. CERAMIC -20+50% 10NF	4822 122 31414	C 3110	CAP. CERAMIC -20+50% 10NF	4822 122 31414
C 2203	CAP. CERAMIC -20+50% 10NF	4822 122 31414	C 3111	CAP. CERAMIC -20+50% 10NF	4822 122 31414
C 2211	CAP. CERAMIC -20+50% 10NF	4822 122 31414	C 3112	CAP. CERAMIC 0.25PF 8.2PF	4822 122 31052
C 2212	CAP. FOIL 63V 10% 100NF	5322 121 42492	C 3113	CAP. CERAMIC 0.25PF 0.82PF	4822 122 31214
C 2213	CAP. FOIL 63V 10% 100NF	5322 121 42492	C 3114	CAP. FOIL 100V 10% 47NF	5322 121 42491
C 2214	CAP. CERAMIC -20+50% 10NF	4822 122 31414	C 3116	CAP. FOIL 63V 10% 100NF	5322 121 42492
C 2215	CAP. CERAMIC -20+50% 10NF	4822 122 31414	C 3130	CAP. CERAMIC 0.25PF 0.68PF	4822 122 32125
C 2216	CAP. CERAMIC 0.25PF 2.7PF	4822 122 31038	C 3200	CAP. CERAMIC 0.25PF 0.56PF	5322 122 32107
C 2217	CAP. CERAMIC 0.25PF 8.2PF	4822 122 31052	C 3201	CAP. CERAMIC 0.25PF 0.56PF	5322 122 32107
C 2218	CAP. CERAMIC 0.25PF 2.7PF	4822 122 31038	C 3202	CAP. FOIL 63V 10% 100NF	5322 121 42492
C 2219	CAP. CERAMIC 10% 1.5NF	4822 122 31169	C 3203	CAP. FOIL 63V 10% 100NF	5322 121 42492
C 2220	CAP. CERAMIC 10% 1.5NF	4822 122 31169	C 3204	CAP. CERAMIC -20+50% 10NF	4822 122 31414
C 2221	CAP. CERAMIC 10% 1.5NF	4822 122 31169	C 3206	CAP. FOIL 63V 10% 100NF	5322 121 42492
C 2223	CAP. CERAMIC 10% 1.5NF	4822 122 31169	C 3208	CAP. CERAMIC 10% 470PF	4822 122 30034
C 2224	CAP. CERAMIC 10% 1.5NF	4822 122 31169	C 3209	CAP. -10+10% 2.2NF	5322 122 33851
C 2225	CAP. CERAMIC 10% 470PF	4822 122 30034	C 3211	CAP. -10+10% 2.2NF	5322 122 33851

POSNR	DESCRIPTION	ORDERING CODE	POSNR	DESCRIPTION	ORDERING CODE
C 3250	CAP. 100V 10% 10NF	4822 121 41857	C 4808	CAP. ELECTROLYT. -10+50% 68UF	4822 124 20689
C 3251	CAP. FOIL 63V 10% 220NF	4822 121 42408	C 4811	CAP. CERAMIC -20+50% 10NF	4822 122 31414
C 3252	CAP. -10+10% 2.2NF	5322 122 33851	C 4815	CAP. CERAMIC -20+50% 10NF	4822 122 31414
C 3253	CAP. CERAMIC -20+50% 10NF	4822 122 31414	C 4816	CAP. CERAMIC -20+50% 10NF	4822 122 31414
C 3254	CAP. CERAMIC -20+50% 10NF	4822 122 31414	C 4817	CAP. CERAMIC -20+50% 10NF	4822 122 31414
C 3256	CAP. CERAMIC 0.25PF 0.56PF	5322 122 32107	C 4818	CAP. CERAMIC -20+50% 10NF	4822 122 31414
C 3257	CAP. CERAMIC -20+50% 10NF	4822 122 31414	C 4819	CAP. CERAMIC -20+50% 10NF	4822 122 31414
C 3258	CAP. -10+10% 2.2NF	5322 122 33851	C 4820	CAP. CERAMIC -20+50% 10NF	4822 122 31414
C 3301	CAP. ELECTROLYT. -10+50% 47UF	4822 124 20699	C 4821	CAP. FOIL 63V 10% 100NF	5322 121 42492
C 3302	CAP. CERAMIC -20+50% 10NF	4822 122 31414	C 4822	CAP. CERAMIC -20+50% 10NF	4822 122 31414
C 3303	CAP. ELECTROLYT. -10+50% 47UF	4822 124 20699	C 4824	CAP. CERAMIC -20+50% 10NF	4822 122 31414
C 3304	CAP. CERAMIC -20+50% 10NF	4822 122 31414	C 4825	CAP. CERAMIC -20+50% 10NF	4822 122 31414
C 3305	CAP. CERAMIC -20+50% 10NF	4822 122 31414	C 4826	CAP. CERAMIC -20+50% 10NF	4822 122 31414
C 3306	CAP. CERAMIC -20+50% 10NF	4822 122 31414	C 4828	CAP. FOIL 63V 10% 100NF	5322 121 42492
C 3307	CAP. CERAMIC -20+50% 10NF	4822 122 31414	C 4829	CAP. CERAMIC -20+50% 10NF	4822 122 31414
C 3308	CAP. CERAMIC -20+50% 10NF	4822 122 31414	C 4830	CAP. CERAMIC -20+50% 10NF	4822 122 31414
C 3309	CAP. CERAMIC -20+50% 10NF	4822 122 31414	C 4831	CAP. CERAMIC -20+50% 10NF	4822 122 31414
C 3311	CAP. ELECTROLYT. -10+50% 47UF	4822 124 20699	C 4832	CAP. ELECTROLYT. -10+50% 47UF	4822 124 20699
C 3312	CAP. ELECTROLYT. -10+50% 47UF	4822 124 20699	C 4833	CAP. CERAMIC -20+50% 10NF	4822 122 31414
C 3313	CAP. CERAMIC -20+50% 10NF	4822 122 31414	C 4835	CAP. CERAMIC -20+50% 10NF	4822 122 31414
C 3314	CAP. ELECTROLYT. -10+50% 15UF	4822 124 20729	C 4836	CAP. CERAMIC -20+50% 10NF	4822 122 31414
C 3316	CAP. CERAMIC -20+50% 10NF	4822 122 31414	C 4837	CAP. ELECTROLYT. -10+50% 47UF	4822 124 20699
C 3317	CAP. CERAMIC -20+50% 10NF	4822 122 31414	C 4838	CAP. ELECTROLYT. -10+50% 47UF	4822 124 20699
C 3318	CAP. CERAMIC -20+50% 10NF	4822 122 31414	C 4839	CAP. CERAMIC -20+50% 2% 12PF	4822 122 31056
C 3319	CAP. ELECTROLYT. -10+50% 15UF	4822 124 20729	C 4841	CAP. CERAMIC -20+50% 2% 12PF	4822 122 31056
C 3321	CAP. CERAMIC -20+50% 10NF	4822 122 31414	C 4888	CAP. ELECTROLYT. -10+50% 47UF	4822 124 20699
C 3322	CAP. CERAMIC -20+50% 10NF	4822 122 31414	C 4889	CAP. ELECTROLYT. -10+50% 47UF	4822 124 20699
C 3324	CAP. CERAMIC -20+50% 10NF	4822 122 31414	C 4891	CAP. CERAMIC -20+50% 10NF	4822 122 31414
C 3326	CAP. CERAMIC -20+50% 10NF	4822 122 31414	C 4892	CAP. CERAMIC -20+50% 10NF	4822 122 31414
C 4001	CAP. CERAMIC 2% 100PF	4822 122 31316	C 4893	CAP. CERAMIC -20+50% 10NF	4822 122 31414
C 4002	CAP. CERAMIC 2% 100PF	4822 122 31316	C 4894	CAP. CERAMIC -20+50% 10NF	4822 122 31414
C 4003	CAP. 100V 10% 10NF	4822 121 41857	C 4895	CAP. CERAMIC -20+50% 10NF	4822 122 31414
C 4004	CAP. CERAMIC 10% 4.7NF	4822 122 31125	C 4896	CAP. FOIL 63V 10% 100NF	5322 121 42492
C 4005	CAP. CERAMIC 10% 4.7NF	4822 122 31125	C 4897	CAP. CERAMIC -20+50% 10NF	4822 122 31414
C 4006	CAP. CERAMIC -20+50% 10NF	4822 122 31414	C 4898	CAP. CERAMIC -20+50% 10NF	4822 122 31414
C 4007	CAP. CERAMIC 10% 470PF	4822 122 30034	C 4899	CAP. CERAMIC -20+50% 10NF	4822 122 31414
C 4011	CAP. CERAMIC -20+50% 10NF	4822 122 31414	C 4901	CAP. FOIL 63V 10% 100NF	5322 121 42492
C 4028	CAP. CERAMIC 2% 100PF	4822 122 31316	C 4902	CAP. CERAMIC -20+50% 10NF	4822 122 31414
C 4029	CAP. CERAMIC 2% 100PF	4822 122 31316	C 4903	CAP. CERAMIC -20+50% 10NF	4822 122 31414
C 4101	CAP. CERAMIC -20+50% 10NF	4822 122 31414	C 4904	CAP. ELECTROLYT. -20+20% 68UF	5322 124 21955
C 4103	CAP. CERAMIC -20+50% 10NF	4822 122 31414	C 4906	CAP. CERAMIC -20+50% 10NF	4822 122 31414
C 4105	CAP. FOIL 63V 10% 100NF	5322 121 42492	C 4907	CAP. ELECTROLYT. -10+50% 150UF	4822 124 20672
C 4106	CAP. ELECTROLYT. -10+50% 150UF	4822 124 20672	C 5001	CAP. CERAMIC -20+50% 10NF	4822 122 31414
C 4107	CAP. FOIL 63V 10% 100NF	5322 121 42492	C 5002	CAP. CERAMIC -20+50% 10NF	4822 122 31414
C 4108	CAP. CERAMIC 2% 100PF	4822 122 31316	C 5003	CAP. CERAMIC -20+50% 10NF	4822 122 31414
C 4109	CAP. CERAMIC -20+50% 10NF	4822 122 31414	C 5004	CAP. CERAMIC -20+50% 10NF	4822 122 31414
C 4110	CAP. FOIL 63V 10% 470NF	5322 121 42979	C 5006	CAP. CERAMIC -20+50% 10NF	4822 122 31414
C 4112	CAP. CERAMIC -20+50% 10NF	4822 122 31414	C 5101	CAP. CHIP V 10% 22NF	5322 122 32654
C 4113	CAP. FOIL 63V 10% 10NF	4822 121 50591	C 5102	CAP. CHIP V 10% 22NF	5322 122 32654
C 4114	CAP. FOIL 100V 10% 10UF	5322 121 41727	C 5103	CAP. CHIP V 5% 15PF	5322 122 33869
C 4116	CAP. CERAMIC 10% 1.5NF	4822 122 31169	C 5104	CAP. CHIP V 5% 33PF	5322 122 32659
C 4117	CAP. CERAMIC 2% 100PF	4822 122 31316	C 5105	CAP. CERAMIC V 0.25PF 1.8PF	5322 126 10343
C 4118	CAP. CERAMIC -20+50% 10NF	4822 122 31414	C 5106	CAP. CHIP V 10% 22NF	5322 122 32654
C 4120	CAP. FOIL 63V 10% 100NF	5322 121 42492	C 5111	CAP. CHIP V 10% 22NF	5322 122 32654
C 4122	CAP. FOIL 63V 10% 100NF	5322 121 42492	C 5112	CAP. CHIP V 10% 22NF	5322 122 32654
C 4123	CAP. ELECTROLYT. -10+50% 47UF	4822 124 20699	C 5113	CAP. CERAMIC V 5% 10PF	5322 122 32448
C 4124	CAP. CERAMIC -20+50% 10NF	4822 122 31414	C 5114	CAP. CHIP V 5% 27PF	5322 122 31946
C 4126	CAP. ELECTROLYT. -10+50% 47UF	4822 124 20699	C 5115	CAP. CERAMIC V 0.25PF 1.8PF	5322 126 10343
C 4201	CAP. CERAMIC -20+50% 10NF	4822 122 31414	C 5116	CAP. CHIP V 10% 22NF	5322 122 32654
C 4241	CAP. CERAMIC -20+50% 10NF	4822 122 31414	C 5121	CAP. CHIP V 10% 1.5NF	4822 122 33174
C 4247	CAP. FOIL 63V 10% 100NF	5322 121 42492	C 5122	CAP. CHIP V 10% 22NF	5322 122 32654
C 4248	CAP. CERAMIC -20+50% 10NF	4822 122 31414	C 5123	CAP. CERAMIC V +0.5PF 6.8PF	5322 126 10728
C 4267	CAP. CHIP 2% 15PF	4822 122 31823	C 5124	CAP. CERAMIC V +0.5PF 6.8PF	5322 126 10728
C 4274	CAP. CERAMIC 2% 100PF	4822 122 31316	C 5126	CAP. CERAMIC V 0.5PF 5.6PF	5322 122 32967
C 4277	CAP. CHIP 0.25PF 4.7PF	4822 122 31822	C 5127	CAP. TRIMMER 63V 2.5-5PF	5322 125 50305
C 4281	CAP. CERAMIC 2% 100PF	4822 122 31316	C 5128	CAP. TRIMMER 63V 3.5-10PF	5322 125 50306
C 4283	CAP. CHIP 0.25PF 4.7PF	4822 122 31822	C 5129	CAP. CHIP V 10% 22NF	5322 122 32654
C 4301	CAP. FOIL 63V 10% 100NF	5322 121 42492	C 5130	CAP. 16V 10UF	5322 124 41979
C 4302	CAP. ELECTROLYT. -20+20% 6.8UF	5322 124 21961	C 5131	CAP. CHIP V 10% 22NF	5322 122 32654
C 4303	CAP. 100V 10% 10NF	4822 121 41857	C 5132	CAP. CHIP V 10% 22NF	5322 122 32654
C 4304	CAP. CERAMIC 2% 220PF	4822 122 30094	C 5133	CAP. CHIP V 10% 22NF	5322 122 32654
C 4306	CAP. CERAMIC -20+50% 10NF	4822 122 31414	C 5134	CAP. CHIP V 10% 22NF	5322 122 32654
C 4307	CAP. CERAMIC -20+50% 10NF	4822 122 31414	C 5136	CAP. CHIP V 10% 22NF	5322 122 32654
C 4311	CAP. CERAMIC 2% 100PF	4822 122 31316	C 5137	CAP. CHIP V 5% 15PF	5322 122 33869
C 4400	CAP. CERAMIC 10% 1NF	4822 122 30027	C 5138	CAP. CHIP V 5% 100PF	5322 122 32531
C 4401	CAP. CERAMIC -20+50% 10NF	4822 122 31414	C 5139	CAP. CHIP V 5% 820PF	5322 126 10184
C 4402	CAP. CERAMIC -20+50% 10NF	4822 122 30027	C 5141	CAP. CHIP V 10% 22NF	5322 122 32654
C 4403	CAP. FOIL 63V 10% 100NF	5322 121 42492	C 5142	CAP. CHIP V 10% 22NF	5322 122 32654
C 4404	CAP. FOIL 63V 10% 100NF	5322 121 42492	C 5143	CAP. CHIP V 10% 22NF	5322 122 32654
C 4405	CAP. CERAMIC -20+50% 10NF	4822 122 31414	C 5144	CAP. 16V 10UF	5322 124 41979
C 4406	CAP. FOIL 63V 10% 100NF	5322 121 42492	C 5202	CAP. CHIP V 10% 22NF	5322 122 32654
C 4407	CAP. FOIL 63V 10% 100NF	5322 121 42492	C 5203	CAP. CHIP V 10% 22NF	5322 122 32654
C 4408	CAP. FOIL 63V 10% 100NF	5322 121 42492	C 5204	CAP. CHIP V 10% 1.5NF	4822 122 33174
C 4409	CAP. CERAMIC -20+50% 10NF	4822 122 31414	C 5206	CAP. CHIP V 10% 1.5NF	4822 122 33174
C 4411	CAP. CERAMIC -20+50% 10NF	4822 122 31414	C 5211	CAP. CERAMIC V 5% 47PF	5322 122 32452
C 4412	CAP. CERAMIC -20+50% 10NF	4822 122 31414	C 5212	CAP. CHIP V 10% 22NF	5322 122 32654
C 4413	CAP. CERAMIC -20+50% 10NF	4822 122 31414	C 5214	CAP. CERAMIC V 5% 47PF	5322 122 32452
C 4414	CAP. CERAMIC -20+50% 10NF	4822 122 31414	C 5221	CAP. CHIP V 10% 22NF	5322 122 32654
C 4416	CAP. CERAMIC 10% 680PF	4822 122 30053	C 5222	CAP. CHIP V 10% 22NF	5322 122 32654
C 4418	CAP. CERAMIC -20+50% 10NF	4822 122 31414	C 5223	CAP. CHIP V 10% 22NF	5322 122 32654
C 4419	CAP. CERAMIC -20+50% 10NF	4822 122 31414	C 5224	CAP. CHIP V 10% 22NF	5322 122 32654
C 4421	CAP. FOIL 63V 10% 100NF	5322 121 42492	C 5226	CAP. CHIP V 10% 22NF	5322 122 32654
C 4501	CAP. CERAMIC -20+50% 10NF	4822 122 31414	C 5227	CAP. CHIP V 10% 22NF	5322 122 32654
C 4502	CAP. CERAMIC -20+50% 10NF	4822 122 31414	C 5228	CAP. CHIP V 10% 22NF	5322 122 32654
C 4503	CAP. CERAMIC 0.25PF 3.9PF	5322 122 34107	C 5229	CAP. CHIP V 10% 22NF	5322 122 32654
C 4521	CAP. FOIL 63V 10% 100NF	5322 121 42492	C 5251	CAP. CHIP V 10% 22NF	5322 122 32654
C 4522	CAP. FOIL 63V 10% 100NF	5322 121 42492	C 5261	CAP. CHIP V 10% 22NF	5322 122 32654
C 4601	CAP. FOIL 63V 10% 100NF	5322 121 42492	C 5262	CAP. CHIP V 10% 22NF	5322 122 32654
C 4602	CAP. CERAMIC 0.25PF 8.2PF	4822 122 31052	C 5272	CAP. CHIP V 10% 22NF	5322 122 32654
C 4603	CAP. CERAMIC 0.25PF 8.2PF	4822 122 31052	C 5273	CAP. CHIP V 10% 22NF	5322 122 32654
C 4611	CAP. CERAMIC -20+50% 10NF	4822 122 31414	C 5276	CAP. CHIP V 10% 22NF	5322 122 32654
C 4612	CAP. CERAMIC -20+50% 10NF	4822 122 31414	C 5277	CAP. CHIP V 10% 22NF	5322 122 32654
C 4613	CAP. CERAMIC 2% 10PF	4822 122 32185	C 5278	CAP. CHIP V 10% 22NF	5322 122 32654
C 4701	CAP. CERAMIC 10% 1NF	4822 122 30027	C 5301	CAP. CHIP V 10% 22NF	5322 122 32654
C 4702	CAP. CERAMIC 2% 220PF	4822 122 30094	C 5303	CAP. CHIP V 10% 22NF	5322 122 32654
C 4703	CAP. CERAMIC 10% 1NF	4822 122 30027	C 5304	CAP. 16V 10UF	5322 124 41979
C 4704	CAP. CERAMIC -20+50% 10NF	4822 122 31414	C 5306	CAP. CHIP V 10% 22NF	5322 122 32654
C 4801	CAP. CERAMIC -20+20% 2200UF	4822 124 21382	C 5307	CAP. 16V 10UF	5322 124 41979
C 4804	CAP. ELECTROLYT. -20+20% 68UF	5322 124 21955	C 5308	CAP. CHIP V 10% 22NF	5322 122 32654
C 4807	CAP. CERAMIC -20+50% 10NF	4822 122 31414	C 5351	CAP. CHIP V 10% 22NF	5322 122 32654

POSNR	DESCRIPTION	ORDERING CODE	POSNR	DESCRIPTION	ORDERING CODE
C 5353	CAP. CHIP	V 10% 22NF 5322 122 32654	C 5816	CAP. CHIP	V 10% 22NF 5322 122 32654
C 5354	CAP. CHIP	V 10% 22NF 5322 122 32654	C 5817	CAP. CHIP	V 10% 22NF 5322 122 32654
C 5356	CAP. CHIP	V 10% 22NF 5322 122 32654	C 5818	CAP. CHIP	V 5% 82PF 4822 122 53515
C 5357	CAP.	V 16V 100F 5322 124 41979	C 5819	CAP. FOIL	V 220PF 1x 400V 4822 121 51555
C 5358	CAP. CHIP	V 10% 22NF 5322 122 32654	C 5832	CAP. CHIP	V 10% 22NF 5322 122 32654
C 5359	CAP.	V 16V 100F 5322 124 41979	C 5841	CAP. CHIP	V 10% 22NF 5322 122 32654
C 5361	CAP. CHIP	V 10% 22NF 5322 122 32654	C 5895	CAP. CHIP	V 10% 22NF 5322 122 32654
C 5362	CAP.	V 16V 100F 5322 124 41979	C 5898	CAP. ELECTROLYT.	V -10+50% 47UF 4822 124 20699
C 5363	CAP. CHIP	V 10% 22NF 5322 122 32654	C 5899	CAP. CHIP	V 10% 22NF 5322 122 32654
C 5374	CAP. CERAMIC	V 0.5PF 5.6PF 5322 122 32967	C 5901	CAP. ELECTROLYT.	V -10+50% 100UF 4822 124 20679
C 5377	CAP. CERAMIC	V 0.5PF 5.6PF 5322 122 32967	C 5902	CAP.	V 16V 100F 5322 124 41979
C 5401	CAP. CHIP	V 10% 22NF 5322 122 32654	C 5903	CAP.	V 16V 100F 5322 124 41979
C 5403	CAP. CHIP	V 10% 22NF 5322 122 32654	C 5904	CAP. CHIP	V 10% 22NF 5322 122 32654
C 5404	CAP.	V 16V 100F 5322 124 41979	C 5906	CAP.	V 16V 100F 5322 124 41979
C 5406	CAP. CHIP	V 10% 22NF 5322 122 32654	C 5907	CAP.	V 16V 100F 5322 124 41979
C 5407	CAP.	V 16V 100F 5322 124 41979	C 5908	CAP. CHIP	V 10% 22NF 5322 122 32654
C 5408	CAP. CHIP	V 10% 22NF 5322 122 32654	C 5909	CAP. CHIP	V 10% 22NF 5322 122 32654
C 5451	CAP. CHIP	V 10% 22NF 5322 122 32654	C 5911	CAP. ELECTROLYT.	V -10+50% 33UF 4822 124 20712
C 5453	CAP. CHIP	V 10% 22NF 5322 122 32654	C 5912	CAP. CHIP	V 10% 22NF 5322 122 32654
C 5454	CAP. CHIP	V 10% 22NF 5322 122 32654	C 5913	CAP. CHIP	V 10% 22NF 5322 122 32654
C 5456	CAP. CHIP	V 10% 22NF 5322 122 32654	C 5914	CAP. CHIP	V 10% 22NF 5322 122 32654
C 5457	CAP.	V 16V 100F 5322 124 41979	C 5916	CAP. ELECTROLYT.	V -10+50% 47UF 4822 124 20699
C 5458	CAP. CHIP	V 10% 22NF 5322 122 32654	C 5917	CAP. CHIP	V 10% 22NF 5322 122 32654
C 5459	CAP.	V 16V 100F 5322 124 41979	C 5918	CAP. ELECTROLYT.	V -10+50% 15UF 4822 124 20729
C 5461	CAP. CHIP	V 10% 22NF 5322 122 32654	C 5922	CAP. ELECTROLYT.	V -10+50% 47UF 4822 124 20699
C 5462	CAP.	V 16V 100F 5322 124 41979	C 5923	CAP. CHIP	V 10% 22NF 5322 122 32654
C 5463	CAP. CHIP	V 10% 22NF 5322 122 32654	C 5927	CAP. ELECTROLYT.	V -10+50% 68UF 4822 124 20689
C 5474	CAP. CERAMIC	V 0.5PF 5.6PF 5322 122 32967	C 5928	CAP. CHIP	V 10% 22NF 5322 122 32654
C 5477	CAP. CERAMIC	V 0.5PF 5.6PF 5322 122 32967	C 5929	CAP. CHIP	V 10% 22NF 5322 122 32654
C 5501	CAP. CHIP	V 0.5PF 6.8PF 5322 122 32269	C 5931	CAP. CHIP	V 10% 22NF 5322 122 32654
C 5502	CAP. CHIP	V 10% 22NF 5322 122 32654	C 5932	CAP. CHIP	V 10% 22NF 5322 122 32654
C 5503	CAP. CERAMIC	V 0.25PF 2.7PF 5322 122 31873	C 5933	CAP. CHIP	V 10% 22NF 5322 122 32654
C 5504	CAP. CERAMIC	V 0.25PF 2.7PF 5322 122 31873	C 5934	CAP. CHIP	V 10% 22NF 5322 122 32654
C 5506	CAP. CHIP	V 10% 22NF 5322 122 32654	C 5936	CAP. CHIP	V 10% 22NF 5322 122 32654
C 5507	CAP. CHIP	V 10% 22NF 5322 122 32654	C 5937	CAP. CHIP	V 10% 22NF 5322 122 32654
C 5508	CAP. CERAMIC	V 0.5PF 5.6PF 5322 122 32967	C 5938	CAP. CHIP	V 10% 22NF 5322 122 32654
C 5509	CAP. CHIP	V 10% 22NF 5322 122 32654	C 5939	CAP. CHIP	V 10% 22NF 5322 122 32654
C 5511	CAP. CHIP	V 10% 22NF 5322 122 32654	C 5943	CAP. ELECTROLYT.	V -10+50% 68UF 4822 124 20689
C 5512	CAP. CHIP	V 10% 10NF 5322 122 34098	C 5944	CAP. CHIP	V 10% 22NF 5322 122 32654
C 5513	CAP. CHIP	V 10% 22NF 5322 122 32654	C 5946	CAP. CHIP	V 10% 22NF 5322 122 32654
C 5551	CAP. CHIP	V 0.5PF 6.8PF 5322 122 32269	C 5947	CAP. CHIP	V 10% 22NF 5322 122 32654
C 5552	CAP. CHIP	V 10% 22NF 5322 122 32654	C 5948	CAP. CHIP	V 10% 22NF 5322 122 32654
C 5553	CAP. CERAMIC	V 0.25PF 2.7PF 5322 122 31873	C 5949	CAP. CHIP	V 10% 22NF 5322 122 32654
C 5554	CAP. CERAMIC	V 0.25PF 2.7PF 5322 122 31873	C 5951	CAP. CHIP	V 10% 22NF 5322 122 32654
C 5556	CAP. CHIP	V 10% 22NF 5322 122 32654	C 5952	CAP. CHIP	V 10% 22NF 5322 122 32654
C 5557	CAP. CHIP	V 10% 22NF 5322 122 32654	C 5953	CAP. ELECTROLYT.	V -10+50% 150UF 4822 124 20672
C 5558	CAP. CERAMIC	V 0.5PF 5.6PF 5322 122 32967	C 5954	CAP. CHIP	V 10% 22NF 5322 122 32654
C 5559	CAP. CHIP	V 10% 22NF 5322 122 32654	C 5956	CAP. CHIP	V 10% 22NF 5322 122 32654
C 5561	CAP. CHIP	V 10% 22NF 5322 122 32654	C 5957	CAP. CHIP	V 10% 22NF 5322 122 32654
C 5562	CAP. CHIP	V 10% 10NF 5322 122 34098	C 5958	CAP. CHIP	V 10% 22NF 5322 122 32654
C 5563	CAP. CHIP	V 10% 22NF 5322 122 32654	C 5959	CAP. CHIP	V 10% 22NF 5322 122 32654
C 5581	CAP. CHIP	V 10% 22NF 5322 122 32654	C 5961	CAP.	V 16V 100F 5322 124 41979
C 5582	CAP. CHIP	V 10% 22NF 5322 122 32654	C 5962	CAP. CHIP	V 10% 22NF 5322 122 32654
C 5601	CAP.	V 16V 100F 5322 124 41979	C 5963	CAP. CHIP	V 10% 22NF 5322 122 32654
C 5602	CAP. CHIP	V 10% 22NF 5322 122 32654	C 5964	CAP. CHIP	V 10% 22NF 5322 122 32654
C 5603	CAP. CHIP	V 10% 22NF 5322 122 32654	C 5966	CAP. CHIP	V 10% 22NF 5322 122 32654
C 5604	CAP. CHIP	V 10% 22NF 5322 122 32654	C 5967	CAP. CHIP	V 10% 22NF 5322 122 32654
C 5606	CAP. CHIP	V 10% 22NF 5322 122 32654	C 5968	CAP. CHIP	V 10% 22NF 5322 122 32654
C 5607	CAP. CHIP	V 10% 22NF 5322 122 32654	C 6001	CAP. PAPER	V 250V 10% 220NF 5322 121 44142
C 5608	CAP. CHIP	V 10% 22NF 5322 122 32654	C 6002	CAP. FOIL	V -20+20% 1NF 5322 121 43656
C 5609	CAP. CHIP	V 10% 22NF 5322 122 32654	C 6003	CAP. FOIL	V 63V 10% 100NF 5322 121 42492
C 5611	CAP. CHIP	V 10% 22NF 5322 122 32654	C 6004	CAP. FOIL	V 63V 10% 100NF 5322 121 42492
C 5612	CAP. CHIP	V 10% 22NF 5322 122 32654	C 6005	CAP. CERAMIC	V -20+50% 1.5NF 5322 122 50092
C 5613	CAP. CHIP	V 10% 22NF 5322 122 32654	C 6006	CAP. FOIL	V -20+20% 1NF 5322 121 43656
C 5614	CAP. CHIP	V 10% 22NF 5322 122 32654	C 6007	CAP. ELECTROLYT.	V -20+20% 68UF 5322 124 21938
C 5651	CAP. CHIP	V 10% 22NF 5322 122 32654	C 6008	CAP. ELECTROLYT.	V -20+20% 68UF 5322 124 21938
C 5652	CAP. CHIP	V 10% 22NF 5322 122 32654	C 6009	CAP. FOIL	V 100V 10% 47NF 5322 121 42491
C 5653	CAP. CHIP	V 10% 22NF 5322 122 32654	C 6011	CAP. ELECTROLYT.	V -10+50% 33UF 4822 124 20712
C 5654	CAP. CHIP	V 10% 22NF 5322 122 32654	C 6012	CAP. CERAMIC	V 2% 220PF 4822 122 30094
C 5656	CAP. CHIP	V 10% 22NF 5322 122 32654	C 6013	CAP. CERAMIC	V 10% 4.7NF 4822 122 31125
C 5671	CAP. CHIP	V 5% 100PF 5322 122 32531	C 6014	CAP. FOIL	V 160V 1x 33NF 5322 121 50997
C 5672	CAP. CHIP	V 5% 100PF 5322 122 32531	C 6017	CAP.	V 2KV 5% 1.5NF 5322 121 43243
C 5691	CAP. CHIP	V 10% 22NF 5322 122 32654	C 6018	CAP. CERAMIC	V 10% 4.7NF 4822 122 31125
C 5692	CAP. CHIP	V 10% 22NF 5322 122 32654	C 6031	CAP.	V 100V 10% 10NF 4822 121 41857
C 5693	CAP. CHIP	V 10% 22NF 5322 122 32654	C 6032	CAP. FOIL	V 63V 10% 220NF 4822 121 42408
C 5694	CAP. CHIP	V 10% 22NF 5322 122 32654	C 6033	CAP.	V 100V 10% 10NF 4822 121 41857
C 5702	CAP. CHIP	V 10% 22NF 5322 122 32654	C 6041	CAP. FOIL	V 63V 10% 100NF 5322 121 42492
C 5703	CAP. CHIP	V 10% 22NF 5322 122 32654	C 6042	CAP. FOIL	V 63V 10% 100NF 5322 121 42492
C 5704	CAP. CHIP	V 10% 22NF 5322 122 32654	C 6100	CAP.	V 20% 6800UF 4822 124 40692
C 5706	CAP. CHIP	V 10% 22NF 5322 122 32654	C 6101	CAP.	V 20% 6800UF 4822 124 40692
C 5707	CAP. CHIP	V 10% 22NF 5322 122 32654	C 6102	CAP. ELECTROLYT.	V -10+50% 680UF 4822 124 20685
C 5708	CAP. CHIP	V 10% 22NF 5322 122 32654	C 6103	CAP.	V -20+20% 1000UF 5322 124 23276
C 5709	CAP. CHIP	V 10% 22NF 5322 122 32654	C 6104	CAP.	V -20+20% 1000UF 5322 124 23276
C 5711	CAP. CHIP	V 10% 22NF 5322 122 32654	C 6106	CAP.	V -20+20% 1000UF 5322 124 23276
C 5712	CAP. CHIP	V 10% 22NF 5322 122 32654	C 6107	CAP. ELECTROLYT.	V -10+50% 150UF 4822 124 20691
C 5713	CAP. CHIP	V 10% 22NF 5322 122 32654	C 6108	CAP.	V -20+20% 1000UF 5322 124 23276
C 5714	CAP. CHIP	V 10% 22NF 5322 122 32654	C 6109	CAP. ELECTROLYT.	V -10+50% 150UF 4822 124 20691
C 5751	CAP. CHIP	V 10% 22NF 5322 122 32654	C 6111	CAP.	V -20+20% 1000UF 5322 124 23276
C 5752	CAP. CHIP	V 10% 22NF 5322 122 32654	C 6112	CAP. ELECTROLYT.	V -10+50% 100UF 4822 124 20701
C 5753	CAP. CHIP	V 10% 22NF 5322 122 32654	C 6113	CAP. ELECTROLYT.	V -10+50% 100UF 4822 124 20701
C 5754	CAP. CHIP	V 10% 22NF 5322 122 32654	C 6114	CAP. ELECTROLYT.	V -10+50% 100UF 4822 124 20701
C 5756	CAP. CHIP	V 10% 22NF 5322 122 32654	C 6116	CAP. ELECTROLYT.	V -10+50% 68UF 4822 124 20734
C 5771	CAP. CHIP	V 5% 100PF 5322 122 32531	C 6117	CAP. ELECTROLYT.	V -10+50% 22UF 4822 124 20731
C 5772	CAP. CHIP	V 5% 100PF 5322 122 32531	C 6119	CAP. ELECTROLYT.	V -10+50% 22UF 4822 124 20731
C 5791	CAP. CHIP	V 10% 22NF 5322 122 32654	C 6120	CAP. CERAMIC	V -20+50% 10NF 4822 122 31414
C 5792	CAP. CHIP	V 10% 22NF 5322 122 32654	C 6121	CAP. ELECTROLYT.	V -10+50% 22UF 4822 124 20731
C 5793	CAP. CHIP	V 10% 22NF 5322 122 32654	C 6122	CAP. FOIL	V 630V 1x 680PF 5322 121 51216
C 5794	CAP. CHIP	V 10% 22NF 5322 122 32654	C 6131	CAP. FOIL	V 63V 10% 470NF 5322 121 42979
C 5801	CAP. CHIP	V 10% 22NF 5322 122 32654	C 6132	CAP. ELECTROLYT.	V -10+50% 100UF 4822 124 20679
C 5802	CAP. CHIP	V 10% 22NF 5322 122 32654	C 6133	CAP. FOIL	V 63V 10% 100NF 5322 121 42492
C 5803	CAP. CHIP	V 5% 82PF 4822 122 33515	C 6134	CAP. CERAMIC	V 10% 1NF 4822 122 30027
C 5804	CAP. FOIL	V 220PF 1x 400V 4822 121 51555	C 6135	CAP. CERAMIC	V -20+50% 10NF 4822 122 31414
C 5806	CAP. CHIP	V 10% 22NF 5322 122 32654	C 6201	CAP. FOIL	V 100V 10% 47NF 4822 121 42491
C 5807	CAP. CHIP	V 10% 22NF 5322 122 32654	C 6202	CAP. CERAMIC	V 2% 47PF 4822 122 31072
C 5808	CAP. CHIP	V 5% 82PF 4822 122 33515	C 6203	CAP. FOIL	V 63V 10% 220NF 4822 121 42408
C 5809	CAP. FOIL	V 220PF 1x 400V 4822 121 51555	C 6204	CAP. FOIL	V 63V 10% 100NF 5322 121 42492
C 5811	CAP. CHIP	V 10% 22NF 5322 122 32654	C 6205	CAP. FOIL	V 63V 10% 100NF 5322 121 42492
C 5812	CAP. CHIP	V 10% 22NF 5322 122 32654	C 6206	CAP. CERAMIC	V 10% 1NF 4822 122 30027
C 5813	CAP. CHIP	V 5% 82PF 4822 122 33515	C 6207	CAP. CERAMIC	V 10% 4.7NF 4822 122 31125
C 5814	CAP. FOIL	V 220PF 1x 400V 4822 121 51555	C 6208	CAP. ELECTROLYT.	V -10+50% 68UF 4822 124 20734

POSNR	DESCRIPTION	ORDERING CODE	POSNR	DESCRIPTION	ORDERING CODE
C 6209	CAP. CERAMIC	-20+50% 2.2NF	R 0421	RES. METAL FILM MRS25	1X 422E
C 6210	CAP. FOIL	63V 10% 100NF	R 0422	RES. METAL FILM MRS25	1X 100E
C 6211	CAP. CERAMIC	-20+50% 10NF	R 0423	RES. METAL FILM MRS25	1X 422E
C 6212	CAP. CERAMIC	-10+10% 33PF	R 0424	RES. METAL FILM MRS25	1X 422E
C 6213	CAP. CERAMIC	10% 4.7NF	R 0426	RES. METAL FILM MRS25	1X 422E
C 6214	CAP. CERAMIC	20% 470PF	R 0427	RES. METAL FILM MRS25	1X 100E
C 6215	CAP. FOIL	63V 10% 100NF	R 0431	RES. METAL FILM MRS25	1X 10K
C 6311	CAP. CERAMIC	-20+50% 10NF	R 0433	RES. METAL FILM MRS25	1X 10K
C 6312	CAP. CERAMIC	-20+50% 10NF	R 0434	RES. METAL FILM MRS25	1X 100E
C 6401	CAP. FOIL	63V 10% 100NF	R 0436	RES. METAL FILM MRS25	1X 100E
C 6402	CAP. ELECTROLYT.	-10+50% 68UF	R 0447	RES. METAL FILM MRS25	1X 100E
C 6500	CAP. ELECTROLYT.	-10+50% 68UF	R 0448	RES. METAL FILM MRS25	1X 100E
C 6501	CAP. CERAMIC	-20+50% 10NF	R 0449	RES. METAL FILM MRS25	1X 215E
C 6502	CAP.	100V 10% 10NF	R 0451	RES. METAL FILM MRS25	1X 100E
C 6503	CAP. CERAMIC	2% 100PF	R 0452	RES. METAL FILM MRS25	1X 10K
C 6506	CAP. CERAMIC	2% 100PF	R 0454	RES. METAL FILM MRS25	1X 100E
C 7004	CAP. CERAMIC	-20+50% 10NF	R 0456	RES. METAL FILM MRS25	1X 100K
C 7006	CAP. CERAMIC	-20+50% 10NF	R 0457	RES. METAL FILM MRS25	1X 10K
C 7007	CAP. FOIL	63V 10% 100NF	R 0458	RES. METAL FILM MRS25	1X 422E
C 7008	CAP. CERAMIC	10% 680PF	R 0501	RES. METAL FILM MRS25	1X 909E
C 7009	CAP. FOIL	63V 10% 220NF	R 0502	RES. METAL FILM MRS25	1X 909E
C 7011	CAP. CERAMIC	-20+50% 10NF	R 0503	RES. METAL FILM MRS25	1X 511E
C 7012	CAP. CERAMIC	-20+50% 10NF	R 0504	RES. METAL FILM MRS25	1X 511E
C 7013	CAP. CERAMIC	-20+50% 10NF	R 0506	RES. METAL FILM MRS25	1X 215E
C 7014	CAP. CERAMIC	-20+50% 10NF	R 0507	RES. METAL FILM MRS25	1X 1K62
C 7016	CAP. CERAMIC	-20+50% 10NF	R 0508	RES. METAL FILM MRS25	1X 909E
C 7017	CAP. CERAMIC	-20+50% 10NF	R 0509	RES. METAL FILM MRS25	1X 909E
C 7019	CAP. CERAMIC	-20+50% 10NF	R 0510	RES. METAL FILM MRS25	1X 511E
C 7101	CAP. CERAMIC	-20+50% 10NF	R 0511	RES. METAL FILM MRS25	1X 511E
C 7102	CAP. CERAMIC	-20+50% 10NF	R 0512	RES. METAL FILM MRS25	1X 215E
C 7103	CAP. CERAMIC	-20+50% 10NF	R 0513	RES. METAL FILM MRS25	1X 1K
C 7104	CAP. ELECTROLYT.	-10+50% 100UF	R 0514	RES. METAL FILM MRS25	1X 1K96
C 7106	CAP. CERAMIC	-20+50% 10NF	R 0515	RES. METAL FILM MRS25	1X 2K37
C 7107	CAP. CERAMIC	-20+50% 10NF	R 0516	RES. METAL FILM MRS25	1X 5K11
C 7108	CAP. CERAMIC	-20+50% 10NF	R 0517	RES. METAL FILM MRS25	1X 10E
C 7109	CAP. CERAMIC	-20+50% 10NF	R 0518	RES. METAL FILM MRS25	1X 10E
C 7111	CAP. CERAMIC	-20+50% 10NF	R 0519	RES. METAL FILM MRS25	1X 10E
C 7112	CAP. CERAMIC	-20+50% 10NF	R 0521	RES. METAL FILM MRS25	1X 287E
C 7114	CAP. ELECTROLYT.	-10+50% 33UF	R 0522	RES. METAL FILM MRS25	1X 1K
C 7116	CAP. CERAMIC	-20+50% 10NF	R 0523	RES. METAL FILM MRS25	1X 10K
C 7117	CAP. CERAMIC	-20+50% 10NF	R 0524	RES. METAL FILM MRS25	1X 1K
			R 0525	RES. METAL FILM MRS25	1X 1K
			R 0526	RES. METAL FILM MRS25	1X 10K
			R 0527	RES. METAL FILM MRS25	1X 1K

25.4.2 RESISTORS

POSNR	DESCRIPTION	ORDERING CODE	POSNR	DESCRIPTION	ORDERING CODE
R 0200	RES. METAL FILM MRS25	1X 10K	R 0528	RES. METAL FILM MRS25	1X 287E
R 0201	RES. METAL FILM MRS25	1X 100K	R 0531	RES. METAL FILM MRS25	1X 2K15
R 0202	RES. METAL FILM MRS25	1X 10K	R 0532	RES. METAL FILM MRS25	1X 10E
R 0203	RES. METAL FILM MRS25	1X 100K	R 0533	RES. METAL FILM MRS25	1X 10E
R 0204	RES. METAL FILM MRS25	1X 10K	R 0534	RES. METAL FILM MRS25	1X 215E
R 0206	RES. METAL FILM MRS25	1X 11K	R 0536	RES. METAL FILM MRS25	1X 422E
R 0207	RES. METAL FILM MRS25	1X 10K	R 0537	RES. METAL FILM MRS25	1X 215E
R 0208	RES. METAL FILM MRS25	1X 1K	R 0538	RES. METAL FILM MRS25	1X 51E1
R 0209	RES. METAL FILM MRS25	1X 90K9	R 0539	RES. METAL FILM MRS25	1X 422E
R 0211	RES. METAL FILM MRS25	1X 1K	R 0541	RES. METAL FILM MRS25	1X 10K
R 0212	RES. METAL FILM MRS25	1X 46K4	R 0542	POTM. SLIDE	0.3M 25% 22K
R 0213	RES. METAL FILM MRS25	1X 3K16	R 0543	RES. METAL FILM MRS25	1X 348K
R 0214	RES. METAL FILM MRS25	1X 46K4	R 0545	RES. METAL FILM MRS25	1X 2K87
R 0216	RES. METAL FILM MRS25	1X 2K15	R 0546	RES. METAL FILM MRS25	1X 2K87
R 0217	RES. METAL FILM MRS25	1X 10K	R 0548	RES. METAL FILM MRS25	1X 10E
R 0218	RES. METAL FILM MRS25	1X 10K	R 0549	RES. METAL FILM MRS25	1X 10K
R 0219	RES. METAL FILM MRS25	1X 10K	R 0550	POTM. SLIDE	0.3M 25% 4K7
R 0220	RES. METAL FILM MRS25	1X 2K15	R 0551	RES. METAL FILM MRS25	1X 10K
R 0221	RES. METAL FILM MRS25	1X 3K16	R 0553	POTM. SLIDE	0.3M 25% 4K7
R 0222	RES. METAL FILM MRS25	1X 3K16	R 0554	RES. METAL FILM MRS25	1X 100E
R 0223	RES. METAL FILM MRS25	1X 3K16	R 0556	RES. METAL FILM MRS25	1X 5K11
R 0224	RES. METAL FILM MRS25	1X 3K16	R 0557	RES. METAL FILM MRS25	1X 1K
R 0226	RES. METAL FILM MRS25	1X 51E1	R 0558	RES. METAL FILM MRS25	1X 3K48
R 0227	RES. METAL FILM MRS25	1X 51E1	R 0559	RES. METAL FILM MRS25	1X 13K3
R 0228	RES. METAL FILM MRS25	1X 10K	R 0560	RES. METAL FILM MRS25	1X 100E
R 0229	RES. METAL FILM MRS25	1X 51E1	R 0561	RES. METAL FILM MRS25	1X 10K
R 0232	RES. METAL FILM MRS25	1X 1E	R 0562	RES. METAL FILM MRS25	1X 10K
R 0233	RES. METAL FILM MRS25	1X 1E	R 0563	RES. METAL FILM MRS25	1X 3K16
R 0234	RES. METAL FILM MRS25	1X 1E	R 0564	RES. METAL FILM MRS25	1X 2K15
R 0251	RES. METAL FILM MRS25	1X 10E	R 0565	RES. METAL FILM MRS25	1X 8K25
R 0252	RES. METAL FILM MRS25	1X 51E1	R 0566	RES. METAL FILM MRS25	1X 5K11
R 0301	RES. METAL FILM MRS25	1X 100E	R 0568	RES. METAL FILM MRS25	1X 4K64
R 0302	RES. METAL FILM MRS25	1X 100E	R 0569	RES. METAL FILM MRS25	1X 42E2
R 0303	RES. METAL FILM MRS25	1X 100E	R 0571	RES. METAL FILM MRS25	1X 3K83
R 0304	RES. METAL FILM MRS25	1X 1K33	R 0572	RES. METAL FILM MRS25	1X 8K25
R 0306	RES. METAL FILM MRS25	1X 1K33	R 0573	RES. METAL FILM MRS25	1X 3K48
R 0307	RES. METAL FILM MRS25	1X 1K33	R 0574	RES. METAL FILM MRS25	1X 1K78
R 0309	RES. METAL FILM MRS25	1X 10K	R 0575	RES. METAL FILM MRS25	1X 10K
R 0312	RES. METAL FILM MRS25	1X 2K15	R 0576	RES. METAL FILM MRS25	1X 5K11
R 0313	RES. METAL FILM MRS25	1X 100K	R 0577	RES. METAL FILM MRS25	1X 5K11
R 0321	RES. METAL FILM MRS25	1X 100E	R 0578	RES. METAL FILM MRS25	1X 10K
R 0322	RES. METAL FILM MRS25	1X 100E	R 0579	RES. METAL FILM MRS25	1X 10E
R 0323	RES. METAL FILM MRS25	1X 100E	R 0581	RES. METAL FILM MRS25	1X 10E
R 0401	RES. METAL FILM MRS25	1X 100E	R 0582	RES. METAL FILM MRS25	1X 1K21
R 0402	RES. METAL FILM MRS25	1X 100E	R 0583	RES. METAL FILM MRS25	1X 10E
R 0403	RES. METAL FILM MRS25	1X 100E	R 0584	RES. METAL FILM MRS25	1X 100E
R 0404	RES. METAL FILM MRS25	1X 100E	R 0585	RES. METAL FILM MRS25	1X 10K
R 0406	RES. METAL FILM MRS25	1X 100E	R 0586	RES. METAL FILM MRS25	1X 10K
R 0407	RES. METAL FILM MRS25	1X 100E	R 0587	RES. METAL FILM MRS25	1X 26K1
R 0408	RES. METAL FILM MRS25	1X 100E	R 0588	RES. METAL FILM MRS25	1X 7K5
R 0409	RES. METAL FILM MRS25	1X 100E	R 0589	RES. METAL FILM MRS25	1X 15K4
R 0411	RES. METAL FILM MRS25	1X 100E	R 0591	RES. METAL FILM MRS25	1X 46K4
R 0412	RES. METAL FILM MRS25	1X 100E	R 0592	RES. METAL FILM MRS25	1X 46K4
R 0413	RES. METAL FILM MRS25	1X 100E	R 0593	RES. METAL FILM MRS25	1X 5K11
R 0414	RES. METAL FILM MRS25	1X 100E	R 0594	RES. METAL FILM MRS25	1X 3K16
R 0416	RES. METAL FILM MRS25	1X 100E	R 0595	RES. METAL FILM MRS25	1X 10E
R 0417	RES. METAL FILM MRS25	1X 100E	R 0596	RES. METAL FILM MRS25	1X 10K
R 0418	RES. METAL FILM MRS25	1X 422E	R 0598	RES. METAL FILM MRS25	1X 51E1
R 0419	RES. METAL FILM MRS25	1X 422E	R 0599	RES. METAL FILM MRS25	1X 511E
			R 0601	POTM. SLIDE	0.3M 25% 22K
			R 0602	RES. METAL FILM MRS25	1X 11K
			R 0603	RES. METAL FILM MRS25	1X 261E
			R 0604	RES. METAL FILM MRS25	1X 10K
			R 0605	RES. METAL FILM MRS25	1X 11K
			R 0606	POTM. SLIDE	0.3M 25% 4K7

POSNR	DESCRIPTION	ORDERING CODE	POSNR	DESCRIPTION	ORDERING CODE
R 0607	RES.METAL FILM MRS25 1x 511E	5322 116 53135	R 0816	RES.METAL FILM MRS25 1x 10E	4822 116 52891
R 0608	RES.METAL FILM MRS25 1x 511E	5322 116 53135	R 0817	RES.METAL FILM MRS25 1x 100E	5322 116 53126
R 0609	RES.METAL FILM MRS25 1x 511E	5322 116 53135	R 0818	RES.METAL FILM MRS25 1x 10E	4822 116 52891
R 0611	RES.METAL FILM MRS25 1x 511E	5322 116 53135	R 0819	RES.METAL FILM MRS25 1x 162E	5322 116 53523
R 0612	RES.METAL FILM MRS25 1x 2K15	5322 116 53239	R 0821	RES.METAL FILM MRS25 1x 162E	5322 116 53523
R 0613	RES.METAL FILM MRS25 1x 7K5	4822 116 53028	R 0822	RES.METAL FILM MRS25 1x 10E	4822 116 52891
R 0614	RES.METAL FILM MRS25 1x 10K	4822 116 53022	R 0823	RES.METAL FILM MRS25 1x 100E	5322 116 53126
R 0615	RES.METAL FILM MRS25 1x 1K47	4822 116 52957	R 0824	RES.METAL FILM MRS25 1x 10E	4822 116 52891
R 0616	RES.METAL FILM MRS25 1x 12K1	4822 116 52957	R 0825	RES.METAL FILM MRS25 1x 162E	5322 116 53523
R 0621	RES.METAL FILM MRS25 1x 5E11	4822 116 52999	R 0826	RES.METAL FILM MRS25 1x 162E	5322 116 53523
R 0622	RES.METAL FILM MRS25 1x 5E11	4822 116 52999	R 0827	RES.METAL FILM MRS25 1x 100E	5322 116 53126
R 0624	RES.METAL FILM MRS25 1x 5E11	4822 116 52999	R 0828	RES.METAL FILM MRS25 1x 215E	5322 116 5325
R 0627	RES.METAL FILM MRS25 1x 5E11	4822 116 52999	R 0829	RES.METAL FILM MRS25 1x 215E	5322 116 5325
R 0628	RES.METAL FILM MRS25 1x 5E11	4822 116 52999	R 0831	RES.METAL FILM MRS25 1x 10E	4822 116 52891
R 0629	RES.METAL FILM MRS25 1x 5E11	4822 116 52999	R 0832	RES.METAL FILM MRS25 1x 100E	5322 116 53126
R 0701	RES.CHIP MCR18 1x 4K7	5322 111 90111	R 0834	RES.METAL FILM MRS25 1x 422E	5322 116 53592
R 0702	RES.CHIP MCR18 1x 47E	4822 111 90217	R 0835	RES.METAL FILM MRS25 1x 316E	5322 116 53499
R 0703	RES.NETWORK MCR18 1x 100E	5322 111 91134	R 0836	RES.METAL FILM MRS25 1x 10E	4822 116 52891
R 0704	RES.CHIP RC-02H 1x 10K	5322 116 80428	R 0837	RES.METAL FILM MRS25 1x 100E	5322 116 53126
R 0706	RES.CHIP MCR18 1x 180E	5322 111 90242	R 0839	RES.METAL FILM MRS25 1x 422E	5322 116 53592
R 0707	RES.CHIP MCR18 1x 47E	4822 111 90217	R 0840	RES.METAL FILM MRS25 1x 316E	5322 116 53499
R 0708	RES.CHIP MCR18 1x 4K7	5322 111 90111	R 0841	RES.METAL FILM MRS25 1x 316E	5322 116 53499
R 0709	RES.CHIP MCR18 1x 330E	5322 111 90106	R 0842	RES.METAL FILM MRS25 1x 1K	4822 116 53108
R 0711	RES.CHIP MCR18 1x 470E	5322 111 90109	R 0843	RES.METAL FILM MRS25 1x 2K61	5322 116 53276
R 0712	RES.CHIP MCR18 1x 3K3	4822 111 90157	R 0844	RES.METAL FILM MRS25 1x 100E	5322 116 53126
R 0713	RES.CHIP MCR18 1x 470E	5322 111 90109	R 0845	RES.METAL FILM MRS25 1x 316E	5322 116 53499
R 0714	RES.CHIP MCR18 1x 330E	5322 111 90106	R 0846	RES.METAL FILM MRS25 1x 10E	4822 116 52891
R 0715	RES.NETWORK MCR18 1x 100E	5322 111 91134	R 0847	RES.METAL FILM MRS25 1x 100E	5322 116 53126
R 0716	RES.CHIP RC-02H 1x 750E	4822 116 82384	R 0848	RES.METAL FILM MRS25 1x 10E	4822 116 52891
R 0717	RES.CHIP RC-02H 1x 10K	5322 116 80428	R 0849	RES.METAL FILM MRS25 1x 162E	5322 116 53523
R 0718	RES.CHIP RC-02H 1x 10K	5322 116 80428	R 0851	RES.METAL FILM MRS25 1x 162E	5322 116 53523
R 0719	RES.CHIP RC-02H 1x 750E	4822 116 82384	R 0852	RES.METAL FILM MRS25 1x 10E	4822 116 52891
R 0720	RES.CHIP MCR18 1x 220E	4822 111 90178	R 0853	RES.METAL FILM MRS25 1x 10E	4822 116 53126
R 0721	RES.CHIP RC-02H 1x 10K	5322 116 80428	R 0854	RES.METAL FILM MRS25 1x 10E	4822 116 52891
R 0722	RES.NETWORK MCR18 1x 3K9	5322 111 91135	R 0855	RES.METAL FILM MRS25 1x 162E	5322 116 53523
R 0723	RES.CHIP MCR18 1x 15K	4822 111 90196	R 0856	RES.METAL FILM MRS25 1x 162E	5322 116 53523
R 0724	RES.CHIP RC-02H 1x 10K	5322 116 80428	R 0857	RES.METAL FILM MRS25 1x 100E	5322 116 53126
R 0725	RES.CHIP MCR18 1x 1K	4822 051 10102	R 0858	RES.METAL FILM MRS25 1x 215E	5322 116 5325
R 0726	RES.NETWORK MCR18 1x 22K	5322 111 91349	R 0859	RES.METAL FILM MRS25 1x 215E	5322 116 5325
R 0727	RES.CHIP MCR18 1x 27K	4822 111 90542	R 0860	RES.METAL FILM MRS25 1x 1E	4822 050 21008
R 0728	RES.CHIP RC-02H 1x 10K	5322 116 80428	R 0861	RES.METAL FILM MRS25 1x 5E11	4822 116 52999
R 0729	RES.CHIP MCR18 1x 12K	4822 111 90253	R 0862	RES.METAL FILM MRS25 1x 2K15	5322 116 53239
R 0731	RES.CHIP MCR18 1x 6K8	4822 111 90544	R 0863	RES.METAL FILM MRS25 1x 1K	4822 116 53108
R 0732	RES.CHIP MCR18 1x 27K	4822 111 90542	R 0864	RES.METAL FILM MRS25 1x 422E	5322 116 53592
R 0733	RES.NETWORK MCR18 1x 100E	5322 111 91134	R 0865	RES.METAL FILM MRS25 1x 1K	4822 116 53108
R 0734	RES.CHIP MCR18 1x 1K2	5322 111 90096	R 0866	RES.METAL FILM MRS25 1x 51E1	5322 116 53213
R 0735	RES.NETWORK MCR18 1x 100E	5322 111 91134	R 0867	RES.METAL FILM MRS25 1x 51E1	5322 116 53213
R 0736	RES.CHIP MCR18 1x 1K	4822 051 10102	R 0868	RES.METAL FILM MRS25 1x 25E1	5322 116 53213
R 0737	RES.NETWORK MCR18 1x 3K9	5322 111 91135	R 0869	RES.METAL FILM MRS25 1x 51E1	5322 116 53213
R 0738	RES.CHIP MCR18 1x 15K	4822 111 90196	R 0870	RES.METAL FILM MRS25 1x 1E	4822 050 21008
R 0739	RES.CHIP MCR18 1x 27K	4822 111 90542	R 0871	RES.METAL FILM MRS25 1x 681E	4822 116 53123
R 0741	RES.CHIP MCR18 1x 3K3	4822 111 90157	R 0872	RES.METAL FILM MRS25 1x 5E11	4822 116 52999
R 0742	RES.CHIP MCR18 1x 15K	4822 111 90196	R 0873	RES.METAL FILM MRS25 1x 2K15	5322 116 53239
R 0743	RES.CHIP MCR18 1x 1K	4822 051 10102	R 0874	RES.METAL FILM MRS25 1x 1K	4822 116 53108
R 0744	RES.NETWORK MCR18 1x 3K9	5322 111 91135	R 0875	RES.METAL FILM MRS25 1x 1K	4822 116 53108
R 0746	RES.CHIP RC-02H 1x 10K	5322 116 80428	R 0876	RES.METAL FILM MRS25 1x 2K15	5322 116 53239
R 0747	RES.CHIP MCR18 1x 330E	5322 111 90106	R 0877	RES.METAL FILM MRS25 1x 2K15	5322 116 53239
R 0748	RES.CHIP MCR18 1x 270E	4822 111 90154	R 0878	RES.METAL FILM MRS25 1x 2K15	5322 116 53239
R 0749	RES.NETWORK MCR18 1x 31E	5322 111 91352	R 0879	RES.METAL FILM MRS25 1x 2K15	5322 116 53239
R 0751	RES.CHIP RC-02H 1x 10K	5322 116 80428	R 0880	RES.METAL FILM MRS25 1x 1E	4822 050 21008
R 0752	RES.CHIP MCR18 1x 68K	4822 111 90202	R 0882	RES.METAL FILM MRS25 1x 100E	5322 116 53126
R 0753	RES.CHIP MCR18 1x 4K7	5322 111 90111	R 0883	RES.METAL FILM MRS25 1x 100E	5322 116 53126
R 0754	RES.CHIP RC-02H 1x 10K	5322 116 80428	R 0884	RES.METAL FILM MRS25 1x 100E	5322 116 53126
R 0755	RES.CHIP MCR18 1x 3K3	4822 111 90157	R 0885	RES.METAL FILM MRS25 1x 1K	4822 116 53108
R 0756	RES.CHIP RC-02H 1x 10K	5322 116 80428	R 0886	RES.METAL FILM MRS25 1x 100E	5322 116 53126
R 0760	RES.CHIP MCR18 1x 1K	4822 051 10102	R 0887	RES.METAL FILM MRS25 1x 2K61	5322 116 53327
R 0761	RES.CHIP MCR18 1x 6K8	4822 111 90544	R 0888	RES.METAL FILM MRS25 1x 10K	4822 116 53022
R 0762	RES.CHIP MCR18 1x 27K	4822 111 90542	R 0889	RES.METAL FILM MRS25 1x 121E	4822 116 52955
R 0763	RES.NETWORK MCR18 1x 100E	5322 111 91134	R 0890	RES.METAL FILM MRS25 1x 316E	5322 116 53499
R 0764	RES.CHIP MCR18 1x 1K2	5322 111 90096	R 0891	RES.METAL FILM MRS25 1x 5K11	5322 116 53494
R 0765	RES.CHIP MCR18 1x 1K	4822 051 10102	R 0892	POTM.TRIMMER 0.3W 25x 10K	4822 105 10455
R 0766	RES.NETWORK MCR18 1x 100E	5322 111 91134	R 0893	RES.METAL FILM MRS25 1x 5K11	5322 116 53494
R 0767	RES.NETWORK MCR18 1x 3K9	5322 111 91135	R 0894	POTM.TRIMMER 0.3W 25x 10K	4822 105 10455
R 0768	RES.CHIP MCR18 1x 15K	4822 111 90196	R 0895	RES.METAL FILM MRS25 1x 17K8	5322 116 53235
R 0769	RES.CHIP MCR18 1x 27K	4822 111 90542	R 0896	RES.METAL FILM MRS25 1x 121K	4822 050 21214
R 0770	RES.CHIP MCR18 1x 1K	4822 051 10102	R 0901	RES.METAL FILM MRS25 1x 3K16	4822 116 53021
R 0771	RES.CHIP MCR18 1x 3K3	4822 111 90157	R 0902	POTM.SLIDE 0.3W 25x 2K2	5322 105 20033
R 0772	RES.CHIP MCR18 1x 15K	4822 111 90196	R 0903	RES.METAL FILM MRS25 1x 4K22	5322 116 53246
R 0773	RES.CHIP MCR18 1x 1K	4822 051 10102	R 0904	RES.METAL FILM MRS25 1x 4K22	5322 116 53246
R 0774	RES.NETWORK MCR18 1x 3K9	5322 111 91135	R 0905	RES.METAL FILM MRS25 1x 4K22	5322 116 53246
R 0776	RES.CHIP RC-02H 1x 10K	5322 116 80428	R 0906	RES.METAL FILM MRS25 1x 4K22	5322 116 53246
R 0777	RES.CHIP MCR18 1x 330E	5322 111 90106	R 0909	RES.METAL FILM MRS25 1x 4K22	5322 116 53246
R 0778	RES.CHIP MCR18 1x 270E	4822 111 90154	R 0911	RES.METAL FILM MRS25 1x 4K22	5322 116 53246
R 0779	RES.NETWORK MCR18 1x 31E	5322 111 91352	R 0914	RES.METAL FILM MRS25 1x 4K22	5322 116 53246
R 0781	RES.CHIP RC-02H 1x 10K	5322 116 80428	R 0915	RES.METAL FILM MRS25 1x 4K22	5322 116 53246
R 0782	RES.CHIP MCR18 1x 68K	4822 111 90202	R 0916	RES.METAL FILM MRS25 1x 3K16	4822 116 53021
R 0783	RES.CHIP MCR18 1x 4K7	5322 111 90111	R 0917	POTM.SLIDE 0.3W 25x 2K2	5322 105 20033
R 0784	RES.CHIP RC-02H 1x 10K	5322 116 80428	R 0919	RES.METAL FILM MRS25 1x 4K22	5322 116 53246
R 0785	RES.CHIP MCR18 1x 3K3	4822 111 90157	R 0921	RES.METAL FILM MRS25 1x 4K22	5322 116 53246
R 0786	RES.CHIP RC-02H 1x 10K	5322 116 80428	R 0922	RES.METAL FILM MRS25 1x 4K22	5322 116 53246
R 0791	RES.CHIP MCR18 1x 10E	4822 051 10109	R 0924	RES.METAL FILM MRS25 1x 5K11	5322 116 53494
R 0792	RES.CHIP MCR18 1x 10E	4822 051 10109	R 0925	RES.METAL FILM MRS25 1x 5K11	5322 116 53494
R 0793	RES.CHIP MCR18 1x 10E	4822 051 10109	R 0926	RES.METAL FILM MRS25 1x 2K87	5322 116 53513
R 0794	RES.CHIP MCR18 1x 10E	4822 051 10109	R 0927	RES.METAL FILM MRS25 1x 100E	5322 116 53126
R 0801	RES.METAL FILM MRS25 1x 10E	4822 116 52891	R 0929	POTM.TRIMMER 0.3W 25x 10K	4822 105 10455
R 0802	RES.METAL FILM MRS25 1x 100E	5322 116 53126	R 0931	RES.METAL FILM MRS25 1x 1K47	5322 116 53185
R 0804	RES.METAL FILM MRS25 1x 422E	5322 116 53592	R 0932	POTM.SLIDE 0.3W 25x 4K7	5322 105 20034
R 0805	RES.METAL FILM MRS25 1x 316E	5322 116 53499	R 0933	RES.METAL FILM MRS25 1x 17K8	5322 116 53235
R 0806	RES.METAL FILM MRS25 1x 10E	4822 116 52891	R 0934	RES.METAL FILM MRS25 1x 5K11	5322 116 53494
R 0807	RES.METAL FILM MRS25 1x 100E	5322 116 53126	R 0935	RES.METAL FILM MRS25 1x 5K11	5322 116 53494
R 0809	RES.METAL FILM MRS25 1x 422E	5322 116 53592	R 0936	RES.METAL FILM MRS25 1x 5K11	5322 116 53494
R 0810	RES.METAL FILM MRS25 1x 316E	5322 116 53499	R 0937	RES.METAL FILM MRS25 1x 100E	5322 116 53126
R 0811	RES.METAL FILM MRS25 1x 316E	5322 116 53499	R 0939	POTM.TRIMMER 0.3W 25x 10K	4822 105 10455
R 0812	RES.METAL FILM MRS25 1x 1K	4822 116 53108	R 0941	RES.METAL FILM MRS25 1x 1K47	5322 116 53185
R 0813	RES.METAL FILM MRS25 1x 2K61	5322 116 53327	R 0942	POTM.SLIDE 0.3W 25x 4K7	5322 105 20034
R 0814	RES.METAL FILM MRS25 1x 100E	5322 116 53126	R 0944	RES.METAL FILM MRS25 1x 5K11	5322 116 53494
R 0815	RES.METAL FILM MRS25 1x 316E	5322 116 53499	R 0945	RES.METAL FILM MRS25 1x 5K11	5322 116 53494

POSNR	DESCRIPTION	ORDERING CODE	POSNR	DESCRIPTION	ORDERING CODE
R 0955	RES.METAL FILM MRS25 1x 5K11	5322 116 53494	R 1082	RES.METAL FILM MRS25 1x 10K	4822 116 53022
R 0956	RES.METAL FILM MRS25 1x 5K11	5322 116 53494	R 1083	RES.METAL FILM MRS25 1x 100K	4822 050 21004
R 0957	RES.METAL FILM MRS25 1x 100E	5322 116 53126	R 1084	RES.METAL FILM MRS25 1x 10K	4822 116 53022
R 0958	RES.METAL FILM MRS25 1x 4K64	5322 116 53213	R 1086	RES.METAL FILM MRS25 1x 1K47	4822 116 53531
R 0961	RES.METAL FILM MRS25 1x 121E	4822 116 52955	R 1087	RES.METAL FILM MRS25 1x 464E	5322 116 53232
R 0962	RES.METAL FILM MRS25 1x 75E	5322 116 53339	R 1088	RES.METAL FILM MRS25 1x 51E1	5322 116 53213
R 0965	RES.METAL FILM MRS25 1x 10K	4822 116 53022	R 1089	RES.METAL FILM MRS25 1x 51E1	5322 116 53213
R 0966	POTM.TRIMMER 0.3W 25x 10K	4822 105 10455	R 1091	POTM.TRIMMER 0.3W 25x 10K	4822 105 10455
R 0967	RES.METAL FILM MRS25 1x 10K	4822 116 53022	R 1092	RES.METAL FILM MRS25 1x 16K2	5322 116 53589
R 0968	RES.METAL FILM MRS25 1x 100E	5322 116 53126	R 1093	RES.METAL FILM MRS25 1x 464E	5322 116 53232
R 0969	RES.METAL FILM MRS25 1x 10K	4822 116 53022	R 1094	RES.METAL FILM MRS25 1x 464E	5322 116 53232
R 0970	POTM.TRIMMER 0.3W 25x 10K	4822 105 10455	R 1095	RES.METAL FILM MRS25 1x 100E	5322 116 53126
R 0971	RES.METAL FILM MRS25 1x 10K	4822 116 53022	R 1097	RES.METAL FILM MRS25 1x 1K	4822 116 53108
R 0972	RES.METAL FILM MRS25 1x 100E	5322 116 53126	R 1098	RES.METAL FILM MRS25 1x 1K	4822 116 53108
R 0973	RES.METAL FILM MRS25 1x 10K	4822 116 53022	R 1101	RES.METAL FILM 0.4W 0.1x 1M	5322 116 51605
R 0974	POTM.TRIMMER 0.3W 25x 10K	4822 105 10455	R 1102	RES.METAL FILM MRS25 1x 42E2	5322 116 53515
R 0975	RES.METAL FILM MRS25 1x 10K	4822 116 53022	R 1103	RES.METAL FILM MRS25 1x 68E1	5322 116 53264
R 0976	RES.METAL FILM MRS25 1x 10K	4822 116 53022	R 1104	RES.METAL FILM MRS25 1x 68E1	5322 116 53264
R 0977	POTM.TRIMMER 0.3W 25x 10K	4822 105 10455	R 1105	RES.METAL FILM MRS25 1x 3A8	4822 050 23489
R 0978	RES.METAL FILM MRS25 1x 10K	4822 116 53022	R 1106	RES.METAL FILM MRS25 1x 100K	4822 050 21004
R 0979	RES.METAL FILM MRS25 1x 5K11	5322 116 53494	R 1107	RES.METAL FILM MRS25 1x 100K	4822 050 21004
R 0981	RES.METAL FILM MRS25 1x 17K8	5322 116 53255	R 1108	RES.METAL FILM MRS25 1x 75E	5322 116 53339
R 0983	RES.METAL FILM MRS25 1x 5E11	4822 116 52999	R 1109	RES.METAL FILM MRS25 1x 100K	4822 050 21004
R 0984	RES.METAL FILM MRS25 1x 5E11	4822 116 52999	R 1110	RES.METAL FILM MRS25 1x 5K11	5322 116 53494
R 0985	RES.METAL FILM MRS25 1x 5E11	4822 116 52999	R 1111	RES.METAL FILM MRS25 1x 10E	4822 116 52891
R 0986	RES.METAL FILM MRS25 1x 5E11	4822 116 52999	R 1112	RES.METAL FILM VR25 10x	5322 116 51785
R 0987	RES.METAL FILM MRS25 1x 10K	4822 116 53022	R 1113	RES.METAL FILM MRS25 1x 42E2	5322 116 53515
R 0988	RES.METAL FILM MRS25 1x 1K47	4822 116 53531	R 1114	RES.METAL FILM MRS25 1x 10E	4822 116 52891
R 0989	RES.METAL FILM MRS25 1x 10K	4822 116 53022	R 1115	RES.METAL FILM MRS25 1x 42E2	5322 116 53515
R 0991	RES.METAL FILM MRS25 1x 1K47	4822 116 53531	R 1116	RES.METAL FILM VR25 10x	5322 116 51785
R 0992	RES.METAL FILM MRS25 1x 1K	4822 116 53108	R 1117	RES.METAL FILM MRS25 1x 10E	4822 116 52891
R 0993	RES.METAL FILM MRS25 1x 1K	4822 116 53108	R 1118	RES.METAL FILM VR25 10x	5322 116 51785
R 0996	RES.METAL FILM MRS25 1x 1E	4822 050 21008	R 1119	RES.METAL FILM MRS25 1x 1K	4822 116 53108
R 0997	RES.METAL FILM MRS25 1x 1K53	5322 116 53512	R 1120	RES.METAL FILM MRS25 1x 1M	4822 116 52843
R 0998	RES.METAL FILM MRS25 1x 6K81	5322 116 53252	R 1121	POTM.SLIDE 0.3W 25x 100K	5322 105 20038
R 0862	RES.CHIP MCR18 1x 2K2	4822 111 90248 (PM3375/77)	R 1122	RES.METAL FILM MRS25 1x 23K7	5322 116 53537
R 0882	RES.NETWORK MCR18 1x 100E	5322 111 91134 (PM3375/77)	R 1124	RES.METAL FILM MRS25 1x 51E1	5322 116 53213
R 0883	RES.NETWORK MCR18 1x 100E	5322 111 91134 (PM3375/77)	R 1126	RES.METAL FILM 1/4W .25x 1M	5322 116 53398
R 0884	RES.NETWORK MCR18 1x 100E	5322 111 91134 (PM3375/77)	R 1127	RES.METAL FILM 1/4W .25x 111K	5322 116 53409
R 0886	RES.NETWORK MCR18 1x 100E	5322 111 91134 (PM3375/77)	R 1128	RES.METAL FILM 1/4W .25x 10K1	5322 116 53404
R 0927	RES.CHIP RC-02H 1x 100E	5322 116 80426 (PM3375/77)	R 1129	RES.METAL FILM MRS25 1x 1K	4822 116 53108
R 0937	RES.CHIP RC-02H 1x 100E	5322 116 80426 (PM3375/77)	R 1150	RES.HI-TENSION VR25 5x 1M8	4822 110 72194
R 0947	RES.CHIP RC-02H 1x 100E	5322 116 80426 (PM3375/77)	R 1151	RES.METAL FILM MRS25 1x 19K6	5322 116 53205
R 0957	RES.CHIP RC-02H 1x 100E	5322 116 80426 (PM3375/77)	R 1152	RES.HI-TENSION VR25 5x 4M7	4822 110 72208
R 1001	RES.METAL FILM 0.4W 0.1x 1M	5322 116 51605	R 1153	RES.METAL FILM MRS25 1x 1K	4822 116 53108
R 1002	RES.METAL FILM MRS25 1x 42E2	5322 116 53515	R 1154	RES.METAL FILM MRS25 1x 100E	5322 116 53126
R 1003	RES.METAL FILM MRS25 1x 68E1	5322 116 53264	R 1156	RES.METAL FILM MRS25 1x 100E	5322 116 53126
R 1004	RES.METAL FILM MRS25 1x 68E1	5322 116 53264	R 1157	RES.METAL FILM MRS25 1x 10K	4822 116 53022
R 1005	RES.METAL FILM MRS25 1x 3A8	4822 050 23489	R 1158	RES.METAL FILM MRS25 1x 10E	4822 116 52891
R 1006	RES.METAL FILM MRS25 1x 100K	4822 050 21004	R 1159	RES.METAL FILM MRS25 1x 10E	4822 116 52891
R 1007	RES.METAL FILM MRS25 1x 100K	4822 050 21004	R 1160	RES.METAL FILM MRS25 1x 100E	5322 116 53126
R 1008	RES.METAL FILM MRS25 1x 75E	5322 116 53339	R 1161	RES.METAL FILM MRS25 1x 26K1	5322 116 53261
R 1009	RES.METAL FILM MRS25 1x 100K	4822 050 21004	R 1162	POTM.TRIMMER 0.3W 25x 10K	4822 105 10455
R 1010	RES.METAL FILM MRS25 1x 5K11	5322 116 53494	R 1163	RES.METAL FILM MRS25 1x 3K48	4822 116 53315
R 1011	RES.METAL FILM MRS25 1x 10E	4822 116 52891	R 1164	POTM.SLIDE 0.3W 25x 100E	5322 105 20029
R 1012	RES.METAL FILM VR25 10x	5322 116 51785	R 1165	RES.METAL FILM MRS25 1x 10E	4822 116 52891
R 1013	RES.METAL FILM MRS25 1x 42E2	5322 116 53515	R 1166	RES.METAL FILM MRS25 1x 133E	5322 116 53424
R 1014	RES.METAL FILM MRS25 1x 10E	4822 116 52891	R 1167	RES.METAL FILM MRS25 1x 10E	4822 116 52891
R 1015	RES.METAL FILM MRS25 1x 42E2	5322 116 53515	R 1168	RES.METAL FILM MRS25 1x 10E	4822 116 52891
R 1016	RES.METAL FILM VR25 10x	5322 116 51785	R 1171	RES.METAL FILM MRS25 1x 26K1	5322 116 53261
R 1017	RES.METAL FILM MRS25 1x 10E	4822 116 52891	R 1172	POTM.TRIMMER 0.3W 25x 10K	4822 105 10455
R 1018	RES.METAL FILM VR25 10x	5322 116 51785	R 1173	RES.METAL FILM MRS25 1x 1K62	5322 116 53257
R 1019	RES.METAL FILM MRS25 1x 1K	4822 116 53108	R 1174	POTM.SLIDE 0.3W 25x 100E	5322 105 20029
R 1020	RES.METAL FILM MRS25 1x 1M	4822 116 52843	R 1176	RES.METAL FILM MRS25 1x 51E1	5322 116 53213
R 1021	POTM.SLIDE 0.3W 25x 100K	5322 105 20038	R 1179	RES.METAL FILM MRS25 1x 1K62	5322 116 53257
R 1022	RES.METAL FILM MRS25 1x 23K7	5322 116 53537	R 1180	RES.METAL FILM MRS25 1x 51E1	5322 116 53135
R 1024	RES.METAL FILM MRS25 1x 51E1	5322 116 53213	R 1181	RES.METAL FILM MRS25 1x 90K9	5322 116 53582
R 1026	RES.METAL FILM 1/4W .25x 1M	5322 116 53398	R 1182	RES.METAL FILM MRS25 1x 10K	4822 116 53022
R 1027	RES.METAL FILM 1/4W .25x 111K	5322 116 53409	R 1183	RES.METAL FILM MRS25 1x 100K	4822 050 21004
R 1028	RES.METAL FILM 1/4W .25x 10K1	5322 116 53404	R 1184	RES.METAL FILM MRS25 1x 10K	4822 116 53022
R 1029	RES.METAL FILM MRS25 1x 1K	4822 116 53108	R 1186	RES.METAL FILM MRS25 1x 1K47	4822 116 53531
R 1030	RES.HI-TENSION VR25 5x 1M8	4822 110 72194	R 1187	RES.METAL FILM MRS25 1x 464E	5322 116 53232
R 1031	RES.METAL FILM MRS25 1x 19K6	5322 116 53205	R 1188	RES.METAL FILM MRS25 1x 51E1	5322 116 53213
R 1032	RES.HI-TENSION VR25 5x 4M7	4822 110 72208	R 1189	RES.METAL FILM MRS25 1x 51E1	5322 116 53213
R 1033	RES.METAL FILM MRS25 1x 1K	4822 116 53108	R 1192	RES.METAL FILM MRS25 1x 16K2	5322 116 53589
R 1034	RES.METAL FILM MRS25 1x 1K21	4822 116 52956	R 1193	RES.METAL FILM MRS25 1x 464E	5322 116 53232
R 1036	RES.METAL FILM MRS25 1x 15K4	5322 116 53234	R 1194	RES.METAL FILM MRS25 1x 464E	5322 116 53232
R 1037	RES.METAL FILM MRS25 1x 51E1	5322 116 53213	R 1195	RES.METAL FILM MRS25 1x 100E	5322 116 53126
R 1038	RES.METAL FILM MRS25 1x 51E1	5322 116 53213	R 1197	RES.METAL FILM MRS25 1x 1K	4822 116 53108
R 1042	RES.METAL FILM MRS25 1x 2K15	5322 116 53239	R 1198	RES.METAL FILM MRS25 1x 1K	4822 116 53108
R 1043	RES.METAL FILM MRS25 1x 31E6	5322 116 54964	R 1201	RES.METAL FILM MRS25 1x 42E2	5322 116 53515
R 1044	RES.METAL FILM MRS25 1x 1K	4822 116 53108	R 1202	RES.METAL FILM MRS25 1x 1K	4822 116 53108
R 1045	RES.METAL FILM MRS25 1x 51E1	5322 116 53213	R 1203	RES.METAL FILM MRS25 1x 31K6	4822 050 23164
R 1046	RES.METAL FILM MRS25 1x 237E	5322 116 53259	R 1204	RES.METAL FILM MRS25 1x 681K	5322 116 53593
R 1047	RES.METAL FILM MRS25 1x 100E	5322 116 53126	R 1206	RES.METAL FILM MRS25 1x 75E	5322 116 53339
R 1051	RES.METAL FILM 1/4W .25x 250E	5322 116 53406	R 1207	RES.METAL FILM VR25 10x	5322 116 51785
R 1052	RES.METAL FILM 1/4W .25x 375E	5322 116 53407	R 1208	RES.METAL FILM MRS25 1x 51E1	5322 116 53213
R 1053	RES.METAL FILM 1/4W .25x 150E	5322 116 53399	R 1209	RES.METAL FILM MRS25 1x 1K	4822 116 53108
R 1054	RES.METAL FILM 1/4W .25x 150E	5322 116 53399	R 1211	RES.METAL FILM MRS25 1x 1K21	4822 116 52957
R 1056	RES.METAL FILM MRS25 1x 100E	5322 116 53126	R 1212	RES.METAL FILM MRS25 1x 12K1	4822 116 52957
R 1057	RES.METAL FILM MRS25 1x 10K	4822 116 53022	R 1213	RES.HI-TENSION VR25 5x 1M8	4822 110 72194
R 1058	RES.METAL FILM MRS25 1x 10E	4822 116 52891	R 1216	RES.METAL FILM MRS25 1x 100E	5322 116 53126
R 1059	RES.METAL FILM MRS25 1x 10E	4822 116 52891	R 1217	RES.METAL FILM MRS25 1x 4K64	5322 116 53213
R 1060	RES.METAL FILM MRS25 1x 100E	5322 116 53126	R 1218	RES.METAL FILM MRS25 1x 51E1	5322 116 53213
R 1061	RES.METAL FILM MRS25 1x 26K1	5322 116 53261	R 1220	RES.METAL FILM MRS25 1x 2K87	5322 116 53513
R 1062	POTM.TRIMMER 0.3W 25x 10K	4822 105 10455			
R 1063	RES.METAL FILM MRS25 1x 3K48	4822 116 53315			
R 1064	POTM.SLIDE 0.3W 25x 100E	5322 105 20029			
R 1065	RES.METAL FILM MRS25 1x 10E	4822 116 52891			
R 1066	RES.METAL FILM MRS25 1x 133E	5322 116 53424			
R 1067	RES.METAL FILM MRS25 1x 10E	4822 116 52891			
R 1068	RES.METAL FILM MRS25 1x 10E	4822 116 52891			
R 1071	RES.METAL FILM MRS25 1x 26K1	5322 116 53261			
R 1072	POTM.TRIMMER 0.3W 25x 10K	4822 105 10455			
R 1073	RES.METAL FILM MRS25 1x 1K62	5322 116 53257			
R 1074	POTM.SLIDE 0.3W 25x 100E	5322 105 20029			
R 1076	RES.METAL FILM MRS25 1x 51E1	5322 116 53213			
R 1079	RES.METAL FILM MRS25 1x 1K62	5322 116 53257			
R 1080	RES.METAL FILM MRS25 1x 51E1	5322 116 53135			
R 1081	RES.METAL FILM MRS25 1x 90K9	5322 116			

POSNR	DESCRIPTION	ORDERING CODE	POSNR	DESCRIPTION	ORDERING CODE
R 1221	RES.METAL FILM MRS25 1x 215E	5322 116 53325	R 1739	POTM.SLIDE 0.3W 25x 1K	5322 105 20032
R 1222	RES.METAL FILM MRS25 1x 5E11	4822 116 52999	R 1741	RES.CHIP MCR18 1x 1K8	5322 111 90101
R 1223	RES.METAL FILM MRS25 1x 1K78	5322 116 53208	R 1742	RES.CHIP MCR18 1x 8K2	5322 111 90118
R 1224	RES.METAL FILM MRS25 1x 1K78	5322 116 53208	R 1743	RES.CHIP MCR18 1x 3K3	4822 111 90157
R 1226	RES.METAL FILM MRS25 1x 14K7	4822 116 53531	R 1744	RES.CHIP MCR18 1x 3K3	4822 111 90157
R 1227	RES.METAL FILM MRS25 1x 16K4	5322 116 53314	R 1746	RES.CHIP MCR18 1x 47E	4822 111 90217
R 1232	POTM.SLIDE 0.3W 25x 470E	5322 105 20028	R 1747	RES.CHIP MCR18 1x 47E	4822 111 90217
R 1401	RES.METAL FILM MRS25 1x 5E11	4822 116 52999	R 1748	RES.CHIP MCR18 1x 4K7	5322 111 90111
R 1402	RES.METAL FILM MRS25 1x 5E11	4822 116 52999	R 1749	RES.CHIP MCR18 1x 150E	5322 111 90098
R 1421	RES.METAL FILM MRS25 1x 5E11	4822 116 52999	R 1751	RES.CHIP MCR18 1x 47E	4822 111 90217
R 1422	RES.METAL FILM MRS25 1x 5E11	4822 116 52999	R 1752	RES.CHIP MCR18 1x 47E	4822 111 90217
R 1441	RES.METAL FILM MRS25 1x 5E11	4822 116 52999	R 1755	RES.CHIP MCR18 1x 2K2	4822 111 90248
R 1442	RES.METAL FILM MRS25 1x 5E11	4822 116 52999	R 1756	RES.NETWORK MCR18 1x 3K	5322 111 91351
R 1443	RES.METAL FILM MRS25 1x 5E11	4822 116 52999	R 1757	RES.CHIP MCR18 1x 160E	4822 111 90345
R 1444	RES.METAL FILM MRS25 1x 5E11	4822 116 52999	R 1759	RES.CHIP MCR18 1x 47E	4822 111 90217
R 1601	RES.CHIP RC-02H 1x 10K	5322 116 80428	R 1760	RES.CHIP MCR18 1x 47E	4822 111 90217
R 1602	RES.CHIP MCR18 1x 8K2	5322 111 90118	R 1761	RES.CHIP MCR18 1x 1K	4822 051 10102
R 1603	RES.CHIP RC-02H 1x 10K	5322 116 80428	R 1762	RES.CHIP MCR18 1x 470E	5322 111 90109
R 1604	RES.CHIP MCR18 1x 8K2	5322 111 90118	R 1763	RES.NETWORK MCR18 1x 3K9	5322 111 91135
R 1605	RES.CHIP MCR18 1x 8K2	5322 111 90118	R 1764	RES.CHIP MCR18 1x 47E	4822 111 90217
R 1606	RES.CHIP RC-02H 1x 10K	5322 116 80428	R 1765	RES.NETWORK MCR18 1x 51E	5322 111 91352
R 1607	RES.CHIP RC-02H 1x 10K	5322 116 80428	R 1766	RES.CHIP MCR18 1x 47E	4822 111 90217
R 1608	RES.CHIP MCR18 1x 10E	4822 051 10109	R 1767	RES.CHIP MCR18 1x 15E	4822 111 90544
R 1609	RES.CHIP MCR18 1x 2K2	4822 111 90248	R 1768	RES.CHIP MCR18 1x 47E	4822 111 90217
R 1610	RES.CHIP MCR18 1x 12K	4822 111 90253	R 1769	RES.CHIP MCR18 1x 15E	4822 111 90144
R 1611	RES.CHIP MCR18 1x 2K2	4822 111 90248	R 1770	RES.CHIP RC-01 5x 1E	4822 111 90184
R 1612	RES.CHIP RC-02H 1x 110E	5322 116 82108	R 1771	RES.CHIP MCR18 1x 47E	4822 111 90217
R 1613	RES.CHIP RC-02H 1x 110E	5322 116 82108	R 1772	RES.CHIP RC-02H 1x 10K	5322 116 80428
R 1614	RES.CHIP RC-02H 1x 10K	5322 116 80428	R 1773	RES.CHIP MCR18 1x 330E	5322 111 90106
R 1616	RES.CHIP RC-02H 1x 110E	5322 116 82108	R 1774	RES.CHIP MCR18 1x 47E	4822 111 90217
R 1617	RES.CHIP RC-02H 1x 110E	5322 116 82108	R 1776	RES.CHIP MCR18 1x 47E	4822 111 90217
R 1620	RES.NETWORK MCR18 1x 22K	5322 111 91349	R 1777	RES.CHIP RC-01 5x 1E	4822 111 90184
R 1621	RES.CHIP MCR18 1x 68K	4822 111 90202	R 1778	RES.CHIP MCR18 1x 47E	4822 111 90217
R 1622	RES.CHIP MCR18 1x 27K	4822 111 90542	R 1779	RES.CHIP MCR18 1x 33E	4822 111 90357
R 1623	RES.CHIP RC-02H 1x 10K	5322 116 80428	R 1780	RES.CHIP MCR18 1x 1K	4822 051 10102
R 1624	RES.CHIP MCR18 1x 4K7	5322 111 90111	R 1781	RES.CHIP MCR18 1x 1K5	4822 051 10152
R 1625	RES.CHIP RC-02H 1x 10K	5322 116 80428	R 1782	RES.CHIP MCR18 1x 510E	4822 111 90245
R 1626	RES.CHIP MCR18 1x 4K7	5322 111 90111	R 1783	RES.CHIP MCR18 1x 1K	4822 051 10102
R 1627	RES.CHIP RC-02H 1x 10K	5322 116 80428	R 1784	RES.NETWORK MCR18 1x 3K9	5322 111 91135
R 1628	RES.CHIP MCR18 1x 4K7	5322 111 90111	R 1786	RES.CHIP MCR18 1x 470E	5322 111 90109
R 1629	RES.NETWORK MCR18 1x 22K	5322 111 91349	R 1787	RES.NETWORK MCR18 1x 100E	5322 111 91134
R 1630	RES.CHIP RC-02H 1x 10K	5322 116 80428	R 1789	RES.CHIP MCR18 1x 1K	4822 051 10102
R 1631	RES.CHIP MCR18 1x 2K2	4822 111 90248	R 1791	RES.CHIP RC-02H 1x 10K	5322 116 80428
R 1633	RES.CHIP MCR18 1x 68K	4822 111 90202	R 1792	RES.CHIP MCR18 1x 2K7	4822 111 90569
R 1634	RES.CHIP MCR18 1x 27K	4822 111 90542	R 1793	RES.CHIP MCR18 1x 1K8	5322 111 90101
R 1636	RES.CHIP MCR18 1x 510E	4822 111 90245	R 1794	RES.CHIP MCR18 1x 3K3	4822 111 90157
R 1637	RES.CHIP MCR18 1x 470E	5322 111 90109	R 1795	RES.CHIP MCR18 1x 1K5	4822 051 10152
R 1638	RES.CHIP MCR18 1x 510E	4822 111 90245	R 1796	RES.CHIP MCR18 1x 120E	4822 111 90339
R 1639	RES.CHIP MCR18 1x 470E	5322 111 90109	R 1797	RES.CHIP MCR18 1x 120E	4822 111 90339
R 1641	RES.CHIP MCR18 1x 1K8	5322 111 90101	R 1798	RES.CHIP MCR18 1x 330E	5322 111 90106
R 1642	RES.CHIP MCR18 1x 68K	4822 111 90544	R 2000	RES.METAL FILM MRS25 1x 100E	5322 116 53126
R 1643	RES.CHIP MCR18 1x 68K	4822 111 90544	R 2001	RES.METAL FILM MRS25 1x 61E9	5322 116 53645
R 1644	RES.CHIP MCR18 1x 27K	4822 111 90542	R 2002	RES.METAL FILM MRS25 1x 34E8	4822 050 23489
R 1646	RES.CHIP MCR18 1x 68K	4822 111 90202	R 2003	RES.METAL FILM MRS25 1x 34E8	4822 050 23489
R 1647	RES.CHIP MCR18 1x 12K	4822 111 90253	R 2004	RES.METAL FILM MRS25 1x 3K48	4822 116 53315
R 1648	RES.CHIP MCR18 1x 4K7	5322 111 90111	R 2005	RES.METAL FILM MRS25 1x 51E1	5322 116 53213
R 1649	RES.CHIP MCR18 1x 4K7	5322 111 90111	R 2007	RES.METAL FILM MRS25 1x 3K83	4822 116 53079
R 1651	RES.CHIP MCR18 1x 2K2	4822 111 90248	R 2008	RES.METAL FILM MRS25 1x 3K83	4822 116 53079
R 1653	RES.CHIP MCR18 1x 12K	4822 111 90253	R 2009	RES. 0.5W 10x 15K	5322 116 30221
R 1654	RES.CHIP MCR18 1x 68K	4822 111 90202	R 2010	RES.METAL FILM MRS25 1x 51E1	5322 116 53213
R 1656	RES.CHIP MCR18 1x 27K	4822 111 90542	R 2011	RES.METAL FILM MRS25 1x 6K19	5322 116 53263
R 1657	RES.CHIP MCR18 1x 510E	4822 111 90245	R 2012	RES.METAL FILM MRS25 1x 1K	4822 116 53108
R 1658	RES.CHIP MCR18 1x 470E	5322 111 90109	R 2013	RES.METAL FILM MRS25 1x 61E9	5322 116 53645
R 1659	RES.CHIP MCR18 1x 510E	4822 111 90245	R 2014	RES.METAL FILM MRS25 1x 51E1	5322 116 53213
R 1661	RES.CHIP MCR18 1x 470E	5322 111 90109	R 2015	RES.METAL FILM MRS25 1x 61E9	5322 116 53337
R 1662	RES.CHIP MCR18 1x 1K8	5322 111 90101	R 2016	RES.METAL FILM MRS25 1x 61E9	5322 116 53337
R 1663	RES.CHIP MCR18 1x 68K	4822 111 90544	R 2017	RES.METAL FILM MRS25 1x 61E9	5322 116 53213
R 1664	RES.CHIP MCR18 1x 68K	4822 111 90544	R 2018	RES.METAL FILM MRS25 1x 1K	4822 116 53108
R 1666	RES.CHIP MCR18 1x 27K	4822 111 90542	R 2019	RES.METAL FILM MRS25 1x 100E	5322 116 53126
R 1667	RES.CHIP MCR18 1x 68K	4822 111 90202	R 2020	RES.METAL FILM MRS25 1x 100E	5322 116 53126
R 1668	RES.CHIP MCR18 1x 4K7	5322 111 90111	R 2021	RES.METAL FILM MRS25 1x 1K78	5322 116 53208
R 1669	RES.CHIP MCR18 1x 4K7	5322 111 90111	R 2022	RES.METAL FILM MRS25 1x 2K15	5322 116 53239
R 1671	RES.NETWORK MCR18 1x 22K	5322 111 91349	R 2023	RES.METAL FILM MRS25 1x 100E	5322 116 53126
R 1672	RES.CHIP MCR18 1x 120K	4822 111 90168	R 2024	RES.METAL FILM MRS25 1x 511E	5322 116 53135
R 1673	RES.CHIP MCR18 1x 120K	4822 111 90168	R 2025	RES.METAL FILM MRS25 1x 100E	5322 116 53126
R 1674	RES.CHIP MCR18 1x 8K2	5322 111 90118	R 2027	RES.METAL FILM MRS25 1x 511E	5322 116 53135
R 1676	RES.CHIP MCR18 1x 2K2	4822 111 90248	R 2028	RES.METAL FILM MRS25 1x 68E1	5322 116 53264
R 1677	RES.NETWORK MCR18 1x 51E	5322 111 91352	R 2029	RES.METAL FILM MRS25 1x 51E1	5322 116 53213
R 1678	RES.NETWORK MCR18 1x 51E	5322 111 91352	R 2031	RES.METAL FILM MRS25 1x 51E1	5322 116 53213
R 1681	RES.CHIP RC-01 5x 4E7	5322 111 90376	R 2032	RES.METAL FILM MRS25 1x 61E9	5322 116 53337
R 1682	RES.CHIP RC-01 5x 4E7	5322 111 90376	R 2033	RES.METAL FILM MRS25 1x 61E9	5322 116 53337
R 1683	RES.CHIP RC-01 5x 4E7	5322 111 90376	R 2035	RES.METAL FILM MRS25 1x 100E	5322 116 53126
R 1684	RES.CHIP RC-01 5x 1E	4822 111 90184	R 2100	RES.METAL FILM MRS25 1x 100E	5322 116 53126
R 1686	RES.CHIP RC-01 5x 1E	4822 111 90184	R 2101	RES.METAL FILM MRS25 1x 61E9	5322 116 53645
R 1687	RES.NETWORK MCR18 1x 100E	5322 111 91134	R 2102	RES.METAL FILM MRS25 1x 34E8	4822 050 23489
R 1701	RES.CHIP MCR18 1x 82E	4822 111 90124	R 2103	RES.METAL FILM MRS25 1x 34E8	4822 050 23489
R 1702	RES.CHIP MCR18 1x 82E	4822 111 90124	R 2104	RES.METAL FILM MRS25 1x 3K48	4822 116 53315
R 1703	RES.CHIP MCR18 1x 510E	4822 111 90245	R 2105	RES.METAL FILM MRS25 1x 51E1	5322 116 53213
R 1704	RES.CHIP MCR18 1x 510E	4822 111 90245	R 2107	RES.METAL FILM MRS25 1x 3K83	4822 116 53079
R 1705	RES.CHIP MCR18 1x 20E	4822 111 90352	R 2108	RES.METAL FILM MRS25 1x 3K83	4822 116 53079
R 1706	RES.CHIP MCR18 1x 4K7	5322 111 90111	R 2109	RES. 0.5W 10x 15K	5322 116 30221
R 1707	RES.CHIP MCR18 1x 47E	4822 111 90217	R 2110	RES.METAL FILM MRS25 1x 51E1	5322 116 53213
R 1708	RES.CHIP MCR18 1x 47E	4822 111 90217	R 2111	RES.METAL FILM MRS25 1x 6K19	5322 116 53263
R 1709	RES.CHIP MCR18 1x 1K5	4822 051 10152	R 2112	RES.METAL FILM MRS25 1x 1K	4822 116 53108
R 1711	RES.CHIP MCR18 1x 1K5	4822 051 10152	R 2113	RES.METAL FILM MRS25 1x 61E9	5322 116 53645
R 1712	RES.CHIP MCR18 1x 1K5	4822 051 10152	R 2114	RES.METAL FILM MRS25 1x 51E1	5322 116 53213
R 1713	RES.CHIP MCR18 1x 180E	5322 111 90242	R 2115	RES.METAL FILM MRS25 1x 61E9	5322 116 53337
R 1714	RES.CHIP MCR18 1x 180E	5322 111 90242	R 2116	RES.METAL FILM MRS25 1x 61E9	5322 116 53337
R 1716	RES.CHIP MCR18 1x 33E	4822 111 90357	R 2117	RES.METAL FILM MRS25 1x 51E1	5322 116 53213
R 1717	POTM.SLIDE 0.3W 25x 220E	5322 105 20031	R 2118	RES.METAL FILM MRS25 1x 1K	4822 116 53108
R 1719	POTM.SLIDE 0.3W 25x 220E	5322 105 20031	R 2119	RES.METAL FILM MRS25 1x 100E	5322 116 53126
R 1721	RES.CHIP MCR18 1x 180E	5322 111 90242	R 2120	RES.METAL FILM MRS25 1x 100E	5322 116 53126
R 1722	RES.CHIP MCR18 1x 220E	4822 111 90178	R 2121	RES.METAL FILM MRS25 1x 1K78	5322 116 53208
R 1723	RES.CHIP MCR18 1x 220E	4822 111 90178	R 2122	RES.METAL FILM MRS25 1x 2K15	5322 116 53239
R 1731	RES.CHIP MCR18 1x 10E	4822 051 10109	R 2123	RES.METAL FILM MRS25 1x 100E	5322 116 53126
R 1732	RES.CHIP MCR18 1x 10E	4822 051 10109	R 2124	RES.METAL FILM MRS25 1x 511E	5322 116 53135
R 1733	RES.CHIP MCR18 1x 1K	4822 051 10102	R 2125	RES.METAL FILM MRS25 1x 100E	5322 116 53126
R 1734	RES.CHIP MCR18 1x 6K8	4822 111 90544	R 2127	RES.METAL FILM MRS25 1x 511E	5322 116 53135
R 1736	RES.CHIP MCR18 1x 6K8	4822 111 90544	R 2128	RES.METAL FILM MRS25 1x 68E1	5322 1

POSNR	DESCRIPTION	ORDERING CODE	POSNR	DESCRIPTION	ORDERING CODE
R 2131	RES.METAL FILM MRS25 1x 51E1	5322 116 53213	R 2369	RES.METAL FILM MRS25 1x 68K1	5322 116 53338
R 2132	RES.METAL FILM MRS25 1x 619E	5322 116 53337	R 2371	RES.METAL FILM MRS25 1x 511E	5322 116 53135
R 2133	RES.METAL FILM MRS25 1x 619E	5322 116 53337	R 2372	RES.METAL FILM MRS25 1x 511E	5322 116 53135
R 2135	RES.METAL FILM MRS25 1x 100E	5322 116 53126	R 2373	RES.METAL FILM MRS25 1x 75K	5322 116 53266
R 2148	RES.METAL FILM MRS25 1x 133E	5322 116 53424	R 2374	RES.METAL FILM MRS25 1x 511E	5322 116 53135
R 2149	RES.METAL FILM MRS25 1x 133E	5322 116 53424	R 2375	RES.METAL FILM MRS25 1x 23K7	5322 116 53537
R 2150	RES.METAL FILM MRS25 1x 2K61	5322 116 53327	R 2376	RES.METAL FILM VR25 10x	5322 116 51785
R 2151	RES.METAL FILM MRS25 1x 5E11	4822 116 52999	R 2377	RES.METAL FILM VR25 10x	5322 116 51785
R 2152	RES.METAL FILM MRS25 1x 2K61	5322 116 53327	R 2378	RES.METAL FILM VR25 10x	5322 116 51785
R 2154	RES.METAL FILM MRS25 1x 100E	5322 116 53126	R 2379	RES.METAL FILM VR25 10x	5322 116 51785
R 2155	RES.METAL FILM MRS25 1x 51E1	5322 116 53213	R 2380	RES.METAL FILM MRS25 1x 750E	5322 116 53265
R 2156	RES.METAL FILM MRS25 1x 100E	5322 116 53126	R 2381	RES.METAL FILM MRS25 1x 2K61	5322 116 53327
R 2157	RES.METAL FILM MRS25 1x 51E1	5322 116 53213	R 2382	RES.METAL FILM MRS25 1x 2K61	5322 116 53327
R 2158	RES.METAL FILM MRS25 1x 51E1	5322 116 53213	R 2383	RES.METAL FILM MRS25 1x 1K	4822 116 53108
R 2196	RES.METAL FILM MRS25 1x 68E1	5322 116 53264	R 2384	RES.METAL FILM MRS25 1x 750E	5322 116 53265
R 2197	RES.METAL FILM MRS25 1x 68E1	5322 116 53264	R 2386	RES.METAL FILM MRS25 1x 1K	4822 116 53108
R 2198	RES.METAL FILM MRS25 1x 68E1	5322 116 53264	R 2387	RES.METAL FILM MRS25 1x 750E	5322 116 53265
R 2199	RES.METAL FILM MRS25 1x 68E1	5322 116 53264	R 2388	RES.METAL FILM MRS25 1x 1K	4822 116 53108
R 2201	RES.METAL FILM MRS25 1x 75K	5322 116 53266	R 2389	RES.METAL FILM MRS25 1x 1K	4822 116 53108
R 2202	RES.METAL FILM MRS25 1x 12K1	4822 116 52957	R 2391	RES.METAL FILM MRS25 1x 42E2	5322 116 53515
R 2203	RES.METAL FILM MRS25 1x 178K	5322 116 53555	R 2393	RES.METAL FILM MRS25 1x 3K48	4822 116 53515
R 2204	RES.CHIP RC-02H 1x 10K	5322 116 80428	R 2394	RES.METAL FILM MRS25 1x 110E	4822 116 52906
R 2205	RES.CHIP MCR18 1x 2K2	4822 111 90248	R 2395	POTM.SLIDE 0.3W 25% 220E	5322 105 20031
R 2206	RES.METAL FILM MRS25 1x 75K	5322 116 53266	R 2396	RES.METAL FILM MRS25 1x 3K48	4822 116 53515
R 2207	RES.METAL FILM MRS25 1x 12K1	4822 116 52957	R 2397	RES.METAL FILM MRS25 1x 42E2	5322 116 53515
R 2208	RES.METAL FILM MRS25 1x 178K	5322 116 53555	R 2398	RES.METAL FILM MRS25 1x 21E5	5322 116 53426
R 2209	RES.CHIP RC-02H 1x 10K	5322 116 80428	R 2399	RES.METAL FILM MRS25 1x 51E1	5322 116 53213
R 2210	RES.CHIP MCR18 1x 2K2	4822 111 90248	R 2400	RES.METAL FILM MRS25 1x 51E1	5322 116 53213
R 2211	RES.METAL FILM MRS25 1x 5K62	5322 116 53495	R 2403	RES.METAL FILM MRS25 1x 42E2	5322 116 53515
R 2212	POTM.TRIMMER 0.3W 25% 10K	4822 105 10455	R 2404	RES.METAL FILM MRS25 1x 619E	5322 116 53337
R 2213	RES.METAL FILM MRS25 1x 19K6	5322 116 53258	R 2406	RES.METAL FILM MRS25 1x 1K62	5322 116 53257
R 2214	RES.CHIP RC-02H 1x 10K	5322 116 80428	R 2408	RES.METAL FILM MRS25 1x 1K33	5322 116 53512
R 2215	RES.CHIP MCR18 1x 2K2	4822 111 90248	R 2409	RES.METAL FILM MRS25 1x 1K62	5322 116 53257
R 2216	RES.METAL FILM MRS25 1x 5K62	5322 116 53495	R 2411	RES.METAL FILM MRS25 1x 42E2	5322 116 53515
R 2218	RES.METAL FILM MRS25 1x 6K19	5322 116 53263	R 2412	RES.METAL FILM MRS25 1x 619E	5322 116 53337
R 2221	RES.MET.GLAZED MCR18 1x 20K	5322 116 80601	R 2416	RES.METAL FILM MRS25 1x 1K	4822 116 53108
R 2222	RES.METAL FILM MRS25 1x 1K78	5322 116 53208	R 2418	RES.METAL FILM MRS25 1x 5K62	5322 116 53495
R 2224	RES.METAL FILM MRS25 1x 3K48	4822 116 53515	R 2419	RES.METAL FILM MRS25 1x 1K1	5322 116 53473
R 2225	RES.METAL FILM MRS25 1x 19K6	5322 116 53258	R 2420	RES.METAL FILM MRS25 1x 133E	5322 116 53424
R 2250	RES.METAL FILM MRS25 1x 68E1	5322 116 53264	R 2421	RES.METAL FILM MRS25 1x 5K62	5322 116 53495
R 2251	RES.METAL FILM MRS25 1x 68E1	5322 116 53264	R 2422	RES.CHIP MCR18 1x 1K	4822 051 10102
R 2252	RES.METAL FILM MRS25 1x 75E	5322 116 53359	R 2426	POTM.SLIDE 0.3W 25% 220E	5322 105 20031
R 2253	RES.METAL FILM MRS25 1x 75E	5322 116 53359	R 2427	POTM.SLIDE 0.3W 25% 1K	5322 105 20032
R 2254	RES.METAL FILM 1/4W .25% 375E	5322 116 53407	R 2430	RES.METAL FILM MRS25 1x 100K	4822 050 21004
R 2255	RES.METAL FILM MRS25 1x 619E	5322 116 53337	R 2431	RES.METAL FILM MRS25 1x 100K	4822 050 21004
R 2256	RES.METAL FILM MRS25 1x 1K62	5322 116 53257	R 2432	RES.METAL FILM MRS25 1x 100K	4822 050 21004
R 2257	RES.METAL FILM MRS25 1x 2K61	5322 116 53327	R 2433	RES.METAL FILM MRS25 1x 100K	4822 050 21004
R 2258	RES.METAL FILM MRS25 1x 38E1	5322 116 53132	R 2409	RES.METAL FILM MRS25 1x 10K	4822 116 53022
R 2259	RES.METAL FILM MRS25 1x 100E	5322 116 53126	R 2435	RES.METAL FILM MRS25 1x 1K	4822 116 53022
R 2260	RES.METAL FILM MRS25 1x 619E	5322 116 53337	R 2601	RES.METAL FILM MRS25 1x 3K48	4822 116 53515
R 2261	POTM.SLIDE 0.3W 25% 470E	5322 105 20028	R 2602	RES.METAL FILM MRS25 1x 5E11	4822 116 52999
R 2262	RES.METAL FILM 1/4W .25% 375E	5322 116 53407	R 2603	RES.METAL FILM MRS25 1x 5K11	5322 116 53494
R 2263	RES.METAL FILM MRS25 1x 1K78	5322 116 53208	R 2604	RES.NETWORK MCR18 1x 5K1	5322 111 91471
R 2264	RES.METAL FILM MRS25 1x 5E11	4822 116 52999	R 2605	RES.METAL FILM MRS25 1x 12K1	4822 116 52957
R 2266	RES.METAL FILM MRS25 1x 511E	5322 116 53135	R 2606	RES.METAL FILM MRS25 1x 1E	4822 050 21008
R 2267	RES.METAL FILM MRS25 1x 511E	5322 116 53135	R 2610	RES.METAL FILM MRS25 1x 10K	4822 116 53022
R 2268	RES.METAL FILM MRS25 1x 31E6	5322 116 54964	R 2611	RES.METAL FILM MRS25 1x 1K	4822 116 53108
R 2269	RES.METAL FILM MRS25 1x 31E6	5322 116 54964	R 2621	RES.METAL FILM MRS25 1x 42E2	5322 116 53592
R 2272	RES.METAL FILM MRS25 1x 261E	5322 116 53549	R 2622	RES.METAL FILM MRS25 1x 681E	4822 116 53123
R 2273	RES.METAL FILM MRS25 1x 511E	5322 116 53135	R 2623	RES.METAL FILM MRS25 1x 1K1	5322 116 53473
R 2274	RES.METAL FILM MRS25 1x 5E11	4822 116 52999	R 2624	RES.METAL FILM MRS25 1x 3K48	4822 116 53515
R 2276	RES.METAL FILM MRS25 1x 511E	5322 116 53135	R 2625	RES.METAL FILM MRS25 1x 681E	4822 116 53123
R 2277	RES.METAL FILM MRS25 1x 75E	5322 116 53359	R 2626	RES.METAL FILM MRS25 1x 68K1	5322 116 53252
R 2278	RES.METAL FILM MRS25 1x 46E4	5322 116 53248	R 2627	RES.METAL FILM MRS25 1x 281E	5322 116 53221
R 2281	RES.METAL FILM MRS25 1x 46E4	5322 116 53248	R 2628	RES.METAL FILM MRS25 1x 2K37	5322 116 53503
R 2282	RES.METAL FILM MRS25 1x 75E	5322 116 53359	R 2629	RES.METAL FILM MRS25 1x 10K	4822 116 53022
R 2283	RES.METAL FILM MRS25 1x 46E4	5322 116 53248	R 2631	RES.METAL FILM MRS25 1x 10K	4822 116 53022
R 2284	RES.METAL FILM MRS25 1x 46E4	5322 116 53248	R 2632	RES.METAL FILM MRS25 1x 383E	5322 116 53532
R 2286	RES.METAL FILM MRS25 1x 19E6	4822 050 21961	R 2635	RES.METAL FILM MRS25 1x 10K	4822 116 53022
R 2287	RES.METAL FILM MRS25 1x 1K47	5322 116 53185	R 2701	RES.METAL FILM MRS25 1x 1E	4822 050 21008
R 2288	RES.METAL FILM MRS25 1x 31E6	5322 116 53499	R 2702	RES.METAL FILM MRS25 1x 8E25	4822 050 28258
R 2289	RES.METAL FILM MRS25 1x 56E2	5322 116 53656	R 2703	RES.METAL FILM MRS25 1x 5E11	4822 116 52999
R 2291	RES.METAL FILM MRS25 1x 1K78	5322 116 53208	R 2704	RES.METAL FILM MRS25 1x 1E	4822 050 21008
R 2301	RES.METAL FILM MRS25 1x 19K6	5322 116 53258	R 2705	RES.METAL FILM MRS25 1x 5E11	4822 116 52999
R 2302	RES.METAL FILM MRS25 1x 19K6	5322 116 53258	R 2711	RES.METAL FILM MRS25 1x 5E11	4822 116 52999
R 2303	RES.METAL FILM MRS25 1x 5K62	5322 116 53495	R 2712	RES.METAL FILM MRS25 1x 5E11	4822 116 52999
R 2304	RES.METAL FILM MRS25 1x 5K62	5322 116 53495	R 2713	RES.METAL FILM MRS25 1x 1E	4822 050 21008
R 2305	RES.METAL FILM MRS25 1x 90E9	4822 050 29099	R 2714	RES.METAL FILM MRS25 1x 5E11	4822 116 52999
R 2306	RES.METAL FILM MRS25 1x 90E9	4822 050 29099	R 2719	RES.METAL FILM MRS25 1x 5E11	4822 116 52999
R 2307	RES.METAL FILM MRS25 1x 90E9	4822 050 29099	R 2720	RES.METAL FILM MRS25 1x 5E11	4822 116 52999
R 2308	RES.METAL FILM MRS25 1x 90E9	4822 050 29099	R 2721	RES.METAL FILM MRS25 1x 5E11	4822 116 52999
R 2311	RES.METAL FILM MRS25 1x 2K87	5322 116 53513	R 2722	RES.METAL FILM MRS25 1x 5E11	4822 116 52999
R 2324	RES.METAL FILM MRS25 1x 5K62	5322 116 53495	R 2723	RES.METAL FILM MRS25 1x 5E11	4822 116 52999
R 2325	RES.METAL FILM MRS25 1x 5K62	5322 116 53495	R 2724	RES.METAL FILM MRS25 1x 5E11	4822 116 52999
R 2326	RES.METAL FILM MRS25 1x 2K87	5322 116 53513	R 2726	RES.METAL FILM MRS25 1x 5E11	4822 116 52999
R 2327	RES.METAL FILM MRS25 1x 3K83	4822 116 53079	R 2733	RES.METAL FILM MRS25 1x 1E	4822 050 21008
R 2328	RES.METAL FILM MRS25 1x 2K87	5322 116 53513	R 2740	RES.METAL FILM MRS25 1x 5E11	4822 116 52999
R 2329	RES.METAL FILM MRS25 1x 825E	5322 116 53941	R 2741	RES.METAL FILM MRS25 1x 31E6	5322 116 54964
R 2330	POTM.TRIMMER 0.3W 25% 10K	4822 105 10455	R 2742	RES.METAL FILM MRS25 1x 5E11	4822 116 52999
R 2333	RES.METAL FILM MRS25 1x 5K62	5322 116 53495	R 2751	RES.METAL FILM MRS25 1x 5E11	4822 116 52999
R 2334	RES.METAL FILM MRS25 1x 5K62	5322 116 53495	R 2752	RES.METAL FILM MRS25 1x 1E	4822 050 21008
R 2335	RES.CHIP RC-02H 1x 10K	5322 116 80428	R 2753	RES.METAL FILM MRS25 1x 5E11	4822 116 52999
R 2336	RES.METAL FILM MRS25 1x 46E4	5322 116 53248	R 2754	RES.METAL FILM MRS25 1x 5E11	4822 116 52999
R 2337	RES.CHIP MCR18 1x 160E	4822 111 90345	R 2801	RES.CHIP MCR18 1x 1K	4822 051 10102
R 2338	RES.MET.GLAZED MCR18 1x 4K3	5322 116 80605	R 2802	RES.METAL FILM RC-02H 1x 1K1	4822 116 82258
R 2339	RES.NETWORK MCR18 1x 390E	5322 111 91205	R 2803	RES.CHIP MCR18 1x 2K7	4822 111 90569
R 2341	RES.METAL FILM MRS25 1x 46E4	5322 116 53248	R 2804	RES.CHIP MCR18 1x 1K	4822 051 10102
R 2342	RES.CHIP MCR18 1x 160E	4822 111 90345	R 2806	RES.NETWORK MCR18 1x 5K1	5322 111 91471
R 2344	RES.CHIP MCR18 1x 510E	4822 111 90245	R 2807	RES.CHIP MCR18 1x 1K	4822 051 10102
R 2345	RES.NETWORK MCR18 1x 100E	5322 111 91134	R 2808	RES.CHIP MCR18 1x 2K7	4822 111 90569
R 2348	RES.CHIP MCR18 1x 8K2	5322 111 90118	R 2809	RES.CHIP MCR18 1x 510E	4822 111 90245
R 2350	RES.NETWORK MCR18 1x 5K1	5322 111 91471	R 2811	RES.CHIP MCR18 1x 510E	4822 111 90245
R 2351	RES.CHIP MCR18 1x 560E	5322 111 90133	R 2812	RES.CHIP MCR18 1x 510E	4822 111 90245
R 2352	RES.CHIP MCR18 1x 820E	4822 111 90171	R 2813	RES.CHIP MCR18 1x 510E	4822 111 90245
R 2358	RES.CHIP MCR18 1x 510E	4822 111 90245	R 2814	RES.CHIP MCR18 1x 1K	4822 051 10102
R 2360	RES.NETWORK MCR18 1x 100E	5322 111 91134	R 2816	RES.CHIP MCR18 1x	

POSNR	DESCRIPTION	ORDERING CODE	POSNR	DESCRIPTION	ORDERING CODE
R 2822	RES.CHIP MCR18 1x 1K	4822 051 10102	R 3138	RES.METAL FILM MRS25 1x 2K37	5322 116 53503
R 2823	RES.CHIP MCR18 1x 1K	4822 051 10102	R 3139	RES.METAL FILM MRS25 1x 619E	5322 116 53337
R 2824	RES.CHIP MCR18 1x 1K	4822 051 10102	R 3141	RES.METAL FILM MRS25 1x 516E	5322 116 53699
R 2826	RES.METAL FILM MCR18 1x 2K	5322 116 80858	R 3142	RES.METAL FILM MRS25 1x 316E	5322 116 53699
R 2827	RES.METAL FILM MCR18 1x 2K	5322 116 80858	R 3143	RES.METAL FILM MRS25 1x 10E	4822 116 52891
R 2828	RES.METAL FILM MCR18 1x 2K	5322 116 80858	R 3144	RES.METAL FILM MRS25 1x 10E	4822 116 52891
R 2829	RES.NETWORK MCR18 1x 390E	5322 111 91205	R 3147	RES.N.T.C. 0.5W 10x 3K3	5322 116 53254
R 2831	RES.NETWORK MCR18 1x 390E	5322 111 91205	R 3148	RES.METAL FILM MRS25 1x 9K909	5322 116 53254
R 2832	RES.CHIP MCR18 1x 2K7	4822 111 90569	R 3149	RES.METAL FILM MRS25 1x 511E	5322 116 53108
R 2833	RES.CHIP MCR18 1x 2K7	4822 111 90569	R 3200	RES.METAL FILM MRS25 1x 6K81	5322 116 53252
R 2834	RES.NETWORK MCR18 1x 390E	5322 111 91205	R 3201	RES.METAL FILM MRS25 1x 1K21	4822 116 52956
R 2836	RES.NETWORK MCR18 1x 390E	5322 111 91205	R 3202	RES.METAL FILM MRS25 1x 100E	5322 116 53126
R 3001	RES.METAL FILM MRS25 1x 75E	5322 116 53339	R 3203	RFS.METAL FILM MRS25 1x 16K2	5322 116 53589
R 3003	RES.METAL FILM MRS25 1x 1K47	5322 116 53185	R 3204	RES.METAL FILM MRS25 1x 562E	5322 116 53656
R 3004	RES.METAL FILM MRS25 1x 511E	5322 116 53135	R 3205	RES.METAL FILM MRS25 1x 4K64	5322 116 53213
R 3005	RES.METAL FILM MRS25 1x 51E1	5322 116 53213	R 3206	RES.METAL FILM MRS25 1x 4K64	5322 116 53213
R 3006	RES.METAL FILM MRS25 1x 2K37	5322 116 53503	R 3207	RES.METAL FILM MRS25 1x 82K5	5322 116 53581
R 3007	POTM.SLIDE 0.3W 25x 2K2	5322 105 20033	R 3208	RES.METAL FILM MRS25 1x 7K5	4822 116 53028
R 3008	RES.METAL FILM MRS25 1x 100E	5322 116 53126	R 3209	RES.METAL FILM MRS25 1x 1K	4822 116 53108
R 3009	RES.METAL FILM MRS25 1x 3K83	4822 116 53079	R 3210	RES.METAL FILM MRS25 1x 4E2E	5322 116 53515
R 3010	RES.METAL FILM MRS25 1x 51E1	5322 116 53213	R 3211	RES.METAL FILM MRS25 1x 10K	4822 116 53022
R 3011	RES.METAL FILM MRS25 1x 100E	5322 116 53126	R 3212	RES.METAL FILM MRS25 1x 1K47	5322 116 53185
R 3012	RES.METAL FILM MRS25 1x 5E11	4822 116 52999	R 3213	RES.METAL FILM MRS25 1x 23K7	5322 116 53377
R 3013	POTM.TRIMMER 0.3W 25x 10K	4822 105 10455	R 3214	RES.METAL FILM MRS25 1x 51K6	5322 116 53262
R 3014	RES.METAL FILM MRS25 1x 287E	5322 116 53221	R 3215	RES.METAL FILM MRS25 1x 4K64	5322 116 53213
R 3015	RES.METAL FILM MRS25 1x 75E	5322 116 53339	R 3216	RES.METAL FILM MRS25 1x 178K	5322 116 53555
R 3016	RES.METAL FILM MRS25 1x 909E	4822 116 53533	R 3217	RES.METAL FILM MRS25 1x 511E	5322 116 53135
R 3017	POTM.TRIMMER 0.3W 25x 10K	4822 105 10455	R 3218	RES.METAL FILM MRS25 1x 61K9	5322 116 53233
R 3018	RES.METAL FILM MRS25 1x 3K16	4822 116 53021	R 3219	RES.METAL FILM MRS25 1x 1M	4822 116 52843
R 3019	RES.METAL FILM MRS25 1x 5E11	4822 116 52999	R 3221	RES.METAL FILM MRS25 1x 100E	5322 116 53126
R 3020	RES.METAL FILM MRS25 1x 133E	5322 116 53424	R 3222	RES.METAL FILM MRS25 1x 100K	4822 050 21004
R 3021	RES.METAL FILM MRS25 1x 511E	5322 116 53135	R 3223	RES.METAL FILM MRS25 1x 3K83	5322 116 53569
R 3022	RES.METAL FILM MRS25 1x 619E	5322 116 53337	R 3224	RES.METAL FILM MRS25 1x 2K37	5322 116 53503
R 3023	RES.METAL FILM MRS25 1x 196E	4822 050 21961	R 3226	RES.METAL FILM MRS25 1x 100E	5322 116 53126
R 3024	RES.METAL FILM MRS25 1x 619E	5322 116 53337	R 3250	RES.METAL FILM MRS25 1x 2K37	5322 116 53503
R 3025	RES.METAL FILM MRS25 1x 133E	5322 116 53424	R 3251	RES.METAL FILM MRS25 1x 1M	4822 116 52843
R 3026	RES.METAL FILM MRS25 1x 511E	5322 116 53135	R 3253	RES.METAL FILM MRS25 1x 75K	5322 116 53266
R 3027	RES.METAL FILM MRS25 1x 511E	5322 116 53135	R 3254	RES.METAL FILM MRS25 1x 1K	4822 116 53108
R 3028	RES.METAL FILM MRS25 1x 511E	5322 116 53135	R 3256	RES.METAL FILM MRS25 1x 178K	5322 116 53555
R 3029	RES.METAL FILM MRS25 1x 2K87	5322 116 53351	R 3257	RES.METAL FILM MRS25 1x 825K	5322 116 53541
R 3031	RES.METAL FILM MRS25 1x 619E	5322 116 53337	R 3258	RES.HI-TENSION VR25 5x 3M3	4822 110 72201
R 3032	RES.METAL FILM MRS25 1x 51E1	5322 116 53213	R 3259	RES.HI-TENSION VR25 5x 3M3	4822 110 72201
R 3033	RES.METAL FILM MRS25 1x 31E6	5322 116 54964	R 3261	RES.HI-TENSION VR25 5x 3M3	4822 110 72201
R 3034	RES.METAL FILM MRS25 1x 100E	5322 116 53126	R 3262	RES.HI-TENSION VR25 5x 7M5	5322 116 60131
R 3035	RES.METAL FILM MRS25 1x 51E1	5322 116 53213	R 3263	RES.HI-TENSION VR25 5x 3M3	4822 110 72201
R 3037	RES.METAL FILM MRS25 1x 31E6	5322 116 54964	R 3268	RES.METAL FILM MRS25 1x 681K	5322 116 53593
R 3038	POTM.SLIDE 0.3W 25x 200E	5322 105 20031	R 3269	RES.METAL FILM MRS25 1x 15K4	5322 116 53234
R 3041	RES.METAL FILM MRS25 1x 4E2E	5322 116 53515	R 3270	RES.METAL FILM MRS25 1x 1K	4822 116 53108
R 3042	POTM.SLIDE 0.3W 25x 200E	5322 105 20031	R 3273	RES.METAL FILM MRS25 1x 215K	5322 116 53425
R 3047	RES.METAL FILM MRS25 1x 61E9	5322 116 53645	R 3302	RES.METAL FILM MRS25 1x 1E	4822 050 21008
R 3048	RES.METAL FILM MRS25 1x 61E9	5322 116 53645	R 3303	RES.METAL FILM MRS25 1x 5E11	4822 116 52999
R 3049	RES.METAL FILM MRS25 1x 61K1	4822 116 53121	R 3304	RES.METAL FILM MRS25 1x 5E11	4822 116 52999
R 3050	RES.METAL FILM MRS25 1x 4E2E	5322 116 53515	R 3306	RES.METAL FILM MRS25 1x 2K87	5322 116 53513
R 3051	RES.METAL FILM MRS25 1x 51K1	4822 116 53121	R 3308	RES.METAL FILM MRS25 1x 10E	4822 116 52891
R 3052	RES.METAL FILM MRS25 1x 4E2E	5322 116 53515	R 3309	RES.METAL FILM MRS25 1x 5E11	4822 116 52999
R 3053	RES.METAL FILM MRS25 1x 51E1	5322 116 53213	R 3311	RES.METAL FILM MRS25 1x 5E11	4822 116 52999
R 3054	RES.METAL FILM MRS25 1x 51E1	5322 116 53213	R 3312	RES.METAL FILM MRS25 1x 1E	4822 050 21008
R 3056	RES.METAL FILM MRS25 1x 287E	5322 116 53221	R 3313	RES.METAL FILM MRS25 1x 10E	4822 116 52891
R 3057	RES.METAL FILM MRS25 1x 287E	5322 116 53221	R 4001	RES.METAL FILM MRS25 1x 51E1	5322 116 53135
R 3058	RES.METAL FILM MRS25 1x 287E	5322 116 53221	R 4002	RES.METAL FILM MRS25 1x 51F1	5322 116 53213
R 3059	RES.METAL FILM MRS25 1x 261E	5322 116 53549	R 4003	RES.METAL FILM MRS25 1x 2K61	5322 116 53327
R 3061	RES.METAL FILM MRS25 1x 261E	5322 116 53549	R 4004	POTM.SLIDE 0.3W 25x 1K	5322 105 20032
R 3062	RES.METAL FILM MRS25 1x 261E	5322 116 53549	R 4006	RES.METAL FILM MRS25 1x 10K	4822 116 53022
R 3063	RES.METAL FILM MRS25 1x 261E	5322 116 53549	R 4007	RES.METAL FILM MRS25 1x 100E	5322 116 53126
R 3064	RES.METAL FILM MRS25 1x 261E	5322 116 53549	R 4008	RES.METAL FILM MRS25 1x 100E	5322 116 53126
R 3066	RES.METAL FILM MRS25 1x 261E	5322 116 53549	R 4009	RES.METAL FILM MRS25 1x 1K	4822 116 53108
R 3067	RES.METAL FILM MRS25 1x 287E	5322 116 53221	R 4011	RES.METAL FILM MRS25 1x 2K15	5322 116 53239
R 3068	RES.METAL FILM MRS25 1x 287E	5322 116 53221	R 4012	RES.METAL FILM MRS25 1x 100E	5322 116 53126
R 3069	RES.METAL FILM MRS25 1x 287E	5322 116 53221	R 4013	RES.METAL FILM MRS25 1x 100E	5322 116 53126
R 3071	RES.METAL FILM MRS25 1x 121E	4822 116 52955	R 4014	RES.METAL FILM MRS25 1x 909E	4822 116 53533
R 3072	RES.METAL FILM MRS25 1x 121E	4822 116 52955	R 4016	RES.METAL FILM MRS25 1x 909F	4822 116 53533
R 3073	RES.METAL FILM MRS25 1x 261E	5322 116 53723	R 4017	RES.METAL FILM MRS25 1x 100E	5322 116 53126
R 3074	RES.METAL FILM MRS25 1x 121E	4822 116 52955	R 4019	RES.METAL FILM MRS25 1x 51E1	5322 116 53108
R 3076	RES.METAL FILM MRS25 1x 121E	4822 116 52955	R 4021	RES.METAL FILM MRS25 1x 1K21	4822 116 52956
R 3077	RES.METAL FILM MRS25 1x 26E1	5322 116 53723	R 4022	RES.METAL FILM MRS25 1x 511E	5322 116 53135
R 3100	RES.METAL FILM MRS25 1x 4E2E	5322 116 53515	R 4023	RES.METAL FILM MRS25 1x 562E	5322 116 53656
R 3101	RES.METAL FILM MRS25 1x 4K64	5322 116 53656	R 4026	RES.METAL FILM MRS25 1x 909F	4822 116 53533
R 3102	RES.METAL FILM MRS25 1x 562E	5322 116 53656	R 4027	RES.METAL FILM MRS25 1x 5K62	5322 116 53495
R 3103	RES.METAL FILM MRS25 1x 1K21	4822 116 52956	R 4028	RES.METAL FILM MRS25 1x 1K	4822 116 53108
R 3104	RES.METAL FILM MRS25 1x 6K81	5322 116 53252	R 4029	RES.METAL FILM MRS25 1x 2K37	5322 116 53503
R 3106	RES.METAL FILM MRS25 1x 4E2E	5322 116 53515	R 4031	RES.METAL FILM MRS25 1x 1M	4822 116 52843
R 3107	RES.METAL FILM MRS25 1x 2K87	5322 116 53513	R 4032	RES.METAL FILM MRS25 1x 5K11	5322 116 53494
R 3108	RES.METAL FILM MRS25 1x 825E	5322 116 53541	R 4033	RES.METAL FILM MRS25 1x 2K61	5322 116 53327
R 3109	RES.METAL FILM MRS25 1x 6K19	5322 116 53263	R 4041	RES.METAL FILM MRS25 1x 5K11	5322 116 53494
R 3110	RES.METAL FILM MRS25 1x 4E2E	5322 116 53515	R 4042	RES.METAL FILM MRS25 1x 3K16	4822 116 55021
R 3111	RES.METAL FILM MRS25 1x 4E2E	5322 116 53515	R 4043	RES.METAL FILM MRS25 1x 5K11	5322 116 53494
R 3112	RES.METAL FILM MRS25 1x 7K5	4822 116 53028	R 4044	RES.METAL FILM MRS25 1x 681K	5322 116 53593
R 3113	RES.METAL FILM MRS25 1x 1K21	4822 116 52956	R 4046	RES.METAL FILM MRS25 1x 9K09	5322 116 53253
R 3114	RES.METAL FILM MRS25 1x 5K62	5322 116 53495	R 4047	RES.METAL FILM MRS25 1x 12K1	4822 116 52957
R 3115	RES.METAL FILM MRS25 1x 4E2E	5322 116 53515	R 4086	RES.METAL FILM MRS25 1x 909E	4822 116 53533
R 3116	RES.METAL FILM MRS25 1x 562E	5322 116 53656	R 4101	RES.METAL FILM MRS25 1x 100K	4822 050 21004
R 3117	RES.METAL FILM MRS25 1x 4K64	5322 116 53213	R 4102	RES.METAL FILM MRS25 1x 4K64	5322 116 53213
R 3118	POTM.SLIDE 0.3W 25x 1K	5322 105 20032	R 4103	RES.METAL FILM MRS25 1x 11K	4822 116 52907
R 3119	RES.METAL FILM MRS25 1x 4K64	5322 116 53213	R 4104	RES.METAL FILM MRS25 1x 4K64	5322 116 53144
R 3120	RES.METAL FILM MRS25 1x 4E2E	5322 116 53515	R 4106	RES.METAL FILM MRS25 1x 4E2E	5322 116 53592
R 3121	RES.METAL FILM MRS25 1x 15K4	5322 116 53234	R 4107	POTM.TRIMMER 0.3W 25x 10K	4822 105 10455
R 3122	RES.METAL FILM MRS25 1x 2K37	5322 116 53503	R 4108	POTM.TRIMMER 0.3W 25x 10K	4822 105 10455
R 3124	RES.METAL FILM MRS25 1x 619E	5322 116 53337	R 4109	RES.METAL FILM MRS25 1x 5K11	5322 116 53494
R 3125	RES.METAL FILM MRS25 1x 4E2E	5322 116 53515	R 4111	RES.METAL FILM MRS25 1x 12K1	4822 116 52957
R 3126	RES.METAL FILM MRS25 1x 14K7	4822 116 53551	R 4117	RES.METAL FILM MRS25 1x 3K16	4822 116 53021
R 3127	RES.METAL FILM MRS25 1x 1K33	5322 116 53512	R 4118	RES.METAL FILM 1/4W .25% 50E	5322 116 53405
R 3128	RES.METAL FILM MRS25 1x 825E	5322 116 53541	R 4119	RES.METAL FILM 1/4W .25% 50E	5322 116 53405
R 3129	RES.METAL FILM MRS25 1x 1K1	5322 116 53473	R 4120	RES.METAL FILM MRS25 1x 1K	4822 116 53108
R 3130	RES.METAL FILM MRS25 1x 4E2E	5322 116 53515	R 4121	RES.METAL FILM 1/4W .25% 150E	5322 116 53399
R 3131	RES.METAL FILM MRS25 1x 1K33	5322 116 53512	R 4122	RES.METAL FILM 1/4W .25% 250E	5322 116 53406

POSNR	DESCRIPTION	ORDERING CODE	POSNR	DESCRIPTION	ORDERING CODE
R 4129	RES.METAL FILM MRS25 1x 1M	4822 116 52843	R 4417	RES.METAL FILM MRS25 1x 1K	4822 116 53108
R 4130	RES.METAL FILM MRS25 1x 1K	4822 116 53108	R 4418	RES.METAL FILM MRS25 1x 2K37	4822 116 53503
R 4131	RES.METAL FILM MRS25 1x 5K11	5322 116 53494	R 4419	RES.METAL FILM MRS25 1x 511E	5322 116 53135
R 4132	RES.METAL FILM MRS25 1x 5K11	5322 116 53494	R 4420	RES.METAL FILM MRS25 1x 1K21	4822 116 52956
R 4134	RES.METAL FILM MRS25 1x 10K	4822 116 53022	R 4421	RES.METAL FILM MRS25 1x 10K	4822 116 53022
R 4135	RES.METAL FILM MRS25 1x 1K	4822 116 53108	R 4422	RES.METAL FILM MRS25 1x 2K87	5322 116 53513
R 4136	RES.METAL FILM MRS25 1x 10K	4822 116 53022	R 4423	RES.METAL FILM MRS25 1x 9K09	5322 116 53253
R 4137	RES.METAL FILM MRS25 1x 14K7	4822 116 53022	R 4427	RES.METAL FILM MRS25 1x 1K96	5322 116 53237
R 4138	RES.METAL FILM MRS25 1x 5E11	4822 116 52999	R 4428	RES.METAL FILM MRS25 1x 100E	5322 116 53126
R 4139	RES.METAL FILM MRS25 1x 10K	4822 116 53022	R 4501	RES.METAL FILM MRS25 1x 13K3	5322 116 53489
R 4140	RES.METAL FILM MRS25 1x 10K	4822 116 53022	R 4502	RES.METAL FILM MRS25 1x 4K22	5322 116 53246
R 4141	RES.METAL FILM MRS25 1x 14K7	4822 116 53531	R 4503	RES.METAL FILM MRS25 1x 6K81	5322 116 53252
R 4142	RES.METAL FILM MRS25 1x 100E	5322 116 53126	R 4504	RES.METAL FILM MRS25 1x 13K5	5322 116 53489
R 4143	RES.METAL FILM 1/4W 0.1x 20K	5322 116 52697	R 4505	RES.METAL FILM MRS25 1x 511E	5322 116 53135
R 4144	RES.METAL FILM 1/4W 0.1x 202E	5322 116 53135	R 4506	RES.METAL FILM MRS25 1x 2K15	5322 116 53239
R 4145	RES.METAL FILM MRS25 1x 1K	4822 116 53108	R 4507	RES.METAL FILM MRS25 1x 750E	5322 116 53265
R 4146	RES.METAL FILM MRS25 1x 10K	4822 116 53022	R 4508	RES.METAL FILM MRS25 1x 11K	4822 116 52907
R 4147	RES.METAL FILM MRS25 1x 511E	5322 116 53135	R 4509	RES.METAL FILM MRS25 1x 2K15	5322 116 53239
R 4148	RES.METAL FILM MRS25 1x 21K5	5322 116 53241	R 4513	RES.METAL FILM MRS25 1x 1K47	5322 116 53185
R 4149	RES.METAL FILM MRS25 1x 31E6	5322 116 54964	R 4521	RES.METAL FILM MRS25 1x 16K2	5322 116 53589
R 4150	RES.METAL FILM MRS25 1x 9E09	5322 116 53516	R 4522	RES.METAL FILM MRS25 1x 23K7	5322 116 53537
R 4151	RES.METAL FILM MRS25 1x 2K61	5322 116 53327	R 4523	RES.METAL FILM MRS25 1x 16K2	5322 116 53589
R 4152	RES.METAL FILM MRS25 1x 162E	5322 116 53523	R 4524	RES.METAL FILM MRS25 1x 14K7	4822 116 53551
R 4153	RES.METAL FILM MRS25 1x 1K1	5322 116 53473	R 4526	RES.METAL FILM MRS25 1x 2K37	5322 116 53503
R 4154	RES.METAL FILM MRS25 1x 1K78	5322 116 53208	R 4527	RES.METAL FILM MRS25 1x 19K6	5322 116 53258
R 4155	RES.METAL FILM MRS25 1x 2K15	5322 116 53239	R 4528	RES.METAL FILM MRS25 1x 5K62	5322 116 53495
R 4156	RES.METAL FILM MRS25 1x 1M	4822 116 52843	R 4529	RES.METAL FILM MRS25 1x 21K5	5322 116 53241
R 4157	RES.METAL FILM MRS25 1x 1E	4822 050 21008	R 4531	RES.METAL FILM MRS25 1x 10K	4822 116 53022
R 4158	RES.METAL FILM MRS25 1x 1M	4822 116 52843	R 4532	RES.METAL FILM MRS25 1x 10K	4822 116 53022
R 4159	RES.METAL FILM MRS25 1x 2K15	5322 116 53239	R 4533	RES.METAL FILM MRS25 1x 3K48	4822 116 53315
R 4160	RES.METAL FILM MRS25 1x 100E	5322 116 53126	R 4601	RES.METAL FILM MRS25 1x 2K37	5322 116 53503
R 4161	RES.METAL FILM MRS25 1x 10K	4822 116 53022	R 4602	RES.METAL FILM MRS25 1x 2K61	5322 116 53261
R 4162	RES.METAL FILM MRS25 1x 100E	5322 116 53126	R 4603	RES.METAL FILM MRS25 1x 23K7	5322 116 53537
R 4163	RES.METAL FILM MRS25 1x 5E11	4822 116 52999	R 4604	RES.METAL FILM MRS25 1x 100K	4822 050 21004
R 4164	RES.METAL FILM MRS25 1x 100E	5322 116 53126	R 4606	RES.METAL FILM MRS25 1x 909E	4822 116 53533
R 4208	POTM.SLIDE 0.3W 25% 2K2	5322 105 20033	R 4607	RES.METAL FILM MRS25 1x 100E	5322 116 53126
R 4209	RES.METAL FILM MRS25 1x 4K64	5322 116 53213	R 4608	RES.METAL FILM MRS25 1x 1K	4822 116 53108
R 4211	RES.METAL FILM MRS25 1x 3K48	4822 116 53405	R 4609	RES.METAL FILM MRS25 1x 4E2E	5322 116 53515
R 4218	RES.METAL FILM 1/4W .25x 50E	5322 116 53405	R 4611	RES.METAL FILM MRS25 1x 10K	4822 116 53022
R 4219	RES.METAL FILM 1/4W .25x 50E	5322 116 53405	R 4612	RES.METAL FILM MRS25 1x 7K5	4822 116 53028
R 4221	RES. 1/4W .25x 100E	5322 116 81216	R 4613	RES.METAL FILM MRS25 1x 10K	4822 116 53022
R 4222	RES.METAL FILM 1/4W 0.1x 300E	5322 116 51814	R 4614	RES.METAL FILM MRS25 1x 51K1	4822 116 53121
R 4224	RES.METAL FILM 1/4W .25x 1K5	5322 116 53401	R 4616	POTM.SLIDE 0.3W 25% 1K	5322 105 20032
R 4241	RES.METAL FILM MRS25 1x 7K5	4822 116 53028	R 4617	RES.METAL FILM MRS25 1x 6K81	5322 116 53252
R 4242	RES.METAL FILM MRS25 1x 5K11	5322 116 53494	R 4618	RES.METAL FILM MRS25 1x 11K	4822 116 52907
R 4245	RES.METAL FILM MRS25 1x 1E	4822 050 21008	R 4619	RES.METAL FILM MRS25 1x 8K25	5322 116 53267
R 4246	RES.METAL FILM MRS25 1x 3K48	4822 050 23485	R 4620	RES.METAL FILM MRS25 1x 7K5	4822 116 53028
R 4247	POTM.TRIMMER 0.3W 25% 10K	4822 105 10455	R 4621	RES.METAL FILM MRS25 1x 909E	4822 116 53533
R 4248	RES.METAL FILM MRS25 1x 51K1	4822 116 53121	R 4622	RES.METAL FILM MRS25 1x 100E	5322 116 53126
R 4249	RES.METAL FILM MRS25 1x 51E1	5322 116 53213	R 4625	RES.METAL FILM MRS25 1x 100E	5322 116 53126
R 4253	RES.METAL FILM MRS25 1x 1K	4822 116 53108	R 4626	RES.METAL FILM MRS25 1x 100E	5322 116 53126
R 4258	RES.METAL FILM MRS25 1x 4K64	5322 116 53213	R 4627	RES.METAL FILM MRS25 1x 10K	4822 116 53022
R 4259	RES.METAL FILM MRS25 1x 4K64	5322 116 53213	R 4628	RES.METAL FILM MRS25 1x 1K	4822 116 53108
R 4261	RES.METAL FILM MRS25 1x 10K	4822 116 53022	R 4629	RES.METAL FILM MRS25 1x 8K25	5322 116 53267
R 4262	RES.METAL FILM MRS25 1x 10K	4822 116 53022	R 4631	RES.METAL FILM MRS25 1x 1K	4822 116 53108
R 4263	RES.METAL FILM MRS25 1x 5K11	5322 116 53494	R 4632	RES.METAL FILM MRS25 1x 100E	5322 116 53126
R 4266	RES.METAL FILM MRS25 1x 100E	5322 116 53126	R 4633	RES.METAL FILM MRS25 1x 1K	4822 116 53108
R 4267	RES.METAL FILM MRS25 1x 75E	5322 116 53339	R 4634	RES.METAL FILM MRS25 1x 1K	4822 116 53108
R 4268	RES.METAL FILM MRS25 1x 215E	5322 116 53325	R 4636	RES.METAL FILM MRS25 1x 1M	4822 116 52843
R 4269	RES.METAL FILM MRS25 1x 1K	4822 116 53108	R 4639	RES.METAL FILM MRS25 1x 383E	5322 116 53332
R 4271	RES.METAL FILM MRS25 1x 4K64	5322 116 53213	R 4701	RES.METAL FILM MRS25 1x 4E2E	5322 116 53515
R 4272	RES.METAL FILM MRS25 1x 1K	4822 116 53108	R 4703	RES.METAL FILM MRS25 1x 562E	5322 116 53656
R 4274	RES.METAL FILM MRS25 1x 2K15	5322 116 53239	R 4705	RES.METAL FILM MRS25 1x 1K	4822 116 53108
R 4276	RES.METAL FILM MRS25 1x 1K	4822 116 53108	R 4706	RES.METAL FILM MRS25 1x 100E	5322 116 53126
R 4277	RES.METAL FILM MRS25 1x 1K	4822 116 53108	R 4707	RES.METAL FILM MRS25 1x 511E	5322 116 53135
R 4278	RES.METAL FILM MRS25 1x 215E	5322 116 53325	R 4708	RES.METAL FILM MRS25 1x 2K87	5322 116 53513
R 4279	RES.METAL FILM MRS25 1x 1K	4822 116 53108	R 4709	RES.METAL FILM MRS25 1x 681E	4822 116 53123
R 4281	RES.METAL FILM MRS25 1x 511E	5322 116 53135	R 4711	RES.METAL FILM MRS25 1x 6K19	5322 116 53263
R 4282	RES.METAL FILM MRS25 1x 1K	4822 116 53108	R 4712	RES.METAL FILM MRS25 1x 511E	5322 116 53135
R 4283	RES.METAL FILM MRS25 1x 1K	4822 116 53108	R 4713	RES.METAL FILM MRS25 1x 1M	4822 116 52843
R 4284	RES.METAL FILM MRS25 1x 215E	5322 116 53325	R 4714	RES.METAL FILM MRS25 1x 1M	4822 116 52843
R 4286	RES.METAL FILM MRS25 1x 31E6	5322 116 54964	R 4716	RES.METAL FILM MRS25 1x 6K81	5322 116 53252
R 4287	RES.METAL FILM MRS25 1x 162E	5322 116 53323	R 4717	RES.METAL FILM MRS25 1x 8K25	5322 116 53267
R 4288	RES.METAL FILM MRS25 1x 215E	5322 116 53325	R 4718	RES.METAL FILM MRS25 1x 1K	4822 116 53108
R 4301	RES.METAL FILM MRS25 1x 51K1	4822 116 53121	R 4719	RES.METAL FILM MRS25 1x 100E	5322 116 53126
R 4302	RES.METAL FILM MRS25 1x 51K1	4822 116 53121	R 4721	POTM.SLIDE 0.3W 25% 1K	5322 105 20032
R 4303	RES.METAL FILM MRS25 1x 6K81	5322 116 53252	R 4722	RES.METAL FILM MRS25 1x 4K64	5322 116 53314
R 4304	RES.METAL FILM MRS25 1x 9K11	5322 116 53494	R 4723	RES.METAL FILM MRS25 1x 81K	5322 116 53533
R 4305	RES.METAL FILM MRS25 1x 51K1	4822 116 53121	R 4724	RES.METAL FILM MRS25 1x 4E2E	5322 116 53515
R 4306	RES.METAL FILM MRS25 1x 681E	4822 116 53123	R 4725	RES.METAL FILM MRS25 1x 4K22	5322 116 53246
R 4307	RES.METAL FILM MRS25 1x 5K11	5322 116 53494	R 4726	RES.METAL FILM MRS25 1x 100K	4822 050 21004
R 4308	RES.METAL FILM MRS25 1x 10K	4822 116 53022	R 4727	RES.METAL FILM MRS25 1x 6K81	5322 116 53252
R 4309	RES.METAL FILM MRS25 1x 8K25	5322 116 53267	R 4728	RES.METAL FILM MRS25 1x 562E	5322 116 53656
R 4310	RES.METAL FILM MRS25 1x 100E	5322 116 53126	R 4801	RES.METAL FILM MRS25 1x 5E11	4822 116 52999
R 4311	RES.METAL FILM MRS25 1x 10K	4822 116 53022	R 4804	RES.METAL FILM MRS25 1x 5E11	4822 116 52999
R 4312	RES.METAL FILM MRS25 1x 9K09	5322 116 53253	R 4807	RES.METAL FILM MRS25 1x 5E11	4822 116 52999
R 4313	RES.METAL FILM MRS25 1x 7K5	4822 116 53028	R 4809	RES.METAL FILM MRS25 1x 5E11	4822 116 52999
R 4314	RES.METAL FILM MRS25 1x 8K25	5322 116 53267	R 4816	RES.METAL FILM MRS25 1x 5E11	4822 116 52999
R 4316	RES.METAL FILM MRS25 1x 511E	5322 116 53135	R 4818	RES.METAL FILM MRS25 1x 5E11	4822 116 52999
R 4317	RES.METAL FILM MRS25 1x 10K	4822 116 53022	R 4819	RES.METAL FILM MRS25 1x 5E11	4822 116 52999
R 4318	RES.METAL FILM MRS25 1x 10K	4822 116 53022	R 4820	RES.METAL FILM MRS25 1x 5E11	4822 116 52999
R 4319	RES.METAL FILM MRS25 1x 10K	4822 116 53022	R 4821	RES.METAL FILM MRS25 1x 5E11	4822 116 52999
R 4330	RES.METAL FILM MRS25 1x 5K11	5322 116 53494	R 4822	RES.METAL FILM MRS25 1x 5E11	4822 116 52999
R 4331	RES.METAL FILM MRS25 1x 21K5	5322 116 53241	R 4824	RES.METAL FILM MRS25 1x 5E11	4822 116 52999
R 4332	RES.METAL FILM MRS25 1x 4K22	5322 116 53246	R 4825	RES.METAL FILM MRS25 1x 5E11	4822 116 52999
R 4334	RES.METAL FILM MRS25 1x 2K15	5322 116 53239	R 4826	RES.METAL FILM MRS25 1x 5E11	4822 116 52999
R 4400	RES.METAL FILM MRS25 1x 100E	5322 116 53126	R 4828	RES.METAL FILM MRS25 1x 5E11	4822 116 52999
R 4401	RES.METAL FILM MRS25 1x 2K61	5322 116 53327	R 4829	RES.METAL FILM MRS25 1x 5E11	4822 116 52999
R 4402	RES.METAL FILM MRS25 1x 82E5	5322 116 53538	R 4831	RES.METAL FILM MRS25 1x 5E11	4822 116 52999
R 4403	RES.METAL FILM MRS25 1x 681E	4822 116 53123	R 4833	RES.METAL FILM MRS25 1x 5E11	4822 116 52999
R 4404	RES.METAL FILM MRS25 1x 2K37	5322 116 53503	R 4835	RES.METAL FILM MRS25 1x 5E11	4822 116 52999
R 4406	POTM.SLIDE 0.3W 25% 22K	5322 116 20035	R 4836	RES.METAL FILM MRS25 1x 5E11	4822 116 52999
R 4407	RES.METAL FILM MRS25 1x 31K6	5322 116 53262	R 4891	RES.METAL FILM MRS25 1x 5E11	4822 116 52999
R 4408	POTM.SLIDE 0.3W 25% 22K	5322 105 20035	R 4892	RES.METAL FILM MRS25 1x 5E11	4822 116 52999
R 4409	RES.METAL FILM MRS25 1x 10K	4822 116 53022	R 4893	RES.METAL FILM MRS25 1x 5E11	4822 116 5299

POSNR	DESCRIPTION	ORDERING CODE	POSNR	DESCRIPTION	ORDERING CODE
R 5002	POTM.CARB.TRACK	CRC17 20% 10K	R 5359	RES.CHIP	RC-02H 1% 10K
R 5003	POTM.CARB.TRACK	CRC17 20% 10K	R 5361	RES.CHIP	MCR18 1% 270E
R 5004	POTM.CARB.TRACK	CRC17 20% 10K	R 5362	RES.CHIP	MCR18 1% 270E
R 5101	RES.CHIP	RC-01 5% 5E6	R 5363	RES.CHIP	MCR18 1% 160E
R 5102	RES.CHIP	MCR18 1% 1K	R 5364	RES.CHIP	MCR18 1% 160E
R 5104	RES.METAL FILM	MCR18 1% 430E	R 5366	RES.NETWORK	MCR18 1% 51E
R 5105	RES.MET.GLAZED	MCR18 1% 200E	R 5367	RES.NETWORK	MCR18 1% 51E
R 5106	RES.CHIP	MCR18 1% 33E	R 5368	RES.NETWORK	MCR18 1% 51E
R 5107	RES.CHIP	MCR18 1% 1K	R 5369	RES.NETWORK	MCR18 1% 51E
R 5108	RES.NETWORK	MCR18 1% 51E	R 5371	RES.NETWORK	MCR18 1% 51E
R 5109	RES.METAL FILM	MCR18 1% 240E	R 5372	RES.NETWORK	MCR18 1% 51E
R 5110	RES.METAL FILM	MCR18 1% 430E	R 5373	RES.NETWORK	MCR18 1% 51E
R 5111	RES.CHIP	RC-01 5% 5E6	R 5374	RES.NETWORK	MCR18 1% 51E
R 5112	RES.CHIP	MCR18 1% 1K	R 5376	RES.CHIP	MCR18 1% 510E
R 5113	RES.CHIP	MCR18 1% 2K2	R 5377	RES.CHIP	MCR18 1% 510E
R 5114	RES.METAL FILM	MCR18 1% 430E	R 5378	RES.NETWORK	MCR18 1% 100E
R 5115	RES.MET.GLAZED	MCR18 1% 200E	R 5379	RES.NETWORK	MCR18 1% 300E
R 5116	RES.CHIP	MCR18 1% 33E	R 5381	RES.NETWORK	MCR18 1% 300E
R 5117	RES.CHIP	MCR18 1% 1K	R 5382	RES.NETWORK	MCR18 1% 300E
R 5118	RES.NETWORK	MCR18 1% 51E	R 5383	RES.NETWORK	MCR18 1% 300E
R 5119	RES.METAL FILM	MCR18 1% 240E	R 5384	RES.NETWORK	MCR18 1% 300E
R 5121	RES.METAL FILM	MCR18 1% 430E	R 5385	RES.CHIP	MCR18 1% 100K
R 5122	RES.NETWORK	MCR18 1% 100E	R 5386	RES.CHIP	MCR18 1% 330E
R 5123	RES.NETWORK	MCR18 1% 51E	R 5387	RES.CHIP	MCR18 1% 330E
R 5124	RES.CHIP	MCR18 1% 68K	R 5388	RES.NETWORK	MCR18 1% 51E
R 5126	RES.CHIP	MCR18 1% 68K	R 5389	RES.NETWORK	MCR18 1% 51E
R 5127	RES.CHIP	MCR18 1% 1K	R 5401	RES.NETWORK	MCR18 1% 51E
R 5128	RES.CHIP	MCR18 1% 2K2	R 5402	RES.NETWORK	MCR18 1% 51E
R 5129	RES.CHIP	RC-02H 1% 10K	R 5403	RES.CHIP	MCR18 1% 10E
R 5130	RES.MET.GLAZED	MCR18 1% 200E	R 5404	RES.CHIP	MCR18 1% 10E
R 5131	RES.NETWORK	MCR18 1% 390E	R 5406	RES.CHIP	RC-01 5% 1E
R 5132	RES.NETWORK	MCR18 1% 51E	R 5407	RES.CHIP	RC-01 5% 1E
R 5133	RES.CHIP	MCR18 1% 1K2	R 5408	RES.METAL FILM	MCR18 1% 360E
R 5134	RES.NETWORK	MCR18 1% 51E	R 5409	RES.METAL FILM	MCR18 1% 360E
R 5136	RES.CHIP	MCR18 1% 270E	R 5411	RES.METAL FILM	MCR18 1% 360E
R 5137	RES.CHIP	MCR18 1% 100K	R 5412	RES.METAL FILM	MCR18 1% 360E
R 5138	RES.CHIP	RC-02H 1% 10K	R 5413	RES.METAL FILM	MCR18 1% 360E
R 5139	RES.CHIP	MCR18 1% 68K	R 5414	RES.METAL FILM	MCR18 1% 360E
R 5141	RES.CHIP	MCR18 1% 680E	R 5416	RES.CHIP	RC-02H 1% 750E
R 5201	RES.CHIP	MCR18 1% 2K2	R 5417	RES.CHIP	MCR18 1% 820E
R 5202	RES.NETWORK	MCR18 1% 51E	R 5418	RES.NETWORK	MCR18 1% 100E
R 5203	RES.NETWORK	MCR18 1% 51E	R 5419	RES.CHIP	MCR18 1% 18E
R 5204	RES.MET.GLAZED	MCR18 1% 6K2	R 5421	RES.CHIP	MCR18 1% 20E
R 5206	RES.CHIP	MCR18 1% 47E	R 5422	RES.CHIP	MCR18 1% 20E
R 5207	RES.CHIP	MCR18 1% 47E	R 5423	RES.CHIP	MCR18 1% 20E
R 5211	RES.CHIP	RC-02H 1% 10K	R 5431	RES.NETWORK	MCR18 1% 100E
R 5212	RES.CHIP	MCR18 1% 68K	R 5432	RES.NETWORK	MCR18 1% 100E
R 5213	RES.CHIP	MCR18 1% 1K	R 5433	RES.CHIP	MCR18 1% 10E
R 5214	RES.CHIP	RC-02H 1% 10K	R 5434	RES.CHIP	MCR18 1% 10E
R 5216	RES.CHIP	MCR18 1% 68K	R 5435	RES.CHIP	MCR18 1% 10E
R 5217	RES.CHIP	MCR18 1% 1K	R 5436	RES.NETWORK	MCR18 1% 5K1
R 5221	RES.CHIP	MCR18 1% 47E	R 5437	RES.NETWORK	MCR18 1% 5K1
R 5222	RES.CHIP	MCR18 1% 47E	R 5438	RES.CHIP	RC-02H 1% 10K
R 5223	RES.CHIP	MCR18 1% 160E	R 5439	RES.CHIP	RC-02H 1% 10K
R 5224	RES.CHIP	MCR18 1% 1K5	R 5461	RES.CHIP	MCR18 1% 270E
R 5226	RES.CHIP	MCR18 1% 3K3	R 5462	RES.CHIP	MCR18 1% 270E
R 5227	RES.NETWORK	MCR18 1% 100E	R 5463	RES.CHIP	MCR18 1% 160E
R 5228	RES.NETWORK	MCR18 1% 100E	R 5464	RES.CHIP	MCR18 1% 160E
R 5229	RES.CHIP	MCR18 1% 3K3	R 5466	RES.NETWORK	MCR18 1% 51E
R 5231	RES.NETWORK	MCR18 1% 390E	R 5467	RES.NETWORK	MCR18 1% 51E
R 5232	RES.CHIP	MCR18 1% 1K8	R 5468	RES.NETWORK	MCR18 1% 51E
R 5234	RES.CHIP	MCR18 1% 47E	R 5469	RES.NETWORK	MCR18 1% 51E
R 5236	RES.CHIP	MCR18 1% 3K3	R 5471	RES.NETWORK	MCR18 1% 51E
R 5237	RES.CHIP	MCR18 1% 47E	R 5472	RES.NETWORK	MCR18 1% 51E
R 5238	RES.CHIP	MCR18 1% 2K2	R 5473	RES.NETWORK	MCR18 1% 51E
R 5239	RES.CHIP	MCR18 1% 160E	R 5474	RES.NETWORK	MCR18 1% 51E
R 5241	RES.NETWORK	MCR18 1% 10E	R 5476	RES.CHIP	MCR18 1% 510E
R 5242	RES.NETWORK	MCR18 1% 100E	R 5477	RES.CHIP	MCR18 1% 510E
R 5243	RES.CHIP	MCR18 1% 3K3	R 5478	RES.NETWORK	MCR18 1% 100E
R 5244	RES.NETWORK	MCR18 1% 390E	R 5479	RES.NETWORK	MCR18 1% 300E
R 5246	RES.CHIP	MCR18 1% 2K7	R 5480	RES.CHIP	MCR18 1% 100K
R 5251	RES.CHIP	MCR18 1% 1K	R 5481	RES.NETWORK	MCR18 1% 300E
R 5252	RES.CHIP	MCR18 1% 1K	R 5482	RES.NETWORK	MCR18 1% 300E
R 5253	RES.CHIP	MCR18 1% 1K	R 5483	RES.NETWORK	MCR18 1% 300E
R 5254	RES.CHIP	MCR18 1% 1K	R 5484	RES.CHIP	MCR18 1% 330E
R 5256	RES.CHIP	MCR18 1% 2K2	R 5485	RES.CHIP	MCR18 1% 100K
R 5257	RES.CHIP	MCR18 1% 2K2	R 5486	RES.CHIP	MCR18 1% 330E
R 5258	RES.CHIP	MCR18 1% 2K2	R 5487	RES.CHIP	MCR18 1% 330E
R 5263	RES.CHIP	MCR18 1% 820E	R 5488	RES.NETWORK	MCR18 1% 51E
R 5264	RES.CHIP	MCR18 1% 47E	R 5489	RES.NETWORK	MCR18 1% 51E
R 5266	RES.CHIP	MCR18 1% 47E	R 5501	RES.NETWORK	MCR18 1% 100E
R 5271	RES.CHIP	MCR18 1% 1K	R 5502	RES.CHIP	MCR18 1% 43E
R 5272	RES.CHIP	MCR18 1% 3K3	R 5503	RES.CHIP	MCR18 1% 43E
R 5273	RES.CHIP	RC-02H 1% 10K	R 5504	RES.CHIP	MCR18 1% 4K7
R 5301	RES.NETWORK	MCR18 1% 51E	R 5506	RES.CHIP	MCR18 1% 1K
R 5302	RES.NETWORK	MCR18 1% 51E	R 5507	RES.CHIP	MCR18 1% 4K7
R 5303	RES.CHIP	MCR18 1% 10E	R 5508	RES.CHIP	MCR18 1% 470E
R 5304	RES.CHIP	MCR18 1% 10E	R 5509	RES.CHIP	MCR18 1% 470E
R 5306	RES.CHIP	RC-01 5% 1E	R 5511	RES.CHIP	MCR18 1% 1K
R 5307	RES.CHIP	RC-01 5% 1E	R 5512	RES.NETWORK	MCR18 1% 51E
R 5308	RES.METAL FILM	MCR18 1% 360E	R 5513	RES.NETWORK	MCR18 1% 51E
R 5309	RES.METAL FILM	MCR18 1% 360E	R 5514	RES.CHIP	RC-02H 1% 10K
R 5311	RES.METAL FILM	MCR18 1% 360E	R 5516	RES.CHIP	MCR18 1% 3K3
R 5312	RES.METAL FILM	MCR18 1% 360E	R 5517	RES.CHIP	MCR18 1% 820E
R 5313	RES.METAL FILM	MCR18 1% 360E	R 5518	RES.CHIP	MCR18 1% 820E
R 5314	RES.METAL FILM	MCR18 1% 360E	R 5519	RES.CHIP	MCR18 1% 510E
R 5316	RES.CHIP	RC-02H 1% 750E	R 5521	RES.CHIP	MCR18 1% 220E
R 5317	RES.CHIP	MCR18 1% 820E	R 5522	RES.NETWORK	MCR18 1% 100E
R 5318	RES.NETWORK	MCR18 1% 100E	R 5523	RES.CHIP	RC-02H 1% 10K
R 5319	RES.CHIP	MCR18 1% 18E	R 5524	RES.CHIP	RC-02H 1% 10K
R 5321	RES.CHIP	MCR18 1% 20E	R 5526	RES.CHIP	RC-02H 1% 10K
R 5322	RES.CHIP	MCR18 1% 20E	R 5527	POTM.TRIMMER	0.3W 25% 10K
R 5323	RES.CHIP	MCR18 1% 20E	R 5528	RES.CHIP	RC-02H 1% 10K
R 5351	RES.NETWORK	MCR18 1% 100E	R 5529	RES.NETWORK	MCR18 1% 100E
R 5352	RES.NETWORK	MCR18 1% 100E	R 5551	RES.NETWORK	MCR18 1% 100E
R 5353	RES.CHIP	MCR18 1% 10E	R 5552	RES.CHIP	MCR18 1% 43E
R 5354	RES.CHIP	MCR18 1% 10E	R 5553	RES.CHIP	MCR18 1% 43E
R 5356	RES.NETWORK	MCR18 1% 5K1	R 5554	RES.CHIP	MCR18 1% 4K7
R 5357	RES.NETWORK	MCR18 1% 5K1	R 5556	RES.CHIP	MCR18 1% 1K
R 5358	RES.CHIP	RC-02H 1% 10K	R 5557	RES.CHIP	MCR18 1% 4K7

POSNR	DESCRIPTION	ORDERING CODE	POSNR	DESCRIPTION	ORDERING CODE
R 5558	RES.CHIP	MCR18 1x 470F	R 5754	RES.CHIP	MCR18 1x 15K
R 5559	RES.CHIP	MCR18 1x 470E	R 5756	RES.CHIP	RC-02H 1x 10K
R 5561	RES.CHIP	MCR18 1x 1K	R 5757	RES.CHIP	RC-02H 1x 10K
R 5562	RES.NETWORK	MCR18 1x 51E	R 5758	RES.CHIP	MCR18 1x 2K2
R 5563	RES.NETWORK	MCR18 1x 51E	R 5759	RES.CHIP	RC-02H 1x 10K
R 5564	RES.CHIP	RC-02H 1x 10K	R 5761	RES.CHIP	MCR18 1x 12K
R 5566	RES.CHIP	MCR18 1x 3K3	R 5771	RES.CHIP	MCR18 1x 4K7
R 5567	RES.CHIP	MCR18 1x 820E	R 5772	RES.CHIP	MCR18 1x 4K7
R 5568	RES.CHIP	MCR18 1x 820E	R 5773	RES.CHIP	MCR18 1x 68K
R 5569	RES.CHIP	MCR18 1x 510E	R 5774	RES.CHIP	MCR18 1x 68K
R 5571	RES.CHIP	MCR18 1x 220E	R 5776	RES.CHIP	RC-02H 1x 10K
R 5572	RES.NETWORK	MCR18 1x 100E	R 5777	RES.CHIP	RC-02H 1x 10K
R 5573	RES.CHIP	RC-02H 1x 10K	R 5778	RES.CHIP	RC-02H 1x 10K
R 5574	RES.CHIP	RC-02H 1x 10K	R 5779	RES.CHIP	RC-02H 1x 10K
R 5576	RES.CHIP	RC-02H 1x 10K	R 5781	RES.CHIP	MCR18 1x 3K3
R 5577	POTM.TRIMMER	0.3W 25x 10K	R 5782	RES.CHIP	MCR18 1x 3K3
R 5578	RES.CHIP	RC-02H 1x 10K	R 5783	RES.CHIP	RC-02H 1x 10K
R 5579	RES.NETWORK	MCR18 1x 100E	R 5784	RES.CHIP	RC-02H 1x 10K
R 5581	RES.CHIP	MCR18 1x 10E	R 5791	RES.CHIP	MCR18 1x 10E
R 5582	RES.CHIP	MCR18 1x 10E	R 5792	RES.CHIP	MCR18 1x 10E
R 5601	RES.NETWORK	MCR18 1x 5K1	R 5793	RES.CHIP	MCR18 1x 10E
R 5602	POTM.TRIMMER	0.3W 25x 10K	R 5801	RES.CHIP	MCR18 1x 3K3
R 5603	RES.NETWORK	MCR18 1x 5K1	R 5802	POTM.SLIDE	0.3W 25x 2K2
R 5604	POTM.TRIMMER	0.3W 25x 10K	R 5804	RES.MET.GLAZED	MCR18 1x 4K3
R 5606	RES.CHIP	MCR18 1x 15K	R 5805	RES.MET.GLAZED	MCR18 1x 4K3
R 5607	RES.CHIP	RC-02H 1x 10K	R 5806	RES.MET.GLAZED	MCR18 1x 4K3
R 5608	POTM.TRIMMER	0.3W 25x 10K	R 5809	RES.MET.GLAZED	MCR18 1x 4K3
R 5609	RES.CHIP	RC-02H 1x 10K	R 5811	RES.MET.GLAZED	MCR18 1x 4K3
R 5611	RES.CHIP	MCR18 1x 1K	R 5814	RES.MET.GLAZED	MCR18 1x 4K3
R 5612	RES.CHIP	MCR18 1x 1K	R 5815	RES.MET.GLAZED	MCR18 1x 4K3
R 5613	RES.NETWORK	MCR18 1x 100E	R 5816	RES.CHIP	MCR18 1x 3K3
R 5614	RES.NETWORK	MCR18 1x 100E	R 5817	POTM.SLIDE	0.3W 25x 2K2
R 5616	RES.CHIP	MCR18 1x 6K8	R 5819	RES.MET.GLAZED	MCR18 1x 4K3
R 5617	RES.CHIP	MCR18 1x 6K8	R 5821	RES.MET.GLAZED	MCR18 1x 4K3
R 5618	RES.CHIP	MCR18 1x 27K	R 5822	RES.MET.GLAZED	MCR18 1x 4K3
R 5619	RES.CHIP	MCR18 1x 27K	R 5824	RES.NETWORK	MCR18 1x 5K1
R 5621	RES.CHIP	MCR18 1x 1K2	R 5825	RES.NETWORK	MCR18 1x 5K1
R 5622	RES.CHIP	MCR18 1x 1K2	R 5826	RES.NETWORK	MCR18 1x 5K
R 5623	RES.NETWORK	MCR18 1x 100E	R 5828	POTM.TRIMMER	0.3W 25x 10K
R 5624	RES.NETWORK	MCR18 1x 100E	R 5829	POTM.TRIMMER	0.3W 25x 10K
R 5626	RES.CHIP	MCR18 1x 1K	R 5830	POTM.SLIDE	0.3W 25x 4K7
R 5627	RES.CHIP	MCR18 1x 1K	R 5831	RES.CHIP	RC-02H 1x 750E
R 5628	RES.CHIP	MCR18 1x 15K	R 5832	POTM.SLIDE	0.3W 25x 4K7
R 5629	RES.CHIP	MCR18 1x 15K	R 5833	RES.CHIP	MCR18 1x 15K
R 5631	RES.CHIP	MCR18 1x 27K	R 5834	RES.NETWORK	MCR18 1x 5K1
R 5632	RES.CHIP	MCR18 1x 27K	R 5835	RES.NETWORK	MCR18 1x 5K1
R 5633	RES.CHIP	MCR18 1x 15K	R 5836	RES.NETWORK	MCR18 1x 5K1
R 5634	RES.CHIP	MCR18 1x 15K	R 5838	POTM.TRIMMER	0.3W 25x 10K
R 5636	RES.CHIP	MCR18 1x 1K	R 5839	POTM.TRIMMER	0.3W 25x 10K
R 5637	RES.CHIP	MCR18 1x 1K	R 5840	POTM.SLIDE	0.3W 25x 4K7
R 5638	RES.CHIP	MCR18 1x 2K2	R 5841	RES.CHIP	RC-02H 1x 750E
R 5639	RES.CHIP	MCR18 1x 2K2	R 5842	POTM.SLIDE	0.3W 25x 4K7
R 5641	RES.NETWORK	MCR18 1x 3K9	R 5844	RES.NETWORK	MCR18 1x 5K1
R 5642	RES.NETWORK	MCR18 1x 3K9	R 5845	RES.NETWORK	MCR18 1x 5K1
R 5651	RES.NETWORK	MCR18 1x 22K	R 5846	RES.NETWORK	MCR18 1x 3K
R 5652	RES.CHIP	MCR18 1x 27K	R 5853	RES.CHIP	MCR18 1x 15K
R 5653	RES.CHIP	MCR18 1x 1K	R 5854	RES.NETWORK	MCR18 1x 5K1
R 5654	RES.CHIP	MCR18 1x 15K	R 5855	RES.NETWORK	MCR18 1x 5K1
R 5656	RES.CHIP	RC-02H 1x 10K	R 5856	RES.NETWORK	MCR18 1x 5K1
R 5657	RES.CHIP	RC-02H 1x 10K	R 5858	RES.CHIP	MCR18 1x 4K7
R 5658	RES.CHIP	MCR18 1x 2K2	R 5903	RES.CHIP	MCR18 1x 160E
R 5659	RES.CHIP	RC-02H 1x 10K	R 5904	RES.CHIP	MCR18 1x 820E
R 5661	RES.CHIP	MCR18 1x 12K	R 5907	RES.CHIP	MCR18 1x 120E
R 5671	RES.CHIP	MCR18 1x 4K7	R 5908	RES.CHIP	MCR18 1x 75E
R 5672	RES.CHIP	MCR18 1x 4K7	R 5909	RES.CHIP	RC-01 5x 1E
R 5673	RES.CHIP	MCR18 1x 68K	R 5911	RES.CHIP	RC-01 5x 1E
R 5674	RES.CHIP	MCR18 1x 68K	R 5912	RES.NETWORK	MCR18 1x 5K1
R 5676	RES.CHIP	RC-02H 1x 10K	R 5913	RES.CHIP	MCR18 1x 15K
R 5677	RES.CHIP	RC-02H 1x 10K	R 5914	RES.CHIP	RC-01 5x 5E6
R 5678	RES.CHIP	RC-02H 1x 10K	R 5916	RES.CHIP	RC-01 5x 5E6
R 5679	RES.CHIP	RC-02H 1x 10K	R 5917	RES.CHIP	RC-02H 1x 10K
R 5681	RES.CHIP	MCR18 1x 3K3	R 5918	RES.CHIP	MCR18 1x 15K
R 5682	RES.CHIP	MCR18 1x 3K3	R 5919	RES.CHIP	RC-02H 1x 10K
R 5683	RES.CHIP	RC-02H 1x 10K	R 5921	RES.CHIP	MCR18 1x 15K
R 5684	RES.CHIP	RC-02H 1x 10K	R 5922	RES.CHIP	MCR18 1x 1K
R 5691	RES.CHIP	MCR18 1x 10E	R 5923	RES.CHIP	MCR18 1x 1K
R 5692	RES.CHIP	MCR18 1x 10E	R 5924	RES.CHIP	RC-01 5x 5E6
R 5693	RES.CHIP	MCR18 1x 10E	R 5926	RES.CHIP	RC-01 5x 5E6
R 5707	RES.CHIP	RC-02H 1x 10K	R 5927	RES.NETWORK	MCR18 1x 22K
R 5708	POTM.TRIMMER	0.3W 25x 10K	R 5928	RES.CHIP	MCR18 1x 4K7
R 5709	RES.CHIP	RC-02H 1x 10K	R 5929	RES.CHIP	MCR18 1x 510E
R 5711	RES.CHIP	MCR18 1x 1K	R 5930	RES.CHIP	MCR18 1x 2K2
R 5712	RES.CHIP	MCR18 1x 1K	R 5931	RES.CHIP	MCR18 1x 560E
R 5713	RES.NETWORK	MCR18 1x 100E	R 5932	RES.CHIP	RC-01 5x 1E
R 5714	RES.NETWORK	MCR18 1x 100E	R 5933	RES.CHIP	RC-01 5x 1E
R 5716	RES.CHIP	MCR18 1x 6K8	R 5935	RES.MET.GLAZED	MCR18 1x 200E
R 5717	RES.CHIP	MCR18 1x 6K8	R 6001	RES.N.T.C.	1.7A 20x 82E
R 5718	RES.CHIP	MCR18 1x 27K	R 6002	RES.METAL FILM	MRS25 1x 383K
R 5719	RES.CHIP	MCR18 1x 27K	R 6003	RES.METAL FILM	MRS25 1x 383K
R 5721	RES.CHIP	MCR18 1x 1K2	R 6004	RES.METAL FILM	MRS25 1x 316E
R 5722	RES.CHIP	MCR18 1x 1K2	R 6005	RES.METAL FILM	MRS25 1x 464E
R 5723	RES.NETWORK	MCR18 1x 100E	R 6006	RES.METAL FILM	MRS25 1x 10K
R 5724	RES.NETWORK	MCR18 1x 100E	R 6007	RES.METAL FILM	MRS25 1x 10K
R 5726	RES.CHIP	MCR18 1x 1K	R 6008	RES.METAL FILM	MRS25 1x 316E
R 5727	RES.CHIP	MCR18 1x 1K	R 6009	RES.N.T.C.	0.5W 10x 1K5
R 5728	RES.CHIP	MCR18 1x 15K	R 6010	RES.METAL FILM	MRS25 1x 14K7
R 5729	RES.CHIP	MCR18 1x 15K	R 6011	RES.METAL FILM	MRS25 1x 237E
R 5731	RES.CHIP	MCR18 1x 27K	R 6012	RES.METAL FILM	MRS25 1x 178E
R 5732	RES.CHIP	MCR18 1x 27K	R 6013	RES.METAL FILM	MRS25 1x 100E
R 5733	RES.CHIP	MCR18 1x 15K	R 6014	RES.METAL FILM	MRS25 1x 3E16
R 5734	RES.CHIP	MCR18 1x 15K	R 6016	RES.METAL FILM	MRS25 1x 10K
R 5736	RES.CHIP	MCR18 1x 1K	R 6017	RES.METAL FILM	MRS25 1x 1E
R 5737	RES.CHIP	MCR18 1x 1K	R 6018	RES.METAL FILM	MRS25 1x 1E
R 5738	RES.CHIP	MCR18 1x 2K2	R 6019	RES.METAL FILM	MRS25 1x 10K
R 5739	RES.CHIP	MCR18 1x 2K2	R 6020	RES.METAL FILM	MRS25 1x 21E5
R 5741	RES.NETWORK	MCR18 1x 3K9	R 6021	RES.METAL FILM	MRS25 1x 10K
R 5742	RES.NETWORK	MCR18 1x 3K9	R 6022	RES.METAL FILM	MRS25 1x 10K
R 5751	RES.NETWORK	MCR18 1x 22K	R 6031	RES.METAL FILM	MRS25 1x 383E
R 5752	RES.CHIP	MCR18 1x 27K	R 6032	RES.METAL FILM	1/4W .25x 5K62
R 5753	RES.CHIP	MCR18 1x 1K	R 6033	RES.METAL FILM	1/4W .25x 7K5
R 5754	RES.CHIP	MCR18 1x 15K	4822 111 90196		
R 5756	RES.CHIP	RC-02H 1x 10K	5322 116 80428		
R 5757	RES.CHIP	RC-02H 1x 10K	5322 116 80428		
R 5758	RES.CHIP	MCR18 1x 2K2	4822 111 90248		
R 5759	RES.CHIP	RC-02H 1x 10K	5322 116 80428		
R 5761	RES.CHIP	MCR18 1x 12K	4822 111 90253		
R 5771	RES.CHIP	MCR18 1x 4K7	5322 111 90111		
R 5772	RES.CHIP	MCR18 1x 4K7	5322 111 90111		
R 5773	RES.CHIP	MCR18 1x 68K	4822 111 90202		
R 5774	RES.CHIP	MCR18 1x 68K	4822 111 90202		
R 5776	RES.CHIP	RC-02H 1x 10K	5322 116 80428		
R 5777	RES.CHIP	RC-02H 1x 10K	5322 116 80428		
R 5778	RES.CHIP	RC-02H 1x 10K	5322 116 80428		
R 5779	RES.CHIP	RC-02H 1x 10K	5322 116 80428		
R 5781	RES.CHIP	MCR18 1x 3K3	4822 111 90157		
R 5782	RES.CHIP	MCR18 1x 3K3	5322 116 80428		
R 5783	RES.CHIP	RC-02H 1x 10K	5322 116 80428		
R 5784	RES.CHIP	RC-02H 1x 10K	5322 116 80428		
R 5791	RES.CHIP	MCR18 1x 10E	4822 051 10109		
R 5792	RES.CHIP	MCR18 1x 10E	4822 051 10109		
R 5793	RES.CHIP	MCR18 1x 10E	4822 051 10109		
R 5801	RES.CHIP	MCR18 1x 3K3	4822 111 90157		
R 5802	POTM.SLIDE	0.3W 25x 2K2	5322 105 20033		
R 5804	RES.MET.GLAZED	MCR18 1x 4K3	5322 116 80605		
R 5805	RES.MET.GLAZED	MCR18 1x 4K3	5322 116 80605		
R 5806	RES.MET.GLAZED	MCR18 1x 4K3	5322 116 80605		
R 5809	RES.MET.GLAZED	MCR18 1x 4K3	5322 116 80605		
R 5811	RES.MET.GLAZED	MCR18 1x 4K3	5322 116 80605		
R 5814	RES.MET.GLAZED	MCR18 1x 4K3	5322 116 80605		
R 5815	RES.MET.GLAZED	MCR18 1x 4K3	5322 116 80605		
R 5816	RES.CHIP	MCR18 1x 3K3	4822 111 90157		
R 5817	POTM.SLIDE	0.3W 25x 2K2	5322 105 20033		
R 5819	RES.MET.GLAZED	MCR18 1x 4K3	5322 116 80605		
R 5821	RES.MET.GLAZED	MCR18 1x 4K3	5322 116 80605		
R 5822	RES.MET.GLAZED	MCR18 1x 4K3	5322 116 80605		
R 5824	RES.NETWORK	MCR18 1x 5K1	5322 111 91471		
R 5825	RES.NETWORK	MCR18 1x 5K1	5322 111 91471		
R 5826	RES.NETWORK	MCR18 1x 5K	5322 111 91351		
R 5828	POTM.TRIMMER	0.3W 25x 10K	4822 105 10455		
R 5829	POTM.TRIMMER	0.3W 25x 10K	4822 105 10455		
R 5830	POTM.SLIDE	0.3W 25x 4K7	5322 105 20034		
R 5831	RES.CHIP	RC-02H 1x 750E	4822 116 82384		
R 5832	POTM.SLIDE	0.3W 25x 4K7	5322 105 20034		
R 5833	RES.CHIP				

POSNR	DESCRIPTION	ORDERING CODE
R 6034	RES.METAL FILM MRS25 1% 6K19	5322 116 53263
R 6036	RES.METAL FILM MRS25 1% 7K5	4822 116 53028
R 6037	RES.METAL FILM MRS25 1% 31K6	5322 116 53262
R 6038	RES.METAL FILM MRS25 1% 100E	5322 116 53126
R 6039	RES.METAL FILM MRS25 1% 10E	4822 116 52891
R 6041	RES.METAL FILM MRS25 1% 3K83	4822 116 53079
R 6042	RES.METAL FILM MRS25 1% 3K83	4822 116 53079
R 6043	RES.METAL FILM MRS25 1% 100K	4822 050 21004
R 6044	RES.METAL FILM MRS25 1% 100K	4822 050 21004
R 6101	RES.METAL FILM MRS25 1% 100E	5322 116 53126
R 6102	RES.METAL FILM MRS25 1% 100E	5322 116 53126
R 6103	RES.METAL FILM MRS25 1% 1K	4822 116 53108
R 6131	RES.METAL FILM MRS25 1% 10E	4822 116 52891
R 6132	RES.METAL FILM MRS25 1% 100K	4822 050 21004
R 6133	RES.METAL FILM MRS25 1% 100K	4822 050 21004
R 6134	RES.METAL FILM MRS25 1% 1K	4822 116 53108
R 6136	RES.METAL FILM MRS25 1% 4K64	5322 116 53213
R 6137	RES.METAL FILM MRS25 1% 31E6	4822 110 72214
R 6138	RES.METAL FILM MRS25 1% 1K	4822 116 53108
R 6139	RES.METAL FILM MRS25 1% 100E	5322 116 53126
R 6201	RES.METAL FILM 1/4W .25% 160K	5322 116 53412
R 6202	RES.HI-TENSION VR37 1% 31M6	5322 116 64103
R 6203	RES.METAL FILM MRS25 1% 100K	4822 050 21004
R 6204	RES.METAL FILM MRS25 1% 10K	4822 116 53022
R 6205	RES.METAL FILM MRS25 1% 1K	4822 116 53108
R 6206	RES.METAL FILM MRS25 1% 16K2	5322 116 53589
R 6207	RES.METAL FILM MRS25 1% 51E1	5322 116 53213
R 6208	RES.METAL FILM MRS25 1% 464E	5322 116 53232
R 6209	RES.METAL FILM MRS25 1% 4K64	5322 116 53213
R 6211	RES.METAL FILM MRS25 1% 46K4	5322 116 53314
R 6212	RES.METAL FILM MRS25 1% 4K64	5322 116 53213
R 6213	RES.METAL FILM MRS25 1% 215E	5322 116 53325
R 6214	RES.HI-TENSION VR25 5% 10M	4822 110 72214
R 6216	RES.METAL FILM MRS25 1% 100E	5322 116 53126
R 6217	RES.METAL FILM MRS25 1% 1E	4822 050 21008
R 6300	RES.METAL FILM MRS25 1% 2K61	5322 116 53327
R 6301	RES.METAL FILM MRS25 1% 464E	5322 116 53232
R 6302	RES.METAL FILM MRS25 1% 909E	4822 116 53533
R 6303	RES.METAL FILM MRS25 1% 3K83	4822 116 53079
R 6304	RES.METAL FILM MRS25 1% 6K81	5322 116 53252
R 6311	RES.METAL FILM MRS25 1% 750E	5322 116 53265
R 6312	RES.METAL FILM MRS25 1% 4K22	5322 116 53246
R 6313	RES.METAL FILM MRS25 1% 825E	5322 116 53541
R 6401	RES.METAL FILM MRS25 1% 1K78	5322 116 53208
R 6402	RES.METAL FILM MRS25 1% 178K	5322 116 53555
R 6403	RES.METAL FILM MRS25 1% 215E	5322 116 53325
R 6404	RES.METAL FILM MRS25 1% 7K5	4822 116 53028
R 6406	RES.METAL FILM MRS25 1% 26K1	5322 116 53261
R 6407	RES.METAL FILM MRS25 1% 4K22	5322 116 53246
R 6408	POTM.TRIMMER OMP10 20% 10K	5322 100 10113
R 6500	RES.METAL FILM MRS25 1% 10E	4822 116 52891
R 6501	RES.METAL FILM MRS25 1% 511E	5322 116 53135
R 6502	RES.METAL FILM MRS25 1% 100K	4822 050 21004
R 6503	RES.METAL FILM MRS25 1% 5K11	5322 116 53494
R 6504	RES.METAL FILM MRS25 1% 19K6	5322 116 53258
R 6506	RES.METAL FILM MRS25 1% 5K62	5322 116 53495
R 6507	RES.METAL FILM MRS25 1% 511E	5322 116 53135
R 6508	RES.METAL FILM 1/4W .25% 3K67	5322 116 53411
R 6509	RES.METAL FILM 1/4W .25% 500E	5322 116 53408
R 6511	RES.METAL FILM MRS25 1% 562E	5322 116 53656
R 7001	RES.METAL FILM MRS25 1% 1K	4822 116 53108
R 7002	RES.METAL FILM MRS25 1% 1K	4822 116 53108
R 7003	RES.METAL FILM MRS25 1% 75K	5322 116 53266
R 7004	RES.METAL FILM MRS25 1% 5K11	5322 116 53494
R 7005	POTM.CARB.TRACK CRC17 20% 10K	5322 101 30546
R 7006	POTM.CARB.TRACK CRC17 20% 10K	5322 101 30546
R 7007	POTM.CARB.TRACK CRC17 20% 10K	5322 101 30546
R 7008	POTM.CARB.TRACK CRC17 20% 10K	5322 101 30546
R 7009	POTM.CARB.TRACK CRC17 20% 10K	5322 101 30546
R 7010	POTM.CARB.TRACK CRC17 20% 10K	5322 101 30546
R 7011	POTM.CARB.TRACK CRC17 20% 10K	5322 101 30546
R 7012	POTM.CARB.TRACK CRC17 20% 10K	5322 101 30546
R 7013	RES.METAL FILM MRS25 1% 100E	5322 116 53126
R 7014	RES.METAL FILM MRS25 1% 162E	5322 116 53235
R 7016	RES.N.T.C. 0.5W 10% 2K2	4822 116 30254
R 7017	RES.METAL FILM MRS25 1% 1K1	5322 116 53473
R 7018	RES.METAL FILM MRS25 1% 1M	4822 116 52843
R 7019	RES.METAL FILM MRS25 1% 100E	5322 116 53126
R 7102	RES.METAL FILM MRS25 1% 100E	5322 116 53126
R 7103	RES.METAL FILM MRS25 1% 5E11	4822 116 52999
R 8001	RES.CHIP RC-02H 1% 10K	5322 116 80428

POSNR	DESCRIPTION	ORDERING CODE
L 1402	COIL 1500UH	4822 156 21293
L 1421	COIL 1500UH	4822 156 21293
L 1422	COIL 1500UH	4822 156 21293
L 1701	COIL 82UH	4822 158 10563
L 1702	COIL 82UH	4822 158 10563
L 4101	COIL 2.0UH	4822 157 51757
L 4801	COIL 0.01H	5322 157 53019
L 5101	COIL 0.22UH 10%	5322 157 62208
L 5111	COIL 0.18UH 10%	5322 157 62207
L 5121	COIL 100KCS 39NH	5322 157 62212
L 5301	COIL 0.15UH 10%	5322 157 62206
L 5302	COIL 0.15UH 10%	5322 157 62206
L 5303	COIL 0.15UH 10%	5322 157 62206
L 5353	COIL 0.15UH 10%	5322 157 62206
L 5401	COIL 0.15UH 10%	5322 157 62206
L 5402	COIL 0.15UH 10%	5322 157 62206
L 5403	COIL 0.15UH 10%	5322 157 62206
L 5453	COIL 0.15UH 10%	5322 157 62206
L 5901	COIL 82UH	4822 158 10563
L 5902	COIL 82UH	4822 158 10563
L 5903	COIL COIL ASSY	5322 157 53597
L 6000	COIL 100UH	5322 157 52363
L 6001	COIL 100UH	5322 157 52363
L 6002	COIL 100UH	5322 157 52363
L 6003	COIL 5.6UH	4822 157 52259
L 6004	COIL 220UH	5322 157 53524
L 6006	COIL 220UH	5322 157 53524
L 6101	COIL 10UH	5322 157 52513
L 6102	COIL 47UH	4822 152 10106
L 6103	COIL 100UH	5322 157 52363
L 6104	COIL 100UH	5322 157 52363
L 6106	COIL 82UH	4822 158 10563
L 6107	COIL 82UH	4822 158 10563
L 6108	COIL 82UH	4822 158 10563
L 6109	COIL 82UH	4822 158 10563
L 6111	COIL 15UH	5322 157 52539
L 6201	COIL 82UH	4822 158 10563
L 6501	COIL 82UH	4822 158 10563
L 7101	COIL 15UH	5322 157 52539
L 0816	COIL 0.52 UH	5322 157 53335
L 0822	COIL 0.52 UH	5322 157 53335
L 0846	COIL 0.52 UH	5322 157 53335
L 0852	COIL 0.52 UH	5322 157 53335

25.4.4 SEMI-CONDUCTORS

POSNR	DESCRIPTION	ORDERING CODE
V 0200	TRANSISTOR BC548C	4822 130 44196
V 0201	DIODE BAW62	4822 130 30613
V 0202	DIODE BAW62	4822 130 30613
V 0203	TRANSISTOR BC548C	4822 130 44196
V 0204	TRANSISTOR BC548C	4822 130 44196
V 0206	DIODE BAW62	4822 130 30613
V 0207	TRANSISTOR BC548C	4822 130 44196
V 0208	TRANSISTOR BC548C	4822 130 44196
V 0213	DIODE BAW62	4822 130 30613
V 0214	DIODE BAW62	4822 130 30613
V 0301	DIODE BAT85	4822 130 31983
V 0302	DIODE BAT85	4822 130 31983
V 0501	DIODE, REFERENCE BZX79-C3V6	5322 130 34484
V 0502	DIODE BAW62	4822 130 30613
V 0503	DIODE BAT85	4822 130 31983
V 0504	DIODE BAW62	4822 130 30613
V 0506	DIODE BAT85	4822 130 31983
V 0512	INTEGR.CIRCUIT LM336Z-2.5	5322 209 81329
V 0521	TRANSISTOR BC548C	4822 130 44196
V 0522	TRANSISTOR BC548C	4822 130 44196
V 0523	DIODE, REFERENCE BZX79-C5V1	4822 130 34233
V 0531	TRANSISTOR BC548C	4822 130 44196
V 0532	TRANSISTOR BC548C	4822 130 44196
V 0551	TRANSISTOR BC558B	4822 130 44197
V 0552	TRANSISTOR BC558B	4822 130 44197
V 0553	DIODE BAW62	4822 130 30613
V 0554	DIODE BAW62	4822 130 30613
V 0555	DIODE, REFERENCE BZX79-C11	4822 130 34488
V 0556	DIODE BAW62	4822 130 30613
V 0557	DIODE BAW62	4822 130 30613
V 0558	TRANSISTOR BC548C	4822 130 44196
V 0566	DIODE, REFERENCE BZX79-C5V1	4822 130 34233
V 0567	TRANSISTOR BF370	4822 130 42589
V 0568	TRANSISTOR BC548C	4822 130 44196
V 0569	TRANSISTOR BC558B	4822 130 44197
V 0591	DIODE, REFERENCE BZX79-C5V1	4822 130 34233
V 0592	DIODE BAW62	4822 130 30613
V 0593	TRANSISTOR BC548C	4822 130 44196
V 0611	TRANSISTOR BC548C	4822 130 44196
V 0612	TRANSISTOR BC558B	4822 130 44197
V 0614	DIODE, REFERENCE BZX79-B27	4822 130 34379
V 0616	DIODE BAW62	4822 130 30613
V 0701	TRANSISTOR,CHIP BCW33	5322 130 44337
V 0702	TRANSISTOR,CHIP BCW33	5322 130 44337
V 0703	TRANSISTOR,CHIP BFR92R	5322 130 44606
V 0704	TRANSISTOR,CHIP BFR92	5322 130 42145
V 0706	TRANSISTOR,CHIP BCW30	5322 130 44335
V 0707	DIODE,CHIP BAW56	5322 130 30691
V 0708	DIODE,CHIP BAW56	5322 130 30691
V 0721	TRANSISTOR,CHIP BCW33	5322 130 44337
V 0730	TRANSISTOR,CHIP BF550	4822 130 42131
V 0731	TRANSISTOR,CHIP BCW30	5322 130 44335
V 0732	TRANSISTOR,CHIP BF550	4822 130 42131
V 0733	TRANSISTOR,CHIP BF550	4822 130 42131
V 0734	TRANSISTOR,CHIP BCW33	5322 130 44337
V 0736	TRANSISTOR,CHIP BCW33	5322 130 44337
V 0760	TRANSISTOR,CHIP BF550	4822 130 42131
V 0761	TRANSISTOR,CHIP BCW30	5322 130 44335
V 0762	TRANSISTOR,CHIP BF550	4822 130 42131
V 0763	TRANSISTOR,CHIP BF550	4822 130 42131
V 0764	TRANSISTOR,CHIP BCW33	5322 130 44337
V 0766	TRANSISTOR,CHIP BCW33	5322 130 44337

25.4.3 COILS

POSNR	DESCRIPTION	ORDERING CODE
L 0201	COIL 15UH	5322 157 52539
L 0301	COIL 82UH	4822 158 10563
L 0401	COIL 82UH	4822 158 10563
L 0501	COIL 82UH	4822 158 10563
L 0502	COIL 82UH	4822 158 10563
L 0503	COIL 82UH	4822 158 10563
L 0504	COIL 82UH	4822 158 10563
L 0801	COIL 0.39UH 10%	5322 157 53334
L 0806	COIL 0.39UH 10%	5322 157 53334
L 0814	COIL 0.15UH 10%	5322 157 62206
L 0827	COIL 0.15UH 10%	5322 157 62206
L 0831	COIL 0.39UH 10%	5322 157 53334
L 0836	COIL 0.39UH 10%	5322 157 53334
L 0844	COIL 0.15UH 10%	5322 157 62206
L 0857	COIL 0.15UH 10%	5322 157 62206
L 0865	COIL 0.15UH 10%	5322 157 53333
L 0881	COIL 82UH	4822 158 10563
L 1001	COIL 0.15UH 10%	5322 157 62206
L 1101	COIL 0.15UH 10%	5322 157 62206
L 1401	COIL 1500UH	4822 156 21293

POSNR	DESCRIPTION	ORDERING CODE	POSNR	DESCRIPTION	ORDERING CODE		
V 0801	TRANSISTOR	BFR96S/02	5322 130 42244	V 1642	TRANSISTOR,CHIP	BCN33	5322 130 44337
V 0806	TRANSISTOR	BFR96S/02	5322 130 42244	V 1643	TRANSISTOR,CHIP	BCN33	5322 130 44337
V 0814	TRANSISTOR	BC337	4822 130 40855	V 1644	DIODE,CHIP	BAV70	5322 130 34331
V 0816	TRANSISTOR	BFR96S/02	5322 130 42244	V 1646	DIODE,CHIP	BAV70	5322 130 34331
V 0822	TRANSISTOR	BFR96S/02	5322 130 42244	V 1648	TRANSISTOR,CHIP	BCN33	5322 130 44337
V 0827	TRANSISTOR	BC337	4822 130 40855	V 1649	TRANSISTOR,CHIP	BCN33	5322 130 44337
V 0831	TRANSISTOR	BFR96S/02	5322 130 42244	V 1651	TRANSISTOR,CHIP	BCN33R	5322 130 44342
V 0836	TRANSISTOR	BFR96S/02	5322 130 42244	V 1652	TRANSISTOR,CHIP	BCN33R	5322 130 44342
V 0844	TRANSISTOR	BC337	4822 130 40855	V 1701	DIODE,CHIP	BAV99	5322 130 34337
V 0846	TRANSISTOR	BFR96S/02	5322 130 42244	V 1703	TRANSISTOR	BFT92R	5322 130 44713
V 0852	TRANSISTOR	BFR96S/02	5322 130 42244	V 1704	TRANSISTOR,CHIP	BFT92	5322 130 44711
V 0857	TRANSISTOR	BC337	4822 130 40855	V 1705	DIODE,CHIP	BAV99	5322 130 34337
V 0862	TRANSISTOR	BC558B	4822 130 44196	V 1706	TRANSISTOR,CHIP	BCN33	5322 130 44337
V 0863	DIODE	BZV86-C1V4	4822 130 81423	V 1709	TRANSISTOR,CHIP	BCN33	5322 130 44337
V 0864	DIODE	BZV86-C2V0	4822 130 81424	V 1711	TRANSISTOR	BFT92R	5322 130 44713
V 0865	DIODE	BAH62	4822 130 30613	V 1712	TRANSISTOR,CHIP	BFT92	5322 130 44711
V 0866	DIODE	BAH62	4822 130 30613	V 1713	TRANSISTOR,CHIP	BCN33	5322 130 44337
V 0867	TRANSISTOR	BFQ22S	5322 130 42031	V 1721	TRANSISTOR,CHIP	BFT92	5322 130 44711
V 0871	TRANSISTOR	BC548C	4822 130 44196	V 1722	TRANSISTOR	BFT92R	5322 130 44713
V 0872	DIODE,REFERENCE	BZX79-C3V0	4822 130 31881	V 1723	TRANSISTOR,CHIP	BF512	5322 130 44875
V 0903	TRANSISTOR,FET	BFQ13	5322 130 44404	V 1724	TRANSISTOR,CHIP	BFR92	5322 130 42145
V 0908	TRANSISTOR,FET	BFQ13	5322 130 44404	V 1726	TRANSISTOR,CHIP	BFR92	5322 130 42145
V 0913	TRANSISTOR,FET	BFQ13	5322 130 44404	V 1727	DIODE,CHIP	BA117	5322 130 31544
V 0918	TRANSISTOR,FET	BFQ13	5322 130 44404	V 1731	TRANSISTOR,CHIP	BSV52	5322 130 44336
V 0921	DIODE,REFERENCE	BZV11	5322 130 34294	V 1732	TRANSISTOR,CHIP	BSV52	5322 130 44336
V 0978	DIODE,REFERENCE	BZX79-C5V1	4822 130 34233	V 1735	TRANSISTOR,CHIP	BCM30	5322 130 44355
V 0981	DIODE,REFERENCE	BZX79-B27	4822 130 34379	V 1734	TRANSISTOR,CHIP	BFT92	5322 130 44711
V 0986	TRANSISTOR	BC548C	4822 130 44196	V 1736	TRANSISTOR,CHIP	BFT92	5322 130 44711
V 0992	DIODE	BZV86-C2V0	4822 130 81424	V 2001	DIODE	BZV86-C2V0	4822 130 81424
V 1001	TRANSISTOR,FET	BSV80	5322 130 34044	V 2002	DIODE	BZV86-C2V0	4822 130 81424
V 1002	DIODE	BAH62	4822 130 30613	V 2003	TRANSISTOR	BF324	4822 130 41448
V 1003	DIODE	BAH62	4822 130 30613	V 2004	TRANSISTOR	BF324	4822 130 41448
V 1004	TRANSISTOR	ON4401	5322 130 61498	V 2101	DIODE	BZV86-C2V0	4822 130 81424
V 1006	DIODE	BA483	4822 130 32656	V 2102	DIODE	BZV86-C2V0	4822 130 81424
V 1007	DIODE	BA483	4822 130 32656	V 2103	TRANSISTOR	BF324	4822 130 41448
V 1008	TRANSISTOR	ON4401	5322 130 61498	V 2104	TRANSISTOR	BF324	4822 130 41448
V 1009	DIODE	BA483	4822 130 32656	V 2152	DIODE,REFERENCE	BZX79-C3V0	4822 130 31881
V 1011	DIODE	BA483	4822 130 32656	V 2153	DIODE,REFERENCE	BZX79-C3V0	4822 130 31881
V 1012	DIODE	BA483	4822 130 32656	V 2201	TRANSISTOR	BFQ24	5322 130 41664
V 1013	TRANSISTOR	ON4401	5322 130 61498	V 2202	TRANSISTOR	BFQ24	5322 130 41664
V 1014	DIODE	BA483	4822 130 32656	V 2203	DIODE	BAH62	4822 130 30613
V 1016	DIODE	BA483	4822 130 32656	V 2204	DIODE	BAH62	4822 130 30613
V 1017	DIODE	BA483	4822 130 32656	V 2206	TRANSISTOR	BC548C	4822 130 44196
V 1021	DIODE	BAH62	4822 130 30613	V 2207	TRANSISTOR	BFQ22S	5322 130 42031
V 1022	DIODE	BAH62	4822 130 30613	V 2208	TRANSISTOR	BFQ22S	5322 130 42031
V 1029	TRANSISTOR	BF199	4822 130 44154	V 2209	TRANSISTOR	BFQ22S	5322 130 42031
V 1031	TRANSISTOR	BF199	4822 130 44154	V 2211	TRANSISTOR	BFQ22S	5322 130 42031
V 1032	DIODE	BZV86-C2V0	4822 130 81424	V 2212	DIODE	BZV86-C2V0	4822 130 81424
V 1033	TRANSISTOR	DFW30	5322 130 40379	V 2213	DIODE	BZV86-C2V0	4822 130 81424
V 1036	TRANSISTOR	BFQ24	5322 130 41664	V 2215	TRANSISTOR	BC558B	4822 130 44197
V 1037	TRANSISTOR	BFQ24	5322 130 41664	V 2311	TRANSISTOR,CHIP	BF550R	4822 130 60687
V 1101	TRANSISTOR,FET	BSV80	5322 130 34044	V 2312	TRANSISTOR,CHIP	BF550	4822 130 42131
V 1102	DIODE	BAH62	4822 130 30613	V 2313	DIODE,CHIP	BAV99	5322 130 34337
V 1103	DIODE	BAH62	4822 130 30613	V 2316	TRANSISTOR,CHIP	BF550R	4822 130 60687
V 1104	TRANSISTOR	ON4401	5322 130 61498	V 2317	TRANSISTOR,CHIP	BC848C	5322 130 42136
V 1106	DIODE	BA483	4822 130 32656	V 2318	TRANSISTOR,CHIP	BF550	4822 130 42131
V 1107	DIODE	BA483	4822 130 32656	V 2319	TRANSISTOR,CHIP	BF550	4822 130 42131
V 1108	TRANSISTOR	ON4401	5322 130 61498	V 2321	TRANSISTOR,CHIP	BF550R	4822 130 60687
V 1109	DIODE	BA483	4822 130 32656	V 2325	DIODE	BAH62	4822 130 30613
V 1111	DIODE	BA483	4822 130 32656	V 2326	DIODE	BAH62	4822 130 30613
V 1112	DIODE	BA483	4822 130 32656	V 2327	TRANSISTOR	BC558B	4822 130 44197
V 1113	TRANSISTOR	ON4401	5322 130 61498	V 2328	DIODE,REFERENCE	BZX79-C5V1	4822 130 34233
V 1114	DIODE	BA483	4822 130 32656	V 2329	DIODE,REFERENCE	BZX79-C9V1	4822 130 30862
V 1116	DIODE	BA483	4822 130 32656	V 2331	TRANSISTOR	BF324	4822 130 41448
V 1117	DIODE	BA483	4822 130 32656	V 2332	TRANSISTOR	BF324	4822 130 41448
V 1121	DIODE	BAH62	4822 130 30613	V 2333	TRANSISTOR	BC558B	4822 130 44197
V 1122	DIODE	BAH62	4822 130 30613	V 2334	TRANSISTOR	BC558B	4822 130 44197
V 1129	TRANSISTOR	BF199	4822 130 44154	V 2341	TRANSISTOR	BFQ22S	5322 130 42031
V 1131	TRANSISTOR	BF199	4822 130 44154	V 2342	TRANSISTOR	BFQ22S	5322 130 42031
V 1132	DIODE	BZV86-C2V0	4822 130 81424	V 2347	TRANSISTOR	BF199	4822 130 44154
V 1133	TRANSISTOR	BFW30	5322 130 40379	V 2349	TRANSISTOR	BF199	4822 130 44154
V 1136	TRANSISTOR	BFQ24	5322 130 41664	V 2356	TRANSISTOR	BC548C	4822 130 44196
V 1137	TRANSISTOR	BFQ24	5322 130 41664	V 2357	TRANSISTOR	BC548C	4822 130 44196
V 1201	DIODE	BAH62	4822 130 30613	V 2366	DIODE	BAH62	4822 130 30613
V 1202	DIODE	BAH62	4822 130 30613	V 2367	DIODE	BAH62	4822 130 30613
V 1203	TRANSISTOR	ON4401	5322 130 61498	V 2368	DIODE	BAH62	4822 130 30613
V 1204	DIODE	BA483	4822 130 32656	V 2369	DIODE	BAH62	4822 130 30613
V 1206	TRANSISTOR	BF199	4822 130 44154	V 2370	TRANSISTOR	BC548C	4822 130 44196
V 1207	DIODE	BA483	4822 130 32656	V 2371	TRANSISTOR	BC558B	4822 130 44197
V 1208	TRANSISTOR	BF199	4822 130 44154	V 2601	DIODE,REFERENCE	BZX79-C6V2	4822 130 34167
V 1209	DIODE	BZV86-C2V0	4822 130 81424	V 2602	TRANSISTOR	BC548C	4822 130 44196
V 1211	TRANSISTOR	BFQ24	5322 130 41664	V 2611	TRANSISTOR	BF199	4822 130 44154
V 1212	TRANSISTOR	BFQ24	5322 130 41664	V 2612	TRANSISTOR	BF199	4822 130 44154
V 1601	TRANSISTOR,CHIP	BCM33	5322 130 44337	V 2615	TRANSISTOR	BC548C	4822 130 44196
V 1602	TRANSISTOR,CHIP	BSV52	5322 130 44336	V 2616	DIODE	BZV86-C1V4	4822 130 81423
V 1603	DIODE,CHIP	BAV70	5322 130 34331	V 2801	TRANSISTOR,CHIP	BF550	4822 130 42131
V 1604	DIODE,CHIP	BAW56	5322 130 30691	V 2802	TRANSISTOR,CHIP	BF550R	4822 130 60687
V 1606	TRANSISTOR,CHIP	BSV52	5322 130 44336	V 2803	TRANSISTOR,CHIP	BF550	4822 130 42131
V 1607	DIODE,CHIP	BAV70	5322 130 34331	V 2804	TRANSISTOR,CHIP	BF550R	4822 130 60687
V 1609	TRANSISTOR,CHIP	BCN33	5322 130 44337	V 3001	TRANSISTOR	BFQ24	5322 130 41664
V 1611	DIODE,CHIP	BAV70	5322 130 34331	V 3002	TRANSISTOR	BFQ24	5322 130 41664
V 1612	DIODE,CHIP	BAV70	5322 130 34331	V 3003	TRANSISTOR	BC558B	4822 130 44197
V 1613	DIODE,CHIP	BAV70	5322 130 34331	V 3004	TRANSISTOR	BFQ22S	5322 130 42031
V 1614	DIODE,CHIP	BAV70	5322 130 34331	V 3005	TRANSISTOR	BF370	4822 130 42589
V 1617	TRANSISTOR,CHIP	BCM30	5322 130 44335	V 3006	TRANSISTOR	BFQ22S	5322 130 42031
V 1618	TRANSISTOR,CHIP	BCN33	5322 130 44337	V 3007	TRANSISTOR	BF370	4822 130 42589
V 1619	TRANSISTOR,CHIP	BCN33	5322 130 44337	V 3008	TRANSISTOR	ON4464	5322 130 61813
V 1621	TRANSISTOR,CHIP	BCM30	5322 130 44335	V 3009	TRANSISTOR	ON4464	5322 130 61813
V 1622	DIODE,CHIP	BAV99	5322 130 34337	V 3010	DIODE	BAH62	4822 130 30613
V 1623	TRANSISTOR,CHIP	BCM30	5322 130 44335	V 3011	TRANSISTOR	2N3866	5322 130 41799
V 1624	TRANSISTOR,CHIP	BCM33	5322 130 44337	V 3012	TRANSISTOR	2N3866	5322 130 41799
V 1631	TRANSISTOR,CHIP	BCM33	5322 130 44337	V 3013	DIODE,REFERENCE	BZX79-B35	4822 130 34142
V 1632	TRANSISTOR,CHIP	BCM33R	5322 130 44342	V 3014	DIODE,REFERENCE	BZX79-B35	4822 130 34142
V 1633	TRANSISTOR,CHIP	BCM33	5322 130 44337	V 3016	DIODE,REFERENCE	BZX79-C3V9	4822 130 31981
V 1634	DIODE,CHIP	BAV70	5322 130 34331	V 3017	DIODE,REFERENCE	BZX79-C3V9	4822 130 31981
V 1636	DIODE,CHIP	BAV70	5322 130 34331	V 3101	TRANSISTOR	BF324	4822 130 41448
V 1637	DIODE,CHIP	BAV70	5322 130 34331	V 3102	TRANSISTOR	BF324	4822 130 41448
V 1638	TRANSISTOR,CHIP	BCN33	5322 130 44337	V 3103	TRANSISTOR	BF324	4822 130 41448
V 1639	TRANSISTOR,CHIP	BCN33R	5322 130 44342	V 3104	TRANSISTOR	BC558B	4822 130 44197
V 1641	TRANSISTOR,CHIP	BCN33R	5322 130 44342	V 3106	TRANSISTOR	BF324	4822 130 41448

POSNR	DESCRIPTION	ORDERING CODE	POSNR	DESCRIPTION	ORDERING CODE		
V 3108	TRANSISTOR	BF472	5322 130 42535	V 4523	TRANSISTOR	BC548C	4822 130 44196
V 3109	TRANSISTOR	BF370	4822 130 42589	V 4601	DIODE	BAW62	4822 130 30613
V 3111	TRANSISTOR	BF370	4822 130 42589	V 4602	DIODE	BAW62	4822 130 30613
V 3112	TRANSISTOR	2N5551	5322 130 44491	V 4613	DIODE	BAW62	4822 130 30613
V 3113	DIODE, REFERENCE	BZX79-B5V6	4822 130 34173	V 4611	TRANSISTOR	BF199	4822 130 44154
V 3114	TRANSISTOR	2N5551	5322 130 44491	V 4612	TRANSISTOR	BF199	4822 130 44154
V 3116	TRANSISTOR	BF472	5322 130 42555	V 4613	DIODE	BAW62	4822 130 30613
V 3200	TRANSISTOR	BF370	4822 130 42589	V 4614	DIODE	BAW62	4822 130 30613
V 3201	TRANSISTOR	BF370	4822 130 42589	V 4616	TRANSISTOR	BC548C	4822 130 44196
V 3202	TRANSISTOR	2N5401	5322 130 42534	V 4617	DIODE	BAW62	4822 130 30613
V 3203	TRANSISTOR	2N5551	5322 130 44491	V 4618	DIODE	BAW62	4822 130 30613
V 3204	TRANSISTOR	BF423	4822 130 41646	V 4702	TRANSISTOR	BF324	4822 130 41448
V 3205	DIODE, REFERENCE	BZX79-B5V6	4822 130 34173	V 4703	DIODE	BAW62	4822 130 30613
V 3206	DIODE	BAW62	4822 130 30613	V 4704	DIODE	BAW62	4822 130 30613
V 3207	TRANSISTOR	BC548C	4822 130 44196	V 4706	TRANSISTOR	BF324	4822 130 41448
V 3208	TRANSISTOR	BF423	4822 130 41646	V 4707	TRANSISTOR	BC558B	4822 130 44197
V 3209	DIODE	BAW62	4822 130 30613	V 4708	TRANSISTOR	BF324	4822 130 41448
V 3211	DIODE	BAW62	4822 130 30613	V 4709	TRANSISTOR	BC558B	4822 130 44197
V 3212	DIODE, REFERENCE	BZX79-B68	4822 130 30864	V 4710	TRANSISTOR	BC548C	4822 130 44196
V 3213	TRANSISTOR	BC548C	4822 130 44196	V 4711	DIODE	BAW62	4822 130 30613
V 3214	DIODE	BAW62	4822 130 30613	V 4712	TRANSISTOR	BF324	4822 130 41448
V 3215	DIODE	BAW62	4822 130 30613	V 4713	DIODE	BAW62	4822 130 30613
V 3216	DIODE, REFERENCE	BZX79-C9V1	4822 130 30862	V 4801	DIODE	BAW62	4822 130 30613
V 3217	DIODE	BAW62	4822 130 30613	V 5101	TRANSISTOR,CHIP	BC858C	5322 130 42145
V 3251	TRANSISTOR	BF423	4822 130 41646	V 5102	DIODE,CHIP	BZX84-C3V6	5322 130 32731
V 3252	DIODE, REFERENCE	BZX79-C6V2	4822 130 34167	V 5103	DIODE,CHIP	BAV99	5322 130 34337
V 3253	TRANSISTOR	BF423	4822 130 41646	V 5104	TRANSISTOR,CHIP	BFR92R	5322 130 44606
V 3254	TRANSISTOR	BF423	4822 130 41646	V 5106	TRANSISTOR,CHIP	BF520	5322 130 42718
V 3256	TRANSISTOR	BF423	4822 130 41646	V 5111	TRANSISTOR,CHIP	BC858B	5322 130 41983
V 3257	DIODE	BAV21	4822 130 30842	V 5112	DIODE,CHIP	BZX84-C3V6	5322 130 32731
V 3258	DIODE, REFERENCE	BZX79-B27	4822 130 34379	V 5113	DIODE,CHIP	BAV99	5322 130 34337
V 3301	DIODE, REFERENCE	BZX79-C6V2	4822 130 34167	V 5114	TRANSISTOR,CHIP	BFR92R	5322 130 44606
V 4001	TRANSISTOR	BF199	4822 130 44154	V 5116	TRANSISTOR,CHIP	BF520	5322 130 42718
V 4002	TRANSISTOR	BF199	4822 130 44154	V 5121	TRANSISTOR,CHIP	BFR92R	5322 130 44606
V 4003	TRANSISTOR	BF324	4822 130 41448	V 5122	TRANSISTOR,CHIP	BC858B	5322 130 41983
V 4004	TRANSISTOR	BF324	4822 130 41448	V 5123	DIODE,CHIP	BAT17	5322 130 31544
V 4005	DIODE, REFERENCE	BZX79-C6V2	4822 130 34167	V 5131	TRANSISTOR,CHIP	BFR92	5322 130 42145
V 4006	DIODE	BAW62	4822 130 30613	V 5132	TRANSISTOR,CHIP	BF967	5322 130 42567
V 4008	TRANSISTOR	BF423	4822 130 41646	V 5133	DIODE,CHIP	BAT17	5322 130 31544
V 4009	TRANSISTOR	BC548C	4822 130 44196	V 5134	DIODE,CHIP	BAT17	5322 130 31544
V 4011	TRANSISTOR	BC548C	4822 130 44196	V 5201	DIODE,CHIP	BZX84-C3V0	5322 130 32739
V 4012	TRANSISTOR	BC548C	4822 130 44196	V 5211	TRANSISTOR,CHIP	BSV52	5322 130 44336
V 4013	DIODE, REFERENCE	BZX79-C5V1	4822 130 34233	V 5212	TRANSISTOR,CHIP	BSV52	5322 130 44336
V 4014	TRANSISTOR	BC548C	4822 130 44196	V 5221	TRANSISTOR,CHIP	BC858B	5322 130 41983
V 4016	DIODE, REFERENCE	BZX79-C3V6	5322 130 34834	V 5222	TRANSISTOR,CHIP	BF192	5322 130 44711
V 4017	DIODE	BAW62	4822 130 30613	V 5223	TRANSISTOR	BFT92R	5322 130 44713
V 4018	TRANSISTOR	BC548C	4822 130 44196	V 5224	TRANSISTOR	BFT92R	5322 130 44713
V 4021	TRANSISTOR	BC548C	4822 130 44196	V 5226	TRANSISTOR,CHIP	BFT92	5322 130 44711
V 4022	DIODE	BAW62	4822 130 30613	V 5227	TRANSISTOR,CHIP	BC858B	5322 130 41983
V 4023	TRANSISTOR	BC548C	4822 130 44196	V 5261	DIODE,CHIP	BAV99	5322 130 34337
V 4101	TRANSISTOR	BC558B	4822 130 44197	V 5262	TRANSISTOR,CHIP	BFR92R	5322 130 44606
V 4102	DIODE	BAW62	4822 130 30613	V 5263	TRANSISTOR,CHIP	BF192	5322 130 44711
V 4103	DIODE	BAW62	4822 130 30613	V 5271	TRANSISTOR,CHIP	BC858C	5322 130 42136
V 4104	TRANSISTOR	BC548C	4822 130 44196	V 5301	TRANSISTOR	BFR96S/02	5322 130 42244
V 4106	DIODE	BAW62	4822 130 30613	V 5302	TRANSISTOR	BFR96S/02	5322 130 42244
V 4107	TRANSISTOR	BC327	4822 130 40854	V 5303	TRANSISTOR,CHIP	BCX54-16	5322 130 62237
V 4108	TRANSISTOR	BC548C	4822 130 44196	V 5351	TRANSISTOR	BFR96S/02	5322 130 42244
V 4109	TRANSISTOR	BC558B	4822 130 44197	V 5352	TRANSISTOR	BFR96S/02	5322 130 42244
V 4111	TRANSISTOR	BC558B	4822 130 44197	V 5353	TRANSISTOR,CHIP	BF550R	4822 130 60687
V 4112	TRANSISTOR	BSX20	4822 130 41705	V 5354	TRANSISTOR,CHIP	BF550	4822 130 42131
V 4113	DIODE	BZV86-C1V4	4822 130 81423	V 5356	TRANSISTOR,CHIP	BCX54-16	5322 130 62237
V 4114	TRANSISTOR	BSX20	4822 130 41705	V 5401	TRANSISTOR	BFR96S/02	5322 130 42244
V 4115	DIODE, REFERENCE	BZX79-C6V2	4822 130 34167	V 5402	TRANSISTOR	BFR96S/02	5322 130 42244
V 4116	DIODE	BAW62	4822 130 30613	V 5403	TRANSISTOR,CHIP	BCX54-16	5322 130 62237
V 4117	TRANSISTOR	BC548C	4822 130 44196	V 5451	TRANSISTOR	BFR96S/02	5322 130 42244
V 4118	TRANSISTOR	BC548C	4822 130 44196	V 5452	TRANSISTOR	BFR96S/02	5322 130 42244
V 4119	TRANSISTOR	BF199	4822 130 44154	V 5453	TRANSISTOR,CHIP	BF550R	4822 130 60687
V 4120	DIODE	BAW62	4822 130 30613	V 5454	TRANSISTOR,CHIP	BF550	4822 130 42131
V 4121	TRANSISTOR	BC548C	4822 130 44196	V 5456	TRANSISTOR,CHIP	BCX54-16	5322 130 62237
V 4122	DIODE	BAW62	4822 130 30613	V 5501	DIODE,CHIP	BAV99	5322 130 34337
V 4123	DIODE	BAW62	4822 130 30613	V 5503	TRANSISTOR,CHIP	BFS20R	5322 130 44177
V 4216	DIODE	BAW62	4822 130 30613	V 5504	TRANSISTOR,CHIP	BF520	5322 130 42718
V 4217	TRANSISTOR	BC548C	4822 130 44196	V 5506	TRANSISTOR,CHIP	BFR92R	5322 130 44606
V 4267	DIODE	BAW62	4822 130 30613	V 5507	TRANSISTOR,CHIP	BFR92	5322 130 42145
V 4268	TRANSISTOR	BC548C	4822 130 44196	V 5508	TRANSISTOR,CHIP	BC858B	5322 130 41983
V 4300	DIODE, REFERENCE	BZX79-C6V2	4822 130 34167	V 5551	DIODE,CHIP	BAV99	5322 130 34337
V 4301	TRANSISTOR	BC558B	4822 130 44197	V 5553	TRANSISTOR,CHIP	BFS20R	5322 130 44177
V 4302	TRANSISTOR	BC548C	4822 130 44196	V 5554	TRANSISTOR,CHIP	BF520	5322 130 42718
V 4304	TRANSISTOR	BC558B	4822 130 44197	V 5556	TRANSISTOR,CHIP	BFR92R	5322 130 44606
V 4305	DIODE, REFERENCE	BZX79-C9V1	4822 130 30862	V 5557	TRANSISTOR,CHIP	BFR92	5322 130 42145
V 4306	DIODE	BAW62	4822 130 30613	V 5558	TRANSISTOR,CHIP	BC858B	5322 130 41983
V 4307	TRANSISTOR	BC548C	4822 130 44196	V 5601	DIODE, REFERENCE	BZV11	5322 130 34294
V 4308	DIODE	BZV86-C1V4	4822 130 81423	V 5602	TRANSISTOR,CHIP	BC858B	5322 130 41983
V 4309	TRANSISTOR	BC548C	4822 130 44196	V 5603	TRANSISTOR,CHIP	BC858B	5322 130 41983
V 4311	TRANSISTOR	BC548C	4822 130 44196	V 5604	TRANSISTOR,CHIP	BF550	4822 130 42131
V 4312	TRANSISTOR	BC558B	4822 130 44197	V 5606	TRANSISTOR,CHIP	BF550	4822 130 42131
V 4321	DIODE	BAW62	4822 130 30613	V 5607	TRANSISTOR,CHIP	BF550R	4822 130 60687
V 4322	TRANSISTOR	BC548C	4822 130 44196	V 5609	TRANSISTOR,CHIP	BF550R	4822 130 60687
V 4323	TRANSISTOR	BC548C	4822 130 44196	V 5651	TRANSISTOR,CHIP	BC848C	5322 130 42136
V 4400	DIODE	BZV86-C1V4	4822 130 81423	V 5671	TRANSISTOR,CHIP	BC848C	5322 130 42136
V 4401	TRANSISTOR	BF324	4822 130 41448	V 5672	TRANSISTOR,CHIP	BC848C	5322 130 42136
V 4402	DIODE, REFERENCE	BZX79-C6V2	4822 130 34167	V 5673	TRANSISTOR,CHIP	BC848C	5322 130 42136
V 4500	DIODE	BAW62	4822 130 30613	V 5674	TRANSISTOR,CHIP	BC848C	5322 130 42136
V 4501	TRANSISTOR	BC548C	4822 130 44196	V 5702	TRANSISTOR,CHIP	BC858B	5322 130 41983
V 4502	TRANSISTOR	BC548C	4822 130 44196	V 5703	TRANSISTOR,CHIP	BC858B	5322 130 41983
V 4503	TRANSISTOR	BC548C	4822 130 44196	V 5704	TRANSISTOR,CHIP	BF550	4822 130 42131
V 4504	TRANSISTOR	BC548C	4822 130 44196	V 5706	TRANSISTOR,CHIP	BF550	4822 130 42131
V 4505	DIODE	BAW62	4822 130 30613	V 5707	TRANSISTOR,CHIP	BF550R	4822 130 60687
V 4506	TRANSISTOR	BC548C	4822 130 44196	V 5709	TRANSISTOR,CHIP	BF550R	4822 130 60687
V 4510	TRANSISTOR	BC558B	4822 130 44197	V 5751	TRANSISTOR,CHIP	BC848C	5322 130 42136
V 4511	TRANSISTOR	BC558B	4822 130 44197	V 5771	TRANSISTOR,CHIP	BC848C	5322 130 42136
V 4512	TRANSISTOR	BC558B	4822 130 44197	V 5772	TRANSISTOR,CHIP	BC848C	5322 130 42136
V 4513	TRANSISTOR	BC558B	4822 130 44197	V 5773	TRANSISTOR,CHIP	BC848C	5322 130 42136
V 4514	TRANSISTOR	BC558B	4822 130 44197	V 5774	TRANSISTOR,CHIP	BC848C	5322 130 42136
V 4516	DIODE	BAW62	4822 130 30613	V 5803	TRANSISTOR,FET	BFQ13	5322 130 44404
V 4517	DIODE	BAW62	4822 130 30613	V 5808	TRANSISTOR,FET	BFQ13	5322 130 44404
V 4518	DIODE	BAW62	4822 130 30613	V 5813	TRANSISTOR,FET	BFQ13	5322 130 44404
V 4519	DIODE	BAW62	4822 130 30613	V 5818	TRANSISTOR,FET	BFQ13	5322 130 44404
V 4521	DIODE	BAW62	4822 130 30613	V 5892	DIODE	BZV86-C2V0	4822 130 81424
V 4522	DIODE	BAW62	4822 130 30613	V 5901	DIODE,CHIP	BZX84-C5V1	5322 130 32835

POSNR	DESCRIPTION	ORDERING CODE	POSNR	DESCRIPTION	ORDERING CODE
V 5902	DIODE,CHIP	BZX84-B27	D 0432	INTEGR.CIRCUIT	PC74HCT00P
V 5903	TRANSISTOR,CHIP	BC248C	D 0433	INTEGR.CIRCUIT	PC74HCT74P
V 5906	TRANSISTOR,CHIP	BC588B	D 0434	I.C. ANALOGUE	PC74HCT157P
V 6001	DIODE	BYV96E	D 0437	I.C. ANALOGUE	PC74HCT157P
V 6002	DIODE	BYV96E	D 0441	INTEGR.CIRCUIT	74F191PC
V 6003	DIODE	BYV96E	D 0442	INTEGR.CIRCUIT	PC74HCT191P
V 6004	DIODE	BYV96E	D 0443	INTEGR.CIRCUIT	PC74HCT191P
V 6007	DIODE	BAX12	D 0444	INTEGR.CIRCUIT	PC74HCT191P
V 6008	DIODE	BAX12	D 0446	INTEGR.CIRCUIT	PC74HCT20P
V 6009	TRANSISTOR	BC337	D 0503	INTEGR.CIRCUIT	C74HCT4053P
V 6011	DIODE	BAX12	D 0504	INTEGR.CIRCUIT	HEF4104BP
V 6012	DIODE,REFERENCE	BZX79-C15	D 0505	INTEGR.CIRCUIT	HEF4066BP
V 6013	THYRISTOR	BRY39	D 0512	INTEGR.CIRCUIT	C74HCT4053P
V 6014	TRANSISTOR	BUZ80	D 0801	INTEGR.CIRCUIT	OQ 0210
V 6016	DIODE	BYV27-150	D 0876	INTEGR.CIRCUIT	74F08PC
V 6017	DIODE	BYV96E	D 0887	INTEGR.CIRCUIT	PC74HCT160P
V 6018	TRANSISTOR	BUM12A	D 0901	INTEGR.CIRCUIT	C74HCT4052P
V 6019	DIODE	BYV26C	D 0903	INTEGR.CIRCUIT	HEF4066BP
V 6021	DIODE,REFERENCE	BZX79-C3V0	D 0904	INTEGR.CIRCUIT	HEF4066BP
V 6031	DIODE,REFERENCE	BZX79-C3V6	D 0911	INTEGR.CIRCUIT	C74HCT4052P
V 6101	DIODE	MBR2545CT	D 0914	INTEGR.CIRCUIT	HEF4066BP
V 6102	DIODE	MBR1045	D 0921	INTEGR.CIRCUIT	HEF4104BP
V 6104	DIODE	BYV28-150	D 0922	I.C. ANALOGUE	PC74HCT08P
V 6106	DIODE	BYV28-150	D 1001	INTEGR.CIRCUIT	TEA1017/N9
V 6107	DIODE	BYV95C	D 1101	INTEGR.CIRCUIT	TEA1017/N9
V 6108	DIODE	BYV27-150	D 1601	INTEGR.CIRCUIT	PLIFIER
V 6109	DIODE	BYV95C	D 1602	INTEGR.CIRCUIT	PLIFIER
V 6110	DIODE	BYV27-150	D 1603	INTEGR.CIRCUIT	C74HCT4053T
V 6113	DIODE	BYV95C	D 2302	INTEGR.CIRCUIT	PLIFIER
V 6115	DIODE	BYV27-150	D 2303	INTEGR.CIRCUIT	PLIFIER
V 6116	DIODE	BYV27-150	D 2601	INTEGR.CIRCUIT	HEF4053BP
V 6131	DIODE	BAX12	D 2602	INTEGR.CIRCUIT	TEA1017/N9
V 6132	DIODE	BAW62	D 2802	INTEGR.CIRCUIT	PCF8574T
V 6133	DIODE,REFERENCE	BZX79-C6V2	D 4001	INTEGR.CIRCUIT	TEA1017/N9
V 6134	TRANSISTOR	BC337	D 4002	INTEGR.CIRCUIT	TEA1017/N9
V 6136	TRANSISTOR	BF423	D 4101	INTEGR.CIRCUIT	HEF4053BP
V 6137	TRANSISTOR	BF423	D 4102	INTEGR.CIRCUIT	HEF4051BP
V 6138	DIODE,REFERENCE	BZX79-C5V6	D 4202	INTEGR.CIRCUIT	HEF4051BP
V 6201	TRANSISTOR	BC327	D 4203	INTEGR.CIRCUIT	74F12PC
V 6202	DIODE,REFERENCE	BZX79-C15	D 4204	INTEGR.CIRCUIT	C74HCT4040P
V 6203	DIODE	BAV21	D 4266	INTEGR.CIRCUIT	MC10216P
V 6204	DIODE	BAV21	D 4267	INTEGR.CIRCUIT	MC10231P
V 6206	DIODE	BAV21	D 5202	INTEGR.CIRCUIT	N74F08D
V 6207	DIODE	BYV27-150	D 5601	INTEGR.CIRCUIT	OQ 0204 SEL
V 6208	TRANSISTOR	BUV26A	D 5701	INTEGR.CIRCUIT	OQ 0204 SEL
V 6209	DIODE	BY509	D 5802	INTEGR.CIRCUIT	HEF4066BT
V 6211	TRANSISTOR	BC337	D 5803	INTEGR.CIRCUIT	HEF4066BT
V 6301	TRANSISTOR	BC548C	D 5804	INTEGR.CIRCUIT	HEF4066BT
V 6302	TRANSISTOR	BC558B	D 5806	INTEGR.CIRCUIT	HEF4053BT
V 6303	TRANSISTOR	BC337	D 5807	INTEGR.CIRCUIT	HEF4053BT
V 6304	TRANSISTOR	BC327	D 5814	INTEGR.CIRCUIT	HEF4066BT
V 6311	TRANSISTOR	BC337	D 6201	CABLE,CONNECT.	B02000-641-5
V 6312	TRANSISTOR	BDX78	D 6501	INTEGR.CIRCUIT	HEF4066BP
V 6401	DIODE,REFERENCE	BZV11	D 7001	INTEGR.CIRCUIT	PCF8574P
V 6402	DIODE	BAX12	D 7002	INTEGR.CIRCUIT	PCF8574P
V 6403	TRANSISTOR	BC337	D 7003	INTEGR.CIRCUIT	PCF8574P
D 8001	INTEGR.CIRCUIT	PCF8577T	D 8001	INTEGR.CIRCUIT	PCF8577T
D 8002	INTEGR.CIRCUIT	PCF8577T	D 8002	INTEGR.CIRCUIT	PCF8577T
D 8003	INTEGR.CIRCUIT	PCF8577T	D 8003	INTEGR.CIRCUIT	PCF8577T
D 0306	INTEGR.CIRCUIT	OQ 0209	D 0306	INTEGR.CIRCUIT	OQ 0209
D 0309	INTEGR.CIRCUIT	OQ 0209	D 0309	INTEGR.CIRCUIT	OQ 0209
D 0314	INTEGR.CIRCUIT	CB1536RC	D 0314	INTEGR.CIRCUIT	CB1536RC
D 0412	INTEGR.CIRCUIT	PCF1106P/029	D 0412	INTEGR.CIRCUIT	PCF1106P/029
D 0601	INTEGR.CIRCUIT	OQ 0020	D 0601	INTEGR.CIRCUIT	OQ 0020
D 0602	INTEGR.CIRCUIT	OQ 0020	D 0602	INTEGR.CIRCUIT	OQ 0020
D 0801	INTEGR.CIRCUIT	OQ 0210	D 0801	INTEGR.CIRCUIT	OQ 0210
D 1002	INTEGR.CIRCUIT	OQ 0221N1	D 1002	INTEGR.CIRCUIT	OQ 0221N1
D 1102	INTEGR.CIRCUIT	OQ 0221N1	D 1102	INTEGR.CIRCUIT	OQ 0221N1
D 2002	INTEGR.CIRCUIT	OQ 0205N2	D 2002	INTEGR.CIRCUIT	OQ 0205N2
D 2102	INTEGR.CIRCUIT	OQ 0205N2	D 2102	INTEGR.CIRCUIT	OQ 0205N2
D 2150	INTEGR.CIRCUIT	OQ 0205N2	D 2150	INTEGR.CIRCUIT	OQ 0205N2
D 2201	INTEGR.CIRCUIT	OQ 0020	D 2201	INTEGR.CIRCUIT	OQ 0020
D 2202	INTEGR.CIRCUIT	OQ 0020	D 2202	INTEGR.CIRCUIT	OQ 0020
D 2302	INTEGR.CIRCUIT	OQ 0020	D 2302	INTEGR.CIRCUIT	OQ 0020
D 2303	INTEGR.CIRCUIT	OQ 0020	D 2303	INTEGR.CIRCUIT	OQ 0020
D 2304	INTEGR.CIRCUIT	OQ 0128	D 2304	INTEGR.CIRCUIT	OQ 0128
D 2603	INTEGR.CIRCUIT	OQ 0200	D 2603	INTEGR.CIRCUIT	OQ 0200
D 4104	INTEGR.CIRCUIT	OQ 0201	D 4104	INTEGR.CIRCUIT	OQ 0201
D 7004	INTEGR.CIRCUIT	OQ 0044	D 7004	INTEGR.CIRCUIT	OQ 0044
N 0201	INTEGR.CIRCUIT	LM393N	N 0201	INTEGR.CIRCUIT	LM393N
N 0501	INTEGR.CIRCUIT	LF356N	N 0501	INTEGR.CIRCUIT	LF356N
N 0502	INTEGR.CIRCUIT	LF356N	N 0502	INTEGR.CIRCUIT	LF356N
N 0503	INTEGR.CIRCUIT	TL082CP	N 0503	INTEGR.CIRCUIT	TL082CP
N 0504	INTEGR.CIRCUIT	LM358N	N 0504	INTEGR.CIRCUIT	LM358N
N 0505	INTEGR.CIRCUIT	AD7824KN	N 0505	INTEGR.CIRCUIT	AD7824KN
N 0506	INTEGR.CIRCUIT	DAC-08EP	N 0506	INTEGR.CIRCUIT	DAC-08EP
N 0507	INTEGR.CIRCUIT	DA10FX	N 0507	INTEGR.CIRCUIT	DA10FX
N 0511	INTEGR.CIRCUIT	LF356N	N 0511	INTEGR.CIRCUIT	LF356N
N 0512	INTEGR.CIRCUIT	LM358N	N 0512	INTEGR.CIRCUIT	LM358N
N 0513	INTEGR.CIRCUIT	TL082CP	N 0513	INTEGR.CIRCUIT	TL082CP
N 0701	INTEGR.CIRCUIT	LM358D	N 0701	INTEGR.CIRCUIT	LM358D
N 0901	INTEGR.CIRCUIT	TL082CP	N 0901	INTEGR.CIRCUIT	TL082CP
N 0904	INTEGR.CIRCUIT	TL082CP	N 0904	INTEGR.CIRCUIT	TL082CP
N 0905	INTEGR.CIRCUIT	TL082CP	N 0905	INTEGR.CIRCUIT	TL082CP
N 0913	INTEGR.CIRCUIT	TL082CP	N 0913	INTEGR.CIRCUIT	TL082CP
N 0914	INTEGR.CIRCUIT	TL082CP	N 0914	INTEGR.CIRCUIT	TL082CP
N 0921	INTEGR.CIRCUIT	LM358N	N 0921	INTEGR.CIRCUIT	LM358N
N 0922	INTEGR.CIRCUIT	LM358N	N 0922	INTEGR.CIRCUIT	LM358N
N 0927	INTEGR.CIRCUIT	TL082CP	N 0927	INTEGR.CIRCUIT	TL082CP

25.4.5 INTEGRATED CIRCUITS

POSNR	DESCRIPTION	ORDERING CODE	POSNR	DESCRIPTION	ORDERING CODE
D 801	INTEGR.CIRCUIT	OQ 0206N3	5322	209	11606
D 0201	INTEGR.CIRCUIT	74F138PC	5322	209	82366
D 0202	INTEGR.CIRCUIT	PC74HCT138P	5322	209	11111
D 0203	INTEGR.CIRCUIT	PC74HCT132P	4822	209	83044
D 0204	INTEGR.CIRCUIT	PC74HCT390P	5322	209	11483
D 0206	INTEGR.CIRCUIT	PC74HCT390P	5322	209	11483
D 0207	INTEGR.CIRCUIT	C74HCT4040P	5322	209	72465
D 0208	INTEGR.CIRCUIT	PC74HCT10P	5322	209	11107
D 0209	INTEGR.CIRCUIT	74F11PC	5322	209	81536
D 0211	INTEGR.CIRCUIT	74F02PC	5322	209	81535
D 0212	INTEGR.CIRCUIT	74F04PC	5322	209	81577
D 0213	I.C. ANALOGUE	PC74HCT32P	5322	209	11266
D 0214	INTEGR.CIRCUIT	MC68008P8	5322	209	11593
D 0216	I.C. E-PROM	C010-200V10	5322	209	51855
D 0217	INTEGR.CIRCUIT	M62256LP-12	5322	209	72129
D 0218	INTEGR.CIRCUIT	P8254	5322	209	82406
D 0219	INTEGR.CIRCUIT	PC74HCT259P	5322	209	11115
D 0221	INTEGR.CIRCUIT	PC74HCT244P	5322	209	11116
D 0222	INTEGR.CIRCUIT	PC74HCT259P	5322	209	11115
D 0223	INTEGR.CIRCUIT	PC74HCT03P	5322	209	11316
D 0301	INTEGR.CIRCUIT	PC74HCT244P	5322	209	11116
D 0302	INTEGR.CIRCUIT	PC74HCT244P	5322	209	11116
D 0303	INTEGR.CIRCUIT	PC74HCT245P	5322	209	11117
D 0304	INTEGR.CIRCUIT	M62256LP-12	5322	209	72129
D 0307	INTEGR.CIRCUIT	PC74HCT86P	5322	209	11473
D 0308	INTEGR.CIRCUIT	M6264ALP-12	5322	209	60192
D 0311	INTEGR.CIRCUIT	PC74HCT174P	5322	209	11478
D 0312	INTEGR.CIRCUIT	PC74HCT174P	5322	209	11478
D 0313	INTEGR.CIRCUIT	PC74HCT259P	5322	209	11115
D 0316	INTEGR.CIRCUIT	PC74HCT138P	5322	209	11111
D 0318	INTEGR.CIRCUIT	HEF4066BP	5322	209	10357
D 0401	INTEGR.CIRCUIT	PC74HCT04P	4822	209	82341
D 0402	INTEGR.CIRCUIT	PC74HCT74P	5322	209	11109
D 0403	INTEGR.CIRCUIT	PC74HCT74P	5322	209	11109
D 0404	INTEGR.CIRCUIT	74F112PC	5322	209	70101
D 0406	INTEGR.CIRCUIT	PC74HCT00P	5322	209	11105
D 0407	I.C. ANALOGUE	PC74HCT08P	5322	209	11265
D 0408	INTEGR.CIRCUIT	PC74HCT10P	5322	209	11107
D 0409	I.C. ANALOGUE	PC74HCT163P	5322	209	11267
D 0411	I.C. ROM	AL16R8A-2CN	5322	209	51424
D 0413	INTEGR.CIRCUIT	PC74HCT574P	5322	209	11489
D 0416	I.C. ANALOGUE	PC74HCT08P	5322	209	11265
D 0431	I.C. ROM	AL16R8A-2CN	5322	209	51424

POSNR	DESCRIPTION	ORDERING CODE	POSNR	DESCRIPTION	ORDERING CODE
N 0947	INTEGR. CIRCUIT	TL082CP	5322 209	86064	
N 0987	INTEGR. CIRCUIT	LM337LZ	5322 209	83228	
N 0988	INTEGR. CIRCUIT	LM337T	5322 209	81236	
N 0989	INTEGR. CIRCUIT	LM317LZ	5322 209	82943	
N 1001	INTEGR. CIRCUIT	OPA121KP	5322 209	72572	
N 1002	TRANSISTOR	OP-77GP	5322 130	60937	
N 1101	INTEGR. CIRCUIT	OPA121KP	5322 209	72572	
N 1102	TRANSISTOR	OP-77GP	5322 130	60937	
N 1201	INTEGR. CIRCUIT	TL080CP	5322 209	72464	
N 1601	INTEGR. CIRCUIT	LM358D	5322 209	82941	
N 1602	INTEGR. CIRCUIT	LM358D	5322 209	82941	
N 1701	INTEGR. CIRCUIT	SL3227MP	5322 209	60194	
N 1702	INTEGR. CIRCUIT	SL3227MP	5322 209	60194	
N 1703	INTEGR. CIRCUIT	LF356M	5322 209	72003	
N 2001	INTEGR. CIRCUIT	CA3227E	5322 209	72568	
N 2101	INTEGR. CIRCUIT	CA3227E	5322 209	72568	
N 4101	INTEGR. CIRCUIT	LM324N	4822 209	80587	
N 4102	TRANSISTOR	OP-77GP	5322 130	60937	
N 4103	INTEGR. CIRCUIT	TL080CP	5322 209	72464	
N 4201	INTEGR. CIRCUIT	DAC10FX	5322 209	71665	
N 4203	INTEGR. CIRCUIT	TL080CP	5322 209	72464	
N 4401	INTEGR. CIRCUIT	TDA1540P	4822 209	81453	
N 4402	INTEGR. CIRCUIT	CA3086	5322 209	11225	
N 4401	INTEGR. CIRCUIT	CA3102E	5322 209	72657	
N 5101	INTEGR. CIRCUIT	LM358D	5322 209	82941	
N 5501	INTEGR. CIRCUIT	LM358D	5322 209	82941	
N 5551	INTEGR. CIRCUIT	LM358D	5322 209	82941	
N 5601	INTEGR. CIRCUIT	LM358D	5322 209	82941	
N 5701	INTEGR. CIRCUIT	LM358D	5322 209	82941	
N 5801	INTEGR. CIRCUIT	TL082CD	5322 209	72002	
N 5804	INTEGR. CIRCUIT	TL082CD	5322 209	72002	
N 5805	INTEGR. CIRCUIT	TL082CD	5322 209	72002	
N 5813	INTEGR. CIRCUIT	TL082CD	5322 209	72002	
N 5814	INTEGR. CIRCUIT	TL082CD	5322 209	72002	
N 5827	INTEGR. CIRCUIT	TL082CD	5322 209	72002	
N 5847	INTEGR. CIRCUIT	TL082CD	5322 209	72002	
N 5901	INTEGR. CIRCUIT	LM358D	5322 209	82941	
N 5902	INTEGR. CIRCUIT	LM317T	4822 209	80591	
N 5903	INTEGR. CIRCUIT	LM337LZ	5322 209	83228	
N 5904	INTEGR. CIRCUIT	LM358D	5322 209	82941	
N 6001	INTEGR. CIRCUIT	LM358N	4822 209	70672	
N 6002	INTEGR. CIRCUIT	LM358N	4822 209	70672	
N 7001	INTEGR. CIRCUIT	LM339AN	5322 209	60188	
N 7002	INTEGR. CIRCUIT	LM324N	4822 209	80587	
N 7003	INTEGR. CIRCUIT	LM324N	4822 209	80587	
S 7017	SWITCH, PUSHBUT.		5322 276	11856	
S 7018	SWITCH, PUSHBUT.		5322 276	11856	
S 7019	SWITCH, PUSHBUT.		5322 276	11856	
S 7020	SWITCH, PUSHBUT.		5322 276	11856	
S 7021	SWITCH, PUSHBUT.		5322 276	11856	
S 7022	SWITCH, TUMBLER	BR	5322 277	10878	
S 7023	SWITCH, PUSHBUT.		5322 276	11856	
S 7026	SWITCH, PUSHBUT.		5322 276	11856	
S 7027	SWITCH, TUMBLER	BR	5322 277	10878	
S 7029	SWITCH, PUSHBUT.		5322 276	11856	
S 7030	SWITCH, PUSHBUT.		5322 276	11856	
S 7031	SWITCH, PUSHBUT.		5322 276	11856	
S 7032	SWITCH, PUSHBUT.		5322 276	11856	
S 7033	SWITCH, PUSHBUT.		5322 276	11856	
S 7034	SWITCH, PUSHBUT.		5322 276	11856	
S 7035	SWITCH, PUSHBUT.		5322 276	11856	
T 6001	TRANSFORMER		5322 146	30591	
T 6201	TRANSFORMER		5322 146	30592	
HS MULTIPLIER			5322 321	21597	
G 0801	CRYSTAL 100 MHZ		5322 242	71737	
G 5101	CRYSTAL 100 MHZ		5322 242	71737	
G 5102	CRYSTAL 125 MHZ		5322 242	71738	

25.4.6 CATHODE RAY TUBE

POSNR	DESCRIPTION	ORDERING CODE
V 0001	TUBE, ELECTRON D14-372GH	5322 131 20169

25.4.7 MISCELLANEOUS

POSNR	DESCRIPTION	ORDERING CODE
E 0001	LAMP T13/4 28V 80MA	5322 134 40534
E 8001	LAMP 60MA MGG9012	5322 134 40849
G 0201	CRYSTAL Q-0-100-16M S. R	5322 242 71445
H 6001	COUPLER, PHOTO CNX35	5322 130 90137
H 8002	INTEGR. CIRCUIT LPH1545-1	5322 209 60193
K 1001	RELAY, REED DRELAIS IL 12 V	5322 280 20125
K 1002	RELAY, REED DRELAIS IL 12 V	5322 280 20125
K 1003	RELAY, REED DRELAIS IL 12 V	5322 280 20125
K 1004	RELAY, REED DRELAIS IL 12 V	5322 280 20125
K 1006	RELAY DSS4-1A12	5322 280 80586
K 1007	RELAY DSS4-1A12	5322 280 80586
K 1008	RELAY DSS4-1A12	5322 280 80586
K 1011	RELAY, REED DRELAIS IL 12 V	5322 280 20125
K 1012	RELAY, REED DRELAIS IL 12 V	5322 280 20125
K 1013	RELAY, REED DRELAIS IL 12 V	5322 280 20125
K 1101	RELAY, REED DRELAIS IL 12 V	5322 280 20125
K 1102	RELAY, REED DRELAIS IL 12 V	5322 280 20125
K 1103	RELAY, REED DRELAIS IL 12 V	5322 280 20125
K 1104	RELAY, REED DRELAIS IL 12 V	5322 280 20125
K 1106	RELAY DSS4-1A12	5322 280 80586
K 1107	RELAY DSS4-1A12	5322 280 80586
K 1108	RELAY DSS4-1A12	5322 280 80586
K 1111	RELAY, REED DRELAIS IL 12 V	5322 280 20125
K 1112	RELAY, REED DRELAIS IL 12 V	5322 280 20125
K 1113	RELAY, REED DRELAIS IL 12 V	5322 280 20125
K 1201	RELAY, REED DRELAIS IL 12 V	5322 280 20125
K 4101	RELAY, REED DRELAIS IL 12 V	5322 280 20125
S 1901	SWITCH, PUSHBUT. 1-P 1VA 1MA	5322 276 12544
S 1902	SWITCH, PUSHBUT. 1-P 1VA 1MA	5322 276 12544
S 1903	SWITCH, PUSHBUT. 1-P 1VA 1MA	5322 276 12544
S 1904	SWITCH, PUSHBUT. 1-P 1VA 1MA	5322 276 12544
S 1905	SWITCH, PUSHBUT. 1-P 1VA 1MA	5322 276 12544
S 6801	SWITCH, PUSHBUT.	5322 276 11859
S 7001	SWITCH, TUMBLER BR	5322 277 10878
S 7003	SWITCH, PUSHBUT.	5322 276 11857
S 7004	SWITCH, PUSHBUT.	5322 276 11856
S 7005	SWITCH, PUSHBUT.	5322 276 11856
S 7006	SWITCH, PUSHBUT.	5322 276 11856
S 7007	SWITCH, PUSHBUT.	5322 276 11856
S 7008	SWITCH, PUSHBUT.	5322 276 11856
S 7009	SWITCH, TUMBLER BR	5322 277 10878
S 7011	SWITCH, PUSHBUT.	5322 276 11856
S 7012	SWITCH, PUSHBUT.	5322 276 11856
S 7013	SWITCH, PUSHBUT.	5322 276 11856
S 7014	SWITCH, TUMBLER BR	5322 277 10878
S 7016	SWITCH, PUSHBUT.	5322 276 11856