

5.8 DIGITIZER A8

5.8.1 Descriptions

5.8.1.1 Diagram 1

5.8.1.2 Diagram 2

Vertical channel inputs

Four input channel signals are derived from the analog oscilloscope section unit A1.

Channel 1 : X1301/X1302

Channel 2 : X2301/X2302

Channel 3 : X3301/X3302

Channel 4 : X4301/X4302

The d.c. current is 4 mA and the sensitivity is 100 $\mu\text{A}/\text{division}$ (200 $\mu\text{A}/\text{division}$ differential).

Buffer/splitters

Each input signal path is split into equal signal paths by the signal splitters consisting of the transistor packages N8023, N8022, N8024 and N8021. One is the vertical input signal path and the other is the input trigger signal path.

The input channel signals are applied to the four buffer/splitter stages N8023, N8022, N8024 and N8021 as four times two symmetrical signals. They are applied by connectors and cables with a characteristic impedance of 50 Ohm. The buffer/splitter stages are configured as level shifters which are formed for channel 1 for example with N8023/9-10-11 and N8023/6-7-8.

For the HF adjustment of each channel, a fixed RC network (C8581/R8581 for channel 1) as well as an adjustable network (R8210/diode-V8188 for channel 1) are present between the two emitters. The capacity of the diodes can be adjusted by signals HFADJ1, HFADJ2, HFADJ3 and HFADJ4 in order to realize correct HF adjustment.

Main Analog Signal Processor Unit (MASPU)

The resulting signal currents in the vertical input signal paths are applied via input stages to the Main Analog Signal Processor Units. These are MASPU-A (N8026) for input channels 1 and 3 and MASPU-B (N8027) for input channels 2 and 4.

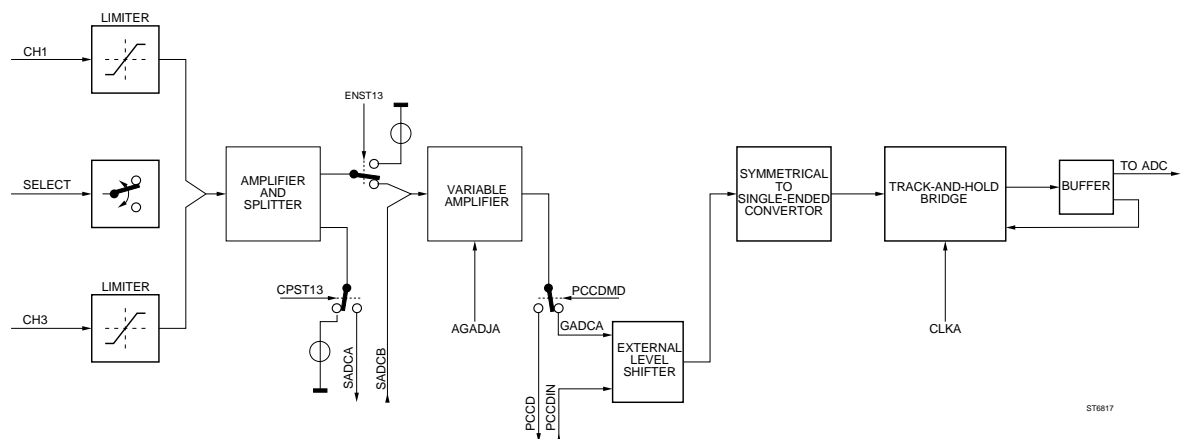

Each MASPU circuit contains the following circuits: limiter, channel selector, amplifier and splitter, variable amplifier, external level shifter, symmetrical to single-ended converter, Track & Hold bridge and buffer. A MASPU is able to handle two symmetrical analog input current (100 $\mu\text{A}/\text{division}$) signals.

MASPU-A description

The channel 1 and 3 signals are amplified and limited to signal levels of +/- 600 $\mu\text{A}/\text{division}$, which cover a dynamic range of +/- 6 vertical divisions on the oscilloscope display.

For the correct functioning of the limiter circuits, dc feedback loops are required, using external transistors V8021 and V8019.

The output currents of the two limiter circuits are applied to amplifier and splitter stages in a multiplexed way. This is controlled by the differential selection signals (2 mA) CHOP1 and CHOP3. This can be done in chopped way (max. 5 MHz) or in alternated way.

The output current of the amplifier is split into two equal signal paths. Splitting offers the possibility to send a replica of the chosen vertical input signal to the second MASPU (MASPU-B) for the channels 2 and 4.

The signal current from the chosen input channel 1 or 3 can either be passed on to the variable amplifier, or as replica (SADCBPB SADCBNB) of the signal be send to the channel combiner in the second MASPU (MASPU-B) for the channels 2 and 4. Also the output signal current (SADCBNA SADCBPA) of the second MASPU can be sent to the channel combiner in the first MASPU (MASPU-A) for the channels 1 and 3. It is possible to apply the same input signal current to both ADC's at the same time in order to make interleaved sampling on a 200 MHz sample rate possible.

Signals CPST13HT and ENST13HT control the circuit.

- Signal CPST13HT determines whether the replica of the chosen input signal is sent to the second MASPU via the SADCBPB and SADCBNB lines or not. (Required for 200 MS/s sampling.)
- Signal ENST13HT determines whether the chosen input signal is passed on to the variable amplifier stage in the MASPU or the signal from the other MASPU.

In timebase setting 250 ns/div., a selected input channel is connected via both MASPU's to both ADC's, resulting in a double sampling rate of 200 MS/s.

Signal VADCA, which is derived from the offset DAC (DACPOT), represents an additional offset applied to MASPU input pin 9. VADCA is used to adjust the circuit for a level in the centre of the ADC input range if no input signal is applied. This corresponds with the centre of the CRT screen. It is also used to give the MASPU an extra offset in the double sampling mode.

Variable amplifier

After combining the direct or replica signals, a circuit for variable overall gain control is available. Signal AGADJA is the control current input for this variable amplifier. The output of this stage is fed to the amplifier section where the signal current is converted from a symmetrical to a single-ended signal voltage.

Track and Hold bridge

After the amplification and combination stages, the analog signal is applied to a Track and Hold bridge, which is used to sample the signal and keep it at a constant level during the conversion period of the ADC circuit.

The sample-clock signal currents for the Track and Hold circuit are the symmetrical logic signals CLKA and NCLKA with a rise-time of about 2 ns and a fixed frequency of 100 MHz. These signals determine the TRACK-to-HOLD transitions.

In the Track-mode the output voltage of the circuit will follow the input signal variations. In the Hold-mode the internal hold capacitor is isolated from the rest of the circuit and will store the value of the input signal at the moment just before the track-to-hold transition.

Both Track and Hold bridges in MASPU-A and MASPU-B are clocked with the same sample-clock frequency. In double sample mode (200 MS/s sample rate for only one channel), the two Track and Hold bridges receive sample-clock signals which are 180 degrees shifted in phase. This results in twice the sample rate.

The resulting T&H output signal BOUT on point 65 of the MASPU is applied via buffer N8013 to the ADC circuit (on diagram 5) as ANINA. The feedback signal BOOT from N8013 is required by the Track & Hold bridge for correct internal leveling.

Supply current ITREEA

The current ITREEA is a constant current from which the MASPU derives a number of internal supply voltages.

5.8.1.3 *Diagram 3*

Control, reference and adjustment voltages:

Digital to Analog Converter DACPOT

The sixteen channel 12 bit Digital to Analog Converter POTentiometer DACPOT N8006 derives 14 different analog output signals from the four input bits GLOD04 ... GLOD07 from the GLOBAL data bus. The chip select signal for the converter is signal DACCS-LT and the refresh signal is derived from signal CK12M via D-type flip-flop D8045. The start is initiated via the enable signal DACPENLT which is also derived from the GLOBAL data bus.

Each of these DACPOT output levels is independently adjustable between 1 Volt and 4 Volt in 4096 steps.

Analog output signals are:

OFFSADCA converted in signal VADCA see diagram 1

OFFSADCB converted in signal VADCB see diagram 2

GAINMPUA converted in signal AGADJA see diagram 1

GAINMPUB converted in signal AGADJB see diagram 2

OFFST&HA converted in signals POSAA/POSBA see diagram 1

OFFST&HB converted in signals POSAB/POSBB see diagram 2

OFFSCMP1 see diagram 6

OFFSCMP2 see diagram 6

OFFSCMP3 see diagram 6

OFFSCMP4 see diagram 6

HF1 converted in signal HFADJ1 see diagram 1

HF2 converted in signal HFADJ2 see diagram 2

HF3 converted in signal HFADJ3 see diagram 3

HF4 converted in signal HFADJ4 see diagram 4

Multiplexer D8501

Seven digital control signals arrive via multiplexer D8501 derived from data bit GLOD09 from the GLOBAL data bus and the three address bits GLOA4 ... GLOA6 from the GLOBAL address bus. Signals are mainly generated to control activities in the RAndom Trigger Engine Logic (RATEL) circuit on diagram 8. Outputs which are not selected via the address lines remain in their previous state.

ITREEA/ITREEB circuit

The ITREEA and ITREEB currents for the Main Analog Signal Processing Units (MASPU's) on diagram 1 and 2 are generated via the opamp circuit N8071 and transistors V8012 and V8014.

Channel selector

The chopper signals CHOP1/CHOP3 and CHOP2/CHOP4 for the Main Analog Signal Processing Units (MASPU's) on diagram 1 and 2 are derived from the SLS12 switching signal from the Data Acquisition and tRigger Logic (DARLIC) circuit on diagram 9.

5.8.1.4 Diagram 4

Clock oscillator

The 200 MHz crystal G8025 forms, together with WHISTLER circuit D8005, a 200 MHz clock generator with ECL level output clocksignals MCAA/MCNAA MCBB MCNBB of 100 MHz each for the Analog to Digital Converters on diagram 5, and MCAAR/MCNAAR for the RAndom Trigger Engine Logic (RATEL) circuit on diagram 8.

Normal mode:

Normally the oscillator output signals MCAA and MCBB are in phase.

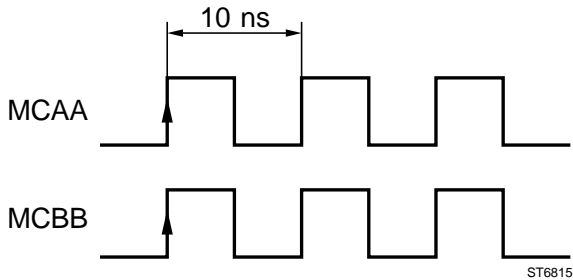

Double sampling mode:

The oscillator is controlled by the signal CLKBINV which is generated via the SBUS (serial bus) shown in diagram 14. This signal in double sampling mode is used to invert the oscillator output signals MCBB/MCNBB. The time between the leading edges of the two signals is now 5 ns and sampling is done at 200 MS/s.

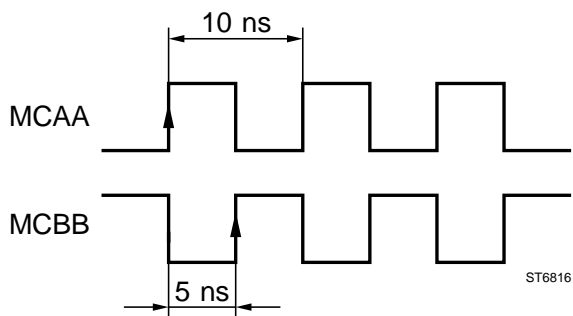

The output signals from the oscillator are applied to the circuits N8067 and N8068, which produce via transistors V8139/V8138 and V8140/V8141 the required clock currents for the Track and Hold bridges. Signals CLKA/NCLKA and CLKB/NCLKB with a frequency of 100 MHz are used on diagrams 1 and 2 as sample-clock signals for the Track and Hold bridges in the Main Analog Signal Processing units.

Clock switches

The clock switches N8067 and N8068 are controlled by signals DSAMPAHT/ DSAMPBHT and TRCKMDHT which are generated via the SBUS (serial bus) shown in diagram 14.

Only clock switch N8067 is now described:
One of the following modes can be selected.

	DSAMP_HT	TRCKMDHT	Clock signal path
Normal mode	L	L	R8541/R8546
Double sampling mode	H	L	R8544/R8545
Track only (autocal)	L	H	R8548/R8549

In normal mode the clock signals are fed from the clock oscillator via R8541 and R8546.

In double sampling mode (double sampling), the signal from path A is not only applied to the T&H in MASPU-A but also via MASPU-B to the second T&H circuit. This causes an additional time delay of about 1.6 ns between the signals which are applied to the two T&H circuits. In order to realize sampling at the correct moment, an additional delay is created between the sample clocks for the two T&H circuits.

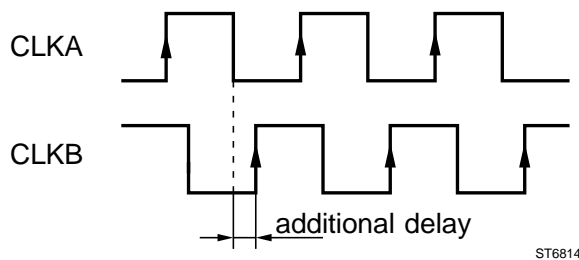

This additional clock signal delay is realized via the circuit traces in the current paths of R8544 and R8545 when signal DSAMP_HT is logic "1" and TRACKMDHT is logic "0".

If autocal is performed, the Track & Hold bridges are switched in TRACK ONLY. Signal levels over R8548 and R8549 are then constant.

5.8.1.5 Diagram 5

Analog to Digital Converters

The output signals ANINA and ANINB from the Track and Hold bridges in the Main Analog Signal Processing Units (MASPU's) on diagrams 1 and 2, are applied to the two Analog to Digital Converters ADC N8002 and ADC N8001.

These are 8 bit parallel Flash ADC's with an input range from 0V to -1V (10 divisions on the CRT screen) and with eight ECL outputs. The -0.5V level corresponds with the centre of the CRT screen. Both Flash ADC's are continuously converting at a rate of 100MS/s each. They are continuously clocked by sample-clock signals MCAA/MCNAA and MCBB/MCNBB with a frequency of 100 MHz. Sample rate reduction for different time-base settings is performed in a later stage in the DARLIC circuit on diagram 9.

The converted input signal is latched in the ADC on the negative going edge of the clock signal. Data is converted and available at the ADC outputs after the positive going edge of the clock signal.

ECL-TTL translators

The ECL level (-1.6V [L] and -0.8V [H]) output data signals from the ADC circuits are buffered and converted into TTL level output data signals by the ECL-TTL translator circuits D8004 and D8003.

This results in the databus signals SDA<7:0> and SDB<7:0> on TTL level which can be handled by the DARLIC circuit on diagram 9

The same is done for the sample-clock signals resulting in TTL level SCLKA/SCLKAN and SCLKB/SCLKBN signals which can also be handled by the DARLIC circuit. All data and clock signals are applied to the Data Acquisition and tRigger Logic IC (DARLIC) circuit on diagram 9 for further processing.

All digital data is stored then into a Fast Acquisition Memory (FAM) by the DARLIC after the necessary processing.

5.8.1.6 Diagram 6

Compass input stage

Signals COMP.1N/COMP.1P, COMP.2N/COMP.2P, COMP.3N/COMP.3P and COMP.4N/COMP.4P arrive from the collectors points 1 and 2 of circuits N8023, N8021, N8024 and N8022 on diagram 1. The sensitivity of these signals is 100 μ A/division. These input currents are converted into voltage levels over resistors R8341/R8337, R8294/R8301, R8329/R8336 and R8306/R8302 and these voltage levels are applied to the COMparator for Pattern and State Selection circuit (COMPASS) N8029.

Compass offset adjust

Offset trigger level signals OFFSCMP1, OFFSCMP2, OFFSCMP3 and OFFSCMP4 from the Digital to Analog Converter DACPOT on diagram 3 are applied to opamps N8019 and as CH1FSET, CH2FSET, CH3FSET and CH2FSET applied to the four level shifters V8089/V8091, V8088/V8087, V8082/V8083 and V8086/V8084 together with the four vertical channel input signals. The offset levels OFFSCMP1, OFFSCMP2, OFFSCMP3 and OFFSCMP4 are dependent of the triggerlevel. The output signals are then applied to the COMparator for Pattern and State Selection (COMPASS) circuit N8029.

COMparator for Pattern and State Selection (COMPASS)

With the aid of the COMPASS circuit the number of trigger modes can be extended with three modes, namely:

- PATTERN triggering
- TIMED-PATTERN triggering
- STATE triggering

Simple blockdiagram of the COMPASS circuit:

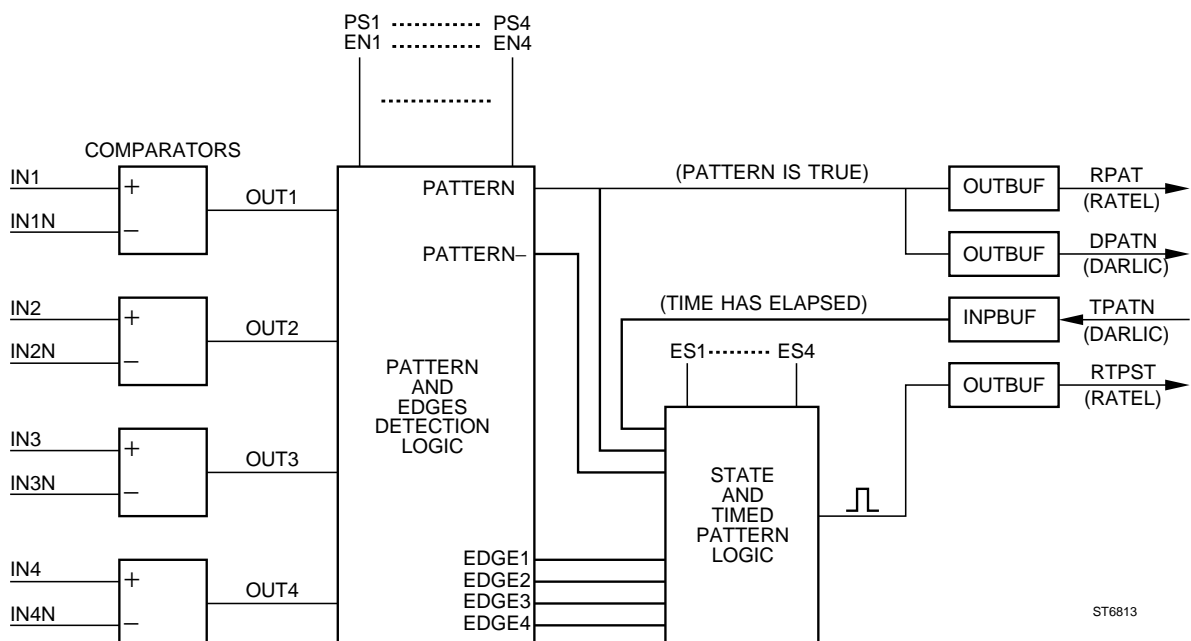

PATTERN triggering

With PATTERN selected, triggering is possible on a preselected combination of "H", "L" and "X" (don't care) values of the input signals from channel 1 to channel 4. Triggering on "ENTER" (start of selected pattern) as well as "EXIT" (end of selected pattern) is possible on user request.

In this mode a logical level will be defined for each input channel signal. This combination of logical levels PS1, PS2, PS3 and PS4 is called a PATTERN and is a condition for triggering. PS1, PS2, PS3 and PS4 are generated via the SBUS (serial bus) on diagram 14.

This user selected pattern is compared with the input signal combination IN1, IN2, IN3 and IN4 in the PATTERN AND EDGES DETECTION LOGIC.

As long as a selected PATTERN condition is true, the PATTERN signal at the output of the PATTERN AND EDGES DETECTION LOGIC becomes active. This signal is via an output buffer applied as symmetrical signal RPA/T/RPATN to the Random Trigger Engine Logic circuit (RATEL) circuit on diagram 8 and enables RATEL to generate a trigger. The trigger can be generated on the positive or the negative edge of the pattern, this is selected in the RATEL circuit and is realized by the inversion of signal RPA/T.

Example of PATTERN mode:

CHANNEL	1	2	3	4	
VALUE	H	X	L	H	L = Logical low H = Logical high X = Don't care

Example of input signals and resulting events:

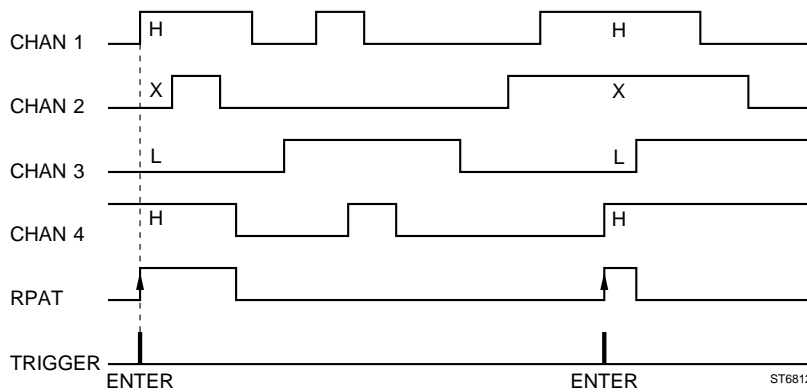

TIMED-PATTERN triggering

With TIMED-PATTERN selected, pattern triggering with a timing condition is possible. This is only possible at the end (EXIT) of a selected pattern. The system has a 10 ns resolution.

The user selected pattern, represented by signals PS1, PS2, PS3 and PS4 is compared with the input signal combination IN1, IN2, IN3 and IN4 in the PATTERN AND EDGES DETECTION LOGIC.

These signals PS1, PS2, PS3 and PS4 are generated via the SBUS (serial bus) on diagram 14.

As long as a selected PATTERN condition is true, the PATTERN signal at the output of the PATTERN AND EDGES DETECTION LOGIC becomes active. This signal is via an output buffer applied as low active DPATN to the DARLIC circuit on diagram 9.

The user selected times t_1 and t_2 are stored in two counters in the DARLIC circuit on diagram 9. These counters will start counting down after a positive edge of the signal DPATN from the COMPASS circuit, and are presetted on the negative edge of this signal. Signal DPATN is active as long as the selected pattern is present. When the presetted counters have counted down to zero, the selected time has elapsed and the active low signal TPATN is generated. It enables the STATE AND TIMED PATTERN LOGIC which produces an output pulse RTPST at the moment that the pattern has changed. With signal TPATN inactive, no RTPST pulse will be produced at the moment that the pattern has changed.

Example of TIMED-PATTERN mode:

CHANNEL	1	2	3	4
VALUE	H	X	L	H

L = Logical low
H = Logical high
X = Don't care

Example of input signals and resulting events:

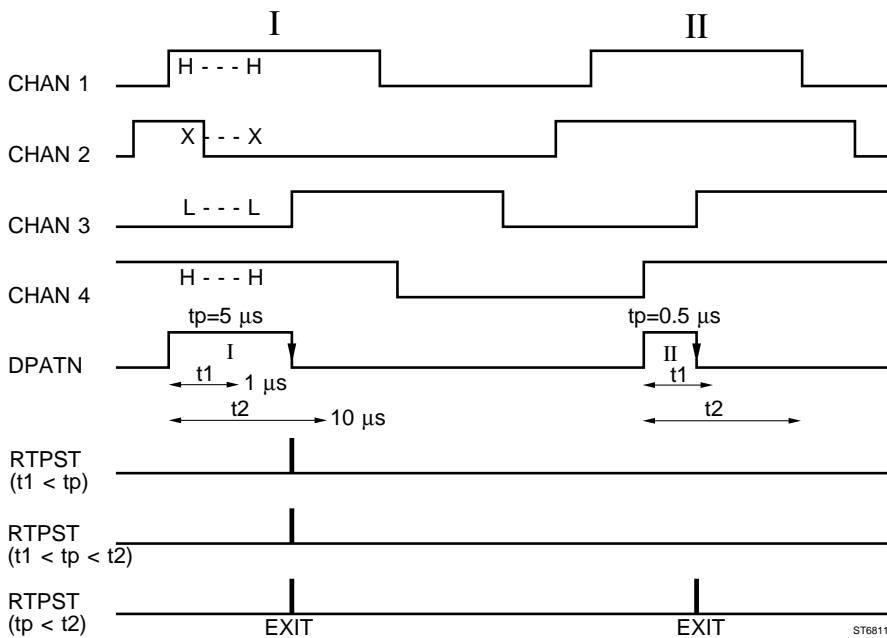

- There are three different situations possible:
- 1) $t_1 < t_p$ For pattern I : true
For pattern II : untrue
 - 2) $t_1 < t_p < t_2$ For pattern I : true
For pattern II : untrue
 - 3) $t_p < t_2$ For pattern I : true
For pattern II : true

Time t_p is the time that the pattern is true.
Times t_1 and t_2 are user selected times.

STATE triggering

With STATE triggering selected, edge-triggering with pattern- condition is possible. Polarity as well as source are to be selected by the user.

Not only a pattern has to be preselected, but also the trigger channel which completes the pattern. The edge can be selected positive as well as negative.

The circuit is controlled by signal SELTP-HT.
 SELTP-HT logic "0" means: STATE-trigger mode selected.
 SELTP-HT logic "1" means: PATTERN-trigger mode selected.

The user selected pattern, represented by signals PS1, PS2, PS3 and PS4 is compared with the input signal combination IN1, IN2, IN3 and IN4 in the PATTERN AND EDGES DETECTION LOGIC. These signals PS1, PS2, PS3 and PS4 are generated via the SBUS (serial bus) on diagram 14. As long as a selected PATTERN condition is true, the PATTERN signal at the output of the PATTERN AND EDGES DETECTION LOGIC becomes active. This signal is applied to the STATE AND TIMED PATTERN LOGIC.

In STATE-trigger mode, only one of the signals ES1, ES2, ES3 and ES4 is logic "1". This is the signal that corresponds with the channel that is selected as STATE-clock.

Signals EN1, EN2, EN3 and EN4 carry the "DON'T CARE" information.
 A logic "1" means: the corresponding channel is part of the triggerword.
 A logic "0" means: the corresponding channel is a "DON'T CARE" for the triggerword.

A channel used as STATE-clock in STATE-trigger mode, has to be disabled from the pattern. This means that the relevant EN_ signal must be a logic "0".

Example of settings in STATE mode:

CHANNEL	1	2	3	4
VALUE	H	↑	X	L

L = Logical low
 H = Logical high
 X = Don't care
 ↑ = Positive-going
 Channel 2 - POSITIVE EDE

Example of input signals and resulting events:

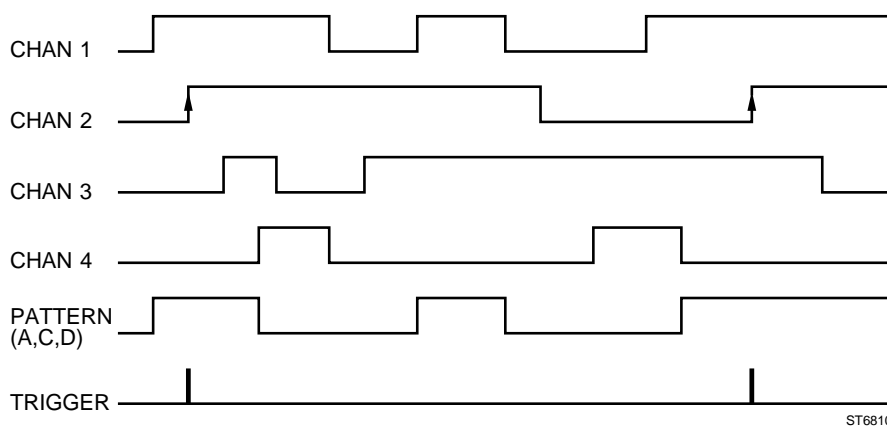

5.8.1.7 Diagram 7

DELTA-T circuit

A DELTA-T circuit is introduced to measure the time between the moment of triggering and the real sample moment. This is needed to know for which memory location converted digital codes have to be stored.

The DELTA-T circuit consists mainly of two current sources. A charge current source (V8044/V8046), which produces a constant current of 30 mA and a discharge current source (V8134/V8136), which produces a constant current of 60 μ A. So the ratio between these two currents is 1:500.

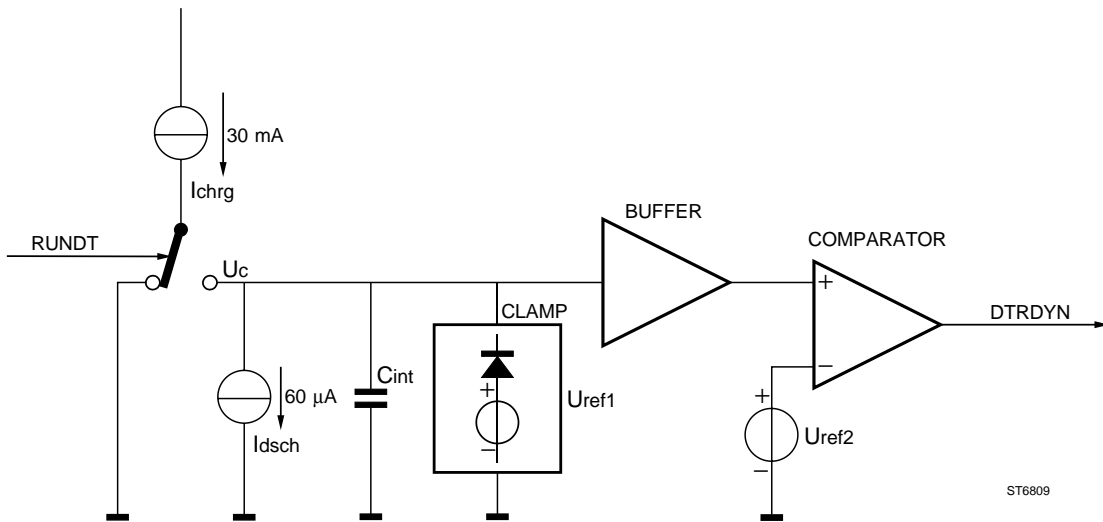

The DELTA-T unit consists of an analog section and a digital section. The digital section in the DARLIC circuit consists of a counter, which runs on the maximum sample clock frequency.

- In direct sampling mode (timebase setting down till 0.25 μ s/div.), the DELTA-T circuit is used to keep the position of the triggerpoint on the screen stable (jitter compensation).
- In random sampling mode, more acquisitions are needed to build a complete picture and to fill the complete acquisition memory. The DELTA-T circuit determines the horizontal position for the first sample of each acquisition cycle.

A symmetrical signal pair RUNDT/RUNDTN (RUN delta-T measurement), which is derived from the trigger circuit in the RATEL circuit on diagram 8, controls the DELTA-T measurement.

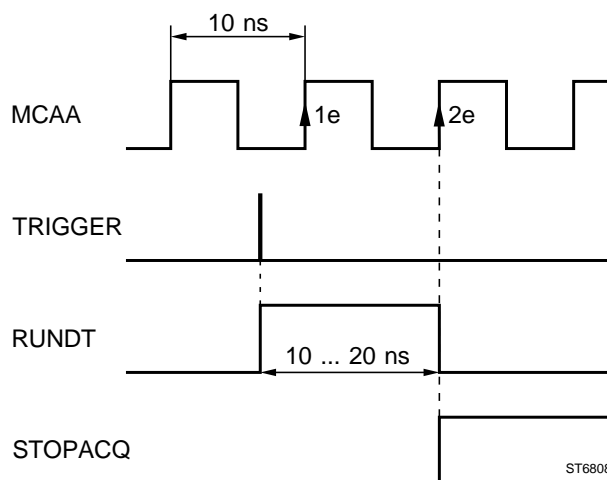

At the moment that an active trigger signal appears, signal RUNDT switches to logic "1" and transistor V8126 is blocked. Transistor V8124 starts conducting. Capacitor C8271 is then charged very fast by a current of 30 mA from the charge current source to a voltage which depends on the time between the trigger pulse and the second positive going edge of the 100 MHz clock signal MCAA. At the second positive going edge of the clocksignal after the triggermoment, the signal RUNDT is switched to logic "0" again. The transistor V8124 is blocked then and the 30 mA current flows via V8126 which is conducting. Capacitor C8271 will now slowly be discharged to the level Uref1 via the 60 μ A discharge current source. The discharge period is 500 times the charge period of the capacitor. The voltage over the capacitor, is applied via buffer V8137 to comparator N8062, where it is compared with reference voltage Uref2.

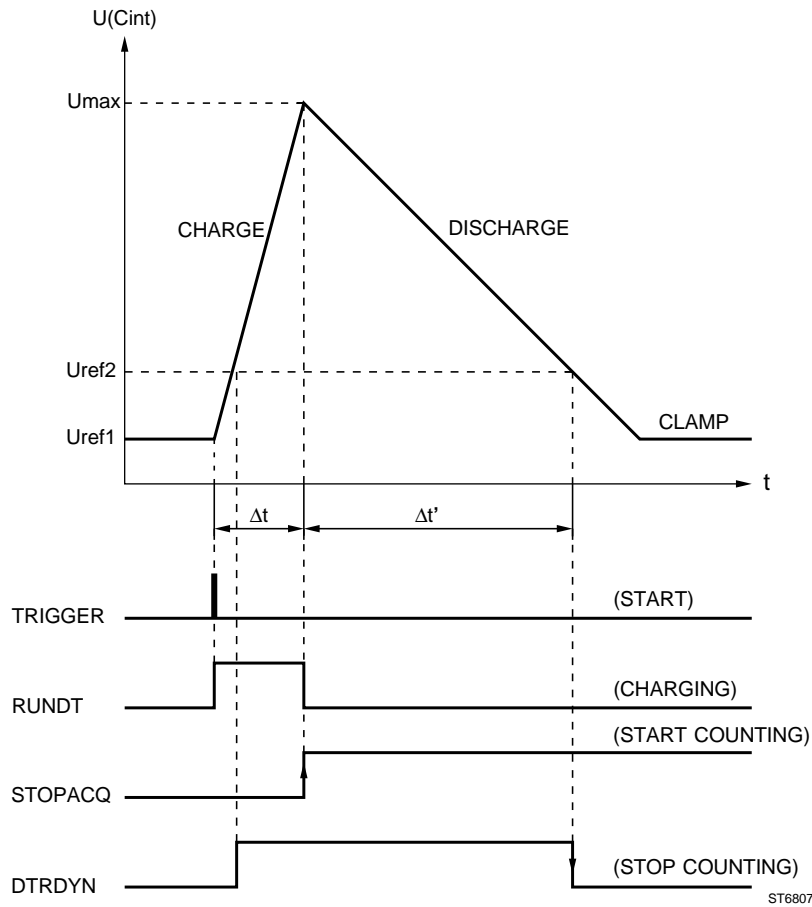

A DELTA-T counter in the DARLIC circuit is enabled for counting by the STOPACQ signal from the RATEL circuit at the moment that the first sample is taken. So at the second positive going edge of the clocksignal. The counter counts in steps of 10 ns. The comparator output signal DTRDYN (DELTA-T ready) is applied to the DELTA-T counter in the DARLIC circuit and the falling edge of this signal DTRDYN stops the counting. At this moment the counter contains a value which is a measure for the time between the trigger pulse and the sample pulse.

The Digital Signal Processor (DSP) circuit on diagram 10 is informed about this completion by an appropriate interrupt bit. After the DSP reads this counter, the counter is reset to zero again, to be ready for the next acquisition cycle and the next DELTA-T measurement.

5.8.1.8 Diagram 8

The RANdom Trigger Engine Logic circuit (RATEL) is a very fast (300MHz) circuit for selection of the source on which triggering takes place. It synchronizes the selected trigger with the 100 MHz system clock. The circuit controls also the DELTA-T circuit by the generation of signal RUNDT.

Trigger source selection

One out of eight trigger sources can be selected via an internal multiplexer, which is controlled by the three source selection signals SLZERO, SLONE and SLTWO.

Trigger source	SLZERO	SLONE	SLTWO
GLITCH (20ns)	0	0	0
DSOM	1	0	0
DSOD	0	1	0
DTB GATE	1	1	0
RTPST	0	0	1
Not used	1	0	1
RPAT	0	1	1
DUAL SLOPE	1	1	1

Input sources for the RATEL circuit D8502 are DTBGATE on X8502, DSOM on X8503 and DSOD on X8501. These signals are derived from the analog oscilloscope section. DSOM is the trigger moment for the Main Time-base, DSOD is the trigger moment for the Delayed Time-base and DTBGATE is active during the delayed sweep.

RPAT/RPATN (pattern trigger mode) and RTPST/RTPSTN (state mode and timed-pattern mode) from the Pattern and State Selector on diagram 6 are also input sources. They are applied to the RATEL circuit via buffers.

Other input sources are GLITCH which is internally derived from RPAT and DUAL SLOPE which is internally derived from DSOM and DSOD.

A GLITCH detection circuit is responsible for generating well defined triggers on small spikes.

The RATEL circuit contains an internal circuit to perform DUAL SLOPE triggering. Dual slope triggering is used in Single Shot mode when it is not known, whether the first signal edge is positive or negative going.

Control signal SLSEL is used for pattern "enter" or "exit" selection by the inversion of signal RPAT. Logic "0" for "enter" and logic "1" for "exit".

Holdoff signal HLONB initializes the RATEL circuit. As long as signal HLONB is logic "0", no new triggers can be processed. Signal HLONB is via a randomizer circuit derived from HLONA to make HLONB asynchronous from the 100 MHz system clock.

Trigger detection and synchronization

The selected trigger signal from the trigger source selector, is internally applied to the trigger detection and synchronization stages.

Here each trigger signal (start of a new acquisition cycle) is synchronized with the 100 MHz sample clock signal MCAAR. A signal ENEV is then generated as input for the trigger synchronization stage and this results after synchronization in the digital trigger signal STOPACQ.

AUTO trigger mode

If no triggers are present and the DARLIC circuit has seen no triggers (via the alias input) for about 100 ms, the AUTO trigger mode is activated and signal STOPACQ is derived from signal AUTOTRHT which is generated by the software.

A trace is then displayed on the CRT screen.

Event trigger mode

Signal ENEV (enable event) is also used for event counting in Event trigger mode. The clockpulse for the Event mode is signal ECLK.

In the Event mode, the source is DSOD selected by the signals SLEONE ("1") and SLETWO ("0").

Switching between normal and event triggering is done with signal EVENT-HT. Signal ENEV starts an event counter in the DARLIC circuit. This counter will count the selected number of events minus one, after which the EVUFN (event underflow) for the RATEL circuit will be activated. With the last ECLK pulse the EVUFN signal is clocked and applied to the trigger synchronization stage resulting in signal STOPACQ.

TV trigger mode

In TV trigger mode the trigger signal is derived from DSOM and as signal ECLK applied to the circuit consisting of D8045, D8030 and D8063. The circuit is enabled by signal ENDGHOHT (enable digital hold-off), if TV-LINE is selected (analog and digital) or if digital DTB acquisition is selected. D-type flipflop D8045 is enabled by signal TVLNSLHT (TV-line selection) which is active high if TV-LINE is selected (analog and digital).

A hold-off signal TVHOLD on X8504 is generated and applied to the hold-off circuit X6010/D8006 in the analog oscilloscope section. This signal enables the time-base generator so that sweeps can then be initiated.

Stop acquisition signal

The signal STOPACQ is generated and applied to the Data Acquisition and tRigger Logic IC (DARLIC) on diagram 9 to stop the acquisition of new input signal information and to enable the DELTA-T counter. This is done on receipt of the active trigger in the RATEL circuit.

Signal STOPACQB is via a delay circuit as STOPACQ applied to the DARLIC circuit to prevent that this signal switches in the edge of the DARLIC clock signal. The STOPACQ signal is reset by signal RSTACQLT.

After generation of signal STOPACQ, a copy cycle starts to copy the new acquisition data to the Main Acquisition Memory (MAM) on diagram 11 for further processing and display on the CRT screen.

DELTA-T circuit

The RATEL circuit derives the RUNDT/RUNDTN signals (10 ... 20 ns) from the triggersignals and the internal 100 MHz clock, to start and stop the measurements in the DELTA-T circuit. Also see the description of diagram 7.

AUTO calibration

In the calibration mode, the DELTA-T circuit is calibrated in 10 ns and 20 ns under the control of the DARLIC circuit. Signal GENTRGNB sets the RATEL circuit in the calibration mode. Holdoff signal HLONB is made active low.

With SELTRG logic "1" a RUNDT signal of 10 ns is generated for 10 ns calibration and with SELTRG logic "0" a RUNDT signal of 20 ns is generated for 20 ns calibration.

5.8.1.9 Diagram 9

Data Acquisition and tRigger Logic IC (DARLIC)

The output datawords SDA<7:0> and SDB<7:0> from the two Analog to Digital Converters on diagram 5 are applied to the DARLIC circuit D8027. The DARLIC circuit is programmed by memory mapped I/O commands.

All tasks can be grouped together in two major functions: a data path and a trigger engine.

The data path is responsible for the total acquisition process from ADC to memory, including time-base generation.

The trigger engine is responsible for the generation of a start/stop acquisition signal that is fed to the data path.

The major headlines of the DATA PATH are:

- Sample clock control via serial data bus.
- Acquisition control and time-base generation. It starts as soon as it is ordered to do so by the Digital Signal Processor (DSP) or system engine. It stops the acquisition as soon as a stopsignal STOPACQ is received from the RATEL circuit.
- Channel switch control via signal SLS12.
- Latching of the 8-bit ADC sample datawords at the maximum sample rate of 100 MS/s and speed conversion from this 100 MS/s data rate to a 25 MHz data rate. This is done by demultiplexing of the two incoming datastreams into four outgoing datastreams for the Fast Acquisition Memory (FAM) behind the DARLIC circuit.
In the fastest (0,5 μ s/div) time-base speed, every 40 ns (25 MHz) four samples will be transferred to the FAM.
- On the fly digital MIN/MAX detection on non stored samples. Each channel has an independent MIN/MAX detector, which detects the minimum and maximum value of all non stored values.
- Gateway function for the data transfer from the Fast Acquisition Memory (FAM) to the Main Acquisition Memory (MAM) by the DSP.

The major headlines of the TRIGGER ENGINE are:

- Generation of a synchronous start/stop acquisition signal for the data path, covering pre- and posttriggering.
- Counting of trigger events and trigger delay.
- It also contains a DELTA-T counter and supports the DELTA-T circuit, to be able to calculate the time between the asynchronous- and the synchronized trigger signal.
- It contains two timers for the timed-pattern mode. Timed- pattern and State detection is realized in combination with the COMPASS circuit on diagram 6.
- Supporting TV line selection in TV trigger mode.

Data path:

The main purpose of the datapath is to establish two gateways. One for guiding the ADC-data to the Fast Acquisition Memory (FAM) in a time-base controlled way, and one for guiding data from the FAM to the Main Acquisition Memory (MAM) by the Digital Signal Processor (DSP).

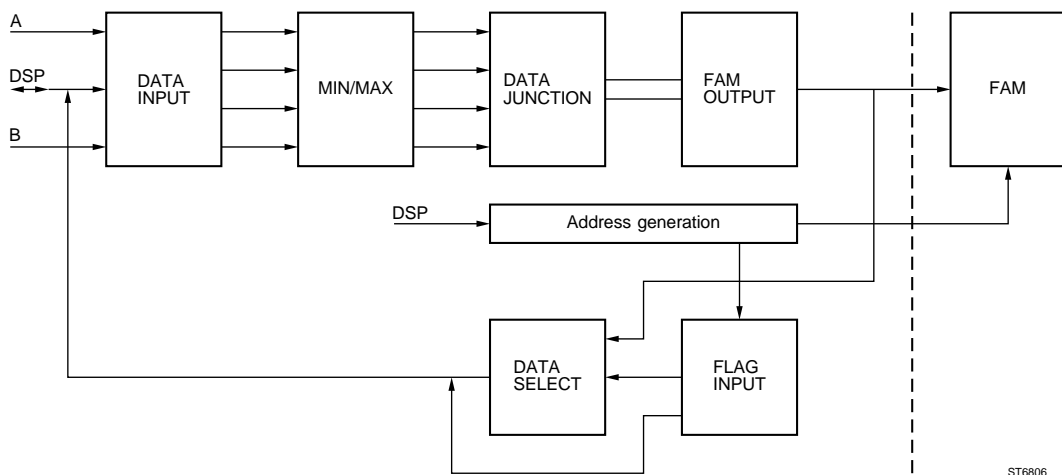

With the Data Input block a selection between the converted sample data from the two ADCs and data obtained from the Digital Signal Processor (DSP) is made. Both channels use the clock used by the corresponding ADC. Furthermore the ADC data is checked on underflow and overflow.

With MIN/MAX selected, minimum and maximum values are calculated by the MIN/MAX circuits. This is not possible in the CHOP mode.

A data junction unit lowers the data rate from 100 MHz streams to 25 MHz streams and guides the data from the MIN/MAX circuit properly to output latches. It also starts up the write cycle to the FAM, if enough bytes have been received. It generates the read signal FRDN, the write signal FWRN and the chip select signals FCSN<7:0> for all the memory banks. The FAM itself is not part of the DARTLIC circuit.

Besides the creation of data to be stored in the FAM, addresses have to be generated. The acquired data later has to be transferred to the Main Acquisition Memory (MAM) by means of the Digital Signal Processor (DSP), this can not directly be done but only via the DARTLIC gateway in a sequential way.

Trigger engine:

The analog input channels which are connected to the channel switch are also applied to level comparators, see the description of diagram 6. Their outputs are connected to a pattern and state detector. When the pattern matches a predefined pattern mask, a "pattern match" signal DPATN will be generated. A pattern mask is defined, in terms of "H", "L" and "don't care". State triggering is an extension of pattern triggering. One of the channels has to be selected as the clock, the others as qualifiers. The active edge of the clock is selectable.

The result of the detector is asynchronous with the sample-clock and therefore also usable for random sampling. Two timers are available in the DARTLIC circuit for use during time measurements. With these timers trigger conditions are defined in terms of trigger on a specific pattern if its present time is $T1 < TP$, or $T1 < TP < T2$, or $TP < T2$.

The pattern and state detector is mainly realized in the COMPASS circuit, see the description of diagram 6.

Edge selector:

Edges can be used for triggering in general but are a prerequisite for random sampling. The following "edges" are available for the trigger engine:

- DSOM and DSOD signals which come directly from the analog oscilloscope section.
- DTBGATE comes directly from the analog oscilloscope section. The oscilloscope can perform the "triggered DTB" function in the analog as well as in the digital mode.
- Pattern match (including timed pattern) or state detect.
- Glitch detection.
- TV field, frame and TV line. This information is retrieved from the DSOM and the VSYNC incoming signals. VSYNC is an asymmetrical signal applied by connectors and cable with a characteristic input of 50 Ohm.

A trigger hold-off line, TVHOLD, is returned to the analog oscilloscope section, so that the analog mode of the oscilloscope can be programmed to trigger on a specific TV- line. TVHOLD signal is an asymmetrical signal applied by connectors and cable with a characteristic impedance of 50 Ohm.

Event counting:

Event count is possible on:

- Edges
- Pattern transitions (match/no match)
- Timed patterns (>20 ns)
- State detections

As soon as a predefined number of events are passed and counted by a 16 bit event counter, the event delay phase is terminated. The entry or exit of the event counting phase is asynchronous with the sample-clock. See also the description of diagram 8.

Delay timer:

After the requested trigger is detected and the event delay is passed, it is possible to count down a specific amount of time in a trigger delay counter, to constitute a delay before the acquisition is stopped.

Delta-T Circuit:

The delta-T circuit measures the time between the sample clock and the edge of the output of the "trigger detection circuit". A delta-T counter in the DARLIC circuit is part of the delta-T circuit, see the description of diagram 7.

The measured digital value is applied to the DSP and is used to position the measured sample values in the Main Acquisition Memory.

Fast Acquisition Memory (FAM):

The acquisition data which is converted by the ADC's, is directly stored in a volatile Fast Acquisition Memory (FAM) by the DARLIC circuit. The access time of this memory is such that it matches the sample speed of the system.

This FAM consists of eight SRAM circuits of 2kx8 each. It can be seen as 2 sets of each 4k words of 8 bits. In single channel mode, these two sets can be combined to 1 set of 8k words of 8 bits. In four channel mode, the two sets can be split up in 4 sets of each 2k words of 8 bits.

The address bus is a fifteen bit bus with lines FA<14:00> and the data bus is an 64 bit bus with lines FD<63:00>. Other memory control lines are the chipselect lines FSCN<7:0> and the output enable line FRDN and read/write line FWRN.

The acquired data has later to be transferred to the Main Acquisition Memory (MAM) by means of the Digital Signal Processor (DSP), this can not directly be done but only via the DARLIC gateway in a sequential way.

A special feature allows the Fast Acquisition Memory to be switched into FIFO (first in first out) mode, in which the acquisition fills, and the DSP empties the Fast Acquisition Memory in a cyclic fashion. This is used in the ROLL-mode.

SBUS system:

The SBUS (serial bus) interface is built-in in the Data Acquisition and tRigger Logic IC (DARLIC) circuit D8027. It is used as an output bus.

The lines are open collector I/O pins, SDA (SerialData) and SCL (SerialClock), and a select line SSEL.

The SBUS is connected to a control signals generator, the dot join circuit and to the intensity control circuit. The SBUS can be controlled by the system engine.

For more detailed information about the serial bus system see section 5.1.1.4.

5.8.1.10 Diagram 10**Digital Signal Processor (DSP):**

The Digital Signal Processor D8069 performs all signal processing activities which are not available in hardware. One of the main tasks is the composition of the trace information out of the available registers.

Digital Signal Processor D8069 runs on a 40 MHz clock-frequency from the circuit G8053 signal CK40M.

The DSP contains a 4K maskable PROM and a dataword RAM, of which a part is used for data or program, and the remaining part for data memory.

The functions of the DSP are:

Pre-processing

Average

Envelope

Post-processing

Mathematical functions

Interpolation (linear, sine)

Filters

Display memory refresh

X-POSITION control

Restart acquisition

Delta-T processing

Conversion to 512 horizontal dots per screen

Control signals are:

- Three interrupt lines DSPIN0LT, DSPIN1LT and DSPIN2LT.
- The DSP can be reset by signal RSDSP-LT.
- A signal DSPRDYHT to extend the current memory cycle from the DSP until the addressed device is ready to accept data (write cycle) or has put data on the global bus (read cycle).
- DSPRW-LT which is active low during a write cycle and high during a read cycle.
- STRB--LT is a strobe signal which is active low for each external bus cycle.
- DS----LT is a data space select signal which is active low during communication with an external device which contains data.
- PS----LT is a program space select signal which is active low during communication with an external device which contains a program.

Program Memory (PRAM):

The DSP program memory consists of the two 8Kx8 SRAM circuits D8049 and D8052 and is the private program memory of the Digital Signal Processor. It is a volatile memory and can not be accessed by any other device. The address lines are the sixteen lines DSPA<15:00> from the Digital Signal Processor D8069 and the data lines are the sixteen lines DSPD<15:00> to and from the DSP. Control lines for the program memory are the chipselect signal PRAMCSLT, the output enable signal PRAMOELT which is low during read actions, and the read/write signal PRAMRWLT from the Bus Arbiter and Trace Generator (BATGE) circuit on diagram 11.

5.8.1.11 Diagram 11

Bus Arbiter and Trace Generator

The main function of the Bus Arbiter and Trace Generator (BATGE) D8048 is the arbitration between multiple processors, multiple memories and memory mapped I/O with a minimum of interference. This circuit is running on a 40MHz clockfrequency from the circuit G8053, signal CK40M on diagram 10. "Active devices" like the DARLIC circuit for example, generate a "not ready signal".

Text and Trace generation

All texts, cursors and eight traces are generated in vector notation technique.

Text and cursors are generated by means of the Cursor Control CURCON circuit on diagram 12. The 8 traces are generated by the BATGE circuit.

The horizontal resolution will always be 9 bits. Sample values are generated from 1 till 512 which covers the entire available X-axis on the CRT screen and corresponds with 50 dots per division. When the acquisition length is "normal", there is a 1 to 1 relation between the acquisition and the display. When the acquisition length is larger than "normal", then data reduction is necessary to present the entire record on the display. The technic used for data reduction is MIN/MAX detection and works on the principle that on every two positions on the screen the minimum and maximum value of a set of acquisition samples is displayed.

The vertical resolution will always be 10 bits. Sample values are generated from 50 till 950, which covers the entire available Y-axis on the CRT screen.

Also four independent X versus Y traces can be generated in vector notation. These traces are generated by the BATGE circuit. The maximum amount of X-Y dots in a trace is 512.

The Y resolution in X versus Y mode is 10 bits. Sample values are generated from 50 till 950, which covers the entire available Y-axis on the screen.

The trace information can be presented on the CRT screen with normal, highlighted or suppressed light.

The BATGE circuit is also responsible for interconnecting all address, data and control busses of the DSP, SYSTEM BUS, Text and Trace Generator, DARLIC, VECTOR, DACPOT and Main Acquisition Memory.

Main Acquisition Memory (MAM)

The Main Acquisition Memory MAM consists of the two 32Kx8 SRAM circuits D8056 and D8054 and contains the trace data which is ready for display on the CRT screen. It contains an acquisition as well as a display memory.

The memory is non-volatile, which means that the information is not lost when mains supply is turned off.

The address lines are the sixteen GLOBAL ADDRESS BUS lines GLOA<15:0> from the DARLIC circuit on diagram 9 and the data lines are the sixteen GLOBAL DATA BUS lines GLOD<15:0>. Control lines for the program memory are the chipselect signal GLOCS1LT, the output enable signal GLOOE-LT and the read/write signals GLOWELLT and GLOWEHLT from the GLOBAL CONTROL BUS. The Digital Signal Processor can directly access this memory in a random way. Information from the FAM memory is written to the MAM acquisition memory part.

The display memory contains always the information for one complete screen of 512 dots. Magnification is performed here under software control. In DOTS-mode less than 512 dots can be displayed and in DOTJOIN-mode interpolation between the dots is performed.

Data flow between BATGE and unit A3:

ALE-HT	Address latch enable ALE-HT = "0" data on CPAD<07:00> ALE-HT = "1" address on CPAD<07:00>
BATRDYHT	Batge ready signal for the wait state logic
BATINTHT	Batge interrupt signal In digital mode, each 16 ms a pulse is generated as indication that text on the CRT display has to be refreshed. Other interrupt events are possible too.
CPA<13:8>	High order address bus
CPAD<07:00>	Multiplexed, bidirectional data/address bus
CPRD--LT	Active low during reading from BATGE by the microprocessor
CPWR--LT	Active low during writing to batge by the microprocessor
RESOPTLT	Reset signal
TXTCS-LT	Active low during main memory access by the microprocessor on unit A3

Data flow between CURCON, VECTOR, INTENS CONTROL, SWITCH CONTROL AND BATGE:

ATXTENLT	Analog text enable signal (generates signal BZ1)
AX<9:0>	10 bits data bus containing the horizontal information of the digital trace for the XDAC
BI0--HT	Signals for intensity control for selection between: - text intensity - intensity in normal mode - intensified intensity
BI1--HT	
BTEH--HT	
BVEC--HT	Track and hold output for the dot-join circuit Static output signal to VECTOR circuit, determines DOT or DOTJOIN mode. BVEC--HT = "0" dots BVEC--HT = "1" dots joined
BXYSW--HT	Control signal for XY switch BXYSW--HT = "0" analog signals to amplifier BXYSW--HT = "1" digital trace or text to amplifier
BZTE--LT	Vector Z control BZTE--LT = "0" variable intensity of text and digital trace via INTENSITY rotaries on the front of the oscilloscope BZTE--LT = "1" blanking of text and trace
CUEN0-LT	Chip select output signal for CURCON
CZSW1-HT	Z-switch signal from CURCON used for generation of signal BZSW--HT BZSW--HT = "0" analog trace intensity to Z-amplifier BZSW--HT = "1" text or digital trace intensity to Z-amplifier
CZTE1-HT	Curcon Z=text information
CXYSW1HT	XY switch input signal from CURCON
DY<9:0>	10 bits data bus containing the vertical information of the digital trace for the YDAC

Data flow between DSP and BATGE:

DS----LT	Input for data space select, active low during communication with an external data device (for example MAM, DARLIC, DACPOT and so on)
DSPA<15:0>	16 bits DSP address bus
DSPD<15:0>	16 bits DSP data bus
DSPIN1LT	Active low DSP interrupt request output signal
DSPRDYHT	Active low output signal indicating from an external device to the DSP that during a read action for the DSP, the data is not yet placed on the databus or that during a write action from the DSP the data is not yet read by the external device. The DSP then extends the wait cycle and checks the ready signal again.

DSPRW-LT	DSP read/write signal DSPRW-LT = "0" write cycle DSPRW-LT = "1" read cycle
GLOA<16:0>	17 bits global address bus
GLOD<15:0>	16 bits bidirectional global data bus
PRAMCSLT	Active low chip select signal for PRAM
PRAMOELT	Active low output enable signal for PRAM
PRAMRWLT	PRAM read/write signal PRAMRWLT = "0" write cycle to PRAM PRAMRWLT = "1" read cycle from PRAM
PS----LT	Input for program space select, active low during communication with an external program device (for example PRAM)
RSDSP-LT	Active low signal for DSP reset
STRB--LT	Strobe signal, active low during each external bus cycle

Signals from the GLOBAL control bus:

GLOA<16:0>	17 bits global address bus
GLOCS1N	Global chip select 1 for MAM
GLOCS2N	Global chip select 2 (option)
GLOD<15:0>	16 bits bidirectional global data bus
GLOWELLT	Global write low byte enable for devices connected to the low byte of the global data bus
GLOWEHLT	Global write high byte enable for devices connected to the high byte of the global data bus

5.8.1.12 Diagram 12

CURsor CONTROL circuit CURCON

The Cursor Control circuit (CURCON) D8047 is used for cursor and text control. Every 16 ms, an active low signal CUEN0-LT is generated and text and traces are refreshed on the screen and the contents of the memory is read.

Text and cursor control memory

The text and cursor control memory consists of one 8Kx8 SRAM circuit D8051 and contains the text and cursor information to be displayed on the CRT. The address lines are the thirteen lines TXTA<12:0> from the CURsor CONTROL (CURCON) circuit D8047 and the data lines are the eight lines TXTD<7:0> to and from the CURCON circuit.

Control lines for the memory are the chipselect signal, the output enable signal and the read/write signal from the CURCON chip.

X- and Y- Digital to Analog Converters

Digital signal and text data to be displayed is applied as AX<9:0> to the Horizontal Digital to Analog Converter XDAC N8057 and as DY<9:0> to the Vertical Digital to Analog Converter YDAC N8058. The analog output signals XDAC0/XDAC1 and YDAC0/YDAC1 from the two Digital to Analog Converters are applied to the output circuits on diagram 13.

Information for the analog oscilloscope section about switching between the analog and the digital signal information, is derived from signals BXYSW-HT (low is analog signal and high is digital trace and text) and TXTOP-HT via transistors V8041 and V8036 and applied as current signals XYSW0 and XYSW1 to R1204 and R1201 on unit A2. Text display is on during the autocal procedure if TXTOP-HT is high. Switching is done in such a way, that text is mostly displayed in the hold-off period between two sweeps.

Intensity control circuit

All conditions under which the Z-control circuit has to switch the CRT beam ON and OFF are combined in the intensity control circuit. The intensity information comes via the SBUS (serial BUS) to the six channel DAC N8070. Selection between text intensity, trace intensity normal and trace intensity intensified is done in multiplexer D8059 which is controlled by the signals BI0---HT and BI1---HT.

	BI1	BI0
Text intensity	0	0
Normal trace intensity	0	1
Not used	1	0
Intensified intensity	1	1

The selected signal is applied to the base of transistor V8004. Symmetrical Z-control output signal pair ZTXT0 and ZTXT1 carries the resulting blanking/unblanking information which is, applied to R3007 and R3008 on unit A2 in the analog oscilloscope section.

Information for the analog oscilloscope section about switching between the analog Z-signal and the digital Z-signal, is derived from signal BZSW--HT (low is analog trace intensity and high is digital trace and text intensity) via transistors V8042 and V8033 and applied as current signals ZSW0 and ZSW1 to D3001/7 and D3001/8 on unit A2.

Signal BZTE is low for unblanking and high for blanking of the trace. In analog oscilloscope mode, signal BZ1 switches between holdoff (low) and sweep (high). In digital oscilloscope mode this signal switches between text display (low) and trace display (high).

5.8.1.13 Diagram 13

Display interface

Frequency divider:

The 40 MHz input clocksignal CK40M is divided via circuit D8055 into a TEH pulse and a 50 ns SCPULS pulse for the control of the VECTOR (dot join circuit) circuit N8061.

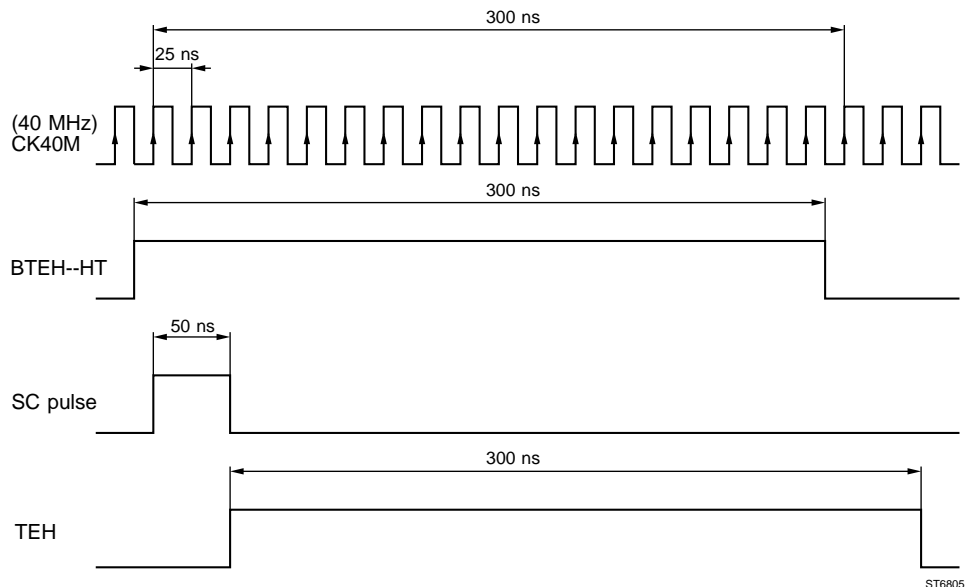

Final offset:

Final offset levels for the X- and Y-axis in the dot join mode, are generated via the SBUS (I2C BUS) and N8009 as levels XOFFS and YOFFS. These levels are via transistors V8201/V8199 and V8203/V8204 applied to the XDAC0/XDAC1 and YDAC0/YDAC1 level signals from the X- and Y-DAC on diagram 12. Resulting X- and Y-signal information is applied to the VECTOR circuit N8061.

Vector circuit:

YDAC0 and YDAC1 as well as XDAC0 and XDAC1 are applied to the vector circuit (dot join circuit) N8061 as symmetrical signals.

The VECTOR circuit is provided with a 2 mA reference current via transistor V8037 and R8384 (signal VECBIAS is not used).

In DOT-mode and during text display, the input signals are directly coupled to the outputs YTXT0/YTXT1 or XTXT0/XTXT1.

The signals YSGPTOUT/YSGNTOUT and XSGPTOUT/XSGNTOUT from level shifters in the VECTOR circuit, are applied to hold capacitors C8256/C8257 and C8258/C8259 during the active TEH pulse of 300 ns. During the SCPULSE of 50 ns, the capacitors are discharged again. Capacitor levels YSGPTSLB/YSGNTSLB and XSGPTSLB/XSGNTSLB are applied to internal voltage/current converters in the VECTOR circuit.

Signal BVEC--HT switches between DOT-mode (0V) and DOTJOIN-mode (5V).

In DOTJOIN-mode the signals are applied via integrator circuits. External capacitors C8102, C8103, C8104 and C8106 are the integrator capacitors for the horizontal signal path and C8107, C8108, C8109 and C8111 are for the vertical signal path.

The integration time to join two dots is 2 microseconds. This is 1 ms per trace of 512 dots and about 8 ms for 8 traces. About 8 ms is used for text display. Each 16 ms a complete new display cycle is performed.

Output signals XTXT0/XTXT1 and YTXT0/YTXT1 are applied to R2063/R2064 and D1001/15, D1001/16 on unit A2 in the analog oscilloscope section for display on the CRT screen.

5.8.1.14 Diagram 14**Control signals via the SBUS (serial BUS) interface**

A large number of control signals for the various circuits on digitizer unit A8 are generated via the SBUS interface system and integrated circuits D8034, D8036, D8033 and D8032 which are placed in series.

D8034	ES2	to diagram 6
	ES4	to diagram 6
	PS3	to diagram 6
	PS1	to diagram 6
	SELTRG	to diagram 8
	SELTP-HT	to diagram 6
	ES1	to diagram 6
	ES3	to diagram 6
D8036	EN2	to diagram 6
	EN4	to diagram 6
	PS2	to diagram 6
	PS4	to diagram 6
	EVENT-LT	to diagram 8
	EN1	to diagram 6
	EN3	to diagram 6
D8033	SLZERO	to diagram 8
	SLTWO	to diagram 8
	SLETWO	to diagram 8
	SLEONE	to diagram 8
	SLONE	to diagram 8
	SLSEL	to diagram 8
	CLKBINV	to diagram 4

D8032	ENST13HT	to diagram 1
	PCCDMDLT	to diagram 1 and 2
	CPST13HT	to diagram 1
	DSAMPBHT	to diagram 4
	ENST24HT	to diagram 2
	DSAMPAHT	to diagram 4
	CPST24HT	to diagram 2
	TRCKMDHT	to diagram 4
	HEFOUT	to X1008 on unit A10

Power distribution

Various circuits for filtering of power supply signals as well as splitting and distribution of power supply signals are shown.

5.8.2 Signal name list digitizer A8

NAME	MEANING	SOURCE	DESTINATION
AGADJA	Amplifier gain adjust A	N8014:3	N8026:1
AGADJB	Amplifier gain adjust B	N8014:3	N8027:2
ALE-HT	Address latch enable	X8101:11	D8048:11
ANINA	Analog input A	N8013:1	N8002:5
ANINB	Analog input B	N8012:2	N8001:5
AUTOTRHT	Autotrigger	D8501:3	D8502:8
AX <9:0>	X- digital trace and text data	D8048:11	D8047:12 N8057:12
BATINTHT	BATGE interrupt	X8101:11	D8048:11
BATRDYHT	BATGE ready	X8101:11	D8048:11
BI0---HT	Intensity control 0	D8048:11	D8059:12
BI1---HT	Intensity control 1	D8048:11	D8059:12
BTEH--HT	Track and hold	D8048:11	D8055:13
BVEC--HT	Vector switch Dots/Dot join	D8048:11	R8530:12 R8531:12 N8061:13 R8853:13
BXYSW-HT	Switch signal Analog/Digital	D8048:11	V8205:12
BZ1	Text enable signal	D8048:11	D8047:12
BZSW--HT	Z-switch signal Analog/Digital	D8048:11	R8422:12
BZTE--LT	Dot Z-control	D8048:11	V8112:12
CHOP1	Chopper signal CH.1	V8047:3	N8026:1
CHOP2	Chopper signal CH.2	V8048:3	N8027:2
CHOP3	Chopper signal CH.3	V8069:3	N8026:1
CHOP4	Chopper signal CH.4	V8071:3	N8027:2
CK12M	Clock signal 12MHz	D8047:12	D8045:3
CK40M	Clock signal 40MHz	G8053:10	D8048:11 D8055:13
CLKA	Clock signal A (100 MHz)	V8138:4	N8026:1
CLKB	Clock signal B (100 MHz)	V8140:4	N8027:2
CLKBINV	Clock B invert	D8033:14	D8005:4
COMP 1N	Logic input channel 1	N8023:1	R8347:6
COMP 1P	Logic input channel 1	N8023:1	R8344:6
COMP 2N	Logic input channel 2	N8022:2	R8317:6
COMP 2P	Logic input channel 2	N8022:2	R8326:6

COMP 3N	Logic input channel 3	N8024:1	R8291:6
COMP 3P	Logic input channel 3	N8024:1	R8288:6
COMP 4N	Logic input channel 4	N8021:2	R8309:6
COMP 4P	Logic input channel 4	N8021:2	R8316:6
CPA<13:08>	CPU address bus	X8101:11	D8048:11
CPAD<07:00>	CPU multiplexed address/data bus	X8101:11	D8048:11
CPRD--LT	CPU read cycle	X8101:11	D8048:11
CPST13HT	Copy set CH. 1/3 (to CH. 2/4)	D8032:14	N8026:1
CPST24HT	Copy set CH. 2/4 (to CH. 1/3)	D8032:14	N8027:2
CPWR--LT	CPU write cycle	X8101:11	D8048:11
CSD1--LT	Chipselect DARLIC	D8048:11	D8027:9
CUENO-LT	CURCON	D8048:11	D8047:12
CXYSW1HT	CURCON XY switch	D8047:12	D8048:11
CZSW1-HT	CURCON Z switch	D8047:12	D8048:11
CZTE1-HT	CURCON text	D8047:12	D8048:11
D210ENHT	Enable digitizer	D8501:3	X8500:8
DACCS-LT	DACPOT chip select	D8048:11	D8006:3
DACPENLT	DACPOT start cycle	D8501:4	D8006:3
DACSTRTN	DACPOT chip select	D8048:11	D8501:3
DPATN	Pattern valid	R8896:6	D8027:9
DS---LT	Data space select	D8069:10	D8048:11
DSAMPAHT	Double sample mode A	D8032:14	R8547:4
DSAMPBHT	Double sample mode B	D8032:14	R8566:4
DSOD	DTB trigger	X8501:8	D8502:8
DSOM	MTB trigger	X8503:8	D8502:8
DSPA<15:00>	DSP address bus	D8069:10	D8048:11
DSPA15 EX	DSP address bit 15	D8050:10	D8048:11
DSPD<15:00>	DSP bidirectional data bus	D8069:10	D8048:11
DSPIN0LT	DSP interrupt request 0	D8027:9	D8069:10
DSPIN1LT	DSP interrupt request 1	D8048:11	D8069:10
DSPIN2LT	DSP interrupt request 2	D8027:9	D8069:10
DSPRDYHT	DSP ready	D8048:11	D8069:10
DSPRW----LT	DSP read/write	D8069:10	D8048:11
DTBGATE	DTB gate	X8502:8	R8729:8
DTRDYN	Delta-t ready	N8062:7	D8027:9
DY<9:0>	Y digital trace and text data	D8048:11	D8047:12 N8058:12
ECLK	Event clock	R8828:8	D8027:9
ECLKB	Event clock	D8502:8	R8828:8
EN1	Logic don't care CH. 1	D8036:14	N8029:6
EN2	Logic don't care CH. 2	D8036:14	N8029:6
EN3	Logic don't care CH. 3	D8036:14	N8029:6
EN4	Logic don't care CH. 4	D8036:14	N8029:6
ENDGHOHT	Enable digital hold off	D8501:3	D8063:8
ENEV	Enable event	D8502:8	D8027:9
ENPTTMLT	Enable timed pattern	D8501:3	D8503:6
ENST13HT	Enable set 1/3	D8032:14	N8026:1
ENST24HT	Enable set 2/4	D8032:14	N8027:2
ES1	State CH. 1	D8034:14	N8029:6
ES2	State CH. 2	D8034:14	N8029:6
ES3	State CH. 3	D8034:14	N8029:6
ES4	State CH. 4	D8034:14	N8029:6
EVENT-LT	Event mode	D8036:14	D8502:8
EVUFN	Event underflow	D8027:9	D8502:8

FA<14:00>	FAM adres bus	D8027:9	FAM:9
FAMWRLT	FAM write (2K)	J8001:9	FAM:9
FD<63:00>	FAM data bus	D8027:9	FAM:9
FRDN	FAM read cycle	D8027:9	FAM:9
FSCN<7:0>	FAM chip select	D8027:9	FAM:9
FWRN	FAM write cycle	D8027:9	J8001:9
GAINMPUA	Gain MASPU A	R8778:3	R8079:3
GAINMPUB	Gain MASPU B	R8775:3	R8098:3
GENTRGNB	Generate trigger not	D8027:9	D8502:8
GLOA<16:00>	Global address bus	D8048:11	D8501:3 D8027:9 D8047:12
GLOCS1LT	Global chip select 1 (MAM)	D8048:11	D8054:11 D8056:11
GLOCS1N	Global chip select 1	D8063:11	D8050:11
GLOCS2N	Global chip select 2	D8048:11	D8050:11 D8063:11
GLOD<15:00>	Global bidirectional data bus	D8048:11	D8006:3 D8501:3 D8027:9 D8047:12
GLOOE-LT	Global bus output enable	D8048:11	D8027:9 D8047:12
GLORDYHT	Global bus ready (wait state)	D8048:11	D8027:9 D8047:12
GLOWEHLT	Global bus write enable high byte	D8048:11	D8027:9 D8047:12
GLOWELLT	Global bus write enable low byte	D8048:11	D8027:9
HEFOUT	HEF bus output	D8032:14	X8101:14
HF1	HF Adjust CH. 1	R8785:3	R8794:3
HF2	HF Adjust CH. 2	R8786:3	R8791:3
HF3	HF Adjust CH. 3	R8787:3	R8795:3
HF4	HF Adjust CH. 4	R8788:3	R8798:3
HFADJ1	HF Adjust CH. 1	R8793:3	R8766:1
HFADJ2	HF Adjust CH. 2	R8790:3	R8772:2
HFADJ3	HF Adjust CH. 3	R8796:3	R8764:1
HFADJ4	HF Adjust CH. 4	R8799:3	R8769:2
HLONA	Holdoff A	D8027:9	D8030:8
HLONB	Holdoff B	D8030:8	D8502:8
INTEGCX	Integrator capacitor X	N8061:13	C8104:13
INTEGCY	Integrator capacitor Y	N8061:13	C8108:13
ITREEA	Supply current for MASPU diode tree	V8014:3	N8026:1
ITREEB	Supply current for MASPU diode tree	V8012:3	N8027:2
MCAA	Clock signal (100 MHz, ECL)	D8005:4	N8002:5
MCAAR	Clock signal (100 MHz, ECL)	R8721:4	D8502:8
MCBB	Clock signal (100 MHz, ECL)	D8005:4	N8002:5
MCNAA	Clock signal (100 MHz, ECL)	D8005:4	D8004:5
MCNAAR	Clock signal (100 MHz, ECL)	R8722:4	D8502:8
MCNBB	Clock signal (100 MHz, ECL)	D8005:4	N8001:5
NCLKA	Clock signal A (100 MHz)	V8138:4	N8026:1
NCLKB	Clock signal B (100 MHz)	V8141:4	N8027:2

OFFSADCA	Offset ADC A	R8783:3	R8111:3
OFFSADCB	Offset ADC B	R8776:3	R8114:3
OFFSCMP1	Logic trigger level control CH. 1	R8782:3	R8762:6
OFFSCMP2	Logic trigger level control CH. 2	R8780:3	R8761:6
OFFSCMP3	Logic trigger level control CH. 3	R8784:3	R8763:6
OFFSCMP4	Logic trigger level control CH. 4	R8781:3	R8760:6
OFFST&HA	Offset track and hold A	R8779:3	R8831:3
OFFST&HB	Offset track and hold B	R8777:3	R8832:3
PCCDINA	For future use	X8016:1	R8187:1
PCCDINB	For future use	X8006:2	R8123:2
PCCDINPA	For future use	X8017:1	R8217:1
PCCDINPB	For future use	X8007:2	R8174:2
PCCDMDLT	For future use	D8032:14	N8026:1 N8027:2
PCCDNA	For future use	X8014:1	N8026:1
PCCDNB	For future use	X8003:2	N8027:2
PCCDPA	For future use	X8013:1	N8026:1
PCCDPB	For future use	X8004:2	R8273:2
POSAA	T&H current source path A	V8081:3	N8026:1
POSAB	T&H current source path A	V8077:3	N8027:2
POSBA	T&H current source path B	V8051:3	N8026:1
POSBB	T&H current source path B	N8074:3	N8027:2
PRAMCSHT	Program RAM chip select	J8003:10	D8049:10
PRAMCSLT	Program RAM select	D8048:11	D8049:10
PRAMOELT	Program RAM output enable	D8048:11	D8049:10
PRAMRWLT	Program RAM read/write	D8048:11	D8049:10
PS1	Pattern select CH. 1	D8034:14	N8029:6
PS2	Pattern select CH. 2	D8036:14	N8029:6
PS3	Pattern select CH. 3	D8034:14	N8029:6
PS4	Pattern select CH. 4	D8036:14	N8029:6
PS----LT	Program space select	D8069:10	D8048:11
RESOPTLT	Reset digitizer	X8101:11	D8027:9 D8048:11 D8047:12
RPAT	Pattern valid	N8029:6	R8747:8
RPATN	Pattern valid	N8029:6	R8734:8
RSDSP-LT	DSP Reset	D8048:11	D8069:10
RSTACQLT	Reset STOPACQ signal	D8501:3	D8502:8
RTPST	Trigger (timed pattern and state)	N8029:6	R8737:8
RTPSTN	Trigger (timed pattern and state)	N8029:6	R8754:8
RUNDT	Run delta-t	D8502:8	R8447:7
RUNDTN	Run delta-t	D8502:8	R8448:7
SADCBNA	Signal copy ADC A to B	N8027:2	N8026:1
SADCBNB	Signal copy ADC A to B	N8026:1	N8027:2
SADCBPA	Signal copy ADC B to A	N8027:2	N8026:1
SADCBPB	Signal copy ADC B to A	N8026:1	N8027:2
SCL	Serial clock	D8027:9	X8500:8 N8070:12 N8009:13 D8032:14 D8033:14 D8034:14 D8036:14

SCLKA	Sample clock A (100 MHz, TTL)	D8004:5	D8027:9
SCLKB	Sample clock B (100 MHz, TTL)	D8003:5	D8027:9
SCLKAN	Sample clock A (100 MHz, TTL)	D8004:5	D8027:9
SCLKBN	Sample clock B (100 MHz, TTL)	D8003:5	C8513:9
SDA	Serial data	D8027:9	X8500:8 N8070:12 N8009:13 D8034:14
SDA<7:0>	Sample data Bus A	D8004:5	D8027:9
SDB<7:0>	Sample data Bus B	D8003:5	D8027:9
SELTP-HT	Select state/pattern	D8034:14	N8029:6
SELTRG	Select trigger	D8034:14	D8502:8
SLEONE	Event source select 1	D8033:14	D8502:8
SLETWO	Event source select 2	D8033:14	D8502:8
SLONE	Trigger source selection 1	D8033:14	D8502:8
SLS12	Chopper clock signal	D8027:9	R8043:3
SLSEL	Slope select	D8033:14	D8502:8
SLTWO	Trigger source selection 2	D8033:14	D8502:8
SLZERO	Trigger source select 0	D8033:14	D8502:8
SSEL	Serial select	R8837:9	R8837:9 D8032:14 D8033:14 D8034:14 D8038:14
STOPACQ	Stop acquisition	L8513:8	D8027:9
STOPACQB	Stop acquisition	D8502:8	R8887:8
STRB--LT	Strobe, DSP global bus access	D8069:10	D8048:11
TBHOTXT	Time base hold text	X8101:11	R8373:11
TPATN	Timed pattern	D8027:9	D8503:6
TRCKMDHT	Track mode (calibration mode)	D8032:14	R8550:4 R8563:4
TVHLD	TV Hold	D8027:9	D8045:8
TVHOLD-LD	TV Hold	D8063:8	X8504:8
TVLNSLHT	TV line select	D8501:3	D8045:8
TXTA<12:00>	Text RAM address bus	D8047:12	D8051:12
TXTCS-LT	Chip select	X8101:11	D8048:11
TXTD<7:0>	Text RAM data bus	D8047:12	D8051:12
TXTOP-HT	Text option bit	D8047:12	V8202:12
VADCA	Offset ADC A	R8116:3	R8261:1
VADCB	Offset ADC B	R8109:3	R8112:2
VECBIAS	Vector bias	N8070:12	R8393:13
VSYNC	TV Sync pulse (FRAME)	X8505:9	D8027:9
XDAC0	X DAC output	N8057:12	N8061:13 V8201:13
XDAC1	X DAC output	N8057:12	N8061:13 V8199:13
XF---HT	External flag	D8069:10	D8050:10
XOFFS	X offset	N8009:13	R8856:13
XSGNTOUT	Vector difference signal X	N8061:13	V8133:13
XSGNTSLB	Sampled difference signal X	V8133:13	N8061:13
XSGPTOUT	Vector difference signal X	N8061:13	V8129:13
XSGPTSLB	Sampled difference signal X	V8133:13	N8061:13
XTXT0	X digital text and trace output	N8061:13	X8101:13

XTXT1	X digital text and trace output	N8061:13	X8101:13
XYSW0	AN/DIG trace switch	V8041:12	X8101:12
XYSW1	AN/DIG trace switch	V8036:12	X8101:12
YDAC0	Y DAC output	N8058:12	N8061:13 V8203:13
YDAC1	Y DAC output	N8058:12	N8061:13 V8204:13
YOFFS	Y offset	N8009:13	R8860:13
YSGNTOUT	Vector difference signal Y	N8061:13	V8132:13
YSGNTSLB	Sampled difference signal Y	V8130:13	N8061:13
YSGPTOUT	Vector difference signal Y	N8061:13	V8131:13
YSGPTSLB	Sampled difference signal Y	V8130:13	N8061:13
YTXT0	Y digital text and trace output	N8061:13	X8101:13
YTXT1	Y digital text and trace output	N8061:13	X8101:13
ZSW0	AN/DIG intensity switch	V8042:12	X8101:12
ZSW1	AN/DIG intensity switch	V8033:12	X8101:12

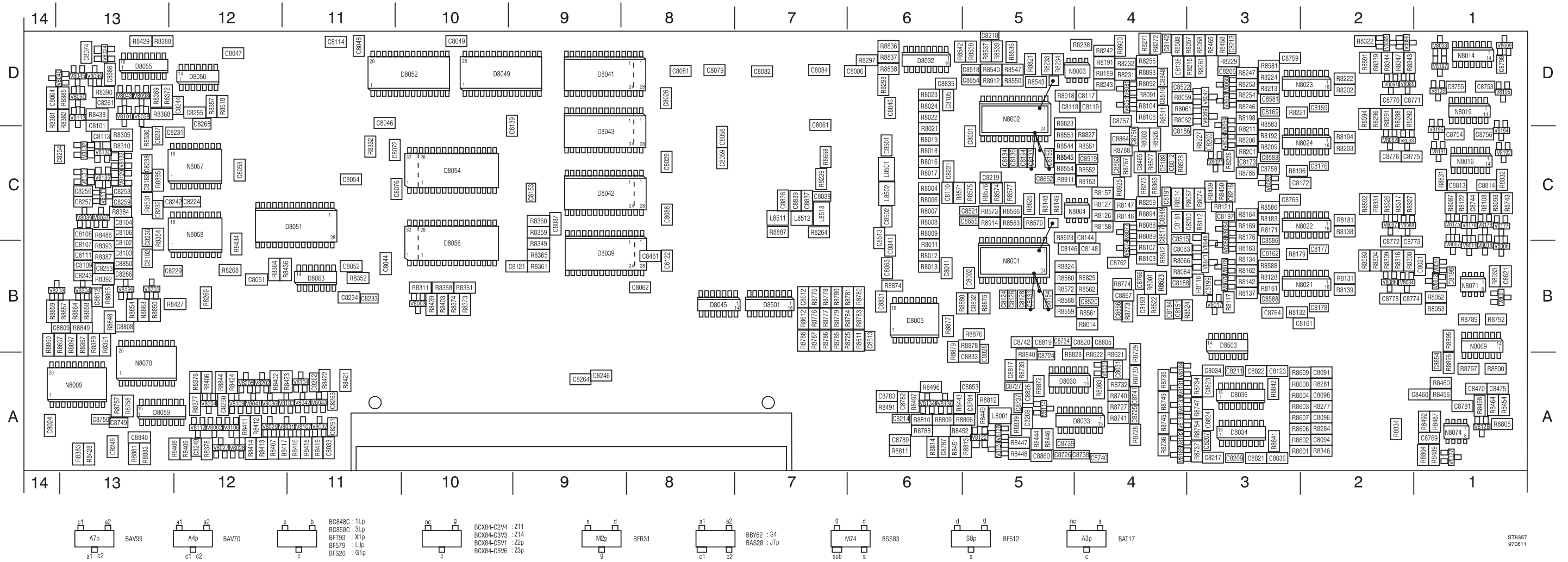

Lay-out 2 - A8 Digitizer, small component side

5.8.4 Location list

Extention -L = Large component side lay-out

No extention = Small component side lay-out

C8001 C5	C8094 A2	C8173 D3	C8236 C13
C8002 B5	C8096 A2	C8175 D3	C8237 C13
C8003 C5-L	C8097 C2-L	C8176 C2	C8238 C13
C8004 D5-L	C8098 A2	C8177 B2	C8242 C13
C8006 C3-L	C8101 D13	C8178 B2	C8243 B13
C8007 D3-L	C8102 B13	C8179 C3	C8244 D12
C8011 B6	C8103 B13	C8180 B3	C8246 A9
C8012 C4	C8104 C13	C8181 C4	C8247 A12-L
C8021 B1	C8105 D6	C8182 B13	C8248 A12
C8023 C3-L	C8106 C13	C8183 C13	C8249 A13
C8024 A14	C8107 B13	C8184 B4	C8251 A11
C8026 D8	C8108 C13	C8186 C4	C8252 A13-L
C8028 A12-L	C8109 B13	C8188 B4	C8253 B13
C8029 C8	C8110 C6	C8189 C4	C8254 C13
C8030 A1-L	C8111 B13	C8190 C4-L	C8255 D12
C8031 A4	C8113 C13	C8191 C4	C8256 C13
C8033 A11	C8114 D11	C8192 A2-L	C8257 C13
C8034 A3	C8116 D5-L	C8193 B4	C8258 C13
C8036 A3	C8121 B10	C8194 C5	C8259 C13
C8044 B11	C8122 B8	C8196 D5-L	C8260 A12
C8046 D11	C8123 A3	C8197 C3	C8261 D13
C8047 D12	C8124 B5	C8198 B1	C8262 A11
C8048 D11	C8126 B5	C8199 B3	C8263 A11
C8049 D10	C8127 B5-L	C8200 C4	C8264 A9
C8051 B12	C8128 B5	C8202 C5-L	C8265 A12-L
C8052 B11	C8129 B5-L	C8203 C3	C8266 B13
C8053 C12	C8131 B5	C8206 D3	C8267 C1-L
C8054 C11	C8132 C5-L	C8207 A3	C8268 D12
C8056 B3-L	C8133 C5	C8209 A3	C8269 A5
C8058 C8	C8134 C5	C8211 A3	C8270 A13-L
C8059 C8	C8136 C5	C8213 D3	C8271 A5-L
C8061 C7	C8137 C5-L	C8214 A6	C8273 B11-L
C8062 B8	C8138 D4	C8216 C3	C8274 B9-L
C8063 B6	C8139 D9	C8217 A3	C8276 B11-L
C8064 D14	C8140 B6-L	C8219 C5	C8277 B9-L
C8071 D8-L	C8142 D4	C8220 D3-L	C8278 A7-L
C8072 C11	C8144 B4	C8221 C6	C8279 A6-L
C8074 D13	C8146 B5	C8222 B6-L	C8286 B9-L
C8076 C11	C8147 C5-L	C8223 D3-L	C8287 B7-L
C8079 D8	C8148 B4	C8224 C12	C8288 B12-L
C8081 D8	C8151 B4	C8225 C3-L	C8289 B10-L
C8082 D7	C8153 C9	C8226 C3-L	C8291 B12-L
C8083 A4	C8154 B5	C8227 B3-L	C8293 A12-L
C8084 D7	C8155 B4-L	C8228 B3-L	C8294 B12-L
C8086 D7	C8156 C5	C8229 B13	C8296 A6-L
C8087 C9	C8158 D6-L	C8230 C3-L	C8460 A2
C8088 C8	C8159 D2	C8231 C13	C8461 B8
C8089 D2-L	C8161 B3	C8232 C13	C8462 D8-L
C8091 A2	C8162 B3	C8233 B11	C8465 C4
C8092 B2-L	C8169 D2-L	C8234 B11	C8470 A1
C8093 D2-L	C8172 C3	C8235 C3-L	C8475 A1

C8501 C6	C8747 A4-L	C8809 B14	D8006 B7-L
C8502 C6	C8748 A3-L	C8810 B13-L	D8027 C7-L
C8503 D1-L	C8749 A13	C8811 B13-L	D8030 A5
C8504 C1-L	C8750 A13	C8812 B13	D8032 D6
C8506 C1-L	C8753 D1	C8813 C1	D8033 A5
C8507 D1-L	C8754 C1	C8814 C1	D8034 A3
C8513 C6	C8755 D1	C8815 D1-L	D8036 A3
C8514 C3-L	C8756 C1	C8816 A5-L	D8037 B8-L
C8515 B4	C8758 C3	C8817 A5	D8038 C8-L
C8517 C4	C8759 D3	C8818 A5-L	D8039 B9
C8518 D5	C8762 B4	C8819 B5	D8041 D9
C8520 B4	C8764 B3	C8820 B4	D8042 C9
C8521 C6	C8765 C3	C8821 A3	D8043 C9
C8522 D4	C8766 B4	C8822 A3	D8044 C8-L
C8581 D3	C8767 C1-L	C8823 A3	D8045 B8
C8583 C3	C8768 C1-L	C8824 A3	D8046 D8-L
C8586 B3	C8769 A1	C8825 B9-L	D8047 C11-L
C8588 B3	C8770 D2	C8826 A5	D8048 C10-L
C8591 D2-L	C8771 D2	C8828 B5	D8049 D10
C8592 C2-L	C8772 B2	C8829 B6-L	D8050 D12
C8593 B2-L	C8773 B2	C8830 B6-L	D8051 C11
C8594 D2-L	C8774 B2	C8831 B6	D8052 D10
C8596 A9-L	C8775 C2	C8832 B5	D8054 C10
C8597 A9-L	C8776 C2	C8833 A6	D8055 D13
C8601 A3-L	C8777 D1-L	C8834 B5-L	D8056 B10
C8602 A3-L	C8778 B2	C8835 D6	D8059 A13
C8603 A3-L	C8779 B1-L	C8836 C7	D8063 B11
C8604 A3-L	C8780 A1-L	C8837 C7	D8069 D11-L
C8611 D3-L	C8781 A1	C8838 C7	D8501 B7
C8612 B7	C8782 A6	C8839 C7	D8502 A4-L
C8613 B6	C8783 A6	C8840 A13	D8503 B3
C8617 B3-L	C8784 A5	C8841 B6	G8024 B11-L
C8621 B1	C8785 A6-L	C8842 C3-L	G8025 A6-L
C8652 C5	C8786 A6-L	C8844 B3-L	G8053 D12-L
C8653 D5-L	C8787 A6	C8845 C3-L	L8001 A5
C8654 D5	C8788 A6	C8846 D6	L8002 B6-L
C8655 C6	C8789 A6	C8847 A2-L	L8003 B6-L
C8656 B5-L	C8790 A5-L	C8849 C4	L8501 C6
C8657 B5-L	C8791 A2-L	C8850 B13	L8502 C6
C8723 A4-L	C8792 A2-L	C8851 A13-L	L8506 B8-L
C8724 A5	C8793 A2-L	C8852 A1-L	L8507 B8-L
C8725 A4	C8794 C4-L	C8853 A5	L8508 B8-L
C8726 A5	C8795 B4-L	C8854 B1	L8511 C7
C8727 A5	C8796 C1-L	C8855 B8-L	L8512 C7
C8733 B3-L	C8797 B1-L	C8860 A5	L8513 C7
C8734 B5	C8798 D1	C8861 D6-L	N8001 B5
C8737 A5	C8799 B6-L	C8862 B8-L	N8002 D5
C8738 A5	C8800 D1-L	C8863 C4	N8004 C5
C8739 A5	C8801 D1-L	C8864 C4	N8007 A1-L
C8740 A4	C8802 D6-L	C8865 D5-L	N8009 A13
C8741 A4	C8803 D6-L	C8866 B4	N8012 B4-L
C8742 B5	C8804 D6-L	C8867 B4	N8013 C4-L
C8743 C1-L	C8805 B4	C8868 C5-L	N8014 D1
C8744 C1	C8806 B12-L	D8003 B6-L	N8015 A13-L
C8745 A4-L	C8807 B13-L	D8004 C6-L	N8016 C1
C8746 A4-L	C8808 B13	D8005 B6	N8018 B1-L

N8019 D1	R8074 C3	R8148 C5	R8218 D1-L
N8021 B3	R8077 D1-L	R8149 C5	R8219 D2-L
N8022 C3	R8078 D1-L	R8151 C4-L	R8221 D3
N8023 D3	R8079 D1-L	R8152 C4-L	R8222 D2
N8024 C3	R8081 D1-L	R8153 C4	R8223 D2-L
N8026 D3-L	R8082 D1-L	R8157 C4	R8224 D3
N8027 B3-L	R8083 C1-L	R8158 C4	R8226 C3
N8029 A3-L	R8084 C1-L	R8159 C4-L	R8227 C3
N8057 C12	R8086 B1-L	R8161 B3	R8228 D3-L
N8058 C12	R8087 C1	R8162 B3	R8229 D3
N8061 C13-L	R8088 C4	R8163 B3	R8231 D4
N8062 A6-L	R8089 C4	R8164 C3	R8232 D4
N8066 A6-L	R8091 D4	R8166 B3-L	R8233 D5
N8067 D5-L	R8092 D4	R8167 C3-L	R8234 D5
N8068 C5-L	R8093 C1	R8168 B3-L	R8236 D4-L
N8069 B1	R8094 B1-L	R8169 C3	R8237 D4-L
N8070 A13	R8096 C1-L	R8171 C3	R8238 D5
N8071 B1	R8097 C1-L	R8172 C2-L	R8239 C7
N8072 A5-L	R8098 D1-L	R8173 C2-L	R8242 D4
N8073 A13-L	R8103 B4	R8174 C4-L	R8243 D4
N8074 A1	R8104 D4	R8176 C3	R8244 D4-L
R8001 B4	R8106 D4	R8178 C2-L	R8246 D3
R8002 D4-L	R8107 B4	R8179 B3	R8247 D3
R8003 C4	R8108 C1	R8181 C2	R8248 D3-L
R8004 C6	R8109 C1-L	R8182 C2-L	R8252 D3-L
R8006 C6	R8111 C1-L	R8183 C3	R8253 D3
R8007 C6	R8112 C3	R8184 B12-L	R8254 D3
R8008 C6	R8114 C1-L	R8186 D1-L	R8256 D4
R8009 C6	R8116 C1-L	R8187 D4-L	R8257 B1-L
R8011 B6	R8117 B3	R8188 C3-L	R8258 B1-L
R8012 B6	R8118 B3	R8189 D4	R8259 C4
R8013 B6	R8119 C3-L	R8191 D4	R8261 D3
R8014 B4	R8121 C3	R8192 C3	R8264 C7
R8016 C6	R8122 C1	R8193 D2-L	R8268 B12
R8017 C6	R8123 C4-L	R8194 C2	R8269 B12
R8018 C6	R8124 B3-L	R8196 C3	R8271 D4
R8019 C6	R8126 C4	R8197 C2-L	R8272 D4
R8021 C6	R8127 C4	R8198 D3	R8273 C4
R8022 D6	R8128 B3	R8199 D2-L	R8274 D1-L
R8023 D6	R8129 B2-L	R8201 C3	R8276 D2-L
R8024 D6	R8130 C3-L	R8202 D2	R8277 A2
R8033 B1	R8131 B2	R8203 C2	R8278 C2-L
R8042 D6-L	R8132 B3	R8204 C2-L	R8279 B1-L
R8043 D6-L	R8133 B2-L	R8205 C3-L	R8281 A2
R8051 B1-L	R8134 B3	R8206 C3	R8282 B2-L
R8052 B1	R8135 B3-L	R8207 C2-L	R8283 B2-L
R8053 B1	R8136 C2-L	R8208 D2-L	R8284 A2
R8054 B1-L	R8137 B3	R8209 C3	R8286 C2-L
R8057 D4	R8138 C2	R8210 D3-L	R8287 C2-L
R8058 D3	R8139 B2	R8211 C3	R8288 D2
R8059 D4	R8141 B2-L	R8212 C3-L	R8289 D2-L
R8061 D4	R8142 B3	R8213 D3	R8291 D2
R8062 D4	R8143 B2-L	R8214 D2-L	R8292 D2
R8064 B4	R8144 B2-L	R8215 D4	R8293 D2-L
R8066 B4	R8146 C4	R8216 D2-L	R8294 A2-L
R8067 C4	R8147 C4	R8217 D4-L	R8296 D2

R8297 D6	R8367 B13	R8439 B10	R8517 B5-L
R8298 D6	R8368 D13	R8441 A6-L	R8518 D12
R8299 B2-L	R8369 D13	R8442 A5-L	R8519 C3-L
R8301 A2-L	R8372 D13	R8443 A6	R8521 C3-L
R8302 A2-L	R8373 B10	R8444 A5	R8522 B4
R8304 B2	R8374 B10	R8446 A5	R8523 B4
R8305 C13	R8376 A12	R8447 A5	R8524 B4
R8306 A2-L	R8377 A12	R8448 A5	R8526 C4
R8307 B2-L	R8378 A12	R8449 A5	R8527 C4
R8308 B2	R8379 A13-L	R8450 C3	R8528 C4
R8309 B2	R8381 D14	R8451 A6	R8530 C13
R8310 C13	R8382 D13	R8452 A6	R8531 C13
R8311 B10	R8383 A13	R8453 A5-L	R8532 B6-L
R8312 C2-L	R8384 C13	R8454 A1	R8533 B6-L
R8316 B2	R8385 D13	R8455 A2-L	R8534 B6-L
R8317 C2	R8386 D13	R8456 A1	R8535 B6-L
R8318 D1-L	R8387 B13	R8458 D3	R8536 D5
R8319 D1-L	R8388 D13	R8459 C3	R8537 D5
R8321 D2-L	R8389 B13	R8460 A1	R8538 D5
R8322 D2	R8390 D13	R8461 B1-L	R8539 D5
R8323 B2-L	R8391 B13	R8462 B1-L	R8540 D5
R8324 C2-L	R8392 B13	R8463 B1-L	R8541 C5-L
R8326 C2	R8393 B13	R8464 A1	R8542 D6
R8327 C2	R8396 D1-L	R8465 D3	R8543 D5
R8328 C2-L	R8397 D1-L	R8466 B1-L	R8544 C5
R8329 A2-L	R8398 A12-L	R8467 B9-L	R8545 C5
R8331 C2	R8399 A13-L	R8469 A11-L	R8546 C5-L
R8332 C11	R8401 A12-L	R8471 B11-L	R8547 D5
R8333 C2-L	R8402 A12	R8472 A12-L	R8548 C5-L
R8334 D1-L	R8403 B10	R8473 A7-L	R8549 C5-L
R8336 A2-L	R8404 A12-L	R8474 A7-L	R8550 D5
R8337 A2-L	R8405 A12-L	R8476 A7-L	R8551 C4
R8338 D1-L	R8406 A12	R8478 B12-L	R8552 C4
R8339 D2	R8407 A12	R8483 B12-L	R8553 C5
R8341 A2-L	R8408 A12	R8484 C12-L	R8554 C5
R8342 D2-L	R8409 A12	R8486 C13	R8555 C5-L
R8343 D2	R8410 A12-L	R8487 A1	R8556 C5-L
R8344 D2	R8411 A12	R8489 A1	R8557 B5-L
R8346 A2	R8412 A12	R8491 A6	R8558 B5-L
R8347 D2	R8413 A12	R8492 A1	R8559 B5
R8348 D2-L	R8414 A12	R8493 A6-L	R8560 B5
R8349 B9	R8416 A11	R8496 A6	R8561 B4
R8351 B10	R8417 A12	R8497 A6	R8562 B4
R8352 B11	R8418 A11	R8498 A1	R8563 C5
R8353 C12-L	R8419 A11	R8501 D8-L	R8564 B5-L
R8354 C13	R8421 A11	R8502 D8-L	R8565 B5-L
R8357 D12	R8422 A11	R8503 D5-L	R8566 C5
R8358 B10	R8423 A11	R8506 D8-L	R8567 B5-L
R8359 C9	R8424 A12	R8507 D8-L	R8568 B5
R8360 C9	R8426 A13-L	R8508 D4	R8569 B5-L
R8361 B9	R8427 B13	R8509 C2-L	R8570 C5
R8362 C3-L	R8428 A13	R8511 D4	R8571 C6
R8363 C4	R8429 D13	R8512 B4	R8572 B5
R8364 B12	R8434 C12	R8513 B4	R8573 C5
R8365 B9	R8436 B11	R8514 C4	R8574 C5
R8366 C1-L	R8438 D13	R8516 B2-L	R8575 C5

R8576 C5	R8751 A4-L	R8809 A6	R8865 B13
R8577 C5	R8752 A4-L	R8810 A6	R8866 D4
R8581 D3	R8753 A4-L	R8811 A6	R8867 C4
R8583 C3	R8754 A3	R8812 A5	R8868 C1-L
R8586 C3	R8755 A4-L	R8813 A5	R8869 C1-L
R8588 B3	R8756 A12-L	R8814 A6	R8870 C1-L
R8591 D2	R8757 A13	R8815 B2-L	R8871 C1-L
R8592 C2	R8758 A13	R8816 D2-L	R8872 A5
R8593 B2	R8760 D1-L	R8817 B1-L	R8874 B6
R8594 D2	R8761 D1-L	R8818 C1-L	R8875 B5
R8596 C12-L	R8762 D1-L	R8819 D1-L	R8876 B5
R8597 C12-L	R8763 D1-L	R8820 D1-L	R8877 B6
R8598 C2-L	R8764 C3-L	R8821 D5	R8878 B6
R8601 A3	R8765 D3-L	R8822 B2-L	R8879 B6
R8602 A3	R8766 D3-L	R8823 C5	R8880 B6
R8603 A3	R8767 C4	R8824 B5	R8881 A13
R8604 A3	R8768 C4	R8825 B4	R8882 C13-L
R8606 A3	R8769 B3-L	R8826 C5	R8883 A13
R8607 A3	R8771 B3-L	R8827 C4	R8884 C13-L
R8608 A3	R8772 C3-L	R8828 A5	R8885 C13
R8609 A3	R8773 B4	R8829 C4-L	R8886 C13-L
R8611 B6	R8774 B4	R8830 B4-L	R8887 C7
R8612 B7	R8775 B7	R8831 C1	R8888 B6-L
R8621 A4	R8776 B7	R8832 C1	R8889 C3-L
R8622 A4	R8777 B7	R8833 B6-L	R8890 D3-L
R8658 C7	R8778 B7	R8834 A2	R8891 B3-L
R8697 B13	R8779 B7	R8835 D1-L	R8892 C3-L
R8721 A6-L	R8780 B7	R8836 D6	R8893 D4
R8722 A6-L	R8781 B7	R8837 D6	R8894 C4
R8723 D1-L	R8782 B6	R8838 D6	R8895 B1
R8725 B7	R8783 B6	R8839 A5	R8896 B1
R8726 A4-L	R8784 B7	R8840 A5	R8897 B13
R8727 A4	R8785 B7	R8841 A3	R8898 A3-L
R8728 A4	R8786 B7	R8842 A3	R8901 B13-L
R8729 B4	R8787 B7	R8843 B13-L	R8902 A13-L
R8730 A4	R8788 B7	R8844 A12	R8903 A13-L
R8731 B13-L	R8789 B1	R8845 B12-L	R8911 C5
R8732 A4	R8790 B1-L	R8846 B13-L	R8912 D5
R8733 A4-L	R8791 B1-L	R8847 B12-L	R8913 B5-L
R8734 A3	R8792 B1	R8848 B13	R8914 C5
R8735 A4	R8793 B1-L	R8849 B13	R8916 D5-L
R8736 A4	R8794 B1-L	R8850 B13	R8917 D5-L
R8737 A3	R8795 A1-L	R8851 B13-L	R8918 D5
R8738 A4-L	R8796 A1-L	R8852 B13-L	R8919 D4-L
R8739 A5	R8797 A1	R8853 B13-L	R8920 D4
R8740 A4	R8798 A1-L	R8854 B13	R8921 D5-L
R8741 A4	R8799 A1-L	R8855 B12-L	R8922 C5-L
R8742 A5-L	R8800 A1	R8856 B12-L	R8923 B5
R8743 C1	R8801 B1-L	R8857 B13	R8924 B4-L
R8744 C1-L	R8802 A3-L	R8858 B13	R8925 C4
R8745 A4	R8803 A3-L	R8859 B14	R8926 C5-L
R8746 A4-L	R8804 A1	R8860 B14	R8927 C5-L
R8747 A3	R8805 A1	R8861 B13-L	R8928 D12-L
R8748 A4-L	R8806 A6	R8862 B13-L	R8931 D3-L
R8749 A4	R8807 A1-L	R8863 B13	R8932 C3-L
R8750 A4-L	R8808 A1-L	R8864 B13	R8933 C3-L

R8934 B3-L	V8050 D13	V8112 A12	V8193 D1
R8936 D3-L	V8051 D4	V8113 D13	V8194 C1
R8937 B3-L	V8053 C4-L	V8114 A5	V8195 D1
R8938 C3-L	V8054 C3	V8117 B13-L	V8196 C1
R8939 B3-L	V8057 C4-L	V8122 A5	V8197 D1
V8001 B1	V8058 B3	V8124 A5	V8198 B13-L
V8002 A12	V8059 D3	V8126 A5	V8199 B13
V8003 B10	V8061 D3	V8127 A1	V8200 B13-L
V8004 A12	V8064 C3	V8128 A1	V8201 B13
V8006 B1	V8066 D4-L	V8129 C13	V8202 A12
V8007 B1	V8067 D4-L	V8130 C13	V8203 B14
V8008 D1	V8068 D3	V8131 C13	V8204 B13
V8009 D1	V8069 D3	V8132 C13	V8205 A12
V8011 B1	V8071 B3	V8133 C13	V8208 C13-L
V8012 B1	V8074 B4	V8134 A6	V8209 C12-L
V8014 B1	V8077 C4	V8135 C13	V8210 B5-L
V8017 B3	V8078 B3	V8136 A6	V8212 B13-L
V8018 B1	V8079 B3	V8137 A5-L	V8216 B3-A
V8019 D3-L	V8081 D4	V8138 C4-L	V8217 B3-A
V8021 C3	V8082 C2	V8139 C4-L	V8218 C3-A
V8022 C3-L	V8083 C2	V8140 B4-L	V8219 C3-A
V8024 D13	V8084 B2	V8141 B4-L	V8221 D3-A
V8027 A12	V8086 B2	V8142 D5-L	V8222 D3-A
V8028 A12	V8087 C2	V8143 C5-L	V8223 C3-A
V8029 A12	V8088 C2	V8151 A4	V8224 C3-A
V8031 A12	V8089 D2	V8175 C1	X8001 D2-L
V8032 A11	V8090 D2	V8176 C1	X8002 D2-L
V8033 A11	V8091 D2	V8177 C1	X8008 B2-L
V8036 A12	V8092 D6-L	V8178 C1	X8009 B2-L
V8037 C13	V8095 D2	V8181 A4	X8011 C2-L
V8038 D13	V8096 D6-L	V8182 A4	X8012 C2-L
V8039 C13	V8097 C3	V8183 A4	X8018 C2-L
V8040 D13	V8098 D13	V8184 A4	X8019 D2-L
V8041 A12	V8099 D13	V8185 A4	X8101 A9-L
V8042 A11	V8101 D13	V8186 A4	X8501 A4-L
V8043 D13	V8103 A12	V8187 C3-L	X8502 A4-L
V8044 A6-L	V8104 A11	V8188 D3-L	X8503 A4-L
V8045 D13	V8106 A12	V8189 B3-L	X8504 A7-L
V8046 A5-L	V8107 A11	V8190 C3-L	X8505 A6-L
V8047 D3	V8109 A12	V8191 C1	
V8048 B3	V8111 C13	V8192 C1	

5.8.5 Circuit diagrams

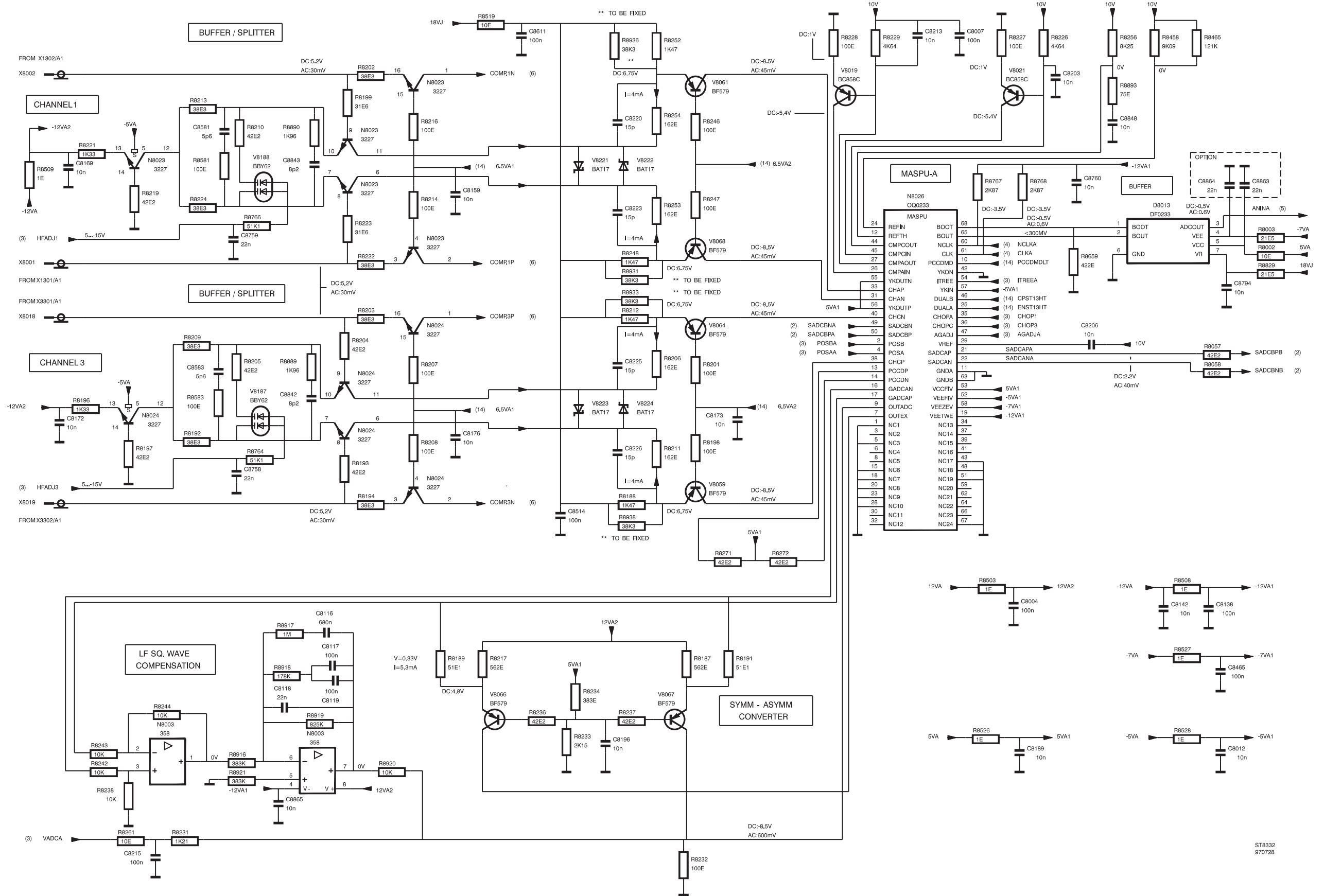

A8 - Diagram 1a; Channel 1 and 3 (200 MHz version)

ST8332
970728

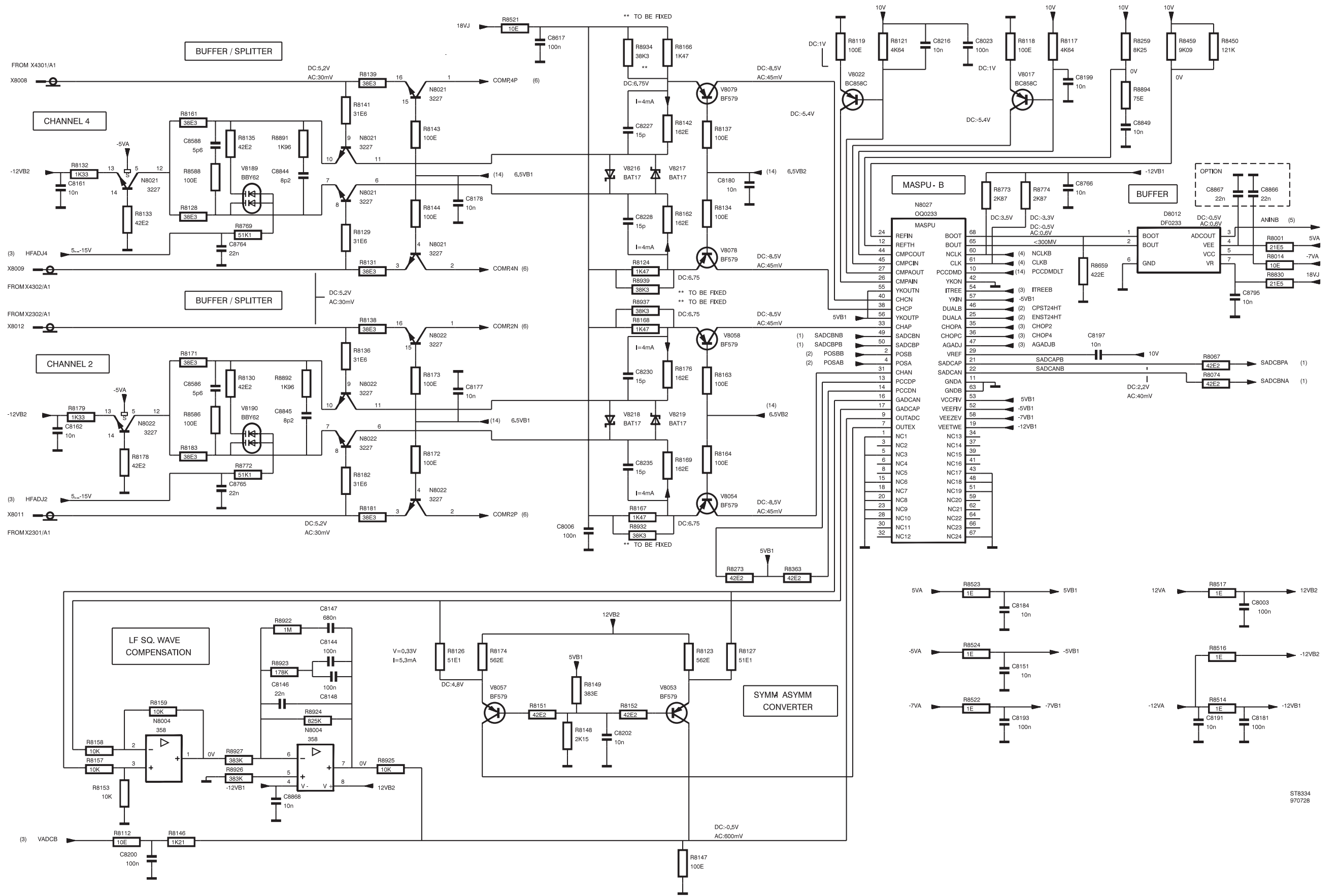

A8 - Diagram 2a; Channel 2 and 4 (200 MHz version)

ST8334
970728

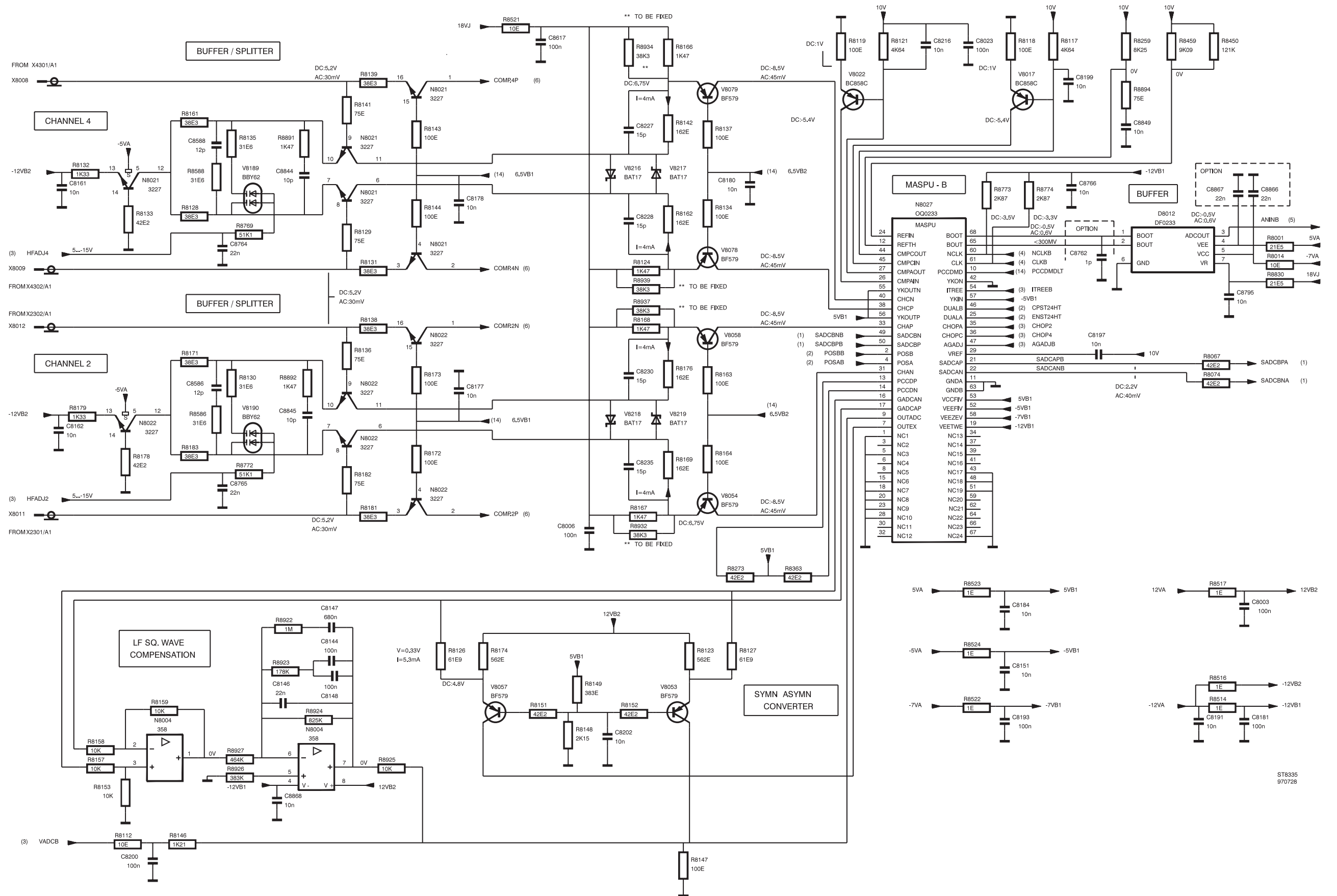

A8 - Diagram 2b; Channel 2 and 4 (100 MHz version)

ST8335
970728

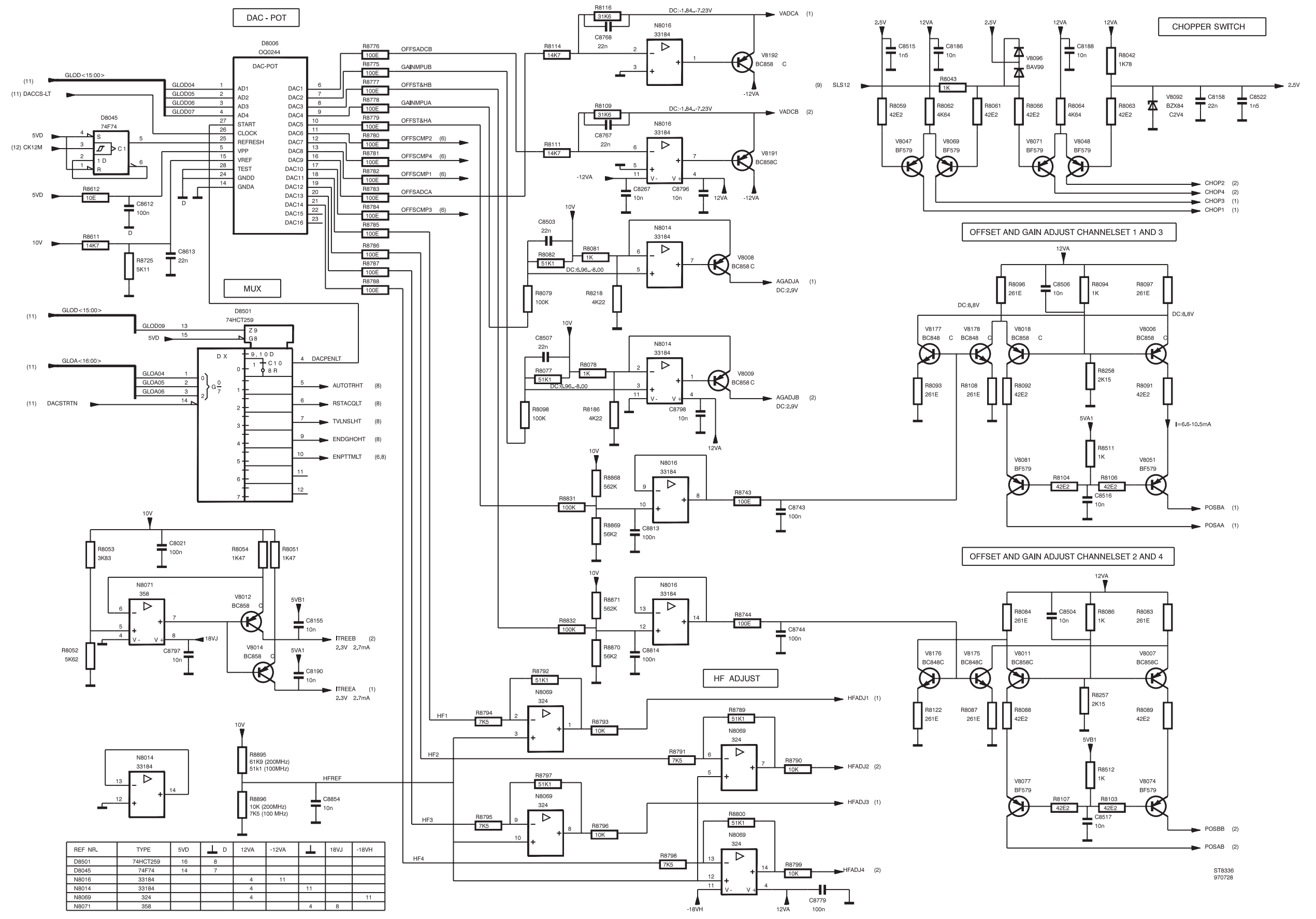

A8 - Diagram 3; Ref. and adj. voltages

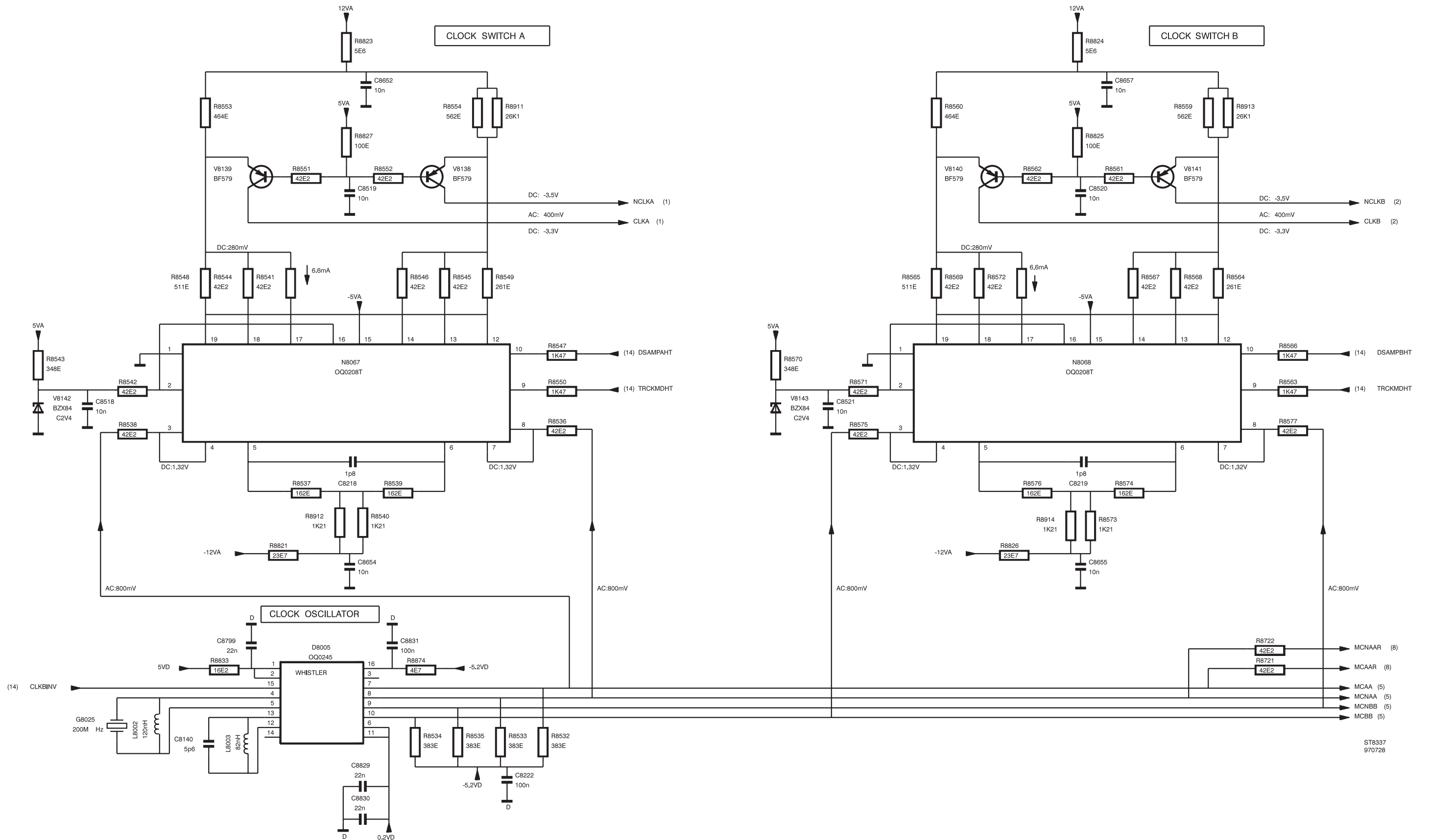

A8 - Diagram 4; Clock

ST8337
970728

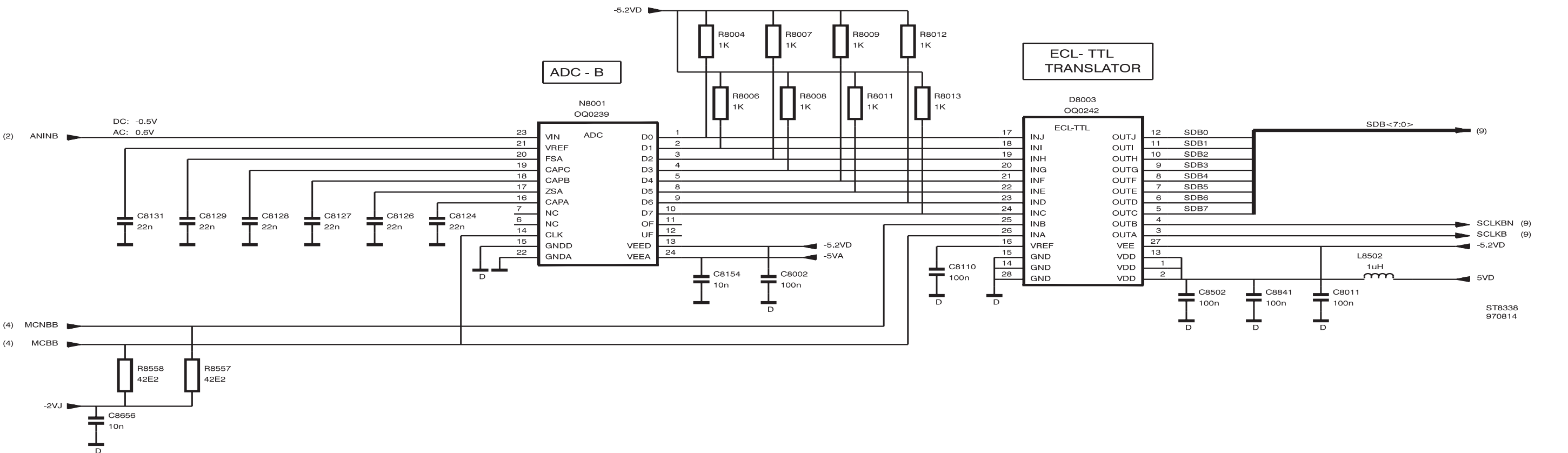
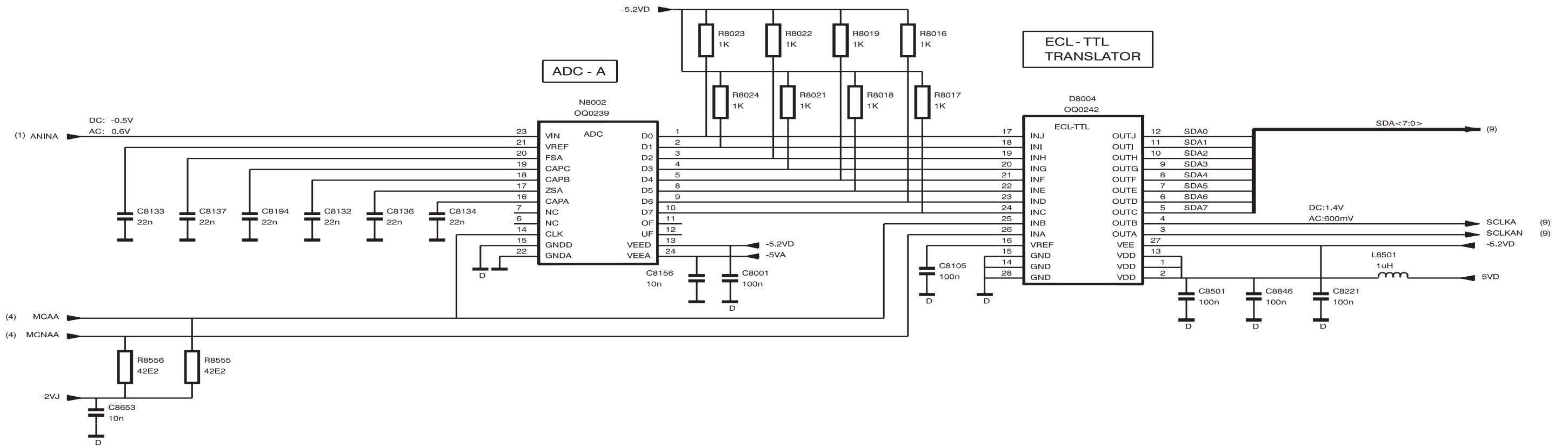

A8 - Diagram 5; ADC and ECL-TTL

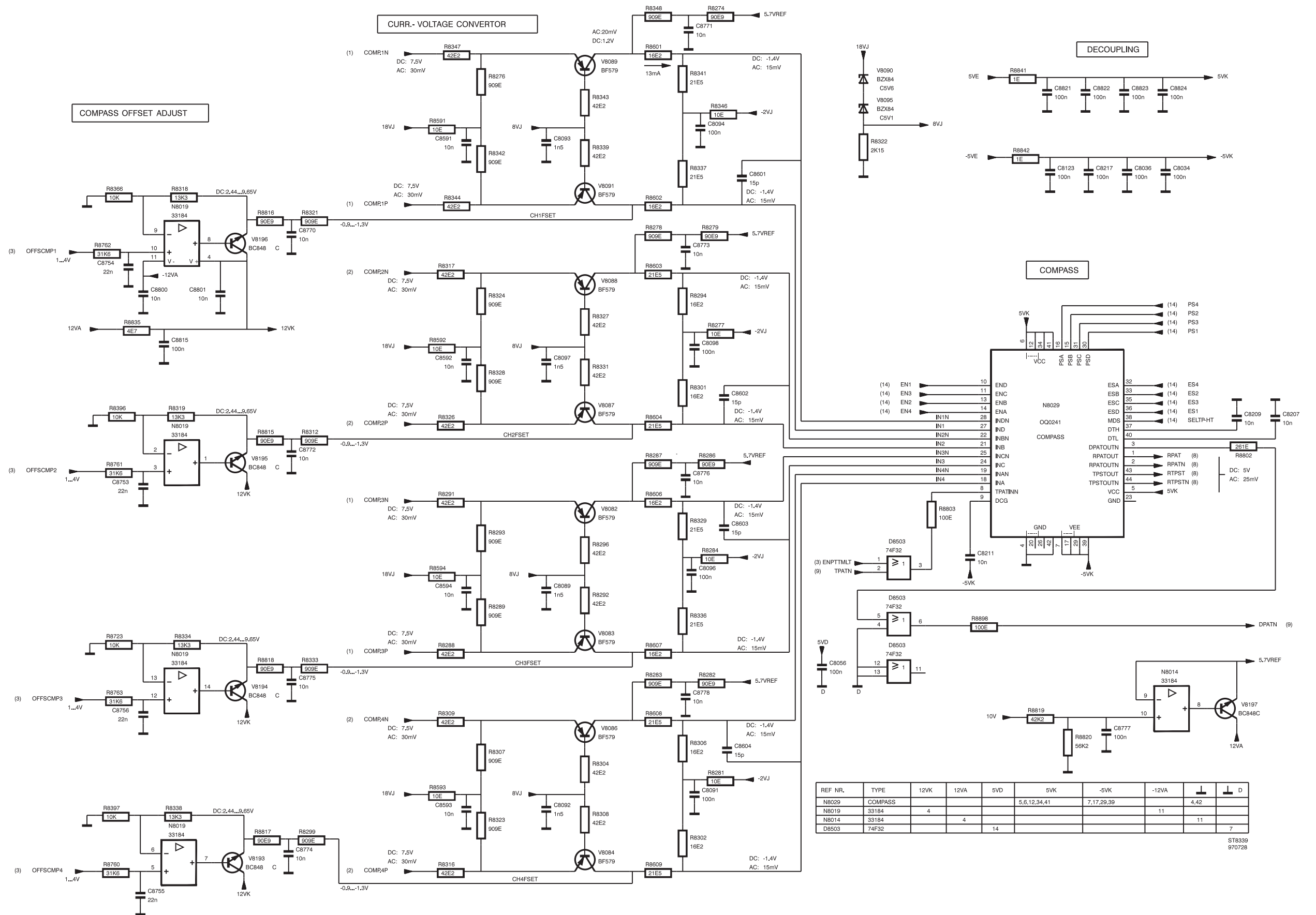

A8 - Diagram 6; COMPASS

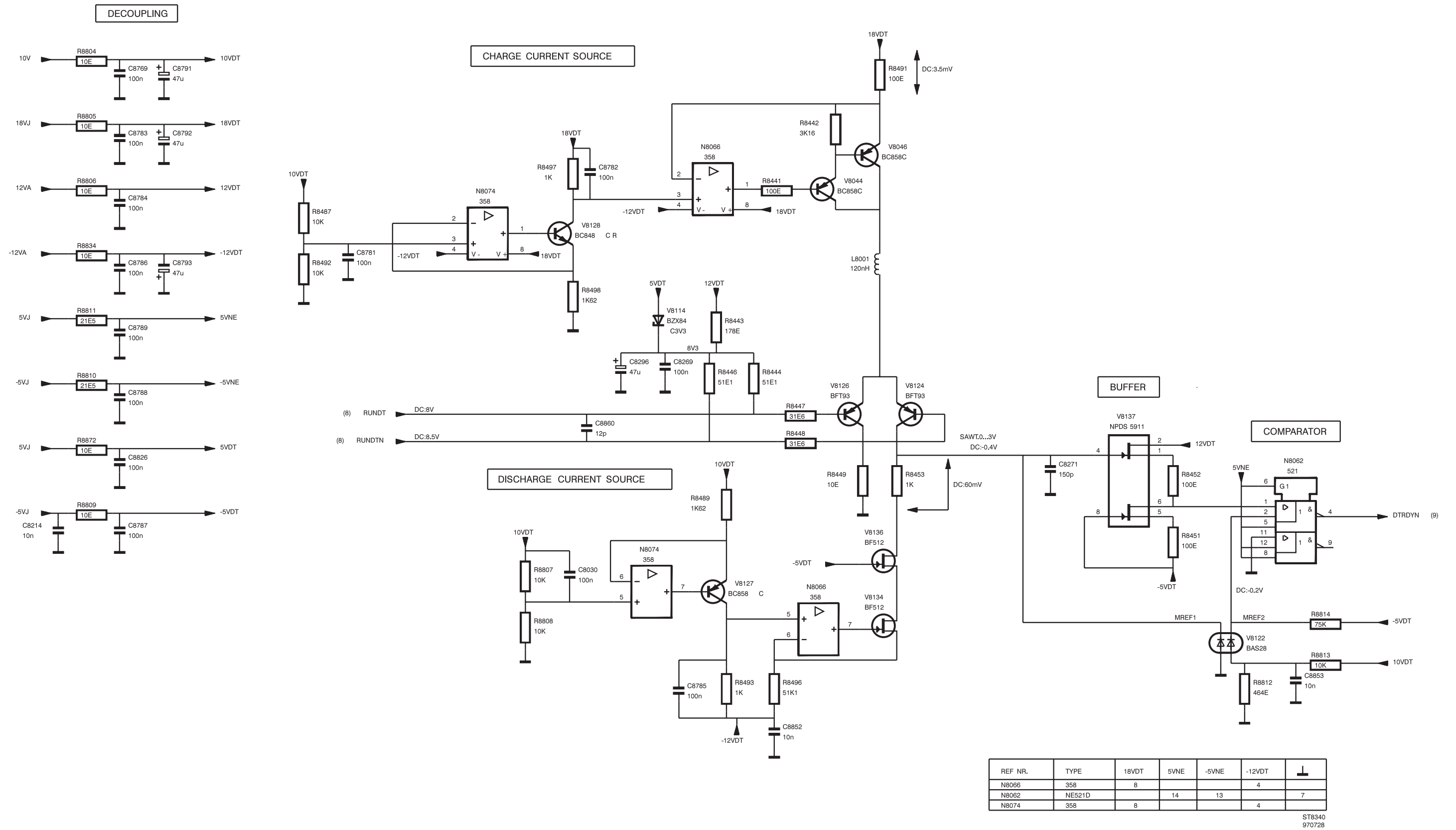

A8 - Diagram 7; Delta T circuit

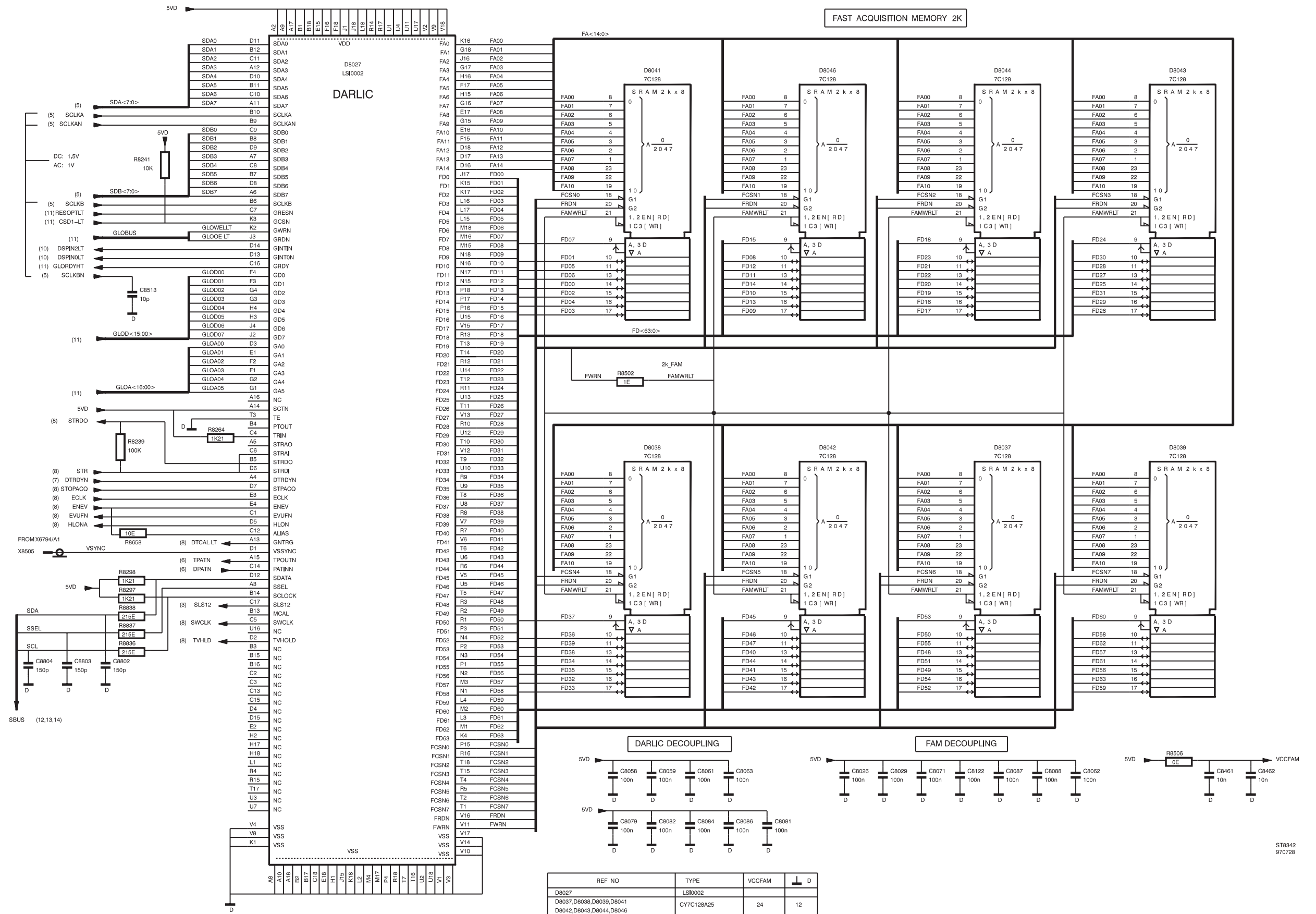

A8 - Diagram 9a; DARLIC and FAM

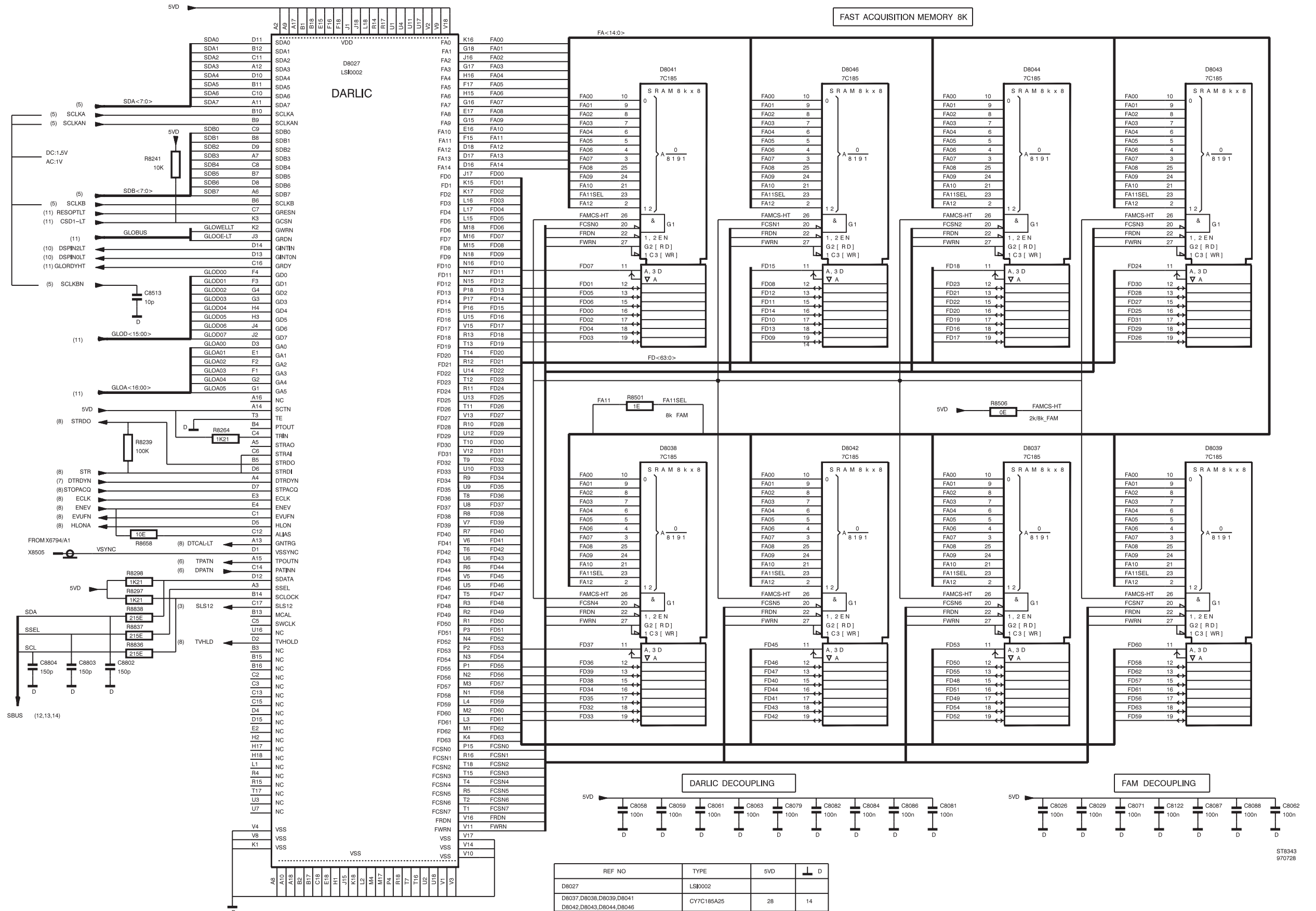

REF NO	TYPE	SVD	I D
D8027	LSI0002		
D8037, D8038, D8039, D8041 D8042, D8043, D8044, D8046	CY7C185A25	28	14

A8 - Diagram 9b; DARLIC and extended FAM

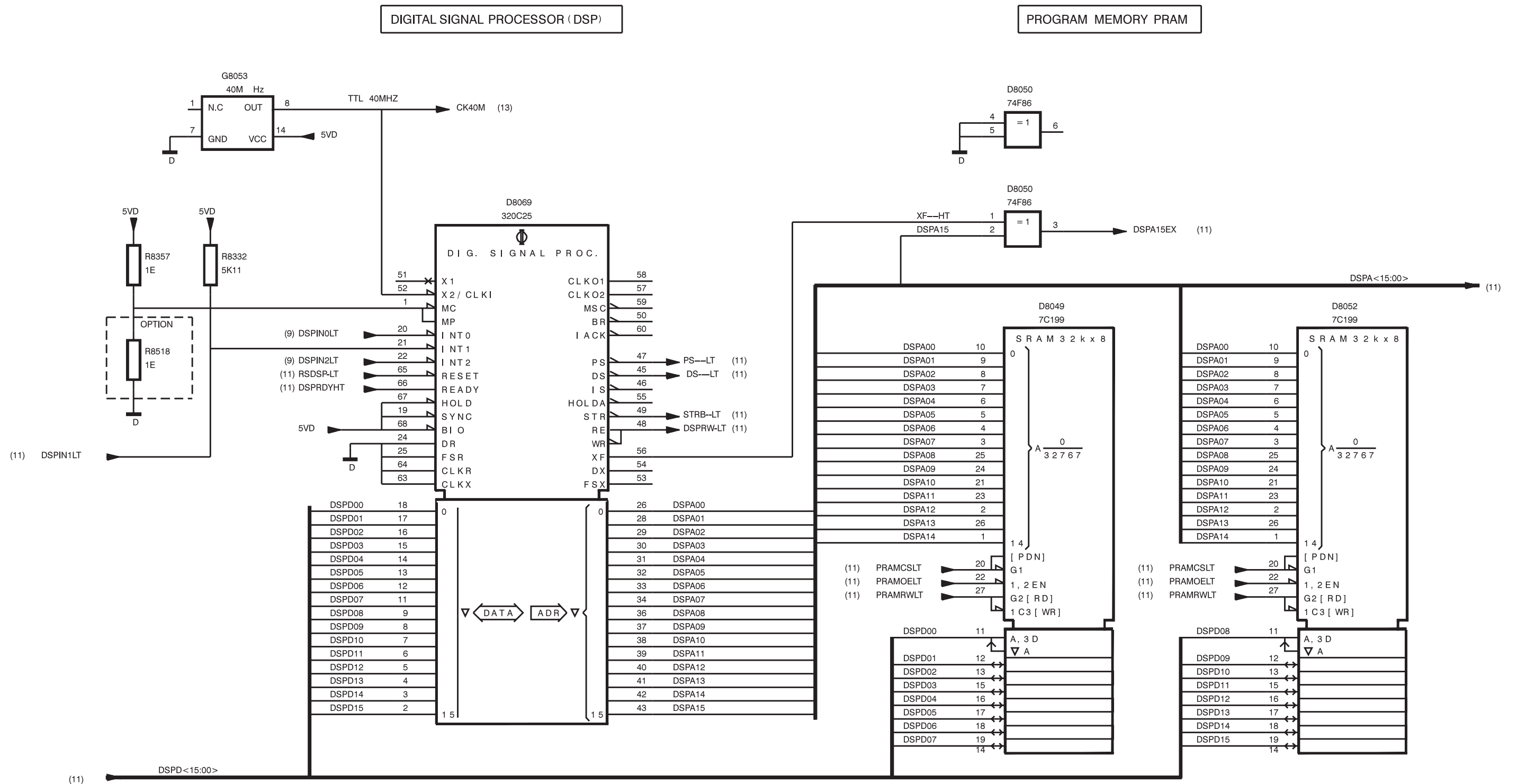

DSP DECOUPLING

PRAM DECOUPLING

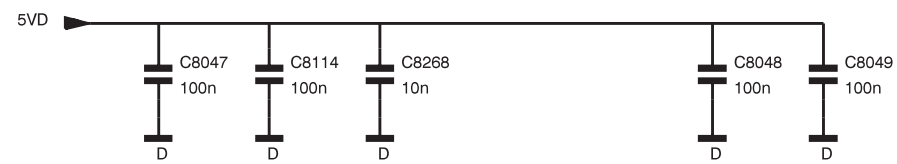

REF NR.	TYPE	5VDC	D
D8069	320C25	23,35,61,62	10,27,44
D8049,D8052	7C199A25	28	14
D8050	74F86	14	7

ST8344
970728

A8 - Diagram 10; Digital Signal Processor

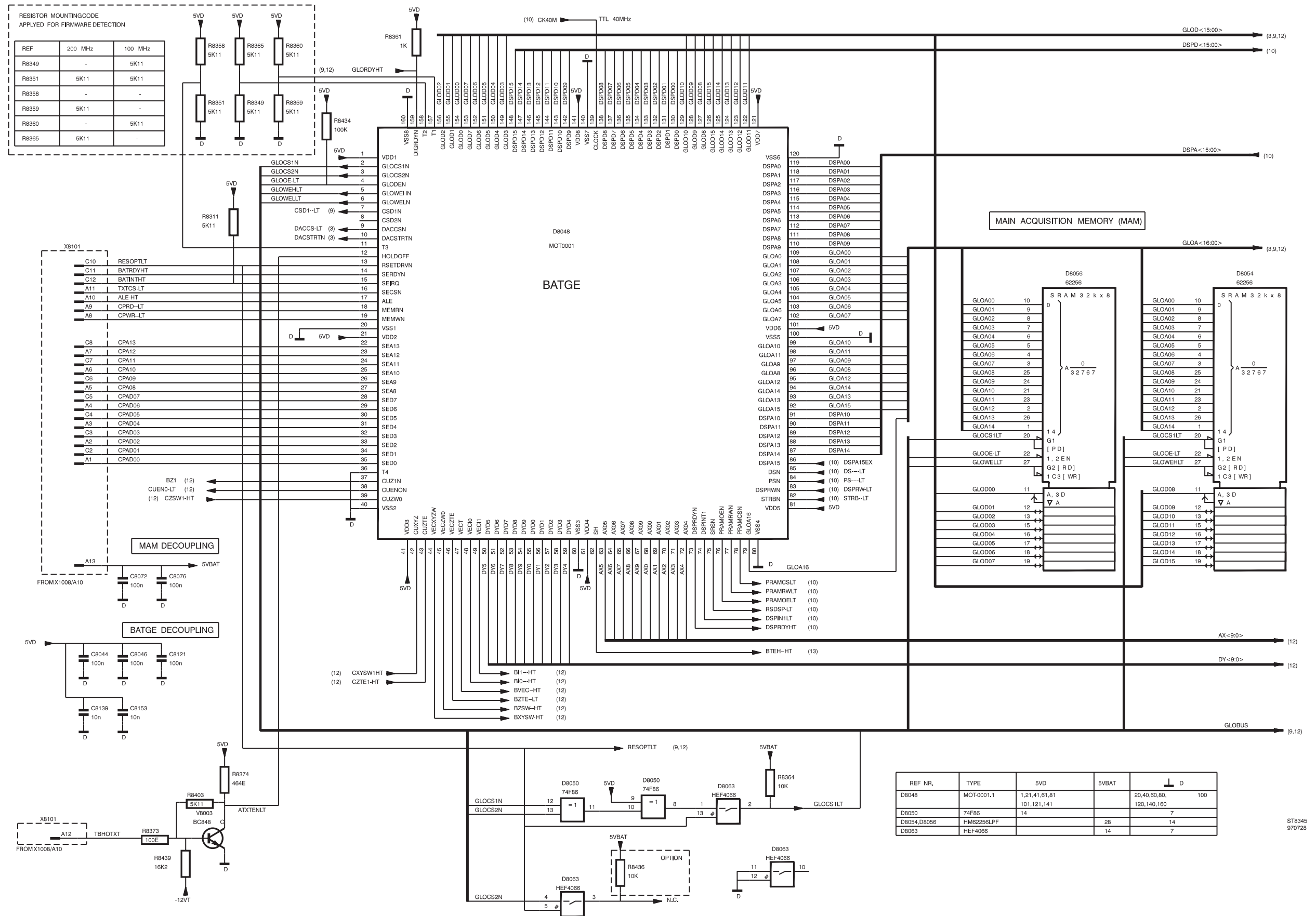

A8 - Diagram 11a; BATGE and MAM

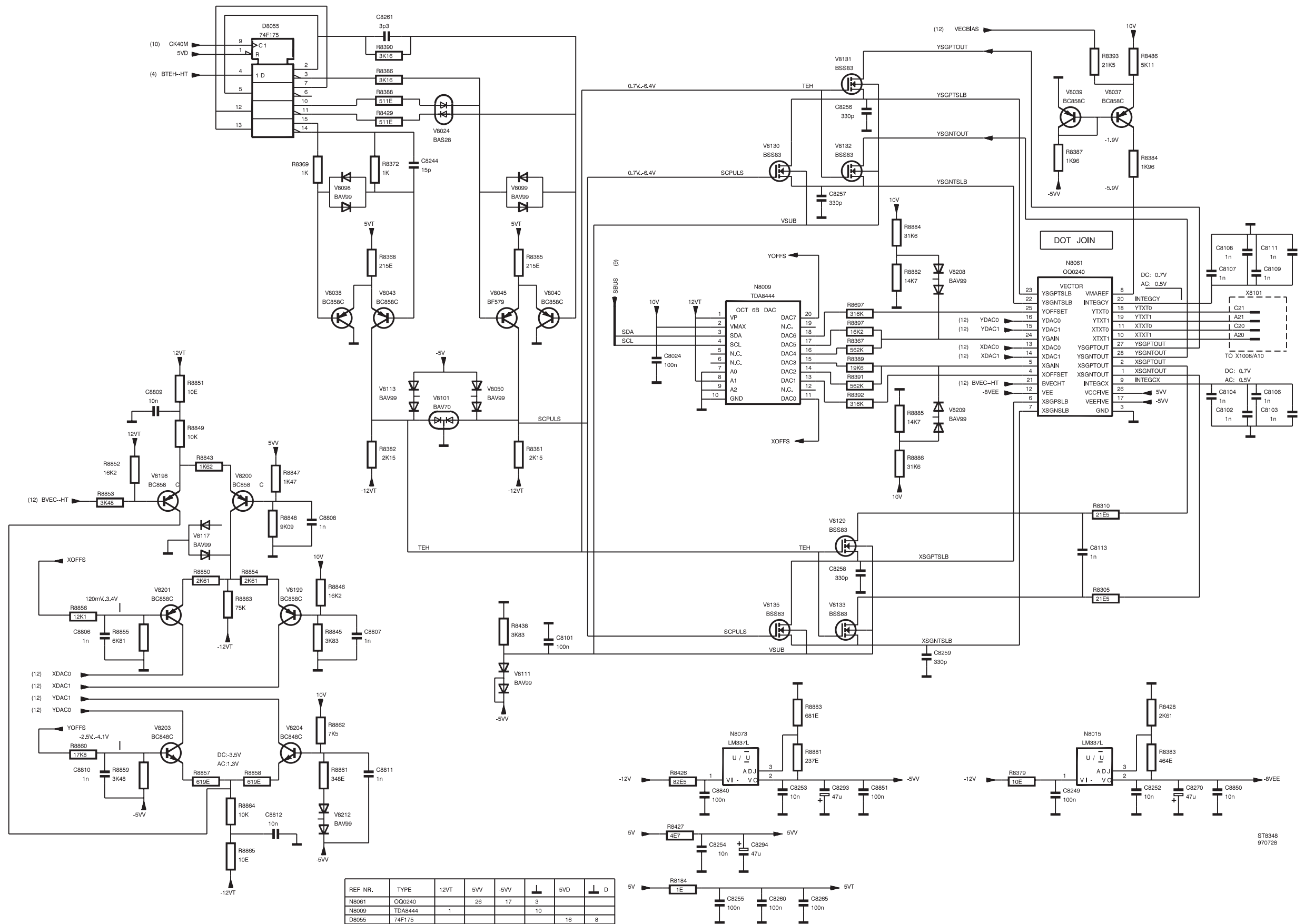

A8 - Diagram 13; Display interface

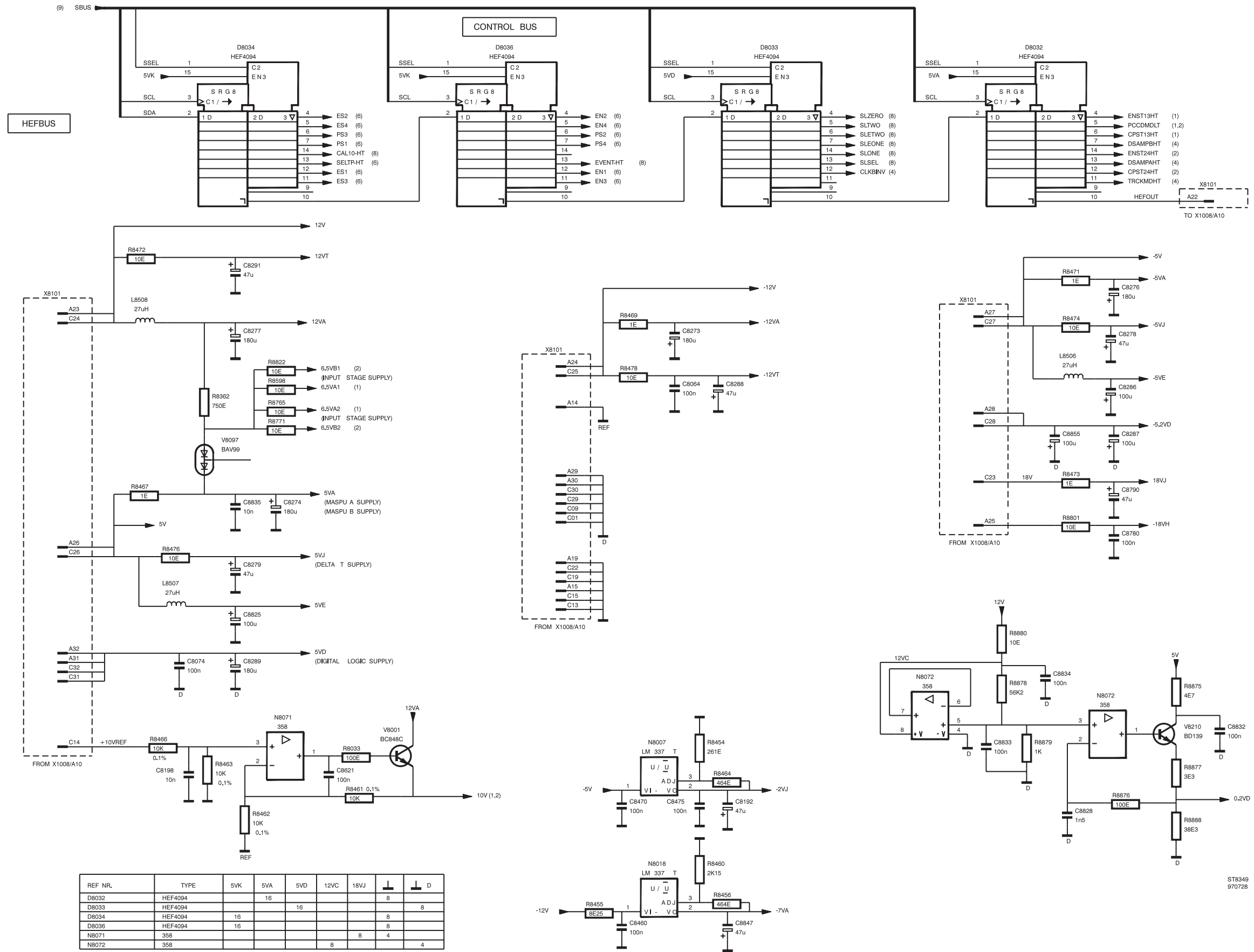

A8 - Diagram 14; Power distribution

Item	Description	Ordering code
5.8.6 Parts list		
CAPACITORS		
C8001	CAP.CHIP 63V 10% 100NF	4822 122 33496
C8002	CAP.CHIP 63V 10% 100NF	4822 122 33496
C8003	CAP.CHIP 63V 10% 100NF	4822 122 33496
C8004	CAP.CHIP 63V 10% 100NF	4822 122 33496
C8006	CAP.CHIP 63V 10% 100NF	4822 122 33496
C8007	CAP.CHIP 63V 10% 100NF	4822 122 33496
C8011	CAP.CHIP 63V 10% 100NF	4822 122 33496
C8012	CAP.CHIP 63V 10% 10NF	5322 122 34098
C8021	CAP.CHIP 63V 10% 100NF	4822 122 33496
C8023	CAP.CHIP 63V 10% 100NF	4822 122 33496
C8024	CAP.CHIP 63V 10% 100NF	4822 122 33496
C8026	CAP.CHIP 63V 10% 100NF	4822 122 33496
C8028	CAP.CHIP 63V 10% 100NF	4822 122 33496
C8029	CAP.CHIP 63V 10% 100NF	4822 122 33496
C8030	CAP.CHIP 63V 10% 100NF	4822 122 33496
C8031	CAP.CHIP 63V 5% 1NF	5322 126 10511
C8033	CAP.CHIP 63V 10% 100NF	4822 122 33496
C8034	CAP.CHIP 63V 10% 100NF	4822 122 33496
C8036	CAP.CHIP 63V 10% 100NF	4822 122 33496
C8044	CAP.CHIP 63V 10% 100NF	4822 122 33496
C8046	CAP.CHIP 63V 10% 100NF	4822 122 33496
C8047	CAP.CHIP 63V 10% 100NF	4822 122 33496
C8048	CAP.CHIP 63V 10% 100NF	4822 122 33496
C8049	CAP.CHIP 63V 10% 100NF	4822 122 33496
C8051	CAP.CHIP 63V 10% 100NF	4822 122 33496
C8052	CAP.CHIP 63V 10% 100NF	4822 122 33496
C8053	CAP.CHIP 63V 10% 100NF	4822 122 33496
C8054	CAP.CHIP 63V 10% 100NF	4822 122 33496
C8056	CAP.CHIP 63V 10% 100NF	4822 122 33496
C8058	CAP.CHIP 63V 10% 100NF	4822 122 33496
C8059	CAP.CHIP 63V 10% 100NF	4822 122 33496
C8061	CAP.CHIP 63V 10% 100NF	4822 122 33496
C8062	CAP.CHIP 63V 10% 100NF	4822 122 33496
C8063	CAP.CHIP 63V 10% 100NF	4822 122 33496
C8064	CAP.CHIP 63V 10% 100NF	4822 122 33496
C8071	CAP.CHIP 63V 10% 100NF	4822 122 33496
C8072	CAP.CHIP 63V 10% 100NF	4822 122 33496
C8074	CAP.CHIP 63V 10% 100NF	4822 122 33496
C8076	CAP.CHIP 63V 10% 100NF	4822 122 33496
C8079	CAP.CHIP 63V 10% 100NF	4822 122 33496
C8081	CAP.CHIP 63V 10% 100NF	4822 122 33496
C8082	CAP.CHIP 63V 10% 100NF	4822 122 33496
C8083	CAP.CHIP 63V 10% 100NF	4822 122 33496
C8084	CAP.CHIP 63V 10% 100NF	4822 122 33496
C8086	CAP.CHIP 63V 10% 100NF	4822 122 33496

Item	Description		Ordering code
C8087	CAP.CHIP	63V 10% 100NF	4822 122 33496
C8088	CAP.CHIP	63V 10% 100NF	4822 122 33496
C8089	CAP.CHIP	63V 10% 1.5NF	5322 122 31865
C8091	CAP.CHIP	63V 10% 100NF	4822 122 33496
C8092	CAP.CHIP	63V 10% 1.5NF	5322 122 31865
C8093	CAP.CHIP	63V 10% 1.5NF	5322 122 31865
C8094	CAP.CHIP	63V 10% 100NF	4822 122 33496
C8096	CAP.CHIP	63V 10% 100NF	4822 122 33496
C8097	CAP.CHIP	63V 10% 1.5NF	5322 122 31865
C8098	CAP.CHIP	63V 10% 100NF	4822 122 33496
C8101	CAP.CHIP	63V 10% 100NF	4822 122 33496
C8102	CAP.CHIP	63V 5% 1NF	5322 126 10511
C8103	CAP.CHIP	63V 5% 1NF	5322 126 10511
C8104	CAP.CHIP	63V 5% 1NF	5322 126 10511
C8105	CAP.CHIP	63V 10% 100NF	4822 122 33496
C8106	CAP.CHIP	63V 5% 1NF	5322 126 10511
C8107	CAP.CHIP	63V 5% 1NF	5322 126 10511
C8108	CAP.CHIP	63V 5% 1NF	5322 126 10511
C8109	CAP.CHIP	63V 5% 1NF	5322 126 10511
C8110	CAP.CHIP	63V 10% 100NF	4822 122 33496
C8111	CAP.CHIP	63V 5% 1NF	5322 126 10511
C8113	CAP.CHIP	63V 5% 1NF	5322 126 10511
C8114	CAP.CHIP	63V 10% 100NF	4822 122 33496
C8116	CAP.FOIL	63V 10% 680NF	5322 121 42498
C8117	CAP.CHIP	63V 10% 100NF	4822 122 33496
C8118	CAP.CHIP	63V 10% 22NF	5322 122 32654
C8119	CAP.CHIP	63V 10% 100NF	4822 122 33496
C8121	CAP.CHIP	63V 10% 100NF	4822 122 33496
C8122	CAP.CHIP	63V 10% 100NF	4822 122 33496
C8123	CAP.CHIP	63V 10% 100NF	4822 122 33496
C8124	CAP.CHIP	63V 10% 22NF	5322 122 32654
C8126	CAP.CHIP	63V 10% 22NF	5322 122 32654
C8127	CAP.CHIP	63V 10% 22NF	5322 122 32654
C8128	CAP.CHIP	63V 10% 22NF	5322 122 32654
C8129	CAP.CHIP	63V 10% 22NF	5322 122 32654
C8131	CAP.CHIP	63V 10% 22NF	5322 122 32654
C8132	CAP.CHIP	63V 10% 22NF	5322 122 32654
C8133	CAP.CHIP	63V 10% 22NF	5322 122 32654
C8134	CAP.CHIP	63V 10% 22NF	5322 122 32654
C8136	CAP.CHIP	63V 10% 22NF	5322 122 32654
C8137	CAP.CHIP	63V 10% 22NF	5322 122 32654
C8138	CAP.CHIP	63V 10% 100NF	4822 122 33496
C8139	CAP.CHIP	63V 10% 10NF	5322 122 34098
C8140	CAP.CERAMIC	63V 0.5PF 5.6PF	5322 122 32967
C8142	CAP.CHIP	63V 10% 10NF	5322 122 34098
C8144	CAP.CHIP	63V 10% 100NF	4822 122 33496
C8146	CAP.CHIP	63V 10% 22NF	5322 122 32654

Item	Description		Ordering code
C8147	CAP.FOIL	63V 10% 680NF	5322 121 42498
C8148	CAP.CHIP	63V 10% 100NF	4822 122 33496
C8151	CAP.CHIP	63V 10% 10NF	5322 122 34098
C8153	CAP.CHIP	63V 10% 10NF	5322 122 34098
C8154	CAP.CHIP	63V 10% 10NF	5322 122 34098
C8155	CAP.CHIP	63V 10% 10NF	5322 122 34098
C8156	CAP.CHIP	63V 10% 10NF	5322 122 34098
C8158	CAP.CHIP	63V 10% 22NF	5322 122 32654
C8159	CAP.CHIP	63V 10% 10NF	5322 122 34098
C8161	CAP.CHIP	63V 10% 10NF	5322 122 34098
C8162	CAP.CHIP	63V 10% 10NF	5322 122 34098
C8169	CAP.CHIP	63V 10% 10NF	5322 122 34098
C8172	CAP.CHIP	63V 10% 10NF	5322 122 34098
C8173	CAP.CHIP	63V 10% 10NF	5322 122 34098
C8176	CAP.CHIP	63V 10% 10NF	5322 122 34098
C8177	CAP.CHIP	63V 10% 10NF	5322 122 34098
C8178	CAP.CHIP	63V 10% 10NF	5322 122 34098
C8180	CAP.CHIP	63V 10% 10NF	5322 122 34098
C8181	CAP.CHIP	63V 10% 100NF	4822 122 33496
C8182	CAP.CHIP	63V 10% 10NF	5322 122 34098
C8183	CAP.CHIP	63V 10% 10NF	5322 122 34098
C8184	CAP.CHIP	63V 10% 10NF	5322 122 34098
C8186	CAP.CHIP	63V 10% 10NF	5322 122 34098
C8188	CAP.CHIP	63V 10% 10NF	5322 122 34098
C8189	CAP.CHIP	63V 10% 10NF	5322 122 34098
C8190	CAP.CHIP	63V 10% 10NF	5322 122 34098
C8191	CAP.CHIP	63V 10% 10NF	5322 122 34098
C8192	CAP.ELECTROLYT.	25V 20% 47UF	5322 121 10472
C8193	CAP.CHIP	63V 10% 100NF	4822 122 33496
C8194	CAP.CHIP	63V 10% 22NF	5322 122 32654
C8196	CAP.CHIP	63V 10% 10NF	5322 122 34098
C8197	CAP.CHIP	63V 10% 10NF	5322 122 34098
C8198	CAP.CHIP	63V 10% 10NF	5322 122 34098
C8199	CAP.CHIP	63V 10% 10NF	5322 122 34098
C8200	CAP.CHIP	63V 10% 100NF	4822 122 33496
C8202	CAP.CHIP	63V 10% 10NF	5322 122 34098
C8203	CAP.CHIP	63V 10% 10NF	5322 122 34098
C8206	CAP.CHIP	63V 10% 10NF	5322 122 34098
C8207	CAP.CHIP	63V 10% 10NF	5322 122 34098
C8209	CAP.CHIP	63V 10% 10NF	5322 122 34098
C8211	CAP.CHIP	63V 10% 10NF	5322 122 34098
C8213	CAP.CHIP	63V 10% 10NF	5322 122 34098
C8214	CAP.CHIP	63V 10% 10NF	5322 122 34098
C8215	CAP.CHIP	63V 10% 100NF	4822 122 33496
C8216	CAP.CHIP	63V 10% 10NF	5322 122 34098
C8217	CAP.CHIP	63V 10% 100NF	4822 122 33496
C8218	CAP.CERAMIC	63V 0.25PF 1.8PF	5322 126 10343

Item	Description		Ordering code
C8219	CAP.CERAMIC	63V 0.25PF 1.8PF	5322 126 10343
C8220	CAP.CHIP	63V 5% 15PF	5322 122 33869
C8221	CAP.CHIP	63V 10% 100NF	4822 122 33496
C8222	CAP.CHIP	63V 10% 100NF	4822 122 33496
C8223	CAP.CHIP	63V 5% 15PF	5322 122 33869
C8224	CAP.CHIP	63V 10% 10NF	5322 122 34098
C8225	CAP.CHIP	63V 5% 15PF	5322 122 33869
C8226	CAP.CHIP	63V 5% 15PF	5322 122 33869
C8227	CAP.CHIP	63V 5% 15PF	5322 122 33869
C8228	CAP.CHIP	63V 5% 15PF	5322 122 33869
C8229	CAP.CHIP	63V 10% 10NF	5322 122 34098
C8230	CAP.CHIP	63V 5% 15PF	5322 122 33869
C8231	CAP.CHIP	63V 10% 10NF	5322 122 34098
C8232	CAP.CHIP	63V 10% 10NF	5322 122 34098
C8233	CAP.CHIP	63V 5% 27PF	5322 122 31946
C8234	CAP.CHIP	63V 5% 27PF	5322 122 31946
C8235	CAP.CHIP	63V 5% 15PF	5322 122 33869
C8236	CAP.CHIP	63V 10% 10NF	5322 122 34098
C8237	CAP.CHIP	63V 10% 10NF	5322 122 34098
C8238	CAP.CHIP	63V 10% 10NF	5322 122 34098
C8242	CAP.CHIP	63V 10% 10NF	5322 122 34098
C8243	CAP.CHIP	63V 5% 470PF	5322 122 32268
C8244	CAP.CHIP	63V 5% 15PF	5322 122 33869
C8246	CAP.CHIP	63V 5% 100PF	5322 122 32531
C8247	CAP.CERAMIC	63V 0.25PF 3.9PF	5322 122 31944
C8247	CAP.CERAMIC	63V 0.25PF 3.9PF	5322 122 31944
C8248	CAP.CHIP	63V 10% 10NF	5322 122 34098
C8249	CAP.CHIP	63V 10% 100NF	4822 122 33496
C8251	CAP.CHIP	63V 10% 10NF	5322 122 34098
C8252	CAP.CHIP	63V 10% 100NF	4822 122 33496
C8253	CAP.CHIP	63V 10% 10NF	5322 122 34098
C8254	CAP.CHIP	63V 10% 10NF	5322 122 34098
C8255	CAP.CHIP	63V 10% 100NF	4822 122 33496
C8256	CAP.CHIP	63V 5% 330PF	5322 122 31863
C8257	CAP.CHIP	63V 5% 330PF	5322 122 31863
C8258	CAP.CHIP	63V 5% 330PF	5322 122 31863
C8259	CAP.CHIP	63V 5% 330PF	5322 122 31863
C8260	CAP.CHIP	63V 10% 100NF	4822 122 33496
C8261	CAP.CHIP	63V 0.25PF 3.3PF	5322 122 32286
C8262	CAP.CHIP	63V 10% 10NF	5322 122 34098
C8263	CAP.CHIP	63V 10% 10NF	5322 122 34098
C8264	CAP.CHIP	63V 5% 100PF	5322 122 32531
C8265	CAP.CHIP	63V 10% 100NF	4822 122 33496
C8266	CAP.CHIP	63V 5% 470PF	5322 122 32268
C8267	CAP.CHIP	63V 10% 10NF	5322 122 34098
C8268	CAP.CHIP	63V 10% 10NF	5322 122 34098
C8269	CAP.CHIP	63V 10% 100NF	4822 122 33496

Item	Description		Ordering code
C8270	CAP.ELECTROLYT.	25V 20% 47UF	5322 121 10472
C8271	CAP.FOIL	400V 5% 150PF	5322 121 51644
C8273	CAP.ELECTROLYT.	25V 20% 180UF	5322 124 42228
C8274	CAP.ELECTROLYT.	25V 20% 180UF	5322 124 42228
C8276	CAP.ELECTROLYT.	25V 20% 180UF	5322 124 42228
C8277	CAP.ELECTROLYT.	25V 20% 180UF	5322 124 42228
C8278	CAP.ELECTROLYT.	25V 20% 47UF	5322 121 10472
C8279	CAP.ELECTROLYT.	25V 20% 47UF	5322 121 10472
C8286	CAP.FOIL	10V 20% 100UF	5322 124 41383
C8287	CAP.FOIL	10V 20% 100UF	5322 124 41383
C8288	CAP.ELECTROLYT.	25V 20% 47UF	5322 121 10472
C8289	CAP.ELECTROLYT.	25V 20% 180UF	5322 124 42228
C8291	CAP.ELECTROLYT.	25V 20% 47UF	5322 121 10472
C8293	CAP.ELECTROLYT.	25V 20% 47UF	5322 121 10472
C8294	CAP.ELECTROLYT.	25V 20% 47UF	5322 121 10472
C8296	CAP.ELECTROLYT.	25V 20% 47UF	5322 121 10472
C8460	CAP.CHIP	63V 10% 100NF	4822 122 33496
C8461	CAP.CHIP	63V 10% 10NF	5322 122 34098
C8462	CAP.CHIP	63V 10% 10NF	5322 122 34098
C8465	CAP.CHIP	63V 10% 100NF	4822 122 33496
C8470	CAP.CHIP	63V 10% 100NF	4822 122 33496
C8475	CAP.CHIP	63V 10% 100NF	4822 122 33496
C8501	CAP.CHIP	63V 10% 100NF	4822 122 33496
C8502	CAP.CHIP	63V 10% 100NF	4822 122 33496
C8503	CAP.CHIP	63V 10% 22NF	5322 122 32654
C8504	CAP.CHIP	63V 10% 10NF	5322 122 34098
C8506	CAP.CHIP	63V 10% 10NF	5322 122 34098
C8507	CAP.CHIP	63V 10% 22NF	5322 122 32654
C8513	CAP.CERAMIC	63V 5% 10PF	5322 122 32448
C8514	CAP.CHIP	63V 10% 100NF	4822 122 33496
C8515	CAP.CHIP	63V 10% 1.5NF	5322 122 31865
C8516	CAP.CHIP	63V 10% 10NF	5322 122 34098
C8517	CAP.CHIP	63V 10% 10NF	5322 122 34098
C8518	CAP.CHIP	63V 10% 10NF	5322 122 34098
C8519	CAP.CHIP	63V 10% 10NF	5322 122 34098
C8520	CAP.CHIP	63V 10% 10NF	5322 122 34098
C8521	CAP.CHIP	63V 10% 10NF	5322 122 34098
C8522	CAP.CHIP	63V 10% 1.5NF	5322 122 31865
C8581	CAP.CHIP	63V 0.25PF 3.3PF	5322 122 32286
C8581	CAP.CHIP	63V 0.25PF 12P	4822 122 33926
C8583	CAP.CHIP	63V 0.25PF 3.3PF	5322 122 32286
C8583	CAP.CHIP	63V 0.25PF 12P	4822 122 33926
C8586	CAP.CHIP	63V 0.25PF 3.9PF	5322 122 31944
C8586	CAP.CHIP	63V 0.25PF 12P	4822 122 33926
C8588	CAP.CHIP	63V 0.25PF 3.9PF	5322 122 31944
C8588	CAP.CHIP	63V 0.25PF 12P	4822 122 33926
C8591	CAP.CHIP	63V 10% 10NF	5322 122 34098

Item	Description		Ordering code
C8592	CAP.CHIP	63V 10% 10NF	5322 122 34098
C8593	CAP.CHIP	63V 10% 10NF	5322 122 34098
C8594	CAP.CHIP	63V 10% 10NF	5322 122 34098
C8596	CAP.CHIP	63V 5% 100PF	5322 122 32531
C8597	CAP.CHIP	63V 5% 100PF	5322 122 32531
C8601	CAP.CHIP	63V 5% 15PF	5322 122 33869
C8602	CAP.CHIP	63V 5% 15PF	5322 122 33869
C8603	CAP.CHIP	63V 5% 15PF	5322 122 33869
C8604	CAP.CHIP	63V 5% 15PF	5322 122 33869
C8611	CAP.CHIP	63V 10% 100NF	4822 122 33496
C8612	CAP.CHIP	63V 10% 100NF	4822 122 33496
C8613	CAP.CHIP	63V 10% 22NF	5322 122 32654
C8617	CAP.CHIP	63V 10% 100NF	4822 122 33496
C8621	CAP.CHIP	63V 10% 100NF	4822 122 33496
C8652	CAP.CHIP	63V 10% 10NF	5322 122 34098
C8653	CAP.CHIP	63V 10% 10NF	5322 122 34098
C8654	CAP.CHIP	63V 10% 10NF	5322 122 34098
C8655	CAP.CHIP	63V 10% 10NF	5322 122 34098
C8656	CAP.CHIP	63V 10% 10NF	5322 122 34098
C8657	CAP.CHIP	63V 10% 10NF	5322 122 34098
C8723	CAP.CHIP	63V 10% 10NF	5322 122 34098
C8724	CAP.CERAMIC	63V 5% 47PF	5322 122 32452
C8725	CAP.CHIP	63V 10% 10NF	5322 122 34098
C8726	CAP.CHIP	63V 10% 10NF	5322 122 34098
C8727	CAP.CHIP	63V 10% 10NF	5322 122 34098
C8733	CAP.CHIP	63V 10% 10NF	5322 122 34098
C8734	CAP.CHIP	63V 10% 10NF	5322 122 34098
C8737	CAP.CHIP	63V 10% 10NF	5322 122 34098
C8738	CAP.CHIP	63V 10% 10NF	5322 122 34098
C8739	CAP.CHIP	63V 10% 10NF	5322 122 34098
C8740	CAP.CHIP	63V 10% 10NF	5322 122 34098
C8741	CAP.CHIP	63V 10% 10NF	5322 122 34098
C8742	CAP.CHIP	63V 10% 100NF	4822 122 33496
C8743	CAP.CHIP	63V 10% 100NF	4822 122 33496
C8744	CAP.CHIP	63V 10% 100NF	4822 122 33496
C8745	CAP.CHIP	63V 10% 10NF	5322 122 34098
C8746	CAP.CHIP	63V 10% 10NF	5322 122 34098
C8747	CAP.CHIP	63V 10% 10NF	5322 122 34098
C8748	CAP.CHIP	63V 10% 10NF	5322 122 34098
C8749	CAP.CHIP	63V 10% 10NF	5322 122 34098
C8750	CAP.CHIP	63V 10% 10NF	5322 122 34098
C8753	CAP.CHIP	63V 10% 22NF	5322 122 32654
C8754	CAP.CHIP	63V 10% 22NF	5322 122 32654
C8755	CAP.CHIP	63V 10% 22NF	5322 122 32654
C8756	CAP.CHIP	63V 10% 22NF	5322 122 32654
C8758	CAP.CHIP	63V 10% 22NF	5322 122 32654
C8759	CAP.CHIP	63V 10% 22NF	5322 122 32654

Item	Description		Ordering code
C8760	CAP.CHIP	63V 10% 10NF	5322 122 34098
C8762	CAP.CERAMIC	63V 0.25PF 1PF	5322 122 32447
C8764	CAP.CHIP	63V 10% 22NF	5322 122 32654
C8765	CAP.CHIP	63V 10% 22NF	5322 122 32654
C8766	CAP.CHIP	63V 10% 10NF	5322 122 34098
C8767	CAP.CHIP	63V 10% 22NF	5322 122 32654
C8768	CAP.CHIP	63V 10% 22NF	5322 122 32654
C8769	CAP.CHIP	63V 10% 100NF	4822 122 33496
C8770	CAP.CHIP	63V 10% 10NF	5322 122 34098
C8771	CAP.CHIP	63V 10% 10NF	5322 122 34098
C8772	CAP.CHIP	63V 10% 10NF	5322 122 34098
C8773	CAP.CHIP	63V 10% 10NF	5322 122 34098
C8774	CAP.CHIP	63V 10% 10NF	5322 122 34098
C8775	CAP.CHIP	63V 10% 10NF	5322 122 34098
C8776	CAP.CHIP	63V 10% 10NF	5322 122 34098
C8777	CAP.CHIP	63V 10% 100NF	4822 122 33496
C8778	CAP.CHIP	63V 10% 10NF	5322 122 34098
C8779	CAP.CHIP	63V 10% 100NF	4822 122 33496
C8780	CAP.CHIP	63V 10% 100NF	4822 122 33496
C8781	CAP.CHIP	63V 10% 100NF	4822 122 33496
C8782	CAP.CHIP	63V 10% 100NF	4822 122 33496
C8783	CAP.CHIP	63V 10% 100NF	4822 122 33496
C8784	CAP.CHIP	63V 10% 100NF	4822 122 33496
C8785	CAP.CHIP	63V 10% 100NF	4822 122 33496
C8786	CAP.CHIP	63V 10% 100NF	4822 122 33496
C8787	CAP.CHIP	63V 10% 100NF	4822 122 33496
C8788	CAP.CHIP	63V 10% 100NF	4822 122 33496
C8789	CAP.CHIP	63V 10% 100NF	4822 122 33496
C8790	CAP.ELECTROLYT.	25V 20% 47UF	5322 121 10472
C8791	CAP.ELECTROLYT.	25V 20% 47UF	5322 121 10472
C8792	CAP.ELECTROLYT.	25V 20% 47UF	5322 121 10472
C8793	CAP.ELECTROLYT.	25V 20% 47UF	5322 121 10472
C8794	CAP.CHIP	63V 10% 10NF	5322 122 34098
C8795	CAP.CHIP	63V 10% 10NF	5322 122 34098
C8796	CAP.CHIP	63V 10% 10NF	5322 122 34098
C8797	CAP.CHIP	63V 10% 10NF	5322 122 34098
C8798	CAP.CHIP	63V 10% 10NF	5322 122 34098
C8799	CAP.CHIP	63V 10% 22NF	5322 122 32654
C8800	CAP.CHIP	63V 10% 10NF	5322 122 34098
C8801	CAP.CHIP	63V 10% 10NF	5322 122 34098
C8802	CAP.CHIP	63V 5% 150PF	5322 122 33538
C8803	CAP.CHIP	63V 5% 150PF	5322 122 33538
C8804	CAP.CHIP	63V 5% 150PF	5322 122 33538
C8805	CAP.CHIP	63V 10% 10NF	5322 122 34098
C8806	CAP.CHIP	63V 5% 1NF	5322 126 10511
C8807	CAP.CHIP	63V 5% 1NF	5322 126 10511
C8808	CAP.CHIP	63V 5% 1NF	5322 126 10511

Item	Description		Ordering code
C8809	CAP.CHIP	63V 10% 10NF	5322 122 34098
C8810	CAP.CHIP	63V 5% 1NF	5322 126 10511
C8811	CAP.CHIP	63V 5% 1NF	5322 126 10511
C8812	CAP.CHIP	63V 10% 10NF	5322 122 34098
C8813	CAP.CHIP	63V 10% 100NF	4822 122 33496
C8814	CAP.CHIP	63V 10% 100NF	4822 122 33496
C8815	CAP.CHIP	63V 10% 100NF	4822 122 33496
C8816	CAP.CHIP	63V 10% 100NF	4822 122 33496
C8817	CAP.CHIP	63V 10% 100NF	4822 122 33496
C8818	CAP.CHIP	63V 10% 100NF	4822 122 33496
C8819	CAP.CHIP	63V 10% 100NF	4822 122 33496
C8820	CAP.CHIP	63V 10% 100NF	4822 122 33496
C8821	CAP.CHIP	63V 10% 100NF	4822 122 33496
C8822	CAP.CHIP	63V 10% 100NF	4822 122 33496
C8823	CAP.CHIP	63V 10% 100NF	4822 122 33496
C8824	CAP.CHIP	63V 10% 100NF	4822 122 33496
C8825	CAP.FOIL	10V 20% 100UF	5322 124 41383
C8826	CAP.CHIP	63V 10% 100NF	4822 122 33496
C8828	CAP.CHIP	63V 10% 1.5NF	5322 122 31865
C8829	CAP.CHIP	63V 10% 22NF	5322 122 32654
C8830	CAP.CHIP	63V 10% 22NF	5322 122 32654
C8831	CAP.CHIP	63V 10% 100NF	4822 122 33496
C8832	CAP.CHIP	63V 10% 100NF	4822 122 33496
C8833	CAP.CHIP	63V 10% 100NF	4822 122 33496
C8834	CAP.CHIP	63V 10% 100NF	4822 122 33496
C8835	CAP.CHIP	63V 10% 10NF	5322 122 34098
C8836	CAP.CERAMIC	63V 5% 10PF	5322 122 32448
C8837	CAP.CHIP	63V 5% 15PF	5322 122 33869
C8838	CAP.CERAMIC	63V 5% 10PF	5322 122 32448
C8839	CAP.CHIP	63V 5% 15PF	5322 122 33869
C8840	CAP.CHIP	63V 10% 100NF	4822 122 33496
C8841	CAP.CHIP	63V 10% 100NF	4822 122 33496
C8842	CAP.CHIP	63V 0.5PF 8.2PF	5322 122 33244
C8842	CAP.CHIP	63V 0.5PF 10P	5322 122 32448
C8843	CAP.CHIP	63V 0.5PF 8.2PF	5322 122 33244
C8843	CAP.CHIP	63V 0.5PF 10P	5322 122 32448
C8844	CAP.CHIP	63V 0.5PF 8.2PF	5322 122 33244
C8844	CAP.CHIP	63V 0.5PF 10P	5322 122 32448
C8845	CAP.CHIP	63V 0.5PF 8.2PF	5322 122 33244
C8845	CAP.CHIP	63V 0.5PF 10P	5322 122 32448
C8846	CAP.CHIP	63V 10% 100NF	4822 122 33496
C8847	CAP.ELECTROLYT.	25V 20% 47UF	5322 121 10472
C8848	CAP.CHIP	63V 10% 10NF	5322 122 34098
C8849	CAP.CHIP	63V 10% 10NF	5322 122 34098
C8850	CAP.CHIP	63V 10% 10NF	5322 122 34098
C8851	CAP.CHIP	63V 10% 100NF	4822 122 33496
C8852	CAP.CHIP	63V 10% 10NF	5322 122 34098

Item	Description		Ordering code
C8853	CAP.CHIP	63V 10% 10NF	5322 122 34098
C8854	CAP.CHIP	63V 10% 10NF	5322 122 34098
C8855	CAP.FOIL	10V 20% 100UF	5322 124 41383
C8860	CAP.CHIP	63V 5% 12PF	4822 122 33926
C8861	CAP.CHIP	63V 10% 220NF	4822 122 32916
C8862	CAP.CHIP	63V 10% 220NF	4822 122 32916
C8863	CAP.CHIP	63V 10% 22NF	5322 122 32654
C8864	CAP.CHIP	63V 10% 22NF	5322 122 32654
C8865	CAP.CHIP	63V 10% 10NF	5322 122 34098
C8866	CAP.CHIP	63V 10% 22NF	5322 122 32654
C8867	CAP.CHIP	63V 10% 22NF	5322 122 32654
C8868	CAP.CHIP	63V 10% 10NF	5322 122 34098

INTEGRATED CIRCUITS

D8003	INTEGR.CIRCUIT	OQ0242 ECL-TTL	5322 209 12513
D8004	INTEGR.CIRCUIT	OQ0242 ECL-TTL	5322 209 12513
D8005	INTEGR.CIRCUIT	OQ0245 XOSC	5322 209 12514
D8006	INTEGR.CIRCUIT	OQ0244 DACPOT	5322 209 12468
D8012	INTEGR.CIRCUIT	DF0233	5322 209 31721
D8013	INTEGR.CIRCUIT	DF0233	5322 209 31721
D8027	INTEGR.CIRCUIT	LSI0002 DARLIC	5322 209 12516
D8030	INTEGR.CIRCUIT	MC74ACT132D MOT	5322 209 32772
D8032	INTEGR.CIRCUIT	HEF4094BT PEL	5322 209 11306
D8033	INTEGR.CIRCUIT	HEF4094BT PEL	5322 209 11306
D8034	INTEGR.CIRCUIT	HEF4094BT PEL	5322 209 11306
D8036	INTEGR.CIRCUIT	HEF4094BT PEL	5322 209 11306
D8037	INTEGR.CIRCUIT	CY7C185-25SC CYP	5322 209 31149
D8037	INTEGR.CIRCUIT	CY7C128A25SC CYP	4822 209 31099
D8038	INTEGR.CIRCUIT	CY7C185-25SC CYP	5322 209 31149
D8038	INTEGR.CIRCUIT	CY7C128A25SC CYP	4822 209 31099
D8039	INTEGR.CIRCUIT	CY7C185-25SC CYP	5322 209 31149
D8039	INTEGR.CIRCUIT	CY7C128A25SC CYP	4822 209 31099
D8041	INTEGR.CIRCUIT	CY7C185-25SC CYP	5322 209 31149
D8041	INTEGR.CIRCUIT	CY7C128A25SC CYP	4822 209 31099
D8042	INTEGR.CIRCUIT	CY7C185-25SC CYP	5322 209 31149
D8042	INTEGR.CIRCUIT	CY7C128A25SC CYP	4822 209 31099
D8043	INTEGR.CIRCUIT	CY7C185-25SC CYP	5322 209 31149
D8043	INTEGR.CIRCUIT	CY7C128A25SC CYP	4822 209 31099
D8044	INTEGR.CIRCUIT	CY7C185-25SC CYP	5322 209 31149
D8044	INTEGR.CIRCUIT	CY7C128A25SC CYP	4822 209 31099
D8045	INTEGR.CIRCUIT	N74F74D PEL	5322 209 61004
D8046	INTEGR.CIRCUIT	CY7C185-25SC CYP	5322 209 31149
D8046	INTEGR.CIRCUIT	CY7C128A25SC CYP	4822 209 31099
D8047	INTEGR.CIRCUIT	PCF3035HP/008 CURCON	5322 209 30217
D8048	INTEGR.CIRCUIT	MOT0001 BATGE	5322 209 12515
D8049	INTEGR.CIRCUIT	CY7C199-25SC CYP	5322 209 32771

Item	Description		Ordering code
D8050	INTEGR.CIRCUIT	N74F86D PEL	5322 209 60265
D8051	INTEGR.CIRCUIT	HM6264ALFP-12T HIT	5322 209 30265
D8052	INTEGR.CIRCUIT	CY7C199-25SC CYP	5322 209 32771
D8054	INTEGR.CIRCUIT	HM628128LFP-7T HIT	5322 209 52733
D8054	INTEGR.CIRCUIT	HM62256LFP-10TZU HIT	5322 209 30228
D8055	INTEGR.CIRCUIT	N74F175D PEL	5322 209 61452
D8056	INTEGR.CIRCUIT	HM628128LFP-7T HIT	5322 209 52733
D8056	INTEGR.CIRCUIT	HM62256LFP-10TZU HIT	5322 209 30228
D8059	INTEGR.CIRCUIT	PC74HCT4052T PEL	5322 209 61132
D8063	INTEGR.CIRCUIT	HEF4066BT PEL	5322 209 14542
D8069	INTEGR.CIRCUIT	TMS320C25FNL T.I	5322 209 62743
D8501	INTEGR.CIRCUIT	PC74HCT259T PEL	4822 209 30086
D8502	INTEGR.CIRCUIT	OQ0251 RATEL	5322 209 12519
D8503	INTEGR.CIRCUIT	N74F32D PEL	5322 209 61003
N8001	INTEGR.CIRCUIT	OQ0239T 100MS/S ADC	5322 209 12509
N8002	INTEGR.CIRCUIT	OQ0239T 100MS/S ADC	5322 209 12509
N8003	INTEGR.CIRCUIT	LM358M NSC	4822 209 60175
N8004	INTEGR.CIRCUIT	LM358M NSC	4822 209 60175
N8007	INTEGR.CIRCUIT	LM337T N.S	5322 209 81236
N8009	INTEGR.CIRCUIT	TDA8444A/N4 PEL	5322 209 30233
N8014	INTEGR.CIRCUIT	MC33184DR2	5322 209 62399
N8015	INTEGR.CIRCUIT	LM337LZ NSC	5322 209 83228
N8016	INTEGR.CIRCUIT	MC33184DR2	5322 209 62399
N8018	INTEGR.CIRCUIT	LM337T N.S	5322 209 81236
N8019	INTEGR.CIRCUIT	MC33184DR2	5322 209 62399
N8021	I.C. ANALOGUE	CA3227M HAR	5322 130 83492
N8022	I.C. ANALOGUE	CA3227M HAR	5322 130 83492
N8023	I.C. ANALOGUE	CA3227M HAR	5322 130 83492
N8024	I.C. ANALOGUE	CA3227M HAR	5322 130 83492
N8026	INTEGR.CIRCUIT	OQ0233WP MASPU	5322 209 12508
N8027	INTEGR.CIRCUIT	OQ0233WP MASPU	5322 209 12508
N8029	INTEGR.CIRCUIT	OQ0241WP COMPASS	5322 209 12512
N8057	INTEGR.CIRCUIT	DAC10GSR AND	5322 209 12469
N8058	INTEGR.CIRCUIT	DAC10GSR AND	5322 209 12469
N8061	INTEGR.CIRCUIT	OQ0240P VECTOR	5322 209 12511
N8062	INTEGR.CIRCUIT	NE521D PEL	5322 209 60297
N8066	INTEGR.CIRCUIT	LM358M NSC	4822 209 60175
N8067	INTEGR.CIRCUIT	OQ0208T CLOCK SWITCH	5322 209 12517
N8068	INTEGR.CIRCUIT	OQ0208T CLOCK SWITCH	5322 209 12517
N8069	INTEGR.CIRCUIT	LM324D	5322 209 83125
N8070	INTEGR.CIRCUIT	TDA8444AT/N2 PEL	5322 209 30233
N8071	INTEGR.CIRCUIT	LM358M NSC	4822 209 60175
N8072	INTEGR.CIRCUIT	LM358M NSC	4822 209 60175
N8073	INTEGR.CIRCUIT	LM337LZ NSC	5322 209 83228
N8074	INTEGR.CIRCUIT	LM358M NSC	4822 209 60175

Item	Description		Ordering code
MISCELLANEOUS			
G8024	RESONATOR	XTAL 12MHZ KYO	5322 242 71444
G8025	CRYSTAL	XTAL UNIT 200MHZ	5322 242 81589
G8053	CRYSTAL	SRQ-0-50-40M S.R	5322 242 72575
COILS			
L8001	COIL	0.12UH 5% TDK	5322 157 63916
L8002	COIL	0.12UH 5% TDK	5322 157 63916
L8003	COIL	0.082UH 5% TDK	5322 157 63382
L8501	COIL	1UH 5% TDK	5322 157 63648
L8502	COIL	1UH 5% TDK	5322 157 63648
L8506	COIL	27UH	4822 158 10551
L8507	COIL	27UH	4822 158 10551
L8508	COIL	27UH	4822 158 10551
L8511	COIL	0.027UH 5% TDK	5322 157 70857
L8512	COIL	0.027UH 5% TDK	5322 157 70857
L8513	COIL	0.027UH 5% TDK	5322 157 70857
RESISTORS			
R8001	RES.CHIP	RMC1/8 1% 21E5	5322 111 92014
R8002	RES.CHIP	RMC1/8 1% 10E	4822 111 91885
R8003	RES.CHIP	RMC1/8 1% 21E5	5322 111 92014
R8004	RES.CHIP	RC-02H 1% 1K	4822 051 10102
R8006	RES.CHIP	RC-02H 1% 1K	4822 051 10102
R8007	RES.CHIP	RC-02H 1% 1K	4822 051 10102
R8008	RES.CHIP	RC-02H 1% 1K	4822 051 10102
R8009	RES.CHIP	RC-02H 1% 1K	4822 051 10102
R8011	RES.CHIP	RC-02H 1% 1K	4822 051 10102
R8012	RES.CHIP	RC-02H 1% 1K	4822 051 10102
R8013	RES.CHIP	RC-02H 1% 1K	4822 051 10102
R8014	RES.CHIP	RMC1/8 1% 10E	4822 111 91885
R8016	RES.CHIP	RC-02H 1% 1K	4822 051 10102
R8017	RES.CHIP	RC-02H 1% 1K	4822 051 10102
R8018	RES.CHIP	RC-02H 1% 1K	4822 051 10102
R8019	RES.CHIP	RC-02H 1% 1K	4822 051 10102
R8021	RES.CHIP	RC-02H 1% 1K	4822 051 10102
R8022	RES.CHIP	RC-02H 1% 1K	4822 051 10102
R8023	RES.CHIP	RC-02H 1% 1K	4822 051 10102
R8024	RES.CHIP	RC-02H 1% 1K	4822 051 10102
R8033	RES.CHIP	RC-02H 1% 100E	4822 051 10101
R8042	RES.METAL FILM	RC-02H 1% 1K78	5322 117 10535
R8043	RES.CHIP	RC-02H 1% 1K	4822 051 10102
R8051	RES.METAL FILM	RC-02H 1% 1K47	5322 117 10527
R8052	RES.METAL FILM	RC-02H 1% 5K62	5322 117 10573
R8053	RES.METAL FILM	RC-02H 1% 3K83	5322 117 10561
R8054	RES.METAL FILM	RC-02H 1% 1K47	5322 117 10527

Item	Description		Ordering code
R8057	RES.CHIP	RMC1/8 1% 42E2	4822 111 91887
R8058	RES.CHIP	RMC1/8 1% 42E2	4822 111 91887
R8059	RES.CHIP	RMC1/8 1% 42E2	4822 111 91887
R8061	RES.CHIP	RMC1/8 1% 42E2	4822 111 91887
R8062	RES.CHIP	RC-02H 1% 4K64	4822 051 54642
R8063	RES.CHIP	RMC1/8 1% 42E2	4822 111 91887
R8064	RES.CHIP	RC-02H 1% 4K64	4822 051 54642
R8066	RES.CHIP	RMC1/8 1% 42E2	4822 111 91887
R8067	RES.CHIP	RMC1/8 1% 42E2	4822 111 91887
R8074	RES.CHIP	RMC1/8 1% 42E2	4822 111 91887
R8077	RES.CHIP	RC-02H 1% 51K1	4822 051 55113
R8078	RES.CHIP	RC-02H 1% 1K	4822 051 10102
R8079	RES.CHIP	RC-02H 1% 100K	4822 051 10104
R8081	RES.CHIP	RC-02H 1% 1K	4822 051 10102
R8082	RES.CHIP	RC-02H 1% 51K1	4822 051 55113
R8083	RES.CHIP	RC-02H 1% 261E	4822 051 52611
R8084	RES.CHIP	RC-02H 1% 261E	4822 051 52611
R8086	RES.CHIP	RC-02H 1% 1K	4822 051 10102
R8087	RES.CHIP	RC-02H 1% 261E	4822 051 52611
R8088	RES.CHIP	RMC1/8 1% 42E2	4822 111 91887
R8089	RES.CHIP	RMC1/8 1% 42E2	4822 111 91887
R8091	RES.CHIP	RMC1/8 1% 42E2	4822 111 91887
R8092	RES.CHIP	RMC1/8 1% 42E2	4822 111 91887
R8093	RES.CHIP	RC-02H 1% 261E	4822 051 52611
R8094	RES.CHIP	RC-02H 1% 1K	4822 051 10102
R8096	RES.CHIP	RC-02H 1% 261E	4822 051 52611
R8097	RES.CHIP	RC-02H 1% 261E	4822 051 52611
R8098	RES.CHIP	RC-02H 1% 100K	4822 051 10104
R8103	RES.CHIP	RMC1/8 1% 42E2	4822 111 91887
R8104	RES.CHIP	RMC1/8 1% 42E2	4822 111 91887
R8106	RES.CHIP	RMC1/8 1% 42E2	4822 111 91887
R8107	RES.CHIP	RMC1/8 1% 42E2	4822 111 91887
R8108	RES.CHIP	RC-02H 1% 261E	4822 051 52611
R8109	RES.METAL FILM	RC-02H 1% 31K6	5322 117 10554
R8111	RES.METAL FILM	RC-02H 1% 14K7	5322 117 10528
R8112	RES.CHIP	RMC1/8 1% 10E	4822 111 91885
R8114	RES.METAL FILM	RC-02H 1% 14K7	5322 117 10528
R8116	RES.METAL FILM	RC-02H 1% 31K6	5322 117 10554
R8117	RES.CHIP	RC-02H 1% 4K64	4822 051 54642
R8118	RES.CHIP	RC-02H 1% 100E	4822 051 10101
R8119	RES.CHIP	RC-02H 1% 100E	4822 051 10101
R8121	RES.CHIP	RC-02H 1% 4K64	4822 051 54642
R8122	RES.CHIP	RC-02H 1% 261E	4822 051 52611
R8123	RES.METAL FILM	RC-02H 1% 562E	5322 117 10572
R8124	RES.METAL FILM	RC-02H 1% 1K47	5322 117 10527
R8126	RES.CHIP	RMC1/8 1% 51E1	5322 111 91893
R8127	RES.CHIP	RMC1/8 1% 51E1	5322 111 91893

Item	Description		Ordering code
R8128	RES.METAL FILM	RMC1/8 1% 38E3	5322 116 83728
R8129	RES.MET.GLAZED	RMC1/8 1% 31E6	5322 116 82895
R8129	RES.CHIP	RC-02H 1% 75E	5322 117 11741
R8130	RES.CHIP	RMC1/8 1% 42E2	4822 111 91887
R8130	RES.CHIP	RC-02H 1% 31E6	5322 117 11732
R8131	RES.METAL FILM	RMC1/8 1% 38E3	5322 116 83728
R8132	RES.METAL FILM	RC-02H 1% 1K33	5322 117 10524
R8133	RES.CHIP	RMC1/8 1% 42E2	4822 111 91887
R8134	RES.CHIP	RC-02H 1% 100E	4822 051 10101
R8135	RES.CHIP	RMC1/8 1% 42E2	4822 111 91887
R8135	RES.CHIP	RC-02H 1% 31E6	5322 117 11732
R8136	RES.MET.GLAZED	RMC1/8 1% 31E6	5322 116 82895
R8136	RES.CHIP	RC-02H 1% 75E	5322 117 11741
R8137	RES.CHIP	RC-02H 1% 100E	4822 051 10101
R8138	RES.METAL FILM	RMC1/8 1% 38E3	5322 116 83728
R8139	RES.METAL FILM	RMC1/8 1% 38E3	5322 116 83728
R8141	RES.MET.GLAZED	RMC1/8 1% 31E6	5322 116 82895
R8141	RES.CHIP	RC-02H 1% 75E	5322 117 11741
R8142	RES.METAL FILM	RC-02H 1% 162E	5322 117 10529
R8143	RES.CHIP	RC-02H 1% 100E	4822 051 10101
R8144	RES.CHIP	RC-02H 1% 100E	4822 051 10101
R8146	RES.METAL FILM	RC-02H 1% 1K21	5322 117 10521
R8147	RES.CHIP	RC-02H 1% 100E	4822 051 10101
R8148	RES.CHIP	RC-02H 1% 2K15	5322 117 10485
R8149	RES.METAL FILM	RC-02H 1% 383E	5322 117 10559
R8151	RES.CHIP	RMC1/8 1% 42E2	4822 111 91887
R8152	RES.CHIP	RMC1/8 1% 42E2	4822 111 91887
R8153	RES.CHIP	RC-02H 1% 10K	4822 051 10103
R8157	RES.CHIP	RC-02H 1% 10K	4822 051 10103
R8158	RES.CHIP	RC-02H 1% 10K	4822 051 10103
R8159	RES.CHIP	RC-02H 1% 10K	4822 051 10103
R8161	RES.METAL FILM	RMC1/8 1% 38E3	5322 116 83728
R8162	RES.METAL FILM	RC-02H 1% 162E	5322 117 10529
R8163	RES.CHIP	RC-02H 1% 100E	4822 051 10101
R8164	RES.CHIP	RC-02H 1% 100E	4822 051 10101
R8166	RES.METAL FILM	RC-02H 1% 1K47	5322 117 10527
R8167	RES.METAL FILM	RC-02H 1% 1K47	5322 117 10527
R8168	RES.METAL FILM	RC-02H 1% 1K47	5322 117 10527
R8169	RES.METAL FILM	RC-02H 1% 162E	5322 117 10529
R8171	RES.METAL FILM	RMC1/8 1% 38E3	5322 116 83728
R8172	RES.CHIP	RC-02H 1% 100E	4822 051 10101
R8173	RES.CHIP	RC-02H 1% 100E	4822 051 10101
R8174	RES.METAL FILM	RC-02H 1% 562E	5322 117 10572
R8176	RES.METAL FILM	RC-02H 1% 162E	5322 117 10529
R8178	RES.CHIP	RMC1/8 1% 42E2	4822 111 91887
R8179	RES.METAL FILM	RC-02H 1% 1K33	5322 117 10524
R8181	RES.METAL FILM	RMC1/8 1% 38E3	5322 116 83728

Item	Description		Ordering code
R8182	RES.MET.GLAZED	RMC1/8 1% 31E6	5322 116 82895
R8182	RES.CHIP	RC-02H 1% 75E	5322 117 11741
R8183	RES.METAL FILM	RMC1/8 1% 38E3	5322 116 83728
R8184	RES.METAL FILM	MRS25 1% 1E	4822 050 21008
R8186	RES.METAL FILM	RC-02H 1% 4K22	5322 117 10565
R8187	RES.METAL FILM	RC-02H 1% 562E	5322 117 10572
R8188	RES.METAL FILM	RC-02H 1% 1K47	5322 117 10527
R8189	RES.CHIP	RMC1/8 1% 51E1	5322 111 91893
R8191	RES.CHIP	RMC1/8 1% 51E1	5322 111 91893
R8192	RES.METAL FILM	RMC1/8 1% 38E3	5322 116 83728
R8193	RES.CHIP	RMC1/8 1% 42E2	4822 111 91887
R8193	RES.CHIP	RC-02H 1% 75E	5322 117 11741
R8194	RES.METAL FILM	RMC1/8 1% 38E3	5322 116 83728
R8196	RES.METAL FILM	RC-02H 1% 1K33	5322 117 10524
R8197	RES.CHIP	RMC1/8 1% 42E2	4822 111 91887
R8198	RES.CHIP	RC-02H 1% 100E	4822 051 10101
R8199	RES.MET.GLAZED	RMC1/8 1% 31E6	5322 116 82895
R8199	RES.CHIP	RC-02H 1% 75E	5322 117 11741
R8201	RES.CHIP	RC-02H 1% 100E	4822 051 10101
R8202	RES.METAL FILM	RMC1/8 1% 38E3	5322 116 83728
R8203	RES.METAL FILM	RMC1/8 1% 38E3	5322 116 83728
R8204	RES.CHIP	RMC1/8 1% 42E2	4822 111 91887
R8204	RES.CHIP	RC-02H 1% 75E	5322 117 11741
R8205	RES.CHIP	RMC1/8 1% 42E2	4822 111 91887
R8205	RES.CHIP	RC-02H 1% 31E6	5322 117 11732
R8206	RES.METAL FILM	RC-02H 1% 162E	5322 117 10529
R8207	RES.CHIP	RC-02H 1% 100E	4822 051 10101
R8208	RES.CHIP	RC-02H 1% 100E	4822 051 10101
R8209	RES.METAL FILM	RMC1/8 1% 38E3	5322 116 83728
R8210	RES.CHIP	RMC1/8 1% 42E2	4822 111 91887
R8210	RES.CHIP	RC-02H 1% 31E6	5322 117 11732
R8211	RES.METAL FILM	RC-02H 1% 162E	5322 117 10529
R8212	RES.METAL FILM	RC-02H 1% 1K47	5322 117 10527
R8213	RES.METAL FILM	RMC1/8 1% 38E3	5322 116 83728
R8214	RES.CHIP	RC-02H 1% 100E	4822 051 10101
R8216	RES.CHIP	RC-02H 1% 100E	4822 051 10101
R8217	RES.METAL FILM	RC-02H 1% 562E	5322 117 10572
R8218	RES.METAL FILM	RC-02H 1% 4K22	5322 117 10565
R8219	RES.CHIP	RMC1/8 1% 42E2	4822 111 91887
R8221	RES.METAL FILM	RC-02H 1% 1K33	5322 117 10524
R8222	RES.METAL FILM	RMC1/8 1% 38E3	5322 116 83728
R8223	RES.MET.GLAZED	RMC1/8 1% 31E6	5322 116 82895
R8223	RES.CHIP	RC-02H 1% 75E	5322 117 11741
R8224	RES.METAL FILM	RMC1/8 1% 38E3	5322 116 83728
R8226	RES.CHIP	RC-02H 1% 4K64	4822 051 54642
R8227	RES.CHIP	RC-02H 1% 100E	4822 051 10101
R8228	RES.CHIP	RC-02H 1% 100E	4822 051 10101

Item	Description		Ordering code
R8229	RES.CHIP	RC-02H 1% 4K64	4822 051 54642
R8231	RES.METAL FILM	RC-02H 1% 1K21	5322 117 10521
R8232	RES.CHIP	RC-02H 1% 100E	4822 051 10101
R8233	RES.CHIP	RC-02H 1% 2K15	5322 117 10485
R8234	RES.METAL FILM	RC-02H 1% 383E	5322 117 10559
R8236	RES.CHIP	RMC1/8 1% 42E2	4822 111 91887
R8237	RES.CHIP	RMC1/8 1% 42E2	4822 111 91887
R8238	RES.CHIP	RC-02H 1% 10K	4822 051 10103
R8239	RES.CHIP	RC-02H 1% 100K	4822 051 10104
R8241	RES.METAL FILM	MRS16T 1% 10K	4822 050 11003
R8242	RES.CHIP	RC-02H 1% 10K	4822 051 10103
R8243	RES.CHIP	RC-02H 1% 10K	4822 051 10103
R8244	RES.CHIP	RC-02H 1% 10K	4822 051 10103
R8246	RES.CHIP	RC-02H 1% 100E	4822 051 10101
R8247	RES.CHIP	RC-02H 1% 100E	4822 051 10101
R8248	RES.METAL FILM	RC-02H 1% 1K47	5322 117 10527
R8252	RES.METAL FILM	RC-02H 1% 1K47	5322 117 10527
R8253	RES.METAL FILM	RC-02H 1% 162E	5322 117 10529
R8254	RES.METAL FILM	RC-02H 1% 162E	5322 117 10529
R8256	RES.METAL FILM	RC-02H 1% 8K25	5322 117 10586
R8257	RES.CHIP	RC-02H 1% 2K15	5322 117 10485
R8258	RES.CHIP	RC-02H 1% 2K15	5322 117 10485
R8259	RES.METAL FILM	RC-02H 1% 8K25	5322 117 10586
R8261	RES.CHIP	RMC1/8 1% 10E	4822 111 91885
R8264	RES.METAL FILM	RC-02H 1% 1K21	5322 117 10521
R8268	RES.CHIP	RC-01 5% 1E	4822 051 10108
R8269	RES.CHIP	RC-01 5% 1E	4822 051 10108
R8271	RES.CHIP	RMC1/8 1% 42E2	4822 111 91887
R8272	RES.CHIP	RMC1/8 1% 42E2	4822 111 91887
R8273	RES.CHIP	RMC1/8 1% 42E2	4822 111 91887
R8274	RES.CHIP	RMC1/8 1% 90E9	5322 111 92018
R8276	RES.METAL FILM	RC-02H 1% 909E	5322 117 10588
R8277	RES.CHIP	RMC1/8 1% 10E	4822 111 91885
R8278	RES.METAL FILM	RC-02H 1% 909E	5322 117 10588
R8279	RES.CHIP	RMC1/8 1% 90E9	5322 111 92018
R8281	RES.CHIP	RMC1/8 1% 10E	4822 111 91885
R8282	RES.CHIP	RMC1/8 1% 90E9	5322 111 92018
R8283	RES.METAL FILM	RC-02H 1% 909E	5322 117 10588
R8284	RES.CHIP	RMC1/8 1% 10E	4822 111 91885
R8286	RES.CHIP	RMC1/8 1% 90E9	5322 111 92018
R8287	RES.METAL FILM	RC-02H 1% 909E	5322 117 10588
R8288	RES.CHIP	RMC1/8 1% 42E2	4822 111 91887
R8289	RES.METAL FILM	RC-02H 1% 909E	5322 117 10588
R8291	RES.CHIP	RMC1/8 1% 42E2	4822 111 91887
R8292	RES.CHIP	RMC1/8 1% 42E2	4822 111 91887
R8293	RES.METAL FILM	RC-02H 1% 909E	5322 117 10588
R8294	RES.	RMC1/8 1% 16E2	5322 116 83564

Item	Description		Ordering code
R8296	RES.CHIP	RMC1/8 1% 42E2	4822 111 91887
R8297	RES.METAL FILM	RC-02H 1% 1K21	5322 117 10521
R8298	RES.METAL FILM	RC-02H 1% 1K21	5322 117 10521
R8299	RES.METAL FILM	RC-02H 1% 909E	5322 117 10588
R8301	RES.	RMC1/8 1% 16E2	5322 116 83564
R8302	RES.	RMC1/8 1% 16E2	5322 116 83564
R8304	RES.CHIP	RMC1/8 1% 42E2	4822 111 91887
R8305	RES.CHIP	RMC1/8 1% 21E5	5322 111 92014
R8306	RES.	RMC1/8 1% 16E2	5322 116 83564
R8307	RES.METAL FILM	RC-02H 1% 909E	5322 117 10588
R8308	RES.CHIP	RMC1/8 1% 42E2	4822 111 91887
R8309	RES.CHIP	RMC1/8 1% 42E2	4822 111 91887
R8310	RES.CHIP	RMC1/8 1% 21E5	5322 111 92014
R8311	RES.CHIP	RC-02H 1% 5K11	5322 117 10487
R8312	RES.METAL FILM	RC-02H 1% 909E	5322 117 10588
R8316	RES.CHIP	RMC1/8 1% 42E2	4822 111 91887
R8317	RES.CHIP	RMC1/8 1% 42E2	4822 111 91887
R8318	RES.METAL FILM	RC-02H 1% 13K3	5322 117 10525
R8319	RES.METAL FILM	RC-02H 1% 13K3	5322 117 10525
R8321	RES.METAL FILM	RC-02H 1% 909E	5322 117 10588
R8322	RES.CHIP	RC-02H 1% 2K15	5322 117 10485
R8323	RES.METAL FILM	RC-02H 1% 909E	5322 117 10588
R8324	RES.METAL FILM	RC-02H 1% 909E	5322 117 10588
R8326	RES.CHIP	RMC1/8 1% 42E2	4822 111 91887
R8327	RES.CHIP	RMC1/8 1% 42E2	4822 111 91887
R8328	RES.METAL FILM	RC-02H 1% 909E	5322 117 10588
R8329	RES.CHIP	RMC1/8 1% 21E5	5322 111 92014
R8331	RES.CHIP	RMC1/8 1% 42E2	4822 111 91887
R8332	RES.CHIP	RC-02H 1% 5K11	5322 117 10487
R8333	RES.METAL FILM	RC-02H 1% 909E	5322 117 10588
R8334	RES.METAL FILM	RC-02H 1% 13K3	5322 117 10525
R8336	RES.CHIP	RMC1/8 1% 21E5	5322 111 92014
R8337	RES.CHIP	RMC1/8 1% 21E5	5322 111 92014
R8338	RES.METAL FILM	RC-02H 1% 13K3	5322 117 10525
R8339	RES.CHIP	RMC1/8 1% 42E2	4822 111 91887
R8341	RES.CHIP	RMC1/8 1% 21E5	5322 111 92014
R8342	RES.METAL FILM	RC-02H 1% 909E	5322 117 10588
R8343	RES.CHIP	RMC1/8 1% 42E2	4822 111 91887
R8344	RES.CHIP	RMC1/8 1% 42E2	4822 111 91887
R8346	RES.CHIP	RMC1/8 1% 10E	4822 111 91885
R8347	RES.CHIP	RMC1/8 1% 42E2	4822 111 91887
R8348	RES.METAL FILM	RC-02H 1% 909E	5322 117 10588
R8349	RES.CHIP	RC-02H 1% 5K11	5322 117 10487
R8351	RES.CHIP	RC-02H 1% 5K11	5322 117 10487
R8352	RES.CHIP	RC-02H 1% 1M	4822 051 10105
R8353	RES.CHIP	RC-02H 1% 10K	4822 051 10103
R8354	RES.CHIP	RC-02H 1% 5K11	5322 117 10487

Item	Description		Ordering code
R8357	RES.CHIP	RC-01 5% 1E	4822 051 10108
R8358	RES.CHIP	RC-02H 1% 5K11	5322 117 10487
R8359	RES.CHIP	RC-02H 1% 5K11	5322 117 10487
R8360	RES.CHIP	RC-02H 1% 5K11	5322 117 10487
R8361	RES.CHIP	RC-02H 1% 1K	4822 051 10102
R8362	RES.METAL FILM	RC-02H 1% 750E	5322 117 10582
R8363	RES.CHIP	RMC1/8 1% 42E2	4822 111 91887
R8364	RES.CHIP	RC-02H 1% 10K	4822 051 10103
R8365	RES.CHIP	RC-02H 1% 5K11	5322 117 10487
R8366	RES.CHIP	RC-02H 1% 10K	4822 051 10103
R8367	RES.METAL FILM	RC-02H 1% 562K	5322 117 10575
R8368	RES.CHIP	RC-02H 1% 215E	5322 117 10484
R8369	RES.CHIP	RC-02H 1% 1K	4822 051 10102
R8372	RES.CHIP	RC-02H 1% 1K	4822 051 10102
R8373	RES.CHIP	RC-02H 1% 100E	4822 051 10101
R8374	RES.METAL FILM	RC-02H 1% 464E	5322 117 10567
R8376	RES.METAL FILM	RC-02H 1% 9K09	5322 117 10589
R8377	RES.METAL FILM	RC-02H 1% 14K7	5322 117 10528
R8378	RES.CHIP	RC-02H 1% 1K	4822 051 10102
R8379	RES.CHIP	RMC1/8 1% 10E	4822 111 91885
R8381	RES.CHIP	RC-02H 1% 2K15	5322 117 10485
R8382	RES.CHIP	RC-02H 1% 2K15	5322 117 10485
R8383	RES.METAL FILM	RC-02H 1% 464E	5322 117 10567
R8384	RES.METAL FILM	RC-02H 1% 1K96	5322 117 10539
R8385	RES.CHIP	RC-02H 1% 215E	5322 117 10484
R8386	RES.METAL FILM	RC-02H 1% 3K16	5322 117 10553
R8387	RES.METAL FILM	RC-02H 1% 1K96	5322 117 10539
R8388	RES.METAL FILM	RC-02H 1% 511E	5322 117 10569
R8389	RES.METAL FILM	RC-02H 1% 19K6	5322 117 10541
R8390	RES.METAL FILM	RC-02H 1% 3K16	5322 117 10553
R8391	RES.METAL FILM	RC-02H 1% 562K	5322 117 10575
R8392	RES.METAL FILM	RC-02H 1% 316K	5322 117 10555
R8393	RES.METAL FILM	RC-02H 1% 21K5	5322 117 10542
R8396	RES.CHIP	RC-02H 1% 10K	4822 051 10103
R8397	RES.CHIP	RC-02H 1% 10K	4822 051 10103
R8398	RES.METAL FILM	RC-02H 1% 383E	5322 117 10559
R8399	RES.METAL FILM	RC-02H 1% 1K62	5322 117 10531
R8401	RES.METAL FILM	RC-02H 1% 3K16	5322 117 10553
R8402	RES.METAL FILM	RC-02H 1% 562E	5322 117 10572
R8403	RES.CHIP	RC-02H 1% 5K11	5322 117 10487
R8404	RES.METAL FILM	RC-02H 1% 3K48	5322 117 10557
R8405	RES.CHIP	RC-02H 1% 5K11	5322 117 10487
R8405	RES.CHIP	RC-02H 1% 5K11	5322 117 10487
R8406	RES.METAL FILM	RC-02H 1% 1K96	5322 117 10539
R8407	RES.METAL FILM	RC-02H 1% 750E	5322 117 10582
R8408	RES.METAL FILM	RC-02H 1% 2K37	5322 117 10545
R8409	RES.METAL FILM	RC-02H 1% 1K96	5322 117 10539

Item	Description		Ordering code
R8410	RES.METAL FILM	RC-02H 1% 215K	5322 117 10543
R8411	RES.METAL FILM	RC-02H 1% 8K25	5322 117 10586
R8412	RES.METAL FILM	RC-02H 1% 12K1	5322 117 10522
R8413	RES.CHIP	RC-02H 1% 215E	5322 117 10484
R8414	RES.CHIP	RC-02H 1% 215E	5322 117 10484
R8416	RES.METAL FILM	RC-02H 1% 14K7	5322 117 10528
R8417	RES.CHIP	RC-02H 1% 4K64	4822 051 54642
R8418	RES.METAL FILM	RC-02H 1% 21K5	5322 117 10542
R8419	RES.METAL FILM	RC-02H 1% 1K47	5322 117 10527
R8421	RES.METAL FILM	RC-02H 1% 1K47	5322 117 10527
R8422	RES.METAL FILM	RC-02H 1% 1K21	5322 117 10521
R8423	RES.METAL FILM	RC-02H 1% 562E	5322 117 10572
R8424	RES.METAL FILM	RC-02H 1% 348E	5322 117 10556
R8426	RES.CHIP	RMC1/8 1% 82E5	5322 111 92017
R8427	RES.CHIP	RC-01 5% 4E7	4822 051 10478
R8428	RES.METAL FILM	RC-02H 1% 2K61	5322 117 10547
R8429	RES.METAL FILM	RC-02H 1% 511E	5322 117 10569
R8434	RES.CHIP	RC-02H 1% 100K	4822 051 10104
R8436	RES.CHIP	RC-02H 1% 10K	4822 051 10103
R8438	RES.METAL FILM	RC-02H 1% 3K83	5322 117 10561
R8439	RES.METAL FILM	RC-02H 1% 16K2	5322 117 10532
R8441	RES.CHIP	RC-02H 1% 100E	4822 051 10101
R8442	RES.METAL FILM	RC-02H 1% 3K16	5322 117 10553
R8443	RES.METAL FILM	RC-02H 1% 178E	5322 117 10534
R8444	RES.CHIP	RMC1/8 1% 51E1	5322 111 91893
R8446	RES.CHIP	RMC1/8 1% 51E1	5322 111 91893
R8447	RES.MET.GLAZED	RMC1/8 1% 31E6	5322 116 82895
R8448	RES.MET.GLAZED	RMC1/8 1% 31E6	5322 116 82895
R8449	RES.CHIP	RMC1/8 1% 10E	4822 111 91885
R8450	RES.METAL FILM	RC-02H 1% 121K	5322 117 10523
R8451	RES.CHIP	RC-02H 1% 100E	4822 051 10101
R8452	RES.CHIP	RC-02H 1% 100E	4822 051 10101
R8453	RES.CHIP	RC-02H 1% 1K	4822 051 10102
R8454	RES.CHIP	RC-02H 1% 261E	4822 051 52611
R8455	RES.METAL FILM	MRS25 1% 8E25	4822 050 28258
R8456	RES.METAL FILM	RC-02H 1% 464E	5322 117 10567
R8458	RES.METAL FILM	RC-02H 1% 9K09	5322 117 10589
R8459	RES.METAL FILM	RC-02H 1% 9K09	5322 117 10589
R8460	RES.CHIP	RC-02H 1% 2K15	5322 117 10485
R8461	RES.METAL FILM	PR24 1/4W 0.1% 10K	5322 116 82868
R8462	RES.METAL FILM	PR24 1/4W 0.1% 10K	5322 116 82868
R8463	RES.METAL FILM	PR24 1/4W 0.1% 10K	5322 116 82868
R8464	RES.METAL FILM	RC-02H 1% 464E	5322 117 10567
R8465	RES.METAL FILM	RC-02H 1% 121K	5322 117 10523
R8466	RES.METAL FILM	PR24 1/4W 0.1% 10K	5322 116 82868
R8467	RES.METAL FILM	MRS25 1% 1E	4822 050 21008
R8469	RES.METAL FILM	MRS25 1% 1E	4822 050 21008

Item	Description		Ordering code
R8471	RES.METAL FILM	MRS25 1% 1E	4822 050 21008
R8472	RES.METAL FILM	MRS25 1% 10E	4822 050 21009
R8473	RES.METAL FILM	MRS25 1% 1E	4822 050 21008
R8474	RES.METAL FILM	MRS25 1% 10E	4822 050 21009
R8476	RES.METAL FILM	MRS25 1% 10E	4822 050 21009
R8478	RES.METAL FILM	MRS25 1% 10E	4822 050 21009
R8483	RES.METAL FILM	PR24 1/4W 0.1% 5K	5322 116 80369
R8484	RES.METAL FILM	PR24 1/4W 0.1% 10K	5322 116 82868
R8486	RES.CHIP	RC-02H 1% 5K11	5322 117 10487
R8487	RES.CHIP	RC-02H 1% 10K	4822 051 10103
R8489	RES.METAL FILM	RC-02H 1% 1K62	5322 117 10531
R8491	RES.CHIP	RC-02H 1% 100E	4822 051 10101
R8492	RES.CHIP	RC-02H 1% 10K	4822 051 10103
R8493	RES.CHIP	RC-02H 1% 1K	4822 051 10102
R8496	RES.CHIP	RC-02H 1% 51K1	4822 051 55113
R8497	RES.CHIP	RC-02H 1% 1K	4822 051 10102
R8498	RES.METAL FILM	RC-02H 1% 1K62	5322 117 10531
R8501	RES.CHIP	RC-01 5% 1E	4822 051 10108
R8502	RES.CHIP	RC-01 5% 1E	4822 051 10108
R8503	RES.CHIP	RC-01 5% 1E	4822 051 10108
R8506	RES.CHIP	RC-01 0E	4822 051 10008
R8507	RES.CHIP	RC-01 5% 1E	4822 051 10108
R8508	RES.CHIP	RC-01 5% 1E	4822 051 10108
R8509	RES.CHIP	RC-01 5% 1E	4822 051 10108
R8511	RES.CHIP	RC-02H 1% 1K	4822 051 10102
R8512	RES.CHIP	RC-02H 1% 1K	4822 051 10102
R8514	RES.CHIP	RC-01 5% 1E	4822 051 10108
R8516	RES.CHIP	RC-01 5% 1E	4822 051 10108
R8517	RES.CHIP	RC-01 5% 1E	4822 051 10108
R8518	RES.CHIP	RC-01 5% 1E	4822 051 10108
R8519	RES.CHIP	RMC1/8 1% 10E	4822 111 91885
R8521	RES.CHIP	RMC1/8 1% 10E	4822 111 91885
R8522	RES.CHIP	RC-01 5% 1E	4822 051 10108
R8523	RES.CHIP	RC-01 5% 1E	4822 051 10108
R8524	RES.CHIP	RC-01 5% 1E	4822 051 10108
R8526	RES.CHIP	RC-01 5% 1E	4822 051 10108
R8527	RES.CHIP	RC-01 5% 1E	4822 051 10108
R8528	RES.CHIP	RC-01 5% 1E	4822 051 10108
R8530	RES.METAL FILM	RC-02H 1% 825K	5322 117 10587
R8531	RES.METAL FILM	RC-02H 1% 464K	5322 117 10568
R8532	RES.METAL FILM	RC-02H 1% 383E	5322 117 10559
R8533	RES.METAL FILM	RC-02H 1% 383E	5322 117 10559
R8534	RES.METAL FILM	RC-02H 1% 383E	5322 117 10559
R8535	RES.METAL FILM	RC-02H 1% 383E	5322 117 10559
R8536	RES.CHIP	RMC1/8 1% 42E2	4822 111 91887
R8537	RES.METAL FILM	RC-02H 1% 162E	5322 117 10529
R8538	RES.CHIP	RMC1/8 1% 42E2	4822 111 91887

Item	Description		Ordering code
R8539	RES.METAL FILM	RC-02H 1% 162E	5322 117 10529
R8540	RES.METAL FILM	RC-02H 1% 1K21	5322 117 10521
R8541	RES.CHIP	RMC1/8 1% 42E2	4822 111 91887
R8542	RES.CHIP	RMC1/8 1% 42E2	4822 111 91887
R8543	RES.METAL FILM	RC-02H 1% 348E	5322 117 10556
R8544	RES.CHIP	RMC1/8 1% 42E2	4822 111 91887
R8545	RES.CHIP	RMC1/8 1% 42E2	4822 111 91887
R8546	RES.CHIP	RMC1/8 1% 42E2	4822 111 91887
R8547	RES.METAL FILM	RC-02H 1% 1K47	5322 117 10527
R8548	RES.METAL FILM	RC-02H 1% 511E	5322 117 10569
R8549	RES.CHIP	RC-02H 1% 261E	4822 051 52611
R8550	RES.METAL FILM	RC-02H 1% 1K47	5322 117 10527
R8551	RES.CHIP	RMC1/8 1% 42E2	4822 111 91887
R8552	RES.CHIP	RMC1/8 1% 42E2	4822 111 91887
R8553	RES.METAL FILM	RC-02H 1% 464E	5322 117 10567
R8554	RES.METAL FILM	RC-02H 1% 562E	5322 117 10572
R8555	RES.CHIP	RMC1/8 1% 42E2	4822 111 91887
R8556	RES.CHIP	RMC1/8 1% 42E2	4822 111 91887
R8557	RES.CHIP	RMC1/8 1% 42E2	4822 111 91887
R8558	RES.CHIP	RMC1/8 1% 42E2	4822 111 91887
R8559	RES.METAL FILM	RC-02H 1% 562E	5322 117 10572
R8560	RES.METAL FILM	RC-02H 1% 464E	5322 117 10567
R8561	RES.CHIP	RMC1/8 1% 42E2	4822 111 91887
R8562	RES.CHIP	RMC1/8 1% 42E2	4822 111 91887
R8563	RES.METAL FILM	RC-02H 1% 1K47	5322 117 10527
R8564	RES.CHIP	RC-02H 1% 261E	4822 051 52611
R8565	RES.METAL FILM	RC-02H 1% 511E	5322 117 10569
R8566	RES.METAL FILM	RC-02H 1% 1K47	5322 117 10527
R8567	RES.CHIP	RMC1/8 1% 42E2	4822 111 91887
R8568	RES.CHIP	RMC1/8 1% 42E2	4822 111 91887
R8569	RES.CHIP	RMC1/8 1% 42E2	4822 111 91887
R8570	RES.METAL FILM	RC-02H 1% 348E	5322 117 10556
R8571	RES.CHIP	RMC1/8 1% 42E2	4822 111 91887
R8572	RES.CHIP	RMC1/8 1% 42E2	4822 111 91887
R8573	RES.METAL FILM	RC-02H 1% 1K21	5322 117 10521
R8574	RES.METAL FILM	RC-02H 1% 162E	5322 117 10529
R8575	RES.CHIP	RMC1/8 1% 42E2	4822 111 91887
R8576	RES.METAL FILM	RC-02H 1% 162E	5322 117 10529
R8577	RES.CHIP	RMC1/8 1% 42E2	4822 111 91887
R8581	RES.METAL FILM	RC-02H 1% 31E6	5322 117 11732
R8581	RES.METAL FILM	RC-02H 1% 100E	4822 051 10101
R8583	RES.METAL FILM	RC-02H 1% 31E6	5322 117 11732
R8583	RES.METAL FILM	RC-02H 1% 100E	4822 051 10101
R8586	RES.METAL FILM	RC-02H 1% 31E6	5322 117 11732
R8586	RES.METAL FILM	RC-02H 1% 100E	4822 051 10101
R8588	RES.METAL FILM	RC-02H 1% 31E6	5322 117 11732
R8588	RES.METAL FILM	RC-02H 1% 100E	4822 051 10101

Item	Description		Ordering code
R8591	RES.CHIP	RMC1/8 1% 10E	4822 111 91885
R8592	RES.CHIP	RMC1/8 1% 10E	4822 111 91885
R8593	RES.CHIP	RMC1/8 1% 10E	4822 111 91885
R8594	RES.CHIP	RMC1/8 1% 10E	4822 111 91885
R8596	RES.METAL FILM	RC-02H 1% 464K	5322 117 10568
R8597	RES.METAL FILM	RC-02H 1% 215K	5322 117 10543
R8598	RES.CHIP	RMC1/8 1% 10E	4822 111 91885
R8601	RES.	RMC1/8 1% 16E2	5322 116 83564
R8602	RES.	RMC1/8 1% 16E2	5322 116 83564
R8603	RES.CHIP	RMC1/8 1% 21E5	5322 111 92014
R8604	RES.CHIP	RMC1/8 1% 21E5	5322 111 92014
R8606	RES.	RMC1/8 1% 16E2	5322 116 83564
R8607	RES.	RMC1/8 1% 16E2	5322 116 83564
R8608	RES.CHIP	RMC1/8 1% 21E5	5322 111 92014
R8609	RES.CHIP	RMC1/8 1% 21E5	5322 111 92014
R8611	RES.METAL FILM	RC-02H 1% 14K7	5322 117 10528
R8612	RES.CHIP	RMC1/8 1% 10E	4822 111 91885
R8621	RES.CHIP	RC-02H 1% 1K	4822 051 10102
R8622	RES.CHIP	RC-02H 1% 100K	4822 051 10104
R8658	RES.CHIP	RMC1/8 1% 10E	4822 111 91885
R8659	RES.METAL FILM	RC-02H 1% 422E	5322 117 10564
R8660	RES.METAL FILM	RC-02H 1% 422E	5322 117 10564
R8697	RES.METAL FILM	RC-02H 1% 316K	5322 117 10555
R8721	RES.CHIP	RMC1/8 1% 42E2	4822 111 91887
R8722	RES.CHIP	RMC1/8 1% 42E2	4822 111 91887
R8723	RES.CHIP	RC-02H 1% 10K	4822 051 10103
R8725	RES.CHIP	RC-02H 1% 5K11	5322 117 10487
R8726	RES.MET.GLAZED	RMC1/8 1% 31E6	5322 116 82895
R8727	RES.METAL FILM	RC-02H 1% 7K5	5322 117 10583
R8728	RES.CHIP	RMC1/8 1% 51E1	5322 111 91893
R8729	RES.CHIP	RMC1/8 1% 42E2	4822 111 91887
R8730	RES.CHIP	RMC1/8 1% 51E1	5322 111 91893
R8731	RES.CHIP	RC-02H 1% 1K	4822 051 10102
R8732	RES.CHIP	RC-02H 1% 100E	4822 051 10101
R8733	RES.METAL FILM	RC-02H 1% 1K62	5322 117 10531
R8734	RES.CHIP	RC-02H 1% 2K15	5322 117 10485
R8735	RES.METAL FILM	RC-02H 1% 1K62	5322 117 10531
R8736	RES.METAL FILM	RC-02H 1% 1K62	5322 117 10531
R8737	RES.CHIP	RC-02H 1% 2K15	5322 117 10485
R8738	RES.METAL FILM	RC-02H 1% 1K62	5322 117 10531
R8739	RES.CHIP	RMC1/8 1% 10E	4822 111 91885
R8740	RES.METAL FILM	RC-02H 1% 7K5	5322 117 10583
R8741	RES.CHIP	RC-02H 1% 100E	4822 051 10101
R8742	RES.METAL FILM	MRS25 1% 3E16	4822 050 23168
R8743	RES.CHIP	RC-02H 1% 100E	4822 051 10101
R8744	RES.CHIP	RC-02H 1% 100E	4822 051 10101
R8745	RES.METAL FILM	RC-02H 1% 1K62	5322 117 10531

Item	Description		Ordering code
R8746	RES.CHIP	RMC1/8 1% 42E2	4822 111 91887
R8747	RES.CHIP	RC-02H 1% 2K15	5322 117 10485
R8748	RES.CHIP	RMC1/8 1% 42E2	4822 111 91887
R8749	RES.METAL FILM	RC-02H 1% 1K62	5322 117 10531
R8750	RES.MET.GLAZED	RMC1/8 1% 31E6	5322 116 82895
R8751	RES.MET.GLAZED	RMC1/8 1% 31E6	5322 116 82895
R8752	RES.MET.GLAZED	RMC1/8 1% 31E6	5322 116 82895
R8753	RES.CHIP	RMC1/8 1% 42E2	4822 111 91887
R8754	RES.CHIP	RC-02H 1% 2K15	5322 117 10485
R8755	RES.CHIP	RMC1/8 1% 42E2	4822 111 91887
R8756	RES.METAL FILM	RC-02H 1% 3K83	5322 117 10561
R8757	RES.METAL FILM	RC-02H 1% 7K5	5322 117 10583
R8758	RES.CHIP	RC-02H 1% 10K	4822 051 10103
R8760	RES.METAL FILM	RC-02H 1% 31K6	5322 117 10554
R8761	RES.METAL FILM	RC-02H 1% 31K6	5322 117 10554
R8762	RES.METAL FILM	RC-02H 1% 31K6	5322 117 10554
R8763	RES.METAL FILM	RC-02H 1% 31K6	5322 117 10554
R8764	RES.CHIP	RC-02H 1% 51K1	4822 051 55113
R8765	RES.CHIP	RMC1/8 1% 10E	4822 111 91885
R8766	RES.CHIP	RC-02H 1% 51K1	4822 051 55113
R8767	RES.METAL FILM	RC-02H 1% 2K87	5322 117 10549
R8768	RES.METAL FILM	RC-02H 1% 2K87	5322 117 10549
R8769	RES.CHIP	RC-02H 1% 51K1	4822 051 55113
R8771	RES.CHIP	RMC1/8 1% 10E	4822 111 91885
R8772	RES.CHIP	RC-02H 1% 51K1	4822 051 55113
R8773	RES.METAL FILM	RC-02H 1% 2K87	5322 117 10549
R8774	RES.METAL FILM	RC-02H 1% 2K87	5322 117 10549
R8775	RES.CHIP	RC-02H 1% 100E	4822 051 10101
R8776	RES.CHIP	RC-02H 1% 100E	4822 051 10101
R8777	RES.CHIP	RC-02H 1% 100E	4822 051 10101
R8778	RES.CHIP	RC-02H 1% 100E	4822 051 10101
R8779	RES.CHIP	RC-02H 1% 100E	4822 051 10101
R8780	RES.CHIP	RC-02H 1% 100E	4822 051 10101
R8781	RES.CHIP	RC-02H 1% 100E	4822 051 10101
R8782	RES.CHIP	RC-02H 1% 100E	4822 051 10101
R8783	RES.CHIP	RC-02H 1% 100E	4822 051 10101
R8784	RES.CHIP	RC-02H 1% 100E	4822 051 10101
R8785	RES.CHIP	RC-02H 1% 100E	4822 051 10101
R8786	RES.CHIP	RC-02H 1% 100E	4822 051 10101
R8787	RES.CHIP	RC-02H 1% 100E	4822 051 10101
R8788	RES.CHIP	RC-02H 1% 100E	4822 051 10101
R8789	RES.CHIP	RC-02H 1% 51K1	4822 051 55113
R8790	RES.CHIP	RC-02H 1% 10K	4822 051 10103
R8791	RES.METAL FILM	RC-02H 1% 7K5	5322 117 10583
R8792	RES.CHIP	RC-02H 1% 51K1	4822 051 55113
R8793	RES.CHIP	RC-02H 1% 10K	4822 051 10103
R8794	RES.METAL FILM	RC-02H 1% 7K5	5322 117 10583

Item	Description		Ordering code
R8795	RES.METAL FILM	RC-02H 1% 7K5	5322 117 10583
R8796	RES.CHIP	RC-02H 1% 10K	4822 051 10103
R8797	RES.CHIP	RC-02H 1% 51K1	4822 051 55113
R8798	RES.METAL FILM	RC-02H 1% 7K5	5322 117 10583
R8799	RES.CHIP	RC-02H 1% 10K	4822 051 10103
R8800	RES.CHIP	RC-02H 1% 51K1	4822 051 55113
R8801	RES.CHIP	RMC1/8 1% 10E	4822 111 91885
R8802	RES.CHIP	RC-02H 1% 261E	4822 051 52611
R8803	RES.CHIP	RC-02H 1% 100E	4822 051 10101
R8804	RES.CHIP	RMC1/8 1% 10E	4822 111 91885
R8805	RES.CHIP	RMC1/8 1% 10E	4822 111 91885
R8806	RES.CHIP	RMC1/8 1% 10E	4822 111 91885
R8807	RES.CHIP	RC-02H 1% 10K	4822 051 10103
R8808	RES.CHIP	RC-02H 1% 10K	4822 051 10103
R8809	RES.CHIP	RMC1/8 1% 10E	4822 111 91885
R8810	RES.CHIP	RMC1/8 1% 21E5	5322 111 92014
R8811	RES.CHIP	RMC1/8 1% 21E5	5322 111 92014
R8812	RES.METAL FILM	RC-02H 1% 464E	5322 117 10567
R8813	RES.CHIP	RC-02H 1% 10K	4822 051 10103
R8814	RES.METAL FILM	RC-02H 1% 75K	5322 117 10584
R8815	RES.CHIP	RMC1/8 1% 90E9	5322 111 92018
R8816	RES.CHIP	RMC1/8 1% 90E9	5322 111 92018
R8817	RES.CHIP	RMC1/8 1% 90E9	5322 111 92018
R8818	RES.CHIP	RMC1/8 1% 90E9	5322 111 92018
R8819	RES.METAL FILM	RC-02H 1% 42K2	5322 117 10566
R8820	RES.METAL FILM	RC-02H 1% 56K2	5322 117 10574
R8821	RES.METAL FILM	RMC1/8 1% 23E7	5322 117 10591
R8822	RES.CHIP	RMC1/8 1% 10E	4822 111 91885
R8823	RES.CHIP	RC-01 5% 5E6	4822 051 10568
R8824	RES.CHIP	RC-01 5% 5E6	4822 051 10568
R8825	RES.CHIP	RC-02H 1% 100E	4822 051 10101
R8826	RES.METAL FILM	RMC1/8 1% 23E7	5322 117 10591
R8827	RES.CHIP	RC-02H 1% 100E	4822 051 10101
R8828	RES.CHIP	RMC1/8 1% 10E	4822 111 91885
R8829	RES.CHIP	RMC1/8 1% 21E5	5322 111 92014
R8830	RES.CHIP	RMC1/8 1% 21E5	5322 111 92014
R8831	RES.CHIP	RC-02H 1% 100K	4822 051 10104
R8832	RES.CHIP	RC-02H 1% 100K	4822 051 10104
R8833	RES.	RMC1/8 1% 16E2	5322 116 83564
R8834	RES.CHIP	RMC1/8 1% 10E	4822 111 91885
R8835	RES.CHIP	RC-01 5% 4E7	4822 051 10478
R8836	RES.CHIP	RC-02H 1% 215E	5322 117 10484
R8837	RES.CHIP	RC-02H 1% 215E	5322 117 10484
R8838	RES.CHIP	RC-02H 1% 215E	5322 117 10484
R8839	RES.MET.GLAZED	RMC1/8 1% 31E6	5322 116 82895
R8840	RES.MET.GLAZED	RMC1/8 1% 31E6	5322 116 82895
R8841	RES.CHIP	RC-01 5% 1E	4822 051 10108

Item	Description		Ordering code
R8842	RES.CHIP	RC-01 5% 1E	4822 051 10108
R8843	RES.METAL FILM	RC-02H 1% 1K62	5322 117 10531
R8844	RES.METAL FILM	RC-02H 1% 1K47	5322 117 10527
R8845	RES.METAL FILM	RC-02H 1% 3K83	5322 117 10561
R8846	RES.METAL FILM	RC-02H 1% 16K2	5322 117 10532
R8847	RES.METAL FILM	RC-02H 1% 1K47	5322 117 10527
R8848	RES.METAL FILM	RC-02H 1% 9K09	5322 117 10589
R8849	RES.CHIP	RC-02H 1% 10K	4822 051 10103
R8850	RES.METAL FILM	RC-02H 1% 2K61	5322 117 10547
R8851	RES.CHIP	RMC1/8 1% 10E	4822 111 91885
R8852	RES.METAL FILM	RC-02H 1% 16K2	5322 117 10532
R8853	RES.METAL FILM	RC-02H 1% 3K48	5322 117 10557
R8854	RES.METAL FILM	RC-02H 1% 2K61	5322 117 10547
R8855	RES.METAL FILM	RC-02H 1% 6K81	5322 117 10581
R8856	RES.METAL FILM	RC-02H 1% 12K1	5322 117 10522
R8857	RES.METAL FILM	RC-02H 1% 619E	5322 117 10576
R8858	RES.METAL FILM	RC-02H 1% 619E	5322 117 10576
R8859	RES.METAL FILM	RC-02H 1% 3K48	5322 117 10557
R8860	RES.METAL FILM	RC-02H 1% 17K8	5322 117 10536
R8861	RES.METAL FILM	RC-02H 1% 348E	5322 117 10556
R8862	RES.METAL FILM	RC-02H 1% 7K5	5322 117 10583
R8863	RES.METAL FILM	RC-02H 1% 75K	5322 117 10584
R8864	RES.CHIP	RC-02H 1% 10K	4822 051 10103
R8865	RES.CHIP	RMC1/8 1% 10E	4822 111 91885
R8868	RES.METAL FILM	RC-02H 1% 562K	5322 117 10575
R8869	RES.METAL FILM	RC-02H 1% 56K2	5322 117 10574
R8870	RES.METAL FILM	RC-02H 1% 56K2	5322 117 10574
R8871	RES.METAL FILM	RC-02H 1% 562K	5322 117 10575
R8872	RES.CHIP	RMC1/8 1% 10E	4822 111 91885
R8874	RES.CHIP	RC-01 5% 4E7	4822 051 10478
R8875	RES.CHIP	RC-01 5% 4E7	4822 051 10478
R8876	RES.CHIP	RC-02H 1% 100E	4822 051 10101
R8877	RES.CHIP	RC-01 5% 3E3	4822 051 10338
R8878	RES.METAL FILM	RC-02H 1% 56K2	5322 117 10574
R8879	RES.CHIP	RC-02H 1% 1K	4822 051 10102
R8880	RES.CHIP	RMC1/8 1% 10E	4822 111 91885
R8881	RES.METAL FILM	RC-02H 1% 237E	5322 117 10544
R8882	RES.METAL FILM	RC-02H 1% 14K7	5322 117 10528
R8883	RES.METAL FILM	RC-02H 1% 681E	5322 117 10579
R8884	RES.METAL FILM	RC-02H 1% 31K6	5322 117 10554
R8885	RES.METAL FILM	RC-02H 1% 14K7	5322 117 10528
R8886	RES.METAL FILM	RC-02H 1% 31K6	5322 117 10554
R8887	RES.CHIP	RMC1/8 1% 21E5	5322 111 92014
R8888	RES.METAL FILM	RMC1/8 1% 38E3	5322 116 83728
R8889	RES.METAL FILM	RC-02H 1% 1K96	5322 117 10539
R8889	RES.CHIP	RC-02H 1% 1K47	4822 051 51472
R8890	RES.METAL FILM	RC-02H 1% 1K96	5322 117 10539

Item	Description		Ordering code
R8890	RES.CHIP	RC-02H 1% 1K47	4822 051 51472
R8891	RES.METAL FILM	RC-02H 1% 1K96	5322 117 10539
R8891	RES.CHIP	RC-02H 1% 1K47	4822 051 51472
R8892	RES.METAL FILM	RC-02H 1% 1K96	5322 117 10539
R8892	RES.CHIP	RC-02H 1% 1K47	4822 051 51472
R8893	RES.CHIP	RMC1/8 1% 75E	4822 111 91937
R8894	RES.CHIP	RMC1/8 1% 75E	4822 111 91937
R8895	RES.METAL FILM	RC-02H 1% 61K9	5322 117 10578
R8895	RES.CHIP	RC-02H 1% 51K1	4822 051 55113
R8896	RES.CHIP	RC-02H 1% 10K	4822 051 10103
R8896	RES.CHIP	RC-02H 1% 7K5	5322 117 10583
R8897	RES.METAL FILM	RC-02H 1% 16K2	5322 117 10532
R8898	RES.CHIP	RC-02H 1% 100E	4822 051 10101
R8901	RES.METAL FILM	RC-02H 1% 1K96	5322 117 10539
R8902	RES.METAL FILM	RC-02H 1% 3K16	5322 117 10553
R8903	RES.METAL FILM	RC-02H 1% 5K62	5322 117 10573
R8911	RES.METAL FILM	RC-02H 1% 26K1	5322 117 10548
R8912	RES.METAL FILM	RC-02H 1% 1K21	5322 117 10521
R8913	RES.METAL FILM	RC-02H 1% 26K1	5322 117 10548
R8914	RES.METAL FILM	RC-02H 1% 1K21	5322 117 10521
R8916	RES.METAL FILM	RC-02H 1% 383K	5322 117 10563
R8917	RES.CHIP	RC-02H 1% 1M	4822 051 10105
R8918	RES.METAL FILM	RC-02H 1% 178K	5322 117 10537
R8919	RES.METAL FILM	RC-02H 1% 825K	5322 117 10587
R8920	RES.CHIP	RC-02H 1% 10K	4822 051 10103
R8921	RES.METAL FILM	RC-02H 1% 316K	5322 117 10555
R8922	RES.CHIP	RC-02H 1% 1M	4822 051 10105
R8923	RES.METAL FILM	RC-02H 1% 178K	5322 117 10537
R8924	RES.METAL FILM	RC-02H 1% 825K	5322 117 10587
R8925	RES.CHIP	RC-02H 1% 10K	4822 051 10103
R8926	RES.METAL FILM	RC-02H 1% 316K	5322 117 10555
R8927	RES.METAL FILM	RC-02H 1% 383K	5322 117 10563
R8928	RES.CHIP	RC-02H 1% 1K	4822 051 10102
R8931	RES.METAL FILM	RC-02H 1% 38K3	5322 117 10562
R8932	RES.METAL FILM	RC-02H 1% 38K3	5322 117 10562
R8933	RES.METAL FILM	RC-02H 1% 38K3	5322 117 10562
R8934	RES.METAL FILM	RC-02H 1% 38K3	5322 117 10562
R8936	RES.METAL FILM	RC-02H 1% 38K3	5322 117 10562
R8937	RES.METAL FILM	RC-02H 1% 38K3	5322 117 10562
R8938	RES.METAL FILM	RC-02H 1% 38K3	5322 117 10562
R8939	RES.METAL FILM	RC-02H 1% 38K3	5322 117 10562

Item	Description		Ordering code
SEMICONDUCTORS			
V8001	TRANSISTOR,CHIP	BC848C PEL	5322 130 42136
V8002	TRANSISTOR,CHIP	BC848C PEL	5322 130 42136
V8003	TRANSISTOR,CHIP	BC848C PEL	5322 130 42136
V8004	TRANSISTOR,CHIP	BC848C PEL	5322 130 42136
V8006	TRANSISTOR,CHIP	BC858C PEL	4822 130 42513
V8007	TRANSISTOR,CHIP	BC858C PEL	4822 130 42513
V8008	TRANSISTOR,CHIP	BC858C PEL	4822 130 42513
V8009	TRANSISTOR,CHIP	BC858C PEL	4822 130 42513
V8011	TRANSISTOR,CHIP	BC858C PEL	4822 130 42513
V8012	TRANSISTOR,CHIP	BC858C PEL	4822 130 42513
V8014	TRANSISTOR,CHIP	BC858C PEL	4822 130 42513
V8017	TRANSISTOR,CHIP	BC858C PEL	4822 130 42513
V8018	TRANSISTOR,CHIP	BC858C PEL	4822 130 42513
V8019	TRANSISTOR,CHIP	BC858C PEL	4822 130 42513
V8021	TRANSISTOR,CHIP	BC858C PEL	4822 130 42513
V8022	TRANSISTOR,CHIP	BC858C PEL	4822 130 42513
V8024	DIODE,CHIP	BAS28 PEL	5322 130 80214
V8027	TRANSISTOR,CHIP	BC858C PEL	4822 130 42513
V8028	TRANSISTOR,CHIP	BC858C PEL	4822 130 42513
V8029	TRANSISTOR,CHIP	BC858C PEL	4822 130 42513
V8031	TRANSISTOR,CHIP	BC858C PEL	4822 130 42513
V8032	TRANSISTOR,CHIP	BC858C PEL	4822 130 42513
V8033	TRANSISTOR,CHIP	BC858C PEL	4822 130 42513
V8036	TRANSISTOR,CHIP	BC858C PEL	4822 130 42513
V8037	TRANSISTOR,CHIP	BC858C PEL	4822 130 42513
V8038	TRANSISTOR,CHIP	BC858C PEL	4822 130 42513
V8039	TRANSISTOR,CHIP	BC858C PEL	4822 130 42513
V8040	TRANSISTOR,CHIP	BC858C PEL	4822 130 42513
V8041	TRANSISTOR,CHIP	BC858C PEL	4822 130 42513
V8042	TRANSISTOR,CHIP	BC858C PEL	4822 130 42513
V8043	TRANSISTOR,CHIP	BC858C PEL	4822 130 42513
V8044	TRANSISTOR,CHIP	BC858C PEL	4822 130 42513
V8045	TRANSISTOR,CHIP	BF579 TEL	5322 130 63453
V8046	TRANSISTOR,CHIP	BC858C PEL	4822 130 42513
V8047	TRANSISTOR,CHIP	BF579 TEL	5322 130 63453
V8048	TRANSISTOR,CHIP	BF579 TEL	5322 130 63453
V8050	DIODE,CHIP	BAV99 PEL	5322 130 34337
V8051	TRANSISTOR,CHIP	BF579 TEL	5322 130 63453
V8053	TRANSISTOR,CHIP	BF579 TEL	5322 130 63453
V8054	TRANSISTOR,CHIP	BF579 TEL	5322 130 63453
V8057	TRANSISTOR,CHIP	BF579 TEL	5322 130 63453
V8058	TRANSISTOR,CHIP	BF579 TEL	5322 130 63453
V8059	TRANSISTOR,CHIP	BF579 TEL	5322 130 63453
V8061	TRANSISTOR,CHIP	BF579 TEL	5322 130 63453
V8064	TRANSISTOR,CHIP	BF579 TEL	5322 130 63453

Item	Description		Ordering code
V8066	TRANSISTOR,CHIP	BF579 TEL	5322 130 63453
V8067	TRANSISTOR,CHIP	BF579 TEL	5322 130 63453
V8068	TRANSISTOR,CHIP	BF579 TEL	5322 130 63453
V8069	TRANSISTOR,CHIP	BF579 TEL	5322 130 63453
V8071	TRANSISTOR,CHIP	BF579 TEL	5322 130 63453
V8074	TRANSISTOR,CHIP	BF579 TEL	5322 130 63453
V8077	TRANSISTOR,CHIP	BF579 TEL	5322 130 63453
V8078	TRANSISTOR,CHIP	BF579 TEL	5322 130 63453
V8079	TRANSISTOR,CHIP	BF579 TEL	5322 130 63453
V8081	TRANSISTOR,CHIP	BF579 TEL	5322 130 63453
V8082	TRANSISTOR,CHIP	BF579 TEL	5322 130 63453
V8083	TRANSISTOR,CHIP	BF579 TEL	5322 130 63453
V8084	TRANSISTOR,CHIP	BF579 TEL	5322 130 63453
V8086	TRANSISTOR,CHIP	BF579 TEL	5322 130 63453
V8087	TRANSISTOR,CHIP	BF579 TEL	5322 130 63453
V8088	TRANSISTOR,CHIP	BF579 TEL	5322 130 63453
V8089	TRANSISTOR,CHIP	BF579 TEL	5322 130 63453
V8090	DIODE,REFERENCE	BZX84-C5V6 PEL	4822 130 80125
V8091	TRANSISTOR,CHIP	BF579 TEL	5322 130 63453
V8092	DIODE,REFERENCE	BZX84-C2V4 PEL	4822 130 33703
V8095	DIODE,REFERENCE	BZX84-C5V1 PEL	5322 130 32835
V8096	DIODE,CHIP	BAV99 PEL	5322 130 34337
V8097	DIODE,CHIP	BAV99 PEL	5322 130 34337
V8098	DIODE,CHIP	BAV99 PEL	5322 130 34337
V8099	DIODE,CHIP	BAV99 PEL	5322 130 34337
V8101	DIODE,CHIP	BAV70 PEL	5322 130 34331
V8103	DIODE,CHIP	BAV99 PEL	5322 130 34337
V8104	DIODE,REFERENCE	BZX84-C2V4 PEL	4822 130 33703
V8106	DIODE,CHIP	BAV99 PEL	5322 130 34337
V8107	DIODE,CHIP	BAV99 PEL	5322 130 34337
V8109	DIODE,CHIP	BAV99 PEL	5322 130 34337
V8111	DIODE,CHIP	BAV99 PEL	5322 130 34337
V8112	DIODE,CHIP	BAV99 PEL	5322 130 34337
V8113	DIODE,CHIP	BAV99 PEL	5322 130 34337
V8114	DIODE,REFERENCE	BZX84-C3V3 PEL	4822 130 33003
V8117	DIODE,CHIP	BAV99 PEL	5322 130 34337
V8122	DIODE,CHIP	BAS28 PEL	5322 130 80214
V8124	TRANSISTOR,CHIP	BFT93 PEL	5322 130 44824
V8126	TRANSISTOR,CHIP	BFT93 PEL	5322 130 44824
V8127	TRANSISTOR,CHIP	BC858C PEL	4822 130 42513
V8128	TRANSISTOR,CHIP	BC848CR PEL	4822 130 42729
V8129	TRANSISTOR,CHIP	BSS83 PEL	5322 130 60502
V8130	TRANSISTOR,CHIP	BSS83 PEL	5322 130 60502
V8131	TRANSISTOR,CHIP	BSS83 PEL	5322 130 60502
V8132	TRANSISTOR,CHIP	BSS83 PEL	5322 130 60502
V8133	TRANSISTOR,CHIP	BSS83 PEL	5322 130 60502
V8134	TRANSISTOR,CHIP	BF512 PEL	5322 130 44875

Item	Description		Ordering code
V8135	TRANSISTOR,CHIP	BSS83 PEL	5322 130 60502
V8136	TRANSISTOR,CHIP	BF512 PEL	5322 130 44875
V8137	INTEGR.CIRCUIT	NPDS5911 NSC	5322 209 31301
V8138	TRANSISTOR,CHIP	BF579 TEL	5322 130 63453
V8139	TRANSISTOR,CHIP	BF579 TEL	5322 130 63453
V8140	TRANSISTOR,CHIP	BF579 TEL	5322 130 63453
V8141	TRANSISTOR,CHIP	BF579 TEL	5322 130 63453
V8142	DIODE,REFERENCE	BZX84-C2V4 PEL	4822 130 33703
V8143	DIODE,REFERENCE	BZX84-C2V4 PEL	4822 130 33703
V8151	DIODE,CHIP	BAT17 PEL	5322 130 31544
V8175	TRANSISTOR,CHIP	BC848C PEL	5322 130 42136
V8176	TRANSISTOR,CHIP	BC848C PEL	5322 130 42136
V8177	TRANSISTOR,CHIP	BC848C PEL	5322 130 42136
V8178	TRANSISTOR,CHIP	BC848C PEL	5322 130 42136
V8181	TRANSISTOR,CHIP	BF579 TEL	5322 130 63453
V8182	TRANSISTOR,CHIP	BF579 TEL	5322 130 63453
V8183	TRANSISTOR,CHIP	BF579 TEL	5322 130 63453
V8184	TRANSISTOR,CHIP	BF579 TEL	5322 130 63453
V8185	TRANSISTOR,CHIP	BF579 TEL	5322 130 63453
V8186	TRANSISTOR,CHIP	BF579 TEL	5322 130 63453
V8187	DIODE	BBY62 PEL	5322 130 82685
V8188	DIODE	BBY62 PEL	5322 130 82685
V8189	DIODE	BBY62 PEL	5322 130 82685
V8190	DIODE	BBY62 PEL	5322 130 82685
V8191	TRANSISTOR,CHIP	BC858C PEL	4822 130 42513
V8192	TRANSISTOR,CHIP	BC858C PEL	4822 130 42513
V8193	TRANSISTOR,CHIP	BC848C PEL	5322 130 42136
V8194	TRANSISTOR,CHIP	BC848C PEL	5322 130 42136
V8195	TRANSISTOR,CHIP	BC848C PEL	5322 130 42136
V8196	TRANSISTOR,CHIP	BC848C PEL	5322 130 42136
V8197	TRANSISTOR,CHIP	BC848C PEL	5322 130 42136
V8198	TRANSISTOR,CHIP	BC858C PEL	4822 130 42513
V8199	TRANSISTOR,CHIP	BC858C PEL	4822 130 42513
V8200	TRANSISTOR,CHIP	BC858C PEL	4822 130 42513
V8201	TRANSISTOR,CHIP	BC858C PEL	4822 130 42513
V8202	TRANSISTOR,CHIP	BC848C PEL	5322 130 42136
V8203	TRANSISTOR,CHIP	BC848C PEL	5322 130 42136
V8204	TRANSISTOR,CHIP	BC848C PEL	5322 130 42136
V8205	TRANSISTOR,CHIP	BC848C PEL	5322 130 42136
V8208	DIODE,CHIP	BAV99 PEL	5322 130 34337
V8209	DIODE,CHIP	BAV99 PEL	5322 130 34337
V8210	TRANSISTOR	BD139 PEL	4822 130 40823
V8212	DIODE,CHIP	BAV99 PEL	5322 130 34337
V8216	DIODE,CHIP	BAT17 PEL	5322 130 31544
V8217	DIODE,CHIP	BAT17 PEL	5322 130 31544
V8218	DIODE,CHIP	BAT17 PEL	5322 130 31544
V8219	DIODE,CHIP	BAT17 PEL	5322 130 31544

Item	Description		Ordering code
V8221	DIODE,CHIP	BAT17 PEL	5322 130 31544
V8222	DIODE,CHIP	BAT17 PEL	5322 130 31544
V8223	DIODE,CHIP	BAT17 PEL	5322 130 31544
V8224	DIODE,CHIP	BAT17 PEL	5322 130 31544
X8001	HOLD,OBJECTIVE	CONTACTPIN	5322 268 14141
X8001	SOCKET,MALE	50 OHM BUS	5322 265 10266
X8002	HOLD,OBJECTIVE	CONTACTPIN	5322 268 14141
X8002	SOCKET,MALE	50 OHM BUS	5322 265 10266
X8008	HOLD,OBJECTIVE	CONTACTPIN	5322 268 14141
X8008	SOCKET,MALE	50 OHM BUS	5322 265 10266
X8009	HOLD,OBJECTIVE	CONTACTPIN	5322 268 14141
X8009	SOCKET,MALE	50 OHM BUS	5322 265 10266
X8011	HOLD,OBJECTIVE	CONTACTPIN	5322 268 14141
X8011	SOCKET,MALE	50 OHM BUS	5322 265 10266
X8012	HOLD,OBJECTIVE	CONTACTPIN	5322 268 14141
X8012	SOCKET,MALE	50 OHM BUS	5322 265 10266
X8018	HOLD,OBJECTIVE	CONTACTPIN	5322 268 14141
X8018	SOCKET,MALE	50 OHM BUS	5322 265 10266
X8019	HOLD,OBJECTIVE	CONTACTPIN	5322 268 14141
X8019	SOCKET,MALE	50 OHM BUS	5322 265 10266
X8101	CONNECTOR	64-P PIN 2.54	5322 265 61243
X8501	HOLD,OBJECTIVE	CONTACTPIN	5322 268 14141
X8501	SOCKET,MALE	50 OHM BUS	5322 265 10266
X8502	HOLD,OBJECTIVE	CONTACTPIN	5322 268 14141
X8502	SOCKET,MALE	50 OHM BUS	5322 265 10266
X8503	HOLD,OBJECTIVE	CONTACTPIN	5322 268 14141
X8503	SOCKET,MALE	50 OHM BUS	5322 265 10266
X8504	HOLD,OBJECTIVE	CONTACTPIN	5322 268 14141
X8504	SOCKET,MALE	50 OHM BUS	5322 265 10266
X8505	HOLD,OBJECTIVE	CONTACTPIN	5322 268 14141
X8505	SOCKET,MALE	50 OHM BUS	5322 265 10266

