

PM3370B - PM3380B - PM3390B PM3384B - PM3394B Autoranging CombiScope™ Instrument

Service Manual

4822 872 05372
3/1-Dec-00

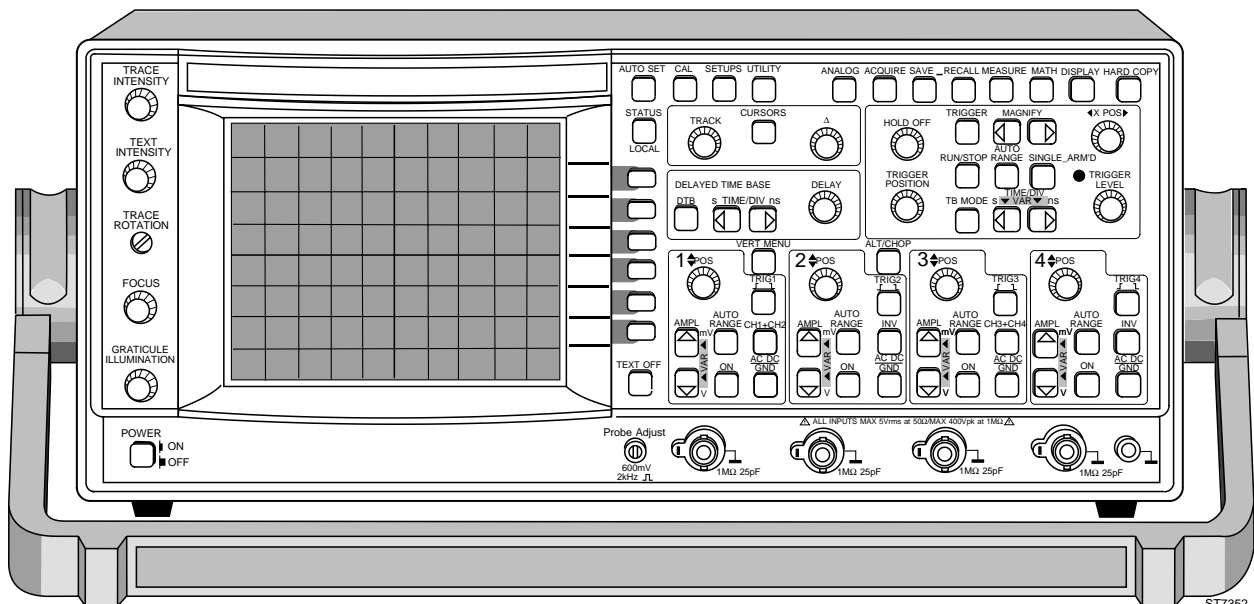

ST7352
9312

Warning: These servicing instructions are for use by qualified personnel only. To reduce the risk of electric shock do not perform any servicing other than that contained in the operating instructions unless you are fully qualified to do so.

FLUKE®

IMPORTANT

In correspondence concerning this instrument please give the model number and serial number as located on the type plate on the rear of the instrument.

For your reference:

Model number: PM 33XXB/YY
Serial number: DM .

Note: The design of this instrument is subject to continuous development and improvement. Consequently, this instrument may incorporate minor changes in detail from the information provided in this manual.

Copyright © 1997, 1998, 2000 Fluke Corporation
All rights reserved. No part of this publication may be reproduced by any means or in any form without written permission of the copyright owner.

Printed in The Netherlands

TABLE OF CONTENTS		Page
1	SAFETY INSTRUCTIONS	1-1
1.1	INTRODUCTION	1-1
1.2	SAFETY PRECAUTIONS	1-1
1.3	CAUTION AND WARNING STATEMENTS	1-1
1.4	SYMBOLS	1-1
2	CHARACTERISTICS	2-1
2.1	VERTICAL	2-2
2.1.1	Channels	2-2
2.1.2	Deflection Modes (Analog Only)	2-2
2.1.3	Bandwidth	2-3
2.1.4	Attenuator	2-3
2.1.5	Input Characteristics	2-4
2.1.6	Coupling	2-4
2.1.7	Dynamic Range	2-4
2.1.8	Position Range	2-4
2.1.9	Trace Separation	2-4
2.1.10	Input Voltage Limits	2-5
2.1.11	Step Response	2-5
2.1.12	Signal Delay	2-6
2.1.13	Vertical Accuracies	2-6
2.2	TIMEBASE	2-7
2.2.1	Timebase (modes)	2-7
2.2.2	Timebase Settings (Analog Mode Only)	2-7
2.2.3	DTB Delay (Analog Mode Only)	2-7
2.2.4	Timebase Settings (Digital Mode Only)	2-8
2.2.5	Timebase Delay (Digital Mode Only)	2-8
2.2.6	DTB Delay (Digital Mode Only)	2-9
2.2.7	Analog Timebase Accuracies	2-9
2.2.8	Delaytime Accuracy (Analog Mode)	2-9
2.2.9	DTB Jitter In Starts (Analog Mode)	2-9
2.2.10	Timebase Accuracies (Digital Mode)	2-9
2.2.11	DTB Jitter In Starts (Digital Mode)	2-10
2.2.12	External Horizontal Deflection	2-10
2.2.13	Horizontal Display Accuracy	2-10
2.3	TRIGGERING	2-11
2.3.1	Source	2-11
2.3.2	Modes	2-11
2.3.3	TV Systems	2-11
2.3.4	Coupling	2-12
2.3.5	Sensitivity	2-13
2.3.6	Slope	2-13
2.3.7	Level	2-14
2.3.8	Logic Triggering Timing (Digital Mode Only)	2-14
2.3.9	Trigger Accuracies	2-15
2.4	EVENT COUNTER	2-15

2.5	HOLD-OFF	2-15
2.6	PROCESSING	2-16
2.6.1	Preprocessing	2-16
2.6.2	Register Processing (Digital Mode)	2-16
2.7	TRACE MEASUREMENTS (DIGITAL MODE)	2-17
2.8	CURSORS	2-17
2.8.1	Cursor Control	2-17
2.8.2	Cursor Readouts	2-18
2.8.3	Cursor Accuracies (Analog Mode)	2-18
2.8.4	Cursor Accuracies (Digital Mode)	2-18
2.9	DIGITAL ACQUISITION	2-19
2.9.1	Modes	2-19
2.9.2	Sample Rate	2-19
2.9.3	Multiplexed Channels	2-19
2.9.4	Trace Memory	2-20
2.9.5	Acquisition Time	2-21
2.9.6	Resolution	2-21
2.9.7	Registers	2-21
2.9.8	Register Manipulations	2-22
2.9.9	Digital Acquisition Accuracies	2-22
2.10	FRONT PANEL MEMORY	2-22
2.11	BLANKING OR Z-AXIS (ONLY FOR ANALOG TRACE)	2-22
2.12	DISPLAY	2-23
2.12.1	CRT	2-23
2.12.2	Modes	2-23
2.12.3	Vertical Display Manipulations (Digital Mode)	2-23
2.12.4	Horizontal Display Manipulations (Digital Mode)	2-24
2.13	EXTERNAL INTERFACES	2-24
2.13.1	Calibrator	2-24
2.13.2	Standard external interface	2-24
2.13.3	Optional external interfaces	2-25
2.13.4	Printers and plotters support	2-26
2.13.5	Real Time Clock	2-26
2.14	AUTO SET & CALIBRATION	2-26
2.14.1	Auto Set	2-26
2.14.2	Calibration	2-26
2.15	POWER SUPPLY AND BATTERY BACKUP	2-27
2.15.1	Power Supply	2-27
2.15.2	Battery Backup	2-27
2.16	MECHANICAL CHARACTERISTICS	2-28
2.17	ENVIRONMENTAL CHARACTERISTICS	2-28
2.17.1	General	2-28
2.17.2	Environmental	2-28
2.17.3	EMI	2-29
2.18	SAFETY	2-32

2.19	ACCESSORIES	2-32
2.20	OPTIONS & OPTIONAL VERSIONS	2-32
2.20.1	Options Line cord	2-32
2.20.2	Options digital versions	2-32
2.20.3	Options analog	2-33
2.20.4	Specification optional outputs	2-33
2.20.5	Specification External trigger option	2-34
2.20.6	Specification IEEE-OPTION	2-35
3	DESCRIPTIONS	3-5
3.1	GENERAL DESCRIPTION	3-5
3.1.1	Introduction to oscilloscope family	3-5
3.1.2	Introduction to descriptions	3-5
3.1.3	Explanation of signal names	3-6
3.1.4	Voltage values in the circuit diagrams	3-6
3.2	BLOCK DIAGRAM DESCRIPTION	3-7
3.2.1	Introduction	3-7
3.2.2	Vertical channels	3-8
3.2.3	Triggering and time bases	3-9
3.2.4	Final amplifiers	3-10
3.2.5	Front unit and microprocessor	3-11
3.2.6	Power supply	3-11
3.2.7	Digitizer	3-12
4	PARTS	4-1
4.1	UNITS	4-1
4.2	INTERCONNECTION CABLES	4-2
4.3	MECHANICAL PARTS	4-4
5	UNIT DESCRIPTIONS	5.1-1
5.1	SIGNAL UNIT A1	5.1-1
5.1.1	Description A1	5.1-1
5.1.2	Signal name list	5.1-14
5.1.3	Unit lay-outs	5.1-21
5.1.4	Location list Signal Unit A1	5.1-25
5.1.5	Circuit diagrams	5.1-35
5.1.6	Parts list	5.1-59
5.2	FINAL XYZ AMPLIFIER A2	5.2-1
5.2.1	Description of A2-200 MHz version	5.2-1
5.2.2	Signal name list A2-200 MHz version	5.2-5
5.2.3	Unit lay-outs A2-200 MHz version	5.2-7
5.2.4	Location list A2-200 MHz version	5.2-9
5.2.5	Circuit diagrams A2-200 MHz version	5.2-13
5.2.6	Parts list A2-200 MHz version	5.2-19
5.2.7	Description of A2-100 MHz version	5.2-35
5.2.8	Signal name list A2-100 MHz version	5.2-39
5.2.9	Unit lay-outs A2-100 MHz version	5.2-41
5.2.10	Location list A2-100 MHz version	5.2-43
5.2.11	Circuit diagrams A2-100 MHz version	5.2-47
5.2.12	Parts list A2-100 MHz version	5.2-53

5.3	MICROPROCESSOR A3	5.3-1
5.3.1	Description A3	5.3-1
5.3.2	Signal name list A3	5.3-2
5.3.3	Location list	5.3-4
5.3.4	Unit lay-outs	5.3-5
5.3.5	Circuit diagrams	5.3-7
5.3.6	Parts list	5.3-13
5.4	FRONT UNIT A4	5.4-1
5.4.1	Description	5.4-1
5.4.2	Signal name list A4	5.4-1
5.4.3	Key switches	5.4-2
5.4.4	Unit lay-outs	5.4-5
5.4.5	Circuit diagrams	5.4-7
5.4.6	Parts list	5.4-9
5.5	CRT CONTROLS UNIT A5	5.5-1
5.5.1	Description	5.5-1
5.5.2	Unit Lay-outs	5.5-2
5.5.3	Circuit diagram	5.5-3
5.5.4	Parts list	5.5-4
5.6	POWER SUPPLY A6	5.6-1
5.6.1	Description A6	5.6-1
5.6.2	Signal name list A6	5.6-5
5.6.3	Unit lay-outs	5.6-7
5.6.4	Circuit diagrams	5.6-9
5.6.5	Parts list	5.6-13
5.7	RESERVED FOR FUTURE EXTENSIONS	5.7-1
5.8	DIGITIZER A8	5.8-1
5.8.1	Descriptions	5.8-1
5.8.2	Signal name list digitizer A8	5.8-23
5.8.3	Unit lay-outs	5.8-29
5.8.4	Location list	5.8-31
5.8.5	Circuit diagrams	5.8-37
5.8.6	Parts list	5.8-55
5.9	RESERVED FOR FUTURE EXTENSIONS	5.9-1
5.10	CONNECTOR BOARD A10	5.10-1
5.10.1	Unit lay-out	5.10-1
5.10.2	Circuit diagrams	5.10-3
5.10.3	Parts list	5.10-5
5.11	FACTORY INSTALLED OPTIONS	5.11-1
5.11.1	IEEE-OPTION	5.11-1
5.11.2	AUXILIARY OUTPUTS OPTION	5.11-1
5.11.3	EXTERNAL TRIGGER OPTION	5.11-7

6	PERFORMANCE TEST	6-1
6.1	GENERAL INFORMATION	6-1
6.2	RECOMMENDED TEST EQUIPMENT	6-2
6.3	TEST PROCEDURE	6-3
6.3.1	Preliminary settings	6-3
6.3.2	Power supply	6-3
6.3.3	Auto set	6-4
6.3.4	Orthogonality	6-5
6.3.5	Trace distortion	6-6
6.3.6	Vertical deflection; deflection coefficients	6-7
6.3.7	Vertical deflection; variable gain control range (continuation of 6.3.6)	6-8
6.3.8	Vertical deflection; input coupling (continuation of 6.3.7)	6-8
6.3.9	Vertical cursor accuracy (continuation of 6.3.8)	6-9
6.3.10	Vertical deflection; high-frequency response	6-9
6.3.11	Vertical deflection; low-frequency response	6-10
6.3.12	Vertical deflection; dynamic range at 15/25/50 MHz	6-11
6.3.13	Vertical deflection; dynamic range at 60/100/200 MHz (continuation of 6.3.12)	6-11
6.3.14	Vertical deflection; position range	6-12
6.3.15	Vertical deflection; crosstalk between channels at 60/100/200 MHz	6-12
6.3.16	Vertical deflection; common mode rejection ratio at 1 MHz	6-13
6.3.17	Vertical deflection; common mode rejection ratio at 50 MHz (continuation of 6.3.16)	6-14
6.3.18	Vertical deflection; LF linearity	6-15
6.3.19	Vertical deflection; visual signal delay	6-15
6.3.20	Vertical deflection; base line instability	6-17
6.3.21	Delay difference between vertical channels	6-17
6.3.22	Horizontal deflection; display modes and trace separation	6-19
6.3.23	Horizontal deflection; X deflection	6-20
6.3.24	Horizontal deflection; MAIN TB deflection coefficients	6-21
6.3.25	Horizontal deflection; VARIABLE mode accuracy MAIN TB	6-22
6.3.26	Time cursor accuracy (continuation of 6.3.25)	6-23
6.3.27	Horizontal deflection; DELAYED TIME BASE deflection coefficients	6-24
6.3.28	Horizontal deflection; delay time multiplier	6-25
6.3.29	Horizontal deflection; delayed timebase jitter	6-26
6.3.30	Horizontal deflection; X deflection coefficient via CH1	6-26
6.3.31	Horizontal deflection; X deflection coefficient via 'line'	6-27
6.3.32	Horizontal deflection; high frequency response	6-28
6.3.33	Maximum phase shift between horizontal and vertical deflection	6-28
6.3.34	MAIN TB triggering PM3390B/3394B; trigger sensitivity via CH1, CH2, CH3 and CH4 (EXT)	6-30
6.3.35	MAIN TB triggering PM3370B/3380B/3384B; trigger sensitivity via CH1, CH2, CH3 and CH4 (EXT)	6-31
6.3.36	MAIN TB/DEL'D TB triggering; trigger sensitivity TVL-TVF	6-32
6.3.37	DEL'D TB triggering PM3390B/94B; trigger sensitivity via CH1, CH2, CH3 and CH4 (EXT)	6-32
6.3.38	DEL'D TB triggering PM3370B/80B/84B; trigger sensitivity via CH1, CH2, CH3 and CH4 (EXT)	6-34
6.3.39	Trigger sensitivity in logic mode PM3394B	6-35
6.3.40	Trigger sensitivity in logic mode PM3384B	6-36
6.3.41	Z-MOD sensitivity	6-37
6.3.42	Probe Adjust signal; frequency and output voltage	6-38
6.3.43	Auto range functions	6-39
6.3.44	Testing the optional auxiliary outputs	6-40

7	CALIBRATION ADJUSTMENT PROCEDURE	7-1
7.1	INTRODUCTION	7-1
7.2	DARK LEVEL OF CRT	7-1
7.3	TRACE ROTATION	7-2
7.4	HORIZONTAL (X) GAIN AND OFFSET (CRT).....	7-2
7.5	TEXT STABILITY AND X-OFFSET (CRT)	7-2
7.6	VERTICAL (Y) GAIN AND OFFSET (CRT)	7-2
7.7	HORIZONTAL GAIN AND OFFSET (VECTOR).....	7-3
7.8	VERTICAL GAIN AND OFFSET (VECTOR).....	7-3
7.9	ASTIGMATISM	7-3
7.10	AUTOCAL PROCEDURE	7-3
7.11	LF SQUARE-WAVE RESPONSE CH1	7-4
7.12	LF SQUARE-WAVE RESPONSE CH2	7-5
7.13	LF SQUARE-WAVE RESPONSE CH3	7-5
7.14	LF SQUARE-WAVE RESPONSE CH4 and EXT TRIG	7-6
7.15	HF SQUARE-WAVE RESPONSE FINAL Y AMPLIFIER	7-7
7.16	HF RESPONSE DSO MODE	7-8
7.17	TRIGGER DELAY ADJUSTMENT	7-9
7.18	SAVING THE CALIBRATION DATA	7-10
7.19	TESTING THE INSTRUMENT'S PERFORMANCE	7-10
8	CORRECTIVE MAINTENANCE PROCEDURES	8-1
8.1	DISMANTLING THE INSTRUMENT	8-1
8.1.1	General information	8-1
8.1.2	Removing the cabinet and carrying handle	8-1
8.2	REPLACEMENTS	8-1
8.2.1	Standard parts	8-2
8.2.2	Special parts	8-2
8.2.3	Transistors and Integrated Circuits	8-2
8.3	STATIC SENSITIVE COMPONENTS	8-2
8.4	SOLDERING TECHNIQUES	8-3
8.4.1	General soldering techniques	8-3
8.4.2	Soldering micro-miniature semi-conductors	8-3

8.5	REMOVING THE UNITS, MECHANICAL PARTS AND CRT	8-4
8.5.1	Removing the rotary knobs	8-4
8.5.2	Detachment of ribbon cables	8-4
8.5.3	Removal of signal unit A1	8-5
8.5.4	Removal of Final XYZ amplifier unit A2	8-6
8.5.5	Removal of unit at socket of CRT	8-7
8.5.6	Removal of Cathode Ray Tube (CRT)	8-7
8.5.7	Removal of microprocessor unit A3	8-7
8.5.8	Removal of the units in the front frame (A4, A5)	8-8
8.5.9	Removal of the Power supply unit A6	8-8
8.5.10	Removal of digitizer unit A8	8-9
8.6	INSTRUMENT REPACKING	8-9
8.7	TROUBLESHOOTING TECHNIQUES	8-9
8.8	TROUBLESHOOTING THE POWER SUPPLY	8-10
8.9	SPECIAL TOOLS	8-11
8.9.1	Extension board	8-11
8.9.2	Flash-ROM loader program	8-11
8.10	RECALIBRATION AFTER REPAIR	8-11
8.11	TESTS BUILT INTO THE INSTRUMENT	8-12
8.11.1	Power-up test	8-12
8.11.2	Introduction to diagnostic tests	8-12
8.11.3	SELFTESTS	8-15
8.11.4	Repair tools	8-17
9	SAFETY INSPECTION AND TESTS AFTER REPAIR AND MAINTENANCE IN THE PRIMARY CIRCUIT	9-1
9.1	GENERAL DIRECTIONS	9-1
9.2	SAFETY COMPONENTS	9-1
9.3	CHECKING PROTECTIVE GROUND	9-1
9.4	CHECKING INSULATION RESISTANCE	9-1
9.5	CHECKING LEAKAGE CURRENT	9-1
9.6	VOLTAGE TEST	9-1



DECLARATION OF CONFORMITY
for

Autoranging CombiScope™ Instrument
PM3370B, PM3380B, PM3390B
PM3384B, PM3394B

Manufacturer

Fluke Industrial B.V.
Lelyweg 1
7602 EA Almelo
The Netherlands

Statement of Conformity

Based on test results using appropriate standards, the product is in conformity with
Electromagnetic Compatibility Directive 89/336/EEC
Low Voltage Directive 73/23/EEC

Sample tests

Standards used:

IEC 348 (1978)

Safety Requirements for Electronic Measuring Apparatus

EN 50081-1 (1992)

Electromagnetic Compatibility. Generic Emission Standard:
EN55022 and EN60555-2

EN 50082-1 (1992)

Electromagnetic Compatibility. Generic Immunity Standard:
IEC801 -2, -3, -4, -5

The tests have been performed in a typical configuration.

This Conformity is indicated by the symbol , i.e. "Conformité européenne".

1 SAFETY INSTRUCTIONS

Read these pages carefully before installation and use of the instrument.

1.1 INTRODUCTION

The following paragraphs contain information, cautions and warnings which must be followed to ensure safe operation and to keep the instrument in a safe condition.

WARNING: Servicing described in this manual is to be done only by qualified service personnel. To avoid electric shock, do not service the instrument unless you are qualified to do so.

1.2 SAFETY PRECAUTIONS

For the correct and safe use of this instrument it is essential that both operating and servicing personnel follow generally accepted safety procedures in addition to the safety precautions specified in this manual.

Specific warning and caution statements, where they apply, will be found throughout the manual. Where necessary, the warning and caution statements and/or symbols are marked on the apparatus.

1.3 CAUTION AND WARNING STATEMENTS

CAUTION: Is used to indicate correct operating or maintenance procedures in order to prevent damage to or destruction of the equipment or other property.

WARNING: Calls attention to a potential danger that requires correct procedures or practices in order to prevent personal injury.

1.4 SYMBOLS



Live part (black/yellow)



High voltage terminal ≥ 1000 V (red)



Attention refer to the manual:
This symbol is to indicate that information about usage of a feature is contained in the manual.



Protective ground terminal (black)



Static sensitive components (black/yellow)

1.5 IMPAIRED SAFETY-PROTECTION

Whenever it is likely that safety has been impaired, the instrument must be turned off and disconnected from line power. The matter should then be referred to qualified technicians. Safety protection is likely to be impaired if, for example, the instrument fails to perform the intended measurements or shows visible damage.

1.6 GENERAL SAFETY INFORMATION

WARNING: Removing the instrument cover or removing parts, except those to which access can be gained by hand, is likely to expose live parts and accessible terminals which can be dangerous to live.

The instrument shall be disconnected from all voltage sources before it is opened.

Capacitors inside the instrument can hold their charge even if the instrument has been separated from all voltage sources.

WARNING: Any interruption of the protective ground conductor inside or outside the instrument, or disconnection of the protective ground terminal, is likely to make the instrument dangerous. Intentional interruption is prohibited.

Components which are important for the safety of the instrument may only be replaced by components obtained through your local FLUKE organisation. (See also section 9).

After repair and maintenance in the primary circuit, safety inspection and tests, as mentioned in section 9 have to be performed.

2 CHARACTERISTICS

A. Performance Characteristics

- Properties expressed in numerical values with tolerances, ranges, or limits stated, are guaranteed by the manufacturer.
- Properties expressed in numerical values without tolerances, ranges, or limits stated, represent the characteristics of an average instrument.
- This specification is valid if the temperature has not changed more than + or - 5 °C since the last AUTO CAL, the probe is of the same type as delivered with the instrument, and if the average factor is 8.
- For definitions of terms, reference is made to IEC Publication 351-1, 359.

B. Safety Characteristics

This instrument has been designed and tested in accordance with IEC Publication 348, Safety Requirements for Electronic Measuring Apparatus, and has been supplied in a safe condition. This manual contains information and warnings which must be followed by the user to ensure safe operation and to keep the instrument in safe condition. The instrument has been designed for indoor use. It may occasionally be subjected to temperatures between +5 °C and 10 °C without degradation of its safety.

C. General Characteristics

- Overall dimensions:
- Height (without feet) : 139 mm (5.5 in)
- Width (without handle) : 341 mm (13.5 in)
- Length (without handle and front cover): 481 mm (19 in)

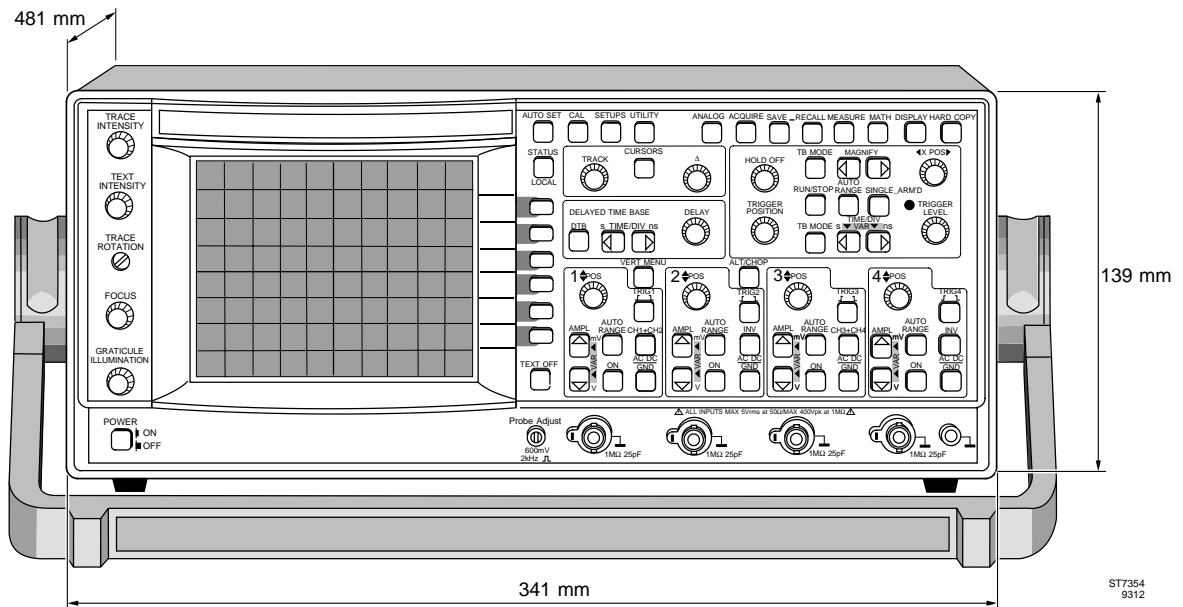

Figure 2.1 Dimensions

Weight 9.5 kg (19.7 lb)

Operating positions:

- a) Horizontally on bottom feet
- b) Vertically on rear feet
- c) On the carrying handle in three sloping positions

Note: All items that refer specifically to only one mode (analog or digital) are identified in the leftmost column with an 'A' or a 'D'.

CHARACTERISTICS	SPECIFICATIONS	ADDITIONAL INFORMATION
-----------------	----------------	------------------------

2.1 VERTICAL

2.1.1 Channels

CHANNELS	CH1; CH2; CH3; CH4	Form a channel set Form a channel set See Note 1
----------	-----------------------	--

Note 1: CH1 and CH2 for PM3370B, PM3380B and PM3390B.

2.1.2 Deflection Modes (Analog Only)

MODES	CH1, CH2, CH3, CH4	See Note 1 CH2 and CH4 can be inverted to allow -CH2 or -CH4
	CH1 + CH2	CH2 can be inverted to allow CH1 - CH2
	CH3 + CH4	CH4 can be inverted to allow CH3 - CH4
Automode: Auto attenuator	CH1, CH2 CH3, CH4	All models PM3384B/94B
Windows ON	CH1, CH2 CH3, CH4	See Note 2 All models PM3384B/94B
	Alternate Chopped	
Chopped mode: Chopped freq.	1 MHz	

Note 1: CH1 and CH2 for PM3370B, PM3380B and PM3390B.

Note 2: If more than one channel ON.

CHARACTERISTICS	SPECIFICATIONS	ADDITIONAL INFORMATION
-----------------	----------------	------------------------

2.1.3 Bandwidth

FREQUENCY RESPONSE		At BNC
Lower transition point of bandwidth input coupling in AC pos	<10 Hz	
PM3394B/90B		
Upper transition point of bandwidth (Ambient 5 to 40 °C)	>200 MHz	See Note 1
(Ambient 0 to 50 °C)	>175 MHz	See Note 1
PM3384B/80B		
Upper transition point of bandwidth (Ambient 5 to 40 °C)	>100 MHz	With external 50Ω
(Ambient 0 to 50 °C)	>90 MHz	With external 50Ω
PM3370B		
Upper transition point of bandwidth (Ambient 5 to 40 °C)	>60 MHz	With external 50Ω
(Ambient 0 to 50 °C)	>55 MHz	With external 50Ω
BANDWIDTH LIMITER		
Upper transition point of bandwidth	20 MHz	

*Note 1: PM3394B CH1 through CH4 in 50Ω position at BNC.
PM3390B CH1 and CH2 in 50Ω position at BNC.*

2.1.4 Attenuator

PM3394B/PM3384B CH1 to CH4 steps	2 mV/div to 5V/div	In 1-2-5 sequence
PM3390B/PM3380B/PM3370B CH1 and CH2 steps EXT TRIG steps	2 mV/div to 5V/div 0.1V/div and 1V/div	In 1-2-5 sequence
Variable gain mode	2 mV/div to 12.5V/div	Continuously variable
Auto Attenuator	2<div<6.4	1-2-5 steps precision (min. 50 mV/div)
Auto Attenuator (Windows ON)	1<div<3.2	1-2-5 steps precision (min. 50 mV/div)

CHARACTERISTICS	SPECIFICATIONS	ADDITIONAL INFORMATION
2.1.5 Input Characteristics		
INPUT CONNECTOR	BNC	See Note 1
INPUT IMPEDANCE (in 1 M Ω pos.)		Measured at freq. <1MHz
R parallel-value	1 M Ω	
- tolerance	± 1 %	
C parallel-value	25 pF	
- tolerance	± 2 pF	
INPUT INPEDANCE (in 50 Ω pos.)		PM3390B on CH1 and CH2 PM3394B all channels
R parallel value	50 Ω	
- tolerance	± 1 %	
VSWR (typical)	1.5:1	See Note 2
<i>Note 1: BNC with Probe Readout pin which causes the instrument to change V/div indication, input impedance, and attenuator setting according to the probe (when equipped with a probe indicator).</i>		
<i>Note 2: Measured up to 200 MHz input frequency; in dc and ac coupling of input.</i>		
2.1.6 Coupling		
COUPLING	dc, ac, ground	See Note 1
<i>Note 1: In GND position: channel disconnected from input, and connected to ground, BNC open (when not in 50Ω position). The GND coupling is available for all channels except EXTTRIG.</i>		
2.1.7 Dynamic Range		
PM3390B/PM3394B		
Up to 50 MHz	± 12 div	Symmetrical
Up to 200 MHz	± 4 div	Symmetrical
PM3380B/PM3384B		
Up to 25 MHz	± 12 div	Symmetrical
Up to 100 MHz	± 4 div	Symmetrical
PM3370B		
Up to 15 MHz	± 12 div	Symmetrical
Up to 60 MHz	± 4 div	Symmetrical
2.1.8 Position Range		
POSITION RANGE	+ or - ≥ 8 div	Symmetrical
2.1.9 Trace Separation		
TRACE SEPARATION		MTB and DTB
Min. range	+ or - ≥ 4 div	MTB fixed, DTB shifts

CHARACTERISTICS	SPECIFICATIONS	ADDITIONAL INFORMATION
-----------------	----------------	------------------------

2.1.10 Input Voltage Limits

INPUT VOLTAGE LIMITS



In high Z position (dc + ac peak)	± 400V
In 50Ω position	
dc	± 5V
ac rms	5V
ac peak	± 50V

See Note 1
See Note 2

See Note 3
See Note 3

Note 1: The instrument should be properly grounded through the protective ground conductor of the power cord.

Note 2: Up to 10 KHz; >10 kHz see figure 1.1

Note 3: Maximum of 50 mJ during any 100 ms interval.

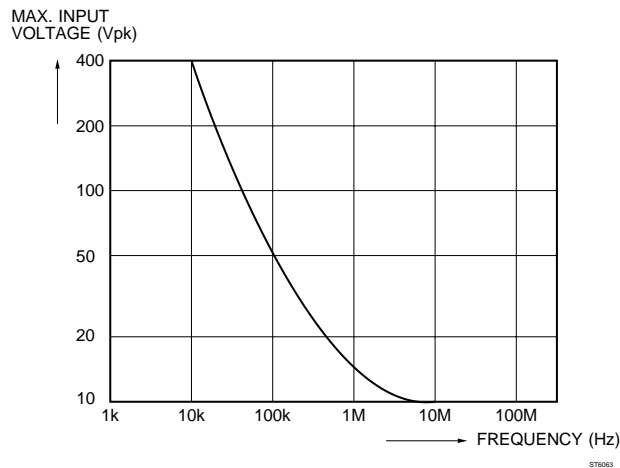

Figure 2.2 Max. input voltage versus frequency

2.1.11 Step Response

5 Divisions Pulse In 50Ω Input Impedance

STEP RESPONSE See Note 1

Note 1: Calculated from the formula: Rise time = 0.35 / Bandwidth and is measured over the central 5 divisions (vertical)

CHARACTERISTICS	SPECIFICATIONS	ADDITIONAL INFORMATION
-----------------	----------------	------------------------

2.1.12 Signal Delay

A: VISUAL SIGNAL DELAY	15 ns 13 ns	PM3390B94B PM3370B/80B/84B
DELAY BETWEEN CHANNELS		
CH1 and CH2	<250 ps	PM3370B/80B/90B
CH1.... CH4	<250 ps	PM3384B/94B

2.1.13 Vertical Accuracies

ACCURACY		
deflection factor		
A: Gain error (dc)	±1.3 %	Over central 6 divisions See Note 1
D: Additional gain error (dc)	±0.7%	
Gain error TrigView	±3 %	
A: Nonlinearity	≤2 %	See Note 2
D: Digital non linearity	≤4.5 %	See Note 2
MAX. BASELINE INSTABILITY		
Jump (all between steps, var, and N/I)	0.2 div or 1 mV	Whichever is greater (after autocal)
Drift	0.1 div/h	
Temperature coefficient	0.03 div/K	
CHANNEL ISOLATION		
Of deselected channels at 10 MHz	100:1	See Note 3
Of deselected channels at upper transition point	50:1	See Note 4
Between selected channels	50:1	See Note 5
CMRR		See Note 6
at 2 MHz	100:1	
at 50 MHz	25:1	

Note 1: Add 1.5% for variable gain mode.

Note 2: 2 division center screen signal with a frequency of 50 kHz, shifted within central 6 divisions.

Note 3: At 10 MHz; input to deselected channel equivalent to 8 divisions or less.

Note 4: Channels with equal V/div; input to deselected channels equivalent to 6 divisions.

Note 5: Channels with equal V/division settings; input to either channel 6 div. PM3390B/94B; max. input amplitude 3Vpp

Note 6: Between any two input channels at same attenuator setting; VAR of V/div setting adjusted for best CMRR; measured with max. 8 div.

CHARACTERISTICS	SPECIFICATIONS	ADDITIONAL INFORMATION
-----------------	----------------	------------------------

2.2 TIMEBASE

2.2.1 Timebase (modes)

TIMEBASE MODES	MTB only MTB and DTB DTB only Variable TB Auto TB	MTB= Main Timebase Alternating TB-mode DTB = Delayed Timebase
MTB trigger modes	AUTO TRIGGERED SINGLE SHOT SINGLE SCAN	Free run after 100 ms
DTB trigger modes	DTB starts DTB triggered	Starts after delay time Starts on first trigger after delay time

2.2.2 Timebase Settings (Analog Mode Only)

MTB PM3390B/PM3394B Settings	0.5s/div to 20 ns/div	See Note 1
Variable Time/div range	1.25s/div to 20 ns/div	MTB continuously variable
MTB PM3370B/PM3380B/PM3384B Settings	0.5s/div to 50 ns/div	See Note 1
Variable Time/div range	1.25s/div to 50 ns/div	MTB continuously variable
DTB PM3390B/PM3394B Settings	0.5s/div to 20 ns/div	See Note 1, See Note 3
DTB PM3370B/PM3380B/PM3384B Settings	0.5s/div to 50 ns/div	See Note 1, See Note 3
TIMEBASE MAGNIFICATION	10x	See Note 2

Note 1: In a 1-2-5 sequence. By means of the timebase magnifier (x10) the range is extended to 2 ns/div (PM3390B/94B) or 5ns/div (PM3370B/80B/84B).

Note 2: Expands the normal time/div by 10 times (MTB and DTB)

Note 3: The DTB sweep speed is higher or equal to MTB time/div setting.

2.2.3 DTB Delay (Analog Mode Only)

DELAY TIME	2 ns to 4.9s
Position range	0.1 div to 9.9 div
Resolution	1: 40000

CHARACTERISTICS	SPECIFICATIONS	ADDITIONAL INFORMATION
-----------------	----------------	------------------------

2.2.4 Timebase Settings (Digital Mode Only)

MTB Settings		
REAL TIME SAMPLING	200s/div to 250 ns/div	See Note 1 and 4
ROLL	200s/div to 200 ms/div	See Note 2
RANDOM SAMPLING		
PM3390B/94B	200 ns/div to 2 ns/div	See Note 2
PM3370B/80B/84B	200 ns/div to 5 ns/div	See Note 2
Variable Timebase	2 nsec ... 1 μ sec/div 1 μ sec ... 500 μ sec/div 500 μ sec ... 200 sec/div	1-2-5 sequence steps 1 μ sec step size equals analog step size
Auto Timebase		
Capture Range	DC up to full bandwidth	
Dynamic Range	2 nsec ... 200 msec/div	
DTB Settings (STARTS/TRIGGERED)		See Note 5
REAL TIME SAMPLING	0.5 ms/div to 250 ns/div or 0.5 ms/div to 0.001x MTB setting	Whichever is greater See Note 1 and 3
RANDOM SAMPLING	200 ns/div to 20 ns/div or 200 μ s/div to 2 ns/div	Whichever is greater 200 ns/div to
only for MTB	0.001x MTB setting	See Note 2 and 3

Note 1: In a 1-2-5 sequence and 250 ns.

Note 2: In a 1-2-5 sequence.

Note 3: The DTB sweep speed is higher or equal to MTB time/div. setting.

Note 4: When DTB is on: 500 ms/div to

Note 5: DTB is only possible with normal acquisition length. Triggered DTB is not possible in combination with tv, logic or event delay trigger mode.

2.2.5 Timebase Delay (Digital Mode Only)

TIME DELAY		
TRIGGER POSITION		
Acquisition length		
normal	-10 to 0 div	pretrigger
Acquisition length max.		
PM3384B/94B	-640 to 0 div	pretrigger
PM3370B/80B/90B	-160 to 0 div	pretrigger, note 1
DELAY		
Resolution	0 to 1000 div steps of 0.02 div	posttrigger sample distance
EVENTS DELAY		
Range	1 to 16384	See event counter

Note 1: When extended memory option is installed Time delay of trigger position at max. acquisition length is -640 to 0 div. pretrigger.

CHARACTERISTICS	SPECIFICATIONS	ADDITIONAL INFORMATION
-----------------	----------------	------------------------

2.2.6 DTB Delay (Digital Mode Only)

TRIGGERED		
DELAY TIME	2 ns to 4.9 s	
Position range	0.1 div to 9.9 div	
Resolution	1 : 40000	
STARTS		
DELAY TIME	0 to 10 div of MTB setting	
Position range	0 div to 10 div	
Resolution	1 : 40000	

2.2.7 Analog Timebase Accuracies

Unmagnified:	\pm (1.3% of reading +0.5% of central 8 div)	See Note 1
Magnified:		See Note 2
Up to 10 ns/div	\pm (1.3% of reading +1.0% of central 8 div)	See Note 1
In 5ns/div and 2ns/div	\pm (1.8% of reading +1.5% of central 8 div)	See Note 1

Note 1: Add 1% of reading in variable mode.

Note 2: Valid over central unmagnified 8 divisions.

2.2.8 Delaytime Accuracy (Analog Mode)

MTB in 20 μ s/div	\pm (0.8% of reading	See Note 1
DTB in 2 μ s/div	+0.3% of central 8 div + Tf)	
PM3390B/94B	Tf = 4 ns	
PM3370B/80B/84B	Tf = 5 ns	

Note 1: add 1% of reading in variable mode.

2.2.9 DTB Jitter In Starts (Analog Mode)

Jitter	1 part of 25000
--------	-----------------

2.2.10 Timebase Accuraries (Digital Mode)

MTB, DTB	
Real Time Mode	\pm 0.010%
Equivalent Time Mode	\pm 0.5%

CHARACTERISTICS	SPECIFICATIONS	ADDITIONAL INFORMATION
-----------------	----------------	------------------------

2.2.11 DTB Jitter In Starts (Digital Mode)

Jitter	120 ps	
--------	--------	--

2.2.12 External Horizontal Deflection

This paragraph is valid only for the analog mode. In the digital mode X versus Y is defined as a display mode.

DEFLECTION SOURCES

PM3384B/94B	Line and CH1 to CH4	
PM3370B/80B/90B	Line, CH1, CH2, EXT TRIG	

LINE DEFLECTION

Deflection amplitude	6 ± 1.7 div	Between 49 and 61 Hz at 220 volts
----------------------	-----------------	-----------------------------------

CHANNEL DEFLECTION

Error limit	$\pm 5\%$	Refer to VERTICAL Over central 6 divisions See Note 1
Linearity error limit	$\pm 2\%$	
Dynamic range up to 100 kHz	20 div	
up to 2 MHz	10 div	

POSITION RANGE	± 5 div	
----------------	-------------	--

FREQUENCY RESPONSE

Upper transition point	2 MHz	
------------------------	-------	--

MAX. PHASE

DIFFERENCE Between horizontal and vertical	3°	Up to 100 kHz
--	-----------	---------------

Note 1: 2 div/50kHz center screen signal shifted within central 8 divisions.

2.2.13 Horizontal Display Accuracy

Display Accuracy	$\pm(0.8\% \text{ of reading} + 0.5\% \text{ of central 8 divisions})$	
------------------	--	--

CHARACTERISTICS	SPECIFICATIONS	ADDITIONAL INFORMATION
2.3 TRIGGERING		
2.3.1 Source		
MTB trigger sources PM3384B/94B PM3370B/80B/90B	CH1 to CH4, Line CH1, CH2, Line, EXT TRIG	
DTB trigger sources PM3384B/94B PM3370B/80B/90B	CH1 to CH4 CH1, CH2	
2.3.2 Modes		
MODES MTB triggering PM3384B/94B	EDGE, TV, D:PATTERN, D:STATE, D:GLITCH	Enter/exit pattern plus timed pattern.
PM3370B/80B/90B	EDGE, TV, D:GLITCH	
MODES DTB triggering	EDGE	
2.3.3 TV Systems		
TV systems	TV HDTV	See Note 1 See Note 1
TV Line	1 to n	See Note 1 and 2
<i>Note 1: Line selection possible in field1 and field2. In digital mode, triggered DTB not possible in combination with TV line.</i>		
<i>Note 2: n is equal to maximum lines of TV system.</i>		

CHARACTERISTICS	SPECIFICATIONS	ADDITIONAL INFORMATION
-----------------	----------------	------------------------

2.3.4 Coupling

BANDWIDTH EDGE TRIGGER MTB Vertical coupling in DC

Lower transition point of BW

BW = Bandwidth

Trigger coupling:

DC	dc
AC	10 Hz
LF-reject	30 kHz
HF-reject	dc

Upper transition point of BW

BW = Bandwidth

Trigger coupling:

DC)
AC)See sensitivity
LF-reject)
HF-reject	30 kHz

BANDWIDTH EDGE TRIGGER DTB

Vertical coupling in DC

Lower transition point of BW

BW = bandwidth

Trigger coupling:

DC	dc
AC	10 Hz
LF-reject	30 kHz
HF-reject	dc

Upper transition point of BW

BW = bandwidth

Trigger coupling:

DC)
AC)See sensitivity
LF-reject)
HF-reject	30 kHz

CHARACTERISTICS	SPECIFICATIONS	ADDITIONAL INFORMATION
-----------------	----------------	------------------------

2.3.5 Sensitivity

EDGE TRIGGER SENSITIVITY MTB and DTB of: PM3390B/94B		See Notes 1, 3, 4
dc to 100 MHz	0.6 div	
dc to 200 MHz	1.2 div	
dc to 300 MHz	2.0 div	See Note 2
PM3380B/84B		
dc to 50 MHz	0.6 div	
dc to 100 MHz	1.2 div	
dc to 200 MHz	2.0 div	See Note 2
PM3370B		
dc to 30 MHz	0.6 div	
dc to 60 MHz	1.2 div	
dc to 150 MHz	2.0 div	See Note 2
TV TRIGGER SENSITIVITY (ampl. of sync. pulse)	0.7 div	See Note 1
TRIGGER SENSITIVITY D: PATTERN/STATE PM3394B		
Rectangle pulses		
t ≥ 10 ns	1.0 div	See Note 5
t ≥ 2 ns	2.0 div	
PM3384B		
Rectangle pulses		
t ≥ 20 ns	1.0 div	See Note 5
t ≥ 4 ns	2.0 div	

Note 1: All figures are valid for an ambient temperature range of 5 to 40 °C, add 20% for ambient 0 to 50 °C.

Note 2: Measured with a 2 divisions center screen signal.

Note 3: In noise trigger multiply stated value by 2.

Note 4: In 2 ... 5 mV/div multiply stated value by 2.

Note 5: Duty cycle 50%.

2.3.6 Slope

Slope selection edge	+ or -	MTB and DTB See Note 1
D:Dual slope	Up to full vertical bandwidth	See note 2

Note 1: In TV-triggering positive/negative video.

Note 2: Only in single shot, real time mode.

CHARACTERISTICS	SPECIFICATIONS	ADDITIONAL INFORMATION
-----------------	----------------	------------------------

2.3.7 Level

LEVEL CONTROL RANGE MTB EDGE	$\geq \pm 8$ div	
Unless: In level p(eak)p(eak) TV	Fixed	See Note 1
D: PATTERN, STATE and GLITCH	± 5 div	PM3370B/80B/90B: glitch mode only
LEVEL CONTROL RANGE DTB EDGE	$\geq \pm 8$ div	

Note 1: The control range of the trigger level is related to the peak-peak value and duty cycle of the trigger signal.

2.3.8 Logic Triggering Timing (Digital Mode Only)

PATTERN/GLITCH DETECTION		PM3370B/80B/90B: glitch detection only
Max. pattern rate	150 MHz	
Min. present time		
PM3390B/94B	2 ns	Pulse amplitude >2 div
PM3380B/84B	4 ns	Pulse amplitude >2 div
PM3370B	6 ns	Pulse amplitude >2 div
range t_1	20 ns, 30 ns, 40 ns, 50 ns to 0.16s	See note 1
range t_2	20 ns, 40 ns, 50 ns, 60 ns to 0.16s	See note 1
accuracy $t_1 t_2$	± 5 ns	
STATE DETECTION		Not in PM3370B/80B/90B
Max. state rate	150 MHz	
Min. setup time	2.5 ns	Pattern to clock
Min. hold time	2.5 ns	Pattern to clock

Note 1: Timing behavior around t_1 and t_2 .

Pattern valid time:

-----|*****|TTTTTTTTTTTTTTTTTTTT|*****|-----

$t_1 t_1 + 10 \text{ ns } t_2 - 10 \text{ ns } t_2$

- : not triggered

* : undefined

T: triggered

CHARACTERISTICS	SPECIFICATIONS	ADDITIONAL INFORMATION
-----------------	----------------	------------------------

2.3.9 Trigger Accuracies

TRIGGER LEVEL		
Accuracy edge	≤0.2 div	At 1 MHz input signal
D: Accuracy logic	≤0.4 div	At 1 MHz input signal
Trigger gap edge	0.4 div	At 1 MHz input signal in noise trigger multiply by 2
FALSE TRIGGERS	1:100 000	See Note 1

Note 1: These values are not tested in production and are based on theoretical estimates and laboratory tests.

2.4 EVENT COUNTER

EVENT delay		
PM3384B/94B		In trigger modes EDGE and LOGIC.
PM3370B/80B/90B		In trigger modes EDGE and GLITCH
Event count	1 to 16384	See Note 1
Event source		
PM3384B/94B	CH1 to CH4	
PM3370B/80B/90B	CH1, CH2, EXT TRIG	
Event slope selection	+ or -	
Event clock sensitivity		
DC to 50 MHz	0.5 div	
Event level	8 div	
Max. count frequency	50 MHz	typical value

Note 1: In digital mode, triggered DTB in combination with Event is not possible

2.5 HOLD-OFF

HOLD OFF SETTING		
A: Minimum	2 μs or 3 divisions of MTB setting	Whichever is greater
A: Maximum	2s or 20 divisions of MTB setting	Whichever is smaller
D: Minimum	4 ms	See Note 1
D: Maximum	20 divisions of MTB setting	

Note 1: For total hold off time, the process time must be included. See also ACQUISITION TIME.

CHARACTERISTICS	SPECIFICATIONS	ADDITIONAL INFORMATION
-----------------	----------------	------------------------

2.6 PROCESSING

2.6.1 Preprocessing

PREPROCESSING FUNCTIONS		See Note 1
	Invert	CH2; CH4
	Add	CH1+CH2; CH3+CH4; See Note 2
	Subtract	CH1-CH2; CH3-CH4; See Note 2
D:	Peak detection	Real time only
D:	Average	See Note 3
D:	Envelope	

Note 1: These functions are performed before the acquisition data is stored in the acquisition registers. PM3370B/80B/90B; offer two channels, CH1 and CH2.

Note 2: Dynamic range in digital mode ± 5 div.

Note 3: Average factor 2 to 4096 in power of 2 sequence.

2.6.2 Register Processing (Digital Mode)

REGISTER PROCESSING FUNCTION		See Note 1
	Add	See Note 2
	Sub	See Note 2
	Mul	See Note 2
	Filter	LF filter with adjustable -3dB point

Note 1: There may be run two processes simultaneously. The acquisition registers can also be used as source registers. The result from process one will be stored in memory one. The result from process two will be stored in memory two.

Note 2: The source can be any trace from any register except the result register. The result can be scaled.

CHARACTERISTICS	SPECIFICATIONS	ADDITIONAL INFORMATION
-----------------	----------------	------------------------

2.7 TRACE MEASUREMENTS (DIGITAL MODE)

TRACE MEASUREMENTS FUNCTIONS

Horizontal	Frequency Period Pulse width Rise / fall	} See Note 1 PM3370B/80B/90B: CH1, CH2
Vertical (with or without offset)	Mean RMS Maximum Minimum Peak/peak Low High Overshoot Preshoot Duty cycle Delay	} PM3370B/80B/90B: CH1, CH2 See Note 2

Note 1: These measurements can be performed on traces stored in the acquisition and memory registers.

Note 2: In PM3370B/80B/90B also available for EXT trigger source and external trigger memory.

2.8 CURSORS

2.8.1 Cursor Control

NUMBER OF CURSORS	4	
CURSOR RELATION D:	Screen Trace	Free Follows the trace
CURSOR MODES	Time Amplitude Both	Only screen cursor
Amplitude cursor modes	Absolute Ratio	See Note 1
Time cursor modes	Absolute Ratio	See Note 1
Phase cursor Modes	Absolute Ratio	See Note 1

Note 1: The ratio range is 0% to 999% where 100% corresponds to the value in the cursor read out at the moment that the "ΔT=100%" button is pressed.

CHARACTERISTICS	SPECIFICATIONS	ADDITIONAL INFORMATION
-----------------	----------------	------------------------

2.8.2 Cursor Readouts

CURSOR READOUTS	dV	See Note 1
	dT	
	V to GND	See Note 1
	1/dT	
	dQ(Q1, Q2)	
T-trig	See Note 3	
READOUT RESOLUTION	3 digits	

Note 1: In the "MTB + DTB timebase" and "DTB", all waveform operations and measurements are performed on the DTB traces.

Note 2: Refer to trigger point (Q1, Q2)

Refer to start of trace (Trace in memory, Q1 and Q2).

Note 3: Gives time differences (delta) between the cursor position and the trigger point (for both cursors).

2.8.3 Cursor Accuracies (Analog Mode)

Voltage measurements Manual	$\pm 1\%$ of FULL SCALE	Note 1
Time measurements Unmagnified timebase	$\pm 1\%$ of FULL SCALE	Note 2
Magnified timebase up to 10 ns/div	$\pm 1.4\%$ of FULL SCALE	
Magnified timebase in 5 ns/div and 2 ns/div	$\pm 2.2\%$ of FULL SCALE	

Note 1: Measured with 1 kHz square wave within central 6 div.

Note 2: within central 8 div.

2.8.4 Cursor Accuracies (Digital Mode)

ERROR LIMIT VERTICAL	See vertical accuracy
ERROR LIMIT HORIZONTAL	See horizontal accuracy

CHARACTERISTICS	SPECIFICATIONS	ADDITIONAL INFORMATION
-----------------	----------------	------------------------

2.9 DIGITAL ACQUISITION

2.9.1 Modes

MODES Select one:	Recurrent Single shot/scan Roll	Stop on trigger continuous
----------------------	---------------------------------------	----------------------------

2.9.2 Sample Rate

Real time	Max. Sample rate 200MS/s	250 ns/div to 200s/div See Note 1
Equivalent time:	Random sampling	See Note 1
PM3390B/94B	Max. 25GS/s	2 ns/div to 0.2 μs/div
PM3370B/80B/84B	Max. 10GS/s	5 ns/div to 0.2 μs/div

Note 1: Sampling rate depends on time/division setting.

2.9.3 Multiplexed Channels

The 4 channel instruments have 4 channels configured as 2 + 2. This implies, that the channels CH1 and CH2 are multiplexed with the channels CH3 and CH4 to share the same dual channel digitizer. The Ext.Trig. channel (TRIG VIEW) is multiplexed the same way as CH4.

Multiplexed channels (CH1 and CH2) or (CH3 and CH4)	simultaneously	See Note 1
Any other combination for timebase settings		
200s/div to 10 μs/div	CHOPPED	See Note 2
5 μs/div to 2 ns/div	ALTERNATED	
Max. Chop freq.	5 MHz	

Note 1: At 250 ns/div each of the four channels is acquired in alternated mode.

Note 2: When peak detection is activated the multiplexing is in alternating mode.

CHARACTERISTICS	SPECIFICATIONS	ADDITIONAL INFORMATION
-----------------	----------------	------------------------

2.9.4 Trace Memory

PM3384B/PM3394B

This digitizer has a total acquisition memory size of 32K bytes. To apply this memory as efficiently as possible, it is shared by all channels connected to it. The following section summarizes the effects:

Record length normal 1 to 4 channels selected	512 samples/channel	
Record length 'Max' 3 or 4 channels selected	8K samples/channel	See Note 1
2 of 4 channels selected	16K samples/channel	
1 of 4 channels selected	32K samples	
Display	501 samples/trace	

PM3370B/80B/90B:

This digitizer has a total acquisition memory size of 8K bytes. To apply this memory as efficiently as possible, it is shared by all channels connected to it. The following section summarizes the effects:

Record length normal 1 and 2 channels selected	512 samples/channel	See Note 2
Record length 'Max' 2 channels selected	2K samples/channel	See Note 1 and 4
2 channels selected	4K samples/channel	See Note 2
1 of 2 channels selected	8K samples	See Note 3
Display	501 samples/trace	

Note 1: When peak detection or envelope is activated, all "max" record length figures have to be divided by 2 because samples are stored as peak/peak combinations.

Note 2: Trigger view possible.

Note 3: No trigger view possible.

Note 4: When extended memory option is installed total acquisition memory is 32K bytes, shared by both channels and external trigger. This results in the following max. record lengths:
2 channels and trig.view 8K samples/channel.
2 channels, no trig.view 16K samples/channel.
1 of 2 channels, no trig.view 32K samples/channel.

CHARACTERISTICS	SPECIFICATIONS	ADDITIONAL INFORMATION
-----------------	----------------	------------------------

2.9.5 Acquisition Time

The process time between acquisitions depends from the selected settings and the selected processing. Therefore it is not possible to catch the process time between acquisitions in a formula. The next table gives an indication of the performance of the processing capabilities.

Process time between acquisitions 500 ns/div one channel no trigger delay acquisition length = 512	6 ms active	See Note 1 Holdoff is min and no processes or measurements are
500 ns/div two channel no trigger delay acquisition length = 512 average = 8	16 ms	Holdoff is min and no other processes or measurements are active
Equivalent time Timebase:		See Note 2
- at 2 ns/div	2s	
- at 0.2 μs/div	100 ms	

Note 1: Time required to fill the acquisition record at the sampling rate corresponding with the selected timebase setting is not included.

Note 2: After the specified time, there is a 99% probability of all sample positions being updated to the new acquisition. Trigger frequency >2 kHz. These values are not tested in production and are based on theoretical estimates and laboratory tests.

2.9.6 Resolution

ACQUISITION RESOLUTION	8 bits	over 10.24 divisions
------------------------	--------	----------------------

2.9.7 Registers

NUMBER OF REGISTERS Acquisition length:		Including current acquisition One set contains:
PM3384B/94B:		
- Normal	51 sets	Four traces
- Max: -4x8K	3 sets	Four traces
-2x16K		Two traces
-1x32K		One trace
WORD LENGTH	16 bits	
PM3370B/80B/90B:		Note 1
- Normal	9 sets	Two traces } + Trig.View
- Max: -2x2K	3 sets	Two traces }
-2x4K		Two traces
-1x8K		One trace
WORD LENGTH	16 bits	

Note1: When extended memory installed: number of register, equal to four channel models. One set contains max. two traces+ trig.view.

CHARACTERISTICS	SPECIFICATIONS	ADDITIONAL INFORMATION
-----------------	----------------	------------------------

2.9.8 Register Manipulations

Clear		The contents of the selected register is set to zero
Save		The contents of the acquisition register is stored in the selected register
Copy		The contents of a selected register is stored in another selected register
Recall		The register can be made visible on the display or can be removed from the display

2.9.9 Digital Acquisition Accuracies

SAMPLING RATE ERROR	$\pm 0.01\%$	X-tal
TIME UNCERTAINTY At double sampling rate	$\pm 100\text{ps}$	

2.10 FRONT PANEL MEMORY

Memory size	10 fronts
-------------	-----------

2.11 BLANKING OR Z-AXIS (ONLY FOR ANALOG TRACE)

Input connector	BNC	
Input impedance	10 k Ω	
Input coupling	dc	
Max input voltage	$\pm 10\text{V}$	
Input voltage unblank	0.5V or less	See Note 1
Input voltage blanked	+ 2.4 V or more	See Note 1
Response time	80 ns	Rise time 2 ns

*Note 1: Half tones are possible at input voltages between +0.8V and +2.4 V.
Blanking has only effect on the trace in analog mode.*

CHARACTERISTICS	SPECIFICATIONS	ADDITIONAL INFORMATION
-----------------	----------------	------------------------

2.12 DISPLAY

2.12.1 CRT

CRT		
Deflection	Electrostatic	Vector
Dimensions (h x w)	80 mm x 100 mm	8 x 10 divisions
Phosphor Standard	Green GH (P31)	
GRATICULE	Fixed	
Y-AXIS ORTHOGONALITY	90 ° ± 0.5 °	
ACCELERATING VOLTAGE	16.5 kV	
Writing speed	>1.8cm/ns	
TRACE ROTATION		Screwdriver adjustment
Min. range	10 °	External field <0.1 mT
Min. overrange	2 °	
TRACE DISTORTION		
At center of screen	<0.3 mm	Deviation from straight line inside 6 x 8 div
Else	<1.0 mm	

2.12.2 Modes

PRESENTATION MODES	Y versus T Y versus X
--------------------	--------------------------

2.12.3 Vertical Display Manipulations (Digital Mode)

Linear		Linear interpolations between measured dots
Sine		Sine like interpolation between measured dots
Vertical magnify	2, 4, 8, 16, 32	
Windows	1, 2, 4	Each trace has his own place on the screen
PM3384B/94B		max. 4 traces
PM3370B/80B/90B		max. 3 traces
Recall trace		Each trace can be made visible on the screen or can be removed from the screen. Note 1
Vertical position	± 8 div	Each trace can be moved over 8 divisions
Max. displayable traces on screen	8	See Note 1

Note 1: At least one trace is visible.

CHARACTERISTICS	SPECIFICATIONS	ADDITIONAL INFORMATION
-----------------	----------------	------------------------

2.12.4 Horizontal Display Manipulations (Digital Mode)

TIMEBASE MAGNIFICATION	2, 4, 8, 16, 32	See Note 1
---------------------------	-----------------	------------

Note 1: For acquisition depth greater than 512 byte it is possible to make the magnification factor less than one (compress mode) to display the complete trace on the screen.

2.13 EXTERNAL INTERFACES

2.13.1 Calibrator

WAVEFORM Shape	square wave	
INTERNAL IMPEDANCE Value	1200Ω	
OUTPUT VOLTAGE Peak-peak value Tolerance	600 mV 1%	See Note 1
OUTPUT CURRENT Peak-peak value	0.5 mA	See Note 2
FREQUENCY Value Tolerance	2kHz ±20%	

Note 1: Positive going with respect to ground; Open voltage (halves when terminated with 1200Ω).

Note 2: When output short circuited (halves when terminated with 1200Ω).

2.13.2 Standard external interface

TYPE OF INTERFACE	RS 232-C	CPL (compact programming language) See operating guide	
PINNING			
PIN	I/O	NAME	
1	-	-	Not connected
2	I	RXD	Received data
3	O	TXD	Transmitted data
4	O	DTR	Data terminal ready
5	-	GND	Signal ground
6	I	DSR	Data set ready
7	O	RTS	Request to send
8	I	CTS	Clear to send
9	-	-	Not connected
TRANSMISSION MODES	Asynchronous Full duplex		
HANDSHAKE			
Hardware	RTS/CTS and DSR/DTR	Default: not active See Note 1	
Software	XON/XOFF	Default: not active See Note 1	

CHARACTERISTICS	SPECIFICATIONS	ADDITIONAL INFORMATION
BAUDRATE	75,110,150,300 600,1200,2000, 2400,4800,9600 19200,38400	Receiving and transmitting Default:1200 See Note 1
NUMBER OF STOP BITS PARITY	1 odd,even,or no	Default: no parity See Note 1
CHARACTER LENGTH	7 or 8	Default:8 See Note 1
ERROR RESPONSE	See CPL, Chapter 6 in Users Manual	
ELECTRICAL TXD and RXD Spacing "0" Marking "1"	$\geq +3V$ $\leq -3V$	
RTS,CTS,DSR and DTR ON OFF	$\geq +3V$ $\leq -3V$	
Current output	$\leq 10mA$	
Impedance Output Input	$300\Omega \pm 10\%$ $\geq 3 k\Omega \leq 7k\Omega$	
Voltage Output Input	$\geq -12V \leq +12V$ $\geq -25V \leq +25V$	
Connector	Shielded	9 pole RAP male connector according MIL-C-24308

Note 1: Selectable via UTILITY menu and CPL. When battery installed, same as last power-off value.

2.13.3 Optional external interfaces

IEEE	ANSI/IEEE 488.2	SCPI See section 1.20.5
------	-----------------	-------------------------

CHARACTERISTICS	SPECIFICATIONS	ADDITIONAL INFORMATION
-----------------	----------------	------------------------

2.13.4 Printers and plotters support

PRINTERS	HP-thinktjet LQ1500 FX80 HP-LASER HP-540
PLOTTERS	HPGL HP7440 HP7550 HP7475A HP7478A PM8277 PM8278

2.13.5 Real Time Clock

(RTC)		
Select:	Time of trigger or Time of pressing hardcopy button	Note 1 Note 2

Note1: These times may be the same when it is not possible to reconstruct the time of trigger.

*Note2: - Stamped on any hardcopy via hardcopybutton
- Time is part of delta transfer waveform.*

2.14 AUTO SET & CALIBRATION

2.14.1 Auto Set

Vertical deflection	2...5 div	Note 1
Horizontal deflection	Max. 6 periods on CRT at input signal 10 mV...25V 40 Hz...30 MHz	Note 1

Note 1: AUTO SET selects the proper channel, sets vertical deflection, timebase speed, intensity, and triggering for an easy-to-read display of input signals, or the user programmable AUTO SET items.

2.14.2 Calibration

CALIBRATION FACILITIES	Auto cal	See Note 1
------------------------	----------	------------

Note 1: Calibrates vertical offset and gain, horizontal offset and gain and sweep time, trigger offset and gain.

CHARACTERISTICS

SPECIFICATIONS

ADDITIONAL INFORMATION

2.15 POWER SUPPLY AND BATTERY BACKUP**2.15.1 Power Supply**

LINE VOLTAGE



ac (rms)

Operation

Tolerance

100V to 240V

±10%

LINE FREQUENCY

Nominal

50 Hz to 400 Hz

Limits of operation

45 Hz to 440 Hz

LINE WAVEFORM

Max. waveform

deviation factor

10%

Crest factor

1.27 to 1.56

At nominal source
voltage

ALLOWABLE POWER

INTERRUPTION

20 ms

See Note 1

POWER CONSUMPTION

Without options

115W

Max. power

consumption

130W

POWER CORD

Length

2.1m (82.7 in)

Power plug

Nat.version

Note 1: At the lowest allowable source voltage. After this time the oscilloscope data is saved before the instrument goes down, and an automatic power-on sequence starts after restoration of the power source voltage.

2.15.2 Battery Backup

DATA AND SETTINGS

RETENTION

See Note 1

Retention time

2 years

Batteries:

Recommended type

LR 6

See Note 2

Quantity

2

Temperature range

0..+70 °C

See Note 3

Note 1: When instrument is switched off or during power failure.

Note 2: According to IEC 285 (=Alkaline Manganese Penlight Battery).

Note 3: At -40 to 0 °C, settings retention is uncertain. It is advised to remove batteries from instrument when it is stored during longer periods (>24 hours) below -30 °C or above 60 °C. UNDER NO CIRCUMSTANCES SHOULD BATTERIES BE LEFT IN THE INSTRUMENT AT TEMPERATURES BEYOND THE RATED RANGE OF THE BATTERY SPECIFICATION

CHARACTERISTICS	SPECIFICATIONS	ADDITIONAL INFORMATION
-----------------	----------------	------------------------

2.16 MECHANICAL CHARACTERISTICS

PORTABLE VERSION

Dimensions:

Length	481 mm (19 in)	Handles excluded Add 5 mm (0.2 in) for cover Add 65 mm (2.5 in) for handle
--------	----------------	--

Width	341 mm (13,5 in)	Add 50 mm (2 in) for handle
-------	------------------	-----------------------------

Height	139 mm (5,5 in)	Add 8 mm (0.3 in) for feet
--------	------------------	----------------------------

Weight:

Instrument	9.5 kg (19,7 lb)	
------------	------------------	--

COOLING

Regulated	No air filter
Forced air	

2.17 ENVIRONMENTAL CHARACTERISTICS

2.17.1 General

The characteristics are valid only if instrument is checked in accordance with the official checking procedure. Warm up and recovery time are in accordance with MIL-T 28800D par. 3.7.1.1.

The instrument meets the environmental requirements of MIL-T-28800D Type III Class 3, Style D, Color R (unless specified otherwise).

2.17.2 Environmental

TEMPERATURE

Operating:

min.low temp.	0 °C	See Note 1
max.high temp.	+50 °C	

Nonoperating (storage):

min. low temp.	-40 °C
max. high temp.	+70 °C

MAX. HUMIDITY

Operating and Non operating (storage)	95%	See Note 1
---------------------------------------	-----	------------

Relative humidity
noncondensing

MAX. ALTITUDE

Operating	4.6 km (15000 ft)	See Note 2
Nonoperating (storage)	12 km (39000 ft)	See Note 3

VIBRATION (OPERATING)

Freq. ranges:

5 Hz to 15 Hz	See Note 4 g level at max. freq.: 0.7 at 15 Hz 1.3 at 25 Hz 3 at 55 Hz
16 Hz to 25 Hz	
26 Hz to 55Hz	

At each freq.range:

Cycling time	15 min	
Resonance search	5 min	
Resonance dwell	10 min	See Note 5

CHARACTERISTICS	SPECIFICATIONS	ADDITIONAL INFORMATION
-----------------	----------------	------------------------

Note 1: In accordance with MIL-T-28800D par. 3.7.2.1.1. (FIGURE 2).

Note 2: In accordance with MIL-T 28800D par. 3.7.3.

Note 3: Maximum operating temperature derated to 3 °C for each km above sea level

Note 4: In accordance with MIL-T-28800D par. 3.7.4.1.

Note 5: At each resonance frequency (or at 33 Hz if no resonance was found).

SHOCK (OPERATING)		See Note 6
Amount of shocks		
total	18	
each axis	6	3 in each direction
Shock waveform	half sinewave	
Duration	6-9 ms	
Peak acceleration	400 m/s ²	

BENCH HANDLING		See Note 7
Meets requirements of	MIL-ST-810 method 516 procedure V	

TRANSPORTATION	Drop height 0.76m	See Note 9
----------------	-------------------	------------

SALT ATMOSPHERE		
Structural parts		See Note 8

Note 6: In accordance with MIL-T-28800 par. 3.7.5.1.

Note 7: In accordance with MIL-T-28800 par. 3.7.5.3.

Note 8: In accordance with MIL-T-28800 par. 3.7.8.1.

Note 9: Drop in shipping container on 8 corners, 12 edges, 6 surfaces.

2.17.3 EMI

2.17.3.1 *Meets MIL-T 28800D Type III Class 3 (Navy requirement, unless specified otherwise).*

Meets MIL-STD-461C as follows:

- Conducted Emissions	Part 2	CEO1	(Narrow band)
	Part 4	CEO3	
- Conducted Susceptibility	Part 2	CSO1	
	Part 5	CSO6	(Limited to 300V)
- Radiated Emissions	Part 5,6	REO1	
	Part 2	REO2	(1 GHz max)

2.17.3.2 *CE (89/336EEC)*

Meets harmonized product requirements of 89/336EEC, EN50081.1 and EN50082.1 with addition of the tables 1 to 8.

2.17.3.3 *VDE requirements*

The instrument meets the requirements of VDE 0871 Grenzwert-klasse B.

CHARACTERISTICS

SPECIFICATIONS

ADDITIONAL INFORMATION

2.17.3.4 Additional EMI requirements

The instrument is tested in accordance with IEC 351-1 par. 5.1.3.1. The maximum deflection factor is 7 mm/mT (0.7 mm/gauss). This value measured with the instrument in a homogeneous field (in any direction with respect to the instrument) with a flux intensity (peak to peak value) of 1.42 mT (14.2 gauss) and of symmetrical sine wave form with a frequency of 45 Hz to 66 Hz.

The PM3370B, PM3380B and PM3384B, including standard accessories, conform with the EEC Directive 89/336 for EMI immunity, as defined by IEC 801-3, with the addition of the following tables.

Table 1.

	Susceptibility: no visible disturbance		
Frequency range: 10 kHz .. 25 MHz	E = < 0.1V/m	E = 1 V/m	E = 3 V/m
Stand alone	2 mV/div ... 5 V/div	2 mV/div ... 5 V/div	2 mV/div ... 5 V/div
With PM9010/091	2 mV/div ... 5 V/div	20 mV/div ... 5 V/div	100 mV/div ... 5 V/div

Table 2.

	Susceptibility: no visible disturbance		
Frequency range: 25 MHz ... 1 GHz	E = < 0.1V/m	E = 1 V/m	E = 3 V/m
Stand alone	2 mV/div ... 5 V/div	2 mV/div ... 5 V/div	10 mV/div ... 5 V/div
With PM9010/091	2 mV/div ... 5 V/div	100 mV/div ... 5 V/div	500 mV/div ... 5 V/div

Table 3.

	Susceptibility: disturbance less than 10 % of full scale		
Frequency range: 10 kHz .. 25 MHz	E = < 0.1V/m	E = 1V/m	E = 3 V/m
Stand alone	N/A	N/A	N/A
With PM9010/091	N/A	5 mV/div ... 10 mV/div	20 mV/div ... 50mV/div

Table 4.

	Susceptibility: disturbance less than 10 % of full scale		
Frequency range: 25 MHz ... 1 GHz	E = < 0.1V/m	E = 1V/m	E = 3 V/m
Stand alone	N/A	N/A	2 mV/div ... 5 mV/div
With PM9010/091	N/A	20 mV/div ... 50 mV/div	50 mV/div 200 mV/div

For conditions not specified in tables 1 - 4, a susceptibility effect of more than 10 % is possible.

CHARACTERISTICS

SPECIFICATIONS

ADDITIONAL INFORMATION

The PM3390B and PM3394B, including standard accessories, conform with the EEC Directive 89/336 for EMI immunity, as defined by IEC 801-3, with the addition of the following tables.

Table 5.

	Susceptibility: no visible disturbance		
Frequency range: 10 kHz .. 25 MHz	E = < 0.1V/m	E = 1 V/m	E = 3 V/m
Stand alone	2 mV/div ... 5 V/div	2 mV/div ... 5 V/div	2 mV/div ... 5 V/div
With PM9020/091	2 mV/div ... 5 V/div	20 mV/div ... 5 V/div	50 mV/div ... 5 V/div

Table 6.

	Susceptibility: no visible disturbance		
Frequency range: 25 MHz ... 1 GHz	E = < 0.1V/m	E = 1 V/m	E = 3 V/m
Stand alone	2 mV/div ... 5 V/div	2 mV/div ... 5 V/div	10 mV/div ... 5 V/div
With PM9020/091	2 mV/div ... 5 V/div	100 mV/div ... 5 V/div	200 mV/div ... 5 V/div

Table 7.

	Susceptibility: disturbance less than 10 % of full scale		
Frequency range: 10 kHz.. 25 MHz	E = < 0.1V/m	E = 1V/m	E = 3 V/m
Stand alone	N/A	N/A	N/A
With PM9020/091	N/A	5 mV/div ... 10 mV/div	10 mV/div ... 20 mV/div

Table 8.

	Susceptibility: disturbance less than 10 % of full scale		
Frequency range: 25 MHz ... 1 GHz	E = < 0.1V/m	E = 1V/m	E = 3 V/m
Stand alone	N/A	N/A	5 mV/div
With PM9020/091	N/A	20 mV/div ... 50 mV/div	50 mV/div ... 100 mV/div

For conditions not specified in tables 5-8,, a susceptibility effect of more than 10 % is possible.

CHARACTERISTICS	SPECIFICATIONS	ADDITIONAL INFORMATION
-----------------	----------------	------------------------

2.18 SAFETY

MEETS
REQUIREMENTS OF

IEC 348 Class I
UL 1244
CSA C22.2 No231
VDE 0411

See Note 1
See Note 2
See Note 2
See Note 1

APPROVALS
(applied for)

CSAC22.2 No231

MAX. X-RADIATION

MIL-T-28800D
par. 3.9.3.4.a

Note 1: Except for power cord, unless shipped with universal European power cord.

Note 2: Except for power cord, unless shipped with North American power cord.

2.19 ACCESSORIES

PACKED WITH
INSTRUMENT
Signal input

2x10 M Ω 10:1 probe
Contrast filter
Front cover

With readout (1.5 m)
Blue
Can be locked on instr.

Operating guide

Reference manual

2.20 OPTIONS & OPTIONAL VERSIONS

2.20.1 Options Line cord

LINE CORD

Universal
European

In accordance with VDE

North American

In accordance with CSA, UL

United Kingdom

In accordance with BSI

Australian

In accordance with SAA

Swiss

In accordance with SAV

2.20.2 Options digital versions

EXTERNAL INTERFACES
INTERNAL EXTENSIONS

IEEE
EXTENDED
MEMORY
MATH+

Factory installed only

Factory installed only
Factory installed only

CHARACTERISTICS	SPECIFICATIONS	ADDITIONAL INFORMATION
-----------------	----------------	------------------------

2.20.3 Options analog

EXTERNAL INTERFACES	Y-out, MTB gate, DTB-gate, ExtTrig. IEEE	See Note 1, Factory installed only Factory installed only
---------------------	--	---

Note 1: Ext trig is a standard feature in PM3370B/80B/90B. For characteristics refer to chapter 1.3.5.

2.20.4 Specification optional outputs

Y SIGNAL OUT	BNC	
Source	CH1	
Coupling	as CH1	
Voltage:		
into 1 M Ω	20mV/div \pm 10%	
into 50 Ω	10mV/div \pm 10%	
Freq. response:		Terminated with 50 Ω
PM3390B/94B	dc to 200 MHz	
PM3380B/84B	dc to 100 MHz	
PM3370B	dc to 60 MHz	
Dynamic range	\pm 10 div	At 50 MHz
MTB GATE OUT		
Connector	BNC	
Output impedance	1 k Ω	
Voltage:Timebase		
not running	0.2 \pm 0.2V	
Timebase running	3.7 \pm 1.3V	
DTB GATE OUT		
Connector	BNC	
Output impedance	1 k Ω	
Voltage:Timebase		
not running	0.2 \pm 0.2V	
Timebase running	3.7 \pm 1.3V	

CHARACTERISTICS	SPECIFICATIONS	ADDITIONAL INFORMATION
-----------------	----------------	------------------------

2.20.5 Specification External trigger option

Valid for ext trig option in PM3384B/94B

(External trigger input is a standard feature in PM3370B/80B/90B)

SOURCE

SOURCE(S) MTB-triggering	CH1 ... CH4 External Line
--------------------------	---------------------------------

INPUT CHARACTERISTICS

INPUT CONNECTOR	BNC	At rear of instrument
INPUT IMPEDANCE		Measured at freq. <1MHz
R parallel - value	1 M Ω	
- tolerance	$\pm 1\%$	
C parallel - value	25 pF	
- tolerance	± 5 pF	
DYNAMIC RANGE		
Up to 10 MHz	± 2.5 V	Symmetrical
INPUT VOLTAGE LIMITS		See note 1
 (d.c. + a.c. peak)	± 400 V	See note 2

Note 1: Apparatus should be properly grounded through the protective ground conductor of the power cord.

Note 2: Up to 10 kHz; >10 kHz see figure 1.1.

SENSITIVITY

EDGE TRIGGER SENSITIVITY		See note 3
d.c. to 5 MHz	100 mV	
d.c. to 10 MHz	200 mV	

Note 3: In noise-trigger multiply stated value by 2.

TRIGGER LEVEL

TRIGGERLEVEL		
Range	± 1.45 V	See note 4
Accuracy	≤ 0.45 V	at 1 kHz input signal
triggercoupling DC		

Note 4: With Level-pp on the range is restricted to the peak-peak value of the trigger signal.

2.20.6 Specification IEEE-OPTION

TYPE OF INTERFACE	ANSI/IEEE 488.2	SCPI (see SCPI programming manual) See Note 1
INTERFACE REPERTORY		
Source handshake	SH1	Complete capability
Acceptor handshake	AH1	Complete capability
Talker	T5	Basic talker: yes Serial poll : yes Talk only : yes Unaddress if MLA: yes
Listener	L3	Basic listener: yes Listener only : yes Unaddress if MTA: yes
Service request	SR1	Complete capability
Remote local	RL1	Complete capability
Parallel poll	PP0	No capability
Device clear	DC1	Complete capability
Device trigger	DT1	Complete capability
Controller	C0	No capability
ELECTRICAL INTERFACE		
Busdrivers	E2	Three state (true=0 to 0.8V;false=2 to 5V)
Connector	Shielded	Amphenol type 57FE-20240-20SD35
Pin 1 ... 4	DIO1...DIO4	
Pin 13 ... 16	DIO5...DIO8	
Pin 18 ... 23	GND	
Pin 24	Logic GND	
Pin 5	EOI	
Pin 6	DAV	
Pin 7	NRFD	
Pin 8	NDAC	
Pin 9	IFC	
Pin 10	SRQ	
Pin 11	ATN	
Pin 12	Shield	
Pin 17	REN	
FUNCTION SELECTION	Via UTILITY-MENU	Busaddress Default: 8 See Note 2
INTERFACE STATUS INDICATOR	On screen	

Note 1: Talker/listener

Note 2: When battery installed, same as last power-off value.

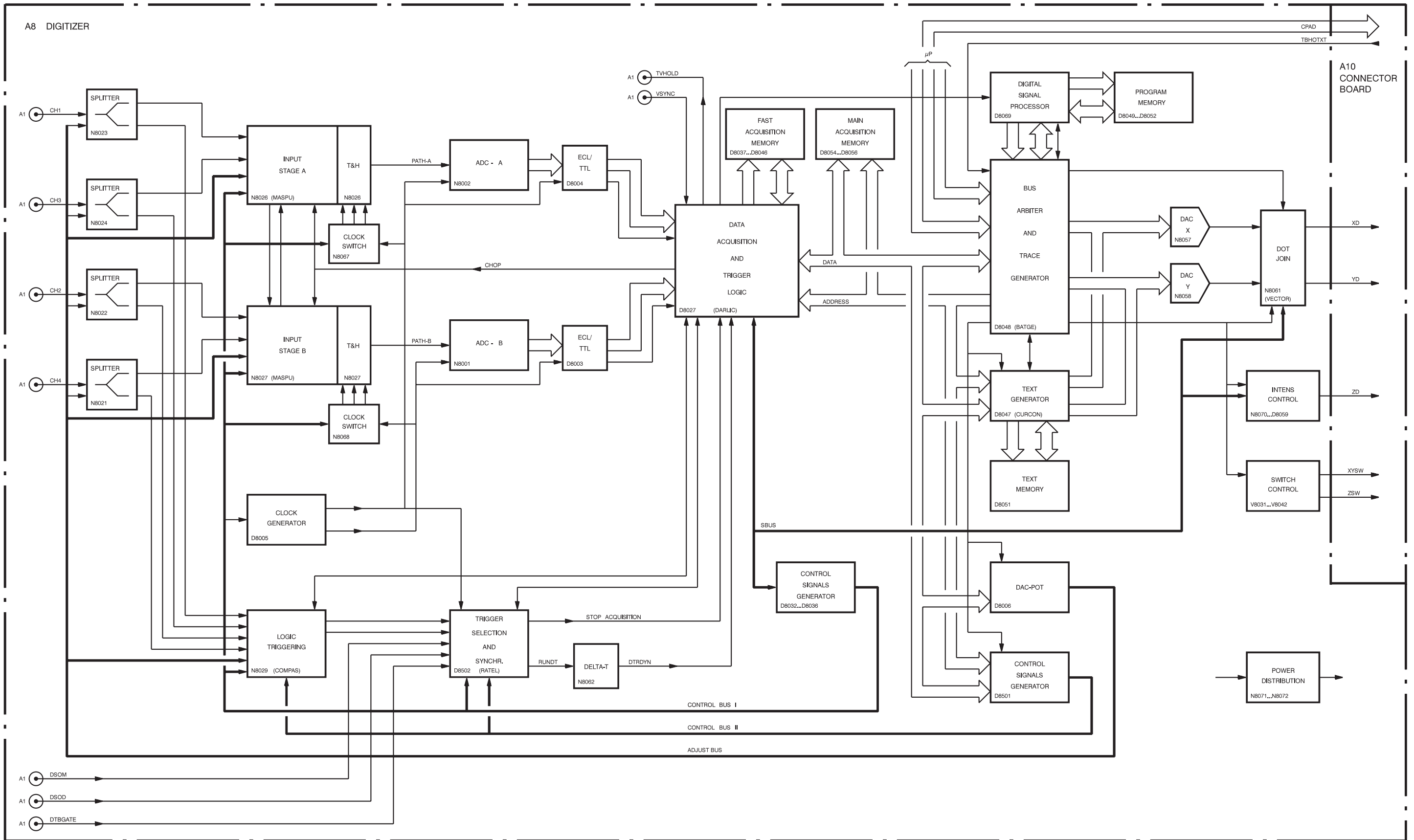

ST8234
970409

Figure 3.1 Blockdiagram, Digital part

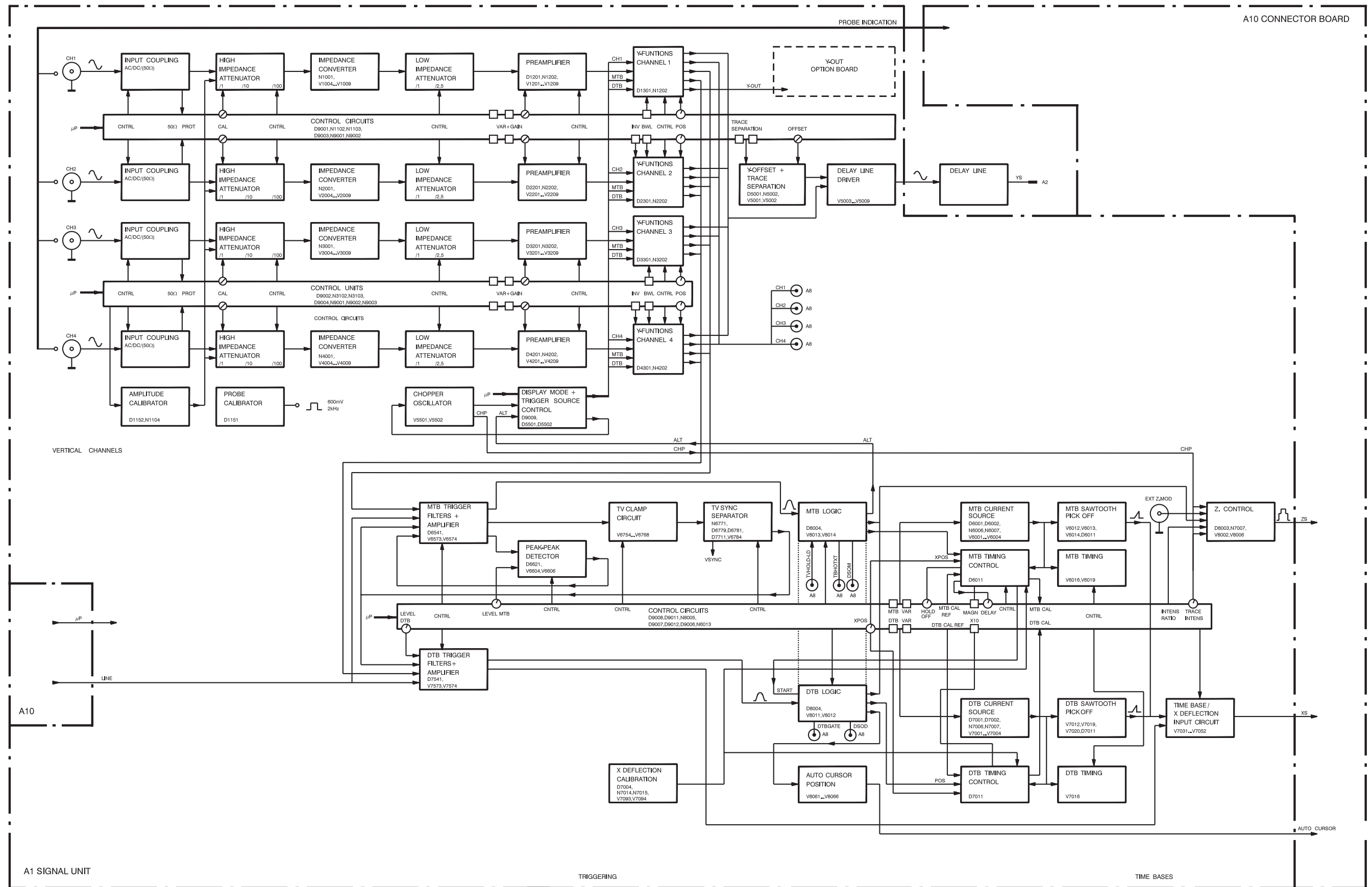
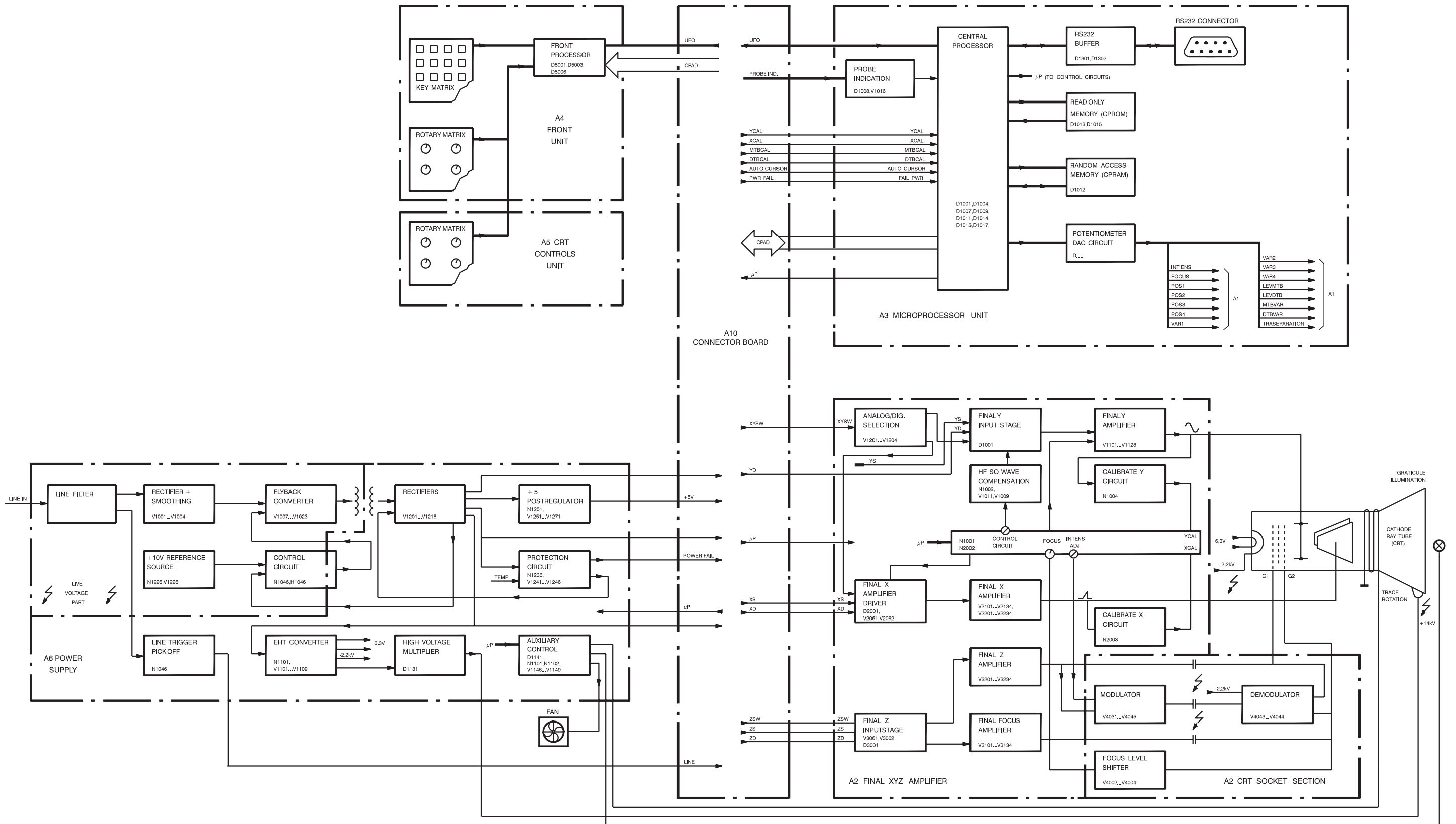

Figure 3.2 Blockdiagram, Analog part 1



ST8233B
970409

Figure 3.3 Blockdiagram, Analog part 2

3 DESCRIPTIONS

3.1 GENERAL DESCRIPTION

3.1.1 Introduction to oscilloscope family

The family consists of seven digital general purpose oscilloscopes with model numbers PM3370B, PM3380B, PM3384B, PM3390B, and PM3394B. Differences between these models are the vertical bandwidth, the features of the vertical channels and the presence of switchable 50Ω input impedance.

Vertical bandwidth is 60, 100 or 200 MHz. The 'true 4 channel' oscilloscopes have four channels with a wide range of input sensitivities. The economy versions offer 2 channel and on External Trigger input. The table below explains the differences.

Type number	Bandwidth	Sample rate	Number of channels	Input impedance
PM3370B	60 MHz	200 MS/s	2	1 MΩ
PM3380B	100 MHz	200 MS/s	2	1 MΩ
PM3384B	100 MHz	200 MS/s	4	1 MΩ
PM3390B	200 MHz	200 MS/s	2	1 MΩ/50Ω
PM3394B	200 MHz	200 MS/s	4	1 MΩ/50Ω

The printed circuit boards (units) and mechanical parts in this family of oscilloscopes have a high degree of standardization. The ordering codes for these parts are listed in chapter 4 'Parts'.

3.1.2 Introduction to descriptions

Section 3.2 contains the description of the block diagram. The information in this diagram is presented in such a way that the link with the circuit diagrams in chapter 5 'Unit descriptions' can be found easily.

In chapter 4 'Parts' all general parts are described. These are, for example, the printed circuit boards (units), cables and mechanical parts that are not fixed to a specific unit. Cables are clearly identified on an interconnection diagram.

In chapter 5 the units are described in sequence of their number (A1, A2, A3, ...). Per unit the following information is given:

- Description
- Signal name list
- Unit lay-out (and location raster for the large units)
- Circuit diagrams (see note)
- Parts lists

Note: Some diagrams are dedicated to one or two type numbers. This is indicated in the diagram description at the bottom.

3.1.3 Explanation of signal names

Throughout the circuit diagrams signal names are used. These names make it easier to trace a signal going from one circuit diagram to another. In many cases the signal name and also the component to which a certain node is connected are given in the circuit diagrams.

For every printed circuit board a signal name list is shown in alphabetical order. It shows:

- The meaning/function of the signal.
- The signal source(s).
- The signal destination(s).

Signal names are chosen up in a logical way. Basically signal names (e.g. MTBPPLEV-HD) consist of two parts:

- A functional part with a maximum of 10 characters (e.g. MTBPPLEV). The part is arranged such that recognition is easy.
- An extension with a maximum of 2 characters (e.g. HD). The extension is not always used.

The first characters (e.g. MTB) in the **functional part** indicate the part of the oscilloscope. Examples are:

- AT1, AT2, AT3, AT4: the input attenuators of channel 1, 2, 3, 4.
- PA1, PA2, PA3, PA4: the preamplifiers of channel 1, 2, 3, 4.
- FNC1, FNC2, FNC3, FNC4: the function selection parts of channel 1, 2, 3, 4. MTR: main time base triggering.
- MTB: main time base.
- DTR: delayed time base triggering.
- DTB: delayed time base.

The last set of characters in the **functional part** (e.g. PPLEV) indicates the function: in this example Peak-Peak LEVel triggering is switched on/off.

The first character of the **extension** indicates if the signal is active when high (H), active when low (L) or that this is not fixed (X, for instance the output of a counter).

The second character of the **extension** indicates the kind of logic. Possible abbreviations are: T (TTL), E (ECL), A (analog signal), C (CMOS 12 ... 15V) and D (CMOS 5V).

3.1.4 Voltage values in the circuit diagrams

Throughout the circuit diagrams voltage values are indicated. This facilitates fault finding in the vertical channels, triggering, time base and final amplifiers. Most of the voltages consist of an AC signal superimposed on a DC biasing voltage. Some of the AC voltages are small. They must be measured with an oscilloscope via a 1:1 probe and AC coupled input. The DC signal component is bigger and must be measured with the measuring oscilloscope with DC coupled input. The nodes where a signal can be measured are indicated with a dot on the p.c.b. lay-outs.

The oscilloscope under test must be prepared as follows:

- Connect the CAL voltage via a 10:1 probe with indication ring to the input of the suspected channel.
- Press the STATUS and TEXT OFF key simultaneously to get a defined starting position.
- Press the AUTOSET key.
- Put AMPL/VAR of the active channel to 0.1 V: this should give 6 vertical divisions of signal on the screen.

Some important notes:

- To measure some signals, it is necessary to unlock units. Refer to chapter 8.5 for details on how to proceed.
- The given AC and DC signals are average values: your oscilloscope under test may deviate from the values given in the circuit diagrams. 100 MHz clock signals and fast switching signals on the digitizer unit A8 require a measuring oscilloscope with a bandwidth of 200 MHz or more.
- Although the oscilloscope is in standard setting, it may be necessary to do manual selections for certain measurements. To measure e.g. the delayed time base and its triggering, it is necessary to activate DTB and to select a channel as DTB trigger source. The same is valid for digitizer functions like logic pattern, timed pattern, double sampling speed (250 ns/div).
- When measuring in the final amplifiers, it is advised to switch off all text. This gives 'cleaner' signals at the outputs. The text is written in between the signal at a random basis.
- Measuring the outputs of the final Y amplifier must be done with a 10 k Ω resistor between probe tip and signal. This avoids oscillations.
- Refer to chapter 8.11.4.7 (Repair tools/DAC) on how to check the range of DAC-generated adjustment voltages.

3.2 BLOCK DIAGRAM DESCRIPTION

3.2.1 Introduction

This block diagram and description are based upon the most complex version of this family of digital oscilloscopes. Therefore there may be minor differences between your oscilloscope and the block diagram and its description. Where differences may occur it is mentioned in the text.

The item numbers of active components are indicated each block of the diagram. This facilitates to make the link with the circuit diagrams.

The oscilloscope is controlled by a microprocessor that connects to many blocks. Therefore throughout this block diagram CONTROL CIRCUITS can be found that are controlled by the microprocessor. The output signals can be simple on/off signals e.g. to switch a certain vertical channel on and off. There are also adjustable dc voltages e.g. to determine the gain of a vertical channel. Blocks that are under control of the microprocessor have the input signal " μ P". In the vertical, horizontal and time base sections, circuits are added for microcomputer controlled automatic calibration.

This description is divided according to the functional blocks that can be distinguished:

- Vertical channels: there are 4 vertical channels (part 1).
- Triggering and time bases: there are sections for main- and delayed time base (part 1).
- Final amplifiers: for vertical (Y) and horizontal (X) deflection, intensity (Z) and focusing control (part 2).
- Front unit and microprocessor unit (part 2).
- Power supply unit (part 2).
- Digitizer unit (part 3).

Also the printed circuit boards (units) are indicated in the block diagram. These units are:

- Signal unit A1: is the largest of all and incorporates 4 vertical channels and main- and delayed triggering and time base.
- Final XYZ amplifier A2: all final amplifiers are present here. A separate part is connected to the CRT socket.
- Microprocessor unit A3.
- Front unit A4: incorporates most of the rotary knobs and keys.
- CRT controls unit A5: incorporates the rotary knobs for the display functions.
- Power supply unit A6: supplies various voltages to the other circuit boards.
- Digitizer unit A8: includes all digital storage circuitry.
- Motherboard A10: many signals are routed via this unit.

3.2.2 Vertical channels

There are 4 vertical channels that are mainly identical. A difference is that the 200 MHz oscilloscope versions have a switchable 50 Ω input impedance while the 100 MHz and 60 MHz types do not have this feature.

Another difference is between the 4 channel and the 2 channel versions. The 4 channel scopes have 4 identical vertical channels (CH1, CH2, CH3 and CH4) with an extensive range of input sensitivities. The various input sensitivities are made by combinations of settings of HIGH IMPEDANCE ATTENUATOR, LOW IMPEDANCE ATTENUATOR and PREAMPLIFIER.

The 2 channel versions have 2 identical vertical channels (CH1 and CH2) with an extensive range of input sensitivities. Channel 1 operation and the differences with channels 2, 3 and 4 are now explained.

In the 2 channel versions the channel CH3 is omitted and the EXT TRIG input has 2 switchable input sensitivities.

The CH1 input signal is applied to the INPUT COUPLING block. Here selection between ac or dc coupled input is done. Moreover in the 200 Mhz oscilloscopes selection between 50 Ω and 1 M Ω input impedance is done here. A signal 50 Ω PROTection signals via the CONTROL CIRCUITS to the microprocessor if the dissipation in the 50 Ω termination resistor gets too high.

The block HIGH IMPEDANCE ATTENUATOR incorporates the attenuation coefficients /100, /10 and /1. This block has a fixed attenuation for the ExtTrig channel in the 2 channel oscilloscopes. The input signal originating from the AMPLITUDE CALIBRATOR is used to automatically calibrate the vertical channels. The AMPLITUDE CALIBRATOR is a generator that can deliver 8 different accurate voltages. The HIGH IMPEDANCE ATTENUATOR also comprises a high-frequency square-wave adjustment; this is done by adjustment of dc signal CAL.

The IMPEDANCE CONVERTER converts the input signal at high input impedance into an output signal at a low impedance. This block is followed by a LOW IMPEDANCE ATTENUATOR that makes the attenuation coefficients /2,5 and /1. This block has a fixed attenuation in the ExtTrig channel of the 2 channel oscilloscopes.

The PREAMPLIFIER incorporates gain/attenuation coefficients x1, x5, /2 and also continuous GAIN control via a microprocessor adjustable dc signal. The PREAMPLIFIER is followed by Y-FUNCTIONS CHANNEL 1. In this block the selection is achieved of vertical display via channel 1, Main Time Base (MTB) triggering via channel 1 and Delayed Time Base (DTB) triggering via channel 1. Also the filter for the Bandwidth Limiter (BWL), the vertical position control (POS) and an output to the digitizer (EXT). From Y-FUNCTIONS CHANNEL 1 the signal for the Y- OUTput socket is derived. The Y-FUNCTIONS blocks of channel 2 and 4 have an INVert function for signal inversion.

The selection of the vertical channel, MTB and DTB trigger source is initiated by the block DISPLAY MODE + TRIGGER SOURCE CONTROL. The channels and trigger sources to be displayed are controlled by the microprocessor (μ P). In ALTernate display mode the switching between channels/trigger sources occurs at the end of the MTB sweep. The signal ALT controls this. For the vertical display mode CHOPped a 2MHz CHOPPER OSCILLATOR is present. Display blanking during switching from one channel to another is done via signal CHP.

The selected vertical channel(s) are applied to the DELAY LINE DRIVER. This block is an amplifier that has the correct output impedance to drive the DELAY LINE. The DELAY LINE itself consists of a coaxial cable giving sufficient signal delay so that propagation delay in the trigger circuits is compensated. Because of this leading edges of fast-rising pulses can be made visible. The Y-OFFSET + TRACE SEPARATION block can influence the offset of the signal applied to the DELAY LINE DRIVER. This is used as offset compensation and also for TRACE SEPARation in ALTernate Time Base mode.

The PROBE CALIBRATOR is a generator delivering a 2kHz/600mV square- wave signal. This signal can be used to adjust the square-wave response of attenuator probes.

3.2.3 Triggering and time bases

The sections for Main Time Base (MTB) and Delayed Time Base (DTB) are for the greater part identical. Therefore the MTB part is extensively described and then the DTB part briefly. The EXTERNAL TRIGGER input of the 2 channel versions is only different in the attenuator part, after that it is equal to and described as CH4.

Main Time Base Description.

The possible trigger sources are applied to the block MTB TRIGGER FILTERS + AMPLIFIER. The selection for triggering on the vertical channels 1, 2, 3 or 4 is done in the Y-FUNCTIONS blocks in the vertical section. Triggering is also possible on the LINE trigger signal that is derived from the mains. The MTB TRIGGER FILTERS + AMPLIFIER incorporates filters for HF-reject, LF-reject and ac or dc signal coupling. The block also incorporates the +/- slope selection. The dc control signal LEVEL MTB originating from the CONTROL CIRCUITS is routed via the PEAK-PEAK DETECTOR. This block limits in peak-peak mode the LEVEL MTB range just within the peak-peak value of the signal. For this purpose the trigger signal is applied to an input of the detector. The LEVEL MTB control signal is not limited if the peak-peak mode is inactive.

For triggering on TV synchronization pulses the blocks TV CLAMP CIRCUIT and TV SYNC SEPARATOR are used. The CLAMP CIRCUIT separates the synchronization pulses from the composite video signal. The video information is not necessary for triggering. The TV SYNC SEPARATOR filters out line, frame and field pulses. This is done for various TV systems including HDTV. A VSYNC output is connected to digitizer unit A8.

The block MTB TRIGGER FILTERS + AMPLIFIER sends trigger pulses to the MTB LOGIC. This logic is combined with the DTB LOGIC. The three output signals are used to start MTB (applied to MTB TIMING CONTROL), to switch intensity on and off (applied to Z CONTROL) and for ALTERNATE display switching (applied to DISPLAY MODE + TRIGGER SOURCE CONTROL). TV HOLD-LD is received from digitizer A8. TB40TXT and MTB trigger DSOM are applied to A8.

The MTB is based on the principle that selectable capacitors (inside block MTB TIMING) are charged with a selectable constant current (from MTB CURRENT SOURCE). This results in a sawtooth voltage across the capacitor(s) that rises linearly with the time. As a consequence a time-linear horizontal deflection is obtained. The sawtooth voltage is routed to the horizontal deflection part via the MTB SAWTOOTH PICK OFF. This block serves as a high to low impedance converter so that the load to the timing capacitor(s) is minimal. Various time base sweep speeds are obtained by selecting different combinations of current values and timing capacitors. The function MTB VARIABLE works via the MTB CURRENT SOURCE.

The MTB TIMING CONTROL discharges the capacitor(s) if the maximum level of the sawtooth is reached. The MTB TIMING CONTROL allows the charging process to start again if a trigger occurs. The functions X POSITION, HOLD OFF and 10x MAGN are applied to and realized in the MTB TIMING CONTROL. HOLD OFF determines the time between discharge of the timing capacitors and the moment that a trigger pulse is allowed to start the MTB again.

The MTB TIMING CONTROL accomplishes the DELAY time function. The sawtooth voltage is compared with an adjustable dc voltage. The DTB is started where both voltages have the same level: this condition is signalled to the DTB LOGIC via signal START.

The MTB TIMING CONTROL also plays a role in the automatic MTB calibration. A reference voltage MTBCALREF is compared with the sawtooth voltage. The time necessary for the sawtooth to reach the MTBCALREF level is monitored by the microprocessor via signal MTBCAL. If necessary the MTB is readjusted. Automatic calibration of the X-path (including output circuit of MTB TIMING CONTROL) is done with accurate voltages from the block X DEFLECTION CALIBRATION.

Delayed Time Base Description.

The function of DTB TRIGGER FILTERS + AMPLIFIER is identical to the corresponding block in the MTB part. A "peak-peak detector" for LEVEL DTB is not present. The range of this control is always fixed and not related to the peak-peak level of the signal. Blocks for TV triggering are not present in the DTB section. TV triggering of the DTB occurs via output signals from the TV SYNC SEPARATOR in the MTB section.

An output signal from DTB TRIGGER FILTERS + AMPLIFIERS can be used for X DEFlection (MTB and DTB are off then) via the block TIME BASE / X DEFLECTION INPUT CIRCUIT.

The function of DTB CURRENT SOURCE, DTB TIMING and DTB SAWTOOTH PICK OFF is identical to the corresponding blocks in the MTB section. For the DTB LOGIC there is an extra input signal START to start the DTB directly after the adjusted delay time. The START signal originates from the MTB TIMING CONTROL. DTB GATE and DTB trigger DSOD are applied to A8. The block AUTO CURSOR POSITION is used to position the voltage cursors automatically on the top and bottom level of the signal. The top and bottom levels are detected via the DTB triggering: the microprocessor scans the waveform by successively changing the DTB LEVEL and checking if triggers are still detected. Automatic calibration of the X-path (including output circuit of DTB TIMING CONTROL) is done with accurate voltages from the block X DEFLECTION CALIBRATION.

The DTB TIMING CONTROL is simpler than the corresponding block in the MTB. The functions DELAY and HOLD OFF are not present. DTB uses the MTB hold off time. This is due to the fact that the DTB can not run while the MTB does not.

X deflection selection and intensity control.

The block TIME BASE/X DEFLECTION INPUT CIRCUIT permits selection between horizontal deflection via MTB/DTB or via a signal selected via the DTB triggering (X DEFL mode).

The block Z-CONTROL controls the intensity of the signal on the screen. This also affects the focusing. Signal intensity and the intensity of text is determined in the final amplifier section.

The signal intensity is determined by the MTB LOGIC (light on/off) and DTB LOGIC (intensified part during run of DTB). The ratio between intensity of MTB and DTB is determined by control signal INTENS RATIO. Input signal CHP gives display blanking in vertical display mode chopped when switching from one channel to another. The control signal TRACE INTENS is influenced by the control with the same name. Intensity can also externally be controlled via input socket EXT Z MOD.

3.2.4 Final amplifiers

The final amplifier can be split up in parts for vertical (Y) and horizontal (X) deflection and parts for intensity (Z) and focusing control. Input signals originate from the analog as well as the digital vertical (Y) channels and time bases (X). The signals that determine X, Y and Z of the text originate from the text generator on the digitizer unit. The signal that switches between analog and digital (XYSW signal) display originates also from the digitizer. The outputs of the final amplifiers drive the Cathode Ray Tube (CRT). The various sections are explained now in sequence.

Vertical deflection.

The FINAL Y INPUT STAGE receives input signal for signal display (YS) from the DELAY LINE. A second input signal (YD) determines the vertical component of the digital trace and text information. The input signal that comes from AN/DIG SELECTION controls switching between analog and digital display. The HF SQ WAVE COMPENSATION is controlled by the microcomputer provides that signal distortion from the DELAY LINE is compensated in the FINAL Y INPUT STAGE. The FINAL Y AMPLIFIER drives the vertical deflection plates of the CRT. The voltage applied to these plates is measured by the block CALIBRATE Y CIRCUIT. Its output signal YCAL is applied to the microprocessor; this is part of the automatic vertical calibration facility.

Horizontal deflection.

The FINAL X AMPLIFIER DRIVER receives input signal for signal display (XS) from the Main and Delayed Time Base sections. A second input signal (XD) determines the horizontal (X) component of the digital trace and text information. The input signal that comes from AN/DIG SELECTION controls switching between analog and digital display. The FINAL X AMPLIFIER drives the horizontal deflection plates of the CRT. The voltage applied to these plates is measured by the block CALIBRATE X CIRCUIT. Its output signal XCAL is applied to the microprocessor; this is part of the automatic horizontal calibration facility.

Intensity and focusing.

The FINAL Z INPUT STAGE receives input signal for trace intensity (ZS) from the Z CONTROL block in the time base section. A second input signal (ZD) determines the intensity (Z) component of the text information. An input signal ZSW that comes from the digitizer allows switching between analog and digital intensity. The FINAL Z AMPLIFIER drives the intensity control electrode G1 of the CRT. This electrode is at a very negative -2.2kV voltage level. It is for that reason that a high-voltage blocking capacitor is necessary between G1 and the output of the FINAL Z AMPLIFIER. However only the ac component in the signal can pass through the capacitor. The dc and lf components are applied to the MODULATOR and modulated on a high-frequency carrier. Now they can pass through a capacitor, are demodulated in the DEMODULATOR and then the dc, lf and hf components are recombined.

The FINAL Z INPUT STAGE drives, in parallel with the FINAL Z AMPLIFIER, the FINAL FOCUS AMPLIFIER. This has the result that a well-focused spot over a large intensity range is obtained. The FINAL FOCUS AMPLIFIER drives the intensity control electrode G3 of the CRT. This electrode is at a very negative -2.2kV voltage level. It is for that reason that a high-voltage blocking capacitor is necessary between G3 and the output of the FINAL FOCUS AMPLIFIER. The ac component in the focusing signal passes through a high-voltage capacitor. The lf and dc components are derived from the DEMODULATOR that is also used in the intensity part. Focus control is possible via the FOCUS LEVEL SHIFTER.

3.2.5 Front unit and microprocessor

The front unit and microprocessor are the sections where all oscilloscope functions are controlled. Also the generation of text and the automatic calibration is controlled by the microprocessor. The operations performed by the microprocessor are determined by the ROTARY MATRIX and KEY MATRIX. Also commands from an external computer connected to the RS232 connector have the same result.

The ROTARY MATRIX and keys in the KEY MATRIX present at front unit A4 are read by the FRONT PROCESSOR. Also the ROTARY MATRIX that is present on the CRT controls unit A5 is read by the FRONT PROCESSOR. The CENTRAL PROCESSOR on the MICROPROCESSOR UNIT A6 is informed by the FRONT PROCESSOR of the settings selected with the front panel controls. Incorporated in the CENTRAL PROCESSOR is a complete RS232 interface. Serial communication is possible via the RS232 BUFFER.

The CENTRAL PROCESSOR has many inputs and outputs and forms the heart of the oscilloscope's control section. First of all there are a READ ONLY MEMORY (CPROM) and a RANDOM ACCESS MEMORY (CPRAM). The POTENTIOMETER DAC CIRCUIT is able to produce 16 independently adjustable dc voltages. These voltages are used for continuous controllable functions such as POSition, FOCUS and VARIable.

The CENTRAL PROCESSOR also has a number of analog inputs that are internally converted into digital. These inputs are used for automatic calibration (YCAL, XCAL, MTBCAL and DTBCAL), AUTOCURsor position, power fail and probe indication (via PROBE DETECTION block). An important output is the "μP" output. It is via this output that the CONTROL CIRCUIT blocks found throughout the block diagram are controlled.

The CENTRAL PROCESSOR communicates to the TEXT/CURSOR CONTROL which text and cursors have to be displayed. This information is stored in the TEXT/CURSOR MEMORY.

3.2.6 Power supply

The power supply is a switched mode type and has high efficiency. It can function on a wide range of LINE input voltages. An important part of the power supply is directly connected to the mains. This part carries LIVE VOLTAGE and measurements and repairs must be carried out via a separation transformer by a qualified technician.

The LINE IN voltage is applied to the LINE FILTER. This block prevents line interference from entering the supply unit. Also interference generated by the power supply does not enter the mains. An output signal of the filter is applied to the LINE TRIGGER PICK OFF in order to facilitate line triggering of the time bases.

The other output signal is applied to RECTIFIER + SMOOTHING: the output of this block has a dc voltage of which the height depends on the applied line voltage. This dc voltage is applied to the FLYBACK CONVERTER. This block incorporates a high voltage switching element that converts the dc voltage into a high-frequency ac voltage. This ac voltage is applied to the primary winding of a transformer. The secondary winding has many taps with connected RECTIFIERS: this gives the required supply voltages for the oscilloscope. The +5V POSTREGULATOR gives additional stabilization of the +5V supply voltage.

Stabilization of the output voltages at different line voltages is achieved by varying the on/off ratio of the switching element in the FLYBACK CONVERTER. The on/off ratio is determined in the CONTROL CIRCUIT by comparing the accurate output voltage of the +10V REFERENCE SOURCE and an output voltage of the RECTIFIERS.

The EHT CONVERTER generates the 6.3V heater voltage and -2.2kV cathode voltage for the Cathode Ray Tube (CRT). The +14kV final accelerator voltage for the CRT is generated in the HIGH VOLTAGE MULTIPLIER.

The AUXILIARY CONTROL is controlled by the microprocessor (μ P) and generates three dc voltages that are used for TRACE ROTATION adjustment, GRATICULE ILLUMINATION adjustment and speed control for the FAN.

The PROTECTION CIRCUIT switches the power supply off in case of over and under output voltage, too low line voltage and too high temperature.

3.2.7 Digitizer

Blockdiagram description of the digitizer unit A8, which contains all digital storage circuits of the oscilloscope.

Main sections of the digitizer are:

- Input Stage
- Analog to Digital Converter and Clock Generator
- Control-signal Generator
- Trigger Comparator, Source Selector and Delta-t circuit
- Data Acquisition and Trigger Logic and Fast Acquisition Memory
- Main Acquisition Memory
- Digital Signal Processor and Program Memory
- Bus Arbiter and Trace Generator
- Text Generator and Text Memory
- X- and Y- Output DAC, Dotjoin circuit and Intensity Control

The digitizer unit contains a large number of integrated circuits that consists of a large amount of functions. It is not possible to measure around inside these circuits and therefore a detailed description of the functions in these integrated circuits is not given.

The functioning of the digitizer is explained using a separate blockdiagram.

In the blockdiagram description as much links as possible are made to the different components in the circuit diagrams and their item numbers.

3.2.7.1 *Input stage*

Four input channel signals for channels 1, 2, 3, and 4 from the analog oscilloscope section are applied to the digitizer unit via eight coaxial cables. Each of these symmetrical input channel signals is splitted in two equal signals by a signal buffer and SPLITTER.

One signal is going to an INPUT STAGE into the vertical signal data path, the other signal is supplied to pattern and state comparators in the LOGIC TRIGGERING block in the trigger signal path.

The MASPU's (Main Analog Signal Processing Unit) A and B take care of the channel switching. The input channel signals 1 and 3 are limited and amplified to be multiplexed by the chopper circuit in MASPU-A. The same for input channel signals 2 and 4 in MASPU-B.

The multiplexed signal is amplified and split in two equal parts again. Part one is fed to a combiner in MASPU-A. Part two is fed to the combiner in the other MASPU-B.

Each channel combiner has two modes, selected by control signals.

In the first mode it supplies its own signal to a variable gain circuit and in the second mode it supplies the signal from the other MASPU to the variable gain circuit.

Via the VAR control circuit the vertical gain information for each path is applied to the circuit.

The output signal from each variable gain circuit is converted into an asymmetric signal, that is fed to a Track and Hold circuit T&H. This circuit is needed to offer a stable input signal to the analog to digital converter behind it. The T&H control signal is a 100MHz clock.

3.2.7.2 *Analog to Digital Converter and Clock Generator*

The T&H circuit offers a stable input signal to an analog to digital converter (ADC).

Both the ADC-A and the ADC-B are under all circumstances continuously clocked by a 100 MHz clocksignal which is generated by a CLOCK GENERATOR. The ECL output data signals of the ADC's are buffered and converted into TTL data signals by ECL/TTL translators.

3.2.7.3 *Control-signal Generator*

A number of control, mode and selection signals come from CONTROL SIGNAL GENERATORS via an SBUS (serial bus interface) and a serial to parallel converter. These control signals have functions in almost all circuits.

3.2.7.4 *Trigger Comparator, Source Selector and Delta-t circuit*

Acquisition of new signal information is stopped on receipt of an active trigger and this is completely controlled by the fully programmable trigger circuits. The time relation between the freezing of the acquisition and the signal STOPACQ depends on the choosen trigger delay.

The trigger signal path provides for three additional trigger modes to the modes which are already present in the analog front end. It are Pattern triggering, Timed-Pattern triggering and State triggering.

The four input channel signals from the buffers and SPLITTERS are applied to four level comparators in the LOGIC TRIGGERING block.

They are compared to a user-defined pattern in a Pattern and Edge selector. When the user-defined pattern conditions are met, an internal PATTERN signal becomes active and is applied to the TRIGGER SELECTION and SYNCHRONIZATION circuit, to Timer circuits and to Timed Pattern and State circuits.

The trigger source selector will select the trigger signal, corresponding with the user-defined trigger mode.

Signals as Main Time Base trigger DSOM, Delayed Time Base trigger DSOD and DTBGATE are derived from the trigger circuits in the analog oscilloscope section.

Trigger selection, mode selection, pattern and control signals are generated via the serial bus interface and a serial to parallel converter. Events clock selection is controlled in the same way.

With events selected, the trigger detection unit catches the first edge. With this edge it enables an event counter in the DATA ACQUISITION AND TRIGGER LOGIC.

When it has finished counting the required number of events, a second stage in the trigger detection unit is enabled to catch the last event clock.

In TV trigger mode the events clock is switched to DSOM. By enabling the event counter with VSYNC (derived from the composite sync signal on DSOM) it is possible to count down with the events counter to any line in a TV signal. In digital mode the events counter is loaded with a count value one less than necessary. Now the trigger sync unit can generate a trigger on the correct TV line. In analog mode the events counter output is fed back to the analog front end as TVHOLD-LD.

In normal trigger mode the event counter is enabled by a signal from the data path. Now we can count trigger pulses for trigger delay activities during the acquisition.

A signal RUNDT is derived from the trigger circuit to start a delta-t measurement by a DELTA-T circuit. This circuit is used to measure the time elapsed between the moment of triggering and the real sample moment. It is a measure to determine the correct location in memory to store the digital code of the first sample of each acquisition cycle.

A DELTA-T counter in the DATA AND ACQUISITION TRIGGER LOGIC is running at the maximum sample clock frequency, enabled by the STOPACQ (stop acquisition) signal. Counting is stopped by the falling edge of the delta-t ready signal DTRDYN from the DELTA-T circuit.

A digital signal processor (DSP) is informed about this completion of the delta-t measurement by an interrupt signal. It then reads the value of the measurement in the DELTA-T counter and it resets the counter to zero again in order to be ready for the next DELTA-T measurement. The measurement is very important for the positioning of the sample in memory as well as on the CRT screen.

3.2.7.5 *Data Acquisition and Trigger Logic and Fast Acquisition Memory*

The output data from the ECL/TTL translators is applied to the DATA ACQUISITION AND TRIGGER LOGIC circuit (DARLIC), which contains a data path and a trigger engine. The data path is responsible for the total acquisition process from ADC to memory, including time-base generation and the trigger engine is responsible for the generation of a start/stop acquisition signal that is fed to the data path.

The data is latched by a register and checked on over/underflow by a detector.

Peak detectors determine minimum and maximum values of the signal. When peak is off, this circuit will pass on all the samples. A data junction lowers the data rate from 100 MHz streams to eight 25MHz data streams and guides the data from the peak circuit properly to output latches.

Data will directly be stored in a FAST ACQUISITION MEMORY (FAM) which consists of 8x a 2kx8 bit SRAM.

The FAM is addressed by two 18 bit wide address pointers, the acquisition pointer and the display pointer.

The acquisition pointer is active during the writing of new signal data information into the FAM. The write cycle starts, if enough bytes have been received. The pointer is loaded by the digital signal processor with the address of the first sample of a display cycle.

FAM data is read, 64 bits at a time, when no write actions are performed and enough time-space is available between two write actions of the acquisition path. The FAM is then addressed by the display pointer, which is automatically presetted with the address where the display should start. A kind of handshake control is responsible for correct operation.

The acquisition control logic separates the time around the trigger point in, gathering of pre- and post trigger information, and the counting down of a specific extra trigger delay.

The SBUS (serial bus interface) is part of the DARLIC circuit. It is supporting a very limited number of capabilities. Its register is controlling two open collector I/O pins, SDA (serial data) and SCL (serial clock), and a select line SSEL. The buffer enables the DSP to read the status on the SDA and SCL lines.

The SBUS is connected to a CONTROL SIGNAL GENERATOR, the DOT JOIN circuit and to the INTENSITY CONTROL circuit.

All interrupt sources within DARLIC's data path, trigger path, and other features are gathered in the interrupt register.

The DSP can write an interrupt mask into the interrupt enable registers. There are two interrupt enable registers, so that different interrupt causes can generate interrupts with different destinations. Bits in these registers that are set, enable the corresponding bit in the interrupt register to generate an interrupt.

Every bit in the interrupt register can be cleared separately by the interface clear control. They can also automatically be cleared upon a read of the interrupt register via the interrupt status buffer.

3.2.7.6 *Main Acquisition Memory*

The converted analog signals are stored directly from the ADC's into a FAST ACQUISITION MEMORY. Acquired data has later to be transferred to a MAIN ACQUISITION MEMORY (MAM) by means of a DIGITAL SIGNAL PROCESSOR (DSP). The MAM consists of 2x a 32kx8 bit SRAM, is non volatile and contains all trace registers. It contains an acquisition memory part as well as a display memory part and contains the data which is ready for display on the CRT screen.

3.2.7.7 *Digital Signal Processor and Program Memory*

The DIGITAL SIGNAL PROCESSOR (DSP) has the control over the entire DIGITIZER and performs all necessary signal processing activities, which are not available in hardware.

Signal processing functions are functions like:

- Pre-processing: Average, envelope
- Postprocessing: Mathematical functions, interpolation, filters
- Other functions: Display memory refresh, X-position control, delta-t processing and so on

One of its main tasks is the composition of the trace information out of the available registers. The SYSTEM ENGINE is responsible for the text data.

The Text and Trace Generator takes care of generating the appropriate X, Y and Z information for the vector oriented CRT.

Although the DSP has full control over the DIGITIZER the SYSTEM ENGINE is able to access all circuits in the same way.

At any point in time, the DIGITAL SIGNAL PROCESSOR can force an exit to the idle state. Under certain conditions the DSP can force a change from state three to state four.

The DSP can also write an interrupt mask into the interrupt enable registers.

The DSP uses its own PROGRAM MEMORY which consists of 2x an 8kx8 bit SRAM. It is a volatile memory and can not be accessed by any other device.

3.2.7.8 *Bus Arbiter and Trace Generator*

The major function of the BUS ARBITER AND TRACE GENERATOR (BATGE) is the arbitration between multiple processors, multiple memories and memory mapped I/O with a minimum of interference.

Wait cycles for memory devices are programmable and active devices like the DARLIC circuit for example, generate a "not ready signal".

The BATGE circuit is also responsible for interconnecting all address, data and control busses of the DSP, SYSTEM BUS, TEXT AND TRACE GENERATOR, DARLIC and MAM.

The eight traces are generated by the TRACE GENERATOR in the BATGE circuit.

3.2.7.9 *Text Generator and Text Memory*

The SYSTEM ENGINE is responsible for the text data and the Text and Trace Generator takes care of generating the appropriate X, Y and Z information in vector notation for the vector oriented CRT.

Text and cursor information to be displayed on the CRT screen, is stored in a TEXT MEMORY which consists of one 8kx8 bit SRAM circuit.

3.2.7.10 *X- and Y- Output DAC, Dotjoin circuit and Intensity Control*

Digital signal and text data from the MAM display part, to be displayed on the CRT screen, is via the BATGE circuit applied to the digital to analog converters DAC X and DAC Y where it is converted into analog signals. They pass a DOTS/DOTJOIN circuit and are fed to the final X- and Y- amplifier stages in the analog oscilloscope section. A switch signal for switching between analog oscilloscope operation and digital oscilloscope operation is generated by the SWITCH CONTROL circuit and fed to the X- and Y- stage. The DOTJOIN circuit is controlled via the BATGE circuit and the SBUS.

All conditions under which the INTENSITY CONTROL has to blank and unblank the CRT beam, are combined in this circuit. Information comes partly via the SBUS and partly via the BATGE circuit. The final intensity signal is fed to the final Z- amplifier stage in the analog oscilloscope section. A switch signal for switching between the analog and the digital intensity signal is generated by the SWITCH CONTROL and fed to the Z-stage.

4 PARTS

4.1 UNITS

Item	Ordering code	Description
A1a	5322 214 91839	A1 Signal unit PM3370B
A1b	5322 214 91501	A1 Signal unit PM3380B
A1d	5322 214 90898	A1 Signal unit PM3384B
A1e	5322 214 91838	A1 Signal unit PM3390B
A1g	5322 214 90724	A1 Signal unit PM3394B
A2a	5322 216 04243	A2 XYZ amplifier unit 100 MHz
A2b	5322 216 04244	A2 XYZ amplifier unit 200 MHz
A3a	5322 216 51282	A3 Microprocessor unit digital
A3b	5322 216 51283	A3 Micro proc. unit digital + IEEE
A4	5322 214 90726	A4 Front PCB
A5	5322 214 90727	A5 CRT controls unit
A6	5322 216 04247	A6 Power supply unit digital.
A8a	5322 214 90894	A8 Digitizer 200 MHz Standard
A8b	5322 214 91029	A8 Digitizer 200 MHz Ext. Mem.
A8c	5322 214 91026	A8 Digitizer 60/100 MHz Standard
A8d	5322 214 91028	A8 Digitizer 60/100 MHz Ext. Mem.
A10	5322 214 90895	A10 Connector board
--	5322 218 61479	Extension unit for A3, A6 and A8

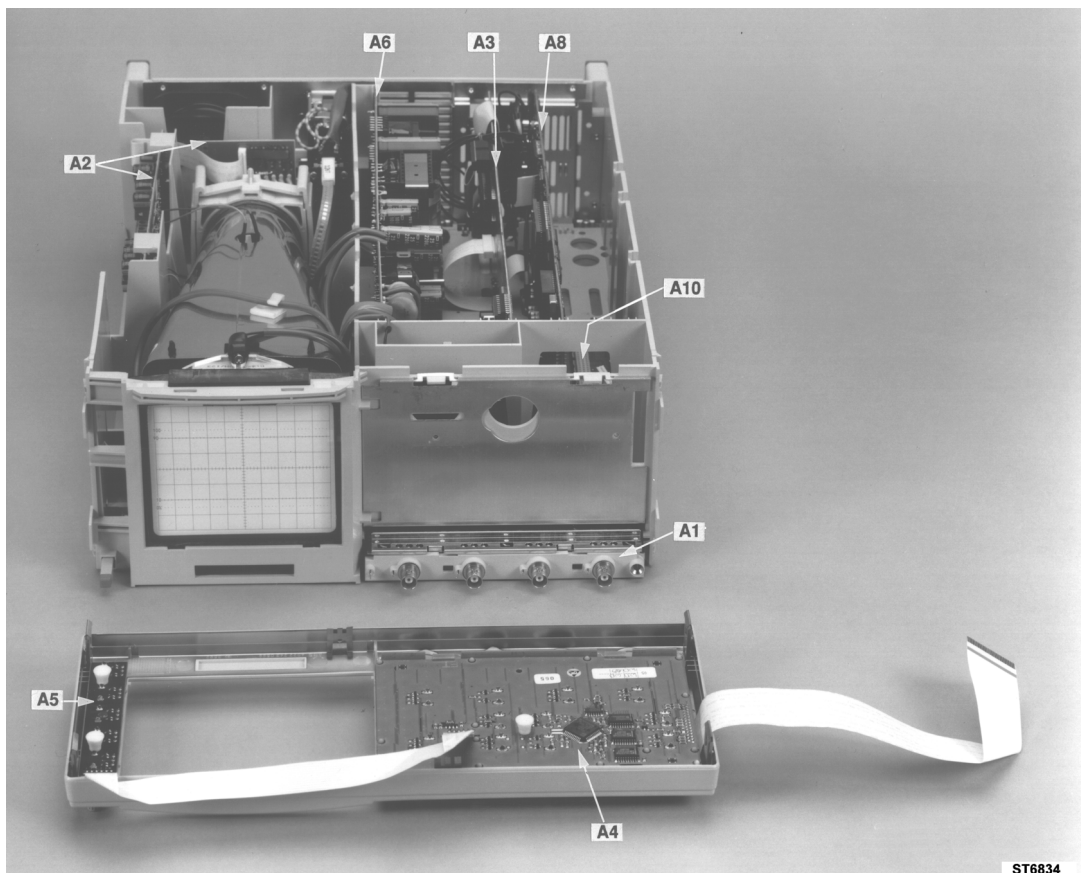

Figure 4.1 Unit Locations

4.2 INTERCONNECTION CABLES

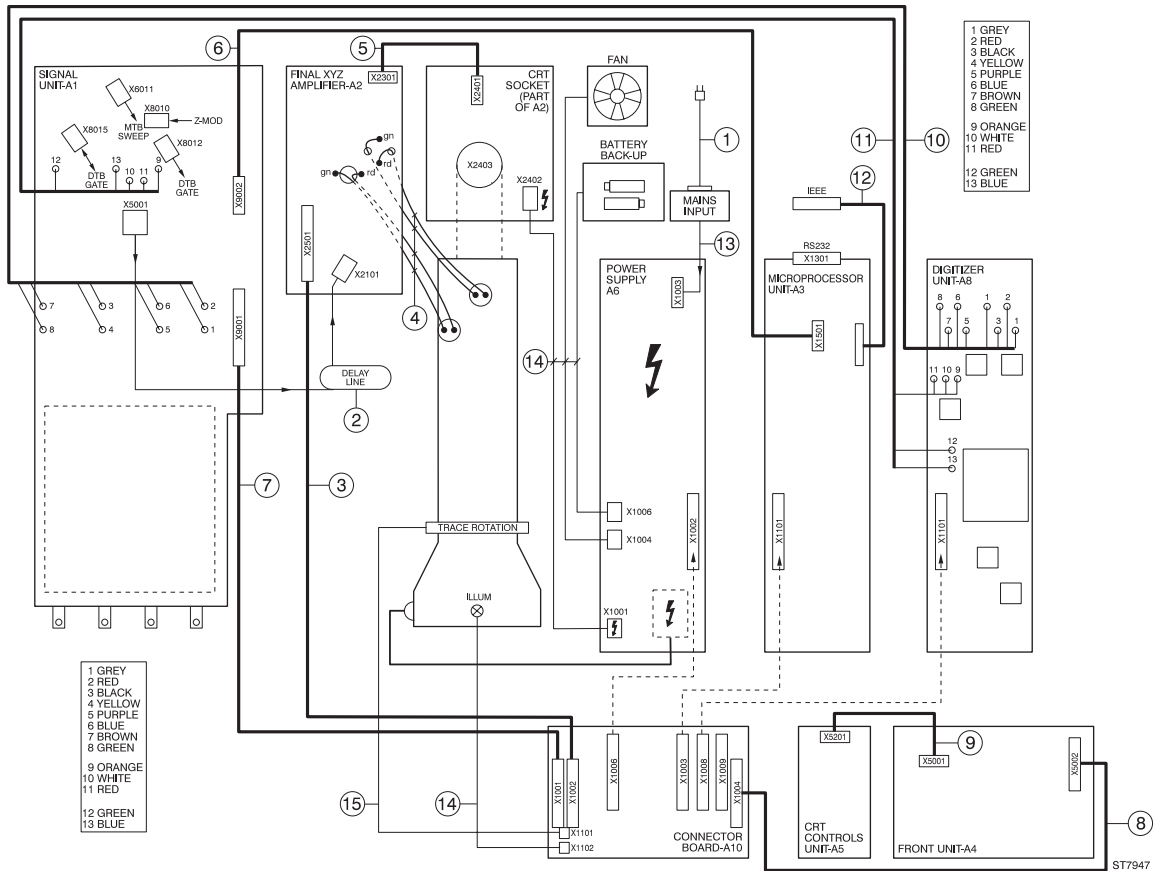

Figure 4.2 Units lay-out and Interconnections

Item	Ordering code	Description
1a	5322 321 21616	Line cord European type
1b	5322 321 10446	Line cord USA type
1c	5322 321 21617	Line cord British type
1d	5322 321 21618	Line cord Swiss type
1e	5322 321 30387	Line cord Australian type
1f	5322 321 30386	Line cord South Africa
2a	5322 320 40281	Delay line PM3370B/8xB
2b	5322 214 90732	Delay line PM339xB
3	5322 321 61284	Flat cable 50-pole 18 cm
4	5322 321 61291	Red wire to CRT, 105 mm (4/instr., can be adapted to otherlengths)
5	5322 321 61287	White flat cable 12-pole
6	5322 321 61286	White flat cable 16-pole
7	5322 321 61283	Flat cable 50-pole 10 cm
8	5322 321 61288	White flat cable 28-pole
9	5322 321 61289	White flat cable 12-pole
10	5322 320 50309	50Ω coax 8 x 60 cm
11	5322 320 50311	50Ω coax 2 x 60 cm + 3 x 47 cm
12	5322 320 50312	IEEE cable with connector
13a	5322 267 50452	Housing 5 pole (2 per cable)
13b	5322 268 24128	Contact pin (3 per cable)
14a	5322 268 40232	Housing 2 pole (1 per cable)
14b	5322 268 20176	Contact pin (2 per cable)
15a	5322 268 40233	Housing 3 pole (2 per cable)
15b	5322 268 20176	Contact pin (6 per cable)

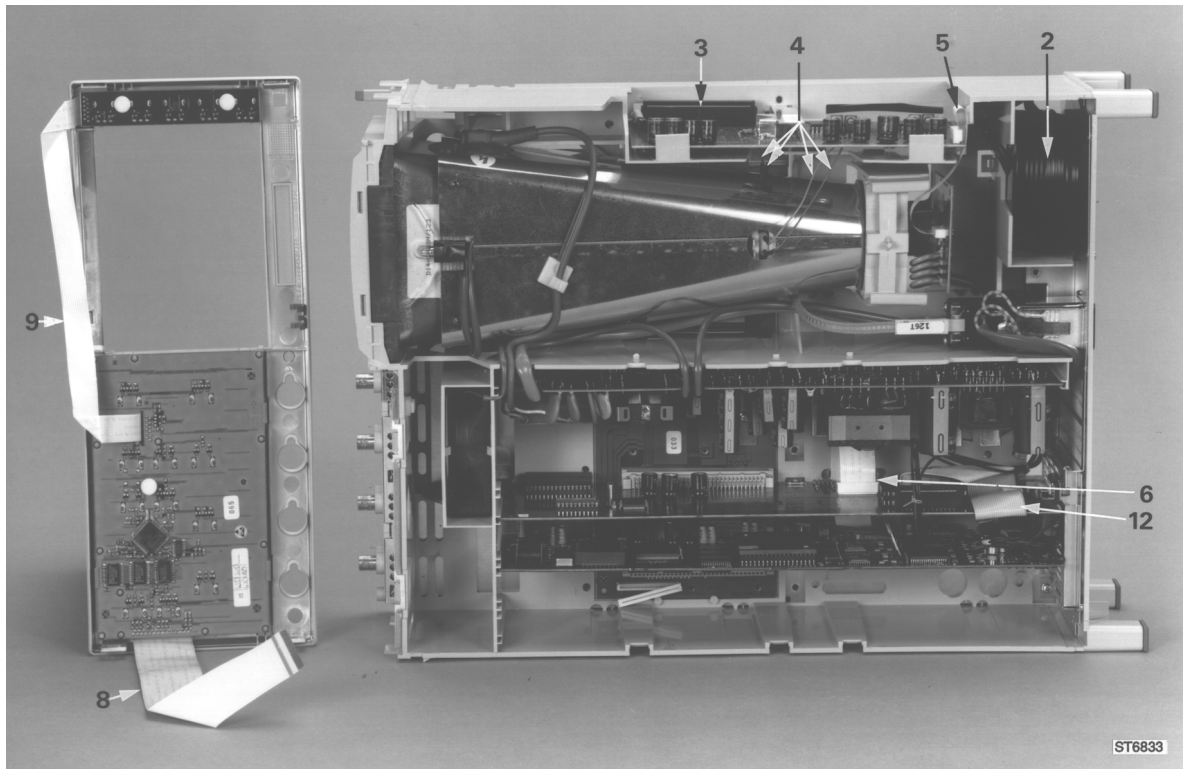

Figure 4.3 Cable locations, top side

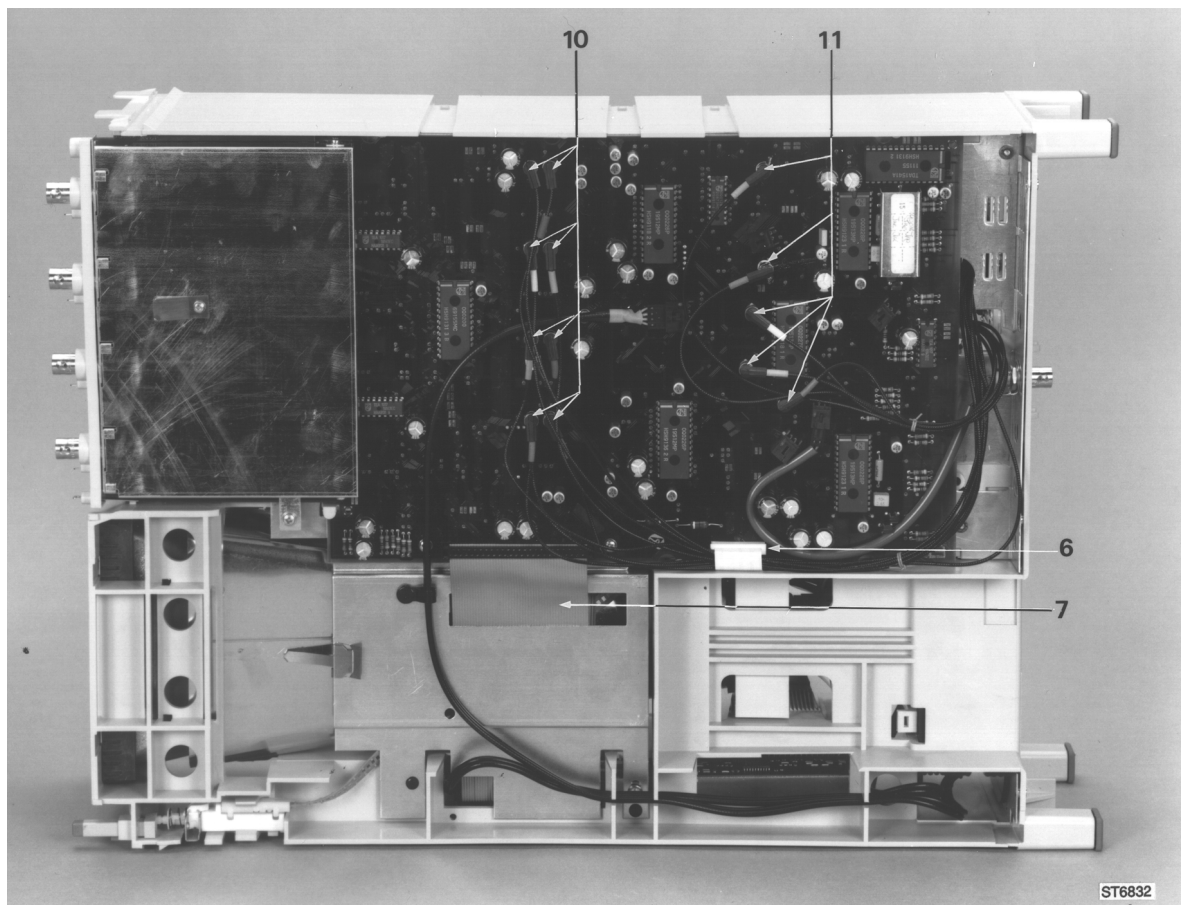
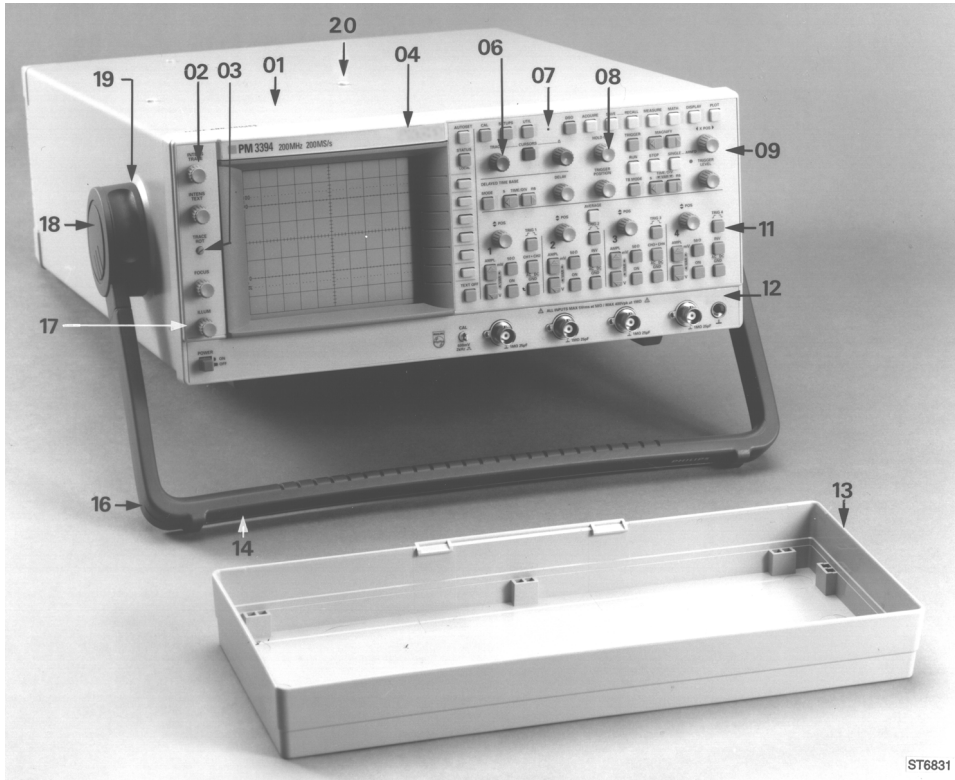

Figure 4.4 Cable locations, bottom side

4.3 MECHANICAL PARTS



ST6831

Figure 4.5 Mechanical parts, front and side panel

Item	Ordering code	Qty	Description
01	5322 447 91922	01	Cabinet
02	5322 414 20404	11	Light grey control knob
03	5322 535 93245	01	TRACE ROT shaft
04a	5322 454 13193	01	Textstrip bezel PM3394B
04c	5322 454 13192	01	Textstrip bezel PM3390B
04d	5322 454 13191	01	Textstrip bezel PM3384B
04f	5322 454 13189	01	Textstrip bezel PM3380B
04g	5322 454 13188	01	Textstrip bezel PM3370B
06	5322 414 20406	02	Dark grey control knob
07	5322 455 81144	01	CAL-SEAL sticker
08	5322 414 20405	02	Dark mushroom control knob
09a	5322 455 81191	01	Textplate (adhesive) PM33x4B
09c	5322 455 81206	01	Textplate (adhesive) PM33x0B
11a	5322 414 20482	01	Pushbutton mat PM33x4B
11c	5322 414 20497	01	Pushbutton mat PM33x0B
12a	5322 456 10025	01	Textstrip BNC's PM3394B
12b	5322 455 81211	01	Textstrip BNC's PM3390B
12c	5322 455 81178	01	Textstrip BNC's PM3384B
12d	5322 455 81207	01	Textstrip BNC's PM3380B/70B
13	5322 447 70121	01	Front cover
14	5322 455 81181	01	Textstrip handle Fluke
16	5322 498 50326	01	Handle complete
17	5322 455 81141	01	Textstrip CRT controls
18	5322 462 41848	02	Handle cover
19	5322 498 50268	02	Locking clip
20	5322 462 41695	04	Plug for pouch holes

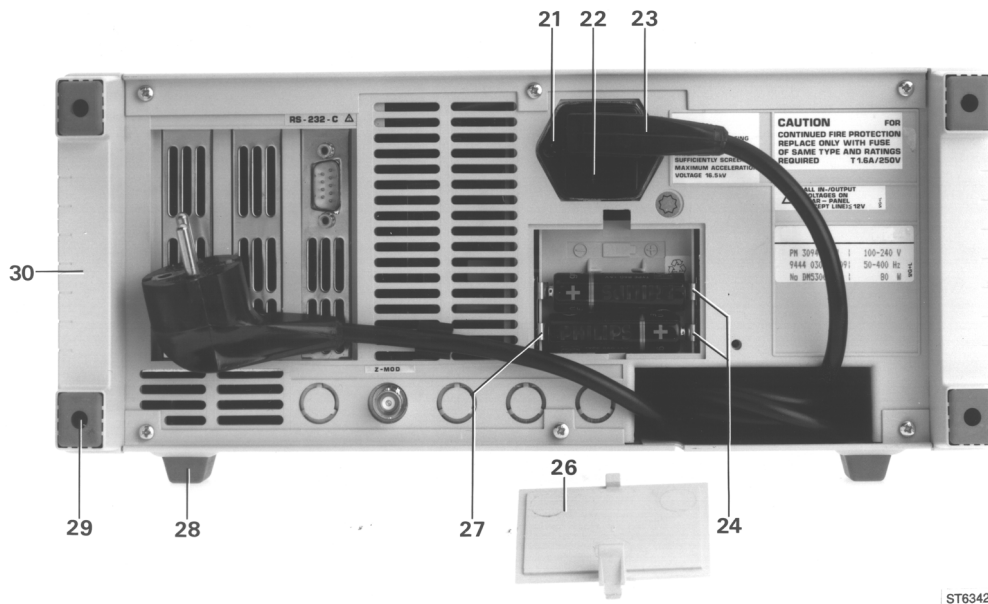

ST6342

Figure 4.6 Mechanical parts, rear panel

Item	Ordering code	Qty	Description
21	5322 219 82813	01	Mains input connector
22	4822 070 33152	01	Fuse 5x20 3,15 AT
23	see interconnections		Line cord
24	5322 492 70941	02	Contact spring single
25	see chapter 2.10.2	02	Batteries
26	5322 456 90426	01	Battery compartment cover
27	5322 492 70975	01	Contact spring dual
28	5322 462 41697	04	Bottom foot
29	5322 462 41846	04	Rear foot
30	5322 256 91793	02	Rear socle

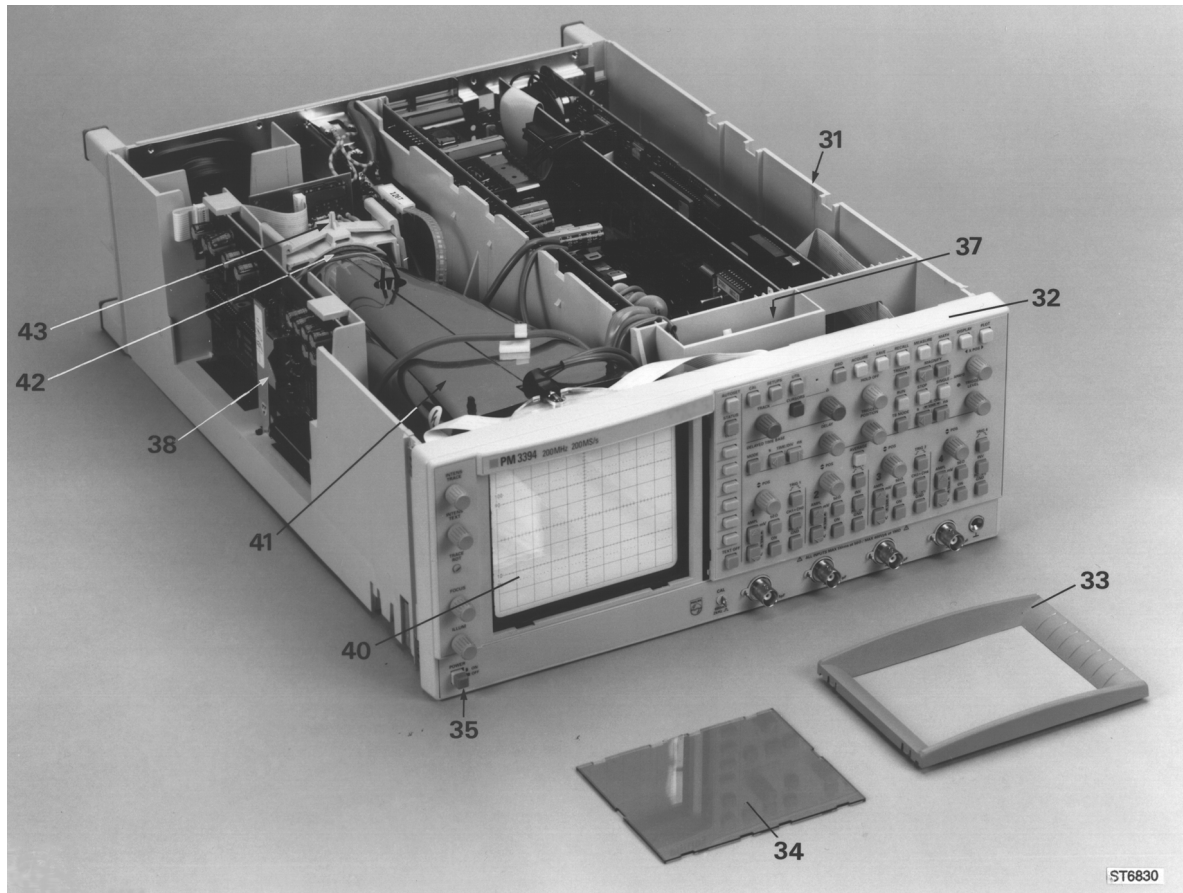

Figure 4.7 Mechanical parts inside instrument

Item	Ordering code	Qty	Description
31	5322 464 90708	01	Chassis complete
32	5322 447 91923	01	Front frame
33	5322 381 11276	01	Bezel
34	5322 480 30181	01	Blue contrast filter
35	5322 414 20568	01	Power on/off knob
37	5322 361 10614	01	Fan
38	5322 255 41227	01	Heatsink
40a	5322 131 11065	01	CRT D14-373GH/123 (V 0001) - PM3370B/8xB
40b	5322 131 11179	01	CRT D14-383GH/123 (V 0001) - PM339xB
41	5322 466 30493	01	CRT shielding
42	5322 466 30164	01	CRT manchet, rubber
43	5322 462 10263	01	CRT support, plastic

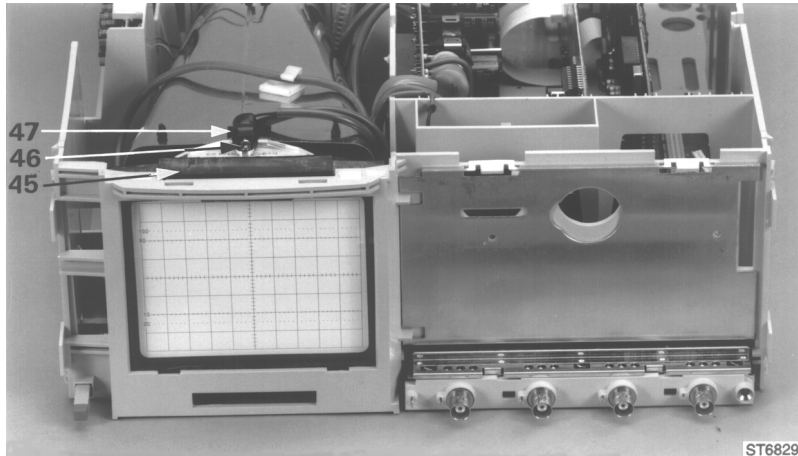

Figure 4.8 Mechanical parts behind front panel

Note: for items not listed refer to chapter 4.1.2 and 4.2.

Item	Ordering code	Qty	Description
45	5322 460 60404	01	CRT frontrubber
46	5322 462 40957	01	Light conductor
47	5322 134 41076	01	Lamp 28V 80mA (E 1001)
60	5322 492 71668	01	Earth contact @ top of front
61	5322 492 71669	01	Earth contact @ bottom of front
62	5322 492 70965	04	Earth contact @ side of front

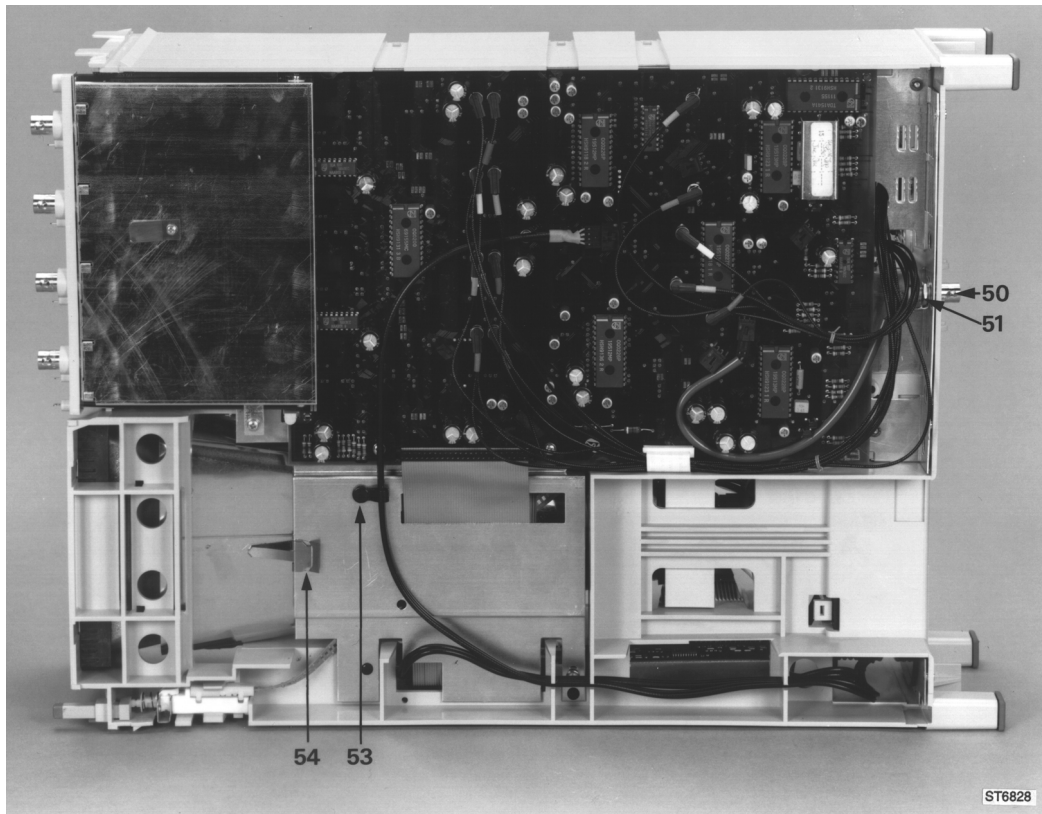

Figure 4.9 Mechanical parts, bottom view

Item	Ordering code	Qty	Description
50	5322 267 10004	01	BNC connector Z-mod
51	5322 290 34022	01	Solder tag for Z-mod
53	5322 401 10954	01	Clamp for delay line (plastic)
54	5322 290 61045	01	Earth contact CRT shielding

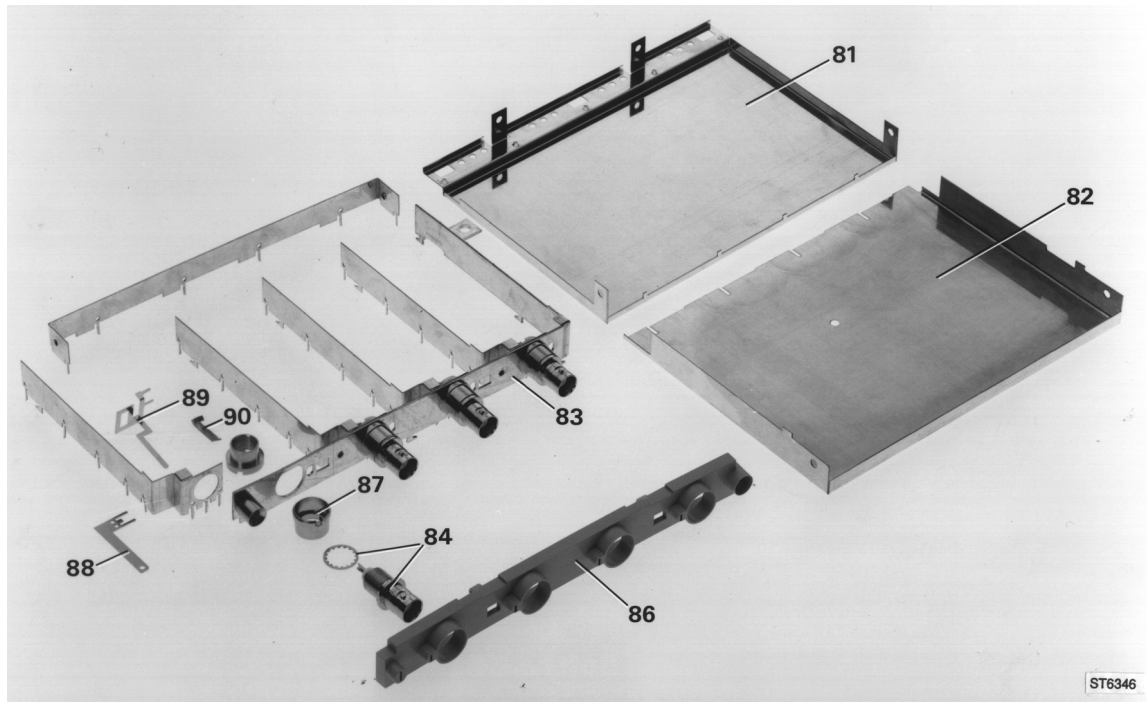

Figure 4.10 Mechanical parts, screening of input circuit

Item	Ordering code	Qty	Description
81	5322 466 30405	01	Top shielding
82	5322 466 30404	01	Bottom shielding
83	5322 256 91792	01	BNC holder
84	5322 267 10191	04	BNC coax connector
86	5322 462 41847	01	BNC insulator, plastic
87	5322 532 21188	04	BNC spacer
88	5322 535 93244	01	Probe calibration pin
89	5322 492 70939	04	Indication spring
90	5322 401 11419	04	Soldering bracket for BNC

5 UNIT DESCRIPTIONS

5.1 SIGNAL UNIT A1

5.1.1 Description A1

5.1.1.1 Introduction

With the exception of the final stages, unit A1 incorporates the vertical channels, the triggering, the time bases and the intensity (Z) control. The unit A1 description is split into the following chapters:

- Input attenuators and calibrator.
- Preamplifiers.
- Y-functions and delay line driver.
- Triggering.
- Main and delayed time base.

The complete signal unit is divided over 18 circuit diagrams. These diagrams and their main interconnections are listed in the table.

Diagram 11 includes the circuitry that controls the functions in the vertical channels.

Diagram 18 shows the connectors that make contact with other units in the oscilloscope via the connector board. These units are:

- The final amplifier unit A2: horizontal deflection signal and intensity control.
- The microprocessor unit A3: control signals and potentiometer functions.
- The power supply unit A6: supply voltages and line trigger signal.

Diagram	Description	Input signal coming from	Output signal going to	Control signal coming from
1,2,3,4	Attenuator ch.1,2,3,4	input 1,2,3,4	diagr.6,7	diagr.5,11
5	Attenuator control	diagr.1,2,3,4	diagr.1,2,3,4,18	diagr.11
6	Preamplifier ch.1,2	diagram 1,2	diagr.8	diagr.11,18
7	Preamplifier ch.3,4	diagram 3,4	diagr.8	diagr.11,18
8	Y-functions	diagram 6,7	diagr.9	diagr.10,11,18
9	Delay line driver	diagram 8	delay line	diagr.10,18
10	Display + trigg control	diagram 18	diagr.8,9	diagr.18
11	Control circuits	diagram 18	diagr. 1,2,3,4,5,6,7,8	diagr.18
12	MTB trigger	diagram 8	diagr.13,15	diagr.12,18
13	TV/line trigger	diagram 12,18	diagr.12,14	diagr.12,14
14	DTB trigger	diagram 8	diagr.15,17	diagr.14,18
15	Time base logic	diagram 12,14	diagr.16,17,18	diagr.15,18
16	Main time base	diagram 15	diagr.17	diagr.18
17	Delayed time base	diagram 15	diagr.18	diagr.18

5.1.1.2 Input attenuators and calibrator

Diagram 1, 2, 3, 4

The attenuators of channels 1, 2, 3 and 4 are identical, therefore only channel 1 is explained. Every attenuator basically consists of four sections. These sections are:

- The input circuit with 50Ω termination resistor and AC/DC input coupling circuit.
- The high impedance attenuator with divide by 1, divide by 10 and divide by 100 sections.
- The impedance converter. This is the active stage.
- The low impedance attenuator that can give an additional divide by 2.5.

The attenuator sections are switched by voltage pulse operated relays. This reduces power dissipation. Every relay has two change-over contacts. After a pulse the contacts stay in the selected position. One side of each relay coil is connected to the common potential AT12REP; the other side to a voltage that differs per relay.

Setting a relay in the position as drawn in the diagram (rest position) is achieved by a positive 10 ms pulse on common line AT12REP while the other control line stays at 0 V level. The other side of the relay coils that must not switch are applied to the already mentioned 10 ms positive pulse. Switching a relay to the position opposite to the one in the diagram (activated position) is achieved by a 10 ms positive pulse at the other side of the relay while AT12REP is kept at 0 V. This principle is demonstrated in figure 5.1 where the /1 relay is switched to the rest position and the /10 relay is activated.

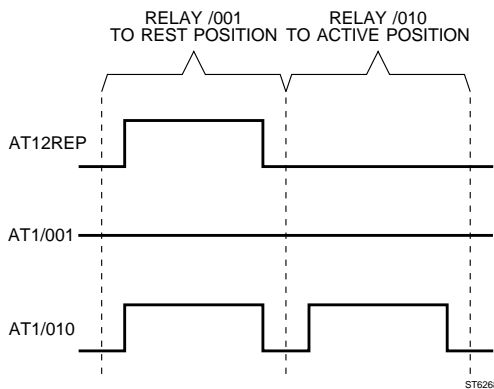

Figure 5.1 Switching pulses for relay

Input circuit

The 50Ω termination resistor is formed by the resistors R1006/R1007. It is switched by relay contact K1001. The NTC resistor R1011 is placed between R1006 and R1007 and measures the temperature of these resistors. This information is routed to the microprocessor on unit A3. If necessary the 50Ω position is switched off.

The DC blocking capacitor is C1001. In DC position the capacitor is not used and discharged via R1002. The signal path is via K1002.

High impedance attenuator

The divide by one section (/1) is switched via the relay contacts K1003. It switches the input signal through without further attenuation.

The divide by ten section (/10) is present between the relay contacts K1004. The /10 is accomplished by R1016, R1027, R1031 and R1032.

The divide by hundred section (/100) is present between the relay contacts K1006 and K1004/6,4. The /100 is accomplished by R1021 and R1023.

LF square wave calibration is achieved via the dual varicap diode V1002. Influence of the signal on the capacitance value is eliminated by two diodes with opposite polarization. The compensation factor and consequently the voltages AT1LFCOR1 and AT1LFCOR0 are depending on the selected attenuator position.

The signal ATCAL is applied to /33 attenuator R1008/R1009. ATCAL can supply several accurate voltages that are used for vertical calibrations.

Impedance converter

This active stage consists of three sections with different frequency ranges. The sections partly make use of the same components:

- The HF section for frequencies above 5 kHz. It is formed by C1021, FET V1006 and the two emitter followers V1008 and V1009. The FETs V1004 and V1005 are used for input protection. V1007 is a current source.
- The LF section for frequencies 30 Hz to 5 kHz. It is formed by operational amplifier N1001 (gain 2x) that receives the LF input signal via divide-by-two attenuator R1031/R1032. The capacitors C1023 and C1025 are frequency determining components in the N1001 feedback loop. The N1001 output signal is routed via R1034, V1006 and the emitter followers V1008 and V1009.
- The DC section for frequencies DC to 30 Hz. It is formed by operational amplifier N1001 (gain 2x) that receives the input signal via divide-by-two attenuator R1031/R1032. Via feedback resistor R1037 the voltage at the output of the impedance converter is compared with the input level via the + and inputs of N1001. This keeps the DC output value of the impedance converter exactly at the required value. This compensates for DC drift. Part of the feedback loop is V1001 that determines the low-frequency gain. The N1001 output signal is routed via R1034, V1006 and the emitter followers V1008 and V1009.

The low impedance attenuator is formed by R1072 and R1073. Switching is accomplished by V1012 and V1013. V1012 conducts in the /1 position and V1013 in the /2,5 position. The attenuator output signal is an unbalanced signal. The unbalanced output signal is applied to the succeeding stage via R1071 and via R1074.

Diagram 5

Probe indication circuit

There are four identical circuits of which the one for channel 1 is described. The resistor in the indication ring of the probe is present between X1002 and ground potential. The resistance value is measured by the microprocessor on unit A3.

The temperature of the 50Ω termination resistors on diagram 1 is measured by NTC resistor R1011. This resistor is placed in between the two termination resistors. If the temperature gets too high, the + input of N1101 becomes lower than the input. This makes output 13 of N1101 low and 0 volt is detected by the microprocessor via the probe indication line PROBE1. This is the sign for the microprocessor that the 50Ω resistor is too hot and it is switched off.

LF square wave calibration

This circuit produces the voltages for the varicap diodes V1002. The diodes require control voltages with opposite polarity. There are four identical circuits for the four vertical channels. The input signal AT1LFCAL is produced by a DAC and has the range 0 ... 10 volt. This is converted via the operational amplifiers N1102, N1103 into two signals that range from -5 ... -15 volt (AT1LFCOR0) and +5 ... +15 volt (AT1LFCOR1) respectively.

Amplitude Calibrator

This circuit consists of 8-position multiplexer D1152 and operational amplifier N1104. It can supply 8 accurate voltages of 10V, 5V, 2V, 1V, 500mV, 200mV and 0V. They are supplied to the vertical channels 1, 2, 3 and 4 for calibration voltages. The voltages are derived from a voltage divider with precision resistors R1192 through R1197. The divider is supplied with an accurate 10 V reference voltage. Under control of a three bit address ATCAL0 ... ATCAL2 one of the outputs of the voltage divider is selected via D1152. This signal is routed to the vertical channels via buffer N1104.

Loop gain calibration

The output voltage range of a digital-to-analog converter (DAC) is changed via resistor network R1112, R1113 and R1114. The output voltage is applied to V1001 that determines the low-frequency gain in the channel 1 attenuator.

Calibrator

This circuit is used for probe adjustment. It is built up around triple analog multiplexer D1151. The sections D1151/1,2,10,15 and D1151/3,4,5,9 form a 2 kHz oscillator. The third section D1151/11,12,13,14 switches in the 2 kHz rate of the oscillator. The oscillation principle is now explained with the simplified diagram in the figure.

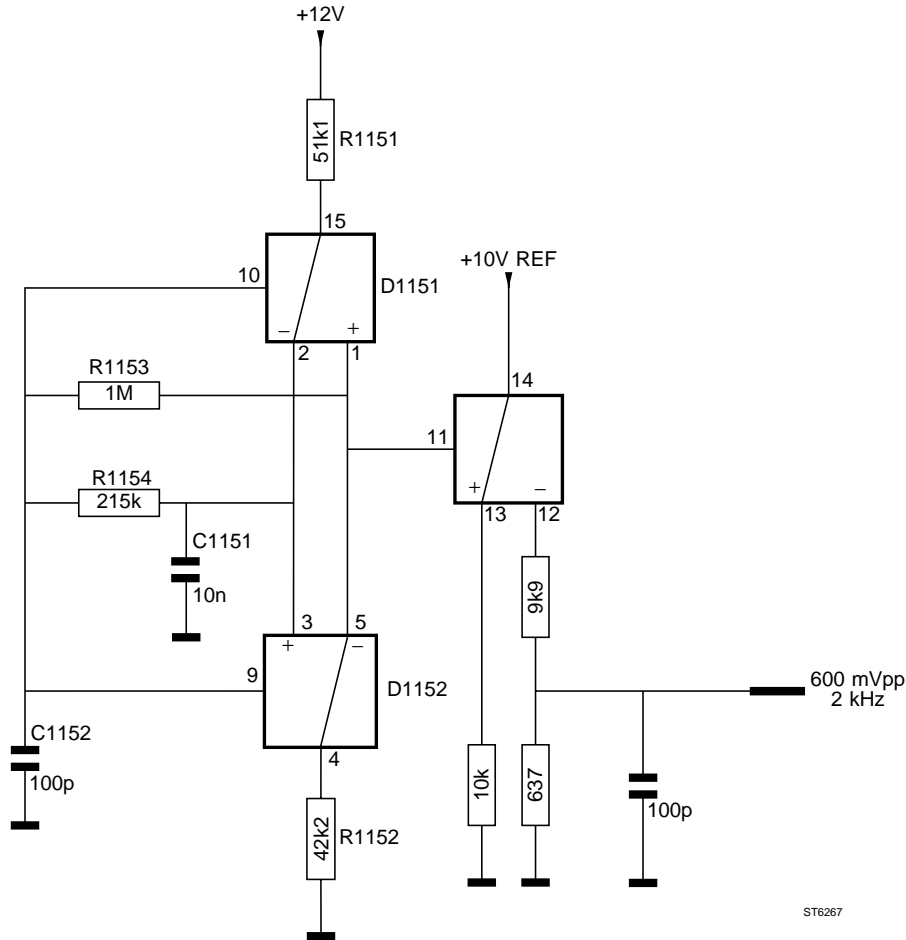

Figure 5.2 Simplified diagram of CAL generator

The start is in the situation as given in the figure. C1151 charges from +12V via R1151 and the switch contacts 15 and 2. After some time the voltage across C1151 reaches the digital "High" level and the switch contacts go to the opposite position. This causes C1151 to discharge to 0V via switch contacts 3 and 4 and R1152. Via switch contacts 15 and 1 and R1153 a gap is created between the switching moments. The charging/discharging process makes pin 11 high and low at a 2 kHz rate. This connects voltage divider R1156/R1157 and R1158, R1159 with + 10VREF or leaves it floating in the 2 kHz rate.

5.1.1.3 Preamplifiers

Diagram 6, 7

The preamplifiers for channel 1 and 2 and associated current sources are given in diagram 6. Diagram 7 gives this for channel 3 and 4. Channel 1, 2, 3 and 4 are identical, therefore only channel 1 is explained.

The output signals AT1OUT1 and AT1OUT0 from the channel 1 attenuator are applied to pin 3 and 5 of amplifier IC D1201. The balanced output signal of this IC is available at pin 18 and 19. This signal is routed to the Y-functions section via the level shifters V1201 and V1202.

The amplifier D1201 can be switched to a number of attenuation/gain positions that are dependent on the channel 1 AMPL position. The gain x1 position is determined by R1205/R1206/C1205 that are present across pin 6 and 7. The x1 is switched by control signal PA1X1.

The attenuation /2 is determined by R1207 and switched by PA1/2.

The gain x5 is determined by R1208/R1210/R1215/C1210 and switched by PA1X5. Continuous gain control is determined by DAC output signal VAR1 that is applied to pin 20. This signal comes from microprocessor unit A3. It is used for front panel gain control in fine steps and also for gain calibration.

The complete range of the channel 1 input sensitivities is controlled via front panel control AMPL. It is accomplished by the combination of input attenuator positions and the x1, /2, x5 and the VAR1 functions.

Offset control is achieved via the DAC output signal PA1OFFSET that is applied to the D1201 input pin 13. The DAC signal PA1OFFSTRG gives an offset signal in the current sources V1208 (PA1LSA) and V1209 (PA1LSB). PA1LSA and PA1LSB are applied to level shifters V1201/V1202. This is used to compensate for offset in the trigger path and also influences the offset in the vertical channel. This in turn is compensated via the POS1 signal in the Y-functions section.

The circuit in the bottom half of the diagram includes a number of current sources for the channel 1 and 2 preamplifiers. The reference for all these current sources is PAVREF that is present at N1251/pin 3. This is converted in a reference voltage at the collector of V1252 that is applied to the current sources. The currents for channel 1 are PA1ICL, PA1ISY, PA1LSA and PA1LSB. The currents for channel 2 are PA2ICL, PA2ISY, PA2LSA and PA2LSB. PA2LSA and PA2LSB are adjustable via DAC output signal PA2OFFSTRG.

5.1.1.4 *Y functions and delay line driver*

Diagram 8

This diagram shows the channel 1, 2, 3 and 4 function circuits D1301, D2301, D3301 and D4301. The balanced output signals of each circuit are available at pin 7 and 8. They are all applied to the resistance network R1313 through R4314 that is shown on the next diagram. The output of this network feeds the delay line driver.

The four function circuits are almost identical. Compared with channel 1 and 3, channels 2 and 4 have additional invert functions. For this reason, only the channel 2 circuit is explained. Here the balanced input signal is applied to pin 25 and 26 of D2301. The balanced output signal at pin 7 and 8 is switched by control signal CNT2CH-HX. The balanced output signals FNC2MTR0 and FNC2MTR1 that are available at pin 13 and 14 are used for triggering the main time base. This is switched via control signal CNT2MT-HT. The balanced output signals FNC2DTR0 and FNC2DTR1 that are available at pin 1 and 2 are used for triggering the delayed time base. This is switched via control signal CNT2DT-HT.

Channel 2 position control is achieved via an adjustable analog DAC voltage POS2 from the microprocessor unit A3. This voltage is applied to input 9 of operational amplifier N2202. This IC converts the DAC voltage POS2 (1 ... 4 V) into a voltage between -8 and +8 V. This voltage is converted into a current via resistor R2311, because pin 12 of D2301 is a virtual ground.

The balanced output signals FNCYOP0 and FNCYOP1 at pin 5 and 6 of D2301 of the channel 1 can be used to provide signals for the Y-out option. The (optional) Y-out circuit (present in channel 1 only) is located on an additional unit that is connected via the connectors X1303 through X1310. This is switched via control signal YOP-HX at pin 4. If no option installed, the signal is switched off by a low level supplied via R1312. If the option is present the switching is achieved by a signal coming from the additional unit.

The balanced output signals FNC1DPO0 and FNC1DPO1 at pin 9 and 10 can be used to provide signals for digital signal storage. The signals are routed via the coaxial sockets X1301 and X1302 to the sockets X8001 and X8002 on digitizer unit A8. This is present on all 4 channels. Biasing current for these outputs is provided via V1302, V1313 and R1307. The capacitor C1301 determines the cut-off frequency if the bandwidth limiter is active. The limiter is switched via signal FNCBWL.

The following table summarizes the functions and related pin numbers of the IC's used in the circuit diagram:

Output (pin)	On/Off (pin)	Invert (pin)	Bandw. Lim. (pin)	Pos (pin)
MTB Trig (13,14)	20	19	--	--
DTB Trig (1,2)	24	23	--	--
Y-out (5,6)	4	3	28	--
Digital out (9,10)	--	3	28	12
Chann. out (7,8)	11	3	28	12

Diagram 9

This diagram shows the delay line driver and associated circuitry. The delay line driver itself consists of the balanced amplifier branches V5003/V5006/V5008 and V5004/V5007/V5009. These amplifiers serve as a 9x amplifier and level shifter. V5011/V5012/V5013/V5014 clamp the input signal in order to reduce the output voltage swing applied to the delay line. The balanced input current (100 uA/div) signals from channel 1, 2, 3 and 4 are FNC1OUT0/FNC2OUT0/FNC3OUT0/FNC4OUT0 and FNC1OUT1/FNC2OUT1/FNC3OUT1/FNC4OUT1. The output voltage (45 mV/div when connected to the delay line, 90 mV/div when open) signals DLDOU0 and DLDOU1 supply the delay line. The resistors R5051 and R5052 give correct 50Ω termination impedance.

The Y-offset control part is supplied with the DAC output signal DLDOFFSET (delay line driver offset) that is used for instrument calibration. The DAC output signal TRASEP gives trace separation between main and delayed time base display in alternate time base mode. TRASEP is passed through via analog switch D5001/6,8,9 if control signal TRASEP-HC is high.

Operational amplifier N5001/5,6,7 makes a stable +4 V reference voltage.

Operational amplifier N5001/2,3,1 keeps DLDDCLEVEL0 and DLDDCLEVEL1 at equal level by influencing the level at DLDDCCORR.

Diagram 10

This diagram comprises the circuitry that controls the vertical channels 1, 2, 3 and 4 and the main (MTR) and delayed (DTR) trigger sources. The heart is formed by IC D9009. The IC is loaded with information about the control functions that must be executed. This happens via the input lines SCL (Serial CLock) and SDA (Serial DAta) that come from the microprocessor unit A3. At turn-on D9009 gets a reset at pin 17. This occurs via V5506 which is controlled by output D9004/11 on the next diagram.

The channels 1, 2, 3 and 4 are switched via the output pins 2, 3, 4 and 5 of D9009. The main time base trigger (MTR) source of channel 1, 2, 3 and 4 is switched via the control signals that are available at pin 2, 12, 1 and 13 of multiplexer D5501. This multiplexer is supplied with 3 lines that come from pin 25, 26 and 27 of D9009. The signal CNT2MTI-HT that is present at pin 11 of AND gate

D5503 gives the necessary inversion of the main trigger path if channel 2 is in the inverted mode. The signal CNT4MTI-HT that is present at pin 4 of AND gate D5503 gives inversion of the main trigger path if channel 4 is in the inverted mode.

The delayed time base trigger (DTR) source of channel 1, 2, 3 and 4 is switched via the control signals that are available at pin 2, 12, 1 and 13 of multiplexer D5502. This multiplexer is supplied with 3 lines that come from pin 22, 23 and 24 of D9009. The signal CNT2DTI-HT that is present at pin 10 of AND gate D5503 gives the necessary inversion of the delayed trigger path if channel 2 is in the inverted mode. The signal CNT4DTI-HT that is present at pin 3 of and-gate D5503 gives inversion of the main trigger path if channel 4 is in the inverted mode.

The input pin 9 ALTCLN of D9009 gives channel/trigger source switching in the alternate display mode. The circuit with V5503 converts the current input signal ALTCLK (ALternate CLock) from the time base logic into a voltage signal. The input pin 17 PUDML gives D9009 a preset when switching the oscilloscope on.

For the chopped display mode a chopper oscillator V5501/V5502 is present. It is switched on when control signal CHSW (CHopper SWitch) is high. The output signal of the oscillator is applied to pin 7 of D9009. The signal CHBLANK gives display blanking when switching between one channel to another.

The D9009 output signal TRASEP-HC activates the trace separation control in alternate time base mode. This signal is high if the delayed time base is active and low for the main time base. The output signal TBSEL controls the choice between main time base (high) and delayed time base (low) for horizontal deflection.

Diagram 11

This diagram includes the generation of control signals for the channel 1, 2, 3 and 4 attenuators, preamplifiers, Y-function and delay line driver circuits. The names of the control signals indicate exactly which circuit part is controlled:

- The signals starting with AT1, AT2, AT3 and AT4 control the ATtenuators of respectively channels 1, 2, 3 and 4. The attenuators and associated signal name lists are indicated in the description belonging to figures 1, 2, 3 and 4.
- The signals starting with PA1, PA2, PA3 and PA4 control the PreAmplifiers of respectively channels 1, 2, 3 and 4. The preamplifiers and associated signal name lists are indicated in the description belonging to figures 6 and 7.
- The signals starting with FNC1, FNC2, FNC3 and FNC4 control the Y- FuNction (channel and trigger source switching) of respectively channels 1, 2, 3 and 4. The Y-function blocks and associated signal name lists are indicated in the description for diagram 8.
- The signals starting with DLD control the Delay Line Driver. This circuit part and associated signal name list are indicated in the description for diagram 9.

A part of the control functions are simple on/off functions; e.g. the switching of a certain attenuator section. Other control functions consist of an adjustable DC voltage; e.g. the DC voltage that determines the gain of an amplifier section.

D9001 and D9002 have outputs that are able to drive the relays in the attenuator sections of channels 1, 2, 3 and 4. The IC's are controlled by the microprocessor on unit A3. This happens via the data signal SDA (Serial DAta) and the synchronization signal SCL (Serial CLock). The enable signals

DLEN0-HT (Data Latch ENable) and DLEN1-HT determine if D9001 or D9002 reacts on the SDA/SCL signals. The figure below indicates the relation between SDA and SCL.

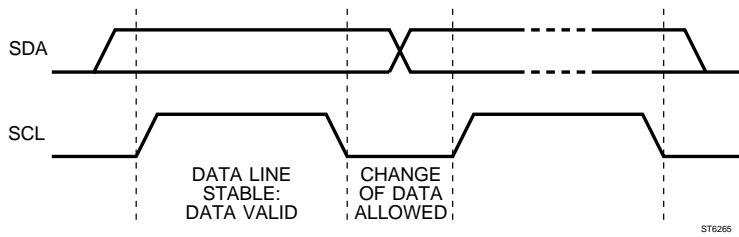

Figure 5.3 Relation of serial bus signals SDA and SCL

D9003 and D9004 have outputs that control a number of on/off functions in the preamplifier. The IC's are connected in cascade as a shift register. The IC's are controlled by the microprocessor on unit A3. This happens via the data signal SDA (Serial Data) and the synchronization signal SCL (Serial Clock). The enable signal STROBE0-HT in relation with SCL and SDA is indicated in the figure below. New data can be clocked into the shift register if STROBE0-HT is low. The new data becomes available at the outputs at the low-to-high transition of STROBE0-HT.

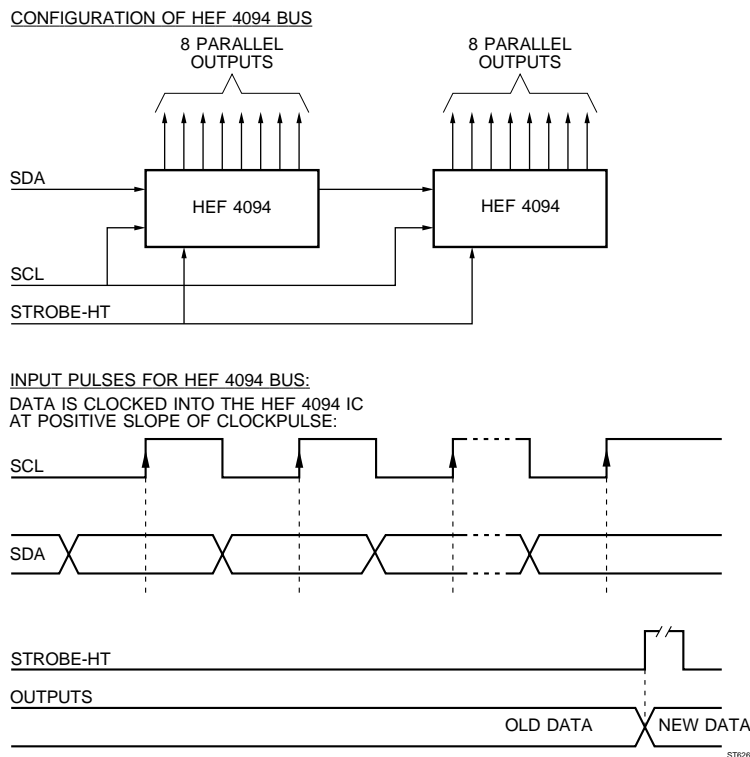

Figure 5.4 Configuration of serial control bus

N9001, N9002 and N9003 are octal digital-to-analog converters (DAC's). Each IC has 8 outputs capable of delivering a DC voltage that is adjustable between 0.5 and 9.5 V. This is controlled by the microprocessor on unit A3 via 6 bits of information that allow 64 adjustment steps. This happens via the data signal SDA (Serial Data) and the synchronization signal SCL (Serial Clock). The data bits are preceded by address bits that are compared with the fixed address A0/A1/A2 applied to pin 7, 8 and 9. This determines if N9001, N9002 or N9003 reacts on the bitstream.

Note: a solder pad is present in the SDA and SCL input lines of every IC. This gives the possibility to isolate a suspected IC from the other in case a fault is suspected.

5.1.1.5 *Main and delayed time base triggering*

Diagram 12

The main time base triggering (MTR) is mainly formed by IC D6541. The other IC D6621 is the peak-peak detector for the trigger level. The balanced input signal for triggering on vertical channels 1, 2, 3 or 4 is applied to pin 7 and 8. This signal can originate from one of the 4 vertical preamplifier sections where the source selection is also done. The dc biasing currents come from the circuit with V6506, V6507 and V6532. This circuit is also supplied with the line trigger sinewave signal MTRLINE that comes from the power supply. This signal can be used for mains/line triggering and is selected on the next diagram.

The output signal of D6541 is available at pin 19 and 20. This signal is routed to the main time base (MTB) via the level shifters V6573 and V6574. The signal MTRVIDEO from output pin 2 of D6541 is routed to the TV trigger circuit.

The IC D6541 incorporates the filters for HF reject (external capacitor C6549), LF reject (external capacitor C6551) and AC (external capacitors C6559, C6561, C6562). These filter modes are switched with the control signals MTRLF-HD (pin 3) and MTRHF-HD (pin 14). Positive/negative slope and video are switched with the control signals MTRSLOPE (pin 21) and MTRTVSEL-HD (pin 4). The logic levels of these control signals are indicated in two tables on the diagram. The signal MTRSEN is a DAC output voltage that determines the gain of the trigger amplifier.

A balanced current signal leaves D6541 at pins 26 and 27. This signal is converted into a voltage signal via V6604 and V6606. The voltage signal is applied to pins 3 and 7 of the peak-peak detector D6621. This IC detects the positive and negative peak values of the trigger signal. It reduces in the peak-peak trigger mode (switched with MTRPPLEV-HD) the range of the level (LEVMTB) to just within the peak-peak signal value.

The output of the peak-peak detector is present at pin 14 and 15 and routed to level input pin 22 and 23 of D6541, via the level shifter with V6667, V6668, V6686 and V6687. At this point a level offset correction is also introduced via DAC signal MTRBAL. The level is fixed in TV trigger mode by giving signal LEVMTB a predefined fixed level. The output pulse MTRTVSYNC from the TV synchronization separator circuit (see next diagram) is applied to the base of V6687. This signal is interrupted if the TV trigger mode is off.

The series parallel converter D9011 has outputs that control a number of on/off functions in the MTB triggering. D9011 is controlled by the microprocessor on unit A3. This happens via the data signal SDA (Serial DAta) and the synchronization signal SCL (Serial CLock). The enable signal is STROBE1-HT.

Diagram 13

This diagram shows the TV trigger circuit. The signal MTRVIDEO from pin 2 of MTR circuit D6541 is applied to the input of the TV CLAMP circuit V6754/V6757/V6759/V6763/V6768. The peak level of the synchronization pulses is detected via V6757 and C6758. The TV signal at the base of V6768 is kept at a constant level via V6759 and V6754. Diode V6761 cuts off the video information so that only synchronization pulses are applied to input pin 2 of N6771.

The TV synchronization separator N6771 is able to decode three different types of sync pulses. The analog control signal MTRTVMODE at pin 6 can have 3 different values that determine the TV standard in which the circuit will work. The standards and respective control voltages are indicated in a table.

N6771 separates the TV synchronization pulses. The following signals are available at its outputs:

- Pin 1 carries negative going line (MTRTVL) pulses. These pulses can be applied to the MTB trigger (MTR) section via multiplexer D6781. Via multiplexer D7711/3,4,5,9 they are applied to the delayed trigger (DTR) section.
- Pin 3 carries the negative going field pulses (MTRTVFR) that appear at the beginning of field 1 and field 2.
- Pin 7. The signal is high during field 1 and low during field 2. Field 1 and Field 2 together form one frame.

The set/reset flipflops D6779 make the field 1 (MTRTVFLD1) and field 2 (MTRTVFLD2) pulses. As input signals are used the output signals at pin 7 and 3 of N6771.

The multiplexers D6781 and D7771 select the TV and line trigger sources for MTR and DTR:

- The MTB TV trigger signal is MTRTVSYNC. It originates from D6781/14.
- The DTB TV trigger signal is DTRTVL. It originates from D7711/15.
- The signal VSYNC from D6781/4 is not used: it will be used for extensions such as digital signal storage.
- The MTB mains/line trigger signal is MTRLINE. It is switched via D5001/10,11,12.
- The DTB mains/line trigger signal is DTRLINE. It originates from D7711/13.
- Signal VSYNC carries the selected TV field 1 or TV field 2 pulse. This signal is used on the digitizer unit A8. It is routed via socket X6794 on unit A1 to X8505 on unit A8.

Diagram 14

This diagram shows the DTB trigger (DTR) circuits. This circuit is build up around D7541. It is a simplified replica of the main trigger circuit. This because of the fact that the DTR is not equipped with peak-peak trigger facility. The level signal LEVDTB is applied almost directly to pin 22 and 23 of D7541. The transistors V7686 and V7687 are used to convert an asymmetrical LEVDTB signal into a symmetrical signal. At this point the TV line synchronization pulses (DTRTVL) are applied to the delayed trigger section when required.

The XDEFLECT CIRCUIIT is used for X-DEFlection via the balanced X deflection signals DTRXDEF1 and DTRXDEF0 (pin 15 and 16 of D7541). The outputs of the circuit are TBXOUT1/TBXOUT0 and are applied to the time base section. It is there where the selection is done between X- deflection signal, MTB sawtooth and DTB sawtooth. Position control is achieved by signal DTRXPOS which is derived from LEVDTB via switch D7711/4,9,3. This switch is indicated on the preceding circuit diagram.

D9013 is used to determine the modification state of the unit A1. This is important in connection with the microprocessor hardware. The 8 outputs of D9013 are made high one by one after the oscilloscope is turned on. Via output diodes V7801 ... V7808 the high level is passed through. Depending on the modification state of the unit, one or more diodes are inserted into the p.c.b.. This gives the possibility to program 256 different modification levels.

5.1.1.6 Main and delayed time base and control logic

Diagram 15

This diagram incorporates the control logic for the main and delayed time base. This logic consists mainly of IC D8004. Also the input signal for the final Z-amplifier is generated on this diagram and occurs in D8003.

The selected trigger signals for the main time base are MTRIG0/MTRIG1 and are applied to pin 7 and pin 6 of D8004. This results via output pin 24 and V8013/V8014 into signal MTBGATE that starts the main time base (MTB). Signal STRCALM-HT is used to start the MTB via V8003. This occurs during autocalibration of the MTB.

The signal ALTCLK is derived here via V8018. This signal is used for display switching in ALternate display mode. This happens in D9009 in the section that controls the display and trigger sources.

The selected trigger signals for delayed time base (DTB) are DTRIG0/DTRIG1 and are applied to pin 9 and pin 8 of D8004. This results via output pin 18 and V8012/V8011 into signal DTBGATE that starts the DTB. Signal STRCALD-HT is used to start the DTB via V8007. This occurs during autocalibration of the DTB.

D8004 has inputs and outputs with the following functions:

- TBEOHO-LX goes low at the end of the hold-off period.
- TBAUTO-LD is low if auto free run mode is active.
- TBEOH-HX goes high at the end of the MTB sweep.
- TBSTD-LX goes low to start the DTB sweep.
- TBEOD-HX goes high at the end of the delayed sweep.

- TBNOTTR-HT goes high if the MTB is not triggered.
- TBSEL selects MTB if high and DTB if low.
- TBSSG-HT goes high at the end of a single sweep.
- DSOM (pin 2) goes high if a MTB trigger occurs. The connected circuit with V8023/8024 generates signal DSOMOUT that is routed via coax socket X8011 to socket X8503 on digitizer unit A8.
- DSOD (pin 14) goes high if a DTB trigger occurs. The connected circuit with V8029/V8031 generates signal DSODOUT that is routed via coax socket X8014 to socket X8501 on digitizer unit A8.
- DSODGATE from V8012/V8011 informs the digitizer on unit A8 that the analog delayed sweep is on. The signal is routed from coax socket X8013 to socket X8502.
- TVHOLD-LD is generated on the digitizer and can extend the hold off time of the main time base. This is used in TV trigger mode. The signal is routed from X8504 on unit A8 to X6010 on unit A1.
- TBHOTXT informs the digitizer A8 about the presence of the hold off period of the analog time base. The signal is routed to X8101/A12 on unit A8 via the connector board A10.

V8061/V8062/V8063/V8066 form the "V peak-peak circuit". It plays a role as the automatic positioning of the cursors on the top and bottom of the signal (Vpp mode). This function works via the DTB trigger circuit and is mainly software based. V8062/V8063 form a set-reset flipflop with inputs with hysteresis. The flipflop is set with the DSOD pulse that goes high at the moment that a DTB trigger pulse is detected. This is signalled to the microprocessor via V8066 which makes the TTL signal VPPTTEST-LD. The shape of the waveform is scanned by the microprocessor by monitoring the signal VPPTTEST-LD at different DTB trigger LEVEL positions. The flipflop is reset by the microprocessor via signal STRCALD-HT.

The balanced output signals ZTRA0 and ZTRA1 from pin 10 and 11 of D8003 are applied to the final Z-amplifier in order to control the intensity on the CRT screen. An important input signal is TBZB from D8004/19. This signal is high if the MTB sweep is on and during this time the light on the CRT is on. The intensified part during the time that the DTB sweep is on is switched on if signal TBZA is high. TBZA originates from D8004/20.

The signal CHBL that is applied to D8003/15 is influenced from the chopper blanking signal CHBLANK-HX and from the external Z-MODulation signal. The DAC output signals TBINTRAT-XA (pin 3) and INTTRA respectively influence the intensity ratio between MTB and DTB display and the total intensity on the CRT.

The signal TBXDEFL-LD (pin 6) switches the light continuously on if it is low. This happens in the X-DEFlection mode.

The circuit with V8002/V8006 is used for Z-MODulation via the BNC socket at the rear of the oscilloscope. The output signal of the circuit is TBZEXT and it is applied to D8003/16.

D9008 has outputs that control a number of on/off functions. The IC's of this type are connected in cascade as a shift register. The IC's are controlled by the microprocessor on unit A3. This happens via the data signal TBD01 (from the preceding D9011); the synchronization signal TBSCCL (Time Base Serial CLock). The enable signal is STROBE1-HT. New data can be clocked into the shift register if STROBE1-HT is low. The new data becomes available at the outputs at the low-to-high transition of STROBE1-HT.

N8005 is an octal digital-to-analog converter. The IC has 8 outputs that can deliver a DC voltage that is adjustable between 0.5 and 9.5 V. This is controlled by the microprocessor on unit A3 via 6 bits of information that allow 64 adjustment steps. This happens via the data signal SDA (Serial DAta) and the synchronization signal SCL (Serial CLock). The data bits are preceded by address bits that are compared with the fixed address A0/A1/A2 applied to pin 7, 8 and 9. This determines if N8005 or similar IC's in the instrument will react on the bitstream.

Note: a solder pad is present in the SDA and SCL input lines of each IC. This gives the possibility to isolate one IC from the others in case a fault is suspected.

Diagram 16

This diagram indicates the timing circuits for the MTB. The principle of the time base is that a capacitor is charged with a constant current. This gives a time-linear voltage across the capacitor; the so-called sawtooth or sweep signal. The timing capacitance consists of C6011 that is always in circuit and C6012, C6013 that are activated via the switching transistors V6016 and V6019. The MTB control is done in IC D6011.

The constant current is supplied via transistor V6003 and V6005. The current source consists of voltage divider R6002 through R6007 with precision resistors. The voltage across this divider can be influenced by DAC output voltage MTBVAR via N6007/5,6,7 and V6001. This is necessary for continuous time/div control (VAR) and calibration. The voltage on a tap of the voltage divider can be selected via multiplexer D6001. This voltage (MCSCONTROL) is applied to the base of V6003 and V6004. This occurs via operational amplifier N6006. Via multiplexer D6002 two different emitter resistance values can be selected for V6003 and another two for V6004. The resistance values differ by a factor of 10: the emitter resistance for V6003 is switchable between R6014 (time base magnifier x10) and R6013 (magnifier x1). The emitter resistance for V6004 is switchable between R6016 (time base magnifier x10) and R6015 (magnifier x1).

The current from V6004 is applied to pin 16 of D6011 and is used as a reference. The sawtooth that is generated across the timing capacitor(s) is applied to pin 18 of D6011. Inside this IC is the time base switching transistor. The start of the sawtooth is initiated by signal MTBGATE that is applied to pin 20 of D6011. The sawtooth is also applied to pin 17 and converted into a balanced output signal that is available pin 12 and 13. The MTB sweep pickoff circuit consists of Source follower V6013 (and matching V6014) and emitter follower V6012. Horizontal position control is achieved via DAC output signal TBXPOS at pin 14.

Input signal TBCALREF at D6011/28 and output signal MTBCALTST at D6011/24 provide autocalibration of the time base. The sweep is switched on via STRCALM-HT and MTBGATE and compared with reference voltage TBCALREF. Via switching of output signal MTBCALTST, the microprocessor knows if the current source delivers the correct current. In case of inaccuracies the microprocessor makes corrections.

The start of the DTB is initiated by a low level of signal TBSTD-LX at pin 1 of D6011. The signal is generated via comparison of the MTB sawtooth signal and the adjustable DC voltage DTBM (delay time multiplier). The DTBM signal is coming from DAC output N6014/6 via operational amplifier N6008/5,6,7.

The signal TBEOM-HX at pin 4 of D6011 becomes high at the end of the MTB sweep. The signal TBEHO-LX at pin 5 of D6011 becomes low at the end of the hold off period. The length of the hold off period is determined by the DAC output voltage HOLDOFF that is applied to D6011/7.

The MTB is switched on by making MTBONOFF (D6011/11) high. This signal is derived from control signal TBSEL. TBSEL is high during X deflection by the MTB and low during DTB. The MTB is also off in external X- deflection mode.

V6006 is on during the fast time base positions. It activates a stabilizing circuit that is connected with D6011/21.

The circuit with V6042 and C6033 assures that the hold off time in the fastest time base positions will never become shorter than 3 μ s. The circuit with C6035, V6002, C6017, V6008 and C6415 is responsible for the hold off timing. C6035 is always in circuit and C6017 and C6415 are activated by switching transistors. The capacitors are charged in parallel with the MTB timing capacitors. During the hold-off time that follows they are discharged by a current source inside D6011. The hold-off time can be varied by varying the discharging current.

The table shows the active main time base sections as a function of time/div setting:

main time base									
Time	Current source				Charge	Timing caps		Hold off caps	
/div	MTBI2	.I1	.I0	.I10	Current V6005/c	C6012 MTBC2	C6013 MTBC3	C6415 HONAN	C6017 HOMU
0.5s	L	L	L	L	8uA	L	H	H	H
0.2s	L	L	H	L	18uA	L	H	H	H
0.1s	L	H	L	L	35uA	L	H	H	H
50ms	L	L	L	H	70uA	L	H	H	H
20ms	L	L	H	H	175uA	L	H	H	H
10ms	L	H	L	H	350uA	L	H	H	L
5ms	L	H	H	H	700uA	L	H	H	L
2ms	H	L	L	H	1.75mA	L	H	H	L
1ms	H	L	H	H	3.5mA	L	H	H	L
.5ms	L	L	L	L	8uA	H	L	H	L
.2ms	L	L	H	L	18uA	H	L	H	L
.1ms	L	H	L	L	35uA	H	L	L	L
50us	L	L	L	H	70uA	H	L	L	L
20us	L	L	H	H	175uA	H	L	L	L
10us	L	H	L	H	350uA	H	L	L	L
5us	L	H	H	H	700uA	H	L	L	L
2us	H	L	L	H	1.75mA	H	L	L	L
1us	H	L	H	H	3.5mA	H	L	L	L
.5us	L	L	L	H	70uA	L	L	L	L
.2us	L	L	H	H	175uA	L	L	L	L
.1us	L	H	L	H	350uA	L	L	L	L
50ns	L	H	H	H	700uA	L	L	L	L
20ns	H	L	L	H	1.75mA	L	L	L	L

Diagram 17

This diagram indicates the timing circuits for the DTB. It is basically identical to the diagram of the MTB. For a description refer to the explanation of the corresponding circuit parts in diagram 16. The additional parts in this diagram are explained below.

The point where the input signals for the final X amplifier are applied is present on this diagram. This point is formed by the emitters of V7031 and V7032. The balanced signals that are applied are the combined MTB and DTB outputs TBXOUT0/TBXOUT1 and the external X-DEFlection signals TBXOUT0-XA/TBXOUT1-XA.

The circuit with N7016 makes an accurate voltage +15TBREF for the MTB and DTB timing circuits. Also the TBCALREF voltage for time base calibration is made here. As a reference for this circuit the +10VREF is used.

The circuit with D7005 converts the 5 digital 0V/5V signals into one analog signal with 32 possible levels. This signal can be read by an analog input of the microprocessor.

The circuit with multiplexer D7004 selects accurate voltages that come from a divider network with precision resistors R7064 through R7067. Operational amplifier N7014/2,3,6 is supplied with these voltages in order to calibrate the X-path from the MTB. Operational amplifier N7015/2,3,6 does the same for DTB. Voltage DSW (present at the DTB output) is made equal to the selected voltage from the voltage divider R7064 through R7067. This occurs via feedback signal DCLOOP. This gives a defined input voltage for the X-path (including the D7011

output stage). The output voltage XCAL at the horizontal deflection plates of the CRT is measured and horizontal calibrations are performed. During normal oscilloscope functioning the multiplexer connects pin 3 + 4 and pin 13 + 11. This switches V7093 and V7094 on and the feedback paths for MTB and DTB are interrupted.

The table shows the active delayed time base sections as a function of time/div setting:

delayed time base						
Time	Current source				Charge	Timing capacitor
/div	DTBI2	.11	.10	.110	Current V7005/c	C7012 DTBC2
.5ms	L	L	L	L	8uA	H
.2ms	L	L	H	L	18uA	H
.1ms	L	H	L	L	35uA	H
50us	L	L	L	H	70uA	H
20us	L	L	H	H	175uA	H
10us	L	H	L	H	350uA	H
5us	L	H	H	H	700uA	H
2us	H	L	L	H	1.75mA	H
1us	H	L	H	H	3.5mA	H
.5us	L	L	L	H	70uA	L
.2us	L	L	H	H	175uA	L
.1us	L	H	L	H	350uA	L
50ns	L	H	H	H	700uA	L
20ns	H	L	L	H	1.75mA	L

5.1.2 Signal name list

Note: In the signal name list you find the itemnumber of the component that is source or destination. Behind this itemnumber (separated by ":") you find the number of the diagram where the source/destination can be found.

NAME	MEANING	SOURCE	DESTINATION
ALTCLK	ALTERNATE DISPLAY MODE CLOCK	V8018:15	V5503:10
ATCAL	SIGNAL FOR GAIN CALIBRATION	N1104:05	R1008:01 R2008:02 R3008:03 R4008:04
AT1AC/DC	AC/DC INPUT COUPLING SELECTION CH1	D9001:11	K1002:01
AT1LFCAL	LF CORRECTION CONTROL SIGNAL CH1	N9001:11	R1102:05
AT1LFCOR0	LF CORRECTION 0 CH1	N1102:05	R1029:01
AT1LFCOR1	LF CORRECTION 1 CH1	N1103:05	R1028:01
AT1LOOPCAL	LF GAIN CONTROL CH1	N9001:11	R1113:05
AT1LOOPCOR	LF GAIN CONTROL IN FEEDBACK LOOP CH1	R1113:05	V1001:01
AT1OFFSET	OFFSET CONTROL SIGNAL CH1	N9001:11	R1039:01
AT1OUT0	ATTENUATOR 1 OUTPUT 0 CH1	R1074:01	D1201:06
AT1OUT1	ATTENUATOR 1 OUTPUT 1 CH1	V1013:01	D1201:06
AT1PROBE	PROBE DETECTION SIGNAL CH1	X1002:01	R1096:05
AT1PROT	50Ω PROTECTION CH1	R1011:01	N1101:05
AT1.50E	50Ω INPUT IMPEDANCE SELECTION CH1	D9001:11	K1001:01

AT1/001	/1 ATTENUATOR SELECTION CH1	D9001:11	K1003:01
AT1/010	/10 ATTENUATOR SELECTION CH1	D9001:11	K1004:01
AT1/100	/100 ATTENUATOR SELECTION CH1	D9001:11	K1006:01
AT1/2.5	/2.5 ATTENUATOR SELECTION CH1	D9001:11	V1017:01
AT12REP	COMMON FOR ALL RELAIS CH 1, 2	D9001:11	K1001:01 K1006:01 K2001:01 K2006:02
AT2AC/DC	AC/DC INPUT COUPLING SELECTION CH2	D9001:11	K2002:02
AT2LFCAL	LF CORRECTION CONTROL SIGNAL CH2	N9001:11	R2102:05
AT2LFCOR0	LF CORRECTION 0 CH2	N1102:05	R2029:02
AT2LFCOR1	LF CORRECTION 1 CH2	N1103:05	R2028:02
AT2LOOPCAL	LF GAIN CONTROL CH2	N9001:11	R2113:05
AT2LOOPCOR	LF GAIN CONTROL IN FEEDBACK LOOP CH2	R2113:05	V2001:02
AT2OFFSET	OFFSET CONTROL SIGNAL CH2	N9002:11	R2039:02
AT2OUT0	ATTENUATOR 2 OUTPUT 0 CH2	R2074:02	D2201:06
AT2OUT1	ATTENUATOR 2 OUTPUT 1 CH2	V2113:02	D2201:06
AT2PROBE	PROBE DETECTION SIGNAL CH2	X2002:02	R2096:05
AT2PROT	50Ω PROTECTION CH2	R2011:02	N1101:05
AT2.50E	50Ω INPUT IMPEDANCE SELECTION CH2	D9001:11	K2001:02
AT2/001	/1 ATTENUATOR SELECTION CH2	D9001:11	K2003:02
AT2/010	/10 ATTENUATOR SELECTION CH2	D9001:11	K2004:02
AT2/100	/100 ATTENUATOR SELECTION CH2	D9001:11	K2006:02
AT2/2.5	/2.5 ATTENUATOR SELECTION CH2	D9001:11	V2017:02
AT3AC/DC	AC/DC INPUT COUPLING SELECTION CH3	D9002:11	K3002:03
AT3LFCAL	LF CORRECTION CONTROL SIGNAL CH3	N9003:11	R3102:05
AT3LFCOR0	LF CORRECTION 0 CH3	N3102:05	R3029:03
AT3LFCOR1	LF CORRECTION 1 CH3	N3103:05	R3028:03
AT3LOOPCAL	LF GAIN CONTROL CH3	N9003:11	R3113:05
AT3LOOPCOR	LF GAIN CONTROL IN FEEDBACK LOOP CH3	R3113:05	V3001:03
AT3OFFSET	OFFSET CONTROL SIGNAL CH3	N9002:11	R3039:03
AT3OUT0	ATTENUATOR 3 OUTPUT 0 CH3	R3074:03	D3201:07
AT3OUT1	ATTENUATOR 3 OUTPUT 1 CH3	V3013:03	D3201:07
AT3PROBE	PROBE DETECTION SIGNAL CH3	X3002:03	R3096:05
AT3PROT	50Ω PROTECTION CH3	R3011:03	N1101:05
AT3.50E	50Ω INPUT IMPEDANCE SELECTION CH3	D9002:11	K3001:03
AT3/001	/1 ATTENUATOR SELECTION CH3	D9002:11	K3003:03
AT3/010	/10 ATTENUATOR SELECTION CH3	D9002:11	K3004:03
AT3/100	/100 ATTENUATOR SELECTION CH3	D9002:11	K3006:03
AT3/2.5	/2.5 ATTENUATOR SELECTION CH3	D9002:11	V3016:03
AT34REP	COMMON FOR ALL RELAIS CH 3, 4	D9002:11	K3001:03 K3006:03 K4001:03 K4006:04
AT4AC/DC	AC/DC INPUT COUPLING SELECTION CH4	D9002:11	K4002:04
AT4LFCAL	LF CORRECTION CONTROL SIGNAL CH4	N9003:11	R4102:05
AT4LFCOR0	LF CORRECTION 0 CH4	N3102:05	R4029:04
AT4LFCOR1	LF CORRECTION 1 CH4	N3103:05	R4028:04
AT4LOOPCAL	LF GAIN CONTROL CH4	N9003:11	R4113:05
AT4LOOPCOR	LF GAIN CONTROL IN FEEDBACK LOOP CH4	R4113:05	V4001:04
AT4OFFSET	OFFSET CONTROL SIGNAL CH4	N9003:11	R4039:04
AT4OUT0	ATTENUATOR 4 OUTPUT 0 CH4	R4074:04	D4201:07
AT4OUT1	ATTENUATOR 4 OUTPUT 1 CH4	R4013:04	D4201:07

AT4PROBE	PROBE DETECTION SIGNAL CH4	X4002:04	R4096:05
AT4PROT	50Ω PROTECTION CH4	R4011:04	N1101:05
AT4.50E	50Ω INPUT IMPEDANCE SELECTION CH4	D9002:11	K4001:04
AT4/001	/1 ATTENUATOR SELECTION CH4	D9002:11	K4003:04
AT4/010	/10 ATTENUATOR SELECTION CH4	D9002:11	K4004:04
AT4/100	/100 ATTENUATOR SELECTION CH4	D9002:11	K4006:04
AT4/2.5	/2.5 ATTENUATOR SELECTION CH4	D9002:11	V4017:04
CNT1CH-HX	CHANNEL 1 ON/OFF SIGNAL	R5559:10	D1301:08
CNT1DT-HT	DTB TRIGGER ON CH1 ON/OFF	D5502:10	D1301:08
CNT1MT-HT	MTB TRIGGER ON CH1 ON/OFF	D5501:10	D1301:08
CNT2CH-HX	CHANNEL 2 ON/OFF SIGNAL	R5558:10	D2301:08
CNT2DT-HT	DTB TRIGGER ON CH2 ON/OFF	D5502:10	D2301:08
CNT2MT-HT	MTB TRIGGER ON CH2 ON/OFF	D5501:10	D2301:08
CNT3CH-HX	CHANNEL 3 ON/OFF SIGNAL	R5557:10	D3301:08
CNT3DT-HT	DTB TRIGGER ON CH3 ON/OFF	D5502:10	D3301:08
CNT3MT-HT	MTB TRIGGER ON CH3 ON/OFF	D5501:10	D3301:08
CNT4CH-HX	CHANNEL 4 ON/OFF SIGNAL	R5556:10	D4301:08
CNT4DT-HT	DTB TRIGGER ON CH4 ON/OFF	D5502:10	D4301:08
CNT4MT-HT	MTB TRIGGER ON CH4 ON/OFF	D5501:10	D4301:08
CPBLANK-HX	CHOPPER BLANKING SIGNAL	R5517:10	C8002:15
DLDOFFSET	DELAY LINE DRIVER OFFSET	N9003:11	R5018:09
DLDOU0	DELAY LINE DRIVER OUTPUT 0	R5063:09	DELAY LINE
DLDOU1	DELAY LINE DRIVER OUTPUT 1	R5062:09	DELAY LINE
DLEN0-HT	DATA LATCH ENABLE 0	X9001:18	D9001:11
DLEN1-HT	DATA LATCH ENABLE 1	X9001:18	D9002:11
DLEN2-HT	DATA LATCH ENABLE 2	X9001:18	D9006:16
DSOD	SET OF FLIPFLOP AUTOPOS Y-CURSOR	D8004:15	R8057:15
DTBCALTST	DTB CAL TEST SIGNAL	D7011:17	D7005:17
DTBVAR	DTB VARIABLE CONTROL SIGNAL	N8005:15	R7009:17
DTBGATE	DTB GATE SIGNAL	V8011:15	D7011:17
DTRHF-HD	DELAYED TRIGGER HF FILTER SWITCH	D9012:14	R7544:14
DTRIG0	DELAYED TRIGGER OUTPUT SIGNAL 0	V7574:14	D8004:15
DTRIG1	DELAYED TRIGGER OUTPUT SIGNAL 1	V7573:14	D8004:15
DTRLF-HD	DELAYED TRIGGER LF FILTER SWITCH	D9007:17	R7542:14
DTRLNE	X-DEFLECTION VIA LINE SIGNAL	D7711:13	V7506:14
DTRLINESW-HD	X-DEFLECTION VIA LINE SWITCHING	D9012:14	D7711:13
DTRSEN	DELAYED TRIGGER SENSITIVITY CONTROL	N8005:15	R7554:14
DTRSLOPE	DELAYED TRIGGER SLOPE CONTROL	D9007:17	R7547:14
DTRTVL	DELAYED TRIGGER TV LINE TRIG SIGNAL	D7711:13	R7696:14
DTRTVSEL-HD	DELAYED TV TRIGGER SELECTION	R7543:14	D7711:13
DTRXDEF0	DELAYED TRIGGER X DEFLECTION SIGNAL 0	D7541:14	R7754:14
DTRXDEF1	DELAYED TRIGGER X DEFLECTION SIGNAL 1	D7541:14	R7753:14
DTRXDSEL-HD	DELAYED TRIGGER X DEFLECTION SELECTION	D9012:14	R7546:14
FNCBWL	BANDWIDTH LIMITER ON/OFF	D9003:11	D1301:08 D2301:08 D3301:08 D4301:08
FNC1DTR0	DTB TRIGGER ON CH1 OUTPUT SIGNAL 0	D1301:08	R7522:14
FNC1DTR1	DTB TRIGGER ON CH1 OUTPUT SIGNAL 1	D1301:08	R7521:14
FNC1MTR0	MTB TRIGGER ON CH1 OUTPUT SIGNAL 0	D1301:08	R6522:12
FNC1MTR1	MTR TRIGGER ON CH1 OUTPUT SIGNAL 1	D1301:08	R6521:12
FNC1OUT0	CHANNEL 1 OUTPUT SIGNAL 0	D1301:08	R1313:09
FNC1OUT1	CHANNEL 1 OUTPUT SIGNAL 1	D1301:08	R1314:09

FNC2DTR0	DTB TRIGGER ON CH2 OUTPUT SIGNAL 0	D2301:08	R7524:14
FNC2DTR1	DTB TRIGGER ON CH2 OUTPUT SIGNAL 1	D2301:08	R7523:14
FNC2MTR0	MTB TRIGGER ON CH2 OUTPUT SIGNAL 0	D2301:08	R6524:12
FNC2MTR1	MTR TRIGGER ON CH2 OUTPUT SIGNAL 1	D2301:08	R6523:12
FNC2OUT0	CHANNEL 2 OUTPUT SIGNAL 0	D2301:08	R2313:09
FNC2OUT1	CHANNEL 2 OUTPUT SIGNAL 1	D2301:08	R2314:09
FNC3DTR0	DTB TRIGGER ON CH3 OUTPUT SIGNAL 0	D3301:08	R7527:14
FNC3DTR1	DTB TRIGGER ON CH3 OUTPUT SIGNAL 1	D3301:08	R7526:14
FNC3MTR0	MTB TRIGGER ON CH3 OUTPUT SIGNAL 0	D3301:08	R6527:12
FNC3MTR1	MTR TRIGGER ON CH3 OUTPUT SIGNAL 1	D3301:08	R6526:12
FNC3OUT0	CHANNEL 3 OUTPUT SIGNAL 0	D3301:08	R3313:09
FNC3OUT1	CHANNEL 3 OUTPUT SIGNAL 1	D3301:08	R3314:09
FNC4DTR0	DTB TRIGGER ON CH4 OUTPUT SIGNAL 0	D4301:08	R7529:14
FNC4DTR1	DTB TRIGGER ON CH4 OUTPUT SIGNAL 1	D4301:08	R7528:14
FNC4MTR0	MTB TRIGGER ON CH4 OUTPUT SIGNAL 0	D4301:08	R6529:12
FNC4MTR1	MTR TRIGGER ON CH4 OUTPUT SIGNAL 1	D4301:08	R6528:12
FNC4OUT0	CHANNEL 4 OUTPUT SIGNAL 0	D4301:08	R4313:09
FNC4OUT1	CHANNEL 4 OUTPUT SIGNAL 1	D4301:08	R4314:09
FNCYOP0	Y-OUT OPTION SIGNAL 0	D1301:08	Y-option
FNCYOP1	Y-OUT OPTION SIGNAL 1	D1301:08	Y-option
HOLDOFF	HOLD OFF CONTROL SIGNAL	X9002:18	R6032:16
INTTRA	TRACE INTENSITY CONTROL	X9002:18	R8049:15
LEVDTB	DELAYED TRIGGER LEVEL CONTROL	X9002:18	R7681:14
LEVMTB	MAIN TRIGGER LEVEL CONTROL	X9002:18	R6622:12
LINE	LINE TRIGGER SIGNAL	X9001:18	R7711:13
MTBCALTST	MTB CAL TEST SIGNAL	D6011:16	D7005:17
MTBGATE	MTB GATE SIGNAL	V8014:15	D6011:16
MTBVAR	MTB VARIABLE CONTROL SIGNAL	X9002:18	R6009:16
MTRBAL	MAIN TRIGGER BALANCE	N8005:15	R6709:12
MTRHF-HD	MAIN TRIGGER HF FILTER SWITCH	D9008:15	R6544:12
MTRIG0	MAIN TRIGGER OUTPUT SIGNAL 0	V6574:12	D8004:15
MTRIG1	MAIN TRIGGER OUTPUT SIGNAL 1	V6573:12	D8004:15
MTRLF-HD	MAIN TRIGGER LF FILTER SWITCH	D9011:12	R6542:12
MTRLINE	MAIN TRIGGER LINE TRIGGER SIGNAL	D5001:13	V6506:12
MTRPPLEV-HD	MAIN TRIGGERING AUTO PP OFF	D9011:12	V6628:12
MTRSEN	MAIN TRIGGER SENSITIVITY CONTROL	N8005:15	R6554:12
MTRSLOPE	MAIN TRIGGER SLOPE CONTROL	D9011:12	R6547:12
MTRTVMODE	MAIN TRIGGER TV SYSTEM SELECTION	N8005:15	R6772:13
MTRTVSEL-HD	MAIN TV TRIGGER SELECTION	D9011:12	V6757:13
MTRVIDEO	MAIN TV TRIGGER INPUT SIGNAL	D6541:12	V6754:13
PA1/2	ATTENUATION /2 CONTROL CH1	D9003:11	D1201:06
PA1ICL	CLAMP LEVEL CURRENT CH1	V1206:06	D1201:06
PA1ISY	SUPPLY CURRENT CH1	V1207:06	D1201:06
PA1LSA	LEVEL SHIFT A CH1	V1208:06	R1216:06
PA1LSB	LEVEL SHIFT B CH1	V1209:06	R1217:06
PA1OFFSET	OFFSET INPUT CIRCUIT CH1	N9001:11	R1203:06
PA1OFFSTRG	OFFSET LEVEL SHIFTER CH1	N9001:11	R1229:06
PA1OUT0	OUTPUT SIGNAL 0 CH1	V1202:06	R1301:08

PA1OUT1	OUTPUT SIGNAL 1 CH1	V1201:06	R1302:08
PA1X1	GAIN X1 CONTROL CH1	D9003:11	D1201:06
PA1X5	GAIN X5 CONTROL CH1	D9003:11	D1201:06
PAVREF	PREAMPL REFERENCE VOLTAGE	N1251:06	R1200:06
			R2200:06
			R3200:07
			R4200:07
PA2/2	ATTENUATION /2 CONTROL CH2	D9003:11	D2201:06
PA2ICL	CLAMP LEVEL CURRENT CH2	V2206:06	D2201:06
PA2ISY	SUPPLY CURRENT CH2	V2207:06	D2201:06
PA2LSA	LEVEL SHIFT A CH2	V2208:06	R2216:06
PA2LSB	LEVEL SHIFT B CH2	V2209:06	R2217:06
PA2OFFSET	OFFSET INPUT CIRCUIT CH2	N9002:11	R2203:06
PA2OFFSTRG	OFFSET LEVEL SHIFTER CH2	N9002:11	R2229:06
PA2OUT0	OUTPUT SIGNAL 0 CH2	V2202:06	R2301:08
PA2OUT1	OUTPUT SIGNAL 1 CH2	V2201:06	R2302:08
PA2X1	GAIN X1 CONTROL CH2	D9003:11	D2201:06
PA2X5	GAIN X5 CONTROL CH2	D9003:11	D2201:06
PA3/2	ATTENUATION /2 CONTROL CH3	D9004:11	D3201:07
PA3ICL	CLAMP LEVEL CURRENT CH3	V3206:07	D3201:07
PA3ISY	SUPPLY CURRENT CH3	V3207:07	D3201:07
PA3LSA	LEVEL SHIFT A CH3	V3208:07	R3216:07
PA3LSB	LEVEL SHIFT B CH3	V3209:07	R3217:07
PA3OFFSET	OFFSET INPUT CIRCUIT CH3	N9003:11	R3203:07
PA3OFFSTRG	OFFSET LEVEL SHIFTER CH3	N9003:11	R3229:07
PA3OUT0	OUTPUT SIGNAL 0 CH3	V3202:07	R3301:08
PA3OUT1	OUTPUT SIGNAL 1 CH3	V3201:07	R3302:08
PA3X1	GAIN X1 CONTROL CH3	D9004:11	D3201:07
PA3X5	GAIN X5 CONTROL CH3	D9004:11	D3201:07
PA4/2	ATTENUATION /2 CONTROL CH4	D9004:11	D4201:07
PA4ICL	CLAMP LEVEL CURRENT CH4	V4206:07	D4201:07
PA4ISY	SUPPLY CURRENT CH4	V4207:07	D4201:07
PA4LSA	LEVEL SHIFT A CH4	V4208:07	R4216:07
PA4LSB	LEVEL SHIFT B CH4	V4209:07	R4217:07
PA4OFFSET	OFFSET INPUT CIRCUIT CH4	N9003:11	R4203:07
PA4OFFSTRG	OFFSET LEVEL SHIFTER CH4	N9003:11	R4229:07
PA4OUT0	OUTPUT SIGNAL 0 CH4	V4202:07	R4301:08
PA4OUT1	OUTPUT SIGNAL 1 CH4	V4201:07	R4302:08
PA4X1	GAIN X1 CONTROL CH4	D9004:11	D4201:07
PA4X5	GAIN X5 CONTROL CH4	D9004:11	D4201:07
POS1	POSITION CONTROL CH1	X9002:18	R1308:08
POS2	POSITION CONTROL CH2	X9002:18	R2308:08
POS3	POSITION CONTROL CH3	X9002:18	R3308:08
POS4	POSITION CONTROL CH4	X9002:18	R4308:08
PROBE1	PROBE DETECTION/50Ω PROTECTION CH1	R1093:05	X9001:18
PROBE2	PROBE DETECTION/50Ω PROTECTION CH2	R2093:05	X9001:18
PROBE3	PROBE DETECTION/50Ω PROTECTION CH3	R3093:05	X9001:18
PROBE4	PROBE DETECTION/50Ω PROTECTION CH4	R4093:05	X9001:18

SCL	SERIAL CLOCK	X9001:18	D9009:10 D9001:11 D9002:11 D9003:11 D9004:11 D9006:16 D9007:17 D9008:15 D9011:12 D9012:14 N8005:15 N9001:11 N9002:11 N9003:11 R8403:16
SDA	SERIAL DATA	X9001:18	D9009:10 D9001:11 D9002:11 D9003:11 D9004:11 D9006:16 D9011:12 N8005:15 N9001:11 N9002:11 N9003:11 R8404:16
STRCALD-HT	RESET FLIPFLOP AUTOPOS Y-CURSOR	X9001:18	V8065:15 V8007:15
STROBE0-HT	STROBE/ENABLE SIGNAL 0	X9001:18	D9003:11 D9004:11
STROBE1-HT	STROBE/ENABLE SIGNAL 1	X9001:18	D9007:17 D9008:15 D9011:12 D9012:14
TBAUTO-LD	TIME BASE AUTO FREE RUN CONTROL	D9007:17	D8004:15
TBCALREF	TIME BASE CALIBRATION REFERENCE	V7011:17	D6011:16 D7011:17
TBD01	TIME BASE SERIAL DATA 01	D9011:12	D9008:15
TBD02	TIME BASE SERIAL DATA 02	D9008:15	D9007:17
TBD03	TIME BASE SERIAL DATA 03	D9007:17	D9012:14
TBEOM-HX	TIME BASE END OF MAIN SWEEP	D6011:16	D8004:15
TBEOD-HX	TIME BASE END OF DELAYED SWEEP	D7011:17	D8004:15
TBEOHO-LX	TIME BASE END OF HOLD OFF	D6011:16	D8004:15
TBHOTXT	TIME BASE HOLD OFF FOR TEXT DISPLAY	R8026:15	X9001:18
TBINTRAT-XA	INTENS RATIO CONTROL SIGNAL	N8005:15	R8007:15
TBNOTTR-HT	TIME BASE NOT TRIGGERED SIGNAL	D8004:15	D7005:17
TDADA	TIME BASE SERIAL DATA	R8404:16	N6014:16
TDACL	TIME BASE SERIAL CLOCK	R8403:16	D9006:16 D9007:17 D9008:15 D9011:12 D9012:14 N6013:16 N8005:15

TBSEL	TIME BASE MTB/DTB SELECTION	R5501:10	R6018:16 R7028:17 R8072:15
TBSTD-LX	TIME BASE START OF DTB	D6011:16	D8004:15
TBSSG-HT	TIME BASE END OF SINGLE SWEEP	D8004:15	D7005:17
TBSMART	TIME BASE TEST SIGNALS	C7054:17	X9001:18
TBXDEFL-LD	X DEFLECTION CONTROL SIGNAL	D9012:14	V8015:15 R7772:
TBXOUT0	TIME BASE OUTPUT 0	D6011:16 D7011:17	R7077:17
TBXOUT0-XA	X DEFLECTION OUTPUT 0	R7754:14	V7031:17
TBXOUT1	TIME BASE OUTPUT 1	D6011:16 D7011:17	R7078:17
TBXOUT1-XA	X DEFLECTION OUTPUT 1	R7753:14	V7032:17
TBXPOS	TIME X POSITION	R8411:16	R6017:16 R7099:17
TRASEP	ANALOG TRACE SEPARATION SIGNAL	X9002:18	R5021:09
TRASEP-HC	DIGITAL TRACE SEPARATION CONTROL	R5524:10	D5001:09
VAR1	VARIABLE GAIN CONTROL CH1	X9002:18	R1211:06
VAR2	VARIABLE GAIN CONTROL CH2	X9002:18	R2211:06
VAR3	VARIABLE GAIN CONTROL CH3	X9002:18	R3211:07
VAR4	VARIABLE GAIN CONTROL CH4	X9002:18	R4211:07
VPPTTEST-LD	VOLT PP TEST AUTOPOS Y-CURSOR	V8066:15	D7005:17
XTRA0	X DEFLECTION OUTPUT SIGNAL 0	V7150:17	X9001:18
XTRA1	X DEFLECTION OUTPUT SIGNAL 1	V7151:17	X9001:18
ZTRA0	INTENSITY OUTPUT SIGNAL 0	D8003:15	X9001:18
ZTRA1	INTENSITY OUTPUT SIGNAL 1	D8003:15	X9001:18

5.1.3 Unit lay-outs

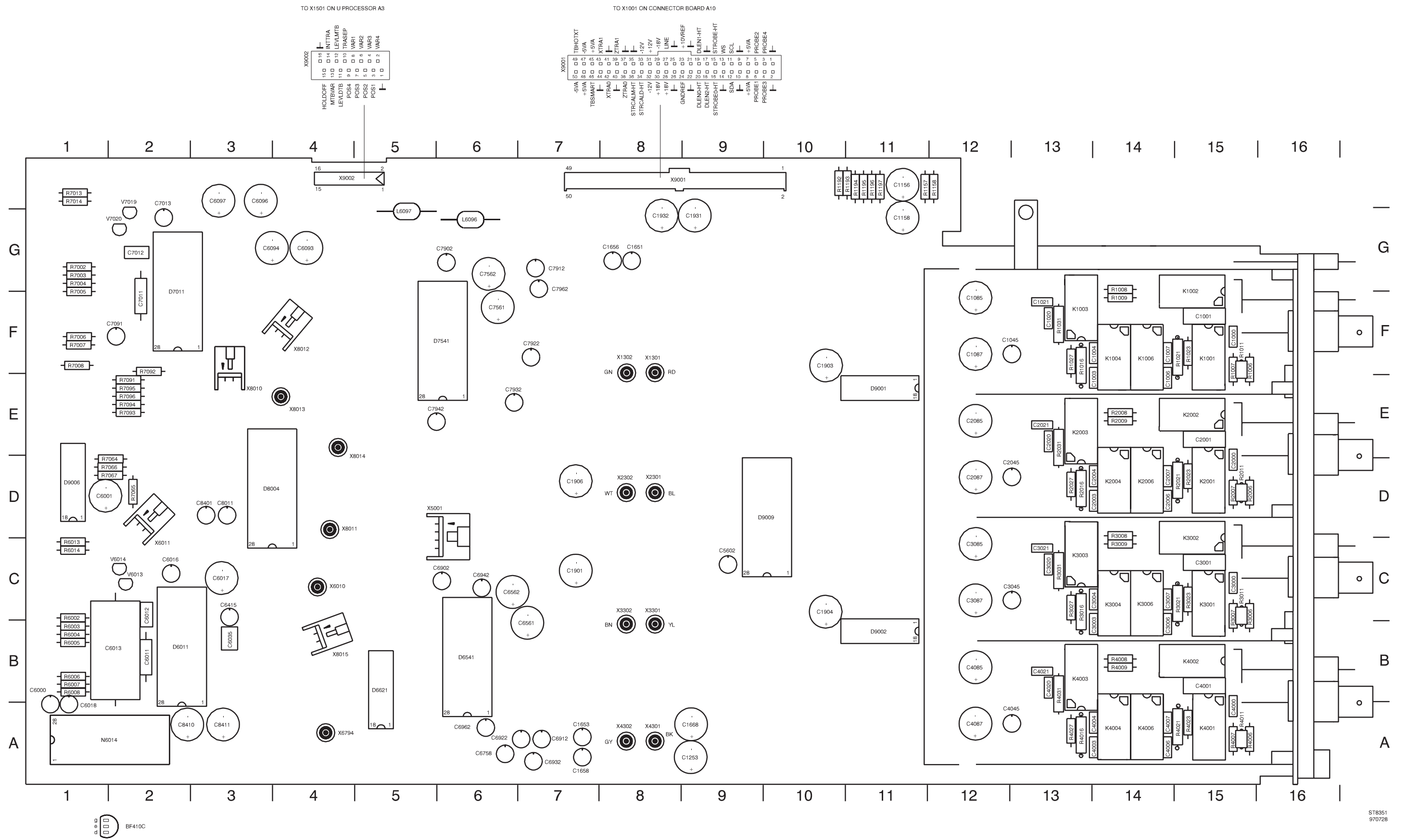

ST8351
970728

Lay-out 1 - Large component side of signal unit A1

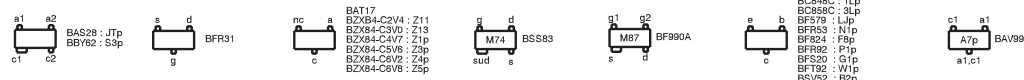

ST8352
970728

Lay-out 2 - Small component side of signal unit A1

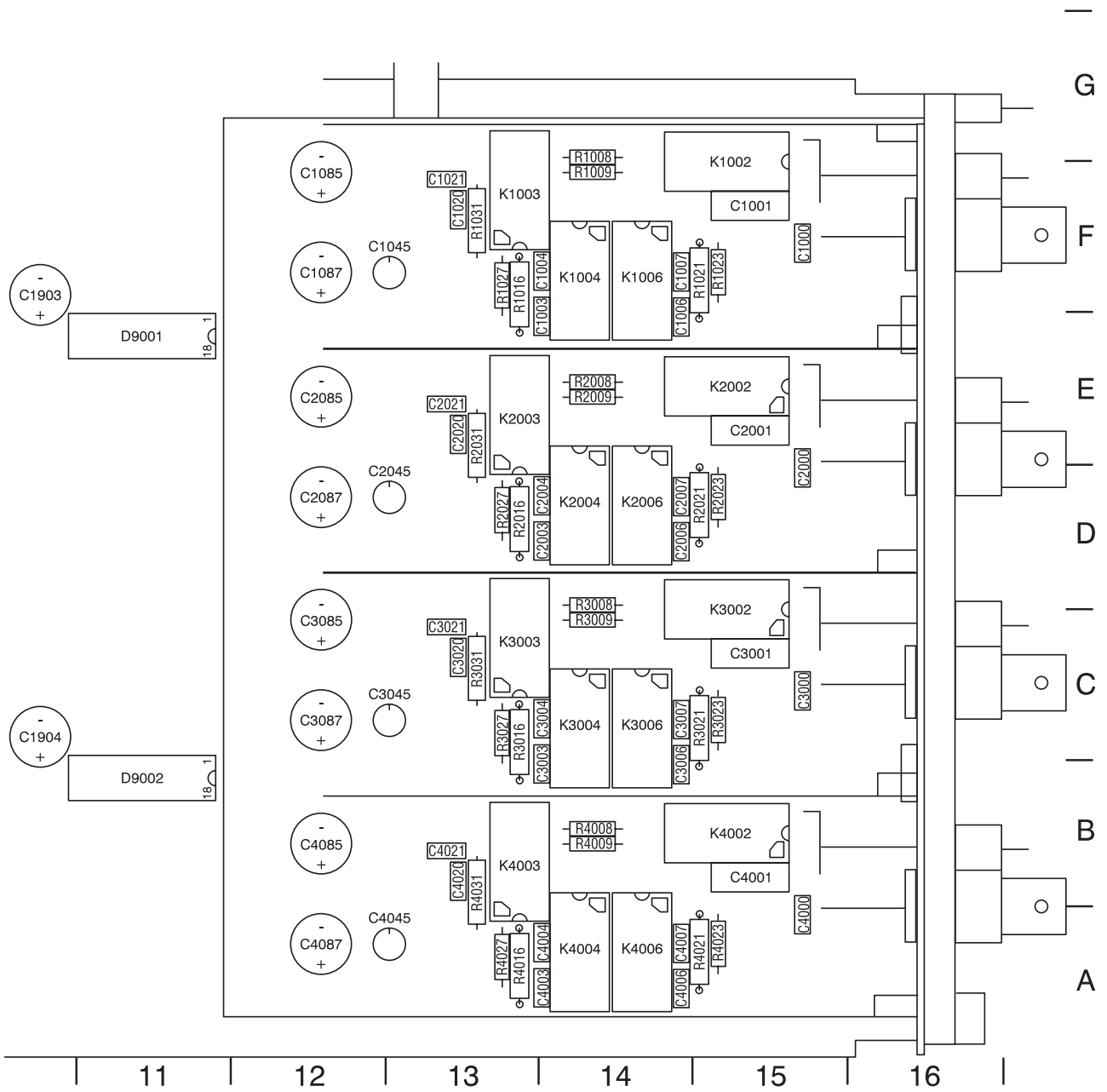

ST7950

Lay-out 1a - Large component side detail of signal unit A1 for PM3384B

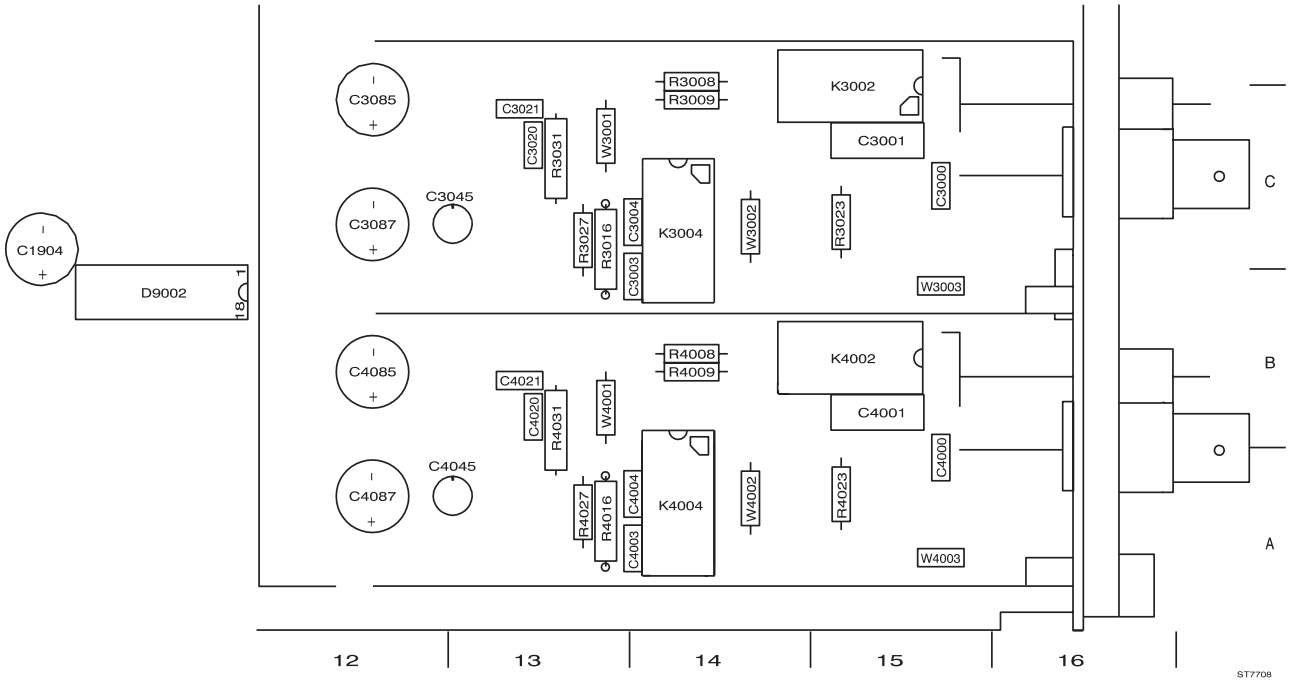

Lay-out 1b - Large component side detail of signal unit A1 for PM3382B/92B

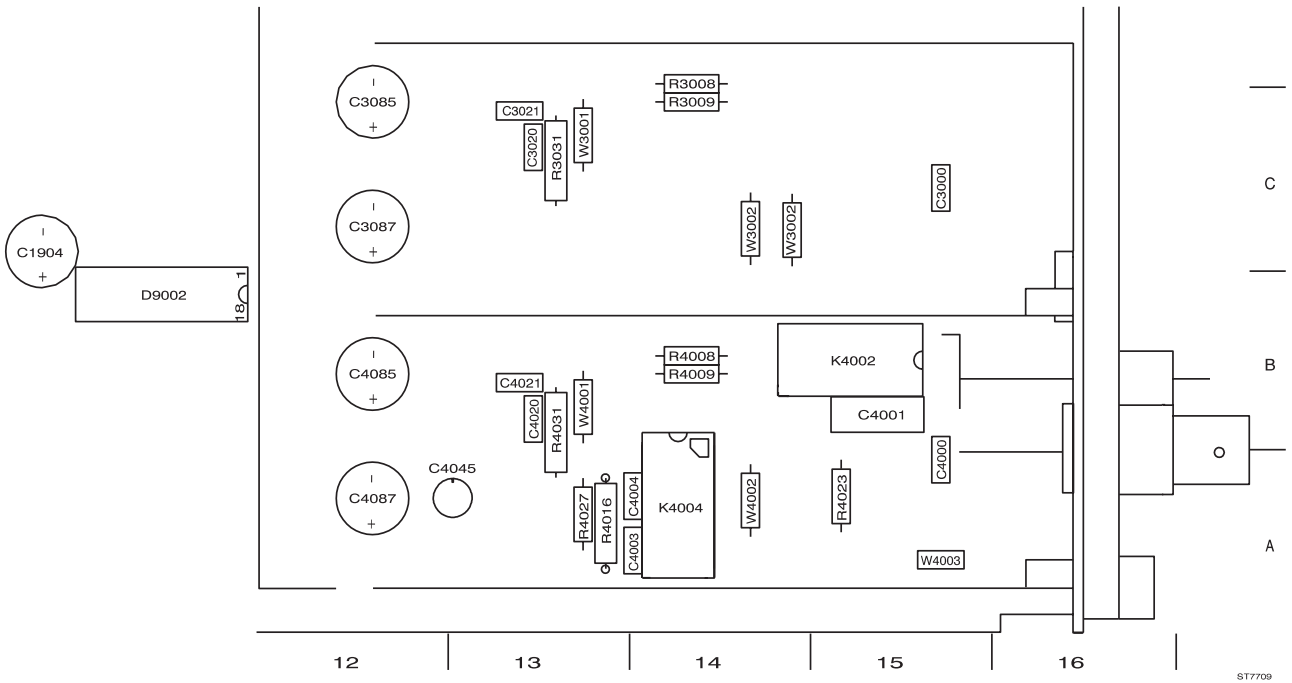

Lay-out 1c - Large component side detail of signal unit A1 for PM3370B/80B/90B

5.1.4 Location list Signal Unit A1

'-L' means that the component is located on the side with the large components. Otherwise the component is located on the side with small components (SMD's: surface mounted devices)

C1000 F15-L	C1087 F12-L	C2004 D14-L	C2204 E11
C1001 F15-L	C1088 F12	C2005 D15	C2205 D11
C1002 F14	C1101 G10	C2006 D14-L	C2208 E10
C1003 F14-L	C1102 G10	C2007 D14-L	C2209 E10
C1004 F14-L	C1151 H12	C2008 D14	C2210 D11
C1005 F15	C1152 H11	C2011 D14	C2211 D11
C1006 F14-L	C1153 G15	C2012 D14	C2301 E8
C1007 F14-L	C1156 H11-L	C2014 D13	C2302 E8
C1008 F14	C1157 H11	C2018 D13	C2303 E10
C1011 F14	C1158 H11-L	C2019 D13	C2304 D8
C1012 F14	C1159 G11	C2020 D13-L	C2305 D8
C1014 F13	C1201 F10	C2021 E13-L	C3000 C15-L
C1018 E13	C1204 G11	C2022 D13	C3001 C15-L
C1019 E13	C1205 F11	C2023 D13	C3002 B14
C1020 F13-L	C1208 F10	C2025 D13	C3003 B14-L
C1021 F13-L	C1209 F10	C2027 D13	C3004 C14-L
C1022 F13	C1210 F11	C2031 D12	C3005 C15
C1023 F13	C1211 F11	C2041 E13	C3006 D14-L
C1025 F13	C1250 G10	C2042 E13	C3007 C14-L
C1027 E13	C1251 G9	C2044 D12	C3008 C14
C1031 E12	C1252 G9	C2045 D13-L	C3011 C14
C1041 G13	C1253 A8-L	C2046 D12	C3012 B14
C1042 G13	C1254 A9	C2047 E13	C3014 C13
C1044 F12	C1301 F8	C2048 E12	C3018 B13
C1045 F13-L	C1302 F8	C2051 E12	C3019 B13
C1046 F12	C1303 G10	C2054 D12	C3020 C13-L
C1047 F13	C1304 F8	C2055 E12	C3021 C13-L
C1048 G12	C1305 F8	C2056 D12	C3022 C13
C1049 G13	C1611 A11	C2057 E12	C3023 C13
C1051 F12	C1651 G8-L	C2058 D12	C3025 C13
C1054 F12	C1652 G8	C2059 E12	C3027 B13
C1055 F12	C1653 A7-L	C2060 D12	C3031 B12
C1056 F12	C1654 D8	C2061 D15	C3041 D13
C1057 F12	C1656 G8-L	C2062 D15	C3042 D13
C1058 F12	C1657 D8	C2063 E14	C3044 C12
C1059 F12	C1658 A7-L	C2064 E14	C3045 C13-L
C1060 F12	C1659 D8	C2066 E13	C3046 C12
C1061 F15	C1661 D8	C2067 E13	C3047 C13
C1062 E15	C1662 D8	C2068 D14	C3048 D12
C1063 F14	C1668 A9-L	C2069 D14	C3051 C12
C1064 G14	C1669 A9	C2071 D15	C3054 C12
C1066 G13	C1901 C7-L	C2072 D14	C3055 C12
C1067 G13	C1903 F10-L	C2076 E15	C3056 C12
C1068 E14	C1904 C10-L	C2077 D15	C3057 C12
C1069 E14	C1906 D7-L	C2085 E12-L	C3058 C12
C1071 E15	C1931 H8-L	C2086 E13	C3059 C12
C1076 G15	C1932 H8-L	C2087 D12-L	C3060 C12
C1077 F15	C2000 D15-L	C2088 E12	C3061 C15
C1082 H10	C2001 E15-L	C2101 H10	C3062 B15
C1085 G12-L	C2002 D14	C2102 H10	C3063 C14
C1086 F13	C2003 D14-L	C2201 D10	C3064 D14

C3066 D13	C4056 A12	C5507 D10	C6113 A2
C3067 D13	C4057 B12	C5508 C10	C6114 A1
C3068 B14	C4058 A12	C5509 C10	C6115 A1
C3069 B14	C4059 B12	C5510 C10	C6116 A1
C3071 B15	C4060 A12	C5511 C10	C6117 A1
C3072 C14	C4061 A15	C5514 E9	C6118 A2
C3076 D15	C4062 A15	C5513 D9	C6305 B3
C3077 C15	C4063 B14	C5601 D9	C6415 C3-L
C3085 C12-L	C4064 B14	C5602 C9-L	C6504 B6
C3086 C13	C4066 B13	C5603 C9	C6549 B6
C3087 C12-L	C4067 B13	C5604 C9	C6551 B6
C3088 C12	C4068 A14	C6000 B1-L	C6557 C6
C3101 A10	C4069 A14	C6001 D2-L	C6559 C6
C3102 A10	C4071 A15	C6002 B1	C6561 C7-L
C3201 C10	C4072 A14	C6004 B2	C6562 C6-L
C3204 D11	C4076 B15	C6005 B2	C6581 B5
C3205 C11	C4077 A15	C6007 C1	C6583 C5
C3208 D10	C4085 B12-L	C6008 A2	C6617 B5
C3209 C10	C4086 B13	C6008 B1	C6623 A5
C3210 C11	C4087 A12-L	C6009 C2	C6624 A5
C3211 C11	C4088 B12	C6011 B2-L	C6639 A5
C3301 C8	C4101 A10	C6012 C2-L	C6642 A5
C3302 C8	C4102 A10	C6013 B2-L	C6644 B5
C3303 D10	C4201 A10	C6014 C2	C6647 B5
C3304 C8	C4204 B11	C6015 C2	C6648 B5
C3305 C8	C4205 A11	C6016 C2-L	C6649 A5
C4000 A15-L	C4208 B10	C6017 C3-L	C6707 B4
C4001 B15-L	C4209 B10	C6018 B1-L	C6751 B6
C4002 A14	C4210 A11	C6031 A3	C6758 A6-L
C4003 A14-L	C4211 A11	C6032 A3	C6768 A6
C4004 A14-L	C4301 B8	C6033 B3	C6773 A5
C4005 A15	C4302 B8	C6035 B3-L	C6777 A6
C4006 A14-L	C4303 B10	C6038 C3	C6779 B5
C4007 A14-L	C4304 A8	C6039 C3	C6783 A5
C4008 A14	C4305 A8	C6062 D2	C6787 A5
C4011 A14	C5000 E5	C6070 C4	C6902 C6-L
C4012 A14	C5001 E7	C6071 B2	C6903 C6
C4014 A13	C5002 E6	C6080 A4	C6904 B6
C4018 A13	C5003 E6	C6093 G4-L	C6912 A7-L
C4019 A13	C5004 C6	C6094 G4-L	C6913 A7
C4020 A13-L	C5005 C6	C6095 B2	C6922 A7-L
C4021 B13-L	C5006 D6	C6096 H3-L	C6923 A7
C4022 A13	C5007 C6	C6097 H3-L	C6924 A5
C4023 A13	C5008 E7	C6098 C3	C6932 A7-L
C4025 A13	C5010 D6	C6101 A2	C6933 A7
C4027 A13	C5012 D6	C6102 A2	C6934 B6
C4031 A12	C5015 D6	C6103 A2	C6942 C6-L
C4041 B13	C5016 D5	C6104 A2	C6943 C6
C4042 B13	C5017 C6	C6105 A2	C6953 A5
C4044 A12	C5018 D6	C6106 A2	C6962 B6-L
C4045 A13-L	C5501 D9	C6107 A2	C6963 A6
C4046 A12	C5502 D10	C6108 A2	C7001 G1
C4047 B13	C5503 D10	C6109 A2	C7002 F1
C4051 B12	C5504 C9	C6110 A2	C7003 E1
C4054 A12	C5505 D9	C6111 A2	C7004 F2
C4055 B12	C5506 D9	C6112 A2	C7005 F2

C7006 F2	C8003 D3	D3201 C11	L1001 F15
C7007 F2	C8004 D3	D3301 C8	L1301 F8
C7008 F2	C8005 E3	D4201 B11	L2001 D15
C7009 G2	C8006 E3	D4301 B8	L2301 D8
C7010 F3	C8007 D4	D5001 D5	L3001 C15
C7011 F2-L	C8008 F3	D5501 C10	L3301 C8
C7012 G2-L	C8009 C3	D5502 D10	L4001 A15
C7013 H2-L	C8010 C4	D5503 D9	L4301 A8
C7014 G2	C8011 D3-L	D6001 B1	L6096 G6-L
C7015 G6	C8013 D3	D6002 C1	L6097 H5-L
C7016 F2	C8014 D4	D6011 B2-L	N1001 F13
C7017 G2	C8015 D4	D6541 B6-L	N1101 H11
C7021 H2	C8017 E1	D6621 B5-L	N1102 G10
C7033 G3	C8020 E4	D6779 A5	N1103 G10
C7034 F2	C8021 D3	D6781 A4	N1104 G11
C7035 F2	C8022 D3	D7001 F1	N1202 G10
C7036 G4	C8032 C4	D7002 G1	N1251 F9
C7054 G4	C8034 G4	D7004 E2	N2001 D13
C7055 G3	C8035 D4	D7005 F3	N2202 E10
C7060 G7	C8036 F4	D7011 G2-L	N3001 C13
C7091 F2-L	C8060 E4	D7541 F6-L	N3102 A10
C7092 E2	C8062 F4	D7711 E6	N3103 A10
C7093 D2	C8063 F4	D8003 D3	N3202 D10
C7099 G3	C8064 E4	D8004 D3-L	N4001 A13
C7161 G7	C8065 E4	D8006 C4	N4202 B10
C7504 F6	C8066 E4	D9001 E11-L	N4204 B10
C7513 F6	C8070 D2	D9002 B11-L	N5001 E7
C7549 F6	C8071 F4	D9003 F10	N5002 E6
C7551 F6	C8093 D4	D9004 C10	N6006 B1
C7557 F5	C8094 D4	D9006 D1-L	N6007 B2
C7559 F6	C8095 E3	D9007 F4	N6008 A3
C7561 F6-L	C8101 C3	D9008 C4	N6014 A2-L
C7562 G6-L	C8102 E3	D9009 D10-L	N6771 A6
C7581 F5	C8401 D3-L	D9011 A4	N7006 G1
C7583 F5	C8403 A1	D9012 G4	N7007 E1
C7682 E6	C8404 A1	D9013 G5	N7014 D2
C7697 E6	C8405 H5	K1001 F15-L	N7015 E2
C7751 G5	C8410 A3-L	K1002 G15-L	N7016 E2
C7813 G5	C8411 A3-L	K1003 F13-L	N7952 F6
C7902 G6-L	C9011 H9	K1004 F14-L	N8005 B4
C7903 G6	C9012 H9	K1006 F14-L	N9001 G9
C7904 F5	C9015 H9	K2001 D15-L	N9002 F9
C7912 G7-L	C9016 H9	K2002 D15-L	N9003 A9
C7913 G6	C9018 H9	K2003 E13-L	N9004 B9
C7922 F7-L	C9019 H9	K2004 D14-L	R1001 F15
C7923 F7	C9020 H9	K2006 D14-L	R1002 F15
C7932 E6-L	C9034 H7	K3001 C15-L	R1003 F15
C7933 E6	C9036 H7	K3002 D15-L	R1006 F15-L
C7934 F5	C9041 H8	K3003 C13-L	R1007 F15-L
C7942 E6-L	C9042 H8	K3004 C14-L	R1008 G14-L
C7943 E5	D1151 H12	K3006 C14-L	R1009 G14-L
C7962 G7-L	D1152 H11	K4001 A15-L	R1010 F14
C7963 E6	D1201 F11	K4002 B15-L	R1011 F15-L
C8000 A4	D1301 F8	K4003 B13-L	R1012 F15
C8001 D3	D2201 E11	K4004 A14-L	R1013 F13
C8002 D2	D2301 E8	K4006 A14-L	R1014 F14

R1016 F14-L	R1095 G11	R1253 G9	R2003 D15
R1019 F15	R1096 G11	R1254 G9	R2006 D15-L
R1021 F15-L	R1097 H10	R1256 G9	R2007 D15-L
R1022 F14	R1101 G10	R1257 F9	R2008 E14-L
R1023 F15-L	R1102 G10	R1258 G10	R2009 E14-L
R1024 F14	R1103 G10	R1259 G10	R2010 D14
R1026 F13	R1104 G10	R1260 G10	R2011 D15-L
R1027 F13-L	R1106 G10	R1262 A7	R2012 D15
R1028 E13	R1112 H9	R1266 A7	R2013 E13
R1029 E13	R1113 H9	R1301 F9	R2014 D14
R1030 F13	R1114 H9	R1302 F9	R2016 D13-L
R1031 F13-L	R1141 G11	R1303 F8	R2019 D15
R1032 F13	R1151 H12	R1304 F8	R2021 D15-L
R1033 F13	R1152 H11	R1306 E8	R2022 D14
R1034 F13	R1153 H11	R1307 E8	R2023 D15-L
R1035 F13	R1154 H11	R1308 G10	R2024 D14
R1036 F12	R1155 H12	R1309 G10	R2026 D13
R1037 F12	R1156 H12	R1310 F8	R2027 D13-L
R1038 F13	R1157 H12-L	R1311 F8	R2028 D13
R1041 E12	R1158 H12-L	R1312 F8	R2029 D13
R1042 F12	R1159 H12	R1313 D7	R2030 E13
R1043 F13	R1192 H10-L	R1314 D7	R2031 E13-L
R1044 F13	R1193 H11-L	R1611 A10	R2032 D13
R1045 F13	R1194 H11-L	R1611 A11	R2033 D13
R1046 F12	R1195 H11-L	R1612 A10	R2034 E13
R1047 F12	R1196 H11-L	R1613 A11	R2035 D13
R1048 G12	R1197 H11-L	R1651 F8	R2036 E12
R1049 F13	R1200 G11	R1652 A8	R2037 E12
R1052 F13	R1201 F11	R1653 F8	R2038 D13
R1053 F13	R1202 F11	R1654 A8	R2039 D12
R1054 F13	R1203 F11	R1656 F8	R2041 D12
R1056 F12	R1204 F11	R1657 A8	R2042 D12
R1057 G12	R1205 F11	R1661 G8	R2043 D13
R1061 G12	R1207 F11	R1662 H8	R2044 D13
R1062 F12	R1208 F11	R1663 A8	R2045 D13
R1063 F12	R1209 F11	R1901 G11	R2046 D12
R1064 F12	R1210 F11	R1902 E10	R2047 D12
R1065 F12	R1211 G11	R1903 D11	R2048 E12
R1071 F12	R1212 G11	R1904 B10	R2049 E13
R1072 F12	R1213 F11	R1906 A7	R2052 E13
R1073 F12	R1214 F11	R1911 G10	R2053 D13
R1074 F12	R1215 F11	R1912 E10	R2054 D13
R1076 F12	R1216 F11	R1913 D11	R2056 D12
R1077 F12	R1217 F11	R1914 B10	R2057 E12
R1078 F12	R1218 F11	R1917 D11	R2061 E12
R1079 F12	R1220 G11	R1921 G10	R2062 E12
R1081 G12	R1222 G11	R1922 D11	R2063 E12
R1082 F12	R1223 G11	R1923 B10	R2064 E12
R1083 F12	R1224 G11	R1924 A11	R2065 D12
R1084 F12	R1226 G11	R1926 F11	R2071 E12
R1086 E12	R1227 G10	R1928 C11	R2072 E12
R1087 F12	R1228 F10	R1929 A11	R2073 D12
R1088 F12	R1229 F10	R1951 H9	R2074 D12
R1092 G11	R1231 G10	R1961 H8	R2076 E12
R1093 G11	R1251 G9	R2001 E15	R2077 D12
R1094 H10	R1252 G9	R2002 E15	R2078 E12

R2079 D12	R2311 D8	R3073 C12	R3304 C8
R2081 E12	R2313 D7	R3074 C12	R3307 B8
R2082 D12	R2314 D7	R3076 C12	R3308 D10
R2083 E12	R3001 C15	R3077 C12	R3309 D10
R2084 D12	R3002 C15	R3078 C12	R3310 C7
R2086 D12	R3003 C15	R3079 C12	R3311 C8
R2087 D12	R3006 C15-L	R3081 D12	R3313 D7
R2088 D12	R3007 C15-L	R3082 C12	R3314 D7
R2092 G11	R3008 D14-L	R3083 C12	R4001 B15
R2093 G11	R3009 D14-L	R3084 C12	R4002 B15
R2094 H10	R3010 C14	R3086 B12	R4003 A15
R2096 G11	R3011 C15-L	R3087 C12	R4006 A15-L
R2101 H10	R3012 B15	R3088 C12	R4007 A15-L
R2102 H10	R3013 C13	R3092 G11	R4008 B14-L
R2103 H10	R3014 C14	R3093 G11	R4009 B14-L
R2104 H10	R3016 C13-L	R3094 H9	R4010 A14
R2106 H10	R3019 C15	R3096 G11	R4011 A15-L
R2112 H9	R3021 C15-L	R3101 A10	R4012 A15
R2113 H9	R3022 C14	R3102 A10	R4013 B13
R2114 H9	R3023 C15-L	R3103 A10	R4014 A14
R2200 E11	R3024 C14	R3104 A10	R4016 A13-L
R2201 E11	R3026 C13	R3106 A10	R4019 A15
R2202 D11	R3027 C13-L	R3112 A9	R4021 A15-L
R2203 D11	R3028 B13	R3113 A9	R4022 A14
R2204 D11	R3029 B13	R3114 A9	R4023 A15-L
R2205 D11	R3030 C13	R3200 D11	R4024 A14
R2205 D11	R3031 C13-L	R3201 D11	R4026 A13
R2207 D11	R3032 C13	R3202 C11	R4027 A13-L
R2208 D11	R3033 C13	R3203 C11	R4028 A13
R2209 D11	R3034 C13	R3204 C11	R4029 A13
R2210 D11	R3035 C13	R3205 C11	R4030 B13
R2211 E11	R3036 C12	R3206 C11	R4031 B13-L
R2212 E11	R3037 C12	R3207 C11	R4032 A13
R2213 E11	R3038 C13	R3208 C11	R4033 A13
R2214 E11	R3039 B12	R3209 C11	R4034 B13
R2215 D11	R3041 B12	R3210 C11	R4035 A13
R2216 E11	R3042 C12	R3211 D11	R4036 B12
R2217 E11	R3043 C13	R3212 D11	R4037 B12
R2218 D11	R3044 C13	R3213 C11	R4038 A13
R2220 E11	R3045 C13	R3214 C11	R4039 A12
R2222 E11	R3046 C12	R3215 C11	R4041 A12
R2223 E11	R3047 C12	R3216 C11	R4042 A12
R2224 E11	R3048 D12	R3217 C11	R4043 A13
R2226 E11	R3049 D13	R3218 C11	R4044 A13
R2227 E10	R3052 C13	R3220 D11	R4045 A13
R2228 E10	R3053 C13	R3222 D11	R4046 A12
R2229 E10	R3054 C13	R3223 D11	R4047 A12
R2231 E10	R3056 C12	R3224 D11	R4048 B12
R2301 E9	R3057 D12	R3226 D11	R4049 B13
R2302 E9	R3061 D12	R3227 D11	R4052 B13
R2303 E8	R3062 C12	R3228 C10	R4053 A13
R2304 E8	R3063 C12	R3229 C10	R4054 A13
R2307 D8	R3064 C12	R3231 D10	R4056 A12
R2308 E10	R3065 C12	R3301 C9	R4061 B12
R2309 E10	R3071 C12	R3302 C9	R4062 B12
R2310 D7	R3072 C12	R3303 C8	R4063 B12

R4064 B12	R4231 B10	R5058 D6	R5561 C10
R4065 A12	R4301 B9	R5060 D5	R5562 D9
R4071 B12	R4302 B9	R5061 D6	R5601 D9
R4072 B12	R4303 B8	R5064 E6	R5602 C9
R4073 A12	R4304 B8	R5065 E7	R5603 C9
R4074 A12	R4307 A8	R5066 D6	R5606 D9
R4076 B12	R4308 B10	R5068 C7	R6001 C1
R4077 A12	R4309 B10	R5069 C6	R6002 C1-L
R4078 B12	R4310 A7	R5070 D6	R6003 B1-L
R4079 A12	R4311 A8	R5071 C6	R6004 B1-L
R4081 B12	R4313 C7	R5072 D6	R6005 B1-L
R4082 A12	R4314 C7	R5076 E6	R6006 B1-L
R4083 B12	R5001 D6	R5501 D10	R6007 B1-L
R4084 A12	R5002 E6	R5502 D9	R6008 B1-L
R4086 A12	R5003 D6	R5503 D9	R6009 B1
R4087 A12	R5004 D6	R5504 C9	R6011 B2
R4088 A12	R5006 E6	R5506 C9	R6012 A1
R4092 G10	R5007 D6	R5507 D10	R6013 C1-L
R4093 G10	R5008 E6	R5508 D10	R6014 C1-L
R4094 H10	R5009 D6	R5509 D10	R6015 C1
R4096 G10	R5011 D6	R5510 D9	R6016 C1
R4101 A10	R5012 D6	R5511 D10	R6017 C3
R4102 A10	R5013 D6	R5512 D10	R6018 C3
R4103 A10	R5014 D6	R5513 D10	R6019 B3
R4104 A10	R5016 D6	R5514 D10	R6020 B3
R4106 A10	R5017 D7	R5516 D10	R6021 B3
R4112 A9	R5018 D6	R5517 D10	R6022 B3
R4113 A9	R5019 D6	R5518 D10	R6023 B2
R4114 A9	R5021 E6	R5519 D9	R6024 B2
R4200 B11	R5024 C6	R5521 D9	R6025 B2
R4201 B11	R5026 D6	R5522 D9	R6026 B2
R4202 A11	R5027 C6	R5523 D9	R6027 C2
R4203 A11	R5028 D6	R5524 D10	R6028 B3
R4204 A11	R5029 C6	R5526 E10	R6029 C2
R4205 A11	R5031 D6	R5527 E10	R6030 C2
R4206 A11	R5032 D7	R5531 E8	R6031 B3
R4207 A11	R5035 D6	R5532 D8	R6032 B3
R4208 A11	R5036 C6	R5533 D8	R6033 B3
R4209 A11	R5037 D6	R5534 B8	R6034 B3
R4210 A11	R5041 C6	R5536 E8	R6035 C3
R4211 B11	R5042 D6	R5537 C8	R6036 A3
R4212 B11	R5043 D6	R5538 D8	R6037 B3
R4213 B11	R5044 C6	R5539 B8	R6038 B2
R4214 B11	R5045 D6	R5541 D9	R6040 C2
R4215 A11	R5046 D6	R5542 D9	R6041 C2
R4216 B11	R5047 D6	R5543 D9	R6042 C2
R4217 B11	R5048 D6	R5544 D9	R6043 C2
R4218 A11	R5049 D6	R5546 C9	R6044 C2
R4220 B11	R5050 E7	R5551 C10	R6045 C2
R4222 B11	R5051 D5	R5552 C10	R6046 C2
R4223 B11	R5052 D5	R5553 C10	R6047 C2
R4224 B11	R5053 C5	R5554 C10	R6048 C2
R4226 B11	R5054 D6	R5556 A8	R6049 C2
R4227 B10	R5055 D5	R5557 C8	R6050 B2
R4228 B10	R5056 E6	R5558 D8	R6051 B2
R4229 B10	R5057 E6	R5559 F8	R6052 C2

R6053 C1	R6627 B5	R7014 H1-L	R7154 G7
R6054 C2	R6629 B4	R7015 G1	R7155 G6
R6061 C2	R6632 A4	R7016 G1	R7156 G6
R6062 D2	R6633 B5	R7017 F2	R7160 G7
R6063 D1	R6634 B4	R7018 G3	R7161 G7
R6070 B3	R6636 A5	R7019 G3	R7180 G4
R6071 A3	R6638 A5	R7021 F3	R7181 G4
R6072 G5	R6641 A5	R7022 F2	R7204 C2
R6073 A3	R6643 B5	R7023 G2	R7205 D2
R6074 A3	R6646 B5	R7024 F2	R7206 D2
R6093 G5	R6649 B5	R7025 F2	R7207 E2
R6094 G5	R6661 B4	R7026 F2	R7208 G2
R6095 A2	R6662 B5	R7027 G2	R7209 D2
R6101 D2	R6684 C5	R7028 F3	R7502 F6
R6104 A3	R6688 C5	R7029 G3	R7503 F6
R6502 B6	R6689 C5	R7031 F3	R7508 F6
R6503 B6	R6692 C5	R7032 G3	R7509 F6
R6508 B6	R6694 C5	R7033 G3	R7511 F6
R6509 B6	R6696 A4	R7034 G6	R7512 F6
R6511 B6	R6706 B4	R7036 G6	R7521 F6
R6512 B6	R6708 B4	R7041 G2	R7522 F6
R6521 B6	R6709 B4	R7042 G2	R7523 F6
R6522 B6	R6752 A6	R7043 H2	R7524 F6
R6523 B7	R6753 A6	R7044 G2	R7526 F6
R6524 B7	R6754 A6	R7045 G6	R7527 F6
R6526 B7	R6756 A6	R7046 H2	R7528 F6
R6527 B7	R6758 A6	R7047 H2	R7529 F6
R6528 B6	R6762 A6	R7048 G2	R7531 F6
R6529 B6	R6764 A6	R7049 G2	R7542 E5
R6531 B6	R6769 A6	R7050 G2	R7543 E6
R6542 B6	R6772 A5	R7051 G2	R7544 G5
R6543 B6	R6774 A5	R7052 F2	R7546 F5
R6544 C5	R6776 A5	R7054 F3	R7547 F5
R6546 A4	R6782 A5	R7056 F3	R7548 E5
R6547 C5	R6783 A5	R7057 F4	R7552 G6
R6548 A6	R6786 A5	R7059 G3	R7554 F5
R6552 C6	R6788 A5	R7064 D2-L	R7556 F5
R6554 C5	R6901 C6	R7065 D2-L	R7558 F5
R6556 B6	R6911 A7	R7066 D2-L	R7563 E5
R6558 C6	R6921 A7	R7067 D2-L	R7571 F5
R6578 B5	R6931 A7	R7077 G5	R7572 F5
R6579 B5	R6941 C6	R7078 G5	R7576 F5
R6584 C5	R6951 B7	R7082 F2	R7577 F5
R6586 C5	R6961 B7	R7091 E2-L	R7578 F5
R6601 B6	R7001 G1	R7092 F2-L	R7579 F5
R6602 B6	R7002 G1-L	R7093 E2-L	R7584 F5
R6603 B5	R7003 G1-L	R7094 E2-L	R7586 F5
R6612 A5	R7004 G1-L	R7095 E2-L	R7681 E5
R6613 B5	R7005 G1-L	R7096 E2-L	R7688 E6
R6614 B5	R7006 F1-L	R7097 E2	R7689 E6
R6616 B5	R7007 F1-L	R7099 G3	R7692 E5
R6621 B4	R7008 F1-L	R7144 G2	R7693 F6
R6622 B4	R7009 E1	R7150 G7	R7694 E6
R6623 B4	R7011 E1	R7151 G7	R7696 F6
R6624 A5	R7012 E1	R7152 G7	R7711 F7
R6626 A5	R7013 H1-L	R7153 G7	R7712 F7

R7713 E5	R8042 C3	R8098 E4	V2003 E12
R7716 D5	R8043 C3	R8099 E4	V2004 E13
R7753 G6	R8044 D4	R8100 F4	V2005 E13
R7754 G6	R8045 D4	R8101 D3	V2006 E13
R7809 G4	R8046 D4	R8102 E1	V2007 D12
R7901 G7	R8047 D4	R8103 D2	V2008 E12
R7911 G7	R8048 D4	R8104 E1	V2009 E12
R7921 F7	R8049 E1	R8105 C4	V2012 E12
R7931 F7	R8050 D4	R8106 D4	V2013 E12
R7941 E7	R8051 D4	R8130 C3	V2015 E12
R7951 G6	R8052 D4	R8131 C4	V2016 D12
R7952 G6	R8053 F3	R8132 B3	V2017 D12
R7953 G6	R8054 C3	R8133 D3	V2018 D12
R7954 F6	R8055 C4	R8134 F4	V2201 E10
R7956 G7	R8056 E4	R8135 F4	V2202 E10
R7957 F7	R8057 E4	R8136 F4	V2206 E11
R7958 F7	R8058 E4	R8137 F3	V2207 E11
R7961 F7	R8059 E4	R8138 B4	V2208 E11
R8001 D3	R8060 E4	R8200 E4	V2209 E10
R8002 D3	R8061 F4	R8403 A1	V2301 D8
R8003 D3	R8062 F4	R8404 A1	V2302 D8
R8004 D3	R8063 F4	R8405 H5	V2303 D8
R8005 E3	R8064 E4	R8410 B3	V2304 E8
R8006 D2	R8065 E4	R8411 A3	V2306 E8
R8007 D3	R8066 D3	V1001 F12	V2307 E8
R8008 D2	R8067 D3	V1002 F13	V3001 C12
R8009 E3	R8068 F4	V1003 G12	V3002 C13
R8010 E3	R8069 E3	V1004 F13	V3003 D12
R8011 E3	R8070 B3	V1005 F13	V3004 C13
R8012 E3	R8071 A4	V1006 F13	V3005 C13
R8013 E3	R8072 E3	V1007 F12	V3006 C13
R8014 E3	R8073 B4	V1008 F12	V3007 C12
R8015 D2	R8074 E4	V1009 F12	V3008 C12
R8016 D2	R8075 E4	V1012 F12	V3009 C12
R8017 F4	R8076 D4	V1013 F12	V3012 C12
R8018 E4	R8077 C4	V1015 G12	V3013 C12
R8019 E3	R8078 E4	V1016 F12	V3015 D12
R8020 E3	R8079 D4	V1017 E12	V3016 C12
R8021 E3	R8080 C4	V1018 F12	V3017 B12
R8022 E3	R8081 D4	V1201 F10	V3201 C10
R8023 E4	R8082 D4	V1202 F10	V3202 C10
R8024 E3	R8083 C2	V1206 G11	V3206 D11
R8025 D4	R8084 C2	V1207 G11	V3207 D11
R8026 B4	R8085 C2	V1208 G11	V3208 D11
R8027 E3	R8086 D4	V1209 F10	V3209 C10
R8028 D4	R8087 D4	V1251 G9	V3301 C8
R8029 C4	R8088 E4	V1252 F10	V3302 B8
R8030 F4	R8089 E4	V1301 E8	V3303 C8
R8031 C4	R8090 D3	V1302 E8	V3304 C8
R8033 C3	R8091 D3	V1304 G8	V3306 C8
R8034 C3	R8092 C4	V1306 G8	V3307 C8
R8035 C3	R8093 C4	V1307 G8	V4001 A12
R8037 B3	R8094 C4	V1308 F8	V4002 A13
R8038 B3	R8095 E3	V1313 F8	V4003 B12
R8040 E4	R8096 E3	V2001 D12	V4004 B13
R8041 F3	R8097 E4	V2002 D13	V4005 B13

V4006 B13	V6006 B2	V7012 G2	V8019 B4
V4007 A12	V6007 B2	V7016 G2	V8023 D4
V4008 B12	V6008 C3	V7017 G2	V8024 D4
V4009 B12	V6012 C2	V7018 F2	V8025 D4
V4012 B12	V6013 C2-L	V7019 H2-L	V8028 D4
V4013 B12	V6014 C2-L	V7020 G2-L	V8029 E4
V4015 B12	V6016 B2	V7031 G6	V8031 D4
V4016 A12	V6017 B2	V7032 G6	V8032 D4
V4017 A12	V6018 C1	V7075 D2	V8040 E3
V4018 A12	V6019 B2	V7091 E2	V8041 D4
V4201 B10	V6022 C2	V7093 C2	V8042 C2
V4202 B10	V6041 B3	V7094 F2	V8043 C2
V4206 B11	V6042 B3	V7150 G7	V8044 F4
V4207 B11	V6044 C4	V7151 G7	V8061 E4
V4208 B11	V6061 D2	V7152 G6	V8062 E4
V4209 B10	V6062 D2	V7506 F6	V8063 E4
V4301 A8	V6101 A2	V7507 F6	V8065 E4
V4302 A8	V6506 B6	V7532 F6	V8066 F4
V4303 A8	V6507 B6	V7553 G6	V8067 D3
V4304 B8	V6532 B6	V7573 F5	V8068 D3
V4306 B8	V6553 C6	V7574 F5	V8101 E4
V4307 B8	V6573 C5	V7686 F6	W3001 C13-L
V5001 D7	V6574 C5	V7687 F6	W3002 C14-L
V5002 D7	V6593 C6	V7691 E6	W3003 B15-L
V5003 D6	V6604 A5	V7714 D5	W4001 B13-L
V5004 D6	V6606 B5	V7801 G5	W4002 A14-L
V5006 D6	V6628 A4	V7802 G5	W4003 A15-L
V5007 D6	V6631 A4	V7803 G5	X1301 E8
V5008 D6	V6637 A4	V7804 G5	X1302 E8
V5009 D6	V6667 B4	V7805 G5	X2301 D8
V5011 D5	V6668 B5	V7806 G5	X2302 D8
V5012 C6	V6686 B5	V7807 G5	X3301 C8
V5013 D6	V6687 B5	V7808 G5	X3302 C8
V5014 D5	V6691 C5	V8001 D3	X4301 A8
V5016 C6	V6754 A6	V8002 E3	X4302 A8
V5017 C6	V6757 A6	V8003 C4	X5001 D6-L
V5018 D6	V6759 A6	V8004 E3	X6010 C4
V5501 D10	V6761 A6	V8005 D4	X6011 D2
V5502 D10	V6763 A6	V8006 E3	X6794 A4
V5503 C9	V6764 A4	V8007 F4	X8010 E3
V5504 D10	V6768 A6	V8008 F3	X8011 D4
V5506 D9	V6784 A5	V8009 F4	X8012 F4
V5601 D9	V7001 F2	V8011 E3	X8013 E4
V6001 B1	V7003 G2	V8012 E3	X8014 E4
V6002 C3	V7004 G2	V8013 C3	X8015 B4
V6003 C1	V7005 G2	V8014 C3	X9001 H8-L
V6004 C1	V7006 F2	V8015 E2	X9002 H4-L
V6005 B2	V7007 F2	V8018 B4	

5.1.5 Circuit diagrams

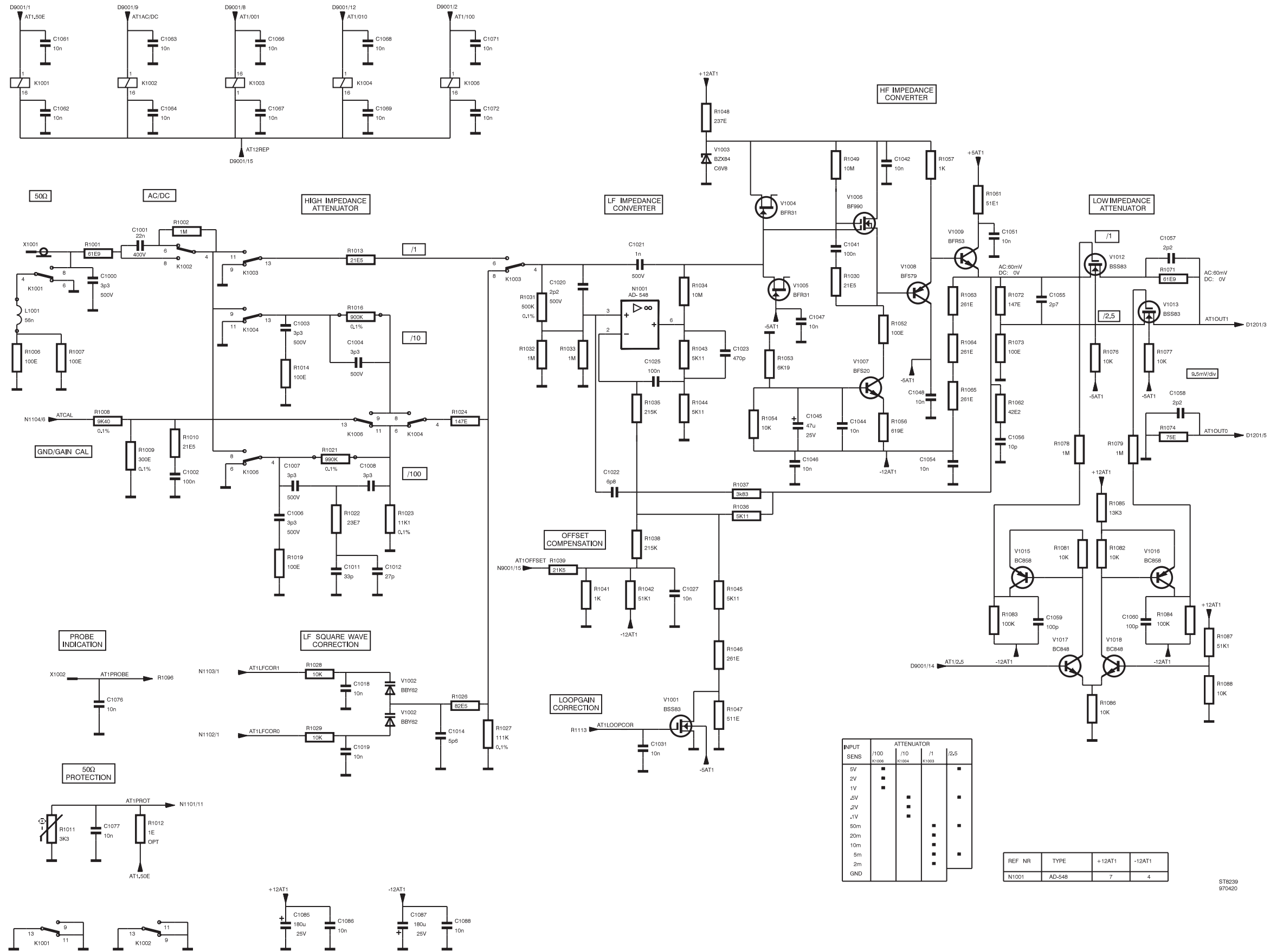

INPUT SENS	ATTENUATOR		
	/100 C1008	/10 C1084	/1 C1003
5V	■		
2V	■		
1V	■		
.5V	■		■
.2V		■	
.1V		■	
50m			■
20m			■
10m			■
5m			■
2m			■
GND			

REF NR	TYPE	+12AT1	-12AT1
N1001	AD-548	7	4

STR239
970420

A1; Diagram 1 - Attenuator CH1 (PM3394B/90B)

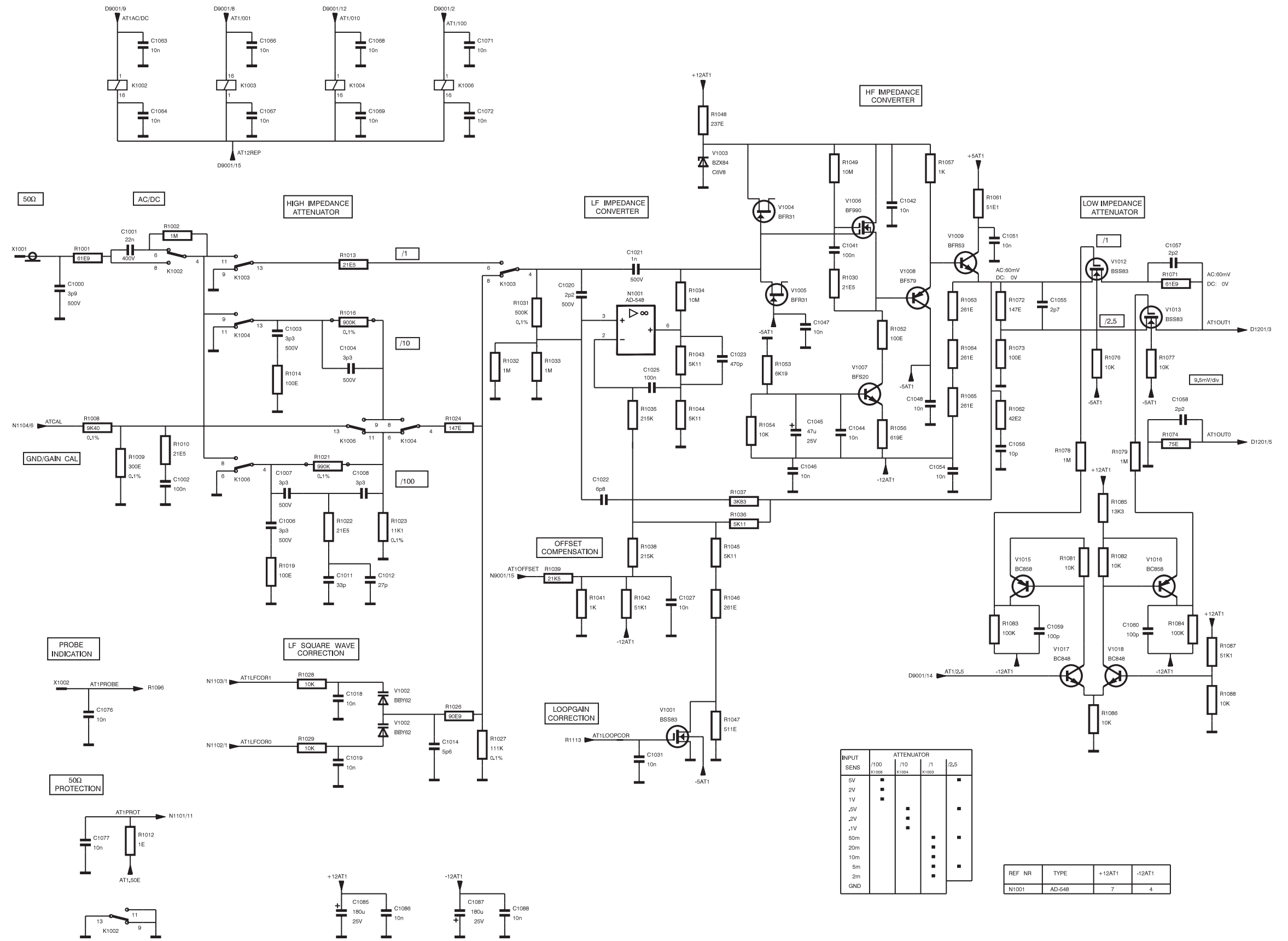

A1; Diagram 1a - Attenuator CH1 (PM3384B/80B/70B)

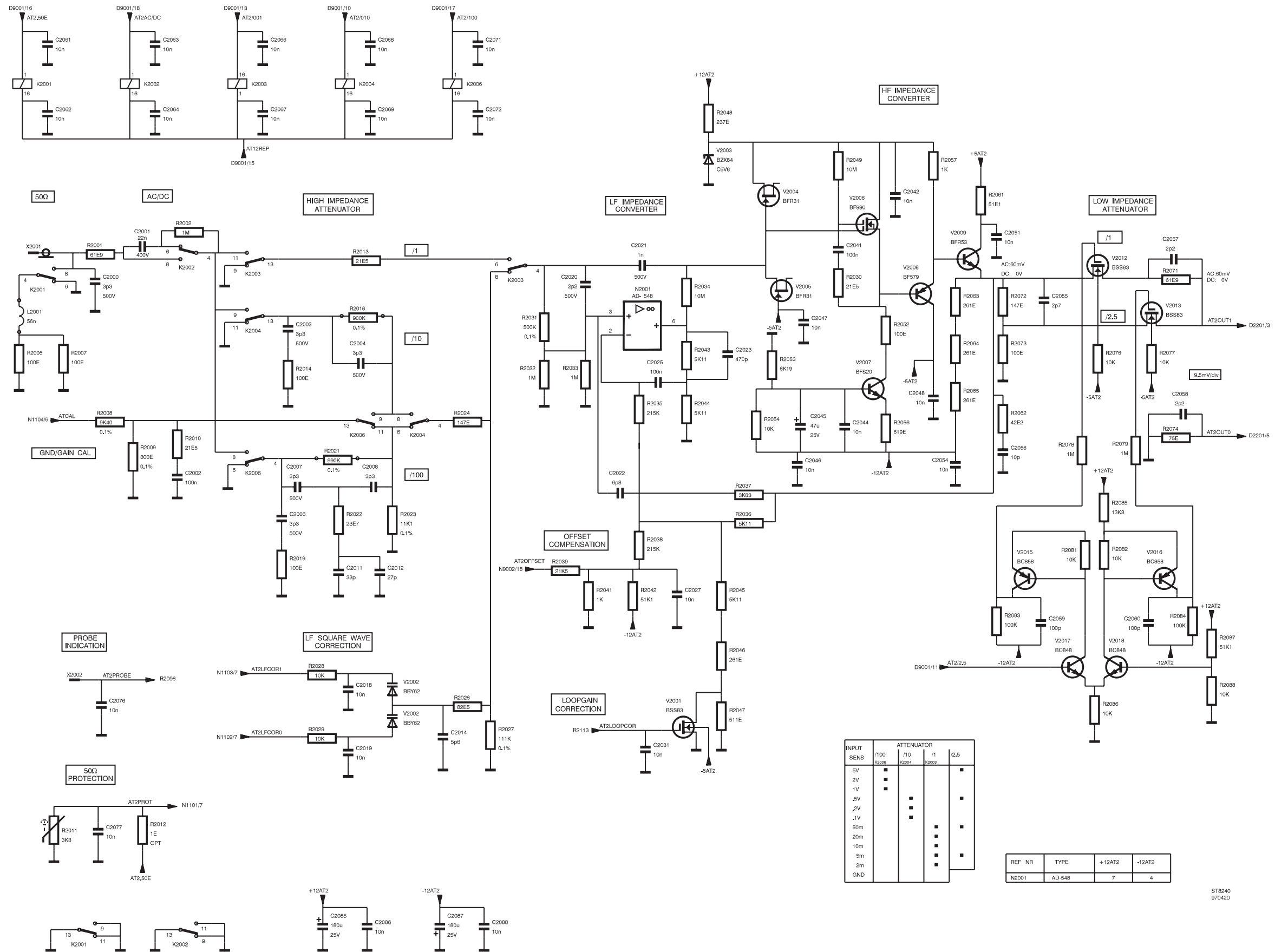

ST8240
970420

A1; Diagram 2 - Attenuator CH2 (PM3394B/90B)

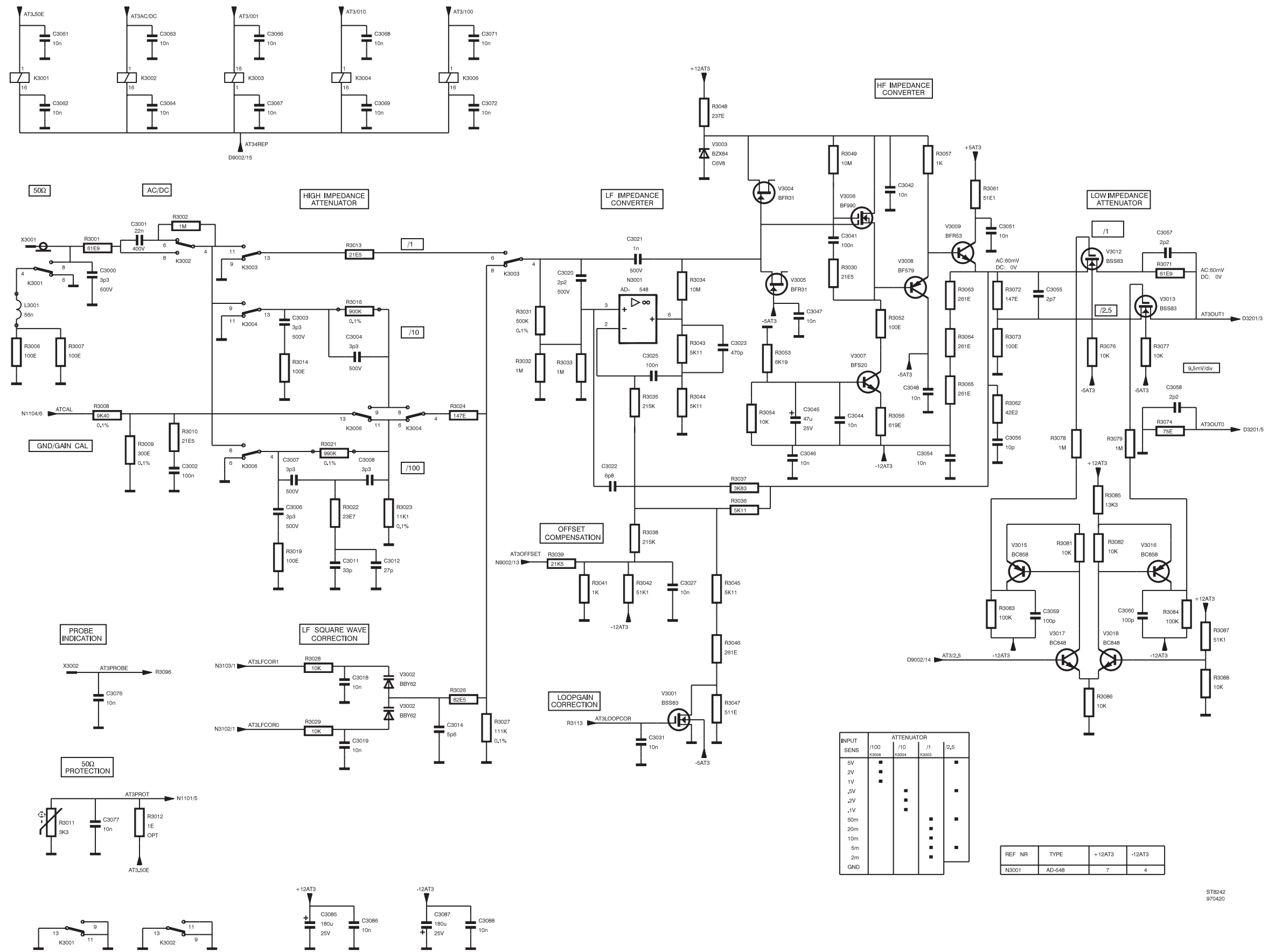
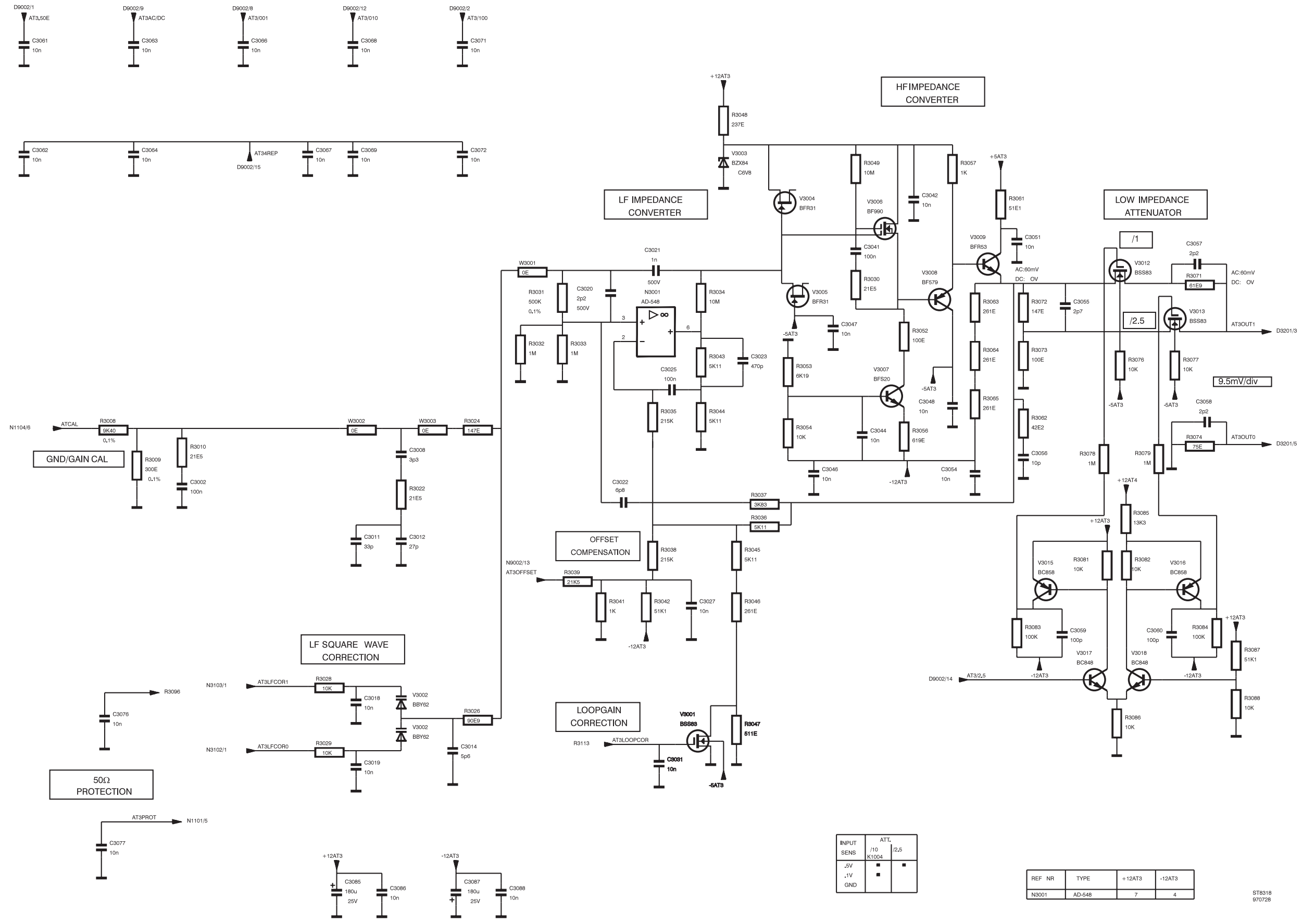

Diagram 3 - Attenuator CH3 (PM3394B)



INPUT SENS	ATT.
.5V	/10
.1V	/K1004
GND	/2.5

REF NR	TYPE	+12AT3	-12AT3
N3001	AD-548	7	4

ST8518
970728

Diagram 3a - Attenuator CH3 (PM3380B/70B)

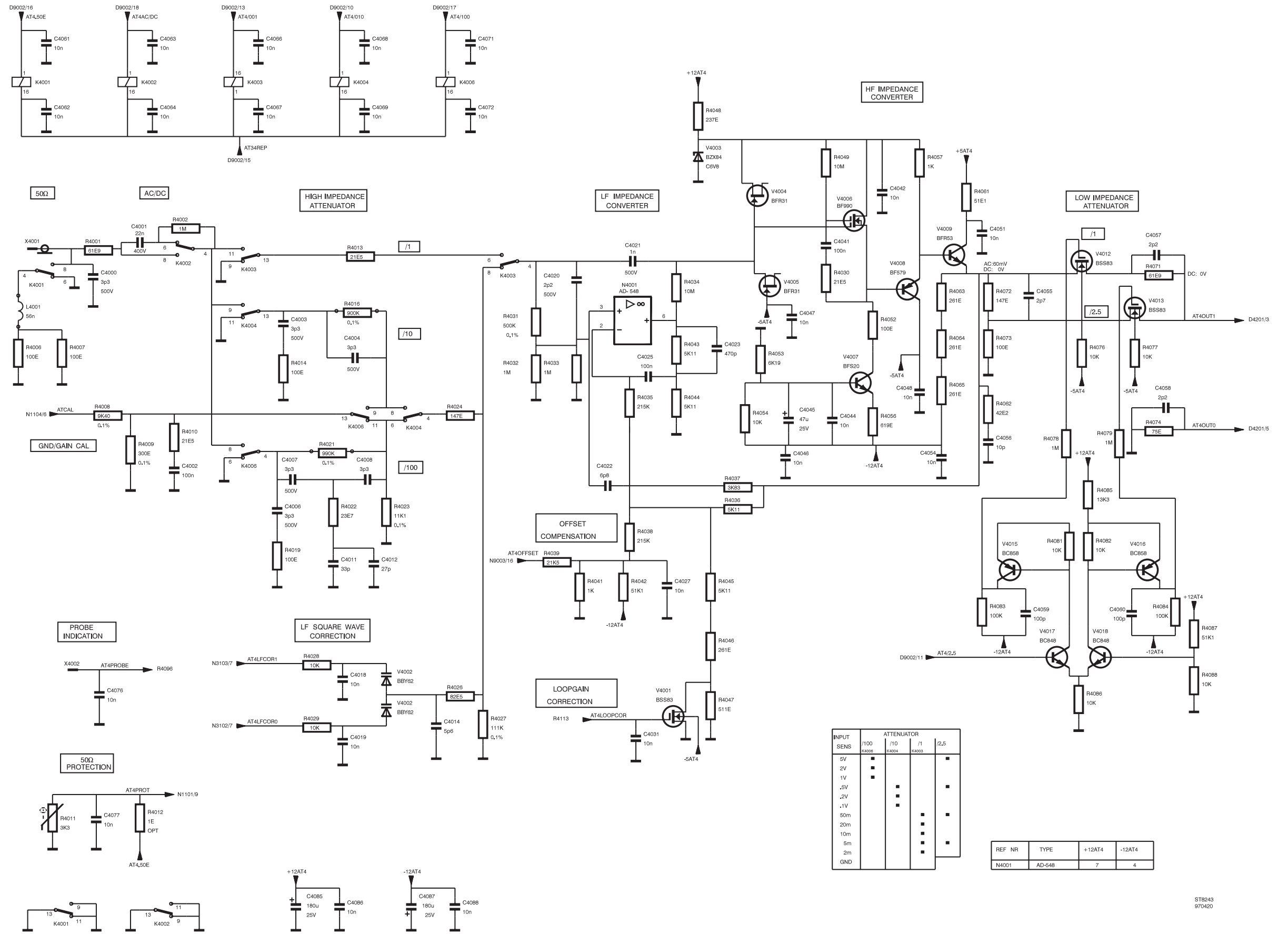
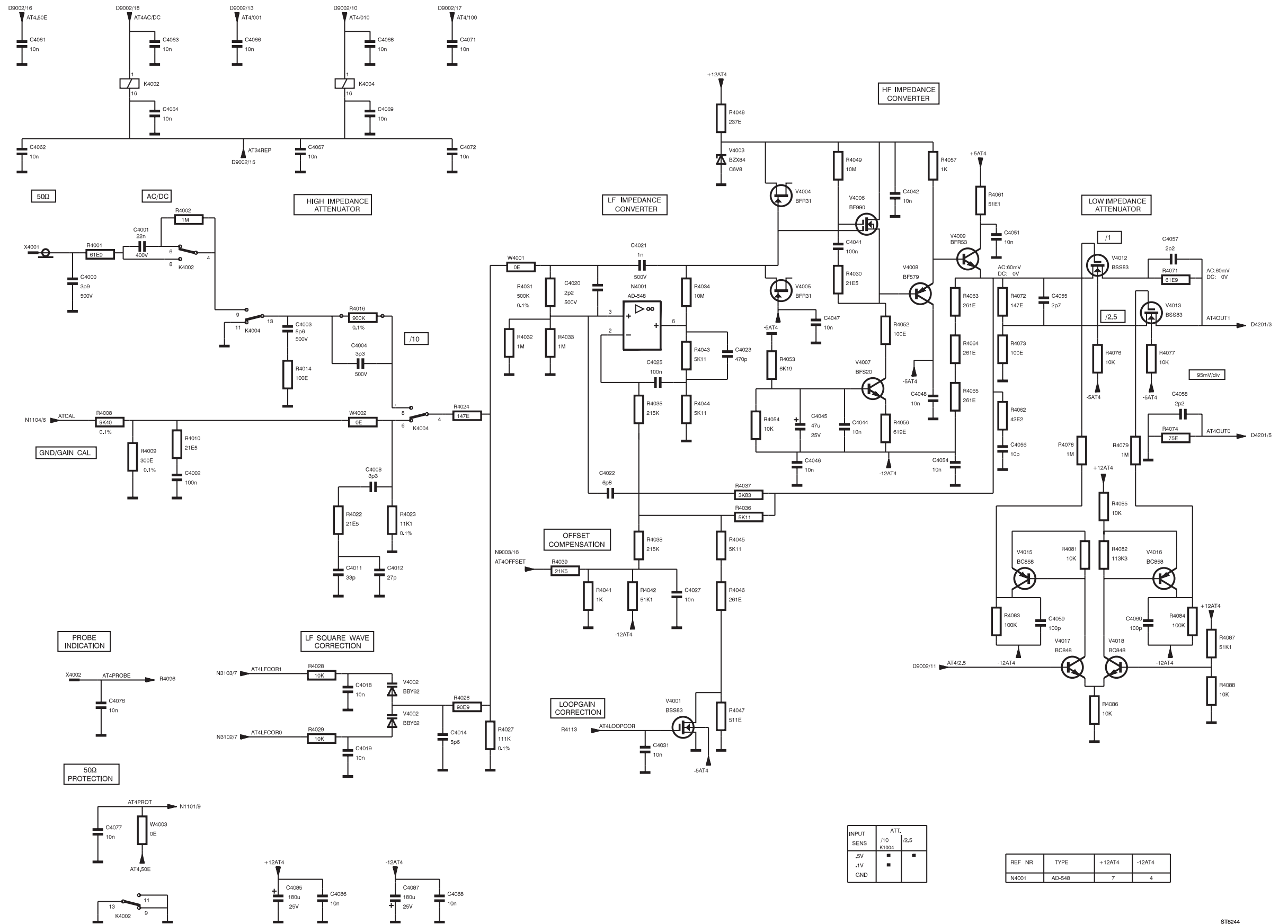

Diagram 4 - Attenuator CH4 (PM3394B)



ST8244
970420

Diagram 4a - Attenuator CH4 (PM3380B/70B)

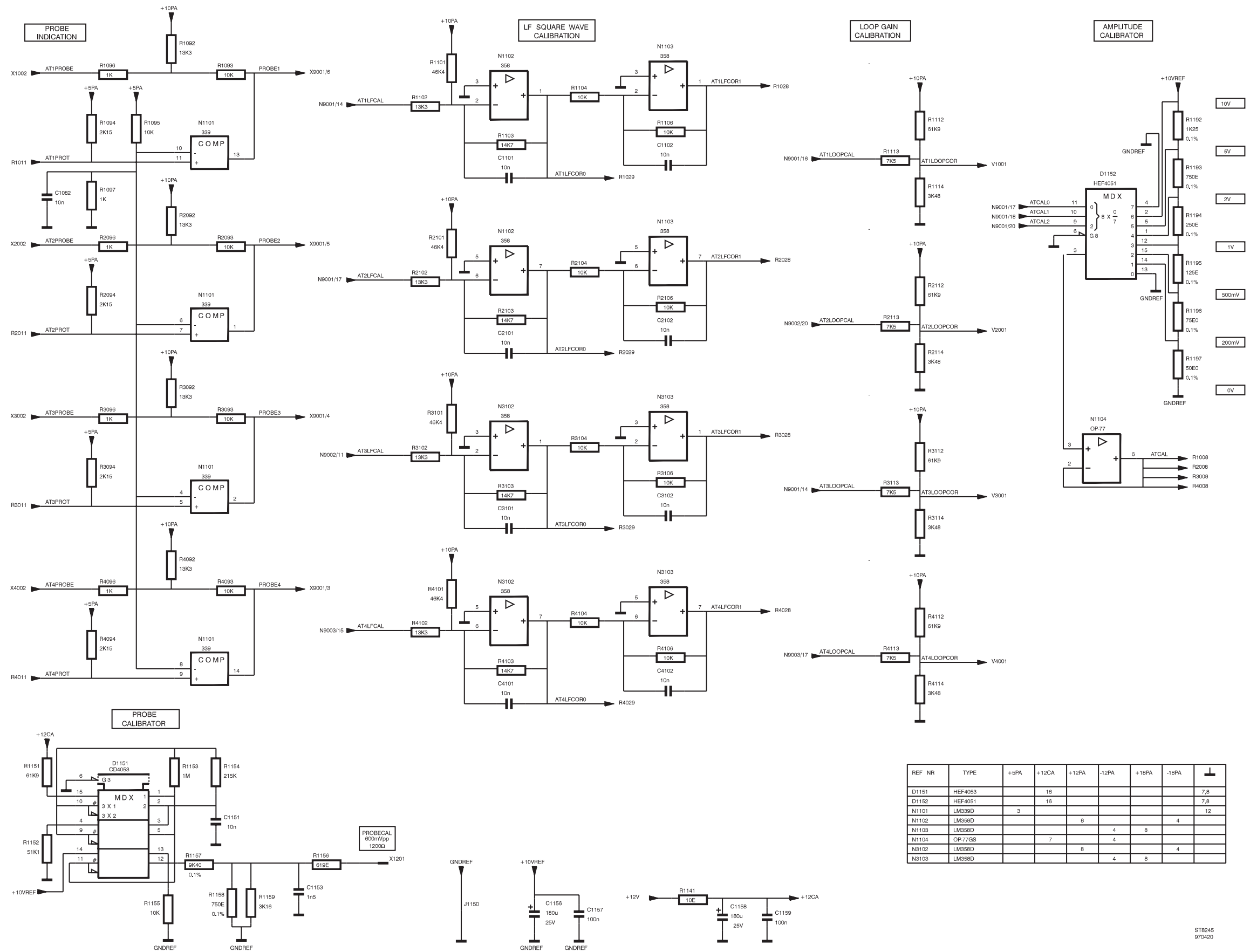

Diagram 5 - Attenuator control + CAL generator

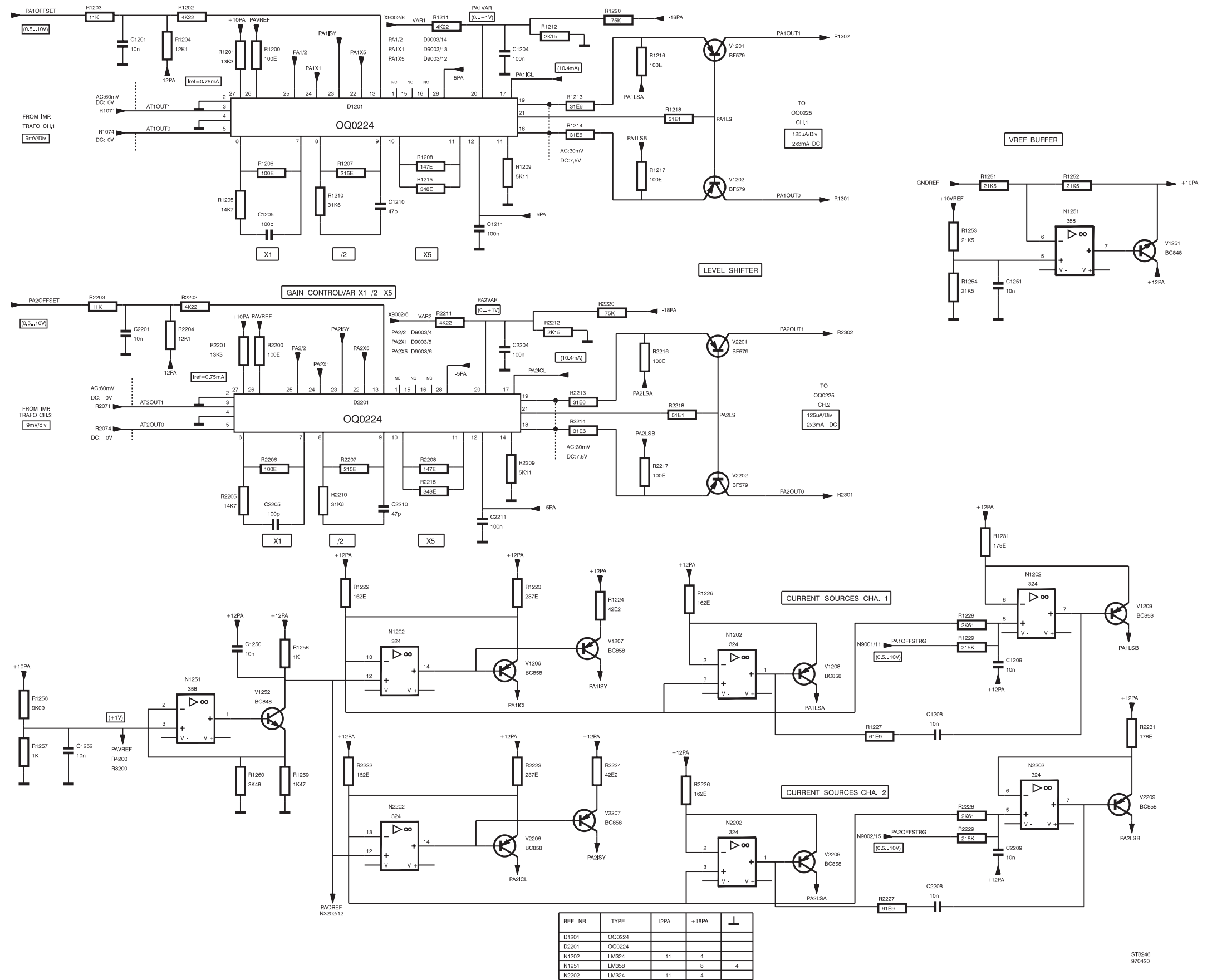

Diagram 6 - Pre-amplifier CH1 and CH2

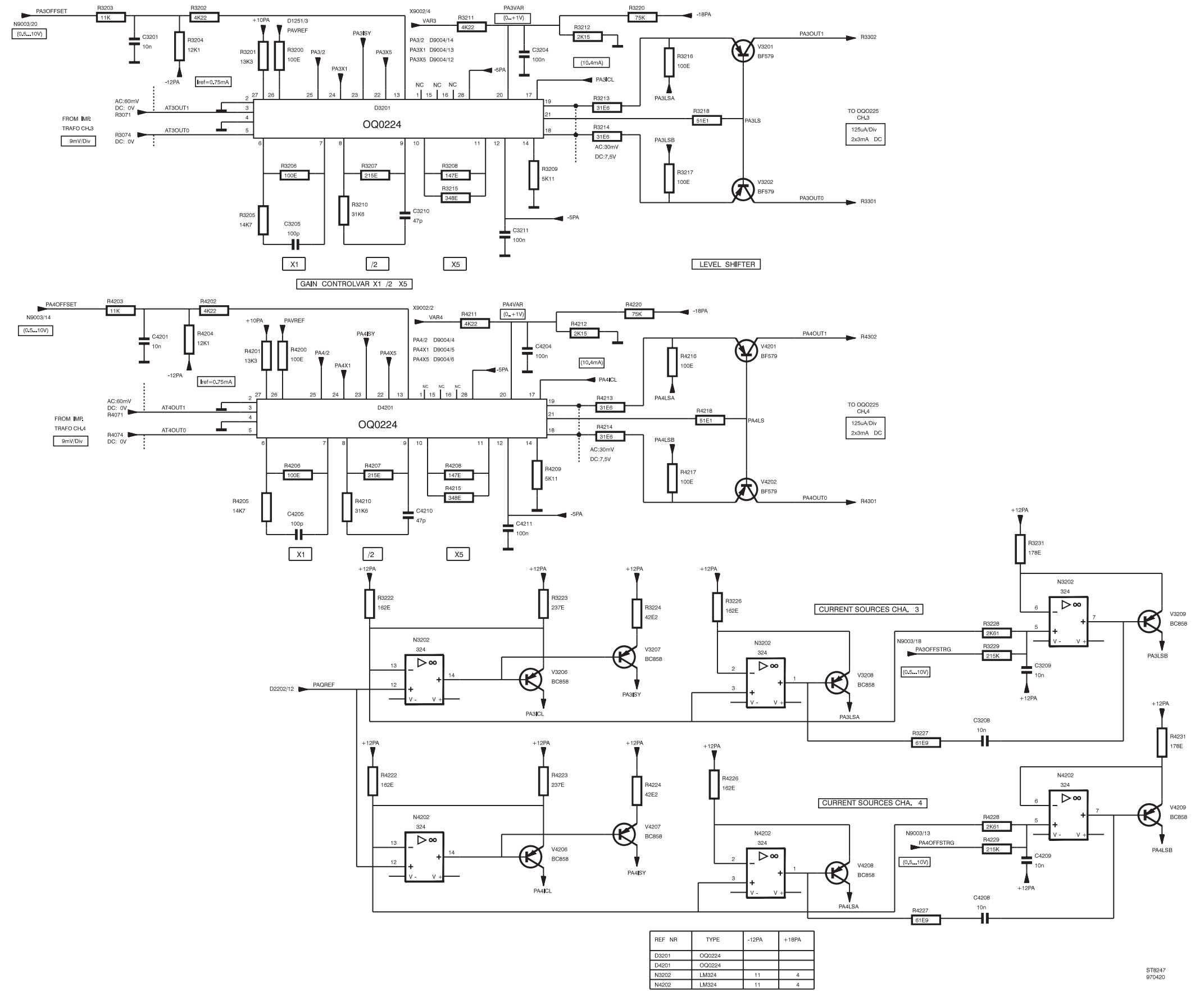

Diagram 7 - Pre-amplifier CH3 and CH4

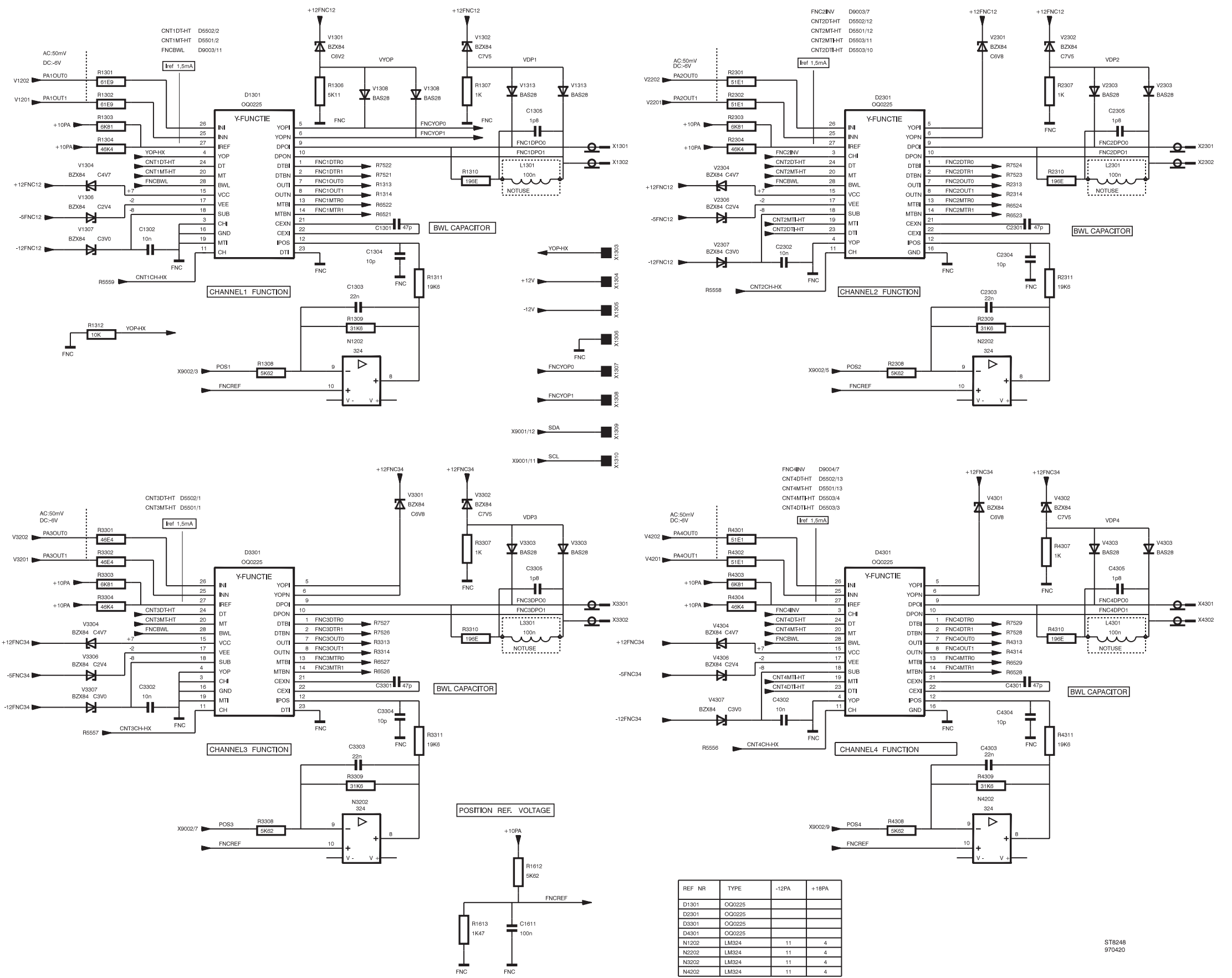

Diagram 8 - Y-functions

ST8248
970420

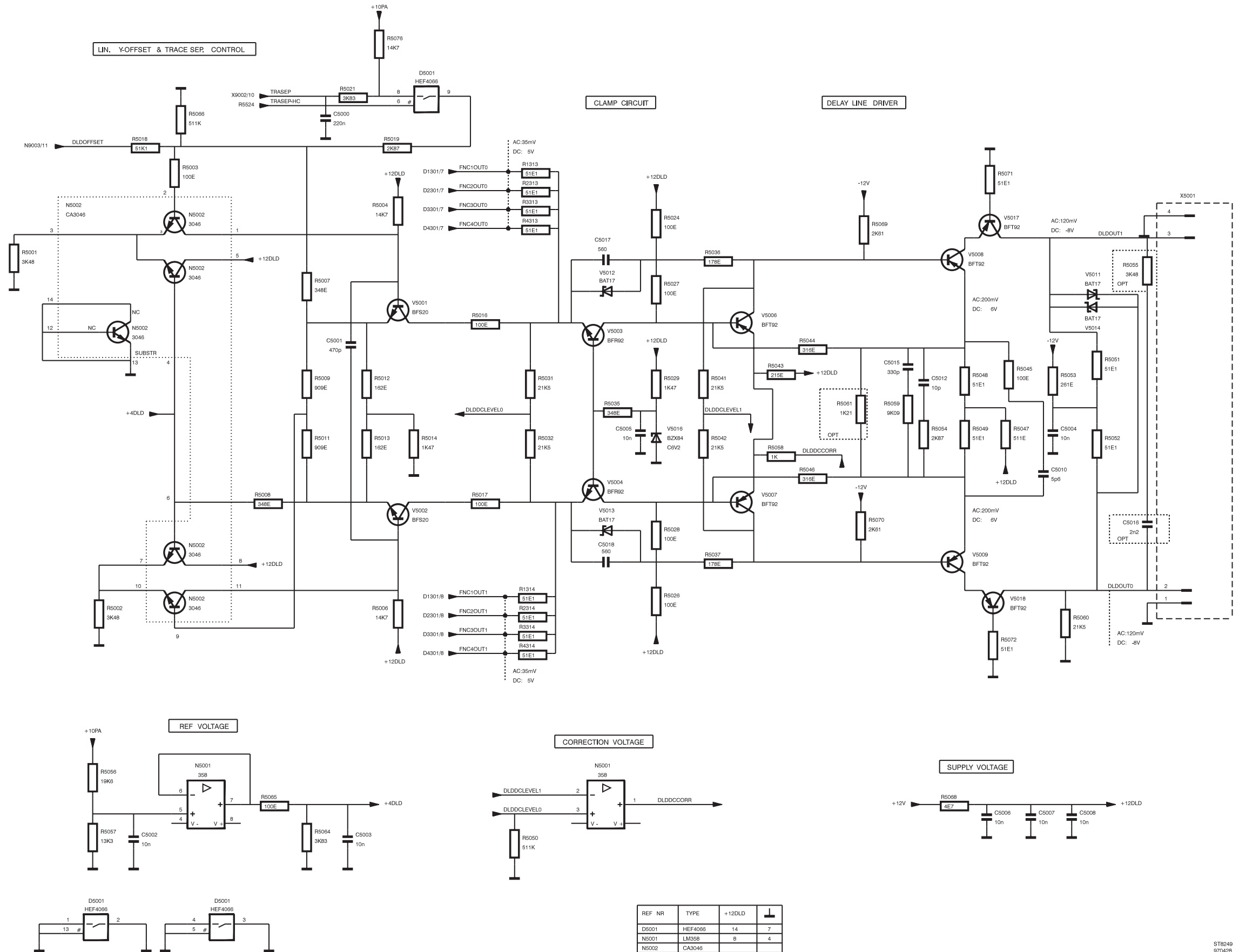

Diagram 9 - Delay line driver (PM3394B/90B)

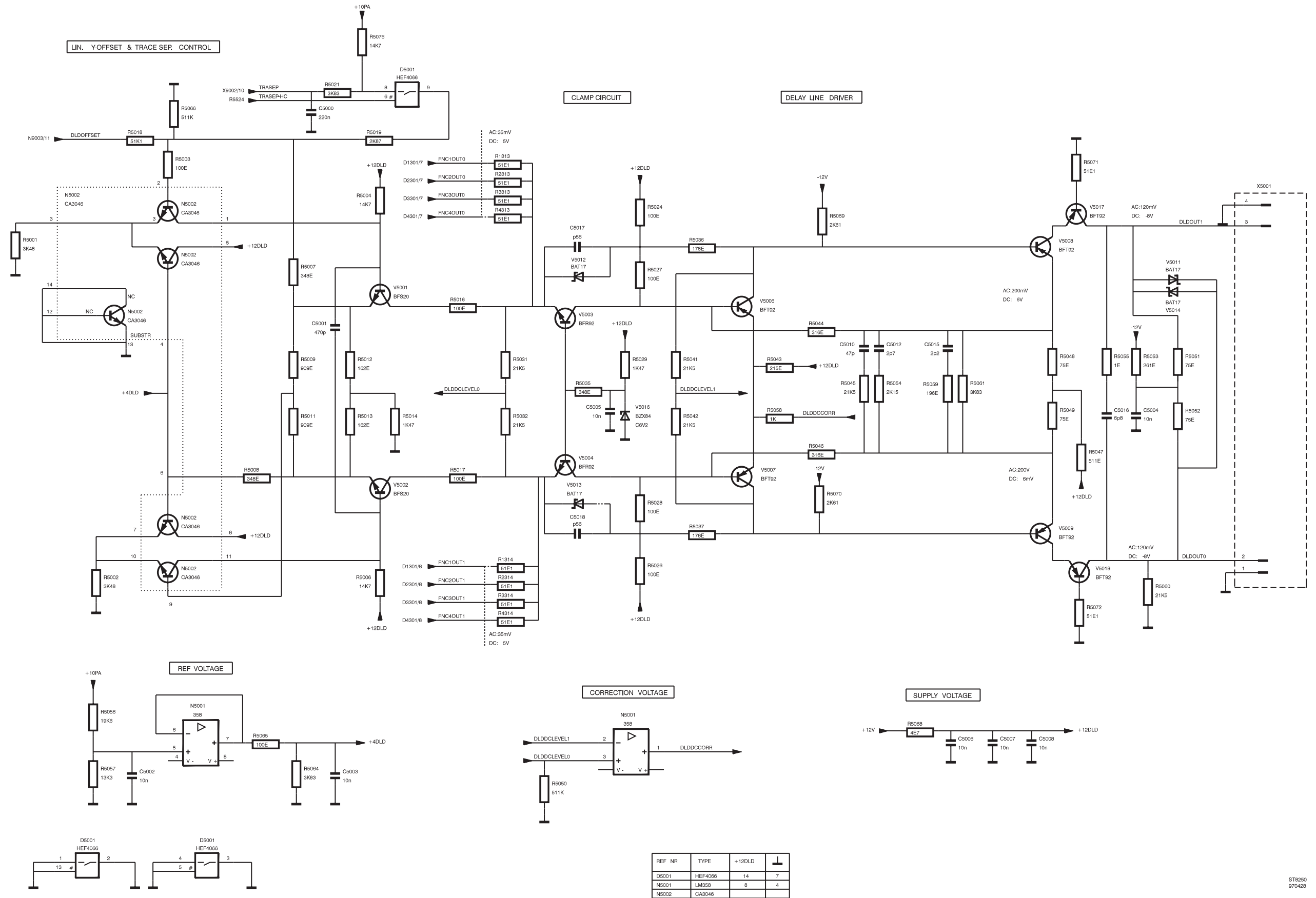
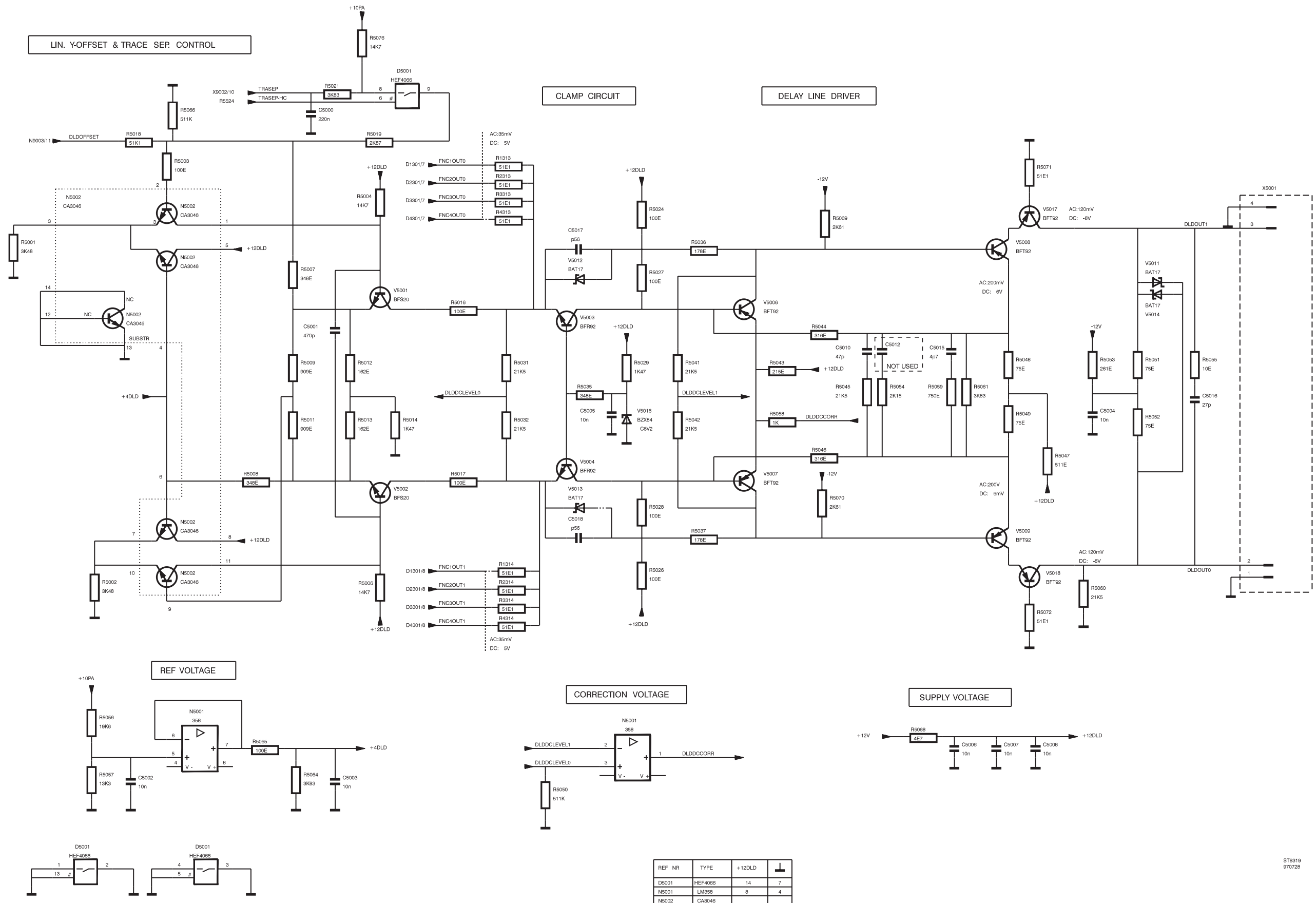

Diagram 9a - Delay line driver (PM3384B/80B)



REF NR	TYPE	+12DLD	⏏
D5001	HEF4098	14	7
N5001	LM358	8	4
N5002	CA3046		

Diagram 9b - Delay line driver (Pm3370A)

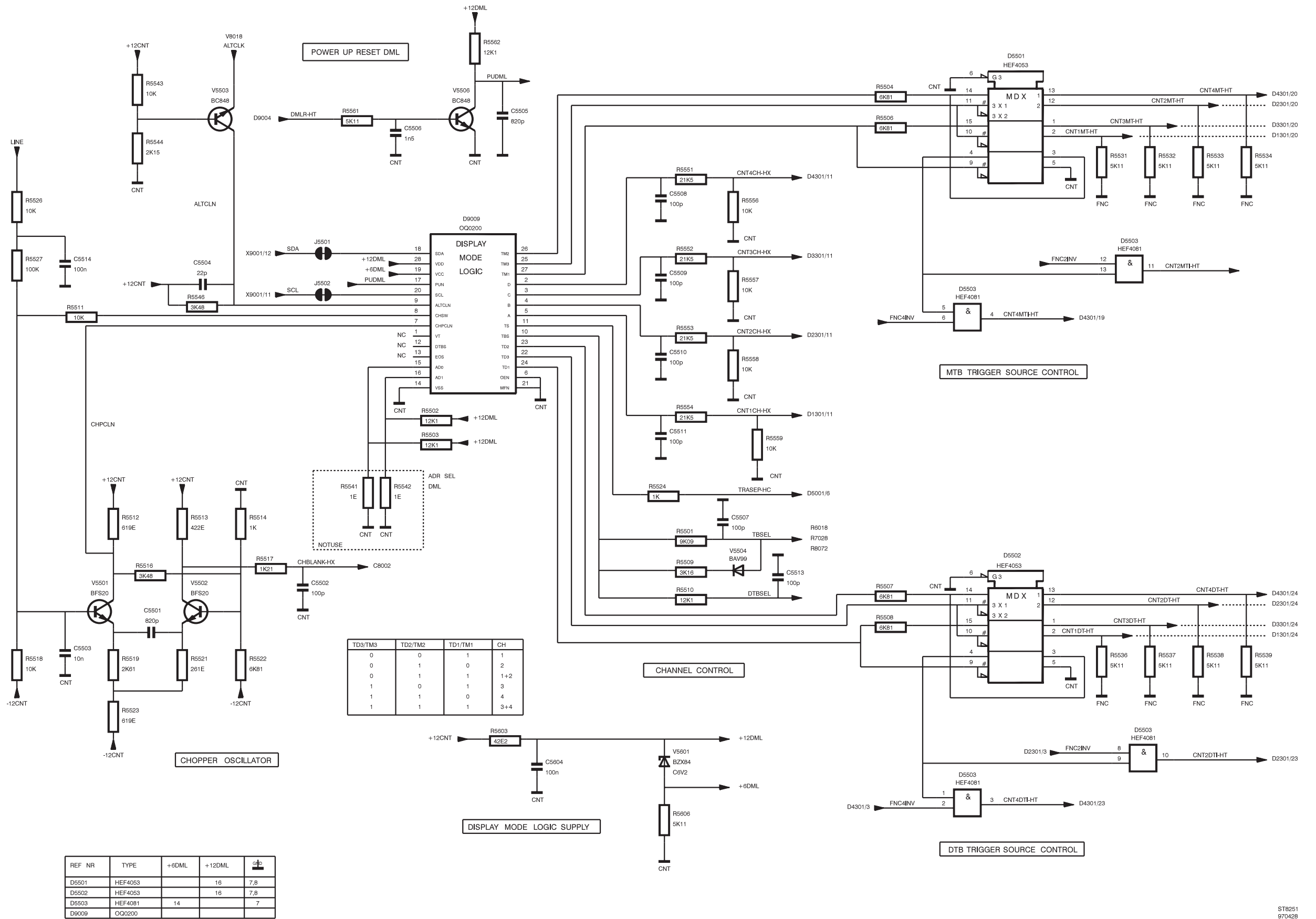

Diagram 10 - Display and trigger control

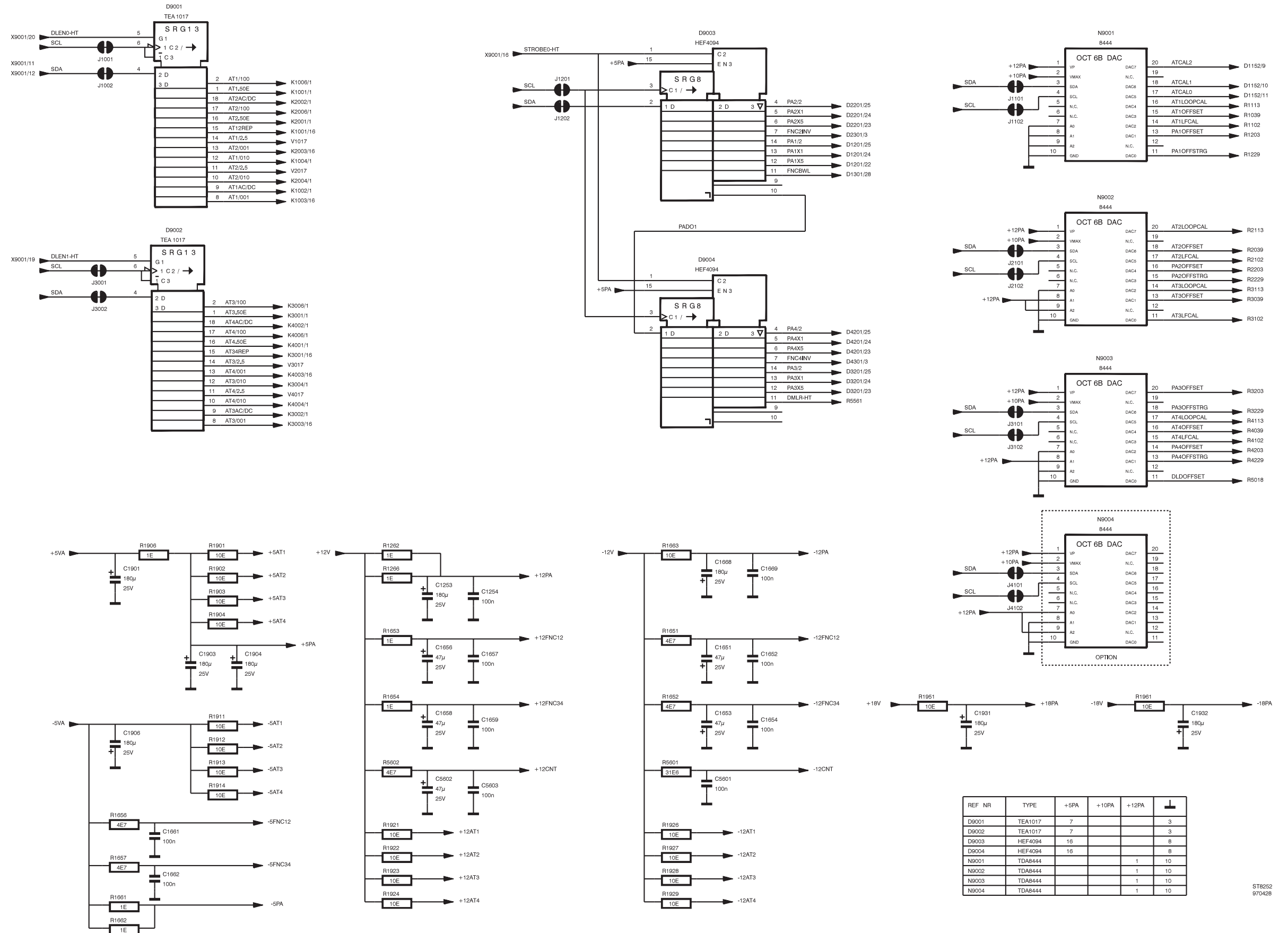

Diagram 11 - Control circuits

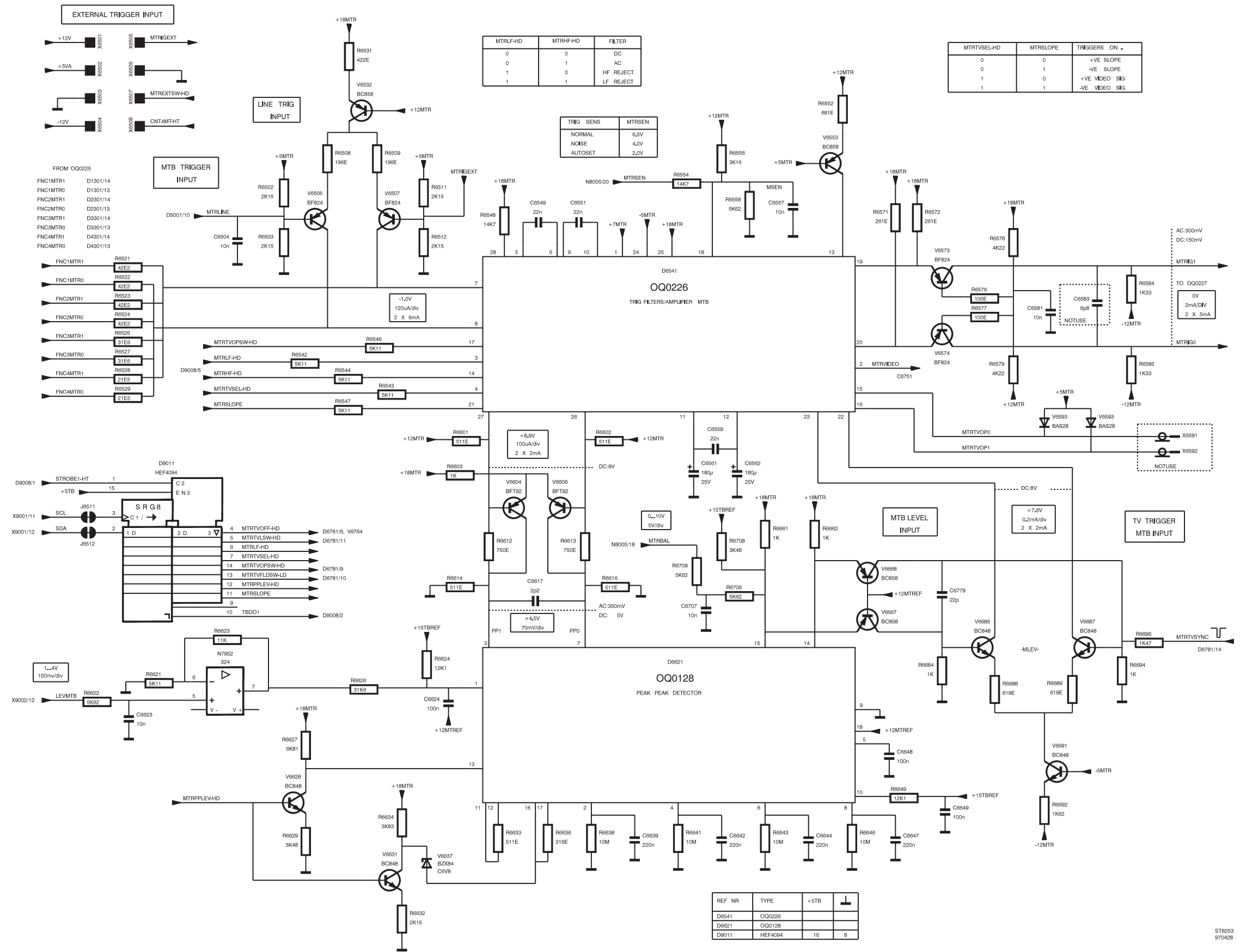

Diagram 12 - MTB trigger

STR253
970428

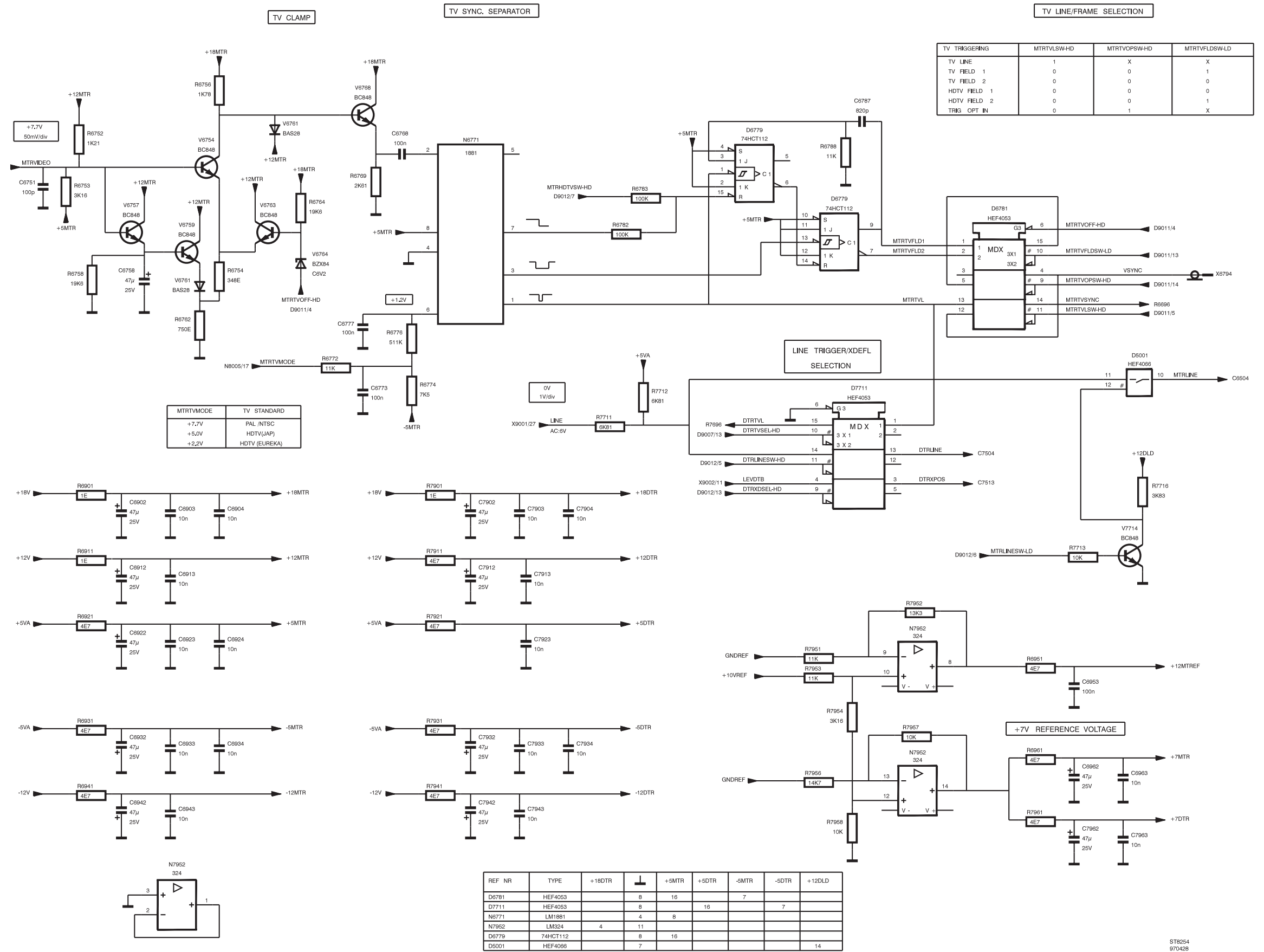

Diagram 13 - TV/line trigger

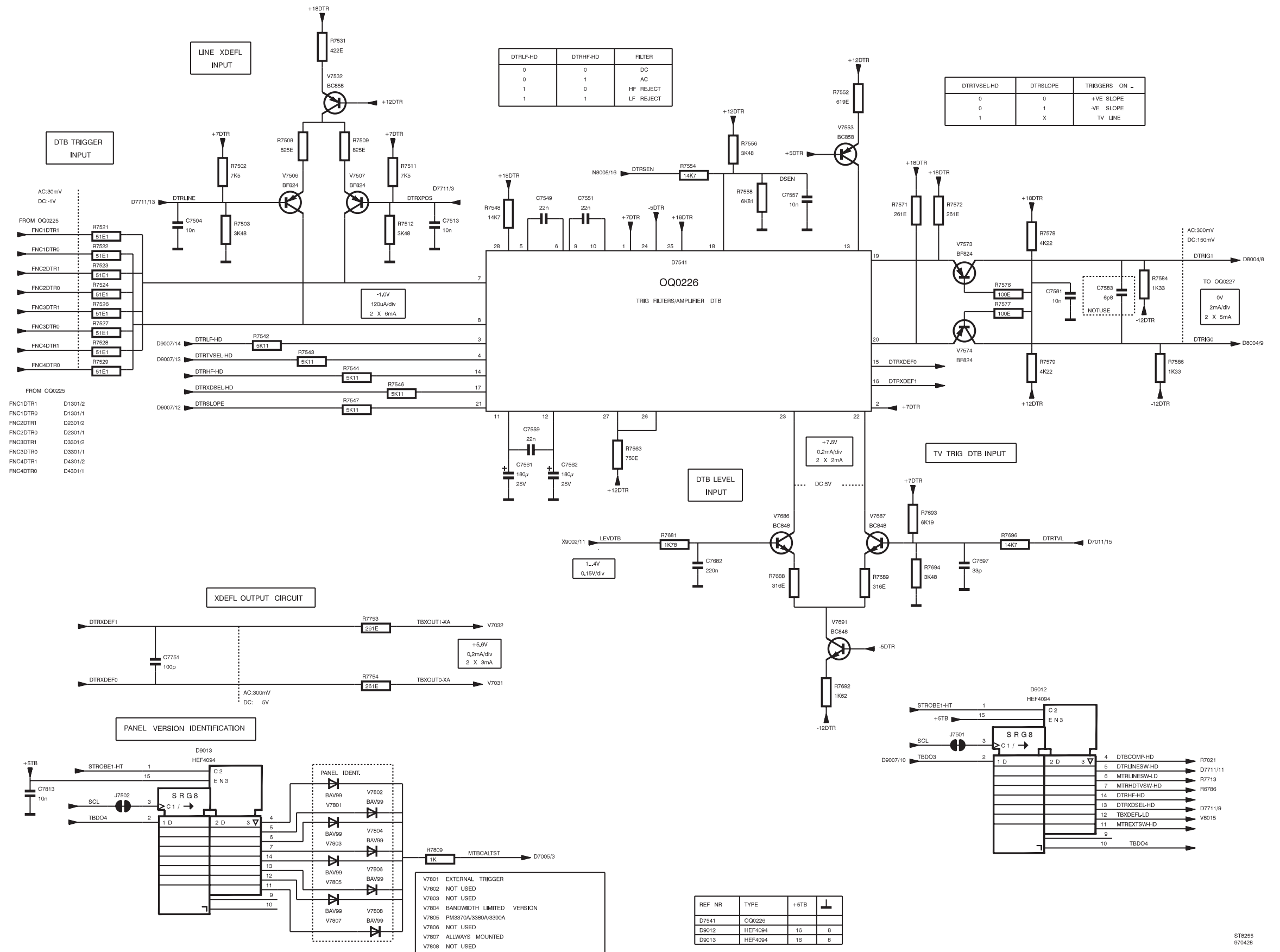

Diagram 14 - DTB trigger

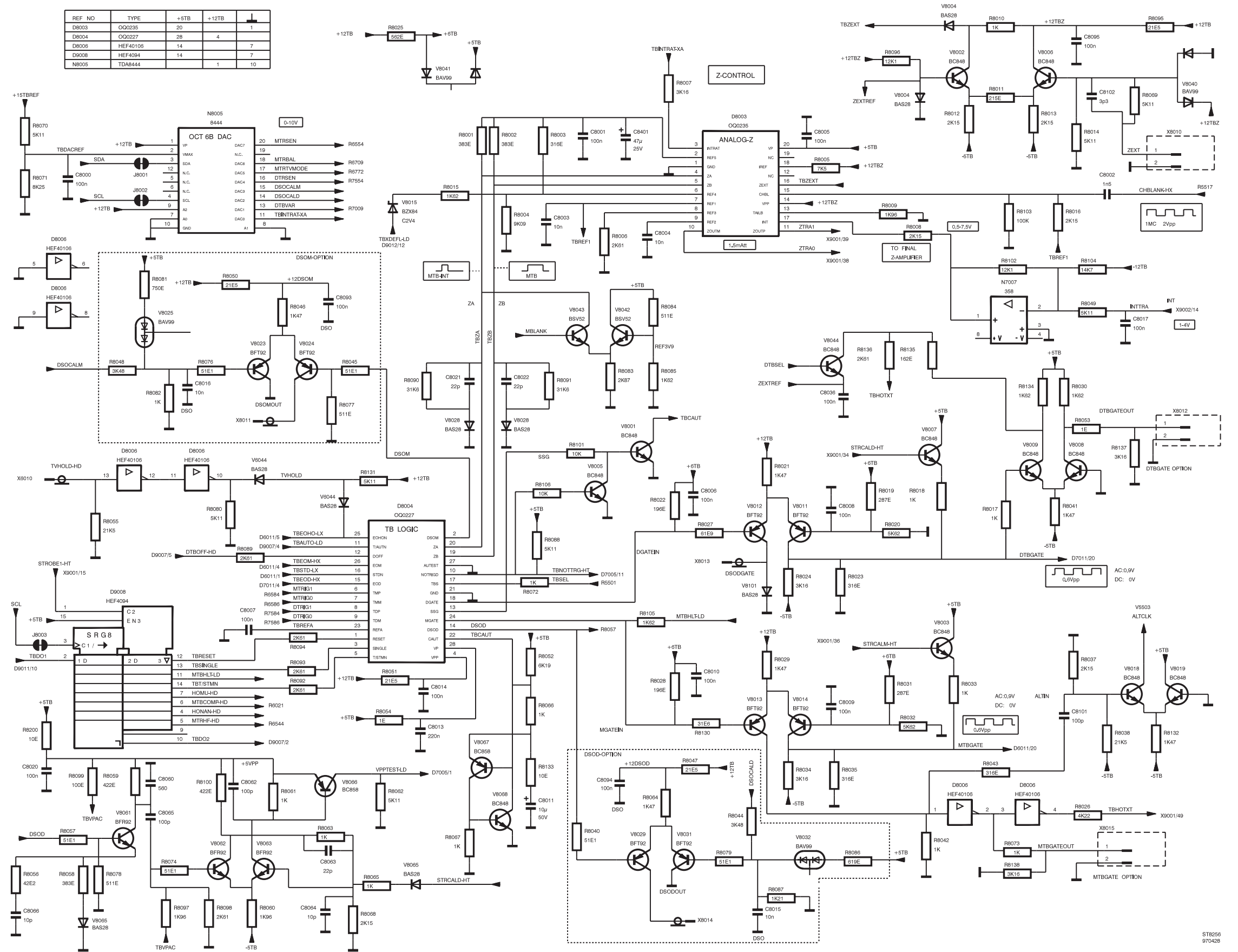

Diagram 15 - Time base logic

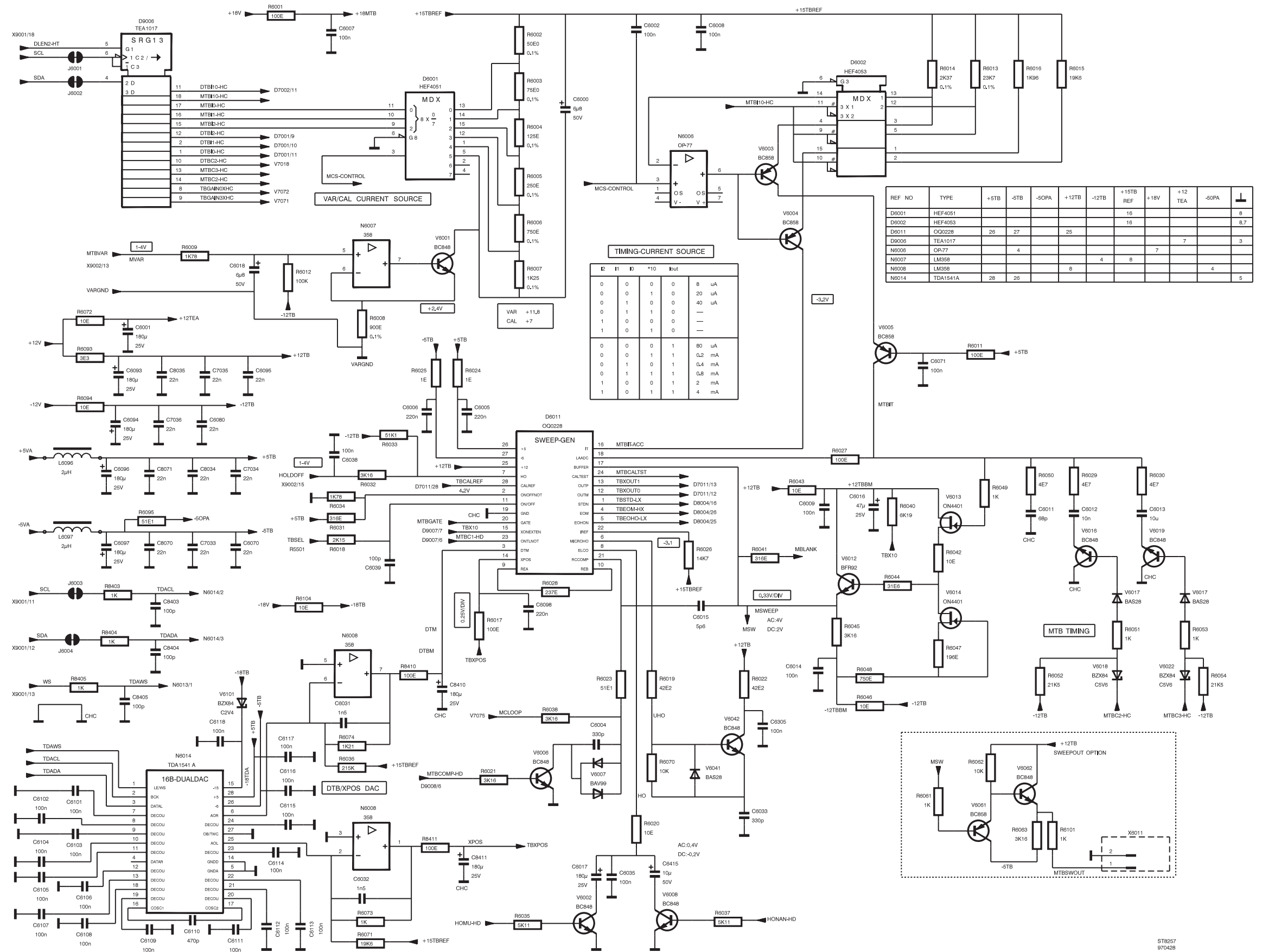

Diagram 16 - Main time base

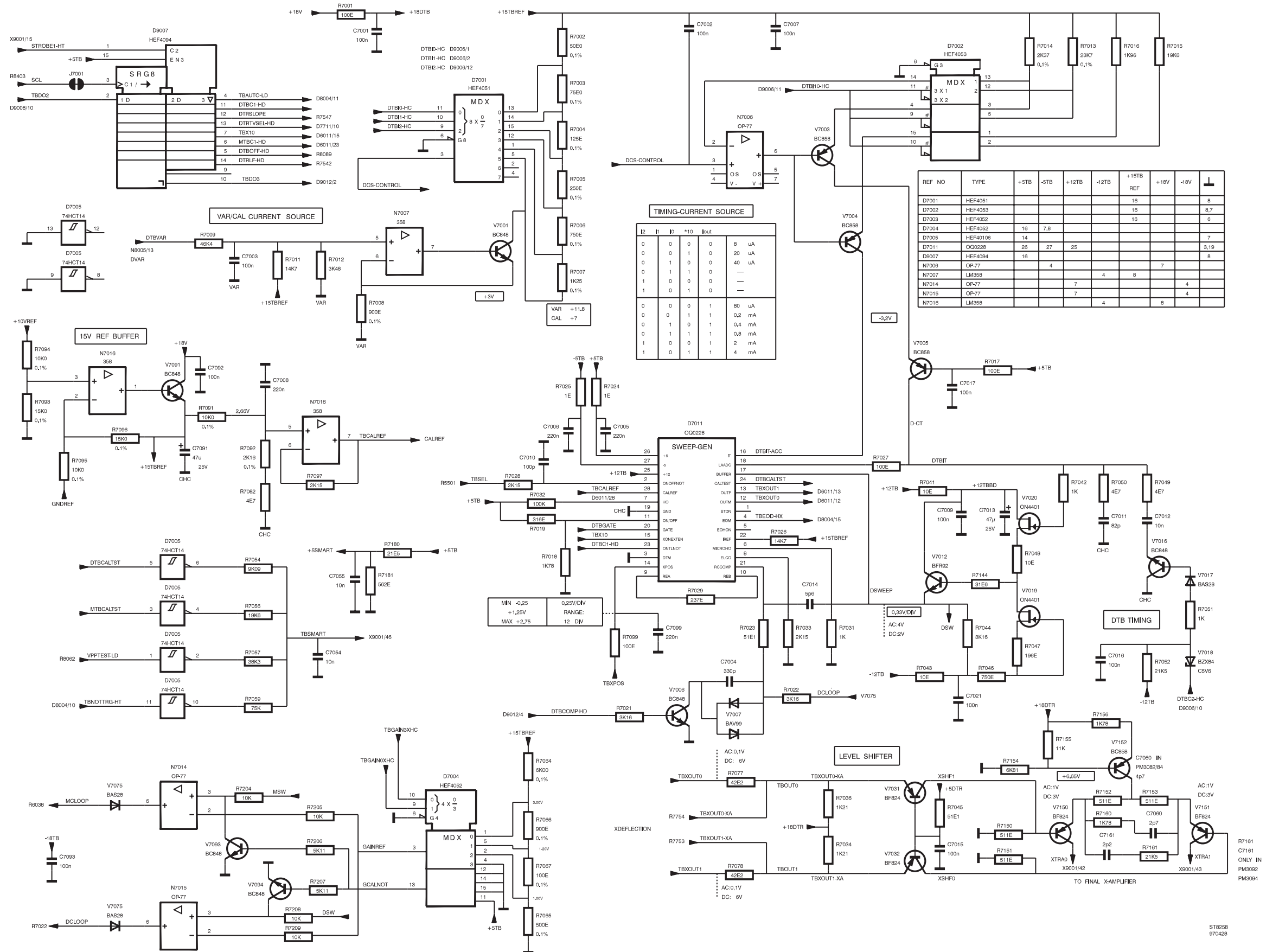
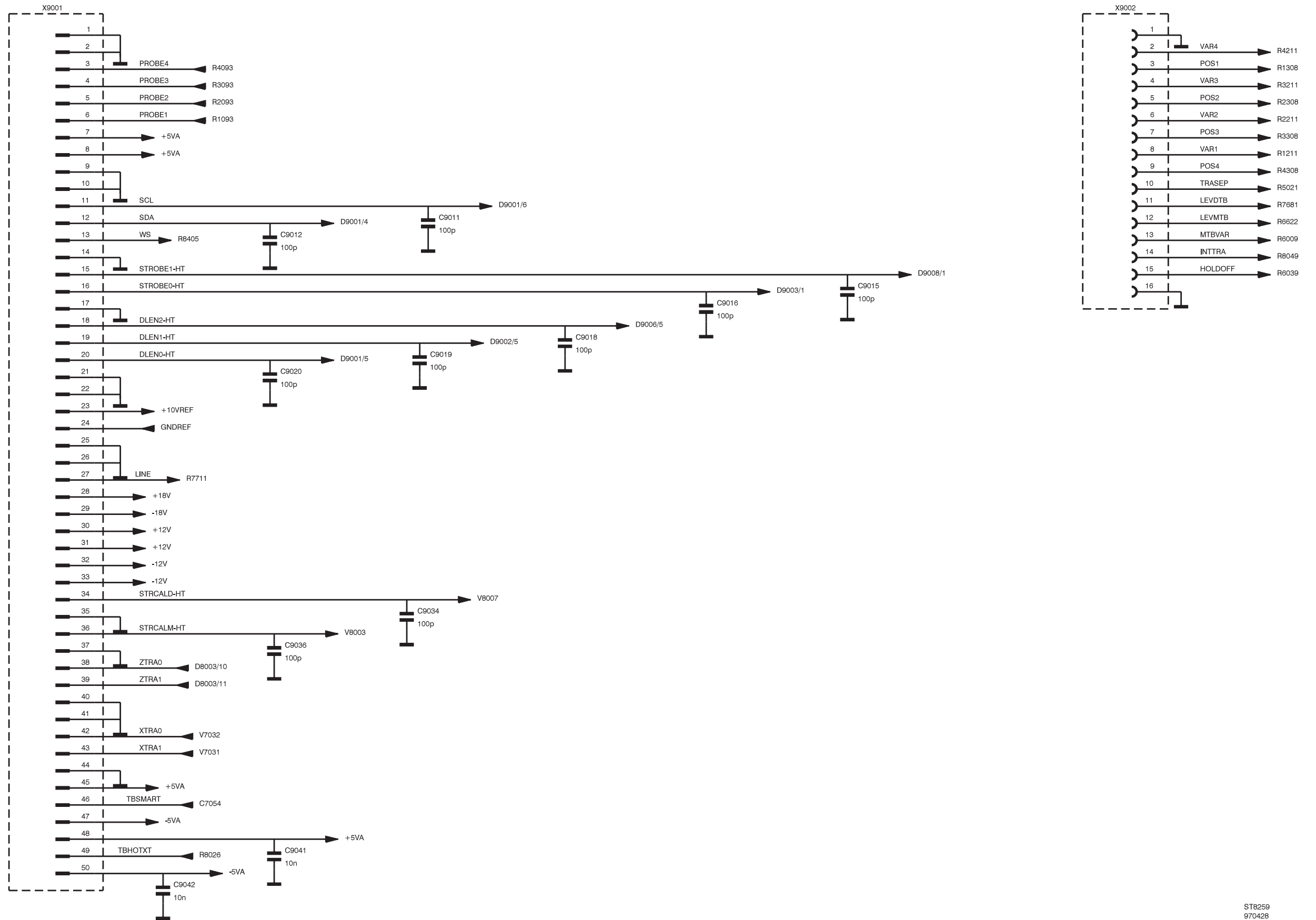

Diagram 17 - Delayed time base



ST8259
970428

Diagram 18 - Connectors

Item	Description	Ordering code
------	-------------	---------------

5.1.6 Parts list**MECHANICAL**

0002	SPECIAL NUT	FOR BNC	5322 506 41006
0003	RING	BNC SPACER	5322 532 21188
0004	HOLDER	BNC HOLDER	5322 256 91792
0005	PLATE	SCREENING PARTITION	5322 466 83049
0006	PIN	CALIBRATION PIN	5322 535 93244
0007	BRACKET	SOLDERING BRACKET	5322 401 11419
0008	SPRING	INDICATION SPRING	5322 492 70939
0010	SHIELD	SCREENING CAP 2	5322 466 30404
0011	SHIELD	SCREENING CAP 1	5322 466 30405
0012	SCREENING	SCREENING PLATE	5322 466 83051
0014	CAP	BNC ISOLATOR	5322 462 41847
0017	CAP,PROTECT.	SCREENING CAP C	5322 447 70131

CAPACITORS

C1000	CAP.CERAMIC	500V 0.25PF 3.3PF	4822 122 31188
C1001	CAP.FOIL	AP 400V 10% 22NF	5322 121 70399
C1002	CAP.CHIP	AP 63V 10% 100NF	4822 122 33496
C1003	CAP.CERAMIC	500V 0.25PF 3.3PF	4822 122 31188
C1004	CAP.CERAMIC	500V 0.25PF 3.3PF	4822 122 31188
C1006	CAP.CERAMIC	500V 0.25PF 3.3PF	4822 122 31188
C1007	CAP.CERAMIC	500V 0.25PF 3.3PF	4822 122 31188
C1008	CAP.CHIP	AP 63V 0.25PF 3.3PF	5322 122 32286
C1011	CAP.CHIP	AP 63V 5% 33PF	5322 122 32659
C1012	CAP.CHIP	AP 63V 5% 27PF	5322 122 31946
C1014	CAP.CHIP	AP 63V 0.5PF 5.6 PF	5322 122 32967
C1018	CAP.CHIP	AP 63V 10% 10NF	5322 122 34098
C1019	CAP.CHIP	AP 63V 10% 10NF	5322 122 34098
C1020	CAP.CERAMIC	500V 0.25PF 2.2PF	5322 122 32774
C1021	CAP.CERAMIC	500V 10% 1NF	4822 122 31175
C1022	CAP.CHIP	AP 63V 0.5PF 6.8PF	5322 122 32269
C1023	CAP.CHIP	AP 63V 5% 470PF	5322 122 32268
C1025	CAP.CHIP	AP 63V 10% 100NF	4822 122 33496
C1027	CAP.CHIP	AP 63V 10% 10NF	5322 122 34098
C1031	CAP.CHIP	AP 63V 10% 10NF	5322 122 34098
C1041	CAP.CHIP	AP 63V 10% 100NF	4822 122 33496
C1042	CAP.CHIP	AP 63V 10% 10NF	5322 122 34098
C1044	CAP.CHIP	AP 63V 10% 10NF	5322 122 34098
C1045	CAP.ELECTROLYT.	25V 20% 47UF	5322 121 10472
C1046	CAP.CHIP	AP 63V 10% 10NF	5322 122 34098
C1047	CAP.CHIP	AP 63V 10% 10NF	5322 122 34098
C1048	CAP.CHIP	AP 63V 10% 10NF	5322 122 34098
C1051	CAP.CHIP	AP 63V 10% 10NF	5322 122 34098
C1054	CAP.CHIP	AP 63V 10% 10NF	5322 122 34098
C1055	CAP.CHIP	AP 63V 0.25PF 2.7PF	5322 122 31873

Item	Description		Ordering code
C1056	CAP.CERAMIC	AP 63V 5% 10PF	5322 122 32448
C1057	CAP.CHIP	AP 63V 0.25PF 2.2PF	5322 122 33063
C1058	CAP.CHIP	AP 63V 0.25PF 2.2PF	5322 122 33063
C1059	CAP.CHIP	AP 63V 5% 100PF	5322 122 32531
C1060	CAP.CHIP	AP 63V 5% 100PF	5322 122 32531
C1061	CAP.CHIP	AP 63V 10% 10NF	5322 122 34098
C1062	CAP.CHIP	AP 63V 10% 10NF	5322 122 34098
C1063	CAP.CHIP	AP 63V 10% 10NF	5322 122 34098
C1064	CAP.CHIP	AP 63V 10% 10NF	5322 122 34098
C1066	CAP.CHIP	AP 63V 10% 10NF	5322 122 34098
C1067	CAP.CHIP	AP 63V 10% 10NF	5322 122 34098
C1068	CAP.CHIP	AP 63V 10% 10NF	5322 122 34098
C1069	CAP.CHIP	AP 63V 10% 10NF	5322 122 34098
C1071	CAP.CHIP	AP 63V 10% 10NF	5322 122 34098
C1072	CAP.CHIP	AP 63V 10% 10NF	5322 122 34098
C1076	CAP.CHIP	AP 63V 10% 10NF	5322 122 34098
C1077	CAP.CHIP	AP 63V 10% 10NF	5322 122 34098
C1082	CAP.CHIP	AP 63V 10% 10NF	5322 122 34098
C1085	CAP.ELECTROLYT.	25V 20% 180UF	5322 124 42228
C1086	CAP.CHIP	AP 63V 10% 10NF	5322 122 34098
C1087	CAP.ELECTROLYT.	25V 20% 180UF	5322 124 42228
C1088	CAP.CHIP	AP 63V 10% 10NF	5322 122 34098
C1101	CAP.CHIP	AP 63V 10% 10NF	5322 122 34098
C1102	CAP.CHIP	AP 63V 10% 10NF	5322 122 34098
C1151	CAP.CHIP	AP 63V 10% 10NF	5322 122 34098
C1153	CAP.CHIP	AP 63V 10% 1.5NF	5322 122 31865
C1156	CAP.ELECTROLYT.	25V 20% 180UF	5322 124 42228
C1157	CAP.CHIP	AP 63V 10% 100NF	4822 122 33496
C1158	CAP.ELECTROLYT.	25V 20% 180UF	5322 124 42228
C1159	CAP.CHIP	AP 63V 10% 100NF	4822 122 33496
C1201	CAP.CHIP	AP 63V 10% 10NF	5322 122 34098
C1204	CAP.CHIP	AP 63V 10% 100NF	4822 122 33496
C1205	CAP.CHIP	AP 63V 5% 100PF	5322 122 32531
C1208	CAP.CHIP	AP 63V 10% 10NF	5322 122 34098
C1209	CAP.CHIP	AP 63V 10% 10NF	5322 122 34098
C1210	CAP.CERAMIC	AP 63V 5% 47PF	5322 122 32452
C1211	CAP.CHIP	AP 63V 10% 100NF	4822 122 33496
C1250	CAP.CHIP	AP 63V 10% 10NF	5322 122 34098
C1251	CAP.CHIP	AP 63V 10% 10NF	5322 122 34098
C1252	CAP.CHIP	AP 63V 10% 10NF	5322 122 34098
C1253	CAP.ELECTROLYT.	25V 20% 180UF	5322 124 42228
C1254	CAP.CHIP	AP 63V 10% 100NF	4822 122 33496
C1301	CAP.CERAMIC	AP 63V 5% 47PF	5322 122 32452
C1302	CAP.CHIP	AP 63V 10% 10NF	5322 122 34098
C1303	CAP.CHIP	AP 63V 10% 22NF	5322 122 32654
C1304	CAP.CERAMIC	AP 63V 5% 10PF	5322 122 32448
C1305	CAP.CERAMIC	AP 63V 0.25PF 1.8PF	5322 126 10343

Item	Description		Ordering code
C1611	CAP.CHIP	AP 63V 10% 100NF	4822 122 33496
C1651	CAP.ELECTROLYT.	25V 20% 47UF	5322 121 10472
C1652	CAP.CHIP	AP 63V 10% 100NF	4822 122 33496
C1653	CAP.ELECTROLYT.	25V 20% 47UF	5322 121 10472
C1654	CAP.CHIP	AP 63V 10% 100NF	4822 122 33496
C1656	CAP.ELECTROLYT.	25V 20% 47UF	5322 121 10472
C1657	CAP.CHIP	AP 63V 10% 100NF	4822 122 33496
C1658	CAP.ELECTROLYT.	25V 20% 47UF	5322 121 10472
C1659	CAP.CHIP	AP 63V 10% 100NF	4822 122 33496
C1661	CAP.CHIP	AP 63V 10% 100NF	4822 122 33496
C1662	CAP.CHIP	AP 63V 10% 100NF	4822 122 33496
C1668	CAP.ELECTROLYT.	25V 20% 180UF	5322 124 42228
C1669	CAP.CHIP	AP 63V 10% 100NF	4822 122 33496
C1901	CAP.ELECTROLYT.	25V 20% 180UF	5322 124 42228
C1903	CAP.ELECTROLYT.	25V 20% 180UF	5322 124 42228
C1904	CAP.ELECTROLYT.	25V 20% 180UF	5322 124 42228
C1906	CAP.ELECTROLYT.	25V 20% 180UF	5322 124 42228
C1931	CAP.ELECTROLYT.	25V 20% 180UF	5322 124 42228
C1932	CAP.ELECTROLYT.	25V 20% 180UF	5322 124 42228
C2000	CAP.CERAMIC	500V 0.25PF 3.3PF	4822 122 31188
C2001	CAP.FOIL	400V 10% 22NF	5322 121 70399
C2002	CAP.CHIP	AP 63V 10% 100NF	4822 122 33496
C2003	CAP.CERAMIC	500V 0.25PF 3.3PF	4822 122 31188
C2004	CAP.CERAMIC	500V 0.25PF 3.3PF	4822 122 31188
C2006	CAP.CERAMIC	500V 0.25PF 3.3PF	4822 122 31188
C2007	CAP.CERAMIC	500V 0.25PF 3.3PF	4822 122 31188
C2008	CAP.CHIP	AP 63V 0.25PF 3.3PF	5322 122 32286
C2011	CAP.CHIP	AP 63V 5% 33PF	5322 122 32659
C2012	CAP.CHIP	AP 63V 5% 27PF	5322 122 31946
C2014	CAP.CHIP	AP 63V 0.5PF 5.6PF	5322 122 32967
C2018	CAP.CHIP	AP 63V 10% 10NF	5322 122 34098
C2019	CAP.CHIP	AP 63V 10% 10NF	5322 122 34098
C2020	CAP.CERAMIC	500V 0.25PF 2.2PF	5322 122 32774
C2021	CAP.CERAMIC	500V 10% 1NF	4822 122 31175
C2022	CAP.CHIP	AP 63V 0.5PF 6.8PF	5322 122 32269
C2023	CAP.CHIP	AP 63V 5% 470PF	5322 122 32268
C2025	CAP.CHIP	AP 63V 10% 100NF	4822 122 33496
C2027	CAP.CHIP	AP 63V 10% 10NF	5322 122 34098
C2031	CAP.CHIP	AP 63V 10% 10NF	5322 122 34098
C2041	CAP.CHIP	AP 63V 10% 100NF	4822 122 33496
C2042	CAP.CHIP	AP 63V 10% 10NF	5322 122 34098
C2044	CAP.CHIP	AP 63V 10% 10NF	5322 122 34098
C2045	CAP.ELECTROLYT.	25V 20% 47UF	5322 121 10472
C2046	CAP.CHIP	AP 63V 10% 10NF	5322 122 34098
C2047	CAP.CHIP	AP 63V 10% 10NF	5322 122 34098
C2048	CAP.CHIP	AP 63V 10% 10NF	5322 122 34098
C2051	CAP.CHIP	AP 63V 10% 10NF	5322 122 34098

Item	Description		Ordering code
C2054	CAP.CHIP	AP 63V 10% 10NF	5322 122 34098
C2055	CAP.CHIP	AP 63V 0.25PF 2.7PF	5322 122 31873
C2056	CAP.CERAMIC	AP 63V 5% 10PF	5322 122 32448
C2057	CAP.CHIP	AP 63V 0.25PF 2.2PF	5322 122 33063
C2058	CAP.CHIP	AP 63V 0.25PF 2.2PF	5322 122 33063
C2059	CAP.CHIP	AP 63V 5% 100PF	5322 122 32531
C2060	CAP.CHIP	AP 63V 5% 100PF	5322 122 32531
C2061	CAP.CHIP	AP 63V 10% 10NF	5322 122 34098
C2062	CAP.CHIP	AP 63V 10% 10NF	5322 122 34098
C2063	CAP.CHIP	AP 63V 10% 10NF	5322 122 34098
C2064	CAP.CHIP	AP 63V 10% 10NF	5322 122 34098
C2066	CAP.CHIP	AP 63V 10% 10NF	5322 122 34098
C2067	CAP.CHIP	AP 63V 10% 10NF	5322 122 34098
C2068	CAP.CHIP	AP 63V 10% 10NF	5322 122 34098
C2069	CAP.CHIP	AP 63V 10% 10NF	5322 122 34098
C2071	CAP.CHIP	AP 63V 10% 10NF	5322 122 34098
C2072	CAP.CHIP	AP 63V 10% 10NF	5322 122 34098
C2076	CAP.CHIP	AP 63V 10% 10NF	5322 122 34098
C2077	CAP.CHIP	AP 63V 10% 10NF	5322 122 34098
C2085	CAP.ELECTROLYT.	25V 20% 180UF	5322 124 42228
C2086	CAP.CHIP	AP 63V 10% 10NF	5322 122 34098
C2087	CAP.ELECTROLYT.	25V 20% 180UF	5322 124 42228
C2088	CAP.CHIP	AP 63V 10% 10NF	5322 122 34098
C2101	CAP.CHIP	AP 63V 10% 10NF	5322 122 34098
C2102	CAP.CHIP	AP 63V 10% 10NF	5322 122 34098
C2201	CAP.CHIP	AP 63V 10% 10NF	5322 122 34098
C2204	CAP.CHIP	AP 63V 10% 100NF	4822 122 33496
C2205	CAP.CHIP	AP 63V 5% 100PF	5322 122 32531
C2208	CAP.CHIP	AP 63V 10% 10NF	5322 122 34098
C2209	CAP.CHIP	AP 63V 10% 10NF	5322 122 34098
C2210	CAP.CERAMIC	AP 63V 5% 47PF	5322 122 32452
C2211	CAP.CHIP	AP 63V 10% 100NF	4822 122 33496
C2301	CAP.CERAMIC	AP 63V 5% 47PF	5322 122 32452
C2302	CAP.CHIP	AP 63V 10% 10NF	5322 122 34098
C2303	CAP.CHIP	AP 63V 10% 22NF	5322 122 32654
C2304	CAP.CERAMIC	AP 63V 5% 10PF	5322 122 32448
C2305	CAP.CERAMIC	AP 63V 0.25PF 1.8PF	5322 126 10343
C3000	CAP.CERAMIC	500V 0.25PF 3.3PF	4822 122 31188
C3001	CAP.FOIL	400V 10% 22NF	5322 121 70399
C3002	CAP.CHIP	AP 63V 10% 100NF	4822 122 33496
C3003	CAP.CERAMIC	500V 0.25PF 3.3PF	4822 122 31188
C3004	CAP.CERAMIC	500V 0.25PF 3.3PF	4822 122 31188
C3006	CAP.CERAMIC	500V 0.25PF 3.3PF	4822 122 31188
C3007	CAP.CERAMIC	500V 0.25PF 3.3PF	4822 122 31188
C3008	CAP.CHIP	AP 63V 0.25PF 3.3PF	5322 122 32286
C3011	CAP.CHIP	AP 63V 5% 33PF	5322 122 32659
C3012	CAP.CHIP	AP 63V 5% 27PF	5322 122 31946

Item	Description		Ordering code
C3014	CAP.CHIP	AP 63V 0.5PF 5.6PF	5322 122 32967
C3018	CAP.CHIP	AP 63V 10% 10NF	5322 122 34098
C3019	CAP.CHIP	AP 63V 10% 10NF	5322 122 34098
C3020	CAP.CERAMIC	500V 0.25PF 2.2PF	5322 122 32774
C3021	CAP.CERAMIC	500V 10% 1NF	4822 122 31175
C3022	CAP.CHIP	AP 63V 0.5PF 6.8PF	5322 122 32269
C3023	CAP.CHIP	AP 63V 5% 470PF	5322 122 32268
C3025	CAP.CHIP	AP 63V 10% 100NF	4822 122 33496
C3027	CAP.CHIP	AP 63V 10% 10NF	5322 122 34098
C3031	CAP.CHIP	AP 63V 10% 10NF	5322 122 34098
C3041	CAP.CHIP	AP 63V 10% 100NF	4822 122 33496
C3042	CAP.CHIP	AP 63V 10% 10NF	5322 122 34098
C3044	CAP.CHIP	AP 63V 10% 10NF	5322 122 34098
C3045	CAP.ELECTROLYT.	25V 20% 47UF	5322 121 10472
C3046	CAP.CHIP	AP 63V 10% 10NF	5322 122 34098
C3047	CAP.CHIP	AP 63V 10% 10NF	5322 122 34098
C3048	CAP.CHIP	AP 63V 10% 10NF	5322 122 34098
C3051	CAP.CHIP	AP 63V 10% 10NF	5322 122 34098
C3054	CAP.CHIP	AP 63V 10% 10NF	5322 122 34098
C3055	CAP.CHIP	AP 63V 0.25PF 2.7PF	5322 122 31873
C3056	CAP.CERAMIC	AP 63V 5% 10PF	5322 122 32448
C3057	CAP.CHIP	AP 63V 0.25PF 2.2PF	5322 122 33063
C3058	CAP.CHIP	AP 63V 0.25PF 2.2PF	5322 122 33063
C3059	CAP.CHIP	AP 63V 5% 100PF	5322 122 32531
C3060	CAP.CHIP	AP 63V 5% 100PF	5322 122 32531
C3061	CAP.CHIP	AP 63V 10% 10NF	5322 122 34098
C3062	CAP.CHIP	AP 63V 10% 10NF	5322 122 34098
C3063	CAP.CHIP	AP 63V 10% 10NF	5322 122 34098
C3064	CAP.CHIP	AP 63V 10% 10NF	5322 122 34098
C3066	CAP.CHIP	AP 63V 10% 10NF	5322 122 34098
C3067	CAP.CHIP	AP 63V 10% 10NF	5322 122 34098
C3068	CAP.CHIP	AP 63V 10% 10NF	5322 122 34098
C3069	CAP.CHIP	AP 63V 10% 10NF	5322 122 34098
C3071	CAP.CHIP	AP 63V 10% 10NF	5322 122 34098
C3072	CAP.CHIP	AP 63V 10% 10NF	5322 122 34098
C3076	CAP.CHIP	AP 63V 10% 10NF	5322 122 34098
C3077	CAP.CHIP	AP 63V 10% 10NF	5322 122 34098
C3085	CAP.ELECTROLYT.	25V 20% 180UF	5322 124 42228
C3086	CAP.CHIP	AP 63V 10% 10NF	5322 122 34098
C3087	CAP.ELECTROLYT.	25V 20% 180UF	5322 124 42228
C3088	CAP.CHIP	AP 63V 10% 10NF	5322 122 34098
C3101	CAP.CHIP	AP 63V 10% 10NF	5322 122 34098
C3102	CAP.CHIP	AP 63V 10% 10NF	5322 122 34098
C3201	CAP.CHIP	AP 63V 10% 10NF	5322 122 34098
C3204	CAP.CHIP	AP 63V 10% 100NF	4822 122 33496
C3205	CAP.CHIP	AP 63V 5% 100PF	5322 122 32531
C3208	CAP.CHIP	AP 63V 10% 10NF	5322 122 34098

Item	Description		Ordering code
C3209	CAP.CHIP	AP 63V 10% 10NF	5322 122 34098
C3210	CAP.CERAMIC	AP 63V 5% 47PF	5322 122 32452
C3211	CAP.CHIP	AP 63V 10% 100NF	4822 122 33496
C3301	CAP.CERAMIC	AP 63V 5% 47PF	5322 122 32452
C3302	CAP.CHIP	AP 63V 10% 10NF	5322 122 34098
C3303	CAP.CHIP	AP 63V 10% 22NF	5322 122 32654
C3304	CAP.CERAMIC	AP 63V 5% 10PF	5322 122 32448
C3305	CAP.CERAMIC	AP 63V 0.25PF 1.8PF	5322 126 10343
C4000	CAP.CERAMIC	500V 0.25PF 3.3PF	4822 122 31188
C4001	CAP.FOIL	400V 10% 22NF	5322 121 70399
C4002	CAP.CHIP	AP 63V 10% 100NF	4822 122 33496
C4003	CAP.CERAMIC	500V 0.25PF 3.3PF	4822 122 31188
C4004	CAP.CERAMIC	500V 0.25PF 3.3PF	4822 122 31188
C4006	CAP.CERAMIC	500V 0.25PF 3.3PF	4822 122 31188
C4007	CAP.CERAMIC	500V 0.25PF 3.3PF	4822 122 31188
C4008	CAP.CHIP	AP 63V 0.25PF 3.3PF	5322 122 32286
C4011	CAP.CHIP	AP 63V 5% 33PF	5322 122 32659
C4012	CAP.CHIP	AP 63V 5% 27PF	5322 122 31946
C4014	CAP.CHIP	AP 63V 0.5PF 5.6PF	5322 122 32967
C4018	CAP.CHIP	AP 63V 10% 10NF	5322 122 34098
C4019	CAP.CHIP	AP 63V 10% 10NF	5322 122 34098
C4020	CAP.CERAMIC	500V 0.25PF 2.2PF	5322 122 32774
C4021	CAP.CERAMIC	500V 10% 1NF	4822 122 31175
C4022	CAP.CHIP	AP 63V 0.5PF 6.8PF	5322 122 32269
C4023	CAP.CHIP	AP 63V 5% 470PF	5322 122 32268
C4025	CAP.CHIP	AP 63V 10% 100NF	4822 122 33496
C4027	CAP.CHIP	AP 63V 10% 10NF	5322 122 34098
C4031	CAP.CHIP	AP 63V 10% 10NF	5322 122 34098
C4041	CAP.CHIP	AP 63V 10% 100NF	4822 122 33496
C4042	CAP.CHIP	AP 63V 10% 10NF	5322 122 34098
C4044	CAP.CHIP	AP 63V 10% 10NF	5322 122 34098
C4045	CAP.ELECTROLYT.	25V 20% 47UF	5322 121 10472
C4046	CAP.CHIP	AP 63V 10% 10NF	5322 122 34098
C4047	CAP.CHIP	AP 63V 10% 10NF	5322 122 34098
C4048	CAP.CHIP	AP 63V 10% 10NF	5322 122 34098
C4051	CAP.CHIP	AP 63V 10% 10NF	5322 122 34098
C4054	CAP.CHIP	AP 63V 10% 10NF	5322 122 34098
C4055	CAP.CHIP	AP 63V 0.25PF 2.7PF	5322 122 31873
C4056	CAP.CERAMIC	AP 63V 5% 10PF	5322 122 32448
C4057	CAP.CHIP	AP 63V 0.25PF 2.2PF	5322 122 33063
C4058	CAP.CHIP	AP 63V 0.25PF 2.2PF	5322 122 33063
C4059	CAP.CHIP	AP 63V 5% 100PF	5322 122 32531
C4060	CAP.CHIP	AP 63V 5% 100PF	5322 122 32531
C4061	CAP.CHIP	AP 63V 10% 10NF	5322 122 34098
C4062	CAP.CHIP	AP 63V 10% 10NF	5322 122 34098
C4063	CAP.CHIP	AP 63V 10% 10NF	5322 122 34098
C4064	CAP.CHIP	AP 63V 10% 10NF	5322 122 34098

Item	Description		Ordering code
C4066	CAP.CHIP	AP 63V 10% 10NF	5322 122 34098
C4067	CAP.CHIP	AP 63V 10% 10NF	5322 122 34098
C4068	CAP.CHIP	AP 63V 10% 10NF	5322 122 34098
C4069	CAP.CHIP	AP 63V 10% 10NF	5322 122 34098
C4071	CAP.CHIP	AP 63V 10% 10NF	5322 122 34098
C4072	CAP.CHIP	AP 63V 10% 10NF	5322 122 34098
C4076	CAP.CHIP	AP 63V 10% 10NF	5322 122 34098
C4077	CAP.CHIP	AP 63V 10% 10NF	5322 122 34098
C4085	CAP.ELECTROLYT.	25V 20% 180UF	5322 124 42228
C4086	CAP.CHIP	AP 63V 10% 10NF	5322 122 34098
C4087	CAP.ELECTROLYT.	25V 20% 180UF	5322 124 42228
C4088	CAP.CHIP	AP 63V 10% 10NF	5322 122 34098
C4101	CAP.CHIP	AP 63V 10% 10NF	5322 122 34098
C4102	CAP.CHIP	AP 63V 10% 10NF	5322 122 34098
C4201	CAP.CHIP	AP 63V 10% 10NF	5322 122 34098
C4204	CAP.CHIP	AP 63V 10% 100NF	4822 122 33496
C4205	CAP.CHIP	AP 63V 5% 100PF	5322 122 32531
C4208	CAP.CHIP	AP 63V 10% 10NF	5322 122 34098
C4209	CAP.CHIP	AP 63V 10% 10NF	5322 122 34098
C4210	CAP.CERAMIC	AP 63V 5% 47PF	5322 122 32452
C4211	CAP.CHIP	AP 63V 10% 100NF	4822 122 33496
C4301	CAP.CERAMIC	AP 63V 5% 47PF	5322 122 32452
C4302	CAP.CHIP	AP 63V 10% 10NF	5322 122 34098
C4303	CAP.CHIP	AP 63V 10% 22NF	5322 122 32654
C4304	CAP.CERAMIC	AP 63V 5% 10PF	5322 122 32448
C4305	CAP.CERAMIC	AP 63V 0.25PF 1.8PF	5322 126 10343
C5000	CAP.CHIP	AP 63V 10% 220NF	4822 122 32916
C5001	CAP.CHIP	AP 63V 5% 470PF	5322 122 32268
C5002	CAP.CHIP	AP 63V 10% 10NF	5322 122 34098
C5003	CAP.CHIP	AP 63V 10% 10NF	5322 122 34098
C5004	CAP.CHIP	AP 63V 10% 10NF	5322 122 34098
C5005	CAP.CHIP	AP 63V 10% 10NF	5322 122 34098
C5006	CAP.CHIP	AP 63V 10% 10NF	5322 122 34098
C5007	CAP.CHIP	AP 63V 10% 10NF	5322 122 34098
C5008	CAP.CHIP	AP 63V 10% 10NF	5322 122 34098
C5010	CAP.CERAMIC	AP 63V 0.5PF 5.6PF	5322 122 32967
C5010	CAP.CERAMIC	AP 63V 5% 47PF	5322 122 32452
C5012	CAP.CERAMIC	AP 63V 5% 10PF	5322 122 32448
C5012	CAP.CERAMIC	AP 63V 0.25PF 2.7PF	5322 122 31873
C5015	CAP.CHIP	AP 63V 5% 330PF	5322 122 31863
C5015	CAP.CHIP	AP 63V 0.25PF 2.2PF	5322 122 33063
C5016	CAP.CHIP	AP 63V 10% 2.2NF	4822 122 33127
C5016	CAP.CHIP	63V 0.5PF 6.8PF	5322 122 32269
C5016	CAP.CHIP	63V 5% 27PF	5322 122 31946
C5017	CAP.CERAMIC	AP 63V 0.25PF 0.56PF	5322 122 33083
C5018	CAP.CERAMIC	AP 63V 0.25PF 0.56PF	5322 122 33083
C5501	CAP.CHIP	AP 63V 5% 820PF	5322 126 10184

Item	Description		Ordering code
C5502	CAP.CHIP	AP 63V 5% 100PF	5322 122 32531
C5503	CAP.CHIP	AP 63V 10% 10NF	5322 122 34098
C5504	CAP.CHIP	AP 63V 5% 22PF	5322 122 32658
C5505	CAP.CHIP	AP 63V 5% 820PF	5322 126 10184
C5506	CAP.CHIP	AP 63V 10% 1.5NF	5322 122 31865
C5507	CAP.CHIP	AP 63V 5% 100PF	5322 122 32531
C5508	CAP.CHIP	AP 63V 5% 100PF	5322 122 32531
C5509	CAP.CHIP	AP 63V 5% 100PF	5322 122 32531
C5510	CAP.CHIP	AP 63V 5% 100PF	5322 122 32531
C5511	CAP.CHIP	AP 63V 5% 100PF	5322 122 32531
C5513	CAP.CHIP	AP 63V 5% 100PF	5322 122 32531
C5514	CAP.CHIP	AP 63V 10% 100NF	4822 122 33496
C5601	CAP.CHIP	AP 63V 10% 100NF	4822 122 33496
C5602	CAP.ELECTROLYT.	25V 20% 47UF	5322 121 10472
C5603	CAP.CHIP	AP 63V 10% 100NF	4822 122 33496
C5604	CAP.CHIP	AP 63V 10% 100NF	4822 122 33496
C6000	CAP.FOIL	50V 20% 6.8UF	5322 124 42389
C6001	CAP.ELECTROLYT.	25V 20% 180UF	5322 124 42228
C6002	CAP.CHIP	AP 63V 10% 100NF	4822 122 33496
C6004	CAP.CHIP	AP 63V 5% 330PF	5322 122 31863
C6005	CAP.CHIP	AP 63V 10% 220NF	4822 122 32916
C6006	CAP.CHIP	AP 63V 10% 220NF	4822 122 32916
C6007	CAP.CHIP	AP 63V 10% 100NF	4822 122 33496
C6008	CAP.CHIP	AP 63V 10% 100NF	4822 122 33496
C6009	CAP.CHIP	AP 63V 10% 100NF	4822 122 33496
C6011	CAP.FOIL	630V 1% 68PF	5322 121 70127
C6012	CAP.FOIL	63V 5% 10NF	5322 121 70116
C6013	CAP.ELECTROLYT.	100V 10% 10UF	5322 124 20164
C6014	CAP.CHIP	AP 63V 10% 100NF	4822 122 33496
C6015	CAP.CERAMIC	AP 63V 0.5PF 5.6PF	5322 122 32967
C6016	CAP.ELECTROLYT.	25V 20% 47UF	5322 121 10472
C6017	CAP.ELECTROLYT.	25V 20% 180UF	5322 124 42228
C6018	CAP.FOIL	50V 20% 6.8UF	5322 124 42389
C6031	CAP.CHIP	AP 63V 10% 1.5NF	5322 122 31865
C6032	CAP.CHIP	AP 63V 10% 1.5NF	5322 122 31865
C6033	CAP.CHIP	AP 63V 5% 330PF	5322 122 31863
C6035	CAP.FOIL	63V 10% 100NF	5322 121 42386
C6038	CAP.CHIP	AP 63V 10% 100NF	4822 122 33496
C6039	CAP.CHIP	AP 63V 5% 100PF	5322 122 32531
C6070	CAP.CHIP	AP 63V 10% 22NF	5322 122 32654
C6071	CAP.CHIP	AP 63V 10% 100NF	4822 122 33496
C6080	CAP.CHIP	AP 63V 10% 22NF	5322 122 32654
C6093	CAP.ELECTROLYT.	25V 20% 180UF	5322 124 42228
C6094	CAP.ELECTROLYT.	25V 20% 180UF	5322 124 42228
C6095	CAP.CHIP	AP 63V 10% 22NF	5322 122 32654
C6096	CAP.ELECTROLYT.	25V 20% 180UF	5322 124 42228
C6097	CAP.ELECTROLYT.	25V 20% 180UF	5322 124 42228

Item	Description		Ordering code
C6098	CAP.CHIP	AP 63V 10% 220NF	4822 122 32916
C6101	CAP.CHIP	AP 63V 10% 100NF	4822 122 33496
C6102	CAP.CHIP	AP 63V 10% 100NF	4822 122 33496
C6103	CAP.CHIP	AP 63V 10% 100NF	4822 122 33496
C6104	CAP.CHIP	AP 63V 10% 100NF	4822 122 33496
C6105	CAP.CHIP	AP 63V 10% 100NF	4822 122 33496
C6106	CAP.CHIP	AP 63V 10% 100NF	4822 122 33496
C6107	CAP.CHIP	AP 63V 10% 100NF	4822 122 33496
C6108	CAP.CHIP	AP 63V 10% 100NF	4822 122 33496
C6109	CAP.CHIP	AP 63V 10% 100NF	4822 122 33496
C6110	CAP.CHIP	AP 63V 5% 470PF	5322 122 32268
C6111	CAP.CHIP	AP 63V 10% 100NF	4822 122 33496
C6112	CAP.CHIP	AP 63V 10% 100NF	4822 122 33496
C6113	CAP.CHIP	AP 63V 10% 100NF	4822 122 33496
C6114	CAP.CHIP	AP 63V 10% 100NF	4822 122 33496
C6115	CAP.CHIP	AP 63V 10% 100NF	4822 122 33496
C6116	CAP.CHIP	AP 63V 10% 100NF	4822 122 33496
C6117	CAP.CHIP	AP 63V 10% 100NF	4822 122 33496
C6118	CAP.CHIP	AP 63V 10% 100NF	4822 122 33496
C6305	CAP.CHIP	AP 63V 10% 100NF	4822 122 33496
C6415	CAP.ELECTROLYT.	50V 20% 10UF	5322 124 21731
C6504	CAP.CHIP	AP 63V 10% 10NF	5322 122 34098
C6549	CAP.CHIP	AP 63V 10% 22NF	5322 122 32654
C6551	CAP.CHIP	AP 63V 10% 22NF	5322 122 32654
C6557	CAP.CHIP	AP 63V 10% 10NF	5322 122 34098
C6559	CAP.CHIP	AP 63V 10% 22NF	5322 122 32654
C6561	CAP.ELECTROLYT.	25V 20% 180UF	5322 124 42228
C6562	CAP.ELECTROLYT.	25V 20% 180UF	5322 124 42228
C6581	CAP.CHIP	AP 63V 10% 10NF	5322 122 34098
C6583	CAP.CHIP	AP 63V 0.5PF 6.8PF	5322 122 32269
C6617	CAP.CHIP	AP 63V 0.25PF 2.2PF	5322 122 33063
C6623	CAP.CHIP	AP 63V 10% 10NF	5322 122 34098
C6624	CAP.CHIP	AP 63V 10% 100NF	4822 122 33496
C6639	CAP.CHIP	AP 63V 10% 220NF	4822 122 32916
C6642	CAP.CHIP	AP 63V 10% 220NF	4822 122 32916
C6644	CAP.CHIP	AP 63V 10% 220NF	4822 122 32916
C6647	CAP.CHIP	AP 63V 10% 220NF	4822 122 32916
C6648	CAP.CHIP	AP 63V 10% 100NF	4822 122 33496
C6649	CAP.CHIP	AP 63V 10% 100NF	4822 122 33496
C6707	CAP.CHIP	AP 63V 10% 10NF	5322 122 34098
C6751	CAP.CHIP	AP 63V 5% 100PF	5322 122 32531
C6758	CAP.ELECTROLYT.	25V 20% 47UF	5322 121 10472
C6768	CAP.CHIP	AP 63V 10% 100NF	4822 122 33496
C6773	CAP.CHIP	AP 63V 10% 100NF	4822 122 33496
C6777	CAP.CHIP	AP 63V 10% 100NF	4822 122 33496
C6779	CAP.CHIP	AP 63V 5% 22PF	5322 122 32658
C6787	CAP.CHIP	AP 63V 5% 820PF	5322 126 10184

Item	Description		Ordering code
C6902	CAP.ELECTROLYT.	25V 20% 47UF	5322 121 10472
C6903	CAP.CHIP	AP 63V 10% 10NF	5322 122 34098
C6904	CAP.CHIP	AP 63V 10% 10NF	5322 122 34098
C6912	CAP.ELECTROLYT.	25V 20% 47UF	5322 121 10472
C6913	CAP.CHIP	AP 63V 10% 10NF	5322 122 34098
C6922	CAP.ELECTROLYT.	25V 20% 47UF	5322 121 10472
C6923	CAP.CHIP	AP 63V 10% 10NF	5322 122 34098
C6924	CAP.CHIP	AP 63V 10% 10NF	5322 122 34098
C6932	CAP.ELECTROLYT.	25V 20% 47UF	5322 121 10472
C6933	CAP.CHIP	AP 63V 10% 10NF	5322 122 34098
C6934	CAP.CHIP	AP 63V 10% 10NF	5322 122 34098
C6942	CAP.ELECTROLYT.	25V 20% 47UF	5322 121 10472
C6943	CAP.CHIP	AP 63V 10% 10NF	5322 122 34098
C6953	CAP.CHIP	AP 63V 10% 100NF	4822 122 33496
C6962	CAP.ELECTROLYT.	25V 20% 47UF	5322 121 10472
C6963	CAP.CHIP	AP 63V 10% 10NF	5322 122 34098
C7001	CAP.CHIP	AP 63V 10% 100NF	4822 122 33496
C7002	CAP.CHIP	AP 63V 10% 100NF	4822 122 33496
C7003	CAP.CHIP	AP 63V 10% 100NF	4822 122 33496
C7004	CAP.CHIP	AP 63V 5% 330PF	5322 122 31863
C7005	CAP.CHIP	AP 63V 10% 220NF	4822 122 32916
C7006	CAP.CHIP	AP 63V 10% 220NF	4822 122 32916
C7007	CAP.CHIP	AP 63V 10% 100NF	4822 122 33496
C7008	CAP.CHIP	AP 63V 10% 220NF	4822 122 32916
C7009	CAP.CHIP	AP 63V 10% 100NF	4822 122 33496
C7010	CAP.CHIP	AP 63V 5% 100PF	5322 122 32531
C7011	CAP.FOIL	630V 1% 82PF	5322 121 70498
C7012	CAP.FOIL	63V 5% 10NF	5322 121 70116
C7013	CAP.ELECTROLYT.	25V 20% 47UF	5322 121 10472
C7014	CAP.CERAMIC	AP 63V 0.5PF 5.6PF	5322 122 32967
C7015	CAP.CHIP	AP 63V 10% 100NF	4822 122 33496
C7016	CAP.CHIP	AP 63V 10% 100NF	4822 122 33496
C7017	CAP.CHIP	AP 63V 10% 100NF	4822 122 33496
C7021	CAP.CHIP	AP 63V 10% 100NF	4822 122 33496
C7033	CAP.CHIP	AP 63V 10% 22NF	5322 122 32654
C7034	CAP.CHIP	AP 63V 10% 22NF	5322 122 32654
C7035	CAP.CHIP	AP 63V 10% 22NF	5322 122 32654
C7036	CAP.CHIP	AP 63V 10% 22NF	5322 122 32654
C7054	CAP.CHIP	AP 63V 10% 10NF	5322 122 34098
C7055	CAP.CHIP	AP 63V 10% 10NF	5322 122 34098
C7060	CAP.CERAMIC	AP 63V 0.25PF 2.7PF	5322 122 31873
C7091	CAP.ELECTROLYT.	25V 20% 47UF	5322 121 10472
C7092	CAP.CHIP	AP 63V 10% 100NF	4822 122 33496
C7093	CAP.CHIP	AP 63V 10% 100NF	4822 122 33496
C7099	CAP.CHIP	AP 63V 10% 220NF	4822 122 32916
C7161	CAP.CHIP	AP 63V 0.25PF 2.2PF	5322 122 33063
C7504	CAP.CHIP	AP 63V 10% 10NF	5322 122 34098

Item	Description		Ordering code
C7513	CAP.CHIP	AP 63V 10% 10NF	5322 122 34098
C7549	CAP.CHIP	AP 63V 10% 22NF	5322 122 32654
C7551	CAP.CHIP	AP 63V 10% 22NF	5322 122 32654
C7557	CAP.CHIP	AP 63V 10% 10NF	5322 122 34098
C7559	CAP.CHIP	AP 63V 10% 22NF	5322 122 32654
C7561	CAP.ELECTROLYT.	25V 20% 180UF	5322 124 42228
C7562	CAP.ELECTROLYT.	25V 20% 180UF	5322 124 42228
C7581	CAP.CHIP	AP 63V 10% 10NF	5322 122 34098
C7583	CAP.CHIP	AP 63V 0.5PF 6.8PF	5322 122 32269
C7682	CAP.CHIP	AP 63V 10% 220NF	4822 122 32916
C7697	CAP.CHIP	AP 63V 5% 33PF	5322 122 32659
C7751	CAP.CHIP	AP 63V 5% 100PF	5322 122 32531
C7813	CAP.CHIP	AP 63V 10% 10NF	5322 122 34098
C7902	CAP.ELECTROLYT.	25V 20% 47UF	5322 121 10472
C7903	CAP.CHIP	AP 63V 10% 10NF	5322 122 34098
C7904	CAP.CHIP	AP 63V 10% 10NF	5322 122 34098
C7912	CAP.ELECTROLYT.	25V 20% 47UF	5322 121 10472
C7913	CAP.CHIP	AP 63V 10% 10NF	5322 122 34098
C7923	CAP.CHIP	AP 63V 10% 10NF	5322 122 34098
C7932	CAP.ELECTROLYT.	25V 20% 47UF	5322 121 10472
C7933	CAP.CHIP	AP 63V 10% 10NF	5322 122 34098
C7934	CAP.CHIP	AP 63V 10% 10NF	5322 122 34098
C7942	CAP.ELECTROLYT.	25V 20% 47UF	5322 121 10472
C7943	CAP.CHIP	AP 63V 10% 10NF	5322 122 34098
C7962	CAP.ELECTROLYT.	25V 20% 47UF	5322 121 10472
C7963	CAP.CHIP	AP 63V 10% 10NF	5322 122 34098
C8000	CAP.CHIP	AP 63V 10% 100NF	4822 122 33496
C8001	CAP.CHIP	AP 63V 10% 100NF	4822 122 33496
C8002	CAP.CHIP	AP 63V 10% 1.5NF	5322 122 31865
C8003	CAP.CHIP	AP 63V 10% 10NF	5322 122 34098
C8004	CAP.CHIP	AP 63V 10% 10NF	5322 122 34098
C8005	CAP.CHIP	AP 63V 10% 100NF	4822 122 33496
C8006	CAP.CHIP	AP 63V 10% 100NF	4822 122 33496
C8007	CAP.CHIP	AP 63V 10% 100NF	4822 122 33496
C8008	CAP.CHIP	AP 63V 10% 100NF	4822 122 33496
C8009	CAP.CHIP	AP 63V 10% 100NF	4822 122 33496
C8010	CAP.CHIP	AP 63V 10% 100NF	4822 122 33496
C8011	CAP.ELECTROLYT.	50V 20% 10UF	5322 124 21731
C8013	CAP.CHIP	AP 63V 10% 220NF	4822 122 32916
C8014	CAP.CHIP	AP 63V 10% 100NF	4822 122 33496
C8015	CAP.CHIP	AP 63V 10% 10NF	5322 122 34098
C8016	CAP.CHIP	AP 63V 10% 10NF	5322 122 34098
C8017	CAP.CHIP	AP 63V 10% 100NF	4822 122 33496
C8020	CAP.CHIP	AP 63V 10% 100NF	4822 122 33496
C8021	CAP.CHIP	AP 63V 5% 22PF	5322 122 32658
C8022	CAP.CHIP	AP 63V 5% 22PF	5322 122 32658
C8034	CAP.CHIP	AP 63V 10% 22NF	5322 122 32654

Item	Description		Ordering code
C8035	CAP.CHIP	AP 63V 10% 22NF	5322 122 32654
C8036	CAP.CHIP	AP 63V 10% 100NF	4822 122 33496
C8060	CAP.CERAMIC	AP 63V 0.25PF 0.56PF	5322 122 33083
C8062	CAP.CHIP	AP 63V 5% 100PF	5322 122 32531
C8063	CAP.CHIP	AP 63V 5% 22PF	5322 122 32658
C8064	CAP.CERAMIC	AP 63V 5% 10PF	5322 122 32448
C8065	CAP.CHIP	AP 63V 5% 100PF	5322 122 32531
C8066	CAP.CERAMIC	AP 63V 5% 10PF	5322 122 32448
C8070	CAP.CHIP	AP 63V 10% 22NF	5322 122 32654
C8071	CAP.CHIP	AP 63V 10% 22NF	5322 122 32654
C8093	CAP.CHIP	AP 63V 10% 100NF	4822 122 33496
C8094	CAP.CHIP	AP 63V 10% 100NF	4822 122 33496
C8095	CAP.CHIP	AP 63V 10% 100NF	4822 122 33496
C8101	CAP.CHIP	AP 63V 5% 100PF	5322 122 32531
C8102	CAP.CHIP	AP 63V 0.25PF 3.3PF	5322 122 32286
C8401	CAP.ELECTROLYT.	25V 20% 47UF	5322 121 10472
C8403	CAP.CHIP	AP 63V 5% 100PF	5322 122 32531
C8404	CAP.CHIP	AP 63V 5% 100PF	5322 122 32531
C8405	CAP.CHIP	AP 63V 5% 100PF	5322 122 32531
C8410	CAP.ELECTROLYT.	25V 20% 180UF	5322 124 42228
C8411	CAP.ELECTROLYT.	25V 20% 180UF	5322 124 42228
C9011	CAP.CHIP	AP 63V 5% 100PF	5322 122 32531
C9012	CAP.CHIP	AP 63V 5% 100PF	5322 122 32531
C9015	CAP.CHIP	AP 63V 5% 100PF	5322 122 32531
C9016	CAP.CHIP	AP 63V 5% 100PF	5322 122 32531
C9018	CAP.CHIP	AP 63V 5% 100PF	5322 122 32531
C9019	CAP.CHIP	AP 63V 5% 100PF	5322 122 32531
C9020	CAP.CHIP	AP 63V 5% 100PF	5322 122 32531
C9034	CAP.CHIP	AP 63V 5% 100PF	5322 122 32531
C9036	CAP.CHIP	AP 63V 5% 100PF	5322 122 32531
C9041	CAP.CHIP	AP 63V 10% 10NF	5322 122 34098
C9042	CAP.CHIP	AP 63V 10% 10NF	5322 122 34098

DIGITAL INTEGRATED CIRCUITS

D1151	INTEGR.CIRCUIT	CD4053BCM NSC	5322 209 33502
D1152	INTEGR.CIRCUIT	HEF4051BT PEL	5322 209 11446
D1201	INTEGR.CIRCUIT	OQ0224 INPUT CIRCUIT	5322 209 12457
D1301	INTEGR.CIRCUIT	OQ0225 OUTPUT CIRC.	5322 209 12458
D2201	INTEGR.CIRCUIT	OQ0224 INPUT CIRCUIT	5322 209 12457
D2301	INTEGR.CIRCUIT	OQ0225 OUTPUT CIRC.	5322 209 12458
D3201	INTEGR.CIRCUIT	OQ0224 INPUT CIRCUIT	5322 209 12457
D3301	INTEGR.CIRCUIT	OQ0225 OUTPUT CIRC.	5322 209 12458
D4201	INTEGR.CIRCUIT	OQ0224 INPUT CIRCUIT	5322 209 12457
D4301	INTEGR.CIRCUIT	OQ0225 OUTPUT CIRC.	5322 209 12458
D5001	INTEGR.CIRCUIT	HEF4066BT PEL	5322 209 14542
D5501	INTEGR.CIRCUIT	CD4053BCM	5322 209 33502

Item	Description		Ordering code
D5502	INTEGR.CIRCUIT	CD4053BCM	5322 209 33502
D5503	INTEGR.CIRCUIT	HEF4081BT PEL	5322 209 14483
D6001	INTEGR.CIRCUIT	HEF4051BT PEL	5322 209 11446
D6002	INTEGR.CIRCUIT	CD4053BCM	5322 209 33502
D6011	INTEGR.CIRCUIT	OQ0228 SAWCHIP	5322 209 12466
D6541	INTEGR.CIRCUIT	OQ0226 TRIGGER AMPL.	5322 209 12464
D6621	INTEGR.CIRCUIT	OQ0128 SSP	5322 209 82925
D6779	INTEGR.CIRCUIT	PC74HCT112T PEL	5322 209 11825
D6781	INTEGR.CIRCUIT	CD4053BCM	5322 209 33502
D7001	INTEGR.CIRCUIT	HEF4051BT PEL	5322 209 11446
D7002	INTEGR.CIRCUIT	CD4053BT BCM	5322 209 33502
D7004	INTEGR.CIRCUIT	HEF4052BT PEL	5322 209 11102
D7005	INTEGR.CIRCUIT	PC74HCT14T PEL	5322 209 71568
D7011	INTEGR.CIRCUIT	OQ0228 SAWCHIP	5322 209 12466
D7541	INTEGR.CIRCUIT	OQ0226 TRIGGER AMPL.	5322 209 12464
D7711	INTEGR.CIRCUIT	CD4053BCM	5322 209 33502
D8003	INTEGR.CIRCUIT	OQ0235 Z-LOGIC	5322 209 12461
D8004	INTEGR.CIRCUIT	OQ0227 TIMEBASE LOG.	5322 209 12465
D8006	INTEGR.CIRCUIT	HEF40106BT PEL	5322 209 14486
D9001	INTEGR.CIRCUIT	TEA1017/N9 PEL	5322 209 60191
D9002	INTEGR.CIRCUIT	TEA1017/N9 PEL	5322 209 60191
D9003	INTEGR.CIRCUIT	HEF4094BT PEL	5322 209 11306
D9004	INTEGR.CIRCUIT	HEF4094BT PEL	5322 209 11306
D9006	INTEGR.CIRCUIT	TEA1017/N9 PEL	5322 209 60191
D9007	INTEGR.CIRCUIT	HEF4094BT PEL	5322 209 11306
D9008	INTEGR.CIRCUIT	HEF4094BT PEL	5322 209 11306
D9009	INTEGR.CIRCUIT	OQ0200 DISPL.MODE LO	5322 209 82924
D9011	INTEGR.CIRCUIT	HEF4094BT PEL	5322 209 11306
D9012	INTEGR.CIRCUIT	HEF4094BT PEL	5322 209 11306
D9013	INTEGR.CIRCUIT	HEF4094BT PEL	5322 209 11306

RELAIS

K1001	RELAY	DPDT RELAIS RAL3W-K	5322 280 80745
K1002	RELAY	DPDT RELAIS RAL3W-K	5322 280 80745
K1003	RELAY	DPDT RELAIS RAL3W-K	5322 280 80745
K1004	RELAY	DPDT RELAIS RAL3W-K	5322 280 80745
K1006	RELAY	DPDT RELAIS RAL3W-K	5322 280 80745
K2001	RELAY	DPDT RELAIS RAL3W-K	5322 280 80745
K2002	RELAY	DPDT RELAIS RAL3W-K	5322 280 80745
K2003	RELAY	DPDT RELAIS RAL3W-K	5322 280 80745
K2004	RELAY	DPDT RELAIS RAL3W-K	5322 280 80745
K2006	RELAY	DPDT RELAIS RAL3W-K	5322 280 80745
K3001	RELAY	DPDT RELAIS RAL3W-K	5322 280 80745
K3002	RELAY	DPDT RELAIS RAL3W-K	5322 280 80745
K3003	RELAY	DPDT RELAIS RAL3W-K	5322 280 80745
K3004	RELAY	DPDT RELAIS RAL3W-K	5322 280 80745
K3006	RELAY	DPDT RELAIS RAL3W-K	5322 280 80745

Item	Description		Ordering code
K4001	RELAY	DPDT RELAIS RAL3W-K	5322 280 80745
K4002	RELAY	DPDT RELAIS RAL3W-K	5322 280 80745
K4003	RELAY	DPDT RELAIS RAL3W-K	5322 280 80745
K4004	RELAY	DPDT RELAIS RAL3W-K	5322 280 80745
K4006	RELAY	DPDT RELAIS RAL3W-K	5322 280 80745

COILS

L1001	COIL	0.056UH 5% TDK	5322 157 63381
L1301	COIL	0.1UH 5% TDK	5322 157 63647
L2001	COIL	0.056UH 5% TDK	5322 157 63381
L2301	COIL	0.1UH 5% TDK	5322 157 63647
L3001	COIL	0.056UH 5% TDK	5322 157 63381
L3301	COIL	0.1UH 5% TDK	5322 157 63647
L4001	COIL	0.056UH 5% TDK	5322 157 63381
L4301	COIL	0.1UH 5% TDK	5322 157 63647
L6096	COIL	2.0UH TDK	4822 157 51757
L6097	COIL	2.0UH TDK	4822 157 51757

ANALOG INTEGRATED CIRCUITS

N1001	INTEGR.CIRCUIT	AD548JR AND	5322 209 31298
N1101	INTEGR.CIRCUIT	LM339D SIG	5322 209 70684
N1102	INTEGR.CIRCUIT	LM358M NSC	4822 209 60175
N1103	INTEGR.CIRCUIT	LM358M NSC	4822 209 60175
N1104	I.C. ANALOGUE	OP-77GSR PMI	5322 130 62791
N1202	INTEGR.CIRCUIT	LM324D NSC	5322 209 83125
N1251	INTEGR.CIRCUIT	LM358M NSC	4822 209 60175
N2001	INTEGR.CIRCUIT	AD548JR AND	5322 209 83125
N2202	INTEGR.CIRCUIT	LM324D NSC	5322 209 61473
N3001	INTEGR.CIRCUIT	AD548JR AND	5322 209 31298
N3102	INTEGR.CIRCUIT	LM358M NSC	4822 209 60175
N3103	INTEGR.CIRCUIT	LM358M NSC	4822 209 60175
N3202	INTEGR.CIRCUIT	LM324D NSC	5322 209 83125
N4001	INTEGR.CIRCUIT	AD548JR AND	5322 209 31298
N4202	INTEGR.CIRCUIT	LM324D NSC	5322 209 83125
N5001	INTEGR.CIRCUIT	LM358M NSC	4822 209 60175
N5002	INTEGR.CIRCUIT	LM3046M NSC	5322 209 30229
N6006	I.C. ANALOGUE	OP-77GSR PMI	5322 130 62791
N6007	INTEGR.CIRCUIT	LM358M NSC	4822 209 60175
N6008	INTEGR.CIRCUIT	LM358M NSC	4822 209 60175
N6014	INTEGR.CIRCUIT	TDA1541A/N2 PEL	4822 209 72544
N6771	INTEGR.CIRCUIT	LM1881M NSC	4822 209 60767
N7006	I.C. ANALOGUE	OP-77GSR PMI	5322 130 62791
N7007	INTEGR.CIRCUIT	LM358M NSC	4822 209 60175
N7014	I.C. ANALOGUE	OP-77GSR PMI	5322 130 62791
N7015	I.C. ANALOGUE	OP-77GSR PMI	5322 130 62791
N7016	INTEGR.CIRCUIT	LM358M NSC	4822 209 60175
N7952	INTEGR.CIRCUIT	LM324D NSC	5322 209 83125
N8005	INTEGR.CIRCUIT	TDA8444AT/N4 PEL	5322 209 30233
N9001	INTEGR.CIRCUIT	TDA8444AT/N4 PEL	5322 209 30233

Item	Description		Ordering code
N9002	INTEGR.CIRCUIT	TDA8444AT/N4 PEL	5322 209 30233
N9003	INTEGR.CIRCUIT	TDA8444AT/N4 PEL	5322 209 30233
N9004	INTEGR.CIRCUIT	TDA8444AT/N4 PEL	5322 209 30233

RESISTORS

R1001	RES.CHIP	RMC1/8 1% 61E9	5322 111 92016
R1002	RES.CHIP	HIP RC-02H 1% 1M	4822 051 10105
R1006	RES.METAL FILM	MRS25 1% 100E	4822 050 21001
R1007	RES.METAL FILM	ST MRS25 1% 100E	4822 050 21001
R1008	RES.METAL FILM	PR24 1/4W 0.1% 9K4	5322 116 83712
R1009	RES.METAL FILM	PR24 1/4W 0.1% 300E	5322 116 51814
R1010	RES.CHIP	RMC1/8 1% 21E5	5322 111 92014
R1011	RES.N.T.C.	NTC 640 2% 3K3	5322 116 30421
R1012	RES.CHIP	HIP RC-01 5% 1E	4822 051 10108
R1013	RES.CHIP	RMC1/8 1% 21E5	5322 111 92014
R1014	RES.CHIP	HIP RC-02H 1% 100E	4822 051 10101
R1016	RES.METAL FILM	PR34 0.4W 0.1% 900K	5322 116 51832
R1019	RES.CHIP	HIP RC-02H 1% 100E	4822 051 10101
R1021	RES.METAL FILM	PR34 0.4W 0.1% 990K	5322 116 83104
R1022	RES.CHIP	RMC1/8 1% 21E5	5322 111 92014
R1022	RES.CHIP	RMC1/1 1% 23E7	5322 117 10591
R1023	RES.METAL FILM	PR24 1/4W 0.1% 11K1	5322 116 83101
R1024	RES.METAL FILM	HIP RC-02H 1% 147E	5322 117 10526
R1026	RES.CHIP	RMC1/8 1% 82E5	5322 111 92017
R1027	RES.METAL FILM	PR24 1/4W 0.1% 111K	5322 116 83099
R1028	RES.CHIP	HIP RC-02H 1% 10K	4822 051 10103
R1029	RES.CHIP	HIP RC-02H 1% 10K	4822 051 10103
R1030	RES.CHIP	RMC1/8 1% 21E5	5322 111 92014
R1031	RES.METAL FILM	PR34 0.4W 0.1% 500K	5322 116 83103
R1032	RES.CHIP	HIP RC-02H 1% 1M	4822 051 10105
R1033	RES.CHIP	HIP RC-02H 1% 1M	4822 051 10105
R1034	RES.CHIP	HIP RC-01 5% 10M	4822 051 10106
R1035	RES.METAL FILM	HIP RC-02H 1% 215K	5322 117 10543
R1036	RES.CHIP	HIP RC-02H 1% 5K11	5322 117 10487
R1037	RES.METAL FILM	HIP RC-02H 1% 3K83	5322 117 10561
R1038	RES.METAL FILM	HIP RC-02H 1% 215K	5322 117 10543
R1039	RES.METAL FILM	HIP RC-02H 1% 21K5	5322 117 10542
R1041	RES.CHIP	HIP RC-02H 1% 1K	4822 051 10102
R1042	RES.CHIP	HIP RC-02H 1% 51K1	4822 051 55113
R1043	RES.CHIP	HIP RC-02H 1% 5K11	5322 117 10487
R1044	RES.CHIP	HIP RC-02H 1% 5K11	5322 117 10487
R1045	RES.CHIP	HIP RC-02H 1% 5K11	5322 117 10487
R1046	RES.CHIP	HIP RC-02H 1% 261E	4822 051 52611
R1047	RES.METAL FILM	HIP RC-02H 1% 511E	5322 117 10569
R1048	RES.METAL FILM	HIP RC-02H 1% 237E	5322 117 10544
R1049	RES.CHIP	HIP RC-01 5% 10M	4822 051 10106

Item	Description		Ordering code
R1052	RES.CHIP	HIP RC-02H 1% 100E	4822 051 10101
R1053	RES.METAL FILM	HIP RC-02H 1% 6K19	5322 117 10577
R1054	RES.CHIP	HIP RC-02H 1% 10K	4822 051 10103
R1056	RES.METAL FILM	HIP RC-02H 1% 619E	5322 117 10576
R1057	RES.CHIP	HIP RC-02H 1% 1K	4822 051 10102
R1061	RES.CHIP	RMC1/8 1% 51E1	5322 111 91893
R1062	RES.CHIP	RMC1/8 1% 42E2	4822 111 91887
R1063	RES.CHIP	HIP RC-02H 1% 261E	4822 051 52611
R1064	RES.CHIP	HIP RC-02H 1% 261E	4822 051 52611
R1065	RES.CHIP	HIP RC-02H 1% 261E	4822 051 52611
R1071	RES.CHIP	RMC1/8 1% 61E9	5322 111 92016
R1072	RES.METAL FILM	HIP RC-02H 1% 147E	5322 117 10526
R1073	RES.CHIP	HIP RC-02H 1% 100E	4822 051 10101
R1074	RES.CHIP	RMC1/8 1% 75E	4822 111 91937
R1076	RES.CHIP	HIP RC-02H 1% 10K	4822 051 10103
R1077	RES.CHIP	HIP RC-02H 1% 10K	4822 051 10103
R1078	RES.CHIP	HIP RC-02H 1% 1M	4822 051 10105
R1079	RES.CHIP	HIP RC-02H 1% 1M	4822 051 10105
R1081	RES.CHIP	HIP RC-02H 1% 10K	4822 051 10103
R1082	RES.CHIP	HIP RC-02H 1% 10K	4822 051 10103
R1083	RES.CHIP	HIP RC-02H 1% 100K	4822 051 10104
R1084	RES.CHIP	HIP RC-02H 1% 100K	4822 051 10104
R1085	RES.CHIP	RC-02H 1% 13K3	4822 051 51333
R1086	RES.CHIP	HIP RC-02H 1% 10K	4822 051 10103
R1087	RES.CHIP	HIP RC-02H 1% 51K1	4822 051 55113
R1088	RES.CHIP	RC-02H 1% 10K	4822 051 10103
R1092	RES.METAL FILM	RC-02H 1% 13K3	4822 051 51333
R1093	RES.CHIP	RC-02H 1% 10K	4822 051 10103
R1094	RES.CHIP	RC-02H 1% 2K15	5322 117 10485
R1095	RES.CHIP	RC-02H 1% 10K	4822 051 10103
R1096	RES.CHIP	RC-02H 1% 1K	4822 051 10102
R1097	RES.CHIP	RC-02H 1% 1K	4822 051 10102
R1101	RES.CHIP	RC-02H 1% 46K4	5322 117 10486
R1102	RES.METAL FILM	RC-02H 1% 13K3	4822 051 51333
R1103	RES.METAL FILM	RC-02H 1% 14K7	5322 117 10528
R1104	RES.CHIP	HIP RC-02H 1% 10K	4822 051 10103
R1106	RES.CHIP	HIP RC-02H 1% 10K	4822 051 10103
R1112	RES.METAL FILM	HIP RC-02H 1% 61K9	5322 117 10578
R1113	RES.METAL FILM	HIP RC-02H 1% 7K5	5322 117 10583
R1114	RES.CHIP	HIP RC-02H 1% 3K48	5322 117 10557
R1141	RES.CHIP	RMC1/8 1% 10E	4822 111 91885
R1151	RES.METAL FILM	HIP RC-02H 1% 61K9	5322 117 10578
R1152	RES.CHIP	HIP RC-02H 1% 51K1	4822 051 55113
R1153	RES.CHIP	HIP RC-02H 1% 1M	4822 051 10105
R1154	RES.METAL FILM	HIP RC-02H 1% 215K	5322 117 10543
R1155	RES.CHIP	HIP RC-02H 1% 10K	4822 051 10103
R1156	RES.METAL FILM	HIP RC-02H 1% 619E	5322 117 10576

Item	Description		Ordering code
R1157	RES.METAL FILM	PR24 1/4W 0.1% 9K4	5322 116 83712
R1158	RES.METAL FILM	PR24 1/4W 0.1% 750E	5322 116 53173
R1159	RES.METAL FILM	HIP RC-02H 1% 3K16	5322 117 10553
R1192	RES.METAL FILM	PR24 1/4W 0.1% 1K25	5322 116 53177
R1193	RES.METAL FILM	PR24 1/4W 0.1% 750E	5322 116 53173
R1194	RES.METAL FILM	PR24 1/4W 0.1% 250E	5322 116 53166
R1195	RES.METAL FILM	PR24 1/4W 0.1% 125E	5322 116 53176
R1196	RES.METAL FILM	PR24 1/4W 0.1% 75E	5322 116 53168
R1197	RES.METAL FILM	PR24 1/4W 0.1% 50E	5322 116 53165
R1200	RES.CHIP	HIP RC-02H 1% 100E	4822 051 10101
R1201	RES.METAL FILM	HIP RC-02H 1% 13K3	4822 051 51333
R1202	RES.METAL FILM	HIP RC-02H 1% 4K22	5322 117 10565
R1203	RES.CHIP	HIP RC-02H 1% 11K	4822 051 10113
R1204	RES.METAL FILM	HIP RC-02H 1% 12K1	5322 117 10522
R1205	RES.METAL FILM	HIP RC-02H 1% 14K7	5322 117 10528
R1206	RES.CHIP	HIP RC-02H 1% 100E	4822 051 10101
R1207	RES.CHIP	HIP RC-02H 1% 215E	5322 117 10484
R1208	RES.METAL FILM	HIP RC-02H 1% 147E	5322 117 10526
R1209	RES.CHIP	HIP RC-02H 1% 5K11	5322 117 10487
R1210	RES.METAL FILM	HIP RC-02H 1% 31K6	5322 117 10554
R1211	RES.METAL FILM	HIP RC-02H 1% 4K22	5322 117 10565
R1212	RES.CHIP	HIP RC-02H 1% 2K15	5322 117 10485
R1213	RES.MET.GLAZED	RMC1/8 1% 31E6	5322 116 82895
R1214	RES.MET.GLAZED	RMC1/8 1% 31E6	5322 116 82895
R1215	RES.METAL FILM	HIP RC-02H 1% 348E	5322 117 10556
R1216	RES.CHIP	HIP RC-02H 1% 100E	4822 051 10101
R1217	RES.CHIP	HIP RC-02H 1% 100E	4822 051 10101
R1218	RES.CHIP	RMC1/8 1% 51E1	5322 111 91893
R1220	RES.METAL FILM	HIP RC-02H 1% 75K	5322 117 10584
R1222	RES.METAL FILM	HIP RC-02H 1% 162E	5322 117 10529
R1223	RES.METAL FILM	HIP RC-02H 1% 237E	5322 117 10544
R1224	RES.CHIP	RMC1/8 1% 42E2	4822 111 91887
R1226	RES.METAL FILM	HIP RC-02H 1% 162E	5322 117 10529
R1227	RES.CHIP	RMC1/8 1% 61E9	5322 111 92016
R1228	RES.METAL FILM	HIP RC-02H 1% 2K61	5322 117 10547
R1229	RES.METAL FILM	HIP RC-02H 1% 215K	5322 117 10543
R1231	RES.METAL FILM	HIP RC-02H 1% 178E	5322 117 10534
R1251	RES.METAL FILM	HIP RC-02H 1% 21K5	5322 117 10542
R1252	RES.METAL FILM	HIP RC-02H 1% 21K5	5322 117 10542
R1253	RES.METAL FILM	HIP RC-02H 1% 21K5	5322 117 10542
R1254	RES.METAL FILM	HIP RC-02H 1% 21K5	5322 117 10542
R1256	RES.METAL FILM	HIP RC-02H 1% 9K09	5322 117 10589
R1257	RES.CHIP	HIP RC-02H 1% 1K	4822 051 10102
R1258	RES.CHIP	HIP RC-02H 1% 1K	4822 051 10102
R1259	RES.METAL FILM	HIP RC-02H 1% 1K47	5322 117 10527
R1260	RES.METAL FILM	HIP RC-02H 1% 3K48	5322 117 10557
R1262	RES.CHIP	HIP RC-01 5% 1E	4822 051 10108

Item	Description		Ordering code
R1266	RES.CHIP	HIP RC-01 5% 1E	4822 051 10108
R1301	RES.CHIP	RMC1/8 1% 61E9	5322 111 92016
R1302	RES.CHIP	RMC1/8 1% 61E9	5322 111 92016
R1303	RES.METAL FILM	HIP RC-02H 1% 6K81	5322 117 10581
R1304	RES.CHIP	HIP RC-02H 1% 46K4	5322 117 10486
R1306	RES.CHIP	HIP RC-02H 1% 5K11	5322 117 10487
R1307	RES.CHIP	HIP RC-02H 1% 1K	4822 051 10102
R1308	RES.METAL FILM	HIP RC-02H 1% 5K62	5322 117 10573
R1309	RES.METAL FILM	HIP RC-02H 1% 31K6	5322 117 10554
R1310	RES.METAL FILM	HIP RC-02H 1% 196E	5322 117 10538
R1311	RES.METAL FILM	HIP RC-02H 1% 19K6	5322 117 10541
R1312	RES.CHIP	HIP RC-02H 1% 10K	4822 051 10103
R1313	RES.CHIP	RMC1/8 1% 51E1	5322 111 91893
R1314	RES.CHIP	RMC1/8 1% 51E1	5322 111 91893
R1612	RES.METAL FILM	HIP RC-02H 1% 5K62	5322 117 10573
R1613	RES.METAL FILM	HIP RC-02H 1% 1K47	5322 117 10527
R1651	RES.CHIP	HIP RC-01 5% 4E7	4822 051 10478
R1652	RES.CHIP	HIP RC-01 5% 4E7	4822 051 10478
R1653	RES.CHIP	HIP RC-01 5% 1E	4822 051 10108
R1654	RES.CHIP	HIP RC-01 5% 1E	4822 051 10108
R1656	RES.CHIP	HIP RC-01 5% 4E7	4822 051 10478
R1657	RES.CHIP	HIP RC-01 5% 4E7	4822 051 10478
R1661	RES.CHIP	HIP RC-01 5% 1E	4822 051 10108
R1662	RES.CHIP	HIP RC-01 5% 1E	4822 051 10108
R1663	RES.CHIP	RMC1/8 1% 10E	4822 111 91885
R1901	RES.CHIP	RMC1/8 1% 10E	4822 111 91885
R1902	RES.CHIP	RMC1/8 1% 10E	4822 111 91885
R1903	RES.CHIP	RMC1/8 1% 10E	4822 111 91885
R1904	RES.CHIP	RMC1/8 1% 10E	4822 111 91885
R1906	RES.CHIP	HIP RC-01 5% 1E	4822 051 10108
R1911	RES.CHIP	RMC1/8 1% 10E	4822 111 91885
R1912	RES.CHIP	RMC1/8 1% 10E	4822 111 91885
R1913	RES.CHIP	RMC1/8 1% 10E	4822 111 91885
R1914	RES.CHIP	RMC1/8 1% 10E	4822 111 91885
R1921	RES.CHIP	RMC1/8 1% 10E	4822 111 91885
R1922	RES.CHIP	RMC1/8 1% 10E	4822 111 91885
R1923	RES.CHIP	RMC1/8 1% 10E	4822 111 91885
R1924	RES.CHIP	RMC1/8 1% 10E	4822 111 91885
R1926	RES.CHIP	RMC1/8 1% 10E	4822 111 91885
R1927	RES.CHIP	RMC1/8 1% 10E	4822 111 91885
R1928	RES.CHIP	RMC1/8 1% 10E	4822 111 91885
R1929	RES.CHIP	RMC1/8 1% 10E	4822 111 91885
R1951	RES.CHIP	RMC1/8 1% 10E	4822 111 91885
R1961	RES.CHIP	RMC1/8 1% 10E	4822 111 91885
R2001	RES.CHIP	RMC1/8 1% 61E9	5322 111 92016
R2002	RES.CHIP	HIP RC-02H 1% 1M	4822 051 10105
R2006	RES.METAL FILM	ST MRS25 1% 100E	4822 050 21001

Item	Description		Ordering code
R2007	RES.METAL FILM	ST MRS25 1% 100E	4822 050 21001
R2008	RES.METAL FILM	PR24 1/4W 0.1% 9K4	5322 116 83712
R2009	RES.METAL FILM	PR24 1/4W 0.1% 300E	5322 116 51814
R2010	RES.CHIP	RMC1/8 1% 21E5	5322 111 92014
R2011	RES.N.T.C.	NTC640 2% 3K3	5322 116 30421
R2012	RES.CHIP	HIP RC-01 5% 1E	4822 051 10108
R2013	RES.CHIP	RMC1/8 1% 21E5	5322 111 92014
R2014	RES.CHIP	HIP RC-02H 1% 100E	4822 051 10101
R2016	RES.METAL FILM	PR34 0.4W 0.1% 900K	5322 116 51832
R2019	RES.CHIP	HIP RC-02H 1% 100E	4822 051 10101
R2021	RES.METAL FILM	PR34 0.4W 0.1% 990K	5322 116 83104
R2022	RES.CHIP	RMC1/8 1% 21E5	5322 111 92014
R2022	RES.CHIP	RMC1/8 1% 23E7	5322 117 10591
R2023	RES.METAL FILM	PR24 1/4W 0.1% 11K1	5322 116 83101
R2024	RES.METAL FILM	HIP RC-02H 1% 147E	5322 117 10526
R2026	RES.CHIP	RMC1/8 1% 82E5	5322 111 92017
R2027	RES.METAL FILM	PR24 1/4W 0.1% 111K	5322 116 83099
R2028	RES.CHIP	HIP RC-02H 1% 10K	4822 051 10103
R2029	RES.CHIP	HIP RC-02H 1% 10K	4822 051 10103
R2030	RES.CHIP	RMC1/8 1% 21E5	5322 111 92014
R2031	RES.METAL FILM	PR34 0.4W 0.1% 500K	5322 116 83103
R2032	RES.CHIP	HIP RC-02H 1% 1M	4822 051 10105
R2033	RES.CHIP	HIP RC-02H 1% 1M	4822 051 10105
R2034	RES.CHIP	HIP RC-01 5% 10M	4822 051 10106
R2035	RES.METAL FILM	HIP RC-02H 1% 215K	5322 117 10543
R2036	RES.CHIP	HIP RC-02H 1% 5K11	5322 117 10487
R2037	RES.METAL FILM	HIP RC-02H 1% 3K83	5322 117 10561
R2038	RES.METAL FILM	HIP RC-02H 1% 215K	5322 117 10543
R2039	RES.METAL FILM	HIP RC-02H 1% 21K5	5322 117 10542
R2041	RES.CHIP	HIP RC-02H 1% 1K	4822 051 10102
R2042	RES.CHIP	HIP RC-02H 1% 51K1	4822 051 55113
R2043	RES.CHIP	HIP RC-02H 1% 5K11	5322 117 10487
R2044	RES.CHIP	HIP RC-02H 1% 5K11	5322 117 10487
R2045	RES.CHIP	HIP RC-02H 1% 5K11	5322 117 10487
R2046	RES.CHIP	HIP RC-02H 1% 261E	4822 051 52611
R2047	RES.METAL FILM	HIP RC-02H 1% 511E	5322 117 10569
R2048	RES.METAL FILM	HIP RC-02H 1% 237E	5322 117 10544
R2049	RES.CHIP	HIP RC-01 5% 10M	4822 051 10106
R2052	RES.CHIP	HIP RC-02H 1% 100E	4822 051 10101
R2053	RES.METAL FILM	HIP RC-02H 1% 6K19	5322 117 10577
R2054	RES.CHIP	HIP RC-02H 1% 10K	4822 051 10103
R2056	RES.METAL FILM	HIP RC-02H 1% 619E	5322 117 10576
R2057	RES.CHIP	HIP RC-02H 1% 1K	4822 051 10102
R2061	RES.CHIP	RMC1/8 1% 51E1	5322 111 91893
R2062	RES.CHIP	RMC1/8 1% 42E2	4822 111 91887
R2063	RES.CHIP	HIP RC-02H 1% 261E	4822 051 52611
R2064	RES.CHIP	HIP RC-02H 1% 261E	4822 051 52611

Item	Description		Ordering code
R2065	RES.CHIP	HIP RC-02H 1% 261E	4822 051 52611
R2071	RES.CHIP	RMC1/8 1% 61E9	5322 111 92016
R2072	RES.METAL FILM	HIP RC-02H 1% 147E	5322 117 10526
R2073	RES.CHIP	HIP RC-02H 1% 100E	4822 051 10101
R2074	RES.CHIP	RMC1/8 1% 75E	4822 111 91937
R2076	RES.CHIP	HIP RC-02H 1% 10K	4822 051 10103
R2077	RES.CHIP	HIP RC-02H 1% 10K	4822 051 10103
R2078	RES.CHIP	HIP RC-02H 1% 1M	4822 051 10105
R2079	RES.CHIP	HIP RC-02H 1% 1M	4822 051 10105
R2081	RES.CHIP	HIP RC-02H 1% 10K	4822 051 10103
R2082	RES.CHIP	HIP RC-02H 1% 10K	4822 051 10103
R2083	RES.CHIP	HIP RC-02H 1% 100K	4822 051 10104
R2084	RES.CHIP	HIP RC-02H 1% 100K	4822 051 10104
R2085	RES.CHIP	RC-02H 1% 13K3	4822 051 51333
R2086	RES.CHIP	HIP RC-02H 1% 10K	4822 051 10103
R2087	RES.CHIP	HIP RC-02H 1% 51K1	4822 051 55113
R2088	RES.CHIP	HIP RC-02H 1% 10K	4822 051 10103
R2092	RES.METAL FILM	HIP RC-02H 1% 13K3	5322 117 10525
R2093	RES.CHIP	HIP RC-02H 1% 10K	4822 051 10103
R2094	RES.CHIP	HIP RC-02H 1% 2K15	5322 117 10485
R2096	RES.CHIP	HIP RC-02H 1% 1K	4822 051 10102
R2101	RES.CHIP	HIP RC-02H 1% 46K4	5322 117 10486
R2102	RES.METAL FILM	HIP RC-02H 1% 13K3	4822 051 51333
R2103	RES.METAL FILM	HIP RC-02H 1% 14K7	5322 117 10528
R2104	RES.CHIP	HIP RC-02H 1% 10K	4822 051 10103
R2106	RES.CHIP	HIP RC-02H 1% 10K	4822 051 10103
R2112	RES.METAL FILM	HIP RC-02H 1% 61K9	5322 117 10578
R2113	RES.METAL FILM	HIP RC-02H 1% 7K5	5322 117 10583
R2114	RES.CHIP	HIP RC-02H 1% 3K48	5322 117 10557
R2200	RES.CHIP	HIP RC-02H 1% 100E	4822 051 10101
R2201	RES.METAL FILM	HIP RC-02H 1% 13K3	4822 051 51333
R2202	RES.METAL FILM	HIP RC-02H 1% 4K22	5322 117 10565
R2203	RES.CHIP	HIP RC-02H 1% 11K	4822 051 10113
R2204	RES.METAL FILM	HIP RC-02H 1% 12K1	5322 117 10522
R2205	RES.METAL FILM	HIP RC-02H 1% 14K7	5322 117 10528
R2206	RES.CHIP	HIP RC-02H 1% 100E	4822 051 10101
R2207	RES.CHIP	HIP RC-02H 1% 215E	5322 117 10484
R2208	RES.METAL FILM	HIP RC-02H 1% 147E	5322 117 10526
R2209	RES.CHIP	HIP RC-02H 1% 5K11	5322 117 10487
R2210	RES.METAL FILM	HIP RC-02H 1% 31K6	5322 117 10554
R2211	RES.METAL FILM	HIP RC-02H 1% 4K22	5322 117 10565
R2212	RES.CHIP	HIP RC-02H 1% 2K15	5322 117 10485
R2213	RES.MET.GLAZED	RMC1/8 1% 31E6	5322 116 82895
R2214	RES.MET.GLAZED	RMC1/8 1% 31E6	5322 116 82895
R2215	RES.METAL FILM	HIP RC-02H 1% 348E	5322 117 10556
R2216	RES.CHIP	HIP RC-02H 1% 100E	4822 051 10101
R2217	RES.CHIP	HIP RC-02H 1% 100E	4822 051 10101

Item	Description		Ordering code
R2218	RES.CHIP	RMC1/8 1% 51E1	5322 111 91893
R2220	RES.METAL FILM	HIP RC-02H 1% 75K	5322 117 10584
R2222	RES.METAL FILM	HIP RC-02H 1% 162E	5322 117 10529
R2223	RES.METAL FILM	HIP RC-02H 1% 237E	5322 117 10544
R2224	RES.CHIP	RMC1/8 1% 42E2	4822 111 91887
R2226	RES.METAL FILM	HIP RC-02H 1% 162E	5322 117 10529
R2227	RES.CHIP	RMC1/8 1% 61E9	5322 111 92016
R2228	RES.METAL FILM	HIP RC-02H 1% 2K61	5322 117 10547
R2229	RES.METAL FILM	HIP RC-02H 1% 215K	5322 117 10543
R2231	RES.METAL FILM	HIP RC-02H 1% 178E	5322 117 10534
R2301	RES.CHIP	RMC1/8 1% 51E1	5322 111 91893
R2302	RES.CHIP	RMC1/8 1% 51E1	5322 111 91893
R2303	RES.METAL FILM	HIP RC-02H 1% 6K81	5322 117 10581
R2304	RES.CHIP	HIP RC-02H 1% 46K4	5322 117 10486
R2307	RES.CHIP	HIP RC-02H 1% 1K	4822 051 10102
R2308	RES.METAL FILM	HIP RC-02H 1% 5K62	5322 117 10573
R2309	RES.METAL FILM	HIP RC-02H 1% 31K6	5322 117 10554
R2310	RES.METAL FILM	HIP RC-02H 1% 196E	5322 117 10538
R2311	RES.METAL FILM	HIP RC-02H 1% 19K6	5322 117 10541
R2313	RES.CHIP	RMC1/8 1% 51E1	5322 111 91893
R2314	RES.CHIP	RMC1/8 1% 51E1	5322 111 91893
R3001	RES.CHIP	RMC1/8 1% 61E9	5322 111 92016
R3002	RES.CHIP	HIP RC-02H 1% 1M	4822 051 10105
R3006	RES.METAL FILM	ST MRS25 1% 100E	4822 050 21001
R3007	RES.METAL FILM	ST MRS25 1% 100E	4822 050 21001
R3008	RES.METAL FILM	PR24 1/4W 0.1% 9K4	5322 116 83712
R3009	RES.METAL FILM	PR24 1/4W 0.1% 300E	5322 116 51814
R3010	RES.CHIP	RMC1/8 1% 21E5	5322 111 92014
R3011	RES.N.T.C.	NTC640 2% 3K3	5322 116 30421
R3012	RES.CHIP	HIP RC-01 5% 1E	4822 051 10108
R3013	RES.CHIP	RMC1/8 1% 21E5	5322 111 92014
R3014	RES.CHIP	HIP RC-02H 1% 100E	4822 051 10101
R3016	RES.METAL FILM	PR34 0.4W 0.1% 900K	5322 116 51832
R3019	RES.CHIP	HIP RC-02H 1% 100E	4822 051 10101
R3021	RES.METAL FILM	PR34 0.4W 0.1% 990K	5322 116 83104
R3022	RES.CHIP	RMC1/8 1% 21E5	5322 111 92014
R3022	RES.CHIP	RMC1/8 1% 23E7	5322 117 10591
R3023	RES.METAL FILM	PR24 1/4W 0.1% 11K1	5322 116 83101
R3024	RES.METAL FILM	HIP RC-02H 1% 147E	5322 117 10526
R3026	RES.CHIP	RMC1/8 1% 82E5	5322 111 92017
R3027	RES.METAL FILM	PR24 1/4W 0.1% 111K	5322 116 83099
R3028	RES.CHIP	HIP RC-02H 1% 10K	4822 051 10103
R3029	RES.CHIP	HIP RC-02H 1% 10K	4822 051 10103
R3030	RES.CHIP	RMC1/8 1% 21E5	5322 111 92014
R3031	RES.METAL FILM	PR34 0.4W 0.1% 500K	5322 116 83103
R3032	RES.CHIP	HIP RC-02H 1% 1M	4822 051 10105
R3033	RES.CHIP	HIP RC-02H 1% 1M	4822 051 10105

Item	Description		Ordering code
R3034	RES.CHIP	HIP RC-01 5% 10M	4822 051 10106
R3035	RES.METAL FILM	HIP RC-02H 1% 215K	5322 117 10543
R3036	RES.CHIP	HIP RC-02H 1% 5K11	5322 117 10487
R3037	RES.METAL FILM	HIP RC-02H 1% 3K83	5322 117 10561
R3038	RES.METAL FILM	HIP RC-02H 1% 215K	5322 117 10543
R3039	RES.METAL FILM	HIP RC-02H 1% 21K5	5322 117 10542
R3041	RES.CHIP	HIP RC-02H 1% 1K	4822 051 10102
R3042	RES.CHIP	HIP RC-02H 1% 51K1	4822 051 55113
R3043	RES.CHIP	HIP RC-02H 1% 5K11	5322 117 10487
R3044	RES.CHIP	HIP RC-02H 1% 5K11	5322 117 10487
R3045	RES.CHIP	HIP RC-02H 1% 5K11	5322 117 10487
R3046	RES.CHIP	HIP RC-02H 1% 261E	4822 051 52611
R3047	RES.METAL FILM	HIP RC-02H 1% 511E	5322 117 10569
R3048	RES.METAL FILM	HIP RC-02H 1% 237E	5322 117 10544
R3049	RES.CHIP	HIP RC-01 5% 10M	4822 051 10106
R3052	RES.CHIP	HIP RC-02H 1% 100E	4822 051 10101
R3053	RES.METAL FILM	HIP RC-02H 1% 6K19	5322 117 10577
R3054	RES.CHIP	HIP RC-02H 1% 10K	4822 051 10103
R3056	RES.METAL FILM	HIP RC-02H 1% 619E	5322 117 10576
R3057	RES.CHIP	HIP RC-02H 1% 1K	4822 051 10102
R3061	RES.CHIP	RMC1/8 1% 51E1	5322 111 91893
R3062	RES.CHIP	RMC1/8 1% 42E2	4822 111 91887
R3063	RES.CHIP	HIP RC-02H 1% 261E	4822 051 52611
R3064	RES.CHIP	HIP RC-02H 1% 261E	4822 051 52611
R3065	RES.CHIP	HIP RC-02H 1% 261E	4822 051 52611
R3071	RES.CHIP	RMC1/8 1% 61E9	5322 111 92016
R3072	RES.METAL FILM	HIP RC-02H 1% 147E	5322 117 10526
R3073	RES.CHIP	HIP RC-02H 1% 100E	4822 051 10101
R3074	RES.CHIP	RMC1/8 1% 75E	4822 111 91937
R3076	RES.CHIP	HIP RC-02H 1% 10K	4822 051 10103
R3077	RES.CHIP	HIP RC-02H 1% 10K	4822 051 10103
R3078	RES.CHIP	HIP RC-02H 1% 1M	4822 051 10105
R3079	RES.CHIP	HIP RC-02H 1% 1M	4822 051 10105
R3081	RES.CHIP	HIP RC-02H 1% 10K	4822 051 10103
R3082	RES.CHIP	HIP RC-02H 1% 10K	4822 051 10103
R3083	RES.CHIP	HIP RC-02H 1% 100K	4822 051 10104
R3084	RES.CHIP	HIP RC-02H 1% 100K	4822 051 10104
R3085	RES.CHIP	RC-02H 1% 13K3	4822 051 51333
R3086	RES.CHIP	HIP RC-02H 1% 10K	4822 051 10103
R3087	RES.CHIP	HIP RC-02H 1% 51K1	4822 051 55113
R3088	RES.CHIP	HIP RC-02H 1% 10K	4822 051 10103
R3092	RES.METAL FILM	HIP RC-02H 1% 13K3	5322 117 10525
R3093	RES.CHIP	HIP RC-02H 1% 10K	4822 051 10103
R3094	RES.CHIP	HIP RC-02H 1% 2K15	5322 117 10485
R3096	RES.CHIP	HIP RC-02H 1% 1K	4822 051 10102
R3101	RES.CHIP	HIP RC-02H 1% 46K4	5322 117 10486
R3102	RES.METAL FILM	HIP RC-02H 1% 13K3	4822 051 51333

Item	Description		Ordering code
R3103	RES.METAL FILM	HIP RC-02H 1% 14K7	5322 117 10528
R3104	RES.CHIP	HIP RC-02H 1% 10K	4822 051 10103
R3106	RES.CHIP	HIP RC-02H 1% 10K	4822 051 10103
R3112	RES.METAL FILM	HIP RC-02H 1% 61K9	5322 117 10578
R3113	RES.METAL FILM	HIP RC-02H 1% 7K5	5322 117 10583
R3114	RES.CHIP	HIP RC-02H 1% 3K48	5322 117 10557
R3200	RES.CHIP	HIP RC-02H 1% 100E	4822 051 10101
R3201	RES.METAL FILM	HIP RC-02H 1% 13K3	4822 051 51333
R3202	RES.METAL FILM	HIP RC-02H 1% 4K22	5322 117 10565
R3203	RES.CHIP	HIP RC-02H 1% 11K	4822 051 10113
R3204	RES.METAL FILM	HIP RC-02H 1% 12K1	5322 117 10522
R3205	RES.METAL FILM	HIP RC-02H 1% 14K7	5322 117 10528
R3206	RES.CHIP	HIP RC-02H 1% 100E	4822 051 10101
R3207	RES.CHIP	HIP RC-02H 1% 215E	5322 117 10484
R3208	RES.METAL FILM	HIP RC-02H 1% 147E	5322 117 10526
R3209	RES.CHIP	HIP RC-02H 1% 5K11	5322 117 10487
R3210	RES.METAL FILM	HIP RC-02H 1% 31K6	5322 117 10554
R3211	RES.METAL FILM	HIP RC-02H 1% 4K22	5322 117 10565
R3212	RES.CHIP	HIP RC-02H 1% 2K15	5322 117 10485
R3213	RES.MET.GLAZED	RMC1/8 1% 31E6	5322 116 82895
R3214	RES.MET.GLAZED	RMC1/8 1% 31E6	5322 116 82895
R3215	RES.METAL FILM	HIP RC-02H 1% 348E	5322 117 10556
R3216	RES.CHIP	HIP RC-02H 1% 100E	4822 051 10101
R3217	RES.CHIP	HIP RC-02H 1% 100E	4822 051 10101
R3218	RES.CHIP	RMC1/8 1% 51E1	5322 111 91893
R3220	RES.METAL FILM	HIP RC-02H 1% 75K	5322 117 10584
R3222	RES.METAL FILM	HIP RC-02H 1% 162E	5322 117 10529
R3223	RES.METAL FILM	HIP RC-02H 1% 237E	5322 117 10544
R3224	RES.CHIP	RMC1/8 1% 42E2	4822 111 91887
R3226	RES.METAL FILM	HIP RC-02H 1% 162E	5322 117 10529
R3227	RES.CHIP	RMC1/8 1% 61E9	5322 111 92016
R3228	RES.METAL FILM	HIP RC-02H 1% 2K61	5322 117 10547
R3229	RES.METAL FILM	HIP RC-02H 1% 215K	5322 117 10543
R3231	RES.METAL FILM	HIP RC-02H 1% 178E	5322 117 10534
R3301	RES.MET.GLAZED	RMC1/8 1% 46E4	5322 116 82896
R3302	RES.MET.GLAZED	RMC1/8 1% 46E4	5322 116 82896
R3303	RES.METAL FILM	HIP RC-02H 1% 6K81	5322 117 10581
R3304	RES.CHIP	HIP RC-02H 1% 46K4	5322 117 10486
R3307	RES.CHIP	HIP RC-02H 1% 1K	4822 051 10102
R3308	RES.METAL FILM	HIP RC-02H 1% 5K62	5322 117 10573
R3309	RES.METAL FILM	HIP RC-02H 1% 31K6	5322 117 10554
R3310	RES.METAL FILM	HIP RC-02H 1% 196E	5322 117 10538
R3311	RES.METAL FILM	HIP RC-02H 1% 19K6	5322 117 10541
R3313	RES.CHIP	RMC1/8 1% 51E1	5322 111 91893
R3314	RES.CHIP	RMC1/8 1% 51E1	5322 111 91893
R4001	RES.CHIP	RMC1/8 1% 61E9	5322 111 92016
R4002	RES.CHIP	HIP RC-02H 1% 1M	4822 051 10105

Item	Description		Ordering code
R4006	RES.METAL FILM	ST MRS25 1% 100E	4822 050 21001
R4007	RES.METAL FILM	ST MRS25 1% 100E	4822 050 21001
R4008	RES.METAL FILM	PR24 1/4W 0.1% 9K4	5322 116 83712
R4009	RES.METAL FILM	PR24 1/4W 0.1% 300E	5322 116 51814
R4010	RES.CHIP	RMC1/8 1% 21E5	5322 111 92014
R4011	RES.N.T.C.	NTC640 2% 3K3	5322 116 30421
R4012	RES.CHIP	HIP RC-01 5% 1E	4822 051 10108
R4013	RES.CHIP	RMC1/8 1% 21E5	5322 111 92014
R4014	RES.CHIP	HIP RC-02H 1% 100E	4822 051 10101
R4016	RES.METAL FILM	PR34 0.4W 0.1% 900K	5322 116 51832
R4019	RES.CHIP	HIP RC-02H 1% 100E	4822 051 10101
R4021	RES.METAL FILM	PR34 0.4W 0.1% 990K	5322 116 83104
R4022	RES.CHIP	RMC1/8 1% 21E5	5322 111 92014
R4022	RES.CHIP	RMC1/8 1% 23E7	5322 117 10591
R4023	RES.METAL FILM	PR24 1/4W 0.1% 11K1	5322 116 83101
R4024	RES.METAL FILM	HIP RC-02H 1% 147E	5322 117 10526
R4026	RES.CHIP	RMC1/8 1% 82E5	5322 111 92017
R4027	RES.METAL FILM	PR24 1/4W 0.1% 111K	5322 116 83099
R4028	RES.CHIP	HIP RC-02H 1% 10K	4822 051 10103
R4029	RES.CHIP	HIP RC-02H 1% 10K	4822 051 10103
R4030	RES.CHIP	RMC1/8 1% 21E5	5322 111 92014
R4031	RES.METAL FILM	PR34 0.4W 0.1% 500K	5322 116 83103
R4032	RES.CHIP	HIP RC-02H 1% 1M	4822 051 10105
R4033	RES.CHIP	HIP RC-02H 1% 1M	4822 051 10105
R4034	RES.CHIP	HIP RC-01 5% 10M	4822 051 10106
R4035	RES.METAL FILM	HIP RC-02H 1% 215K	5322 117 10543
R4036	RES.CHIP	HIP RC-02H 1% 5K11	5322 117 10487
R4037	RES.METAL FILM	HIP RC-02H 1% 3K83	5322 117 10561
R4038	RES.METAL FILM	HIP RC-02H 1% 215K	5322 117 10543
R4039	RES.METAL FILM	HIP RC-02H 1% 21K5	5322 117 10542
R4041	RES.CHIP	HIP RC-02H 1% 1K	4822 051 10102
R4042	RES.CHIP	HIP RC-02H 1% 51K1	4822 051 55113
R4043	RES.CHIP	HIP RC-02H 1% 5K11	5322 117 10487
R4044	RES.CHIP	HIP RC-02H 1% 5K11	5322 117 10487
R4045	RES.CHIP	HIP RC-02H 1% 5K11	5322 117 10487
R4046	RES.CHIP	HIP RC-02H 1% 261E	4822 051 52611
R4047	RES.METAL FILM	HIP RC-02H 1% 511E	5322 117 10569
R4048	RES.METAL FILM	HIP RC-02H 1% 237E	5322 117 10544
R4049	RES.CHIP	HIP RC-01 5% 10M	4822 051 10106
R4052	RES.CHIP	HIP RC-02H 1% 100E	4822 051 10101
R4053	RES.METAL FILM	HIP RC-02H 1% 6K19	5322 117 10577
R4054	RES.CHIP	HIP RC-02H 1% 10K	4822 051 10103
R4056	RES.METAL FILM	HIP RC-02H 1% 619E	5322 117 10576
R4057	RES.CHIP	HIP RC-02H 1% 1K	4822 051 10102
R4061	RES.CHIP	RMC1/8 1% 51E1	5322 111 91893
R4062	RES.CHIP	RMC1/8 1% 42E2	4822 111 91887
R4063	RES.CHIP	HIP RC-02H 1% 261E	4822 051 52611

Item	Description		Ordering code
R4064	RES.CHIP	HIP RC-02H 1% 261E	4822 051 52611
R4065	RES.CHIP	HIP RC-02H 1% 261E	4822 051 52611
R4071	RES.CHIP	RMC1/8 1% 61E9	5322 111 92016
R4072	RES.METAL FILM	HIP RC-02H 1% 147E	5322 117 10526
R4073	RES.CHIP	HIP RC-02H 1% 100E	4822 051 10101
R4074	RES.CHIP	RMC1/8 1% 75E	4822 111 91937
R4076	RES.CHIP	HIP RC-02H 1% 10K	4822 051 10103
R4077	RES.CHIP	HIP RC-02H 1% 10K	4822 051 10103
R4078	RES.CHIP	HIP RC-02H 1% 1M	4822 051 10105
R4079	RES.CHIP	HIP RC-02H 1% 1M	4822 051 10105
R4081	RES.CHIP	HIP RC-02H 1% 10K	4822 051 10103
R4082	RES.CHIP	HIP RC-02H 1% 10K	4822 051 10103
R4083	RES.CHIP	HIP RC-02H 1% 100K	4822 051 10104
R4084	RES.CHIP	HIP RC-02H 1% 100K	4822 051 10104
R4085	RES.CHIP	RC-02H 1% 13K3	4822 051 51333
R4086	RES.CHIP	HIP RC-02H 1% 10K	4822 051 10103
R4087	RES.CHIP	HIP RC-02H 1% 51K1	4822 051 55113
R4088	RES.CHIP	HIP RC-02H 1% 10K	4822 051 10103
R4092	RES.METAL FILM	HIP RC-02H 1% 13K3	5322 117 10525
R4093	RES.CHIP	HIP RC-02H 1% 10K	4822 051 10103
R4094	RES.CHIP	HIP RC-02H 1% 2K15	5322 117 10485
R4096	RES.CHIP	HIP RC-02H 1% 1K	4822 051 10102
R4101	RES.CHIP	HIP RC-02H 1% 46K4	5322 117 10486
R4102	RES.METAL FILM	HIP RC-02H 1% 13K3	4822 051 51333
R4103	RES.METAL FILM	HIP RC-02H 1% 14K7	5322 117 10528
R4104	RES.CHIP	HIP RC-02H 1% 10K	4822 051 10103
R4106	RES.CHIP	HIP RC-02H 1% 10K	4822 051 10103
R4112	RES.METAL FILM	HIP RC-02H 1% 61K9	5322 117 10578
R4113	RES.METAL FILM	HIP RC-02H 1% 7K5	5322 117 10583
R4114	RES.CHIP	HIP RC-02H 1% 3K48	5322 117 10557
R4200	RES.CHIP	HIP RC-02H 1% 100E	4822 051 10101
R4201	RES.METAL FILM	HIP RC-02H 1% 13K3	4822 051 51333
R4202	RES.METAL FILM	HIP RC-02H 1% 4K22	5322 117 10565
R4203	RES.CHIP	HIP RC-02H 1% 11K	4822 051 10113
R4204	RES.METAL FILM	HIP RC-02H 1% 12K1	5322 117 10522
R4205	RES.METAL FILM	HIP RC-02H 1% 14K7	5322 117 10528
R4206	RES.CHIP	HIP RC-02H 1% 100E	4822 051 10101
R4207	RES.CHIP	HIP RC-02H 1% 215E	5322 117 10484
R4208	RES.METAL FILM	HIP RC-02H 1% 147E	5322 117 10526
R4209	RES.CHIP	HIP RC-02H 1% 5K11	5322 117 10487
R4210	RES.METAL FILM	HIP RC-02H 1% 31K6	5322 117 10554
R4211	RES.METAL FILM	HIP RC-02H 1% 4K22	5322 117 10565
R4212	RES.CHIP	HIP RC-02H 1% 2K15	5322 117 10485
R4213	RES.MET.GLAZED	RMC1/8 1% 31E6	5322 116 82895
R4214	RES.MET.GLAZED	RMC1/8 1% 31E6	5322 116 82895
R4215	RES.METAL FILM	HIP RC-02H 1% 348E	5322 117 10556
R4216	RES.CHIP	HIP RC-02H 1% 100E	4822 051 10101

Item	Description		Ordering code
R4217	RES.CHIP	HIP RC-02H 1% 100E	4822 051 10101
R4218	RES.CHIP	RMC1/8 1% 51E1	5322 111 91893
R4220	RES.METAL FILM	HIP RC-02H 1% 75K	5322 117 10584
R4222	RES.METAL FILM	HIP RC-02H 1% 162E	5322 117 10529
R4223	RES.METAL FILM	HIP RC-02H 1% 237E	5322 117 10544
R4224	RES.CHIP	RMC1/8 1% 42E2	4822 111 91887
R4226	RES.METAL FILM	HIP RC-02H 1% 162E	5322 117 10529
R4227	RES.CHIP	RMC1/8 1% 61E9	5322 111 92016
R4228	RES.METAL FILM	HIP RC-02H 1% 2K61	5322 117 10547
R4229	RES.METAL FILM	HIP RC-02H 1% 215K	5322 117 10543
R4231	RES.METAL FILM	HIP RC-02H 1% 178E	5322 117 10534
R4301	RES.CHIP	RMC1/8 1% 51E1	5322 111 91893
R4302	RES.CHIP	RMC1/8 1% 51E1	5322 111 91893
R4303	RES.METAL FILM	HIP RC-02H 1% 6K81	5322 117 10581
R4304	RES.CHIP	HIP RC-02H 1% 46K4	5322 117 10486
R4307	RES.CHIP	HIP RC-02H 1% 1K	4822 051 10102
R4308	RES.METAL FILM	HIP RC-02H 1% 5K62	5322 117 10573
R4309	RES.METAL FILM	HIP RC-02H 1% 31K6	5322 117 10554
R4310	RES.METAL FILM	HIP RC-02H 1% 196E	5322 117 10538
R4311	RES.METAL FILM	HIP RC-02H 1% 19K6	5322 117 10541
R4313	RES.CHIP	RMC1/8 1% 51E1	5322 111 91893
R4314	RES.CHIP	RMC1/8 1% 51E1	5322 111 91893
R5001	RES.METAL FILM	HIP RC-02H 1% 3K48	5322 117 10557
R5002	RES.METAL FILM	HIP RC-02H 1% 3K48	5322 117 10557
R5003	RES.CHIP	HIP RC-02H 1% 100E	4822 051 10101
R5004	RES.METAL FILM	HIP RC-02H 1% 14K7	5322 117 10528
R5006	RES.METAL FILM	HIP RC-02H 1% 14K7	5322 117 10528
R5007	RES.METAL FILM	HIP RC-02H 1% 348E	5322 117 10556
R5008	RES.METAL FILM	HIP RC-02H 1% 348E	5322 117 10556
R5009	RES.METAL FILM	HIP RC-02H 1% 909E	5322 117 10588
R5011	RES.METAL FILM	HIP RC-02H 1% 909E	5322 117 10588
R5012	RES.METAL FILM	HIP RC-02H 1% 162E	5322 117 10529
R5013	RES.METAL FILM	HIP RC-02H 1% 162E	5322 117 10529
R5014	RES.METAL FILM	HIP RC-02H 1% 1K47	5322 117 10527
R5016	RES.CHIP	HIP RC-02H 1% 100E	4822 051 10101
R5017	RES.CHIP	HIP RC-02H 1% 100E	4822 051 10101
R5018	RES.CHIP	HIP RC-02H 1% 51K1	4822 051 55113
R5019	RES.METAL FILM	HIP RC-02H 1% 2K87	5322 117 10549
R5021	RES.METAL FILM	HIP RC-02H 1% 3K83	5322 117 10561
R5024	RES.CHIP	HIP RC-02H 1% 100E	4822 051 10101
R5026	RES.CHIP	HIP RC-02H 1% 100E	4822 051 10101
R5027	RES.CHIP	HIP RC-02H 1% 100E	4822 051 10101
R5028	RES.CHIP	HIP RC-02H 1% 100E	4822 051 10101
R5029	RES.METAL FILM	HIP RC-02H 1% 1K47	5322 117 10527
R5031	RES.METAL FILM	HIP RC-02H 1% 21K5	5322 117 10542
R5032	RES.METAL FILM	HIP RC-02H 1% 21K5	5322 117 10542
R5035	RES.METAL FILM	HIP RC-02H 1% 348E	5322 117 10556

Item	Description		Ordering code
R5036	RES.METAL FILM	HIP RC-02H 1% 178E	5322 117 10534
R5037	RES.METAL FILM	HIP RC-02H 1% 178E	5322 117 10534
R5041	RES.METAL FILM	HIP RC-02H 1% 21K5	5322 117 10542
R5042	RES.METAL FILM	HIP RC-02H 1% 21K5	5322 117 10542
R5043	RES.CHIP	HIP RC-02H 1% 215E	5322 117 10484
R5044	RES.METAL FILM	HIP RC-02H 1% 316E	5322 117 10552
R5045	RES.CHIP	HIP RC-02H 1% 215E	4822 051 10484
R5046	RES.METAL FILM	HIP RC-02H 1% 316E	5322 117 10552
R5047	RES.METAL FILM	HIP RC-02H 1% 511E	5322 117 10569
R5048	RES.MET.GLAZED	RMC1/8 1% 51E1	5322 117 11737
R5049	RES.MET.GLAZED	RMC1/8 1% 51E1	5322 117 11731
R5050	RES.METAL FILM	HIP RC-02H 1% 511K	5322 117 10571
R5051	RES.CHIP	RMC1/8 1% 51E1	5322 111 91893
R5052	RES.CHIP	RMC1/8 1% 51E1	5322 111 91893
R5053	RES.CHIP	HIP RC-02H 1% 261E	4822 051 52611
R5054	RES.METAL FILM	HIP RC-02H 1% 2K87	5322 117 10549
R5055	RES.METAL FILM	HIP RC-02H 1% 3K48	5322 117 10557
R5055	RES.CHIP	RC-02H 1% 1E	4822 051 10108
R5055	RES.CHIP	RC-02H 1% 10E	4822 051 10109
R5056	RES.METAL FILM	HIP RC-02H 1% 19K6	5322 117 10541
R5057	RES.METAL FILM	HIP RC-02H 1% 13K3	5322 117 10525
R5058	RES.CHIP	HIP RC-02H 1% 1K	4822 051 10102
R5059	RES.METAL FILM	HIP RC-02H 1% 9K09	5322 117 10589
R5060	RES.METAL FILM	HIP RC-02H 1% 21K5	5322 117 10542
R5061	RES.METAL FILM	HIP RC-02H 1% 1K21	5322 117 51212
R5061	RES.CHIP	RC-02H 1% 3K83	5322 117 10561
R5064	RES.METAL FILM	HIP RC-02H 1% 3K83	5322 117 10561
R5065	RES.CHIP	HIP RC-02H 1% 100E	4822 051 10101
R5066	RES.METAL FILM	HIP RC-02H 1% 511K	5322 117 10571
R5068	RES.CHIP	HIP RC-01 5% 4E7	4822 051 10478
R5069	RES.METAL FILM	HIP RC-02H 1% 2K61	5322 117 10547
R5070	RES.METAL FILM	HIP RC-02H 1% 2K61	5322 117 10547
R5071	RES.CHIP	RMC1/8 1% 51E1	5322 111 91893
R5072	RES.CHIP	RMC1/8 1% 51E1	5322 111 91893
R5076	RES.METAL FILM	HIP RC-02H 1% 14K7	5322 117 10528
R5501	RES.METAL FILM	HIP RC-02H 1% 9K09	5322 117 10589
R5502	RES.METAL FILM	HIP RC-02H 1% 12K1	5322 117 10522
R5503	RES.METAL FILM	HIP RC-02H 1% 12K1	5322 117 10522
R5504	RES.METAL FILM	HIP RC-02H 1% 6K81	5322 117 10581
R5506	RES.METAL FILM	HIP RC-02H 1% 6K81	5322 117 10581
R5507	RES.METAL FILM	HIP RC-02H 1% 6K81	5322 117 10581
R5508	RES.METAL FILM	HIP RC-02H 1% 6K81	5322 117 10581
R5509	RES.METAL FILM	HIP RC-02H 1% 3K16	5322 117 10553
R5510	RES.METAL FILM	HIP RC-02H 1% 12K1	5322 117 10522
R5511	RES.CHIP	HIP RC-02H 1% 10K	4822 051 10103
R5512	RES.METAL FILM	HIP RC-02H 1% 619E	5322 117 10576
R5513	RES.METAL FILM	HIP RC-02H 1% 422E	5322 117 10564

Item	Description		Ordering code
R5514	RES.CHIP	HIP RC-02H 1% 1K	4822 051 10102
R5516	RES.METAL FILM	HIP RC-02H 1% 3K48	5322 117 10557
R5517	RES.METAL FILM	HIP RC-02H 1% 1K21	5322 117 10521
R5518	RES.CHIP	HIP RC-02H 1% 10K	4822 051 10103
R5519	RES.METAL FILM	HIP RC-02H 1% 2K61	5322 117 10547
R5521	RES.CHIP	HIP RC-02H 1% 261E	4822 051 52611
R5522	RES.METAL FILM	HIP RC-02H 1% 6K81	5322 117 10581
R5523	RES.METAL FILM	HIP RC-02H 1% 619E	5322 117 10576
R5524	RES.CHIP	HIP RC-02H 1% 1K	4822 051 10102
R5526	RES.CHIP	HIP RC-02H 1% 10K	4822 051 10103
R5527	RES.CHIP	HIP RC-02H 1% 100K	4822 051 10104
R5531	RES.CHIP	HIP RC-02H 1% 5K11	5322 117 10487
R5532	RES.CHIP	HIP RC-02H 1% 5K11	5322 117 10487
R5533	RES.CHIP	HIP RC-02H 1% 5K11	5322 117 10487
R5534	RES.CHIP	HIP RC-02H 1% 5K11	5322 117 10487
R5536	RES.CHIP	HIP RC-02H 1% 5K11	5322 117 10487
R5537	RES.CHIP	HIP RC-02H 1% 5K11	5322 117 10487
R5538	RES.CHIP	HIP RC-02H 1% 5K11	5322 117 10487
R5539	RES.CHIP	HIP RC-02H 1% 5K11	5322 117 10487
R5541	RES.CHIP	HIP RC-01 5% 1E	4822 051 10108
R5542	RES.CHIP	HIP RC-01 5% 1E	4822 051 10108
R5543	RES.CHIP	HIP RC-02H 1% 10K	4822 051 10103
R5544	RES.CHIP	HIP RC-02H 1% 2K15	5322 117 10485
R5546	RES.METAL FILM	HIP RC-02H 1% 3K48	5322 117 10557
R5551	RES.METAL FILM	HIP RC-02H 1% 21K5	5322 117 10542
R5552	RES.METAL FILM	HIP RC-02H 1% 21K5	5322 117 10542
R5553	RES.METAL FILM	HIP RC-02H 1% 21K5	5322 117 10542
R5554	RES.METAL FILM	HIP RC-02H 1% 21K5	5322 117 10542
R5556	RES.CHIP	HIP RC-02H 1% 10K	4822 051 10103
R5557	RES.CHIP	HIP RC-02H 1% 10K	4822 051 10103
R5558	RES.CHIP	HIP RC-02H 1% 10K	4822 051 10103
R5559	RES.CHIP	HIP RC-02H 1% 10K	4822 051 10103
R5561	RES.CHIP	HIP RC-02H 1% 5K11	5322 117 10487
R5562	RES.METAL FILM	HIP RC-02H 1% 12K1	5322 117 10522
R5601	RES.MET.GLAZED	RMC1/8 1% 31E6	5322 116 82895
R5602	RES.CHIP	HIP RC-01 5% 4E7	4822 051 10478
R5603	RES.CHIP	RMC1/8 1% 42E2	4822 111 91887
R5606	RES.CHIP	HIP RC-02H 1% 5K11	5322 117 10487
R6001	RES.CHIP	HIP RC-02H 1% 100E	4822 051 10101
R6002	RES.METAL FILM	PR24 1/4W 0.1% 50E	5322 116 53165
R6003	RES.METAL FILM	PR24 1/4W 0.1% 75E	5322 116 53168
R6004	RES.METAL FILM	PR24 1/4W 0.1% 125E	5322 116 53176
R6005	RES.METAL FILM	PR24 1/4W 0.1% 250E	5322 116 53166
R6006	RES.METAL FILM	PR24 1/4W 0.1% 750E	5322 116 53173
R6007	RES.METAL FILM	PR24 1/4W 0.1% 1K25	5322 116 53177
R6008	RES.METAL FILM	PR24 1/4W 0.1% 900E	5322 116 83098
R6009	RES.METAL FILM	HIP RC-02H 1% 1K78	5322 117 10535

Item	Description		Ordering code
R6011	RES.CHIP	HIP RC-02H 1% 100E	4822 051 10101
R6012	RES.CHIP	HIP RC-02H 1% 100K	4822 051 10104
R6013	RES.METAL FILM	PR24 1/4W 0.1% 23K7	5322 116 53169
R6014	RES.METAL FILM	PR24 1/4W 0.1% 2K37	5322 116 53171
R6015	RES.METAL FILM	HIP RC-02H 1% 19K6	5322 117 10541
R6016	RES.METAL FILM	HIP RC-02H 1% 1K96	5322 117 10539
R6017	RES.CHIP	HIP RC-02H 1% 100E	4822 051 10101
R6018	RES.CHIP	HIP RC-02H 1% 2K15	5322 117 10485
R6019	RES.CHIP	RMC1/8 1% 42E2	4822 111 91887
R6020	RES.CHIP	RMC1/8 1% 10E	4822 111 91885
R6021	RES.METAL FILM	HIP RC-02H 1% 3K16	5322 117 10553
R6022	RES.CHIP	RMC1/8 1% 42E2	4822 111 91887
R6023	RES.CHIP	RMC1/8 1% 51E1	5322 111 91893
R6024	RES.CHIP	HIP RC-01 5% 1E	4822 051 10108
R6025	RES.CHIP	HIP RC-01 5% 1E	4822 051 10108
R6026	RES.METAL FILM	HIP RC-02H 1% 14K7	5322 117 10528
R6027	RES.CHIP	HIP RC-02H 1% 100E	4822 051 10101
R6028	RES.METAL FILM	HIP RC-02H 1% 237E	5322 117 10544
R6029	RES.CHIP	HIP RC-01 5% 4E7	4822 051 10478
R6030	RES.CHIP	HIP RC-01 5% 4E7	4822 051 10478
R6031	RES.METAL FILM	HIP RC-02H 1% 316E	5322 117 10552
R6032	RES.METAL FILM	HIP RC-02H 1% 3K16	5322 117 10553
R6033	RES.CHIP	HIP RC-02H 1% 51K1	4822 051 55113
R6034	RES.METAL FILM	HIP RC-02H 1% 1K78	5322 117 10535
R6035	RES.CHIP	HIP RC-02H 1% 5K11	5322 117 10487
R6036	RES.METAL FILM	HIP RC-02H 1% 215K	5322 117 10543
R6037	RES.CHIP	HIP RC-02H 1% 5K11	5322 117 10487
R6038	RES.METAL FILM	HIP RC-02H 1% 3K16	5322 117 10553
R6040	RES.METAL FILM	HIP RC-02H 1% 6K19	5322 117 10577
R6041	RES.METAL FILM	HIP RC-02H 1% 316E	5322 117 10552
R6042	RES.CHIP	RMC1/8 1% 10E	4822 111 91885
R6043	RES.CHIP	RMC1/8 1% 10E	4822 111 91885
R6044	RES.MET.GLAZED	RMC1/8 1% 31E6	5322 116 82895
R6045	RES.METAL FILM	HIP RC-02H 1% 3K16	5322 117 10553
R6046	RES.CHIP	RMC1/8 1% 10E	4822 111 91885
R6047	RES.METAL FILM	HIP RC-02H 1% 196E	5322 117 10538
R6048	RES.METAL FILM	HIP RC-02H 1% 750E	5322 117 10582
R6049	RES.CHIP	HIP RC-02H 1% 1K	4822 051 10102
R6050	RES.CHIP	HIP RC-01 5% 4E7	4822 051 10478
R6051	RES.CHIP	HIP RC-02H 1% 1K	4822 051 10102
R6052	RES.METAL FILM	HIP RC-02H 1% 21K5	5322 117 10542
R6053	RES.CHIP	HIP RC-02H 1% 1K	4822 051 10102
R6054	RES.METAL FILM	HIP RC-02H 1% 21K5	5322 117 10542
R6061	RES.CHIP	HIP RC-02H 1% 1K	4822 051 10102
R6062	RES.CHIP	HIP RC-02H 1% 10K	4822 051 10103
R6063	RES.METAL FILM	HIP RC-02H 1% 3K16	5322 117 10553
R6070	RES.CHIP	HIP RC-02H 1% 10K	4822 051 10103

Item	Description		Ordering code
R6071	RES.METAL FILM	HIP RC-02H 1% 19K6	5322 117 10541
R6072	RES.CHIP	RMC1/8 1% 10E	4822 111 91885
R6073	RES.CHIP	HIP RC-02H 1% 1K	4822 051 10102
R6074	RES.METAL FILM	HIP RC-02H 1% 1K21	5322 117 10521
R6093	RES.CHIP	HIP RC-01 5% 3E3	4822 051 10338
R6094	RES.CHIP	RMC1/8 1% 10E	4822 111 91885
R6095	RES.CHIP	RMC1/8 1% 51E1	5322 111 91893
R6101	RES.CHIP	HIP RC-02H 1% 1K	4822 051 10102
R6104	RES.CHIP	RMC1/8 1% 10E	4822 111 91885
R6502	RES.CHIP	HIP RC-02H 1% 2K15	5322 117 10485
R6503	RES.CHIP	HIP RC-02H 1% 2K15	5322 117 10485
R6508	RES.METAL FILM	HIP RC-02H 1% 196E	5322 117 10538
R6509	RES.METAL FILM	HIP RC-02H 1% 196E	5322 117 10538
R6511	RES.CHIP	HIP RC-02H 1% 2K15	5322 117 10485
R6512	RES.CHIP	HIP RC-02H 1% 2K15	5322 117 10485
R6521	RES.CHIP	RMC1/8 1% 42E2	4822 111 91887
R6522	RES.CHIP	RMC1/8 1% 42E2	4822 111 91887
R6523	RES.CHIP	RMC1/8 1% 42E2	4822 111 91887
R6524	RES.CHIP	RMC1/8 1% 42E2	4822 111 91887
R6526	RES.MET.GLAZED	RMC1/8 1% 31E6	5322 116 82895
R6527	RES.MET.GLAZED	RMC1/8 1% 31E6	5322 116 82895
R6528	RES.CHIP	RMC1/8 1% 21E5	5322 111 92014
R6529	RES.CHIP	RMC1/8 1% 21E5	5322 111 92014
R6531	RES.METAL FILM	HIP RC-02H 1% 422E	5322 117 10564
R6542	RES.CHIP	HIP RC-02H 1% 5K11	5322 117 10487
R6543	RES.CHIP	HIP RC-02H 1% 5K11	5322 117 10487
R6544	RES.CHIP	HIP RC-02H 1% 5K11	5322 117 10487
R6546	RES.CHIP	HIP RC-02H 1% 5K11	5322 117 10487
R6547	RES.CHIP	HIP RC-02H 1% 5K11	5322 117 10487
R6548	RES.METAL FILM	HIP RC-02H 1% 14K7	5322 117 10528
R6552	RES.METAL FILM	HIP RC-02H 1% 681E	5322 117 10579
R6554	RES.METAL FILM	HIP RC-02H 1% 14K7	5322 117 10528
R6556	RES.METAL FILM	HIP RC-02H 1% 3K16	5322 117 10553
R6558	RES.METAL FILM	HIP RC-02H 1% 5K62	5322 117 10573
R6571	RES.CHIP	HIP RC-02H 1% 261E	4822 051 52611
R6572	RES.CHIP	HIP RC-02H 1% 261E	4822 051 52611
R6576	RES.CHIP	HIP RC-02H 1% 100E	4822 051 10101
R6577	RES.CHIP	HIP RC-02H 1% 100E	4822 051 10101
R6578	RES.METAL FILM	HIP RC-02H 1% 4K22	5322 117 10565
R6579	RES.METAL FILM	HIP RC-02H 1% 4K22	5322 117 10565
R6584	RES.METAL FILM	HIP RC-02H 1% 1K33	5322 117 10524
R6586	RES.METAL FILM	HIP RC-02H 1% 1K33	5322 117 10524
R6601	RES.METAL FILM	HIP RC-02H 1% 511E	5322 117 10569
R6602	RES.METAL FILM	HIP RC-02H 1% 511E	5322 117 10569
R6603	RES.CHIP	HIP RC-02H 1% 1K	4822 051 10102
R6612	RES.METAL FILM	HIP RC-02H 1% 750E	5322 117 10582
R6613	RES.METAL FILM	HIP RC-02H 1% 750E	5322 117 10582

Item	Description		Ordering code
R6614	RES.METAL FILM	HIP RC-02H 1% 511E	5322 117 10569
R6616	RES.METAL FILM	HIP RC-02H 1% 511E	5322 117 10569
R6621	RES.CHIP	HIP RC-02H 1% 5K11	5322 117 10487
R6622	RES.METAL FILM	HIP RC-02H 1% 5K62	5322 117 10573
R6623	RES.CHIP	HIP RC-02H 1% 11K	4822 051 10113
R6624	RES.METAL FILM	HIP RC-02H 1% 12K1	5322 117 10522
R6626	RES.METAL FILM	HIP RC-02H 1% 31K6	5322 117 10554
R6627	RES.METAL FILM	HIP RC-02H 1% 6K81	5322 117 10581
R6629	RES.METAL FILM	HIP RC-02H 1% 3K48	5322 117 10557
R6632	RES.CHIP	HIP RC-02H 1% 2K15	5322 117 10485
R6633	RES.METAL FILM	HIP RC-02H 1% 511E	5322 117 10569
R6634	RES.METAL FILM	HIP RC-02H 1% 3K83	5322 117 10561
R6636	RES.METAL FILM	HIP RC-02H 1% 316E	5322 117 10552
R6638	RES.CHIP	HIP RC-01 5% 10M	4822 051 10106
R6641	RES.CHIP	HIP RC-01 5% 10M	4822 051 10106
R6643	RES.CHIP	HIP RC-01 5% 10M	4822 051 10106
R6646	RES.CHIP	HIP RC-01 5% 10M	4822 051 10106
R6649	RES.METAL FILM	HIP RC-02H 1% 12K1	5322 117 10522
R6661	RES.CHIP	HIP RC-02H 1% 1K	4822 051 10102
R6662	RES.CHIP	HIP RC-02H 1% 1K	4822 051 10102
R6684	RES.CHIP	HIP RC-02H 1% 1K	4822 051 10102
R6688	RES.METAL FILM	HIP RC-02H 1% 619E	5322 117 10576
R6689	RES.METAL FILM	HIP RC-02H 1% 619E	5322 117 10576
R6692	RES.METAL FILM	HIP RC-02H 1% 1K62	5322 117 10531
R6694	RES.CHIP	HIP RC-02H 1% 1K	4822 051 10102
R6696	RES.METAL FILM	HIP RC-02H 1% 1K47	5322 117 10527
R6706	RES.METAL FILM	HIP RC-02H 1% 5K62	5322 117 10573
R6708	RES.METAL FILM	HIP RC-02H 1% 3K48	5322 117 10557
R6709	RES.METAL FILM	HIP RC-02H 1% 5K62	5322 117 10573
R6752	RES.METAL FILM	HIP RC-02H 1% 1K21	5322 117 10521
R6753	RES.METAL FILM	HIP RC-02H 1% 3K16	5322 117 10553
R6754	RES.METAL FILM	HIP RC-02H 1% 348E	5322 117 10556
R6756	RES.METAL FILM	HIP RC-02H 1% 1K78	5322 117 10535
R6758	RES.METAL FILM	HIP RC-02H 1% 19K6	5322 117 10541
R6762	RES.METAL FILM	HIP RC-02H 1% 750E	5322 117 10582
R6764	RES.METAL FILM	HIP RC-02H 1% 19K6	5322 117 10541
R6769	RES.METAL FILM	HIP RC-02H 1% 2K61	5322 117 10547
R6772	RES.CHIP	HIP RC-02H 1% 11K	4822 051 10113
R6774	RES.METAL FILM	HIP RC-02H 1% 7K5	5322 117 10583
R6776	RES.METAL FILM	HIP RC-02H 1% 511K	5322 117 10571
R6782	RES.CHIP	HIP RC-02H 1% 100K	4822 051 10104
R6783	RES.CHIP	HIP RC-02H 1% 100K	4822 051 10104
R6788	RES.CHIP	HIP RC-02H 1% 11K	4822 051 10113
R6901	RES.CHIP	HIP RC-01 5% 1E	4822 051 10108
R6911	RES.CHIP	HIP RC-01 5% 1E	4822 051 10108
R6921	RES.CHIP	HIP RC-01 5% 4E7	4822 051 10478
R6931	RES.CHIP	HIP RC-01 5% 4E7	4822 051 10478

Item	Description		Ordering code
R6941	RES.CHIP	HIP RC-01 5% 4E7	4822 051 10478
R6951	RES.CHIP	HIP RC-01 5% 4E7	4822 051 10478
R6961	RES.CHIP	HIP RC-01 5% 4E7	4822 051 10478
R7001	RES.CHIP	HIP RC-02H 1% 100E	4822 051 10101
R7002	RES.METAL FILM	PR24 1/4W 0.1% 50E	5322 116 53165
R7003	RES.METAL FILM	PR24 1/4W 0.1% 75E	5322 116 53168
R7004	RES.METAL FILM	PR24 1/4W 0.1% 125E	5322 116 53176
R7005	RES.METAL FILM	PR24 1/4W 0.1% 250E	5322 116 53166
R7006	RES.METAL FILM	PR24 1/4W 0.1% 750E	5322 116 53173
R7007	RES.METAL FILM	PR24 1/4W 0.1% 1K25	5322 116 53177
R7008	RES.METAL FILM	PR24 1/4W 0.1% 900E	5322 116 83098
R7009	RES.CHIP	HIP RC-02H 1% 46K4	5322 117 10486
R7011	RES.METAL FILM	HIP RC-02H 1% 14K7	5322 117 10528
R7012	RES.METAL FILM	HIP RC-02H 1% 3K48	5322 117 10557
R7013	RES.METAL FILM	PR24 1/4W 0.1% 23K7	5322 116 53169
R7014	RES.METAL FILM	PR24 1/4W 0.1% 2K37	5322 116 53171
R7015	RES.METAL FILM	HIP RC-02H 1% 19K6	5322 117 10541
R7016	RES.METAL FILM	HIP RC-02H 1% 1K96	5322 117 10539
R7017	RES.CHIP	HIP RC-02H 1% 100E	4822 051 10101
R7018	RES.METAL FILM	HIP RC-02H 1% 1K78	5322 117 10535
R7019	RES.METAL FILM	HIP RC-02H 1% 316E	5322 117 10552
R7021	RES.METAL FILM	HIP RC-02H 1% 3K16	5322 117 10553
R7022	RES.METAL FILM	HIP RC-02H 1% 3K16	5322 117 10553
R7023	RES.CHIP	RMC1/8 1% 51E1	5322 111 91893
R7024	RES.CHIP	HIP RC-01 5% 1E	4822 051 10108
R7025	RES.CHIP	HIP RC-01 5% 1E	4822 051 10108
R7026	RES.METAL FILM	HIP RC-02H 1% 14K7	5322 117 10528
R7027	RES.CHIP	HIP RC-02H 1% 100E	4822 051 10101
R7028	RES.CHIP	HIP RC-02H 1% 2K15	5322 117 10485
R7029	RES.METAL FILM	HIP RC-02H 1% 237E	5322 117 10544
R7031	RES.CHIP	HIP RC-02H 1% 1K	4822 051 10102
R7032	RES.CHIP	HIP RC-02H 1% 100K	4822 051 10104
R7033	RES.CHIP	HIP RC-02H 1% 2K15	5322 117 10485
R7034	RES.METAL FILM	HIP RC-02H 1% 1K21	5322 117 10521
R7036	RES.METAL FILM	HIP RC-02H 1% 1K21	5322 117 10521
R7041	RES.CHIP	RMC1/8 1% 10E	4822 111 91885
R7042	RES.CHIP	HIP RC-02H 1% 1K	4822 051 10102
R7043	RES.CHIP	RMC1/8 1% 10E	4822 111 91885
R7044	RES.METAL FILM	HIP RC-02H 1% 3K16	5322 117 10553
R7045	RES.CHIP	RMC1/8 1% 51E1	5322 111 91893
R7046	RES.METAL FILM	HIP RC-02H 1% 750E	5322 117 10582
R7047	RES.METAL FILM	HIP RC-02H 1% 196E	5322 117 10538
R7048	RES.CHIP	RMC1/8 1% 10E	4822 111 91885
R7049	RES.CHIP	HIP RC-01 5% 4E7	4822 051 10478
R7050	RES.CHIP	HIP RC-01 5% 4E7	4822 051 10478
R7051	RES.CHIP	HIP RC-02H 1% 1K	4822 051 10102
R7052	RES.METAL FILM	HIP RC-02H 1% 21K5	5322 117 10542

Item	Description		Ordering code
R7054	RES.METAL FILM	HIP RC-02H 1% 9K09	5322 117 10589
R7056	RES.METAL FILM	HIP RC-02H 1% 19K6	5322 117 10541
R7057	RES.METAL FILM	HIP RC-02H 1% 38K3	5322 117 10562
R7059	RES.METAL FILM	HIP RC-02H 1% 75K	5322 117 10584
R7064	RES.METAL FILM	PR24 1/4W 0.1% 6K	5322 116 83102
R7065	RES.METAL FILM	PR24 1/4W 0.1% 500E	5322 116 83097
R7066	RES.METAL FILM	PR24 1/4W 0.1% 900E	5322 116 83098
R7067	RES.METAL FILM	PR24 1/4W 0.1% 100E	5322 116 51701
R7077	RES.CHIP	RMC1/8 1% 42E2	4822 111 91887
R7078	RES.CHIP	RMC1/8 1% 42E2	4822 111 91887
R7082	RES.CHIP	HIP RC-01 5% 4E7	4822 051 10478
R7091	RES.METAL FILM	PR24 1/4W 0.1% 10K	5322 116 82868
R7092	RES.METAL FILM	PR24 1/4W 0.1% 2K16	5322 116 83126
R7093	RES.METAL FILM	PR24 1/4W 0.1% 15K	5322 117 10592
R7094	RES.METAL FILM	PR24 1/4W 0.1% 10K	5322 116 82868
R7095	RES.METAL FILM	PR24 1/4W 0.1% 10K	5322 116 82868
R7096	RES.METAL FILM	PR24 1/4W 0.1% 15K	5322 117 10592
R7097	RES.CHIP	HIP RC-02H 1% 2K15	5322 117 10485
R7099	RES.CHIP	HIP RC-02H 1% 100E	4822 051 10101
R7144	RES.MET.GLAZED	RMC1/8 1% 31E6	5322 116 82895
R7150	RES.METAL FILM	HIP RC-02H 1% 511E	5322 117 10569
R7151	RES.METAL FILM	HIP RC-02H 1% 511E	5322 117 10569
R7152	RES.METAL FILM	HIP RC-02H 1% 511E	5322 117 10569
R7153	RES.METAL FILM	HIP RC-02H 1% 511E	5322 117 10569
R7154	RES.METAL FILM	HIP RC-02H 1% 6K81	5322 117 10581
R7155	RES.CHIP	HIP RC-02H 1% 11K	4822 051 10113
R7156	RES.METAL FILM	HIP RC-02H 1% 1K78	5322 117 10535
R7160	RES.METAL FILM	HIP RC-02H 1% 1K78	5322 117 10535
R7161	RES.METAL FILM	HIP RC-02H 1% 21K5	5322 117 10542
R7180	RES.CHIP	RMC1/8 1% 21E5	5322 111 92014
R7181	RES.METAL FILM	HIP RC-02H 1% 562E	5322 117 10572
R7204	RES.CHIP	HIP RC-02H 1% 10K	4822 051 10103
R7205	RES.CHIP	HIP RC-02H 1% 10K	4822 051 10103
R7206	RES.CHIP	HIP RC-02H 1% 5K11	5322 117 10487
R7207	RES.CHIP	HIP RC-02H 1% 5K11	5322 117 10487
R7208	RES.CHIP	HIP RC-02H 1% 10K	4822 051 10103
R7209	RES.CHIP	HIP RC-02H 1% 10K	4822 051 10103
R7502	RES.METAL FILM	HIP RC-02H 1% 7K5	5322 117 10583
R7503	RES.METAL FILM	HIP RC-02H 1% 3K48	5322 117 10557
R7508	RES.METAL FILM	HIP RC-02H 1% 825E	5322 117 10585
R7509	RES.METAL FILM	HIP RC-02H 1% 825E	5322 117 10585
R7511	RES.METAL FILM	HIP RC-02H 1% 7K5	5322 117 10583
R7512	RES.METAL FILM	HIP RC-02H 1% 3K48	5322 117 10557
R7521	RES.CHIP	RMC1/8 1% 51E1	5322 111 91893
R7522	RES.CHIP	RMC1/8 1% 51E1	5322 111 91893
R7523	RES.CHIP	RMC1/8 1% 51E1	5322 111 91893
R7524	RES.CHIP	RMC1/8 1% 51E1	5322 111 91893

Item	Description		Ordering code
R7526	RES.CHIP	RMC1/8 1% 51E1	5322 111 91893
R7527	RES.CHIP	RMC1/8 1% 51E1	5322 111 91893
R7528	RES.CHIP	RMC1/8 1% 51E1	5322 111 91893
R7529	RES.CHIP	RMC1/8 1% 51E1	5322 111 91893
R7531	RES.METAL FILM	HIP RC-02H 1% 422E	5322 117 10564
R7542	RES.CHIP	HIP RC-02H 1% 5K11	5322 117 10487
R7543	RES.CHIP	HIP RC-02H 1% 5K11	5322 117 10487
R7544	RES.CHIP	HIP RC-02H 1% 5K11	5322 117 10487
R7546	RES.CHIP	HIP RC-02H 1% 5K11	5322 117 10487
R7547	RES.CHIP	HIP RC-02H 1% 5K11	5322 117 10487
R7548	RES.METAL FILM	HIP RC-02H 1% 14K7	5322 117 10528
R7552	RES.METAL FILM	HIP RC-02H 1% 619E	5322 117 10576
R7554	RES.METAL FILM	HIP RC-02H 1% 14K7	5322 117 10528
R7556	RES.METAL FILM	HIP RC-02H 1% 3K48	5322 117 10557
R7558	RES.METAL FILM	HIP RC-02H 1% 6K81	5322 117 10581
R7563	RES.METAL FILM	HIP RC-02H 1% 750E	5322 117 10582
R7571	RES.CHIP	HIP RC-02H 1% 261E	4822 051 52611
R7572	RES.CHIP	HIP RC-02H 1% 261E	4822 051 52611
R7576	RES.CHIP	HIP RC-02H 1% 100E	4822 051 10101
R7577	RES.CHIP	HIP RC-02H 1% 100E	4822 051 10101
R7578	RES.METAL FILM	HIP RC-02H 1% 4K22	5322 117 10565
R7579	RES.METAL FILM	HIP RC-02H 1% 4K22	5322 117 10565
R7584	RES.METAL FILM	HIP RC-02H 1% 1K33	5322 117 10524
R7586	RES.METAL FILM	HIP RC-02H 1% 1K33	5322 117 10524
R7681	RES.METAL FILM	HIP RC-02H 1% 1K78	5322 117 10535
R7688	RES.METAL FILM	HIP RC-02H 1% 316E	5322 117 10552
R7689	RES.METAL FILM	HIP RC-02H 1% 316E	5322 117 10552
R7692	RES.METAL FILM	HIP RC-02H 1% 1K62	5322 117 10531
R7693	RES.METAL FILM	HIP RC-02H 1% 6K19	5322 117 10577
R7694	RES.METAL FILM	HIP RC-02H 1% 3K48	5322 117 10557
R7696	RES.METAL FILM	HIP RC-02H 1% 14K7	5322 117 10528
R7711	RES.METAL FILM	HIP RC-02H 1% 6K81	5322 117 10581
R7712	RES.METAL FILM	HIP RC-02H 1% 6K81	5322 117 10581
R7713	RES.CHIP	HIP RC-02H 1% 10K	4822 051 10103
R7716	RES.METAL FILM	HIP RC-02H 1% 3K83	5322 117 10561
R7753	RES.CHIP	HIP RC-02H 1% 261E	4822 051 52611
R7754	RES.CHIP	HIP RC-02H 1% 261E	4822 051 52611
R7809	RES.CHIP	HIP RC-02H 1% 1K	4822 051 10102
R7901	RES.CHIP	HIP RC-01 5% 1E	4822 051 10108
R7911	RES.CHIP	HIP RC-01 5% 4E7	4822 051 10478
R7921	RES.CHIP	HIP RC-01 5% 4E7	4822 051 10478
R7931	RES.CHIP	HIP RC-01 5% 4E7	4822 051 10478
R7941	RES.CHIP	HIP RC-01 5% 4E7	4822 051 10478
R7951	RES.CHIP	HIP RC-02H 1% 11K	4822 051 10113
R7952	RES.METAL FILM	HIP RC-02H 1% 13K3	5322 117 10525
R7953	RES.CHIP	HIP RC-02H 1% 11K	4822 051 10113
R7954	RES.METAL FILM	HIP RC-02H 1% 3K16	5322 117 10553

Item	Description		Ordering code
R7956	RES.METAL FILM	HIP RC-02H 1% 14K7	5322 117 10528
R7957	RES.CHIP	HIP RC-02H 1% 10K	4822 051 10103
R7958	RES.CHIP	HIP RC-02H 1% 10K	4822 051 10103
R7961	RES.CHIP	HIP RC-01 5% 4E7	4822 051 10478
R8001	RES.METAL FILM	HIP RC-02H 1% 383E	5322 117 10559
R8002	RES.METAL FILM	HIP RC-02H 1% 383E	5322 117 10559
R8003	RES.METAL FILM	HIP RC-02H 1% 316E	5322 117 10552
R8004	RES.METAL FILM	HIP RC-02H 1% 9K09	5322 117 10589
R8005	RES.METAL FILM	HIP RC-02H 1% 7K5	5322 117 10583
R8006	RES.METAL FILM	HIP RC-02H 1% 2K61	5322 117 10547
R8007	RES.METAL FILM	HIP RC-02H 1% 3K16	5322 117 10553
R8008	RES.CHIP	HIP RC-02H 1% 2K15	5322 117 10485
R8009	RES.METAL FILM	HIP RC-02H 1% 1K96	5322 117 10539
R8010	RES.CHIP	HIP RC-02H 1% 1K	4822 051 10102
R8011	RES.CHIP	HIP RC-02H 1% 215E	5322 117 10484
R8012	RES.CHIP	HIP RC-02H 1% 2K15	5322 117 10485
R8013	RES.CHIP	HIP RC-02H 1% 2K15	5322 117 10485
R8014	RES.CHIP	HIP RC-02H 1% 5K11	5322 117 10487
R8015	RES.METAL FILM	HIP RC-02H 1% 1K62	5322 117 10531
R8016	RES.CHIP	HIP RC-02H 1% 5K11	5322 117 10487
R8016	RES.CHIP	RC-02H 1% 2K15	5322 117 10485
R8017	RES.CHIP	HIP RC-02H 1% 1K	4822 051 10102
R8018	RES.CHIP	HIP RC-02H 1% 1K	4822 051 10102
R8019	RES.CHIP	HIP RC-02H 1% 287E	4822 051 52871
R8020	RES.METAL FILM	HIP RC-02H 1% 5K62	5322 117 10573
R8021	RES.METAL FILM	HIP RC-02H 1% 1K47	5322 117 10527
R8022	RES.METAL FILM	HIP RC-02H 1% 196E	5322 117 10538
R8023	RES.METAL FILM	HIP RC-02H 1% 316E	5322 117 10552
R8024	RES.METAL FILM	HIP RC-02H 1% 3K16	5322 117 10553
R8025	RES.METAL FILM	HIP RC-02H 1% 562E	5322 117 10572
R8026	RES.METAL FILM	HIP RC-02H 1% 4K22	5322 117 10565
R8027	RES.CHIP	RMC1/8 1% 61E9	5322 111 92016
R8028	RES.METAL FILM	HIP RC-02H 1% 196E	5322 117 10538
R8029	RES.METAL FILM	HIP RC-02H 1% 1K47	5322 117 10527
R8030	RES.METAL FILM	HIP RC-02H 1% 1K62	5322 117 10531
R8031	RES.CHIP	HIP RC-02H 1% 287E	4822 051 52871
R8032	RES.METAL FILM	HIP RC-02H 1% 5K62	5322 117 10573
R8033	RES.CHIP	HIP RC-02H 1% 1K	4822 051 10102
R8034	RES.METAL FILM	HIP RC-02H 1% 3K16	5322 117 10553
R8035	RES.METAL FILM	HIP RC-02H 1% 316E	5322 117 10552
R8037	RES.CHIP	HIP RC-02H 1% 2K15	5322 117 10485
R8038	RES.METAL FILM	HIP RC-02H 1% 21K5	5322 117 10542
R8040	RES.CHIP	RMC1/8 1% 51E1	5322 111 91893
R8041	RES.METAL FILM	HIP RC-02H 1% 1K47	5322 117 10527
R8042	RES.CHIP	HIP RC-02H 1% 1K	4822 051 10102
R8043	RES.METAL FILM	HIP RC-02H 1% 316E	5322 117 10552
R8044	RES.METAL FILM	HIP RC-02H 1% 3K48	5322 117 10557

Item	Description		Ordering code
R8045	RES.CHIP	RMC1/8 1% 51E1	5322 111 91893
R8046	RES.METAL FILM	HIP RC-02H 1% 1K47	5322 117 10527
R8047	RES.CHIP	RMC1/8 1% 21E5	5322 111 92014
R8048	RES.METAL FILM	HIP RC-02H 1% 3K48	5322 117 10557
R8049	RES.CHIP	HIP RC-02H 1% 5K11	5322 117 10487
R8050	RES.CHIP	RMC1/8 1% 21E5	5322 111 92014
R8051	RES.CHIP	RMC1/8 1% 21E5	5322 111 92014
R8052	RES.METAL FILM	HIP RC-02H 1% 6K19	5322 117 10577
R8053	RES.CHIP	HIP RC-01 5% 1E	4822 051 10108
R8054	RES.CHIP	HIP RC-01 5% 1E	4822 051 10108
R8055	RES.METAL FILM	HIP RC-02H 1% 21K5	5322 117 10542
R8056	RES.CHIP	RMC1/8 1% 42E2	4822 111 91887
R8057	RES.CHIP	RMC1/8 1% 51E1	5322 111 91893
R8058	RES.METAL FILM	HIP RC-02H 1% 383E	5322 117 10559
R8059	RES.METAL FILM	HIP RC-02H 1% 422E	5322 117 10564
R8060	RES.METAL FILM	HIP RC-02H 1% 1K96	5322 117 10539
R8061	RES.CHIP	HIP RC-02H 1% 1K	4822 051 10102
R8062	RES.CHIP	HIP RC-02H 1% 5K11	5322 117 10487
R8063	RES.CHIP	HIP RC-02H 1% 1K	4822 051 10102
R8064	RES.METAL FILM	HIP RC-02H 1% 1K47	5322 117 10527
R8065	RES.CHIP	HIP RC-02H 1% 1K	4822 051 10102
R8066	RES.CHIP	HIP RC-02H 1% 1K	4822 051 10102
R8067	RES.CHIP	HIP RC-02H 1% 1K	4822 051 10102
R8068	RES.CHIP	HIP RC-02H 1% 2K15	5322 117 10485
R8069	RES.CHIP	HIP RC-02H 1% 5K11	5322 117 10487
R8070	RES.CHIP	HIP RC-02H 1% 5K11	5322 117 10487
R8071	RES.CHIP	HIP RC-02H 1% 8K25	5322 117 10586
R8072	RES.CHIP	HIP RC-02H 1% 1K	4822 051 10102
R8073	RES.CHIP	HIP RC-02H 1% 1K	4822 051 10102
R8074	RES.CHIP	RMC1/8 1% 51E1	5322 111 91893
R8075	RES.CHIP	RMC1/8 1% 51E1	5322 111 91893
R8076	RES.CHIP	RMC1/8 1% 51E1	5322 111 91893
R8077	RES.METAL FILM	HIP RC-02H 1% 511E	5322 117 10569
R8078	RES.METAL FILM	HIP RC-02H 1% 511E	5322 117 10569
R8079	RES.CHIP	RMC1/8 1% 51E1	5322 111 91893
R8080	RES.CHIP	HIP RC-02H 1% 5K11	5322 117 10487
R8081	RES.METAL FILM	HIP RC-02H 1% 750E	5322 117 10582
R8082	RES.CHIP	HIP RC-02H 1% 1K	4822 051 10102
R8083	RES.METAL FILM	HIP RC-02H 1% 2K87	5322 117 10549
R8084	RES.METAL FILM	HIP RC-02H 1% 511E	5322 117 10569
R8085	RES.METAL FILM	HIP RC-02H 1% 1K62	5322 117 10531
R8086	RES.METAL FILM	HIP RC-02H 1% 619E	5322 117 10576
R8087	RES.METAL FILM	HIP RC-02H 1% 1K21	5322 117 10521
R8088	RES.CHIP	HIP RC-02H 1% 5K11	5322 117 10487
R8089	RES.METAL FILM	HIP RC-02H 1% 2K61	5322 117 10547
R8090	RES.METAL FILM	HIP RC-02H 1% 31K6	5322 117 10554
R8091	RES.METAL FILM	HIP RC-02H 1% 31K6	5322 117 10554

Item	Description		Ordering code
R8092	RES.METAL FILM	HIP RC-02H 1% 2K61	5322 117 10547
R8093	RES.METAL FILM	HIP RC-02H 1% 2K61	5322 117 10547
R8094	RES.METAL FILM	HIP RC-02H 1% 2K61	5322 117 10547
R8095	RES.CHIP	RMC1/8 1% 21E5	5322 111 92014
R8096	RES.METAL FILM	HIP RC-02H 1% 12K1	5322 117 10522
R8097	RES.METAL FILM	HIP RC-02H 1% 1K96	5322 117 10539
R8098	RES.METAL FILM	HIP RC-02H 1% 2K61	5322 117 10547
R8099	RES.CHIP	RC-02H 1% 100E	4822 051 10101
R8100	RES.METAL FILM	HIP RC-02H 1% 422E	5322 117 10564
R8101	RES.CHIP	HIP RC-02H 1% 10K	4822 051 10103
R8102	RES.METAL FILM	HIP RC-02H 1% 12K1	5322 117 10522
R8103	RES.CHIP	HIP RC-02H 1% 100K	4822 051 10104
R8104	RES.METAL FILM	HIP RC-02H 1% 14K7	5322 117 10528
R8105	RES.METAL FILM	HIP RC-02H 1% 1K62	5322 117 10531
R8106	RES.CHIP	HIP RC-02H 1% 10K	4822 051 10103
R8130	RES.MET.GLAZED	RMC1/8 1% 31E6	5322 116 82895
R8131	RES.CHIP	HIP RC-02H 1% 5K11	5322 117 10487
R8132	RES.METAL FILM	HIP RC-02H 1% 1K47	5322 117 10527
R8133	RES.CHIP	RMC1/8 1% 10E	4822 111 91885
R8134	RES.METAL FILM	HIP RC-02H 1% 1K62	5322 117 10531
R8135	RES.METAL FILM	HIP RC-02H 1% 162E	5322 117 10529
R8136	RES.METAL FILM	HIP RC-02H 1% 2K61	5322 117 10547
R8137	RES.METAL FILM	HIP RC-02H 1% 3K16	5322 117 10553
R8138	RES.METAL FILM	HIP RC-02H 1% 3K16	5322 117 10553
R8200	RES.CHIP	RMC1/8 1% 10E	4822 111 91885
R8403	RES.CHIP	HIP RC-02H 1% 1K	4822 051 10102
R8404	RES.CHIP	HIP RC-02H 1% 1K	4822 051 10102
R8405	RES.CHIP	HIP RC-02H 1% 1K	4822 051 10102
R8410	RES.CHIP	HIP RC-02H 1% 100E	4822 051 10101
R8411	RES.CHIP	HIP RC-02H 1% 100E	4822 051 10101

SEMICONDUCTORS

V1001	TRANSISTOR,CHIP	BSS83 PEL	5322 130 60502
V1002	DIODE	BBY62 PEL	5322 130 82685
V1003	DIODE,REFERENCE	BZX84-C6V8 PEL	5322 130 80406
V1004	TRANSISTOR,CHIP	BFR31 PEL	5322 130 44787
V1005	TRANSISTOR,CHIP	BFR31 PEL	5322 130 44787
V1006	TRANSISTOR,CHIP	BF990A PEL	4822 130 62657
V1007	TRANSISTOR,CHIP	BFS20 PEL	5322 130 42718
V1008	TRANSISTOR,CHIP	BF579 TEL	5322 130 63453
V1009	TRANSISTOR,CHIP	BFR53 PEL	5322 130 61244
V1012	TRANSISTOR,CHIP	BSS83 PEL	5322 130 60502
V1013	TRANSISTOR,CHIP	BSS83 PEL	5322 130 60502
V1015	TRANSISTOR,CHIP	BC858C PEL	4822 130 42513
V1016	TRANSISTOR,CHIP	BC858C PEL	4822 130 42513
V1017	TRANSISTOR,CHIP	BC848C PEL	5322 130 42136
V1018	TRANSISTOR,CHIP	BC848C PEL	5322 130 42136

Item	Description		Ordering code
V1201	TRANSISTOR,CHIP	BF579 TEL	5322 130 63453
V1202	TRANSISTOR,CHIP	BF579 TEL	5322 130 63453
V1206	TRANSISTOR,CHIP	BC858C PEL	4822 130 42513
V1207	TRANSISTOR,CHIP	BC858C PEL	4822 130 42513
V1208	TRANSISTOR,CHIP	BC858C PEL	4822 130 42513
V1209	TRANSISTOR,CHIP	BC858C PEL	4822 130 42513
V1251	TRANSISTOR,CHIP	BC848C PEL	5322 130 42136
V1252	TRANSISTOR,CHIP	BC848C PEL	5322 130 42136
V1301	DIODE,REFERENCE	BZX84-C6V2 PEL	5322 130 33671
V1302	DIODE,REFERENCE	BZX84-C7V5 PEL	5322 130 33763
V1304	DIODE,REFERENCE	BZX84-C4V7 PEL	5322 130 31937
V1306	DIODE,REFERENCE	BZX84-C2V4 PEL	4822 130 33703
V1307	DIODE,REFERENCE	BZX84-C3V0 PEL	5322 130 32739
V1308	DIODE,CHIP	BAS28 PEL	5322 130 80214
V1313	DIODE,CHIP	BAS28 PEL	5322 130 80214
V2001	TRANSISTOR,CHIP	BSS83 PEL	5322 130 60502
V2002	DIODE	BBY62 PEL	5322 130 82685
V2003	DIODE,REFERENCE	BZX84-C6V8 PEL	5322 130 80406
V2004	TRANSISTOR,CHIP	BFR31 PEL	5322 130 44787
V2005	TRANSISTOR,CHIP	BFR31 PEL	5322 130 44787
V2006	TRANSISTOR,CHIP	BF990A PEL	4822 130 62657
V2007	TRANSISTOR,CHIP	BFS20 PEL	5322 130 42718
V2008	TRANSISTOR,CHIP	BF579 TEL	5322 130 63453
V2009	TRANSISTOR,CHIP	BFR53 PEL	5322 130 61244
V2012	TRANSISTOR,CHIP	BSS83 PEL	5322 130 60502
V2013	TRANSISTOR,CHIP	BSS83 PEL	5322 130 60502
V2015	TRANSISTOR,CHIP	BC858C PEL	4822 130 42513
V2016	TRANSISTOR,CHIP	BC858C PEL	4822 130 42513
V2017	TRANSISTOR,CHIP	BC848C PEL	5322 130 42136
V2018	TRANSISTOR,CHIP	BC848C PEL	5322 130 42136
V2201	TRANSISTOR,CHIP	BF579 TEL	5322 130 63453
V2202	TRANSISTOR,CHIP	BF579 TEL	5322 130 63453
V2206	TRANSISTOR,CHIP	BC858C PEL	4822 130 42513
V2207	TRANSISTOR,CHIP	BC858C PEL	4822 130 42513
V2208	TRANSISTOR,CHIP	BC858C PEL	4822 130 42513
V2209	TRANSISTOR,CHIP	BC858C PEL	4822 130 42513
V2301	DIODE,REFERENCE	BZX84-C6V8 PEL	5322 130 80406
V2302	DIODE,REFERENCE	BZX84-C7V5 PEL	5322 130 33763
V2303	DIODE,CHIP	BAS28 PEL	5322 130 80214
V2304	DIODE,REFERENCE	BZX84-C4V7 PEL	5322 130 31937
V2306	DIODE,REFERENCE	BZX84-C2V4 PEL	4822 130 33703
V2307	DIODE,REFERENCE	BZX84-C3V0 PEL	5322 130 32739
V3001	TRANSISTOR,CHIP	BSS83 PEL	5322 130 60502
V3002	DIODE	BBY62 PEL	5322 130 82685
V3003	DIODE,REFERENCE	BZX84-C6V8 PEL	5322 130 80406
V3004	TRANSISTOR,CHIP	BFR31 PEL	5322 130 44787
V3005	TRANSISTOR,CHIP	BFR31 PEL	5322 130 44787

Item	Description		Ordering code
V3006	TRANSISTOR,CHIP	BF990A PEL	4822 130 62657
V3007	TRANSISTOR,CHIP	BFS20 PEL	5322 130 42718
V3008	TRANSISTOR,CHIP	BF579 TEL	5322 130 63453
V3009	TRANSISTOR,CHIP	BFR53 PEL	5322 130 61244
V3012	TRANSISTOR,CHIP	BSS83 PEL	5322 130 60502
V3013	TRANSISTOR,CHIP	BSS83 PEL	5322 130 60502
V3015	TRANSISTOR,CHIP	BC858C PEL	4822 130 42513
V3016	TRANSISTOR,CHIP	BC858C PEL	4822 130 42513
V3017	TRANSISTOR,CHIP	BC848C PEL	5322 130 42136
V3018	TRANSISTOR,CHIP	BC848C PEL	5322 130 42136
V3201	TRANSISTOR,CHIP	BF579 TEL	5322 130 63453
V3202	TRANSISTOR,CHIP	BF579 TEL	5322 130 63453
V3206	TRANSISTOR,CHIP	BC858C PEL	4822 130 42513
V3207	TRANSISTOR,CHIP	BC858C PEL	4822 130 42513
V3208	TRANSISTOR,CHIP	BC858C PEL	4822 130 42513
V3209	TRANSISTOR,CHIP	BC858C PEL	4822 130 42513
V3301	DIODE,REFERENCE	BZX84-C6V8 PEL	5322 130 80406
V3302	DIODE,REFERENCE	BZX84-C7V5 PEL	5322 130 33763
V3303	DIODE,CHIP	BAS28 PEL	5322 130 80214
V3304	DIODE,REFERENCE	BZX84-C4V7 PEL	5322 130 31937
V3306	DIODE,REFERENCE	BZX84-C2V4 PEL	4822 130 33703
V3307	DIODE,REFERENCE	BZX84-C3V0 PEL	5322 130 32739
V4001	TRANSISTOR,CHIP	BSS83 PEL	5322 130 60502
V4002	DIODE	BBY62 PEL	5322 130 82685
V4003	DIODE,REFERENCE	BZX84-C6V8 PEL	5322 130 80406
V4004	TRANSISTOR,CHIP	BFR31 PEL	5322 130 44787
V4005	TRANSISTOR,CHIP	BFR31 PEL	5322 130 44787
V4006	TRANSISTOR,CHIP	BF990A PEL	4822 130 62657
V4007	TRANSISTOR,CHIP	BFS20 PEL	5322 130 42718
V4008	TRANSISTOR,CHIP	BF579 TEL	5322 130 63453
V4009	TRANSISTOR,CHIP	BFR53 PEL	5322 130 61244
V4012	TRANSISTOR,CHIP	BSS83 PEL	5322 130 60502
V4013	TRANSISTOR,CHIP	BSS83 PEL	5322 130 60502
V4015	TRANSISTOR,CHIP	BC858C PEL	4822 130 42513
V4016	TRANSISTOR,CHIP	BC858C PEL	4822 130 42513
V4017	TRANSISTOR,CHIP	BC848C PEL	5322 130 42136
V4018	TRANSISTOR,CHIP	BC848C PEL	5322 130 42136
V4201	TRANSISTOR,CHIP	BF579 TEL	5322 130 63453
V4202	TRANSISTOR,CHIP	BF579 TEL	5322 130 63453
V4206	TRANSISTOR,CHIP	BC858C PEL	4822 130 42513
V4207	TRANSISTOR,CHIP	BC858C PEL	4822 130 42513
V4208	TRANSISTOR,CHIP	BC858C PEL	4822 130 42513
V4209	TRANSISTOR,CHIP	BC858C PEL	4822 130 42513
V4301	DIODE,REFERENCE	BZX84-C6V8 PEL	5322 130 80406
V4302	DIODE,REFERENCE	BZX84-C7V5 PEL	5322 130 33763
V4303	DIODE,CHIP	BAS28 PEL	5322 130 80214
V4304	DIODE,REFERENCE	BZX84-C4V7 PEL	5322 130 31937

Item	Description		Ordering code
V4306	DIODE,REFERENCE	BZX84-C2V4 PEL	4822 130 33703
V4307	DIODE,REFERENCE	BZX84-C3V0 PEL	5322 130 32739
V5001	TRANSISTOR,CHIP	BFS20 PEL	5322 130 42718
V5002	TRANSISTOR,CHIP	BFS20 PEL	5322 130 42718
V5003	TRANSISTOR,CHIP	BFR92 PEL	5322 130 42145
V5004	TRANSISTOR,CHIP	BFR92 PEL	5322 130 42145
V5006	TRANSISTOR,CHIP	BFT92 PEL	5322 130 44711
V5007	TRANSISTOR,CHIP	BFT92 PEL	5322 130 44711
V5008	TRANSISTOR,CHIP	BFT92 PEL	5322 130 44711
V5009	TRANSISTOR,CHIP	BFT92 PEL	5322 130 44711
V5011	DIODE,CHIP	BAT17 PEL	5322 130 31544
V5012	DIODE,CHIP	BAT17 PEL	5322 130 31544
V5013	DIODE,CHIP	BAT17 PEL	5322 130 31544
V5014	DIODE,CHIP	BAT17 PEL	5322 130 31544
V5016	DIODE,REFERENCE	BZX84-C6V2 PEL	5322 130 33671
V5017	TRANSISTOR,CHIP	BFT92 PEL	5322 130 44711
V5018	TRANSISTOR,CHIP	BFT92 PEL	5322 130 44711
V5501	TRANSISTOR,CHIP	BFS20 PEL	5322 130 42718
V5502	TRANSISTOR,CHIP	BFS20 PEL	5322 130 42718
V5503	TRANSISTOR,CHIP	BC848C PEL	5322 130 42136
V5504	DIODE,CHIP	BAV99 PEL	5322 130 34337
V5506	TRANSISTOR,CHIP	BC848C PEL	5322 130 42136
V5601	DIODE,REFERENCE	BZX84-C6V2 PEL	5322 130 33671
V6001	TRANSISTOR,CHIP	BC848C PEL	5322 130 42136
V6002	TRANSISTOR,CHIP	BC848C PEL	5322 130 42136
V6003	TRANSISTOR,CHIP	BC858C PEL	4822 130 42513
V6004	TRANSISTOR,CHIP	BC858C PEL	4822 130 42513
V6005	TRANSISTOR,CHIP	BC858C PEL	4822 130 42513
V6006	TRANSISTOR,CHIP	BC848C PEL	5322 130 42136
V6007	DIODE,CHIP	BAV99 PEL	5322 130 34337
V6008	TRANSISTOR,CHIP	BC848C PEL	5322 130 42136
V6012	TRANSISTOR,CHIP	BFR92 PEL	5322 130 42145
V6013	TRANSISTOR	FET ON4401 PEL	5322 130 61498
V6014	TRANSISTOR	FET ON4401 PEL	5322 130 61498
V6016	TRANSISTOR,CHIP	BC848C PEL	5322 130 42136
V6017	DIODE,CHIP	BAS28 PEL	5322 130 80214
V6018	DIODE,REFERENCE	BZX84-C5V6 PEL	4822 130 80125
V6019	TRANSISTOR,CHIP	BC848C PEL	5322 130 42136
V6022	DIODE,REFERENCE	BZX84-C5V6 PEL	4822 130 80125
V6041	DIODE,CHIP	BAS28 PEL	5322 130 80214
V6042	TRANSISTOR,CHIP	BC848C PEL	5322 130 42136
V6044	DIODE,CHIP	BAS28 PEL	5322 130 80214
V6061	TRANSISTOR,CHIP	BC858C PEL	4822 130 42513
V6062	TRANSISTOR,CHIP	BC848C PEL	5322 130 42136
V6101	DIODE,REFERENCE	BZX84-C2V4 PEL	4822 130 33703
V6506	TRANSISTOR,CHIP	BF824 PEL	4822 130 60383
V6507	TRANSISTOR,CHIP	BF824 PEL	4822 130 60383

Item	Description		Ordering code
V6532	TRANSISTOR,CHIP	BC858C PEL	4822 130 42513
V6553	TRANSISTOR,CHIP	BC858C PEL	4822 130 42513
V6573	TRANSISTOR,CHIP	BF824 PEL	4822 130 60383
V6574	TRANSISTOR,CHIP	BF824 PEL	4822 130 60383
V6593	DIODE,CHIP	BAS28 PEL	5322 130 80214
V6604	TRANSISTOR,CHIP	BFT92 PEL	5322 130 44711
V6606	TRANSISTOR,CHIP	BFT92 PEL	5322 130 44711
V6628	TRANSISTOR,CHIP	BC848C PEL	5322 130 42136
V6631	TRANSISTOR,CHIP	BC848C PEL	5322 130 42136
V6637	DIODE,REFERENCE	BZX84-C6V8 PEL	5322 130 80406
V6667	TRANSISTOR,CHIP	BC858C PEL	4822 130 42513
V6668	TRANSISTOR,CHIP	BC858C PEL	4822 130 42513
V6686	TRANSISTOR,CHIP	BC848C PEL	5322 130 42136
V6687	TRANSISTOR,CHIP	BC848C PEL	5322 130 42136
V6691	TRANSISTOR,CHIP	BC848C PEL	5322 130 42136
V6754	TRANSISTOR,CHIP	BC848C PEL	5322 130 42136
V6757	TRANSISTOR,CHIP	BC848C PEL	5322 130 42136
V6759	TRANSISTOR,CHIP	BC848C PEL	5322 130 42136
V6761	DIODE,CHIP	BAS28 PEL	5322 130 80214
V6763	TRANSISTOR,CHIP	BC848C PEL	5322 130 42136
V6764	DIODE,REFERENCE	BZX84-C6V2 PEL	5322 130 33671
V6768	TRANSISTOR,CHIP	BC848C PEL	5322 130 42136
V7001	TRANSISTOR,CHIP	BC848C PEL	5322 130 42136
V7003	TRANSISTOR,CHIP	BC858C PEL	4822 130 42513
V7004	TRANSISTOR,CHIP	BC858C PEL	4822 130 42513
V7005	TRANSISTOR,CHIP	BC858C PEL	4822 130 42513
V7006	TRANSISTOR,CHIP	BC848C PEL	5322 130 42136
V7007	DIODE,CHIP	BAV99 PEL	5322 130 34337
V7012	TRANSISTOR,CHIP	BFR92 PEL	5322 130 42145
V7016	TRANSISTOR,CHIP	BC848C PEL	5322 130 42136
V7017	DIODE,CHIP	BAS28 PEL	5322 130 80214
V7018	DIODE,REFERENCE	BZX84-C5V6 PEL	4822 130 80125
V7019	TRANSISTOR	FET ON4401 PEL	5322 130 61498
V7020	TRANSISTOR	FET ON4401 PEL	5322 130 61498
V7031	TRANSISTOR,CHIP	BF824 PEL	4822 130 60383
V7032	TRANSISTOR,CHIP	BF824 PEL	4822 130 60383
V7075	DIODE,CHIP	BAS28 PEL	5322 130 80214
V7091	TRANSISTOR,CHIP	BC848C PEL	5322 130 42136
V7093	TRANSISTOR,CHIP	BC848C PEL	5322 130 42136
V7094	TRANSISTOR,CHIP	BC848C PEL	5322 130 42136
V7150	TRANSISTOR,CHIP	BF824 PEL	4822 130 60383
V7151	TRANSISTOR,CHIP	BF824 PEL	4822 130 60383
V7152	TRANSISTOR,CHIP	BC858C PEL	4822 130 42513
V7506	TRANSISTOR,CHIP	BF824 PEL	4822 130 60383
V7507	TRANSISTOR,CHIP	BF824 PEL	4822 130 60383
V7532	TRANSISTOR,CHIP	BC858C PEL	4822 130 42513
V7553	TRANSISTOR,CHIP	BC858C PEL	4822 130 42513

Item	Description		Ordering code
V7573	TRANSISTOR,CHIP	BF824 PEL	4822 130 60383
V7574	TRANSISTOR,CHIP	BF824 PEL	4822 130 60383
V7686	TRANSISTOR,CHIP	BC848C PEL	5322 130 42136
V7687	TRANSISTOR,CHIP	BC848C PEL	5322 130 42136
V7691	TRANSISTOR,CHIP	BC848C PEL	5322 130 42136
V7714	TRANSISTOR,CHIP	BC848C PEL	5322 130 42136
V7801	DIODE,CHIP	BAV99 PEL	5322 130 34337
V7802	DIODE,CHIP	BAV99 PEL	5322 130 34337
V7803	DIODE,CHIP	BAV99 PEL	5322 130 34337
V7804	DIODE,CHIP	BAV99 PEL	5322 130 34337
V7805	DIODE,CHIP	BAV99 PEL	5322 130 34337
V7806	DIODE,CHIP	BAV99 PEL	5322 130 34337
V7807	DIODE,CHIP	BAV99 PEL	5322 130 34337
V7808	DIODE,CHIP	BAV99 PEL	5322 130 34337
V8001	TRANSISTOR,CHIP	BC848C PEL	5322 130 42136
V8002	TRANSISTOR,CHIP	BC848C PEL	5322 130 42136
V8003	TRANSISTOR,CHIP	BC848C PEL	5322 130 42136
V8004	DIODE,CHIP	BAS28 PEL	5322 130 80214
V8005	TRANSISTOR,CHIP	BC848C PEL	5322 130 42136
V8006	TRANSISTOR,CHIP	BC848C PEL	5322 130 42136
V8007	TRANSISTOR,CHIP	BC848C PEL	5322 130 42136
V8008	TRANSISTOR,CHIP	BC848C PEL	5322 130 42136
V8009	TRANSISTOR,CHIP	BC848C PEL	5322 130 42136
V8011	TRANSISTOR,CHIP	BFT92 PEL	5322 130 44711
V8012	TRANSISTOR,CHIP	BFT92 PEL	5322 130 44711
V8013	TRANSISTOR,CHIP	BFT92 PEL	5322 130 44711
V8014	TRANSISTOR,CHIP	BFT92 PEL	5322 130 44711
V8015	DIODE,REFERENCE	BZX84-C2V4 PEL	4822 130 33703
V8018	TRANSISTOR,CHIP	BC848C PEL	5322 130 42136
V8019	TRANSISTOR,CHIP	BC848C PEL	5322 130 42136
V8023	TRANSISTOR,CHIP	BFT92 PEL	5322 130 44711
V8024	TRANSISTOR,CHIP	BFT92 PEL	5322 130 44711
V8025	DIODE,CHIP	BAV99 PEL	5322 130 34337
V8028	DIODE,CHIP	BAS28 PEL	5322 130 80214
V8029	TRANSISTOR,CHIP	BFT92 PEL	5322 130 44711
V8031	TRANSISTOR,CHIP	BFT92 PEL	5322 130 44711
V8032	DIODE,CHIP	BAV99 PEL	5322 130 34337
V8040	DIODE,CHIP	BAV99 PEL	5322 130 34337
V8041	DIODE,CHIP	BAV99 PEL	5322 130 34337
V8042	TRANSISTOR,CHIP	BSV52 PEL	5322 130 44336
V8043	TRANSISTOR,CHIP	BSV52 PEL	5322 130 44336
V8044	TRANSISTOR,CHIP	BC848C PEL	5322 130 42136
V8061	TRANSISTOR,CHIP	BFR92 PEL	5322 130 42145
V8062	TRANSISTOR,CHIP	BFR92 PEL	5322 130 42145
V8063	TRANSISTOR,CHIP	BFR92 PEL	5322 130 42145
V8065	DIODE,CHIP	BAS28 PEL	5322 130 80214
V8066	TRANSISTOR,CHIP	BC858C PEL	4822 130 42513

Item	Description		Ordering code
V8067	TRANSISTOR,CHIP	BC858C PEL	4822 130 42513
V8068	TRANSISTOR,CHIP	BC848C PEL	5322 130 42136
V8101	DIODE,CHIP	BAS28 PEL	5322 130 80214

CONNECTORS

X1301	SOCKET,MALE	50 OHM BUS	5322 265 10266
X1301	HOLD,OBJECTIVE	CONTACTPIN	5322 268 14141
X1302	HOLD,OBJECTIVE	CONTACTPIN	5322 268 14141
X1302	SOCKET,MALE	50 OHM BUS	5322 265 10266
X2301	HOLD,OBJECTIVE	CONTACTPIN	5322 268 14141
X2301	SOCKET,MALE	50 OHM BUS	5322 265 10266
X2302	SOCKET,MALE	50 OHM BUS	5322 265 10266
X2302	HOLD,OBJECTIVE	CONTACTPIN	5322 268 14141
X3301	HOLD,OBJECTIVE	CONTACTPIN	5322 268 14141
X3301	SOCKET,MALE	50 OHM BUS	5322 265 10266
X3302	HOLD,OBJECTIVE	CONTACTPIN	5322 268 14141
X3302	SOCKET,MALE	50 OHM BUS	5322 265 10266
X4108	SOCKET,MALE	50 OHM BUS	5322 265 10266
X4108	HOLD,OBJECTIVE	CONTACTPIN	5322 268 14141
X4301	HOLD,OBJECTIVE	CONTACTPIN	5322 268 14141
X4301	SOCKET,MALE	50 OHM BUS	5322 265 10266
X4302	SOCKET,MALE	50 OHM BUS	5322 265 10266
X4302	HOLD,OBJECTIVE	CONTACTPIN	5322 268 14141
X5001	CONNECTOR	DIPS 4-P HAAKS OMSL	5322 265 30907
X6010	SOCKET,MALE	50 OHM BUS	5322 265 10266
X6010	HOLD,OBJECTIVE	CONTACTPIN	5322 268 14141
X6591	HOLD,OBJECTIVE	CONTACTPIN	5322 268 14141
X6591	SOCKET,MALE	50 OHM BUS	5322 265 10266
X6592	HOLD,OBJECTIVE	CONTACTPIN	5322 268 14141
X6592	SOCKET,MALE	50 OHM BUS	5322 265 10266
X6794	HOLD,OBJECTIVE	CONTACTPIN	5322 268 14141
X6794	SOCKET,MALE	50 OHM BUS	5322 265 10266
X8011	HOLD,OBJECTIVE	CONTACTPIN	5322 268 14141
X8011	SOCKET,MALE	50 OHM BUS	5322 265 10266
X8013	HOLD,OBJECTIVE	CONTACTPIN	5322 268 14141
X8013	SOCKET,MALE	50 OHM BUS	5322 265 10266
X8014	HOLD,OBJECTIVE	CONTACTPIN	5322 268 14141
X8014	SOCKET,MALE	50 OHM BUS	5322 265 10266
X9001	CONNECTOR	50-P DBL STRGHT	5322 265 61242
X9002	CONNECTOR	16-P 1.25MM STR	5322 267 51107

5.2 FINAL XYZ AMPLIFIER A2

5.2.1 Description of A2-200 MHz version

5.2.1.1 Final Y amplifier

Diagram 1

The output signal from the delay line is applied to the input pins 6 and 9 of amplifier IC D1001. Also the vertical output signals YTXT0 and YTXT1 from the digitizer unit A8 are applied to D1001 (pin 15 and 16). The switching between digital and analog mode is done via control signals that are applied to pin 17 and 18 of D1001. Digital mode is active if the voltage at pin 18 is higher than at pin 17. This switching signal is derived from the collector of the transistors V1201 and V1202. The control signals XYSW1 and XYSW0 come from the output stage V8036/V8041 on the digitizer unit A8. Via the transistors V1203 and V1204 similar switching signals XSW1 and XSW0 are routed to the X-deflection section for switching between digital and analog mode.

The output signals from pin 21 and 22 of D1001 are routed to the final Y-amplifier that drives the vertical deflection plates of the CRT. This final stage is indicated on the next diagram.

The delay line leads are terminated into 50Ω . The impedance is composed by 300Ω inside D1001 paralleled by external impedances of 60Ω formed by the external resistors R1024/R1026 and R1027/R1028. All termination resistors are applied to a voltage controlled by D1001/pin 13. Pin 13 determines the common mode voltage level of the D1001 inputs. The HF square wave compensation is achieved by the two dual varicap diodes V1009 and V1011 together with associated resistors. A fixed mid-frequency compensation network is formed by C1006 and associated resistors.

Varicap V1009 is controlled by the output signal at pin 20 of octal DAC N1001. This output voltage can be in the range 0 to 10 V and controls varicap V1009 via operational amplifier N1002/1,2,3. This operational amplifier converts the N1001 output voltage (that is related to 0 V) into a voltage related to the voltage at D1001/pin 13.

Varicap V1011 is controlled by the output signal at pin 18 of octal DAC N1001. This output voltage can be in the range 0 to 10 V and controls varicap V1011 via operational amplifier N1002/5,6,7. This operational amplifier converts the N1001 output voltage (that is related to 0 V) into a voltage related to the voltage at D1001/pin 13.

LF square wave compensation is also done inside D1001. This is controlled via currents applied to pin 27 and 28. These currents are derived from the N1001 DAC voltage outputs 13 and 11 via the transistors V1014 and V1016. The actual compensating components are situated outside D1001 and are R1037/C1011/R1038 and R1029/C1009/R1031. V1023 and V1024 form a 20 mA current source to supply the bias current for the final stage inside D1001. V1024 is switched as a diode and gives temperature compensation.

Offset is adjusted via the currents from the collectors of V1021 and V1022. These currents are controlled by the DAC output pins 17 (Most Significant DAC) and 16 (Least Significant DAC). Two parallel DAC outputs are used to obtain sufficient resolution. V1018 is a current source and V1019 is for temperature compensation. Gain control occurs via an adjustable current applied to D1001/pin 26. This is done via N1001/pin 14 and R1051

DAC output N1001/15 applies via operational amplifier N1003/1,2,3 the signal YFSHF to the final stage on the next diagram. YFSHF is an adjustable dc voltage that is applied to varicap diodes that control the HF square wave response.

Diagram 2

This diagram shows the push-pull output amplifier. The input signal is a current and the output signal is a voltage. The output signal is applied to the vertical upper and lower plates of the CRT. The total sensitivity at the plates is 4V/div. One plate is driven by push-pull stage V1106/V1111. The driver transistors are V1102 and V1103. The input signal is YPREOUT1.

The other plate is driven by push-pull stage V1107/V1112. The driver transistors are V1101 and V1104. The input signal is YPREOUT0. The output voltage applied to the CRT deflection plates is controlled by the feedback networks R1101/R1141/R1143/C1101/V1113/R1140/C1121 and R1102/R1142/R1144/C1102/V1113/R1145/C1122.

The push-pull amplifier stages are connected between +18 V and -18V supply voltages via current sources. One of these is V1122 with temperature compensation via V1121. The other is V1123 and is adjusted via operational amplifier N1003/5,6,7. This assures that the common mode voltage at the plates of the CRT is 0 V.

The resistance network between L1101 and L1102 avoids extreme differences in power dissipation in the output transistors when a dc voltage difference exists between the CRT deflection plates.

The input of the final stage is at a common mode level of 9V dc because of the output level from D1001. This voltage is made by the dc current sources V1021 and V1022. The current from these sources is partly used by the D1001 output stage (pin 21 and 22). The remaining currents give a 9 V dc across the feedback resistors R1101/R1141 and R1102/1142. Because the output lines to the CRT plates are at 0V common mode level, the inputs are at 9V common mode level. The current in the feedback resistors runs via L1101, L1102 and V1126 to the -18V supply.

The bias current for the driver stage V1101/V1102/V1103/V1104 is controlled by V1127 and V1128 via R1167 and R1168. V1127 converts voltage into current. This current is compared with current from source V1128/R1166. In case of a difference between these currents, the resulting current feeds the base of V1103 and V1104.

The circuit with operational amplifier N1004/2,3,6 is used for automatic calibration of the vertical deflection. It measures the voltage at the vertical deflection plates of the CRT. This value is applied as signal YCAL to the microprocessor on unit A3.

5.2.1.2 *Final X and Z amplifiers*

Diagram 3

This diagram shows the final X amplifier. It drives the horizontal plates of the CRT. The plate sensitivity equals 8.5 V/div. The input circuit is formed by IC D2001. The octal DAC N2002 supplies the analog control signals that are used throughout the circuit.

Input pin 5 and 6 of D2001 receive the analog time base sawtooth or the X-deflection signal. Input pin 9 and 10 receive the X-deflection signals XTXT0 and XTXT1 from digitizer unit A8. The selection between analog and digital mode is done via the signals XSW0 and XSW1 that are applied to pin 7 and pin 8 of D2001. These signals are derived from XYSW0 and XYSW1 that come from output stage V8036/V8041 on the digitizer unit A8. Digital mode is on with XSW0 at 0 mA and XSW1 at 1 mA. Analog mode is on with XSW0 at 1 mA and XSW1 at 0 mA.

Gain control is possible via pin 1 of D2001. This is used for trace gain control via signal XTRAGC. Gain control to compensate for CRT tolerances is achieved via pin 14 of D2001. This is controlled via the DAC output signals XCRTGCL and XCRTGCH. Offset control to compensate for CRT tolerances is achieved via pin 15 of D2001. This is controlled via the DAC output signals XCRTOFH and XCRTOFL. Adjustment of the HF response (and linearity) is achieved via signal XHFADJ via pin 17 and 26 of D2001.

The final X-amplifier consists of two identical halves that receive input signals that are in opposite phase. These signals originate from the D2001 outputs pin 24/25 (XDRIL0/XDRIL1) and pin 18/19 (XDRIR0/XDRIR1). The two X-amplifier sections drive respectively the left and right deflection plate of the CRT.

The final X amplifier half that drives the left deflection plate is explained now. Its function is identical to that of the other amplifier half. The balanced input signals XDRIL1 and XDRIL0 are applied to input stage V2101. V2104 is a current source. XDRIL0 is not used and connected to +5 V. In the collector circuit of V2101 are the zener diodes V2102/V2103 that function as level shifters. The emitter followers V2132 and V2111 supply the output stage V2134/V2113 with signal. V2113 functions as an amplifier stage and V2134 mainly as a current source. V2134 receives signal via C2131 and mainly functions as amplifier stage in the fastest sweep speeds. Via R2133/R2134 however some dc drive is also applied to V2134.

The circuit with operational amplifier N2003 is used to measure the output voltage that is applied to the X-deflection plates of the CRT. This measurement is done via high-ohmic resistors R2301 and R2302. The analog output voltage XCAL of N2003 is applied to an ADC incorporated in the microprocessor on unit A3. This enables the microprocessor to exactly measure the horizontal output voltage. This is used for automatic calibration of the horizontal deflection.

Diagram 4

This diagram shows the final intensity (Z) and focusing amplifiers. These amplifiers drive the intensity electrode G1 and the focusing electrode G3 of the CRT. The input circuit is formed by IC D3001.

Input pin 5 and 6 of D3001 receive the Z-pulses that determine intensity during the analog mode. Input pin 9 and 10 receive the Z-pulses ZTXT0 and ZTXT1 from output stage V8027/V8028 on digitizer unit A8. The selection between analog and digital mode is done via the signals ZSW0 and ZSW1 that are applied to pin 7 and 8 of D3001. These signals are coming from output stage V8042/V8033 on the digitizer unit A8. Digital mode is on with ZSW0 at 0 mA and ZSW1 at 1 mA. Analog mode is on with ZSW0 at 1 mA and ZSW1 at 0 mA.

The final Z-amplifier and the focusing amplifier are identical halves that receive input signals that are in opposite phase. These signals originate from the D3001 outputs pin 24/25 (ZDRIF1/ZDRIF0) and pin 18/19 (ZDRIF0/ZDRIF1).

Via V3002 part of the ripple on the negative CRT cathode voltage (ZRIPPLE) is applied to pin 15 of D3001. This compensates for unwanted intensity modulation due to this ripple.

The diodes V3236, V3136, V3237 and V3137 protect D3001 against possible high voltage surges.

V3301 supplies the intensity determining signal INTEN-DA. This signal adjusts the "dark level" of the CRT. V3301 is controlled by DAC N2002 output signal DARK. V3311 supplies signal ASTIG that determines the astigmatism of the CRT. V3311 is controlled by DAC N2002 output signal ASTDR.

The upper amplifier half that is used for the dynamic focus control is explained now. Its function is identical to that of the lower amplifier half that is used for intensity (Z) control. The balanced input signals ZDRIF1 and ZDRIF0 are applied to input stage V3101. V3104 is a current source. ZDRIF0 is not used and connects to +5 V. In the collector circuit of V3101 are the zener diodes V3102/V3103 that function as level shifters. The emitter followers V3132 and V3111 supply the output stage V3134/V3113 with signal. V3113 functions as an amplifier stage and V3134 mainly as a current source. V3134 receives signal via C3131 and mainly functions as amplifier stage for fast input signals. Via R3133/R3134 however some dc drive is also applied to V3134.

The circuit with V3282/V3212 suppresses the light on the screen at power down. V3282 becomes conductive via the fast falling +12 V and the slowly falling charge in C3281.

Diagram 5

In this diagram the circuit is shown that forms an interface between the signals that determine the intensity/focusing and the CRT electrodes G1/G3 that control intensity/focusing. These electrodes, the cathode and filament (heater) of the CRT are at a high negative voltage. This voltage is separated from the other oscilloscope circuits via the 3kV capacitors C4004, C4061, C4036 and C4037.

The intensity is influenced by the output signal INTEN-AA of the Z- amplifier and the signal INTEN-DA. INTEN-AA is determined via the front-panel INTENS TRACE, INTENS TEXT, MTBI and chopper blanking control signals. The HF component in the INTEN-AA signal is applied to G1 of the CRT via C4037. The DC and LF components are applied to the base of V4034. The INTEN-DA signal is applied to the base of V4032 and forms the clamp level (dark level) of the DC and LF part of INTEN-AA derived from V4034. These two transistors form the inputs of a 150kHz modulator that basically consists of V4031 and V4033. The LF and DC components that are modulated on the 150 kHz carrier signal can pass via buffer stage V4038/V4039 and then via high voltage blocking capacitor C4036. Behind capacitor C4036 demodulation takes place via the diodes V4043 and V4044. This results in the original INTEN-AA signal that is superpositioned on the INTEN-DA voltage that corrects the cut-off voltage of the CRT applied to G1 and via R4051 also to G3. Across R4044 a small negative voltage (compared with the cathode) is developed for G1. This voltage is not big enough to make the CRT screen dark. This means that the signals to darken the screen and to control intensity are applied via C4036 and C4037.

The HF component from the focusing amplifier output signal FOCUS-AA is applied to G3 via C4004 and voltage divider R4008/R4009/C4002/C4003. This assures optimal tracking between focus and intensity. The signal FOCUS-DA is determined via the FOCUS control at the instruments front panel. The signal FOCUS-DA is then mixed with the LF component of FOCUS-AA before its level is adapted to the nominal G3 voltage via transistors V4002/V4003/V4004.

Diagram 6

This diagram shows the RC-branches and regulators N5131 that give the supply voltages for the various circuits. Also the connectors X2501 and X2301 are indicated here. X2301 is the connector where the flat cable leaves for the small unit that incorporates the CRT-socket X2403. The flat cable arrives at the small CRT-socket unit at X2401.

5.2.2 Signal name list A2-200 MHz version

Note: In the signal name list you find the itemnumber of the component that is source or destination. Behind this itemnumber (separated by ":") you find the number of the diagram where the source/destination can be found.

NAME	MEANING	SOURCE	DESTINATION
ASTDR	DRIVER SIGNAL FOR ASTIGMATISM	N2002:03	R3313:04
ASTIG	ASTIGMATISM CONTROL	V3311:04	X2301:06 X2401:05 X2403:05
DARK	DRIVER SIGNAL FOR DC PART INTENS	N2002:03	V3301:04
FOCUS-AA	AC PART FOCUSING SIGNAL	R3161:04	X2301:06 X2401:05 R4008:05
FOCUS-DA	DC PART FOCUSING SIGNAL	X2501:06	X2301:06 X2401:05 C4001:05 R4001:05
G1	INTENSITY GRID 1 OF CRT	C4037:05 R4044:05	X2403:05
G3	FOCUSING GRID 3 OF CRT	C4004:05 R4051:05	X2403:05
HEATER1	FILAMENT SUPPLY F1 OF CRT	X2402:05	X2403:05
HEATER2	FILAMENT SUPPLY F2 OF CRT	X2402:05	X2403:05
INTEN-AA	AC PART OF INTENSITY SIGNAL	R3261:04	X2401:05 C4037:05
INTEN-DA	DC PART OF INTENSITY SIGNAL	V3301:04	X2301:06 X2401:05 V4032:05
SCL	SERIAL CLOCK	X2501:06	J1002:06 J2002:06
SDA	SERIAL DATA	X2501:06	J1001:06 J2001:06
XCAL	AUTOCAL SIGNAL X DEFLECTION	R2313:03	X2501:06
XDRIL0	DRIVE SIGNAL 0 LEFT X AMPLIFIER	D2001:03	R2101:03
XDRIL1	DRIVE SIGNAL 1 LEFT X AMPLIFIER	D2001:03	R2103:03
XDRIR0	DRIVE SIGNAL 0 RIGHT X AMPLIFIER	D2001:03	R2203:03
XDRIR1	DRIVE SIGNAL 1 RIGHT X AMPLIFIER	D2001:03	R2201:03
XHFADJ	HF ADJUSTMENT X AMPLIFIER	N2002:03	R2018:03
XLTXT0	X SHIFT TEXT 0	V2062:03	D2001:03
XLTXT1	X SHIFT TEXT 1	V2061:03	D2001:03
XOUT0	X OUTPUT 0	V2134:03 V2113:03	R2171:03
XOUT1	X OUTPUT 1	V2234:03 V2213:03	R2271:03
XPLATE0	X OUTPUT 0 TO CRT	R2161:03	CRT LEFT PLATE
XPLATE1	X OUTPUT 1 TO CRT	R2261:03	CRT RIGHT PLATE

XSCL	SERIAL CLOCK X SECTION	J2002:06	N2002:03
XSDA	SERIAL DATA X SECTION	J2001:06	N2002:03
XSW0	X SWITCH SIGNAL 0 TRACE/TEXT	V1204:01	D2001:03
XSW1	X SWITCH SIGNAL 1 TRACE/TEXT	V1203:01	D2001:03
XYSW0	X/Y SWITCH SIGNAL 0 TRACE/TEXT	X2501:06	R1204:01
XYSW1	X/Y SWITCH SIGNAL 1 TRACE/TEXT	X2501:06	R1201:01
XTRA0	X TRACE 0 SIGNAL	X2501:06	R2004:03
XTRA1	X TRACE 1 SIGNAL	X2501:06	R2006:03
XTXT0	X TEXT 0 SIGNAL	X2501:06	R2063:03
XTXT1	X TEXT 1 SIGNAL	X2501:06	R2064:03
YCAL	AUTOCAL SIGNAL Y DEFLECTION	R1309:02	X2501:06
YFSH	HF SQ WAVE RESPONSE FINAL Y	N1003:01	R1146:02
			R1147:02
YPREOUT0	Y PREAMPLIFIER OUT 0	R1061:01	V1101:01
YPREOUT1	Y PREAMPLIFIER OUT 1	R1059:01	V1102:01
YSCL	SERIAL CLOCK Y SECTION	J1002:06	N1001:01
YSDA	SERIAL DATA Y SECTION	J1001:06	N1001:01
YSW0	Y SWITCH SIGNAL 0 TRACE/TEXT	V1202:01	D1001:01
YSW1	Y SWITCH SIGNAL 1 TRACE/TEXT	V1201:01	D1001:01
YTRA0	Y TRACE 0 OUT FROM DELAY LINE	X2101:01	D1001:01
YTRA1	Y TRACE 1 OUT FROM DELAY LINE	X2102:01	D1001:01
YTXT0	Y TEXT 0 SIGNAL	X2501:01	D1001:01
YTXT1	Y TEXT 1 SIGNAL	X2501:01	D1001:01
ZDRIF0	DRIVER SIGNAL 0 FOCUS AMPLIFIER	D3001:04	R3101:04
ZDRIF1	DRIVER SIGNAL 1 FOCUS AMPLIFIER	D3001:04	R3103:04
ZDRII0	DRIVER SIGNAL 0 INTENS AMPLIFIER	D3001:04	R3203:04
ZDRII1	DRIVER SIGNAL 1 INTENS AMPLIFIER	D3001:04	R3201:04
ZLTRA0	Z LEVEL TRACE INTENSITY 0	V3062:04	R3004:04
ZLTRA1	Z LEVEL TRACE INTENSITY 1	V3061:04	R3006:04
ZOUTF	FEEDBACK SIGNAL FOCUS AMPLIFIER	V3113:04	R3171:04
ZOUTI	FEEDBACK SIGNAL INTENSITY AMPL.	V3213:04	R3271:04
ZRIPPLE	RIPPLE ON NEGATIVE HIGH VOLTAGE	C4061:05	V3001:04
ZSW0	Z SWITCH SIGNAL 0 TEXT/TRACE	X2501:06	D3001:04
ZSW1	Z SWITCH SIGNAL 1 TEXT/TRACE	X2501:06	D3001:04
ZTRA0	Z TRACE INTENSITY 0	X2501:06	R3063:04
ZTRA1	Z TRACE INTENSITY 1	X2501:06	R3064:04
ZTXT0	Z TEXT 0 SIGNAL	X2501:06	R3007:04
ZTXT1	Z TEXT 1 SIGNAL	X2501:06	R3008:04

5.2.3 Unit lay-outs A2-200 MHz version

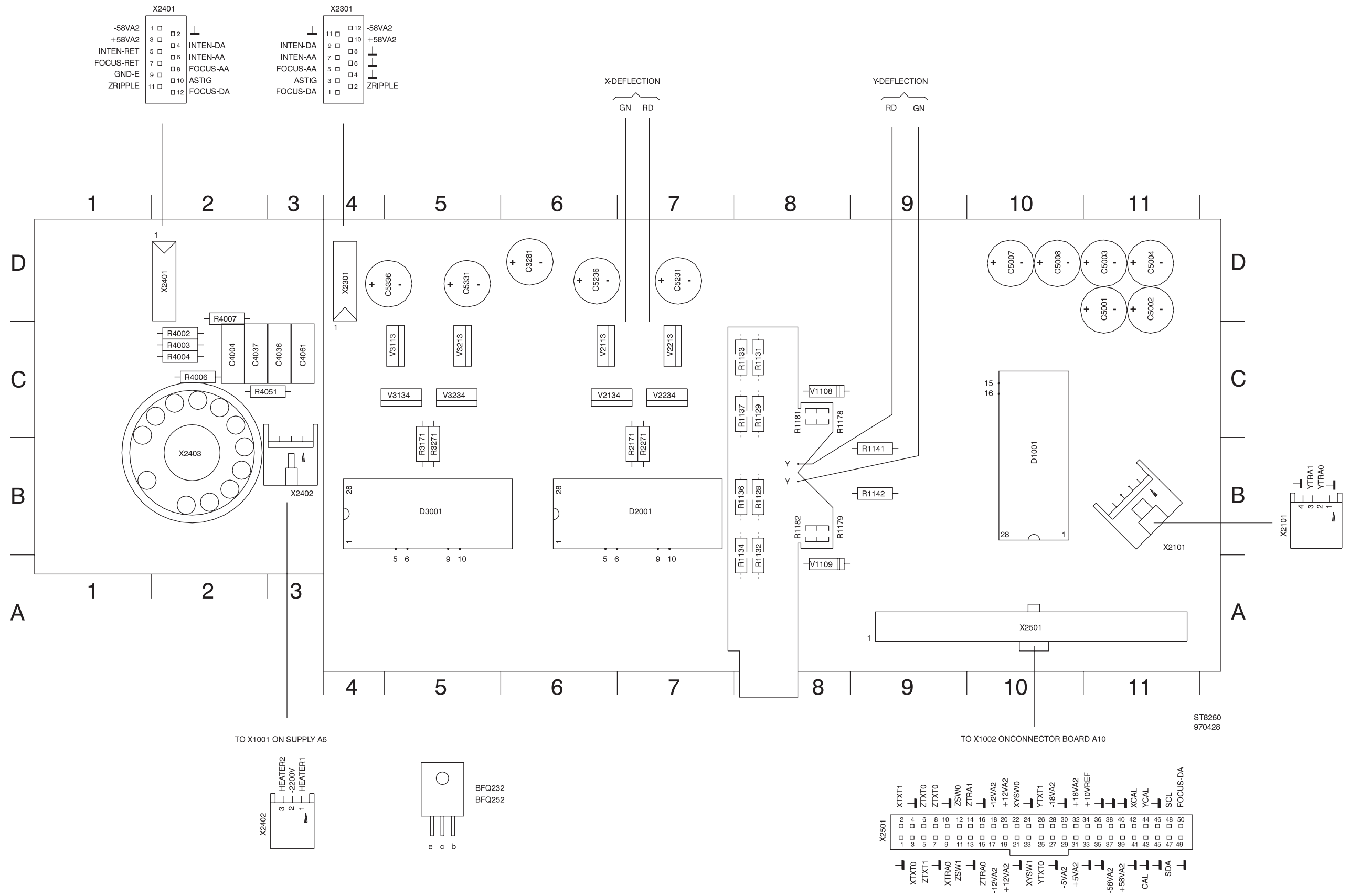

Lay-out 1 - Large component side of XYZ amplifier unit A2-200 MHz

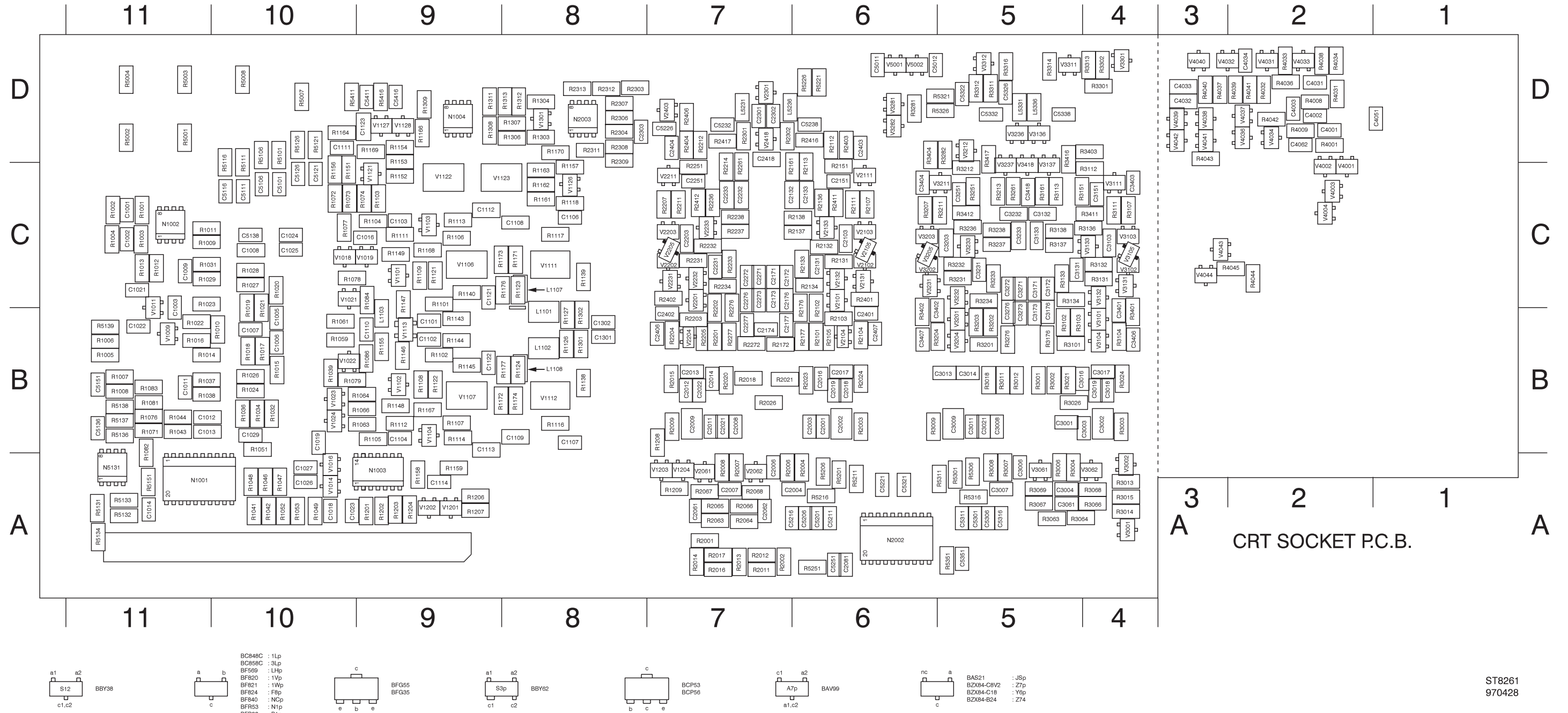

Lay-out 2 - Small component side of XYZ amplifier unit A2-200 MHz

ST8261
970428

5.2.4 Location list A2-200 MHz version

'-L' means that the component is located on the side with the large components. Otherwise the component is located on the side with small components.

C1001 C11	C2013 B7	C3013 B6	C5007 D10-L
C1002 C11	C2014 B7	C3014 B5	C5008 D10-L
C1003 B11	C2016 B6	C3016 B5	C5011 D6
C1005 B10	C2017 B6	C3017 B4	C5012 D6
C1006 B10	C2018 B6	C3018 B4	C5101 C10
C1007 B10	C2019 B6	C3019 B4	C5106 C10
C1008 C10	C2021 B7	C3021 B5	C5111 C10
C1009 C11	C2022 B7	C3061 A5	C5116 C10
C1011 B11	C2061 A7	C3103 C4	C5121 C10
C1012 B11	C2062 A7	C3131 C5	C5126 C10
C1013 B11	C2081 A6	C3132 C5	C5136 B11
C1014 A11	C2103 C6	C3133 C5	C5138 C10
C1016 C10	C2131 C6	C3151 C4	C5151 B11
C1018 A10	C2132 C7	C3171 C5	C5201 A6
C1019 B10	C2133 C6	C3172 C5	C5206 A6
C1021 C11	C2151 C6	C3173 B5	C5211 A6
C1022 B11	C2171 C7	C3176 B5	C5216 A7
C1023 A10	C2172 C7	C3203 C5	C5221 A6
C1024 C10	C2173 C7	C3231 C5	C5226 D7
C1025 C10	C2174 B7	C3232 C5	C5231 D7-L
C1026 A10	C2176 C7	C3233 C5	C5232 D7
C1027 A10	C2177 B7	C3251 C5	C5236 D6-L
C1029 B10	C2203 C7	C3271 C5	C5238 D6
C1101 B9	C2231 C7	C3272 C5	C5251 A6
C1102 B9	C2232 C7	C3273 B5	C5301 A5
C1103 C9	C2233 C7	C3276 B5	C5306 A5
C1104 B9	C2251 C7	C3281 D6-L	C5311 A5
C1106 C8	C2271 C7	C3401 B4	C5316 A5
C1107 B8	C2272 C7	C3402 B6	C5321 A6
C1108 C9	C2273 C7	C3403 C4	C5322 D5
C1109 B9	C2276 C7	C3404 C6	C5326 D5
C1110 B9	C2277 B7	C3406 B4	C5331 D5-L
C1111 D10	C2301 D7	C3407 B6	C5332 D5
C1112 C9	C2302 D7	C3418 C5	C5336 D5-L
C1113 B9	C2303 D7	C4001 D2	C5338 D5
C1114 A9	C2401 B6	C4002 D2	C5351 A5
C1121 C9	C2402 B7	C4003 D2	C5411 D9
C1122 B9	C2403 D6	C4004 C2-L	C5416 D9
C1123 D9	C2404 D7	C4031 D2	D1001 B10-L
C1301 B8	C2406 B7	C4032 D3	D2001 B7-L
C1302 B8	C2407 B6	C4033 D3	D3001 B5-L
C2001 B6	C2418 D7	C4034 D2	L1101 B8
C2002 B6	C3001 B5	C4036 C3-L	L1102 B8
C2003 B6	C3002 B4	C4037 C2-L	L1103 B9
C2004 A7	C3003 B5	C4051 D2	L1107 C8
C2006 A7	C3004 A5	C4061 C3-L	L1108 B8
C2007 A7	C3006 A5	C4062 D2	L5231
C2008 B7	C3007 A5	C5001 D11-L	L5236
C2009 B7	C3008 B5	C5002 D11-L	L5331
C2011 B7	C3009 B5	C5003 D11-L	L5336
C2012 B7	C3011 B5	C5004 D11-L	N1001 A11

N1002 C11	R1066 B10	R1150 B9	R2011 A7
N1003 A9	R1071 B11	R1151 C10	R2012 A7
N1004 D9	R1072 C10	R1152 C9	R2013 A7
N2002 A6	R1073 C10	R1153 D9	R2014 A7
N2003 D8	R1074 C10	R1154 D9	R2015 B7
N5131 A11	R1076 B11	R1155 B9	R2016 A7
R1001 C11	R1077 C10	R1156 C10	R2017 A7
R1002 C11	R1078 C10	R1157 D8	R2018 B7
R1003 C11	R1079 B10	R1158 A9	R2020 B7
R1004 C11	R1081 B11	R1159 A9	R2021 B7
R1005 B11	R1082 A11	R1161 C8	R2023 B6
R1006 B11	R1083 B11	R1162 C8	R2024 B6
R1007 B11	R1084 C9	R1163 C8	R2026 B7
R1008 B11	R1086 B9	R1164 D10	R2063 A7
R1009 C11	R1101 C9	R1166 D9	R2064 A7
R1010 B11	R1102 B9	R1167 B9	R2065 A7
R1011 C11	R1103 C9	R1168 C9	R2066 A7
R1012 C11	R1104 C9	R1169 D10	R2067 A7
R1013 C11	R1105 B9	R1170 D8	R2068 A7
R1014 B11	R1106 C9	R1171 C8-L	R2101 B6
R1015 B10	R1107 B9	R1172 B8-L	R2102 B6
R1016 B11	R1108 B9	R1173 C8-L	R2103 B6
R1017 B10	R1109 C9	R1174 B8-L	R2104 B6
R1018 B10	R1111 C9	R1176 C9	R2105 B6
R1019 B10	R1112 B9	R1177 B9	R2107 C6
R1020 C10	R1113 C9	R1178 C8-L	R2111 C6
R1021 B10	R1114 B9	R1179 B8-L	R2112 D6
R1022 B11	R1116 B9	R1181 C8-L	R2113 C6
R1023 C11	R1117 C9	R1182 B8-L	R2131 C6
R1024 B10	R1118 C8	R1201 A9	R2132 C6
R1026 B10	R1121 C8	R1202 A9	R2133 C6
R1027 C10	R1122 B8	R1203 A9	R2134 C6
R1028 C10	R1123 C8	R1204 A9	R2136 C6
R1029 C11	R1124 B8	R1206 A9	R2137 C7
R1031 C11	R1126 B8	R1207 A9	R2138 C7
R1032 B10	R1127 B8	R1208 B7	R2151 D6
R1034 B10	R1128 B8-L	R1209 A7	R2161 C7
R1036 B10	R1129 C8-L	R1301 B8	R2171 B7-L
R1037 B11	R1131 C8-L	R1302 B8	R2172 B7
R1038 B11	R1132 A8-L	R1303 D8	R2176 B6
R1039 B10	R1133 C8-L	R1304 D8	R2177 B6
R1041 A10	R1134 A8-L	R1306 D9	R2201 B7
R1042 A10	R1136 B8-L	R1307 D9	R2202 B7
R1043 B11	R1137 C8-L	R1308 D9	R2203 B7
R1044 B11	R1138 B8	R1309 D9	R2204 B7
R1046 A10	R1139 C8	R1311 D9	R2205 B7
R1047 A10	R1140 C9	R1312 D8	R2207 C7
R1048 A10	R1141 C9-L	R1313 D9	R2211 C7
R1049 A10	R1142 B9-L	R2001 A7	R2212 D7
R1051 B10	R1143 B9	R2002 A7	R2214 C7
R1052 A10	R1144 B9	R2003 B6	R2231 C7
R1053 A10	R1145 B9	R2004 A6	R2232 C7
R1059 B10	R1146 B9	R2006 A7	R2233 C7
R1061 B10	R1147 B9	R2007 A7	R2234 C7
R1063 B10	R1148 B9	R2008 A7	R2236 C7
R1064 B10	R1149 C9	R2009 B7	R2237 C7

R2238 C7	R3112 C5	R4009 D2	R5416 D9
R2251 D7	R3113 C5	R4031 D2	V1009 B11
R2261 C7	R3131 C4	R4032 D2	V1011 B11
R2271 B7-L	R3132 C4	R4033 D2	V1014 A10
R2272 B7	R3133 C5	R4034 D2	V1016 A10
R2276 B7	R3134 C5	R4036 D2	V1018 C10
R2277 B7	R3136 C5	R4037 D3	V1019 C10
R2301 D7	R3137 C5	R4038 D2	V1021 C10
R2302 D7	R3138 C5	R4039 D2	V1022 B10
R2303 D8	R3151 C5	R4040 D3	V1023 B10
R2304 D8	R3161 C5	R4041 D2	V1024 B10
R2306 D8	R3171 B5-L	R4042 D2	V1101 C9
R2307 D8	R3176 B5	R4043 D3	V1102 B9
R2308 D8	R3201 B5	R4044 C2	V1103 C9
R2309 D8	R3202 B5	R4045 C3	V1104 B9
R2311 D8	R3203 B5	R4051 C2-L	V1106 C9
R2312 D8	R3204 B6	R5001 D11	V1107 B9
R2313 D8	R3207 C6	R5002 D11	V1108 C8-L
R2401 C6	R3211 C6	R5003 D11	V1109 B8-L
R2402 C7	R3212 C5	R5004 D11	V1111 C8
R2403 D6	R3213 C5	R5007 D10	V1112 B8
R2404 D7	R3231 C5	R5008 D10	V1113 B9
R2406 D7	R3232 C5	R5101 D10	V1121 C9
R2411 C6	R3233 C5	R5106 D10	V1122 C9
R2412 C7	R3234 C5	R5111 C10	V1123 C9
R2416 D6	R3236 C5	R5116 C10	V1126 C8
R2417 D7	R3237 C5	R5121 D10	V1127 D9
R3001 B5	R3238 C5	R5126 D10	V1128 D9
R3002 B5	R3251 C5	R5131 A11	V1201 A9
R3003 B4	R3261 C5	R5132 A11	V1202 A9
R3004 A5	R3271 B5-L	R5133 A11	V1203 A7
R3006 A5	R3276 B5	R5134 A11	V1204 A7
R3007 A5	R3281 D6	R5136 B11	V1301 D8
R3008 A5	R3282 D5	R5137 B11	V2019 B6
R3009 B6	R3301 D4	R5138 B11	V2061 A7
R3011 B5	R3302 D4	R5139 B11	V2062 A7
R3012 B5	R3311 D5	R5151 A11	V2101 C6
R3013 A4	R3312 D5	R5201 A6	V2102 C6
R3014 A4	R3313 D4	R5206 A6	V2103 C6
R3015 A4	R3314 D5	R5211 A6	V2104 B6
R3018 B5	R3316 D5	R5216 A6	V2105 C6
R3021 B5	R3401 B4	R5221 D6	V2111 C6
R3024 B4	R3402 B6	R5226 D6	V2113 C6-L
R3026 B5	R3403 D5	R5231 D7	V2131 C6
R3063 A5	R3404 D6	R5236 D7	V2132 C6
R3064 A5	R3411 C5	R5251 A6	V2133 C6
R3066 A5	R3412 C5	R5301 A5	V2134 C7-L
R3067 A5	R3416 D5	R5306 A5	V2201 C7
R3068 A5	R3417 D5	R5311 A6	V2202 C7
R3069 A5	R4001 D2	R5316 A5	V2203 C7
R3101 B5	R4002 C2-L	R5321 D6	V2204 B7
R3102 B5	R4003 C2-L	R5326 D6	V2205 C7
R3103 B5	R4004 C2-L	R5331 D5	V2211 C7
R3104 B4	R4006 C2-L	R5336 D5	V2213 C7-L
R3107 C4	R4007 D2-L	R5351 A5	V2231 C7
R3111 C4	R4008 D2	R5411 D10	V2232 C7

V2233 C7	V3132 C4	V3236 D5	V4037 D2
V2234 C7-L	V3133 C4	V3237 D5	V4038 D3
V2301 D7	V3134 C5-L	V3281 D6	V4039 D3
V2403 D7	V3136 D5	V3282 D6	V4040 D3
V2418 D7	V3137 D5	V3301 D4	V4041 D3
V3001 A4	V3201 B5	V3311 D5	V4042 D3
V3002 A4	V3202 C6	V3312 D5	V4043 C3
V3061 A5	V3203 C6	V3418 D5	V4044 C3
V3062 A5	V3204 B5	V4001 D2	V5001 D6
V3101 B4	V3205 C6	V4002 D2	V5002 D6
V3102 C4	V3211 C6	V4003 C2	X2101 A11-L
V3103 C4	V3212 D5	V4004 C2	X2301 D4-L
V3104 B4	V3213 C5-L	V4031 D2	X2401 D2-L
V3105 C4	V3231 C6	V4032 D3	X2402 B3-L
V3111 C4	V3232 C5	V4033 D2	X2403 B3-L
V3113 C5-L	V3233 C5	V4034 D2	X2501 A10-L
V3131 C4	V3234 C5-L	V4036 D2	

5.2.5 Circuit diagrams A2-200 MHz version

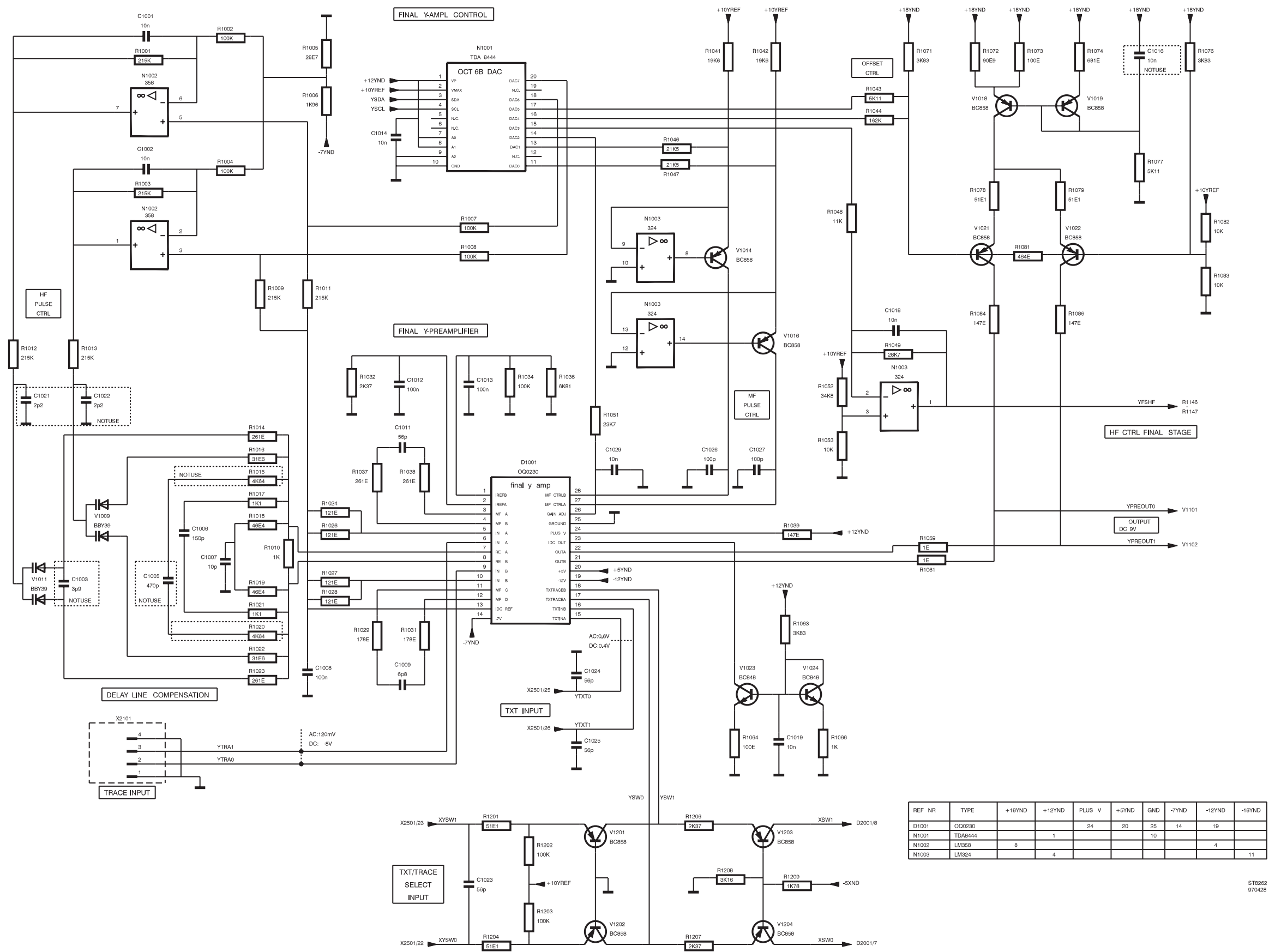

A2 (200 MHz) - Diagram 1 ; Final Y preamplifier and control

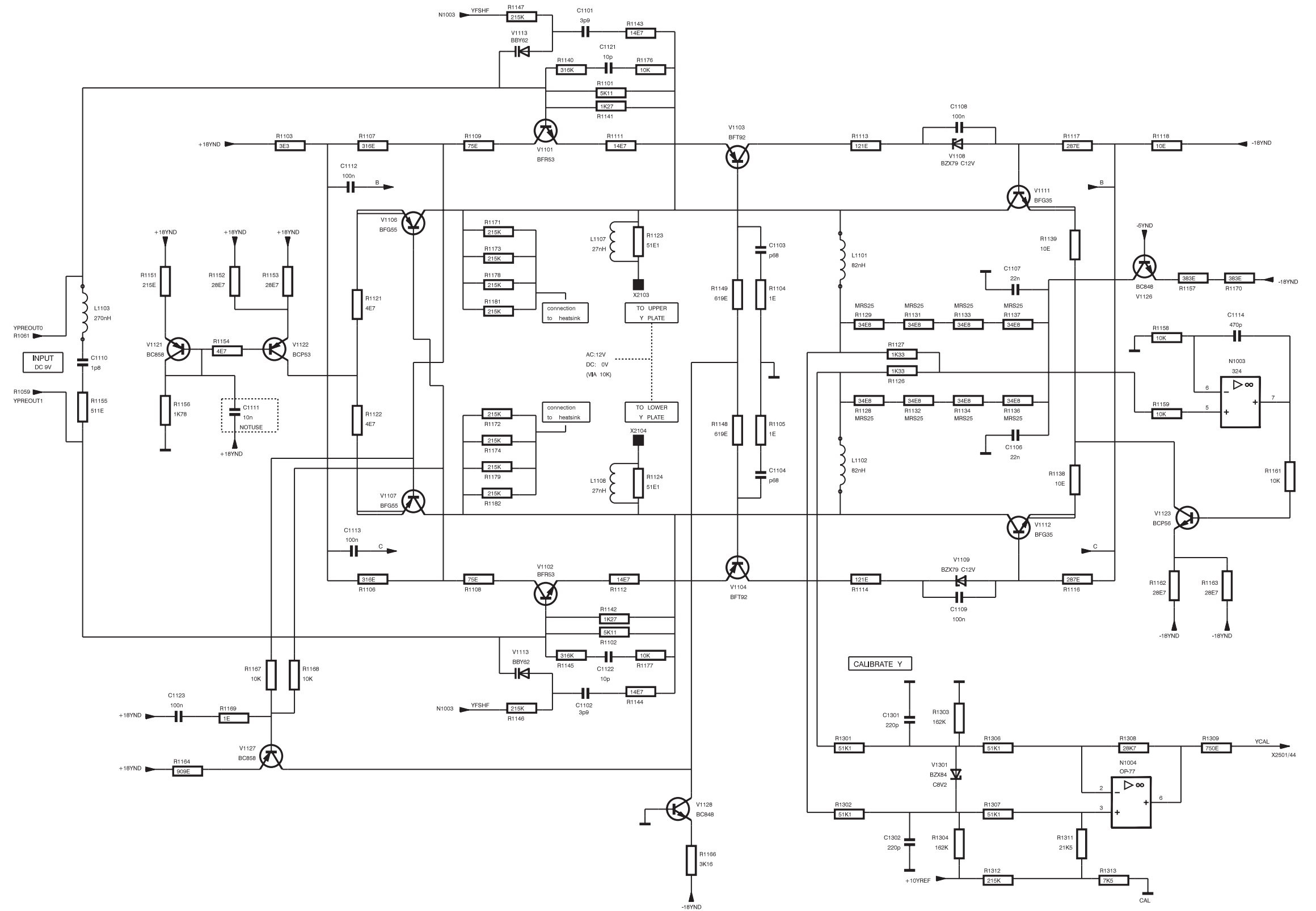

REF NR	TYPE	+12VND	+12CND	GND	-12CND	-18VND
N1003	LM324	4				11
N1004	OP-77		7		4	

ST8263
970428

A2 (200 MHz) - Diagram 2 ; Final Y output stage

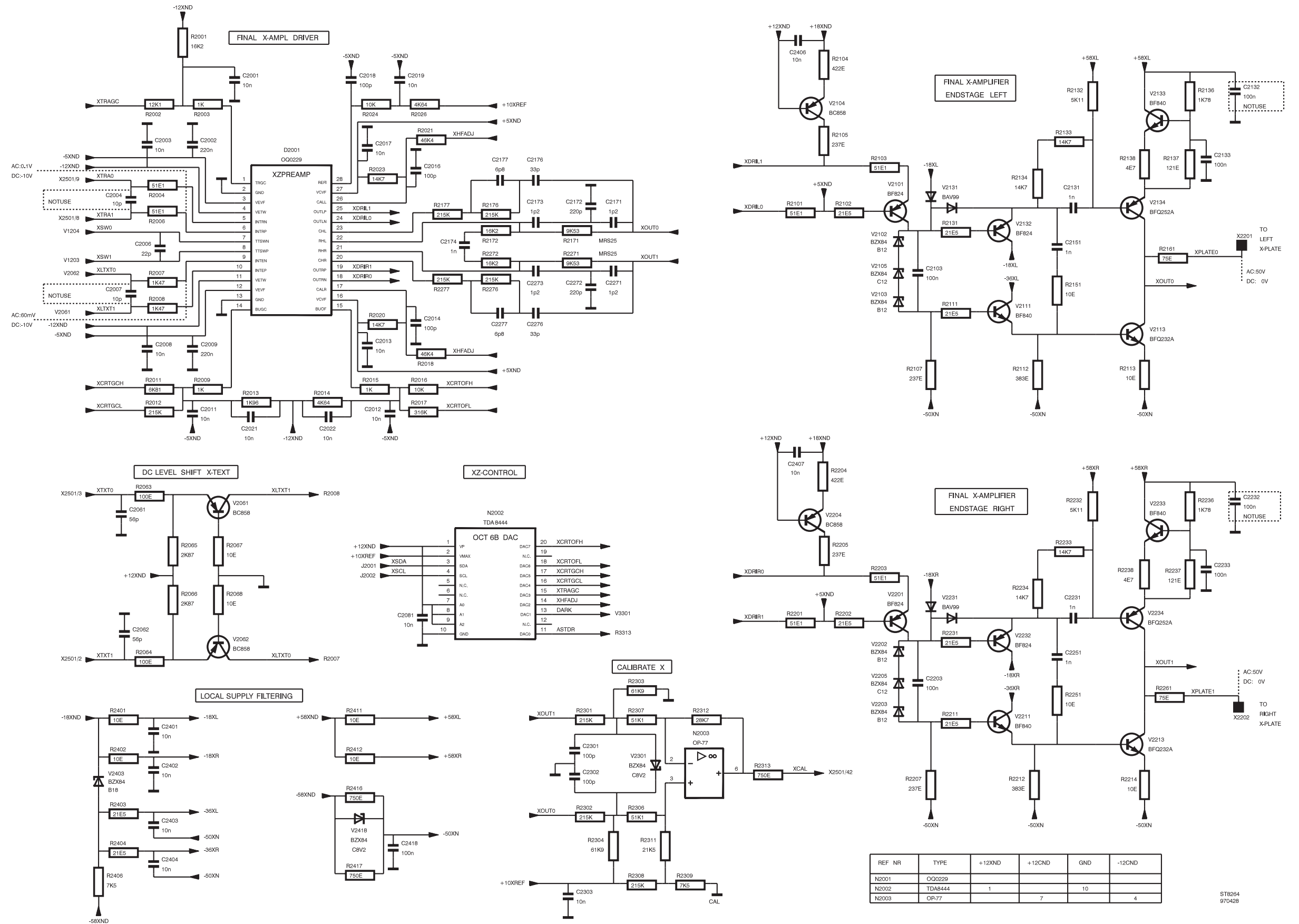

REF NR	TYPE	+12XND	+12CND	GND	-12CND
N2001	OQ0229				
N2002	TDA8444	1		10	4
N2003	OP-77		7		

STR254
970428

A2 (200 MHz) - Diagram 3 ; Final X amplifier and control

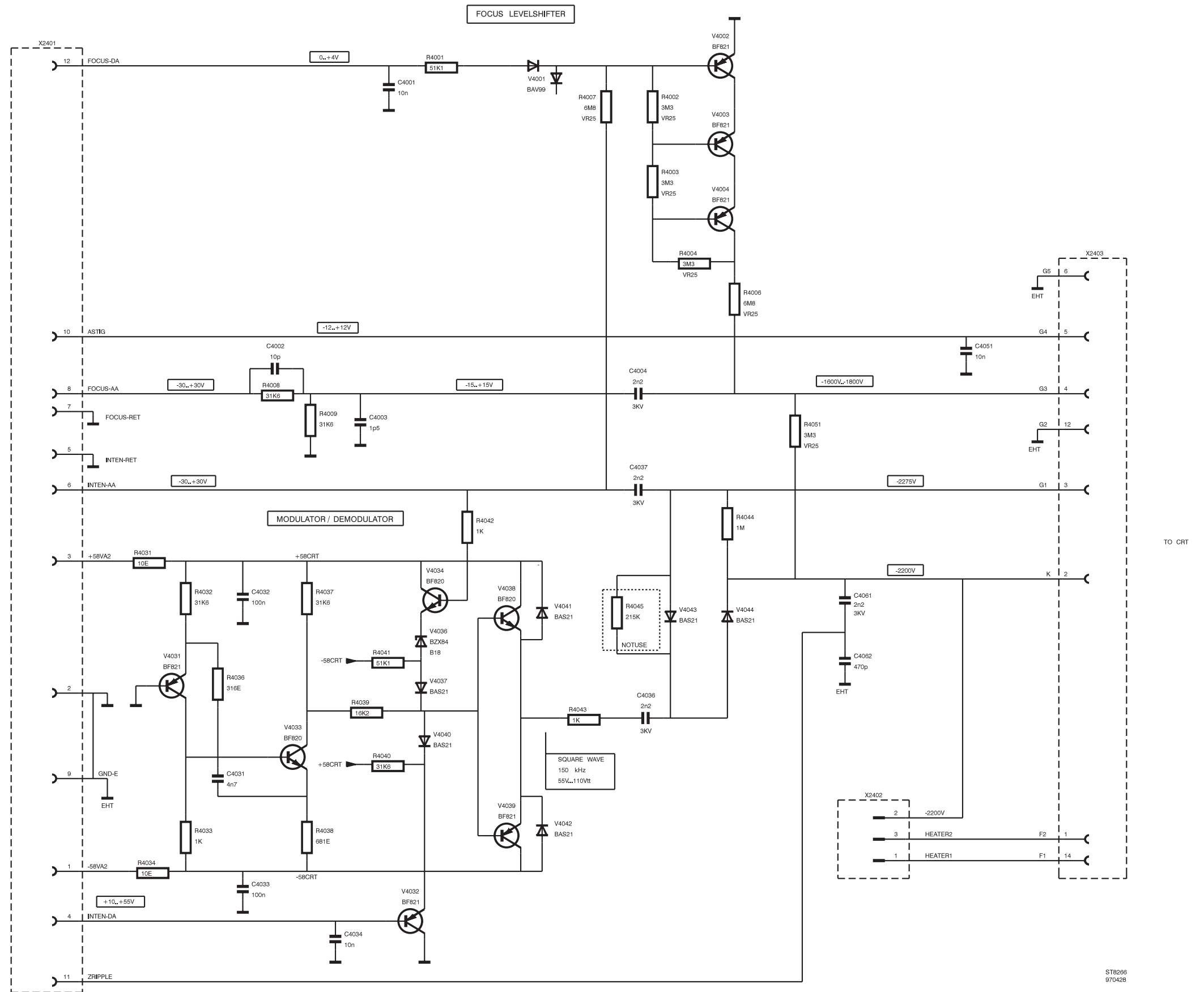

ST8266
970428

A2 (200 MHz) - Diagram 5 ; Modulator/demodulator and focus control

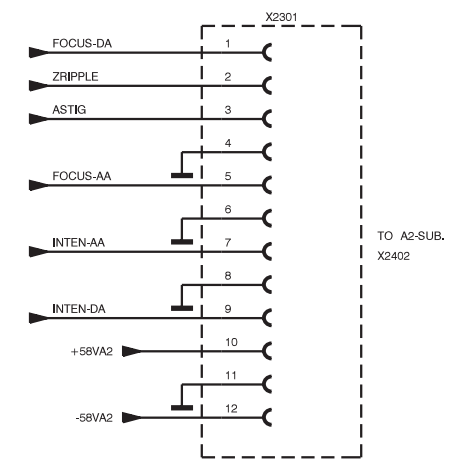
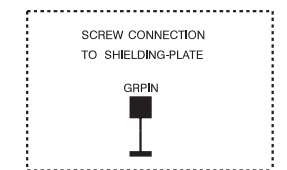
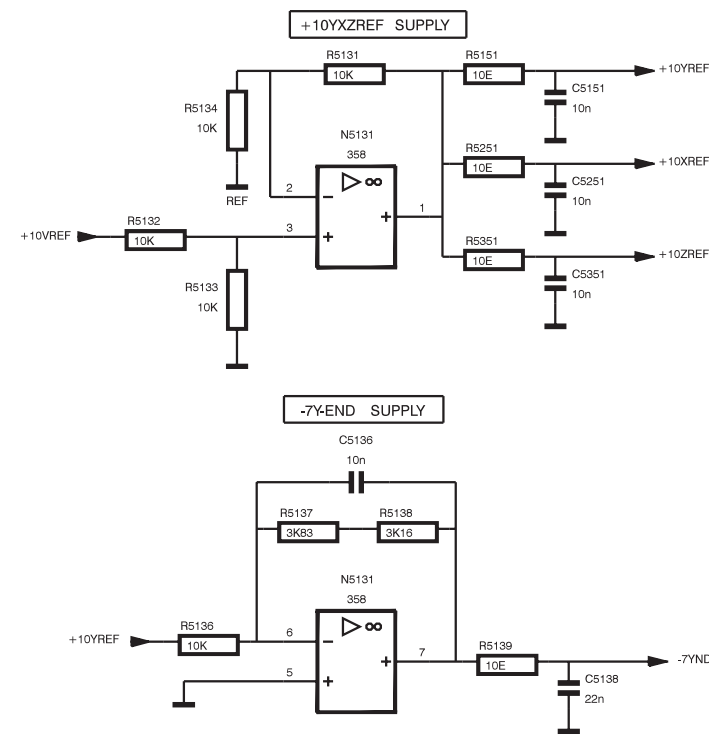
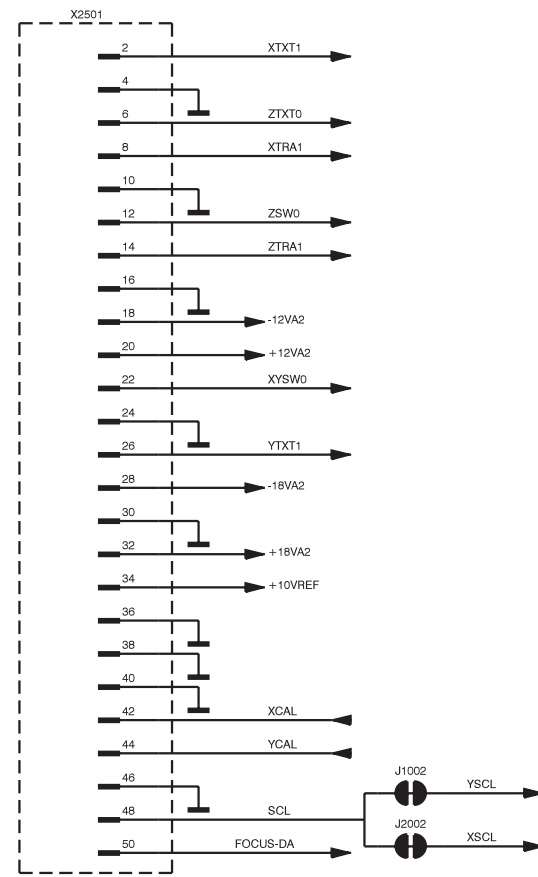
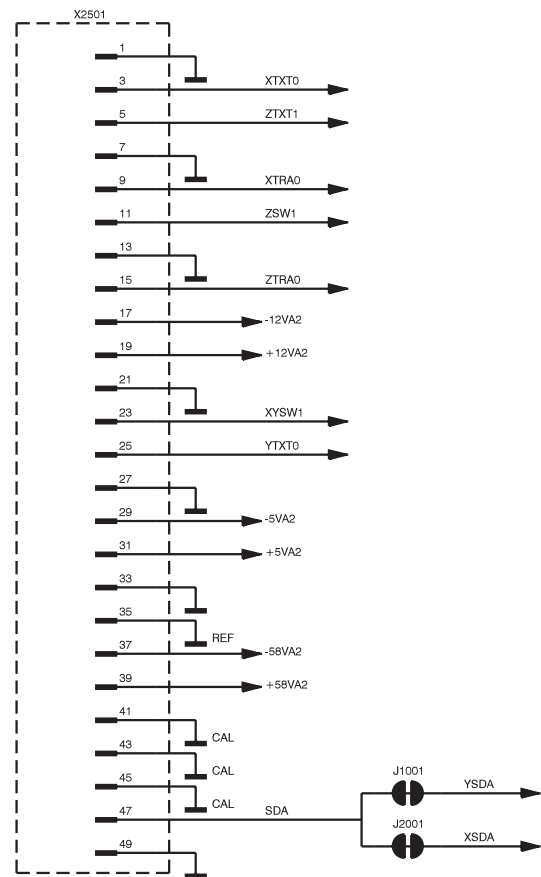
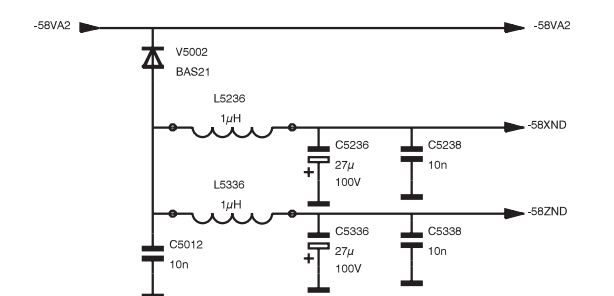
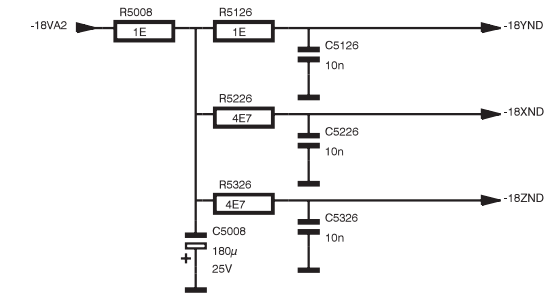
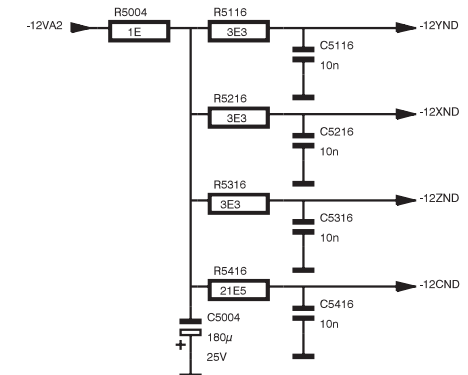
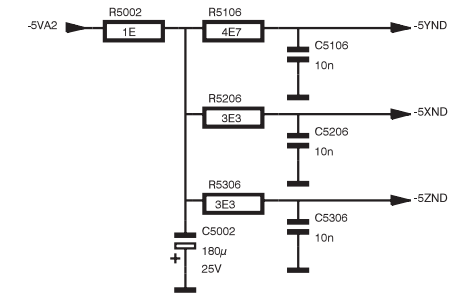
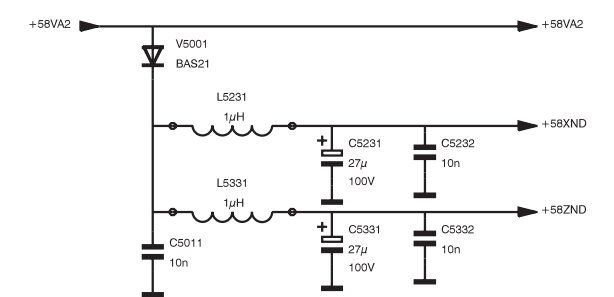
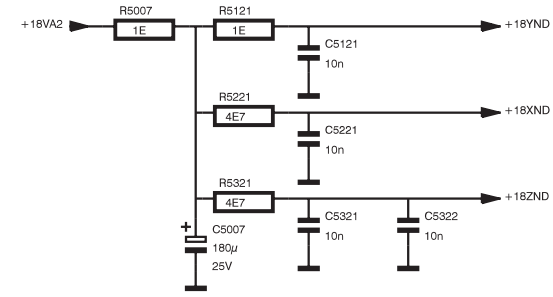
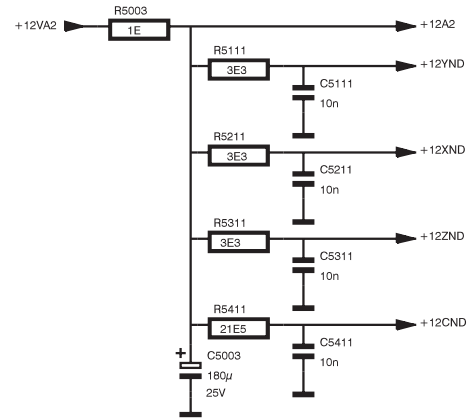
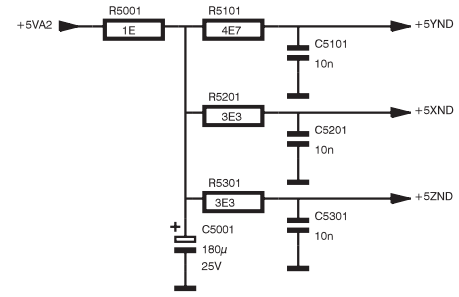

REF NR	TYPE	-12YND	+18YND
N5131	LM358	4	8

ST8267
970428

A2 (200 MHz) - Diagram 6 ; Supply circuits

Item	Description	Ordering code
------	-------------	---------------

5.2.6 Parts list A2-200 MHz version

MECHANICAL

0001	CABLE,CONNECT.	ASSY CABLE CRT	5322 321 62202
0003	CABLE,CONNECT.	ASSY CABLE CRT	5322 321 62198
0004	CABLE,CONNECT.	ASSY CABLE CRT	5322 321 62199

CAPACITORS

C1001	CAP.CHIP	AP 63V 10% 10NF	5322 122 34098
C1002	CAP.CHIP	AP 63V 10% 10NF	5322 122 34098
C1003	CAP.CERAMIC	AP 63V 0.25PF 3.9PF	5322 122 31944
C1005	CAP.CHIP	AP 63V 5% 470PF	5322 122 32268
C1006	CAP.CHIP	AP 63V 5% 150PF	5322 122 33538
C1007	CAP.CERAMIC	AP 63V 5% 10PF	5322 122 32448
C1008	CAP.CHIP	AP 63V 10% 100NF	4822 122 33496
C1009	CAP.CHIP	AP 63V 0.5PF 6.8PF	5322 122 32269
C1011	CAP.CHIP	AP 63V 5% 56PF	5322 122 32661
C1012	CAP.CHIP	AP 63V 10% 100NF	4822 122 33496
C1013	CAP.CHIP	AP 63V 10% 100NF	4822 122 33496
C1014	CAP.CHIP	AP 63V 10% 10NF	5322 122 34098
C1016	CAP.CHIP	AP 63V 10% 10NF	5322 122 34098
C1018	CAP.CHIP	AP 63V 10% 10NF	5322 122 34098
C1019	CAP.CHIP	AP 63V 10% 10NF	5322 122 34098
C1021	CAP.CHIP	AP 63V 0.25PF 2.2PF	5322 122 33063
C1022	CAP.CHIP	AP 63V 0.25PF 2.2PF	5322 122 33063
C1023	CAP.CHIP	AP 63V 5% 56PF	5322 122 32661
C1024	CAP.CHIP	AP 63V 5% 56PF	5322 122 32661
C1025	CAP.CHIP	AP 63V 5% 56PF	5322 122 32661
C1026	CAP.CHIP	AP 63V 5% 100PF	5322 122 32531
C1027	CAP.CHIP	AP 63V 5% 100PF	5322 122 32531
C1029	CAP.CHIP	AP 63V 10% 10NF	5322 122 34098
C1101	CAP.CERAMIC	AP 63V 0.25PF 3.9PF	5322 122 31944
C1102	CAP.CERAMIC	AP 63V 0.25PF 3.9PF	5322 122 31944
C1103	CAP.CHIP	AP 63V 0.25PF 0.68PF	4822 126 12342
C1104	CAP.CHIP	AP 63V 0.25PF 0.68PF	4822 126 12342
C1106	CAP.CHIP	AP 63V 10% 22NF	5322 122 32654
C1107	CAP.CHIP	AP 63V 10% 22NF	5322 122 32654
C1108	CAP.CHIP	AP 63V 10% 100NF	4822 122 33496
C1109	CAP.CHIP	AP 63V 10% 100NF	4822 122 33496
C1110	CAP.CHIP	AP 63V 0.25PF 1.8PF	5322 126 10343
C1111	CAP.CHIP	AP 63V 10% 10NF	5322 122 34098
C1112	CAP.CHIP	AP 63V 10% 100NF	4822 122 33496
C1113	CAP.CHIP	AP 63V 10% 100NF	4822 122 33496
C1114	CAP.CHIP	AP 63V 5% 470PF	5322 122 32268
C1121	CAP.CERAMIC	AP 63V 5% 10PF	5322 122 32448
C1122	CAP.CERAMIC	AP 63V 5% 10PF	5322 122 32448
C1123	CAP.CHIP	AP 63V 10% 100NF	4822 122 33496
C1301	CAP.CHIP	AP 63V 5% 220PF	4822 122 33575

Item	Description		Ordering code
C1302	CAP.CHIP	AP 63V 5% 220PF	4822 122 33575
C2001	CAP.CHIP	AP 63V 10% 10NF	5322 122 34098
C2002	CAP.CHIP	AP 63V 10% 220NF	4822 122 32916
C2003	CAP.CHIP	AP 63V 10% 10NF	5322 122 34098
C2004	CAP.CERAMIC	AP 63V 5% 10PF	5322 122 32448
C2006	CAP.CHIP	AP 63V 5% 22PF	5322 122 32658
C2007	CAP.CERAMIC	AP 63V 5% 10PF	5322 122 32448
C2008	CAP.CHIP	AP 63V 10% 10NF	5322 122 34098
C2009	CAP.CHIP	AP 63V 10% 220NF	4822 122 32916
C2011	CAP.CHIP	AP 63V 10% 10NF	5322 122 34098
C2012	CAP.CHIP	AP 63V 10% 10NF	5322 122 34098
C2013	CAP.CHIP	AP 63V 10% 10NF	5322 122 34098
C2014	CAP.CHIP	AP 63V 5% 100PF	5322 122 32531
C2016	CAP.CHIP	AP 63V 5% 100PF	5322 122 32531
C2017	CAP.CHIP	AP 63V 10% 10NF	5322 122 34098
C2018	CAP.CHIP	AP 63V 5% 100PF	5322 122 32531
C2019	CAP.CHIP	AP 63V 10% 10NF	5322 122 34098
C2021	CAP.CHIP	AP 63V 10% 10NF	5322 122 34098
C2022	CAP.CHIP	AP 63V 10% 10NF	5322 122 34098
C2061	CAP.CHIP	AP 63V 5% 56PF	5322 122 32661
C2062	CAP.CHIP	AP 63V 5% 56PF	5322 122 32661
C2081	CAP.CHIP	AP 63V 10% 10NF	5322 122 34098
C2103	CAP.CHIP	AP 63V 10% 100NF	4822 122 33496
C2131	CAP.CHIP	AP 63V 5% 1NF	5322 126 10511
C2132	CAP.CHIP	AP 63V 10% 100NF	4822 122 33496
C2133	CAP.CHIP	AP 63V 10% 100NF	4822 122 33496
C2151	CAP.CHIP	AP 63V 5% 1NF	5322 126 10511
C2171	CAP.CHIP	AP 63V 0.25PF 1.2PF	5322 122 33537
C2172	CAP.CHIP	AP 63V 5% 220PF	4822 122 33575
C2173	CAP.CHIP	AP 63V 0.25PF 1.2PF	5322 122 33537
C2174	CAP.CHIP	AP 63V 5% 1NF	5322 126 10511
C2176	CAP.CHIP	AP 63V 5% 33PF	5322 122 32659
C2177	CAP.CHIP	AP 63V 0.5PF 6.8PF	5322 122 32269
C2203	CAP.CHIP	AP 63V 10% 100NF	4822 122 33496
C2231	CAP.CHIP	AP 63V 5% 1NF	5322 126 10511
C2232	CAP.CHIP	AP 63V 10% 100NF	4822 122 33496
C2233	CAP.CHIP	AP 63V 10% 100NF	4822 122 33496
C2251	CAP.CHIP	AP 63V 5% 1NF	5322 126 10511
C2271	CAP.CHIP	AP 63V 0.25PF 1.2PF	5322 122 33537
C2272	CAP.CHIP	AP 63V 5% 220PF	4822 122 33575
C2273	CAP.CHIP	AP 63V 0.25PF 1.2PF	5322 122 33537
C2276	CAP.CHIP	AP 63V 5% 33PF	5322 122 32659
C2277	CAP.CHIP	AP 63V 0.5PF 6.8PF	5322 122 32269
C2301	CAP.CHIP	AP 63V 5% 100PF	5322 122 32531
C2302	CAP.CHIP	AP 63V 5% 100PF	5322 122 32531
C2303	CAP.CHIP	AP 63V 10% 10NF	5322 122 34098
C2401	CAP.CHIP	AP 63V 10% 10NF	5322 122 34098

Item	Description		Ordering code
C2402	CAP.CHIP	AP 63V 10% 10NF	5322 122 34098
C2403	CAP.CHIP	AP 63V 10% 10NF	5322 122 34098
C2404	CAP.CHIP	AP 63V 10% 10NF	5322 122 34098
C2406	CAP.CHIP	AP 63V 10% 10NF	5322 122 34098
C2407	CAP.CHIP	AP 63V 10% 10NF	5322 122 34098
C2418	CAP.CHIP	AP 63V 10% 100NF	4822 122 33496
C3001	CAP.CHIP	AP 63V 10% 10NF	5322 122 34098
C3002	CAP.CHIP	AP 63V 10% 220NF	4822 122 32916
C3003	CAP.CHIP	AP 63V 10% 10NF	5322 122 34098
C3004	CAP.CERAMIC	AP 63V 5% 10PF	5322 122 32448
C3006	CAP.CHIP	AP 63V 5% 22PF	5322 122 32658
C3007	CAP.CHIP	AP 63V 5% 22PF	5322 122 32658
C3008	CAP.CHIP	AP 63V 10% 10NF	5322 122 34098
C3009	CAP.CHIP	AP 63V 10% 220NF	4822 122 32916
C3011	CAP.CHIP	AP 63V 10% 10NF	5322 122 34098
C3013	CAP.CHIP	AP 63V 10% 10NF	5322 122 34098
C3014	CAP.CHIP	AP 63V 5% 100PF	5322 122 32531
C3016	CAP.CHIP	AP 63V 5% 100PF	5322 122 32531
C3017	CAP.CHIP	AP 63V 10% 10NF	5322 122 34098
C3018	CAP.CHIP	AP 63V 5% 100PF	5322 122 32531
C3019	CAP.CHIP	AP 63V 10% 10NF	5322 122 34098
C3021	CAP.CHIP	AP 63V 10% 10NF	5322 122 34098
C3061	CAP.CERAMIC	AP 63V 5% 10PF	5322 122 32448
C3103	CAP.CHIP	AP 63V 10% 100NF	4822 122 33496
C3131	CAP.CHIP	AP 63V 5% 1NF	5322 126 10511
C3132	CAP.CHIP	AP 63V 10% 100NF	4822 122 33496
C3133	CAP.CHIP	AP 63V 10% 100NF	4822 122 33496
C3151	CAP.CHIP	AP 63V 5% 1NF	5322 126 10511
C3171	CAP.CHIP	AP 63V 0.25PF 2.2PF	5322 122 33063
C3172	CAP.CHIP	AP 63V 5% 220PF	4822 122 33575
C3173	CAP.CHIP	AP 63V 0.25PF 2.2PF	5322 122 33063
C3176	CAP.CHIP	AP 63V 0.25PF 2.2PF	5322 122 33063
C3203	CAP.CHIP	AP 63V 10% 100NF	4822 122 33496
C3231	CAP.CHIP	AP 63V 5% 1NF	5322 126 10511
C3232	CAP.CHIP	AP 63V 10% 100NF	4822 122 33496
C3233	CAP.CHIP	AP 63V 10% 100NF	4822 122 33496
C3251	CAP.CHIP	AP 63V 5% 1NF	5322 126 10511
C3271	CAP.CHIP	AP 63V 0.25PF 2.2PF	5322 122 33063
C3272	CAP.CHIP	AP 63V 5% 220PF	4822 122 33575
C3273	CAP.CHIP	AP 63V 0.25PF 2.2PF	5322 122 33063
C3276	CAP.CHIP	AP 63V 0.25PF 2.2PF	5322 122 33063
C3281	CAP.FOIL	25V 20% 470UF	5322 121 43885
C3401	CAP.CHIP	AP 63V 10% 10NF	5322 122 34098
C3402	CAP.CHIP	AP 63V 10% 10NF	5322 122 34098
C3403	CAP.CHIP	AP 63V 10% 10NF	5322 122 34098
C3404	CAP.CHIP	AP 63V 10% 10NF	5322 122 34098
C3406	CAP.CHIP	AP 63V 10% 10NF	5322 122 34098

Item	Description		Ordering code
C3407	CAP.CHIP	AP 63V 10% 10NF	5322 122 34098
C3418	CAP.CHIP	AP 63V 10% 100NF	4822 122 33496
C4001	CAP.CHIP	AP 63V 10% 10NF	5322 122 34098
C4002	CAP.CERAMIC	AP 63V 5% 10PF	5322 122 32448
C4003	CAP.CHIP	AP 63V 0.25PF 1.5PF	5322 126 10225
C4004	CAP.	-10+10% 2.2NF	5322 122 33851
C4031	CAP.CHIP	AP 63V 10% 4.7NF	5322 126 10223
C4032	CAP.CHIP	AP 63V 10% 100NF	4822 122 33496
C4033	CAP.CHIP	AP 63V 10% 100NF	4822 122 33496
C4034	CAP.CHIP	AP 63V 10% 10NF	5322 122 34098
C4036	CAP.	-10+10% 2.2NF	5322 122 33851
C4037	CAP.	-10+10% 2.2NF	5322 122 33851
C4051	CAP.CHIP	AP 63V 10% 10NF	5322 122 34098
C4061	CAP.	-10+10% 2.2NF	5322 122 33851
C4062	CAP.CHIP	AP 63V 5% 470PF	5322 122 32268
C5001	CAP.ELECTROLYT.	25V 20% 180UF	5322 124 42228
C5002	CAP.ELECTROLYT.	25V 20% 180UF	5322 124 42228
C5003	CAP.ELECTROLYT.	25V 20% 180UF	5322 124 42228
C5004	CAP.ELECTROLYT.	25V 20% 180UF	5322 124 42228
C5007	CAP.ELECTROLYT.	25V 20% 180UF	5322 124 42228
C5008	CAP.ELECTROLYT.	25V 20% 180UF	5322 124 42228
C5011	CAP.CHIP	AP 63V 10% 10NF	5322 122 34098
C5012	CAP.CHIP	AP 63V 10% 10NF	5322 122 34098
C5101	CAP.CHIP	AP 63V 10% 10NF	5322 122 34098
C5106	CAP.CHIP	AP 63V 10% 10NF	5322 122 34098
C5111	CAP.CHIP	AP 63V 10% 10NF	5322 122 34098
C5116	CAP.CHIP	AP 63V 10% 10NF	5322 122 34098
C5121	CAP.CHIP	AP 63V 10% 10NF	5322 122 34098
C5126	CAP.CHIP	AP 63V 10% 10NF	5322 122 34098
C5136	CAP.CHIP	AP 63V 10% 10NF	5322 122 34098
C5138	CAP.CHIP	AP 63V 10% 22NF	5322 122 32654
C5151	CAP.CHIP	AP 63V 10% 10NF	5322 122 34098
C5201	CAP.CHIP	AP 63V 10% 10NF	5322 122 34098
C5206	CAP.CHIP	AP 63V 10% 10NF	5322 122 34098
C5211	CAP.CHIP	AP 63V 10% 10NF	5322 122 34098
C5216	CAP.CHIP	AP 63V 10% 10NF	5322 122 34098
C5221	CAP.CHIP	AP 63V 10% 10NF	5322 122 34098
C5226	CAP.CHIP	AP 63V 10% 10NF	5322 122 34098
C5231	CAP.ELECTROLYT.	100V 20% 27UF	5322 124 42193
C5232	CAP.CHIP	AP 63V 10% 10NF	5322 122 34098
C5236	CAP.ELECTROLYT.	100V 20% 27UF	5322 124 42193
C5238	CAP.CHIP	AP 63V 10% 10NF	5322 122 34098
C5251	CAP.CHIP	AP 63V 10% 10NF	5322 122 34098
C5301	CAP.CHIP	AP 63V 10% 10NF	5322 122 34098
C5306	CAP.CHIP	AP 63V 10% 10NF	5322 122 34098
C5311	CAP.CHIP	AP 63V 10% 10NF	5322 122 34098
C5316	CAP.CHIP	AP 63V 10% 10NF	5322 122 34098

Item	Description		Ordering code
C5321	CAP.CHIP	AP 63V 10% 10NF	5322 122 34098
C5322	CAP.CHIP	AP 63V 10% 10NF	5322 122 34098
C5326	CAP.CHIP	AP 63V 10% 10NF	5322 122 34098
C5331	CAP.ELECTROLYT.	100V 20% 27UF	5322 124 42193
C5332	CAP.CHIP	AP 63V 10% 10NF	5322 122 34098
C5336	CAP.ELECTROLYT.	100V 20% 27UF	5322 124 42193
C5338	CAP.CHIP	AP 63V 10% 10NF	5322 122 34098
C5351	CAP.CHIP	AP 63V 10% 10NF	5322 122 34098
C5411	CAP.CHIP	AP 63V 10% 10NF	5322 122 34098
C5416	CAP.CHIP	AP 63V 10% 10NF	5322 122 34098

INTEGRATED CIRCUITS

D1001	INTEGR.CIRCUIT	OQ0230 FINAL Y AMPL	5322 209 12467
D2001	INTEGR.CIRCUIT	OQ0229 FINAL X-Z AMP	5322 209 12459
D3001	INTEGR.CIRCUIT	OQ0229 FINAL X-Z AMP	5322 209 12459
N1001	INTEGR.CIRCUIT	TDA8444AT/N4 PEL	5322 209 30233
N1002	INTEGR.CIRCUIT	LM358M NSC	4822 209 60175
N1003	INTEGR.CIRCUIT	LM324D NSC	5322 209 83125
N1004	I.C. ANALOGUE	OP-77GSR PMI	5322 130 62791
N2002	INTEGR.CIRCUIT	TDA8444AT/N4 PEL	5322 209 30233
N2003	I.C. ANALOGUE	OP-77GSR PMI	5322 130 62791
N5131	INTEGR.CIRCUIT	LM358M NSC	4822 209 60175

COILS

L1101	COIL	0.082UH 5% TDK	5322 157 63382
L1102	COIL	0.082UH 5% TDK	5322 157 63382
L1103	COIL	0.27UH 5% TDK	5322 157 70204
L1107	COIL	0.027UH	5322 157 70857
L1108	COIL	0.027UH	5322 157 70857
L5231	COIL	1UH 5% TDK	5322 157 63648
L5236	COIL	1UH 5% TDK	5322 157 63648
L5331	COIL	1UH 5% TDK	5322 157 63648
L5336	COIL	1UH 5% TDK	5322 157 63648

RESISTORS

R1001	RES.METAL FILM	HIP RC-02H 1% 215K	5322 117 10543
R1002	RES.CHIP	HIP RC-02H 1% 100K	4822 051 10104
R1003	RES.METAL FILM	HIP RC-02H 1% 215K	5322 117 10543
R1004	RES.CHIP	HIP RC-02H 1% 100K	4822 051 10104
R1005	RES.CHIP	RMC1/8 1% 28E7	5322 111 92015
R1006	RES.METAL FILM	HIP RC-02H 1% 1K96	5322 117 10539
R1007	RES.CHIP	HIP RC-02H 1% 100K	4822 051 10104
R1008	RES.CHIP	HIP RC-02H 1% 100K	4822 051 10104
R1009	RES.METAL FILM	HIP RC-02H 1% 215K	5322 117 10543
R1010	RES.CHIP	HIP RC-02H 1% 1K	4822 051 10102
R1011	RES.METAL FILM	HIP RC-02H 1% 215K	5322 117 10543
R1012	RES.METAL FILM	HIP RC-02H 1% 215K	5322 117 10543
R1013	RES.METAL FILM	HIP RC-02H 1% 215K	5322 117 10543

Item	Description		Ordering code
R1014	RES.CHIP	HIP RC-02H 1% 261E	4822 051 52611
R1015	RES.CHIP	HIP RC-02H 1% 4K64	4822 051 54642
R1016	RES.CHIP	RMC1/8 1% 31E6	5322 117 11732
R1017	RES.CHIP	HIP RC-02H 1% 1K1	4822 051 51102
R1018	RES.MET.GLAZED	RMC1/8 1% 46E4	5322 116 82896
R1019	RES.MET.GLAZED	RMC1/8 1% 46E4	5322 116 82896
R1020	RES.CHIP	HIP RC-02H 1% 4K64	4822 051 54642
R1021	RES.CHIP	HIP RC-02H 1% 1K1	4822 051 51102
R1022	RES.CHIP	RMC1/8 1% 31E6	5322 117 11732
R1023	RES.CHIP	HIP RC-02H 1% 261E	4822 051 52611
R1024	RES.METAL FILM	HIP RC-02H 1% 121E	5322 117 10519
R1026	RES.METAL FILM	HIP RC-02H 1% 121E	5322 117 10519
R1027	RES.METAL FILM	HIP RC-02H 1% 121E	5322 117 10519
R1028	RES.METAL FILM	HIP RC-02H 1% 121E	5322 117 10519
R1029	RES.METAL FILM	HIP RC-02H 1% 178E	5322 117 10534
R1031	RES.METAL FILM	HIP RC-02H 1% 178E	5322 117 10534
R1032	RES.METAL FILM	HIP RC-02H 1% 2K37	5322 117 10545
R1034	RES.CHIP	HIP RC-02H 1% 100K	4822 051 10104
R1036	RES.METAL FILM	HIP RC-02H 1% 6K81	5322 117 10581
R1037	RES.CHIP	HIP RC-02H 1% 261E	4822 051 52611
R1038	RES.CHIP	HIP RC-02H 1% 261E	4822 051 52611
R1039	RES.METAL FILM	HIP RC-02H 1% 147E	5322 117 10526
R1041	RES.METAL FILM	HIP RC-02H 1% 19K6	5322 117 10541
R1042	RES.METAL FILM	HIP RC-02H 1% 19K6	5322 117 10541
R1043	RES.CHIP	HIP RC-02H 1% 5K11	5322 117 10487
R1044	RES.METAL FILM	HIP RC-02H 1% 162K	5322 117 10533
R1046	RES.METAL FILM	HIP RC-02H 1% 21K5	5322 117 10542
R1047	RES.METAL FILM	HIP RC-02H 1% 21K5	5322 117 10542
R1048	RES.CHIP	HIP RC-02H 1% 11K	4822 051 10113
R1049	RES.METAL FILM	HIP RC-02H 1% 28K7	5322 117 10551
R1051	RES.METAL FILM	HIP RC-02H 1% 23K7	5322 117 10546
R1052	RES.METAL FILM	HIP RC-02H 1% 34K8	5322 117 10558
R1053	RES.CHIP	HIP RC-02H 1% 10K	4822 051 10103
R1059	RES.CHIP	HIP RC-01 5% 1E	4822 051 10108
R1061	RES.CHIP	HIP RC-01 5% 1E	4822 051 10108
R1063	RES.METAL FILM	HIP RC-02H 1% 3K83	5322 117 10561
R1064	RES.CHIP	HIP RC-02H 1% 100E	4822 051 10101
R1066	RES.CHIP	HIP RC-02H 1% 1K	4822 051 10102
R1071	RES.METAL FILM	HIP RC-02H 1% 3K83	5322 117 10561
R1072	RES.CHIP	HIP RC-02H 1% 90E9	5322 117 12557
R1073	RES.CHIP	HIP RC-02H 1% 100E	4822 051 10101
R1074	RES.METAL FILM	HIP RC-02H 1% 681E	5322 117 10579
R1076	RES.METAL FILM	HIP RC-02H 1% 3K83	5322 117 10561
R1077	RES.CHIP	HIP RC-02H 1% 5K11	5322 117 10487
R1078	RES.CHIP	RMC1/8 1% 51E1	5322 111 91893
R1079	RES.CHIP	RMC1/8 1% 51E1	5322 111 91893
R1081	RES.METAL FILM	HIP RC-02H 1% 464E	5322 117 10567

Item	Description		Ordering code
R1082	RES.CHIP	HIP RC-02H 1% 10K	4822 051 10103
R1083	RES.CHIP	HIP RC-02H 1% 10K	4822 051 10103
R1084	RES.METAL FILM	HIP RC-02H 1% 147E	5322 117 10526
R1086	RES.METAL FILM	HIP RC-02H 1% 147E	5322 117 10526
R1101	RES.CHIP	HIP RC-02H 1% 5K11	5322 117 10487
R1102	RES.CHIP	HIP RC-02H 1% 5K11	5322 117 10487
R1103	RES.CHIP	HIP RC-01 5% 3E3	4822 051 10338
R1104	RES.CHIP	HIP RC-01 5% 1E	4822 051 10108
R1105	RES.CHIP	HIP RC-01 5% 1E	4822 051 10108
R1106	RES.METAL FILM	HIP RC-02H 1% 316E	5322 117 10552
R1107	RES.METAL FILM	HIP RC-02H 1% 316E	5322 117 10552
R1108	RES.CHIP	RMC1/8 1% 75E	4822 111 91937
R1109	RES.CHIP	RMC1/8 1% 75E	4822 111 91937
R1111	RES.CHIP	HIP RC-01 5% 14E7	5322 117 12555
R1112	RES.CHIP	HIP RC-01 5% 14E7	5322 117 12555
R1113	RES.METAL FILM	HIP RC-02H 1% 121E	5322 117 10519
R1114	RES.METAL FILM	HIP RC-02H 1% 121E	5322 117 10519
R1116	RES.CHIP	HIP RC-02H 1% 287E	4822 051 52871
R1117	RES.CHIP	HIP RC-02H 1% 287E	4822 051 52871
R1118	RES.CHIP	RMC1/8 1% 10E	4822 111 91885
R1121	RES.CHIP	HIP RC-01 5% 4E7	4822 051 10478
R1122	RES.CHIP	HIP RC-01 5% 4E7	4822 051 10478
R1123	RES.CHIP	HIP RC-01 5% 1E	4822 051 10108
R1124	RES.CHIP	HIP RC-01 5% 1E	4822 051 10108
R1126	RES.METAL FILM	HIP RC-02H 1% 1K33	5322 117 10524
R1127	RES.METAL FILM	HIP RC-02H 1% 1K33	5322 117 10524
R1128	RES.METAL FILM	ST MRS25 1% 34E8	4822 050 23489
R1129	RES.METAL FILM	ST MRS25 1% 34E8	4822 050 23489
R1131	RES.METAL FILM	ST MRS25 1% 34E8	4822 050 23489
R1132	RES.METAL FILM	ST MRS25 1% 34E8	4822 050 23489
R1133	RES.METAL FILM	ST MRS25 1% 34E8	4822 050 23489
R1134	RES.METAL FILM	ST MRS25 1% 34E8	4822 050 23489
R1136	RES.METAL FILM	ST MRS25 1% 34E8	4822 050 23489
R1137	RES.METAL FILM	ST MRS25 1% 34E8	4822 050 23489
R1138	RES.CHIP	RMC1/8 1% 10E	4822 111 91885
R1139	RES.CHIP	RMC1/8 1% 10E	4822 111 91885
R1140	RES.METAL FILM	HIP RC-02H 1% 316K	5322 117 10555
R1141	RES.METAL FILM	ST MRS25 1% 1K47	4822 050 21472
R1142	RES.METAL FILM	ST MRS25 1% 1K47	4822 050 21472
R1143	RES.CHIP	HIP RC-01 5% 14E7	5322 117 12555
R1144	RES.CHIP	HIP RC-01 5% 41E7	5322 117 12555
R1145	RES.METAL FILM	HIP RC-02H 1% 316K	5322 117 10555
R1146	RES.METAL FILM	HIP RC-02H 1% 215K	5322 117 10543
R1147	RES.METAL FILM	HIP RC-02H 1% 215K	5322 117 10543
R1148	RES.METAL FILM	HIP RC-02H 1% 619E	5322 117 10576
R1149	RES.METAL FILM	HIP RC-02H 1% 619E	5322 117 10576
R1151	RES.CHIP	HIP RC-02H 1% 215E	5322 117 10484

Item	Description		Ordering code
R1152	RES.CHIP	RMC1/8 1% 28E7	5322 111 92015
R1153	RES.CHIP	RMC1/8 1% 28E7	5322 111 92015
R1154	RES.CHIP	HIP RC-01 5% 4E7	4822 051 10478
R1155	RES.METAL FILM	HIP RC-02H 1% 511E	5322 117 10569
R1156	RES.METAL FILM	HIP RC-02H 1% 1K78	5322 117 10535
R1157	RES.METAL FILM	HIP RC-02H 1% 383E	5322 117 10559
R1158	RES.CHIP	HIP RC-02H 1% 10K	4822 051 10103
R1159	RES.CHIP	HIP RC-02H 1% 10K	4822 051 10103
R1161	RES.CHIP	HIP RC-02H 1% 10K	4822 051 10103
R1162	RES.CHIP	RMC1/8 1% 28E7	5322 111 92015
R1163	RES.CHIP	RMC1/8 1% 28E7	5322 111 92015
R1164	RES.METAL FILM	HIP RC-02H 1% 909E	5322 117 10588
R1166	RES.METAL FILM	HIP RC-02H 1% 3K16	5322 117 10553
R1167	RES.CHIP	HIP RC-02H 1% 10K	4822 051 10103
R1168	RES.CHIP	HIP RC-02H 1% 10K	4822 051 10103
R1169	RES.CHIP	HIP RC-01 5% 1E	4822 051 10108
R1170	RES.METAL FILM	HIP RC-02H 1% 383E	5322 117 10559
R1171	RES.METAL FILM	HIP RC-02H 1% 215K	5322 117 10543
R1172	RES.METAL FILM	HIP RC-02H 1% 215K	5322 117 10543
R1173	RES.METAL FILM	HIP RC-02H 1% 215K	5322 117 10543
R1174	RES.METAL FILM	HIP RC-02H 1% 215K	5322 117 10543
R1176	RES.CHIP	HIP RC-02H 1% 10K	4822 051 10103
R1177	RES.CHIP	HIP RC-02H 1% 10K	4822 051 10103
R1178	RES.METAL FILM	HIP RC-02H 1% 215K	5322 117 10543
R1179	RES.METAL FILM	HIP RC-02H 1% 215K	5322 117 10543
R1181	RES.METAL FILM	HIP RC-02H 1% 215K	5322 117 10543
R1182	RES.METAL FILM	HIP RC-02H 1% 215K	5322 117 10543
R1201	RES.CHIP	RMC1/8 1% 51E1	5322 111 91893
R1202	RES.CHIP	HIP RC-02H 1% 100K	4822 051 10104
R1203	RES.CHIP	HIP RC-02H 1% 100K	4822 051 10104
R1204	RES.CHIP	RMC1/8 1% 51E1	5322 111 91893
R1206	RES.METAL FILM	HIP RC-02H 1% 2K37	5322 117 10545
R1207	RES.METAL FILM	HIP RC-02H 1% 2K37	5322 117 10545
R1208	RES.METAL FILM	HIP RC-02H 1% 3K16	5322 117 10553
R1209	RES.METAL FILM	HIP RC-02H 1% 1K78	5322 117 10535
R1301	RES.CHIP	HIP RC-02H 1% 51K1	4822 051 55113
R1302	RES.CHIP	HIP RC-02H 1% 51K1	4822 051 55113
R1303	RES.METAL FILM	HIP RC-02H 1% 162K	5322 117 10533
R1304	RES.METAL FILM	HIP RC-02H 1% 162K	5322 117 10533
R1306	RES.CHIP	HIP RC-02H 1% 51K1	4822 051 55113
R1307	RES.CHIP	HIP RC-02H 1% 51K1	4822 051 55113
R1308	RES.METAL FILM	HIP RC-02H 1% 28K7	5322 117 10551
R1309	RES.METAL FILM	HIP RC-02H 1% 750E	5322 117 10582
R1311	RES.METAL FILM	HIP RC-02H 1% 21K5	5322 117 10542
R1312	RES.METAL FILM	HIP RC-02H 1% 215K	5322 117 10543
R1313	RES.METAL FILM	HIP RC-02H 1% 7K5	5322 117 10583
R2001	RES.METAL FILM	HIP RC-02H 1% 16K2	5322 117 10532

Item	Description		Ordering code
R2002	RES.METAL FILM	HIP RC-02H 1% 12K1	5322 117 10522
R2003	RES.CHIP	HIP RC-02H 1% 1K	4822 051 10102
R2004	RES.CHIP	RMC1/8 1% 51E1	5322 111 91893
R2006	RES.CHIP	RMC1/8 1% 51E1	5322 111 91893
R2007	RES.METAL FILM	HIP RC-02H 1% 1K47	5322 117 10527
R2008	RES.METAL FILM	HIP RC-02H 1% 1K47	5322 117 10527
R2009	RES.CHIP	HIP RC-02H 1% 1K	4822 051 10102
R2011	RES.METAL FILM	HIP RC-02H 1% 6K81	5322 117 10581
R2012	RES.METAL FILM	HIP RC-02H 1% 215K	5322 117 10543
R2013	RES.METAL FILM	HIP RC-02H 1% 1K96	5322 117 10539
R2014	RES.CHIP	HIP RC-02H 1% 4K64	4822 051 54642
R2015	RES.CHIP	HIP RC-02H 1% 1K	4822 051 10102
R2016	RES.CHIP	HIP RC-02H 1% 10K	4822 051 10103
R2017	RES.METAL FILM	HIP RC-02H 1% 316K	5322 117 10555
R2018	RES.CHIP	HIP RC-02H 1% 46K4	5322 117 10486
R2020	RES.METAL FILM	HIP RC-02H 1% 14K7	5322 117 10528
R2021	RES.CHIP	HIP RC-02H 1% 46K4	5322 117 10486
R2023	RES.METAL FILM	HIP RC-02H 1% 14K7	5322 117 10528
R2024	RES.CHIP	HIP RC-02H 1% 10K	4822 051 10103
R2026	RES.CHIP	HIP RC-02H 1% 4K64	4822 051 54642
R2063	RES.CHIP	HIP RC-02H 1% 100E	4822 051 10101
R2064	RES.CHIP	HIP RC-02H 1% 100E	4822 051 10101
R2065	RES.METAL FILM	HIP RC-02H 1% 2K87	5322 117 10549
R2066	RES.METAL FILM	HIP RC-02H 1% 2K87	5322 117 10549
R2067	RES.CHIP	RMC1/8 1% 10E	4822 111 91885
R2068	RES.CHIP	RMC1/8 1% 10E	4822 111 91885
R2101	RES.CHIP	RMC1/8 1% 51E1	5322 111 91893
R2102	RES.CHIP	RMC1/8 1% 21E5	5322 111 92014
R2103	RES.CHIP	RMC1/8 1% 51E1	5322 111 91893
R2104	RES.METAL FILM	RC-02H 1% 422E	5322 117 10564
R2105	RES.CHIP	RC-02H 1% 237E	5322 117 10544
R2107	RES.METAL FILM	RC-02H 1% 237E	5322 117 10544
R2111	RES.CHIP	RMC1/8 1% 21E5	5322 111 92014
R2112	RES.METAL FILM	RC-02H 1% 383E	5322 117 10559
R2113	RES.CHIP	RMC1/8 1% 10E	4822 111 91885
R2131	RES.CHIP	RMC1/8 1% 21E5	5322 111 92014
R2132	RES.CHIP	HIP RC-02H 1% 5K11	5322 117 10487
R2133	RES.METAL FILM	HIP RC-02H 1% 14K7	5322 117 10528
R2134	RES.METAL FILM	HIP RC-02H 1% 14K7	5322 117 10528
R2136	RES.METAL FILM	HIP RC-02H 1% 1K78	5322 117 10535
R2137	RES.METAL FILM	HIP RC-02H 1% 121E	5322 117 10519
R2138	RES.CHIP	HIP RC-01 5% 4E7	4822 051 10478
R2151	RES.CHIP	RMC1/8 1% 10E	4822 111 91885
R2161	RES.CHIP	RMC1/8 1% 75E	4822 111 91937
R2171	RES.METAL FILM	ST MRS25 1% 9K53	4822 050 29532
R2172	RES.METAL FILM	HIP RC-02H 1% 16K2	5322 117 10532
R2176	RES.METAL FILM	HIP RC-02H 1% 215K	5322 117 10543

Item	Description		Ordering code
R2177	RES.METAL FILM	HIP RC-02H 1% 215K	5322 117 10543
R2201	RES.CHIP	RMC1/8 1% 51E1	5322 111 91893
R2202	RES.CHIP	RMC1/8 1% 21E5	5322 111 92014
R2203	RES.CHIP	RMC1/8 1% 51E1	5322 111 91893
R2204	RES.METAL FILM	RC-02H 1% 422E	5322 117 10564
R2205	RES.CHIP	RC-02H 1% 237E	5322 117 10544
R2207	RES.METAL FILM	HIP RC-02H 1% 237E	5322 117 10544
R2211	RES.CHIP	RMC1/8 1% 21E5	5322 111 92014
R2212	RES.METAL FILM	HIP RC-02H 1% 383E	5322 117 10559
R2214	RES.CHIP	RMC1/8 1% 10E	4822 111 91885
R2231	RES.CHIP	RMC1/8 1% 21E5	5322 111 92014
R2232	RES.CHIP	HIP RC-02H 1% 5K11	5322 117 10487
R2233	RES.METAL FILM	HIP RC-02H 1% 14K7	5322 117 10528
R2234	RES.METAL FILM	HIP RC-02H 1% 14K7	5322 117 10528
R2236	RES.METAL FILM	HIP RC-02H 1% 1K78	5322 117 10535
R2237	RES.METAL FILM	HIP RC-02H 1% 121E	5322 117 10519
R2238	RES.CHIP	HIP RC-01 5% 4E7	4822 051 10478
R2251	RES.CHIP	RMC1/8 1% 10E	4822 111 91885
R2261	RES.CHIP	RMC1/8 1% 75E	4822 111 91937
R2271	RES.METAL FILM	ST MRS25 1% 9K53	4822 050 29532
R2272	RES.METAL FILM	HIP RC-02H 1% 16K2	5322 117 10532
R2276	RES.METAL FILM	HIP RC-02H 1% 215K	5322 117 10543
R2277	RES.METAL FILM	HIP RC-02H 1% 215K	5322 117 10543
R2301	RES.METAL FILM	HIP RC-02H 1% 215K	5322 117 10543
R2302	RES.METAL FILM	HIP RC-02H 1% 215K	5322 117 10543
R2303	RES.METAL FILM	HIP RC-02H 1% 61K9	5322 117 10578
R2304	RES.METAL FILM	HIP RC-02H 1% 61K9	5322 117 10578
R2306	RES.CHIP	HIP RC-02H 1% 51K1	4822 051 55113
R2307	RES.CHIP	HIP RC-02H 1% 51K1	4822 051 55113
R2308	RES.METAL FILM	HIP RC-02H 1% 215K	5322 117 10543
R2309	RES.METAL FILM	HIP RC-02H 1% 7K5	5322 117 10583
R2311	RES.METAL FILM	HIP RC-02H 1% 21K5	5322 117 10542
R2312	RES.METAL FILM	HIP RC-02H 1% 28K7	5322 117 10551
R2313	RES.METAL FILM	HIP RC-02H 1% 750E	5322 117 10582
R2401	RES.CHIP	RMC1/8 1% 10E	4822 111 91885
R2402	RES.CHIP	RMC1/8 1% 10E	4822 111 91885
R2403	RES.CHIP	RMC1/8 1% 21E5	5322 111 92014
R2404	RES.CHIP	RMC1/8 1% 21E5	5322 111 92014
R2406	RES.METAL FILM	HIP RC-02H 1% 7K5	5322 117 10583
R2411	RES.CHIP	RMC1/8 1% 10E	4822 111 91885
R2412	RES.CHIP	RMC1/8 1% 10E	4822 111 91885
R2416	RES.METAL FILM	HIP RC-02H 1% 750E	5322 117 10582
R2417	RES.METAL FILM	HIP RC-02H 1% 750E	5322 117 10582
R3001	RES.METAL FILM	HIP RC-02H 1% 19K6	5322 117 10541
R3002	RES.CHIP	HIP RC-02H 1% 11K	4822 051 10113
R3003	RES.CHIP	HIP RC-02H 1% 1K	4822 051 10102
R3004	RES.CHIP	HIP RC-02H 1% 100E	4822 051 10101

Item	Description		Ordering code
R3006	RES.CHIP	HIP RC-02H 1% 100E	4822 051 10101
R3007	RES.CHIP	HIP RC-02H 1% 100E	4822 051 10101
R3008	RES.CHIP	HIP RC-02H 1% 100E	4822 051 10101
R3009	RES.CHIP	HIP RC-02H 1% 1K	4822 051 10102
R3011	RES.CHIP	HIP RC-02H 1% 11K	4822 051 10113
R3012	RES.METAL FILM	HIP RC-02H 1% 19K6	5322 117 10541
R3013	RES.METAL FILM	HIP RC-02H 1% 5K62	5322 117 10573
R3014	RES.METAL FILM	HIP RC-02H 1% 21K5	5322 117 10542
R3015	RES.METAL FILM	HIP RC-02H 1% 28K7	5322 117 10551
R3018	RES.METAL FILM	HIP RC-02H 1% 19K6	5322 117 10541
R3021	RES.METAL FILM	HIP RC-02H 1% 19K6	5322 117 10541
R3024	RES.CHIP	HIP RC-02H 1% 10K	4822 051 10103
R3026	RES.CHIP	HIP RC-02H 1% 4K64	4822 051 54642
R3063	RES.CHIP	HIP RC-02H 1% 100E	4822 051 10101
R3064	RES.CHIP	HIP RC-02H 1% 100E	4822 051 10101
R3066	RES.METAL FILM	HIP RC-02H 1% 909E	5322 117 10588
R3067	RES.METAL FILM	HIP RC-02H 1% 909E	5322 117 10588
R3068	RES.CHIP	RMC1/8 1% 10E	4822 111 91885
R3069	RES.CHIP	RMC1/8 1% 10E	4822 111 91885
R3101	RES.CHIP	RMC1/8 1% 51E1	5322 111 91893
R3102	RES.CHIP	RMC1/8 1% 21E5	5322 111 92014
R3103	RES.CHIP	RMC1/8 1% 51E1	5322 111 91893
R3104	RES.METAL FILM	HIP RC-02H 1% 422E	5322 117 10564
R3107	RES.METAL FILM	HIP RC-02H 1% 237E	5322 117 10544
R3111	RES.CHIP	RMC1/8 1% 21E5	5322 111 92014
R3112	RES.METAL FILM	HIP RC-02H 1% 383E	5322 117 10559
R3113	RES.CHIP	RMC1/8 1% 10E	4822 111 91885
R3131	RES.CHIP	RMC1/8 1% 21E5	5322 111 92014
R3132	RES.CHIP	HIP RC-02H 1% 5K11	5322 117 10487
R3133	RES.METAL FILM	HIP RC-02H 1% 14K7	5322 117 10528
R3134	RES.METAL FILM	HIP RC-02H 1% 14K7	5322 117 10528
R3136	RES.METAL FILM	HIP RC-02H 1% 1K78	5322 117 10535
R3137	RES.METAL FILM	HIP RC-02H 1% 121E	5322 117 10519
R3138	RES.CHIP	HIP RC-01 5% 4E7	4822 051 10478
R3151	RES.CHIP	RMC1/8 1% 10E	4822 111 91885
R3161	RES.CHIP	RMC1/8 1% 75E	4822 111 91937
R3171	RES.METAL FILM	ST MRS25 1% 9K53	4822 050 29532
R3176	RES.CHIP	HIP RC-02H 1% 51K1	4822 051 55113
R3201	RES.CHIP	RMC1/8 1% 51E1	5322 111 91893
R3202	RES.CHIP	RMC1/8 1% 21E5	5322 111 92014
R3203	RES.CHIP	RMC1/8 1% 51E1	5322 111 91893
R3204	RES.METAL FILM	HIP RC-02H 1% 422E	5322 117 10564
R3207	RES.METAL FILM	HIP RC-02H 1% 237E	5322 117 10544
R3211	RES.CHIP	RMC1/8 1% 21E5	5322 111 92014
R3212	RES.METAL FILM	HIP RC-02H 1% 383E	5322 117 10559
R3213	RES.CHIP	RMC1/8 1% 10E	4822 111 91885
R3231	RES.CHIP	RMC1/8 1% 21E5	5322 111 92014

Item	Description		Ordering code
R3232	RES.CHIP	HIP RC-02H 1% 5K11	5322 117 10487
R3233	RES.METAL FILM	HIP RC-02H 1% 14K7	5322 117 10528
R3234	RES.METAL FILM	HIP RC-02H 1% 14K7	5322 117 10528
R3236	RES.METAL FILM	HIP RC-02H 1% 1K78	5322 117 10535
R3237	RES.METAL FILM	HIP RC-02H 1% 121E	5322 117 10519
R3238	RES.CHIP	HIP RC-01 5% 4E7	4822 051 10478
R3251	RES.CHIP	RMC1/8 1% 10E	4822 111 91885
R3261	RES.CHIP	RMC1/8 1% 75E	4822 111 91937
R3271	RES.METAL FILM	ST MRS25 1% 9K53	4822 050 29532
R3276	RES.CHIP	HIP RC-02H 1% 51K1	4822 051 55113
R3281	RES.METAL FILM	HIP RC-02H 1% 2K87	5322 117 10549
R3282	RES.CHIP	HIP RC-02H 1% 5K11	5322 117 10487
R3301	RES.METAL FILM	HIP RC-02H 1% 61K9	5322 117 10578
R3302	RES.CHIP	HIP RC-02H 1% 12K1	4822 051 51213
R3311	RES.METAL FILM	HIP RC-02H 1% 511E	5322 117 10569
R3312	RES.METAL FILM	HIP RC-02H 1% 2K87	5322 117 10549
R3313	RES.METAL FILM	HIP RC-02H 1% 2K87	5322 117 10549
R3314	RES.CHIP	HIP RC-02H 1% 10K	4822 051 10103
R3316	RES.METAL FILM	HIP RC-02H 1% 14K7	5322 117 10528
R3401	RES.CHIP	RMC1/8 1% 10E	4822 111 91885
R3402	RES.CHIP	RMC1/8 1% 10E	4822 111 91885
R3403	RES.CHIP	HIP RC-02H 1% 5K11	5322 117 10487
R3404	RES.CHIP	HIP RC-02H 1% 5K11	5322 117 10487
R3411	RES.CHIP	RMC1/8 1% 10E	4822 111 91885
R3412	RES.CHIP	RMC1/8 1% 10E	4822 111 91885
R3416	RES.METAL FILM	HIP RC-02H 1% 750E	5322 117 10582
R3417	RES.METAL FILM	HIP RC-02H 1% 750E	5322 117 10582
R4001	RES.CHIP	HIP RC-02H 1% 51K1	4822 051 55113
R4002	RES.HI-TENSION	RST VR25 5% 3M3	4822 053 20335
R4003	RES.HI-TENSION	RST VR25 5% 3M3	4822 053 20335
R4004	RES.HI-TENSION	RST VR25 5% 3M3	4822 053 20335
R4006	RES.HI-TENSION	RST VR25 5% 6M8	4822 053 20685
R4007	RES.HI-TENSION	RST VR25 5% 6M8	4822 053 20685
R4008	RES.METAL FILM	HIP RC-02H 1% 31K6	5322 117 10554
R4009	RES.METAL FILM	HIP RC-02H 1% 31K6	5322 117 10554
R4031	RES.CHIP	RMC1/8 1% 10E	4822 111 91885
R4032	RES.METAL FILM	HIP RC-02H 1% 31K6	5322 117 10554
R4033	RES.CHIP	HIP RC-02H 1% 1K	4822 051 10102
R4034	RES.CHIP	RMC1/8 1% 10E	4822 111 91885
R4036	RES.METAL FILM	HIP RC-02H 1% 316E	5322 117 10552
R4037	RES.METAL FILM	HIP RC-02H 1% 31K6	5322 117 10554
R4038	RES.METAL FILM	HIP RC-02H 1% 681E	5322 117 10579
R4039	RES.METAL FILM	HIP RC-02H 1% 16K2	5322 117 10532
R4040	RES.METAL FILM	HIP RC-02H 1% 31K6	5322 117 10554
R4041	RES.CHIP	HIP RC-02H 1% 51K1	4822 051 55113
R4042	RES.CHIP	HIP RC-02H 1% 1K	4822 051 10102
R4043	RES.CHIP	HIP RC-02H 1% 1K	4822 051 10102

Item	Description		Ordering code
R4044	RES.CHIP	HIP RC-02H 1% 1M	4822 051 10105
R4045	RES.METAL FILM	HIP RC-02H 1% 215K	5322 117 10543
R4051	RES.HI-TENSION	RST VR25 5% 3M3	4822 053 20335
R5001	RES.CHIP	HIP RC-01 5% 1E	4822 051 10108
R5002	RES.CHIP	HIP RC-01 5% 1E	4822 051 10108
R5003	RES.CHIP	HIP RC-01 5% 1E	4822 051 10108
R5004	RES.CHIP	HIP RC-01 5% 1E	4822 051 10108
R5007	RES.CHIP	HIP RC-01 5% 1E	4822 051 10108
R5008	RES.CHIP	HIP RC-01 5% 1E	4822 051 10108
R5101	RES.CHIP	HIP RC-01 5% 4E7	4822 051 10478
R5106	RES.CHIP	HIP RC-01 5% 4E7	4822 051 10478
R5111	RES.CHIP	HIP RC-01 5% 3E3	4822 051 10338
R5116	RES.CHIP	HIP RC-01 5% 3E3	4822 051 10338
R5121	RES.CHIP	HIP RC-01 5% 1E	4822 051 10108
R5126	RES.CHIP	HIP RC-01 5% 1E	4822 051 10108
R5131	RES.CHIP	HIP RC-02H 1% 10K	4822 051 10103
R5132	RES.CHIP	HIP RC-02H 1% 10K	4822 051 10103
R5133	RES.CHIP	HIP RC-02H 1% 10K	4822 051 10103
R5134	RES.CHIP	HIP RC-02H 1% 10K	4822 051 10103
R5136	RES.CHIP	HIP RC-02H 1% 10K	4822 051 10103
R5137	RES.METAL FILM	HIP RC-02H 1% 3K83	5322 117 10561
R5138	RES.METAL FILM	HIP RC-02H 1% 3K16	5322 117 10553
R5139	RES.CHIP	RMC1/8 1% 10E	4822 111 91885
R5151	RES.CHIP	RMC1/8 1% 10E	4822 111 91885
R5201	RES.CHIP	HIP RC-01 5% 3E3	4822 051 10338
R5206	RES.CHIP	HIP RC-01 5% 3E3	4822 051 10338
R5211	RES.CHIP	HIP RC-01 5% 3E3	4822 051 10338
R5216	RES.CHIP	HIP RC-01 5% 3E3	4822 051 10338
R5221	RES.CHIP	HIP RC-01 5% 4E7	4822 051 10478
R5226	RES.CHIP	HIP RC-01 5% 4E7	4822 051 10478
R5251	RES.CHIP	RMC1/8 1% 10E	4822 111 91885
R5301	RES.CHIP	HIP RC-01 5% 3E3	4822 051 10338
R5306	RES.CHIP	HIP RC-01 5% 3E3	4822 051 10338
R5311	RES.CHIP	HIP RC-01 5% 3E3	4822 051 10338
R5316	RES.CHIP	HIP RC-01 5% 3E3	4822 051 10338
R5321	RES.CHIP	HIP RC-01 5% 4E7	4822 051 10478
R5326	RES.CHIP	HIP RC-01 5% 4E7	4822 051 10478
R5351	RES.CHIP	RMC1/8 1% 10E	4822 111 91885
R5411	RES.CHIP	RMC1/8 1% 21E5	5322 111 92014
R5416	RES.CHIP	RMC1/8 1% 21E5	5322 111 92014

Item	Description		Ordering code
SEMICONDUCTORS			
V1009	DIODE,CHIP	BBY39 PEL	5322 130 82199
V1011	DIODE,CHIP	BBY39 PEL	5322 130 82199
V1014	TRANSISTOR,CHIP	BC858C PEL	4822 130 42513
V1016	TRANSISTOR,CHIP	BC858C PEL	4822 130 42513
V1018	TRANSISTOR,CHIP	BC858C PEL	4822 130 42513
V1019	TRANSISTOR,CHIP	BC858C PEL	4822 130 42513
V1021	TRANSISTOR,CHIP	BC858C PEL	4822 130 42513
V1022	TRANSISTOR,CHIP	BC858C PEL	4822 130 42513
V1023	TRANSISTOR,CHIP	BC848C PEL	5322 130 42136
V1024	TRANSISTOR,CHIP	BC848C PEL	5322 130 42136
V1101	TRANSISTOR,CHIP	BFR53 PEL	5322 130 61244
V1102	TRANSISTOR,CHIP	BFR53 PEL	5322 130 61244
V1103	TRANSISTOR,CHIP	BFT92 PEL	5322 130 44711
V1104	TRANSISTOR,CHIP	BFT92 PEL	5322 130 44711
V1106	TRANSISTOR	BFG55 PEL	5322 130 62806
V1107	TRANSISTOR	BFG55 PEL	5322 130 62806
V1108	DIODE,REFERENCE	BZX79-C12 PEL	4822 130 34197
V1109	DIODE,REFERENCE	BZX79-C12 PEL	4822 130 34197
V1111	TRANSISTOR,CHIP	BFG35 PEL	5322 130 62805
V1112	TRANSISTOR,CHIP	BFG35 PEL	5322 130 62805
V1113	DIODE	BBY62 PEL	5322 130 82685
V1121	TRANSISTOR,CHIP	BC858C PEL	4822 130 42513
V1122	TRANSISTOR,CHIP	BCP53 PEL	5322 130 62804
V1123	TRANSISTOR,CHIP	BCP56 PEL	5322 130 63033
V1126	TRANSISTOR,CHIP	BC848C PEL	5322 130 42136
V1127	TRANSISTOR,CHIP	BC858C PEL	4822 130 42513
V1128	TRANSISTOR,CHIP	BC848C PEL	5322 130 42136
V1201	TRANSISTOR,CHIP	BC858C PEL	4822 130 42513
V1202	TRANSISTOR,CHIP	BC858C PEL	4822 130 42513
V1203	TRANSISTOR,CHIP	BC858C PEL	4822 130 42513
V1204	TRANSISTOR,CHIP	BC858C PEL	4822 130 42513
V1301	DIODE,REFERENCE	BZX84-C8V2 PEL	5322 130 80255
V2061	TRANSISTOR,CHIP	BC858C PEL	4822 130 42513
V2062	TRANSISTOR,CHIP	BC858C PEL	4822 130 42513
V2101	TRANSISTOR,CHIP	BF824 PEL	4822 130 60383
V2102	DIODE	BZX84-B12 PEL	4822 130 83566
V2103	DIODE	BZX84-B12 PEL	4822 130 83566
V2104	TRANSISTOR,CHIP	BC858C PEL	4822 130 42513
V2105	DIODE	BZX84-B12 PEL	4822 130 83566
V2111	TRANSISTOR,CHIP	BF840 PEL	4822 130 60887
V2113	TRANSISTOR	BFQ232A PEL	4822 130 62751
V2131	DIODE,CHIP	BAV99 PEL	5322 130 34337
V2132	TRANSISTOR,CHIP	BF824 PEL	4822 130 60383
V2133	TRANSISTOR,CHIP	BF840 PEL	4822 130 60887
V2134	TRANSISTOR	BFQ252A PEL	4822 130 62932

Item	Description		Ordering code
V2201	TRANSISTOR,CHIP	BF824 PEL	4822 130 60383
V2202	DIODE	BZX84-B12 PEL	4822 130 83566
V2203	DIODE	BZX84-B12 PEL	4822 130 83566
V2204	TRANSISTOR,CHIP	BC858C PEL	4822 130 42513
V2205	DIODE	BZX84-B12 PEL	4822 130 83566
V2211	TRANSISTOR,CHIP	BF840 PEL	4822 130 60887
V2213	TRANSISTOR	BFQ232A PEL	4822 130 62751
V2231	DIODE,CHIP	BAV99 PEL	5322 130 34337
V2232	TRANSISTOR,CHIP	BF824 PEL	4822 130 60383
V2233	TRANSISTOR,CHIP	BF840 PEL	4822 130 60887
V2234	TRANSISTOR	BFQ252A PEL	4822 130 62932
V2301	DIODE,REFERENCE	BZX84-C8V2 PEL	5322 130 80255
V2403	DIODE	BZX84-B18 PEL	5322 130 83709
V2418	DIODE,REFERENCE	BZX84-C8V2 PEL	5322 130 80255
V3001	DIODE,CHIP	BAV99 PEL	5322 130 34337
V3002	TRANSISTOR,CHIP	BC858C PEL	4822 130 42513
V3061	TRANSISTOR,CHIP	BF824 PEL	4822 130 60383
V3062	TRANSISTOR,CHIP	BF824 PEL	4822 130 60383
V3101	TRANSISTOR,CHIP	BF824 PEL	4822 130 60383
V3102	DIODE	BZX84-B12 PEL	4822 130 83566
V3103	DIODE	BZX84-B12 PEL	4822 130 83566
V3104	TRANSISTOR,CHIP	BC858C PEL	4822 130 42513
V3105	DIODE	BZX84-B12 PEL	4822 130 83566
V3111	TRANSISTOR,CHIP	BF840 PEL	4822 130 60887
V3113	TRANSISTOR	BFQ232A PEL	4822 130 62751
V3131	DIODE,CHIP	BAV99 PEL	5322 130 34337
V3132	TRANSISTOR,CHIP	BF824 PEL	4822 130 60383
V3133	TRANSISTOR,CHIP	BF840 PEL	4822 130 60887
V3134	TRANSISTOR	BFQ252A PEL	4822 130 62932
V3136	DIODE,CHIP	BAS21 PEL	4822 130 33702
V3137	DIODE,CHIP	BAS21 PEL	4822 130 33702
V3201	TRANSISTOR,CHIP	BF824 PEL	4822 130 60383
V3202	DIODE	BZX84-B12 PEL	4822 130 83566
V3203	DIODE	BZX84-B12 PEL	4822 130 83566
V3204	TRANSISTOR,CHIP	BC858C PEL	4822 130 42513
V3205	DIODE	BZX84-B12 PEL	4822 130 83566
V3211	TRANSISTOR,CHIP	BF840 PEL	4822 130 60887
V3212	TRANSISTOR,CHIP	BF820 PEL	5322 130 62802
V3213	TRANSISTOR	BFQ232A PEL	4822 130 62751
V3231	DIODE,CHIP	BAV99 PEL	5322 130 34337
V3232	TRANSISTOR,CHIP	BF824 PEL	4822 130 60383
V3233	TRANSISTOR,CHIP	BF840 PEL	4822 130 60887
V3234	TRANSISTOR	BFQ252A PEL	4822 130 62932
V3236	DIODE,CHIP	BAS21 PEL	4822 130 33702
V3237	DIODE,CHIP	BAS21 PEL	4822 130 33702
V3281	DIODE,CHIP	BAV99 PEL	5322 130 34337
V3282	TRANSISTOR,CHIP	BF821 PEL	4822 130 61923

Item	Description		Ordering code
V3301	TRANSISTOR,CHIP	BF820 PEL	5322 130 62802
V3311	TRANSISTOR,CHIP	BC858C PEL	4822 130 42513
V3312	DIODE,CHIP	BAV99 PEL	5322 130 34337
V3418	DIODE,REFERENCE	BZX84-C8V2 PEL	5322 130 80255
V4001	DIODE,CHIP	BAV99 PEL	5322 130 34337
V4002	TRANSISTOR,CHIP	BF821 PEL	4822 130 61923
V4003	TRANSISTOR,CHIP	BF821 PEL	4822 130 61923
V4004	TRANSISTOR,CHIP	BF821 PEL	4822 130 61923
V4031	TRANSISTOR,CHIP	BF821 PEL	4822 130 61923
V4032	TRANSISTOR,CHIP	BF821 PEL	4822 130 61923
V4033	TRANSISTOR,CHIP	BF820 PEL	5322 130 62802
V4034	TRANSISTOR,CHIP	BF820 PEL	5322 130 62802
V4036	DIODE,REFERENCE	BZX84-B18 PEL	5322 130 83709
V4037	DIODE,CHIP	BAS21 PEL	4822 130 33702
V4038	TRANSISTOR,CHIP	BF820 PEL	5322 130 62802
V4039	TRANSISTOR,CHIP	BF821 PEL	4822 130 61923
V4040	DIODE,CHIP	BAS21 PEL	4822 130 33702
V4041	DIODE,CHIP	BAS21 PEL	4822 130 33702
V4042	DIODE,CHIP	BAS21 PEL	4822 130 33702
V4043	DIODE,CHIP	BAS21 PEL	4822 130 33702
V4044	DIODE,CHIP	BAS21 PEL	4822 130 33702
V5001	DIODE,CHIP	BAS21 PEL	4822 130 33702
V5002	DIODE,CHIP	BAS21 PEL	4822 130 33702

CONNECTORS

X2101	CONNECTOR	4-P HAAKS OMSL	5322 265 30907
X2301	CONNECTOR	12-P 1.25MM STR	4822 267 50668
X2401	CONNECTOR	12-P 1.25MM STR	4822 267 50668
X2402	CONNECTOR	3-P SNG RT.ANG	5322 265 30433
X2403	SOCKET	55595 CRT SOCKET	5322 255 40502
X2501	CONNECTOR	50-P DBL STRGHT	5322 265 61242

5.2.7 Description of A2-100 MHz version

5.2.7.1 Final Y amplifier

Diagram 1

The output signal from the delay line is applied to the input pins 6 and 9 of amplifier IC D1001. This IC and surrounding components comprise the MF and HF square wave compensations. Also the vertical CRT text signal is applied to D1001 (pin 15 and 16). The switching between text/cursors and signal is done via control signals that are applied to pin 17 and 18 of D1001. Text is written if the voltage at pin 18 is higher than at pin 17. This switching signal is derived from the collector of the transistors V1201 and V1202. The control signals XYSW1 and XYSW0 come from the text/cursor generator IC on microprocessor unit A3. Via the transistors V1203 and V1204 similar switching signals XSW1 and XSW0 are routed to the X-deflection section for switching between text and signal.

The output signals from pin 21 and 22 of D1001 are routed via the common base circuits V1026 / V1027 to the final Y-amplifier. The final amplifier is located on the small printed circuit board at the CRT socket. It drives the vertical deflection plates of the CRT. This final stage is indicated on diagram 2.

The delay line leads are terminated into 75Ω . The impedance is composed by 300Ω inside D1001 paralleled by external impedances of 60Ω formed by the external resistors R1024/R1026 and R1027/R1028. All termination resistors are applied to a voltage controlled by D1001/pin 13. Pin 13 determines the common mode voltage level of the D1001 inputs. The HF square wave compensation is achieved by the two dual varicap diodes V1009 and V1011 together with associated resistors. Varicap V1009 is controlled by the output signal at pin 20 of octal DAC N1001. This output voltage can be in the range 0 to 10 V and controls varicap V1009 via operational amplifier N1002/1,2,3. This operational amplifier converts the N1001 output voltage (that is related to 0 V) into a voltage related to the voltage at D1001/pin 13.

Varicap V1011 is controlled by the output signal at pin 18 of octal DAC N1001. This output voltage can be in the range 0 to 10 V and controls varicap V1011 via operational amplifier N1002/5,6,7. This operational amplifier converts the N1001 output voltage (that is related to 0 V) into a voltage related to the voltage at D1001/pin 13.

LF square wave compensation is also done inside D1001. This is controlled via currents applied to pin 27 and 28. These currents are derived from the N1001 DAC voltage outputs 13 and 11 via the transistors V1014 and V1016. The actual compensating components are situated outside D1001 and are R1037/C1011/R1038 and R1029/C1009/R1031. V1023 and V1024 form a 20 mA current source to supply the bias current for the final stage inside D1001. V1024 is switched as a diode and gives temperature compensation.

Offset is adjusted via the currents from the collectors of V1021 and V1022. These currents are controlled by the DAC output pins 17 (coarse) and 16 (fine). Two parallel DAC outputs are used to obtain sufficient resolution. V1018 is a current source and V1019 is for temperature compensation. Gain control occurs via an adjustable current applied to D1001/pin 26. This is done via N1001/pin 14 and R1051

DAC output N1001/15 applies via operational amplifier N1003/1,2,3 the signal YFSHF to the final stage on diagram 2. YFSHF is an adjustable dc voltage that is applied to varicap diodes V4113 that control the HF square wave response of the output stage.

The circuit with operational amplifier N1004/2,3,6 is used for automatic calibration of the vertical deflection. It measures the voltage at the vertical deflection plates of the CRT. This value is applied as signal YCAL to the microprocessor on unit A3.

Diagram 2

This diagram shows the Y-output amplifier. The amplifier is located at the small printed circuit board at the CRT socket. The input signal is a current and is applied to V4101 and V4102. The output signal is voltage and is applied to the vertical deflection plates of the CRT. Total sensitivity at the plates is 4V/div. One plate is driven by output stage V4111/V4108. V4111 and V4114 form a current source. The current source is an amplifier for higher frequencies because of coupling capacitor C4118. The driver transistors are V4103 and V4106. The input signal is YPREOUT1.

The other plate is driven by output stage V4109/V4112. V4112 is a current source. The current source is an amplifier for higher frequencies because of coupling capacitor C4119. The driver transistors are V4104 and V4107. The input signal is YPREOUT0.

The output signals ACALFB0 and ACALFB1 are routed to a circuit for automatic calibration of the vertical amplifiers. This circuit is present on the larger part of unit A2 and indicated on diagram 1.

5.2.7.2 Final X and Z amplifiers

Diagram 3

This diagram shows the final X amplifier. It drives the horizontal plates of the CRT. Total plate sensitivity equals 8.5 V/div. The input circuit is formed by IC D2001. The octal DAC N2002 supplies the analog control signals that are used throughout the circuit.

Input pin 5 and 6 of D2001 receive the time base sawtooth or the X- deflection signal signal. Input pin 9 and 10 receive the horizontal text/cursor signal. The selection between text/cursors and sawtooth/X- deflection signal is done via the signals XSW0 and XSW1 that are applied to pin 7 and 8 of D2001. These signals are derived from XYSW0 and XYSW1 that come from the text generator IC on microprocessor unit A3. Text is displayed with XSW0 at 0 mA and XSW1 at 1 mA. Trace is displayed with XSW0 at 1 mA and XSW1 at 0 mA.

Gain control is possible via pin 1 of D2001. This is used for trace gain control via signal XTRAGC. Gain control to compensate for CRT tolerances is achieved via pin 14 of D2001. This is controlled via the DAC output signals XCRTGCL (fine) and XCRTGCH (coarse). Offset control to compensate for CRT tolerances is achieved via pin 15 of D2001. This is controlled via the DAC output signals XCRTOFH (coarse) and XCRTOFL (fine). Adjustment of the HF response (and linearity) is achieved via signal XHFADJ via pin 17 and 26 of D2001.

The final X-amplifier consists of two identical halves that receive input signals that are in opposite phase. These signals originate from the D2001 outputs pin 24/25 (XDRIL0/XDRIL1) and pin 18/19 (XDRIR0/XDRIR1). The two X-amplifier sections drive respectively the left and right deflection plate of the CRT.

The final X amplifier half that drives the left deflection plate is explained now. Its function is identical to that of the other amplifier half. The balanced input signals XDRIL1 and XDRIL0 are applied to input stage V2101. V2134 is a current source. XDRIL0 is not used and connected to +6.8 V. In the collector circuit of V2101 are the zener diodes V2102/V2103 that function as level shifters. The emitter followers V2132 and V2111 supply the output stage V2134/V2113 with signal. V2113 functions as an amplifier stage and V2134 mainly as a current source. V2134 receives signal via C2131 and C2134 and functions as amplifier stage in the fastest sweep speeds. Via R2133/R2134 however some dc drive is also applied to V2134.

The circuit with operational amplifier N2003 is used to measure the output voltage that is applied to the X-deflection plates of the CRT. This measurement is done via high-ohmic resistors R2301 and R2302. The analog output voltage XCAL of N2003 is applied to an ADC incorporated in the microprocessor on unit A3. This enables the microprocessor to exactly measure the horizontal output voltage. This is used for automatic calibration of the horizontal deflection.

Diagram 4

This diagram shows the final intensity (Z) and focusing amplifiers. These amplifiers drive the intensity electrode G1 and the focusing electrode G3 of the CRT. The input circuit is formed by IC D3001.

Input pin 5 and 6 of D3001 receive the Z-pulses ZLTRA0 and ZLTRA1 that determine the intensity during signal display. Input pin 9 and 10 receive the Z-pulse ZTXT0 and ZTXT1 that determine the intensity during text/cursor display. The selection between signal intensity and text intensity is done via the signals ZSW0 and ZSW1 that are applied to pin 7 and 8 of D3001. These signals originate from the text generator IC on microprocessor unit A3. Text is displayed with ZSW0 at 0 mA and ZSW1 at 1 mA. Trace is displayed with ZSW0 at 1 mA and ZSW1 at 0 mA.

The final Z-amplifier and the focusing amplifier are identical halves that receive input signals that are in opposite phase. These signals originate from the D3001 outputs pin 24/25 (ZDRIF1/ZDRIF0) and pin 18/19 (ZDRIF0/ZDRIF1).

Via V3002 part of the ripple on the negative CRT cathode voltage (ZRIPPLE) is applied to pin 15 of D3001. This compensates for unwanted intensity modulation due to this ripple.

The diodes V3236, V3136, V3237 and V3137 protect D3001 against possible high voltage surges.

V3301 supplies the intensity determining signal INTEN-DA. This signal adjusts the "dark level" of the CRT. V3301 is controlled by DAC N2002 output signal DARK. V3311 supplies signal ASTIG that determines the astigmatism of the CRT. V3311 is controlled by DAC N2002 output signal ASTDR.

The upper amplifier half that is used for the dynamic focus control is explained now. Its function is identical to that of the lower amplifier half that is used for intensity (Z) control. The balanced input signals ZDRIF1 and ZDRIF0 are applied to input stage V3101. ZDRIF0 is not used and connected to +6.8 V. In the collector circuit of V3101 are the zener diodes V3102/V3103 that function as level shifters. The emitter followers V3132 and V3111 supply the output stage V3134/V3113 with signal. V3113 functions as an amplifier stage and V3134 mainly as a current source. V3134 receives signal via C3131 and C3134. It mainly functions as amplifier stage for fast input signals. Via R3133/R3134 however some dc drive is also applied to V3134.

Diagram 5

In this diagram the circuit is shown that forms an interface between the signals that determine the intensity/focusing and the CRT electrodes G1/G3 that control intensity/focusing. These electrodes, the cathode and filament (heater) of the CRT are at a high negative voltage. This voltage is separated from the other oscilloscope circuits via the 3kV capacitors C4004, C4061, C4036 and C4037.

The intensity is influenced by the output signal INTEN-AA of the Z- amplifier and the signal INTEN-DA. INTEN-AA is determined via the front-panel INTENS TRACE, INTENS TEXT, MTB on, DTB on and chopper blanking control signals. The HF component in the INTEN-AA signal is applied to G1 of the CRT via C4037. The DC and LF components are applied to the base of V4034. The INTEN-DA signal is applied to the base of V4032 and forms the clamp level (dark level) of the DC and LF part of INTEN-AA derived from V4034. These two transistors form the inputs of a 150kHz modulator that basically consists of V4031 and V4033. The LF and DC components that are modulated on the 150 kHz carrier signal can pass via buffer stage V4038/V4039 and then via high voltage blocking capacitor C4036.

Behind capacitor C4036 demodulation takes place via the diodes V4043 and V4044. This results in the original INTEN-AA signal that is superpositioned on the INTEN-DA voltage that corrects the cut-off voltage of the CRT applied to G1 and via R4051 also to G3. Across R4044 a small negative voltage (compared with the cathode) is developed for G1. This voltage is not big enough to make the CRT screen dark. This means that the signals to darken the screen and to control intensity are applied via C4036 and C4037.

The HF component from the focusing amplifier output signal FOCUS-AA is applied to G3 via C4004 and voltage divider R4008/R4009/C4002/C4003. This assures optimal tracking between focus and intensity. The signal FOCUS-DA is determined via the FOCUS control at the instruments front panel. The signal FOCUS-DA is then mixed with the LF component of FOCUS-AA before its level is adapted to the nominal G3 voltage via transistors V4002/V4003/V4004.

Diagram 6

This diagram shows the RC-branches and regulators N5131 that give the supply voltages for the various circuits. Also the connectors X2501 and X2301 are indicated here. X2301 is the connector where the flat cable leaves for the small unit that incorporates the CRT-socket X2403. The flat cable arrives at the small CRT-socket unit at X2411.

5.2.8 Signal name list A2-100 MHz version

Note: In the signal name list you find the itemnumber of the component that is source or destination. Behind this itemnumber (separated by ":") you find the number of the diagram where the source/destination can be found

NAME	MEANING	SOURCE	DESTINATION
ACALF B0	AUTOCALL FUNCTION SIGNAL	R4164:02 X2301:01	X2411:02 R1307:01
ACALF B1	AUTOCALL FUNCTION SIGNAL	R4163:02 X2301:01	X2411:02 R1306:01
ASTDR	DRIVER SIGNAL FOR ASTIGMATISM	N2002:03	R3313:04
ASTIG	ASTIGMATISM CONTROL	V3311:04 X2411:06	X2301:06 X2403:05
DARK	DRIVER SIGNAL FOR DC PART INTENS	N2002:03	V3301:04
FOCUS-AA	AC PART FOCUSING SIGNAL	R3161:04 X2411:05	X2301:06 R4008:05
FOCUS-DA	DC PSRT FOCUSING SIGNAL	X2501:06 X2411:05	X2301:06 R4001:05
G1	INTENSITY GRID 1 OF CRT	C4037:05	X2403:05 R4044:05
G3	FOCUSING GRID 3 OF CRT	C4004:05	X2403:05 R4051:05
HEATER1	FILAMENT SUPPLY F1 OF CRT	X2402:05	X2403:05
HEATER2	FILAMENT SUPPLY F2 OF CRT	X2402:05	X2403:05
INTEN-AA	AC PART OF INTENSITY SIGNAL	R3261:04 X2411:05	X2301:06 C4037:05
INTEN-DA	DC PART OF INTENSITY SIGNAL	V3301:04 X2411:05	X2301:06 V4032:05
SCL	SERIAL CLOCK	X2501:06	J1002:06 J2002:06
SDA	SERIAL DATA	X2501:06	J1002:06 J2001:06
XCAL	AUTOCAL SIGNAL X DEFLECTION	R2313:03	X2501:06
XCRTGCH	CRT X-GAIN CONTROL HIGH	N2002:03	R2011:03
XCRTGCL	CRT X-GAIN CONTROL LOW	N2002:03	R2012:03
XCRTOFH	CRT OFFSET CONTROL HIGH	N2002:03	R2016:03
XCRTOFL	CRT OFFSET CONTROL LOW	N2002:03	R2017:03
XDRIL0	DRIVE SIGNAL 0 LEFT X AMPLIFIER	D2001:03	R2101:03
XDRIL1	DRIVE SIGNAL 1 LEFT X AMPLIFIER	D2001:03	R2103:03
XDRIR0	DRIVE SIGNAL 0 RIGHT X AMPLIFIER	D2001:03	R2203:03
XDRIR1	DRIVE SIGNAL 1 RIGHT X AMPLIFIER	D2001:03	R2201:03
XHFADJ	HF ADJUSTMENT X AMPLIFIER	N2002:03	R2021:03
XLTXT0	X SHIFT TEXT 0	V2062:03	R2007:03
XLTXT1	X SHIFT TEST 1	V2062:03	R2008:03
XOUTO	X OUTPUT 0	V2134:03 V2113:03	R2171:03 R2302:03

NAME	MEANING	SOURCE	DESTINATION
XOUT1	X OUTPUT 1	V2234:03	R2271:03
		V2213:03	R2301:03
XPLATE0	X OUTPUT 0 TO CRT LEFT PLATE	R2161:03	X2411:02
XPLATE1	X OUTPUT 1 TO CRT RIGHT PLATE	R2261:03	X2411:02
XPLATEC0	X OUTPUT 0 TO CRT LEFT PLATE	R4261:02	X2403:02
XPLATEC1	X OUTPUT 1 TO CRT RIGHT PLATE	R4262:02	X2403:02
XSCL	SERIAL CLOCK X SECTION	J2002:06	N2002:03
XSDA	SERIAL DATA X SECTION	J2001:06	N2002:03
XSW0	X SWITCH SIGNAL 0 TRACE/TEXT	V1204:01	D2001:03
XSW1	X SWITCH SIGNAL 1 TRACE/TEXT	V1203:01	D2001:03
XTRA0	X TRACE 0 SIGNAL	X2501:06	R2006:03
XTRA1	X TRACE 1 SIGNAL	X2501:06	R2006:03
XTRAGC	X TRACE SIGNAL GAIN CONTROL	N2002:03	R2002:03
XTXT0	X TEXT 0 SIGNAL	X2501:06	R2063:03
XTXT1	X TEXT 1 SIGNAL	X2501:06	R2064:03
XYSW0	X/Y SWITCH SIGNAL 0 TRACE/TEXT	X2501:06	R1204:01
XYSW1	X/Y SWITCH SIGNAL 1 TRACE/TEXT	X2501:06	R1201:01
YCAL	AUTOCAL SIGNAL Y DEFLECTION	R1309:01	X2501:06
YFSHF	HF SQ WAVE RESPONSE FINAL Y	R1091:01	X2301:06
		X2411:02	R4181:02
			R4182:02
YFSHF1	HF SQ WAVE RESPONSE FINAL Y 1	R4181:02	V4113:02
YFSHF2	HF SQ WAVE RESPONSE FINAL Y 2	R4182:02	V4114:02
YPREOUT0	Y PREAMPLIFIER OUT 0	V1027:01	X2301:06
		X2411:02	R4112:02
YPREOUT1	Y PREAMPLIFIER OUT 1	V1026:01	X2301:06
		X2411:02	R4111:02
YSCL	SERIAL CLOCK Y SECTION	J1002:06	N1001:01
YSDA	SERIAL DATA Y SECTION	J1001:06	N1001:01
YSW0	Y SWITCH SIGNAL 0 TRACE/TEXT	V1202:01	D1001:01
YSW1	Y SWITCH SIGNAL 1 TRACE/TEXT	V1201:01	D1001:01
YTRA0	Y TRACE 0 OUT FROM DELAY LINE	X2101:01	D1001:01
YTRA1	Y TRACE 1 OUT FROM DELAY LINE	X2101:01	D1001:01
YTXT0	Y TEXT 0 SIGNAL	X2501:06	D1001:01
YTXT1	Y TEXT 1 SIGNAL	X2501:06	D1001:01
ZDRIF0	DRIVER SIGNAL 0 FOCUS AMPLIFIER	D3001:04	R3101:04
ZDRIF1	DRIVER SIGNAL 1 FOCUS AMPLIFIER	D3001:04	R3103:04
ZDRII0	DRIVER SIGNAL 0 INTENS AMPLIFIER	D3001:04	R3203:04
ZDRII1	DRIVER SIGNAL 1 INTENS AMPLIFIER	D3001:04	R3201:04
ZLTRA0	Z LEVEL TRACE INTENSITY 0	V3062:04	R3004:04
ZLTRA1	Z LEVEL TRACE INTENSITY 1	V3061:04	R3006:04
ZOUTF	FEEDBACK SIGNAL FOCUS AMPLIFIER	V3113:04	R3171:04
ZOUTI	FEEDBACK SIGNAL INTENSITY AMPLIFIER	V3213:04	R3271:04
ZRIPPLE	RIPPLE ON NEGATIVE HIGH VOLTAGE	C4061:05	X2411:05
		X2301:06	R3014:04
ZRSUP	Z RIPPLE SUPPRESS	V3002:04	D3001:04
ZSW0	Z SWITCH SIGNAL 0 TEXT/TRACE	X2501:06	D3001:04
ZSW1	Z SWITCH SIGNAL 1 TEXT/TRACE	X2501:06	D3001:04
ZTRA0	Z TRACE INTENSITY 0	X2501:06	R3063:04
ZTRA1	Z TRACE INTENSITY 1	X2501:06	R3064:04
ZTXT0	Z TEXT 0 SIGNAL	X2501:06	R3007:04
ZTXT1	Z TEXT 1 SIGNAL	X2501:06	R3008:04

5.2.9 Unit lay-outs A2-100 MHz version

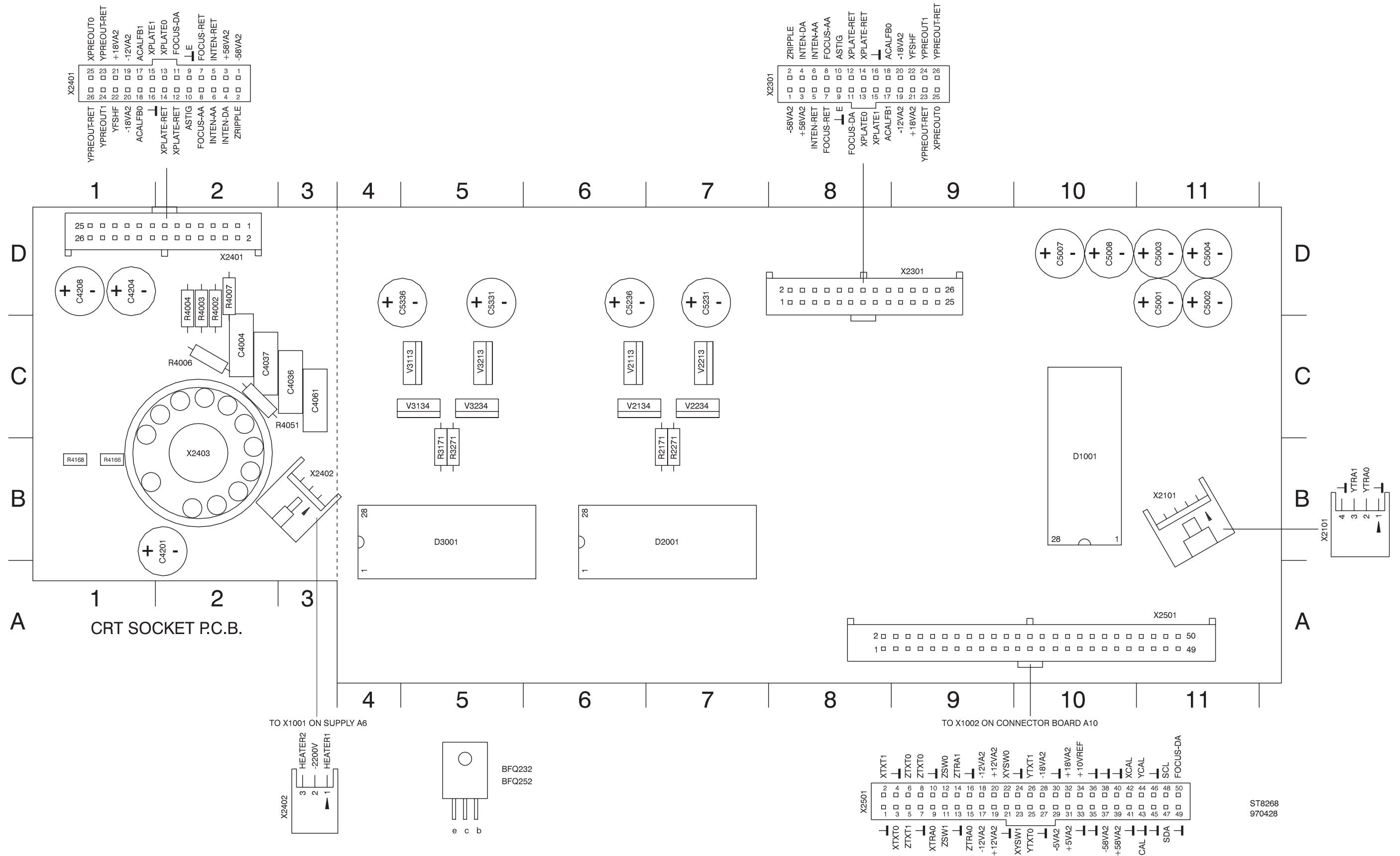

Lay-out 1 - Large component side of XYZ amplifier unit A2-100 MHz

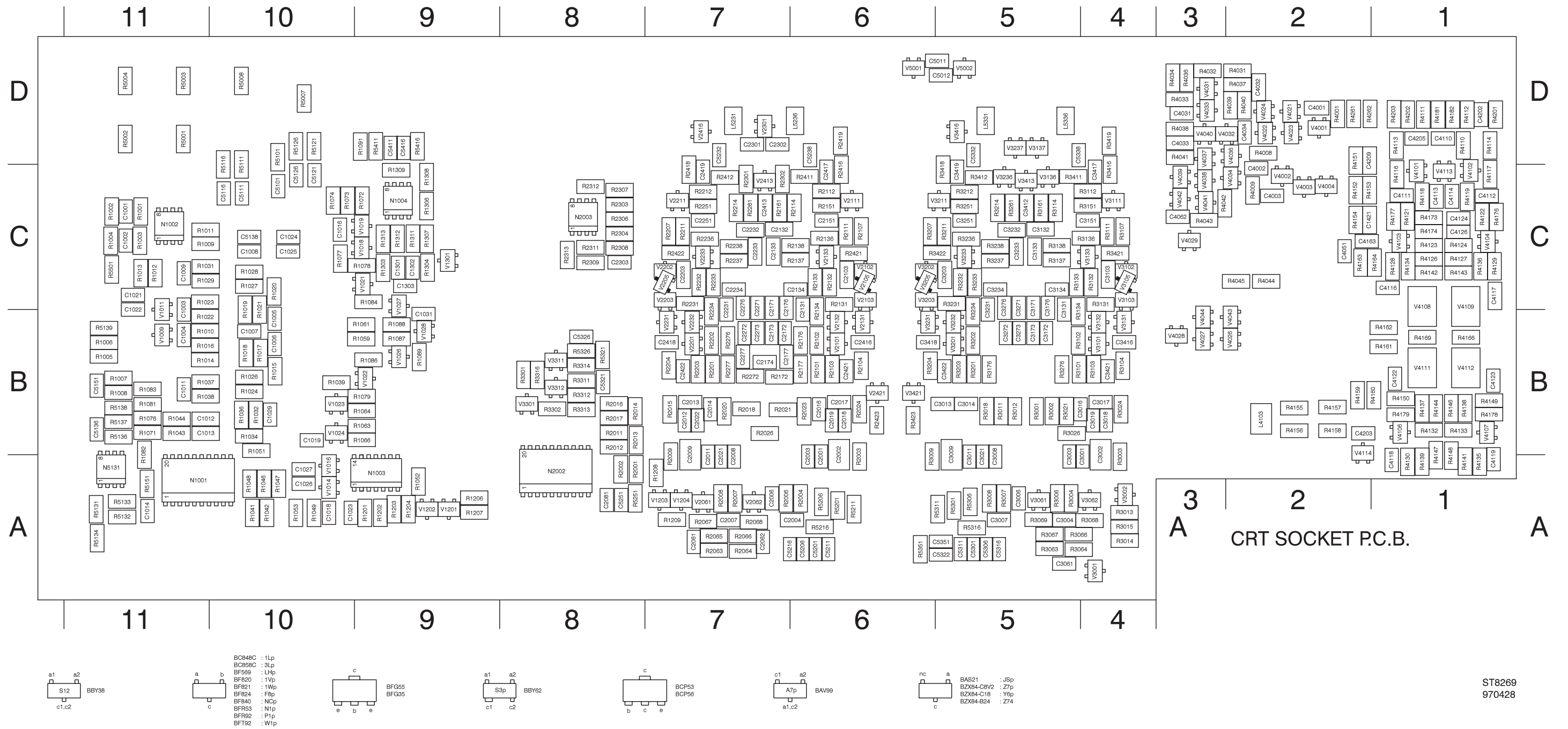

Lay-out 2 - Small component side of XYZ amplifier unit A2-100 MHZ

ST8269
970428

5.2.10 Location list A2-100 MHz version

'-L' means that the component is located on the side with the large components. Otherwise the component is located on the side with small components.

C1001 C11	C2132 C7	C3133 C5	C4163 D2
C1002 C11	C2133 C7	C3134 C5	C4201 B1-L
C1003 C11	C2134 C7	C3151 C5	C4202 D1
C1004 B11	C2151 C6	C3171 C5	C4203 B2
C1005 B10	C2171 C7	C3172 B5	C4204 D1-L
C1006 B10	C2172 B7	C3173 B5	C4205 D1
C1007 B10	C2173 B7	C3176 C5	C4206 C1
C1008 C10	C2174 B7	C3203 C6	C4207 C1
C1009 C11	C2176 C7	C3231 B5	C4208 D1-L
C1011 B11	C2177 B7	C3232 C5	C4209 D2
C1012 B11	C2203 C7	C3233 C5	C5001 D11-L
C1013 B11	C2231 B7	C3234 C5	C5002 D11-L
C1014 A11	C2232 C7	C3251 C5	C5003 D11-L
C1016 C10	C2233 C7	C3271 C5	C5004 D11-L
C1018 A10	C2234 C7	C3272 B5	C5007 D10-L
C1019 B10	C2251 C7	C3273 B5	C5008 D10-L
C1021 C11	C2271 C7	C3276 C5	C5011 D6
C1022 C11	C2272 B7	C3412 C5	C5012 D6
C1023 A10	C2273 B7	C3416 B4	C5101 C10
C1024 C10	C2276 C7	C3417 C4	C5111 C10
C1025 C10	C2277 B7	C3418 B6	C5116 C10
C1026 A10	C2301 D7	C3419 C5	C5121 C10
C1027 A10	C2302 D7	C3421 B4	C5126 C10
C1029 B10	C2303 C8	C3422 B6	C5136 B11
C1031 C9	C2413 C7	C4001 D2	C5138 C10
C1301 C9	C2416 B6	C4002 D2	C5151 B11
C1302 C9	C2417 C6	C4003 C2	C5201 A6
C1303 C9	C2418 B7	C4004 C2-L	C5206 A6
C2001 A6	C2419 C7	C4031 D3	C5211 A6
C2002 A6	C2421 B6	C4032 D2	C5216 A7
C2003 A6	C2422 B7	C4033 D3	C5231 D7-L
C2004 A7	C3001 A5	C4034 D2	C5232 D7
C2006 A7	C3002 A4	C4036 C3-L	C5236 D6-L
C2007 A7	C3003 A5	C4037 C2-L	C5238 D6
C2008 A7	C3004 A5	C4051 C2	C5251 A8
C2009 A7	C3006 A5	C4061 C3-L	C5301 A5
C2011 A7	C3007 A5	C4062 C3	C5306 A5
C2012 B7	C3008 A5	C4110 D1	C5311 A5
C2013 B7	C3009 A5	C4111 C1	C5316 A5
C2014 B7	C3011 A5	C4112 C1	C5321 B8
C2016 B6	C3013 B6	C4113 C1	C5322 A6
C2017 B6	C3014 B5	C4114 C1	C5326 B8
C2018 B6	C3016 B5	C4116 C1	C5331 C5-L
C2019 B6	C3017 B4	C4117 C1	C5332 D5
C2021 A7	C3018 B4	C4118 A1	C5336 C5-L
C2022 B7	C3019 B4	C4119 A1	C5338 D5
C2061 A7	C3021 A5	C4121 C2	C5351 A6
C2062 A7	C3061 A5	C4122 B1	C5411 D9
C2081 A8	C3103 C4	C4123 B1	C5416 D9
C2103 C6	C3131 C5	C4124 C1	D1001 B10-L
C2131 B6	C3132 C5	C4126 C1	D2001 B7-L

D3001 B5-L	R1048 A10	R2015 B7	R2277 B7
L4101 B2	R1049 A10	R2016 B8	R2301 C7
L4102 B2	R1051 B10	R2017 B8	R2302 C7
L4103 B2	R1052 A9	R2018 B7	R2303 C8
L5231 D7	R1053 A10	R2020 B7	R2304 C8
L5236 D6	R1059 B10	R2021 B7	R2306 C8
L5331 D5	R1061 B10	R2023 B6	R2307 C8
L5336 D5	R1063 B10	R2024 B6	R2308 C8
N1001 A11	R1064 B10	R2026 B7	R2309 C8
N1002 C11	R1066 B10	R2063 A7	R2311 C8
N1003 A9	R1071 B11	R2064 A7	R2312 C8
N1004 C9	R1072 C10	R2065 A7	R2313 C8
N2002 A8	R1073 C10	R2066 A7	R2411 C7
N2003 C8	R1074 C10	R2067 A7	R2412 C7
N5131 A11	R1076 B11	R2068 A7	R2416 C6
R1001 C11	R1077 C10	R2101 B6	R2418 C7
R1002 C11	R1078 C10	R2102 B6	R2419 D6
R1003 C11	R1079 B10	R2103 B6	R2421 C6
R1004 C11	R1081 B11	R2104 B6	R2422 C7
R1005 B11	R1082 A11	R2107 C6	R2423 B6
R1006 B11	R1083 B11	R2111 C6	R3001 B5
R1007 B11	R1084 C10	R2112 C6	R3002 B5
R1008 B11	R1086 B10	R2114 C7	R3003 A4
R1009 C11	R1087 B9	R2131 C6	R3004 A5
R1010 B11	R1088 B9	R2132 C6	R3006 A5
R1011 C11	R1089 B9	R2133 C6	R3007 A5
R1012 C11	R1091 D10	R2134 B6	R3008 A5
R1013 C11	R1201 A10	R2136 C6	R3009 A6
R1014 B11	R1202 A9	R2137 C7	R3011 B5
R1015 B10	R1203 A9	R2138 C7	R3012 B5
R1016 B11	R1204 A9	R2151 C6	R3013 A4
R1017 B10	R1206 A9	R2161 C7	R3014 A4
R1018 B10	R1207 A9	R2171 B7-L	R3015 A4
R1019 C10	R1208 A7	R2172 B7	R3018 B5
R1020 C10	R1209 A7	R2176 B6	R3021 B5
R1021 C10	R1303 C9	R2177 B6	R3024 B4
R1022 C11	R1304 C9	R2201 B7	R3026 B5
R1023 C11	R1306 C9	R2202 B7	R3063 A5
R1024 B10	R1307 C9	R2203 B7	R3064 A5
R1026 B10	R1308 C9	R2204 B7	R3066 A5
R1027 C10	R1309 D9	R2207 C7	R3067 A5
R1028 C10	R1311 C9	R2211 C7	R3068 A5
R1029 C11	R1312 C9	R2212 C7	R3069 A5
R1031 C11	R1313 C9	R2214 C7	R3101 B5
R1032 B10	R2001 A8	R2231 C7	R3102 B5
R1034 B10	R2002 A8	R2232 C7	R3103 B4
R1036 B10	R2003 A6	R2233 C7	R3104 B4
R1037 B11	R2004 A6	R2234 B7	R3107 C4
R1038 B11	R2006 A7	R2236 C7	R3111 C4
R1039 B10	R2007 A7	R2237 C7	R3112 C5
R1041 A10	R2008 A7	R2238 C7	R3114 C5
R1042 A10	R2009 A7	R2251 C7	R3131 C4
R1043 B11	R2011 B8	R2261 C7	R3132 C4
R1044 B11	R2012 B8	R2271 B7-L	R3133 C5
R1046 A10	R2013 B8	R2272 B7	R3134 B5
R1047 A10	R2014 B8	R2276 B7	R3136 C5

R3137 C5	R4040 D2	R4163 C2	R5411 D9
R3138 C5	R4041 D3	R4164 C1	R5416 D9
R3151 C5	R4042 C2	R4166 B1	R5501 C11
R3161 C5	R4043 C3	R4167 B1-L	V1009 B11
R3171 B5-L	R4044 C2	R4168 B1-L	V1011 C11
R3176 B5	R4045 C3	R4169 B1	V1014 A10
R3201 B5	R4051 C3-L	R4173 C1	V1016 A10
R3202 B5	R4104 C2	R4174 C1	V1018 C10
R3203 B5	R4110 D1	R4176 C1	V1019 C10
R3204 B6	R4111 D1	R4177 C1	V1021 C10
R3207 C6	R4112 D1	R4178 B1	V1022 B10
R3211 C6	R4113 D1	R4179 B1	V1023 B10
R3212 C5	R4114 D1	R4181 D1	V1024 B10
R3214 C5	R4116 C1	R4182 D1	V1026 B9
R3231 C6	R4117 C1	R4201 D1	V1027 C9
R3232 C5	R4118 C1	R4202 D1	V1028 A9
R3233 C5	R4119 C1	R4203 D1	V1201 B9
R3234 B5	R4121 C1	R4261 D2	V1202 A9
R3236 C5	R4122 C1	R4262 D2	V1203 A7
R3237 C5	R4123 C1	R5001 D11	V1204 A7
R3238 C5	R4124 C1	R5002 D11	V1301 C9
R3251 C5	R4126 C1	R5003 D11	V2061 A7
R3261 C5	R4127 C1	R5004 D11	V2062 A7
R3271 B5-L	R4128 C1	R5007 D10	V2101 B6
R3276 B5	R4129 C1	R5008 D10	V2102 C6
R3301 B8	R4130 A1	R5101 D10	V2103 C6
R3302 B8	R4131 B1	R5111 D10	V2105 C6
R3311 B8	R4132 B1	R5116 D10	V2111 C6
R3312 B8	R4133 B1	R5121 D10	V2113 C7-L
R3313 B8	R4134 C1	R5126 D10	V2131 B6
R3314 B8	R4135 A1	R5131 A11	V2132 B6
R3316 B8	R4136 C1	R5132 A11	V2133 C6
R3411 C5	R4137 B1	R5133 A11	V2134 C7-L
R3412 C5	R4138 B1	R5134 A11	V2201 B7
R3416 C4	R4139 A1	R5136 B11	V2202 C7
R3418 C6	R4141 A1	R5137 B11	V2203 C7
R3419 D4	R4142 C1	R5138 B11	V2205 C7
R3421 C4	R4143 C1	R5139 B11	V2211 C7
R3422 C6	R4144 B1	R5151 A11	V2213 C7-L
R3423 B6	R4146 B1	R5201 A6	V2231 B7
R4001 D2	R4147 A1	R5202 A6	V2232 B7
R4002 D2-L	R4148 A1	R5206 A6	V2233 C7
R4003 D2-L	R4149 B1	R5211 A6	V2234 C7-L
R4004 D2-L	R4150 B1	R5216 A6	V2301 D7
R4006 C2-L	R4151 B2	R5231 D7	V2413 C7
R4007 D2-L	R4152 C2	R5236 D7	V2416 D7
R4008 D2	R4153 C2	R5251 A8	V2421 B6
R4009 C2	R4154 C2	R5301 A5	V3001 A4
R4031 D2	R4155 B2	R5306 A5	V3002 A4
R4032 D3	R4156 B2	R5311 A6	V3061 A5
R4033 D3	R4157 B2	R5316 A5	V3062 A5
R4034 D3	R4158 B2	R5321 B8	V3101 B4
R4036 D3	R4159 B2	R5326 B8	V3102 C4
R4037 D2	R4160 B1	R5331 D5	V3103 C4
R4038 D3	R4161 B1	R5336 D5	V3105 C4
R4039 D2	R4162 B1	R5351 A6	V3111 C4

V3113 C5-L	V3237 D5	V4029 C3	V4104 C1
V3131 C4	V3301 B8	V4031 D3	V4106 B1
V3132 B4	V3311 B8	V4032 D3	V4107 B1
V3133 C4	V3312 B8	V4033 D3	V4108 C1
V3134 C5-L	V3413 C5	V4034 C2	V4109 C1
V3136 C5	V3416 D5	V4036 D2	V4111 B1
V3137 D5	V3421 B6	V4037 D3	V4112 B1
V3201 B5	V4001 D2	V4038 C3	V4113 D1
V3202 C6	V4002 C2	V4039 C3	V4114 B2
V3203 C6	V4003 C2	V4040 D3	V5001 D6
V3205 C6	V4004 C2	V4041 C3	V5002 D5
V3211 C6	V4021 D2	V4042 C3	X2101 B11-L
V3213 C5-L	V4022 D2	V4043 B3	X2301 D9-L
V3231 B6	V4023 D2	V4044 B3	X2401 D2-L
V3232 B5	V4024 D2	V4084 C3	X2402 B3-L
V3233 C5	V4026 B2	V4101 C1	X2403 B2-L
V3234 C5-L	V4027 B3	V4102 C1	X2501 A8-L
V3236 C5	V4028 B3	V4103 C1	

5.2.11 Circuit diagrams A2-100 MHz version

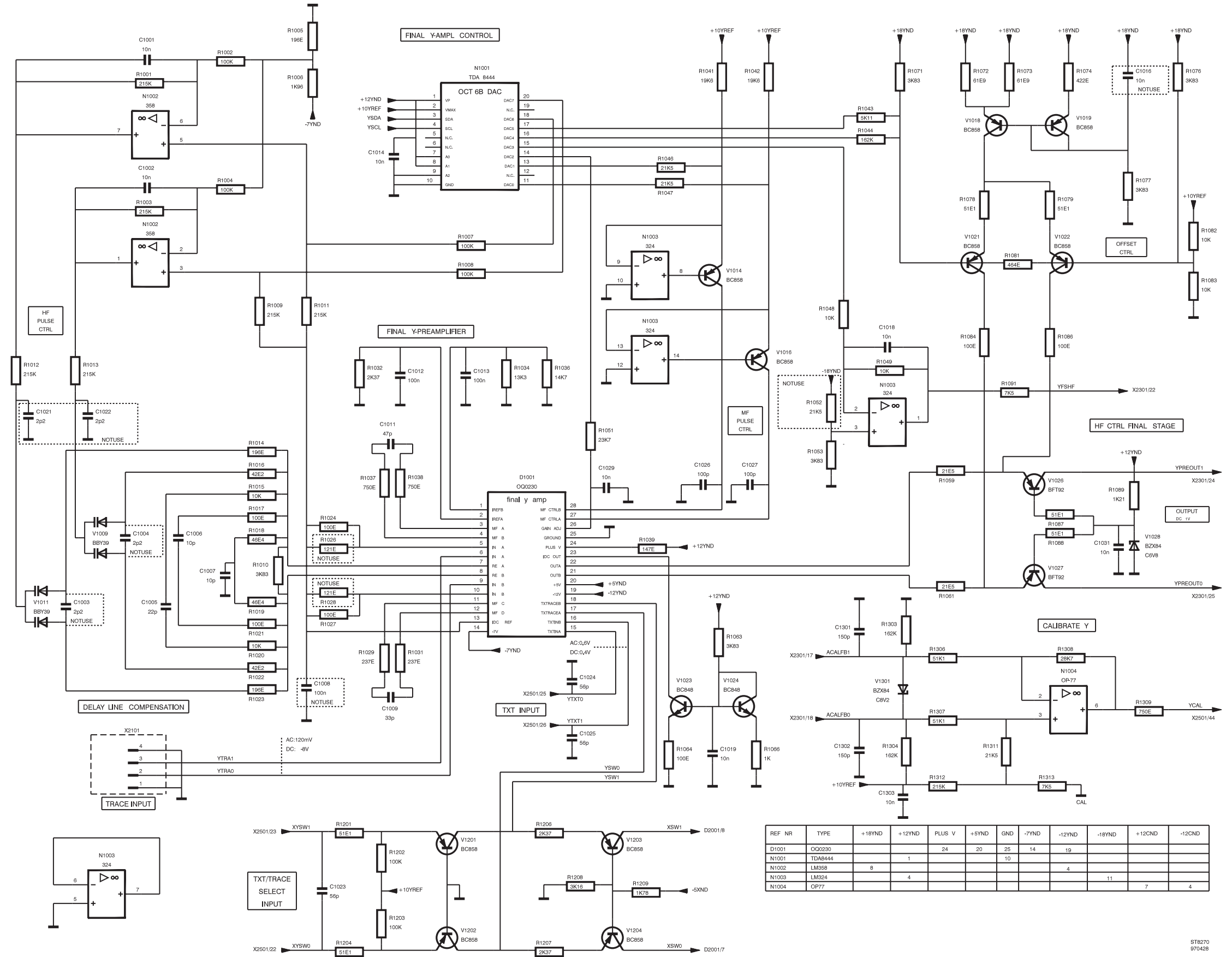

A2 (100 MHz) - Diagram 1a ; Final Y preamplifier and control

ST8270
970428

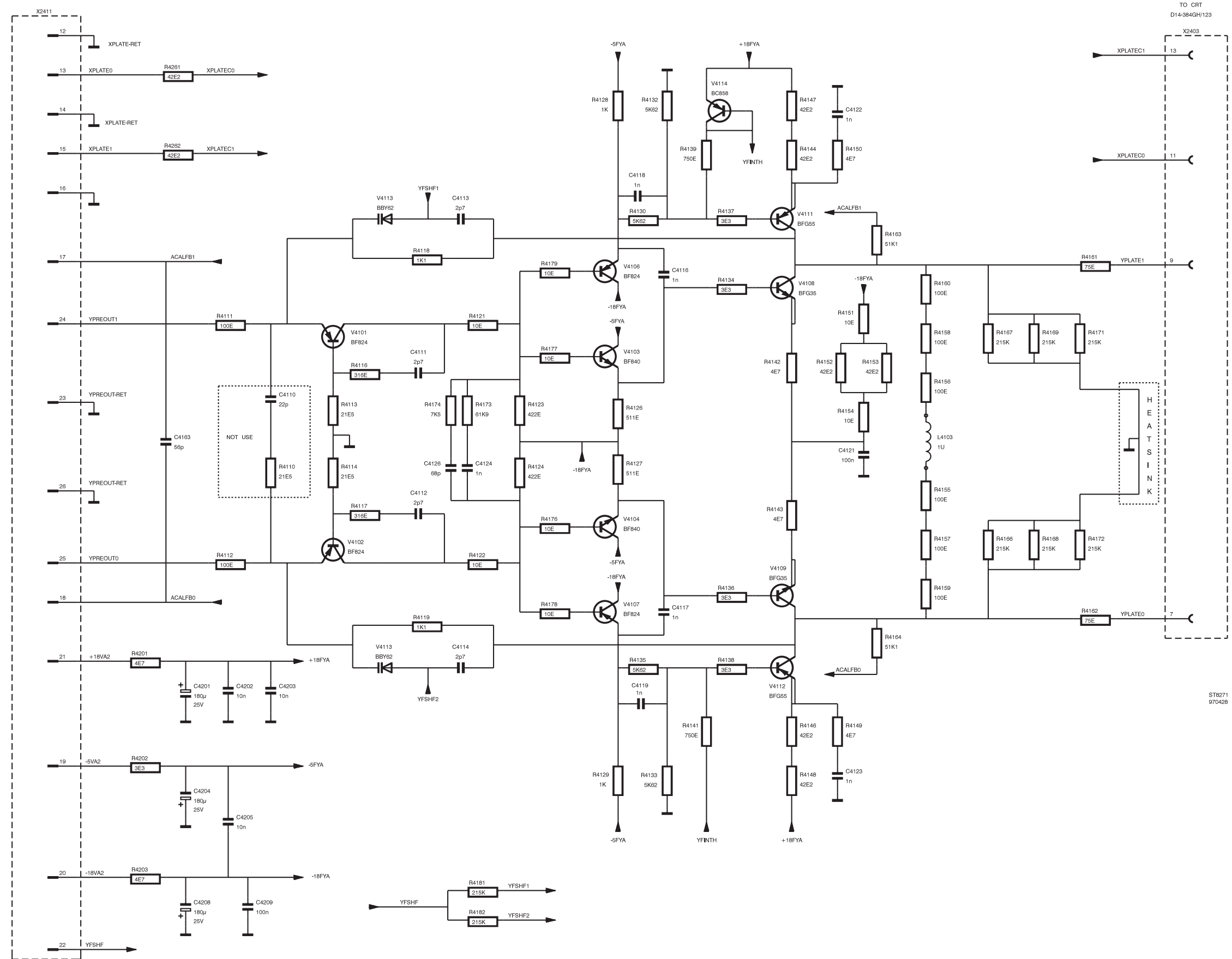

A2 (100 MHz) - Diagram 2a ; Final Y output stage

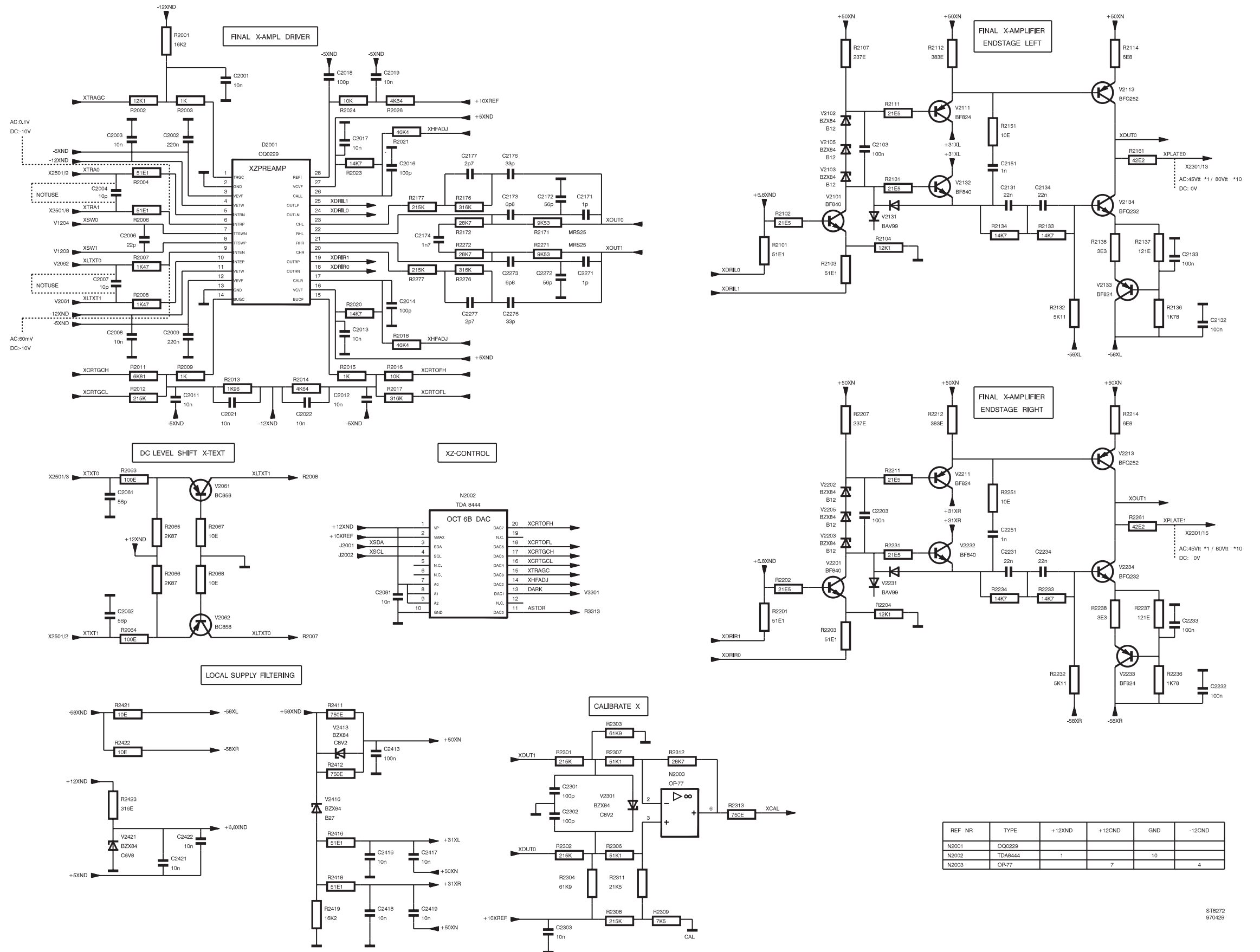

REF NR	TYPE	+12XND	+12CND	GND	-12CND
N2001	OQ0229				
N2002	TDA8444	1	7	10	
N2003	OR-77				4

STR272
970428

A2 (100 MHz) - Diagram 3a ; Final X amplifier and control

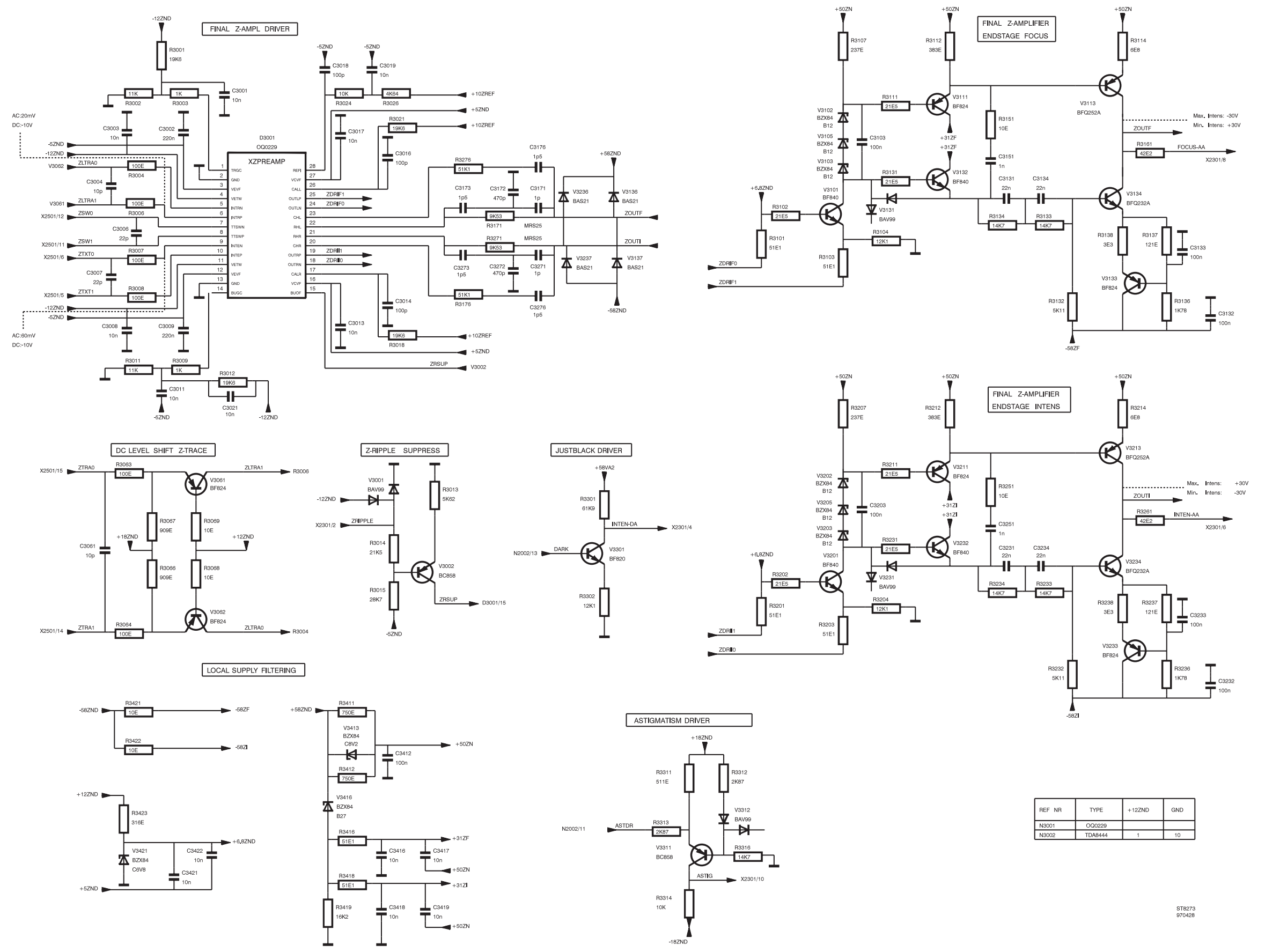

REF NR	TYPE	+12ZND	GND
N3001	OQ0229		
N3002	TDA8444	1	10

A2 (100 MHz) - Diagram 4a ; Final Z amplifier

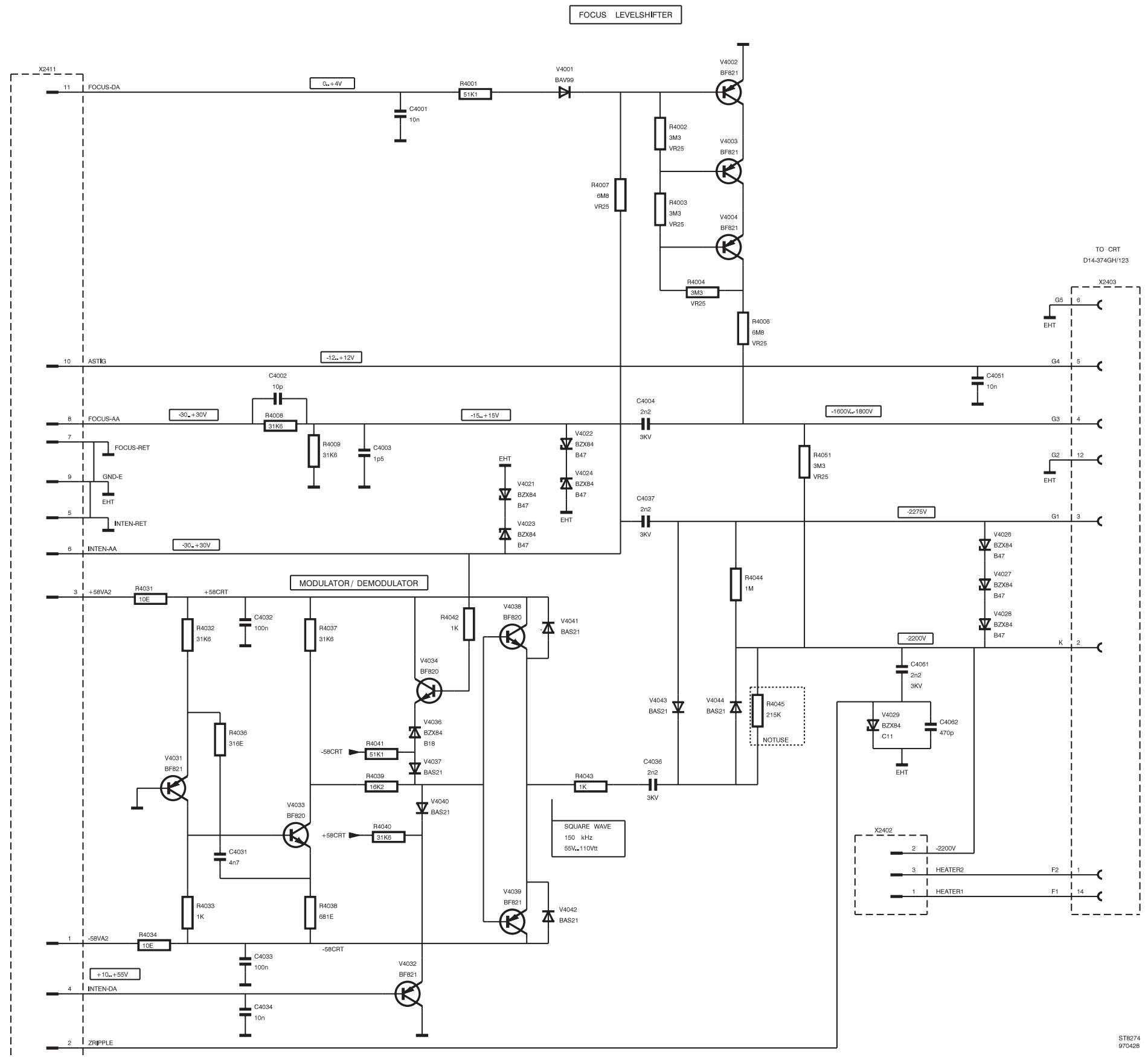

ST8274
970428

A2 (100 MHz) - Diagram 5a ; Modulator/demodulator and focus control

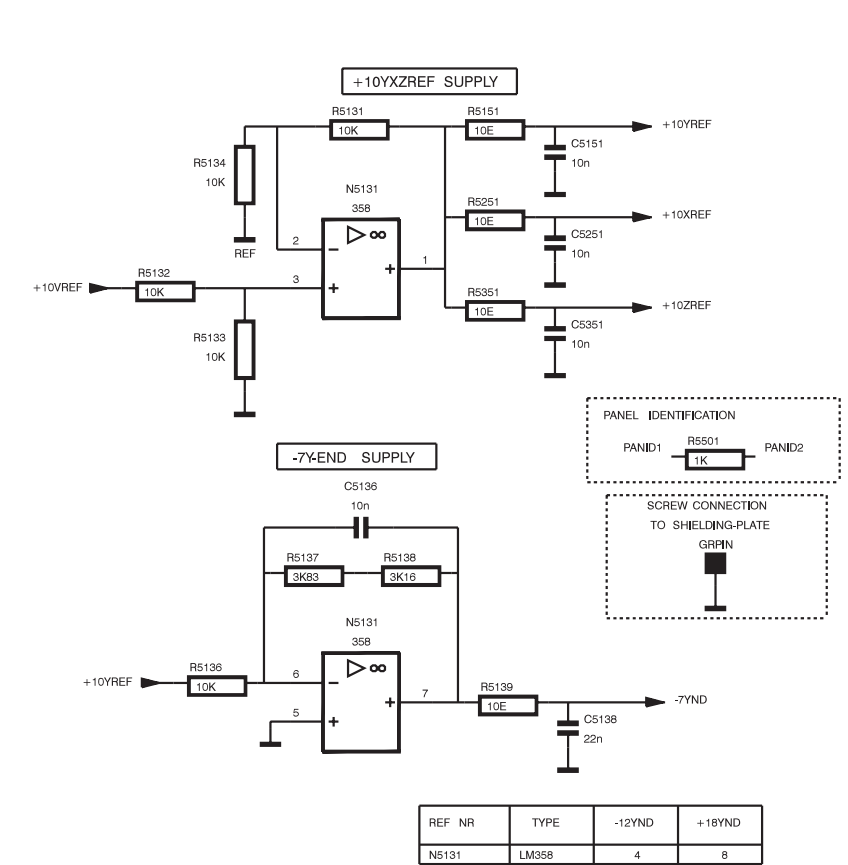
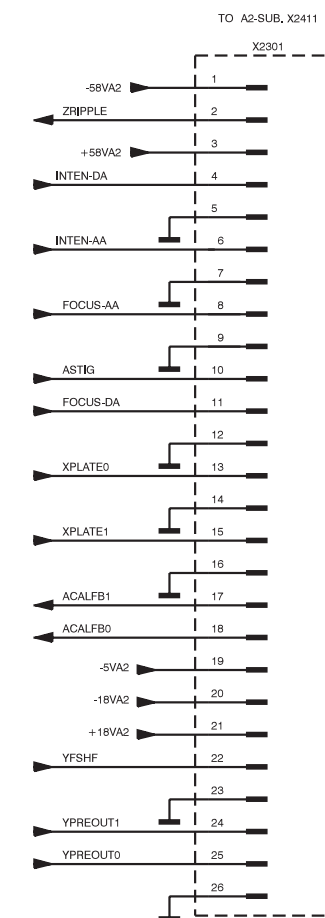
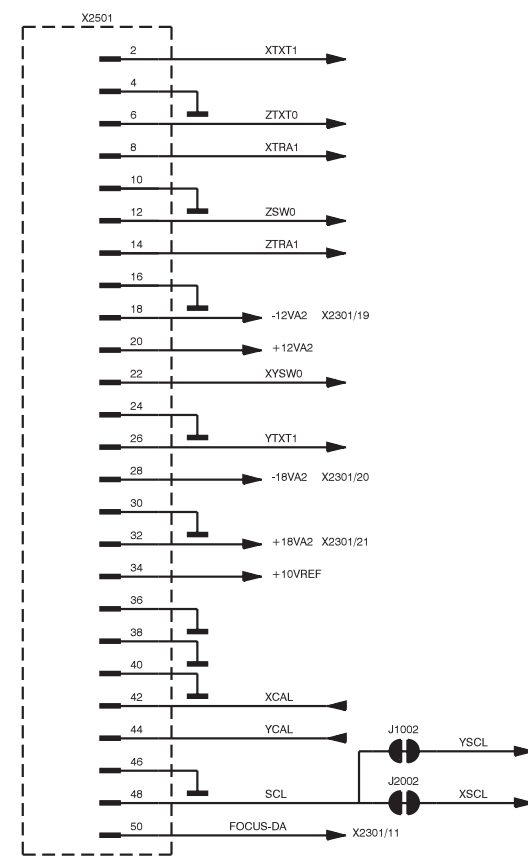
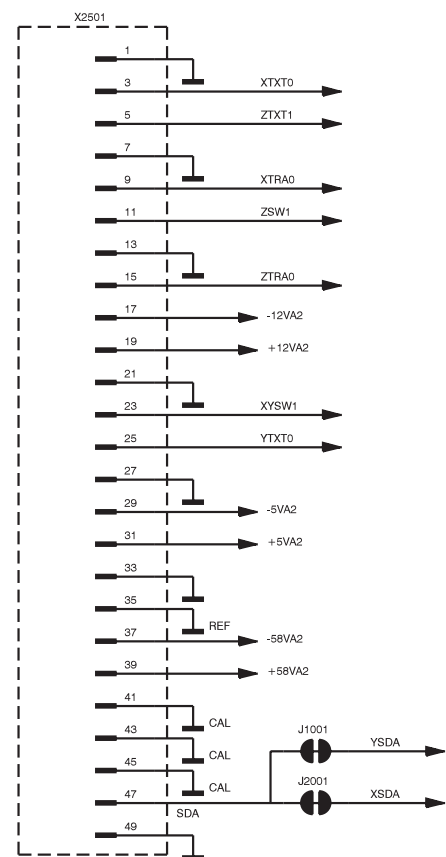
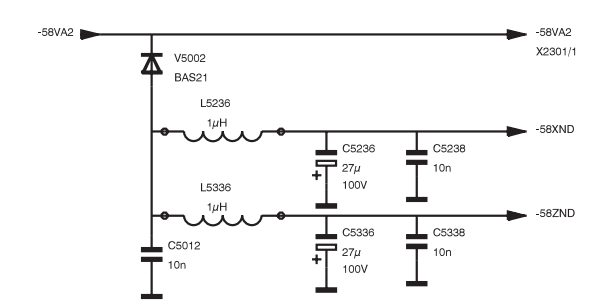
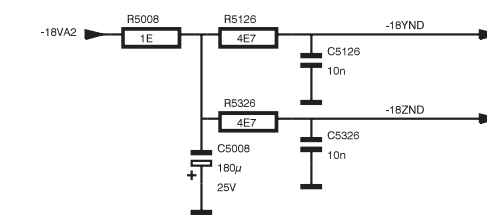
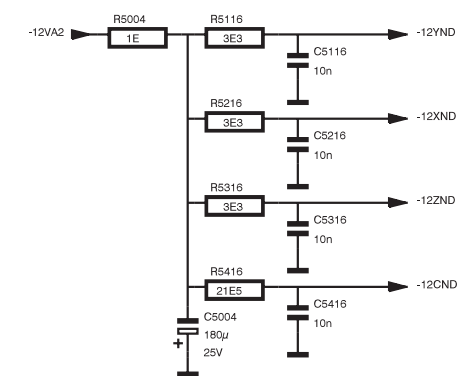
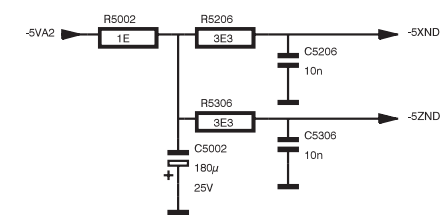
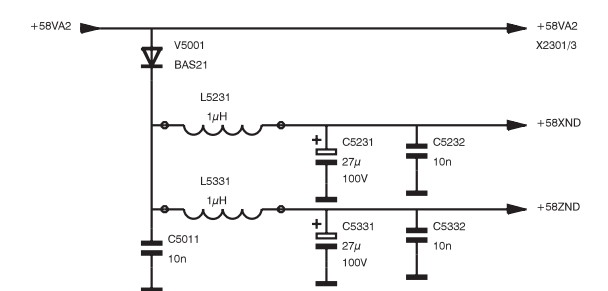
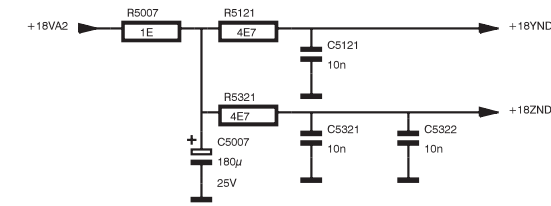
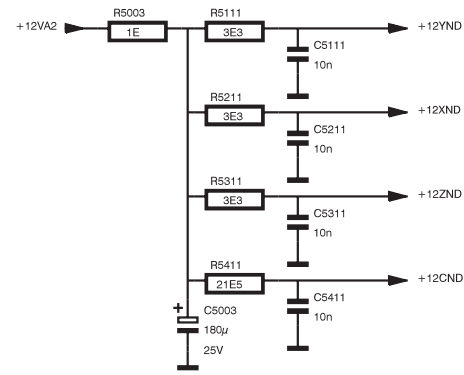
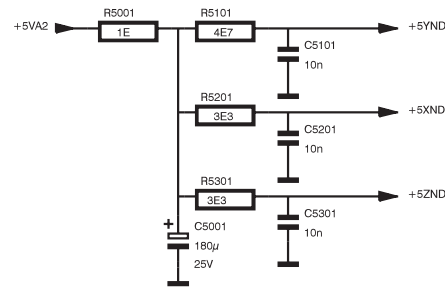

A2 (100 MHz) - Diagram 6a ; Supply circuits

Item	Description	Ordering code
------	-------------	---------------

5.2.12 Parts list A2-100 MHz version

CAPACITORS

C 1001	CAP.CHIP	63V 10% 10NF	5322 122 34098
C 1002	CAP.CHIP	63V 10% 10NF	5322 122 34098
C 1003	CAP.CHIP	63V 0.25PF 2.2PF	5322 122 33063
C 1005	CAP.CHIP	63V 5% 22PF	5322 122 32658
C 1006	CAP.CHIP	63V 5% 10PF	5322 122 32448
C 1007	CAP.CERAMIC	63V 5% 10PF	5322 122 32448
C 1009	CAP.CERAMIC	63V 5% 33PF	5322 122 32659
C 1011	CAP.CHIP	63V 5% 47PF	5322 122 32452
C 1012	CAP.CHIP	63V 10% 100NF	4822 122 33496
C 1013	CAP.CHIP	63V 10% 100NF	4822 122 33496
C 1014	CAP.CHIP	63V 10% 10NF	5322 122 34098
C 1018	CAP.CHIP	63V 10% 10NF	5322 122 34098
C 1019	CAP.CHIP	63V 10% 10NF	5322 122 34098
C 1023	CAP.CHIP	63V 5% 56PF	5322 122 32661
C 1024	CAP.CHIP	63V 5% 56PF	5322 122 32661
C 1025	CAP.CHIP	63V 5% 56PF	5322 122 32661
C 1026	CAP.CHIP	63V 5% 100PF	5322 122 32531
C 1027	CAP.CHIP	63V 5% 100PF	5322 122 32531
C 1029	CAP.CHIP	63V 10% 10NF	5322 122 34098
C 1031	CAP.CHIP	63V 10% 10NF	5322 122 34098
C 1301	CAP.CHIP	63V 5% 150PF	5322 122 33538
C 1302	CAP.CHIP	63V 5% 150PF	5322 122 33538
C 1303	CAP.CHIP	63V 10% 10NF	5322 122 34098
C 2001	CAP.CHIP	63V 10% 10NF	5322 122 34098
C 2002	CAP.CHIP	63V 10% 220NF	4822 122 32916
C 2003	CAP.CHIP	63V 10% 10NF	5322 122 34098
C 2006	CAP.CHIP	63V 5% 22PF	5322 122 32658
C 2008	CAP.CHIP	63V 10% 10NF	5322 122 34098
C 2009	CAP.CHIP	63V 10% 220NF	4822 122 32916
C 2011	CAP.CHIP	63V 10% 10NF	5322 122 34098
C 2012	CAP.CHIP	63V 10% 10NF	5322 122 34098
C 2013	CAP.CHIP	63V 10% 10NF	5322 122 34098
C 2014	CAP.CHIP	63V 5% 100PF	5322 122 32531
C 2016	CAP.CHIP	63V 5% 100PF	5322 122 32531
C 2017	CAP.CHIP	63V 10% 10NF	5322 122 34098
C 2018	CAP.CHIP	63V 5% 100PF	5322 122 32531
C 2019	CAP.CHIP	63V 10% 10NF	5322 122 34098
C 2021	CAP.CHIP	63V 10% 10NF	5322 122 34098
C 2022	CAP.CHIP	63V 10% 10NF	5322 122 34098
C 2061	CAP.CHIP	63V 5% 56PF	5322 122 32661
C 2062	CAP.CHIP	63V 5% 56PF	5322 122 32661
C 2081	CAP.CHIP	63V 10% 10NF	5322 122 34098
C 2103	CAP.CHIP	63V 10% 100NF	4822 122 33496
C 2131	CAP.CHIP	63V 10% 22NF	5322 122 32654
C 2132	CAP.CHIP	63V 10% 100NF	4822 122 33496

Item	Description		Ordering code
C 2133	CAP.CHIP	63V 10% 100NF	4822 122 33496
C 2134	CAP.CHIP	63V 10% 22NF	5322 122 32654
C 2151	CAP.CHIP	63V 5% 1NF	5322 126 10511
C 2171	CAP.CHIP	63V 0.25PF 1PF	5322 122 32447
C 2172	CAP.CHIP	63V 5% 56PF	5322 122 32661
C 2173	CAP.CHIP	63V 5% 6.8PF	5322 122 32269
C 2174	CAP.CHIP	63V 5% 1NF	5322 126 10511
C 2176	CAP.CHIP	63V 5% 33PF	5322 122 32659
C 2177	CAP.CHIP	63V 0.5PF 2.7PF	5322 122 31873
C 2203	CAP.CHIP	63V 10% 100NF	4822 122 33496
C 2231	CAP.CHIP	63V 10% 22NF	5322 122 32654
C 2232	CAP.CHIP	63V 10% 100NF	4822 122 33496
C 2233	CAP.CHIP	63V 10% 100NF	4822 122 33496
C 2231	CAP.CHIP	63V 10% 22NF	5322 122 32654
C 2251	CAP.CHIP	63V 5% 1NF	5322 126 10511
C 2271	CAP.CHIP	63V 0.25PF 1PF	5322 122 32447
C 2272	CAP.CHIP	63V 5% 56PF	5322 122 32661
C 2273	CAP.CHIP	63V 5% 6.8PF	5322 122 32269
C 2276	CAP.CHIP	63V 5% 33PF	5322 122 32659
C 2277	CAP.CHIP	63V 0.5PF 2.7PF	5322 122 31873
C 2301	CAP.CHIP	63V 5% 100PF	5322 122 32531
C 2302	CAP.CHIP	63V 5% 100PF	5322 122 32531
C 2303	CAP.CHIP	63V 10% 10NF	5322 122 34098
C 2413	CAP.CHIP	63V 10% 100NF	4822 122 33496
C 2416	CAP.CHIP	63V 10% 10NF	5322 122 34098
C 2417	CAP.CHIP	63V 10% 10NF	5322 122 34098
C 2418	CAP.CHIP	63V 10% 10NF	5322 122 34098
C 2419	CAP.CHIP	63V 10% 10NF	5322 122 34098
C 2421	CAP.CHIP	63V 10% 10NF	5322 122 34098
C 2422	CAP.CHIP	63V 10% 10NF	5322 122 34098
C 3001	CAP.CHIP	63V 10% 10NF	5322 122 34098
C 3002	CAP.CHIP	63V 10% 220NF	4822 122 32916
C 3003	CAP.CHIP	63V 10% 10NF	5322 122 34098
C 3004	CAP.CHIP	63V 5% 10PF	5322 122 32448
C 3006	CAP.CHIP	63V 5% 22PF	5322 122 32658
C 3007	CAP.CHIP	63V 5% 22PF	5322 122 32658
C 3008	CAP.CHIP	63V 10% 10NF	5322 122 34098
C 3009	CAP.CHIP	63V 10% 220NF	4822 122 32916
C 3011	CAP.CHIP	63V 10% 10NF	5322 122 34098
C 3013	CAP.CHIP	63V 10% 10NF	5322 122 34098
C 3014	CAP.CHIP	63V 5% 100PF	5322 122 32531
C 3016	CAP.CHIP	63V 5% 100PF	5322 122 32531
C 3017	CAP.CHIP	63V 10% 10NF	5322 122 34098
C 3018	CAP.CHIP	63V 5% 100PF	5322 122 32531
C 3019	CAP.CHIP	63V 10% 10NF	5322 122 34098
C 3021	CAP.CHIP	63V 10% 10NF	5322 122 34098
C 3061	CAP.CHIP	63V 5% 10PF	5322 122 32448

Item	Description		Ordering code
C 3103	CAP.CHIP	63V 10% 100NF	4822 122 33496
C 3131	CAP.CHIP	63V 10% 22NF	5322 122 32654
C 3132	CAP.CHIP	63V 10% 100NF	4822 122 33496
C 3133	CAP.CHIP	63V 10% 100NF	4822 122 33496
C 3134	CAP.CHIP	63V 10% 22NF	5322 122 32654
C 3151	CAP.CHIP	63V 5% 1NF	5322 126 10511
C 3171	CAP.CHIP	63V 0.25PF 1PF	5322 122 32447
C 3172	CAP.CHIP	63V 5% 470PF	5322 122 32268
C 3173	CAP.CHIP	63V 0.25PF 1.5PF	5322 126 10225
C 3176	CAP.CHIP	63V 0.25PF 1.5PF	5322 126 10225
C 3203	CAP.CHIP	63V 10% 100NF	4822 122 33496
C 3231	CAP.CHIP	63V 10% 22NF	5322 122 32654
C 3232	CAP.CHIP	63V 10% 100NF	4822 122 33496
C 3233	CAP.CHIP	63V 10% 100NF	4822 122 33496
C 3234	CAP.CHIP	63V 10% 22NF	5322 122 32654
C 3251	CAP.CHIP	63V 5% 1NF	5322 126 10511
C 3271	CAP.CHIP	63V 0.25PF 1PF	5322 122 32447
C 3272	CAP.CHIP	63V 5% 470PF	5322 122 32268
C 3273	CAP.CHIP	63V 0.25PF 1.5PF	5322 126 10225
C 3276	CAP.CHIP	63V 0.25PF 1.5PF	5322 126 10225
C 3412	CAP.CHIP	63V 10% 100NF	4822 122 33496
C 3416	CAP.CHIP	63V 10% 10NF	5322 122 34098
C 3417	CAP.CHIP	63V 10% 10NF	5322 122 34098
C 3418	CAP.CHIP	63V 10% 10NF	5322 122 34098
C 3419	CAP.CHIP	63V 10% 10NF	5322 122 34098
C 3421	CAP.CHIP	63V 10% 10NF	5322 122 34098
C 3422	CAP.CHIP	63V 10% 10NF	5322 122 34098
C 4001	CAP.CHIP	63V 10% 10NF	5322 122 34098
C 4002	CAP.CHIP	63V 5% 150PF	5322 122 33538
C 4003	CAP.CHIP	63V 0.25PF 1.5PF	5322 126 10225
C 4004	CAP.	-10+10% 2.2NF	5322 122 33851
C 4031	CAP.CHIP	63V 10% 4.7NF	5322 126 10223
C 4032	CAP.CHIP	63V 10% 100NF	4822 122 33496
C 4033	CAP.CHIP	63V 10% 100NF	4822 122 33496
C 4034	CAP.CHIP	63V 10% 10NF	5322 122 34098
C 4036	CAP.	-10+10% 2.2NF	5322 122 33851
C 4037	CAP.	-10+10% 2.2NF	5322 122 33851
C 4051	CAP.CHIP	63V 10% 10NF	5322 122 34098
C 4061	CAP.	-10+10% 2.2NF	5322 122 33851
C 4062	CAP.CHIP	63V 5% 470PF	5322 122 32268
C 4110	CAP.CHIP	63V 5% 22PF	5322 122 32658
C 4111	CAP.CHIP	63V 0.25PF 2.7PF	5322 122 31873
C 4112	CAP.CHIP	63V 0.25PF 2.7PF	5322 122 31873
C 4113	CAP.CHIP	63V 0.25PF 2.7PF	5322 122 31873
C 4114	CAP.CHIP	63V 0.25PF 2.7PF	5322 122 31873
C 4116	CAP.CHIP	63V 5% 1NF	5322 126 10511
C 4117	CAP.CHIP	63V 5% 1NF	5322 126 10511

Item	Description		Ordering code
C 4118	CAP.CHIP	63V 5% 1NF	5322 126 10511
C 4119	CAP.CHIP	63V 5% 1NF	5322 126 10511
C 4121	CAP.CHIP	63V 10% 100NF	4822 122 33496
C 4122	CAP.CHIP	63V 5% 1NF	5322 126 10511
C 4123	CAP.CHIP	63V 5% 1NF	5322 126 10511
C 4124	CAP.CHIP	63V 5% 1NF	5322 126 10511
C 4126	CAP.CHIP	63V 5% 68PF	4822 122 33514
C 4163	CAP.CHIP	63V 5% 56PF	5322 122 32661
C 4201	CAP.ELECTROLYT.	25V 20% 180UF	5322 124 42228
C 4202	CAP.CHIP	63V 10% 10NF	5322 122 34098
C 4203	CAP.CHIP	63V 10% 10NF	5322 122 34098
C 4204	CAP.ELECTROLYT.	25V 20% 180UF	5322 124 42228
C 4205	CAP.CHIP	63V 10% 10NF	5322 122 34098
C 4206	CAP.CHIP	63V 10% 10NF	5322 122 34098
C 4207	CAP.CHIP	63V 10% 10NF	5322 122 34098
C 4208	CAP.ELECTROLYT.	25V 20% 180UF	5322 124 42228
C 4209	CAP.CHIP	63V 10% 100NF	4822 122 33496
C 5001	CAP.ELECTROLYT.	25V 20% 180UF	5322 124 42228
C 5002	CAP.ELECTROLYT.	25V 20% 180UF	5322 124 42228
C 5003	CAP.ELECTROLYT.	25V 20% 180UF	5322 124 42228
C 5004	CAP.ELECTROLYT.	25V 20% 180UF	5322 124 42228
C 5007	CAP.ELECTROLYT.	25V 20% 180UF	5322 124 42228
C 5008	CAP.ELECTROLYT.	25V 20% 180UF	5322 124 42228
C 5011	CAP.CHIP	63V 10% 10NF	5322 122 34098
C 5012	CAP.CHIP	63V 10% 10NF	5322 122 34098
C 5101	CAP.CHIP	63V 10% 10NF	5322 122 34098
C 5111	CAP.CHIP	63V 10% 10NF	5322 122 34098
C 5116	CAP.CHIP	63V 10% 10NF	5322 122 34098
C 5121	CAP.CHIP	63V 10% 10NF	5322 122 34098
C 5126	CAP.CHIP	63V 10% 10NF	5322 122 34098
C 5136	CAP.CHIP	63V 10% 10NF	5322 122 34098
C 5138	CAP.CHIP	63V 10% 22NF	5322 122 32654
C 5151	CAP.CHIP	63V 10% 10NF	5322 122 34098
C 5201	CAP.CHIP	63V 10% 10NF	5322 122 34098
C 5206	CAP.CHIP	63V 10% 10NF	5322 122 34098
C 5211	CAP.CHIP	63V 10% 10NF	5322 122 34098
C 5216	CAP.CHIP	63V 10% 10NF	5322 122 34098
C 5231	CAP.ELECTROLYT.	100V 20% 27UF	5322 124 42193
C 5232	CAP.CHIP	63V 10% 10NF	5322 122 34098
C 5236	CAP.ELECTROLYT.	100V 20% 27UF	5322 124 42193
C 5238	CAP.CHIP	63V 10% 10NF	5322 122 34098
C 5251	CAP.CHIP	63V 10% 10NF	5322 122 34098
C 5301	CAP.CHIP	63V 10% 10NF	5322 122 34098
C 5306	CAP.CHIP	63V 10% 10NF	5322 122 34098
C 5311	CAP.CHIP	63V 10% 10NF	5322 122 34098
C 5316	CAP.CHIP	63V 10% 10NF	5322 122 34098
C 5321	CAP.CHIP	63V 10% 10NF	5322 122 34098

Item	Description		Ordering code
C 5322	CAP.CHIP	63V 10% 10NF	5322 122 34098
C 5326	CAP.CHIP	63V 10% 10NF	5322 122 34098
C 5331	CAP.ELECTROLYT.	100V 20% 27UF	5322 124 42193
C 5332	CAP.CHIP	63V 10% 10NF	5322 122 34098
C 5336	CAP.ELECTROLYT.	100V 20% 27UF	5322 124 42193
C 5338	CAP.CHIP	63V 10% 10NF	5322 122 34098
C 5351	CAP.CHIP	63V 10% 10NF	5322 122 34098
C 5411	CAP.CHIP	63V 10% 10NF	5322 122 34098
C 5416	CAP.CHIP	63V 10% 10NF	5322 122 34098

COILS

L 4101	COIL	0.082UH 5% TDK	5322 157 63382
L 4102	COIL	0.082UH 5% TDK	5322 157 63382
L 41032	COIL	1UH 5% TDK	5322 157 63648

INTEGRATED CIRCUITS

D 1001	INTEGR.CIRCUIT	OQ0230 FINAL Y	5322 209 12467
D 2001	INTEGR.CIRCUIT	OQ0229 FINAL X-Z	5322 209 12459
D 3001	INTEGR.CIRCUIT	OQ0229 FINAL X-Z	5322 209 12459
N 1001	INTEGR.CIRCUIT	TDA8444AT/N4 PEL	5322 209 30233
N 1002	INTEGR.CIRCUIT	LM358M NSC	4822 209 60175
N 1003	INTEGR.CIRCUIT	LM324D NSC	5322 209 83125
N 1004	I.C. ANALOGUE	OP-77GSR PMI	5322 130 62791
N 2002	INTEGR.CIRCUIT	TDA8444AT/N4 PEL	5322 209 30233
N 2003	I.C. ANALOGUE	OP-77GSR PMI	5322 130 62791
N 5131	INTEGR.CIRCUIT	LM358M NSC	4822 209 60175

RESISTORS

R 1001	RES.CHIP	RC-02H 1% 215K	4822 051 52154
R 1002	RES.CHIP	RC-02H 1% 100K	4822 051 51004
R 1003	RES.CHIP	RC-02H 1% 215K	4822 051 52154
R 1004	RES.CHIP	RC-02H 1% 100K	4822 051 51004
R 1005	RES.CHIP	RC-02H 1% 196E	4822 051 51961
R 1006	RES.CHIP	RC-02H 1% 1K96	4822 051 51962
R 1007	RES.CHIP	RC-02H 1% 100K	4822 051 51004
R 1008	RES.CHIP	RC-02H 1% 100K	4822 051 51004
R 1009	RES.CHIP	RC-02H 1% 215K	4822 051 52154
R 1010	RES.CHIP	RC-02H 1% 3K83	4822 051 53832
R 1011	RES.CHIP	RC-02H 1% 215K	4822 051 52154
R 1012	RES.CHIP	RC-02H 1% 215K	4822 051 52154
R 1013	RES.CHIP	RC-02H 1% 215K	4822 051 52154
R 1014	RES.CHIP	RC-02H 1% 196E	5322 117 10538
R 1015	RES.CHIP	RC-02H 1% 10K	4822 051 10103
R 1016	RES.CHIP	RMC1/8 1% 42E2	5322 117 11753
R 1017	RES.CHIP	RC-02H 1% 100E	4822 051 10101
R 1018	RES.MET.GLAZED	RMC1/8 1% 46E4	5322 116 82896
R 1019	RES.MET.GLAZED	RMC1/8 1% 46E4	5322 116 82896
R 1020	RES.CHIP	RC-02H 1% 10K	4822 051 10103

Item	Description		Ordering code
R 1021	RES.CHIP	RC-02H 1% 100E	4822 051 10101
R 1022	RES.CHIP	RMC1/8 1% 42E2	5322 117 11753
R 1023	RES.CHIP	RC-02H 1% 196E	5322 117 10538
R 1024	RES.CHIP	RC-02H 1% 100E	4822 051 51001
R 1027	RES.CHIP	RC-02H 1% 100E	4822 051 51001
R 1029	RES.CHIP	RC-02H 1% 237E	5322 117 10544
R 1031	RES.CHIP	RC-02H 1% 237E	5322 117 10544
R 1032	RES.CHIP	RC-02H 1% 2K37	4822 051 52372
R 1034	RES.CHIP	RC-02H 1% 13K3	4822 051 51333
R 1036	RES.CHIP	RC-02H 1% 14K7	5322 117 10528
R 1037	RES.CHIP	RC-02H 1% 750E	5322 117 10582
R 1038	RES.CHIP	RC-02H 1% 750E	5322 117 10582
R 1039	RES.CHIP	RC-02H 1% 147E	4822 051 51471
R 1041	RES.CHIP	RC-02H 1% 19K6	4822 051 51963
R 1042	RES.CHIP	RC-02H 1% 19K6	4822 051 51963
R 1043	RES.CHIP	RC-02H 1% 5K11	4822 051 55112
R 1044	RES.CHIP	RC-02H 1% 162K	4822 051 51624
R 1046	RES.CHIP	RC-02H 1% 21K5	4822 051 52153
R 1047	RES.CHIP	RC-02H 1% 21K5	4822 051 52153
R 1048	RES.CHIP	RC-02H 1% 10K	4822 051 51003
R 1049	RES.CHIP	RC-02H 1% 10K	4822 051 51003
R 1051	RES.CHIP	RC-02H 1% 23K7	4822 051 52373
R 1053	RES.CHIP	RC-02H 1% 3K83	4822 051 53832
R 1059	RES.CHIP	RMC1/8 1% 21E5	5322 117 11734
R 1061	RES.CHIP	RMC1/8 1% 21E5	5322 117 11734
R 1063	RES.CHIP	RC-02H 1% 3K83	4822 051 53832
R 1064	RES.CHIP	RC-02H 1% 100E	4822 051 51001
R 1066	RES.CHIP	RC-02H 1% 1K	4822 051 51002
R 1071	RES.CHIP	RC-02H 1% 3K83	4822 051 53832
R 1072	RES.CHIP	RMC1/8 1% 75E	4822 111 91937
R 1073	RES.CHIP	RMC1/8 1% 75E	4822 111 91937
R 1074	RES.CHIP	RC-02H 1% 422E	5322 117 10564
R 1076	RES.CHIP	RC-02H 1% 3K83	4822 051 53832
R 1077	RES.CHIP	RC-02H 1% 3K83	5322 117 10561
R 1078	RES.CHIP	RMC1/8 1% 51E1	5322 111 91893
R 1079	RES.CHIP	RMC1/8 1% 51E1	5322 111 91893
R 1081	RES.CHIP	RC-02H 1% 464E	4822 051 54641
R 1082	RES.CHIP	RC-02H 1% 10K	4822 051 51003
R 1083	RES.CHIP	RC-02H 1% 10K	4822 051 51003
R 1084	RES.CHIP	RC-02H 1% 100E	4822 051 51001
R 1086	RES.CHIP	RC-02H 1% 100E	4822 051 51001
R 1087	RES.CHIP	RC-02H 1% 51E1	5322 117 11737
R 1088	RES.CHIP	RC-02H 1% 51E1	5322 117 11737
R 1089	RES.CHIP	RC-02H 1% 1K21	4822 051 51212
R 1091	RES.CHIP	RC-02H 1% 7K5	4822 051 57502
R 1201	RES.CHIP	RMC1/8 1% 51E1	5322 111 91893
R 1202	RES.CHIP	RC-02H 1% 100K	4822 051 51004

Item	Description		Ordering code
R 1203	RES.CHIP	RC-02H 1% 100K	4822 051 51004
R 1204	RES.CHIP	RMC1/8 1% 51E1	5322 111 91893
R 1206	RES.CHIP	RC-02H 1% 2K37	4822 051 52372
R 1207	RES.CHIP	RC-02H 1% 2K37	4822 051 52372
R 1208	RES.CHIP	RC-02H 1% 3K16	4822 051 53162
R 1209	RES.CHIP	RC-02H 1% 1K78	4822 051 51782
R 1303	RES.CHIP	RC-02H 1% 162K	4822 051 51624
R 1304	RES.CHIP	RC-02H 1% 162K	4822 051 51624
R 1306	RES.CHIP	RC-02H 1% 51K1	4822 051 55113
R 1307	RES.CHIP	RC-02H 1% 51K1	4822 051 55113
R 1308	RES.CHIP	RC-02H 1% 28K7	4822 051 52873
R 1309	RES.CHIP	RC-02H 1% 750E	4822 051 57501
R 1311	RES.CHIP	RC-02H 1% 21K5	4822 051 52153
R 1312	RES.CHIP	RC-02H 1% 215K	4822 051 52154
R 1313	RES.CHIP	RC-02H 1% 7K5	4822 051 57502
R 2001	RES.CHIP	RC-02H 1% 16K5	5322 117 10532
R 2002	RES.CHIP	RC-02H 1% 12K1	4822 051 51213
R 2003	RES.CHIP	RC-02H 1% 1K	4822 051 51002
R 2004	RES.CHIP	RMC1/8 1% 51E1	5322 111 91893
R 2006	RES.CHIP	RMC1/8 1% 51E1	5322 111 91893
R 2007	RES.CHIP	RC-02H 1% 1K47	4822 051 51472
R 2008	RES.CHIP	RC-02H 1% 1K47	4822 051 51472
R 2009	RES.CHIP	RC-02H 1% 1K	4822 051 51002
R 2011	RES.CHIP	RC-02H 1% 6K81	4822 051 56812
R 2012	RES.CHIP	RC-02H 1% 215K	4822 051 52154
R 2013	RES.CHIP	RC-02H 1% 1K96	4822 051 51962
R 2014	RES.CHIP	RC-02H 1% 4K64	4822 051 54642
R 2015	RES.CHIP	RC-02H 1% 1K	4822 051 51002
R 2016	RES.CHIP	RC-02H 1% 10K	4822 051 51003
R 2017	RES.CHIP	RC-02H 1% 316K	4822 051 53164
R 2018	RES.CHIP	RC-02H 1% 46K4	4822 051 54643
R 2020	RES.CHIP	RC-02H 1% 14K7	4822 051 51473
R 2021	RES.CHIP	RC-02H 1% 46K4	4822 051 54643
R 2023	RES.CHIP	RC-02H 1% 14K7	4822 051 51473
R 2024	RES.CHIP	RC-02H 1% 14K7	4822 051 51473
R 2026	RES.CHIP	RMC1/8 1% 10E	4822 111 91885
R 2063	RES.CHIP	RC-02H 1% 100E	4822 051 51001
R 2064	RES.CHIP	RC-02H 1% 100E	4822 051 51001
R 2065	RES.CHIP	RC-02H 1% 2K87	4822 051 52872
R 2066	RES.CHIP	RC-02H 1% 2K87	4822 051 52872
R 2067	RES.CHIP	RMC1/8 1% 10E	4822 111 91885
R 2068	RES.CHIP	RMC1/8 1% 10E	4822 111 91885
R 2101	RES.CHIP	RMC1/8 1% 51E1	5322 111 91893
R 2102	RES.CHIP	RMC1/8 1% 21E5	5322 111 92014
R 2103	RES.CHIP	RMC1/8 1% 51E1	5322 111 91893
R 2104	RES.CHIP	RC-02H 1% 12K1	5322 117 10522
R 2107	RES.CHIP	RC-02H 1% 237E	4822 051 52371

Item	Description		Ordering code
R 2111	RES.CHIP	RMC1/8 1% 21E5	5322 111 92014
R 2112	RES.CHIP	RC-02H 1% 383E	4822 051 53831
R 2114	RES.CHIP	RC-01 1% 6E8	4822 051 10688
R 2131	RES.CHIP	RMC1/8 1% 21E5	5322 111 92014
R 2132	RES.CHIP	RC-02H 1% 5K11	4822 051 55112
R 2133	RES.CHIP	RC-02H 1% 14K7	4822 051 51473
R 2134	RES.CHIP	RC-02H 1% 14K7	4822 051 51473
R 2136	RES.CHIP	RC-02H 1% 1K78	5322 117 10535
R 2137	RES.CHIP	RC-02H 1% 121E	4822 051 51211
R 2138	RES.CHIP	RC-01 5% 3E3	4822 051 10338
R 2151	RES.CHIP	RMC1/8 1% 10E	4822 111 91885
R 2161	RES.CHIP	RMC1/8 1% 42E2	4822 111 91887
R 2171	RES.METAL FILM	MRS25 1% 9K53	4822 050 29532
R 2172	RES.CHIP	RC-02H 1% 28K7	4822 051 52873
R 2176	RES.CHIP	RC-02H 1% 316K	4822 051 53164
R 2177	RES.CHIP	RC-02H 1% 261K	4822 051 52614
R 2201	RES.CHIP	RMC1/8 1% 51E1	5322 111 91893
R 2202	RES.CHIP	RMC1/8 1% 21E5	5322 111 92014
R 2203	RES.CHIP	RMC1/8 1% 51E1	5322 111 91893
R 2204	RES.CHIP	RC-02H 1% 12K1	5322 117 10522
R 2207	RES.CHIP	RC-02H 1% 237E	4822 051 52371
R 2211	RES.CHIP	RMC1/8 1% 21E5	5322 111 92014
R 2212	RES.CHIP	RC-02H 1% 383E	4822 051 53831
R 2214	RES.CHIP	RMC1/8 1% 6E8	4822 051 10688
R 2231	RES.CHIP	RMC1/8 1% 21E5	5322 111 92014
R 2232	RES.CHIP	RC-02H 1% 5K11	4822 051 55112
R 2233	RES.CHIP	RC-02H 1% 14K7	4822 051 51473
R 2234	RES.CHIP	RC-02H 1% 14K7	4822 051 51473
R 2236	RES.CHIP	RC-02H 1% 1K78	5322 117 10535
R 2237	RES.CHIP	RC-02H 1% 121E	4822 051 51211
R 2238	RES.CHIP	RC-01 5% 3E3	4822 051 10338
R 2251	RES.CHIP	RMC1/8 1% 10E	4822 111 91885
R 2261	RES.CHIP	RMC1/8 1% 42E2	4822 111 91887
R 2271	RES.METAL FILM	MRS25 1% 9K53	4822 050 29532
R 2272	RES.CHIP	RC-02H 1% 28K7	4822 051 52873
R 2276	RES.CHIP	RC-02H 1% 316K	4822 051 53164
R 2277	RES.CHIP	RC-02H 1% 261K	4822 051 52614
R 2301	RES.CHIP	RC-02H 1% 215K	4822 051 52154
R 2302	RES.CHIP	RC-02H 1% 215K	4822 051 52154
R 2303	RES.CHIP	RC-02H 1% 61K9	4822 051 56193
R 2304	RES.CHIP	RC-02H 1% 61K9	4822 051 56193
R 2306	RES.CHIP	RC-02H 1% 51K1	4822 051 55113
R 2307	RES.CHIP	RC-02H 1% 51K1	4822 051 55113
R 2308	RES.CHIP	RC-02H 1% 215K	4822 051 52154
R 2309	RES.CHIP	RC-02H 1% 7K5	4822 051 57502
R 2311	RES.CHIP	RC-02H 1% 21K5	4822 051 52153
R 2312	RES.CHIP	RC-02H 1% 28K7	4822 051 52873

Item	Description	Ordering code
R 2313	RES.CHIP	RC-02H 1% 750E
R 2411	RES.CHIP	RC-02H 1% 750E
R 2412	RES.CHIP	RC-02H 1% 750E
R 2416	RES.CHIP	RMC1/8 1% 42E2
R 2418	RES.CHIP	RMC1/8 1% 42E2
R 2419	RES.CHIP	RC-02H 1% 16K2
R 2421	RES.CHIP	RMC1/8 1% 10E
R 2422	RES.CHIP	RMC1/8 1% 10E
R 2423	RES.CHIP	RC-02H 1% 316E
R 3001	RES.CHIP	RC-02H 1% 19K6
R 3002	RES.CHIP	RC-02H 1% 11K
R 3003	RES.CHIP	RC-02H 1% 1K
R 3004	RES.CHIP	RC-02H 1% 100E
R 3006	RES.CHIP	RC-02H 1% 100E
R 3007	RES.CHIP	RC-02H 1% 100E
R 3008	RES.CHIP	RC-02H 1% 100E
R 3009	RES.CHIP	RC-02H 1% 1K
R 3011	RES.CHIP	RC-02H 1% 11K
R 3012	RES.CHIP	RC-02H 1% 19K6
R 3013	RES.CHIP	RC-02H 1% 5K62
R 3014	RES.CHIP	RC-02H 1% 21K5
R 3015	RES.CHIP	RC-02H 1% 28K7
R 3018	RES.CHIP	RC-02H 1% 19K6
R 3021	RES.CHIP	RC-02H 1% 19K6
R 3024	RES.CHIP	RC-02H 1% 14K7
R 3026	RES.CHIP	RMC1/8 1% 10E
R 3063	RES.CHIP	RC-02H 1% 100E
R 3064	RES.CHIP	RC-02H 1% 100E
R 3066	RES.CHIP	RC-02H 1% 909E
R 3067	RES.CHIP	RC-02H 1% 909E
R 3068	RES.CHIP	RMC1/8 1% 10E
R 3069	RES.CHIP	RMC1/8 1% 10E
R 3101	RES.CHIP	RMC1/8 1% 51E1
R 3102	RES.CHIP	RMC1/8 1% 21E5
R 3103	RES.CHIP	RMC1/8 1% 51E1
R 3104	RES.CHIP	RC-02H 1% 12K1
R 3107	RES.CHIP	RC-02H 1% 237E
R 3111	RES.CHIP	RMC1/8 1% 21E5
R 3112	RES.CHIP	RC-02H 1% 383E
R 3114	RES.CHIP	RC-01 5% 6E8
R 3131	RES.CHIP	RMC1/8 1% 21E5
R 3132	RES.CHIP	RC-02H 1% 5K11
R 3133	RES.CHIP	RC-02H 1% 14K7
R 3134	RES.CHIP	RC-02H 1% 14K7
R 3136	RES.CHIP	RC-02H 1% 1K78
R 3137	RES.CHIP	RC-02H 1% 121E
R 3138	RES.CHIP	RC-01 5% 3E3

Item	Description		Ordering code
R 3151	RES.CHIP	RMC1/8 1% 10E	4822 111 91885
R 3161	RES.CHIP	RMC1/8 1% 42K2	4822 111 91887
R 3171	RES.METAL FILM	MRS25 1% 9K53	4822 050 29532
R 3176	RES.CHIP	RC-02H 1% 51K1	4822 051 55113
R 3201	RES.CHIP	RMC1/8 1% 51E1	5322 111 91893
R 3202	RES.CHIP	RMC1/8 1% 21E5	5322 111 92014
R 3203	RES.CHIP	RMC1/8 1% 51E1	5322 111 91893
R 3204	RES.CHIP	RC-02H 1% 12K1	4822 051 51213
R 3207	RES.CHIP	RC-02H 1% 237E	4822 051 52371
R 3211	RES.CHIP	RMC1/8 1% 21E5	5322 111 92014
R 3212	RES.CHIP	RC-02H 1% 383E	4822 051 53831
R 3214	RES.CHIP	RC-01 5% 6E8	4822 051 10688
R 3231	RES.CHIP	RMC1/8 1% 21E5	5322 111 92014
R 3232	RES.CHIP	RC-02H 1% 5K11	4822 051 55112
R 3233	RES.CHIP	RC-02H 1% 14K7	4822 051 51473
R 3234	RES.CHIP	RC-02H 1% 14K7	4822 051 51473
R 3236	RES.CHIP	RC-02H 1% 1K78	4822 051 51782
R 3237	RES.CHIP	RC-02H 1% 121E	4822 051 51211
R 3238	RES.CHIP	RC-01 5% 3E3	4822 051 10338
R 3251	RES.CHIP	RMC1/8 1% 10E	4822 111 91885
R 3261	RES.CHIP	RMC1/8 1% 42E2	4822 111 91887
R 3271	RES.METAL FILM	MRS25 1% 9K53	4822 050 29532
R 3276	RES.CHIP	RC-02H 1% 51K1	4822 051 55113
R 3301	RES.CHIP	RC-02H 1% 61K9	4822 051 56193
R 3302	RES.CHIP	RC-02H 1% 12K1	4822 051 51213
R 3311	RES.CHIP	RC-02H 1% 511E	4822 051 55111
R 3312	RES.CHIP	RC-02H 1% 2K87	4822 051 52872
R 3313	RES.CHIP	RC-02H 1% 2K87	4822 051 52872
R 3314	RES.CHIP	RC-02H 1% 10K	4822 051 51003
R 3316	RES.CHIP	RC-02H 1% 14K7	4822 051 51473
R 3411	RES.CHIP	RC-02H 1% 750E	4822 051 57501
R 3412	RES.CHIP	RC-02H 1% 750E	4822 051 57501
R 3416	RES.CHIP	RMC1/8 1% 51E1	5322 111 91893
R 3418	RES.CHIP	RMC1/8 1% 51E1	5322 111 91893
R 3419	RES.CHIP	RC-02H 1% 16K2	4822 051 51623
R 3421	RES.CHIP	RMC1/8 1% 10E	4822 111 91885
R 3422	RES.CHIP	RMC1/8 1% 10E	4822 111 91885
R 3423	RES.CHIP	RC-02H 1% 316E	4822 051 53161
R 4001	RES.CHIP	RC-02H 1% 51K1	4822 051 55113
R 4002	RES.HI-TENSION	VR25 5% 3M3	4822 053 20335
R 4003	RES.HI-TENSION	VR25 5% 3M3	4822 053 20335
R 4004	RES.HI-TENSION	VR25 5% 3M3	4822 053 20335
R 4006	RES.HI-TENSION	VR25 5% 6M8	4822 053 20685
R 4007	RES.HI-TENSION	VR25 5% 6M8	4822 053 20685
R 4008	RES.CHIP	RC-02H 1% 31K6	4822 051 53163
R 4009	RES.CHIP	RC-02H 1% 31K6	4822 051 53163
R 4031	RES.CHIP	RMC1/8 1% 10E	4822 111 91885

Item	Description		Ordering code
R 4032	RES.CHIP	RC-02H 1% 31K6	4822 051 53163
R 4033	RES.CHIP	RC-02H 1% 1K	4822 051 51002
R 4034	RES.CHIP	RMC1/8 1% 10E	4822 111 91885
R 4036	RES.CHIP	RC-02H 1% 316E	4822 051 53161
R 4037	RES.CHIP	RC-02H 1% 31K6	4822 051 53163
R 4038	RES.CHIP	RC-02H 1% 681E	4822 051 56811
R 4039	RES.CHIP	RC-02H 1% 16K2	4822 051 51623
R 4040	RES.CHIP	RC-02H 1% 31K6	4822 051 53163
R 4041	RES.CHIP	RC-02H 1% 51K1	4822 051 55113
R 4042	RES.CHIP	RC-02H 1% 1K	4822 051 51002
R 4043	RES.CHIP	RC-02H 1% 1K	4822 051 51002
R 4044	RES.CHIP	RC-02H 1% 1M	4822 051 51005
R 4051	RES.HI-TENSION	VR25 5% 3M3	4822 053 20335
R 4110	RES.CHIP	RC-02H 1% 21E5	5322 111 92014
R 4111	RES.CHIP	RMC1/8 1% 100E	4822 051 10101
R 4112	RES.CHIP	RMC1/8 1% 100E	4822 051 10101
R 4113	RES.CHIP	RMC1/8 1% 21E5	5322 117 11734
R 4114	RES.CHIP	RMC1/8 1% 21E5	5322 117 11734
R 4116	RES.CHIP	RC-02H 1% 316E	5322 117 10552
R 4117	RES.CHIP	RC-02H 1% 316E	5322 117 10552
R 4118	RES.CHIP	RC-02H 1% 1K1	4822 051 51102
R 4119	RES.CHIP	RC-02H 1% 1K1	4822 051 51102
R 4121	RES.CHIP	RMC1/8 1% 10E	4822 111 91885
R 4122	RES.CHIP	RMC1/8 1% 10E	4822 111 91885
R 4123	RES.CHIP	RC-02H 1% 422E	4822 051 54221
R 4124	RES.CHIP	RC-02H 1% 422E	4822 051 54221
R 4126	RES.CHIP	RC-02H 1% 511E	4822 051 55111
R 4127	RES.CHIP	RC-02H 1% 511E	4822 051 55111
R 4128	RES.CHIP	RC-02H 1% 1K	4822 051 51002
R 4129	RES.CHIP	RC-02H 1% 1K	4822 051 51002
R 4130	RES.CHIP	RC-02H 1% 5K62	4822 051 55622
R 4132	RES.CHIP	RC-02H 1% 5K62	4822 051 55622
R 4133	RES.CHIP	RC-02H 1% 5K62	4822 051 55622
R 4134	RES.CHIP	RC-01 5% 3E3	4822 051 10338
R 4135	RES.CHIP	RC-02H 1% 5K62	4822 051 55622
R 4136	RES.CHIP	RC-01 5% 3E3	4822 051 10338
R 4137	RES.CHIP	RC-01 5% 3E3	4822 051 10338
R 4138	RES.CHIP	RC-01 5% 3E3	4822 051 10338
R 4139	RES.CHIP	RC-02H 1% 750E	4822 051 57501
R 4141	RES.CHIP	RC-02H 1% 750E	4822 051 57501
R 4142	RES.CHIP	RC-01 5% 4E7	4822 051 10478
R 4143	RES.CHIP	RC-01 5% 4E7	4822 051 10478
R 4144	RES.CHIP	RMC1/8 1% 42E2	4822 111 91887
R 4146	RES.CHIP	RMC1/8 1% 42E2	4822 111 91887
R 4147	RES.CHIP	RMC1/8 1% 42E2	4822 111 91887
R 4148	RES.CHIP	RMC1/8 1% 42E2	4822 111 91887
R 4149	RES.CHIP	RC-01 5% 4E7	4822 051 10478

Item	Description		Ordering code
R 4150	RES.CHIP	RC-01 5% 4E7	4822 051 10478
R 4151	RES.CHIP	RC-01 5% 10E	4822 111 91885
R 4152	RES.CHIP	RMC1/8 1% 42E2	4822 111 91887
R 4153	RES.CHIP	RMC1/8 1% 42E2	4822 111 91887
R 4154	RES.CHIP	RC-02H 1% 10E	4822 111 91885
R 4155	RES.CHIP	RC-02H 1% 100E	4822 051 51001
R 4156	RES.CHIP	RC-02H 1% 100E	4822 051 51001
R 4157	RES.CHIP	RC-02H 1% 100E	4822 051 51001
R 4158	RES.CHIP	RC-02H 1% 100E	4822 051 51001
R 4159	RES.CHIP	RC-02H 1% 100E	4822 051 51001
R 4160	RES.CHIP	RC-02H 1% 100E	4822 051 51001
R 4161	RES.CHIP	RMC1/8 1% 75E	4822 111 91937
R 4162	RES.CHIP	RMC1/8 1% 75E	4822 111 91937
R 4163	RES.CHIP	RC-02H 1% 51K1	4822 051 55113
R 4164	RES.CHIP	RC-02H 1% 51K1	4822 051 55113
R 4166	RES.CHIP	RC-02H 1% 215K	4822 051 52154
R 4167	RES.CHIP	RC-02H 1% 215K	4822 051 52154
R 4168	RES.CHIP	RC-02H 1% 215K	4822 051 52154
R 4169	RES.CHIP	RC-02H 1% 215K	4822 051 52154
R 4171	RES.CHIP	RC-02H 1% 215K	4822 051 52154
R 4172	RES.CHIP	RC-02H 1% 215K	4822 051 52154
R 4173	RES.CHIP	RC-02G 1% 61K9	4822 051 56193
R 4174	RES.CHIP	RC-02G 1% 7K50	4822 051 57502
R 4176	RES.CHIP	RC-02H 1% 10E	4822 111 91885
R 4177	RES.CHIP	RC-02H 1% 10E	4822 111 91885
R 4178	RES.CHIP	RC-02H 1% 10E	4822 111 91885
R 4179	RES.CHIP	RC-02H 1% 10E	4822 111 91885
R 4181	RES.CHIP	RC-02H 1% 215K	4822 051 52154
R 4182	RES.CHIP	RC-02H 1% 215K	4822 051 52154
R 4201	RES.CHIP	RC-01 5% 4E7	4822 051 10478
R 4202	RES.CHIP	RC-01 5% 3E3	4822 051 10338
R 4203	RES.CHIP	RC-01 5% 4E7	4822 051 10478
R 4261	RES.CHIP	RMC1/8 1% 42E2	4822 111 91887
R 4262	RES.CHIP	RMC1/8 1% 42E2	4822 111 91887
R 5001	RES.CHIP	RC-01 5% 1E	4822 051 10108
R 5002	RES.CHIP	RC-01 5% 1E	4822 051 10108
R 5003	RES.CHIP	RC-01 5% 1E	4822 051 10108
R 5004	RES.CHIP	RC-01 5% 1E	4822 051 10108
R 5007	RES.CHIP	RC-01 5% 1E	4822 051 10108
R 5008	RES.CHIP	RC-01 5% 1E	4822 051 10108
R 5101	RES.CHIP	RC-01 5% 4E7	4822 051 10478
R 5111	RES.CHIP	RC-01 5% 3E3	4822 051 10338
R 5116	RES.CHIP	RC-01 5% 3E3	4822 051 10338
R 5121	RES.CHIP	RC-01 5% 4E7	4822 051 10478
R 5126	RES.CHIP	RC-01 5% 4E7	4822 051 10478
R 5131	RES.CHIP	RC-02H 1% 10K	4822 051 51003
R 5132	RES.CHIP	RC-02H 1% 10K	4822 051 51003

Item	Description		Ordering code
R 5133	RES.CHIP	RC-02H 1% 10K	4822 051 51003
R 5134	RES.CHIP	RC-02H 1% 10K	4822 051 51003
R 5136	RES.CHIP	RC-02H 1% 10K	4822 051 51003
R 5137	RES.CHIP	RC-02H 1% 3K83	4822 051 53832
R 5138	RES.CHIP	RC-02H 1% 3K16	4822 051 53162
R 5139	RES.CHIP	RMC1/8 1% 10E	4822 111 91885
R 5151	RES.CHIP	RMC1/8 1% 10E	4822 111 91885
R 5201	RES.CHIP	RC-01 5% 3E3	4822 051 10338
R 5206	RES.CHIP	RC-01 5% 3E3	4822 051 10338
R 5211	RES.CHIP	RC-01 5% 3E3	4822 051 10338
R 5216	RES.CHIP	RC-01 5% 3E3	4822 051 10338
R 5231	RES.CHIP	RMC1/8 1% 10E	4822 111 91885
R 5236	RES.CHIP	RMC1/8 1% 10E	4822 111 91885
R 5251	RES.CHIP	RMC1/8 1% 10E	4822 111 91885
R 5301	RES.CHIP	RC-01 5% 3E3	4822 051 10338
R 5306	RES.CHIP	RC-01 5% 3E3	4822 051 10338
R 5311	RES.CHIP	RC-01 5% 3E3	4822 051 10338
R 5316	RES.CHIP	RC-01 5% 3E3	4822 051 10338
R 5321	RES.CHIP	RC-01 5% 4E7	4822 051 10478
R 5326	RES.CHIP	RC-01 5% 4E7	4822 051 10478
R 5331	RES.CHIP	RMC1/8 1% 10E	4822 111 91885
R 5336	RES.CHIP	RMC1/8 1% 10E	4822 111 91885
R 5351	RES.CHIP	RMC1/8 1% 10E	4822 111 91885
R 5411	RES.CHIP	RMC1/8 1% 21E5	5322 111 92014
R 5416	RES.CHIP	RMC1/8 1% 21E5	5322 111 92014
R 5501	RES.CHIP	RC-02H 1% 1K	4822 051 51002

SEMI CONDUCTORS

V 1009	DIODE,CHIP	BBY39 PEL	5322 130 82199
V 1011	DIODE,CHIP	BBY39 PEL	5322 130 82199
V 1014	TRANSISTOR,CHIP	BC858C PEL	4822 130 42513
V 1016	TRANSISTOR,CHIP	BC858C PEL	4822 130 42513
V 1018	TRANSISTOR,CHIP	BC858C PEL	4822 130 42513
V 1019	TRANSISTOR,CHIP	BC858C PEL	4822 130 42513
V 1021	TRANSISTOR,CHIP	BC858C PEL	4822 130 42513
V 1022	TRANSISTOR,CHIP	BC858C PEL	4822 130 42513
V 1023	TRANSISTOR,CHIP	BC848C PEL	5322 130 42136
V 1024	TRANSISTOR,CHIP	BC848C PEL	5322 130 42136
V 1026	TRANSISTOR,CHIP	BFT92 PEL	5322 130 44711
V 1027	TRANSISTOR,CHIP	BFT92 PEL	5322 130 44711
V 1028	DIODE,CHIP	BZX84-C6V8 PEL	5322 130 80406
V 1201	TRANSISTOR,CHIP	BC858C PEL	4822 130 42513
V 1202	TRANSISTOR,CHIP	BC858C PEL	4822 130 42513
V 1203	TRANSISTOR,CHIP	BC858C PEL	4822 130 42513
V 1204	TRANSISTOR,CHIP	BC858C PEL	4822 130 42513
V 1301	DIODE,CHIP	BZX84-C8V2 PEL	5322 130 80255
V 2061	TRANSISTOR,CHIP	BC858C PEL	4822 130 42513
V 2062	TRANSISTOR,CHIP	BC858C PEL	4822 130 42513

Item	Description		Ordering code
V 2101	TRANSISTOR,CHIP	BF824 PEL	4822 130 60383
V 2102	DIODE,CHIP	BZX84-B12 PEL	4822 130 83566
V 2103	DIODE,CHIP	BZX84-B12 PEL	4822 130 83566
V 2105	DIODE,CHIP	BZX84-B12 PEL	4822 130 83566
V 2111	TRANSISTOR,CHIP	BF824 PEL	4822 130 60383
V 2113	TRANSISTOR	BFQ251 PEL	5322 130 63035
V 2131	DIODE,CHIP	BAV99 PEL	5322 130 34337
V 2133	TRANSISTOR,CHIP	BF824 PEL	4822 130 60383
V 2132	TRANSISTOR,CHIP	BF840 PEL	4822 130 60887
V 2134	TRANSISTOR	BFQ231 PEL	5322 130 63034
V 2201	TRANSISTOR,CHIP	BF840 PEL	4822 130 60887
V 2202	DIODE,CHIP	BZX84-B12 PEL	4822 130 83566
V 2203	DIODE,CHIP	BZX84-B12 PEL	4822 130 83566
V 2205	DIODE,CHIP	BZX84-B12 PEL	4822 130 83566
V 2211	TRANSISTOR,CHIP	BF824 PEL	4822 130 60383
V 2213	TRANSISTOR	BFQ251 PEL	5322 130 63035
V 2231	DIODE,CHIP	BAV99 PEL	5322 130 34337
V 2232	TRANSISTOR,CHIP	BF840 PEL	4822 130 60887
V 2233	TRANSISTOR,CHIP	BF824 PEL	4822 130 60383
V 2234	TRANSISTOR	BFQ231 PEL	5322 130 63034
V 2301	DIODE,CHIP	BZX84-C8V2 PEL	5322 130 80255
V 2413	DIODE,CHIP	BZX84-C8V2 PEL	5322 130 80255
V 2416	DIODE,CHIP	BZX84-B27 PEL	5322 130 82039
V 2421	DIODE,CHIP	BZX84-C6V8 PEL	5322 130 80406
V 3001	DIODE,CHIP	BAV99 PEL	5322 130 34337
V 3002	TRANSISTOR,CHIP	BC858C PEL	4822 130 42513
V 3061	TRANSISTOR,CHIP	BF824 PEL	4822 130 60383
V 3062	TRANSISTOR,CHIP	BF824 PEL	4822 130 60383
V 3101	TRANSISTOR,CHIP	BF840 PEL	4822 130 60887
V 3102	DIODE,CHIP	BZX84-B12 PEL	4822 130 83566
V 3103	DIODE,CHIP	BZX84-B12 PEL	8822 130 83566
V 3105	DIODE,CHIP	BZX84-B12 PEL	8822 130 83566
V 3111	TRANSISTOR,CHIP	BF824 PEL	4822 130 60383
V 3113	TRANSISTOR	BFQ251 PEL	5322 130 63035
V 3131	DIODE,CHIP	BAV99 PEL	5322 130 34337
V 3132	TRANSISTOR,CHIP	BF840 PEL	4822 130 60887
V 3133	TRANSISTOR,CHIP	BF824 PEL	4822 130 60383
V 3134	TRANSISTOR	BFQ231 PEL	5322 130 63034
V 3136	DIODE,CHIP	BAS21 PEL	4822 130 33702
V 3137	DIODE,CHIP	BAS21 PEL	4822 130 33702
V 3201	TRANSISTOR,CHIP	BF840 PEL	4822 130 60887
V 3202	DIODE,CHIP	BZX84-B12 PEL	4822 130 83566
V 3203	DIODE,CHIP	BZX84-B12 PEL	4822 130 83566
V 3205	DIODE,CHIP	BZX84-B12 PEL	4822 130 83566
V 3211	TRANSISTOR,CHIP	BF824 PEL	4822 130 60383
V 3213	TRANSISTOR	BFQ251 PEL	5322 130 63035
V 3231	DIODE,CHIP	BAV99 PEL	5322 130 34337

Item	Description		Ordering code
V 3232	TRANSISTOR,CHIP	BF840 PEL	4822 130 60887
V 3233	TRANSISTOR,CHIP	BF824 PEL	4822 130 60383
V 3234	TRANSISTOR	BFQ231 PEL	5322 130 63034
V 3236	DIODE,CHIP	BAS21 PEL	4822 130 33702
V 3237	DIODE,CHIP	BAS21 PEL	4822 130 33702
V 3301	TRANSISTOR,CHIP	BF820 PEL	5322 130 62802
V 3311	TRANSISTOR,CHIP	BC858C PEL	4822 130 42513
V 3312	DIODE,CHIP	BAV99 PEL	5322 130 34337
V 3413	DIODE,CHIP	BZX84-C8V2 PEL	5322 130 80255
V 3416	DIODE,CHIP	BZX84-B27 PEL	5322 130 82039
V 3421	DIODE,CHIP	BZX84-C6V8 PEL	5322 130 80406
V 4001	DIODE,CHIP	BAV99 PEL	5322 130 34337
V 4002	TRANSISTOR,CHIP	BF821 PEL	4822 130 61923
V 4003	TRANSISTOR,CHIP	BF821 PEL	4822 130 61923
V 4004	TRANSISTOR,CHIP	BF821 PEL	4822 130 61923
V 4021	DIODE, CHIP	BZX84-B47	4822 130 82521
V 4022	DIODE, CHIP	BZX84-B47	4822 130 82521
V 4023	DIODE, CHIP	BZX84-B47	4822 130 82521
V 4024	DIODE, CHIP	BZX84-B47	4822 130 82521
V 4026	DIODE, CHIP	BZX84-B47	4822 130 82521
V 4027	DIODE, CHIP	BZX84-B47	4822 130 82521
V 4028	DIODE, CHIP	BZX84-B47	4822 130 82521
V 4029	DIODE, CHIP	BZX84-C11	4822 130 81338
V 4031	TRANSISTOR,CHIP	BF821 PEL	4822 130 61923
V 4032	TRANSISTOR,CHIP	BF821 PEL	4822 130 61923
V 4033	TRANSISTOR,CHIP	BF820 PEL	5322 130 62802
V 4034	TRANSISTOR,CHIP	BF820 PEL	5322 130 62802
V 4036	DIODE,CHIP	BZX84-B18 PEL	5322 130 83709
V 4037	DIODE,CHIP	BAS21 PEL	4822 130 33702
V 4038	TRANSISTOR,CHIP	BF820 PEL	5322 130 62802
V 4039	TRANSISTOR,CHIP	BF821 PEL	4822 130 61923
V 4040	DIODE,CHIP	BAS21 PEL	4822 130 33702
V 4041	DIODE,CHIP	BAS21 PEL	4822 130 33702
V 4042	DIODE,CHIP	BAS21 PEL	4822 130 33702
V 4043	DIODE,CHIP	BAS21 PEL	4822 130 33702
V 4044	DIODE,CHIP	BAS21 PEL	4822 130 33702
V 4101	TRANSISTOR,CHIP	BF824 PEL	4822 130 60383
V 4102	TRANSISTOR,CHIP	BF824 PEL	4822 130 60383
V 4103	TRANSISTOR,CHIP	BF840 PEL	4822 130 60887
V 4104	TRANSISTOR,CHIP	BF840 PEL	4822 130 60887
V 4106	TRANSISTOR,CHIP	BF824 PEL	4822 130 60383
V 4107	TRANSISTOR,CHIP	BF824 PEL	4822 130 60383
V 4108	TRANSISTOR,CHIP	BFG35 PEL	5322 130 62805
V 4109	TRANSISTOR,CHIP	BFG35 PEL	5322 130 62805
V 4111	TRANSISTOR,CHIP	BFG55 PEL	5322 130 62806
V 4112	TRANSISTOR,CHIP	BFG55 PEL	5322 130 62806
V 4113	DIODE,CHIP	BBY62 PEL	5322 130 82685

Item	Description		Ordering code
V 4114	TRANSISTOR,CHIP	BC858C PEL	4822 130 42513
V 5001	DIODE,CHIP	BAS21 PEL	4822 130 33702
V 5002	DIODE,CHIP	BAS21 PEL	4822 130 33702

CONNECTORS AND SOCKETS

X 2101	CONNECTOR	4-P SNG RT.ANG	5322 265 30907
X 2301	CONNECTOR	26-P DBL STRGHT	4822 267 50668
X 2402	CONNECTOR	3-P SNG RT.ANG	5322 265 30433
X 2403	SOCKET	55595 PEL	5322 255 40502
X 2411	CONNECTOR	26-P DBL STRGHT	4822 267 50558
X 2501	CONNECTOR	50-P DBL STRGHT	5322 265 61242

5.3 MICROPROCESSOR A3

5.3.1 Description A3

Introduction

The unit can be seen as the heart of the oscilloscope. It controls all oscilloscope functions and receives input signals from the following sources:

- the rotary and push button knobs present at front unit A4 and CRT controls unit A5.
- commands from an external computer that are applied to the RS232 interface that is part of microprocessor D1001.
- circuits throughout the oscilloscope indicating the state of the circuitry.
- commands from an external computer that are applied via the optional IEEE-488 interface. This interface is also located on unit A3.

Control signals coming from the microprocessor unit can be split up as follows:

- serial data that is applied to numerous digital-to-analog converters that control the continuous oscilloscope functions.
- serial data that is applied to latches that control "on/off" oscilloscope functions.
- 16 analog output voltages that control continuously variable "potentiometer" functions in the oscilloscope.

Diagram 1 and 2

The microprocessor system is formed by microprocessor D1001, FlashROMs D1021 ... D1024 and RAM D1012. Amongst other features the processor incorporates 8 analog "ADC" inputs (ACH0 ... ACH7), a RS232 interface (CPTXD, CPRXD, CPDTR, CPRTS, CPCTS, CPDSR) and a I2C bus (SDAUP/SDA, SCLUP/SCL). Via the I2C bus structure many control buffers and digital-to-analog converters are loaded with data. D1001 has a 12 MHz clock with crystal G1001 that is connected between pin 8 and 9. Half the clock frequency is available as CPCLOCK at output pin 7. The 8 analog ADC inputs ACH0 ... ACH7 are used for the autocal function (YCAL and XCAL) and probe identification (PROBE1 ... PROBE4). These inputs are also used for temperature measurement (R1009) and time base status indication (signal TBSMART).

D1011 demultiplexes the combined address and databits CPAD00 through CPAD07. The output consists of address-information only. Address information is present on the address/data bus if input ALE-HT is high.

The output latch D1017 creates the enable signals for the I2C bus latches and digital-to-analog converters that control the circuits throughout the oscilloscope.

Signal POWER-HT is low the first 250 ms after switching-on. This results via the gates D1007 in a low signal CPRESET-LT that initializes the microprocessor D1001. RESET-LT resets a number of chips at the unit A3 and also front unit A4. Signal EA is made high; this has the result that the microprocessor can only reach its internal ROM. This ROM incorporates the start-up routine. The routine ends by applying signal CPRSTCSLT to pin 11 of flipflop D1014. This makes signal EA low and the microprocessor can reach the FLASHROMs D1021 ... D1024.

D1006 is a PAL that makes the selection for various chips on the unit. Examples are D1012 RAM selection via RAMCS-LT (pin 19) that results in RCS-LT via gate D1006. D1018 also generates the FlashROM write pulse FLSHWRLT for D1021 ... D1024. The EPROM selection occurs via D1006 output signals FLS.CSLT.

D1016 is a 3 to 8 decoder that controls circuits on unit A3. Depending on the state of the 3 inputs CPA04 through CPA06, one of the 8 outputs is low at a time.

Diagram 3

The resistance value of the indication ring in the probe at channels 1, 2, 3 and 4 is present between ground and the ADC input pins 16, 18, 20 and 24 of the processor. The analog probe resistance value results in a certain DC voltage that is converted by the ADC input of the processor D1001.

The circuit part indicated with 'RS232-C INTERFACE' consists of a buffer D1302 that converts the microprocessor's TTL signals (0 and 5 volt) into -12 and +12 volt RS232 output levels. The buffer D1301 does the same in the opposite direction.

The buzzer circuit incorporates an oscillator built around the buffer D1301 and amplifier D1302. D1302 is enabled by flipflop D1102. The buzzer H1001 is a piezo ceramic transducer.

The +5 V reference voltage for the A.D.C.'s inside D1001 is derived from the instrument's +10 V reference voltage via operational amplifier N1801.

Diagram 4

This diagram shows the "DAC-POT" IC D1112 that converts the digital data from the microprocessor into 16 analog voltages. Each of these voltages is independently adjustable between 1 V and 4 V. The reference voltage for this D/A converter comes from N1101.

This diagram also shows the IEEE interface that is a factory-installed option. The heart of the interface is IEEE-controller D1104. The registers inside D1104 can be controlled by microprocessor D1001 via the buffer D1103. The clock for D1104 is generated by crystal oscillator G1111, D1101 and divider stage D1102. The bidirectional buffers D1107, D1108, D1109, D1111 form an interface between D1104 and the IEEE bus devices outside the oscilloscope. D1106 controls the bidirectional buffers.

Diagram 5

Diagram 5 shows the pinning of the two connectors on microprocessor unit A3. Connector X1101 makes contact with the motherboard. Connector X1501 makes contact with the signal unit A1 via a flat cable. D1931 is a real-time clock that is controlled and read by the processor via the serial bus.

5.3.2 Signal name list A3

Note: In the signal name list you find the itemnumber of the component that is source or destination. Behind this itemnumber (separated by ":") you find the number of the diagram where the source/destination can be found (n.c. = not connected).

NAME	MEANING	SOURCE	DESTINATION
ALE	ADDRESS LATCH ENABLE	D1001:01	D1103:04 X1101:05 D1011:01 D1007:01
BATINTHT	BATGE INTERRUPT	X1101:05	D1001:01
CPCTS	RS232 CLEAR TO SEND (TTL)	D1301:02	D1001:01
CPDSR	RS232 DATA SET READY (TTL)	D1301:02	D1001:01
CPDTR	RS232 DATA TERMINAL READY (TTL)	D1019:01	D1302:02
CPRTS	RS232 REQUEST TO SEND (TTL)	D1019:01	D1302:02
CPRXD	RS232 RECEIVE DATA (TTL)	D1301:02	D1001:01
CPTXD	RS232 TRANSMIT DATA (TTL)	D1001:01	D1302:02
DACPEN-LT	ENABLE SIGNAL FOR DACPOT CIRCUIT	D1016:01	D1112:03

DACPWR-LT	WRITE SIGNAL FOR DACPOT CIRCUIT	D1016:01	D1112:03
DLEN0-HT	DATA LATCH ENABLE 0	R1063:01	X1101:04
DLEN1-HT	DATA LATCH ENABLE 1	R1064:01	X1101:04
DLEN2-HT	DATA LATCH ENABLE 2	R1066:01	X1101:04
FOCUS-DA	DC PART FOCUSING SIGNAL	R1136:03	X1101:04
HOLDOFF	HOLD OFF CONTROL SIGNAL	R1122:03	X1501:04
INTTRA	TRACE INTENSITY CONTROL SIGNAL	R1123:03	X1501:04
		R1123:04	X1501:05
		R1123:03	X1501:04
		R1123:02	X1501:03
MTBVAR	MAIN TB VAR CONTROL SIGNAL	R1124:03	X1501:04
LEVDTB	DELAYED TB LEVEL CONTROL SIGNAL	R1126:03	X1501:04
LEVMTB	MAIN TB LEVEL CONTROL SIGNAL	R1125:03	X1501:04
POS1	CH1 POSITION CONTROL SIGNAL	R1130:03	X1501:04
POS2	CH2 POSITION CONTROL SIGNAL	R1132:03	X1501:04
POS3	CH3 POSITION CONTROL SIGNAL	R1134:03	X1501:04
POS4	CH4 POSITION CONTROL SIGNAL	R1128:03	X1501:04
POWER-HT	POWER UP INDICATION SIGNAL	X1101:04	D1007:01
		D1001:01	D1008:02
		D1001:01	D1008:02
			D1001:01
		D1001:01	D1008:02
PROBE1	PROBE DETECTION/50Ω PROTECT CH1	X1101:04	V1014:02
			D1001:01
PROBE2	PROBE DETECTION/50Ω PROTECT CH2	X1101:04	V1013:02
			D1001:01
PROBE3	PROBE DETECTION/50Ω PROTECT CH3	X1101:04	V1012:02
			D1001:01
PROBE4	PROBE DETECTION/50Ω PROTECT CH4	X1101:04	V1011:02
			D1001:01
SCL	SERIAL CLOCK	R1054:01	X1101:04
SCLUP	SERIAL CLOCK AT MICROPROCESSOR	D1001:01	R1054:01
SDA	SERIAL DATA	R1052:01	X1101:04
SDAUP	SERIAL DATA AT MICROPROCESSOR	D1001:01	R1052:01
STRDTB	STROBE FOR DTB	R1058:01	X1101:05
STRMTB	STROBE FOR MTB	R1057:01	x1101:05
STROBE0-HT	STROBE/ENABLE SIGNAL 0	R1067:01	X1101:04
STROBE1-HT	STROBE/ENABLE SIGNAL 1	R1068:01	X1101:04
TRASEP	TRACE SEPARATION CONTROL SIGNAL	R1127:03	X1501:04
UFODAVLT	FRONT WRITES TO MICROPROCESSOR	X1101:04	D1001:01
UFORD-LT	MICROPROCESSOR READS FRONT	D1004:01	X1101:05
UFOWR-LT	MICROPROCESSOR WRITES TO FRONT	D1004:01	X1101:04
UFORD-LT	MICROPROCESSOR READS FRONT	D1004:01	X1101:05
VAR1	CH1 VARIABLE GAIN CONTROL SIGNAL	R1135:03	X1501:04
VAR2	CH2 VARIABLE GAIN CONTROL SIGNAL	R1133:03	X1501:04
VAR3	CH3 VARIABLE GAIN CONTROL SIGNAL	R1131:03	X1501:04
VAR4	CH4 VARIABLE GAIN CONTROL SIGNAL	R1129:03	X1501:04
XCAL	SIGNAL FOR X CALIBRATION	X1101:04	D1001:01
YCAL	SIGNAL FOR Y CALIBRATION	X1101:04	D1001:01

5.3.3 Location list

'-L' means that the component is located on the 'Large component side'. Others are components located on the 'small component side'.

C1002 C11	C1833 C2	D1111 D3	R1066 B9
C1003 C11	C1861 B4-L	D1112 A5	R1067 B9
C1004 D11	C1862 B3-L	D1301 C1	R1068 B9
C1006 C8	C1863 B3-L	D1302 C1	R1071 D11
C1011 B9	C1867 B2	D1931 C9	R1081 B1
C1012 B8	C1868 B2	G1001 C11-L	R1082 B1
C1013 B9	C1881 C9	G1111 B2-L	R1083 B1
C1014 B9	C1882 C2	H1001 B1-L	R1084 B1
C1021 A12	C1891 B6	L1111 B2-L	R1101 A6-L
C1022 B2	C1892 B9-L	N1101 A6	R1102 A6-L
C1023 A13	C1893 A6	N1801 A6	R1103 A5-L
C1024 A13	C1894 B10-L	R1001 D10	R1104 A6-L
C1026 A11	C1897 A6	R1002 C11	R1106 A5
C1027 A13	C1898 B10-L	R1003 C8	R1121 A5
C1028 A12	C1899 A6	R1005 B11	R1122 A5
C1051 B10	C1900 B5	R1006 C8	R1123 B5
C1052 B10	C1901 B5	R1007 C11	R1124 A5
C1053 B7	C1902 B5	R1008 D12	R1125 B5
C1054 B7	C1903 B5	R1009 C11-L	R1126 A5
C1056 B9	C1904 B5	R1010 C9	R1127 B5
C1057 D11	C1905 B5	R1018 B2	R1128 A5
C1059 C10	C1906 B5	R1019 B2	R1129 B5
C1060 C13	C1907 B5	R1021 A12	R1130 A5
C1101 B2	C1908 B5	R1022 A11	R1131 B5
C1102 B3	C1909 B5	R1023 A12	R1132 A5
C1103 C4	C1910 B5	R1024 A13	R1133 B5
C1104 C3	C1911 B5	R1026 C8	R1134 A5
C1106 C2	C1912 B5	R1028 C1	R1135 B5
C1107 D3	C1913 B5	R1029 C1	R1136 A5
C1108 D2	C1914 B5	R1031 C5	R1137 B4
C1109 D3	C1915 B5	R1032 C5	R1801 B10
C1111 D4	C1931 C10	R1033 C5	R1807 B11
C1112 A4	C1932 C9	R1034 C5	R1862 B4
C1121 B3	D1001 C11-L	R1036 C5	R1871 A6-L
C1122 B2	D1004 C12	R1037 C5	R1872 A6-L
C1123 A5	D1006 D12	R1038 C5	R1873 A6-L
C1301 B1	D1007 C9	R1039 C5	R1874 A6-L
C1302 C1	D1010 C9	R1041 A12	R1876 C11
C1303 C2	D1011 B12	R1042 A13	R1877 A6
C1304 C1	D1012 B13	R1043 A12	R1881 C9
C1306 C1	D1014 D9	R1044 A12	R1882 C2
C1307 C2	D1016 C12	R1046 A13	R1883 C2
C1801 C11	D1017 B9	R1047 A12	R1884 C2
C1803 A11	D1018 A11	R1048 A11	R1901 A5
C1804 A11	D1019 C13	R1049 C11	V1006 C9
C1806 C12	D1021 A12-L	R1051 B10	V1011 B9
C1807 B12	D1022 A11-L	R1052 B9	V1012 B8
C1809 D11	D1023 A13-L	R1053 B10	V1013 B9
C1811 D9	D1024 A13-L	R1054 B9	V1014 B9
C1812 C9	D1101 B2	R1057 B9	V1016 C8
C1814 B9	D1102 B3	R1058 B9	V1901 D1
C1815 C9	D1103 C4	R1059 C10	V1902 D1
C1816 A11	D1104 C3-L	R1060 C13	X1101 A9
C1817 C12	D1106 C2	R1061 B10	X1102 D2-L
C1819 A12	D1107 D4	R1062 B9	X1201 D13-L
C1823 A13	D1108 C2	R1063 B9	X1301 C1-L
C1832 C2	D1109 D4	R1064 B9	X1501 B5-L

5.3.4 Unit lay-outs

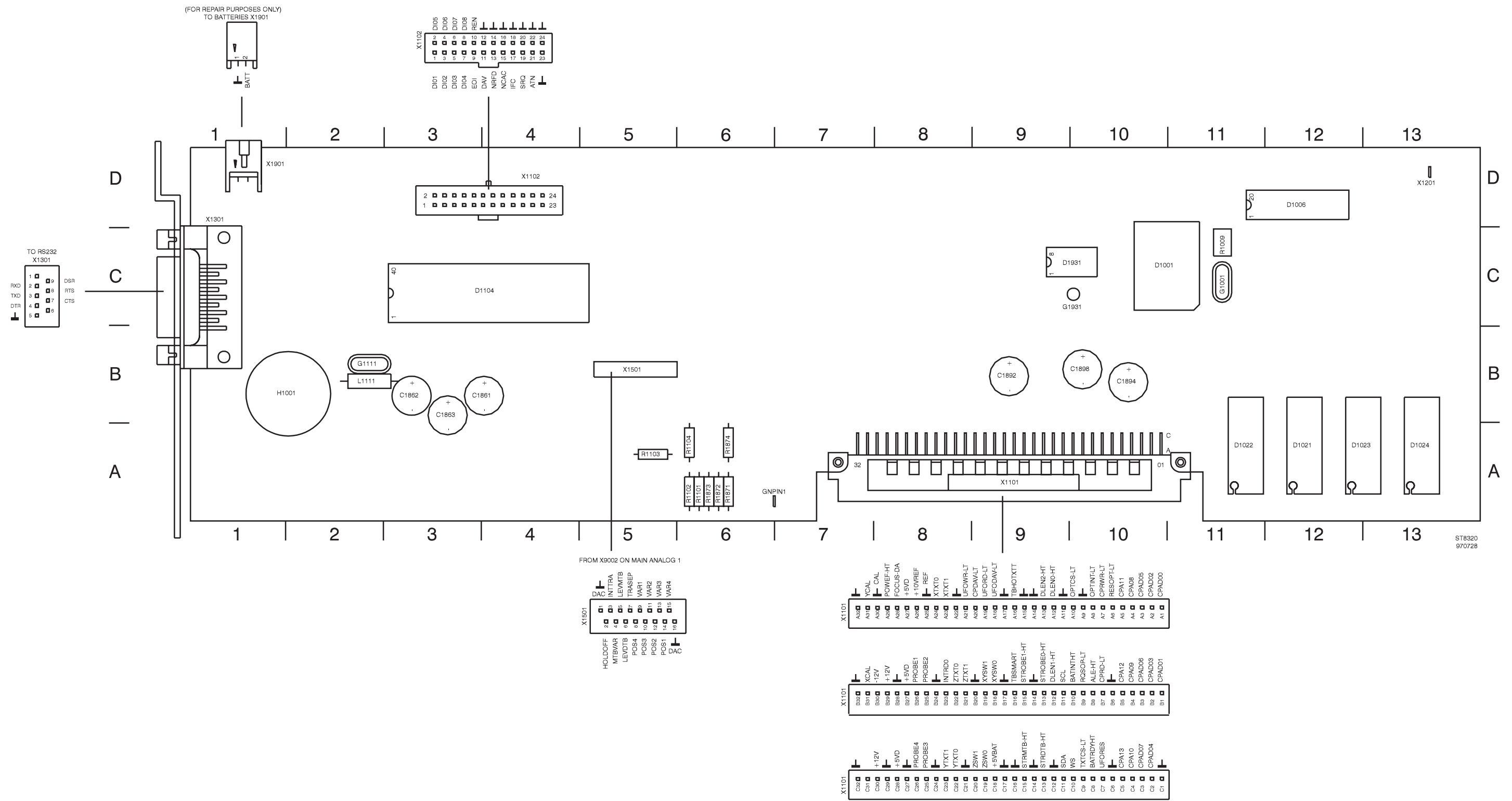

Lay-out 1 - Large component side of microprocessor unit A3

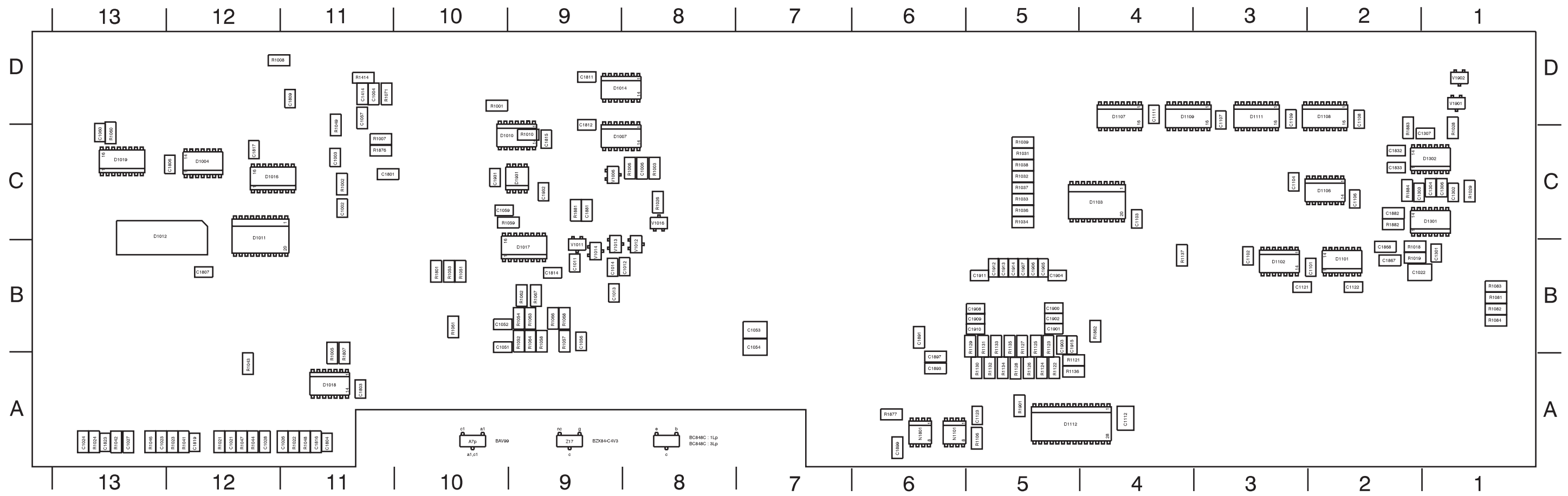

ST8321
970728

Lay-out 2 - Small component side of microprocessor unit A3

5.3.5 Circuit diagrams

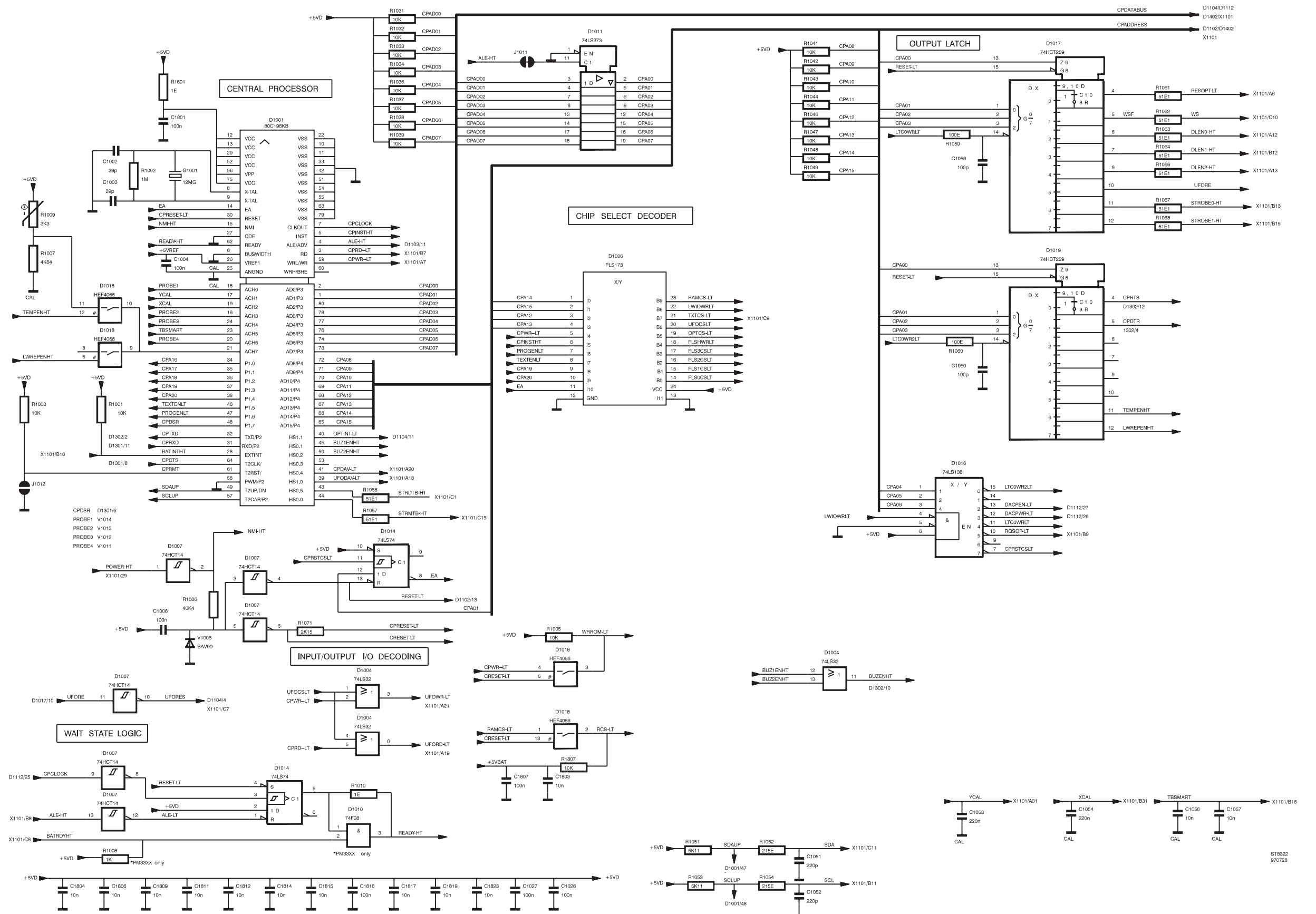

A3 - Diagram 1; Central processor unit

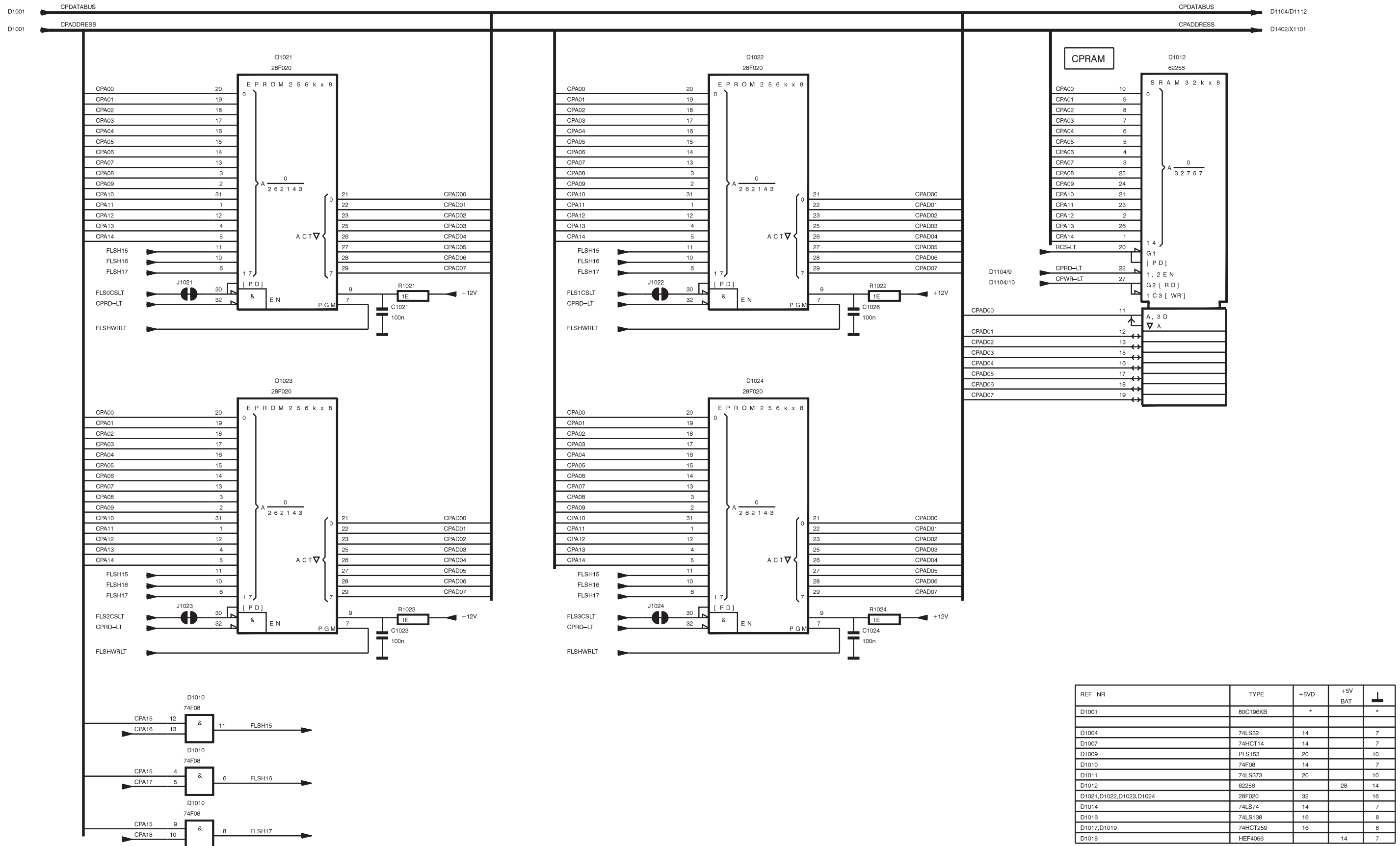

REF NR	TYPE	+5VD	+5V BAT	
D1001	80C196KB	*		*
D1004	74LS32	14		7
D1007	74HCT14	14		7
D1009	PLS153	20		10
D1010	74F08	14		7
D1011	74LS373	20		10
D1012	62256		28	14
D1021,D1022,D1023,D1024	28F020	32		16
D1014	74LS74	14		7
D1016	74LS138	16		8
D1017,D1019	74HCT259	16		8
D1018	HEF4066		14	7

A3 - Diagram 2; Processor memory

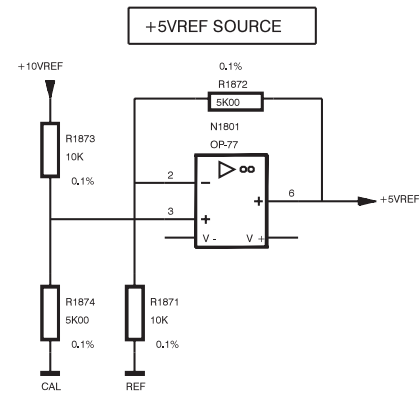
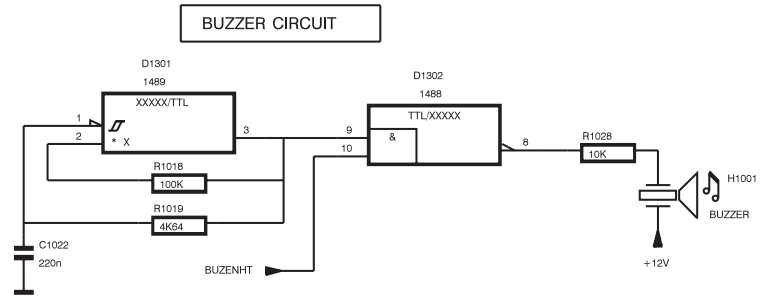
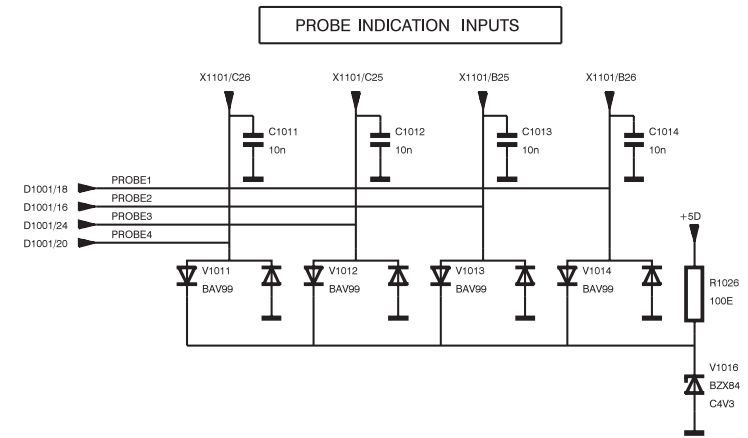

REF#NR	VALUE	STANDARD
R1081	1K	STANDARD PM33XX
R1082	100E	IEEE PM33XX
R1083	10K	STANDARD PM33XX
R1084	316E	IEEE PM30XX

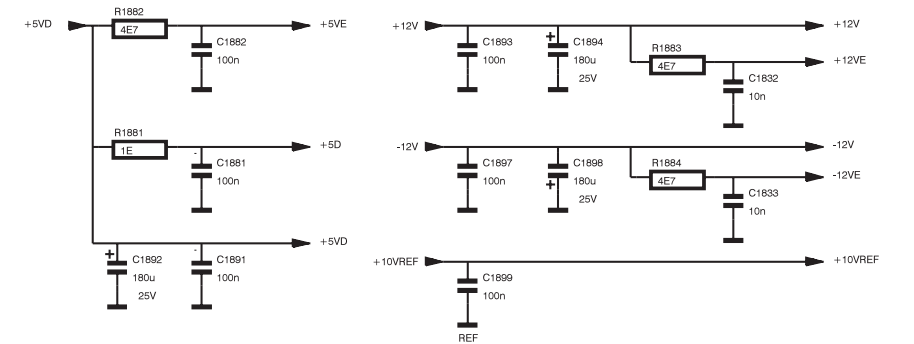
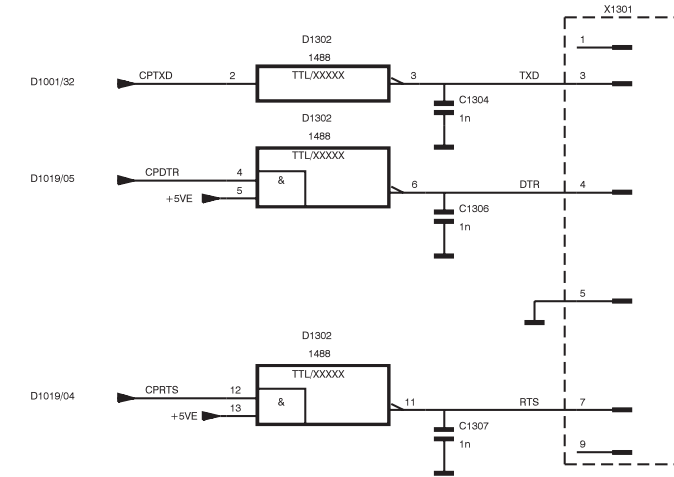
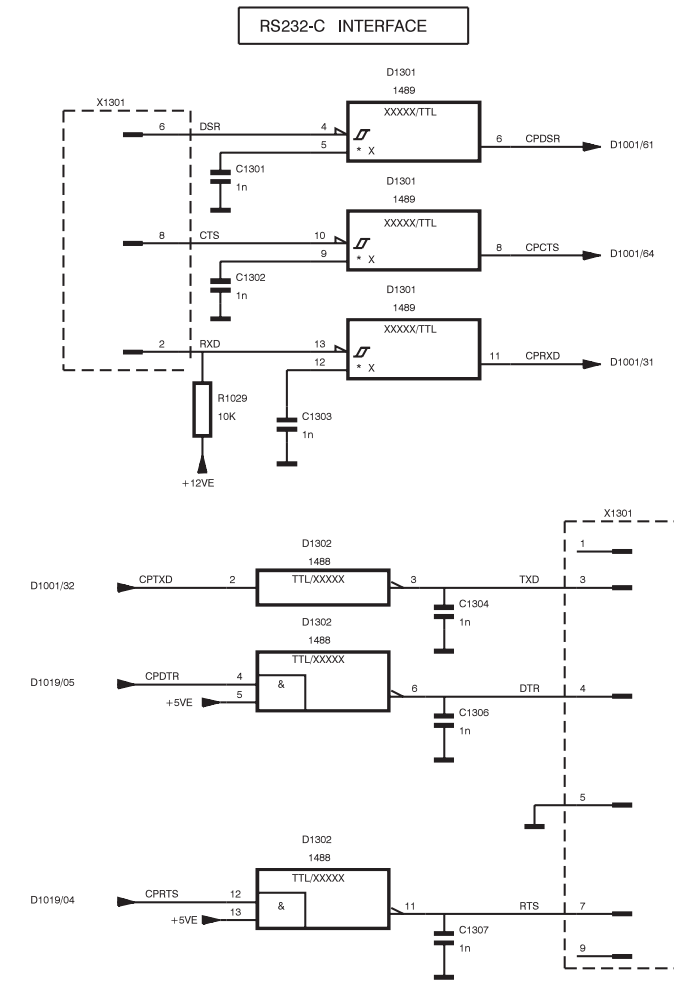
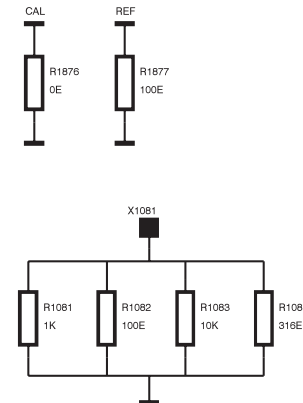

REF NR	TYPE	+5D	+5VE	+12V	-12V	+12VE	-12VE	C
D1008	HEF4051	16						7,8
D1301	1489		14					7, C1831
D1302	1488			4		14	1	7, C1832, C1833
N1801	OP77			7	4			

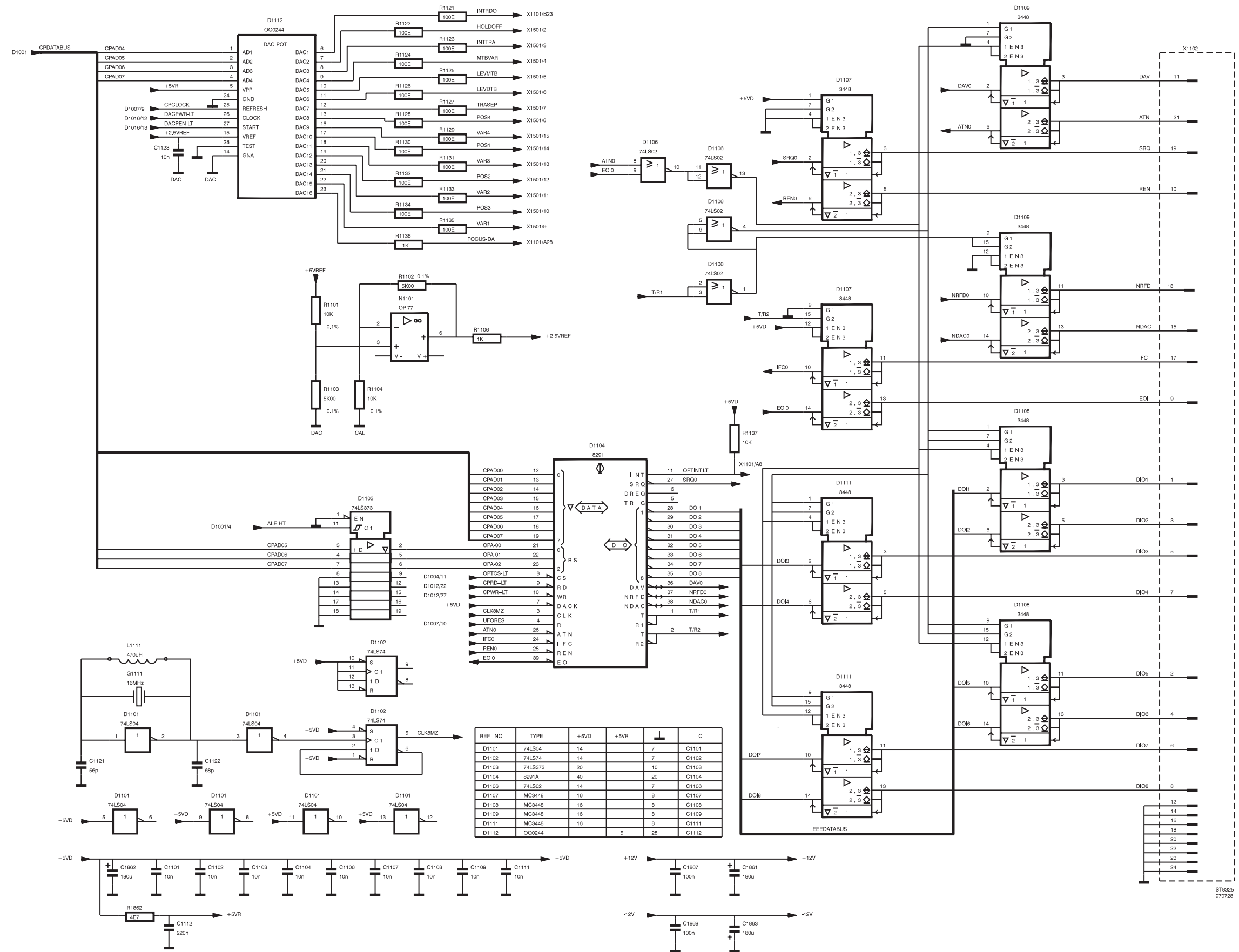

A3 - Diagram 4; Potentiometer DAC and IEEE-option

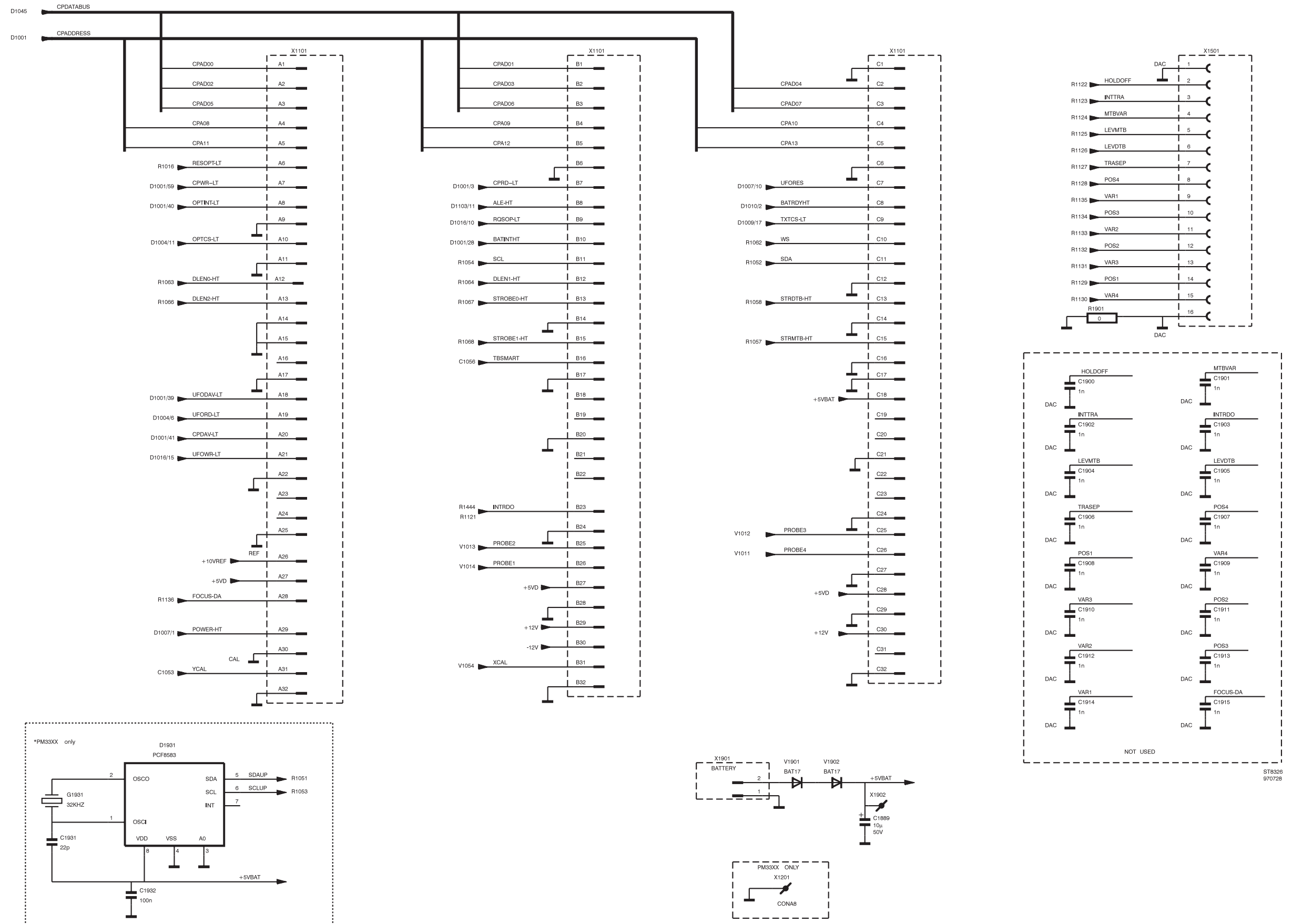

A3 - Diagram 5; Text and cursor circuit

ST8326
970728

Item	Description		Ordering code
5.3.6 Parts list			
CAPACITORS			
C1002	CAP.CERAMIC	AP 63V 5% 39PF	5322 122 32966
C1003	CAP.CERAMIC	AP 63V 5% 39PF	5322 122 32966
C1004	CAP.CHIP	AP 63V 10% 100NF	4822 122 33496
C1006	CAP.CHIP	AP 63V 10% 100NF	4822 122 33496
C1011	CAP.CHIP	AP 63V 10% 10NF	5322 122 34098
C1012	CAP.CHIP	AP 63V 10% 10NF	5322 122 34098
C1013	CAP.CHIP	AP 63V 10% 10NF	5322 122 34098
C1014	CAP.CHIP	AP 63V 10% 10NF	5322 122 34098
C1021	CAP.CHIP	AP 63V 10% 100NF	4822 122 33496
C1022	CAP.CHIP	AP 63V 10% 220NF	4822 122 32916
C1023	CAP.CHIP	AP 63V 10% 100NF	4822 122 33496
C1024	CAP.CHIP	AP 63V 10% 100NF	4822 122 33496
C1026	CAP.CHIP	AP 63V 10% 100NF	4822 122 33496
C1027	CAP.CHIP	AP 63V 10% 100NF	4822 122 33496
C1028	CAP.CHIP	AP 63V 10% 100NF	4822 122 33496
C1051	CAP.CHIP	AP 63V 5% 220PF	4822 122 33575
C1052	CAP.CHIP	AP 63V 5% 220PF	4822 122 33575
C1053	CAP.CHIP	AP 63V 10% 220NF	4822 122 32916
C1054	CAP.CHIP	AP 63V 10% 220NF	4822 122 32916
C1056	CAP.CHIP	AP 63V 10% 10NF	5322 122 34098
C1057	CAP.CHIP	AP 63V 10% 10NF	5322 122 34098
C1059	CAP.CHIP	AP 63V 5% 100PF	5322 122 32531
C1060	CAP.CHIP	AP 63V 5% 100PF	5322 122 32531
C1101	CAP.CHIP	AP 63V 10% 10NF	5322 122 34098
C1102	CAP.CHIP	AP 63V 10% 10NF	5322 122 34098
C1103	CAP.CHIP	AP 63V 10% 10NF	5322 122 34098
C1104	CAP.CHIP	AP 63V 10% 10NF	5322 122 34098
C1106	CAP.CHIP	AP 63V 10% 10NF	5322 122 34098
C1107	CAP.CHIP	AP 63V 10% 10NF	5322 122 34098
C1108	CAP.CHIP	AP 63V 10% 10NF	5322 122 34098
C1109	CAP.CHIP	AP 63V 10% 10NF	5322 122 34098
C1111	CAP.CHIP	AP 63V 10% 10NF	5322 122 34098
C1112	CAP.CHIP	AP 63V 10% 220NF	4822 122 32916
C1121	CAP.CHIP	AP 63V 5% 56PF	5322 122 32661
C1122	CAP.CHIP	AP 63V 5% 68PF	4822 122 33514
C1123	CAP.CHIP	AP 63V 10% 10NF	5322 122 34098
C1301	CAP.CHIP	AP 63V 5% 1NF	5322 126 10511
C1302	CAP.CHIP	AP 63V 5% 1NF	5322 126 10511
C1303	CAP.CHIP	AP 63V 5% 1NF	5322 126 10511
C1304	CAP.CHIP	AP 63V 5% 1NF	5322 126 10511
C1306	CAP.CHIP	AP 63V 5% 1NF	5322 126 10511
C1307	CAP.CHIP	AP 63V 5% 1NF	5322 126 10511
C1801	CAP.CHIP	AP 63V 10% 100NF	4822 122 33496
C1803	CAP.CHIP	AP 63V 10% 10NF	5322 122 34098
C1804	CAP.CHIP	AP 63V 10% 10NF	5322 122 34098

Item	Description		Ordering code
C1806	CAP.CHIP	AP 63V 10% 10NF	5322 122 34098
C1807	CAP.CHIP	AP 63V 10% 100NF	4822 122 33496
C1809	CAP.CHIP	AP 63V 10% 10NF	5322 122 34098
C1811	CAP.CHIP	AP 63V 10% 10NF	5322 122 34098
C1812	CAP.CHIP	AP 63V 10% 10NF	5322 122 34098
C1814	CAP.CHIP	AP 63V 10% 10NF	5322 122 34098
C1815	CAP.CHIP	AP 63V 10% 10NF	5322 122 34098
C1816	CAP.CHIP	AP 63V 10% 100NF	4822 122 33496
C1817	CAP.CHIP	AP 63V 10% 10NF	5322 122 34098
C1819	CAP.CHIP	AP 63V 10% 10NF	5322 122 34098
C1823	CAP.CHIP	AP 63V 10% 10NF	5322 122 34098
C1832	CAP.CHIP	AP 63V 10% 10NF	5322 122 34098
C1833	CAP.CHIP	AP 63V 10% 10NF	5322 122 34098
C1861	CAP.ELECTROLYT.	25V 20% 180UF	5322 124 42228
C1862	CAP.ELECTROLYT.	25V 20% 180UF	5322 124 42228
C1863	CAP.ELECTROLYT.	25V 20% 180UF	5322 124 42228
C1867	CAP.CHIP	AP 63V 10% 100NF	4822 122 33496
C1868	CAP.CHIP	AP 63V 10% 100NF	4822 122 33496
C1881	CAP.CHIP	AP 63V 10% 100NF	4822 122 33496
C1882	CAP.CHIP	AP 63V 10% 100NF	4822 122 33496
C1891	CAP.CHIP	AP 63V 10% 100NF	4822 122 33496
C1892	CAP.ELECTROLYT.	25V 20% 180UF	5322 124 42228
C1893	CAP.CHIP	AP 63V 10% 100NF	4822 122 33496
C1894	CAP.ELECTROLYT.	25V 20% 180UF	5322 124 42228
C1897	CAP.CHIP	AP 63V 10% 100NF	4822 122 33496
C1898	CAP.ELECTROLYT.	25V 20% 180UF	5322 124 42228
C1899	CAP.CHIP	AP 63V 10% 100NF	4822 122 33496
C1900	CAP.CHIP	AP 63V 5% 1NF	5322 126 10511
C1901	CAP.CHIP	AP 63V 5% 1NF	5322 126 10511
C1902	CAP.CHIP	AP 63V 5% 1NF	5322 126 10511
C1903	CAP.CHIP	AP 63V 5% 1NF	5322 126 10511
C1904	CAP.CHIP	AP 63V 5% 1NF	5322 126 10511
C1905	CAP.CHIP	AP 63V 5% 1NF	5322 126 10511
C1906	CAP.CHIP	AP 63V 5% 1NF	5322 126 10511
C1907	CAP.CHIP	AP 63V 5% 1NF	5322 126 10511
C1908	CAP.CHIP	AP 63V 5% 1NF	5322 126 10511
C1909	CAP.CHIP	AP 63V 5% 1NF	5322 126 10511
C1910	CAP.CHIP	AP 63V 5% 1NF	5322 126 10511
C1911	CAP.CHIP	AP 63V 5% 1NF	5322 126 10511
C1912	CAP.CHIP	AP 63V 5% 1NF	5322 126 10511
C1913	CAP.CHIP	AP 63V 5% 1NF	5322 126 10511
C1914	CAP.CHIP	AP 63V 5% 1NF	5322 126 10511
C1915	CAP.CHIP	AP 63V 5% 1NF	5322 126 10511
C1931	CAP.CHIP	AP 63V 5% 22PF	5322 122 32658
C1932	CAP.CHIP	AP 63V 10% 100NF	4822 122 33496

Item	Description		Ordering code
INTEGRATED CIRCUITS			
D1001	MICROPROCESSOR	INT0001N1 UPROC	5322 209 12591
D1004	INTEGR.CIRCUIT	SN74LS32DR2 MOT	5322 209 52442
D1006	INTEGR.CIRCUIT	PAL PROGR CHIP SEL	5322 209 33501
D1007	INTEGR.CIRCUIT	PC74HCT14T PEL	5322 209 71568
D1010	INTEGR.CIRCUIT	N74F08D PEL	5322 209 61002
D1011	INTEGR.CIRCUIT	SN74LS373DW MOT	5322 209 52445
D1012	INTEGR.CIRCUIT	HM62256LFP-10TZU HIT	5322 209 30228
D1014	INTEGR.CIRCUIT	SN74LS74ADR2 MOT	5322 209 52443
D1016	INTEGR.CIRCUIT	SN74LS138DR2MOT	5322 209 52444
D1017	INTEGR.CIRCUIT	PC74HCT259T PEL	4822 209 30086
D1018	INTEGR.CIRCUIT	HEF4066BT PEL	5322 209 14542
D1019	INTEGR.CIRCUIT	PC74HCT259T PEL	4822 209 30086
D1021	I.C. ROM	E28F020-150 FLASH 2M	5322 209 52565
D1022	I.C. ROM	E28F020-150 FLASH 2M	5322 209 52565
D1023	I.C. ROM	E28F020-150 FLASH 2M	5322 209 52565
D1024	I.C. ROM	E28F020-150 FLASH 2M	5322 209 52565
D1101	INTEGR.CIRCUIT	74LS04D	5322 209 12596
D1102	INTEGR.CIRCUIT	SN74LS74ADR2 MOT	5322 209 52443
D1103	INTEGR.CIRCUIT	SN74LS373DW MOT	5322 209 52445
D1104	INTEGR.CIRCUIT	P8291A GPIB	5322 209 81264
D1106	INTEGR.CIRCUIT	74LS02D	5322 209 12595
D1107	INTEGR.CIRCUIT	MC3448ADR1 MOT	5322 209 12597
D1108	INTEGR.CIRCUIT	MC3448ADR1 MOT	5322 209 12597
D1109	INTEGR.CIRCUIT	MC3448ADR1 MOT	5322 209 12597
D1111	INTEGR.CIRCUIT	MC3448ADR1 MOT	5322 209 12597
D1112	INTEGR.CIRCUIT	OQ0244 DACPOT	5322 209 12468
D1301	INTEGR.CIRCUIT	MC1489ADR2 MOT	5322 209 30232
D1302	INTEGR.CIRCUIT	MC1488DR2 MOT	5322 209 30269
D1931	INTEGR.CIRCUIT	PCF8583T/F4 PEL	4822 209 32504
N1101	I.C. ANALOGUE	OP-77GSR PMI	5322 130 62791
N1801	I.C. ANALOGUE	OP-77GSR PMI	5322 130 62791
RESISTORS			
R1001	RES.CHIP	HIP RC-02H 1% 10K	4822 051 10103
R1002	RES.CHIP	HIP RC-02H 1% 1M	4822 051 10105
R1003	RES.CHIP	HIP RC-02H 1% 10K	4822 051 10103
R1005	RES.CHIP	HIP RC-02H 1% 10K	4822 051 10103
R1006	RES.CHIP	HIP RC-02H 1% 46K4	5322 117 10486
R1007	RES.CHIP	HIP RC-02H 1% 4K64	4822 051 54642
R1008	RES.CHIP	HIP RC-02H 1% 1K	4822 051 10102
R1009	RES.N.T.C.	NTC640 2% 3K3	5322 116 30421
R1010	RES.CHIP	HIP RC-01 5% 1E	4822 051 10108
R1018	RES.CHIP	HIP RC-02H 1% 100K	4822 051 10104
R1019	RES.CHIP	HIP RC-02H 1% 4K64	4822 051 54642
R1021	RES.CHIP	HIP RC-01 5% 1E	4822 051 10108
R1022	RES.CHIP	HIP RC-01 5% 1E	4822 051 10108

Item	Description		Ordering code
R1023	RES.CHIP	HIP RC-01 5% 1E	4822 051 10108
R1024	RES.CHIP	HIP RC-01 5% 1E	4822 051 10108
R1026	RES.CHIP	HIP RC-02H 1% 100E	4822 051 10101
R1028	RES.CHIP	HIP RC-02H 1% 10K	4822 051 10103
R1029	RES.CHIP	HIP RC-02H 1% 10K	4822 051 10103
R1031	RES.CHIP	HIP RC-02H 1% 10K	4822 051 10103
R1032	RES.CHIP	HIP RC-02H 1% 10K	4822 051 10103
R1033	RES.CHIP	HIP RC-02H 1% 10K	4822 051 10103
R1034	RES.CHIP	HIP RC-02H 1% 10K	4822 051 10103
R1036	RES.CHIP	HIP RC-02H 1% 10K	4822 051 10103
R1037	RES.CHIP	HIP RC-02H 1% 10K	4822 051 10103
R1038	RES.CHIP	HIP RC-02H 1% 10K	4822 051 10103
R1039	RES.CHIP	HIP RC-02H 1% 10K	4822 051 10103
R1041	RES.CHIP	HIP RC-02H 1% 10K	4822 051 10103
R1042	RES.CHIP	HIP RC-02H 1% 10K	4822 051 10103
R1043	RES.CHIP	HIP RC-02H 1% 10K	4822 051 10103
R1044	RES.CHIP	HIP RC-02H 1% 10K	4822 051 10103
R1046	RES.CHIP	HIP RC-02H 1% 10K	4822 051 10103
R1047	RES.CHIP	HIP RC-02H 1% 10K	4822 051 10103
R1048	RES.CHIP	HIP RC-02H 1% 10K	4822 051 10103
R1049	RES.CHIP	HIP RC-02H 1% 10K	4822 051 10103
R1051	RES.CHIP	HIP RC-02H 1% 5K11	5322 117 10487
R1052	RES.CHIP	HIP RC-02H 1% 215E	5322 117 10484
R1053	RES.CHIP	HIP RC-02H 1% 5K11	5322 117 10487
R1054	RES.CHIP	HIP RC-02H 1% 215E	5322 117 10484
R1057	RES.CHIP	RMC1/8 1% 51E1	5322 111 91893
R1058	RES.CHIP	RMC1/8 1% 51E1	5322 111 91893
R1059	RES.CHIP	HIP RC-02H 1% 100E	4822 051 10101
R1060	RES.CHIP	HIP RC-02H 1% 100E	4822 051 10101
R1061	RES.CHIP	RMC1/8 1% 51E1	5322 111 91893
R1062	RES.CHIP	RMC1/8 1% 51E1	5322 111 91893
R1063	RES.CHIP	RMC1/8 1% 51E1	5322 111 91893
R1064	RES.CHIP	RMC1/8 1% 51E1	5322 111 91893
R1066	RES.CHIP	RMC1/8 1% 51E1	5322 111 91893
R1067	RES.CHIP	RMC1/8 1% 51E1	5322 111 91893
R1068	RES.CHIP	RMC1/8 1% 51E1	5322 111 91893
R1071	RES.CHIP	HIP RC-02H 1% 2K15	5322 117 10485
R1081	RES.CHIP	HIP RC-02H 1% 1K	4822 051 10102
R1082	RES.CHIP	RC-02H 1% 100E	4822 051 10101
R1083	RES.CHIP	HIP RC-02H 1% 10K	4822 051 10103
R1084	RES.METAL FILM	RC-02H 1% 316E	5322 117 10552
R1101	RES.METAL FILM	PR24 1/4W 0.1% 10K	5322 116 82868
R1102	RES.METAL FILM	PR24 1/4W 0.1% 5K	5322 116 80369
R1103	RES.METAL FILM	PR24 1/4W 0.1% 5K	5322 116 80369
R1104	RES.METAL FILM	PR24 1/4W 0.1% 10K	5322 116 82868
R1106	RES.CHIP	HIP RC-02H 1% 1K	4822 051 10102
R1121	RES.CHIP	HIP RC-02H 1% 100E	4822 051 10101

Item	Description		Ordering code
R1122	RES.CHIP	HIP RC-02H 1% 100E	4822 051 10101
R1123	RES.CHIP	HIP RC-02H 1% 100E	4822 051 10101
R1124	RES.CHIP	HIP RC-02H 1% 100E	4822 051 10101
R1125	RES.CHIP	HIP RC-02H 1% 100E	4822 051 10101
R1126	RES.CHIP	HIP RC-02H 1% 100E	4822 051 10101
R1127	RES.CHIP	HIP RC-02H 1% 100E	4822 051 10101
R1128	RES.CHIP	HIP RC-02H 1% 100E	4822 051 10101
R1129	RES.CHIP	HIP RC-02H 1% 100E	4822 051 10101
R1130	RES.CHIP	HIP RC-02H 1% 100E	4822 051 10101
R1131	RES.CHIP	HIP RC-02H 1% 100E	4822 051 10101
R1132	RES.CHIP	HIP RC-02H 1% 100E	4822 051 10101
R1133	RES.CHIP	HIP RC-02H 1% 100E	4822 051 10101
R1134	RES.CHIP	HIP RC-02H 1% 100E	4822 051 10101
R1135	RES.CHIP	HIP RC-02H 1% 100E	4822 051 10101
R1136	RES.CHIP	HIP RC-02H 1% 1K	4822 051 10102
R1137	RES.CHIP	HIP RC-02H 1% 10K	4822 051 10103
R1801	RES.CHIP	HIP RC-01 5% 1E	4822 051 10108
R1807	RES.CHIP	HIP RC-02H 1% 10K	4822 051 10103
R1862	RES.CHIP	HIP RC-01 5% 4E7	4822 051 10478
R1871	RES.METAL FILM	PR24 1/4W 0.1% 10K	5322 116 82868
R1872	RES.METAL FILM	PR24 1/4W 0.1% 5K	5322 116 80369
R1873	RES.METAL FILM	PR24 1/4W 0.1% 10K	5322 116 82868
R1874	RES.METAL FILM	PR24 1/4W 0.1% 5K	5322 116 80369
R1876	RES.CHIP	HIP RC-01 0E	4822 051 10008
R1877	RES.CHIP	HIP RC-02H 1% 100E	4822 051 10101
R1881	RES.CHIP	HIP RC-01 5% 1E	4822 051 10108
R1882	RES.CHIP	HIP RC-01 5% 4E7	4822 051 10478
R1883	RES.CHIP	HIP RC-01 5% 4E7	4822 051 10478
R1884	RES.CHIP	HIP RC-01 5% 4E7	4822 051 10478
R1901	RES.CHIP	HIP RC-01 0E	4822 051 10008

SEMICONDUCTORS

V1006	DIODE,CHIP	DE BAV99 PEL	5322 130 34337
V1011	DIODE,CHIP	DE BAV99 PEL	5322 130 34337
V1012	DIODE,CHIP	DE BAV99 PEL	5322 130 34337
V1013	DIODE,CHIP	DE BAV99 PEL	5322 130 34337
V1014	DIODE,CHIP	DE BAV99 PEL	5322 130 34337
V1016	DIODE,REFERENCE	IODE BZX84-C4V3 PEL	5322 130 80256
V1901	DIODE,CHIP	IODE BAT17 PEL	5322 130 31544
V1902	DIODE,CHIP	IODE BAT17 PEL	5322 130 31544

CONNECTORS

X1101	CONNECTOR	96-P PIN 2.54	5322 265 61238
X1102	CONNECTOR	26-P DBL STRGHT	5322 265 61071
X1201	PIN	CONTACT PIN	5322 268 14156
X1301	CONNECTOR	SQR 9-P PIN DIPS	5322 265 41143
X1501	CONNECTOR	16-P 1.25MM STR	5322 267 51107

Item	Description		Ordering code
MISCELLANEOUS			
G1001	CRYSTAL	XTAL 12.0MHZ PEL	4822 242 71663
G1111	RESONATOR	XTAL 16MHZ MUR	5322 242 72193
H1001	BUZZER	PKM17EPP-4001 MUR	4822 280 10198
L1111	COIL	470UH TDK	5322 157 52362

5.4 FRONT UNIT A4

5.4.1 Description

Diagram 1

The front unit incorporates several keys and a number of rotary knobs that are read by a microcomputer D5001. This microcomputer can communicate with the instrument's main microprocessor on unit A3 via connector X5002. The communication from front unit A4 to unit A3 occurs via buffer D5003. The communication in the opposite direction happens via buffer D5006. The flipflops D5004 are used to facilitate this communication.

If unit A3 wants to write information to front unit A4 the following occurs: D5006 is loaded with 8 bits of information via write pulse UFOWR-LT. This pulse is also applied to flipflop D5004/11 and this makes CPDAV-LT low. This causes an interrupt for the front processor D5001. D5001 reads D5006 via the signal CPURD-LT.

If the front A4 wants to send information to A3 the following occurs: D5003 is loaded with 8 bits of information via write pulse CPUWR-LT. This pulse is also applied to flipflop D5004/3 and this makes UFODAVLT low. This is recognized by the main microprocessor on unit A3. This device reads the contents of D5003 via signal UFORD-LT.

The rotaries and the keys are read via the 4 bit ROT-BUS and the 8 bit SW-BUS respectively. One bit in these busses is made low at a time and via the 8 bit UFOAD-BUS an 8 bit pattern is sent back to processor D5001. This bit pattern incorporates information concerning the keys/rotaries that are activated.

Diagram 2

The keys and rotaries are both grouped in a matrix. The key position is read out by making one of the SW lines low at a time. If a key is pressed, a low level is switched through to one of the 8 input lines of key latch D5002. The other lines stay at a high level via the pull-up resistors R5121 through R5129.

Each rotary can occupy 4 different states. A rotary incorporates a rotor contact that can make contact with one of the two stator contacts. It is also possible that the rotor makes no contact. The last possibility is that the rotor makes contact with both stator contacts. Most of the rotaries are present on front unit A4. Via connector X5001 the rotaries on the CRT controls unit A5 are read out. The rotaries are read out via the ROT-BUS lines RA, RB, RC and RD that are made low one at a time. This results in a certain bit pattern at the input of key latch D5002. This bit pattern is read by the microprocessor via enable signal PSEN--LT.

Diodes are used throughout the key and rotary matrix to guarantee that false information is not read by the microprocessor in case more than one control is operated at a time.

5.4.2 Signal name list A4.

Note: In the signal name list you find the itemnumber of the component that is source or destination. Behind this itemnumber (separated by ":") you find the number of the diagram where the source/destination can be found.

NAME	MEANING	SOURCE	DESTINATION
PSEN-LT	READ SIGNAL FOR KNOBS AND KEYS	D5001:01	D5002:02
UFODAVLT	FRONT WRITES TO MICROPROCESSOR	D5004:01	X5002:01
UFOWR-LT	MICROPROCESSOR WRITES TO FRONT	X5002:01	D5006:01 D5004:01

5.4.3 Key switches

Test code is obtained via the UTIL MAINTENANCE menu. Refer to section 8.11.4.2 for detailed information.

SWITCH	PM33x4A	PM33x2A	PM33x0A	TEST CODE
S5001	DISPLAY	DISPLAY	DISPLAY	70
S5002	MATH	MATH	MATH	60
S5003	MEASURE	MEASURE	MEASURE	50
S5004	RECALL	RECALL	RECALL	40
S5006	SAVE	SAVE	SAVE	30
S5007	ANALOG	ANALOG	ANALOG	20
S5008	UTIL	UTIL	UTIL	10
S5009	CAL	CAL	CAL	00
S5011	HARDCOPY	HARDCOPY	HARDCOPY	71
S5012	MAGNIFY-R	MAGNIFY-R	MAGNIFY-R	61
S5013	MAGNIFY-L	MAGNIFY-L	MAGNIFY-L	51
S5014	TRIGGER	TRIGGER	TRIGGER	41
S5016	ACQUIRE	ACQUIRE	ACQUIRE	31
S5017	pin hole	pin hole	pin hole	(21)
S5018	SETUPS	SETUPS	SETUPS	11
S5019	AUTO SET	AUTO SET	AUTO SET	(01)
S5021	SINGLE	SINGLE	SINGLE	72
S5022	AUTORANGE TB	AUTORANGE TB	AUTORANGE TB	62
S5023	RUN/STOP	RUN/STOP	RUN/STOP	52
S5024	CURSORS	CURSORS	CURSORS	42
S5026	DTB s	DTB s	DTB s	32
S5027	SOFTKEY 2	SOFTKEY 2	SOFTKEY 2	22
S5028	SOFTKEY 1	SOFTKEY 1	SOFTKEY 1	12
S5029	STATUS/LOCAL	STATUS/LOCAL	STATUS/LOCAL	02
S5031	TIME/DIV ns	TIME/DIV ns	TIME/DIV ns	73
S5032	TIME/DIV s	TIME/DIV s	TIME/DIV s	63
S5033	TB MODE	TB MODE	TB MODE	53
S5034	DTB ns	DTB ns	DTB ns	43
S5036	DTB	DTB	DTB	33
S5037	SOFTKEY 3	SOFTKEY 3	SOFTKEY 3	23
S5038	SOFTKEY 4	SOFTKEY 4	SOFTKEY 4	13
S5039	SOFTKEY 5	SOFTKEY 5	SOFTKEY 5	03
S5041	AC/DC GND CH4	AC/DC CH4	AC/DC EXT TRIG	74
S5042	INV CH4	INV CH4		64
S5043	TRIG CH4	TRIG CH4	EXT TRIG	54
S5044	AVERAGE	AVERAGE	AVERAGE	44
S5046	VERTMENU	VERTMENU	VERTMENU	34
S5047	AUTORANGE CH1	AUTORANGE CH1	AUTORANGE CH1	24
S5048	AMPL mV CH1	AMPL mV CH1	AMPL mV CH1	14
S5049	SOFTKEY 6	SOFTKEY 6	SOFTKEY 6	04

SWITCH	PM33x4A	PM33x2A	PM33x0A	TEST CODE
S5051	ON CH4	ON CH4	TRIG VIEW	75
S5052	AUTORANGE CH4	AMPL	AMPL	65
S5053	TRIG CH3	TRIG CH3		55
S5054	TRIG CH2	TRIG CH2	TRIG CH2	45
S5056	TRIG CH1	TRIG CH1	TRIG CH1	35
S5057	ON CH1	ON CH1	ON CH1	25
S5058	AMPL V CH1	AMPL V CH1	AMPL V CH1	15
S5059	TEXT OFF	TEXT OFF	TEXT OFF	05
S5061	AMPL mV CH4			76
S5062	CH3+CH4	CH3+CH4		66
S5063	AUTORANGE CH3	AMPL		56
S5064	AMPL mV CH3			46
S5066	INV CH2	INV CH2	INV CH2	36
S5067	AUTORANGE CH2	AUTORANGE CH2	AUTORANGE CH2	26
S5068	AMPL mV CH2	AMPL mV CH2	AMPL mV CH2	16
S5069	CH1+CH2	CH1+CH2	CH1+CH2	06
S5071	AMPL V CH4			77
S5072	AC/DC/GND CH3	AC/DC CH3		67
S5073	ON CH3	ON CH3		57
S5074	AMPL V CH3			47
S5076	AC/DC/GND CH2	AC/DC/GND CH2	AC/DC/GND CH2	37
S5077	ON CH2	ON CH2	ON CH2	27
S5078	AMPL V CH2	AMPL V CH2	AMPL V CH2	17
S5079	AC/DC/GND CH1	AC/DC/GND CH1	AC/DC/GND CH1	07
R5001	TRACK	TRACK	TRACK	.A
R5002	POS 1	POS 1	POS 1	.B
R5003	POS 2	POS 2	POS 2	.3
R5004	DELTA	DELTA	DELTA	.C
R5006	DELAY	DELAY	DELAY	.4
R5007	TRIGGER POSITION	TRIGGER POSITION	TRIGGER POSITION	.D
R5008	HOLD OFF	HOLD OFF	HOLD OFF	.5
R5009	POS 3	POS 3		.E
R5011	POS 4	POS 4		.6
R5012	X-POS	X-POS	X-POS	.F
R5013	TRIGGER LEVEL	TRIGGER LEVEL	TRIGGER LEVEL	.7

5.4.4 Unit lay-outs

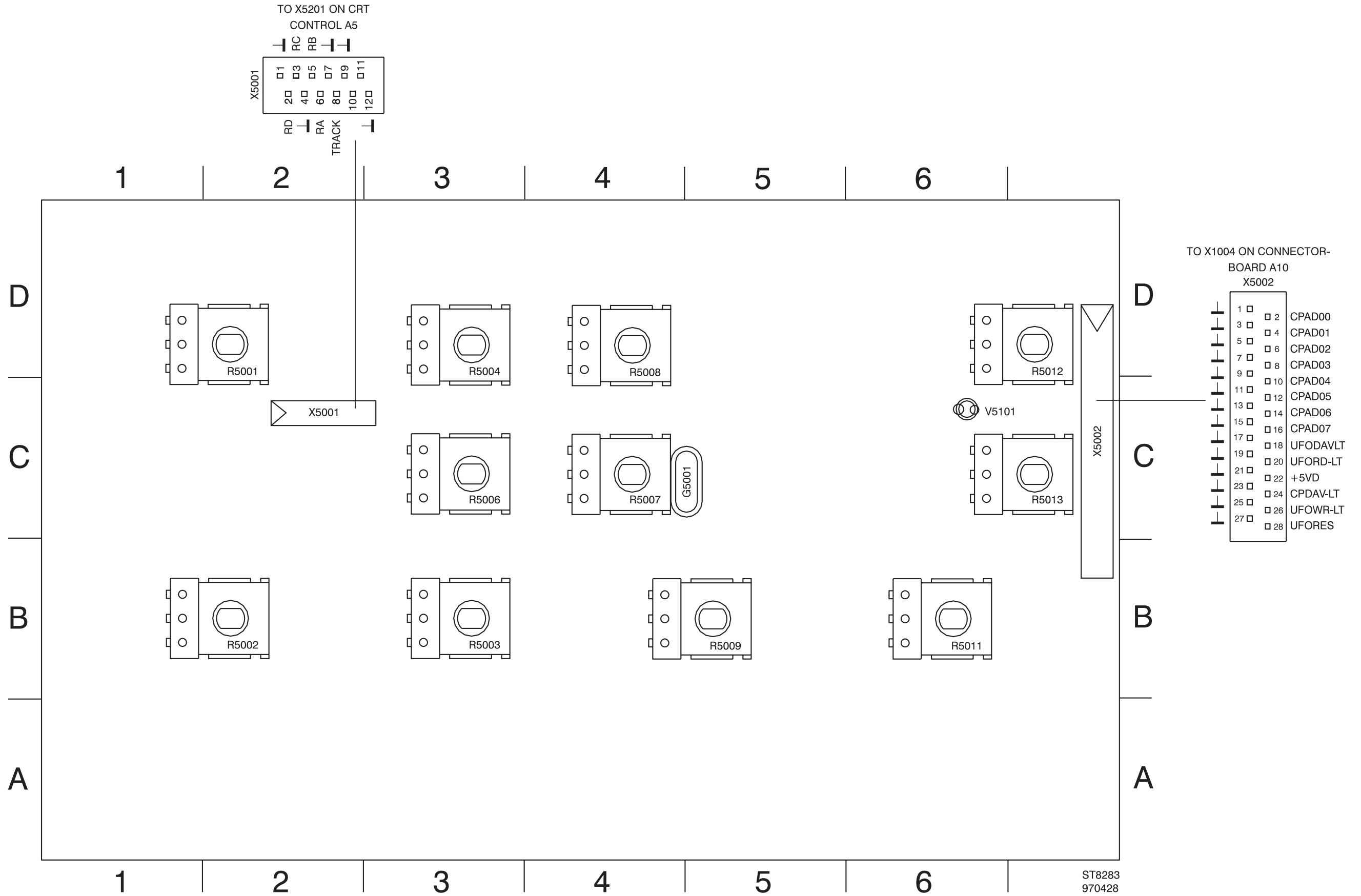

Lay-out 1 - Large component side of front unit A4

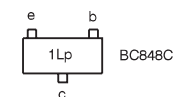
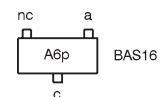
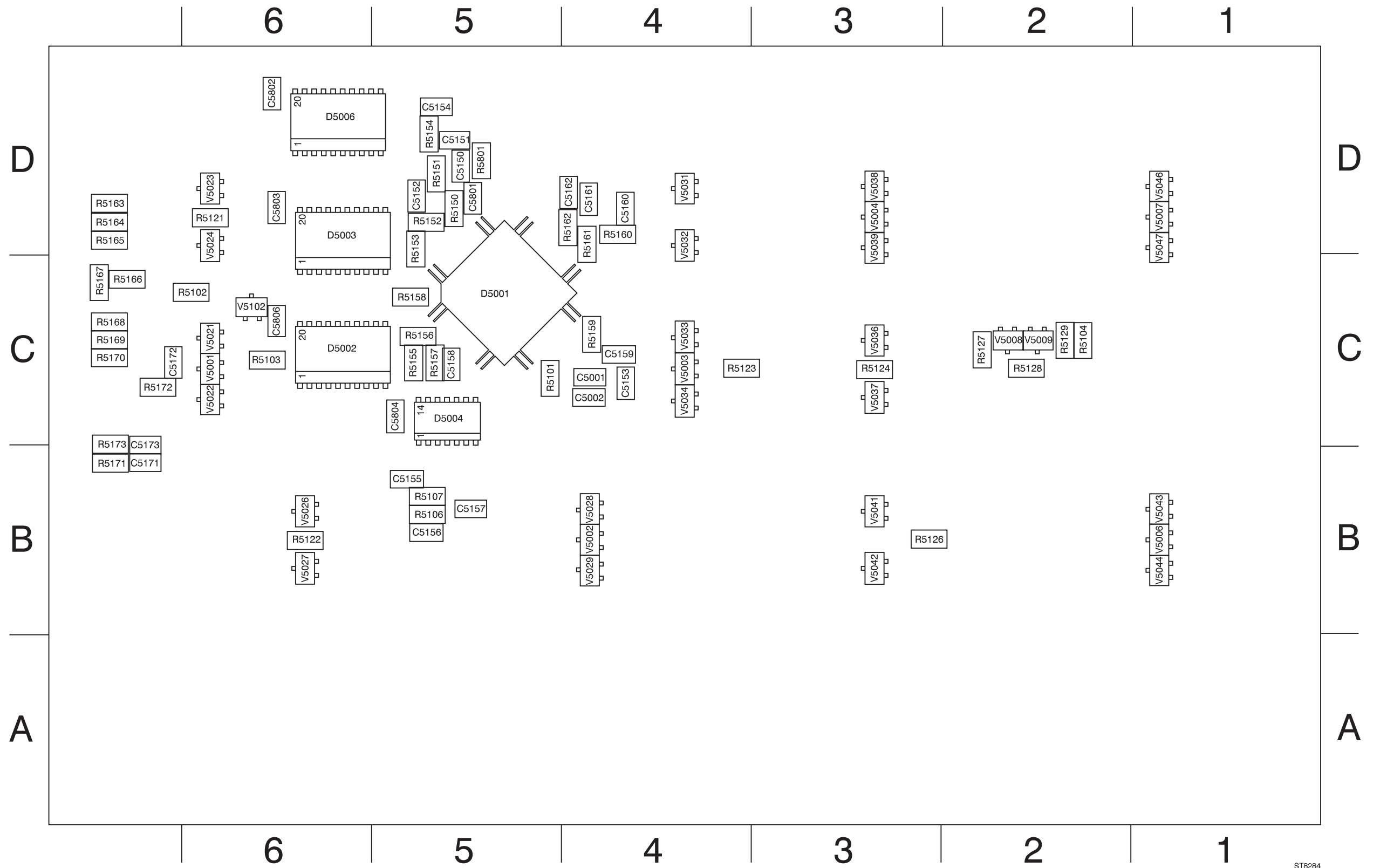

Lay-out 2 - Small component side of front unit A4

5.4.5 Circuit diagrams

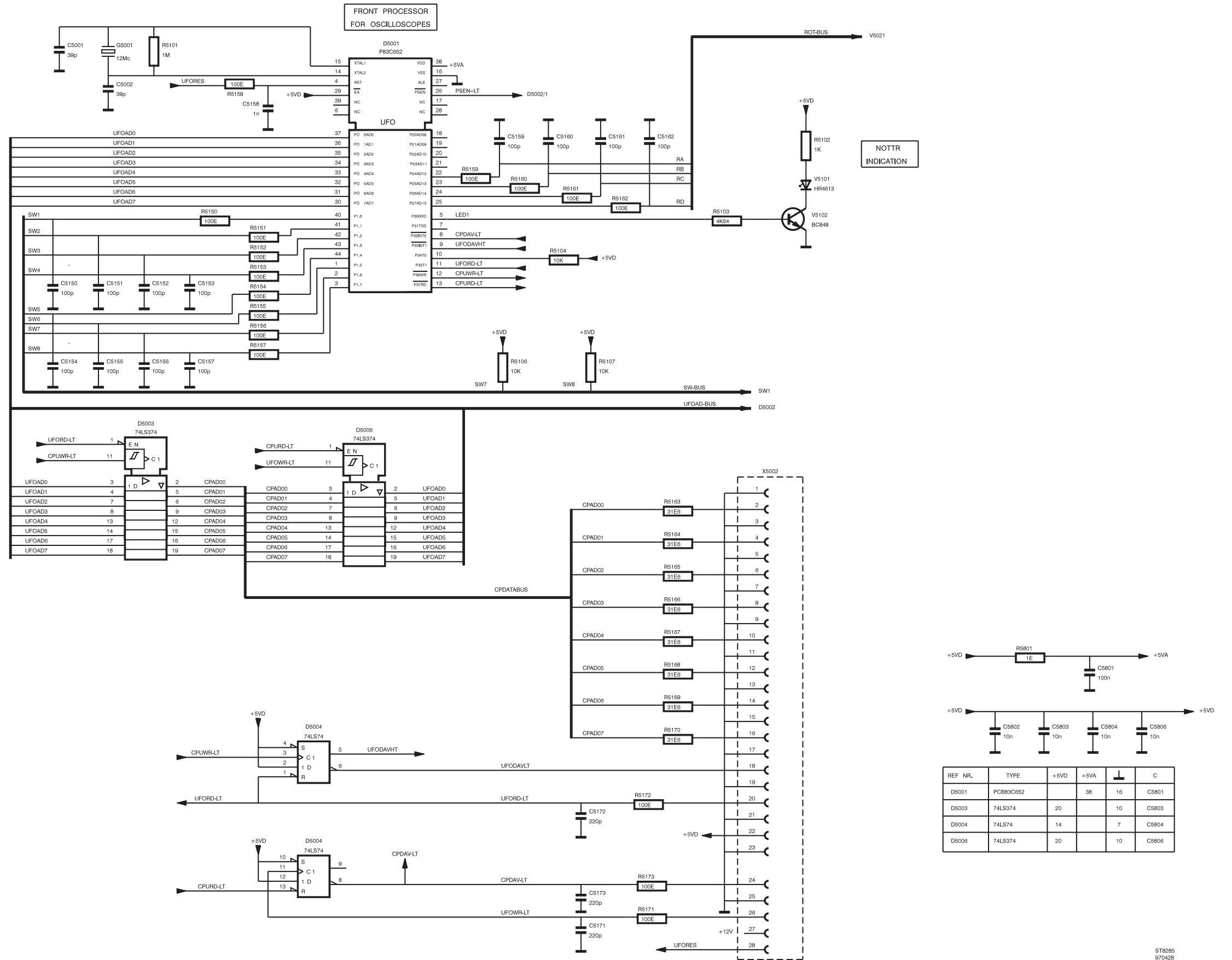

A4 - Diagram 1; front processor

ST8285
970428

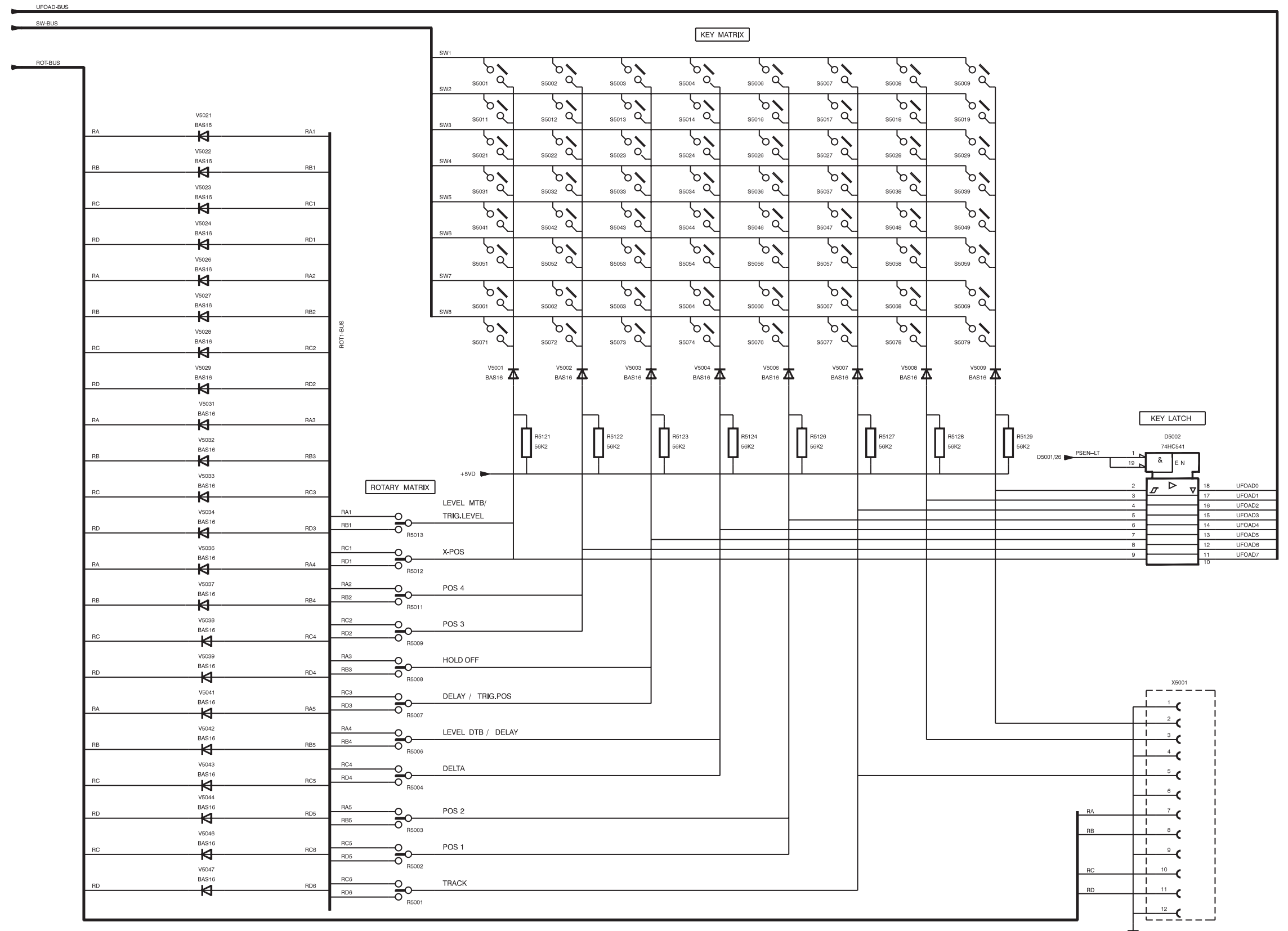

REF	NRL	TYPE	+5VD	↓	C
D5002		74HC541	20	10	C5802

ST8286
970428

A4 - Diagram 2; Key matrix

Item	Description		Ordering code
5.4.6 Parts list			
CAPACITORS			
C5001	CAP.CERAMIC	AP 63V 5% 39PF	5322 122 32966
C5002	CAP.CERAMIC	AP 63V 5% 39PF	5322 122 32966
C5150	CAP.CHIP	AP 63V 5% 100PF	5322 122 32531
C5151	CAP.CHIP	AP 63V 5% 100PF	5322 122 32531
C5152	CAP.CHIP	AP 63V 5% 100PF	5322 122 32531
C5153	CAP.CHIP	AP 63V 5% 100PF	5322 122 32531
C5154	CAP.CHIP	AP 63V 5% 100PF	5322 122 32531
C5155	CAP.CHIP	AP 63V 5% 100PF	5322 122 32531
C5156	CAP.CHIP	AP 63V 5% 100PF	5322 122 32531
C5157	CAP.CHIP	AP 63V 5% 100PF	5322 122 32531
C5158	CAP.CHIP	AP 63V 5% 1NF	5322 126 10511
C5159	CAP.CHIP	AP 63V 5% 100PF	5322 122 32531
C5160	CAP.CHIP	AP 63V 5% 100PF	5322 122 32531
C5161	CAP.CHIP	AP 63V 5% 100PF	5322 122 32531
C5162	CAP.CHIP	AP 63V 5% 100PF	5322 122 32531
C5171	CAP.CHIP	AP 63V 5% 220PF	4822 122 33575
C5172	CAP.CHIP	AP 63V 5% 220PF	4822 122 33575
C5173	CAP.CHIP	AP 63V 5% 220PF	4822 122 33575
C5801	CAP.CHIP	AP 63V 10% 100NF	4822 122 33496
C5802	CAP.CHIP	AP 63V 10% 10NF	5322 122 34098
C5803	CAP.CHIP	AP 63V 10% 10NF	5322 122 34098
C5804	CAP.CHIP	AP 63V 10% 10NF	5322 122 34098
C5806	CAP.CHIP	AP 63V 10% 10NF	5322 122 34098
INTEGRATED CIRCUITS			
D5001	INTEGR.CIRCUIT	P83C652EBB/077	5322 209 90095
D5002	I.C. INTERFACE	PC74HC541T PEL	4822 209 63763
D5003	INTEGR.CIRCUIT	SN74LS374DW MOT	5322 209 32773
D5004	INTEGR.CIRCUIT	SN74LS74ADR2 MOT	5322 209 52443
D5006	INTEGR.CIRCUIT	SN74LS374DW MOT	5322 209 32773
RESISTORS			
R5101	RES.CHIP	RC-02H 1% 1M	4822 051 10105
R5102	RES.CHIP	RC-02H 1% 1K	4822 051 10102
R5103	RES.CHIP	RC-02H 1% 4K64	4822 051 54642
R5104	RES.CHIP	RC-02H 1% 10K	4822 051 10103
R5106	RES.CHIP	RC-02H 1% 10K	4822 051 10103
R5107	RES.CHIP	HIP RC-02H 1% 10K	4822 051 10103
R5121	RES.METAL FILM	HIP RC-02H 1% 56K2	5322 117 10574
R5122	RES.METAL FILM	HIP RC-02H 1% 56K2	5322 117 10574
R5123	RES.METAL FILM	HIP RC-02H 1% 56K2	5322 117 10574
R5124	RES.METAL FILM	HIP RC-02H 1% 56K2	5322 117 10574
R5126	RES.METAL FILM	HIP RC-02H 1% 56K2	5322 117 10574
R5127	RES.METAL FILM	HIP RC-02H 1% 56K2	5322 117 10574

Item	Description		Ordering code
R5128	RES.METAL FILM	HIP RC-02H 1% 56K2	5322 117 10574
R5129	RES.METAL FILM	HIP RC-02H 1% 56K2	5322 117 10574
R5150	RES.CHIP	HIP RC-02H 1% 100E	4822 051 10101
R5151	RES.CHIP	HIP RC-02H 1% 100E	4822 051 10101
R5152	RES.CHIP	HIP RC-02H 1% 100E	4822 051 10101
R5153	RES.CHIP	HIP RC-02H 1% 100E	4822 051 10101
R5154	RES.CHIP	HIP RC-02H 1% 100E	4822 051 10101
R5155	RES.CHIP	HIP RC-02H 1% 100E	4822 051 10101
R5156	RES.CHIP	HIP RC-02H 1% 100E	4822 051 10101
R5157	RES.CHIP	HIP RC-02H 1% 100E	4822 051 10101
R5158	RES.CHIP	HIP RC-02H 1% 100E	4822 051 10101
R5159	RES.CHIP	HIP RC-02H 1% 100E	4822 051 10101
R5160	RES.CHIP	HIP RC-02H 1% 100E	4822 051 10101
R5161	RES.CHIP	HIP RC-02H 1% 100E	4822 051 10101
R5162	RES.CHIP	HIP RC-02H 1% 100E	4822 051 10101
R5163	RES.MET.GLAZED	RMC1/8 1% 31E6	5322 116 82895
R5164	RES.MET.GLAZED	RMC1/8 1% 31E6	5322 116 82895
R5165	RES.MET.GLAZED	RMC1/8 1% 31E6	5322 116 82895
R5166	RES.MET.GLAZED	RMC1/8 1% 31E6	5322 116 82895
R5167	RES.MET.GLAZED	RMC1/8 1% 31E6	5322 116 82895
R5168	RES.MET.GLAZED	RMC1/8 1% 31E6	5322 116 82895
R5169	RES.MET.GLAZED	RMC1/8 1% 31E6	5322 116 82895
R5170	RES.MET.GLAZED	RMC1/8 1% 31E6	5322 116 82895
R5171	RES.CHIP	HIP RC-02H 1% 100E	4822 051 10101
R5172	RES.CHIP	HIP RC-02H 1% 100E	4822 051 10101
R5173	RES.CHIP	HIP RC-02H 1% 100E	4822 051 10101
R5801	RES.CHIP	HIP RC-01 5% 1E	4822 051 10108

SEMICONDUCTORS

V5001	DIODE,CHIP	BAS16 PEL	5322 130 31928
V5002	DIODE,CHIP	BAS16 PEL	5322 130 31928
V5003	DIODE,CHIP	BAS16 PEL	5322 130 31928
V5004	DIODE,CHIP	BAS16 PEL	5322 130 31928
V5006	DIODE,CHIP	BAS16 PEL	5322 130 31928
V5007	DIODE,CHIP	BAS16 PEL	5322 130 31928
V5008	DIODE,CHIP	BAS16 PEL	5322 130 31928
V5009	DIODE,CHIP	BAS16 PEL	5322 130 31928
V5021	DIODE,CHIP	BAS16 PEL	5322 130 31928
V5022	DIODE,CHIP	BAS16 PEL	5322 130 31928
V5023	DIODE,CHIP	BAS16 PEL	5322 130 31928
V5024	DIODE,CHIP	BAS16 PEL	5322 130 31928
V5026	DIODE,CHIP	BAS16 PEL	5322 130 31928
V5027	DIODE,CHIP	BAS16 PEL	5322 130 31928
V5028	DIODE,CHIP	BAS16 PEL	5322 130 31928
V5029	DIODE,CHIP	BAS16 PEL	5322 130 31928
V5031	DIODE,CHIP	BAS16 PEL	5322 130 31928

Item	Description		Ordering code
V5032	DIODE,CHIP	BAS16 PEL	5322 130 31928
V5033	DIODE,CHIP	BAS16 PEL	5322 130 31928
V5034	DIODE,CHIP	BAS16 PEL	5322 130 31928
V5036	DIODE,CHIP	BAS16 PEL	5322 130 31928
V5037	DIODE,CHIP	BAS16 PEL	5322 130 31928
V5038	DIODE,CHIP	BAS16 PEL	5322 130 31928
V5039	DIODE,CHIP	BAS16 PEL	5322 130 31928
V5041	DIODE,CHIP	BAS16 PEL	5322 130 31928
V5042	DIODE,CHIP	BAS16 PEL	5322 130 31928
V5043	DIODE,CHIP	BAS16 PEL	5322 130 31928
V5044	DIODE,CHIP	BAS16 PEL	5322 130 31928
V5046	DIODE,CHIP	BAS16 PEL	5322 130 31928
V5047	DIODE,CHIP	BAS16 PEL	5322 130 31928
V5102	TRANSISTOR,CHIP	BC848C PEL	5322 130 42136

MISCELLANEOUS

G5004	RESONATOR	XTAL 12MHZ KYO	5322 242 71444
H5101	LED	TLHR4613 AEG	5322 130 81522

ROTARY SWITCHES

R5001	POTM.+SWI.TAND.	PHILICODER 15-SL	5322 105 90036
R5002	POTM.+SWI.TAND.	PHILICODER 15-SL	5322 105 90036
R5003	POTM.+SWI.TAND.	PHILICODER 15-SL	5322 105 90036
R5004	POTM.+SWI.TAND.	PHILICODER 15-SL	5322 105 90036
R5006	POTM.+SWI.TAND.	PHILICODER 15-SL	5322 105 90036
R5007	POTM.+SWI.TAND.	PHILICODER 15-SL	5322 105 90036
R5008	POTM.+SWI.TAND.	PHILICODER 15-SL	5322 105 90036
R5009	POTM.+SWI.TAND.	PHILICODER 15-SL	5322 105 90036
R5011	POTM.+SWI.TAND.	PHILICODER 15-SL	5322 105 90036
R5012	POTM.+SWI.TAND.	PHILICODER 15-SL	5322 105 90036
R5013	POTM.+SWI.TAND.	PHILICODER 15-SL	5322 105 90036

CONDUCTORS

X5001	CONNECTOR	12-P 1.25MM STR	4822 267 50668
X5002	CONNECTOR	28-P 1.25MM STR	5322 267 60311

5.5 CRT CONTROLS UNIT A5

5.5.1 Description

Each rotary can occupy 4 different states. A rotary incorporates a rotor contact that can make contact with one of the two stator contacts. It is also possible that the rotor makes no contact. The last possibility is that the rotor makes contact with both stator contacts. Most of the rotaries are present on front unit A4. Via connector X5201 the rotaries on the CRT controls unit A5 are read out. The rotaries are read out via the ROT-BUS lines RA, RB, RC and RD that are made low one at a time. This results in a certain bit pattern at the input of key latch D5002 on unit A4. This bit pattern is read by the microprocessor via enable signal PSEN--LT from the front processor on unit A4.

Diodes are used throughout the key and rotary matrix to guarantee that false information is not read by the microprocessor in case more than one control is operated at a time.

Note: The connectors X5001 on unit A4 and X5201 on unit A5 have opposite numeration.

5.5.2 Unit Lay-outs

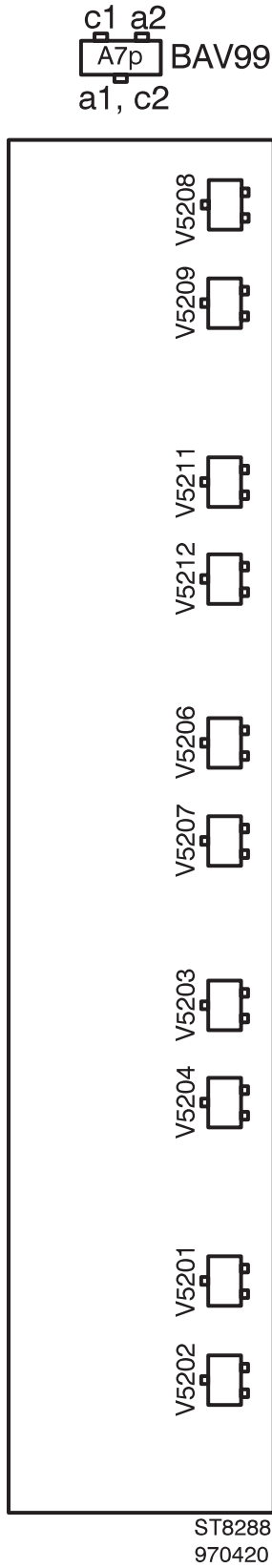

Lay-out 1; Small component side of CRT controls unit A5

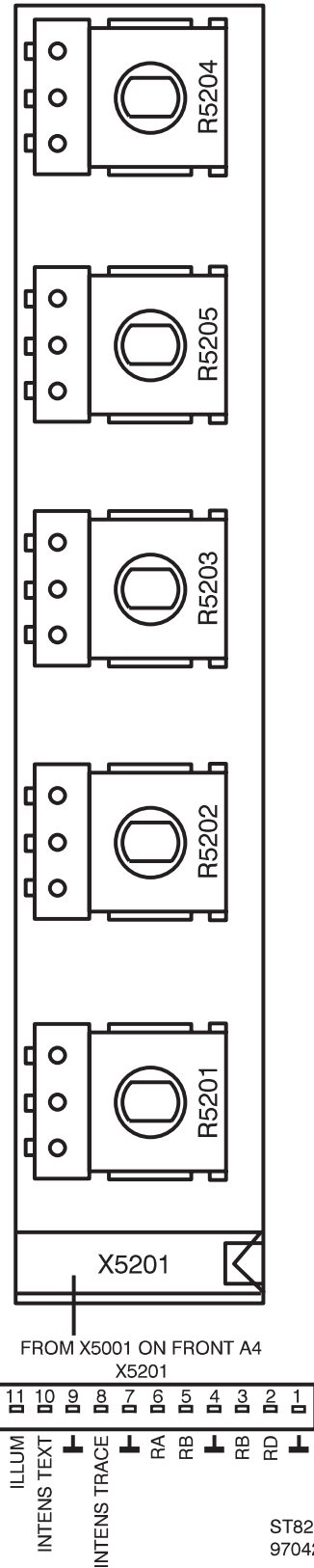

Lay-out 2; Large component side of CRT controls unit A5

5.5.3 Circuit diagram

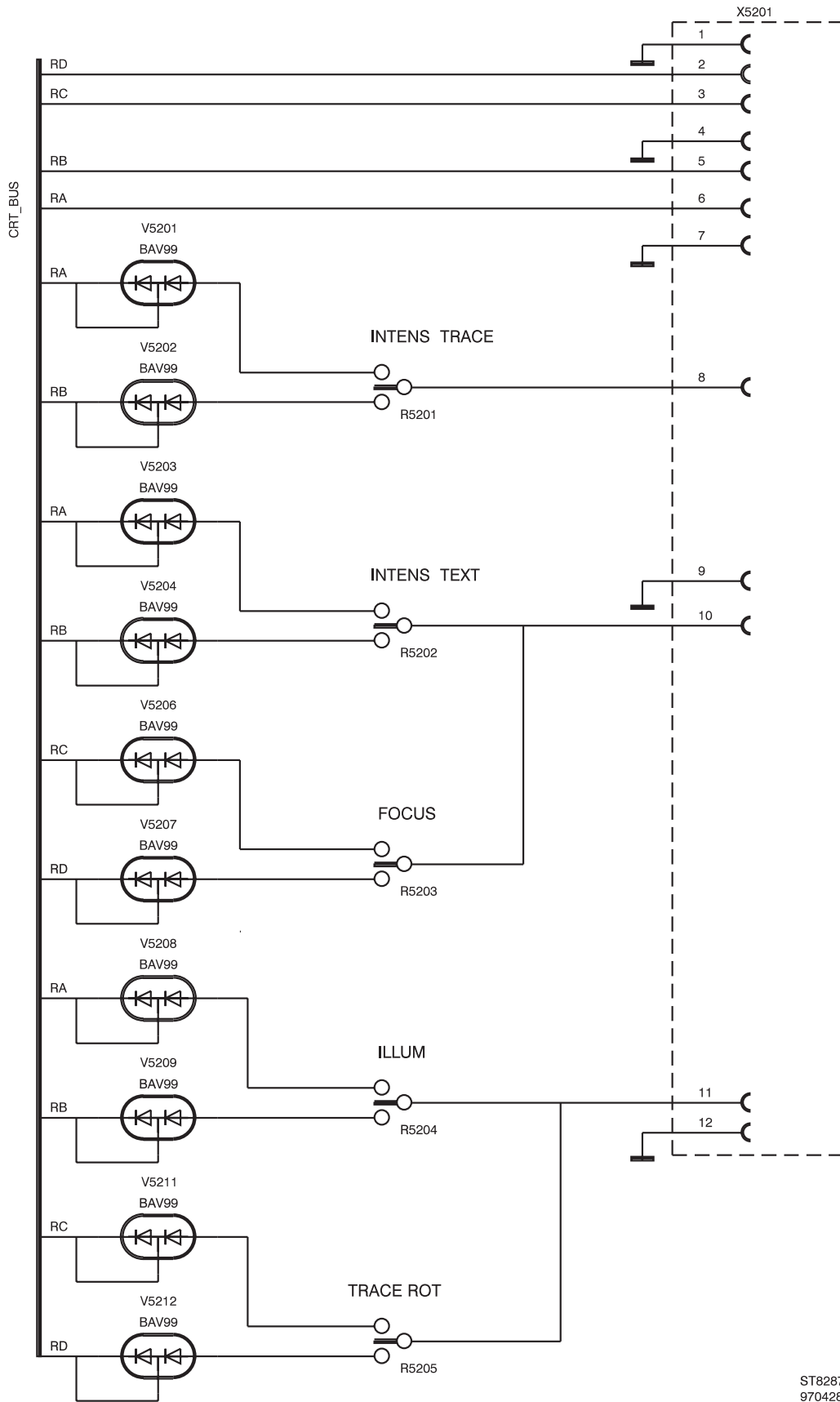

ST8287
970428

A5 - Diagram 1; CRT controls unit

5.5.4 Parts list**SEMICONDUCTORS**

V 5201	DIODE,CHIP	BAV99 PEL	5322 130 34337
V 5202	DIODE,CHIP	BAV99 PEL	5322 130 34337
V 5203	DIODE,CHIP	BAV99 PEL	5322 130 34337
V 5204	DIODE,CHIP	BAV99 PEL	5322 130 34337
V 5206	DIODE,CHIP	BAV99 PEL	5322 130 34337
V 5207	DIODE,CHIP	BAV99 PEL	5322 130 34337
V 5208	DIODE,CHIP	BAV99 PEL	5322 130 34337
V 5209	DIODE,CHIP	BAV99 PEL	5322 130 34337
V 5211	DIODE,CHIP	BAV99 PEL	5322 130 34337
V 5212	DIODE,CHIP	BAV99 PEL	5322 130 34337

ROTARY SWITCHES

R 5201	SWITCH,ROTARY	15-SL.PHILICODER	5322 105 90036
R 5202	SWITCH,ROTARY	15-SL.PHILICODER	5322 105 90036
R 5203	SWITCH,ROTARY	15-SL.PHILICODER	5322 105 90036
R 5204	SWITCH,ROTARY	15-SL.PHILICODER	5322 105 90036
R 5205	SWITCH,ROTARY	15-SL.PHILICODER	5322 105 90036

CONNECTORS

X 5201	CONNECTOR	P 1.25MM STR	4822 267 50668
--------	-----------	--------------	----------------

5.6 POWER SUPPLY A6

5.6.1 Description A6

Diagram 1

Diagram 1 comprises the following circuit parts:

- input circuit
- converter circuit
- line trigger circuit

Input circuit

Input to the circuit is the mains voltage. The following voltages are allowed:

- AC voltage between 90 and 250 V
- Theoretically a DC voltage between 100 and 380 V can be applied.

The mains input is primarily protected by a slow acting 1.6 A fuse (1.6 AT), which is located on the rear of the instrument.

Inrush current limiting is provided by NTC resistor R1001.

By means of the capacitors C1002, C1003, C1004 and C1006, an input signal for the line trigger generator is made. The capacitors form a voltage divider. This functions only if the mains voltage is AC.

C1001, 1002, 1006, 1007 and L1001 are for interference suppression.

The mains voltage is rectified by V1001 through 1004 and smoothed by C1008 and C1009.

The output voltage from the rectifier at C1009 can be between 100 and 380 V.

WARNING: For measurements in the primary circuit, the use of an isolating transformer is strongly recommended. If no isolating transformer is used, all measurements in the primary circuit must be carried out with floating measuring instruments.

Converter circuit

The power supply is a multiple output flyback converter of the SOPS (Self Oscillating Power Supply) principle. Basically, the converter consists of a switch with control circuitry (transistor V1019) and a transformer (T1001).

The first switching-on of V1019 is initiated by a small current via R1007/R1008. When V1019 is ON, the control voltage of T1001 pin 18 to C1011 is positive and this keeps V1016 and V1019 ON. During the ON or FORWARD cycle, the current through the primary winding of T1001 increases linearly, and energy ($0.5 LI^2$) is stored into this transformer. At about 2.5 A, this value is determined by the control circuit, thyristor V1014 is switched ON and due to this, V1019 is switched OFF. This is the beginning of the OFF or FLYBACK cycle. Now, the transformer voltages are reversed and the stored energy is transformed to the secondary windings. As long as the transformer is not fully demagnetized, the voltage from pin 18 to C1011 is negative and this will keep V1007, V1016 and V1019 switched OFF. As soon as the transformer demagnetizing has ended, this voltage becomes zero and so, a positive going voltage appears at C1011. Due to this, V1007, V1016 and V1019 are switched ON and the FORWARD cycle starts again.

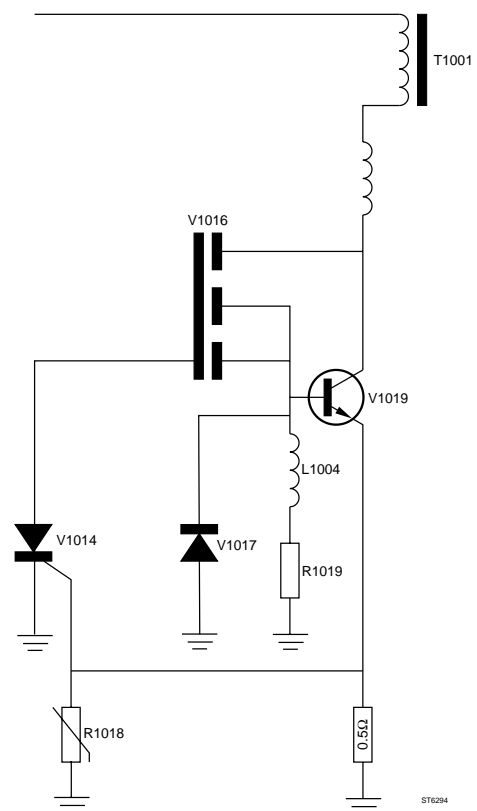

Figure 5.5 Converter circuit

To reduce the switching losses in V1019, a dV/dt limiter, often called "snubber", is used. C1021 decreases the dV/dt of the collector voltage of V1019 during switching off, as the current to the transistor can pass during a certain time through C1021. This slowing down of the collector voltage will reduce the switching losses during switching off. During the ON cycle, the energy in C1021 is transferred to L1006 and the capacitor is discharged. During the OFF cycle, the energy in L1006 is transferred to C1018 and during the next ON cycle, the energy in C1018 is delivered to the transformer. In that way, no energy is wasted. As a consequence of this system, the voltage at the transformer is slightly increased during the first part of the ON cycle, but this has no disadvantages.

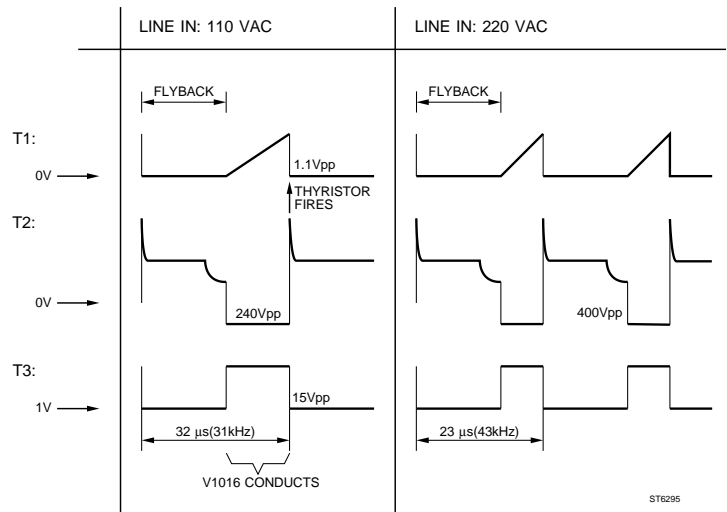

Figure 5.6 Timing diagram converter circuit

Voltage regulation takes place by varying the control voltage from R1046 to the gate of V1014. A more positive voltage will cause a smaller peak current through the transformer and this results in smaller output voltages. The converter frequency can be 20 to 50 kHz. This depends on the mains voltage and the load of the power supply. The lower the mains voltage, the lower the frequency. A lower load means a higher frequency. R1018 compensates for gate-cathode voltage variations of V1014 due to the temperature.

Line trigger circuit

For triggering purposes, a sinusoidal signal at the mains frequency is available. Of course there will be no LINE signal if the mains voltage is DC.

A small signal is picked up with capacitors C1002, C1003, C1004 and C1006 and amplified in N1046. This results in output signal at pin 1. This circuit provides a sine-wave with low distortion and with an amplitude of 3 to 8 V, depending on the mains voltage.

Diagram 2

Diagram 2 comprises the following circuit parts:

- trace rotation control
- fan control
- illumination control
- EHT converter

Trace rotation control

To supply the trace rotation coil, of which the resistance is about 200 Ω, a voltage of -10 V to +10 V is created in amplifier V1146-1147. Control takes place via a part of N1101 by means of the signal DAC3 which can be 1 to 10 V, together with the signal DAC0 with a level between 1 and 3V. The signals DAC3 and DAC0 originate from the microprocessor unit A3.

Fan control

The speed the cooling fan depends on the temperature in the oscilloscope. This temperature is measured at the microprocessor unit A3 by a NTC resistor. The microprocessor generates the signal DAC1 with a level of about 1.7 to 4 V. The fan is supplied by amplifier V1148 which is controlled by this signal. The output from the amplifier is a DC voltage of -10 to +10 V.

Illumination control

The illumination of the graticule must be variable. For this reason the illumination voltage can be varied between about 2 and 28 V. Control of the illumination amplifier V1148 takes place by means of the signal DAC2, level about 1.7 to 4 V. The output voltage from the amplifier is -16 to +10 V.

EHT converter

The EHT converter supplies three voltages.

- An AC voltage of 6,3 V (F1, F2), to supply the filament of the CRT.
- The cathode voltage to the CRT, a DC voltage of -2200 V.
- The post acceleration voltage to the CRT, a DC voltage of +14 kV.

These voltages are made in a separate converter, equipped with a separate transformer. The EHT converter is a resonant flyback converter, the output voltages of the transformer are sinusoidal.

Basically, the converter consists of a resonant LC circuit formed by the transformer with its parasitic capacitances. This resonance circuit defines the converter frequency which is about 80 kHz. Energy is supplied to this LC circuit by injecting current to it from the supply voltage, the +58 V, by switching ON V1109. Most of the time, V1109 is OFF. The primary peak to peak amplitude is about 200 V, the negative peak about -40 V. During the positive half of the sine-wave, capacitor C1111 is discharged very little via R1114.

When the sine-wave reaches its most negative value, a small current will pass through C1111 and V1106 and this acts as base current for V1102. Due to this, the thyristor configuration V1102-1109 will be switched ON and energy is supplied to the resonant circuit. The ON time of V1109 can be controlled by the operational amplifier N1101 pin 7.

To protect against too high voltages, e.g. caused by a defective N1101, the circuit is provided with an over-voltage protection. This circuit consists of V1103 and V1104. The maximum output voltage is defined by this circuit as it will overrule the control circuit at too high voltage.

The AC voltage at T1002 pins 4 and 5 is used to supply the CRT filament voltage of 6.3 V. The voltage at pins 11 and 3 is rectified and this -2200 V is used as CRT cathode voltage. The voltage at pins 11 and 2 is rectified and multiplied in a cascade circuit. The output, +14 kV, is used as post acceleration voltage to the CRT.

Diagram 3

Diagram 3 comprises the following circuit parts:

- secondary output circuitry
- over- and under-voltage protection
- power fail circuit
- temperature protection
- 10 V reference circuit
- +5V postregulator circuit

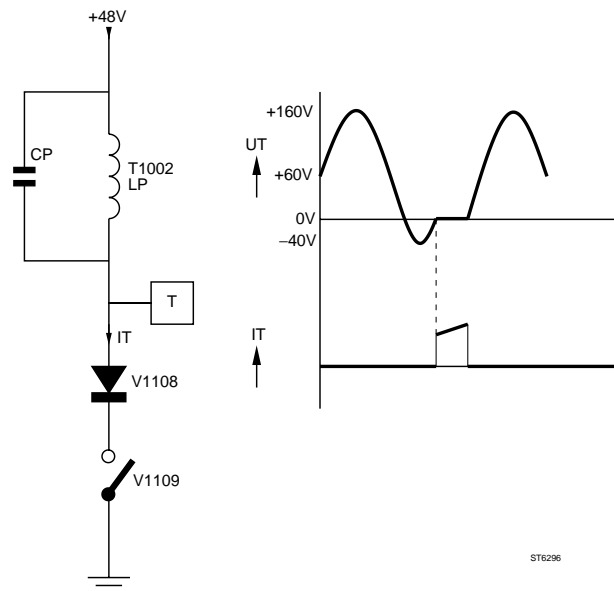

Figure 5.7 High tension generator

Secondary output circuitry

The secondary output circuits consist of rectifier diodes and buffer capacitors, followed by chokes and capacitors for ripple suppression. The output circuits are protected against overload by the under voltage protection.

Over and under-voltage protection

To protect the oscilloscope circuitry against over-voltage and the supply circuits against overload, the power supply is provided with a protection circuit. As, due to the multiple output principle, the output voltages are interdependent, it is sufficient to check only one voltage. In case of overload, the output voltages will decrease and this will be detected by the under-voltage detection, V1241, which monitors the -12 V. This will cause the collector of V1241 to be LOW. In case of over-voltage, the over-voltage detection detects a too high +12 V or +5 V and this will cause pin 13 of N1236 to be LOW. Due to this LOW signal, the intervention circuit V1241-1242-1243 will cause a current, the TPDOWN signal, to V1213. This will switch ON this thyristor and this causes switching off the converter by decreasing all output voltages to a very low, safe value.

Powerfail circuit

In normal cases, about 250 ms after switching on, the signal POWER HT will become HIGH and stay HIGH. In case of an over- or under-voltage failure, the signal will become LOW due to V1242. In case of a too low mains voltage, i.e. less than 80 V (AC) or 100 V (DC), the signal will become LOW due to N1236 pin 2. The signal POWER HT is a logic signal, it will not switch off the main convertor circuit, but it will shut down the EHT-convertor. POWER HT signals to the microprocessor unit A3 that power is going down. This gives the processor the opportunity to save important data.

Temperature protection.

To protect the circuits against too high temperatures, the oscilloscope is provided with an overheat shutdown circuit. The temperature of the power supply printed circuit board is monitored by NTC resistor R1231, which is located on the PCB. At temperatures higher than about +80 °C, pin 8 of N1236 will become HIGH and this will cause pin 14 to be LOW. Due to this, the TPDOWN signal becomes active and the converter is switched off by triggering V1213. This temperature protection is only meant for the power supply.

+10 V reference circuit

For application in the power supply and at other places in the oscilloscope, a stable +10 V reference voltage is needed. This voltage is made by N1226/V1226 in the power supply. The voltage is not adjustable. The accuracy is ± 5 mV. Temperature coefficient is $\pm 0,001^\circ\text{K}$. The load of the +10 V is about 10 mA.

+5 V postregulator circuit

The +5 V supply voltage originates from the T1001/16,15 transformer winding that supplies current during the forward stroke of the power supply: thus during the time that V1019 conducts. The current runs via transductor coil L1271, diode V1271 and the coils L1272/L1273. During the flyback stroke (power transistor V1019 off) the current runs via diode V1271 (anode connected to earth) and L1272/L1273.

Output voltage regulation occurs via the operational amplifier N1251/1,2,2 and the paralleled transistors V1251/V1252. N1252 compares the actual +5 V output voltage with the +10 VREF reference voltage. Output N1251/1 becomes lower in case that the +5 V output voltage tends to become too high. The result is an increase of the collector current of V1252/V1252. This gives a current in L1271 opposite to the +5 V supply current. This delays the moment that L1271 comes into saturation. Thus L1271 behaves like a coil during a longer period of time with the result that a certain loss of voltage across it stays. As a result the output voltage becomes lower. If saturated the voltage loss across L1271 is 0 volt.

5.6.2 Signal name list A6

Note: In the signal name list you find the itemnumber of the component that is source or destination. Behind this itemnumber (separated by ":") you find the number of the diagram where the source/destination can be found.

NAME	MEANING	SOURCE	DESTINATION
+5 SENS	+5 V OUTPUT SENSE SIGNAL	X1002:02	R1253:03
FAN0	FAN SUPPLY 0	S-12V:02	X1004:02
FAN1	FAN SUPPLY 1	L1146:02	X1004:02
GNSENS	GROUND FOR +5 V SENSE SIGNAL	X1002:02	R1257:03
ILLUM0	GRATICULE ILLUMINATION 0	S-18V:02	X1002:02
ILLUM1	GRATICULE ILLUMINATION 1	V1149:02	X1002:02
LINE	LINE/MAINS TRIGGER SIGNAL	N1046:01	X1002:01
POWER-HT	POWER UP INDICATION SIGNAL	N1236:03	X1002:03
			V1111:02
SCL	SERIAL CLOCK	X1002:02	N1141:02
SDA	SERIAL DATA	X1002:02	N1141:02
TROT0	TRACE ROTATION 0	EARTH:02	X1002:02
TROT1	TRACE ROTATION 1	V1146:02	X1002:02

5.6.3 Unit lay-outs

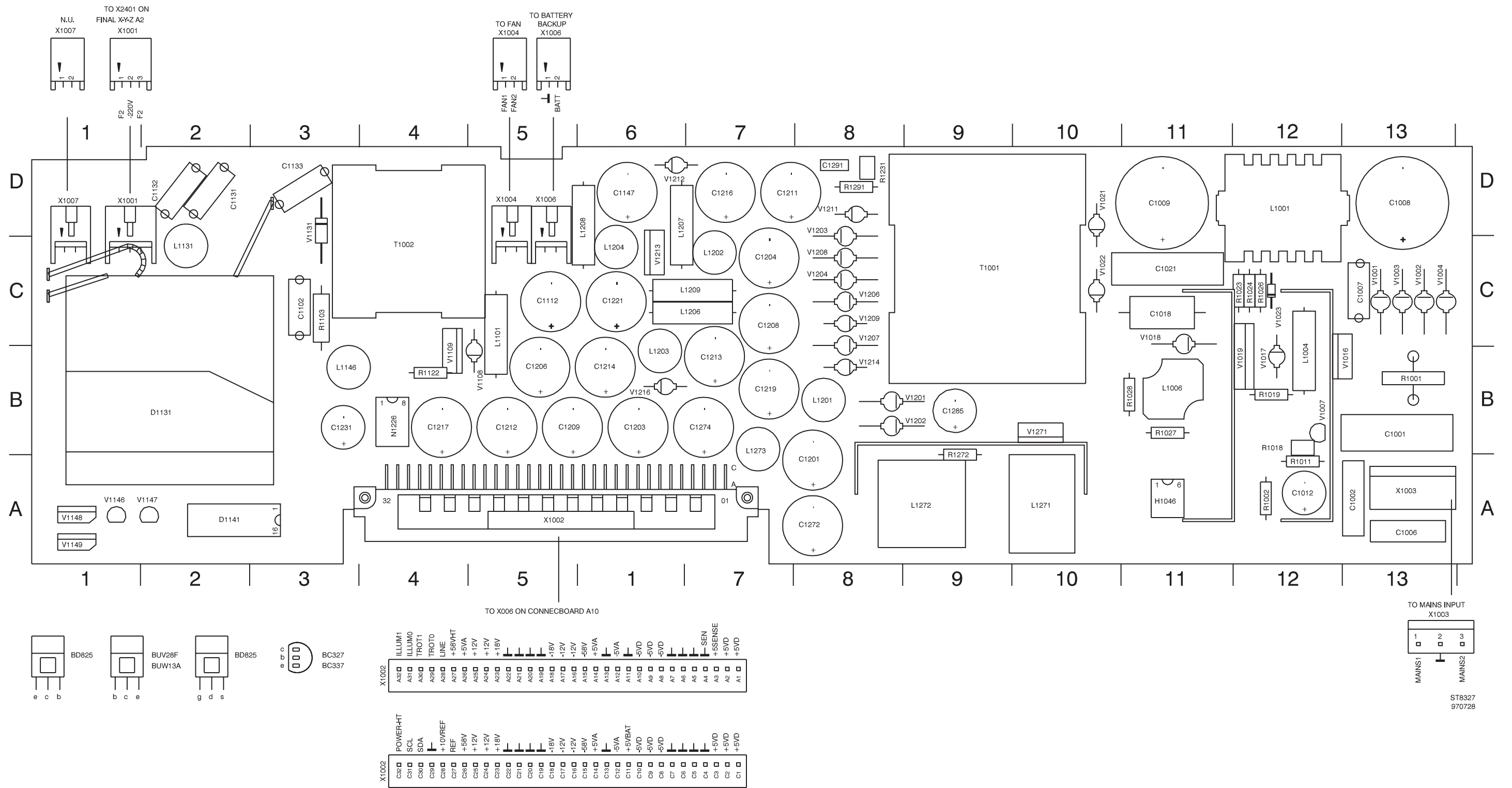

Lay-out 1 - Large component side of Power Supply unit A6

5.6.4 Circuit diagrams

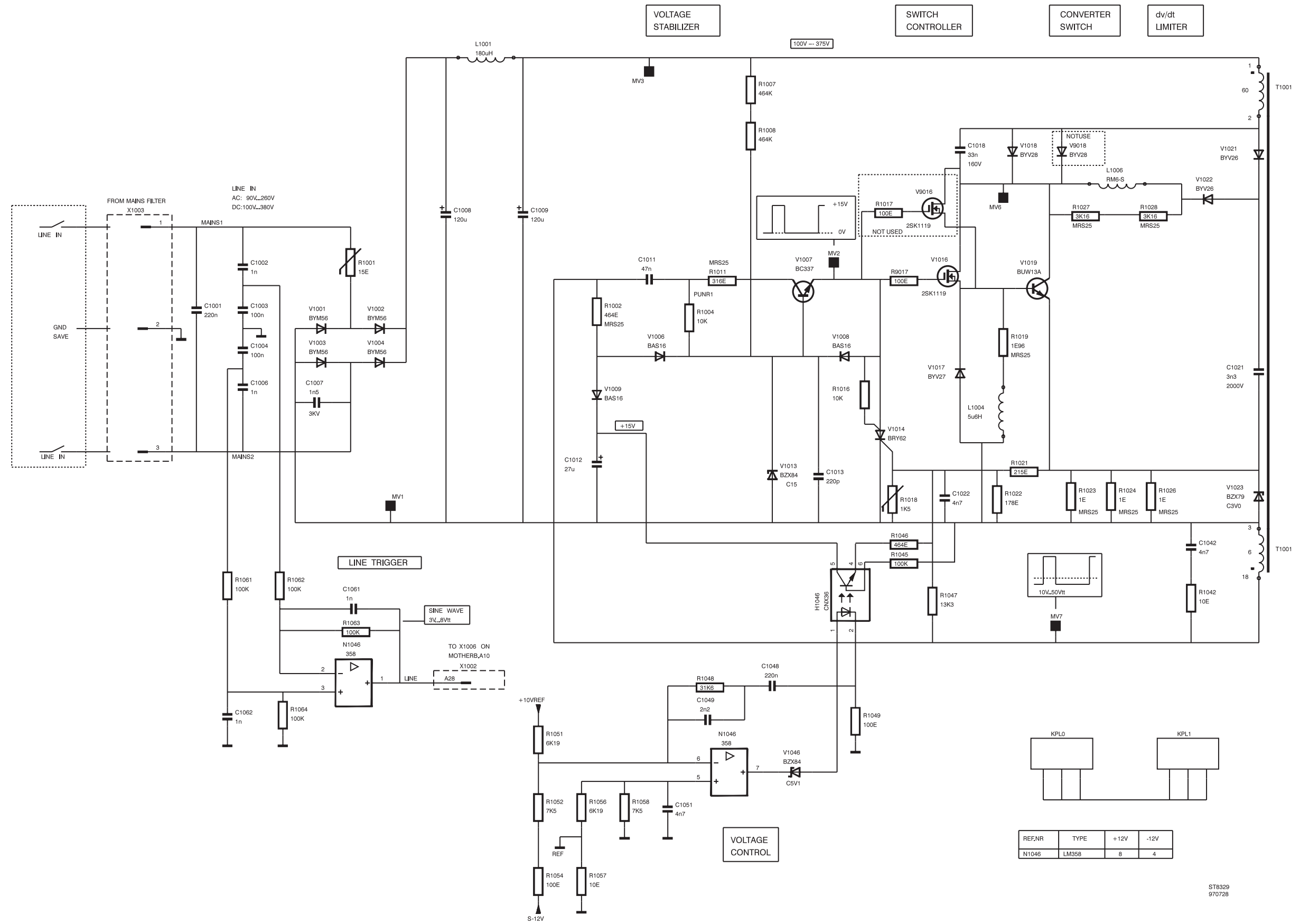

REFNR	TYPE	+12V	-12V
N1046	LM358	8	4

ST8329
970728

A6 - Diagram 1; Converter circuit

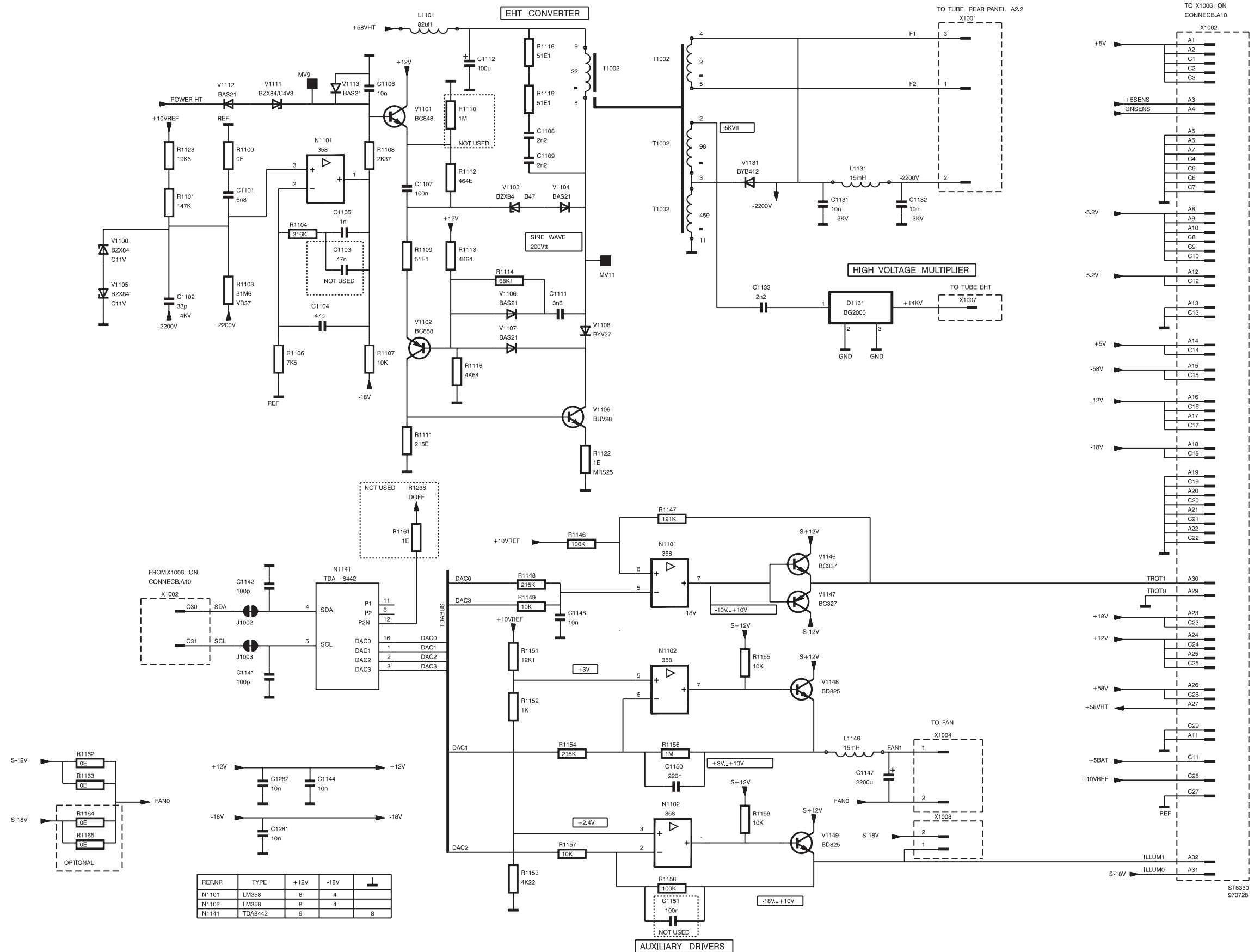

A6 - Diagram 2; EHT converter and auxiliary circuits

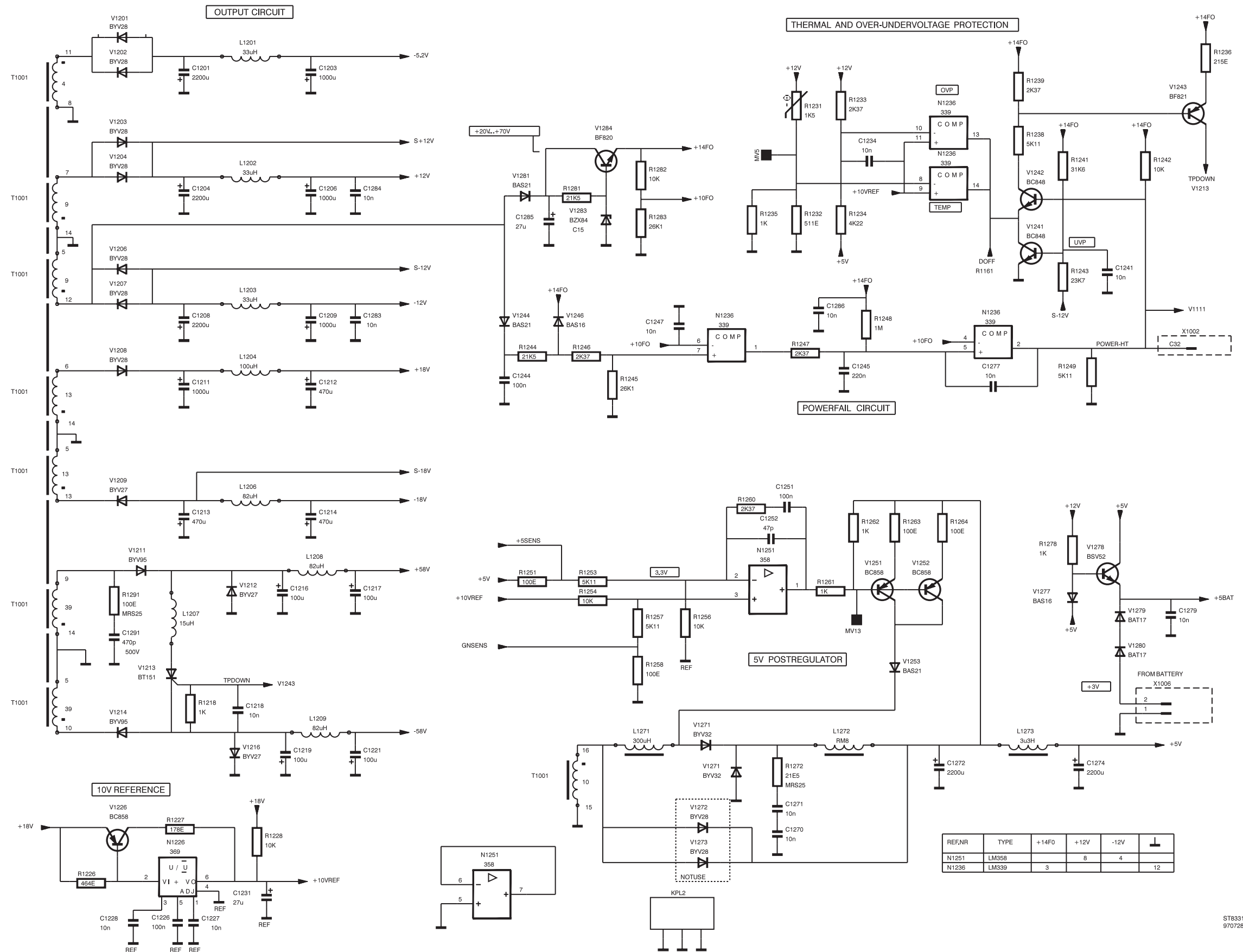

A6 - Diagram 3; Output circuit and protection circuits

Item	Description	Ordering code
------	-------------	---------------

5.6.5 Parts list**CAPACITORS**

C1001	CAP.FOIL	250V 20% 220NF	5322 121 44372
C1002	CAP.FOIL	-20+20% 1NF	5322 121 43656
C1003	CAP.CHIP	AP 63V 10% 100NF	4822 122 33496
C1004	CAP.CHIP	AP 63V 10% 100NF	4822 122 33496
C1006	CAP.FOIL	-20+20% 1NF	5322 121 43656
C1007	CAP.CERAMIC	3KV -20+50% 1.5NF	5322 122 50092
C1008	CAP.ELECTROLYT.	400V 20% 120UF	5322 124 42231
C1009	CAP.ELECTROLYT.	400V 20% 120UF	5322 124 42231
C1011	CAP.CHIP	AP 63V 10% 47NF	4822 122 32542
C1012	CAP.ELECTROLYT.	100V 20% 27UF	5322 124 42193
C1013	CAP.CHIP	AP 63V 5% 220PF	4822 122 33575
C1018	CAP.FOIL	160V 1% 33NF	5322 121 50997
C1021	CAP.FOIL	2KV 5% 3.3NF	5322 121 70117
C1022	CAP.CHIP	AP 63V 10% 4.7NF	5322 126 10223
C1042	CAP.CHIP	AP 63V 10% 4.7NF	5322 126 10223
C1048	CAP.CHIP	AP 63V 10% 220NF	4822 122 32916
C1049	CAP.CHIP	AP 63V 10% 2.2NF	4822 122 33127
C1051	CAP.CHIP	AP 63V 10% 4.7NF	5322 126 10223
C1061	CAP.CHIP	AP 63V 10% 1NF	5322 126 10511
C1062	CAP.CHIP	AP 63V 10% 1NF	5322 126 10511
C1101	CAP.CHIP	AP 63V 10% 6.8NF	5322 122 31866
C1102	CAP.CERAMIC	4KV -10+10% 33PF	5322 122 33081
C1103	CAP.CHIP	AP 63V 10% 47NF	4822 122 32542
C1104	CAP.CERAMIC	AP 63V 5% 220PF	4822 122 33575
C1105	CAP.CHIP	AP 63V 10% 1NF	5322 126 10511
C1106	CAP.CHIP	AP 63V 10% 10NF	5322 122 34098
C1107	CAP.CHIP	AP 63V 10% 100NF	4822 122 33496
C1108	CAP.CHIP	AP 63V 10% 2.2NF	4822 122 33127
C1109	CAP.CHIP	AP 63V 10% 2.2NF	4822 122 33127
C1111	CAP.CHIP	AP 63V 10% 3.3NF	4822 122 33891
C1112	CAP.ELECTROLYT.	100V 20% 100UF	5322 124 42227
C1131	CAP.CERAMIC	3KV +50 -20% 10NF	5322 126 12921
C1132	CAP.CERAMIC	3KV +50 -20% 10NF	5322 126 12921
C1133	CAP.	-10+10% 2.2NF	5322 122 33851
C1141	CAP.CHIP	AP 63V 5% 100PF	5322 122 32531
C1142	CAP.CHIP	AP 63V 5% 100PF	5322 122 32531
C1144	CAP.CHIP	AP 63V 10% 10NF	5322 122 34098
C1147	CAP.ELECTROLYT.	25V 20% 2200UF	5322 124 42229
C1148	CAP.CHIP	AP 63V 10% 10NF	5322 122 34098
C1201	CAP.ELECTROLYT.	25V 20% 2200UF	5322 124 42229
C1203	CAP.	25V -20+20% 1000UF	5322 124 23276
C1204	CAP.ELECTROLYT.	25V 20% 2200UF	5322 124 42229
C1206	CAP.	25V -20+20% 1000UF	5322 124 23276
C1208	CAP.ELECTROLYT.	25V 20% 2200UF	5322 124 42229
C1209	CAP.	25V -20+20% 1000UF	5322 124 23276

Item	Description		Ordering code
C1211	CAP.	25V -20+20% 1000UF	5322 124 23276
C1212	CAP.FOIL	25V 20% 470UF	5322 121 43885
C1213	CAP.FOIL	25V 20% 470UF	5322 121 43885
C1214	CAP.FOIL	25V 20% 470UF	5322 121 43885
C1216	CAP.ELECTROLYT.	100V 20% 100UF	5322 124 42227
C1217	CAP.ELECTROLYT.	100V 20% 100UF	5322 124 42227
C1218	CAP.CHIP	AP 63V 10% 10NF	5322 122 34098
C1219	CAP.ELECTROLYT.	100V 20% 100UF	5322 124 42227
C1221	CAP.ELECTROLYT.	100V 20% 100UF	5322 124 42227
C1226	CAP.CHIP	AP 63V 10% 100NF	4822 122 33496
C1227	CAP.CHIP	AP 63V 10% 10NF	5322 122 34098
C1231	CAP.ELECTROLYT.	100V 20% 27UF	5322 124 42193
C1234	CAP.CHIP	AP 63V 10% 10NF	5322 122 34098
C1241	CAP.CHIP	AP 63V 10% 10NF	5322 122 34098
C1244	CAP.CHIP	AP 63V 10% 100NF	4822 122 33496
C1245	CAP.CHIP	AP 63V 10% 220NF	4822 122 32916
C1247	CAP.CHIP	AP 63V 10% 10NF	5322 122 34098
C1251	CAP.CHIP	AP 63V 10% 100NF	4822 122 33496
C1252	CAP.CERAMIC	AP 63V 5% 47PF	5322 122 32452
C1270	CAP.CHIP	AP 63V 10% 10NF	5322 122 34098
C1271	CAP.CHIP	AP 63V 10% 10NF	5322 122 34098
C1272	CAP.ELECTROLYT.	25V 20% 2200UF	5322 124 42229
C1274	CAP.ELECTROLYT.	25V 20% 2200UF	5322 124 42229
C1277	CAP.CHIP	AP 63V 10% 10NF	5322 122 34098
C1279	CAP.CHIP	AP 63V 10% 10NF	5322 122 34098
C1281	CAP.CHIP	AP 63V 10% 10NF	5322 122 34098
C1282	CAP.CHIP	AP 63V 10% 10NF	5322 122 34098
C1283	CAP.CHIP	AP 63V 10% 10NF	5322 122 34098
C1284	CAP.CHIP	AP 63V 10% 10NF	5322 122 34098
C1285	CAP.ELECTROLYT.	100V 20% 27UF	5322 124 42193
C1286	CAP.CHIP	AP 63V 10% 10NF	5322 122 34098
C1291	CAP.CERAMIC	500V 10% 470PF	4822 122 31177
C9972	CAP.ELECTROLYT.	25V 20% 2200UF	5322 124 42229

INTEGRATED CIRCUITS

D1131	UNIT,ELECTRICAL	BG2000-641-512	5322 130 10177
N1046	INTEGR.CIRCUIT	LM358M NSC	4822 209 60175
N1101	INTEGR.CIRCUIT	LM358M NSC	4822 209 60175
N1102	INTEGR.CIRCUIT	LM358M NSC	4822 209 60175
N1141	INTEGR.CIRCUIT	TDA8442/N3 PEL	4822 209 71703
N1226	INTEGR.CIRCUIT	LM369DN NSC	5322 209 30266
N1236	INTEGR.CIRCUIT	LM339D SIG	5322 209 70684
N1251	INTEGR.CIRCUIT	LM358M NSC	4822 209 60175

Item	Description		Ordering code
COILS			
L1001	COIL	ECH30 180UH TDK	5322 157 63378
L1004	COIL	5.6UH	4822 157 52259
L1006	COIL	PG1 RM6S T&M OSC.	5322 157 70858
L1101	COIL	82UH	4822 158 10563
L1131	COIL	0.015H TDK	5322 157 63383
L1146	COIL	0.015H TDK	5322 157 63383
L1201	COIL	33UH TDK	4822 157 62886
L1202	COIL	33UH TDK	4822 157 62886
L1203	COIL	33UH TDK	4822 157 62886
L1204	COIL	100UH TDK	5322 157 52363
L1206	COIL	82UH	4822 158 10563
L1207	COIL	15UH	4822 157 53066
L1208	COIL	82UH	4822 158 10563
L1209	COIL	82UH	4822 158 10563
L1271	COIL	TRANSDUCTORCOIL	5322 157 63931
L1273	COIL	3.3UH TDK	5322 157 53017
RESISTORS			
R1001	RES.N.T.C.	NTC 2.2A 15E	5322 116 34035
R1002	RES.METAL FILM	ST MRS25 1% 464E	4822 050 24641
R1004	RES.CHIP	HIP RC-02H 1% 10K	4822 051 10103
R1007	RES.METAL FILM	HIP RC-02H 1% 464K	5322 117 10568
R1008	RES.METAL FILM	HIP RC-02H 1% 464K	5322 117 10568
R1011	RES.METAL FILM	ST MRS25 1% 316E	4822 050 23161
R1016	RES.CHIP	HIP RC-02H 1% 10K	4822 051 10103
R1017	RES.CHIP	HIP RC-02H 1% 100E	4822 051 10101
R1018	RES.N.T.C.	NTC 0.5W 10% 1K5	4822 116 30248
R1019	RES.METAL FILM	ST MRS25 1% 1E96	4822 050 21968
R1021	RES.CHIP	HIP RC-02H 1% 215E	5322 117 10484
R1022	RES.METAL FILM	HIP RC-02H 1% 178E	5322 117 10534
R1023	RES.METAL FILM	ST MRS25 1% 1E	4822 050 21008
R1024	RES.METAL FILM	ST MRS25 1% 1E	4822 050 21008
R1026	RES.METAL FILM	ST MRS25 1% 1E	4822 050 21008
R1027	RES.METAL FILM	ST MRS25 1% 3K16	4822 050 23162
R1028	RES.METAL FILM	ST MRS25 1% 3K16	4822 050 23162
R1042	RES.CHIP	RMC1/8 1% 10E	4822 111 91885
R1045	RES.CHIP	RC-02H 1% 100K	4822 051 10104
R1046	RES.METAL FILM	HIP RC-02H 1% 464E	5322 117 10567
R1047	RES.METAL FILM	HIP RC-02H 1% 13K3	5322 117 10525
R1048	RES.METAL FILM	HIP RC-02H 1% 31K6	5322 117 10554
R1049	RES.CHIP	HIP RC-02H 1% 100E	4822 051 10101
R1051	RES.METAL FILM	HIP RC-02H 1% 6K19	5322 117 10577
R1052	RES.METAL FILM	HIP RC-02H 1% 7K5	5322 117 10583
R1054	RES.CHIP	HIP RC-02H 1% 100E	4822 051 10101
R1056	RES.METAL FILM	HIP RC-02H 1% 6K19	5322 117 10577

Item	Description		Ordering code
R1057	RES.CHIP	RMC1/8 1% 10E	4822 111 91885
R1058	RES.METAL FILM	HIP RC-02H 1% 7K5	5322 117 10583
R1061	RES.CHIP	HIP RC-02H 1% 100K	4822 051 10104
R1062	RES.CHIP	HIP RC-02H 1% 100K	4822 051 10104
R1063	RES.CHIP	HIP RC-02H 1% 100K	4822 051 10104
R1064	RES.CHIP	HIP RC-02H 1% 100K	4822 051 10104
R1100	RES.METAL FILM	HIP RC-02H 0E	4822 051 10008
R1101	RES.METAL FILM	HIP RC-02H 1% 121K	5322 117 10523
R1103	RES.HI-TENSION	RST VR37 1% 31M6	5322 116 64103
R1104	RES.METAL FILM	HIP RC-02H 1% 316K	5322 117 10555
R1106	RES.METAL FILM	HIP RC-02H 1% 7k5	5322 117 10583
R1107	RES.CHIP	HIP RC-02H 1% 10K	4822 051 10103
R1108	RES.METAL FILM	HIP RC-02H 1% 2K37	5322 117 10545
R1109	RES.CHIP	RMC1/8 1% 51E1	5322 111 91893
R1111	RES.CHIP	HIP RC-02H 1% 215E	5322 117 10484
R1112	RES.METAL FILM	HIP RC-02H 1% 464E	5322 117 10567
R1113	RES.CHIP	HIP RC-02H 1% 4K64	4822 051 54642
R1114	RES.CHIP	HIP RC-02H 1% 68K1	4822 051 56813
R1116	RES.CHIP	HIP RC-02H 1% 4K64	4822 051 54642
R1118	RES.CHIP	RMC1/8 1% 51E1	5322 111 91893
R1119	RES.CHIP	RMC1/8 1% 51E1	5322 111 91893
R1122	RES.METAL FILM	ST MRS25 1% 1E	4822 050 21008
R1123	RES.METAL FILM	HIP RC-02H 1% 19K6	5322 117 10541
R1146	RES.CHIP	HIP RC-02H 1% 100K	4822 051 10104
R1147	RES.METAL FILM	HIP RC-02H 1% 121K	5322 117 10523
R1148	RES.METAL FILM	HIP RC-02H 1% 215K	5322 117 10543
R1149	RES.CHIP	HIP RC-02H 1% 10K	4822 051 10103
R1151	RES.METAL FILM	HIP RC-02H 1% 12K1	5322 117 10522
R1152	RES.CHIP	HIP RC-02H 1% 1K	4822 051 10102
R1153	RES.METAL FILM	HIP RC-02H 1% 4K22	5322 117 10565
R1154	RES.METAL FILM	HIP RC-02H 1% 215K	5322 117 10543
R1155	RES.CHIP	HIP RC-02H 1% 10K	4822 051 10103
R1156	RES.CHIP	HIP RC-02H 1% 1M	4822 051 10105
R1157	RES.CHIP	HIP RC-02H 1% 10K	4822 051 10103
R1158	RES.CHIP	HIP RC-02H 1% 100K	4822 051 10104
R1159	RES.CHIP	HIP RC-02H 1% 10K	4822 051 10103
R1161	RES.CHIP	HIP RC-01 5% 1E	4822 051 10108
R1162	RES.CHIP	HIP RC-02H 0E	4822 051 10008
R1163	RES.CHIP	HIP RC-02H 0E	4822 051 10008
R1218	RES.CHIP	HIP RC-02H 1% 1K	4822 051 10102
R1226	RES.METAL FILM	HIP RC-02H 1% 464E	5322 117 10567
R1227	RES.METAL FILM	HIP RC-02H 1% 178E	5322 117 10534
R1228	RES.CHIP	HIP RC-02H 1% 10K	4822 051 10103
R1231	RES.N.T.C.	NTC 0.5W 10% 1K5	4822 116 30248
R1232	RES.METAL FILM	HIP RC-02H 1% 511E	5322 117 10569
R1233	RES.METAL FILM	HIP RC-02H 1% 2K37	5322 117 10545
R1234	RES.METAL FILM	HIP RC-02H 1% 4K22	5322 117 10565

Item	Description		Ordering code
R1235	RES.CHIP	HIP RC-02H 1% 1K	4822 051 10102
R1236	RES.CHIP	HIP RC-02H 1% 215E	5322 117 10484
R1238	RES.CHIP	HIP RC-02H 1% 5K11	5322 117 10487
R1239	RES.METAL FILM	HIP RC-02H 1% 2K37	5322 117 10545
R1241	RES.METAL FILM	HIP RC-02H 1% 31K6	5322 117 10554
R1242	RES.CHIP	HIP RC-02H 1% 10K	4822 051 10103
R1243	RES.METAL FILM	HIP RC-02H 1% 23K7	5322 117 10546
R1244	RES.METAL FILM	HIP RC-02H 1% 21K5	5322 117 10542
R1245	RES.METAL FILM	HIP RC-02H 1% 26K1	5322 117 10548
R1246	RES.METAL FILM	HIP RC-02H 1% 2K37	5322 117 10545
R1247	RES.METAL FILM	HIP RC-02H 1% 2K37	5322 117 10545
R1248	RES.CHIP	HIP RC-02H 1% 1M	4822 051 10105
R1249	RES.CHIP	HIP RC-02H 1% 5K11	5322 117 10487
R1251	RES.CHIP	HIP RC-02H 1% 100E	4822 051 10101
R1253	RES.CHIP	HIP RC-02H 1% 5K11	5322 117 10487
R1254	RES.CHIP	HIP RC-02H 1% 10K	4822 051 10103
R1256	RES.CHIP	HIP RC-02H 1% 10K	4822 051 10103
R1257	RES.CHIP	HIP RC-02H 1% 5K11	5322 117 10487
R1258	RES.CHIP	HIP RC-02H 1% 100E	4822 051 10101
R1260	RES.CHIP	HIP RC-02H 1% 2K37	5322 117 10545
R1261	RES.CHIP	HIP RC-02H 1% 1K	4822 051 10102
R1262	RES.CHIP	HIP RC-02H 1% 1K	4822 051 10102
R1263	RES.CHIP	HIP RC-02H 1% 100E	4822 051 10101
R1264	RES.CHIP	HIP RC-02H 1% 100E	4822 051 10101
R1272	RES.METAL FILM	ST MRS25 1% 21E5	4822 050 22159
R1278	RES.CHIP	HIP RC-02H 1% 1K	4822 051 10102
R1281	RES.METAL FILM	HIP RC-02H 1% 21K5	5322 117 10542
R1282	RES.CHIP	HIP RC-02H 1% 10K	4822 051 10103
R1283	RES.METAL FILM	HIP RC-02H 1% 26K1	5322 117 10548
R1291	RES.METAL FILM	ST MRS25 1% 100E	4822 050 21001
R9017	RES.CHIP	HIP RC-02H 1% 100E	4822 051 10101

SEMICONDUCTORS

V1001	DIODE	BYM56E PEL	4822 130 80254
V1002	DIODE	BYM56E PEL	4822 130 80254
V1003	DIODE	BYM56E PEL	4822 130 80254
V1004	DIODE	BYM56E PEL	4822 130 80254
V1006	DIODE,CHIP	BAS16 PEL	5322 130 31928
V1007	TRANSISTOR	BC337 PEL	4822 130 40855
V1008	DIODE,CHIP	BAS16 PEL	5322 130 31928
V1009	DIODE,CHIP	BAS16 PEL	5322 130 31928
V1013	DIODE,REFERENCE	BZX84-C15 PEL	5322 130 33662
V1014	TRANSISTOR,CHIP	BRY62 PEL	5322 130 62661
V1016	TRANSISTOR	2SK119 TOS	5322 130 63358
V1017	RECTIFIER	BYV27-150 PEL	4822 130 31628
V1018	RECTIFIER	BYV28-150 PEL	5322 130 32043
V1019	TRANSISTOR	BUW13A PEL	5322 130 42047
V1021	RECTIFIER	BYV26C PEL	4822 130 32343

Item	Description		Ordering code
V1022	RECTIFIER	BYV26C PEL	4822 130 32343
V1023	DIODE,REFERENCE	BZX79-C3V0 PEL	4822 130 31881
V1046	DIODE,REFERENCE	BZX84-C5V1 PEL	5322 130 32835
V1100	DIODE,REFERENCE	BZX84-C11 PEL	4822 130 81338
V1102	TRANSISTOR,CHIP	BC858C PEL	4822 130 42513
V1103	DIODE,REFERENCE	BZX84-B47 PEL	4822 130 82521
V1104	DIODE,CHIP	BAS21 PEL	4822 130 33702
V1105	DIODE,REFERENCE	BZX84-C11 PEL	4822 130 81338
V1106	DIODE,CHIP	BAS21 PEL	4822 130 33702
V1107	DIODE,CHIP	BAS21 PEL	4822 130 33702
V1108	RECTIFIER	BYV27-150 PEL	4822 130 31628
V1109	TRANSISTOR	BUL147 MOT	5322 130 63515
V1111	DIODE,REFERENCE	BZX84-C4V3 PEL	5322 130 80256
V1112	DIODE,CHIP	BAS21	4822 130 33702
V1113	DIODE,CHIP	BAS21	4822 130 33702
V1131	DIODE	BY709 PEL	5322 130 82711
V1146	TRANSISTOR	BC337 PEL	4822 130 40855
V1147	TRANSISTOR	BC327 PEL	4822 130 40854
V1148	TRANSISTOR	BD825 PEL	4822 130 41746
V1149	TRANSISTOR	BD825 PEL	4822 130 41746
V1201	RECTIFIER	BYV28-150 PEL	5322 130 32043
V1202	RECTIFIER	BYV28-150 PEL	5322 130 32043
V1203	RECTIFIER	BYV28-150 PEL	5322 130 32043
V1204	RECTIFIER	BYV28-150 PEL	5322 130 32043
V1206	RECTIFIER	BYV28-150 PEL	5322 130 32043
V1207	RECTIFIER	BYV28-150 PEL	5322 130 32043
V1208	RECTIFIER	BYV28-150 PEL	5322 130 32043
V1209	RECTIFIER	BYV27-150 PEL	4822 130 31628
V1211	RECTIFIER	BYV95C PEL	4822 130 41487
V1212	RECTIFIER	BYV27-150 PEL	4822 130 31628
V1213	THYRISTOR	BT151-500R PEL	5322 130 24081
V1214	RECTIFIER	BYV95C PEL	4822 130 41487
V1216	RECTIFIER	BYV27-150 PEL	4822 130 31628
V1226	TRANSISTOR,CHIP	BC858C PEL	4822 130 42513
V1241	TRANSISTOR,CHIP	BC848C PEL	5322 130 42136
V1242	TRANSISTOR,CHIP	BC848C PEL	5322 130 42136
V1243	TRANSISTOR,CHIP	BF821 PEL	4822 130 61923
V1244	DIODE,CHIP	BAS21 PEL	4822 130 33702
V1246	DIODE,CHIP	BAS16 PEL	5322 130 31928
V1251	TRANSISTOR,CHIP	BC858C PEL	4822 130 42513
V1252	TRANSISTOR,CHIP	BC858C PEL	4822 130 42513
V1253	DIODE,CHIP	BAS21 PEL	4822 130 33702
V1271	RECTIFIER	BYV32-150E PEL	5322 130 83489
V1272	RECTIFIER	BYV28-150 PEL	5322 130 32043
V1273	RECTIFIER	BYV28-150 PEL	5322 130 32043
V1277	DIODE,CHIP	BAS16 PEL	5322 130 31928
V1278	TRANSISTOR,CHIP	BSV52 PEL	5322 130 44336

Item	Description		Ordering code
V1279	DIODE,CHIP	BAT17 PEL	5322 130 31544
V1281	DIODE,CHIP	BAS21 PEL	4822 130 33702
V1283	DIODE,REFERENCE	BZX84-C15 PEL	5322 130 33662
V1284	TRANSISTOR,CHIP	BF820 PEL	5322 130 62802
V9016	TRANSISTOR	2SK119 TOS	5322 130 63358
V9018	RECTIFIER	BYV28-150 PEL	5322 130 32043

MISCELLANEOUS

T1001	TRANSF,INPUT	PG1 ETD44 TRANSF.	5322 142 50172
T1002	TRANSFORMER	PG1 TRANSFORMER	5322 148 60255
X1001	CONNECTOR	3-P SNG RT.ANG	5322 140 10587
X1002	CONNECTOR	64-P PIN 2.54	5322 265 61243
X1003	CONNECTOR	5-P SNG STRGHT	5322 265 30436

5.7 RESERVED FOR FUTURE EXTENSIONS

5.8 DIGITIZER A8

5.8.1 Descriptions

5.8.1.1 Diagram 1

5.8.1.2 Diagram 2

Vertical channel inputs

Four input channel signals are derived from the analog oscilloscope section unit A1.

Channel 1 : X1301/X1302

Channel 2 : X2301/X2302

Channel 3 : X3301/X3302

Channel 4 : X4301/X4302

The d.c. current is 4 mA and the sensitivity is 100 μA /division (200 μA /division differential).

Buffer/splitters

Each input signal path is split into equal signal paths by the signal splitters consisting of the transistor packages N8023, N8022, N8024 and N8021. One is the vertical input signal path and the other is the input trigger signal path.

The input channel signals are applied to the four buffer/splitter stages N8023, N8022, N8024 and N8021 as four times two symmetrical signals. They are applied by connectors and cables with a characteristic impedance of 50 Ohm. The buffer/splitter stages are configured as level shifters which are formed for channel 1 for example with N8023/9-10-11 and N8023/6-7-8.

For the HF adjustment of each channel, a fixed RC network (C8581/R8581 for channel 1) as well as an adjustable network (R8210/diode-V8188 for channel 1) are present between the two emitters. The capacity of the diodes can be adjusted by signals HFADJ1, HFADJ2, HFADJ3 and HFADJ4 in order to realize correct HF adjustment.

Main Analog Signal Processor Unit (MASPU)

The resulting signal currents in the vertical input signal paths are applied via input stages to the Main Analog Signal Processor Units. These are MASPU-A (N8026) for input channels 1 and 3 and MASPU-B (N8027) for input channels 2 and 4.

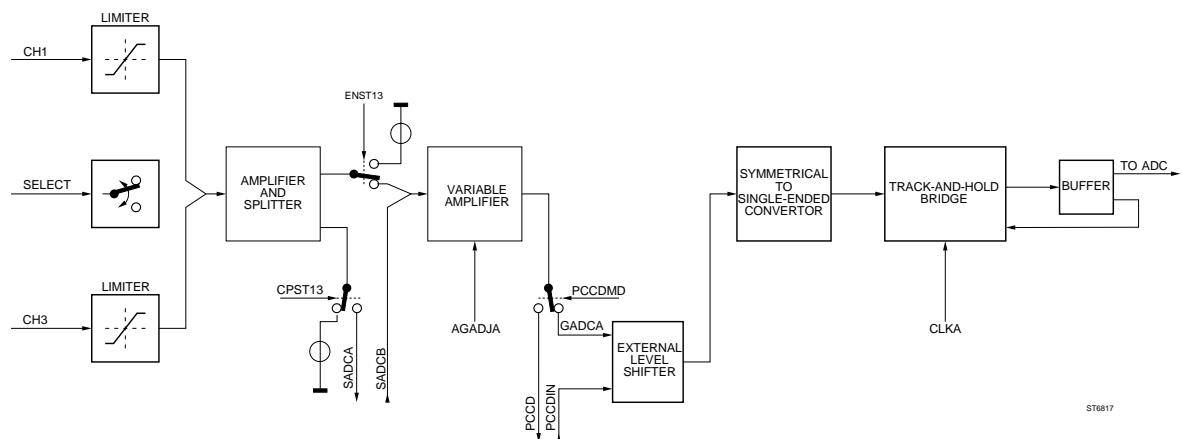

Each MASPU circuit contains the following circuits: limiter, channel selector, amplifier and splitter, variable amplifier, external level shifter, symmetrical to single-ended converter, Track & Hold bridge and buffer. A MASPU is able to handle two symmetrical analog input current (100 μA /division) signals.

MASPU-A description

The channel 1 and 3 signals are amplified and limited to signal levels of +/- 600 μA /division, which cover a dynamic range of +/- 6 vertical divisions on the oscilloscope display.

For the correct functioning of the limiter circuits, dc feedback loops are required, using external transistors V8021 and V8019.

The output currents of the two limiter circuits are applied to amplifier and splitter stages in a multiplexed way. This is controlled by the differential selection signals (2 mA) CHOP1 and CHOP3. This can be done in chopped way (max. 5 MHz) or in alternated way.

The output current of the amplifier is split into two equal signal paths. Splitting offers the possibility to send a replica of the chosen vertical input signal to the second MASPU (MASPU-B) for the channels 2 and 4.

The signal current from the chosen input channel 1 or 3 can either be passed on to the variable amplifier, or as replica (SADCBPB SADCBNB) of the signal be send to the channel combiner in the second MASPU (MASPU-B) for the channels 2 and 4. Also the output signal current (SADCBNA SADCBPA) of the second MASPU can be sent to the channel combiner in the first MASPU (MASPU-A) for the channels 1 and 3. It is possible to apply the same input signal current to both ADC's at the same time in order to make interleaved sampling on a 200 MHz sample rate possible.

Signals CPST13HT and ENST13HT control the circuit.

- Signal CPST13HT determines whether the replica of the chosen input signal is sent to the second MASPU via the SADCBPB and SADCBNB lines or not. (Required for 200 MS/s sampling.)
- Signal ENST13HT determines whether the chosen input signal is passed on to the variable amplifier stage in the MASPU or the signal from the other MASPU.

In timebase setting 250 ns/div., a selected input channel is connected via both MASPU's to both ADC's, resulting in a double sampling rate of 200 MS/s.

Signal VADCA, which is derived from the offset DAC (DACPOT), represents an additional offset applied to MASPU input pin 9. VADCA is used to adjust the circuit for a level in the centre of the ADC input range if no input signal is applied. This corresponds with the centre of the CRT screen. It is also used to give the MASPU an extra offset in the double sampling mode.

Variable amplifier

After combining the direct or replica signals, a circuit for variable overall gain control is available. Signal AGADJA is the control current input for this variable amplifier. The output of this stage is fed to the amplifier section where the signal current is converted from a symmetrical to a single-ended signal voltage.

Track and Hold bridge

After the amplification and combination stages, the analog signal is applied to a Track and Hold bridge, which is used to sample the signal and keep it at a constant level during the conversion period of the ADC circuit.

The sample-clock signal currents for the Track and Hold circuit are the symmetrical logic signals CLKA and NCLKA with a rise-time of about 2 ns and a fixed frequency of 100 MHz. These signals determine the TRACK-to-HOLD transitions.

In the Track-mode the output voltage of the circuit will follow the input signal variations. In the Hold-mode the internal hold capacitor is isolated from the rest of the circuit and will store the value of the input signal at the moment just before the track-to-hold transition.

Both Track and Hold bridges in MASPU-A and MASPU-B are clocked with the same sample-clock frequency. In double sample mode (200 MS/s sample rate for only one channel), the two Track and Hold bridges receive sample-clock signals which are 180 degrees shifted in phase. This results in twice the sample rate.

The resulting T&H output signal BOUT on point 65 of the MASPU is applied via buffer N8013 to the ADC circuit (on diagram 5) as ANINA. The feedback signal BOOT from N8013 is required by the Track & Hold bridge for correct internal leveling.

Supply current ITREEA

The current ITREEA is a constant current from which the MASPU derives a number of internal supply voltages.

5.8.1.3 *Diagram 3*

Control, reference and adjustment voltages:

Digital to Analog Converter DACPOT

The sixteen channel 12 bit Digital to Analog Converter POTentiometer DACPOT N8006 derives 14 different analog output signals from the four input bits GLOD04 ... GLOD07 from the GLOBAL data bus. The chip select signal for the converter is signal DACCS-LT and the refresh signal is derived from signal CK12M via D-type flip-flop D8045. The start is initiated via the enable signal DACPENLT which is also derived from the GLOBAL data bus.

Each of these DACPOT output levels is independently adjustable between 1 Volt and 4 Volt in 4096 steps.

Analog output signals are:

OFFSADCA converted in signal VADCA see diagram 1

OFFSADCB converted in signal VADCB see diagram 2

GAINMPUA converted in signal AGADJA see diagram 1

GAINMPUB converted in signal AGADJB see diagram 2

OFFST&HA converted in signals POSAA/POSBA see diagram 1

OFFST&HB converted in signals POSAB/POSBB see diagram 2

OFFSCMP1 see diagram 6

OFFSCMP2 see diagram 6

OFFSCMP3 see diagram 6

OFFSCMP4 see diagram 6

HF1 converted in signal HFADJ1 see diagram 1

HF2 converted in signal HFADJ2 see diagram 2

HF3 converted in signal HFADJ3 see diagram 3

HF4 converted in signal HFADJ4 see diagram 4

Multiplexer D8501

Seven digital control signals arrive via multiplexer D8501 derived from data bit GLOD09 from the GLOBAL data bus and the three address bits GLOA4 ... GLOA6 from the GLOBAL address bus. Signals are mainly generated to control activities in the RAndom Trigger Engine Logic (RATEL) circuit on diagram 8. Outputs which are not selected via the address lines remain in their previous state.

ITREEA/ITREEB circuit

The ITREEA and ITREEB currents for the Main Analog Signal Processing Units (MASPU's) on diagram 1 and 2 are generated via the opamp circuit N8071 and transistors V8012 and V8014.

Channel selector

The chopper signals CHOP1/CHOP3 and CHOP2/CHOP4 for the Main Analog Signal Processing Units (MASPU's) on diagram 1 and 2 are derived from the SLS12 switching signal from the Data Acquisition and tRigger Logic (DARLIC) circuit on diagram 9.

5.8.1.4 Diagram 4

Clock oscillator

The 200 MHz crystal G8025 forms, together with WHISTLER circuit D8005, a 200 MHz clock generator with ECL level output clocksignals MCAA/MCNAA MCBB MCNBB of 100 MHz each for the Analog to Digital Converters on diagram 5, and MCAAR/MCNAAR for the RAndom Trigger Engine Logic (RATEL) circuit on diagram 8.

Normal mode:

Normally the oscillator output signals MCAA and MCBB are in phase.

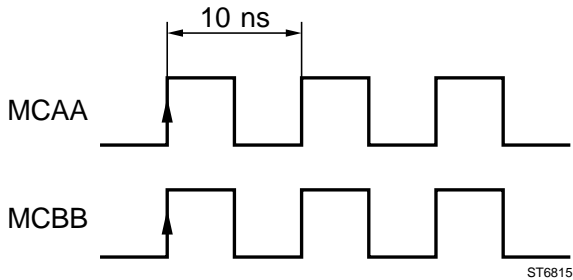

Double sampling mode:

The oscillator is controlled by the signal CLKBINV which is generated via the SBUS (serial bus) shown in diagram 14. This signal in double sampling mode is used to invert the oscillator output signals MCBB/MCNBB. The time between the leading edges of the two signals is now 5 ns and sampling is done at 200 MS/s.

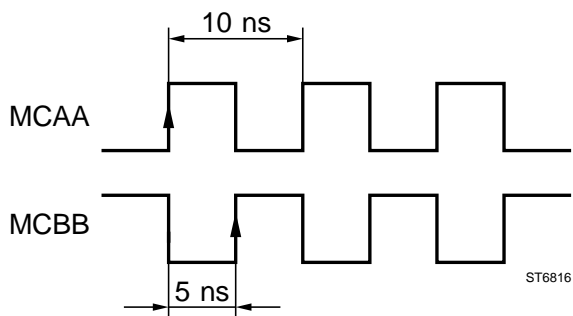

The output signals from the oscillator are applied to the circuits N8067 and N8068, which produce via transistors V8139/V8138 and V8140/V8141 the required clock currents for the Track and Hold bridges. Signals CLKA/NCLKA and CLKB/NCLKB with a frequency of 100 MHz are used on diagrams 1 and 2 as sample-clock signals for the Track and Hold bridges in the Main Analog Signal Processing units.

Clock switches

The clock switches N8067 and N8068 are controlled by signals DSAMPAHT/ DSAMPBHT and TRCKMDHT which are generated via the SBUS (serial bus) shown in diagram 14.

Only clock switch N8067 is now described:
One of the following modes can be selected.

	DSAMP_HT	TRCKMDHT	Clock signal path
Normal mode	L	L	R8541/R8546
Double sampling mode	H	L	R8544/R8545
Track only (autocal)	L	H	R8548/R8549

In normal mode the clock signals are fed from the clock oscillator via R8541 and R8546.

In double sampling mode (double sampling), the signal from path A is not only applied to the T&H in MASPU-A but also via MASPU-B to the second T&H circuit. This causes an additional time delay of about 1.6 ns between the signals which are applied to the two T&H circuits. In order to realize sampling at the correct moment, an additional delay is created between the sample clocks for the two T&H circuits.

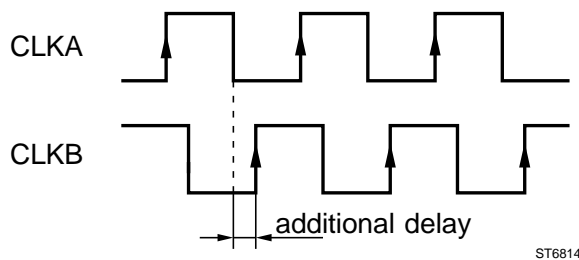

This additional clock signal delay is realized via the circuit traces in the current paths of R8544 and R8545 when signal DSAMP_HT is logic "1" and TRACKMDHT is logic "0".

If autocal is performed, the Track & Hold bridges are switched in TRACK ONLY. Signal levels over R8548 and R8549 are then constant.

5.8.1.5 Diagram 5

Analog to Digital Converters

The output signals ANINA and ANINB from the Track and Hold bridges in the Main Analog Signal Processing Units (MASPU's) on diagrams 1 and 2, are applied to the two Analog to Digital Converters ADC N8002 and ADC N8001.

These are 8 bit parallel Flash ADC's with an input range from 0V to -1V (10 divisions on the CRT screen) and with eight ECL outputs. The -0.5V level corresponds with the centre of the CRT screen. Both Flash ADC's are continuously converting at a rate of 100MS/s each. They are continuously clocked by sample-clock signals MCAA/MCNAA and MCBB/MCNBB with a frequency of 100 MHz. Sample rate reduction for different time-base settings is performed in a later stage in the DARLIC circuit on diagram 9.

The converted input signal is latched in the ADC on the negative going edge of the clock signal. Data is converted and available at the ADC outputs after the positive going edge of the clock signal.

ECL-TTL translators

The ECL level (-1.6V [L] and -0.8V [H]) output data signals from the ADC circuits are buffered and converted into TTL level output data signals by the ECL-TTL translator circuits D8004 and D8003.

This results in the databus signals SDA<7:0> and SDB<7:0> on TTL level which can be handled by the DARLIC circuit on diagram 9

The same is done for the sample-clock signals resulting in TTL level SCLKA/SCLKAN and SCLKB/SCLKBN signals which can also be handled by the DARLIC circuit. All data and clock signals are applied to the Data Acquisition and tRigger Logic IC (DARLIC) circuit on diagram 9 for further processing.

All digital data is stored then into a Fast Acquisition Memory (FAM) by the DARLIC after the necessary processing.

5.8.1.6 Diagram 6

Compass input stage

Signals COMP.1N/COMP.1P, COMP.2N/COMP.2P, COMP.3N/COMP.3P and COMP.4N/COMP.4P arrive from the collectors points 1 and 2 of circuits N8023, N8021, N8024 and N8022 on diagram 1. The sensitivity of these signals is 100 μ A/division. These input currents are converted into voltage levels over resistors R8341/R8337, R8294/R8301, R8329/R8336 and R8306/R8302 and these voltage levels are applied to the COMparator for Pattern and State Selection circuit (COMPASS) N8029.

Compass offset adjust

Offset trigger level signals OFFSCMP1, OFFSCMP2, OFFSCMP3 and OFFSCMP4 from the Digital to Analog Converter DACPOT on diagram 3 are applied to opamps N8019 and as CH1FSET, CH2FSET, CH3FSET and CH2FSET applied to the four level shifters V8089/V8091, V8088/V8087, V8082/V8083 and V8086/V8084 together with the four vertical channel input signals. The offset levels OFFSCMP1, OFFSCMP2, OFFSCMP3 and OFFSCMP4 are dependent of the triggerlevel. The output signals are then applied to the COMparator for Pattern and State Selection (COMPASS) circuit N8029.

COMparator for Pattern and State Selection (COMPASS)

With the aid of the COMPASS circuit the number of trigger modes can be extended with three modes, namely:

- PATTERN triggering
- TIMED-PATTERN triggering
- STATE triggering

Simple blockdiagram of the COMPASS circuit:

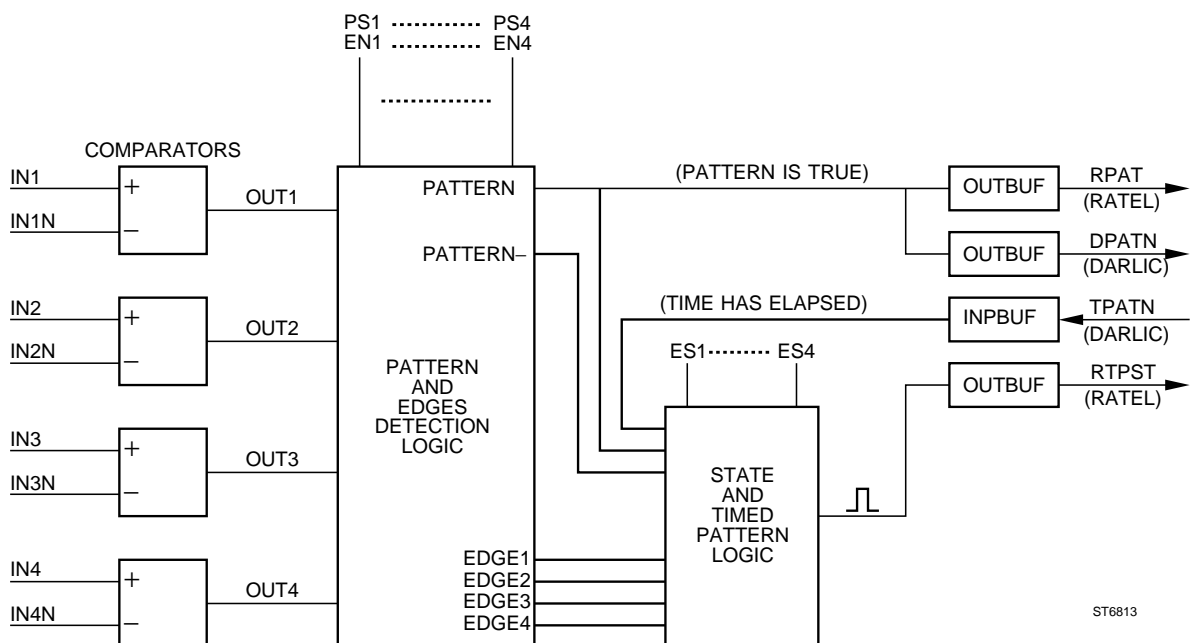

PATTERN triggering

With PATTERN selected, triggering is possible on a preselected combination of "H", "L" and "X" (don't care) values of the input signals from channel 1 to channel 4. Triggering on "ENTER" (start of selected pattern) as well as "EXIT" (end of selected pattern) is possible on user request.

In this mode a logical level will be defined for each input channel signal. This combination of logical levels PS1, PS2, PS3 and PS4 is called a PATTERN and is a condition for triggering. PS1, PS2, PS3 and PS4 are generated via the SBUS (serial bus) on diagram 14.

This user selected pattern is compared with the input signal combination IN1, IN2, IN3 and IN4 in the PATTERN AND EDGES DETECTION LOGIC.

As long as a selected PATTERN condition is true, the PATTERN signal at the output of the PATTERN AND EDGES DETECTION LOGIC becomes active. This signal is via an output buffer applied as symmetrical signal RPA/T/RPATN to the Random Trigger Engine Logic circuit (RATEL) circuit on diagram 8 and enables RATEL to generate a trigger. The trigger can be generated on the positive or the negative edge of the pattern, this is selected in the RATEL circuit and is realized by the inversion of signal RPA/T.

Example of PATTERN mode:

CHANNEL	1	2	3	4	
VALUE	H	X	L	H	L = Logical low H = Logical high X = Don't care

Example of input signals and resulting events:

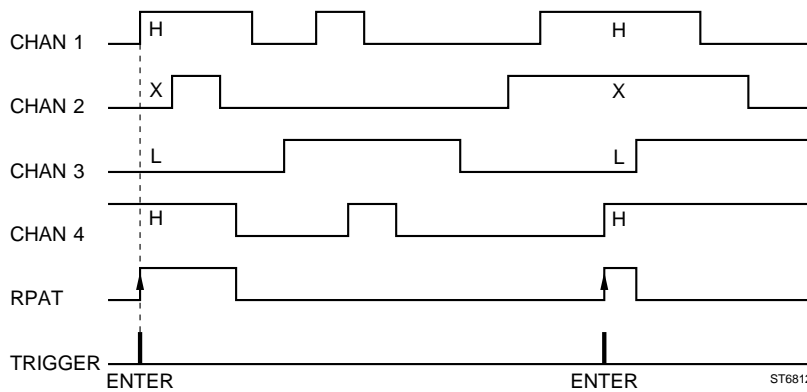

TIMED-PATTERN triggering

With TIMED-PATTERN selected, pattern triggering with a timing condition is possible. This is only possible at the end (EXIT) of a selected pattern. The system has a 10 ns resolution.

The user selected pattern, represented by signals PS1, PS2, PS3 and PS4 is compared with the input signal combination IN1, IN2, IN3 and IN4 in the PATTERN AND EDGES DETECTION LOGIC.

These signals PS1, PS2, PS3 and PS4 are generated via the SBUS (serial bus) on diagram 14.

As long as a selected PATTERN condition is true, the PATTERN signal at the output of the PATTERN AND EDGES DETECTION LOGIC becomes active. This signal is via an output buffer applied as low active DPATN to the DARLIC circuit on diagram 9.

The user selected times t_1 and t_2 are stored in two counters in the DARLIC circuit on diagram 9. These counters will start counting down after a positive edge of the signal DPATN from the COMPASS circuit, and are presetted on the negative edge of this signal. Signal DPATN is active as long as the selected pattern is present. When the presetted counters have counted down to zero, the selected time has elapsed and the active low signal TPATN is generated. It enables the STATE AND TIMED PATTERN LOGIC which produces an output pulse RTPST at the moment that the pattern has changed. With signal TPATN inactive, no RTPST pulse will be produced at the moment that the pattern has changed.

Example of TIMED-PATTERN mode:

CHANNEL	1	2	3	4
VALUE	H	X	L	H

L = Logical low
H = Logical high
X = Don't care

Example of input signals and resulting events:

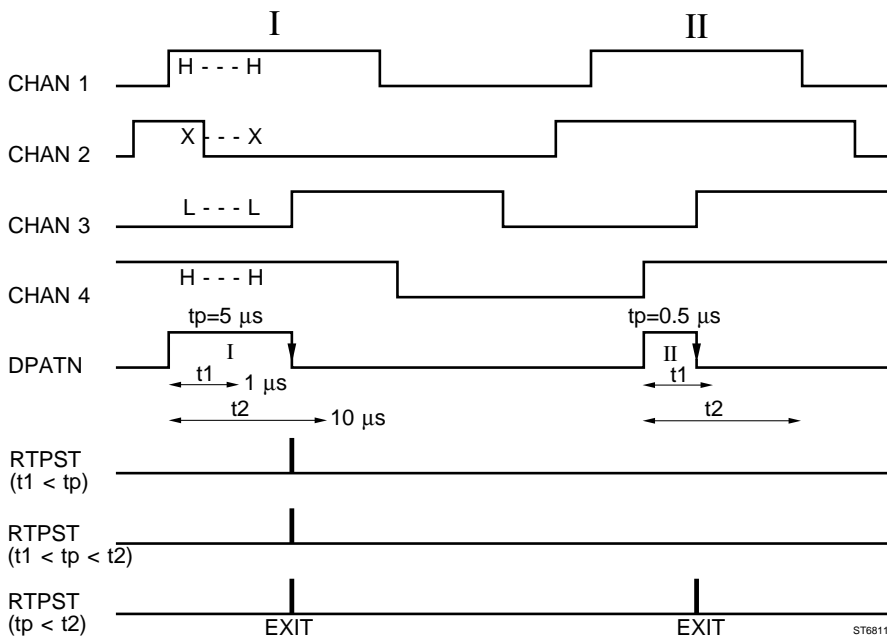

There are three different situations possible:

- 1) $t_1 < t_p$ For pattern I : true
For pattern II : untrue
- 2) $t_1 < t_p < t_2$ For pattern I : true
For pattern II : untrue
- 3) $t_p < t_2$ For pattern I : true
For pattern II : true

Time t_p is the time that the pattern is true.
Times t_1 and t_2 are user selected times.

STATE triggering

With STATE triggering selected, edge-triggering with pattern- condition is possible. Polarity as well as source are to be selected by the user.

Not only a pattern has to be preselected, but also the trigger channel which completes the pattern. The edge can be selected positive as well as negative.

The circuit is controlled by signal SELTP-HT.
 SELTP-HT logic "0" means: STATE-trigger mode selected.
 SELTP-HT logic "1" means: PATTERN-trigger mode selected.

The user selected pattern, represented by signals PS1, PS2, PS3 and PS4 is compared with the input signal combination IN1, IN2, IN3 and IN4 in the PATTERN AND EDGES DETECTION LOGIC. These signals PS1, PS2, PS3 and PS4 are generated via the SBUS (serial bus) on diagram 14. As long as a selected PATTERN condition is true, the PATTERN signal at the output of the PATTERN AND EDGES DETECTION LOGIC becomes active. This signal is applied to the STATE AND TIMED PATTERN LOGIC.

In STATE-trigger mode, only one of the signals ES1, ES2, ES3 and ES4 is logic "1". This is the signal that corresponds with the channel that is selected as STATE-clock.

Signals EN1, EN2, EN3 and EN4 carry the "DON'T CARE" information.
 A logic "1" means: the corresponding channel is part of the triggerword.
 A logic "0" means: the corresponding channel is a "DON'T CARE" for the triggerword.

A channel used as STATE-clock in STATE-trigger mode, has to be disabled from the pattern. This means that the relevant EN_ signal must be a logic "0".

Example of settings in STATE mode:

CHANNEL	1	2	3	4
VALUE	H	↑	X	L

L = Logical low
 H = Logical high
 X = Don't care
 ↑ = Positive-going
 Channel 2 - POSITIVE EDE

Example of input signals and resulting events:

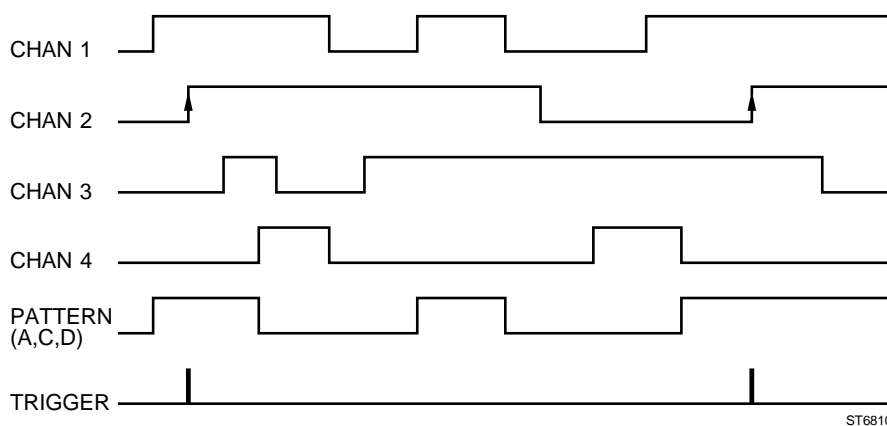

5.8.1.7 Diagram 7

DELTA-T circuit

A DELTA-T circuit is introduced to measure the time between the moment of triggering and the real sample moment. This is needed to know for which memory location converted digital codes have to be stored.

The DELTA-T circuit consists mainly of two current sources. A charge current source (V8044/V8046), which produces a constant current of 30 mA and a discharge current source (V8134/V8136), which produces a constant current of 60 μ A. So the ratio between these two currents is 1:500.

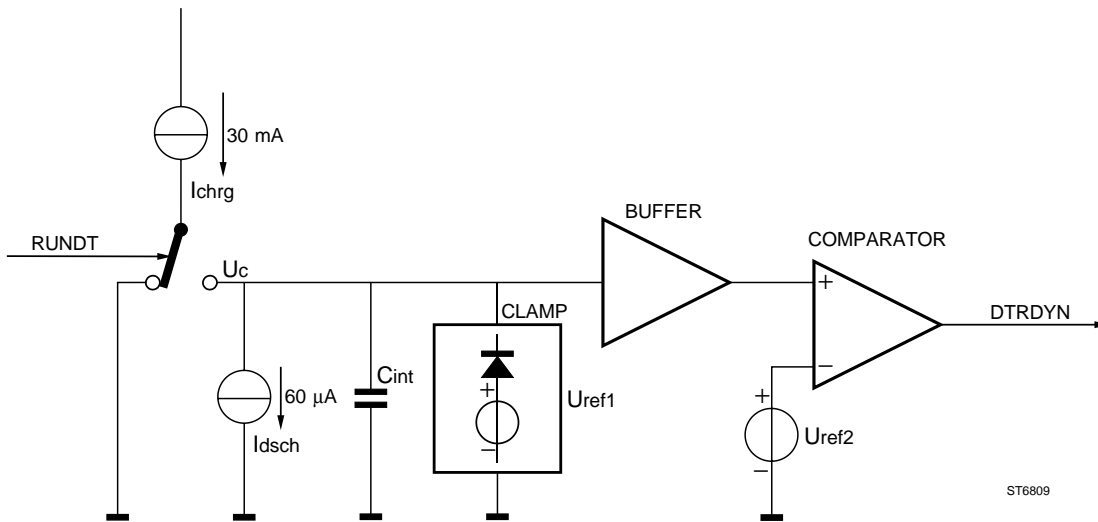

The DELTA-T unit consists of an analog section and a digital section. The digital section in the DARLIC circuit consists of a counter, which runs on the maximum sample clock frequency.

- In direct sampling mode (timebase setting down till 0.25 μ s/div.), the DELTA-T circuit is used to keep the position of the triggerpoint on the screen stable (jitter compensation).
- In random sampling mode, more acquisitions are needed to build a complete picture and to fill the complete acquisition memory. The DELTA-T circuit determines the horizontal position for the first sample of each acquisition cycle.

A symmetrical signal pair RUNDT/RUNDTN (RUN delta-T measurement), which is derived from the trigger circuit in the RATEL circuit on diagram 8, controls the DELTA-T measurement.

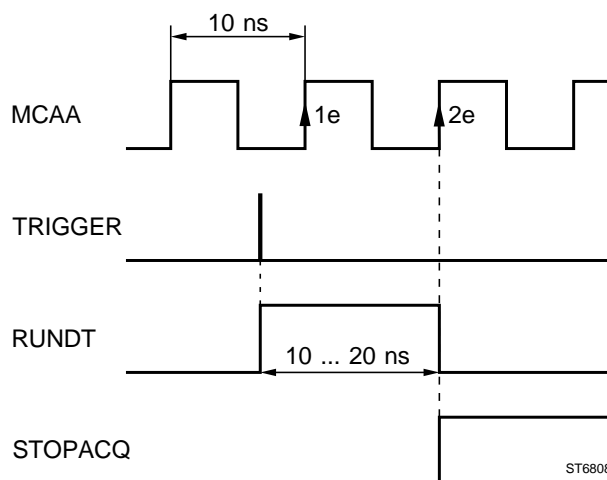

At the moment that an active trigger signal appears, signal RUNDT switches to logic "1" and transistor V8126 is blocked. Transistor V8124 starts conducting. Capacitor C8271 is then charged very fast by a current of 30 mA from the charge current source to a voltage which depends on the time between the trigger pulse and the second positive going edge of the 100 MHz clock signal MCAA. At the second positive going edge of the clocksignal after the triggermoment, the signal RUNDT is switched to logic "0" again. The transistor V8124 is blocked then and the 30 mA current flows via V8126 which is conducting. Capacitor C8271 will now slowly be discharged to the level Uref1 via the 60 μ A discharge current source. The discharge period is 500 times the charge period of the capacitor. The voltage over the capacitor, is applied via buffer V8137 to comparator N8062, where it is compared with reference voltage Uref2.

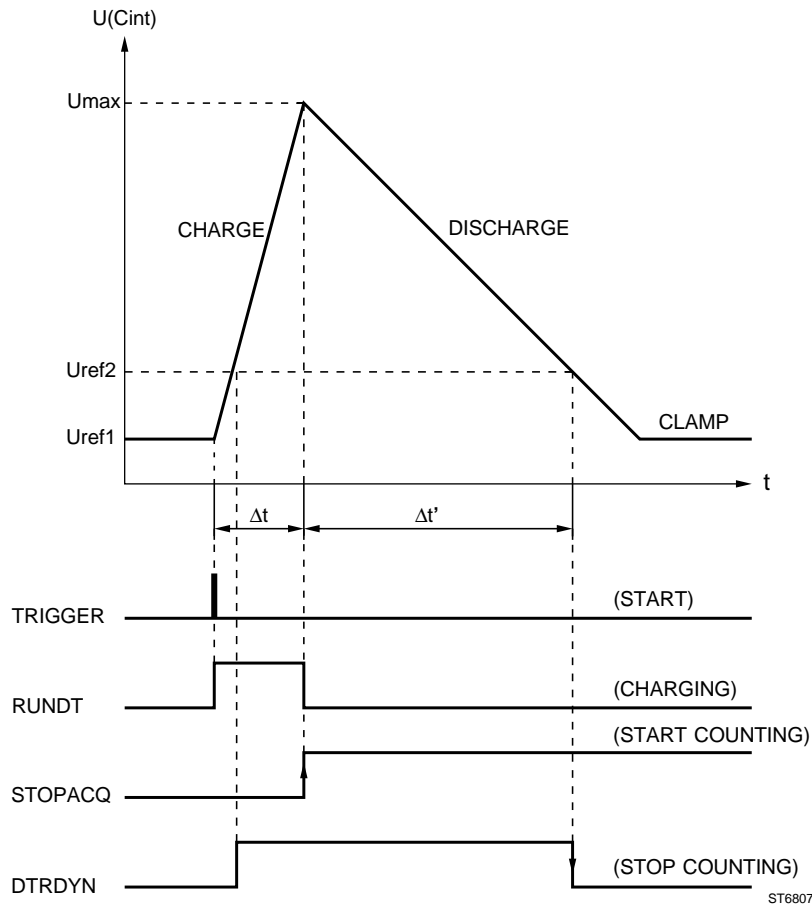

A DELTA-T counter in the DARLIC circuit is enabled for counting by the STOPACQ signal from the RATEL circuit at the moment that the first sample is taken. So at the second positive going edge of the clocksignal. The counter counts in steps of 10 ns. The comparator output signal DTRDYN (DELTA-T ready) is applied to the DELTA-T counter in the DARLIC circuit and the falling edge of this signal DTRDYN stops the counting. At this moment the counter contains a value which is a measure for the time between the trigger pulse and the sample pulse.

The Digital Signal Processor (DSP) circuit on diagram 10 is informed about this completion by an appropriate interrupt bit. After the DSP reads this counter, the counter is reset to zero again, to be ready for the next acquisition cycle and the next DELTA-T measurement.

5.8.1.8 Diagram 8

The RAndom Trigger Engine Logic circuit (RATEL) is a very fast (300MHz) circuit for selection of the source on which triggering takes place. It synchronizes the selected trigger with the 100 MHz system clock. The circuit controls also the DELTA-T circuit by the generation of signal RUNDT.

Trigger source selection

One out of eight trigger sources can be selected via an internal multiplexer, which is controlled by the three source selection signals SLZERO, SLONE and SLTWO.

Trigger source	SLZERO	SLONE	SLTWO
GLITCH (20ns)	0	0	0
DSOM	1	0	0
DSOD	0	1	0
DTB GATE	1	1	0
RTPST	0	0	1
Not used	1	0	1
RPAT	0	1	1
DUAL SLOPE	1	1	1

Input sources for the RATEL circuit D8502 are DTBGATE on X8502, DSOM on X8503 and DSOD on X8501. These signals are derived from the analog oscilloscope section. DSOM is the triggermoment for the Main Time-base, DSOD is the triggermoment for the Delayed Time-base and DTBGATE is active during the delayed sweep.

RPAT/RPATN (pattern trigger mode) and RTPST/RTPSTN (state mode and timed-pattern mode) from the Pattern and State Selector on diagram 6 are also input sources. They are applied to the RATEL circuit via buffers.

Other input sources are GLITCH which is internally derived from RPAT and DUAL SLOPE which is internally derived from DSOM and DSOD.

A GLITCH detection circuit is responsible for generating well defined triggers on small spikes.

The RATEL circuit contains an internal circuit to perform DUAL SLOPE triggering. Dual slope triggering is used in Single Shot mode when it is not known, whether the first signal edge is positive or negative going.

Control signal SLSEL is used for pattern "enter" or "exit" selection by the inversion of signal RPAT. Logic "0" for "enter" and logic "1" for "exit".

Holdoff signal HLONB initializes the RATEL circuit. As long as signal HLONB is logic "0", no new triggers can be processed. Signal HLONB is via a randomizer circuit derived from HLONA to make HLONB asynchronous from the 100 MHz system clock.

Trigger detection and synchronization

The selected trigger signal from the trigger source selector, is internally applied to the trigger detection and synchronization stages.

Here each trigger signal (start of a new acquisition cycle) is synchronized with the 100 MHz sample clocksignal MCAAR. A signal ENEV is then generated as input for the trigger synchronization stage and this results after synchronization in the digital trigger signal STOPACQ.

AUTO trigger mode

If no triggers are present and the DARLIC circuit has seen no triggers (via the alias input) for about 100 ms, the AUTO trigger mode is activated and signal STOPACQ is derived from signal AUTOTRHT which is generated by the software.

A trace is then displayed on the CRT screen.

Event trigger mode

Signal ENEV (enable event) is also used for event counting in Event trigger mode. The clockpulse for the Event mode is signal ECLK.

In the Event mode, the source is DSOD selected by the signals SLEONE ("1") and SLETWO ("0").

Switching between normal and event triggering is done with signal EVENT-HT. Signal ENEV starts an event counter in the DARLIC circuit. This counter will count the selected number of events minus one, after which the EVUFN (event underflow) for the RATEL circuit will be activated. With the last ECLK pulse the EVUFN signal is clocked and applied to the trigger synchronization stage resulting in signal STOPACQ.

TV trigger mode

In TV trigger mode the trigger signal is derived from DSOM and as signal ECLK applied to the circuit consisting of D8045, D8030 and D8063. The circuit is enabled by signal ENDGHOHT (enable digital hold-off), if TV-LINE is selected (analog and digital) or if digital DTB acquisition is selected. D-type flipflop D8045 is enabled by signal TVLNSLHT (TV-line selection) which is active high if TV-LINE is selected (analog and digital).

A hold-off signal TVHOLD on X8504 is generated and applied to the hold-off circuit X6010/D8006 in the analog oscilloscope section. This signal enables the time-base generator so that sweeps can then be initiated.

Stop acquisition signal

The signal STOPACQ is generated and applied to the Data Acquisition and tRigger Logic IC (DARLIC) on diagram 9 to stop the acquisition of new input signal information and to enable the DELTA-T counter. This is done on receipt of the active trigger in the RATEL circuit.

Signal STOPACQB is via a delay circuit as STOPACQ applied to the DARLIC circuit to prevent that this signal switches in the edge of the DARLIC clock signal. The STOPACQ signal is reset by signal RSTACQLT.

After generation of signal STOPACQ, a copy cycle starts to copy the new acquisition data to the Main Acquisition Memory (MAM) on diagram 11 for further processing and display on the CRT screen.

DELTA-T circuit

The RATEL circuit derives the RUNDT/RUNDTN signals (10 ... 20 ns) from the triggersignals and the internal 100 MHz clock, to start and stop the measurements in the DELTA-T circuit. Also see the description of diagram 7.

AUTO calibration

In the calibration mode, the DELTA-T circuit is calibrated in 10 ns and 20 ns under the control of the DARLIC circuit. Signal GENTRGNB sets the RATEL circuit in the calibration mode. Holdoff signal HLONB is made active low.

With SELTRG logic "1" a RUNDT signal of 10 ns is generated for 10 ns calibration and with SELTRG logic "0" a RUNDT signal of 20 ns is generated for 20 ns calibration.

5.8.1.9 Diagram 9

Data Acquisition and tRigger Logic IC (DARLIC)

The output datawords SDA<7:0> and SDB<7:0> from the two Analog to Digital Converters on diagram 5 are applied to the DARLIC circuit D8027. The DARLIC circuit is programmed by memory mapped I/O commands.

All tasks can be grouped together in two major functions: a data path and a trigger engine.

The data path is responsible for the total acquisition process from ADC to memory, including time-base generation.

The trigger engine is responsible for the generation of a start/stop acquisition signal that is fed to the data path.

The major headlines of the DATA PATH are:

- Sample clock control via serial data bus.
- Acquisition control and time-base generation. It starts as soon as it is ordered to do so by the Digital Signal Processor (DSP) or system engine. It stops the acquisition as soon as a stopsignal STOPACQ is received from the RATEL circuit.
- Channel switch control via signal SLS12.
- Latching of the 8-bit ADC sample datawords at the maximum sample rate of 100 MS/s and speed conversion from this 100 MS/s data rate to a 25 MHz data rate. This is done by demultiplexing of the two incoming datastreams into four outgoing datastreams for the Fast Acquisition Memory (FAM) behind the DARLIC circuit.
In the fastest (0,5 μ s/div) time-base speed, every 40 ns (25 MHz) four samples will be transferred to the FAM.
- On the fly digital MIN/MAX detection on non stored samples. Each channel has an independent MIN/MAX detector, which detects the minimum and maximum value of all non stored values.
- Gateway function for the data transfer from the Fast Acquisition Memory (FAM) to the Main Acquisition Memory (MAM) by the DSP.

The major headlines of the TRIGGER ENGINE are:

- Generation of a synchronous start/stop acquisition signal for the data path, covering pre- and posttriggering.
- Counting of trigger events and trigger delay.
- It also contains a DELTA-T counter and supports the DELTA-T circuit, to be able to calculate the time between the asynchronous- and the synchronized trigger signal.
- It contains two timers for the timed-pattern mode. Timed- pattern and State detection is realized in combination with the COMPASS circuit on diagram 6.
- Supporting TV line selection in TV trigger mode.

Data path:

The main purpose of the datapath is to establish two gateways. One for guiding the ADC-data to the Fast Acquisition Memory (FAM) in a time-base controlled way, and one for guiding data from the FAM to the Main Acquisition Memory (MAM) by the Digital Signal Processor (DSP).

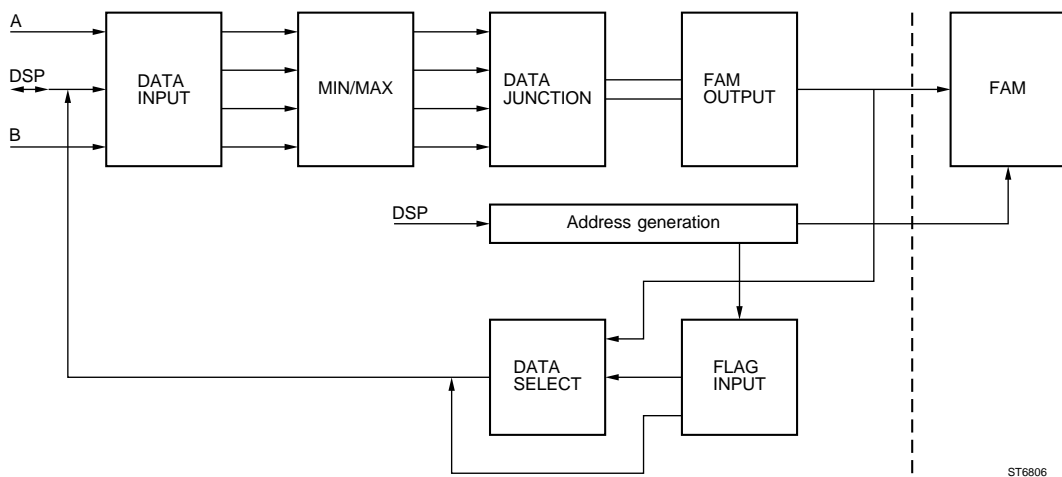

With the Data Input block a selection between the converted sample data from the two ADCs and data obtained from the Digital Signal Processor (DSP) is made. Both channels use the clock used by the corresponding ADC. Furthermore the ADC data is checked on underflow and overflow.

With MIN/MAX selected, minimum and maximum values are calculated by the MIN/MAX circuits. This is not possible in the CHOP mode.

A data junction unit lowers the data rate from 100 MHz streams to 25 MHz streams and guides the data from the MIN/MAX circuit properly to output latches. It also starts up the write cycle to the FAM, if enough bytes have been received. It generates the read signal FRDN, the write signal FWRN and the chip select signals FCSN<7:0> for all the memory banks. The FAM itself is not part of the DARTIC circuit.

Besides the creation of data to be stored in the FAM, addresses have to be generated. The acquired data later has to be transferred to the Main Acquisition Memory (MAM) by means of the Digital Signal Processor (DSP), this can not directly be done but only via the DARTIC gateway in a sequential way.

Trigger engine:

The analog input channels which are connected to the channel switch are also applied to level comparators, see the description of diagram 6. Their outputs are connected to a pattern and state detector. When the pattern matches a predefined pattern mask, a "pattern match" signal DPATN will be generated. A pattern mask is defined, in terms of "H", "L" and "don't care". State triggering is an extension of pattern triggering. One of the channels has to be selected as the clock, the others as qualifiers. The active edge of the clock is selectable.

The result of the detector is asynchronous with the sample-clock and therefore also usable for random sampling. Two timers are available in the DARTIC circuit for use during time measurements. With these timers trigger conditions are defined in terms of trigger on a specific pattern if its present time is $T1 < TP$, or $T1 < TP < T2$, or $TP < T2$.

The pattern and state detector is mainly realized in the COMPASS circuit, see the description of diagram 6.

Edge selector:

Edges can be used for triggering in general but are a prerequisite for random sampling. The following "edges" are available for the trigger engine:

- DSOM and DSOD signals which come directly from the analog oscilloscope section.
- DTBGATE comes directly from the analog oscilloscope section. The oscilloscope can perform the "triggered DTB" function in the analog as well as in the digital mode.
- Pattern match (including timed pattern) or state detect.
- Glitch detection.
- TV field, frame and TV line. This information is retrieved from the DSOM and the VSYNC incoming signals. VSYNC is an asymmetrical signal applied by connectors and cable with a characteristic input of 50 Ohm.

A trigger hold-off line, TVHOLD, is returned to the analog oscilloscope section, so that the analog mode of the oscilloscope can be programmed to trigger on a specific TV- line. TVHOLD signal is an asymmetrical signal applied by connectors and cable with a characteristic impedance of 50 Ohm.

Event counting:

Event count is possible on:

- Edges
- Pattern transitions (match/no match)
- Timed patterns (>20 ns)
- State detections

As soon as a predefined number of events are passed and counted by a 16 bit event counter, the event delay phase is terminated. The entry or exit of the event counting phase is asynchronous with the sample-clock. See also the description of diagram 8.

Delay timer:

After the requested trigger is detected and the event delay is passed, it is possible to count down a specific amount of time in a trigger delay counter, to constitute a delay before the acquisition is stopped.

Delta-T Circuit:

The delta-T circuit measures the time between the sample clock and the edge of the output of the "trigger detection circuit". A delta-T counter in the DARLIC circuit is part of the delta-T circuit, see the description of diagram 7.

The measured digital value is applied to the DSP and is used to position the measured sample values in the Main Acquisition Memory.

Fast Acquisition Memory (FAM):

The acquisition data which is converted by the ADC's, is directly stored in a volatile Fast Acquisition Memory (FAM) by the DARLIC circuit. The access time of this memory is such that it matches the sample speed of the system.

This FAM consists of eight SRAM circuits of 2kx8 each. It can be seen as 2 sets of each 4k words of 8 bits. In single channel mode, these two sets can be combined to 1 set of 8k words of 8 bits. In four channel mode, the two sets can be split up in 4 sets of each 2k words of 8 bits.

The address bus is a fifteen bit bus with lines FA<14:00> and the data bus is an 64 bit bus with lines FD<63:00>. Other memory control lines are the chipselect lines FSCN<7:0> and the output enable line FRDN and read/write line FWRN.

The acquired data has later to be transferred to the Main Acquisition Memory (MAM) by means of the Digital Signal Processor (DSP), this can not directly be done but only via the DARLIC gateway in a sequential way.

A special feature allows the Fast Acquisition Memory to be switched into FIFO (first in first out) mode, in which the acquisition fills, and the DSP empties the Fast Acquisition Memory in a cyclic fashion. This is used in the ROLL-mode.

SBUS system:

The SBUS (serial bus) interface is built-in in the Data Acquisition and tRigger Logic IC (DARLIC) circuit D8027. It is used as an output bus.

The lines are open collector I/O pins, SDA (SerialData) and SCL (SerialClock), and a select line SSEL.

The SBUS is connected to a control signals generator, the dot join circuit and to the intensity control circuit. The SBUS can be controlled by the system engine.

For more detailed information about the serial bus system see section 5.1.1.4.

5.8.1.10 Diagram 10**Digital Signal Processor (DSP):**

The Digital Signal Processor D8069 performs all signal processing activities which are not available in hardware. One of the main tasks is the composition of the trace information out of the available registers.

Digital Signal Processor D8069 runs on a 40 MHz clock-frequency from the circuit G8053 signal CK40M.

The DSP contains a 4K maskable PROM and a dataword RAM, of which a part is used for data or program, and the remaining part for data memory.

The functions of the DSP are:

Pre-processing

Average

Envelope

Post-processing

Mathematical functions

Interpolation (linear, sine)

Filters

Display memory refresh

X-POSITION control

Restart acquisition

Delta-T processing

Conversion to 512 horizontal dots per screen

Control signals are:

- Three interrupt lines DSPIN0LT, DSPIN1LT and DSPIN2LT.
- The DSP can be reset by signal RSDSP-LT.
- A signal DSPRDYHT to extend the current memory cycle from the DSP until the addressed device is ready to accept data (write cycle) or has put data on the global bus (read cycle).
- DSPRW-LT which is active low during a write cycle and high during a read cycle.
- STRB--LT is a strobe signal which is active low for each external bus cycle.
- DS----LT is a data space select signal which is active low during communication with an external device which contains data.
- PS----LT is a program space select signal which is active low during communication with an external device which contains a program.

Program Memory (PRAM):

The DSP program memory consists of the two 8Kx8 SRAM circuits D8049 and D8052 and is the private program memory of the Digital Signal Processor. It is a volatile memory and can not be accessed by any other device. The address lines are the sixteen lines DSPA<15:00> from the Digital Signal Processor D8069 and the data lines are the sixteen lines DSPD<15:00> to and from the DSP. Control lines for the program memory are the chipselect signal PRAMCSLT, the output enable signal PRAMOELT which is low during read actions, and the read/write signal PRAMRWLT from the Bus Arbiter and Trace Generator (BATGE) circuit on diagram 11.

5.8.1.11 Diagram 11

Bus Arbiter and Trace Generator

The main function of the Bus Arbiter and Trace Generator (BATGE) D8048 is the arbitration between multiple processors, multiple memories and memory mapped I/O with a minimum of interference. This circuit is running on a 40MHz clockfrequency from the circuit G8053, signal CK40M on diagram 10. "Active devices" like the DARLIC circuit for example, generate a "not ready signal".

Text and Trace generation

All texts, cursors and eight traces are generated in vector notation technique.

Text and cursors are generated by means of the Cursor Control CURCON circuit on diagram 12. The 8 traces are generated by the BATGE circuit.

The horizontal resolution will always be 9 bits. Sample values are generated from 1 till 512 which covers the entire available X-axis on the CRT screen and corresponds with 50 dots per division. When the acquisition length is "normal", there is a 1 to 1 relation between the acquisition and the display. When the acquisition length is larger than "normal", then data reduction is necessary to present the entire record on the display. The technic used for data reduction is MIN/MAX detection and works on the principle that on every two positions on the screen the minimum and maximum value of a set of acquisition samples is displayed.

The vertical resolution will always be 10 bits. Sample values are generated from 50 till 950, which covers the entire available Y-axis on the CRT screen.

Also four independent X versus Y traces can be generated in vector notation. These traces are generated by the BATGE circuit. The maximum amount of X-Y dots in a trace is 512.

The Y resolution in X versus Y mode is 10 bits. Sample values are generated from 50 till 950, which covers the entire available Y-axis on the screen.

The trace information can be presented on the CRT screen with normal, highlighted or suppressed light.

The BATGE circuit is also responsible for interconnecting all address, data and control busses of the DSP, SYSTEM BUS, Text and Trace Generator, DARLIC, VECTOR, DACPOT and Main Acquisition Memory.

Main Acquisition Memory (MAM)

The Main Acquisition Memory MAM consists of the two 32Kx8 SRAM circuits D8056 and D8054 and contains the trace data which is ready for display on the CRT screen. It contains an acquisition as well as a display memory.

The memory is non-volatile, which means that the information is not lost when mains supply is turned off.

The address lines are the sixteen GLOBAL ADDRESS BUS lines GLOA<15:0> from the DARLIC circuit on diagram 9 and the data lines are the sixteen GLOBAL DATA BUS lines GLOD<15:0>. Control lines for the program memory are the chipselect signal GLOCS1LT, the output enable signal GLOOE-LT and the read/write signals GLOWELLT and GLOWEHLT from the GLOBAL CONTROL BUS. The Digital Signal Processor can directly access this memory in a random way. Information from the FAM memory is written to the MAM acquisition memory part.

The display memory contains always the information for one complete screen of 512 dots. Magnification is performed here under software control. In DOTS-mode less than 512 dots can be displayed and in DOTJOIN-mode interpolation between the dots is performed.

Data flow between BATGE and unit A3:

ALE-HT	Address latch enable ALE-HT = "0" data on CPAD<07:00> ALE-HT = "1" address on CPAD<07:00>
BATRDYHT	Batge ready signal for the wait state logic
BATINTHT	Batge interrupt signal In digital mode, each 16 ms a pulse is generated as indication that text on the CRT display has to be refreshed. Other interrupt events are possible too.
CPA<13:8>	High order address bus
CPAD<07:00>	Multiplexed, bidirectional data/address bus
CPRD--LT	Active low during reading from BATGE by the microprocessor
CPWR--LT	Active low during writing to batge by the microprocessor
RESOPTLT	Reset signal
TXTCS-LT	Active low during main memory access by the microprocessor on unit A3

Data flow between CURCON, VECTOR, INTENS CONTROL, SWITCH CONTROL AND BATGE:

ATXTENLT	Analog text enable signal (generates signal BZ1)
AX<9:0>	10 bits data bus containing the horizontal information of the digital trace for the XDAC
BI0---HT	Signals for intensity control for selection between: - text intensity - intensity in normal mode - intensified intensity
BI1---HT	
BTEH--HT	Track and hold output for the dot-join circuit
BVEC--HT	Static output signal to VECTOR circuit, determines DOT or DOTJOIN mode. BVEC--HT = "0" dots BVEC--HT = "1" dots joined
BXYSW--HT	Control signal for XY switch BXYSW--HT = "0" analog signals to amplifier BXYSW--HT = "1" digital trace or text to amplifier
BZTE--LT	Vector Z control BZTE--LT = "0" variable intensity of text and digital trace via INTENSITY rotaries on the front of the oscilloscope BZTE--LT = "1" blanking of text and trace
CUEN0-LT	Chip select output signal for CURCON
CZSW1-HT	Z-switch signal from CURCON used for generation of signal BZSW--HT BZSW--HT = "0" analog trace intensity to Z-amplifier BZSW--HT = "1" text or digital trace intensity to Z-amplifier
CZTE1-HT	Curcon Z=text information
CXYSW1HT	XY switch input signal from CURCON
DY<9:0>	10 bits data bus containing the vertical information of the digital trace for the YDAC

Data flow between DSP and BATGE:

DS----LT	Input for data space select, active low during communication with an external data device (for example MAM, DARLIC, DACPOT and so on)
DSPA<15:0>	16 bits DSP address bus
DSPD<15:0>	16 bits DSP data bus
DSPIN1LT	Active low DSP interrupt request output signal
DSPRDYHT	Active low output signal indicating from an external device to the DSP that during a read action for the DSP, the data is not yet placed on the databus or that during a write action from the DSP the data is not yet read by the external device. The DSP then extends the wait cycle and checks the ready signal again.

DSPRW-LT	DSP read/write signal DSPRW-LT = "0" write cycle DSPRW-LT = "1" read cycle
GLOA<16:0>	17 bits global address bus
GLOD<15:0>	16 bits bidirectional global data bus
PRAMCSLT	Active low chip select signal for PRAM
PRAMOELT	Active low output enable signal for PRAM
PRAMRWLT	PRAM read/write signal PRAMRWLT = "0" write cycle to PRAM PRAMRWLT = "1" read cycle from PRAM
PS----LT	Input for program space select, active low during communication with an external program device (for example PRAM)
RSDSP-LT	Active low signal for DSP reset
STRB--LT	Strobe signal, active low during each external bus cycle

Signals from the GLOBAL control bus:

GLOA<16:0>	17 bits global address bus
GLOCS1N	Global chip select 1 for MAM
GLOCS2N	Global chip select 2 (option)
GLOD<15:0>	16 bits bidirectional global data bus
GLOWELLT	Global write low byte enable for devices connected to the low byte of the global data bus
GLOWEHLT	Global write high byte enable for devices connected to the high byte of the global data bus

5.8.1.12 Diagram 12

CURsor CONTROL circuit CURCON

The Cursor Control circuit (CURCON) D8047 is used for cursor and text control. Every 16 ms, an active low signal CUEN0-LT is generated and text and traces are refreshed on the screen and the contents of the memory is read.

Text and cursor control memory

The text and cursor control memory consists of one 8Kx8 SRAM circuit D8051 and contains the text and cursor information to be displayed on the CRT. The address lines are the thirteen lines TXTA<12:0> from the CURsor CONTROL (CURCON) circuit D8047 and the data lines are the eight lines TXTD<7:0> to and from the CURCON circuit.

Control lines for the memory are the chipselect signal, the output enable signal and the read/write signal from the CURCON chip.

X- and Y- Digital to Analog Converters

Digital signal and text data to be displayed is applied as AX<9:0> to the Horizontal Digital to Analog Converter XDAC N8057 and as DY<9:0> to the Vertical Digital to Analog Converter YDAC N8058. The analog output signals XDAC0/XDAC1 and YDAC0/YDAC1 from the two Digital to Analog Converters are applied to the output circuits on diagram 13.

Information for the analog oscilloscope section about switching between the analog and the digital signal information, is derived from signals BXYSW-HT (low is analog signal and high is digital trace and text) and TXTOP-HT via transistors V8041 and V8036 and applied as current signals XYSW0 and XYSW1 to R1204 and R1201 on unit A2. Text display is on during the autocal procedure if TXTOP-HT is high. Switching is done in such a way, that text is mostly displayed in the hold-off period between two sweeps.

Intensity control circuit

All conditions under which the Z-control circuit has to switch the CRT beam ON and OFF are combined in the intensity control circuit. The intensity information comes via the SBUS (serial BUS) to the six channel DAC N8070. Selection between text intensity, trace intensity normal and trace intensity intensified is done in multiplexer D8059 which is controlled by the signals BI0---HT and BI1---HT.

	BI1	BI0
Text intensity	0	0
Normal trace intensity	0	1
Not used	1	0
Intensified intensity	1	1

The selected signal is applied to the base of transistor V8004. Symmetrical Z-control output signal pair ZTXT0 and ZTXT1 carries the resulting blanking/unblanking information which is, applied to R3007 and R3008 on unit A2 in the analog oscilloscope section.

Information for the analog oscilloscope section about switching between the analog Z-signal and the digital Z-signal, is derived from signal BZSW--HT (low is analog trace intensity and high is digital trace and text intensity) via transistors V8042 and V8033 and applied as current signals ZSW0 and ZSW1 to D3001/7 and D3001/8 on unit A2.

Signal BZTE is low for unblanking and high for blanking of the trace. In analog oscilloscope mode, signal BZ1 switches between holdoff (low) and sweep (high). In digital oscilloscope mode this signal switches between text display (low) and trace display (high).

5.8.1.13 Diagram 13

Display interface

Frequency divider:

The 40 MHz input clocksignal CK40M is divided via circuit D8055 into a TEH pulse and a 50 ns SCPULS pulse for the control of the VECTOR (dot join circuit) circuit N8061.

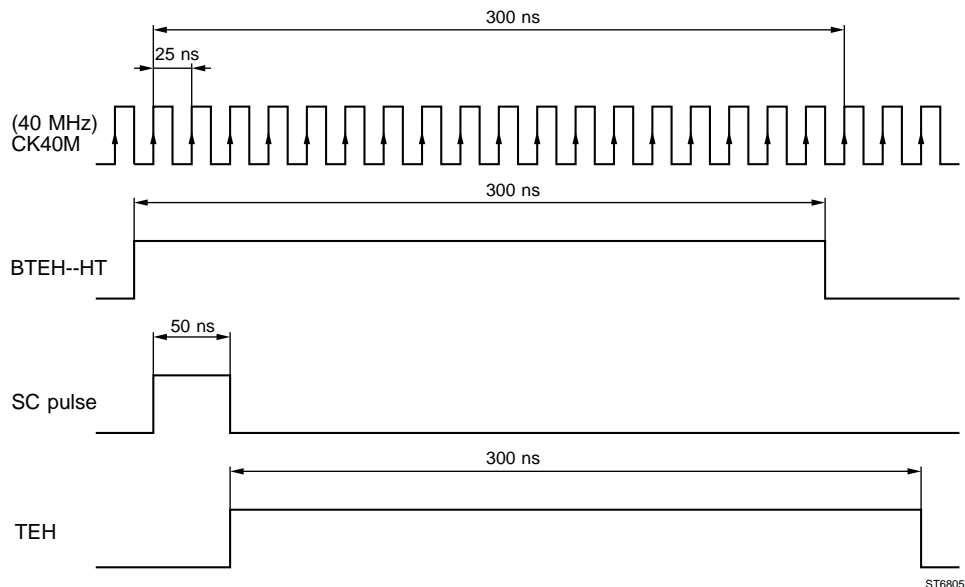

Final offset:

Final offset levels for the X- and Y-axis in the dot join mode, are generated via the SBUS (I2C BUS) and N8009 as levels XOFFS and YOFFS. These levels are via transistors V8201/V8199 and V8203/V8204 applied to the XDAC0/XDAC1 and YDAC0/YDAC1 level signals from the X- and Y-DAC on diagram 12. Resulting X- and Y-signal information is applied to the VECTOR circuit N8061.

Vector circuit:

YDAC0 and YDAC1 as well as XDAC0 and XDAC1 are applied to the vector circuit (dot join circuit) N8061 as symmetrical signals.

The VECTOR circuit is provided with a 2 mA reference current via transistor V8037 and R8384 (signal VECBIAS is not used).

In DOT-mode and during text display, the input signals are directly coupled to the outputs YTXT0/YTXT1 or XTXT0/XTXT1.

The signals YSGPTOUT/YSGNTOUT and XSGPTOUT/XSGNTOUT from level shifters in the VECTOR circuit, are applied to hold capacitors C8256/C8257 and C8258/C8259 during the active TEH pulse of 300 ns. During the SCPULSE of 50 ns, the capacitors are discharged again. Capacitor levels YSGPTSLB/YSGNTSLB and XSGPTSLB/XSGNTSLB are applied to internal voltage/current converters in the VECTOR circuit.

Signal BVEC--HT switches between DOT-mode (0V) and DOTJOIN-mode (5V).

In DOTJOIN-mode the signals are applied via integrator circuits. External capacitors C8102, C8103, C8104 and C8106 are the integrator capacitors for the horizontal signal path and C8107, C8108, C8109 and C8111 are for the vertical signal path.

The integration time to join two dots is 2 microseconds. This is 1 ms per trace of 512 dots and about 8 ms for 8 traces. About 8 ms is used for text display. Each 16 ms a complete new display cycle is performed.

Output signals XTXT0/XTXT1 and YTXT0/YTXT1 are applied to R2063/R2064 and D1001/15, D1001/16 on unit A2 in the analog oscilloscope section for display on the CRT screen.

5.8.1.14 Diagram 14**Control signals via the SBUS (serial BUS) interface**

A large number of control signals for the various circuits on digitizer unit A8 are generated via the SBUS interface system and integrated circuits D8034, D8036, D8033 and D8032 which are placed in series.

D8034	ES2	to diagram 6
	ES4	to diagram 6
	PS3	to diagram 6
	PS1	to diagram 6
	SELTRG	to diagram 8
	SELTP-HT	to diagram 6
	ES1	to diagram 6
	ES3	to diagram 6
D8036	EN2	to diagram 6
	EN4	to diagram 6
	PS2	to diagram 6
	PS4	to diagram 6
	EVENT-LT	to diagram 8
	EN1	to diagram 6
	EN3	to diagram 6
D8033	SLZERO	to diagram 8
	SLTWO	to diagram 8
	SLETWO	to diagram 8
	SLEONE	to diagram 8
	SLONE	to diagram 8
	SLSEL	to diagram 8
	CLKBINV	to diagram 4

D8032	ENST13HT	to diagram 1
	PCCDMDLT	to diagram 1 and 2
	CPST13HT	to diagram 1
	DSAMPBHT	to diagram 4
	ENST24HT	to diagram 2
	DSAMPAHT	to diagram 4
	CPST24HT	to diagram 2
	TRCKMDHT	to diagram 4
	HEFOUT	to X1008 on unit A10

Power distribution

Various circuits for filtering of power supply signals as well as splitting and distribution of power supply signals are shown.

5.8.2 Signal name list digitizer A8

NAME	MEANING	SOURCE	DESTINATION
AGADJA	Amplifier gain adjust A	N8014:3	N8026:1
AGADJB	Amplifier gain adjust B	N8014:3	N8027:2
ALE-HT	Address latch enable	X8101:11	D8048:11
ANINA	Analog input A	N8013:1	N8002:5
ANINB	Analog input B	N8012:2	N8001:5
AUTOTRHT	Autotrigger	D8501:3	D8502:8
AX <9:0>	X- digital trace and text data	D8048:11	D8047:12 N8057:12
BATINTHT	BATGE interrupt	X8101:11	D8048:11
BATRDYHT	BATGE ready	X8101:11	D8048:11
BI0---HT	Intensity control 0	D8048:11	D8059:12
BI1---HT	Intensity control 1	D8048:11	D8059:12
BTEH--HT	Track and hold	D8048:11	D8055:13
BVEC--HT	Vector switch Dots/Dot join	D8048:11	R8530:12 R8531:12 N8061:13 R8853:13
BXYSW-HT	Switch signal Analog/Digital	D8048:11	V8205:12
BZ1	Text enable signal	D8048:11	D8047:12
BZSW--HT	Z-switch signal Analog/Digital	D8048:11	R8422:12
BZTE--LT	Dot Z-control	D8048:11	V8112:12
CHOP1	Chopper signal CH.1	V8047:3	N8026:1
CHOP2	Chopper signal CH.2	V8048:3	N8027:2
CHOP3	Chopper signal CH.3	V8069:3	N8026:1
CHOP4	Chopper signal CH.4	V8071:3	N8027:2
CK12M	Clock signal 12MHz	D8047:12	D8045:3
CK40M	Clock signal 40MHz	G8053:10	D8048:11 D8055:13
CLKA	Clock signal A (100 MHz)	V8138:4	N8026:1
CLKB	Clock signal B (100 MHz)	V8140:4	N8027:2
CLKBINV	Clock B invert	D8033:14	D8005:4
COMP 1N	Logic input channel 1	N8023:1	R8347:6
COMP 1P	Logic input channel 1	N8023:1	R8344:6
COMP 2N	Logic input channel 2	N8022:2	R8317:6
COMP 2P	Logic input channel 2	N8022:2	R8326:6

COMP 3N	Logic input channel 3	N8024:1	R8291:6
COMP 3P	Logic input channel 3	N8024:1	R8288:6
COMP 4N	Logic input channel 4	N8021:2	R8309:6
COMP 4P	Logic input channel 4	N8021:2	R8316:6
CPA<13:08>	CPU address bus	X8101:11	D8048:11
CPAD<07:00>	CPU multiplexed address/data bus	X8101:11	D8048:11
CPRD--LT	CPU read cycle	X8101:11	D8048:11
CPST13HT	Copy set CH. 1/3 (to CH. 2/4)	D8032:14	N8026:1
CPST24HT	Copy set CH. 2/4 (to CH. 1/3)	D8032:14	N8027:2
CPWR--LT	CPU write cycle	X8101:11	D8048:11
CSD1--LT	Chipselect DARLIC	D8048:11	D8027:9
CUENO-LT	CURCON	D8048:11	D8047:12
CXYSW1HT	CURCON XY switch	D8047:12	D8048:11
CZSW1-HT	CURCON Z switch	D8047:12	D8048:11
CZTE1-HT	CURCON text	D8047:12	D8048:11
D210ENHT	Enable digitizer	D8501:3	X8500:8
DACCS-LT	DACPOT chip select	D8048:11	D8006:3
DACPENLT	DACPOT start cycle	D8501:4	D8006:3
DACSTRTN	DACPOT chip select	D8048:11	D8501:3
DPATN	Pattern valid	R8896:6	D8027:9
DS---LT	Data space select	D8069:10	D8048:11
DSAMPAHT	Double sample mode A	D8032:14	R8547:4
DSAMPBHT	Double sample mode B	D8032:14	R8566:4
DSOD	DTB trigger	X8501:8	D8502:8
DSOM	MTB trigger	X8503:8	D8502:8
DSPA<15:00>	DSP address bus	D8069:10	D8048:11
DSPA15 EX	DSP address bit 15	D8050:10	D8048:11
DSPD<15:00>	DSP bidirectional data bus	D8069:10	D8048:11
DSPIN0LT	DSP interrupt request 0	D8027:9	D8069:10
DSPIN1LT	DSP interrupt request 1	D8048:11	D8069:10
DSPIN2LT	DSP interrupt request 2	D8027:9	D8069:10
DSPRDYHT	DSP ready	D8048:11	D8069:10
DSPRW----LT	DSP read/write	D8069:10	D8048:11
DTBGATE	DTB gate	X8502:8	R8729:8
DTRDYN	Delta-t ready	N8062:7	D8027:9
DY<9:0>	Y digital trace and text data	D8048:11	D8047:12 N8058:12
ECLK	Event clock	R8828:8	D8027:9
ECLKB	Event clock	D8502:8	R8828:8
EN1	Logic don't care CH. 1	D8036:14	N8029:6
EN2	Logic don't care CH. 2	D8036:14	N8029:6
EN3	Logic don't care CH. 3	D8036:14	N8029:6
EN4	Logic don't care CH. 4	D8036:14	N8029:6
ENDGHOHT	Enable digital hold off	D8501:3	D8063:8
ENEV	Enable event	D8502:8	D8027:9
ENPTTMLT	Enable timed pattern	D8501:3	D8503:6
ENST13HT	Enable set 1/3	D8032:14	N8026:1
ENST24HT	Enable set 2/4	D8032:14	N8027:2
ES1	State CH. 1	D8034:14	N8029:6
ES2	State CH. 2	D8034:14	N8029:6
ES3	State CH. 3	D8034:14	N8029:6
ES4	State CH. 4	D8034:14	N8029:6
EVENT-LT	Event mode	D8036:14	D8502:8
EVUFN	Event underflow	D8027:9	D8502:8

FA<14:00>	FAM adres bus	D8027:9	FAM:9
FAMWRLT	FAM write (2K)	J8001:9	FAM:9
FD<63:00>	FAM data bus	D8027:9	FAM:9
FRDN	FAM read cycle	D8027:9	FAM:9
FSCN<7:0>	FAM chip select	D8027:9	FAM:9
FWRN	FAM write cycle	D8027:9	J8001:9
GAINMPUA	Gain MASPU A	R8778:3	R8079:3
GAINMPUB	Gain MASPU B	R8775:3	R8098:3
GENTRGNB	Generate trigger not	D8027:9	D8502:8
GLOA<16:00>	Global address bus	D8048:11	D8501:3 D8027:9 D8047:12
GLOCS1LT	Global chip select 1 (MAM)	D8048:11	D8054:11 D8056:11
GLOCS1N	Global chip select 1	D8063:11	D8050:11
GLOCS2N	Global chip select 2	D8048:11	D8050:11 D8063:11
GLOD<15:00>	Global bidirectional data bus	D8048:11	D8006:3 D8501:3 D8027:9 D8047:12
GLOOE-LT	Global bus output enable	D8048:11	D8027:9 D8047:12
GLORDYHT	Global bus ready (wait state)	D8048:11	D8027:9 D8047:12
GLOWEHLT	Global bus write enable high byte	D8048:11	D8027:9 D8047:12
GLOWELLT	Global bus write enable low byte	D8048:11	D8027:9
HEFOUT	HEF bus output	D8032:14	X8101:14
HF1	HF Adjust CH. 1	R8785:3	R8794:3
HF2	HF Adjust CH. 2	R8786:3	R8791:3
HF3	HF Adjust CH. 3	R8787:3	R8795:3
HF4	HF Adjust CH. 4	R8788:3	R8798:3
HFADJ1	HF Adjust CH. 1	R8793:3	R8766:1
HFADJ2	HF Adjust CH. 2	R8790:3	R8772:2
HFADJ3	HF Adjust CH. 3	R8796:3	R8764:1
HFADJ4	HF Adjust CH. 4	R8799:3	R8769:2
HLONA	Holdoff A	D8027:9	D8030:8
HLONB	Holdoff B	D8030:8	D8502:8
INTEGCX	Integrator capacitor X	N8061:13	C8104:13
INTEGCY	Integrator capacitor Y	N8061:13	C8108:13
ITREEA	Supply current for MASPU diode tree	V8014:3	N8026:1
ITREEB	Supply current for MASPU diode tree	V8012:3	N8027:2
MCAA	Clock signal (100 MHz, ECL)	D8005:4	N8002:5
MCAAR	Clock signal (100 MHz, ECL)	R8721:4	D8502:8
MCBB	Clock signal (100 MHz, ECL)	D8005:4	N8002:5
MCNAA	Clock signal (100 MHz, ECL)	D8005:4	D8004:5
MCNAAR	Clock signal (100 MHz, ECL)	R8722:4	D8502:8
MCNBB	Clock signal (100 MHz, ECL)	D8005:4	N8001:5
NCLKA	Clock signal A (100 MHz)	V8138:4	N8026:1
NCLKB	Clock signal B (100 MHz)	V8141:4	N8027:2

OFFSADCA	Offset ADC A	R8783:3	R8111:3
OFFSADCB	Offset ADC B	R8776:3	R8114:3
OFFSCMP1	Logic trigger level control CH. 1	R8782:3	R8762:6
OFFSCMP2	Logic trigger level control CH. 2	R8780:3	R8761:6
OFFSCMP3	Logic trigger level control CH. 3	R8784:3	R8763:6
OFFSCMP4	Logic trigger level control CH. 4	R8781:3	R8760:6
OFFST&HA	Offset track and hold A	R8779:3	R8831:3
OFFST&HB	Offset track and hold B	R8777:3	R8832:3
PCCDINA	For future use	X8016:1	R8187:1
PCCDINB	For future use	X8006:2	R8123:2
PCCDINPA	For future use	X8017:1	R8217:1
PCCDINPB	For future use	X8007:2	R8174:2
PCCDMDLT	For future use	D8032:14	N8026:1 N8027:2
PCCDNA	For future use	X8014:1	N8026:1
PCCDNB	For future use	X8003:2	N8027:2
PCCDPA	For future use	X8013:1	N8026:1
PCCDPB	For future use	X8004:2	R8273:2
POSAA	T&H current source path A	V8081:3	N8026:1
POSAB	T&H current source path A	V8077:3	N8027:2
POSBA	T&H current source path B	V8051:3	N8026:1
POSBB	T&H current source path B	N8074:3	N8027:2
PRAMCSHT	Program RAM chip select	J8003:10	D8049:10
PRAMCSLT	Program RAM select	D8048:11	D8049:10
PRAMOELT	Program RAM output enable	D8048:11	D8049:10
PRAMRWLT	Program RAM read/write	D8048:11	D8049:10
PS1	Pattern select CH. 1	D8034:14	N8029:6
PS2	Pattern select CH. 2	D8036:14	N8029:6
PS3	Pattern select CH. 3	D8034:14	N8029:6
PS4	Pattern select CH. 4	D8036:14	N8029:6
PS----LT	Program space select	D8069:10	D8048:11
RESOPTLT	Reset digitizer	X8101:11	D8027:9 D8048:11 D8047:12
RPAT	Pattern valid	N8029:6	R8747:8
RPATN	Pattern valid	N8029:6	R8734:8
RSDSP-LT	DSP Reset	D8048:11	D8069:10
RSTACQLT	Reset STOPACQ signal	D8501:3	D8502:8
RTPST	Trigger (timed pattern and state)	N8029:6	R8737:8
RTPSTN	Trigger (timed pattern and state)	N8029:6	R8754:8
RUNDT	Run delta-t	D8502:8	R8447:7
RUNDTN	Run delta-t	D8502:8	R8448:7
SADCBNA	Signal copy ADC A to B	N8027:2	N8026:1
SADCBNB	Signal copy ADC A to B	N8026:1	N8027:2
SADCBPA	Signal copy ADC B to A	N8027:2	N8026:1
SADCBPB	Signal copy ADC B to A	N8026:1	N8027:2
SCL	Serial clock	D8027:9	X8500:8 N8070:12 N8009:13 D8032:14 D8033:14 D8034:14 D8036:14

SCLKA	Sample clock A (100 MHz, TTL)	D8004:5	D8027:9
SCLKB	Sample clock B (100 MHz, TTL)	D8003:5	D8027:9
SCLKAN	Sample clock A (100 MHz, TTL)	D8004:5	D8027:9
SCLKBN	Sample clock B (100 MHz, TTL)	D8003:5	C8513:9
SDA	Serial data	D8027:9	X8500:8 N8070:12 N8009:13 D8034:14
SDA<7:0>	Sample data Bus A	D8004:5	D8027:9
SDB<7:0>	Sample data Bus B	D8003:5	D8027:9
SELTP-HT	Select state/pattern	D8034:14	N8029:6
SELTRG	Select trigger	D8034:14	D8502:8
SLEONE	Event source select 1	D8033:14	D8502:8
SLETWO	Event source select 2	D8033:14	D8502:8
SLONE	Trigger source selection 1	D8033:14	D8502:8
SLS12	Chopper clock signal	D8027:9	R8043:3
SLSEL	Slope select	D8033:14	D8502:8
SLTWO	Trigger source selection 2	D8033:14	D8502:8
SLZERO	Trigger source select 0	D8033:14	D8502:8
SSEL	Serial select	R8837:9	R8837:9 D8032:14 D8033:14 D8034:14 D8038:14
STOPACQ	Stop acquisition	L8513:8	D8027:9
STOPACQB	Stop acquisition	D8502:8	R8887:8
STRB--LT	Strobe, DSP global bus access	D8069:10	D8048:11
TBHOTXT	Time base hold text	X8101:11	R8373:11
TPATN	Timed pattern	D8027:9	D8503:6
TRCKMDHT	Track mode (calibration mode)	D8032:14	R8550:4 R8563:4
TVHLD	TV Hold	D8027:9	D8045:8
TVHOLD-LD	TV Hold	D8063:8	X8504:8
TVLNSLHT	TV line select	D8501:3	D8045:8
TXTA<12:00>	Text RAM address bus	D8047:12	D8051:12
TXTCS-LT	Chip select	X8101:11	D8048:11
TXTD<7:0>	Text RAM data bus	D8047:12	D8051:12
TXTOP-HT	Text option bit	D8047:12	V8202:12
VADCA	Offset ADC A	R8116:3	R8261:1
VADCB	Offset ADC B	R8109:3	R8112:2
VECBIAS	Vector bias	N8070:12	R8393:13
VSYNC	TV Sync pulse (FRAME)	X8505:9	D8027:9
XDAC0	X DAC output	N8057:12	N8061:13 V8201:13
XDAC1	X DAC output	N8057:12	N8061:13 V8199:13
XF---HT	External flag	D8069:10	D8050:10
XOFFS	X offset	N8009:13	R8856:13
XSGNTOUT	Vector difference signal X	N8061:13	V8133:13
XSGNTSLB	Sampled difference signal X	V8133:13	N8061:13
XSGPTOUT	Vector difference signal X	N8061:13	V8129:13
XSGPTSLB	Sampled difference signal X	V8133:13	N8061:13
XTXT0	X digital text and trace output	N8061:13	X8101:13

XTXT1	X digital text and trace output	N8061:13	X8101:13
XYSW0	AN/DIG trace switch	V8041:12	X8101:12
XYSW1	AN/DIG trace switch	V8036:12	X8101:12
YDAC0	Y DAC output	N8058:12	N8061:13 V8203:13
YDAC1	Y DAC output	N8058:12	N8061:13 V8204:13
YOFFS	Y offset	N8009:13	R8860:13
YSGNTOUT	Vector difference signal Y	N8061:13	V8132:13
YSGNTSLB	Sampled difference signal Y	V8130:13	N8061:13
YSGPTOUT	Vector difference signal Y	N8061:13	V8131:13
YSGPTSLB	Sampled difference signal Y	V8130:13	N8061:13
YTXT0	Y digital text and trace output	N8061:13	X8101:13
YTXT1	Y digital text and trace output	N8061:13	X8101:13
ZSW0	AN/DIG intensity switch	V8042:12	X8101:12
ZSW1	AN/DIG intensity switch	V8033:12	X8101:12

5.8.3 Unit lay-outs

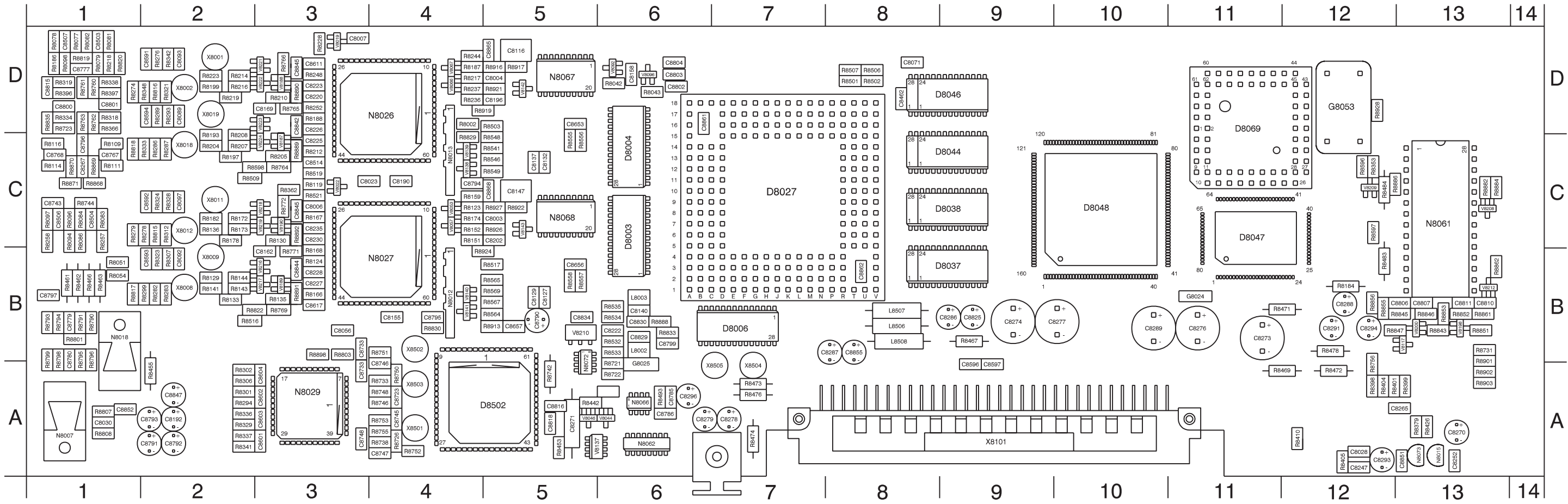

ST8356
970807

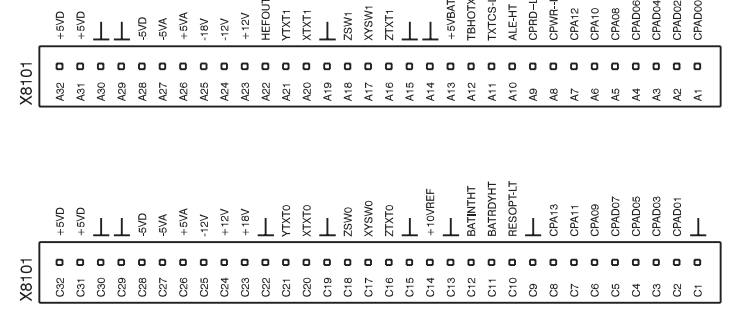

Lay-out 1 - A8 Digitizer, large component side (extension -L)

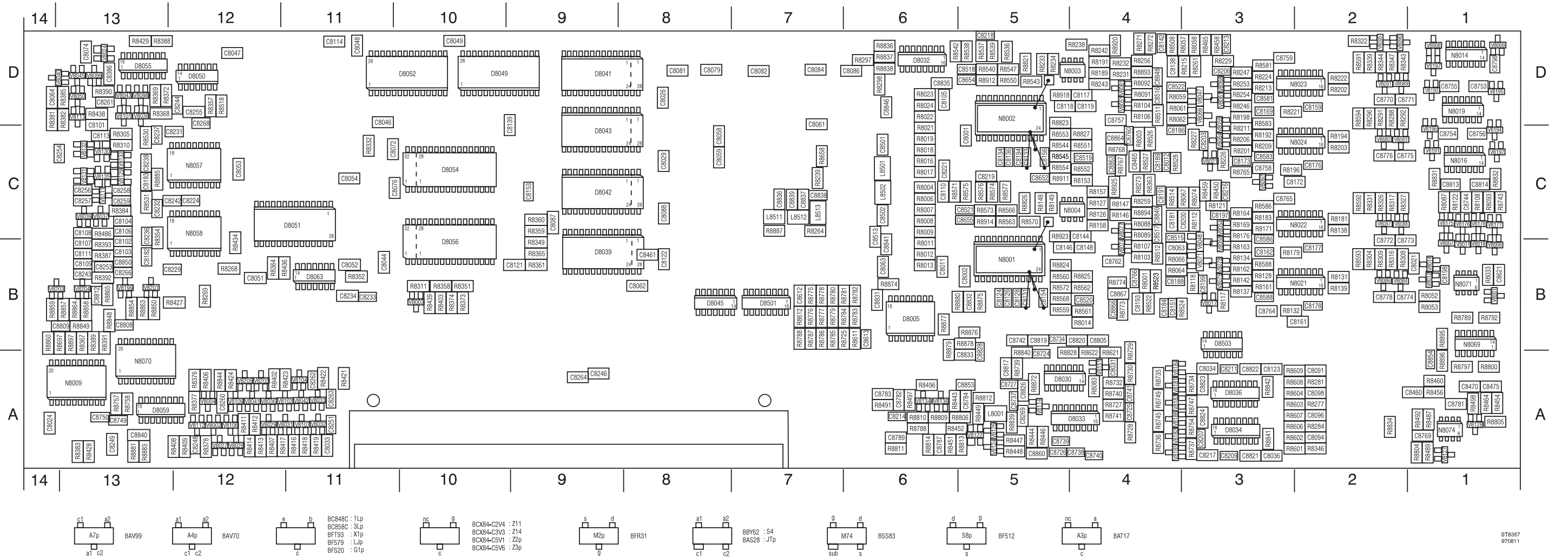

Lay-out 2 - A8 Digitizer, small component side

5.8.4 Location list

Extention -L = Large component side lay-out

No extention = Small component side lay-out

C8001 C5	C8094 A2	C8173 D3	C8236 C13
C8002 B5	C8096 A2	C8175 D3	C8237 C13
C8003 C5-L	C8097 C2-L	C8176 C2	C8238 C13
C8004 D5-L	C8098 A2	C8177 B2	C8242 C13
C8006 C3-L	C8101 D13	C8178 B2	C8243 B13
C8007 D3-L	C8102 B13	C8179 C3	C8244 D12
C8011 B6	C8103 B13	C8180 B3	C8246 A9
C8012 C4	C8104 C13	C8181 C4	C8247 A12-L
C8021 B1	C8105 D6	C8182 B13	C8248 A12
C8023 C3-L	C8106 C13	C8183 C13	C8249 A13
C8024 A14	C8107 B13	C8184 B4	C8251 A11
C8026 D8	C8108 C13	C8186 C4	C8252 A13-L
C8028 A12-L	C8109 B13	C8188 B4	C8253 B13
C8029 C8	C8110 C6	C8189 C4	C8254 C13
C8030 A1-L	C8111 B13	C8190 C4-L	C8255 D12
C8031 A4	C8113 C13	C8191 C4	C8256 C13
C8033 A11	C8114 D11	C8192 A2-L	C8257 C13
C8034 A3	C8116 D5-L	C8193 B4	C8258 C13
C8036 A3	C8121 B10	C8194 C5	C8259 C13
C8044 B11	C8122 B8	C8196 D5-L	C8260 A12
C8046 D11	C8123 A3	C8197 C3	C8261 D13
C8047 D12	C8124 B5	C8198 B1	C8262 A11
C8048 D11	C8126 B5	C8199 B3	C8263 A11
C8049 D10	C8127 B5-L	C8200 C4	C8264 A9
C8051 B12	C8128 B5	C8202 C5-L	C8265 A12-L
C8052 B11	C8129 B5-L	C8203 C3	C8266 B13
C8053 C12	C8131 B5	C8206 D3	C8267 C1-L
C8054 C11	C8132 C5-L	C8207 A3	C8268 D12
C8056 B3-L	C8133 C5	C8209 A3	C8269 A5
C8058 C8	C8134 C5	C8211 A3	C8270 A13-L
C8059 C8	C8136 C5	C8213 D3	C8271 A5-L
C8061 C7	C8137 C5-L	C8214 A6	C8273 B11-L
C8062 B8	C8138 D4	C8216 C3	C8274 B9-L
C8063 B6	C8139 D9	C8217 A3	C8276 B11-L
C8064 D14	C8140 B6-L	C8219 C5	C8277 B9-L
C8071 D8-L	C8142 D4	C8220 D3-L	C8278 A7-L
C8072 C11	C8144 B4	C8221 C6	C8279 A6-L
C8074 D13	C8146 B5	C8222 B6-L	C8286 B9-L
C8076 C11	C8147 C5-L	C8223 D3-L	C8287 B7-L
C8079 D8	C8148 B4	C8224 C12	C8288 B12-L
C8081 D8	C8151 B4	C8225 C3-L	C8289 B10-L
C8082 D7	C8153 C9	C8226 C3-L	C8291 B12-L
C8083 A4	C8154 B5	C8227 B3-L	C8293 A12-L
C8084 D7	C8155 B4-L	C8228 B3-L	C8294 B12-L
C8086 D7	C8156 C5	C8229 B13	C8296 A6-L
C8087 C9	C8158 D6-L	C8230 C3-L	C8460 A2
C8088 C8	C8159 D2	C8231 C13	C8461 B8
C8089 D2-L	C8161 B3	C8232 C13	C8462 D8-L
C8091 A2	C8162 B3	C8233 B11	C8465 C4
C8092 B2-L	C8169 D2-L	C8234 B11	C8470 A1
C8093 D2-L	C8172 C3	C8235 C3-L	C8475 A1

C8501 C6	C8747 A4-L	C8809 B14	D8006 B7-L
C8502 C6	C8748 A3-L	C8810 B13-L	D8027 C7-L
C8503 D1-L	C8749 A13	C8811 B13-L	D8030 A5
C8504 C1-L	C8750 A13	C8812 B13	D8032 D6
C8506 C1-L	C8753 D1	C8813 C1	D8033 A5
C8507 D1-L	C8754 C1	C8814 C1	D8034 A3
C8513 C6	C8755 D1	C8815 D1-L	D8036 A3
C8514 C3-L	C8756 C1	C8816 A5-L	D8037 B8-L
C8515 B4	C8758 C3	C8817 A5	D8038 C8-L
C8517 C4	C8759 D3	C8818 A5-L	D8039 B9
C8518 D5	C8762 B4	C8819 B5	D8041 D9
C8520 B4	C8764 B3	C8820 B4	D8042 C9
C8521 C6	C8765 C3	C8821 A3	D8043 C9
C8522 D4	C8766 B4	C8822 A3	D8044 C8-L
C8581 D3	C8767 C1-L	C8823 A3	D8045 B8
C8583 C3	C8768 C1-L	C8824 A3	D8046 D8-L
C8586 B3	C8769 A1	C8825 B9-L	D8047 C11-L
C8588 B3	C8770 D2	C8826 A5	D8048 C10-L
C8591 D2-L	C8771 D2	C8828 B5	D8049 D10
C8592 C2-L	C8772 B2	C8829 B6-L	D8050 D12
C8593 B2-L	C8773 B2	C8830 B6-L	D8051 C11
C8594 D2-L	C8774 B2	C8831 B6	D8052 D10
C8596 A9-L	C8775 C2	C8832 B5	D8054 C10
C8597 A9-L	C8776 C2	C8833 A6	D8055 D13
C8601 A3-L	C8777 D1-L	C8834 B5-L	D8056 B10
C8602 A3-L	C8778 B2	C8835 D6	D8059 A13
C8603 A3-L	C8779 B1-L	C8836 C7	D8063 B11
C8604 A3-L	C8780 A1-L	C8837 C7	D8069 D11-L
C8611 D3-L	C8781 A1	C8838 C7	D8501 B7
C8612 B7	C8782 A6	C8839 C7	D8502 A4-L
C8613 B6	C8783 A6	C8840 A13	D8503 B3
C8617 B3-L	C8784 A5	C8841 B6	G8024 B11-L
C8621 B1	C8785 A6-L	C8842 C3-L	G8025 A6-L
C8652 C5	C8786 A6-L	C8844 B3-L	G8053 D12-L
C8653 D5-L	C8787 A6	C8845 C3-L	L8001 A5
C8654 D5	C8788 A6	C8846 D6	L8002 B6-L
C8655 C6	C8789 A6	C8847 A2-L	L8003 B6-L
C8656 B5-L	C8790 A5-L	C8849 C4	L8501 C6
C8657 B5-L	C8791 A2-L	C8850 B13	L8502 C6
C8723 A4-L	C8792 A2-L	C8851 A13-L	L8506 B8-L
C8724 A5	C8793 A2-L	C8852 A1-L	L8507 B8-L
C8725 A4	C8794 C4-L	C8853 A5	L8508 B8-L
C8726 A5	C8795 B4-L	C8854 B1	L8511 C7
C8727 A5	C8796 C1-L	C8855 B8-L	L8512 C7
C8733 B3-L	C8797 B1-L	C8860 A5	L8513 C7
C8734 B5	C8798 D1	C8861 D6-L	N8001 B5
C8737 A5	C8799 B6-L	C8862 B8-L	N8002 D5
C8738 A5	C8800 D1-L	C8863 C4	N8004 C5
C8739 A5	C8801 D1-L	C8864 C4	N8007 A1-L
C8740 A4	C8802 D6-L	C8865 D5-L	N8009 A13
C8741 A4	C8803 D6-L	C8866 B4	N8012 B4-L
C8742 B5	C8804 D6-L	C8867 B4	N8013 C4-L
C8743 C1-L	C8805 B4	C8868 C5-L	N8014 D1
C8744 C1	C8806 B12-L	D8003 B6-L	N8015 A13-L
C8745 A4-L	C8807 B13-L	D8004 C6-L	N8016 C1
C8746 A4-L	C8808 B13	D8005 B6	N8018 B1-L

N8019 D1	R8074 C3	R8148 C5	R8218 D1-L
N8021 B3	R8077 D1-L	R8149 C5	R8219 D2-L
N8022 C3	R8078 D1-L	R8151 C4-L	R8221 D3
N8023 D3	R8079 D1-L	R8152 C4-L	R8222 D2
N8024 C3	R8081 D1-L	R8153 C4	R8223 D2-L
N8026 D3-L	R8082 D1-L	R8157 C4	R8224 D3
N8027 B3-L	R8083 C1-L	R8158 C4	R8226 C3
N8029 A3-L	R8084 C1-L	R8159 C4-L	R8227 C3
N8057 C12	R8086 B1-L	R8161 B3	R8228 D3-L
N8058 C12	R8087 C1	R8162 B3	R8229 D3
N8061 C13-L	R8088 C4	R8163 B3	R8231 D4
N8062 A6-L	R8089 C4	R8164 C3	R8232 D4
N8066 A6-L	R8091 D4	R8166 B3-L	R8233 D5
N8067 D5-L	R8092 D4	R8167 C3-L	R8234 D5
N8068 C5-L	R8093 C1	R8168 B3-L	R8236 D4-L
N8069 B1	R8094 B1-L	R8169 C3	R8237 D4-L
N8070 A13	R8096 C1-L	R8171 C3	R8238 D5
N8071 B1	R8097 C1-L	R8172 C2-L	R8239 C7
N8072 A5-L	R8098 D1-L	R8173 C2-L	R8242 D4
N8073 A13-L	R8103 B4	R8174 C4-L	R8243 D4
N8074 A1	R8104 D4	R8176 C3	R8244 D4-L
R8001 B4	R8106 D4	R8178 C2-L	R8246 D3
R8002 D4-L	R8107 B4	R8179 B3	R8247 D3
R8003 C4	R8108 C1	R8181 C2	R8248 D3-L
R8004 C6	R8109 C1-L	R8182 C2-L	R8252 D3-L
R8006 C6	R8111 C1-L	R8183 C3	R8253 D3
R8007 C6	R8112 C3	R8184 B12-L	R8254 D3
R8008 C6	R8114 C1-L	R8186 D1-L	R8256 D4
R8009 C6	R8116 C1-L	R8187 D4-L	R8257 B1-L
R8011 B6	R8117 B3	R8188 C3-L	R8258 B1-L
R8012 B6	R8118 B3	R8189 D4	R8259 C4
R8013 B6	R8119 C3-L	R8191 D4	R8261 D3
R8014 B4	R8121 C3	R8192 C3	R8264 C7
R8016 C6	R8122 C1	R8193 D2-L	R8268 B12
R8017 C6	R8123 C4-L	R8194 C2	R8269 B12
R8018 C6	R8124 B3-L	R8196 C3	R8271 D4
R8019 C6	R8126 C4	R8197 C2-L	R8272 D4
R8021 C6	R8127 C4	R8198 D3	R8273 C4
R8022 D6	R8128 B3	R8199 D2-L	R8274 D1-L
R8023 D6	R8129 B2-L	R8201 C3	R8276 D2-L
R8024 D6	R8130 C3-L	R8202 D2	R8277 A2
R8033 B1	R8131 B2	R8203 C2	R8278 C2-L
R8042 D6-L	R8132 B3	R8204 C2-L	R8279 B1-L
R8043 D6-L	R8133 B2-L	R8205 C3-L	R8281 A2
R8051 B1-L	R8134 B3	R8206 C3	R8282 B2-L
R8052 B1	R8135 B3-L	R8207 C2-L	R8283 B2-L
R8053 B1	R8136 C2-L	R8208 D2-L	R8284 A2
R8054 B1-L	R8137 B3	R8209 C3	R8286 C2-L
R8057 D4	R8138 C2	R8210 D3-L	R8287 C2-L
R8058 D3	R8139 B2	R8211 C3	R8288 D2
R8059 D4	R8141 B2-L	R8212 C3-L	R8289 D2-L
R8061 D4	R8142 B3	R8213 D3	R8291 D2
R8062 D4	R8143 B2-L	R8214 D2-L	R8292 D2
R8064 B4	R8144 B2-L	R8215 D4	R8293 D2-L
R8066 B4	R8146 C4	R8216 D2-L	R8294 A2-L
R8067 C4	R8147 C4	R8217 D4-L	R8296 D2

R8297 D6	R8367 B13	R8439 B10	R8517 B5-L
R8298 D6	R8368 D13	R8441 A6-L	R8518 D12
R8299 B2-L	R8369 D13	R8442 A5-L	R8519 C3-L
R8301 A2-L	R8372 D13	R8443 A6	R8521 C3-L
R8302 A2-L	R8373 B10	R8444 A5	R8522 B4
R8304 B2	R8374 B10	R8446 A5	R8523 B4
R8305 C13	R8376 A12	R8447 A5	R8524 B4
R8306 A2-L	R8377 A12	R8448 A5	R8526 C4
R8307 B2-L	R8378 A12	R8449 A5	R8527 C4
R8308 B2	R8379 A13-L	R8450 C3	R8528 C4
R8309 B2	R8381 D14	R8451 A6	R8530 C13
R8310 C13	R8382 D13	R8452 A6	R8531 C13
R8311 B10	R8383 A13	R8453 A5-L	R8532 B6-L
R8312 C2-L	R8384 C13	R8454 A1	R8533 B6-L
R8316 B2	R8385 D13	R8455 A2-L	R8534 B6-L
R8317 C2	R8386 D13	R8456 A1	R8535 B6-L
R8318 D1-L	R8387 B13	R8458 D3	R8536 D5
R8319 D1-L	R8388 D13	R8459 C3	R8537 D5
R8321 D2-L	R8389 B13	R8460 A1	R8538 D5
R8322 D2	R8390 D13	R8461 B1-L	R8539 D5
R8323 B2-L	R8391 B13	R8462 B1-L	R8540 D5
R8324 C2-L	R8392 B13	R8463 B1-L	R8541 C5-L
R8326 C2	R8393 B13	R8464 A1	R8542 D6
R8327 C2	R8396 D1-L	R8465 D3	R8543 D5
R8328 C2-L	R8397 D1-L	R8466 B1-L	R8544 C5
R8329 A2-L	R8398 A12-L	R8467 B9-L	R8545 C5
R8331 C2	R8399 A13-L	R8469 A11-L	R8546 C5-L
R8332 C11	R8401 A12-L	R8471 B11-L	R8547 D5
R8333 C2-L	R8402 A12	R8472 A12-L	R8548 C5-L
R8334 D1-L	R8403 B10	R8473 A7-L	R8549 C5-L
R8336 A2-L	R8404 A12-L	R8474 A7-L	R8550 D5
R8337 A2-L	R8405 A12-L	R8476 A7-L	R8551 C4
R8338 D1-L	R8406 A12	R8478 B12-L	R8552 C4
R8339 D2	R8407 A12	R8483 B12-L	R8553 C5
R8341 A2-L	R8408 A12	R8484 C12-L	R8554 C5
R8342 D2-L	R8409 A12	R8486 C13	R8555 C5-L
R8343 D2	R8410 A12-L	R8487 A1	R8556 C5-L
R8344 D2	R8411 A12	R8489 A1	R8557 B5-L
R8346 A2	R8412 A12	R8491 A6	R8558 B5-L
R8347 D2	R8413 A12	R8492 A1	R8559 B5
R8348 D2-L	R8414 A12	R8493 A6-L	R8560 B5
R8349 B9	R8416 A11	R8496 A6	R8561 B4
R8351 B10	R8417 A12	R8497 A6	R8562 B4
R8352 B11	R8418 A11	R8498 A1	R8563 C5
R8353 C12-L	R8419 A11	R8501 D8-L	R8564 B5-L
R8354 C13	R8421 A11	R8502 D8-L	R8565 B5-L
R8357 D12	R8422 A11	R8503 D5-L	R8566 C5
R8358 B10	R8423 A11	R8506 D8-L	R8567 B5-L
R8359 C9	R8424 A12	R8507 D8-L	R8568 B5
R8360 C9	R8426 A13-L	R8508 D4	R8569 B5-L
R8361 B9	R8427 B13	R8509 C2-L	R8570 C5
R8362 C3-L	R8428 A13	R8511 D4	R8571 C6
R8363 C4	R8429 D13	R8512 B4	R8572 B5
R8364 B12	R8434 C12	R8513 B4	R8573 C5
R8365 B9	R8436 B11	R8514 C4	R8574 C5
R8366 C1-L	R8438 D13	R8516 B2-L	R8575 C5

R8576 C5	R8751 A4-L	R8809 A6	R8865 B13
R8577 C5	R8752 A4-L	R8810 A6	R8866 D4
R8581 D3	R8753 A4-L	R8811 A6	R8867 C4
R8583 C3	R8754 A3	R8812 A5	R8868 C1-L
R8586 C3	R8755 A4-L	R8813 A5	R8869 C1-L
R8588 B3	R8756 A12-L	R8814 A6	R8870 C1-L
R8591 D2	R8757 A13	R8815 B2-L	R8871 C1-L
R8592 C2	R8758 A13	R8816 D2-L	R8872 A5
R8593 B2	R8760 D1-L	R8817 B1-L	R8874 B6
R8594 D2	R8761 D1-L	R8818 C1-L	R8875 B5
R8596 C12-L	R8762 D1-L	R8819 D1-L	R8876 B5
R8597 C12-L	R8763 D1-L	R8820 D1-L	R8877 B6
R8598 C2-L	R8764 C3-L	R8821 D5	R8878 B6
R8601 A3	R8765 D3-L	R8822 B2-L	R8879 B6
R8602 A3	R8766 D3-L	R8823 C5	R8880 B6
R8603 A3	R8767 C4	R8824 B5	R8881 A13
R8604 A3	R8768 C4	R8825 B4	R8882 C13-L
R8606 A3	R8769 B3-L	R8826 C5	R8883 A13
R8607 A3	R8771 B3-L	R8827 C4	R8884 C13-L
R8608 A3	R8772 C3-L	R8828 A5	R8885 C13
R8609 A3	R8773 B4	R8829 C4-L	R8886 C13-L
R8611 B6	R8774 B4	R8830 B4-L	R8887 C7
R8612 B7	R8775 B7	R8831 C1	R8888 B6-L
R8621 A4	R8776 B7	R8832 C1	R8889 C3-L
R8622 A4	R8777 B7	R8833 B6-L	R8890 D3-L
R8658 C7	R8778 B7	R8834 A2	R8891 B3-L
R8697 B13	R8779 B7	R8835 D1-L	R8892 C3-L
R8721 A6-L	R8780 B7	R8836 D6	R8893 D4
R8722 A6-L	R8781 B7	R8837 D6	R8894 C4
R8723 D1-L	R8782 B6	R8838 D6	R8895 B1
R8725 B7	R8783 B6	R8839 A5	R8896 B1
R8726 A4-L	R8784 B7	R8840 A5	R8897 B13
R8727 A4	R8785 B7	R8841 A3	R8898 A3-L
R8728 A4	R8786 B7	R8842 A3	R8901 B13-L
R8729 B4	R8787 B7	R8843 B13-L	R8902 A13-L
R8730 A4	R8788 B7	R8844 A12	R8903 A13-L
R8731 B13-L	R8789 B1	R8845 B12-L	R8911 C5
R8732 A4	R8790 B1-L	R8846 B13-L	R8912 D5
R8733 A4-L	R8791 B1-L	R8847 B12-L	R8913 B5-L
R8734 A3	R8792 B1	R8848 B13	R8914 C5
R8735 A4	R8793 B1-L	R8849 B13	R8916 D5-L
R8736 A4	R8794 B1-L	R8850 B13	R8917 D5-L
R8737 A3	R8795 A1-L	R8851 B13-L	R8918 D5
R8738 A4-L	R8796 A1-L	R8852 B13-L	R8919 D4-L
R8739 A5	R8797 A1	R8853 B13-L	R8920 D4
R8740 A4	R8798 A1-L	R8854 B13	R8921 D5-L
R8741 A4	R8799 A1-L	R8855 B12-L	R8922 C5-L
R8742 A5-L	R8800 A1	R8856 B12-L	R8923 B5
R8743 C1	R8801 B1-L	R8857 B13	R8924 B4-L
R8744 C1-L	R8802 A3-L	R8858 B13	R8925 C4
R8745 A4	R8803 A3-L	R8859 B14	R8926 C5-L
R8746 A4-L	R8804 A1	R8860 B14	R8927 C5-L
R8747 A3	R8805 A1	R8861 B13-L	R8928 D12-L
R8748 A4-L	R8806 A6	R8862 B13-L	R8931 D3-L
R8749 A4	R8807 A1-L	R8863 B13	R8932 C3-L
R8750 A4-L	R8808 A1-L	R8864 B13	R8933 C3-L

R8934 B3-L	V8050 D13	V8112 A12	V8193 D1
R8936 D3-L	V8051 D4	V8113 D13	V8194 C1
R8937 B3-L	V8053 C4-L	V8114 A5	V8195 D1
R8938 C3-L	V8054 C3	V8117 B13-L	V8196 C1
R8939 B3-L	V8057 C4-L	V8122 A5	V8197 D1
V8001 B1	V8058 B3	V8124 A5	V8198 B13-L
V8002 A12	V8059 D3	V8126 A5	V8199 B13
V8003 B10	V8061 D3	V8127 A1	V8200 B13-L
V8004 A12	V8064 C3	V8128 A1	V8201 B13
V8006 B1	V8066 D4-L	V8129 C13	V8202 A12
V8007 B1	V8067 D4-L	V8130 C13	V8203 B14
V8008 D1	V8068 D3	V8131 C13	V8204 B13
V8009 D1	V8069 D3	V8132 C13	V8205 A12
V8011 B1	V8071 B3	V8133 C13	V8208 C13-L
V8012 B1	V8074 B4	V8134 A6	V8209 C12-L
V8014 B1	V8077 C4	V8135 C13	V8210 B5-L
V8017 B3	V8078 B3	V8136 A6	V8212 B13-L
V8018 B1	V8079 B3	V8137 A5-L	V8216 B3-A
V8019 D3-L	V8081 D4	V8138 C4-L	V8217 B3-A
V8021 C3	V8082 C2	V8139 C4-L	V8218 C3-A
V8022 C3-L	V8083 C2	V8140 B4-L	V8219 C3-A
V8024 D13	V8084 B2	V8141 B4-L	V8221 D3-A
V8027 A12	V8086 B2	V8142 D5-L	V8222 D3-A
V8028 A12	V8087 C2	V8143 C5-L	V8223 C3-A
V8029 A12	V8088 C2	V8151 A4	V8224 C3-A
V8031 A12	V8089 D2	V8175 C1	X8001 D2-L
V8032 A11	V8090 D2	V8176 C1	X8002 D2-L
V8033 A11	V8091 D2	V8177 C1	X8008 B2-L
V8036 A12	V8092 D6-L	V8178 C1	X8009 B2-L
V8037 C13	V8095 D2	V8181 A4	X8011 C2-L
V8038 D13	V8096 D6-L	V8182 A4	X8012 C2-L
V8039 C13	V8097 C3	V8183 A4	X8018 C2-L
V8040 D13	V8098 D13	V8184 A4	X8019 D2-L
V8041 A12	V8099 D13	V8185 A4	X8101 A9-L
V8042 A11	V8101 D13	V8186 A4	X8501 A4-L
V8043 D13	V8103 A12	V8187 C3-L	X8502 A4-L
V8044 A6-L	V8104 A11	V8188 D3-L	X8503 A4-L
V8045 D13	V8106 A12	V8189 B3-L	X8504 A7-L
V8046 A5-L	V8107 A11	V8190 C3-L	X8505 A6-L
V8047 D3	V8109 A12	V8191 C1	
V8048 B3	V8111 C13	V8192 C1	

5.8.5 Circuit diagrams

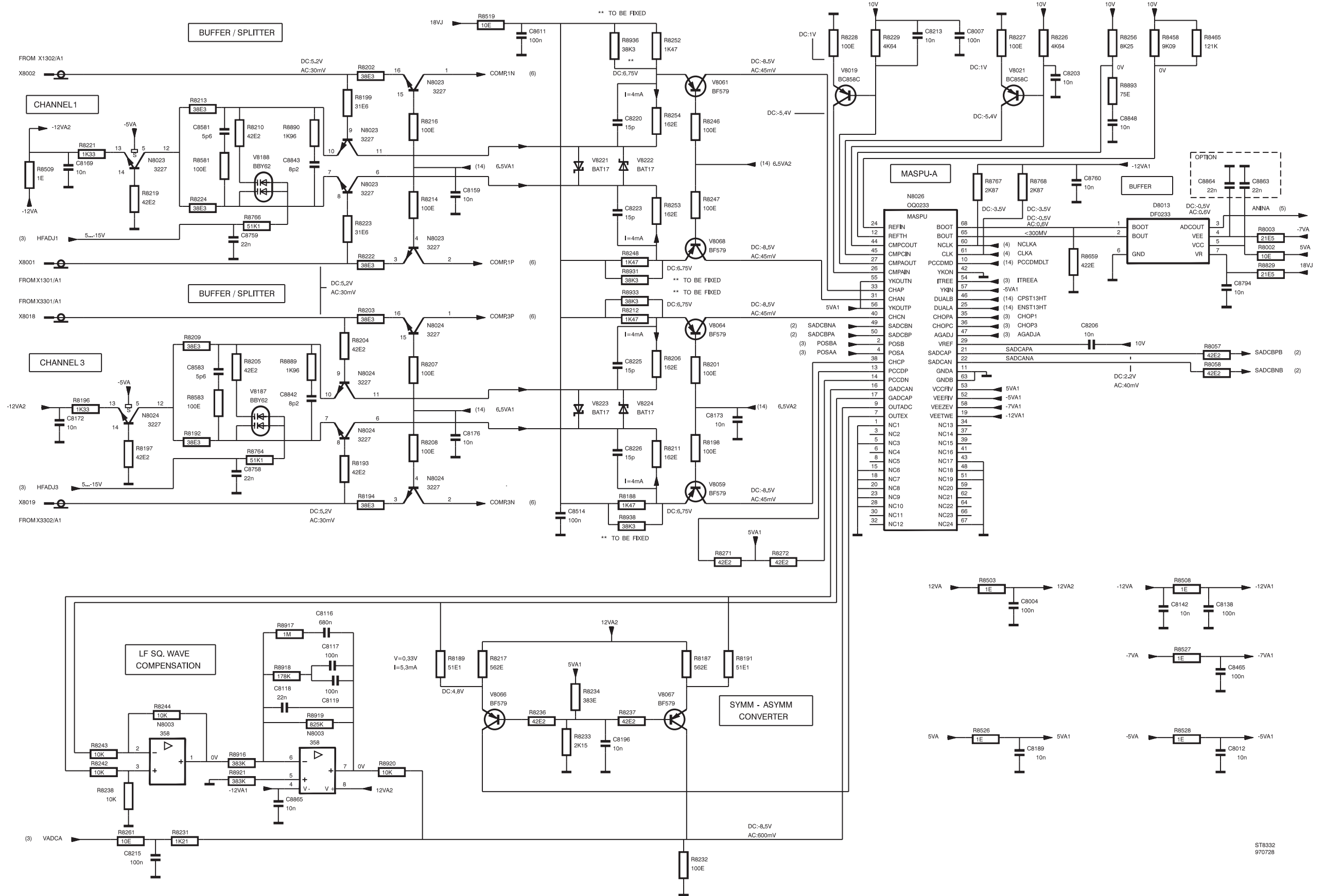

A8 - Diagram 1a; Channel 1 and 3 (200 MHz version)

ST8332
970728

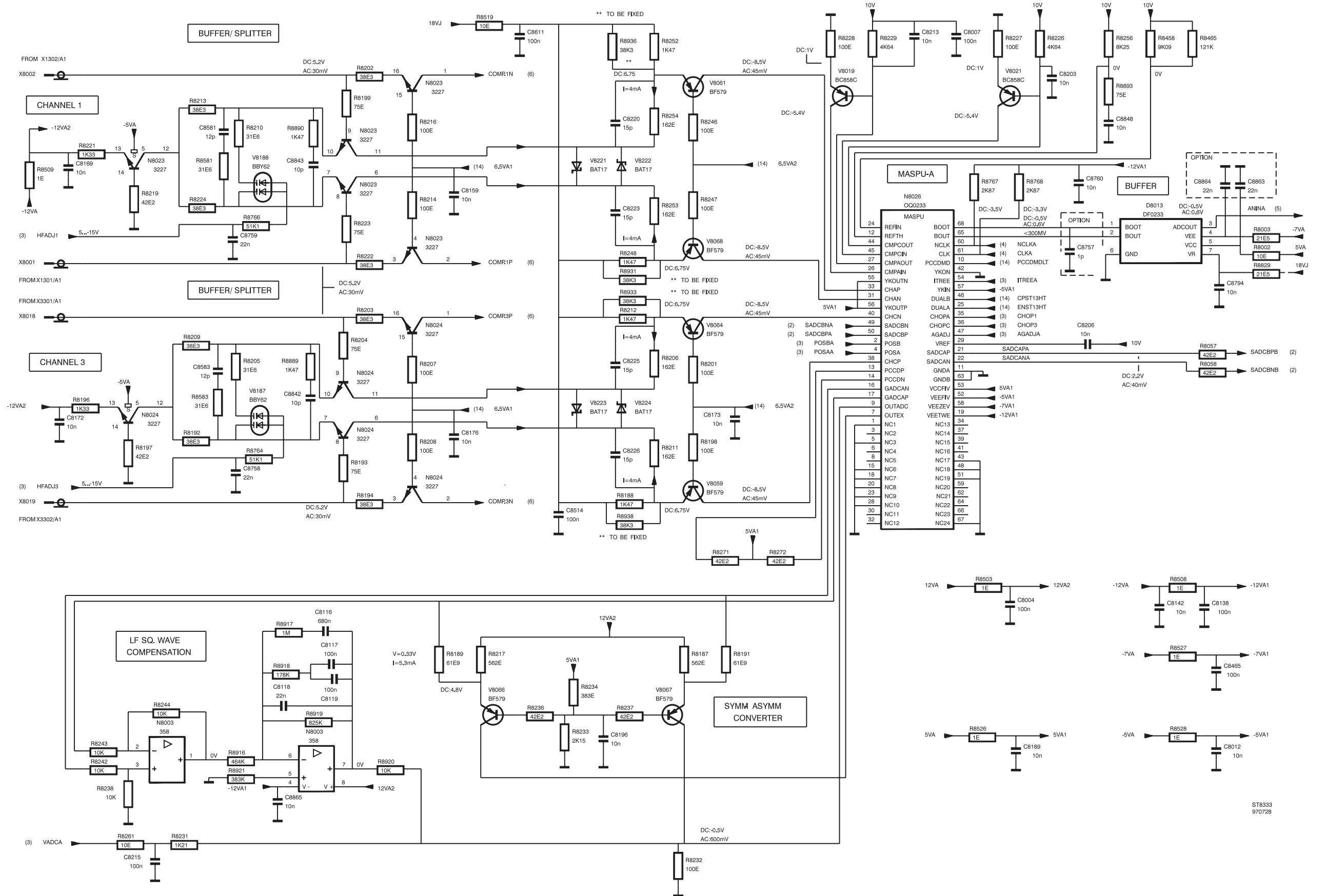

A8 - Diagram 1b; Channel 1 and 3 (100 MHz version)

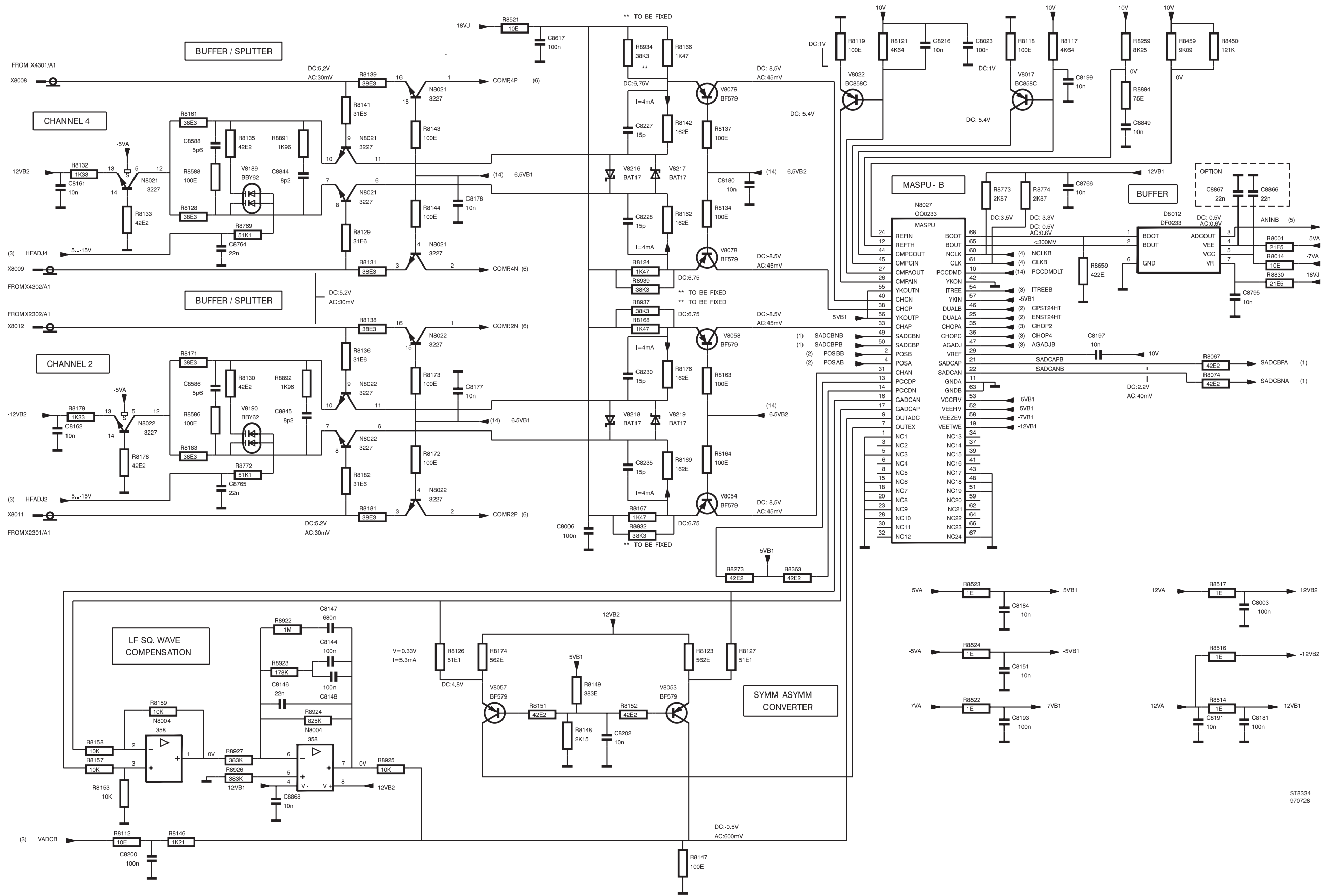

A8 - Diagram 2a; Channel 2 and 4 (200 MHz version)

ST8334
970728

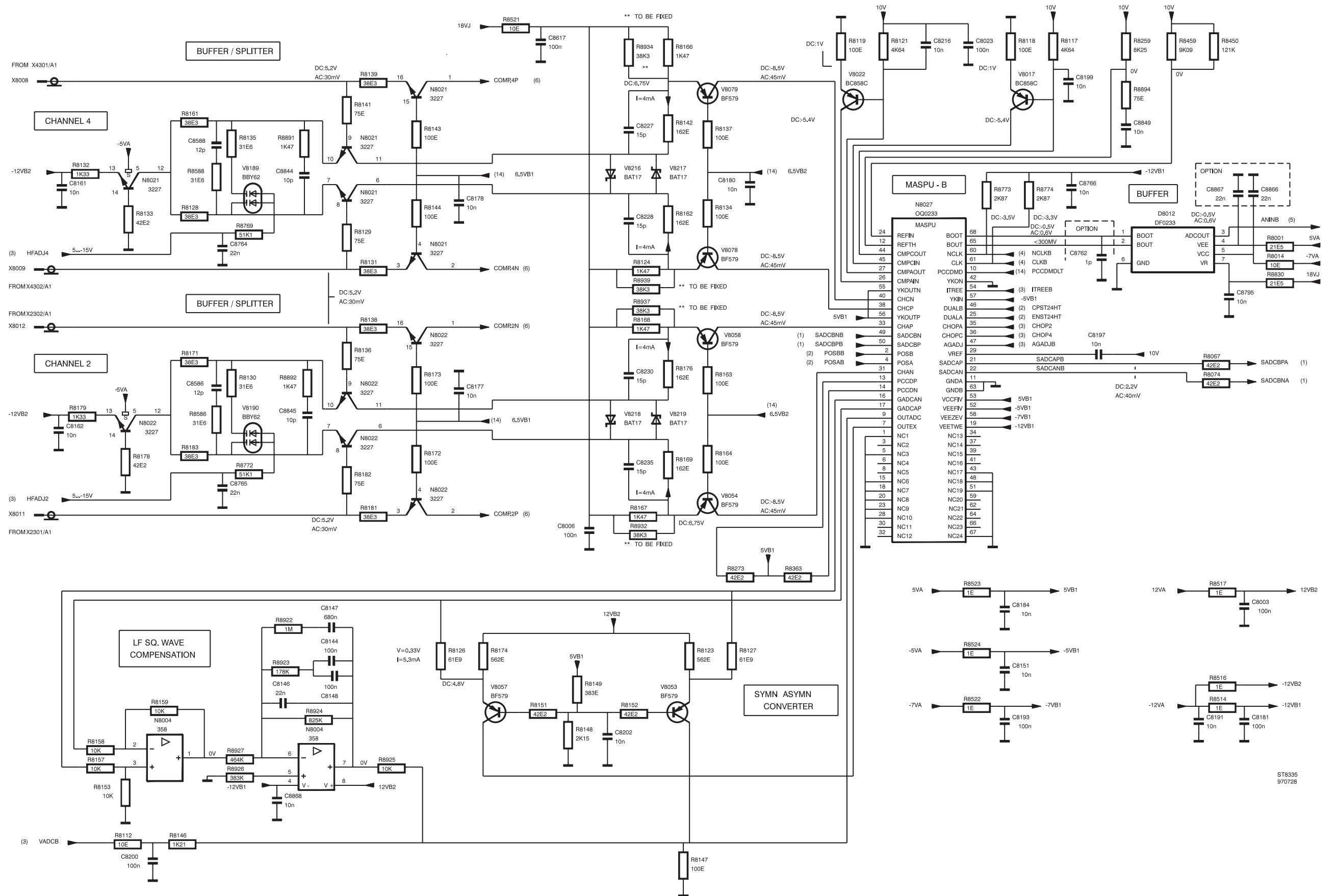

A8 - Diagram 2b; Channel 2 and 4 (100 MHz version)

ST8335
970728

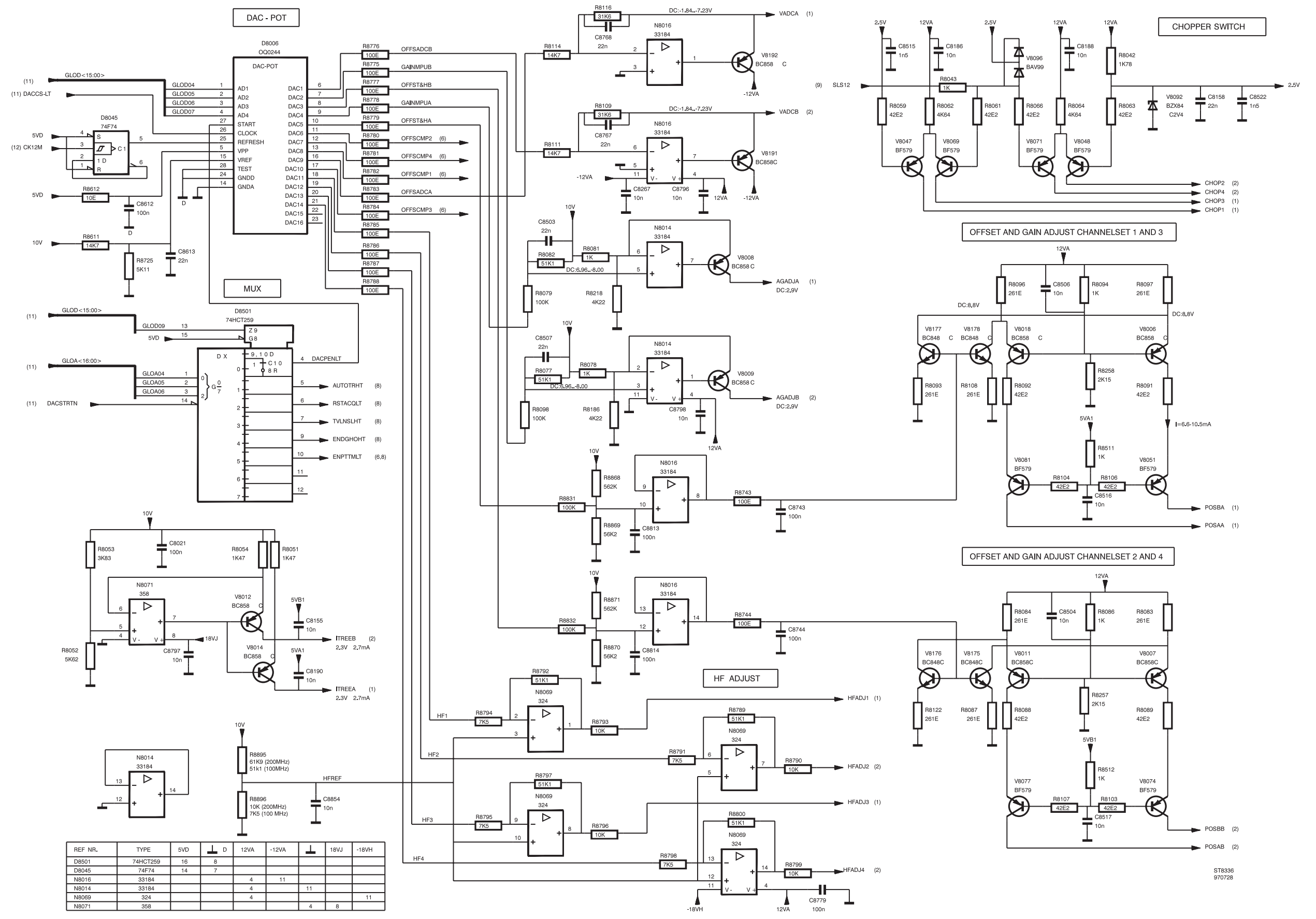

A8 - Diagram 3; Ref. and adj. voltages

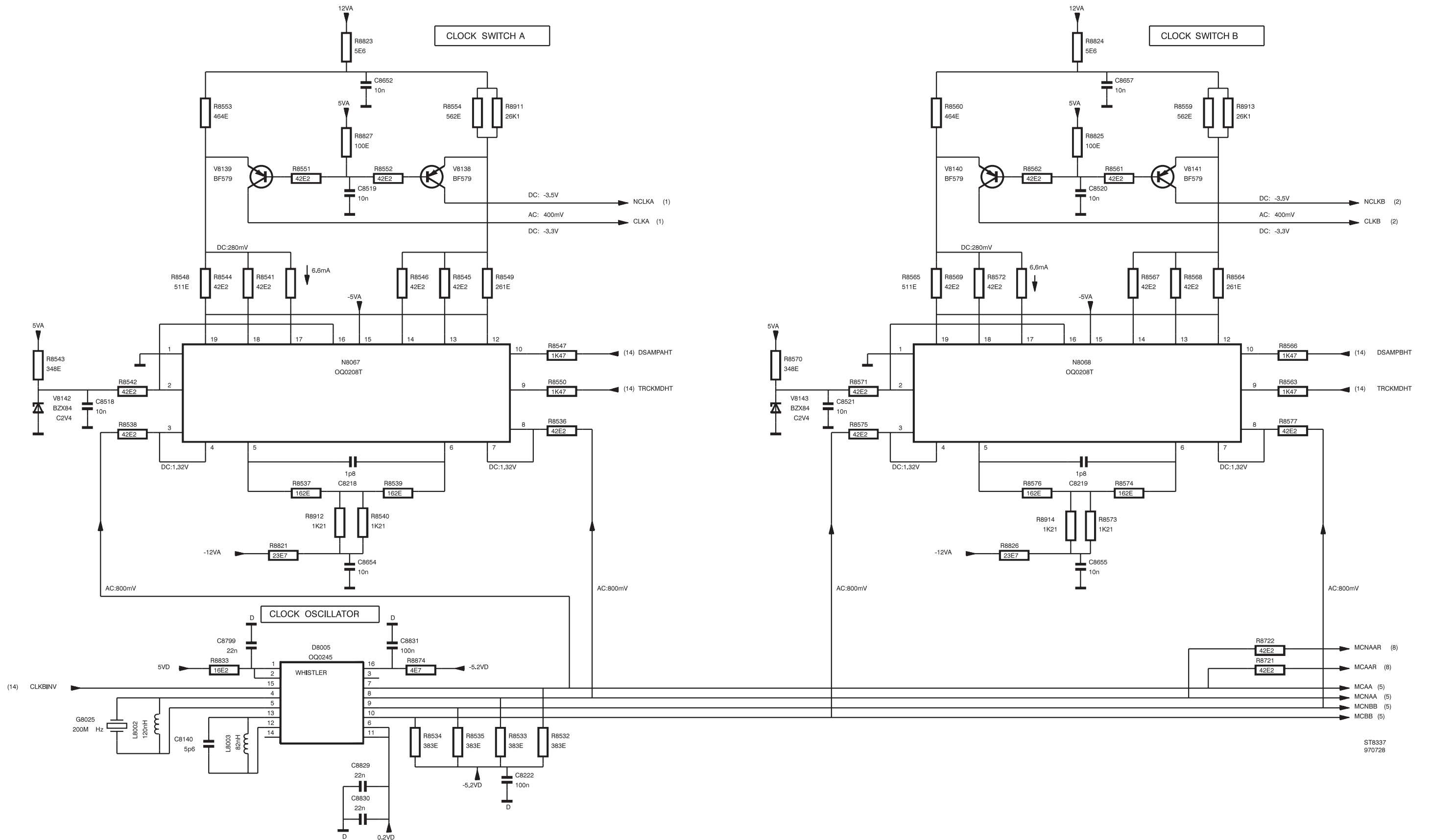

A8 - Diagram 4; Clock

ST8337
970728

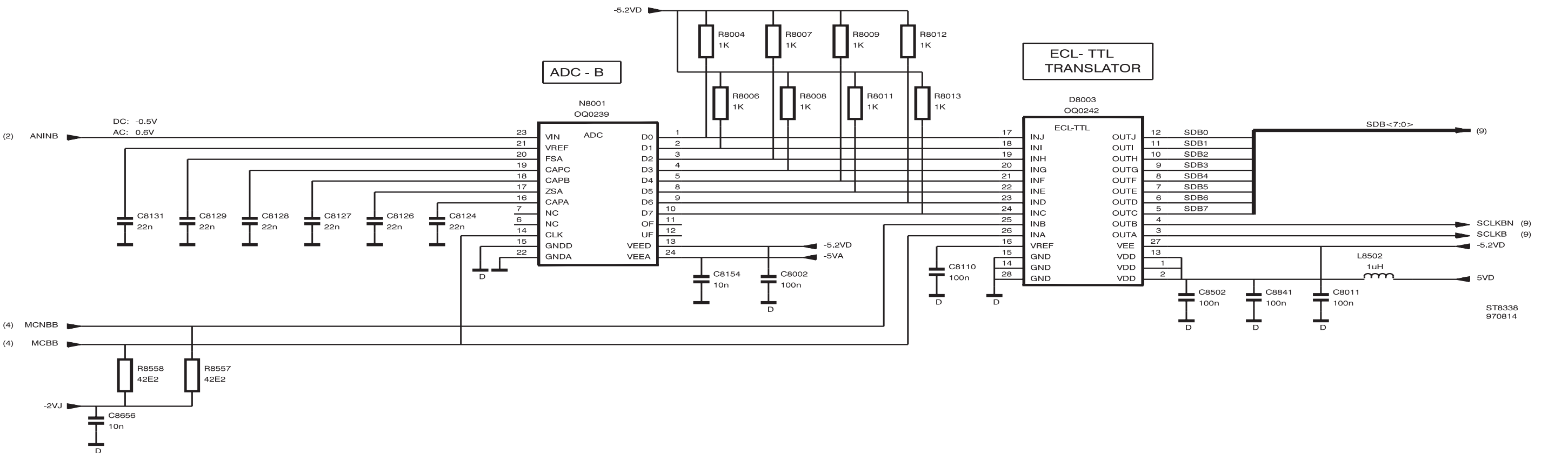
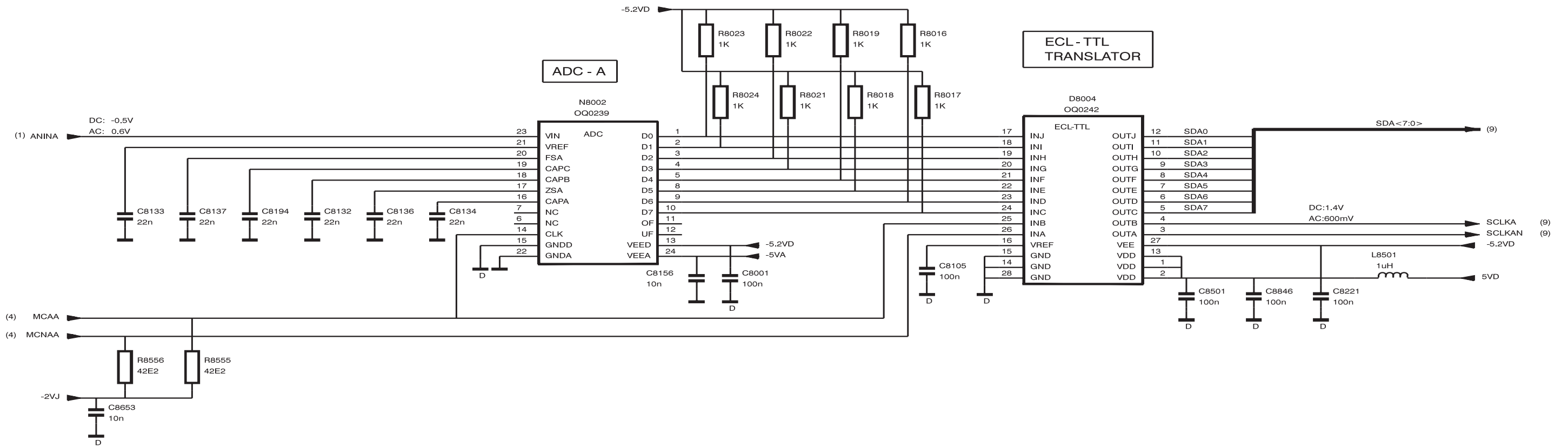

A8 - Diagram 5; ADC and ECL-TTL

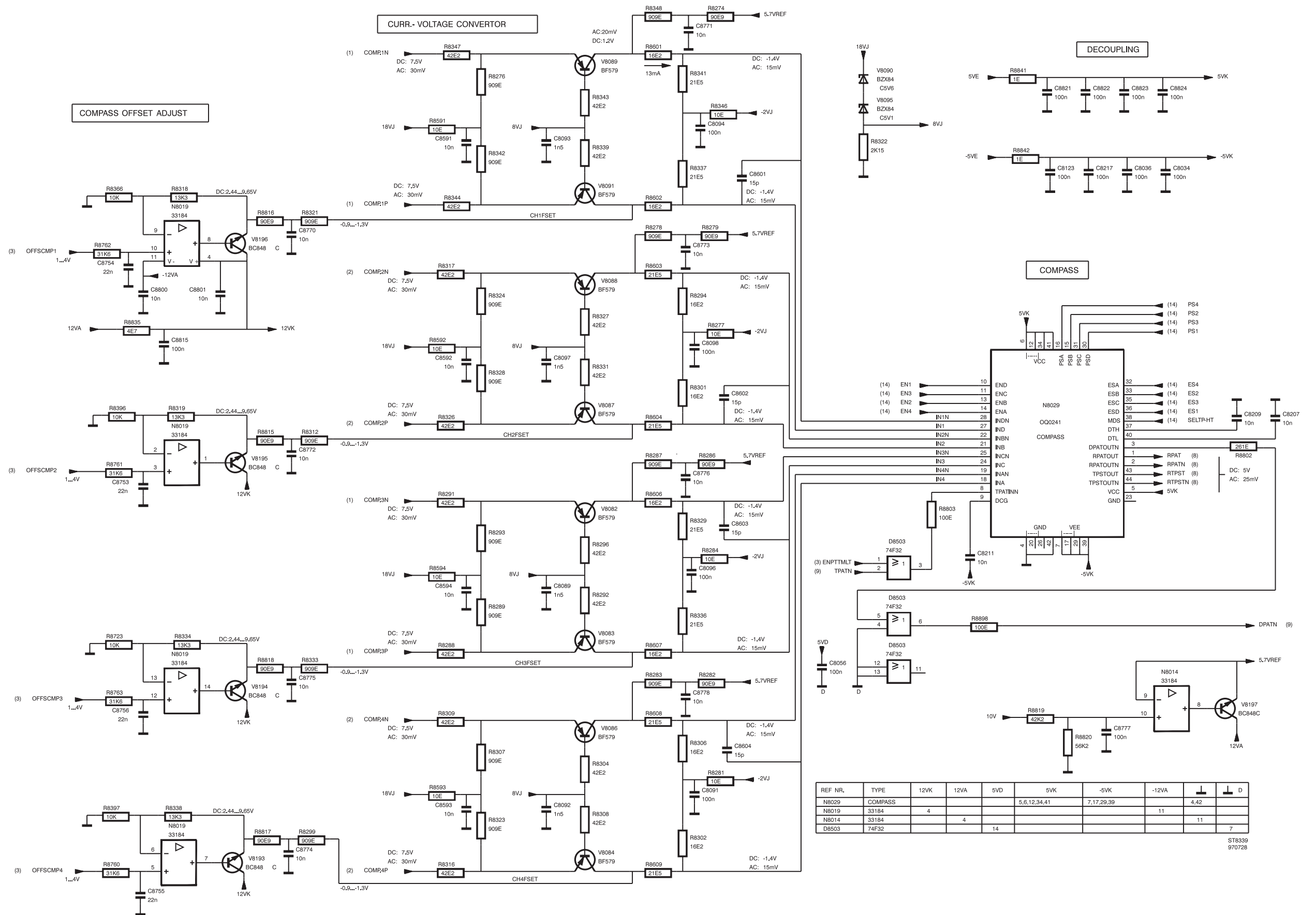

REF NR.	TYPE	12VK	12VA	5VD	5VK	-5VK	-12VA	D
N8029	COMPASS				5,6,12,34,41	7,17,29,39		4,42
N8019	33184	4					11	
N8014	33184		4				11	
D8503	74F32			14				7

ST8339
970728

A8 - Diagram 6; COMPASS

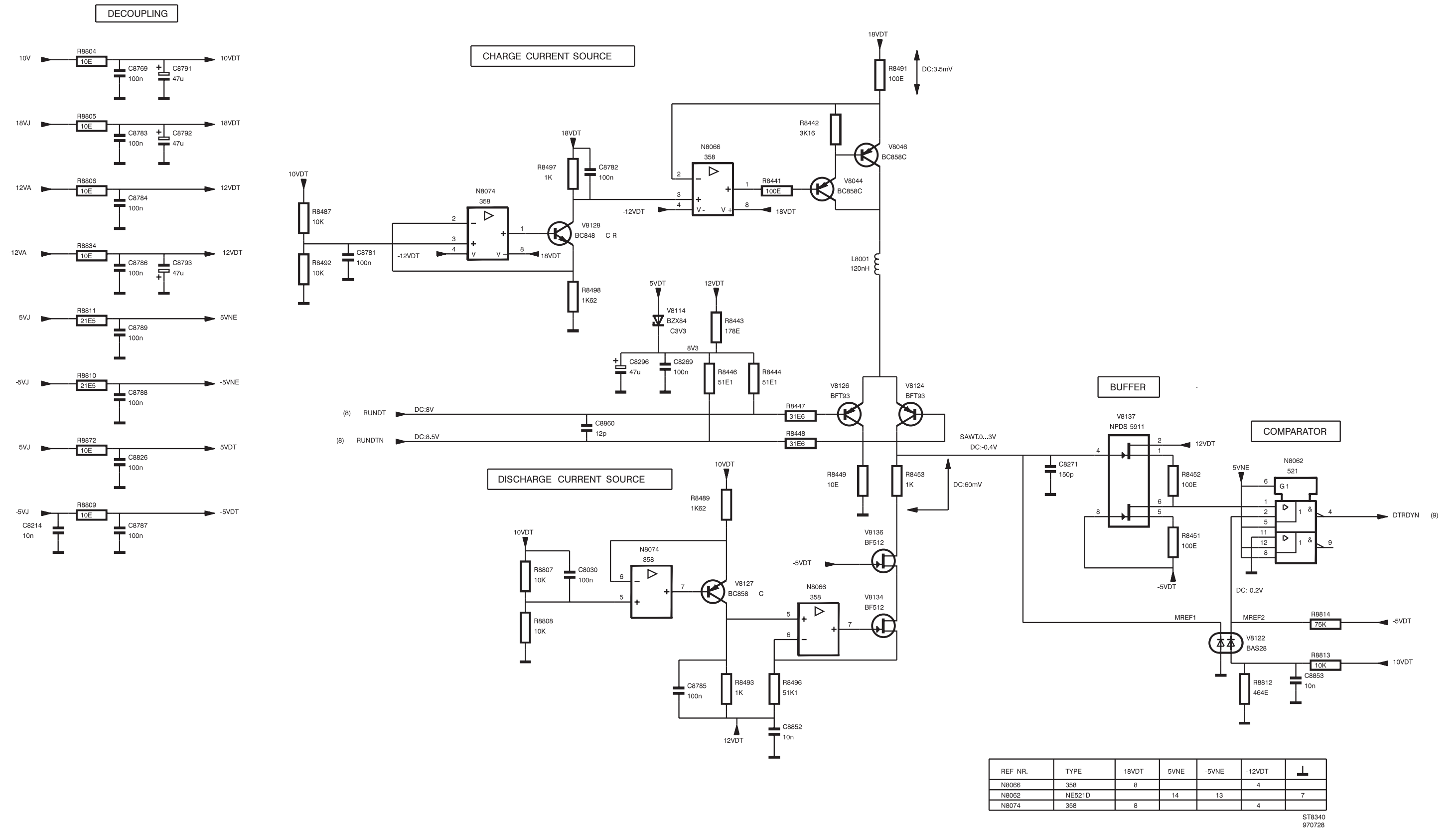

A8 - Diagram 7; Delta T circuit

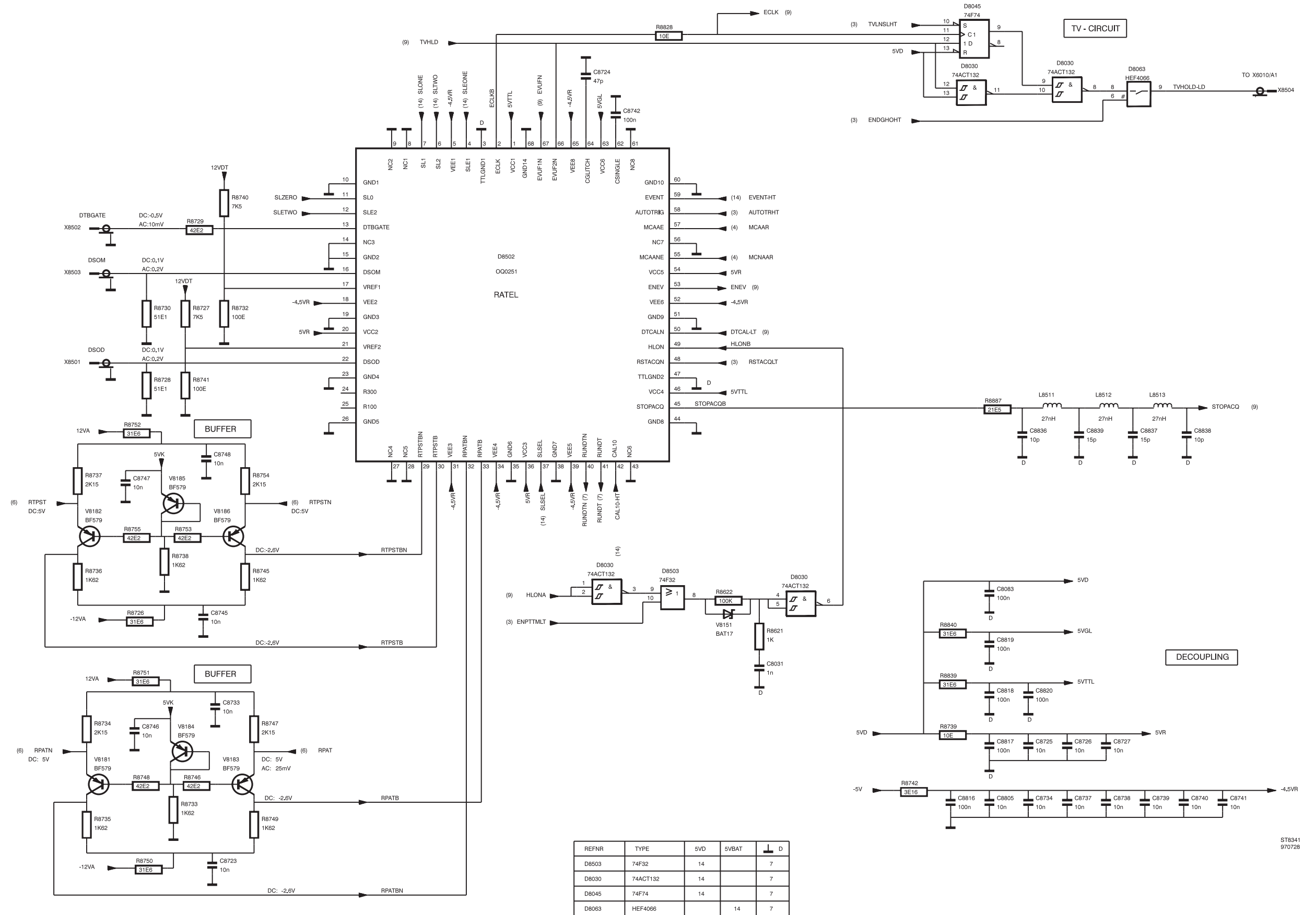

A8 - Diagram 8; Trigger logic

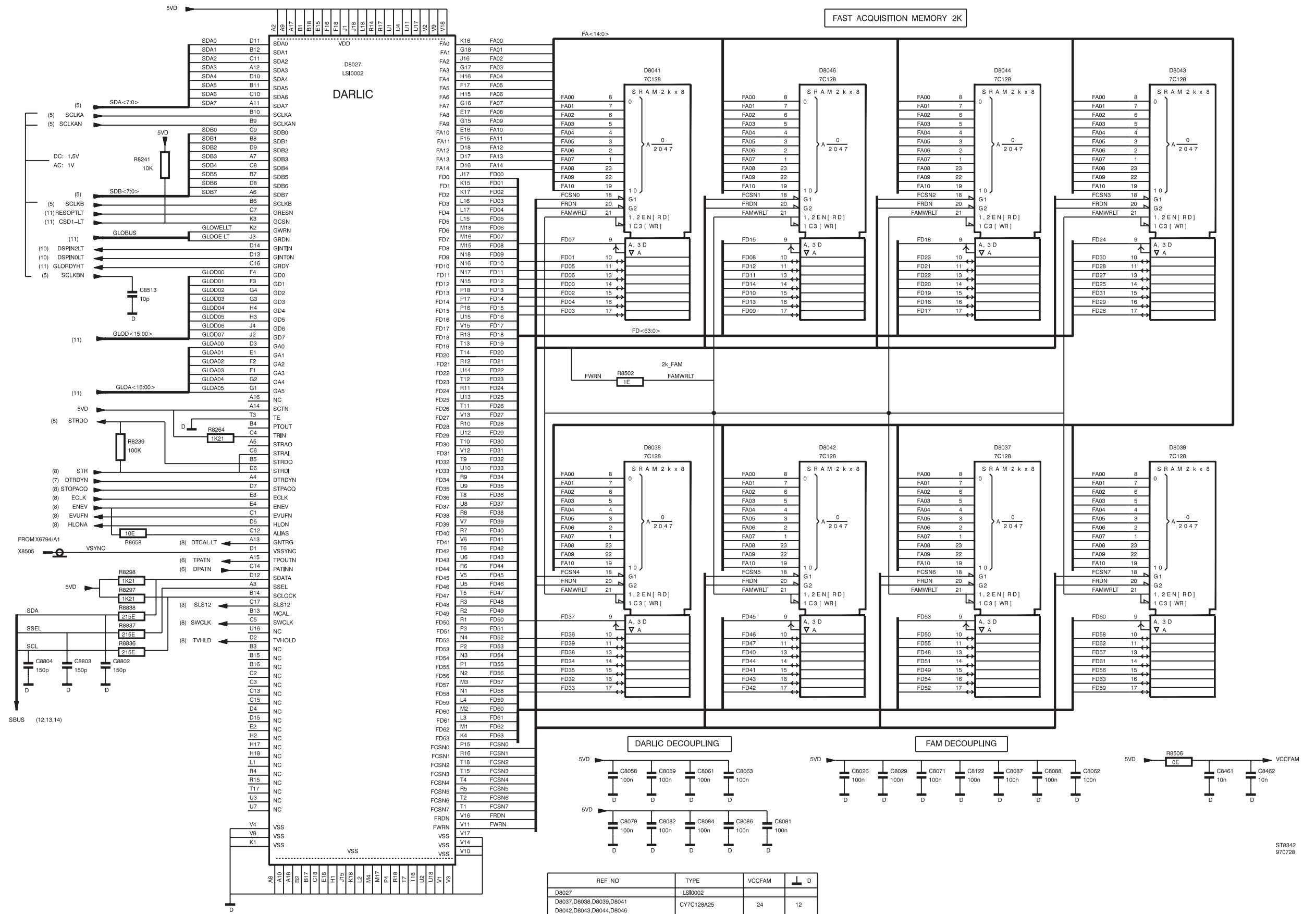

A8 - Diagram 9a; DARLIC and FAM

ST8342
970728

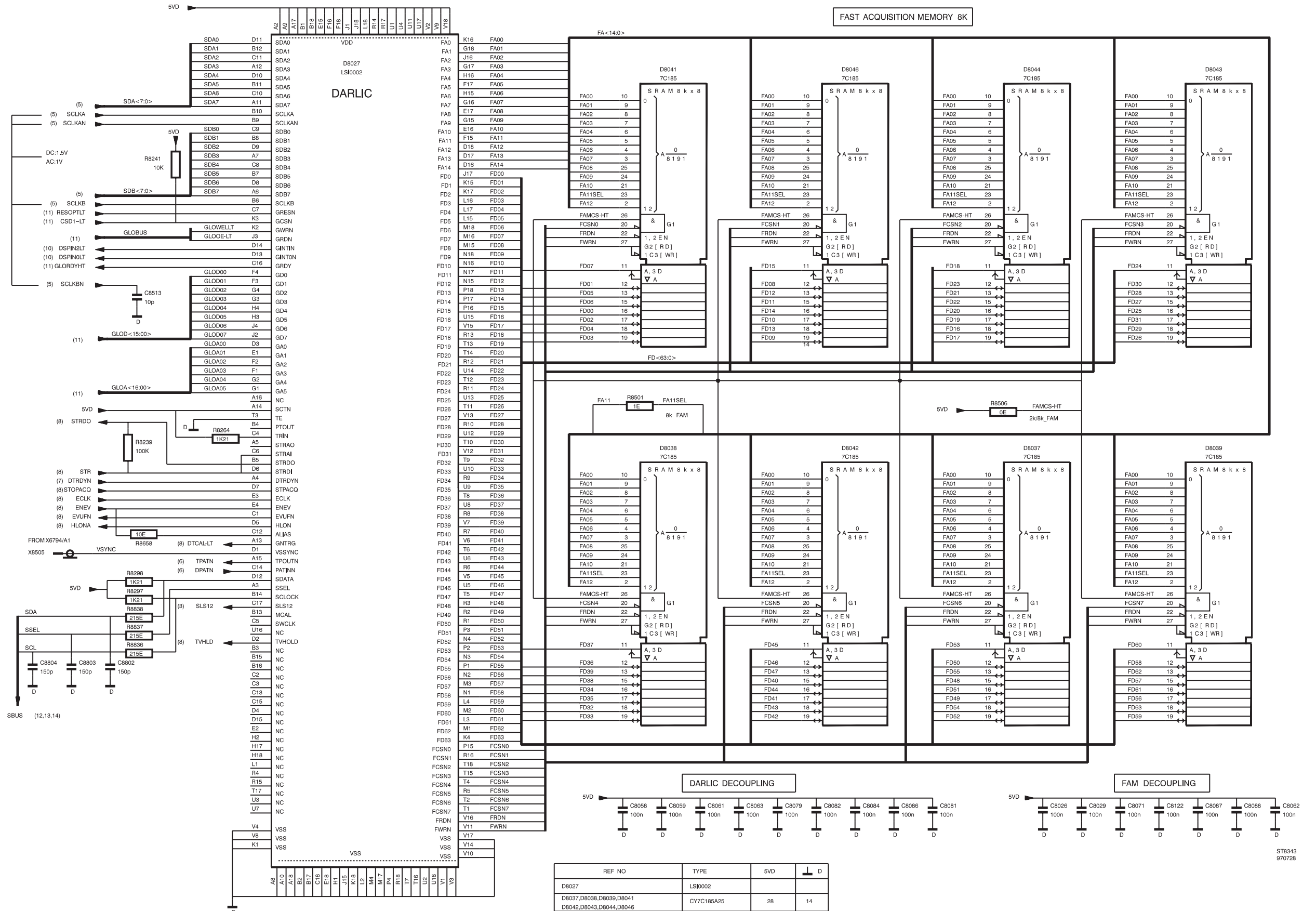

REF NO	TYPE	SVD	I	D
D8027	LSI0002			
D8037, D8038, D8039, D8041 D8042, D8043, D8044, D8046	CY7C185A25	28		14

A8 - Diagram 9b; DARLIC and extended FAM

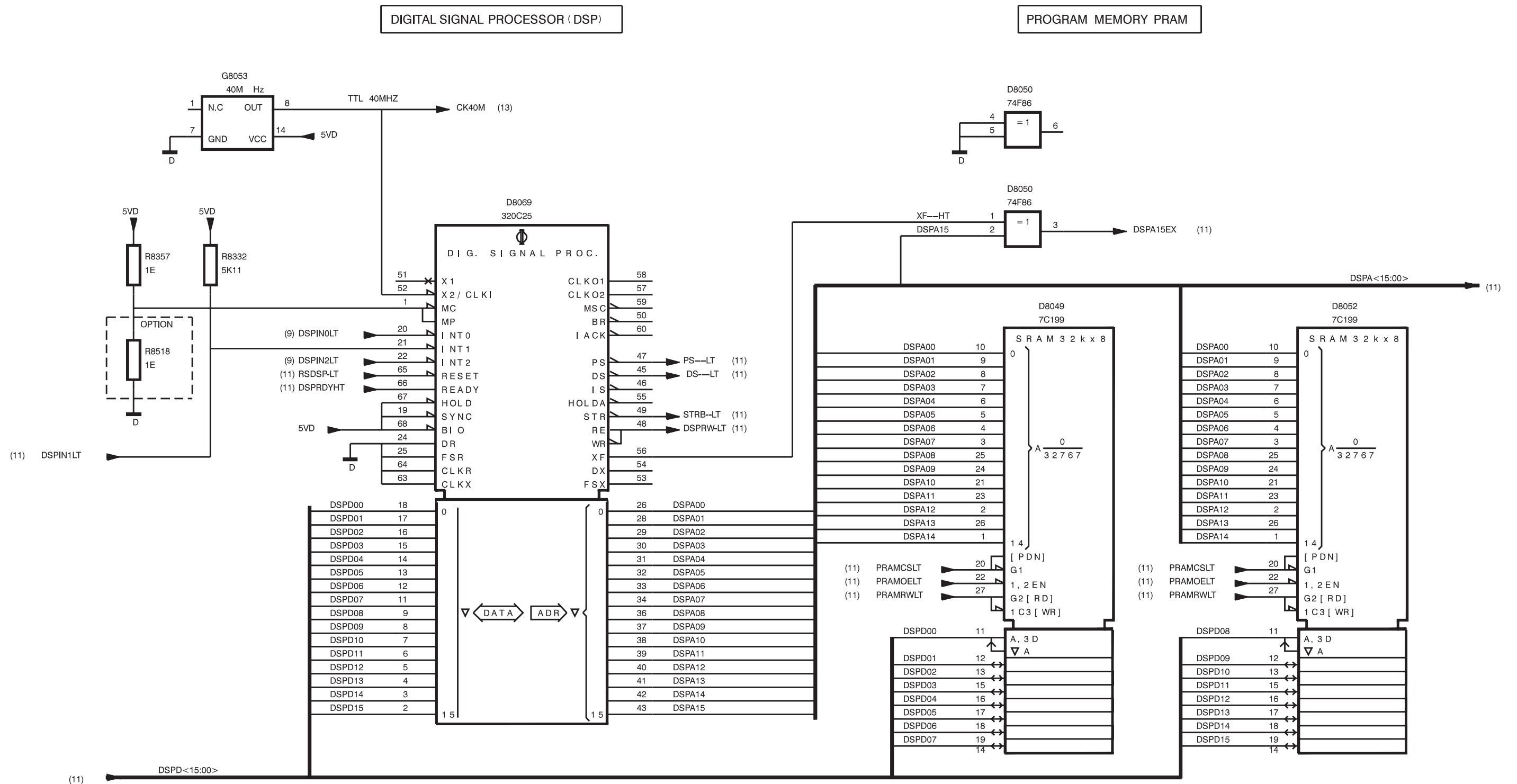

DSP DECOUPLING

PRAM DECOUPLING

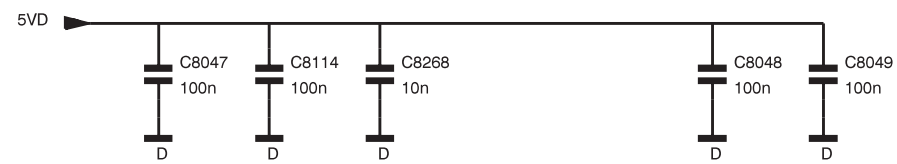

REF NR.	TYPE	5VDC	D
D8069	320C25	23,35,61,62	10,27,44
D8049,D8052	7C199A25	28	14
D8050	74F86	14	7

ST8344
970728

A8 - Diagram 10; Digital Signal Processor

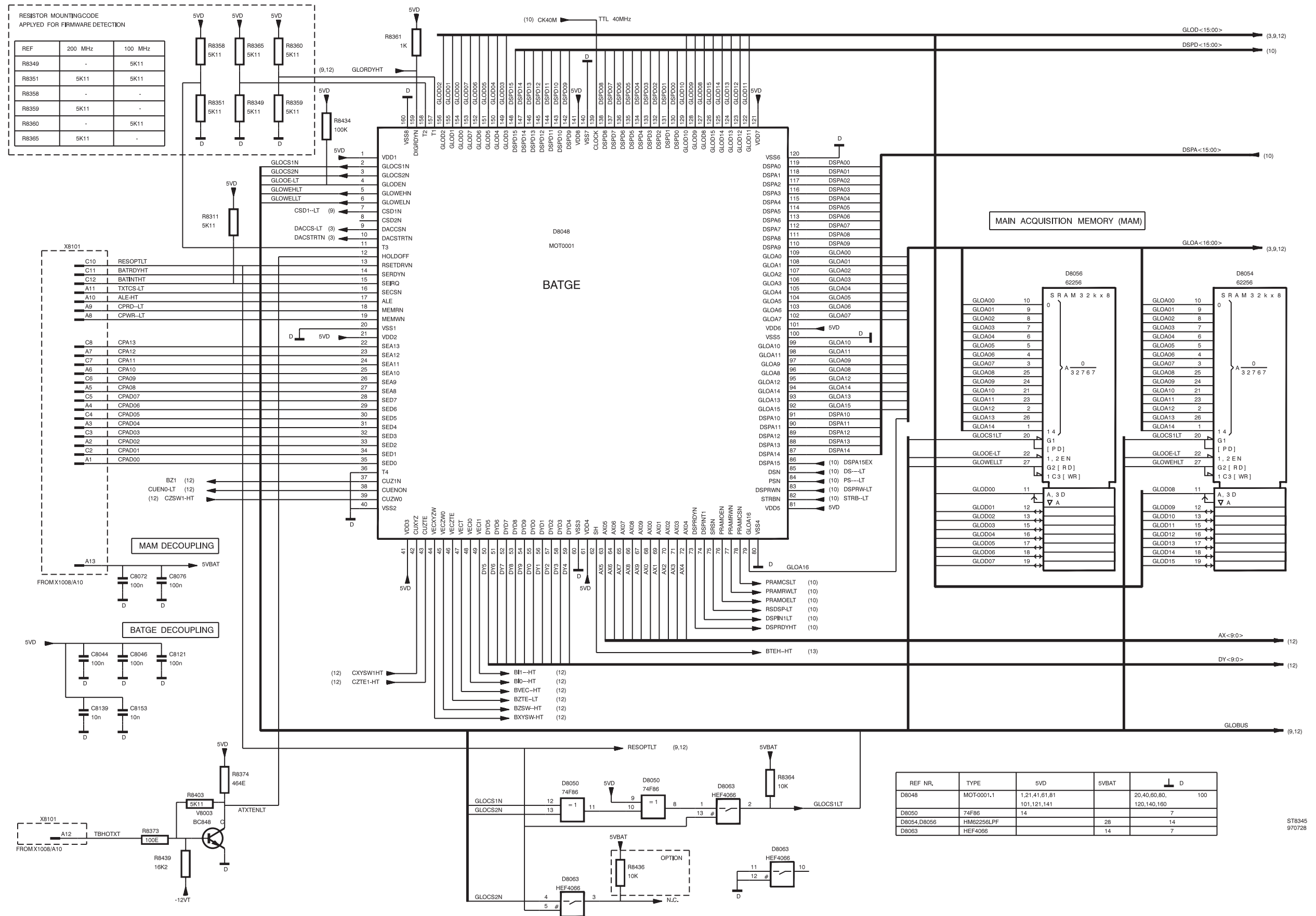

A8 - Diagram 11a; BATGE and MAM

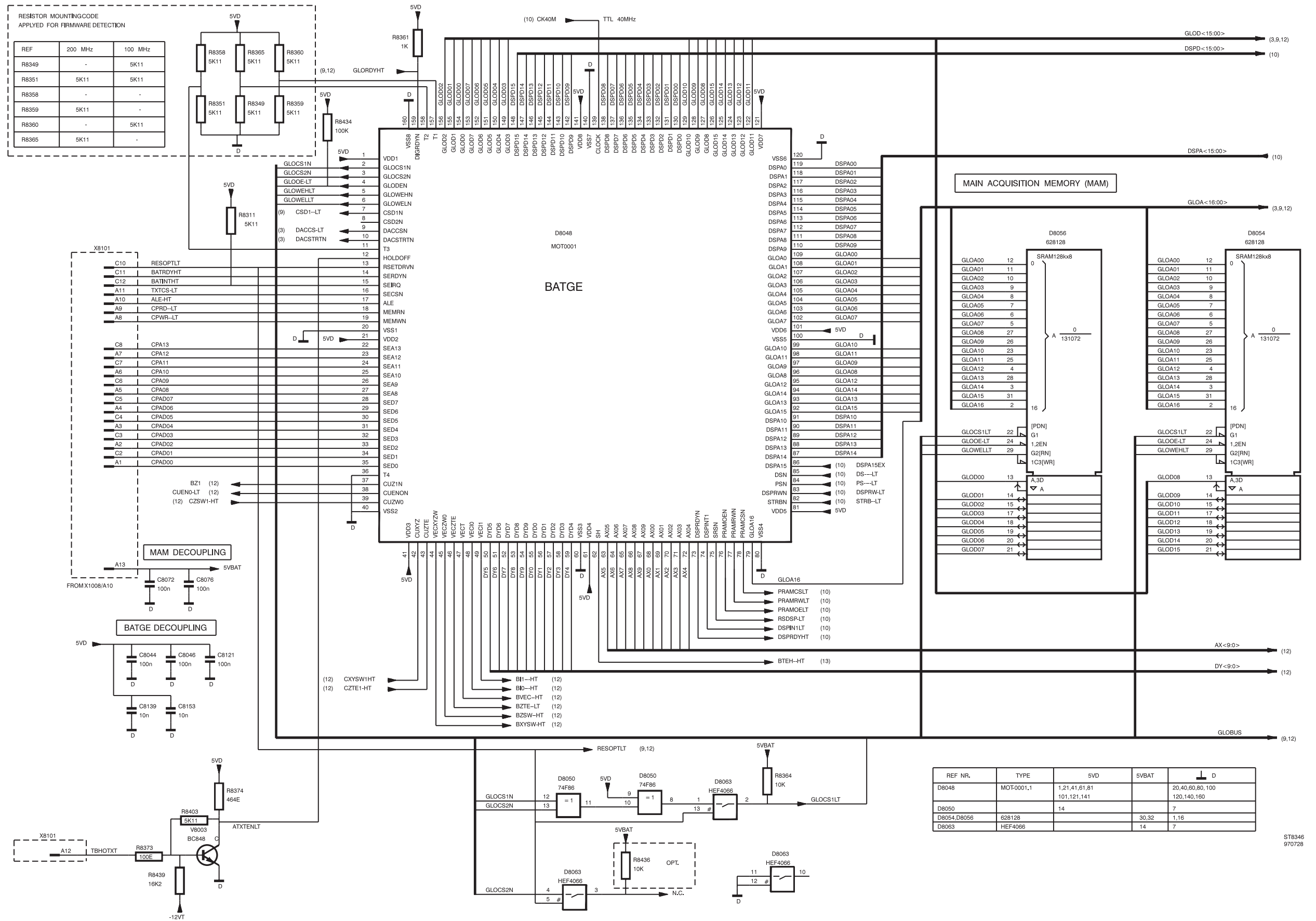

A8 - Diagram 11b; BATGE and extended MAM

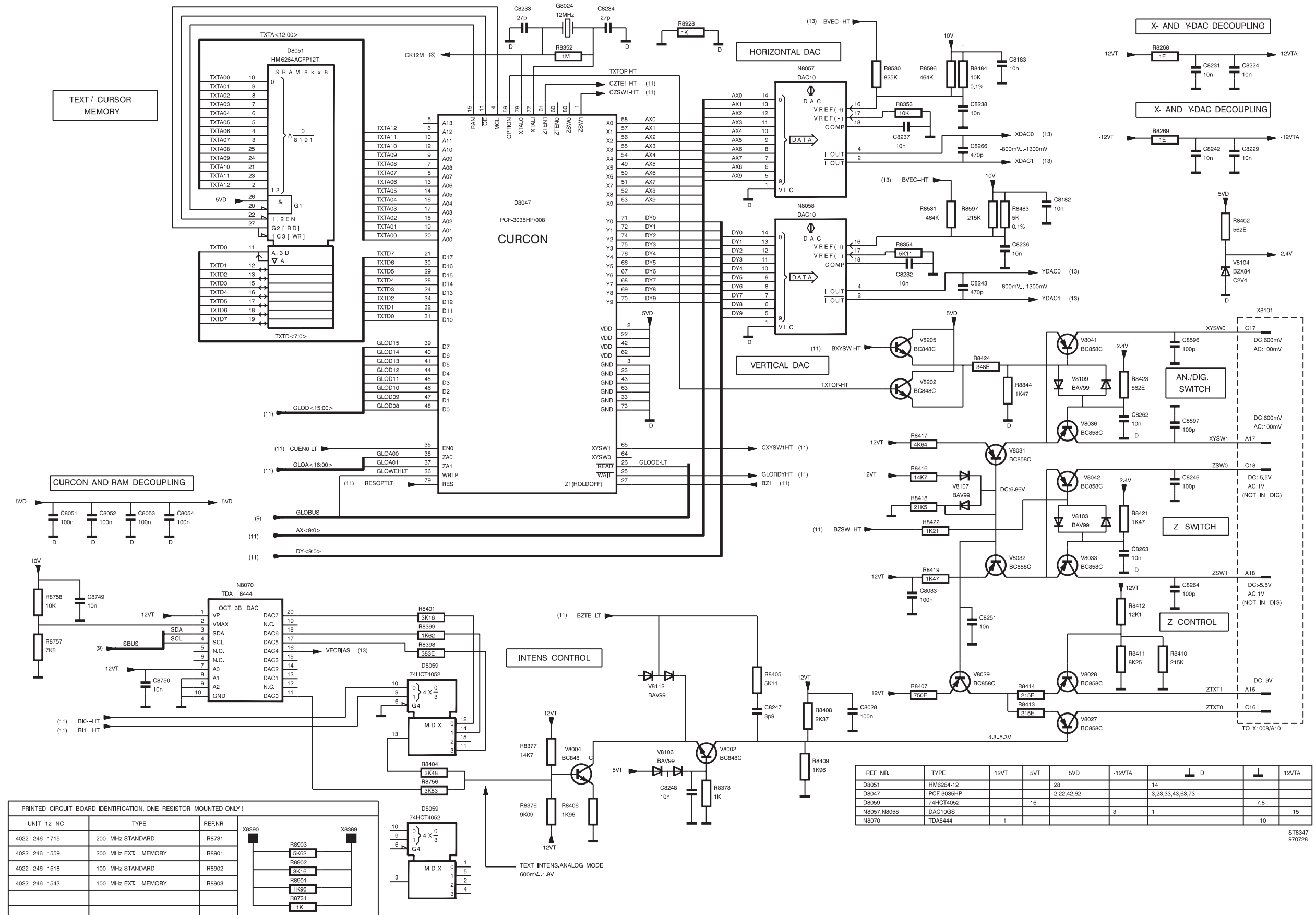

A8 - Diagram 12; CURCON and XYZ Control

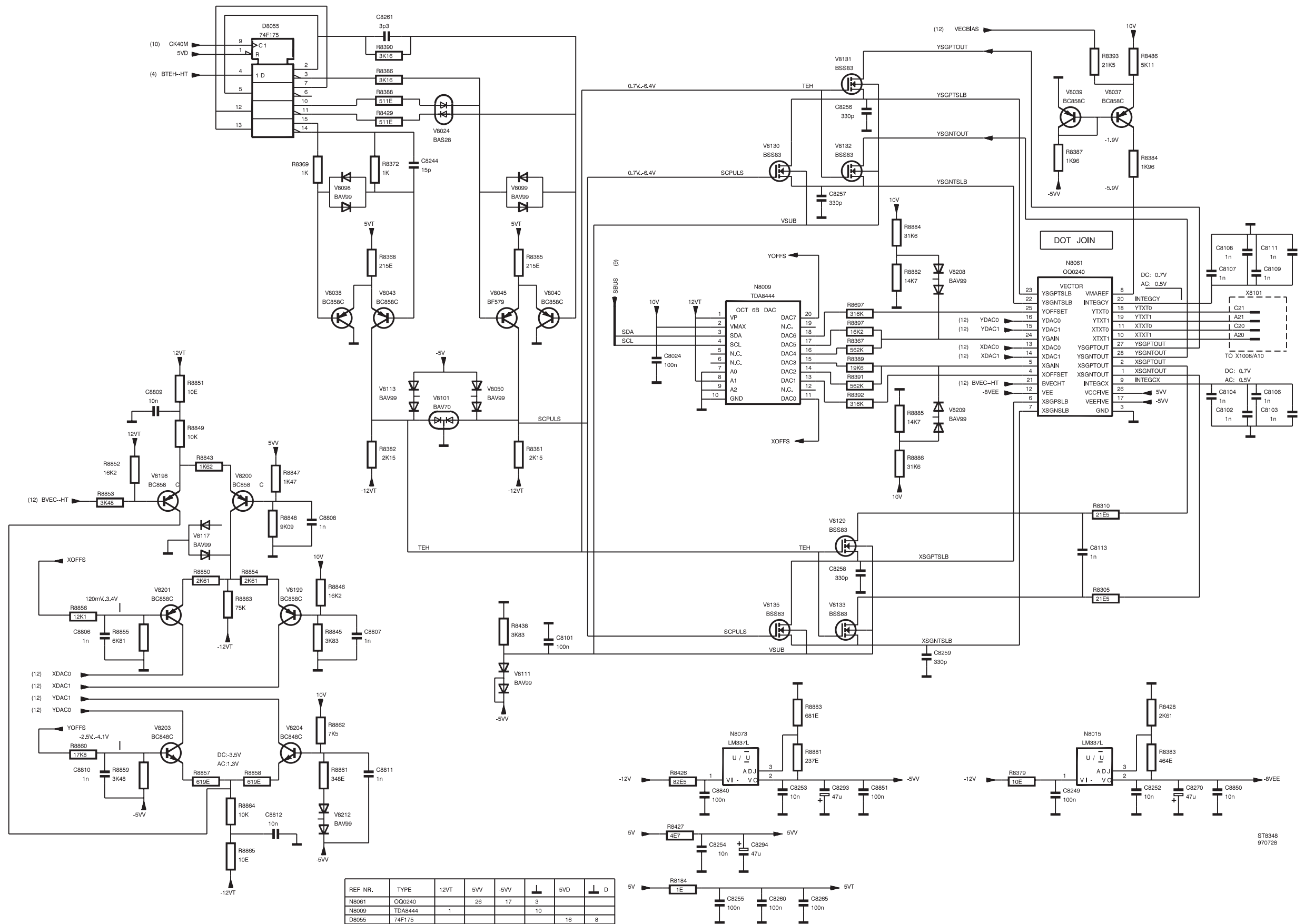

A8 - Diagram 13; Display interface

ST8348
970728

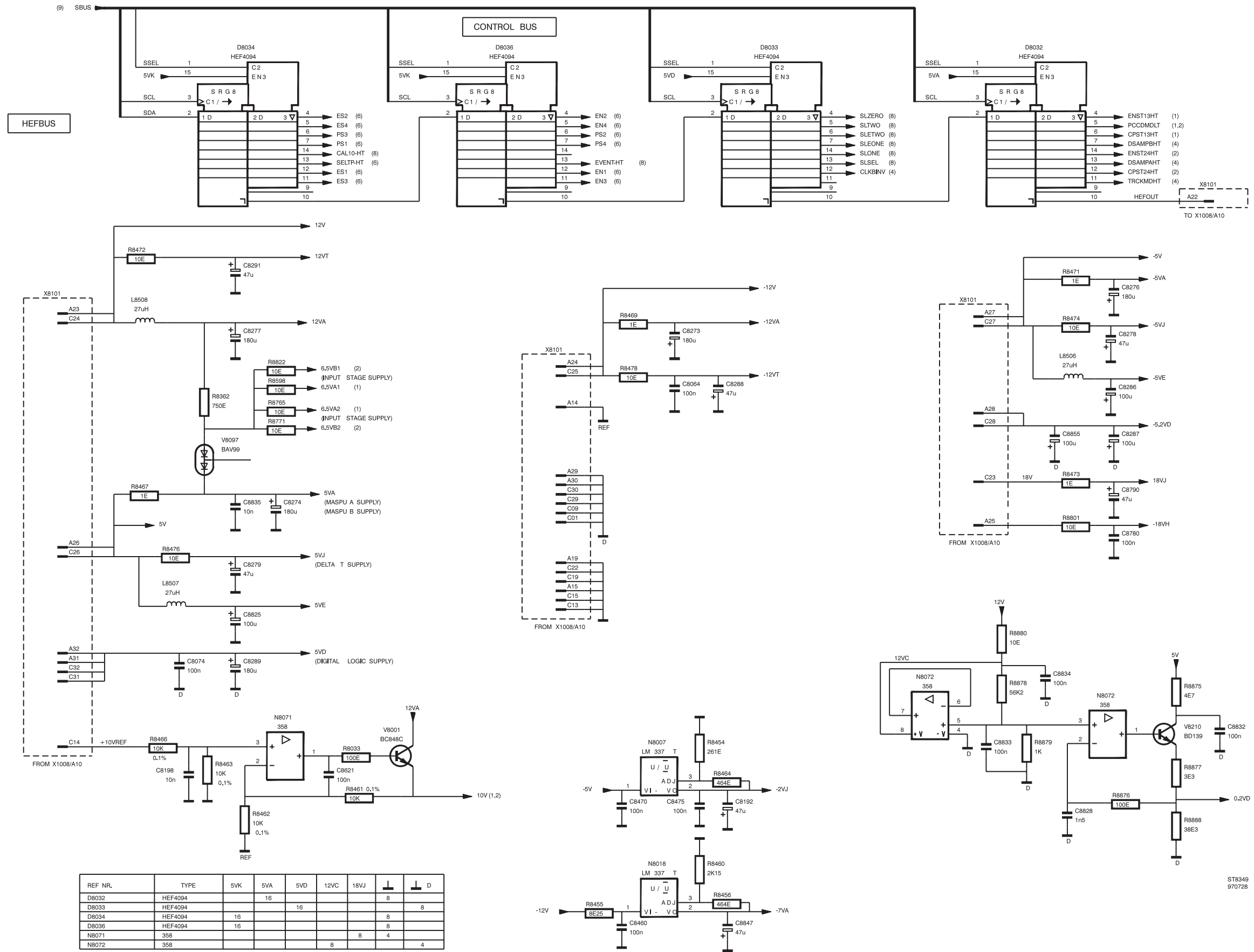

A8 - Diagram 14; Power distribution

Item	Description	Ordering code
5.8.6 Parts list		
CAPACITORS		
C8001	CAP.CHIP 63V 10% 100NF	4822 122 33496
C8002	CAP.CHIP 63V 10% 100NF	4822 122 33496
C8003	CAP.CHIP 63V 10% 100NF	4822 122 33496
C8004	CAP.CHIP 63V 10% 100NF	4822 122 33496
C8006	CAP.CHIP 63V 10% 100NF	4822 122 33496
C8007	CAP.CHIP 63V 10% 100NF	4822 122 33496
C8011	CAP.CHIP 63V 10% 100NF	4822 122 33496
C8012	CAP.CHIP 63V 10% 10NF	5322 122 34098
C8021	CAP.CHIP 63V 10% 100NF	4822 122 33496
C8023	CAP.CHIP 63V 10% 100NF	4822 122 33496
C8024	CAP.CHIP 63V 10% 100NF	4822 122 33496
C8026	CAP.CHIP 63V 10% 100NF	4822 122 33496
C8028	CAP.CHIP 63V 10% 100NF	4822 122 33496
C8029	CAP.CHIP 63V 10% 100NF	4822 122 33496
C8030	CAP.CHIP 63V 10% 100NF	4822 122 33496
C8031	CAP.CHIP 63V 5% 1NF	5322 126 10511
C8033	CAP.CHIP 63V 10% 100NF	4822 122 33496
C8034	CAP.CHIP 63V 10% 100NF	4822 122 33496
C8036	CAP.CHIP 63V 10% 100NF	4822 122 33496
C8044	CAP.CHIP 63V 10% 100NF	4822 122 33496
C8046	CAP.CHIP 63V 10% 100NF	4822 122 33496
C8047	CAP.CHIP 63V 10% 100NF	4822 122 33496
C8048	CAP.CHIP 63V 10% 100NF	4822 122 33496
C8049	CAP.CHIP 63V 10% 100NF	4822 122 33496
C8051	CAP.CHIP 63V 10% 100NF	4822 122 33496
C8052	CAP.CHIP 63V 10% 100NF	4822 122 33496
C8053	CAP.CHIP 63V 10% 100NF	4822 122 33496
C8054	CAP.CHIP 63V 10% 100NF	4822 122 33496
C8056	CAP.CHIP 63V 10% 100NF	4822 122 33496
C8058	CAP.CHIP 63V 10% 100NF	4822 122 33496
C8059	CAP.CHIP 63V 10% 100NF	4822 122 33496
C8061	CAP.CHIP 63V 10% 100NF	4822 122 33496
C8062	CAP.CHIP 63V 10% 100NF	4822 122 33496
C8063	CAP.CHIP 63V 10% 100NF	4822 122 33496
C8064	CAP.CHIP 63V 10% 100NF	4822 122 33496
C8071	CAP.CHIP 63V 10% 100NF	4822 122 33496
C8072	CAP.CHIP 63V 10% 100NF	4822 122 33496
C8074	CAP.CHIP 63V 10% 100NF	4822 122 33496
C8076	CAP.CHIP 63V 10% 100NF	4822 122 33496
C8079	CAP.CHIP 63V 10% 100NF	4822 122 33496
C8081	CAP.CHIP 63V 10% 100NF	4822 122 33496
C8082	CAP.CHIP 63V 10% 100NF	4822 122 33496
C8083	CAP.CHIP 63V 10% 100NF	4822 122 33496
C8084	CAP.CHIP 63V 10% 100NF	4822 122 33496
C8086	CAP.CHIP 63V 10% 100NF	4822 122 33496

Item	Description		Ordering code
C8087	CAP.CHIP	63V 10% 100NF	4822 122 33496
C8088	CAP.CHIP	63V 10% 100NF	4822 122 33496
C8089	CAP.CHIP	63V 10% 1.5NF	5322 122 31865
C8091	CAP.CHIP	63V 10% 100NF	4822 122 33496
C8092	CAP.CHIP	63V 10% 1.5NF	5322 122 31865
C8093	CAP.CHIP	63V 10% 1.5NF	5322 122 31865
C8094	CAP.CHIP	63V 10% 100NF	4822 122 33496
C8096	CAP.CHIP	63V 10% 100NF	4822 122 33496
C8097	CAP.CHIP	63V 10% 1.5NF	5322 122 31865
C8098	CAP.CHIP	63V 10% 100NF	4822 122 33496
C8101	CAP.CHIP	63V 10% 100NF	4822 122 33496
C8102	CAP.CHIP	63V 5% 1NF	5322 126 10511
C8103	CAP.CHIP	63V 5% 1NF	5322 126 10511
C8104	CAP.CHIP	63V 5% 1NF	5322 126 10511
C8105	CAP.CHIP	63V 10% 100NF	4822 122 33496
C8106	CAP.CHIP	63V 5% 1NF	5322 126 10511
C8107	CAP.CHIP	63V 5% 1NF	5322 126 10511
C8108	CAP.CHIP	63V 5% 1NF	5322 126 10511
C8109	CAP.CHIP	63V 5% 1NF	5322 126 10511
C8110	CAP.CHIP	63V 10% 100NF	4822 122 33496
C8111	CAP.CHIP	63V 5% 1NF	5322 126 10511
C8113	CAP.CHIP	63V 5% 1NF	5322 126 10511
C8114	CAP.CHIP	63V 10% 100NF	4822 122 33496
C8116	CAP.FOIL	63V 10% 680NF	5322 121 42498
C8117	CAP.CHIP	63V 10% 100NF	4822 122 33496
C8118	CAP.CHIP	63V 10% 22NF	5322 122 32654
C8119	CAP.CHIP	63V 10% 100NF	4822 122 33496
C8121	CAP.CHIP	63V 10% 100NF	4822 122 33496
C8122	CAP.CHIP	63V 10% 100NF	4822 122 33496
C8123	CAP.CHIP	63V 10% 100NF	4822 122 33496
C8124	CAP.CHIP	63V 10% 22NF	5322 122 32654
C8126	CAP.CHIP	63V 10% 22NF	5322 122 32654
C8127	CAP.CHIP	63V 10% 22NF	5322 122 32654
C8128	CAP.CHIP	63V 10% 22NF	5322 122 32654
C8129	CAP.CHIP	63V 10% 22NF	5322 122 32654
C8131	CAP.CHIP	63V 10% 22NF	5322 122 32654
C8132	CAP.CHIP	63V 10% 22NF	5322 122 32654
C8133	CAP.CHIP	63V 10% 22NF	5322 122 32654
C8134	CAP.CHIP	63V 10% 22NF	5322 122 32654
C8136	CAP.CHIP	63V 10% 22NF	5322 122 32654
C8137	CAP.CHIP	63V 10% 22NF	5322 122 32654
C8138	CAP.CHIP	63V 10% 100NF	4822 122 33496
C8139	CAP.CHIP	63V 10% 10NF	5322 122 34098
C8140	CAP.CERAMIC	63V 0.5PF 5.6PF	5322 122 32967
C8142	CAP.CHIP	63V 10% 10NF	5322 122 34098
C8144	CAP.CHIP	63V 10% 100NF	4822 122 33496
C8146	CAP.CHIP	63V 10% 22NF	5322 122 32654

Item	Description		Ordering code
C8147	CAP.FOIL	63V 10% 680NF	5322 121 42498
C8148	CAP.CHIP	63V 10% 100NF	4822 122 33496
C8151	CAP.CHIP	63V 10% 10NF	5322 122 34098
C8153	CAP.CHIP	63V 10% 10NF	5322 122 34098
C8154	CAP.CHIP	63V 10% 10NF	5322 122 34098
C8155	CAP.CHIP	63V 10% 10NF	5322 122 34098
C8156	CAP.CHIP	63V 10% 10NF	5322 122 34098
C8158	CAP.CHIP	63V 10% 22NF	5322 122 32654
C8159	CAP.CHIP	63V 10% 10NF	5322 122 34098
C8161	CAP.CHIP	63V 10% 10NF	5322 122 34098
C8162	CAP.CHIP	63V 10% 10NF	5322 122 34098
C8169	CAP.CHIP	63V 10% 10NF	5322 122 34098
C8172	CAP.CHIP	63V 10% 10NF	5322 122 34098
C8173	CAP.CHIP	63V 10% 10NF	5322 122 34098
C8176	CAP.CHIP	63V 10% 10NF	5322 122 34098
C8177	CAP.CHIP	63V 10% 10NF	5322 122 34098
C8178	CAP.CHIP	63V 10% 10NF	5322 122 34098
C8180	CAP.CHIP	63V 10% 10NF	5322 122 34098
C8181	CAP.CHIP	63V 10% 100NF	4822 122 33496
C8182	CAP.CHIP	63V 10% 10NF	5322 122 34098
C8183	CAP.CHIP	63V 10% 10NF	5322 122 34098
C8184	CAP.CHIP	63V 10% 10NF	5322 122 34098
C8186	CAP.CHIP	63V 10% 10NF	5322 122 34098
C8188	CAP.CHIP	63V 10% 10NF	5322 122 34098
C8189	CAP.CHIP	63V 10% 10NF	5322 122 34098
C8190	CAP.CHIP	63V 10% 10NF	5322 122 34098
C8191	CAP.CHIP	63V 10% 10NF	5322 122 34098
C8192	CAP.ELECTROLYT.	25V 20% 47UF	5322 121 10472
C8193	CAP.CHIP	63V 10% 100NF	4822 122 33496
C8194	CAP.CHIP	63V 10% 22NF	5322 122 32654
C8196	CAP.CHIP	63V 10% 10NF	5322 122 34098
C8197	CAP.CHIP	63V 10% 10NF	5322 122 34098
C8198	CAP.CHIP	63V 10% 10NF	5322 122 34098
C8199	CAP.CHIP	63V 10% 10NF	5322 122 34098
C8200	CAP.CHIP	63V 10% 100NF	4822 122 33496
C8202	CAP.CHIP	63V 10% 10NF	5322 122 34098
C8203	CAP.CHIP	63V 10% 10NF	5322 122 34098
C8206	CAP.CHIP	63V 10% 10NF	5322 122 34098
C8207	CAP.CHIP	63V 10% 10NF	5322 122 34098
C8209	CAP.CHIP	63V 10% 10NF	5322 122 34098
C8211	CAP.CHIP	63V 10% 10NF	5322 122 34098
C8213	CAP.CHIP	63V 10% 10NF	5322 122 34098
C8214	CAP.CHIP	63V 10% 10NF	5322 122 34098
C8215	CAP.CHIP	63V 10% 100NF	4822 122 33496
C8216	CAP.CHIP	63V 10% 10NF	5322 122 34098
C8217	CAP.CHIP	63V 10% 100NF	4822 122 33496
C8218	CAP.CERAMIC	63V 0.25PF 1.8PF	5322 126 10343

Item	Description		Ordering code
C8219	CAP.CERAMIC	63V 0.25PF 1.8PF	5322 126 10343
C8220	CAP.CHIP	63V 5% 15PF	5322 122 33869
C8221	CAP.CHIP	63V 10% 100NF	4822 122 33496
C8222	CAP.CHIP	63V 10% 100NF	4822 122 33496
C8223	CAP.CHIP	63V 5% 15PF	5322 122 33869
C8224	CAP.CHIP	63V 10% 10NF	5322 122 34098
C8225	CAP.CHIP	63V 5% 15PF	5322 122 33869
C8226	CAP.CHIP	63V 5% 15PF	5322 122 33869
C8227	CAP.CHIP	63V 5% 15PF	5322 122 33869
C8228	CAP.CHIP	63V 5% 15PF	5322 122 33869
C8229	CAP.CHIP	63V 10% 10NF	5322 122 34098
C8230	CAP.CHIP	63V 5% 15PF	5322 122 33869
C8231	CAP.CHIP	63V 10% 10NF	5322 122 34098
C8232	CAP.CHIP	63V 10% 10NF	5322 122 34098
C8233	CAP.CHIP	63V 5% 27PF	5322 122 31946
C8234	CAP.CHIP	63V 5% 27PF	5322 122 31946
C8235	CAP.CHIP	63V 5% 15PF	5322 122 33869
C8236	CAP.CHIP	63V 10% 10NF	5322 122 34098
C8237	CAP.CHIP	63V 10% 10NF	5322 122 34098
C8238	CAP.CHIP	63V 10% 10NF	5322 122 34098
C8242	CAP.CHIP	63V 10% 10NF	5322 122 34098
C8243	CAP.CHIP	63V 5% 470PF	5322 122 32268
C8244	CAP.CHIP	63V 5% 15PF	5322 122 33869
C8246	CAP.CHIP	63V 5% 100PF	5322 122 32531
C8247	CAP.CERAMIC	63V 0.25PF 3.9PF	5322 122 31944
C8247	CAP.CERAMIC	63V 0.25PF 3.9PF	5322 122 31944
C8248	CAP.CHIP	63V 10% 10NF	5322 122 34098
C8249	CAP.CHIP	63V 10% 100NF	4822 122 33496
C8251	CAP.CHIP	63V 10% 10NF	5322 122 34098
C8252	CAP.CHIP	63V 10% 100NF	4822 122 33496
C8253	CAP.CHIP	63V 10% 10NF	5322 122 34098
C8254	CAP.CHIP	63V 10% 10NF	5322 122 34098
C8255	CAP.CHIP	63V 10% 100NF	4822 122 33496
C8256	CAP.CHIP	63V 5% 330PF	5322 122 31863
C8257	CAP.CHIP	63V 5% 330PF	5322 122 31863
C8258	CAP.CHIP	63V 5% 330PF	5322 122 31863
C8259	CAP.CHIP	63V 5% 330PF	5322 122 31863
C8260	CAP.CHIP	63V 10% 100NF	4822 122 33496
C8261	CAP.CHIP	63V 0.25PF 3.3PF	5322 122 32286
C8262	CAP.CHIP	63V 10% 10NF	5322 122 34098
C8263	CAP.CHIP	63V 10% 10NF	5322 122 34098
C8264	CAP.CHIP	63V 5% 100PF	5322 122 32531
C8265	CAP.CHIP	63V 10% 100NF	4822 122 33496
C8266	CAP.CHIP	63V 5% 470PF	5322 122 32268
C8267	CAP.CHIP	63V 10% 10NF	5322 122 34098
C8268	CAP.CHIP	63V 10% 10NF	5322 122 34098
C8269	CAP.CHIP	63V 10% 100NF	4822 122 33496

Item	Description		Ordering code
C8270	CAP.ELECTROLYT.	25V 20% 47UF	5322 121 10472
C8271	CAP.FOIL	400V 5% 150PF	5322 121 51644
C8273	CAP.ELECTROLYT.	25V 20% 180UF	5322 124 42228
C8274	CAP.ELECTROLYT.	25V 20% 180UF	5322 124 42228
C8276	CAP.ELECTROLYT.	25V 20% 180UF	5322 124 42228
C8277	CAP.ELECTROLYT.	25V 20% 180UF	5322 124 42228
C8278	CAP.ELECTROLYT.	25V 20% 47UF	5322 121 10472
C8279	CAP.ELECTROLYT.	25V 20% 47UF	5322 121 10472
C8286	CAP.FOIL	10V 20% 100UF	5322 124 41383
C8287	CAP.FOIL	10V 20% 100UF	5322 124 41383
C8288	CAP.ELECTROLYT.	25V 20% 47UF	5322 121 10472
C8289	CAP.ELECTROLYT.	25V 20% 180UF	5322 124 42228
C8291	CAP.ELECTROLYT.	25V 20% 47UF	5322 121 10472
C8293	CAP.ELECTROLYT.	25V 20% 47UF	5322 121 10472
C8294	CAP.ELECTROLYT.	25V 20% 47UF	5322 121 10472
C8296	CAP.ELECTROLYT.	25V 20% 47UF	5322 121 10472
C8460	CAP.CHIP	63V 10% 100NF	4822 122 33496
C8461	CAP.CHIP	63V 10% 10NF	5322 122 34098
C8462	CAP.CHIP	63V 10% 10NF	5322 122 34098
C8465	CAP.CHIP	63V 10% 100NF	4822 122 33496
C8470	CAP.CHIP	63V 10% 100NF	4822 122 33496
C8475	CAP.CHIP	63V 10% 100NF	4822 122 33496
C8501	CAP.CHIP	63V 10% 100NF	4822 122 33496
C8502	CAP.CHIP	63V 10% 100NF	4822 122 33496
C8503	CAP.CHIP	63V 10% 22NF	5322 122 32654
C8504	CAP.CHIP	63V 10% 10NF	5322 122 34098
C8506	CAP.CHIP	63V 10% 10NF	5322 122 34098
C8507	CAP.CHIP	63V 10% 22NF	5322 122 32654
C8513	CAP.CERAMIC	63V 5% 10PF	5322 122 32448
C8514	CAP.CHIP	63V 10% 100NF	4822 122 33496
C8515	CAP.CHIP	63V 10% 1.5NF	5322 122 31865
C8516	CAP.CHIP	63V 10% 10NF	5322 122 34098
C8517	CAP.CHIP	63V 10% 10NF	5322 122 34098
C8518	CAP.CHIP	63V 10% 10NF	5322 122 34098
C8519	CAP.CHIP	63V 10% 10NF	5322 122 34098
C8520	CAP.CHIP	63V 10% 10NF	5322 122 34098
C8521	CAP.CHIP	63V 10% 10NF	5322 122 34098
C8522	CAP.CHIP	63V 10% 1.5NF	5322 122 31865
C8581	CAP.CHIP	63V 0.25PF 3.3PF	5322 122 32286
C8581	CAP.CHIP	63V 0.25PF 12P	4822 122 33926
C8583	CAP.CHIP	63V 0.25PF 3.3PF	5322 122 32286
C8583	CAP.CHIP	63V 0.25PF 12P	4822 122 33926
C8586	CAP.CHIP	63V 0.25PF 3.9PF	5322 122 31944
C8586	CAP.CHIP	63V 0.25PF 12P	4822 122 33926
C8588	CAP.CHIP	63V 0.25PF 3.9PF	5322 122 31944
C8588	CAP.CHIP	63V 0.25PF 12P	4822 122 33926
C8591	CAP.CHIP	63V 10% 10NF	5322 122 34098

Item	Description		Ordering code
C8592	CAP.CHIP	63V 10% 10NF	5322 122 34098
C8593	CAP.CHIP	63V 10% 10NF	5322 122 34098
C8594	CAP.CHIP	63V 10% 10NF	5322 122 34098
C8596	CAP.CHIP	63V 5% 100PF	5322 122 32531
C8597	CAP.CHIP	63V 5% 100PF	5322 122 32531
C8601	CAP.CHIP	63V 5% 15PF	5322 122 33869
C8602	CAP.CHIP	63V 5% 15PF	5322 122 33869
C8603	CAP.CHIP	63V 5% 15PF	5322 122 33869
C8604	CAP.CHIP	63V 5% 15PF	5322 122 33869
C8611	CAP.CHIP	63V 10% 100NF	4822 122 33496
C8612	CAP.CHIP	63V 10% 100NF	4822 122 33496
C8613	CAP.CHIP	63V 10% 22NF	5322 122 32654
C8617	CAP.CHIP	63V 10% 100NF	4822 122 33496
C8621	CAP.CHIP	63V 10% 100NF	4822 122 33496
C8652	CAP.CHIP	63V 10% 10NF	5322 122 34098
C8653	CAP.CHIP	63V 10% 10NF	5322 122 34098
C8654	CAP.CHIP	63V 10% 10NF	5322 122 34098
C8655	CAP.CHIP	63V 10% 10NF	5322 122 34098
C8656	CAP.CHIP	63V 10% 10NF	5322 122 34098
C8657	CAP.CHIP	63V 10% 10NF	5322 122 34098
C8723	CAP.CHIP	63V 10% 10NF	5322 122 34098
C8724	CAP.CERAMIC	63V 5% 47PF	5322 122 32452
C8725	CAP.CHIP	63V 10% 10NF	5322 122 34098
C8726	CAP.CHIP	63V 10% 10NF	5322 122 34098
C8727	CAP.CHIP	63V 10% 10NF	5322 122 34098
C8733	CAP.CHIP	63V 10% 10NF	5322 122 34098
C8734	CAP.CHIP	63V 10% 10NF	5322 122 34098
C8737	CAP.CHIP	63V 10% 10NF	5322 122 34098
C8738	CAP.CHIP	63V 10% 10NF	5322 122 34098
C8739	CAP.CHIP	63V 10% 10NF	5322 122 34098
C8740	CAP.CHIP	63V 10% 10NF	5322 122 34098
C8741	CAP.CHIP	63V 10% 10NF	5322 122 34098
C8742	CAP.CHIP	63V 10% 100NF	4822 122 33496
C8743	CAP.CHIP	63V 10% 100NF	4822 122 33496
C8744	CAP.CHIP	63V 10% 100NF	4822 122 33496
C8745	CAP.CHIP	63V 10% 10NF	5322 122 34098
C8746	CAP.CHIP	63V 10% 10NF	5322 122 34098
C8747	CAP.CHIP	63V 10% 10NF	5322 122 34098
C8748	CAP.CHIP	63V 10% 10NF	5322 122 34098
C8749	CAP.CHIP	63V 10% 10NF	5322 122 34098
C8750	CAP.CHIP	63V 10% 10NF	5322 122 34098
C8753	CAP.CHIP	63V 10% 22NF	5322 122 32654
C8754	CAP.CHIP	63V 10% 22NF	5322 122 32654
C8755	CAP.CHIP	63V 10% 22NF	5322 122 32654
C8756	CAP.CHIP	63V 10% 22NF	5322 122 32654
C8758	CAP.CHIP	63V 10% 22NF	5322 122 32654
C8759	CAP.CHIP	63V 10% 22NF	5322 122 32654

Item	Description		Ordering code
C8760	CAP.CHIP	63V 10% 10NF	5322 122 34098
C8762	CAP.CERAMIC	63V 0.25PF 1PF	5322 122 32447
C8764	CAP.CHIP	63V 10% 22NF	5322 122 32654
C8765	CAP.CHIP	63V 10% 22NF	5322 122 32654
C8766	CAP.CHIP	63V 10% 10NF	5322 122 34098
C8767	CAP.CHIP	63V 10% 22NF	5322 122 32654
C8768	CAP.CHIP	63V 10% 22NF	5322 122 32654
C8769	CAP.CHIP	63V 10% 100NF	4822 122 33496
C8770	CAP.CHIP	63V 10% 10NF	5322 122 34098
C8771	CAP.CHIP	63V 10% 10NF	5322 122 34098
C8772	CAP.CHIP	63V 10% 10NF	5322 122 34098
C8773	CAP.CHIP	63V 10% 10NF	5322 122 34098
C8774	CAP.CHIP	63V 10% 10NF	5322 122 34098
C8775	CAP.CHIP	63V 10% 10NF	5322 122 34098
C8776	CAP.CHIP	63V 10% 10NF	5322 122 34098
C8777	CAP.CHIP	63V 10% 100NF	4822 122 33496
C8778	CAP.CHIP	63V 10% 10NF	5322 122 34098
C8779	CAP.CHIP	63V 10% 100NF	4822 122 33496
C8780	CAP.CHIP	63V 10% 100NF	4822 122 33496
C8781	CAP.CHIP	63V 10% 100NF	4822 122 33496
C8782	CAP.CHIP	63V 10% 100NF	4822 122 33496
C8783	CAP.CHIP	63V 10% 100NF	4822 122 33496
C8784	CAP.CHIP	63V 10% 100NF	4822 122 33496
C8785	CAP.CHIP	63V 10% 100NF	4822 122 33496
C8786	CAP.CHIP	63V 10% 100NF	4822 122 33496
C8787	CAP.CHIP	63V 10% 100NF	4822 122 33496
C8788	CAP.CHIP	63V 10% 100NF	4822 122 33496
C8789	CAP.CHIP	63V 10% 100NF	4822 122 33496
C8790	CAP.ELECTROLYT.	25V 20% 47UF	5322 121 10472
C8791	CAP.ELECTROLYT.	25V 20% 47UF	5322 121 10472
C8792	CAP.ELECTROLYT.	25V 20% 47UF	5322 121 10472
C8793	CAP.ELECTROLYT.	25V 20% 47UF	5322 121 10472
C8794	CAP.CHIP	63V 10% 10NF	5322 122 34098
C8795	CAP.CHIP	63V 10% 10NF	5322 122 34098
C8796	CAP.CHIP	63V 10% 10NF	5322 122 34098
C8797	CAP.CHIP	63V 10% 10NF	5322 122 34098
C8798	CAP.CHIP	63V 10% 10NF	5322 122 34098
C8799	CAP.CHIP	63V 10% 22NF	5322 122 32654
C8800	CAP.CHIP	63V 10% 10NF	5322 122 34098
C8801	CAP.CHIP	63V 10% 10NF	5322 122 34098
C8802	CAP.CHIP	63V 5% 150PF	5322 122 33538
C8803	CAP.CHIP	63V 5% 150PF	5322 122 33538
C8804	CAP.CHIP	63V 5% 150PF	5322 122 33538
C8805	CAP.CHIP	63V 10% 10NF	5322 122 34098
C8806	CAP.CHIP	63V 5% 1NF	5322 126 10511
C8807	CAP.CHIP	63V 5% 1NF	5322 126 10511
C8808	CAP.CHIP	63V 5% 1NF	5322 126 10511

Item	Description		Ordering code
C8809	CAP.CHIP	63V 10% 10NF	5322 122 34098
C8810	CAP.CHIP	63V 5% 1NF	5322 126 10511
C8811	CAP.CHIP	63V 5% 1NF	5322 126 10511
C8812	CAP.CHIP	63V 10% 10NF	5322 122 34098
C8813	CAP.CHIP	63V 10% 100NF	4822 122 33496
C8814	CAP.CHIP	63V 10% 100NF	4822 122 33496
C8815	CAP.CHIP	63V 10% 100NF	4822 122 33496
C8816	CAP.CHIP	63V 10% 100NF	4822 122 33496
C8817	CAP.CHIP	63V 10% 100NF	4822 122 33496
C8818	CAP.CHIP	63V 10% 100NF	4822 122 33496
C8819	CAP.CHIP	63V 10% 100NF	4822 122 33496
C8820	CAP.CHIP	63V 10% 100NF	4822 122 33496
C8821	CAP.CHIP	63V 10% 100NF	4822 122 33496
C8822	CAP.CHIP	63V 10% 100NF	4822 122 33496
C8823	CAP.CHIP	63V 10% 100NF	4822 122 33496
C8824	CAP.CHIP	63V 10% 100NF	4822 122 33496
C8825	CAP.FOIL	10V 20% 100UF	5322 124 41383
C8826	CAP.CHIP	63V 10% 100NF	4822 122 33496
C8828	CAP.CHIP	63V 10% 1.5NF	5322 122 31865
C8829	CAP.CHIP	63V 10% 22NF	5322 122 32654
C8830	CAP.CHIP	63V 10% 22NF	5322 122 32654
C8831	CAP.CHIP	63V 10% 100NF	4822 122 33496
C8832	CAP.CHIP	63V 10% 100NF	4822 122 33496
C8833	CAP.CHIP	63V 10% 100NF	4822 122 33496
C8834	CAP.CHIP	63V 10% 100NF	4822 122 33496
C8835	CAP.CHIP	63V 10% 10NF	5322 122 34098
C8836	CAP.CERAMIC	63V 5% 10PF	5322 122 32448
C8837	CAP.CHIP	63V 5% 15PF	5322 122 33869
C8838	CAP.CERAMIC	63V 5% 10PF	5322 122 32448
C8839	CAP.CHIP	63V 5% 15PF	5322 122 33869
C8840	CAP.CHIP	63V 10% 100NF	4822 122 33496
C8841	CAP.CHIP	63V 10% 100NF	4822 122 33496
C8842	CAP.CHIP	63V 0.5PF 8.2PF	5322 122 33244
C8842	CAP.CHIP	63V 0.5PF 10P	5322 122 32448
C8843	CAP.CHIP	63V 0.5PF 8.2PF	5322 122 33244
C8843	CAP.CHIP	63V 0.5PF 10P	5322 122 32448
C8844	CAP.CHIP	63V 0.5PF 8.2PF	5322 122 33244
C8844	CAP.CHIP	63V 0.5PF 10P	5322 122 32448
C8845	CAP.CHIP	63V 0.5PF 8.2PF	5322 122 33244
C8845	CAP.CHIP	63V 0.5PF 10P	5322 122 32448
C8846	CAP.CHIP	63V 10% 100NF	4822 122 33496
C8847	CAP.ELECTROLYT.	25V 20% 47UF	5322 121 10472
C8848	CAP.CHIP	63V 10% 10NF	5322 122 34098
C8849	CAP.CHIP	63V 10% 10NF	5322 122 34098
C8850	CAP.CHIP	63V 10% 10NF	5322 122 34098
C8851	CAP.CHIP	63V 10% 100NF	4822 122 33496
C8852	CAP.CHIP	63V 10% 10NF	5322 122 34098

Item	Description		Ordering code
C8853	CAP.CHIP	63V 10% 10NF	5322 122 34098
C8854	CAP.CHIP	63V 10% 10NF	5322 122 34098
C8855	CAP.FOIL	10V 20% 100UF	5322 124 41383
C8860	CAP.CHIP	63V 5% 12PF	4822 122 33926
C8861	CAP.CHIP	63V 10% 220NF	4822 122 32916
C8862	CAP.CHIP	63V 10% 220NF	4822 122 32916
C8863	CAP.CHIP	63V 10% 22NF	5322 122 32654
C8864	CAP.CHIP	63V 10% 22NF	5322 122 32654
C8865	CAP.CHIP	63V 10% 10NF	5322 122 34098
C8866	CAP.CHIP	63V 10% 22NF	5322 122 32654
C8867	CAP.CHIP	63V 10% 22NF	5322 122 32654
C8868	CAP.CHIP	63V 10% 10NF	5322 122 34098

INTEGRATED CIRCUITS

D8003	INTEGR.CIRCUIT	OQ0242 ECL-TTL	5322 209 12513
D8004	INTEGR.CIRCUIT	OQ0242 ECL-TTL	5322 209 12513
D8005	INTEGR.CIRCUIT	OQ0245 XOSC	5322 209 12514
D8006	INTEGR.CIRCUIT	OQ0244 DACPOT	5322 209 12468
D8012	INTEGR.CIRCUIT	DF0233	5322 209 31721
D8013	INTEGR.CIRCUIT	DF0233	5322 209 31721
D8027	INTEGR.CIRCUIT	LSI0002 DARLIC	5322 209 12516
D8030	INTEGR.CIRCUIT	MC74ACT132D MOT	5322 209 32772
D8032	INTEGR.CIRCUIT	HEF4094BT PEL	5322 209 11306
D8033	INTEGR.CIRCUIT	HEF4094BT PEL	5322 209 11306
D8034	INTEGR.CIRCUIT	HEF4094BT PEL	5322 209 11306
D8036	INTEGR.CIRCUIT	HEF4094BT PEL	5322 209 11306
D8037	INTEGR.CIRCUIT	CY7C185-25SC CYP	5322 209 31149
D8037	INTEGR.CIRCUIT	CY7C128A25SC CYP	4822 209 31099
D8038	INTEGR.CIRCUIT	CY7C185-25SC CYP	5322 209 31149
D8038	INTEGR.CIRCUIT	CY7C128A25SC CYP	4822 209 31099
D8039	INTEGR.CIRCUIT	CY7C185-25SC CYP	5322 209 31149
D8039	INTEGR.CIRCUIT	CY7C128A25SC CYP	4822 209 31099
D8041	INTEGR.CIRCUIT	CY7C185-25SC CYP	5322 209 31149
D8041	INTEGR.CIRCUIT	CY7C128A25SC CYP	4822 209 31099
D8042	INTEGR.CIRCUIT	CY7C185-25SC CYP	5322 209 31149
D8042	INTEGR.CIRCUIT	CY7C128A25SC CYP	4822 209 31099
D8043	INTEGR.CIRCUIT	CY7C185-25SC CYP	5322 209 31149
D8043	INTEGR.CIRCUIT	CY7C128A25SC CYP	4822 209 31099
D8044	INTEGR.CIRCUIT	CY7C185-25SC CYP	5322 209 31149
D8044	INTEGR.CIRCUIT	CY7C128A25SC CYP	4822 209 31099
D8045	INTEGR.CIRCUIT	N74F74D PEL	5322 209 61004
D8046	INTEGR.CIRCUIT	CY7C185-25SC CYP	5322 209 31149
D8046	INTEGR.CIRCUIT	CY7C128A25SC CYP	4822 209 31099
D8047	INTEGR.CIRCUIT	PCF3035HP/008 CURCON	5322 209 30217
D8048	INTEGR.CIRCUIT	MOT0001 BATGE	5322 209 12515
D8049	INTEGR.CIRCUIT	CY7C199-25SC CYP	5322 209 32771

Item	Description		Ordering code
D8050	INTEGR.CIRCUIT	N74F86D PEL	5322 209 60265
D8051	INTEGR.CIRCUIT	HM6264ALFP-12T HIT	5322 209 30265
D8052	INTEGR.CIRCUIT	CY7C199-25SC CYP	5322 209 32771
D8054	INTEGR.CIRCUIT	HM628128LFP-7T HIT	5322 209 52733
D8054	INTEGR.CIRCUIT	HM62256LFP-10TZU HIT	5322 209 30228
D8055	INTEGR.CIRCUIT	N74F175D PEL	5322 209 61452
D8056	INTEGR.CIRCUIT	HM628128LFP-7T HIT	5322 209 52733
D8056	INTEGR.CIRCUIT	HM62256LFP-10TZU HIT	5322 209 30228
D8059	INTEGR.CIRCUIT	PC74HCT4052T PEL	5322 209 61132
D8063	INTEGR.CIRCUIT	HEF4066BT PEL	5322 209 14542
D8069	INTEGR.CIRCUIT	TMS320C25FNL T.I	5322 209 62743
D8501	INTEGR.CIRCUIT	PC74HCT259T PEL	4822 209 30086
D8502	INTEGR.CIRCUIT	OQ0251 RATEL	5322 209 12519
D8503	INTEGR.CIRCUIT	N74F32D PEL	5322 209 61003
N8001	INTEGR.CIRCUIT	OQ0239T 100MS/S ADC	5322 209 12509
N8002	INTEGR.CIRCUIT	OQ0239T 100MS/S ADC	5322 209 12509
N8003	INTEGR.CIRCUIT	LM358M NSC	4822 209 60175
N8004	INTEGR.CIRCUIT	LM358M NSC	4822 209 60175
N8007	INTEGR.CIRCUIT	LM337T N.S	5322 209 81236
N8009	INTEGR.CIRCUIT	TDA8444A/N4 PEL	5322 209 30233
N8014	INTEGR.CIRCUIT	MC33184DR2	5322 209 62399
N8015	INTEGR.CIRCUIT	LM337LZ NSC	5322 209 83228
N8016	INTEGR.CIRCUIT	MC33184DR2	5322 209 62399
N8018	INTEGR.CIRCUIT	LM337T N.S	5322 209 81236
N8019	INTEGR.CIRCUIT	MC33184DR2	5322 209 62399
N8021	I.C. ANALOGUE	CA3227M HAR	5322 130 83492
N8022	I.C. ANALOGUE	CA3227M HAR	5322 130 83492
N8023	I.C. ANALOGUE	CA3227M HAR	5322 130 83492
N8024	I.C. ANALOGUE	CA3227M HAR	5322 130 83492
N8026	INTEGR.CIRCUIT	OQ0233WP MASPU	5322 209 12508
N8027	INTEGR.CIRCUIT	OQ0233WP MASPU	5322 209 12508
N8029	INTEGR.CIRCUIT	OQ0241WP COMPASS	5322 209 12512
N8057	INTEGR.CIRCUIT	DAC10GSR AND	5322 209 12469
N8058	INTEGR.CIRCUIT	DAC10GSR AND	5322 209 12469
N8061	INTEGR.CIRCUIT	OQ0240P VECTOR	5322 209 12511
N8062	INTEGR.CIRCUIT	NE521D PEL	5322 209 60297
N8066	INTEGR.CIRCUIT	LM358M NSC	4822 209 60175
N8067	INTEGR.CIRCUIT	OQ0208T CLOCK SWITCH	5322 209 12517
N8068	INTEGR.CIRCUIT	OQ0208T CLOCK SWITCH	5322 209 12517
N8069	INTEGR.CIRCUIT	LM324D	5322 209 83125
N8070	INTEGR.CIRCUIT	TDA8444AT/N2 PEL	5322 209 30233
N8071	INTEGR.CIRCUIT	LM358M NSC	4822 209 60175
N8072	INTEGR.CIRCUIT	LM358M NSC	4822 209 60175
N8073	INTEGR.CIRCUIT	LM337LZ NSC	5322 209 83228
N8074	INTEGR.CIRCUIT	LM358M NSC	4822 209 60175

Item	Description		Ordering code
MISCELLANEOUS			
G8024	RESONATOR	XTAL 12MHZ KYO	5322 242 71444
G8025	CRYSTAL	XTAL UNIT 200MHZ	5322 242 81589
G8053	CRYSTAL	SRQ-0-50-40M S.R	5322 242 72575
COILS			
L8001	COIL	0.12UH 5% TDK	5322 157 63916
L8002	COIL	0.12UH 5% TDK	5322 157 63916
L8003	COIL	0.082UH 5% TDK	5322 157 63382
L8501	COIL	1UH 5% TDK	5322 157 63648
L8502	COIL	1UH 5% TDK	5322 157 63648
L8506	COIL	27UH	4822 158 10551
L8507	COIL	27UH	4822 158 10551
L8508	COIL	27UH	4822 158 10551
L8511	COIL	0.027UH 5% TDK	5322 157 70857
L8512	COIL	0.027UH 5% TDK	5322 157 70857
L8513	COIL	0.027UH 5% TDK	5322 157 70857
RESISTORS			
R8001	RES.CHIP	RMC1/8 1% 21E5	5322 111 92014
R8002	RES.CHIP	RMC1/8 1% 10E	4822 111 91885
R8003	RES.CHIP	RMC1/8 1% 21E5	5322 111 92014
R8004	RES.CHIP	RC-02H 1% 1K	4822 051 10102
R8006	RES.CHIP	RC-02H 1% 1K	4822 051 10102
R8007	RES.CHIP	RC-02H 1% 1K	4822 051 10102
R8008	RES.CHIP	RC-02H 1% 1K	4822 051 10102
R8009	RES.CHIP	RC-02H 1% 1K	4822 051 10102
R8011	RES.CHIP	RC-02H 1% 1K	4822 051 10102
R8012	RES.CHIP	RC-02H 1% 1K	4822 051 10102
R8013	RES.CHIP	RC-02H 1% 1K	4822 051 10102
R8014	RES.CHIP	RMC1/8 1% 10E	4822 111 91885
R8016	RES.CHIP	RC-02H 1% 1K	4822 051 10102
R8017	RES.CHIP	RC-02H 1% 1K	4822 051 10102
R8018	RES.CHIP	RC-02H 1% 1K	4822 051 10102
R8019	RES.CHIP	RC-02H 1% 1K	4822 051 10102
R8021	RES.CHIP	RC-02H 1% 1K	4822 051 10102
R8022	RES.CHIP	RC-02H 1% 1K	4822 051 10102
R8023	RES.CHIP	RC-02H 1% 1K	4822 051 10102
R8024	RES.CHIP	RC-02H 1% 1K	4822 051 10102
R8033	RES.CHIP	RC-02H 1% 100E	4822 051 10101
R8042	RES.METAL FILM	RC-02H 1% 1K78	5322 117 10535
R8043	RES.CHIP	RC-02H 1% 1K	4822 051 10102
R8051	RES.METAL FILM	RC-02H 1% 1K47	5322 117 10527
R8052	RES.METAL FILM	RC-02H 1% 5K62	5322 117 10573
R8053	RES.METAL FILM	RC-02H 1% 3K83	5322 117 10561
R8054	RES.METAL FILM	RC-02H 1% 1K47	5322 117 10527

Item	Description		Ordering code
R8057	RES.CHIP	RMC1/8 1% 42E2	4822 111 91887
R8058	RES.CHIP	RMC1/8 1% 42E2	4822 111 91887
R8059	RES.CHIP	RMC1/8 1% 42E2	4822 111 91887
R8061	RES.CHIP	RMC1/8 1% 42E2	4822 111 91887
R8062	RES.CHIP	RC-02H 1% 4K64	4822 051 54642
R8063	RES.CHIP	RMC1/8 1% 42E2	4822 111 91887
R8064	RES.CHIP	RC-02H 1% 4K64	4822 051 54642
R8066	RES.CHIP	RMC1/8 1% 42E2	4822 111 91887
R8067	RES.CHIP	RMC1/8 1% 42E2	4822 111 91887
R8074	RES.CHIP	RMC1/8 1% 42E2	4822 111 91887
R8077	RES.CHIP	RC-02H 1% 51K1	4822 051 55113
R8078	RES.CHIP	RC-02H 1% 1K	4822 051 10102
R8079	RES.CHIP	RC-02H 1% 100K	4822 051 10104
R8081	RES.CHIP	RC-02H 1% 1K	4822 051 10102
R8082	RES.CHIP	RC-02H 1% 51K1	4822 051 55113
R8083	RES.CHIP	RC-02H 1% 261E	4822 051 52611
R8084	RES.CHIP	RC-02H 1% 261E	4822 051 52611
R8086	RES.CHIP	RC-02H 1% 1K	4822 051 10102
R8087	RES.CHIP	RC-02H 1% 261E	4822 051 52611
R8088	RES.CHIP	RMC1/8 1% 42E2	4822 111 91887
R8089	RES.CHIP	RMC1/8 1% 42E2	4822 111 91887
R8091	RES.CHIP	RMC1/8 1% 42E2	4822 111 91887
R8092	RES.CHIP	RMC1/8 1% 42E2	4822 111 91887
R8093	RES.CHIP	RC-02H 1% 261E	4822 051 52611
R8094	RES.CHIP	RC-02H 1% 1K	4822 051 10102
R8096	RES.CHIP	RC-02H 1% 261E	4822 051 52611
R8097	RES.CHIP	RC-02H 1% 261E	4822 051 52611
R8098	RES.CHIP	RC-02H 1% 100K	4822 051 10104
R8103	RES.CHIP	RMC1/8 1% 42E2	4822 111 91887
R8104	RES.CHIP	RMC1/8 1% 42E2	4822 111 91887
R8106	RES.CHIP	RMC1/8 1% 42E2	4822 111 91887
R8107	RES.CHIP	RMC1/8 1% 42E2	4822 111 91887
R8108	RES.CHIP	RC-02H 1% 261E	4822 051 52611
R8109	RES.METAL FILM	RC-02H 1% 31K6	5322 117 10554
R8111	RES.METAL FILM	RC-02H 1% 14K7	5322 117 10528
R8112	RES.CHIP	RMC1/8 1% 10E	4822 111 91885
R8114	RES.METAL FILM	RC-02H 1% 14K7	5322 117 10528
R8116	RES.METAL FILM	RC-02H 1% 31K6	5322 117 10554
R8117	RES.CHIP	RC-02H 1% 4K64	4822 051 54642
R8118	RES.CHIP	RC-02H 1% 100E	4822 051 10101
R8119	RES.CHIP	RC-02H 1% 100E	4822 051 10101
R8121	RES.CHIP	RC-02H 1% 4K64	4822 051 54642
R8122	RES.CHIP	RC-02H 1% 261E	4822 051 52611
R8123	RES.METAL FILM	RC-02H 1% 562E	5322 117 10572
R8124	RES.METAL FILM	RC-02H 1% 1K47	5322 117 10527
R8126	RES.CHIP	RMC1/8 1% 51E1	5322 111 91893
R8127	RES.CHIP	RMC1/8 1% 51E1	5322 111 91893

Item	Description		Ordering code
R8128	RES.METAL FILM	RMC1/8 1% 38E3	5322 116 83728
R8129	RES.MET.GLAZED	RMC1/8 1% 31E6	5322 116 82895
R8129	RES.CHIP	RC-02H 1% 75E	5322 117 11741
R8130	RES.CHIP	RMC1/8 1% 42E2	4822 111 91887
R8130	RES.CHIP	RC-02H 1% 31E6	5322 117 11732
R8131	RES.METAL FILM	RMC1/8 1% 38E3	5322 116 83728
R8132	RES.METAL FILM	RC-02H 1% 1K33	5322 117 10524
R8133	RES.CHIP	RMC1/8 1% 42E2	4822 111 91887
R8134	RES.CHIP	RC-02H 1% 100E	4822 051 10101
R8135	RES.CHIP	RMC1/8 1% 42E2	4822 111 91887
R8135	RES.CHIP	RC-02H 1% 31E6	5322 117 11732
R8136	RES.MET.GLAZED	RMC1/8 1% 31E6	5322 116 82895
R8136	RES.CHIP	RC-02H 1% 75E	5322 117 11741
R8137	RES.CHIP	RC-02H 1% 100E	4822 051 10101
R8138	RES.METAL FILM	RMC1/8 1% 38E3	5322 116 83728
R8139	RES.METAL FILM	RMC1/8 1% 38E3	5322 116 83728
R8141	RES.MET.GLAZED	RMC1/8 1% 31E6	5322 116 82895
R8141	RES.CHIP	RC-02H 1% 75E	5322 117 11741
R8142	RES.METAL FILM	RC-02H 1% 162E	5322 117 10529
R8143	RES.CHIP	RC-02H 1% 100E	4822 051 10101
R8144	RES.CHIP	RC-02H 1% 100E	4822 051 10101
R8146	RES.METAL FILM	RC-02H 1% 1K21	5322 117 10521
R8147	RES.CHIP	RC-02H 1% 100E	4822 051 10101
R8148	RES.CHIP	RC-02H 1% 2K15	5322 117 10485
R8149	RES.METAL FILM	RC-02H 1% 383E	5322 117 10559
R8151	RES.CHIP	RMC1/8 1% 42E2	4822 111 91887
R8152	RES.CHIP	RMC1/8 1% 42E2	4822 111 91887
R8153	RES.CHIP	RC-02H 1% 10K	4822 051 10103
R8157	RES.CHIP	RC-02H 1% 10K	4822 051 10103
R8158	RES.CHIP	RC-02H 1% 10K	4822 051 10103
R8159	RES.CHIP	RC-02H 1% 10K	4822 051 10103
R8161	RES.METAL FILM	RMC1/8 1% 38E3	5322 116 83728
R8162	RES.METAL FILM	RC-02H 1% 162E	5322 117 10529
R8163	RES.CHIP	RC-02H 1% 100E	4822 051 10101
R8164	RES.CHIP	RC-02H 1% 100E	4822 051 10101
R8166	RES.METAL FILM	RC-02H 1% 1K47	5322 117 10527
R8167	RES.METAL FILM	RC-02H 1% 1K47	5322 117 10527
R8168	RES.METAL FILM	RC-02H 1% 1K47	5322 117 10527
R8169	RES.METAL FILM	RC-02H 1% 162E	5322 117 10529
R8171	RES.METAL FILM	RMC1/8 1% 38E3	5322 116 83728
R8172	RES.CHIP	RC-02H 1% 100E	4822 051 10101
R8173	RES.CHIP	RC-02H 1% 100E	4822 051 10101
R8174	RES.METAL FILM	RC-02H 1% 562E	5322 117 10572
R8176	RES.METAL FILM	RC-02H 1% 162E	5322 117 10529
R8178	RES.CHIP	RMC1/8 1% 42E2	4822 111 91887
R8179	RES.METAL FILM	RC-02H 1% 1K33	5322 117 10524
R8181	RES.METAL FILM	RMC1/8 1% 38E3	5322 116 83728

Item	Description		Ordering code
R8182	RES.MET.GLAZED	RMC1/8 1% 31E6	5322 116 82895
R8182	RES.CHIP	RC-02H 1% 75E	5322 117 11741
R8183	RES.METAL FILM	RMC1/8 1% 38E3	5322 116 83728
R8184	RES.METAL FILM	MRS25 1% 1E	4822 050 21008
R8186	RES.METAL FILM	RC-02H 1% 4K22	5322 117 10565
R8187	RES.METAL FILM	RC-02H 1% 562E	5322 117 10572
R8188	RES.METAL FILM	RC-02H 1% 1K47	5322 117 10527
R8189	RES.CHIP	RMC1/8 1% 51E1	5322 111 91893
R8191	RES.CHIP	RMC1/8 1% 51E1	5322 111 91893
R8192	RES.METAL FILM	RMC1/8 1% 38E3	5322 116 83728
R8193	RES.CHIP	RMC1/8 1% 42E2	4822 111 91887
R8193	RES.CHIP	RC-02H 1% 75E	5322 117 11741
R8194	RES.METAL FILM	RMC1/8 1% 38E3	5322 116 83728
R8196	RES.METAL FILM	RC-02H 1% 1K33	5322 117 10524
R8197	RES.CHIP	RMC1/8 1% 42E2	4822 111 91887
R8198	RES.CHIP	RC-02H 1% 100E	4822 051 10101
R8199	RES.MET.GLAZED	RMC1/8 1% 31E6	5322 116 82895
R8199	RES.CHIP	RC-02H 1% 75E	5322 117 11741
R8201	RES.CHIP	RC-02H 1% 100E	4822 051 10101
R8202	RES.METAL FILM	RMC1/8 1% 38E3	5322 116 83728
R8203	RES.METAL FILM	RMC1/8 1% 38E3	5322 116 83728
R8204	RES.CHIP	RMC1/8 1% 42E2	4822 111 91887
R8204	RES.CHIP	RC-02H 1% 75E	5322 117 11741
R8205	RES.CHIP	RMC1/8 1% 42E2	4822 111 91887
R8205	RES.CHIP	RC-02H 1% 31E6	5322 117 11732
R8206	RES.METAL FILM	RC-02H 1% 162E	5322 117 10529
R8207	RES.CHIP	RC-02H 1% 100E	4822 051 10101
R8208	RES.CHIP	RC-02H 1% 100E	4822 051 10101
R8209	RES.METAL FILM	RMC1/8 1% 38E3	5322 116 83728
R8210	RES.CHIP	RMC1/8 1% 42E2	4822 111 91887
R8210	RES.CHIP	RC-02H 1% 31E6	5322 117 11732
R8211	RES.METAL FILM	RC-02H 1% 162E	5322 117 10529
R8212	RES.METAL FILM	RC-02H 1% 1K47	5322 117 10527
R8213	RES.METAL FILM	RMC1/8 1% 38E3	5322 116 83728
R8214	RES.CHIP	RC-02H 1% 100E	4822 051 10101
R8216	RES.CHIP	RC-02H 1% 100E	4822 051 10101
R8217	RES.METAL FILM	RC-02H 1% 562E	5322 117 10572
R8218	RES.METAL FILM	RC-02H 1% 4K22	5322 117 10565
R8219	RES.CHIP	RMC1/8 1% 42E2	4822 111 91887
R8221	RES.METAL FILM	RC-02H 1% 1K33	5322 117 10524
R8222	RES.METAL FILM	RMC1/8 1% 38E3	5322 116 83728
R8223	RES.MET.GLAZED	RMC1/8 1% 31E6	5322 116 82895
R8223	RES.CHIP	RC-02H 1% 75E	5322 117 11741
R8224	RES.METAL FILM	RMC1/8 1% 38E3	5322 116 83728
R8226	RES.CHIP	RC-02H 1% 4K64	4822 051 54642
R8227	RES.CHIP	RC-02H 1% 100E	4822 051 10101
R8228	RES.CHIP	RC-02H 1% 100E	4822 051 10101

Item	Description		Ordering code
R8229	RES.CHIP	RC-02H 1% 4K64	4822 051 54642
R8231	RES.METAL FILM	RC-02H 1% 1K21	5322 117 10521
R8232	RES.CHIP	RC-02H 1% 100E	4822 051 10101
R8233	RES.CHIP	RC-02H 1% 2K15	5322 117 10485
R8234	RES.METAL FILM	RC-02H 1% 383E	5322 117 10559
R8236	RES.CHIP	RMC1/8 1% 42E2	4822 111 91887
R8237	RES.CHIP	RMC1/8 1% 42E2	4822 111 91887
R8238	RES.CHIP	RC-02H 1% 10K	4822 051 10103
R8239	RES.CHIP	RC-02H 1% 100K	4822 051 10104
R8241	RES.METAL FILM	MRS16T 1% 10K	4822 050 11003
R8242	RES.CHIP	RC-02H 1% 10K	4822 051 10103
R8243	RES.CHIP	RC-02H 1% 10K	4822 051 10103
R8244	RES.CHIP	RC-02H 1% 10K	4822 051 10103
R8246	RES.CHIP	RC-02H 1% 100E	4822 051 10101
R8247	RES.CHIP	RC-02H 1% 100E	4822 051 10101
R8248	RES.METAL FILM	RC-02H 1% 1K47	5322 117 10527
R8252	RES.METAL FILM	RC-02H 1% 1K47	5322 117 10527
R8253	RES.METAL FILM	RC-02H 1% 162E	5322 117 10529
R8254	RES.METAL FILM	RC-02H 1% 162E	5322 117 10529
R8256	RES.METAL FILM	RC-02H 1% 8K25	5322 117 10586
R8257	RES.CHIP	RC-02H 1% 2K15	5322 117 10485
R8258	RES.CHIP	RC-02H 1% 2K15	5322 117 10485
R8259	RES.METAL FILM	RC-02H 1% 8K25	5322 117 10586
R8261	RES.CHIP	RMC1/8 1% 10E	4822 111 91885
R8264	RES.METAL FILM	RC-02H 1% 1K21	5322 117 10521
R8268	RES.CHIP	RC-01 5% 1E	4822 051 10108
R8269	RES.CHIP	RC-01 5% 1E	4822 051 10108
R8271	RES.CHIP	RMC1/8 1% 42E2	4822 111 91887
R8272	RES.CHIP	RMC1/8 1% 42E2	4822 111 91887
R8273	RES.CHIP	RMC1/8 1% 42E2	4822 111 91887
R8274	RES.CHIP	RMC1/8 1% 90E9	5322 111 92018
R8276	RES.METAL FILM	RC-02H 1% 909E	5322 117 10588
R8277	RES.CHIP	RMC1/8 1% 10E	4822 111 91885
R8278	RES.METAL FILM	RC-02H 1% 909E	5322 117 10588
R8279	RES.CHIP	RMC1/8 1% 90E9	5322 111 92018
R8281	RES.CHIP	RMC1/8 1% 10E	4822 111 91885
R8282	RES.CHIP	RMC1/8 1% 90E9	5322 111 92018
R8283	RES.METAL FILM	RC-02H 1% 909E	5322 117 10588
R8284	RES.CHIP	RMC1/8 1% 10E	4822 111 91885
R8286	RES.CHIP	RMC1/8 1% 90E9	5322 111 92018
R8287	RES.METAL FILM	RC-02H 1% 909E	5322 117 10588
R8288	RES.CHIP	RMC1/8 1% 42E2	4822 111 91887
R8289	RES.METAL FILM	RC-02H 1% 909E	5322 117 10588
R8291	RES.CHIP	RMC1/8 1% 42E2	4822 111 91887
R8292	RES.CHIP	RMC1/8 1% 42E2	4822 111 91887
R8293	RES.METAL FILM	RC-02H 1% 909E	5322 117 10588
R8294	RES.	RMC1/8 1% 16E2	5322 116 83564

Item	Description		Ordering code
R8296	RES.CHIP	RMC1/8 1% 42E2	4822 111 91887
R8297	RES.METAL FILM	RC-02H 1% 1K21	5322 117 10521
R8298	RES.METAL FILM	RC-02H 1% 1K21	5322 117 10521
R8299	RES.METAL FILM	RC-02H 1% 909E	5322 117 10588
R8301	RES.	RMC1/8 1% 16E2	5322 116 83564
R8302	RES.	RMC1/8 1% 16E2	5322 116 83564
R8304	RES.CHIP	RMC1/8 1% 42E2	4822 111 91887
R8305	RES.CHIP	RMC1/8 1% 21E5	5322 111 92014
R8306	RES.	RMC1/8 1% 16E2	5322 116 83564
R8307	RES.METAL FILM	RC-02H 1% 909E	5322 117 10588
R8308	RES.CHIP	RMC1/8 1% 42E2	4822 111 91887
R8309	RES.CHIP	RMC1/8 1% 42E2	4822 111 91887
R8310	RES.CHIP	RMC1/8 1% 21E5	5322 111 92014
R8311	RES.CHIP	RC-02H 1% 5K11	5322 117 10487
R8312	RES.METAL FILM	RC-02H 1% 909E	5322 117 10588
R8316	RES.CHIP	RMC1/8 1% 42E2	4822 111 91887
R8317	RES.CHIP	RMC1/8 1% 42E2	4822 111 91887
R8318	RES.METAL FILM	RC-02H 1% 13K3	5322 117 10525
R8319	RES.METAL FILM	RC-02H 1% 13K3	5322 117 10525
R8321	RES.METAL FILM	RC-02H 1% 909E	5322 117 10588
R8322	RES.CHIP	RC-02H 1% 2K15	5322 117 10485
R8323	RES.METAL FILM	RC-02H 1% 909E	5322 117 10588
R8324	RES.METAL FILM	RC-02H 1% 909E	5322 117 10588
R8326	RES.CHIP	RMC1/8 1% 42E2	4822 111 91887
R8327	RES.CHIP	RMC1/8 1% 42E2	4822 111 91887
R8328	RES.METAL FILM	RC-02H 1% 909E	5322 117 10588
R8329	RES.CHIP	RMC1/8 1% 21E5	5322 111 92014
R8331	RES.CHIP	RMC1/8 1% 42E2	4822 111 91887
R8332	RES.CHIP	RC-02H 1% 5K11	5322 117 10487
R8333	RES.METAL FILM	RC-02H 1% 909E	5322 117 10588
R8334	RES.METAL FILM	RC-02H 1% 13K3	5322 117 10525
R8336	RES.CHIP	RMC1/8 1% 21E5	5322 111 92014
R8337	RES.CHIP	RMC1/8 1% 21E5	5322 111 92014
R8338	RES.METAL FILM	RC-02H 1% 13K3	5322 117 10525
R8339	RES.CHIP	RMC1/8 1% 42E2	4822 111 91887
R8341	RES.CHIP	RMC1/8 1% 21E5	5322 111 92014
R8342	RES.METAL FILM	RC-02H 1% 909E	5322 117 10588
R8343	RES.CHIP	RMC1/8 1% 42E2	4822 111 91887
R8344	RES.CHIP	RMC1/8 1% 42E2	4822 111 91887
R8346	RES.CHIP	RMC1/8 1% 10E	4822 111 91885
R8347	RES.CHIP	RMC1/8 1% 42E2	4822 111 91887
R8348	RES.METAL FILM	RC-02H 1% 909E	5322 117 10588
R8349	RES.CHIP	RC-02H 1% 5K11	5322 117 10487
R8351	RES.CHIP	RC-02H 1% 5K11	5322 117 10487
R8352	RES.CHIP	RC-02H 1% 1M	4822 051 10105
R8353	RES.CHIP	RC-02H 1% 10K	4822 051 10103
R8354	RES.CHIP	RC-02H 1% 5K11	5322 117 10487

Item	Description		Ordering code
R8357	RES.CHIP	RC-01 5% 1E	4822 051 10108
R8358	RES.CHIP	RC-02H 1% 5K11	5322 117 10487
R8359	RES.CHIP	RC-02H 1% 5K11	5322 117 10487
R8360	RES.CHIP	RC-02H 1% 5K11	5322 117 10487
R8361	RES.CHIP	RC-02H 1% 1K	4822 051 10102
R8362	RES.METAL FILM	RC-02H 1% 750E	5322 117 10582
R8363	RES.CHIP	RMC1/8 1% 42E2	4822 111 91887
R8364	RES.CHIP	RC-02H 1% 10K	4822 051 10103
R8365	RES.CHIP	RC-02H 1% 5K11	5322 117 10487
R8366	RES.CHIP	RC-02H 1% 10K	4822 051 10103
R8367	RES.METAL FILM	RC-02H 1% 562K	5322 117 10575
R8368	RES.CHIP	RC-02H 1% 215E	5322 117 10484
R8369	RES.CHIP	RC-02H 1% 1K	4822 051 10102
R8372	RES.CHIP	RC-02H 1% 1K	4822 051 10102
R8373	RES.CHIP	RC-02H 1% 100E	4822 051 10101
R8374	RES.METAL FILM	RC-02H 1% 464E	5322 117 10567
R8376	RES.METAL FILM	RC-02H 1% 9K09	5322 117 10589
R8377	RES.METAL FILM	RC-02H 1% 14K7	5322 117 10528
R8378	RES.CHIP	RC-02H 1% 1K	4822 051 10102
R8379	RES.CHIP	RMC1/8 1% 10E	4822 111 91885
R8381	RES.CHIP	RC-02H 1% 2K15	5322 117 10485
R8382	RES.CHIP	RC-02H 1% 2K15	5322 117 10485
R8383	RES.METAL FILM	RC-02H 1% 464E	5322 117 10567
R8384	RES.METAL FILM	RC-02H 1% 1K96	5322 117 10539
R8385	RES.CHIP	RC-02H 1% 215E	5322 117 10484
R8386	RES.METAL FILM	RC-02H 1% 3K16	5322 117 10553
R8387	RES.METAL FILM	RC-02H 1% 1K96	5322 117 10539
R8388	RES.METAL FILM	RC-02H 1% 511E	5322 117 10569
R8389	RES.METAL FILM	RC-02H 1% 19K6	5322 117 10541
R8390	RES.METAL FILM	RC-02H 1% 3K16	5322 117 10553
R8391	RES.METAL FILM	RC-02H 1% 562K	5322 117 10575
R8392	RES.METAL FILM	RC-02H 1% 316K	5322 117 10555
R8393	RES.METAL FILM	RC-02H 1% 21K5	5322 117 10542
R8396	RES.CHIP	RC-02H 1% 10K	4822 051 10103
R8397	RES.CHIP	RC-02H 1% 10K	4822 051 10103
R8398	RES.METAL FILM	RC-02H 1% 383E	5322 117 10559
R8399	RES.METAL FILM	RC-02H 1% 1K62	5322 117 10531
R8401	RES.METAL FILM	RC-02H 1% 3K16	5322 117 10553
R8402	RES.METAL FILM	RC-02H 1% 562E	5322 117 10572
R8403	RES.CHIP	RC-02H 1% 5K11	5322 117 10487
R8404	RES.METAL FILM	RC-02H 1% 3K48	5322 117 10557
R8405	RES.CHIP	RC-02H 1% 5K11	5322 117 10487
R8405	RES.CHIP	RC-02H 1% 5K11	5322 117 10487
R8406	RES.METAL FILM	RC-02H 1% 1K96	5322 117 10539
R8407	RES.METAL FILM	RC-02H 1% 750E	5322 117 10582
R8408	RES.METAL FILM	RC-02H 1% 2K37	5322 117 10545
R8409	RES.METAL FILM	RC-02H 1% 1K96	5322 117 10539

Item	Description		Ordering code
R8410	RES.METAL FILM	RC-02H 1% 215K	5322 117 10543
R8411	RES.METAL FILM	RC-02H 1% 8K25	5322 117 10586
R8412	RES.METAL FILM	RC-02H 1% 12K1	5322 117 10522
R8413	RES.CHIP	RC-02H 1% 215E	5322 117 10484
R8414	RES.CHIP	RC-02H 1% 215E	5322 117 10484
R8416	RES.METAL FILM	RC-02H 1% 14K7	5322 117 10528
R8417	RES.CHIP	RC-02H 1% 4K64	4822 051 54642
R8418	RES.METAL FILM	RC-02H 1% 21K5	5322 117 10542
R8419	RES.METAL FILM	RC-02H 1% 1K47	5322 117 10527
R8421	RES.METAL FILM	RC-02H 1% 1K47	5322 117 10527
R8422	RES.METAL FILM	RC-02H 1% 1K21	5322 117 10521
R8423	RES.METAL FILM	RC-02H 1% 562E	5322 117 10572
R8424	RES.METAL FILM	RC-02H 1% 348E	5322 117 10556
R8426	RES.CHIP	RMC1/8 1% 82E5	5322 111 92017
R8427	RES.CHIP	RC-01 5% 4E7	4822 051 10478
R8428	RES.METAL FILM	RC-02H 1% 2K61	5322 117 10547
R8429	RES.METAL FILM	RC-02H 1% 511E	5322 117 10569
R8434	RES.CHIP	RC-02H 1% 100K	4822 051 10104
R8436	RES.CHIP	RC-02H 1% 10K	4822 051 10103
R8438	RES.METAL FILM	RC-02H 1% 3K83	5322 117 10561
R8439	RES.METAL FILM	RC-02H 1% 16K2	5322 117 10532
R8441	RES.CHIP	RC-02H 1% 100E	4822 051 10101
R8442	RES.METAL FILM	RC-02H 1% 3K16	5322 117 10553
R8443	RES.METAL FILM	RC-02H 1% 178E	5322 117 10534
R8444	RES.CHIP	RMC1/8 1% 51E1	5322 111 91893
R8446	RES.CHIP	RMC1/8 1% 51E1	5322 111 91893
R8447	RES.MET.GLAZED	RMC1/8 1% 31E6	5322 116 82895
R8448	RES.MET.GLAZED	RMC1/8 1% 31E6	5322 116 82895
R8449	RES.CHIP	RMC1/8 1% 10E	4822 111 91885
R8450	RES.METAL FILM	RC-02H 1% 121K	5322 117 10523
R8451	RES.CHIP	RC-02H 1% 100E	4822 051 10101
R8452	RES.CHIP	RC-02H 1% 100E	4822 051 10101
R8453	RES.CHIP	RC-02H 1% 1K	4822 051 10102
R8454	RES.CHIP	RC-02H 1% 261E	4822 051 52611
R8455	RES.METAL FILM	MRS25 1% 8E25	4822 050 28258
R8456	RES.METAL FILM	RC-02H 1% 464E	5322 117 10567
R8458	RES.METAL FILM	RC-02H 1% 9K09	5322 117 10589
R8459	RES.METAL FILM	RC-02H 1% 9K09	5322 117 10589
R8460	RES.CHIP	RC-02H 1% 2K15	5322 117 10485
R8461	RES.METAL FILM	PR24 1/4W 0.1% 10K	5322 116 82868
R8462	RES.METAL FILM	PR24 1/4W 0.1% 10K	5322 116 82868
R8463	RES.METAL FILM	PR24 1/4W 0.1% 10K	5322 116 82868
R8464	RES.METAL FILM	RC-02H 1% 464E	5322 117 10567
R8465	RES.METAL FILM	RC-02H 1% 121K	5322 117 10523
R8466	RES.METAL FILM	PR24 1/4W 0.1% 10K	5322 116 82868
R8467	RES.METAL FILM	MRS25 1% 1E	4822 050 21008
R8469	RES.METAL FILM	MRS25 1% 1E	4822 050 21008

Item	Description		Ordering code
R8471	RES.METAL FILM	MRS25 1% 1E	4822 050 21008
R8472	RES.METAL FILM	MRS25 1% 10E	4822 050 21009
R8473	RES.METAL FILM	MRS25 1% 1E	4822 050 21008
R8474	RES.METAL FILM	MRS25 1% 10E	4822 050 21009
R8476	RES.METAL FILM	MRS25 1% 10E	4822 050 21009
R8478	RES.METAL FILM	MRS25 1% 10E	4822 050 21009
R8483	RES.METAL FILM	PR24 1/4W 0.1% 5K	5322 116 80369
R8484	RES.METAL FILM	PR24 1/4W 0.1% 10K	5322 116 82868
R8486	RES.CHIP	RC-02H 1% 5K11	5322 117 10487
R8487	RES.CHIP	RC-02H 1% 10K	4822 051 10103
R8489	RES.METAL FILM	RC-02H 1% 1K62	5322 117 10531
R8491	RES.CHIP	RC-02H 1% 100E	4822 051 10101
R8492	RES.CHIP	RC-02H 1% 10K	4822 051 10103
R8493	RES.CHIP	RC-02H 1% 1K	4822 051 10102
R8496	RES.CHIP	RC-02H 1% 51K1	4822 051 55113
R8497	RES.CHIP	RC-02H 1% 1K	4822 051 10102
R8498	RES.METAL FILM	RC-02H 1% 1K62	5322 117 10531
R8501	RES.CHIP	RC-01 5% 1E	4822 051 10108
R8502	RES.CHIP	RC-01 5% 1E	4822 051 10108
R8503	RES.CHIP	RC-01 5% 1E	4822 051 10108
R8506	RES.CHIP	RC-01 0E	4822 051 10008
R8507	RES.CHIP	RC-01 5% 1E	4822 051 10108
R8508	RES.CHIP	RC-01 5% 1E	4822 051 10108
R8509	RES.CHIP	RC-01 5% 1E	4822 051 10108
R8511	RES.CHIP	RC-02H 1% 1K	4822 051 10102
R8512	RES.CHIP	RC-02H 1% 1K	4822 051 10102
R8514	RES.CHIP	RC-01 5% 1E	4822 051 10108
R8516	RES.CHIP	RC-01 5% 1E	4822 051 10108
R8517	RES.CHIP	RC-01 5% 1E	4822 051 10108
R8518	RES.CHIP	RC-01 5% 1E	4822 051 10108
R8519	RES.CHIP	RMC1/8 1% 10E	4822 111 91885
R8521	RES.CHIP	RMC1/8 1% 10E	4822 111 91885
R8522	RES.CHIP	RC-01 5% 1E	4822 051 10108
R8523	RES.CHIP	RC-01 5% 1E	4822 051 10108
R8524	RES.CHIP	RC-01 5% 1E	4822 051 10108
R8526	RES.CHIP	RC-01 5% 1E	4822 051 10108
R8527	RES.CHIP	RC-01 5% 1E	4822 051 10108
R8528	RES.CHIP	RC-01 5% 1E	4822 051 10108
R8530	RES.METAL FILM	RC-02H 1% 825K	5322 117 10587
R8531	RES.METAL FILM	RC-02H 1% 464K	5322 117 10568
R8532	RES.METAL FILM	RC-02H 1% 383E	5322 117 10559
R8533	RES.METAL FILM	RC-02H 1% 383E	5322 117 10559
R8534	RES.METAL FILM	RC-02H 1% 383E	5322 117 10559
R8535	RES.METAL FILM	RC-02H 1% 383E	5322 117 10559
R8536	RES.CHIP	RMC1/8 1% 42E2	4822 111 91887
R8537	RES.METAL FILM	RC-02H 1% 162E	5322 117 10529
R8538	RES.CHIP	RMC1/8 1% 42E2	4822 111 91887

Item	Description		Ordering code
R8539	RES.METAL FILM	RC-02H 1% 162E	5322 117 10529
R8540	RES.METAL FILM	RC-02H 1% 1K21	5322 117 10521
R8541	RES.CHIP	RMC1/8 1% 42E2	4822 111 91887
R8542	RES.CHIP	RMC1/8 1% 42E2	4822 111 91887
R8543	RES.METAL FILM	RC-02H 1% 348E	5322 117 10556
R8544	RES.CHIP	RMC1/8 1% 42E2	4822 111 91887
R8545	RES.CHIP	RMC1/8 1% 42E2	4822 111 91887
R8546	RES.CHIP	RMC1/8 1% 42E2	4822 111 91887
R8547	RES.METAL FILM	RC-02H 1% 1K47	5322 117 10527
R8548	RES.METAL FILM	RC-02H 1% 511E	5322 117 10569
R8549	RES.CHIP	RC-02H 1% 261E	4822 051 52611
R8550	RES.METAL FILM	RC-02H 1% 1K47	5322 117 10527
R8551	RES.CHIP	RMC1/8 1% 42E2	4822 111 91887
R8552	RES.CHIP	RMC1/8 1% 42E2	4822 111 91887
R8553	RES.METAL FILM	RC-02H 1% 464E	5322 117 10567
R8554	RES.METAL FILM	RC-02H 1% 562E	5322 117 10572
R8555	RES.CHIP	RMC1/8 1% 42E2	4822 111 91887
R8556	RES.CHIP	RMC1/8 1% 42E2	4822 111 91887
R8557	RES.CHIP	RMC1/8 1% 42E2	4822 111 91887
R8558	RES.CHIP	RMC1/8 1% 42E2	4822 111 91887
R8559	RES.METAL FILM	RC-02H 1% 562E	5322 117 10572
R8560	RES.METAL FILM	RC-02H 1% 464E	5322 117 10567
R8561	RES.CHIP	RMC1/8 1% 42E2	4822 111 91887
R8562	RES.CHIP	RMC1/8 1% 42E2	4822 111 91887
R8563	RES.METAL FILM	RC-02H 1% 1K47	5322 117 10527
R8564	RES.CHIP	RC-02H 1% 261E	4822 051 52611
R8565	RES.METAL FILM	RC-02H 1% 511E	5322 117 10569
R8566	RES.METAL FILM	RC-02H 1% 1K47	5322 117 10527
R8567	RES.CHIP	RMC1/8 1% 42E2	4822 111 91887
R8568	RES.CHIP	RMC1/8 1% 42E2	4822 111 91887
R8569	RES.CHIP	RMC1/8 1% 42E2	4822 111 91887
R8570	RES.METAL FILM	RC-02H 1% 348E	5322 117 10556
R8571	RES.CHIP	RMC1/8 1% 42E2	4822 111 91887
R8572	RES.CHIP	RMC1/8 1% 42E2	4822 111 91887
R8573	RES.METAL FILM	RC-02H 1% 1K21	5322 117 10521
R8574	RES.METAL FILM	RC-02H 1% 162E	5322 117 10529
R8575	RES.CHIP	RMC1/8 1% 42E2	4822 111 91887
R8576	RES.METAL FILM	RC-02H 1% 162E	5322 117 10529
R8577	RES.CHIP	RMC1/8 1% 42E2	4822 111 91887
R8581	RES.METAL FILM	RC-02H 1% 31E6	5322 117 11732
R8581	RES.METAL FILM	RC-02H 1% 100E	4822 051 10101
R8583	RES.METAL FILM	RC-02H 1% 31E6	5322 117 11732
R8583	RES.METAL FILM	RC-02H 1% 100E	4822 051 10101
R8586	RES.METAL FILM	RC-02H 1% 31E6	5322 117 11732
R8586	RES.METAL FILM	RC-02H 1% 100E	4822 051 10101
R8588	RES.METAL FILM	RC-02H 1% 31E6	5322 117 11732
R8588	RES.METAL FILM	RC-02H 1% 100E	4822 051 10101

Item	Description		Ordering code
R8591	RES.CHIP	RMC1/8 1% 10E	4822 111 91885
R8592	RES.CHIP	RMC1/8 1% 10E	4822 111 91885
R8593	RES.CHIP	RMC1/8 1% 10E	4822 111 91885
R8594	RES.CHIP	RMC1/8 1% 10E	4822 111 91885
R8596	RES.METAL FILM	RC-02H 1% 464K	5322 117 10568
R8597	RES.METAL FILM	RC-02H 1% 215K	5322 117 10543
R8598	RES.CHIP	RMC1/8 1% 10E	4822 111 91885
R8601	RES.	RMC1/8 1% 16E2	5322 116 83564
R8602	RES.	RMC1/8 1% 16E2	5322 116 83564
R8603	RES.CHIP	RMC1/8 1% 21E5	5322 111 92014
R8604	RES.CHIP	RMC1/8 1% 21E5	5322 111 92014
R8606	RES.	RMC1/8 1% 16E2	5322 116 83564
R8607	RES.	RMC1/8 1% 16E2	5322 116 83564
R8608	RES.CHIP	RMC1/8 1% 21E5	5322 111 92014
R8609	RES.CHIP	RMC1/8 1% 21E5	5322 111 92014
R8611	RES.METAL FILM	RC-02H 1% 14K7	5322 117 10528
R8612	RES.CHIP	RMC1/8 1% 10E	4822 111 91885
R8621	RES.CHIP	RC-02H 1% 1K	4822 051 10102
R8622	RES.CHIP	RC-02H 1% 100K	4822 051 10104
R8658	RES.CHIP	RMC1/8 1% 10E	4822 111 91885
R8659	RES.METAL FILM	RC-02H 1% 422E	5322 117 10564
R8660	RES.METAL FILM	RC-02H 1% 422E	5322 117 10564
R8697	RES.METAL FILM	RC-02H 1% 316K	5322 117 10555
R8721	RES.CHIP	RMC1/8 1% 42E2	4822 111 91887
R8722	RES.CHIP	RMC1/8 1% 42E2	4822 111 91887
R8723	RES.CHIP	RC-02H 1% 10K	4822 051 10103
R8725	RES.CHIP	RC-02H 1% 5K11	5322 117 10487
R8726	RES.MET.GLAZED	RMC1/8 1% 31E6	5322 116 82895
R8727	RES.METAL FILM	RC-02H 1% 7K5	5322 117 10583
R8728	RES.CHIP	RMC1/8 1% 51E1	5322 111 91893
R8729	RES.CHIP	RMC1/8 1% 42E2	4822 111 91887
R8730	RES.CHIP	RMC1/8 1% 51E1	5322 111 91893
R8731	RES.CHIP	RC-02H 1% 1K	4822 051 10102
R8732	RES.CHIP	RC-02H 1% 100E	4822 051 10101
R8733	RES.METAL FILM	RC-02H 1% 1K62	5322 117 10531
R8734	RES.CHIP	RC-02H 1% 2K15	5322 117 10485
R8735	RES.METAL FILM	RC-02H 1% 1K62	5322 117 10531
R8736	RES.METAL FILM	RC-02H 1% 1K62	5322 117 10531
R8737	RES.CHIP	RC-02H 1% 2K15	5322 117 10485
R8738	RES.METAL FILM	RC-02H 1% 1K62	5322 117 10531
R8739	RES.CHIP	RMC1/8 1% 10E	4822 111 91885
R8740	RES.METAL FILM	RC-02H 1% 7K5	5322 117 10583
R8741	RES.CHIP	RC-02H 1% 100E	4822 051 10101
R8742	RES.METAL FILM	MRS25 1% 3E16	4822 050 23168
R8743	RES.CHIP	RC-02H 1% 100E	4822 051 10101
R8744	RES.CHIP	RC-02H 1% 100E	4822 051 10101
R8745	RES.METAL FILM	RC-02H 1% 1K62	5322 117 10531

Item	Description		Ordering code
R8746	RES.CHIP	RMC1/8 1% 42E2	4822 111 91887
R8747	RES.CHIP	RC-02H 1% 2K15	5322 117 10485
R8748	RES.CHIP	RMC1/8 1% 42E2	4822 111 91887
R8749	RES.METAL FILM	RC-02H 1% 1K62	5322 117 10531
R8750	RES.MET.GLAZED	RMC1/8 1% 31E6	5322 116 82895
R8751	RES.MET.GLAZED	RMC1/8 1% 31E6	5322 116 82895
R8752	RES.MET.GLAZED	RMC1/8 1% 31E6	5322 116 82895
R8753	RES.CHIP	RMC1/8 1% 42E2	4822 111 91887
R8754	RES.CHIP	RC-02H 1% 2K15	5322 117 10485
R8755	RES.CHIP	RMC1/8 1% 42E2	4822 111 91887
R8756	RES.METAL FILM	RC-02H 1% 3K83	5322 117 10561
R8757	RES.METAL FILM	RC-02H 1% 7K5	5322 117 10583
R8758	RES.CHIP	RC-02H 1% 10K	4822 051 10103
R8760	RES.METAL FILM	RC-02H 1% 31K6	5322 117 10554
R8761	RES.METAL FILM	RC-02H 1% 31K6	5322 117 10554
R8762	RES.METAL FILM	RC-02H 1% 31K6	5322 117 10554
R8763	RES.METAL FILM	RC-02H 1% 31K6	5322 117 10554
R8764	RES.CHIP	RC-02H 1% 51K1	4822 051 55113
R8765	RES.CHIP	RMC1/8 1% 10E	4822 111 91885
R8766	RES.CHIP	RC-02H 1% 51K1	4822 051 55113
R8767	RES.METAL FILM	RC-02H 1% 2K87	5322 117 10549
R8768	RES.METAL FILM	RC-02H 1% 2K87	5322 117 10549
R8769	RES.CHIP	RC-02H 1% 51K1	4822 051 55113
R8771	RES.CHIP	RMC1/8 1% 10E	4822 111 91885
R8772	RES.CHIP	RC-02H 1% 51K1	4822 051 55113
R8773	RES.METAL FILM	RC-02H 1% 2K87	5322 117 10549
R8774	RES.METAL FILM	RC-02H 1% 2K87	5322 117 10549
R8775	RES.CHIP	RC-02H 1% 100E	4822 051 10101
R8776	RES.CHIP	RC-02H 1% 100E	4822 051 10101
R8777	RES.CHIP	RC-02H 1% 100E	4822 051 10101
R8778	RES.CHIP	RC-02H 1% 100E	4822 051 10101
R8779	RES.CHIP	RC-02H 1% 100E	4822 051 10101
R8780	RES.CHIP	RC-02H 1% 100E	4822 051 10101
R8781	RES.CHIP	RC-02H 1% 100E	4822 051 10101
R8782	RES.CHIP	RC-02H 1% 100E	4822 051 10101
R8783	RES.CHIP	RC-02H 1% 100E	4822 051 10101
R8784	RES.CHIP	RC-02H 1% 100E	4822 051 10101
R8785	RES.CHIP	RC-02H 1% 100E	4822 051 10101
R8786	RES.CHIP	RC-02H 1% 100E	4822 051 10101
R8787	RES.CHIP	RC-02H 1% 100E	4822 051 10101
R8788	RES.CHIP	RC-02H 1% 100E	4822 051 10101
R8789	RES.CHIP	RC-02H 1% 51K1	4822 051 55113
R8790	RES.CHIP	RC-02H 1% 10K	4822 051 10103
R8791	RES.METAL FILM	RC-02H 1% 7K5	5322 117 10583
R8792	RES.CHIP	RC-02H 1% 51K1	4822 051 55113
R8793	RES.CHIP	RC-02H 1% 10K	4822 051 10103
R8794	RES.METAL FILM	RC-02H 1% 7K5	5322 117 10583

Item	Description		Ordering code
R8795	RES.METAL FILM	RC-02H 1% 7K5	5322 117 10583
R8796	RES.CHIP	RC-02H 1% 10K	4822 051 10103
R8797	RES.CHIP	RC-02H 1% 51K1	4822 051 55113
R8798	RES.METAL FILM	RC-02H 1% 7K5	5322 117 10583
R8799	RES.CHIP	RC-02H 1% 10K	4822 051 10103
R8800	RES.CHIP	RC-02H 1% 51K1	4822 051 55113
R8801	RES.CHIP	RMC1/8 1% 10E	4822 111 91885
R8802	RES.CHIP	RC-02H 1% 261E	4822 051 52611
R8803	RES.CHIP	RC-02H 1% 100E	4822 051 10101
R8804	RES.CHIP	RMC1/8 1% 10E	4822 111 91885
R8805	RES.CHIP	RMC1/8 1% 10E	4822 111 91885
R8806	RES.CHIP	RMC1/8 1% 10E	4822 111 91885
R8807	RES.CHIP	RC-02H 1% 10K	4822 051 10103
R8808	RES.CHIP	RC-02H 1% 10K	4822 051 10103
R8809	RES.CHIP	RMC1/8 1% 10E	4822 111 91885
R8810	RES.CHIP	RMC1/8 1% 21E5	5322 111 92014
R8811	RES.CHIP	RMC1/8 1% 21E5	5322 111 92014
R8812	RES.METAL FILM	RC-02H 1% 464E	5322 117 10567
R8813	RES.CHIP	RC-02H 1% 10K	4822 051 10103
R8814	RES.METAL FILM	RC-02H 1% 75K	5322 117 10584
R8815	RES.CHIP	RMC1/8 1% 90E9	5322 111 92018
R8816	RES.CHIP	RMC1/8 1% 90E9	5322 111 92018
R8817	RES.CHIP	RMC1/8 1% 90E9	5322 111 92018
R8818	RES.CHIP	RMC1/8 1% 90E9	5322 111 92018
R8819	RES.METAL FILM	RC-02H 1% 42K2	5322 117 10566
R8820	RES.METAL FILM	RC-02H 1% 56K2	5322 117 10574
R8821	RES.METAL FILM	RMC1/8 1% 23E7	5322 117 10591
R8822	RES.CHIP	RMC1/8 1% 10E	4822 111 91885
R8823	RES.CHIP	RC-01 5% 5E6	4822 051 10568
R8824	RES.CHIP	RC-01 5% 5E6	4822 051 10568
R8825	RES.CHIP	RC-02H 1% 100E	4822 051 10101
R8826	RES.METAL FILM	RMC1/8 1% 23E7	5322 117 10591
R8827	RES.CHIP	RC-02H 1% 100E	4822 051 10101
R8828	RES.CHIP	RMC1/8 1% 10E	4822 111 91885
R8829	RES.CHIP	RMC1/8 1% 21E5	5322 111 92014
R8830	RES.CHIP	RMC1/8 1% 21E5	5322 111 92014
R8831	RES.CHIP	RC-02H 1% 100K	4822 051 10104
R8832	RES.CHIP	RC-02H 1% 100K	4822 051 10104
R8833	RES.	RMC1/8 1% 16E2	5322 116 83564
R8834	RES.CHIP	RMC1/8 1% 10E	4822 111 91885
R8835	RES.CHIP	RC-01 5% 4E7	4822 051 10478
R8836	RES.CHIP	RC-02H 1% 215E	5322 117 10484
R8837	RES.CHIP	RC-02H 1% 215E	5322 117 10484
R8838	RES.CHIP	RC-02H 1% 215E	5322 117 10484
R8839	RES.MET.GLAZED	RMC1/8 1% 31E6	5322 116 82895
R8840	RES.MET.GLAZED	RMC1/8 1% 31E6	5322 116 82895
R8841	RES.CHIP	RC-01 5% 1E	4822 051 10108

Item	Description		Ordering code
R8842	RES.CHIP	RC-01 5% 1E	4822 051 10108
R8843	RES.METAL FILM	RC-02H 1% 1K62	5322 117 10531
R8844	RES.METAL FILM	RC-02H 1% 1K47	5322 117 10527
R8845	RES.METAL FILM	RC-02H 1% 3K83	5322 117 10561
R8846	RES.METAL FILM	RC-02H 1% 16K2	5322 117 10532
R8847	RES.METAL FILM	RC-02H 1% 1K47	5322 117 10527
R8848	RES.METAL FILM	RC-02H 1% 9K09	5322 117 10589
R8849	RES.CHIP	RC-02H 1% 10K	4822 051 10103
R8850	RES.METAL FILM	RC-02H 1% 2K61	5322 117 10547
R8851	RES.CHIP	RMC1/8 1% 10E	4822 111 91885
R8852	RES.METAL FILM	RC-02H 1% 16K2	5322 117 10532
R8853	RES.METAL FILM	RC-02H 1% 3K48	5322 117 10557
R8854	RES.METAL FILM	RC-02H 1% 2K61	5322 117 10547
R8855	RES.METAL FILM	RC-02H 1% 6K81	5322 117 10581
R8856	RES.METAL FILM	RC-02H 1% 12K1	5322 117 10522
R8857	RES.METAL FILM	RC-02H 1% 619E	5322 117 10576
R8858	RES.METAL FILM	RC-02H 1% 619E	5322 117 10576
R8859	RES.METAL FILM	RC-02H 1% 3K48	5322 117 10557
R8860	RES.METAL FILM	RC-02H 1% 17K8	5322 117 10536
R8861	RES.METAL FILM	RC-02H 1% 348E	5322 117 10556
R8862	RES.METAL FILM	RC-02H 1% 7K5	5322 117 10583
R8863	RES.METAL FILM	RC-02H 1% 75K	5322 117 10584
R8864	RES.CHIP	RC-02H 1% 10K	4822 051 10103
R8865	RES.CHIP	RMC1/8 1% 10E	4822 111 91885
R8868	RES.METAL FILM	RC-02H 1% 562K	5322 117 10575
R8869	RES.METAL FILM	RC-02H 1% 56K2	5322 117 10574
R8870	RES.METAL FILM	RC-02H 1% 56K2	5322 117 10574
R8871	RES.METAL FILM	RC-02H 1% 562K	5322 117 10575
R8872	RES.CHIP	RMC1/8 1% 10E	4822 111 91885
R8874	RES.CHIP	RC-01 5% 4E7	4822 051 10478
R8875	RES.CHIP	RC-01 5% 4E7	4822 051 10478
R8876	RES.CHIP	RC-02H 1% 100E	4822 051 10101
R8877	RES.CHIP	RC-01 5% 3E3	4822 051 10338
R8878	RES.METAL FILM	RC-02H 1% 56K2	5322 117 10574
R8879	RES.CHIP	RC-02H 1% 1K	4822 051 10102
R8880	RES.CHIP	RMC1/8 1% 10E	4822 111 91885
R8881	RES.METAL FILM	RC-02H 1% 237E	5322 117 10544
R8882	RES.METAL FILM	RC-02H 1% 14K7	5322 117 10528
R8883	RES.METAL FILM	RC-02H 1% 681E	5322 117 10579
R8884	RES.METAL FILM	RC-02H 1% 31K6	5322 117 10554
R8885	RES.METAL FILM	RC-02H 1% 14K7	5322 117 10528
R8886	RES.METAL FILM	RC-02H 1% 31K6	5322 117 10554
R8887	RES.CHIP	RMC1/8 1% 21E5	5322 111 92014
R8888	RES.METAL FILM	RMC1/8 1% 38E3	5322 116 83728
R8889	RES.METAL FILM	RC-02H 1% 1K96	5322 117 10539
R8889	RES.CHIP	RC-02H 1% 1K47	4822 051 51472
R8890	RES.METAL FILM	RC-02H 1% 1K96	5322 117 10539

Item	Description		Ordering code
R8890	RES.CHIP	RC-02H 1% 1K47	4822 051 51472
R8891	RES.METAL FILM	RC-02H 1% 1K96	5322 117 10539
R8891	RES.CHIP	RC-02H 1% 1K47	4822 051 51472
R8892	RES.METAL FILM	RC-02H 1% 1K96	5322 117 10539
R8892	RES.CHIP	RC-02H 1% 1K47	4822 051 51472
R8893	RES.CHIP	RMC1/8 1% 75E	4822 111 91937
R8894	RES.CHIP	RMC1/8 1% 75E	4822 111 91937
R8895	RES.METAL FILM	RC-02H 1% 61K9	5322 117 10578
R8895	RES.CHIP	RC-02H 1% 51K1	4822 051 55113
R8896	RES.CHIP	RC-02H 1% 10K	4822 051 10103
R8896	RES.CHIP	RC-02H 1% 7K5	5322 117 10583
R8897	RES.METAL FILM	RC-02H 1% 16K2	5322 117 10532
R8898	RES.CHIP	RC-02H 1% 100E	4822 051 10101
R8901	RES.METAL FILM	RC-02H 1% 1K96	5322 117 10539
R8902	RES.METAL FILM	RC-02H 1% 3K16	5322 117 10553
R8903	RES.METAL FILM	RC-02H 1% 5K62	5322 117 10573
R8911	RES.METAL FILM	RC-02H 1% 26K1	5322 117 10548
R8912	RES.METAL FILM	RC-02H 1% 1K21	5322 117 10521
R8913	RES.METAL FILM	RC-02H 1% 26K1	5322 117 10548
R8914	RES.METAL FILM	RC-02H 1% 1K21	5322 117 10521
R8916	RES.METAL FILM	RC-02H 1% 383K	5322 117 10563
R8917	RES.CHIP	RC-02H 1% 1M	4822 051 10105
R8918	RES.METAL FILM	RC-02H 1% 178K	5322 117 10537
R8919	RES.METAL FILM	RC-02H 1% 825K	5322 117 10587
R8920	RES.CHIP	RC-02H 1% 10K	4822 051 10103
R8921	RES.METAL FILM	RC-02H 1% 316K	5322 117 10555
R8922	RES.CHIP	RC-02H 1% 1M	4822 051 10105
R8923	RES.METAL FILM	RC-02H 1% 178K	5322 117 10537
R8924	RES.METAL FILM	RC-02H 1% 825K	5322 117 10587
R8925	RES.CHIP	RC-02H 1% 10K	4822 051 10103
R8926	RES.METAL FILM	RC-02H 1% 316K	5322 117 10555
R8927	RES.METAL FILM	RC-02H 1% 383K	5322 117 10563
R8928	RES.CHIP	RC-02H 1% 1K	4822 051 10102
R8931	RES.METAL FILM	RC-02H 1% 38K3	5322 117 10562
R8932	RES.METAL FILM	RC-02H 1% 38K3	5322 117 10562
R8933	RES.METAL FILM	RC-02H 1% 38K3	5322 117 10562
R8934	RES.METAL FILM	RC-02H 1% 38K3	5322 117 10562
R8936	RES.METAL FILM	RC-02H 1% 38K3	5322 117 10562
R8937	RES.METAL FILM	RC-02H 1% 38K3	5322 117 10562
R8938	RES.METAL FILM	RC-02H 1% 38K3	5322 117 10562
R8939	RES.METAL FILM	RC-02H 1% 38K3	5322 117 10562

Item	Description		Ordering code
SEMICONDUCTORS			
V8001	TRANSISTOR,CHIP	BC848C PEL	5322 130 42136
V8002	TRANSISTOR,CHIP	BC848C PEL	5322 130 42136
V8003	TRANSISTOR,CHIP	BC848C PEL	5322 130 42136
V8004	TRANSISTOR,CHIP	BC848C PEL	5322 130 42136
V8006	TRANSISTOR,CHIP	BC858C PEL	4822 130 42513
V8007	TRANSISTOR,CHIP	BC858C PEL	4822 130 42513
V8008	TRANSISTOR,CHIP	BC858C PEL	4822 130 42513
V8009	TRANSISTOR,CHIP	BC858C PEL	4822 130 42513
V8011	TRANSISTOR,CHIP	BC858C PEL	4822 130 42513
V8012	TRANSISTOR,CHIP	BC858C PEL	4822 130 42513
V8014	TRANSISTOR,CHIP	BC858C PEL	4822 130 42513
V8017	TRANSISTOR,CHIP	BC858C PEL	4822 130 42513
V8018	TRANSISTOR,CHIP	BC858C PEL	4822 130 42513
V8019	TRANSISTOR,CHIP	BC858C PEL	4822 130 42513
V8021	TRANSISTOR,CHIP	BC858C PEL	4822 130 42513
V8022	TRANSISTOR,CHIP	BC858C PEL	4822 130 42513
V8024	DIODE,CHIP	BAS28 PEL	5322 130 80214
V8027	TRANSISTOR,CHIP	BC858C PEL	4822 130 42513
V8028	TRANSISTOR,CHIP	BC858C PEL	4822 130 42513
V8029	TRANSISTOR,CHIP	BC858C PEL	4822 130 42513
V8031	TRANSISTOR,CHIP	BC858C PEL	4822 130 42513
V8032	TRANSISTOR,CHIP	BC858C PEL	4822 130 42513
V8033	TRANSISTOR,CHIP	BC858C PEL	4822 130 42513
V8036	TRANSISTOR,CHIP	BC858C PEL	4822 130 42513
V8037	TRANSISTOR,CHIP	BC858C PEL	4822 130 42513
V8038	TRANSISTOR,CHIP	BC858C PEL	4822 130 42513
V8039	TRANSISTOR,CHIP	BC858C PEL	4822 130 42513
V8040	TRANSISTOR,CHIP	BC858C PEL	4822 130 42513
V8041	TRANSISTOR,CHIP	BC858C PEL	4822 130 42513
V8042	TRANSISTOR,CHIP	BC858C PEL	4822 130 42513
V8043	TRANSISTOR,CHIP	BC858C PEL	4822 130 42513
V8044	TRANSISTOR,CHIP	BC858C PEL	4822 130 42513
V8045	TRANSISTOR,CHIP	BF579 TEL	5322 130 63453
V8046	TRANSISTOR,CHIP	BC858C PEL	4822 130 42513
V8047	TRANSISTOR,CHIP	BF579 TEL	5322 130 63453
V8048	TRANSISTOR,CHIP	BF579 TEL	5322 130 63453
V8050	DIODE,CHIP	BAV99 PEL	5322 130 34337
V8051	TRANSISTOR,CHIP	BF579 TEL	5322 130 63453
V8053	TRANSISTOR,CHIP	BF579 TEL	5322 130 63453
V8054	TRANSISTOR,CHIP	BF579 TEL	5322 130 63453
V8057	TRANSISTOR,CHIP	BF579 TEL	5322 130 63453
V8058	TRANSISTOR,CHIP	BF579 TEL	5322 130 63453
V8059	TRANSISTOR,CHIP	BF579 TEL	5322 130 63453
V8061	TRANSISTOR,CHIP	BF579 TEL	5322 130 63453
V8064	TRANSISTOR,CHIP	BF579 TEL	5322 130 63453

Item	Description		Ordering code
V8066	TRANSISTOR,CHIP	BF579 TEL	5322 130 63453
V8067	TRANSISTOR,CHIP	BF579 TEL	5322 130 63453
V8068	TRANSISTOR,CHIP	BF579 TEL	5322 130 63453
V8069	TRANSISTOR,CHIP	BF579 TEL	5322 130 63453
V8071	TRANSISTOR,CHIP	BF579 TEL	5322 130 63453
V8074	TRANSISTOR,CHIP	BF579 TEL	5322 130 63453
V8077	TRANSISTOR,CHIP	BF579 TEL	5322 130 63453
V8078	TRANSISTOR,CHIP	BF579 TEL	5322 130 63453
V8079	TRANSISTOR,CHIP	BF579 TEL	5322 130 63453
V8081	TRANSISTOR,CHIP	BF579 TEL	5322 130 63453
V8082	TRANSISTOR,CHIP	BF579 TEL	5322 130 63453
V8083	TRANSISTOR,CHIP	BF579 TEL	5322 130 63453
V8084	TRANSISTOR,CHIP	BF579 TEL	5322 130 63453
V8086	TRANSISTOR,CHIP	BF579 TEL	5322 130 63453
V8087	TRANSISTOR,CHIP	BF579 TEL	5322 130 63453
V8088	TRANSISTOR,CHIP	BF579 TEL	5322 130 63453
V8089	TRANSISTOR,CHIP	BF579 TEL	5322 130 63453
V8090	DIODE,REFERENCE	BZX84-C5V6 PEL	4822 130 80125
V8091	TRANSISTOR,CHIP	BF579 TEL	5322 130 63453
V8092	DIODE,REFERENCE	BZX84-C2V4 PEL	4822 130 33703
V8095	DIODE,REFERENCE	BZX84-C5V1 PEL	5322 130 32835
V8096	DIODE,CHIP	BAV99 PEL	5322 130 34337
V8097	DIODE,CHIP	BAV99 PEL	5322 130 34337
V8098	DIODE,CHIP	BAV99 PEL	5322 130 34337
V8099	DIODE,CHIP	BAV99 PEL	5322 130 34337
V8101	DIODE,CHIP	BAV70 PEL	5322 130 34331
V8103	DIODE,CHIP	BAV99 PEL	5322 130 34337
V8104	DIODE,REFERENCE	BZX84-C2V4 PEL	4822 130 33703
V8106	DIODE,CHIP	BAV99 PEL	5322 130 34337
V8107	DIODE,CHIP	BAV99 PEL	5322 130 34337
V8109	DIODE,CHIP	BAV99 PEL	5322 130 34337
V8111	DIODE,CHIP	BAV99 PEL	5322 130 34337
V8112	DIODE,CHIP	BAV99 PEL	5322 130 34337
V8113	DIODE,CHIP	BAV99 PEL	5322 130 34337
V8114	DIODE,REFERENCE	BZX84-C3V3 PEL	4822 130 33003
V8117	DIODE,CHIP	BAV99 PEL	5322 130 34337
V8122	DIODE,CHIP	BAS28 PEL	5322 130 80214
V8124	TRANSISTOR,CHIP	BFT93 PEL	5322 130 44824
V8126	TRANSISTOR,CHIP	BFT93 PEL	5322 130 44824
V8127	TRANSISTOR,CHIP	BC858C PEL	4822 130 42513
V8128	TRANSISTOR,CHIP	BC848CR PEL	4822 130 42729
V8129	TRANSISTOR,CHIP	BSS83 PEL	5322 130 60502
V8130	TRANSISTOR,CHIP	BSS83 PEL	5322 130 60502
V8131	TRANSISTOR,CHIP	BSS83 PEL	5322 130 60502
V8132	TRANSISTOR,CHIP	BSS83 PEL	5322 130 60502
V8133	TRANSISTOR,CHIP	BSS83 PEL	5322 130 60502
V8134	TRANSISTOR,CHIP	BF512 PEL	5322 130 44875

Item	Description		Ordering code
V8135	TRANSISTOR,CHIP	BSS83 PEL	5322 130 60502
V8136	TRANSISTOR,CHIP	BF512 PEL	5322 130 44875
V8137	INTEGR.CIRCUIT	NPDS5911 NSC	5322 209 31301
V8138	TRANSISTOR,CHIP	BF579 TEL	5322 130 63453
V8139	TRANSISTOR,CHIP	BF579 TEL	5322 130 63453
V8140	TRANSISTOR,CHIP	BF579 TEL	5322 130 63453
V8141	TRANSISTOR,CHIP	BF579 TEL	5322 130 63453
V8142	DIODE,REFERENCE	BZX84-C2V4 PEL	4822 130 33703
V8143	DIODE,REFERENCE	BZX84-C2V4 PEL	4822 130 33703
V8151	DIODE,CHIP	BAT17 PEL	5322 130 31544
V8175	TRANSISTOR,CHIP	BC848C PEL	5322 130 42136
V8176	TRANSISTOR,CHIP	BC848C PEL	5322 130 42136
V8177	TRANSISTOR,CHIP	BC848C PEL	5322 130 42136
V8178	TRANSISTOR,CHIP	BC848C PEL	5322 130 42136
V8181	TRANSISTOR,CHIP	BF579 TEL	5322 130 63453
V8182	TRANSISTOR,CHIP	BF579 TEL	5322 130 63453
V8183	TRANSISTOR,CHIP	BF579 TEL	5322 130 63453
V8184	TRANSISTOR,CHIP	BF579 TEL	5322 130 63453
V8185	TRANSISTOR,CHIP	BF579 TEL	5322 130 63453
V8186	TRANSISTOR,CHIP	BF579 TEL	5322 130 63453
V8187	DIODE	BBY62 PEL	5322 130 82685
V8188	DIODE	BBY62 PEL	5322 130 82685
V8189	DIODE	BBY62 PEL	5322 130 82685
V8190	DIODE	BBY62 PEL	5322 130 82685
V8191	TRANSISTOR,CHIP	BC858C PEL	4822 130 42513
V8192	TRANSISTOR,CHIP	BC858C PEL	4822 130 42513
V8193	TRANSISTOR,CHIP	BC848C PEL	5322 130 42136
V8194	TRANSISTOR,CHIP	BC848C PEL	5322 130 42136
V8195	TRANSISTOR,CHIP	BC848C PEL	5322 130 42136
V8196	TRANSISTOR,CHIP	BC848C PEL	5322 130 42136
V8197	TRANSISTOR,CHIP	BC848C PEL	5322 130 42136
V8198	TRANSISTOR,CHIP	BC858C PEL	4822 130 42513
V8199	TRANSISTOR,CHIP	BC858C PEL	4822 130 42513
V8200	TRANSISTOR,CHIP	BC858C PEL	4822 130 42513
V8201	TRANSISTOR,CHIP	BC858C PEL	4822 130 42513
V8202	TRANSISTOR,CHIP	BC848C PEL	5322 130 42136
V8203	TRANSISTOR,CHIP	BC848C PEL	5322 130 42136
V8204	TRANSISTOR,CHIP	BC848C PEL	5322 130 42136
V8205	TRANSISTOR,CHIP	BC848C PEL	5322 130 42136
V8208	DIODE,CHIP	BAV99 PEL	5322 130 34337
V8209	DIODE,CHIP	BAV99 PEL	5322 130 34337
V8210	TRANSISTOR	BD139 PEL	4822 130 40823
V8212	DIODE,CHIP	BAV99 PEL	5322 130 34337
V8216	DIODE,CHIP	BAT17 PEL	5322 130 31544
V8217	DIODE,CHIP	BAT17 PEL	5322 130 31544
V8218	DIODE,CHIP	BAT17 PEL	5322 130 31544
V8219	DIODE,CHIP	BAT17 PEL	5322 130 31544

Item	Description		Ordering code
V8221	DIODE,CHIP	BAT17 PEL	5322 130 31544
V8222	DIODE,CHIP	BAT17 PEL	5322 130 31544
V8223	DIODE,CHIP	BAT17 PEL	5322 130 31544
V8224	DIODE,CHIP	BAT17 PEL	5322 130 31544
X8001	HOLD,OBJECTIVE	CONTACTPIN	5322 268 14141
X8001	SOCKET,MALE	50 OHM BUS	5322 265 10266
X8002	HOLD,OBJECTIVE	CONTACTPIN	5322 268 14141
X8002	SOCKET,MALE	50 OHM BUS	5322 265 10266
X8008	HOLD,OBJECTIVE	CONTACTPIN	5322 268 14141
X8008	SOCKET,MALE	50 OHM BUS	5322 265 10266
X8009	HOLD,OBJECTIVE	CONTACTPIN	5322 268 14141
X8009	SOCKET,MALE	50 OHM BUS	5322 265 10266
X8011	HOLD,OBJECTIVE	CONTACTPIN	5322 268 14141
X8011	SOCKET,MALE	50 OHM BUS	5322 265 10266
X8012	HOLD,OBJECTIVE	CONTACTPIN	5322 268 14141
X8012	SOCKET,MALE	50 OHM BUS	5322 265 10266
X8018	HOLD,OBJECTIVE	CONTACTPIN	5322 268 14141
X8018	SOCKET,MALE	50 OHM BUS	5322 265 10266
X8019	HOLD,OBJECTIVE	CONTACTPIN	5322 268 14141
X8019	SOCKET,MALE	50 OHM BUS	5322 265 10266
X8101	CONNECTOR	64-P PIN 2.54	5322 265 61243
X8501	HOLD,OBJECTIVE	CONTACTPIN	5322 268 14141
X8501	SOCKET,MALE	50 OHM BUS	5322 265 10266
X8502	HOLD,OBJECTIVE	CONTACTPIN	5322 268 14141
X8502	SOCKET,MALE	50 OHM BUS	5322 265 10266
X8503	HOLD,OBJECTIVE	CONTACTPIN	5322 268 14141
X8503	SOCKET,MALE	50 OHM BUS	5322 265 10266
X8504	HOLD,OBJECTIVE	CONTACTPIN	5322 268 14141
X8504	SOCKET,MALE	50 OHM BUS	5322 265 10266
X8505	HOLD,OBJECTIVE	CONTACTPIN	5322 268 14141
X8505	SOCKET,MALE	50 OHM BUS	5322 265 10266

5.9 RESERVED FOR FUTURE EXTENSIONS

5.10 CONNECTOR BOARD A10

5.10.1 Unit lay-out

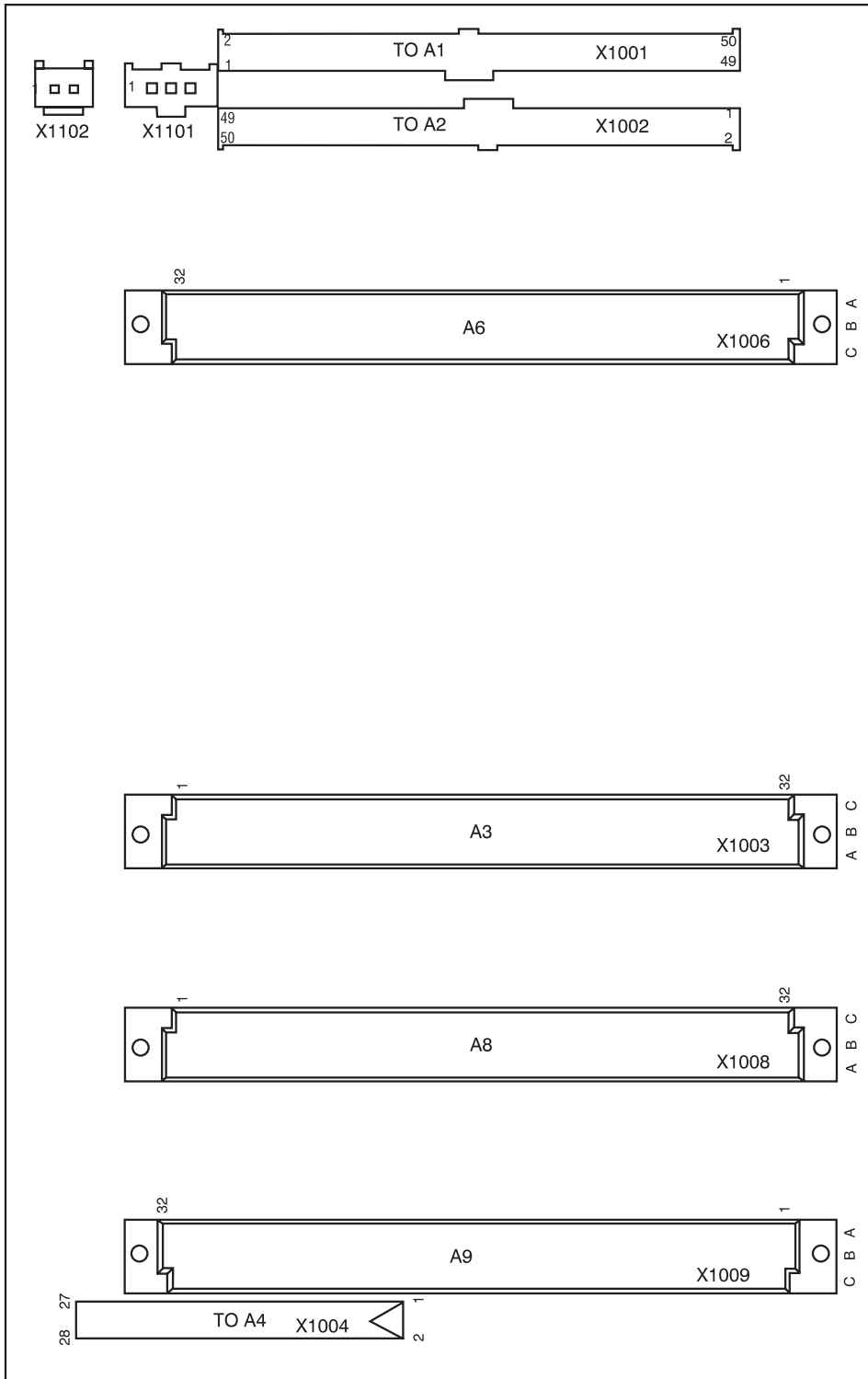

ST8350
970728

Lay-out 1 - lay-out of connector board A10

5.10.2 Circuit diagrams

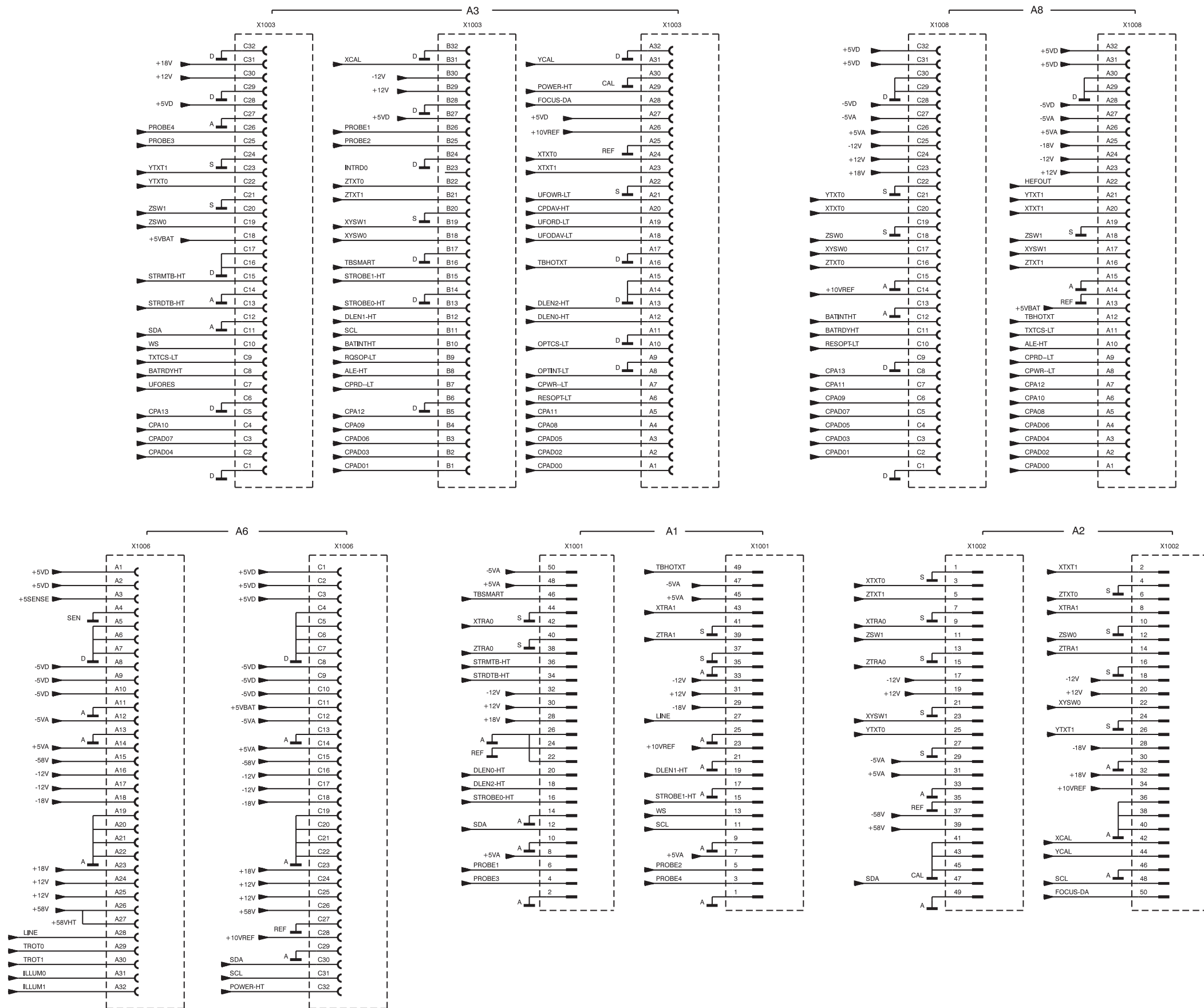

ST8354
970728

A10 - Diagram 1; Connectors to unit A1, A2 A3 and A6

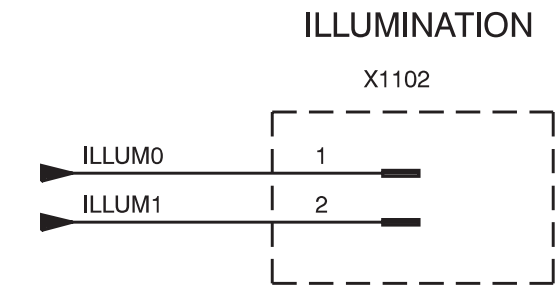
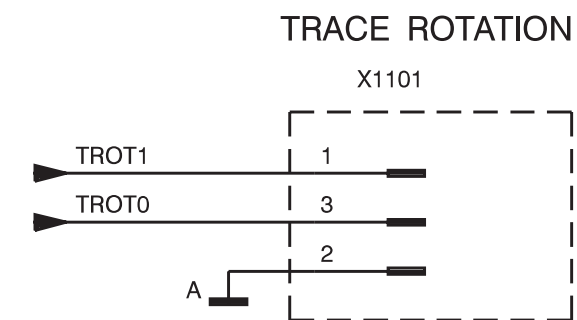
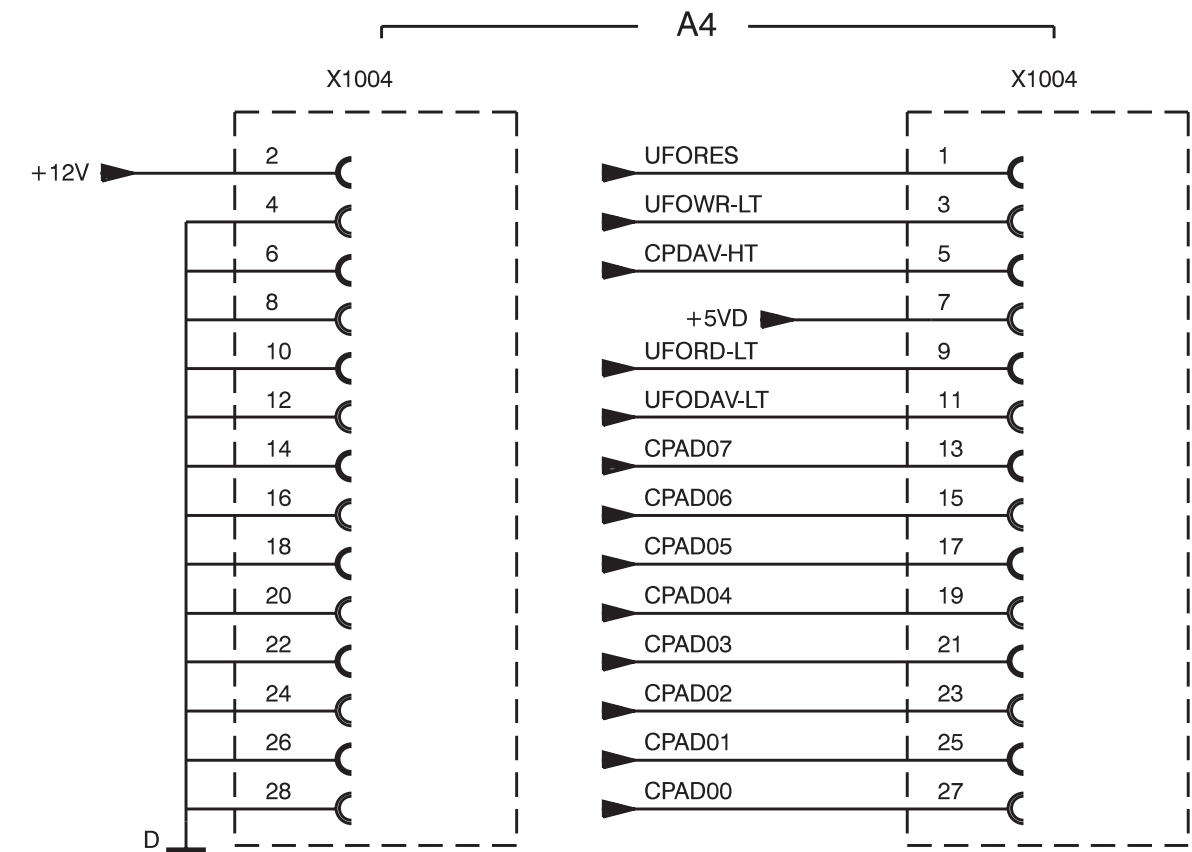
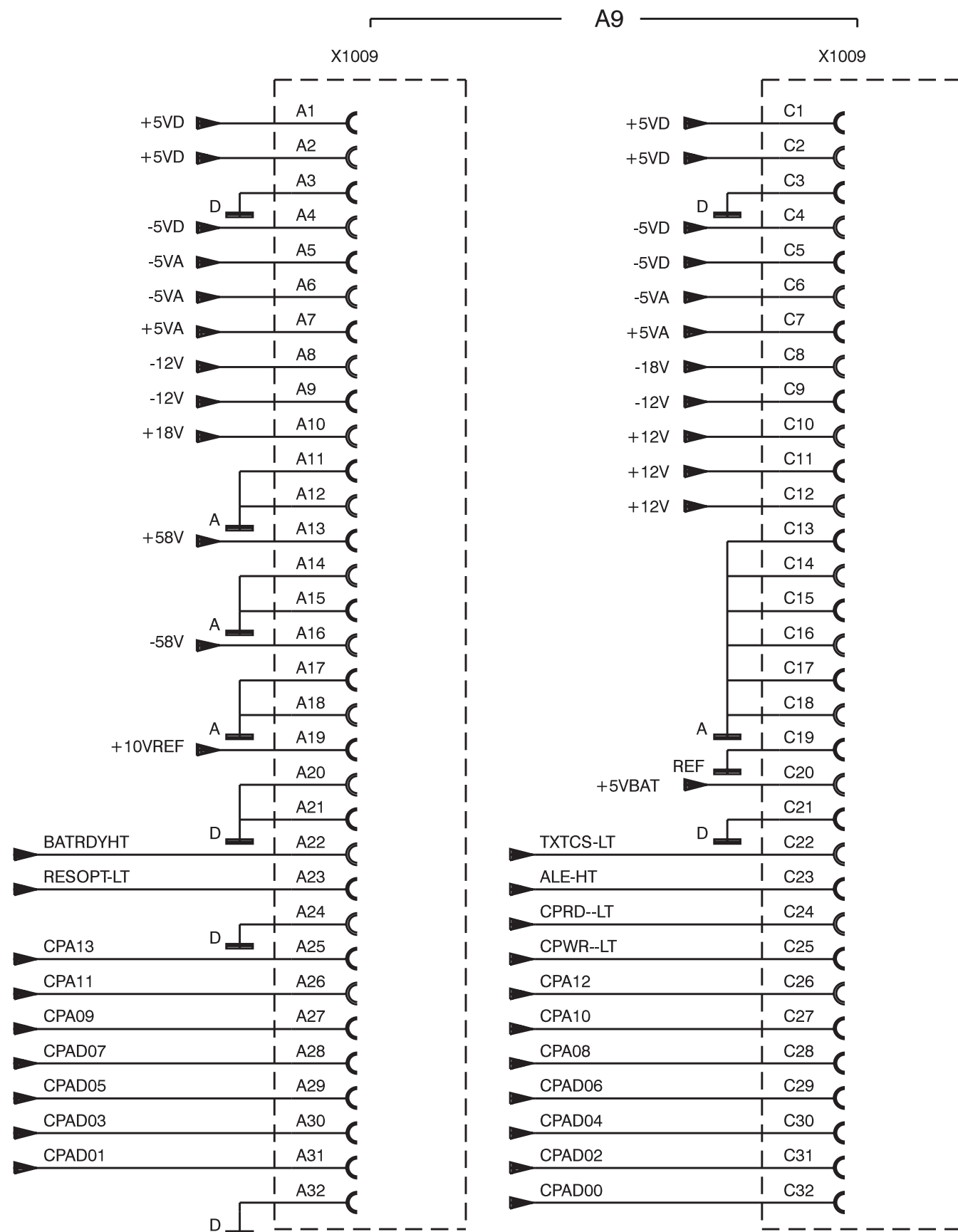

ST8355
970728

A10 - Diagram 2; Connectors to unit A4, A9, trace rotation and illumination

Item	Description		Ordering code
5.10.3 Parts list			
CONNECTORS			
X 1001	CONNECTOR	50-P DBL STRGHT	5322 265 61242
X 1002	CONNECTOR	50-P DBL STRGHT	5322 265 61242
X 1003	CONNECTOR	96-P 2.54MM	5322 267 51108
X 1004	CONNECTOR	P 1.25MM STR	5322 267 60311
X 1006	CONNECTOR	64-P 2.54MM	5322 267 70308
x 1008	CONNECTOR	96-P 2.54MM	5322 267 51108
X 1009	CONNECTOR	96-P 2.54MM	5322 267 51108
X 1101	CONNECTOR	3-P SNG STRGHT	5322 265 30434
X 1102	CONNECTOR	2-P SNG STRGHT	5322 265 20275

5.11 FACTORY INSTALLED OPTIONS

5.11.1 IEEE-OPTION

This option enables the oscilloscope to be controlled by an IEEE-system using the SCPI protocol (SCPI = Standard Commands for Programmable Instruments). The IEEE connector is located at the rear panel of the oscilloscope. The version number of this factory-installable option is /40. The interface circuitry is located at the microprocessor unit A3. The specification of the interface is given in chapter 2.17. Programming data is given in a separate 'SCPI Programming Manual'.

The description is a part of the explanation of the complete unit A3 and is given in chapter 5.3. The IEEE-option requires additional software and thus requires an additional flash-ROM D1015. The IEEE-components in an oscilloscope without IEEE- option are not inserted.

5.11.2 AUXILIARY OUTPUTS OPTION

Introduction

This option comprises 3 rear panel BNC outputs that provide Y- out, MTB-gate-out and DTB-gate-out signals. The characteristics of the output signals are listed in chapter 2.16.3 'Optional outputs' in this manual. This option is always combined with the EXTTRIG option (see section 5.11.3).

General description

MTB-gate-out and DTB-gate-out are realized by adding rear panel BNC sockets and coaxial interconnection cables. The coaxial cables lead to the already existing 2-pole connectors on signal unit A1. The necessary circuitry is already present on unit A1. Refer for this to figure 1. The Y- out requires a small printed circuit board, a rear panel BNC socket and a coaxial interconnection cable. The small printed circuit board is equipped with soldering pins that fit directly into unit A1. The lay-out of this unit is given in figure 2; the belonging circuit diagram in figure 3.

Circuit description

The balanced input signals for the Y-out unit are FNCYOP0 and FNCYOP1. The signals originate from pin 5 and 6 of D1301 in the Y-functions section of signal unit A1.

The input current signal is applied to common base circuit V1001/V1002. Then it is applied as current signal to pin 9 and 8 of N1001. The output current signals are routed from pin 11 and 6 to pin 13 and 16. The voltage signal at output pins 12 is used as feedback via C1002/R1009. The voltage signal at output pin 1 is used as output signal via the emitterfollowers N1001/2,3,4 and V1006. Feedback is achieved via R1024/C1011.

Parts list

Item number	Description	Service ord code
C 1001	10nF/63V	5322 122 34098
C 1002	3.3pF/63V	5322 122 32286
C 1005	3.9pF/63V	5322 122 31944
C 1006	1pF/63V	5322 122 32447
C 1009	10pF/63V	5322 122 32448
C 1011	3.9pF/63V	5322 122 31944
C 1012	10nF/63V	5322 122 34098
C 1013	10nF/63V	5322 122 34098
C 1014	22pF/63V	4822 122 33575
C 1017	22nF/63V	5322 122 32654
C 1018	100nF/63V	4822 122 33496
C 1019	100nF/63V	4822 122 33496
C 1021	100nF/63V	4822 122 33496

Item	Description	Service ord code
R 1001	12k1/1%	4822 051 51213
R 1002	1k1/1%	4822 051 51102
R 1003	1k/1%	4822 051 51002
R 1004	51E1/1%	5322 111 91893
R 1005	1L/1%	4822 051 10102
R 1006	5k11/1%	4822 051 55112
R 1007	750E/1%	4822 051 57501
R 1008	750E/1%	4822 051 57501
R 1009	21E5/1%	5322 111 92014
R 1011	51E1/5%	5322 111 91893
R 1012	51E1/5%	5322 111 91893
R 1013	100E/1%	4822 051 51001
R 1014	100E/1%	4822 051 51001
R 1015	5k11/1%	4822 051 55112
R 1016	110E/1%	4822 051 51101
R 1017	750E/1%	4822 051 57501
R 1018	110E/1%	4822 051 51101
R 1019	5K11/1%	4822 051 55112
R 1021	562E/1%	5322 117 10487
R 1022	562E/1%	5322 117 10487
R 1023	147E/1%	4822 051 51471
R 1024	31E6/1%	5322 117 117 32
R 1026	100E/1%	4822 051 51001
R 1027	101E/1%	5322 117 11733
R 1028	750E/1%	4822 051 57501
R 1029	1k33/1%	4822 051 51332
R 1031	1K/1%	4822 051 51002
R 1032	5k11/1%	4822 051 55112
R 1033	75E/1%	5322 117 11741
R 1034	75E/1%	5322 117 11741
R 1036	1k/1%	4822 051 51002
R 1037	51E1/1%	5322 111 91893
R 1038	511E/1%	4822 051 55111
R 1039	511E/1%	4822 051 55111
R 1041	4E7/5%	4822 051 10478
R 1042	4E7/5%	4822 051 10478
R 6101	1k/1%	4822 051 51002
R 8053	1E/5%	4822 051 10108
R 8073	1k/1%	4822 051 51002
R 8137	3k16/1%	4822 724 53162
R 8138	3k16/1%	4822 724 53162
V 1001	BF579	5322 130 61819
V 1002	BF579	5322 130 61819
V 1006	BFR53	5322 130 61244
V 1007	BZX84-C6V2	5322 130 33671
X 1011	Male Header	5322 265 20525

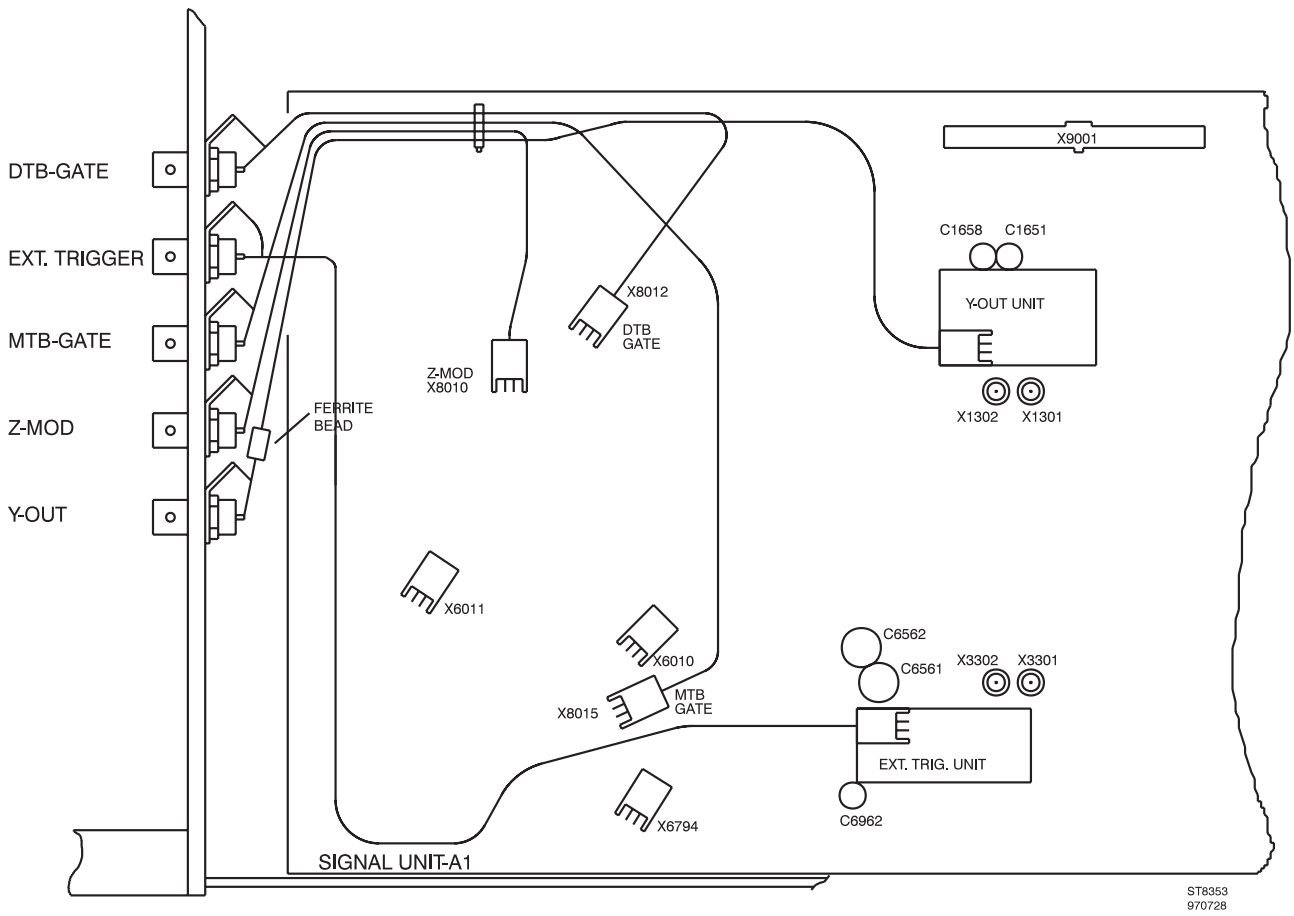

ST8353
970728

Fig. 1. Location of options Y-out and external trigger

5.11.3 EXTERNAL TRIGGER OPTION

Introduction

The External Trigger Input option provides an extra input at the rear of the oscilloscope. This input can be used as the trigger source for the Main Time Base (MTB). The option is factory-installable only. The external trigger requires a small printed circuit board, a rear panel BNC socket and a coaxial interconnection cable.

The small printed circuit board is equipped with soldering pins that fit directly into unit A1. Refer to figure 1 for the exact location. The lay-out of this unit is given in figure 4; the belonging circuit diagram in figure 5.

The EXT TRIG input is suitable for use with the supplied 10:1 probe. The input characteristics are similar to those of CH1...CH4.

If External is chosen as trigger source, then the following trigger functions remain available:

- trigger filters ac, dc, lf_rej and hf_rej
- level-pp function
- +/- slope selection
- noise on/off

If External trigger is chosen as trigger source, then TV trigger mode is not available.

Line (50/60 Hz mains) as trigger source is not available.

If the External trigger option is present together with 'Y- out' option, then the DTB gate output of the Y-out is not available.

A diode V7801 (BAV99, 5322 130 34337) is added on signal unit A1. This diode is connected to the 'panel version identification' circuit D9013. By means of this, the internal software knows that the external trigger option is present. Diode V7801 is located on unit A1 between V7802 and R7077.

Circuit description

Refer to figure 5 for the circuit diagram. The input signal is routed via RC circuit R1001/C1002 and a coaxial cable to the small printed circuit board. Via protection diodes V2002 the signal is applied to the operational amplifier N2021. This device functions as amplifier and level shifter. The analog multiplexer D2031 the output signal MTRIGEXT. This signal is applied to the base of transistor V6507 in the MTB trigger section on unit A1 (diagram 12). Multiplexer D2031 applies -9 V (-9EXT) to the diodes V2012 if the external trigger signal is not needed. This suppresses the signal directly at the input.

Item	Description	Service ord code
Parts list		
C 1001	33pF/500V	4822 122 31202
C 2082	47uF/25V	4822 124 20699
C 2091	47uF/25V	4822 124 20699
C 2001	68pF/63V	4822 126 13694
C 2003	100nF/63V	4822 122 33496
C 2004	100nF/63V	4822 122 33496
C 2011	10nF/63V	5322 122 34098
C 2016	100nF/63V	4822 122 33496
C 2021	100pF/63V	5322 122 32531
C 2023	33pF/63V	5322 122 32659
C 2032	100nF/63V	4822 122 33496
C 2082	100nF/63V	4822 122 33496
C 2086	100nF/63V	4822 122 33496
C 2092	100nF/63V	4822 122 33496
C 2094	100nF/63V	4822 122 33496
D 2031	HEF4053CM	5322 209 33502
R 1001	750k/0.25%	5322 116 53588
R 2001	511k/1%	4822 051 55114
R 2002	511k/1%	4822 051 55114
R 2013	10M/5%	4822 051 10106
R 2014	10M/5%	4822 051 10106
R 2021	1K96/1%	5322 117 10539
R 2022	14k7/1%	4822 051 51473
R 2023	1k47/1%	4822 051 51472
R 2024	3k16/1%	4822 051 53162
R 2033	1k47/1%	4822 051 51472
R 2051	14k7/1%	4822 051 51473
R 2052	2k15/1%	4822 051 52152
R 2054	5k11/1%	4822 051 55112
R 2061	2k15/1%	4822 051 51252
R 2062	14k7/1%	4822 051 51473
R 2063	5k11/1%	4822 051 55112
R 2081	4E7/5%	4822 051 10478
R 2086	4E7/5%	4822 051 10478
R 2091	4E7/5%	4822 051 10478
R 2094	5k11/5%	4822 051 55112
V 2002	BAS28	5322 130 80214
V 2012	BAS28	5322 130 80214
V 2053	BC848C	5322 130 42136
V 2064	BC858C	4822 130 42513
V 2093	BZX84-C3V0	5322 130 32739
X 2001	Male Header	5322 265 20525

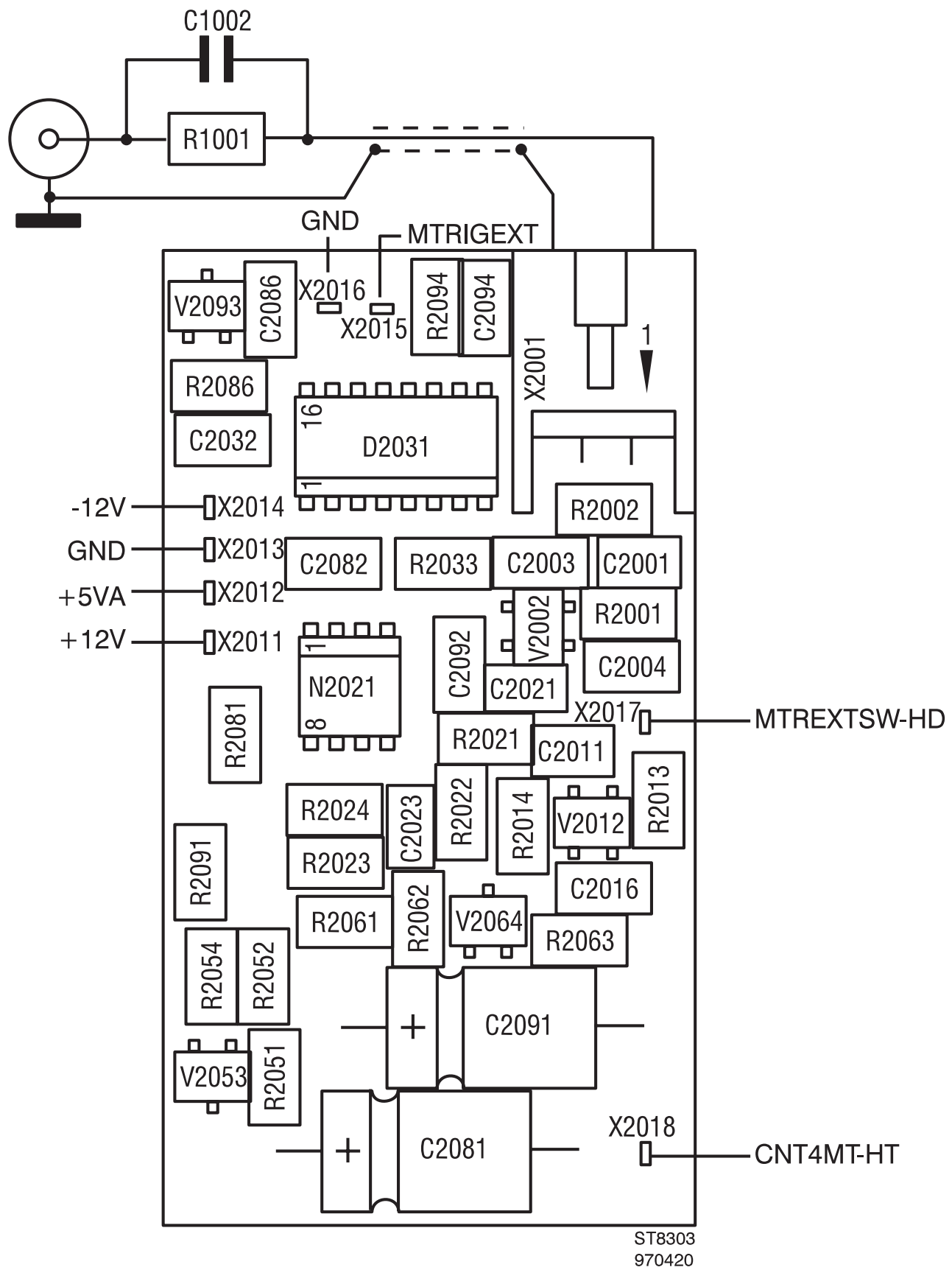

Fig. 4. Printed circuit board lay-out of external trigger unit

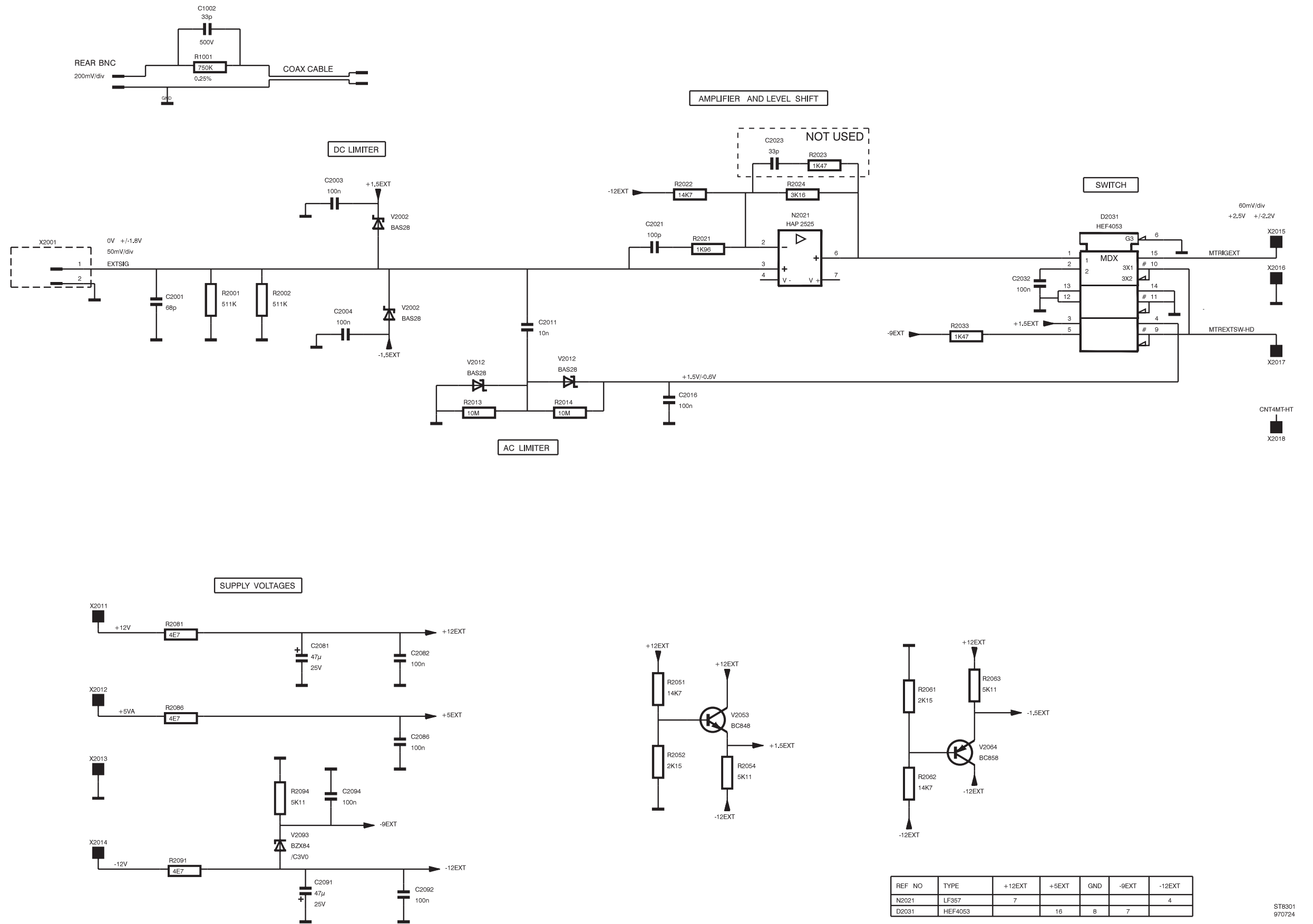

Fig. 5. Printed circuit board lay-out of external trigger unit

6 PERFORMANCE TEST

6.1 GENERAL INFORMATION

WARNING: Before turning on the instrument, ensure that it has been installed in accordance with the Installation Instructions, outlined in Section 2 of the Operation Guide.

This procedure is intended to:

- Check the instrument's specification.
- Be used for incoming inspection to determine the acceptability of newly purchased instruments and/or recently recalibrated instruments.
- Check the necessity of recalibration after the specified recalibration intervals.

NOTE: *The procedure does not check every facet of the instrument's calibration; rather, it is concerned primarily with those parts of the instrument which are essential to measurement accuracy and correct operation. Removing the instrument covers is not necessary to perform this procedure. All tests are made from the outside of the instrument.*

If the test is started shortly after turning on the instrument, steps may be out of specification, due to insufficient warm up time. Be sure to allow the full warm up time of 35 minutes (under average conditions).

The tests are made with a stable, well-focused, low-intensity display. Unless otherwise noted, adjust the intensity, position, and trigger level controls as needed.

IMPORTANT NOTES

- The input voltage must be supplied to the CH1 input, unless otherwise stated. Set the MAIN TB TIME/div key pair to a suitable position, unless otherwise stated.
- Tolerances given are for the instrument under test and do not include test equipment error. Bear in mind that the test equipment and connecting cables are properly terminated. In case of high-frequency signals, this termination must be 50Ω. This is achieved with a 50Ω termination at the end of the cable. Such termination is not necessary for the PM3394B (all channels), or CH1, CH2 of the PM3390B; these oscilloscopes feature switchable internal 50Ω input impedance.
- In some tests vertical channels CH2, CH3, CH4 appear in parentheses after CH1, e.g., CH1 (CH2, CH3, CH4). This indicates that the CH1 test should be performed first, followed by the tests for CH2, CH3 and CH4.
- Some of the tests are not necessary for all five oscilloscope types. An example are the channels CH3, CH4 that are not present in PM3370B/80B/90B. This is indicated as necessary. The test step may then be skipped.
- Where required, tests are done in either analog or digital mode. Switching between analog and digital mode is done by pressing the ANALOG key. When you enter either analog or digital mode, the display indicates 'ANALOG MODE' or 'DIGITAL MODE' briefly.
- Test steps where the use of a 10:1 probe is mentioned, must be done with the probe type such as delivered with the oscilloscope.
- The test set-up figures in this section are universal: they indicate the most extensive 4 channel instrument.
For PM3370B/80B/90B, the CH3 input is not present and the CH4 input socket is an EXTERNAL TRIGGER input.

6.2 RECOMMENDED TEST EQUIPMENT

Note: The FLUKE 5500A has to be equipped with the SCOPE option and is always used in SCOPE mode (SCOPE button active).

Note: The digital multimeter and oscilloscope are not required for this test. they are used for corrective maintenance.

Type of instrument	Required specification	Example of recommended instrument
Function generator	Freq: 10 Hz...100 kHz Sine /square-wave Ampl: 1.8mV...55V (pp)	FLUKE 5500A mode: wavegen
Constant amplitude sine wave generator	Freq: 50kHz...300 MHz Constant pp. amplitude of 5mV to 5.5V.	FLUKE 5500A mode: le sine
Square-wave calibration generator	For ampl. calibration: Freq: 10 Hz...10kHz Ampl: 1.8 mV...2.2V pp	FLUKE 5500A mode: volt
	For rise time measurements: Freq: 1kHz...1MHz Ampl: 4.5mV...2.75V	FLUKE 5500A mode: edge
Time marker generator	Repetition rate: 5 sec...2 nsec	FLUKE 5500A mode: marker
Digital multimeter	Wide voltage and current ranges.	Fluke 29 / 79 with AC, DC and resistance ranges. High voltage probe. Required: 1% accuracy, model 80K40
Variable voltage transformer (VARIAC)	Well insulated output voltage 90...264V	
TV pattern generator	with video output	Fluke PM5418
Oscilloscope	The bandwidth must be the same or higher than the bandwidth of the instrument under test.	PM3394B
50Ω cables, 75Ω cables, 50Ω termination, 75Ω termination, 10:1 attenuator, 2:1 attenuator, T-piece, power splitter	Tektronix and Fluke BNC types for fast rise time square-wave, high frequency sine wave and other applications.	PM9074 PM9075 PM9585 (1W), PM9581 (3W) TEK 011-0055-01 TEK 011-0059-02 TEK 011-0069-02 PM9067 PM9584/02

6.3 TEST PROCEDURE

6.3.1 Preliminary settings

Test equipment:

None

Settings/procedure and requirements:

- 1 - If not present install 2 penlight (LR6) back up batteries in the holder at the rear panel of the oscilloscope.
- 2 - Turn on the oscilloscope under test.
- 3 - Press the STATUS and TEXT OFF keys simultaneously. This assures that the oscilloscope follows the default reaction when the green AUTOSET key is pressed. You can verify that the oscilloscope is in analog mode by pressing the RUN/STOP key. If you are in analog mode, the message 'PLEASE FIRST SWITCH TO DSO' is displayed. The now following steps are applicable for PM3390B and PM3394B.
- 4 - Press the UTILITY menu key to display the UTILITY menu.
- 5 - Press softkey AUTOSET to display the UTILITY AUTOSET menu.
- 6 - Press the relevant softkey to put the oscilloscope in the 'userprog' mode; the text 'userprog' must be intensified.
- 7 - Press softkey VERT.
- 8 - Select with softkey '1M Ω / 50 Ω / unaffected' the 'unaffected' position.
- 9 - Check for the instrument settings in the lower part of the viewing area: when not available press TEXT OFF until the maximum amount of information is displayed.

6.3.2 Power supply

This test checks the proper operation of the power supply at all possible line voltages.

Test equipment:

Variable voltage transformer (VARIAC)

Test set-up:

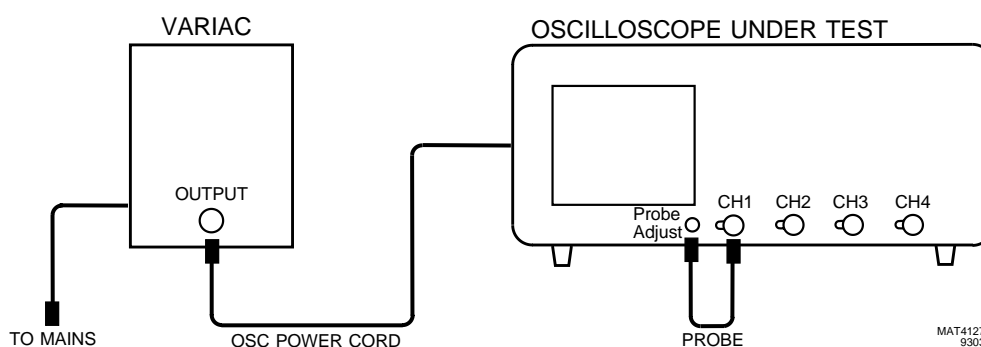

Settings/procedure:

- 1 - Adjust the input line voltage to the oscilloscope (output from VARIAC) to a desired value between 100 and 240V (rms), frequency 50...400 Hz.
- 2 - Press POWER ON on the oscilloscope.
- 3 - Apply the Probe Adjust signal from the front panel of the oscilloscope to input CH1, e.g., by means of a 10:1 probe.
- 4 - Press the green AUTOSET key.

Requirements:

- 1 - Verify that the oscilloscope starts at any input voltage between 100 and 240V; in particular the line voltages 100, 120, 220 and 240V must be checked.
- 2 - Verify that the instrument's performance does not change over the indicated voltage range; and that the displayed Probe Adjust signal is distortion-free and has equal intensity.
- 3 - Press the ANALOG key ('DIGITAL MODE' is displayed briefly), and verify that the instrument's performance does not change in digital mode at the indicated line voltages (100, 120, 220 and 240V). The displayed Probe Adjust signal must be free from distortion.
- 4 - Press the ANALOG key ('ANALOG MODE' is displayed briefly) to switch to analog mode.

6.3.3 Auto set

This test checks the correct working of the AUTOSET function.

Test equipment:

Fluke 5500A mode lev sine (Alternative: Constant amplitude sine wave generator SG 503).

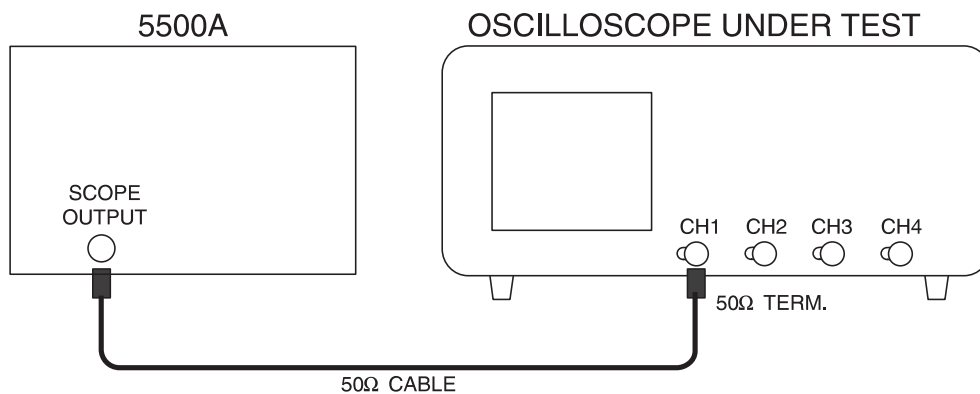
Test set-up:

ST8103

Settings/procedure:

- 1 - Apply a 10 MHz sine wave signal of 600 mV (pp into 50Ω) to input CH1;.
- 2 - Press the green AUTOSET key. Use a 50Ω termination at the end of the coax cable. For instruments with switchable 50Ω input impedance (attainable via VERT MENU key) it is recommended to use the internal termination (when active, the text 'LZ' appears in the lower part of the viewing area). For instruments without internal termination, an external termination should be used.

Requirements:

- 1 - Verify that the displayed waveform is stable and properly triggered. Amplitude should be within the screen area. Horizontally some signal periods should be displayed.
- 2 - Repeat the same settings and procedure for CH2, CH3 and CH4. For PM3370B/80B/90B: check CH2 and input EXT TRIG.
- 3 - Press the ANALOG key to return to digital mode. The message 'DIGITAL MODE' appears briefly.
- 4 - Repeat the AUTOSET check in the digital mode for CH2, CH3, and CH4. For PM3370B/80B/90B: check CH2 and input EXT TRIG.

6.3.4 Orthogonality

This test checks the angle between the horizontal and vertical deflection plates (orthogonality).

Test equipment:

Fluke 5500A mode wavegen, wave sine (Alternative: function generator PM5136).

Test set up:

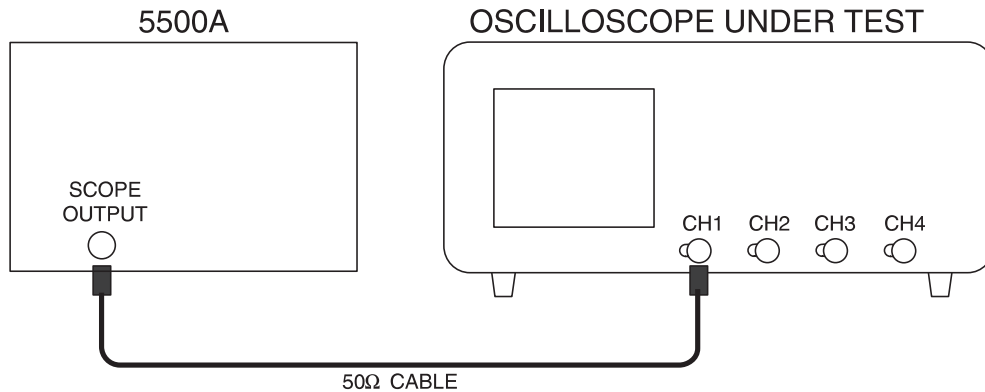

Settings/procedure:

- 1 - Press the CAL key for a few seconds to start the autocal procedure. This takes approximately 4 minutes. When ready, the oscilloscope is fine tuned to optimal accuracy.
- 2 - Apply a 50 Hz sine wave signal of 8V (pp) to input CH1;
- 3 - Press the AUTOSSET key and adjust the input signal to a trace- height of 8 div (CH1 in 1V/div).
- 4 - Activate the GND function and verify that the straight line is exactly parallel to the horizontal graticule lines. If not, readjust the TRACE ROTATION.
- 5 - Switch the GND function off and verify that a signal of 8 divisions is displayed.
- 6 - Press the DISPLAY menu key.
- 7 - Press the X-DEFL softkey.
- 8 - Select 'on' and 'ch2' from the X-DEFL menu.
- 9 - Use the X POS control to move the vertical line to the center of the screen.

Requirements:

- 1 - Verify that the vertical line is parallel to the vertical graticule line in the center of the screen.
- 2 - Verify that the angle with respect to the horizontal graticule lines is $90^\circ \pm 0.5^\circ$ as indicated in the figure.

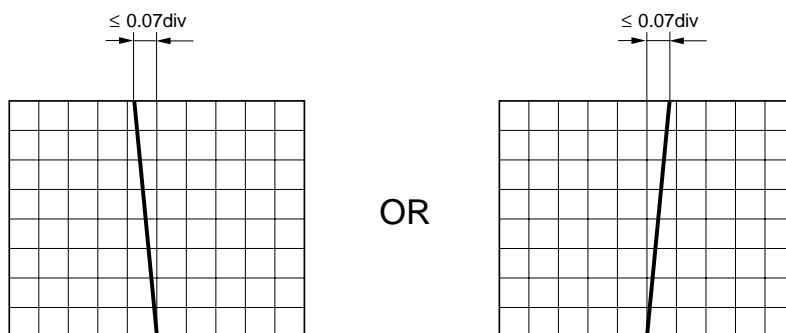

Figure 6.1 Orthogonality

6.3.5 Trace distortion

This test checks the distortion of a horizontal line in the central 6 x 8 divisions of the screen.

Test equipment:

None

Settings/procedure:

- 1 - Press the AUTOSET key with no input signal applied to the scope.
- 2 - Use the CH1 POS control to shift the timebase line vertically across the center 6 divisions of the screen.

Requirements:

- Verify that the deviation from the ideal straight line does not exceed 0.03 divisions in the center of screen and 0.1 divisions elsewhere.

Test equipment:

Fluke 5500A mode: wavegen, wave sine (Alternative: function generator PM5136).

Test set-up:

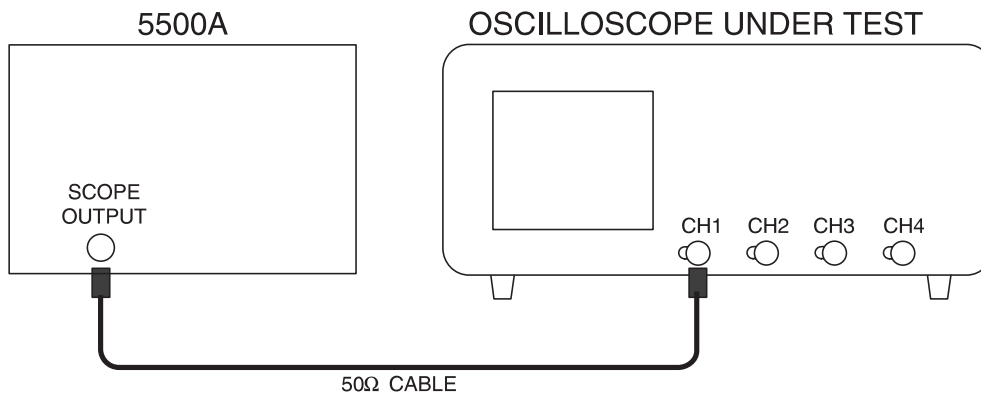

ST8104

Settings/procedure:

- 1 - Apply a 50 Hz sine wave signal of 8V (pp) to input CH1;
- 2 - Press the AUTOSET key and adjust the input signal to an amplitude of 8 divisions (CH1 in 1V/div).
- 3 - Using the CH1 POS control, adjust the display around the center of the screen.
- 6 - Press the DISPLAY menu key.
- 7 - Press the X-DEFL softkey.
- 8 - Select 'on' and 'ch2' from the X-DEFL menu.
- 9 - Use the X POS control to shift the vertical line across the middle eight divisions of the screen.

Requirements:

- Verify that the deviation from the ideal straight line does not exceed 0.03 divisions in the center of screen and 0.1 divisions elsewhere.

6.3.6 Vertical deflection; deflection coefficients

The vertical deflection coefficients of channels CH1, CH2, CH3, and CH4 are checked by means of a calibrated signal. PM3370B/80B/90B: the channels CH1, CH2 and TRIG VIEW via input EXT TRIG are checked.

Test equipment:

Fluke 5500A mode: volt (Alternative: Square-wave calibration generator PG 506).

Test set up:

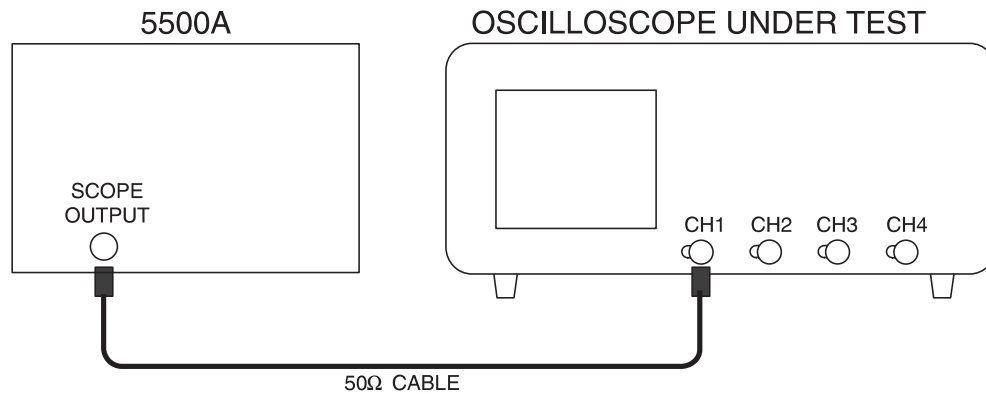

ST8104

Settings/procedure:

- 1 - Apply a 1 kHz square-wave signal of 30 mV to input CH1. Set the generator in 'volt' mode. The generator must not be terminated with 50Ω (the text 'LZ' must not be visible in the lower part of the viewing area).
- 2 - Press the green AUTOSET key.
- 3 - Set CH1 to 5 mV/div and to DC input coupling. The waveform must be in the vertical middle of the screen.
- 4 - Press the ACQUIRE menu key.
- 5 - Select BW LIMIT 'on' from the VERT MENU key.
- 6 - Press the TRIGGER menu key.
- 7 - Select noise 'on' and 'hf-rej' from the TRIGGER MAIN TB menu.
- 8 - Change the input voltage and the setting of CH1 according to table I and verify that the amplitude of the signal agrees with this table. The signal should remain positioned in the vertical center of the screen.

Note: Only the input sensitivities essential for input accuracy are checked.

Requirements:

table I.

Input voltage (pp)	Setting	Requirements analog mode	Requirements digital mode
30 mV	5 mV	5.92...6.08 div (±1.3%)	5.88...6.12 div (±2%)
60 mV	10 mV	5.92...6.08 div (±1.3%)	5.88...6.12 div (±2%)
1.2V	0.2V	5.92...6.08 div (±1.3%)	5.88...6.12 div (±2%)
6V	1V	5.92...6.08 div (±1.3%)	5.88...6.12 div (±2%)

Repeat the settings/procedure in table I for CH2, CH3 and CH4. Use table II for PM3370B/80B/90B to test TRIG VIEW via input EXT TRIG. Select AC input coupling to center the trace on the screen.

table II.

Input voltage (pp)	Setting	Requirements analog mode	Requirements digital mode
0.6V	0.1V	5.82...6.18 div ($\pm 3\%$)	5.82...6.18 ($\pm 3\%$)
6V	1V	5.82...6.18 div ($\pm 3\%$)	5.82...6.18 ($\pm 3\%$)

- Press the ANALOG key ('DIGITAL MODE' is displayed briefly), and repeat the tests in this chapter for the digital mode.
- Press the ANALOG key ('ANALOG MODE' is displayed briefly) to return to analog mode.

6.3.7 Vertical deflection; variable gain control range (continuation of 6.3.6)

This test checks the vertical VARIable gain control.

Settings/procedure:

- 1 - Apply a square-wave signal of 0.2V to input CH1 and press AUTOSET.
- 2 - Set CH1 to 50 mV/div and input coupling to DC. Using the CH1 POS control, center the waveform in the screen.
- 3 - Select the VARIable mode by simultaneously pressing both AMPL keys. The readout changes into 50.0 mV/div.
- 4 - Press the mV key to adjust an input sensitivity of 40.0 mV/div.

Requirements:

- 1 - Verify that the displayed amplitude is between 4.86 and 5.14 divisions ($\pm 2.8\%$).
- 2 - Repeat the settings and procedure for CH2. For the PM3394B and PM3384B repeat the same steps for CH3 and CH4.

6.3.8 Vertical deflection; input coupling (continuation of 6.3.7)

This test verifies the operation of the AC input coupling. Also, the operation of the ground (GND) function is checked.

Settings/procedure:

- 1 - Switch the CH1 VARIable mode off by simultaneously pressing both AMPL/VAR keys. The readout changes to 50 mV.
- 2 - CH1 sensitivity is 50 mV/div; the vertical deflection is now 4 divisions.

Requirements:

- 1 - Activate the CH1 GND function and verify that a horizontal line is displayed.
- 2 - Select the AC input coupling and verify that a 4 divisions square-wave signal is displayed. Center this signal in the middle of the screen.
- 3 - Select the DC input coupling and verify that the 4 divisions square-wave signal moves up. This shift is caused by the signal's positive dc component: this component is not blocked in DC coupled mode.

Repeat the settings and procedure for CH2, CH3, and CH4. PM3370B/80B/90B: check CH2 and TRIG VIEW via EXT TRIG input for AC and DC coupling.

6.3.9 Vertical cursor accuracy (continuation of 6.3.8.)

This test verifies the accuracy of the voltage cursors

Settings/procedure:

- 1 - Change the generator output voltage to 0.1V.
- 2 - Apply this voltage to CH1.
- 3 - Switch CH1 to ON, and switch the other channels off.
- 4 - Select DC coupled input and 20 mV/division for CH1.
- 5 - Select CH1 as trigger source (TRIG 1).
- 6 - Use the POS control to center the 5 division square wave on the dotted horizontal lines of the graticule.
- 7 - Press the CURSORS menu key.
- 8 - Select 'on' and volt cursors (=) from in the CURSORS menu.
- 9 - Select ΔV from the READOUT menu.

Requirements:

- 1 - Use the TRACK and Δ controls to position both cursor lines exactly on top and bottom of the signal. Check for a cursor readout between 98.4 and 101.6 mV.
- 2 - Press the ANALOG key ('DIGITAL MODE' is displayed briefly) and repeat the check in this chapter for the digital mode.
- 3 - Press the ANALOG key ('ANALOG MODE' is displayed briefly) to return to analog mode.

6.3.10 Vertical deflection; high-frequency response

This test verifies the upper transition point of the vertical bandwidth.

Test equipment:

Fluke 5500A mode: levsine (Alternative: constant amplitude sine wave generator SG 503).

Test set-up:

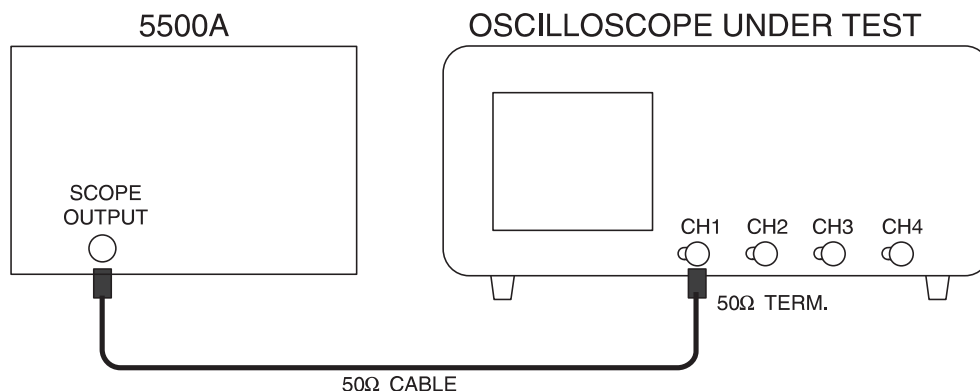

ST8103

Settings/procedure:

- 1 - Apply a 50 kHz sine wave signal of 600 mV (pp into 50 Ω) to input CH1, and press the AUTOSET key.
- 2 - Use an external 50 Ω termination. Use the internal termination of the oscilloscope, when available (if active, the text 'LZ' is visible in the lower part of the viewing area). Internal 50 Ω termination is attainable via the VERT MENU key (PM3390B/94B).
- 3 - Set CH1 to 0.1V/div.
- 4 - Adjust the input signal to an amplitude of exactly 6 divisions.
- 5 - Slowly increase the frequency to 200 MHz (PM3390B, PM3394B), 100 MHz (PM3384B, PM3380B) or 60 MHz (PM3370B) and verify that the displayed amplitude does not drop below 4.2 divisions.
- 6 - Switch the frequency of the sine wave signal back to 50 kHz.

- 7 - Press the ACQUIRE menu key.
- 8 - Select BW LIMIT 'on' via the VERT MENU key.
- 9 - Slowly increase the frequency to 20 MHz and verify that the vertical deflection has decreased to 4.2 div approximately at 20 MHz.
- 10 - Switch the bandwidth limiter to 'off'.

Requirements:

- The vertical deflection must be 4.2 divisions or more. For the bandwidth limiter the requirement is 4.2 div approximately at 20 MHz.

Repeat the above settings and procedure for CH2, CH3 and CH4. PM3370B/80B/90B: check CH2 and TRIG VIEW via EXT TRIG input. Oscilloscope in 1V/div and generator voltage 5 Vpp into 50Ω. Termination resistor directly at generator output. Use a BNC / probe tip adapter between termination and 10:1 probe. Adjust the amplitude at 50 kHz to 5 divisions. Check that the amplitude at higher frequencies does not drop below 3.5 div.

- Press the ANALOG key ('DIGITAL MODE' is displayed briefly) and repeat the tests in this section for the digital mode. Adjust the MAIN TB TIME/DIV if required.

6.3.11 Vertical deflection; low-frequency response

This test verifies the lower transition point of the vertical bandwidth.

Test equipment:

Fluke 5500A mode: wavgen, wave sine (Alternative: function generator PM5136).

Test set up:

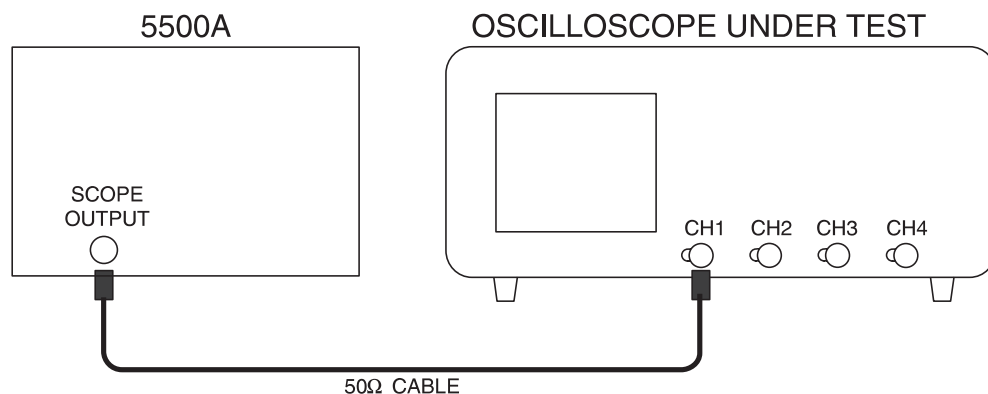

ST8104

Settings/procedure:

- 1 - Apply a 5 kHz sine wave signal of 600 mV (pp into 50Ω) to input CH1, and press the AUTASET key.
- 2 - Set CH1 to 0.1V/div.
- 3 - Adjust the input signal to an amplitude of exactly 6 divisions.
- 4 - Lower the frequency to 10 Hz and verify that the displayed amplitude does not drop below 4.2 divisions.

Requirements:

- The vertical deflection must be 4.2 divisions or more.

Repeat the above settings and procedure for CH2, CH3, and CH4. PM3370B/80B/90B: check CH2 and TRIG VIEW via EXT TRIG input.

Press the ANALOG key ('ANALOG MODE' is displayed briefly) to return to analog mode.

6.3.12 Vertical deflection; dynamic range at 15/25/50 MHz

The oscilloscope must be capable of displaying signal amplitudes that are larger than the screen. In practice, a low frequency signal with an amplitude equivalent to 24 divisions must be displayed with no distortion.

Test equipment:

Fluke 5500A mode: levsine (Alternative: constant amplitude sine wave generator SG 503).

Test set up:

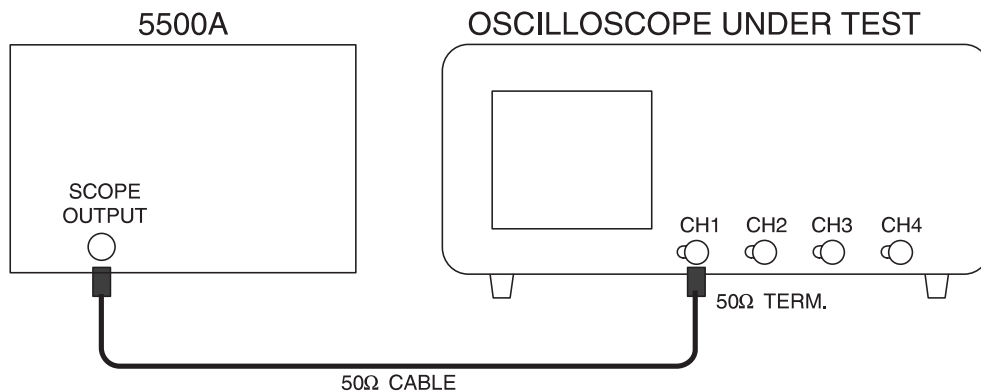

ST8103

Settings/procedure:

- 1 - Apply a 50 MHz (PM3390B/94B), 25 MHz (PM3380B/84B) or 15 MHz (PM3370B) sine wave signal of 2.4 V(pp into 50Ω) to input CH1 and press the AUTOSET key.
- 2 - Use a 50Ω termination. Use the internal termination when available.
- 3 - Set CH1 to 0.1V/div.
- 4 - Using the CH1 POS control, shift the sine wave vertically over the screen.

Requirements:

- Verify that top and bottom of the sine-wave signal of 24 divisions in amplitude can be displayed with no distortion.

Repeat the above settings and procedure for CH2, CH3, and CH4. PM3370B/80B/90B: check CH2.

6.3.13 Vertical deflection; dynamic range at 60/100/200 MHz (continuation of 6.3.12)

In this test, the dynamic range of the amplifier is checked at a high frequency.

Settings/procedure:

- 1 - Apply a 200 MHz (PM3390B/94B), 100 MHz (PM3380B/84B) or 60 MHz (PM3370B) sine-wave signal of 0.8 V(pp into 50Ω) to input CH1.
- 2 - Press the AUTOSET key, and set CH1 to 0.1V/div.
- 3 - Use a 50Ω termination. Use the internal termination when available.
- 4 - Set the amplitude to exactly 8 divisions.

Requirements:

- Verify that the sine wave of 8 divisions in amplitude is displayed with no distortion.

Repeat the above settings and procedure for CH2, CH3, and CH4. PM3370B/80B/90B: check CH2.

6.3.14 Vertical deflection; position range

The range of the vertical shift is checked with a sine-wave signal of 8 divisions in amplitude.

Test equipment

Fluke 5500A mode: wavegen, wave sine (Alternative function generator PM5136).

Test set up:

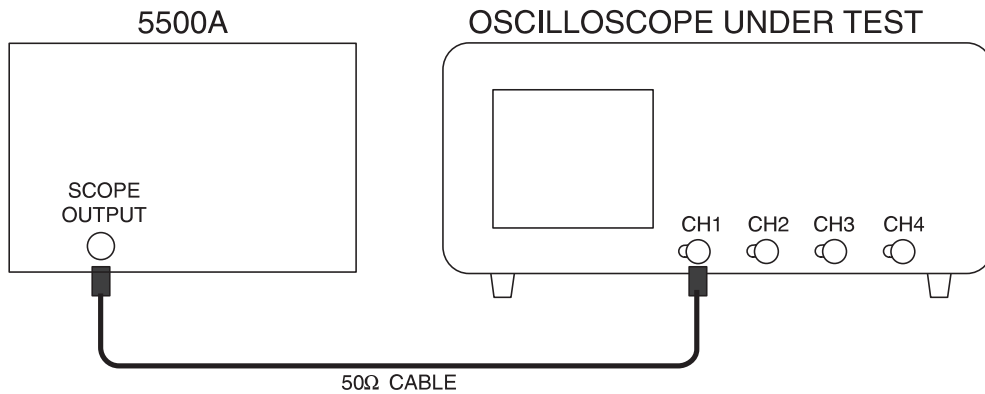

Settings/procedure:

- 1 - Apply a 1 kHz sine wave signal with an amplitude of 0.8 V (pp) to input CH1.
- 2 - Press the AUTOSSET key and set CH1 to 0.1V/div.
- 3 - Adjust the generator so that the displayed amplitude is exactly 8 divisions.

Requirements

- Turn the CH1 POS control fully clockwise and counterclockwise and verify that top and bottom of the 8 divisions signal can be positioned outside the graticule.

Repeat the above settings and procedure for CH2, CH3, and CH4. PM3370B/80B/90B: check CH2.

6.3.15 Vertical deflection; crosstalk between channels at 60/100/200 MHz

At higher frequencies there exists some crosstalk between any two channels. In the following test, crosstalk is verified at a high frequency.

Test equipment:

Fluke 5500A mode: levsine (Alternative constant amplitude sine wave generator SG 503).

Test set up:

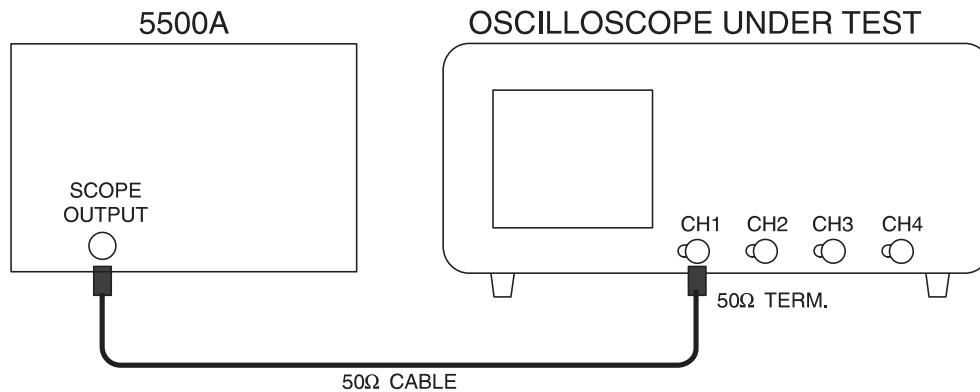

ST8103

Settings/procedure:

- 1 - Apply a 200 MHz (PM3390B/94B), 100 MHz (PM3380B/84B) or 60 MHz (PM3370B) sine-wave signal of 0.8 V(pp into 50Ω) to input CH1.
- 2 - Press the AUTOSET key.
- 3 - Use a 50Ω termination. Use the internal termination when available.
- 4 - Switch all channels ON. PM3370B/80B/90B: switch CH2 on.
- 5 - Set all channels to 0.1 V/div.
- 6 - Adjust the generator to a signal amplitude of 8 div.
- 7 - Activate the GND function of CH2, CH3, and CH4. PM3370B/80B/90B: activate GND of CH2.

Requirements:

- Verify that the displayed amplitude the channels with no input signal applied is less than 0.16 divisions, (better than 50:1).

Repeat the above settings and procedure for PM3384B/94B:

- Input signal applied to CH2. CH1, CH3, and CH4 input GND.
- Input signal applied to CH3. CH1, CH2, and CH4 input GND.
- Input signal applied to CH4. CH1, CH2, and CH3 input GND.

Repeat the above settings and procedures for PM3370B/80B/90B:

- Input signal applied to CH2. CH1 input GND.

For all models:

- Press the ANALOG key ('DIGITAL MODE' is displayed briefly) and repeat the tests in this chapter for the digital mode.
- Press the ANALOG key ('ANALOG MODE' is displayed briefly) to return to analog mode.

6.3.16 Vertical deflection; common mode rejection ratio at 1 MHz

The common mode rejection ratio (CMRR) is a measure of susceptibility to common mode signals. This susceptibility is verified in this test.

Test equipment:

Fluke 5500A mode: levsine (Alternative: HF constant amplitude sine wave generator SG 503)
Power splitter

Test set up:

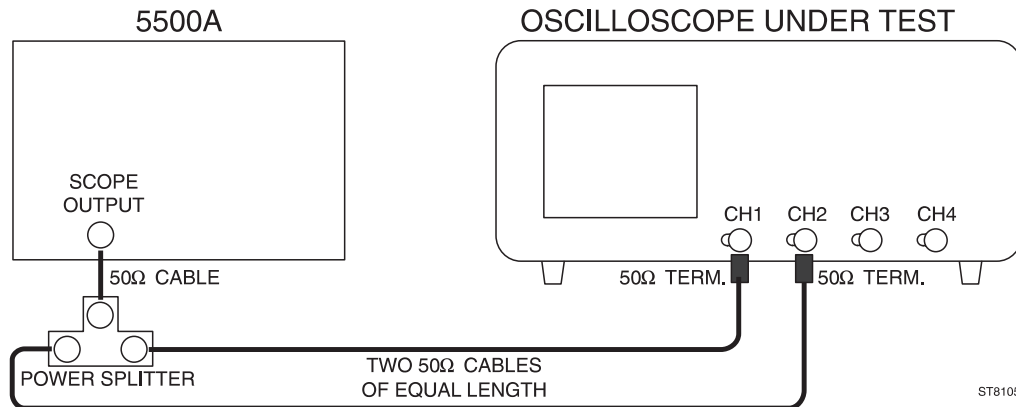

Settings/procedure:

- 1 - Use a power splitter and two cables of equal length to CH1 and CH2. Apply a 2 MHz sine-wave signal of 1.6 V(pp into 50Ω) to inputs CH1 and CH2.
- 2 - Press the AUTOSET key.
- 3 - Use 50Ω terminations. Use the internal terminations when available (via VERT MENU key).
- 4 - Set CH1 and CH2 to 0.1V/div and adjust the generator voltage for a deflection of 8 divisions.
- 5 - Set CH1 and CH2 to DC input coupling.
- 6 - Press the CH1+CH2 key to activate the 'added' mode.
- 7 - Press the INV key of CH2; the result is the display of CH1-CH2.
- 8 - Press the ON keys of CH1 and CH2; this switches CH1 and CH2 off and only the differential signal (CH1 CH2) is now visible.
- 9 - Readjust the VAR function of CH1 or CH2 for minimum amplitude.

Requirements

- Verify that the trace-height of the CH1-CH2 differential signal is less than 0.08 divisions.
Repeat the above settings and procedure for CH3 and CH4 (for PM3384B and PM3394B only).

6.3.17 Vertical deflection; common mode rejection ratio at 50 MHz (continuation of 6.3.16)

The common mode rejection ratio (CMRR) indicates the susceptibility to common mode signals at higher frequencies. The susceptibility is verified in this test.

Settings/procedure:

- 1 - Use a power splitter and two cables of equal length to CH1 and CH2. Apply a sine-wave signal of 50 MHz with an amplitude of 0.6 V(pp into 50Ω) to inputs CH1 and CH2.
- 2 - Press the AUTOSET key.
- 3 - Use a 50Ω termination. Use the internal termination when available.
- 4 - Set CH1 and CH2 to 0.1 V/div and adjust the generator voltage for a deflection of 6 divisions.
- 5 - Set CH1 and CH2 to DC input coupling.
- 6 - Press the CH1+CH2 key; to activate the added mode.
- 7 - Press the INV key of CH2; the result is the display of the differential signal of CH1-CH2.
- 8 - Press the ON keys of CH1 and CH2; this switches CH1 and CH2 off and only the differential signal of CH1 CH2 display is now visible.
- 9 - Readjust the VAR function of CH1 or CH2 for minimum amplitude.

Requirements:

- Verify that the amplitude of the CH1-CH2 differential signal is less than 0.24 divisions.
Repeat the above settings and procedure for CH3 and CH4 (for PM3384B and PM3394B only).

6.3.18 Vertical deflection; LF linearity

The linearity of the vertical amplifier is checked by moving a signal with a fixed amplitude vertically over the entire screen area.

Test equipment

Fluke 5500A mode: wavegen, wave square (Alternative: function generator PM5136).

Test set up:

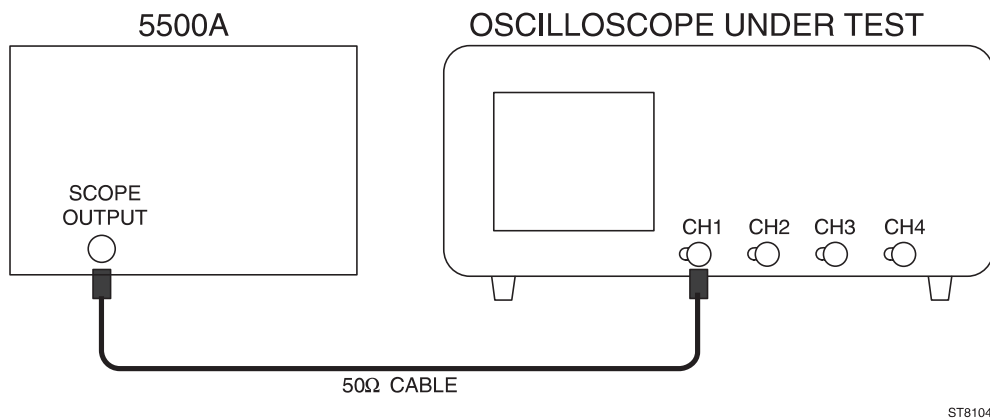

Settings/procedure

- 1 - Apply a 50 kHz square-wave signal of 200 mV(pp into 50Ω) to input CH1.
- 2 - Press the AUTOSET key and set CH1 to 0.1V/div.
- 3 - Move the square-wave signal to the vertical center of the screen.
- 4 - Adjust the generator output so that the displayed amplitude is exactly 2 divisions.
- 5 - Use the CH1 POS control to shift the signal upwards and downwards within the central 6 divisions of the screen.

Requirements

- Verify that the amplitude of the sq. wave in the central 6 divisions screen area is between 1.96 ... 2.04 divisions (+ or - 2%).

Repeat the above settings and procedure for CH2, CH3 and CH4. PM3370B/80B/90B: repeat this for CH2.

Press the ANALOG key ('DIGITAL MODE' is displayed briefly) and repeat the check in this chapter for the digital mode. The requirement for the digital mode is that the sq. wave amplitude in the central 6 div. screen area is between 1.94 ... 2.06 divisions (+ or 3%).

Press the ANALOG key ('ANALOG MODE' is displayed briefly) to return to analog mode.

6.3.19 Vertical deflection; visual signal delay

Many applications require that the leading edge of a fast pulse triggering the oscilloscope be made visible. A fixed amount of signal delay is introduced in the vertical channels of this instrument to allow the timebase to start before the triggering leading edge causes vertical deflection to occur. This delay is verified in the following test.

Test equipment

Fluke 5500A mode: edge (Alternative: Square-wave calibration generator PG 506).

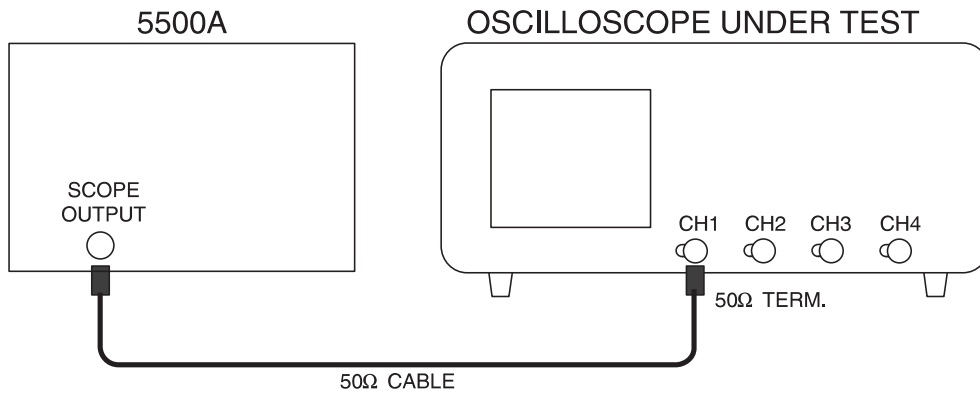
Test set-up:

ST8103

Settings/procedure:

- 1 - Apply a signal with a fast rise time of less than 1 ns and an amplitude of 0.5V (into 50Ω), and a frequency of 1 MHz, to input CH1.
- 2 - Press the AUTOSET button and set CH1 to 0.1V/div.
- 3 - Use a 50Ω termination. Use the internal termination when provided (via VERT MENU key).
- 4 - Set the MAIN TB TIME/DIV to 50.0 ns/div.
- 5 - Press the MAGNIFY key and turn the X POS control to display the leading edge.
- 6 - Turn the TRACE INTENSITY control clockwise for maximum intensity.
- 7 - Press the TRIGGER menu key.
- 8 - Select level pp 'off' and 'dc' trigger coupling from the TRIGGER MAIN TB menu.
- 9 - Adjust TRIGGER LEVEL for a triggered display and maximum visible signal delay.

Requirements

- Verify that the visible signal delay is at least 15 ns (3 divisions).

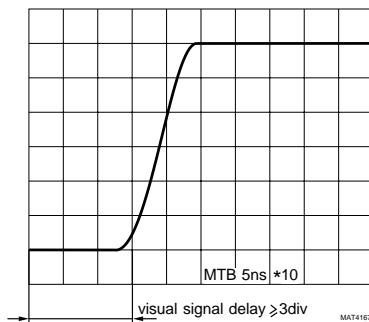

Figure 6.2 Visual signal delay

6.3.20 Vertical deflection; base line instability

In the following test, several adjustments of balance, offset and jump, are checked.

Test equipment

None

Settings/procedure and requirements:

- 1 - Press the AUTOSSET key (no input signal) and set CH1 to 5V/div.
- 2 - Use the CH1 POS control to position the trace in the vertical middle of the screen.
- 3 - Press both CH1 AMPL keys simultaneously to select the VARiable mode. The readout changes to 5.00V. The input sensitivity can be adjusted now in very fine steps between 2 mV and 12.5V/div.
- 4 - Press the 'V' key and verify that the base line jump is not more than 0.2 divisions between 5.00V to 12.5V/div.
- 5 - Press the 'mV' key and verify that the base line jump is not more than 0.2 divisions between 12.5V/div to 5 mV/div.
- 6 - Press the ON keys of CH2 and CH1; CH2 is now on and CH1 is off.
- 7 - Using the CH2 POS control, position the trace in the vertical middle of the screen.
- 8 - Press both CH2 AMPL keys simultaneously to select the VARiable mode. The readout changes to 5.00V. The input sensitivity can be adjusted now in very fine steps between 2 mV and 12.5V/div.
- 9 - Press the 'V' key and verify that the base line jump is not more than 0.2 divisions between 5.00V to 12.5V/div.
- 10 - Press the 'mV' key and verify that the base line jump does not 0.2 divisions between 12.5V/div to 5 mV/div.
- 11 - Press the INV key repeatedly and verify that the base line jump is not more than 0.2 divisions.

For the PM3394B and PM3384B repeat the above procedure for CH3 and CH4. The CH3 settings are equal to those of CH1; the CH4 settings are equal to CH2.

For PM3390B, PM3380B and PM3370B no further steps required.

6.3.21 Delay difference between vertical channels

The delay difference between CH1, CH2, CH3, and CH4 is checked here.

Test equipment:

Fluke 5500A mode: edge (Alternative: Square wave calibration generator PG 506).

Power splitter

Test set up:

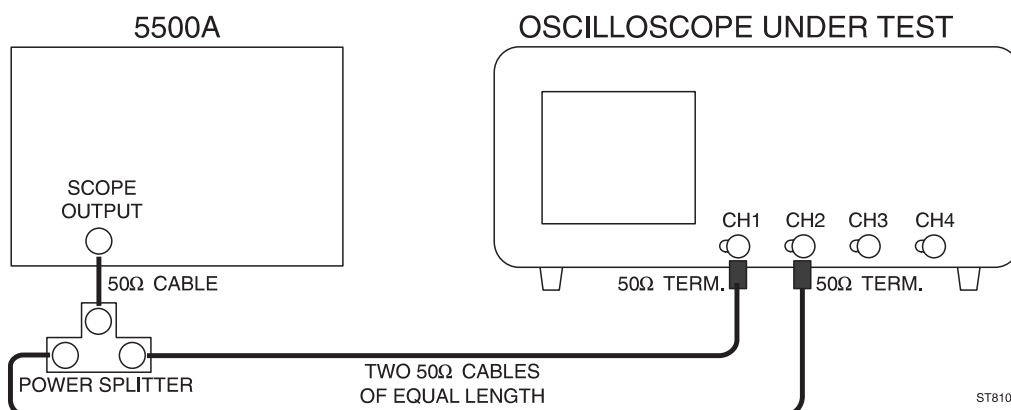

Settings/procedure:

- 1 - Apply a square-wave signal with a fast rise time of less than 1 ns, and an amplitude of 1V (into 50Ω), with a frequency of 1 MHz, to inputs CH1 and CH2.
Use a power splitter and two cables of equal length to CH1 and CH2.
- 2 - Press the AUTOSET key.
- 3 - Use 50Ω terminations. Use the internal terminations when available on both channels (via VERT MENU key).
- 4 - Set CH1 and CH2 to 0.1V/div and input coupling to DC.
- 5 - Press the MAGNIFY keys and set the MAIN TB TIME/DIV to 2.00 ns/div (PM3390B/94B) or to 5.00 ns/div (PM3370B/80B/84B).
- 6 - Press the TRIGGER menu key.
- 7 - Select level-pp 'off' and 'dc' trigger coupling from the related menu.
- 8 - Press the TB MODE menu key.
- 9 - Select 'trig' from the related menu.
- 10 - Adjust TRIGGER LEVEL for a triggered display of the leading edge.
- 11 - Using the X POS control, position the leading edges of the signals in the horizontal center of the screen.
- 12 - Using both CH1 and CH2 POS controls, adjust the vertical position of each trace between the dotted 0% and 100% lines. The signals appear to be superimposed.

Requirements

- Verify that the delay difference between the two displayed signals is less than 0.25 ns. This equals 0.13 divisions in PM3390B/94B or 0.05 divisions in PM3370B/80B/84B.

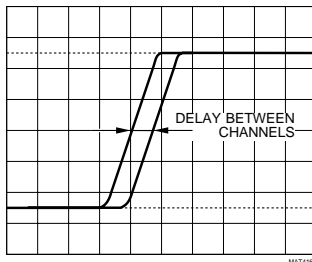

Figure 6.3 Delay difference ≤ 0.13 div in PM3390B/94B or ≤ 0.05 div in PM3370B/80B/84B.

Repeat the above settings and procedure for CH3 and CH4 (not necessary for PM3370B/80B/90B).

Press the ANALOG key ('DIGITAL MODE' is displayed briefly) and repeat the tests in this chapter for the digital mode. In digital mode, it is not necessary to activate the MAGNIFY function since the timebase ranges up to

2.00 ns/division (PM3390B/94B) or 5.00 ns/division (PM3370B/80B/84B).

Press the ANALOG key ('ANALOG MODE' is displayed briefly) to return to analog mode.

6.3.22 Horizontal deflection; display modes and trace separation

The correct working of main timebase (MAIN TB), delayed timebase (DELAYED TIME BASE) and the trace separation is checked.

Test equipment:

Fluke 5500A mode: wavegen, wave sine (Alternative: function generator, PM5136).

Test set-up:

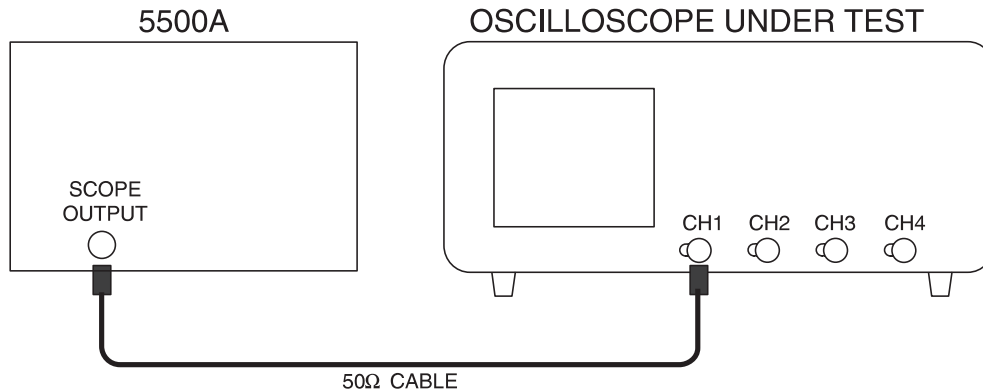

ST8104

Settings/procedure and requirements:

- 1 - Apply a 2 kHz sine-wave signal of 400 mV(pp into 50Ω) to input CH1.
- 2 - Press the AUTOSSET key and set CH1 to 0.1V/div.
- 3 - Adjust the generator signal to a trace height of 4 divisions.
- 4 - Set MAIN TB to 500 μs.
- 5 - Press the DTB menu key.
- 6 - Set DEL'D TB to 'on' in the DELAYED TIMEBASE menu.
- 7 - Set MAIN TB to 'on' in the DELAYED TIMEBASE menu.
- 8 - Set the DELAYED TIMEBASE to 50.0 μs.
- 9 - Turn the DELAY control (in the DELAYED TIMEBASE section), and verify that the intensified part can be shifted horizontally along the MAIN TB display.
- 10 - Operate the TRACK control and check that the DEL'D TB and MAIN TB display can be shifted so that they do not cover each other.

6.3.23 Horizontal deflection; X deflection

The correct working of the X Y mode (X-DEFL 'on') is tested.

Test equipment:

Fluke 5500A mode: wavegen, wave sine (Alternative: function generator, PM5136)

Test set-up:

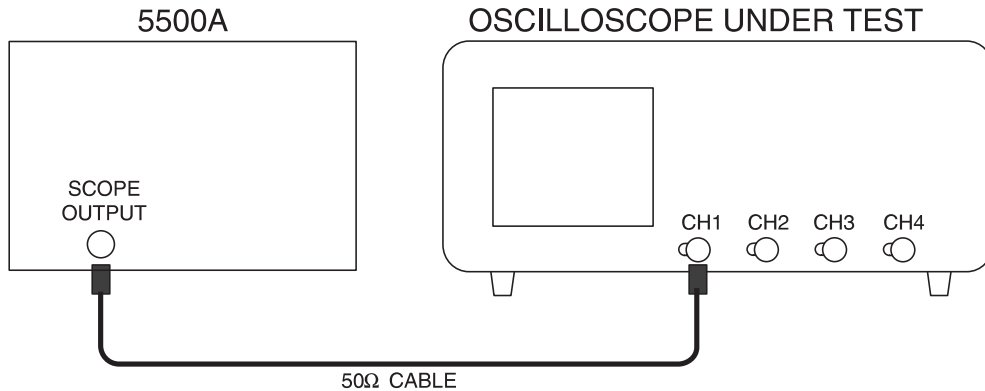

ST8104

Settings/procedure:

- 1 - Apply a 2 kHz sine-wave signal of 800 mV (pp) to input CH1.
- 2 - Press the AUTOSET key and set CH1 to 0.1V/div.
- 3 - Adjust the generator signal to a trace height of 8 divisions.
- 4 - Press the DISPLAY menu key.
- 5 - Press the X-DEFL softkey in the DISPLAY menu.
- 6 - Select 'on' and 'ch1' as X-SOURCE in the X-DEFL menu.
- 7 - Use the CH1 POS and X POS controls to obtain the display shown in the figure below.

Requirements:

- Verify that a line with an angle of 45° is displayed.

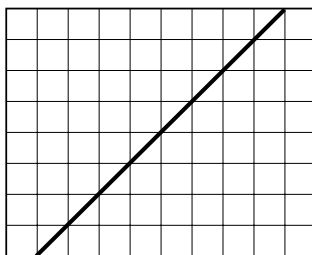

MAT3837

Figure 6.4 X deflection

6.3.24 Horizontal deflection; MAIN TB deflection coefficients

The deflection coefficients of the main timebase generator (MAIN TB) are verified by means of a calibration signal.

Test equipment:

Fluke 5500A mode: marker (Alternative: time marker generator TG 501).

Test set-up:

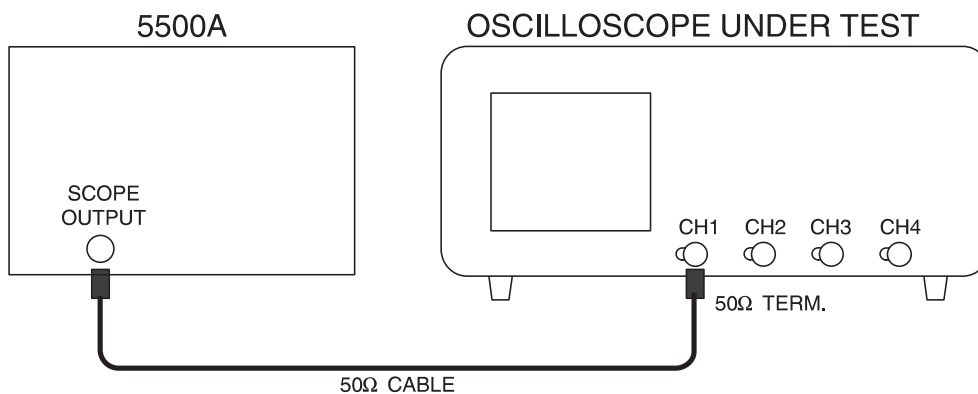

ST8103

Settings/procedure:

- 1 - Apply a 50.0 ns time marker signal to input CH1.
- 2 - Press the AUTOSET key.
- 3 - Use a 50Ω termination. For instruments with switchable 50Ω input impedance it is recommended to make use of this feature (via VERT MENU key).
- 4 - Press the TRIGGER menu key.
- 5 - Select level-pp 'off' and 'dc' from the TRIGGER MAIN TB menu.
- 6 - Press the TB MODE menu key.
- 7 - Select 'trig' from the TB MODE menu.
- 8 - Adjust the TRIGGER LEVEL control for a correctly triggered display.
- 9 - Verify the deflection coefficients of MAIN TB with MAGNIFY off (*1) and MAGNIFY on (*10) according to the requirements in the tables. Use the deflection error facility of the time marker generator.

Note:

- Error limits must be measured between the 2nd and the 10th graticule line (there are 11 graticule lines). These are the central 8 divisions.
- With MAGNIFY on (*10), the central 10 divisions of the expanded 100 divisions of MAIN TB are measured.
- Only the timebase positions essential for instrument accuracy are checked.

Press the ANALOG key ('DIGITAL MODE' is displayed briefly) to perform the tests for the digital mode. Press the TEXT OFF key for full visibility of the time marker pulses in the central 8 divisions. Press the ANALOG key ('ANALOG MODE' is displayed briefly) to return to analog mode.

Requirements for analog mode MAGNIFY off (*1):

MAIN TB setting	Marker pulse	Max. error
20.0 ns (PM3390B/94B)	20 ns	1.8%
100 ns	0.1 μ s	1.8%
500 ns	0.5 μ s	1.8%
1.00 μ s	1 μ s	1.8%
5.00 μ s	5 μ s	1.8%
20.0 μ s	20 μ s	1.8%
500 μ s	0.5 ms	1.8%
1.00 ms	1 ms	1.8%
10.0 ms	10 ms	1.8%

Requirements for analog mode MAGNIFY on (*10):

MAIN TB setting	Marker pulse	Max. error
2.00 ns (PM3390B/94B)	2 ns	3.3%
5.00 ns	5 ns	3.3%
10.0 ns	10 ns	2.3%
100 ns	0.1 μ s	2.3%

Requirements for digital mode:

MAIN TB setting	Marker pulse	Max. error
2.00 ns (PM3390B/94B)	2 ns	1.8%
5.00 ns	5 ns	1.8%
250 ns	0.5 μ s	1.3%
500 ns	0.5 μ s	1.3%
20.0 ms	20 ms	1.3%
1.00 s	1 s	1.3%

Check for an undistorted display of the time marker pulses. Timing accuracy should not show a noticeable error. In the MAIN TB setting 250 ns/division, the interval between successive time marker pulses should be 2 div.'

6.3.25 Horizontal deflection; VARiable mode accuracy MAIN TB.

The horizontal MAIN TB deflection coefficients can be varied in steps such as done in 6.3.24. A range of much finer steps can also be selected. Here, the accuracy of this range is checked.

Test equipment:

Fluke 5500A mode: marker (Alternative time marker generator TG 501).

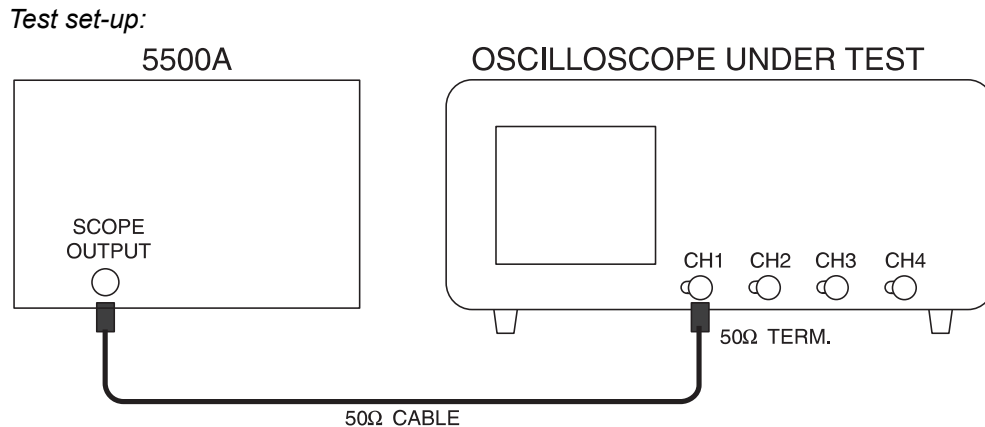

ST8103

Settings/procedure:

- 1 - Apply a 5 us time marker signal to input CH1.
- 2 - Press the AUTOSET key.
- 3 - Use a 50Ω termination. For instruments with switchable 50Ω input impedance it is recommended to make use of this feature.
- 4 - Press the TRIGGER menu key.
- 5 - Select level-pp 'off' and trigger coupling 'dc' from the TRIGGER MAIN TB menu.
- 6 - Adjust the TRIGGER LEVEL control for a correctly triggered display.
- 7 - Set the MAIN TB TIME/DIV to 5.00 us.
- 8 - Select the MTB VARIABLE mode by pressing both MAIN TB TIME/DIV keys at a time: the message; 'VARIABLE TIMEBASE' is displayed briefly.
- 9 - Press the 'ns' key and adjust the readout to 2.50 us.

Requirements:

- Verify that the horizontal distance between the time markers equals 2 divisions.
- Use the X POS control to align the marker pulses with the graticule.
- Now check (across the central 8 divisions) if the timebase accuracy is $\pm 2.8\%$: make use of the deflection error facility of the time marker generator to check this.

6.3.26 Time cursor accuracy (continuation of 6.3.25)

This test verifies the accuracy of the time cursors.

Settings/procedure:

- 1 - Switch the MAIN TB VARIABLE mode off by pressing both MAIN TB TIME/DIV keys at a time. The message '1-2-5 STEPS'.
- 2 - Select 5.00 μs /division for the MAIN TB.
- 3 - Switch off the deflection error facility of the time marker generator.
- 4 - Press the CURSORS menu key.
- 5 - Select 'on' and time cursors (//) from the CURSORS menu.
- 6 - Select ΔT in the READOUT menu.

Requirements:

- Position one cursor line exactly on the 2nd time marker on the screen and the other cursor on the 10th time marker. The distance between both cursors is now 8 time marker intervals. Check for a cursor readout between 39.5 and 40.5 μs .

Press the ANALOG key ('DIGITAL MODE' is displayed briefly) and repeat the check in this section for the digital mode. Press the TEXT OFF key to have the full screen width available to display the time markers.

Press the ANALOG key ('ANALOG MODE' is displayed briefly) to return to analog mode.

6.3.27 Horizontal deflection; DELAYED TIME BASE deflection coefficients

The deflection coefficients of the delayed timebase generator (DEL'D TB) are verified by means of a calibration signal.

Test equipment:

Fluke 5500A mode: marker (Alternative: time marker generator TG 501).

Test set-up:

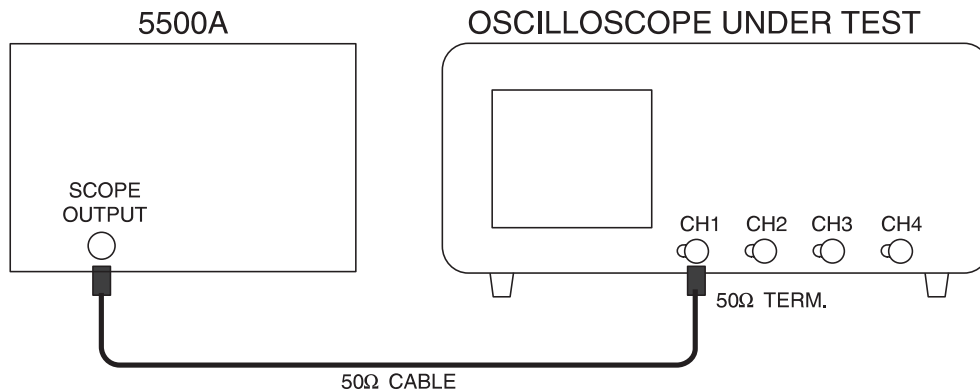

ST8103

Settings/procedure:

- 1 - Apply a 0.5 ms time marker signal to input CH1.
- 2 - Press the AUTOSET key.
- 3 - Use a 50Ω termination. For instruments with switchable 50Ω input impedance it is recommended to make use of this feature (via VERT MENU key).
- 4 - Press the TRIGGER menu key.
- 5 - Select level-pp 'off' and 'dc' trigger coupling from the TRIGGER MAIN TB menu.
- 6 - Press the TB MODE menu key and select 'trig' from the related menu.
- 7 - Adjust TRIGGER LEVEL for a correctly triggered display.
- 8 - Set the trace height to about 4 divisions.
- 9 - Press the DTB menu key and select DEL'D TB 'on' and MAIN TB 'on' from the related menu .
- 10 - Set MAIN TB to 1.00 ms and DELAYED TIME BASE to 5.00 μs.
- 11 - Use the DELAY control (in the DELAYED TIMEBASE SECTION) to set the time delay to about 0 seconds.
- 12 - Adjust the vertical position of the MAIN TB display with the CH1 POS control in the top half of the viewing area.
- 13 - Adjust the vertical position of the DELAYED TIMEBASE display with the TRACK control.
- 14 - Verify the DELAYED TIMEBASE deflection coefficients with MAGNIFY off (*1) and MAGNIFY on (*10) according to the requirements in the tables. Use the deflection error facility of the time marker generator.

Note:

- Error limits must be measured between the 2nd and the 10th graticule line (there are 11 graticule lines). These are the central 8 divisions.
- With MAGNIFY on (*10), the central 10 divisions of the expanded 100 divisions of DEL'D TB are measured.
- Only the timebase positions that are essential for instrument accuracy are checked.
- DEL'D TB TIME/DIV is electrically coupled to MAIN TB TIME/DIV; to check the settings in the table press only the MAIN TB TIME/DIV VAR keys.

Requirements for analog mode MAGNIFY off (*1):

DEL'D TB setting	MAIN TB setting	Marker pulse	Max. error
500 μ s	500 μ s	0.5 ms	1.8%
20.0 μ s	20.0 μ s	20 μ s	1.8%
5.00 μ s	5.00 μ s	5 μ s	1.8%
1.00 μ s	1.00 μ s	1 μ s	1.8%
500 ns	500 ns	0.5 μ s	1.8%
100 ns	100 ns	0.1 μ s	1.8%
50.0 ns	50.0 ns	50 ns	1.8%
20.0 ns (PM3390B/94B)	20.0 ns	20 ns	1.8%

Requirements for analog mode MAGNIFY on (*10):

DEL'D TB setting	MAIN TB setting	Marker pulse	Max. error
100 ns	100 ns	0.1 μ s	2.3%
10.0 ns	10.0 ns	10 ns	2.3%
5.00 ns	5.00 ns	5 ns	3.3%
2.00 ns (PM3390B/94B)	2.00 ns	2 ns	3.3%

6.3.28 Horizontal deflection; delay time multiplier

In this test the minimum and maximum delay time is checked.

Test equipment:

None

Settings/procedure and requirements:

- 1 - Press the AUTOSSET key.
- 2 - Press the DTB menu key and select DEL'D TB 'on' and MAIN TB 'on' from the appropriate menu .
- 3 - Set MAIN TB to 500 ns.
- 4 - Set DEL'D TB to 50.0 ns.
- 5 - Separate the MAIN TB and DEL'D TB traces with the TRACK control.
- 6 - Adjust the delay time to 500.0 ns using of the DELAY control (in the DELAYED TIMEBASE section).
- 7 - Adjust the start of the MAIN TB display exactly on the first graticule line by using the X POS control (at maximum TRACE INTENSITY).
- 8 - Verify that the difference between the start of MAIN TB and the start of the intensified part is between 0.9 to 1.1 divisions.
- 9 - Adjust the delay time to 5.00 μ s with the DELAY control (in the DELAYED TIMEBASE section).
- 10 - Verify that the difference between the start of MAIN TB and the start of the intensified part is between 9.9 and 10.1 divisions.

6.3.29 Horizontal deflection; delayed timebase jitter

There is a certain instability in the starting point, the so called jitter, of the DEL'D TB. The maximum allowed jitter is checked in this test.

Test equipment:

Fluke 5500A mode: levsine (Alternative: function generator PM5136).

Test set-up:

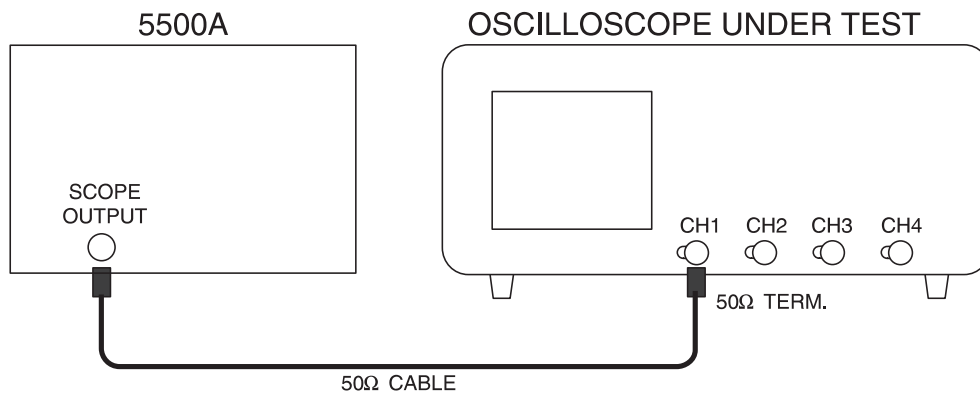

ST8103

Settings/procedure:

- 1 - Apply a 1 MHz sine-wave signal of 120 mV(pp into 50Ω) to input CH1.
- 2 - Press the AUTOSET key and set for a trace-height of 6 divisions.
- 3 - Use a 50Ω termination. For instruments with switchable 50Ω input impedance it is recommended to make use of this feature (via VERT MENU key).
- 4 - Press the DTB menu key and select DEL'D TB 'on' and MAIN TB 'on' from the appropriate menu.
- 5 - Set MAIN TB to 500 μs.
- 6 - Set DEL'D TB to 500 ns.
- 7 - Adjust the delay time to 0s using the DELAY control (in the DELAYED TIMEBASE section).
- 8 - Switch the MAIN TB display to 'off' in the DELAYED TIMEBASE menu; only the DEL'D TB is displayed now.

Requirements:

- Verify that the jitter of the DEL'D TB is not more than 0.4 divisions (1 part per 25000).

6.3.30 Horizontal deflection; X deflection coefficient via CH1

The amplification of the horizontal amplifier via the vertical input amplifier is checked.

Test equipment:

Fluke 5500A mode: volt (Alternative: Square-wave calibration generator PG 506).

Test set-up:

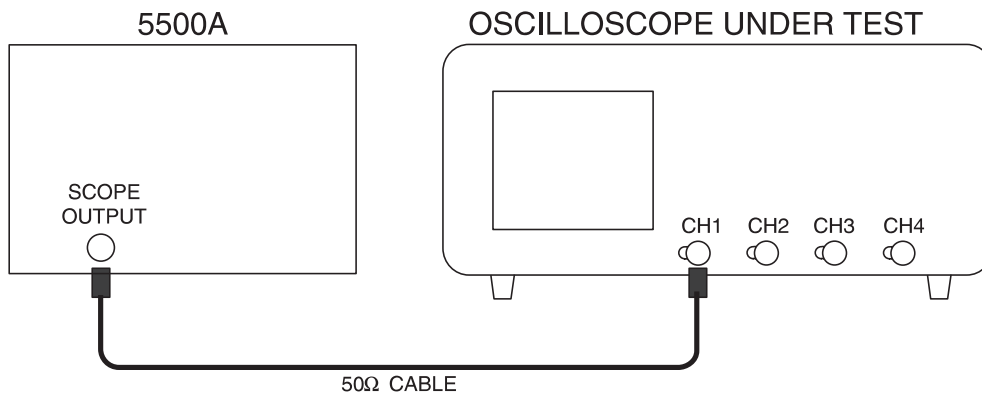

ST8104

Settings/procedure:

- 1 - Apply a 1 kHz square-wave signal of 0.1V to input CH1. Output not terminated into 50Ω ('LZ' must not appear in lower part of viewing area).
- 2 - Press the AUTOSET key.
- 3 - Set CH1 to 20 mV and DC coupled input.
- 4 - Press the DISPLAY menu key.
- 5 - Press X-DEFL softkey.
- 6 - Select 'on' and 'ch1' from the X-DEFL menu.
- 7 - Press the CH2 ON key and then the CH1 ON key; the result is that CH2 is on and CH1 is off.

Requirements:

- Verify that two dots with a horizontal distance of 4.7 ... 5.3 divisions are displayed.

6.3.31 Horizontal deflection; X deflection coefficient via 'line'

The amplification of the horizontal amplifier via the line trigger signal is checked. Do this test only when 220V line voltage is available.

Test equipment:

None

Settings/procedure:

- 1 - Press the AUTOSET key.
- 2 - Press the DISPLAY menu key.
- 3 - Press X-DEFL softkey.
- 4 - Select 'on' and 'line' from the X-DEFL menu.

Requirements:

- Verify that a horizontal line of 4.3 to 7.7 divisions is displayed when the line voltage is 220V (rms).

6.3.32 Horizontal deflection; high frequency response

In this test, the bandwidth of the horizontal amplifier is checked.

Test equipment:

Fluke 5500A mode: levsine (Alternative: constant amplitude sine wave generator SG 503).

Test set-up:

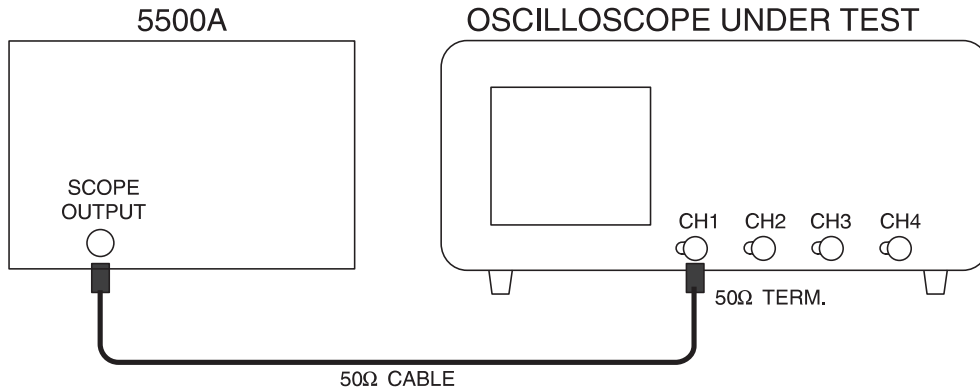

ST8103

Settings/procedure:

- 1 - Apply a 50 kHz sine-wave signal of 30 mV(pp into 50Ω) to input CH1.
- 2 - Press the AUTOSET key and set CH1 to 5 mV.
- 3 - Use a 50Ω termination. For instruments with switchable 50Ω input impedance it is recommended to make use of this feature ('LZ' must be visible in lower part of viewing area).
- 4 - Press the DISPLAY menu key and then press the X-DEFL softkey.
- 5 - Select 'on' and 'ch1' from the X-DEFL menu.
- 6 - Press the CH2 ON key and then the CH1 ON key: the result is that CH2 is on and CH1 off.
- 7 - Adjust the input voltage for exactly 6 divisions horizontal deflection.
- 8 - Increase the input frequency up to 2 MHz.

Requirements:

- Verify that the trace width is at least 4.2 divisions over the complete bandwidth range.

6.3.33 Maximum phase shift between horizontal and vertical deflection

There will be a certain phase shift between the horizontal and vertical amplifier. The value of this shift is measured here.

Test equipment:

Fluke 5500A mode: wavegen, wave sine (Alternative: function generator, PM 5136).

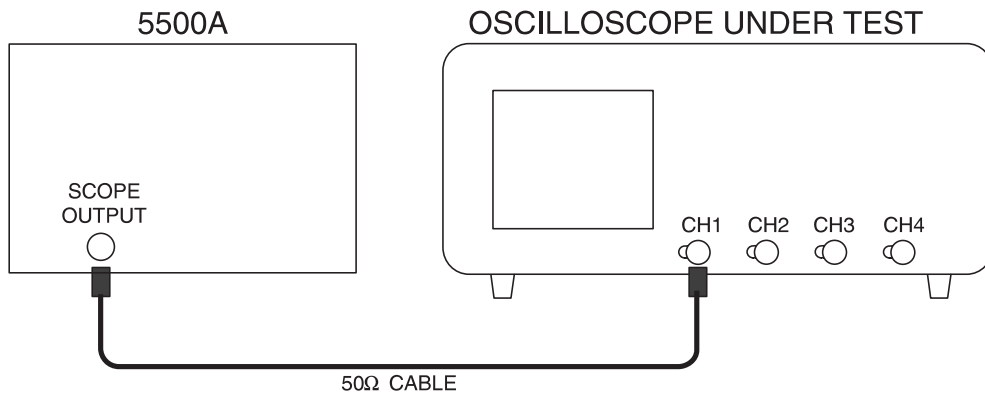
Test set-up:

ST8104

Settings/procedure:

- 1 - Apply a 2 kHz sine-wave signal of 1.2 V(pp into 50Ω) to CH1.
- 2 - Press the AUTOSET key and set CH1 to 0.2V/div.
- 3 - Adjust the generator to a trace height of exactly 6 divisions.
- 4 - Press the DISPLAY menu key and then press the X-DEFL softkey.
- 5 - Select 'on' and 'ch1' from the X-DEFL menu.
- 6 - Increase the input frequency to 100 kHz.

Requirements:

- Verify that the phase shift is less than 3°, ≤ 0.32 div, see figure).

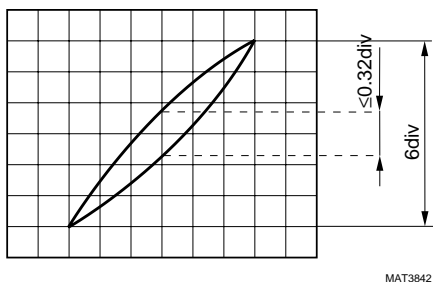

MAT3842

Figure 6.5 Phase shift between horizontal and vertical channel

6.3.34 MAIN TB triggering PM3390B/3394B; trigger sensitivity via CH1, CH2, CH3 and CH4 (EXT)

The trigger sensitivity depends on the amplitude and frequency of the trigger signal. In this test the main timebase trigger sensitivity via the CH1, CH2, CH3 and CH4 inputs is checked. For the PM3390B, this is checked for CH1, CH2 and EXTERNAL TRIGGER input.

Test equipment:

Fluke 5500A mode: levsine

(Alternative: constant amplitude sine wave generators SG 503 + SG 504).

Test set-up:

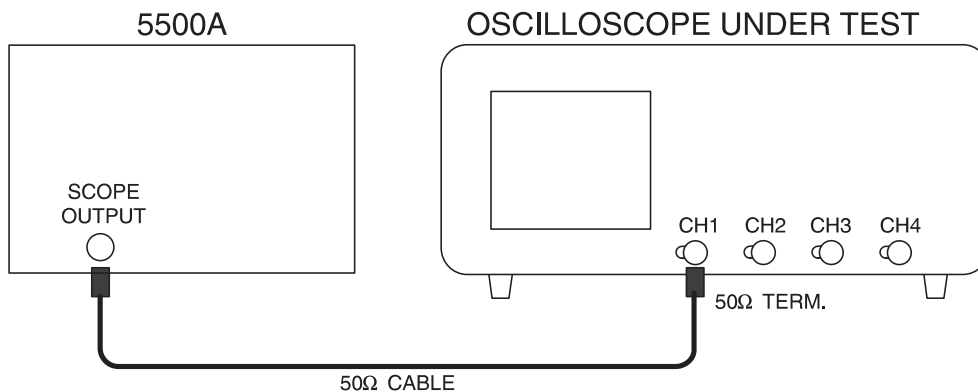

ST8103

Settings/procedure and requirements:

- 1 - Apply a 100 MHz sine-wave signal of 1 V(pp into 50Ω) from the SG 503 to input CH1.
- 2 - Press the AUTOSET key and set CH1 to 0.5V/div.
- 3 - Use a 50Ω termination. For instruments with switchable 50Ω input impedance it is recommended to make use of this feature (via VERT MENU key).
- 4 - Set the input coupling of CH1 to DC and POSition the signal in the vertical center of screen.
- 5 - Select 'trig' from in the menu under the TB MODE mode key.
- 6 - Press the TRIGGER menu key and select level-pp 'off' and 'dc' trigger coupling from the TRIGGER MAIN TB menu
- 7 - Adjust TRIGGER LEVEL for a correctly triggered display.
- 8 - Decrease the amplitude of the input signal.
- 9 - Verify that the signal is well-triggered at amplitudes of 0.6 divisions and more.
- 10 - Decrease the input frequency to 50 kHz.
- 11 - Verify that the signal stays well-triggered at amplitudes of 0.6 divisions and more.
- 12 - Increase the input frequency to 200 MHz.
- 13 - Increase the input voltage to 1.2 division.
- 14 - Turn TRIGGER LEVEL.
- 15 - Verify that the signal is well-triggered at amplitudes of 1 division and more.
- 16 - Apply a 300 MHz sine-wave signal of 2V (pp into 50Ω) from the SG 504 to input CH1.
- 17 - Adjust the input voltage to 2 divisions. Signal must be in vertical center of screen.
- 18 - Verify that the signal is well-triggered at amplitudes of 2 divisions and more; adjust TRIGGER LEVEL when necessary.

PM3394B: repeat the procedure for CH2, CH3 and CH4 for the frequencies 50 kHz (0.6 division input signal) and 300 MHz (2 division input signal)

PM3390B: repeat the procedure for CH2 and the EXTTRIG input for the frequencies 50 kHz (0.6 division input signal) and 300 MHz (2 division input signal)

Press the ANALOG key ('DIGITAL MODE' is displayed briefly), then repeat the tests in this chapter for the digital mode.

Press the ANALOG key ('ANALOG MODE' is displayed briefly) to return to analog mode.

6.3.35 MAIN TB triggering PM3370B/3380B/3384B; trigger sensitivity via CH1, CH2, CH3 and CH4 (EXT).

The trigger sensitivity depends on the amplitude and frequency of the trigger signal. In this test the main timebase trigger sensitivity via the CH1, CH2, CH3 and CH4 inputs is checked. For PM3370B and PM3380B, this is checked for CH1, CH2 and the EXTERNAL TRIGGER input. For PM3370B; frequency setting between ().

Test equipment.

Fluke 5500A mode: levsine (Alternative: constant amplitude sine wave generator (SG 503))

Test set-up:

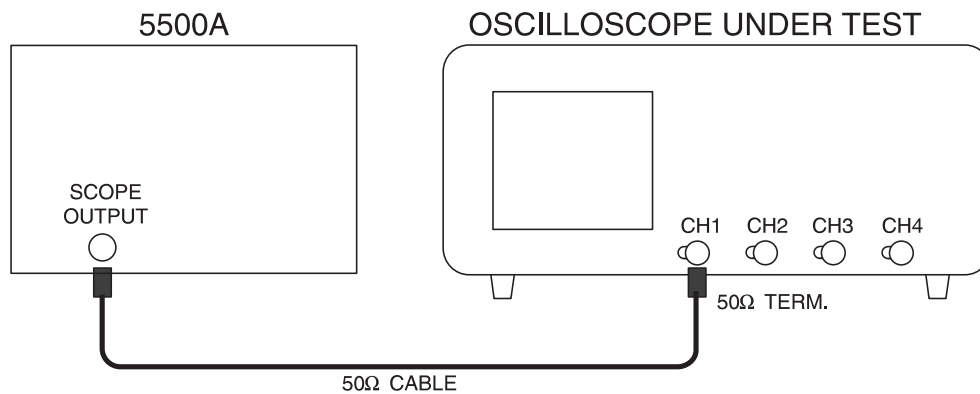

ST8103

Settings/procedure and requirements:

- 1 - Apply a 50 MHz (30 MHz) sine-wave signal of 1 V(pp into 50Ω) to input CH1.
- 2 - Press the AUTOSET key and set CH1 to 0.5V/div.
- 3 - Use a 50Ω termination.
- 4 - Set the input coupling of CH1 to DC and POSition the signal in the vertical center of screen.
- 5 - Select 'trig' from the menu under the TB MODE menu key.
- 6 - Press the TRIGGER menu key and select level-pp 'off' and 'dc' trigger coupling from the TRIGGER MAIN TB menu
- 7 - Adjust TRIGGER LEVEL for a correctly triggered display.
- 8 - Decrease the amplitude of the input signal.
- 9 - Verify that the signal is well-triggered at amplitudes of 0.6 divisions and more.
- 10 - Decrease the input frequency to 50 kHz.
- 11 - Verify that the signal stays well-triggered at amplitudes of 0.6 divisions and more.
- 12 - Increase the input frequency to 100 MHz (60 MHz).
- 13 - Increase the input voltage to 1.2 division.
- 14 - Turn TRIGGER LEVEL.
- 15 - Verify that the signal is well-triggered at amplitudes of 1.2 division and more.
- 16 - Increase the input frequency to 200 MHz (150 MHz).
- 17 - Adjust the input voltage to 2 divisions. Signal must be in vertical center of screen.
- 18 - Verify that the signal is well-triggered at amplitudes of 2 divisions and more; adjust TRIGGER LEVEL when necessary.

PM3384B: repeat the procedure for CH2, CH3 and CH4 for the frequencies 50 kHz (0.6 division input signal) and 200 MHz (2 division input signal).

PM3370B/80B: repeat the procedure for CH2 and the EXT TRIG input for the frequencies 50 kHz (0.6 division input signal) and 200 MHz (150 MHz) (2 division input signal).

Press the ANALOG key ('DIGITAL MODE' is displayed briefly) and repeat the tests in this chapter for the digital mode.

Press the ANALOG key ('ANALOG MODE is displayed briefly) to return to analog mode.

6.3.36 MAIN TB/DEL'D TB triggering; trigger sensitivity TVL-TVF

This test checks the trigger sensitivity for television line- and field synchronization pulses.

Test equipment:

TV pattern generator with video output (PM 5418)

Test set-up:

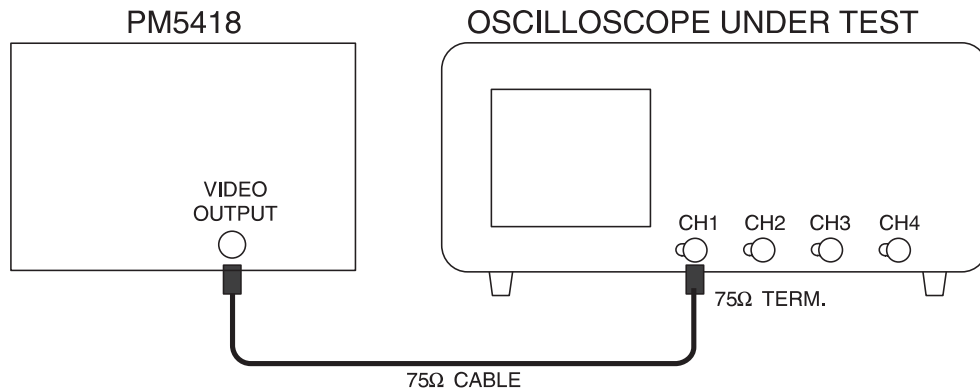

ST8107

Note: the number a various tests to be performed is numerous. Therefore it is recommended only to check the tv system(s) as used in your country. The number of tests is also limited by the available TV pattern generator.

- 1 - Apply a video signal to input CH1 with an amplitude of about 1V synchronization pulse amplitude; use a 75Ω termination instead of internal or external 50Ω.
- 2 - Press the AUTOSET key.
- 3 - Press menu key TRIGGER and select 'tv' in the related menu.
- 4 - Select field 1 or field 2 in the menu.
- 5 - Select a line number (e.g. 25) by means of the TRACK control.
- 6 - Select pos or neg (depending on the available TV pattern generator).
- 7 - Select in the VIDEO SYSTEM submenu hdtv, ntsc, pal or secam (depending on the available TV pattern generator). The maximum number of lines for hdtv can be selected if hdtv is active.

Requirements:

- Decrease the amplitude of the input signal and verify that the signal is well-triggered on the tv pulses, at sync pulse amplitudes of 0.7 divisions and more.

6.3.37 DEL'D TB triggering PM3390B/94B; trigger sensitivity via CH1, CH2, CH3 and CH4 (EXT)

The trigger sensitivity depends on the amplitude and frequency of the trigger signal. In this test the main timebase trigger sensitivity via the CH1, CH2, CH3 and CH4 inputs is checked. For the PM3390B, this is checked for CH1, CH2 and the EXTERNAL TRIGGER input.

Test equipment:

Fluke 5500A mode: levsine

(Alternative: constant amplitude sine wave generators SG 503 + SG 504).

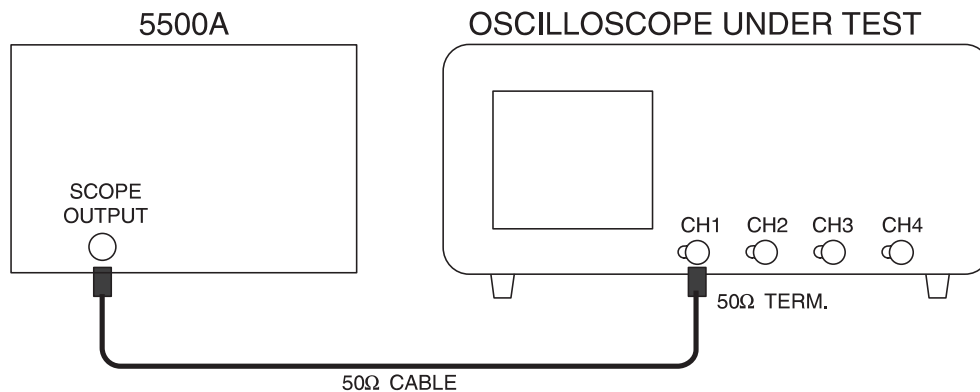
Test set-up:

ST8103

Settings/procedure and requirements:

- 1 - Apply a 100 MHz sine-wave signal of 1 V(pp into 50Ω) from the SG 503 to input CH1.
- 2 - Press the AUTOSET key and set CH1 to 0.5V/div.
- 3 - Use a 50Ω termination. For instruments with switchable 50Ω input impedance it is recommended to make use of this feature (via VERT MENU KEY).
- 4 - Set the input coupling of CH1 to DC and POSition the signal in the vertical center of screen.
- 5 - Select 'trig' from the menu under the TB MODE menu key.
- 6 - Press the TRIGGER menu key and select level-pp 'off' and 'dc' trigger coupling from the TRIGGER MAIN TB menu.
- 7 - Adjust TRIGGER LEVEL for a correctly triggered display.
- 8 - Press the DTB menu key and select DEL'D TB 'on' and MAIN TB 'on' in the related menu.
- 9 - Set MAIN TB to 200 ns/division and DELAYED TIMEBASE to 20.0 ns/division.
- 10 - Adjust the DELAY control in the DELAYED TIMEBASE section to a delay time of 1.000 μs.
- 11 - Select 'trig'd' and 'dc' coupling from the DELAYED TIME BASE menu, and press the front panel key TRIG1. Or TRIG2 (if CH2 on), TRIG3 (if CH3 on), TRIG4 (if CH4 on).
- 12 - Adjust the DEL'D TB trigger level via the Δ control for a well- triggered signal (intensified part must be visible).
- 13 - Operate the TRACK control to separate MAIN TB and DEL'D TB for clearly visible displays.
- 14 - Decrease the amplitude of the input signal.
- 15 - Verify that the DEL'D TB is well triggered at signal amplitudes of 0.6 divisions and more.
- 16 - Decrease the input frequency to 50 kHz. Set the MAIN TB to 50.0 μs/division and DEL'D TB to 20.0 μs/division.
- 17 - Verify that the DEL'D TB stays well triggered at signal amplitudes of 0.6 divisions and more.
- 18 - Increase the input frequency to 200 MHz.
- 19 - Increase the input voltage to 1.2 division.
- 20 - Operate the Δ control (controls DEL'D TB trigger level).
- 21 - Verify that the DEL'D TB is well triggered at all amplitudes of 1.2 divisions or more.
- 22 - Apply a 300 MHz sine-wave signal of 2V (pp into 50 ohm) from the SG504 generator to input CH1.
- 23 - Adjust the input voltage to 2 divisions. Signal must be in vertical center of screen.
- 24 - Verify that the DEL'D TB is well triggered at signal amplitudes of 2 divisions and more: adjust the Δ control (DEL'D TB trigger level) if necessary.

PM3394B: repeat the procedure for CH2, CH3 and CH4 for the frequencies 50 kHz (0.6 division input signal) and 300 MHz (2 division input signal).

PM3390B: repeat the procedure for CH2 and the EXTTRIG input for the frequencies 50 kHz (0.6 division input signal) and 300 MHz (2 division input signal).

Press the ANALOG key ('DIGITAL MODE' is displayed briefly) and repeat the tests in this chapter for the digital mode.

Then press the ANALOG key ('ANALOG MODE' is displayed briefly) to return to analog mode.

6.3.38 DEL'D TB triggering PM3370B/80B/84B; trigger sensitivity via CH1, CH2, CH3 and CH4 (EXT).

The trigger sensitivity depends on the amplitude and frequency of the trigger signal. In this test the main timebase trigger sensitivity via the CH1, CH2, CH3 and CH4 inputs is checked. For PM3370B/80B, this is checked for CH1, CH2 and the EXTERNAL TRIGGER input. For PM3370B; frequency setting between ().

Test equipment:

Fluke 5500A mode: levsine (Alternative: constant amplitude sine wave generator SG 503)

Test set-up:

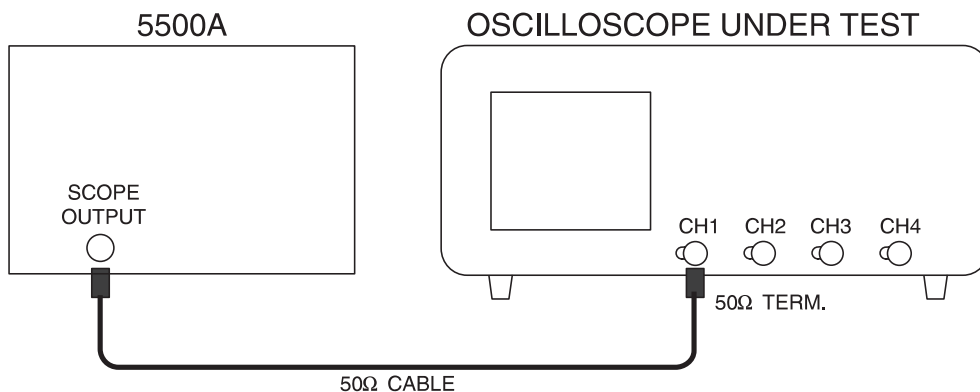

ST8103

Settings/procedure and requirements:

- 1 - Apply a 50 MHz (30 MHz) sine-wave signal of 1 V(pp into 50Ω) from the SG 503 to input CH1.
- 2 - Press the AUTOSET key and set CH1 to 0.5V/div.
- 3 - Use a 50Ω termination.
- 4 - Set the input coupling of CH1 to DC and POSition the signal in the vertical center of screen.
- 5 - Select 'trig' from the menu under the TB MODE menu key.
- 6 - Press the TRIGGER menu key and select level-pp 'off' and 'dc' trigger coupling from the TRIGGER MAIN TB menu
- 7 - Adjust TRIGGER LEVEL for a correctly triggered display.
- 8 - Press the DTB menu key and select DEL'D TB 'on' and MAIN TB 'on' from the related menu.
- 9 - Set the MAIN TB to 200 ns/division and DELAYED TIMEBASE to 50.0 ns/division.
- 10 - Adjust the DELAY control in the DELAYED TIMEBASE section to a delay time of 1.000 μs.
- 11 - Select 'trig'd' and 'dc' coupling from the DELAYED TIMEBASE menu and press the front panel key TRIG1. Or TRIG2 (if CH2 on), TRIG3 (if CH3 on), TRIG4 (if CH4 on).
- 12 - Adjust the DEL'D TB trigger level via the Δ control for a well- triggered signal (intensified part must be visible).
- 13 - Operate the TRACK control to separate the MAIN TB and DEL'D TB for clearly visible displays.
- 14 - Decrease the amplitude of the input signal.
- 15 - Verify that the DEL'D TB is well triggered at signal amplitudes of 0.6 divisions and more.
- 16 - Decrease the input frequency to 50 kHz. Set the MAIN TB to 50.0 μs/division and DEL'D TB to 20.0 μs/division.
- 17 - Verify that the DEL'D TB stays well triggered at signal amplitudes of 0.6 divisions and more.
- 18 - Increase the input frequency to 100 MHz (60 MHz).
- 19 - Increase the input voltage to 1.2 division.
- 20 - Operate the Δ control (controls the DEL'D TB trigger level).
- 21 - Verify that the DEL'D TB is well triggered at all amplitudes of 1.2 division or more.
- 22 - Increase the input frequency to 200 MHz (150 MHz).
- 23 - Adjust the input voltage to 2 divisions.
- 24 - Verify that the DEL'D TB is well-triggered at signal amplitudes of 2 divisions and more. Signal must be in vertical center of screen. Adjust the Δ control (DEL'D TB trigger level) if necessary.

PM3384B: repeat the procedure for CH2, CH3 and CH4 for the frequencies 50 kHz (0.6 division input signal) and 200 MHz (2 division input signal).

PM3370B/80B: repeat the procedure for CH2 and the EXT TRIG input for the frequencies 50 kHz (0.6 division input signal) and 200 MHz (150 MHz) (2 division input signal).

Press the ANALOG key ('DIGITAL MODE' is displayed briefly), and repeat the tests in this chapter for the digital mode.

Then press the ANALOG key ('ANALOG MODE' is displayed briefly) to return to analog mode.

6.3.39 Trigger sensitivity in logic mode PM3394B

The trigger sensitivity in the logic mode 'pattern' depends on the amplitude and frequency of the trigger signal. In this test, the trigger sensitivity is tested with a sine wave via the CH1, CH2, CH3, and CH4 inputs.

Test equipment:

Fluke 5500A mode: levsine (Alternative: constant amplitude sine wave generator SG 503).

Test setup:

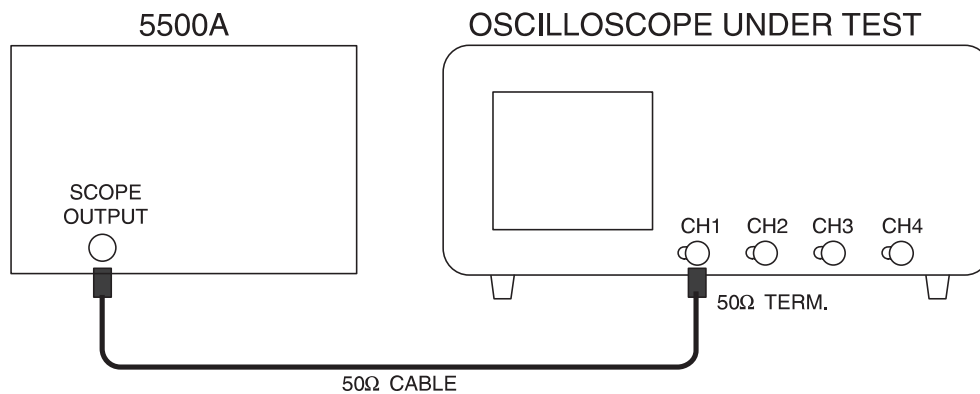

- 1 - Press the ANALOG key ('DIGITAL MODE' is displayed briefly) to activate the digital mode.
- 2 - Apply a 100 MHz sine-wave signal of 1 V(pp into 50 ohm) from the constant amplitude sine-wave generator to input CH1.
- 3 - Press the AUTOSSET key, and set CH1 to 0.5V/division.
- 4 - Use a 50 ohm termination. For instruments with switchable 50 ohm input impedance it is recommended to make use of this feature (via VERT MENU key).
- 5 - Set the input coupling to DC and POSITION the signal in the vertical center of the screen.
- 6 - Select 5.00 ns/division for MAIN TB.
- 7 - Press the TRIGGER menu key and select 'logic', 'pattern', and 'enter' from the related menu.
- 8 - Operate the front panel keys TRIG1, TRIG2, TRIG3 and TRIG4 to obtain the trigger pattern Hxxx (x = don't care) in the menu.
- 9 - Press the TB MODE menu key and select 'trig' from the related menu.
- 10 - Decrease the amplitude of the generator voltage to 1 division.
- 11 - Turn the TRIGGER LEVEL control and check that a well-triggered signal is obtained.
- 12 - Apply a 300 MHz sine-wave signal of 2 V(pp into 50Ω) from the SG 504 to input CH1.
- 13 - Adjust the input voltage to 2 divisions.
- 14 - Verify that the signal is well triggered at amplitudes of 2 divisions and more; adjust TRIGGER LEVEL when necessary.
- 15 - Press the ANALOG key ('ANALOG MODE' is displayed briefly) to return to analog mode.

Repeat the procedure for CH2 with trigger pattern xHxx

Repeat the procedure for CH3 with trigger pattern xxHx

Repeat the procedure for CH4 with trigger pattern xxxH

6.3.40 Trigger sensitivity in logic mode PM3384B

The trigger sensitivity in the logic mode 'pattern' depends on the amplitude and frequency of the trigger signal. In this test, the trigger sensitivity is tested with a sine wave via the CH1, CH2, CH3, and CH4 inputs.

Test equipment:

Fluke 5500A mode: levsine: (Alternative: constant amplitude sine wave generator SG 503).

Test setup:

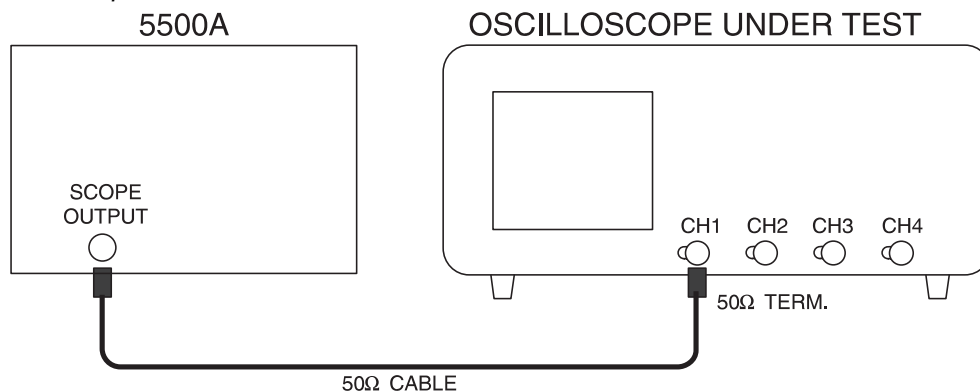

ST8103

- 1 - Press the ANALOG key ('DIGITAL MODE' is displayed briefly) to activate the digital mode.
- 2 - Apply a 50 MHz sine-wave signal of 1 V(pp into 50 ohm) from the constant amplitude sine-wave generator to input CH1.
- 3 - Press the AUTOSSET key, and set CH1 to 0.5V/division.
- 4 - Use a 50 ohm termination.
- 5 - Set the input coupling to DC and POSition the signal in the vertical center of the screen.
- 6 - Select 5.00 ns/division for MAIN TB.
- 7 - Press the TRIGGER menu key and select 'logic', 'pattern', and 'enter' from the related menu.
- 8 - Operate the front panel keys TRIG1, TRIG2, TRIG3 and TRIG4 to obtain the trigger pattern Hxxx (x = don't care) in the menu.
- 9 - Press the TB MODE menu key and select 'trig' from the related menu.
- 10 - Decrease the amplitude of the generator voltage to 1 division.
- 11 - Turn the TRIGGER LEVEL control and check that a well-triggered signal is obtained.
- 12 - Increase the input frequency to 200 MHz.
- 13 - Increase the input voltage to 2 division.
- 14 - Turn the TRIGGER LEVEL control, and check that a well-triggered signal is obtained.
- 15 - Press the ANALOG key ('ANALOG MODE' is displayed briefly) to return to analog mode.

Repeat the procedure for CH2 with trigger pattern xHxx

Repeat the procedure for CH3 with trigger pattern xxHx

Repeat the procedure for CH4 with trigger pattern xxxH

6.3.41 Z-MOD sensitivity

This test checks the sensitivity of the Z modulation facility.

Test equipment:

Fluke 5500A mode: wavegen, wave square (Alternative: function generator PM 5136).
T-piece.

Test set-up:

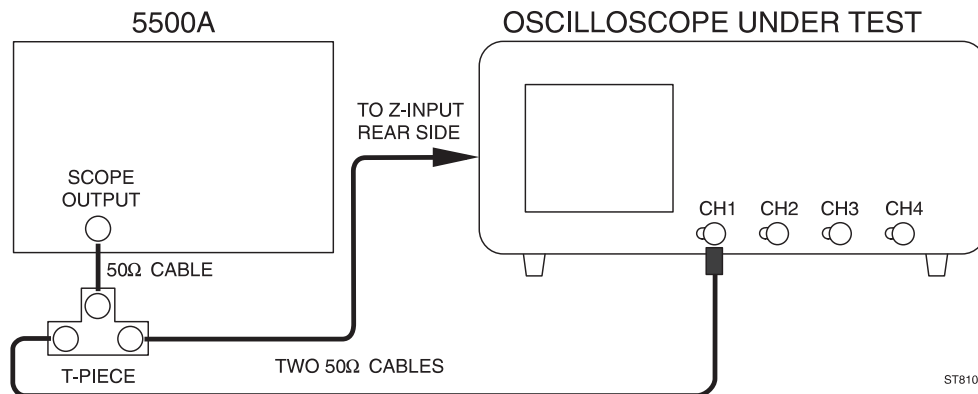

Settings/procedure and requirements:

- 1 - Apply a 1 kHz square-wave signal, duty cycle 50%, amplitude between 0 to +2.5V, to input CH1. Adjust the generator to a signal of 2.5 Vpp with an offset of 1.25V.
- 2 - Press the AUTOSET key.
- 3 - Set MTB to 0.5 ms/div.
- 4 - Set the trace of CH1 in mid position with the CH1 POS control.
- 5 - Apply the same signal by means of the T-piece to the Z input (rear side).
- 6 - Adjust TRACE INTENSITY so that only the bottom half of the squarewave is displayed. The top half must be invisible (0.5 ms light on; 0.5 ms light off).
- 7 - Decrease the input signal to 0.5 Vpp with an offset of 0.25V.
- 8 - Set CH1 to 0.5V/division.
- 9 - Verify that the top half of the square wave is visible at full intensity.

6.3.42 Probe Adjust signal; frequency and output voltage

The Probe Adjust signal is a calibration signal with fixed frequency and voltage. In this test, the values of frequency and voltage are checked.

Test equipment:

None

Test set-up:

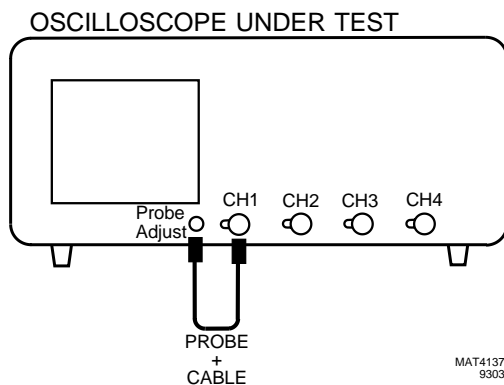

Settings/procedure:

- 1 - Connect the Probe Adjust signal to input CH1 and press the AUTOSSET key.
- 2 - Select GND of CH1.
- 3 - Set the trace in the center of the screen.
- 4 - Select DC input coupling for CH1.

Requirements:

- 1 - Verify that a positive going square-wave signal of 0.6 V(pp) is displayed, i.e. 3 divisions vertical at 0.2V.
- 2 - Verify that the frequency of the displayed signal is about 2 kHz, i.e. a period time between 4.0 ... 6.0 divisions horizontal at MTB 100 μ s/div.

6.3.43 Auto range functions

The AUTO RANGE function of the vertical channels automatically selects the input sensitivity. The result is that the input signal is displayed with 2 to 6.4 divisions amplitude. The AUTO RANGE function of the main time base (MAIN TB) adjusts the time base automatically so that approximately 2 to 6 waveform periods are displayed.

Test equipment:

Fluke 5500A mode: waven, wave sine (Alternative: function generator, PM5136)

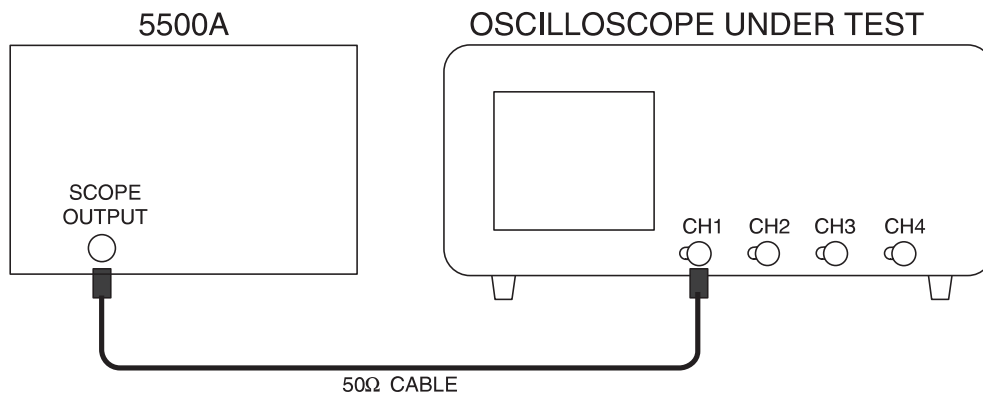

ST8104

Settings/procedure:

- 1 - Apply a 50kHz sine-wave signal of 2 V(pp) to CH1.
- 2 - Press the AUTOSET key.
- 3 - Adjust the generator output voltage to maximum (20 ... 30 V approximately). The signal amplitude now exceeds the 8 div screen height.
- 4 - Press the ANALOG key ('DIGITAL MODE' is displayed briefly) to switch the digital mode to on.
- 5 - Press the CH1 AUTO RANGE key. Check that the vertical amplitude is automatically adjusted to between 2 and 6.4 divisions.
- 6 - Vary the generator output voltage from maximum to 100 mV.

Requirements:

- Check that the signal amplitude stays between 2 and 6.4 divisions.
- Repeat this procedure for the other vertical channels that have an AUTO RANGE key.

Settings/procedure:

- 1 - Adjust the generator to a 1 kHz sine-wave of 2 V(pp) applied to CH1.
- 2 - Press the AUTOSET key.
- 3 - Press the AUTO RANGE key of the main time base MAIN TB.
- 4 - Vary the generator output frequency between 1kHz and maximum (10 MHz approximately).

Requirement:

- Check that between 2 and 6 waveform periods are displayed.

6.3.44 Testing the optional auxiliary outputs

MTB-GATE and DTB-GATE outputs.

Test equipment: measuring oscilloscope.

Test set up:

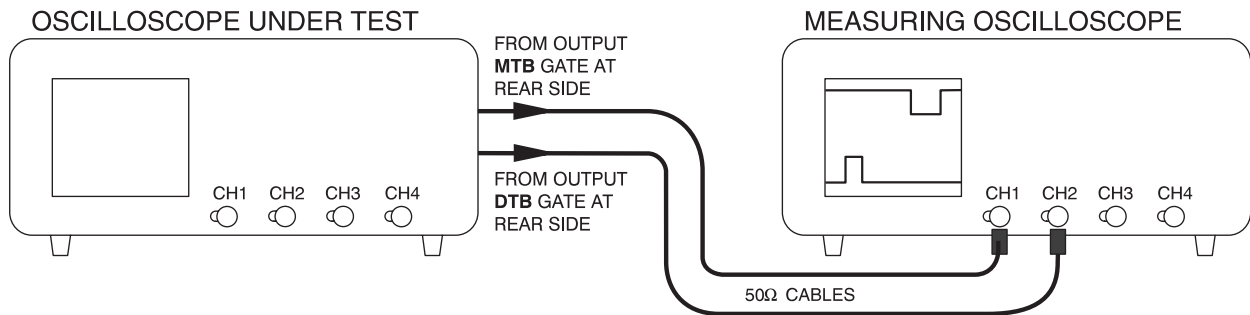

ST8143

Settings/procedure:

Oscilloscope under test:

- Take care that no input signal is applied to the oscilloscope inputs.
- Press the STATUS and TEXT OFF keys simultaneously. This assures that the oscilloscope occupies its default position.
- Press the DTB menu key to display the DELAYED TIME BASE menu. Select the 'on' position of the DEL'D TB softkey. The result is that MTB is in 1.00 ms/div and that DTB is in 100 μ s/div and that both time bases are on.
- Apply a 50 Ω coaxial cable to rear panel output 'MTB-GATE'.
- Apply another 50 Ω coaxial cable to rear panel output 'DTB-GATE'.

Measuring oscilloscope:

- Apply the coaxial cable from signal 'MTB GATE' of the oscilloscope under test to input CH1 of the measuring oscilloscope.
- Apply the coaxial cable from signal 'DTB GATE' of the oscilloscope under test to input CH2 of the measuring oscilloscope.
- Press the green AUTOSET key.
- Adjust CH1 and CH2 to DC input coupling; if the oscilloscope is in 50 Ω ('LZ') position, select an input impedance of 1M Ω .
- Adjust CH1 and CH2 to 2 V/div.
- Select 2 ms/div for MTB.

Requirements:

- Verify that two square-wave signals are displayed via CH1 and CH2 of the measuring oscilloscope.
- Verify that the 'low' level of both square-waves is between 0 .. 0.4 V.
- Verify that the 'high' level of both square-waves is between 2.4 .. 5 V.
- Verify that the 'MTB GATE' signal (is displayed via CH1) is high during 10 ms or more.
- Verify that the 'DTB GATE' signal (is displayed via CH2) is high during 1 ms or more.

Y-OUTput signal.

Test equipment: Fluke 5500A mode: levsine (Alternative: constant amplitude sine-wave generator SG503).

Test set up:

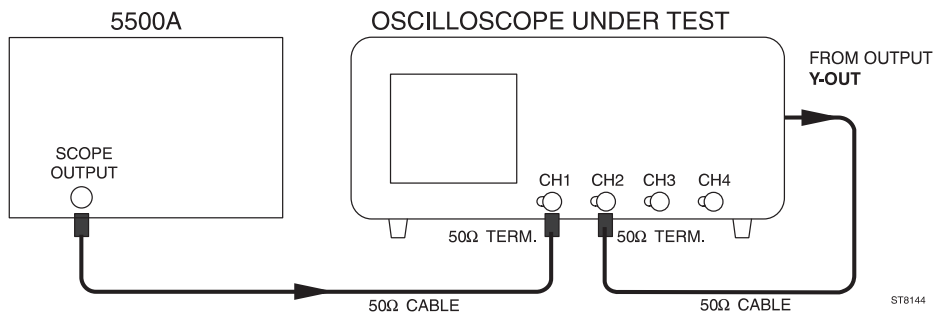

Settings/procedure:

- Apply a 50 kHz sine-wave signal of 600 mV (pp into 50Ω) to input CH1 and press the green AUTOSET key.
- Use external 50Ω termination at the CH1 input. Use the internal termination of the oscilloscope, when available (if active, the text 'LZ' is visible in the lower part of the viewing area).
- Set CH1 to 0.1 V/div.
- Adjust the generator signal to an amplitude of exactly 6 divisions.
- Connect the rear side output Y-OUT via a coaxial cable with the CH2 input. Use external 50Ω termination at the CH2 input. Use the internal termination of the oscilloscope, when available (if active, the text 'LZ' is visible in the lower part of the viewing area).
- Switch CH2 to on and CH1 to off.
- Put CH2 in 10 mV/div.

Requirement:

Check for a vertical amplitude of the 50 kHz sine-wave signal between 5.3 .. 6.7 divisions.

Settings/procedure:

- Adjust the 50 kHz sine-wave signal to an amplitude of exactly 6 divisions.
- Slowly increase the frequency of the generator to 60 MHz (PM3370B) or 100 MHz (PM3380B/84B) or 200 MHz (PM3390B/94B).

Requirement:

Verify that the displayed sine-wave does not drop below an amplitude of 3 divisions across the frequency range 50 kHz .. full bandwidth. The observed bandwidth curve is that of CH1 and CH2 in cascade.

EXT TRIGger input.

Test equipment:

- Fluke 5500A mode: levsine (Alternative: constant amplitude sine-wave generator SG503).
- Power splitter.

Test set up:

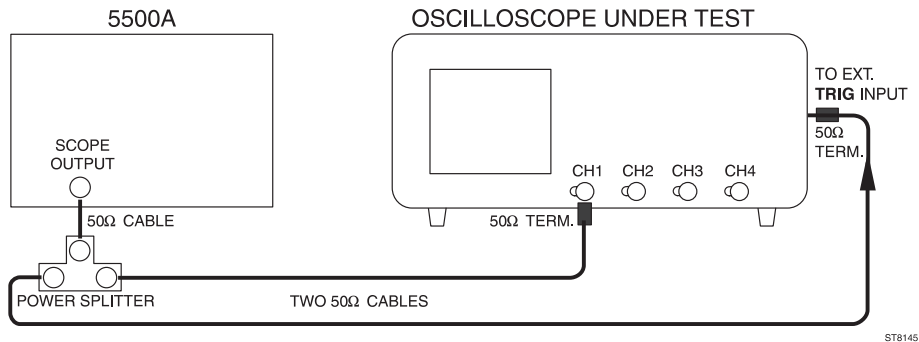

Settings/procedure:

- Use a power splitter and two coaxial 50Ω cables to apply the generator output signal to input CH1 and the rear panel input 'EXT TRIG'.
- Use an external 50Ω termination at the end of each cable. When available, use the internal termination of input CH1 (if active, the text 'LZ' is visible in the lower part of the viewing area).
- Adjust the generator output signal for a 50 kHz sine-wave of 200 mV (pp output amplitude into 50Ω).
- Press the green AUTOSET key.
- Press the TRIGGER menu key to display the TRIGGER MAIN TB menu. Select with softkey 'ch1, extern, line' the 'extern' trigger source.
- Put CH1 in 50 mV/div and adjust the generator output voltage to a vertical display of 2 divisions.
- Slowly increase the frequency of the generator signal from 50 kHz to 5 MHz.

Requirement:

Check that the signal displayed via CH1 stays well triggered across the indicated frequency range (the 'ARM'D LED must stay dimmed).

Settings/procedure:

- Adjust the generator output voltage to a vertical display of 4 divisions.
- Slowly increase the frequency of the generator signal from 5 MHz to 10 MHz.

Requirements:

Check that the signal displayed via CH1 stays well triggered across the indicated frequency range (the 'ARM'D LED must stay dimmed).

7 CALIBRATION ADJUSTMENT PROCEDURE

7.1 INTRODUCTION

The calibration adjustment procedure can be split up in two:

- Manual adjustment
- Automatic calibration (AUTOCAL).

All calibration is done with the oscilloscope's cabinet closed. This eliminates calibration inaccuracies due to temperature changes.

Manual calibration data are protected by a keyword and a seal and must be changed by qualified personnel only. Some of the adjustments require external calibration equipment. A list of necessary equipment is given in chapter 6 (performance test). Manual calibration should be done after 2000 service hours or once a year.

Operation of the front panel CAL key activates the automatic calibration. AUTOCAL can only function usefully if the manual adjustments (especially the 'screen calibrations') are correct. The AUTOCAL function should in general be activated once a week. AUTOCAL should be used always after warming-up if the oscilloscope is used in extreme environmental conditions such as very high or low temperatures while maximum accuracy is needed. AUTOCAL requires no external calibration equipment.

The calibration adjustment should be started after a warming-up time of 30 minutes.

The most accurate adjustments are done with a well-focused low intensity display.

The calibration parameters are saved after power-down if the memory back-up batteries are installed. Additionally these parameters can be saved into the instrument's non-volatile memory. This is done by pressing softkey 'save calibr data' and then activation of the pin hole key. The number of times that this save action can be done is limited. The memory is full after a number (10x) of actions and needs to be cleared. Refer to chapter 8 (corrective maintenance) for how to proceed then.

7.2 DARK LEVEL OF CRT

- Press the STATUS and TEXT OFF keys simultaneously: this gives a defined position of the instrument settings.
- Adjust MTB/VAR to 1.00 ms/div.
- Select the key sequence 'UTILITY > MAINTENANCE > ENTER KEYWORD'.
- Enter the five digit keyword '3 2 4 1 5'. If correct, an automatic return to the UTIL MAINTENANCE menu is done.
- Press softkey MANUAL CALIBR.
- Select 'dark' with the TRACK rotary.
- Press softkey 'analog': the Δ sign is displayed behind 'analog'.
- Put the TRACE INTENSITY rotary in minimal intensity position.
- Adjust the Δ rotary so that the dot at the beginning of the CH1 trace is just invisible. Use X POS to move the start of the trace away from the ground level indicator.
- Press softkey 'digital': the Δ sign is displayed behind 'digital'.
- Press the front panel key 'ANALOG' (message DIGITAL MODE appears briefly) and the oscilloscope switches to digital mode.
- Put the TRACE INTENSITY rotary in minimal intensity position.
- Adjust the Δ rotary so that the CH1 trace is just invisible.
- Put TRACE INTENSITY rotary in normal intensity position again.
- Press softkey RETURN to go to the UTIL MAINTENANCE MENU.

7.3 TRACE ROTATION

- * Press the ANALOG key (message ANALOG MODE appears briefly) and the oscilloscope switches to analog mode.
- Adjust the INTENS TRACE rotary for a well-visible horizontal on the screen.
- Align the CH1 trace exactly in parallel with the horizontal graticule lines using screw-driver operated TRACE ROT rotary.

7.4 HORIZONTAL (X) GAIN AND OFFSET (CRT)

- Press softkey SCREEN CALIBR. This activates the UTIL SCREEN CALIBR CRT menu.
- Select 'x-gain' with the softkeys.
- Adjust the TRACK (gain) and Δ (offset) rotary so that the two vertical lines coincide exactly with the 3rd and 9th graticule line.

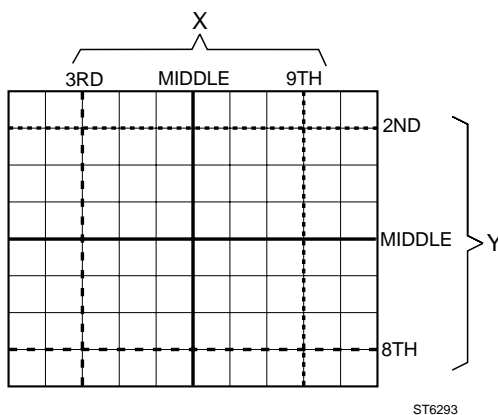

Figure 7.1 Position of lines for horizontal (X) and vertical (Y) gain and offset calibration.

7.5 TEXT STABILITY AND X-OFFSET (CRT)

- Select 'x-text' with the softkeys (menu header is UTIL SCREEN CALIBR CRT).
- Adjust the TRACK rotary to maximal stability of the text
- Adjust the Δ rotary so that the vertical line is exactly in the middle of the graticule.

7.6 VERTICAL (Y) GAIN AND OFFSET (CRT)

- Select 'y-gain' with the softkeys (menu header is UTIL SCREEN CALIBR CRT).
- Adjust the TRACK (gain) and Δ (offset) rotary so that the two horizontal lines coincide exactly with the 2nd and 8th graticule line.
- Select 'y-offs' with the softkeys.
- Adjust the TRACK rotary so that the horizontal line is exactly in the middle of the graticule.

7.7 HORIZONTAL GAIN AND OFFSET (VECTOR)

- Push the second softkey again to obtain 'x-gain' (menu header is changed into UTIL SCREEN CALIBR VECTOR).
- Adjust the TRACK rotary to minimal over- or undershoot in horizontal direction.
- Select 'x-offs' with the softkeys.
- Adjust the TRACK rotary so that the lines of the test pattern coincide exactly with the graticule in horizontal direction.

7.8 VERTICAL GAIN AND OFFSET (VECTOR)

- Select 'y-gain' with the softkeys (menu header is UTIL SCREEN CALIBR VECTOR).
- Adjust the TRACK rotary to minimal over- or undershoot in vertical direction.
- Select 'y-offs' with the softkeys.
- Adjust the TRACK rotary so that the lines of the test pattern coincide exactly with the graticule in vertical direction.
- Press softkey 'accept' if the screen calibrations are correct.
- Press softkey RETURN to go to the UTIL MAINTENANCE MENU.

7.9 ASTIGMATISM

- Press softkey MANUAL CALIBR.
- Select 'astig' with the TRACK rotary.
- Position the CH1 trace in the centre of the graticule.
- Adjust the Δ rotary for the best possible sharpness of text across the screen: the small dots from which the text is composed must be well visible. Adjustment of the FOCUS rotary is necessary during the adjustment.

7.10 AUTOCAL PROCEDURE

- Press the CAL key during 2 seconds.
- Within 4 minutes the instrument automatically does its main calibrations.
- Watch the CRT and check that no errors are reported. If errors are mentioned, the oscilloscope will need corrective maintenance. The error number indicates in what part of the oscilloscope the fault may be expected.

7.11 LF SQUARE-WAVE RESPONSE CH1

- Press the STATUS and TEXT OFF keys simultaneously: this gives a defined position of the instrument settings.
- Select the key sequence UTILITY > MAINTENANCE > MANUAL CALIBR.
- Select 'lf ch1' with the TRACK rotary.
- Select 'lfx100' with the softkeys: the Δ sign is displayed behind 'lfx100'.
- Put CH1 in 1 V/div with DC coupled input.
- Apply a 100 kHz square-wave signal of 2.75V (pp into 50 Ω) from a calibrator (mode 'edge') to CH1. As an alternative you may use a 100 kHz / 5 Vpp square-wave from a function generator.
- Select 50 Ω input impedance; if not available use a 50 Ω termination resistor between cable and oscilloscope input.
- Adjust MTB/VAR to 2.00 μ s/div.
- Adjust the Δ rotary for a flat pulse top (the initial overshoot should not be adjusted).

- Select 'lfx10' with the softkeys: the Δ sign is displayed behind 'lfx10'.
- Put CH1 in 0.1 V/div.
- Change the square-wave signal into 10 kHz/500 mV peak-peak.
- Adjust MTB/VAR to 20.0 μ s/div.
- Adjust the Δ rotary for a flat pulse top (the initial overshoot should not be adjusted).
- Remove the input signal.

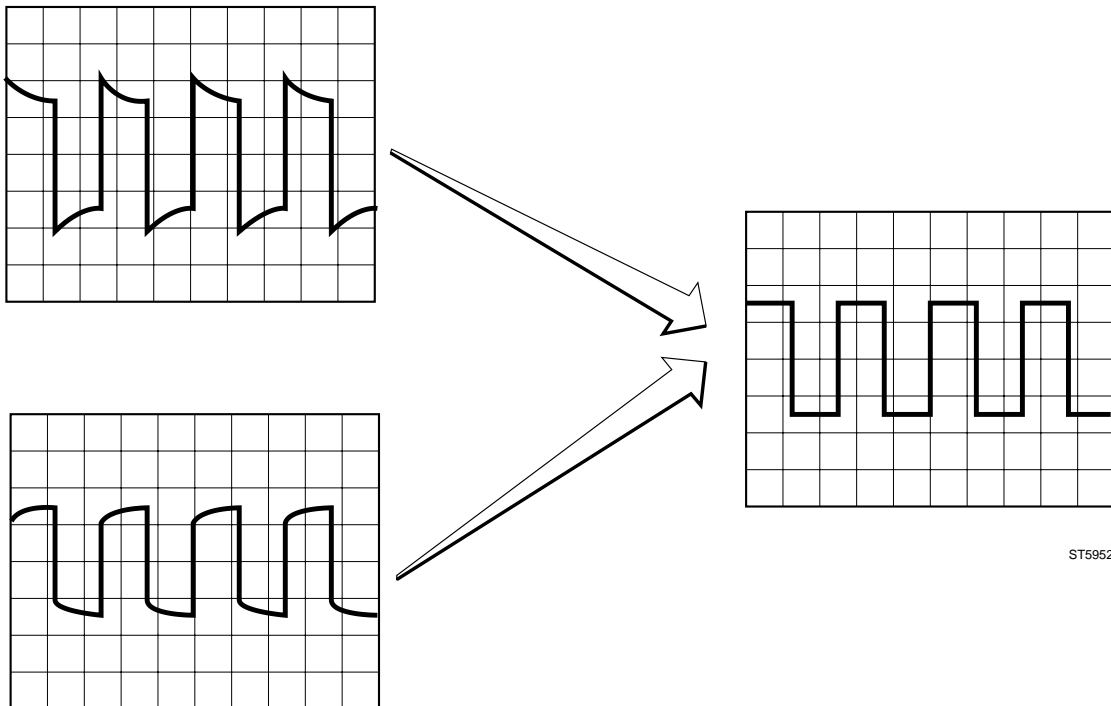

ST5952

Figure 7.2 Adjustment of LF square wave response CH1, CH2, CH3 and CH4.

7.12 LF SQUARE-WAVE RESPONSE CH2

- Select 'lf ch2' with the TRACK rotary.
- Select 'lfx100' with the softkeys: the Δ sign is displayed behind 'lfx100'.
- Switch CH2 to ON and CH1 off.
- Press the TRIG 2 key.
- Put CH2 in 1 V/div with DC coupled input.
- Apply a square-wave signal of 100 kHz and 2.75V (pp into 50 Ω) from a calibrator (mode 'edge') to CH2. As an alternative you may use a 100 kHz / 5 Vpp square-wave from a function generator.
- Select 50 Ω input impedance; if not available use a 50 Ω termination resistor between cable and oscilloscope input.
- Adjust MTB/VAR to 2.00 μ s/div.
- Adjust the Δ rotary for a flat pulse top (the initial overshoot should not be adjusted).

- Select 'lfx10' with the softkeys: the Δ sign is displayed behind 'lfx10'.
- Put CH2 in 0.1 V/div.
- Change the square-wave signal into 10 kHz/500 mV peak-peak.
- Adjust MTB/VAR to 20.0 μ s/div.
- Adjust the Δ rotary for a flat pulse top (the initial overshoot should not be adjusted).
- Remove the input signal.

7.13 LF SQUARE-WAVE RESPONSE CH3

This section can be skipped for PM3370A, PM3380A and PM3390A.
For PM3382A and PM3392A only the step 'lfx10' has to be adjusted.

- Select 'lf ch3' with the TRACK rotary.
- Select 'lfx100' with the softkeys: the Δ sign is displayed behind 'lfx100'.
- Switch CH3 to ON and CH2 off.
- Press the TRIG 3 key.
- Put CH3 in 1 V/div with DC coupled input.
- Apply a square-wave signal of 100 kHz and 2.75V (pp into 50 Ω) from a calibrator (mode 'edge') to CH2. As an alternative you may use a 100 kHz / 5 Vpp square-wave from a function generator.
- Select 50 Ω input impedance; if not available use a 50 Ω termination resistor between cable and oscilloscope input.
- Adjust MTB/VAR to 2.00 μ s/div.
- Adjust the Δ rotary for a flat pulse top (the initial overshoot should not be adjusted).

- Select 'lfx10' with the softkeys: the Δ sign is displayed behind 'lfx10'.
- Put CH3 in 0.1 V/div.
- Change the square-wave signal into 10kHz/500 mV peak-peak.
- Adjust MTB/VAR to 20.0 μ s/div.
- Adjust the Δ rotary for a flat pulse top (the initial overshoot should not be adjusted).
- Remove the input signal.

7.14 LF SQUARE-WAVE RESPONSE CH4 and EXT TRIG

For PM3370A, PM3380A, PM3382A, PM3390A and PM3392A only the step 'lfx10' has to be adjusted.

- Select 'lf ch4' with the TRACK rotary.
- Select 'lfx100' with the softkeys: the Δ sign is displayed behind 'lfx100'.
- Switch CH4 to ON and CH3 off.
- Press the TRIG 4 key.
- Put CH4 in 1 V/div with DC coupled input.
- Apply a square-wave signal of 100 kHz and 2.75V (pp into 50 Ω) from a calibrator (mode 'edge') to CH2. As an alternative you may use a 100 kHz / 5 Vpp square-wave from a function generator.
- Select 50 Ω input impedance; if not available use a 50 Ω termination resistor between cable and oscilloscope input.
- Adjust MTB/VAR to 2.00 μ s/div.
- Adjust the Δ rotary for a flat pulse top (the initial overshoot should not be adjusted).
- Select 'lfx10' with the softkeys: the Δ sign is displayed behind 'lfx10'.
- Put CH4 in 0.1 V/div.
- Change the square-wave signal into 10 kHz/500 mV peak-peak.
- Adjust MTB/VAR to 20.0 μ s/div.
- Adjust the Δ rotary for a flat pulse top (the initial overshoot should not be adjusted).
- Remove the input signal.

7.15 HF SQUARE-WAVE RESPONSE FINAL Y AMPLIFIER

- Apply a 1V/1 MHz square-wave signal with a rise-time faster than 1 nsec to CH1. This signal is delivered in the 'edge' mode of the calibrator. As an alternative you may use the fast-rise output of the square-wave calibration generator. Use a 10x attenuator at the end of the cable from the generator. For reduced channels (0.1 and 0.5 V/div) and EXT TRIG (0.1 and 1 V/div) use a 2:1 (6dB) attenuator.
- Press AUTOSET.
- Put CH1 in 20 mV/div with DC coupled input.
- Select 50Ω input impedance; if not available use a 50Ω termination resistor directly at the oscilloscope input.
- Adjust MTB/VAR to its fastest position (20.0 or 50.0 ns/div). Small adjustments of MTB/VAR may be necessary to have a good view of signal details of interest.
- Select the key sequence 'UTILITY > MAINTENANCE > MANUAL CALIBR' and then select 'hf y' with the TRACK rotary .

- Select in succession 'pulse t4', 'pulse t3', 'pulse t2', 'pulse t1' and 'pulse t0' with the softkeys. Adjust the pulse top to maximum flatness and the risetime to the required value with the Δ rotary. The adjustments are a compromise between fast risetime and minimal pulse distortion (aberrations). The influence of these adjustments ranges from mid-frequency (pulse t4) to high-frequency (pulse t0). The requirement is a rise-time of ≤ 6ns for 60 MHz, ≤ 3,6 ns for 100 MHz and ≤ 2 ns for 200 MHz instruments. This value includes the generator rise-time. The pulse aberrations must not exceed + or - 10%.

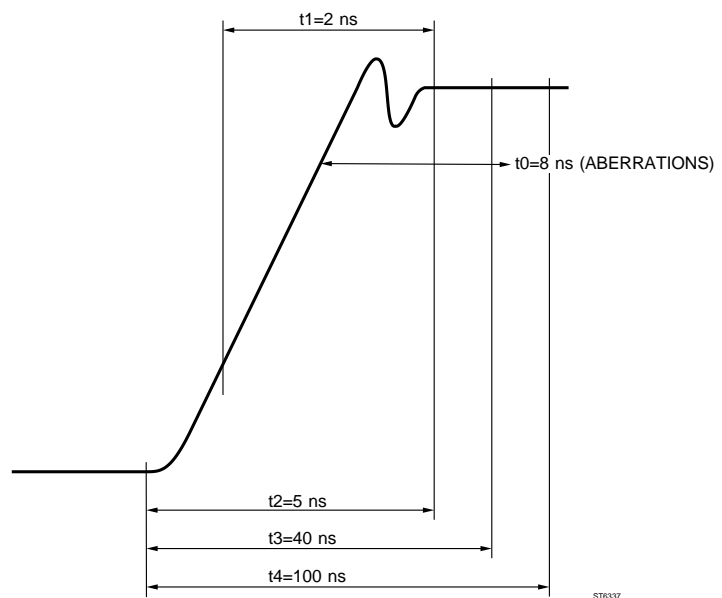

Figure 7.3 Influence of t4, t3, t2, t1 and t0 on HF square wave response.

- Remove the input signal.
- Pulse response and bandwidth are interdependent: the higher the pulse aberrations, the higher the bandwidth and vice versa. To check the bandwidth apply a 120 mV/50 kHz sinewave from a constant amplitude sinewave generator (5500A in mode 'levsine') to CH1. For reduced channels and EXT TRIG input apply 600 mV / 50 kHz.
- Press AUTOSET.
- Select 50Ω input impedance; if not available use a 50Ω termination resistor directly at the oscilloscope input.
- Adjust the amplitude of the sine-wave to 6 div exactly.
- Increase the frequency of the sinewave up to 60 MHz (for 60 MHz instruments), 100 MHz (for 100 MHz instruments) or 200 MHz (for 200 MHz instruments) and check that the amplitude on the screen does not become smaller than 4,2 div.
- Remove the input signal.
- Repeat the bandwidth check for CH2, CH3, CH4 and EXT TRIG input (the bandwidth check for CH3 and CH4 of PM3392A and EXT TRIG input of PM3390A must be checked via the 10:1 probe that is delivered with the oscilloscope).
- Remove the input signal.

7.16 HF RESPONSE DSO MODE

- Press the ANALOG key (message DIGITAL MODE appears briefly) and the oscilloscope switches to digital mode.
- Apply a 1V/1 MHz square-wave signal with a rise-time faster than 1 nsec to CH1. This signal is delivered in the 'edge' mode of the calibrator. As an alternative you may use the fast-rise output of the square-wave calibration generator. Use a 10x attenuator at the end of the cable from the generator. For reduced channels (0.1 and 0.5 V/div) and EXT TRIG (0.1 and 1V/div) use a 2:1 (6 dB) attenuator.
- Press AUTOSET.
- Put CH1 in 20 mV/div with DC coupled input. Reduced channels and EXT TRIG must be put in 0.1 V/div.
- Put MTB/VAR in 5.00 ns/div position.
- Select 50 Ω input impedance; if not available use a 50 Ω termination resistor directly at the oscilloscope input.
- Use POS CH1 to position the signal in the vertical mid of screen.
- Adjust the TRIGGER LEVEL to -100%.
- Select key sequence UTILITY > MAINTENANCE > MANUAL CALIBR and then 'hfdso' with the TRACK rotary.
- Select 'hf CH1' with the softkeys: the Δ sign appears behind 'hf CH1'. Adjust the pulse top to maximum flatness and the risetime to the required value with the Δ rotary. The adjustments are a compromise between fast risetime and minimal pulse distortion (aberrations). The requirement is a rise-time of ≤ 6 ns for 60 MHz, $\leq 3,6$ ns for 100 MHz and ≤ 2 ns for 200 MHz instruments. This value includes the generator rise-time. The pulse aberrations must not exceed + or - 12%.
- Remove the input signal from CH1.
- Check for an equal pulse response (rise-time and aberrations) of all input channels in 20 mV/div. For reduced channels and EXT TRIG input use 0.1 V/div. In case of major differences, repeat the adjustment for a pulse response as equal as possible.
- Remove the input signal.
- Pulse response and bandwidth are interdependent: the higher the pulse aberrations, the higher the bandwidth and vice versa. To check the bandwidth apply a 120 mV/50 kHz sinewave from a constant amplitude sinewave generator (5500A in mode 'levsine') to CH1. For reduced channels and EXT TRIG input apply 600 mV/50 kHz
- Press AUTOSET.
- Select 50 Ω input impedance; if not available use a 50 Ω termination resistor directly at the oscilloscope input.
- Adjust the amplitude of the sine-wave to 6 div exactly.
- Increase the frequency of the sinewave up to 60 MHz (for 60 MHz instruments), 100 MHz (for 100 MHz instruments) or 200 MHz (for 200 MHz instruments) and check that the amplitude on the screen does not become smaller than 4,2 div.
- Remove the input signal.
- Repeat the bandwidth check in sequence for CH2, CH3, CH4 and EXT TRIG input (the bandwidth check for CH3 and CH4 of PM3392A and EXT TRIG input of PM3390A must be checked via the 10:1 probe that is delivered with the oscilloscope).
- Remove the input signal.

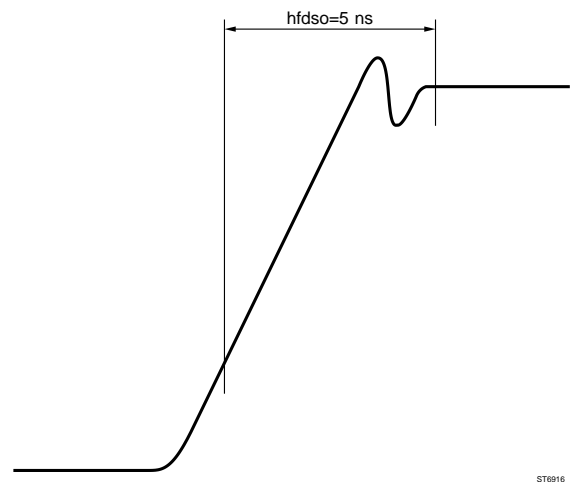

Figure 7.4 Influence of 'hfdso' on HF square wave response.

7.17 TRIGGER DELAY ADJUSTMENT

For PM3390A, PM3380A and PM3370A the 'logic' and 'state' adjustment can be skipped.

- Apply a 1V/1 MHz square-wave signal with a rise-time faster than 1 nsec to CH1. This signal is delivered in the 'edge' mode of the calibrator. as an alternative you may use the fast-rise output of the square-wave calibration generator.
- Press AUTOSET.
- Put CH1 in 0.2 V/div with DC coupled input.
- Select 50Ω input impedance; if not available use a 50Ω termination resistor directly at the oscilloscope input.
- Position the signal exactly in the vertical mid of screen.
- Put MTB/VAR TIME/DIV in 2.00 ns/div (200 MHz instruments) or in 5.00 ns/div position.
- Press menu key TRIGGER and select 'edge', level-pp 'off' and 'dc' trigger coupling.
- Turn the TRIGGER LEVEL rotary and adjust the level indicator (-T) 0.2 div under the vertical mid of screen.
- Adjust the TRIGGER POSITION rotary to a Delay read out of -5 div.
- Select the key sequence UTIL > MAINTENANCE > MANUAL and then select 'tr com' with the TRACK rotary .
- Select 'edge' with the softkey: the Δ sign appears behind 'edge'.
- Adjust the Δ rotary so that the leading edge crosses the center of the screen.

- Press menu key TRIGGER and select 'logic' and 'state' (not present in PM3370A/80A/90A).
- Use the front panel keys TRIG1 ... TRIG4 to obtain the trigger pattern '↑xxx' in the TRIGGER MAIN TB menu.
- Turn the TRIGGER LEVEL rotary and adjust the level indicator (-T) 0.2 div under the vertical mid of screen.
- Select the key sequence UTIL > MAINTENANCE > MANUAL and then select 'tr com' with the TRACK rotary .
- Select 'logic' with the softkey: the Δ sign appears behind 'logic'.
- Adjust the Δ rotary so that the leading edge crosses the center of the screen.

- Select key sequence TB MODE > EVENT DELAY > 'on' and 'CHANNEL 1'.
- Turn the TRIGGER LEVEL rotary and adjust the level indicator (-T) 0.2 div under the vertical mid of screen.
- Turn the Δ rotary to adjust the event level indicator (-E) 0.2 div under the vertical mid of screen.
- Select the key sequence UTIL > MAINTENANCE > MANUAL and then select 'tr com' with the TRACK rotary .
- Select 'events' with the softkey: the Δ sign appears behind 'events'.
- Adjust the Δ rotary so that the leading edge crosses the center of the screen.

- Select the key sequence TB MODE > EVENT DELAY > off.
- Press menu key TRIGGER and select 'edge'.
- Press menu key DTB and select DEL'D TB on, trig'd, dc and MAIN TB off.
- Put MAIN TB TIME/DIV to 100 ns/div and DEL'D TB TIME/DIV to 20.0 ns/div.
- Adjust MAGNIFY to 4x.
- Turn the Δ rotary (DTB TRIGGER LEVEL) and adjust the level indicator (-D) 0.2 div under the vertical mid of screen.
- Select the key sequence UTIL > MAINTENANCE > MANUAL and then select 'tr com' with the TRACK rotary .
- Select 'dtb' with the softkey: the Δ sign appears behind 'dtb'.
- Adjust the Δ rotary so that the leading edge crosses the center of the screen.

7.18 SAVING THE CALIBRATION DATA

If you are sure that the instrument is well calibrated, the calibration data must be saved. For this proceed as follows:

- Press softkey RETURN.
- If present, remove the calibration sticker from the pin hole.
- Press softkey 'save calibr data'.
- Press the pin hole key (e.g. with a paperclip). When doing this, it is indicated in the viewing area how many 'calibration fields' are free to save calibration data.

Note: The number of times that this 'save' action can be done is limited to 10. Refer to chapter 8.9.2 for how to proceed if the memory is full.

- Close the pin hole key with a new calibration sticker, part number 5322 455 81144.

7.19 TESTING THE INSTRUMENT'S PERFORMANCE

If you want, you can check the instrument's performance by means of chapter 6 'PERFORMANCE TEST'. In general a quick check of the instrument's main characteristics will be sufficient. For this use the following paragraphs in chapter 6 of this manual:

- Vertical deflection; deflection coefficients (6.3.6).
- Horizontal deflection; MAIN TB deflection coefficients (6.3.24).
- Horizontal deflection; delayed time-base deflection coefficients (6.3.27).

8 CORRECTIVE MAINTENANCE PROCEDURES

8.1 DISMANTLING THE INSTRUMENT

8.1.1 General information

This section contains the dismantling procedures required for the removal and testing of components during repair.

All circuit boards removed from the instrument must be adequately protected against damage, and all normal precautions regarding the use of tools must be observed.

During the dismantling a careful note must be made of all disconnected leads so that they can be reconnected to their correct terminals during assembly.

CAUTION: Damage may result if:

- The instrument is switched-on when a circuit board has been removed.
- A circuit board is removed within one minute after switching-off the instrument.

8.1.2 Removing the cabinet and carrying handle

Note: The cabinet does not need to be removed to do the calibration adjustment procedure.

To remove the cabinet proceed as follows:

- Fit the front cover on to the instrument.
- Hinge the carrying handle clear of the front cover.
- Place the instrument with the front cover on a flat surface.
- Pull off both plastic parts that are around the instrument's rear feet.
- Remove the screws (6) that secure the cabinet to the instrument's rear panel.
- Gently slide the cabinet (and carrying handle) off the instrument.

ATTENTION:

- *When installing the cabinet again, special care must be taken that cables are not damaged between the cabinet and the chassis. This is especially important for the flat cable above the Cathode Ray Tube (CRT) that connects Front unit A4 and CRT controls unit A5.*
- *Also take care that the cabinet fits well into the plastic front frame and that grounding fingers are not damaged during installation.*

The rotation points of the carrying handle are secured by means of metal 'omega' clips. After removal of these clips the handle can be removed by pulling both handle ends outwards away from the instrument.

8.2 REPLACEMENTS

WARNING: The Extremely High Tension (EHT) cable is directly connected to the EHT-multiplier unit. When the EHT cable to the post-acceleration anode is disconnected, the cable must be discharged by shorting the terminal to the instrument's earth.

8.2.1 Standard parts

Electrical and mechanical replacement parts can be obtained through your local PHILIPS/FLUKE organization or representative. However, many of the standard electronic components can be obtained from other local suppliers. Before purchasing or ordering replacement parts, check the parts list for value, tolerance, rating and description.

NOTE: Physical size and shape of a component may affect the instrument's performance, particularly at high frequencies. Always use direct-replacement components, unless it is known that a substitute will not degrade the instrument's performance.

8.2.2 Special parts

In addition to the standard electronic components, some special components are used:

- Components, manufactured or selected by FLUKE to meet specific performance requirements.
- Components which are important for the safety of the instrument.

ATTENTION: Both type of components may only be replaced by components obtained through your local FLUKE organization or representative.

8.2.3 Transistors and Integrated Circuits

- Return transistors and IC's to their original positions, if removed during routine maintenance.
- Do not replace or switch semi-conductor devices unnecessarily, as it may affect the calibration of the instrument.
- Any replacement component should be of the original type or a direct replacement. Bend the leads to fit the socket or p.c.b. holes and cut the leads to the same length as on the component being replaced. See also the Performance Test in this manual.
- When a device has been replaced, check the operation of the part of the instrument that may be affected.

8.3 STATIC SENSITIVE COMPONENTS

In the oscilloscope the black/yellow 'static sensitive components' symbol is present (see also figure 8.1). This means that this instrument contains electrical components that can be damaged by electrostatical discharge. Although all MOS integrated circuits incorporate protection against electrostatic discharge, they nevertheless can be damaged by accidental over-voltages.

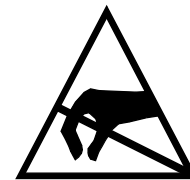

Figure 8.1 Static sensitive symbol (black/yellow)

It is also possible that a delayed failure or 'wounding' effect may occur. When this happens the component will fail anywhere between two hours to six months later.

In storing and handling static sensitive components, the normal precautions for these devices are recommended. Handling and servicing static sensitive assemblies and components should be performed only at a static free workstation by qualified personnel.

CAUTION: Testing, handling and mounting call for special attention. Personnel, handling static sensitive devices, should normally be connected to ground via a high-ohmic resistor.

Extensive information on how to deal with static sensitive components is contained in Support Bulletin OSC296 (ordering number 4822 872 08407).

8.4 SOLDERING TECHNIQUES

8.4.1 General soldering techniques

Working method:

- Carefully unsolder the soldering tags of a semi-conductor one after the other.
- Remove all superfluous soldering material. Use desolder braided wire; ordering code: 4822 321 40042.
- Check that the leads of the replacement part are clean and pre-tinned on the soldering places.
- Place the replacement semiconductor exactly in the same position, and solder each lead to the relevant printed conductor on the printed circuit board.

NOTE: The maximum permissible soldering time is 10 seconds during which the temperature of the leads must not exceed 250 °C. The use of solder with a low melting point is recommended. Take care not to damage the plastic encapsulation of the semiconductor (softening point of the plastic is 150 °C).

ATTENTION: When you are soldering inside the instrument it is essential to use a low voltage soldering iron, the tip of which must be grounded to the chassis of the oscilloscope.

A suitable soldering iron is:

Mini soldering iron station, WECP-COD3 (regulated transformer) and Weller LR-20 (soldering iron).

Ordinary 60/40 solder with core and 35 ... 40 W pencil-type soldering iron can be used to do the majority of the soldering. If a higher wattage-rating soldering iron is used on the printed circuit board, excessive heat can cause the circuit wiring to separate from the base material.

8.4.2 Soldering micro-miniature semi-conductors

Because of the small dimensions of these SOT semi-conductors and the lack of space between the components on the printed circuit board, it is necessary to use a miniature soldering iron with a pin-point tip (max. diameter 1mm) to solder a SOT on to a printed circuit board.

Suitable soldering tools are:

- Mini soldering iron station, WECP-COD3 (regulated transformer) and Weller MLR-20 (mini soldering iron).
- A hot-air solder tool: Leister Hot-Jet.

Next, the following materials are recommended:

- Soldering tin, diameter 0.8 mm, SnPb 60/40 with a Resin Mildly Activated (RMA) flux. Ordering code: 4822 390 80133.
- Desolder braided wire; ordering code 4822 321 40042.
- Solder paste 26.
- Non-corrosive and Resin Mildly Activated (RMA) flux-Colophony. Ordering code: 4822 390 50025.

Refer to the Support Bulletin OSC296 (ordering code 4822 872 08407) for a complete discussion of the soldering techniques for SMD's.

8.5 REMOVING THE UNITS, MECHANICAL PARTS AND CRT

NOTE: For installation, reverse the sequence.

8.5.1 Removing the rotary knobs

Rotary knobs can be removed by simply pulling them off. The knobs have an integrated shaft and fixing device. Most of the knobs (11) have a light grey colour. The knobs for cursor positioning are dark grey. The knobs DELAY and LEVEL DTB are almost white ('dark mushroom').

For installation push the rotary into its hole, rotate it gently until it clicks into place.

8.5.2 Detachment of ribbon cables

The white ribbon cables are used together with white connectors with integrated locking device. Proceed as follows to take the cable out of the connector:

- Lift the outside part of the connector: this unlocks the cable.
- Pull the ribbon cable out of the connector.

Proceed as follows to connect the the ribbon cable again:

- Push the ribbon cable fully into the connector. The blue line on the cable must be on the connector side where the contacts are visible (in unlocked position). Figure 8.2 explains this.
- Push down the outside part of the connector in order to lock the cable.

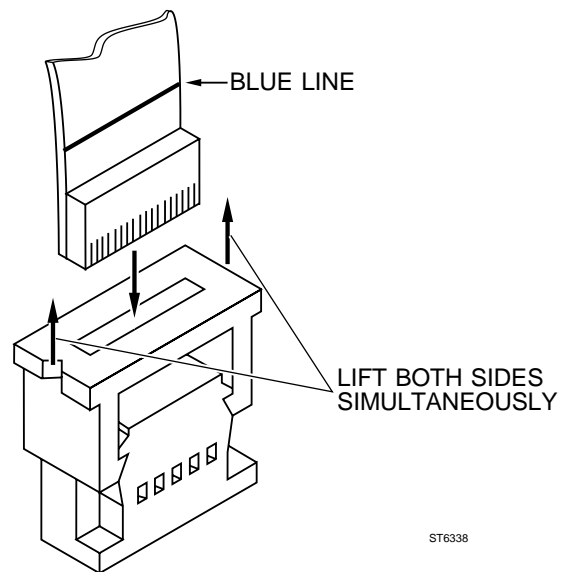

Figure 8.2 Mounting position of white ribbon cables in connector

8.5.3 Removal of signal unit A1

- Remove 3 screws with washers that fix the printed circuit board to the chassis plate.
- Remove 1 long screw that fixes (and grounds) the screen of the input attenuators to the chassis plate.
- Unplug the blue ribbon cable.
- Lift the rear side of the unit over the plastic stud and slide the unit backwards: the unit becomes loose from the chassis now.

NOTE: The unit can be toppled over. The SMD component side is accessible now and can be measured in working condition after reinstallation of the blue ribbon cable. Figure 8.4 shows this.

- Unplug the white ribbon cable and the coaxial delayline connector.
- Unplug the connectors for the output options (MTB gate, DTB gate, MTB sweep) if they are present in the instrument.
- Remove the unit from the instrument.

For removal of the screen of the attenuators proceed as follows:

Pull off the plastic bracket between the BNC inputs.

Remove the two screws between the BNC's.

Remove the two screws in the sides of the screening plate.

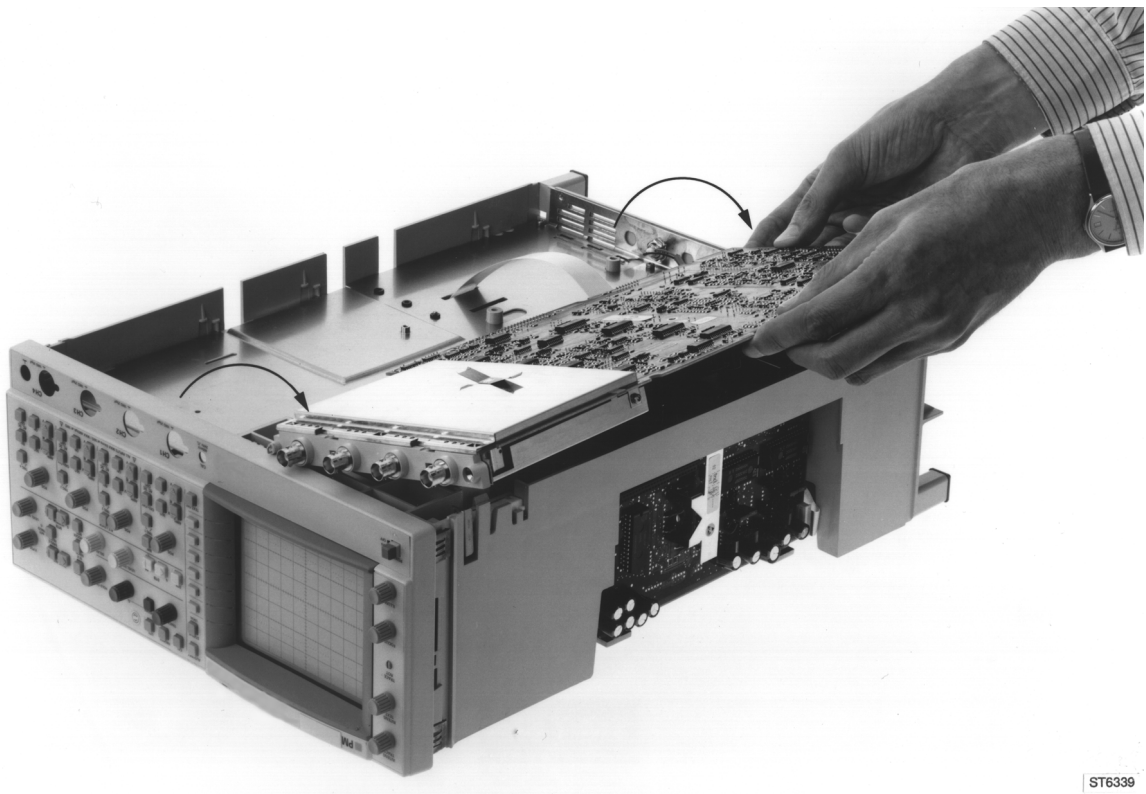

ST6339

Figure 8.3 Signal unit in position to measure SMD component side

8.5.4 Removal of Final XYZ amplifier unit A2

ATTENTION: On the XYZ unit there are parts that carry high voltages. If working on the unit under live condition cannot be avoided, it must be done by a qualified technician who is aware of the dangers involved.

- Remove the screw that secures (and grounds) the unit to the bottom chassis plate.
- Disconnect the 4 wires that lead to the CRT (The X- and Y-deflection plates): this action must be done carefully to avoid damage to the side connections of the CRT. For correct reinstallation refer to the wiring diagram in chapter 4.2.
- Bend out the two clamping lips that secure the unit at the top side. The unit is loosened now.

NOTE: The unit can be put now in an inclined position as shown in figure 8.3. Measuring on the SMD-component side in working condition is possible then. Measuring the output wires that lead to the X- and Y-deflection plates is possible with a 10 k Ω damping resistor between measuring point and probe tip. This avoids oscillations.

- Unplug two ribbon cables and take the unit out of the chassis.
- Unplug the delayline connector.

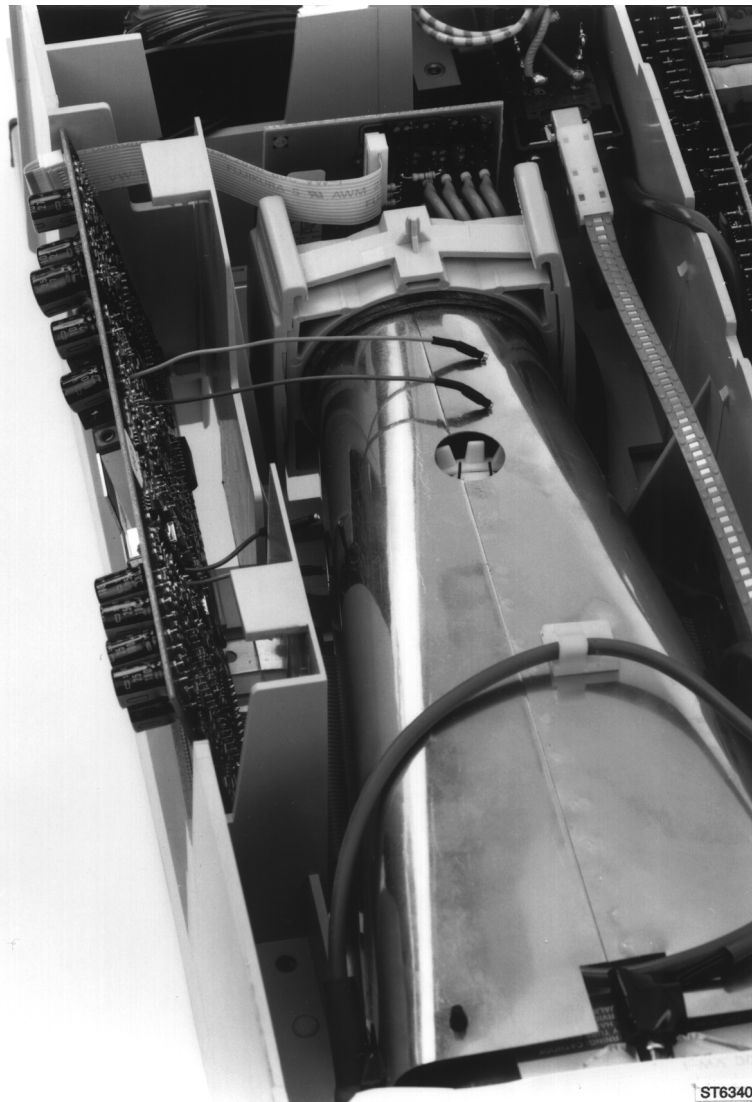

Figure 8.4 Final XYZ amplifier in inclined position

8.5.5 Removal of unit at socket of CRT

WARNING: On this unit there are parts that carry dangerous high voltages (-2.2 kV). Some of these voltages remain some time after disconnecting the instrument from the mains. Therefore it is recommended to wait at least five minutes after having disconnected the instrument from the mains, before removing the printed circuit board. If working on the unit under live condition cannot be avoided, it must be done by a qualified technician who is aware of the dangers involved.

Now proceed as follows:

- Unplug the ribbon cable at the Final XYZ amplifier or at the CRT socket unit.
- Pull the unit gently off the CRT socket.
- Unplug the -2.2 kV cathode/filament (3 wires).

8.5.6 Removal of Cathode Ray Tube (CRT)

IMPORTANT:

- Handle the CRT and its side connections carefully. Rough handling or scratching can cause the CRT to implode.
- When installing the CRT, first remove its protective cover. Then take care that its screen is pressed tight to the front side of the chassis.

- Remove the unit from the socket of the CRT (refer to 8.5.5).
- Disconnect the 4 wires that lead to the CRT (The X- and Y-deflection plates): this action must be done carefully to avoid damage to the side connections of the CRT. For correct reinstallation refer to the wiring diagram in chapter 4.2.
- Pull the graticule lamp holder out of the front rubber.
- Remove the bezel and contrast filter.
- Unplug the trace rotation cable (3 wires) at the connector board.

WARNING: The E.H.T. cable is directly connected to the E.H.T. multiplier that is present on the power supply. When the E.H.T. cable is disconnected from the CRT, the cable must be discharged by shorting it to the instrument's ground (e.g. the CRT screen).

- Unlock the EHT cable and discharge it to ground potential.
- Push the two plastic clamping lips that secure the CRT support to the chassis and gently lift the CRT including its shield out of the oscilloscope.

8.5.7 Removal of microprocessor unit A3

- To preserve the memory contents, move the battery back-up plug X1006 on unit A6 to X1901 on unit A3 when the instrument is turned ON.
- Remove the screw that secures the unit to the rear panel.
- Remove the screw that secures (and grounds) the unit to the bottom chassis plate.
- Unplug the ribbon cable that leads to signal unit A1.
- If the IEEE option is installed, unplug the ribbon cable that leads to the IEEE-connector.
- Slide the unit upwards out of the instrument.

NOTE: The microprocessor unit can be measured under working conditions, by using the extension board with ordering code 5322 218 61479. On this board there is a jumper that can be removed to switch off the EHT- converter. This feature is not used when testing the microprocessor.

8.5.8 Removal of the units in the front frame (A4, A5)

The plastic front frame incorporates the Front unit A4 and the CRT controls unit A5. The frame can be removed from the chassis by bending out four clamping lips. Before doing so unlock the ribbon cable at the connector board.

Removal of Front unit A4:

- Pull the self-locking white plastic clamps.
- Remove the rotary knobs.
- Bend out the four clamping lips that secure unit A4 to the front frame and take the unit out.
- If required separate the rubber key mat from the printed circuit board.

NOTE: - *Do not allow dirt to reach the contact areas of the printed circuit board and the key mat. If dirty, contact areas may be cleaned with cleansing alcohol.*

- *Small studs on the key mat position it on the printed circuit board. During installation the studs must be pressed gently into the matching holes of the circuit board. This can be done by using a small screwdriver.*
- *The key mat as delivered as a spare part is universal. It may be that the number of keys are too much for your instrument. If so, the unnecessary keys must be cut off with a sharp knife.*

Removal of CRT controls unit A5:

- Remove the rotary knobs.
- Pull the two self-locking white plastic clamps.
- Take the unit out of the front frame.

8.5.9 Removal of the Power supply unit A6

- Turn ON the instrument.
- Move the back-up voltage plug (X1006) to the microprocessor unit A3 (X1901) to back-up the memory.
- Turn OFF the instrument.

WARNING: **On the power supply unit there are many parts that carry dangerous high voltages. Some of these voltages remain some time after disconnecting the instrument from the mains. Therefore it is recommended to wait at least five minutes after having disconnected the instrument from the mains, before removing the printed circuit board. If working on the power supply under live condition cannot be avoided, it must be done by a qualified technician who is aware of the dangers involved.**

- Disconnect the oscilloscope from the mains.
- Remove the screw that secures the unit to the chassis.
- Unplug the cables from the -2.2 kV cathode/filament (3 wires) and the fan (2 wires).

WARNING: **The E.H.T. cable is directly connected to the E.H.T. multiplier that is present on the power supply. When the E.H.T. cable is disconnected from the CRT, the cable must be discharged by shorting it to the instrument's ground (e.g. the CRT shielding).**

- Unplug the +14.3 kV connector from the CRT.
- Unlock the plastic clamps (are part of the chassis) that secure the lower edges of the unit.
- Slide the unit upwards out of the instrument and unplug the mains input connector (3 thick wires).

NOTE: The power supply unit can be measured under working conditions, by using the extension board with ordering code 5322 218 61479. On this board there is a jumper that can be removed to switch off the EHT- converter. For safety reasons it is strongly recommended to use this feature. Refer to chapter 8.8 for more faultfinding hints.

NOTE: Return the Battery Back-Up voltage to original position (X1006) on unit A6 when the instrument is turned ON.

8.5.10 Removal of digitizer unit A8.

- Remove the screw that secures (and grounds) the unit to the bottom chassis plate.
- Slide the unit upwards out of the instrument.
- Unplug the coaxial cables from the unit (the cables and connectors have colour coded rings to facilitate correct reinstallation).

NOTE: The IC's DARLIC (D8027) and DSP (D8069) are placed on sockets. Since these IC's have numerous pins, special tools are recommended to pull them out of their sockets. For DSP the type 821566-1 (for PLCC68) manufactured by AMP is a suitable tool. For DARLIC the type TW2068 (for pin grid array) manufactured by Terminal is suitable. Reinstallation of DARLIC requires considerable pressure; however take care that pins are not bent and that components of the other side of the printed circuit board are not damaged.

The unit can be measured under working conditions, by using the extension board with ordering code 5322 218 61479. On this board there is a jumper that can be removed to switch off the EHT-converter on the power supply A8. This feature needs not to be used when testing the digitizer.

8.6 INSTRUMENT REPACKING

If the instrument is to be shipped to a Service Centre for service or repair, attach a tag showing the full address and the name of the individual at the users firm that can be contacted. The Service Centre needs the complete instrument, its serial number and a fault description. If the original packing is not available, repack the instrument in such a way that no damage occurs during transport.

8.7 TROUBLESHOOTING TECHNIQUES

If a fault appears, the following test sequence can be used to assist in locating the defective component:

- Check to verify that the control settings of the instrument are correct. Consult the operating instructions in the Operating guide.
- Check the equipment to which the instrument is connected, and check the interconnection cables.
- Verify that the instrument is properly calibrated. If it is not, start the autocalibration procedure by pressing the CAL key for 2 seconds. If this does not solve the problem refer to Chapter 7 'Calibration Adjustment Procedure'.
- Locate the circuit(s) in which the fault is suspected: the symptom often indicates the faulty circuit. If the power supply is defective, the symptom may appear in several circuits.
- Visually check the circuit(s) in which the fault is suspected. Often it is possible to find faults such as 'cold' or defective solder joints, intermittent or open interconnection plugs and wires or damaged components.

8.8 TROUBLESHOOTING THE POWER SUPPLY

WARNING: On the power supply there are many parts that carry dangerous high voltages. Some of these voltages remain some time after disconnecting the unit from the mains. Therefore, it is recommended to wait at least five minutes after having disconnected the unit from the mains, before removing the unit. If working on the power supply unit under live condition cannot be avoided, it must be done by a qualified technician who is aware of the dangers involved. The use of an mains isolation transformer is strongly recommended.

The table below indicates the output voltages, currents and power figures delivered by the power supply. To determine whether a certain fault condition is initiated by the power supply itself or by the connected oscilloscope circuits, a dummy load is listed in the table. The table gives also an example of the resistor types that can be used to compose the dummy load. The resistors and connector (ordering number 5322 267 70308) that fits on connector X1002 can be ordered at Consumer Service.

Supply voltage	Current drain	Substitution resistance	Dissipated power	Dummy load resistors
+5 V	3000 mA	1.7 Ω	15 W	5x 10 Ω /4W (4822 112 21054) in parallel
-5.2 V	1750 mA	2.9 Ω	8.7 W	3x 10 Ω /4W (4822 112 21054) in parallel
+12 V	1750 mA	6.8 Ω	21 W	3x 22 Ω /7W (4822 112 41063) in parallel
-12 V	1450 mA	8.3 Ω	17.4 W	3x 27 Ω /7W (4822 112 41065) in parallel
+18 V	550 mA	32.8 Ω	10 W	3x 10 Ω /4W (4822 112 21054) in series
-18 V	195 mA	92.5 Ω	3.5 W	2x 47 Ω /4W (4822 112 21072) in series
+58 V	60 mA	966 Ω	12.1 W	2x 470 Ω /7W (4822 112 41098) in series
-58 V	80 mA	725 Ω	4.7 W	330 Ω /4W (4822 112 21094) and 390 Ω /4W (4822 112 21096) in series
+10 Vref	9 mA	1100 Ω	0.1 W	--
6.3 Vac	240 mA	26.3 Ω	1.5 W	--
-2.2 kV	700 μ A	3.1 M Ω	1.55 W	--
+14.5 kV	50 μ A	290 M Ω	0.7 W	--

Another way of fault location is the use of the extension board with ordering code 5322 218 61479. On this board there is a jumper that can be removed to switch off the EHT-converter. For safety reasons it is strongly recommended to use this feature.

The current drawn from a certain supply voltage can be measured after having removed the series choke and connecting a current meter instead of it. The chokes are L1273 (+5 V), L1201 (-5.2 V), L1202 (+12 V), L1203 (-12 V), L1204 (+18 V), L1206 (-18 V), L1208 (+58 V) and L1209 (-58 V).

8.9 SPECIAL TOOLS

8.9.1 Extension board

For test and repair purposes the units A3 and A6 can be plugged in their connectors via an extension board. This board is available under ordering number 5322 218 61479. On this board there is a jumper that can be removed to switch off the EHT-converter. For safety reasons it is strongly recommended to use this feature.

8.9.2 Flash-ROM loader program

After calibration of the oscilloscope, the softkey 'save calibr data' must be pressed. This saves the calibration data in the oscilloscope's internal Flash-ROM's. When the oscilloscope is turned off now, calibration data does not disappear with no back-up batteries installed. The save action can be done 10 times.

The Flash-ROM's contain blocks of calibration data (of which the most recent block is valid) and the operating software. After operation of softkey 'save calibr data', the text 'XX CALIBRATION FIELDS FREE' is displayed. XX can be a figure between 10 ... 1 or 'NO'. In case of 'NO', the Flash ROM must be emptied and redundant blocks of calibration data must be removed. To have this done, send your oscilloscope to the nearest Service Center.

The data exchange takes place via the oscilloscope's RS232 interface. It occurs via a program running on a Personal Computer with RS232 interface.

The Flash-ROM's D1013 and D1015 as listed in the parts lists is empty. After exchange it must be filled with operating software and calibration data. Also for this the oscilloscope must be sent to the nearest Service Center.

8.10 RECALIBRATION AFTER REPAIR

After any electrical component has been renewed the calibration of its associated circuit should be checked, as well as the calibration of other closely-related circuits.

Since the power supply affects all circuits, calibration of the entire instrument should be checked if work has been done in the power supply or if the transformer has been renewed.

8.11 TESTS BUILT INTO THE INSTRUMENT.

8.11.1 Power-up test.

After turning the oscilloscope on, power-up tests start automatically. The tests take less than a second. A message appears on the screen when errors are found. With no message displayed, the oscilloscope is ready for use. The tests that are sequentially done and the associated error messages are:

- The oscilloscope's internal control bus is checked. This is done by addressing N9001, N9002, N9003, N8005, N6014, D9009 (unit A1), N1001, N2002 (unit A2), N1141 (unit A6) and N8009, N8070 (unit A8). Error message: 'NO ACKNOWLEDGE ON I2C BUS'.
- The oscilloscope's hardware configuration is tested on the units A1, A3 and A8. On unit A1 is tested for 60, 100 or 200 MHz and 4, 2+2 or 2 channels. On A3 the presence of an IEEE interface and on A8 the amount of memories. Also is tested if the the software version corresponds with the hardware modification level. Error messages: 'WRONG A1 HARDWARE VERSION', 'WRONG A3 HARDWARE VERSION' or 'WRONG A8 HARDWARE VERSION'.
- The communication between the front unit A4 (named 'ufo') and microprocessor A3 is checked. Message: 'CANNOT COMMUNICATE WITH UFO'.
- The contents of the settings memory is checked if back-up batteries are installed. Message: 'NO BATTERY BACKUP'.
- Many IC's and belonging bus structures on unit A8 such as BATGE, DARLIC, CURCON, MAM and PRAM are tested. In case of an error, a message such as DARLIC ERROR, CURCON ERROR or similar is displayed.

8.11.2 Introduction to diagnostic tests.

The tests are accessible via the softkey menu's. A good knowledge of the circuitry of the oscilloscope is necessary to take advantage of these tests. Refer to chapter 5 'Unit descriptions' for additional information and circuit diagrams.

Tests can be performed on:

- The microprocessor system.
- The inputs for the microprocessor (rotaries and keys via the processor in the front unit).
- The outputs from the microprocessor (digital to analog converters and output buffers).
- The IC's and bus structures of digitizer unit A8.

The configuration of the control part under direct microprocessor influence is given in the figure. The lines SDA (Serial DATA) and SCL (Serial CLOCK) are fed to the many circuits, where the serial information is converted into the different control signals.

NOTE: For servicing, solder joints are added in the p.c.b. tracks. These can be used to localize a fault in the bus by means of isolating a suspected IC from SCL or SDA lines.

Proceed as follows to reach the tests:

- Press menukey 'UTIL'.
- Press softkey 'MAINTENANCE'.
- Now softkey selection is possible between 'SELFTTEST' and 'REPAIR TOOLS'.

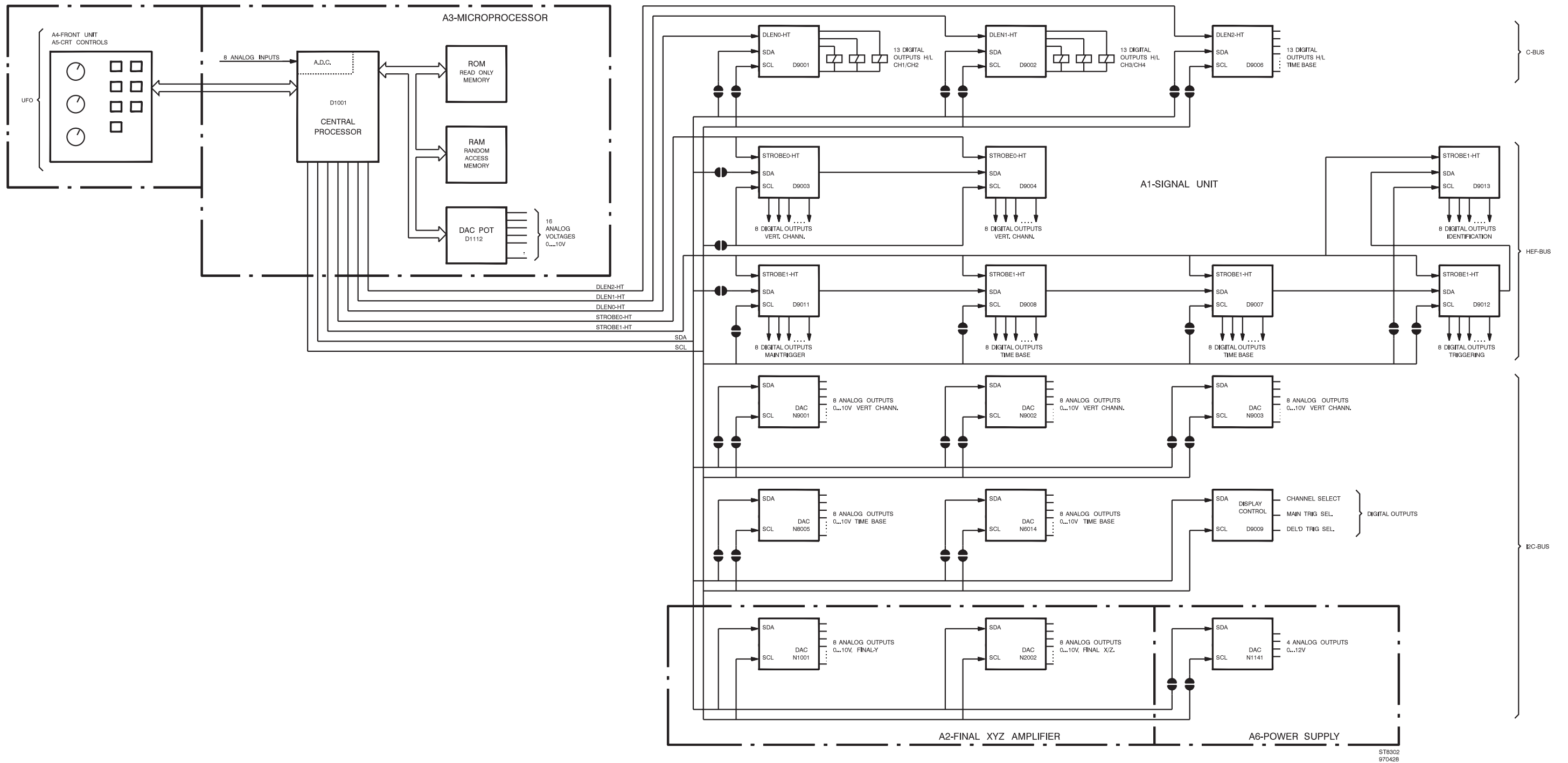

Figure 8.3. Configuration of control part under direct control of microprocessor

8.11.3 SELFTESTS

Under the softkey 'SELFTEST' it is possible to run tests for the microprocessor and digitizer units. With a toggle softkey, selection is possible between 'test-all' and 'specific'.

A test is started with softkey 'start'. A test that is being executed can be interrupted with softkey 'abort'. A test completed successfully gives the screen message 'TEST PASSED'. The selection 'test all' starts a sequence of all tests. If a fault is found, 'specific' must be selected: this gives the possibility to determine what part is defective. By means of the 'TRACK' rotary, one of the specific tests can be selected. Softkey 'RETURN' is used to move upwards in the menu structure.

The selftests mainly check the bus structures that interconnect the IC's on digitizer unit A8 and microprocessor unit A3. The tests are done with bitpatterns such as 1111 ... (FF hex), 0000 ... (00 hex), 1010 ... (AA hex) and 0101 ... (55 hex) that are 16 or 8 bits wide. It is tested for bit(s) stuck at one (+5 V), bit(s) is stuck at zero (0 V), bits interconnected or bit(s) interrupted. The message 'TEST PASSED' is displayed on the screen if a test is terminated successfully; if not 'TEST FAILED' or an error code is displayed. The error code gives information about the kind of fault that has occurred. The tests of the random access memories (e.g. MAM, FAM, PRAM) are done for many memory locations: the message 'TEST PASSED' gives a good certainty that the chip is error free. Tests for other devices (e.g. BATGE, DARLIC, CURCON) do not test each and every aspect of the chip. The tests write bitpatterns into a certain buffer. Then the pattern is read from the buffer and checked. It must also be borne in mind that tests cannot be run if certain parts (e.g. the microprocessor on unit A3, text generator) are not functioning. The tests are initiated from the microprocessor and routed to digitizer A8 via bus lines and connector board A10.

CPURAM

This test checks the RAM (D1012) on unit A3. D1012 belongs to microprocessor D1001 on unit A3.

If completed successfully the message 'TEST PASSED' is displayed.

In case of an error the message 'TEST FAILED' is displayed.

BATGE (Bus Arbiter and Trace GEnerator)

Main function(s) of BATGE (D8048) are arbitration between multiple processors and memories at high speed (40 MHz clock). D8048 has a connection with MAM (D8054, D8056).

During the BATGE test 4 bitpatterns are send to a testregister inside D8048. Then they are read and verified. This test does not cover every aspect of the functioning of D8048. Moreover the fact that the microprocessor address and databits 00 ... 07 are combined can give incorrect error messages.

In case of an error, the message 'TEST FAILED' is displayed. The second line of this message has five positions that give information about the kind of fault that is detected. This information is intended for factory use.

DSP (Digital Signal Processor)

Main function(s) of DSP (D8069) are Average, Envelope, Mathematical, Interpolation, Filters, Display memory refresh, X position control, Delta T processing. D8069 has a connection with the PRAM (D8049, D8052).

The DSP test checks the communication between DSP and microprocessor on unit A3. A message is sent to the DSP and this device should answer with an acknowledge. In case of an error, the message 'TEST FAILED' is displayed.

DARLIC (Data Acquisition and tRigger Logic IC)

Main function(s) of DARLIC (D8027) are data path (speed conversion, transfer from FAM to MAM) and trigger engine (start/stop acquisition, pre/posttriggering, delta-t counter, timed pattern mode).

During the DARLIC test 2 bitpatterns (FF hex and 00 hex) are send to a register inside D8027. Then they are read and verified. The test does not cover each and every aspect of the functioning of DARLIC.

In case of an error, the message 'TEST FAILED' is displayed without any further specification.

CURCON (CURsor and text CONtrol IC)

Main functions of CURCON (D8047) are generation of text and cursors. CURCON has a connection with RAM D8051.

During the CURCON test the databus is checked for stuck at 0, stuck at 1, opens and interconnections. Also the databus connection between Curcon and belonging RAM (D8051) is tested. This test does not cover each and every aspect of the functioning of D8047.

In case of an error, the message 'TEST FAILED' is displayed. The second line of this message has five positions that gives information about the kind of fault that is detected. This information is intended for factory use.

MAM (Main Acquisition Memory)

In this memory (D8054, D8056) the register contents, display information and other data are stored.

During the MAM test the global databus from BATGE to MAM is checked for stuck at 0, stuck at 1, opens and interconnections. This test does not cover each and every aspect of the functioning of D8054/56.

In case of an error, the message 'TEST FAILED' is displayed. The second line of this message has five positions that give information about the kind of fault that is detected. This information is intended for factory use.

FAM (Fast Acquisition Memory)

In this memory the signal samples from the ADC are stored. The memory consists of 8 RAM's D8037 ... D8046.

The FAM test is a databus test. In case of an error, the message 'TEST FAILED' is displayed. The second line of this message has five positions that give information about the kind of fault that is detected. This information is intended for factory use.

PRAM (PRoGrAm Memory)

Serves as program memory (D8049, D8052) for the DSP (Digital Signal Processor). Has a connection with DSP.

In case of an error during the PRAM test, the message 'TEST FAILED' is displayed. The second line of this message has five positions that give information about the kind of fault that is detected. This information is intended for factory use.

ROM0, ROM1,

Flash-ROM 0 (D1013) and Flash-ROM 1 (D1015) on unit A3 belong to microprocessor D1001. If completed succesfully the message 'TEST PASSED' and the belonging checksum are displayed. In case of a ROM0 or ROM1 error, the oscilloscope will not function normally.

8.11.4 Repair tools

8.11.4.1 General

Under the softkey 'REPAIR TOOLS', tests can be selected concerning the exchange of information in the area around the microprocessor and digitizer unit A8:

- Data exchange between keys/rotaries and microprocessor.
- Data exchange between microprocessor and the devices that control the oscilloscope circuits.
- Data exchange between microprocessor unit A3 and digitizer A8.

Tests can be selected with a softkey pair. A test can be activated with toggle softkey 'on off'. Data in connection with the tests is displayed in the viewing area as two lines of information. The last setting is present in the utmost right position of the lowest of the two lines.

8.11.4.2 Repair tools / ufo

With this test the proper functioning of the keys and rotaries at the front panel (ufo) can be tested. Each control has its own number. There is also information given concerning the position occupied by the controls. The tables below indicate the information from controls towards microprocessor. This is separately listed for rotaries and keys.

Rotaries (L is rotation left to right, R is rotation right to left, X indicates the rotation speed):

ILLUM	L/R0X	INTENS TEXT	L/R1X	INTENS TRACE	L/R2X
POS CH2	L/R3X	DELAY	L/R4X	HOLD OFF	L/R5X
POS CH4	L/R6X	TRIGGER LEVEL	L/R7X	FOCUS	L/R8X
FOCUS	L/R8X	TRACE ROT	L/R9X	TRACK	L/RAX
POS CH1	L/RBX	Δ	L/RCX	TRIGGER POS	L/RDX
POS CH3	L/REX	X POS	L/RFX		

Keys (A = autorepeat, M = more than 1 key pressed, X=P is function off, X=U is function on):

CAL	X00	AUTOSET	X01	ANALOG	X20
STATUS/LOCAL	X02	Softkey 5	X03	Softkey 6	X04
TEXT OFF	X05	CH1 + CH2	X06	AC DC GND CH1	X07
UTIL	X10	SETUPS	X11	Softkey 1	X12
Softkey 4	X13	AMPL mV CH1	X14	AMPL V CH1	X15
AMPL mV CH2	X16	AMPL V CH2	X17	pin hole	X21
Softkey 2	X22	Softkey 3	X23	AUTO RANGE CH1	X24
ON CH1	X25	AUTO RANGE CH2	X26	ON CH2	X27
DTB s	X32	DTB	X33	VERT MENU	X34
TRIG1	X35	INV CH2	X36	AC DC GND CH2	X37
TRIGGER	X41	CURSORS	X42	DTB ns	X43
AVERAGE	X44	TRIG2	X45	AMPL mV CH3	X46
AMPL V CH3	X47	MAGNIFY down	X51	RUN/STOP	X52
TB MODE	X53	TRIG4	X54	TRIG3	X55
AUTO RANGE CH3	X56	ON CH3	X57	MAGNIFY up	X61
MTB s	X63	INV CH4	X64	AUTO RANGE CH4	X65
CH3 + CH4	X66	AC DC GND CH3	X67	SINGLE	X72
MTB ns	X73	AC DC GND CH4	X74	ON CH4	X75
AMPL mV CH4	X76	AMPL V CH4	X77	ACQUIRE	X31
AUTO RANGE TB	X62				
SAVE	X30	RECALL	X40	MEASURE	X50
MATH	X60	DISPLAY	X70	PLOT	X71

Note: the table with keys is based upon PM3394A. In other oscilloscope versions some of the keys are not present or have a different function.

8.11.4.3 Repair tools / I²C bus

This test displays the data (SDA) that is send by the microprocessor to a number of addressable devices. Synchronization is achieved via SCL. Each data block sent by the microprocessor is preceeded by an address on which the device can respond. The characters 'A, B, C, D, E and F' represent one hexadecimal character. The devices are the ADC's mentioned under 'REPAIR TOOLS / DAC ' and DAC N1141 on power supply unit A1.

Device	Unit	Name of circuit diagram	Address	Data format
D9009	A1	Display and trigger control	36	AB CD EF
N9001	A1	Control circuits	40	AB CD
N9002	A1	Control circuits	4C	AB CD
N9003	A1	Control circuits	44	AB CD
N8005	A1	Time base logic	48	AB CD
N1001	A2	Final Y preampl. + control	46	AB CD
N2002	A2	Final X amplifier + control	4E	AB CD
N1141	A6	EHT converter + auxiliary	88	AB CD
N8070	A8	Curcon, DAC's, Z-control	42 *	AB CD
N8009	A8	Display interface	44 *	AB CD

*) The DAC's on digitizer unit A8 are directly controlled by DARLIC (D8027).

8.11.4.4 Repair tools / adc

This test displays the decimal representation of the input voltage applied to the analog inputs ACH0 ... ACH7 of the microprocessor D1001. The readout consists of two lines of information.

The first line displays in sequence the analog inputs:

- ACH7: the NTC-resistor R1009 (on unit A3) that measures the temperature inside the oscilloscope is connected to this input.
- ACH6 (PROBE 4): the voltage value applied to this input represents the type of the probe applied to CH4.
- ACH5 (TBSMART): the voltage value representing the state of a number of time base circuits is applied here. TBSMART originates from unit A1 and is applied to unit A3.
- ACH4 (PROBE 3): the voltage value applied to this input represents the type of the probe applied to CH3.

The second line displays in sequence:

- ACH3 (PROBE 2): the voltage value applied to this input represents the type of the probe applied to CH2.
- ACH2 (XCAL): the applied voltage originates from the measuring circuit of the horizontal output on unit A2. This is used for automatic calibration of he horizontal section.
- ACH1 (YCAL): the applied voltage originates from the measuring circuit of the vertical output on unit A2. This is used for automatic calibration of he vertical section.
- ACH0 (PROBE 1): the voltage value applied to this input represents the type of the probe applied to CH1.

8.11.4.5 Repair tools / hef

To control simple on/off functions there are 7 buffers (of the type HEF4094) on unit A1: this structure is called the 'HEF-bus'. Each buffer has 8 outputs as shown in the figure. The buffers are divided into 2 groups: group 0 consists of 2 buffers and group 1 consists of 5 buffers. A group can be regarded as a shift register of 16 or 40 bits. Each group of buffers has its common enable signal: STROBE0-HT or STROBE1-HT.

The test makes the data (SDA) visible that is shifted by the microprocessor into the shift register. Data is displayed in the viewing area as two lines of information. The last data block is present in the utmost right position of the lowest of the two lines. Synchronization is achieved via SCL.

The configuration of group 0 and 1 is shown in the table:

Group	Enable signal	Buffers	Name of circuit diagram
0 D9004	STROBE0-HT Control circuits	D9003	Control circuits
1 D9008 D9007 D9012 D9013	STROBE1-HT Time base logic Delayed time base DTB trigger DTB trigger	D9011	MTB trigger

The data representation for group 0 is '0:ABCD'. Each character represents the hexadecimal (16 possible states) information for 4 outputs (total 16 outputs):

- Character 'A' represents the information for D9004 outputs 14, 13, 12, 11.
- Character 'B' represents the information for D9004 outputs 4, 5, 6, 7.
- Character 'C' represents the information for D9003 outputs 14, 13, 12, 11.
- Character 'D' represents the information for D9003 outputs 4, 5, 6, 7.

The data representation for group 1 is '1:ABCD 1:EFGH'. Each character represents the hexadecimal (16 possible states) information for 4 outputs (total 32 outputs):

- Character 'A' represents the information for D9012 outputs 14, 13, 12, 11.
- Character 'B' represents the information for D9012 outputs 4, 5, 6, 7.
- Character 'C' represents the information for D9007 outputs 14, 13, 12, 11.
- Character 'D' represents the information for D9007 outputs 4, 5, 6, 7.
- Character 'E' represents the information for D9008 outputs 14, 13, 12, 11.
- Character 'F' represents the information for D9008 outputs 4, 5, 6, 7.
- Character 'G' represents the information for D9011 outputs 14, 13, 12, 11.
- Character 'H' represents the information for D9011 outputs 4, 5, 6, 7.

Note: The data for D9013 is not displayed. This buffer is only used when turning-on the oscilloscope: it tests if hardware and software belong to each other.

There also exists a HEF-bus on digitizer unit A8. This bus consists of D8034, D8036, D8033 and D8032 and is directly controlled by DARLIC (D8027). The data applied to this bus cannot be displayed on the CRT screen.

8.11.4.6 Repair tools / cbus

To control on/off functions in the CH1 ... CH4 attenuators and in the main and delayed time base, there are 3 buffers on unit A1 of the instrument. This configuration is called the 'c-bus'. Each buffer has 13 outputs and can be regarded as a shift register of 13 bits. Each buffer has its own enable signal. The test makes the data (SDA) visible that is shifted by the microprocessor into the buffer. Synchronization is achieved via SCL.

The configuration is shown in the table:

Enable signal	Buffer	Name of circuit diagram
DLEN0-HT	D9001	Control circuits
DLEN1-HT	D9002	Control circuits
DLEN2-HT	D9006	Main time base

The data representation for D9006 is '0:ABCD'. Each character represents the hexadecimal (16 possible states) information for 4 outputs. The data representation for D9001 and D9002 is more complex: these buffers drive the pulse relays in the CH1 ... CH4 attenuators. Changing an attenuator setting can cause the generation of several '0:ABCD' blocks of data. Refer to chapter 5.1.1 for information on how the pulse relays are controlled. D9001 controls CH1 and CH2: data blocks have the configuration '0:ABCD'. D9002 controls CH3 and CH4: data blocks have the configuration '1:ABCD'.

8.11.4.7 Repair tools / DAC

Throughout the oscilloscope there are several digital-to-analog converters (DAC's) that are controlled by the microprocessor. The 'REPAIR TOOLS' menu enables to select a certain DAC output (via TRACK) and to determine the output voltage (via Δ) at this output. After having opened the instrument, the voltage can be measured with a voltmeter or oscilloscope. The DAC output voltage range is between 0 ... 10V (1 ... 4V for D1112 and D8006). This test is not influenced by softkey 'on off'. A DAC VALUE once changed returns to the old value if the menu is left.

The selections with the TRACK rotary have the configuration X.Y. The character X points to a certain DAC IC. The table shows the relation:

X-value	IC reference number	Unit number	Name of circuit diagram
0.Y	N9001	A1	Control circuits
2.Y	N9003	A1	Control circuits
3.Y	N1001	A2	Final Y preampl. + control
4.Y	N8005	A1	Time base logic
6.Y	N9002	A1	Control circuits
7.Y	N2002	A2	Final X amplifier + control
8.Y	D1112	A3	Potentiometer DAC + IEEE
d1.Y	N8070	A8	Curcon, DAC's, Z-control
d2.Y	N8009	A8	Display interface
d8.Y	D8006	A8	Reference + adjustment

The character Y points to a certain output within the selected DAC IC. The table shows this for N9001, N9002, N9003 and N8005 on unit A1:

Y-value	Pin number	Name of generated signal:			
		N9001	N9002	N9003	N8005
X.0	11	PA1OFFSTRG	AT3LFCAL	DLDOFFSET	TBINTRAT-XA
X.1	13	PA1OFFSET	AT3OFFSET	PA4OFFSTRG	DTBVAR
X.2	14	AT1LFCAL	AT3LOOPCAL	PA4OFFSET	DSOCALD
X.3	15	AT1OFFSET	PA2OFFSTRG	AT4LFCAL	DSOCALM
X.4	16	AT1LOOPCAL	PA2OFFSET	AT4OFFSET	DTRSEN
X.5	17	ATCAL0	AT2LFCAL	AT4LOOPCAL	MTRTVMODE
X.6	18	ATCAL1	AT2OFFSET	PA3OFFSTRG	MTRBAL
X.7	20	ATCAL2	AT2LOOPCAL	PA3OFFSET	MTRSEN

Note: for explanation of signal names, refer to chapter 5.1.2

For N1001 and N2002 (unit A2) refer to the table below:

Y-value	Pin number	Name/function of generated signal:	
		N1001	N2002
X.0	11	LF sq. wave	ASTDR
X.1	13	LF sq. wave	DARK
X.2	14	Gain	XHFADJ
X.3	15	HF sq. wave	XTRAGC
X.4	16	Offset	XCRTGCL
X.5	17	Offset	XCRTGCH
X.6	18	MF sq. wave	XCRTOFL
X.7	20	MF sq. wave	XCRTOFH

Note: for explanation of signal names, refer to chapter 5.2.2

For N8070 and N8009 on unit A8 a separate table is not given. The relation between pin number and Y-value is identical to those given in the tables for the units A1 and A2. The main function of N8070 is intensity control on the digitizer. N8009 controls the gain and offset of the output stage of the digitizer.

For D1112 (unit A3) and D8006 (unit A8) refer to the table below:

Y-value	Pin number	Pin name	
		D1112	D8006
X.7	16	POS CH1	OFFSET ADC A
X.4	19	POS CH2	HF SQ WAVE ADJ CH2
X.2	21	POS CH3	HF SQ WAVE ADJ CH4
X.8	13	POS CH4	OFFSET COMPASS CH1
X.1	22	VAR CH1	NOT USED
X.3	20	VAR CH2	HF SQ WAVE ADJ CH3
X.5	18	VAR CH3	HF SQ WAVE ADJ CH1
X.6	17	VAR CH4	OFFSET COMPASS CH3
X.12	9	VAR MTB	GAIN MASPU A
X.11	10	LEVEL MTB	OFFSET CH 1 AND 3
X.10	11	LEVEL DTB	OFFSET COMPASS CH2
X.15	6	INTENS TEXT	OFFSET ADC B
X.9	12	TRACE SEP	OFFSET COMPASS CH4
X.0	23	FOCUS-DA	NOT USED
X.14	7	HOLD OFF	GAIN MASPU B
X.13	8	INTENS TRACE	OFFSET CH 2 AND 4

IMPORTANT: *After having completed these tests, it is recommended to reset the oscilloscope. Therefore press the keys 'STATUS' and 'TEXT OFF' simultaneously.*

9 SAFETY INSPECTION AND TESTS AFTER REPAIR AND MAINTENANCE IN THE PRIMARY CIRCUIT

9.1 GENERAL DIRECTIONS

- Take care that the creepage distances and clearances have not been reduced.
- Before soldering, bend the wires through the holes of the solder leads, or wrap the wires around the leads in the form of an open U, or, maintain wiring rigidity by cable clamps or cable lacing.
- Replace all insulating guards and plates after performing all repairs.

9.2 SAFETY COMPONENTS

For safety reasons, components in the primary circuit may only be replaced by components indicated in the replaceable parts list.

9.3 CHECKING PROTECTIVE GROUND

The correct connection and condition is checked by visual control and by measuring the resistance between the protective ground connection at the plug and the cabinet/frame. The resistance shall not be more than 0.5Ω , test current 25A. During measurement the line cable should be removed from line power. Resistance variations indicate a defect.

9.4 CHECKING INSULATION RESISTANCE

Measure the insulation resistance at $U = 500 \text{ V dc}$ between the line connections and the protective ground connections. For this purpose, set the mains switch to ON. The insulation resistance shall not be less than $2 \text{ M}\Omega$.

NOTE: The insulation resistance of $2 \text{ M}\Omega$ is a minimum requirement at 40°C and 95% relative humidity. Under normal conditions the insulation resistance should be much higher ($10 \dots 20 \text{ M}\Omega$).

9.5 CHECKING LEAKAGE CURRENT

The leakage current shall be measured between each pole of the line power supply in turn, and all accessible conductive parts connected together (including the measuring ground terminal). The leakage current is not excessive if the measured currents from the mentioned parts is $\leq 0.5 \text{ mA rms}$ (without filter capacitor) or $\leq 3.5 \text{ mA rms}$ (with filter capacitor).

9.6 VOLTAGE TEST

The instrument shall withstand, without electrical breakdown, the application of a test voltage between the supply circuit and accessible conductive parts that are likely to become energized. The test potential shall be 1500 V rms or dc equivalent at supply-circuit frequency, applied for one second. The test shall be conducted when the instrument is fully assembled, and with the primary switch in the ON position.

During the test, both sides of the primary circuit of the instrument are connected together and to one terminal of the voltage test equipment; the other voltage test equipment terminal is connected to the accessible conductive parts.

