



ROHDE & SCHWARZ

Test and Measurement
Division

Operating Manual

Software Option: AMPS-MS for CMU-B21

R&S CMU-K29

1115.6807.02

Printed in Germany

Dear Customer,

throughout this manual, CMU-K29 is generally used as an abbreviation for software option R&S CMU-K29. The Universal Radio Communication Tester R&S CMU 200 is abbreviated as CMU200.

Tabbed Divider Overview

List of Figures and Tables

Certificate of Quality

List of R&S Representatives

Contents of Manuals for Universal Radio Communication Tester CMU

Tabbed Divider

1	Chapter 1: Installation
2	Chapter 2: Getting Started
3	Chapter 3: Manual Operation
4	Chapter 4: Functions and their Application
5	Chapter 5: Remote Control – Basics
6	Chapter 6: Remote Control – Commands
10	Index

AMPS Functionality of R&S CMU Models

AMPS measurements can be performed with the following R&S CMU 200 models:

- **Universal Radio Communication Tester** R&S CMU 200, stock no. 1100.0008.02. If equipped with the appropriate options (as stated in the relevant sections), this model provides the full AMPS functionality described in this manual. All AMPS and AMPS-related options are supported by this R&S CMU model.
- **High End Service Tester** R&S CMU 200v10, stock no. 1100.0008.10. If equipped with options R&S CMU-B21 var. 54 and R&S CMU-B41, this model supports all AMPS TX and RX measurements. Optional extensions of the service tester are listed below.
- **Non Signalling Tester** R&S CMU 200v30, stock no. 1100.0008.30. If equipped with option R&S CMU-B41, this model supports all AMPS TX measurements in Non Signalling mode. The functionality of R&S CMU options which are particularly relevant for production (R&S CMU-K14, R&S CMU-K47, R&S CMU-K48) is included in the basic configuration of the non signalling tester. Optional extensions of the non signalling tester are listed below; note that not all AMPS options described in this manual are supported.

The different R&S CMU 200 models are also described in the product brochures.



The high end service tester and the non signalling tester also support the WCDMA, GSM, and CDMA200/1xEV-DO (non signalling tester only) network standards. For details refer to the relevant operating manuals.

Table 1 Basic configuration and options for service tester R&S CMU 200v10

Functionality	Option	Remarks
Basic configuration (included in AMPS-MS software package for R&S CMU 200v10)		
AMPS software package	Corresponding R&S CMU 200 options: R&S CMU-K29	Requires universal signalling unit, option R&S CMU-B21 var. 54, and audio generator and analyzer, option R&S CMU-B41
Reference oscillator	R&S CMU-B12	OXCO, aging $3.5 \cdot 10^{-8}$ /year
Additional options		
Universal signalling unit	R&S CMU-B21 var. 54	Required for all AMPS tests
Audio generator and analyzer	R&S CMU-B41	Required for all AMPS tests

Table 2 Basic configuration and options for non signalling tester R&S CMU 200v30

Functionality	Option	Remarks
Basic configuration (included in AMPS-MS software package for R&S CMU 200v30)		
AMPS non signalling measurements FM stereo transmitter R&S smart alignment I/Q versus slot	Corresponding R&S CMU 200 options: R&S CMU-K29 R&S CMU-K14 R&S CMU-K47 R&S CMU-K48	Requires audio generator and analyzer, option R&S CMU-B41 Extended functionality, relevant for production tests
Additional options		
Audio generator and analyzer	R&S CMU-B41	Required for all AMPS non signalling tests

List of Figures

Fig. 4-1	Measurement menu Analyzer / Generator	4.2
Fig. 4-2	Test setup for TX Tests.....	4.5
Fig. 4-3	Measurement menu TX Tests.....	4.6
Fig. 4-4	Display of measurement results (TX Tests – Modulation application)	4.12
Fig. 4-5	Power Configuration – Control	4.15
Fig. 4-6	TX Tests Configuration – Limit Lines	4.17
Fig. 4-7	Signal path for TX tests.....	4.18
Fig. 4-8	Electrical frequency response of the pre-emphasis and a de-emphasis filter.....	4.19
Fig. 4-9	TX Tests Configuration – Filter	4.19
Fig. 4-10	Measurement menu TX Audio Freq. Response.....	4.22
Fig. 4-11	Display of measurement results (TX Audio Freq. Response).....	4.24
Fig. 4-12	TX Audio Freq. Response Configuration – Control.....	4.26
Fig. 4-13	TX Audio Freq. Response Configuration Configuration – Limit Lines.....	4.26
Fig. 4-14	TX Audio Freq. Response Configuration Configuration – Filter	4.27
Fig. 4-15	Test setup for RX Tests	4.30
Fig. 4-16	Measurement menu RX Tests	4.31
Fig. 4-17	Display of measurement results (RX Tests – AF Analyzer application)	4.34
Fig. 4-18	RX Tests Configuration – Control	4.36
Fig. 4-19	RX Tests Configuration – Limit Lines.....	4.37
Fig. 4-20	Signal path for RX Tests	4.38
Fig. 4-21	Measurement menu RX Audio Freq. Response	4.40
Fig. 4-22	Display of measurement results (RX Audio Freq. Response).....	4.42
Fig. 4-23	Connection Control – Generator (softkey).....	4.50
Fig. 4-24	Connection Control – Generator (table)	4.54
Fig. 4-25	Connection Control – RF connectors	4.55
Fig. 4-26	Connection Control – Sync.....	4.57
Fig. 4-27	Signalling states of the CMU	4.60
Fig. 4-28	Connection Control – Connection (Signal Off)	4.61
Fig. 4-29	Connection Control – Connection (Signal On)	4.63
Fig. 4-30	Overview menu	4.64
Fig. 4-31	Measurement menu TX Tests.....	4.66
Fig. 4-32	Measurement menu TX Audio Freq. Response.....	4.68
Fig. 4-33	Measurement menu RX Tests	4.69
Fig. 4-34	Measurement menu RX Audio Freq. Response	4.70
Fig. 4-35	Connection Control – Connection (Registered).....	4.72
Fig. 4-36	Connection Control – Connection (Alerting).....	4.73
Fig. 4-37	Connection Control – Connection (Call Established)	4.75
Fig. 4-38	Connection Control – Other call (destination selection)	4.76
Fig. 4-39	Connection Control – Other Call (destination network preparation).....	4.77
Fig. 4-40	Connection Control – Handoff (destination selection).....	4.79
Fig. 4-41	Connection Control – Handoff (destination network preparation)	4.80
Fig. 4-42	Connection Control – MS Signal (table)	4.81
Fig. 4-43	Connection Control – MS Signal (softkey)	4.82
Fig. 4-44	Connection Control – BS Signal (table).....	4.83
Fig. 4-45	Connection Control – BS Signal (softkey)	4.84
Fig. 4-46	Connection Control – Network parameters	4.85
Fig. 4-47	Connection Control – MS Signal (table)	4.88
Fig. 4-48	Connection Control – Misc	4.89
Fig. 6-1	Signalling states of the CMU and transitions including Other Call/Handoff.....	6.94

List of Tables

Table 3-1	Measurement Groups in the <i>Signalling</i> and <i>Non Signalling</i> Mode	3.4
Table 4-1	AMPS analog voice channels in the reverse path (mobile phone transmit)	4.47
Table 4-2	AMPS analog voice channels in the forward path (base station transmit)	4.52
Table 4-3	AMPS power classes and voice mobile attenuation codes (VMAC)	4.65
Table 5-1	Measurement objects in the <i>Signalling</i> and <i>Non Signalling</i> mode	5.2
Table 5-2	Repetition mode in remote control	5.3
Table 5-3	Limits and limit check	5.4
Table 5-4	Meaning of the bits used in the <code>STATUS:OPERation:CMU:SUM1 2:CMU<nr></code> sub-registers assigned to <i>AMPS-MS Non Signalling</i>	5.5
Table 5-5	Meaning of the bits used in the <code>STATUS:OPERation:CMU:SUM1 2:CMU<nr></code> sub-registers assigned to <i>AMPS-MS Signalling</i>	5.5
Table 6-1	Remote-control commands: Non Signalling	6.110
Table 6-2	Remote-control commands: Signalling mode	6.112
Table 6-3	Remote-control commands: Signalling mode	6.120
Table 6-4	Remote-control commands: Non Signalling mode	6.123
Table 6-5	Remote-control commands: Signalling mode	6.128

Contents of Manuals for Universal Radio Communication Tester CMU

Operating Manual CMU-K29 (Software Option: AMPS-MS for CMU-B21)

The present operating manual describes the application of the CMU200 for AMPS mobile tests. It gives comprehensive information about the installation of the required software options and about manual and remote control of the instrument. For introduction, some typical measurement tasks are explained in detail using the functions of the graphical user interface.

The manual is organized as follows:

- Chapter 1** Describes the steps necessary for installing the software and putting the instrument into operation.
- Chapter 2** Gives an introduction to the application of the CMU for AMPS mobile tests and presents some typical measurement examples.
- Chapter 3** Gives an overview of the user interface and describes the concepts of measurement control and instrument configuration.
- Chapter 4** Represents the reference chapter providing detailed information on all functions of the user interface and their application.
- Chapter 5** Describes the basics of remote control of the instrument for AMPS mobile tests.
- Chapter 6** Lists all remote control commands defined for AMPS mobile tests. At the end of the chapter the commands are grouped together according to their function (measurement groups or configurations) and sorted in alphabetical order.

- Chapter 10** Contains an index for the operating manual.

Operating Manual CMU200/CMU300

In the operating manual for CMU basic unit you will find everything that is needed to make yourself familiar with your Universal Radio Communication Tester CMU. This includes information about the technical specifications of the CMU, the controls and connectors on the front and rear panel, necessary steps for putting the instrument into operation, the basic operating concept, manual and remote control. Typical measurement tasks are explained in detail using the functions of the user interface and program examples.

General concepts of CMU control are described in the operating manual CMU and not repeated in the manuals for the individual software options.

Service Manual Instrument

The service manual informs on how to check compliance with rated specifications, on instrument function, repair, troubleshooting and fault elimination. It contains all information required for the maintenance of the CMU by exchanging modules.

Service Manual Modules

The service manual modules is not delivered with the instrument but may be obtained from your R&S service department with the order number 1100.4903.91.

Service manual modules contains information about the individual modules of the CMU. This comprises the test and adjustment of the modules, fault detection within the modules and the interface description.

Further Operating Manuals for Network Tests

The operating manuals listed in the following table describe the test of radio communication equipment supporting different standards by means of the CMU and the appropriate software and hardware options. The network test operating manuals are organized like the present AMPS operating manual.

Manual	Order Number	For Options		
		Type	Description	Stock No.
Operating Manual CMU-K20/-K21/ K22/-K23/-K24	1115.6088.12	CMU-K20	GSM400-MS for CMU-B21	1115.5900.02
		CMU-K21	GSM900-MS for CMU-B21	1115.6007.02
		CMU-K22	GSM1800-MS for CMU-B21	1115.6107.02
		CMU-K23	GSM1900-MS for CMU-B21	1115.6207.02
		CMU-K24	GSM850-MS for CMU-B21	1115.6307.02
		CMU-K42	GPRS software extension for GSM	1115.4691.02
CMU-K43	EGPRS software extension for GSM	1115.6907.02		
CMU-K45	AMR GSM for CMU200	1150.3100.02		
Operating Manual CMU-K27/-K28	1115.6688.12	CMU-K27	TDMA800-MS for CMU-B21	1115.6607.02
		CMU-K28	TDMA1900-MS for CMU-B21	1115.6707.02
Operating Manual CMU-K30/-K31/ -K32/-K33/-K34	1115.4185.12	CMU-K30	GSM400-BS for CMU-B21	1115.4004.02
		CMU-K31	GSM900-BS for CMU-B21	1115.4104.02
		CMU-K32	GSM1800-BS for CMU-B21	1115.4204.02
		CMU-K33	GSM1900-BS for CMU-B21	1115.4304.02
		CMU-K34	GSM850-BS for CMU-B21	1115.4404.02
		CMU-K39	MOC/MTC	1115.4791.02
CMU-K41	EDGE for CMU-K30/31/32/33	1115.4604.02		
Operating Manual CMU-K53	1115.5081.12	CMU-K53	Bluetooth for CMU	1115.5000.02
Operating Manual CMU-K65/.../-K69	1115.4962.12	CMU-K65	WCDMA UE TX Test (3GPP/FDD)	1115.4891.02
		CMU-K66	WCDMA UE DL Generator	1115.5100.02
		CMU-K67	WCDMA UE Band III Signalling	1150.3000.02
		CMU-K68	WCDMA UE Band I Signalling	1115.5300.02
		CMU-K69	WCDMA UE Band II Signalling	1115.5400.02
Operating Manual CMU-K75/-K76	1150.3398.12	CMU-K75	WCDMA Node B TX Tests	1150.3200.02
		CMU-K76	WCDMA Generator (3GPP/FDD, Release 99, Uplink)	1150.3300.02
Operating Manual CMU-K81/-K82	1115.5581.12	CMU-K81	CDMA800-MS (IS95) for CMU-B81	1115.5500.02
		CMU-K82	CDMA1900-MS (IS95) for CMU-B81	1115.5600.02
Operating Manual CMU-K83/-K84/ -K85/-K86	1150.0382.12	CMU-K83	CDMA2000 (450 MHz band) for CMU-B83	1150.3500.02
		CMU-K84	CDMA2000 (cellular band) for CMU-B83	1150.3600.02
		CMU-K85	CDMA2000 (PCS band) for CMU-B83	1150.3700.02
		CMU-K86	CDMA2000 (IMT2000 band) for CMU-B83	1150.3800.02
Operating Manual CMU-K88	1150.3900.02	CMU-K88	1xEV-DO for CMU-B88	1150.3998.12

The GSM base station tests described in operating manual CMU-K30/-K31/-K32/-K33/-K34 and the WCDMA Node B tests described in operating manual CMU-K75/-K76 require a CMU300 (Universal Radio Communication Tester for BTS). Bluetooth tests can be performed with model CMU200, var. 02 or 53. All other radio communication equipment is tested with model CMU200, var.02.

What's new in this Revision?

This operating manual describes version V3.52 ff. of the AMPS-MS software. Compared to previous versions, this firmware provides numerous extensions and improvements. The new features described in this manual are listed below.

New Features	Description	Refer to...
Wideband Data	New <i>TX Tests</i> measurement application provides the peak deviation of a carrier that is modulated with a 10 kilobit/s Manchester-encoded wideband data signal and indicates whether the WORD SYNC sequence could be received and demodulated correctly.	Chapter 4 AMPS Module Tests (Non Signalling) → TX Tests
Peak Audio Distortion	The target audio peak deviation can be calculated either from the RMS frequency deviation or from the peak value of the frequency deviation.	Chapter 4 AMPS Module Tests (Non Signalling) → TX Tests (Target Dev. Type)
Parameter Coupling	Coupling between the <i>default</i> , <i>current</i> and <i>other call/handoff</i> parameter values can be (de)activated.	Chapter 4, AMPS Mobile Tests (Signalling) → Connection Control – Miscellaneous Settings
Notch filter	A notch filter with selectable bandwidth is provided to improve the <i>AF SINAD</i> and the <i>Sensitivity</i> measurement.	Chapter 4, AMPS Module Tests (Non Signalling) → RX Tests
SN in hex format	The new command <code>[SENSe:]MSSInfo:SN:HEX?</code> returns the Serial Number of the MS in hexadecimal format.	Chapter 6, AMPS Mobile Tests (Signalling) Subsystem MSSInfo

Frequently Used Abbreviations

AF	Audio Frequency
AMPS	Advanced Mobile Phone System; by AMPS mobile stations we understand devices supporting the analog AMPS standard, specified in TIA/EIA-136.xxx (once IS-136) and related standards
Att.	Attenuation
AVC	Analog Voice Channel
B(T)S	Base (Transceiver) Station
CC	(Analog) Control Channel
Ch.	Channel
CMAC	Control Mobile Attenuation Code
DCC	Digital Color Code
Dist.	Distortion
DTC	Digital Traffic Channel
DTX	Discontinuous Transmission
Ext.	External
Freq. Resp.	Frequency Response
Int.	Internal
MIN	Mobile Identification Number
Min.	Minimum
Mod.	Modulation
MPCI	Mobile Protocol Capability Indicator
MS	Mobile Station
Reg.	Registration
REF	Reference
RF	Radio Frequency
RMS	Root Mean Square (averaging)
RX	Receiver
SAT	Supervisory Audio Tone
SCC	SAT Color Code
SID	System Identity
SN	(Electronical) Serial Number
ST	Signalling Tone
TX	Transmitter
VC	Voice Channel
VMAC	Voice Mobile Attenuation Code

Contents

1 Installation	1.1
Software Installation or Update.....	1.1
Creating a new Software Configuration	1.3
Enabling Software Options.....	1.5

1 Installation

This chapter describes how to enable, to install or update the firmware containing the *AMPS-MS* software option for the Universal Radio Communication Tester CMU200.

Before proceeding to perform any of the steps described in this manual, please make sure that the instrument is properly connected and put into operation according to the instructions given in chapter 1 of the CMU manual. The hardware and software options available are shown in the *Startup* menu. The status of the software options required for AMPS-MS device tests is indicated in the line "AMPS-MS":

- If a version number is indicated, the CMU is ready to perform AMPS mobile tests. In this case you may skip this chapter, except if you wish to update the current software version or activate another version.
- If disabled is indicated, the software option must be enabled using a key code; see section *Creating a new Software Configuration* on page 1.3.
- If not installed is indicated, the software must be installed via the PCMCIA interface or the floppy disk drive, see below.

Software Installation or Update

The CMU is always delivered with the latest software version available. New CMU software versions are available for download on the R&S Lotus Notes Service board. To be loaded via the PCMCIA interface, the software must be copied to one or several flash disks/memory cards or PCMCIA hard disks. An appropriate memory card CMU-Z1, order no. 1100.7490.02, can be obtained from Rohde & Schwarz.

Note: *If your CMU is equipped with a floppy disk drive (option CMU-U61), a set of installation floppy disks must be generated instead of a flash disk. All other steps do not depend on the storage medium.*

To install the AMPS-MS software proceed as follows:

- Switch off the CMU.
- Insert the flash disk into one of the two slots of the PCMCIA interface.
- Switch on the CMU.

The installation is started automatically while the CMU performs its start-up procedure. To this end the *VersionManager* is called up (for a detailed description of the *VersionManager* refer to chapter 1 of the CMU operating manual or to the on-line help accessible via *Info*):

```

VersionManager Ver 2.20
the active CMU base software is the version: 2U20
-----
<-- Activate other software                               Write log files to disk -->
<-- Delete software                                       Delete non volatile ram -->
<-- Install software from PC-card slot 0                  Scan disk -->
<-- List software                                         List all versions to disk -->
<-- Firmware update after board change                   Copy non volatile ram to disk -->
<-- Edit service tables                                   Defragment disk -->
<-- Exit                                                  Info -->

```

Softkey no. 5 on the left softkey bar, *Install software...*, is used to install new software from an external storage medium. The CMU automatically recognizes the storage medium and indicates the corresponding slot number: Slot 0 or 1 denotes the left or right slot of the PCMCIA interface. If a floppy disk is used the menu option reads *Install software version <version> from floppy*.

- Press left softkey no. 5 (*Install software...*) to start the installation.

If your storage medium contains several installation versions, the software version selection dialog is opened:

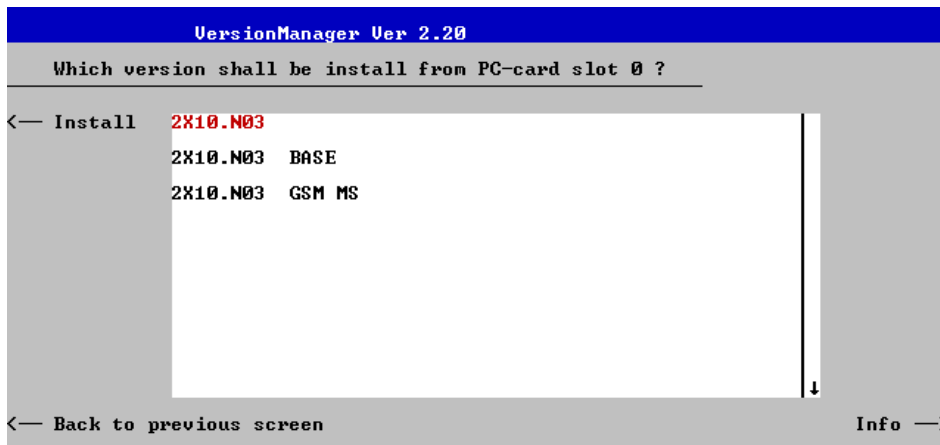

- Use the rotary knob or the cursor keys to scroll the list and select the AMPS-MS version you intend to install.
- Press *Install* to start the installation.

The installation is started. To be operable on your instrument, a network option must be combined with a compatible version of the CMU base software. Any base software version installed on the CMU hard disk can be combined with one or several network options to form an independent software configuration. If none of the configurations is compatible to the new AMPS-MS option, the *VersionManager* displays an error message and takes you back to the software selection dialog; see section *Creating a new Software Configuration* on page 1.3. Otherwise, the following upgrade selection dialog is opened:

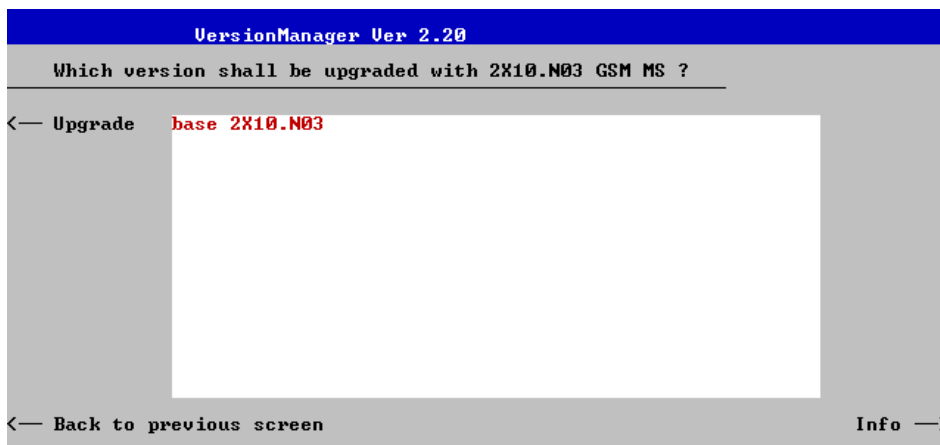

The upgrade selection dialog displays a list of base software versions that can be combined with the new AMPS-MS software.

- Select the appropriate base version and press *Upgrade*.

The new AMPS-MS option is added to the configuration or updates the previous AMPS-MS version of the configuration. To indicate that the storage medium must be changed the CMU issues the *Change volume* message:

```

Change volume
Process next volume
Exit

```

- Replace the current disk with the disk requested.
- Use the cursor up/down keys to select “Process next volume” (default setting).
- Press *ENTER* to confirm that the new disk has been inserted and to continue the installation.

After processing the last disk the CMU displays the following screen:

```

VersionManager Ver 2.20
What do you want to do next with version 2020 ?

<— Install next software upgrade from PC-card slot 0
<— Install next software upgrade 2020 GSM MS from PC-card slot 1
<— Change disks

<— Finish installation                               Info —>

```

- If you wish to install or upgrade other software versions, press left softkey no 4 or 5 (*Install next software...*) or insert new storage medium into the PCMCIA slot or floppy disk drive and press *Change disks*.
- To finish the installation, remove all disks from the drive and press *Finish installation*.

The *VersionManager* is closed and the CMU is rebooted. The new firmware options are now operational and listed in the *Menu Select* menu together with their version number. Besides, the last software configuration installed is automatically taken as the active one in the next measurement session.

Creating a new Software Configuration

The CMU handles base software versions and network options on a separate basis. Different versions of the base software can be combined with different options to create new firmware configurations. For example, it is possible to update the base software without affecting the associated network options or vice versa. Moreover, the same base software version can be installed several times and combined with different network options (and vice versa), so it may enter into several firmware configurations.

If no compatible base software version can be found on the hard disk, then the CMU will refuse to install a new AMPS-MS software option selected in the software selection dialog (see previous section). Instead, it displays the following error message:

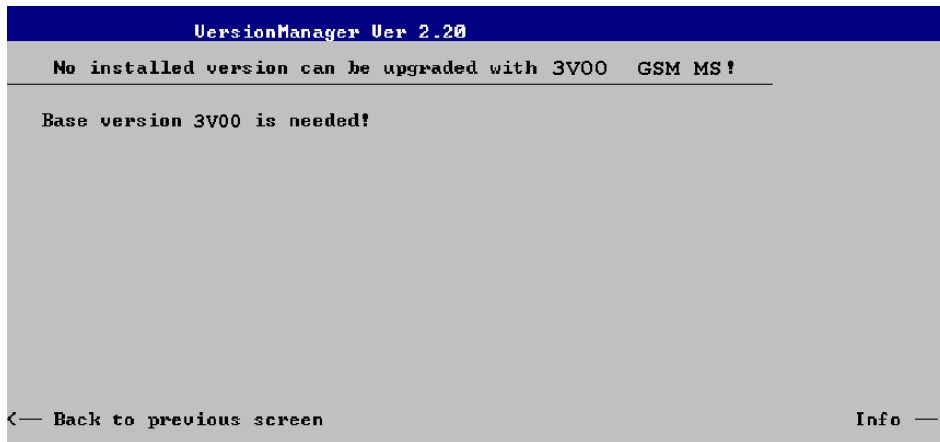

➤ Press *Back to installation* to return to the software version selection dialog.

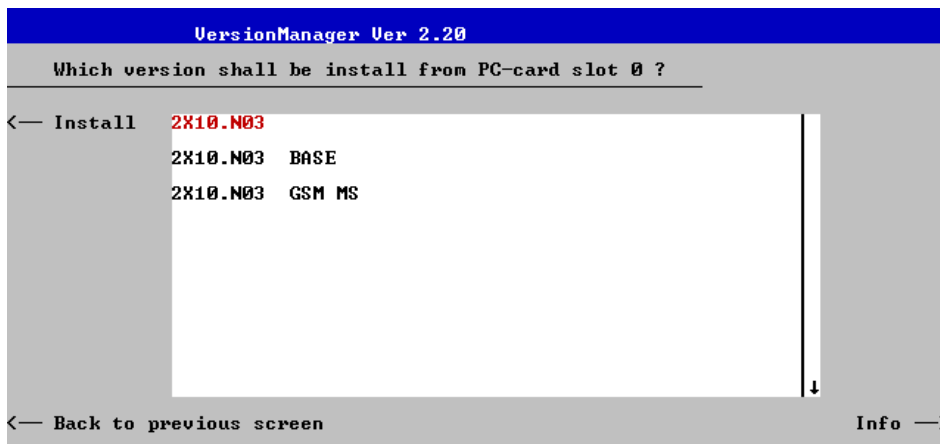

➤ Select a base software version that is compatible to your AMPS-MS software option and press *Install*.

Note: *In general, the AMPS-MS firmware version number must be identical to the base software version number.*

With a new base software version, it is possible to either update an existing configuration or create a new one. A dialog selecting between the two alternatives is opened:

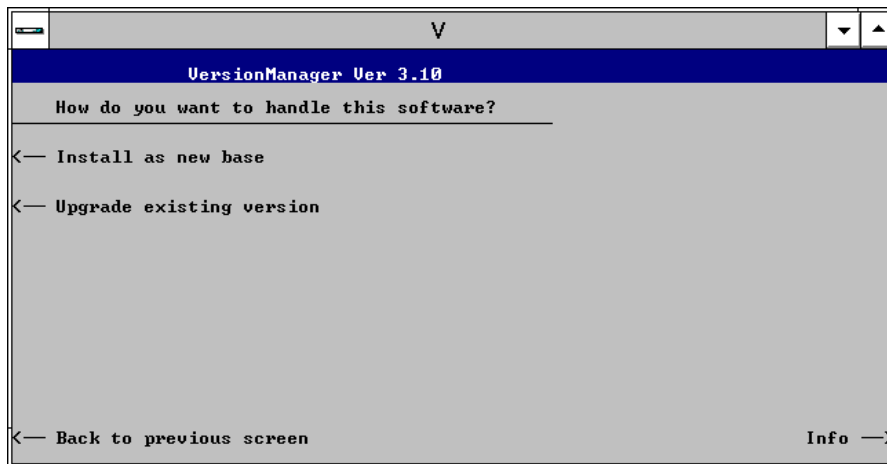

Note: *This dialog is skipped if the new base software version is not compatible with any of the existing configurations. An incompatible new base software must be installed as a new base software.*

- If you wish to add a new configuration to your hard disk, press *Install as new base*.
- To upgrade an existing configuration with the selected base software version in order to make it compatible to the new AMPS-MS software option, press *Upgrade existing version*. The existing version to be upgraded must be selected in an additional dialog.

The installation is performed as described in section *Software Installation or Update*. After adding the new base software as a new configuration or updating the existing configuration, the CMU displays the following screen:

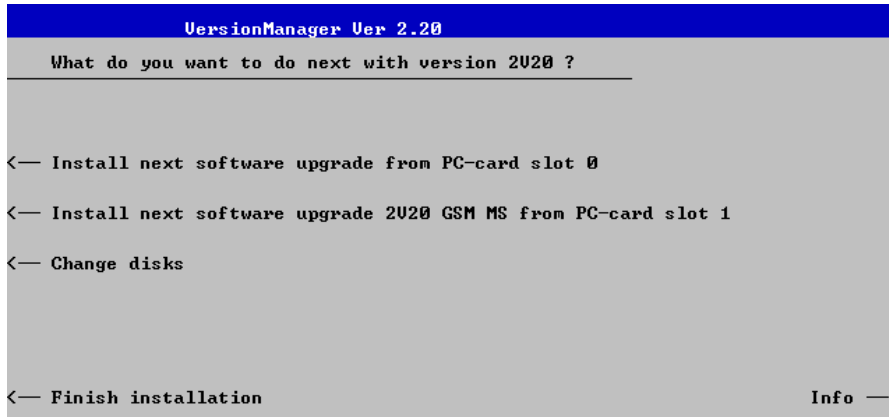

- Press left softkey no 4 or 5 (*Install next software...*) and proceed as described in section *Software Installation or Update* to install the new AMPS-MS version and assign it to the new configuration.

Enabling Software Options

A new CMU software option purchased is ready to operate after it is enabled by means of a key code supplied with the option. This key code is to be entered into the *Option Enable* popup window which in turn can be opened via from the *Setup – Options* menu. For details refer to Chapter 4 of the CMU200 operating manual.

Note: *Together with options TDMA800-MS and TDMA1900-MS, the AMPS-MS software option is part of a single software package termed AMPS/TDMA-MS, so the three options must be installed or updated together. However, they must be enabled and operated separately. Software installation and enabling of software options are completely independent from each other.*

Contents

2 Getting Started.....	2.1
Preparing an AMPS Mobile Phone Test.....	2.2
Non Signalling Mode	2.6
Transmitter Measurements	2.6
Receiver Measurements.....	2.14
Signalling Mode	2.16

2 Getting Started

The following chapter presents a sample AMPS mobile test with the universal radio communication tester CMU. It is intended to provide a quick overview of the function groups *AMPS-MS Non Signalling* and *AMPS-MS Signalling* and to lead through the most common tests which are performed on AMPS mobile phones.

Before starting any measurement with the CMU, please note the instructions for putting the instrument into operation given in chapter 1 of the operating manual for the CMU basic unit. In chapters 2 to 4 of that manual you will also find information on customizing the instrument and the display according to your personal preferences. General notes on controls, menu types, and on the entry or selection of values and parameters are given in chapter 3 of the CMU manual and will not be repeated here.

For installation instructions for the *AMPS* software (CMU-K29) refer to chapter 1 of the present manual.

The tests reported below include

- Connection of the phone and selection of the AMPS function group
- Transmitter and receiver tests in *Non Signalling* mode
- Selection and measurement of signalling parameters

The steps to perform are explained on the left side of each double-page together with the results obtained on the CMU screen. On the right side, additional information is given. We also point out alternative settings and related measurements which could not be reported in detail.

The principles of manual operation are discussed in chapter 3. For a systematic explanation of all menus, functions and parameters including AMPS background information refer to the reference part in chapter 4.

Preparing an AMPS Mobile Phone Test

This chapter describes how to use the CMU for AMPS mobile phone tests. As a prerequisite for starting the session, the instrument must be correctly set up and connected to the AC power supply as described in chapter 1 of the CMU operating manual. Furthermore, the AMPS software must be properly installed following the instructions given in chapter 1 of the present manual.

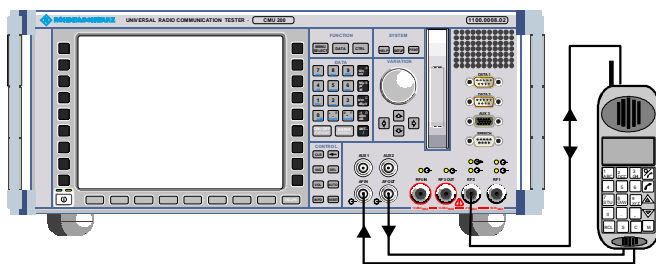
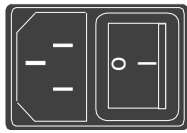

Step 1

- Switch on the CMU using the mains switch at the rear. ①
- Check the operating mode of the instrument at the ON/STANDBY key on the front panel. ②

Step 2

- Connect the bi-directional RF connector RF 2 of the CMU to the antenna connector of the mobile phone. In addition, make sure that your mobile phone is properly connected to the AF input/output connectors AF IN and AF OUT of the CMU. ③
- Make sure that the mobile phone is supplied with the correct operating voltage (battery or power supply).

Step 3

- Switch on the CMU by pressing the ON/STANDBY key on the front panel.

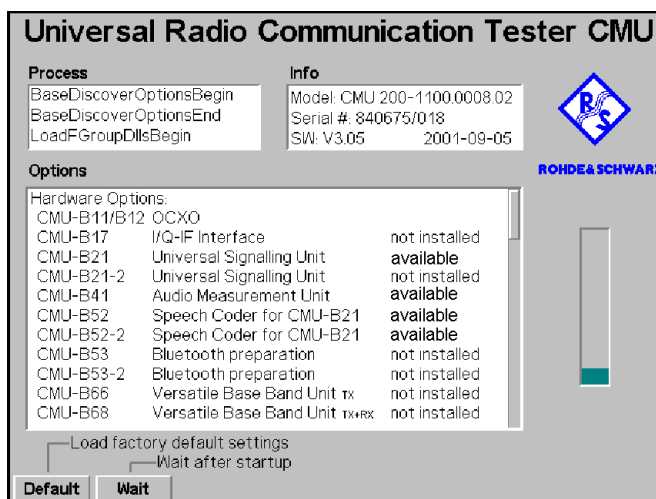

The startup menu is displayed while the CMU performs a power-up test. ④

After a few seconds the CMU displays the last menu used in the previous session.

Additional Information...

... on Step 1

① Mains switch on the rear panel

When the mains switch at the rear is set to the *OFF* position, the complete instrument is disconnected from the power supply. When the mains switch is set to the *ON* position, the instrument is in standby mode or in operation, depending on the position of the power switch on the front panel.

② *ON/STANDBY* key on the front panel

The *ON/STANDBY* key at the front of the instrument determines whether the instrument is in standby mode or in operation.

Standby mode:

Only the reference frequency oscillator is supplied with operating voltage, and the yellow LED (*STANDBY*) is lit.

Operation:

The green LED (*ON*) is lit and all modules of the instrument are supplied with operating voltage.

... on Step 2

③ RF and AF connection of the mobile phone

To carry out the tests described in this chapter, it is essential to provide the following signal paths:

- Transmission of an RF carrier signal from the tester to the mobile and back. The forward path signal (from the tester to the mobile) is essential for RX measurements; the reverse path signal (from the mobile to the tester) is measured in TX measurements.
- Transmission of an AF test signal from the tester (connector *AF OUT*) to the input of the mobile transmitter (in particular for TX audio frequency response measurements).
- Transmission of an AF signal from the output of the mobile receiver to the tester (connector *AF IN*, for RX measurements).

The details of the test setup depend on your measurement equipment. For the RF connection, a high-quality cable should be used, ideally with an attenuation of less than 0.5 dB. For portable phones, the car installation set supplied by telephone manufacturers can be used.

Alternative Settings and Measurements

☞ Chapter 1 of CMU manual

The CMU provides two bi-directional RF connectors *RF1* and *RF2* differing by their input and output level ranges. *RF2* is the recommended standard connector for AMPS mobile phones (see data sheet).

The unidirectional connectors *RF4 IN* and *RF3 OUT* are intended for connection of modules requiring high input levels or modules with low RF output levels. *RF4 IN* and *RF3 OUT* can also be used to connect AMPS mobiles off the air via antenna adapters.

Input and output connectors can be selected in the *AF/RF*  tab of the *Connect* menu that is called up via the softkey of the same name to the right of the header line of each measurement menu.

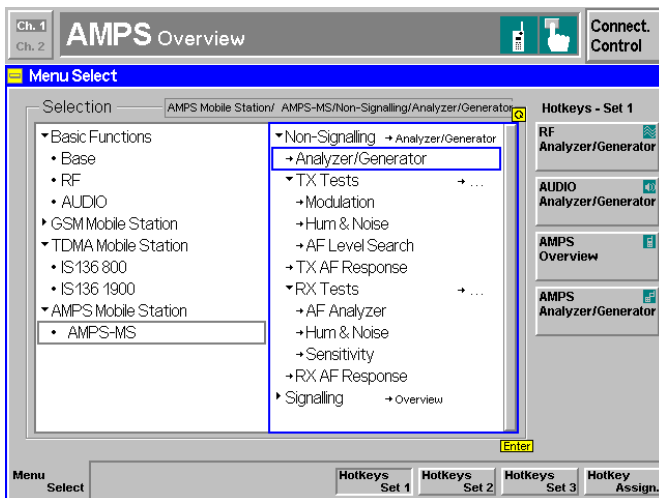
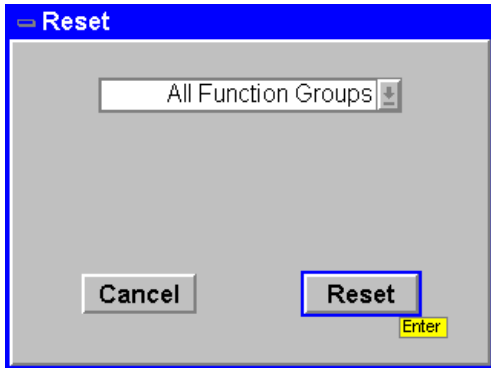
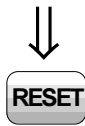

Step 4

- Press the *RESET* key.

The *Reset* popup menu is opened.

- Use the left and right arrow keys to toggle between the two buttons *Cancel* and *Reset*.
- Select *Reset* and press the *ENTER* key.
- In the popup window opened (*Are you sure?*), select *Yes* to confirm the instrument reset.

The CMU indicates that it performs a general reset of all device settings and is then ready to carry out the following steps. The *Reset* popup menu is closed automatically.

Step 5

- Press the *Menu Select* key to open the *Menu Select* menu.⑤

The *Menu Select* menu indicates the function groups available. If a function group is selected, the corresponding modes and measurement menus are indicated.

- Select the *AMPS-MS* function group.
- Select the *Non Signalling* test mode.
- Select the *Analyzer/Generator* menu.
- Press the *Enter* key to activate the measurement selected and open the *Analyzer/Generator* menu.

Additional Information...**... on Step 3****④ Startup menu**

The startup menu displays the following information:

- The status of the startup test (*Process*)
- The device name, serial number and software version (*Info*)
- The options and equipment installed (*Options*)
- The progress of the startup test (*Startup* bar graph)

Before starting a measurement, a reset is recommended to set the instrument with all its functions into a definite state.

... on Step 5**⑤ Menu Select menu**

The *Menu Select* menu shows all function groups installed on your CMU. Function Group *AMPS-MS* is subdivided in the two test modes *Non Signalling* and *Signalling*, each containing a number of measurement menus.

The differences between the test modes are explained in the sections *Non Signalling Mode* and *Signalling Mode* below. The measurements provided in both test modes are largely identical.

Alternative Settings and Measurements

 Chapter 4 of CMU manual

That chapter also contains information on customizing the CMU.

 Chapter 3 and chapter 4

Non Signalling Mode

In the *Non Signalling* mode, a AMPS-specific RF signal can be generated and a RF signal with AMPS characteristics can be analyzed. Compared to the *Signalling* mode test times may be reduced considerably. Moreover, the measurements are not restricted to the specified channel and MS output power ranges of the network.①

Transmitter Measurements

In tests assessing the mobile station transmitter quality, the CMU demodulates and analyzes the RF output signal of the MS transmitter, which can be modulated with an audio tone, the SAT, or the ST. To test the transmitter audio frequency response, the CMU provides an additional audio test signal.

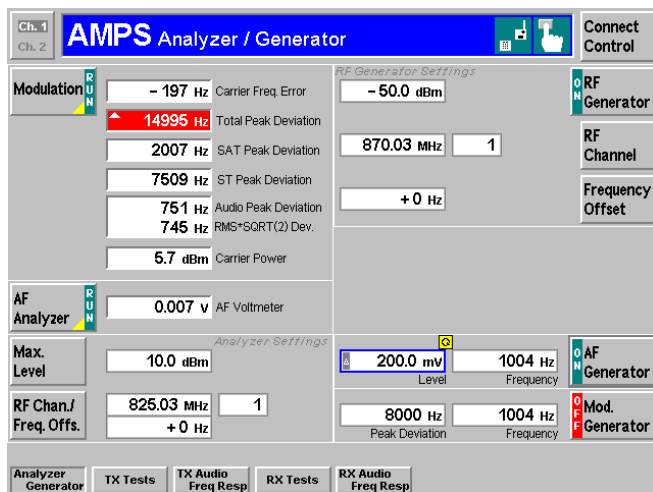
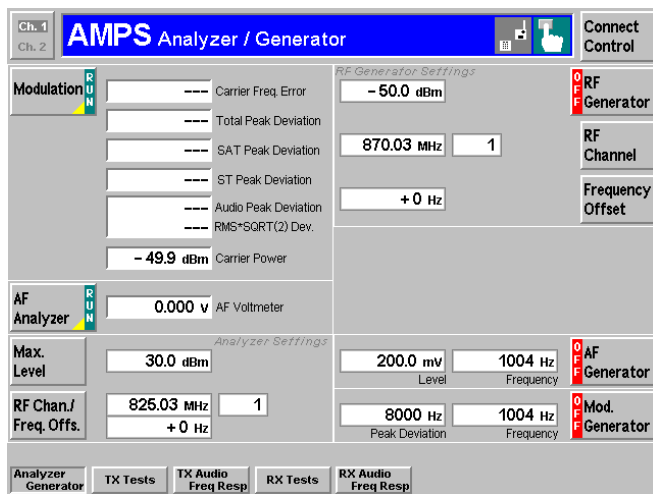

Step 1

The *Analyzer/Generator* menu configures the signals generated by CMU (right half of the menu) and sets the RF and AF analyzers.②

At present, all parameters are set to default values. They can be changed directly in the *Analyzer/Generator* menu. User-defined parameters will be saved for later sessions when the CMU is switched off.

In addition, the current results of the Modulation measurement which is part of the MS transmitter tests (*TX Tests*) are displayed. Most of the output fields show "---", indicating that no valid measurement results are available. ③

- At your mobile station, activate the TX carrier (using an arbitrary voice carrier channel supported by your mobile and an appropriate output power), the SAT, the ST, and the TX audio signal.
- Press the *Max. Level* softkey and adapt the maximum expected RF input level to the output power of the mobile. ④
- Press the *RF Chan./Freq. Offs.* softkey and set the RF channel equal to the voice carrier channel of the mobile phone.
- Press the *RF Generator* softkey and *ON/OFF* to switch on the RF generator.
- Press the *AF Generator* softkey and *ON/OFF* to switch on the AF generator.

The main results of the *TX Tests* – *Modulation* measurement (see below) are now indicated in the output fields associated to the *Modulation* softkey.

Additional Information...

Non Signalling Mode

① Test mode of the mobile phone

To demonstrate the features of the *Non Signalling* mode, we use an AMPS mobile phone that has been set to its "test mode". The settings and properties of the test mode depend on the mobile type.

... on Step 1

② Analyzer/Generator menu

In the right half, the *Analyzer/Generator* menu contains three configuration panels used to configure the RF generator, the *AF Generator*, and the *Modulation Generator* signals.

The assignment between RF carrier frequency and channel number is according to AMPS specifications. As the CMU simulates a base station, the generator signal corresponds to the forward path (signal direction from the base station towards the mobile station), the signal analyzed corresponds to the reverse path (signal direction from the mobile station towards the base station). The channel/frequency assignment changes accordingly.

The RF frequency can be set in multiples of 10 kHz. With an additional *Frequency Offset*, an RF signal with an arbitrary frequency that is in the range supported by the tester can be generated and analyzed.

③ Measurement and Generator State

The state indication of the different measurements and generators is included in the corresponding softkeys. For ongoing measurements, the results in the output fields are constantly updated.

For various reasons, an output field may fail to show a valid measurement result (indication "---"):

- The analyzer settings do not match the properties of the input signal.
- The input signal is missing.
- The measurement is switched off (*OFF* is indicated in the softkey controlling the measurement).

④ Max. Level

The *Max. Level* softkey sets the maximum RF input power which can be measured and is used to adjust the RF input path to the expected power of the measured signal. The permissible range *Max. Level* depends on the RF connector and the external attenuation used.

Alternative Settings and Measurements

The CMU *Non Signalling* mode is also suitable for module tests.

☞ Chapter 4

To facilitate and speed up the operation, many CMU settings are accessible from different menus. The RF generator and analyzer settings are also part of the *Signal tab* in the Connect. Control menu.

Selecting a definite RF channel and level in the *BS Signal Settings* panel implies that signals with these properties are generated.

Selecting a definite RF frequency in the *Analyzer Settings* panel implies that only signals with this frequency are analyzed.

The current options for the measurement state are *RUN* (default) and *OFF*. A third state, *HLT*, occurs after a single-shot measurement is terminated (see below, step 3).

Once selected, the *TX Tests – Modulation* measurement can be switched off and on by means of the toggle key *ON/OFF*.

Generators may also be switched on (state *ON*) and off (state *OFF*) by means of the *ON/OFF* key.

☞ Chapter 4

The RF *Max. Level* and the analogous *AF Max. Level* can also be set in the *Connection Control* menu. If *Automatic* is selected, the levels are adapted to the power of the AF and RF input signal.

TX Tests

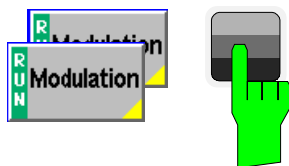
Step 2

- Press the *TX Tests* hotkey to switch over to the *TX Tests* measurement menu.

- Deactivate the ST at your mobile as it will impair the measurement of the *Total Peak Deviation*.

The *TX Tests* menu gives an overview of quantities characterizing the mobile transmitter quality. ⑤

Measurement results are displayed in the left half of the menu. The *Setup* table in the right half shows the test configurations that can be changed by means of the softkeys on the right softkey bar and associated hotkeys or in the *TX Tests* configuration popup menu.

Step 3

- Press the *Modulation* softkey twice to open the *TX Tests Configuration* menu. ⑥

- Press the *Control* hotkey to open the *Control* tab of the configuration menu.

- Select the *Modulation – Repetition* table line (rotary knob), press *ENTER*, and turn the rotary knob to select *Single Shot*. ⑦

- Press *ENTER* to confirm and then *ESCAPE* to close the *TX Tests Configuration* menu and return to the main menu.

The *TX Tests* measurement is stopped after one statistic count. The status indication next to the *Modulation* softkey is set to *HLT*. ⑧

Additional Information...

... on Step 2

⑤ TX Tests – Modulation

The *TX Tests – Modulation* menu shows the frequency error and peak deviation of the voice carrier, the SAT, the ST, and the audio signal. All these signals are transmitted by the mobile phone over the RF carrier. The SAT, ST, and the audio signal are demodulated from the carrier and measured in separate input paths.

It is instructive to switch on and off the individual signals at the mobile station and check the behavior of the measured quantities.

Under normal operating conditions, the Signalling Tone (ST) is used for signalling purposes and not transmitted permanently. The ST must therefore be switched off to measure the *Total Peak Deviation* and perform a realistic limit check.

... on Step 3

⑥ TX Tests Configuration menu

The *TX Tests Configuration* menu contains three tabs to set

- Parameters controlling the scope of the measurement (*Control*)
- Tolerance values (*Limits*)
- The input path configuration (*Filter*) of the *TX Tests*

⑦ Repetition mode and Stop Condition

If no stop condition is imposed (*Stop Condition = None*), the *Repetition* mode determines whether the measurement is

- Continued until explicitly stopped (*Continuous*)
- Stopped after one measurement cycle, i.e. after the system has settled and a valid result is obtained (*Single Shot*)

With *Stop Condition = On Limit Failure*, the measurement is stopped as soon as one of the results is out of tolerance.

⑧ HLT state

After termination of one single shot, the measurement is in the *HLT* state. This means that the last results are displayed in the output fields and no longer updated. The measurement is stopped, but a new single shot can be triggered via the *CONT/HALT* key.

Alternative Settings and Measurements

☞ Chapter 4, section *TX Tests*.

☞ Chapter 4.

Settings made in the *TX Tests Configuration* menu apply to *TX Tests* only.

Settings made in the *Connect. Control* menus apply to the entire function group *AMPS Non Signalling* but can be overwritten in the individual measurement groups.

☞ Chapter 3.

The stop condition *On Limit Failure* should be selected if the limit check represents the main purpose of the measurement.

The limits can be modified in the *Limits* tab of the *TX Tests Configuration* menu.

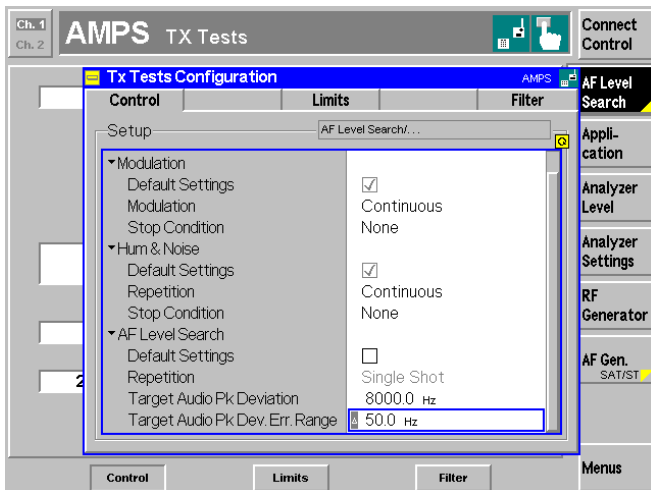
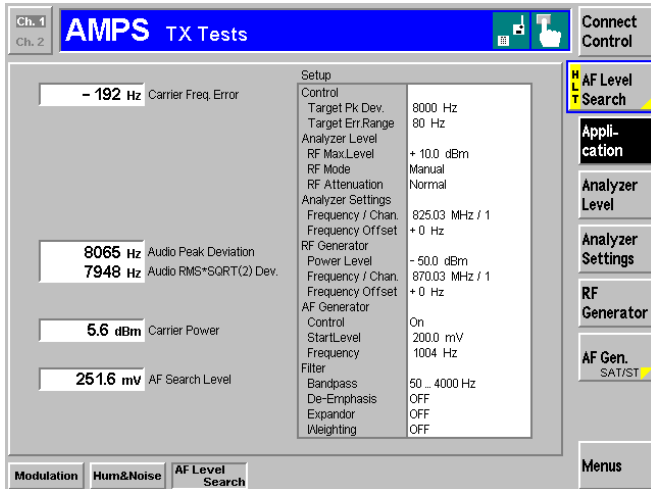
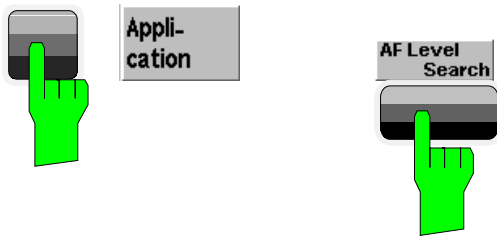

Step 4

- Press the *Application* softkey to change the hotkeys displayed below the diagram. ①
- Press the *AF Level Search* hotkey to change the application. ②

The *AF Level Search* menu is displayed. In this application, the CMU searches the AF level corresponding to a definite audio peak deviation (*Target Deviation*). The result is indicated in the lowest output field of the menu (*AF Search Level*).

The target deviation can be set in the *Control* tab of the *TX Tests Configuration* menu:

- Press the *AF Level Search* softkey twice to open the *TX Tests Configuration* menu.

Step 5

- Press the *Control* hotkey to open the *Control* tab of the configuration menu.
- Select the *AF Level Search – Target Audio Pk Deviation* table line (rotary knob), press *ENTER*, and set a target deviation of 7000 Hz. Press *ENTER* to confirm your entries. ③
- Select the *AF Level Search – Target Audio Pk Dev. Error Range* table line (rotary knob), press *ENTER*, and set an error range of 50 Hz. Press *ENTER* to confirm your entries.
- Press *ESCAPE* to close the *TX Tests Configuration* menu and return to the main menu.

Additional Information...

... on Step 4

① Softkeys and hotkeys

To leave more space for the output fields or enlarge the diagram area in graphical measurement menus, the left softkey column is often not used. Instead, hotkeys are assigned to the softkeys on the right side to complement their functionality. These hotkeys are displayed across the hotkey bar below the diagram while the softkey is selected.

Some of the softkey/hotkey combinations provide settings that can be also accessed via configuration menus. For example, the *Analyzer Level* settings are also accessible in the *Analyzer* tab in the *Connection Control* menu. Entries via hotkey and via the *Connection Control* menu are equivalent; the last value entered is valid for the entire function group and test mode.

Many softkeys and hotkeys are available in all measurement menus.

② Applications

Applications are different measurements belonging to the same measurement group. Each application is assigned its own set of configuration parameters. Therefore, the applications of a measurement group can be configured individually and serviced in parallel.

The TX Tests menu comprises the three applications *Modulation*, *Hum & Noise*, and *AF Level Search*.

... on Step 5

③ AF Level Search Routine

The audio peak deviation is a monotonic, ascending function of the AF level that can be inverted in its entire setting range. It makes sense therefore to ask for the AF level that corresponds to a given audio peak deviation. The CMU determines this target AF level by iteration, starting at the AF level set via the *AF Generator – Start Level* hotkey. The iteration is stopped as soon as the measured peak deviation is close enough to the target peak deviation set in the *Control* tab of the *TX Tests Configuration* menu. The corresponding AF level is displayed in the *AF Level Search* output field of the *TX Tests* menu.

Alternative Settings and Measurements

☞ Chapter 4.

The *Application* softkey displays the hotkeys to switch over between the different *TX Tests* applications (see below).

The *Analyzer Level* softkey configures the RF input signal path.

The *Analyzer Settings* softkey defines the frequency of the AF analyzer.

The *RF Generator* softkey configures the generated RF signal.

The *AF Generator* softkey configures the AF generator and the parameters of the *AF Level Search* iteration (see below).

The *Menus* softkey displays the hotkeys to switch over between the different measurement groups in *AMPS-MS Non Signalling*.

☞ Chapter 5 of CMU manual

Another set of applications is provided in the *RX Tests* menu.

☞ Chapter 4.

A search routine similar to the *AF Level Search* is provided in the *Sensitivity* application of the *RX Tests* menu. The receiver sensitivity measurement consists of determining the RF level corresponding to a definite *Target SINAD*.

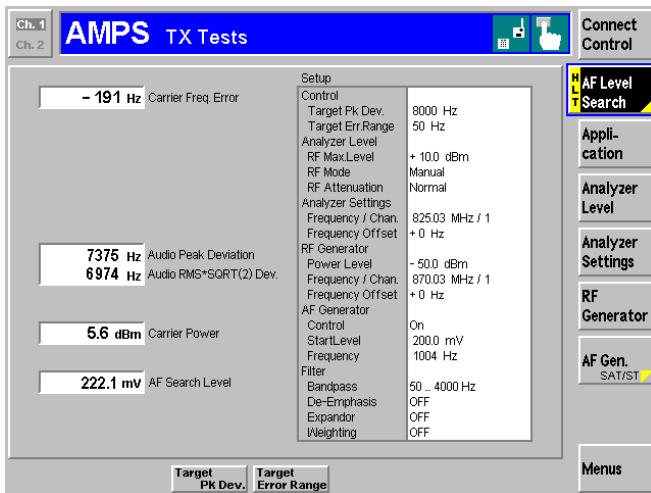

The AF level search is performed again, this time with a lower target deviation of 7000 Hz. As expected, the new AF search level is smaller than the previous one, which was obtained with a target deviation of 8000 Hz.

Before leaving the *TX Tests* menu, we encourage you to modify more of the settings and test their impact on the measurement results. ④

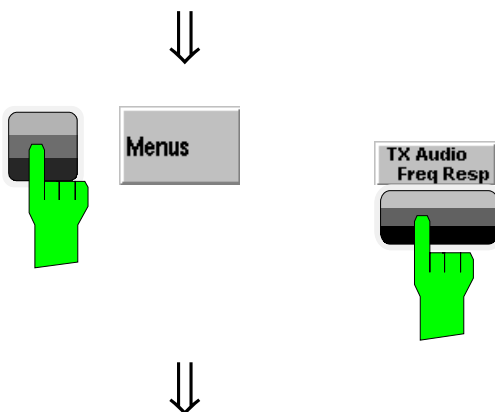

Step 6

- Press the *Menus* softkey to change the hotkeys displayed below the diagram.
- Press the *TX Audio Freq. Response* hotkey to change the measurement group.

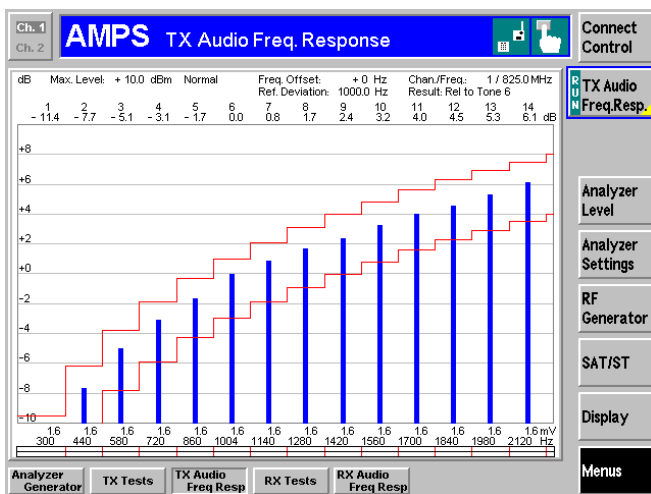

The *TX Audio Freq. Response* menu shows the electrical audio frequency response of the mobile station transmitter represented by a set of up to 14 out of 20 distinct test points. ⑤

Together with the bar graph, a tolerance template as specified in the standard is displayed. Settings (at present, the default settings) and scalar results are displayed in two parameter lines above the diagram.

- Press the *Display* softkey and then the *Frequency Scale* hotkey to shift the horizontal axis (AF frequency) of the diagram.
- Press the *Level Scale* hotkey to modify the vertical axis (AF frequency response) of the diagram.
- Press the *TX Audio Freq. Response* softkey twice to call up the *TX Audio Freq. Response* configuration menu. ⑥

Additional Information...

④ **Advanced Settings**

Besides the *Control* tab discussed above, the *TX Tests Configuration* menu comprises two other tabs providing the following settings:

<i>Limits</i>	Tolerance values; upper and (if applicable) lower limits for all measurement results in the <i>TX Tests</i> menu
<i>Filter</i>	Configuration of the audio input path by varying and switching on or off various filter stages in the audio receive path

The result of the *AF Level Search* can be used to define the total test tone level for the TX Audio Freq. Response measurement.

... on Step 6

⑤ **TX Audio Frequency Response Diagram**

The *TX Audio Frequency Response* menu is an example of a graphical measurement menu: The main measurement result (the electrical audio frequency response of the mobile transmitter as a function of the frequency of its audio input signal) is displayed in a two-dimensional diagram (a bar chart). The vertical scale of the diagram can be adjusted via softkeys and hotkeys.

Test configurations are shown in two parameter lines above the diagram; they can be modified by means of the softkey/hotkey combinations or in a special configuration menu (see below).

In general, the tolerance limits in graphical measurement menus are functions of the variable scaling the x-axis and therefore called *limit lines*. The *TX Audio Frequency Response* menu shows two step functions corresponding to an upper and a lower limit line; both limit lines can be modified in the configuration menu.

⑥ **TX Audio Frequency Response Configuration**

The *TX Audio Frequency Response Configuration* popup menu contains four tabs to set

- Parameters controlling the measurement and its scope (*Control*)
- Tolerance values (*Limit Lines*)
- The test points (frequencies and voltages) for the measurement (*Freq./Lev.*)
- The input path configuration (*Filter*)

The name and function of tabs belonging to different measurement groups was chosen to be as similar as possible. For example, the *Filter* tab is identical to the *Filter* tab of the *TX Tests Configuration* menu discussed before.

Alternative Settings and Measurements

☞ Chapter 4.

The *Filter* settings have a direct impact on the results obtained in the audio receive path. A circuit diagram and an application example is given in the *Path Configuration* sections in chapter 4.

☞ Chapter 4.

See *Level Selection* parameter in the *Tone Def.* tab of the *TX Audio Freq. Response Configuration* menu.

☞ Chapter 4.

The general menu types are discussed in chapter 3 of the CMU manual.

It is possible to disable the measurement at a particular test point and remove the corresponding bar from the diagram. This is done in the *Freq./Lev.* tab of the *TX Audio Frequency Response Configuration* menu, see below.

☞ Chapter 4.

The *Tone Def.* tab defines the frequency and RMS voltage of the test tones at which the audio frequency response is measured. These two values are indicated below the x-axis of the test diagram. Note that the frequencies of the tones may be arbitrary (not necessarily in ascending order). The **numbers** of the tones (1 to 20) define the x-axis of the test diagram.

Receiver Measurements

In tests assessing the mobile station receiver quality, the CMU provides an RF voice signal that can be modulated with a modulation signal (in the AF range), the SAT, and the ST, and measures the AF output signal of the MS receiver fed in via *AF IN*.

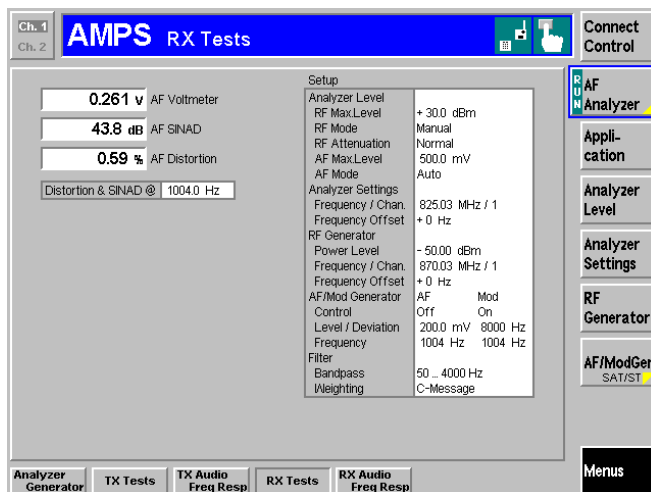
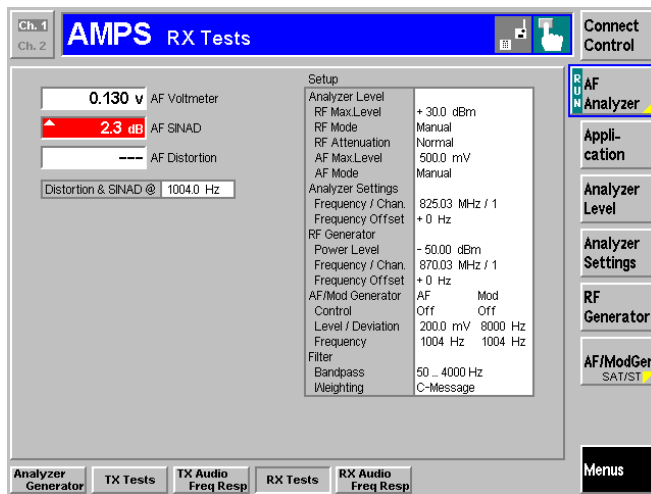
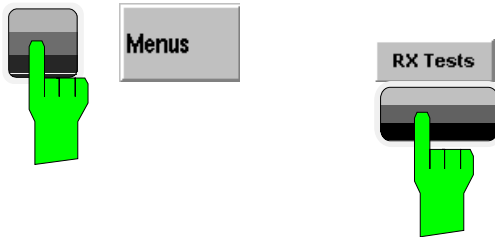

Step 1

- Press the *Menu* softkey to change the hotkeys displayed below the diagram.
- Press the *RX Tests* hotkey to change the measurement group.

The *RX Tests* menu gives an overview of quantities characterizing the mobile receiver quality. ①

Measurement results are displayed in the left half of the menu. The *Configuration* table in the right half shows the test configurations that can be changed by means of the softkeys on the right softkey bar and associated hotkeys or in the *TX Tests* configuration popup menu.

At present, all parameters are set to default values. The output fields show "---", indicating that no valid measurement results are available. The reason is that the CMU provides no appropriate RF input signal to the MS receiver.

Step 2

- Press the *Ana./Gen.* hotkey to return to the Analyzer/Generator menu.
- Switch on the RF generator (press the *RF Generator* softkey and the *ON/OFF* key).
- Press the *RF Channel* softkey and adjust the RF frequency to a value supported by your mobile phone.
- Switch on the *Mod. Generator*. ②
- Press the *Connect. Control* softkey and select the *Analyzer* tab (table-oriented version). Set the *AF Max. Level – Mode* to *Auto*. ③
- Close the *Connection Control* menu (press *ESCAPE* or *Connect. Control* again) and press *RX Tests* to return to the *RX Tests* menu.

Additional Information...

... on Step 1

① RX Tests – AF Analyzer

In the *AF Analyzer* (default) application, the *RX Tests* menu shows the quantities characterizing the AF output signal of the MS receiver: RMS voltage (*AF Voltmeter*), *AF SINAD* (signal to noise and distortion ratio), and *AF Distortion* (total harmonic distortion) of the signal measured at input connector *AF IN*. The output of the MS receiver and all measured quantities depend on the signal modulating the RF voice carrier signal (softkey *Mod. Generator*). The frequency of the *Mod. Generator* signal is therefore indicated in an output field below the measurement results.

Note that, compared to TX tests, a reverse signal path is used in RX tests: The CMU provides an RF signal (modulated with an AF frequency) but measures the AF signal from the DUT.

... on Step 2

② Modulation Generator

It is essential to distinguish the different signal generators of the CMU and their purpose in the different types of measurements:

- The *RF Generator* provides an RF voice channel carrier signal that can be modulated with the signal of the *Mod. Generator* (modulation signal), the SAT, and the ST, if so desired. An RF carrier signal modulated with a modulation signal is required for MS receiver measurements (*RX Tests*, *RX Audio Frequency Response*).
- The *AF Generator* provides an AF signal that is output via *AF OUT*. This signal is required for *TX Audio Frequency Response* measurements.
- The *Mod. Generator* provides an AF signal that is modulated onto the RF voice channel carrier. An RF carrier signal modulated with a modulation signal is required for MS receiver measurements (*RX Tests*, *RX Audio Frequency Response*).
- The *SAT Generator* and the *ST Generator* provide signals with a definite frequency and peak deviation that can also be used to modulate the RF voice channel carrier.

③ Autoranging

If *AF Max. Level – Mode* is set to *Auto*, the CMU measures the average input level at *AF IN* and adjusts the input path such that the maximum AF level that can be measured corresponds to the measured value plus an appropriate overload margin. Alternatively, a fixed *AF Max. Level* can be entered manually. The same holds for the *RX Max. Level*.

For all RF and AF input connectors, observe the level ranges reported in the data sheet.

Alternative Settings and Measurements

☞ Chapter 4, section RX Tests.

Like the *TX Tests* measurement group, the *RX Tests* group is split up in three different applications, each with its own set of configurations and measured quantities. The three applications are named *AF Analyzer*, *Hum & Noise*, and *Sensitivity*.

In the *Sensitivity* application, a search routine determines the RF level corresponding to a definite SINAD (receiver sensitivity).

☞ Chapter 4.

Instead of a fixed signalling tone (ST), the *ST Generator* is able to provide a wideband data signal specified in the standard.

The signal of the modulation generator can be replaced by an arbitrary external modulation signal fed in via AUX 1. To this end, *Mod. Extern* must be selected in the *AF/RF*  tab of the *Connection Control* menu.

☞ Chapter 4.

The *RX Audio Freq. Response* menu measures the electrical audio frequency response of the MS receiver. It is controlled like the *TX Audio Freq. Response* menu.

Signalling Mode

In the *Signalling* mode the CMU first transmits a control channel signal to which the mobile is able to synchronize. A call can then be established from either the CMU or the mobile. The measurement must be triggered by the signal transmitted by the mobile or by the CMU signalling unit; an external trigger signal can not be used.

The signalling process is controlled via the *Connection Control* popup menu. The first of four *Signalling* tabs contained in the *Connection Control* popup menu is automatically displayed when the *Signalling* Mode is selected (see *Menu Select* menu on page 2.4; for the following examples, *AMPS-MS Signalling* with the *Overview* menu was selected).

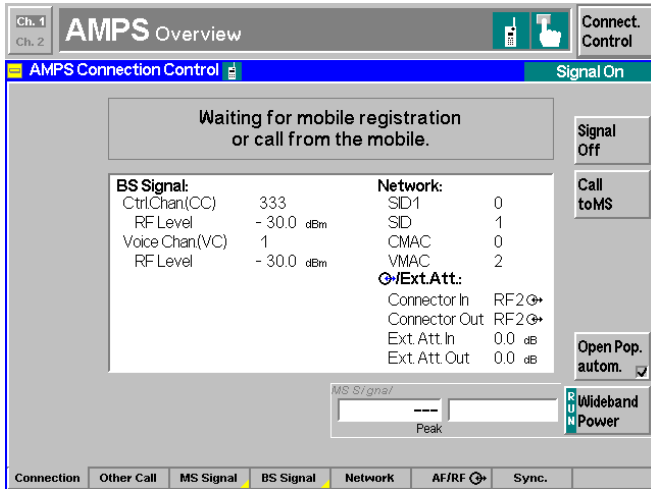

Step 1

The *Signalling (Signal On)* tab indicates the parameters characterizing the signals generated by the CMU (*BS Signal*).^①

In addition the system identity, the mobile attenuation codes, and the characteristics of the input and output connectors are shown.^②

Below the list, the *Wideband Power* softkey shows the current status of the wideband power measurement for RF input signals, the current measured peak power and its ratio to the effective radiated power of the mobile.^③

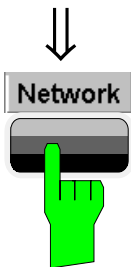

Step 2

➤ Press the *Network* hotkey.

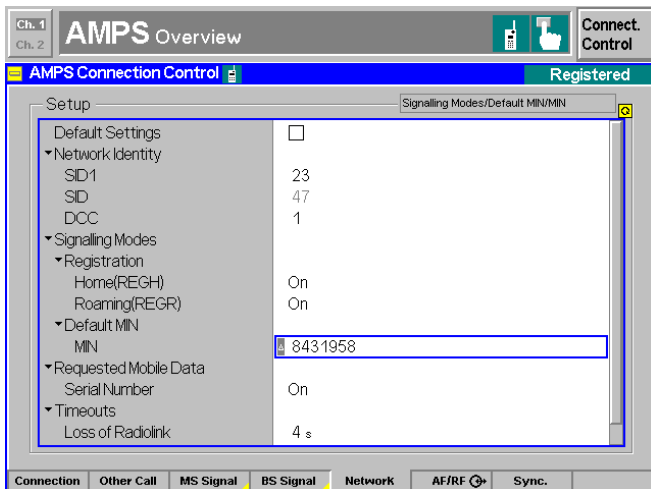

The *Network* tab is displayed. ^④

➤ Press the *ON/OFF* key to expand the menu tables.

➤ Select the *Default MIN – MIN* field and enter the 34-bit default mobile station identification number of your mobile phone.

Additional Information...

... on Step 1

① **BS Signal**

The CMU is able to generate two different RF carrier signals (control channel and voice channel) that can be configured separately. This allows a complete simulation of what happens in a real AMPS network.

② **Network, /Ext.Att.**

The network is identified by the *SID*, consisting of the *SID 1* (14-bit system identity 1), plus a 1-bit identifier for the channel system (A or B). These codes are transmitted to the mobile station on the control channel. The CMU uses the default settings shown in the diagram on the left side.

Input/output connectors suitable for the type of measurements and signal levels must be chosen – see section *RF and AF connection* on page 2.3. An external input/output attenuation value can be specified in order to compensate for a known attenuation of the input/output signal like those caused by cables.

③ **Input level**

The softkey *Wideband Power* has no configuration menu assigned but can be used like any other softkey controlling a measurement. In particular, it is used to switch over between the measurement states *RUN* and *OFF* (softkey selection plus *ON/OFF* key) and *RUN/HLT* (softkey selection plus *CONT/HALT* key).

... on Step 2

④ **Network parameters**

The *Network* tab defines a variety of parameters related to the network and the operating mode of the mobile station.

The purpose of these settings is to simulate the operating conditions of a mobile station in the AMPS network as realistically as possible. Many of the settings have an impact on the speed of the *Signalling* measurements.

Alternative Settings and Measurements

 Chapter 4.

The control and voice channels are configured in the *BS Signal* tab of the *Connection Control* menu. To access this tab press the associated hotkey.

 Chapter 4.

The network identity and other parameters characterizing the network are configured in the *Network* tab of the *Connection Control* menu. To access this tab press the associated hotkey (see below).

Input/output connectors and external attenuation are configured in the *AF/RF * tab.

 CMU manual chapter 3.

See also the diagrams on measurement control in chapter 5 of the present manual.

 Chapter 4.

If the MIN of the mobile station is not known, the CMU is unable to set up a call. Instead, a registration or a call must be initiated from the mobile station. After first registration, or after a call has been established for the first time, the MIN is transferred to the tester and is available for future calls. MS registration can also be enabled or disabled in the *Network* tab.

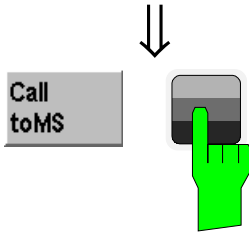

➤ Press the *Call to MS* softkey.

The header message *Paging in progress* is displayed. When the mobile starts ringing, the *Signalling (Alerting)* tab is displayed.

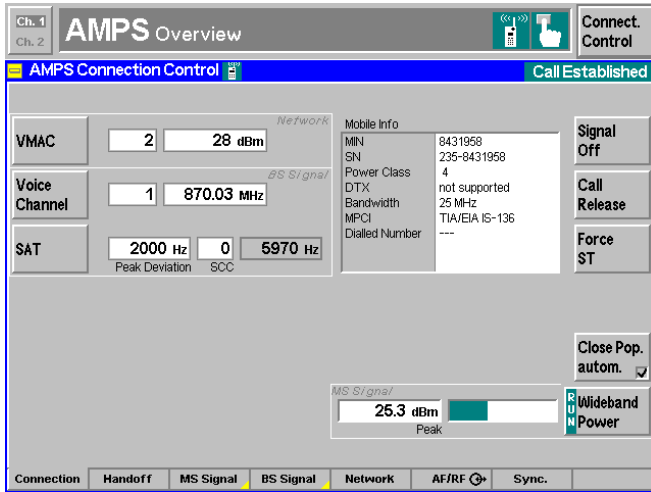

As soon as the call is accepted at the mobile, the *Signalling (Call Established)* tab is displayed (this tab is closed automatically after a short while but can be reopened by pressing the *Connect. Control* softkey).

The *Signalling (Call Established)* tab presents a comprehensive list of the signalling parameters (see *Mobile Info* on page 2.19).

Besides the voice mobile attenuation code (VMAC) ⑤, the parameters of the voice channel signals transmitted by the CMU ⑥, and the SAT can be configured.

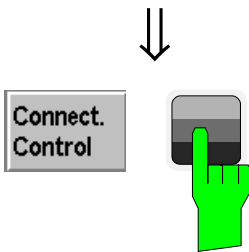

Step 3

➤ Press the *Connect. Control* softkey or the *ESCAPE* key.

The *Connect. Control* menu is closed; the CMU displays the *Overview* menu.

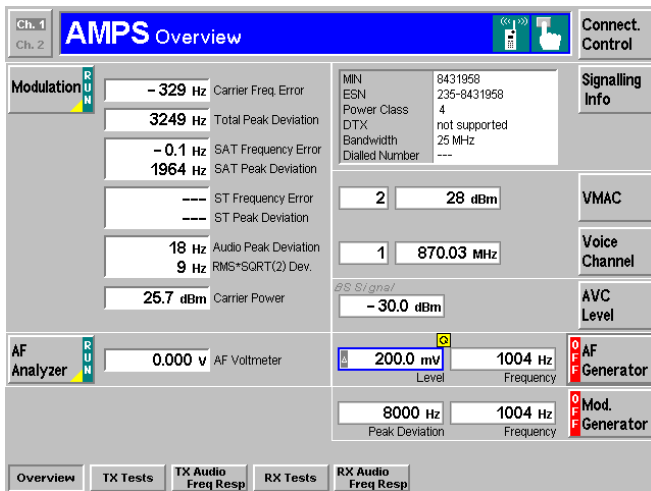

The *Overview* menu indicates the most important settings in the function group *AMPS-MS Signalling* and the main results of the *TX Tests – Modulation* measurements (the *ST Frequency Error* and the *ST Peak Deviation* can not be measured in *Call Established* state; see *Force ST* softkey in Chapter 4). Moreover the signalling info from the mobile station is displayed. ⑦

MS transmitter tests (*TX Tests, TX Audio Frequency Response*) and receiver tests (*RX Tests, RX Audio Frequency Response*) can be performed in close analogy to the *Non Signalling* mode. The differences between the two modes are related to the settings which can be made at the mobile station.

Additional Information...

... on Step 3

⑤ **Mobile Attenuation Code (VMAC)**

Dynamic power control is used in AMPS networks to reduce the output power of the mobile station as far as possible: In practice the mobile station is set to one of eight Voice Mobile Attenuation Codes (VMAC) ranging from 0 to 7, where VMAC equal to 0 corresponds to the largest nominal output power.

The *power class* characterizes the nominal maximum output power of the mobile. The Effective Radiated Power (ERP) of the mobile is a function of both its VMAC and its power class.

The VMAC can be used to control the maximum expected RF input level at the CMU and to vary the RF input power for the individual measurements.

⑥ **Voice channel**

The channel number of the BS voice channel signal is defined according to AMPS specifications as explained for the *Non Signalling* mode (forward path, see *Analyzer/Generator menu* on page 2.7).

VMAC, Voice Channel and Trigger

The VMAC of the mobile station and the voice channel number can be changed in all measurement groups while a call is established. This is in contrast to the *Non Signalling* mode where no settings concerning the device under test can be made.

⑦ **Mobile Info**

The *Mobile Info* list shows the basic properties of the connected mobile station. Note that the values shown are no default values (like the *Default MIN* set in the *Network* tab) but represent the information provided by the mobile station and transferred to the CMU. The parameters are therefore available in the *Call Established* and *Registered* signalling states only.

Alternative Settings and Measurements

☞ Chapter 4.

VMAC levels and power classes are listed in section *Overview of the Function Group* in chapter 4.

☞ Chapter 4.

☞ Chapter 4.

☞ Chapter 4.

For a comprehensive overview of signalling states and possible transitions refer to the figure at the beginning of section *AMPS Mobile Tests*.

Contents

3 Manual Control 3.1

Menu Structure..... 3.1

 Test Modes 3.1

 Configurations..... 3.2

 Measurement Groups..... 3.3

General Settings 3.5

Menu Overview 3.6

 AMPS Non Signalling – General Configurations 3.6

 AMPS Non Signalling – TX Tests and TX Audio Freq. Response 3.7

 AMPS Non Signalling – RX Tests and RX Audio Freq. Response..... 3.8

 AMPS Signalling – General Configurations I 3.9

 AMPS Signalling – General Configurations II 3.10

 AMPS Signalling – TX Tests and TX Audio Freq. Response 3.11

 AMPS Signalling – RX Tests and RX Audio Freq. Response 3.12

3 Manual Control

This chapter gives a brief survey of the operating concept and structure of the user interface AMPS MS tests. The CMU was designed for maximum operating convenience and flexibility. All instrument functions are grouped together in menus, each of them provides a number of related configuration settings or displays a group of measured quantities. All menus show a similar structure so that many settings, once defined, can be used in several menu groups. Switchover between the different menu groups and test modes (*Non Signalling – Signalling*) is possible at any time.

In the following, the different measurement modes and measured quantities are discussed. Settings and measurement parameters frequently encountered are explained from a general point of view.

The formal aspects of measurement control are discussed in more detail in chapter 5 (*Remote Control – Basics*). For a presentation of the CMU's control elements, menu types and dialog elements within the menus refer to chapter 3 of the operating manual for the CMU basic unit.

Menu Structure

The menus used to control AMPS-MS measurements can be arranged in different ways. From a functional point of view, they form the following groups:

- The two test modes *Signalling* and *Non Signalling* provided for each function group
- General configurations (*Connection Control*), measurement groups (*Receiver Quality*, *TX Tests*, *TX Audio Freq. Response*, *RX Tests*, *RX Audio Freq. Response*), and configurations specific to these measurement groups (*TX Tests Configuration*, *TX Audio Freq. Response Configuration*, *RX Tests Configuration*, *RX Audio Freq. Response Configuration*).

In a more formal sense, the CMU uses main menus, popup menus, graphical measurement menus and dialog windows of various size. This aspect is discussed in chapter 3 of the CMU operating manual.

Test Modes

AMPS-MS measurements are performed in one of the two modes *Signalling* or *Non Signalling*. The *Non Signalling* mode is typically used for module tests or test of mobiles in a special "test mode". The *Signalling* mode serves to measure the mobile phone performance under realistic operating conditions where the CMU mimics an AMPS base transceiver station.

Definition The term signalling denotes all actions necessary to establish, control and terminate a communication between the base station (CMU) and the mobile phone. The signalling messages conveyed allow the mobile station and the network to discuss the management of issues either related to the user or concerning technical aspects of the communication.

Non Signalling Mode In the *Non Signalling* mode, the CMU generates an RF voice signal that can be frequency-modulated with an AF modulation signal, the SAT, and the ST and analyzes the modulated RF carrier signal with AMPS characteristics retransmitted by the device under test. The test signal may be inside or outside the designated AMPS channel range.

To test the transmitter quality, the CMU provides an additional AF test signal that is applied to the input of the mobile station transmitter. To test the receiver quality, the CMU analyzes the AF output signal from the mobile station receiver. No signalling parameters are transferred, and no call is set up, so that test times can be reduced considerably.

Signalling Mode In the *Signalling* mode, the CMU transmits a control channel (CC) signal (*BS Signal*) to which the mobile phone can synchronize. With this signal, a call setup and registration of the mobile may be initiated by either the mobile or the CMU. A call from the current to another network can be set up, and an established call can be handed off from the current to another network.

The CMU is able to configure a broad range of network parameters, to vary the settings and monitor the VMAC and DMAC of the mobile phone. With the appropriate RF and AF signal configuration, transmitter and receiver measurements can be performed as in the *Non Signalling* mode.

Symbols for Signalling Mode and State

The *signalling mode* and *state* is indicated to the left of the operating mode in each main menu and graphical measurement menu (see chapter 3 of CMU operating manual). The following symbols occur in function group *AMPS-MS*:



Non signalling mode



Signalling mode, Signal Off



Signalling mode, Signal On



Signalling mode, Registered



Signalling mode, Call Established

Configurations

The CMU offers a wide range of settings for the signal generators and analyzers, the signalling procedures, and the individual measurements. Configurations may apply to the whole function group (*Connection Control*, signalling parameters) or to a particular measurement.

Connection Control

The *Connect. Control* softkey is located to the right of the title bar in each main and graphical measurement menu. It opens a popup menu with several tabs configuring and controlling

- The signal generators and analyzers of the instrument (*Analyzer* and *Generator* in Non Signalling, *MS Signal* and *BS Signal* in Signalling mode)
- The CMU receiver settings and input path configuration (included in *Analyzer*, *MS Signal*)
- The RF connectors to be used and the external attenuation (*RF Input/Output*)
- The reference signal and the system clock (*Sync.*)
- In *Signalling* mode, all actions changing the CMU's signalling state (*Connection*)
- In *Signalling* mode, a call (*Other Call*) or a handoff (Handoff) to another network
- In *Signalling* mode, parameters of the network and the mobile station under test (*Network*)

All settings made in the *Connect. Control* menu are valid for the whole function group. Many of them can be overwritten, however, by means of the softkeys and hotkeys offered in the graphical measurement menus.

Configuration of measurements

A popup menu offering specific settings is assigned to most measurement groups (*TX Tests, TX Audio Freq. Response, RX Tests, RX Audio Freq. Response*). The following parameters can be defined in separate tabs:

- The repetition mode and stop condition for the measurement (*Control*)
- Tolerances for the measured quantities (*Limits, Limit Lines*)

These settings are explained in more detail below (see section *General Settings* on page 3.5).

Configuration via hotkeys

The softkeys and associated hotkeys in the graphical measurement menus provide the most important configurations for the current measurement; see chapter 4 and chapter 3 of the CMU operating manual. Settings made via hotkeys supersede the corresponding *Connection Control* settings.

Measurement Groups

Measurement results are indicated in two different ways:

- Discrete values and parameters are displayed in output fields, lists and tables. In remote control, these results are referred to as scalars.
- Relatively small sets of test points are viewed in a bar graph. In remote control, results of this type are also referred to as scalars.

While the measurement is running in repetition mode *Continuous* (see page 3.5), the results are constantly updated. As shown in the table below, the measurement groups slightly differ in the two test modes.

Table 3-1 Measurement Groups in the *Signalling* and *Non Signalling* Mode

Non Signalling	Signalling
Analog AMPS (Function group AMPS-MS)	
Wideband Power Measurement of the peak power of the input signal using a wideband filter at the CMU's RF Frontend.	Wideband Power Measurement of the peak power of the input signal using a wideband filter at the CMU's RF Frontend.
Analyzer/Generator Configuration of the RF signal, the AF and the (AF) modulation signal generated, RF analyzer settings. AF analyzer results, results of the <i>Modulation</i> measurement.	Overview Configuration of the voice channel signal, the AF and the (AF) modulation signal generated. AF analyzer results, results of the <i>Modulation</i> measurement, and parameters of the mobile station are indicated.
TX Tests Measurement of modulation parameters (frequency stability and frequency deviation) characterizing the MS transmitter and of quantities characterizing the amount and the source of unwanted signals in the mobile phone output (hum & noise, residual amplitude modulation, modulation distortion and noise), including limit check.	TX Tests Measurement of modulation parameters (frequency stability and frequency deviation) characterizing the MS transmitter and of quantities characterizing the amount and the source of unwanted signals in the mobile phone output (hum & noise, residual amplitude modulation, modulation distortion and noise), including limit check. The measurement can be performed at variable VMAC levels of the mobile phone.
TX Audio Freq. Response Measurement of the electrical audio frequency response of the MS transmitter at up to 20 distinct audio frequencies including limit check.	TX Audio Freq. Response Measurement of the electrical audio frequency response of the MS transmitter at up to 20 distinct audio frequencies including limit check. The measurement can be performed at variable VMAC levels of the mobile phone.
RX Tests Measurement of quantities characterizing the amount and the source of unwanted signals in the receiver audio output of the mobile phone (AF distortion, hum & noise, SINAD), and of the MS receiver sensitivity level including limit check.	RX Tests Measurement of quantities characterizing the amount and the source of unwanted signals in the receiver audio output of the mobile phone (AF distortion, hum & noise, SINAD), and of the MS receiver sensitivity level including limit check. The measurement can be performed at variable VMAC levels of the mobile phone.
RX Audio Freq. Response Measurement of the electrical audio frequency response of the MS receiver at up to 20 distinct audio frequencies including limit check.	RX Audio Freq. Response Measurement of the electrical audio frequency response of the MS receiver at up to 20 distinct audio frequencies including limit check. The measurement can be performed at variable VMAC levels of the mobile phone.

A graphical overview of the menus is given at the end of this chapter.

General Settings

A number of settings can be made in several of the configuration menus assigned to the measurement groups. In combination, these settings define the scope of the measurement, i.e. the duration of the measurement and the results displayed. The following brief overview is intended to avoid confusion of terms.

Application *Applications* are different measurements belonging to the same measurement group. They effectively split up a measurement group into various related sub-groups which can be configured separately.

They are selected via the *Application* softkey in the graphical measurement menus.

Repetition Mode The *repetition mode* defines when a measurement that is not stopped by a limit failure (see stop condition *On Limit Failure* below) will be completed. Two modes are available for all measurements:

Single Shot The measurement is stopped after one *statistic count* (digital network tests) or after a valid result is obtained (analog network tests).

Continuous The measurement is continued until explicitly terminated by the user; the results are periodically updated.

A third repetition mode is available with remote control:

Counting Repeated single shot measurement with a fixed number of statistic counts.

The *repetition mode* is set in the *Control* tab of the configuration popup-menus assigned to the individual measurement groups.

Note: *In contrast to other measurement settings, these repetition modes in manual and remote control are independent and do not overwrite each other. In most measurements, the default repetition mode in manual control is Continuous (observe results over an extended period of time), the default mode in remote control is Single Shot (perform one measurement and retrieve results).*

Stop Condition A *stop condition* can be set for most measurements:

None The measurement is performed according to its repetition mode, irrespective of the measurement results and the limits set.

On Limit Failure the measurement is stopped as soon as one of the limits is exceeded, irrespective of the repetition mode set. If no limit failure occurs, it is performed according to its repetition mode.

The *stop condition* is set in the *Control* tab of the configuration popup-menus assigned to the measurement groups.

Menu Overview

AMPS Non Signalling – General Configurations

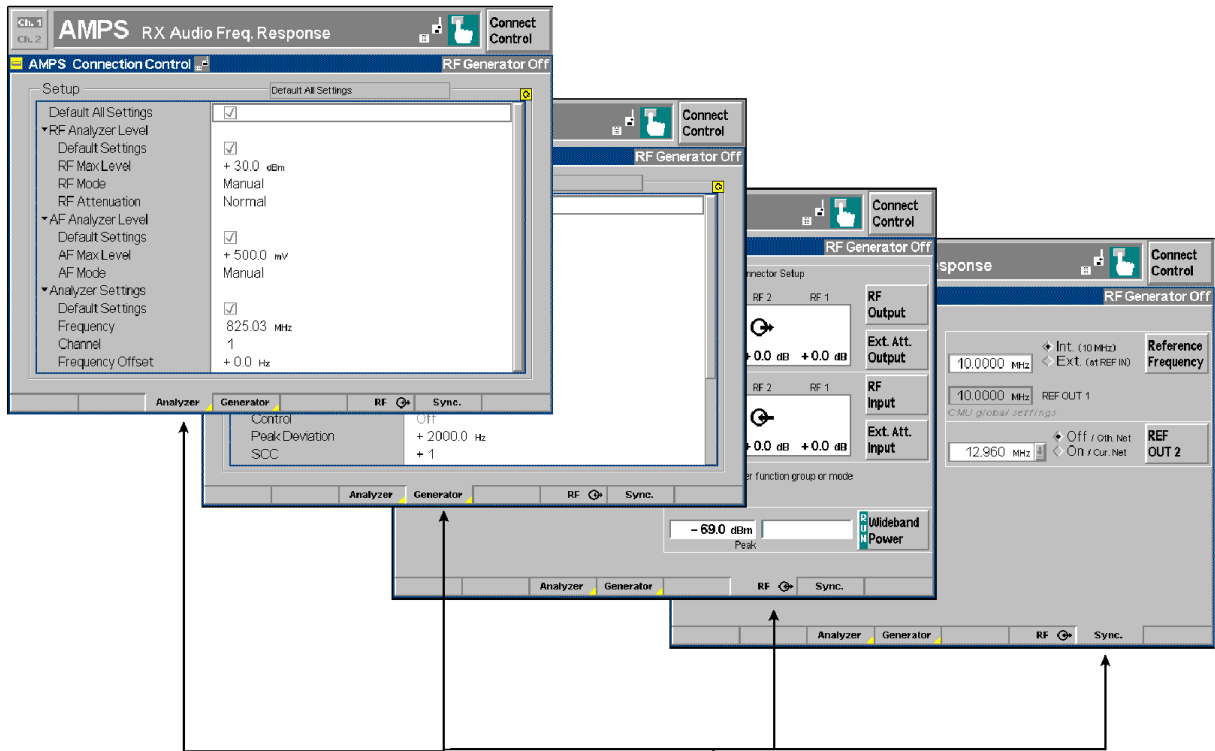

Ch. 1
Ch. 2

AMPS Analyzer / Generator

Connect Control

Modulation	366 Hz	Carrier Freq. Error	-50.0 dBm	RF Generator
	1519 Hz	Total Peak Deviation		RF Channel
	5526 Hz	SAT Peak Deviation	870.03 MHz	1
	7472 Hz	ST Peak Deviation		Frequency Offset
	5549 Hz	Audio Peak Deviation	+0 Hz	
	702 Hz	RMS-SQRT(2) Dev.		
	-923.2 dBm	Carrier Power		
AF Analyzer	3.506 v	AF Voltmeter		
Max. Level	30.0 dBm	200.0 mV	1004 Hz	AF Generator
RF Chan / Freq. Offs.	825.03 MHz	1	8000 Hz	1004 Hz
	+0 Hz		Peak Deviation	Mod. Generator

Analyzer Generator TX Tests TX Audio Freq Resp RX Tests RX Audio Freq Resp

Measurement groups, see next pages

AMPS Non Signalling – TX Tests and TX Audio Freq. Response

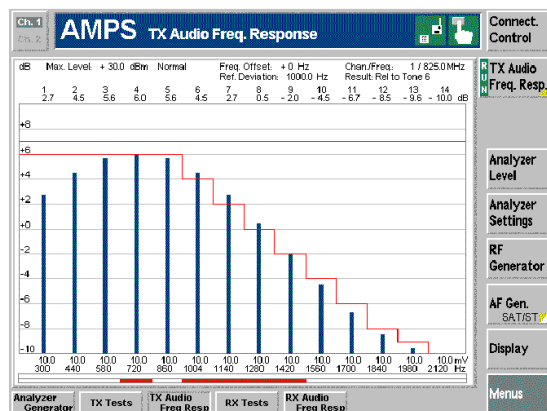
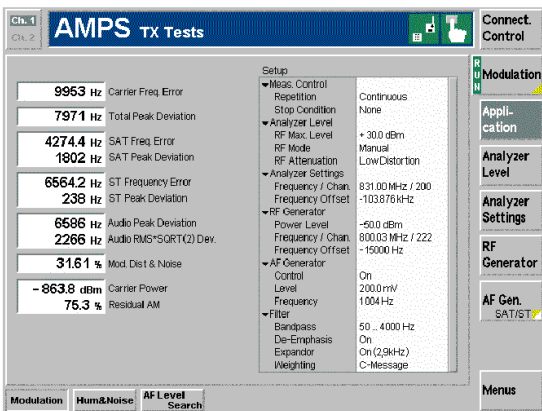
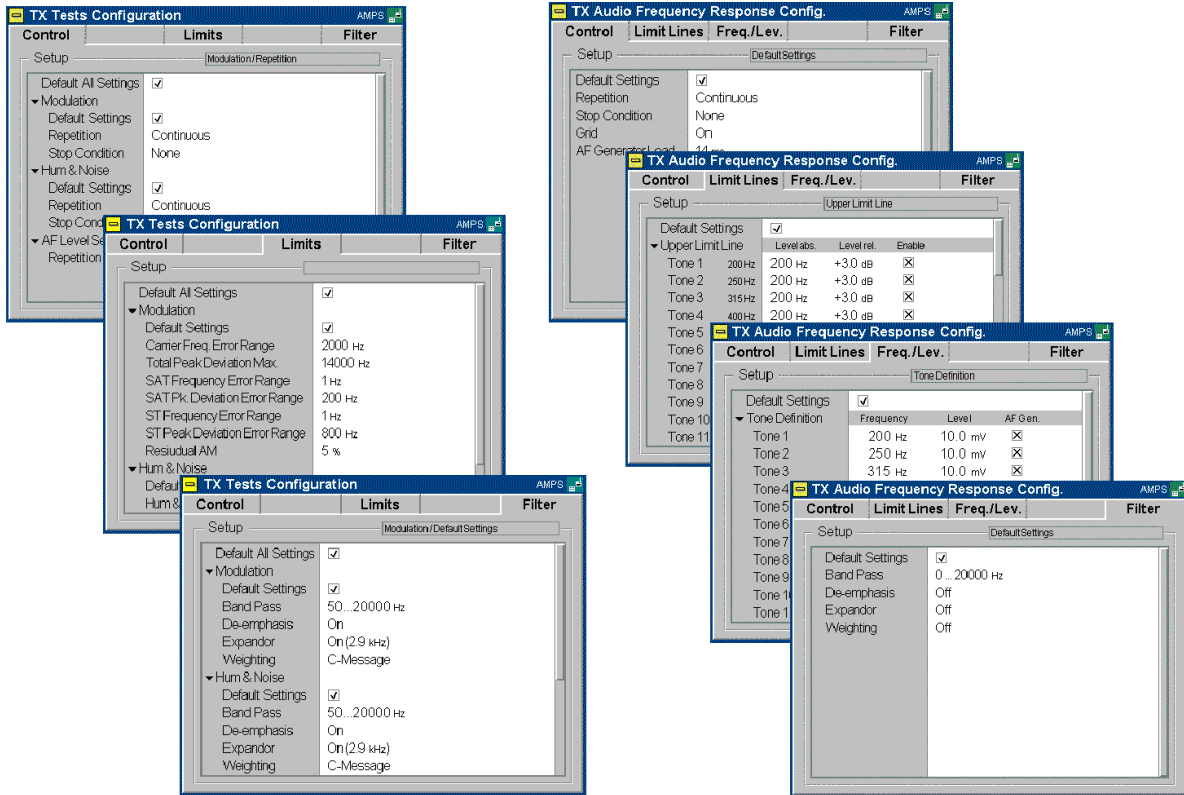

Analogous measurement menus

AMPS Non Signalling – RX Tests and RX Audio Freq. Response

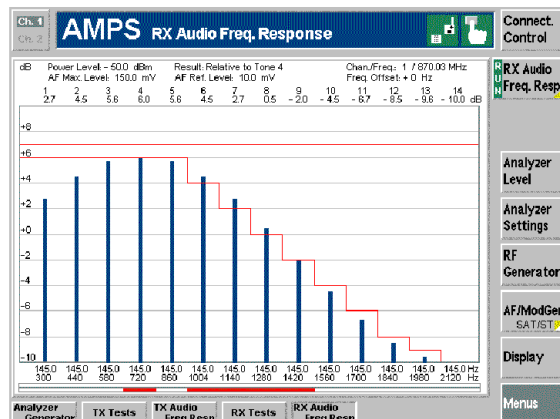
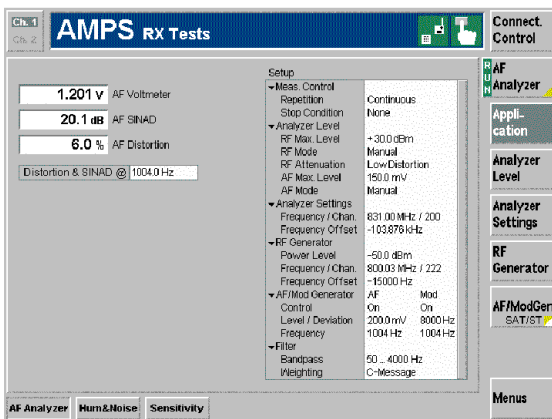
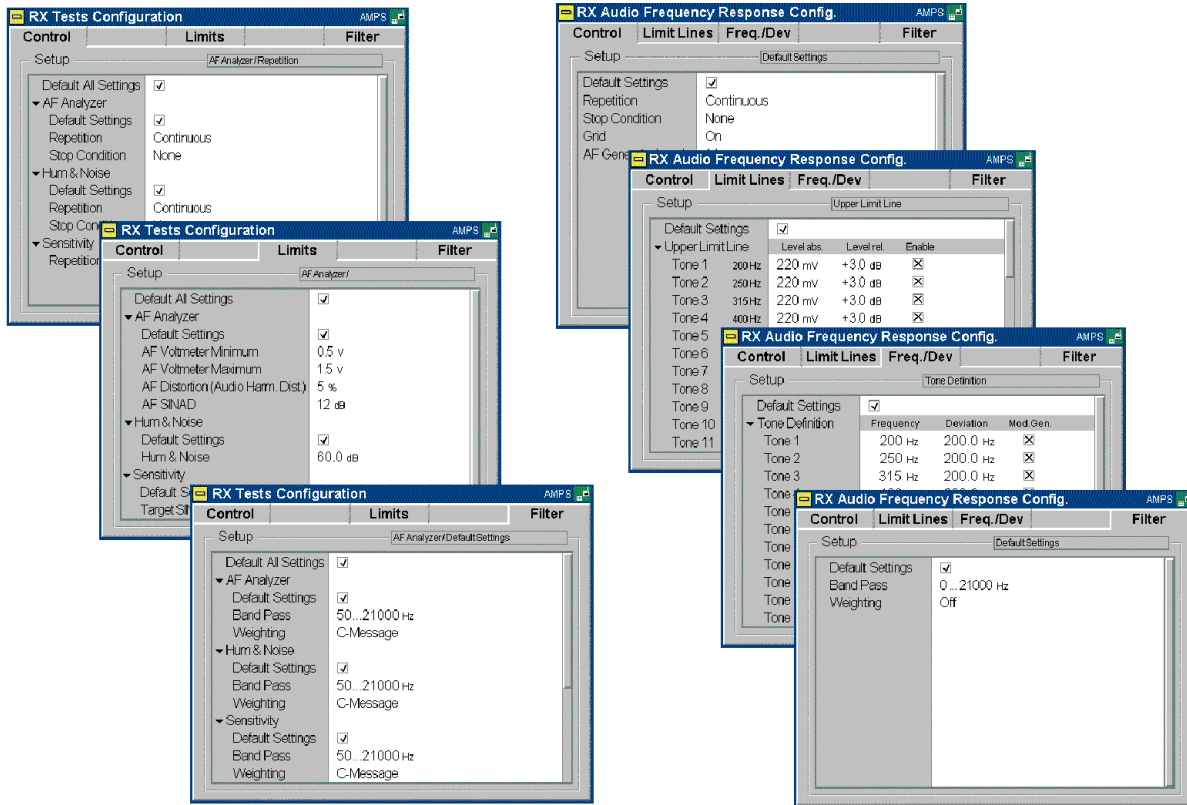

Analogous measurement menus

AMPS Signalling – General Configurations I

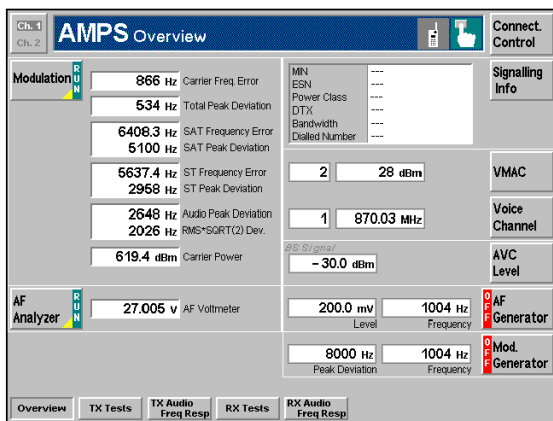
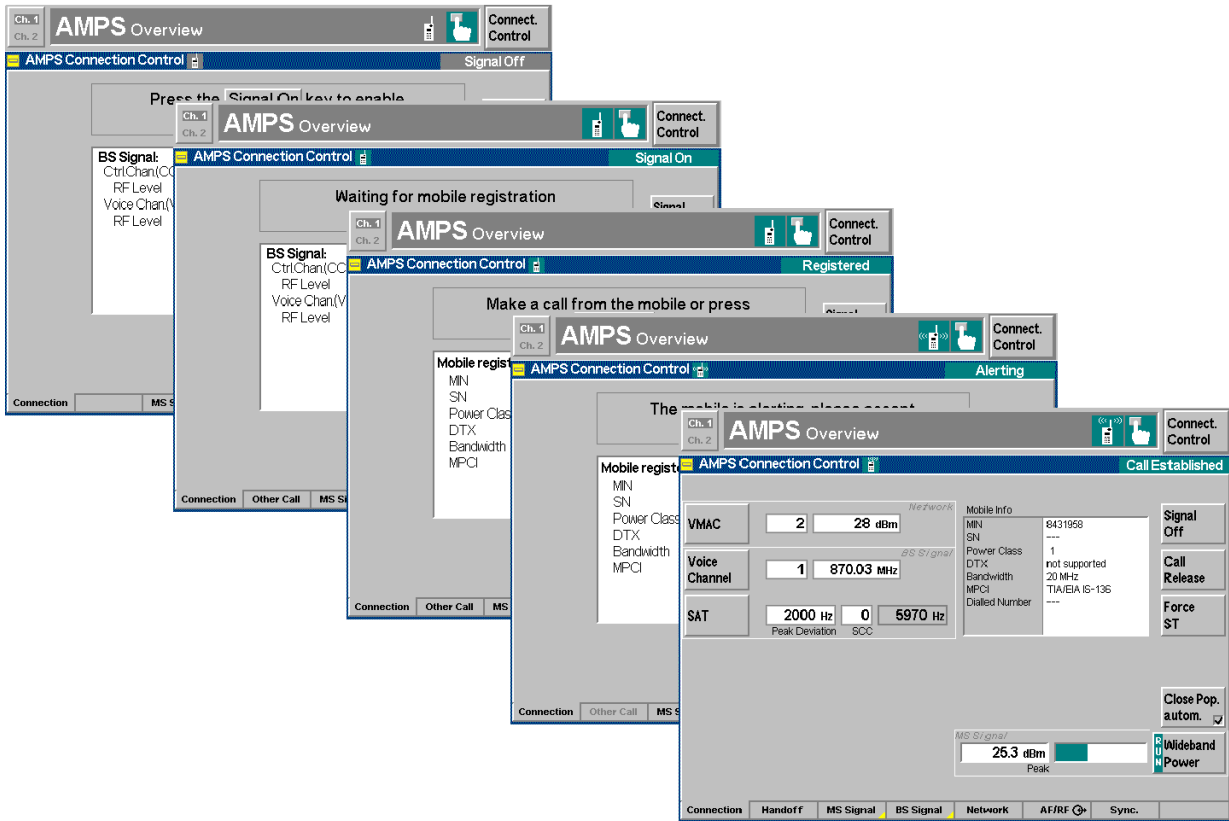

More Connect. Control menus, see next pages

AMPS Signalling – General Configurations II

The image displays several overlapping screenshots of the AMPS software interface:

- AMPS Overview (Top Left):** Shows call control options like 'Call to MS' and 'Destination Selection' with a 'Connect. Control' button.
- AMPS Connection Control (Top Middle):** Displays call status such as 'Registered', 'Reg. Pending', 'Call Established', and 'Call Pending'. It includes fields for 'Destination Selection' (e.g., IS 136 600) and 'Destination Parameter'.
- AMPS TX Tests (Middle Left):** Features a 'Setup' dialog with various test parameters:
 - Default All Settings: Read Control Filer Msg: On
 - MAC: Default Settings CMAC: 0 VMAC: 2
 - Other Call / Handoff Parameter: Default Settings VMAC: 0
 - RF Analyzer Level: Default Settings RF Max Level: 30.0 dBm RF Mode: VMAC RF Attenuation: Normal
 - AF Analyzer Level:
- AMPS Overview (Bottom Left):** A detailed measurement screen with the following data:
 - Modulation:** 866 Hz Carrier Freq Error, 534 Hz Total Peak Deviation, 6408.3 Hz SAT Frequency Error, 5100 Hz SAT Peak Deviation, 5637.4 Hz ST Frequency Error, 2958 Hz ST Peak Deviation, 2648 Hz Audio Peak Deviation, 2026 Hz RMS*SQRT(2) Dev., 619.4 dBm Carrier Power.
 - Signalling Info:** MN, EN, Power Class, DTX, Bandwidth, Delayed Number.
 - VMAC:** 2, 28 dBm
 - Voice Channel:** 1, 870.03 MHz
 - AVC Level:** -30.0 dBm
 - AF Analyzer:** 27.006 v AF Voltmeter, 200.0 mV Level, 1004 Hz Frequency, 8000 Hz Peak Deviation, 1004 Hz Frequency.
- AMPS Overview (Bottom Right):** Shows 'Measurement menus, see next pages' with an arrow pointing to the right.

AMPS Signalling – TX Tests and TX Audio Freq. Response

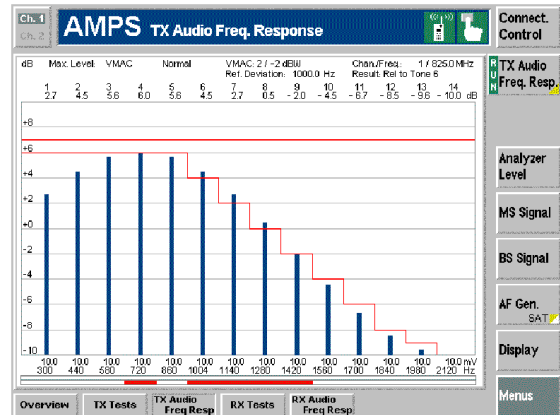
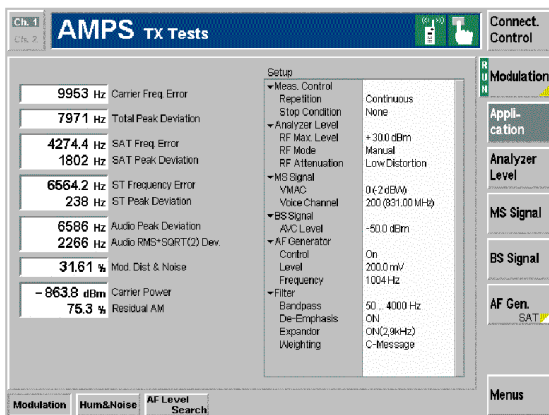
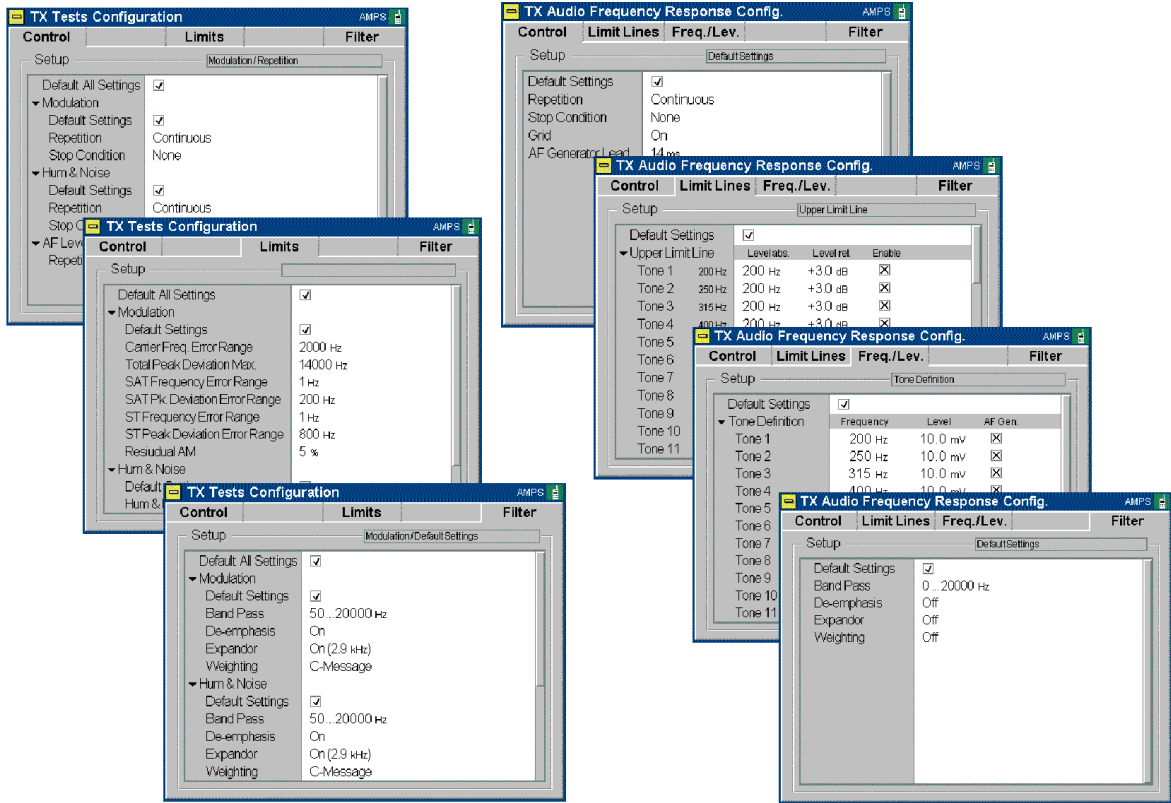

Analogous measurement menus

AMPS Signalling – RX Tests and RX Audio Freq. Response

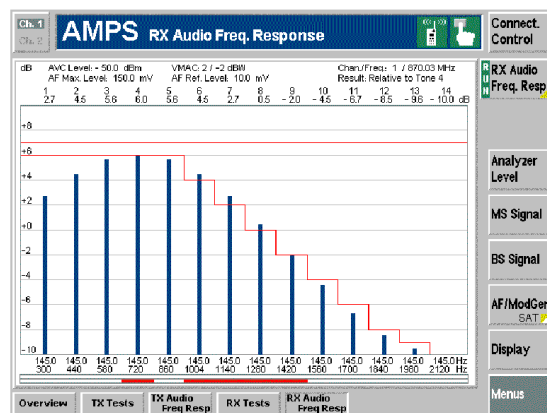
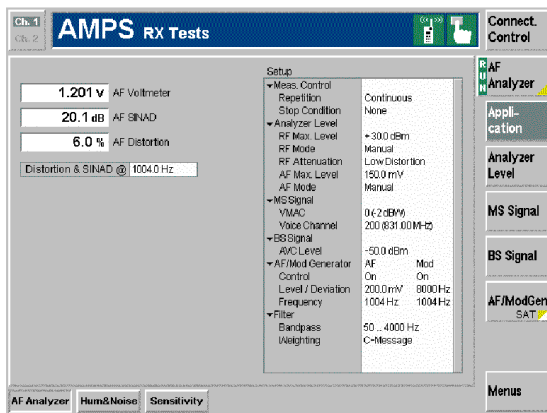
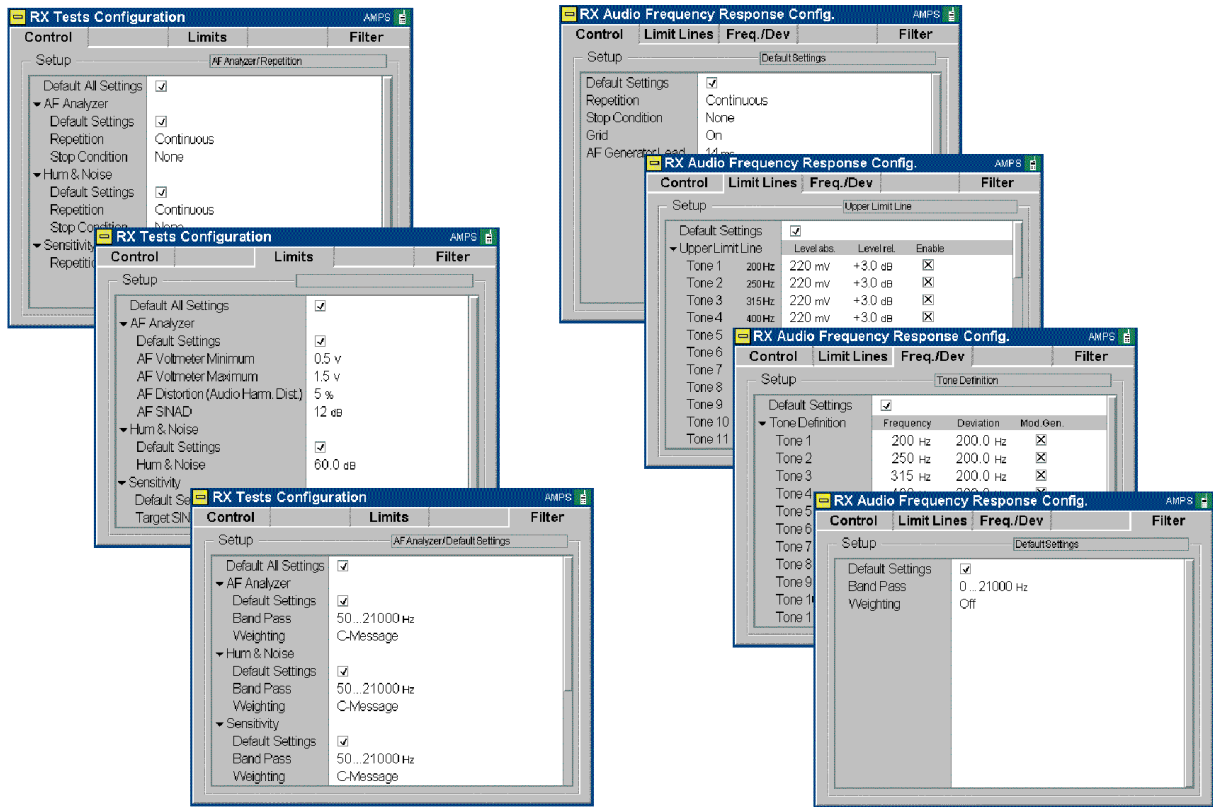

Analogous measurement menus

Contents

4 Functions and their Application.....	4.1
AMPS Module Tests (Non Signalling)	4.2
Analyzer/Generator Menu	4.2
TX Tests	4.5
Measurement Menu (TX Tests)	4.5
Test Settings	4.7
a) Measurement Control	4.7
b) Selecting the Application.....	4.8
c) Signal Settings	4.9
Measurement Results	4.12
Measurement Configurations (TX Tests Configuration)	4.15
Measurement Control (TX Tests Configuration – Control).....	4.15
Limits (TX Tests Configuration – Limits).....	4.17
Path Configuration (TX Tests Configuration – Filter)	4.18
TX Audio Freq. Response	4.21
Measurement Menu (TX Audio Freq. Response)	4.21
Test Settings	4.22
Measurement Results	4.24
Measurement Configurations (TX Audio Freq. Response Configuration)	4.25
Measurement Control (TX Audio Freq. Response Configuration – Control).....	4.25
Limit Lines (TX Audio Freq. Response Configuration – Limit Lines)	4.26
Test Tones (TX Audio Freq. Response Configuration – Tone Def.).....	4.27
Path Configuration (TX Audio Freq. Response Configuration – Filter)	4.29
RX Tests	4.30
Measurement Menu (RX Tests).....	4.30
Test Settings	4.31
Measurement Results	4.33
Measurement Configurations (RX Tests Configuration).....	4.35
Measurement Control (RX Tests Configuration – Control)	4.36
Limits (RX Tests Configuration – Limits).....	4.37
Path Configuration (RX Tests Configuration – Filter).....	4.38
RX Audio Freq. Response.....	4.39
Measurement Menu (RX Audio Freq. Response).....	4.39
Test Settings	4.40
Measurement Results	4.41
Measurement Configurations (RX Audio Freq. Response Configuration)	4.43
Measurement Control (RX Audio Freq. Response Configuration – Control) ..	4.43
Limit Lines (RX Audio Freq. Response Configuration – Limit Lines)	4.43
Test Tones (RX Audio Freq. Response Configuration – Freq./Dev.).....	4.44
Path Configuration (RX Audio Freq. Response Configuration – Filter).....	4.44
Connection Control.....	4.45
Control of Input Signals (Connection Control – Analyzer).....	4.45
Softkey-Oriented Version	4.45
Table-Oriented Version	4.48
Control of Output Signals (Connection Control – Generator)	4.50
Softkey-Oriented Version	4.50
SAT and ST	4.52
Table-Oriented Version	4.53

Connectors (Connection Control – AF/RF Inputs/Outputs).....	4.54
Reference Frequency (Connection Control – Sync.)	4.57
AMPS Mobile Tests (Signalling Mode)	4.59
Connection Control (Call Setup).....	4.59
Connection Control with "Signal Off".....	4.60
Connection Control with "Signal On".....	4.62
Overview Menu	4.64
TX Tests.....	4.66
TX Audio Freq. Response.....	4.68
RX Tests	4.69
RX Audio Freq. Response.....	4.70
Connection Control (Contd.).....	4.71
Connection Control in the Registered State.....	4.71
Connection Control in the Alerting State	4.73
Connection Control with Call Established	4.74
Call to Another Network (Connection Control – Other Call).....	4.76
Handoff to another Network (Connection Control – Handoff).....	4.78
Signals of the Mobile Phone (Connection Control – MS Signal).....	4.81
Table-Oriented Version	4.81
Softkey-Oriented Version	4.82
Signals of the CMU (Connection Control – BS Signal)	4.83
Table-Oriented Version	4.83
Softkey-Oriented Version	4.84
Network Parameters (Connection Control – Network).....	4.85
Connectors (Connection Control – AF/RF Input/Output)	4.87
Reference Frequency (Connection Control – Sync.)	4.87
Analyzer Settings (Connection Control – Analyzer)	4.87
Miscellaneous Settings (Connection Control – Misc).....	4.88

4 Functions and their Application

This chapter explains in detail all functions for the measurement of AMPS mobile stations.

It is divided into two sections describing the following test modes:

1. Analog AMPS module tests (*AMPS-MS Non Signalling*)
2. Analog AMPS mobile tests (*AMPS-MS Signalling*)

This reference chapter is organized according to the provided measurements and configurations (see graphical overview at the end of chapter 3). In contrast to chapter 6, *Remote Control – Commands*, general measurement configurations are relegated to the end of each section. The description of each softkey, select or input field is followed by the corresponding remote-control commands. Similarly, the description of the commands in chapter 6 also contains the corresponding menus of the user interface.

Each menu and each panel is briefly described first and then illustrated together with its call button. The menu functions are explained in the following way:

Softkey	Short function definition
Designation of select/input field	<p>Definition of field function.</p> <p>Further description of the field: purpose, interaction with other settings, notes...</p> <p><i>Parameter 1</i> Description of parameter 1</p> <p><i>Parameter 2</i> Description of parameter 2</p> <p>...</p> <p>Further description of the parameters: purpose, interaction with other settings, notes...</p>
Remote control	Remote-control command (long form) Parameter1 Parameter2 ...

For all numerical values, including their ranges and default settings, please refer to the description of the remote-control commands in chapter 6.

The description of the operating concept is to be found in chapter 3 of the operating manual for the CMU basic instrument; besides, a description of measurement control and the essential settings and an overview of the most important menus is given at the end of chapter 3 in the present AMPS manual. A comprehensive index listing important keywords and the proper names of all menus, dialog elements and softkeys is appended to the end of this manual.

AMPS Module Tests (Non Signalling)

This section provides detailed information on the measurement and configuration menus defined in function groups *AMPS-MS Non Signalling*. It is organized like a typical measurement session including the following stages:

1. General settings (*Analyzer/Generator*) and display of generator signals
2. Measurement menus (*TX Tests, TX Audio Freq. Response, RX Tests, RX Audio Freq. Response*): control of the measurements, output of measurement results, specific measurement configurations
3. Global configurations (*Connection Control*)

Analyzer/Generator Menu

The main menu *Analyzer/Generator* configures the RF and AF generator signals and the signals received and analyzed by the CMU.

The RF generator and analyzer settings are also provided in the *Analyzer* and *Generator* tabs of the menu group *Connection Control*:

<i>Analyzer Settings</i> panel	<i>Analyzer</i> tab	See page 4.45 ff.
<i>RF Generator Settings</i> panel	<i>Generator</i> tab	See page 4.50 ff.

The remaining softkeys indicate various measurement results and control the AF and modulation frequency generators:

<i>Modulation</i>	Results of the <i>TX Modulation</i> measurement (see p. 4.12 ff.)
<i>AF Analyzer</i>	Result of the audio voltage measurement
<i>AF Generator/Mod. Generator</i>	AF and modulation generator control

The main menu *Analyzer/Generator* can be opened from the main menu *Menu Select* (with associated key at the front of instrument). The hotkeys across the bottom of the menu switch over to the remaining measurement menus of the function group *AMPS-MS Non Signalling Mode*.

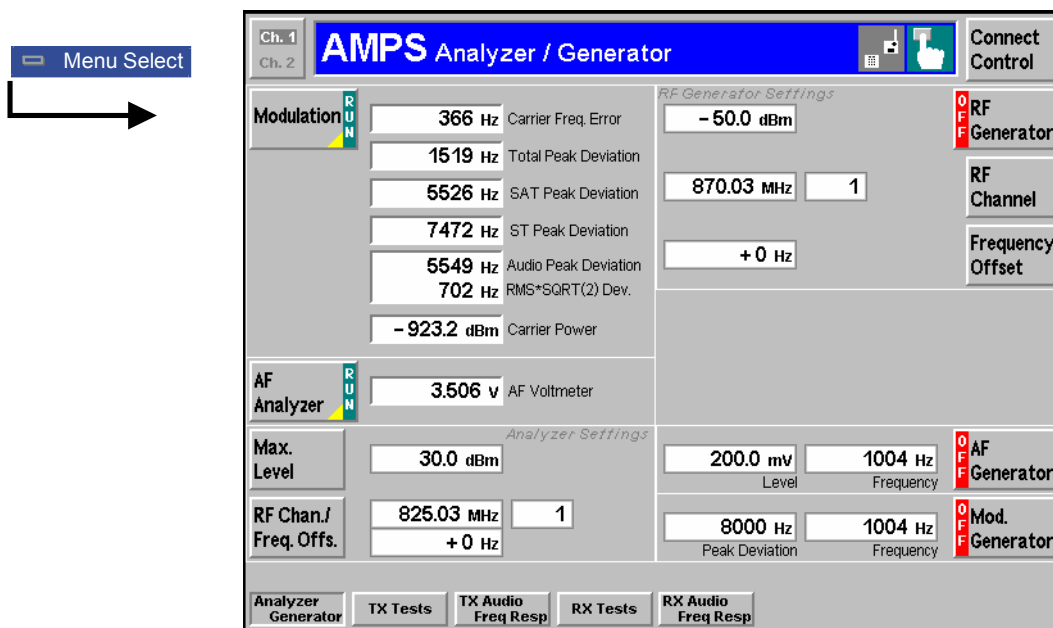

Fig. 4-1 Measurement menu Analyzer / Generator

**AF
Analyzer**

The *AF Analyzer* softkey controls the audio measurement and indicates its status (*RUN / HLT / OFF*).

This status can be changed by means of the *ON/OFF* key or the *CONT/HALT* key while the softkey is selected (press once). While the measurement is running, the RMS voltage measured is indicated and continuously updated in an output field.

The AF signal is fed in via the input connector *AF IN* at the front panel of the CMU.

Pressing the selected *AF Analyzer* softkey for a second time calls up the *Control* tab of the popup menu *RX Tests Configuration* (see page 4.36) providing configuration settings for the audio measurement. The *RX Tests Configuration* menu can be closed on pressing *AF Analyzer* for a third time.

Remote control

```
INITiate:RXTests:AFANalyzer; STOP:RXTests:AFANalyzer
ABORt:RXTests:AFANalyzer; CONTInue:RXTests:AFANalyzer

FETCh:RXTests:AFANalyzer:STATUs?

READ[:SCALar]:RXTests:AFANalyzer[:RESult]? etc.
```

**AF
Generator**

The *AF Generator* softkey controls the audio generator (*ON / OFF*) and indicates its status.

The generator can be switched on or off by means of the *ON/OFF* key while the softkey is selected (press once). The parameters determining the generated sinusoidal audio signal can be set in two input fields:

Level Effective (RMS averaged) voltage of the AF signal
Frequency Frequency of the AF signal

The AF signal is applied to the output connector *AF OUT* at the front panel of the CMU and is primarily used for TX measurements. In contrast, the audio signal to be modulated onto the RF voice signal is configured via the *Mod. Generator* softkey; see below.

Remote control

```
INITiate:AFGenerator; ABORt:AFGenerator

FETCh:AFGenerator:STATUs?

SOURce:AFGenerator:LEVel <Level>
SOURce:AFGenerator:FREQuency <Frequency>
```

**Mod.
Generator**

The *Mod. Generator* softkey controls the modulation frequency generator and indicates its status (*ON / OFF*).

The generator can be switched on or off by means of the *ON/OFF* key while the softkey is selected (press once). The modulation signal generated is a sinusoidal test tone modulating the base station carrier (i.e. the RF *BS Signal* transmitted by the CMU, applied to the *RF Output* connectors selected in the *Connection Control – RF Connector* menu, see p. 4.54). Its parameters can be set in two input fields:

Peak deviation Peak frequency deviation used to transmit the modulation signal
Frequency Frequency of the modulation signal

The modulation signal is modulated onto the RF voice signal and is primarily used for RX measurements. In contrast, the AF signal applied to the output connector *AF OUT* at the front panel of the CMU is configured via the *AF Generator* softkey, see above.

Note: *Instead of CW modulation signal provided by the modulation generator, an arbitrary external modulation signal fed in via AUX 1 can be used.*

To this end, Mod. Extern modulation must be selected in the AF/RF  tab of the Connection Control menu; see section [Connectors \(Connection Control – AF/RF Inputs/Outputs\)](#) on p. 4.54 ff.

With an external modulation signal, the Peak deviation and Frequency input fields indicate Extern and can not be edited. Extern is also indicated in the setup tables of the RX Test menus.

Remote control INITiate:MODGenerator; ABORT:MODGenerator
 FETCh:MODGenerator:STATus? etc.
 SOURce:MODGenerator:DEVIation <Deviation>
 SOURce:MODGenerator:FREQuency <Frequency>

TX Tests

The menu group *TX Tests* comprises the measurement of parameters characterizing the transmitter quality of the mobile phone. The measurement results are displayed in the measurement menu *TX Tests*, the popup menu *TX Tests Configuration* is used for configuration of the measurements.

Quantities characterizing the mobile phone transmitter quality are determined as follows:

The mobile is connected to the CMU via one of the bidirectional RF connectors and the AF output as shown in [Fig. 4-2](#). With this test setup, the CMU represents a signal source providing an audio signal (signal output *AF OUT*) and the RF voice carrier transmitted via one of the RF connectors. The RF carrier can be modulated with the SAT and the ST, or with a 10 kilobit/s Manchester-encoded wideband data signal, if so desired. To obtain the measured quantities, the CMU demodulates and analyzes the RF output signal of the mobile phone transmitter. The signals are configured in the *Analyzer/Generator* (see p. 4.2) and the *Connection Control* menu (see p. 4.50).

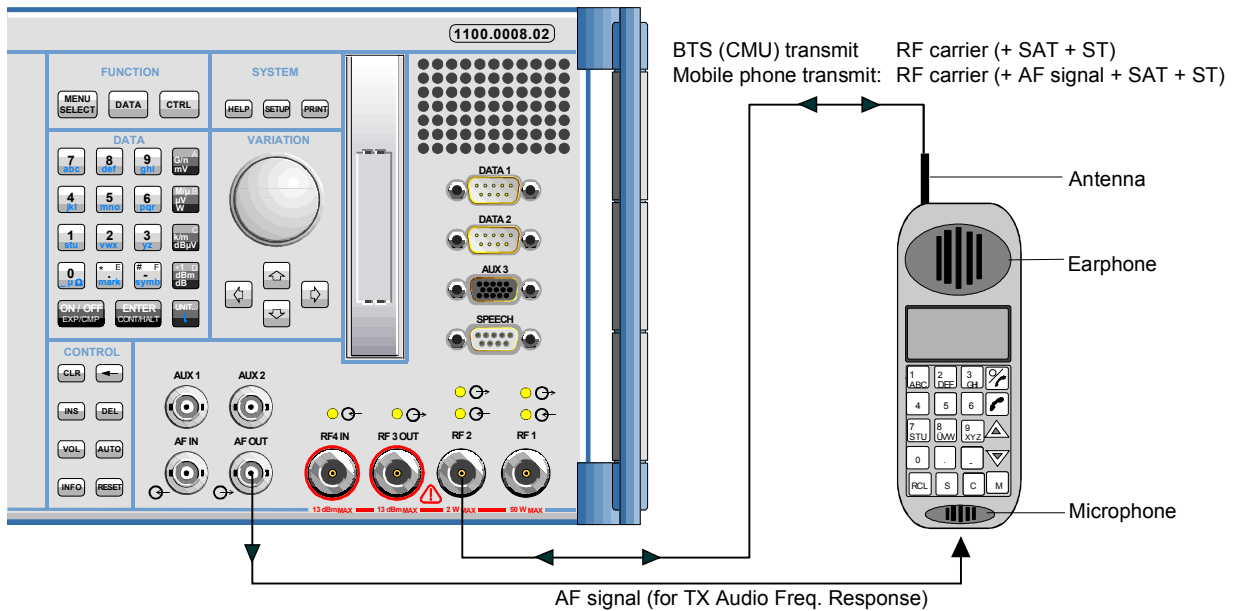

Fig. 4-2 Test setup for TX Tests

The standard describes various quantities to be measured and specifies the minimum requirements and the method of measurement for each quantity. The measurement group is divided into four independent menus corresponding to different configuration data sets and different results (applications *Modulation*, *Hum & Noise*, *AF Level Search*, *Wideband Data*), which are explained in more detail in section [Measurement Results](#) on page 4.12 ff.

Note that the CMU analyzer functions as a standard test receiver with several switchable voice-processing stages. This equipment can be configured in the *Filter* tab of the *TX Tests Configuration* menu (see p. 4.18) to meet the requirements for the different methods of measurement described in the standard.

Measurement Menu (TX Tests)

The measurement menu *TX Tests* shows the results of the transmitter tests.

- The measurement control softkey *Modulation* changes to *Hum & Noise*, *AF Level Search* or *Wideband Data*, depending on the applications selected. This softkey indicates the status of the *TX Tests* (*RUN* | *HLT* | *OFF*) and opens the configuration menu *TX Tests Configuration* (press twice). The hotkeys associated to the measurement control softkey define the scope of the measurement.

- The other softkeys to the right of the test diagram are combined with various hotkeys (e.g. the hotkeys *RF Max. Level*, *RFMode* and *RF Attenuation* belong to the softkey *Analyzer Settings*). The softkey/hotkey combinations provide test settings and switch over between different measurements.

Types of settings The purpose of the *TX Tests* menu (and of all other measurement menus) is to provide quick access to all settings and to present the measurement results at a glance. The four measurement applications *Modulation*, *Hum & Noise*, *AF Level Search* or *Wideband Data* can be selected with the *Application* softkey. The remaining softkeys/hotkey combinations provide two different types of settings:

- General settings are valid for all applications of function group *AMPS-MS Non Signalling*. Changing general settings in an arbitrary application will have an impact on all measurements and applications of the function group. All general settings are also provided in the *Connection Control* menu (see p. 4.45 ff.). Examples of general settings are the RF input level (softkey *Analyzer Level*) and the configuration of the RF generator (softkey *RF Generator*).
- Specific settings are relevant for one application only, or they can be set independently for several applications. Changing specific settings in an application will not affect the other measurements and applications of the function group. No specific settings are provided in the *Connection Control* menu (see p. 4.45 ff.). Examples of specific settings are the *Repetition* mode (to be set independently for all applications) and *Target Deviation* (relevant for the *AF Level Search* application only).

The measurement menu *TX Tests* is opened from the main menu *Menu Select* (with the associated key at the front of the instrument) or using the *TX Tests* hotkey. The hotkeys associated to the *Menus* softkey switch over between the *TX Tests* menu and the remaining measurement menus of function group *AMPS-MS Non Signalling*.

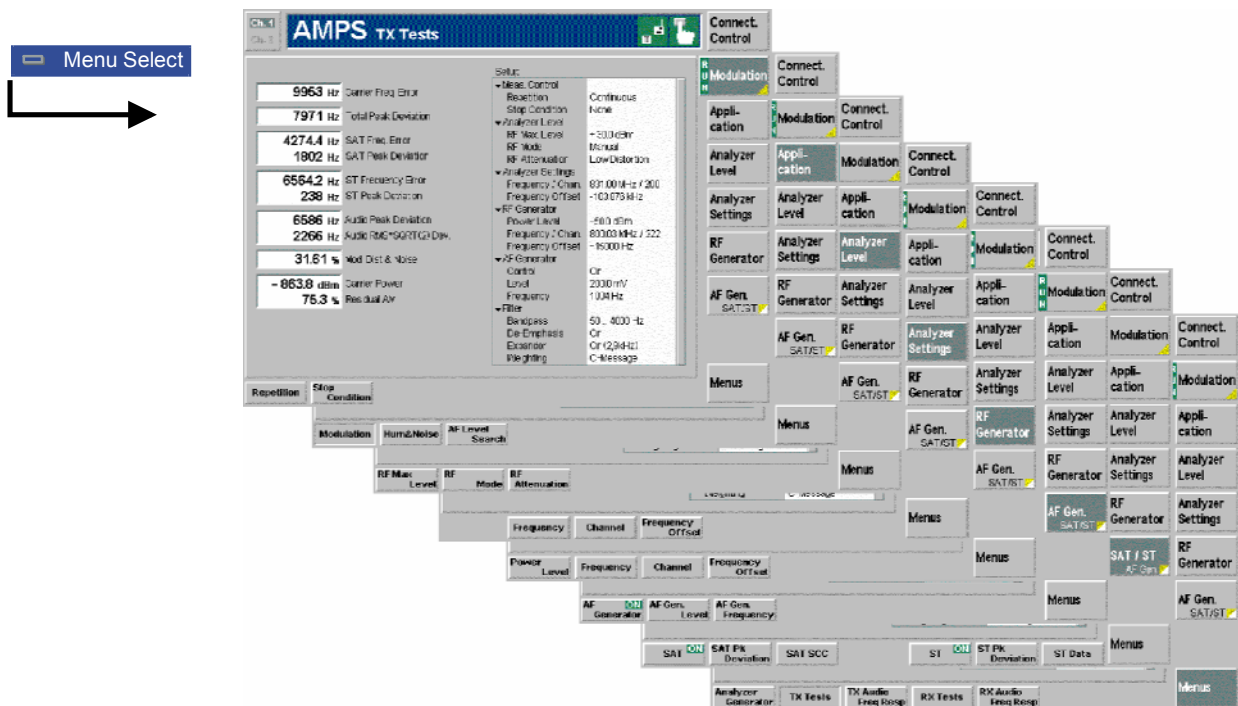

Fig. 4-3 Measurement menu TX Tests

Test Settings

The settings for the *TX Tests* menu are accessible via softkey/hotkey combinations. If a softkey (located in the softkey bar on the right side of the menu) is selected and an associated hotkey (displayed across the bottom of the menu) is pressed, a popup window indicating the current setting and enabling an entry will appear.

Example:

**BS
Signal**

The *BS Signal* softkey displays a hotkey bar including the hotkey labeled *AVC Level*.

AVC Level

The *AVC Level* hotkey opens the input window *AVC Level*.

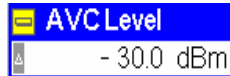

Input windows indicate the current parameter value (in this case: the level of the generated analog voice channel signal) or a list of possible settings. Parameters are changed by

- Overwriting/incrementing numerical values (for numerical parameters)
- Selecting from the list of parameters (for select parameters)

a) Measurement Control

Each *TX Tests* application is controlled by means of the measurement control softkey below the *Connect. Control* softkey and the associated hotkeys.

Modulation

The *Modulation* softkey (which changes to *Hum & Noise*, *AF Level Search* or *Wideband Data*, depending on the application selected) controls the measurement application and indicates its status (*RUN* | *HLT* | *OFF*). This status can be changed after softkey selection (pressing once) by means of the *ON/OFF* key or the *CONT/HALT* key. The status can be set independently for all three applications.

Remote control

```
INITiate:TXTests:<Applic> etc.
FETCh:TXTests:<Applic>:STATus?
where <Applic> = MODulation | HNOise | AFLSearch
```

**Measurement
configuration**

Pressing the *Modulation* softkey twice opens the popup menu *TX Tests Configuration* (see page 4.18). Besides, the measurement control softkey provides hotkeys to define the scope of the measurement. All these settings are described in more detail in section [Measurement Control \(TX Tests Configuration – Control\)](#) on page 4.15 ff.

The following hotkeys are available in the *Modulation*, *Hum & Noise* and *Wideband Data* applications.

Repetition

The hotkey *Repetition* determines the repetition mode of the measurement (*Single Shot* or *Continuous* measurement).

Remote control

```
CONFigure:TXTests:<Applic>:CONTrol:REPetition
<Repetition>,<StopCond>,<Stepmode>
where <Applic> = MODulation | HNOise | WBData
```

Stop Condition

The *Stop Condition* hotkey sets a stop condition for the measurement (*None* or *On Limit Failure*).

Remote control
 CONFigure:TXTests:<Applic>:CONTrol:REPetition
 <Repetition>, <StopCond>, <Stepmode>
 where <Applic> = MODulation | HNOise | WBData

The following hotkeys are available in the *AF Level Search* application only.

Target Deviation

The *Target Deviation* hotkey defines the deviation searched by variation of the AF level.

Remote control
 CONFigure:TXTests:AFLSearch:CONTrol:TAPDeviation <TargetDev>

Target Error Range

The *Target Error Range* hotkey defines the width of a deviation range centered around the *target deviation* which provides the stop criterion for the *AF Level Search* iteration.

Remote control
 CONFigure:TXTests:AFLSearch:CONTrol:TDERange <Range>

b) Selecting the Application

Appli- cation

The *Application* softkey selects the type of measurement to be performed and the measured quantities.

The results of the three alternative measurements (applications) are displayed in separate measurement menus. When an application is selected, the corresponding measurement menu is called up and the labeling of the main softkey controlling the measurement is adapted. The configuration settings for all applications, however, are listed in a common popup-menu (see p. 4.15 ff.).

Modulation

The *Modulation* hotkey activates the measurement of the modulation parameters.

In this mode, the frequency stability and deviation parameters related to the voice carrier, the SAT and ST (if available), and the audio signal plus the *Modulation Distortion & Noise* and the *Audio Peak Deviation*, are displayed; see p. 4.12 ff.

Note: *Two additional fast Modulation applications omitting the SAT and ST measurement are available in remote control. The first application is optimized for peak deviation evaluation; see RXTests:AFANalyzer:TADeviation. The second application is optimized for carrier power and frequency error evaluation; see RXTests:AFANalyzer:CPOwer.*

Remote control
 No explicit switchover command. All *TX Tests – Modulation* measurements are identified by the 2nd/3rd level keywords ...TXTests:MODulation...

Hum & Noise

The *Hum & Noise* hotkey activates the hum & noise measurement.

In this mode, parameters characterizing the voice carrier signal and the SAT plus the *Hum & Noise* are displayed; see p. 4.12 ff.

Note: *An additional fast Hum & Noise application omitting the SAT and ST measurement is available in remote control; see RXTests:HNOise:FHNoise.*

Remote control
 No explicit switchover command. All *TX Tests – Hum & Noise* measurements are identified by the 2nd/3rd level keywords ...TXTests:HNoise...

AF Level Search

The *AF Level Search* hotkey activates the measurement of the AF level corresponding to a definite audio peak deviation. The CMU performs repeated single shot measurements at varying AF signal levels until the *Target Audio Peak Deviation* (defined in the *Control* tab of the *TX Tests Configuration* menu, see p. 4.16 ff.) is found or a stop condition is met.

Remote control
 No explicit switchover command. All *TX Tests – AF Level Search* measurements are identified by the 2nd/3rd level keywords ...TXTests:AFLSearch...

Wideband Data

The *Wideband Data* hotkey activates the measurement of the peak deviation of a carrier that is modulated with a 10 kilobit/s Manchester-encoded wideband data signal and indicates whether the WORD SYNC sequence could be received and demodulated correctly.

Remote control
 No explicit switchover command. All *TX Tests – Wideband Data* measurements are identified by the 2nd/3rd level keywords ...TXTests:WBData...

c) Signal Settings

Analyzer Level

The *Analyzer Level* softkey controls the level in the RF input signal path. The input level settings are also provided in the *Analyzer* tab of the *Connection Control* menu. For a detailed description see section [Table-Oriented Version](#) on p. 4.48 ff.

RF Max. Level

The *RF Max. Level* hotkey sets the maximum expected input level in dBm.

Remote control
 [SENSE:]LEVel:MAXimum <Level>

RF Mode

The *RF Mode* hotkey determines how the input level is defined.
Manual Manual input via *RF Max. Level* hotkey
Auto Automatic setting according to the power of the applied signal.

Remote control
 [SENSE:]LEVel:MODE MANual | AUTOMATIC

RF Attenuation

The *RF Attenuation* hotkey selects a strategy for tuning the RF analyzer.
Normal Input signal is kept unchanged
Low Noise Enhanced mixer level. This setting ensures the full dynamic range of the CMU and is therefore recommended for power measurements.
Low Distortion Decreased mixer level. This setting ensures a high transmission reserve and is therefore recommended for modulation measurements.

Remote control
 [SENSE:]LEVel:ATTenuation NORMal | LNOise | LDISTortion

Analyzer Settings

The *Analyzer Settings* softkey configures the RF analyzer, in particular by setting the frequency of the measured RF voice channel. The settings are described in more detail in section [Control of Input Signals \(Connection Control – Analyzer\)](#) on p. 4.45 ff.

Frequency

The *Frequency* hotkey defines the signal frequency in MHz of the RF voice signal to be analyzed.

Remote control

```
[SENSe:]RFANalyzer:FREQuency <Frequency>
```

Channel

The *Channel* hotkey defines the channel number of the RF voice signal to be analyzed.

Remote control

```
[SENSe:]RFANalyzer:FREQuency:UNIT CH
[SENSe:]RFANalyzer:FREQuency <CH_Number>
```

Frequency Offset

The *Frequency Offset* hotkey defines the frequency offset of the RF voice signal to be analyzed.

Remote control

```
[SENSe:]RFANalyzer:FREQuency:OFFSet <Offset>
```

RF Generator

The *RF Generator* softkey configures the RF signal generated.

The following generator settings are described in more detail in section [Control of Output Signals \(Connection Control – Generator\)](#) on p. 4.50 ff.

Power Level

The *Power Level* hotkey defines the RF generator level in dBm.

Remote control

```
SOURce:RFGenerator:LEVel <Level>
```

Frequency

The *Frequency* hotkey defines the frequency of the RF generator signal in MHz.

Remote control

```
SOURce:RFGenerator:FREQuency <Frequency>
```

Channel

The *Channel* hotkey defines the AMPS channel number of the generator signal.

Remote control

```
SOURce:RFGenerator:FREQuency:UNIT CH
SOURce:RFGenerator:FREQuency <Channel>
```

Frequency Offset

The *Frequency Offset* hotkey defines a frequency offset relative to the signal frequency or AMPS channel frequency defined with the *Frequency* or *Channel* hotkeys.

Remote control

```
SOURce:RFGenerator:FREQuency:OFFSet <Offset>
```

**AF Gen.
SAT/ST**

The *AF Gen.* softkey configures the AF signal generated by the CMU. The hotkey is equivalent to the *AF Generator* softkey and the associated hotkeys in the Analyzer/Generator menu; see section [Analyzer/Generator](#) on page 4.2 ff.

If pressed once again, the selected *AF Gen.* softkey changes to the *SAT/ST* softkey, see below.

**AF
Generator**

The *AF Generator* hotkey switches the AF generator on or off.

The hotkey is operative in the *Modulation* application only; the other two applications require the AF generator to be switched on permanently.

Remote control

INITiate:AFGenerator; ABORT:AFGenerator
FETCh:AFGenerator:STATus?

**AF Gen.
Level**

The *AF Gen. Level* hotkey defines the effective voltage of the AF signal.

Remote control

SOURce:AFGenerator:LEVel <LEVel>

**AF Gen.
Frequency**

The *AF Gen. Frequency* hotkey defines the AF signal frequency in Hz.

Remote control

SOURce:AFGenerator:FREQuency <FREQuency>

**Start
Level**

The *Start Level* hotkey defines the start value for the *AF Level Search* iteration. This hotkey is available in the *AF Level Search* application only.

Remote control

SOURce:AFGenerator:SLEVel <LEVel>

**SAT/ST
AF Gen.**

The *SAT/ST* softkey configures the SAT and the ST signals provided by the CMU and transmitted over the RF voice channel. The hotkey is equivalent to the *SAT Generator* and *ST Generator* softkeys and the associated input fields in the *Generator* tab of the *Connection Control* menu; see section [Analyzer/Generator](#) on page 4.2 ff.

If pressed once again, the selected *SAT/ST* softkey changes to the *AF Gen.* softkey, see above.

SAT

The *SAT* hotkey controls the SAT generator and indicates its status (*ON/OFF*).

Remote control

INITiate:SAT; ABORT:SAT

**SAT Pk.
Deviation**

The *SAT Pk. Deviation* hotkey defines the maximum frequency deviation that the CMU uses to transmit the SAT to the mobile phone.

Remote control

SOURce:SAT:PEAKdev

SAT SCC

The *SAT SCC* hotkey defines the SAT Color Code.

Remote control

SOURce:SAT:SCC

ST

The *ST* hotkey controls the ST generator and indicates its status (*ON/OFF*).

Remote control
 INITiate:ST; ABORt:ST

ST Pk. Deviation

The *ST Pk. Deviation* hotkey defines the maximum frequency deviation that the CMU uses to transmit the ST to the mobile phone.

Remote control
 SOURce:ST:PEAKdev

ST Data

The *ST Data* hotkey switches between the ST (*ST Data Off*) and a 10 kbps wideband data signal (*ST Data On*).

Remote control
 SOURce:ST:DAT

Menus

The *Menus* softkey displays the hotkey bar for changing to the other measurement menus.

Measurement Results

The measurement menu *TX Tests* is divided into two sections:

- The output fields in the left half of the menu show the results of the *TX Tests*
- The table in the right half of the menu shows the current configuration settings

The results of the four alternative measurements (applications) in the *TX Tests* measurement group are displayed in four separate but similar measurement menus. The description below contains all possible results and settings of the measurement group but also indicates which of the values are application-specific (e.g. the *AF Search Level* which occurs in the *AF Level Search* application only).

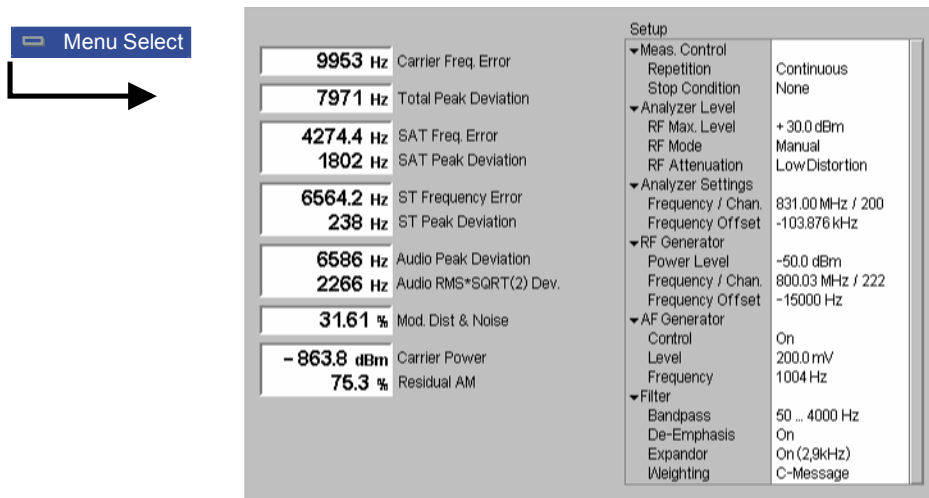

Fig. 4-4 Display of measurement results (TX Tests – Modulation application)

Measurement results:	The measurement results are indicated in the output fields in the left half of the <i>TX Tests</i> menu. From top to bottom, they read:	
Modulation	<i>Carrier Frequency Error</i>	Deviation of the unmodulated transmitted carrier frequency from the assigned channel frequency (see Table 4-1 on p. 4.47).
	<i>Total Peak Deviation</i>	Maximum frequency deviation of the transmitted carrier due to the sum of the AF signal + SAT + ST. This result is measured in the unfiltered path; see Fig. 4-7 on page 4.18. It is available in the <i>Modulation</i> application only.
	<i>SAT Frequency Error</i>	Deviation of the measured Supervisory Audio Tone (SAT) frequency from the nominal SAT frequency set in the <i>Connection Control</i> menu (see p. 4.50 ff.). This result is not available in the <i>AF Level Search</i> application. If the <i>SAT Peak Deviation</i> (see below) is not present, the result is invalid and the output field indicates "---".
	<i>SAT Peak Deviation</i>	Maximum frequency deviation of the transmitted carrier due to the SAT. This result is not available in the <i>AF Level Search</i> application. If the <i>SAT Peak Deviation</i> is not present, the result is invalid and the output field indicates "---".
	<i>ST Frequency Error</i>	Deviation of the measured Signalling Tone (ST) frequency from the nominal ST frequency of 10 kHz. This result is available in the <i>Modulation</i> application only. If the <i>ST Peak Deviation</i> (see below) is not present, the result is invalid and the output field indicates "---".
	<i>ST Peak Deviation</i>	Maximum frequency deviation of the transmitted carrier due to the ST. This result is available in the <i>Modulation</i> application only. If the <i>ST Peak Deviation</i> is not present, the result is invalid and the output field indicates "---".
	<i>Audio Peak Deviation</i>	Maximum frequency deviation of the transmitted carrier in the audio path (see Fig. 4-7). This result is not available in the <i>Hum & Noise</i> application.
	<i>RMS*SQRT(2) Dev.</i>	RMS-averaged frequency deviation of the carrier in the audio path multiplied by the square root of 2.
	<i>Mod. Dist. & Noise</i>	Level of the demodulated RMS noise and distortion in the audio path (produced by the audio distortion in the transmitter) relative to the level of the complete demodulated audio signal (including noise and distortion) in percent. This result is available in the <i>Modulation</i> application only.
	<i>Carrier Power</i>	Absolute power of the voice channel carrier in dBm.
	<i>Residual AM</i>	Residual amplitude modulation, i.e. the ratio of the peak AC voltage to the DC voltage detected from the transmitter carrier which is modulated with the audio signal. The residual AM is indicated in percent; it is available in the <i>Modulation</i> application only.
Measurement results:	<i>Hum & Noise</i>	Level change of the audio signal demodulated by the CMU which is caused by the signal modulating the MS transmitter, i.e. the audio output level with modulated RF transmitter relative to the audio output level with unmodulated RF transmitter.
Hum & Noise		

Measurement results:	<i>AF Search Level</i>	AF level corresponding to the <i>Target Audio Peak Deviation</i> set in the <i>Control</i> tab of the configuration menu; see p. 4.16 ff.
AF Level Search		
Measurement results:	The following two measured quantities are available in the <i>Wideband Data</i> application only. This application measures the reverse voice channel message stream. To obtain valid results in Non Signalling mode, the MS transmitter must be operated with the wideband data signal enabled. In <i>Signalling</i> mode, the CMU automatically commands the MS to transmit wideband data as soon as a connection is established and the <i>Wideband Data</i> application is activated.	
Wideband Data		
	<i>Wideband Data Peak Deviation</i>	Maximum frequency deviation of the transmitted carrier while it is modulated with the 10 kilobit/s Manchester-encoded wideband data signal that the MS uses for cellular system signalling and control. The nominal deviation is ± 8 kHz.
	Word Sync.	Information whether the 11-bit WORD SYNC sequence (11100010010) in the wideband data signal could be received and demodulated correctly.
Additional Measurements	Note:	<p><i>Two additional fast Modulation applications omitting the SAT and ST measurement are available in remote control. The first application is optimized for peak deviation evaluation; see <code>RXTTests:AFANalyzer:TADeviation</code>. The second application is optimized for carrier power and frequency error evaluation; see <code>RXTTests:AFANalyzer:CPOwer</code>.</i></p> <p><i>An additional fast Hum & Noise application omitting the SAT and ST measurement is available in remote control; see <code>RXTTests:HNOise:FHNoise</code>.</i></p>
Limit Check	A red output field and an arrow pointing upwards or downwards indicates that the measurement result exceeds the upper or lower limit set in the <i>Limits</i> tab of the <i>TX Tests</i> configuration menu, see p. 4.16.	
Remote control	<pre>READ[:SCALar]:TXTests:<Applic>[:RESult]? FETCh[:SCALar]:TXTests:<Applic>[:RESult]? SAMPlE[:SCALar]:TXTests:<Applic>[:RESult]? CALCulate[:SCALar]:TXTests:<Applic>[:RESult]:MATChing:LIMit? where <Applic> = MODulation HNOise AFLSearch WBData</pre>	
Configurations	The current configuration settings are indicated in the table in the right half of the <i>TX Tests</i> menu. From top to bottom, they form the following groups:	
	<i>Control</i>	Measurement control parameters as defined by means of the hotkeys associated to the measurement control softkey (see section Measurement Control on p. 4.7 ff.).
	<i>Analyzer Level</i>	RF input path configuration as defined by means of the <i>Analyzer Level</i> softkey (see section Signal Settings on p. 4.9 ff.).
	<i>Analyzer Settings</i>	AF analyzer frequency as defined by means of the <i>Analyzer Settings</i> softkey (see section Signal Settings on p. 4.9 ff.).
	<i>RF Generator</i>	RF generator settings as defined by means of the <i>RF Generator</i> softkey (see section Signal Settings on p. 4.9 ff.).
	<i>AF Generator</i>	Control and configuration of the AF generator as defined by means of the <i>AF Generator</i> softkey (see section Signal Settings

Filter on p. 4.9 ff.).
 Audio receive path configuration as defined in the *Filter* tab of the *TX Tests Configuration* menu (see section *Path Configuration (TX Tests Configuration – Filter)* on p. 4.18 ff.).

Remote control The settings are read out using the query corresponding to the setting command (setting command with appended question mark).

Measurement Configurations (TX Tests Configuration)

The popup menu *TX Tests Configuration* contains three tabs to determine the parameters of the TX tests including the error tolerances.

The popup menu *TX Tests Configuration* is activated by pressing the measurement control softkey (labeled *Modulation*, *Hum & Noise*, or *AF Level Search*, according to the application selected) in the measurement menu *TX Tests* twice. It is possible to change between the tabs by pressing the associated hotkeys.

Measurement Control (TX Tests Configuration – Control)

The *Control* tab controls the *TX Tests* by determining

- The *Repetition* mode and the *Stop Condition* for the measurement (applications *Modulation*, *Hum & Noise*, *Wideband Data*)
- The target value (*Target Audio Peak Deviation*) and error range (*Target Audio Pk. Dev. Err. Range*) for the *AF Level Search*.

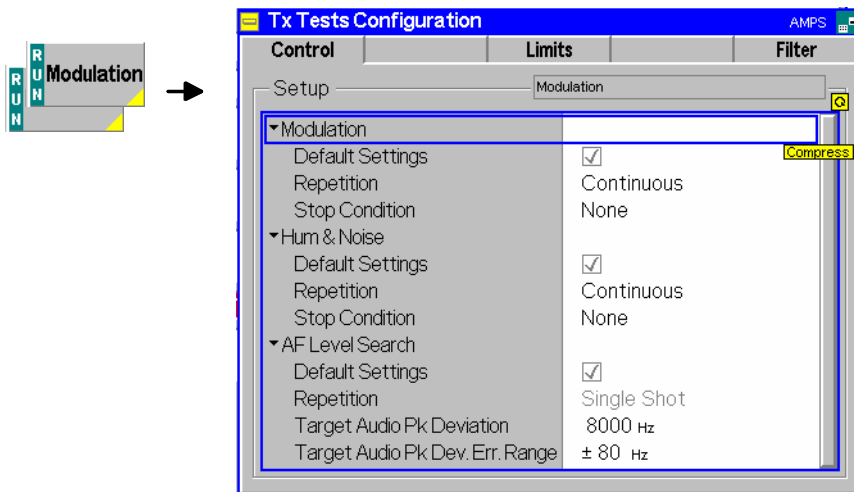

Fig. 4-5 Power Configuration – Control

Default Settings The *Default All Settings* switch assigns default values to all settings in the *Control* tab (the default values are quoted in the command description in chapter 6 of this manual). In addition, a default switch is provided for each of the three applications.

Remote Control `CONFigure:TXTests:<Applic>:CONTrol:DEFault ON | OFF`
 where `<Applic> = MODulation | HNOise | AFLSearch | WBData`

Repetition	<p>The <i>Repetition</i> table row determines the repetition mode:</p> <p><i>Single Shot</i> Single-shot measurement: the measurement is stopped after the system has settled and a valid result is available. It is stopped even before if the stop condition <i>On Limit failure</i> is set and if and if any of the tolerances are exceeded during the measurement. A stopped measurement is indicated by the status display <i>HLT</i> in the measurement control softkey <i>Modulation/Hum & Noise/AF Level Search</i>.</p> <p><i>Continuous</i> Continuous measurement: The CMU continues the measurement until it is terminated explicitly, or until the stop condition (see below) is met. The output is updated after each measurement cycle, i.e. after each single shot measurement. However, the measurement is continued, and the output is continuously updated. An ongoing measurement is indicated by the status display <i>RUN</i> in the softkey <i>Power</i>.</p> <p>Single shot should be selected to obtain a measurement result under fixed conditions. The continuous mode is suitable for monitoring the evolution of a measured quantity in time, for example for adjustments.</p> <p>Note: <i>In remote mode, the counting measurement (counting mode) is available as a further measurement mode with a defined number of measurement cycles to be performed, see chapter 6 of this manual.</i></p>
Remote control	<pre>CONFigure:TXTests:<Applic>:CONTrol:REPetition CONTinuous SINGleshot 1 ... 10000,<StopCondition>, <Stepmode> where <Applic> = MODulation HNOise AFLSearch WBData</pre>
Stop Condition	<p>The <i>Stop Condition</i> table row defines a stop condition for the measurement:</p> <p><i>NONE</i> Continue measurement irrespective of the results of the limit check</p> <p><i>On Limit Failure</i> Stop measurement as soon as the limit check fails (one of the tolerances is exceeded)</p>
Remote control	<pre>CONFigure:TXTests:<Applic>:CONTrol:REPetition <REPetition>,<SONerror NONE,<Stepmode> where <Applic> = MODulation HNOise AFLSearch WBData</pre>
AF Level Search	<p>The table section <i>AF Level Search</i> configures the iteration which is to determine the AF level causing a particular peak frequency deviation of the voice signal.</p> <p><i>Target Dev. Type</i> Specifies how the <i>Target Audio Peak Deviation</i> for the <i>AF Level Search</i> is calculated from the time-dependent frequency deviation of the voice signal. The <i>Target Audio Peak Deviation</i> can be equal to the RMS frequency deviation multiplied by the square root of 2 (<i>RMS * SQRT(2) Deviation</i>) or equal to the peak value of the frequency deviation (<i>Peak Deviation</i>). The two settings are equivalent if the frequency deviation of the voice signal is sine-shaped.</p> <p><i>Target Audio Peak Deviation</i> Target value for the iteration in Hz</p> <p><i>Target Audio Pk. Dev. Err. Range</i> Width of a frequency interval centered around the <i>Target Audio Peak Deviation</i> [target –range, target + range]</p>

The *AF Level Search* consists of an iteration starting at the AF level set via the *Start Level* hotkey (see p. 4.11). The iteration is successfully stopped as soon as the audio peak deviation measured is within the *Target Audio Pk. Dev. Err. Range*. The search fails if no AF level corresponding to a deviation within the error range is found after a fixed maximum number of iteration steps.

Remote control `CONFigure:TXTests:AFLSearch:TDTyPe RMS | PEAK`
`CONFigure:TXTests:AFLSearch:CONTRol:TAPDeviation <TargetDev>`
`CONFigure:TXTests:AFLSearch:CONTRol:TDERange <ErrRange>`

Limits (TX Tests Configuration – Limits)

The *Limits* tab defines upper limits for the measured quantities in all four applications (*Modulation*, *Hum & Noise*, and *AF Level Search*, *Wideband Data*) of the *TX Tests* measurement group.

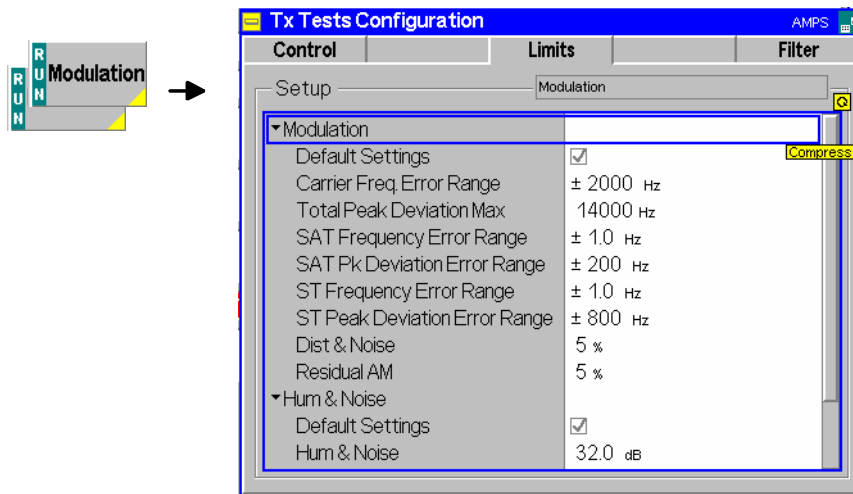

Fig. 4-6 TX Tests Configuration – Limit Lines

Default All Settings The *Default All Settings* switch assigns default values to all fields in the *Limits* tab (the default values are quoted in the command description in chapter 6 of this manual). In addition, a default switch is provided for each of the three applications.

Remote control `CONFigure:TXTests:<Applic>:LIMit:DEFault ON | OFF`
 where `<Applic> = MODulation | HNOise | AFLSearch | WBData`

Limits The table sections *Modulation*, *Hum & Noise*, *AF Level Search* and *Wideband Data* define limits for all measured quantities of corresponding applications. For an explanation of these quantities refer to the introduction at the beginning of section *TX Tests* on page 4.5 and to section *Measurement Results* on page 4.12. The limits are to be interpreted as follows:

- Frequency Errors* Upper limit for the absolute value of the frequency error in Hz.
- Peak Deviations* Upper limit for the frequency deviation in Hz.
- Residual AM* Upper limit of the residual amplitude modulation, expressed in percent.
- Hum & Noise* Lower limit of the FM Hum & Noise, expressed in dB.

If the limit check fails for one of the measured quantities the corresponding output field in the *TX Tests* menu is red and an arrow pointing upwards or downwards indicates that the limit is exceeded.

Remote control `CONFigure:TXTests:<Applic>:LIMit <CarrFreqErrRange>, ...`
 where `<Applic> = MODulation | HNOise | AFLSearch`
 (note the different parameter lists in the three applications)

Path Configuration (TX Tests Configuration – Filter)

The *Filter* tab configures the voice-processing equipment of the CMU and determines the audio receive path of the CMU for each of the three applications *Modulation*, *Hum & Noise*, and *AF Level Search* (see Fig. 4-7).

The *Wideband Data* application results are obtained without the voice-processing stages (CMU unfiltered path).

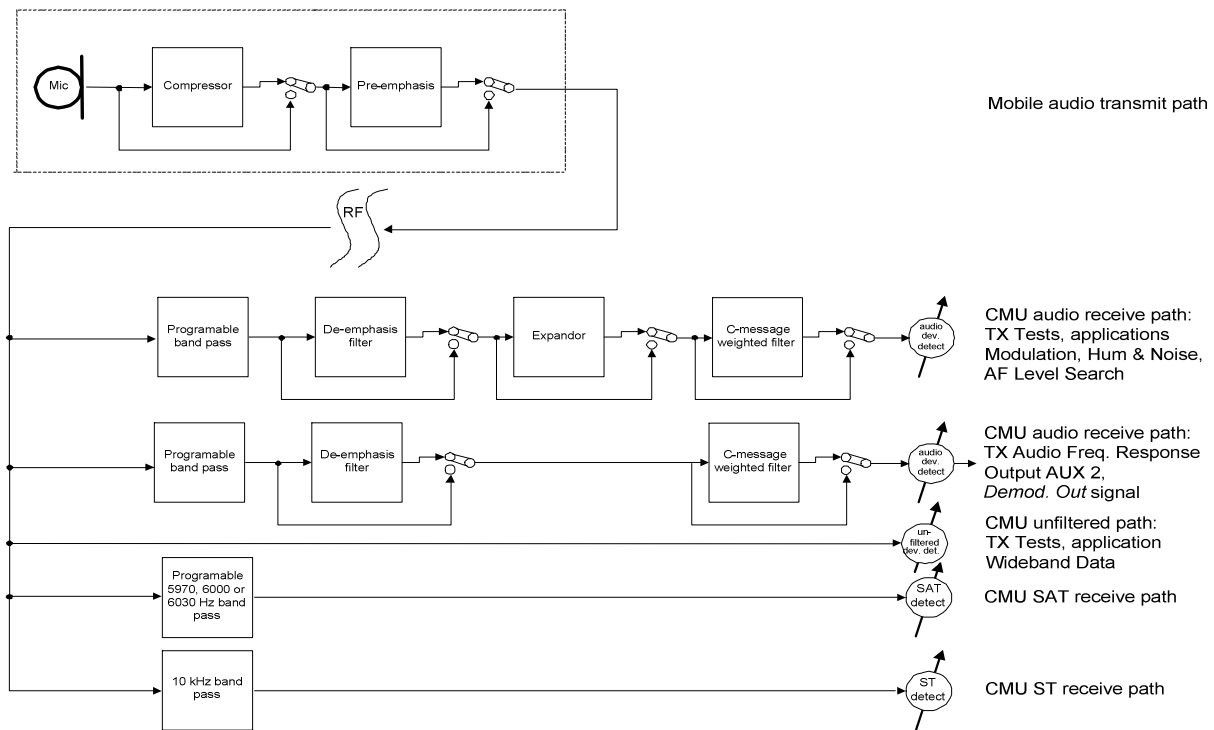

Fig. 4-7 Signal path for TX tests

The audio receive path of the CMU contains the following voice-processing stages:

- Band Pass** Audio band pass filter with variable bandwidth to limit the input frequencies to a definite audio band and thus eliminate unwanted signal components that might affect the operation of the expander. E.g. selection of the band between 50 Hz and 4000 Hz is recommended to eliminate the SAT from the audio path.
- De-emphasis** Filter varying the gain of the input amplifier as a function of frequency. Together with the pre-emphasis of the mobile phone, this filter is to improve transmission of the high-frequency portions of the audio signal.
- Expander** Stage varying the gain of the output audio amplifier when an audio signal is received. According to the specifications of the standard, the expander attenuates signals below a reference frequency deviation of 2.9 kHz; it amplifies signals that are above this reference deviation.
- Weighting** Weighting filter according to CCITT or C-message weighted filter.

The audio results calculated by the tester (such as the *Audio Peak Deviation* etc.) are generated at the end of the audio receive path, after the audio signal has passed all filter stages. In addition, the 'on air' deviation is measured by the broad-band deviation meter and indicated as the *Total Peak Deviation*. This result corresponds to the *Audio Peak Deviation* with a bandpass filter of unlimited bandwidth and with all level-modifying components switched off.

As shown in Fig. 4-8, the de-emphasis of the tester decreases the frequency deviation of a 1000 Hz tone by approx. 13.6 dB, which amounts to a factor of 4.8. This means that, for an 'on air' deviation of 8000 MHz required for most of the TX tests, the de-emphasis decreases the measured *Audio Peak Deviation* of a 1000 Hz tone to about 1666 Hz. With the 2.9 kHz expander switched into the signal path, this result is further decreased (as 1666 Hz < 2900 Hz); the displayed *Audio Peak Deviation* is approx. 957 Hz.

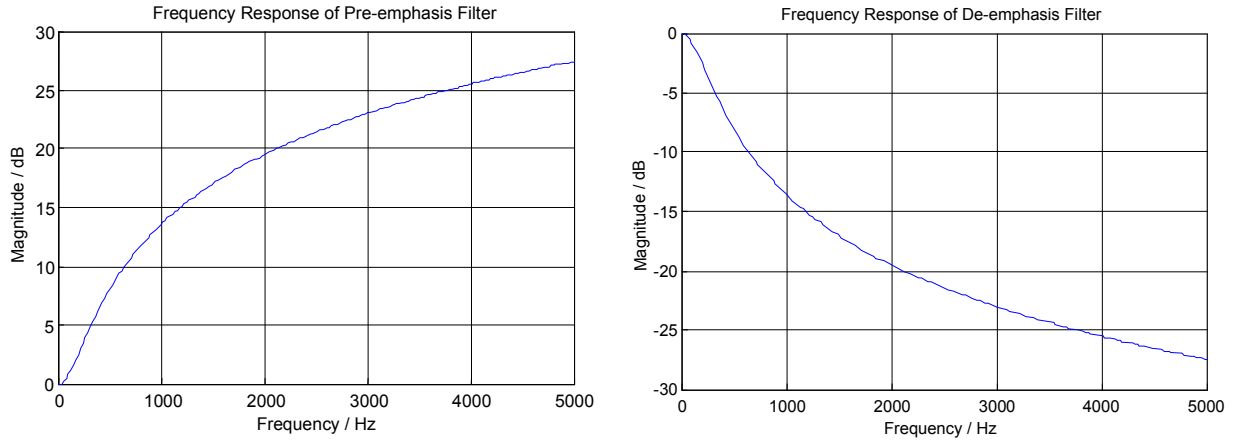

Fig. 4-8 Electrical frequency response of the pre-emphasis and a de-emphasis filter

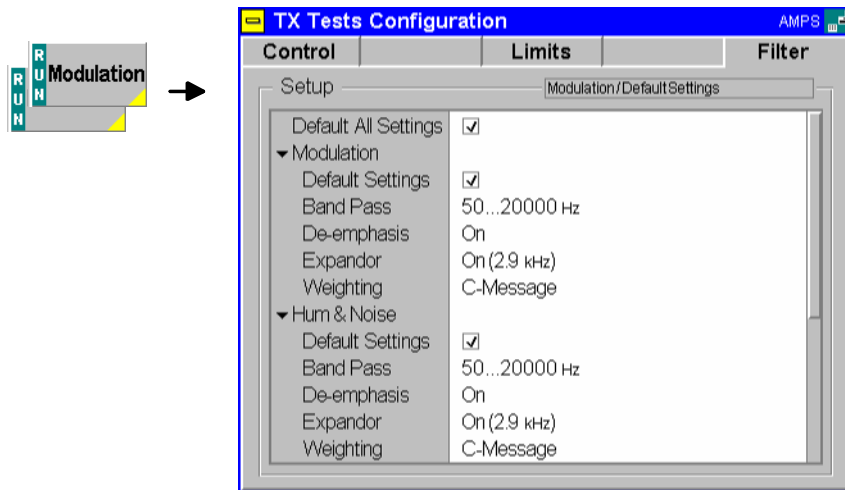

Fig. 4-9 TX Tests Configuration – Filter

Default All Settings The *Default All Settings* switch assigns default values to all fields in the *Filter* tab (the default values are quoted in the command description in chapter 6 of this manual). In addition, a default switch is provided for each of the three applications.

Remote control `CONFigure:TXTests:<Applic>:FILTer:DEFault ON | OFF`
 where <Applic> = MODulation | HNOise | AFLSearch

Modulation / Hum & Noise / AF Level Search The table sections *Modulation*, *Hum & Noise*, and *AF Level Search* define the method of measurement for all quantities shown in the *TX Tests* menu in the corresponding application. For all three applications, the following settings are provided:

- Band pass* Selection of the bandwidth of the CMU's audio band pass.
- De-emphasis* Switching the 750 μs de-emphasis *On* or *Off*.
- Expander* Switching the 2.9 kHz expander *On* or *Off*.

TX Audio Freq. Response

The menu group *TX Audio Freq. Response* provides the measurement of the electrical audio response of the mobile phone transmitter. The measurement results are displayed in the graphical measurement menu *TX Audio Freq. Response*, the popup menu *TX Audio Freq. Response Configuration* is used for configuration of the measurements.

The electrical audio frequency response is the ratio of the frequency deviation of the analog MS voice transmitter Δf to the frequency deviation of a reference pre-emphasis Δf_{ref} . This quantity is measured as a function of the audio input frequency and expressed in dB¹. The test is to ensure that the frequency deviation is sufficiently close to the prescribed pre-emphasis characteristic when the input frequency varies over the relevant range.

To speed up the measurement, the CMU generates a composite audio signal which represents the superposition of up to 20 individual fixed-frequency tones with configurable frequency and level. By demodulating the MS transmitter output, the electrical audio frequency response for all these tones can be determined simultaneously. With an appropriate configuration of the test tones, it is possible to evaluate the electrical frequency response in a single measurement over the whole specified range of audio frequencies. The test setup is as shown in [Fig. 4-2](#) on page 4.5.

Note: It is advisable to switch off the mobile compressor as it might impair the TX Audio Freq. Response measurement.

Measurement Menu (TX Audio Freq. Response)

The graphical measurement menu *TX Audio Freq. Response* shows the results of the transmitter frequency response test.

- The measurement control softkey *TX Audio Freq. Response* controls the *TX Audio Freq. Response* measurement, indicates its status (*RUN* | *HLT* | *OFF*) and opens the configuration menu *TX Audio Freq. Response Configuration* (press twice).
- The other softkeys to the right of the test diagram are combined with various hotkeys (e.g. the hotkeys *Power Level*, *Frequency*, *Channel*, and *Frequency Offset* belong to the softkey *RF Generator*). If a softkey is selected and an associated hotkey pressed, a popup window will appear which indicates the current setting and enables an entry (for an example, see section *Measurement Menu (TX Tests)* on page 4.5 ff.).

The measurement menu *TX Audio Freq. Response* is opened via the main menu *Menu Select* (with the associated key at the front of the instrument) or using the *TX Audio Freq. Response* hotkey.

¹ The frequency deviation is treated as voltage to calculate the dB-ratio, i.e. the frequency response is $20 \log_{10} \frac{\Delta f}{\Delta f_{ref}}$ dB.

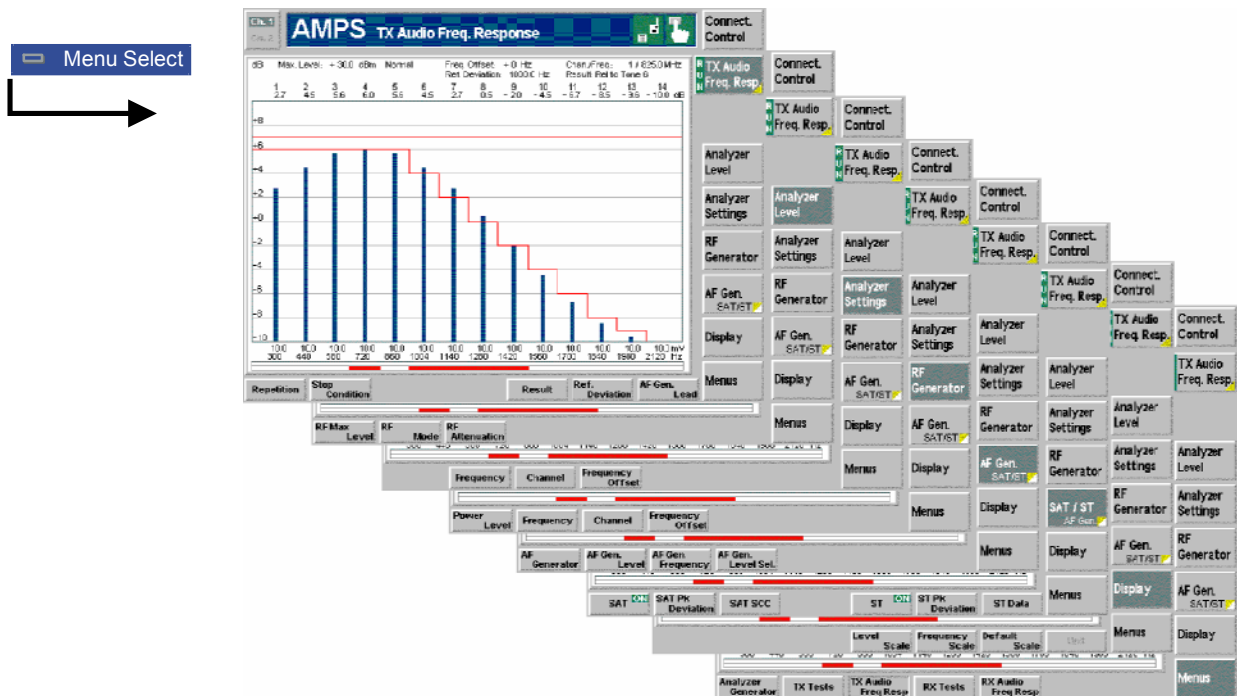

Fig. 4-10 Measurement menu TX Audio Freq. Response

Test Settings

The *Analyzer Level*, *Analyzer Settings*, *RF Generator*, and *SAT/ST* test settings are identical with those in the *TX Tests* menu; see section [Signal Settings](#) on page 4.9 ff. The *TX Audio Freq. Response* measurement control softkey is analogous to the *Modulation* softkey; see section [Measurement Control](#) on p. 4.7. The following softkeys and hotkeys differ from the *TX Tests* measurement:

TX Audio Freq. Resp.

The *TX Audio Freq. Response* softkey controls the measurement application and indicates its status (*RUN* | *HLT* | *OFF*). This status can be changed after softkey selection (pressing once) by means of the *ON/OFF* key or the *CONT/HALT* key.

Remote control

INITiate:TXAFresp etc.
 FETCh:TXAFresp:STATus?

Measurement configuration

Pressing the *TX Audio Freq. Resp.* softkey twice opens the popup menu *TX Audio Freq. Response Configuration* (see page 4.18). Besides, the measurement control softkey provides hotkeys to define the scope of the measurement. These settings are described in more detail in section [Measurement Control \(TX Tests Configuration – Control\)](#) on page 4.15 ff. and in section [Measurement Control \(TX Audio Freq. Response Configuration – Control\)](#) on p. 4.25 ff.

Result

The *Result* hotkey defines the reference value for all measurement results. This corresponds to the 0 dB reference line in the diagram.

Relative to Ref. Deviation [dB] All results are referenced to a particular reference deviation

Relative to Tone 1 [dB] All results are referenced to the measurement result at tone 1 (if available)

...

Relative to Tone 20 [dB] All results are referenced to the measurement result at tone 20 (if available)

The reference deviation is defined via the *Reference Deviation* hotkey described below. The measurement is taken at up to 20 audio frequencies (tone 1 to 20) which can be defined and switched on or off in the *Freq./Level* tab of the configuration menu (see page 4.26 ff.). For a description of the test diagram refer to section [Measurement Results](#) on page 4.24.

Remote control

```
CONFigure:TXAFresp:CONTRol:RREQuest RDEV | TON<nr>
```

Ref. Deviation

The *Reference Deviation* hotkey defines a reference frequency deviation. This value is taken as reference deviation, i.e. it defines the 0-dB line of the test diagram provided that this is selected as an option via the *Result* hotkey (see above).

Remote control

```
CONFigure:TXAFresp:CONTRol:RDEVIation <Deviation>
```

AF Gen. Lead

The *AF Gen. Lead* hotkey defines a settling time for the measurement to be applied after a change of the AF generator settings. A small value accelerates the measurement but may impair its accuracy.

Remote control

```
CONFigure:TXAFresp:CONTRol:AFGLead <Time>
```

Display

The *Display* softkey sets the scales of the *TX Audio Freq. Response* test diagram.

Freq. Resp. Scale

The *Freq. Resp. Scale* hotkey defines the y-axis scale of the test diagram.

Min. Value Lower edge of the test diagram; minimum value (in dB) that can be viewed

Max. Value Upper edge of the test diagram; maximum value (in dB) that can be viewed

Remote control

```
DISPlay:TXAFresp[:WINDow]:TRACe:Y:SCALE <ScaleMin, <ScaleMax>
```

Frequency Scale

The *Frequency Scale* hotkey defines the display range (x-axis scale) of the test diagram. The display range comprises 14 different tones which must be in consecutive order. This condition leaves the following selections:

Tone 1 to 14 Display all results between tone 1 and tone 14

...

Tone 7 to 20 Display all results between tone 7 and tone 20

If a tone is within the selected range but disabled in the *Freq./Level* tab of the configuration menu (see p. 4.27 ff.), the corresponding result is not indicated, i.e. the bar is omitted and a gap occurs in the test diagram.

Remote control
No command, screen configuration only.

Default Scale

The *Default Scale* hotkey resets the *Level Scale* and the *Frequency Scale* to default settings. It is disabled (grayed) if both scales are already set to default.

Remote control
No command, screen configuration only.

Measurement Results

In the *TX Audio Freq. Response* measurement, the electrical audio frequency response of the MS transmitter at up to 14 out of 20 different test tones (corresponding to 20 not necessarily distinct audio input frequencies) is displayed. These results and the test settings are indicated in two parameter lines and the actual test diagram (bar graph):

Parameter lines

Test tone no. and frequency response

Bar graph with upper and lower limit lines

Test tone voltage and frequency

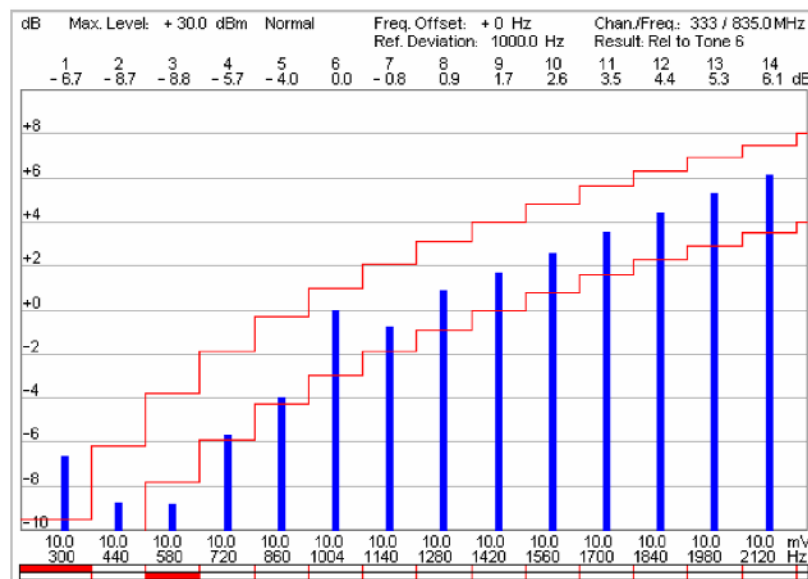

Fig. 4-11 Display of measurement results (TX Audio Freq. Response)

Parameter lines

The first parameter line contains the following settings:

RF Max. Level Maximum RF input level as set in *Input Level - Mode* (see section [Table-Oriented Version](#) on p. 4.48 ff.)

Attenuation Setting for the external attenuation of the input level (*Normal, Low Noise, Low Distortion*)

Freq. Offset Frequency offset relative to the nominal channel frequency

Chan./Freq. RF channel and associated frequency

The second parameter line contains the following settings:

Ref. Deviation Reference deviation as set via the *Reference Deviation* softkey (see p. 4.23)

Result Reference value for all deviations as set via the *Result* softkey (see p. 4.23)

Remote control

The settings are read out using the query corresponding to the setting command (setting command with appended question mark).

Bar graph	The bar graph shows the transmitter audio frequency response in dB at a maximum of 14 different audio frequencies corresponding to a continuous range of test tones configured in the <i>Freq./Level</i> tab of the configuration menu (see p. 4.27 ff.). If a test tone is disabled in the configuration menu, the corresponding bar is omitted.
Frequency axis (abscissa)	The range of test tones (no. 1 to 14, 2 to 15 etc.) to be viewed can be selected via the <i>Frequency</i> softkey. The bars representing the frequency response at the different tones are equidistantly distributed over the whole diagram width. This optimizes the readability of the diagram but implies that the abscissa scale is not necessarily linear. Therefore, the frequency and voltage of every single test tone is displayed below the frequency axis.
Frequency response axis (ordinate)	The ordinate can be arbitrarily scaled by setting a maximum and minimum value (both in dB). With a fixed ordinate, the adjustable 0 dB reference line (see <i>Result</i> softkey on p. 4.23) allows to shift the whole diagram vertically.
Remote control	READ:ARRay:TXAFresp[:RESult]? etc. READ[:SCALar]:TXAFresp[:RESult]:TONE<nr>? etc.
Limit Check	The upper and lower limit lines for each test point defined in the <i>Limit Lines</i> tab of the configuration menu (see p. 4.26) yield the two red step functions in the diagram. The result of the limit check is visualized in two colored bars below the diagram. At each test point, the upper (lower) bar turns red if the result exceeds (falls below) the limit lines.
Remote control	CALCulate:ARRay:TXAFresp[:RESult]:MATChing:LIMit[:LINE]:TONE? CALCulate[:SCALar]:TXAFresp[:RESult]:MATChing:LIMit[:LINE]:TONE<nr>?

Measurement Configurations (TX Audio Freq. Response Configuration)

The popup menu *TX Audio Freq. Response Configuration* contains four tabs which determine the parameters of the *TX Audio Freq. Response* measurement including the error tolerances.

The popup menu *TX Audio Freq. Response Configuration* is activated by pressing the measurement control softkey *TX Audio Freq. Resp.* in the measurement menu *TX Audio Freq. Response* twice. It is possible to change between the tabs by pressing the associated hotkeys.

Measurement Control (TX Audio Freq. Response Configuration – Control)

The *Control* tab controls the *TX Audio Freq. Response* measurement by determining

- The *Repetition* mode
- The *Stop Condition* for the measurement
- A settling time for the AF generator (*AF GeneratorLead*).

Besides, it configures the measurement diagram by adding or removing the *Grid*.

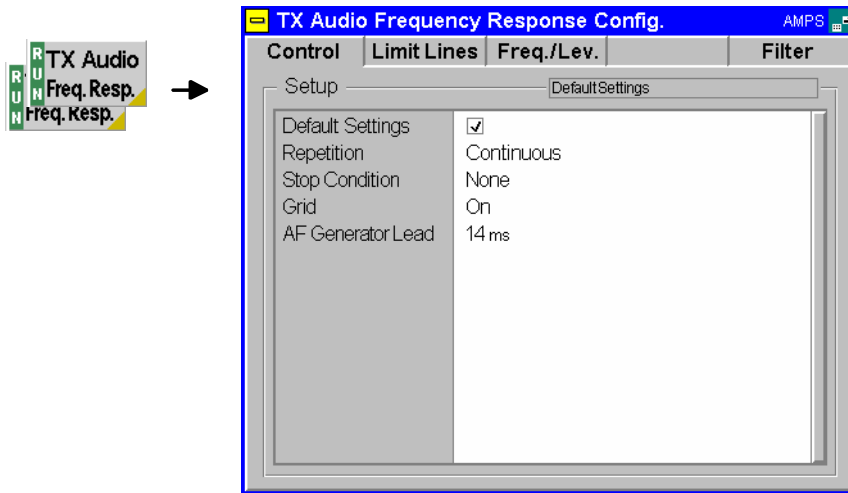

Fig. 4-12 TX Audio Freq. Response Configuration – Control

The settings for the *Repetition* mode, the *Stop Condition*, and the *Grid* comply with those of the menu *Control* in the menu group *TX Tests* (see page 4.15). In the remote-control commands, the keywords `TXTests:<Applic>` are to be replaced by `TXAFresp`.

AF Generator Lead The *AF Generator Lead* line defines a settling time for the measurement to be applied after a change of the AF generator settings. A small value accelerates the measurement but may impair its accuracy.

Remote control `CONFigure:TXAFresp:CONTrol:AFGLead <Time>`

Limit Lines (TX Audio Freq. Response Configuration – Limit Lines)

The *Limit Lines* tab defines upper and lower limits for the electrical audio frequency response at all test tones and enables or disables the limit check.

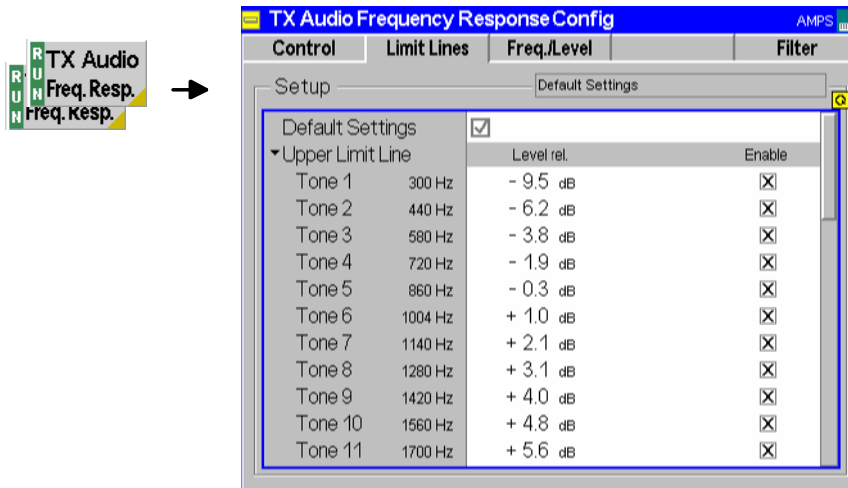

Fig. 4-13 TX Audio Freq. Response Configuration Configuration – Limit Lines

Default Settings The *Default All Settings* switch assigns default values to all fields in the *Limit Lines* tab (the default values are quoted in the command description in chapter 6 of this manual).

Remote control `CONFigure:TXAFresp:LIMit[:LINE]:DEFault ON | OFF`

Upper Limit Line/ Lower Limit Line Upper and lower limit lines for all 20 test points can be defined separately in the two table sections *Upper Limit Line* and *Lower Limit Line*.

The tone nos. and the corresponding frequencies are indicated in the two left columns of the table as defined in the *Freq./Level* tab (see p. 4.27). For each tone, the upper and lower limit can be entered as a single value in dB. The corresponding *Enable* checkbox switches the limit line in the test diagram and the limit check on (if checked) or off.

Remote control `CONFigure:TXAFresp:LIMit[:LINE][:ASYMmetrical]:UPPer <Limit_1>, <Enable_1>...`
`CONFigure:TXAFresp:LIMit[:LINE][:ASYMmetrical]:UPPer:TONE<nr> <Limit>, <Enable>...`
`CONFigure:TXAFresp:LIMit[:LINE][:ASYMmetrical]:LOWer <Limit_1>, <Enable_1>...`
`CONFigure:TXAFresp:LIMit[:LINE][:ASYMmetrical]:LOWer:TONE<nr> <Limit>, <Enable>...`

Test Tones (TX Audio Freq. Response Configuration – Tone Def.)

The *Tone Def.* tab configures the audio test signal to be applied to the input of the mobile station transmitter. This signal is composed of up to 20 test tones with different frequencies and levels.

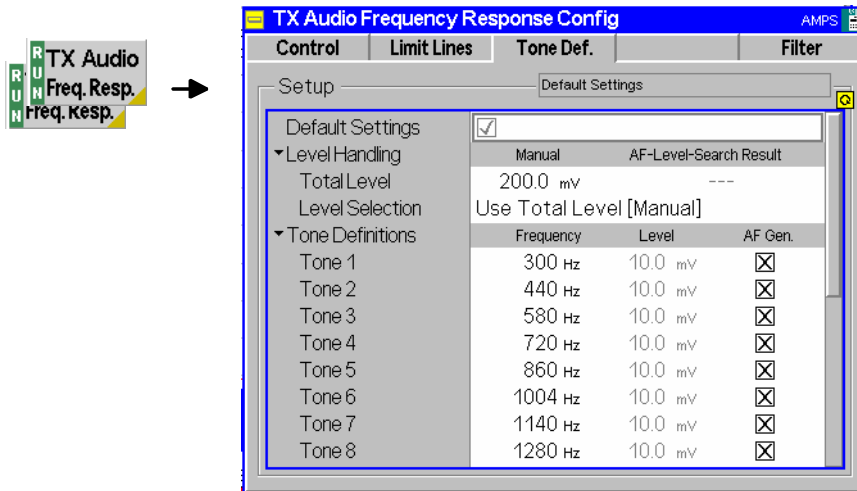

Fig. 4-14 TX Audio Freq. Response Configuration Configuration – Filter

Default Settings The *Default All Settings* switch assigns default values to all fields in the *Freq./Level* tab (the default values are quoted in the command description in chapter 6 of this manual).

Remote control `CONFigure:TXAFresp:AFGenerator:DEFault ON | OFF`

Path Configuration (TX Audio Freq. Response Configuration – Filter)

The *Filter* tab configures the voice-processing equipment of the CMU and thus specifies the audio receive path of the CMU for the *TX Audio Freq. Response* tests.

All functions of this menu are described in section [Path Configuration \(TX Tests Configuration – Filter\)](#) on page 4.18. In the remote control commands, the keywords `TXTests:<Applic>` are to be replaced by `TXAFresp`.

Note: *In contrast to the receive path for TX Tests, the TX Audio Freq. Response audio receive path does not contain an expander; see [Fig. 4-7](#) on p. 4.18.*

RX Tests

The menu group *RX Tests* comprises the measurement of parameters characterizing the receiver quality of the mobile phone. The measurement results are displayed in the measurement menu *RX Tests*, the popup menu *RX Tests Configuration* is used for configuration of the measurements.

Quantities characterizing the mobile phone receiver quality are determined as follows:

The mobile is connected to the CMU via one of the bidirectional RF connectors and the AF inputs/outputs as shown in [Fig. 4-15](#). With this test setup, the CMU transmits the RF voice carrier which can be modulated with an audio signal, the SAT and the ST, if so desired. The CMU measures the AF output signal of the mobile phone receiver (fed in via *AF IN*). The signals are configured in the *Analyzer/Generator* (see p. 4.2, note that the audio signal modulated onto the RF carrier is the one configured via the *Mod. Generator* softkey) and the *Connection Control* menu (see p. 4.50).

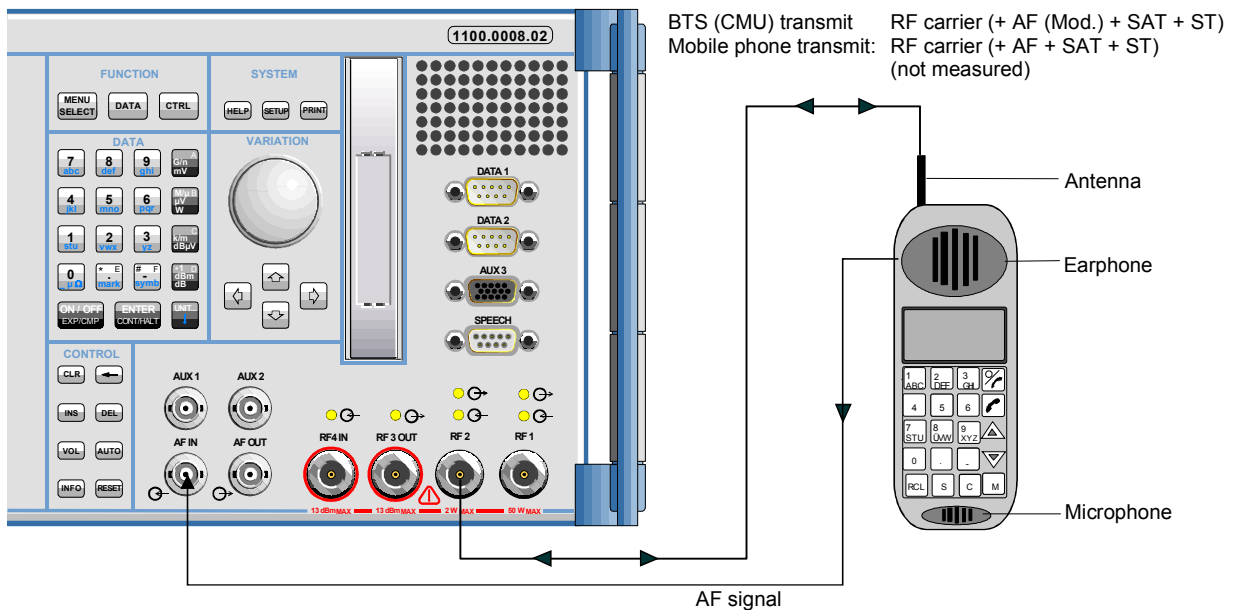

Fig. 4-15 Test setup for RX Tests

The standard describes the quantities to be measured and specifies the minimum requirements and the method of measurement for each quantity. The measurement group is divided into three independent menus corresponding to different configuration data sets and different results (applications *AF Analyzer*, *Hum & Noise*, *Sensitivity*), which are explained in more detail in section [Measurement Results](#) on page 4.33 ff.

Note that the CMU analyzer functions as a standard test receiver with several switchable voice-processing stages. This equipment can be configured in the *Filter* tab of the *RX Tests Configuration* menu (see p. 4.38) to meet the requirements for the different methods of measurement described in the standard.

Measurement Menu (RX Tests)

The measurement menu *RX Tests* shows the results of the receiver tests.

- The measurement control softkey *AF Analyzer* (which changes to *Hum & Noise* and *Sensitivity* if one of these applications is selected) indicates the status of the *RX Tests* (*RUN* | *HLT* | *OFF*) and opens the configuration menu *RX Tests Configuration* (press twice).
- The other softkeys to the right of the test diagram are combined with various hotkeys (e.g. the hotkeys *Power Level*, *Frequency*, *Channel*, and *Frequency Offset* belong to the softkey *RF Generator*). If a softkey is selected and an associated hotkey pressed, a popup window will appear

which indicates the current setting and enables an entry (for an example, see section *Measurement Menu (TX Tests)* on page 4.5 ff.).

The measurement menu *RX Tests* is opened via the main menu *Menu Select* (with the associated key at the front of the instrument) or using the *RX Tests* hotkey.

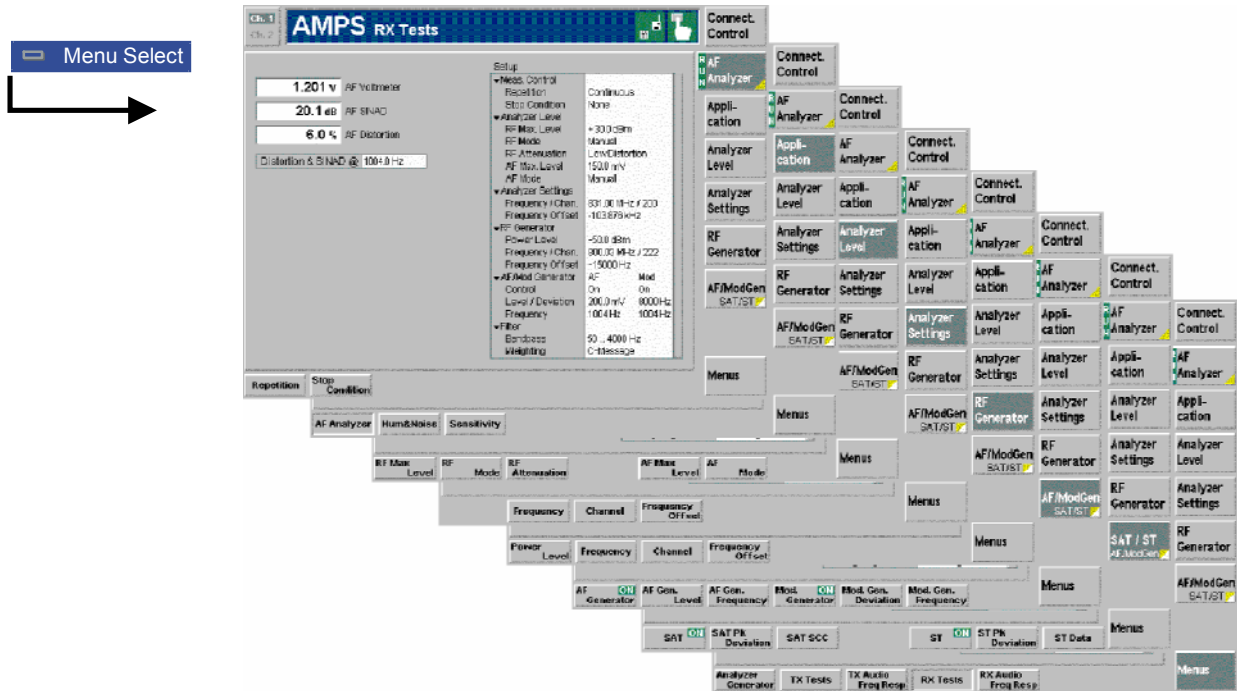

Fig. 4-16 Measurement menu RX Tests

Test Settings

The *Analyzer Settings*, *RF Generator*, and *SAT/ST* test settings are identical with those in the *TX Tests* menu; see section *Signal Settings* on page 4.9 ff. The *AF Analyzer* measurement control softkey is analogous to the *Modulation* softkey; see section *Measurement Control* on p. 4.7. The following softkeys and hotkeys differ from the *TX Tests* measurement:

AF Analyzer

The *AF Analyzer* softkey (which changes to *Hum & Noise* and *Sensitivity* if one of these applications is selected) controls the measurement application and indicates its status (*RUN* | *HLT* | *OFF*). This status can be changed after softkey selection (pressing once) by means of the *ON/OFF* key or the *CONT/HALT* key. The status can be set independently for all three applications.

Remote control

```
INITiate:RXTests:<Applic> etc.
FETCh:RXTests:<Applic>:STATus?
where <Applic> = AFANalyzer | HNOise | SENsitivity
```

Measurement configuration

Pressing the *AF Analyzer* softkey twice opens the popup menu *RX Tests Configuration* (see page 4.35). Besides, the measurement control softkey provides hotkeys to define the scope of the measurement. These settings are described in more detail in section *Measurement Control (TX Tests Configuration – Control)* on page 4.15 ff. and in section *Measurement Control (RX Tests Configuration – Control)* on p. 4.36 ff.

The following settings are specific to the *Sensitivity* application.

Target
SINAD

The *Target SINAD* hotkey defines the SINAD searched by variation of the RF level.

Remote control

CONFigure:RXTests:SENSitivity:CONTrol:TSINad <Target>

Target
Err. Range

The *Target Error Range* hotkey defines the width of a SINAD range centered around the target SINAD which provides the stop criterion for the *Sensitivity* search iteration.

Remote control

CONFigure:RXTests:SENSitivity:CONTrol:TSERange <Range>

Appli-
cation

The *Application* softkey selects the type of measurement to be performed and the measured quantities.

The results of the three alternative measurements (applications) are displayed in separate measurement menus. When an application is selected, the corresponding measurement menu is called up and the labeling of the main softkey controlling the measurement is adapted. The configuration settings for all applications, however, are listed in a common popup-menu (see p. 4.35 ff.).

Note: *An additional fast SINAD measurement is available in remote control; see RXTests:AFAnalyzer:VMSinad.*

AF
Analyzer

The *AF Analyzer* hotkey activates the measurement of received audio signal parameters, in particular the *AF SINAD* (see definition at the beginning of this section on page 4.21), and the AF distortion.

Remote control

No explicit switchover command. All *RX Tests – AF Analyzer* measurements are identified by the 2nd/3rd level keywords ...RXTests:AFAnalyzer...

Hum &
Noise

The *Hum & Noise* hotkey activates the hum & noise measurement. See explanation at the beginning of this section on page 4.21.

Remote control

No explicit switchover command. All *RX Tests – Hum & Noise* measurements are identified by the 2nd/3rd level keywords ...RXTests:HNoise...

Sensitivity

The *Sensitivity* hotkey activates the measurement of the sensitivity level of the receiver, i.e. the RF signal strength in dBm corresponding to a definite *Target SINAD*. The CMU performs repeated single shot measurements at varying RF signal levels until the *Target SINAD* (defined in the *Control tab* of the *RX Tests Configuration* menu, see p. 4.37 ff.) is found or a stop condition met.

Remote control

No explicit switchover command. All *RX Tests – Sensitivity* measurements are identified by the 2nd/3rd level keywords ...RXTests:SENSitivity...

Analyzer
Level

The *Analyzer Level* softkey controls the level in the RF input signal path.

The input level settings are also provided in the *Analyzer* tab of the *Connection Control* menu. For a detailed description see section *Table-Oriented Version* on p. 4.48 ff. The RF level settings (first three hotkeys associated to the Analyzer Level softkey) are described in section *Signal Settings* on p. 4.9 ff. The remaining AF level settings are specific to the *RX Tests* measurement.

The input level settings are also provided in the *Analyzer* tab of the *Connection Control* menu. For a detailed description see section [Table-Oriented Version](#) on p. 4.48 ff.

**AF Max.
Level**

The *AF Max. Level* hotkey defines the maximum expected audio input level. An entry can be made in manual mode only; see description of the next hotkey.

Remote control

[SENSE:]AFLevel:MAXimum <Level>

**AF
Mode**

The *AF Mode* hotkey determines how the maximum audio input level is defined.

Manual Manual input of maximum audio level

Auto Automatic setting according to the level of the applied AF input signal. This is more convenient but may also be more time-consuming than the manual setting.

Remote control

[SENSE:]AFLevel:MODE MANual | AUTOMATIC

**AF/Mod Gen
SAT/ST**

The *AF/Mod. Generator* softkey configures the audio signal and the modulation signal generated by the CMU. See section [Analyzer/Generator](#) on page 4.2 ff.

If pressed once again, the selected *AF/Mod. Generator* softkey changes to the *SAT/ST* softkey; see section [Signal Settings](#) on page 4.9 ff.

The AF generator settings are identical with the ones provided in the *TX Tests* measurement menu; see section [Signal Settings](#) on page 4.9 ff. The remaining hotkeys configure the modulation generator.

**Mod.
Generator**

The *Mod. Generator* hotkey switches the modulation generator on or off.

The hotkey is operative in the *Modulation* application only; the other two applications require the modulation generator to be switched on permanently.

Remote control

INITiate:MODGenerator; ABORt:MODGenerator
FETCh:MODGenerator:STATus?

**Mod. Gen.
Deviation**

The *Mod. Gen. Deviation* hotkey defines the peak frequency deviation used to transmit the modulation signal.

Remote control

SOURce:MODGenerator:DEViation <Deviation>

**Mod. Gen.
Frequency**

The *Mod. Gen. Frequency* hotkey defines the modulation signal frequency in Hz.

Remote control

SOURce:MODGenerator:FREQuency <FREQuency>

Measurement Results

The measurement menu *RX Tests* is divided into two sections:

- The output fields in the left half of the menu show the results of the *RX Tests*.
- The table in the right half of the menu shows the current configuration settings.

The results of the three alternative measurements (applications) in the *RX Tests* measurement group are displayed in three separate but similar measurement menus. The description below contains all

possible results and settings of the measurement group but also indicates which of the values are application-specific (e.g. the *AF Search Level* which occurs in the *Sensitivity* application only).

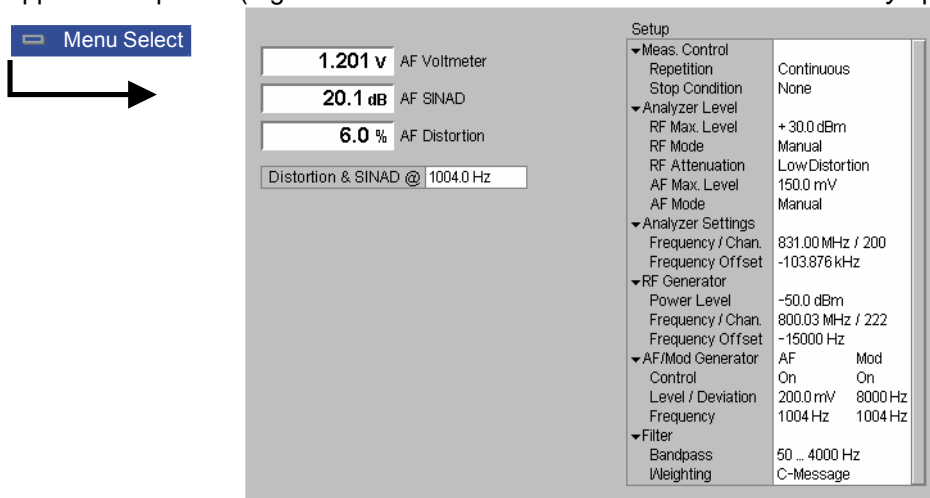

Fig. 4-17 Display of measurement results (RX Tests – AF Analyzer application)

Measurement results

The measurement results are indicated in the output fields in the left half of the *RX Tests* menu. From top to bottom, they read:

- AF Voltmeter* RMS voltage of the audio signal fed in via *AF IN*.
- AF Distortion* RMS voltage of the sum of the second and higher harmonic components in the audio output of the receiver relative to the RMS voltage of the complete audio output signal for a specified input signal at the receiver. This result expressed in percent and is available in the *AF Analyzer* application only.
- AF SINAD* *Signal to noise and distortion* ratio, i.e. the ratio of the receiver audio output level with its noise and distortion components to the level of the noise and distortion components alone, expressed in dB. This result is not available in the *Hum & Noise* application.
- Hum & Noise* Audio output level with modulated RF signal relative to the audio output level with unmodulated RF signal. To determine the numerator, the receiver is modulated with a fixed audio tone. The Hum & Noise is expressed in dB; it is available in the *Hum & Noise* application only.
- Sensitivity* RF level corresponding to the *Target SINAD* set in the *Control* tab of the configuration menu; see p. 4.37 ff. This result is available in the *Sensitivity* application only.

Below the measurement results, the frequency of the modulating test signal (*Mod. Generator* signal) used to determine the SINAD is indicated in an output field.

Note: *The measurement results are obtained with different filter settings in the audio receive path; see section [Path Configuration \(RX Tests Configuration – Filter\)](#) on p. 4.38. In particular, a notch filter can be selected for the SINAD and Sensitivity measurement. An additional fast SINAD measurement is available in remote control; see `RXTests:AFANalyzer:VMSinad`.*

Limit Check	A red output field and an arrow pointing upwards/downwards indicates that the measurement result exceeds the upper/lower limit set in the <i>Limits</i> tab of the <i>RX Tests</i> configuration menu, see p. 4.37.
Remote control	<pre> READ[:SCALar]:RXTests:<Applic>[:RESult]? FETCh[:SCALar]:RXTests:<Applic>[:RESult]? SAMPle[:SCALar]:RXTests:<Applic>[:RESult]? CALCulate[:SCALar]:RXTests:<Applic>[:RESult]:MATChing:LIMit? where <Applic> = AFANalyzer HNOise SENSitivity </pre>
Configurations	<p>The current configuration settings are indicated in the table in the right half of the <i>RX Tests</i> menu. From top to bottom, they form the following groups:</p> <p><i>Pow. Lvl. / Voice Ch.</i> RF voice channel parameters: RF power and frequency. In the <i>Sensitivity</i> application, the <i>Start Pow. Level</i> for the search of the receiver sensitivity and the <i>Target SINAD</i>, both set via the <i>Pow. Lvl. / Voice Ch.</i> softkey, are indicated in addition.</p> <p><i>Input Level</i> AF expected maximum input level as defined via the <i>Input Level</i> softkey and mode to set the max. input level.</p> <p><i>AF Generator</i> Control and configuration of the AF generator corresponding to the <i>AF Generator</i> softkey.</p> <p><i>Mod. Generator</i> Control and configuration of the modulation generator corresponding to the <i>Mod. Generator</i> softkey.</p>
Remote control	<pre> SOURce:RFGenerator:LEVel? etc. [SENSe:]AFLevel:MAXimum? etc. FETCh:AFGenerator:STATus? etc. FETCh:MODGenerator:STATus? etc. </pre>
Configurations	<p>The current configuration settings are indicated in the table in the right half of the <i>TX Tests</i> menu. The table shows the settings displayed in the <i>TX Tests</i> menu (see section Measurement Results on p. 4.12 ff.) plus the current <i>Modulation Generator</i> settings.</p>
Remote control	<p>The settings are read out using the query corresponding to the setting command (setting command with appended question mark).</p>

Measurement Configurations (RX Tests Configuration)

The popup menu *RX Tests Configuration* contains three tabs which determine the parameters of the *RX* tests including the error tolerances.

The popup menu *RX Tests Configuration* is activated by pressing the measurement control softkey (labeled *AF Analyzer*, *Hum & Noise*, or *Sensitivity*, according to the application selected) in the measurement menu *RX Tests* twice. It is possible to change between the tabs by pressing the associated hotkeys.

Measurement Control (RX Tests Configuration – Control)

The *Control* tab controls the *RX Tests* by determining

- The *Repetition* mode and *Stop Condition* for *AF Analyzer* and *Hum & Noise* measurements
- The *Repetition* mode, *Target SINAD* and *Error Range* for *Sensitivity* measurements

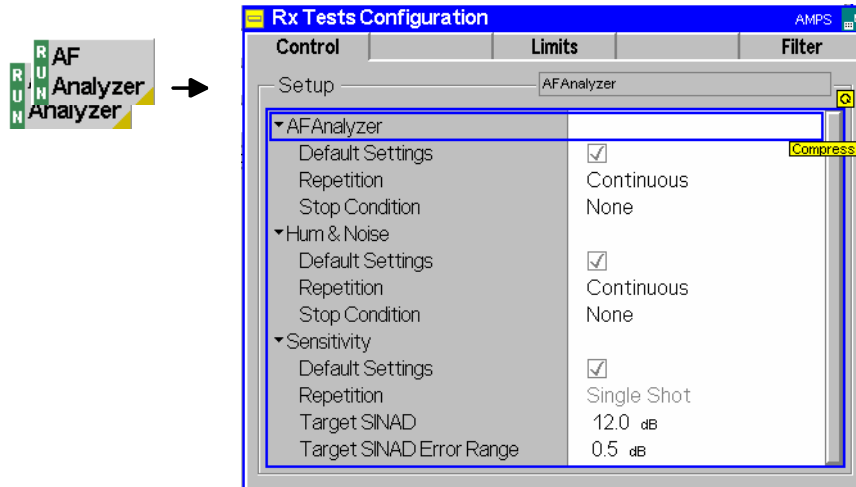

Fig. 4-18 RX Tests Configuration – Control

The *Repetition* and *Stop Condition* settings comply with those of the menu *Control* in the menu group *TX Tests* (see page 4.15). In the remote-control commands, the keyword `TXTests:<Applic>` are to be replaced by `RXTests:<Applic>`.

Default All Settings The *Default All Settings* switch assigns default values to all fields in the *Control* tab (the default values are quoted in the command description in chapter 6 of this manual). In addition, a default switch is provided for each of the three applications.

Remote control `CONFigure:RXTests:<Applic>:CONTrol:DEFault ON | OFF`
 where `<Applic>` = `AFAnalyzer` | `HNOise` | `SENSitivity`

Sensitivity The table section *Sensitivity* configures the iteration which is to determine the RF level corresponding to a particular target *signal to noise and distortion* ratio at the receiver output.

<i>Target SINAD</i>	Target value for the iteration in dB
<i>Target SINAD Err. Range</i>	Width of a level interval centered around the <i>Target SINAD</i> [<code>Target – range</code> , <code>target + range</code>]

The *Sensitivity* measurement is successfully terminated as soon as the SINAD measured is within the range around the target SINAD defined by *Target SINAD Err. Range*. The search fails if no RF level corresponding to a deviation within the error range is found after a fixed maximum number of iteration steps.

Remote control `CONFigure:RXTests:SENSitivity:CONTrol:TSINad <Target>`
`CONFigure:RXTests:SENSitivity:CONTrol:TSERange <Range>`

Limits (RX Tests Configuration – Limits)

The *Limits* tab defines upper and lower limits for the measured quantities in all three applications (*AF Analyzer*, *Hum & Noise*, and *Sensitivity*) of the *RX Tests* measurement group.

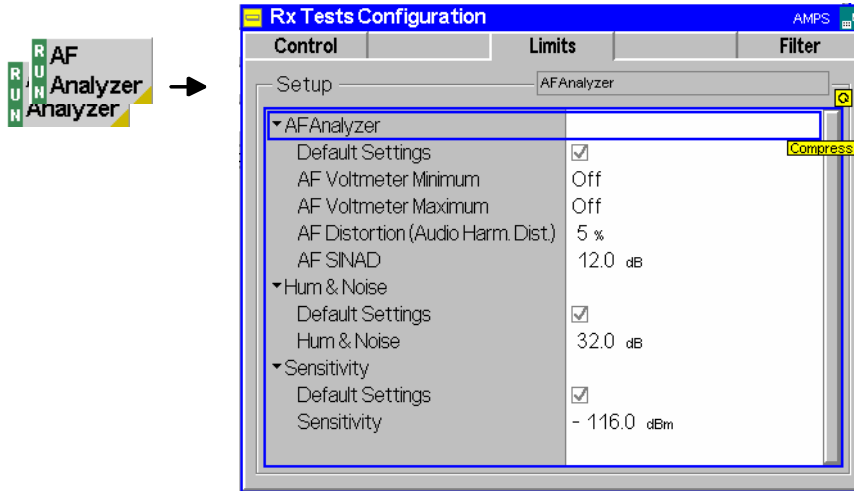

Fig. 4-19 RX Tests Configuration – Limit Lines

Default All Settings The *Default All Settings* switch assigns default values to all fields in the *Limits* tab (the default values are quoted in the command description in chapter 6 of this manual). In addition, a default switch is provided for each of the three applications.

Remote control `CONFigure:RXTests:<Applic>:LIMit:DEFault ON | OFF`
 where <Applic> = AFANalyzer | HNOise | SENSitivity

Limits The table sections *AF Analyzer*, *Hum & Noise*, and *Sensitivity* define upper or lower limits for all measured quantities of corresponding applications. For an explanation of these quantities refer to the introduction at the beginning of section *RX Tests* on page 4.30 and to section *Measurement Results* on page 4.33 ff. The limits are to be interpreted as follows:

- AF Voltmeter* Upper and lower limit (*Maximum/Minimum*) of the RMS audio voltage (in V) fed in via *AF IN*
- AF Distortion* Upper limit of the AF harmonic distortion in %
- AF SINAD* Lower limit of the SINAD in dB
- Hum & Noise* Lower limit of the receiver Hum & Noise, expressed in dB
- Sensitivity* Upper limit of the sensitivity level determined in the *Sensitivity* search application

If the limit check fails for one of the measured quantities the corresponding output field in the *RX Tests* menu is red and an arrow pointing upwards/downwards indicates that the upper/lower limit is exceeded.

Remote control `CONFigure:RXTests:AFANalyzer:LIMit`
`<AFVltmtr.>, <AFSINAD>, <AFDist>`
`CONFigure:RXTests:HNOise:LIMits <AFVltmtr.>, <HNOise>`
`CONFigure:RXTests:SENSitivity:LIMits`
`<AFVltmtr.>, <AFSINAD>, <Sensitivity>`

Sensitivity The table section *Sensitivity* configures the iteration which is to determine the RF level corresponding to a particular target *signal to noise and distortion* ratio at the receiver output.

Target SINAD Target value for the iteration in dB

Target SINAD Err. Range Width of a level interval centered around the *Target SINAD* [Target – range, target + range]

The *Sensitivity* measurement is successfully terminated as soon as the SINAD measured is within the range around the target SINAD defined by *Target SINAD Err. Range*. The search fails if no RF level corresponding to a deviation within the error range is found after a fixed maximum number of iteration steps.

Remote control `CONFigure:RXTests:SENSitivity:LIMits <ErrRange>`

Path Configuration (RX Tests Configuration – Filter)

The *Filter* tab configures the voice-processing equipment of the CMU and thus specifies the audio receive path for each of the three applications (*AF Analyzer*, *Hum & Noise*, and *Sensitivity*).

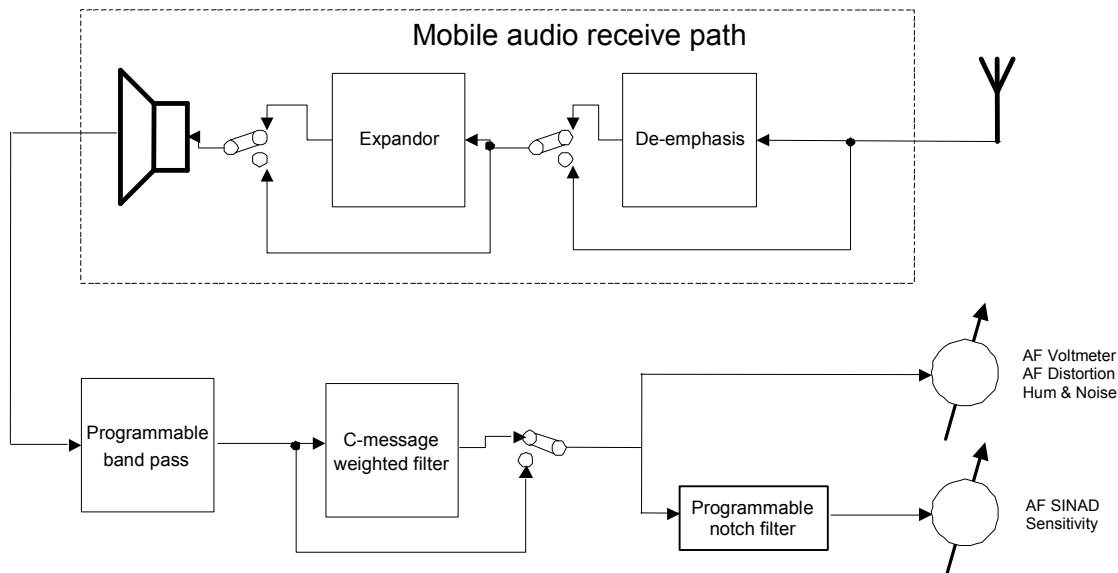

Fig. 4-20 Signal path for RX Tests

The notch filter used for the *AF SINAD* and *Sensitivity* measurement. It is available for the *AF Analyzer* and *Sensitivity* applications but not used for *Hum & Noise* measurements.

Notch Filter 3-dB bandwidth of the notch filter relative to the center frequency

A wider notch filter eliminates more of the distortion and noise components around the center frequency and therefore tends to increase the SINAD. For mobiles with good receiver quality, the results for both notch filter bandwidths are very similar. Note that the filter does not affect the measurement parameters *AF Voltmeter*, *AF Distortion*, *Hum & Noise*.

The remaining filter stages are analogous to the ones described in section [Path Configuration \(TX Tests Configuration – Filter\)](#) on page 4.18.

Remote control `CONFigure:RXTests:AFANalyzer:FILTer:NOTCh <Bandwidth>`
`CONFigure:RXTests:SENSitivity:FILTer:NOTCh <Bandwidth>`

RX Audio Freq. Response

The menu group *RX Audio Freq. Response* provides the measurement of the electrical audio frequency response of the mobile phone receiver. The measurement results are displayed in the graphical measurement menu *RX Audio Freq. Response*, the popup menu *RX Audio Freq. Response Configuration* is used for configuration of the measurements.

The electrical audio frequency response is the ratio of the output of the MS receiver to the output of a reference de-emphasis. This quantity is measured as a function of the audio output frequency and expressed in dB. The test is to ensure that the audio output level is sufficiently close to the prescribed de-emphasis characteristic when the input frequency varies over the relevant range.

To speed up the measurement, the CMU generates a composite audio signal which represents the superposition of up to 20 individual, configurable tones with configurable frequency and level and is transmitted over the voice channel carrier signal. By analyzing the MS audio signal output, the electrical frequency response for all these tones can be determined simultaneously. With an appropriate configuration of the test tones, the behavior of the frequency response over the whole specified range of audio frequencies can be evaluated in a single measurement. The test setup is as shown in [Fig. 4-15](#) on page [4.30](#).

Note: It is advisable to switch off the mobile expander as it might impair the RX Audio Freq. Response measurement.

Measurement Menu (*RX Audio Freq. Response*)

The graphical measurement menu *RX Audio Freq. Response* shows the results of the receiver electrical audio frequency response test.

- The measurement control softkey *RX Audio Freq. Response* controls the *RX Audio Freq. Response* measurement (*RUN* | *HLT* | *OFF*), indicates its status and opens the configuration menu *RX Audio Freq. Response Configuration* (press twice).
- The other softkeys to the right of the test diagram are combined with various hotkeys (e.g. the hotkeys *Power Level*, *Frequency*, *Channel*, and *Frequency Offset* belong to the softkey *RF Generator*). If a softkey is selected and an associated hotkey is pressed, a popup window will appear which indicates the current setting and enables an entry (for an example, see section *Measurement Menu (TX Tests)* on page [4.5](#) ff.).

The measurement menu *RX Audio Freq. Response* is opened via the main menu *Menu Select* (with the associated key at the front of the instrument) or using the *RX Audio Freq. Response* hotkey.

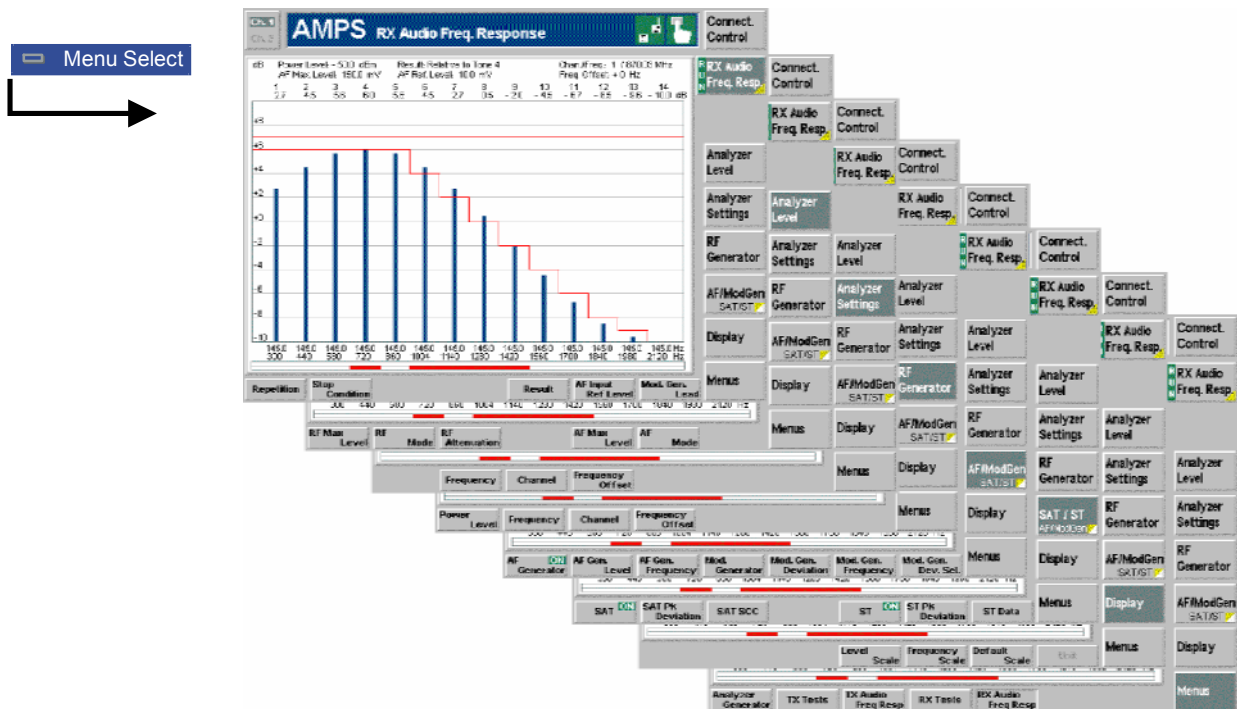

Fig. 4-21 Measurement menu RX Audio Freq. Response

Test Settings

Most of the test settings in the *RX Audio Freq. Response* menu are identical with those in the *TX Audio Freq. Response* menu. The differences reflect the different test setup and signal paths, in particular the type of input signal analyzed:

- In the TX audio frequency response measurement, the (modulated) RF signal.
- In the RX audio frequency response measurement, the audio signal fed in via *AF IN*.

For all other settings refer to section [Test Settings](#) on page 4.22.

RX Audio Freq. Resp.

The *RX Audio Freq. Resp.* softkey controls the measurement application and indicates its status (*RUN* | *HLT* | *OFF*). This status can be changed after softkey selection (pressing once) by means of the *ON/OFF* key or the *CONT/HALT* key.

Remote control
 INITiate:RXAFresp etc.
 FETCh:RXAFresp:STATus?

Measurement configuration

Pressing the *RX Audio Freq. Resp.* softkey twice opens the popup menu *RX Audio Frequency Response Configuration* (see page 4.43). Besides, the measurement control softkey provides hotkeys to define the scope of the measurement. These settings are described in more detail in section [Measurement Control \(TX Tests Configuration – Control\)](#) on page 4.15 ff. and in section [Measurement Control \(TX Audio Freq. Response Configuration – Control\)](#) on p. 4.25 ff.

Result

The *Result* hotkey defines the reference value for all measurement results. This corresponds to the 0 dB reference line in the diagram.

Relative to AF Ref. Lev. [dB] All results are referenced to a particular reference level

Relative to Tone 1 [dB] All results are referenced to the measurement result at tone 1 (if available)

...

Relative to Tone 20 [dB] All results are referenced to the measurement result at tone 20 (if available)

The reference level is defined via the *AF Input Ref. Level* hotkey described below. The measurement is taken at up to 20 audio frequencies (tone 1 to 20) which can be defined and switched on or off in the *Freq./Level* tab of the configuration menu (see page 4.44 ff.).

Remote control

```
CONFigure:RXAFresp:CONTrol:RREQuest RDEV | TON<nr>
```

**AF Input
Ref. Level**

The *AF Input Ref. Level* hotkey defines an audio reference level. This reference level is entered as an RMS voltage (in mV) and defines the 0 dB line of the test diagram provided that this is selected as an option via the *Result* hotkey (see above).

Remote control

```
CONFigure:RXAFresp:CONTrol:RLEVel <Voltage>
```

**Mod. Gen.
Lead**

The *Mod. Gen. Lead* hotkey defines a settling time for the measurement to be applied after a change of the modulation generator settings. A small value accelerates the measurement but may impair its accuracy.

Remote control

```
CONFigure:RXAFresp:CONTrol:MGLead <Time>
```

Measurement Results

In the *RX Audio Freq. Response* measurement, the frequency response of the MS receiver at up to 14 out of 20 different audio input frequencies (corresponding to 20 not necessarily distinct audio input frequencies) is displayed. These results and the test settings are indicated in two parameter lines and the actual test diagram (bar graph):

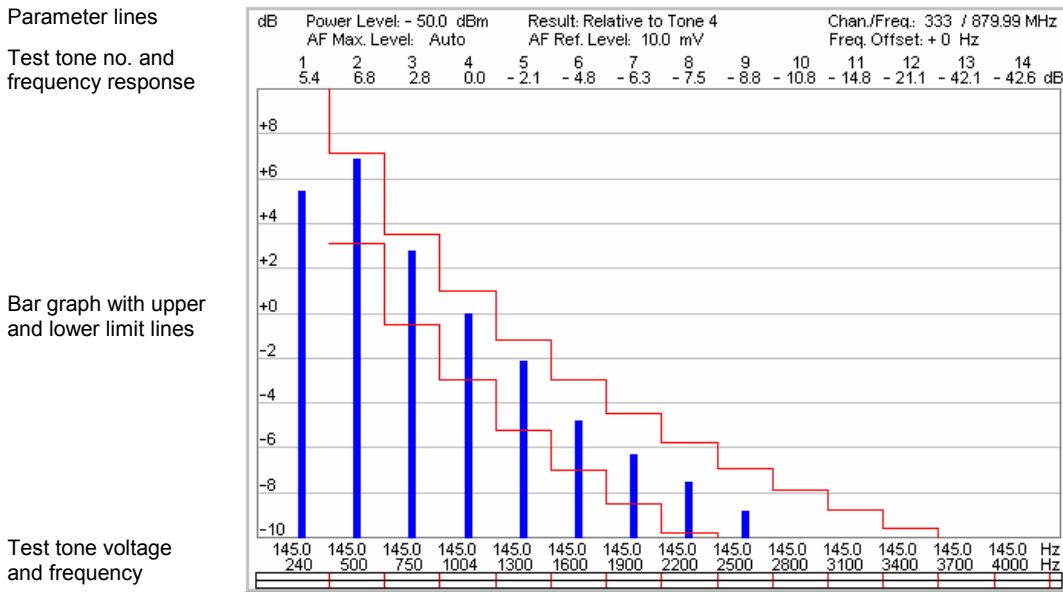

Fig. 4-22 Display of measurement results (RX Audio Freq. Response)

Parameter lines The first parameter line contains the following settings:
Power Level Maximum RF input level set as in *Input Level - Mode* (see section [Table-Oriented Version](#) on p. 4.48 ff.)
Result Reference value for all levels as set via the *Result* hotkey (see p. 4.41)
Chan./Freq. RF channel and associated frequency
 The second parameter line contains the following settings:
AF Max. Level Maximum expected audio input level at AF IN as set via the *AF Max. Level* hotkey (see p. 4.33)
AF Ref. Level Reference level as set via the *AF Input Ref. Level* softkey (see p. 4.41)
Freq. Offset Frequency offset relative to the nominal channel frequency

Remote control The settings are read out using the query corresponding to the setting command (setting command with appended question mark).

Bar graph The bar graph shows the receiver audio frequency response in dB at a maximum of 14 out of 20 different audio frequencies corresponding to a continuous range of test tones configured in the *Freq./Level* tab of the configuration menu (see p. 4.27 ff.). If a test tone is disabled in the configuration menu, the corresponding bar is omitted.

Frequency axis (abscissa) The range of test tones (no. 1 to 14, 2 to 15 etc.) to be viewed can be selected via the *Frequency* softkey. The bars representing the frequency response at the different tones are equidistantly distributed over the whole diagram width. This optimizes the readability of the diagram but implies that the abscissa scale is not necessarily linear. Therefore, the frequency and voltage of every single test tone is displayed below the frequency axis.

Frequency response axis (ordinate) The ordinate can be arbitrarily scaled by setting a maximum and minimum value (both in dB). With a fixed ordinate, the adjustable 0 dB reference line (see *Result* softkey on p. 4.41) allows to shift the whole diagram vertically.

Remote control	READ:ARRay:RXAFresp[:RESult]? etc. READ[:SCALar]:RXAFresp[:RESult]:TONE<nr>? etc.
Limit Check	The upper and lower limit lines for each test point defined in the <i>Limit Lines</i> tab of the configuration menu (see p. 4.26) yield the two red step functions in the diagram. The result of the limit check is visualized in two colored bars below the diagram. At each test point, the upper (lower) bar turns red if the result exceeds (falls below) the limit lines.
Remote control	CALCulate:ARRay:TXAFresp[:RESult]:MATChing:LIMit[:LINE]:TONE? CALCulate[:SCALar]:TXAFresp[:RESult]:MATChing:LIMit[:LINE] :TONE<nr>?

Measurement Configurations (RX Audio Freq. Response Configuration)

The popup menu *RX Audio Freq. Response Configuration* contains four tabs which determine the parameters of the *RX Audio Freq. Response* measurement including the error tolerances.

The popup menu *RX Audio Freq. Response Configuration* is activated by pressing the measurement control softkey *RX Audio Freq. Resp.* in the measurement menu *RX Audio Freq. Response* twice. It is possible to change between the tabs by pressing the associated hotkeys.

Measurement Control (RX Audio Freq. Response Configuration – Control)

The *Control* tab controls the *RX Audio Freq. Response* by determining

- The *Repetition* mode
- The *Stop Condition* for the measurement
- A settling time for the measurement after a change of the modulation generator settings (*Mod. Generator Lead*, analogous to the *AF Generator Lead* for *TX Audio Freq. Response* measurements)

Besides, it configures the measurement diagram by adding or removing the *Grid*.

All functions of this menu are described in section [Measurement Control \(TX Audio Freq. Response Configuration – Control\)](#) on page 4.25. In the remote control commands, the keyword `TXAFresp` is to be replaced by `RXAFresp`.

Limit Lines (RX Audio Freq. Response Configuration – Limit Lines)

The *Limit Lines* tab defines upper and lower limits for the audio frequency response at all test tones and enables or disables the limit check.

All functions of this menu are described in section [Limit Lines \(TX Audio Freq. Response Configuration – Limit Lines\)](#) on page 4.26. In the remote control commands, the keyword `TXAFresp` is to be replaced by `RXAFresp`.

Test Tones (RX Audio Freq. Response Configuration – Freq./Dev.)

The *Freq./Dev.* tab configures the audio test signal to be applied to the input of the mobile station receiver. This signal is composed of up to 20 test tones with different frequencies and frequency deviations.

All functions of this menu are described in section [Limit Lines \(TX Audio Freq. Response Configuration – Limit Lines\)](#) on page 4.26. Note that frequency deviations are assigned to the individual tones instead of levels and that either separate deviations for each tone or a total frequency deviation can be defined (the *Deviation Selection* parameter can be set to either *Use separate dev. for each tone* or *Use total freq. deviation*; there is no equivalent for *Use AF Level Search Result*). In the remote control commands, the keyword TXAFresp is to be replaced by RXAFresp.

Path Configuration (RX Audio Freq. Response Configuration – Filter)

The *Filter* tab configures the voice-processing equipment of the CMU and thus specifies the method of measurement for the *RX Audio Freq. Response* tests. See also introduction at the beginning of section [TX Tests](#) on page 4.5.

All functions of this menu are described in section [Path Configuration \(TX Tests Configuration – Filter\)](#) on page 4.18. In the remote control commands, the keyword TXAFresp is to be replaced by RXAFresp.

Connection Control

The popup menu *Connection Control* consists of four tabs which configure the inputs and outputs of the CMU and the respective signals in the function group *AMPS-MS Non Signalling*.

The menu is opened by pressing the softkey *Connect. Control* to the right of the header of each measurement menu. The individual popup menus (*Analyzer, Generator, RF* ↻ and *Sync.*) can be accessed via the hotkeys at the lower edge of the screen.

Control of Input Signals (Connection Control – Analyzer)

The *Analyzer* tab determines the maximum input level (*Max. Level*) of the RF analyzer, defines the frequency (*RF Channel, Frequency Offset*) of the analyzed RF input signal and configures the RF input path. Besides it controls the wideband peak power measurement (*Power*) and indicates the result.

The CMU provides a softkey-oriented version of the *Analyzer* tab and a table-oriented version with extended functionality. The *Analyzer* hotkey toggles between the two versions if it is pressed repeatedly.

Softkey-Oriented Version

The softkey-oriented version of the *Analyzer* tab determines

- The maximum input level (*Max. Level*)
- The frequency (*RF Channel, Frequency Offset*) and the *Training Sequence* of the analyzed RF input signal.

Besides it controls the wideband peak power measurement (*Wideband Power*) and indicates the result. All setting values of this menu are also displayed in the main menu *Analyzer/Generator* (see page 4.2).

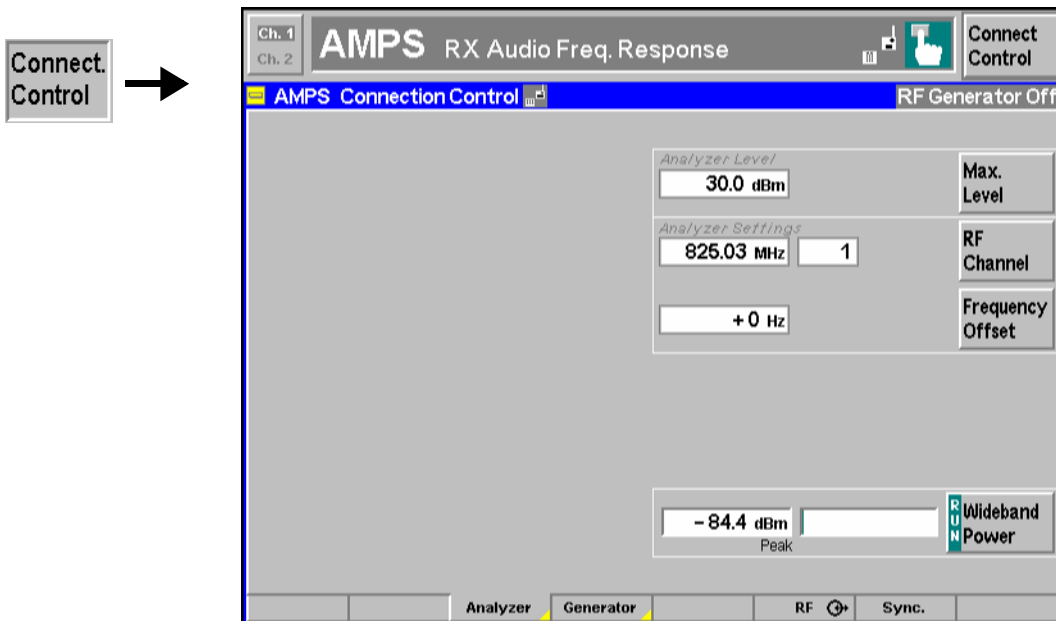

Fig. 4-1 Connection Control – Analyzer (softkey)

Max. Level

The *Max. Level* softkey sets the maximum expected input level (overload level). This level corresponds to the maximum RF level that the CMU is able to measure. The CMU allows for an appropriate overdrive reserve. Input levels exceeding the *Max. Level* plus the reserve overdrive the input path and cause invalid results (“--”). The CMU generates a message *Overload at Connector <Connector_no>*.

In the table-oriented version of the *Analyzer* tab, either manual or automatic setting of the input level can be selected. The behavior of the *Max. Level* softkey depends on the way the input level is set:

- In manual mode, the input level is indicated in the input field to the right of the softkey. This field can be activated and the level can be changed by pressing the *Max. Level* softkey. Note the remarks on external input attenuation on p. 4.48.
- If autoranging is selected, *Auto* is indicated in the input field to the right of the softkey. *Max. Level* is not active. To change the input level and mode, the table-oriented *Analyzer* tab must be opened by pressing the *Analyzer* hotkey again.

Remote control

```
[SENSe:]LEVel:MAXimum <Level>
```

RF Channel

The *RF Channel* softkey defines the channel number (if applicable) or frequency of the measured voice signal.

In *Non Signalling* mode, RF frequencies can be entered in multiples of 10 kHz. It can be modified by an additional *Frequency Offset* entered in the input field below. If the frequency entered does not correspond to a designated AMPS channel number, "----" is indicated in the associated channel input field. On turning the rotary knob, the current frequency is incremented or decremented by 30 kHz.

The assignment of channel numbers and frequencies is specified in the AMPS standard for both signal directions. Therefore, inside the bands, it is sufficient to enter only one value (frequency **or** channel number), the other one is automatically determined by the CMU.

The following tables contain the channel assignment in the reverse path (i.e. from mobile to base station/CMU). Channel numbers which are not listed in the tables are not assigned.

Table 4-1 AMPS analog voice channels in the reverse path (mobile phone transmit)

Center Frequency / [MHz]	Channel	Band
0.03 ↓ 824.01	--- ↓ 990	not used
824.04 ↓ 825	991 ↓ 1023	A" (1 MHz) Expanded Spectrum
825.03 ↓ 834.99	1 ↓ 333	A (10 MHz) Non-Expanded Spectrum
835.02 ↓ 844.98	334 ↓ 666	B (10 MHz) Non-Expanded Spectrum
845.01 ↓ 846.48	667 ↓ 716	A' (1.5 MHz) Expanded Spectrum
846.51 ↓ 848.97	717 ↓ 799	B' (2.5 MHz) Expanded Spectrum
849 MHz ↓ 2700 MHz	--- ↓ ---	not used

Remote control `[SENSe:]RFANalyzer:FREQuency:UNIT <Unit>`
`[SENSe:]RFANalyzer:FREQuency <Frequency>`

Frequency Offset

The *Frequency Offset* softkey modifies the analyzer frequency set via *Voice Channel* by a positive or negative offset value.

This enables fine-tuning of the frequency measured by the CMU, e.g. in order to simulate a Doppler shift (caused by a relative movement between mobile and base station) or de-tuning of the mobile.

Remote control `[SENSe:]RFANalyzer:FREQuency:OFFSet <Offset>`

Wideband Power

The *Wideband Power* softkey controls the wideband power measurement and indicates its status (*RUN* | *HLT* | *OFF*). The status can be changed after softkey selection (pressing once) by means of the *ON/OFF* key or the *CONT/HALT* key. The measurement result in units of dBm. The analog bar to the right of the softkey shows the measured power relative to the *Max. Level*: The display range is between *Max. Level - 10 dB* and *Max. Level + 10 dB*.

The wideband power measurement is performed at the Front End of the CMU and yields the peak power of the input signal inside a wide frequency range. The main purpose of the wideband power measurement is to indicate whether an input signal is available and whether it is advisable to change the *Max Level* settings.

Remote control
`INITiate:WPOWer`
`FETCh:WPOWer:STATus?`
`READ[:SCALar]:WPOWer[:RESult]?`
`FETCh[:SCALar]:WPOWer[:RESult]?`
`SAMPle[:SCALar]:WPOWer[:RESult]?`

Table-Oriented Version

The table-oriented version of the *Analyzer* tab controls:

- The maximum expected RF input level (*RF Max. Level*) and the way it is defined (*RF Mode*)
- An external input attenuation or gain (*RF Attenuation*)
- The maximum expected AF input level (*AF Max. Level*) and the way it is defined (*AF Mode*)
- All *Analyzer Settings* described in section *Softkey-Oriented Version* on p. 4.45 ff.

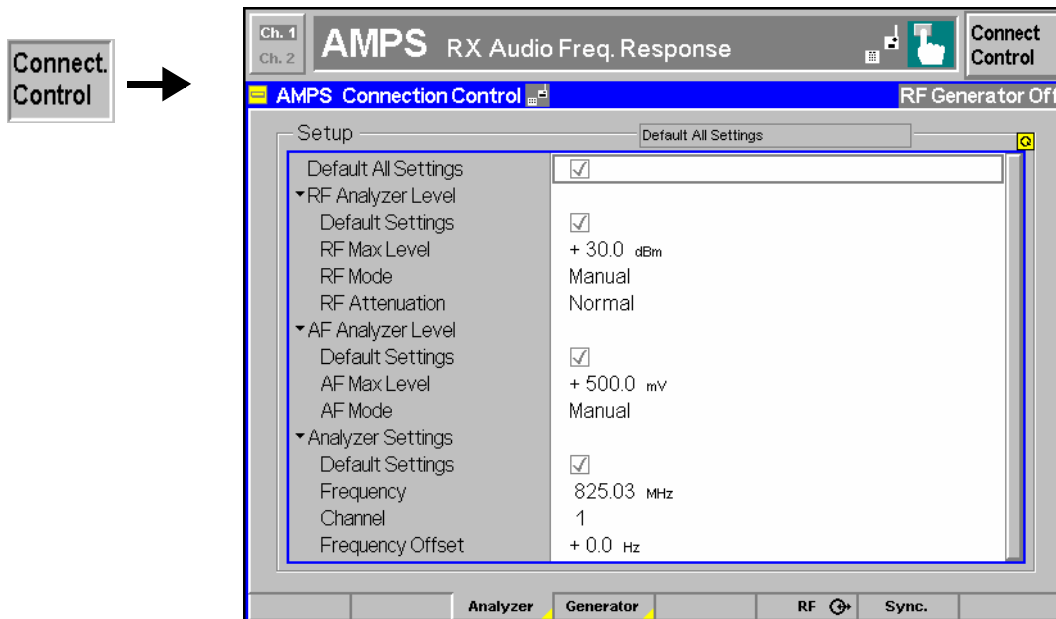

Fig. 4-2 Connection Control – Analyzer (table)

Default Settings The *Default All Settings* switch assigns default values to all settings in the *Analyzer* tab (the default values are quoted in the command description in chapter 6 of this manual). In addition, a default switch is provided for each of the individual table sections.

Remote control [SENSe]:LEVel:DEFault
[SENSe]:AFLeVel:DEFault

RF Analyzer Level – RF Mode The *RF Analyzer Level* table section sets the maximum input level which can be measured. The maximum input level is displayed next to the softkey *Max. Level* in the main menu *Analyzer/Generator* (see page 4.2).

Manual Manual input of maximum input level in the *RF Max. Level* field
Auto Automatic setting of maximum input level (*autoranging*) according to average power of applied signal (plus an appropriate overload margin)

RF Analyzer Level – RF Max. Level The maximum expected input level can be entered in the *RF Max. Level* input field. Input levels exceeding the *RF Max. Level* overdrive the input path and cause invalid results (“---”).

External attenuation The range of values depends on the RF input used. If an external input attenuation is reported to the instrument (see section *Connectors (Connection Control – AF/RF Inputs/Outputs)* on page 4.54), all levels measured are referenced to the output of

the DUT and therefore shifted with respect to the actual level at the input connectors of the CMU. The level ranges for the input connectors are shifted as well.

Error messages If the value determined for *Max. Level* is too high or too low, a window with the error message "*<Max_Level> is out of range. <permissible max. value> is limit.*" and three fields will appear:

- Accept* The permissible max. value is accepted as Max. Level
- Re-edit* Max. Level is entered once again
- Cancel* The last valid input value is maintained

When switching over to another input, the current value of *Max. Level* is automatically adapted, if required:

- Towards lower values to the maximum value of the new input
- Towards upper values to the minimum value of the new input

Note: *A maximum input level can be entered even if automatic level setting (autoranging) is selected. It serves as a start value for the autoranging algorithm and is important to ensure safe switchover to manual setting.*

Remote control [SENSe:]LEVel:MAXimum <Level>

RF Attenuation The *RF Attenuation* field defines how the RF analyzer of the CMU is tuned to meet the requirements of the current measurement type. In general, a compromise between the acceptable noise level in the displayed result and the contribution of internally generated distortion must be reached.

- Normal* Mixer level in normal range,
- Low noise* Mixer level enhanced by +10 dB (full dynamic range of CMU, therefore recommended for power measurements),
- Low distortion* Mixer level reduced by –10 dB (high intermodulation spacing, therefore recommended for modulation measurements).

The *Attenuation* setting permits the CMU to be adapted to the requirements of the measurement. The advantages and disadvantages of the settings *Low noise* and *Low distortion* are listed in the following table.

	Advantages	Disadvantages
Low noise	Low noise high dynamic range	No RF overload reserve Risk of intermodulation
Low distortion	High intermodulation spacing	Lower dynamic range

Remote control [SENSe:]LEVel:ATTenuation NORMal | LNOise | LDISTortion

AF Analyzer Level The *AF Analyzer Level* table section sets the maximum expected AF input level. Levels exceeding this value can not be measured. The *AF Mode* field determines how the *AF Max. Level* is defined:

- Manual* Manual input of maximum input level in the *AF Max. Level* field
- Auto* Automatic setting of maximum input level (*autoranging*) according to average power of applied AF signal (plus an appropriate overload margin)

Remote control [SENSe:]AFLevel:MODE <Mode>

- Error messages If the value set for *Max. Level* is too high or too low, a window with the error message "*<Max_Level> is out of range. <permissible max. value> is limit.*" and three fields will appear:
- Accept* The permissible max. value is accepted as Max. Level,
 - Re-edit* Max. Level is entered once again,
 - Cancel* The last valid input value is maintained.
- Remote control [SENSe:]AFLevel:MAXimum <Level>

Control of Output Signals (Connection Control – Generator)

The *Generator* tab controls the RF, SAT, and ST generators and configures the generated signals. The CMU provides a softkey-oriented version of the *Generator* tab and a table-oriented version with extended functionality. The *Generator* hotkey toggles between the two versions if it is pressed repeatedly.

Softkey-Oriented Version

The softkey-oriented version of the *Generator* tab controls and configures the RF, SAT, and ST generators. It defines:

- Power (*RF Generator*) and frequency (*RF Channel*, *Frequency Offset*) of the generated RF signal
- Parameters of the supervisory audio tone (*SAT*) and the signalling tone (*ST*) provided by the CMU.

The RF generator settings are also available in the main menu *Analyzer/Generator* (see page 4.2).

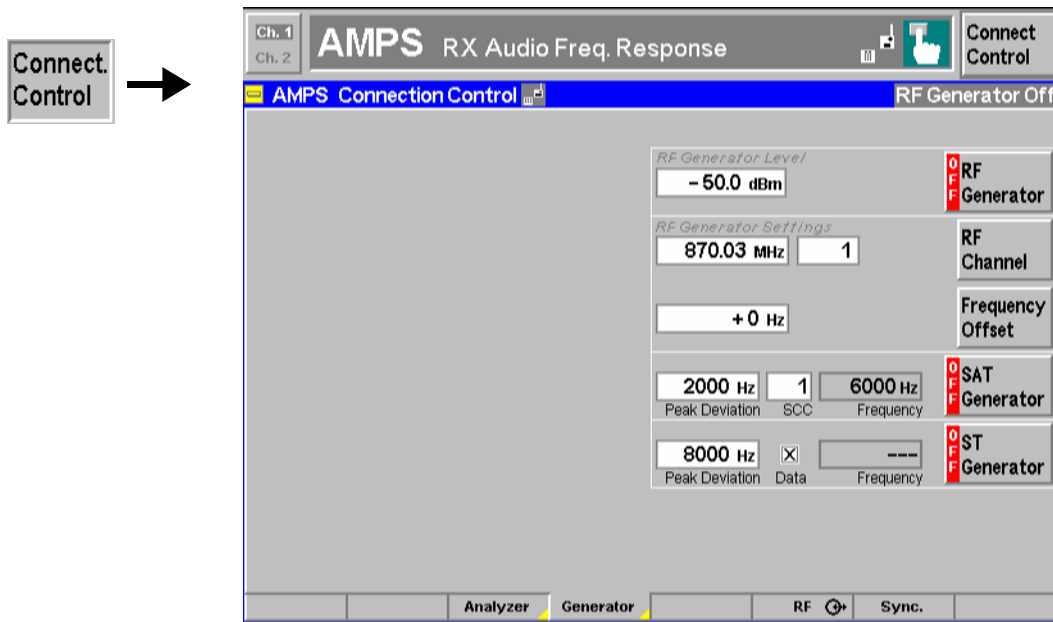

Fig. 4-23 Connection Control – Generator (softkey)

RF Generator

The softkey *RF Generator* defines the generator level and indicates the operating status of the RF generator (*ON | OFF*).

The level is entered in dBm. The value range depends on the selected RF output (RF 1, RF 2 or RF 3 OUT). The RF generator can be switched on or of after softkey selection (press once) using the ON/OFF key.

Remote control INITiate:RFGenerator; ABORt:RFGenerator
 FETCh:RFGenerator:STATus?

External attenuation If an external gain or attenuation is used and reported to the instrument (see softkey *Ext. Att. Output*) the RF generator level is adjusted to maintain the commanded power after the attenuation or gain. As a consequence, all levels indicated are referenced to the input of the DUT and no longer correspond to the actual level at the output connectors of the CMU (see section [Connectors \(Connection Control – AF/RF Inputs/Outputs\)](#) on page 4.54). The default value for the generator power is also shifted provided that the generator can output the required power, compensating for the external attenuation or gain.

Error messages If the level defined for *RF Level* is too high or too low, a window will appear with the error message "*<RF_Level> is out of range. <Permissible max. value> is limit.*" and three fields:

Accept Permissible max. value is accepted as *Max. Level*
Re-edit The *Max. Level* is entered once again
Cancel The last valid input is maintained

When switching over to a different output, the current value of *Max. Level* is automatically adapted, if required:

- Towards lower values to the maximum permissible value of the new output
- Towards higher values to the minimum value of the new output

Remote control SOURce:RFGenerator:LEVel <Level>

RF Channel

The *RF Channel* softkey defines the channel number (if applicable) or the frequency of the generated RF signal.

RF frequencies can be entered in multiples of 30 kHz. It can be modified by an additional *Frequency Offset* entered in the input field below. The assignment of channel numbers and frequencies is specified in the AMPS standard for both signal directions. Therefore, inside the bands, it is sufficient to enter only one value (frequency **or** channel number), the other one is automatically determined by the CMU.

In *Non Signalling* mode, the measurements may also be taken outside the AMPS band. If an out-of-band frequency is entered, the associated channel field indicates '---'.

The following tables contain the channel assignment in the forward path (from the base station/CMU to the mobile phone). The channel frequencies are shifted by +45 MHz compared with the reverse path (duplex spacing, see above, *Panel Analyzer Settings*). Channel numbers which are not listed in the tables are not assigned.

Table 4-2 AMPS analog voice channels in the forward path (base station transmit)

Center Frequency / [MHz]	Channel	Band
0.03 ↓ 869.01	--- ↓ 990	not used
869.04 ↓ 870	991 ↓ 1023	A" (1 MHz) Expanded Spectrum
870.03 ↓ 879.99	1 ↓ 333	A (10 MHz) Non-Expanded Spectrum
880.02 ↓ 889.98	334 ↓ 666	B (10 MHz) Non-Expanded Spectrum
890.01 ↓ 891.48	667 ↓ 716	A' (1.5 MHz) Expanded Spectrum
891.51 ↓ 893.97	717 ↓ 799	B' (2.5 MHz) Expanded Spectrum
894 ↓ 2700	--- ↓ ---	not used

Remote control `SOURCE:RFGenerator:FREQUENCY:UNIT <Unit>`
`SOURCE:RFGenerator:FREQUENCY <Frequency>`

Frequency Offset

The *Frequency Offset* softkey defines an offset shifting the generated RF channel frequency from its nominal value.

This enables fine-tuning of the RF frequency generated by the CMU, for example for simulating a Doppler shift (due to a relative movement between mobile and base station) or de-tuning of the mobile.

Remote control `SOURCE:RFGenerator:FREQUENCY:OFFSET <FrequencyOffset>`

SAT and ST

SAT

The *SAT* softkey configures the supervisory audio tone provided by the CMU and transmitted over the voice channel.

In the network, the supervisory audio tone (SAT) is transmitted over the forward voice channel (CMU/base station to mobile) and transponded by the mobile back to the base station. Its purpose is to indicate the continuity of a call and to identify the base station with which the mobile station is communicating. To distinguish different base stations, three different SAT color codes (SCC) corresponding to three SAT frequencies f_{SAT} are defined in AMPS:

- SCC = 0 $f_{SAT} = 5970$ Hz
- SCC = 1 $f_{SAT} = 6000$ Hz
- SCC = 2 $f_{SAT} = 6030$ Hz

The SAT must be switched on to perform several of the tests specified in the standard.

Peak Deviation The *Peak Deviation* input field defines the maximum frequency deviation that the CMU uses to transmit the SAT to the mobile phone. The *SAT Peak Deviation* in the reverse path (mobile phone to base station) can be measured in the *TX Tests* measurement menu, see p. 4.5 ff.

SCC The *SCC* input field defines the SAT color code. The frequency corresponding to the SCC selected is indicated to the right of the SCC input field.

Remote control
 INITiate:SAT; ABORt:SAT
 FETCh:SAT:STATus?
 SOURce:SAT:PEAKdev <Deviation>
 [SENSe:]SAT:SCC <Code>

ST

The *ST* softkey configures the signalling tone or the wide-band data provided by the CMU and transmitted over the voice channel.

In the network, the signalling tone (ST) is transmitted over the reverse voice channel by the mobile and is used to acknowledge certain commands received from the base station. The frequency of the ST is fixed to 10 kHz.

Peak Deviation The *Peak Deviation* input field defines the maximum frequency deviation that the CMU uses to transmit the ST. The *ST Peak Deviation* in the reverse path (mobile phone to base station) can be measured in the *TX Tests* measurement menu, see p. 4.5 ff.

Frequency The *Frequency* field indicates the fixed ST frequency of 10 kHz.

Data If the *Data* checkbox is enabled, the ST signal is replaced by the 10 kilobit/s Manchester-encoded data signal (wideband data) specified in the standard. In the network, wideband data is used for cellular system signalling and control.

Remote control
 INITiate:ST; ABORt:ST
 FETCh:ST:STATus?
 SOURce:ST:PEAKdev <Deviation>
 [SENSe:]ST:DAT OON | OFF

Table-Oriented Version

The table-oriented version of the *Generator* tab contains all settings of the softkey-oriented version (see section [Softkey-Oriented Version](#) on p. 4.50 ff.). Besides, it provide switches to restore the default settings.

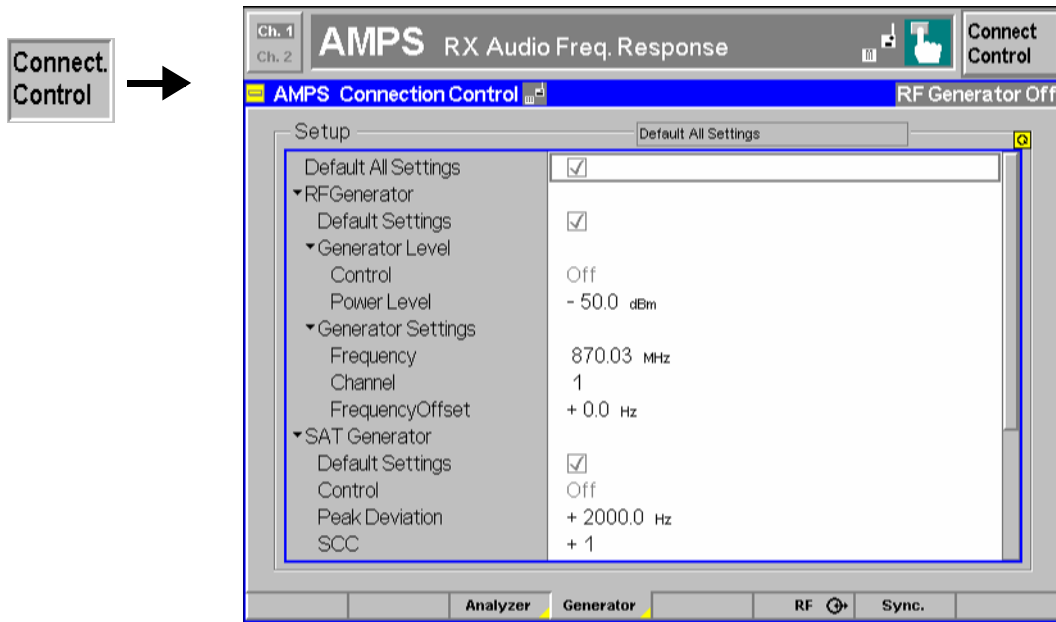



Fig. 4-24 Connection Control – Generator (table)

Default Settings The *Default All Settings* switch assigns default values to all settings in the *Generator* tab (the default values are quoted in the command description in chapter 6 of this manual). In addition, a default switch is provided for each of the individual table sections.

Remote control –

Connectors (Connection Control – AF/RF Inputs/Outputs)

The *AF/RF*  tab configures the RF connectors. This includes the setting of

- The RF input and output of the CMU (*RF Output, RF Input*)
- An external attenuation at the connectors (*Ext. Att. Output, Ext. Att. Input*)
- Switchover between internal and external modulation signal (*Mod. Source*)

The tab also controls the wideband peak power measurement (see *Wideband Power* softkey on p. 4.47) and indicates the result.

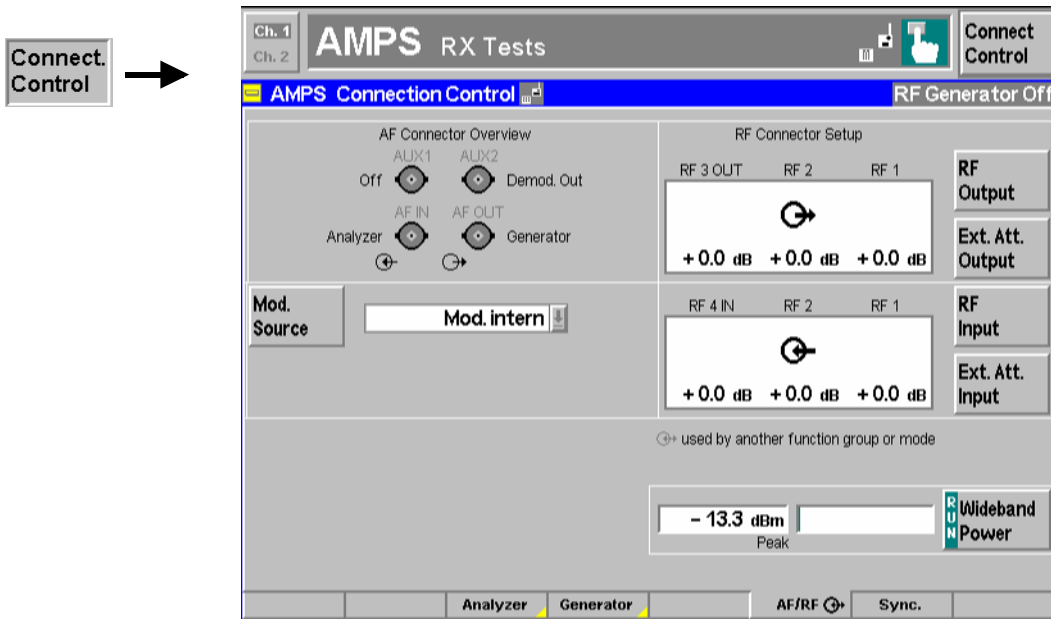

Fig. 4-25 Connection Control – RF connectors

Mod. Source

The *Mod. Source* softkey defines which type of modulation signal is used.

Mod. intern Use CW modulation signal from the internal modulation generator. The peak deviation and frequency of the signal can be set in the Analyzer/Generator menu; see section [Analyzer/Generator Menu](#) on p. 4.2 ff.

Mod. extern Use an arbitrary modulation signal fed in via AUX 1 at the front panel of the CMU (see specifications below). The external modulation signal may be composed of several tones, it may vary in time etc. The internal modulation generator is switched off when *Mod. Extern* is selected.

The modulation signal is modulated onto the RF carrier signal and is primarily used for RX tests.

Remote control `[SENSe:]AFConnect:MSource INTern | EXTern`

AUX 1 specifications

AUX 1 is a high-impedance, AC-coupled FM modulation input. The input impedance is equal to the impedance of the AF analyzer quoted in the data sheet. An external modulation signal fed in at AUX1 is processed as follows:

- Bandwidth 6 Hz to 4000 Hz
- Deviation gain: 20 kHz / 1 V(peak)
- Deviation range: 100 Hz to 20 kHz

The receive path at AUX 1 includes no voice processing stages (like a compressor or pre-emphasis filter).

AUX 2 specifications

AUX 2 is a low-impedance output for an FM-demodulated signal from an AMPS RF connection. The output impedance is equal to the impedance of the AF generator quoted in the data sheet. The demodulated signal in the CMU audio receive path is routed to AUX 2 as soon as a *TX Tests* or *TX Audio Frequency Response* measurement is active. The signal is demodulated with a deviation gain of 20 kHz/1 V(peak) and processed with the filter stages of the CMU audio receive path except the expander; see [Fig. 4-7](#) on p. 4.18. In particular, the bandwidth of the demodulated signal is as set in the *Filter* tabs of the *TX Tests Configuration* or *TX Audio Frequency Response Configuration* menus.

AF Connector Overview

The *AF Connector Overview* shows the destination of the input signals fed in via AF IN and AUX 1 and the signals sources for the two audio output connectors AF OUT and AUX 2. The connectors AF IN and AF OUT are used as input and output for the AF analyzer and AF generator. AUX 1 is used as an input for the external modulation signal; it is switched *Off* as long as the internal modulation signal is used (*Mod. Source = Mod. intern.*). AUX 2 is used as an output for the demodulated signal from an AMPS RF connection; the signal is available only while a *TX Tests* or *TX Audio Frequency Response* measurement is active.

RF Output

The *RF Output* softkey defines which of the three connectors RF 1, RF 2 and RF 3 OUT is to be used as RF output connector.

The selected RF output is indicated by a \odot symbol.

Note: *Input and output connectors can be arbitrarily combined. The bidirectional connectors RF 1 and RF 2 can be selected as RF inputs and outputs at the same time.*

The LEDs on the front panel are only „on“ (light) if the generator is switched on.

Remote control

OUTPut[:STATe] RF1 | RF2 | RF3

Ext. Att. Output

The softkey *Ext. Att. Output* defines an external attenuation (or gain, if the value is negative) at the selected RF output.

Input of an external attenuation is suitable if, e.g., a path attenuation (cable) is included in the test setup, which is to be corrected by an increased signal level.

If an external attenuation is defined, the output signal level is referenced to the input of the DUT, the generator level is therefore shifted with respect to the actual level at the input connector of the CMU. The default value for the generator power and the level ranges for the RF outputs are also shifted provided that the generator can output the required power, compensating for the external attenuation or gain. Otherwise it is adapted to the level closest to the shifted default value.

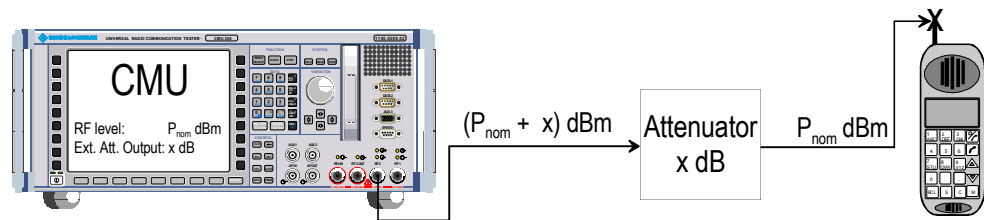

Remote control

[SENSE:]CORRection:LOSS:INPut<nr>[:MAGNitude]
SOURce:CORRection:LOSS:INPut<nr>[:MAGNitude]

RF Input

The *RF Input* softkey determines which of the three connectors RF 1, RF 2 and RF 4 IN is to be used as RF input connector.

The selected RF output is indicated by a \odot symbol. Input and output connectors can be arbitrarily combined.

Remote control

INPut[:STATe] RF1 | RF2 | RF4

Ext. Att. Input

The softkey *Ext. Att. Input* enters the value of the external attenuation (or gain) at the selected RF input.

Input of an external attenuation is required if, for example, external attenuator pads are used for protection of the sensitive RF inputs of the CMU or if a path attenuation is included in the test setup.

If an external input attenuation is reported to the instrument, all levels measured are referenced to the output of the DUT and therefore shifted with respect to the actual level at the input connectors of the CMU. The level ranges for the input connectors are shifted as well.

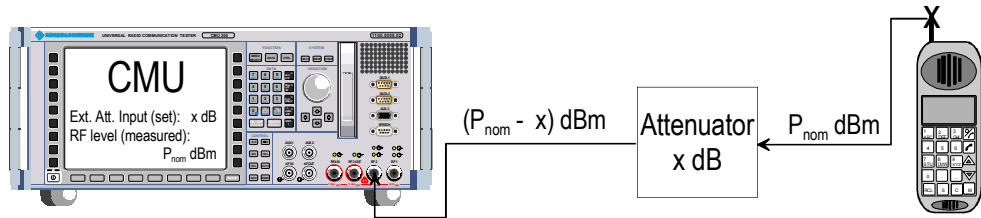

Note: The LEDs on the front panel are only “on” (light) if the measurement is active.

Remote control `[SENSe:]CORRection:LOSS:OUTPut<nr>[:MAGNitude]`
`SOURce:CORRection:LOSS:OUTPut<nr>[:MAGNitude]`

Reference Frequency (Connection Control – Sync.)

The *Sync.* tab defines the reference signals for synchronization. This includes

- The internal or external *Reference Frequency*
- The output mode for the network-specific system clock (*REF OUT 2*)

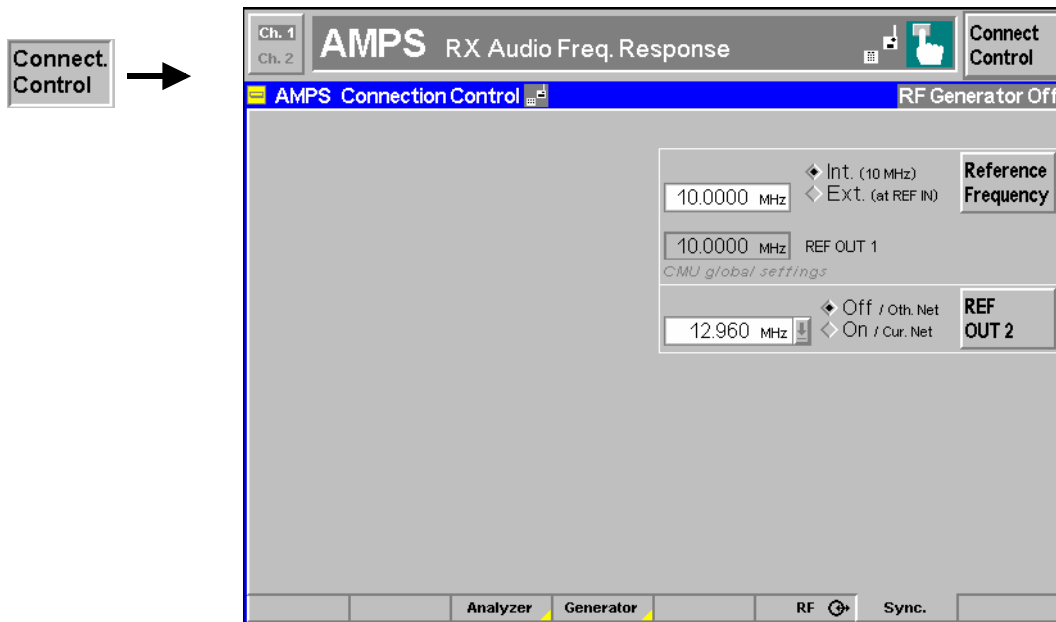

Fig. 4-26 Connection Control – Sync.

Reference Frequency

The *Reference Frequency* softkey determines the source and the frequency of the reference signal.

The associated field permits to select between two alternatives:

Int. (10 MHz) internal synchronization with 10 MHz (TCXO or OCXO, CMU-B11/-

B12) applied to output REF OUT 1 at the rear of the instrument.

Ext. (at REF IN) external reference signal to be fed in via input *REF IN* and applied to output REF OUT 1 at the rear of the instrument.

The frequency of the external reference signal must be entered in the input field next to the *External* button.

The reference signal used is applied to output *REF OUT 1* so that it can be fed to other instruments as well. It can be used for synchronization to another instrument.

Notes:

1. *With external synchronization selected, the header cyclically displays a warning if no synchronization has been performed e.g. because of missing or faulty input signal. At the same time, bit no. 6 (RFNL, Reference Frequency Not Locked) is set in the STATUS:OPERation:CMU:SUM1:CMU1 sub-register associated to the CMU base system.*
2. *In the case of external synchronization with squarewave signals (TTL) ensure correct signal matching to avoid reflections. Otherwise, resulting overshoots may cause trigger problems at the CMU input. A possible remedy is to use a lowpass filter or an attenuator pad directly at the CMU input. Correct synchronization may be checked by comparing the signal REF OUT 1 or REF OUT 2 with the input signal.*
3. *This configuration is valid in all CMU function groups.*

Remote control

The commands for the reference frequency are part of the CMU base system (see CMU200/300 operating manual):

```
CONFigure:SYNChronize:FREQuency:REFerence:MODE
    INTernal | EXTernal
```

```
CONFigure:SYNChronize:FREQuency:REFerence <Frequency>
```

**REF
OUT 2**

The softkey *REF OUT 2* configures a network-specific system clock REF OUT 2 to be fed to the output *REF OUT 2* at the rear of the instrument.

The associated field permits to select between two alternatives:

OFF (other network) The clock frequency of the current function group is not fed to the output *REF OUT 2*.

With this setting the system clock of another active function group (e.g. the 1800 MHz hyperband while the current hyperband is 800 MHz) is still applied to *REF OUT 2* provided that the output *REF OUT 2* is switched on in the other function group. However, if *REF OUT 2* is explicitly switched over from *On* to *Off* the clock signal is definitely removed.

On (current network) The network-specific system clock of the current function group is fed to output REF OUT 2. The system clock of any other function group applied to REF OUT 2 before is replaced.

The following clock frequencies may be selected:

38.88 MHz, 19.44 MHz, 12.96 MHz, 9.72 MHz

(The values are calculated according to the formula $F_{out} = 38.88 \text{ MHz} / n$ where $n = 1, \dots, 4$)

The clock frequency can be used to synchronize other instruments.

Remote control

```
SOURce:DM:CLOCK:STATE ON | OFF
SOURce:DM:CLOCK:FREQuency <Frequency>
```

AMPS Mobile Tests (Signalling Mode)

This section provides detailed information on the measurement and configuration menus defined in function group *AMPS-MS Signalling*. It is organized like a typical measurement session including the following stages:

1. Call setup to the mobile station (*Connection Control – Connection*)
2. Overview of measurements and general settings (*Overview*)
3. Measurement menus (*TX Tests, TX Audio Freq. Response, RX Tests, RX Audio Freq. Response*): control of the measurements, output of measurement results, specific measurement configurations
4. Global configurations (*Connection Control*)

The most important menus of the function group *AMPS-MS Signalling* are shown in an overview at the end of chapter 3 in the present manual.

A lot of menus and controls are similar or identical in the two operating modes for *AMPS-MS* with and without signalling. These menus will only be presented with a summary explanation; the detailed description is found in the section *AMPS-MS Non Signalling*.

Connection Control (Call Setup)

The menu group *Connection Control* controls signalling (call setup and release, services, signalling parameters) and configures the inputs and outputs with the external attenuation values and the reference frequency.

The purpose of the *Signalling* test mode is to perform transmitter and receiver test with an existing connection to the mobile station. Therefore the tabs controlling the call setup (*Connection Control – Connection*) appear immediately after selection of the function group *AMPS-MS Signalling* in the *Menu Select* menu. Alternatively, the *Connection Control* menu can be called up by pressing the softkey *Connect. Control* at the top right in every measurement menu; the individual tabs can be accessed via the hotkey bar at the lower edge of the screen. By pressing the *Escape* key, the *Connection Control* menu is closed and the CMU changes to the measurement mode.

In the following the first two tabs *Connection Control – Connection* displayed immediately after activation of the function group are described. A description of the other tabs of the *Connection Control* menu is given at the end of this chapter (see section [Connection Control in the Registered State](#) on page 4.71).

The term signalling denotes all procedures that are necessary for call setup and release and for control of a connection in the mobile radio network. In the case of AMPS mobile station tests, a distinction is made between five different signalling states:

<i>Signal Off</i>	CMU transmits no signal
<i>Signal On</i>	CMU outputs a AMPS control channel signal to which a mobile station can synchronize
<i>Registered</i>	Registration of the mobile station completed
<i>Alerting</i>	Mobile is being called by the CMU (after registration or without registration)
<i>Call Established</i>	Call connection to mobile station established, mobile picked up

A number of control commands which can be initiated both by the CMU (*Call to MS*) and by the mobile station (*Call from MS*) switch between these states (in Fig. 4-1, processes initiated by the mobile station are indicated by dashed lines).

Many applications in function group *AMPS-MS Signalling* are only possible or useful in a particular signalling state (for example, a handoff between various networks requires an existing connection between CMU and mobile station, i.e. it is only possible in the *Call Established* state). Accordingly, the *Connection Control* menus may vary depending on the signalling state.

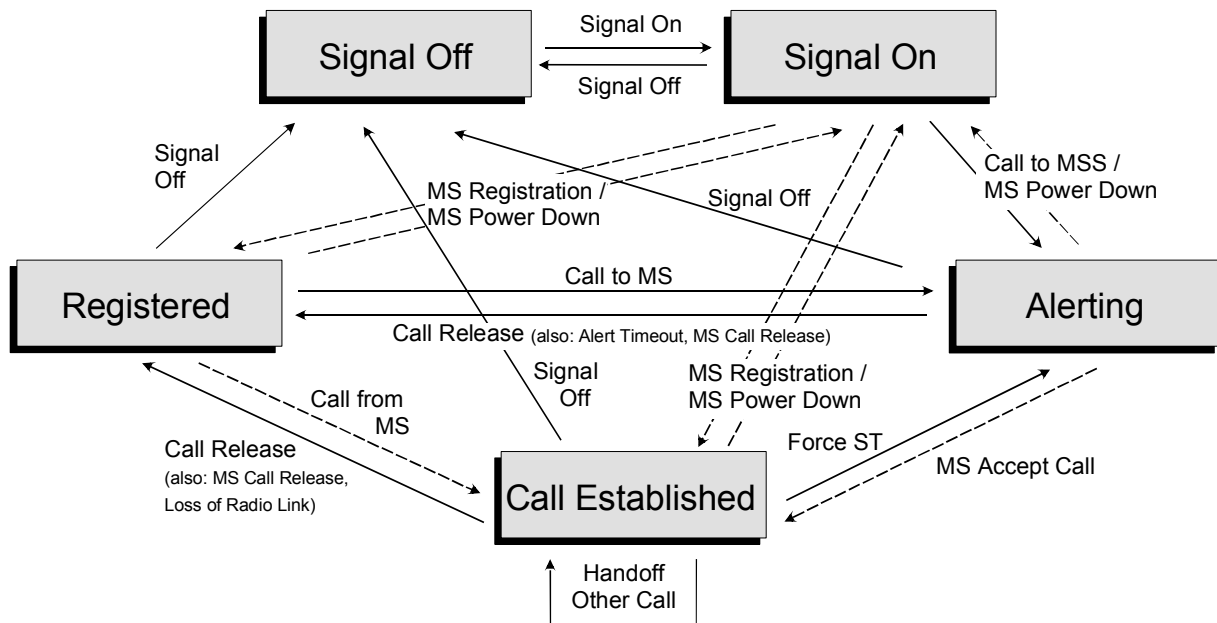

Fig. 4-27 Signalling states of the CMU

Corresponding to the five possible signalling states, five different *Signalling* menus are available. When a signalling state is reached, the corresponding menu is opened automatically (exception: see softkey *Open Pop. autom.*).

Note: For a complete overview of signalling states including the Handoff process see Fig. 6.1 in chapter 6 of this manual.

Connection Control with "Signal Off"

The popup menu *Connection (Signal Off)* provides information on:

- The most important parameters concerning the frequency and level of the signal transmitted by the CMU in the state *Signal On (BS Signal)*
- Important *Network* parameters
- Selected RF connectors and external attenuation (⊕ *Ext. Att.*)
- Status and result of the wide-band peak-power measurement (*Wideband Power*)

Besides, it activates the control channel signal for the call setup to the mobile station (*Signal On*).

The popup menu *Connection (Signal Off)* is opened when the function group *AMPS MS Signalling* is selected, or if the registration signal (control channel, CC) is switched off (*Signal Off* softkey) while the system is in another signalling state. It is replaced by the *Connection (Signal On)* menu after the CC signal on the CMU is switched on (Softkey *Signal On*, see Fig. 4-27).

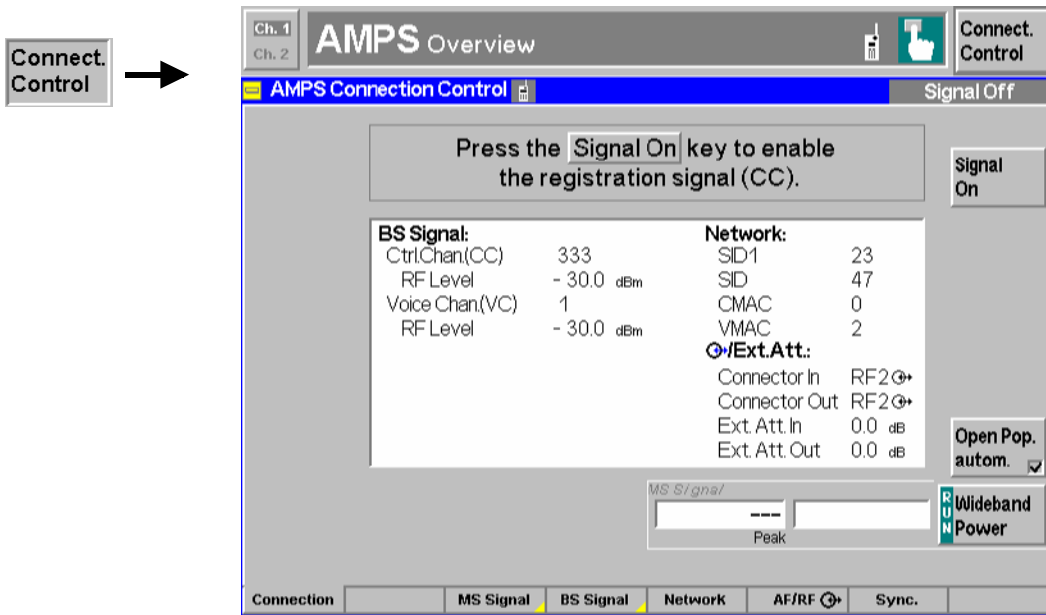

Fig. 4-28 Connection Control – Connection (Signal Off)

BS Signal The table *BS Signal* indicates the most important parameters concerning the frequency and level of the control and voice channel signals transmitted by the CMU in the state *Signal On*. These parameters are set in the tab *BS Signal* and explained in more detail there (see section *Signals of the CMU (Connection Control – BS Signal)* on page 4.83).

Remote control `CONFigure:BSSignal...`

Network The table *Network* indicates the 14-bit (*SID 1*) and the 15-bit System Identity (*SID*). The *SID 1* is a unique number identifying the cellular system (network). The *SID* consists of the *SID 1* plus one bit identifying the control channel (CC) system A or B (see [Table 4-1](#) on p. 4.47 and [Table 4-2](#) on page 4.52). The *SID 1* is set in the *Network* tab (see section *Network Parameters (Connection Control – Network)* on page 4.85); the *SID* is calculated from the *SID 1* and the channel information.

Below the *SID*, the voice channel (*VMAC*) and control channel mobile attenuation code (*CMAC*) is displayed. The MAC levels are set in the *Network* tab, see p. 4.85 ff.

Remote control `CONFigure:NETWork...`

Ext. Att. The table *Ext. Att.* indicates the RF connectors and external attenuation settings. These parameters are set in the tab *RF* and are explained in more detail there (see section *RF Connectors (Connection Control – RF/AF Connector)* on page 4.50).

Remote control `[SENSe:]CORRection:LOSS...?`

Wideband Power

The *Wideband Power* softkey controls the wide-band power measurement and indicates its state (*RUN* | *HLT* | *OFF*).

In the associated fields, the peak power of the received signal is indicated as absolute numerical value and relative to the effective radiated power (ERP) of the mobile (analog bar). The analog bar views the RF input power range between *ERP - 10 dB* and *ERP + 10 dB*. The ERP depends on the VMAC set in the *Overview* menu and on the power class of the mobile; see [Table 4-3](#) on page 4.65.

Remote control INITiate:WPOWer
 FETCh:WPOWer:STATus?
 READ[:SCALar]:WPOWer[:RESult]?
 FETCh[:SCALar]:WPOWer[:RESult]?
 SAMPlE[:SCALar]:WPOWer[:RESult]?

Signal On

The *Signal On* softkey switches on a control channel signal (CC) to which the mobile station can synchronize.

By switching on the signal, the CMU changes to the signalling state *Signal On*. A user prompt below the menu header indicates the function of this softkey.

Remote control PROCedure:SIGNalling:ACTion SON

Open Pop. autom.

The *Open Pop. autom.* softkey contains a field which activates or suppresses display of the popup menu *Connection (Signal Off)*.

- In the default setting (*Open Pop. autom. on*), the popup menu is displayed each time the *Signal Off* state is reached (due to a change of the signalling state or function group).
- In the alternative setting (*Open Pop. autom. off*), the popup-menu is suppressed. Signalling may still be controlled, e.g., via the mobile. Moreover, the popup menu *Connection (Signal Off)* can also be opened explicitly by pressing the corresponding hotkey in the menu group *Connection Control*.

Remote control -

Connection Control with "Signal On"

The popup menu *Connection (Signal On)* provides information on

- The signals transmitted by the CMU (*BS Signal*)
- The network parameters (*Network*)
- Selected RF connectors and external attenuation (↻ *Ext. Att.*)
- The status and result of the wideband peak power measurement (*Wideband Power*)

Besides, it contains softkeys which lead to other signalling states:

- Deactivating the control channel signal for establishing the first connection to the mobile station (*Signal Off*)
- Setting up a call to the mobile station (*Call to MS* ⇒ state *Alerting*)

The popup menu *Connection (Signal On)* is opened after the CC signal on the CMU is switched on (Softkey *Signal On* in the popup menu *Connection (Signal Off)*). It is replaced by the *Connection (Registered)* menu after the mobile station initializes a registration by itself. It is replaced by the *Connection (Call Established)* menu if the mobile station sets up a call to the CMU. It is replaced by the *Connection (Alerting)* menu if a mobile is called via the *Call to MS* softkey (see [Fig. 4-27](#)).

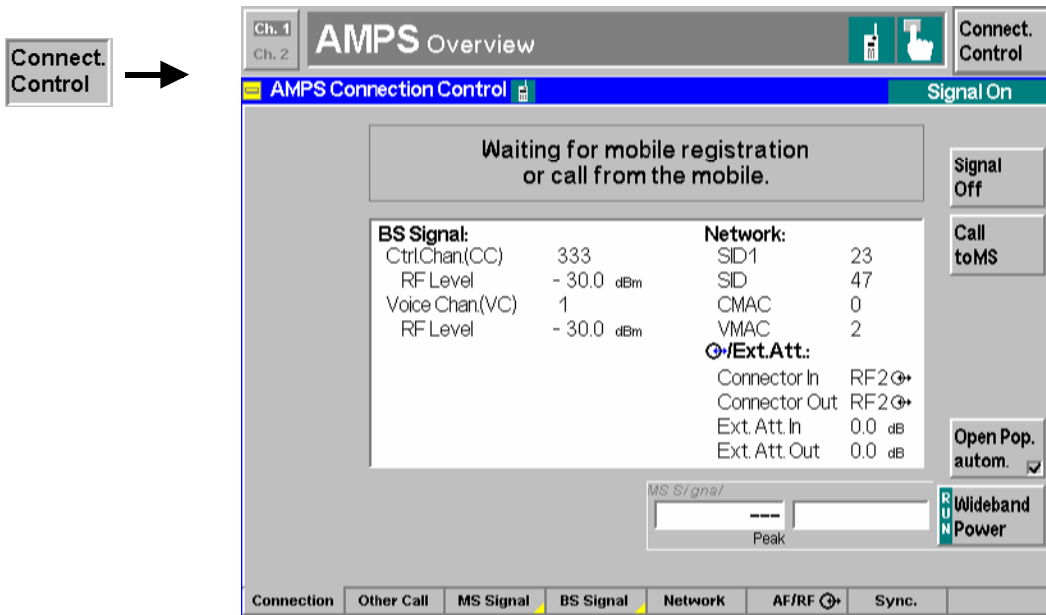

Fig. 4-29 Connection Control – Connection (Signal On)

The meaning of the displays under *BS Signal*, *Network* and *RF* \odot as well as of the *Wideband Power* softkey is described in section [Connection Control](#) on page 4.60.

Signal Off

The *Signal Off* softkey switches off the CMU's control channel signal to which the mobile station can synchronize.

The CMU changes to the signalling state *Signal Off*.

Remote control

PROCedure:SIGNalling:ACTion SOFF

Call to MS

The *Call to MS* softkey sets up a call to the mobile station.

A user prompt below the header indicates that the mobile station must synchronize to the CMU signal first. After successful synchronization, the message *Paging in progress ...* is displayed below the header; the CMU changes to the signalling state *Alerting*. As soon as the mobile is picked up the CMU changes to the signalling state *Call Established*.

Note: *To set up a call, the CMU transmits five page messages at maximum. If the Call to MS procedure still fails (e.g. because the mobile was not properly connected), the message Call to mobile was not successful ! is displayed in a message window. The message window is closed after a while or after it is confirmed by pressing the ENTER key.*

Remote control

PROCedure:SIGNalling:ACTion CTM

Open Pop. autom.

The softkey *Open Pop. autom.* contains a field which activates or suppresses the display of the popup menu *Connection (Signal On)*.

- In the default setting (*Open Pop. autom. on*), the popup menu is displayed each time the *Signal On* state is reached (due to a change of the signalling state or function group).
- In the alternative setting (*Open Pop. autom. off*), the popup-menu is suppressed. Signalling may still be controlled, e.g., via the mobile. Moreover, the popup menu *Connection (Signal On)* can also be opened explicitly by pressing the corresponding hotkey in the menu group *Connection Control*.

Overview Menu

The main menu *Overview* gives an overview of the function group *AMPS-MS Signalling* including the most important settings and measurement results.

The panels on the left side report the following basic measurement results:

- The measurement control softkey *Modulation* in the upper part controls the *TX Tests* and informs on their current status (*RUN* | *HALT* | *OFF*). The displayed measurement results of the *Modulation* application are discussed under the measurement menu *TX Tests* on page 4.12 ff.
- The measurement control softkey *AF Analyzer* controls the audio analyzer and informs on its current status (*RUN* | *HALT* | *OFF*). The RMS voltage of the AF signal fed in via *AF IN* is displayed.

The panels on the right side display signalling information and provide settings concerning the mobile station and the signals transmitted by the CMU:

Panel <i>Signalling Info</i>	Parameters of the mobile station	See page 4.71 ff.
Panel <i>VMAC</i>	Voice channel settings	See below
Panel <i>BS Signal</i>	BS signal settings	See page 4.84
Softkey <i>AF Generator</i>	Configuration of the audio generator	See page 4.2
Softkey <i>Mod. Generator</i>	Configuration of the modulation generator	See page 4.2

The main menu *Overview* is opened from the main menu *Menu Select* (with associated key at the front of the instrument) and after closing the configuration menu *Connection Control - Connection* (using the *Escape* key or automatically after establishing a call connection). From the *Overview* menu, the remaining measurement menus of the function group (*TX Tests*, *TX Audio Freq. Response*, *RX Tests*, and *RX Audio Freq. Response*) can be accessed via hotkeys.

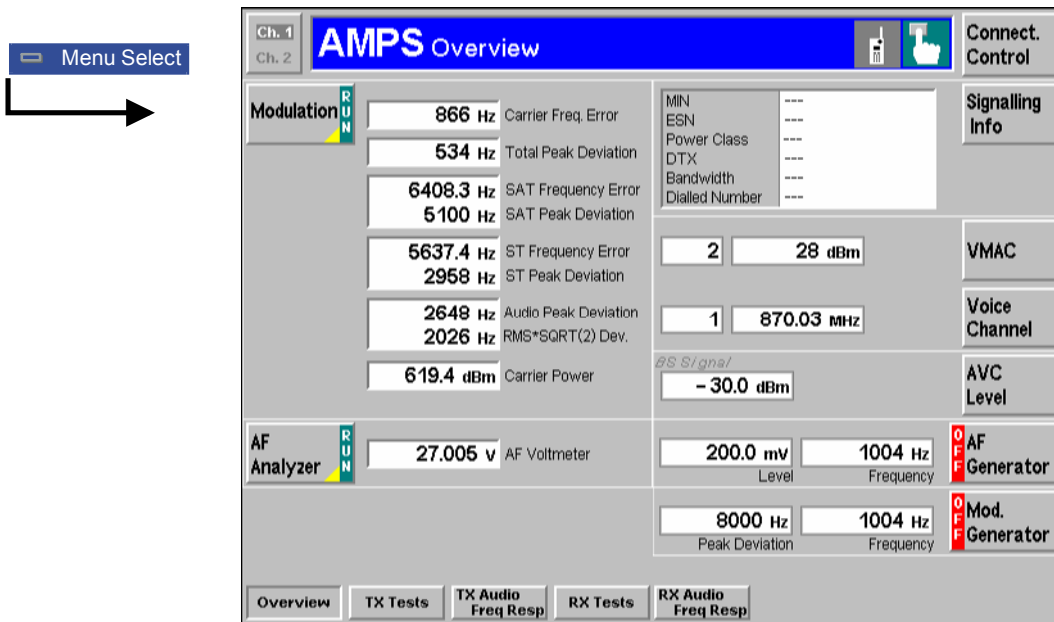

Fig. 4-30 Overview menu

VMAC

The *VMAC* softkey sets the voice mobile attenuation code.

The *VMAC* can be entered either as a dimensionless number or a maximum output power in dBm. The 8 voice mobile attenuation codes and four power classes defined for AMPS mobile phones are shown in *Table 4-3* below along with the corresponding effective radiated power (ERP) ranges.

Remote control PROCedure:Signalling[:AVC]:MAC 0 ... 7 (Call Established)

Table 4-3 AMPS power classes and voice mobile attenuation codes (VMAC)

VMAC (CMAC)	ERP in dBm				Tolerance in dB
	Class I	Class II	Class III	Class IV	
0	36	32	28	28	+2 / -4
1	32	32	28	28	+2 / -4
2	28	28	28	28	+2 / -4
3	24	24	24	24	+2 / -4
4	20	20	20	20	+2 / -4
5	16	16	16	16	+2 / -4
6	12	12	12	12	+2 / -4
7	8	8	8	8	+2 / -4

Voice Channel

The *Voice Channel* softkey defines the channel number and frequency of the CMU's voice signal.

It is sufficient to enter either the channel number or the frequency; the other value is automatically determined according to the AMPS channel assignment. For an overview of the AMPS channel assignment in the forward path (from base station/CMU to the mobile) see [Table 4-2](#) on p. 4.52.

Remote control

```
CONFigure:BSSignal[:AVC]:CHANnel <Number>
PROCedure:SIGNalling[:AVC]:CHANnel <Number>
```

Important note: current vs. default and other call/handoff values

Some parameters of the CMU can assume three independent values:

- The **default** value is used to set up a connection; it can be modified in the signalling states Signal Off, Signal On and Registered.
- The **current** value is valid during the connection (signalling state Call Established). Whenever the CMU enters the Call Established state the default value overwrites the current value. The current value can still be changed during the connection, however, modifying this current value does not alter the default value.
- The **other call/handoff** value comes into effect only after an Other Call or Handoff from another to the current network.

Examples of such triple parameters in AMPS-MS are the BS Signal Voice Channel (VC) Level and Voice Channel number, the SAT Peak Deviation and SCC, and the VMAC.

In cases where signalling state dependent parameter sets are not needed, it is possible to couple all three values; see [Parameter Coupling](#) on p. 4.89.

In remote control, default values are set with a CONFigure ... command, current values are set with a PROCedure ... command.

TX Tests

The menu group *TX Tests* comprises the measurement of parameters characterizing the transmitter quality of the mobile phone. The measurement results are displayed in the measurement menu *TX Tests*, the popup menu *TX Tests Configuration* is used for configuration of the measurements.

Most settings and functions of this menu do not depend on the signalling state and correspond to those of the menu *TX Tests* in the operating mode *AMPS-MS Non Signalling* (for a detailed description see p. 4.5 ff.). The additional features in *Signalling* mode are related to the voice mobile attenuation code (VMAC, see [Table 4-3](#) on page 4.65) which is set via the *Analyzer Level* softkey and can be used to determine the maximum input level the CMU is able to measure:

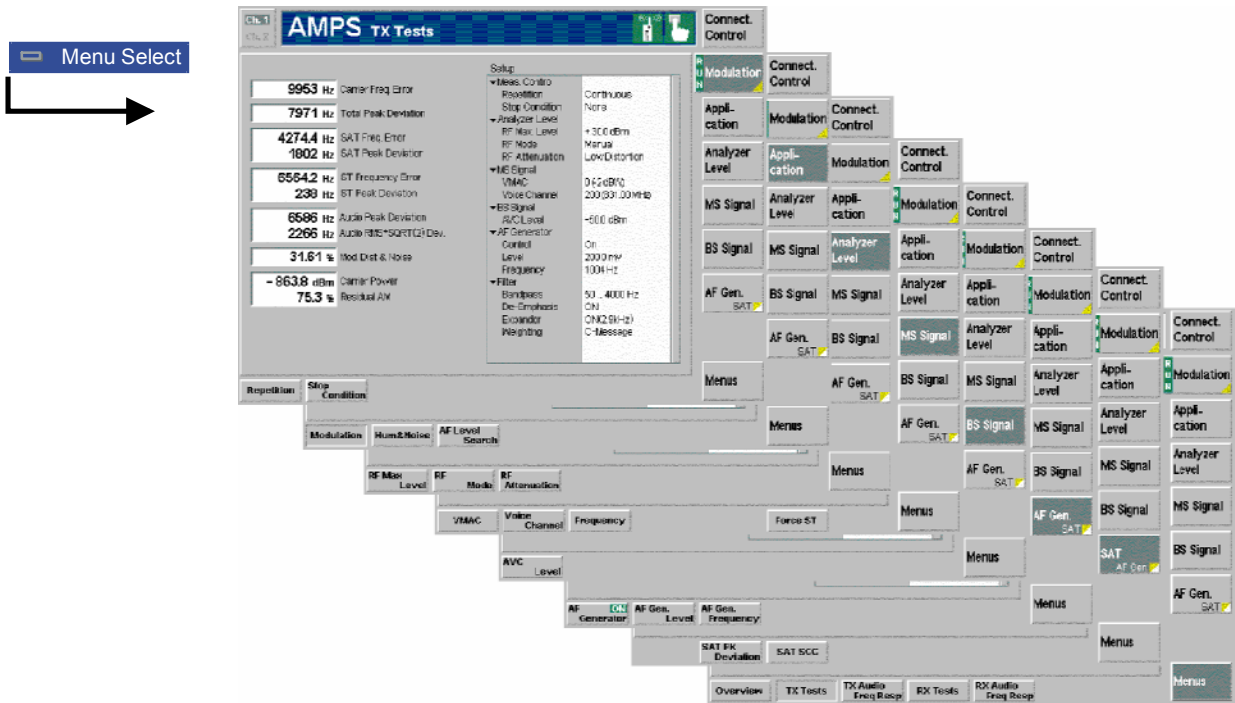

Fig. 4-31 Measurement menu TX Tests

- MS Signal**

The *MS Signal* softkey configures the RF analyzer and sets the VMAC of the mobile phone.
- VMAC**

The *VMAC* hotkey sets the voice mobile attenuation code. Together with the MS power class the VMAC determines the effective radiated power of the mobile. It is also indicated in the *Overview* menu (see p. 4.64).
- Remote control PROCEDURE:Signalling[:AVC]:MAC 0 ... 7
- Force ST**

The *Force ST* hotkey forces the connected mobile to switch from the *Call Established* state back to the *Alerting* state where it transmits a ST tone.

Force ST is available in the *Call Established* signalling state and is to provide a short cut to the *ST Frequency Error* and *ST Peak Deviation* measurements. These quantities can not be determined during a call where the AMPS mobile doesn't transmit the ST (see section [SAT and ST](#) on p. 4.52 ff). To return to *Call Established* after the measurement of the ST parameters it is sufficient to pick up the mobile and accept the attempted call.
- Remote control PROCEDURE:SIGNalling:ACTION FST

BS Signal	<p>The <i>BS Signal</i> softkey configures the Analog Voice Channel (AVC) signal of the CMU.</p> <p>The settings are also provided in the <i>BS Signal</i> tab of the <i>Connection Control</i> menu; see section Softkey-Oriented Version on p. 4.84 f.</p>						
AVC Level	<p>The <i>AVC Level</i> hotkey defines the level (in dBm) of the Analog Voice Channel signal of the CMU.</p>						
Remote control	<pre>CONFigure:BSSignal[:AVC]:LEVel <Channel> or PROCEDURE:Signalling[:AVC]:LEVel <Channel></pre>						
Voice Channel	<p>The <i>Voice Channel</i> hotkey defines the channel number of the Analog Voice Channel signal of the CMU. The RF frequency is automatically adapted according to the AMPS channel assignment in the forward path (see Table 4-2 on p. 4.52).</p>						
Remote control	<pre>CONFigure:BSSignal[:AVC]:CHANnel <Channel> or PROCEDURE:Signalling[:AVC]:CHANnel <Channel></pre>						
Frequency	<p>The <i>Frequency</i> hotkey defines the signal frequency in MHz of the Analog Voice Channel signal of the CMU. The AMPS voice channel number is automatically adapted according to the AMPS channel assignment in the forward path (see Table 4-2 on p. 4.52).</p>						
Remote control	<pre>UNIT:CHANnel Hz CONFigure:BSSignal[:AVC]:LEVel <Frequency> or PROCEDURE:Signalling[:AVC]:LEVel <Frequency></pre>						
Analyzer Level	<p>The <i>Analyzer Level</i> softkey configures the RF input level. See also section Signals of the Mobile Phone (Connection Control – MS Signal) on page 4.81 ff.</p>						
Max. Level	<p>The <i>Max. Level</i> hotkey determines the maximum expected input level in dBm.</p>						
Remote control	<pre>[SENSE:]LEVel:MAXimum <Level></pre>						
Mode	<p>The <i>Mode</i> hotkey determines how the maximum input level is defined.</p> <table border="0" style="margin-left: 20px;"> <tr> <td style="padding-right: 20px;"><i>Manual</i></td> <td>Manual input of reference level</td> </tr> <tr> <td><i>VMAC</i></td> <td>Automatic setting according to the digital mobile attenuation code of the mobile phone. The VMAC is set in the <i>Overview</i> menu or using the softkey <i>MS Signal</i> (see above).</td> </tr> </table>	<i>Manual</i>	Manual input of reference level	<i>VMAC</i>	Automatic setting according to the digital mobile attenuation code of the mobile phone. The VMAC is set in the <i>Overview</i> menu or using the softkey <i>MS Signal</i> (see above).		
<i>Manual</i>	Manual input of reference level						
<i>VMAC</i>	Automatic setting according to the digital mobile attenuation code of the mobile phone. The VMAC is set in the <i>Overview</i> menu or using the softkey <i>MS Signal</i> (see above).						
Remote control	<pre>[SENSE:]LEVel:MODE MANual VMAC</pre>						
Attenuation	<p>The <i>Attenuation</i> hotkey defines an (internal) attenuation factor for the input signal.</p> <table border="0" style="margin-left: 20px;"> <tr> <td style="padding-right: 20px;"><i>Normal</i></td> <td>Input signal is kept unchanged</td> </tr> <tr> <td><i>Low Noise</i></td> <td>Enhanced mixer level, full dynamic range</td> </tr> <tr> <td><i>Low Distortion</i></td> <td>Decreased mixer level, high transmission reserve</td> </tr> </table>	<i>Normal</i>	Input signal is kept unchanged	<i>Low Noise</i>	Enhanced mixer level, full dynamic range	<i>Low Distortion</i>	Decreased mixer level, high transmission reserve
<i>Normal</i>	Input signal is kept unchanged						
<i>Low Noise</i>	Enhanced mixer level, full dynamic range						
<i>Low Distortion</i>	Decreased mixer level, high transmission reserve						
Remote control	<pre>[SENSE:]LEVel:ATTenuation NORMal LNOise LDISTortion</pre>						

For all other settings, measurement results and the configuration menu please refer to section [TX Tests](#) on page 4.5 ff.

TX Audio Freq. Response

The menu group *TX Audio Freq. Response* provides the measurement of the electrical audio response of the mobile phone transmitter. The measurement results are displayed in the graphical measurement menu *TX Audio Freq. Response*, the popup menu *TX Audio Freq. Response Configuration* is used for configuration of the measurements.

Most settings and functions of this menu do not depend on the signalling state and correspond to those of the menu *TX Audio Freq. Response* in the operating mode *AMPS-MS Non Signalling* (for a detailed description see p. 4.21 ff). The differences to the *Non Signalling* mode are related to the voice mobile attenuation code (*VMAC*, see [Table 4-3](#) on page 4.65) which is set via the *Analyzer Level* softkey and can be used to determine the maximum input level the CMU is able to measure. This is analogous to the TX Tests menu described above (see p. 4.66 ff).

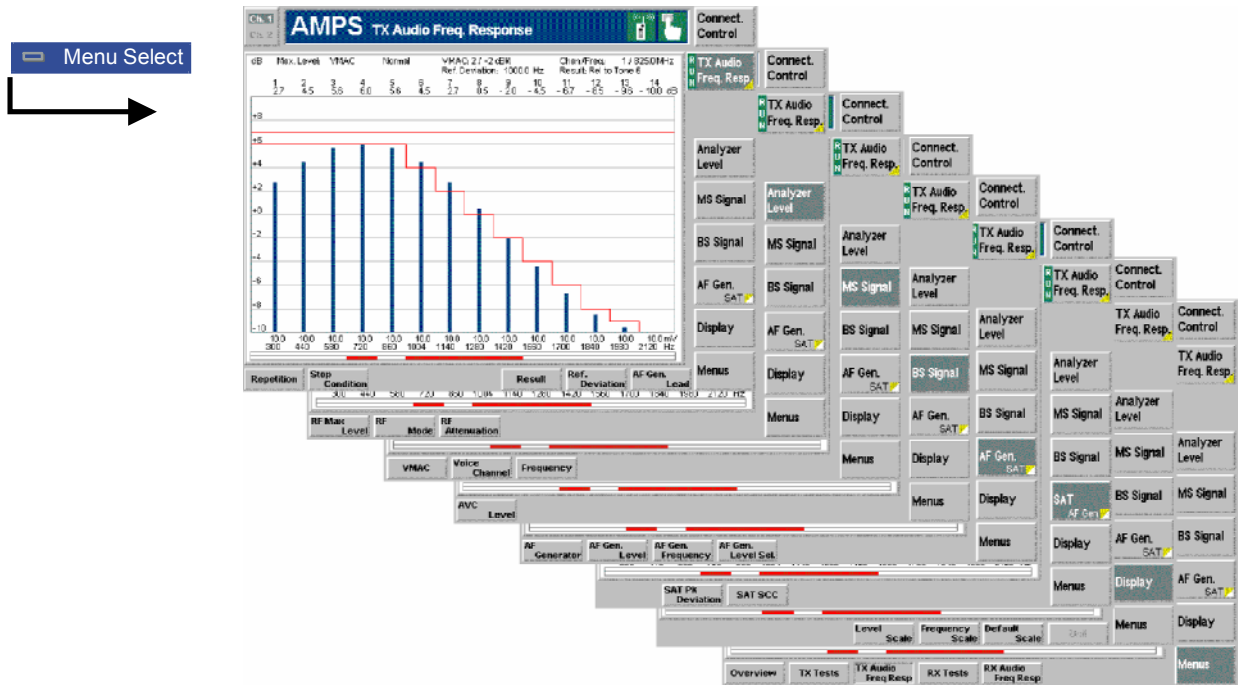

Fig. 4-32 Measurement menu TX Audio Freq. Response

RX Audio Freq. Response

The menu group *RX Audio Freq. Response* provides the measurement of the electrical audio frequency response of the mobile phone receiver. The measurement results are displayed in the graphical measurement menu *RX Audio Freq. Response*, the popup menu *RX Audio Freq. Response Configuration* is used for configuration of the measurements.

Most settings and functions of this menu do not depend on the signalling state and correspond to those of the menu *RX Audio Freq. Response* in the operating mode *AMPS-MS Non Signalling* (for a detailed description see p. 4.39 ff). The differences to the *Non Signalling* mode are related to the voice mobile attenuation code (VMAC, see [Table 4-3](#) on page 4.65) which is set via the *Analyzer Level* softkey and can be used to determine the maximum input level the CMU is able to measure. This is analogous to the TX Tests menu described above (see p. 4.66 ff).

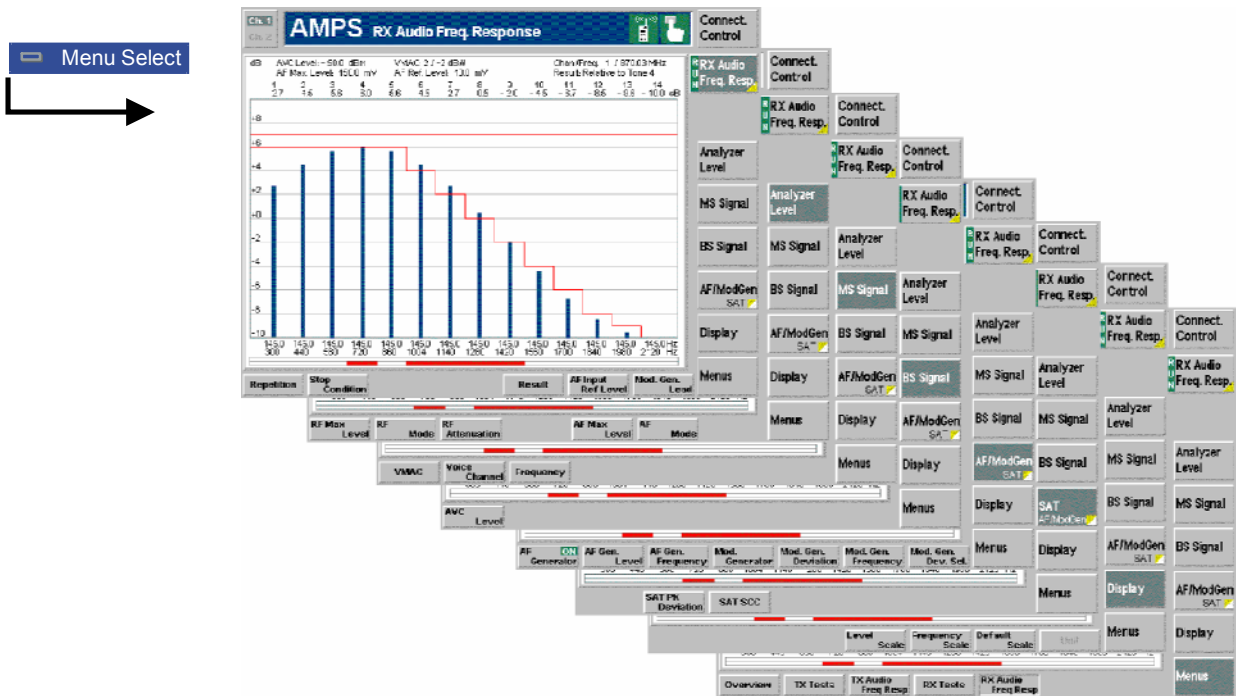

Fig. 4-34 Measurement menu RX Audio Freq. Response

Connection Control (Contd.)

The menu group *Connection Control* controls the signalling procedures (call setup and release, signalling parameters) and determines the inputs and outputs with the external attenuation values and the reference frequency.

The purpose of the *Signalling* test mode is to perform measurements with an existing call connection to the mobile station. Therefore the first two tabs for setting up the call (*Connection Control – Connection*) appear immediately after selection of the function group *AMPS-MS Signalling* in the *Menu Select* menu. Alternatively, the *Connection Control* menu can be called up by pressing the softkey *Connect. Control* at the top right in every measurement menu; the individual tabs can be accessed via the hotkey bar at the lower edge of the screen. By pressing the *Escape* key, the *Connection Control* menu is closed and the CMU changes to the measurement mode.

The two tabs *Connection Control – Connection* displayed immediately after the function group *AMPS-MS Signalling* is activated are described at the beginning of section [AMPS Mobile Tests \(Signalling Mode\)](#) on p. 4.59 ff. The remaining tabs of the *Connection Control – Connection* menu are described below.

Connection Control in the Registered State

The popup menu *Connection (Registered)* provides information on

- The current data of the mobile station (*Mobile registered*),
- The status and result of the wideband peak power measurement (*Wideband Power*).

Besides, it contains softkeys which lead to other signalling states:

- Deactivation of the control channel signal for synchronization and call release to the mobile station (*Signal Off*),
- Establishing a call to the mobile station (*Call to MS* → state *Call Established*),

The popup menu *Connection (Registered)* is opened when a successful call (in which case the mobile is considered as being registered) is released (*Call Release* softkey in the *Alerting* or in the *Call Established* state, MS call release, loss of radio link) or when registration is initiated by the mobile phone. It is replaced by the *Connection (Alerting)* menu if the CMU initiates a call to the mobile phone (Softkey *Call to MS*), or by the *Connection (Call Established)* menu if the mobile phone initiates a call to the CMU, see [Fig. 4-27](#).

Note: *If the synchronization is lost during operation (because of a low signal level etc.) the warning Loss of radio link ! will appear.*

At the same time, bit 2 is set in the STATus:OPERation register. The message window is closed after a while or after it is confirmed by pressing the ENTER key.

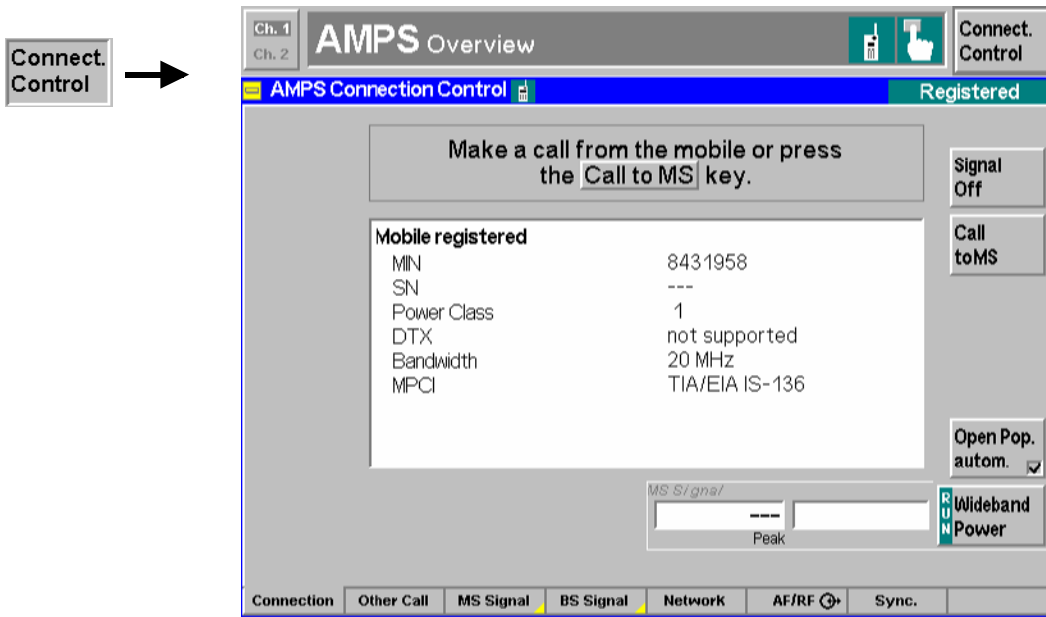

Fig. 4-35 Connection Control – Connection (Registered)

The function of the *Wideband Power* softkey is described in the section [Connection Control](#) on page 4.60, the softkey *Signal Off* in the section [Connection Control](#) on page 4.62.

Mobile registered

The table *Mobile registered* indicates the mobile parameters transferred to the CMU in the registration. A selection of the signalling parameters appears also when the call has been established (see section [Connection Control with Call Established](#) on page 4.74).

<i>MIN</i>	Mobile identification number (typically equal to the customer's telephone number). Together with the serial number, the MIN is used to identify the phone and its status.
<i>SN</i>	32-bit (electrical) serial number (only if requested, see Connection Control – Network menu on page 4.85 ff.).
<i>Power Class</i>	Power class of the mobile, see Table 4-3 on page 4.65.
<i>DTX</i>	Discontinuous transmission mode, see section Network Parameters (Connection Control – Network) on page 4.85 ff.
<i>Bandwidth</i>	Width of the whole RF band (20 MHz or 25 MHz).
<i>MPCI</i>	Mobile Protocol Capability Indicator, 2-bit field indicating the mobile station's capabilities: 00 indicates TIA/EIA-553 or IS-54A mobile station 01 indicates TIA/EIA-627 dual-mode mobile station 10 reserved (see TIA/EIA IS-95) 11 indicates TIA/EIA-136 dual-mode mobile station

Remote control [SENSe:]MSSinfo:...?

Call to MS

The softkey *Call to MS* sets up a call to the mobile station.

A user prompt below the header indicates the function of this softkey. On pressing it the message *Paging in progress ...* is displayed below the header. *The CMU changes to the signalling state Alerting.* As soon as the mobile is picked up the CMU changes to the signalling state *Call Established*.

Remote control PROCedure:SIGNalling:ACTion CTM

Open Pop. autom.

The softkey *Open Pop. autom.* contains a field which activates or suppresses the display of the popup menu *Connection (Registered)*.

- In the default setting (*Open Pop. autom. on*), the popup menu is displayed each time the *Registered* state is reached (due to a change of the signalling state or function group).
- In the alternative setting (*Open Pop. autom. off*), the popup-menu is suppressed. Signalling may still be controlled, e.g., via the mobile. Moreover, the popup menu *Connection (Registered)* can also be opened explicitly by pressing the corresponding hotkey in the menu group *Connection Control*.

Remote control –

Connection Control in the Alerting State

The popup menu *Connection (Alerting)* provides information on

- The characteristics of the registered mobile station (*Mobile registered*)
- The status and result of the wideband peak power measurement (*Wideband Power*)

Besides, it contains softkeys which lead to other signalling states:

- Deactivation of the control channel signal for synchronization and call release (*Signal Off*)
- *Call Release* while keeping the control channel signal switched on (⇒ state *Registered*)

The popup menu *Connection (Alerting)* is opened while the mobile phone is ringing during a call setup (*Call to MS* softkey in the *Signal On* or in the *Registered* state). It is replaced by the *Connection (Call Established)* menu when the mobile phone accepts the call (is picked up), or by the *Connection (Registered)* menu if the call is released (*Call Release* softkey, MS call release, alert timeout after 5 page messages, loss of radio link), see [Fig. 4-27](#).

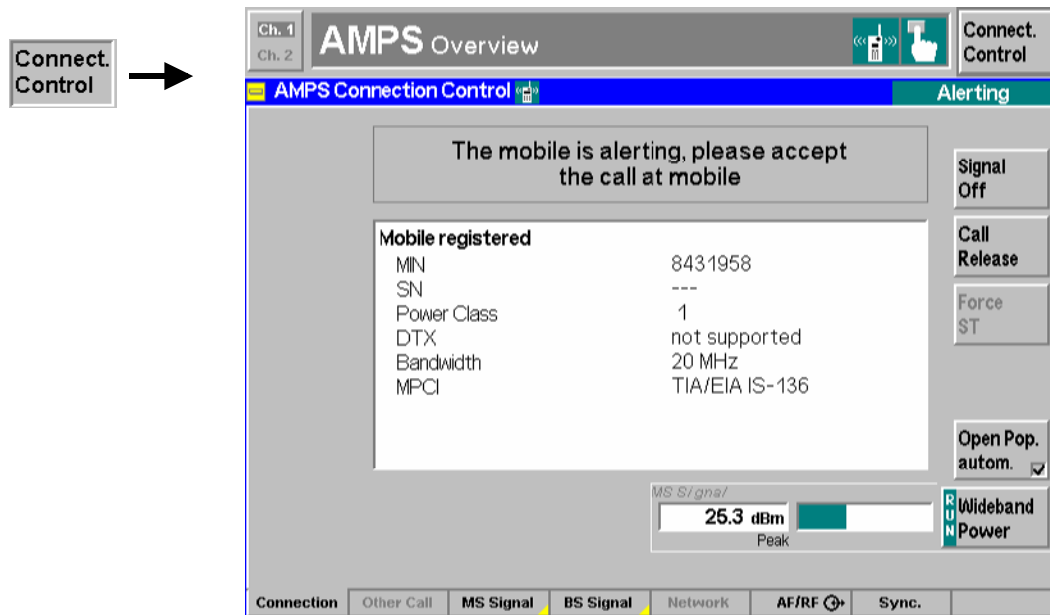

Fig. 4-36 Connection Control – Connection (Alerting)

The function of the *Wideband Power* softkey is described in the section [Connection Control](#) on page 4.60, the softkey *Signal Off* in the section [Connection Control](#) on page 4.62.

Mobile registered	The table <i>Mobile registered</i> indicates the characteristics of the called mobile station. All parameters are already displayed in the <i>Registered</i> state and described on page 4.71 ff.
Remote control	[SENSe:]MSSinfo: . . . ?

Call Release

The *Call Release* softkey releases the call to the mobile station.
The CMU changes to the signalling state *Registered*.

Remote control PROCedure:SIGNalling:ACTion CRELease

Close Pop. autom.

The softkey *Close Pop. autom.* contains a button which can be used to close the menu *Connection (Alerting)* automatically when a call is set up.

- In the default setting (*Close Pop. autom. on*), the popup menu is closed as soon as the signalling state *Alerting* is reached or a handoff is performed.
- In the alternative setting (*Close Pop. autom. off*), the popup-menu must be closed explicitly (e.g. via the *Escape* key) to continue the measurement.

Remote control -

Connection Control with Call Established (Signalling State Call Established)

The popup menu *Connection (Call Established)* provides information on

- A selection of signalling parameters of the mobile station (*Mobile Info*)
- The status and result of the wideband peak power measurement (*Wideband Power*)

It contains softkeys which lead to other signalling states (see [Fig. 4-27](#)):

- Deactivation of the signal for synchronization and release of the call to the mobile station (*Signal Off*)
- Release of the call to the mobile station (*Call Release* ⇒ state *Registered*)
- Call release and return to the *Alerting* state (*Force ST* ⇒ state *Alerting*)

It permits the following network and signal parameters to be entered:

- Voice mobile attenuation code (*VMAC*)
- Number and frequency of the voice channel (*Voice Channel*)
- Frequency and peak deviation of the supervisory audio tone (*SAT*)

The popup menu *Connection (Call Established)* is opened when a call is initiated by a mobile station which is already registered (*Signal On* or *Registered* state), or after a call initiated by the CMU is accepted by the mobile station. It is replaced by the *Connection (Signal Off)* menu after the CC signal is switched off (*Signal Off* softkey), or by the *Connection (Registered)* menu if the call is released (*Call Release* softkey, MS call release, loss of radio link), see [Fig. 4-27](#). Besides, the *Force ST* hotkey provides a short cut back to the *Alerting* state.

Note: *If the synchronization is lost during operation (because of a low signal level etc.) the warning Loss of radio link ! will appear.*

At the same time, bit 2 is set in the STATus:OPERation register. Prior to further operation, confirm the reception of the message by pressing the ENTER key.

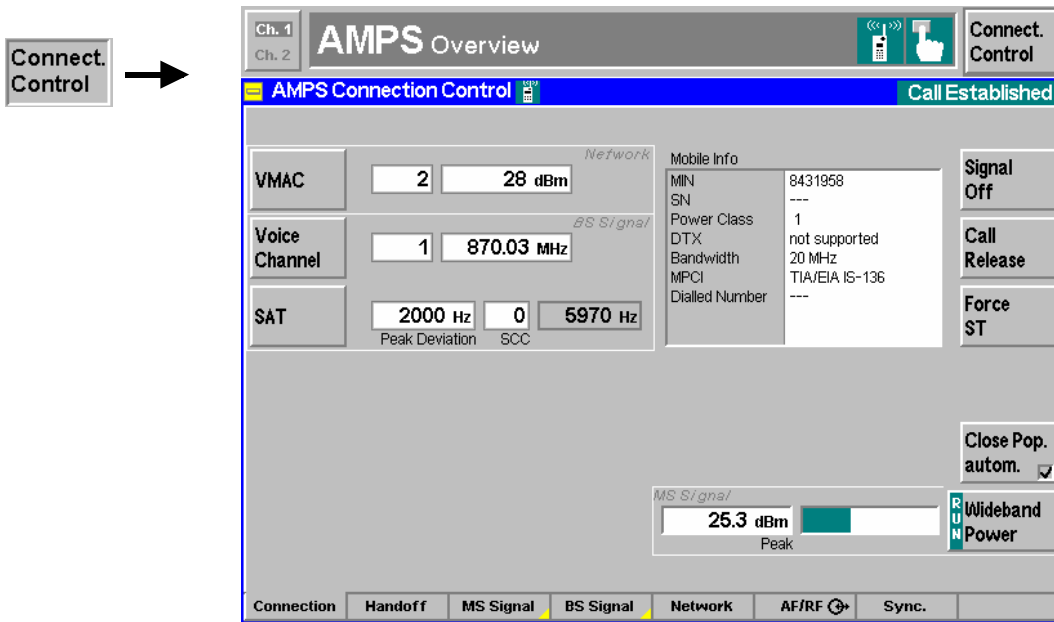

Fig. 4-37 Connection Control – Connection (Call Established)

The function of the softkeys *Signal Off* and *Wideband Power* is described in the section *Connection Control without Signal* on page 4.60. The softkeys *Call Release* and *Close Pop. autom.* are described in the previous section, *Connection Control in the Alerting State*. For a description of the *VMAC* softkey refer to section *Overview* on page 4.64.

The panel *BS Signal* contains two softkeys to configure the signals generated by the CMU.

Voice Channel

The *Voice Channel* softkey defines the channel number and frequency of the CMU's voice channel signal.

It is sufficient to enter either the channel number or the frequency; the other value is automatically determined according to the AMPS channel assignment. For an overview of the *AMPS* channel assignment in the forward path (from the base station/CMU to the mobile) see *Table 4-2* on p. 4.52 ff.

Remote control

```
PROCedure:SIGNalling[:AVC]:CHANnel <Channel>
```

SAT

The *SAT* softkey configures the supervisory audio tone provided by the CMU and transmitted over the voice channel.

In the network, the supervisory audio tone (SAT) is transmitted over the forward voice channel (CMU/base station to mobile) and retransmitted by the mobile back to the base station. Its purpose is to indicate the continuity of a call and to identify the base station with which the mobile station is communicating. To distinguish different base stations, three different SAT color codes (SCC) corresponding to three SAT frequencies f_{SAT} are defined in AMPS:

SCC = 0	$f_{SAT} = 5970$ Hz
SCC = 1	$f_{SAT} = 6000$ Hz
SCC = 2	$f_{SAT} = 6030$ Hz

The SAT must be switched on to perform several of the tests specified in the standard.

Peak Deviation

The *Peak Deviation* input field defines the maximum frequency deviation that the CMU uses to transmit the SAT to the mobile phone. The *SAT Peak Deviation* in the reverse path (mobile phone to base station) can be measured in the *TX Tests* measurement menu, see p. 4.5 ff.

SCC The SCC input field defines the SAT color code. The frequency corresponding to the SCC selected is indicated to the right of the SCC input field.

Remote control PROCedure:SIGNalling[:AVC]:SAT:PEAKdev
PROCedure:SIGNalling[:AVC]:SAT:SCC

Mobile Info The table *Mobile Info* indicates the characteristics of the connected mobile station:

Dialed number Number dialed at the mobile station (Call from MS)

The remaining parameters are already displayed in the *Registered* state and described on page 4.71 ff.

Remote control [SENSe:]MSSinfo...?

Force ST

The *Force ST* softkey releases the call and forces the mobile back to the *Alerting* state.

This function is particularly suitable for *TX Tests*, application *Modulation*. In this application, parameters involving the Signalling Tone (ST) from the mobile can not be obtained in the *Call Established* state; see *Force ST* softkey on p. 4.66.

Remote control PROCedure:SIGNalling:ACTion FST

Call to Another Network (Connection Control – Other Call)

The *Other Call* tab sets up a call from the current (*Origin*) to a different (*Destination*) network. While the call is still set up in the origin network (via CC), the voice channel is in the destination network. Therefore, in contrast to a *Handoff* procedure (see p. 4.78), an *Other Call* is possible in the *Signal On* or *Registered* signalling states only. The call process includes:

- Selection of the target network (*Destination Selection*) and special parameters of this network (*Destination Parameter, Destination Defaults*)
- Start of the call procedure (*Call to MS*)
- Return to of the original network (*Origin Parameter*)

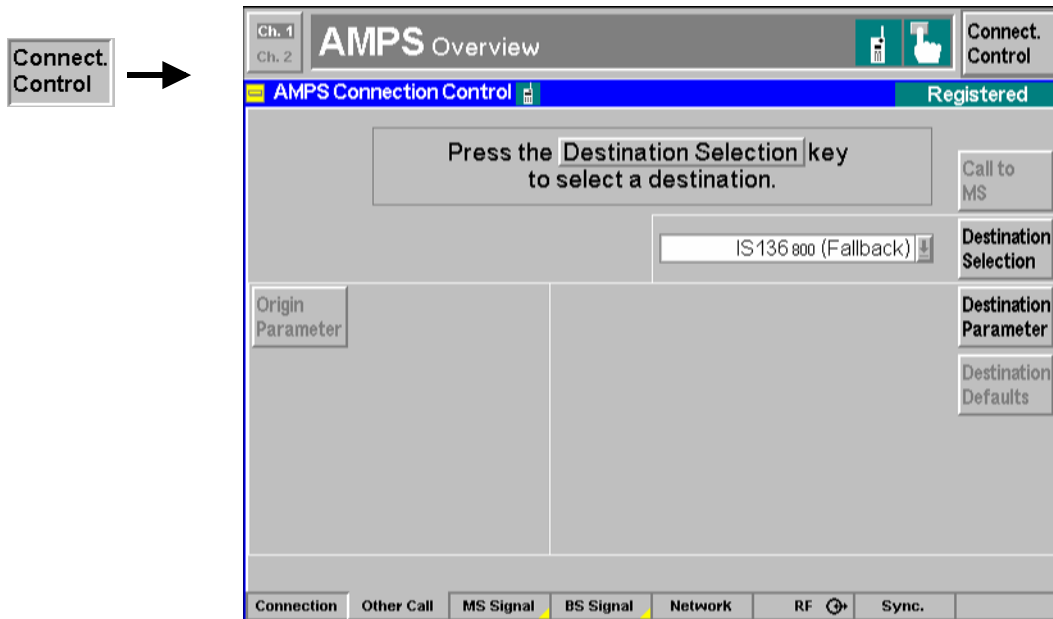

Fig. 4-38 Connection Control – Other call (destination selection)

Destination Selection

The softkey *Destination Selection* selects the target network for the call.

If the current function group is *AMPS-MS*, the default list of target networks contains the 800 MHz and the 1900 MHz band of the digital IS 136 network (provided that the mobile under test can be operated in these target networks). Furthermore, an *Other Call* destination with fallback (e.g. *IS 136 800 (Fallback)*) means that the CMU returns to the function group of the origin network after the call is released.

Once the selection of the target network is confirmed via *Enter*, the CMU changes to the *Reg. Pending* signalling state. In this state, the entire *Connection Control* menu is mapped onto the target function group, so it is possible to edit the *Destination Parameters* (see below), the *BS Signal*, and the *Network* parameters of the target network.

Remote control STATus:OCALl:TARGet:LIST?
 CONFigure:OCALl:TARGet <Target>

Note: *Reg. Pending is an intermediate signalling state that only occurs in the context of an Other Call process and is therefore not shown in Fig. 4-27 (page 4.60). For a complete overview of signalling states see Fig. 6.1 in chapter 6 of this manual.*

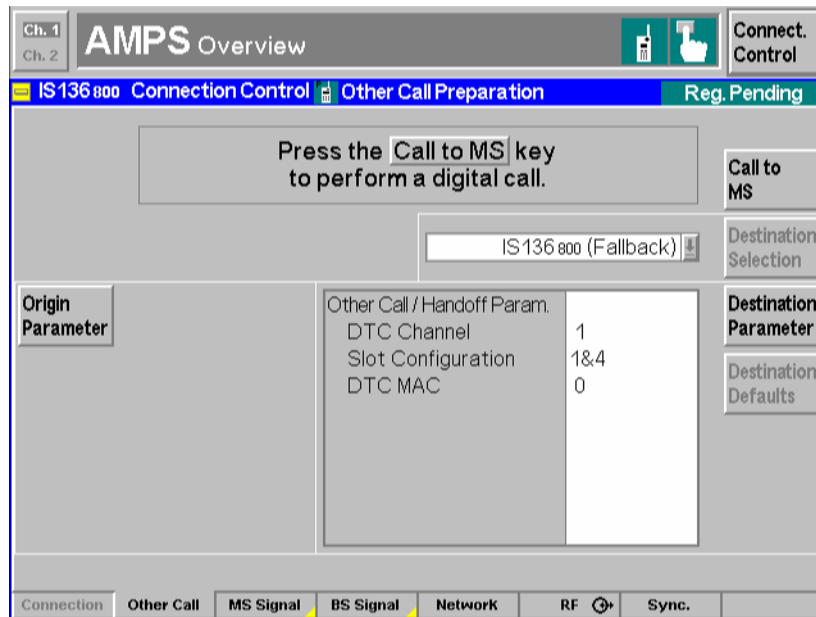

Fig. 4-39 Connection Control – Other Call (destination network preparation)

Destination Parameter

The *Destination Parameter* softkey sets important target network parameters that come into effect as soon as the call is established.

The entries depend on the target network selected via *Destination Selection*. For *AMPS* destination networks, the following list is provided:

- Voice Channel* Number of the *voice* channel used in the destination network.
- VMAC* Voice mobile attenuation code (set at the mobile), see [Table 4-3](#) on page 4.65.

More destination parameters can be set in the *BS Signal* (see p. 4.81 ff) and the *Network* tabs (see p. 4.85 ff).

Note: *By default the destination parameters (other call/handoff parameters) are independent from the (current or default) parameters used in the*

origin network. It is possible though to couple the different sets of parameters; see [Parameter Coupling](#) on p. 4.89.

Remote control CONFigure:BSSignal:OCHandoff[:AVC]:CHANnel <Channel>
 CONFigure:NETWork:OCHandoff[:MS]VMAC <MAC>

Destination Defaults

The *Destination Defaults* softkey resets all changed *Destination Parameters* to default values.

The softkey is disabled if no changes have been made in the *Destination Parameter* list.

Remote control CONFigure:BSSignal:OCHandoff[:AVC]:CHANnel DEF
 CONFigure:NETWork:OCHandoff[:MS]VMAC DEF

Call to MS

The *Call to MS* initiates the call to the target network.

Remote control PROCedure:SIGNalling:ACTion OCALl

Origin Parameter

The *Origin Parameter* softkey cancels the *Other Call* and resets the CMU to the previous signalling state (*Signal On* or *Registered*; see [Fig. 4-38](#)).

The destination parameters set in the *Reg. Pending* state are maintained. To drop the *Other Call* and return to the measurement mode, press the *ESCAPE* key or the *Connection Control* softkey.

Handoff to another Network (Connection Control – Handoff)

The *Handoff* tab initiates a handoff of the call connection to a different network. It is therefore available in the *Call Established* signalling state only. The handoff process includes:

- Selection of the target network (*Destination Selection*) and the handoff parameters (*Destination Parameter, Destination Defaults*)
- Start of the handoff procedure (*Handoff*)
- Return to the original network (*Origin Parameter*)

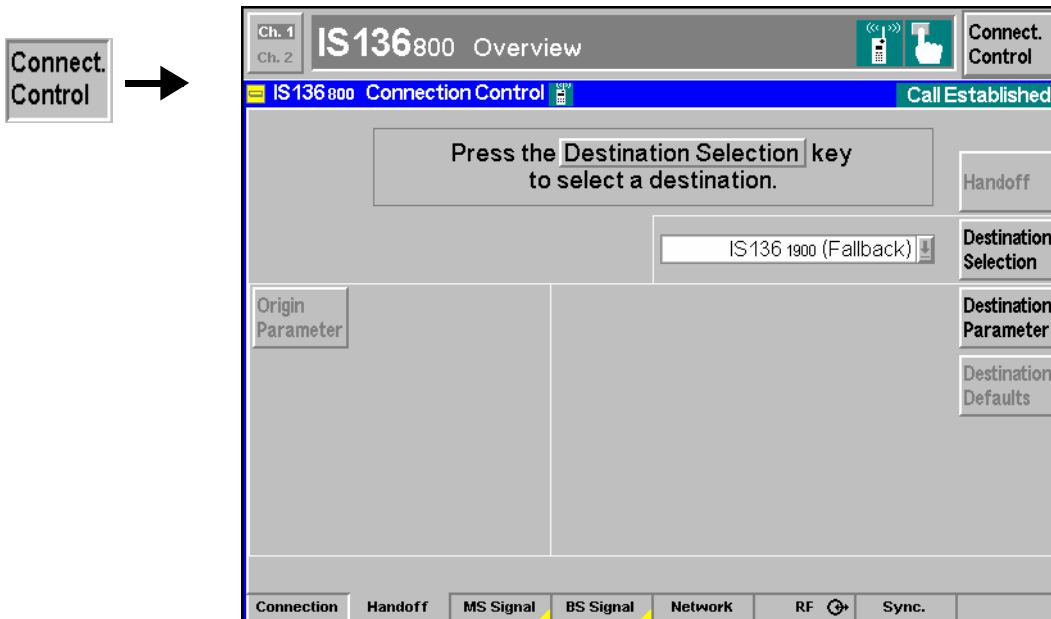

Fig. 4-40 Connection Control – Handoff (destination selection)

Destination Selection

The softkey *Destination Selection* selects the target network for handoff.

For function group *AMPS-MS*, handoff to the 800 MHz and the 1900 MHz band of the digital IS 136 network is provided. Furthermore, a *Handoff* destination with fallback (e.g. *IS 136 800 (Fallback)*) means that the CMU returns to the function group of the origin network after the call is released. The target network list may be restricted if the mobile under test does not support all target networks.

Once the selection of the target network is confirmed via *Enter*, the CMU changes to the *Call Pending* signalling state. In this state, the entire *Connection Control* menu is mapped onto the target function group, so it is possible to edit the *Destination Parameters* (see below), the *BS Signal*, and the *Network* parameters of the target network.

Remote control `STATus:HANDoff:TARGet:LIST?`
 `CONFigure:HANDoff:TARGet <Target>`

Note: *Call Pending* is an intermediate signalling state that only occurs in the context of a handoff process and is therefore not shown in Fig. 4-27 (page 4.60). For a complete overview of signalling states see Fig. 6.1 in chapter 6 of this manual.

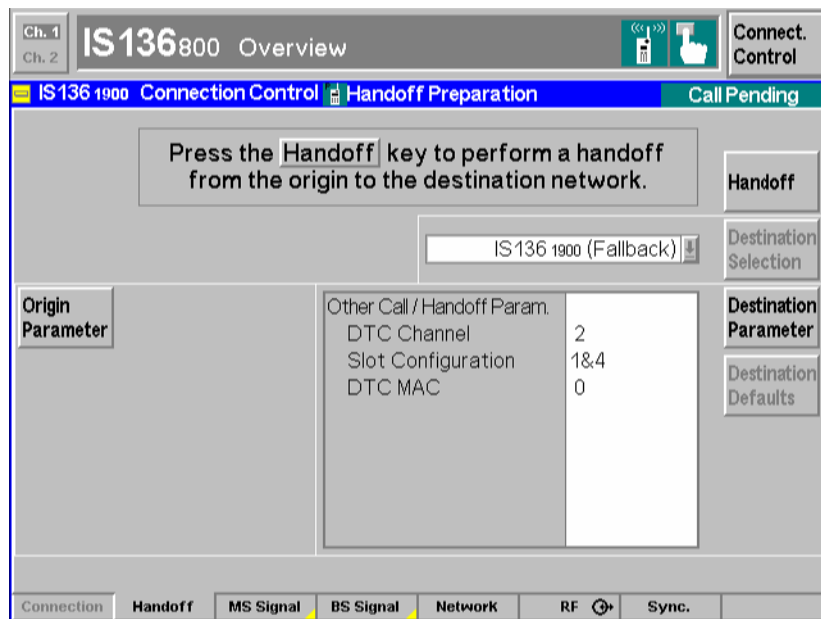

Fig. 4-41 Connection Control – Handoff (destination network preparation)

Destination Parameter

The *Destination Parameter* softkey sets the parameters of the target network for handoff.

The entries depend on the target network selected via *Destination Selection*. For AMPS destination networks, the following list is provided:

- Voice Channel* Number of the BS voice channel used in the destination network.
- VMAC* Voice mobile attenuation code (set at the mobile), see [Table 4-3](#) on page 4.65.

More destination parameters can be set in the *BS Signal* tab, see section [Signals of the CMU \(Connection Control – BS Signal\)](#) on page 4.83 ff.

Note: *By default the destination parameters (other call/handoff parameters) are independent from the (current or default) parameters used in the origin network. It is possible though to couple the different sets of parameters; see [Parameter Coupling](#) on p. 4.89.*

Remote control `CONFigure:BSsignal:OCHandoff[:AVC]:CHANnel <Channel>`
`CONFigure:NETWork:OCHandoff[:MS]VMAC <MAC>`

Destination Defaults

The *Destination Defaults* softkey resets all changed *Destination Parameters* to default values.

Remote control `CONFigure:BSsignal:OCHandoff[:AVC]:CHANnel DEF`
`CONFigure:NETWork:OCHandoff[:MS]VMAC DEF`

Handoff

The *Handoff* softkey initiates handoff to the target network.

Remote control `PROCedure:SIGNalling:ACTion HANDoff`

Origin Parameter

The *Origin Parameter* softkey cancels the *Handoff* procedure and resets the CMU to the *Call Established* signalling state (see [Fig. 4-40](#)).

The destination parameters set in the *Call Pending* state are maintained. To drop the *Handoff* procedure and return to the measurement mode, press the *ESCAPE* key or the *Connection Control* softkey.

Signals of the Mobile Phone (Connection Control – MS Signal)

The popup menu *MS Signal* configures the signals of the mobile phone and the RF and AF input paths. The functionality of the menu depends on the signalling state:

- Most signal parameters must be set before a call is attempted to the mobile station. They are available in the signalling states *Signal Off*, *Signal On* and *Registered* (otherwise grayed). These parameters are listed in a table-oriented version of the *MS Signal* tab.
- The Voice Mobile Attenuation Code (*VMAC*) can still be changed after the call has been set up, i.e. in the signalling state *Call Established*. This parameter is listed in a softkey-oriented version of the *MS Signal* tab.

The *MS Signal* hotkey toggles between the two versions if it is pressed repeatedly.

Table-Oriented Version

The table-oriented version of the *MS Signal* tab configures the signals of the mobile phone (default values; see note on [current vs. default and other call/handoff values](#) on p. 4.65) and the RF and AF input paths of the CMU. This includes:

- The *Read Control Filler Msg.* statement
- The Mobile Attenuation Code for control and voice channels (*VMAC*, *CMAC*)
- For processes switching between different networks, the *VMAC* in the destination network (*Other Call/Handoff Parameters*)

All settings are available in the signalling states *Signal Off*, *Signal On*, and *Registered*.

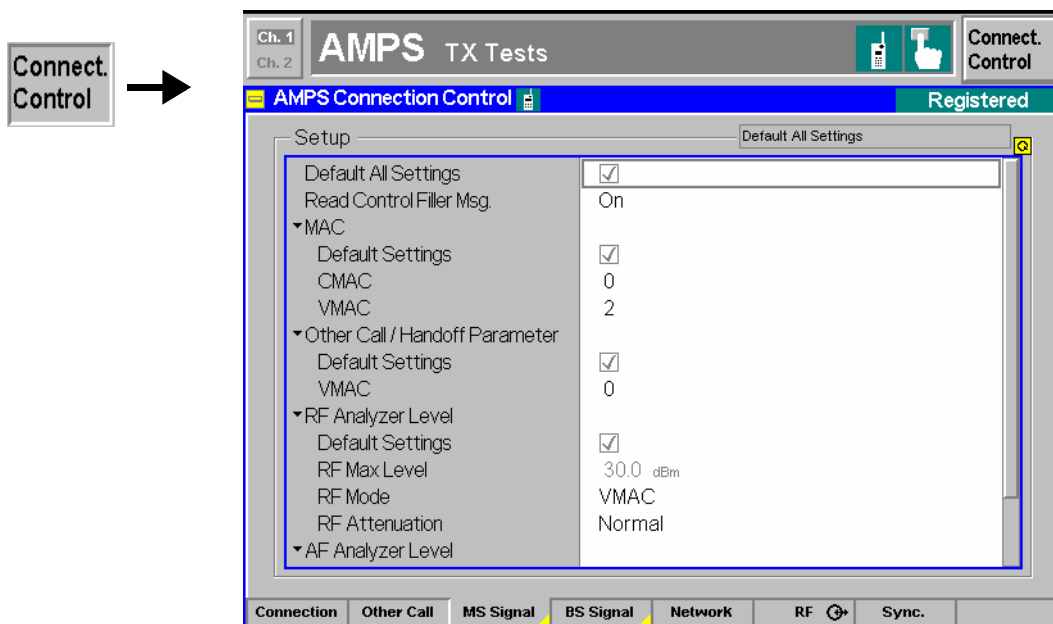

Fig. 4-42 Connection Control – MS Signal (table)

Default Settings The *Default All Settings* switch assigns default values to all settings in the *MS Signal* tab (the default values are quoted in the command description in chapter 6 of this

manual). In addition, a default switch is provided for some of the individual table sections.

Read Control Filler Msg. The *Read Control Filter Msg.* parameter defines whether the mobile must read a control filler message (setting *ON*) before accessing a system on a reverse analog control channel.

Remote control `CONFigure:NETWork[:MS]:RCFM ON | OFF`

MAC The *MAC* section sets the *Mobile Attenuation Code* for the control channel and voice channel signals (*CMAC* and *VMAC*) of the mobile phone. The MAC values determine the output power at which the mobile station sets up a call to the network and performs a registration. The MAC scale defined in the standard is listed in [Table 4-3](#) on page 4.65 ff.

Remote control `CONFigure:NETWork[:MS]:CMAC 0 to 7`
`CONFigure:NETWork[:MS]:VMAC 0 to 7`

Other Call / Handoff Parameter The *Other Call / Handoff Parameter* section defines the *VMAC* which come into effect if the call is set up or handed off from another network. See sections [Call to Another Network \(Connection Control – Other Call\)](#) on page 4.76 and [Handoff to another Network \(Connection Control – Handoff\)](#) on page 4.78.

Remote control `CONFigure:NETWork:OCHandoff[:MS]:VMAC 0 to 7`

Softkey-Oriented Version

The softkey-oriented version of the *MS Signal* tab sets the Voice Mobile Attenuation Code (*VMAC*). This parameter can be set in the signalling states *Signal Off*, *Signal On* and *Registered* (default value). However, it can still be changed while a call connection is established (current value, signalling state *Call Established*). See note on [current vs. default and other call/handoff values](#) on p. 4.65.

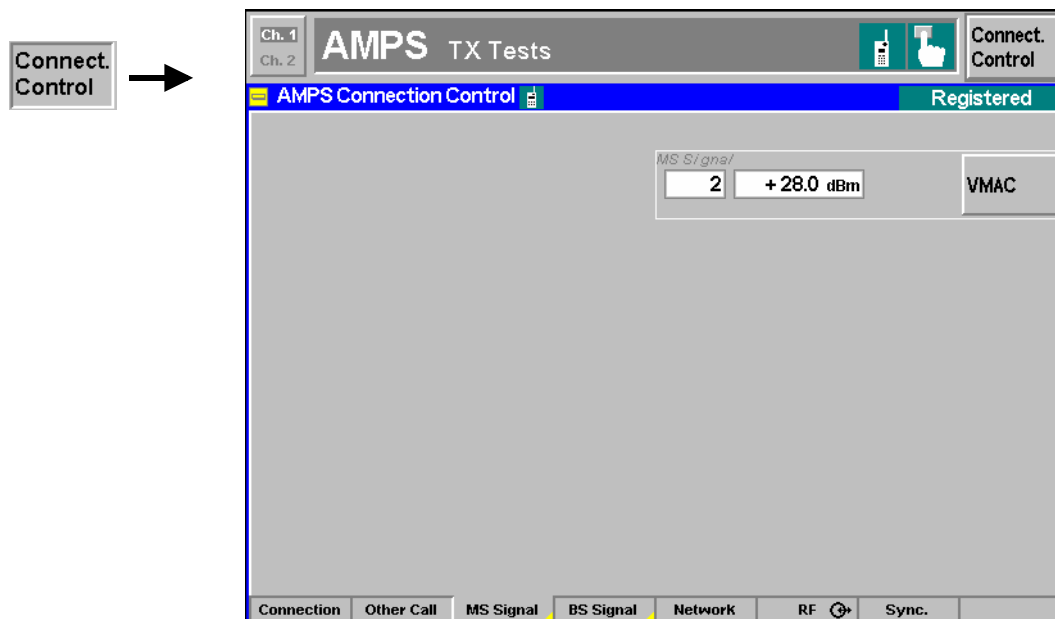

Fig. 4-43 Connection Control – MS Signal (softkey)

The MAC scale defined in the standard is listed in [Table 4-3](#) on page 4.65 ff.

Signals of the CMU (Connection Control – BS Signal)

The popup menu *BS Signal* configures the signals of the CMU which simulates a base station transmitting a control channel (CC) and a voice channel (VC) signal plus several signals in the AF range. The functionality of the menu depends on the signalling state:

- Most signal parameters must be set before a call is attempted to the mobile station. They are available in the signalling states *Signal Off*, *Signal On* and *Registered* (otherwise grayed). These parameters are listed in a table-oriented version of the *BS Signal* tab.
- The channel number and level in the voice channel (*Voice Channel, AVC Level*) level can still be changed after the call has been set up, i.e. in the signalling state *Call Established*. These parameters are listed in a softkey-oriented version of the *BS Signal* tab.

The *BS Signal* hotkey toggles between the two versions if it is pressed repeatedly.

Table-Oriented Version

The table-oriented version of the *BS Signal* tab configures the signals that the CMU uses to attempt a call to the mobile phone (default values; see note on [current vs. default and](#) other call/handoff values on p. 4.65). This includes:

- The parameters of the control and voice channels and the SAT
- For processes switching between different networks, the voice channel and SAT parameters in the destination network (*Other Call/Handoff Parameters*)

All settings are available in the signalling states *Signal Off*, *Signal On*, and *Registered*.

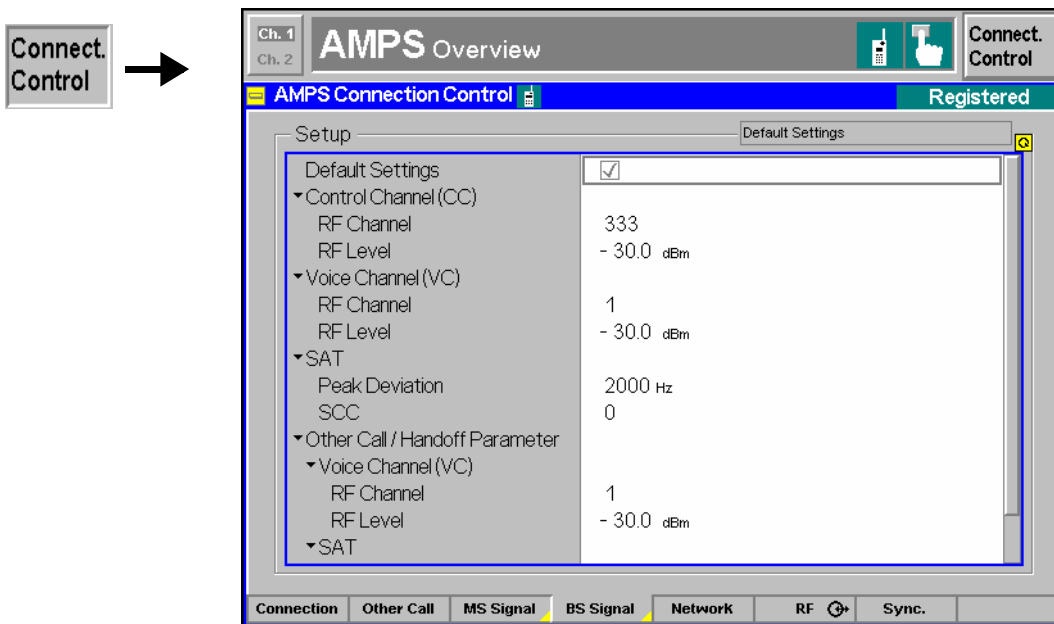

Fig. 4-44 Connection Control – BS Signal (table)

Default Settings The *Default Settings* switch assigns default values to all parameters of the popup menu *BS Signal*. The default values are quoted in the command description in chapter 6 of this manual.

Control channel / Voice channel / SAT The sections *Control Channel (CC)* and *Voice Channel (VC)* define the channel number, RF level of the control and voice channel signals and of the SAT generated by the CMU. See also section [Connection Control with Call Established](#) on page 4.74 ff.

Remote control `CONFigure:BSSignal:ACC:CHANnel <ACChannel>`
`CONFigure:BSSignal:ACC:LEVel <Level> etc.`

Other Call / Handoff Parameter The *Other Call / Handoff Parameter* section defines voice channel (VC) and SAT parameters of the mobile in the current network, which come into effect if the call is set up or handed off from another network. See sections [Call to Another Network \(Connection Control – Other Call\)](#) on page 4.76 and [Handoff to another Network \(Connection Control – Handoff\)](#) on page 4.78.

Remote control `CONFigure:BSSignal[:AVC]:CHANnel <VChannel> etc.`

Softkey-Oriented Version

The softkey-oriented version of the *BS Signal* tab sets the channel number and level of the Analog Voice Channel (AVC). These parameters can be set in the signalling states *Signal Off*, *Signal On* and *Registered* (default values). However, they can still be changed while a call connection is established (current values, signalling state *Call Established*). See note on [current vs. default and other call/handoff values](#) on p. 4.65.

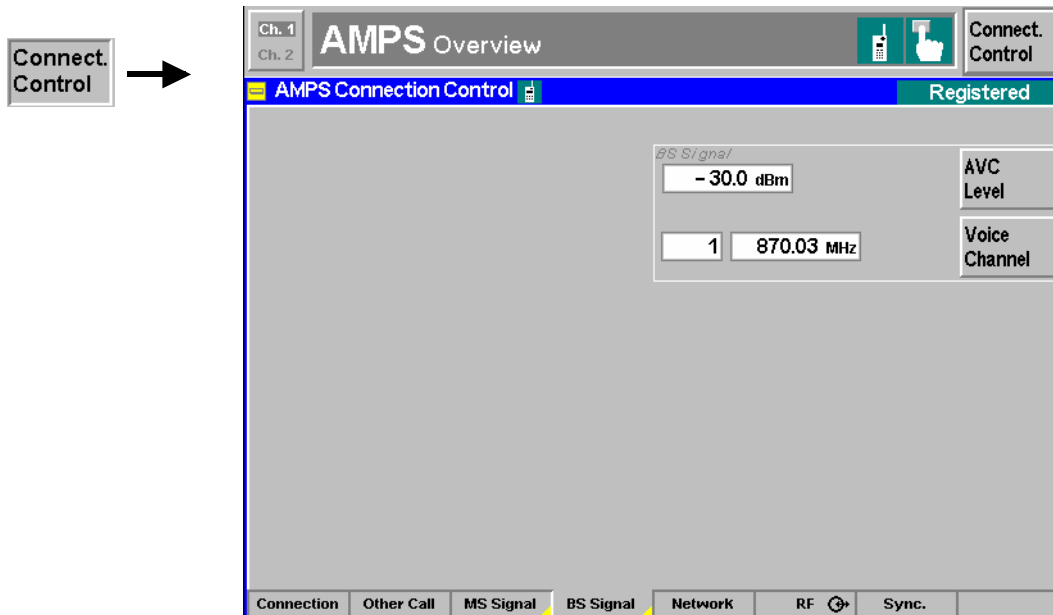

Fig. 4-45 Connection Control – BS Signal (softkey)

AVC Level

The *AVC Level* softkey defines the level of the CMU's voice channel signal.

Remote control `CONFigure:BSSignal[:AVC]:LEVel <Level>`
`PROCedure:BSSignal[:AVC]:LEVel <Level>`

Voice Channel

The *Voice Channel* softkey defines the channel number and frequency of the CMU's voice channel signal.

It is sufficient to enter either the channel number or the frequency; the other value is automatically determined according to the AMPS channel assignment. For an overview of the *AMPS* channel assignment in the forward path (from the base station/CMU to the mobile) see [Table 4-2](#) on p. 4.52 ff.

Remote control

```
CONFigure:BSsignal[:AVC]:CHANnel <Channel_No>
PROCedure:SIGNalling[:AVC]:CHANnel <Channel_No>
```

Network Parameters (Connection Control – Network)

The popup menu *Network* defines various parameters of the network and the mobile station. This includes

- Parameters characterizing the network (*Network Identity*)
- Control parameters for Registration and default IMSI (*Signalling Modes*)
- Parameters of the mobile station that are requested by the CMU during registration or when a call is being established (*Requested Mobile Data*)
- *System Parameters*
- *Timeouts*
- For processes switching between different networks, voice channel parameters in the destination network (*Other Call/Handoff Parameter*).

This menu is not available in the *Alerting* and in the *Call Established* signalling states.

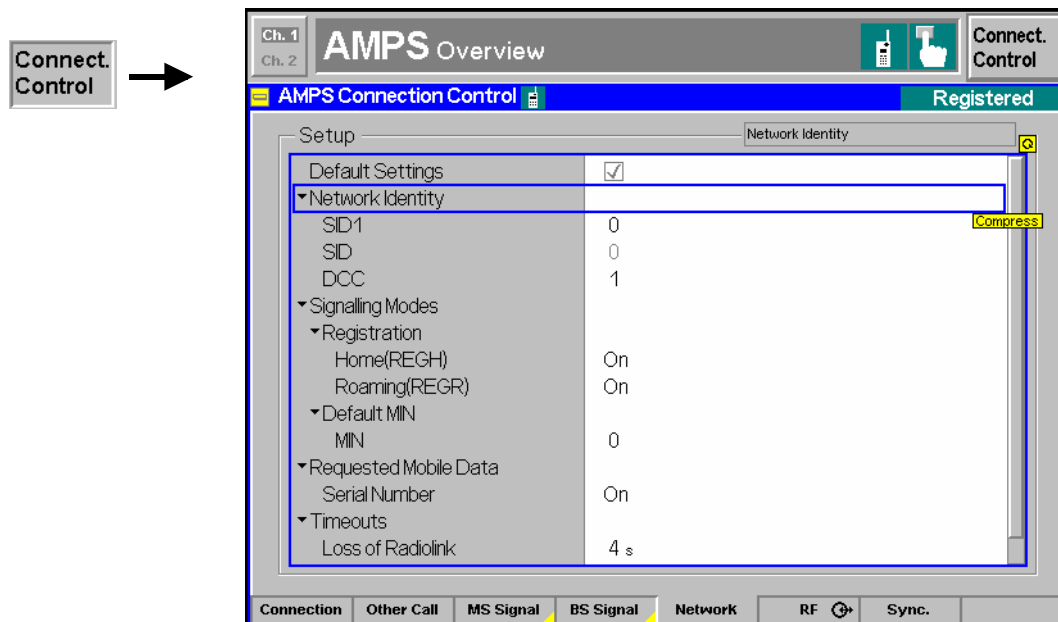

Fig. 4-46 Connection Control – Network parameters

Network Identity	<p>The field <i>Network Identity</i> contains the parameters identifying the radio network:</p> <p><i>SID 1</i> 14-bit System Identity (<i>SID 1</i>) – a unique number identifying the cellular system (network). Together with a 1-bit identifier for the channel system A or B, the <i>SID 1</i> forms the 15-bit <i>SID</i> (see also section Connection Control on page 4.60 ff).</p> <p><i>DCC</i> Digital Color Code – a digital signal transmitted by the base station on a forward analog control channel that is used to detect capture of a base station by an interfering mobile station.</p>
Remote control	<pre>CONFigure:NETWork:IDENtity:SID1 <Code> CONFigure:NETWork:IDENtity:DCC <Code></pre>
Signalling Modes	<p>The <i>Signalling Modes</i> field determines signalling parameters that the CMU sends to the mobile station to control its function (the parameters for CMU signals, on the other hand, are set in the popup menu BS-Signal, see section Signals of the CMU (Connection Control – BS Signal) on p. 4.83 ff.). The parameters refer to:</p> <ul style="list-style-type: none"> • <i>Registration</i>, • Input of a mobile station identification (<i>Default MIN</i>).
Registration	<p>The section <i>Registration</i> defines when a registration procedure is to be executed. All of the following registration type parameters can be switched <i>On</i> and <i>Off</i>.</p> <p><i>Home (REGH)</i> Registration for home mobile stations allowed/not allowed. A home mobile station is a MS operating in the cellular system (network) from which service is subscribed.</p> <p><i>Roaming (REGR)</i> Registration for roaming mobile stations allowed/not allowed. A roaming mobile station is a MS operating outside the cellular system (network) from which service is subscribed.</p> <div style="background-color: #f0f0f0; padding: 5px; margin-top: 10px;"> <p>Registration is the process by which the mobile phone identifies itself to the network and makes itself available for service. Registration may be in order in many cases where the operating mode of the mobile is changed.</p> <p>In practice, when the mobile encounters a registration type, it checks whether the associated registration parameter is set. If this is true, it sends a registration message including the registration type to the network. The network may either accept or reject registration. After successful registration of the mobile phone under test, the CMU passes on to the signalling state <i>Registered</i>.</p> </div>
Remote control	<pre>CONFigure:NETWork:SMODE:REGH ON OFF CONFigure:NETWork:SMODE:REGR ON OFF CONFigure:NETWork:SMODE:IDMin <Code></pre>
Default MIN	<p>The section <i>Default MIN</i> defines the 34-bit mobile station identification number (MIN) which is used to set up a call to the mobile. Thus, the default setting enables a call to a mobile station with known MIN which is not registered yet.</p> <p>If the MIN is not known, a call can still be set up from the mobile. In this case (and if the mobile initiates a registration, see above) the actual MIN of the mobile station supersedes the default MIN as soon as it is transferred to the tester.</p>
Remote control	<pre>CONFigure:NETWork:SMODE:IDMin <Code></pre>
Requested Mobile Data	<p>The field <i>Requested Mobile Data</i> determines the signalling parameters of the mobile station to be requested during registration and displayed in the <i>Connection Control – Signalling (Registered)</i> menu (see page 4.71 ff.):</p> <p><i>Serial Number</i> Request of the mobile's serial number (<i>On</i>) or no request (<i>Off</i>).</p>
Remote control	<pre>CONFigure:NETWork:SNUMber ON OFF</pre>

Timeouts	The <i>Timeouts</i> field defines a timeout period after which an interrupted radio link is aborted:	
	<i>Loss of Radiolink</i>	Time (in s) after which the CMU drops an established but interrupted connection (e.g. due to low signal level).
	<i>Registration period</i>	Time period in s after which the CMU forces the mobile station to (re-)register (or <i>Off</i> , for no forced registration). With forced registration, it is possible to return to the <i>Registered</i> state automatically if the BS signal is temporarily switched off.
	The time limit is of particular importance in remote-control mode. For example, the remote-control program will not be able to continue if the keyboard of the mobile station is defective and the mobile is therefore not able to answer the call.	
Remote control	CONFigure:NETWork:TIMEout:LOrLink	<Time>
	CONFigure:NETWork:TIMEout:RPERiod	<Time>

Connectors (Connection Control – AF/RF Input/Output)

The popup menu *AF/RF*  selects the connectors for RF signals. This includes determination of

- RF input and RF output at the CMU (*RF Output*, *RF Input*)
- An external attenuation at the connectors (*Ext. Att. Output*, *Ext. Att. Input*)
- Switchover between internal and external modulation signal (*Mod. Source*)

The functions of this menu are described in the section *AMPS-MS Non Signalling* on page [4.54](#).

Reference Frequency (Connection Control – Sync.)

The popup menu *Sync.* determines the reference signal for synchronization. This includes:

- The selection of internal or external reference frequency,
- The output mode for the reference frequency (*F REF OUT 2*).

The functions of this menu are described in the section *AMPS-MS Non Signalling* on page [4.57](#).

Analyzer Settings (Connection Control – Analyzer)

The *Analyzer* tab is part of the second group of tabs in the *Connection Control* menu. It is accessible after pressing the *1 / 2* toggle hotkey once. Pressing *1 / 2* again switches back to the first group of tabs described above.

The *Analyzer* tab configures the RF and AF input path of the CMU (*RF Analyzer Level*, *AF Analyzer Level*). The settings are available in all signalling states.

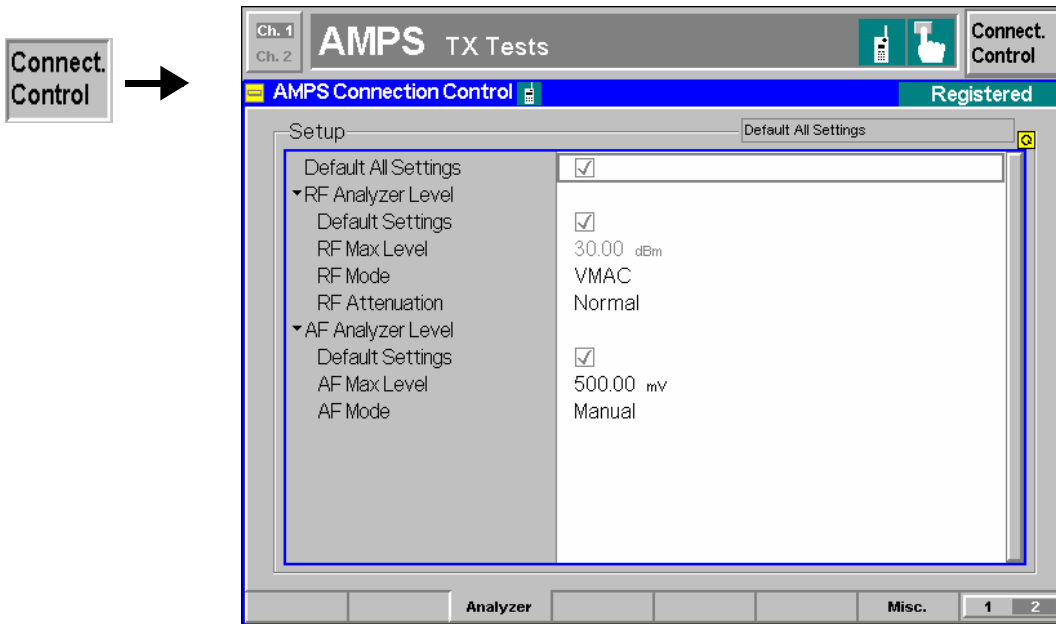

Fig. 4-47 Connection Control – MS Signal (table)

Default Settings The *Default All Settings* switch assigns default values to all settings in the *Analyzer* tab (the default values are quoted in the command description in chapter 6 of this manual). In addition, a default switch is provided for some of the individual table sections.

```
[SENSe:]LEVel:DEFAult ON | OFF
[SENSe:]AFLeVel:DEFAult ON | OFF
```

RF Analyzer Level The *RF Analyzer Level* section configures the RF input signal path. All settings are identical to the corresponding settings in *Non Signalling* mode (*Analyzer* tab of the *Connection Control* menu; see section [Table-Oriented Version](#) on p. 4.48 ff.). In addition, the RF level can also be set according to the VMAC of the mobile phone (setting *RF Mode* = VMAC).

Remote control [:SENSe]:LEVel...

AF Analyzer Level The *AF Analyzer Level* section configures the AF input signal path. All settings are identical to the corresponding settings in *Non Signalling* mode (*Analyzer* tab of the *Connection Control* menu; see section [Table-Oriented Version](#) on p. 4.48 ff.).

Remote control [:SENSe]:AFLeVel...

Miscellaneous Settings (Connection Control – Misc)

The *Misc.* tab is part of the second group of tabs in the *Connection Control* menu. It is accessible after pressing the 1 / 2 toggle hotkey once. Pressing 1 / 2 again switches back to the first group of tabs described above.

The *Misc.* tab defines in what instances the *Connection Control* popup menu is automatically opened or closed (*Connect. Control Guidance*) and enables or disables the coupling of current and default parameters.

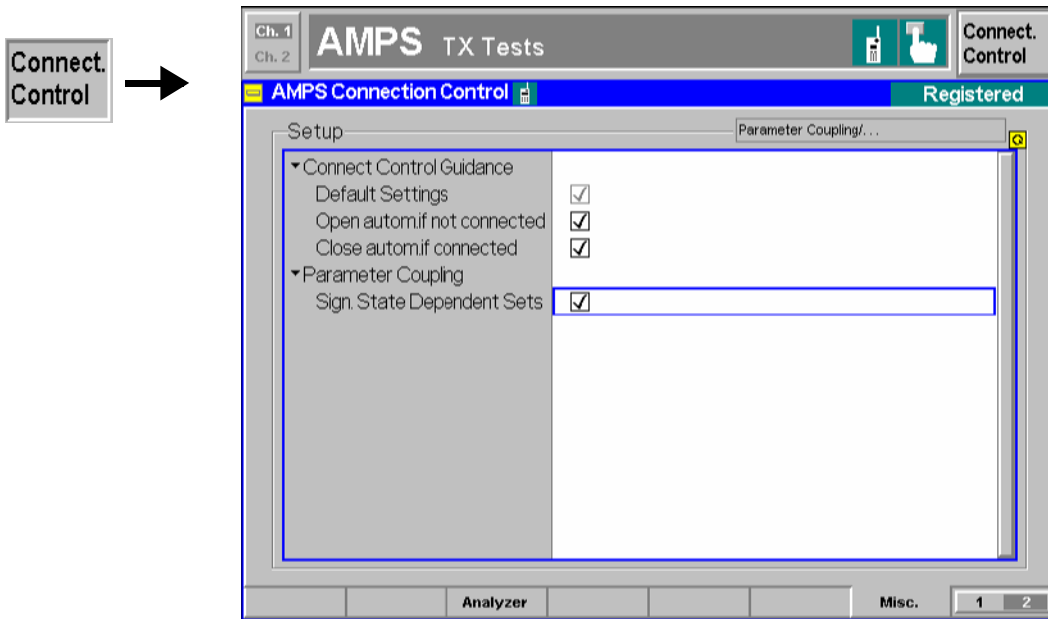

Fig. 4-48 Connection Control – Misc

Connect. Control Guidance Defines in what instances the *Connection Control* popup menu is automatically opened or closed:

Open autom. if not connected

In the *Open automatically* mode, the *Connection Control* menu is automatically opened each time the WCDMA function group is accessed in *Signalling* test mode, each time a measurement menu is opened while the DUT is not connected and each time a connection is lost. Otherwise the menu must be opened manually.

Close autom. if connected

In the *Close automatically* mode, the *Connection Control* menu is automatically closed as soon as the CMU reaches the *Call Established* state. Otherwise the menu must be closed manually.

Remote control No command; screen configuration only.

Parameter Coupling Qualifies whether *default*, *current* and *other call/handoff* parameter values are coupled or independent (see also note on *current vs. default and other call/handoff* values on p. 4.65):

Sign. State Dependent Sets

If the parameter is enabled (box checked), the CMU uses independent parameter sets for *current* and *default* values and for *other call/handoff* values. In particular, changing the current value during a call does not alter the default value used to set up the next call.

If the parameter is disabled (box unchecked), *default*, *current* and *other call/handoff* values are equal. In particular, changing the default value (in one of the signalling states *Signal Off*, *Signal On* or *Registered*) affects the current value (used in signalling state *Call Established*) and vice versa.

The reset values for the default parameter set are optimized for a call setup. Selecting *Sign. State Dependent Sets* generally ensures that a subsequent call will not fail after the parameters have been changed in the *Call Established* state.

Remote control CONFIGure:SDSets:ENABLE ON | OFF

Contents

5 Remote Control – Basics.....	5.1
Structure of the AMPS-MS Function Groups.....	5.1
Measurement Control.....	5.2
Measurement Groups	5.2
Measurement Statistics.....	5.3
Specifying Limits	5.4
Status Reporting System.....	5.5
Special Terms and Notation	5.6

Measurement groups (MSSinfo).

The structure of chapter 6 differs from chapter 4 (*Functions and their Application*) where the measurements are presented first and configurations pertaining to the whole function group and test mode are reported at the end of each section.

The menu of the graphical user interface corresponding to a group of commands is quoted at the beginning of each section. Lists of all commands (by function and alphabetical) are annexed to chapter 6.

SCPI Conformity

In view of the particular requirements of AMPS-MS measurements, not all commands could be taken from the SCPI standard. However, the syntax and structure of all commands is based on SCPI rules. For a detailed description of the SCPI standard refer to chapter 5 of the CMU operating manual.

SCPI confirmed and SPCI approved commands are explicitly marked throughout chapter 6.

Remote Control

All commands may be used for control of the CMU via GPIB interface or serial (RS-232) interface.

Measurement Control

The commands in the measurement groups quoted above (WPOWER, TXTests..., RXTests... etc.) have an analogous structure and syntax. The measurements are controlled according to the common concepts outlined in Chapter 5 of the CMU operating manual. The following sections show how the general concepts are applied to AMPS-MS measurements.

Measurement Groups

The measurement groups are referred to as *measurement objects* (keyword <meas_obj>) in remote control. For AMPS-MS measurements, the following measurement objects are defined:

Table 5-1 Measurement objects in the *Signalling* and *Non Signalling* mode

AMPS-MS Non Signalling	AMPS-MS Signalling
<p>WPOWER</p> <p>Wide-band peak power measurement of the input signal.</p>	<p>WPOWER</p> <p>Wide-band peak power measurement of the input signal.</p>
<p>TXTests</p> <p>Quantities characterizing the mobile transmitter quality (TXTests:MODulation, TXTests:HNOise, TXTests:AFLevel, TXTests:WBData), measured with variable RF and AF output signals of the CMU, including limit check.</p> <p>Three fast TXTests applications omitting the SAT and ST measurements are available in remote control: See subsystems</p> <p>...TXTests:MODulation:TADeviation ...TXTests:MODulation:CPOWER ...TXTests:HNOise:FHNOise</p>	<p>TXTests</p> <p>Quantities characterizing the mobile transmitter quality (TXTests:MODulation, TXTests:HNOise, TXTests:AFLevel, TXTests:WBData), measured with variable RF channels and AF output signals of the CMU and at variable VMAC level of the mobile phone, including limit check.</p> <p>Three fast TXTests applications omitting the SAT and ST measurements are available in remote control: See subsystems</p> <p>...TXTests:MODulation:TADeviation ...TXTests:MODulation:CPOWER ...TXTests:HNOise:FHNOise</p>

AMPS-MS Non Signalling	AMPS-MS Signalling
<p>TXAFresp</p> <p>Electrical audio frequency response of the MS transmitter including limit check.</p>	<p>TXAFresp</p> <p>Electrical audio frequency response of the MS transmitter at variable VMAC level of the mobile phone including limit check.</p>
<p>RXTests</p> <p>Quantities characterizing the mobile receiver quality (RXTests:AFAnalyzer, RXTests:HNOIse, TXTests:SENSitivity), measured with variable RF CMU output signals, including limit check.</p> <p>A fast RXTests application omitting the AF distortion measurement is available in remote control: See subsystem ...RXTests:AFAnalyzer:VMSinad</p>	<p>RXTests</p> <p>Quantities characterizing the mobile receiver quality (RXTests:AFAnalyzer, RXTests:HNOIse, TXTests:SENSitivity), measured with variable RF CMU output signals and at variable VMAC level of the mobile phone, including limit check.</p> <p>A fast RXTests application omitting the AF distortion measurement is available in remote control: See subsystem ...RXTests:AFAnalyzer:VMSinad</p>
<p>RXAFresp</p> <p>Electrical audio frequency response of the MS receiver including limit check.</p>	<p>RXAFresp</p> <p>Electrical audio frequency response of the MS receiver at variable VMAC level of the mobile phone including limit check.</p>

The measurement objects in Table 5-1 are complemented by groups of commands used to retrieve results that are automatically provided by the mobile station (e.g. the receiver parameters reported by the mobile phone). These command groups do not represent real measurement objects; they consist of queries only. For an overview, see the list of remote control commands at the end of chapter 6.

Measurement Statistics

A single shot AMPS measurement (called one measurement cycle) lasts until valid (stable) results can be obtained. As a consequence, no *Statistic Count* can be defined; and there is no equivalent to the `CONFigure:<meas_obj>:CONTRol SCALar | ARRay, 1 ... 1000 | NONE` commands available in digital networks. The *Repetition Mode*, however, can be set using the `CONFigure:<meas_obj>:CONTRol:REPetition...` commands (see Table 5-2 below).

In many instances, the average, minimum or maximum over several measurement cycles is calculated. This aspect is explained in chapter 3 of this manual.

Table 5-2 Repetition mode in remote control

Setting	Description	Command
<p>Repetition mode Single Shot</p>	<p>The measurement is stopped after one cycle.</p>	<p><code>CONFigure:<meas_obj>:CONTRol:REPetition SINGleshot, <StopCondition>, <Stepmode> (<meas_obj> = TXTests:<Applic> TXAFresp RXTests:<Applic> RXAFresp)</code></p>
<p>Continuous</p>	<p>The measurement is continued until stopped explicitly or by a limit failure. The statistics window for the calculation of average results is continuously shifted (continuous averaging).</p>	<p><code>CONFigure:<meas_obj>:CONTRol:REPetition CONTinuous, <StopCondition>, <Stepmode> (<meas_obj> = TXTests:<Applic> TXAFresp RXTests:<Applic> RXAFresp)</code></p>
<p>Counting</p>	<p>Repeated single shot measurement with configured measurement cycles.</p>	<p><code>CONFigure:<meas_obj>:CONTRol:REPetition 1 ... 10000, <StopCondition>, <Stepmode> (<meas_obj> = TXTests:<Applic> TXAFresp RXTests:<Applic> RXAFresp)</code></p>

Specifying Limits

The following table gives an overview of the types of limits and possible results of the limit check.

Table 5-3 Limits and limit check

Type	Description	Command
Scalar limits	Limit values for a single (scalar) measured quantity. Depending on the measured quantity, upper or lower limits can be defined.	<pre>CONFigure:<meas_obj>:LIMit <LowerLimit_1> <UpperLimit_1>, <LowerLimit_2> <UpperLimit_2>, ...</pre> <p><meas_obj> denotes the measurement groups TXTests or RXTests with their applications.</p>
Limit lines	For audio frequency response (TXAFresp or RXAFresp) measurements, a tolerance template consisting of several areas can be defined.	<pre>CONFigure:<meas_obj>:LIMit[:LINE] [:ASYMmetrical]:UPPer <Limit_line_param.></pre> <pre>CONFigure:<meas_obj>:LIMit[:LINE] [:ASYMmetrical]:LOWer <Limit_line_param.></pre> <p><meas_obj> denotes the measurement groups TXAFresp or RXAFresp.</p> <p><Limit_line_param.> denotes a list of limit values an enable/disable variable for each area.</p>
	The areas of the tolerance template can be defined and enabled separately.	<pre>CONFigure:<meas_obj>:LIMit[:LINE] [:ASYMmetrical]:UPPer:TONE<nr> <Limit>, <Enable></pre> <pre>CONFigure:<meas_obj>:LIMit[:LINE] [:ASYMmetrical]:LOWer:TONE<nr> <Limit>, <Enable></pre> <p><meas_obj> denotes the measurement groups TXAFresp or RXAFresp.</p>
Limit check	All scalar limits belonging to the same measurement group are read out together with the command on the right side.	<pre>CALCulate[:SCALar]:<meas_obj.> [:RESult]:MATChing:LIMit?</pre> <p><meas_obj> denotes the measurement groups TXTests or RXTests with their applications.</p>
	Possible results of the scalar limit check are listed on the right side. Further messages assessing, e.g., the power ramp or the result of the BER test in general, may be issued in particular cases (see detailed command description in chapter 6).	<pre>NMAU not matching, underflow NMAL not matching, overflow INV measured value invalid OK no limit failure</pre>
	Limits for different areas can be evaluated with a single combined command or for each area separately.	<pre>CALCulate[:SCALar]:<meas_obj.> [:RESult]:MATChing:LIMit[:LINE][:ASYMme trical][:COMBined]?</pre> <pre>CALCulate[:SCALar]:<meas_obj.> [:RESult]:MATChing:LIMit[:LINE][:ASYMme trical][:COMBined]:TONE<nr>?</pre> <p><meas_obj> denotes the measurement groups TXAFresp or RXAFresp.</p>

Status Reporting System

A general description of SCPI status registers and of the status reporting system is given in chapter 5 of the CMU operating manual. This section is devoted to the particular features concerning AMPS-MS measurements.

The CMU offers 30 independent `STATUS:OPERation:CMU:SUM1|2:CMU<nr>` sub-registers (<nr>=1 ... 15) which are implemented in hierarchical form. The bits of the 30 `STATUS:OPERation` registers are set only after the registers are assigned to a function group and measurement mode.

In the `CONDition` part, the `STATUS:OPERation` register contains information on which actions the instrument is being executing or, in the `EVENT` part, information on which actions the instrument has executed since the last readout. All five parts of the registers can be read using one of the commands of the subsystem `STATUS:OPERation:SUM1|2:CMU<nr>:...` in the CMU base system.

Note: *Symbolic status register evaluation by means of the commands `STATUS:OPERation:SYMBOLic:ENABLE` and `STATUS:OPERation:SYMBOLic[:EVENT]?` is a convenient alternative method of retrieving status information. See chapter 6 of this manual.*

AMPS-MS mobile tests comprise the two signalling modes *Non Signalling* and *Signalling* so that 2 different secondary addresses are used. In the status register for the *Non Signalling* mode the bit assignment is as follows:

Table 5-4 Meaning of the bits used in the `STATUS:OPERation:CMU:SUM1|2:CMU<nr>` sub-registers assigned to *AMPS-MS Non Signalling*

Bit-No.	Meaning	Symbol in <code>STAT:OPER:SYMB...</code>
4	Measurement Invalid This bit is set if the active measurement could not performed and terminated correctly (e.g. because of a low signal level) so that the measurement results are invalid.	MINV
11	RF Input Overdriven This bit is set if the RF input level at connector RF1, RF2 or RF 4 IN is larger than the specified <i>RF Max. Level</i> plus an appropriate margin.	RFIO
12	RF Input Underdriven This bit is set while the RF input level at connector RF1, RF2 or RF 4 IN falls below the measurement range controlled by the specified <i>RF Max. Level</i> .	RFIU

In the status register for the *Signalling* mode the bit assignment is as follows:

Table 5-5 Meaning of the bits used in the `STATUS:OPERation:CMU:SUM1|2:CMU<nr>` sub-registers assigned to *AMPS-MS Signalling*

Bit-No.	Meaning	Symbol in <code>STAT:OPER:SYMB...</code>
0	Call from Mobile This bit is set when the CMU receives a call from the mobile under test.	CFM
1	Release from Mobile This bit is set when the connection to the mobile is being released.	RFM

Bit-No.	Meaning	Symbol in STAT:OPER:SYMB...
2	Loss of Radio Link This bit is set if the CMU had to leave the signalling state "Call Established" (because of a low signal etc.).	LORL
3	Mobile Registered This bit is set when a registration was successfully performed.	MREG
4	Measurement Invalid This bit is set if the active measurement could not be performed and terminated correctly (e.g. because of a low signal level) so that the measurement results are invalid.	MINV
7	Mobile Deregistered This bit is set if the CMU had to leave the signalling state "Registered" (because of a low signal etc.).	MDER
9	Traffic Channel Active This bit is set when voice data is transmitted via the analog voice channel.	TCH
11	RF Input overdriven This bit is set if one of the three RF input connectors is overdriven.	RFIO
12	RF Input underdriven This bit is set if one of the three RF input connectors is underdriven.	RFIU
13	AF Input overdriven This bit is set if the AF input connector AF IN is overdriven.	AFIO
14	AF Input underdriven This bit is set if the AF input connector AF IN is underdriven.	AFIU

Special Terms and Notation

Below we list some particular features in the syntax of the AMPS-MS commands. The general description of the SCPI command syntax can be found in chapter 5 of the CMU operating manual, section "Structure and Syntax of Device Messages".

Description of commands

The commands are arranged in tables. From top to bottom, the table rows contain the following entries:

1. Complete command syntax including the parameter list and a short description of the command
2. List and description of the parameters with their default values, the units and unit rings
3. Detailed description of the command, signalling state required for command execution (in *Signalling* mode), required firmware version

Detailed lists of default values are annexed to the command description. Occasionally, groups of analogous commands are described in common tables.

Order of commands

The commands are arranged according to their function specified by the keyword in the second level or in the second/third level combined. Lower-level keywords define the command in more detail. This means that commands with the

same second-level, third-level etc. keywords are generally grouped together in the same sections.

Example: `CONFigure:WPOWer:CONTRol:REPetition`

Commands with the keyword *WPOWer* in the second level belong to the wide-band power measurement. The keywords in the third and fourth level indicate that the command controls the repetition mode of the power measurement.

Combined measurements

To limit the number of remote control commands in an application program, scalar results are always measured together and returned in a common list.

Parameters

Setting commands are usually supplemented by a parameter or a list of several parameters. Parameters either provide alternative options (setting a or setting b or setting c ..., see special character "|"), or they form a list separated by commas (setting x,y).

<Par_Name>

In the command tables and lists, parameters are generally described by a name (literal) written in angle brackets (<>). This literal merely serves as a parameters description; in an application program it must be replaced by one of the possible settings reported in the detailed parameter description.

Example: `[SENSE:]AFLevel:MODE <Mode>`
 with `<Mode>` = `MANual` | `AUTomatic`
 possible command syntax: `AFL:MODE MAN`

NAN

NAN (not a number) is generally used to represent missing data, e.g. if a portion of a trace has not been acquired yet. It is also returned after invalid mathematical operations such as division by zero. As defined in the SCPI standard, NAN is represented as 9.91 E 37.

INV

INV (invalid) is returned if a limit check is performed without defining the appropriate tolerance values.

Upper / lower case

Upper/lower case characters characterize the long and short form of the keywords in a command. The short form consists of all upper-case characters, the long form of all upper case plus all lower case characters. On the CMU, either the short form or the long form are allowed; mixed forms will generally not be recognized. Note that the instrument itself does not distinguish upper case and lower case characters.

Special characters

| A vertical stroke in the parameter list characterizes alternative parameter settings. Only one of the parameters separated by | must be selected.

Example: The following command has two alternative settings:

`[SENSE:]AFLevel:DEFault ON | OFF`

[] *Key words* in square brackets can be omitted when composing the command header (see chapter 5 of the CMU manual, section "Structure of a Command"). The complete command must be recognized by the instrument for reasons of compatibility with the SCPI standard.

Parameters in square brackets are optional as well. They may be entered in the command or omitted.

{ } Braces or curly brackets enclose one or more parameters that may be included zero or more times.

<nr> This symbol denotes a numeric suffix, e.g. an enumeration index for input and output connectors.

Lists of commands

- Command:** The *Command* column of the table contains all remote control commands arranged according to their function (configurations or measurement objects). Within a section, the commands are listed in alphabetical order.
- Parameters:** The *Parameter* column lists the parameters of the commands.
- Remarks:** The *Remarks* column gives additional information about the commands which
- Have no query form (*no query*)
 - Have only a query form (*query only*)
 - Can be used both as setting commands and as queries (*with query*, this applies to all commands belonging to none of the two preceding categories)
- Alphabetical Lists** Chapter 6 concludes with alphabetical command lists for both test modes.

Contents

6 Remote Control – Commands 6.1

AMPS Module Tests (Non Signalling) 6.1

- Connection Control 6.1
 - Subsystem LEVel (RF Input Level)..... 6.1
 - Subsystem AFLevel (AF Input Level) 6.3
 - Subsystem RFANalyzer (Analyzed Input Signals) 6.4
 - Subsystem "RFGenerator" – Generator control 6.5
 - Generator Level – Subsystem RFGenerator:LEVel..... 6.5
 - RF Generator Frequency – Subsystem RFGenerator:FREQuency 6.6
 - Subsystem "AFGenerator" – Generator control..... 6.6
 - Generator Level – Subsystem AFGenerator:LEVel..... 6.7
 - AF Generator Frequency – Subsystem AFGenerator:FREQuency..... 6.7
 - Subsystem "MODGenerator" – Generator control..... 6.8
 - Generator Level – Subsystem MODGenerator:DEViation 6.8
 - Mod. Generator Frequency – Subsystem MODGenerator:FREQuency 6.8
 - Subsystem "SAT" – SAT Generator control 6.9
 - Subsystem "ST" – ST Generator control 6.9
 - Connectors and External Attenuation 6.10
 - Subsystem DM:CLOCK (Network Clock) 6.12
- Symbolic Status Event Register Evaluation..... 6.13

Measurement Groups (Non Signalling and Signalling) 6.14

- WPOWER (Wideband Power) 6.14
- TXTests:MODulation 6.17
 - Control of Measurement – Subsystem TXTests:MODulation..... 6.17
 - Test Configuration..... 6.18
 - Subsystem TXTests:MODulation:CONTRol 6.18
 - Tolerance values – Subsystem TXTests:MODulation:LIMit 6.19
 - Path Configuration – Subsystem TXTests:MODulation:FILTer 6.20
 - Measured Values – Subsystem TXTests:MODulation[:RESult] 6.21
- TXTests:MODulation:TADeViation 6.22
 - Control of Measurement – Subsystem TXTests:MODulation:TADeViation 6.22
 - Test Configuration..... 6.23
 - Subsystem TXTests:MODulation:TADeViation:CONTRol..... 6.23
 - Measured Values – Subsystem TXTests:MODulation:TADeViation[:RESult] 6.24
- TXTests:MODulation:CPOWER 6.25
 - Control of Measurement – Subsystem TXTests:MODulation:CPOWER 6.25
 - Test Configuration..... 6.26
 - Subsystem TXTests:MODulation:CPOWER:CONTRol..... 6.26
 - Measured Values – Subsystem TXTests:MODulation:CPOWER[:RESult]..... 6.27
- TXTests:HNOise 6.28
 - Control of Measurement – Subsystem TXTests:HNOise 6.28
 - Test Configuration..... 6.29
 - Subsystem TXTests:HNOise:CONTRol..... 6.29
 - Tolerance values – Subsystem TXTests:HNOise:LIMit..... 6.30
 - Path Configuration – Subsystem TXTests:HNOise:FILTer..... 6.31
 - Measured Values – Subsystem TXTests:HNOise[:RESult]..... 6.32

TXTests:HNOise:FHNoise	6.33
Control of Measurement – Subsystem TXTests:HNOise:FHNoise	6.33
Test Configuration.....	6.34
Subsystem TXTests:HNOise:FHNoise:CONTRol	6.34
Measured Values – Subsystem TXTests:HNOise:FHNoise[:RESult]	6.35
TXTests:AFLSearch.....	6.36
Control of Measurement – Subsystem TXTests:AFLSearch.....	6.36
Test Configuration.....	6.37
Subsystem TXTests:AFLSearch:CONTRol.....	6.37
Tolerance values – Subsystem TXTests:AFLSearch:LIMit	6.38
Path Configuration – Subsystem TXTests:AFLSearch:FILTer	6.39
Measured Values – Subsystem TXTests:AFLSearch[:RESult]	6.40
TXTests:WBData	6.41
Control of Measurement – Subsystem TXTests:WBData	6.41
Test Configuration.....	6.42
Subsystem TXTests:WBData:CONTRol	6.42
Tolerance values – Subsystem TXTests:WBData:LIMit.....	6.43
Measured Values – Subsystem TXTests:WBData[:RESult].....	6.43
TXAFresp	6.45
Control of Measurement – Subsystem TXAFresp	6.45
Test Configuration.....	6.46
Subsystem TXAFresp:CONTRol.....	6.46
Subsystem TXAFresp:TRACe	6.47
Subsystem SUBarrays:TXAFresp.....	6.48
Tolerance values – Subsystem TXAFresp:LIMit.....	6.49
Test Tones – Subsystem TXAFresp:TDEFinition	6.51
Test Tones – Subsystem TXAFresp:AFGenerator	6.52
Path Configuration – Subsystem TXAFresp:FILTer	6.55
Measured Values – Subsystem TXAFresp[:RESult]	6.56
RXTests:AFANalyzer	6.58
Control of Measurement – Subsystem RXTests:AFANalyzer	6.58
Test Configuration.....	6.59
Subsystem RXTests:AFANalyzer:CONTRol	6.59
Tolerance values – Subsystem RXTests:AFANalyzer:LIMit.....	6.60
Path Configuration – Subsystem RXTests:AFANalyzer:FILTer	6.61
Measured Values – Subsystem RXTests:AFANalyzer[:RESult]	6.63
RXTests:AFANalyzer:VMSinad	6.64
Control of Measurement – Subsystem RXTests:AFANalyzer:VMSinad	6.64
Test Configuration.....	6.65
Subsystem RXTests:AFANalyzer:VMSinad:CONTRol	6.65
Measured Values – Subsystem RXTests:AFANalyzer:VMSinad[:RESult].....	6.66
RXTests:HNOise.....	6.67
Control of Measurement – Subsystem RXTests:HNOise.....	6.67
Test Configuration.....	6.68
Subsystem RXTests:HNOise:CONTRol.....	6.68
Tolerance values – Subsystem RXTests:HNOise:LIMit	6.69
Path Configuration – Subsystem RXTests:HNOise:FILTer	6.70
Measured Values – Subsystem RXTests:HNOise[:RESult]	6.71
RXTests:SENSitivity.....	6.72
Control of Measurement – Subsystem RXTests:SENSitivity.....	6.72

Test Configuration.....	6.73
Subsystem RXTests:SENSitivity:CONTRol	6.73
Tolerance values – Subsystem RXTests:SENSitivity:LIMit	6.74
Path Configuration – Subsystem RXTests:SENSitivity:FILTer.....	6.75
Measured Values – Subsystem RXTests:SENSitivity[:RESult].....	6.77
RXAFresp.....	6.78
Control of Measurement – Subsystem RXAFresp.....	6.78
Test Configuration.....	6.79
Subsystem RXAFresp:CONTRol	6.79
Subsystem RXAFresp:TRACe	6.80
Subsystem SUBarrays:RXAFresp	6.81
Tolerance values – Subsystem RXAFresp:LIMit	6.82
Test Tones – Subsystem RXAFresp:TDEFinition.....	6.84
Test Tones – Subsystem RXAFresp:MODGenerator	6.85
Path Configuration – Subsystem RXAFresp:FILTer	6.88
Measured Values – Subsystem RXAFresp[:RESult]	6.89
AMPS Mobile Tests (Signalling Mode)	6.91
Channel Units – System UNIT	6.91
Connection Control	6.91
Subsystem LEVel (RF Input Level).....	6.92
Subsystem AFLevel (AF Input Level)	6.93
Signalling – Subsystem SIGNalling (Call Setup and Cleardown).....	6.94
Subsystem OCALI (Other Call Target)	6.96
Subsystem HANDOff (Handoff Target)	6.96
Subsystem BSSignal (Signal of Base Station/CMU)	6.97
Subsystem NETWORK.....	6.100
Subsystem NETWork:IDENTity	6.100
Subsystem NETWork:SMODE (Signalling Modes).....	6.100
Subsystem NETWork:REQuest (Requested Mobile Data).....	6.101
Subsystem NETWork[:MS] (Mobile Settings)	6.101
Subsystem NETWork:TIMEout	6.102
Subsystem NETWork:OCHandoff.....	6.103
Connectors and External Attenuation	6.103
Subsystem DM:CLOCK (Network Clock).....	6.104
Subsystem MSSInfo.....	6.105
(Signalling information of mobile phone)	6.105
Subsystem "AFGenerator" – Generator control.....	6.106
Generator Level – Subsystem AFGenerator:LEVel.....	6.107
AF Generator Frequency – Subsystem AFGenerator:FREQuency.....	6.107
Subsystem "MODGenerator" – Generator control.....	6.108
Generator Level – Subsystem MODGenerator:DEViation	6.108
Mod. Generator Frequency – Subsystem MODGenerator:FREQuency	6.108
Symbolic Status Event Register Evaluation.....	6.109
List of Commands	6.110
Commands for AMPS Module Tests (Non Signalling).....	6.110
Commands for Measurement Groups (Non Signalling and Signalling).....	6.112
Commands for AMPS Mobile Tests (Signalling).....	6.120
Alphabetical Command Lists.....	6.123

6 Remote Control – Commands

In the following, all remote-control commands for the function groups *AMPS-MS* are presented in tabular form with their parameters and the ranges of values. The structure of this chapter differs from that of the reference part for manual operation (chapter 4):

- The measurement modes *Non Signalling* and *Signalling* are presented separately.
- Within the measurement modes, first the general configuration and then the individual measurement groups are described.
- Measurement groups that are identical in both test modes (*TXTests*, *TXAFresp*, *RXTests*, *RXAFresp*) are presented in a separate section between the two test modes.

General notes on remote control in the function group *AMPS-MS* can be found in Chapter 5. An introduction to remote control according to SCPI standard and the status registers of the CMU is given in chapter 5 of the operating manual for the CMU basic instrument.

AMPS Module Tests (Non Signalling)

In the *Non Signalling* mode, the CMU generates an RF voice signal that can be frequency-modulated with an AF modulation signal, the SAT, and the ST, and analyzes the modulated RF carrier signal with AMPS characteristics and the audio signal retransmitted by the device under test. Receiver and transmitter tests can be performed; no signalling parameters are transferred.

Connection Control

The remote-control commands in this section are used to configure the measurements in the function group *AMPS-MS Non Signalling* globally, i.e., they provide settings that are valid for all measurements within the function group. They correspond to the settings in the popup menu of the softkey *Connect Control* located to the right of the headline of each main menu.

Subsystem LEVel (RF Input Level)

The subsystem *LEVel* controls the level in the RF input signal path. It corresponds to the table section *RF Analyzer Level* in the *Analyzer* tab of the *Connection Control* menu.

[SENSe:]LEVel:MODE <Mode>		Input level – RF Mode		
<Mode>	Description of parameters	Def. value	Def. unit	Unit ring
MANual AUTomatic	Manual setting Automatic setting corresponding to average power of signal applied	MANual	–	
Description of command				FW vers.
This command defines the mode for setting the maximum RF input level.				V2.41 ¹

¹ Autoranging is included in firmware versions ≥ V3.05.

[SENSe:]LEVel:MAXimum <Level>				Max. Level
<Level>	Description of parameters	Def. value	Def. unit	Unit ring
0 dBm to +53 dBm	Maximum input level for RF 1	+30.0	dBm	
-14 dBm to 39 dBm	Maximum input level for RF 2	+30.0	dBm	
-37 dBm to 0 dBm	Maximum input level for RF 4 IN	+0.0	dBm	
Description of command				FW vers.
This command defines the maximum expected input level. The value range depends on the RF input used and the external attenuation set (see [SENSe:]CORREction:LOSS:INPut<nr>[:MAGNitude] command).				V2.41

[SENSe:]LEVel:ATTenuation <Mode>				Attenuation
<Mode>	Description of parameters	Def. value	Def. unit	Unit ring
NORMal 	Mixer level in normal range	NORMal	–	
LNOise 	Low noise (mixer level 10 dB higher than in normal setting)			
LDIStortion	Low distortion (mixer level 10 dB lower than in normal setting)			
Description of command				FW vers.
This command tunes the RF analyzer for normal setting, low noise level (full dynamic range), or low distortion (high intermodulation spacing).				V2.41

[SENSe:]LEVel:DEFault				Default Settings
<Enable>	Description of parameters	Def. value	Def. unit	Unit ring
ON 	The parameters are set to their default values	ON	–	
OFF	Some or all parameters differ from the default values			
Description of command				FW vers.
If used as a setting command with the parameter <i>ON</i> this command sets all parameters of the sub-system to their default values (the setting <i>OFF</i> results in an error message).				V2.41
If used as a query the command returns whether all parameters are set to their default values (<i>ON</i>) or not (<i>OFF</i>).				

Subsystem AFLevel (AF Input Level)

The subsystem *AFLevel* controls the level in the AF input signal path. It corresponds to the table section *AF Analyzer Level* in the *Analyzer* tab of the *Connection Control* menu.

[SENSe:]AFLevel:MODE <Mode>		Input level – Mode		
<Mode>	Description of parameters	Def. value	Def. unit	Unit ring
MANual AUTomatic	Manual setting Automatic setting corresponding to average power of signal applied	MANual	–	
Description of command				FW vers.
This command defines the mode for setting the maximum input level.				V2.41

[SENSe:]AFLevel:MAXimum <Level>		AF Max. Level		
<Level>	Description of parameters	Def. value	Def. unit	Unit ring
0 V to +30 V	Maximum audio input voltage	+0.15	V	
Description of command				FW vers.
This command defines the maximum expected AF input level.				V2.41

[SENSe:]AFLevel:DEFault		Default Settings		
<Enable>	Description of parameters	Def. value	Def. unit	Unit ring
ON OFF	The parameters are set to their default values Some or all parameters differ from the default values	ON	–	
Description of command				FW vers.
If used as a setting command with the parameter <i>ON</i> this command sets all parameters of the sub-system to their default values (the setting <i>OFF</i> results in an error message).				V2.41
If used as a query the command returns whether all parameters are set to their default values (<i>ON</i>) or not (<i>OFF</i>).				

Subsystem RFAnalyzer (Analyzed Input Signals)

The subsystem *RFAnalyzer* configures the RF analyzer, i.e., it specifies which type of RF signals can be analyzed. It corresponds to the panel *Analyzer Settings* in the tab *Analyzer* in the popup menu *Connect. Control*.

[SENSe:]RFAnalyzer:FREQUENCY <Number>				RF Channel
<Number>	Description of parameters	Def. value	Def. unit	Unit ring
210 000 Hz to 2 700 000 000 Hz (see also data sheet)	Input frequency (in multiples of 10 kHz)	825 030 000	Hz	
Description of command				FW vers.
This command defines the frequency of the RF signal analyzed. With the command [SENSe:]RFAnalyzer:FREQUENCY:UNIT, the default frequency unit can be changed, and even AMPS channel numbers can be entered instead of frequencies. In the latter case, the assignment of channel numbers and frequencies meets the specification for the reverse channel (signal direction from mobile to CMU).				V2.41

[SENSe:]RFAnalyzer:FREQUENCY:UNIT <Unit>				Frequency Unit
<Unit>	Description of parameters	Def. value	Def. unit	Unit ring
Hz KHZ MHZ GHZ CH	Frequency unit Channel number	Hz	Hz	
Description of command				FW vers.
This command defines whether the frequency of the RF signal analyzed is specified in frequency units or as an AMPS channel number. Frequency units must be used to select input signals that are outside the designated AMPS channel range.				V2.41

[SENSe:]RFAnalyzer:FREQUENCY:OFFSet <FreqOffset>				Voice Ch. Offset
<FreqOffset>	Description of parameters	Def. value	Def. unit	Unit ring
-15 000 Hz to +15 000 Hz	Offset for channel frequency	0	Hz	
Description of command				FW vers.
This command defines an offset for the RF analyzer frequency set with the command [SENSe:]RFAnalyzer:FREQUENCY <Number>. The offset frequency must be in multiples of 1 Hz.				V2.41

Subsystem "RFGenerator" – Generator control

The subsystem *RFGenerator* configures the RF signals generated by the CMU. It corresponds to the softkey *RF Generator* in the *Generator* tab of the popup menu *Connection Control* and the measurement menu *Analyzer/Generator*.

INITiate:RFGenerator	Start RF generator, reserve resources	⇒	<i>RUN</i>
ABORt:RFGenerator	Switch off RF generator, release resources	⇒	<i>OFF</i>
Description of command			FW vers.
These commands have no query form. They start and stop the RF generator, setting it to the status indicated in the top right column.			V2.41

FETCh:RFGenerator:STATus?		Generator Status		
Returned values	Description of parameters	Def. value	Def. unit	Unit ring
OFF 	Generator switched off (ABORt or *RST)	OFF	–	
RUN 	Running (INITiate)			
ERR	Switched off (could not be started)			
Description of command			FW vers.	
This command is always a query. It returns the current RF generator status.			V2.41	

Generator Level – Subsystem RFGenerator:LEVel

The subsystem *RFGenerator:LEVel* determines the level of the generated RF signal. It corresponds to the input field associated to the *RF Generator* softkey in the *Generator* tab of the popup menu *Connect. Control* and in the measurement menu *Analyzer/Generator*.

SOURce:RFGenerator:LEVel <Level>		Power Level		
<Level>	Description of parameters	Def. value	Def. unit	Unit ring
–137 dBm to –27 dBm	Output level at RF1	–50	dBm	
–137 dBm to –10 dBm	Output level at RF2	–50	dBm	
–90 dBm to +13 dBm	Output level at RF 3 OUT	–50	dBm	
Description of command			FW vers.	
This command determines the RF generator level. The value range depends on the used RF output of the CMU and the external attenuation set (see [SENSe :] CORRection:LOSS:OUTPut <nr>[: MAGNitude] command).			V2.41	

RF Generator Frequency – Subsystem RFGenerator:FREQUENCY

The subsystem *RFGenerator:FREQUENCY* determines the frequency of the generated RF signals. It corresponds to the softkeys *RF Channel* and *Frequency Offset* of the panel *RF Generator Settings*.

SOURce:RFGenerator:FREQUENCY <Number>				Voice Channel
<Number>	Description of parameters	Def. value	Def. unit	Unit ring
30 000 Hz to 2 700 000 000 Hz	Input frequency (in multiples of 10 kHz) (see also data sheet)	870 030 000	Hz	
Description of command				FW vers.
This command defines the frequency of the RF signal generated. With the command <code>SOURce:RFGenerator:FREQUENCY:UNIT</code> , the default frequency unit can be changed, and even AMPS channel numbers can be entered instead of frequencies. In the latter case, the assignment of channel numbers and frequencies meets the specification for the forward channel (signal direction from CMU to mobile under test).				V2.41

SOURce:RFGenerator:FREQUENCY:UNIT <Unit>				Frequency Unit
<Unit>	Description of parameters	Def. value	Def. unit	Unit ring
Hz KHZ MHZ GHZ CH	Frequency unit Channel number	Hz	Hz	
Description of command				FW vers.
This command defines whether the frequency of the RF signal generated is specified in frequency units or as an AMPS channel number. Frequency units must be used to select input signals that are outside the designated AMPS channel range.				V2.41

SOURce:RFGenerator:FREQUENCY:OFFSet <FrequencyOffset>				Voice Ch. Offset
<FrequencyOffset>	Description of parameters	Def. value	Def. unit	Unit ring
-15 000 Hz to +15 000 Hz	Frequency offset	0	Hz	
Description of command				FW vers.
This command defines an offset for the RF generator frequency set with the command <code>[SENSe:]RFGenerator:FREQUENCY <Number></code> . The offset frequency must be in multiples of 1 Hz.				V2.41

Subsystem "AFGenerator" – Generator control

The subsystem *AFGenerator* configures the AF signals generated by the CMU. It corresponds to the softkey *AF Generator* in the measurement menu *Analyzer/Generator*.

INITiate:AFGenerator	Start AF generator, reserve resources	⇒	<i>RUN</i>
ABORT:AFGenerator	Switch off AF generator, release resources	⇒	<i>OFF</i>
Description of command			FW vers.
These commands have no query form. They start and stop the AF generator, setting it to the status indicated in the top right column.			V2.41

FETCh:AFGenerator:STATus?			Generator Status	
Returned values	Description of parameters	Def. value	Def. unit	Unit ring
OFF RUN ERR	Generator switched off (ABORt or *RST) Running (INITiate) Switched off (could not be started)	OFF	–	
Description of command			Status	FW vers.
This command is always a query. It returns the current AF generator status.			all	V2.41

Generator Level – Subsystem AFGenerator:LEVel

The subsystem *AFGenerator:LEVel* determines the voltage of the generated AF signal. It corresponds to the *Level* input field assigned to the *AF Generator* softkey in the measurement menu *Analyzer/Generator*.

SOURce:AFGenerator:LEVel <Level>			AF Gen. Level	
<Level>	Description of parameters	Def. value	Def. unit	Unit ring
0 V to 5 V	Effective (RMS averaged) voltage of the AF signal	0.2	V	
Description of command				FW vers.
This command determines the voltage of the AF signal.				V2.41

SOURce:AFGenerator:SLEVel <Level>			Start Level	
<Level>	Description of parameters	Def. value	Def. unit	Unit ring
0 V to 5 V	Start value for <i>AF Level Search</i>	0.2	V	
Description of command				FW vers.
This command determines the start value for the <i>AF Level Search</i> iteration (relevant for <i>TX Tests – AF Level Search</i> application only).				V3.05

AF Generator Frequency – Subsystem AFGenerator:FREQuency

The subsystem *AFGenerator:FREQuency* determines the frequency of the generated AF signals. It corresponds to the *Frequency* input field assigned to the *AF Generator* softkey in the measurement menu *Analyzer/Generator*.

SOURce:AFGenerator:FREQuency <Frequency>			AF Gen. Frequency	
<Number>	Description of parameters	Def. value	Def. unit	Unit ring
20 Hz to 20 000 Hz	AF frequency	1004	Hz	
Description of command				FW vers.
This command defines the frequency of the AF signal generated.				V2.41

Subsystem "MODGenerator" – Generator control

The subsystem *MODGenerator* configures the modulation signals generated by the CMU. It corresponds to the softkey *Mod. Generator* in the measurement menu *Analyzer/Generator*.

INITiate:MODGenerator	Start Mod. generator, reserve resources	⇒	<i>RUN</i>
ABORT:MODGenerator	Switch off Mod. generator, release resources	⇒	<i>OFF</i>
Description of command			FW vers.
These commands have no query form. They start and stop the modulation generator, setting it to the status indicated in the top right column.			V2.41

FETCH:MODGenerator:STATus?		Generator Status		
Returned values	Description of parameters	Def. value	Def. unit	Unit ring
OFF 	Generator switched off (ABORT or *RST)	OFF	–	
RUN 	Running (INITiate)			
ERR	Switched off (could not be started)			
Description of command			FW vers.	
This command is always a query. It returns the current modulation generator status.			V2.41	

Generator Level – Subsystem MODGenerator:DEVIation

The subsystem *MODGenerator:DEVIation* determines the peak deviation of the generated modulation signal. It corresponds to the *Peak Deviation* input field assigned to the *Mod. Generator* softkey in the measurement menu *Analyzer/Generator*.

SOURce:MODGenerator:DEVIation <Deviation>		Mod. Deviation		
<Deviation>	Description of parameters	Def. value	Def. unit	Unit ring
0 Hz to 20000 Hz	Peak deviation	8000	Hz	
Description of command			FW vers.	
This command determines the peak frequency deviation of the modulation signal.			V2.41	

Mod. Generator Frequency – Subsystem MODGenerator:FREQuency

The subsystem *MODGenerator:FREQuency* determines the frequency of the generated modulation signals. It corresponds to the *Frequency* input field assigned to the *Mod. Generator* softkey in the measurement menu *Analyzer/Generator*.

SOURce:MODGenerator:FREQuency <Frequency>		Mod. Frequency		
<Number>	Description of parameters	Def. value	Def. unit	Unit ring
1 Hz to 15 999 Hz	Mod. frequency	1004	Hz	
Description of command			FW vers.	
This command defines the frequency of the modulation signal generated.			V2.41	

Subsystem "SAT" – SAT Generator control

The subsystem *SAT* configures the Supervisory Audio Tone (SAT) generated by the CMU. It corresponds to the softkey *SAT* in the *Generator* tab of the popup menu *Connect. Control* and the associated input fields.

INITiate:SAT	Start SAT generator, reserve resources	⇒	<i>RUN</i>
ABORT:SAT	Switch off RF generator, release resources	⇒	<i>OFF</i>
Description of command			FW vers.
These commands have no query form. They start and stop the SAT generator, setting it to the status indicated in the top right column.			V2.41

FETCH:SAT:STATus?		Generator Status		
Returned values	Description of parameters	Def. value	Def. unit	Unit ring
OFF 	Generator switched off (<i>ABORT</i> or <i>*RST</i>)	OFF	–	
RUN 	Running (<i>INITiate</i>)			
ERR	Switched off (could not be started)			
Description of command			FW vers.	
This command is always a query. It returns the current SAT generator status.			V2.41	

SOURce:SAT:PEAKdev <Deviation>		Peak Deviation		
<Deviation>	Description of parameters	Def. value	Def. unit	Unit ring
0 Hz to 20000 Hz	SAT peak deviation	2000	Hz	
Description of command			FW vers.	
This command determines the peak deviation that the CMU uses to transmit the SAT.			V2.41	

SOURce:SAT:SCC <Code>		SAT Color Code		
<Code>	Description of parameters	Def. value	Def. unit	Unit ring
0 1 2	SAT Color Code (SCC)	2	–	
Description of command			FW vers.	
This command determines the SAT Color Code and thus the frequency of the SAT (see chapter 4).			V2.41	

Subsystem "ST" – ST Generator control

The subsystem *ST* configures the Signalling Tone (ST) generated by the CMU. It corresponds to the softkey *ST* in the *Generator* tab of the popup menu *Connect. Control* and the associated input fields.

INITiate:ST	Start ST generator, reserve resources	⇒	<i>RUN</i>
ABORT:ST	Switch off RF generator, release resources	⇒	<i>OFF</i>
Description of command			FW vers.
These commands have no query form. They start and stop the ST generator, setting it to the status indicated in the top right column.			V2.41

FETCH:ST:STATUS?		Generator Status		
Returned values	Description of parameters	Def. value	Def. unit	Unit ring
OFF RUN ERR	Generator switched off (ABORT or *RST) Running (INITiate) Switched off (could not be started)	OFF	–	
Description of command				FW vers.
This command is always a query. It returns the current ST generator status.				V2.41

SOURCE:ST:PEAKdev <Deviation>		Peak Deviation		
<Deviation>	Description of parameters	Def. value	Def. unit	Unit ring
0 Hz to 20000 Hz	ST peak deviation	8000	Hz	
Description of command				FW vers.
This command determines the peak deviation that the CMU uses to transmit the ST.				V2.41

SOURCE:ST:DAT <Enable>		Data Signal		
<Enable>	Description of parameters	Def. value	Def. unit	Unit ring
ON OFF	ST generator provides data signal ST generator provides ST	OFF	–	
Description of command				FW vers.
This command switches between the ST and a 10 kilobit/s wideband data signal.				V2.41

Connectors and External Attenuation

The following commands configure the input and output connectors and the external attenuation. The subsystem corresponds to the tab *AF/RF*  in the popup menu *Connect. Control*.

INPut[:STATe] <State>		RF Input		
<State>	Description of parameters	Def. value	Def. unit	Unit ring
RF1 RF2 RF4	Connector RF 1 used as input Connector RF 2 used as input Connector RF 4 IN used as input	RF2	–	
Description of command				FW vers.
This command determines the connector to be used for RF input signals. The bidirectional connectors RF 1 and RF 2 can be used both as input and output connectors in the same measurement (see <code>OUTPut[:STATe]</code>).				V2.41
Only one input and one output may be active at the same time, a new RF input setting supersedes the previous one.				

OUTPut[:STATe] <State>				RF Output
<State>	Description of parameters	Def. value	Def. unit	Unit ring
RF1 RF2 RF3	Connector RF 1 used as output Connector RF 2 used as output Connector RF 3 OUT used as output	RF2	–	
Description of command				FW vers.
This command determines the connector to be used for RF output signals. The bidirectional connectors RF 1 and RF 2 can be used as input and output connectors in the same measurement (see <code>INPut[:STATe]</code>).				V2.41
Only one input and one output may be active at the same time, a new RF output setting supersedes the previous one.				

[SENSe:]CORRection:LOSS:INPut<nr>[:MAGNitude] <Attenuation> SOURce:CORRection:LOSS:INPut<nr>[:MAGNitude] <Attenuation>				Ext. Att. Input
<Attenuation>	Description of parameters	Def. value	Def. unit	Unit ring
–50 dB to +90 dB	External attenuation	0.0	dB	
Description of command				FW vers.
This command assigns an external attenuation value to the inputs of the instrument (<i>RF 1, RF 2, RF 4 IN</i>).				V2.41

[SENSe:]CORRection:LOSS:OUTput<nr>[:MAGNitude] <Attenuation> SOURce:CORRection:LOSS:OUTput<nr>[:MAGNitude] <Attenuation>				Ext. Att. Output
<Attenuation>	Description of parameters	Def. value	Def. unit	Unit ring
–50 dB to +90 dB	External attenuation	0.0	dB	
Description of command				FW vers.
This command assigns an external attenuation value to the outputs of the instrument (<i>RF 1, RF 2, RF 3 OUT</i>).				V2.41

[SENSe:]AFConnect:MSOURCE <Source>Mod. Source				
<Source>	Description of parameters	Def. value	Def. unit	Unit ring
INTern EXTern	Internal modulation signal from the mod. generator External modulation signal fed in via AUX 1	INTern	–	–
Description of command				FW vers.
This command selects the internal CW modulation signal or an arbitrary external modulation signal to be modulated onto the RF carrier.				V3.05

Subsystem DM:CLOCK (Network Clock)

The subsystem *DM:CLOCK* sets a system clock frequency specific to the network. This frequency is set in the tab *Sync.* in the popup menu *Connect. Control.*

SOURce:DM:CLOCK:STATe <Mode>				REF OUT 2 on/off
<Mode>	Description of parameters	Def. value	Def. unit	Unit ring
ON OFF	Switch on/off system clock	OFF	–	
Description of command				FW vers.
This commands switches the system clock specific to the network at the <i>REF OUT 2</i> connector on or off.				V2.41

SOURce:DM:CLOCK:FREQuency <Frequency>				REF OUT 2
<Frequency>	Description of parameters	Def. value	Def. unit	Unit ring
9.72 MHz to 38.88 MHz	System clock frequency	12.96	MHz	
Description of command				FW vers.
This command determines the system clock frequency applied to <i>REF OUT 2</i> . The frequency entered is internally rounded to one of the following discrete values:				V2.41
38.88 MHz, 19.44 MHz, 12.96 MHz, 9.72 MHz				

Symbolic Status Event Register Evaluation

The following commands are used to retrieve the events reported in function group *AMPS-MS Non Signalling*; see section *Symbolic Status Event Register Evaluation* in Chapter 5 of the CMU operating manual.

STATus:OPERation:SYMBOLic:ENABle <Event>{,<Event>}		Symbolic status evaluation		
Parameter list	Parameter description	Def. Value ²	Default Unit	Unit Ring
<Event>{,<Event>} NONE	List of symbols for events to be reported No event reported	NONE	–	
Command description				FW vers.
This command enables event reporting for one or several events in the current <i>AMPS-MS Non Signalling</i> function group, i.e. it sets the corresponding bits in the <i>STATus:OPERation:CMU:SUM<nr>:CMU<nr_event>:ENABle</i> register (<nr> = 1 2, <nr_event> denotes the current function group) and in all sum registers up to the status byte. The events and the corresponding symbols for the function group are listed in Chapter 5 (see section <i>Status Registers</i>). The symbols may be entered in arbitrary order.				V3.05

STATus:OPERation:SYMBOLic[:EVENT]?		Symbolic status evaluation		
Response	Parameter description	Def. Value ³	Default Unit	Unit Ring
NONE <Event>{,<Event>}	No event in the <i>RF</i> function group List of reported events	NONE	–	
Command description				FW vers.
This command is always a query. It lists the events reported in the current <i>AMPS-MS Non Signalling</i> function group and deletes these events in the <i>STATus:OPERation:CMU:SUM<nr>:CMU<nr_event>:EVENT</i> register as well as in all sum registers.				V3.05

² The default values quoted in this command are achieved after a *STATus:PRESet* command. *RST does not supersede the entries in the status registers; see section *Reset Values of the Status Reporting Systems* in chapter 5.

³ The default values quoted in this command are achieved after a *CLS command. *RST does not supersede the entries in the status registers; see section *Reset Values of the Status Reporting Systems* in chapter 5.

Measurement Groups (Non Signalling and Signalling)

The commands for the measurement groups in this section are identical in both test modes; they can be used in *Non Signalling* as well as in *Signalling* measurements.

Note:

In order to perform any kind of measurement and obtain a meaningful result, an appropriate test setup is required (see application examples in chapter 2 of this manual). Consequently, if the measurements reported in this section are performed in Signalling mode, the Call Established (CEST) signalling state must be reached before most of the commands retrieving test results (READ...[:RESult]?, FETCh...[:RESult]?, SAMPlE...[:RESult]?, or CALCu-late...LIMit?) can be used. Test configurations, however, can be defined any time. The following exceptions apply:

1. *The WPOWer measurement is available in all signalling states.*
2. *In the TXTests:MODulation subsystem (see section Measured Values... on p. 6.21), the ST Frequency Error and ST Peak Deviation measurement requires that the AMPS mobile transmits a signalling tone; the quantities can be obtained in the Alerting (ALER) state only. The remaining quantities are available in the Call Established (CEST) state.*

WPOWer (Wideband Power)

The subsystem `WPOWer` contains the commands for measuring the power of the RF input signal using a wide-band filter. It corresponds to the softkey *Wideband Power* of the index card *Analyzer (Non Signalling)* or *Connection (Signalling)* in the menu group *Connect. Control*.

Note:

In contrast to the measurement groups reported in the following sections, the WPOWer measurement can be performed in all signalling states.

INITiate:WPOWer	Start new measurement	⇒ RUN
ABORt:WPOWer	Abort running measurement and switch off	⇒ OFF
STOP:WPOWer	Stop measurement after current stat. cycle	⇒ STOP
CONTInue:WPOWer	Next measurement step (only <i>stepping mode</i>)	⇒ RUN
Description of command		FW vers.
These commands have no query form. They start or stop the measurement, setting it to the status given in the top right column.		V2.41 ⁴

⁴ To use the commands of the WPOWer subsystem in function group *AMPS-MS Non Signalling*, a firmware version \geq V2.50 is required.

CONFigure:WPOWER:EREPorting <Mode>				Event Reporting	
<Mode>	Description of parameters	Def. value	Def. unit	Unit ring	
SRQ SOPC SRSQ OFF	Service request Single operation complete SRQ and SOPC No reporting	OFF	–		
Description of command				FW vers.	
This command defines the events generated when the measurement is terminated or stopped (<i>event reporting</i> , see chapter 5).				V2.41	

FETCh:WPOWER:STATus?				Measurement Status	
Return	Description of parameters	Def. value	Def. unit	Unit ring	
OFF RUN STOP ERR STEP RDY, 1 to 10000 NONE	Measurement in the OFF state (*RST or ABORT) Running (after INITiate, CONTinue or READ) Stopped (STOP) OFF (could not be started) Stepping mode (<stepmode>=STEP) Stopped according to repetition mode and stop condition Counter for current statistics cycle No counting mode set	OFF NONE	– –	– –	
Description of command				FW vers.	
This command is always a query. It returns the status of the measurement (see chapters 3 and 5 of CMU manual).				V2.41	

CONFigure:WPOWER:CONTRol:REPetition <Repetition>,<StopCond>,<Stepmode>				Test cycles	
<Repetition>	Description of parameters	Def. value	Def. unit	Unit ring	
CONTinuous SINGleshot 1 to 10000,	Continuous measurement (until STOP or ABORT) Single shot measurement (until Status = RDY) Multiple measurement (counting, until Status = STEP RDY)	SING	–	–	
<StopCond>	Description of parameters	Def. value	Def. unit	Unit ring	
SONerror NONE,	Start measurement in case of error (<i>stop on error</i>) Continue measurement even in case of error	NONE	–	–	
<Stepmode>	Description of parameters	Def. value	Def. unit	Unit ring	
STEP NONE	Interrupt measurement after each statistics cycle Continue measurement according to its rep. mode	NONE	–	–	
Description of command				FW vers.	
This command determines the number of statistics cycles, the stop condition and the stepping mode for the measurement.				V2.41	
Note: In the case of READ commands (READ:...), the <Repetition> parameter has no effect; the measurement is always aborted after a single shot.					

READ[:SCALar]:WPOWer[:RESult]?		Start single shot measurement and return results		
FETCh[:SCALar]:WPOWer[:RESult]?		Read out measurement results (unsynchronized)		
SAMPlE[:SCALar]:WPOWer[:RESults]?		Read out measurement results (synchronized)		
<i>Return</i>	Description of parameters	Def. value	Def. unit	Unit ring
-30.0 dBm to +30.0 dBm	Maximum power (not averaged)	NAN	dBm	
Description of command				FW vers.
These commands are always queries. They start the wide-band power and output the result.				V2.41

TXTests:MODulation

The subsystem *TXTests:MODulation* measures modulation parameters characterizing the mobile phone transmitter quality. The subsystem corresponds to the measurement menu *TX Tests*, application *Modulation*, and the associated popup menu *TX Tests Configuration*.

Control of Measurement – Subsystem TXTests:MODulation

The subsystem *TXTests:MODulation* controls the measurement. It corresponds to the softkey *MODulation* in the measurement menu *TX Tests*.

INITiate:TXTests:MODulation	Start new measurement	⇒ <i>RUN</i>
ABORT:TXTests:MODulation	Abort running measurement and switch off	⇒ <i>OFF</i>
STOP:TXTests:MODulation	Stop measurement after current stat. cycle	⇒ <i>STOP</i>
CONTinue:TXTests:MODulation	Next measurement step (only <i>stepping mode</i>)	⇒ <i>RUN</i>
Description of command		FW vers.
These commands have no query form. They start and stop the measurement, setting it to the status indicated in the top right column.		V2.41

CONFigure:TXTests:MODulation:EREPorting <Mode>		Event Reporting		
<Mode>	Description of parameters	Def. value	Def. unit	Unit ring
SRQ 	Service request	OFF	–	–
SOPC 	Single operation complete			
SRSQ 	SRQ and SOPC			
OFF	No reporting			
Description of command		FW vers.		
This command defines the events generated when the measurement is terminated or stopped (<i>event reporting</i> , see chapter 5 of CMU200 manual).		V2.41		

FETCH:TXTests:MODulation:STATus?		Measurement Status		
Ret. values	Description of parameters	Def. value	Def. unit	Unit ring
OFF 	Measurement in the <i>OFF</i> state (*RST or ABORt)	OFF	–	
RUN 	Running (after INITiate, CONTinue or READ)			
STOP 	Stopped (STOP)			
ERR 	<i>OFF</i> (could not be started)			
STEP 	Stepping mode (<stepmode>=STEP)			
RDY,	Stopped according to repetition mode and stop condition			
	Counter for current statistics cycle			
1 to 10000 	No counting mode set	NONE	–	
NONE				
Description of command		FW vers.		
This command is always a query. It returns the status of the measurement (see chapters 3 and 5 of CMU manual).		V2.41		

Test Configuration

The commands of the following subsystems configure the *Modulation* measurement. They correspond to the sections in the *TX Tests Configuration* menu that are related to the *Modulation* application.

Subsystem TXTests:MODulation:CONTROL

The subsystem *TXTests:MODulation:CONTROL* configures the modulation measurement. It corresponds to the *Control* tab in the popup menu *TX Tests Config*.

CONFigure:TXTests:MODulation:CONTROL:REPetition <Repetition>, <StopCond>, <Stepmode>				
Test Cycles				
<Repetition>	Description of parameters	Def. value	Def. unit	Unit ring
CONTinuous SINGleshot 1 to 10000	Continuous measurement (until STOP or ABORT) Single shot measurement (until Status = RDY) Multiple measurement (<i>counting</i> , until Status = STEP RDY)	SING	–	
<StopCond>	Description of parameters	Def. value	Def. unit	Unit ring
SONerror NONE	Stop measurement in case of error (<i>stop on error</i>) Continue measurement even in case of error	NONE	–	
<Stepmode>	Description of parameters	Def. value	Def. unit	Unit ring
STEP NONE	Interrupt measurement after each statistics cycle Continue measurement according to its rep. mode	NONE	–	
Description of command				FW vers.
This command determines the number of statistics cycles, the stop condition and the stepping mode for the measurement.				V2.41
Note: <i>In the case of READ commands (READ:...), the <Repetition> parameter has no effect; the measurement is always stopped after a single shot.</i>				

CONFigure:TXTests:MODulation:CONTROL:DEFault <Enable>		Default Settings		
<Enable>	Description of parameters	Def. value	Def. unit	Unit ring
ON OFF	The parameters are set to their default values Some or all parameters differ from the default values	ON	–	
Description of command				FW vers.
If used as a setting command with the parameter ON this command sets all parameters of the subsystem to their default values (the setting OFF results in an error message).				V2.41
If used as a query the command returns whether all parameters are set to their default values (ON) or not (OFF).				

Tolerance values – Subsystem TXTests:MODulation:LIMit

The subsystem *TXTests:MODulation:LIMit* defines tolerance values for the *Modulation* application of the *TX Tests* measurement. The subsystem corresponds to the relevant section in the *Limits* tab of the popup menu *TX Tests Configuration*.

CONFigure:TXTests:MODulation:LIMit			Limits Modulation	
<i><CarrFreqErrRange></i> , <i><TotPeakDevMax></i> , <i><SATFreqErrRge></i> , <i><SATPeakDevErrRge></i> , <i><STFreqErrRange></i> , <i><STPeakDevErrRge></i> , <i><ModDistNoise></i> , <i><ResAM></i>				
Parameter	Description of parameters	Def. value	Def. unit	Unit ring
0 Hz to 48000 Hz,	Carrier Frequency Error Range,	2000	Hz	
0 Hz to 48000 Hz,	Total Peak Deviation Max,	14000	Hz	
0.0 Hz to 10000.0 Hz,	SAT Frequency Error Range,	1.0	Hz	
0 Hz to 48000 Hz,	SAT Peak Deviation Error Range,	200	Hz	
0.0 Hz to 10000.0 Hz,	ST Frequency Error Range,	1.0	Hz	
0 Hz to 48000 Hz,	ST Peak Deviation Error Range,	800	Hz	
0% to 100%,	Modulation Distortion and Noise,	5	%	
0% to 100%	Residual AM (amplitude modulation)	5	%	
Description of command				FW vers.
This command defines upper limits for the quantities measured in the <i>TX Tests – Modulation</i> application.				V2.41

CONFigure:TXTests:MODulation:LIMit:DEFault <i><Enable></i>			Default Settings	
<i><Enable></i>	Description of parameters	Def. value	Def. unit	Unit ring
ON OFF	The parameters are set to their default values Some or all parameters differ from the default values	ON	–	
Description of command				FW vers.
If used as a setting command with the parameter <i>ON</i> this command sets all parameters of the subsystem to their default values (the setting <i>OFF</i> results in an error message).				V2.41
If used as a query the command returns whether all parameters are set to their default values (<i>ON</i>) or not (<i>OFF</i>).				

Path Configuration – Subsystem TXTests:MODulation:FILTer

The subsystem *TXTests:MODulation:FILTer* configures the voice-processing equipment used in the *Modulation* application of the *TX Tests* measurement. The subsystem corresponds to the relevant section in the *Filters* tab of the popup menu *TX Tests Configuration*.

CONFigure:TXTests:MODulation:FILTer <Bandpass>, <Expandor>, <Deemphasis>, <Weighting>		Path Configuration: TX Tests – Modulation		
<Bandpass>	Description of parameters	Def. value	Def. unit	Unit ring
BP01 BP02 BP03 BP04 BP05 BP06 BP07 BP08 BP09 BP10 BP11 BP12 BP13 BP14 BP15 BP16 BP17 BP 18 ,	CMU band pass filter with a bandwidth of 0 Hz to 250 Hz 6 Hz to 250 Hz 50 Hz to 250 Hz 0 Hz to 3000 Hz 6 Hz to 3000 Hz 50 Hz to 3000 Hz 300 Hz to 3000 Hz 0 Hz to 4000 Hz 6 Hz to 4000 Hz 50 Hz to 4000 Hz 300 Hz to 4000 Hz 0 Hz to 15000 Hz 6 Hz to 15000 Hz 50 Hz to 15000 Hz 300 Hz to 15000 Hz 0 Hz to 20000 Hz 6 Hz to 20000 Hz 50 Hz to 20000 Hz	BP10	–	
<Deemphasis>	Description of parameters	Def. value	Def. unit	Unit ring
ON OFF ,	Switch de-emphasis on or off	ON	–	
<Expandor>	Description of parameters	Def. value	Def. unit	Unit ring
ON OFF ,	Switch expandor on or off	ON	–	
<Weighting>	Description of parameters	Def. value	Def. unit	Unit ring
CME CCI OFF	Switch on C-message weighted filter Switch on CCITT weighting filter No weighting filter	CME	–	
Description of command				FW vers.
This command defines the measuring equipment in the <i>TX Tests – Modulation</i> application.				V2.41

CONFigure:TXTests:MODulation:FILTer:DEFault <Enable>		Default Settings		
<Enable>	Description of parameters	Def. value	Def. unit	Unit ring
ON OFF	The parameters are set to their default values Some or all parameters differ from the default values	ON	–	
Description of command				FW vers.
If used as a setting command with the parameter <i>ON</i> this command sets all parameters of the sub-system to their default values (the setting <i>OFF</i> results in an error message).				V2.41
If used as a query the command returns whether all parameters are set to their default values (<i>ON</i>) or not (<i>OFF</i>).				

Measured Values – Subsystem TXTests:MODulation[:RESult]

The subsystem *TXTests:MODulation[:RESULT]* measures and returns the modulation parameters and compares them with the tolerance values. The subsystem corresponds to the various output elements in the measurement menu *TX Tests*, application *Modulation*.

READ[:SCALar]:TXTests:MODulation[:RESult]? Scalar Results: Start single shot measurement and return results				
FETCh[:SCALar]:TXTests:MODulation[:RESult]? Read out meas. results (unsynchronized)				
SAMPle[:SCALar]:TXTests:MODulation[:RESult]? Read out measurement results (synchronized)				
Returned values	Value range	Def. value	Def. unit	Unit ring
Carrier Frequency Error,	-48 000 Hz to +48 000 Hz	NAN	Hz	
Total Peak Deviation,	0 Hz to +48 000 Hz	NAN	Hz	
SAT Frequency Error,	-6 000 Hz to +10 000 Hz	NAN	Hz	
SAT Peak Deviation,	0 Hz to +48 000 Hz	NAN	Hz	
ST Frequency Error ¹ ,	-10 000 Hz to +10 000 Hz	NAN	Hz	
ST Peak Deviation,	0 Hz to +48 000 Hz	NAN	Hz	
Audio Peak Deviation	0 Hz to +48 000 Hz	NAN	Hz	
Audio RMS Deviation,	0 Hz to +48 000 Hz	NAN	Hz	
Mod. Distortion & Noise,	0% to 100%	NAN	%	
Carrier Power,	-90 dBm to +55 dBm	NAN	dBm	
Residual AM	0% to 100%	NAN	%	
Description of command				FW vers.
These commands are always queries. They start a <i>TX Tests – Modulation</i> measurement and output all measurement results (see chapter 4).				V2.41

CALCulate[:SCALar]:TXTests:MODulation[:RESult]:MATChing:LIMit? Results out of Tolerance				
Returned values	Value range	Def. value	Def. unit	Unit ring
Carrier Frequency Error,	For all measured values: NMAU NMAL INV OK	INV	–	
Total Peak Deviation,		INV	–	
SAT Frequency Error,		INV	–	
SAT Peak Deviation,		INV	–	
ST Frequency Error ¹ ,		INV	–	
ST Peak Deviation,		INV	–	
Audio Peak Deviation		INV	–	
Audio RMS Deviation,		INV	–	
Mod. Distortion & Noise,		INV	–	
Residual AM		INV	–	
Description of command				FW vers.
This command is always a query. It indicates whether and in which way the error limits for the measured values (see above command) have been exceeded. The following messages may be output for all measured values:				V2.41
NMAU	Underflow of tolerance value	<i>not matching, underflow</i>		
NMAL	Tolerance value exceeded	<i>not matching, overflow</i>		
INV	Measurement invalid	<i>invalid</i>		
OK	all tolerances matched			

¹ The *ST Frequency Error* and *ST Peak Deviation* measurement requires that the AMPS mobile transmits a signalling tone; the quantities can be obtained in the *Alerting (ALER)* state only. The remaining quantities are available in the *Call Established (CEST)* state.

TXTests:MODulation:TADeviation

The subsystem *TXTests:MODulation:TADeviation* measures modulation parameters characterizing the mobile phone transmitter quality, omitting the (more time-consuming) SAT and ST measurements. It represents a simplified and faster version of the *TXTests:MODulation* measurement, optimized for fast peak deviation measurements. An additional fast modulation measurement is optimized for carrier power and frequency error measurements; see section *TXTests:MODulation:CPOWer* on p. 6.25 ff.

The limit values and filter settings are taken from the *TXTests:MODulation* sub-system; see section *Tolerance values – Subsystem TXTests:MODulation:LIMit* on p. 6.19 ff. and *Path Configuration – Subsystem TXTests:MODulation:FILTer* on p. 6.20 ff. The *TXTests:MODulation:TADeviation* subsystem has no equivalent in manual control.

Control of Measurement – Subsystem TXTests:MODulation:TADeviation

The subsystem *TXTests:MODulation:TADeviation* controls the measurement.

INITiate:TXTests:MODulation:TADeviation	Start new measurement	⇒ <i>RUN</i>
ABORT:TXTests:MODulation:TADeviation	Abort running measurement and switch off	⇒ <i>OFF</i>
STOP:TXTests:MODulation:TADeviation	Stop measurement after current stat. cycle	⇒ <i>STOP</i>
CONTinue:TXTests:MODulation:TADeviation	Next measurement step (only <i>stepping mode</i>)	⇒ <i>RUN</i>
Description of command		FW vers.
These commands have no query form. They start and stop the measurement, setting it to the status indicated in the top right column.		V3.05

CONFigure:TXTests:MODulation:TADeviation:EREPorting <Mode>		Event Reporting		
<Mode>	Description of parameters	Def. value	Def. unit	Unit ring
SRQ 	Service request	OFF	–	–
SOPC 	Single operation complete			
SRSQ 	SRQ and SOPC			
OFF	No reporting			
Description of command				FW vers.
This command defines the events generated when the measurement is terminated or stopped (<i>event reporting</i> , see chapter 5 of CMU200 manual).				V3.05

FETCH:TXTests:MODulation:TADeviation:STATus?		Measurement Status		
Ret. values	Description of parameters	Def. value	Def. unit	Unit ring
OFF 	Measurement in the OFF state (*RST or ABORT)	OFF	–	
RUN 	Running (after INITiate, CONTinue or READ)			
STOP 	Stopped (STOP)			
ERR 	OFF (could not be started)			
STEP 	Stepping mode (<stepmode>=STEP)			
RDY,	Stopped according to repetition mode and stop condition			
	Counter for current statistics cycle			
1 to 10000 	No counting mode set	NONE	–	
NONE				
Description of command				FW vers.
This command is always a query. It returns the status of the measurement (see chapters 3 and 5 of CMU manual).				V3.05

Test Configuration

The commands of the following subsystems configure the *Modulation:TADevelopment* measurement.

Subsystem TXTests:MODulation:TADevelopment:CONTROL

The subsystem *TXTests:MODulation:TADevelopment:CONTROL* defines the scope of the *Modulation:TADevelopment* measurement.

CONFigure:TXTests:MODulation:TADevelopment:CONTROL:REPetition <Repetition>, <StopCond>, <Stepmode>				Test Cycles
<Repetition>	Description of parameters	Def. value	Def. unit	Unit ring
CONTinuous SINGleshot 1 to 10000	Continuous measurement (until STOP or ABORT) Single shot measurement (until Status = RDY) Multiple measurement (counting, until Status = STEP RDY)	SING	–	
<StopCond>	Description of parameters	Def. value	Def. unit	Unit ring
SONerror NONE	Stop measurement in case of error (stop on error) Continue measurement even in case of error	NONE	–	
<Stepmode>	Description of parameters	Def. value	Def. unit	Unit ring
STEP NONE	Interrupt measurement after each statistics cycle Continue measurement according to its rep. mode	NONE	–	
Description of command				FW vers.
This command determines the number of statistics cycles, the stop condition and the stepping mode for the measurement.				V3.05
Note: In the case of READ commands (READ:...), the <Repetition> parameter has no effect; the measurement is always stopped after a single shot.				

CONFigure:TXTests:MODulation:TADevelopment:CONTROL:DEFault <Enable>				Default Settings
<Enable>	Description of parameters	Def. value	Def. unit	Unit ring
ON OFF	The parameters are set to their default values Some or all parameters differ from the default values	ON	–	
Description of command				FW vers.
If used as a setting command with the parameter ON this command sets all parameters of the subsystem to their default values (the setting OFF has no effect).				V3.05
If used as a query the command returns whether all parameters are set to their default values (ON) or not (OFF).				

Measured Values – Subsystem TXTests:MODulation:TADeviation[:RESult]

The subsystem *TXTests:MODulation:TADeviation[:RESULT]* measures and returns the modulation parameters and compares them with the tolerance values.

READ[:SCALar]:TXTests:MODulation:TADeviation [:RESult]?		Scalar Results:		
		Start single shot measurement and return results		
FETCh[:SCALar]:TXTests:MODulation:TADeviation[:RESult]?		Read out meas. results (unsynchronized)		
SAMPlE[:SCALar]:TXTests:MODulation:TADeviation[:RESult]?		Read out measurement results (synchronized)		
<i>Returned values</i>	Value range	Def. value	Def. unit	Unit ring
TotalPeakDeviation,	0 Hz to +48 000 Hz	NAN	Hz	
AudioPeakDeviation	0 Hz to +48 000 Hz	NAN	Hz	
AudioRMSDeviation	0 Hz to +48 000 Hz	NAN	Hz	
Description of command				FW vers.
These commands are always queries. They start a <i>TX Tests – Modulation:TADeviation</i> measurement and output all measurement results (see chapter 4).				V3.05

CALCulate[:SCALar]:TXTests:MODulation:TADeviation [:RESult]:MATChing:LIMit?		Results out of Tolerance		
<i>Returned values</i>	Value range	Def. value	Def. unit	Unit ring
TotalPeakDeviation,	For all measured values:	INV	–	
AudioPeakDeviation		INV	–	
AudioRMSDeviation	NMAU NMAL INV OK	INV	–	
Description of command				FW vers.
This command is always a query. It indicates whether and in which way the error limits for the measured values (see above command) have been exceeded.				V3.05
The following messages may be output for all measured values:				
NMAU	Underflow of tolerance value	<i>not matching, underflow</i>		
NMAL	Tolerance value exceeded	<i>not matching, overflow</i>		
INV	Measurement invalid	<i>invalid</i>		
OK	all tolerances matched			

TXTests:MODulation:CPOWer

The subsystem *TXTests:MODulation:CPOWer* measures modulation parameters characterizing the mobile phone transmitter quality, omitting the (more time-consuming) SAT and ST measurements. It represents a simplified and faster version of the *TXTests:MODulation* measurement, optimized for fast carrier power and frequency error measurements. An additional fast modulation measurement is optimized for peak deviation measurements; see section *TXTests:MODulation:TADeviation* on p. 6.22 ff.

The limit values and filter settings are taken from the *TXTests:MODulation* sub-system; see section Tolerance values – Subsystem *TXTests:MODulation:LIMit* on p. 6.19 ff. and Path Configuration – Subsystem *TXTests:MODulation:FILTer* on p. 6.20 ff. The *TXTests:MODulation:CPOWer* subsystem has no equivalent in manual control.

Control of Measurement – Subsystem TXTests:MODulation:CPOWer

The subsystem *TXTests:MODulation:CPOWer* controls the measurement.

INITiate:TXTests:MODulation:CPOWer	Start new measurement	⇒ <i>RUN</i>
ABORT:TXTests:MODulation:CPOWer	Abort running measurement and switch off	⇒ <i>OFF</i>
STOP:TXTests:MODulation:CPOWer	Stop measurement after current stat. cycle	⇒ <i>STOP</i>
CONTinue:TXTests:MODulation:CPOWer	Next measurement step (only <i>stepping mode</i>)	⇒ <i>RUN</i>
Description of command		FW vers.
These commands have no query form. They start and stop the measurement, setting it to the status indicated in the top right column.		V3.05

CONFigure:TXTests:MODulation:CPOWer:EREPorting <Mode>		Event Reporting		
<Mode>	Description of parameters	Def. value	Def. unit	Unit ring
SRQ 	Service request	OFF	–	–
SOPC 	Single operation complete			
SRSQ 	SRQ and SOPC			
OFF	No reporting			
Description of command				FW vers.
This command defines the events generated when the measurement is terminated or stopped (<i>event reporting</i> , see chapter 5 of CMU200 manual).				V3.05

FETCH:TXTests:MODulation:CPOWer:STATus?		Measurement Status		
Ret. values	Description of parameters	Def. value	Def. unit	Unit ring
OFF 	Measurement in the <i>OFF</i> state (*RST or ABORT)	OFF	–	
RUN 	Running (after <i>INITiate</i> , <i>CONTinue</i> or <i>READ</i>)			
STOP 	Stopped (<i>STOP</i>)			
ERR 	<i>OFF</i> (could not be started)			
STEP 	Stepping mode (< <i>stepmode</i> >= <i>STEP</i>)			
RDY,	Stopped according to repetition mode and stop condition			
1 to 10000 	Counter for current statistics cycle			
NONE	No counting mode set	NONE	–	
Description of command				FW vers.
This command is always a query. It returns the status of the measurement (see chapters 3 and 5 of CMU manual).				V3.05

Test Configuration

The commands of the following subsystems configure the *Modulation:CPOWer* measurement.

Subsystem TXTests:MODulation:CPOWer:CONTRol

The subsystem *TXTests:MODulation:CPOWer:CONTRol* defines the scope of the *Modulation:CPOWer* measurement.

CONFigure:TXTests:MODulation:CPOWer:CONTRol:REPetition <Repetition>, <StopCond>, <Stepmode>				Test Cycles
<Repetition>	Description of parameters	Def. value	Def. unit	Unit ring
CONTInuous SINGleshot 1 to 10000	Continuous measurement (until STOP or ABORT) Single shot measurement (until Status = RDY) Multiple measurement (counting, until Status = STEP RDY)	SING	–	
<StopCond>	Description of parameters	Def. value	Def. unit	Unit ring
SONerror NONE	Stop measurement in case of error (stop on error) Continue measurement even in case of error	NONE	–	
<Stepmode>	Description of parameters	Def. value	Def. unit	Unit ring
STEP NONE	Interrupt measurement after each statistics cycle Continue measurement according to its rep. mode	NONE	–	
Description of command				FW vers.
This command determines the number of statistics cycles, the stop condition and the stepping mode for the measurement.				V3.05
Note: In the case of READ commands (READ:...), the <Repetition> parameter has no effect; the measurement is always stopped after a single shot.				

CONFigure:TXTests:MODulation:CPOWer:CONTRol:DEFault <Enable>				Default Settings
<Enable>	Description of parameters	Def. value	Def. unit	Unit ring
ON OFF	The parameters are set to their default values Some or all parameters differ from the default values	ON	–	
Description of command				FW vers.
If used as a setting command with the parameter ON this command sets all parameters of the subsystem to their default values (the setting OFF has no effect).				V3.05
If used as a query the command returns whether all parameters are set to their default values (ON) or not (OFF).				

Measured Values – Subsystem TXTests:MODulation:CPOwer[:RESult]

The subsystem *TXTests:MODulation:CPOwer[:RESult]* measures and returns the modulation parameters and compares them with the tolerance values.

READ[:SCALar]:TXTests:MODulation:CPOwer[:RESult]?		Scalar Results:		
		Start single shot measurement and return results		
FETCh[:SCALar]:TXTests:MODulation:CPOwer[:RESult]?		Read out meas. results (unsynchronized)		
SAMPlE[:SCALar]:TXTests:MODulation:CPOwer[:RESult]?		Read out measurement results (synchronized)		
<i>Returned values</i>	Value range	Def. value	Def. unit	Unit ring
CarrierFreqError, CarrierPower	–48000 Hz to +48 000 Hz –90 dBm to +55 dBm	NAN NAN	Hz dBm	
Description of command				FW vers.
These commands are always queries. They start a <i>TX Tests – Modulation:CPOwer</i> measurement and output all measurement results (see chapter 4).				V3.05

CALCulate[:SCALar]:TXTests:MODulation:CPOwer[:RESult]:MATChing:LIMit?		Results out of Tolerance		
<i>Returned values</i>	Value range	Def. value	Def. unit	Unit ring
CarrierFreqError, CarrierPower	For all measured values: NMAU NMAL INV OK	INV INV	– –	
Description of command				FW vers.
This command is always a query. It indicates whether and in which way the error limits for the measured values (see above command) have been exceeded.				V3.05
The following messages may be output for all measured values:				
NMAU	Underflow of tolerance value	<i>not matching, underflow</i>		
NMAL	Tolerance value exceeded	<i>not matching, overflow</i>		
INV	Measurement invalid	<i>invalid</i>		
OK	all tolerances matched			

TXTests:HNOise

The subsystem *TXTests:HNOise* measures the FM Hum & Noise of the mobile phone transmitter. The subsystem corresponds to the measurement menu *TX Tests*, application *Hum & Noise*, and the associated popup menu *TX Tests Configuration*.

Control of Measurement – Subsystem TXTests:HNOise

The subsystem *TXTests:HNOise* controls the measurement. It corresponds to the softkey *Hum & Noise* in the measurement menu *TX Tests*.

INITiate:TXTests:HNOise	Start new measurement	⇒ <i>RUN</i>
ABORT:TXTests:HNOise	Abort running measurement and switch off	⇒ <i>OFF</i>
STOP:TXTests:HNOise	Stop measurement after current stat. cycle	⇒ <i>STOP</i>
CONTinue:TXTests:HNOise	Next measurement step (only <i>stepping mode</i>)	⇒ <i>RUN</i>
Description of command		FW vers.
These commands have no query form. They start and stop the measurement, setting it to the status indicated in the top right column.		V2.41

CONFigure:TXTests:HNOise:EREPorting <Mode>		Event Reporting		
<Mode>	Description of parameters	Def. value	Def. unit	Unit ring
SRQ 	Service request	OFF	–	–
SOPC 	Single operation complete			
SRSQ 	SRQ and SOPC			
OFF	No reporting			
Description of command		FW vers.		
This command defines the events generated when the measurement is terminated or stopped (<i>event reporting</i> , see chapter 5 of CMU200 manual).		V2.41		

FETCH:TXTests:HNOise:STATUS?		Measurement Status		
Ret. values	Description of parameters	Def. value	Def. unit	Unit ring
OFF 	Measurement in the <i>OFF</i> state (*RST or ABORT)	OFF	–	
RUN 	Running (after INITiate, CONTinue or READ)			
STOP 	Stopped (STOP)			
ERR 	OFF (could not be started)			
STEP 	Stepping mode (<stepmode>=STEP)			
RDY,	Stopped according to repetition mode and stop condition			
1 to 10000 	Counter for current statistics cycle			
NONE	No counting mode set	NONE	–	
Description of command		FW vers.		
This command is always a query. It returns the status of the measurement (see chapters 3 and 5 of CMU manual).		V2.41		

Test Configuration

The commands of the following subsystems configure the *Hum & Noise* measurement. They correspond to the sections in the *TX Tests Configuration* menu that are related to the *Hum & Noise* application.

Subsystem TXTests:HNOise:CONTRol

The subsystem *TXTests:HNOise:CONTRol* configures the modulation measurement. It corresponds to the *Control* tab in the popup menu *TX Tests Config*.

CONFigure:TXTests:HNOise:CONTRol:REPetition <Repetition> ,<StopCond>,<Stepmode>				Test Cycles
<Repetition>	Description of parameters	Def. value	Def. unit	Unit ring
CONTinuous SINGleshot 1 to 10000	Continuous measurement (until <i>STOP</i> or <i>ABORT</i>) Single shot measurement (until <i>Status = RDY</i>) Multiple measurement (<i>counting</i> , until <i>Status = STEP RDY</i>)	SING	–	
<StopCond>	Description of parameters	Def. value	Def. unit	Unit ring
SONerror NONE	Stop measurement in case of error (<i>stop on error</i>) Continue measurement even in case of error	NONE	–	
<Stepmode>	Description of parameters	Def. value	Def. unit	Unit ring
STEP NONE	Interrupt measurement after each statistics cycle Continue measurement according to its rep. mode	NONE	–	
Description of command				FW vers.
This command determines the number of statistics cycles, the stop condition and the stepping mode for the measurement.				V2.41
Note: <i>In the case of READ commands (READ:...), the <Repetition> parameter has no effect; the measurement is always stopped after a single shot.</i>				

CONFigure:TXTests:HNOise:CONTRol:DEFault <Enable> Default Settings				
<Enable>	Description of parameters	Def. value	Def. unit	Unit ring
ON OFF	The parameters are set to their default values Some or all parameters differ from the default values	ON	–	
Description of command				FW vers.
If used as a setting command with the parameter <i>ON</i> this command sets all parameters of the subsystem to their default values (the setting <i>OFF</i> results in an error message).				V2.41
If used as a query the command returns whether all parameters are set to their default values (<i>ON</i>) or not (<i>OFF</i>).				

Tolerance values – Subsystem TXTests:HNOise:LIMit

The subsystem *TXTests:HNOise:LIMit* defines tolerance values for the *Hum & Noise* application of the *TX Tests* measurement. The subsystem corresponds to the relevant section in the *Limits* tab of the popup menu *TX Tests Configuration*.

CONFigure:TXTests:HNOise:LIMit <CarrierFreqError>, <SATFreqError>, <SATPeakDev>, <Hum&Noise>				Limits Hum & Noise	
Parameters	Description of parameters	Def. value	Def. unit	Unit ring	
CarrierFreqError	0 Hz to 48000 Hz	2000	Hz		
SATFreqError,	0 Hz to 10000 Hz	1.0	Hz		
SATPeakDeviation,	0 Hz to 48000 Hz	200	Hz		
Hum&Noise	FM Hum & Noise	32.0	dB		
Description of command				FW vers.	
This command defines the upper limit for the <i>FM Hum & Noise</i> .				V2.41	

CONFigure:TXTests:HNOise:LIMit:DEFAULT <Enable>				Default Settings	
<Enable>	Description of parameters	Def. value	Def. unit	Unit ring	
ON	The parameters are set to their default values	ON	–		
OFF	Some or all parameters differ from the default values				
Description of command				FW vers.	
If used as a setting command with the parameter <i>ON</i> this command sets all parameters of the sub-system to their default values (the setting <i>OFF</i> results in an error message).				V2.41	
If used as a query the command returns whether all parameters are set to their default values (<i>ON</i>) or not (<i>OFF</i>).					

Path Configuration – Subsystem TXTests:HNOise:FILTer

The subsystem *TXTests:HNOise:FILTer* configures the voice-processing equipment used in the *Hum & Noise* application of the *TX Tests* measurement. The subsystem corresponds to the relevant section in the *Filters* tab of the popup menu *TX Tests Configuration*.

CONFigure:TXTests:HNOise:FILTer		Path Configuration: TX Tests – Modulation		
<Bandpass>, <Expandor>, <Deemphasis>, <Weighting>				
<Bandpass>	Description of parameters	Def. value	Def. unit	Unit ring
	CMU band pass filter with a bandwidth of	BP10	–	
BP01 	0 Hz to 250 Hz			
BP02 	6 Hz to 250 Hz			
BP03 	50 Hz to 250 Hz			
BP04 	0 Hz to 3000 Hz			
BP05 	6 Hz to 3000 Hz			
BP06 	50 Hz to 3000 Hz			
BP07 	300 Hz to 3000 Hz			
BP08 	0 Hz to 4000 Hz			
BP09 	6 Hz to 4000 Hz			
BP10 	50 Hz to 4000 Hz			
BP11 	300 Hz to 4000 Hz			
BP12 	0 Hz to 15000 Hz			
BP13 	6 Hz to 15000 Hz			
BP14 	50 Hz to 15000 Hz			
BP15 	300 Hz to 15000 Hz			
BP16 	0 Hz to 20000 Hz			
BP17 	6 Hz to 20000 Hz			
BP 18,	50 Hz to 20000 Hz			
<Deemphasis>	Description of parameters	Def. value	Def. unit	Unit ring
ON OFF,	Switch de-emphasis on or off	ON	–	
<Expandor>	Description of parameters	Def. value	Def. unit	Unit ring
ON OFF,	Switch expandor on or off	ON	–	
<Weighting>	Description of parameters	Def. value	Def. unit	Unit ring
CME 	Switch on C-message weighted filter	CME	–	
CCI 	Switch on CCITT weighting filter			
OFF	No weighting filter			
Description of command				FW vers.
This command defines the measuring equipment in the <i>TX Tests – Hum & Noise</i> application.				V2.41

CONFigure:TXTests:HNOise:FILTer:DEfault <Enable>		Default Settings		
<Enable>	Description of parameters	Def. value	Def. unit	Unit ring
ON 	The parameters are set to their default values	ON	–	
OFF	Some or all parameters differ from the default values			
Description of command				FW vers.
If used as a setting command with the parameter <i>ON</i> this command sets all parameters of the sub-system to their default values (the setting <i>OFF</i> results in an error message).				V2.41
If used as a query the command returns whether all parameters are set to their default values (<i>ON</i>) or not (<i>OFF</i>).				

Measured Values – Subsystem TXTests:HNOise[:RESult]

The subsystem *TXTests:HNOise[:RESULT]* measures and returns the modulation parameters and compares them with the tolerance values. The subsystem corresponds to the various output elements in the measurement menu *TX Tests*, application *Hum & Noise*.

		Scalar Results:		
READ[:SCALar]:TXTests:HNOise[:RESult]?		Start single shot measurement and return results		
FETCh[:SCALar]:TXTests:HNOise[:RESult]?		Read out meas. results (unsynchronized)		
SAMPlE[:SCALar]:TXTests:HNOise[:RESult]?		Read out measurement results (synchronized)		
Returned values	Value range	Def. value	Def. unit	Unit ring
CarrierFreqError	–48 000 Hz to +48 000 Hz	NAN	Hz	
SATFreqError,	–6 000 Hz to +10 000 Hz	NAN	Hz	
SATPeakDeviation,	0 Hz to +48 000 Hz	NAN	Hz	
Hum&Noise,	0 dB to 100 dB	NAN	dB	
CarrierPower	–90 dBm to +55 dBm	NAN	dBm	
Description of command				FW vers.
These commands are always queries. They start a <i>TX Tests – Hum & Noise</i> measurement and output all measurement results (see chapter 4).				V2.41

		Results out of Tolerance		
CALCulate[:SCALar]:TXTests:HNOise[:RESult]:MATChing:LIMit?				
Returned values	Value range	Def. value	Def. unit	Unit ring
CarrierFreqError	For all measured values: NMAU NMAL INV OK	INV	–	
SATFreqError,		INV	–	
SATPeakDeviation,		INV	–	
Hum&Noise		INV	–	
Description of command				FW vers.
This command is always a query. It indicates whether and in which way the error limits for the measured values (see above command) have been exceeded.				V2.41
The following messages may be output for all measured values:				
NMAU	Underflow of tolerance value	<i>not matching, underflow</i>		
NMAL	Tolerance value exceeded	<i>not matching, overflow</i>		
INV	Measurement invalid	<i>invalid</i>		
OK	all tolerances matched			

TXTests:HNOise:FHNoise

The subsystem *TXTests:HNOise:FHNoise* measures the FM Hum & Noise of the mobile phone transmitter, omitting the (more time-consuming) SAT and ST measurements. It represents a simplified and faster version of the *TXTests:HNOise* measurement, optimized for faster Hum & Noise measurements.

The limit values and filter settings are taken from the *TXTests:HNOise* sub-system; see sections Tolerance values – Subsystem TXTests:HNOise:LIMit on p. 6.30 ff. and Path Configuration – Subsystem TXTests:HNOise:FILTer on p. 6.31 ff. The *TXTests:HNOise:FHNoise* subsystem has no equivalent in manual control.

Control of Measurement – Subsystem TXTests:HNOise:FHNoise

The subsystem *TXTests:HNOise:FHNoise* controls the measurement.

INITiate:TXTests:HNOise:FHNoise	Start new measurement	⇒ <i>RUN</i>
ABORT:TXTests:HNOise:FHNoise	Abort running measurement and switch off	⇒ <i>OFF</i>
STOP:TXTests:HNOise:FHNoise	Stop measurement after current stat. cycle	⇒ <i>STOP</i>
CONTinue:TXTests:HNOise:FHNoise	Next measurement step (only <i>stepping mode</i>)	⇒ <i>RUN</i>
Description of command		FW vers.
These commands have no query form. They start and stop the measurement, setting it to the status indicated in the top right column.		V3.05

CONFigure:TXTests:HNOise:FHNoise:EREPorting <Mode>		Event Reporting		
<Mode>	Description of parameters	Def. value	Def. unit	Unit ring
SRQ 	Service request	OFF	–	–
SOPC 	Single operation complete			
SRSQ 	SRQ and SOPC			
OFF	No reporting			
Description of command		FW vers.		
This command defines the events generated when the measurement is terminated or stopped (<i>event reporting</i> , see chapter 5 of CMU200 manual).		V3.05		

FETCH:TXTests:HNOise:FHNoise:STATus?		Measurement Status		
Ret. values	Description of parameters	Def. value	Def. unit	Unit ring
OFF 	Measurement in the <i>OFF</i> state (*RST or ABORT)	OFF	–	
RUN 	Running (after INITiate, CONTinue or READ)			
STOP 	Stopped (STOP)			
ERR 	<i>OFF</i> (could not be started)			
STEP 	Stepping mode (<stepmode>=STEP)			
RDY,	Stopped according to repetition mode and stop condition			
	Counter for current statistics cycle			
1 to 10000 	No counting mode set	NONE	–	
NONE				
Description of command		FW vers.		
This command is always a query. It returns the status of the measurement (see chapters 3 and 5).		V3.05		

Test Configuration

The commands of the following subsystems configure the fast *Hum & Noise* measurement.

Subsystem TXTests:HNOise:FHNoise:CONTRol

The subsystem *TXTests:HNOise:FHNoise:CONTRol* defines the scope of the fast Hum & Noise measurement.

CONFigure:TXTests:HNOise:FHNoise:CONTRol:REPetition <Repetition> , <StopCond> , <Stepmode>				Test Cycles
<Repetition>	Description of parameters	Def. value	Def. unit	Unit ring
CONTinuous SINGleshot 1 to 10000	Continuous measurement (until <i>STOP</i> or <i>ABORT</i>) Single shot measurement (until <i>Status = RDY</i>) Multiple measurement (<i>counting</i> , until <i>Status = STEP RDY</i>)	SING	–	
<StopCond>	Description of parameters	Def. value	Def. unit	Unit ring
SONerror NONE	Stop measurement in case of error (<i>stop on error</i>) Continue measurement even in case of error	NONE	–	
<Stepmode>	Description of parameters	Def. value	Def. unit	Unit ring
STEP NONE	Interrupt measurement after each statistics cycle Continue measurement according to its rep. mode	NONE	–	
Description of command				FW vers.
This command determines the number of statistics cycles, the stop condition and the stepping mode for the measurement.				V3.05
Note: <i>In the case of READ commands (READ:...), the <Repetition> parameter has no effect; the measurement is always stopped after a single shot.</i>				

CONFigure:TXTests:HNOise:FHNoise:CONTRol:DEFault <Enable>				Default Settings
<Enable>	Description of parameters	Def. value	Def. unit	Unit ring
ON OFF	The parameters are set to their default values Some or all parameters differ from the default values	ON	–	
Description of command				FW vers.
If used as a setting command with the parameter <i>ON</i> this command sets all parameters of the subsystem to their default values (the setting <i>OFF</i> has no effect).				V3.05
If used as a query the command returns whether all parameters are set to their default values (<i>ON</i>) or not (<i>OFF</i>).				

Measured Values – Subsystem TXTests:HNOise:FHNoise[:RESult]

The subsystem *TXTests:HNOise:FHNoise[:RESULT]* measures the Hum & Noise value and compares it with the tolerance value.

READ[:SCALar]:TXTests:HNOise:FHNoise[:RESult]? Scalar Results: Start single shot measurement and return results				
FETCh[:SCALar]:TXTests:HNOise:FHNoise[:RESult]? Read out meas. results (unsynchronized)				
SAMPlE[:SCALar]:TXTests:HNOise:FHNoise[:RESult]? Read out measurement results (synchronized)				
Returned values	Value range	Def. value	Def. unit	Unit ring
Hum&Noise	0 dB to 100 dB	NAN	dB	
Description of command				FW vers.
These commands are always queries. They start a <i>TX Tests – Hum & Noise</i> measurement and output all measurement results (see chapter 4).				V3.05

Results out of Tolerance				
CALCulate[:SCALar]:TXTests:HNOise:FHNoise[:RESult]:MATChing:LIMit?				
Returned values	Value range	Def. value	Def. unit	Unit ring
Hum&Noise	NMAU NMAL INV OK	INV	–	
Description of command				FW vers.
This command is always a query. It indicates whether and in which way the error limits for the measured values (see above command) have been exceeded.				V3.05
The following messages may be output for all measured values:				
NMAU	Underflow of tolerance value	<i>not matching, underflow</i>		
NMAL	Tolerance value exceeded	<i>not matching, overflow</i>		
INV	Measurement invalid	<i>invalid</i>		
OK	all tolerances matched			

TXTests:AFLSearch

The subsystem *TXTests:AFLSearch* searches the AF Level of the mobile phone transmitter corresponding to a definite audio peak deviation. The subsystem corresponds to the measurement menu *TX Tests*, application *AF Level Search*, and the associated popup menu *TX Tests Configuration*.

Control of Measurement – Subsystem TXTests:AFLSearch

The subsystem *TXTests:AFLSearch* controls the measurement. It corresponds to the softkey *AF Level Search* in the measurement menu *TX Tests*.

INITiate:TXTests:AFLSearch	Start new measurement	⇒ <i>RUN</i>
ABORT:TXTests:AFLSearch	Abort running measurement and switch off	⇒ <i>OFF</i>
STOP:TXTests:AFLSearch	Stop measurement after current stat. cycle	⇒ <i>STOP</i>
CONTinue:TXTests:AFLSearch	Next measurement step (only <i>stepping mode</i>)	⇒ <i>RUN</i>
Description of command		FW vers.
These commands have no query form. They start and stop the measurement, setting it to the status indicated in the top right column.		V2.41

CONFigure:TXTests:AFLSearch:EREPorting <Mode>		Event Reporting		
<Mode>	Description of parameters	Def. value	Def. unit	Unit ring
SRQ 	Service request	OFF	–	–
SOPC 	Single operation complete			
SRSQ 	SRQ and SOPC			
OFF	No reporting			
Description of command		FW vers.		
This command defines the events generated when the measurement is terminated or stopped (<i>event reporting</i> , see chapter 5 of CMU200 manual).		V2.41		

FETCh:TXTests:AFLSearch:STATus?		Measurement Status		
Ret. values	Description of parameters	Def. value	Def. unit	Unit ring
OFF 	Measurement in the <i>OFF</i> state (*RST or ABORT)	OFF	–	
RUN 	Running (after INITiate, CONTinue or READ)			
STOP 	Stopped (STOP)			
ERR 	OFF (could not be started)			
STEP 	Stepping mode (<stepmode>=STEP)			
RDY,	Stopped according to repetition mode and stop condition			
1 to 10000 	Counter for current statistics cycle			
NONE	No counting mode set	NONE	–	
Description of command		FW vers.		
This command is always a query. It returns the status of the measurement (see chapters 3 and 5 of CMU manual).		V2.41		

Test Configuration

The commands of the following subsystems configure the *AF Level Search* measurement. They correspond to the sections in the *TX Tests Configuration* menu that are related to the *AF Level Search* application.

Subsystem TXTests:AFLSearch:CONTROL

The subsystem *TXTests:AFLSearch:CONTROL* configures the modulation measurement. It corresponds to the *Control* tab in the popup menu *TX Tests Config*.

CONFigure:TXTests:AFLSearch:TDTyPe <Type>			Target Dev. Type	
<Type>	Description of parameters	Def. value	Def. unit	
RMS	RMS frequency deviation times sqrt(2)	RMS		
PEAK	Peak value of the frequency deviation			
Description of command				FW vers.
This command selects the how the <i>Target Audio Peak Deviation</i> for the <i>AF Level Search</i> is calculated from the frequency deviation of the voice signal.				V3.51

CONFigure:TXTests:AFLSearch:CONTROL:TAPDeviation <TargetDev>			Target Audio Peak Deviation	
<ErrRange>	Description of parameters	Def. value	Def. unit	Unit ring
0 Hz to 48000 Hz	Target audio peak deviation	8000	Hz	
Description of command				FW vers.
This command defines the target audio peak deviation for the <i>AF Level Search</i> .				V2.41

CONFigure:TXTests:AFLSearch:CONTROL:TDERange <ErrRange>			Target Error Range	
<ErrRange>	Description of parameters	Def. value	Def. unit	Unit ring
0 Hz to 48000 Hz	Target audio peak deviation error range	80	Hz	
Description of command				FW vers.
This command defines the target error range, i.e. a frequency interval centered around the target audio peak deviation (see previous command).				V2.41

CONFigure:TXTests:AFLSearch:CONTROL:DEFault <Enable>			Default Settings	
<Enable>	Description of parameters	Def. value	Def. unit	Unit ring
ON 	The parameters are set to their default values	ON		
OFF	Some or all parameters differ from the default values			
Description of command				FW vers.
If used as a setting command with the parameter <i>ON</i> this command sets all parameters of the subsystem to their default values (the setting <i>OFF</i> results in an error message).				V2.41
If used as a query the command returns whether all parameters are set to their default values (<i>ON</i>) or not (<i>OFF</i>).				

Tolerance values – Subsystem TXTests:AFLSearch:LIMit

The subsystem *TXTests:AFLSearch:LIMit* configures the *AF Level Search* iteration in the *TX Tests* measurement. The subsystem corresponds to the relevant section in the *Limits* tab of the popup menu *TX Tests Configuration*.

CONFigure:TXTests:AFLSearch:LIMit <CarrierFrequencyError>			Limits AF Level Search	
Parameter	Description of parameters	Def. value	Def. unit	Unit ring
0 Hz to 48000 Hz	Carrier Frequency Error	2000	Hz	
Description of command				FW vers.
This command defines an upper limit for the carrier frequency error.				V2.41

CONFigure:TXTests:AFLSearch:LIMit:DEfault <Enable>			Default Settings	
<Enable>	Description of parameters	Def. value	Def. unit	Unit ring
ON OFF	The parameters are set to their default values Some or all parameters differ from the default values	ON	–	
Description of command				FW vers.
If used as a setting command with the parameter <i>ON</i> this command sets all parameters of the sub-system to their default values (the setting <i>OFF</i> results in an error message).				V2.41
If used as a query the command returns whether all parameters are set to their default values (<i>ON</i>) or not (<i>OFF</i>).				

Path Configuration – Subsystem TXTests:AFLSearch:FILTer

The subsystem *TXTests:AFLSearch:FILTer* configures the voice-processing equipment used in the *AF Level Search* application of the *TX Tests* measurement. The subsystem corresponds to the relevant section in the *Filters* tab of the popup menu *TX Tests Configuration*.

CONFigure:TXTests:AFLSearch:FILTer <Bandpass>, <Expandor>, <Deemphasis>, <Weighting>		Path Configuration: TX Tests – AFLSearch		
<Bandpass>	Description of parameters	Def. value	Def. unit	Unit ring
BP01 BP02 BP03 BP04 BP05 BP06 BP07 BP08 BP09 BP10 BP11 BP12 BP13 BP14 BP15 BP16 BP17 BP 18,	CMU band pass filter with a bandwidth of 0 Hz to 250 Hz 6 Hz to 250 Hz 50 Hz to 250 Hz 0 Hz to 3000 Hz 6 Hz to 3000 Hz 50 Hz to 3000 Hz 300 Hz to 3000 Hz 0 Hz to 4000 Hz 6 Hz to 4000 Hz 50 Hz to 4000 Hz 300 Hz to 4000 Hz 0 Hz to 15000 Hz 6 Hz to 15000 Hz 50 Hz to 15000 Hz 300 Hz to 15000 Hz 0 Hz to 20000 Hz 6 Hz to 20000 Hz 50 Hz to 20000 Hz	BP10	–	
<Deemphasis>	Description of parameters	Def. value	Def. unit	Unit ring
ON OFF,	Switch de-emphasis on or off	OFF	–	
<Expandor>	Description of parameters	Def. value	Def. unit	Unit ring
ON OFF,	Switch expandor on or off	OFF	–	
<Weighting>	Description of parameters	Def. value	Def. unit	Unit ring
CME CCI OFF	Switch on C-message weighted filter Switch on CCITT weighting filter No weighting filter	OFF	–	
Description of command				FW vers.
This command defines the measuring equipment in the <i>TX Tests – AF Level Search</i> application.				V2.41

CONFigure:TXTests:AFLSearch:FILTer:DEFault <Enable>		Default Settings		
<Enable>	Description of parameters	Def. value	Def. unit	Unit ring
ON OFF	The parameters are set to their default values Some or all parameters differ from the default values	ON	–	
Description of command				FW vers.
If used as a setting command with the parameter <i>ON</i> this command sets all parameters of the sub-system to their default values (the setting <i>OFF</i> results in an error message).				V2.41
If used as a query the command returns whether all parameters are set to their default values (<i>ON</i>) or not (<i>OFF</i>).				

Measured Values – Subsystem TXTests:AFLSearch[:RESult]

The subsystem *TXTests:AFLSearch[:RESULT]* measures and returns the modulation parameters and compares them with the tolerance values. The subsystem corresponds to the various output elements in the measurement menu *TX Tests*, application *AF Level Search*.

		Scalar Results:		
READ[:SCALar]:TXTests:AFLSearch[:RESult]?		Start single shot measurement and return results		
FETCh[:SCALar]:TXTests:AFLSearch[:RESult]?		Read out meas. results (unsynchronized)		
SAMPlE[:SCALar]:TXTests:AFLSearch[:RESult]?		Read out measurement results (synchronized)		
Returned values	Value range	Def. value	Def. unit	Unit ring
CarrierFreqError	–48 000 Hz to +48 000 Hz	NAN	Hz	
AudioPeakDeviation,	–6 000 Hz to +10 000 Hz	NAN	Hz	
AudioRMSDeviation,	0 Hz to +48 000 Hz	NAN	Hz	
CarrierPower,	0 dB to 100 dB	NAN	dBm	
AFSearchLevel	0 V to +5 V	NAN	V	
Description of command				FW vers.
These commands are always queries. They start a <i>TX Tests – AF Level Search</i> measurement and output all measurement results (see chapter 4).				V2.41

		Results out of Tolerance		
CALCulate[:SCALar]:TXTests:AFLSearch[:RESult]:MATChing?				
Returned values	Value range	Def. value	Def. unit	Unit ring
CarrierFreqError	For all measured values: NMAU NMAL INV OK	INV	–	
AudioPeakDeviation,		INV	–	
AudioRMSDeviation		INV	–	
Description of command				FW vers.
This command is always a query. It indicates whether and in which way the error limits for the measured values (see above command) have been exceeded.				V2.41
The following messages may be output for all measured values:				
NMAU	Underflow of tolerance value	<i>not matching, underflow</i>		
NMAL	Tolerance value exceeded	<i>not matching, overflow</i>		
INV	Measurement invalid	<i>invalid</i>		
OK	all tolerances matched			

TXTests:WBData

The subsystem *TXTests:WBData* measures modulation parameters of a received wideband data signal. The subsystem corresponds to the measurement menu *TX Tests*, application *Wideband Data*, and the associated popup menu *TX Tests Configuration*.

Control of Measurement – Subsystem TXTests:WBData

The subsystem *TXTests:WBData* controls the measurement. It corresponds to the softkey *Wideband Data* in the measurement menu *TX Tests*.

INITiate:TXTests:WBData	Start new measurement	⇒ <i>RUN</i>
ABORT:TXTests:WBData	Abort running measurement and switch off	⇒ <i>OFF</i>
STOP:TXTests:WBData	Stop measurement after current stat. cycle	⇒ <i>STOP</i>
CONTinue:TXTests:WBData	Next measurement step (only <i>stepping mode</i>)	⇒ <i>RUN</i>
Description of command		FW vers.
These commands have no query form. They start and stop the measurement, setting it to the status indicated in the top right column.		V3.52

CONFigure:TXTests:WBData:EREPorting <Mode>		Event Reporting		
<Mode>	Description of parameters	Def. value	Def. unit	Unit ring
SRQ 	Service request	OFF	–	–
SOPC 	Single operation complete			
SRSQ 	SRQ and SOPC			
OFF	No reporting			
Description of command		FW vers.		
This command defines the events generated when the measurement is terminated or stopped (<i>event reporting</i> , see chapter 5 of CMU200 manual).		V3.52		

FETCH:TXTests:WBData:STATus?		Measurement Status		
Ret. values	Description of parameters	Def. value	Def. unit	Unit ring
OFF 	Measurement in the <i>OFF</i> state (*RST or ABORt)	OFF	–	
RUN 	Running (after INITiate, CONTinue or READ)			
STOP 	Stopped (STOP)			
ERR 	<i>OFF</i> (could not be started)			
STEP 	Stepping mode (<stepmode>=STEP)			
RDY,	Stopped according to repetition mode and stop condition			
1 to 10000 	Counter for current statistics cycle			
NONE	No counting mode set	NONE	–	
Description of command		FW vers.		
This command is always a query. It returns the status of the measurement (see chapters 3 and 5 of CMU manual).		V3.52		

Test Configuration

The commands of the following subsystems configure the *Wideband Data* measurement. They correspond to the sections in the *TX Tests Configuration* menu that are related to the *Wideband Data* application.

Subsystem TXTests:WBData:CONTRol

The subsystem *TXTests:WBData:CONTRol* configures the *Wideband Data* measurement. It corresponds to the relevant section in the *Control* tab in the popup menu *TX Tests Configuration*.

CONFigure:TXTests:WBData:CONTRol:REPetition <Repetition>, <StopCond>, <Stepmode>				
Test Cycles				
<Repetition>	Description of parameters	Def. value	Def. unit	Unit ring
CONTinuous SINGleshot 1 to 10000	Continuous measurement (until <i>STOP</i> or <i>ABORT</i>) Single shot measurement (until <i>Status = RDY</i>) Multiple measurement (<i>counting</i> , until <i>Status = STEP RDY</i>)	SING	–	
<StopCond>	Description of parameters	Def. value	Def. unit	Unit ring
SONerror NONE	Stop measurement in case of error (<i>stop on error</i>) Continue measurement even in case of error	NONE	–	
<Stepmode>	Description of parameters	Def. value	Def. unit	Unit ring
STEP NONE	Interrupt measurement after each statistics cycle Continue measurement according to its rep. mode	NONE	–	
Description of command				FW vers.
This command determines the number of statistics cycles, the stop condition and the stepping mode for the measurement.				V3.52
Note: <i>In the case of READ commands (READ:...), the <Repetition> parameter has no effect; the measurement is always stopped after a single shot.</i>				

CONFigure:TXTests:WBData:CONTRol:DEFault <Enable>				Default Settings
<Enable>	Description of parameters	Def. value	Def. unit	Unit ring
ON OFF	The parameters are set to their default values Some or all parameters differ from the default values	ON	–	
Description of command				FW vers.
If used as a setting command with the parameter <i>ON</i> this command sets all parameters of the subsystem to their default values (the setting <i>OFF</i> results in an error message).				V3.52
If used as a query the command returns whether all parameters are set to their default values (<i>ON</i>) or not (<i>OFF</i>).				

Tolerance values – Subsystem TXTests:WBData:LIMit

The subsystem *TXTests:WBData:LIMit* defines tolerance values for the *Wideband Data* application of the *TX Tests* measurement. The subsystem corresponds to the relevant section in the *Limits* tab of the popup menu *TX Tests Configuration*.

CONFigure:TXTests:WBData:LIMit				Limits Modulation
<CarrFreqErrRange>, <TotPeakDevMax>, <SATFreqErrRge>, <SATPeakDevErrRge>, <STFreqErrRange>, <STPeakDevErrRge>, <ModDistNoise>, <ResAM>				
Parameter	Description of parameters	Def. value	Def. unit	Unit ring
0 Hz to 48000 Hz	Peak Deviation Error Range	800	Hz	
Description of command				FW vers.
This command defines upper limits for the quantities measured in the <i>TX Tests – Wideband Data</i> application.				V3.52

CONFigure:TXTests:WBData:LIMit:DEFAULT <Enable>				Default Settings	
<Enable>	Description of parameters	Def. value	Def. unit	Unit ring	
ON OFF	The parameters are set to their default values Some or all parameters differ from the default values	ON	–		
Description of command				FW vers.	
If used as a setting command with the parameter <i>ON</i> this command sets all parameters of the sub-system to their default values (the setting <i>OFF</i> results in an error message).				V3.52	
If used as a query the command returns whether all parameters are set to their default values (<i>ON</i>) or not (<i>OFF</i>).					

Measured Values – Subsystem TXTests:WBData[:RESult]

The subsystem *TXTests:WBData[:RESULT]* returns the results of the *Wideband Data* measurement and performs a limit check. The subsystem corresponds to the output elements in the measurement menu *TX Tests*, application *Wideband Data*.

READ[:SCALar]:TXTests:WBData[:RESult]?	Scalar Results: Start single shot measurement and return results			
FETCh[:SCALar]:TXTests:WBData[:RESult]?	Read out meas. results (unsynchronized)			
SAMPlE[:SCALar]:TXTests:WBData[:RESult]?	Read out measurement results (synchronized)			
Returned values	Value range	Def. value	Def. unit	Unit ring
Word Synchronization, Peak Deviation	OK FAIL 0 Hz to +48000 Hz	NAN NAN	– Hz	
Description of command				FW vers.
These commands are always queries. They start a <i>TX Tests – Wideband</i> measurement and return all measurement results (see chapter 4).				V3.52

CALCulate[:SCALar]:TXTests:WBData[:RESult]:MATChing:LIMit?		Results out of Tolerance		
Returned values	Value range	Def. value	Def. unit	Unit ring
Peak Deviation	NMAU SNMAL INV OK	INV	–	
Description of command				FW vers.
This command is always a query. It indicates whether and in which way the error limits for the measured values (see above command) have been exceeded.				V3.52
The following messages may be output for all measured values:				
NMAU	Underflow of tolerance value	<i>not matching, underflow</i>		
NMAL	Tolerance value exceeded	<i>not matching, overflow</i>		
INV	Measurement invalid	<i>invalid</i>		
OK	all tolerances matched			

TXAFresp

The subsystem *TXAFresp* measures the electrical audio frequency response of the mobile phone transmitter quality. The subsystem corresponds to the measurement menu *TX Audio Freq. Response* and the associated popup menu *TX Audio Freq. Response Configuration*.

Control of Measurement – Subsystem TXAFresp

The subsystem *TXAFresp* controls the measurement. It corresponds to the softkey *TX Audio Freq. Response* in the measurement menu *TX Audio Freq. Response*.

INITiate:TXAFresp	Start new measurement	⇒ <i>RUN</i>
ABORT:TXAFresp	Abort running measurement and switch off	⇒ <i>OFF</i>
STOP:TXAFresp	Stop measurement after current stat. cycle	⇒ <i>STOP</i>
CONTinue:TXAFresp	Next measurement step (only <i>stepping mode</i>)	⇒ <i>RUN</i>
Description of command		FW vers.
These commands have no query form. They start and stop the measurement, setting it to the status indicated in the top right column.		V2.41

CONFigure:TXAFresp:EREPorting <Mode>		Event Reporting		
<Mode>	Description of parameters	Def. value	Def. unit	Unit ring
SRQ 	Service request	OFF	–	–
SOPC 	Single operation complete			
SRSQ 	SRQ and SOPC			
OFF	No reporting			
Description of command		FW vers.		
This command defines the events generated when the measurement is terminated or stopped (<i>event reporting</i> , see chapter 5 of CMU200 manual).		V2.41		

FETCH:TXAFresp:STATus?		Measurement Status		
Ret. values	Description of parameters	Def. value	Def. unit	Unit ring
OFF 	Measurement in the <i>OFF</i> state (*RST or ABORT)	OFF	–	
RUN 	Running (after INITiate, CONTinue or READ)			
STOP 	Stopped (STOP)			
ERR 	OFF (could not be started)			
STEP 	Stepping mode (<stepmode>=STEP)			
RDY,	Stopped according to repetition mode and stop condition			
	Counter for current statistics cycle			
1 to 10000 	No counting mode set	NONE	–	
NONE				
Description of command		FW vers.		
This command is always a query. It returns the status of the measurement (see chapters 3 and 5 of CMU manual).		V2.41		

Test Configuration

The commands of the following subsystems configure the *TX Audio Freq. Response* measurement. They correspond to the *TX Audio Freq. Response Configuration* menu.

Subsystem TXAFresp:CONTROL

The subsystem *TXAFresp:CONTROL* configures the measurement. It corresponds to the *Control* tab in the popup menu *TX Audio Freq. Response Config* and the *Reference Deviation* hotkey.

CONFigure:TXAFresp:CONTROL:REPetition <Repetition>, <StopCond>, <Stepmode>				Test Cycles
<Repetition>	Description of parameters	Def. value	Def. unit	Unit ring
CONTinuous SINGleshot 1 to 10000	Continuous measurement (until STOP or ABORT) Single shot measurement (until Status = RDY) Multiple measurement (counting, until Status = STEP RDY)	SING	–	
<StopCond>	Description of parameters	Def. value	Def. unit	Unit ring
SONerror NONE	Stop measurement in case of error (stop on error) Continue measurement even in case of error	NONE	–	
<Stepmode>	Description of parameters	Def. value	Def. unit	Unit ring
STEP NONE	Interrupt measurement after each statistics cycle Continue measurement according to its rep. mode	NONE	–	
Description of command				FW vers.
This command determines the number of statistics cycles, the stop condition and the stepping mode for the measurement.				V2.41
Note: In the case of READ commands (READ:...), the <Repetition> parameter has no effect; the measurement is always stopped after a single shot.				

DISPlay:TXAFresp:CONTROL:GRID <Enable>				Grid on/off
<Enable>	Description of parameters	Def. value	Def. unit	Unit ring
ON OFF	Switch on grid lines Switch off grid lines	ON	–	
Description of command				FW vers.
This command switches the grid lines in the test diagrams on or off.				V2.41

CONFigure:TXAFresp:CONTROL:RDEViation <Deviation>				Reference Deviation
<Deviation>	Description of parameters	Def. value	Def. unit	Unit ring
10.0 Hz to 20000.0 Hz	Reference deviation	1000.0	Hz	
Description of command				FW vers.
This command defines the reference frequency deviation (0 dB line of test diagram).				V2.41

CONFigure:TXAFresp:CONTRol:AFGLead <Time>				AF Generator Lead
<Time>	Description of parameters	Def. value	Def. unit	Unit ring
0 ms to 0.1 s	Holdoff time	14	ms	
Description of command				FW vers.
This command defines a holdoff time for the AF generator.				V2.41

CONFigure:TXAFresp:CONTRol:RREQuest <Reference>				Default Settings
<Reference>	Description of parameters	Def. value	Def. unit	Unit ring
RDEV TON<nr>	Results relative to the reference deviation Results relative to freq. response at test tone <nr>, where <nr> = 1 to 20	TON6	–	
Description of command				FW vers.
This command defines the reference value for the results of the <i>TX Audio Freq. Response</i> measurement. The reference deviation is defined via CONFigure:TXAFresp:CONTRol:RDEViation. To choose one of the test tones no. 1 to 20, it must be enabled via the CONFigure:TXAFresp:TDEFinition:TONE<nr> command.				V2.41

CONFigure:TXAFresp:CONTRol:DEFault <Enable>				Default Settings
<Enable>	Description of parameters	Def. value	Def. unit	Unit ring
ON OFF	The parameters are set to their default values Some or all parameters differ from the default values	ON	–	
Description of command				FW vers.
If used as a setting command with the parameter ON this command sets all parameters of the sub-system to their default values (the setting OFF results in an error message).				V2.41
If used as a query the command returns whether all parameters are set to their default values (ON) or not (OFF).				

Subsystem TXAFresp:TRACe

The subsystem *TXAFresp:TRACe* defines the upper and lower edge of the test diagram. It corresponds to the *Scale Min.* and *Scale Max.* hotkeys in the measurement menu *TX Audio Freq. Response*.

DISPlay:TXAFresp[:WINDow]:TRACe:Y:SCALE <ScaleMin>, <ScaleMax>				Grid on/off
<ScaleMin>	Description of parameters	Def. value	Def. unit	Unit ring
–150.0 dB to 0.0 dB	Lower edge of test diagram	–10.0	dB	
<ScaleMax>	Description of parameters	Def. value	Def. unit	Unit ring
0.0 dB to +150.0 dB	Upper edge of test diagram	+10.0	dB	
Description of command				FW vers.
This command defines the upper and lower edge of the test diagram. The values are relative to the reference deviation defined via CONFigure:TXAFresp:CONTRol:RDEViation (see p. 6.46).				V2.41

Subsystem SUBarrays:TXAFresp

The subsystem *SUBarrays:TXAFresp* defines the measurement range and the type of output values.

CONFigure:SUBarrays:TXAFresp <Mode>,<Start>,<Samples>{,<Start>,<Samples>}				
				Definition of Subarrays
<Mode>	Description of parameters	Def. value	Def. unit	Unit ring
ALL ARITHmetical MINimum MAXimum,	Return all measurement values Return arithm. mean value in every range Return minimum value in every range Return maximum value in every range	ALL	–	
<Start>	Description of parameters	Def. value	Def. unit	Unit ring
1 to 20,	Start test tone in current range	1	–	
<Samples>	Description of parameters	Def. value	Def. unit	Unit ring
1 to 20	Number of test tones in current range	20	–	
Description of command				FW vers.
<p>This command configures the <code>READ:SUBarrays:TXAFresp...</code>, <code>FETCh:SUBarrays:TXAFresp...</code>, and <code>SAMPlE:SUBarrays:TXAFresp</code> commands. It restricts the measurement to up to 32 subranges where either all measurement results (the number of which is given by the <Samples> parameter) or a single statistical value is returned.</p> <p>The subranges are subsets of the full range of test tones defined via <code>CONFigure:TXAFresp:TONE<nr></code>. Each subrange contains all test tones between the start test tone (test tone no. <Start>) and test tone no. <Start>+<Samples>-1. Test points inside this range that are disabled are not measured (result <i>NAN</i>) and do not enter into the ARITHmetical, MINimum and MAXimum values.</p> <p>By default, only one range corresponding to the total measurement range is used and all measurement values are returned.</p>				V2.41

Tolerance values – Subsystem TXAFresp:LIMit

The subsystem *TXAFresp:LIMit* defines tolerance values for the *TX Audio Freq. Response* measurement. The subsystem corresponds to the *Limits* tab of the popup menu *TX Audio Freq. Response Configuration*.

CONFigure:TXAFresp:LIMit[:LINE][:ASYMmetrical]:UPPer				Upper Limit Line	
<Limit_1>, <Enable_1>, ... <Limit_20>, <Enable_20>					
<Limit_nr>	Description of parameters	Def. value	Def. unit	Unit ring	
-80 dB to +80 dB,	Upper limit line at tone <nr>	See below	dB		
<Enable_nr>	Description of parameters	Def. value	Def. unit	Unit ring	
ON OFF	Enable upper limit line at tone <nr>	ON	–		
Description of command				FW vers.	
This command configures the upper limit lines and enables the limit check at the 20 test tones that can be defined via <code>CONFigure:TXAFresp:TONE<nr></code> .				V2.41	
By default, the limit check is switched on at all tones and the following limit lines apply:					
Tone <nr>	Limit Line/[dB]	Enable	Tone <nr>	Limit Line/[dB]	Enable
1	-9.5	ON	11	+5.6	ON
2	-6.2	ON	12	+6.3	ON
3	-3.8	ON	13	+6.9	ON
4	-1.9	ON	14	+7.5	ON
5	-0.3	ON	15	+8.0	ON
6	+1.0	ON	16	+8.6	ON
7	+2.1	ON	17	+9.1	ON
8	+3.1	ON	18	+9.6	ON
9	+4.0	ON	19	+10.0	ON
10	+4.8	ON	20	+10.5	ON

CONFigure:TXAFresp:LIMit[:LINE][:ASYMmetrical]:UPPer:TONE<nr>				Upper Limit	
<Limit>, <Enable>					
<Limit>	Description of parameters	Def. value	Def. unit	Unit ring	
-80 dB to +80 dB,	Upper limit line at tone <nr>	See below	dB		
<Enable>	Description of parameters	Def. value	Def. unit	Unit ring	
ON OFF	Enable upper limit line at tone <nr>	ON	–		
Description of command				FW vers.	
This command configures the upper limit and enables the limit check at one of 20 test tones that can be defined via <code>CONFigure:TXAFresp:TONE<nr></code> . The test tones are numbered by <nr> = 1 to 20. The default limits at all test points are quoted in the previous command.				V2.41	

CONFigure:TXAFresp:LIMit[:LINE][:ASYMmetrical]:LOWer				Lower Limit Line	
<i><Limit_1>, <Enable_1>, ... <Limit_20>, <Enable_20></i>					
<i><Limit_nr></i>	Description of parameters	Def. value	Def. unit	Unit ring	
-80 dB to +80 dB,	Lower limit line at tone <nr>	See below	dB		
<i><Enable_nr></i>	Description of parameters	Def. value	Def. unit	Unit ring	
ON OFF	Enable lower limit line at tone <nr>	ON	-		
Description of command				FW vers.	
This command configures the lower limit lines and enables the limit check at the 20 test tones that can be defined via <code>CONFigure:TXAFresp:TONE<nr></code> .				V2.41	
By default, the limit check is switched on at all tones and the following limit lines apply:					
Tone <nr>	Limit Line/[dB]	Enable	Tone <nr>	Limit Line/[dB]	Enable
1	-13.5	ON	11	+1.6	ON
2	-10.2	ON	12	+2.3	ON
3	-7.8	ON	13	+2.9	ON
4	-5.9	ON	14	+3.5	ON
5	-4.3	ON	15	+4.0	ON
6	-3.0	ON	16	+4.6	ON
7	-1.9	ON	17	+5.0	ON
8	-0.9	ON	18	+5.0	ON
9	0.0	ON	19	+5.0	ON
10	+0.8	ON	20	+5.0	ON

CONFigure:TXAFresp:LIMit[:LINE][:ASYMmetrical]:LOWer:TONE<nr>				Upper Limit	
<i><Limit>, <Enable></i>					
<i><Limit></i>	Description of parameters	Def. value	Def. unit	Unit ring	
-80 dB to +80 dB,	Lower limit line at tone <nr>	See below	dB		
<i><Enable></i>	Description of parameters	Def. value	Def. unit	Unit ring	
ON OFF	Enable lower limit line at tone <nr>	ON	-		
Description of command				FW vers.	
This command configures the lower limit and enables the limit check at one of 20 test tones that can be defined via <code>CONFigure:TXAFresp:TONE<nr></code> . The test tones are numbered by <nr> = 1 to 20. The default limits at all test points are quoted in the previous command.				V2.41	

CONFigure:TXAFresp:LIMit[:LINE]:DEFault <i><Enable></i>				Default Settings	
<i><Enable></i>	Description of parameters	Def. value	Def. unit	Unit ring	
ON OFF	The parameters are set to their default values Some or all parameters differ from the default values	ON	-		
Description of command				FW vers.	
If used as a setting command with the parameter <i>ON</i> this command sets all parameters of the sub-system to their default values (the setting <i>OFF</i> results in an error message).				V2.41	
If used as a query the command returns whether all parameters are set to their default values (<i>ON</i>) or not (<i>OFF</i>).					

Test Tones – Subsystem TXAFresp:TDEFinition

The subsystem *TXAFresp:TDEFinition* configures the audio test signal used for the *TX Audio Freq. Response* measurement. The subsystem corresponds to the *Freq./Lev.* tab of the popup menu *TX Audio Freq. Response Configuration*.

Note: For firmware versions \geq V2.44 (except V2.50, CDMA/AMPS), the *Freq./Lev.* tab of the TX Audio Freq. Response Configuration menu is replaced by the *Tone Def.* tab with an extended functionality concerning the level handling of each tone. To make use of the new features, it is recommended to rely upon the *TXAFresp:AFGenerator* subsystem (see p. 6.52 ff) instead of the *TXAFresp:TDEFinition* subsystem.

The default configurations of the *TXAFresp:TDEFinition* subsystem and of its successor, the *TXAFresp:AFGenerator* subsystem, are identical.

CONFigure:TXAFresp:TDEFinition						Test Tones	
<Freq_1>, <Lev_1>, <Enable_1>, ... <Freq_20>, <Lev_20>, <Enable_20>							
<Freq_nr>	Description of parameters			Def. value	Def. unit	Unit ring	
10 Hz to 15999 Hz,	Frequency of test tone <nr>			See below	Hz		
<Lev_nr>	Description of parameters			Def. value	Def. unit	Unit ring	
0.0 V to 5.0 V,	Level at test tone <nr>			See below	V		
<Enable_nr>	Description of parameters			Def. value	Def. unit	Unit ring	
ON OFF	Switch on / off test tone <nr>			See below	–		
Description of command						FW vers.	
This command enables and configures up to 20 test tones. Several tones may coincide; their frequencies must be in multiples of 1 Hz. The sum of all test tones must not exceed the maximum AF generator level quoted in the data sheet.						V2.41	
The following default test tones are provided:							
Tone <nr>	Frequency/[Hz]	Level/[V]	Enable	Tone <nr>	Frequency/[Hz]	Level/[V]	Enable
1	300	0.01	ON	11	1700	0.01	ON
2	440	0.01	ON	12	1840	0.01	ON
3	580	0.01	ON	13	1980	0.01	ON
4	720	0.01	ON	14	2120	0.01	ON
5	860	0.01	ON	15	2260	0.01	ON
6	1004	0.01	ON	16	2400	0.01	ON
7	1140	0.01	ON	17	2540	0.01	ON
8	1280	0.01	ON	18	2680	0.01	ON
9	1420	0.01	ON	19	2820	0.01	ON
10	1560	0.01	ON	20	3000	0.01	ON

CONFigure:TXAFresp:TDEFinition:TONE<nr> <Frequency>, <Level>, <Enable>				Freq./Level
<Frequency>	Description of parameters	Def. value	Def. unit	Unit ring
10 Hz to 15 999 Hz,	Frequency of test tone <nr>	See below	Hz	
<Level>	Description of parameters	Def. value	Def. unit	Unit ring
0.0 V to 5.0 V,	AF level test tone <nr>	See below	V	
<Enable>	Description of parameters	Def. value	Def. unit	Unit ring
ON OFF	Switch on / off test tone <nr>	See below	–	
Description of command				FW vers.
This command enables and configures one of up to 20 test tones (<nr> = 1 to 20). The default values for all test tones are given in the previous command.				V2.41

CONFigure:TXAFresp:TDEFinition:Default <Enable>			Default Settings	
<Enable>	Description of parameters	Def. value	Def. unit	Unit ring
ON OFF	The parameters are set to their default values Some or all parameters differ from the default values	ON	–	
Description of command				FW vers.
If used as a setting command with the parameter ON this command sets all parameters of the subsystem to their default values (the setting OFF results in an error message).				V2.41
If used as a query the command returns whether all parameters are set to their default values (ON) or not (OFF).				

Test Tones – Subsystem TXAFresp:AFGenerator

The subsystem *TXAFresp:AFGenerator* configures the audio test signal used for the *TX Audio Freq. Response* measurement. The subsystem corresponds to the *Tone Def.* tab of the popup menu *TX Audio Freq. Response Configuration*.

Note: For firmware versions < V2.44 and for V2.50, CDMA/AMPS, the *Tone Def.* tab of the *TX Audio Freq. Response Configuration* menu is replaced by the *Freq./Lev.* tab with a restricted functionality concerning the level handling of each tone. The test tones must be defined by means of the *TXAFresp:TDEFinition* subsystem; see p. 6.51 f.

The default configurations of the *TXAFresp:TDEFinition* subsystem and of its successor, the *TXAFresp:AFGenerator* subsystem, are identical.

CONFigure:TXAFresp:AFGenerator:ENABLE<Enable> AF Gen. on/off				
<Enable>	Description of parameters	Def. value	Def. unit	Unit ring
ON OFF,	Switch on / off test tone no 1	ON	–	
...,				
ON OFF	Switch on / off test tone no 20	ON	–	
Description of command				FW vers.
This command enables or disables all 20 test tones provided in the <i>TXAFresp</i> measurement.				V2.44 ≠V2.50

CONFigure:TXAFresp:AFGenerator:ENABLE:TONE<nr> <Enable> AF Gen. on/off				
<Enable>	Description of parameters	Def. value	Def. unit	Unit ring
ON OFF	Switch on / off test tone <nr>	ON	–	
Description of command				FW vers.
This command enables or disables one of the 20 test tones provided in the TXAFresp measurement (<nr> = 1 to 20).				V2.44 ≠V2.50

CONFigure:TXAFresp:AFGenerator:FREQUENCY <Frequency> Test Tone Frequency				
<Frequency>	Description of parameters	Def. value	Def. unit	Unit ring
10 Hz to 15 999 Hz, ..., 10 Hz to 15 999 Hz	Frequency of test tone no. 1 ... Frequency of test tone no. 20	See below See below	Hz Hz	
Description of command				FW vers.
This command defines the frequency of the 20 test tones (<nr> = 1 to 20) provided in the TXAFresp measurement. All frequencies must be in multiples of 1 Hz, however, several tones may be at the same frequency. The following default test tones are provided:				V2.44 ≠V2.50
Tone <nr>	Frequency/[Hz]	Level/[V]	Enable	Tone <nr>
1	300	0.01	ON	11
2	440	0.01	ON	12
3	580	0.01	ON	13
4	720	0.01	ON	14
5	860	0.01	ON	15
6	1004	0.01	ON	16
7	1140	0.01	ON	17
8	1280	0.01	ON	18
9	1420	0.01	ON	19
10	1560	0.01	ON	20
				Frequency/[Hz]
				Level/[V]
				Enable

CONFigure:TXAFresp:AFGenerator:FREQUENCY:TONE<nr> <Frequency> Test Tone Frequency				
<Frequency>	Description of parameters	Def. value	Def. unit	Unit ring
10 Hz to 15 999 Hz	Frequency of test tone <nr>	See CONFigure:TXAFresp: AF-Generator:FREQUENCY <Frequency> command above	Hz	
Description of command				FW vers.
This command defines the frequency of one of the 20 test tones (<nr> = 1 to 20) provided in the TXAFresp measurement. All frequencies must be in multiples of 1 Hz, however, several tones may be at the same frequency.				V3.00 ≠V2.50

CONFigure:TXAFresp:AFGenerator:LEVel:LMODe <Mode> Level Selection				
<Mode>	Description of parameters	Def. value	Def. unit	Unit ring
TLEV SLEV SRES	Use total level (manual) Use separate levels for each tone Use AF Level Search result (as total level)	TLEV	Hz	

Description of command		FW vers.
<p>This command defines how the voltage of each of the test tones is determined.</p> <ul style="list-style-type: none"> In the default setting <code>TLEV</code>, the total AF generator level of 200 mV (see command <code>CONFigure:TXAFresp:AFGenerator:LEVel:TLEVel</code>) is evenly distributed among all 20 enabled test tones. This is identical with the default configuration of the <code>TXAFresp:TDEfinition</code> subsystem; see p. 6.51 f. To define test tone voltages that differ from each other, the parameter <code>SLEV</code> must be selected. The <code>SRES</code> parameter is available only after an <i>AF Level Search</i>, see section TXTests:AFLSearch on page 6.36 ff. If an attempt is made to set the <code>SRES</code> parameter while no valid search results is available the CMU returns an SCPI error message "-221, Settings conflict". 		V3.00 ≠V2.50

CONFigure:TXAFresp:AFGenerator:LEVel:TLEVel		<Total_Level>Total Level (Manual)		
<Total_Level>	Description of parameters	Def. value	Def. unit	Unit ring
0.001 V to 5.0 V	Total level/voltage (sum of all test tones)	0.200	V	
Description of command		FW vers.		
<p>This command defines the total AF generator level that is evenly distributed among all enabled test tones. The total level setting comes into effect after the level selection mode is set to <code>TLEV</code> (see <code>CONFigure:TXAFresp:AFGenerator:LEVel:LMODe</code> command above). The total level must not exceed the maximum AF generator level quoted in the data sheet.</p>		V3.00 ≠V2.50		

CONFigure:TXAFresp:AFGenerator:LEVel:SLEVel		<Separate_Levels>Separate Levels		
<Separate_Level>	Description of parameters	Def. value	Def. unit	Unit ring
0.0 V to 5.0 V, ..., 0.0 V to 5.0 V	Level/voltage of test tone no. 1 ... Level/voltage of test tone no. 20	0.010 ... 0.010	V ... V	
Description of command		FW vers.		
<p>This command defines separate AF generator levels for all 20 test tones provided in the <code>TXAFresp</code> measurement. The level settings come into effect after the level selection mode is set to <code>SLEV</code> (see <code>CONFigure:TXAFresp:AFGenerator:LEVel:LMODe</code> command above). The total level, i.e. the sum of the separate levels of all enabled test tones, must not exceed the maximum AF generator level quoted in the data sheet.</p>		V3.00 ≠V2.50		

CONFigure:TXAFresp:AFGenerator:LEVel:SLEVel:TONE<nr>		<Separate_Level>Separate Level		
<Separate_Level>	Description of parameters	Def. value	Def. unit	Unit ring
0.0 V to 5.0 V	Level/voltage of test tone no. <nr>	0.010	V	
Description of command		FW vers.		
<p>This command defines separate AF generator levels for one of the 20 test tones (<nr> = 1 to 20) provided in the <code>TXAFresp</code> measurement. The level settings come into effect after the level selection mode is set to <code>SLEV</code> (see <code>CONFigure:TXAFresp:AFGenerator:LEVel:LMODe</code> command above). The total level, i.e. the sum of the separate levels of all enabled test tones, must not exceed the maximum AF generator level quoted in the data sheet.</p>		V3.00 ≠V2.50		

CONFigure:TXAFresp:AFGenerator:DEFAULT <Enable>			Default Settings	
<Enable>	Description of parameters	Def. value	Def. unit	Unit ring
ON OFF	The parameters are set to their default values Some or all parameters differ from the default values	ON	–	
Description of command				FW vers.
If used as a setting command with the parameter ON this command sets all parameters of the sub-system to their default values (the setting OFF results in an error message).				V3.00 ≠V2.50
If used as a query the command returns whether all parameters are set to their default values (ON) or not (OFF).				

Path Configuration – Subsystem TXAFresp:FILTer

The subsystem *TXAFresp:FILTer* configures the voice-processing equipment used for the *TX Audio Freq. Response* measurement. The subsystem corresponds to the *Filters* tab of the popup menu *TX Audio Freq. Response Configuration*.

CONFigure:TXAFresp:FILTer <Bandpass>, <Expandor>, <Deemphasis>, <Weighting>		Path Configuration: TX Audio Freq. Response		
<Bandpass>	Description of parameters	Def. value	Def. unit	Unit ring
BP01 BP02 BP03 BP04 BP05 BP06 BP07 BP08 BP09 BP10 BP11 BP12 BP13 BP14 BP15 BP16 BP17 BP 18,	CMU band pass filter with a bandwidth of 0 Hz to 250 Hz 6 Hz to 250 Hz 50 Hz to 250 Hz 0 Hz to 3000 Hz 6 Hz to 3000 Hz 50 Hz to 3000 Hz 300 Hz to 3000 Hz 0 Hz to 4000 Hz 6 Hz to 4000 Hz 50 Hz to 4000 Hz 300 Hz to 4000 Hz 0 Hz to 15000 Hz 6 Hz to 15000 Hz 50 Hz to 15000 Hz 300 Hz to 15000 Hz 0 Hz to 20000 Hz 6 Hz to 20000 Hz 50 Hz to 20000 Hz	BP16	–	
<Deemphasis>	Description of parameters	Def. value	Def. unit	Unit ring
ON OFF,	Switch de-emphasis on or off	OFF	–	
<Expandor>	Description of parameters	Def. Value	Def. unit	Unit ring
ON OFF,	Switch expandor on or off	OFF	–	
<Weighting>	Description of parameters	Def. Value	Def. unit	Unit ring
CME CCI OFF	Switch on C-message weighted filter Switch on CCITT weighting filter No weighting filter	OFF	–	

Description of command	FW vers.
This command defines the measuring equipment in the <i>TX Audio Freq. Response</i> application.	V2.41

CONFigure:TXAFresp:FILTer:DEFault <Enable>				Default Settings	
<Enable>	Description of parameters	Def. value	Def. unit	Unit ring	
ON 	The parameters are set to their default values	ON	–		
OFF	Some or all parameters differ from the default values				
Description of command					FW vers.
If used as a setting command with the parameter <i>ON</i> this command sets all parameters of the sub-system to their default values (the setting <i>OFF</i> results in an error message).					V2.41
If used as a query the command returns whether all parameters are set to their default values (<i>ON</i>) or not (<i>OFF</i>).					

Measured Values – Subsystem TXAFresp[:RESult]

The subsystem *TXAFresp[:RESULT]* measures and returns the electrical Audio Frequency Response and compares it with the tolerance values. The subsystem corresponds to the various output elements in the measurement menu *TX Audio Freq. Response*.

TX Audio Frequency Response, Single Point					
READ[:SCALar]:TXAFresp[:RESult]:TONE<nr>?		Start single shot measurement and return results		⇒ <i>RUN</i>	
FETCh[:SCALar]:TXAFresp[:RESult]:TONE<nr>?		Read meas. results (unsynchronized)		⇒ <i>RUN</i>	
SAMPlE[:SCALar]:TXAFresp[:RESult]:TONE<nr>?		Read results (synchronized)		⇒ <i>RUN</i>	
Returned values	Description of parameters	Def. value	Def. unit	Unit ring	
–150.0 dB to +150.0 dB	AF response at test tone <nr>	NAN	dB		
Description of command					FW vers.
These commands are always queries. They output the TX Audio Frequency Response at a single test tone defined via <code>CONFigure:TXAFresp:TONE<nr></code> (<nr> = 1 to 20).					V2.41

TX Audio Frequency Response, Overall					
READ:ARRay:TXAFresp[:RESult]?		Start single shot measurement and return results		⇒ <i>RUN</i>	
FETCh:ARRay:TXAFresp[:RESult]?		Read meas. results (unsynchronized)		⇒ <i>RUN</i>	
SAMPlE:ARRay:TXAFresp[:RESult]?		Read results (synchronized)		⇒ <i>RUN</i>	
Returned values	Description of parameters	Def. value	Def. unit	Unit ring	
–150.0 dB to +150.0 dB,	FreqResp[1], 1 st value for AF response	NAN	dB		
...		
–150.0 dB to +150.0 dB	FreqResp[20], 20th value for AF resp.	NAN	dB		
Description of command					FW vers.
These commands are always queries. They output the TX Audio Frequency Response at the 20 test tones defined via <code>CONFigure:TXAFresp:TONE<nr></code> .					V2.41

				Subarray Results
READ:SUBarrays:TXAFresp[:RESult]?		Start single shot measurement and return results		⇒ <i>RUN</i>
FETCh:SUBarrays:TXAFresp[:RESult]?		Read meas. results (unsynchronized)		⇒ <i>RUN</i>
SAMPlE:SUBarrays:TXAFresp[:RESult]?		Read results (synchronized)		⇒ <i>RUN</i>
<i>Ret. values per subrange</i>	Description of parameters	Def. value	Def. unit	Unit ring
-150.0 dB to +150.0 dB	FreqResp[1], 1 st value for AF response	NAN	dB	
...	
-150.0 dB to +150.0 dB	FreqResp[n], nth value for AF response	NAN	dB	
Description of command				FW vers.
<p>These commands are always queries. They output the AF response in the subranges defined by means of the <code>CONFIgure:SUBarrays:TXAFresp</code> command. In the default setting of the configuration command the <code>READ:SUBarrays...</code>, <code>FETCh:SUBarrays...</code>, and <code>SAMPlE:SUBarrays...</code> command group is equivalent to the <code>READ:ARRay...</code>, <code>FETCh:ARRay...</code>, and <code>SAMPlE:ARRay...</code> command group described above.</p> <p>The <code>CONFIgure:SUBarrays:TXAFresp</code> command defines a maximum of 32 subranges. If one of the statistical modes (<code>ARITHmetical</code>, <code>MINimum</code>, <code>MAXimum</code>) is set, only one value is returned by subrange.</p>				V2.41

CALCulate[:SCALar]:TXAFresp[:RESult]:MATChing:LIMit[:LINE][:ASYMmetrical] [:COMBined]:TONE<nr>?				Limit Matching, Single Point													
<i>Returned result</i>	Value range	Def. value	Def. unit	Unit ring													
Limit matching at tone <nr>	NMAU NMAL INV OK	INV	–														
Description of command				FW vers.													
<p>This command is always a query. It indicates whether and in which way the error limits at tone <nr> (<nr> = 1 to 20) have been exceeded.</p> <p>The following messages may be output for for test tone <nr>:</p> <table style="width: 100%; border: none;"> <tr> <td style="padding-right: 20px;">NMAU</td> <td style="padding-right: 20px;">Underflow of tolerance value</td> <td><i>not matching, underflow</i></td> </tr> <tr> <td>NMAL</td> <td>Tolerance value exceeded</td> <td><i>not matching, overflow</i></td> </tr> <tr> <td>INV</td> <td>Measurement invalid</td> <td><i>invalid</i></td> </tr> <tr> <td>OK</td> <td>all tolerances matched</td> <td></td> </tr> </table>				NMAU	Underflow of tolerance value	<i>not matching, underflow</i>	NMAL	Tolerance value exceeded	<i>not matching, overflow</i>	INV	Measurement invalid	<i>invalid</i>	OK	all tolerances matched		V2.41	
NMAU	Underflow of tolerance value	<i>not matching, underflow</i>															
NMAL	Tolerance value exceeded	<i>not matching, overflow</i>															
INV	Measurement invalid	<i>invalid</i>															
OK	all tolerances matched																

CALCulate:ARRay:TXAFresp[:RESult]:MATChing:LIMit[:LINE][:ASYMmetrical] [:COMBined]?				Limit Matching, Overall	
<i>Returned result</i>	Value range	Def. value	Def. unit	Unit ring	
20 bit field,	Indicator for upper limit matching in area 1 to 20,	NAN	–		
20 bit field	Indicator for lower limit matching in area 1 to 20	NAN	–		
Description of command				FW vers.	
<p>This command is always a query. Any set bit of the two returned fields indicates that the limits at the corresponding point are exceeded.</p>				V2.41	

RXTTests:AFANalyzer

The subsystem *RXTTests:AFANalyzer* measures parameters characterizing the received audio signal from the mobile phone receiver. The subsystem corresponds to the measurement menu *RX Tests*, application *AF Analyzer*, and the associated popup menu *RX Tests Configuration*.

Control of Measurement – Subsystem RXTTests:AFANalyzer

The subsystem *RXTTests:AFANalyzer* controls the measurement. It corresponds to the softkey *AF Analyzer* in the measurement menu *RX Tests*.

INITiate:RXTTests:AFANalyzer	Start new measurement	⇒ <i>RUN</i>
ABORT:RXTTests:AFANalyzer	Abort running measurement and switch off	⇒ <i>OFF</i>
STOP:RXTTests:AFANalyzer	Stop measurement after current stat. cycle	⇒ <i>STOP</i>
CONTinue:RXTTests:AFANalyzer	Next measurement step (only <i>stepping mode</i>)	⇒ <i>RUN</i>
Description of command		FW vers.
These commands have no query form. They start and stop the measurement, setting it to the status indicated in the top right column.		V2.41

CONFigure:RXTTests:AFANalyzer:EREPorting <Mode>		Event Reporting		
<Mode>	Description of parameters	Def. value	Def. unit	Unit ring
SRQ 	Service request	OFF	–	–
SOPC 	Single operation complete			
SRSQ 	SRQ and SOPC			
OFF	No reporting			
Description of command				FW vers.
This command defines the events generated when the measurement is terminated or stopped (<i>event reporting</i> , see chapter 5 of CMU200 manual).				V2.41

FETCH:RXTTests:AFANalyzer:STATus?		Measurement Status		
Ret. values	Description of parameters	Def. value	Def. unit	Unit ring
OFF 	Measurement in the <i>OFF</i> state (*RST or ABORT)	OFF	–	
RUN 	Running (after INITiate, CONTinue or READ)			
STOP 	Stopped (STOP)			
ERR 	OFF (could not be started)			
STEP 	Stepping mode (<stepmode>=STEP)			
RDY,	Stopped according to repetition mode and stop condition			
	Counter for current statistics cycle			
1 to 10000 	No counting mode set	NONE	–	
NONE				
Description of command				FW vers.
This command is always a query. It returns the status of the measurement (see chapters 3 and 5 of CMU manual).				V2.41

Test Configuration

The commands of the following subsystems configure the *AF Analyzer* measurement. They correspond to the sections in the *RX Tests Configuration* menu that are related to the *AF Analyzer* application.

Subsystem RXTests:AFANalyzer:CONTROL

The subsystem *RXTests:AFANalyzer:CONTROL* configures the measurement. It corresponds to the *Control* tab in the popup menu *RX Tests Config*.

CONFigure:RXTests:AFANalyzer:CONTROL:REPetition <Repetition>, <StopCond>, <Stepmode>				
Test Cycles				
<Repetition>	Description of parameters	Def. value	Def. unit	Unit ring
CONTinuous SINGleshot 1 to 10000,	Continuous measurement (until STOP or ABORT) Single shot measurement (until Status = RDY) Multiple measurement (<i>counting</i> , until Status = STEP RDY)	SING	–	
<StopCond>	Description of parameters	Def. value	Def. unit	Unit ring
SONerror NONE,	Stop measurement in case of error (<i>stop on error</i>) Continue measurement even in case of error	NONE	–	
<Stepmode>	Description of parameters	Def. value	Def. unit	Unit ring
STEP NONE	Interrupt measurement after each statistics cycle Continue measurement according to its rep. mode	NONE	–	
Description of command				FW vers.
This command determines the number of statistics cycles, the stop condition and the stepping mode for the measurement.				V2.41
Note: <i>In the case of READ commands (READ:...), the <Repetition> parameter has no effect; the measurement is always stopped after a single shot.</i>				

CONFigure:RXTests:AFANalyzer:CONTROL:DEFault <Enable>		Default Settings		
<Enable>	Description of parameters	Def. value	Def. unit	Unit ring
ON OFF	The parameters are set to their default values Some or all parameters differ from the default values	ON	–	
Description of command				FW vers.
If used as a setting command with the parameter ON this command sets all parameters of the subsystem to their default values (the setting OFF results in an error message).				V2.41
If used as a query the command returns whether all parameters are set to their default values (ON) or not (OFF).				

Tolerance values – Subsystem RXTests:AFAnalyzer:LIMit

The subsystem *RXTests:AFAnalyzer:LIMit* defines tolerance values for the *AF Analyzer* application of the *RX Tests* measurement. The subsystem corresponds to the relevant section in the *Limits* tab of the popup menu *RX Tests Configuration*.

CONFigure:RXTests:AFAnalyzer:LIMit <AFVoltMtrMin>, <AFVoltMtrMax>, <AFDist>, <AFSINAD>		Limits AF Analyzer		
Parameter	Description of parameters	Def. value	Def. unit	Unit ring
0.0 V to 30.0 V OFF ON, 0.0 V to 30.0 V OFF ON, 0% to 100%, -99.0 dB to +100.0 dB	AF Voltmeter Minimum limit check off reactivate limit check	OFF	V	
	AF Voltmeter Maximum limit check off reactivate limit check	OFF	V	
	AF Distortion (audio harmonic distortion)	5	%	
	AF SINAD (0.1 dB steps)	+12.0	dB	
Description of command				FW vers.
This command defines upper limits for the quantities measured in the <i>RX Tests – AF Analyzer</i> application. The settings <i>ON</i> and <i>OFF</i> have a reverse effect; <i>OFF</i> is suitable for activating a limit check with limits that were previously defined but temporarily suspended.				V2.41

CONFigure:RXTests:AFAnalyzer:LIMit:Default <Enable>		Default Settings		
<Enable>	Description of parameters	Def. value	Def. unit	Unit ring
ON OFF	The parameters are set to their default values Some or all parameters differ from the default values	ON	–	
Description of command				FW vers.
If used as a setting command with the parameter <i>ON</i> this command sets all parameters of the subsystem to their default values (the setting <i>OFF</i> results in an error message).				V2.41
If used as a query the command returns whether all parameters are set to their default values (<i>ON</i>) or not (<i>OFF</i>).				

Path Configuration – Subsystem RXTests:AFAnalyzer:FILTER

The subsystem *RXTests:AFAnalyzer:FILTER* configures the voice-processing equipment used in the *AF Analyzer* application of the *RX Tests* measurement. The subsystem corresponds to the relevant section in the *Filters* tab of the popup menu *RX Tests Configuration*.

CONFigure:RXTests:AFAnalyzer:FILTER <Bandpass>, <Weighting>				
Path Configuration: RX Tests – AF Analyzer				
<Bandpass>	Description of parameters	Def. value	Def. unit	Unit ring
BP01	CMU band pass filter with a bandwidth of	BP10	–	
BP02	0 Hz to 250 Hz			
BP03	6 Hz to 250 Hz			
BP04	50 Hz to 250 Hz			
BP05	0 Hz to 3000 Hz			
BP06	6 Hz to 3000 Hz			
BP07	50 Hz to 3000 Hz			
BP08	300 Hz to 3000 Hz			
BP09	0 Hz to 4000 Hz			
BP10	6 Hz to 4000 Hz			
BP11	50 Hz to 4000 Hz			
BP12	300 Hz to 4000 Hz			
BP13	0 Hz to 15000 Hz			
BP14	6 Hz to 15000 Hz			
BP15	50 Hz to 15000 Hz			
BP16	300 Hz to 15000 Hz			
BP17	0 Hz to 21000 Hz			
BP 18,	6 Hz to 21000 Hz			
	50 Hz to 21000 Hz			
<Weighting>	Description of parameters	Def. value	Def. unit	Unit ring
CME	Switch on C-message weighted filter	CME	–	
CCI	Switch on CCITT weighting filter			
OFF	No weighting filter			
Description of command				FW vers.
This command defines the voice-processing equipment for the <i>RX Tests – AF Analyzer</i> application.				V2.41

CONFigure:RXTests:AFAnalyzer:FILTER:NOTCh <Bandwidth>			Notch Filter	
<Bandwidth>	Description of parameters	Def. value	Def. unit	
N01	Notch filter bandwidth 0.1	N05	–	
N05	Notch filter bandwidth 0.5			
Description of command				FW vers.
This command selects the 3-dB bandwidth of the notch filter used to measure the AF SINAD. The value is expressed relative to the center frequency.				V3.51

CONFigure:RXTests:AFANalyzer:FILTer:DEFault <Enable>				Default Settings
<Enable>	Description of parameters	Def. value	Def. unit	Unit ring
ON OFF	The parameters are set to their default values Some or all parameters differ from the default values	ON	–	
Description of command				FW vers.
If used as a setting command with the parameter <i>ON</i> this command sets all parameters of the sub-system to their default values (the setting <i>OFF</i> results in an error message).				V2.41
If used as a query the command returns whether all parameters are set to their default values (<i>ON</i>) or not (<i>OFF</i>).				

Measured Values – Subsystem RXTests:AFAnalyzer[:RESult]

The subsystem *RXTests:AFAnalyzer[:RESULT]* measures and returns the received audio signal parameters and compares them with the tolerance values. The subsystem corresponds to the various output elements in the measurement menu *RX Tests*, application *AF Analyzer*.

READ[:SCALar]:RXTests:AFAnalyzer[:RESult]? Scalar Results: Start single shot measurement and return results				
FETCh[:SCALar]:RXTests:AFAnalyzer[:RESult]? Read out meas. results (unsynchronized)				
SAMPlE[:SCALar]:RXTests:AFAnalyzer[:RESult]? Read out measurement results (synchronized)				
Returned values	Value range	Def. value	Def. unit	Unit ring
AFVoltmeter,	0 V to 30 V	NAN	V	
AFSINAD,	0 dB to 100 dB	NAN	dB	
AFDistortion,	0% to 100%	NAN	%	
Dist&SINADat	–	NAN	Hz	
Description of command				FW vers.
These commands are always queries. They start a <i>RX Tests – AF Analyzer</i> measurement and output all measurement results (see chapter 4).				V2.41

CALCulate[:SCALar]:RXTests:AFAnalyzer[:RESult]:MATChing:LIMit?				
Results out of Tolerance				
Returned values	Value range	Def. value	Def. unit	Unit ring
AFVoltmeter,	For all measured values: NMAU NMAL INV OK	INV	–	
AFSINAD,		INV	–	
AFDistortion		INV	–	
Description of command				FW vers.
This command is always a query. It indicates whether and in which way the error limits for the measured values (see above command) have been exceeded.				V2.41
The following messages may be output for all measured values:				
NMAU	Underflow of tolerance value	<i>not matching, underflow</i>		
NMAL	Tolerance value exceeded	<i>not matching, overflow</i>		
INV	Measurement invalid	<i>invalid</i>		
OK	all tolerances matched			

RXTests:AFANalyzer:VMSinad (Fast SINAD Measurement)

The subsystem *RXTests:AFANalyzer:VMSinad* measures the audio voltage and the SINAD of the audio signal from the mobile phone receiver, omitting the (more time-consuming) AF distortion measurement. It represents a simplified version of the *RXTests:AFANalyzer* measurement (see p. 6.58 ff), optimized for fast SINAD tests. The limit values and filter settings are taken from the *RXTests:AFANalyzer* subsystem (see p. 6.60 ff). The *RXTests:AFANalyzer:VMSinad* subsystem has no equivalent in manual control.

Control of Measurement – Subsystem RXTests:AFANalyzer:VMSinad

The subsystem *RXTests:AFANalyzer:VMSinad* controls the fast SINAD measurement.

INITiate:RXTests:AFANalyzer:VMSinad	Start new measurement	⇒ <i>RUN</i>
ABORt:RXTests:AFANalyzer:VMSinad	Abort running measurement and switch off	⇒ <i>OFF</i>
STOP:RXTests:AFANalyzer:VMSinad	Stop measurement after current stat. cycle	⇒ <i>STOP</i>
CONTinue:RXTests:AFANalyzer:VMSinad	Next measurement step (only <i>stepping mode</i>)	⇒ <i>RUN</i>
Description of command		FW vers.
These commands have no query form. They start and stop the measurement, setting it to the status indicated in the top right column.		V3.00

CONFigure:RXTests:AFANalyzer:VMSinad:EREPorting <Mode>		Event Reporting		
<Mode>	Description of parameters	Def. value	Def. unit	Unit ring
SRQ 	Service request	OFF	–	–
SOPC 	Single operation complete			
SRSQ 	SRQ and SOPC			
OFF	No reporting			
Description of command		FW vers.		
This command defines the events generated when the measurement is terminated or stopped (<i>event reporting</i> , see chapter 5 of CMU200 manual).		V3.00		

FETCH:RXTests:AFANalyzer:VMSinad:STATus?		Measurement Status		
Ret. values	Description of parameters	Def. value	Def. unit	Unit ring
OFF 	Measurement in the <i>OFF</i> state (*RST or ABORt)	OFF	–	
RUN 	Running (after INITiate, CONTinue or READ)			
STOP 	Stopped (STOP)			
ERR 	<i>OFF</i> (could not be started)			
STEP 	Stepping mode (<stepmode>=STEP)			
RDY,	Stopped according to repetition mode and stop condition			
	Counter for current statistics cycle			
1 to 10000 	No counting mode set	NONE	–	
NONE				
Description of command		FW vers.		
This command is always a query. It returns the status of the measurement (see chapters 3 and 5 of CMU manual).		V3.00		

Test Configuration

The commands of the following subsystems configure the fast SINAD measurement.

Subsystem RXTests:AFANalyzer:VMSinad:CONTROL

The subsystem *RXTests:AFANalyzer:VMSinad:CONTROL* configures the measurement.

CONFigure:RXTests:AFANalyzer:VMSinad:CONTROL:REPetition <Repetition>, <StopCond>, <Stepmode>				Test Cycles	
<Repetition>	Description of parameters	Def. value	Def. unit	Unit ring	
CONTinuous SINGleshot 1 to 10000,	Continuous measurement (until <i>STOP</i> or <i>ABORT</i>) Single shot measurement (until <i>Status = RDY</i>) Multiple measurement (<i>counting</i> , until <i>Status = STEP RDY</i>)	SING	–		
<StopCond>	Description of parameters	Def. value	Def. unit	Unit ring	
SONerror NONE,	Stop measurement in case of error (<i>stop on error</i>) Continue measurement even in case of error	NONE	–		
<Stepmode>	Description of parameters	Def. value	Def. unit	Unit ring	
STEP NONE	Interrupt measurement after each statistics cycle Continue measurement according to its rep. mode	NONE	–		
Description of command				FW vers.	
This command determines the number of statistics cycles, the stop condition and the stepping mode for the measurement.				V3.00	
Note: <i>In the case of READ commands (READ:...), the <Repetition> parameter has no effect; the measurement is always stopped after a single shot.</i>					

CONFigure:RXTests:AFANalyzer:VMSinad:CONTROL:MTIME <MeasTime>				Default Settings	
<MeasTime>	Description of parameters	Def. value	Def. unit	Unit ring	
0.025 s to 1 s	Measurement time	0.3	s		
Description of command				FW vers.	
This command defines the time after which the result of the fast SINAD measurement is regarded as valid and returned.				V3.00	

CONFigure:RXTests:AFANalyzer:VMSinad:CONTROL:DEFault <Enable>				Default Settings	
<Enable>	Description of parameters	Def. value	Def. unit	Unit ring	
ON OFF	The parameters are set to their default values Some or all parameters differ from the default values	ON	–		
Description of command				FW vers.	
If used as a setting command with the parameter <i>ON</i> this command sets all parameters of the subsystem to their default values (the setting <i>OFF</i> results in an error message).				V3.00	
If used as a query the command returns whether all parameters are set to their default values (<i>ON</i>) or not (<i>OFF</i>).					

Measured Values – Subsystem RXTests:AFAnalyzer:VMSinad[:RESult]

The subsystem *RXTests:AFAnalyzer:VMSinad[:RESULT]* measures and returns the received audio signal parameters and compares them with the tolerance values. The subsystem corresponds to the various output elements in the measurement menu *RX Tests*, application *AF Analyzer*.

READ[:SCALar]:RXTests:AFAnalyzer:VMSinad[:RESult]?		Scalar Results:		
		Start single shot measurement and return results		
FETCh[:SCALar]:RXTests:AFAnalyzer:VMSinad[:RESult]?		Read out meas. results (unsynchronized)		
SAMPlE[:SCALar]:RXTests:AFAnalyzer:VMSinad[:RESult]?		Read out measurement results (synchronized)		
<i>Returned values</i>	Value range	Def. value	Def. unit	Unit ring
AFVoltmeter,	0 V to 30 V	NAN	V	
AFSINAD,	0 dB to 100 dB	NAN	dB	
SINADat	–	NAN	Hz	
Description of command				FW vers.
These commands are always queries. They start a <i>RX Tests – AF Analyzer</i> measurement and output all measurement results (see chapter 4).				V3.00

CALCulate[:SCALar]:RXTests:AFAnalyzer:VMSinad[:RESult]:MATChing:LIMit?		Bursts out of Tolerance		
<i>Returned values</i>	Value range	Def. value	Def. unit	Unit ring
AFVoltmeter,	For all measured values: NMAU NMAL INV OK	INV	–	
AFSINAD		INV	–	
Description of command				FW vers.
This command is always a query. It indicates whether and in which way the error limits for the measured values have been exceeded. The limits are defined in the <i>RXTests:AFAnalyzer</i> subsystem (see p. 6.60 ff).				V3.00
The following messages may be output for all measured values:				
NMAU	Underflow of tolerance value	<i>not matching, underflow</i>		
NMAL	Tolerance value exceeded	<i>not matching, overflow</i>		
INV	Measurement invalid	<i>invalid</i>		
OK	all tolerances matched			

RXTests:HNOise

The subsystem *RXTests:HNOise* measures the FM Hum & Noise of the mobile phone receiver. The subsystem corresponds to the measurement menu *RX Tests*, application *Hum & Noise*, and the associated popup menu *RX Tests Configuration*.

Control of Measurement – Subsystem RXTests:HNOise

The subsystem *RXTests:HNOise* controls the measurement. It corresponds to the softkey *Hum & Noise* in the measurement menu *RX Tests*.

INITiate:RXTests:HNOise	Start new measurement	⇒ <i>RUN</i>
ABORT:RXTests:HNOise	Abort running measurement and switch off	⇒ <i>OFF</i>
STOP:RXTests:HNOise	Stop measurement after current stat. cycle	⇒ <i>STOP</i>
CONTinue:RXTests:HNOise	Next measurement step (only <i>stepping mode</i>)	⇒ <i>RUN</i>
Description of command		FW vers.
These commands have no query form. They start and stop the measurement, setting it to the status indicated in the top right column.		V2.41

CONFigure:RXTests:HNOise:EREPorting <Mode>		Event Reporting		
<Mode>	Description of parameters	Def. value	Def. unit	Unit ring
SRQ 	Service request	OFF	–	–
SOPC 	Single operation complete			
SRSQ 	SRQ and SOPC			
OFF	No reporting			
Description of command		FW vers.		
This command defines the events generated when the measurement is terminated or stopped (<i>event reporting</i> , see chapter 5 of CMU200 manual).		V2.41		

FETCH:RXTests:HNOise:STATUS?		Measurement Status		
Ret. values	Description of parameters	Def. value	Def. unit	Unit ring
OFF 	Measurement in the <i>OFF</i> state (*RST or ABORT)	OFF	–	
RUN 	Running (after INITiate, CONTinue or READ)			
STOP 	Stopped (STOP)			
ERR 	OFF (could not be started)			
STEP 	Stepping mode (<stepmode>=STEP)			
RDY,	Stopped according to repetition mode and stop condition			
	Counter for current statistics cycle			
1 to 10000 	No counting mode set	NONE	–	
NONE				
Description of command		FW vers.		
This command is always a query. It returns the status of the measurement (see chapters 3 and 5 of CMU manual).		V2.41		

Test Configuration

The commands of the following subsystems configure the *Hum & Noise* measurement. They correspond to the sections in the *RX Tests Configuration* menu that are related to the *Hum & Noise* application.

Subsystem RXTests:HNOise:CONTRol

The subsystem *RXTests:HNOise:CONTRol* configures the measurement. It corresponds to the *Control* tab in the popup menu *RX Tests Config*.

CONFigure:RXTests:HNOise:CONTRol:REPetition <Repetition> , <StopCond> , <Stepmode>				Test Cycles
<Repetition>	Description of parameters	Def. value	Def. unit	Unit ring
CONTinuous SINGleshot 1 to 10000 ,	Continuous measurement (until <i>STOP</i> or <i>ABORT</i>) Single shot measurement (until <i>Status = RDY</i>) Multiple measurement (<i>counting</i> , until <i>Status = STEP RDY</i>)	SING	–	
<StopCond>	Description of parameters	Def. value	Def. unit	Unit ring
SONerror NONE ,	Stop measurement in case of error (<i>stop on error</i>) Continue measurement even in case of error	NONE	–	
<Stepmode>	Description of parameters	Def. value	Def. unit	Unit ring
STEP NONE	Interrupt measurement after each statistics cycle Continue measurement according to its rep. mode	NONE	–	
Description of command				FW vers.
This command determines the number of statistics cycles, the stop condition and the stepping mode for the measurement.				V2.41
Note: <i>In the case of READ commands (READ:...), the <Repetition> parameter has no effect; the measurement is always stopped after a single shot.</i>				

CONFigure:RXTests:HNOise:CONTRol:DEFault <Enable>				Default Settings
<Enable>	Description of parameters	Def. value	Def. unit	Unit ring
ON OFF	The parameters are set to their default values Some or all parameters differ from the default values	ON	–	
Description of command				FW vers.
If used as a setting command with the parameter <i>ON</i> this command sets all parameters of the subsystem to their default values (the setting <i>OFF</i> results in an error message).				V2.41
If used as a query the command returns whether all parameters are set to their default values (<i>ON</i>) or not (<i>OFF</i>).				

Tolerance values – Subsystem RXTests:HNOise:LIMit

The subsystem *RXTests:HNOise:LIMit* defines tolerance values for the *Hum & Noise* application of the *RX Tests* measurement. The subsystem corresponds to the relevant section in the *Limits* tab of the popup menu *RX Tests Configuration*.

CONFigure:RXTests:HNOise:LIMit <AFVoltmMin>,<AFVoltmMax>,<Hum&Noise>				
Limits Hum & Noise				
<Hum&Noise>	Description of parameters	Def. value	Def. unit	Unit ring
0.0 V to 30.0 V OFF ON, 0.0 V to 30.0 V OFF ON, 0.0 dB to 100.0 dB	AF Voltmeter Minimum limit check off reactivate limit check	OFF	V	
	AF Voltmeter Maximum limit check off reactivate limit check	OFF	V	
	FM Hum & Noise	32.0	dB	
Description of command				FW vers.
This command defines the upper limit for the <i>FM Hum & Noise</i> . The settings <i>ON</i> and <i>OFF</i> have a reverse effect; <i>OFF</i> is suitable for activating a limit check with limits that were previously defined but temporarily suspended.				V2.41

CONFigure:RXTests:HNOise:LIMit:DEFAult <Enable>				
Default Settings				
<Enable>	Description of parameters	Def. value	Def. unit	Unit ring
ON OFF	The parameters are set to their default values Some or all parameters differ from the default values	ON	–	
Description of command				FW vers.
If used as a setting command with the parameter <i>ON</i> this command sets all parameters of the sub-system to their default values (the setting <i>OFF</i> results in an error message).				V2.41
If used as a query the command returns whether all parameters are set to their default values (<i>ON</i>) or not (<i>OFF</i>).				

Path Configuration – Subsystem RXTests:HNOise:FILTer

The subsystem *RXTests:HNOise:FILTer* configures the voice-processing equipment used in the *Hum & Noise* application of the *RX Tests* measurement. The subsystem corresponds to the relevant section in the *Filters* tab of the popup menu *RX Tests Configuration*.

CONFigure:RXTests:HNOise:FILTer <Bandpass>, <Weighting>		Path Configuration: RX Tests – AF Analyzer		
<Bandpass>	Description of parameters	Def. value	Def. unit	Unit ring
BP01	CMU band pass filter with a bandwidth of	BP10	–	
BP02	0 Hz to 250 Hz			
BP03	6 Hz to 250 Hz			
BP04	50 Hz to 250 Hz			
BP05	0 Hz to 3000 Hz			
BP06	6 Hz to 3000 Hz			
BP07	50 Hz to 3000 Hz			
BP08	300 Hz to 3000 Hz			
BP09	0 Hz to 4000 Hz			
BP10	6 Hz to 4000 Hz			
BP11	50 Hz to 4000 Hz			
BP12	300 Hz to 4000 Hz			
BP13	0 Hz to 15000 Hz			
BP14	6 Hz to 15000 Hz			
BP15	50 Hz to 15000 Hz			
BP16	300 Hz to 15000 Hz			
BP17	0 Hz to 21000 Hz			
BP 18,	6 Hz to 21000 Hz			
	50 Hz to 21000 Hz			
<Weighting>	Description of parameters	Def. value	Def. unit	Unit ring
CME	Switch on C-message weighted filter	CME	–	
CCI	Switch on CCITT weighting filter			
OFF	No weighting filter			
Description of command				FW vers.
This command defines the measuring equipment in the <i>RX Tests – Hum & Noise</i> application.				V2.41

CONFigure:RXTests:HNOise:FILTer:DEFAult <Enable>		Default Settings		
<Enable>	Description of parameters	Def. value	Def. unit	Unit ring
ON	The parameters are set to their default values	ON	–	
OFF	Some or all parameters differ from the default values			
Description of command				FW vers.
If used as a setting command with the parameter <i>ON</i> this command sets all parameters of the sub-system to their default values (the setting <i>OFF</i> results in an error message).				V2.41
If used as a query the command returns whether all parameters are set to their default values (<i>ON</i>) or not (<i>OFF</i>).				

Measured Values – Subsystem RXTests:HNOise[:RESult]

The subsystem *RXTests:HNOise[:RESULT]* measures and returns the hum & noise and compares it with the tolerance values. The subsystem corresponds to the output elements in the measurement menu *RX Tests*, application *Hum & Noise*.

READ[:SCALar]:RXTests:HNOise[:RESult]?		Scalar Results:		
FETCh[:SCALar]:RXTests:HNOise[:RESult]?		Start single shot measurement and return results		
SAMPle[:SCALar]:RXTests:HNOise[:RESult]?		Read out meas. results (unsynchronized)		
SAMPle[:SCALar]:RXTests:HNOise[:RESult]?		Read out measurement results (synchronized)		
Returned values	Value range	Def. value	Def. unit	Unit ring
AFVoltmeter, Hum&Noise	0 V to 30 V	NAN	V	
	0 dB to 100 dB	NAN	dB	
Description of command				FW vers.
These commands are always queries. They start a <i>RX Tests – Hum & Noise</i> measurement and output all measurement results (see chapter 4).				V2.41

CALCulate[:SCALar]:RXTests:HNOise[:RESult]:MATChing:LIMit?		Results out of Tolerance		
Returned values	Value range	Def. value	Def. unit	Unit ring
AFVoltmeter, Hum&Noise	For all measured values:	INV	–	
	NMAU NMAL INV OK	INV	–	
Description of command				FW vers.
This command is always a query. It indicates whether and in which way the error limits for the measured values (see above command) have been exceeded.				V2.41
The following messages may be output for all measured values:				
NMAU	Underflow of tolerance value	<i>not matching, underflow</i>		
NMAL	Tolerance value exceeded	<i>not matching, overflow</i>		
INV	Measurement invalid	<i>invalid</i>		
OK	all tolerances matched			

RXTests:SENSitivity

The subsystem *RXTests:SENSitivity* searches the sensitivity level of the mobile phone receiver. The subsystem corresponds to the measurement menu *RX Tests*, application *Sensitivity*, and the associated popup menu *RX Tests Configuration*.

Control of Measurement – Subsystem RXTests:SENSitivity

The subsystem *RXTests:SENSitivity* controls the measurement. It corresponds to the softkey *Sensitivity* in the measurement menu *RX Tests*.

INITiate:RXTests:SENSitivity	Start new measurement	⇒ <i>RUN</i>
ABORT:RXTests:SENSitivity	Abort running measurement and switch off	⇒ <i>OFF</i>
STOP:RXTests:SENSitivity	Stop measurement after current stat. cycle	⇒ <i>STOP</i>
CONTinue:RXTests:SENSitivity	Next measurement step (only <i>stepping mode</i>)	⇒ <i>RUN</i>
Description of command		FW vers.
These commands have no query form. They start and stop the measurement, setting it to the status indicated in the top right column.		V2.41

CONFigure:RXTests:SENSitivity:EREPorting <Mode>		Event Reporting		
<Mode>	Description of parameters	Def. value	Def. unit	Unit ring
SRQ 	Service request	OFF	–	–
SOPC 	Single operation complete			
SRSQ 	SRQ and SOPC			
OFF	No reporting			
Description of command		FW vers.		
This command defines the events generated when the measurement is terminated or stopped (<i>event reporting</i> , see chapter 5 of CMU200 manual).		V2.41		

FETCH:RXTests:SENSitivity:STATus?		Measurement Status		
Ret. values	Description of parameters	Def. value	Def. unit	Unit ring
OFF 	Measurement in the <i>OFF</i> state (*RST or ABORt)	OFF	–	
RUN 	Running (after INITiate, CONTinue or READ)			
STOP 	Stopped (STOP)			
ERR 	<i>OFF</i> (could not be started)			
STEP 	Stepping mode (<stepmode>=STEP)			
RDY,	Stopped according to repetition mode and stop condition			
	Counter for current statistics cycle			
1 to 10000 	No counting mode set	NONE	–	
NONE				
Description of command		FW vers.		
This command is always a query. It returns the status of the measurement (see chapters 3 and 5 of CMU manual).		V2.41		

Test Configuration

The commands of the following subsystems configure the *Sensitivity* measurement. They correspond to the sections in the *RX Tests Configuration* menu that are related to the *Sensitivity* application.

Subsystem RXTests:SENSitivity:CONTROL

The subsystem *RXTests:SENSitivity:CONTROL* configures the measurement. It corresponds to the *Control* tab in the popup menu *RX Tests Config*.

CONFigure:RXTests:SENSitivity:CONTROL:TSINad <Target>			Target SINAD	
<Repetition>	Description of parameters	Def. value	Def. unit	Unit ring
-99 dB to + 200 dB	Target SINAD	+12	dB	
Description of command				FW vers.
This command determines the target SINAD for the <i>RX Sensitivity</i> iteration.				V2.41

CONFigure:RXTests:SENSitivity:CONTROL:TSERange <Range>			Tgt. SINAD Err. Range	
<Range>	Description of parameters	Def. value	Def. unit	Unit ring
0.0 dB to 100.0 dB	Target SINAD error range	0.5	dB	
Description of command				FW vers.
This command determines the target SINAD error range providing the stop criterion for the sensitivity iteration.				V2.41

CONFigure:RXTests:SENSitivity:CONTROL:DEFAULT <Enable>			Default Settings	
<Enable>	Description of parameters	Def. value	Def. unit	Unit ring
ON OFF	The parameters are set to their default values Some or all parameters differ from the default values	ON	–	
Description of command				FW vers.
If used as a setting command with the parameter <i>ON</i> this command sets all parameters of the subsystem to their default values (the setting <i>OFF</i> results in an error message).				V2.41
If used as a query the command returns whether all parameters are set to their default values (<i>ON</i>) or not (<i>OFF</i>).				

Tolerance values – Subsystem RXTests:SENSitivity:LIMit

The subsystem *RXTests:SENSitivity:LIMit* configures the *Sensitivity* iteration in the *RX Tests* measurement. The subsystem corresponds to the relevant section in the *Limits* tab of the popup menu *RX Tests Configuration*.

CONFigure:RXTests:SENSitivity:LIMit <AFVolmMin>, <AFVolmMax>, <Sensitivity>				
AF Voltmeter, Sensitivity Limit				
Parameters	Description of parameters	Def. value	Def. unit	Unit ring
0.0 V to 30.0 V OFF ON,	AF Voltmeter Minimum limit check off reactivate limit check	OFF	V	
0.0 V to 30.0 V OFF ON,	AF Voltmeter Maximum limit check off reactivate limit check	OFF	V	
-150 dBm to 0 dBm	Sensitivity limit	-116	dBm	
Description of command				FW vers.
This command defines the input voltage range for the AF analyzer and the upper limit of the sensitivity level. The settings <i>ON</i> and <i>OFF</i> have a reverse effect; <i>OFF</i> is suitable for activating a limit check with limits that were previously defined but temporarily suspended.				V2.41

CONFigure:RXTests:SENSitivity:LIMit:DEFault <Enable>				
Default Settings				
<Enable>	Description of parameters	Def. value	Def. unit	Unit ring
ON OFF	The parameters are set to their default values Some or all parameters differ from the default values	ON	–	
Description of command				FW vers.
If used as a setting command with the parameter <i>ON</i> this command sets all parameters of the subsystem to their default values (the setting <i>OFF</i> results in an error message).				V2.41
If used as a query the command returns whether all parameters are set to their default values (<i>ON</i>) or not (<i>OFF</i>).				

Path Configuration – Subsystem RXTests:SENSitivity:FILTer

The subsystem *RXTests:SENSitivity:FILTer* configures the voice-processing equipment used in the *Sensitivity* application of the *RX Tests* measurement. The subsystem corresponds to the relevant section in the *Filters* tab of the popup menu *RX Tests Configuration*.

CONFigure:RXTests:SENSitivity:FILTer <Bandpass>, <Weighting>				
Path Configuration: RX Tests – AF Analyzer				
<Bandpass>	Description of parameters	Def. value	Def. unit	Unit ring
BP01	CMU band pass filter with a bandwidth of	BP10	–	
BP02	0 Hz to 250 Hz			
BP03	6 Hz to 250 Hz			
BP04	50 Hz to 250 Hz			
BP05	0 Hz to 3000 Hz			
BP06	6 Hz to 3000 Hz			
BP07	50 Hz to 3000 Hz			
BP08	300 Hz to 3000 Hz			
BP09	0 Hz to 4000 Hz			
BP10	6 Hz to 4000 Hz			
BP11	50 Hz to 4000 Hz			
BP12	300 Hz to 4000 Hz			
BP13	0 Hz to 15000 Hz			
BP14	6 Hz to 15000 Hz			
BP15	50 Hz to 15000 Hz			
BP16	300 Hz to 15000 Hz			
BP17	0 Hz to 21000 Hz			
BP 18,	6 Hz to 21000 Hz			
	50 Hz to 21000 Hz			
<Weighting>	Description of parameters	Def. value	Def. unit	Unit ring
CME	Switch on C-message weighted filter	CME	–	
CCI	Switch on CCITT weighting filter			
OFF	No weighting filter			
Description of command				FW vers.
This command defines the measuring equipment in the <i>RX Tests – Sensitivity</i> application.				V2.41

CONFigure:RXTests:SENSitivity:FILTer:NOTCh <Bandwidth>			Notch Filter	
<Bandwidth>	Description of parameters	Def. value	Def. unit	
N01	Notch filter bandwidth 0.1	N05	–	
N05	Notch filter bandwidth 0.5			
Description of command				FW vers.
This command selects the 3-dB bandwidth of the notch filter used to measure the sensitivity. The value is expressed relative to the center frequency.				V3.51

CONFigure:RXTests:SENSitivity:FILTer:DEFault <Enable>				Default Settings
<Enable>	Description of parameters	Def. value	Def. unit	Unit ring
ON OFF	The parameters are set to their default values Some or all parameters differ from the default values	ON	–	
Description of command				FW vers.
If used as a setting command with the parameter <i>ON</i> this command sets all parameters of the sub-system to their default values (the setting <i>OFF</i> results in an error message). If used as a query the command returns whether all parameters are set to their default values (<i>ON</i>) or not (<i>OFF</i>).				V2.41

Measured Values – Subsystem RXTests:SENSitivity[:RESult]

The subsystem *RXTests:SENSitivity[:RESULT]* measures and returns the sensitivity and compares it with the tolerance values. The subsystem corresponds to the various output elements in the measurement menu *RX Tests*, application *Sensitivity*.

READ[:SCALar]:RXTests:SENSitivity[:RESult]? Scalar Results: Start single shot measurement and return results				
FETCh[:SCALar]:RXTests:SENSitivity[:RESult]? Read out meas. results (unsynchronized)				
SAMPlE[:SCALar]:RXTests:SENSitivity[:RESult]? Read out measurement results (synchronized)				
Returned values	Value range	Def. value	Def. unit	Unit ring
AFV oltmeter,	0 V to 30 V	NAN	V	
AFSINAD ,	0 dB to 100 dB	NAN	dB	
Sensitivity ,	-150.0 dBm to 13 dBm	NAN	dBm	
SINADat	100 Hz to 10 000 Hz	NAN	Hz	
Description of command				FW vers.
These commands are always queries. They start a <i>RX Tests – Sensitivity</i> measurement and output all measurement results (see chapter 4).				V2.41

CALCulate[:SCALar]:RXTests:SENSitivity[:RESult]:MATChing:LIMit? Results out of Tolerance				
Returned values	Value range	Def. value	Def. unit	Unit ring
AFV oltmeter,	For all measured values: NMAU MAL INV OK	INV	–	
AFSINAD ,		INV	–	
Sensitivity		INV	–	
Description of command				FW vers.
This command is always a query. It indicates whether and in which way the error limits for the measured values (see above command) have been exceeded.				V2.41
The following messages may be output for all measured values:				
NMAU	Underflow of tolerance value	<i>not matching, underflow</i>		
NMAL	Tolerance value exceeded	<i>not matching, overflow</i>		
INV	Measurement invalid	<i>invalid</i>		
OK	all tolerances matched			

RXAFresp

The subsystem *RXAFresp* measures the electrical audio frequency response of the mobile phone receiver quality. The subsystem corresponds to the measurement menu *RX Audio Freq. Response* and the associated popup menu *RX Audio Freq. Response Configuration*.

Control of Measurement – Subsystem RXAFresp

The subsystem *RXAFresp* controls the measurement. It corresponds to the softkey *RX Audio Freq. Response* in the measurement menu *RX Audio Freq. Response*.

INITiate:RXAFresp	Start new measurement	⇒ <i>RUN</i>
ABORT:RXAFresp	Abort running measurement and switch off	⇒ <i>OFF</i>
STOP:RXAFresp	Stop measurement after current stat. cycle	⇒ <i>STOP</i>
CONTinue:RXAFresp	Next measurement step (only <i>stepping mode</i>)	⇒ <i>RUN</i>
Description of command		FW vers.
These commands have no query form. They start and stop the measurement, setting it to the status indicated in the top right column.		V2.41

CONFigure:RXAFresp:EREPorting <Mode>		Event Reporting		
<Mode>	Description of parameters	Def. value	Def. unit	Unit ring
SRQ 	Service request	OFF	–	–
SOPC 	Single operation complete			
SRSQ 	SRQ and SOPC			
OFF	No reporting			
Description of command		FW vers.		
This command defines the events generated when the measurement is terminated or stopped (<i>event reporting</i> , see chapter 5 of CMU200 manual).		V2.41		

FETCH:RXAFresp:STATus?		Measurement Status		
Ret. values	Description of parameters	Def. value	Def. unit	Unit ring
OFF 	Measurement in the <i>OFF</i> state (*RST or ABORT)	OFF	–	
RUN 	Running (after <i>INITiate</i> , <i>CONTinue</i> or <i>READ</i>)			
STOP 	Stopped (<i>STOP</i>)			
ERR 	<i>OFF</i> (could not be started)			
STEP 	Stepping mode (< <i>stepmode</i> >= <i>STEP</i>)			
RDY,	Stopped according to repetition mode and stop condition			
	Counter for current statistics cycle			
1 to 10000 	No counting mode set	NONE	–	
NONE				
Description of command		FW vers.		
This command is always a query. It returns the status of the measurement (see chapters 3 and 5 of CMU manual).		V2.41		

Test Configuration

The commands of the following subsystems configure the *RX Audio Freq. Response* measurement. They correspond to the *RX Audio Freq. Response Configuration* menu.

Subsystem RXAFresp:CONTROL

The subsystem *RXAFresp:CONTROL* configures the measurement. It corresponds to the *Control* tab in the popup menu *RX Audio Freq. Response Config* and the *Reference Deviation* hotkey.

CONFigure:RXAFresp:CONTROL:REPetition <Repetition>, <StopCond>, <Stepmode>				Test Cycles
<Repetition>	Description of parameters	Def. value	Def. unit	Unit ring
CONTinuous SINGleshot 1 to 10000,	Continuous measurement (until STOP or ABORT) Single shot measurement (until Status = RDY) Multiple measurement (counting, until Status = STEP RDY)	SING	–	
<StopCond>	Description of parameters	Def. value	Def. unit	Unit ring
SONerror NONE,	Stop measurement in case of error (stop on error) Continue measurement even in case of error	NONE	–	
<Stepmode>	Description of parameters	Def. value	Def. unit	Unit ring
STEP NONE	Interrupt measurement after each statistics cycle Continue measurement according to its rep. mode	NONE	–	
Description of command				FW vers.
This command determines the number of statistics cycles, the stop condition and the stepping mode for the measurement.				V2.41
Note: In the case of READ commands (READ:...), the <Repetition> parameter has no effect; the measurement is always stopped after a single shot.				

DISPlay:RXAFresp:CONTROL:GRID <Enable>				Grid on/off
<Enable>	Description of parameters	Def. value	Def. unit	Unit ring
ON OFF	Switch on grid lines Switch off grid lines	ON	–	
Description of command				FW vers.
This command switches the grid lines in the test diagrams on or off.				V2.41

CONFigure:RXAFresp:CONTROL:RLEVel <Voltage>				Reference Level
<Voltage>	Description of parameters	Def. value	Def. unit	Unit ring
0.001 V to 5.000 V	Reference Level	0.010	V	
Description of command				FW vers.
This command defines the reference level for the electrical audio frequency response.				V2.41

CONFigure:RXAFresp:CONTRol:RREQuest <Reference>				Result
<Reference>	Description of parameters	Def. value	Def. unit	Unit ring
RLEV TON<nr>	Results relative to the reference level Results relative to freq. response at test tone <nr>, where <nr> = 1 to 20	TON4	–	
Description of command				FW vers.
This command defines the reference value for the results of the <i>RX Audio Freq. Response</i> measurement. The reference level is defined via <code>CONFigure:RXAFresp:CONTRol:LEVel</code> . To choose one of the test tones no. 1 to 20, it must be enabled via the <code>CONFigure:RXAFresp:TONE<nr></code> command.				V2.41

CONFigure:RXAFresp:CONTRol:MGLead <Time>				Modulation Generator Lead
<Time>	Description of parameters	Def. value	Def. unit	Unit ring
0 s to 100 ms	Holdoff time	14	ms	
Description of command				FW vers.
This command defines a holdoff time for the modulation generator.				V2.41

CONFigure:RXAFresp:CONTRol:DEFAult <Enable>				Default Settings
<Enable>	Description of parameters	Def. value	Def. unit	Unit ring
ON OFF	The parameters are set to their default values Some or all parameters differ from the default values	ON	–	
Description of command				FW vers.
If used as a setting command with the parameter <i>ON</i> this command sets all parameters of the sub-system to their default values (the setting <i>OFF</i> results in an error message).				V2.41
If used as a query the command returns whether all parameters are set to their default values (<i>ON</i>) or not (<i>OFF</i>).				

Subsystem RXAFresp:TRACe

The subsystem *RXAFresp:TRACe* defines the upper and lower edge of the test diagram. It corresponds to the *Scale Min.* and *Scale Max.* hotkeys in the measurement menu *RX Audio Freq. Response*.

DISPlay:RXAFresp[:WINDow]:TRACe:Y:SCALE <ScaleMin>, <ScaleMax>				Grid on/off
<ScaleMin>	Description of parameters	Def. value	Def. unit	Unit ring
–150.0 dB to 0.0 dB	Lower edge of test diagram	–10.0	dB	
<ScaleMax>	Description of parameters	Def. value	Def. unit	Unit ring
0.0 dB to +150.0 dB	Upper edge of test diagram	+10.0	dB	
Description of command				FW vers.
This command defines the upper and lower edge of the test diagram. The values are relative to the reference level defined via <code>CONFigure:RXAFresp:CONTRol:RLEVel</code> (see p. 6.79).				V2.41

Subsystem SUBarrays:RXAFresp

The subsystem *SUBarrays:RXAFresp* defines the measurement range and the type of output values.

CONFigure:SUBarrays:RXAFresp		Definition of Subarrays		
<Mode>,<Start>,<Samples>{,<Start>,<Samples>}				
<Mode>	Description of parameters	Def. value	Def. unit	Unit ring
ALL ARITHmetical MINimum MAXimum,	Return all measurement values Return arithm. mean value in every range Return minimum value in every range Return maximum value in every range	ALL	–	
<Start>	Description of parameters	Def. value	Def. unit	Unit ring
1 to 20,	Start test tone in current range	1	–	
<Samples>	Description of parameters	Def. value	Def. unit	Unit ring
1 to 20	Number of test tones in current range	20	–	
Description of command				FW vers.
<p>This command configures the <code>READ:SUBarrays:RXAFresp...</code>, <code>FETCh:SUBarrays:RXAFresp...</code>, and <code>SAMPlE:SUBarrays:RXAFresp</code> commands. It restricts the measurement to up to 32 subranges where either all measurement results (the number of which is given by the <code><Samples></code> parameter) or a single statistical value is returned.</p> <p>The subranges are subsets of the full range of test tones defined via <code>CONFigure:RXAFresp:TONE<nr></code>. Each subrange contains all test tones between the start test tone (test tone no. <code><Start></code>) and test tone no. <code><Start>+<Samples>-1</code>. Test points inside this range that are disabled are not measured (result <i>NAN</i>) and do not enter into the ARITHmetical, MINimum and MAXimum values.</p> <p>By default, only one range corresponding to the total measurement range is used and all measurement values are returned.</p>				V2.41

Tolerance values – Subsystem RXAFresp:LIMit

The subsystem *RXAFresp:LIMit* defines tolerance values for the *RX Audio Freq. Response* measurement. The subsystem corresponds to the *Limits* tab of the popup menu *RX Audio Freq. Response Configuration*.

CONFigure:RXAFresp:LIMit[:LINE][:ASYMmetrical]:UPPer				Upper Limit, Overall	
<Limit_1>, <Enable_1>, ... <Limit_20>, <Enable_20>					
<Limit_nr>	Description of parameters	Def. value	Def. unit	Unit ring	
-80 dB to +80 dB,	Upper limit line at tone <nr>	See below	dB		
<Enable_nr>	Description of parameters	Def. value	Def. unit	Unit ring	
ON OFF	Enable upper limit line at tone <nr>	ON	–		
Description of command					FW vers.
This command configures the upper limit lines and enables the limit check at the 20 test tones that can be defined via <code>CONFigure:RXAFresp:TONE<nr></code> .					V2.41
By default, the limit check is switched on at all tones and the following limit lines apply:					
Tone <nr>	Limit Line/[dB]	Enable	Tone <nr>	Limit Line/[dB]	Enable
1	13.4	ON	11	-8.8	ON
2	+7.1	ON	12	-9.6	ON
3	+3.5	ON	13	-10.3	ON
4	+1.0	ON	14	-13.3	ON
5	-1.2	ON	15	-17.0	ON
6	-3.0	ON	16	-20.6	ON
7	-4.5	ON	17	-24.4	ON
8	-5.8	ON	18	-27.9	ON
9	-6.9	ON	19	-31.3	ON
10	-7.9	ON	20	-34.4	ON

CONFigure:RXAFresp:LIMit[:LINE][:ASYMmetrical]:UPPer:TONE<nr>				Upper Limit, Single Point	
<Limit>, <Enable>					
<Limit>	Description of parameters	Def. value	Def. unit	Unit ring	
-80 dB to +80 dB,	Upper limit line at tone <nr>	See below	dB		
<Enable>	Description of parameters	Def. value	Def. unit	Unit ring	
ON OFF	Enable upper limit line at tone <nr>	ON	–		
Description of command					FW vers.
This command configures the upper limit and enables the limit check at one of 20 test tones that can be defined via <code>CONFigure:RXAFresp:TONE<nr></code> . The test tones are numbered by <nr> = 1 to 20. The default limits at all test points are quoted in the previous command.					V2.41

CONFigure:RXAFresp:LIMit[:LINE][:ASYMmetrical]:LOWer				Lower Limits, Overall	
<Limit_1>, <Enable_1>, ... <Limit_20>, <Enable_20>					
<Limit_nr>	Description of parameters	Def. value	Def. unit	Unit ring	
-80 dB to +80 dB,	Lower limit line at tone <nr>	See below	dB		
<Enable_nr>	Description of parameters	Def. value	Def. unit	Unit ring	
ON OFF	Enable lower limit line at tone <nr>	ON	-		
Description of command				FW vers.	
This command configures the lower limit lines and enables the limit check at the 20 test tones that can be defined via <code>CONFigure:RXAFresp:TONE<nr></code> .				V2.41	
By default, the limit check is switched on at all tones and the following limit lines apply:					
Tone <nr>	Limit Line/[dB]	Enable	Tone <nr>	Limit Line/[dB]	Enable
1	-80.0	OFF	11	-15.8	OFF
2	+3.1	ON	12	-16.6	OFF
3	-0.5	ON	13	-17.3	OFF
4	-3.0	ON	14	-80.0	OFF
5	-5.2	ON	15	-80.0	OFF
6	-7.0	ON	16	-80.0	OFF
7	-8.5	ON	17	-80.0	OFF
8	-9.8	ON	18	-80.0	OFF
9	-13.9	ON	19	-80.0	OFF
10	-14.9	ON	20	-80.0	OFF

CONFigure:RXAFresp:LIMit[:LINE][:ASYMmetrical]:LOWer:TONE<nr>				
<Limit>, <Enable> Lower Limit, Single Point				
<Limit>	Description of parameters	Def. value	Def. unit	Unit ring
-80 dB to +80 dB,	Lower limit line at tone <nr>	See below	dB	
<Enable>	Description of parameters	Def. value	Def. unit	Unit ring
ON OFF	Enable lower limit line at tone <nr>	ON	-	
Description of command				FW vers.
This command configures the lower limit and enables the limit check at one of 20 test tones that can be defined via <code>CONFigure:RXAFresp:TONE<nr></code> . The test tones are numbered by <nr> = 1 to 20. The default limits at all test points are quoted in the previous command.				V2.41

CONFigure:RXAFresp:LIMit[:LINE]:DEFault <Enable>				Default Settings	
<Enable>	Description of parameters	Def. value	Def. unit	Unit ring	
ON OFF	The parameters are set to their default values Some or all parameters differ from the default values	ON	-		
Description of command				FW vers.	
If used as a setting command with the parameter <i>ON</i> this command sets all parameters of the sub-system to their default values (the setting <i>OFF</i> results in an error message).				V2.41	
If used as a query the command returns whether all parameters are set to their default values (<i>ON</i>) or not (<i>OFF</i>).					

Test Tones – Subsystem RXAFresp:TDEFinition

The subsystem *RXAFresp:TDEFinition* configures the audio test signal used for the *RX Audio Freq. Response* measurement. The subsystem corresponds to the *Freq./Dev.* tab of the popup menu *RX Audio Freq. Response Configuration*.

Note: For firmware versions $\geq V3.00$ (except V2.50, CDMA/AMPS), the *Freq./Lev.* tab of the *RX Audio Freq. Response Configuration* menu is replaced by the *Tone Def.* tab with an extended functionality concerning the frequency deviation handling of each tone. To make use of the new features, it is recommended to rely upon the *RXAFresp:MODGenerator* subsystem (see p. 6.85 ff) instead of the *RXAFresp:TDEFinition* subsystem.

The default configurations of the *RXAFresp:TDEFinition* subsystem and of its successor, the *RXAFresp:MODGenerator* subsystem, are identical.

CONFigure:RXAFresp:TDEFinition				Test Tones			
<Freq_1>, <Dev_1>, <Enable_1>, ... <Freq_20>, <Dev_20>, <Enable_20>							
<Freq_nr>	Description of parameters	Def. value	Def. unit	Unit ring			
10 Hz to 15999 Hz,	Frequency of test tone <nr>	See below	Hz				
<Dev_nr>	Description of parameters	Def. value	Def. unit	Unit ring			
10 Hz to 20000 Hz,	Frequency deviation at test tone <nr>	See below	Hz				
<Enable_nr>	Description of parameters	Def. value	Def. unit	Unit ring			
ON OFF	Switch on / off test tone <nr>	See below	–				
Description of command				FW vers.			
This command enables and configures up to 20 test tones. The minimum frequency spacing between two tones is 1 Hz. The sum of all test tones must not exceed the maximum AF generator level quoted in the data sheet.				V2.41			
The following default test tones are provided:							
Tone <nr>	Frequency/[Hz]	Dev./[Hz]	Enable	Tone <nr>	Frequency/[Hz]	Dev./[Hz]	Enable
1	240	145.0	ON	11	3100	145.0	ON
2	500	145.0	ON	12	3400	145.0	ON
3	750	145.0	ON	13	3700	145.0	ON
4	1004	145.0	ON	14	4000	145.0	ON
5	1300	145.0	ON	15	4300	145.0	ON
6	1600	145.0	ON	16	4600	145.0	ON
7	1900	145.0	ON	17	4950	145.0	ON
8	2200	145.0	ON	18	5300	145.0	ON
9	2500	145.0	ON	19	5650	145.0	ON
10	2800	145.0	ON	20	6000	145.0	ON

CONFigure:RXAFresp:TDEFinition:TONE<nr> <Frequency>, <Deviation>, <Enable>				Test Tones
<Frequency>	Description of parameters	Def. value	Def. unit	Unit ring
10 Hz to 15999 Hz,	Frequency of test tone <nr>	See below	Hz	
<Level>	Description of parameters	Def. value	Def. unit	Unit ring
10 Hz to 20000 Hz,	Frequency deviation test tone <nr>	See below	Hz	
<Enable>	Description of parameters	Def. value	Def. unit	Unit ring
ON OFF	Switch on / off test tone <nr>	See below	–	
Description of command				FW vers.
This command enables and configures one of up to 20 test tones (<nr> = 1 to 20). The default values for all test tones are given in the previous command.				V2.41

CONFigure:RXAFresp:TDEFinition:Default <Enable>		Default Settings		
<Enable>	Description of parameters	Def. value	Def. unit	Unit ring
ON OFF	The parameters are set to their default values Some or all parameters differ from the default values	ON	–	
Description of command				FW vers.
If used as a setting command with the parameter ON this command sets all parameters of the sub-system to their default values (the setting OFF results in an error message).				V2.41
If used as a query the command returns whether all parameters are set to their default values (ON) or not (OFF).				

Test Tones – Subsystem RXAFresp:MODGenerator

The subsystem *RXAFresp:MODGenerator* configures the audio test signal used for the *RX Audio Freq. Response* measurement. The subsystem corresponds to the *Tone Def.* tab of the popup menu *RX Audio Freq. Response Configuration*.

Note: For firmware versions < V3.00 and for V2.50, CDMA/AMPS, the *Tone Def.* tab of the *RX Audio Freq. Response Configuration* menu is replaced by the *Freq./Lev.* tab with a restricted functionality concerning the frequency deviation handling of each tone. The test tones must be defined by means of the *RXAFresp:TDEFinition* subsystem; see p. 6.51 f.

The default configurations of the *RXAFresp:TDEFinition* subsystem and of its successor, the *RXAFresp:MODGenerator* subsystem, are identical.

CONFigure:RXAFresp:MODGenerator:ENABLE<Enable> Mod. Gen. on/off				
<Enable>	Description of parameters	Def. value	Def. unit	Unit ring
ON OFF,	Switch on / off test tone no 1	ON	–	
....,				
ON OFF	Switch on / off test tone no 20	ON	–	
Description of command				FW vers.
This command enables or disables all 20 test tones provided in the <i>RXAFresp</i> measurement.				V3.00 ≠V2.50

CONFigure:RXAFresp:MODGenerator:ENABLE:TONE<nr> <Enable> Mod. Gen. on/off				
<Enable>	Description of parameters	Def. value	Def. unit	Unit ring
ON OFF	Switch on / off test tone <nr>	ON	–	
Description of command				FW vers.
This command enables or disables one of the 20 test tones provided in the RXAFresp measurement (<nr> = 1 to 20).				V3.00 ≠V2.50

CONFigure:RXAFresp:MODGenerator:FREQUENCY <Frequency> Test Tone Frequency				
<Frequency>	Description of parameters	Def. value	Def. unit	Unit ring
10 Hz to 15 999 Hz, ..., 10 Hz to 15 999 Hz	Frequency of test tone no. 1 ... Frequency of test tone no. 20	See below See below	Hz Hz	
Description of command				FW vers.
This command defines the frequency of the 20 test tones (<nr> = 1 to 20) provided in the RXAFresp measurement. All frequencies must be in multiples of 1 Hz, however, several tones may be at the same frequency. The following default test tones are provided:				V3.00 ≠V2.50
Tone <nr>	Frequency/[Hz]	Dev./[Hz]	Enable	Tone <nr>
1	240	145.0	ON	11
2	500	145.0	ON	12
3	750	145.0	ON	13
4	1004	145.0	ON	14
5	1300	145.0	ON	15
6	1600	145.0	ON	16
7	1900	145.0	ON	17
8	2200	145.0	ON	18
9	2500	145.0	ON	19
10	2800	145.0	ON	20
				Frequency/[Hz]
				Dev./[Hz]
				Enable

CONFigure:RXAFresp:MODGenerator:FREQUENCY:TONE<nr> <Frequency>				
				Test Tone Frequency
<Frequency>	Description of parameters	Def. value	Def. unit	Unit ring
10 Hz to 15 999 Hz	Frequency of test tone <nr>	See CONFigure:RXAFresp:MODGenerator:FREQUENCY<Frequency> command above	Hz	
Description of command				FW vers.
This command defines the frequency of one of the 20 test tones (<nr> = 1 to 20) provided in the RXAFresp measurement. All frequencies must be in multiples of 1 Hz, however, several tones may be at the same frequency.				V3.00 ≠V2.50

CONFigure:RXAFresp:MODGenerator:FDEVIation:FDMODE <Mode>				Deviation Selection
<Mode>	Description of parameters	Def. value	Def. unit	Unit ring
TDEV	Use total frequency deviation (manual)	TDEV	Hz	
SDEV	Use separate frequency deviations for each tone			
Description of command				FW vers.
<p>This command defines how the frequency deviation of each of the test tones is determined.</p> <ul style="list-style-type: none"> In the default setting TDEV, the total modulation generator frequency deviation of 2900 Hz (see command <code>CONFigure:RXAFresp:MODGenerator:FDEVIation:TFDeviation</code>) is evenly distributed among all 20 enabled test tones. This is identical with the default configuration of the <code>RXAFresp:TDEFinition</code> subsystem; see p. 6.84 f. To define test tone frequency deviations that differ from each other, the parameter SDEV must be selected. 				V3.00 ≠V2.50

CONFigure:RXAFresp:MODGenerator:FDEVIation:TFDeviation		<Total_Dev>Total Freq. Dev. (Manual)		
<Total_Dev>	Description of parameters	Def. value	Def. unit	Unit ring
0 Hz to 20000 Hz	Total frequency deviation (sum of all test tones)	2900	Hz	
Description of command				FW vers.
<p>This command defines the total modulation generator frequency deviation that is evenly distributed among all enabled test tones. The total frequency deviation setting comes into effect after the frequency deviation selection mode is set to TDEV (see <code>CONFigure:RXAFresp:MODGenerator:FDEVIation:LMODe</code> command above).</p>				V3.00 ≠V2.50

CONFigure:RXAFresp:MODGenerator:FDEVIation:SFDeviation		<Separate_Devs>Separate Deviations		
<Separate_Devs>	Description of parameters	Def. value	Def. unit	Unit ring
10 Hz to 20000 Hz,	Frequency deviation of test tone no. 1	145	Hz	
....,	...			
10 Hz to 20000 Hz	Frequency deviation of test tone no. 20	145	Hz	
Description of command				FW vers.
<p>This command defines separate modulation generator frequency deviations for all 20 test tones provided in the <code>RXAFresp</code> measurement. The frequency deviation settings come into effect after the frequency deviation selection mode is set to SDEV (see <code>CONFigure:RXAFresp:MODGenerator:FDEVIation:LMODe</code> command above).</p>				V3.00 ≠V2.50

CONFigure:RXAFresp:MODGenerator:FDEVIation:SFDeviation:TONE<nr>		<Separate_Dev>Separate Deviation		
<Separate_Dev>	Description of parameters	Def. value	Def. unit	Unit ring
10 Hz to 20000 Hz	Frequency deviation of test tone no. <nr>	145	Hz	
Description of command				FW vers.
<p>This command defines separate modulation generator frequency deviations for one of the 20 test tones (<nr> = 1 to 20) provided in the <code>RXAFresp</code> measurement. The frequency deviation settings come into effect after the frequency deviation selection mode is set to SDEV (see <code>CONFigure:RXAFresp:MODGenerator:FDEVIation:LMODe</code> command above).</p>				V3.00 ≠V2.50

CONFigure:RXAFresp:MODGenerator:DEFault <Enable>			Default Settings	
<Enable>	Description of parameters	Def. value	Def. unit	Unit ring
ON OFF	The parameters are set to their default values Some or all parameters differ from the default values	ON	–	
Description of command				FW vers.
If used as a setting command with the parameter <i>ON</i> this command sets all parameters of the sub-system to their default values (the setting <i>OFF</i> results in an error message).				V3.00 ≠V2.50
If used as a query the command returns whether all parameters are set to their default values (<i>ON</i>) or not (<i>OFF</i>).				

Path Configuration – Subsystem RXAFresp:FILTer

The subsystem *RXAFresp:FILTer* configures the voice-processing equipment used for the *RX Audio Freq. Response* measurement. The subsystem corresponds to the *Filters* tab of the popup menu *RX Audio Freq. Response Configuration*.

CONFigure:RXAFresp:FILTer <Bandpass>, <Weighting>		Path Configuration: RX Audio Freq. Response		
<Bandpass>	Description of parameters	Def. value	Def. unit	Unit ring
BP01 BP02 BP03 BP04 BP05 BP06 BP07 BP08 BP09 BP10 BP11 BP12 BP13 BP14 BP15 BP16 BP17 BP 18,	CMU band pass filter with a bandwidth of 0 Hz to 250 Hz 6 Hz to 250 Hz 50 Hz to 250 Hz 0 Hz to 3000 Hz 6 Hz to 3000 Hz 50 Hz to 3000 Hz 300 Hz to 3000 Hz 0 Hz to 4000 Hz 6 Hz to 4000 Hz 50 Hz to 4000 Hz 300 Hz to 4000 Hz 0 Hz to 15000 Hz 6 Hz to 15000 Hz 50 Hz to 15000 Hz 300 Hz to 15000 Hz 0 Hz to 21000 Hz 6 Hz to 21000 Hz 50 Hz to 21000 Hz	BP16	–	
<Weighting>	Description of parameters	Def. value	Def. unit	Unit ring
CME CCI OFF	Switch on C-message weighted filter Switch on CCITT weighting filter No weighting filter	OFF	–	
Description of command				FW vers.
This command defines the measuring equipment in the <i>RX Tests – Sensitivity</i> application.				V2.41

CONFigure:RXAFresp:FILTer:DEFault <Enable>			Default Settings		
<Enable>	Description of parameters	Def. value	Def. unit	Unit ring	
ON OFF	The parameters are set to their default values Some or all parameters differ from the default values	ON	–		
Description of command				FW vers.	
If used as a setting command with the parameter <i>ON</i> this command sets all parameters of the sub-system to their default values (the setting <i>OFF</i> results in an error message).				V2.41	
If used as a query the command returns whether all parameters are set to their default values (<i>ON</i>) or not (<i>OFF</i>).					

Measured Values – Subsystem RXAFresp[:RESult]

The subsystem *RXAFresp[:RESULT]* measures and returns the electrical Audio Frequency Response and compares it with the tolerance values. The subsystem corresponds to the various output elements in the measurement menu *RX Audio Freq. Response*.

READ[:SCALar]:RXAFresp[:RESult]:TONE<nr>?	RX Audio Frequency Response Start single shot measurement and return results				⇒ <i>RUN</i>
FETCh[:SCALar]:RXAFresp[:RESult]:TONE<nr>?	Read meas. results (unsynchronized)				⇒ <i>RUN</i>
SAMPle[:SCALar]:RXAFresp[:RESult]:TONE<nr>?	Read results (synchronized)				⇒ <i>RUN</i>
Returned values	Description of parameters	Def. value	Def. unit	Unit ring	
–150.0 dB to +150.0 dB	AF response at point <nr>	NAN	dB		
Description of command				FW vers.	
These commands are always queries. They output the RX Audio Frequency Response at test tones <nr> (<nr> = 1 to 20) defined via <code>CONFigure:RXAFresp:TONE<nr></code> .				V2.41	

READ:ARRay:RXAFresp[:RESult]?	RX Audio Frequency Response Start single shot measurement and return results				⇒ <i>RUN</i>
FETCh:ARRay:RXAFresp[:RESult]?	Read meas. results (unsynchronized)				⇒ <i>RUN</i>
SAMPle:ARRay:RXAFresp[:RESult]?	Read results (synchronized)				⇒ <i>RUN</i>
Returned values	Description of parameters	Def. value	Def. unit	Unit ring	
–150.0 dB to +150.0 dB,	FreqResp[1], 1 st value for AF response	NAN	dB		
...		
–150.0 dB to +150.0 dB	FreqResp[20], 20th value for AF resp.	NAN	dB		
Description of command				FW vers.	
These commands are always queries. They output the RX Audio Frequency Response at the 20 test tones defined via <code>CONFigure:RXAFresp:TONE<nr></code> .				V2.41	

				Subarray Results
READ:SUBarrays:RXAFresp[:RESult]?		Start single shot measurement and return results	⇒ RUN	
FETCh:SUBarrays:RXAFresp[:RESult]?		Read meas. results (unsynchronized)	⇒ RUN	
SAMPlE:SUBarrays:RXAFresp[:RESult]?		Read results (synchronized)	⇒ RUN	
Ret. values per subrange	Description of parameters	Def. value	Def. unit	Unit ring
-150.0 dB to +150.0 dB,	FreqResp[1], 1 st value for AF response	NAN	dB	
...	
-150.0 dB to +150.0 dB	FreqResp[n], nth value for AF response	NAN	dB	
Description of command				FW vers.
<p>These commands are always queries. They output the AF response in the subranges defined by means of the <code>CONFIgure:SUBarrays:RXAFresp</code> command. In the default setting of the configuration command the <code>READ:SUBarrays...</code>, <code>FETCh:SUBarrays...</code>, and <code>SAMPlE:SUBarrays...</code> command group is equivalent to the <code>READ:ARRay...</code>, <code>FETCh:ARRay...</code>, and <code>SAMPlE:ARRay...</code> command group described above.</p> <p>The <code>CONFIgure:SUBarrays:RXAFresp</code> command defines a maximum of 32 subranges. If one of the statistical modes (<code>ARIThmetical</code>, <code>MINimum</code>, <code>MAXimum</code>) is set, only one value is returned by subrange.</p>				V2.41

CALCulate[:SCALar]:RXAFresp[:RESult]:MATChing:LIMit[:LINE][:ASYMmetrical] [:COMBined]:TONE<nr>?				Limit Matching												
Returned result	Value range	Def. value	Def. unit	Unit ring												
Limit matching at tone <nr>	NMAU NMAL INV OK	INV	-													
Description of command				FW vers.												
<p>This command is always a query. It indicates whether and in which way the error limits at tone <nr> (<nr> = 1 to 20) have been exceeded.</p> <p>The following messages may be output for test tone <nr>:</p> <table style="width: 100%; border-collapse: collapse;"> <tr> <td style="padding: 2px;">NMAU</td> <td style="padding: 2px;">Underflow of tolerance value</td> <td style="padding: 2px;"><i>not matching, underflow</i></td> </tr> <tr> <td style="padding: 2px;">NMAL</td> <td style="padding: 2px;">Tolerance value exceeded</td> <td style="padding: 2px;"><i>not matching, overflow</i></td> </tr> <tr> <td style="padding: 2px;">INV</td> <td style="padding: 2px;">Measurement invalid</td> <td style="padding: 2px;"><i>invalid</i></td> </tr> <tr> <td style="padding: 2px;">OK</td> <td style="padding: 2px;">all tolerances matched</td> <td></td> </tr> </table>				NMAU	Underflow of tolerance value	<i>not matching, underflow</i>	NMAL	Tolerance value exceeded	<i>not matching, overflow</i>	INV	Measurement invalid	<i>invalid</i>	OK	all tolerances matched		V2.41
NMAU	Underflow of tolerance value	<i>not matching, underflow</i>														
NMAL	Tolerance value exceeded	<i>not matching, overflow</i>														
INV	Measurement invalid	<i>invalid</i>														
OK	all tolerances matched															

CALCulate:ARRay:RXAFresp[:RESult]:MATChing:LIMit[:LINE][:ASYMmetrical] [:COMBined]?				Limit Matching, Overall
Returned result	Value range	Def. value	Def. unit	Unit ring
20 bit field,	Indicator for upper limit matching in area 1 to 20,	NAN	-	
20 bit field	Indicator for lower limit matching in area 1 to 20	NAN	-	
Description of command				FW vers.
<p>This command is always a query. Any set bit of the two returned fields indicates that the limits at the corresponding point are exceeded.</p>				V2.41

AMPS Mobile Tests (Signalling Mode)

In the *Signalling* mode, the CMU is able to generate control channel (CC) and voice channel signals and to set up a call to the mobile. A broad range of signalling parameters can be configured and measurements may be performed with a call connection established.

Channel Units – System UNIT

The remote-control commands in the *UNIT* system control the default physical units to be used in certain groups of commands. Default units defined by a *UNIT* command are superseded by an explicit unit definition in one of the associated commands.

UNIT:CHANnel <Unit>		RF Channel Units		
<Mode>	Description of parameters	Def. value	Def. unit	Unit ring
CH HZ KHZ MHZ GHZ	AMPS channel numbers Frequency units	CH	–	
Description of command			Sig. State	FW vers.
This command defines the default unit for all RF channel specifications. This includes the input and output signals in the control channels and voice channels.			all	V2.41

Connection Control

The remote-control commands in this section are used to configure the measurements in the menu group *AMPS-MS Signalling* globally, i.e., they provide settings that are valid for all measurements within the function group. They correspond to the settings in the popup menu of the softkey *Connect Control* located to the right of the headline of each main menu.

In particular, the remote-control commands control the input signal paths, the signalling (call setup and release, services, signalling parameters), determine the inputs and outputs as well as the reference frequency.

Important note: current vs. default and other call/handoff values

Some parameters of the CMU can assume three independent values:

- The **default** value is used to set up a connection; it can be modified in the signalling states Signal Off, Signal On and Registered.
- The **current** value is valid during the connection (signalling state Call Established). Whenever the CMU enters the Call Established state the default value overwrites the current value. The current value can still be changed during the connection, however, modifying this current value does not alter the default value.
- The **other call/handoff** value comes into effect only after an Other Call or Handoff from another to the current network.

Examples of such triple parameters in AMPS-MS are the BS Signal Voice Channel (VC) Level and Voice Channel number, the SAT Peak Deviation and SCC, and the VMAC.

In remote control, default values are set with CONFigure... commands, current values are set with PROCEDURE... commands, other call/handoff values are set with CONFigure...:OCHandoff... commands. In cases where signalling state dependent parameter sets are not needed, it is possible to couple all three values; see CONFigure:SDSets:ENABLE command description below.

CONFigure:SDSets:ENABLE <Enable>		Sign. State Dependent Sets		
<Enable>	Description of parameters	Def. value	Def. unit	Unit ring
ON 	The CMU uses different <i>current</i> , <i>default</i> and <i>other call/handoff</i> parameters	ON	–	
OFF	The three parameter values are coupled and always equal			
Description of command			Sig. State	FW vers.
This command enables or disables the signalling state dependent parameter sets (independent current and default values; see note above). If it is set to <i>OFF</i> , <i>default</i> , <i>current</i> and <i>other call/handoff</i> values are always equal.			all	V3.52

Subsystem LEVEL (RF Input Level)

The subsystem *LEVEL* controls the level in the RF input signal path. It corresponds to the table section *RF Analyzer Level* in the *Analyzer* tab of the *Connection Control* menu.

[SENSe:]LEVel:MODE <Mode>		Input level – RF Mode		
<Mode>	Description of parameters	Def. value	Def. unit	Unit ring
MANual 	Manual setting	VMAC	–	
VMAC 	According to voice mobile attenuation code			
AUTomatic	Automatic setting according to average power of signal applied			
Description of command			Sig. State	FW vers.
This command defines the mode for setting the maximum input level.			all	V2.41 ¹

[SENSe:]LEVel:MAXimum <Level>		Max. Level		
<Level>	Description of parameters	Def. value	Def. unit	Unit ring
0 dBm to +53 dBm	Maximum input level for RF 1	+30.0	dBm	
–14 dBm to 39 dBm	Maximum input level for RF 2	+30.0	dBm	
–37 dBm to 0 dBm	Maximum input level for RF 4 IN	+0.0	dBm	
Description of command			Sig. State	FW vers.
This command defines the maximum expected input level. The value range depends on the RF input used and the external attenuation set (see [SENSe:]CORRection:LOSS:INPut<nr>[:MAGNitude] command).			all	V2.41

[SENSe:]LEVel:ATTenuation <Mode>		Attenuation		
<Mode>	Description of parameters	Def. value	Def. unit	Unit ring
NORMal 	Mixer level in normal range	NORMal	–	
LNOise 	Low noise (mixer level 10 dB higher than in normal setting)			
LDIstortion	Low distortion (mixer level 10 dB lower than in normal setting)			
Description of command			Sig. State	FW vers.
This command tunes the RF analyzer for normal setting, low noise level (full dynamic range), or low distortion (high intermodulation spacing).			all	V2.41

¹ Autoranging is included in firmware versions ≥ V3.05.

[SENSe:]LEVel:DEFAult		Default Settings		
<Enable>	Description of parameters	Def. value	Def. unit	Unit ring
ON OFF	The parameters are set to their default values Some or all parameters differ from the default values	ON	–	
Description of command			Sig. State	FW vers.
If used as a setting command with the parameter <i>ON</i> this command sets all parameters of the subsystem to their default values (the setting <i>OFF</i> results in an error message).			all	V2.41
If used as a query the command returns whether all parameters are set to their default values (<i>ON</i>) or not (<i>OFF</i>).				

Subsystem AFLevel (AF Input Level)

The subsystem *AFLevel* controls the level in the AF input signal path. It corresponds to the table section *AF Analyzer Level* in the *Analyzer* tab of the *Connection Control* menu.

[SENSe:]AFLevel:MODE <Mode>		Input level – AF Mode		
<Mode>	Description of parameters	Def. value	Def. unit	Unit ring
MANual VMAC AUTomatic	Manual setting Setting according to the VMAC of the mobile phone Automatic setting corresponding to average power of signal applied	VMAC	–	–
Description of command			Sig. State	FW vers.
This command defines the mode for setting the maximum input level.			all	V2.41

[SENSe:]AFLevel:MAXimum <Level>		AF Max. Level		
<Level>	Description of parameters	Def. value	Def. unit	Unit ring
0 V to +30 V	Maximum audio input voltage	+0.15	V	
Description of command			Sig. State	FW vers.
This command defines the maximum expected AF input level.			all	V2.41

[SENSe:]AFLevel:DEFAult		Default Settings		
<Enable>	Description of parameters	Def. value	Def. unit	Unit ring
ON OFF	The parameters are set to their default values Some or all parameters differ from the default values	ON	–	
Description of command			Sig. State	FW vers.
If used as a setting command with the parameter <i>ON</i> this command sets all parameters of the subsystem to their default values (the setting <i>OFF</i> results in an error message).			all	V2.41
If used as a query the command returns whether all parameters are set to their default values (<i>ON</i>) or not (<i>OFF</i>).				

[SENSe:]SIGNalling:STATe?		Signalling State		
<i>Return</i>	Description of parameters	Def. value	Def. unit	Unit ring
SOFF	Control channel signal switched off (Signal Off)	SOFF	–	–
SON	Control channel signal switched on (Signal On)			
REG	MS registration performed (Registered)			
ALER	Mobile is ringing (Alerting)			
CEST	Call to mobile set up (Call Established)			
CPEN	Call pending (Handoff procedures)			
RPEN	Registration pending (Other Call procedures)			
FPEN	Fallback pending (Other Call/Handoff procedures)			
Description of command			Sig. State	FW vers.
This command is always a query. It returns the current signalling state.			all	V2.41

PROCedure:SIGNalling[:AVC]:CHANnel <Number>		Voice Channel		
<Number>	Description of parameters	Def. value	Def. unit	Unit ring
1 to 799 990 to 1023	Number of voice channel	1	–	–
Description of command			Sig. State	FW vers.
This command changes the traffic channel number (and thus the frequency) while a call is established. If the current, default and other call/handoff values are coupled (<code>CONFigure:SDSets:ENABLE OFF</code> ; see p. 6.92), then it is replaced by <code>CONFigure:BSSignal[:AVC]:CHANnel</code> .			CEST	V2.41

PROCedure:SIGNalling[:AVC]:MAC <MAC>		VMAC		
<MAC>	Description of parameters	Def. value	Def. unit	Unit ring
0 to 7	Power of mobile phone in voice MAC units	2	–	–
Description of command			Sig. State	FW vers.
This command changes the mobile attenuation code (and thus the effective radiated power of the mobile phone) while a call is established. For an overview of MACs see chapter 4. If the current, default and other call/handoff values are coupled (<code>CONFigure:SDSets:ENABLE OFF</code> ; see p. 6.92), then it is replaced by <code>CONFigure:NETWork[:MS]:VMAC</code> .			CEST	V2.41

PROCedure:SIGNalling[:AVC]:SAT:PEAKdev <Deviation>		SAT Peak Deviation		
<Deviation>	Description of parameters	Def. value	Def. unit	Unit ring
1 Hz to 20 000 Hz	SAT peak deviation	2000	Hz	–
Description of command			Sig. State	FW vers.
This command changes the maximum frequency deviation that the CMU uses to transmit the SAT to the mobile phone while a call is established. If the current, default and other call/handoff values are coupled (<code>CONFigure:SDSets:ENABLE OFF</code> ; see p. 6.92), then it is replaced by <code>CONFigure:BSSignal:SAT:PEAKdev</code> .			CEST	V2.41

PROCedure:SIGNalling[:AVC]:SAT:SCC <Code>		SCC		
<Deviation>	Description of parameters	Def. value	Def. unit	Unit ring
0 1 2	SAT color code	0	–	–
Description of command			Sig. State	FW vers.
This command changes the SAT color code and thus the frequency of the SAT while a call is established. If the current, default and other call/handoff values are coupled (<code>CONFigure:SDSets:ENABLE OFF</code> ; see p. 6.92), then it is replaced by <code>CONFigure:BSSignal:SAT:SCC</code> .			CEST	V2.41

Subsystem OCALI (Other Call Target)

The subsystem *OCALI* sets the target for a call from the current to a different network. The corresponding softkeys are located in the index card *Other Call* in the popup menu *Connect. Control*.

STATus:OCALI:TARGet:LIST?			Destination List	
Response	Description of parameters	Def. value	Def. unit	Unit ring
"IS136800MS", "IS136800MSFallback"	Possible destination list for AMPS mobile	complete list	–	–
Description of command			Sig. State	FW vers.
This command is always a query and returns a list of all networks that are available for a OCALI. On registration, the complete (default) target list is replaced by the actual target list depending on the capabilities of the mobile station.			all	V2.41

CONFigure:OCALI:TARGet <Target>			Destination Selection	
<Target>	Description of parameters	Def. value	Def. unit	Unit ring
"IS136800MS" "IS136800MSFallback" NONE	Possible destination for AMPS mobile No OCALI	NONE	–	–
Description of command			Sig. State	FW vers.
This command selects a OCALI target. The targets available depend on the capabilities of the mobile station; see previous command. The query returns NONE unless a destination has been selected before.			SON REG Q: all	V2.41
OCALI is initiated via the PROCedure:SIGNalling:ACTion OCALl command.				

Subsystem HANDoff (Handoff Target)

The subsystem *HANDoff* sets the target for a forced handoff of the mobile phone. The corresponding softkeys are located in the index card *Handoff* in the popup menu *Connect. Control*.

STATus:HANDoff:TARGet:LIST?			Destination List	
Response	Description of parameters	Def. value	Def. unit	Unit ring
"IS136800MS", "IS136800MSFallback"	Possible destination list for AMPS mobile	complete list	–	–
Description of command			Sig. State	FW vers.
This command is always a query and returns a list of all networks that are available for a handoff. On registration, the complete (default) target list is replaced by the actual target list depending on the capabilities of the mobile station.			all	V2.41

CONFigure:HANDoff:TARGet <Target>			Destination Selection	
<Target>	Description of parameters	Def. value	Def. unit	Unit ring
"IS136800MS" "IS136800MSFallback" NONE	Possible destination for AMPS mobile No handoff	NONE	–	–
Description of command			Sig. State	FW vers.
This command selects a handoff target. The targets available depend on the capabilities of the mobile station; see previous command. The query returns NONE unless a destination has been selected before.			CEST Q: all	V2.41
Handoff is initiated via the PROCedure:SIGNalling:ACTion HANDoff command.				

Subsystem BSSignal (Signal of Base Station/CMU)

The subsystem *BSSignal* configures the control and traffic channels for the signals sent by the CMU to the mobile phone. It corresponds to the index card *BS Signal* in the popup menu *Connect. Control*.

CONFigure:BSSignal:ACC:CHANnel <Channel>			Control Channel (CC)	
<Channel>	Description of parameters	Def. value	Def. unit	Unit ring
1 to 799 990 to 1023	Channel number	333	–	
Description of command			Sig. State	FW vers.
This command determines the RF channel number for the CMU control channel signals (forward channel).			SON SOFF REG Q: all	V2.41

CONFigure:BSSignal:ACC:LEVel <Level>			Control Channel RF Level	
<Level>	Description of parameters	Def. value	Def. unit	Unit ring
–137 dBm to –27 dBm	Absol. level of control channel, RF1	–30	dBm	
–137 dBm to –10 dBm	Absol. level of control channel, RF2	–30	dBm	
–90 dBm to +13 dBm	Absol. level of control channel, RF 3 OUT	–30	dBm	
Description of command			Sig. State	FW vers.
This command determines the level in the control channel in absolute units.			SON SOFF REG Q: all	V2.41

CONFigure:BSSignal[:AVC]:CHANnel <AVChannel>			Voice Channel (VC)	
<AVChannel>	Description of parameters	Def. value	Def. unit	Unit ring
1 to 799 990 to 1023	Channel number	1	–	
Description of command			Sig. State	FW vers.
This command selects the RF channel number for the CMU voice channel signals (forward channel). To change the parameter during a call use <code>PROCedure:SIGNalling[:AVC]:CHANnel</code> .			SON SOFF REG Q: all	V2.41
If the current, default and other call/handoff values are coupled (<code>CONFigure:SDSets:ENABle OFF</code> ; see p. 6.92), then <code>CONFigure:BSSignal[:AVC]:CHANnel</code> can be used in all signalling states; <code>PROCedure:SIGNalling[:AVC]:CHANnel</code> and <code>CONFigure:BSSignal:OCHandoff[:AVC]:CHANnel</code> are not needed.				

CONFigure:BSSignal[:AVC]:LEVel <Level> PROCedure:BSSignal[:AVC]:LEVel <Level>			VC RF Level	
<Level>	Description of parameters	Def. value	Def. unit	Unit ring
-137 dBm to -27 dBm	Absol. level of traffic channel, RF1	-30	dBm	
-137 dBm to -10 dBm	Absol. level of traffic channel, RF2	-30	dBm	
-90 dBm to +13 dBm	Absol. level of traffic channel, RF 3 OUT	-30	dBm	
Description of command			Sig. State	FW vers.
<p>These commands determine the level in the voice channel in absolute units.</p> <p>The <code>CONFigure...</code> command is available in the signalling states <code>SOFF</code>, <code>SON</code> and <code>REG</code> (as a query: also <code>CEST</code>). It configures the traffic channel before it is switched on (default value). The <code>PROCedure...</code> command is available in the signalling state <code>CEST</code>. It changes the traffic channel level during a call and continues the measurement (current value).</p> <p>If the current, default and other call/handoff values are coupled (<code>CONFigure:SDSets:ENABLE OFF</code>; see p. 6.92), then <code>CONFigure...</code> can be used in all signalling states and <code>PROCedure...</code> and <code>CONFigure:BSSignal:OCHandoff[:AVC]:LEVel</code> are not needed.</p>			See description	V2.41

CONFigure:BSSignal:SAT:PEAKdev <Deviation>			SAT Peak Deviation	
<Deviation>	Description of parameters	Def. value	Def. unit	Unit ring
1 Hz to 20 000 Hz	SAT peak deviation	2000	Hz	-
Description of command			Sig. State	FW vers.
<p>This command specifies the maximum frequency deviation that the CMU uses to transmit the SAT to the mobile phone. To change the parameter during a call use <code>PROCedure:SIGNalling[:AVC]:SAT:PEAKdev</code>.</p> <p>If the current, default and other call/handoff values are coupled (<code>CONFigure:SDSets:ENABLE OFF</code>; see p. 6.92), then <code>CONFigure:BSSignal:SAT:PEAKdev</code> can be used in all signalling states; <code>PROCedure:SIGNalling[:AVC]:SAT:PEAKdev</code> and <code>CONFigure:BSSignal:OCHandoff:SAT:PEAKdev</code> are not needed.</p>			SON SOFF REG Q: all	V2.41

CONFigure:BSSignal:SAT:SCC <Code>			SCC	
<Deviation>	Description of parameters	Def. value	Def. unit	Unit ring
0 1 2	SAT color code	0	-	-
Description of command			Sig. State	FW vers.
<p>This command specifies the SAT color code and thus the frequency of the SAT. To change the parameter during a call use <code>PROCedure:SIGNalling[:AVC]:SAT:SCC</code>.</p> <p>If the current, default and other call/handoff values are coupled (<code>CONFigure:SDSets:ENABLE OFF</code>; see p. 6.92), then <code>CONFigure:BSSignal:SAT:SCC</code> can be used in all signalling states; <code>PROCedure:SIGNalling[:AVC]:SAT:SCC</code> and <code>CONFigure:BSSignal:OCHandoff:SAT:SCC</code> are not needed.</p>			SON SOFF REG Q: all	V2.41

CONFigure:BSSignal:OCHandoff[:AVC]:CHANnel <VChannel>		Other Call/Handoff: RF Channel		
<VChannel>	Description of parameters	Def. value	Def. unit	Unit ring
1 to 799 990 to 1023	Channel number	1	–	
Description of command			Sig. State	FW vers.
This command determines the RF channel number for the CMU voice channel signals (forward channel VC) that comes into effect after an <i>Other Call</i> or <i>Handoff</i> from another to the current network. If the current, default and other call/handoff values are coupled (CONFigure:SDSets:ENABLE OFF; see p. 6.92), then it is not needed and replaced by CONFigure:BSSignal[:AVC]:CHANnel .			SON SOFF REG Q: all	V2.41

CONFigure:BSSignal:OCHandoff[:AVC]:LEVel <Level>		Other Call/Handoff: RF Level		
<Level>	Description of parameters	Def. value	Def. unit	Unit ring
–137 dBm to –27 dBm	Absol. level of traffic channel, RF1	–30	dBm	
–137 dBm to –10 dBm	Absol. level of traffic channel, RF2	–30	dBm	
–90 dBm to +13 dBm	Absol. level of traffic channel, RF 3 OUT	–30	dBm	
Description of command			Sig. State	FW vers.
This command determines the level in the traffic channel in absolute units that comes into effect after an <i>Other Call</i> or <i>Handoff</i> from another to the current network. If the current, default and other call/handoff values are coupled (CONFigure:SDSets:ENABLE OFF; see p. 6.92), then it is not needed and replaced by CONFigure:BSSignal[:AVC]:LEVel .			all	V2.41

CONFigure:BSSignal:OCHandoff:SAT:PEAKdev <Deviation>		Other Call/Handoff: SAT Peak Deviation		
<Deviation>	Description of parameters	Def. value	Def. unit	Unit ring
1 Hz to 20 000 Hz	SAT peak deviation	2000	Hz	–
Description of command			Sig. State	FW vers.
This command specifies the maximum frequency deviation that the CMU uses to transmit the SAT to the mobile phone after an <i>Other Call</i> or <i>Handoff</i> from another to the current network. If the current, default and other call/handoff values are coupled (CONFigure:SDSets:ENABLE OFF; see p. 6.92), then it is not needed and replaced by CONFigure:BSSignal:SAT:PEAKdev .			all	V2.41

CONFigure:BSSignal:OCHandoff:SAT:SCC <Code>		Other Call/Handoff: SCC		
<Deviation>	Description of parameters	Def. value	Def. unit	Unit ring
0 1 2	SAT color code	0	–	–
Description of command			Sig. State	FW vers.
This command specifies the SAT color code and thus the frequency of the SAT that comes into effect after an <i>Other Call</i> or <i>Handoff</i> from another to the current network. If the current, default and other call/handoff values are coupled (CONFigure:SDSets:ENABLE OFF; see p. 6.92), then it is not needed and replaced by CONFigure:BSSignal:SAT:SCC .			all	V2.41

Subsystem NETWORK

The subsystem *NETWork* determines the parameters of the radio network and the existing radio link. The subsystem corresponds to the popup menu *Network* in the menu group *Connect. Control*.

Subsystem NETWork:IDENTity

The subsystem *NETWork:IDENTity* defines the identity of the mobile radio network. The subsystem corresponds to the table field *Network Identity* in the popup menu *Network*.

CONFigure:NETWork:IDENTity:SID1 <Code>				SID
<Code>	Description of parameters	Def. value	Def. unit	Unit ring
0 to 16383	14-bit SID 1	0	–	–
Description of command			Sig. State	FW vers.
This command defines the 14-bit system identity code. Together with the channel identifier, the SID 1 forms the 15-bit SID.			SOFF, SON, REG Q: all	V2.41

CONFigure:NETWork:IDENTity:DCC <Code>				DCC
<Code>	Description of parameters	Def. value	Def. unit	Unit ring
0 to 3	Digital color code	1	–	–
Description of command			Sig. State	FW vers.
This command defines the digital color code.			SOFF, SON, REG Q: all	V2.41

Subsystem NETWork:SMODE (Signalling Modes)

The subsystem *NETWork:SMODE* defines the signalling parameters controlling the function of the mobile. The subsystem corresponds to the table field *Signalling Modes* in the popup menu *Network*.

CONFigure:NETWork:SMODE:REGH <Enable>				Home Registration
<Mode>	Description of parameters	Def. value	Def. unit	Unit ring
ON OFF	Registration for home mobiles on/off	ON	–	–
Description of command			Sig. State	FW vers.
This command determines whether registration is allowed for home mobiles.			SOFF, SON, REG Q: All	V2.41

CONFigure:NETWork:SMODE:REGR <Enable>				Roaming Registration
<Mode>	Description of parameters	Def. value	Def. unit	Unit ring
ON OFF	Registration for roaming mobiles on/off	ON	–	–
Description of command			Sig. State	FW vers.
This command determines whether registration is allowed for roaming mobiles.			SOFF, SON, REG Q: All	V2.41

CONFigure:NETWork:SMODE:IDMin <MIN>				MIN
<MIN>	Description of parameters	Def. value	Def. unit	Unit ring
"0 to 2 ³⁴ - 1"	34-bit MIN (mobile ident. number)	0	–	–
Description of command			Sig. State	FW vers.
This command defines the default MIN used to set up a call to the mobile phone.			SOFF, SON, REG Q: All	V2.41

Subsystem NETWork:REQuest (Requested Mobile Data)

The subsystem *NETWork:REQuest* determines the signalling parameters of the mobile to be requested. The subsystem corresponds to the table field *Requested Mobile Data* in the popup menu *Network*.

CONFigure:NETWork:REQuest:SNUMBER <Enable>			Serial Number Request	
<Enable>	Description of parameters	Def. value	Def. unit	Unit ring
ON OFF	Request of the mobile's serial number or no request	ON	–	–
Description of command			Sig. State	FW vers.
This command determines whether the serial number of the mobile phone is requested during registration.			SOFF, SON, REG Q: all	V2.41

Subsystem NETWork[:MS] (Mobile Settings)

The subsystem *NETWork[:MS]* defines the mobile parameters. The subsystem corresponds to the mobile-related settings in the popup menu *MS Signal*.

CONFigure:NETWork[:MS]:CMAC <MAC>				CMAC
<MAC>	Description of parameters	Def. value	Def. unit	Unit ring
0 to 7	Mobile attenuation code	0	–	–
Description of command			Sig. State	FW vers.
This command defines the mobile attenuation code (MAC) for control channel signals. An overview of MAC levels in AMPS and the corresponding effective radiated powers is given in chapter 4.			SOFF, SON REG Q: all	V2.41

CONFigure:NETWork[:MS]:VMAC <MAC>				VMAC
<MAC>	Description of parameters	Def. value	Def. unit	Unit ring
0 to 7	Mobile attenuation code	2	–	–
Description of command			Sig. State	FW vers.
This command defines the mobile attenuation code (MAC) for traffic channel signals. An overview of MAC levels in AMPS and the corresponding effective radiated powers is given in chapter 4. To change the parameter during a call use PROCedure:SIGNalling[:AVC]:MAC.			SOFF, SON REG Q: all	V2.41
If the current, default and other call/handoff values are coupled (CONFigure:SDSets:ENABLE OFF; see p. 6.92), then CONFigure:NETWork[:MS]:VMAC can be used in all signalling states; PROCedure:SIGNalling[:AVC]:MAC and CONFigure:NETWork:OCHandoff[:MS]:VMAC are not needed.				

CONFigure:NETWork[:MS]:RCFM <Enable>		Read Control Filler Message		
<Enable>	Description of parameters	Def. value	Def. unit	Unit ring
ON OFF	Read control filler message on/off	ON	–	
Description of command			Sig. State	FW vers.
This command determines whether the mobile must read a control filler message before accessing a system.			SOFF, SON REG Q: all	V2.41

Subsystem NETWork:TIMEout

The subsystem *NETWork:TIMEout* defines timeouts for dropping an unused radio link or forcing a registration. The subsystem corresponds to the table field *Timeouts* in the popup menu *Network*.

CONFigure:NETWork:TIMEout:LORLINK <Time>		Loss of Radio Link		
<Time>	Description of parameters	Def. value	Def. unit	Unit ring
1 s to 60 s	Loss of radio link	4	s	
Description of command			Sig. State	FW vers.
This command defines the time after which the CMU drops an interrupted connection.			SON, SOFF REG Q: all	V2.41

CONFigure:NETWork:TIMEout:RPERiod <Time>		Registration Period		
<Enable>	Description of parameters	Def. value	Def. unit	Unit ring
4 s to 360 s OFF	Timeout for forced registration No forced registration	OFF	s	
Description of command			Sig. State	FW vers.
This command determines a period of time after which the CMU forces the mobile station to (re-)register. In the setting OFF, no forced registration takes place.			SON, SOFF REG Q: all	V2.41

Subsystem NETWORK:OCHandoff

The subsystem *NETWORK:OCHandoff* defines parameters that come into effect after an *Other Call* or a *Handoff* from another to the current network. The subsystem corresponds to the table field *Other Call/Handoff Parameter* in the popup menu *MS Signal*.

CONFigure:NETWork:OCHandoff[:MS]:VMAC <MAC>			Other Call/Handoff: VMAC	
<MAC>	Description of parameters	Def. value	Def. unit	Unit ring
0 to 7	Voice mobile attenuation code	0	–	
Description of command			Sig. State	FW vers.
This command determines the voice MAC that comes into effect after an <i>Other Call</i> or <i>Handoff</i> from another to the current network. If the current, default and other call/handoff values are coupled (CONFigure:SDSets:ENABLE OFF; see p. 6.92), then it is not needed and replaced by CONFigure:NETWork[:MS]:VMAC.			SON, SOFF REG Q: all	V2.41

Connectors and External Attenuation

The following commands configure the input and output connectors and the external attenuation. The subsystem corresponds to the tab *AF/RF* in the popup menu *Connect. Control*.

INPut[:STATe] <State>			RF Input	
<State>	Description of parameters	Def. value	Def. unit	Unit ring
RF1	Connector RF1 used as input	RF2	–	–
RF2	Connector RF2 used as input			
RF4	Connector RF4 IN used as input			
Description of command			Sig. State	FW vers.
This command determines the connector to be used for RF input signals. The bidirectional connectors RF 1 and RF 2 can be used both as input and output connectors in the same measurement (see OUTPut[:STATe]).			all	V2.41
Only one input and one output may be active at the same time, a new RF input setting overwrites the previous one.				

OUTPut[:STATe] <State>			RF Output	
<State>	Description of parameters	Def. value	Def. unit	Unit ring
RF1	Connector RF1 used as output	RF2	–	–
RF2	Connector RF2 used as output			
RF3	Connector RF3 OUT used as output			
Description of command			Sig. State	FW vers.
This command determines the connector to be used for RF output signals. The bidirectional connectors RF 1 and RF 2 can be used as input and output connectors in the same measurement (see INPut[:STATe]).			all	V2.41
Only one input and one output may be active at the same time, a new RF output setting overwrites the previous one.				

[SENSe:]CORRection:LOSS:INPut<nr>[:MAGNitude] <Attenuation> SOURce:CORRection:LOSS:INPut<nr>[:MAGNitude] <Attenuation>				Ext. Att. Input	
<Attenuation>	Description of parameters	Def. value	Def. unit	Unit ring	
-50 dB to +50 dB -90 dB to +90 dB	External attenuation at input <nr>, (<nr> = 1, 2) External attenuation at input <nr>, (<nr> = 4)	0.0 0.0	dB dB		
Description of command				Sig. State	FW vers.
This command assigns an external attenuation value to the inputs of the instrument (RF 1, RF 2, RF 4 IN).				all	V2.41

[SENSe:]CORRection:LOSS:Output<nr>[:MAGNitude] <Attenuation> SOURce:CORRection:LOSS:Output<nr>[:MAGNitude] <Attenuation>				Ext. Att. Output	
<Attenuation>	Description of parameters	Def. value	Def. unit	Unit ring	
-50 dB to +50 dB -90 dB to +90 dB	External atten. at output <nr>, (<nr> = 1, 2) External atten. at output <nr>, (<nr> = 3)	0.0 0.0	dB dB		
Description of command				Sig. State	FW vers.
This command assigns an external attenuation value to the outputs of the instrument (RF 1, RF 2, RF 3 OUT).				all	V2.41

[SENSe:]AFConnect:MSource <Source>Mod. Source				
<Source>	Description of parameters	Def. value	Def. unit	Unit ring
INTern EXTern	Internal modulation signal from the mod. generator External modulation signal fed in via AUX 1	INTern	-	-
Description of command				FW vers.
This command selects the internal CW modulation signal or an arbitrary external modulation signal to be modulated onto the RF carrier.				V3.05

Subsystem DM:CLOCK (Network Clock)

The subsystem *DM:CLOCK* sets a system clock frequency specific to the network. This frequency is set in the index card *Sync.* in the popup menu *Connect. Control.*

SOURce:DM:CLOCK:STATe <Mode>				REF OUT 2 on/off	
<Mode>	Description of parameters	Def. value	Def. unit	Unit ring	
ON OFF	Switch on/off system clock	OFF	-	-	
Description of command				Sig. State	FW vers.
This command switches the system clock at output <i>REF OUT 2</i> on or off.				all	V2.41

SOURce:DM:CLOCK:FREquency <Frequency>				REF OUT 2	
<Frequency>	Description of parameters	Def. value	Def. unit	Unit ring	
9.72 MHz to 38.88 MHz	System clock frequency	12.96	MHz		
Description of command				Sig. State	FW vers.
This command determines the system clock frequency applied to <i>REF OUT 2</i> . The frequency entered is internally rounded to one of the following discrete values: 38.88 MHz, 19.44 MHz, 12.96 MHz, 9.72 MHz				all	V2.41

Subsystem MSSinfo (Signalling information of mobile phone)

The subsystem *MSSinfo* contains the commands for querying the properties of the mobile phone. The subsystem corresponds to the *Signalling Info* output table in the main menu *AMPS-MS Overview*. The mobile phone properties do not actually represent measured values, they are reported by the mobile phone during registration.

Note:

If no mobile is connected, or if the mobile under test is not registered (signalling states SOFF, SON), the queries in this section will return the default values INV. Most true mobile properties are available in the REG and CEST states, the DNUMBER in the CEST state only. They are overwritten by INV as soon as registration is lost (transition from REG or CEST to SON or SOFF).

[SENSe:]MSSinfo:MIN[:NUMBER]?				MIN
<Returned Value>	Description of parameters	Def. value	Def. unit	Unit ring
"Max. 12 digits"	Mobile identification number	INV	–	
Description of command			Sig. State	FW vers.
This command is always a query and returns the mobile station identification number.			all	V2.41

[SENSe:]MSSinfo:SN?				SN
<Returned Value>	Description of parameters	Def. value	Def. unit	Unit ring
0 to 2³² – 1	32-bit Serial Number (SN)	INV	–	
Description of command			Sig. State	FW vers.
This command is always a query and returns the Serial Number (SN) of the mobile phone.			all	V2.41

[SENSe:]MSSinfo:SN:HEX?				SN (hex)
<Returned Value>	Description of parameters	Def. value	Def. unit	Unit ring
#H0 to #FFFFFFF	32-bit Serial Number (SN), hex value	INV	–	
Description of command			Sig. State	FW vers.
This command is always a query and returns the Serial Number (SN) of the mobile phone in hexadecimal format.			all	V2.52

[SENSe:]MSSinfo:PCLass?				Power Class
<Returned Value>	Description of parameters	Def. value	Def. unit	Unit ring
1 to 3	Power class of the mobile phone	INV	–	
Description of command			Sig. State	FW vers.
This command is always a query and returns the power class of the mobile phone. For a list of AMPS power classes and mobile attenuation codes refer to chapter 4.			SOFF, SON REG Q: All	V2.41

[SENSe:]MSSinfo:BANDwidth?				Bandwidth
<Returned Value>	Description of parameters	Def. value	Def. unit	Unit ring
MH20 MH25	20 MHz or 25 MHz bandwidth	INV	–	
Description of command			Sig. State	FW vers.
This command is always a query and returns the width of the whole RF band used.			all	V2.41

[SENSe:]MSSinfo:MPCI?				MPCI
<Returned Value>	Description of parameters	Def. value	Def. unit	Unit ring
0	TIA/EIA-553 mobile station	INV	–	
1	TIA/EIA-627 dual-band mobile station			
2	reserved			
3	TIA/EIA-136 dual-mode mobile station			
Description of command			Sig. State	FW vers.
This command is always a query and returns the MPCI of the mobile.			all	V2.41

[SENSe:]MSSinfo:DNUMBER?				Dialed Number
<Returned Value>	Description of parameters	Def. value	Def. unit	Unit ring
"Max. 16 digits"	Dialed number	INV	–	
Description of command			Sig. State	FW vers.
This command is always a query and returns the number dialed at the mobile station (Call from MS). The current value is available in the CEST signalling state only.			all	V2.41

Subsystem "AFGenerator" – Generator control

The subsystem *AFGenerator* configures the AF signals generated by the CMU. It corresponds to the softkey *AF Generator* in the measurement menu *Overview*.

INITiate:AFGenerator	Start AF generator, reserve resources	⇒	RUN
ABORT:AFGenerator	Switch off AF generator, release resources	⇒	OFF
Description of command			Sig. State
These commands have no query form. They start and stop the AF generator, setting it to the status indicated in the top right column.			all
			FW vers.
			V2.41

FETCh:AFGenerator:STATus?				Generator Status
Returned values	Description of parameters	Def. value	Def. unit	Unit ring
OFF	Generator switched off (ABORT or *RST)	OFF	–	
RUN	Running (INITiate)			
ERR	Switched off (could not be started)			
Description of command			Sig. State	FW vers.
This command is always a query. It returns the current AF generator status.			all	V2.41

Generator Level – Subsystem AFGenerator:LEVel

The subsystem *AFGenerator:LEVel* determines the voltage of the generated AF signal. It corresponds to the *Level* input field assigned to the *AF Generator* softkey in the measurement menu *Overview*.

SOURce:AFGenerator:LEVel <Level>			AF Voltage	
<Level>	Description of parameters	Def. value	Def. unit	Unit ring
0 V to 5 V	Effective (RMS averaged) voltage of the AF signal	0.2	V	
Description of command			Sig. State	FW vers.
This command determines the voltage of the AF signal.			all	V2.41

SOURce:AFGenerator:SLEVel <Level>			Start Level	
<Level>	Description of parameters	Def. value	Def. unit	Unit ring
0 V to 5 V	Start value for <i>AF Level Search</i>	0.2	V	
Description of command				FW vers.
This command determines the start value for the <i>AF Level Search</i> iteration (relevant for <i>TX Tests – AF Level Search</i> application only).				V3.05

AF Generator Frequency – Subsystem AFGenerator:FREQUENCY

The subsystem *AFGenerator:FREQUENCY* determines the frequency of the generated AF signals. It corresponds to the *Frequency* input field assigned to the *AF Generator* softkey in the measurement menu *Overview*.

SOURce:AFGenerator:FREQUENCY <Frequency>			AAF Gen. Frequency	
<Number>	Description of parameters	Def. value	Def. unit	Unit ring
20 Hz to 20 000 Hz	AF frequency	1004	Hz	
Description of command			Sig. State	FW vers.
This command defines the frequency of the AF signal generated.			all	V2.41

Subsystem "MODGenerator" – Generator control

The subsystem *MODGenerator* configures the modulation signals generated by the CMU. It corresponds to the softkey *Mod. Generator* in the measurement menu *Overview*.

INITiate:MODGenerator	Start Mod. generator, reserve resources	⇒	<i>RUN</i>
ABORT:MODGenerator	Switch off Mod. generator, release resources	⇒	<i>OFF</i>
Description of command		Sig. State	FW vers.
These commands have no query form. They start and stop the modulation generator, setting it to the status indicated in the top right column.		all	V2.41

FETCH:MODGenerator:STATus?		Generator Status		
Returned values	Description of parameters	Def. value	Def. unit	Unit ring
OFF 	Generator switched off (ABORT or *RST)	OFF	–	
RUN 	Running (INITiate)			
ERR	Switched off (could not be started)			
Description of command		Sig. State	FW vers.	
This command is always a query. It returns the current modulation generator status.		all	V2.41	

Generator Level – Subsystem MODGenerator:DEVIation

The subsystem *MODGenerator:DEVIation* determines the peak deviation of the generated modulation signal. It corresponds to the *Peak Deviation* input field assigned to the *Mod. Generator* softkey in the measurement menu *Overview*.

SOURce:MODGenerator:DEVIation <Deviation>		Mod. Deviation		
<Deviation>	Description of parameters	Def. value	Def. unit	Unit ring
0 Hz to 20000 Hz	Effective (RMS averaged) voltage of the mod. signal	8000	Hz	
Description of command		Sig. State	FW vers.	
This command determines the frequency deviation of the modulation signal.		all	V2.41	

Mod. Generator Frequency – Subsystem MODGenerator:FREQuency

The subsystem *MODGenerator:FREQuency* determines the frequency of the generated modulation signals. It corresponds to the *Frequency* input field assigned to the *Mod. Generator* softkey in the measurement menu *Overview*.

SOURce:MODGenerator:FREQuency <Frequency>		Mod. Frequency		
<Number>	Description of parameters	Def. value	Def. unit	Unit ring
1 Hz to 15 999 Hz	Mod. frequency	1004	Hz	
Description of command		Sig. State	FW vers.	
This command defines the frequency of the modulation signal generated.		all	V2.41	

Symbolic Status Event Register Evaluation

The following commands are used to retrieve the events reported in function group *AMPS-MS Signalling*; see section *Symbolic Status Event Register Evaluation* in Chapter 5 of the CMU operating manual.

STATus:OPERation:SYMBOLic:ENABLE <Event>{,<Event>}		Symbolic status evaluation		
<i>Parameter list</i>	Parameter description	Def. Value ³	Default Unit	Unit Ring
<Event>{,<Event>} NONE	List of symbols for events to be reported No event reported	NONE	–	
Command description				FW vers.
This command enables event reporting for one or several events in the current <i>AMPS-MS Signalling</i> function group, i.e. it sets the corresponding bits in the <code>STATus:OPERation:CMU:SUM<nr>:CMU<nr_event>:ENABLE</code> register (<code><nr> = 1 2</code> , <code><nr_event></code> denotes the current function group) and in all sum registers up to the status byte. The events and the corresponding symbols for the function group are listed in Chapter 5 (see section <i>Status Registers</i>). The symbols may be entered in arbitrary order.				V3.05

STATus:OPERation:SYMBOLic[:EVENT]?		Symbolic status evaluation		
<i>Response</i>	Parameter description	Def. Value ⁴	Default Unit	Unit Ring
NONE <Event>{,<Event>}	No event in the <i>RF</i> function group List of reported events	NONE	–	
Command description				FW vers.
This command is always a query. It lists the events reported in the current <i>AMPS-MS Signalling</i> function group and deletes these events in the <code>STATus:OPERation:CMU:SUM<nr>:CMU<nr_event>:EVENT</code> register as well as in all sum registers.				V3.05

³ The default values quoted in this command are achieved after a `STATus:PRESet` command. `*RST` does not overwrite the entries in the status registers; see section *Reset Values of the Status Reporting Systems* in chapter 5.

⁴ The default values quoted in this command are achieved after a `*CLS` command. `*RST` does not overwrite the entries in the status registers; see section *Reset Values of the Status Reporting Systems* in chapter 5.

List of Commands

In the following, all remote-control commands of the function group AMPS-MS are listed with their parameters and page numbers. They are arranged alphabetically according to the **second** keyword of the command so that related commands belong to the same group. The commands for the two test modes *Non Signalling* and *Signalling* are listed separately.

Commands for AMPS Module Tests (Non Signalling)

Table 6-1 Remote-control commands: Non Signalling

Command	Parameter	Remark	Page
AF Connector			
[SENSe:]AFConnect:MSOource	INTern EXTern	with query	6.11
AF Generator			
INITiate:AFGenerator	–	no query	6.6
ABORt:AFGenerator	–	no query	6.6
SOURce:AFGenerator:FREQuency	20 Hz to 20000 Hz	with query	6.7
SOURce:AFGenerator:LEVel	<Level>	with query	6.7
SOURce:AFGenerator:SLEVel	<Level>	with query	6.7
FETCh:AFGenerator:STATus?	OFF RUN ERR	query only	6.7
AF Input Level			
[SENSe:]AFLevel:DEFault	ON OFF	with query	6.3
[SENSe:]AFLevel:MAXimum	<Level>	with query	6.3
[SENSe:]AFLevel:MODE	MANual AUTomatic	with query	6.3
Inputs and outputs			
[SENSe:]CORRection:LOSS:INPut<nr>[:MAGNitude]	–50 dB to +50 dB	with query	6.11
SOURce:CORRection:LOSS:INPut<nr>[:MAGNitude]	–50 dB to +50 dB	with query	6.11
[SENSe:]CORRection:LOSS:OUTPut<nr>[:MAGNitude]	–50 dB to 50 dB	with query	6.11
SOURce:CORRection:LOSS:OUTPut<nr>[:MAGNitude]	–50 dB to 50 dB	with query	6.11
SOURce:DM:CLOCK:FREQuency	9.72 MHz to 38.88 MHz	with query	6.12
SOURce:DM:CLOCK:STATE	ON OFF	with query	6.12
INPut[::STATE]	RF1 RF2 RF4	with query	6.10
OUTPut[::STATE]	RF1 RF2 RF3	with query	6.10
RF Input Level			
[SENSe:]LEVel:ATTenuation	NORMal LNOise LDISTortion	with query	6.2
[SENSe:]LEVel:DEFault	ON OFF	with query	6.2
[SENSe:]LEVel:MAXimum	<Level>	with query	6.2

Command	Parameter	Remark	Page
[SENSe:]LEVel:MODE	MANual AUTomatic	with query	6.1
Modulation Generator			
INITiate:MODGenerator	–	no query	6.8
ABORt:MODGenerator	–	no query	6.8
SOURce:MODGenerator:DEVIation	0 Hz to 20000 Hz	with query	6.8
SOURce:MODGenerator:FREQuency	20 Hz to 20000 Hz	with query	6.8
FETCh:MODGenerator:STATus?	OFF RUN ERR	query only	6.8
RF Generator and Analyzer Settings			
[SENSe:]RFANalyzer:FREQuency	210,000 Hz to 2,700,000,000 Hz	with query	6.4
[SENSe:]RFANalyzer:FREQuency:OFFSet	–15 kHz to 15 kHz	with query	6.4
[SENSe:]RFANalyzer:FREQuency:UNIT	Hz KHZ MHZ GHZ CH	with query	6.4
SOURce:RFGenerator:FREQuency	0.2 MHz to 2700 MHz	with query	6.6
SOURce:RFGenerator:FREQuency:OFFSet	–15 kHz to 15 kHz	with query	6.6
SOURce:RFGenerator:FREQuency:UNIT	Hz KHZ MHZ GHZ CH	with query	6.6
SOURce:RFGenerator:LEVel	<Level>	with query	6.5
FETCh:RFGenerator:STATus?	OFF RUN ERR	query only	6.5
SAT Generator			
INITiate:SAT	–	no query	6.9
ABORt:SAT	–	no query	6.9
SOURce:SAT:PEAKdev	0 Hz to 20000 Hz	with query	6.9
SOURce:SAT:SCC	0 1 2	with query	6.9
FETCh:SAT:STATus?	OFF RUN ERR	query only	6.9
ST Generator			
INITiate:ST	–	no query	6.9
ABORt:ST	–	no query	6.9
SOURce:ST:DAT	ON OFF	with query	6.10
SOURce:ST:PEAKdev	0 Hz to 20000 Hz	with query	6.10
FETCh:ST:STATus?	OFF RUN ERR	query only	6.10
Symbolic Status Register Evaluation			
STATus:OPERation:SYMBOLic:ENABLE	<Event>{,<Event>}	with query	6.13
STATus:OPERation:SYMBOLic:EVENT{?}	NONE <Event>{,<Event>}	query only	6.13

Commands for Measurement Groups (Non Signalling and Signalling)

Table 6-2 Remote-control commands: Signalling mode

Command	Parameter	Remark	Page
RX Audio Frequency Response Measurement			
INITiate:RXAFresp	–	no query	6.78
ABORt:RXAFresp	–	no query	6.78
STOP:RXAFresp	–	no query	6.78
CONTInue:RXAFresp	–	no query	6.78
CONFigure:SUBarrays:RXAFresp	ALL ARITHmetical MINimum MAXimum, <Range>{, <Range>}	with query	6.81
CONFigure:RXAFresp:CONTRol:DEFault	ON OFF	with query	6.80
DISPlay:RXAFresp:CONTRol:GRID	ON OFF	with query	6.79
CONFigure:RXAFresp:CONTRol:MGLead	0 s to 100 ms	with query	6.80
CONFigure:RXAFresp:CONTRol:MODGenerator:DEFault	ON OFF	with query	6.88
CONFigure:RXAFresp:CONTRol:REPetition	CONTInuous SINGleshot 1 to 10000, SONerror NONE, STEP NONE	with query	6.79
CONFigure:RXAFresp:CONTRol:RLEVel	0.001 V to 5.000 V	with query	6.79
CONFigure:RXAFresp:CONTRol:RREQuest	RLEV TON1 ... TON20	with query	6.80
CONFigure:RXAFresp:CONTRol:TDEFinition	ON OFF	with query	6.85
CONFigure:RXAFresp:EREPorting	SRQ SOPC SRSQ OFF	with query	6.78
CONFigure:RXAFresp:FILTer	<Bandpass>, <Weighting>	with query	6.88
CONFigure:RXAFresp:FILTer:DEFault	ON OFF	with query	6.89
CONFigure:RXAFresp:LIMit[:LINE]:DEFault	ON OFF	with query	6.83
CONFigure:RXAFresp:LIMit[:LINE][:ASYMmetrical]:LOWer	<Limit_1>, <Enable_1>, ... <Limit_20>, <Enable_20>	with query	6.83
CONFigure:RXAFresp:LIMit[:LINE][:ASYMmetrical]:LOWer:TONE<nr>	<Limit>, <Enable>	with query	6.83
CONFigure:RXAFresp:LIMit[:LINE][:ASYMmetrical]:UPPer	<Limit_1>, <Enable_1>, ... <Limit_20>, <Enable_20>	with query	6.82
CONFigure:RXAFresp:LIMit[:LINE][:ASYMmetrical]:UPPer:TONE<nr>	<Limit>, <Enable>	with query	6.82
CONFigure:RXAFresp:MODGenerator:ENABle	ON OFF, ON OFF, ...	with query	6.85
CONFigure:RXAFresp:MODGenerator:ENABle:TONE<nr>	ON OFF	with query	6.86
CONFigure:RXAFresp:MODGenerator:FDEVIation:FDMODE	TDEV SDEV	with query	6.87
CONFigure:RXAFresp:MODGenerator:FDEVIation:SFDeVIation	<Separate_Devs>	with query	6.87
CONFigure:RXAFresp:MODGenerator:FDEVIation:SFDeVIation:TONE<nr>	<Separate_Dev>	with query	6.87
CONFigure:RXAFresp:MODGenerator:FDEVIation:TFDeVIation	<Total_Dev>	with query	6.87
CONFigure:RXAFresp:MODGenerator:FREQUency	<Frequency>	with query	6.86
CONFigure:RXAFresp:MODGenerator:FREQUency:TONE<nr>	<Frequency>	with query	6.86

Command	Parameter	Remark	Page
FETCh:RXAFresp:STATus?	OFF RUN STOP ERR STEP RDY, 1 to 10000 NONE	query only	6.78
CONFigure:RXAFresp:TDEFinition	<Freq_1>, <Dev_1>, <Enable_1>, ... <Freq_20>, <Dev_20>, <Enable_20>	with query	6.84
CONFigure:RXAFresp:TDEFinition:TONE<nr>	<Frequency>, <Deviation>, ON OFF	with query	6.85
CALCulate[:SCALar]:RXAFresp[:RESult]:MATChing:LIMit[:LINE][:ASYMmetrical][:COMBined]:TONE<nr>?	<Result>	query only	6.90
CALCulate:ARRay:RXAFresp[:RESult]:MATChing:LIMit[:LINE][:ASYMmetrical][:COMBined]:TONE?	<Result>	query only	6.90
READ[:SCALar]:RXAFresp[:RESult]:TONE<nr>?	-150.0 dB to +150.0 dB	query only	6.89
FETCh[:SCALar]:RXAFresp[:RESult]:TONE<nr>?	-150.0 dB to +150.0 dB	query only	6.89
SAMPlE[:SCALar]:RXAFresp[:RESult]:TONE<nr>?	-150.0 dB to +150.0 dB	query only	6.89
READ:ARRay:RXAFresp[:RESult]?	-150.0 dB to +150.0 dB	query only	6.89
FETCh:ARRay:RXAFresp[:RESult]?	-150.0 dB to +150.0 dB	query only	6.89
SAMPlE:ARRay:RXAFresp[:RESult]?	-150.0 dB to +150.0 dB	query only	6.89
READ:SUBarrays:RXAFresp[:RESult]?	-150.0 dB to +150.0 dB	query only	6.90
FETCh:SUBarrays:RXAFresp[:RESult]?	-150.0 dB to +150.0 dB	query only	6.90
SAMPlE:SUBarrays:RXAFresp[:RESult]?	-150.0 dB to +150.0 dB	query only	6.90
DISPlay:RXAFresp[:WINDow]:TRACe:Y:SCALE	<ScaleMin>, <ScaleMax>	with query	6.80
RX Tests			
INITiate:RXTests:AFANalyzer	-	no query	6.58
ABORt:RXTests:AFANalyzer	-	no query	6.58
STOP:RXTests:AFANalyzer	-	no query	6.58
CONTinue:RXTests:AFANalyzer	-	no query	6.58
CONFigure:RXTests:AFANalyzer:CONTRol:DEFault	ON OFF	with query	6.59
CONFigure:RXTests:AFANalyzer:CONTRol:REPetition	CONTInuous SINGleshot 1 to 10000, SONerror NONE, STEP NONE	with query	6.59
CONFigure:RXTests:AFANalyzer:EREPorting	SRQ SOPC SRSQ OFF	with query	6.58
CONFigure:RXTests:AFANalyzer:FILTer	<Bandpass>, <Weighting>	with query	6.61
CONFigure:RXTests:AFANalyzer:FILTer:DEFault	ON OFF	with query	6.62
CONFigure:RXTests:AFANalyzer:FILTer:NOTCh	N01 N05	with query	6.61
CONFigure:RXTests:AFANalyzer:LIMit	<AFVoltMtrMin>, <AFVoltMtrMax>, <AFDist>, <AFSINAD>	with query	6.60
CONFigure:RXTests:AFANalyzer:LIMit:DEFault	ON OFF	with query	6.60
FETCh:RXTests:AFANalyzer:STATus?	OFF RUN STOP ERR STEP RDY, 1 to 10000 NONE	query only	6.58
INITiate:RXTests:AFANalyzer:VMSinad	-	no query	6.64
ABORt:RXTests:AFANalyzer:VMSinad	-	no query	6.64
STOP:RXTests:AFANalyzer:VMSinad	-	no query	6.64
CONTinue:RXTests:AFANalyzer:VMSinad	-	no query	6.64

Command	Parameter	Remark	Page
CONFigure:RXTests:AFANalyzer:VMSinad:CONTRol:DEFault	ON OFF	with query	6.65
CONFigure:RXTests:AFANalyzer:VMSinad:CONTRol:MTIME	0.025 s to 1 s	with query	6.65
CONFigure:RXTests:AFANalyzer:VMSinad:CONTRol:REPetition	CONTInuous SINGleshot 1 to 10000, SONerror NONE, STEP NONE	with query	6.65
CONFigure:RXTests:AFANalyzer:VMSinad:EREPorting	SRQ SOPC SRSQ OFF	with query	6.64
FETCh:RXTests:AFANalyzer:VMSinad:STATus?	OFF RUN STOP ERR STEP RDY, 1 to 10000 NONE	query only	6.64
CALCulate[:SCALAR]:RXTests:AFANalyzer:VMSinad[:RESult]:MATChing:LIMit?	<Result>	query only	6.66
READ[:SCALAR]:RXTests:AFANalyzer:VMSinad[:RESult]?	<Result>	query only	6.66
FETCh[:SCALAR]:RXTests:AFANalyzer:VMSinad[:RESult]?	<Result>	query only	6.66
SAMPLE[:SCALAR]:RXTests:AFANalyzer:VMSinad[:RESult]?	<Result>	query only	6.66
CALCulate[:SCALAR]:RXTests:AFANalyzer[:RESult]:MATChing:LIMit?	<Result>	query only	6.63
READ[:SCALAR]:RXTests:AFANalyzer[:RESult]?	<Result>	query only	6.63
FETCh[:SCALAR]:RXTests:AFANalyzer[:RESult]?	<Result>	query only	6.63
SAMPLE[:SCALAR]:RXTests:AFANalyzer[:RESult]?	<Result>	query only	6.63
INITiate:RXTests:HNOise	–	no query	6.67
ABORt:RXTests:HNOise	–	no query	6.67
STOP:RXTests:HNOise	–	no query	6.67
CONTInue:RXTests:HNOise	–	no query	6.67
CONFigure:RXTests:HNOise:CONTRol:DEFault	ON OFF	with query	6.68
CONFigure:RXTests:HNOise:CONTRol:REPetition	CONTInuous SINGleshot 1 to 10000, SONerror NONE, STEP NONE	with query	6.68
CONFigure:RXTests:HNOise:EREPorting	SRQ SOPC SRSQ OFF	with query	6.67
CONFigure:RXTests:HNOise:FILTer	<Bandpass>, <Weighting>	with query	6.70
CONFigure:RXTests:HNOise:FILTer:DEFault	ON OFF	with query	6.70
CONFigure:RXTests:HNOise:LIMit	<AFVoltmMin>, <AFVoltmMax>, <Hum&Noise>	with query	6.69
CONFigure:RXTests:HNOise:LIMit:DEFault	ON OFF	with query	6.69
FETCh:RXTests:HNOise:STATus?	OFF RUN STOP ERR STEP RDY, 1 to 10000 NONE	query only	6.67
CALCulate[:SCALAR]:RXTests:HNOise[:RESult]:MATChing:LIMit?	<Result>	query only	6.71
READ[:SCALAR]:RXTests:HNOise[:RESult]?	<Result>	query only	6.71
FETCh[:SCALAR]:RXTests:HNOise[:RESult]?	<Result>	query only	6.71
SAMPLE[:SCALAR]:RXTests:HNOise[:RESult]?	<Result>	query only	6.71
INITiate:RXTests:SENSitivity	–	no query	6.72
ABORt:RXTests:SENSitivity	–	no query	6.72
STOP:RXTests:SENSitivity	–	no query	6.72
CONTInue:RXTests:SENSitivity	–	no query	6.72
CONFigure:RXTests:SENSitivity:CONTRol:DEFault	ON OFF	with query	6.73

Command	Parameter	Remark	Page
CONFigure:RXTests:SENSitivity:CONtrol:TSERange	0 dB to 100 dB	with query	6.73
CONFigure:RXTests:SENSitivity:CONtrol:TSINad	-99 dB to +200 dB	with query	6.73
CONFigure:RXTests:SENSitivity:EREPorting	SRQ SOPC SRSQ OFF	with query	6.72
CONFigure:RXTests:SENSitivity:FILTer	<Bandpass>, <Weighting>	with query	6.75
CONFigure:RXTests:SENSitivity:FILTer:DEFault	ON OFF	with query	6.76
CONFigure:RXTests:SENSitivity:FILTer:NOTCh	N01 N05	with query	6.75
CONFigure:RXTests:SENSitivity:LIMit	<AFVolmMin>, <AFVolmMax>, <ErrRange>	with query	6.74
CONFigure:RXTests:SENSitivity:LIMit:DEFault	ON OFF	with query	6.74
FETCh:RXTests:SENSitivity:STATus?	OFF RUN STOP ERR STEP RDY, 1 to 10000 NONE	query only	6.72
CALCulate[:SCALar]:RXTests:SENSitivity[:RESult]:MATChing:LIMit?	<Result>	query only	6.77
READ[:SCALar]:RXTests:SENSitivity[:RESult]?	<Result>	query only	6.77
FETCh[:SCALar]:RXTests:SENSitivity[:RESult]?	<Result>	query only	6.77
SAMPle[:SCALar]:RXTests:SENSitivity[:RESult]?	<Result>	query only	6.77
TX Audio Freq. Response Measurement			
INITiate:TXAFresp	-	no query	6.45
ABORt:TXAFresp	-	no query	6.45
STOP:TXAFresp	-	no query	6.45
CONtinue:TXAFresp	-	no query	6.45
CONFigure:SUBarrays:TXAFresp	ALL ARITHmetical MINimum MAXimum,<Range>{,<Range>}	with query	6.48
CONFigure:TXAFresp:AFGenerator:ENABLE	ON OFF, ON OFF, ...	with query	6.52
CONFigure:TXAFresp:AFGenerator:ENABLE:TONE<nr>	ON OFF	with query	6.53
CONFigure:TXAFresp:AFGenerator:FREQuency	<Frequency>	with query	6.53
CONFigure:TXAFresp:AFGenerator:FREQuency:TONE<nr>	<Frequency>	with query	6.53
CONFigure:TXAFresp:AFGenerator:LEVel:LMODe	TLEV SLEV SRES	with query	6.53
CONFigure:TXAFresp:AFGenerator:LEVel:SLEVel	<Separate_Level>	with query	6.54
CONFigure:TXAFresp:AFGenerator:LEVel:SLEVel:TONE<nr>	<Separate_Level>	with query	6.54
CONFigure:TXAFresp:AFGenerator:LEVel:TLEVel	<Total_Level>	with query	6.54
CONFigure:TXAFresp:CONtrol:AFGenerator:DEFault	ON OFF	with query	6.55
CONFigure:TXAFresp:CONtrol:AFGLead	0 s to 0.1 s	with query	6.47
CONFigure:TXAFresp:CONtrol:DEFault	ON OFF	with query	6.47
DISPlay:TXAFresp:CONtrol:GRID	ON OFF	with query	6.46
CONFigure:TXAFresp:CONtrol:RDEViation	10.0 Hz to 10000.0 Hz	with query	6.46
CONFigure:TXAFresp:CONtrol:REPetition	CONTinuous SINGleshot 1 to 10000, SONerror NONE, STEP NONE	with query	6.46
CONFigure:TXAFresp:CONtrol:RREQuest	RDEV TON1 ... TON20	with query	6.47
CONFigure:TXAFresp:CONtrol:TDEFinition:DEFault	ON OFF	with query	6.52

Command	Parameter	Remark	Page
CONFigure:TXAFresp:EREPorting	SRQ SOPC SRSQ OFF	with query	6.45
CONFigure:TXAFresp:FILTer	<Bandpass>, <Expander>, <Deemphasis>, <Weighting>	with query	6.55
CONFigure:TXAFresp:FILTer:DEFault	ON OFF	with query	6.56
CONFigure:TXAFresp:LIMit[:LINE]:DEFault	ON OFF	with query	6.50
CONFigure:TXAFresp:LIMit[:LINE][:ASYMmetrical]:LOWer	<Limit_1>, <Enable_1>, ... <Limit_20>, <Enable_20>	with query	6.50
CONFigure:TXAFresp:LIMit[:LINE][:ASYMmetrical]:LOWer:TONE<nr>	<Limit>, <Enable>	with query	6.50
CONFigure:TXAFresp:LIMit[:LINE][:ASYMmetrical]:UPPer	<Limit_1>, <Enable_1>, ... <Limit_20>, <Enable_20>	with query	6.49
CONFigure:TXAFresp:LIMit[:LINE][:ASYMmetrical]:UPPer:TONE<nr>	<Limit>, <Enable>	with query	6.49
FETCh:TXAFresp:STATus?	OFF RUN STOP ERR STEP RDY, 1 to 10000 NONE	query only	6.45
CONFigure:TXAFresp:TDEFinition	<Freq_1>, <Dev_1>, <Enable_1>, ... <Freq_20>, <Dev_20>, <Enable_20>	with query	6.51
CONFigure:TXAFresp:TDEFinition:TONE<nr>	<Frequency>, <Level>, ON OFF	with query	6.52
CALCulate[:SCALar]:TXAFresp[:RESult]:MATChing:LIMit[:LINE][:ASYMmetrical][:COMBined]:TONE<nr>?	<Result>	query only	6.57
CALCulate:ARRay:TXAFresp[:RESult]:MATChing:LIMit[:LINE][:ASYMmetrical][:COMBined]?	<Result>	query only	6.57
READ[:SCALar]:TXAFresp[:RESult]:TONE<nr>?	-150.0 dB to +150.0 dB	query only	6.56
FETCh[:SCALar]:TXAFresp[:RESult]:TONE<nr>?	-150.0 dB to +150.0 dB	query only	6.56
SAMPlE[:SCALar]:TXAFresp[:RESult]:TONE<nr>?	-150.0 dB to +150.0 dB	query only	6.56
READ:ARRay:TXAFresp[:RESult]?	-150.0 dB to +150.0 dB	query only	6.56
FETCh:ARRay:TXAFresp[:RESult]?	-150.0 dB to +150.0 dB	query only	6.56
SAMPlE:ARRay:TXAFresp[:RESult]?	-150.0 dB to +150.0 dB	query only	6.56
READ:SUBarrays:TXAFresp[:RESult]?	-150.0 dB to +150.0 dB	query only	6.57
FETCh:SUBarrays:TXAFresp[:RESult]?	-150.0 dB to +150.0 dB	query only	6.57
SAMPlE:SUBarrays:TXAFresp[:RESult]?	-150.0 dB to +150.0 dB	query only	6.57
DISPlay:TXAFresp[:WINDow]:TRACe:Y:SCALe	<ScaleMin>, <ScaleMax>	with query	6.47
TX Tests			
INITiate:TXTests:AFLSearch	-	no query	6.36
ABORt:TXTests:AFLSearch	-	no query	6.36
STOP:TXTests:AFLSearch	-	no query	6.36
CONTInue:TXTests:AFLSearch	-	no query	6.36
CONFigure:TXTests:AFLSearch:CONTRol:DEFault	ON OFF	with query	6.37
CONFigure:TXTests:AFLSearch:CONTRol:TAPDeviation	<TargetDev>	with query	6.37
CONFigure:TXTests:AFLSearch:CONTRol:TDERange	<ErrRange>	with query	6.37
CONFigure:TXTests:AFLSearch:EREPorting	SRQ SOPC SRSQ OFF	with query	6.36
CONFigure:TXTests:AFLSearch:FILTer	<Bandpass>, <Expander>, <Deemphasis>, <Weighting>	with query	6.39

Command	Parameter	Remark	Page
CONFigure:TXTests:AFLSearch:FILTer:DEfault	ON OFF	with query	6.39
CONFigure:TXTests:AFLSearch:LIMit	<CarrierFrequencyError>	with query	6.38
CONFigure:TXTests:AFLSearch:LIMit:DEfault	ON OFF	with query	6.38
FETCh:TXTests:AFLSearch:STATus?	OFF RUN STOP ERR STEP RDY, 1 to 10000 NONE	query only	6.36
CONFigure:TXTests:AFLSearch:TDTYpe	RMS PEAK	with query	6.37
CALCulate[:SCALar]:TXTests:AFLSearch[:RESult]:MATChing?	<Result>	query only	6.40
READ[:SCALar]:TXTests:AFLSearch[:RESult]?	<Result>	query only	6.40
FETCh[:SCALar]:TXTests:AFLSearch[:RESult]?	<Result>	query only	6.40
SAMPle[:SCALar]:TXTests:AFLSearch[:RESult]?	<Result>	query only	6.40
INITiate:TXTests:HNOise	–	no query	6.28
ABORt:TXTests:HNOise	–	no query	6.28
STOP:TXTests:HNOise	–	no query	6.28
CONTInue:TXTests:HNOise	–	no query	6.28
CONFigure:TXTests:HNOise:CONTRol:DEfault	ON OFF	with query	6.29
CONFigure:TXTests:HNOise:CONTRol:REPetition	CONTInuous SINGleshot 1 to 10000, SONerror NONE, STEP NONE	with query	6.29
CONFigure:TXTests:HNOise:EREPorting	SRQ SOPC SRSQ OFF	with query	6.28
INITiate:TXTests:HNOise:FHNoise	–	no query	6.33
ABORt:TXTests:HNOise:FHNoise	–	no query	6.33
STOP:TXTests:HNOise:FHNoise	–	no query	6.33
CONTInue:TXTests:HNOise:FHNoise	–	no query	6.33
CONFigure:TXTests:HNOise:FHNoise:CONTRol:DEfault	ON OFF	with query	6.34
CONFigure:TXTests:HNOise:FHNoise:CONTRol:REPetition	CONTInuous SINGleshot 1 to 10000, SONerror NONE, STEP NONE	with query	6.34
CONFigure:TXTests:HNOise:FHNoise:EREPorting	SRQ SOPC SRSQ OFF	with query	6.33
FETCh:TXTests:HNOise:FHNoise:STATus?	OFF RUN STOP ERR STEP RDY, 1 to 10000 NONE	query only	6.33
CALCulate[:SCALar]:TXTests:HNOise:FHNoise[:RESult]:MATChing:LIMit?	<Result>	query only	6.35
READ[:SCALar]:TXTests:HNOise:FHNoise[:RESult]?	<Result>	query only	6.35
FETCh[:SCALar]:TXTests:HNOise:FHNoise[:RESult]?	<Result>	query only	6.35
SAMPle[:SCALar]:TXTests:HNOise:FHNoise[:RESult]?	<Result>	query only	6.35
CONFigure:TXTests:HNOise:FILTer	<Bandpass>, <Expandor>, <Deemphasis>, <Weighting>	with query	6.31
CONFigure:TXTests:HNOise:FILTer:DEfault	ON OFF	with query	6.31
CONFigure:TXTests:HNOise:LIMit	<CarrierFreqError>, <SATFreqError>, <SATPeakDev>, <Hum&Noise>	with query	6.30
CONFigure:TXTests:HNOise:LIMit:DEfault	ON OFF	with query	6.30
FETCh:TXTests:HNOise:STATus?	OFF RUN STOP ERR STEP RDY, 1 to 10000 NONE	query only	6.28

Command	Parameter	Remark	Page
CALCulate[:SCALar]:TXTests:HNOise[:RESult]:MATChing:LIMit?	<Result>	query only	6.32
READ[:SCALar]:TXTests:HNOise[:RESult]?	<Result>	query only	6.32
FETCh[:SCALar]:TXTests:HNOise[:RESult]?	<Result>	query only	6.32
SAMPlE[:SCALar]:TXTests:HNOise[:RESult]?	<Result>	query only	6.32
INITiate:TXTests:MODulation	–	no query	6.17
ABORt:TXTests:MODulation	–	no query	6.17
STOP:TXTests:MODulation	–	no query	6.17
CONTinue:TXTests:MODulation	–	no query	6.17
CONFigure:TXTests:MODulation:CONTRol:DEFault	ON OFF	with query	6.18
CONFigure:TXTests:MODulation:CONTRol:REPetition	CONTinuous SINGleshot 1 to 10000, SONerror NONE, STEP NONE	with query	6.18
INITiate:TXTests:MODulation:CPOWer	–	no query	6.25
ABORt:TXTests:MODulation:CPOWer	–	no query	6.25
STOP:TXTests:MODulation:CPOWer	–	no query	6.25
CONTinue:TXTests:MODulation:CPOWer	–	no query	6.25
CONFigure:TXTests:MODulation:CPOWer:CONTRol:DEFault	ON OFF	with query	6.26
CONFigure:TXTests:MODulation:CPOWer:CONTRol:REPetition	CONTinuous SINGleshot 1 to 10000, SONerror NONE, STEP NONE	with query	6.26
CONFigure:TXTests:MODulation:CPOWer:EREPorting	SRQ SOPC SRSQ OFF	with query	6.25
FETCh:TXTests:MODulation:CPOWer:STATus?	OFF RUN STOP ERR STEP RDY, 1 to 10000 NONE	query only	6.25
CALCulate[:SCALar]:TXTests:MODulation:CPOWer[:RESult]:MATChing:LIMit?	<Result>	query only	6.27
READ[:SCALar]:TXTests:MODulation:CPOWer[:RESult]?	<Result>	query only	6.27
FETCh[:SCALar]:TXTests:MODulation:CPOWer[:RESult]?	<Result>	query only	6.27
SAMPlE[:SCALar]:TXTests:MODulation:CPOWer[:RESult]?	<Result>	query only	6.27
CONFigure:TXTests:MODulation:EREPorting	SRQ SOPC SRSQ OFF	with query	6.17
CONFigure:TXTests:MODulation:FILTer	<Bandpass>, <Expandor>, <Deemphasis>, <Weighting>	with query	6.20
CONFigure:TXTests:MODulation:FILTer:DEFault	ON OFF	with query	6.20
CONFigure:TXTests:MODulation:LIMit	<CarrFreqErrRange>, <TotPeakDevMax>, <SATFreqErrRge>, <SATPeakDevErrRge>, <STFreqErrRange>, <STPeakDevErrRge>, <ModDistNoise>, <ResAM>	with query	6.19
CONFigure:TXTests:MODulation:LIMit:DEFault	ON OFF	with query	6.19
FETCh:TXTests:MODulation:STATus?	OFF RUN STOP ERR STEP RDY, 1 to 10000 NONE	query only	6.17
INITiate:TXTests:MODulation:TADeviation	–	no query	6.22
ABORt:TXTests:MODulation:TADeviation	–	no query	6.22
STOP:TXTests:MODulation:TADeviation	–	no query	6.22

Command	Parameter	Remark	Page
CONTInue:TXTests:MODulation:TADeviation	–	no query	6.22
CONFigure:TXTests:MODulation:TADeviation:CONTRol:DEFault	ON OFF	with query	6.23
CONFigure:TXTests:MODulation:TADeviation:CONTRol:REPetition	CONTInuous SINGleshot 1 to 10000, SONerror NONE, STEP NONE	with query	6.23
CONFigure:TXTests:MODulation:TADeviation:EREPorting	SRQ SOPC SRSQ OFF	with query	6.22
FETCh:TXTests:MODulation:TADeviation:STATus?	OFF RUN STOP ERR STEP RDY, 1 to 10000 NONE	query only	6.22
CALCulate[:SCALar]:TXTests:MODulation:TADeviation[:RESult]:MATChing:LIMit?	<Result>	query only	6.24
READ[:SCALar]:TXTests:MODulation:TADeviation[:RESult]?	<Result>	query only	6.24
FETCh[:SCALar]:TXTests:MODulation:TADeviation[:RESult]?	<Result>	query only	6.24
SAMPle[:SCALar]:TXTests:MODulation:TADeviation[:RESult]?	<Result>	query only	6.24
CALCulate[:SCALar]:TXTests:MODulation[:RESult]:MATChing:LIMit?	<Result>	query only	6.21
READ[:SCALar]:TXTests:MODulation[:RESult]?	<Result>	query only	6.21
FETCh[:SCALar]:TXTests:MODulation[:RESult]?	<Result>	query only	6.21
SAMPle[:SCALar]:TXTests:MODulation[:RESult]?	<Result>	query only	6.21
INITiate:TXTests:WBData	–	no query	6.41
ABORT:TXTests:WBData	–	no query	6.41
STOP:TXTests:WBData	–	no query	6.41
CONTInue:TXTests:WBData	–	no query	6.41
CONFigure:TXTests:WBData:CONTRol:DEFault	ON OFF	with query	6.42
CONFigure:TXTests:WBData:CONTRol:REPetition	CONTInuous SINGleshot 1 to 10000, SONerror NONE, STEP NONE	with query	6.42
CONFigure:TXTests:WBData:EREPorting	SRQ SOPC SRSQ OFF	with query	6.41
CONFigure:TXTests:WBData:LIMit	<CarrFreqErrRange>, <TotPeakDevMax>, <SATFreqErrRge>, <SATPeakDevErrRge>, <STFreqErrRange>, <STPeakDevErrRge>, <ModDistNoise>, <ResAM>	with query	6.43
CONFigure:TXTests:WBData:LIMit:DEFault	ON OFF	with query	6.43
FETCh:TXTests:WBData:STATus?	OFF RUN STOP ERR STEP RDY, 1 to 10000 NONE	query only	6.41
CALCulate[:SCALar]:TXTests:WBData[:RESult]:MATChing:LIMit?	<Result>	query only	6.44
READ[:SCALar]:TXTests:WBData[:RESult]?	<Result>	query only	6.43
FETCh[:SCALar]:TXTests:WBData[:RESult]?	<Result>	query only	6.43
SAMPle[:SCALar]:TXTests:WBData[:RESult]?	<Result>	query only	6.43
Wide-Band Power			
INITiate:WPOWER	–	no query	6.14

Command	Parameter	Remark	Page
ABORt:WPOWer	–	no query	6.14
STOP:WPOWer	–	no query	6.14
CONTInue:WPOWer	–	no query	6.14
CONFigure:WPOWer:CONTRol:REPetition	CONTInuous SINGleshot 1 to 10000, SONerror NONE,STEP NONE	with query	6.15
CONFigure:WPOWer:EREPorting	SRQ SOPC SRSQ OFF	with query	6.15
FETCh:WPOWer:STATus?	OFF RUN STOP ERR STEP RDY, 1 to 10000 NONE	query only	6.15
READ[:SCALar]:WPOWer[:RESult]?	–30 dBm to 30 dBm	query only	6.16
FETCh[:SCALar]:WPOWer[:RESult]?	–30 dBm to 30 dBm	query only	6.16
SAMPle[:SCALar]:WPOWer[:RESult]?	–30 dBm to 30 dBm	query only	6.16

Commands for AMPS Mobile Tests (Signalling)

Table 6-3 Remote-control commands: Signalling mode

Command	Parameter	Remark	Page
AF Connector			
[SENSe:]AFConnect:MSource	INTern EXTern	with query	6.104
AF Generator			
INITiate:AFGenerator	–	no query	6.106
ABORt:AFGenerator	–	no query	6.106
SOURce:AFGenerator:FREQuency	20 Hz to 20000 Hz	with query	6.107
SOURce:AFGenerator:LEVel	<Level>	with query	6.107
SOURce:AFGenerator:SLEVel	<Level>	with query	6.107
FETCh:AFGenerator:STATus?	OFF RUN ERR	query only	6.106
AF Input Level			
[SENSe:]AFLevel:DEFault	ON OFF	with query	6.93
[SENSe:]AFLevel:MAXimum	<Level>	with query	6.93
[SENSe:]AFLevel:MODE	MANual AUTomatic	with query	6.93
RF Signals of the CMU (Base Station)			
CONFigure:BSSignal:ACC:CHANnel	<Channel>	with query	6.97
CONFigure:BSSignal:ACC:LEVel	<Level>	with query	6.97
CONFigure:BSSignal:OCHandoff:SAT:PEAKdev	1 Hz to 20000 Hz	with query	6.99
CONFigure:BSSignal:OCHandoff:SAT:SCC	0 1 2	with query	6.99
CONFigure:BSSignal:OCHandoff[:AVC]:CHANnel	<VChannel>	with query	6.99

Command	Parameter	Remark	Page
CONFigure:BSSignal:OCHandoff[:AVC]:LEVel	<Level>	with query	6.99
CONFigure:BSSignal:SAT:PEAKdev	1 Hz to 20000 Hz	with query	6.98
CONFigure:BSSignal:SAT:SCC	0 1 2	with query	6.98
CONFigure:BSSignal[:AVC]:CHANnel	<AVCChannel>	with query	6.97
CONFigure:BSSignal[:AVC]:LEVel	<Level>	with query	6.98
PROCedure:BSSignal[:AVC]:LEVel	<Level>	with query	6.98
Channel Unit			
UNIT:CHANnel	CH HZ KHZ MHZ GHZ	with query	6.91
Inputs and Outputs			
[SENSe:]CORRection:LOSS:INPut<nr>[:MAGNitude]	-50 dB to +50 dB	with query	6.104
SOURce:CORRection:LOSS:INPut<nr>[:MAGNitude]	-50 dB to +50 dB	with query	6.104
[SENSe:]CORRection:LOSS:Output<nr>[:MAGNitude]	-50 dB to 50 dB	with query	6.104
SOURce:CORRection:LOSS:Output<nr>[:MAGNitude]	-50 dB to 50 dB	with query	6.104
SOURce:DM:CLOCK:FREQuency	9.72 MHz to 38.88 MHz	with query	6.104
SOURce:DM:CLOCK:STATE	ON OFF	with query	6.104
INPut[:STATE]	RF1 RF2 RF4	with query	6.103
OUTPut[:STATE]	RF1 RF2 RF3	with query	6.103
Handoff			
CONFigure:HANDOff:TARGet	<Target>	with query	6.96
STATus:HANDOff:TARGet:LIST?	<List>	query only	6.96
RF Input Level			
[SENSe:]LEVel:ATTenuation	NORMal LNOise LDISTortion	with query	6.92
[SENSe:]LEVel:DEFault	ON OFF	with query	6.93
[SENSe:]LEVel:MAXimum	<Level>	with query	6.92
[SENSe:]LEVel:MODE	MANual AUTomatic VMAC	with query	6.92
Modulation Generator			
INITiate:MODGenerator	-	no query	6.108
ABORt:MODGenerator	-	no query	6.108
SOURce:MODGenerator:Deviation	0 Hz to 20000 Hz	with query	6.108
SOURce:MODGenerator:FREQuency	20 Hz to 20000 Hz	with query	6.108
FETCh:MODGenerator:STATus?	OFF RUN ERR	query only	6.108
Mobile Info			
[SENSe:]MSSInfo:BANDwidth?	<numeric_value>	query only	6.105
[SENSe:]MSSInfo:DNUMBER?	<numeric_value>	query only	6.106
[SENSe:]MSSInfo:MIN[:NUMBER]?	<numeric_value>	query only	6.105

Command	Parameter	Remark	Page
[SENSe:]MSSInfo:MPCI?	'<Protocol_Capability>'	query only	6.106
[SENSe:]MSSInfo:PClass?	<numeric_value>	query only	6.105
[SENSe:]MSSInfo:SN:HEX?	<numeric_value>	query only	6.105
[SENSe:]MSSInfo:SN?	<numeric_value>	query only	6.105
Network Parameters			
CONFigure:NETWork:IDENtity:DCC	0 to 999	with query	6.100
CONFigure:NETWork:IDENtity:SID1	0 to 16383	with query	6.100
CONFigure:NETWork:OCHandoff[:MS]:VMAC	0 to 7	with query	6.103
CONFigure:NETWork:REQuest:SNUMber	ON OFF	with query	6.101
CONFigure:NETWork:SMODE:IDMin	0 to $2^{34} - 1$	with query	6.101
CONFigure:NETWork:SMODE:REGH	ON OFF	with query	6.100
CONFigure:NETWork:SMODE:REGR	ON OFF	with query	6.100
CONFigure:NETWork:TIMEout:LORLINK	4 to 64	with query	6.102
CONFigure:NETWork:TIMEout:RPERiod	0 s to 60 s OFF	with query	6.102
CONFigure:NETWork[:MS]:CMAC	0 to 7	with query	6.101
CONFigure:NETWork[:MS]:RCFM	ON OFF	with query	6.102
CONFigure:NETWork[:MS]:VMAC	0 to 7	with query	6.101
Other Call Target			
CONFigure:OCALI:TARGet	<Target>	with query	6.96
STATus:OCALI:TARGet:LIST?	<List>	query only	6.96
Signalling State Dependent Parameter Sets			
CONFigure:SDSets:ENABLE	ON OFF	with query	6.92
Signalling			
PROCedure:SIGNalling:ACTIon	SOFF SON CTM CRELease HANDoff OCALI	with query	6.94
[SENSe:]SIGNalling:STATe?	SOFF SON REG ALER CEST CPEN RPEN FPEN	query only	6.95
PROCedure:SIGNalling[:AVC]:CHANnel	<Number>	with query	6.95
PROCedure:SIGNalling[:AVC]:MAC	0 to 7	with query	6.95
PROCedure:SIGNalling[:AVC]:SAT:PEAKdev	1 Hz to 20000 Hz	with query	6.95
PROCedure:SIGNalling[:AVC]:SAT:SCC	0 1 2	with query	6.95
Symbolic Status Register Evaluation			
STATus:OPERation:SYMBOLic:ENABLE	<Event>{,<Event>}	with query	6.109
STATus:OPERation:SYMBOLic[:EVENT]?	NONE <Event>{,<Event>}	query only	6.109

Alphabetical Command Lists

Table 6-4 Remote-control commands: Non Signalling mode

Command (Non Signalling, alphabetical)	Page
[SENSe:]AFConnect:MSOource	6.11
[SENSe:]AFLevel:DEFault	6.3
[SENSe:]AFLevel:MAXimum	6.3
[SENSe:]AFLevel:MODE	6.3
[SENSe:]CORRection:LOSS:INPut<nr>[:MAGNitude]	6.11
[SENSe:]CORRection:LOSS:OUTput<nr>[:MAGNitude]	6.11
[SENSe:]LEVel:ATTenuation	6.2
[SENSe:]LEVel:DEFault	6.2
[SENSe:]LEVel:MAXimum	6.2
[SENSe:]LEVel:MODE	6.1
[SENSe:]RFANalyzer:FREQuency	6.4
[SENSe:]RFANalyzer:FREQuency:OFFSet	6.4
[SENSe:]RFANalyzer:FREQuency:UNIT	6.4
ABORt:AFGenerator	6.6
ABORt:MODGenerator	6.8
ABORt:RFGenerator	6.5
ABORt:RXAFresp	6.78
ABORt:RXTests:AFANalyzer	6.58
ABORt:RXTests:AFANalyzer:VMSinad	6.64
ABORt:RXTests:HNOise	6.67
ABORt:RXTests:SENSitivity	6.72
ABORt:SAT	6.9
ABORt:ST	6.9
ABORt:TXAFresp	6.45
ABORt:TXTests:AFLSearch	6.36
ABORt:TXTests:HNOise	6.28
ABORt:TXTests:HNOise:FHNoise	6.33
ABORt:TXTests:MODulation	6.17
ABORt:TXTests:MODulation:CPOWer	6.25
ABORt:TXTests:MODulation:TADeviation	6.22
ABORt:TXTests:WBData	6.41
ABORt:WPOWer	6.14
CALCulate:ARRay:RXAFresp[:RESult]:MATChing:LIMit[:LINE][:ASYMmetrical][:COMBined]:TONE?	6.90
CALCulate:ARRay:TXAFresp[:RESult]:MATChing:LIMit[:LINE][:ASYMmetrical][:COMBined]?	6.57
CALCulate[:SCALar]:RXAFresp[:RESult]:MATChing:LIMit[:LINE][:ASYMmetrical][:COMBined]:TONE<nr>?	6.90
CALCulate[:SCALar]:RXTests:AFANalyzer:VMSinad[:RESult]:MATChing:LIMit?	6.66
CALCulate[:SCALar]:RXTests:AFANalyzer[:RESult]:MATChing:LIMit?	6.63
CALCulate[:SCALar]:RXTests:HNOise[:RESult]:MATChing:LIMit?	6.71
CALCulate[:SCALar]:RXTests:SENSitivity[:RESult]:MATChing:LIMit?	6.77
CALCulate[:SCALar]:TXAFresp[:RESult]:MATChing:LIMit[:LINE][:ASYMmetrical][:COMBined]:TONE<nr>?	6.57
CALCulate[:SCALar]:TXTests:AFLSearch[:RESult]:MATChing?	6.40
CALCulate[:SCALar]:TXTests:HNOise:FHNoise[:RESult]:MATChing:LIMit?	6.35
CALCulate[:SCALar]:TXTests:HNOise[:RESult]:MATChing:LIMit?	6.32
CALCulate[:SCALar]:TXTests:MODulation:CPOWer[:RESult]:MATChing:LIMit?	6.27
CALCulate[:SCALar]:TXTests:MODulation:TADeviation[:RESult]:MATChing:LIMit?	6.24
CALCulate[:SCALar]:TXTests:MODulation[:RESult]:MATChing:LIMit?	6.21
CALCulate[:SCALar]:TXTests:WBData[:RESult]:MATChing:LIMit?	6.44
CONFigure:RXAFresp:CONTRol:DEFault	6.80
CONFigure:RXAFresp:CONTRol:MGLead	6.80
CONFigure:RXAFresp:CONTRol:MODGenerator:DEFault	6.88
CONFigure:RXAFresp:CONTRol:REPetition	6.79
CONFigure:RXAFresp:CONTRol:RLEVel	6.79
CONFigure:RXAFresp:CONTRol:RREQuest	6.80

Command (Non Signalling, alphabetical)	Page
CONFigure:RXAFresp:CONTRol:TDEFinition	6.85
CONFigure:RXAFresp:EREPorting	6.78
CONFigure:RXAFresp:FILTer	6.88
CONFigure:RXAFresp:FILTer:DEFault	6.89
CONFigure:RXAFresp:LIMit[:LINE]:DEFault	6.83
CONFigure:RXAFresp:LIMit[:LINE][:ASYMmetrical]:LOWer	6.83
CONFigure:RXAFresp:LIMit[:LINE][:ASYMmetrical]:LOWer:TONE<nr>	6.83
CONFigure:RXAFresp:LIMit[:LINE][:ASYMmetrical]:UPPer	6.82
CONFigure:RXAFresp:LIMit[:LINE][:ASYMmetrical]:UPPer:TONE<nr>	6.82
CONFigure:RXAFresp:MODGenerator:ENABle	6.85
CONFigure:RXAFresp:MODGenerator:ENABle:TONE<nr>	6.86
CONFigure:RXAFresp:MODGenerator:FDEViatiOn:FDMODE	6.87
CONFigure:RXAFresp:MODGenerator:FDEViatiOn:SFDeviatiOn	6.87
CONFigure:RXAFresp:MODGenerator:FDEViatiOn:SFDeviatiOn:TONE<nr>	6.87
CONFigure:RXAFresp:MODGenerator:FDEViatiOn:TFDeviatiOn	6.87
CONFigure:RXAFresp:MODGenerator:FREQuency	6.86
CONFigure:RXAFresp:MODGenerator:FREQuency:TONE<nr>	6.86
CONFigure:RXAFresp:TDEFinition	6.84
CONFigure:RXAFresp:TDEFinition:TONE<nr>	6.85
CONFigure:RXTests:AFANalyzer:CONTRol:DEFault	6.59
CONFigure:RXTests:AFANalyzer:CONTRol:REPetiTiOn	6.59
CONFigure:RXTests:AFANalyzer:EREPorting	6.58
CONFigure:RXTests:AFANalyzer:FILTer	6.61
CONFigure:RXTests:AFANalyzer:FILTer:DEFault	6.62
CONFigure:RXTests:AFANalyzer:FILTer:NOTCh	6.61
CONFigure:RXTests:AFANalyzer:LIMit	6.60
CONFigure:RXTests:AFANalyzer:LIMit:DEFault	6.60
CONFigure:RXTests:AFANalyzer:VMSinad:CONTRol:DEFault	6.65
CONFigure:RXTests:AFANalyzer:VMSinad:CONTRol:MTIME	6.65
CONFigure:RXTests:AFANalyzer:VMSinad:CONTRol:REPetiTiOn	6.65
CONFigure:RXTests:AFANalyzer:VMSinad:EREPorting	6.64
CONFigure:RXTests:HNOise:CONTRol:DEFault	6.68
CONFigure:RXTests:HNOise:CONTRol:REPetiTiOn	6.68
CONFigure:RXTests:HNOise:EREPorting	6.67
CONFigure:RXTests:HNOise:FILTer	6.70
CONFigure:RXTests:HNOise:FILTer:DEFault	6.70
CONFigure:RXTests:HNOise:LIMit	6.69
CONFigure:RXTests:HNOise:LIMit:DEFault	6.69
CONFigure:RXTests:SENSitivity:CONTRol:DEFault	6.73
CONFigure:RXTests:SENSitivity:CONTRol:TSERange	6.73
CONFigure:RXTests:SENSitivity:CONTRol:TSINad	6.73
CONFigure:RXTests:SENSitivity:EREPorting	6.72
CONFigure:RXTests:SENSitivity:FILTer	6.75
CONFigure:RXTests:SENSitivity:FILTer:DEFault	6.76
CONFigure:RXTests:SENSitivity:FILTer:NOTCh	6.75
CONFigure:RXTests:SENSitivity:LIMit	6.74
CONFigure:RXTests:SENSitivity:LIMit:DEFault	6.74
CONFigure:SUBarrays:RXAFresp	6.81
CONFigure:SUBarrays:TXAFresp	6.48
CONFigure:TXAFresp:AFGenerator:ENABle	6.52
CONFigure:TXAFresp:AFGenerator:ENABle:TONE<nr>	6.53
CONFigure:TXAFresp:AFGenerator:FREQuency	6.53
CONFigure:TXAFresp:AFGenerator:FREQuency:TONE<nr>	6.53
CONFigure:TXAFresp:AFGenerator:LEVel:LMODE	6.53
CONFigure:TXAFresp:AFGenerator:LEVel:SLEVel	6.54
CONFigure:TXAFresp:AFGenerator:LEVel:SLEVel:TONE<nr>	6.54
CONFigure:TXAFresp:AFGenerator:LEVel:TLEVel	6.54

Command (Non Signalling, alphabetical)	Page
CONFigure:TXAFresp:CONTRol:AFGenerator:DEFault	6.55
CONFigure:TXAFresp:CONTRol:AFGLead	6.47
CONFigure:TXAFresp:CONTRol:DEFault	6.47
CONFigure:TXAFresp:CONTRol:RDEviation	6.46
CONFigure:TXAFresp:CONTRol:REPetition	6.46
CONFigure:TXAFresp:CONTRol:RREQuest	6.47
CONFigure:TXAFresp:CONTRol:TDEFinition:DEFault	6.52
CONFigure:TXAFresp:EREPorting	6.45
CONFigure:TXAFresp:FILTer	6.55
CONFigure:TXAFresp:FILTer:DEFault	6.56
CONFigure:TXAFresp:LIMit[:LINE]:DEFault	6.50
CONFigure:TXAFresp:LIMit[:LINE]:ASYMmetrical:LOWer	6.50
CONFigure:TXAFresp:LIMit[:LINE]:ASYMmetrical:LOWer:TONE<nr>	6.50
CONFigure:TXAFresp:LIMit[:LINE]:ASYMmetrical:UPPer	6.49
CONFigure:TXAFresp:LIMit[:LINE]:ASYMmetrical:UPPer:TONE<nr>	6.49
CONFigure:TXAFresp:TDEFinition	6.51
CONFigure:TXAFresp:TDEFinition:TONE<nr>	6.52
CONFigure:TXTests:AFLSearch:CONTRol:DEFault	6.37
CONFigure:TXTests:AFLSearch:CONTRol:TAPDeviation	6.37
CONFigure:TXTests:AFLSearch:CONTRol:TDERange	6.37
CONFigure:TXTests:AFLSearch:EREPorting	6.36
CONFigure:TXTests:AFLSearch:FILTer	6.39
CONFigure:TXTests:AFLSearch:FILTer:DEFault	6.39
CONFigure:TXTests:AFLSearch:LIMit	6.38
CONFigure:TXTests:AFLSearch:LIMit:DEFault	6.38
CONFigure:TXTests:AFLSearch:TDTYpe	6.37
CONFigure:TXTests:HNOise:CONTRol:DEFault	6.29
CONFigure:TXTests:HNOise:CONTRol:REPetition	6.29
CONFigure:TXTests:HNOise:EREPorting	6.28
CONFigure:TXTests:HNOise:FHNOise:CONTRol:DEFault	6.34
CONFigure:TXTests:HNOise:FHNOise:CONTRol:REPetition	6.34
CONFigure:TXTests:HNOise:FHNOise:EREPorting	6.33
CONFigure:TXTests:HNOise:FILTer	6.31
CONFigure:TXTests:HNOise:FILTer:DEFault	6.31
CONFigure:TXTests:HNOise:LIMit	6.30
CONFigure:TXTests:HNOise:LIMit:DEFault	6.30
CONFigure:TXTests:MODulation:CONTRol:DEFault	6.18
CONFigure:TXTests:MODulation:CONTRol:REPetition	6.18
CONFigure:TXTests:MODulation:CPOWER:CONTRol:DEFault	6.26
CONFigure:TXTests:MODulation:CPOWER:CONTRol:REPetition	6.26
CONFigure:TXTests:MODulation:CPOWER:EREPorting	6.25
CONFigure:TXTests:MODulation:EREPorting	6.17
CONFigure:TXTests:MODulation:FILTer	6.20
CONFigure:TXTests:MODulation:FILTer:DEFault	6.20
CONFigure:TXTests:MODulation:LIMit	6.19
CONFigure:TXTests:MODulation:LIMit:DEFault	6.19
CONFigure:TXTests:MODulation:TADeviation:CONTRol:DEFault	6.23
CONFigure:TXTests:MODulation:TADeviation:CONTRol:REPetition	6.23
CONFigure:TXTests:MODulation:TADeviation:EREPorting	6.22
CONFigure:TXTests:WBDData:CONTRol:DEFault	6.42
CONFigure:TXTests:WBDData:CONTRol:REPetition	6.42
CONFigure:TXTests:WBDData:EREPorting	6.41
CONFigure:TXTests:WBDData:LIMit	6.43
CONFigure:TXTests:WBDData:LIMit:DEFault	6.43
CONFigure:WPOWER:CONTRol:REPetition	6.15
CONFigure:WPOWER:EREPorting	6.15
CONTinue:RXAFresp	6.78

Command (Non Signalling, alphabetical)	Page
CONTInue:RXTests:AFANalyzer.....	6.58
CONTInue:RXTests:AFANalyzer:VMSinad.....	6.64
CONTInue:RXTests:HNOise.....	6.67
CONTInue:RXTests:SENSitivity.....	6.72
CONTInue:TXAFresp.....	6.45
CONTInue:TXTests:AFLSearch.....	6.36
CONTInue:TXTests:HNOise.....	6.28
CONTInue:TXTests:HNOise:FHNoise.....	6.33
CONTInue:TXTests:MODulation.....	6.17
CONTInue:TXTests:MODulation:CPOwer.....	6.25
CONTInue:TXTests:MODulation:TADeviation.....	6.22
CONTInue:TXTests:WBData.....	6.41
CONTInue:WPOwer.....	6.14
DISPlay:RXAFresp:CONTRol:GRID.....	6.79
DISPlay:RXAFresp[:WINDow]:TRACe:Y:SCALe.....	6.80
DISPlay:TXAFresp:CONTRol:GRID.....	6.46
DISPlay:TXAFresp[:WINDow]:TRACe:Y:SCALe.....	6.47
FETCh:AFGenerator:STATus?.....	6.7
FETCh:ARRay:RXAFresp[:RESult]?.....	6.89
FETCh:ARRay:TXAFresp[:RESult]?.....	6.56
FETCh:MODGenerator:STATus?.....	6.8
FETCh:RFGenerator:STATus?.....	6.5
FETCh:RXAFresp:STATus?.....	6.78
FETCh:RXTests:AFANalyzer:STATus?.....	6.58
FETCh:RXTests:AFANalyzer:VMSinad:STATus?.....	6.64
FETCh:RXTests:HNOise:STATus?.....	6.67
FETCh:RXTests:SENSitivity:STATus?.....	6.72
FETCh:SAT:STATus?.....	6.9
FETCh:ST:STATus?.....	6.10
FETCh:SUBarrays:RXAFresp[:RESult]?.....	6.90
FETCh:SUBarrays:TXAFresp[:RESult]?.....	6.57
FETCh:TXAFresp:STATus?.....	6.45
FETCh:TXTests:AFLSearch:STATus?.....	6.36
FETCh:TXTests:HNOise:FHNoise:STATus?.....	6.33
FETCh:TXTests:HNOise:STATus?.....	6.28
FETCh:TXTests:MODulation:CPOwer:STATus?.....	6.25
FETCh:TXTests:MODulation:STATus?.....	6.17
FETCh:TXTests:MODulation:TADeviation:STATus?.....	6.22
FETCh:TXTests:WBData:STATus?.....	6.41
FETCh:WPOwer:STATus?.....	6.15
FETCh[:SCALar]:RXAFresp[:RESult]:TONE<nr>?.....	6.89
FETCh[:SCALar]:RXTests:AFANalyzer:VMSinad[:RESult]?.....	6.66
FETCh[:SCALar]:RXTests:AFANalyzer[:RESult]?.....	6.63
FETCh[:SCALar]:RXTests:HNOise[:RESult]?.....	6.71
FETCh[:SCALar]:RXTests:SENSitivity[:RESult]?.....	6.77
FETCh[:SCALar]:TXAFresp[:RESult]:TONE<nr>?.....	6.56
FETCh[:SCALar]:TXTests:AFLSearch[:RESult]?.....	6.40
FETCh[:SCALar]:TXTests:HNOise:FHNoise[:RESult]?.....	6.35
FETCh[:SCALar]:TXTests:HNOise[:RESult]?.....	6.32
FETCh[:SCALar]:TXTests:MODulation:CPOwer[:RESult]?.....	6.27
FETCh[:SCALar]:TXTests:MODulation:TADeviation[:RESult]?.....	6.24
FETCh[:SCALar]:TXTests:MODulation[:RESult]?.....	6.21
FETCh[:SCALar]:TXTests:WBData[:RESult]?.....	6.43
FETCh[:SCALar]:WPOwer[:RESult]?.....	6.16
INITiate:AFGenerator.....	6.6
INITiate:MODGenerator.....	6.8
INITiate:RFGenerator.....	6.5

Command (Non Signalling, alphabetical)	Page
INITiate:RXAFresp.....	6.78
INITiate:RXTests:AFANalyzer.....	6.58
INITiate:RXTests:AFANalyzer:VMSinad.....	6.64
INITiate:RXTests:HNOise.....	6.67
INITiate:RXTests:SENSitivity.....	6.72
INITiate:SAT.....	6.9
INITiate:ST.....	6.9
INITiate:TXAFresp.....	6.45
INITiate:TXTests:AFLSearch.....	6.36
INITiate:TXTests:HNOise.....	6.28
INITiate:TXTests:HNOise:FHNoise.....	6.33
INITiate:TXTests:MODulation.....	6.17
INITiate:TXTests:MODulation:CPOwer.....	6.25
INITiate:TXTests:MODulation:TADeviation.....	6.22
INITiate:TXTests:WBData.....	6.41
INITiate:WPOwer.....	6.14
INPut[:STATe].....	6.10
OUTPut[:STATe].....	6.11
READ:ARRay:RXAFresp[:RESult]?.....	6.89
READ:ARRay:TXAFresp[:RESult]?.....	6.56
READ:SUBarrays:RXAFresp[:RESult]?.....	6.90
READ:SUBarrays:TXAFresp[:RESult]?.....	6.57
READ[:SCALar]:RXAFresp[:RESult]:TONE<nr>?.....	6.89
READ[:SCALar]:RXTests:AFANalyzer:VMSinad[:RESult]?.....	6.66
READ[:SCALar]:RXTests:AFANalyzer[:RESult]?.....	6.63
READ[:SCALar]:RXTests:HNOise[:RESult]?.....	6.71
READ[:SCALar]:RXTests:SENSitivity[:RESult]?.....	6.77
READ[:SCALar]:TXAFresp[:RESult]:TONE<nr>?.....	6.56
READ[:SCALar]:TXTests:AFLSearch[:RESult]?.....	6.40
READ[:SCALar]:TXTests:HNOise:FHNoise[:RESult]?.....	6.35
READ[:SCALar]:TXTests:HNOise[:RESult]?.....	6.32
READ[:SCALar]:TXTests:MODulation:CPOwer[:RESult]?.....	6.27
READ[:SCALar]:TXTests:MODulation:TADeviation[:RESult]?.....	6.24
READ[:SCALar]:TXTests:MODulation[:RESult]?.....	6.21
READ[:SCALar]:TXTests:WBData[:RESult]?.....	6.43
READ[:SCALar]:WPOwer[:RESult]?.....	6.16
SAMPlE:ARRay:RXAFresp[:RESult]?.....	6.89
SAMPlE:ARRay:TXAFresp[:RESult]?.....	6.56
SAMPlE:SUBarrays:RXAFresp[:RESult]?.....	6.90
SAMPlE:SUBarrays:TXAFresp[:RESult]?.....	6.57
SAMPlE[:SCALar]:RXAFresp[:RESult]:TONE<nr>?.....	6.89
SAMPlE[:SCALar]:RXTests:AFANalyzer:VMSinad[:RESult]?.....	6.66
SAMPlE[:SCALar]:RXTests:AFANalyzer[:RESult]?.....	6.63
SAMPlE[:SCALar]:RXTests:HNOise[:RESult]?.....	6.71
SAMPlE[:SCALar]:RXTests:SENSitivity[:RESult]?.....	6.77
SAMPlE[:SCALar]:TXAFresp[:RESult]:TONE<nr>?.....	6.56
SAMPlE[:SCALar]:TXTests:AFLSearch[:RESult]?.....	6.40
SAMPlE[:SCALar]:TXTests:HNOise:FHNoise[:RESult]?.....	6.35
SAMPlE[:SCALar]:TXTests:HNOise[:RESult]?.....	6.32
SAMPlE[:SCALar]:TXTests:MODulation:CPOwer[:RESult]?.....	6.27
SAMPlE[:SCALar]:TXTests:MODulation:TADeviation[:RESult]?.....	6.24
SAMPlE[:SCALar]:TXTests:MODulation[:RESult]?.....	6.21
SAMPlE[:SCALar]:TXTests:WBData[:RESult]?.....	6.43
SAMPlE[:SCALar]:WPOwer[:RESult]?.....	6.16
SOURce:AFGenerator:FREQUency.....	6.7
SOURce:AFGenerator:LEVel.....	6.7
SOURce:AFGenerator:SLEVel.....	6.7

Command (Non Signalling, alphabetical)	Page
<i>SOURce:CORRection:LOSS:INPut<nr>[:MAGNitude]</i>	6.11
<i>SOURce:CORRection:LOSS:OUTPut<nr>[:MAGNitude]</i>	6.11
<i>SOURce:DM:CLOCK:FREQuency</i>	6.12
<i>SOURce:DM:CLOCK:STATe</i>	6.12
<i>SOURce:MODGenerator:DEVIation</i>	6.8
<i>SOURce:MODGenerator:FREQuency</i>	6.8
<i>SOURce:RFGenerator:FREQuency</i>	6.6
<i>SOURce:RFGenerator:FREQuency:OFFSet</i>	6.6
<i>SOURce:RFGenerator:FREQuency:UNIT</i>	6.6
<i>SOURce:RFGenerator:LEVel</i>	6.5
<i>SOURce:SAT:PEAKdev</i>	6.9
<i>SOURce:SAT:SCC</i>	6.9
<i>SOURce:ST:DAT</i>	6.10
<i>SOURce:ST:PEAKdev</i>	6.10
<i>STATus:OPERation:SYMBOLic:ENABLE</i>	6.13
<i>STATus:OPERation:SYMBOLic:EVENTj?</i>	6.13
<i>STOP:RXAFresp</i>	6.78
<i>STOP:RXTests:AFANalyzer</i>	6.58
<i>STOP:RXTests:AFANalyzer:VMSinad</i>	6.64
<i>STOP:RXTests:HNOise</i>	6.67
<i>STOP:RXTests:SENSitivity</i>	6.72
<i>STOP:TXAFresp</i>	6.45
<i>STOP:TXTests:AFLSearch</i>	6.36
<i>STOP:TXTests:HNOise</i>	6.28
<i>STOP:TXTests:HNOise:FHNoise</i>	6.33
<i>STOP:TXTests:MODulation</i>	6.17
<i>STOP:TXTests:MODulation:CPOWer</i>	6.25
<i>STOP:TXTests:MODulation:TADeviation</i>	6.22
<i>STOP:TXTests:WBDData</i>	6.41
<i>STOP:WPOWer</i>	6.14

Table 6-5 Remote-control commands: Signalling mode

Command (Signalling, alphabetical)	Page
<i>[SENSe:]AFConnect:MSORce</i>	6.104
<i>[SENSe:]AFLevel:DEFault</i>	6.93
<i>[SENSe:]AFLevel:MAXimum</i>	6.93
<i>[SENSe:]AFLevel:MODE</i>	6.93
<i>[SENSe:]CORRection:LOSS:INPut<nr>[:MAGNitude]</i>	6.104
<i>[SENSe:]CORRection:LOSS:Output<nr>[:MAGNitude]</i>	6.104
<i>[SENSe:]LEVel:ATTenuation</i>	6.92
<i>[SENSe:]LEVel:DEFault</i>	6.93
<i>[SENSe:]LEVel:MAXimum</i>	6.92
<i>[SENSe:]LEVel:MODE</i>	6.92
<i>[SENSe:]MSSinfo:BANDwidth?</i>	6.105
<i>[SENSe:]MSSinfo:DNUMber?</i>	6.106
<i>[SENSe:]MSSinfo:MIN[:NUMBer]?</i>	6.105
<i>[SENSe:]MSSinfo:MPCI?</i>	6.106
<i>[SENSe:]MSSinfo:PCLass?</i>	6.105
<i>[SENSe:]MSSinfo:SN:HEX?</i>	6.105
<i>[SENSe:]MSSinfo:SN?</i>	6.105
<i>[SENSe:]SIGNalling:STATe?</i>	6.95
<i>ABORt:AFGenerator</i>	6.106
<i>ABORt:MODGenerator</i>	6.108
<i>ABORt:RXAFresp</i>	6.78

Command (Signalling, alphabetical)	Page
ABORt:RXTests:AFANalyzer	6.58
ABORt:RXTests:AFANalyzer:VMSinad	6.64
ABORt:RXTests:HNOise	6.67
ABORt:RXTests:SENSitivity	6.72
ABORt:TXAFresp	6.45
ABORt:TXTests:AFLSearch	6.36
ABORt:TXTests:HNOise	6.28
ABORt:TXTests:HNOise:FHNoise	6.33
ABORt:TXTests:MODulation	6.17
ABORt:TXTests:MODulation:CPOwer	6.25
ABORt:TXTests:MODulation:TADeviation	6.22
ABORt:TXTests:WBData	6.41
ABORt:WPOwer	6.14
CALCulate:ARRay:RXAFresp[:RESult]:MATChing:LIMit[:LINE][:ASYMmetrical][:COMBined]:TONE?	6.90
CALCulate:ARRay:TXAFresp[:RESult]:MATChing:LIMit[:LINE][:ASYMmetrical][:COMBined]?	6.57
CALCulate[:SCALar]:RXAFresp[:RESult]:MATChing:LIMit[:LINE][:ASYMmetrical][:COMBined]:TONE<nr>?	6.90
CALCulate[:SCALar]:RXTests:AFANalyzer:VMSinad[:RESult]:MATChing:LIMit?	6.66
CALCulate[:SCALar]:RXTests:AFANalyzer[:RESult]:MATChing:LIMit?	6.63
CALCulate[:SCALar]:RXTests:HNOise[:RESult]:MATChing:LIMit?	6.71
CALCulate[:SCALar]:RXTests:SENSitivity[:RESult]:MATChing:LIMit?	6.77
CALCulate[:SCALar]:TXAFresp[:RESult]:MATChing:LIMit[:LINE][:ASYMmetrical][:COMBined]:TONE<nr>?	6.57
CALCulate[:SCALar]:TXTests:AFLSearch[:RESult]:MATChing?	6.40
CALCulate[:SCALar]:TXTests:HNOise:FHNoise[:RESult]:MATChing:LIMit?	6.35
CALCulate[:SCALar]:TXTests:HNOise[:RESult]:MATChing:LIMit?	6.32
CALCulate[:SCALar]:TXTests:MODulation:CPOwer[:RESult]:MATChing:LIMit?	6.27
CALCulate[:SCALar]:TXTests:MODulation:TADeviation[:RESult]:MATChing:LIMit?	6.24
CALCulate[:SCALar]:TXTests:MODulation[:RESult]:MATChing:LIMit?	6.21
CALCulate[:SCALar]:TXTests:WBData[:RESult]:MATChing:LIMit?	6.44
CONFigure:BSSignal:ACC:CHANnel	6.97
CONFigure:BSSignal:ACC:LEVel	6.97
CONFigure:BSSignal:OCHandoff:SAT:PEAKdev	6.99
CONFigure:BSSignal:OCHandoff:SAT:SCC	6.99
CONFigure:BSSignal:OCHandoff[:AVC]:CHANnel	6.99
CONFigure:BSSignal:OCHandoff[:AVC]:LEVel	6.99
CONFigure:BSSignal:SAT:PEAKdev	6.98
CONFigure:BSSignal:SAT:SCC	6.98
CONFigure:BSSignal[:AVC]:CHANnel	6.97
CONFigure:BSSignal[:AVC]:LEVel	6.98
CONFigure:HANDoff:TARGet	6.96
CONFigure:NETWork:IDENtity:DCC	6.100
CONFigure:NETWork:IDENtity:SID1	6.100
CONFigure:NETWork:OCHandoff[:MS]:VMAC	6.103
CONFigure:NETWork:REQuest:SNUMber	6.101
CONFigure:NETWork:SMODE:IDMin	6.101
CONFigure:NETWork:SMODE:REGH	6.100
CONFigure:NETWork:SMODE:REGR	6.100
CONFigure:NETWork:TIMEout:LORLINK	6.102
CONFigure:NETWork:TIMEout:RPERiod	6.102
CONFigure:NETWork[:MS]:CMAC	6.101
CONFigure:NETWork[:MS]:RCFM	6.102
CONFigure:NETWork[:MS]:VMAC	6.101
CONFigure:OCALI:TARGet	6.96
CONFigure:RXAFresp:CONTRol:DEFault	6.80
CONFigure:RXAFresp:CONTRol:MGLead	6.80
CONFigure:RXAFresp:CONTRol:MODGenerator:DEFault	6.88
CONFigure:RXAFresp:CONTRol:REPetition	6.79
CONFigure:RXAFresp:CONTRol:RLEVel	6.79

Command (Signalling, alphabetical)	Page
CONFigure:RXAFresp:CONTRol:RREQuest	6.80
CONFigure:RXAFresp:CONTRol:TDEFinition	6.85
CONFigure:RXAFresp:EREPorting	6.78
CONFigure:RXAFresp:FILTer	6.88
CONFigure:RXAFresp:FILTer:DEFault	6.89
CONFigure:RXAFresp:LIMit[:LINE]:DEFault	6.83
CONFigure:RXAFresp:LIMit[:LINE][:ASYMmetrical]:LOWer	6.83
CONFigure:RXAFresp:LIMit[:LINE][:ASYMmetrical]:LOWer:TONE<nr>	6.83
CONFigure:RXAFresp:LIMit[:LINE][:ASYMmetrical]:UPPer	6.82
CONFigure:RXAFresp:LIMit[:LINE][:ASYMmetrical]:UPPer:TONE<nr>	6.82
CONFigure:RXAFresp:MODGenerator:ENABle	6.85
CONFigure:RXAFresp:MODGenerator:ENABle:TONE<nr>	6.86
CONFigure:RXAFresp:MODGenerator:FDEVIation:FDMODE	6.87
CONFigure:RXAFresp:MODGenerator:FDEVIation:SFDEVIation	6.87
CONFigure:RXAFresp:MODGenerator:FDEVIation:SFDEVIation:TONE<nr>	6.87
CONFigure:RXAFresp:MODGenerator:FDEVIation:TFDEVIation	6.87
CONFigure:RXAFresp:MODGenerator:FREQuency	6.86
CONFigure:RXAFresp:MODGenerator:FREQuency:TONE<nr>	6.86
CONFigure:RXAFresp:TDEFinition	6.84
CONFigure:RXAFresp:TDEFinition:TONE<nr>	6.85
CONFigure:RXTests:AFANalyzer:CONTRol:DEFault	6.59
CONFigure:RXTests:AFANalyzer:CONTRol:REPetition	6.59
CONFigure:RXTests:AFANalyzer:EREPorting	6.58
CONFigure:RXTests:AFANalyzer:FILTer	6.61
CONFigure:RXTests:AFANalyzer:FILTer:DEFault	6.62
CONFigure:RXTests:AFANalyzer:FILTer:NOTCh	6.61
CONFigure:RXTests:AFANalyzer:LIMit	6.60
CONFigure:RXTests:AFANalyzer:LIMit:DEFault	6.60
CONFigure:RXTests:AFANalyzer:VMSinad:CONTRol:DEFault	6.65
CONFigure:RXTests:AFANalyzer:VMSinad:CONTRol:MTIME	6.65
CONFigure:RXTests:AFANalyzer:VMSinad:CONTRol:REPetition	6.65
CONFigure:RXTests:AFANalyzer:VMSinad:EREPorting	6.64
CONFigure:RXTests:HNOise:CONTRol:DEFault	6.68
CONFigure:RXTests:HNOise:CONTRol:REPetition	6.68
CONFigure:RXTests:HNOise:EREPorting	6.67
CONFigure:RXTests:HNOise:FILTer	6.70
CONFigure:RXTests:HNOise:FILTer:DEFault	6.70
CONFigure:RXTests:HNOise:LIMit	6.69
CONFigure:RXTests:HNOise:LIMit:DEFault	6.69
CONFigure:RXTests:SENSitivity:CONTRol:DEFault	6.73
CONFigure:RXTests:SENSitivity:CONTRol:TSERange	6.73
CONFigure:RXTests:SENSitivity:CONTRol:TSINad	6.73
CONFigure:RXTests:SENSitivity:EREPorting	6.72
CONFigure:RXTests:SENSitivity:FILTer	6.75
CONFigure:RXTests:SENSitivity:FILTer:DEFault	6.76
CONFigure:RXTests:SENSitivity:FILTer:NOTCh	6.75
CONFigure:RXTests:SENSitivity:LIMit	6.74
CONFigure:RXTests:SENSitivity:LIMit:DEFault	6.74
CONFigure:SDSets:ENABle	6.92
CONFigure:SUBarrays:RXAFresp	6.81
CONFigure:SUBarrays:TXAFresp	6.48
CONFigure:TXAFresp:AFGenerator:ENABle	6.52
CONFigure:TXAFresp:AFGenerator:ENABle:TONE<nr>	6.53
CONFigure:TXAFresp:AFGenerator:FREQuency	6.53
CONFigure:TXAFresp:AFGenerator:FREQuency:TONE<nr>	6.53
CONFigure:TXAFresp:AFGenerator:LEVel:LMODE	6.53
CONFigure:TXAFresp:AFGenerator:LEVel:SLEVel	6.54

Command (Signalling, alphabetical)	Page
CONFigure:TXAFresp:AFGenerator:LEVel:SLEVel:TONE<nr>	6.54
CONFigure:TXAFresp:AFGenerator:LEVel:TLEVel	6.54
CONFigure:TXAFresp:CONTRol:AFGenerator:DEFault	6.55
CONFigure:TXAFresp:CONTRol:AFGLead	6.47
CONFigure:TXAFresp:CONTRol:DEFault	6.47
CONFigure:TXAFresp:CONTRol:RDEVIation	6.46
CONFigure:TXAFresp:CONTRol:REPetition	6.46
CONFigure:TXAFresp:CONTRol:RREQuest	6.47
CONFigure:TXAFresp:CONTRol:TDEFinition:DEFault	6.52
CONFigure:TXAFresp:EREPorting	6.45
CONFigure:TXAFresp:FILTer	6.55
CONFigure:TXAFresp:FILTer:DEFault	6.56
CONFigure:TXAFresp:LIMit[:LINE]:DEFault	6.50
CONFigure:TXAFresp:LIMit[:LINE][:ASYMmetrical]:LOWer	6.50
CONFigure:TXAFresp:LIMit[:LINE][:ASYMmetrical]:LOWer:TONE<nr>	6.50
CONFigure:TXAFresp:LIMit[:LINE][:ASYMmetrical]:UPPer	6.49
CONFigure:TXAFresp:LIMit[:LINE][:ASYMmetrical]:UPPer:TONE<nr>	6.49
CONFigure:TXAFresp:TDEFinition	6.51
CONFigure:TXAFresp:TDEFinition:TONE<nr>	6.52
CONFigure:TXTests:AFLSearch:CONTRol:DEFault	6.37
CONFigure:TXTests:AFLSearch:CONTRol:TAPDeviation	6.37
CONFigure:TXTests:AFLSearch:CONTRol:TDERange	6.37
CONFigure:TXTests:AFLSearch:EREPorting	6.36
CONFigure:TXTests:AFLSearch:FILTer	6.39
CONFigure:TXTests:AFLSearch:FILTer:DEFault	6.39
CONFigure:TXTests:AFLSearch:LIMit	6.38
CONFigure:TXTests:AFLSearch:LIMit:DEFault	6.38
CONFigure:TXTests:AFLSearch:TDTyPe	6.37
CONFigure:TXTests:HNOise:CONTRol:DEFault	6.29
CONFigure:TXTests:HNOise:CONTRol:REPetition	6.29
CONFigure:TXTests:HNOise:EREPorting	6.28
CONFigure:TXTests:HNOise:FHNoise:CONTRol:DEFault	6.34
CONFigure:TXTests:HNOise:FHNoise:CONTRol:REPetition	6.34
CONFigure:TXTests:HNOise:FHNoise:EREPorting	6.33
CONFigure:TXTests:HNOise:FILTer	6.31
CONFigure:TXTests:HNOise:FILTer:DEFault	6.31
CONFigure:TXTests:HNOise:LIMit	6.30
CONFigure:TXTests:HNOise:LIMit:DEFault	6.30
CONFigure:TXTests:MODulation:CONTRol:DEFault	6.18
CONFigure:TXTests:MODulation:CONTRol:REPetition	6.18
CONFigure:TXTests:MODulation:CPOWER:CONTRol:DEFault	6.26
CONFigure:TXTests:MODulation:CPOWER:CONTRol:REPetition	6.26
CONFigure:TXTests:MODulation:CPOWER:EREPorting	6.25
CONFigure:TXTests:MODulation:EREPorting	6.17
CONFigure:TXTests:MODulation:FILTer	6.20
CONFigure:TXTests:MODulation:FILTer:DEFault	6.20
CONFigure:TXTests:MODulation:LIMit	6.19
CONFigure:TXTests:MODulation:LIMit:DEFault	6.19
CONFigure:TXTests:MODulation:TADeviation:CONTRol:DEFault	6.23
CONFigure:TXTests:MODulation:TADeviation:CONTRol:REPetition	6.23
CONFigure:TXTests:MODulation:TADeviation:EREPorting	6.22
CONFigure:TXTests:WBDData:CONTRol:DEFault	6.42
CONFigure:TXTests:WBDData:CONTRol:REPetition	6.42
CONFigure:TXTests:WBDData:EREPorting	6.41
CONFigure:TXTests:WBDData:LIMit	6.43
CONFigure:TXTests:WBDData:LIMit:DEFault	6.43
CONFigure:WPOWER:CONTRol:REPetition	6.15

Command (Signalling, alphabetical)	Page
CONFigure:WPOWer:EREPorting	6.15
CONTInue:RXAFresp	6.78
CONTInue:RXTests:AFANalyzer.....	6.58
CONTInue:RXTests:AFANalyzer:VMSinad	6.64
CONTInue:RXTests:HNOise	6.67
CONTInue:RXTests:SENSitivity.....	6.72
CONTInue:TXAFresp	6.45
CONTInue:TXTests:AFLSearch	6.36
CONTInue:TXTests:HNOise	6.28
CONTInue:TXTests:HNOise:FHNoise.....	6.33
CONTInue:TXTests:MODulation	6.17
CONTInue:TXTests:MODulation:CPOWer	6.25
CONTInue:TXTests:MODulation:TADeviation.....	6.22
CONTInue:TXTests:WBData	6.41
CONTInue:WPOWer.....	6.14
DISPlay:RXAFresp:CONTRol:GRID.....	6.79
DISPlay:RXAFresp[:WINDow]:TRACe:Y:SCALe.....	6.80
DISPlay:TXAFresp:CONTRol:GRID	6.46
DISPlay:TXAFresp[:WINDow]:TRACe:Y:SCALe	6.47
FETCh:AFGenerator:STATus?	6.106
FETCh:ARRAy:RXAFresp[:RESult]?	6.89
FETCh:ARRAy:TXAFresp[:RESult]?	6.56
FETCh:MODGenerator:STATus?.....	6.108
FETCh:RXAFresp:STATus?	6.78
FETCh:RXTests:AFANalyzer:STATus?	6.58
FETCh:RXTests:AFANalyzer:VMSinad:STATus?	6.64
FETCh:RXTests:HNOise:STATus?.....	6.67
FETCh:RXTests:SENSitivity:STATus?.....	6.72
FETCh:SUBarrays:RXAFresp[:RESult]?	6.90
FETCh:SUBarrays:TXAFresp[:RESult]?.....	6.57
FETCh:TXAFresp:STATus?.....	6.45
FETCh:TXTests:AFLSearch:STATus?	6.36
FETCh:TXTests:HNOise:FHNoise:STATus?.....	6.33
FETCh:TXTests:HNOise:STATus?	6.28
FETCh:TXTests:MODulation:CPOWer:STATus?.....	6.25
FETCh:TXTests:MODulation:STATus?	6.17
FETCh:TXTests:MODulation:TADeviation:STATus?.....	6.22
FETCh:TXTests:WBData:STATus?	6.41
FETCh:WPOWer:STATus?.....	6.15
FETCh[:SCALAr]:RXAFresp[:RESult]:TONE<nr>?	6.89
FETCh[:SCALAr]:RXTests:AFANalyzer:VMSinad[:RESult]?	6.66
FETCh[:SCALAr]:RXTests:AFANalyzer[:RESult]?	6.63
FETCh[:SCALAr]:RXTests:HNOise[:RESult]?	6.71
FETCh[:SCALAr]:RXTests:SENSitivity[:RESult]?	6.77
FETCh[:SCALAr]:TXAFresp[:RESult]:TONE<nr>?	6.56
FETCh[:SCALAr]:TXTests:AFLSearch[:RESult]?	6.40
FETCh[:SCALAr]:TXTests:HNOise:FHNoise[:RESult]?	6.35
FETCh[:SCALAr]:TXTests:HNOise[:RESult]?	6.32
FETCh[:SCALAr]:TXTests:MODulation:CPOWer[:RESult]?	6.27
FETCh[:SCALAr]:TXTests:MODulation:TADeviation[:RESult]?	6.24
FETCh[:SCALAr]:TXTests:MODulation[:RESult]?	6.21
FETCh[:SCALAr]:TXTests:WBData[:RESult]?	6.43
FETCh[:SCALAr]:WPOWer[:RESult]?	6.16
INITiate:AFGenerator.....	6.106
INITiate:MODGenerator.....	6.108
INITiate:RXAFresp.....	6.78
INITiate:RXTests:AFANalyzer.....	6.58

Command (Signalling, alphabetical)	Page
INITiate:RXTests:AFANalyzer:VMSinad.....	6.64
INITiate:RXTests:HNOise	6.67
INITiate:RXTests:SENSitivity	6.72
INITiate:TXAFresp	6.45
INITiate:TXTests:AFLSearch	6.36
INITiate:TXTests:HNOise.....	6.28
INITiate:TXTests:HNOise:FHNoise	6.33
INITiate:TXTests:MODulation	6.17
INITiate:TXTests:MODulation:CPOwer	6.25
INITiate:TXTests:MODulation:TADeviation	6.22
INITiate:TXTests:WBData	6.41
INITiate:WPOwer.....	6.14
INPut[:STATe].....	6.103
OUTPut[:STATe].....	6.103
PROcedure:BSSignal[:AVC]:LEVel	6.98
PROcedure:SIGNalling:ACTion.....	6.94
PROcedure:SIGNalling[:AVC]:CHANnel.....	6.95
PROcedure:SIGNalling[:AVC]:MAC	6.95
PROcedure:SIGNalling[:AVC]:SAT:PEAKdev	6.95
PROcedure:SIGNalling[:AVC]:SAT:SCC.....	6.95
READ:ARRay:RXAFresp[:RESult]?	6.89
READ:ARRay:TXAFresp[:RESult]?.....	6.56
READ:SUBarrays:RXAFresp[:RESult]?.....	6.90
READ:SUBarrays:TXAFresp[:RESult]?.....	6.57
READ[:SCALar]:RXAFresp[:RESult]:TONE<nr>?	6.89
READ[:SCALar]:RXTests:AFANalyzer:VMSinad[:RESult]?	6.66
READ[:SCALar]:RXTests:AFANalyzer[:RESult]?	6.63
READ[:SCALar]:RXTests:HNOise[:RESult]?.....	6.71
READ[:SCALar]:RXTests:SENSitivity[:RESult]?.....	6.77
READ[:SCALar]:TXAFresp[:RESult]:TONE<nr>?	6.56
READ[:SCALar]:TXTests:AFLSearch[:RESult]?.....	6.40
READ[:SCALar]:TXTests:HNOise:FHNoise[:RESult]?.....	6.35
READ[:SCALar]:TXTests:HNOise[:RESult]?	6.32
READ[:SCALar]:TXTests:MODulation:CPOwer[:RESult]?	6.27
READ[:SCALar]:TXTests:MODulation:TADeviation[:RESult]?	6.24
READ[:SCALar]:TXTests:MODulation[:RESult]?	6.21
READ[:SCALar]:TXTests:WBData[:RESult]?	6.43
READ[:SCALar]:WPOwer[:RESult]?.....	6.16
SAMple:ARRay:RXAFresp[:RESult]?	6.89
SAMple:ARRay:TXAFresp[:RESult]?	6.56
SAMple:SUBarrays:RXAFresp[:RESult]?	6.90
SAMple:SUBarrays:TXAFresp[:RESult]?	6.57
SAMple[:SCALar]:RXAFresp[:RESult]:TONE<nr>?	6.89
SAMple[:SCALar]:RXTests:AFANalyzer:VMSinad[:RESult]?	6.66
SAMple[:SCALar]:RXTests:AFANalyzer[:RESult]?	6.63
SAMple[:SCALar]:RXTests:HNOise[:RESult]?	6.71
SAMple[:SCALar]:RXTests:SENSitivity[:RESult]?	6.77
SAMple[:SCALar]:TXAFresp[:RESult]:TONE<nr>?	6.56
SAMple[:SCALar]:TXTests:AFLSearch[:RESult]?	6.40
SAMple[:SCALar]:TXTests:HNOise:FHNoise[:RESult]?	6.35
SAMple[:SCALar]:TXTests:HNOise[:RESult]?	6.32
SAMple[:SCALar]:TXTests:MODulation:CPOwer[:RESult]?	6.27
SAMple[:SCALar]:TXTests:MODulation:TADeviation[:RESult]?	6.24
SAMple[:SCALar]:TXTests:MODulation[:RESult]?	6.21
SAMple[:SCALar]:TXTests:WBData[:RESult]?	6.43
SAMple[:SCALar]:WPOwer[:RESult]?.....	6.16
SOURce:AFGenerator:FREquency	6.107

Command (Signalling, alphabetical)	Page
<i>SOURce:AFGenerator:LEVel</i>	6.107
<i>SOURce:AFGenerator:SLEVel</i>	6.107
<i>SOURce:CORRection:LOSS:INPut<nr>[:MAGNitude]</i>	6.104
<i>SOURce:CORRection:LOSS:Output<nr>[:MAGNitude]</i>	6.104
<i>SOURce:DM:CLOCK:FREQuency</i>	6.104
<i>SOURce:DM:CLOCK:STATE</i>	6.104
<i>SOURce:MODGenerator:Deviation</i>	6.108
<i>SOURce:MODGenerator:FREQuency</i>	6.108
<i>STATus:HANDoff:TARGet:LIST?</i>	6.96
<i>STATus:OCALI:TARGet:LIST?</i>	6.96
<i>STATus:OPERation:SYMBOLic:ENABle</i>	6.109
<i>STATus:OPERation:SYMBOLic[EVENT]?</i>	6.109
<i>STOP:RXAFresp</i>	6.78
<i>STOP:RXTests:AFANalyzer</i>	6.58
<i>STOP:RXTests:AFANalyzer:VMSinad</i>	6.64
<i>STOP:RXTests:HNOise</i>	6.67
<i>STOP:RXTests:SENSitivity</i>	6.72
<i>STOP:TXAFresp</i>	6.45
<i>STOP:TXTests:AFLSearch</i>	6.36
<i>STOP:TXTests:HNOise</i>	6.28
<i>STOP:TXTests:HNOise:FHNoise</i>	6.33
<i>STOP:TXTests:MODulation</i>	6.17
<i>STOP:TXTests:MODulation:CPOWer</i>	6.25
<i>STOP:TXTests:MODulation:TADeviation</i>	6.22
<i>STOP:TXTests:WBDData</i>	6.41
<i>STOP:WPOWer</i>	6.14
<i>UNIT:CHANnel</i>	6.91

Index

A

- Address (secondary) 5.1
- AF Analyzer
 - Analyzer/Generator 4.3
 - RX Tests 4.32
 - softkey 4.31
- AF Analyzer Level 4.49
 - Signalling 4.88
- AF Connector Overview 4.56
- AF Distortion 4.34
- AF Gen. Frequency 4.11, 6.7, 6.107
- AF Gen. Lead 4.23
- AF Gen. Level 4.11, 6.7
- AF Generator 4.3, 4.11
 - remote control (NS) 6.6
 - remote control (Sig) 6.106
- AF Generator Lead 4.26
 - remote control (TX) 6.47
- AF Input Ref. Level 4.41
- AF Level
 - remote control (NS) 6.3
 - remote control (Sig) 6.93
- AF Level Search 4.9
 - remote control 6.37
- AF Max. Level 4.49
 - remote control (NS) 6.3
 - remote control (Sig) 6.93
 - RX Tests 4.33
- AF Mode 4.33, 4.49
 - remote control (NS) 6.3
 - remote control (Sig) 6.93
- AF Search Level 4.14
- AF SINAD 4.34
- AF Voltage 6.107
- AF Voltmeter 4.34
- AF Voltmeter Min./Max. 6.74
- AF/Mod. Generator 4.33
- Alerting 4.59
- Analyzer
 - menu 4.87
- Analyzer (Non Signalling) 4.45, 4.50
- Analyzer Level
 - Non Signalling 4.48
 - Power vs. Time (NS) 4.9, 4.32
 - TX Tests 4.67
- Analyzer Settings
 - remote control (NS) 6.4
 - softkey 4.10
- Analyzer/Generator 4.2
- Application 3.5
- Application (softkey)
 - RX Tests 4.32
 - TX Tests 4.8
- Attenuation 6.2, 6.92
 - input level 4.49
 - output level 4.56
 - TX Tests, Signalling 4.67
- Audio Peak Deviation 4.13
- Autoranging 4.48
- AUX 1 4.55
- AUX 2 4.55
- AVC Level 4.84
 - BS signal 4.67

B

- Band Pass 4.18
- Bandwidth 6.105
- Braces 5.7
- BS Signal 2.17, 4.61, 4.75
 - menu 4.83
 - remote control 6.97
 - softkey 4.67

C

- Call Established 4.59
- Call from MS 4.59
- Call Pending 4.79
- Call Release 4.74
- Call to MS 4.59
 - Other Call 4.78
- Carrier Frequency Error 4.13
- Carrier Power 4.13
- CCITT weighting filter 4.18
- Channel
 - analyzer 4.10
 - generator 4.10
- Channel Units 6.91
- CMAC 4.82, 6.101
- C-message weighted filter 4.18
- Command
 - order 5.1, 5.6
 - structure 5.1
 - tables (description) 5.6
- Configurations 3.2
- Connect mobile phone 2.2
- Connect. Control Guidance 4.89
- Connection (Alerting) 4.73
- Connection (Registered) 4.71
- Connection (remote control) 6.94
- Connection (Signal Off) 4.60
- Connection (Signal On) 4.62
- Connection Control
 - Non Signalling 4.45
 - remote control (NS) 6.1
 - remote control (Sig) 6.91
 - Signalling 4.59, 4.71
- Connectors (RF) 2.3
- Continuous 4.16, 5.3
- Control Channel (CC) 4.84, 6.97
- Counting 5.3
- Current values 4.65, 6.91

D

- Data 4.53, 6.10
- DCC 4.86, 6.100
- De-emphasis 4.18
- Default 4.15, 4.81, 4.88
- Default MIN 4.86
- Default Scale 4.24
- Default values 4.65, 6.91
- Demodulated signal 4.56
- Destination Defaults
 - Handoff 4.80
 - Other Call 4.78
- Destination Parameter
 - Handoff 4.80
 - Other Call 4.77

Destination Selection.....	6.96
Handoff.....	4.79
Other Call.....	4.77
Deviation Selection.....	6.87
Dialed number.....	4.76, 6.106
Display.....	4.23
Duplex spacing.....	4.51
Dynamic power control.....	2.19
Dynamic range.....	4.49

E

Enable software.....	1.5
Expander.....	4.18
Ext. Att. (table).....	4.61
Ext. Att. Input.....	4.56, 6.11, 6.104
Ext. Att. Output.....	4.56, 6.11, 6.104
External attenuation.....	4.56
remote control (NS).....	6.10
remote control (Sig).....	6.103
External modulation.....	4.3, 4.55

F

Fast RX tests	
VMSinad (remote control).....	6.64
Fast TX tests	
CPOWer (remote control).....	6.25
FHNoise (remote control).....	6.33
TADeviation (remote control).....	6.22
Filter	
RX Audio Freq. Configuration.....	4.44
RX Audio Freq. Response.....	6.88
RX Tests.....	4.38
RXTests – AF Analyzer.....	6.61
TX Audio Freq. Response.....	4.29
TX Audio Freq. Response.....	6.55
TX Tests.....	4.18
TXTests – AF Level Search.....	6.39
TXTests – Hum & Noise.....	6.31
TXTests – Modulation.....	6.20
Force ST.....	4.66, 4.76, 6.94
Freq. Resp. Scale.....	4.23
Freq./Dev. (RX Audio Freq. Response).....	4.44
Frequency	
analyzer.....	4.10
BS signal.....	4.67
generator.....	4.10
ST.....	4.53
Frequency Offset	
analyzer.....	4.10, 4.47
generator.....	4.10, 4.52
Frequency Scale.....	4.23
Frequency Unit.....	6.4, 6.6
Function group	
AMPS-MS Non Signalling.....	4.2
AMPS-MS Signalling.....	4.59

G

Gain.....	4.56
Generator	
AF.....	4.3
Mod.....	4.3
RF.....	4.50, 4.51
tab (Non Signalling).....	4.50
Getting Started.....	2.1
Grid	
RX Audio Freq. Response.....	6.79
TX Audio Freq. Response.....	6.46

H

Handoff.....	4.78
remote control.....	6.96
softkey.....	4.80
HLT state.....	2.9
Home Registration.....	6.100
Hotkey.....	2.11
Hum & Noise	
definition (RX Tests).....	4.34
definition (TX Tests).....	4.13
RX Tests.....	4.32
TX Tests.....	4.8

I

Input level	
remote control (NS).....	6.1
remote control (Sig).....	6.92
Inputs/outputs	
Non Signalling.....	4.54
Signalling.....	4.87
Installation (software).....	1.1
Intermodulation.....	4.49
INV.....	5.7

L

Level Handling.....	4.28
Level Selection.....	4.28, 6.53
Limit	
check.....	5.4
lines.....	5.4
specify.....	5.4
Limit lines	
RX Audio Freq. Response.....	4.43
TX Audio Freq. Response.....	4.26
Limit Matching	
RX Audio Freq. Response.....	6.90
RX Tests – AF Analyzer.....	6.63, 6.66
RX Tests – Hum & Noise.....	6.71
RX Tests – Sensitivity.....	6.77
TX Audio Freq. Response.....	6.57
TX Tests – AF Level Search.....	6.40
TX Tests – Hum & Noise.....	6.32, 6.35
TX Tests – Modulation.....	6.21, 6.24, 6.27, 6.44
Limits	
RX Audio Freq. Response.....	6.82
RX Tests – AF Analyzer.....	6.60
RX Tests – Hum & Noise.....	6.69
RX Tests – Sensitivity.....	6.74
RX Tests, Non Signalling.....	4.37
RXTests – AF Analyzer.....	6.60
RXTests – Hum & Noise.....	6.69, 6.70
RXTests – Sensitivity.....	6.74, 6.75
TX Audio Freq. Response.....	6.49
TX Tests – AF Level Search.....	6.38
TX Tests – Hum & Noise.....	6.30
TX Tests – Modulation.....	6.19, 6.43
TX Tests, Non Signalling.....	4.17
TXTests – AF Level Search.....	6.38
TXTests – Hum & Noise.....	6.30
TXTests – Modulation.....	6.19, 6.43
List of Commands.....	6.110
alphabetical.....	6.123
description.....	5.8
Literal.....	5.7
Loss of Radio Link.....	6.102
Low distortion.....	4.49
Low noise.....	4.49
Lower Limit Line	
RX Audio Freq. Response.....	6.83

TX Audio Freq. Response..... 4.27, 6.50

M

Mains switch 2.2
 Manual control..... 3.1
 Max. Level..... 4.46, 4.48, 6.2, 6.92
 Measurement control..... 5.2
 Measurement groups 3.3
 Menu Select..... 2.4, 2.16
 Menu structure 3.1
 MIN 6.101, 6.105
 Misc. 4.88
 Mobile Info 4.76
 Mobile phone (connection) 2.2
 Mobile registered..... 4.72
 Mobile tests..... 4.59
 Mod. Deviation..... 6.8, 6.108
 Mod. Dist. & Noise 4.13
 Mod. frequency 6.8, 6.108
 Mod. Gen. Deviation..... 4.33
 Mod. Gen. Frequency..... 4.33
 Mod. Gen. Lead 4.41
 remote control..... 6.80
 Mod. Generator 4.3, 6.8, 6.108
 remote control (NS)..... 6.8
 remote control (Sig)..... 6.108
 Mod. Source..... 4.55, 6.11, 6.104
 Modulation (TX Tests)..... 4.7, 4.8
 MPC1..... 6.106
 MS Signal (menu)..... 4.81
 MS Signal (softkey)..... 4.66

N

NAN 5.7
 Network..... 4.85
 remote control..... 6.100
 Network (table)..... 4.61
 Network Identity 4.86
 Non Signalling..... 3.1, 4.2
 Non signalling measurements 2.6
 Notation (remote control)..... 5.6
 Notch Filter..... 4.38, 6.61, 6.75

O

On Limit Failure..... 4.16
 Operating concept..... 3.1
 OPERation status register..... 5.5
 Origin Parameter
 Handoff 4.80
 Other Call..... 4.78
 Other Call..... 4.76
 remote control..... 6.96
 Other Call/Handoff
 RF Channel..... 6.99
 RF Level 6.99
 VMAC 6.103
 Other Call/Handoff Parameter..... 4.82, 4.84, 6.103
 Other call/handoff values..... 4.65, 6.91
 Overview..... 4.64

P

Parameter
 current vs. default 4.65, 6.91
 in SCPI command..... 5.7
 other call/handoff 4.65, 6.91
 Parameter Coupling 4.89
 Path Configuration
 RX Audio Freq. Response..... 6.88

RX Tests – AF Analyzer 6.61, 6.70, 6.75
 TX Audio Freq. Response 6.55
 TX Tests..... 4.18
 TX Tests – Hum & Noise..... 6.39
 TX Tests – Modulation..... 6.20, 6.31
 PCL level..... 2.19
 Peak Deviation
 SAT 6.9
 SAT (Call Established) 4.75
 SAT (Connection Control)..... 4.52
 ST 4.53, 6.10
 Power (wide band)
 Non Signalling 4.47
 Power (wideband)
 remote control 6.14
 Power Class 6.105
 Power Level..... 6.5
 generator..... 4.10
 Power switch 2.3
 Pre-emphasis 4.18
 Primary address 5.1

R

Read Control Filler Msg. 6.102
 Read Control Filter Msg. 4.82
 REF OUT 2..... 4.58, 6.12, 6.104
 Reference Deviation 4.23, 6.46
 Reference Frequency
 Non Signalling 4.57
 remote control (Sig)..... 6.104
 Signalling..... 4.87
 Reference Level 6.79
 Reference part..... 4.1
 Reg. Pending..... 4.77
 Registered 4.59
 Registration 4.86
 Registration Period 6.102
 Remote control
 basics..... 5.1
 commands..... 6.1
 notation 5.6
 Repetition 4.16
 AF Analyzer..... 6.59, 6.65
 Hum & Noise..... 6.29, 6.34, 6.68
 Modulation..... 6.18, 6.23, 6.26, 6.42
 RX Audio Freq. Response..... 6.79
 TX Audio Freq. Response 6.46
 TX Tests..... 4.7
 Repetition mode..... 3.5, 5.3
 Requested Mobile Data 4.86
 Residual AM 4.13
 Result (RX Audio Freq. Response)
 Non Signalling 4.41
 remote control 6.89
 Result (RX Tests) 4.33, 4.41
 remote control 6.63, 6.66, 6.71, 6.77
 Result (TX Audio Freq. Response) 4.23, 4.24
 remote control 6.56
 Result (TX Tests)..... 4.12
 remote control ...6.21, 6.24, 6.27, 6.32, 6.35, 6.40, 6.43
 RF Analyzer Level 4.48
 Signalling..... 4.88
 RF Attenuation..... 4.9
 input level..... 4.49
 RF carrier signals 2.17
 RF Channel 6.4
 analyzer..... 4.46
 generator..... 4.51
 RF connectors 2.3
 RF Generator..... 4.50, 6.5
 remote control (NS) 6.5

- softkey 4.10
- RF Input 4.56, 6.10, 6.103
- RF Max. Level 4.9, 4.48
- RF Mode 4.48
 - hotkey 4.9
 - remote control (NS) 6.1
 - remote control (Sig) 6.92
- RF Output 4.56, 6.11, 6.103
- Roaming Registration 6.100
- RX Audio Freq. Resp. (softkey) 4.40
- RX Audio Freq. Response
 - Non Signalling 4.39
 - remote control 6.78
 - Signalling 4.70
- RX Audio Freq. Response (control)
 - Non Signalling 4.43
 - remote control 6.79
- RX Audio Freq. Response Configuration
 - Non Signalling 4.43
 - remote control 6.79
- RX Tests
 - Non Signalling 4.30
 - remote control 6.58
 - Signalling 4.69
- RX Tests (control)
 - Non Signalling 4.36
 - remote control 6.58, 6.64, 6.67, 6.72
- RX Tests Configuration
 - Non Signalling 4.35
 - remote control 6.59, 6.68, 6.73
- S**
- SAT
 - Call Established 4.75
 - Connection Control 4.52
 - remote control (NS) 6.9
 - TX Tests 4.11
 - SAT Frequency Error 4.13
 - SAT Peak Deviation 4.13, 6.95, 6.98, 6.99
 - SAT Pk. Deviation (hotkey) 4.11
 - SAT SCC 4.11
 - SAT/ST 4.11
 - Scale Max.
 - RX 6.80
 - TX 6.47
 - Scale Min.
 - RX 6.80
 - TX 6.47
 - SCC (SAT color code)
 - Call Established 4.76
 - Connection Control 4.53
 - remote control 6.9, 6.95, 6.98, 6.99
 - SCPI standard 5.2
 - Secondary address 5.1, 5.5
 - Second-level keyword 5.1
 - Sensitivity
 - definition 4.34
 - hotkey 4.32
 - Sensitivity limit 6.74
 - Separate Deviations 6.87
 - Separate Levels 6.54
 - Serial Number 4.86
 - Serial Number Request 6.101
 - SID 4.86, 6.100
 - SID 1 4.86
 - Sign. State Dependent Sets 4.89, 6.92
 - Signal Off 4.59
 - softkey 4.63
 - Signal On 4.59
 - softkey 4.62
 - Signalling 3.1, 3.2, 4.59
 - Signalling Info 6.105
 - Signalling Measurements 2.16
 - Signalling modes 3.1, 4.86
 - Signalling states 6.94
 - overview 4.60
 - Signalling tone (ST) 4.53
 - Single Shot 4.16, 5.3
 - SN 6.105
 - hex output 6.105
 - Software (enable) 1.5
 - Special character 5.7
 - Square brackets 5.7
 - ST 4.53
 - Force ST 4.66
 - remote control (NS) 6.9
 - TX Tests 4.12
 - ST Data 4.12
 - ST Frequency Error 4.13
 - ST Peak Deviation 4.13
 - ST Pk. Deviation (hotkey) 4.12
 - Standby mode 2.3
 - Start Level 4.11, 6.7, 6.107
 - Startup menu 1.1, 2.2
 - Statistics
 - manual control 3.5
 - remote control 5.3
 - Status indication 2.7
 - STATus OPERation register 5.5
 - symbolic evaluation 6.13, 6.109
 - Status reporting system 5.5
 - Stepping mode
 - AF Analyzer 6.59, 6.65
 - Hum & Noise 6.29, 6.34, 6.68
 - Modulation 6.18, 6.23, 6.26, 6.42
 - RX Audio Freq. Response 6.79
 - TX Audio Freq. Response 6.46
 - Stop Condition 3.5, 4.8, 4.16
 - AF Analyzer 6.59, 6.65
 - Hum & Noise 6.29, 6.34, 6.68
 - Modulation 6.18, 6.23, 6.26, 6.42
 - RX Audio Freq. Response 6.79
 - TX Audio Freq. Response 6.46
 - Subarrays
 - RX Audio Freq. Response 6.81
 - TX Audio Freq. Response 6.48
 - Supervisory audio tone (SAT) 4.52, 4.75
 - Symbolic evaluation of status register
 - Non Signalling 6.13
 - Signalling 6.109
 - Symbols (Signalling Mode) 3.2
 - Synchronization
 - remote control (NS) 6.12
 - remote control (Sig) 6.104
 - System clock 4.57
 - T**
 - Target Audio Peak Deviation 4.16, 6.37
 - Target Audio Pk. Dev. Err. Range 4.16
 - Target Dev. Type 4.16, 6.37
 - Target Deviation 4.8
 - Target Error Range 4.8, 4.32, 6.37
 - Target SINAD 4.32, 6.73
 - Test Tones
 - RX Audio Freq. Response 6.84, 6.85
 - TX Audio Freq. Response 6.51, 6.52
 - Tgt. SINAD Err. Range 6.73
 - Timeouts 4.87, 6.102
 - Tone Definitions 4.28
 - Total Freq. Dev. 6.87
 - Total Level 4.28, 6.54
 - Total Peak Deviation 4.13

Transmission reserve 4.49
 TX Audio Freq. Resp. (softkey) 4.22
 TX Audio Freq. Response
 Non Signalling 4.21
 remote control 6.45
 Signalling 4.68
 TX Audio Freq. Response (control)
 Non Signalling 4.25
 remote control 6.45, 6.46
 TX Audio Freq. Response Configuration
 Non Signalling 4.25
 remote control 6.46
 TX Tests
 Non Signalling 4.5
 remote control 6.17
 Signalling 4.66
 TX Tests (control)
 Non Signalling 4.15
 TX Tests Configuration
 Non Signalling 4.15
 remote control 6.18, 6.29, 6.37, 6.42

U

UNIT 6.91
 Update (software) 1.1
 Upper Limit Line
 RX Audio Freq. Response 6.82

TX Audio Freq. Response 4.27, 6.49
 Upper/lower case characters 5.7

V

VMAC 4.66, 4.82
 remote control 6.95, 6.101
 softkey 4.64
 Voice Ch. Offset 6.4, 6.6
 Voice Channel 6.6, 6.95
 BS signal 4.67
 BS Signal 4.85
 Call Established 4.75
 Overview 4.65
 Voice Channel (VC) 4.84, 6.97

W

Weighting 4.18
 Wideband Data 4.9
 remote control 6.41
 Wideband Data Peak Deviation 4.14
 Wideband power
 remote control 6.14
 Wideband Power
 Non Signalling 4.47
 Signalling 4.62
 Word Sync 4.14

Supplement to the Operating Manual for Software Option AMPS-MS for R&S CMU-B21

New Features in Version V3.60 and V3.61

Dear CMU Customer,

With the new software versions V3.60 and V3.61 of option R&S® CMU-K29, *AMPS-MS for CMU-B21*, your Universal Radio Communication Tester R&S® CMU200 provides an extended measurement functionality that could not be reported yet in the current revision of the operating manual, 1115.6888.12-06-. The following pages are to provide you with comprehensive information about the new features.

Compressor and Pre-Emphasis for External Modulation Signal	1
AF Level Search with Phone Compressor on.....	2
Test Signal with Low Crest Factor.....	3
SAT Measurement with Different Filter Bandwidths	4
FM TX Test Mode.....	4

Compressor and Pre-Emphasis for External Modulation Signal

The R&S CMU can generate a new type of modulation signal, modifying an external audio signal fed in via AUX 1 by means of two internal voice-processing stages. The modulation signal is particularly suited for electro-acoustic tests of CDMA2000/AMPS mobile stations according to the recommended minimum performance specification 3GPP2 C.P0056. The full range of tests specified in this standard (send and receive audio tests, loudness contrast measurement) can be performed using the acoustic test platform R&S UPL + CMU200.

The new signal *Mod. extern. ref.* is selected in the *AF/RF* ↻ tab of the *Connection Control* menu.

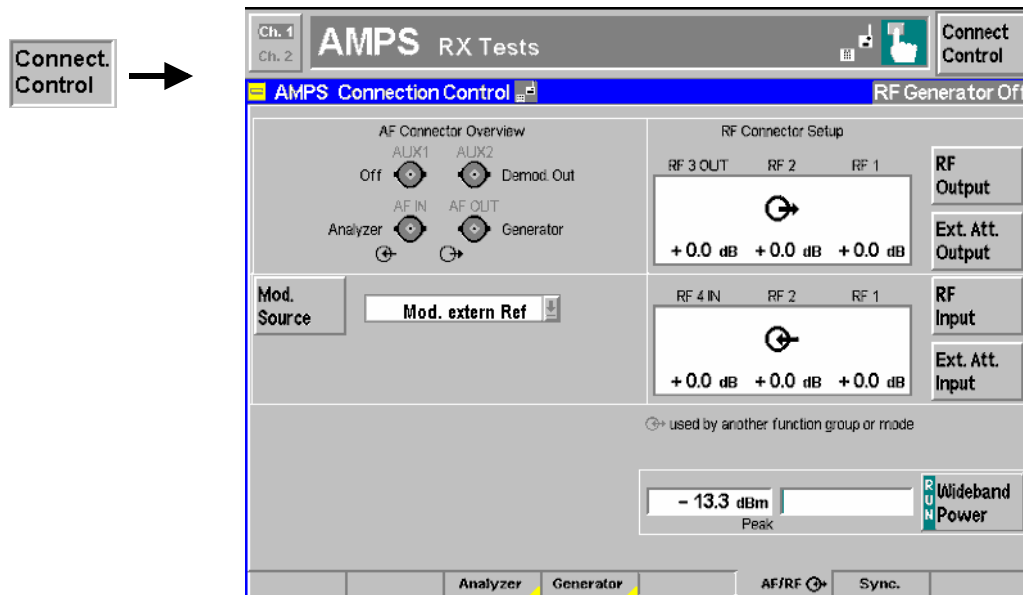

Fig. 1 Connection Control – AF/RF connectors

Mod. Source

The *Mod. Source* softkey selects the modulation signal.

The *Mod. intern* and *Mod. extern* signals are described on p. 4.54 of the operating manual. In addition the following signal is available:

Mod. extern ref. Use an arbitrary modulation signal fed in via AUX 1 at the front panel of the CMU and modified by a standard compressor and a pre-emphasis filter. The modified signal is modulated onto the RF carrier signal.



To comply with the standard test conditions stipulated in the performance specification 3GPP2 C.P0056, the sensitivity of the input AUX 1 is such that a 1004 Hz tone with a level of -18 dBm produces a ±2.9 kHz peak frequency deviation of the transmitted carrier. If the deemphasis filter and the expander in the audio receive path is switched on, a received 1004 Hz tone with a ±2.9 kHz peak frequency deviation produces a level of -18 dBm at the audio output connector AUX 2.

Due to the specifications described above the 20 kHz/1 V (peak) deviation gain for AUX 1 and AUX 2 quoted on p. 4.54 of the operating manual is no longer valid. The other properties of the audio input and output remain unchanged.

The external modulation signal may be composed of several tones, it may vary in time etc. The internal modulation generator is switched off when one of the external modulation signals is selected.

Remote control [SENSe:]AFConnect:MSource INTern | EXTern | EREF

[SENSe:]AFConnect:MSource <Source>		Mod. Source		
<Source>	Description of parameters	Def. value	Def. unit	FW vers.
INTern	Internal modulation signal from the mod. generator	INTern	-	V3.05
EXTern	External modulation signal fed in via AUX 1			
EREF	External signal modified by compressor and pre-emphasis			V3.60
Description of command				
This command selects the internal CW modulation signal or an external modulation signal to be modulated onto the RF carrier.				

AF Level Search with Phone Compressor on

An AF level search consists of repeated measurements at varying AF signal levels until a specified *Target Audio Peak Deviation* is found. The default *AF Level Search* algorithm is optimized for a scenario with phone compressor off. An alternative algorithm is available for mobiles with their compressor on.

The phone compressor state can be selected in the *TX Tests – AF Level Search* measurement menu using the *AF Level Search – Phone Compressor* hotkey.

Phone Compressor Selects an *AF Level Search* algorithm according to the mobile phone configuration.

On Algorithm for mobiles with compressor on

Off Algorithm for mobiles with compressor off

In general the R&S CMU is able to find the *AF Search Level* even with the wrong phone compressor setting. Adjusting the algorithm accelerates the measurement.

Remote control `CONFigure:TXTests:AFLSearch:CONTROL:PCOMPRESSOR ON | OFF`

CONFigure:TXTests:AFLSearch:CONTROL:PCOMPRESSOR <Enable>		Phone Compressor		
<Enable>	Description of parameters	Def. value	Def. unit	FW vers.
ON OFF	Select AF Level Search algorithm for mobile with compressor on or off	OFF	–	V3.60
Description of command				
This command selects the AF Level Search algorithm.				

Test Signal with Low Crest Factor

The *Tone Def.* tabs of the *TX Audio Frequency Response Configuration* and *RX Audio Frequency Response Configuration* menus configure an audio test signal composed of up to 20 test tones with different frequencies and levels. By default the tones are superimposed with equal phase, which means that the crest factor increases with the number of tones.

The *Crest Factor* parameter provides an alternative scheme of adding the test tones.

Crest Factor Selects the relative phase of the test tones.

Max Test tones are superimposed with equal phase; the audio test signal has a maximum crest factor.

Low The relative phase of the test tones is selected such that a lower crest factor is achieved. This setting is recommended in case that a high crest factor impairs the mobile phone compressor.

Remote control `CONFigure:RXAFresp:MODGenerator:FDEVIATION:CFACTOR MAX | LOW`
`CONFigure:TXAFresp:AFGenerator:LEVEL:CFACTOR MAX | LOW`

CONFigure:RXAFresp:MODGenerator:FDEVIATION:CFACTOR <Mode>		Crest Factor		
<Mode>	Description of parameters	Def. value	Def. unit	FW vers.
MAX LOW	Test signal with maximum crest factor Test signal with lower crest factor	MAX	–	V3.60
Description of command				
This command selects the relative phase of the individual test tones in the audio test signal with the aim of maximizing or lowering the crest factor.				

CONFigure:TXAFresp:AFGenerator:LEVEL:CFACTOR <Mode>		Crest Factor		
<Mode>	Description of parameters	Def. value	Def. unit	FW vers.
MAX LOW	Test signal with maximum crest factor Test signal with lower crest factor	MAX	–	V3.60
Description of command				
This command selects the relative phase of the individual test tones in the audio test signal with the aim of maximizing or lowering the crest factor.				

SAT Measurement with Different Filter Bandwidths

In the default configuration the Supervisory Audio Tone (SAT) is measured in a 20 Hz bandwidth. This filter bandwidth can be increased to 100 Hz, e.g. in order to avoid problems due to a large *SAT Frequency Error*.

Two independent SAT filter bandwidth settings are provided for the two *TX Tests* applications *Modulation* and *Hum & Noise*, respectively. The two parameters *SAT-Filter BW* are located in the *Filter* tab of the *TX Tests Configuration* menu.

CONFigure:TXTests:MODulation:FILTer:SFBW <Bandwidth>		SAT Filter Bandwidth		
<Mode>	Description of parameters	Def. value	Def. unit	FW vers.
F020 F100	SAT measured in a 20 Hz bandwidth SAT measured in a 100 Hz bandwidth	F020	–	V3.60
Description of command				
This command selects the filter bandwidth for the SAT measurement in the <i>Modulation</i> application.				

CONFigure:TXTests:HNOise:FILTer:SFBW <Bandwidth>		SAT Filter Bandwidth		
<Mode>	Description of parameters	Def. value	Def. unit	FW vers.
F020 F100	SAT measured in a 20 Hz bandwidth SAT measured in a 100 Hz bandwidth	F020	–	V3.60
Description of command				
This command selects the filter bandwidth for the SAT measurement in the <i>Hum & Noise</i> application.				

FM TX Test Mode

In *Non Signalling* mode the *TX Tests – Modulation* application provides a special test mode where the FM parameters are measured in a wide RF bandwidth (approx. 1.5 MHz instead of the 136 kHz quoted in the data sheet). The *FM TX Test* is appropriate for FM measurements over the whole acoustic range between 24 Hz and 16000 Hz.

Performing FM TX Tests

To obtain accurate *FM TX Test* results the de-emphasis filter, expander, and C-message weighted filter stages in the R&S CMU audio receive path should be switched off. The bandwidth of the programmable band pass filter is set automatically to cover the whole acoustic range. To activate the test,

1. Press *MENU SELECT* and activate the *Non Signalling – TX Tests – Modulation* measurement.
2. Press the *Modulation* measurement control softkey twice to open the *TX Tests Configuration* menu. In the *Filter* tab, deactivate the *De-emphasis*, the *Expander*, and the *Weighting* filter for the *Modulation* application.
3. Press *Modulation* again to close the configuration menu.
4. Activate the *FM TX Test* hotkey.

The *Filter* section of the *Setup* table shows a *Bandpass* of 6 ... 4000 Hz. Under the conditions of the *FM TX Test*, this corresponds to an effective pass band of 24 Hz to 16000 Hz. The SAT and ST detection is disabled during the test.

The FM TX Test is also accessible via *Non Signalling – Analyzer/Generator – Modulation*.

Remote control CONFigure:TXTests:MODulation:CONTRol:WBFMtest

CONFigure:TXTests:MODulation:WBFMtest <Enable>				FM TX Test	
<Enable>	Description of parameters	Def. value	Def. unit	FW vers.	
ON OFF	Enable or disable the test	OFF	–	V3.61	
Description of command					
This command determines whether the FM TX Test is enabled.					