

Speech coder for CDMA2000 audio measurements

The quality of a mobile phone is defined above all by its acoustic characteristics. When the audio signal is tested, the radio communication tester must be fitted with a speech coder. Due to the high complexity of the mobile radio standards cdmaOne and CDMA2000, no speech coder had been provided in a test set before now; the audio section of CDMA mobile phones was usually tested in the analog AMPS standard. Fitted with the new speech coder option, the R&S CMU200 is the first mobile radio test set capable of performing audio tests on CDMA mobile radios.

Market gap filled

Radio communication testers for digital-standard mobile phones primarily test their RF parameters, for example waveform quality (rho factor) and frequency error. The decisive factor for the acoustic quality of a mobile phone, however, is the audio signal. To verify the audio signal quality, a speech coder is required in the radio communication tester converting analog audio signals into digital signals, which are transmitted to the mobile phone after channel coding; plus, a speech decoder is needed to reconvert the digital signals coming from the receive direction into audio signals. While speech coders for GSM and TDMA (TIA/EIA-IS-136) for mobile radio testers have been on the market for some time, none was available for cdmaOne (TIA/EIA-95) and CDMA2000 (TIA/EIA-IS-2000). The R&S CMU 200 is now filling an important market gap.

The R&S CMU 200 currently supports the 8k speech coder (TIA/EIA/IS-96-B) as well as the 8k enhanced speech coder (TIA/EIA/IS-127, enhanced variable rate codec EVRC), i.e. service options 1 and 3. The 13k speech coder (TIA/EIA/IS-733), i.e. service option 17, will soon be available as well.

Speech coding: methods

Human speech can be described by means of a source filter model, which is based on the assumption that speech is generated in response to a time-variable filter with specific signals. Voiced sounds (vowels) can be modelled via a periodic pulse sequence, unvoiced sounds (consonants) via noise. The time-variable filter usually includes a formant synthesis filter or linear predictive coding (LPC) synthesis filter and a pitch synthesis filter.

For speech coding, there are two basic methods, analysis and synthesis (AaS) and analysis by synthesis (AbS). Analysis and synthesis are separate in the AaS method. The encoder extracts a parameter set which corresponds to the source filter model and transmits it to the decoder, which in turn reconstructs speech from the parameters received.

A better approach is the AbS method, for which the encoder provides a local synthesizer. A trial and error procedure determines the optimum parameters. This ensures good speech quality – even at lower data rates. The code excited linear predictive (CELP) algorithm is one procedure based on this method. A special feature of the QCELP (Qualcomm CELP) algorithm is its dynamic adaptation of the data rate, depending on signal energy, background noise and speech characteristics. The average data rate can thus be significantly decreased without impairing the speech quality. ►

More information and data sheet at
www.rohde-schwarz.com
(search term: CMU 200)

REFERENCES

- [*] Audio Analyzer R&S UPL – Measuring the acoustic characteristics of 3G mobile phones. News from Rohde & Schwarz (2002) No. 173, pp 15–17

► **Speech coding: several steps**

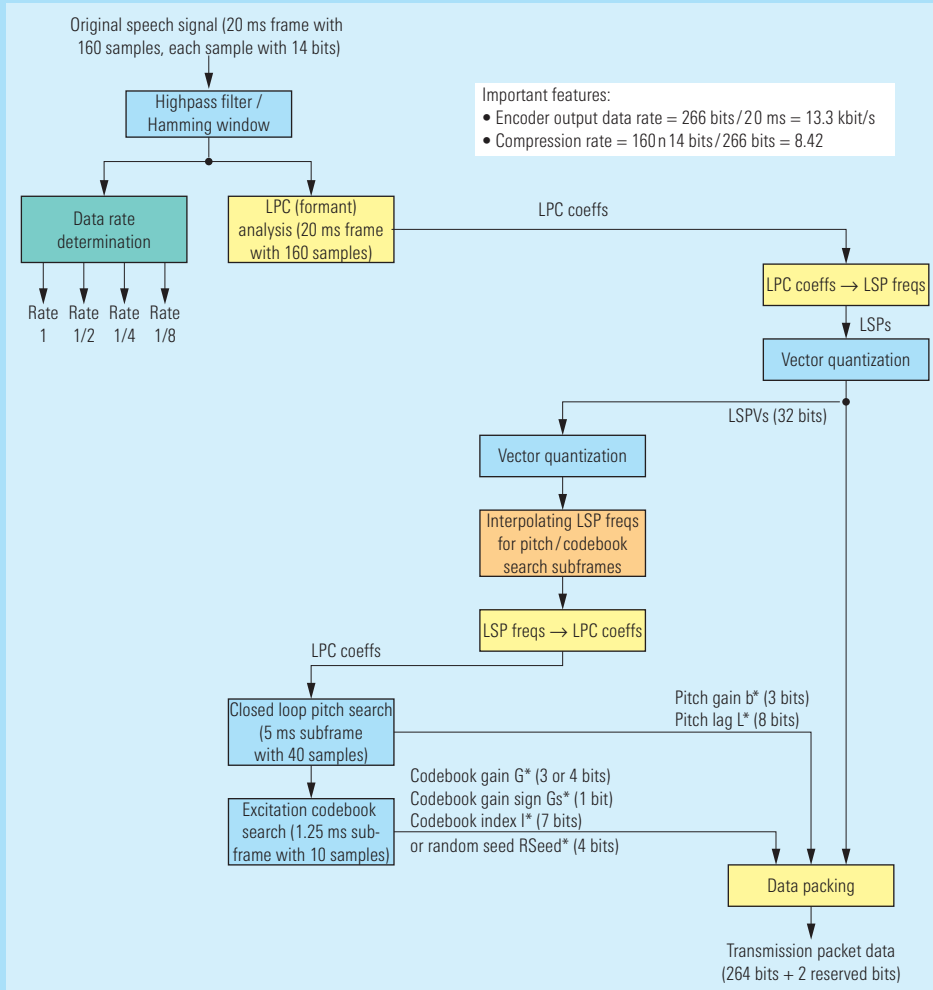

FIG 1 Coding process with LPC (formant) analysis, data rate determination, pitch search and codebook search by example of the 13k speech coder.

Coding is performed roughly in four steps (FIG 1):

- ◆ LPC (formant) analysis
- ◆ Data rate determination
- ◆ Pitch search (also referred to as long-term predictor, LTP)
- ◆ Codebook search

In a first step, the LPC (formant) is analyzed to find the optimum filter coefficients. A formant is a resonance frequency of the human vocal tract, discernible by a peak in the short-term spectrum. Each frame of the input signal (which is divided into 20 ms frames) first passes through a highpass and a Hamming window filter.

In a second step, the data rate is determined for each frame. Background noise and pauses are transmitted at 1/8 rate, unvoiced sounds at 1/4 rate, stationary, periodic and well-modelled frames at 1/2 rate; frames with speech transitions, non-periodic frames and frames that are poorly modelled are transmitted at full rate.

The third step is the pitch search. A pitch is the fundamental frequency of periodic signal sections in the human voice. The pitch search is based on subframes.

By means of the parameters thus determined, the vector, which best describes the input signal and thus minimizes the weighted error between input signal and synthesized signal, is selected from a codebook in the final stage.

Once these parameters (LPC filter and pitch filter coefficients, codebook vector) are transmitted, the synthesized speech signal is produced by filtering the codebook vector by means of the pitch synthesis filter and the formant synthesis filter (FIG 2).

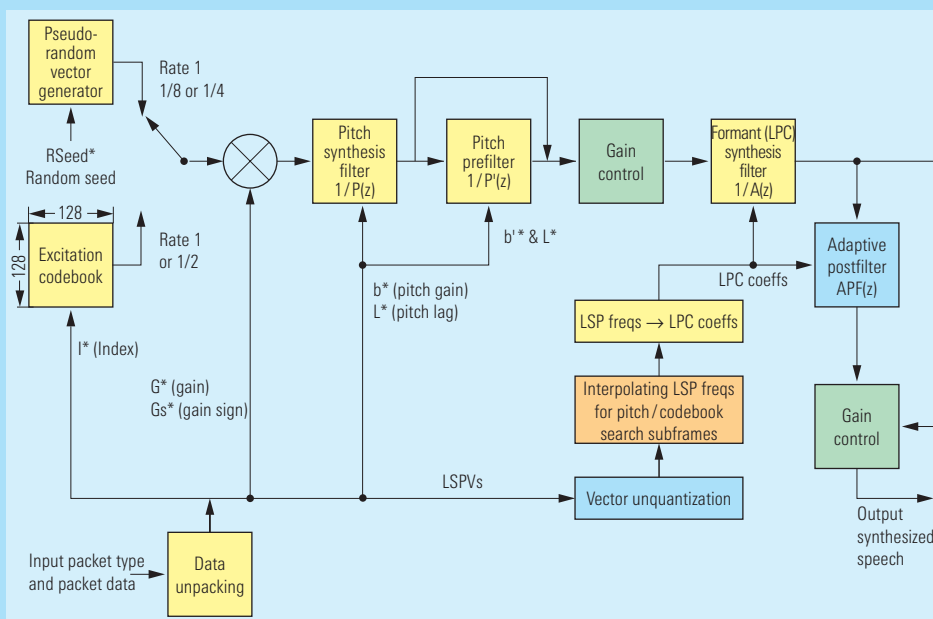

FIG 2 Generation of the synthesized speech signal by filtering the codebook vector by means of the pitch synthesis filter and the formant synthesis filter.

Everything under control with the R&S CMU200

The R&S CMU 200 allows user-friendly configuration of all parameters that are relevant to setting up a speech connection (FIG 3), particularly the service option and the associated radio configurations (RC).

The new speech coder option provides a wide variety of applications. With the appropriate setup, the R&S CMU 200 internal audio signal generator, for example, is able to generate a test signal for the forward link (base station to mobile phone) and the reverse link (mobile phone to base station) and evaluate the resulting audio signal by means of the AF analyzer (FIG 4). However, CDMA speech coders are not ideally suited for transmitting individual audio tones, but rather more complex signals that simulate a speech signal. For this purpose, the Audio Analyzer R&S UPL [*] can be connected to the R&S CMU 200, for example.

The new speech coder also allows testing of data transmission applications that operate with an analog modem. This is a common implementation, for example in automotive engineering, to set up emergency call systems.

Thomas Rösner; Peter Sterly

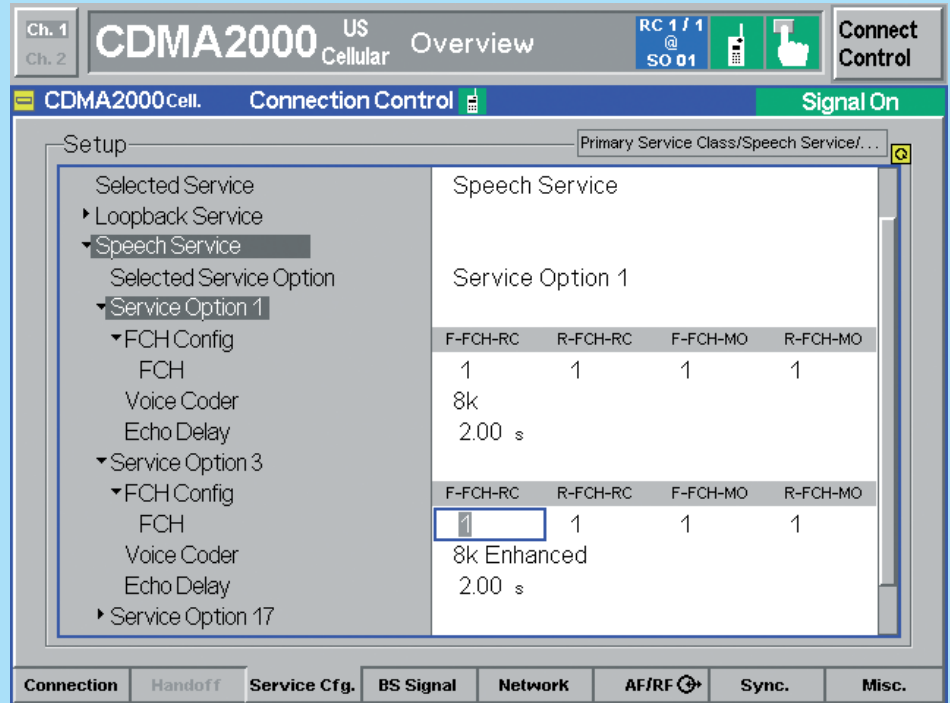

FIG 3 User-friendly configuration of all relevant base station, network and connection parameters in the R&S CMU200.

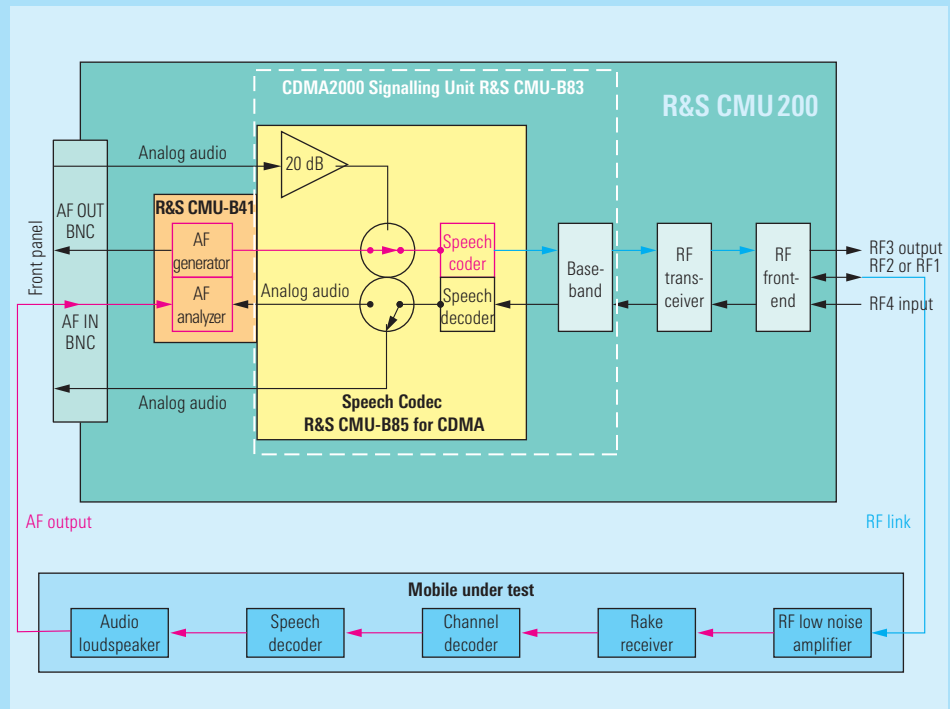

FIG 4 The block diagram shows the versatile tests that are possible with the R&S CMU-B85 speech coder in combination with an external audio analyzer (e.g. the R&S UPL) or the internal R&S CMU-B41 audio option.