

9343M LCR DATABRIDGE
USERS MANUAL

Racal Instruments Ltd
480 Bath Road
Slough
Berkshire
SL1 6BE

Issue No. 3
October 1990

W A R R A N T Y

Racal Instruments Limited warrants each instrument supplied by them to be free from defects in material and workmanship. Their obligation under this Warranty is limited to servicing or adjusting an instrument returned to the Racal Service Department for that purpose, and to making good in the Service Department any part or parts thereof which shall, within 3 years after making delivery, be returned with the transportation charges prepaid, and which upon their examination shall disclose to their satisfaction to have been thus defective. If the fault has been caused by misuse or abnormal conditions of operation, repairs will be chargeable at our prevailing service rates.

If a fault develops during the Warranty period, the steps should be taken:

1. Notify Racal Instruments, giving details of the problem including the Model Number and Serial Number.
2. Forward the instrument, carriage and insurance prepaid, to Racal Instruments and repairs will be carried out as quickly as possible. An estimate for non-Warranty repairs will be made before work begins.

TABLE OF CONTENTS

| <u>Section</u> | <u>Title</u> | <u>Page</u> |
|----------------|--|-------------|
| 1 | 1.0 GENERAL DESCRIPTION | 1 |
| | 1.1 Technical Specification | 1 |
| 2 | OPERATING INSTRUCTIONS | 3 |
| | 2.1 Introduction | 3 |
| | 2.2 Packing | 3 |
| | 2.3 Loose Shipping Items | 3 |
| | 2.4 Preparation for Use | 4 |
| | 2.5 Switching On | 4 |
| | 2.6 Connection to Component | 5 |
| | 2.7 Controls | 5 |
| | 2.8 Display | 8 |
| | 2.9 Range Indicator | 8 |
| | 2.10 User Prompts | 8 |
| | 2.11 Suggested Measurement Conditions | 10 |
| | 2.12 Connection of External dc Bias | 11 |
| 3 | 3.0 MEASUREMENT THEORY AND PRACTICE | 14 |
| | 3.1 Measurement Technique | 14 |
| | 3.2 Measurement Theory | 14 |
| | 3.3 Accuracy | 16 |
| | 3.4 Measuring Resistance on AC | 20 |
| | 3.5 Techniques to minimise lead errors | 20A |
| 4 | 4.0 MAINTENANCE | 21 |
| | 4.1 Performance/Operational Checks | 21/22 |
| | 4.2 Performance/Calibration Checks | 24 |
| | 4.3 RS232/IEEE Interface Operation Check | 27 |
| | 4.4 Calibration Check Interval | 29 |
| 5 | 5.0 OPTIONS AND ACCESSORIES | 30 |
| | 5.1 Test Leads and Plug | 30 |
| | 5.2 Chip Component Probes | 30 |
| | 5.3 Test Leads and Kelvin Clips | 30 |
| | 5.4 BNC Adaptor Box | 30 |
| 6 | 6.0 IEEE-488/RS232 INTERFACE OPERATION | 31 |
| | 6.1 Switch Settings | 31 |
| | 6.2 RS232 Interface | 32 |
| | 6.3 IEEE-488 Interface | 37 |
| | 6.4 Error Messages - Option 55 Interface | 40 |
| | 6.5 RS232 and IEEE-488 Commands | 40 |
| | 6.6 Remote Operation | 44 |
| | 6.7 Interactive Measurement | 45 |

LIST OF ILLUSTRATIONS & TABLES

| <u>Figure</u> | <u>Title</u> | <u>Page</u> |
|---------------|---------------------------------------|-------------|
| 2.1 | Recommended Measurement Conditions | 11 |
| 2.2 | Connection of an external bias supply | 13 |
| 3.1 | Vector Diagram | 15 |
| 3.2 | Graph of Accuracy v. Q | 17 |
| 3.3 | Graph of Accuracy v. Reading | 18 |
| 3.4 | Graph of Accuracy of Q v. Reading | 19 |
| 4.1 | Equipment for Maintenance and Service | 21 |

1.0 GENERAL DESCRIPTION

The Racal Dana 9343M LCR Databridge measures inductance, capacitance, resistance, D and Q, to a basic accuracy of $\pm 0.1\%$ of reading, for values up to 2000 H, 2000 μF , 1 M ohm and 99, respectively. Measurements can be made at frequencies of 100 Hz, 1 kHz or 10 kHz, as required, and either the Series Equivalent or Parallel Equivalent component values can be displayed. Range selection is fully automatic and the Databridge automatically discriminates between inductors, capacitors and resistors. The automatic mode can be manually cancelled to enable measurement of the minor term. An internal d.c. bias voltage of 2 Volts can be selected for use when testing electrolytic capacitors. The operating system of the Databridge provides assistance to the user, in selecting the measurement mode and frequency, to give best accuracy. Loss of basic accuracy due to measurement of the minor term in any component is also indicated. Measurements up to 9999 H, 9999 μF and 100 Mohm can be made, albeit at a degraded accuracy.

1.1 Technical Specification

| | |
|---|---|
| Variables measured | : R, L, C, D and Q |
| Modes | : Series or parallel equivalent |
| Measurement frequency | : User settable 100Hz, 1kHz or 10kHz |
| Accuracy of measurement frequency | : $\pm 0.01\%$ of nominal |
| Maximum voltage across component | : 0.3 V rms |
| Measurement update rate | : 2 per second |
| Maximum time for valid reading after user connecting component | : 1 second |
| Display | : 5 digit, 14 mm LED with automatic decimal point |
| Connection to component under test | : 4 terminal integral test jig |

Measurement ranges

| | |
|---|-------------------------|
| R | : 0.1m ohm to 990 M ohm |
| L | : 0.001 uH to 9900 H |
| C | : 0.001 pF to 9999 uF |
| D | : 0.001 to 999 |
| Q | : 0.001 to 999 |

Basic accuracy : $\pm 0.1\%$ of reading
 ± 1 digit

Ultimate resolution

| | |
|---|-------------|
| L | : 0.001 uH |
| C | : 0.001 pF |
| R | : 0.1 m ohm |

Conditions for basic accuracy

| | | | |
|-------------------------------|----------------|----------------|----------------|
| Measurement frequency | : 100 Hz | 1 kHz | 10 kHz |
| Range of inductance (Q > 10) | : 4mH - 2000H | 400uH - 200H | 40uH - 10H |
| Range of capacitance(Q > 10) | : 4nF - 2000uF | 400pF - 200uF | 40pF - 10uF |
| Range of resistance (Q < 0.1) | : 2ohm - 1Mohm | 2ohm - 500kohm | 2ohm - 100kohm |

Input protection : The input is protected
against connection of capacitors
of up to 10 mF charged to not
more than 50 V

Operating temperature range : -0°C to $+50^{\circ}\text{C}$ (useable -5°C to $+55^{\circ}\text{C}$)

Power supply : 188V to 265V 45Hz to 66Hz
(Switch selectable) 94V to 127V 45Hz to 66Hz
188V to 212V 360Hz to 440Hz
108V to 122V 360Hz to 440Hz

Fuse rating : For nominal 240V : 20mm 160mA anti surge
For nominal 120V : 20mm 630mA anti surge

Size : 440 mm x 250 mm

Weight : 7.0 kg.

2.0 OPERATING INSTRUCTIONS

2.1 Introduction

This Section of the manual contains information on the correct operation of the Racal Dana 9343M LCR Databridge. It is recommended that the contents of this Section are read and understood before attempting to operate the instrument. Should any difficulties arise during operation, please contact:

| | |
|-----------------------------|--------------------------|
| Racal Dana Instruments Ltd, | Telephone: (0628) 604455 |
| 480 Bath Road, | Telex: 847020 |
| Slough, | Fax: (0628) 662017 |
| Berks. SL1 6BE | |

2.2 Packing

The Racal Dana 9343M LCR Databridge was shipped in packing materials especially designed to provide adequate protection. On receipt, please inspect the instrument for possible transit damage.

If reshipment of the instrument is ever necessary, it is advisable to use the original packing. If this is not available, a new pack can be obtained from Racal Dana Instruments Limited.

2.3 Check to CES 46300

On unpacking the Racal Dana 9343M LCR Databridge, check that the following items are present:

- i) Racal Dana 9343M LCR Databridge
- ii) Accessory Pouch containing
- iii) Three core mains cable with moulded-on IEC socket and 13A plug
- iv) User's Manual
- v) One pair of adaptors for measuring axial lead components complete with support plate, M3 screw and washer
- vi) 1401 Remote test lead
- vii) 3401 Remote test lead with clips
- viii) Fuse 630mA (for 110V mains operation)

2.4 Preparation for Use

Ensure the Voltage Selector Switch on the side of the unit, beside the main switch, is set to the required nominal voltage and that the correct fuse is fitted – See 1.1 Fuse Rating.

2.5 Switching On

Plug the mains cable into the IEC connector at the rear of the left hand side of the instrument. Now plug the other end into a suitable mains outlet. To switch on the instrument operate the rocker switch located next to the instrument's mains inlet connector. The displays, range and function indicators will light. The Databridge then performs a self-calibration routine which takes approximately ten seconds, indicated by the display counting down from 9 to 0. The Databridge is now ready for use and will have initialised to AUTO mode, PARALLEL, 1KHz.

2.6 Connection to Component Under Test

The Databridge's integral test jig accepts most common diameters of component leads. Radial lead components can be plugged directly into the jaws, which will spring apart with gentle insertion pressure. The insertion of components with particularly flexible leads will be aided by operation of the release bar situated directly in front of the test jig.

To avoid bending the leads of axial lead components, in order to insert them into the test jig, the axial lead adaptors may be used. These should be plugged into each side of the test jig and their separation adjusted to accommodate the component to be measured. The leads of the component can then be positioned across the jaws of the two adaptors.

It should be noted that, when the adaptors are in use and no component has been connected, the connections to the four terminal test fixture on the LCR Databridge are isolated from one another. This may cause random digits to appear on the display. However, on connecting a component to the adaptors, the instrument will read normally.

A support plate is provided for use in circumstances where the axial lead adaptors must be fixed fairly rigidly, for example, when testing a large number of similar components. To fit the support plate, first adjust the axial lead adaptors to the correct position. Now place the support plate over the adaptors so that each protrudes through one of the slots. Now position the plate, so that the fixing screw aligns with the threaded hole on the Databridge's front panel, then tighten up the fixing screw. Take care not to overtighten.

Remote test leads may be used where it is not practical to directly connect the component to be tested to the Databridge. See Section 5, Options and Accessories.

WARNING

Although the Databridge includes protection against the effects of connection of pre-charged capacitors to the measurement points, it is advisable where there is a possibility that a capacitor has been pre-charged, to discharge it through a suitable resistor.

2.7 Controls

The controls consist of eight momentary action push buttons situated to the right of the display panel. Each button has associated with it one or two red LEDs to indicate the state of the function selected by that button.

On pushing any button, the function controlled by that button will change state. The button must be released and pressed again before the state can be changed once more.

2.7.1 LC-R Auto Button

This button determines the mode of operation of the Databridge. On power up it is set to AUTO. The component under test is identified as either a capacitor, inductor or resistor and the measured value is displayed.

Pressing the button once sets the Databridge to the LC MODE. The reactive component (inductance or capacitance) of the device under test is measured and displayed. NOTE: this could be the major term of a capacitor or inductor or the minor term of a resistor.

Pressing the button again sets the Databridge to the RESISTANCE MODE and the resistive component of the device under test is measured and displayed NOTE: this could be the minor term of a capacitor or inductor or the major term of a resistor.

Pressing the button again sets the Databridge back to AUTO, both indicators are lit (LC and R).

In the AUTO mode the criterium used by the bridge to decide if a component is to be displayed as a resistance or reactance is the component's Q. If $Q < 0.5$ the component is taken to be a resistance, and conversely $Q > 0.5$ the component is taken to be reactive. This implies that low Q reactors may be displayed as resistors and high Q resistors displayed as reactors. In the AUTO mode both the Ser-Par and Bias buttons are inoperative. Pressing one of these buttons causes the display to flash "Auto", momentarily, to alert the operator. It is necessary to leave the AUTO mode, in order to change the equivalent circuit, or apply bias voltage.

2.7.2 Ser-Par Button

The equivalent circuit of a component under test can be expressed either in terms of its series or its parallel equivalent values at the given frequency.

In order to display the equivalent series values the SER indicator should be lit; to display the equivalent parallel values, the PAR indicator should be lit. Note that for inductors and capacitors with a high Q, or for resistors with a low Q, the equivalent values of the major term (i.e. inductance for inductors, capacitance for capacitors, resistance for resistors) will be virtually identical in the two modes.

2.7.3 100Hz, 1kHz, 10kHz Button

This button selects the frequency at which the measurement is made, i.e. press the Freq button until the required frequency is selected. The choice of measurement frequency depends on the type of component under test. It is important to note that, to obtain full use of the Databridge's extended measurement ranges on inductance and capacitance measurement, the correct measurement frequency must be selected. High values should be measured at 100 Hz, low values at 1 kHz or 10 kHz. The Databridge's automatic prompt system will suggest a change of frequency, when necessary, by flashing the frequency indicator.

2.7.4 Q Button

When Q measurement has been selected, the Q indicator will be lit and all of the Range Indicators will be extinguished.

2.7.5 D Button

When D measurement has been selected, the D indicator will be lit and all of the Range Indicators will be extinguished.

2.7.6 Bias Button

The button labelled Bias may be operated in order to provide a 2 Volt polarising voltage for use when measuring electrolytic capacitors. Note that the Databridge requires about thirty seconds to settle after application or removal of the bias voltage.

During the settling period, the display will show "bIAS". Once the display of "bIAS" has disappeared, components can be connected and measured at the normal operating speed of the instrument and no further settling delays will occur.

To remove the Bias Voltage, press the Bias button again and wait for the "bIAS" display to disappear.

2.7.7 Zero C Button

The Zero C button enables stray capacitance in the test fixture (up to a maximum of 99.9 pF) to be zeroed. The capacitance measured when Zero C is first enabled is subtracted from all further measurements until Zero C is disabled by pressing the button again.

Values outside this range, inductive or resistive values will cause the display "C or" or "Not C" and the function will not be performed.

2.7.8 Hold Button

This button freezes the display and holds the value being measured at the instant the hold button is pressed. This button has a particular significance when using the IEEE - 488/RS232 interface.

Other buttons pressed while hold is invoked will be ignored and the display will show "hold".

2.8 Display

The measured value is displayed on a five digit, seven segment, LED display. The decimal point is set automatically. Under certain measurement conditions, the measured value will not be displayed using all five digits. This is because the Databridge has determined that the undisplayed digits will be sufficiently unstable as to be unusable, due to the type of measurement which it has been set to perform.

If the most significant digit of the display is "1" or "2", the Databridge will use a maximum of five digits. Where the most significant digit is 3 thru 9, four digits will be used.

The display of high value capacitance is of particular note. The very low impedance of large capacitors causes measurement uncertainties that do not justify the display of five digits. If the displayed value lies between 10,000 and 29,999 uF, the last digit will always be zero. If the displayed value lies between 30,000 and 99,999 uF, the last two digits will be zero.

2.9 Range Indicators

The units, in which the measured value is being displayed, are indicated on the Range Indicators to the right of the numerical display.

Note that, as D and Q are dimensionless quantities, when these are displayed, no Range Indicators will be lit.

2.10 User Prompts

The LCR Databridge is provided with User Prompt services which are intended to guide the operator to obtain the most accurate measurement and to indicate when the measurement cannot be made to the basic accuracy of $\pm 0.1\%$

2.10.1 Low Accuracy Prompt

Whenever the Databridge is set to display a value which it cannot measure to the basic accuracy, it will make the measurement but will indicate Low Accuracy by flashing the Range Indicator in use, once per second. In addition, if there is some change which the operator can make to the controls to improve the accuracy, this is indicated by flashing the appropriate Control Indicator.

The internal system, which determines that an accurate reading is or is not possible, operates by inspecting the relative and absolute magnitudes of the actual currents and voltages in the component under test. The Databridge's published specification is a general one covering the minimum operating performance over a wide range of measurement ranges and modes. However, with particular component values, the Databridge may continue to measure within its basic accuracy even, for example, under adverse Q conditions. As the Low Accuracy Prompt is determined by the real measurement conditions, it does indicate whether the displayed reading is actually within the basic accuracy of the instrument or not. This may often far surpass the published specification.

2.10.2 SER-PAR Prompts

Although the Databridge provides the option of displaying equivalent Series or Parallel component values, under adverse Q conditions it may not be possible to obtain the basic accuracy in both modes. When a mode change is required to improve accuracy, this is indicated by the SER or PAR indicator flashing. If this occurs, the SER-PAR button may be operated to change mode and thus improve accuracy.

2.10.3 Frequency Prompt

If the measurement accuracy can be improved by a change of frequency the associated frequency indicator will flash.

2.10.4 Key Error Prompts

| <u>Display</u> | <u>Meaning</u> |
|----------------|--|
| Auto | Auto mode has been selected so Ser-Par and Bias keys are inoperative |
| bIAS | Bias mode is being entered or exited, the display indicates the unit is settling and components cannot be measured |
| C or | Zero C has been pressed when the measured value of the capacitance of the test fixture is greater than 99.9 pF |
| Not C | Zero C has been pressed when the measured value is resistive or inductive – a component has probably been left in the fixture or R has been selected |
| hold | A key other than hold has been pressed while in hold mode |
| or | The component being measured is outside the specified range of the unit |
| rrrr | A key has been pressed while in Remote mode, see Section 2.17 |
| Error 1-6 | An error has occurred either due to calibration of the unit or a failure in communication to the IEEE-488/RS232 Interface. Switch unit off, then on again after a short delay, if error persists consult your dealer |

2.11 Suggested Measurement Conditions

Whilst the Databridge is capable of providing both Series and Parallel equivalent values of components, at frequencies of 100 Hz, 1 kHz and 10 kHz, we recommend that certain types or values of components are measured in specified ways. This is to achieve measurements which have the most relevance either to the physical form of the component or to the manner in which it is most commonly used. For example, large value electrolytic capacitors are often used for power supply smoothing applications with a typical ripple frequency of 100 Hz. Due to physical factors the capacitance value of a large electrolytic will fall significantly as frequency increases and therefore measurement at 100 Hz is most appropriate. The loss term of such capacitors is usually expressed as Equivalent Series Resistance (ESR) and therefore the Series capacitance and resistance value should be measured.

A table of recommended measurement conditions is given below.

Fig. 2.1 Recommended Measurement Conditions

| <u>COMPONENT</u> | | <u>FREQUENCY</u> | <u>SER or PAR</u> |
|------------------|-------------------------|------------------|-------------------|
| Capacitor | 1 uf | 1 kHz | PAR |
| Capacitor | 1 uf (non-electrolytic) | 100 Hz | PAR |
| Capacitor | 1 uf (electrolytic) | 100 Hz | SER |
| Capacitor | 400 pF | 10 kHz | PAR |
| Inductor | 1 H | 1 kHz | SER |
| Inductor | 1 H | 100 Hz | SER |
| Inductor | 400 uH | 10 kHz | SER |
| Resistor | 10 kohm | 100 Hz | SER |
| Resistor | 10 kohm | 100 Hz | PAR |

2.12 Connection of External d.c. Bias

Electrolytic capacitors are normally measured whilst biased to a suitable d.c. voltage. A 2 volt internal bias is available for this purpose and the use of the bias control is explained in Section 2.7.6. A bias voltage of 2 V should be suitable for almost all such measurements.

If, however, a different bias voltage of up to 50 V, is required, it is possible to connect an external d.c. supply to achieve this. A full floating mains power supply or a battery may be used as external d.c. bias sources. Mains power supplies should have a ripple voltage of less than 2 mV peak to peak.

To connect an external d.c. bias supply, it is necessary to achieve a separate electrical connection between the two jaws of the +ve (i.e. right hand) side of the Databridge's test jig. This connection may be made by using separate Remote Test Leads supplied, Part No: 1401 (Remote Lead Adaptor Box). The remote lead adaptor is plugged into the jaws of the test jig and wired to an external power supply as shown in Fig 2.2. The remote leads are terminated in two pairs, red and white plus two screens and blue and yellow plus two screens. The red and white pair are connected to the external power supply, white to the +ve terminal and red to the negative terminal, the screens are not used in the application. The blue and yellow wires are connected together. Note the positive side of the capacitor should go to the positive connection of the external power supply and the negative side of the capacitor should go to the blue and yellow wires.

The Databridge's internal circuitry may require at least 30 seconds to settle, after connection of the external supply, and no stable readings will be obtained during this period.

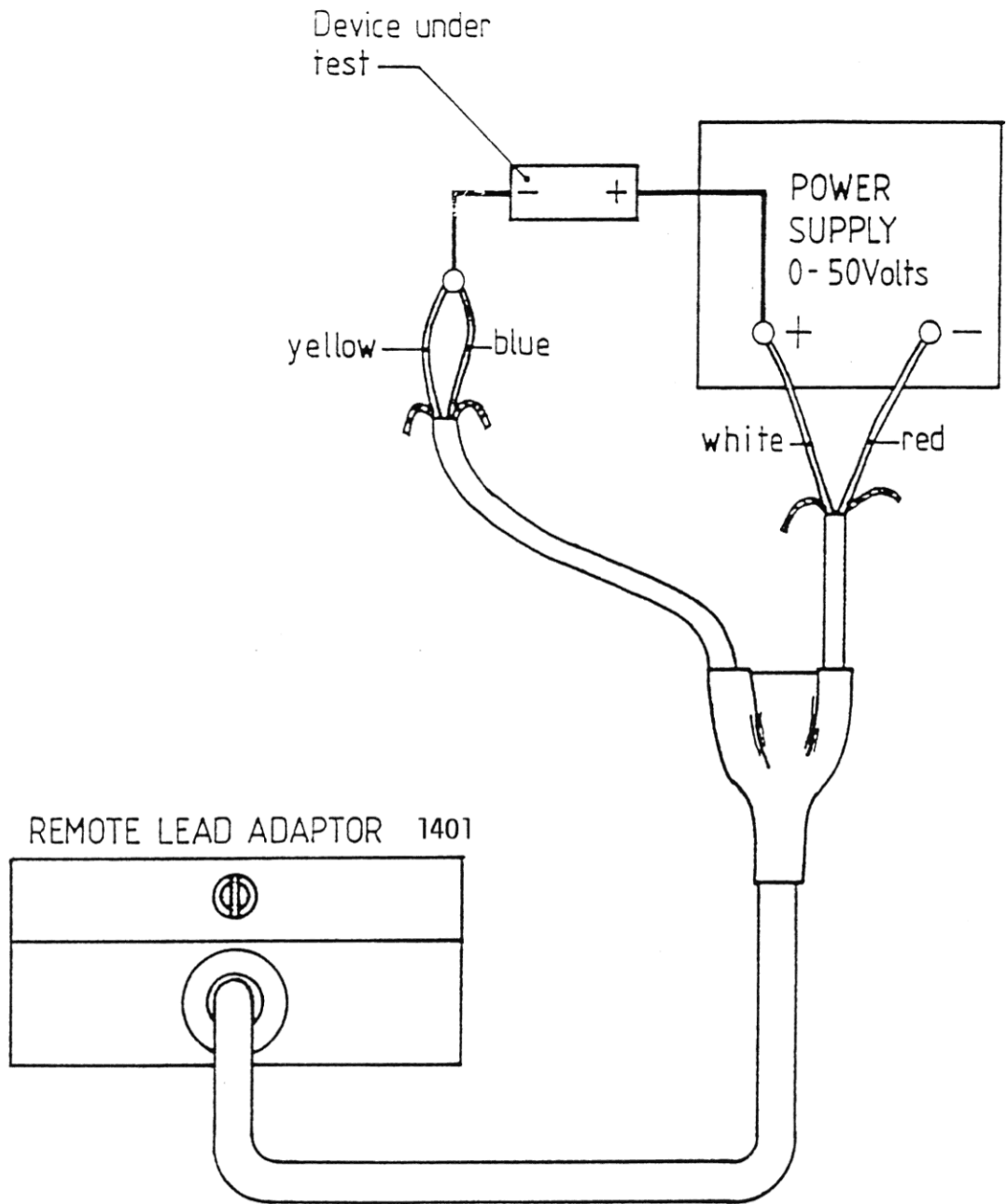

Fig. 2.2 Connection of an external power supply to bias electrolytic capacitors.

3.0 MEASUREMENT THEORY AND PRACTICE

3.1 Measurement Technique

The Racal Dana 9343M LCR Databridge computes the value of the component under test after making measurements of the voltage across and the current through the component. The component is stimulated by a sinusoidal voltage at an accurately known frequency, derived from a crystal oscillator. Two reference square wave signals are also produced at the same frequency. The phase relationship between these two signals is exactly one quarter of a cycle, or ninety degrees. The voltage, across the component, and the current through it, are each measured relative to these two reference signals, which provide, in effect, two phase references in quadrature with one another. Computation of the equivalent series or parallel reactance or resistance is a simple arithmetic operation once the four voltage and current values have been determined. The polarity of the reactance term indicates whether the reactance is capacitive or inductive. The value of the reactive component is then computed from the reactance value, as the frequency of measurement is accurately known.

3.2 Measurement Theory

The Databridge uses a Phase Sensitive Analogue to Digital Convertor (PSADC) to measure the voltage and current resolved into each of the two orthogonal reference vectors. The PSADC has a transfer function of the form $KV\cos A$ where K is a scaling constant, V is the amplitude of the voltage being measured and A is the phase angle between this voltage and the phase reference to the PSADC. The current through the component under test is measured in terms of a voltage derived by a precision current to voltage convertor. These voltage and current

measurements, resolved into the two reference vectors are indicated in Fig. 3.1.

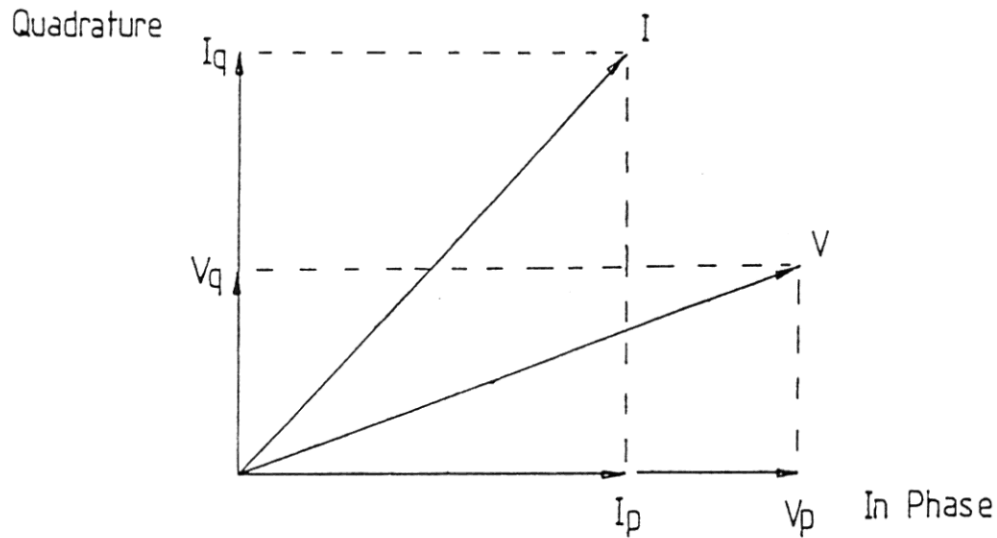

Fig. 3.1 Vector diagram showing the voltage (V) and current (I) of the component under test, measured in two reference vectors.

To compute, for example, the equivalent series resistance term, it is necessary to compute the component, of each of the two voltage measurements, in phase with the current vector I . The component of the in-phase voltage, V_p , in the same phase as the current vector I is $\frac{V_p \times I_p}{I}$.

Similarly, the component of the quadrature voltage, V_q in the same phase as the current vector I is $\frac{V_q \times I_q}{I}$. Therefore the total voltage in phase with I is $\frac{V_p I_p + V_q I_q}{I}$.

To obtain the series resistance R_s , this voltage must be divided by the current I , so

$$R_s = \frac{V_p I_p + V_q I_q}{I^2} = \frac{V_p I_p + V_q I_q}{I_p^2 + I_q^2}$$

Similarly, it can be shown that the equivalent series reactance is given by

$$X_s = \frac{V_q I_p - V_p I_q}{I_p^2 + I_q^2}$$

The equivalent parallel resistance is given by: $R_p = \frac{V_p^2 + V_q^2}{V_p I_p + V_q I_q}$

The equivalent parallel reactance is given by: $X_p = \frac{V_p^2 + V_q^2}{V_q I_p - V_p I_q}$

The Q of a component is given by: $Q = \frac{X_s}{R_s} = \frac{R_p}{X_p} = \frac{V_q I_p - V_p I_q}{V_p I_p + V_q I_q}$

3.3 Accuracy

As with all instruments designed to measure passive components, the accuracy of measurement, which can be achieved, depends on a number of factors, which may change from one measurement to the next. The factors are:

- i) The measurement type – reactance or resistance
- ii) The frequency at which the measurement is made
- iii) The magnitude of the measured value
- iv) The Q of the component being measured

The specification of the Databridge states that, within certain boundaries determined by these factors, the accuracy achieved is $\pm 0.1\%$ of reading ± 1 digit. However, to make full use of the extended range capability of the Databridge, it is important to be able to estimate the accuracy of measurement beyond these boundaries. This variation is described in the following sections.

3.3.1 Accuracy Variation with Q

Fig. 3.2 shows a graph indicating the typical variation of measurement accuracy as Q varies. Note that, although the basic accuracy of the instrument is guaranteed for Qs greater than 10 (reactance measurements) and less than 0.1 (resistance measurements), the Databridge's typical performance is considerably better than this and full accuracy is generally achieved for Q greater than 1 (reactance measurement) and less than 1 (resistance measurement). The user is able to confirm this as the Databridge signals a loss of basic accuracy by flashing the Range Indicator.

Fig. 3.2 Graph showing a typical variation of measurement accuracy as Q varies. (N.B.) The Q scale for reactors (x) is the inverse of the Q scale for resistors (R)).

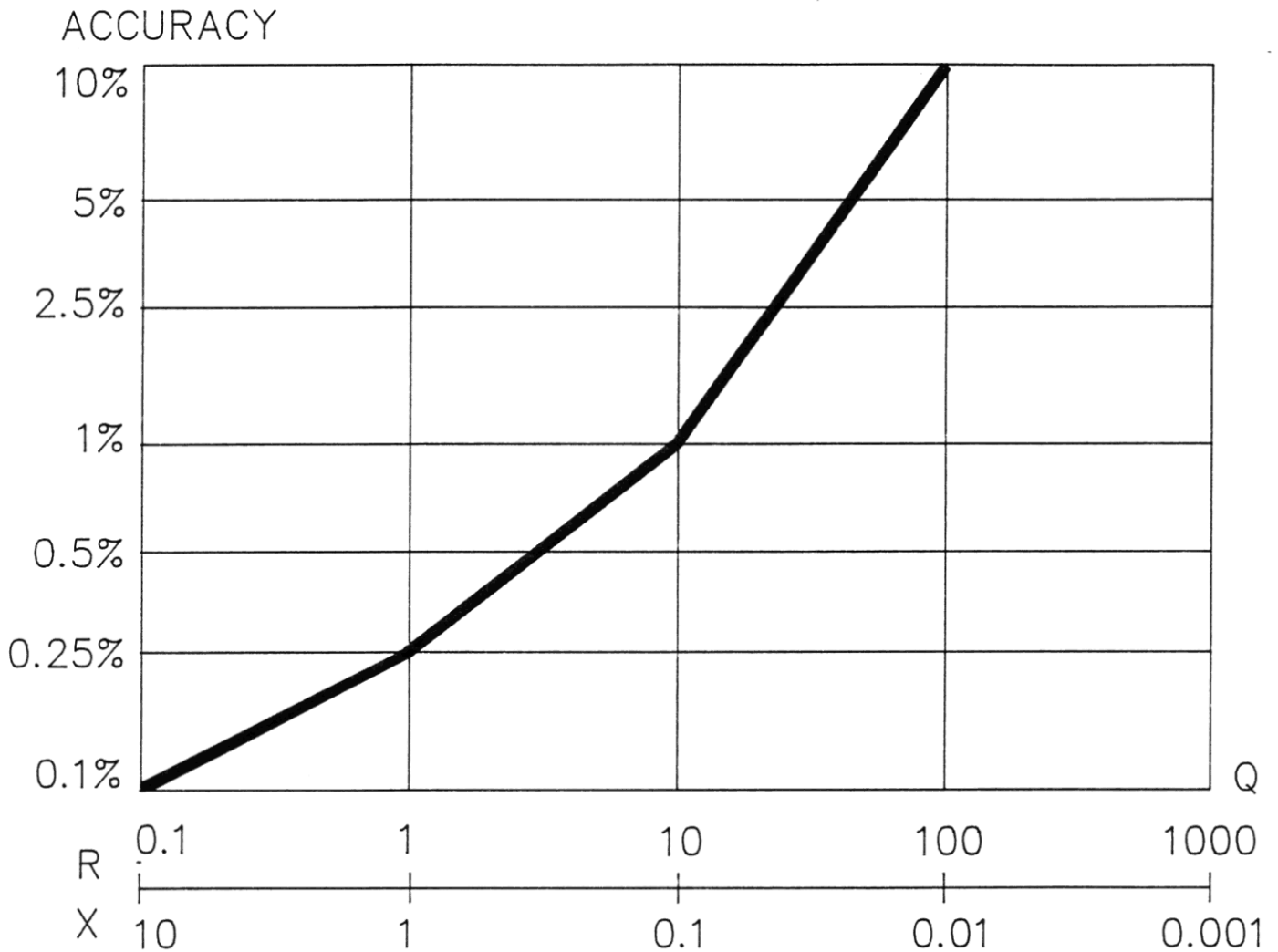

3.3.2 Accuracy Variation with Range Extension and Frequency

Fig. 3.3 shows the typical variation of accuracy with the magnitude of the value measured, both at 100 Hz and 1 kHz measurement frequencies, where the Q of the component under test is respectively less than 10 or greater than 0.1 for reactance and resistance measurement.

Fig. 3.3 Graph showing typical variation of accuracy with reading at 100Hz, 1kHz and 10kHz
 $Q > 10$ for L & C. $Q < 0.1$ for R.

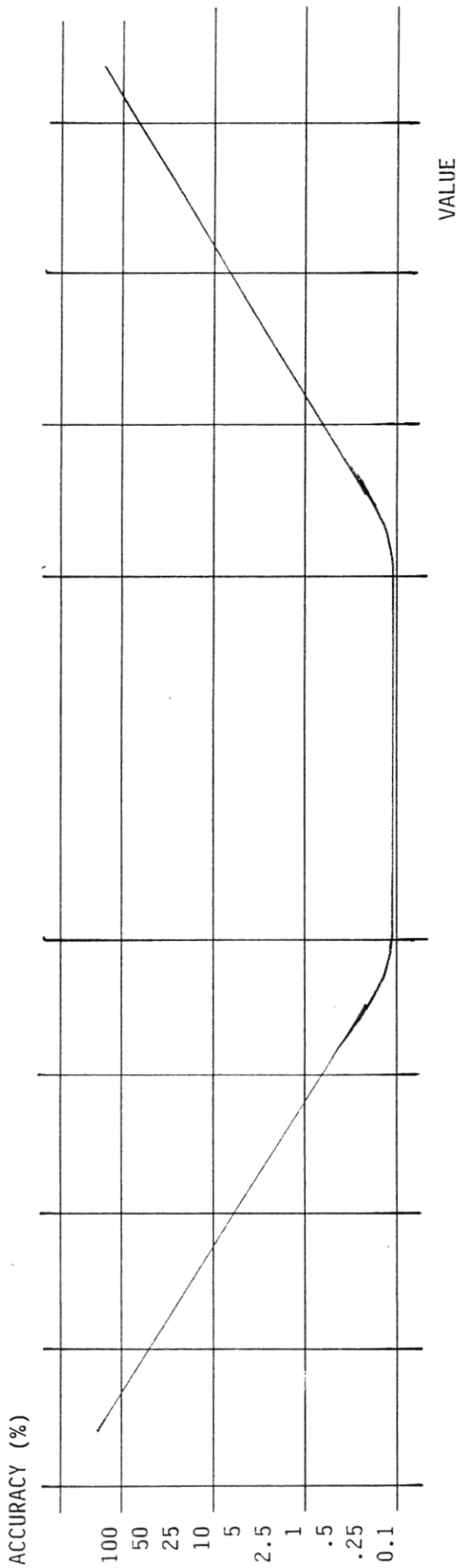

| | | | | | | | | | |
|---------|--------|--------|---------|-------|---------------|---------|---------|---------|---------|
| 0.2mohm | 2mohm | 20mohm | 200mohm | 2ohm | 100Hz (120Hz) | 1Mohm | 10Mohm | 100Mohm | 990Mohm |
| 0.4pF | 4pF | 40pF | 400pF | 4nF | 100uH | 2000uF | 20mF | 100mF | |
| 0.4uH | 4uH | 40uH | 400uH | 4mH | | 2000H | 10,000H | | |
| 0.2mohm | 2mohm | 20mohm | 200mohm | 2ohm | 1kHz | 500kohm | 5Mohm | 50Mohm | 500Mohm |
| 0.04pF | 0.4pF | 4pF | 40pF | 400pF | | 200uF | 2mF | 20mF | 100mF |
| 0.04uH | 0.4uH | 4uH | 40uH | 400uH | | 200H | 2000H | 10,000H | |
| 0.2mohm | 2mohm | 20mohm | 200mohm | 2ohm | 10kHz | 100kohm | 1Mohm | 10Mohm | 100Mohm |
| 0.004pF | 0.04pF | 0.4pF | 4pF | 40pF | | 10uF | 100uF | 1mF | 10mF |
| 0.004uH | 0.04uH | 0.4uH | 4uH | 40uH | | 10H | 100H | 1000H | 10,000H |

3.3.3 Accuracy of Q Measurement

The Databridge measures Q to a basic accuracy of $\pm 0.1\% \pm 1$ digit, for Q values from 0.25 to 4. Outside of this range, the accuracy is degraded so that, at Qs of 0.01 or 100 the accuracy is $\pm 3.5\% \pm 1$ digit. A graph, showing the typical variation of Q accuracy with the value of Q measured, is shown in Fig. 3.4.

Fig. 3.4 Graph showing the typical variation of Q accuracy with the value of Q

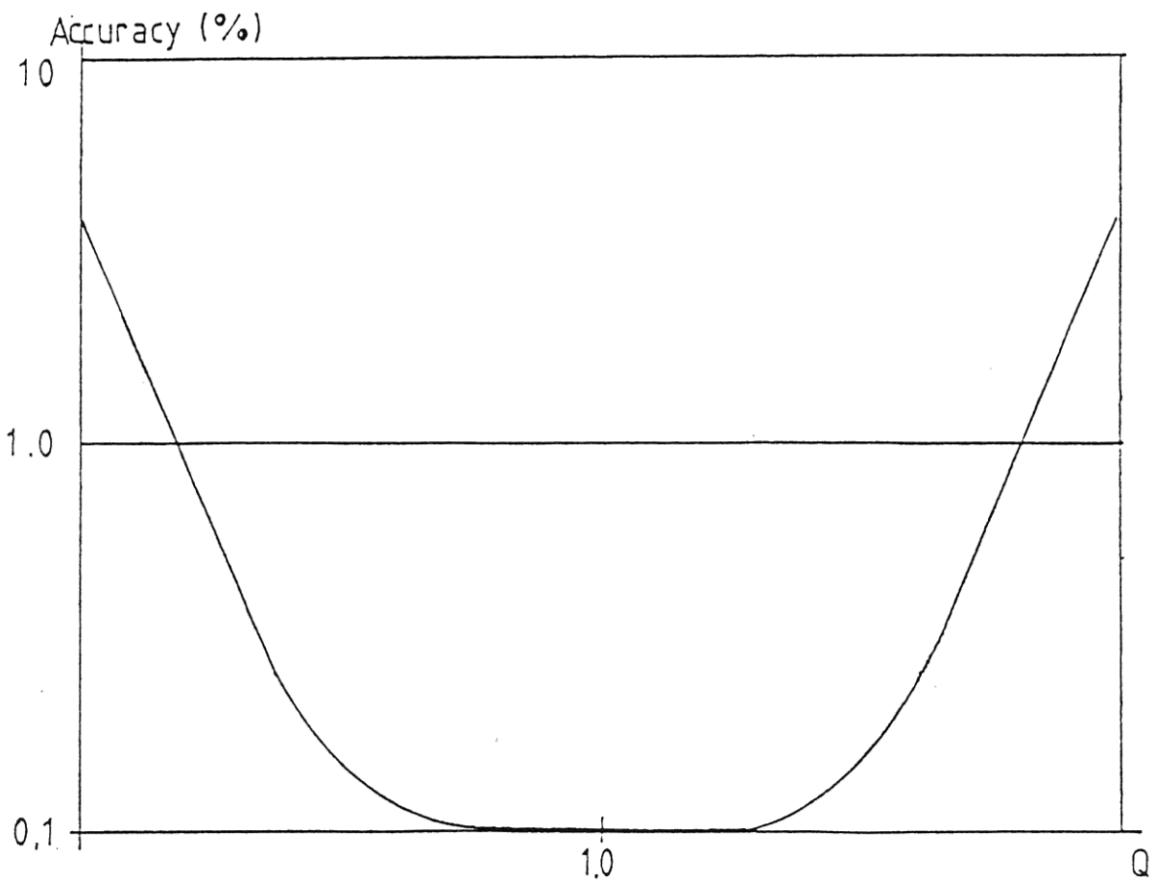

3.3.4 Dealing with Two Error Terms

In some measurements, outside the conditions in which the Databridge achieves its basic accuracy, the effects of both the Range Extension and the Low Q error terms may apply. In order to estimate the likely magnitude of the combined error effect, it is possible to sum the two error terms to provide a worst case error figure. However, as the error sources are not usually correlated, it is highly unlikely that this worst case figure would be ever obtained in practice. A realistic and practical method of computing the error term is to take the square root of the sum of the squares of the contributing error terms.

3.4 Measuring resistance on A.C.

The value of a resistor measured by alternating current will seldom agree with its known d.c. value.

This is because all resistors have some parallel capacitance and some series inductance however carefully they are designed. These parasitic reactances will have associated losses which must appear as a resistance added to, or subtracted from, the resistor.

At low frequencies the effect may be negligible, but at higher frequencies it may cause a very large difference between the d.c. and a.c. values.

This is particularly so in the case of resistance standards intended for use on d.c. bridges.

These standard resistances are constructed to provide long term stability, and little attention is paid to the a.c. performance. Most types consist of a wire element wound onto a metal former, which accentuates the inter winding capacity and couples inductively to the winding. The insulation covering the wire forms the dielectric of the inter winding capacitance and this may well have high a.c. losses.

The inductive coupling will induce a.c. currents into the metal former with consequent losses in the resistance of the former. The practical result of these effects is that the dielectric losses cause an apparent reduction, and the inductive losses cause an increase in resistance.

The bridge will read what it sees, and it is possible for the inductive and capacitance reactances to become equal at high frequencies in the case of a high value standard, which will lead to the anomalous display of a low Q but very large deviation from the d.c. value.

This is because the reactive terms cancel in the Q calculation but the dielectric and eddy current losses are still present.

(a) NORMAL CONNECTION

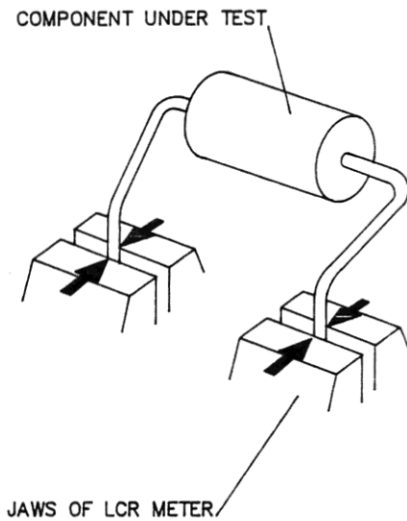

(b) 4 TERMINAL CONNECTION

(Using remote test leads)

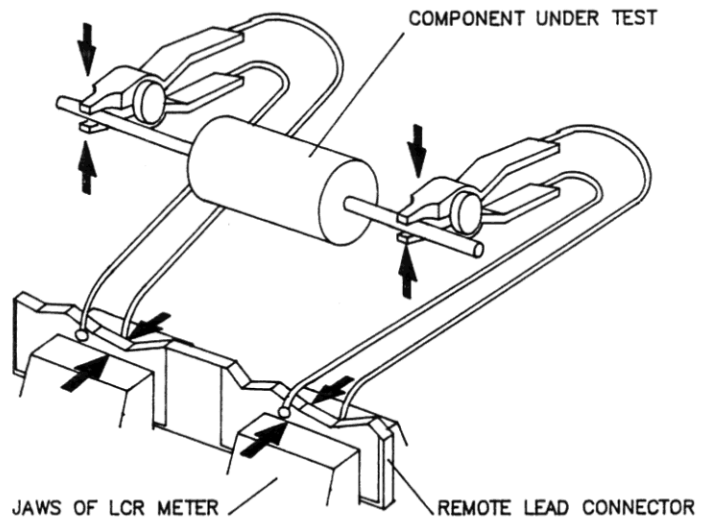

➔ SHOWS 4 ELECTRICAL CONNECTIONS WHEN COMPONENT IS INSERTED INTO JAWS

3.5 Techniques to minimise connecting lead errors

Errors introduced by the impedance of the connecting leads are usually negligible when measuring components in the jaws of the bridge, except in the case of very low resistors or large capacitors at high frequency where four terminal connection is necessary. See Fig. 3.5.

But if longer leads are used to connect to the bridge, as will be the case when using standards to check the bridge, some precautions must be observed to minimise lead errors.

Resistance

First, check that the resistance standard has been calibrated at the frequency to be used.

If the resistance value is low, less than 100 ohms, make a four terminal connection using the adapter.

If the value is high, above 10K ohms, separate the leads to minimise the capacity between them.

Capacitance

For low value capacitors, less than 1000pF, check the calibration certificate to see if it refers to a 2 terminal or a 3 terminal measurement.

If 3 terminal, connect the capacitor guard to the bridge guard terminal.

For high values, above 10,000pF, use the 4 terminal adapter.

Inductance

Check that the inductor has been calibrated at the frequency to be used. Minimise the lead capacitance for high value inductors, use the 4 terminal adapter for low values.

4.0 MAINTENANCE

WARNING!

SERVICING MUST BE CONDUCTED BY QUALIFIED PERSONNEL ONLY. TO AVOID ELECTRIC SHOCK, DO NOT PERFORM ANY OPERATION OTHER THAN THAT CONTAINED IN THE OPERATING INSTRUCTIONS AND THE PERFORMANCE CHECKS, UNLESS YOU ARE QUALIFIED TO DO SO.

This section of the manual gives a procedure to check the operation and calibration of the Databridge. The performance check is recommended as a preventative maintenance aid and should be executed when it is necessary to verify that the instrument is operating within its specification limits. Table 4.1 lists the recommended equipment necessary for this check. If the specified equipment is not available, other equipment having equivalent specifications may be used.

TABLE 4.1 - Equipment for Performance Check

| <u>DEVICE</u> | <u>NOMINAL VALUE</u> | <u>MINIMUM SPECIFICATION</u> | | <u>RECOMMENDED EQUIPMENT</u> |
|---------------|--------------------------|------------------------------|--------------|------------------------------|
| | | <u>Accuracy</u> | <u>(T/C)</u> | |
| Resistor | 2 | ±0.025% | (±10ppm/°C) | Tinsley Type 6616 |
| Resistor | 20 | ±0.025% | (±10ppm/°C) | Tinsley Type 6617 |
| Resistor | 500 | ±0.025% | (±10ppm/°C) | Tinsley Type 6618 |
| Resistor | 2K | ±0.025% | (±10ppm/°C) | Tinsley Type 6619 |
| Resistor | 20K | ±0.025% | (±10ppm/°C) | Tinsley Type 6620 |
| Resistor | 50K | ±0.025% | (±10ppm/°C) | Tinsley Type 6621 |
| Resistor | 100K | ±0.025% | (±10ppm/°C) | Tinsley Type 6622 |
| Resistor | 2M | ±0.025% | (±10ppm/°C) | Tinsley Type 6623 |
| Capacitor | 10nF | ±5.0% | (±0.3%/°C) | Tinsley Type 6615 |

Capacitor 10nF (Nominal)

Measured value to an uncertainty of better than ±0.05% at 20°C

Table 4.1 continued

| <u>DEVICE</u> | <u>MINIMUM SPECIFICATION</u> | <u>RECOMMENDED EQUIPMENT</u> |
|--------------------------|------------------------------|------------------------------|
| Capacitor 10 uF | Not Critical | Any |
| Inductor 20 uH | " " | " |
| " 10 mH | " " | " |
| " 10 H | " " | " |
| DMM | DC & AC Volts to 0.1% | Racal Dana 4009 |
| Frequency Meter | 0-50 KHz | Racal Dana 1998 |
| Distortion Measuring Set | | HP 339 A |
| RS232 Terminal | 1200 Baud, Full Duplex | |
| IEEE-488 Controller | | |

4.1. Operational Checks

The checks detailed below are intended to fully exercise all the operating functions of the Databridge and to ensure that it is operating within its performance specification.

4.1.1 Switch on the Databridge, with no component inserted into the jaws, the axial lead adaptors should be removed. The display and indicators should be initially all ON then follows a Calibration sequence -9- to -0-, then the display should be as follows

| | | |
|-----------------|---|----------------------------|
| Display Reading | : | 0.00 |
| Range | : | pF (flashing) |
| Function | : | Auto (LC and R indicators) |
| Mode | : | PAR |
| Frequency | : | 1 kHz |

4.1.2 Connect the 10 nF reference capacitor to the test jig. The reading should indicate the known value of the reference capacitor, to an accuracy of $\pm 0.1\%$ ± 1 digit, and the nF range indicator should be lit.

4.1.3 Operate the Auto LC-R button to set LC then the Ser-Par button to change to SER mode, noting that the SER indicator becomes lit. Check that the displayed value is still within $\pm 0.1\% \pm 1$ digit of the known value of the reference capacitor.

4.1.4 Operate the Freq button to change the measurement frequency to 10 kHz, checking that the two frequency indicators become lit. Check that the displayed value is still within $\pm 0.1\% \pm 1$ digit of the known value of the reference capacitor. Operate the Freq button again to select 100 Hz, checking that the 100 Hz indicator is lit. Check the displayed value again.

4.1.5 Operate the Ser-Par button to revert to PAR mode. Check that the displayed value is still within $\pm 0.1\% \pm 1$ digit of the known value of the reference capacitor.

4.1.6. Connect the 50 kohm reference resistor in parallel with the 10 nF capacitor already connected to the test jig. Operate the Q button, noting that the Q indicator becomes lit and the range indicators are all extinguished. Check that the Q reading is between 0.30 and 0.32, inclusive. Check at 1 KHz the Q reading is between 3.0 and 3.2, and at 10 KHz the Q reading is between 30 and 32.

4.1.7 Operate the D button noting that the D indicator becomes lit and all range indicators are extinguished. Check the display value is equivalent to $1/Q$.

4.1.8. Remove the 50 kohm resistor and operate the D button again, noting that the D indicator is extinguished and the nF range indicator is lit once more. Operate the BIAS button, noting that the BIAS indicator becomes lit and that the display shows "bIAS". After approximately 40 seconds, check that the display has reverted to normal operation and shows the value is within $\pm 0.1\% \pm 1$ digit of the known value of the reference capacitor.

4.1.9 Operate the BIAS button once more, noting that the BIAS indicator becomes extinguished and that message "bIAS" is again displayed. After a delay of approximately 40 seconds, note that the displayed "bIAS" message has been removed and that the reading is stable. Remove the 10nF reference capacitor. Operate the LC-R button to change to resistance measurement. Insert the 2 kohm reference resistor and then operate the HOLD button, note that the display remains stable at $2\text{ k} \pm 0.1\% \pm 1$ digit with the HOLD indicator ON.

4.1.10 Operate the HOLD button, noting that the HOLD indicator is extinguished. Remove the resistor and operate the LC-R button to revert to AUTO mode.

4.1.11 Using the 10 uF, 20 uH, 10 mH and 10 H general purpose components, check that the uF, uH, mH and H range indicators operate correctly as measurements are made on each component.

4.1.12 Operate the LC-R button twice to change to resistance measurement, noting that the R indicator is lit and the LC one is extinguished.

4.2 Performance and Calibration Checks

4.2.1 Connect each of the precision reference resistors in turn, checking that the measured value of each is within the ranges shown in Table 3.2 and that the appropriate range indicator is lit in each case; measurements should be taken in series and parallel mode, and at 100 Hz, 1 KHz and 10 KHz.

Table 4.2

CALIBRATION AGAINST STANDARD RESISTORS

| <u>NOMINAL</u> <u>TEST VALUE</u> | <u>READING and TOLERANCE (SER & PAR)</u> | | | | | |
|-------------------------------------|--|----------------|-------------|----------------|-------------|----------------|
| | 100 Hz | | 1 KHz | | 10 KHz | |
| 2 ohms | $\pm 0.1\%$ | ± 1 m ohms | $\pm 0.1\%$ | ± 1 m ohms | $\pm 0.1\%$ | ± 5 m ohms |
| 20 ohms | $\pm 0.1\%$ | ± 1 m ohms | $\pm 0.1\%$ | ± 1 m ohms | $\pm 0.1\%$ | ± 1 m ohms |
| 500 ohms | $\pm 0.1\%$ | ± 0.1 ohms | $\pm 0.1\%$ | ± 0.1 ohms | $\pm 0.1\%$ | ± 0.1 ohms |
| 2 k ohms | $\pm 0.1\%$ | ± 0.1 ohms | $\pm 0.1\%$ | ± 0.1 ohms | $\pm 0.1\%$ | ± 0.1 ohms |
| 20 k ohms | $\pm 0.1\%$ | ± 1 ohms | $\pm 0.1\%$ | ± 1 ohms | $\pm 0.1\%$ | ± 1 ohms |
| 100 k ohms | $\pm 0.1\%$ | ± 10 ohms | $\pm 0.1\%$ | ± 10 ohms | $\pm 0.1\%$ | ± 10 ohms |
| 2 M ohms | $\pm 0.1\%$ | ± 100 ohms | | | | |

NOTE: Permissible errors refer to actual values of test resistors.

4.2.2 Excitation Voltage Check

Connect a DVM between the Jaws and Ground. AC Volts at all frequencies should be $280\text{mV} \pm 15\text{mV}$ (DVM must have greater than 10 KHz bandwidth for this measurement). This is equivalent to a pk-pk value of $790\text{mV} \pm 45\text{mV}$.

4.2.3 Voltage Check

Operate the 'BIAS' button and connect a DVM between the (+VE) Jaws (-VE) Jaws. DC Volts at all frequencies should be $2\text{V} \pm 0.2\text{V}$.

4.2.4 Frequency Checks

Connect a frequency meter between the Jaws and Ground. Check the frequency is within specification.

| Frequency | Period |
|----------------------|---------------------|
| 100 Hz ± 0.01 Hz | 9999.00–10001.00 us |
| 1 KHz ± 0.1 Hz | 999.90–1000.10 us |
| 10 KHz ± 0.5 Hz | 99.995–100.005 us |

4.2.5 Distortion

Connect the distortion meter between the +VE Jaws and Ground. Distortion levels should be less than 0.05% at all frequencies.

4.3 RS232/IEEE Interface Operation Check

4.3.1 Set Interface to 8 bits no parity 1 stop bit using the rear panel switches as defined in Sections 6.1.2 and 6.2.2 (interface will assume 1200 baud at power up).

4.3.2 Set RS232 terminal to 1200 baud, 8 data bits, 1 stop bit, no parity, full duplex (Databridge echoes all characters typed).

4.3.3 Connect the Option 55 interface to the RS232 terminal with a suitably configured cable as defined in Section 6.2.1.

4.3.4 Remove any component from the Databridge jaws.

4.3.5 Apply power to Databridge and RS232 terminal.

4.3.6 Type (RETURN)

Terminal should receive "E10" message.

4.3.7 Type GES (RETURN)

Terminal should receive "GES2PA FO".

4.3.8 Type GER (RETURN)

Terminal should receive "GER 0.00pF".

4.3.9 Type HFL (RETURN)

HOLD lamp on Databridge should begin to flash.

4.3.10 Type HOF (RETURN)

HOLD lamp on Databridge should cease flashing.

4.3.11 Type EXT

Databridge should appear unchanged.

4.3.12 At Databridge press each key in turn

Databridge should display 'rrrrr' for each key press.

Checking the IEEE-488 interface

To functionally check the IEEE-488 interface requires the use of an IEEE-488 controller.

The IEEE-488 interface must be set to a known IEEE-488 address to receive commands, using the rear panel switches as directed in Section 6.3.2.

The test may be performed either by writing a dedicated program to execute the required sequence of test steps, or may be achieved by direct execution of the required test steps via the keyboard.

To test the performance of the Option 55 IEEE-488 interface each of the commands shown in bold type for the RS232 test above should be sent to the IEEE-488 interface. Use the OUTPUT command appropriate for your controller and ensure data has been routed to the selected device address.

Where the above sequence indicates data should be received via the RS232 terminal, this expected data should be read via the INPUT command appropriate to the controller used, together with the specified address.

NB:- The commands used to send and receive data via the IEEE-488 interface, will vary from controller to controller and also dependant upon the language implemented. All data should be set to terminate on the IEEE-488 EOI signal and INPUT commands should be set to ignore line feed characters if possible the Option 55 interface terminates all output data with CRLF with EOI true on the second LF. If a controller accepts LF as a terminator then every other item of data read will be a null string, this is notably a problem when using HP controllers.

4.4 Calibration Check Interval

It is recommended that the Databridge's calibration is checked every twelve months. Racal Dana Instruments will carry out a full functional and calibration check for a standard fee, if the instrument is returned, carriage paid, to:

The Service Department,
Racal Dana Instruments Limited,
480 Bath Road,
Slough,
Berks., SL1 6BE.

Contact the Racal Dana Service Department for details of calibration fee and turnaround time.

5.0 OPTIONS AND ACCESSORIES

A number of options and accessories are available to extend the performance and range of applications of the Racal Dana 9343M LCR Databridge. These are described briefly below and further information may be obtained from Racal Dana Instruments Limited.

5.1 Remote Test Leads (1401) – Supplied

The Test Leads may be plugged into the Databridge's integral, four terminal test jig and secured via a single fixing screw, which also provides the earth connection for the screening on each lead. These leads may then be used to connect to any purpose made test fixture or probes. The connection colour code is:

| | |
|----|--------|
| V+ | White |
| V- | Blue |
| I+ | Red |
| I- | Yellow |

5.2 Remote Test Leads with Kelvin Clips (3401) – Supplied

These are similar to the 1401 remote test leads but are complete with Kelvin clips permitting rapid connection for four terminal measurement of remote components.

5.3 Chip Component Probes (Order Code 2401)

The Four terminal chip component probes are for measuring chip capacitors or resistors. They are supplied pre-wired to 1401 Test Leads and Plug.

5.4 BNC Adaptor Box (Order Code 4401)

The BNC Adaptor Box may be plugged into the Databridge's integral, four terminal test jig, it provides an external connection to the Databridge's measurement points via four BNC connectors.

6.0 IEEE-488/RS232 INTERFACE OPERATION

6.1.1 Introduction

The Option 55 interface provides a means to control each function of the Racal Dana 9343M databridge, together with the ability to monitor all available status information and component under test data, via either the RS232 or the IEEE-488 (GPIB) interfaces.

Each function of the databridge normally available via the front panel key switches may be accessed via either the RS232 or IEEE-488 interfaces using a unique command mnemonic.

Additional command mnemonics are provided to allow the interrogation of the databridge for specific data and to facilitate the use of interactive measurement cycles.

The command mnemonics used are common to both RS232 and IEEE-488 operation.

6.1.2 Switch Settings

A bank of eight set up switches is located at the rear of the instrument next to the IEEE-488 interface connector.

The switches are numbered 1 - 8 and may be set as a '1' or '0'. The switch selects '0' when in the 'ON' position.

Switch numbers 1 - 5 are used for IEEE-488 address setup.

Switch numbers 6 - 8 the RS232 word format.

6.2 RS232 Interface

6.2.1 RS232 Connections

The RS232 connector at the rear of the Option 55 interface is configured as shown below:-

| Pin No | Function | I/O |
|--------|----------|-------------------------|
| 1 | PROT GND | CHASSIS |
| 2 | Tx DATA | OUTPUT |
| 3 | Rx DATA | INPUT |
| 4 | RTS | INPUT (internal pullup) |
| 5 | CTS | OUTPUT |
| 6 | DSR | OUTPUT (-8V via 6k8) |
| 7 | GND | |
| 8 | N/C | |
| 20 | DTR | INPUT (internal pullup) |

Connection to the RS232 connector must be made via a standard 25 pin 'D' female plug at the databridge end. The computer or terminal end of the cable must be configured as defined in the respective manual.

The RS232 interface operates in full duplex mode and all characters received are echoed back to the host.

Examples:-

Connecting an Option 55 interface to a IBM-PC type serial port.

| <u>Computer serial port</u> | <u>9343M Option 55</u> |
|-----------------------------|------------------------|
| Txd 2 | 2 Txd |
| Rxd 3 | 3 Rxd |
| RTS 4 | 4 RTS |
| CTS 5 | 5 CTS |
| DSR 6 | 6 DSR |
| GND 7 | 7 GND |
| DCD 8 | 8 NC |
| DTR 20 | 20 DTR |

6.2.2 RS232 setup

To enable correct data transfer between the host computer or terminal and the Option 55 interface, both devices must be configured to use the same baud rate and word format.

On power up the Option 55 interface assumes 1200 baud as a default communication speed. This may be changed on command via either the RS232 or IEEE-488 interfaces once the system is running. This is the only manner in which the baud rate may be changed.

To configure the host computer or terminal, refer to the appropriate manual.

To set the RS232 word format for use by the Option 55 interface, setup switches 6 - 8 are used in the following manner to set the required word format.

| Switch No | | | Data format | | |
|-----------|---|---|-------------|-----------|-----------|
| 8 | 7 | 6 | Parity | Data bits | Stop bits |
| 0 | 0 | 0 | None | 8 | 2 |
| 0 | 0 | 1 | None | 8 | 1 |
| 0 | 1 | 0 | Even | 8 | 1 |
| 0 | 1 | 1 | Odd | 8 | 1 |
| 1 | 0 | 0 | Even | 7 | 2 |
| 1 | 0 | 1 | Odd | 7 | 2 |
| 1 | 1 | 0 | Even | 7 | 1 |
| 1 | 1 | 1 | Odd | 7 | 1 |

*****CAUTION***** If the switches numbered 1 - 5 indicate an IEEE-488 bus address of 0, both the RS232 and IEEE-488 interfaces will become inoperative.

6.2.3 Control of the 9343M databridge via the RS232 interface

Response to data received via the Option 55 interface RS232 port. Every alpha numeric character sent to the bridge is echoed back via the RS232 link.

CR is echoed as CRLF

CRLF is echoed as CRLF

, is echoed as ,

; is echoed as ;

The first data received from the Databridge following a command is a copy of the original command sequence, followed by CRLF.

If any part of the command sequence was in error then the echo of the command sequence will be followed immediately by the appropriate error message, prior to any expected response to the issued command.

The command sequence B;GER CRLF will be echoed back in the following manner:-

```
B;GER  CRLF
E10    CRLF          (due to unrecognised command "B")
GER measured data  CRLF
```

In general, host computers will automatically place incoming characters in a dedicated RS232 buffer to avoid any data loss. If errors occur, the databridge will output an error message for each occurring error. These error messages will be followed by any data requested by valid commands in the otherwise erroneous command sequence.

It is important that all of the returned data is read from the RS232 buffer to ensure correct operation of the databridge. If an error message exists and is not read from the buffer then this error message will be read instead of the next requested data as each discrete message is terminated with CRLF . This will cause commands and the ensuing responses to become out of step.

It is advisable for each command to be sent to the databridge separately, as this will facilitate easier validation of the echoed command and easier detection of error messages.

ie:- A multiple command sequence may generate multiple error messages.

To ensure that this does not occur, the control software should operate in the following manner.

```
BEGIN
  REPEAT
    OUTPUT command to databridge.
    READ echoed command from databridge.
    IF echoed data = sent data THEN (dont forget inherent
                                   translations)
  BEGIN
    REPEAT
      READ data from databridge. (may or may not be present)
      IF 1st character = 'E' THEN process error.
    UNTIL no more data. (probably flagged as error by host
                        machine)
  IF valid command response received THEN process data.
END
```



```
ELSE (interface error)
BEGIN
  REPEAT
    READ data from databridge (may or may not be present)
    Discard data (data error has occurred)
  UNTIL no more data (probably flagged as error by host machine)
END
UNTIL success (ie repeat until command successfully sent or decide
system is faulty).
```

END

Data being present when attempting to read data, depends entirely upon the type of command issued.

ie:- Any valid command starting with the letters "GE" such as "GER" will generate a response and any invalid command will generate an error message. Except for these the only returned data will be an echoed copy of the command sequence.

6.2.4 Error messages which may be returned by the Option 55 interface.

| | |
|-----|----------------------|
| E10 | Unrecognised command |
| E18 | Invalid Baud rate. |
| E32 | RS232 parity error. |
| E33 | RS232 framing error |
| E34 | RS232 overrun error. |

6.3 IEEE-488 Interface

The IEEE-488 interface conforms to IEEE STD 488-1978.

The interface functions supported are:-

SH1 AH1 T6 TEO L4 LEO SRO RL2 PPO DCO DTO CO E2

Consult IEEE-STD 488 1978 for a full explanation of these functions.

6.3.1 IEEE-488 Connections

Connection to an IEEE-488 (GPIB) controller is via a standard 24 way 'D' type GPIB male plug.

Up to 15 devices may be connected to an IEEE-488 bus providing each is assigned a unique address, the maximum distance between instruments does not exceed 2 meters, and the overall bus length does not exceed 20 meters.

Connector pin assignments

| PIN NO | SIGNAL | PIN NO | SIGNAL |
|--------|----------|--------|-----------|
| 1 | DIO 1 | 13 | DIO 5 |
| 2 | DIO 2 | 14 | DIO 6 |
| 3 | DIO 3 | 15 | DIO 7 |
| 4 | DIO 4 | 16 | DIO 8 |
| 5 | EIO (24) | 17 | REN (24) |
| 6 | DAV | 18 | GND (6) |
| 7 | NRFD | 19 | GND (7) |
| 8 | NDAC | 20 | GND (8) |
| 9 | IFC | 21 | GND (9) |
| 10 | SRQ | 22 | GND (10) |
| 11 | AIN | 23 | GND (11) |
| 12 | SHIELD | 24 | GND LOGIC |

NB: GND (n) refers to the signal ground return of the indicated contact. 'EOI' and 'REN' return via pin

6.3.2 IEEE-488 setup

The only setup required for IEEE-488 operation is to assign the Option 55 interface a unique address on the IEEE-488 bus. The required instrument address must be set as a binary value using switches 1 - 5 located at the rear of the instrument.

The switches may set as follows for the required instrument address.

| Address | Switches | Address | Switches |
|---------|-----------|---------|-----------|
| | 5 4 3 2 1 | | 5 4 3 2 1 |
| **00 | 0 0 0 0 0 | 16 | 1 0 0 0 0 |
| 01 | 0 0 0 0 1 | 17 | 1 0 0 0 1 |
| 02 | 0 0 0 1 0 | 18 | 1 0 0 1 0 |
| 03 | 0 0 0 1 1 | 19 | 1 0 0 1 1 |
| 04 | 0 0 1 0 0 | 20 | 1 0 1 0 0 |
| 05 | 0 0 1 0 1 | 21 | 1 0 1 0 1 |
| 06 | 0 0 1 1 0 | 22 | 1 0 1 1 0 |
| 07 | 0 0 1 1 1 | 23 | 1 0 1 1 1 |
| 08 | 0 1 0 0 0 | 24 | 1 1 0 0 0 |
| 09 | 0 1 0 0 1 | 25 | 1 1 0 0 1 |
| 10 | 0 1 0 1 0 | 26 | 1 1 0 1 0 |
| 11 | 0 1 0 1 1 | 27 | 1 1 0 1 1 |
| 12 | 0 1 1 0 0 | 28 | 1 1 1 0 0 |
| 13 | 0 1 1 0 1 | 29 | 1 1 1 0 1 |
| 14 | 0 1 1 1 0 | 30 | 1 1 1 1 0 |
| 15 | 0 1 1 1 1 | 31 | *ILLEGAL* |

***** CAUTION ***** The standard IEEE-488 defines address 31 as illegal

***** CAUTION ***** Using bus address 0 will cause the RS232 and IEEE-488 interfaces to become inoperative

6.3.3 Control of the 9343M Databridge via the IEEE-488 Interface

All data returned to the IEEE-488 bus by the databridge will be terminated in the following manner.

DATA CRLF LF ← The EOI bus management line will be true with the last line feed

Many controllers, including Hewlett Packard, under normal operating conditions, will consider the data, by default, to have terminated on reception of the first LF. Thus if data is read from the bus there remains within the databridge an unread LF, further interrogation of the Databridge interface will return a NULL string terminated by this additional LF.

The correct syntax for the HP basic ENTER command to allow termination of data via EOI is as follows

ENTER 7xx USING "#%,K";variable name
Device_____↑
address_____↑

indicates the_____
following data_____
is an IMAGE_____
SPECIFIER_____↑

No LF termination_____
Terminate on EOI_____
Free field format_____↑

This will allow EOI to be used for termination of incoming data, however any line feed characters within the data will be interpreted as part of the data and not terminator or control characters.

If it is not possible to use the EOI line to terminate incoming data, then steps should be taken to ensure all unwanted LF characters are discarded and termination is effected on CR.

The Databridge will terminate received data on any combination of CR, LF and EOI.

6.4 Error messages which may be returned by the Option 55 interface

E10 Unrecognised command

6.5 RS232 and IEEE-488 Commands

The commands recognised by the interface can be broken down into two distinct groups.

Commands not generating a reply:-

| Command | Function |
|---------|--|
| A | Auto mode |
| BOF | Bias Off |
| BON | Bias On |
| C | Set RS232 baud rate (see note below) |
| DOF | Cancel 'D' display |
| DON | Display 'D' |
| EXT | External control, disable front panel |
| FR1 | Frequency range 100 Hz or 120 Hz (factory preset) |
| FR2 | Frequency range 1 kHz |
| FR3 | Frequency range 10 kHz |
| HFL | Hold Flash |
| HOF | Hold Off |
| HON | Hold On |
| LOC | Local control, enable front panel |
| P | Parallel mode |
| QOF | Cancel/'Q' display |
| QON | Display/'Q' |
| R | Display resistance |
| S | Series mode |
| X | Display reactance ('L' or 'C') |
| ZOF | Zero capacitance disabled |
| ZON | Zero capacitance enabled |

NB:- All commands received via the RS232 are echoed back.

The command to set the RS232 baud rate, 'C' must be followed by a valid baud rate (110, 300, 600, 1200).

This command is valid when executed via either the RS232 or IEEE-488 interfaces.

e.g. C600 sets a baud rate of 600.

Commands which generate a reply:-

| Command | Function |
|---------|-----------------------------------|
| GES | Get status information |
| GEI | Get interface error information |
| GEO | Get operational error information |
| GEQ | Get 'Q' value |
| GED | Get 'D' value |
| GER | Get reading |
| GEF | Get flash status |

6.5.1 Replies to the 'GE' commands.

GES, GEI, GEO and GEF return strings of characters indicating the status of the databridge.

GES provides an overall view of the instrument status whilst the latter three provide greater detail.

GEI and GEO clear any current error condition. When GEI or GEO are issued, the databridge will always return the last error that occurred, however transient.

Reading GEO and GEI twice will indicate if the condition was transient or is persistent.

Persistent interface faults are likely to prevent reply, however the error number will be displayed by the databridge (See 2.10.4).

6.5.2 Command reply formats

NB:- "spc" is a space character which indicates that the particular function is not selected.

Command:- GES Function:- Get status

Reply:- GES + 12 ASCII characters

| Char No | Option | Meaning |
|---------|---------|--------------------------------|
| 1 | 1,2,3 | Frequency range |
| 2 | S,P | Series or parallel mode |
| 3 | A,X,R | Auto, LC, or R selected |
| 4 | Q,D,spc | Q or D selected for display |
| 5 | B,spc | Bias On |
| 6 | Z,spc | Zero-C operative |
| 7 | H,spc | Hold operative |
| 8 | E,spc | External control only |
| 9 | O,spc | Operational error has occurred |
| 10 | I,spc | Interface error has occurred |
| 11 | F,spc | Flash prompt active |
| 12 | O,1 | 100 or 120 Hz operative |

Frequency range 1, 2 or 3 displays the selected measurement frequency of 100 or 120 Hz, 1 kHz and 10 kHz respectively. Whether range 1 selects 100 or 120 Hz depends upon the internal setting of the databridge, this is indicated by the last digit in the status reply.

Command:- GEI Function:- Get interface errors

Reply :- GEI + 1 ASCII character

| Char no | Option | Meaning |
|---------|--------|--------------------------|
| 1 | 0 | No error |
| | 4 | Unrecognised command |
| | 5 | Timeout on incoming data |
| | 6 | Timeout on outgoing data |

Command:- GEO Function:- Get operational errors

Reply:- GEO + ASCII character

| Char no | Option | Meaning |
|---------|--------|-------------------------|
| 1 | 0 | No error |
| | 1 | Initialisation error |
| | 2 | Under range |
| | 3 | Over range |
| | 4 | Bias setting |
| | 5 | Auto active |
| | 6 | C over range |
| | 8 | Hold |
| | 9 | External Operation Only |

Command:- GEF Function:- Get Flash status

Reply :- GEF + 5 ASCII characters

| Char no | Option | Meaning |
|---------|---------|-------------------------|
| 1 | F,spc | Frequency range |
| 2 | S,P,spc | Series or parallel mode |
| 3 | Q,D,spc | Q or D |
| 4 | H,spc | Hold |
| 5 | R,spc | Range |

The remainder of the commands (GEQ,GED and GER) respond with numeric data.

Command:- GEQ Function:- Get Q value

Reply :- GEQ + N + space

Command:- GED Function:- Get D value

Reply :- GED + N + space + space

Command:- GER Function:- Get reading

Reply :- GER + N + U

Replies are a fixed length of 11 characters. The three character command is echoed back, followed by the numeric data 'N' in five digits with an optional decimal point, right justified within the next six characters.

There will be only one leading zero prior to a decimal point.

If there are no significant digits after the decimal point, the decimal point will not be transmitted.

The numeric data will be followed by a two character representation of the units of measurement 'U', consisting of a multiplier and measurement unit, which may be replaced with spaces if not required. The qualifier 'U' will be of the following:-

| 'U' | Units |
|---------|--------------|
| uf | Microfarads |
| nf | Nanofarads |
| pf | Picofarads |
| Mo | Megohms |
| Ko | Kilohms |
| spc o | Ohms |
| spc H | Henries |
| mH | Millihenries |
| uH | Microhenries |
| spc,spc | No qualifier |

6.6 Remote operation

Operation of the databridge keys may be prevented by issuing the "EXT" command via the Option 55 interface in all but one case.

When the "EXT" command is active, only the Hold key may be pressed to cancel the flashing hold LED.

Any other keypress will cause the display to briefly show "rrrrr".

6.7 Interactive measurement

The databridge continuously makes measurements whether there is a component under test or not.

A means has been provided to allow the databridge to be used interactively with a controlling computer, indicating that the current measurement is required.

The Hold LED can be made to flash by the controlling computer sending the command "HFL". This indicates that the controlling computer is awaiting confirmation that the current reading is valid.

Confirmation of the readings validity is provided by pressing the Hold key and permanently illuminating the Hold LED.

By examining the status of the databridge using the "GES" command, the controlling computer can detect that the Hold key has been pressed and then obtain the required measurement reading.

The controlling computer may now signal that the measurement has been completed, and that another component for test may be connected, by setting the Hold LED flashing once more.