

M100/M500

OPERATION

AND

SERVICE MANUAL

Rod-L Electronics, Inc.
923 Hamilton Avenue
Menlo Park, CA 94025
(415) 322-0711

60001-05
Revised
22 September 1992

CERTIFICATION

Rod-L certifies that this instrument was thoroughly inspected and tested and found to meet its published specifications when it was shipped from the factory.

WARRANTY AND ASSISTANCE

All Rod-L Electronics' instruments are warranted against defects in materials and workmanship. This warranty applies for one year from date of delivery to the original purchaser. We will repair or replace instruments which prove to be defective during the warranty period provided they are returned to Rod-L Electronics.

For prompt, efficient service of your instrument, send it directly to Rod-L Electronics along with a statement describing the nature of the problem.

A Return Material Authorization Number must be obtained from Rod-L Electronics before returning any instruments for repair. Transportation must be prepaid. Rod-L Electronics will assume cost of surface transportation when returning equipment to customer.

This warranty is void if the instrument has been modified or subjected to gross misuse. No other warranty is expressed or implied. Rod-L Electronics is not liable for consequential damages.

Table of Contents

Section		Page
1	Introduction	
	1-1. General	6
	1-2. Safety Features	7
	1-3. Supplied Equipment	7
	1-4. Product Specifications (Table 1-1)	8
2	Installation and Operation	
	2-1. General Information	9
	2-2. Unpacking and Inspection	9
	2-3. Installation	9
	2-4. Power Requirements	9
	2-5. Operating Controls	9
	2-6. Storage	9
	2-7. Repackaging for Shipment	10
	2-8. Factory Settings	11
	2-9. Initial Installation and Power-Up	12
	2-10. Operational Check	12
	2-11. Fail Indications	13
	2-12. Automatic Test Procedure	14
3	Theory of Operation	
	3.1 General Introduction	16
	3-2. Instrument Functions	17
	3-3. Instrument Assembly	19
	3-4. Major Layout Revisions to the Hipot Testers ..	21
	3-5. A11 Power Supply / Under Current PCB	21
	3-6. A6-S5 High Voltage Control / Ramp Rate PCB ...	22
	3-7. A21 Hipot Control Logic PCB	23
	3-8. Understanding Real Current	25
	3-9. BV Operation	26
	3-10. A2-1 Real Current Detect Circuit PCB	28

Table of Contents

Section		Page
4	Maintenance and Service	
4-1.	Introduction	30
4-2.	Equipment Needed	30
4-3.	Factory Calibration Procedures	30
4-4.	Set Up	31
4-5.	Meter Mechanical Zero	31
4-6.	Chassis Ground Sense Calibration	31
4-7.	A6-S5 AC HV Control PCB & Ramp Rate Calib. ...	32
4-8.	A21 Logic Control and Current Meter Calib. ...	34
4-9.	Voltmeter Calibration	35
4-10.	A2-1 Real Current Calibration	36
4-11.	Set Test Time	38
4-12.	Set Total Current Fail "Trip" Point	39
4-13.	Set Real Current "Trip" Point (BV models only)	40
4-14.	Set Under Current Fail "Trip" Point	41
4-15.	List of Adjustment Pots	41
4-16.	Troubleshooting	41
5	Options	
5-1.	A8, Option 01 Digital Remote Control PCB	44
5-2.	Option 02 Front Panel Test (Dwell) Time Adj ..	46
	Option 03 Front Panel Rise Time Adjustment ...	46
5-3.	Option 06 Rear Panel Lockout Cover	46
5-4.	A25 Hands-Off(Opt05)/Sw.Sel.Fail Points(Opt08)	47
5-5.	A27, Option 10 Audible Test Tone	49
5-6.	Option 15, Rack Mounting	49
5-7.	Option 16, ÷ 10 Current Scale and Trip Point .	49
5-8.	A24, Option 18 Ohms Sense PCB	50
5-9.	Option 22, Front Panel Voltage Adjust	51
5-10.	Option 23, Digital Meters	52
5-11.	Option 24, Blank Start/HV Receptacle	52
5-12.	Option 27, No Load Trip Point Setting	52
5-13.	Option 28, 2-Pos. Switch Select Current Scale	52
5-14.	Option 29C, 3-Pos. Switch Select Voltages	53

Section

Page

6

Bills of Materials, Schematics, Diagrams

Wiring Diagrams
Assembly A11 Power Supply
 Schematic A11 Power Supply
Assembly A21 Hipot Control Logic
 Schematic A21 Hipot Control Logic
Assembly A6-S5 AC Control
 Schematic A6-S5 AC Control
Assembly A2-1 Real Current
 Schematic A2-1 Real Current
Assembly A25 Hands-Off / Switch Sel Fail Points
 Schematic A25 Hands-Off / Switch Sel Fail Point
Assembly A24 Ohms Sense
 Schematic A24 Ohms Sense
Assembly A8 Digital Remote Control
 Schematic A8 Digital Remote Control

Tables, Specification Charts, and Diagrams

Table 1-1	Specifications	8
Figure 2-1	Front Panel Controls	10
Figure 2-2	Rear Panel Controls	11
Table 2-1	Factory Settings	11
Figure 3-1	Functional Diagram	17
Figure 3-2	HV Amplitude Control	18
Figure 3-3	Ramp Up Control	18
Figure 3-4	General Control	19
Figure 3-5	Assembly Diagram	19
Figure 3-6	Detail Assembly Diagram	20
Figure 4-1	Test Cycle Parameters	32
Figure 4-2	Setting Up With a Digital Ammeter	34
Table 4-1	Load Requirements for Rod-L AC Hipot Testers	36

Section 1 INTRODUCTION

1-1. General

This publication provides operating and servicing instructions for the **Rod-L Electronics, Inc.** AC Hipot Tester Models M100AVS5, M100BVS5, M500AVS5, M500BVS5, and also earlier versions of these like the M100A and M100AV. It is divided into six sections.

- Section 1 - Introduction (capabilities and specifications)
- Section 2 - Installation and Operation
- Section 3 - Theory of Operation
- Section 4 - Maintenance and Service
- Section 5 - Options
- Section 6 - Parts Lists, Schematics and Diagrams

The **Rod-L** AC Hipot Testers are completely self-contained, rugged, high voltage potential test instruments designed for laboratory and production testing environments. They also have safety ground continuity test capability for performance of dielectric withstand tests in accordance with applicable UL, CSA, IEC, FCC, BABT, and other standards. The AV in the designation refers to units that test and display total current, while the BV units test and display total current as well as the resistive part of the AC current. For further information, see Section 3.

The **Rod-L Electronics** AC Hipot Testers perform an AC high voltage leakage and breakdown dielectric withstand test. Test limits for high voltage, time, voltage ramp rate (rate of rise,) total current, (and for the resistive part of the AC current using BVs) are preset by the user. AC current and voltage are displayed on front panel meters. Specifications are given in Table 1-1, page 8.

The Device Under Test (DUT) plugs into the front panel test connector. For operator safety, a Chassis Ground Cable must be connected to a secure low resistance point on the chassis of the DUT. Without this connection, the Hipot Tester will not enter the READY state, and therefore won't begin a TEST. Both the Chassis Ground and the power cord safety Ground of the DUT are monitored and tested electronically. If either ground fails during a test, the Hipot Tester automatically goes into failure mode; i.e., the high voltage is shut down and there is a continuous audible and visual alarm.

NOTE: The CHASSIS GROUND SENSE circuit is intended to act as a safety ground and ground continuity test for devices employing a chassis ground plane. For testing of two-wire devices or three-wire devices that are exempted by the pertinent regulatory agency from performing a chassis ground continuity test, the CHASSIS GROUND SENSE connection can be made to either Pin 2 of the rear panel high voltage connector or to any appropriate hipot chassis point (e.g., handle, screw, etc.)

1-2. Safety Features

- A) "Chassis Ground Sense" - Safety ground required to begin a test
- B) Loss of safety ground terminates test cycle
- C) Front panel receptacle accepts 3-pronged power cord from DUT providing maximum safety and significantly reduces time required to perform the test
- D) Recessed START button
- E) Visual alarm at failure
- F) Audible alarm at failure (continuous tone)
- G) Fast electronic shut down of AC High Voltage
- H) Hard RESET after failure required to perform next test
- I) Adjustable, linear Ramp Up of High Voltage

1-3. Supplied Equipment

- A) Hipot Test Instrument
Rod-L Model M100AVS5, M100BVS5, M500AVS5, or M500BVS5
- B) Power Cord, three pronged, 6 ft
- C) Chassis Ground Sense cable, 3 ft
- D) Kit for HV connector mate
- E) Operation/Service Manual
- F) Extra fuse set for the alternate AC supply voltage

1-4. Product Specifications (Table 1-1)

Table 1-1: Specifications

Test Voltage
User specified up to 5000 VAC

Test Current
5 milliamperes (mA) to 333 mA full scale (F.S.)

NOTE: Voltage and current range combinations are user specified. See the Dielectric Withstand Datasheet.

Voltage Rate of Rise
50 V/second to 5000 V/second (adjustable)

High Voltage Test Time
1 second to 90 seconds (adjustable)

High Voltage Shutdown
Within 2 milliseconds after a fault or end of test is detected (electronic shut down circuits)

Safety Ground Continuity
Reject level: 0.5 Ω standard, 0.1 Ω on request

Accuracy (Current and Voltage Monitoring)
Better than 1%

Resolution (Output Current and Voltage Scales)
 $\pm 3\%$ of F.S.

Initial Turn-On Period
Requires 3 seconds normally before starting Hipot test

Input Power
115/230 VAC, 44-66 Hz;
360 watts, max on M100s, 30 watts typical
500 watts, max on M500s

Environmental Operating Temperature
0° to 50° C, 32° to 122° F

Exterior Color
Mint grey / Olive grey

Weight
35 lbs (15.9 kg) net, 38 lbs (17.2 kg) shipping

Dimensions
16.75 x 13.25 x 5.5 inches (43 x 34 x 14 cm)

Section 2

INSTALLATION AND OPERATION

2-1. General Information

This section contains the recommended procedures for unpacking, inspection, installation, and operation.

2-2. Unpacking and Inspection

A shipping carton that appears damaged should be inspected and unpacked with the carrier's agent present. Inspect the instrument for damage (scratches, dents, broken knobs or meters, etc.)

If the instrument is found to be damaged upon receipt, notify the carrier and **Rod-L Electronics** immediately. Retain the shipping carton and the padding material for the carrier's inspection, and for return shipment.

2-3. Installation

The **Rod-L** AC Hipot Testers are suitable for either bench or rack mounting. To rack mount the instrument, use Option 15A. The instructions for rack mounting are on page 50.

2-4. Power Requirements

The **Rod-L Electronics, Inc.** Hipot Testers require a power source of either 115 or 230 volts AC, 44 to 66 Hz, single-phase. Prior to applying power to the instrument, ensure the AC line voltage selector switch on the Rear Panel is in the appropriate position. When using the **Rod-L** Hipot with other **Rod-L** Testers, the Ground Sense Circuit often works better when the **Rod-L** Testers are connected to a line input with the same ground circuit.

2-5. Operating Controls

The front panel and rear panel controls and indicators are shown and briefly described in Figures 2-1 and 2-2.

2-6. Storage

It is strongly recommended that the Hipot be packed as if for reshipment. Environmental conditions during storage and reshipment should be as follows:

- A) Maximum temperature: 167°F (75°C)
- B) Minimum temperature: -40°F (-40°C)

Figure 2-1: Front Panel Controls

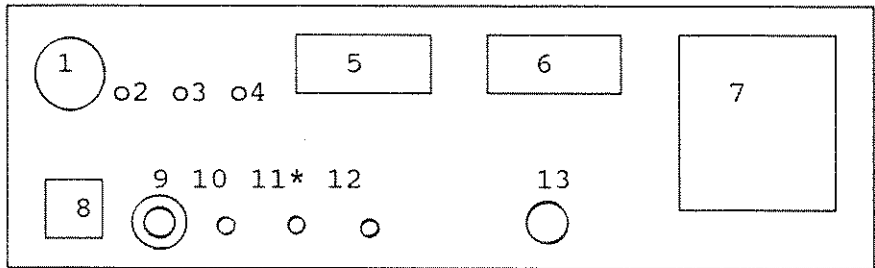

- | | |
|--------------------------|---|
| 1. Alarm | emits audible signal on failure |
| 2. READY lamp | on when ready to begin Hipot Test |
| 3. TESTING lamp | on during AC Hipot Test |
| 4. FAIL lamp | on if DC Hipot Test fails |
| 5. Current meter | indicates AC current in mA |
| 6. Voltage meter | indicates AC volts in kV |
| 7. HV Output Block | input for Device Under Test (DUT) where AC is applied |
| 8. AC ON switch | turns on and indicates AC power input |
| 9. START switch | initiates AC Hipot Test if READY |
| 10. RESET button | resets Hipot |
| 11.* REAL switch | (*BV only) when pressed, displays Real Current |
| 12. A/B switch | chooses A or B Ramp Rate and Test Time |
| 13. Chassis Ground Sense | for DUT chassis ground connection |

2-7. Repackaging for Shipment

If possible, use the original shipping container and packing materials. Otherwise:

- A) Wrap the Hipot in heavy paper or plastic before placing in the shipping container.
- B) Use plenty of packing material around the instrument. Protect the front panel with cardboard or plastic packing. Protect the instrument with two inch rubber foam pads placed along all surfaces of the instrument with a layer of excelsior about 6 inches thick and firmly against all surfaces of the instrument.
- C) Use a strong, well-sealed shipping container (350 in. bursting test.)
- D) Mark the container "FRAGILE - DELICATE INSTRUMENT."

Figure 2-2: Rear Panel Controls

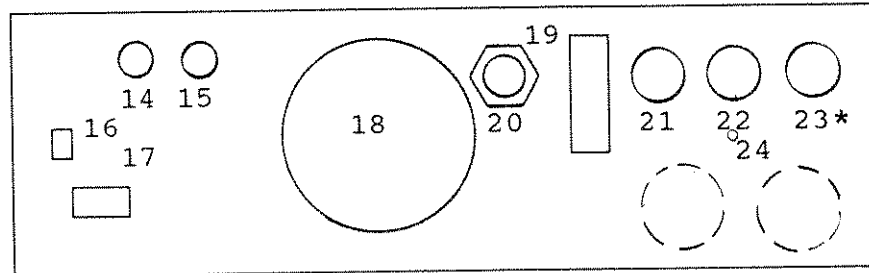

- | | | |
|------|----------------------------|---|
| 14. | AC Fuse 1 | .5A 250V norm blo for 115VAC,
.5A 250V norm blo for 230VAC |
| 15. | AC Fuse 2 | 2A (for M100, 5A for M500) 250V norm blo fuse
for 115VAC,
1A (for M100, 2.5A for M500) 250V norm
blo fuse for 230VAC |
| 16. | Voltage
Selector Switch | chooses 115VAC or 230VAC input;
be sure to install correct fuses |
| 17. | AC line power in | receptacle |
| 18. | Variac | High Voltage Output Adjust |
| 19. | Remote | Remote Interface connector |
| 20. | HV Out | AC Hipot Interface connector |
| 21. | Under I pot | Under Current Trip (Fail) Point Potentiometer |
| 22. | Total I pot | Total Current Trip (Fail) Point Potentiometer |
| 23.* | Real I pot | (*BV only) Real Current Trip (Fail) Point Pot |
| 24. | Hands-Off | Optional palm-switches Hands-off connectors |

2-8. Factory Settings

The Rod-L AC Hipot Testers are shipped with the following factory-selected settings (unless otherwise requested in writing by the customer):

Table 2-1: Factory Settings

Input Line Voltage Select	115 VAC	
TEST MODE SWITCH	"A"	"B"
Test (Dwell) Time	60 sec	1 sec
Ramp Rate (2.8 or 5kV units)	500 V/sec	1000 V/sec
Ramp Rate (1.5kV units)	300 V/sec	500 V/sec

2-9. Initial Installation and Power-Up

The Rod-L AC Hipot Tester is shipped configured for 115 VAC operation. (See Figure 2-2 for correct fuse usage.) Appropriate fuses are provided for 230 VAC operation in the shipping accessories kit. Before applying 230 VAC power to the Hipot, perform the following:

WARNING

This instrument to be used ONLY in THREE WIRE GROUNDED OUTLETS. It is recommended that periodic checks of the outlet and the ground wire be made to ensure operator safety.

CAUTION

Changing Fuses: Turn off the Hipot Tester and DISCONNECT THE POWER CORD. Then install the proper fuses. Otherwise, damage to the instrument and/or operator could result.

2-10. Operational Check

This is an operator oriented procedure which allows operational check of the Rod-L AC Hipot Test Instrument without test equipment. Refer to Section 4 of this manual for a complete calibration procedure.

Place the instrument in a sturdy position, preferably on an insulated surface, with all surrounding metal/conductors grounded. Position the power cord so as to avoid being walked on or pinched by other equipment.

- A) Set LINE POWER switch to OFF.
- B) Set the TOTAL CURRENT control to the full CW (clockwise) position.
- C) Set the REAL CURRENT control to the full CW position (BV models only.)
- D) Validate that fuses F1 and F2 are the proper values. (See Figure 2-2 for correct fuse usage.)
- E) Verify Input Line Voltage Select Switch position.
- F) Connect AC Power Cord to AC receptacle on the rear panel.

- G) Connect the AC Power Cord to a 115 VAC $\pm 10\%$ power source.
- H) Connect low current Ground Sense Cable to the CHASSIS GROUND SENSE terminal on the front panel. Then attach the alligator clip end of the cable to the Hipot Tester chassis (the handle is a convenient point.)
- I) Set LINE POWER switch to ON. The lamp in the switch should illuminate.
- J) Press the RESET button. The green READY lamp should illuminate.

NOTE: *If the lamp in the power switch remains off, check for proper AC line voltage. If the lamp in the power switch is ON and the green READY lamp remains off, check the CHASSIS GROUND SENSE connections.*

- K) With the READY lamp lit, push the START switch. The TESTING lamp will light. Now quickly disconnect the CHASSIS GROUND SENSE cable. The FAIL lamp should light and the alarm sound a continuous tone, indicating a Safety Ground failure.

WARNING

AC high voltage is present at the front panel HV receptacle block and the rear panel cylindrical connector when the TESTING LAMP is lit.

- L) Push the RESET switch to extinguish the FAIL lamp and the alarm.
- M) Reconnect the CHASSIS GROUND SENSE cable per step "H." The READY lamp should re-illuminate after the RESET button is pressed.
- N) Push START. The TESTING lamp will light and the OUTPUT VOLTAGE meter will indicate the controlled rise to the preset voltage. The TESTING light will remain on until the test time has expired or a test failure is detected.

2-11. Fail Indications

Over Current failures are represented with the FAIL lamp and audible alarm coming on continuously until the RESET button is pressed.

Ground Continuity faults are also depicted with the FAIL lamp and audible alarm coming on continuously, and additionally, the READY lamp turns off. The Hipot Tester must be manually RESET.

An Under Current FAIL is indicated with a tone that is about one second long, then the Hipot Tester resets itself.

Option 05 Hands-Off FAIL signal is about two seconds long, and then the Hipot Tester is reset.

Option 18 Ohm Sense FAIL emits beeps at about 1 to 2 per second until it is reset. Also, there are no TESTING nor FAIL lights.

This does not denote failure, but when Option 10 Audible Test Tone is installed in a Hipot Tester, the alarm will sound pulses at 3 to 6 beeps per second whenever a TEST is in progress.

2-12. Automatic Test Procedure

The following procedure assumes the **Rod-L** AC Hipot Tester has been calibrated and adjusted for normal operation. Proceed as follows:

- A) Place the Device Under Test (DUT) next to the Hipot Tester.
- B) Plug the power cord of the DUT into the high voltage connector of the Hipot Tester.
- C) Connect the GROUND SENSE cable between the DUT and CHASSIS GROUND SENSE banana jack of the Hipot Tester. If this ground connection is less than 0.5Ω , (0.1Ω optional,) the READY lamp will light.
- D) Press the START button. The TESTING lamp should light. (If the Ohms Sense option is used, refer to Section 5, page 50.)

WARNING

High voltage is applied to the Device Under Test. Do not touch the DUT power cord or chassis while the TESTING lamp is lit. If you do, extreme shock may result.

- E) Check that the OUTPUT VOLTAGE meter indicates the test selected voltage. If voltage is high or low, adjust the VARIAC on the rear panel to compensate.

- F) Restart the test. Observe the total current indication. (The BV Model has an additional feature: press the PUSH FOR REAL CURRENT ÷ 10 push button to observe the "real" or resistive part of the current.)
- G) For a normal test, the TESTING lamp will extinguish at completion of the preset test time. If one of the preset current failure setpoints is exceeded, the ground sense connection is interrupted, or an arcing condition occurs due to dielectric insulation breakdown, the test will automatically abort, giving a failure indication, i.e. the FAIL lamp will light and the audible alarm will sound continuously. The operator must then manually press the RESET push button before a test can be repeated.
- H) In the event of a FAIL indication, the operator should investigate carefully to determine which failure occurred. For this reason the ammeter should be continuously monitored during the test.

NOTE: At least five seconds must elapse between TURN-ON and the first hipot test, and three seconds must elapse between successive hipot tests, or random FAIL indications may occur.

NOTE: If the AC Hipot Tester is operated at maximum voltage and maximum current simultaneously, then the operation duty cycle must not exceed 80%—where duty cycle shall be defined as:

$$\frac{\text{operation time}}{\text{operation time} + \text{rest time}} \times 100\%$$

Section 3

THEORY OF OPERATION

3.1. General Introduction

This section outlines the circuit theory for the M100 and M500 series AC Hipot Testers. This system was designed to ensure high quality, accuracy, flexibility, and safety of operation.

Briefly, the Rod-L AC Hipot Tester applies a sine wave at the input Hz of the set voltage between the two current carrying leads of a Device Under Test (DUT.) The HOT and NEUTRAL conductors are tied together and tested with high voltage compared to the GROUND conductor.

The safety CHASSIS GROUND SENSE cable must be connected from the banana jack on the front panel of the AC Hipot Tester to the chassis or other secure low resistance point of the DUT. This will allow the READY light to turn on and the AC Hipot Tester to operate. This wire parallels the normal ground wire in the power cord. To insure that both wires are secure, 1 Amp RMS at 1.5 VAC is passed through both wires. If the total path resistance proves greater than $.5\Omega$, ($.1\Omega$ optional) the READY lamp will not light.

After the parameters are set up, the test can be started manually with the recessed START button, or automatically "remotely" through the Remote Interface, or with the "Hands-Off" Option connected. Then, the A21 Hipot Control PCB signals the A6-S5 HV Control PCB to begin high voltage generation. The TEST lamp turns on to indicate a test in progress, and HV will be at the output receptacle on the front panel and the one on the rear panel.

Finishing a test — either manual with the Reset switch, automatically through the Remote Interface, because the test time has expired, or a failure was detected — makes the A21 Hipot Control PCB stop the HV control.

The Hipot Tester can be digitally controlled through the different statuses via the optically isolated REMOTE. The INTERFACE is used to interconnect the Hipot Tester with a Rod-L DC Hipot Tester or Ground Continuity Tester.

3-2. Instrument Functions

Functionally, the AC Hipot Tester is divided into three sections: The HV GENERATOR, the HV CONTROL, and the GENERAL CONTROL. A REMOTE CONTROL option can be added to the system as shown in Figure 3-1.

The HV GENERATOR consists of an AC HV transformer (50/60 Hz) specially designed to provide the high voltage and current needed in hipot testing.

The HV CONTROL contains: the unique solid state HV AMPLITUDE CONTROL and the RAMP UP CONTROL circuitry on the A6-S5 HV Control PCB. The HV AMPLITUDE CONTROL operates under the principle of generating an adjustable amount of blocking voltage to the input line voltage coming from the variac as shown in Figure 3-2.

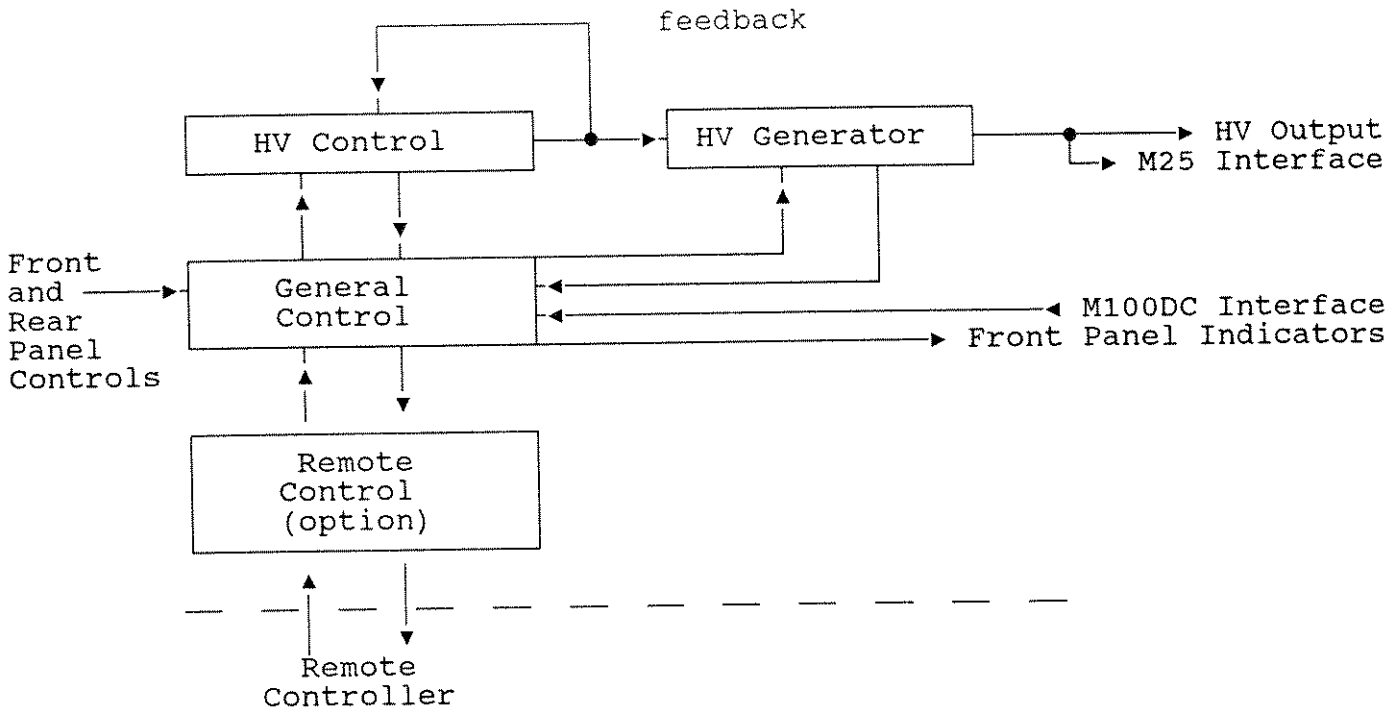

Figure 3-1: Functional Diagram

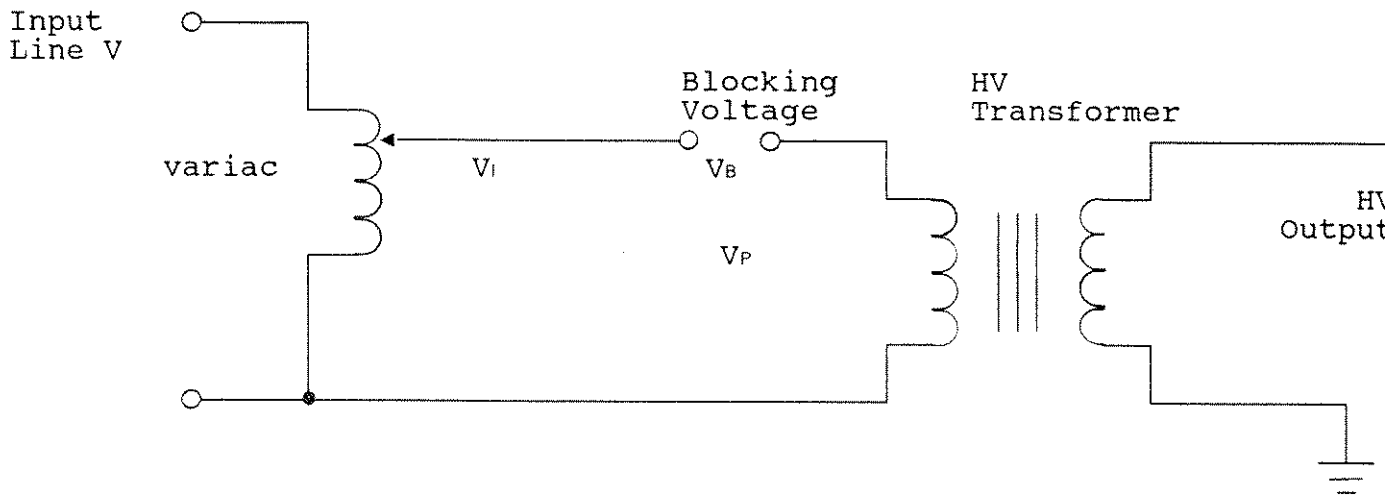

Figure 3-2: HV Amplitude Control

The HV output is directly proportional to V_P . Where V_P is the voltage V_I given by the variac minus the blocking voltage V_B generated across the HV AMPLITUDE CONTROL. When V_B equals or exceeds the voltage across V_I , V_P is zero as is the HV output. As V_B decreases, V_P begins to be different from zero, producing HV in the output of the HV transformer.

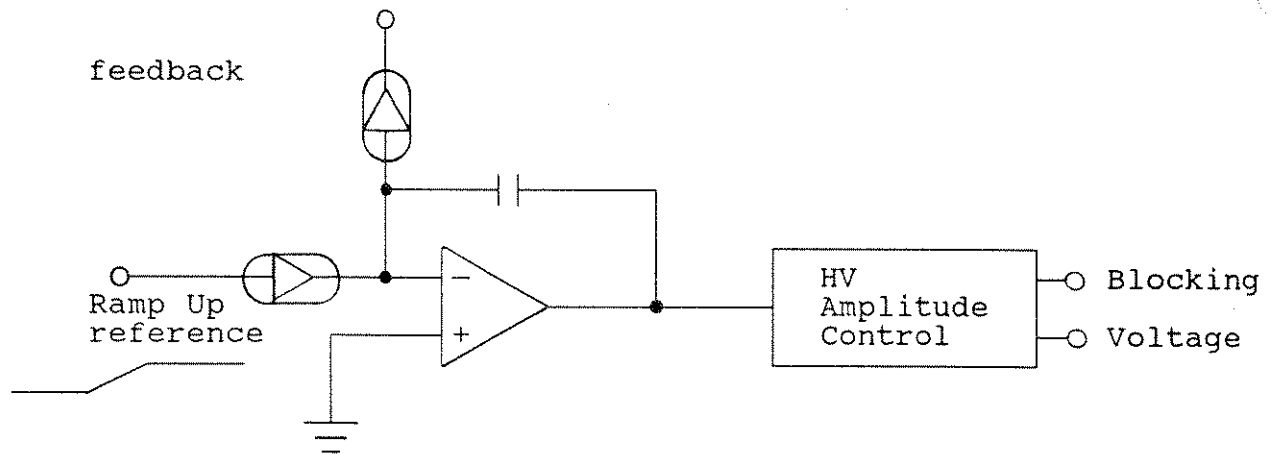

Figure 3-3: Ramp Up Control

The RAMP UP CONTROL circuitry integrates the difference between the ramp up reference signal and the voltage feedback producing a controlling signal. This signal controls key parameters in the HV AMPLITUDE CONTROL, causing the HV output to follow the ramp up signal as shown in Figure 3-3.

The GENERAL CONTROL performs the coordination of the different activities and monitoring. As shown in Figure 3-4, the GENERAL CONTROL can be commanded from the different front and rear panel controls shown on the left side of the diagram. It coordinates the HV CONTROL activities and senses the status of the operation, providing continuous monitoring through the front panel lights, alarm, and meter as shown on the right side of the diagram.

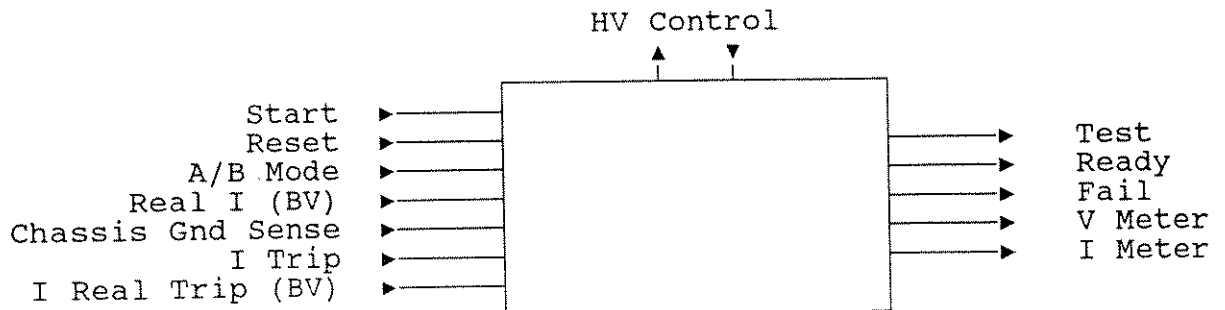

Figure 3-4: General Control

3-3. Instrument Assembly

The instrument is divided into two major subassemblies as shown in Figure 3-5. The right side contains the A6-S5 HV Control P. C. Board and the electrical transformers needed for the operation. The left side contains the low voltage circuitry: the A11 Power Supply / Under Current PCB and A21 Hipot Control PCB, the A2-1 Real Current PCB for BV models, and, when needed, the Remote Option P. C. Board.

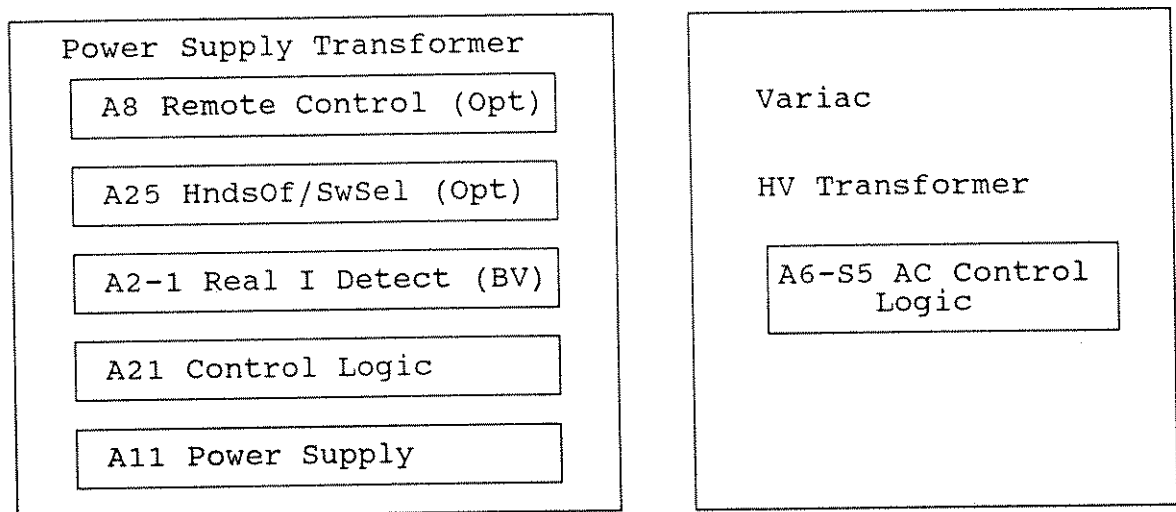

Figure 3-5: Assembly Diagram

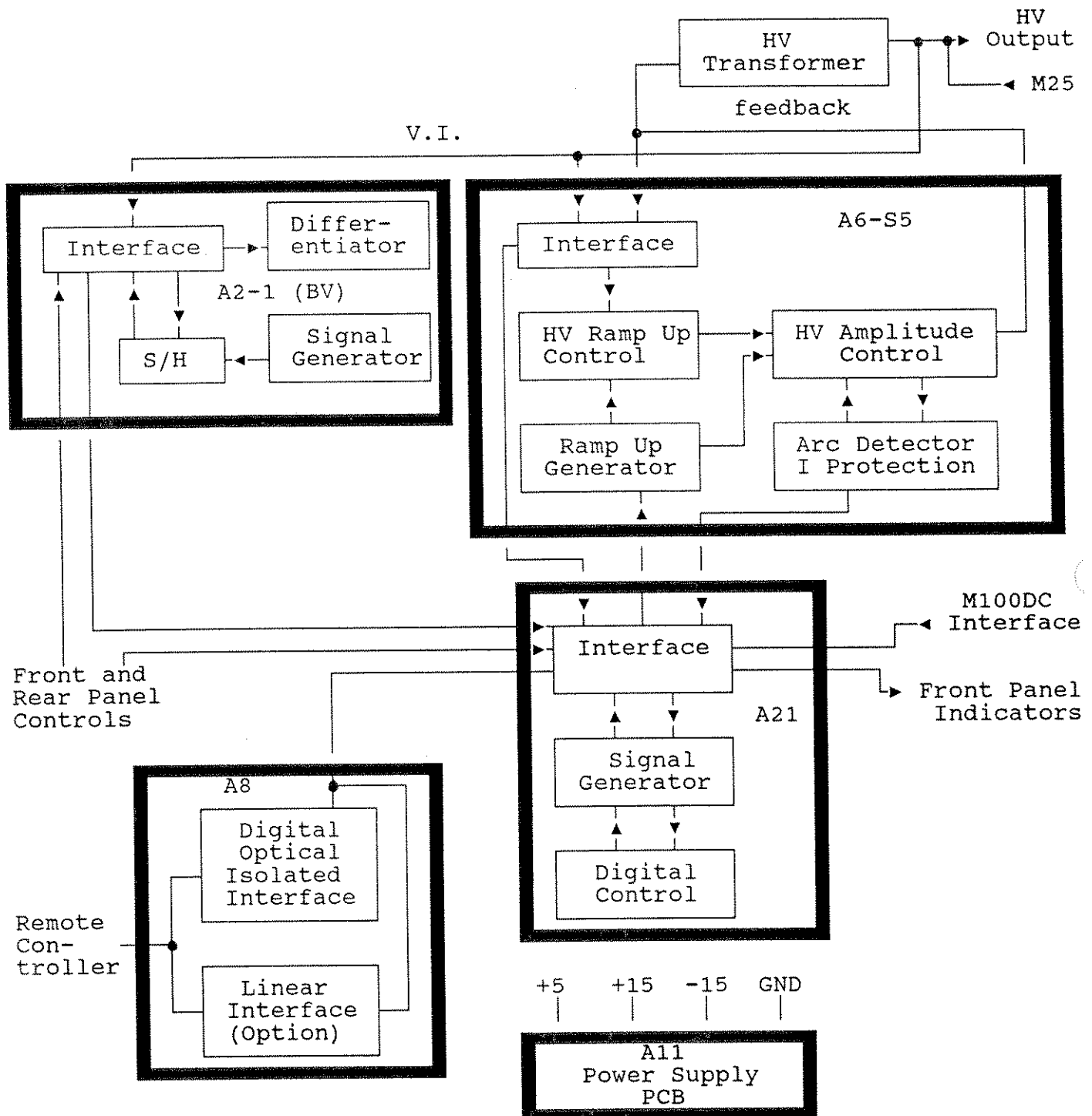

Figure 3-6: Detail Assembly Diagram

3-4. Major Layout Revisions to the Hipot Testers

In 1985 **Rod-L** made several major cosmetic changes to the M100AV Hipot Testers. Prior to this the chassis used was more or less "Z-shaped" (with "L-shaped" right angles,) separating some of p. c. boards from the rest of the circuitry. These Edge-card connectors were hand wired. With the flat chassis design, the A57 Mother P. C. Board was designed to eliminate this work, though the A6-S5 Edge-card connectors are still hand wired.

At the same time a Power Supply P. C. Board was designed to replace the A10. It was called the A11 and included the circuitry for Option 05 Hands Off and Option 21 Under Current, which, when used together, was called Option 04. For Option 05 descriptions, see the Options chapter in this manual. Option 21 became a standard feature very shortly after these other changes were made, and the A11 was changed to Revision B, removing the Option 05 circuitry.

In 1987 the power switch was also changed. We stopped using the toggle switch with the separate neon bulb to indicate that the power to the Hipot Tester was on, and started using a rocker switch that had an internal lamp indicator. The unit wiring diagrams, numbers 00587-01, 00588-01, 00569-01, and 00601-01 were upgraded from Revision A to Revision B. Prior to 1985 they were 00490-08, 00489-08, or 00475-08.

3-5. A11 Power Supply / Under Current P. C. Board

3-5.1. Description

The A11 PCB contains two circuits: the POWER SUPPLY and UNDER CURRENT. Since 1985, Under Current has been a standard of **Rod-L** Hipot Testers. Prior to that it was an option; 21, or, when in combination with Option 05 it was called Option 04.

For further PCB Revision notes, see the paragraphs in Section 3-4. Revision C in 1986 removed R10.

The POWER SUPPLY section provides +15 VDC and -15 VDC regulated for the analog circuits. It also provides +5 VDC regulated for the digital circuits.

The UNDER CURRENT portion enables the detection of a minimum amount of current required during a hipot test. If there is not enough current flowing as determined by the under current potentiometer setting, it is interpreted that the Device Under Test (DUT) is not connected, and a *FAIL* signal of about one second is produced. The *FAIL* signal activates both the fail light and the alarm. At the end of the fail indication, the unit is completely *RESET* if no restart is attempted.

3-5.2. Theory

Referring to schematic # 00267-01, the POWER SUPPLY section takes the 18VAC from Edge-card connector Pins 3 and 4 and feeds it through the full wave bridge rectifier U5. C1 and C2 are the filtering capacitors. The regulator 7815, VR2, provides the +15V, while the regulator 7915, VR3, provides the -15V. 9VAC is rectified by U6 and regulated by the 7805, VR1, to +5.

The UNDER CURRENT section uses the capacitor C10 as part of the U3 timing circuit, and its charging up time determines the length of the pulse produced by U3. U3 is triggered when the TEST signal goes low, in other words, when the test begins and a high level is produced at the output, Pin 3. That output will remain high until C10 charges up to 2/3 of the +5V supply. However, the comparator U4 has to sense the presence of current higher than the tripping point before C10 charges up. U4 must drive Q3 after a certain length of time and discharge C10. Otherwise the output of U3 will fall, triggering U2 which gives a pulse driving the FAIL and the RESET of the system.

The TRIP point value is fed through Edge-card connector Pin R. The RETURN of the ammeter is on Pin E, which is compared at U4 with the TRIP point value.

3-6. A6-S5 High Voltage Control / Ramp Rate P. C. Board

3-6.1. Description

The A6-S5 PCB contains the HV CONTROL and SLOW RISE TIME "RAMP UP CONTROL." Supporting these sections are circuits for the RAMP UP GENERATOR, the VOLTAGE FEEDBACK, the output CURRENT and VOLTAGE monitoring, and the CURRENT PROTECTION and ARC DETECTION.

Revision A changes made in 1978 added notes and R30, and also relocated parts. Revision B in 1980 also relocated parts, and strengthened traces. Revision C in 1986 deleted C4 and 5, and changed the value of R7. Revision D in 1987 was completely redrawn.

3-6.2. Theory

The HV CONTROL was briefly discussed in Section 3-2. Referring to the wiring diagram, # 00587-01 or 00588-01, R1 on the HV and Current Sense Resistor PCB is a set of high voltage resistors for limiting the current through the ammeter to 1 mA for the meter which may have a different scale value. These resistors are factory selected for producing a voltage of about 3 volts RMS for monitoring the high voltage output.

As shown on the schematic # 00239-XX, the amount of blocking voltage V_B depends on the resistance of the photo resistor, PC1.

Q1 and Q2 are used to drive the primary of the HV transformer. When the relay, K1, closes, the gate, Q3, is enabled, allowing the input line voltage to go through and set the circuitry in an initial condition prior to the driving of the HV transformer.

VOLTAGE FEEDBACK AND MONITORING: the voltage at the primary of the HV transformer is fed back through the optical isolators, U3 and U4, producing a full wave rectified current proportional to that voltage. The HV output is fed back through precision resistors, R3 and R6, to produce an average current through the voltmeter proportional to the RMS value. The resistor R12 is in series to provide a HV monitoring.

RAMP UP GENERATOR: when the *TEST* signal at TP2 is low, the voltage at the input of CR1 becomes negative and no current flows through it, so only the current flowing through R29 and determined by one of the potentiometers, R4 or R30, goes through the capacitor, C2, charging it. Since the charging current is constant, the output of the operational amplifier, U1 Pin 6, is a linear RAMP UP.

RAMP UP CONTROL: The operational amplifier, U2, compares the current produced through R10 and R11 with the full wave rectified current from U3 and U4, and integrates the difference. An amount of voltage appears at the primary of the HV transformer, such that a certain value of voltage different from the initial +5V is produced at Pin 6 of U2, permitting an increase in the amount of current sunk by LED1. This value of current determines the resistance of PC1 to produce the amount of HV at equilibrium.

ARC DETECTION: The optical coupler, U5, senses for currents that are several times higher than the full scale value. This condition occurs during arcing, and as it does, a signal is sent to the A21 board.

3-7. A21 Hipot Control Logic P. C. Board

3-7.1. Description

The A21 Hipot Control PCB receives the voltage from across the current sense resistor, rectifies and filters it, and sends it to a comparator that triggers when preset limits of total current are exceeded. This board also has a ground loop circuit to detect safety ground violation.

Prior to 1975 the Logic Control PCB was the A20. In 1975 the A21 was designed, and the schematic # 00236-01 revision was up to H by 1981 with a Fab # 00235-02 at Rev F in 1983. In 1984 new part numbers were assigned; Schematic # 00462-01, Fab # 00462-03, and Assembly # 00462-02, with new drawings and with improved arc detection sensitivity. In 1987 they were redrawn again, as Schematic # 00982-XX and Fab drawing # 00958-01 using resistorpacks

in place of some resistors. The Edge-card connector pinout is the same on all revisions. If you need a schematic for an older revision you may have, call **Rod-L** and have available the serial number of the unit, the fab part number etched on the back of the PCB, and the assembly part number silkscreened onto the front of the PCB.

3-7.2. Theory

ACTIVE RECTIFIER-FILTER: with reference to schematic # 00462-01 or 00982-XX, the operational amplifier, U5, functions as a precision full wave rectifier of the AC voltage present on the current sense resistor during a test. U5 overcomes diode nonlinearities by placing the rectifying elements, CR2 and CR3, in the feedback path. Summing this signal with 1/2 the input signal provides a full wave rectified output. C6 filters the signal with operational amplifier U4. The output is passed through the TOTAL CURRENT METER calibration potentiometer, R19, to the ammeter.

CURRENT COMPARATORS: Operational amplifier U1 is used as a high gain amplifier with weak negative feedback, and acts as a comparator. R21 and R22 provide common mode protection. C7 provides extra filtering.

SAFETY GROUND DETECT CIRCUIT: The operational amplifier, U8, plus R24, R25, CR4, and CR5, half wave rectifies the voltage between ground and the CHASSIS GROUND SENSE binding post. This voltage is 1.5 VAC if the CHASSIS GROUND SENSE binding post is OPEN. When the Device Under Test (DUT) completes the circuit through its ground wire to ground, the voltage at the binding post is proportional to the resistance of the ground wire in the DUT. R26, R27, and C20 determine the trip point for the Darlington pair, Q3 and Q4. The resistors are selected such that a 0.5Ω loop resistance leaves the transistors OFF. Q3 then turns on the READY lamp and allows the START button to be pressed.

CONTROL LOGIC: This circuit receives all push button inputs and sense outputs from the fail comparators and the ground sense logic. When the proper conditions are satisfied, a test sequence is permitted. The duration of a test is set by a timing circuit. In the event of an operator reset or fail condition, the test is aborted. If there is a failure, a warning is presented until manually reset by the user. This circuit includes a zero crossing detector, a timer, and a set-reset latch with associated logic.

INPUT/OUTPUT LINES: There are three digital inputs: *OVERLOAD*, *START*, and *RESET*.

An *OVERLOAD* signal is produced whenever an arcing condition is detected by the A6-S5 HV Control PCB, (or a failure is produced by the A2-1 Real Current PCB on BV models.) This signal combines with the overcurrent signal generated by the operational amplifier, U1,

and the ground failure signal generated by the operational amplifier, U4 Pin 3, to set the fail latch at U7 Pin 5. The ground fail is generated only when a faulty ground is detected during a test. This gating is produced by U7 Pin 2.

The *START* signal is produced by the start switch, which is tied externally to the ground test signal. If this is low, a *START* signal is produced at the NAND Gate, U3 Pin 13. U3 Pin 8 produces pulses synchronized with the AC line's zero crossings if no failure has been latched and if the machine is not in a test. The timer, U2, controls the total test time with R2, R3, R37, and C2. It can be reset by the *FAIL* latch.

The *RESET* signal resets the timer, U2, and the fail latch.

There are 3 outputs: *GROUND TEST*, *TESTING*, and *ALARM*, all of which also drive the corresponding lamps.

The *GND TEST* signal is low whenever the *CHASSIS GROUND SENSE* loop does not exceed the resistance trip value.

The *ALARM* signal goes low whenever the fail latch is set.

The *TESTING* signal is delivered in parallel by Q1 and Q8, and they are low whenever the machine is in a test mode.

TIMER AND ENABLE CIRCUITS: To trigger a timing period at the timer, U2, a start pulse must occur and no failure can be present. The AC Hipot Tester also requires a zero crossing on the 60 Hz AC line. The NAND Gate, U3, detects this and passes it to U2, R2, R3, and R37, and C2 determines the test time. Parts of the hex inverter, U6, drive the *RESET* input of the timer if a test abort is required.

FAIL LATCH: Two NAND Gates on U7 are cross coupled to form the *FAIL* latch. The latch shows a ground fail condition only during a test cycle attempt gated by U7 Pin 2. Pins 9 and 10 sense for failures caused when arcing or overcurrent conditions are produced.

3-8. Understanding Real Current

It may be thought that if there is no physical connection between the AC power line and the chassis of the Device Under Test there can be no current flow. But there are always parasitic capacitances and resistances present which allow some current to flow. At 1500 VAC, 60 Hz, every 1770pF of stray capacitance allows 1 mA of current flow.

If a power transformer is contained in the circuit, interwinding leakage capacitances of from 100pF to 1000pF are common. Furthermore, many instruments require capacitors to be connected

between the AC power line and chassis to eliminate any RF energy being transmitted through the line cord.

Leakage current for any capacitors of this type can be computed using this formula:

$$I_C = V_C (2\pi fC) = 1500 \times 377 \times C \text{ (at 1500 VAC 60 Hz)}$$

The above formula assumes that the capacitors being tested are "perfect," i.e., linear, and have "zero" dissipation. However, ceramic capacitors (commonly used for this purpose) have tolerances of 20%, or worse, have very nonlinear I-V responses at high voltages, and have dissipation factors at high voltages of 30% or more. Thus, the actual current flow may be 150% or more of the theoretical flow for that capacitor. Actual currents can only be confirmed by testing a large number of instruments and computing tables of expected and worst-case values. Then, any current above this worst-case value can be considered a cause for rejection.

Resistive parasitic effects can occur as well. These can be caused by moisture or dust between conductors, rosin or acid flux bridges between PCB traces, leaky insulating materials, and so on. Considerable power can become concentrated in these potential leakage paths. Only 1 mA of current at 1500 volts means that some point must dissipate 1.5 watts of power. That much power concentrated in the very small area of a flux bridge can easily cause a fire hazard.

Real current also flows due to nonideal filter capacitors. The real current flow in a capacitor can be computed by multiplying the capacitor dissipation factor by the total current flow, and, as has been stated, this can be appreciable and very nonlinear. The published low voltage dissipation factors of capacitors gives only a limited projection of what to expect at high voltages, and actual results are invariably high.

Capacitors are also frequency dependent, generating extra harmonics, crossover distortion, and phase shifts in an undetermined manner. This makes every effort of applying linear approximation to the problem difficult, more so in high voltage applications. In hipot testing, most of the capacitance and dissipating resistance are essentially nonlinear, as is line input distortion. Therefore the zero crossing of the voltage and total current waveforms may be asymmetrical or the peaks may not be situated at 90° and 270°, and so, are not used as references.

3-9. BV Operation

The BV model Hipot Testers measure the "real" (resistive) part of the AC current as well as the total current. Nonlinear operations (sparks, arc-overs, etc.) invariably influence the real current much more than they influence the total current. Thus, these effects can be more easily detected on the BV models.

The high voltage configuration is essentially the one used in the standard AV Hipot Tester models. Referring to the wiring diagram, # 00587-01, R2 on the HV and Current Sense Resistor PCB is the current sense resistor and is also factory selected for producing about 5 volts RMS maximum for monitoring the leakage current. Assuming a pure resistive load, the current monitoring waveform is 180° out of phase with respect to the voltage monitoring waveform.

The high voltage waveform is mainly a sinusoidal one with a certain percentage of distortion. The AC input line voltage is a waveform already distorted by 5% to 6%. The primary effect is that the peak of the voltage waveform does not necessarily correspond with the 90° position and does not necessarily remain stable.

Since the real component of interest during the hipot testing is the one reflecting dissipation and not those of the harmonics of the 60 Hz sinusoidal, it is of primary importance to determine where exactly the peak of the voltage waveform occurs under any circumstance. The integration of the waveform is not practical because the undesirable offset effects and the low pass filtering version of the integration would provide only a predetermined amount of phase shift, which does not necessarily correspond to the location of the peak voltage waveform.

In the BV Hipot Testers the voltage waveform is processed and a time derivative is taken to determine the real location of the positive peak. The total current waveform should be falling, and the zero crossing exactly where the peak of the voltage waveform occurs, even if the capacitance changes in a nonlinear way with respect to the voltage. If the sample taken on the total current waveform at this point is different from zero, that value reflects a linear dissipating resistive element in parallel with the ideal capacitance.

This approach permits us to determine a dissipative current component which can tolerate a large amount of distortion in the voltage waveform. One big limitation of the circuitry, however, is the sensitivity of the differentiator to uncommon amounts of noise and distortion. Revision level C of the A2-1 Real Current PCB has upgraded immunity to this with extra filtering and timing circuitry. This permits the sampling of the leakage current waveform only when the peak of the voltage waveform occurs around 90°, where, ideally, it should be.

An advantage of this method is the lack of frequency dependence of the capacitance around 60Hz. This sample of current taken at the positive peak of the voltage represents the sum of all the real components of all the harmonics present in the current waveform. This real current is displayed and is calibrated to give the RMS sum of all the real components.

3-10. A2-1 P. C. Board: Real Current Detect Circuit

The former Revision level C from 1984 of the A2-1 Real Current Detect PCB is an upgraded version of the former A2-1 where an extra immunity to noise and distortion is included as well as real current remote monitoring and trip point programming.

In 1984 the board was upgraded to revision level D for adapting it to the high voltage configuration described above. In 1986 the drawings were remade.

Referring to drawing 00442-01, the A2-1 Real Current Detect PCB receives at Edge-card connector Pin 5 the voltage generated across the voltage sense resistor in the from the A6-S5 HV Control PCB. The first half of the operational amplifier, U1, operates as a buffer. The first half of operational amplifier U2 provides the derivative of the voltage signal which is proportional to the HV output, and the second half of U2 converts this signal to a square wave signal, which rises and falls at the peaks of the voltage signal. The NAND Gate, U8, produces a small pulse of approximately 10 μ S width coincident with the negative peak of the voltage signal. The sample and hold, U4, provides the necessary filtering, along with C13, of the current waveform.

The second half of operational amplifier U1 is a leading circuit which is adjusted to provide the exact triggering at the negative peak of the voltage signal to compensate for the circuit delays.

The output of the operational amplifier, U3 Pin 10, is the amplified value given by U4, the sample and hold. It is calibrated by R7 for giving RMS current values to the ammeter through R18. The second half of U3 is comparing the actual current with the real current trip point to identify overcurrent failures.

Severe nonlinearities in a Device Under Test can produce a false reading on the hipot ammeter. To avoid this, the timer, U7, generates a 10 μ S pulse only for transitions of the waveform at U2 Pin 12 occurring near the peak of the voltage waveform.

U6 provides buffering for external trip programming. U5 is an analog switch for selecting remote trip output meter operation.

The voltage across the voltage monitoring resistor RV is connected to a differential amplifier, U1. Its output, at Pin 12, is fed to the phase shifter so that the output at U1 Pin 10 is leading by a small amount for compensating for the different delays in the circuitry. The output is applied to the differentiator to obtain the inverse of the derivative with the leading zero crossing being coincident with the positive peak of the voltage waveform. The output of the differentiator is applied to the squaring

amplifier to get a square waveform in phase with the derivative, but with the rising edge being coincident with the negative peak of the high voltage monitoring waveform. This is because the leakage current we want to look at is 180° out of phase with respect to high voltage.

The voltage monitoring signal is fed to U6, a timing circuit, through Pin 1 of RN3, which squares the waveform and produces the triggering of the monostable multivibrator, U7. This puts a single pulse out of U8 Pin 8, the NAND Gate, around the negative peak of the voltage monitoring signal. This pulse allows the zero crossing signal represented by the rising edge of the output of U2 Pin 10 to go through U8 producing a signal pulse of about 7μS from the output, U8 Pin 4, coincident with the negative peak of the voltage monitoring signal. This pulse is used in the sample and hold, U4, to sample the leakage current waveform, which comes in through U4 Pin 3 after being buffered by U6. Any positive value which is sampled is reflecting a dissipative current, and is fed to the noninverting amplifier for driving the ammeter. R7 adjusts the gain of this amplifier, U3. The other half of U3 is used to compare the tripping value with the actual current, giving a failure signal if this exceeds the former. The dissipative value from U3 is also used externally for monitoring purposes.

U6 can also accept external trip point programming, which is selected through the Option 01 A8 Remote PCB, activating the *REMOTE* signal through Edge-card connector Pin 6. The analog switch, U5, permits the driving of the ammeter while in a test situation. The component of the current in phase with the negative peak of the voltage monitoring signal reflects a dissipative current, i.e., is positive.

Section 4 MAINTENANCE AND SERVICE

WARNING

These Service Instructions are for use by qualified personnel ONLY. To avoid electric shock, do not perform any servicing other than that contained in the operating instructions unless you are qualified to do so!

4-1. Introduction

This section provides maintenance and service information for the **Rod-L** AC Hipot Testers. Included is a list recommended test equipment, calibration procedures and adjustment data.

Rod-L recommends that the hipot testers be calibrated on a 6 or 12 month cycle at the discretion of the customer based on volume of usage. Under no circumstance should a 12 month cycle be exceeded.

4-2. Equipment Needed

The following equipment will be needed to complete the factory calibration procedures:

- A) Oscilloscope
- B) Digital Multi-Meter (DMM) (Voltage floating input)
- C) High Voltage Probe
- D) 115 - 230 VAC Line Step Up Transformer
- E) AC Variac
- F) High Voltage Loads (see Table 4-1)
- G) Standard Resistors 1%: 0.4 Ω and 0.6 Ω

4-3. Factory Calibration Procedures

There are ten major calibration points on the AC Hipot Testers. They are:

- A) Meter Mechanical Zero
- B) Chassis Ground Sense Calibration
- C) Ramp Rate and A6-S5 PCB Calibration
- D) Current Meter and A21 Hipot Logic Control Calibration
- E) Voltmeter Calibration
- F) Real Current Meter calibration (BV model only)
- G) Set Test Time
- H) Set Total Current Fail "Trip" Point
- I) Set Real Current Fail "Trip" Point (BV models only)
- J) Set Under Current Fail "Trip" Point

4-4. Set Up

It is recommended that the AC Hipot Tester be calibrated at the same line input voltage as will be used for normal operation. If line frequency is different from 60Hz, remember that required capacitor values will change.

4-5. Meter Mechanical Zero

With the Hipot Tester turned *OFF*, note the position of the volt and ammeter pointers on the front panel. They should read 0 ± 1 minor division. If they do not, adjust the null screw.

4-6. Chassis Ground Sense Calibration

- A) Connect a 0.5Ω resistor between the Chassis Ground Sense banana jack on the front panel and the chassis, or handle, of the Hipot Tester. Make sure that the contact resistance of the connecting wires is negligible.
- B) Turn on the Hipot Tester. The READY lamp should come on.
- C) Push the START button.

WARNING

AC high voltage is present at the front panel HV receptacle block and the rear panel cylindrical connector when the TESTING LAMP is lit.

- D) The high voltage should come up normally and no FAIL condition should occur.
- E) Push the RESET button.
- F) Replace the 0.5Ω resistor with a 0.6Ω resistor and connect the CHASSIS GROUND SENSE as above. The READY lamp should NOT come on. Push RESET if necessary. The limits on the Safety Ground Test circuit have been verified. If the limits are not correct, troubleshoot the Safety Ground Detect circuit or call Rod-L for assistance.
- G) Finally, disconnect the load to the Hipot Tester. Connect the CHASSIS GROUND SENSE cable to the chassis (or handle) of the Hipot Tester. The READY lamp should come on.
- H) Push the START button.
- I) While the high voltage is on, disconnect the CHASSIS GROUND SENSE cable. There should be a FAIL indication (lamp and alarm) immediately, and the high voltage should drop to zero.
- J) Push RESET. The READY lamp should NOT light until the CHASSIS GROUND SENSE cable is again connected to the Hipot Tester.

WARNING

The ground sense can be adjusted to other values. However, in no event should the value exceed 0.5Ω .

4-7. A6-S5 AC HV Control PCB and Ramp Rate Calibration

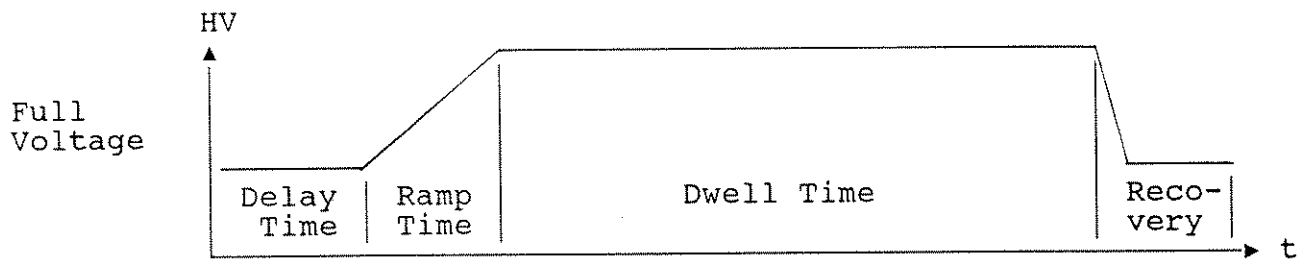

Figure 4-1: Test Cycle Parameter

Figure 4-1 shows the relation between the different parameters of control. The *DELAY TIME* is the time between pushing the START button and the beginning of the rising voltage. It should be between 0.5 and 1.5 seconds. Thus:

$$\text{DELAY} = 0.5 + K (\text{RAMP RATE} \div \text{Full Scale Voltage Per Second})$$

The *RAMP RATE* is a controllable parameter adjusted by R30 and R4 for MODE A and B respectively. For each instrument, the *RAMP RATE* varies from about *FULL SCALE VOLTAGE* in one second to *FULL SCALE VOLTAGE* in 30 seconds. For example, for a 5kV unit the *RAMP RATE* is adjustable from 5000 V/second to 166 V/second. "K" is an instrument constant and varies from about 30 milliSeconds to 50 mS, so the expected *DELAY TIME* is from about 0.54 to 1.54 seconds.

The *RAMP TIME* is the time between the minimum point and the 100% point of the rising voltage, and is dependent on the *RAMP RATE* adjustment and the *FULL VOLTAGE* selected.

$$\text{RAMP TIME} = \frac{\text{FULL VOLTAGE}}{\text{RAMP RATE}}$$

If the same *RAMP TIME* is to be maintained when the *FULL VOLTAGE* is changed with the *VARIAC* control, the *RAMP RATE* has to be readjusted.

TEST TIME is the total *DELAY*, plus *RAMP*, plus *DWELL TIME*. The recovery time is about 0.5 second. So, for a 5kV unit with 5000V/second *RAMP RATE*, 5kV full voltage, and 1 second dwell time, the *TEST TIME* selected has to be 0.54 second + 1 second + 1 second + 2.54 seconds, and the total *TEST* cycle time is 2.54 + 0.5 second (recovery time) = 3.04 seconds. *TEST TIME* is controlled by the A21 Hipot Control PCB.

Proper operation of the *RAMP UP CONTROL* on the A6-S5 HV Control PCB should be verified by watching the *OUTPUT VOLTAGE METER*. No spurious oscillations should be seen on the output voltage waveform. At the end of the turn-on period, the voltage waveform should be sinusoidal except for very small amounts of crossover distortion (assuming a low distortion AC power line.)

Under full load conditions (use test load from Table 4-1,) the output voltage should vary less than 8% for capacitive loads. The waveform should still look essentially sinusoidal, with, in fact, less distortion than the one received at the input line. If not, troubleshoot the A6-S5 PCB or call **Rod-L** for assistance.

For initial calibration of the A6-S5 PCB adjust the following:

- A) Adjust R9 to read approximately -100 millivolts at TP3.
- B) Select MODE A on the front panel and adjust the *TEST TIME* for approximately 30 seconds (or according to the desired *RAMP TIME*) with R37 on the A21 PCB while running the test.

- C) Then adjust R30 on the A6-S5 for the desired RAMP RATE. Clockwise decreases the RAMP RATE.
- D) Select MODE B on the front panel and adjust the TEST TIME for approximately 30 seconds (or according to the desired RAMP TIME) with R2 on the A21 PCB while running the test.
- E) Then adjust R4 on the A6-S5 for the desired RAMP RATE. Clockwise decreases the RAMP RATE.
- F) R20 is factory adjusted for waveform symmetry.
- G) Readjust the TEST TIME if necessary.

4-8. A21 Hipot Logic Control and Total Current Meter Calibration

Turn the Hipot Tester on and note that the TOTAL CURRENT METER position is at zero \pm one division. Connect the SAFETY GROUND SENSE wire to the chassis so that the READY lamp lights. The METER should still be zero. If not, troubleshoot the FULL WAVE TOTAL CURRENT DETECT circuit.

Insure that no load is placed in the HIGH VOLTAGE OUTPUT SOCKET. Push the START button.

WARNING

AC high voltage is present at the front panel HV receptacle block and the rear panel cylindrical connector when the TESTING LAMP is lit.

Note the meter reading. It should be zero \pm one division.

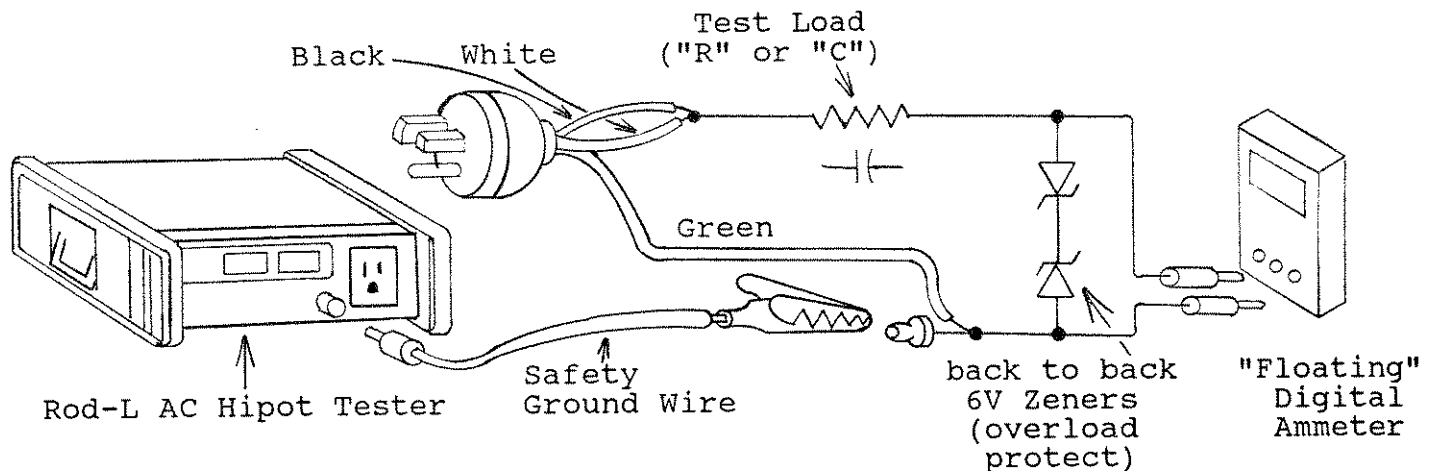

Figure 4-2: Setting Up With a Digital Ammeter

Push the RESET button. Insert a Digital Ammeter in series with a 0.95% of full scale high voltage load resistor (AV only) or a high voltage load capacitor (AV and BV) as shown in Figure 4-2.

WARNING

The ammeter must be inserted on low voltage side of the resistor or capacitor. Otherwise the ammeter's breakdown voltage to ground may be exceeded. The resistor and capacitor should be tested first to insure that they can withstand the rated voltage.

Set the ammeter to 100 mA Full Scale. Push the START button on the Hipot Tester. The ammeter's current reading should agree with the reading on the TOTAL CURRENT meter allowing for 3% tolerance. For example, for a 10 mA F.S. meter the two readings should be within 0.30 mA of each other.

If they do not agree, adjust the TOTAL CURRENT AMMETER calibration potentiometer, R19, on the A21 Hipot Control PCB until the TOTAL CURRENT meter reading agrees with the DMM reading with 1% tolerance. See Drawing # 00959-09 for potentiometer positions.

4-9. Voltmeter Calibration

- A) Disconnect all loads from the Hipot Tester. Connect a high voltage probe to a DVM. The HV probe is connected as a 1000:1 voltage divider by shunting the output with a 50k Ω resistor. Trim the value to compensate for DVM input impedance so that the system accuracy can be 1% or better.
- B) Connect the Ground lead of the HV probe and the CHASSIS GROUND SENSE cable from the front panel of the Hipot Tester to the chassis (or handle) Hipot Tester frame.
- C) Push the START button.

WARNING

AC high voltage is present at the front panel HV receptacle block and the rear panel cylindrical connector when the TESTING LAMP is lit.

- D) The voltmeter should rise slowly from zero after an initial delay. Note the voltage reading. Insert the HV probe into the HV OUTPUT SOCKET and read the voltage from the DVM. The two should agree within $\pm 3\%$ of full scale. If they do not, change the value of R6 on the A6-S5 HV Control PCB (R3 on the A6-S5-3) until they do.

Table 4-1: Load Requirements for Rod-L AC Hipot Testers

ROD-L AC HIPOT TESTER	REQUIRED LOAD
M100AV 1.5kV - 10 mA	160kΩ 3% 3kV 20W resistor or 0.016μF 2k VAC capacitor
M100AV 1.5kV - 50 mA	28kΩ 3% 3kV 100W resistor or 0.08μF 2k VAC capacitor
M100BV 1.5kV - 10 mA	1.6MΩ 3% 3kV 3W noninductive res. and 0.016μF 2k VAC capacitor
M100BV 1.5kV - 50 mA	320kΩ 3% 3kV 10W noninductive res. or 0.08μF 2k VAC capacitor
Other M100AV and M500AV Units	Calculate resistor value from this formula: $R = \frac{\text{Hipot Voltage}}{0.95 \times \text{Full Scale Current}}$ $C = \frac{0.95 \times \text{F.S. Total Current}}{2\mu\text{f} \times \text{Hipot Voltage}}$
All BV Models	Calculate resistor value from this formula: $R = \frac{\text{Hipot Voltage}}{0.095 \times \text{F.S. } (\div 10) \text{ Real Current}}$

4-10. A2-1 Real Current Calibration

A) Offset Adjustment:

- 1) Take the A21 Hipot Control PCB out.
- 2) Short Pins 5 and 13 of the Edge-card connector on the A2-1 Real Current PCB to Ground. Put the PCB back into the unit.
- 3) To adjust the Offset, turn R1 to get 0 (zero) V DC at TP2.
- 4) Remove the A2-1 Real Current PCB and short Edge-card connector Pins 5 and 13 of the to +5V and replace the PCB.

- 5) To adjust the Gain, turn R37 to get 0 (zero) V DC at TP2.
- 6) Turn R3 fully CCW (counterclockwise.)
- 7) Remove the A2-1 Real Current PCB and remove +5V from Edge-card connector Pins 5 and 13 and connect them back to ground. Replace the A2-1.
- 8) To adjust the Balance, adjust R2 to read 0 (zero) V DC at TP3.
- 9) Adjust R6 to read 0V DC at TP12 (20mV scale.)
- 10) Adjust R4 to read 0V DC at TP4 (20mV scale.)
- 11) Adjust R5 and notice the level change from about 0 (zero) V to 15V at TP11. Leave R5 exactly where level change occurs.
- 12) Turn R7 fully clockwise.
- 13) Remove ground from Edge-card connector Pins 5 and 13.
- 14) Short TP8 to ground (U4 Pin 3.)
- 15) Adjust R8 to read 0 (zero) V DC at TP7 (20mV scale.)
- 16) Short TP5 and TP6 together.
- 17) Adjust R9 to produce a level change from 0 Volts to about 7.5V at TP10 (5V scale.) Leave R9 exactly where the level change occurs. Now R29 has an insignificant effect on the 2.9mV at TP9.
- 18) Replace the A21 Hipot Control PCB.

NOTE: *Be sure to check zero every time the reference scale is changed on the oscilloscope and throughout the procedure. After a 20 mV scale is used, a 5 mV scale is advised.*

B) Trigger and Meter Calibration:

- 1) Turn R7 three times CCW.
- 2) Connect a resistor

	High Voltage
	0.95 x F.S. Real Curr

(as in Table 4-1) to the output with an external DMM or ammeter in series with the low side of the high voltage.

- 3) Push the START button to generate HV. Push the $\div 10$ REAL button and turn R3 slowly CW until the CURRENT METER deflects in the positive direction. The CURRENT METER will ascend rather rapidly when at the low end of the scale. The reading on the CURRENT METER must be equal to F.S. (full scale) when the $\div 10$ REAL button is pushed. If necessary, slowly turn up the variac to get current.
- 4) Adjust R7 to read the same current (remember to divide the scale value by 10) on the front panel CURRENT METER as on the external DMM.
- 5) Push the RESET button.
- 6) Connect a capacitor (typically $0.016\mu\text{F}$ 5KV) in parallel to the resistor. Push the START button and check that the reading on the DMM is about the same as before. If not, adjust R3 slowly to get a reading about 3% above the reading when the resistor was alone.
- 7) Take the test load resistor out and push the START button. Check the REAL CURRENT reading after the ramp up. This value added to the one when the resistor was alone gives the real current value when both capacitor and resistor are in place. If it does not, repeat step 4.

4-11. Set Test Time

The TEST TIME ADJUSTMENT potentiometer is set as outlined in Table 2-1 at the factory. To check the test time limits, turn the TEST TIME potentiometers (R37 for "A," R2 for "B") on the A21 Hipot Control PCB to minimum and then maximum. Minimum should be a test one second long, and maximum greater than ninety seconds long. If not, troubleshoot the timer or call Rod-L for assistance.

The TEST TIME ADJUSTMENT potentiometer should be set in accordance with the regulatory agency's suggested test time for the Device Under Test (DUT) if different from the standard factory setting. To reset the TEST TIME duration, proceed as follows:

- A) Turn off power to the AC Hipot Tester.
- B) Remove the top cover and locate the TEST TIME ADJUSTMENT potentiometer R37 on the A21 Hipot Control PCB. Set the TIMING switch on the front panel to "A." (The following steps are the same for position "A" or "B.")
- C) Reapply power to the AC Hipot Tester.

- D) With top cover removed from the AC Hipot Tester, use a stopwatch to time the duration that the TESTING lamp remains on.
- E) By adjusting the TEST TIME ADJUSTMENT potentiometer and timing the TESTING lamp duration with a stopwatch, you should be able to set any duration desired between one and ninety seconds.

CAUTION

Do not touch any of the other potentiometers on the p. c. boards, otherwise the calibration of the instrument will be voided.

4-12. Set Total Current Fail "Trip" Point

To find the correct total current trip point, it is recommended that several DUTs (Device Under Test) known to be in good condition are tested, and the typical amount of current be recorded. _____ mA. The trip point should be set a few milliamps above this amount.

Although the scale on the TOTAL CURRENT TRIP POINT pot on the rear panel approximately corresponds to the current, a better way to set the trip point is to start with the pot completely clockwise (CW,) that is, at the highest possible value, or "Full Scale." (Follow the instructions below.) Any load that draws current within the meter range will pass a test.

While testing a DUT or other load, current will register on the meter. If using a High Voltage resistor load, the High Voltage can be adjusted with the variac knob on the rear panel so that the current meter is reading the value of current that you want to set the trip point to. While the current meter is active, turn the TOTAL CURRENT TRIP POINT pot on the rear panel slowly CCW until the FAIL lamp and audible alarm are activated.

- A) Turn the TOTAL CURRENT and REAL CURRENT (on BV models only) failure TRIP POINT potentiometers fully CW. Turn the UNDER CURRENT failure TRIP POINT potentiometer fully CCW. Insert the calibration load (see Table 4-1) to pull nearly F.S. Current into the Hipot Tester HV output receptacle. The DMM shown in Figure 4-2 is not needed in this test. However, the dual banana jacks should be shorted together.
- B) Push the START button.

WARNING

AC high voltage is present at the front panel HV receptacle block and the rear panel cylindrical connector (including the test load) when the TESTING LAMP is lit.

- C) While the high voltage is on, slowly turn the TOTAL CURRENT TRIP POINT potentiometer CCW until the FAIL lamp comes on.
- D) Push RESET.
- E) Note the position of the slot on the potentiometer. It should be near 10 on the dial scale. If it is less than 8, troubleshoot the A21 Hipot Control PCB or call Rod-L for assistance.

4-13. Set Real Current Fail "Trip" Point (BV models only)

This procedure is identical to that above, except that the REAL CURRENT potentiometer is adjusted and the PUSH FOR REAL CURRENT \div 10 push button is depressed to read real current.

- A) To check the REAL CURRENT TRIP POINT potentiometer, a resistive load such as that used in Section 4-12 A) is required (BV only.) The DMM is not necessary for this test. If it is deleted, short the dual banana plug. Reset all TRIP POINT potentiometers fully CW. Set up the test load and plug into the Hipot Tester.
- B) Push START button.

WARNING

AC high voltage is present at the front panel HV receptacle block and the rear panel cylindrical connector (including the test load) when the TESTING LAMP is lit.

- C) While the high voltage is on, slowly turn the REAL CURRENT TRIP POINT potentiometer CCW until the FAIL lamp comes on.
- D) Push RESET.
- E) Note the position of the slot on the potentiometer. If it is less than 6, troubleshoot the A21 Hipot Control PCB or call Rod-L for assistance.

- F) Repeat the test but turn the REAL CURRENT TRIP POINT potentiometer until the FAIL lamp comes on. It should be near 1 on the dial scale. AV users may also want to do this by constructing the appropriate load; see Table 4-1.

4-14. Set Under Current Fail "Trip" Point

The UNDER CURRENT TRIP POINT pot on the rear panel works the opposite way that the TOTAL CURRENT TRIP POINT pot does. The Hipot Tester is looking for enough current to be drawn, so that one might, for example, be sure that the power switch on the DUT is in the on position. (Because there are more components in the circuit, this would draw more current than if the switch were off.)

The Under Current detect feature requires a minimum of three seconds to react. That is, the Hipot Tester will not sense for under current until the high voltage has reach 95% of the output voltage setting.

To set the UNDER CURRENT TRIP POINT, follow the Set Total Current Trip Point instructions, except that the UNDER CURRENT TRIP POINT pot on the rear panel works the opposite, so the starting point should be minimum current trip point, or completely CCW. The FAIL will be indicated at all current levels below the selected level.

4-15. List of Adjustment Pots

R6 (not pot) on the A6-S5 PCB	Volt Meter
R20 on the A6-S5 PCB	symmetry during Rise Time
R9 on the A6-S5 PCB	Delay Time
R30 on the A6-S5 PCB	A Rise Time
R4 on the A6-S5 PCB	B Rise Time
R37 on the A21 PCB	A Test Time
R2 on the A21 PCB	B Test Time
R19 on the A21 PCB	Current Meter

4-16. Troubleshooting

Below is a list of problems, probable causes, and remedies for fault location. It should assist the technician in isolating a fault location. This table does not tabulate all the possible symptoms; only those Customer Service has determined most likely to occur.

A) No AC power:

- 1) Check fuses F1 and F2 (Figure 2-2 for correct usage.)
- 2) Check for bad AC power switch, S1.
- 3) Check for bad line filter.

- 4) Measure for line voltage on the A6-S5 HV Control PCB, TP6 and TP7, with the high voltage off.
- B) Instrument blows fuses (See Figure 2-2 for correct usage:)
- 1) If only F1 is blowing:
Check for shorted output power transistors on the heatsink.
Check for internal short on transformer T2.
 - 2) If only F2 is blowing:
Check for shorted MOV1 or MOV2.
Check for shorted transformer T1.
Troubleshoot A11 Power Supply / Under Current PCB.
- C) High Voltage Meter does not ramp up slowly:
- 1) Check for shorted output power transistors on the heatsink.
 - 2) Check for leaky Q2 on the A6-S5 HV Control PCB.
- D) Ready Lamp does not work:
- 1) Check for burned out bulb.
 - 2) Check for bad connection at BP1 or bad 10 3W resistor on the A6-S5 HV Control PCB.
 - 3) Troubleshoot safety CHASSIS GROUND SENSE DETECT circuit on the A21 Hipot Control PCB.
- E) No High Voltage:
- 1) Check for bad fuses F1 and F2.
 - 2) Check for bad START switch.
 - 3) Check wiring harness for frayed wiring.
 - 4) Troubleshoot the A6-S5 HV Control PCB digital logic.
- F) Failure indicators do not work or work erratically:
- 1) Check to see if the leakage current meter works.
 - 2) Check signals given by U5 on the A6-S5 HV Control PCB.

- 3) Determine which of three possible failure modes is being detected:
 - CHASSIS GROUND SENSE FAULT.
 - TOTAL CURRENT OVERLOAD.
 - OVERLOAD: T2 Primary current greater than 1.2ATroubleshoot appropriate functional block.
 - 4) Check initial condition voltage at the base of Q1 on the A6-S5 HV Control PCB.
- G) Excessive power dissipation on the A6-S5 HV Control PCB:
- 1) Check for shorts, low beta, etc.
 - 2) Check for internal shorts, corona, etc.
 - 3) Measure the voltage on the A6-S5 HV Control PCB, TP6 and TP7 with the high voltage off. This voltage should equal the line voltage. With high voltage on, this voltage should be less than 5 VAC RMS fully loaded after the RAMP UP.
- H) Arcing shutdown does not work:
- 1) Connect oscilloscope to the A21 Hipot Control PCB Edge-card connector Pin 7, which is the optoisolator output. Short the Hipot Tester output. Adjust the oscilloscope trigger for a single sweep as optoisolator switches from +5V to 0 (zero) V and back.
 - 2) Push START.
 - 3) The FAIL lamp should go on after an approximate delay of one second when the HV comes up. The oscilloscope should show a 0.2 to 1 mS negative pulse from the optoisolator, thus verifying operation.
 - 4) If no pulse appears or the pulse does not fall below 1 volt, repair optoisolator or associated circuitry.
 - 5) If pulse appears, check with Rod-L for increased sensitivity for low level energy arcing.

Section 5

OPTIONS

5-1. A8, Option 01, Digital Remote Control P. C. Board

5-1.1. Description

Option 01 Digital Remote Control provides optically isolated control and monitoring of the main digital functions of the unit. The Analog Remote Options are not available on the M100/500 series testers. (Also, there is a monitoring signal including a relay that is on some versions of the A8 PCB which is used by Rod-L Ground Continuity Testers, but not the M100/500 series testers.)

The A8 Option 01 Digital Remote Control PCB uses these inputs: START, RESET, and SELECT "A." The outputs are READY, TEST, FAIL (ALARM,) and PASS.

There are two different series of A8 PCBs with concomitant revision levels. The assembly part number for PCBs made prior to 1987 is probably in the 00975-XX series, and uses fabs marked with one of the following part numbers: 00324-03, 00445-03, or 00297-05. Any of these boards with a Revision Level up to D will provide high active current driven inputs at 25 mA and low active TTL outputs. Revision E or above of this series provides low active TTL inputs and low active TTL outputs.

Rod-L does not recommend this, but under certain circumstances an *AUTO RESET* signal can be added. This signal is available only with assembly numbers of the 00975-XX series of A8s up to Revision H. It generates short *FAIL* and *RESET* pulses after the A21 latches a failure, enabling the system to completely reset and be ready for the next *START* signal.

A8 PCBs made after 1987 are in the assembly series of 01208-03, -13, or -16, using fabs marked 01209-01, -02, -03, or -04. These boards provide low active TTL inputs and low active TTL outputs as most earlier revisions. Additionally, they include the *PASS* signal and a connector going directly to the rear panel instead of going through the A57 Mother board. The PCB fabs marked with -02, -03, Revision B, or Revision C were upgraded in order to fix layout errors which, otherwise, were hand fixed. Revision D, -04, adds an optical isolator to protect a U4 input.

5-1.2. Theory

The schematic number has been 00980-XX since 1986, and 01210-04 since 1992. Earlier revisions from 01210-04 were not used in the AC Hipot Testers. Prior to 1986 the schematics would have been either 00265-01, 00276-01, 00471-01, or 00445-01. Revisions updated these PCBs to either add circuits like the Pass signal, take away signals like the Auto Reset, correct layouts like dual use of connector Pins, or to make connections easier, but the Edge-card connector pin-outs remain the same. The two most commonly used schematics are included in the manual. If you have need of another schematic, call Rod-L for assistance and be prepared to give the serial number of the unit, the fab part number etched on the back of the PCB, and the assembly part number silkscreened onto the front of the PCB.

The Optically Isolated Control provides three inputs: *START*, *RESET*, and *SELECT A*, and four outputs: *READY*, *TEST*, *FAIL (ALARM)*, and *PASS*.

The input current requirements (see above) are:

LOW INPUT REVISIONS:	HIGH INPUT REVISIONS:
high level: 40 μ A @ +5V	high level: 18 mA @ +5V
low level: 1.6 mA @ 0.4V	low level: 0 mA

The output current capabilities (see above) are:

high level: 2.27 mA @ +5V
low level: 2.27 mA max @ +5V

When the optical coupler, U1 on schematic # 00980-XX, (U2 on schematic # 01210-XX) (U3 on schematic # 00445-01 or U1 with the Auto Reset is used,) is driven, a *RESET* signal is produced at Edge-card connector Pin 5, through the C to D jump.

An optical coupler, U2 on schematic # 00980-XX, (U11 on schematic # 01210-XX) (U2 on schematic # 00445-01,) drives the *START* signal through Edge-card connector Pin 9.

Referring to schematic # 00980-XX, (or 00445-01) the optical coupler, U9, could drive the voltage at U9 Pin 5 causing a low, and Q1 will not drive the relay, K1. This connection is called *STAND BY*, and the A *RISE* and *TEST TIMES* are selected. If U9 is not driven, U9 Pin 5 goes high and Q1 drives the relay, so that the B *RISE* and *TEST TIMES* are selected. (On schematic # 01210-XX, the optical coupler driving Q1 and K1 is U8.)

If the *GROUND TEST* signal through Edge-card connector Pin 10 is low, an optical coupler, is activated and a low level *READY* is available on the *REMOTE* connector through the Mother Board and Edge-card connector Pin L on schematic # 00980-XX or 00445-01, and directly to the Remote connector J1 Pin 21 on schematic # 01210-XX.

When a test is in progress, the *TEST* line, Edge-card connector Pin 11, is low. An optical coupler is activated and a low level is available on the REMOTE connector through Edge-card connector Pin M on schematic # 00980-XX or 00445-01, and directly to the Remote connector J1 Pin 21 on schematic # 01210-XX.

A *FAIL* signal activates the optical coupler providing a low level on the REMOTE connector through Edge-card connector Pin N on schematic # 00980-XX or 00445-01, and directly to the Remote connector J1 Pin 21 on schematic # 01210-XX.

The remote controller's +5V and GND are fed through Edge-card connector Pins K and 15 respectively.

REMOTE CONTROL OPTION DB25 CONNECTOR PIN ASSIGNMENT

1	GND (external)	20	+5V (remote)
4	GND (chassis)	21	-READY
15	AC/DC	22	-TEST
16	GND RETURN	23	-FAIL
18	RESET	25	SELECT A
19	START		

5-1.3. Installation

Because of the special wiring involved this option can only be installed and calibrated at the factory.

**5-2. Option 02, Front Panel Test (Dwell) Time Adjustment
Option 03, Front Panel Rise Time Adjustment**

Front Panel Test (Dwell) Time Adjustment and Front Panel Rise Time Adjustment are installed at the factory. A special front panel is used with access to potentiometer set screws that affect the time adjustments so that the top of the unit does not have to be taken off to set the times on the A21 Hipot Control PCB.

5-3. Option 06, Rear Panel Lockout Cover

Option 06 provides .125" thick transparent lexan cover over rear panel controls on 1.5" long standoffs. To install:

- A) Remove the top cover
- B) Add the standoffs (4 each) to the rear panel corners with the screws provided

- C) Secure the cover to the standoffs with the screws provided
- D) Replace the top cover

5-4. **A25, Option 05 / Option 08,
Hands-Off / Switch Selectable Failure Points P. C. Board**

5-4.1. **Description**

The A25 PCB contains two options: HANDS-OFF and SWITCH SELECTABLE FAILURE POINTS.

The OPTION 05 HANDS-OFF OPERATION option requires the operator or remote controller to hold the *START* line to logic low during the hipot test. If a hipot test is initiated and the *START* line is found high, or the *START* button released, a *FAIL* signal is produced. The *FAIL* signal activates both the fail light and the alarm for about two seconds. Then, the unit is completely *RESET* if no restart is attempted.

The OPTION 08 SWITCH SELECTABLE TRIP POINTS option provides five extra total current failure trip points, that, with the dial on the rear make a total of six. Each of six failure points are set by individual potentiometers. On models made prior to 1984, the option potentiometers were located on a wired general-purpose p. c. board on the inside of the front panel, mounted with the switch.

The trip point that will be used during a given test is selected by a six-position switch on the front panel.

The assembly # for the A25 silkscreened onto the front of the board is 00981-XX. The first A25 PCBs (which were probably replaced immediately) were for Under Current and Hands Off in 1984. Within two months it was decided to make Under Current standard and add it to the All Power Supply PCB, so Option 08 was added to the empty space on the A25 at Rev A. Rev B in 1984 improved ground fault sensing. Rev D in 1986 was redrawn using resistor packs and adding further signals. Rev E in 1987 corrected the layout. The fab # etched into the back of the PCB is 00433-XX.

5-4.2. **Theory**

The HANDS-OFF option consists of a comparator and a set of timers which provide *FAILURE*, *RESET* and *START* signals to the rest of the system. Refer to schematic # 00948-XX. If your unit was purchased in 1984, you may need schematic # 00435-01 or 00433-01. Call **Rod-L** and have available the serial number of the unit, the fab part number etched on the back of the PCB, and the assembly part number silkscreened onto the front of the PCB. The Edge-card connector pinout is the same on all revisions.

The start switch is connected to Edge-card connector Pin 9 of the board. The comparator, U2, inverts and cleans the *START* signal, putting out a high level when the start switch is held down. The *TEST* signal is also inverted, giving a high level output when the unit is testing. The inverted *START* and *TEST* signals are fed to the inputs of the monostable multivibrator, U3.

While the *TEST* signal in the monostable multivibrator, U3, is low, the output through Pin 1 is high. If the *TEST* signal goes high due to a test in progress, U3 is gated to accept triggering from the *START* signal. If the *START* signal goes low during a test in progress, U3 will be triggered and a low level pulse of about 100 μ S is produced through Pin 1, detecting the condition when the start switch is released during a test.

This pulse from U3, Pin 1 triggers one of the two timers in U1 at Pin 6. A high level pulse is produced at U5, Pin 1 of about one second, and this creates a *FAIL* signal of about two seconds through Q1 and Q2. The *FAIL* signal activates both the fail light and the alarm. At the end of the fail indication, the unit is completely *RESET*, and a start can be reattempted.

The start switch is also connected to the second timer through C2, which will produce a high level pulse at U1, Pin 9 on the falling edge of the *START* signal, that is, when the switch is depressed. This pulse drives Q3, giving a *START* pulse to the rest of the system.

When this board is combined with the OHMS SENSE option, the *START* pulse is given by the A24 Ohms Sense PCB instead of the start switch. It must be noted that even when this option is used with the A8 REMOTE CONTROL option, the *START* signal has to be held low through-out the test.

The SWITCH SELECTABLE FAILURE POINTS option allows six different trip points to be easily chosen by simply changing the switch position. The five potentiometers on the board with the switch provide five of those trip points, and the sixth potentiometer is the standard set dial on the rear panel.

A decision must be made as to what point a current will be considered too high. That point is the desired trip point, and when the actual current reaches that point, the alarm and fail light will turn on. A potentiometer allows the user to calibrate that trip point, and then select that trip point for use in a test.

The five 100k Ω potentiometers on the optional A25 Hands Off / Switch Selectable Failure Points PCB put out corresponding voltages through Edge-card connector Pins 6, 8, 10, 12, and 14 to the six-position switch on the front panel. The common of the switch connects to Edge-card connector Pin J of the A21 Hipot Control PCB. This signal is the TRIP POINT, and is at a voltage level set by the

potentiometer which has been selected by the switch. It is compared with the actual current value on the A21 Hipot Control PCB.

5-4.3. Installation

Both Option 05 and 08 are factory installed and calibrated because special panels are used with holes that need to be properly positioned and labeled.

5-5. A27, Option 10 Audible Test Tone P. C. Board

5-5.1. Description

When Option 10 Audible Test Tone is installed in an AC Hipot Tester, the alarm will sound pulses at 3 to 6 beeps per second whenever a TEST is in progress.

This feature is produced by a small PCB attached to the inside of the unit near the alarm. The board is called the A27 Audible Test Tone PCB, and the assembly # 00432-02 is silkscreened onto the front of the PCB, fab # 00432-03 etched into the back of the PCB, and schematic # is 00432-01.

5-5.2. Installation

This option is factory installed and calibrated because of the special wiring involved.

5-6. Option 15, Rack Mounting

Option 15 allows a Rod-L unit to be mounted in a standard 19" wide cabinet.

The procedure for installing the Rack Mounting Kit on the Hipot Tester is as follows:

- A) Remove Extrusion insert (2 each) from both sides of instrument
- B) Place L-Bracket (2) and secure to chassis with four machine screws furnished with Mounting Kit
- C) Check that the screws and brackets are firmly secure

5-7. Option 16, Divide by 10 Current Scale and Trip Point

A toggle switch is mounted on the front panel and allows the bottom 10% of the Full Scale current to be divided by 10 for finer resolution. Any trip point less than the full scale is divided by 10 as well. If the Current Meter full scale is less than 10mA, this option is not possible. If this Option is on the BV where a

toggle switch is already used for choosing to read the Total or the Real Current, the $\div 10$ feature divides the current trip point by 10, but not the scale.

5-8. A24, Option 18, Ohms Sense P. C. Board

5-8.1. Description

Option 18 OHMS SENSE was developed to detect that the Device Under Test (DUT) has the HOT and NEUTRAL leads tied together before the hipot test can begin.

The hipot test normally ties the HOT (or LINE) and NEUTRAL leads on a DUT together. For Ohm Sense, before the hipot test is started, the HOT and NEUTRAL leads are disconnected, so that a small voltage of 1.5 VAC RMS can be applied across the leads. The TESTING light does not come on until and unless the Ohm Sense Test passes. If the test is passed, the HOT and NEUTRAL are reconnected and the hipot test begins. If the Ohm Sense Test fails, the TESTING light will not have come on and the alarm pulses at about 1 to 2 beeps per second until reset.

The CHASSIS GROUND SENSE in the A21 Hipot Control PCB is used to process the voltage across HOT and NEUTRAL leads during this operation. The reference resistance, used normally for the Ground Sense Test, is momentarily substituted by an adjusted potentiometer which provides tripping for impedances in the 1500 Ω range. If the READY signal given by the Ground Sense circuitry during the test goes high, there will be an Ohms Sense failure at the end of the Ohms Sense test cycle. If the test is passed, the HOT and NEUTRAL are reconnected, the reference resistance for the Ground Sense Test is reconnected, and a START pulse is delivered to the A21 PCB to start a hipot test.

The assembly # silkscreened onto the front of the PCB is 00983-01 or -02. The fab # etched onto the back of the PCB is 00434-03. The schematic was # 00434-01 from 1984 to 1986, and is now 00957-XX. Trace layout errors were corrected in Revisions B and C, and diode protection added to the relays in Revision D when it was redrawn.

5-8.2. Theory

When the Hipot Tester is initially turned on, relay K4 is activated, contacts "A" and "D" of K4 are closed, and K2 is closed. The normal Ground Sense is performed on the A21 Hipot Control PCB, so the READY lamp is lit. When the START switch is depressed, Edge-card connector Pins 1, 2, and therefore U2, Pin 11, a NAND gate, go low. U1 is triggered and the output at Pin 1 goes high for one second. This one second pulse places a high on U4, Pins 1 & 2, the peripheral driver, causing a low output at Pin 3. It deactivates K4, opening contacts "A" and "D," and K2 is opened. It

also activates, or closes, K1 and K3. Normal Ground Sense is interrupted.

At this time, the 1.5 VAC is applied across the potentiometer, R16. Current flows through R16 and K3 to W3, which is connected to the NEUTRAL of the Device Under Test (DUT.) Current will return from the DUT through the HV RETURN which is tied to the CHASSIS. The HOT wire is momentarily connected to HV RETURN at K1.

One side of R16 is connected to the Chassis Volt Sense, Edge-card connector Pin 13 of the A21 Hipot Control PCB. This circuitry senses that the impedance of the DUT is approximately 1/2 of the resistance of R16. If this is not true, a high logic level will appear at A21 Edge-card connector Pin 10, *READY*.

At the end of the one second pulse, a pulse is produced at U1, Pin 8. If *READY* is high, the *FAIL* Latch, U3, will be set. When the *FAIL* Latch is set, U5, a timer, will be triggered to send out pulses for the alarm. The *FAIL* output at Q2 is connected back to the *RESET* circuitry so that the board can be reset regardless of failure type. To stop the alarm beeping and reset the failure mode, the *RESET* line must be triggered with either the front panel push button or the Remote Option.

If the resistance of the DUT is equal to or less than 1500 Ω , the negative edge of a pulse generated at U1, Pin 8 will trigger U1, Pin 11. A one second pulse at U1, Pin 9 is generated to allow the normal Ground Sense Circuitry to settle down. When the one second pulse at U1 ends, K4 and K2 are activated and K1 and K3 opened.

The trailing edge of the one second pulse at U1, Pin 9 triggers a 20 mS pulse at U1, Pin 16 which will start the normal cycle of the Hipot Tester.

R15 is used to adjust the timing of the *FAIL* pulsing signal.

5-8.3. Installation

This option is factory installed and calibrated because of the special wiring involved.

5-9. Option 22, Front Panel Voltage Adjust

Front Panel Voltage Adjust is installed at the factory. A long shaft is run from the rear panel variac to a knob on the front panel. This means that the adjustment is made backwards to what would be done if facing the rear panel. It also means that a special front panel is used so that the meters are in a different section of the panel, out of the way of the variac shaft.

5-10. Option 23, Digital Meters

Digital Meters have a circuit accuracy of $\pm 1\%$ and the meters themselves are accurate to within $\pm 0.05\%$. A PCB, the A73, schematic # 01123-03, sits in the A25 Hands Off / Switch Selectable Failure Points PCB slot and adds an op amp to interface to the meters. Prior to 1990 the addition was made by changing the circuitry on the A6-S5 HV Control PCB.

Because the A57 Mother Board must be modified and a special front panel used, this option can only be added at the factory.

5-11. Option 24, Blank Front Panel Start Switch / Blank Front Panel High Voltage Receptacle Block

This option removes the start switch, the front panel High Voltage receptacle block, or both.

5-12. Option 27, A14 No Load Trip Point Setting P. C. Board

This option allows the user to set the trip point by turning a dial on the rear panel and observing the trip point on the current meter. Thus the current trip point can be set without using a test load or having test voltage present.

Prior to 1990 we used a General Purpose PCB to add the ICs. Since 1990 the PCB has been the A14 Option 27 No Load Trip Point Setting PCB. Either board fits into the A25 slot of the A57 Mother board, switches are added to the rear panel, and the unit is further rewired. The diagram # 00955-01 shows how a BV would be rewired, and # 00961-01 shows how the switches are wired. Schematic # 00963-02 is the 1990 A14 PCB, and drawing # 00964-02 shows the assembly layout of the A14 PCB.

The J1 connector on the A14 (or General Purpose PCB in earlier units) in the A25 slot goes to the switches on the rear panel. The Current Sense signal going into the A21 Hipot Control PCB is modified with changes on that board as well as circuitry on the A14 and accompanying switches, enabling the Current Trip Point to be read on the current meter when the switch is in the "set" position. The switch must always be in the "run" position before doing a hipot test.

5-13. Option 28 Two-Position Switch Selectable Current Scale

The current meter has two scales drawn on it. A toggle switch on the front panel will select one or the other scale without affecting the trip point setting.

5-14. **Option 29C Three-Position Switch Selectable Voltages**

A switch on the front panel allows up to two fixed and one variable switch selectable voltages.

Section 6

BILLS OF MATERIALS, SCHEMATICS, DIAGRAMS

Following are M100BV Bills Of Materials for help in identifying typical Rod-L part numbers.

Rod-L Electronics, Inc. -- Bill Of Materials
 01170-09 Assy Kit Ship M100BVS5 Box w/ Accessories

Rod-L P/N	Description	qty	Reference
50667-02	Box Shipping 9.5x18x21 Letrd fr M100,GT,DC,RT,M988	1.0	Box
50663-03	Foam Shipping EndCap M100 5.5''	2.0	Box
77152-01	NIN Envelope 'Packing Slip' Clear Front,Stick Back	1.0	Box
50502-01	Bag poly clear 2mil x2x3 w/sealing	1.0	Bag
50502-05	Bag poly clear 2mil x4x6 w/sealing	1.0	Bag
50510-01	Asm Kit Con Plug HV cord mtg 4pin 863022-2	1.0	HV Con Mate
50015-01	Asm Cable Power AC std 18AWG 1250W 7.5'L	1.0	Power Cord
50342-36	Asm Cable Jumper 18AWG Bana/Allig 36'' blk	1.0	Ground Cable
50305-03	Cover Hole Plug .25''dia blk plastic HH Smith3089	1.0	Remote switch cover
00109-53	Label 'Alert I!' instruction in manual (for UL)	1.0	Label
01347-01	Label 'Stop! Use correct voltage/fuse' (for UL)	1.0	Label
50683-01	Label 'Calibration' green & white	1.0	Certification label
01372-01	Label 'This product is U.L....' 2x5.5 box outside	1.0	Box label
60001-04	Manual M100/500 AC Hipot Tester 26 Jy 91	1.0	Manual
90074-01	NIN Form Certificate Technical	1.0	Certification
ONE-EACH	NIN Of the Following Parts, Only what is Ordered:	0.0	SEE BELOW!!!
50062-02	Fuse Norm Blo .50A 250V 3AG .25x1.25''	1.0	For 115V or 230V Op
50062-04	Fuse Norm Blo 1.00A 250V 3AG .25x1.25''	1.0	For 230V Op
50062-06	Fuse Norm Blo 2.00A 250V 3AG .25x1.25''	0.0	For 115V Op
REV-A	NIN Rev-A This Assy is at Rev-A	0.0	

Rod-L Electronics, Inc. -- Bill Of Materials
 01028-01 Assy Unit M100BVS5-2.8-40 Tested Hipot

Rod-L P/N	Description	qty	Reference
01027-01	Assy Unit M100BVS5-2.8-40 Untested Hipot	1.0	Untested Unit
00571-06	Assy PCB A57 M100/500BV Mother Std	1.0	A57 PCB Assy
00238-11	Assy PCB A 6-S5 AC Control M100 AV/BV (RevD)	1.0	A6S5 PCB Assy
00294-01	Assy PCB A11 PwrSply UndrCur AV w/o Opt05 HandsOff	1.0	A11 PCB Assy
00959-01	Assy PCB A21 Control Logic AV/BV for A11	1.0	A21 PCB Assy
00950-05	Assy PCB A 2-1 BV Real Current Detect (RevE)	1.0	A2-1 PCB Assy
50530-02	Screw PanSem Phl 4-40 x .250	6.0	HW A57
REV-A	NIN Rev-A This Assy is at Rev-A	0.0	

Rod-L Electronics, Inc. -- Bill Of Materials
 01027-01 Assy Unit M100BVS5-2.8-40 Untested Hipot

Rod-L P/N	Description	qty	Reference
00681-01	Assy Plate Front M100BVS5	1.0	Front Panel Assy
00682-01	Assy Plate Rear M100BVS5	1.0	Rear Panel Assy
00683-02	Assy Plate Chassis M100BVS5 2.8kv	1.0	Chassis Assy
00343-05	Asmy Plate Frame Side 5x13 fin & polshd M100s	2.0	Frames
00647-01	Label Model No., Logo, U.L. Logo: 1x3 on Pin Feed	2.0	S/N
50532-02	Screw PanSem Phl 8-32 x .250	4.0	HW Frames
50778-03	Screw Fl Hd 100d Phl 8-32 x .375	18.0	HW Frames
90072-02	NIN Form Traveler Mfg Ord, Prod Tst, QC Data ACs	1.0	Traveller
REV-A	NIN Rev-A This Assy is at Rev-A	0.0	

Rod-L Electronics, Inc. -- Bill Of Materials
00681-01 Assy Plate Front M100BVS5

Rod-L P/N	Description	qty	Reference
00587-01	NIN Diag Wire Unit M100/500BVS5 115V	0.0	Reference
01002-01	Assy Harness Plate Front BV	1.0	Wiring
00430-05	Plate Front M100BV MintGrey screened	1.0	Front Panel
00671-01	Assy Con Recp HV Block 3P All Units	1.0	J1 (Recp)
00977-01	Assy Switch START Rev A ALL Instruments	1.0	S2 (Start)
01139-01	Bracket L-Shape 1hole ea side .5Wx.5x.35 mtg ALL	8.0	M1,2,J1
00641-01	Label Desc and Test Status M100BVS5 Hipot Tester	1.0	FP Label
50527-01	Con Post Binding .875 L Term .9375 Base Cerm	1.0	BP1
50449-05	Con Terminal Strip 5lug, lgnd mtg, solder	1.0	TS1
50565-02	Switch Toggle DPDT 125VDC O-N-O Alco MTA 206A	1.0	S4 (Gnd/Hipot)
50710-01	Switch Rocker SPDT w/ Lamp 125VAC Alco XRL210A004	1.0	S1 (AC ON)
50555-01	Switch PushButton Momntry SPDT wiringLug C&K 8121Z	1.0	S3 (Reset)
50554-01	Switch PushButton Momntry DPDT wiringLug C&K 8221	1.0	S5 (Real)
50007-01	Button Red .375 dia x.25 Tall C&K 7527-RED	1.0	S3 (Reset)
50007-02	Button White .375 dia x.25 Tall C&K 7527-WHITE	1.0	S5 (Real)
50193-01	Lamp Incand Amber pnl mnt 6''Leads Alco MC-680LT	1.0	I3 (Test)
50193-02	Lamp Incand Green pnl mnt 6''Leads Alco MC-680LT	1.0	I2 (Ready)
50193-03	Lamp Incand Red pnl mnt 6''Leads Alco MC-680LT	1.0	I4 (Fail)
50520-01	Alarm 3-30VDC Sonalert AI 380	1.0	AL1
50204-21	Meter Analog w/scale 0- 3.0 kV AC	1.0	M1 (V)
50204-25	Meter Analog w/scale 0- 40 mA AC	1.0	M2 (I)
50204-00	Meter Analog 0-1mA misc scale KYCO 7521	0.0	M1,2
50202-03	Lug Solder # 6 1 solder hole, 1 internal lock	6.0	AL1,M1,2
50173-05	Washer Shoulder # 6 .375 x.031 x.093 nylon	4.0	M1,2
50827-01	Nut Push-On Flat 3/16'' Clip	3.0	I2-4
50530-02	Screw PanSem Phl 4-40 x .250	4.0	J1
REV-B	NIN Rev-B This Assy is at Rev-B	0.0	Sq Sw, Brackets

Rod-L Electronics, Inc. -- Bill Of Materials
00682-01 Assy Plate Rear M100BVS5

Rod-L P/N	Description	qty	Reference
00484-03	Plate Rear M100BV screened	1.0	Rear Panel
50285-02	Variac Type 22 240:0-240 2.25 amps .54kVA	1.0	T3
50706-02	Pot K 5 10 turns pnl mnt 3 lug 2W .875 x.75	3.0	R2-4
50227-01	Knob Dual Counting Dial w/ Brake 020H 1413-66123	3.0	R2-4
50509-01	Con Recp 4p HV Housing pnl mtg blk plastic Amp	1.0	J3
50451-01	Con Nut 1'' for HV Con blk plastic	1.0	J3
50049-01	Con Recp Filter 3P 115/250VAC 60hz 8200pF 20%	1.0	J2 (AC IN)
50075-01	Fuse-Holder Littlefuse 342014	2.0	F1,2
50062-02	Fuse Norm Blo .50A 250V 3AG .25x1.25''	1.0	F1 (for 115V or 230V)
50062-06	Fuse Norm Blo 2.00A 250V 3AG .25x1.25''	1.0	F2 (for 115V)
50062-04	Fuse Norm Blo 1.00A 250V 3AG .25x1.25''	0.0	F2 (for 230V)
50560-01	Switch Slide 4PDT 115/230VAC Sel Sw.Crft47227LFE	1.0	A7AV
50202-03	Lug Solder # 6 1 solder hole, 1 internal lock	2.0	Chassis Ground
50258-07	Rivet .250''L .120''dia stem A7 Switch	2.0	A7AV
50585-04	Washer Star # 4	2.0	Lugs
50587-20	Washer Internal Lock .875 OD x.53125 ID	2.0	F1,2
50544-06	Nut Kep 1/4-20 x .438 (7/16) O.D.	4.0	T3
50544-01	Nut Kep 4-40 x .250 (1/4) O.D.	4.0	J2 (filter), Lugs
50530-03	Screw PanSem Phl 4-40 x .375	2.0	Lugs
50530-04	Screw PanSem Phl 4-40 x .500	2.0	J2 (Filter)
50531-02	Screw PanSem Phl 6-32 x .250	2.0	T3
REV-A	NIN Rev-A This Assy is at Rev-A	0.0	

Rod-L Electronics, Inc. -- Bill Of Materials
 00683-02 Assy Plate Chassis M100BVS5 2.8kv

Rod-L P/N	Description	qty	Reference
01004-01	Assy Harness Plate Chassis & Rear BV	1.0	Wiring
00670-01	Assy Heatsink 2ea 2N6677 XS	1.0	HS Assy
00581-01	Assy PCB A71 HV & Curr Sense AV 1.5 or 2.8kv	1.0	A71 PCB Assy
00526-08	Plate Chassis M100AV/BV 5.0kv (RevC) slotforXF	1.0	Chassis Plate
00226-07	Trnsfrmr 22W: 18(2),8,1.38V RevB AC,GT PS Q 4495	1.0	PS XF
00257-04	Trnsfrmr 120W 10,20,120(2): 2800V M100AV T 4-4392	1.0	HV XF
00859-01	Insulation Paper Cut 4.4x7.5 A6S5	1.0	A6S5
50071-01	Con Guide PCB 3''L 4-40 mtg SAE 1250V	2.0	A6S5
50299-01	Con 12p Recp Block for Angle pin Molx 09-02-2122	2.0	A6S5
50074-10	Washer Flat #10 3/8 OD steel zinc pltg	4.0	HV XF
50544-01	Nut Kep 4-40 x .250 (1/4) O.D.	4.0	A6S5
50544-03	Nut Kep 8-32 x .344 (11/32) O.D.	2.0	PS XF
50544-04	Nut Kep 10-32 x .375 (3/8) O.D.	4.0	HV XF
50530-02	Screw PanSem Phl 4-40 x .250	2.0	Card Guides
50530-04	Screw PanSem Phl 4-40 x .500	4.0	A6S5
50532-03	Screw PanSem Phl 8-32 x .375	4.0	PS XF, HS
50533-04	Screw PanSem Phl 10-32 x .500	4.0	HV XF
REV-A	NIN Rev-A This Assy is at Rev-A	0.0	

Rod-L Electronics, Inc. -- Bill Of Materials
 00571-06 Assy PCB A57 M100/500BV Mother Std

Rod-L P/N	Description	qty	Reference
00570-01	NIN Schem PCB A57 M100/500 AV/BV Mother Interconne	0.0	Reference
00572-04	PCB Fab A57 M100/500 AV/BV Mother RevD for A25RevE	1.0	A57 PCB Fab
50817-04	Jumper Wire #22 AWG .4 long	6.0	H1,3-7
50817-05	Jumper Wire #22 AWG .5 long	1.0	CR1
50817-06	Jumper Wire #22 AWG .6 long	1.0	H8
50612-01	Standoff 4-40 x .375 x.25 OD FF hexBrassCad	6.0	A57 mounting
50584-02	Washer Fiber # 4 black HH Smith 2161	1.0	A57 mounting
50530-02	Screw PanSem Phl 4-40 x .250	12.0	A57 mtg, Card Guides
50409-01	Con 30p Cardedge 15pos PCB mtg pins no Ears	3.0	A2-1,11,21
50222-07	Con Header w/FricLock 7p M lro .100 C/C .025sq	1.0	P9
50222-12	Con Header w/FricLock 12p M lro .100 C/C .025sq	4.0	P1,2,4,7
50071-01	Con Guide PCB 3''L 4-40 mtg SAE 1250V	6.0	A2-1,11,21
REV-B	NIN Rev-B This Assy is at Rev-B	0.0	

Rod-L Electronics, Inc. -- Bill Of Materials
 00294-01 Assy PCB All PwrSply UndrCur AV w/o Opt05 HandsOff

Rod-L P/N	Description	qty	Reference
00267-01	NIN Schem PCB All PwrSply/UndrCur w/o Opt05 HndOff	0.0	Reference
00278-03	PCB Fab All Power Supply / Undercurrent (RevB)	1.0	All PCB Fab
00487-06	Heatsink L-Shape 3holes .7x1.8 blk anodz All	1.0	HS1
50264-08	IC-Socket 8p Lo Profile .3 DIP	3.0	X2-4
50091-01	IC Timer NE555 or MOTOROLA MC1455P	2.0	U2,3
50102-01	IC Op Amp Hi Slew 8p DIP UA741 TC	1.0	U4
50130-01	IC V Reg +5 TO-220 UA7805 or LM340T5	1.0	VR1
50169-01	IC V Reg +15 TO-220 UA7815	1.0	VR2
50123-01	IC V Reg -15 TO-220 7915 or K1703-B or LM320T-15	1.0	VR3
50659-01	Trnstor-Insulator Thermal for TO-220	3.0	VR1-3
50708-01	Pot K 500 20 turns offset pins rectangle	1.0	R13
50702-06	Pot K 5 20 turns offset pins rectangle	1.0	R19
50032-01	Diode 1N4002 Rec 100V 1A	3.0	CR9-11
50036-01	Diode 1N914B Signal 100V	3.0	CR12-14
50030-01	Diode-Bridge CSB05 70V 1A	2.0	U5,6
50272-01	Trnstor 2N3904 NPN SS Gen Purp RF 40VbrCEO TO-92	2.0	Q3,4
50267-01	Trnstor 2N2222 NPN SS Gen Purp Amp 30VbrCEO TO-18	1.0	Q5
50830-01	Fuse-Pico 4A 125V Littlefuse 275004 (251004?)	1.0	F1
50125-44	Res K 10 1/4W 5% CC	5.0	R5,9,11,14,17
50125-36	Res K 2.2 1/4W 5% CC	2.0	R8,26
50125-40	Res K 4.7 1/4W 5% CC	1.0	R12
50125-79	Res K 20 1/4W 5% CC	1.0	R15
50125-59	Res K 100 1/4W 5% CC	1.0	R16
50125-31	Res K 1 1/4W 5% CC	1.0	R18
50125-15	Res Ohm 470 1/4W 5% CC	1.0	R29
50125-69	Res K 330 1/4W 5% CC	1.0	R30
50320-02	Cap 470 uF 50VDC 20% elect axial	2.0	C1,2
50324-04	Cap 3000 uF 16VDC 10% elect axial	1.0	C3
50209-14	Cap .01 uF 100V 20% cerm disc lo V	5.0	C4,8,9,11,12
50060-01	Cap 1 uF 35V 10% tant axial	2.0	C5,6
50013-01	Cap 4.7 uF 20V 10% tant bullet axial	2.0	C10,13
50173-04	Washer Shoulder # 4 .235 x.125 x.047 nylon	3.0	VR1-3
50544-01	Nut Kep 4-40 x .250 (1/4) O.D.	3.0	VR1-3
50530-03	Screw PanSem Phl 4-40 x .375	3.0	VR1-3
77710-01	NIN Dwg Loc not used See Ref	0.0	R1-4,6,7,10, CR1-8,
77710-01	NIN Dwg Loc not used See Ref	0.0	Q1,2
REV-C	NIN Rev-C This Assy is at Rev-C	0.0	

Rod-L Electronics, Inc. -- Bill Of Materials
00959-01 Assy PCB A21 Control Logic AV/BV for All

Rod-L P/N	Description	qty	Reference
00982-01	NIN Schem PCB A21 Control Logic for use w/ All	0.0	Reference
00958-01	PCB Fab A21 Control Logic (RevH)	1.0	A21 PCB Fab
50264-08	IC-Socket 8p Lo Profile .3 DIP	5.0	X1,2,4,5,8
50264-14	IC-Socket 14p Lo Profile .3 DIP	3.0	X3,6,7
50102-01	IC Op Amp Hi Slew 8p DIP UA741 TC	4.0	U1,4,5,8
50091-01	IC Timer NE555 or MOTOROLA MC1455P	1.0	U2
50135-01	IC NAND 2-In quad 7400	1.0	U7
50138-01	IC Inverter OC hex 7405	1.0	U6
50142-01	IC NAND 4-In dual 7420	1.0	U3
50349-01	ResPak SIP K 4.7 10p 9r 1%	1.0	RP1
50338-03	ResPak SIP K 20 8p 4r 1%	1.0	RP2
50702-05	Pot K 2 20 turns offset pins rectangle	1.0	R19
50708-01	Pot K 500 20 turns offset pins rectangle	2.0	R2,37
50125-31	Res K 1 1/4W 5% CC	5.0	R10,11,33,34,40
50125-38	Res K 3 1/4W 5% CC	1.0	R29
50125-39	Res K 3.3 1/4W 5% CC	1.0	R20
50125-40	Res K 4.7 1/4W 5% CC	1.0	R30
50125-43	Res K 6.8 1/4W 5% CC	1.0	R3
50125-84	Res K 7.5 1/4W 5% CC	1.0	R18
50125-85	Res K 8.2 1/4W 5% CC	1.0	R43
50125-44	Res K 10 1/4W 5% CC	5.0	R22-24,28,35
50125-47	Res K 18 1/4W 5% CC	1.0	R26
50125-79	Res K 20 1/4W 5% CC	1.0	R15
50125-54	Res K 51 1/4W 5% CC	1.0	R17
50125-55	Res K 56 1/4W 5% CC	1.0	R38
50125-56	Res K 68 1/4W 5% CC	3.0	R25,36,41
50125-59	Res K 100 1/4W 5% CC	2.0	R27,39
50125-10	Res Meg 10 1/4W 5% CC	1.0	R21
50125-02	NIN Res selected 5% 1/4W CC	2.0	R31,32
50125-01	Diode 1N914B Signal 100V	6.0	CR2-5,8,9
50125-01	Diode 1N750 Zen 4.7V	1.0	CR6
50125-01	Trnstor 2N2222 NPN SS Gen Purp Amp 30VbrCEO TO-18	6.0	Q1-3,7-9
50125-01	Trnstor 2N2907 PNP SS Gen Purp Amp 40VbrCEO TO-18	1.0	Q6
50125-01	Trnstor 2N3904 NPN SS Gen Purp RF 40VbrCEO TO-92	2.0	Q4,5
50125-14	Cap .01 uF 100V 20% cerm disc lo V	10.0	C1,3,4,7-9,11-13,15
50125-07	Cap .47 uF 50V 20% mono dip .25 leads	1.0	C14
50125-02	Cap 4.7 uF 35V 10% tant bullet axial	1.0	C6
50125-05	Cap 10 uF 25VDC 10% elect axial	1.0	C5
50125-20	Cap 22 uF 15V 10% tant axial	1.0	C10
50125-02	Cap 150 uF 16VDC 10% elect axial	1.0	C2
50125-01	Pin-Micro Test .070dia .3/.062 ID x.145 gold	7.0	TP1-7
50125-01	NIN Dwg Loc not used See Ref	0.0	R1,4-9,12-14,16,31,3
50125-01	NIN Dwg Loc not used See Ref	0.0	42,44,CR1,7
REV-H	NIN Rev-H This Assy is at Rev-H	0.0	

Rod-L Electronics, Inc. -- Bill Of Materials
00238-11 Assy PCB A 6-S5 AC Control M100 AV/BV (RevD)

Rod-L P/N	Description	qty	Reference
00239-01	NIN Schem PCB A 6-S5 AC Control M100 AV/BV	0.0	Reference
00212-12	PCB Fab A 6-S5 AC Control Slow Rise (RevD)	1.0	A6-S5 PCB Fab
50102-01	IC Op Amp Hi Slew 8p DIP UA741 TC	2.0	U1,2
50089-01	IC Optical Coupler MCT2E (Motorola only)	3.0	U3-5
50264-06	IC-Socket 6p Lo Profile .3 DIP	3.0	X3-5
50264-08	IC-Socket 8p Lo Profile .3 DIP	2.0	X1,2
50702-08	Pot K 20 20 turns offset pins rectangle	1.0	R9
50702-09	Pot K 25 20 turns offset pins rectangle	1.0	R20
50702-12	Pot Meg 1 20 turns offset pins rectangle	2.0	R4,30
50036-01	Diode 1N914B Signal 100V	11.0	CR1-8,11-13
50034-01	Diode 1N4005 Rec 600V 1A	4.0	CR14-17
50041-01	Diode 1N5245B Zen 15V	2.0	CR9,10
50270-01	Trnstor 2N3439 NPN SS HV HiCur Amp 350VbrCEO TO-39	1.0	Q1
50277-01	Trnstor 2N5416 PNP SS HV HiCur Amp 300VbrCEO TO-39	1.0	Q2
50284-01	Trnstor T2700D or SK3507 Triac 400V TO-66	1.0	Q3
50175-01	Trnstor-Insulator Thermal TO-66 Silicon Rubber	1.0	Q3
50316-17	Res Ohm .33 3W 1% WW	2.0	R24,27
50316-01	Res Ohm 1 3W 1% WW	1.0	R13
50150-06	Res Ohm 68 1/2W 5% CC	2.0	R14,21
50150-07	Res Ohm 100 1/2W 5% CC	3.0	R16,22,28
50150-30	Res K 1 1/2W 5% CC	1.0	R23
50350-54	Res K 1.21 1/4W 1% MF	1.0	R5
50350-14	Res K 1.62 1/4W 1% MF	1.0	R1
50125-35	Res K 2 1/4W 5% CC	1.0	R7
50350-21	Res K 3.48 1/4W 1% MF	1.0	R10
50150-33	Res K 3.6 1/2W 5% CC	1.0	R15
50350-41	Res K 4.64 1/4W 1% MF	1.0	R8
50150-34	Res K 7.5 1/2W 5% CC	1.0	R17
50350-31	Res K 15 1/4W 1% MF	1.0	R2
50125-79	Res K 20 1/4W 5% CC	1.0	R29
50200-43	Res K 82 1W 5% CC	1.0	R25
50200-44	Res K 100 1W 5% CC	1.0	R26
50150-52	Res K 330 1/2W 5% CC	3.0	R6,18,19
50835-02	NIN Res selected 5% 1/4W CC	1.0	R11
50836-06	NIN Res selected 1% 3W MF	1.0	R12
50209-14	Cap .01 uF 100V 20% cerm disc lo V	1.0	C8
50209-03	Cap .01 uF 1000V 20% cerm disc lo V	1.0	C7
50324-05	Cap 10 uF 25VDC 10% elect axial	1.0	C1
50060-06	Cap 22 uF 35V 10% tant axial	1.0	C3
50060-08	Cap 33 uF 10V 10% tant axial	1.0	C6
50060-07	Cap 220 uF 10V 10% tant axial	1.0	C2
50151-01	Pin-Micro Test .070dia .3/.062 ID x.145 gold	7.0	TP1-7
00124-11	Relay Reed 1kVDC .20amp Metal Case F81-5053A	1.0	K1
00698-01	Assy Housing LED & Photocell	1.0	LED
00665-05	Heatsink L-Shape 1 TO-66 .85x1.1x1.5 clear A6S5	1.0	Q3
50254-01	Photo Cell NSL-446	1.0	PC1
50584-01	Washer Fiber # 6 black HH Smith 2162	2.0	LED
50173-05	Washer Shoulder # 6 .375 x.031 x.093 nylon	2.0	Q3
50544-05	Nut Kep 6-32 x .250 (1/4) O.D.	2.0	Q3
50531-04	Screw PanSem Phl 6-32 x .500	2.0	Q3
50530-02	Screw PanSem Phl 4-40 x .250	2.0	LED
00109-52	Label 'Danger High Voltage' 2x3 in Wht w/Red & Blk	1.0	Q3
77710-01	NIN Dwg Loc not used See Ref	0.0	C4,5
REV-C	NIN Rev-C This Assy is at Rev-C	0.0	

Rod-L Electronics, Inc. -- Bill Of Materials
00247-02 Assy PCB A 7AV Line Select Switch

Rod-L P/N	Description	qty	Reference
00247-03	PCB Fab A 7AV AC Voltage Input Select Switch (RevB	1.0	A7 PCB Fab
50286-01	Varistor 10 Joules GE VA130LA10A	2.0	V1,2
REV-B	NIN Rev-B This Assy is at Rev-B	0.0	

Rod-L Electronics, Inc. -- Bill Of Materials
 00950-05 Assy PCB A 2-1 BV Real Current Detect (RevE)

Rod-L P/N	Description	qty	Reference
00442-01	NIN Schem PCB A 2-1 BV Real Current Detect	0.0	Reference
00951-05	PCB Fab A 2-1 BV Real Current Detect (RevE)	1.0	A2-1 PCB Fab
50264-14	IC-Socket 14p Lo Profile .3 DIP	6.0	X1-3,5,6,8
50264-08	IC-Socket 8p Lo Profile .3 DIP	1.0	X4
50264-16	IC-Socket 16p Lo Profile .3 DIP	1.0	X7
50103-01	IC Op Amp dual UA747	3.0	U1-3
50124-01	IC Sample & Hold Monolythic LF398	1.0	U4
50077-01	IC Switch Bilateral CMOS quad CD4066B	1.0	U5
50128-01	IC Op Amp Lo Power quad LM324	1.0	U6
50093-01	IC Timer quad NE558	1.0	U7
50110-01	IC NAND 2-In CMOS quad CD4011	1.0	U8
50702-07	Pot K 10 20 turns offset pins rectangle	7.0	R1,2,5-9
50702-11	Pot K 100 20 turns offset pins rectangle	1.0	R3
50702-08	Pot K 20 20 turns offset pins rectangle	1.0	R4
50702-04	Pot K 1 20 turns offset pins rectangle	1.0	R29
50702-09	Pot K 25 20 turns offset pins rectangle	1.0	R37
50335-02	ResPak SIP K 4.7 8p 4r 1%	1.0	RN1
50334-10	ResPak SIP K 1 8p 4r 1%	2.0	RN2,3
50336-01	ResPak SIP K 100 8p 4r 1%	1.0	RN4
50335-01	ResPak SIP K 10 8p 4r 1%	1.0	RN6
50337-01	ResPak SIP K 2.2 8p 4r 1%	1.0	RN7
50036-01	Diode 1N914B Signal 100V	6.0	CR1-4,7,8
50044-01	Diode 1N750 Zen 4.7V	4.0	CR5,6,9,10
50267-01	Trnstor 2N2222 NPN SS Gen Purp Amp 30VbrCEO TO-18	2.0	Q1,2
50269-01	Trnstor 2N2907 PNP SS Gen Purp Amp 40VbrCEO TO-18	1.0	Q3
50209-14	Cap .01 uF 100V 20% cerm disc lo V	11.0	C1,4,5,7-12,16,17
50066-07	Cap .47 uF 50V 20% mono dip .25 leads	1.0	C2
50066-03	Cap .01 uF 50V 20% mono dip .25 leads	2.0	C3,6
50320-01	Cap 47 uF 25VDC 20% elect axial	5.0	C13-15,21,22
50060-01	Cap 1 uF 35V 10% tant axial	2.0	C18,19
50209-01	Cap .002 uF 1000V 20% cerm disc lo V	1.0	C20
50125-59	Res K 100 1/4W 5% CC	4.0	R10,14,34,35
50125-31	Res K 1 1/4W 5% CC	6.0	R11,16,17,19-21
50125-74	Res K 680 1/4W 5% CC	1.0	R12
50125-44	Res K 10 1/4W 5% CC	4.0	R13,18,23,24
50125-21	Res Ohm 330 1/4W 5% CC	1.0	R15
50125-53	Res K 47 1/4W 5% CC	2.0	R22,26
50125-08	Res Ohm 100 1/4W 5% CC	1.0	R25
50125-79	Res K 20 1/4W 5% CC	1.0	R27
50125-40	Res K 4.7 1/4W 5% CC	2.0	R28,32
50125-46	Res K 15 1/4W 5% CC	2.0	R30,39
50126-10	Res Meg 10 1/4W 5% CC	1.0	R33
50350-36	Res K 100 1/4W 1% MF	1.0	R36
50350-43	Res K 86.6 1/4W 1% MF	1.0	R38
50151-01	Pin-Micro Test .070dia .3/.062 ID x.145 gold	12.0	TP1-12
77710-01	NIN Dwg Loc not used See Ref	0.0	C23
REV-E	NIN Rev-E This Assy is at Rev-E	0.0	

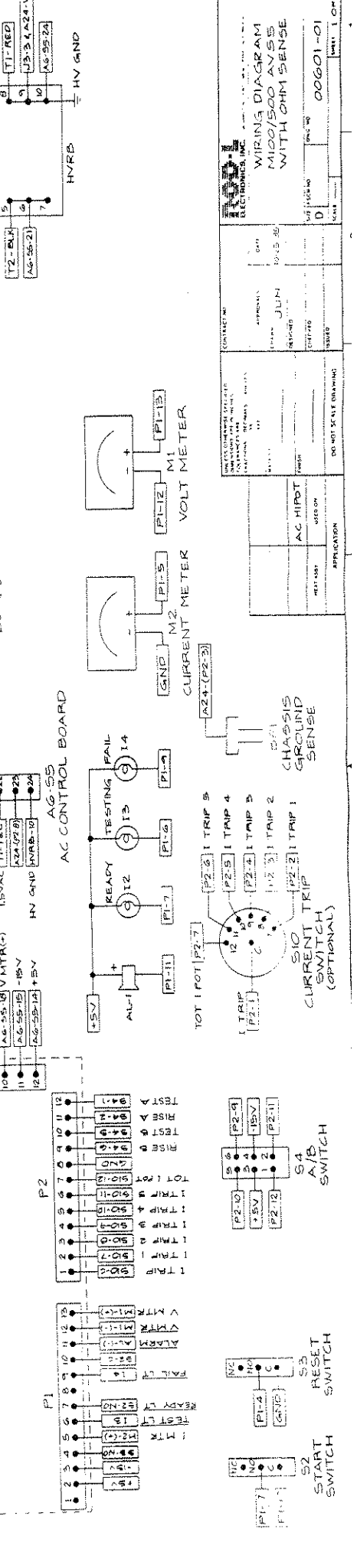
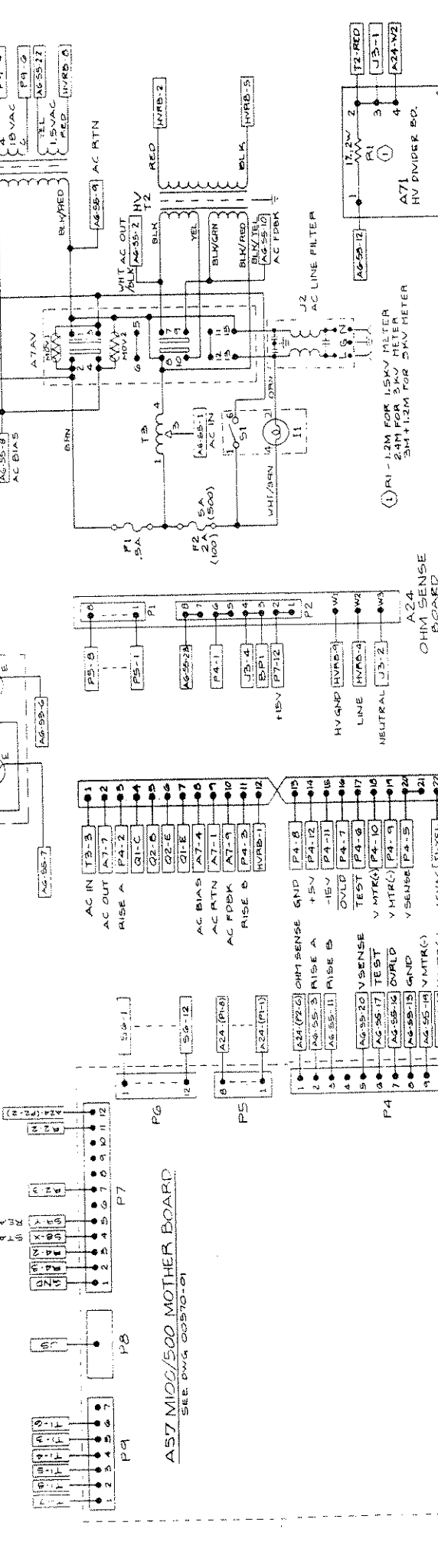
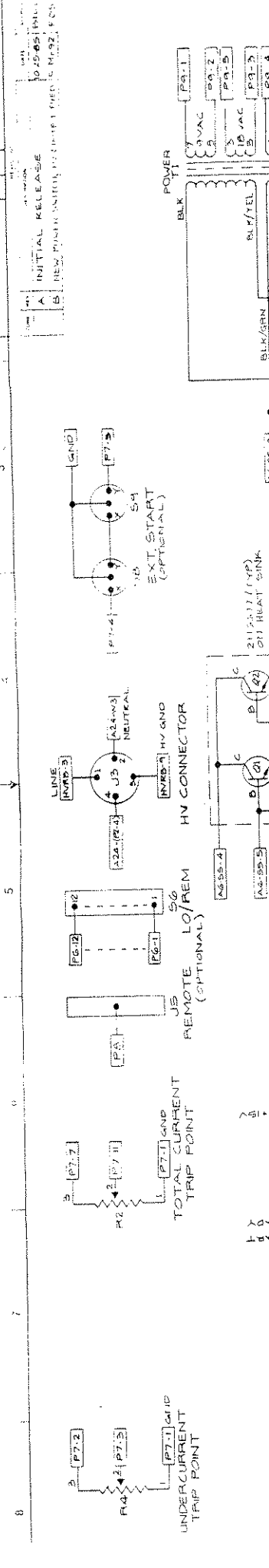
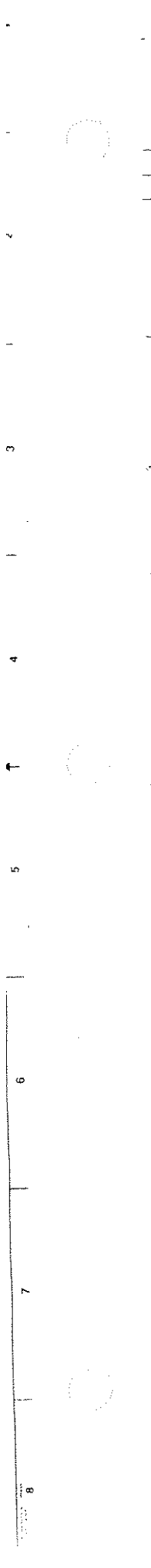

INITIAL RELEASE	02505 (MKT)
NEW POWER SWITCH (OPTIONAL)	02505 (MKT)

DATE	02505 (MKT)
REVISION	02505 (MKT)
DESIGNED BY	02505 (MKT)
CHECKED BY	02505 (MKT)
APPROVED BY	02505 (MKT)

CONTACT NAME	02505 (MKT)
APPROVAL	02505 (MKT)
DATE	02505 (MKT)
TESTED	02505 (MKT)
SHIP TO	02505 (MKT)
SHIP FROM	02505 (MKT)
DO NOT SCALE DRAWING	

WIRING DIAGRAM	MIDCO/500 AVSS	WITH OHM SENSE
DATE	02505 (MKT)	
REVISION	02505 (MKT)	
DESIGNED BY	02505 (MKT)	
CHECKED BY	02505 (MKT)	
APPROVED BY	02505 (MKT)	
CONTACT NAME	02505 (MKT)	
APPROVAL	02505 (MKT)	
DATE	02505 (MKT)	
TESTED	02505 (MKT)	
SHIP TO	02505 (MKT)	
SHIP FROM	02505 (MKT)	
DO NOT SCALE DRAWING		

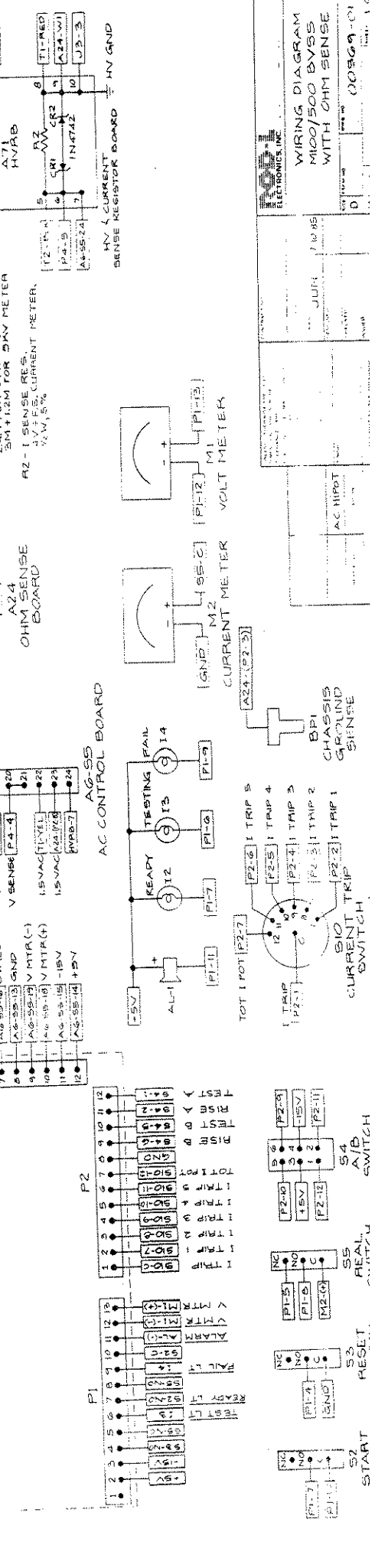
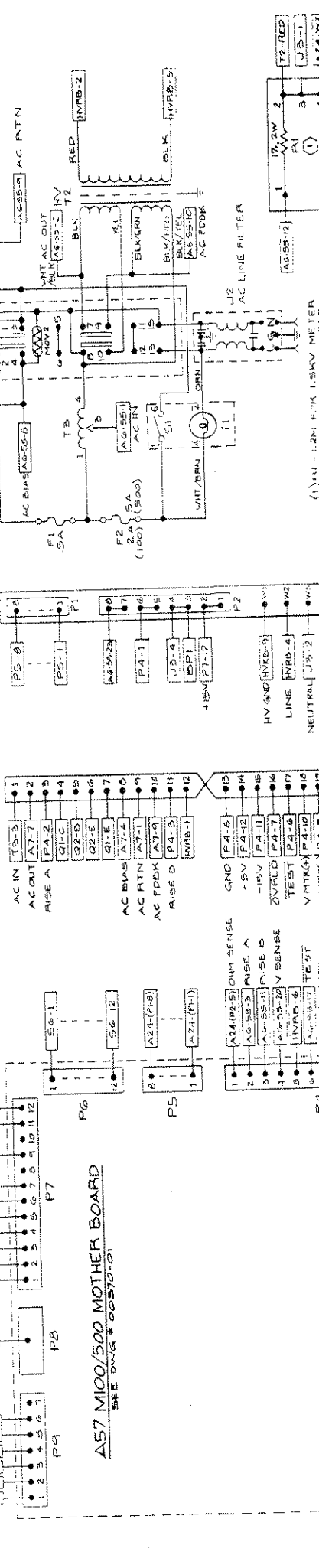
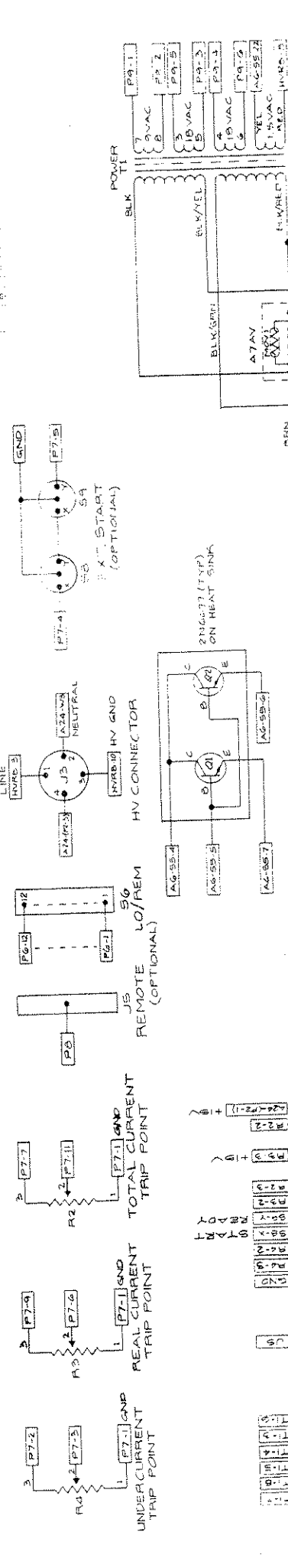
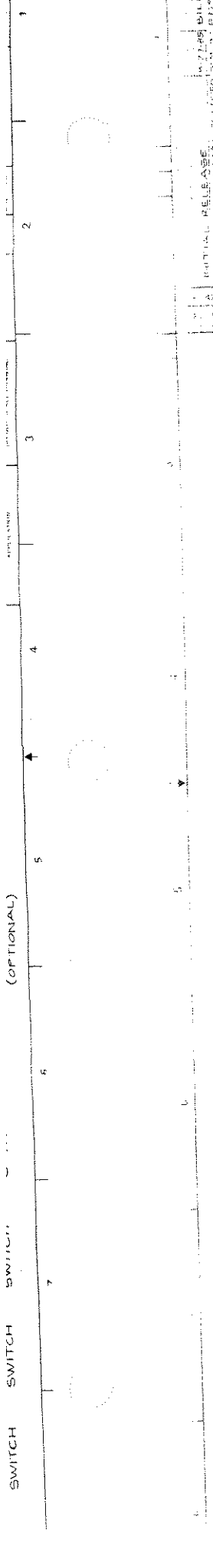

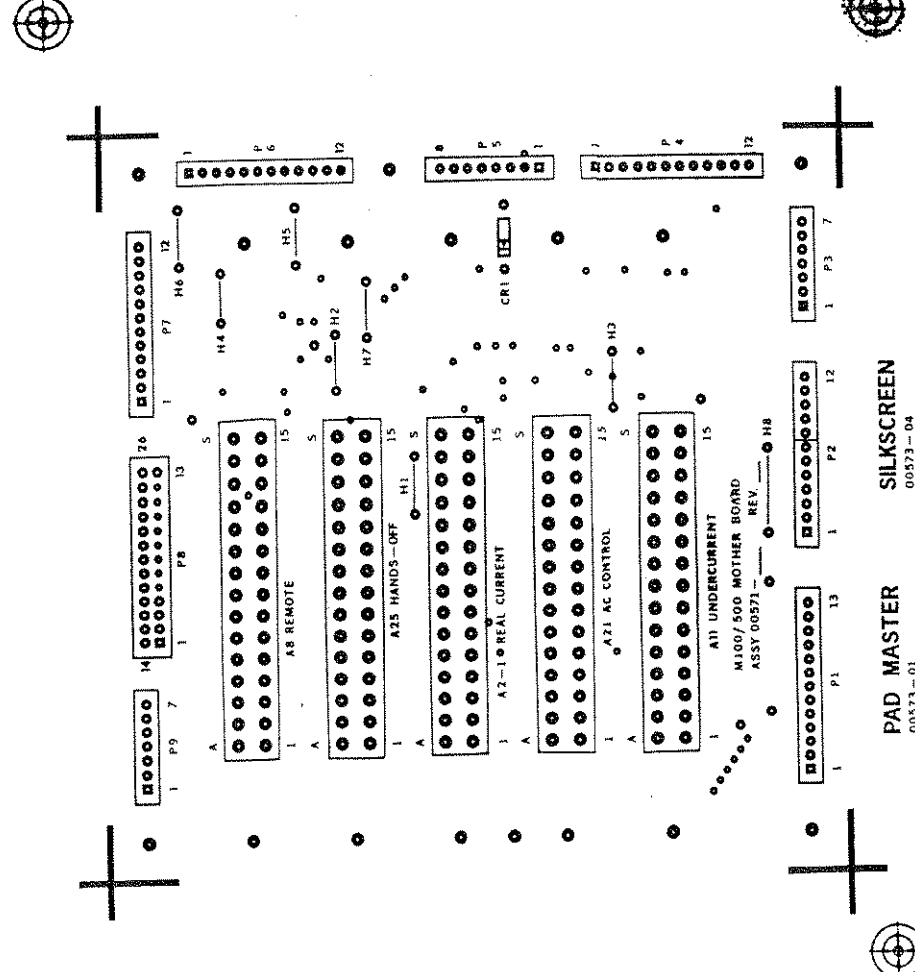

TABULATION BLOCK

DASH#	DESCRIPTION	CONNECTORS USED	LUMBERS USED
-01	STANDARD AVSS	PI,2,4,7,9	HI,3-B,CRI
-02	AVSS WITH A8	PI,2,4,6-9	HI,3-B,CRI
-03	AVSS WITH A8,A24	PI,2,4-9	HI,3-B,CRI
-04	AVSS WITH A25	PI,2,4,7,9	HI,2,4-7,CRI
-05	AVSS WITH A25,A24	PI,2,4,5,7,9	HI,2,4-7,CRI
-06	STANDARD BVSS	PI,2,4,6-9	HI,3-B,CRI
-07	BVSS WITH A8	PI,2,4-9	HI,3-B,CRI
-08	BVSS WITH A8,A24	PI,2,4-9	HI,3-B,CRI
-09	BVSS WITH A25	PI,2,4,7,9	HI,2,4-7,CRI
-10	BVSS WITH A25,A24	PI,2,4,5,7,9	HI,2,4-7,CRI
-11	BVSS WITH A8,A24,A25	PI,2,4-9	CRI
-12	AVSS WITH A8,A24,A25	PI,2,4-9	H2,4,6,8,CRI

- NOTES:**
1. REFER TO WIRING INTERCONNECTION DRAWING # 00570 01.
 2. ASSY DASH NO. TO BE STAMPED AS PER TABULATION BLOCK ABOVE.
 3. CRI TO BE IN 002 WHEN EITHER AUDIBLE TESTING TONE OR A24 OHM SENSE IS USED.

SILKSCREEN
00573-04

PAD MASTER
00573-01

ELECTRONICS, INC.
 ASSEMBLY DRAWING
 M100/500
 DATE: JUN 79
 DRAWING NO: 8-65
 SHEET: 1 OF 1

REV	DESCRIPTION	DATE	APPROVED
B	ADDED R29, R30	8-85	BILL
C	DELETED R10	7-86	CDH

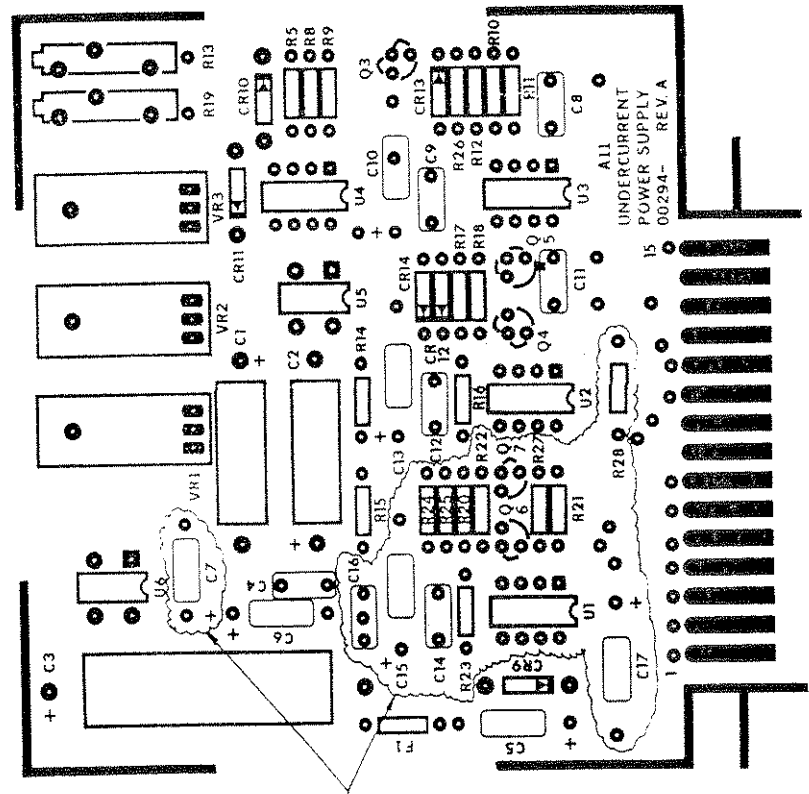

USED ON
-02 ONLY

DASH NO.	DESCRIPTION
-01	WITHOUT HANDS-OFF
-02	WITH HANDS-OFF

- NOTES:
1. REFERENCE SCHEMATIC DRAWING # 00267-XX
 2. SEE PARTS LIST # 00294-XX



PADMASTER SILKSCREEN

REV	DESCRIPTION	DATE	APPROVED
C	ASSEMBLY DRAWING	JUN 6-85	
	ALL UNDERCURRENT		
	POWER SUPPLY BOARD		

CONTRACT NO. _____
 DRAWN BY _____
 CHECKED BY _____
 DATE JUN 6-85
 SCALE 2:1
 SHEET 1 OF 1

DATE	REV
JUN 6-85	C
DESCRIPTION	00294-XX
SCALE	2:1
SHEET	1 OF 1

REV.	DESCRIPTION	DATE	BY
A	REDESIGNED	6/11/73	BILL
B	ADDED R21, R20	6/20/73	BILL
C	DELETED R10	7/27/73	BILL

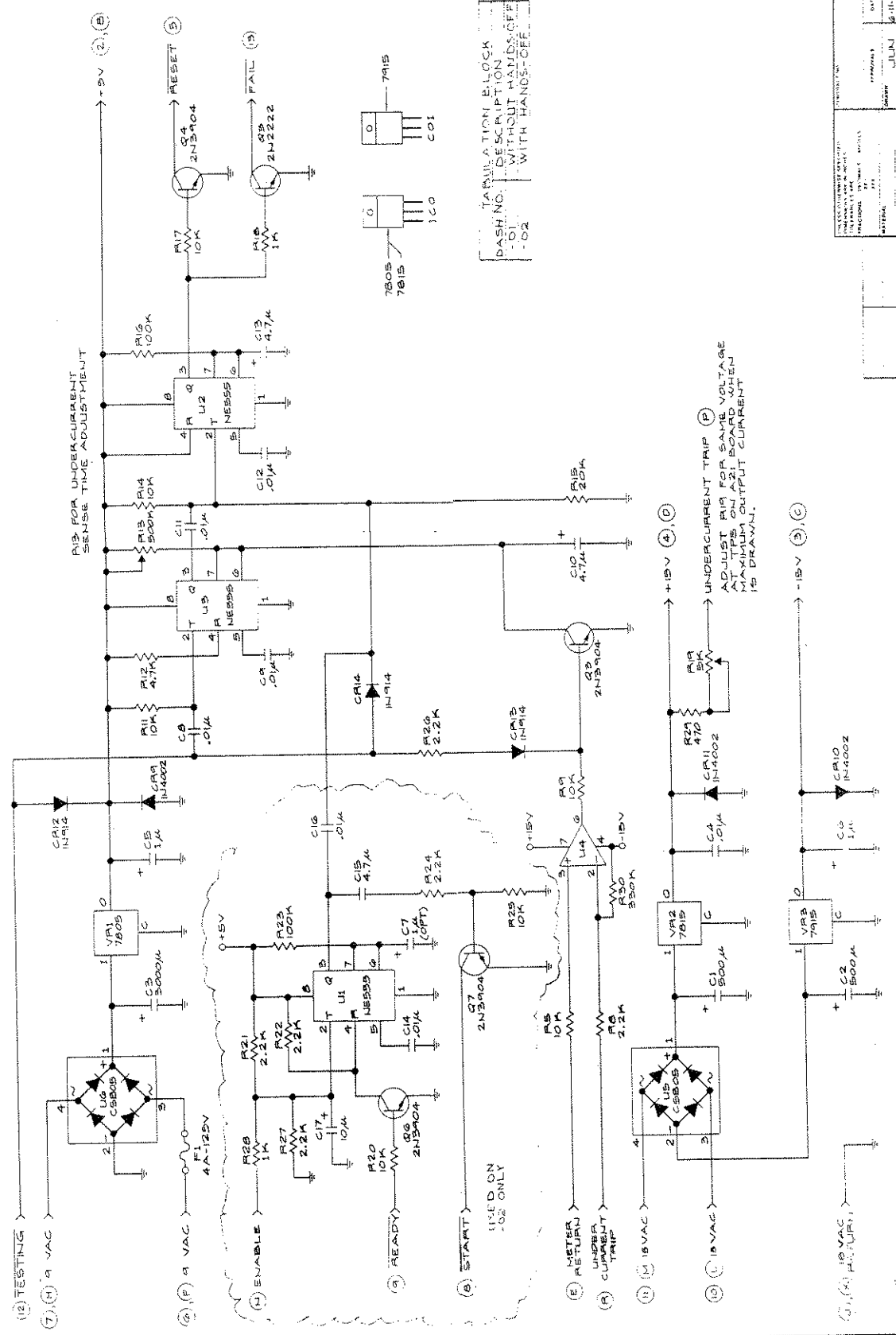

TABULATION BLOCK
 DASH NO. DESCRIPTION
 -01 WITHOUT HANDS-OFF
 -02 WITH HANDS-OFF

REV	DESCRIPTION	DATE	BY
H	REPLACED DWG # 00462-02 REV. G	5-30-86	W. Kelly
I	REDESIGN LAYOUT	2-29-88	JUN

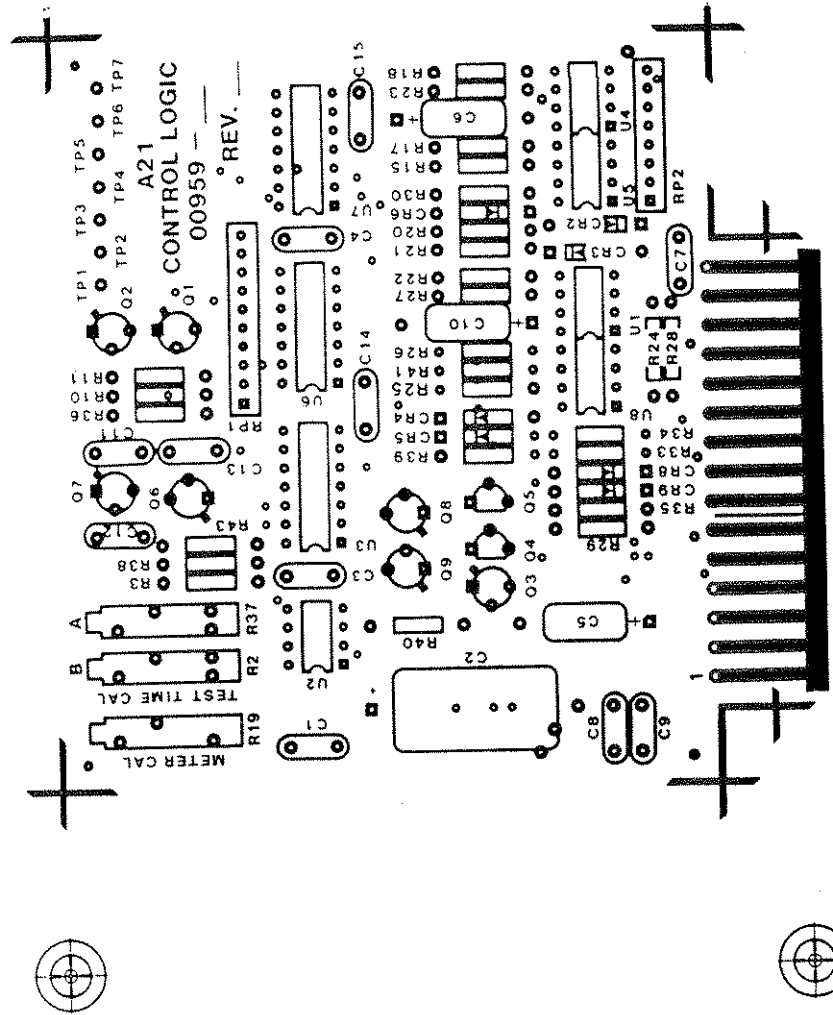

- NOTES:
1. REFERENCE SCHEMATIC DRAWING # 00982-XX
 2. SEE SEPARATE PARTS LIST

TABULATION BLOCK	DASH#	DESCRIPTION
-01		USED WITH A11
-02		USED WITH A10
-03		USED ON OHM SENSE TESTK

PADMASTER 00960-01
 SILKSCREEN 00960-04

		DATE: JUN 5-86 DRAWN: JUN 5-86 DESIGNED: JUN 5-86 CHECKED: JUN 5-86 APPROVED: JUN 5-86
PROJECT NO: A21 PCB ASSEMBLY CONTROL LOGIC		SIZE / FROM NO: C / 00959-09 SHEET NO: 1 SCALE: 1:1

STEVEN S. SCHAFFNER ACHIEVOT	100 NOT SCALE DRAWING
---------------------------------	-----------------------

REV.	DATE	DESCRIPTION
1	05-87	ISSUED FOR FAB LAYOUT

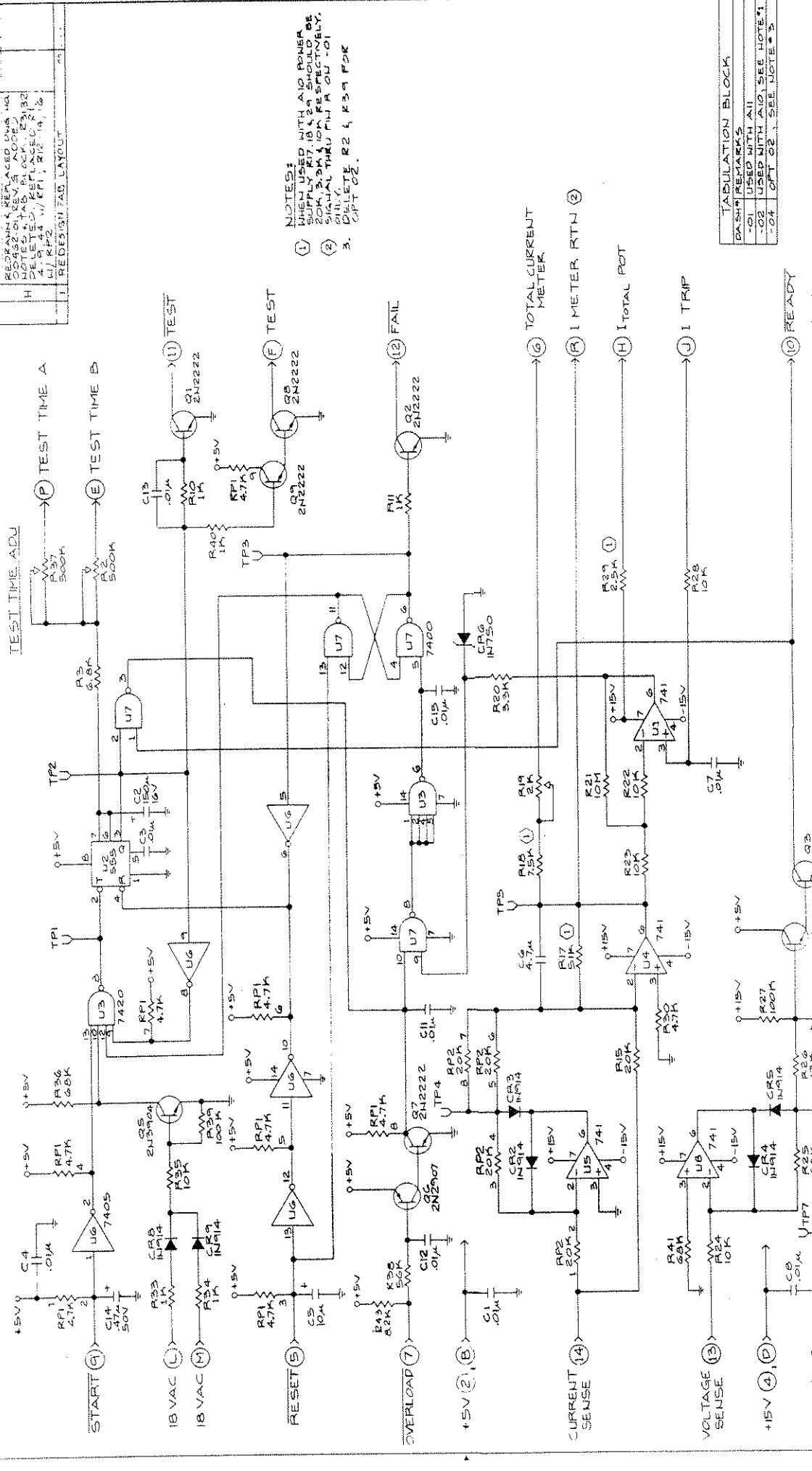

NOTES:
 ① WHEN USED WITH A10 POWER SUPPLY R7, R18, R29 SHOULD BE 20K, 3.3K & 10K RESPECTIVELY.
 ② SIGNAL THRU PIN A ON -01
 ③ DELETE R2 & R39 FOR OPT 02.

TABULATION BLOCK

DASH	REMARKS
-01	USED WITH A10
-02	USED WITH A10, SEE NOTE 1
-04	OPT 02, SEE NOTE 3

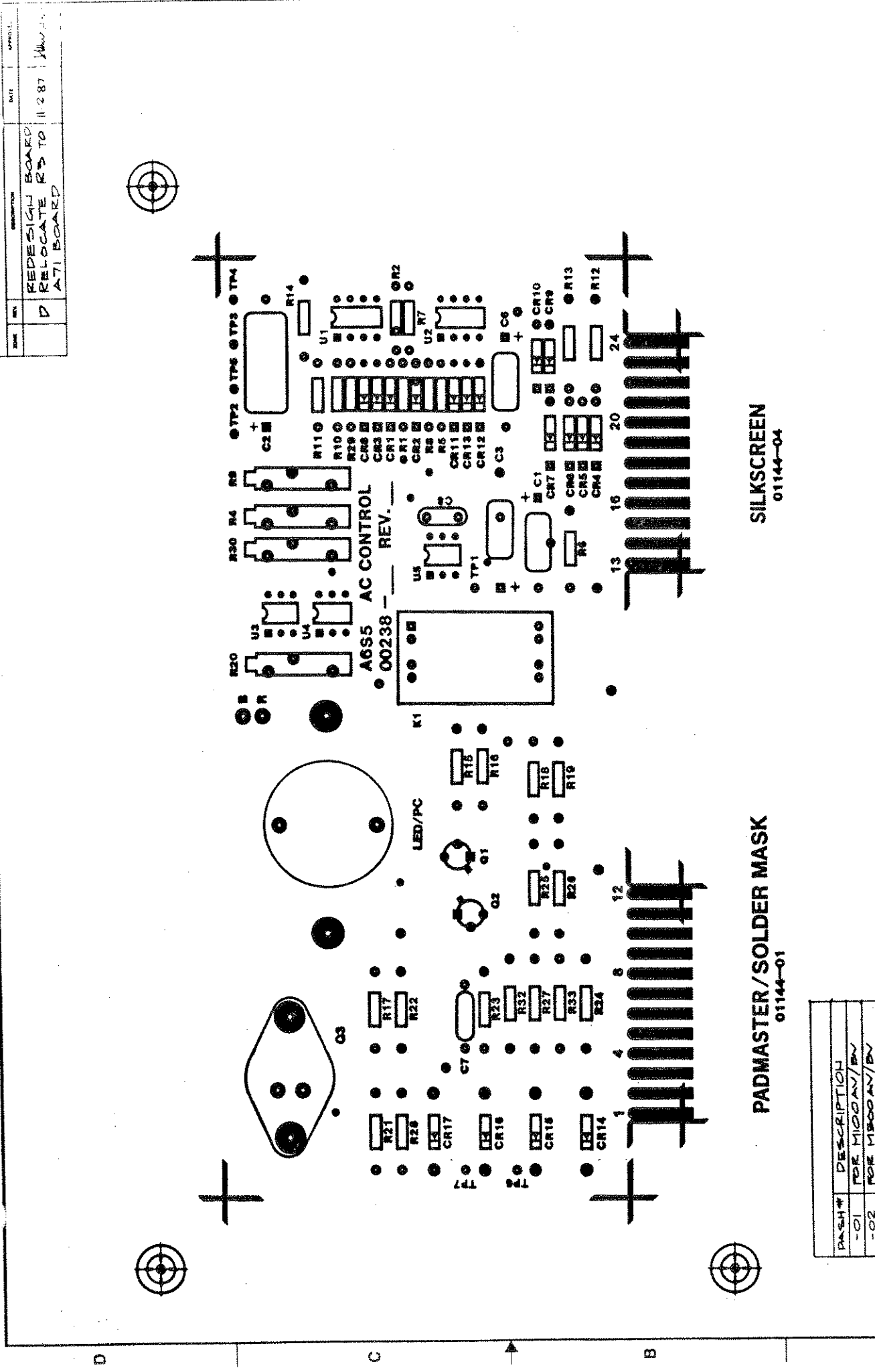

SILKSCREEN
 01144-04

PADMASTER/SOLDER MASK
 01144-01

PART#	DESCRIPTION
-01	FOR MICROAN/PN
-02	FOR MICROAN/PN
-03	FOR M488

NOTES:
 1. FOR REFERENCE, SEE SCHEMATIC
 DWG # 00237-KX
 2. SEE SEPARATE PARTS LIST.

CONTRACT NO.
 DATE
 APPROVALS
 JUN 2-88
 SIGNATURE
 TITLE
 AC HIBT



BOB-1 ELECTRONICS, INC.
 1000 W. 10TH ST., SUITE 100
 DENVER, CO 80202
 TEL: 303-733-1111
 FAX: 303-733-1112

REV	DESCRIPTION	DATE	APPROVED
D	ADDED R34-38 DELETED R15; ADDED R39 R11-7 TO +5V. REPLACED DNG # 00442-02 REV.D	6-22-84	RAMON
E		5-30-84	LHOLLEY

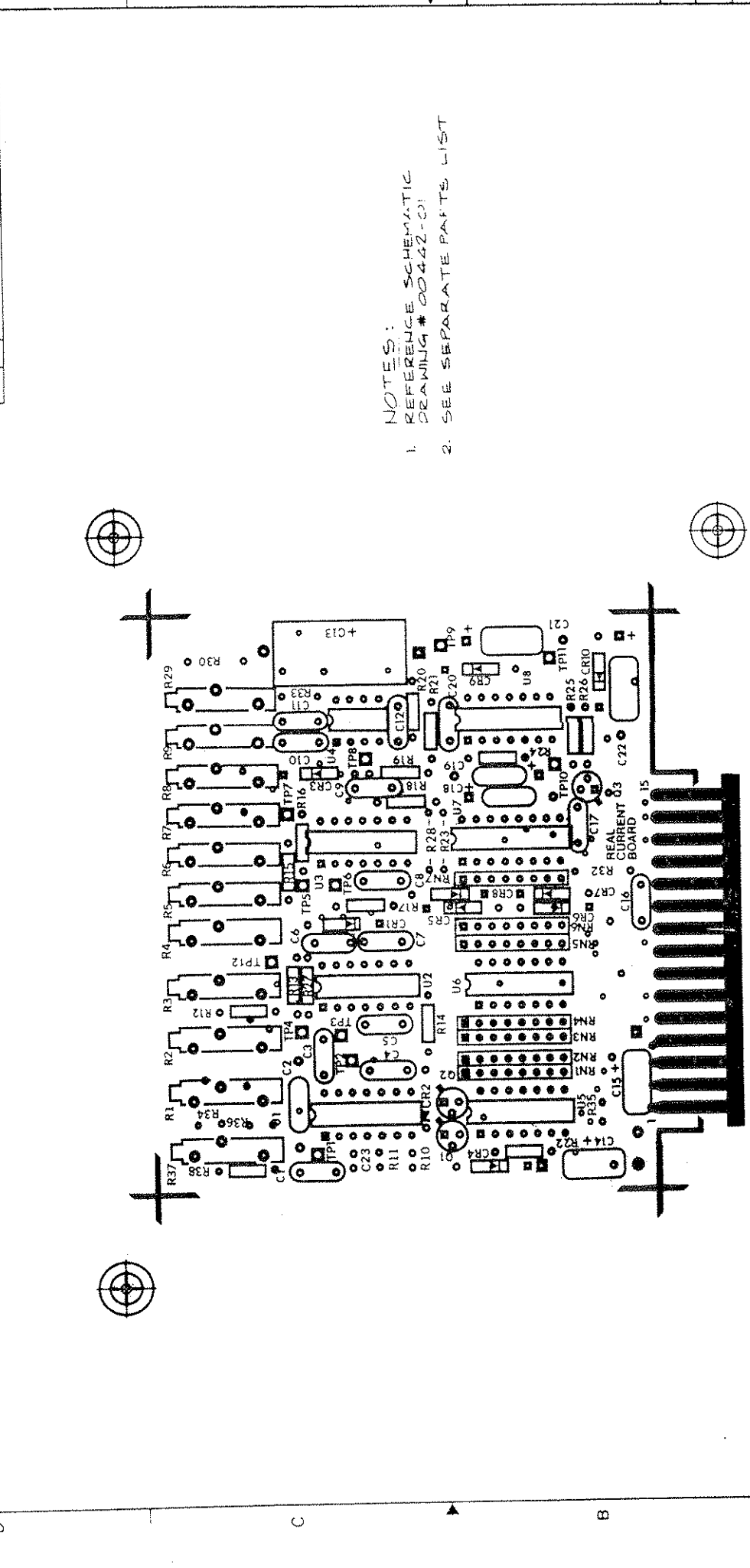

- NOTES:
1. REFERENCE SCHEMATIC DRAWING # 00442-01
 2. SEE SEPARATE PARTS LIST

PADMASTER
 SILKSCREEN

REV	DATE	DESCRIPTION
C	JUN 7-84	ASSEMBLY PCB A
		REAL CURRENT BOARD
		DWG NO. 00442-01



DATE	BY	DESCRIPTION
JUN 7-84		ASSEMBLY PCB A
		REAL CURRENT BOARD
		DWG NO. 00442-01

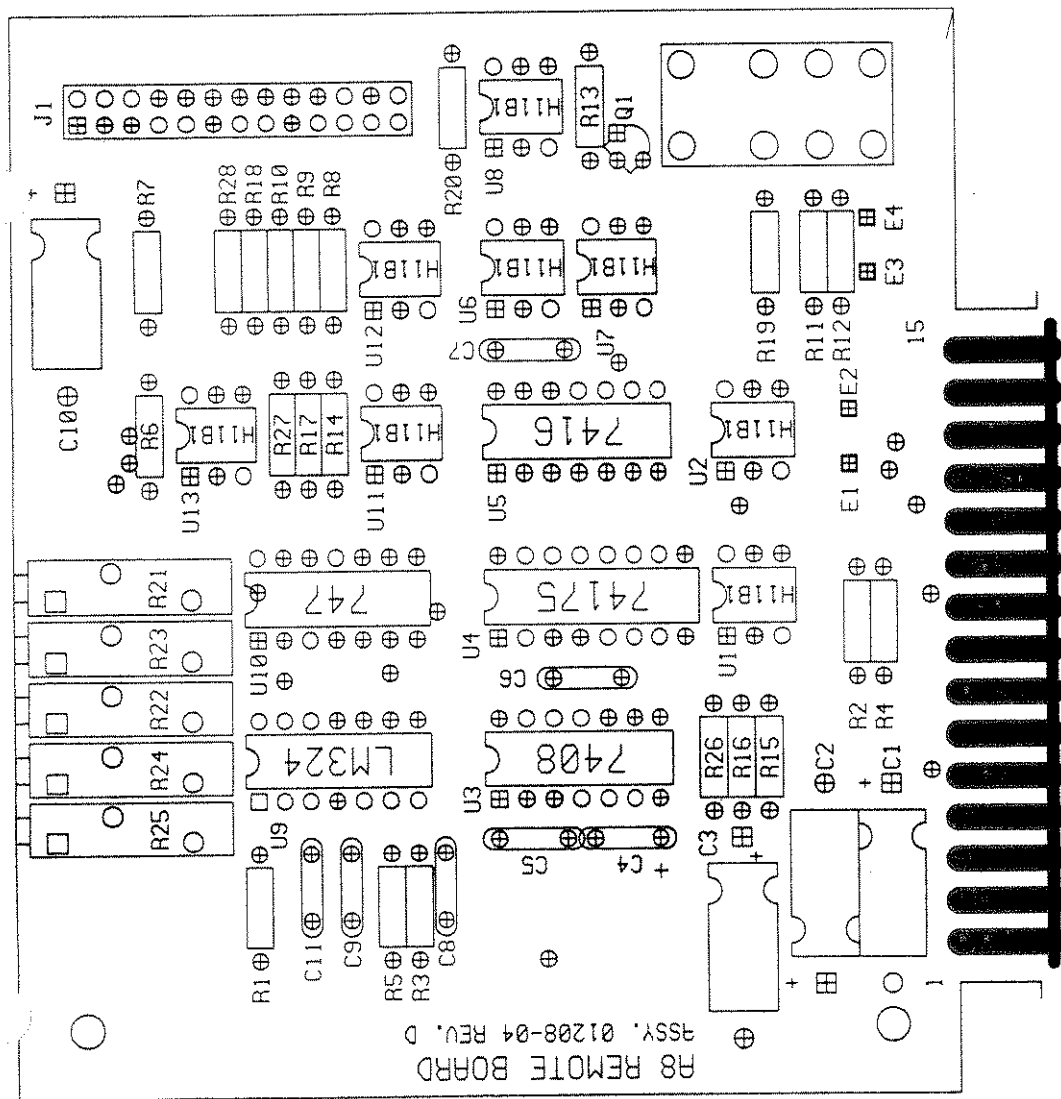

UNLESS OTHERWISE SPECIFIED DIMENSIONS ARE IN INCHES TOLERANCES ARE:		CONTRACT NO.	
FRACTIONS	DECIMALS	APPROVALS	DATE
ANGLES 30° ± 0.10 45° ± 0.05	.010 .005	DESIGN SMITH EPPOSITIS CHECKED	11-15-91
MATERIAL		ISSUED	DRAWING NO.
FINISH		D	01208-04
ROD-L ELECTRONICS, INC. 923 HARRINGTON AVE. MENLO PARK, CALIFORNIA 94025 (415) 322-8711		ASSEMBLY DRAWING A8 REMOTE CONTROL	

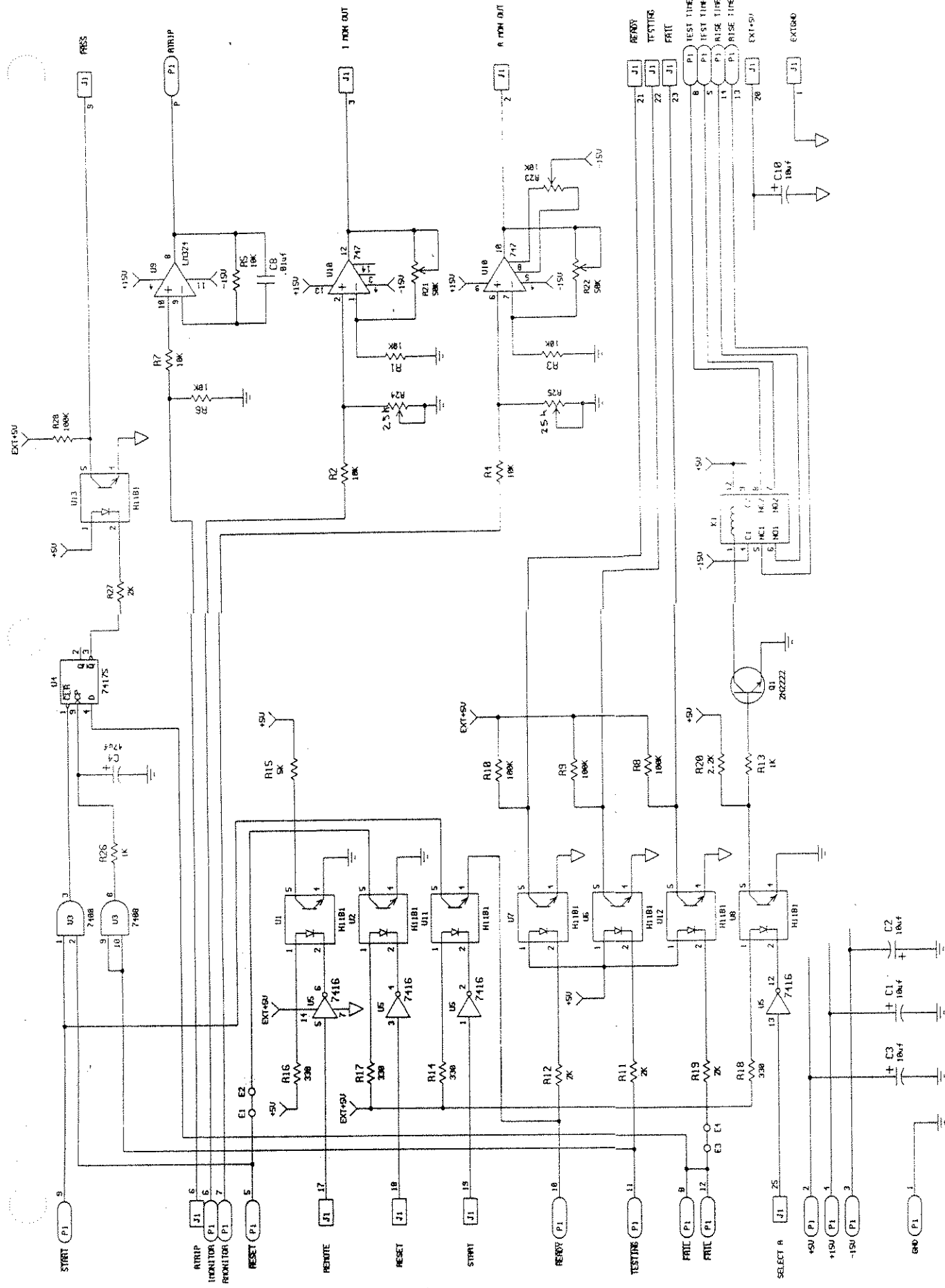

DATE	REV.

SCHEMATIC DIAGRAM
 AB REPDIS CONTROL

REVISIONS		DATE	APPROVED
REV.	DESCRIPTION		

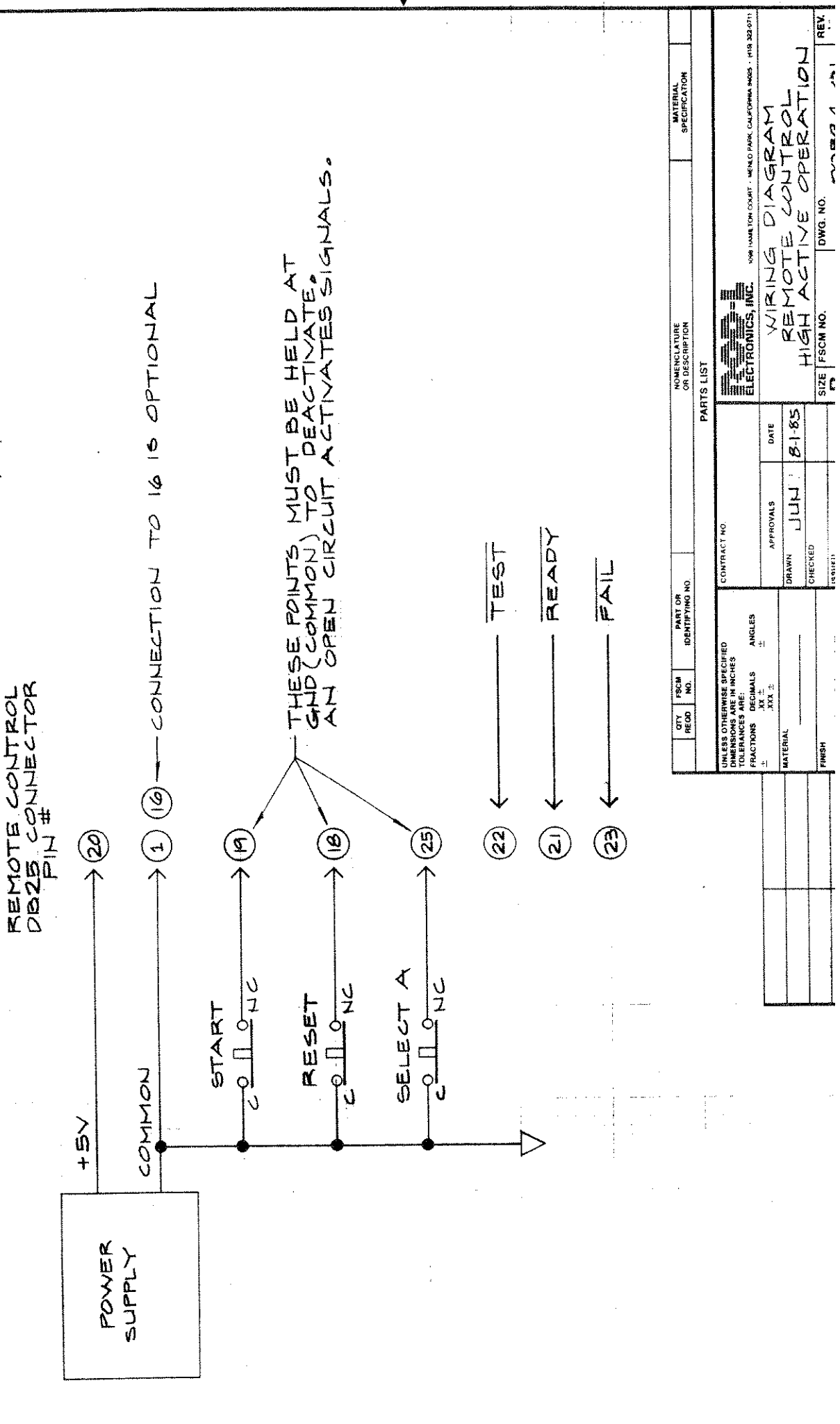

QTY	FCM	PART OR IDENTIFYING NO.	NOMENCLATURE OR DESCRIPTION	MATERIAL SPECIFICATION

PARTS LIST

CONTRACT NO.		DATE	
		JUN 81-85	
DRAWN		CHECKED	

UNLESS OTHERWISE SPECIFIED DIMENSIONS ARE IN INCHES
 TOLERANCES ARE: FRACTIONS DECIMALS ANGLES
 .XX ± .XX ± °

MATERIAL: FINISH:

DWG. NO. REV.

ELECTRONICS, INC.
 509 HAMMILL COURT - MENLO PARK, CALIFORNIA 94025
 WIRING DIAGRAM
 REMOTE CONTROL
 HIGH ACTIVE OPERATION

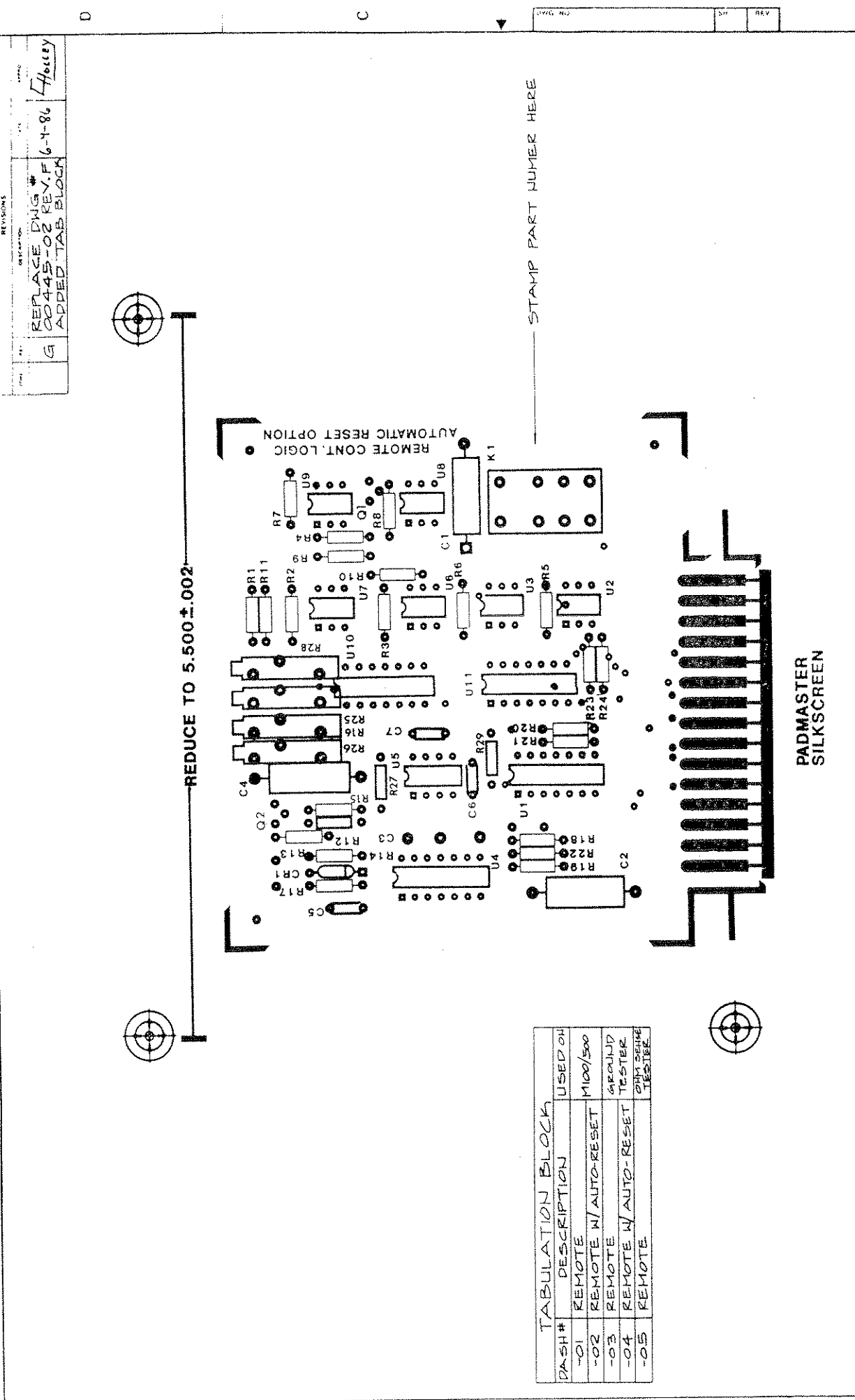

REV	DESCRIPTION	DATE	BY
G	REPLACE DWG # 00445-02 REV. F ADDED TAB BLOCK	6-1-86	Holley

TABULATION BLOCK		USED ON
DASH#	DESCRIPTION	
-01	REMOTE	100/500
-02	REMOTE W/AUTO-RESET	GROUND
-03	REMOTE	TESTER
-04	REMOTE W/AUTO-RESET	DATA REPAIR
-05	REMOTE	TESTER

- NOTES:
1. REFERENCE SCHEMATIC DRAWING # 00980-XX
 2. SEE SEPARATE PARTS LIST

DATE: JUN 4 1984

DESIGNED BY: M2S

APPROVED BY: AG HIPPT

PROJECT: ASSEMBLY PCB A8 REMOTE CIRCUIT LOGIC WITH AUTO-RESET OPTION

REV: 1

DATE: 6-1-86

BY: HOLLEY

DESCRIPTION: REPLACE DWG # 00445-02 REV. F ADDED TAB BLOCK

SCALE: 2X

SHEET: 1 OF 1

REV: 1

DATE: 6-1-86

BY: HOLLEY

DESCRIPTION: REPLACE DWG # 00445-02 REV. F ADDED TAB BLOCK

SCALE: 2X

SHEET: 1 OF 1



ASSEMBLY PCB A8 REMOTE CIRCUIT LOGIC WITH AUTO-RESET OPTION

REV	DATE	BY	REASON
G	0043-01 REV F	531-X	REPRAN & REPLACED DMG
H	ADDED JUMPER C0 TO U1	7	(RELS)
	CHANGED R20 TO 100K	2	2.08.11.17
	CHANGED R21 TO 100K	2	2.08.11.17

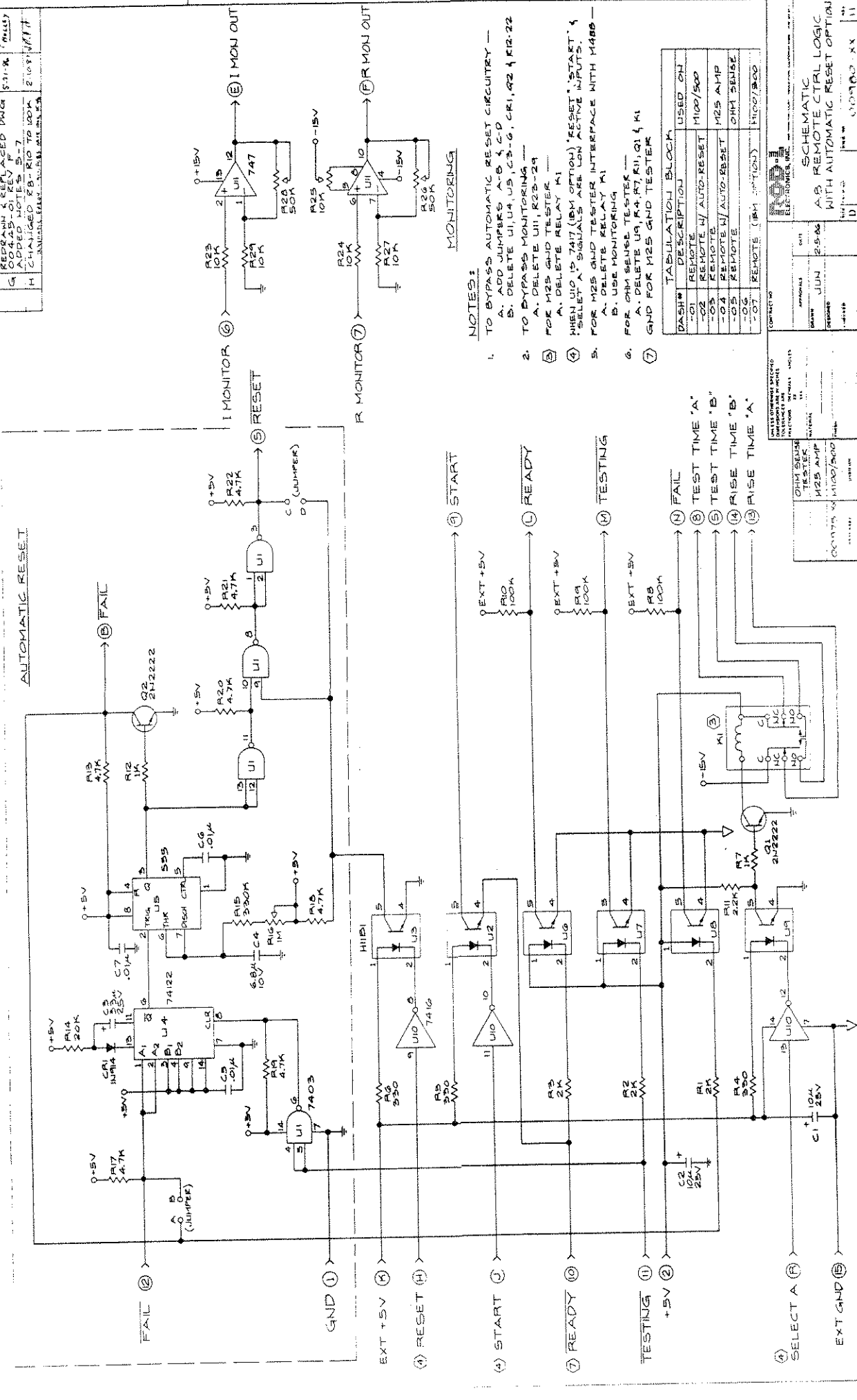

REV	DATE	DESCRIPTION	BY
C	11-16-84	ADDED R25, R26, C12 REPLACED DWG 00433-02 REV. C	RAMON HOLLEY
D	6-4-86	ADDED TAB BLOCK ADDED CIRCUITRY, REPLACED RES'S WITH RESPAH	BB
E	JULY		

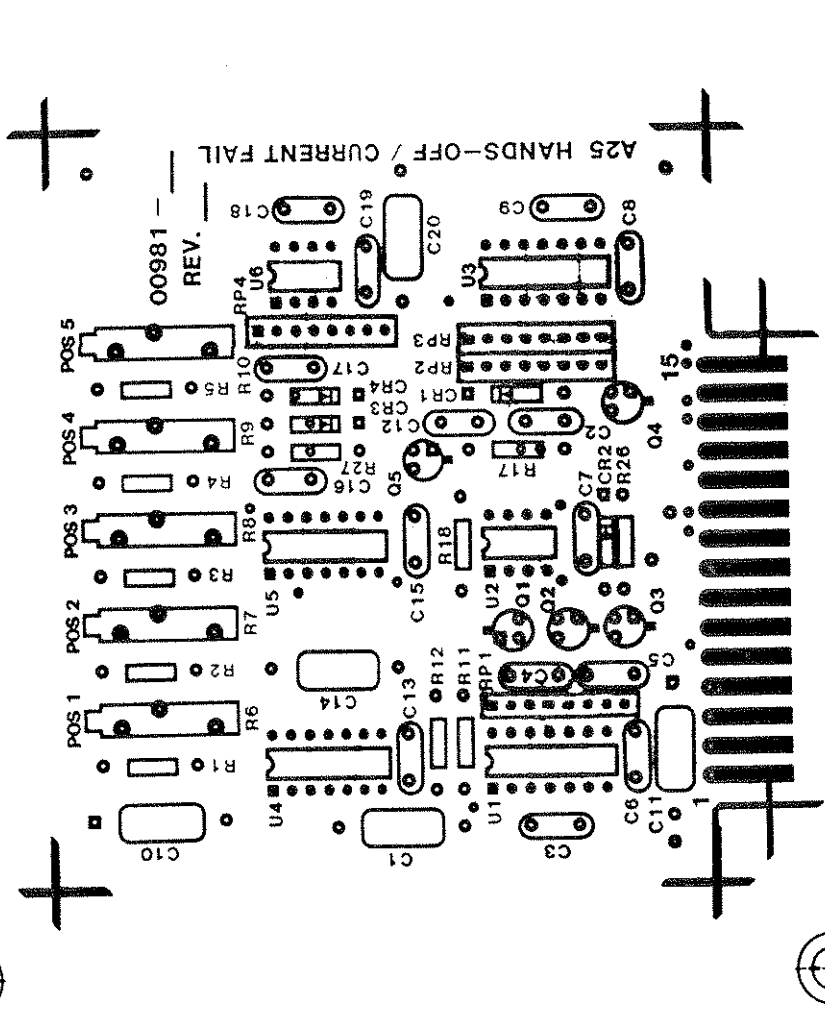

TABULATION BLOCK	DASH #	DESCRIPTION
-01		CURRENT FAIL ONLY
-02		HANDS-OFF ONLY
-03		HANDS-OFF & CURRENT FAIL

PADMASTER SILKSCREEN

REVISIONS	
DATE	DESCRIPTION
9-84	SEE DNG # 00957-01 ADDED CR5, R18, R3 FOR -02 DNG, REPLACED DNG 00434-02 REV.C
6-7-86	F. HOLLEY

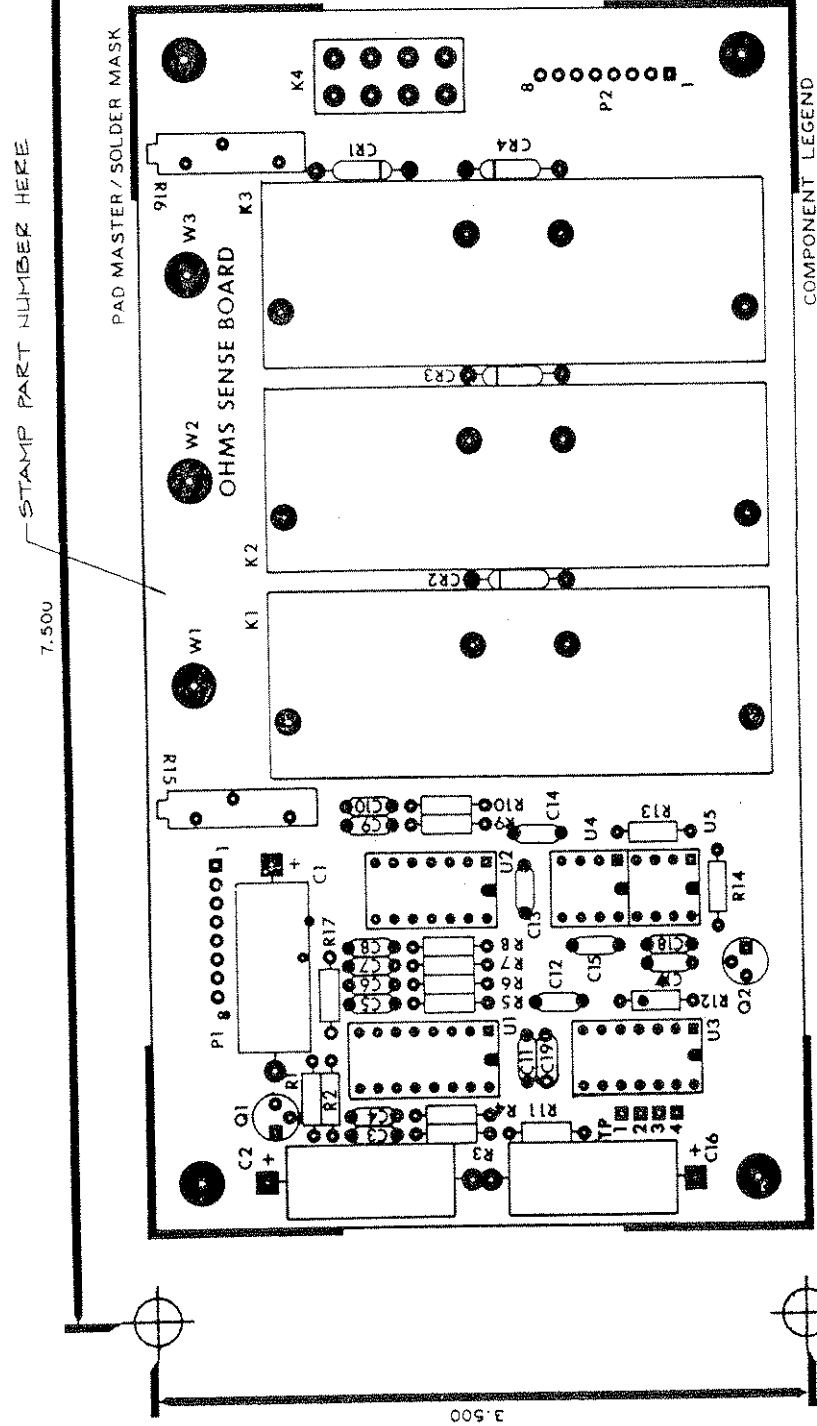

- NOTES:
- REFERENCE SCHEMATIC DRAWING # 00957-XX
 - SEE SEPARATE PARTS LIST

TABULATION BLOCK
 DASH# USED ON
 -02 MICRO/500 AC HIPOUT

PARTS LIST	
QTY	PART OR IDENTIFICATION NO
1	ASSEMBLY PCB A
1	OHMS SENSE BOARD

TOP-1 ELECTRONICS

DATE	APPROVAL
JUN 9-84	F. HOLLEY

DATE	APPROVAL
JUN 9-84	F. HOLLEY

DATE	APPROVAL
JUN 9-84	F. HOLLEY

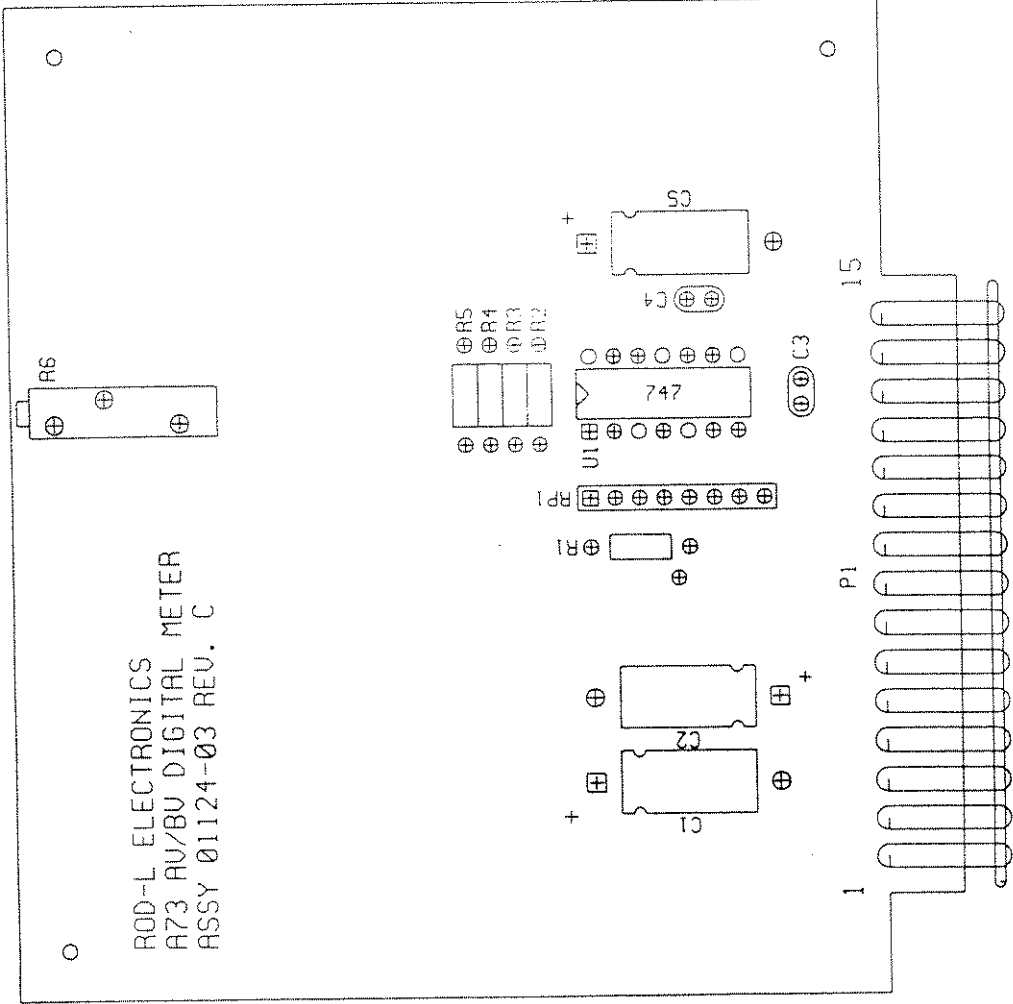

ROD-L ELECTRONICS
 A73 AU/BU DIGITAL METER
 ASSY 01124-03 REV. C

		CONTRACT NO. _____	
UNLESS OTHERWISE SPECIFIED DIMENSIONS ARE IN INCHES TOLERANCES ARE:		APPROVALS DATE	
FRACTIONS DECIMALS ANGLES XXX . XXX °		DRAWN _____ DESIGNED _____ CHECKED _____	
MATERIAL _____		FINISH _____	
ASSEMBLY DRAFTER A73 AU/BU DIGITAL METER		SIZE FSCM NO. _____ DWG. NO. 01124-03	

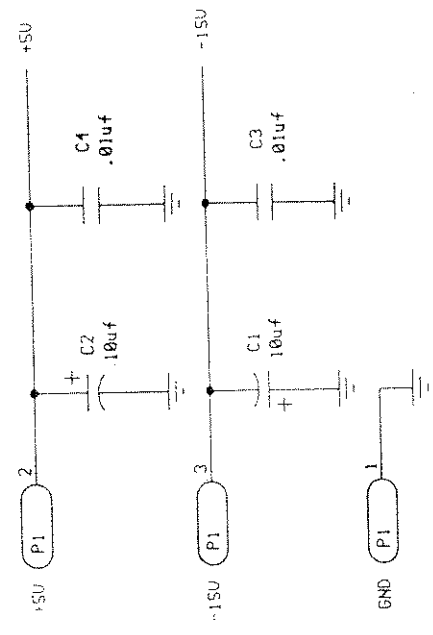
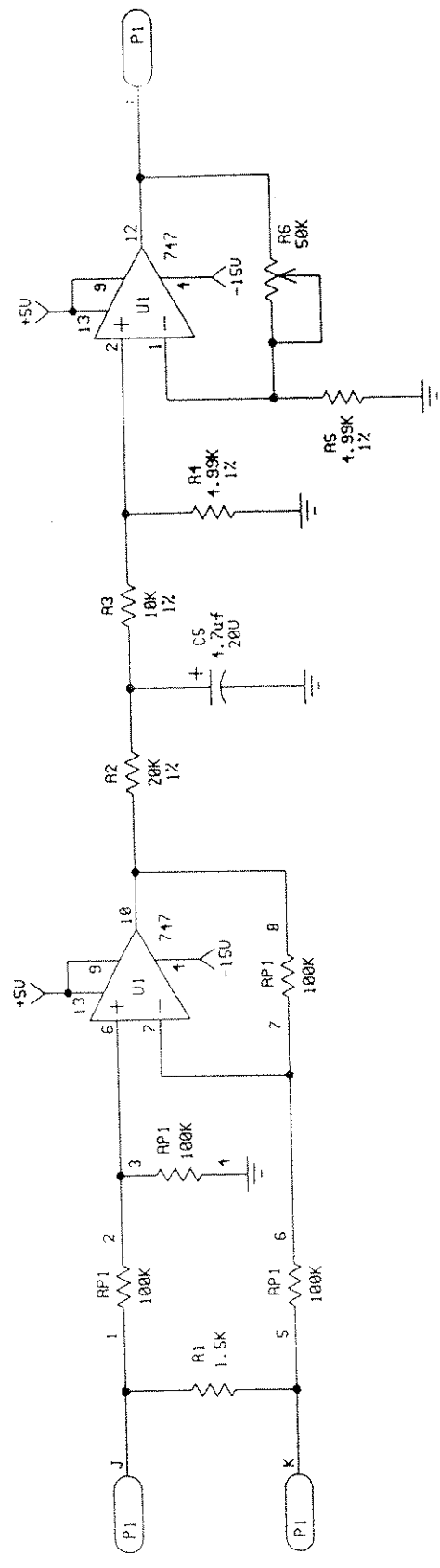

UNLESS OTHERWISE SPECIFIED DIMENSIONS ARE IN INCHES FRACTIONS DECIMALS ANGLES MATERIAL XXX: XXX:		CONTRACT NO.	
DRAWN SMITH		DATE 4 '70	
DESIGNED		APPROVALS	
CHECKED		SIZE FSCM NO.	
FINISH		DWG NO. 0123-03	
REV C		REV C	

ELECTRONICS, INC.
 1000 CALIFORNIA ROAD - P.O. BOX 1000
 WENLO PARK, CALIF. 94088

SCHEMATIC
 R73 AU/BU DIGITAL METER

ROD-L ELECTRONICS
 R14 NO LOAD TRIP POINT SETTING
 ASSY 00964-02 REV. B

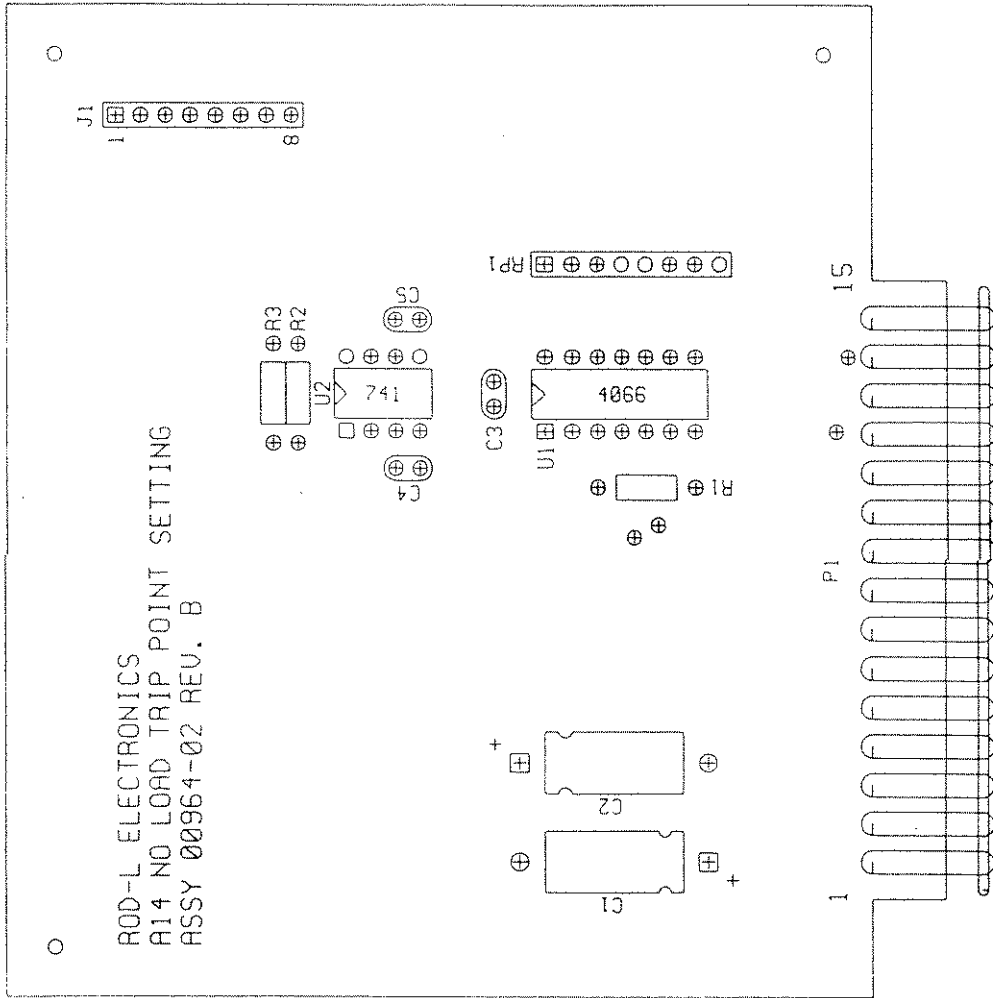

UNLESS OTHERWISE SPECIFIED DIMENSIONS ARE IN INCHES TOLERANCES ARE: FRACTIONS DECIMALS ANGLES XX: XXI: XXII:		CONTRACT NO.		DATE	
MATERIAL		APPROVALS		DRAWN	
FINISH		DESIGNED		CHECKED	
NEXT ASSY		ISSUED		SCALE N.T.S.	
APPLICATION		USED ON		DWG. NO. 00964-02	
DO NOT SCALE DRAWING		SIZE FSCM NO. C		REV. B	
		SHEET 1		OF 1	



ROD-L ELECTRONICS, INC.
 1000 WILSON COURT - BERKELEY, CALIFORNIA 94703 - (415) 224-2711
 ASSEMBLY DRAWING
 R14 NO LOAD TRIP POINT SETTING

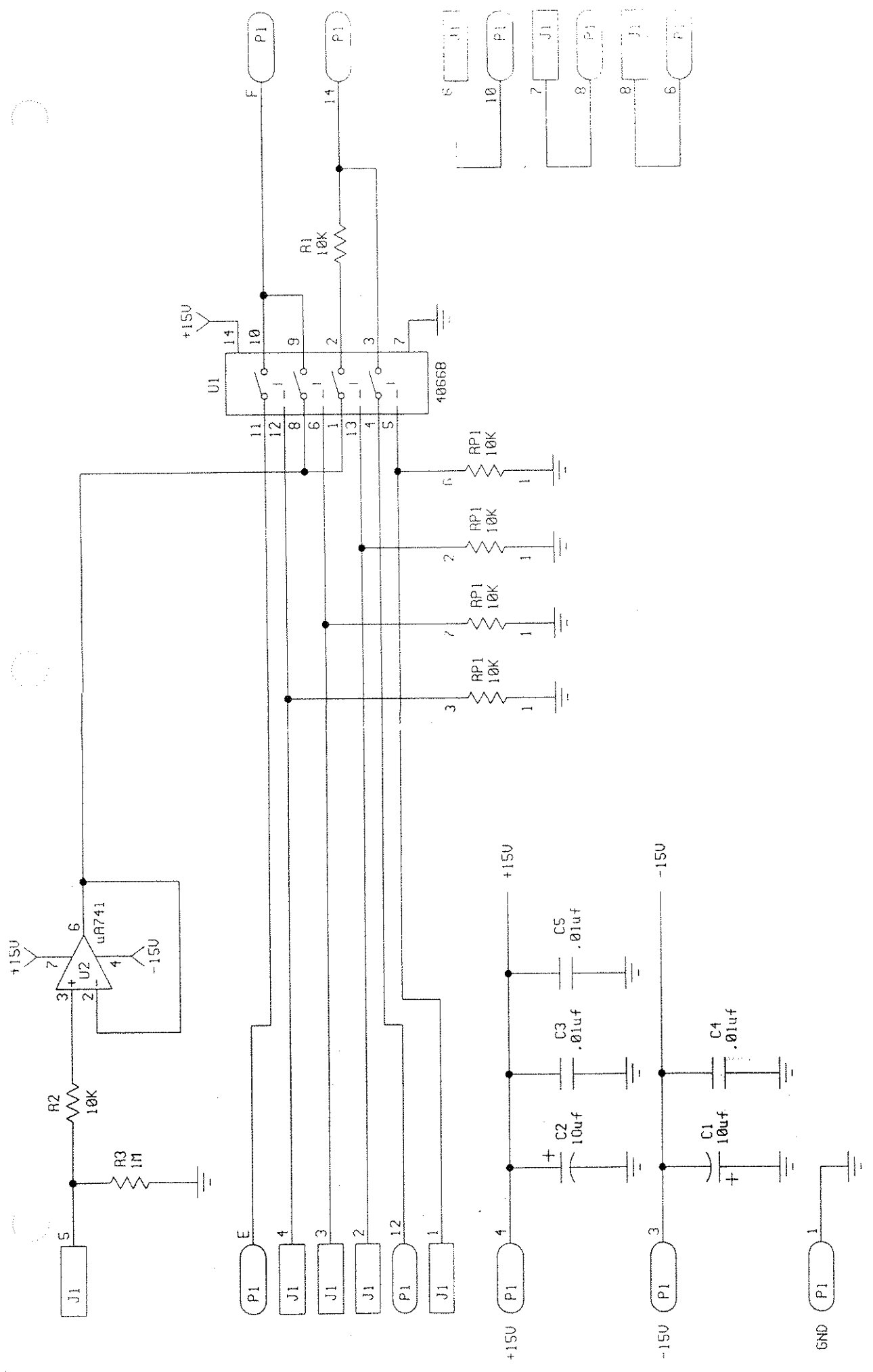

CONTRACT NO. _____ APPROVALS: _____ DATE: 4-90		SCHEMATIC R14 NO LOAD TRIP POINT SETTING	
UNLESS OTHERWISE SPECIFIED DIMENSIONS ARE IN INCHES FRACTIONS: DECIMALS: ANGLES:		SIZE: FSCM NO. _____ 100613-02	
MATERIAL: _____ DESIGNED: _____ CHECKED: _____		ELECTRONICS, INC. 100 HAWKTON COURT, HAWKTON, N.J. 07015	

REV	DESCRIPTION	DATE	APPROVED
A	INITIAL RELEASE	4-86	5/4/4
B	CHANGED PS TO J1 CONNECTOR	9-29-86	

1

2

3

4

NOTES:

1. CUT SHAFT ABOUT 5/8" BEYOND THE BUSHING THREAD
2. REMOVE TWO FINGERS ON STOP PLATE AS SHOWN TO MAKE SWITCH A POSITION SWITCH
3. ALL WIRES TO BE 10 INCHES LONG EXCEPT FOR INTERCONNECTING FINS OF THE SWITCH
4. SECTION A IS THE FIRST CONTACT PLATE OF THE SWITCH VIEWING FROM THE REAR. SECTION B WOULD BE THE ONE AT THE BACK OF PA-1013 SWITCH TO BE CENTRALAB PA-1013
5. SEE MOUNTING INSTRUCTIONS TO MOUNT SWITCH AT REAR PANEL
6. ALL CONNECTOR/HEADER REFERENCES USE THE CONNECTOR NUMBERING SCHEME.
- 7.

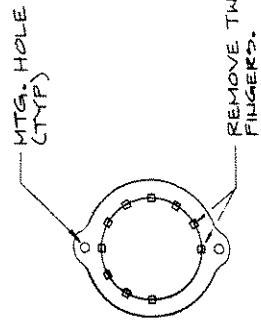

STOP PLATE

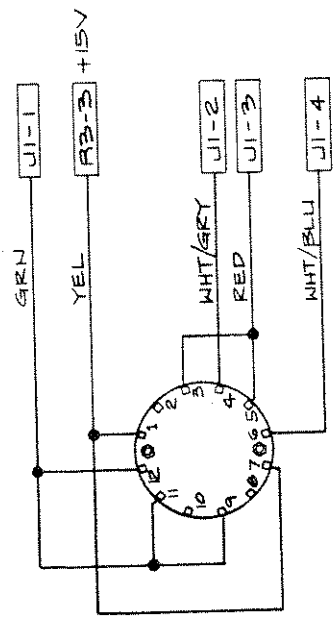

SECTION A

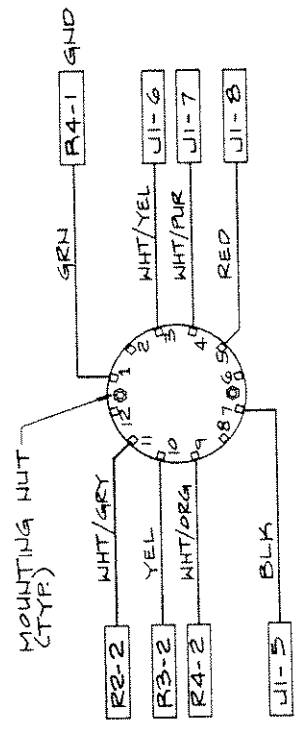

SECTION B

CITY	STATE	COUNTRY	DATE	APPROVALS	DATE
			JUN 4-86		

CONTRACT NO. _____
 DRAWN BY _____
 CHECKED BY _____
 APPROVED BY _____
 DATE _____
 TITLE _____
 PARTS LIST
 CONTRACT NO. _____
 DRAWN BY _____
 CHECKED BY _____
 APPROVED BY _____
 DATE _____
 TITLE _____
 PARTS LIST
 CONTRACT NO. _____
 DRAWN BY _____
 CHECKED BY _____
 APPROVED BY _____
 DATE _____
 TITLE _____

ELECTRONIC INC.
 4800 FINE COURT - MILPITAS, CALIFORNIA 95031
 A ASSEMBLY SWITCH ROTARY
 NO LOAD TRIP POINT SETTING
 SIZE TECH NO. (DWG NO. 00000000) REV 02

REV	DATE	BY	CHKD	DESCRIPTION
1	4-25-84			INITIAL RELEASE
2	4-25-84			CHANGED PINS TO A-B
3	7-27-84			REDESIGNED

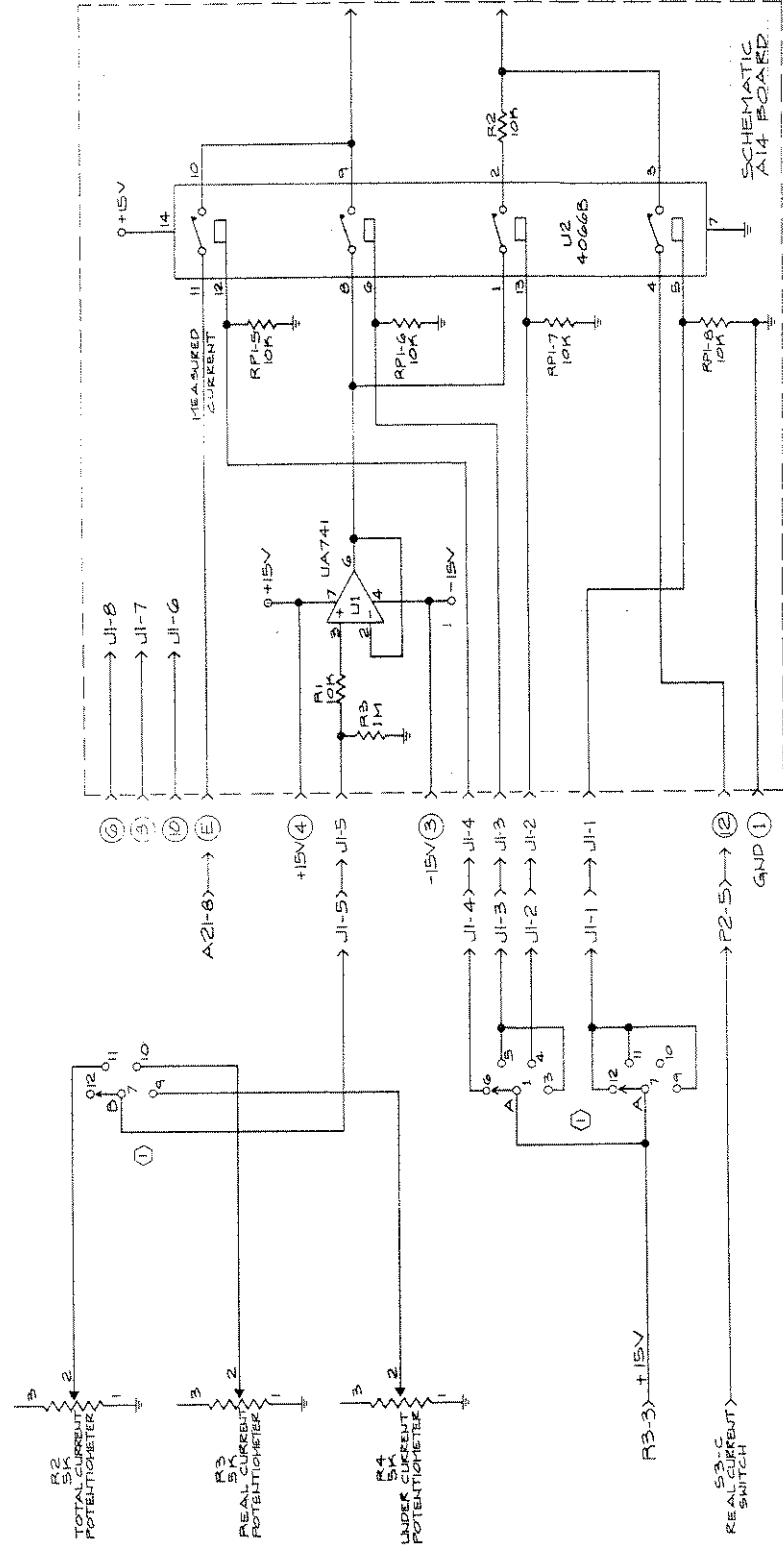

NOTES:

- SEE DNG. *CORRECT FOR SWITCH ASSEMBLY
- ALL CONNECTORS/HEADERS REFERENCES, USE THE HEADER NUMBERING SCHEME.
- OTHER BOARD MODIFICATIONS:
 - JUMP A21-R TO A25-F
 - JUMP A21-C TO A25-B
 - JUMP A21-B TO A25-E
 - JUMP A21-A TO A25-D
- A21 CONTROL LOGIC BOARD MODIFICATIONS:
 - JUMP R18 TO BOARD MEMBER R18
 - JUMP R19 TO BOARD MEMBER R19
 - JUMP R23 BOTTOM TO PIN 6
- WIRING DIAGRAM DNG # 00567-01 MODIFICATIONS:
 - DELETE CONNECTION BETWEEN S5-C AND S5-A
 - DELETE CONNECTION BETWEEN S5-C AND S5-B
 - ADD CONNECTION BETWEEN S5-C AND S5-B

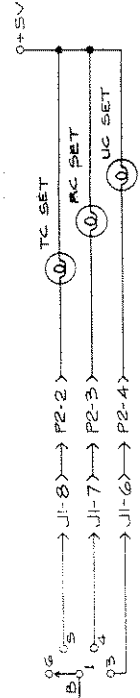

DESIGN NO.	REV.	DATE	BY	CHKD.
APPROVALS:				
DESIGNER	DATE	BY	CHKD.	
WIRING DIAGRAM				
TRIP POINT SETTING				
DATE	BY	CHKD.	DATE	BY

00567-01 AC MPOT
WEST BAY

REVISIONS		DATE	APPROVED
1	A INITIAL RELEASE	8-21-86	CH/ALSO

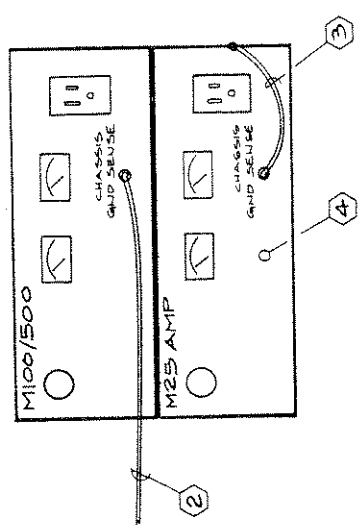

FRONT VIEW

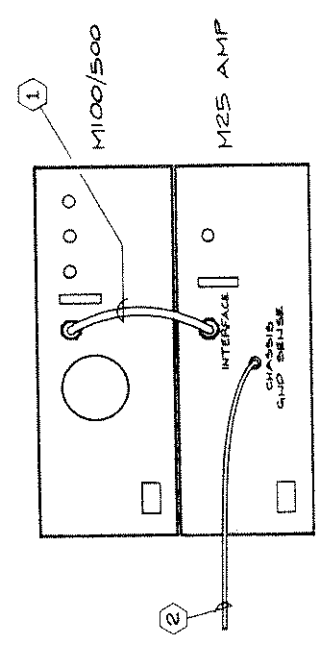

REAR VIEW

SYSTEM OBJECTIVE

THE ABILITY TO PERFORM GND CONTINUITY AND AC HIPOT TESTS AUTOMATICALLY THRU ONE HV RECEPTACLE.

SYSTEM SELF CHECK

- ① CONNECT INTERFACE CONNECTOR AT REAR OF EACH UNIT TOGETHER BY INTERFACE CABLE P/N 00333-04
- ② CONNECT BP2 (CHASSIS GND SENSE) AT REAR OF M25 AMP WITH BP1 (CHASSIS GND SENSE) AT THE FRONT OF M100/500.
- ③ CONNECT GROUND CABLE P/N 00436-04 TO THE CHASSIS GND SENSE AT THE FRONT OF M25 AMP AND TO ITS METAL CHASSIS-FRAME.
- ④ FUNCTION SELECT SWITCH SHOULD BE IN GND/HIPOT POSITION.

5. PLUG BOTH UNITS TO AC OUTLET THEN TURN POWER ON OF BOTH UNITS (M25 AMP FIRST). AT THIS STAGE BOTH READY LIGHTS SHOULD BE ON.
 6. PRESS M25 AMP'S START BUTTON TEST BEGINS AND AFTER THE TEST CYCLE IS COMPLETED, IT WILL AUTOMATICALLY INITIATE THE TEST ON M100/500.
- NOW THE SYSTEM IS READY FOR USE.

SYSTEM USE

1. ASSUMING UNITS ARE CALIBRATED TO THE DESIRED TRIP POINTS, REMOVE GROUND CABLE CONNECTION TO THE M100/500 AND CONNECT IT TO THE METAL CHASSIS FRAME OF DEVICE UNDER TEST.
2. PLUG DEVICE UNDER TEST TO HV RECEPTACLE OF M25 AMP.
3. PRESS M25 AMP'S START BUTTON TO BEGIN TEST.
4. FOR INDIVIDUAL MACHINE DIFFICULTIES SEE APPROPRIATE MANUAL

CONTRACT NO.	DATE	APPROVALS	DATE	APPROVALS
	JUN 8-86		8-86	

CONTRACT NO. _____
 DATE _____
 APPROVALS _____
 DATE _____
 APPROVALS _____

CONTRACT NO. _____
 DATE _____
 APPROVALS _____
 DATE _____
 APPROVALS _____

CONTRACT NO.	DATE	APPROVALS	DATE	APPROVALS
	JUN 8-86		8-86	

CONTRACT NO. _____
 DATE _____
 APPROVALS _____
 DATE _____
 APPROVALS _____

REV.	DATE	APPROVED
A	8-19-86	PHILLEY

SYSTEM OBJECTIVE - GND CONTINUITY AND DC HIPOUT TESTS PERFORMED AUTOMATICALLY THRU ONE HV RECEPTACLE

SYSTEM SELF CHECK

- ① CONNECT INTERFACE CONNECTOR AT REAR OF M25 AMP WITH THAT OF MIOODC CONNECTOR LABELED "GND TESTER" AT REAR BY INTERFACE CABLE P/N 00333-04.
 - ② CONNECT CHASSIS GND SENSE (BINDING POST) AT REAR STANDARD BANANA PLUG AT EACH END.
 - ③ CONNECT GROUND CABLE P/N 00436-04 TO THE CHASSIS GND SENSE AT THE FRONT OF M25 AMP AND TO ITS METAL CHASSIS FRAME
 - ④ FUNCTION SELECT SWITCH OF M25AMP SHOULD BE IN THE GND/HIPOUT POSITION.
 5. PLUG BOTH UNITS TO AC OUTLET THEN TURN POWER ON OF BOTH UNITS (M25 AMP FIRST). AT THIS STAGE BOTH READY LIGHTS SHOULD BE ON. IF MIOODC READY LIGHT IS NOT ON, PRESS RESET BUTTON.
 6. PRESS M25 AMP'S START BUTTON, TEST BEGINS AND AFTER TEST CYCLE IS COMPLETED, IT WILL AUTOMATICALLY INITIATE TEST ON MIOODC.
- NOW THE SYSTEM IS READY FOR USE.

SYSTEM USE WITH DEVICE UNDER TEST

1. ASSUMING UNITS ARE CALIBRATED TO THE DESIRED TRIP POINTS, REMOVE GROUND CABLE CONNECTION TO THE MIOODC, AND CONNECT IT TO THE METAL CHASSIS FRAME OF DEVICE UNDER TEST.
2. PLUG DEVICE UNDER TEST TO HV RECEPTACLE OF M25 AMP.
3. PRESS M25 AMP'S START BUTTON TO BEGIN TEST.
4. FOR INDIVIDUAL MACHINE DIFFICULTIES, SEE APPROPRIATE MANUAL.

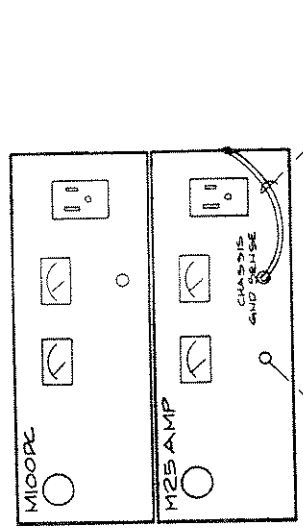

FRONT VIEW

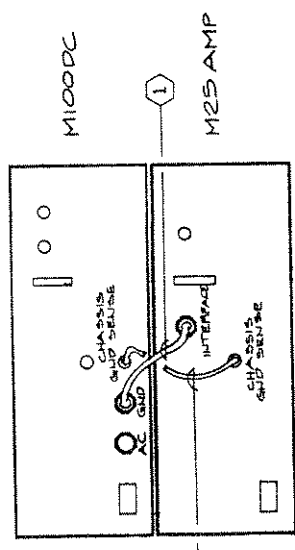

REAR VIEW

* WHEN LOW CURRENT OPTION IS PRESENT ON MIOODC, CONNECT M25 CHASSIS GND SENSE TO GND PIN OF ITS HV RECEPTACLE. IF M25 CHASSIS GND SENSE IS CONNECTED TO ITS CHASSIS FRAME MIOODC WILL NOT START.

QTY	ITEM NO.	NAME OR DESCRIPTION	PARTS LIST	NATURE OF DEFECT

UNITS OVERHAULING REPAIR	CONTRACT NO.	DATE	APPROVALS
FUNCTIONS ORIGINALS		JUN 8-86	
MATERIAL			
WARRANTY			

DIAGRAM SYSTEM	DATE	APPROVED
M25AMP-MIOODC INTERFACE	JUN 8-86	PHILLEY

SIZE	ESCROW NO.	DWG. NO.	REV.
C		01076-01	A

1. The first part of the document discusses the importance of maintaining accurate records of all transactions. This is essential for ensuring the integrity of the financial statements and for providing a clear audit trail. The records should be kept up-to-date and should be easily accessible to all relevant parties.

2. The second part of the document outlines the procedures for handling discrepancies. It is important to identify any errors as soon as possible and to take appropriate corrective action. This may involve reviewing the records, contacting the relevant parties, and making necessary adjustments to the accounts.

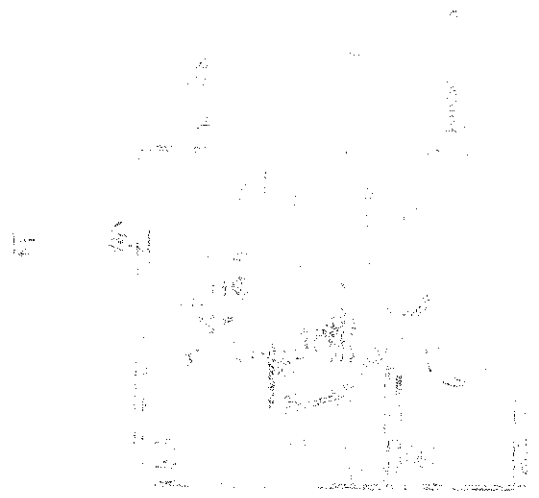

3. The third part of the document discusses the importance of maintaining accurate records of all transactions. This is essential for ensuring the integrity of the financial statements and for providing a clear audit trail. The records should be kept up-to-date and should be easily accessible to all relevant parties.

4. The fourth part of the document outlines the procedures for handling discrepancies. It is important to identify any errors as soon as possible and to take appropriate corrective action. This may involve reviewing the records, contacting the relevant parties, and making necessary adjustments to the accounts.

SYSTEM OBJECTIVE

THE ABILITY TO PERFORM GROUND CONTINUITY AND AC OR DC HIPOD TESTS AUTOMATICALLY THRU ONE HV RECEPTACLE.

SYSTEM SELF CHECK

1. STACK THREE UNITS AS SHOWN
2. CONNECT INTERFACE CONNECTOR AT REAR OF M25AMP WITH THAT OF M100DC CONNECTOR LABELED "GND TESTER" AT REAR BY INTERFACE CABLE P/N 00333-04
3. CONNECT INTERFACE CONNECTOR AT REAR OF M100/500 WITH THAT OF M100DC CONNECTOR LABELED "AC HIPOD" AT REAR BY INTERFACE CABLE P/N 00333-04
4. CONNECT A JUMPER CABLE BETWEEN THE CHASSIS GND SENSE AT REAR OF M25AMP AND THAT OF M100DC AT REAR
5. CONNECT A JUMPER CABLE BETWEEN THE CHASSIS GND SENSE AT FRONT OF M100/500 AND THAT OF M100DC LABELED "AC CHASSIS GND SENSE" AT REAR
6. CONNECT GROUND CABLE P/N 00346-04 BETWEEN M25AMP'S CHASSIS GND SENSE AT FRONT AND ITS METAL CHASSIS FRAME
7. FUNCTION SELECT SWITCH OF M25 AMP SHOULD BE AT "GND/HIPOD" POSITION
8. PLUG ALL UNITS TO AC OUTLET AND TURN POWER ON. AT THIS STAGE M25AMP READY LIGHT IS ON. READY LIGHTS FOR M100/500 AND M100DC CORRESPOND TO THE POSITION OF "AC/DC" SWITCH ON M100DC. ALWAYS PRESS RESET BUTTON AFTER CHANGING FROM "AC" TO "DC" POSITION. IT HAVE READY LIGHT ON M100DC.
9. WITH THE SWITCH AT "DC" POSITION, PRESS START BUTTON OF M25AMP TO BEGIN THE GND CONTINUITY AND INITIATE DC TEST AFTERWARDS, AUTOMATICALLY.

SYSTEM USE WITH DEVICE UNDER TEST

1. ASSUMING UNITS ARE CALIBRATED TO THE DESIRED TRIP POINTS, REMOVE GROUND CABLE CONNECTION TO M25AMP METAL FRAME AND CONNECT TO DEVICE UNDER TESTS METAL CHASSIS FRAME.
2. PLUG DEVICE UNDER TEST TO M25AMP HV RECEPTACLE AND FOLLOW PROCEDURE 9 FOR INDIVIDUAL MACHINE DIFFICULTIES
3. SEE APPROPRIATE MANUAL

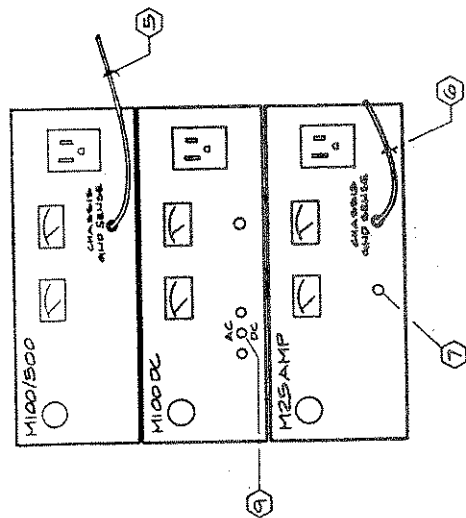

FRONT VIEW

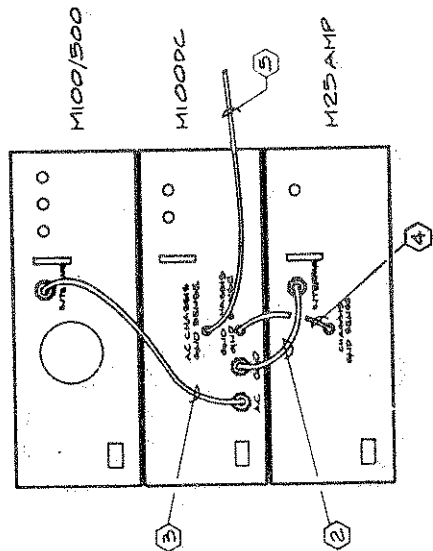

REAR VIEW

UNLESS OTHERWISE SPECIFIED DIMENSIONS ARE IN INCHES FRACTIONS DECIMALS ANGLES 16 100 1000		CONTRACT NO.	
MATERIAL		APPROVALS	DATE
		DRAWN JUN	8-28-86
		REWORK	

DIAGRAM SYSTEM HOOK-UP
M25AMP-M100DC-M100/500
INTERFACE

