

MANUAL # M360645

The Manuals in LP are intended for internal Elgar use only. When you print this manual some drawings may not be legible.

All drawings within the manuals are printed at 8 1/2 X 11. However you can download or print an 11 X 17 copy of each drawing from LP as needed.

Otherwise, contact Document Control for a hard copy manual if needed.

Sorensen

DCR-B2 SERIES **500-Watt & 1000-Watt** **Power Supplies**

Service Manual

Manual covers DCR-B2 models:

500-Watt

10-40B2
20-25B2
40-13B2
60-9B2
80-6B2
150-3B2
300-1.5B2
600-.75B2

1000-Watt

10-80B2
20-50B2
40-25B2
60-18B2
80-12B2
150-6B2
300-3B2
600-1.5B2

SORENSEN

Division of Elgar
9250 Brown Deer Road
San Diego, CA 92121-2294

1-800-733-5427

Tel: (858) 450-0085

Fax: (858) 458-0267

Email: sales@elgar.com

www.elgar.com

©2000 by Sorensen, Division of Elgar Electronics Corporation
This document contains information proprietary to Sorensen, Elgar Electronics Corporation. The information contained herein is not to be duplicated or transferred in any manner without prior written permission from Sorensen.

March, 2000

Document No. M360645 Rev E

SORENSEN FIVE-YEAR WARRANTY

Sorensen, a division of Elgar Electronics Corporation, warrants its products to be free from defects in material and workmanship. This warranty is effective for five years from the date of shipment of the product to the original purchaser. Liability of Sorensen under this warranty shall exist provided that:

- the Buyer exposes the product to normal use and service and provides normal maintenance on the product;
- Sorensen is promptly notified of defects by the Buyer and that notification occurs within the warranty period;
- the Buyer receives a Return Material Authorization (RMA) number from Sorensen's Repair Department prior to the return of the product to Sorensen for repair, phone 800-458-4258;
- the Buyer returns the defective product in the original, or equivalent, shipping container;
- if, upon examination of such product by Sorensen it is disclosed that, in fact, a defect in materials and/or workmanship does exist, that the defect in the product was not caused by improper conditions, misuse, or negligence; and,
- that Sorensen QA seal and nameplates have not been altered or removed and the equipment has not been repaired or modified by anyone other than Sorensen authorized personnel.

This warranty is exclusive and in lieu of all other warranties, expressed or implied, including, but not limited to, implied warranties of merchantability and fitness of the product to a particular purpose. Sorensen, its agents, or representatives shall in no circumstance be liable for any direct, indirect, special, penal, or consequential loss or damage of any nature resulting from the malfunction of the product. Remedies under this warranty are expressly limited to repair or replacement of the product.

CONDITIONS OF WARRANTY

- To return a defective product, contact a Sorensen representative or the Sorensen factory for an RMA number. Unauthorized returns will not be accepted and will be returned at the shipper's expense.
- For Sorensen products found to be defective within thirty days of receipt by the original purchaser, Sorensen will absorb all ground freight charges for the repair. Products found defective within the warranty period, but beyond the initial thirty-day period, should be returned prepaid to Sorensen for repair. Sorensen will repair the unit and return it by ground freight pre-paid.
- Normal warranty service is performed at Sorensen during the weekday hours of 7:30 am to 4:30 pm Pacific time. Warranty repair work requested to be accomplished outside of normal working hours will be subject to Sorensen non-warranty service rates.
- Warranty field service is available on an emergency basis. Travel expenses (travel time, per diem expense, and related air fare) are the responsibility of the Buyer. A Buyer purchase order is required by Sorensen prior to scheduling.
- A returned product found, upon inspection by Sorensen, to be in specification is subject to an inspection fee and applicable freight charges.
- Equipment purchased in the United States carries only a United States warranty for which repair must be accomplished at the Sorensen factory.

Sorensen

Committed to Quality...Striving for Excellence

TABLE OF CONTENTS

SECTION 1	THEORY OF OPERATION	PAGE
1.1	INTRODUCTION	1
1.2	PHASE CONTROL PRINCIPLE	1
1.3	BLOCK DIAGRAM ANALYSIS (FIGURE 1-2)	3
1.4	DETAILED CIRCUIT DESCRIPTION	3
1.4.1	REFERENCE AND BIAS SUPPLIES	3
1.4.2	VOLTAGE MODE SECTION	4
1.4.3	CURRENT MODE SECTION	5
1.4.4	RAMP GENERATOR, RESET CIRCUIT AND COMPARATOR	5
1.4.5	BLOCKING OSCILLATOR CIRCUIT	6
1.4.6	TURN-ON AND SHUT-DOWN CIRCUIT	6
1.4.7	POWER SECTION	7
1.4.8	OVERVOLTAGE PROTECTOR	7
1.4.9	INDICATOR LAMPS	7
1.4.10	CHANGEABLE CURRENT PROGRAMMING PARAMETERS	8
SECTION 2	MAINTENANCE	
2.1	GENERAL	9
2.2	PERIODIC SERVICING	9
2.3	TROUBLESHOOTING	9
2.4	CALIBRATION	9
2.5	PERFORMANCE TESTING	11
2.5.1	VOLTAGE MODE REGULATION AND RIPPLE	12
2.5.2	CURRENT MODE REGULATION	13
2.5.3	TRANSIENT RESPONSE	13
2.6	HI-POT TEST PROCEDURE	16
SECTION 3	DRAWINGS AND PARTS LISTS	
3.1	GENERAL	17
3.1.1	CIRCUIT SYMBOL	17
3.1.2	SORENSEN PART NUMBER	17
3.2	REPLACEMENT PARTS LISTS	17
3.3	ASSEMBLY DRAWINGS (SEE ATTACHED)	17

LIST OF FIGURES

FIGURE	TITLE	PAGE
1-1	Phase Control Firing Angles.....	1
1-2	DCR-B2 Functional Block Diagram.....	2
1-3	Passing Stage Principle.....	4
2-1	Performance Test Setup.....	12

LIST OF TABLES

TABLE	TITLE	PAGE
2-1	DCR-B2 Troubleshooting.....	11
2-2	Sensing Resistor Values.....	14
2-3	Unit Calibration Specification.....	15

SECTION 1 _____ THEORY OF OPERATION

1.1 INTRODUCTION

This section provides a basic discussion of unit operating principles, which may be used in conjunction with the troubleshooting chart provided in Section 3, to enable the logical and rapid isolation of unit faults. A brief description of the phase control principle is given first, followed by a block diagram analysis of system functions. The function of each section is then described in detail.

1.2 PHASE CONTROL PRINCIPLE

The sinusoidal wave in Figure 1-1 represents normal ac line voltage. If, by some means, conduction of this voltage is delayed, the average voltage output will be reduced. Control of the delay then results in control of the average voltage. This is phase control. The silicon controlled rectifier (SCR) acts like a switch, activated by the delay circuit, to provide the phase control. The delay is expressed in degrees and is known as the firing angle. Figure 1-1 shows firing angles of 60° and 120° .

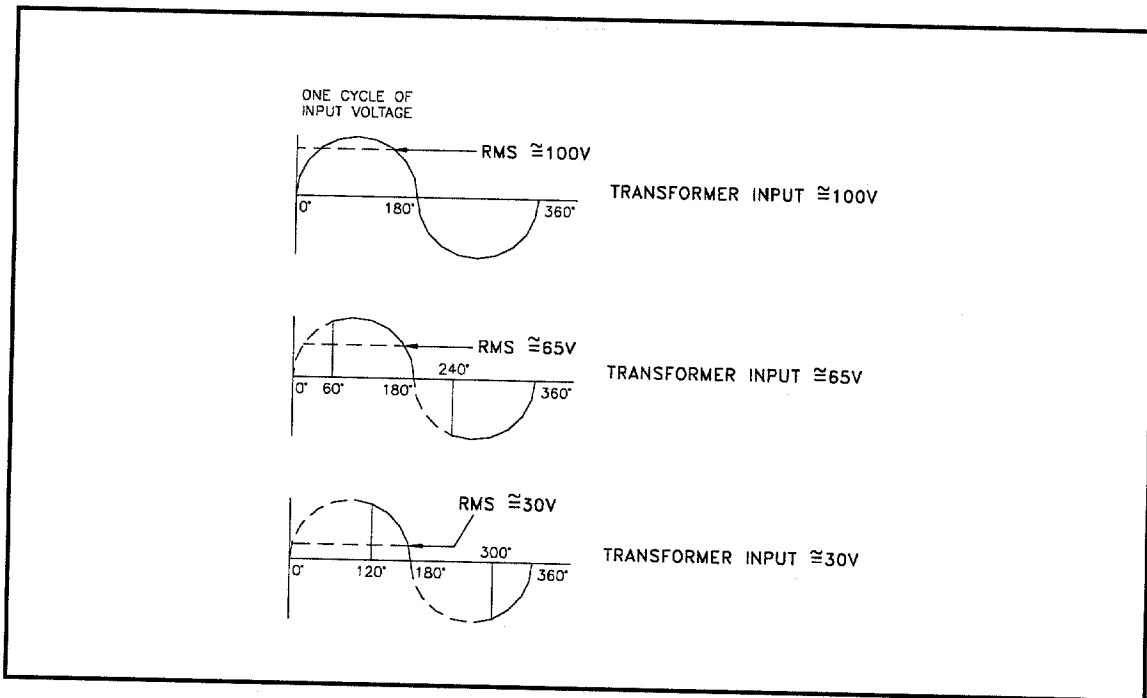

Figure 1-1 Phase Control Firing Angles

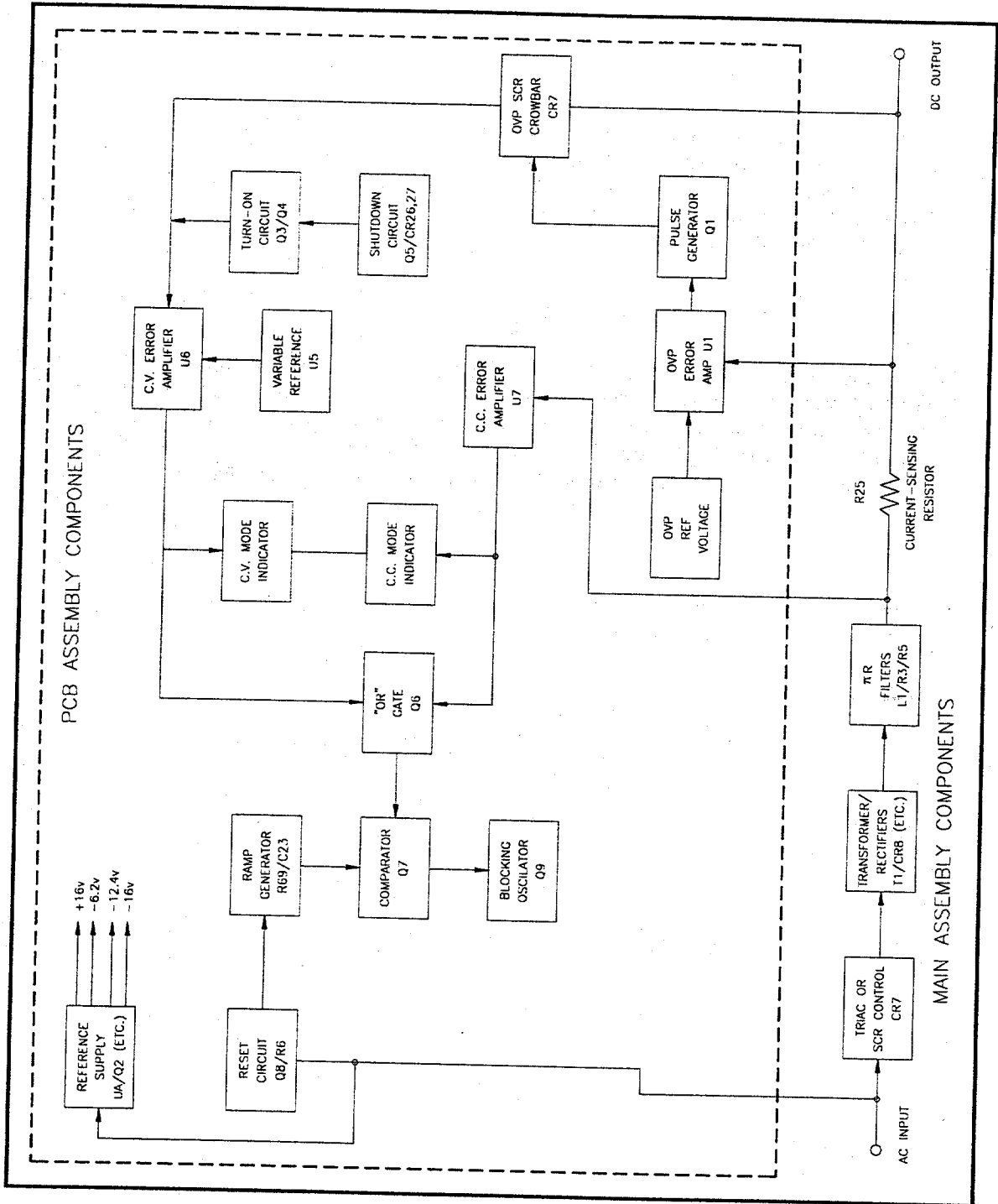

Figure 1-2 DCR-B2 Functional Block Diagram

1.3 BLOCK DIAGRAM ANALYSIS (FIGURE 1-2)

The ac input voltage is first applied to CR7 (Triac), which is in series with power transformer T1. CR7 functions with the control circuits to form a feedback loop which prevents a change in output voltage when either the line or load changes.

To accomplish this, the control circuits issue a phase adjusted firing pulse to CR7 once during each half cycle of the input ac voltage. These circuits continuously sample the output voltage, which establishes the precise time at which the firing pulse is to be generated. The phase controlled ac voltage is stepped up or down by power transformer T1, and coupled through a full-wave rectifier and filtering circuits to the output terminals.

Feedback signals from the output back to CR7 originate in the constant voltage/current error amplifiers U6/U7. In the constant voltage mode, U6 continuously compares the supply output with a reference voltage generated by a variable reference programming circuit, (U5). A difference in these voltages appears as an error signal, which is delivered to amplifier U6. This dc error signal is applied to Q6 (comparator input #1). A sawtooth ramp voltage, generated by Q8, R69 and C23, is applied to Q7 (comparator input #2). The comparator output (across R62) sets the conduction angle of blocking oscillator Q9. The duration of Q9 conduction is directly proportional to the error signal, and its output triggers CR7 into conduction. CR7 acts as a switch, whose firing angle is dependent on the magnitude of dc error signal, thus controlling the overall supply output.

Similarly, in the constant current mode, changes in line or load are sensed by R25, in series with the output. It is then amplified by U7, and applied to Q6 comparator input. Output control from this point is essentially the same as in the constant voltage analysis, above.

1.4 DETAILED CIRCUIT DESCRIPTION

NOTE
All component designators are referenced to PCB schematic diagram Figure 3-1 unless otherwise noted.

1.4.1 REFERENCE AND BIAS SUPPLIES

The precisely regulated voltage required for operation of the control circuitry is produced by a reference supply consisting of zener diodes D5/D6, operational amplifier U4, passing stage Q2, transformer T2 and center-tapped full wave rectifier D35/D36/D37/D38. (See main schematic).

The reference supply output appears across a comparison bridge composed of divider R31/R32, D16, and R77. Error signals are sensed across this bridge and amplified by U4. The variable impedance characteristic of passing stage Q2 changes the level of absorbed voltage across the stage, maintaining the output at a precisely controlled negative 12.4 volts (Figure 1-3).

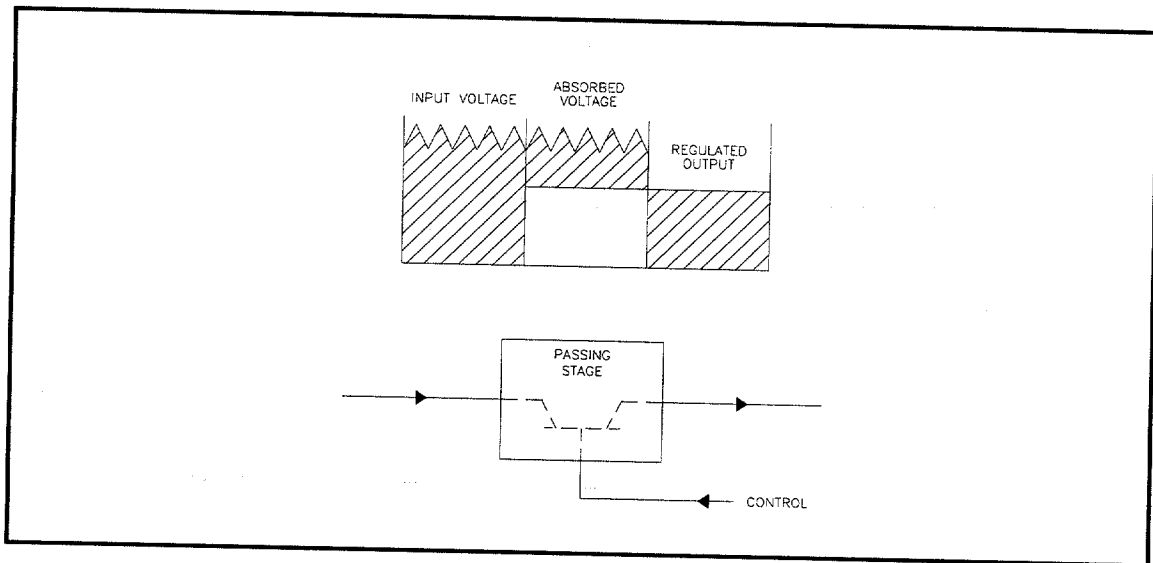

Figure 1-3 Passing Stage Principle

To illustrate circuit operation, assume an increase in the T2 (Figure 3-4) supply output. Pin 2 of U4 will become more negative, and the output at pin 6 more positive, tending to turn Q2 off. The reduction in drive current increases the impedance of Q2, and consequently its absorbed voltage, resulting in precise regulation of reference supply output.

Several other bias supplies are used to power the control circuitry:

1. +20 volts from D7. Note that there is no filtering on this 20 volt output. This signal is used as a time reference to the ac line. The +20 volt source is then gated through D21, and filtered by C18 to provide the +20 Vdc primary operating power for the control PCB.
2. The 20 volts across C18 is fed to R47 and D8, to create +16 volts for sections of the control circuitry. The +16 volts across D8 is then fed to R23 and D4 to generate and precisely regulate the +11.7V for the current amplifier reference voltage.
3. +30 Vdc unregulated (D35 and D37 on the overall schematic) is used to operate the current/voltage mode lamps, OVP control circuit, and remote current voltage select reference.

1.4.2 VOLTAGE MODE SECTION

Primary components of this circuit include constant voltage error amplifier U6, variable reference voltage programmer U5, and emitter-follower stage Q6. The circuit functions as follows:

Pin 3 of U5 is connected to plus sense. Front panel voltage controls R10/R11 function as variable feedback resistances from U5 pin 6 to pin 2. The negative 12.4 volt reference through R39/38/37 establishes the desired programming current range, so that 0 to 10 volt signal is obtained at pin 6 of U5.

The main error amplifier is U6. Pin 4 of U6 is at virtual dc ground since pin 5 is at ground (+sense). Thus, the current through R74 can be varied from 0 to 1 milliampere. This current, through R79, programs the supply to the desired output. U6 pin 5 senses this output, and compares it to the voltage developed at U6 pin 4. The resultant is an error signal, amplified by U6, and coupled to R61 through the emitter of Q6.

An illustration of voltage mode operation: An increase in system output drives U6 pin 4 more negative. U6 pin 11, and thus the Q6 emitter also become more negative, creating the error voltage necessary to retard the firing angle of CR7 through T1/Q9 action as noted in the block diagram analysis.

C15/R44 establishes ac loop stability, aided by C16/R45.

1.4.3 CURRENT MODE SECTION

The primary component in this section is constant current amplifier U7. The 11.7V reference voltage is divided down by bridge dividers R20/R21 and R24/R19 to U7 pins 5 and 4 respectively. The resultant voltages are referenced to the positive output, through a current sensing resistor (R21), with R12/R13 serving as the front panel current adjust potentiometers.

R46/C17 establishes ac loop stability. C11/R36 (Variable) is a secondary stability network used for inductive load compensation.

R22/C7 acts to prevent rapid changes in the phase delay angle, caused by large transients. This protects the power components from overstress.

Trimmer R17 is used to adjust zero output current (compensating for current tolerances and offset voltage of U7).

Trimmer R18 is used to adjust for maximum current setting (compensating for tolerances in panel pot R12 and current shunt R25).

An illustration of current mode operation: If the output current approaches the current limit setting, the voltage across the sensing resistor becomes larger. This is seen as a positive error voltage at U7 pin 5, which is amplified and applied to the U7 output, pin 10. The output of U7, pin 10 (emitter) is passed through D20 to the base of the output stage of U7 at pin 13. The injected current causes the collector of U7, pin 11 to fall, reducing output. (See Voltage Mode section, para. 1.4.2, for additional details).

1.4.4 RAMP GENERATOR, RESET CIRCUIT AND COMPARATOR

The ramp generator consists of R69 and C23. The ramp voltage at the junction of R69/C23 is coupled through D30 to the base of Q7. This voltage starts at a maximum level, and decreases exponentially until reset by Q8 at 8.3 millisecond intervals (each 1/2 cycle of line voltage). The reset pulse for Q8 is generated through D7/R48 as follows:

The reset circuit consists of Q8 and R68. The full wave rectified ac input from T2 is impressed across D7/R48. D7 clamps the base of Q8 at its zener level, keeping it shut off (D21 is forward biased). As the impressed voltage drops toward zero, the zener voltage follows. D21 becomes reverse biased. Q8 then turns on from base bias through R68, charging C23 when the line voltage crosses zero.

The comparator consists of Q7/Q6, D30, R61, and R62. Comparator Q7/Q6 compares the dc signal from either the voltage or current mode amplifier (applied to Q6) with the ramp generator voltage. The varying output of Q7 (across R62) establishes the conduction angle of blocking oscillator Q9.

1.4.5 BLOCKING OSCILLATOR CIRCUIT

Q9 functions as a switch, providing the triggering voltage for D33 and D32 proportional to the error signal received from the comparator circuit. The blocking oscillator circuit functions as follows: Assume that at a given time the Q7 dc emitter voltage is several volts below the reference level provided by the reference supply circuit (paragraph 1.4.1). At a point when the ramp voltage, appearing at the base of Q7, is more negative than that on its emitter, Q7 conducts. This drives the base of Q9 positive, causing Q9 to conduct. As its collector current (I_c) increases, regenerative action occurs through pulse transformer T2, forcing Q9 into saturation. (I_c) continues to increase until T2 core saturates. Then T2 voltage decreases, removing Q9 base current. At this point Q9 comes out of saturation. The cycle is then repeated. The output of the pulse generator is a series of narrow pulses, continuing until the end of the line halfcycle.

1.4.6 TURN-ON AND SHUT-DOWN CIRCUITS

Primary components of the turn-on circuit are Q3, Q4, R56, R55, D28 and C22. Circuit operation is as follows: When power is initially applied to the unit, the bases of Q3/Q4 are driven positive, due to C22 coupling the rising voltage of the +16 volt bias supply. Q3 and Q4 are thus in saturation. The resultant negative voltage at the Q3/Q4 collector maintains voltage error amplifier U6 and the blocking oscillator/mixer circuits at cut off.

This action inhibits the output of the power supply from coming up. As C22 charges, the supply output will increase exponentially. Q3/Q4 gradually come out of saturation until the voltage across C22 reaches the point where they are shut off. The supply is then functioning in its normal manner.

The shut-down circuit, consisting of Q5, R58, R59, and D26/D27, cuts off the unit output when the cathode of either diode is connected to the plus sense connection. The circuit function is to actuate Q5, which turns Q3 and Q4 on. When the connection is removed, the power supply returns to normal, with the slow start described above.

D27 (TB3 pin 11) is available for customer use to shut down the dc output. Terminal 11 can be connected to +sense (TB3 Term 1) by either an isolated relay contact or an open collector logic signal (sinking approximately 0.2mA).

D26 is used internally to shut down the DCR-B2 output when the OVP is tripped.

1.4.7 POWER SECTION

The input ac voltage is applied to the primary of power transformer T1 through an SCR, (CR7). The output is rectified by a full wave bridge, and filtered by a Pi network with a damping resistor (R3). The filtered dc is then applied to the output terminals.

1.4.8 OVERVOLTAGE PROTECTOR

The OVP consists of a fast-response silicon-controlled rectifier crowbar (CR8). A reference voltage (+12V) is generated by zener D1 and R3. This reference voltage is compared to the output voltage in a bridge circuit, by the ratio of R6 to R16 plus R18 (adjust pot). The bridge output is applied to U1, pins 3 and 4. Assume that the resistor ratio is set (by adjust pot R18) to produce a balanced bridge at a specified output voltage. If the output voltage exceeds this preset value, U41, pin 3 will be driven positive relative to pin 4. The result is a positive output at pin 9 to turn on Q1. Q1 applies the +30V unregulated voltage to the primary of T1. The induced current in the secondary of T1 provides a trigger for the SCR crowbar. D12 activates the SCR, causing a crowbar function across the power supply output terminals.

The SCR recovers as soon as the output voltage is dropped, and removes the crowbar current. R5 supplies holding current to CR8 to hold the crowbar on.

To reset the OVP, power must be removed from the power supply input. After a moment to reset, lower the output voltage control, and reapply power to the input.

1.4.9 INDICATOR LAMPS

DS2, which indicates Constant Voltage mode, is wired across P49 and P1-19 as shown on the Control PCB schematic, Figure 6-1. DS3, which indicates Constant Current mode, is wired across P1-9 and P1-19.

U8 is an operational amplifier used to drive DS2 and DS3. The lamps and U8 are powered from the +30V supply.

The input signal to U8 determines which lamp lights, as follows:

A. Constant Current Mode (Current Limit) DS3

The input terminals of U8 are pins 2 and 3. Pin 2 is driven positive relative to pin 3 when the current amplifier (U7) output (pin 10) is in control (i.e., during current mode operation). Pin 2 positive signal will drive U8 output (pin 6) low (towards the +30V return). Pin 6 acts to reduce the voltage on DS2 and increases the voltage on DS3. DS3 is turned on brightly and DS2 is turned off.

B. Constant Voltage Mode (DS2)

During Voltage Mode operation, U8 pin 2 polarity reverses due to loss of U7 pin 10 voltage, so that U8 pin 6 output is driven high (towards +30V). This turns on DS2 and turns off DS3.

1.4.10 CHANGEABLE CURRENT PROGRAMMING PARAMETERS

0-400 mV Operation:

Dual range current mode signal programming is controlled by SW1, U3, U2 and associated parts. The signal programming voltage is applied between TB3-8(+) and TB3-9() with the jumper between TB3-7 and TB3-8 removed. For 0-400mV signal control voltage, SW1-1 is closed. This directly connects TB3-8 to R17 as in the standard DCR-B2 current mode signal programming. SW1-2 and SW1-3 are open.

0-10V Operation:

For 0-10V signal control voltage, SW1 is open; SW2 and SW3 are closed. Thus, the input voltage goes to pin U3B-5 via R12 and R11. D3 and R12 limit the input voltage to 15V maximum. R11, R9, R10 and U3A (pins 1,2,&3) comprise an inverting amplifier with a gain of 20-25. The gain inverting amplifier is set so that the output at SW1-2 is equal to .4V with $V_{in}=10V$ (approx. 24). As input voltage goes from 0-10V, the output voltage goes from 0-400mV.

U2 and associated parts allow the front panel control pots to output a variable voltage even when they are disconnected from the control circuitry, ie, TB3-8.

SECTION 2 _____ MAINTENANCE

2.1 GENERAL

This section provides troubleshooting data, periodic servicing, calibration, performance and hi-pot testing procedures. The troubleshooting data should be used in conjunction with the schematic diagrams and Section 1 which outlines the principles of operation. Any questions pertaining to repair should be directed to the nearest Sorensen representative or to the factory. Include the model and serial numbers in any correspondence. Should it be necessary to return a unit to the factory for repair, prior authorization from Sorensen Company must be obtained.

2.2 PERIODIC SERVICING

Whenever a unit is removed from service, it should be cleaned, using naphtha or an equivalent solvent on painted surfaces, and a weak solution of soap and warm water for the front panel. Compressed air may be used to blow dust from in and around components.

2.3 TROUBLESHOOTING

Table 2-1 provides a list of malfunction symptoms along with a tabulation of the possible cause(s) for each symptom. Note that the failure of a single component may result in a chain reaction effect. As additional aids to troubleshooting, voltage checkpoints have been designated on the printed circuit schematic diagram.

2.4 CALIBRATION

Following repair, the unit should be recalibrated to insure that replacement components have not altered performance. Refer to Table 2-3 for unit calibration specifications. The following is the calibration procedure to ensure that full rated voltage output is available:

1. Make sure input power has been removed from unit and circuit breaker set to "OFF" position.
2. Set SW1 on PCB to "ON", "OFF", "OFF".
3. Adjust course voltage knob to midpoint and course current fully clockwise.
4. Set power to unit and turn circuit breaker "ON".
5. Check to see if output is approximately 1/2 rated voltage.
6. Adjust course voltage fully clockwise. With maximum voltage pot (R37 on PCB) adjust output voltage to 105% of rated.
7. Set output to rated voltage with four significant digits.
8. Set both course and fine current knobs fully counter clockwise.

9. Verify unit has gone from voltage mode to current mode by noting a significant drop in output voltage, by illumination of DS3.
10. Set fine current adjustment to midpoint and apply short circuit.
11. Using minimum current Adj. (R17 on PCB) adjust output current to exactly 0 amps.
12. Adjust fine current fully clockwise; slowly adjust course current fully clockwise.
13. Using maximum current Adj. (R18 on PCB) adjust output current to 115% of rated.
14. Turn circuit breaker "OFF".
15. Set SW1 to "OFF", "ON", "ON".
16. Turn course current knob counter clockwise fully.
17. Turn circuit breaker "ON".
18. Slowly Adj. course current knob fully clockwise.
19. With short circuit still applied, set current using 10V gain Adj. (R75 on PCB) to 115% of rated current.
20. Remove short circuit.
21. Turn unit "OFF". Reset SW1 to "ON", "OFF", "OFF".
22. Turn unit back "ON".
23. Apply rated load with rated voltage out.
24. With voltmeter (positive lead on inside of R21 and negative lead on cathode of D24) use R7 on front panel to set 400 MV, $\pm 1\%$. Reset current meter with R6.
25. Apply pot lock to all pots, also R6 & R7.
26. Calibration complete.

Table 2-1 DCR-B2 Troubleshooting

1	No output (voltage mode)	<ul style="list-style-type: none"> a) Wrong input voltage b) Open fuses and circuit breaker* c) Reference voltages (check levels) d) Defective U6 or U5 e) Collector to emitter short on Q8, Q6, Q3, Q5 or Q4 f) Q9 open or shorted
2	Fuse opens or circuit breaker trips	<ul style="list-style-type: none"> a) CR7 shorted* b) Input capacitors shorted* c) D32, D33 shorted or open*
3	High output voltage (meter pointer pegs)	<ul style="list-style-type: none"> a) Sensing or programming leads or link open* b) Defective U6 or U5 c) Q7 shorted collector to emitter d) Q6 open collector to emitter e) CR7 shorted*
4	No output (current mode), or unit will not current limit	<ul style="list-style-type: none"> a) Defective U7 b) C7 shorted c) D20 open d) Shorted COARSE CURRENT potentiometer* e) Collector to emitter short on Q8, Q6, Q3, Q5 or Q4 f) Q9 open or shorted
5	Output oscillates (current mode)	<ul style="list-style-type: none"> a) Potentiometer R36 on unit PCB improperly adjusted

*Chassis components (ref. Figure 2-3)

2.5 PERFORMANCE TESTING

Sensitive instruments like the DCR-B require rigorous testing methods if a true performance evaluation is to be made. Wherever possible, twisted leads should be used with test equipment to reduce stray pickup. At the power supply terminal board, these leads must be firmly held by the terminal screws. Alligator clips and similar types of connectors are not suitable. Grounding techniques in which more than one device in the setup is grounded may introduce extraneous ripple that, although unrelated to the power output ripple, is displayed on the test oscilloscope.

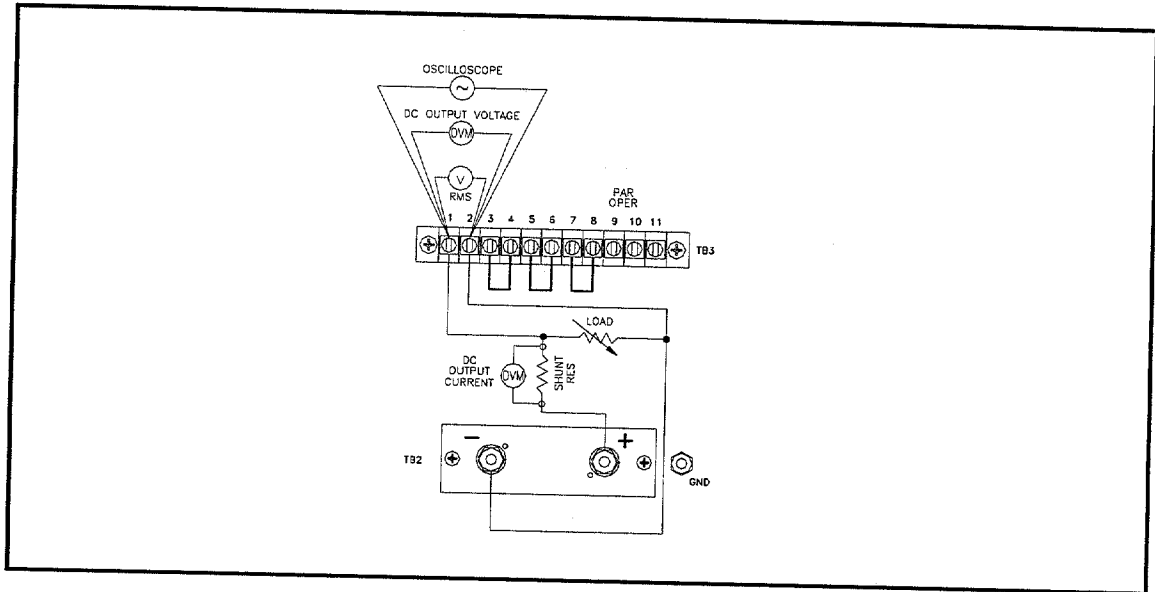

Figure 2-1 Performance Test Setup

2.5.1Voltage Mode Regulation and Ripple

To check voltage mode regulation and ripple, proceed as follows:

1. Connect a sensitive digital voltmeter and an RMS ac voltmeter across unit output terminals per Figure 2-1. Select a current shunt per Table 2-2 with a DVM for current output readings.

Use an autotransformer for AC line input with a current rating that exceeds the maximum unit input current called out in the unit specifications.

NOTE

Input devices such as autotransformers or line regulators can distort the input wave sufficiently to adversely affect performance measurements.

2. Apply high ac line input per specifications and remove load. Set the POWER switch to ON.
3. Rotate COARSE CURRENT control fully clockwise.
4. Use COARSE and FINE VOLTAGE controls to obtain rated output voltage. Note DVM reading after a few minutes of warm up time.

5. Decrease ac input voltage to low line specification. Output voltage change should not exceed limits specified in Table 2-3.
6. Close load switch and adjust load for rated current. Using high ac line specification and full load, verify ripple meets specification.

2.5.2 Current Mode Regulation

To check current mode regulation, proceed as follows:

1. At no load, adjust output to maximum rated voltage, and set COARSE CURRENT control fully clockwise.
2. Connect a sense resistor (Table 2-2) or a precision meter shunt in series with a variable load across the output terminals.
3. Connect input power at low line per unit specifications. Apply load until rated current of supply is reached. (Unit has voltage mode indicated.) Adjust COARSE CURRENT control until CURRENT mode indicator is lit and output voltage drops at least 5% off full scale value.
4. Connect a digital voltmeter across the sensing resistor, and note the indication.
5. Increase input voltage until voltage is at high line, and reduce the load resistance to zero (short). Note indication on the DVM. Change in voltmeter reading (expressed in millivolts) should be divided by sense resistor value to obtain regulation in milliamperes. Limits are provided in Table 2-3.

2.5.3 Transient Response

Test for transient response as follows:

1. Connect an oscilloscope across the unit output terminals.
2. Set unit POWER switch to ON. Adjust COARSE VOLTAGE control for rated output, and COARSE CURRENT control fully clockwise.
3. Apply half load, and then abruptly apply full load (or switch from full load to half load). Return to steady state operation should occur within 50 milliseconds (typical). See Table 2-3 for typical transient deviation voltage values.

NOTE

Load switching time should be less than 3 milliseconds.

Table 2-2

Sensing Resistor Values (Current Mode Regulation Check)

DCR MODEL	SENSE RESISTOR (Ohms)
10-40B2	0.01, 50W
10-80B2	.00625, 50W
20-25B2	0.01, 50W
20-50B2	.0200, 50W
40-13B2	0.01, 50W
40-25B2	.0400, 25W
60-9B2	0.1, 25W
60-18B2	.0556, 20W
80-6B2	0.1, 25W
80-12B2	.0833, 12W
150-3B2	0.1, 25W
150-6B2	.167, 6W
300-1.5B2	1.0, 10W
300-3B2	.333, 3W
600-.75B2	1.0, 10W
600-1.5B2	.333, 1W

**Table 2-3
Unit Calibration Specifications**

DCR Model	Regulation		Ripple Volt Mode (mV)	Transient Deviation (Volts)	Maximum Compliance (Vdc)	Cur. Mode Upper Lim. Set Pt. (A)
	Voltage Mode (mV)	Current Mode (mA)				
10-40B2	3	100	65	0.6	10	46
10-80B2	3	200	65	1.0	10	92
20-25B2	6	62.5	65	1.2	20	28.75
20-50B2	10	125	65	1.6	20	58
40-13B2	12	32.5	90	2.4	40	14.95
40-25B2	12	63	90	2.9	40	29
60-9B2	18	22.5	125	3.6	60	10.35
60-18B2	18	45	125	4.0	60	21
80-6B2	24	15	150	4.8	80	6.9
80-12B2	24	33	150	5.3	80	14
150-3B2	45	7.5	300	9.0	150	3.45
150-6B2	45	16	300	9.5	150	7.0
300-1.5B2	90	3.75	700	18	300	1.725
300-3B2	90	8	700	20	300	3.5
600-.75B2	180	2	1200	36	600	0.8625
600-1.5B2	180	4	1200	40	600	1.7

2.6HI-POT TEST PROCEDURE

High potential test procedures have been carefully carried out at the factory. These units are 100% tested and should not require further testing in the field.

CAUTION

High potential test can overstress or destroy the power semiconductors in this power supply if improperly applied.

Isolation measurements may be made using a standard VOM (Simpson 260 or equivalent) on the highest resistance scale available.

If it is essential to use the high potential test method, please contact the factory for information on special precautions that should be taken.

CAUTION

Sorensen Company cannot be held liable for any malfunctions resulting from the application of a high potential test (greater than 100V). See standard Sorensen Company warranty.

SECTION 3 _____ DRAWINGS AND PARTS LISTS

3.1.....GENERAL

This manual contains schematic diagrams, PCB parts location drawings, and replaceable parts lists. The parts lists are keyed to the applicable schematic diagrams, and assembly drawings by the Reference Designator and Item Number.

3.1.1..... Circuit Symbol (Reference Designator)

This is an alpha-numeric identification of the component as called out on the unit drawings.

3.1.2..... Sorensen Part Number

The Sorensen part number should be used when ordering parts directly from:

Sorensen
 Sales & Technical Support
 9250 Brown Deer Road
 San Diego, CA 92121-2294
 1-800-525-2024
 Tel: (858) 450-0085
 Fax: (858) 458-0267
 Email: sales@sorensen.com
 www.sorensen.com

3.2.....REPLACEMENT PARTS LISTS (See Attached)

3.3.....ASSEMBLY DRAWINGS (See Attached)

DRAWING #		DESCRIPTION
500 WATT	1000 WATT	
M360646	M360646	REPLACEMENT PARTS LIST
1063996	1063996	DWG OUTLINE
1064093	1064377	SCHEMATIC, UNIT
1063006	1063006	SCHEMATIC, CONTROL PCB
1063829	1064371	FINAL ASSY
	1064436	BASE ASSY
1063513	1063513	FRONT PANEL ASSY
1064468	1063514	REAR PANEL ASSY
1063005	1063005	CONTROL PCB ASSY
1063865	1063865	CAP ASSY
1063518	1063518	POT ASSY

NOTES: UNLESS OTHERWISE SPECIFIED.

- ASSEMBLE PER ELGAR WORKMANSHIP STANDARD DOCUMENT NO. 0050003-01.

2 TORQUE ALL POTENTIOMETERS IN POSITION SHOWN 10 IN-LBS.

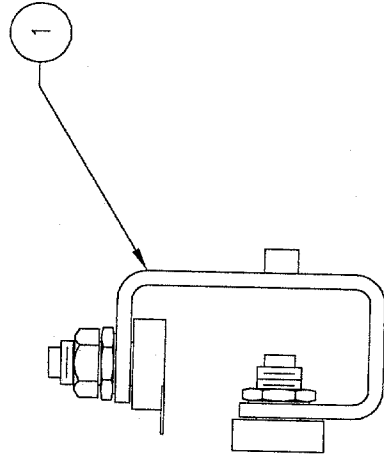
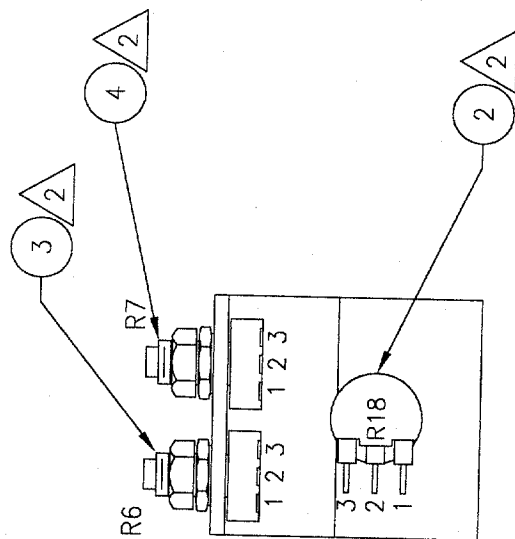
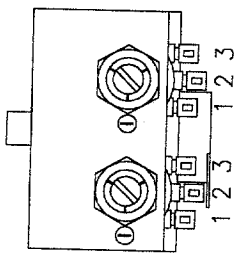

ZONE	REV	DESCRIPTION	DATE	APPROVED
A	PROD REL PER	B9A340 AR	10/13/88	S.A.
B	REV PER ECN	N950370	5/10/85	

SEE SEPARATE PARTS LIST: 1063518-1 THRU -8

CONTRACT NO.		UNLESS OTHERWISE SPECIFIED DIMENSIONS ARE IN INCHES	
DATE	10/13/88	DECIMAL TOLERANCES ON DIMENSIONS	± 0.01 ± 1/32 ± 1/2
DRAWN	4/20/88	ALL DIMENSIONS UNLESS OTHERWISE SPECIFIED	DO NOT SCALE THIS DRAWING
CHECKED		MATERIAL	
ENGINEER		USED ON	
QA-REL.		APPLICATION	
SEE DOCUMENT CONTROL FOR ORIGINAL SIGNATURES		THIS IS AN ORIGINAL DRAWING. ANY CHANGES MUST BE APPROVED BY THE ORIGINAL DESIGNER AND THE MANUFACTURING AND INSPECTION DEPARTMENTS. ANY CHANGES TO THIS DRAWING MUST BE APPROVED BY THE ORIGINAL DESIGNER AND THE MANUFACTURING AND INSPECTION DEPARTMENTS.	
SIZE	B	DWG. NO.	1063518
SCALE	1/1	REV	B
DWG ASSY BKT		SHEET 1 OF 1	

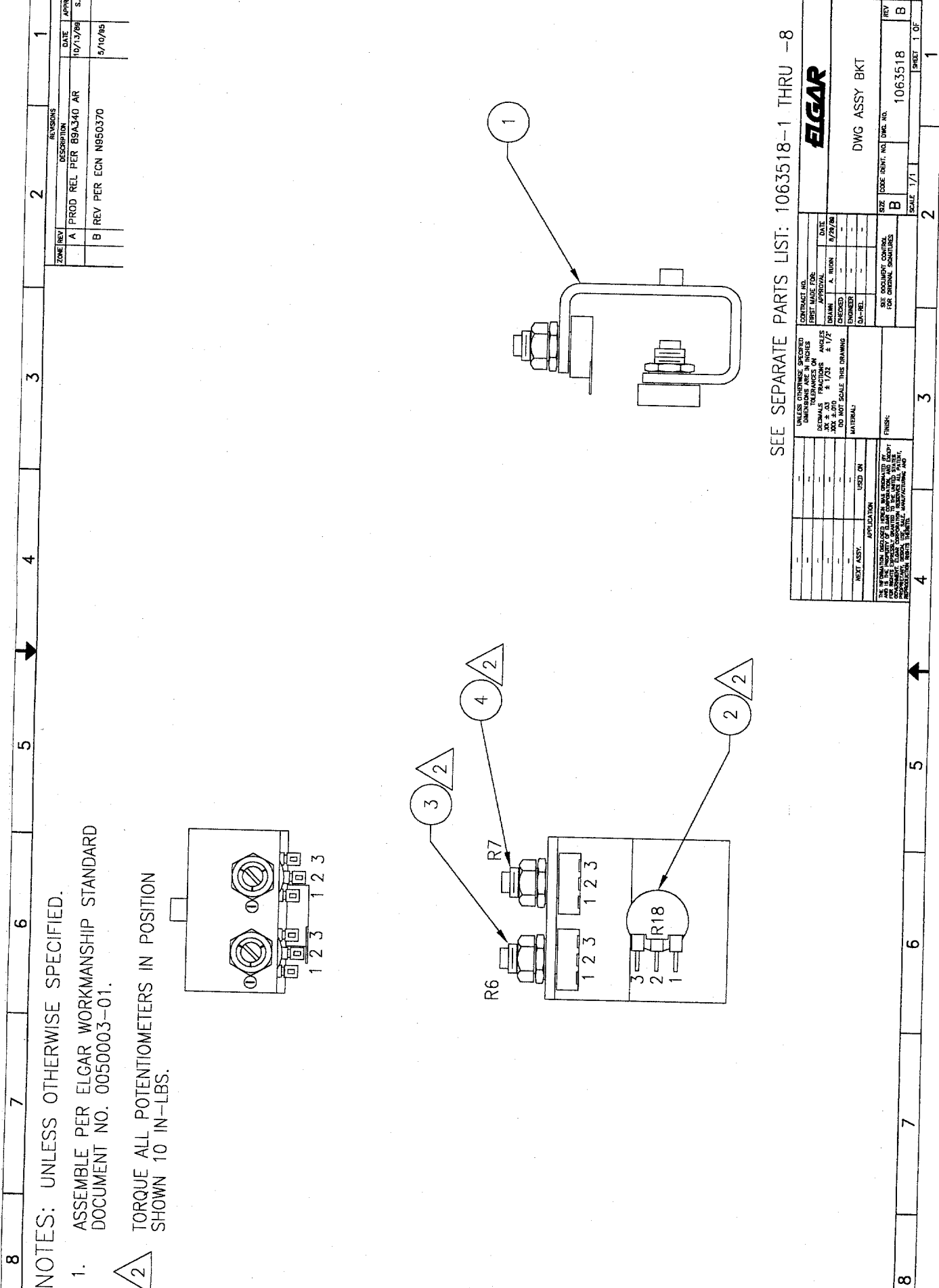

NOTES: UNLESS OTHERWISE SPECIFIED.

1. ASSEMBLE PER ELGAR WORKMANSHIP STANDARD DOCUMENT NO. 0050003-01.

2. ITEM 3 USED ONLY ON 1063865-4 AND -5.

3. REMOVE PROTECTIVE COVERING FROM INSULATED SURFACE OF PLATE BEFORE INSTALLING CAPACITORS ON ITEM #1.

4. DO NOT USE HARDWARE SUPPLIED WITH CAPACITORS.

5. SECURE CAPACITORS WITH TIEWRAPS WITHOUT DISTORTING CAPACITOR CASE. DO NOT OVER TIGHTEN.

6. TORQUE AS SPECIFIED ± 1 IN.-LBS. OR 10% WHICHEVER IS GREATER.

7. INSTALL NUTS FINGER TIGHT.

ZONE	REV	DESCRIPTION	DATE	APPROVED
A	REL TO PROD.	EO 90A340	AR 9/22/90	AR
B	REV PER EO	90A354	AR 10/26/90	AR
C	REV PER EO	90A398	AR 11/17/90	AR
D	REV PER EO	90A130	AR 3/9/90	AR
E	REV PER EO	90A198	AR 4/4/90	AR
F	CHANGE DASH LEVELS	NO AR 1/23/90	AR 1/23/90	AR
G	REV PER EO	90A591	AR 8/9/90	AR
H	REV PER EO	90A639	AR 8/17/90	AR
I	REV PER EO	90A753	JK 11/28/90	AR
J	REV PER EO	91A358	AR 8/29/91	AR
K	REV PER EON	NG60370	MS 5/10/95	AR
L	REVISED PER EON	NG50847	RAC 11/21/95	AR

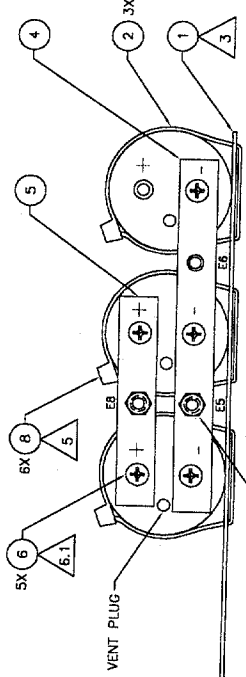

DETAIL "B" 1063865-2, -3, -12, -17

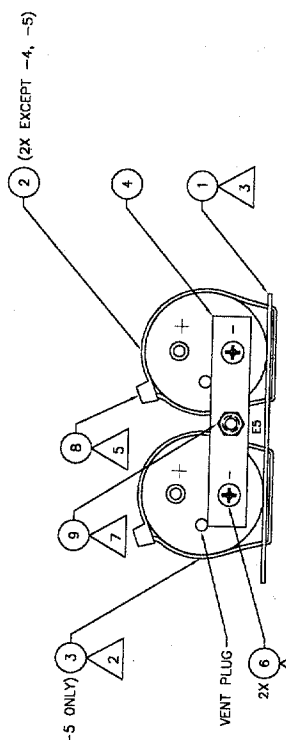

DETAIL "C" 1063865-4, -5, -6, -7, -14, -15

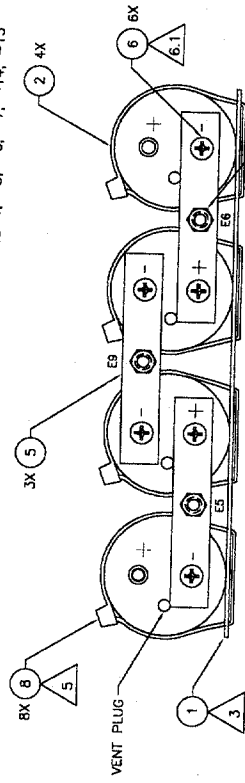

DETAIL "D" 1063865-8, -16

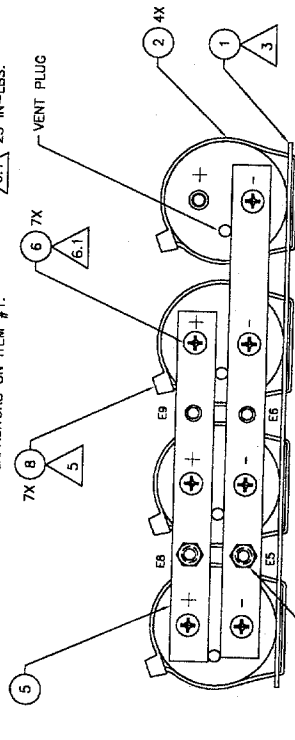

DETAIL "A" 1063865-1, -9

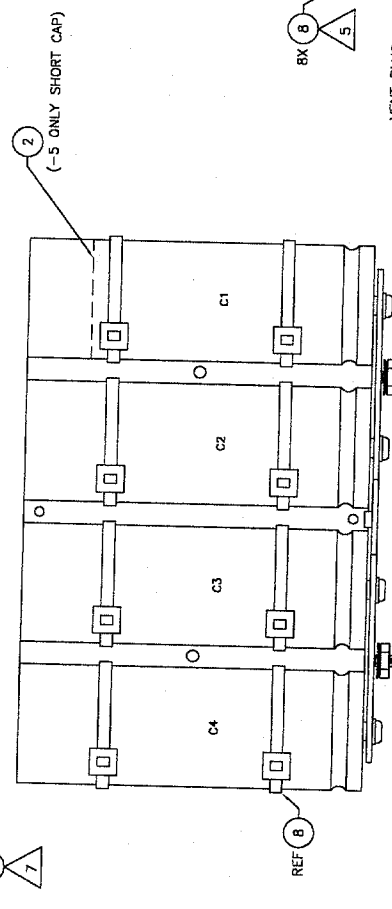

DETAIL "E" 1063865-10, -11, -13

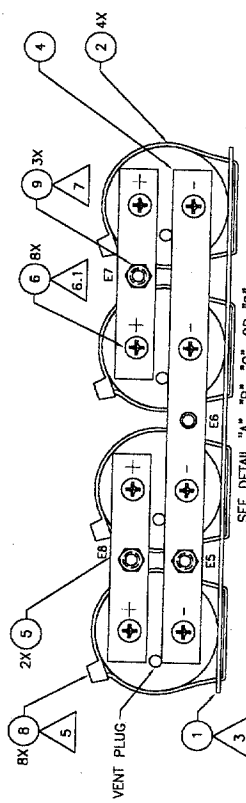

DETAIL "F" 1063865-11, -12, -18

SEE SEPARATE PARTS LIST

CONTRACT NO.		DATE	
FIRST APPROVAL		DATE	
DESIGNED	A. BLUM	CHECKED	8/22/90
ENGINEER		QA-REL.	
MATERIAL			
FINISH			
IF YOU HAVE ANY QUESTIONS CONCERNING THIS DRAWING, CONTACT THE DRAWING ENGINEER OR THE QUALITY CONTROL DEPARTMENT. THE QUALITY CONTROL DEPARTMENT IS NOT RESPONSIBLE FOR THE ACCURACY OF THE INFORMATION CONTAINED HEREIN.			
SEE DOCUMENT CONTROL FOR ORIGINAL SIGNATURES		SIZE	D
DWG. NO.		1063865	L
SCALE		1/1	1



DWG ASSY, CAP

REV	L
1063865	
1/1	
1	

ZONE	REV	DESCRIPTION	DATE	APPROVED
A	ORIGINATED		860412	
B	REVISED		860512	
C	REVISED		860907	
D	REVISED PER ECO	89A377	861118	
E	REVISED PER ECO	92A148	920400	
F	REVISED PER ECO	92A537	921002	
G	REVISED PER ECO	92A713	921108	
H	REVISED PER ECO	92A242	940630	
J	REVISED PER ECO	N940122	941213	
K	REV PER ECO	N940147	950510	
L	REV PER ECO	N950370	950512	
M	REV PER ECO	N950374	950602	ML
N	REVISED PER ECO	N960079	02/05/96	ML
P	REVISED PER ECO	N960100	03/11/96	ML
R	REVISED PER ECO	N960165	04/29/96	ML
T	REVISED PER ECO	N981232	12/4/98	STAPP

PIN 1 COMPONENT SIDE
PIN 29 FAR SIDE

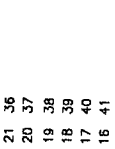
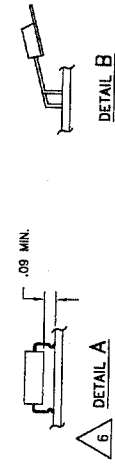
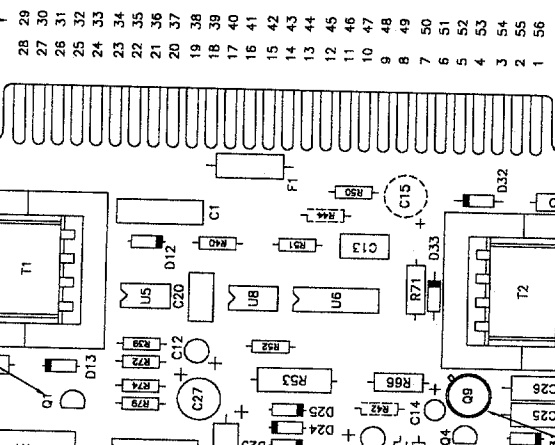

- NOTES: UNLESS OTHERWISE SPECIFIED.
- ASSEMBLE PER ELGAR WORKMANSHIP STANDARD DOCUMENT NO. 0050003-01.
 - REFERENCE SCHEMATIC NUMBER 1063006
 - ELECTRICAL COMPONENTS ARE KEYS TO PARTS LIST BY REFERENCE DESIGNATORS
 - INK STAMP APPROPRIATE REVISION LEVEL USING BLACK EPOXY INK
 - COMPONENTS SHOWN DASHED ARE TO BE INSTALLED AT ANOTHER ASSEMBLY DASH LEVEL
 - COMPONENTS 2W OR LARGER MUST BE ELEVATED WITH FORMED LEADS RESISTORS AFFECTED ARE R1, R4, R5, R16, R33, R48, R53 AND R76, AND F1 ALSO (SEE DETAIL A)
 - REMOVE Q1 ON -XM61 VERSION.

ELECTROSTATIC DISCHARGE CONTROL PROGRAM FOR PROTECTION OF ELECTRICAL AND ELECTRONIC PARTS, ASSEMBLIES AND EQUIPMENT PER IP 0460007-01.

SEE SEPARATE PARTS LIST : 1063005-XXX

		ASSEMBLY, PCB DCRB CONTROL BOARD	
CONTRACT NO. FIRST MADE FOR	DATE DRAWN CHECKED ENGINEER APP'G QTY-REL.	SIZE CODE IDENT. NO. DWG. NO.	REV T
UNLESS OTHERWISE SPECIFIED DIMENSIONS ARE IN INCHES DECIMALS TOLERANCES ON .010 & .015 ± 1/32 ± 1/32 ± 1/32 DO NOT SCALE THIS DRAWING	MATERIAL	SCALE 2/1	SHEET 1 OF 1
NEXT ASST.	USED ON	FINISH:	1063005

106 SEE DETAIL "C"

SEE DETAIL "D"

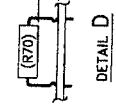
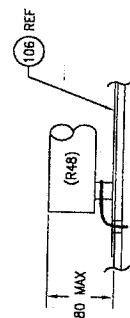

- 3. SELECT P/L DASH LEVEL
- 4. BASIC ASSEMBLY P/L NUMBER
- 4. BASIC ASSEMBLY DWG. REV. LEVEL
- 4. BASIC PL. REV. LEVEL
- 4. SELECT P/L REV. LEVEL
- 4. ASSEMBLER'S STAMP



ZONE	REV	DESCRIPTION	DATE	APPROVED
A	REL TO MANUFAC.		AR 8/9/90	
B	REL PER ECO 91A		WMS 4/30/91	
C	REV PER ECO 91A169		DJ 9/27/91	
D	REV PER ECO 92A454		JM 8/22/92	
E	REV PER ECO 92A827		DM 10/12/92	
F	REV PER ECO 94A242		AR 8-30-94	
G	REVISED PER ECN N940122		RC 941214	
H	REVISED PER ECN N950370		MS 5/10/95	
J	REVISED PER ECN N950818		RAC 11/21/95	
K	REVISED PER ECN N970377		CS 5/12/97	

- NOTES: UNLESS OTHERWISE SPECIFIED.
- ASSEMBLE PER ELGAR WORKMANSHIP STANDARD DOCUMENT NO. 0050003-01.
 - R20 AND R26 (ITEMS 5 AND 29) ARE USED ON -7 AND -8 MODELS ONLY.
 - TEXT IN PARENTHESES () REFERENCES WIRE LISTS AND SCHEMATICS.
 - BOTH NUTS: FINGER TIGHT.

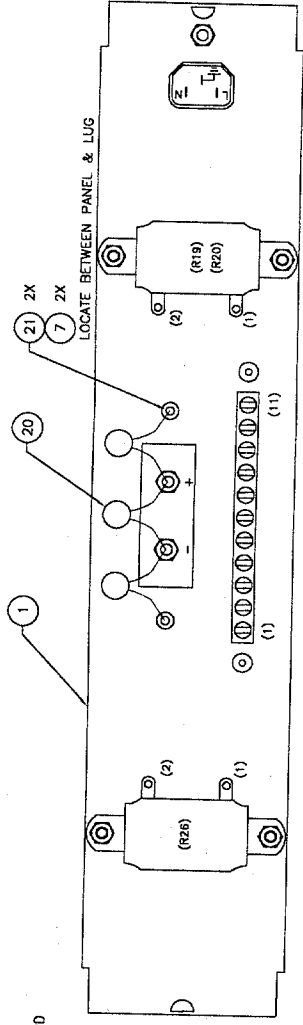

INSIDE VIEW

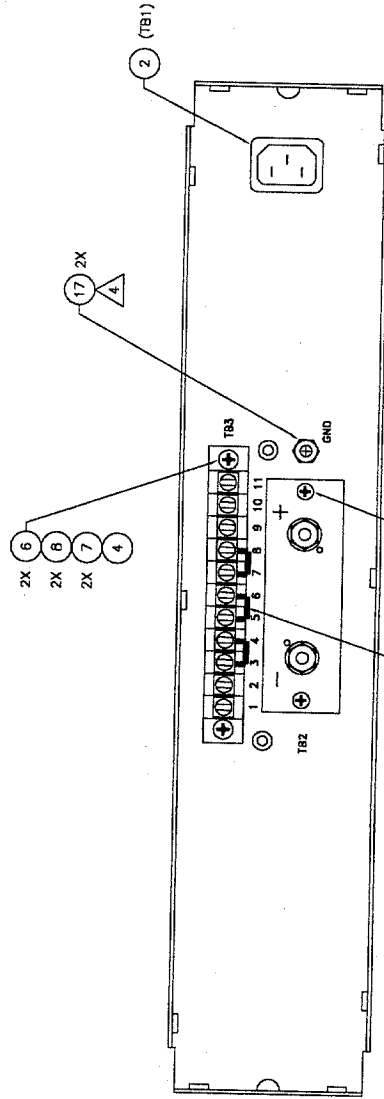
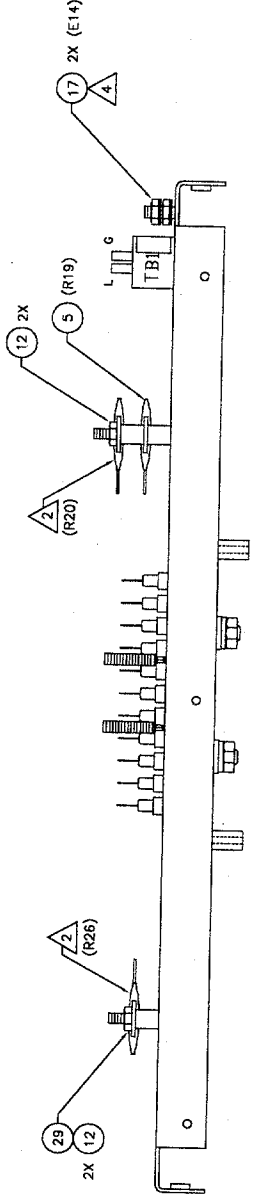

OUTSIDE VIEW

SEE SEPARATE PART LISTS: 1064468-1 THRU -8

ELGAR

DWG ASSY REAR PANEL

SIZE: CODE IDENT. NO. DWG. NO. 1064468

D 25965

SCALE: 1/1

SHEET 1 OF 1

CONTRACT NO.	DATE
DRAWN	4/19/90
CHECKED	
ENGINEER	
QA-REL.	
MATERIAL	
APPLICATION	
USED ON	
FINISH	

UNLESS OTHERWISE SPECIFIED DIMENSIONS ARE IN INCHES DECIMALS FRACTIONS ± 1/32 ± 1/2 DO NOT SCALE THIS DRAWING

IF DIMENSIONS ARE NOT SPECIFIED, DIMENSIONS ARE TO BE TAKEN FROM THE CENTER OF THE PART UNLESS OTHERWISE SPECIFIED.

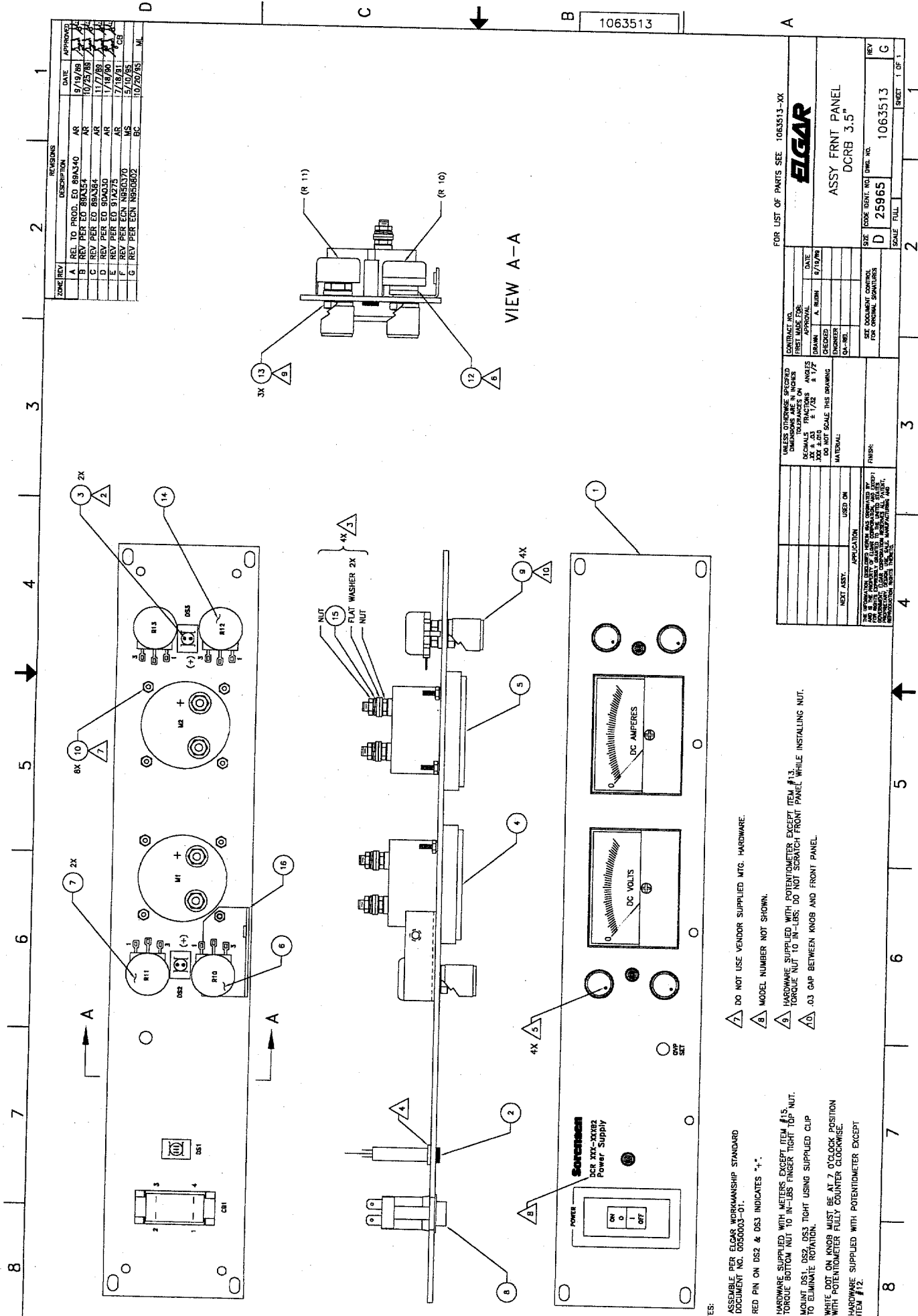

ZONE	REV	DESCRIPTION	REVISIONS	DATE	APPROVED
A	REL TO PROD	EO 88A340	AR	9/19/88	[Signature]
B	REV PER	EO 88A342	AR	10/25/88	[Signature]
C	REV PER	EO 88A364	AR	11/7/88	[Signature]
D	REV PER	EO 90A030	AR	7/19/90	[Signature]
E	REV PER	EO 91A275	AR	7/19/91	[Signature]
F	REV PER	EON N85A0370	MS	5/10/93	[Signature]
G	REV PER	EON N850602	EC	10/20/93	[Signature]

1063513

VIEW A-A

FOR LIST OF PARTS SEE 1063513-XX



ASSY FRNT PANEL
DCRB 3.5"

CONTRACT NO.	DATE	APPROVAL
FIRST MADE FOR	DATE	APPROVAL
DRAWN	DATE	APPROVAL
CHECKED	DATE	APPROVAL
ENGINEER	DATE	APPROVAL
UP-DEL.	DATE	APPROVAL

UNLESS OTHERWISE SPECIFIED DIMENSIONS SHALL BE IN INCHES DECIMALS FRACTIONS OR ANGLES SHALL BE TO 1/32 ± 1/2 DO NOT SCALE THIS DRAWING MATERIAL:

FINISH:

SEE DRAWING FOR DIMENSIONS FOR ORIGINAL SIZES

SCALE FULL

REV D 1063513

SHEET 1 OF 1

- NOTES:
- ASSEMBLE PER ELGAR WORKMANSHIP STANDARD DOCUMENT NO. 0550003-01.
 - RED PIN ON DS2 & DS3 INDICATES "+".
 - HARDWARE SUPPLIED WITH METERS EXCEPT ITEM #15. TORQUE BOTTOM NUT TO IN-LBS FINGER TIGHT TOP NUT.
 - MOUNT DS1, DS2, DS3 TIGHT USING SUPPLIED CLIP TO ELIMINATE ROTATION.
 - WHITE DOT ON KNOB MUST BE AT 7 O'CLOCK POSITION WITH POTENTIOMETER FULLY COUNTER CLOCKWISE.
 - HARDWARE SUPPLIED WITH POTENTIOMETER EXCEPT ITEM #12.
 - DO NOT USE VENDOR SUPPLIED MTG. HARDWARE.
 - MODEL NUMBER NOT SHOWN.
 - HARDWARE SUPPLIED WITH POTENTIOMETER EXCEPT TORQUE NUT TO IN-LBS; DO NOT SCRATCH FRONT PANEL WHILE INSTALLING NUT.
 - .03 GAP BETWEEN KNOB AND FRONT PANEL.

ZONE REV	REVISIONS	DATE	APPROVED
SEE SHEET 1	DESCRIPTION		

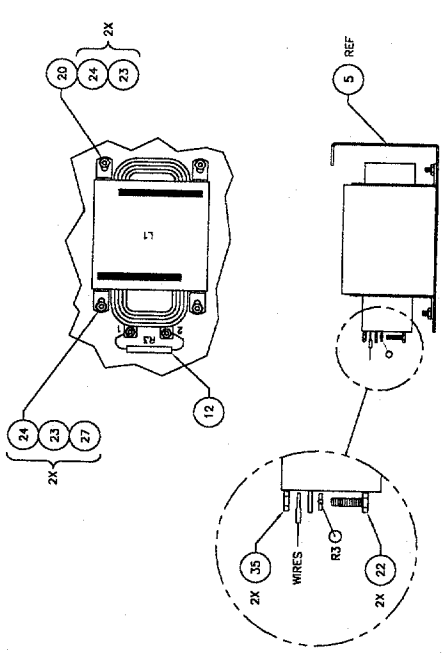

VIEW C 15 18
SCALE: 1/1

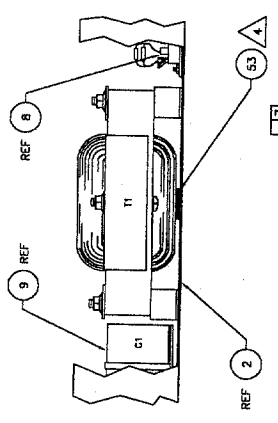

VIEW F-F 17 18
ROTATED AS REQUIRED

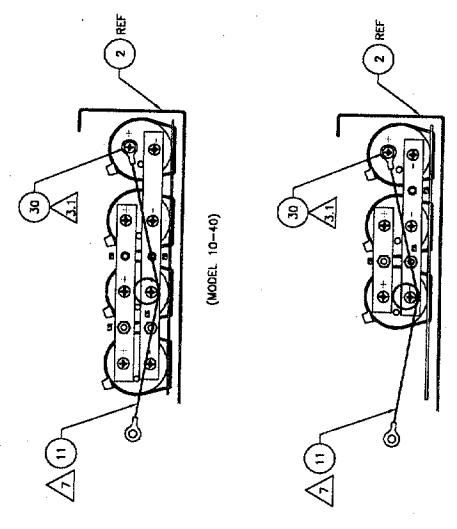

(MODELS 20-25 & 40-13)

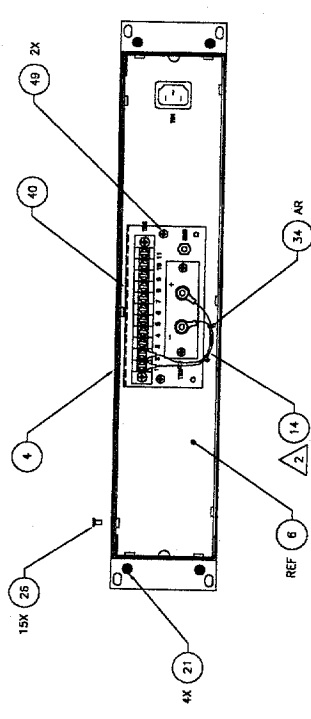

VIEW D-D 18 18
ROTATED AS REQUIRED

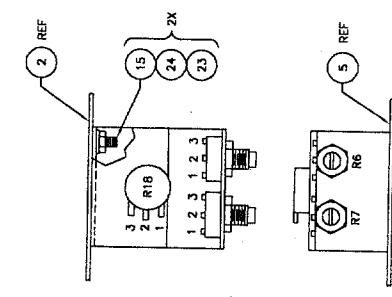

VIEW B 16 16
SCALE: 1/1

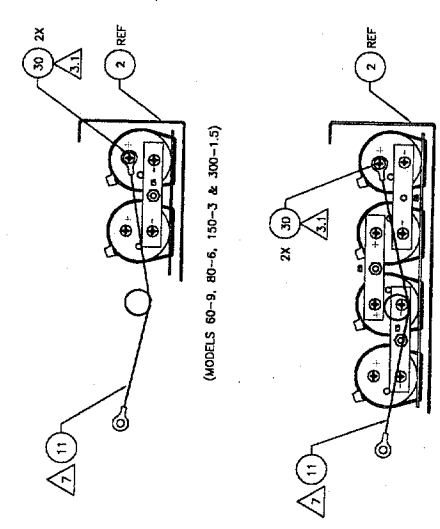

(MODELS 60-9, 80-6, 150-3 & 300-1.5)

VIEW E-E 12 12
ROTATED AS REQUIRED

1063829

SIZE	CODE IDENT. NO.	DWG. NO.	REV
D	25965	1063829	U
SCALE	1/2		SHEET 2 OF 2

1 2 3 4 5 6 7 8

ZONE	REV	REVISIONS	DATE	APPROVED
N		REDRAW FOR CLARITY	RC 5/7/95	
P		REV PER ECN N950370	MS 5/10/95	
R		REV PER ECN N950309	DR 8/2/95	ML
T		REV PER ECN N950619	DR 9/18/95	ML
U		REVISED PER ECN N010606	JPM 4/12/02	G. Stapp

NOTES: UNLESS OTHERWISE SPECIFIED.

- ASSEMBLE PER ELDAR WORKMANSHIP STANDARD DOCUMENT NO. 0050003-01.
- FOR WIRING TERMINATIONS OF ITEM 13 & 14, SEE TABLE 1.
- TORQUE AS SPECIFIED ±1 IN.-LBS OR 10X WHICHEVER IS GREATER.
 - ▲1 10 IN.-LBS.
- ALIGN UP TO 3 PIECES OF ACRYLIC FOAM (APPROX. 1" SQ.) ON TOP OF EACH OTHER AND STICK ONTO THE CHASSIS RIB, CENTERED UNDER TRANSFORMER.

▲5 USE ON -7 (300-1.5), & -8 (600-75) ONLY.
 ▲6 APPLY SPOT OF RTV TO P2 CHASSIS.
 ▲7 LOCATE SHUNT ASSY FROM C1 (+) TO TB2 (+).
 ▲8 USE ON -1 (10-40), -2 (20-25) & -8 (600-75) ONLY.

▲9 APPLY A THIN LAYER OF THERMAL GREASE, ITEM 39 BEFORE INSTALLATION OF THE RECTIFIER, ITEM 18.

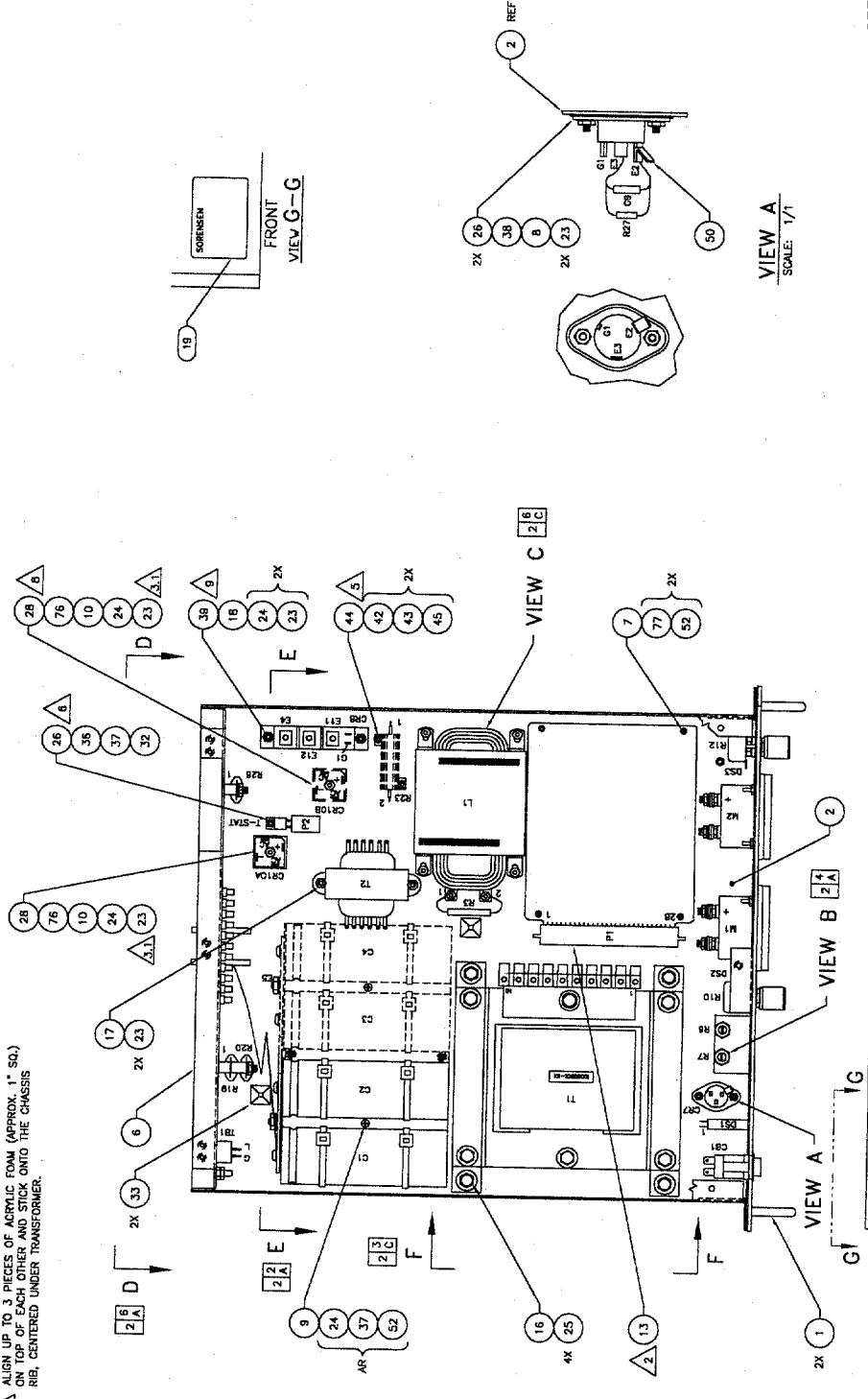

TABLE 1

WIRING DIAGRAM MODEL	WIRING DIAGRAM
10-40	W300178-01
20-25	W300177-01
40-13	W300177-01
60-3	W300178-01
80-8	W300178-01
150-3	W300178-01
300-1.5	W300178-01
600-75	W300184-01

SEE SEPARATE PARTS LIST 1063829-1 THRU -8

ELGAR

DWG ASSY FINAL, DCRB2 3.5"

CONTRACT NO. _____ DATE _____
 DRAWN BY A. RICHIN 9/22/06
 CHECKED BY _____
 ENGINEER _____
 QA-REL. _____

UNLESS OTHERWISE SPECIFIED DIMENSIONS ARE IN INCHES
 DECIMALS FRACTIONS ON ANGLES
 XX ± .03 ± 1/32 ± 1/2
 DO NOT SCALE THIS DRAWING

MATERIAL: _____
 USED ON: _____
 APPLICATION: _____

THIS INFORMATION AND DATA ARE CONTROLLED BY THE MANUFACTURING AND SERVICE DEPARTMENT OF ELGAR ELECTRONICS CORPORATION. NO PARTS, INFORMATION, OR DATA ARE TO BE RELEASED TO ANY OTHER MANUFACTURING AND SERVICE DEPARTMENT WITHOUT THE WRITTEN PERMISSION OF THE MANUFACTURING AND SERVICE DEPARTMENT.

SEE DOCUMENT CONTROL FOR ORIGINAL SIGNATURES

SIZE CODE IDENT. NO. DWG. NO. 1063829 U
 D 25965

SCALE: 1/2 SHEET 1 OF 2

NOTES: UNLESS OTHERWISE SPECIFIED,
 1. ALL CAPACITORS IN MFD'S UNLESS OTHERWISE SPECIFIED.
 2. ALL RESISTORS IN OHMS AND 1/4W ±1% UNLESS OTHERWISE SPECIFIED.
 3. THESE COMPONENTS ARE ADDED BY SORENSEN, DEPENDING ON MODEL.
 4. NUMBERS IN PARENTHESES ARE FOR THE LM317H, NUMBERS NOT IN PARENTHESES ARE FOR THE LM317T.
 5. NEXT AVAILABLE DESIGNATORS ARE: R80,C28,D40,Q10,U9,T3,SW2,TB4,F2
 6. DESIGNATORS NOT USED ARE: TB1,TB2.

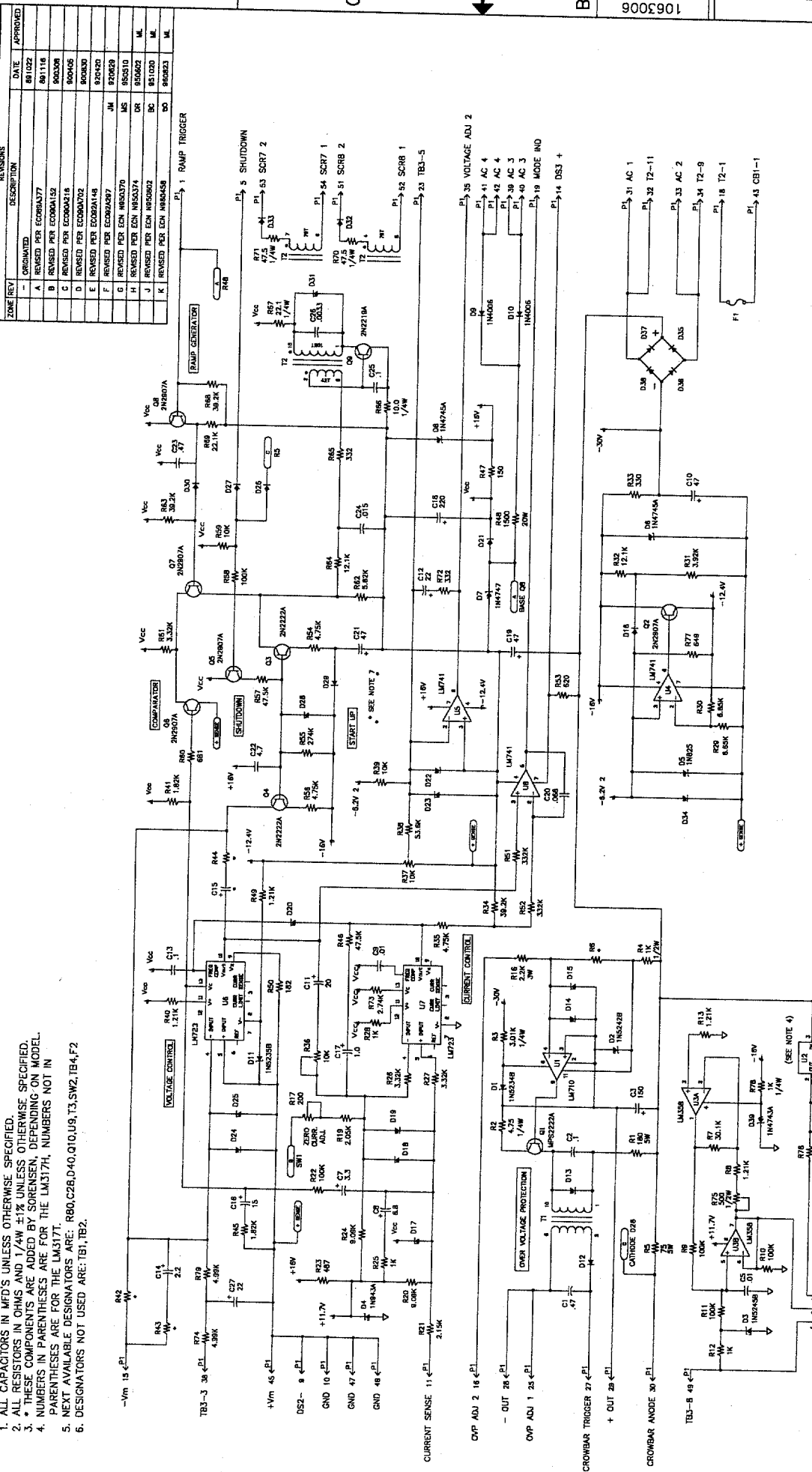

ZONE	REV	DESCRIPTION	REVISIONS	DATE	APPROVED
A	1	ORIGINATED		08/10/22	
B	1	REVISED PER ECOM04377		08/11/18	
C	1	REVISED PER ECOM04152		08/03/09	
D	1	REVISED PER ECOM04118		08/04/05	
E	1	REVISED PER ECOM04702		08/03/00	
F	1	REVISED PER ECOM04948		08/04/00	
G	1	REVISED PER ECOM04987		08/06/09	
H	1	REVISED PER ECOM04370		08/05/10	
I	1	REVISED PER ECOM04374		08/06/02	
J	1	REVISED PER ECOM04502		08/10/00	
K	1	REVISED PER ECOM04548		08/09/23	

SCHEMATIC BOARD
DCRB CONTROL BOARD

CONTRACT NO. DATE DRAWN BY CHECKED BY ENGINEER QA-REL.	DESIGNED BY APPROVAL DATE J.R. MARCH B. KOSMANA B. KOSMANA	SIZE CODE IDENT. NO. DIM. NO.	REV SHEET 1 OF 1
UNLESS OTHERWISE SPECIFIED DIMENSIONS ARE IN INCHES DECIMALS ARE IN THIRDS XX ± .03 FRACTIONS XX ± 1/32 ± 1/32 DO NOT SCALE THIS DRAWING		SEE DOCUMENT CONTROL FOR ORIGINAL SIGNATURES	
MATERIAL USED ON APPLICATION		FINISH	

CONTRACT NO. _____

DATE _____

DRAWN BY _____

CHECKED BY _____

ENGINEER _____

QA-REL. _____

DESIGNED BY _____

APPROVAL _____

DATE _____

J.R. MARCH

B. KOSMANA

B. KOSMANA

SIZE _____

CODE IDENT. NO. _____

DIM. NO. _____

REV _____

SHEET 1 OF 1

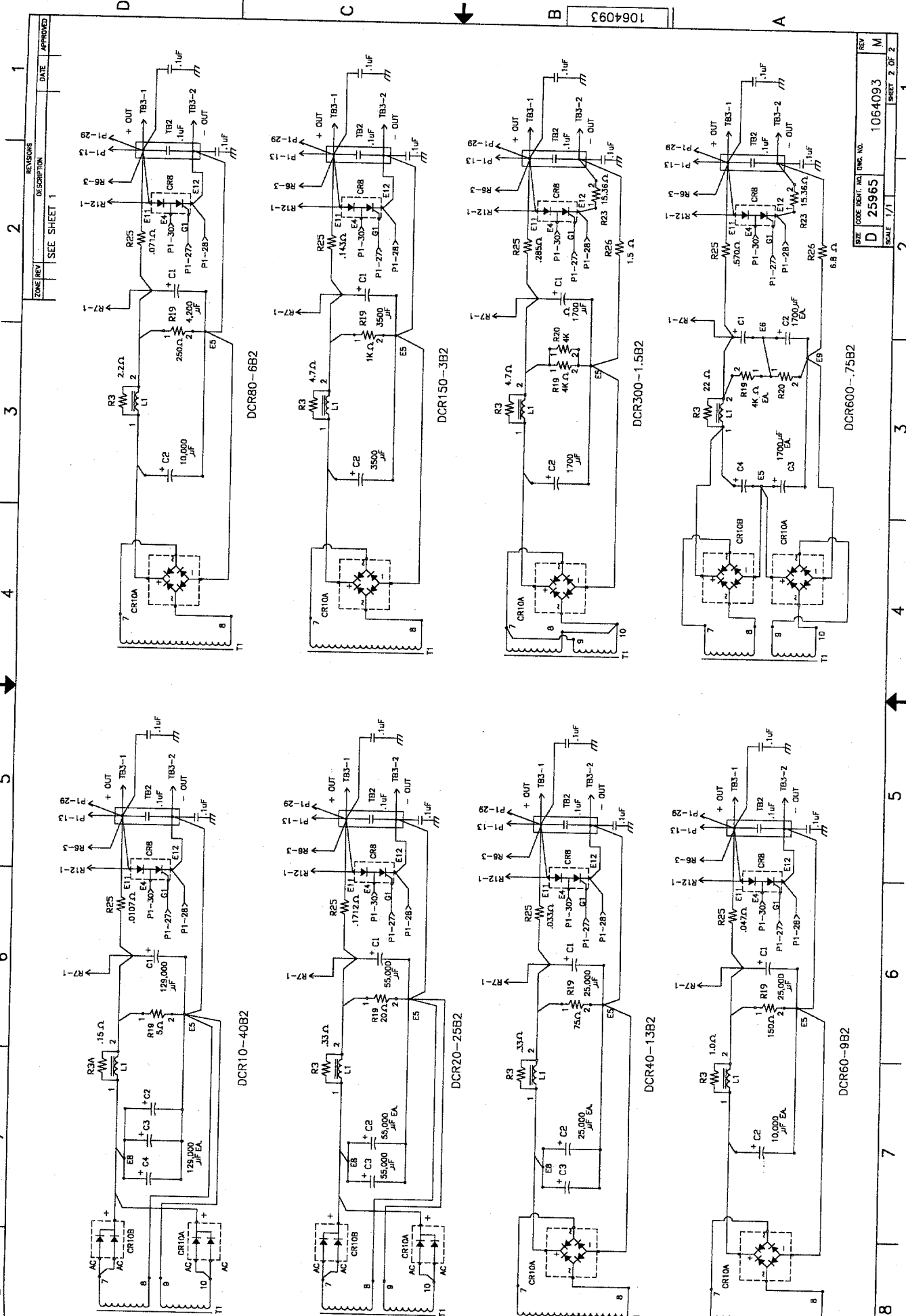

ZONE REV SEE SHEET 1 DESCRIPTION DATE APPROVED
 1
 2
 3
 4
 5
 6
 7
 8

1064093
 A
 B
 C
 D

SIZE CODE WEIGHT. NO. DIM. NO. 1064093
 D 25965
 SCALE 1/1
 SHEET 2 OF 2

1
 2
 3
 4
 5
 6
 7
 8

ZONE	REV	DESCRIPTION	DATE	APPROVED
A	REL PER E.O. 904093	AR	8/17/90	
B	REVISED	AR	9/4/90	
C	REV PER E.O. 90460A	AR	8/7/90	
D	REV PER E.O. 904690	AR	8/24/90	
E	NO E.O. FIXED LINE	AR	8/9/90	
F	REV PER E.O. 904721	JK	11/13/90	
G	REV PER E.O. 91A222	AR	8/18/91	
H	REV PER E.O. 91A358	AR	8/29/90	
I	REV PER E.O. 91A169	DJ	10/17/91	
J	REV PER E.O. 92A238	JRM	6/16/92	
K	REV PER E.O. N950370	MS	5-10-85	ML
L	REV PER E.O. N960458	MS	8-23-88	ML
M	REV PER E.O. N970377	MS	8-13-87	ML
N	REV PER E.O. N981060	MS	1/9/89	STAPP

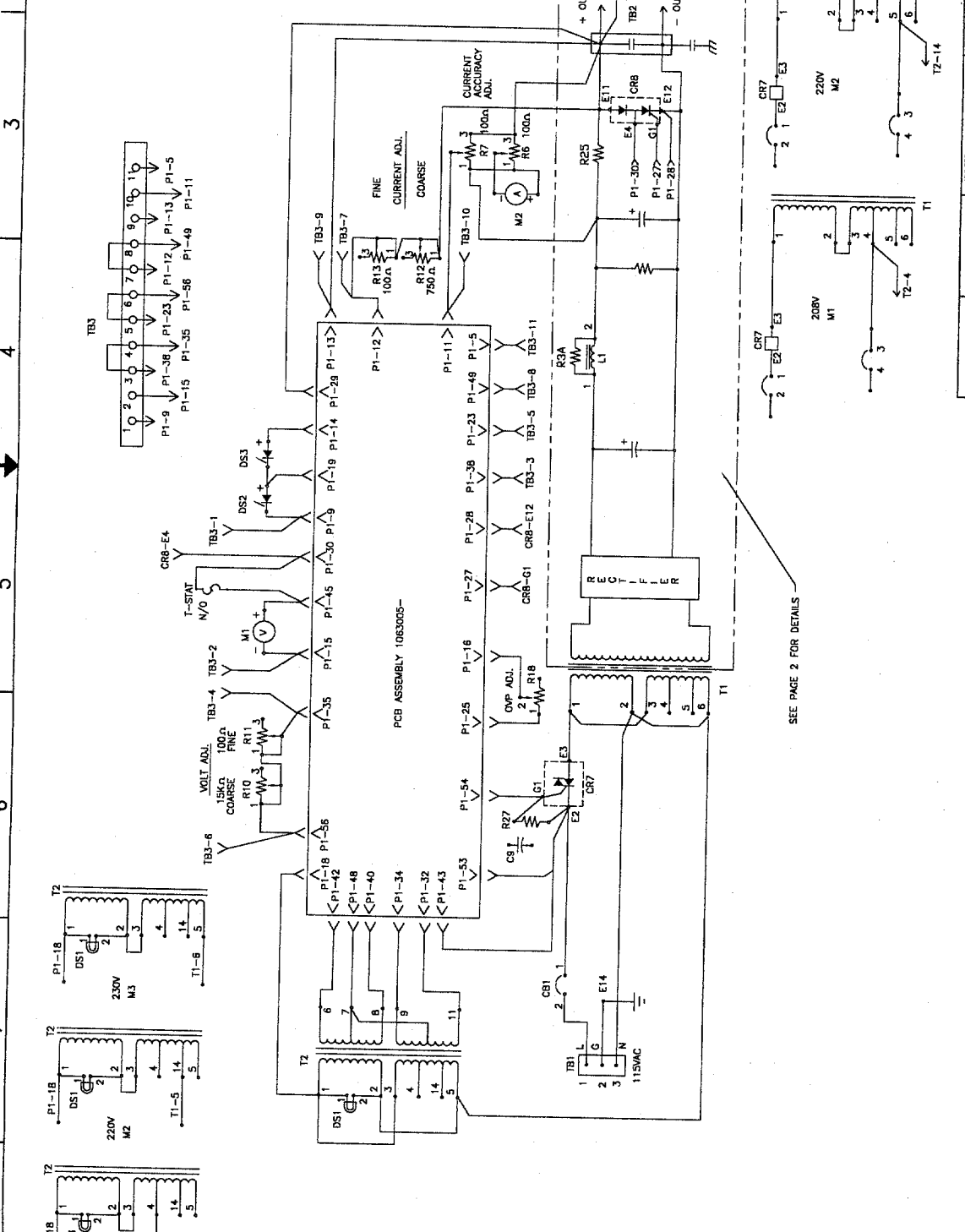

1064093

FIGAR

SCHMATIC, WIRING
DCRB 500W

CONTRACT NO. _____
 DRAWN BY: A. RUDON
 CHECKED: _____
 DATE: 11/20/88
 APPROVAL: _____

UNLESS OTHERWISE SPECIFIED
 DIMENSIONS ARE IN INCHES
 DECIMALS FRACTIONS ± 1/32
 ANGLES ± 1/2°
 DO NOT SCALE THIS DRAWING
 MATERIAL: _____
 USED ON: _____

SEE DOCUMENT CONTROL
 FOR ORIGINAL SIGNATURES

SIZE: D 25965
 SCALE: 1/1

REV: M
 1064093

SHEET 1 OF 2

NOTES: UNLESS OTHERWISE SPECIFIED.
 1. ALL DIMENSIONS ARE IN INCHES (mm).
 2. SLIDE-RAIL OPTION AVAILABLE.

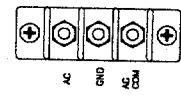
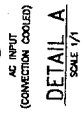
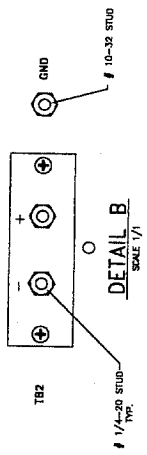
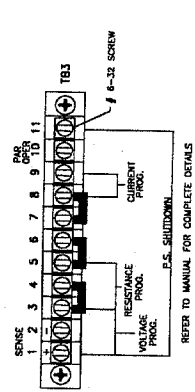
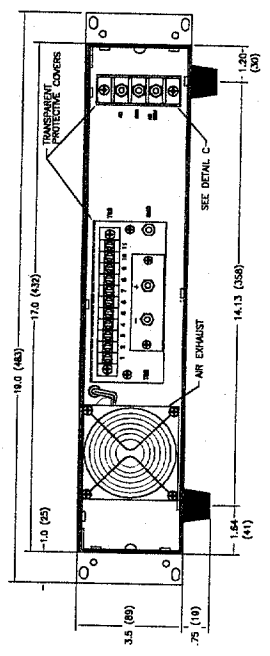
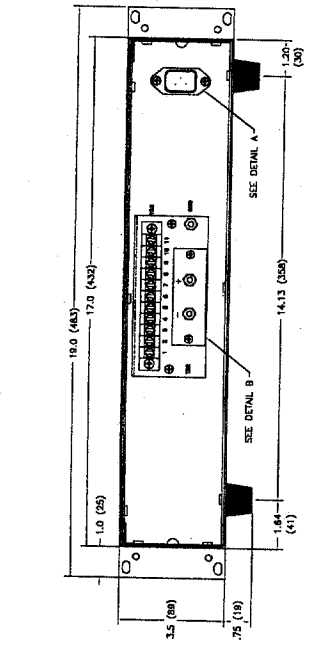
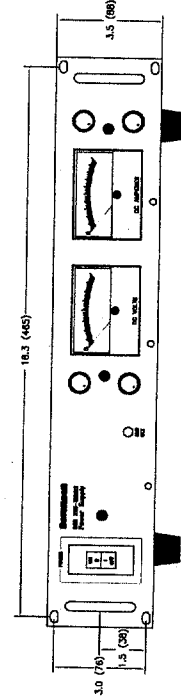
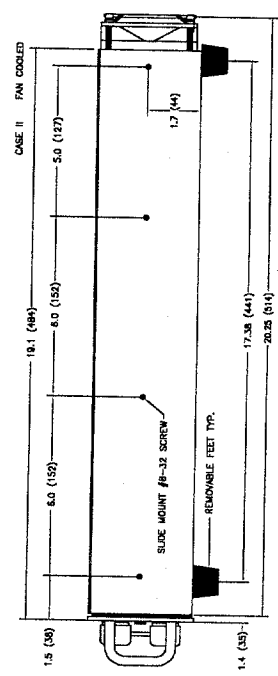
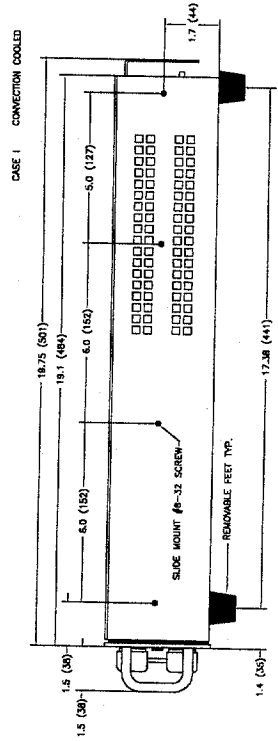

ZONE	REV	DESCRIPTION	DATE	APPROVED
A	1	REDRAW FOR CLARITY	4/4/95	MS
B	1	REV PER EGN N850370	5/10/95	MS

UNLESS OTHERWISE SPECIFIED, DIMENSIONS ARE IN INCHES (mm) AND TOLERANCES ON ANGLES SHALL BE 1/2° ± 1/2° UNLESS OTHERWISE SPECIFIED.		CONTRACT NO.	
SCALE	1/2	1063996	1063996
DATE	19/13/98	DATE	19/13/98
DRAWN	A. RYON	APPROVAL	
CHECKED		DESIGNED	
INCHES		FINISHED	
DI-MET		DI-MET	
MATERIAL:		SEE REQUIR'D. CONTROLS FOR ORIGINAL QUANTITIES	
FINISH:			
TEST ASSY.	DEREF		
USED ON	APPLICATION		
<p>THE INFORMATION CONTAINED HEREIN IS THE PROPERTY OF ELGAR CORPORATION AND IS NOT TO BE REPRODUCED OR TRANSMITTED IN ANY FORM OR BY ANY MEANS, ELECTRONIC OR MECHANICAL, INCLUDING PHOTOCOPYING, RECORDING, OR BY ANY INFORMATION STORAGE AND RETRIEVAL SYSTEM, WITHOUT THE WRITTEN PERMISSION OF ELGAR CORPORATION.</p>			

ELGAR

DWG OUTLINE
DCRB2 3.5"

REV	DESCRIPTION	DATE	APPROVED
D	25965		
B	1063996		

ZONE REV	REVISIONS	DATE	APPROVED
	DESCRIPTION		
	SEE SHEET 1		

PCB CONTROL ASSY DRAWING NUMBER	500W	1000W
R04	DCR10-40B2	DCR10-40B2
R05	DCR20-25B2	DCR20-25B2
R06	DCR40-13B2	DCR40-13B2
R07	DCR60-9B2	DCR60-9B2
R08	DCR80-6B2	DCR80-6B2
R09	DCR100-13B2	DCR100-13B2
R10	DCR150-3B2	DCR150-3B2
R11	DCR200-25B2	DCR200-25B2
R12	DCR300-13B2	DCR300-13B2
R13	DCR400-9B2	DCR400-9B2
R14	DCR500-6B2	DCR500-6B2
R15	DCR600-4B2	DCR600-4B2
R16	DCR700-2B2	DCR700-2B2
R17	DCR800-1B2	DCR800-1B2
R18	DCR900-1B2	DCR900-1B2
R19	DCR1000-1B2	DCR1000-1B2
R20	DCR1100-1B2	DCR1100-1B2
R21	DCR1200-1B2	DCR1200-1B2
R22	DCR1300-1B2	DCR1300-1B2
R23	DCR1400-1B2	DCR1400-1B2
R24	DCR1500-1B2	DCR1500-1B2
R25	DCR1600-1B2	DCR1600-1B2
R26	DCR1700-1B2	DCR1700-1B2
R27	DCR1800-1B2	DCR1800-1B2
R28	DCR1900-1B2	DCR1900-1B2
R29	DCR2000-1B2	DCR2000-1B2
R30	DCR2100-1B2	DCR2100-1B2
R31	DCR2200-1B2	DCR2200-1B2
R32	DCR2300-1B2	DCR2300-1B2
R33	DCR2400-1B2	DCR2400-1B2
R34	DCR2500-1B2	DCR2500-1B2
R35	DCR2600-1B2	DCR2600-1B2
R36	DCR2700-1B2	DCR2700-1B2
R37	DCR2800-1B2	DCR2800-1B2
R38	DCR2900-1B2	DCR2900-1B2
R39	DCR3000-1B2	DCR3000-1B2
R40	DCR3100-1B2	DCR3100-1B2
R41	DCR3200-1B2	DCR3200-1B2
R42	DCR3300-1B2	DCR3300-1B2
R43	DCR3400-1B2	DCR3400-1B2
R44	DCR3500-1B2	DCR3500-1B2
R45	DCR3600-1B2	DCR3600-1B2
R46	DCR3700-1B2	DCR3700-1B2
R47	DCR3800-1B2	DCR3800-1B2
R48	DCR3900-1B2	DCR3900-1B2
R49	DCR4000-1B2	DCR4000-1B2
R50	DCR4100-1B2	DCR4100-1B2
R51	DCR4200-1B2	DCR4200-1B2
R52	DCR4300-1B2	DCR4300-1B2
R53	DCR4400-1B2	DCR4400-1B2
R54	DCR4500-1B2	DCR4500-1B2
R55	DCR4600-1B2	DCR4600-1B2
R56	DCR4700-1B2	DCR4700-1B2

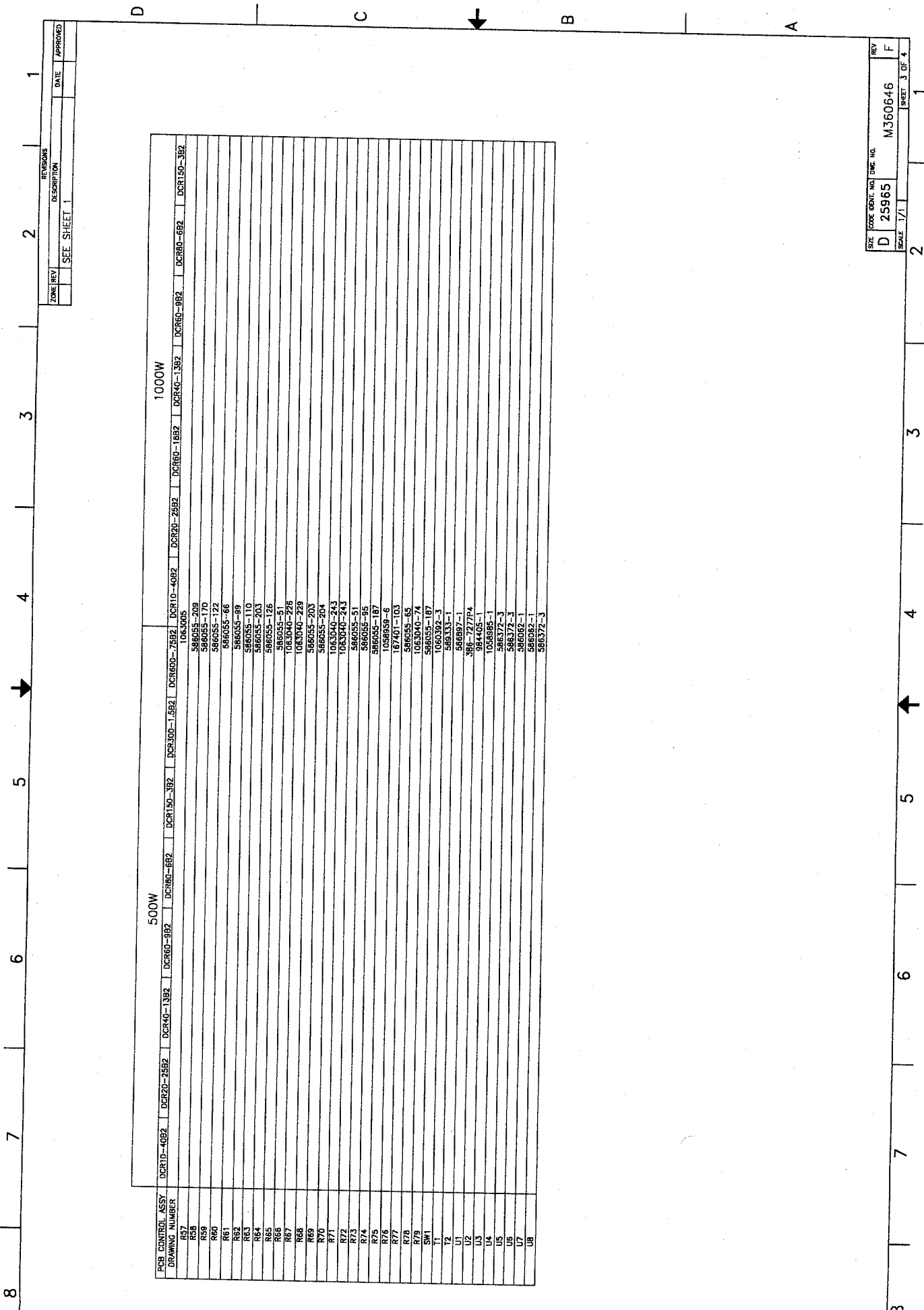

ZONE REV	REVISIONS
SEE SHEET 1	DESCRIPTION
	DATE
	APPROVED

FOR CONTROL ASST DRAWING NUMBER	DCR10-40B2	DCR20-25B2	DCR40-13B2	DCR60-9B2	DCR80-6B2	DCR150-3B2	DCR300-1.5B2	DCR600-75B2	DCR10-40B2	DCR20-25B2	DCR60-18B2	DCR140-1.3B2	DCR260-9B2	DCR480-6B2	DCR150-3B2
R57								1053005							
R58								586055-209							
R59								586055-170							
R60								586055-172							
R61								586055-86							
R62								586055-89							
R63								586055-110							
R64								586055-203							
R65								586055-126							
R66								1053005-208							
R67								1053005-208							
R68								586055-203							
R69								586055-204							
R70								1053005-204							
R71								1053005-243							
R72								586055-86							
R73								586055-86							
R74								586055-86							
R75								1053005-187							
R76								1053005-187							
R77								167401-103							
R78								586055-85							
R79								1053005-74							
SW1								586055-187							
T2								1053005-3							
T2								586055-1							
U1								586055-1							
U2								386-7277P4							
U3								984405-1							
U4								1053005-1							
U5								586055-3							
U6								586055-3							
U7								586055-1							
U8								586055-1							

1000W

500W

SIZE	CODE	IDENT.	AND	DATE	NO.	REV
D	25965					F
SCALE	1/1					
						M360646
						SHEET 3 OF 4

NOTES: UNLESS OTHERWISE SPECIFIED.

ZONE	REV	REVISIONS	DATE	APPROVED
B		REVISED PER ECN N970566A	11/6/97	ML
C		REVISED PER ECN N960442	6/1/96	STAPP
D		REVISED PER ECN N981060	1/5/99	STAPP
E		REVISED PER ECN N990014	2/2/99	STAPP
F		REVISED PER ECN N000297	1/7/99	G. Stupp

FINAL ASSY DRAWING NUMBER	DCR10-4082	DCR20-2592	DCR40-1382	DCR60-682	DCR80-1582	DCR300-382	DCR150-682	DCR300-382	DCR600-1582
CR7									
CR8									
CR9									
CR10A									
CR10B									
L1									
L2									
L3									
T-STAT									
FRONT PANEL ASSY DRAWING NUMBER	DCR10-4082	DCR20-2592	DCR40-1382	DCR60-682	DCR80-1582	DCR300-382	DCR150-682	DCR300-382	DCR600-1582
CS1									
CS2									
CS3									
M1									
M2									
M10									
R12									
R13									
REAR PANEL ASSY DRAWING NUMBER	DCR10-4082	DCR20-2592	DCR40-1382	DCR60-682	DCR80-1582	DCR300-382	DCR150-682	DCR300-382	DCR600-1582
R19									
R20									
R26									
RESISTOR ASSY DRAWING NUMBER	DCR10-4082	DCR20-2592	DCR40-1382	DCR60-682	DCR80-1582	DCR300-382	DCR150-682	DCR300-382	DCR600-1582
R3									
CAP ASSY DRAWING NUMBER	DCR10-4082	DCR20-2592	DCR40-1382	DCR60-682	DCR80-1582	DCR300-382	DCR150-682	DCR300-382	DCR600-1582
C1									
C2									
C3									
C4									
C5									
C6									
C7									
PCB CONTROL ASSY DRAWING NUMBER	DCR10-4082	DCR20-2592	DCR40-1382	DCR60-682	DCR80-1582	DCR300-382	DCR150-682	DCR300-382	DCR600-1582
C1									
C2									
C3									
C4									
C5									
C6									
C7									

CONTRACT NO. _____
 FIRST MADE PER _____
 APPROVAL _____
 DATE _____

DESIGNER _____
 CHECKED _____
 ENGR. _____
 DATE _____

SCALE 1/1

SIZE CODE DENT. NO. DIM. NO. M360646

REV F

SHEET 1 OF 4

REPLACEMENT PARTS 500/1000W

ELGAR

REVISIONS

DATE

DESCRIPTION

APPROVED

DATE

DESCRIPTION

APPROVED

DATE

DESCRIPTION

APPROVED

UNLESS OTHERWISE SPECIFIED, DIMENSIONS ARE IN INCHES. TOLERANCES ON DIMENSIONS ARE AS SHOWN. UNLESS OTHERWISE SPECIFIED, DIMENSIONS ARE IN INCHES. TOLERANCES ON DIMENSIONS ARE AS SHOWN. UNLESS OTHERWISE SPECIFIED, DIMENSIONS ARE IN INCHES. TOLERANCES ON DIMENSIONS ARE AS SHOWN.

APPLICATION USED ON _____

FINISH _____

THE INFORMATION CONTAINED HEREIN IS UNCLASSIFIED EXCEPT FOR DATE SPECIFIED. IT IS THE POLICY OF THE NATIONAL ARCHIVE TO MAKE ALL INFORMATION CONTAINED HEREIN AVAILABLE TO THE PUBLIC.