



045-0142-02

M64414, M64442, M64679
M64799, M65928, M66772

RELIABILITY IMPROVEMENTS

For TEKTRONIX® 11A32 Two Channel Amplifier

Serial Numbers B010100 - B019999

This kit contains parts and instructions that will improve the plug-in amplifier's reliability. To eliminate component failures caused by high humidity, both attenuators, the EPROM and both hybrid preamplifiers are to be replaced.

Copyright © 1988
Tektronix, Inc.
All Rights Reserved

27-APRIL-1988
Supersedes 045-0142-01

page 1

KIT PARTS LIST:

Ckt. Number	Quantity	Part Number	Description
	2 ea	119-2000-02	Attenuator: Actively trimmed novar
	4 ea	131-3383-01	Conn assy, elec: Elastomeric, MOE strip
A1U700	1 ea	160-4009-08	Microckt, dgtl: HMOS, EPROM, Ver 3.6
A1U310	2 ea	165-2089-05	Microckt, linear: Vertical preamp
A1U410	1 ea	-----	Label: 045-Kit

INSTRUCTIONS:**WARNING**

Dangerous shock hazards may be exposed when the instrument covers are removed. Before proceeding, ensure the mainframe power switch is in the off position. Then, remove the plug-in from the instrument. Disassembly should only be attempted by qualified service personnel.

CAUTION

Many components within the 11A32 Two Channel Amplifier plug-in are extremely susceptible to static-discharge damage. Service the instrument only in a static-free environment. Observe standard handling precautions for static-sensitive devices while installing this kit. Always wear a grounded wrist strap.

The Following Instructions Are Divided Into Four Sections:

- Section A.** Attenuator replacement.
- Section B.** Vertical preamp microcircuit (hybrid) replacement.
- Section C.** EPROM microcircuit replacement.
- Section D.** Programming The Unit Identification.

Section A. Attenuator replacement.

- () 1. Remove the left and right electrical shields. Take care not to bend or damage the electrical shields during removal.
- () 2. Unhook the return spring from the latch, and set it aside.
- () 3. Remove the four (4) torx screws that secure subpanel to the top and bottom frames using a T-9 torx screwdriver.
- () 4. Pull the latch out to the extended position.
- () 5. Separate the front panel from subpanel. 11A32, use the two (2) large holes located in the subpanel casting to push the front panel out away from the instrument. 11A34, use a slender, sharp-pointed tool. Insert the tool at the notch around the latch area, be careful not to bend or damage front panel during this separation.

NOTE

It may be necessary to pull the top and bottom frames away from the subpanel tabs.

- () 6. Remove the two (2) torx screws that secure the attenuator to the Main circuit board using a T-9 torx screwdriver. The screws are located on the front (component) side of the Main circuit board.
- () 7. Disconnect the coaxial cables that connect the attenuators to the rear (solder) side of the Main circuit board. Disconnect the circuit board end of the coaxial cables, not the attenuator end.
- () 8. Set the instrument on its side with the attenuator bodies facing up.
- () 9. Remove the four (4) torx screws that secure the attenuator to the front subpanel, using a T-6 screwdriver. Use T-6 tip only, any other size may damage the screw drive system.
- () 10. Lift the rear of the attenuator up about a 1/4 inch from the circuit board, then carefully withdraw the attenuator from the instrument. the plastic bezels may fall out from the front panel while removing the attenuator/bnc's. Set the bezels aside for later assembly.
- () 11. Remove the old metal-on-elastomer (MOE) strips from the MOE holder.
- () 12. Install the two (2) new MOE strips that are provided in this kit, placing the strips in the holders. The exposed elastomer side of the MOE strips face towards the center of the holder, refer to figure 1.

NOTE

Before installing the new attenuator bnc's into the front panel, make sure that the plastic bezels are in the proper position.

- () 13. Install the new attenuator that is provided in this kit. Insert the bnc's through the holes in the front subpanel, then let the attenuator rest on the Main circuit board.
- () 14. While holding the attenuator against the MOE assembly, install the two (2) torx screws T-9 that secure the attenuator to the Main circuit board. Do not tighten, fasten just enough to hold the attenuator in place.
- () 15. Replace the four torx screws T-6, that secure the attenuator to the front subpanel.
- () 16. While the latch is in the extended position, place the front panel so that the notch in the bottom fits over the latch rod. Carefully insert the four front panel-tabs into the slots in the front subpanel.

NOTE

It may be necessary to pull the top and bottom frames away from the subpanel tabs to allow the front-panel tabs to fit between the casting and the frames.

- () 17. Gently snap the edges of the front panel into place around the input connectors and the outer edges of the panel.
- () 18. Replace the four torx screws T-9, that secure the subpanel to the top and bottom frames removed in step 3. Hold the front panel firmly in place while installing the four screws.
- () 19. Install the latch spring removed in step 2. Orient the spring so that its loop fits over the frame hook correctly.
- () 20. Tighten the two (2) screws T-9, installed in step 14.
- () 21. Connect the coaxial cable disconnected in step 8.

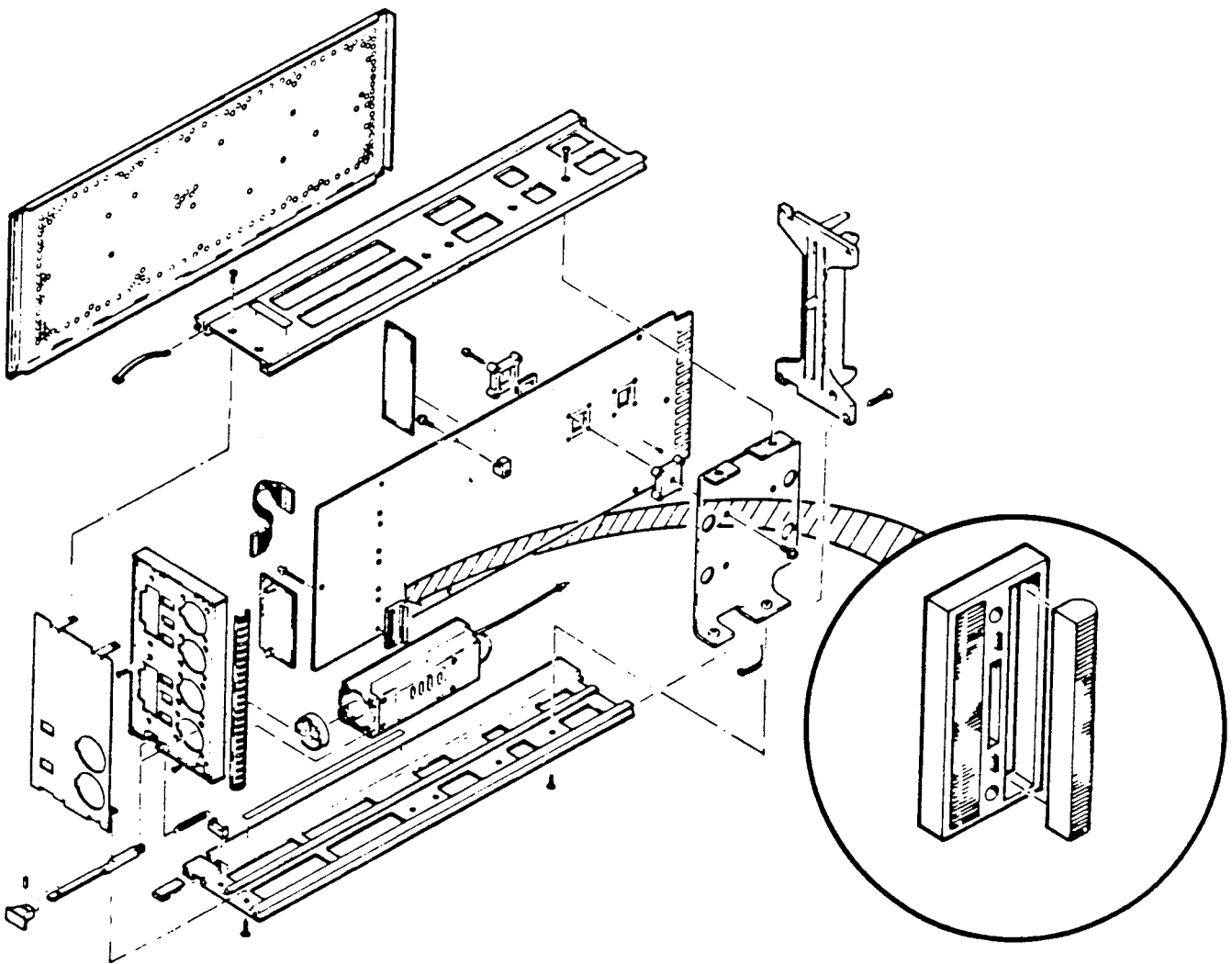

Figure 1. - Exploded view.

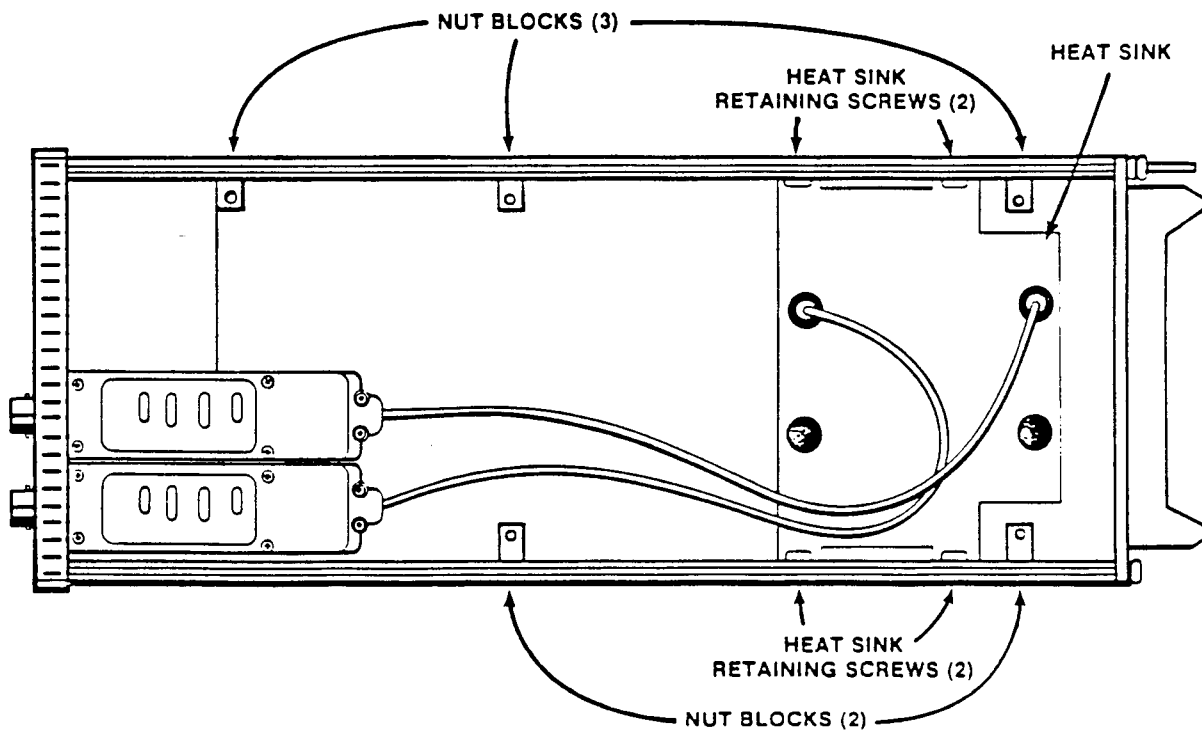
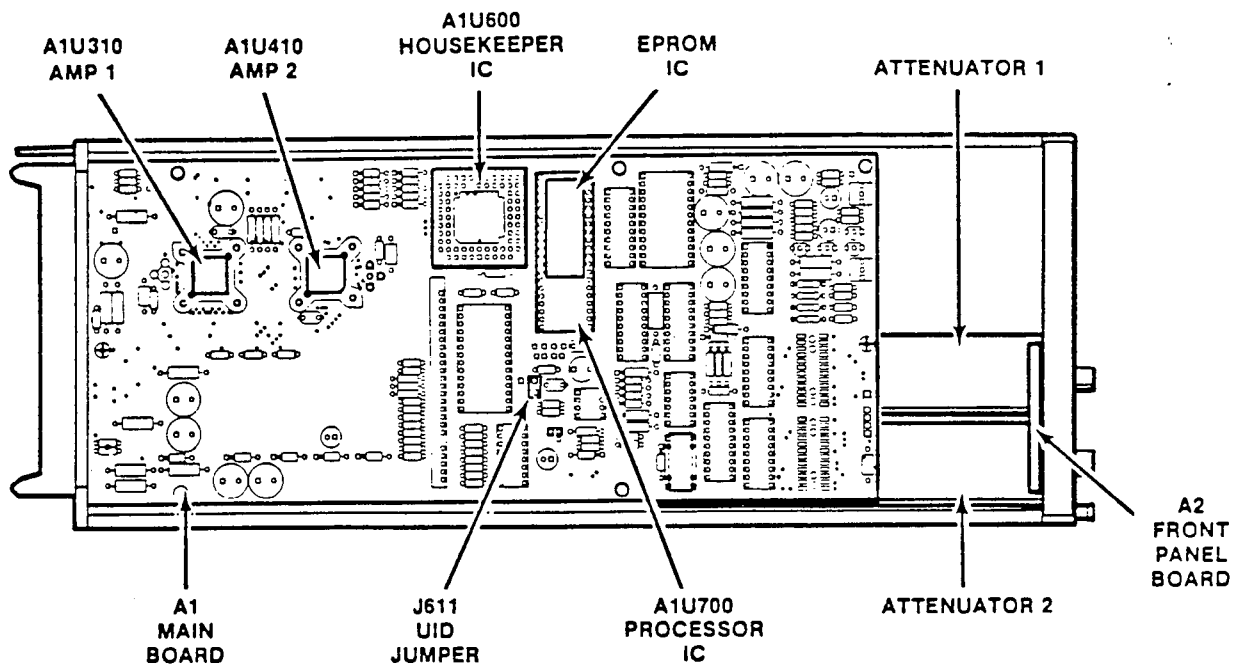

Figure 2. - Component locations.

Section B. Vertical pre-amp microcircuit (hybrid) replacement.

- () 1. Replace A1U310 and A1U410, vertical pre-amp microcircuits, with the new microcircuits, pn 165-2089-05, provided in this kit. For disassembly and replacement of the microcircuit from the Hypcon assembly connector refer to the following steps. Refer to Figure 3, for component locations.

- () 2. Unscrew and remove the 4 screw/washer assemblies, noting the index on the circuit board (arrow) and plastic frame (pointed tab), for later assembly.
- () 3. Remove the plastic frame away from the board.
- () 4. Remove the hybrid from the circuit board using tweezers, noting the index location for later assembly.

NOTE

Cleanliness is very important. Small hairs and elastomer flash under the contacts, which are almost invisible to the naked eye, will prevent good electrical contact. Most apparent failures of the hybrid are actually due to contamination of the Hypcon. Do not touch the gold-plated contacts with fingers. Refer to pages 5 and 6 for additional information.

- () 5. Place the new hybrid microcircuit into the square hole in the circuit board. The hybrid is keyed so that it will properly fit into the circuit board in only one position. When the back of the hybrid rests on the heat sink pedestal, the top of the hybrid should be flush with the top of the circuit board. Misalignment may result in a fractured hybrid when the frame is reinstalled.
- () 6. Place the plastic frame with elastomer installed over hybrid so that the key (pointed tab) is aligned with the corner arrow on the circuit board.
- () 7. Replace the mounting hardware. Apply two (2) inch-pounds of torque (2.3 cm-kg) to the four (4) mounting screws. Do not overtighten. To do so will strip the microcircuit stiffener/heat sink mounting threads.

Amplifier Hybrids

Refer to Figure 3, Hypcon assembly removal and replacement. When replacing the hybrid, do not touch the elastomer's gold-plated contacts with your fingers. Use a cleaner (such as alcohol) that will not lessen contact reliability. The Hypcon socket contacts are fragile. Use caution when removing and replacing a Hypcon to avoid damaging these contacts.

Before reinstallation, use a 4X (or greater) magnifying glass to examine the hybrid, elastomer, and the Hypcon contacts under light for dust, hair, lint, etc. If the etched circuit board surfaces require more cleaning, scrub lightly, with a soft rubber eraser. Do not use an eraser on the hybrid. Blow or vacuum clean, while dusting the surface with small clean brush.

If the hybrid and elastomer contact holder are contaminated, clean them by flushing or spraying with alcohol and oven dry at +50°C or air dry for 20 minutes. Do not scrub with a cotton-tipped swab or similar device. (Cotton fibers may adhere to the contacts.) If the contact holder is excessively contaminated, replace it with a new one.

Tighten the mounting screws with two inch-pounds of torque (in the English Unit System) or 2.3 centimeter-kilograms (in the MKS Unit System) to secure the Hypcon to the circuit board.

Make sure that the elastomer is properly seated in the contact holder before remounting the assembly to the circuit board. Use care when mounting the whole assembly to the circuit board to prevent misalignment between the connector and board.

WARNING

Because of close tolerances involved, special care must be taken to ensure correct index alignment of each Hypcon part during reassembly. Refer to Figure 3 for the index locations. Failure to do so can result in a cracked hybrid substrate.

EXPLODED VIEW OF HYPCON CONNECTOR

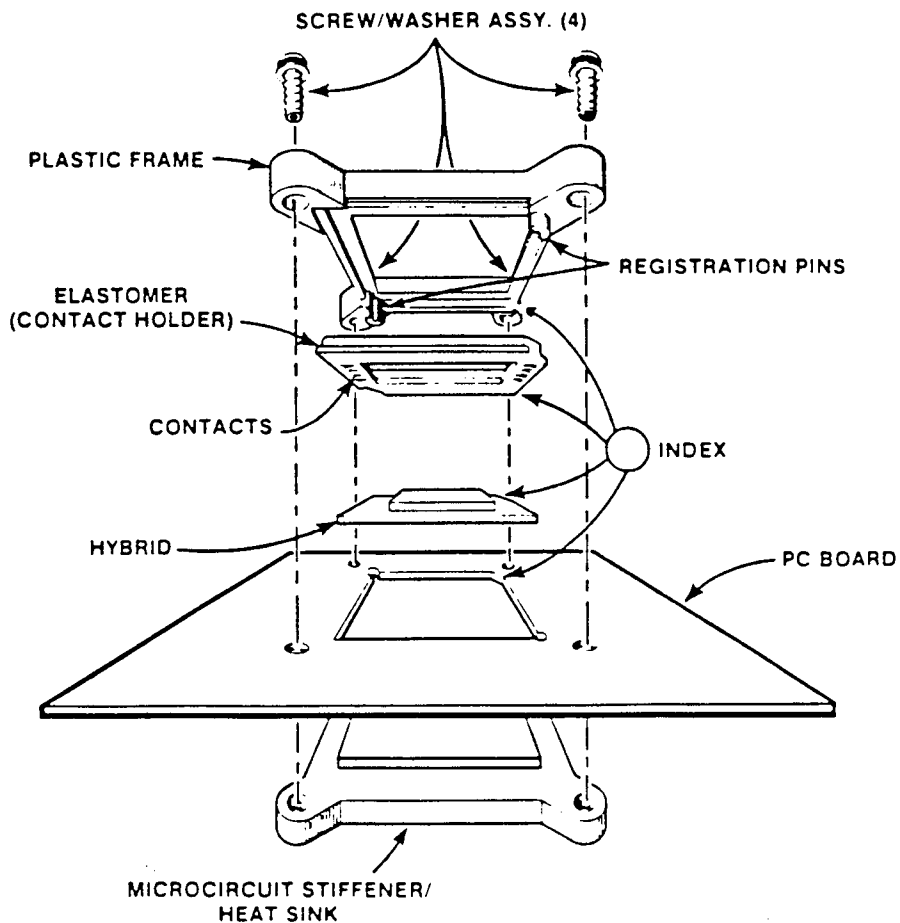

CROSS SECTION VIEW OF HYPCON CONNECTOR

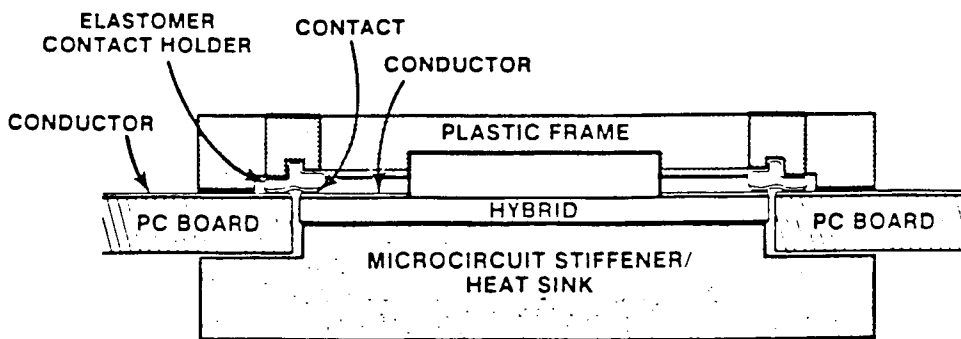

Figure 3. - Hypcon assembly removal and replacement.

Section C. EPROM microcircuit replacement.

CAUTION

Do not remove the label affixed to the top of the EPROMs. Removing this label will allow light into the chip, and may cause partial erasure of its data. Avoid touching the microcircuits pins or socket contacts. Finger oils can lessen contact reliability.

- () 1. Remove A1U700, EPROM microcircuit, using an Insertion - Extraction Pliers (such as General Tool's pn U505BG, a 28-pin type). Refer to Figure 2, for component location.
- () 2. Position the pliers around the outside of the EPROM microcircuit. Squeeze the handles to grasp the EPROM and slowly pull it from the socket.
- () 3. Install the new EPROM microcircuit into the socket, using the same tool used in step 2 in this section. Check that all the microcircuit pins are straight and evenly spaced to ensure proper installation. Refer to Figure 4, EPROM indexing diagram.

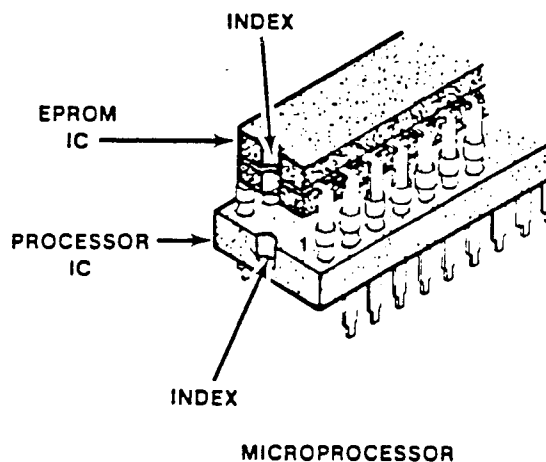

Figure 4. - EPROM indexing diagram.

Section D. Programming The Unit Identification.

NOTE

The Unit Identification (UID) is identical to the plug-in's serial number and is stored in NV RAM. It is necessary to enter this number if the firmware or Main circuit board A1 are replaced.

- () 1. 11401 and 11402, remove the bottom cover of the mainframe and install a Term Conn Link (shorting strap) on the CAL-LOCK terminals located on the Time Base circuit board A6. Refer to Figure 5. for pin locations.

NOTE

No special set-up needed with the 11301/11302 mainframes.

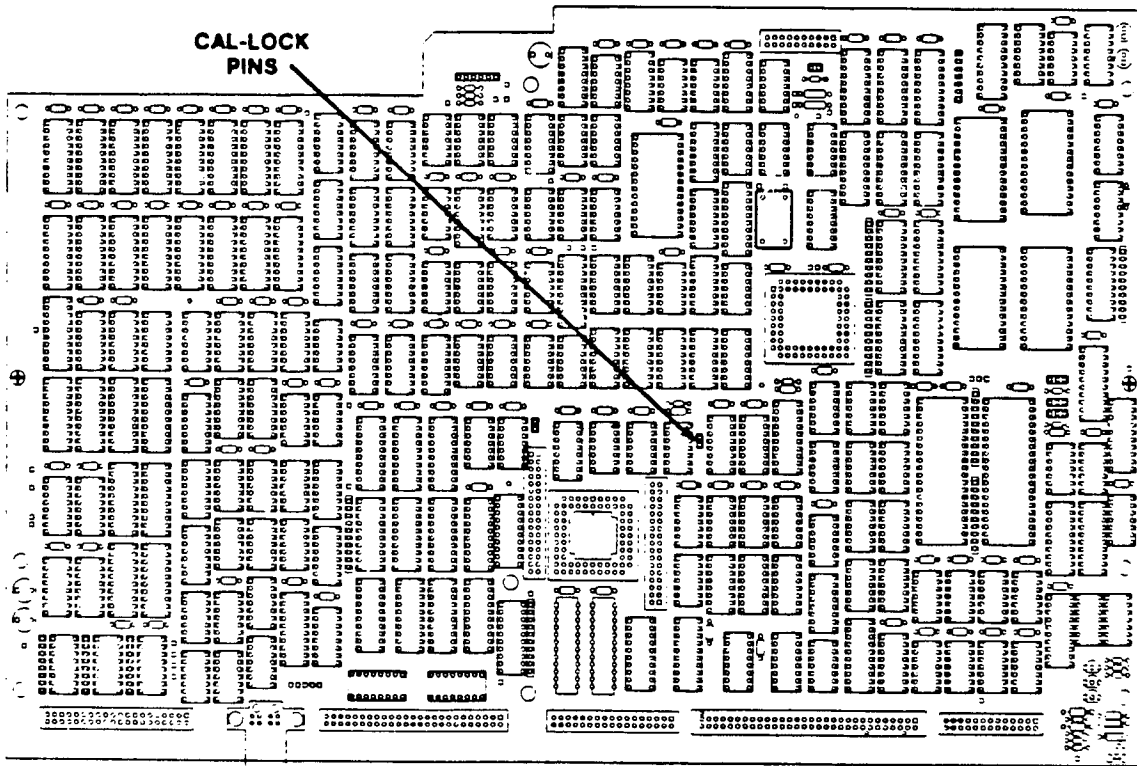

Figure 5. - 11401/11402 Time base ckt bd A6

To Enter the UID, use this procedure:

- () 2. Connect the Terminal to the mainframe's RS-232-C port. (Refer to the mainframe User's Reference Manual for instructions on setting up the RS-232-C parameters).
- () 3. Move the UID Term Conn Link (jumper) J611 on the Main circuit board A1. The jumper should be vertical in its normal position. Remove the jumper and install it horizontally. (Refer to Figure 2).
- () 4. Install the plug-in into center compartment. Turn the power on. Wait until Diagnostics checks are completed. **Serial Sum** error messages will be displayed.
- () 5. At the Terminal, type the command:

UID [Center]: "<B0XXXXX>"

. Center refers to the name of the compartment.
- () 6. At the Terminal, type the query:

UID? [Center]

Observe that the correct UID is reported.
- () 7. Push the ENHANCED ACCURACY button on the mainframe front panel.
- () 8. Move the ON/STANDBY switch to STANDBY.
- () 9. Remove the plug-in from the mainframe.
- () 10. Return the jumper J611 on the Main circuit board A1 to its normal vertical position.
- () 11. Replace the plug-in's right and left electrical shields.
- () 12. Remove the protective backing from the 045-kit label, included in this kit, and place it on a clean, dry area on the top frame rail. The label indicates installation of the kit for future reference.
- () 13. **11401 and 11402.** Remove the Term Conn Link (shorting strap) on the CAL-LOCK terminals located on the Time Base circuit board A6. Replace the bottom cover on the mainframe.