

222

Digital Storage Oscilloscope Service

WARNING

THE FOLLOWING SERVICING INSTRUCTIONS ARE FOR USE BY QUALIFIED PERSONNEL ONLY. TO AVOID PERSONAL INJURY, DO NOT PERFORM ANY SERVICING OTHER THAN THAT CONTAINED IN OPERATING INSTRUCTIONS UNLESS YOU ARE QUALIFIED TO DO SO. REFER TO OPERATORS SAFETY SUMMARY AND SERVICE SAFETY SUMMARY PRIOR TO PERFORMING ANY SERVICE.

Copyright © 1990 Tektronix, Inc. All rights reserved. Contents of this publication may not be reproduced in any form without the written permission of Tektronix, Inc.

Products of Tektronix, Inc. and its subsidiaries are covered by U.S. and foreign patents issued and pending.

TEKTRONIX, TEK, SCOPE-MOBILE, and  are registered trademarks of Tektronix, Inc.

Printed in U.S.A. Specification and price change privileges are reserved.

TABLE OF CONTENTS

	Page		Page
LIST OF ILLUSTRATIONS	iii	ALTERNATE METHOD FOR	
LIST OF TABLES	iii	BATTERY CHARGING	2-3
OPERATORS SAFETY SUMMARY	iv	BATTERY REPLACEMENT	2-3
SERVICING SAFETY SUMMARY	iv		
 		SECTION 3 BLOCK DIAGRAM OVERVIEW	
SECTION 1 PERFORMANCE CHARACTERISTICS		INTRODUCTION	3-1
INTRODUCTION	1-1	ACQUISITION SYSTEM	3-1
RECOMMENDED		TIME BASE	3-4
PERFORMANCE CHECK		PROCESSOR SYSTEM	3-4
SCHEDULE	1-1	DISPLAY SYSTEM	3-7
ELECTRICAL		BATTERY CHARGER	
SPECIFICATIONS	1-1	REGULATOR	3-9
VERTICAL DEFLECTION		POWER SUPPLY	3-10
SYSTEM	1-1		
TRIGGER SYSTEM	1-3	SECTION 4 PERFORMANCE CHECK	
HORIZONTAL SYSTEM	1-3	PROCEDURE	
X-Y OPERATION	1-4	INTRODUCTION	4-1
RS-232 INTERFACE	1-4	TEST EQUIPMENT	
EXTERNAL POWER		REQUIRED	4-1
REQUIREMENTS	1-4	PERFORMANCE	
ENVIRONMENTAL		CONDITIONS	4-1
SPECIFICATIONS	1-5	PERFORMANCE CHECK	
MECHANICAL		INTERVAL	4-1
SPECIFICATIONS	1-5	PREPARATION	4-1
		INDEX TO PERFORMANCE	
SECTION 2 OPERATING INFORMATION		CHECK PROCEDURE	4-5
SAFETY	2-1	DISPLAY CHECKS	4-6
BATTERY-CHARGER		INITIAL CONTROL SETTINGS ...	4-6
ADAPTER	2-1	PROCEDURE	4-6
EXTERNAL SUPPLY		VERTICAL	4-7
VOLTAGE	2-1	INITIAL CONTROL SETTINGS ...	4-7
BATTERY OPERATION	2-2	PROCEDURE	4-7
FIRST TIME BATTERY		HORIZONTAL	4-11
OPERATION	2-2	INITIAL CONTROL SETTINGS ..	4-11
START-UP	2-2	PROCEDURE	4-11
AUTO TIMEOUT	2-2	TRIGGER	4-12
VIEWING A SIGNAL QUICKLY ...	2-2	INITIAL CONTROL	
TIPS ON BATTERY CARE	2-2	SETTINGS	4-12
		PROCEDURE	4-12

	Page		Page
SECTION 5 ADJUSTMENT PROCEDURE		TRUBLESHOOTING	6-5
INTRODUCTION	5-1	INTRODUCTION	6-5
TEST EQUIPMENT	5-1	TRUBLESHOOTING AIDS	6-5
LIMITS AND TOLERANCES	5-1	TRUBLESHOOTING TECHNIQUES	6-5
ADJUSTMENTS AFFECTED BY CIRCUIT BOARD REPLACEMENT	5-1	CORRECTIVE MAINTENANCE	6-8
PREPARATION FOR ADJUSTMENT	5-1	INTRODUCTION	6-8
PROCEDURE STEPS	5-2	REPACKAGING FOR SHIPMENT	6-8
PREPARATION	5-2	MAINTENANCE PRECAUTIONS	6-8
ADJUSTMENTS	5-2	REMOVAL AND REPLACEMENT PROCEDURES	6-9
SECTION 6 MAINTENANCE		SECTION 7 OPTIONS AND ACCESSORIES	
STATIC-SENSITIVE COMPONENTS	6-1	INTRODUCTION	7-1
PREVENTIVE MAINTENANCE	6-2	OPTIONS	7-1
INTRODUCTION	6-2	 	
INSPECTION AND CLEANING ...	6-2	SECTION 8 – REPLACEABLE ELECTRICAL PARTS	
LUBRICATION	6-4	 	
PERIODIC READJUSTMENT	6-4	SECTION 9 – DIAGRAMS	
		SECTION 10 – REPLACEABLE MECHANICAL PARTS	

LIST OF ILLUSTRATIONS

Figure	Page
1-1 Maximum normal-mode voltage versus frequency derating curve	1-2
1-2 Maximum common-mode voltage versus frequency derating curve	1-3
2-1 External Power Input	2-1
3-1 Simplified block diagram of the 222 DSO	3-2
3-2 Floating Acquisition System	3-3
3-3 Time Base block diagram	3-4
3-4 Processor System simplified block diagram	3-5
3-5 Display System	3-8
3-6 Battery Charger block diagram	3-9
3-7 Power Supply block diagram	3-10
4-1 RS-232 interconnection cable wiring between a PC XT® (or compatible) and the 222	4-4
4-2 Trigger Jitter check	4-14
5-1 Locations at which horizontal and vertical gains are adjusted	5-3
5-2 Rear Panel adjustments	5-3
5-3 Top accessible adjustments	5-4
5-4 CH1 and CH2 Input Compensation	5-5
5-5 Clock Delay adjustment	5-6
6-1 Circuit board locations	6-10

LIST OF TABLES

Table	Page
4-1 Test Equipment Required	4-2
4-2 VOLTS/DIV Accuracy Settings	4-9
6-1 Relative Susceptibility to Static-Discharge Damage	6-1
6-2 External Inspection Checklist	6-2
6-3 Internal Inspection Checklist	6-3
6-4 Power Up Error Codes	6-5
6-5 Self Cal Error Codes	6-6
6-6 Index To Self Cal Procedures	6-7
6-7 Error Codes Occurring During Normal Operations	6-7

OPERATORS SAFETY SUMMARY

The safety information in this summary is for operating personnel. Warnings and cautions will also be found throughout the manual where they apply.

Terms in this Manual

CAUTION statements identify conditions or practices that could result in damage to the equipment or other property.

WARNING statements identify conditions or practices that could result in personal injury or loss of life.

Terms as Marked on Equipment

CAUTION indicates a personal injury hazard not immediately accessible as one reads the markings, or a hazard to property, including the equipment itself.

DANGER indicates a personal injury hazard immediately accessible as one reads the marking.

Symbols in this Manual



Indicates where applicable cautionary or other information is to be found. For maximum input voltage ratings, see the Specifications.



Indicates that the instrument is double insulated. A safety earth ground is not needed.

Symbols as Marked on Equipment



DANGER – High voltage.



ATTENTION – Refer to manual.



DOUBLE INSULATED – No safety ground required.

Safety Grounding

This instrument is double insulated and does not use or require a safety-grounding conductor.

Do Not Operate in an Explosive Atmosphere

To avoid explosion, do not operate this product in an explosive atmosphere unless the product is certified for such operation.

Do Not Remove Covers or Panels

To avoid personal injury, do not remove the product covers or panels. Do not operate the product without the covers and panels properly installed.

SERVICING SAFETY SUMMARY

FOR QUALIFIED SERVICE PERSONNEL ONLY

Refer also to the preceding Operators Safety Summary

Do Not Service Alone

Do not perform internal service or adjustment of this product unless another person capable of rendering first aid and resuscitation is present.

Use Care When Servicing With Power On

Dangerous voltages exist at several points in this product. To avoid personal injury, do not touch exposed connections or components while power is on.

Disconnect power and remove the battery before removing protective panels, soldering, or replacing components.

PERFORMANCE CHARACTERISTICS

INTRODUCTION

Performance characteristics given in the Electrical Specifications apply when the instrument has been self calibrated within $\pm 5^\circ\text{C}$ of the ambient temperature, has warmed up at least 20 minutes, and is operating in an ambient temperature between -10°C and $+55^\circ\text{C}$ (unless otherwise noted).

Environmental and Mechanical Specifications are listed after the Electrical Specifications.

RECOMMENDED PERFORMANCE CHECK SCHEDULE

To ensure accurate measurements, check the performance of this instrument every 2000 hours of operation (once each year if used infrequently). If repairs are made, affected circuits may need to be readjusted.

ELECTRICAL SPECIFICATIONS

VERTICAL DEFLECTION SYSTEM

Deflection Factor

5 mV per division to 50 V per division in a 1–2–5 sequence.¹

Vertical Resolution

8–bits, 25 levels per division. 10.24 divisions of dynamic range.¹

DC Accuracy

+ 15°C to + 35°C	$\pm 3\%$. ²
-15°C to + 15°C	$\pm 4\%$. ²
+ 35°C to + 55°C	$\pm 4\%$. ²

¹Performance Requirement not checked in manual.

²When the self calibration has been done within $\pm 5^\circ\text{C}$ of the ambient temperature.

VOLTS/DIV Variable Control

Increases the deflection factor by 2.5 to 1.

Aberrations

+ 6%, -6%, 6% p-p or less.¹

Measured with a 5–division reference signal from a $50\text{-}\Omega$ source driving a $50\text{-}\Omega$ load at the probe tip. Vertically center the top of the reference signal.

Useful Rise Time

$$\frac{\text{SEC/DIV} \times 1.6}{50} \text{ } ^1$$

Rise time is limited to 35 ns by the vertical amplifier response.

Useful Bandwidth

$$\text{SAMPLE} \frac{5}{\text{SEC/DIV}} \text{ Hz.} ^1$$

Useful-storage bandwidth is limited to the frequency where there are 10 samples per sine-wave signal period at the maximum sampling rate. This yields a maximum amplitude error of 5%. Maximum sampling rate is 10 MHz at 5 μs per division.

Accuracy at the useful-storage-bandwidth limit is measured with respect to a 6–division, 50–kHz sine wave.

REPETITIVE

0.5 $\mu\text{s}/\text{div}$ to 50 $\mu\text{s}/\text{div}$	10 MHz.
1 $\mu\text{s}/\text{div}$	5 MHz. ¹
2 $\mu\text{s}/\text{div}$	2.5 MHz. ¹

Repetitive bandwidth is limited to 10 MHz by the analog system.

PEAK DETECT (ENV and CONT ENV acquisition modes at 20 μ s per division and slower)

Sine-wave Amplitude Capture
(5% p-p maximum amplitude uncertainty) 1 MHz.

Pulse Width Amplitude Capture
(50% p-p maximum amplitude uncertainty). 100 ns.

A/D Converter Linearity

Monotonic with no missing codes.¹

Position Control Range

± 12 divisions.

Input Linear Range

± 20 divisions.¹

DC Balance

0.2 division or less trace shift when switching between VOLTS/DIV switch settings when the ambient temperature is within $\pm 5^\circ\text{C}$ of the temperature at which the last self calibration was done.¹

INVERT Balance

0.4 division or less trace shift when switching between INVERT and non-INVERT displays when the ambient temperature is within $\pm 5^\circ\text{C}$ of the temperature at which the last self calibration was done.¹

Input Current

2.5 nA or less (0.5 division or less trace shift when switching between DC and GND input coupling with the VOLTS/DIV switch at 5 mV per division).¹

Input R and C

Input Resistance 1 M Ω \pm 10%.¹

Input Capacitance 27 pF \pm 3 pF.¹

These R and C characteristics include the probe.

Common-to-Ground

Capacitance Less than 150 pF.¹



Maximum Rated Normal-Mode Input Voltage (probe tip to probe common)

400 V (dc + peak ac) to 2 MHz.¹

See Figure 1-1 for voltage versus frequency derating curve.



Maximum Common-Mode Potential (probe common to chassis)

400 V (dc + peak ac) to 1 kHz.¹

See Figure 1-2 for voltage versus frequency derating curve.



Maximum Rated Potential Between Channels

800 V (dc + peak ac).¹

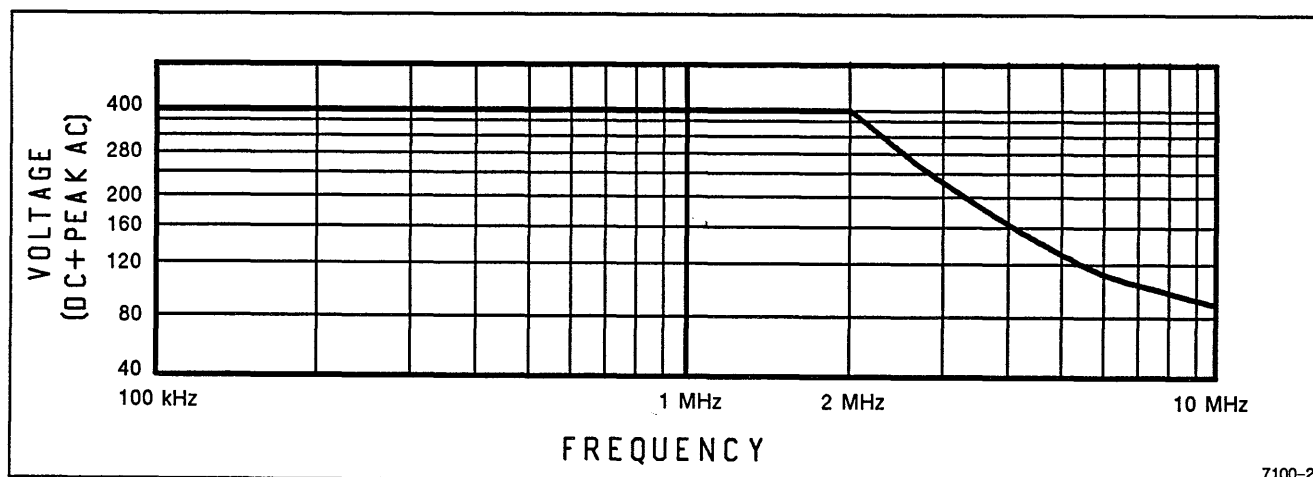

Figure 1-1. Maximum normal-mode voltage versus frequency derating curve.

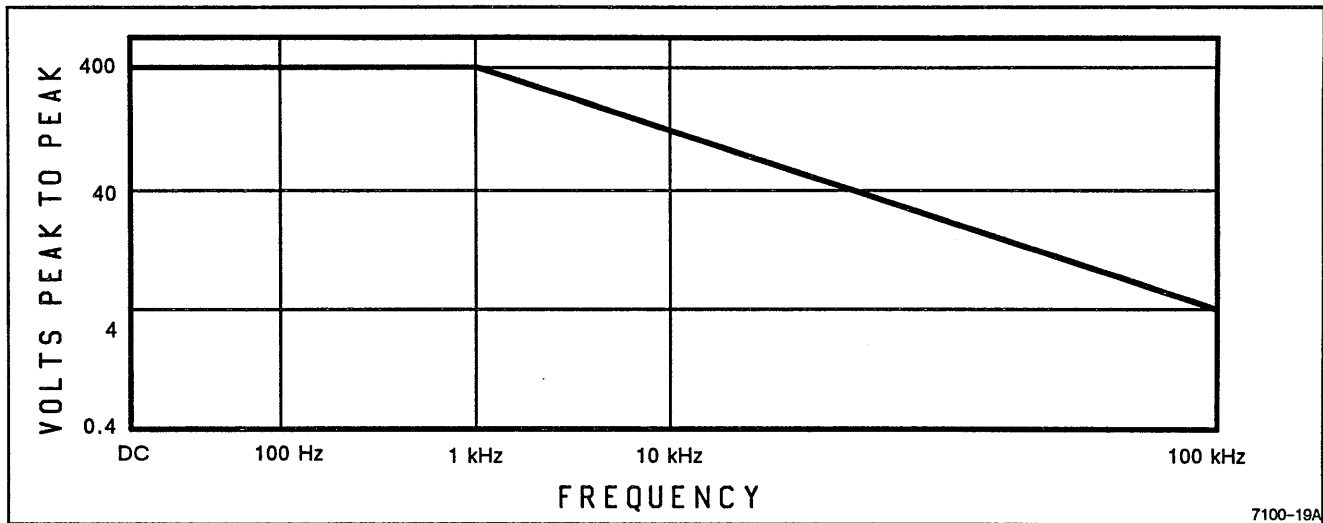

Figure 1-2. Maximum common-mode voltage versus frequency derating curve.

Common-Mode Rejection Ratio

DC-to-1 kHz	80 dB or more. ¹
1 kHz-to-100 kHz	60 dB or more. ¹

Trigger Jitter

2 μ s/div to 50 ns/div (5 ns/div in X10 MAG).	
X1	1/50th division \pm 2 ns. ¹
X10 MAG	1/5th division \pm 2 ns.

Isolation: Channel Signal to Channel Signal

DC-to-10 MHz	80 dB or more. ¹
--------------	-----------------------------

HORIZONTAL SYSTEM

Range

50 ns per division to 20 s per division.¹
 The X10 MAG control extends the maximum sweep speed to 5 ns per division.

Isolation: Channel Common to Channel Signal

DC-to-1 kHz	80 dB or more. ¹
1 kHz-to-100 kHz	60 dB or more. ¹

Displayed Accuracy

X1	\pm 2 %.
X10 MAG	\pm 5%. ¹
Accuracy is over 10 divisions.	

TRIGGER SYSTEM

Internal

Sensitivity	0.5 division to 20 MHz.
Level	\pm 20 divisions. ¹

Sample Rate

NORMAL	$\frac{50}{\text{SEC/DIV}}$ Hz. ¹
PEAKDET (ENV and CONT ENV)	10 MHz. ¹
REPETITIVE	

External

Sensitivity	250 mV at 10 MHz.
Level	\pm 2.3 V.
Input Resistance	1 M Ω \pm 10%. ¹
Input Capacitance	18 pF \pm 5 pF. ¹

50 ns/div to 1 μ s/div	10 MHz. ¹
2 μ s/div	5 MHz. ¹
ACCURACY	0.01%. ¹

Sample accuracy is based on the accuracy of the 20-MHz oscillator.

¹Performance Requirement not checked in manual.

Record Length

512 data points; calibrated to 50 points per division.¹

POSITION Control Range

Start of the first division and end of the tenth division can be positioned past the center vertical graticule.

Displayed Trace Length

10.24 divisions.¹

X-Y OPERATION

Accuracy

Same as the Vertical system.¹

Useful Bandwidth

$$\frac{5}{\text{SEC/DIV}} \text{ Hz.}^1$$

Skew Between CH 1 and CH 2

5 ns.¹

RS-232 INTERFACE

Maximum Applied Voltage (any pin)

25 V (dc + peak ac).¹

Baud Rates

300, 1200, 2400, 9600; 0.1% accuracy based on the microprocessor clock.¹

Signals

RD, TD, and SGND. SGND is connected internally to EXTERNAL TRIG COM. DSR and CTS are always high, and DTR and RTS are ignored.¹

Levels

Compatible with RS-232C.

EXTERNAL POWER REQUIREMENTS

Voltage Range

Pin-to-pin

AC 16.0 to 20 Vac
at 47 to 400 Hz.¹

DC 12 to 28 Vdc.¹

Either Power Pin-to-EXT
TRIG COMM or RS-232

COMM -0.5 V to 28 Vac
peak.¹

Current

1 ampere maximum when charging batteries.¹

Maximum Power Consumption

15 watts or 16 volt-amperes (when charging batteries).¹

Internal Batteries

Battery

Sealed, lead-acid battery.¹

Charge Time

Three hours for full charge with oscilloscope not operating.¹

Battery Excessive Discharge Protection

Instrument operation is automatically interrupted when battery charge drops to 7.32 V.¹

Typical Operating Time

Two hours at maximum sample rate, no trigger, and AUTO TIMEOUT feature turned off.¹

Battery Capacity versus Temperature

-15°C	20°C to 30°C	55°C
80%	100%	110%

¹Performance Requirement not checked in manual.

ENVIRONMENTAL SPECIFICATIONS

Environmental Requirements

Instrument will meet the requirements of Tektronix Standard 062-2853-00, Class 3.

The instruments meets all the following MIL-T-28000D requirements for Type III, Class 3 equipment, except where noted otherwise.

Temperature

Operating	-10°C to +55°C (+ 14°F to + 131°F). ¹
Nonoperating	-51°C to +71°C (-60°F to + 160°F). ¹

Tested to MIL-T-28800D, para 4.5.5.1.3 and 4.5.5.1.4 except that in para 4.5.5.1.3, steps 4 and 5 are performed before step 2 (-51°C nonoperating test). Equipment shall remain off upon return to room-ambient temperature during step 6. Excessive condensation shall be removed before operating during step 7.¹

Altitude

Operating	4,570 meters (15,000 feet). Maximum operating temperature decreases 1°C per 1,000 feet above 5,000 feet. ¹
Nonoperating	To 15,240 meters (50,000 feet). ¹

Humidity (Operating and Nonoperating)

Five cycles (120 hours) referenced to MIL-T-28800D para 4.5.5.1.2 for type III, Class 3 instruments. Operating and nonoperating at 95% (-5%, +0%) relative humidity. Operating at +30°C and +55°C for all modes of operation; nonoperating at +30°C and +60°C.¹

EMI

Meets radiated and conducted emission requirements per VDE 0871, Class B. Meets FCC section 15, sub-part J, Class A.¹

To meet EMI regulations and specifications, use the specified shielded cable and metal

¹Performance Requirement not checked in manual.

connector housing with the housing grounded to the cable shield on the RS-232 connector.

Vibration (operating)

15 minutes along each of 3 major axes at a total displacement of 0.025 inch p-p (3.8 g at 55 Hz) with frequency varied from 10 Hz to 55 Hz in 1-minute sweeps. Hold for 10 minutes at 55 Hz in each of the three major axes. All major resonances must be above 55 Hz.¹

Shock (Operating and Nonoperating)

100 g, half-sine, 1-ms duration, 3 shocks per axis each direction, for a total of 18 shocks.¹

MECHANICAL SPECIFICATIONS

Weight

Without accessories	4.4 lbs (2 kg).
With accessories	6lbs.
Domestic Shipping Weight	7lbs.

Dimensions

Length	9.9 in (252 mm).
Height	3.4 in (86.4 mm).
Width	6.25 in (158.8 mm).

Cooling

There are no cooling vents provided.

Finish

Tektronix Blue pebble finish with black synthetic rubber hand grips and black vinyl probe pouch.

Construction

Plastic cabinet. Glass-laminate circuit boards with surface-mounted components.

CRT

CRT graticule area is 8 divisions high by 10 divisions wide. The divisions are 0.5 cm on a side and the diagonal size is 6.4 cm (approximately 2.5 inches). A special low-reflectance surface on the crt face aids viewing in high-ambient light areas.

*This Document is a complete Scan from the original
Tektronix manual*

*For enquiries about our complete
High quality line of technical Manuals in PDF*

mailto : Qservice@otenet.gr

**SEE
OTHER
SIDE**

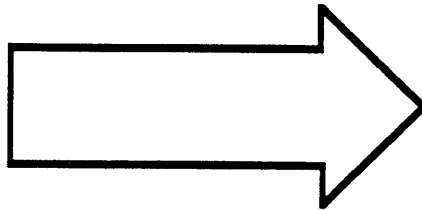

OPERATING INFORMATION

SAFETY

Refer to the Operator's Safety Summary at the front of this manual for safety information about the use of this instrument. Before connecting the instrument to a power source, read this section and the Safety Summary.

BATTERY-CHARGER ADAPTER

Instruments are shipped with a detachable battery-charger adapter (wall transformer) that plugs into an ac power-source outlet. The adapter converts the power-source ac voltage to the 16 to 20 Vac input voltage needed to operate the instrument (with or without the battery installed) and charge the oscilloscope's internal battery. Use the battery-charger adapter to operate the oscilloscope when an ac line voltage source is available to maintain battery charge for use when totally portable

operation of the oscilloscope is needed. Use the appropriate battery charger adapter for the available power source voltage (115 Vac and 230 Vac). The adapter plugs into the instrument's external power receptacle as shown in Figure 2-1.

EXTERNAL SUPPLY VOLTAGE

The 222 operates on an external supply voltage range of either 12 to 28 Vdc or 16 to 20 Vac (47 to 400 Hz) from a supply that provides at least 15 watts or 16 volt-amperes. If the battery charge state is very low, the current drawn by a charging battery from the supplied battery-charger adapter (wall transformer) is current limited, and the crt display may not be stable. If this effect is seen, either charge the battery for 1 hour before operating the oscilloscope or operate without the battery installed until it can be charged.

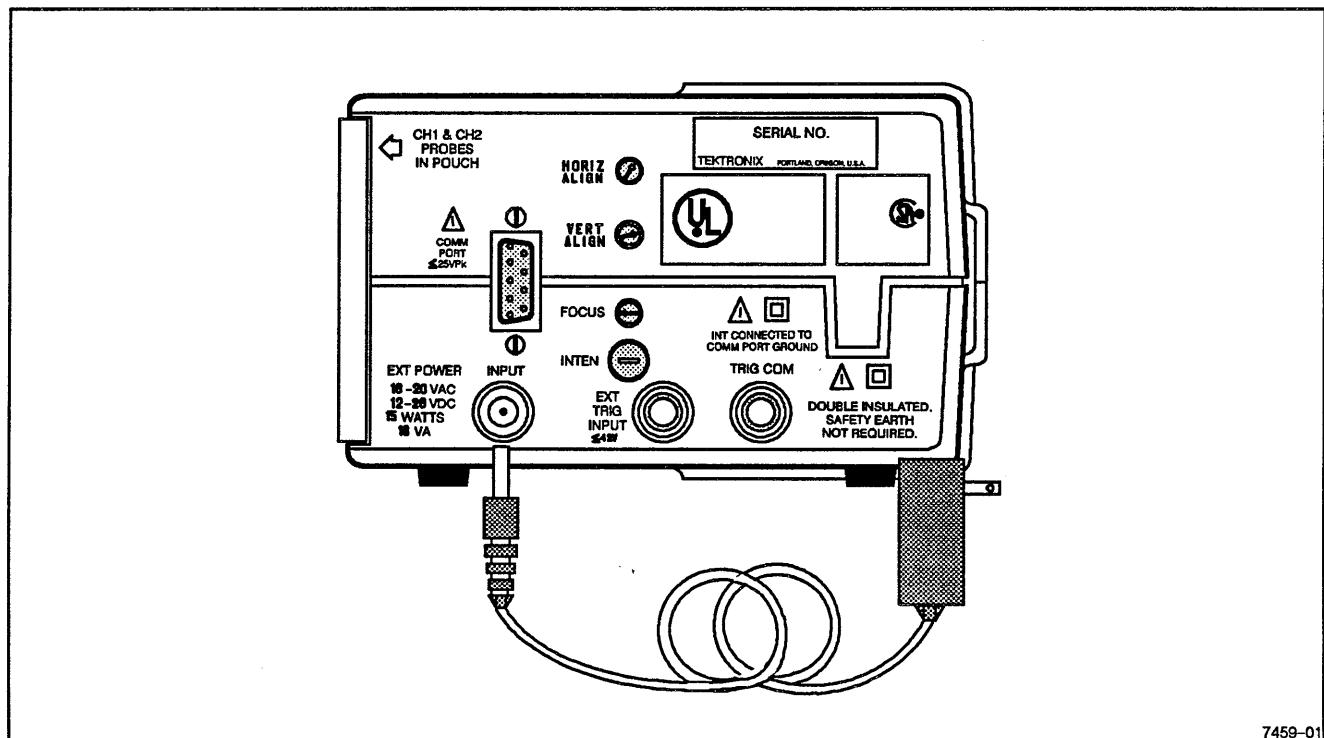



Figure 2-1. External Power Input.

7459-01

BATTERY OPERATION

The internal battery of the instrument is a sealed lead-acid type with four cells. The sealed cells are rechargeable using the battery-charger adapter supplied with the instrument. Operating time is at least two hours with a fully charged battery. When the charge level reaches a point where only a short amount of operating time remains, a low-battery indicator () is displayed in the upper right corner of the readout. The oscilloscope turns off automatically when the battery voltage drops below +7.32 V.

If the charge level of the battery is less than about 20%, the instrument will not come on without the external power provided by the battery-charger adapter. Typical worst-case operating time for an instrument with fully charged batteries is two hours at normal room temperature with the AUTO TIMEOUT feature turned off.

One or two charged batteries may be carried in optional pouches that attach to the carrying case for extended use away from an ac power source. See Section 6 for the battery removal and replacement instructions.

An external power-on indicator () appears in the upper right corner of the readout when external power is on. The battery is charging anytime external power is being supplied and will charge while the instrument is operating. However, the battery charges faster when the instrument is not operating. Completely recharge the battery as soon as possible after each discharge cycle.

Refer to "Tips on Battery Care" in this section for information on how to extend the operating lifetime of the battery.





When storing the instrument for periods longer than two months, fully charge the batteries; then remove the batteries and store them in a cool place. Storing partially discharged batteries for an extended time or in high temperatures can deplete the remaining charge, leading to a deep-discharge condition. Refer to "Tips on Battery Care" in this section for information on restoring a deep-discharged battery.

FIRST TIME BATTERY OPERATION

The battery supplied with the oscilloscope is charged at the factory and shipped unplugged to preserve its shelf

life. However, the state of battery charge at the time you receive it will be unknown. It is recommended that you charge the battery for three hours before operating the oscilloscope the first time.

START-UP

Press the  button to enable the display and acquisition system. Pressing the  button a second time turns off the oscilloscope operation but does not disconnect the battery or external power source.

AUTO TIMEOUT

There is an AUTO TIMEOUT feature that extends the oscilloscope operating time on battery operation. With a two-minute period of no front panel control activity, the oscilloscope turns off. The acquisition and display can be turned back on by pressing the  button. The AUTO TIMEOUT feature does not turn off the oscilloscope when external power is applied. The feature may also be disabled from turning off the oscilloscope when operating on battery power alone. See Section 4 of the Operators Manual for operating instructions.

VIEWING A SIGNAL QUICKLY

Connect one or both of the probe tips to the signals to be viewed.

Press . This gives you a quick setup of the front-panel controls to view the signals applied to the probe tip(s). A channel that does not have a signal connected is turned off (except CH 1 will not be turned off if neither channel has a signal applied). If signals are applied to both channels, each will be autoranged vertically (setting the VOLTS/DIV and vertical position for each), but the signal applied to channel 1 will determine the SEC/DIV and Trigger LEVEL settings. If only channel 2 has a signal applied, that signal is used to determine the SEC/DIV setting and Trigger LEVEL.

NOTE

AUTO SETUP does not set the SEC/DIV setting into the ROLL region (0.1 s/div and slower). The practical low frequency for using the AUTO SETUP feature is about 20 Hz.

TIPS ON BATTERY CARE

The battery in your instrument is a sealed lead–acid type battery with four cells. These tips will help extend the battery life.

1. Completely recharge the battery after each discharge cycle. Continued partial recharges shorten the battery life. The battery is on charge any time external power is used to operate the instrument. However, the battery recharges faster when the instrument is not operating.
2. Avoid situations that can lead to deep discharge of the battery.

If the instrument starts and remains on only briefly before shutting off, the battery charge state is low. The instrument will not start on battery if the voltage drops below 7.32 V. The battery must be recharged as soon as possible when it is in this state. Do not store the battery (or instrument with the battery installed) in a discharged state. Extended storage or storage in high temperatures will deplete the remaining charge, leading to deep discharge. When deep discharge occurs, the battery accepts charge very slowly, and, in some cases, may not recharge.

3. If a deep–discharge condition occurs, it may be possible to recover the battery with the following procedure.

Leave the battery on charge for 24 hours. If it still does not accept a charge, remove it from the instrument and attempt to charge it using a 20 V power supply that is current limited to 100 milliamperes. When attempting to recover the battery using an external power supply, check the battery frequently for the current–limit state. If the battery recovers from the deep–discharge state, it will pull the power supply into current limit. When this happens, reinstall it in the instrument and charge it normally. Do not leave the battery on the external power supply for long periods of time without checking it. If the battery does not recover, dispose of it safely.

4. When storing the instrument for an extended period of time, fully charge the battery and remove it from the instrument. Store the fully charged battery in a cool place. For short periods of storage, the battery may remain installed. During “sleep” mode, the current drawn from the battery is less than 1 mA. With the battery installed, the data stored in nonvolatile memory will remain stored and be available when the oscilloscope is turned on again.

5. The instrument will operate from the battery–charger adapter or other suitable ac or dc power source with the battery removed from the instrument.

ALTERNATE METHOD FOR BATTERY CHARGING

Batteries may be charged outside the instrument using the External Battery Charger accessory (see section 7 for part number) or a user provided dc power supply. The lead–acid cells of the battery require a constant charging voltage as provided by the External Battery Charger accessory. An alternate charger must supply 9.8 Vdc at 20°C with the supply current limited to 1 ampere. For best results over a wide temperature range, the charging voltage should be thermally compensated for –10 mV per degree C. For example, at 50°C, the charging voltage should be:

$$9.80 \text{ V} + [(50 - 20) \times -10 \text{ mV}] = 9.50 \text{ V}$$

BATTERY REPLACEMENT

If you frequently operate the oscilloscope using the battery only, you may wish to obtain one or two extra batteries and carry them in a fully–charged condition to the servicing site. When the charge level on the battery in the oscilloscope reaches the shut–off level, one of the spare batteries may be used to provide more operating time.

The battery is in a compartment behind the probe pouch. To remove and replace it, follow this procedure:

1. Open the probe pouch and take the probes out of it. This allows the battery compartment cover freedom to move away from the oscilloscope.
2. Place the oscilloscope on its right side and slide the battery compartment cover toward the rear to disengage the locking tabs. The hole for the probe leads makes a convenient place to apply the needed force with your finger.
3. Lift the battery compartment cover up and slide it far enough down the probe leads to lay the cover down.
4. Disconnect the 3–wire battery connector.

NOTE

If you reconnect power to the battery connector from the charged battery in less than 30 seconds, the saved waveforms and front–panel set–ups will not be lost.

Operating Information – 222 Service

5. Lift the battery pack out of the battery compartment.
6. Place the charged replacement battery into the battery compartment with the battery leads on the bottom side facing toward the rear.
7. Reconnect the battery plug.
8. Slide the battery compartment cover back up the probe leads and place the cover locking tabs into the matching slots in the battery compartment. Make sure the locking tab are all the way into the slots on both the top and bottom of the cover. If the tabs don't seat easily seat the top tabs first then press on the bottom of the cover to seat the bottom tabs.
9. Push forward on the rear of the battery compartment cover to engage the locking tabs.
10. Remember to recharge the low battery at the first opportunity. This prevents it from going into a deep-discharge state.

BLOCK DIAGRAM OVERVIEW

INTRODUCTION

The 222 Digital Storage Oscilloscope comprises five major functional blocks (see Figure 3-1). These are: the Floating Acquisition System, the Time Base, the Processor System, the Display System, and the Power Supplies. The operation of each of these functional blocks is described. A brief overview follows.

The signal is applied to the Floating Acquisition System (so named because of the electrical isolation of the inputs from the remainder of the functional blocks). There it is amplified, offset (for position and calibration), and limited (to the dynamic range of the A/D converter). The signal is then digitized and stored in Acquisition Memory.

An internal trigger signal is also derived from the input signal. That signal starts events in the Time Base that cause the acquisition of the input signal to be completed. (Acquisition is the digitization of the input signal and storing of the digital values.)

The Processor System transfers the digital waveform information from the Acquisition Memory to the Display Memory. That data can then be displayed or stored in the Save Memory for later recall and viewing. The Processor System scans the Front-Panel and Top-Panel switches to determine when the user presses a button. It also controls the Time Base, the Acquisition System, and the Power Supplies. An RS-232C compatible serial port provides the Processor System with an interface to external communication devices. Waveform data may be sent or received over the interface, and the control settings of the 222 may be changed or queried.

In the Display System the digital waveform data is converted back to analog signals. These analog signals are amplified and applied to the crt deflection plate to provide a visual display of the signal's waveshape.

Either the internal battery or the external wall transformer provides the supply voltage for the power supplies. A battery charger circuit supplies charging current to the battery whenever external power is applied to the instrument. The external power may be used to run the instrument with or without the battery installed. Separate

supplies provide power for the crt, the Floating Acquisition System, and the remaining digital circuitry of the instrument.

ACQUISITION SYSTEM

The Acquisition System contains two complete, isolated vertical channels, each with its own attenuator, amplifier, trigger circuit, A/D converter, peak detector, acquisition memory, and isolated power supply (see Figure 3-2). The channel grounds are isolated from each other and instrument ground. Data and clock signals are passed through pulse transformers and opto-couplers to maintain the isolation.

The attenuator, amplifier, and trigger circuit for each channel are formed by a hybrid circuit on a single ceramic carrier. Passive attenuators provide X1, X10, X100, and X1000 attenuator of the input signal. The gain amplifier has a high input impedance and a low output impedance. A high-speed trigger pulse is derived from the input signal by the trigger circuit portion of the hybrid component. Output signals from the amplifier are in the range of 0 to 2.5 V to be applied to the A/D converter.

Output voltage samples from the amplifier are converted into 8-bit digital words. Conversions occur at a sample rate of 10 MHz that does not change with the SEC/DIV setting. To provide lower sampling rates of the input signal, the data words are stored in the acquisition memory at a save clock rate that varies with the SEC/DIV setting.

The Acquisition Memory is a FIFO (first in, first out) memory system. The length of the data pipeline is 512 data bytes (of 8 bits each). In the normal sample mode, each data byte produced by the A/D Converter is stored into the pipeline at the sample clock rate (10 MHz). At Time Base settings above 5 μ s/div, the save clock rate (which changes with the SEC/DIV setting) is used to store converted samples into the pipeline. With PEAK DETECT enabled, two data bytes are stored into the pipeline for each save clock. The data bytes are loaded into a shift register at the output of the FIFO and the bits of the data byte are shifted out serially through an isolation pulse transfer to be placed into the display memory for eventual display.

Block Diagram Overview – 222 Service

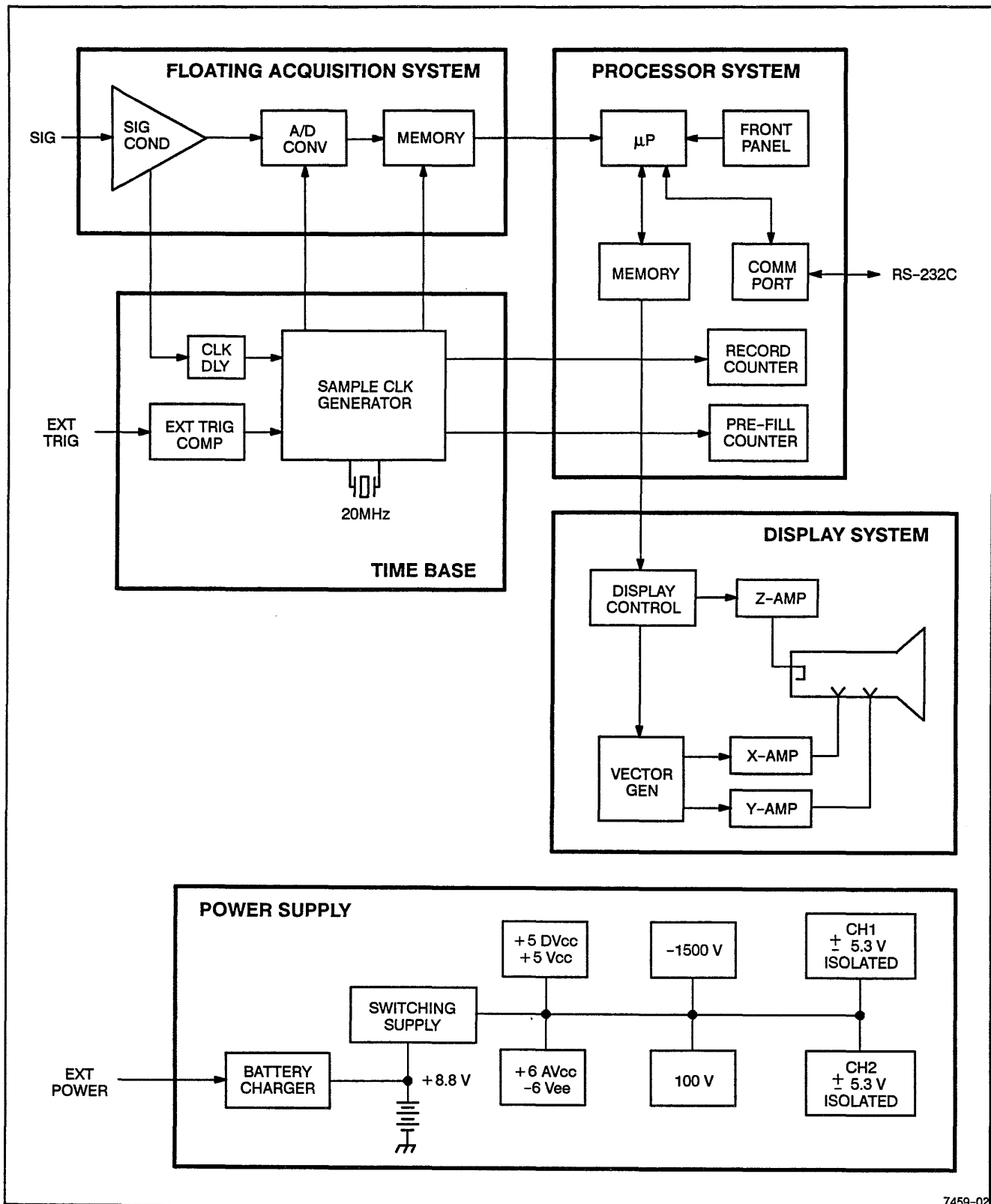

7459-02

Figure 3-1. Simplified block diagram of the 222 DSO.

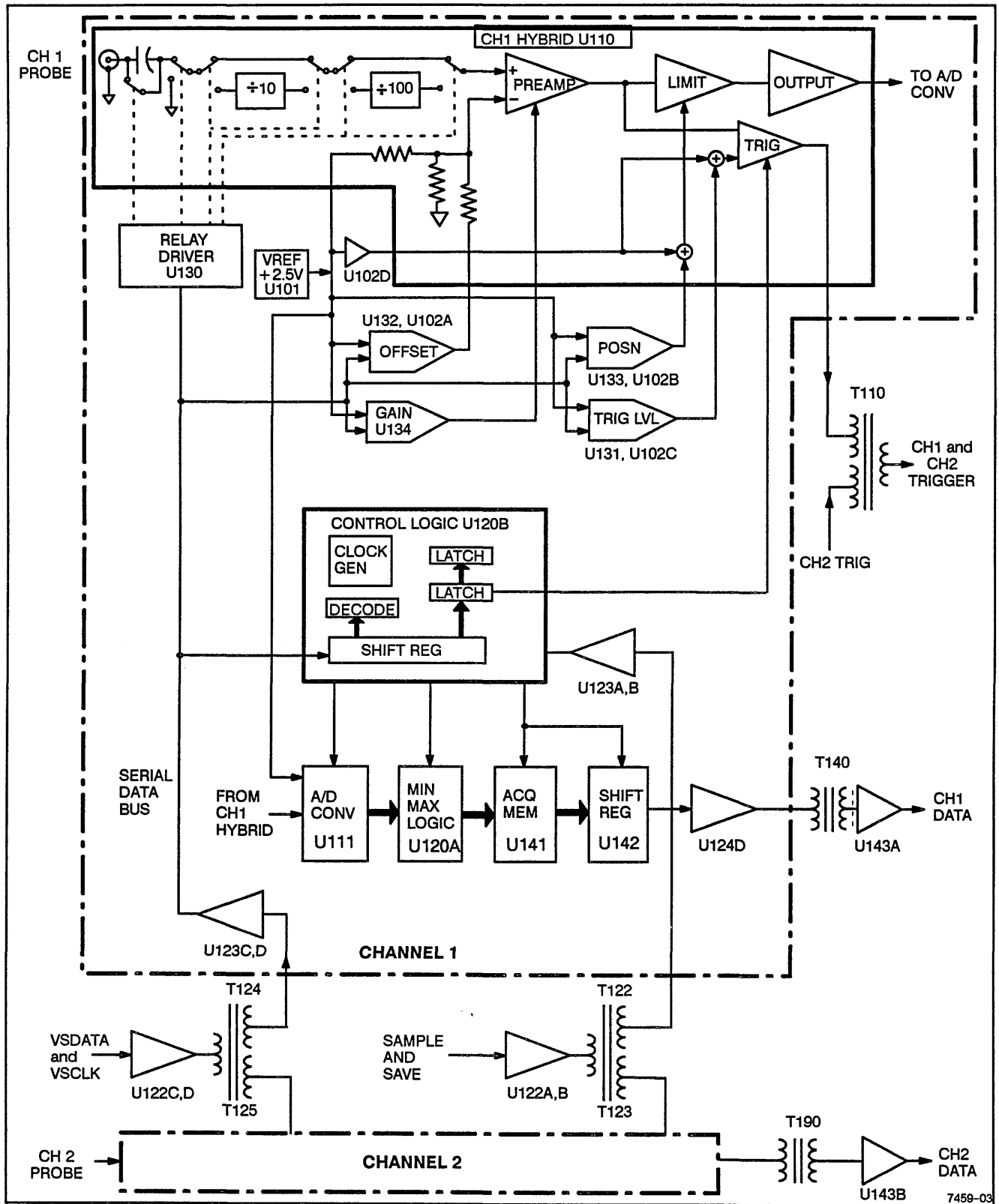

Figure 3-2. Floating Acquisition System.

TIME BASE

All acquisition clock signals are derived from a free-running 20 MHz master oscillator. The Sample Clock Generator contains counters and multiplexers to produce the various clocking signals to the A/D Converter, the Acquisition Memory, and the data counters that keep track of the number of samples taken for a waveform record (see Figure 3-3).

The Pre-Fill Counter counts to determine when the pretrigger waveform data has been acquired. Then the trigger circuit is enabled to accept a trigger event. When the trigger occurs, the remaining data points needed to fill the waveform record are acquired. The Record counter determines when those data points have been acquired and then halts the acquisition system. A complete waveform record is then held in the Acquisition Memory. An interrupt is also generated to the Processor to inform that device that the acquisition is completed.

The output of the Clock Delay circuit is used during Repetitive Store Mode. The time difference between the

trigger event and the rising edge of the sample clock is measured so that repetitive samples taken on different triggers may be correctly placed in the waveform record. The resolution of the Clock Delay timer is 0.5 ns.

When external trigger signals are connected to the instrument, the External Trigger Comparator is used to produce the actual trigger event from the applied signals. For operation on internal trigger signals, the Schmitt trigger circuit is used to allow the signal to return to zero with producing a false trigger signal.

PROCESSOR SYSTEM

The Processor System contains a microcontroller, a memory, chip-select logic, and the RS-232 interface (see Figure 3-4). It receives inputs from the Front Panel or RS-232 interface and controls the Acquisition System, Time Base, and Display System through its synchronous serial interface. The Processor System is clocked by an 8 MHz oscillator that is not frequency related to the Time Base clocks (not derived from the 20 MHz Time Base oscillator).

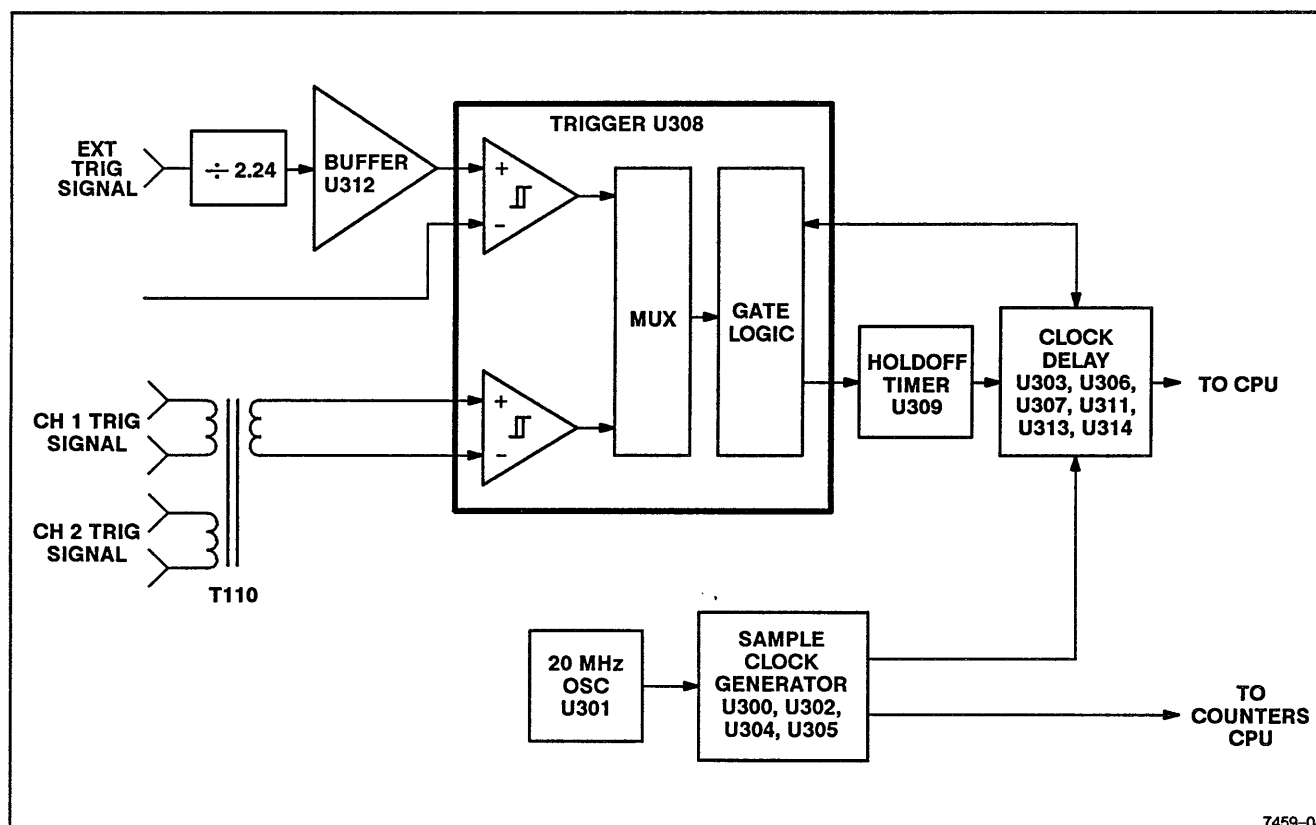

Figure 3-3. Time Base block diagram.

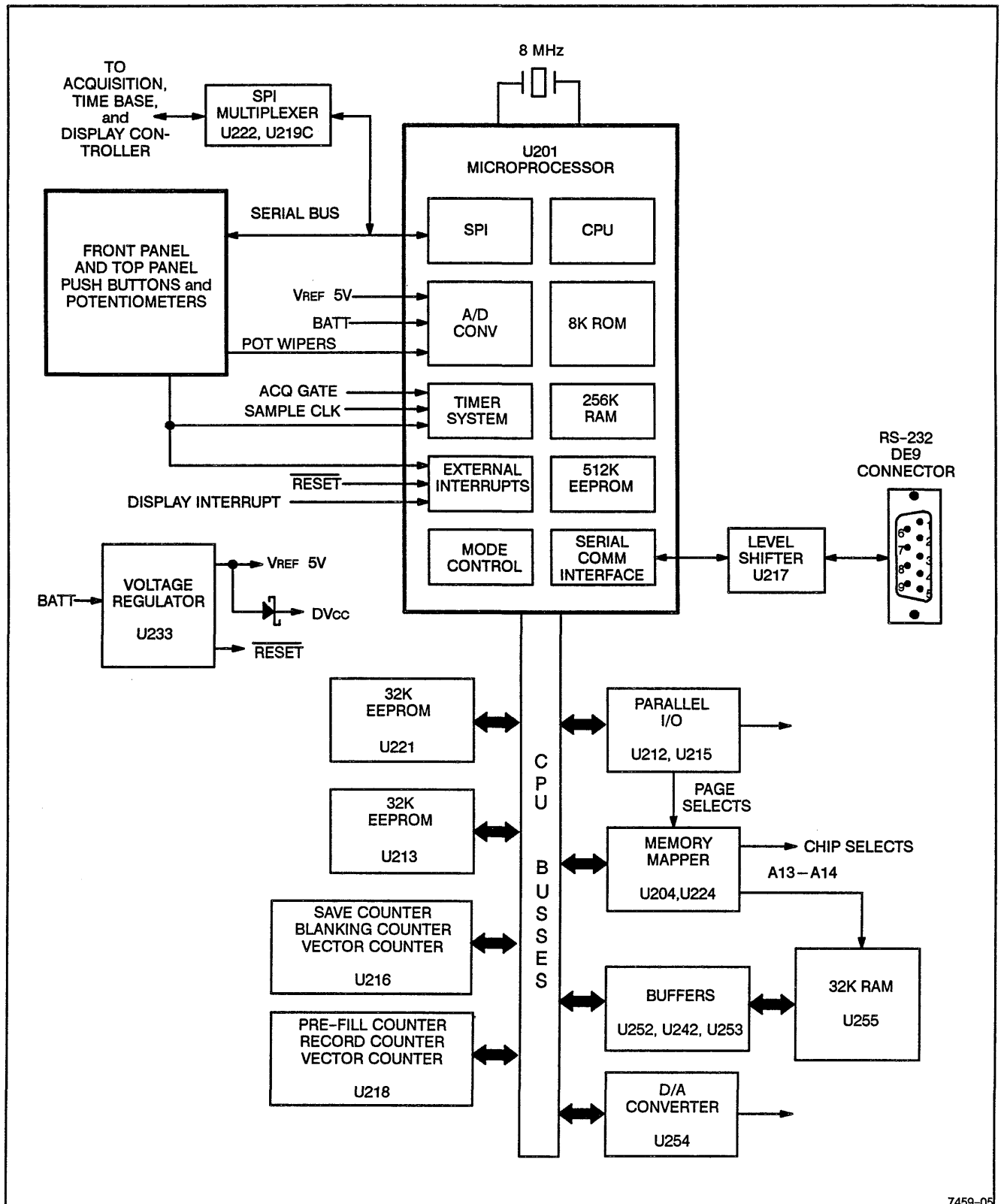

Figure 3-4. Processor System simplified block diagram.

Microprocessor

The heart of the Processor is an 8-bit microprocessor with built-in RAM, ROM, EEPROM, Timers, A/D Converter, and serial and parallel ports. An internal crystal-controlled, 8-MHz oscillator produces the timing for all the Processor and Display operations.

The microprocessor has its own internal reset circuitry for handling power down and does not require an external reset circuit. However, the EEPROM circuitry requires some handling on loss of power to maintain its stored data intact. A reset signal is generated when the voltage falls below 6 volts. Placing a shorting jumper between pins 1 and 2 of P7 will cause the microprocessor to reset.

A dedicated address bus is used for addressing the ROM, the address decoders and timers of the Processor circuitry.

The internal ROM of the microprocessor contains the diagnostic routines used to check out the external devices on the bus when the EEPROMs cannot be accessed.

The Display Memory is formed by an external 32K by 8 bit static CMOS RAM that is accessed by the microprocessor for loading in waveform data or reading out waveform data when it is being sent over the RS-232 interface.

An internal A/D Converter in the microprocessor is used to encode the Front Panel potentiometer settings and monitor the battery voltage level.

Control data used to set the external devices for such things as gain, attenuation, and time base multiplexing is sent simultaneously to the Display System, the Acquisition System, the Front Panel, and the Acquisition Control latch. The Display System only accepts serial data when its select line is high. The Front Panel, Acquisition Control Latch, and the Acquisition System contain latches that are strobed so that only the desired latch is loaded and the only the serial data needed for a chosen latch is sent.

RS-232 Interface

The microprocessor has an asynchronous communications port for interfacing with external RS-232 devices. Baud rates of 300, 1200, 2400, and 9600 are available with 9600 being the default. The diagnostic software also uses this port to export error messages to a terminal or host computer so that the results can be seen even if the

instrument display system fails. The CMOS levels output from the microprocessor are level shifted to $\pm 6V$ to conform with the RS-232 $\pm 5V$ minimum operating levels. The external RS-232 connector is non-standard and the pin assignments conform to that of the IBM® AT PC except that it is a female connector and configured as a DTE (modem) device. This setup allows a direct connections to an IBM AT (or compatible). A special adapter cable is required to make the interconnection. (See the Performance Check for information on the pin assignments.) Pin 9 of the RS-232 connector is used to provide the 12 volts needed to program the EEPROMs, it is enabled only when a jumper is installed internally in the instrument.

Front Panel

The Front Panel consists of a switch matrix, three potentiometers, two shaft encoders, and an LED. All controls on the Front Panel are routed through the Processor. With the exception of the three potentiometers, the Front Panel is interrupt driven and is only serviced when a control is moved or a button is pressed. Data is sent and received serially to keep the number of interconnections between the Processor and the Front Panel to a minimum.

The Front Panel and Top Panel keypad are encoded using the same switch matrix. When one of the buttons is pressed, an interrupt is sent to the Processor. The Processor then latches the row data from the switch matrix and processes it to determine if a switch in that row was pressed. Each row is processed in turn to determine which switch was pressed.

Shaft Encoders

The VOLTS/DIV and SEC/DIV shaft encoders are 16-position devices that produce a quadrature or (gray code), 2-bit output. Each position change causes only one of the two bits to change states. This change is sensed and an interrupt is sent to the Processor. On an interrupt, the Processor latches the encoder's outputs, and then processes that information against the previous settings to determine the direction and amount of shaft rotation.

Potentiometers

The three potentiometers are scanned by the Processor's internal 8-bit A/D converter. Their voltage outputs are compared with previously digitized values to determine if a new level setting has been made.

DISPLAY SYSTEM

The Display System consists of the Display Memory, the Display Controller, X and Y Vector generators, and the crt drivers (see Figure 3-5). A static 32K by 8-bit random-access memory (RAM) makes up the Display Memory. The memory is organized as 512, 16-bit words. When displaying a waveform, the 16-bit word contain waveform data only and just the upper (even) byte is displayed. In XY mode and when displaying characters, the 16-bit word contains Y data in the upper byte and X data in the lower one. The least significant bit of the X data is used as a blanking bit in character mode.

Access to the Display Memory is shared by the Processor and the Display System. Each has access on alternate halves of an enabling clock. During a display cycle, data is read from the memory and transferred to a dual 8-bit digital-to-analog converter (DAC). The analog output from the DAC drives the X- and Y-axis circuits. When displaying waveform data, the X-axis is driven by a simple single-speed sweep generator.

During a memory write cycle, the Processor stores newly acquired waveform data in preparation for the next display cycle.

Display Controller

The Display Controller consists of a state machine, display address counter, vector counter, and a blanking counter. The state machine produces read and write signals to the Display Memory and clocks the address counter, vector counter, and blanking counter. It also controls the sweep, vector generators, and crt blanking. The Processor loads control data to the Display Controller serially via the microprocessor's serial interface.

The display address counter is a programmable logic array used to address the Display Memory. Counting data is loaded serially from the Processor. The vector counter keeps track of the number of vectors displayed, and when the preloaded count for a display is reached it resets the display state machine. The blanking counter is used to extend the initial blanking period by a number of vector periods. The effects of the blanking counter combined with moving the starting address of the Display Address counter produces the scanning effect of moving the display to the right on the face of the crt.

Vector Generator

The X- and Y-Vector Generators are identical. They both produce a range of output voltages from 0 to 3.2 V. These voltages correspond to 10.24 divisions of deflection (X and Y) when the X and Y amplifiers are calibrated. A description of the Y Vector Generator follows.

Y data is read from the Display Memory and latched. The latched data is then converted to an analog value in the DAC. Output current from the DAC is converted to a voltage signal and applied to a differential amplifier. The differential amplifier produces an output signal that is the difference between the present analog value (next display position) and the previous analog value (present display position). This difference signal is integrated to produce a vector that will cause a straight line to be drawn between the current display position and the next display position (vector display mode). The vector generator is bypassed in dot display mode and the crt is blanked between dot displays.

Sweep Generator

Only a single sweep speed is needed when the display is being updated. The sweep generator produces a 500 volt/second ramp during sweep periods.

X- and Y-Amplifiers

The X- and Y-amplifiers are identical; operation of the Y-amplifier is described. The Y-amplifier consists of a differential amplifier pair and a grounded base amplifier pair. The differential pair provides the signal gain, which is adjustable to match the crt characteristics. A 0 to 3.2 V change from the Y Vector Generator will produce a 70 V swing at the collectors of the grounded base amplifiers.

One side of the differential pair is driven by the Y-Vector Generator; the other is driven by a dc voltage level that is varied to produce the vertical positioning of the waveform display.

Since the gain of the X and Y amplifiers is identical (with only slight gain differences) electronic trace rotation is done. A small portion of the X signal is applied to the Y amplifier and vice versa. The amount of opposite signal added can be varied from 0 to 10% for ± 5.4 degrees of trace rotation.

Block Diagram Overview – 222 Service

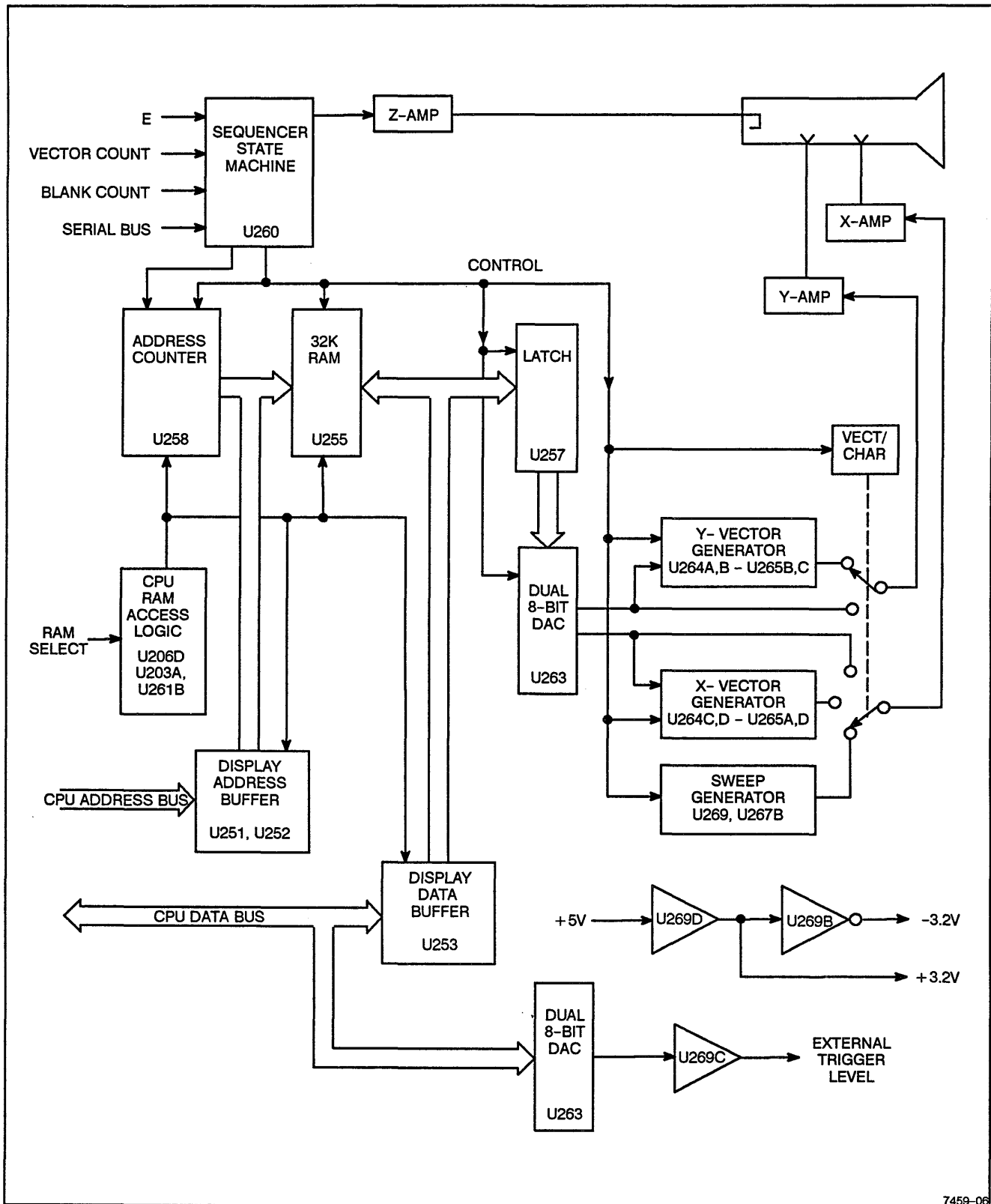

7459-06

Figure 3-5. Display System.

Z-Amplifier

The Z-amplifier is a class B stage that is nonlinear, since it only needs two output states: blanked and unblanked. When on the output of the amplifier is about 0.2 volt; when off, its output goes to 119.3 volts. This pulse is coupled via a dc restorer to the grid of the crt to turn the electron beam on and off for blanking. The grid voltage of the crt is about -1550 V and the dc restorer circuit allows the Z-amplifier to take the grid 119 V below that level to blank. Blanking times are under control of the Processor and are held to less than 10 ms.

BATTERY CHARGER REGULATOR

The battery charger circuit (see Figure 3-6) is active whenever appropriate external power (ac or dc) is applied. When external power is not applied, operating power is drawn from the battery.

Ac power from the mains supply is transformed to approximately 18 Vac for application to the external power supply connector. The external power is applied to an input bridge rectifier via line filters and two line fuses. The rectified input is filtered by a large capacitor and applied to the battery charger switching transformer and a pulse-width-modulator regulator device.

The regulator develops the drive signal to a switching FET. Feedback from the output of the battery charger rectifier controls the width of the switching pulses to the FET to maintain a constant output voltage to the battery and instrument power supply. Switching current is monitored by an overcurrent sensing circuit. The sensing circuit acts to shut down the switching supply if current exceeds the design limit.

Secondary voltage from the switching transformer is rectified and filtered to produce the charging and operating power for the instrument.

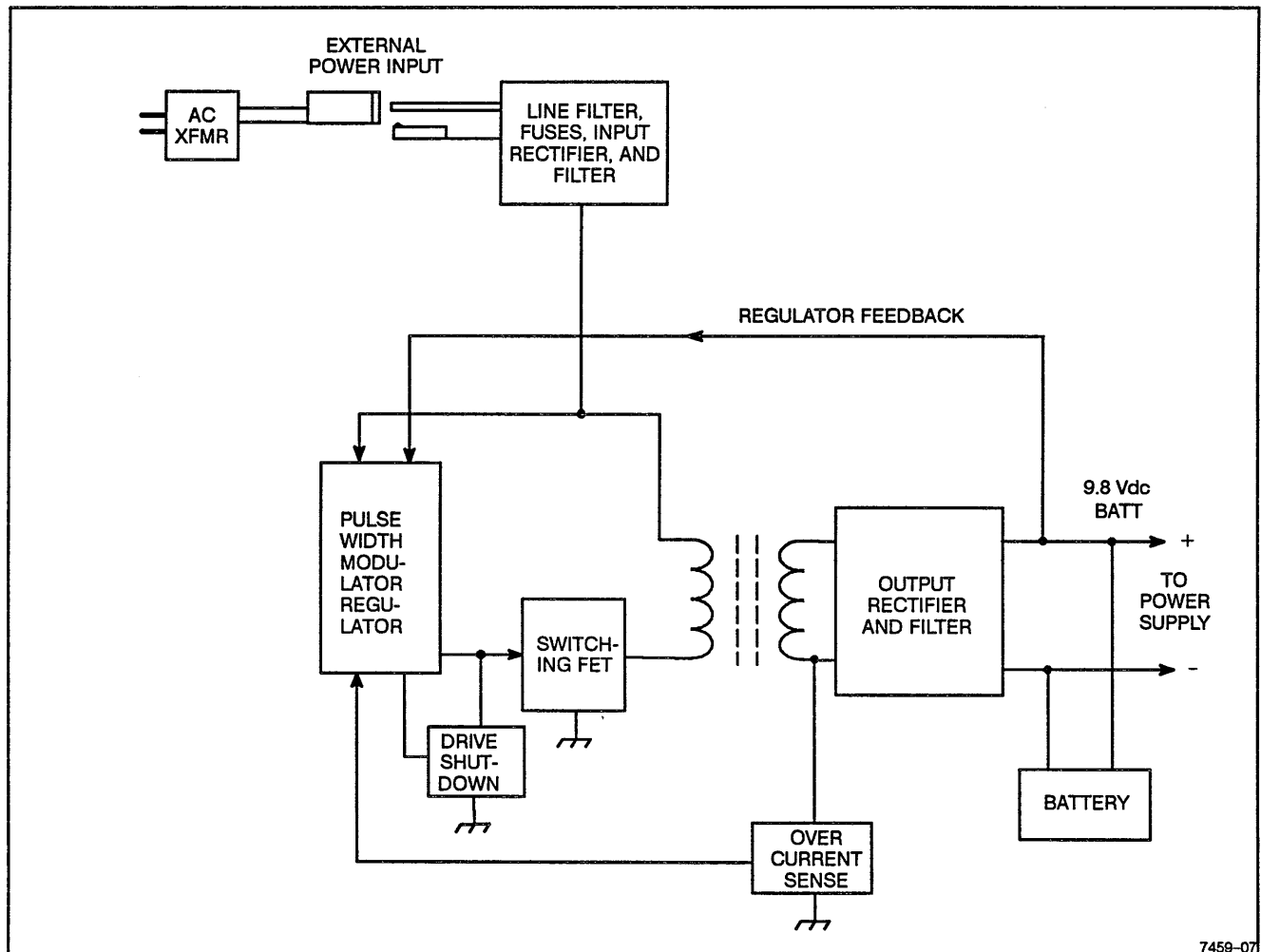

Figure 3-6. Battery Charger block diagram.

POWER SUPPLY

Dc power from either the battery or the battery charger circuit is applied to a center-tapped switching transformer in the power supply circuit (see Figure 3-7). Power is applied to a pulse-width modulator device (identical to the one used in the battery-charger circuit) via an ON/OFF circuit controlled by the oscilloscope's operating system. When the applied voltage is high enough, the supply will be permitted to turn on. While operating on battery power, the automatic time out will shut down the power supply after two minutes of no front panel activity. Also, the power supply will be shut down if the battery voltage drops to below 7.32 volts.

As with the battery charger circuit, the regulator develops the drive signals, in this case to a pair of switching FETs. The switching transformer has two secondary windings: one isolated winding supplies the crt heater voltage; one multi-tapped winding supplies the various secondary

levels to power the instrument and the crt. The secondary voltages are rectified and filtered to produce the operating dc potentials.

Output voltage is regulated by monitoring the output of the high voltage secondary tap. A feedback voltage is applied to the pulse-width modulator regulator to control the width of the drive signals to the switching FETs. The width is adjusted as needed to maintain the correct operating voltage at the output. Switching current is also monitored. Excess switching current will cause the regulator to shut down the drive to the switching FETs.

High voltage to the crt is developed by a voltage multiplier circuit off the high voltage tap of the transformer secondary winding. The negative high voltage is applied to the cathode of the crt to provide acceleration potential for the electron beam. That level is also referenced to the crt grid and Z-axis circuit for proper biasing of the intensity grid. Focus voltage is derived from a resistive divider across a portion of the high voltage multiplier circuit.

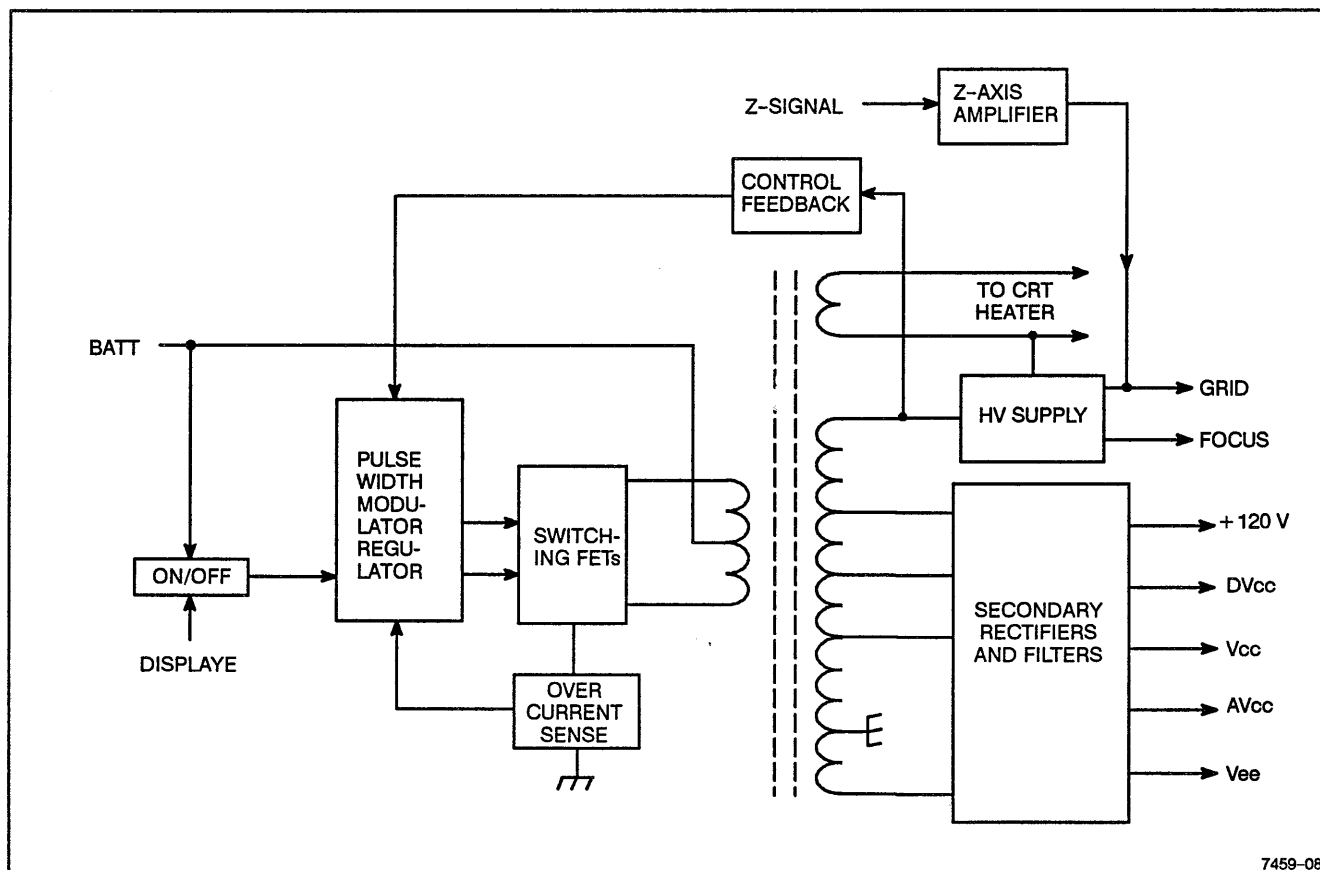

Figure 3-7. Power Supply block diagram.

PERFORMANCE CHECK PROCEDURE

INTRODUCTION

This Performance Check Procedure verifies the Performance Requirements of the 222 DSO as listed in the Specifications (Section 1). These checks may be used as an acceptance test or as a preliminary troubleshooting aid to help determine the need for repair or readjustment.

You do not have to remove the instrument cabinet to do these checks. All checks can be made with operator-accessible controls and connectors.

TEST EQUIPMENT REQUIRED

Table 4-1 lists all the test equipment required to do the Performance Check Procedure, the Adjustment Procedure and the tools needed for disassembly and assembly. Test equipment specifications described are the minimum necessary to provide accurate results. For test equipment operation information, refer to the appropriate test equipment instruction manual.

When you use equipment other than that recommended, you may have to make some changes to the test setups. If the exact equipment in Table 4-1 is not available, use the Minimum Specification column to determine if any other available test equipment is adequate to do the check.

PERFORMANCE CONDITIONS

The performance limits in this performance verification document are valid under the following conditions:

The instrument must have been self calibrated within $\pm 5^{\circ}\text{C}$ of the ambient operating temperature.

The instrument must be checked at an ambient temperature between -10°C and $+55^{\circ}\text{C}$.

PERFORMANCE CHECK INTERVAL

It is recommended that a complete performance check be done on the instrument at least once each year. A more frequent interval is advised if the instrument is used under severe conditions.

PREPARATION

This procedure is divided into subsections to let you check individual sections of the instrument when it is not necessary to do the complete Performance Check. An Equipment Required block at the beginning of each subsection lists the equipment from Table 4-1 that is needed to do the checks in that subsection.

The initial control settings at the beginning of each subsection prepare the instrument for the first step of the subsection. Do each of the steps in a subsection completely and in order to ensure the correct control settings for the following steps. Let the instrument and test equipment warm up for 10 minutes to obtain a valid performance check to the accuracies stated in the Performance Characteristics (Section 1).

Set-Up

- a. Plug the wall transformer into the ac power source.
- b. Plug the low voltage ac power cord from the wall transformer into the EXT POWER INPUT jack on the rear of the oscilloscope.
- c. Press the ON button of the oscilloscope to toggle it into the operating mode.
- d. Turn on the test equipment and allow a 10-minute warm-up period to obtain a stable operating temperature.

**Table 4-1
Test Equipment Required**

Item and Description	Minimum Specification	Use	Example of Test Equipment
Leveled Sine-Wave Generator	Frequency: 50 kHz to above 20 MHz. Output amplitude: variable from 10 mV to 5 V p-p. Output impedance: 50 Ω. Amplitude accuracy: constant within 1.5% of reference frequency to 20 MHz.	Vertical, triggering, and bandwidth checks.	TEKTRONIX SG 503 Leveled Sine-Wave Generator. ^a
Calibration Generator	Standard-amplitude signal levels (dc and square wave): 5 mV to 50 V. Accuracy: ±0.25%. High-amplitude signal levels: 1 V to 60 V. Repetition rate: 1 kHz. Fast-rise signal level: 1 V. Repetition rate: 1 MHz. Rise time: 1 ns or less. Flatness: ±0.5%.	Gain and transient response checks.	TEKTRONIX PG 506A Calibration Generator. ^a
Time-Mark Generator	Marker outputs: 5 ns to 0.5 s Marker accuracy: ±0.1%.	Horizontal checks.	TEKTRONIX TG 501A Time-Mark Generator. ^a
Coaxial Cable	Impedance: 50 Ω. Length: 42 in. Connectors: BNC.	External trigger checks.	Tektronix Part Number 012-0057-01.
Termination	Impedance: 50 Ω. Connectors: BNC.	Signal termination.	Tektronix Part Number 011-0049-01.
Adapter (2 required)	Connectors: BNC male-to-miniature-probe tip.	Signal interconnection.	Tektronix Part Number 013-0084-02.
Open-end Wrench	3/16 inch.	Assembly and disassembly.	
Torx Screwdriver Tip and Handle	#T15 Torx Tip and Screwdriver Handle.	Assembly and disassembly.	Tektronix Part Numbers: #T15 Tip 003-0966-00 Handle 003-0293-00
Hex Wrench	1/16 inch.	Assembly and disassembly.	Allen Wrench
Adapter	Connectors: BNC female-to-dual-banana.	External trigger check.	Tektronix Part Number 103-0090-00.
T-Connector	Connectors: BNC.	Signal interconnection.	Tektronix Part Number 103-0030-00.

^aRequires a TM500-series power module.

Table 4-1 (cont)

Item and Description	Minimum Specification	Use	Example of Test Equipment
Small, Flat-tip screwdriver	Length: 3-in shaft. Bit size: 1/8 inch.	Adjust Horizontal and Vertical display alignment. Adjust intensity and focus controls.	
Alignment Tool	Length: 1-in shaft. Bit size: 3/32 in. Low capacitance; insulated.	Adjust CH1 and CH2 Probe Compensation.	Tektronix Part Number 003-0675-00.
Short Jumper Wire	Connectors: Banana; length 3 inches or more.	External trigger self calibration.	
0.3 V Calibration Reference Voltage	0.3 V \pm 0.5%; no ripple.	CH1 and CH2 offset calibration.	Fluke DMM Calibrator.

Self Calibration

After the warm-up period, run the acquisition system self calibration routine.

Press **AUX FUNCT** on the top panel.

From the AUX FUNCT menu, the SELF CAL choice calls up an additional menu used to run the self calibration routines. A terminal, or a PC operating in terminal mode, may be connected to determine the testing results of the routines, but it is not required. A PASS/FAIL indication is displayed on the crt when a test is finished.

- Press **SELF CAL** to call up the calibration menu.
- Press **CH 1** to start the Channel 1 self calibration.
- When the PASS/FAIL message is displayed the first routine is done.

- Press **CH 2** to start the Channel 2 self calibration.
- When the PASS/FAIL message is displayed the second routine is done.
- Press **EXT TRIG** to bring up the menu for running the external trigger self calibration.

NOTE

For this self calibration, the EXT TRIG COMM and EXT TRIG INPUT connectors must be connected together. A short jumper with banana plug connectors may be used to make the connection.

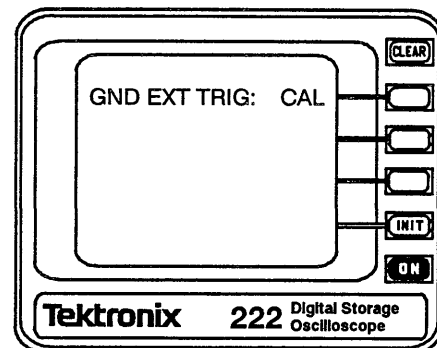
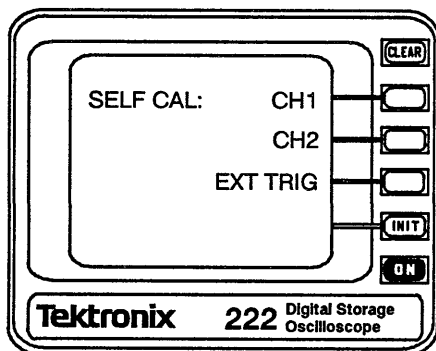

Performance Check Procedure – 222 Service

- g. Press **CAL** to start the External Trigger self calibration routine when the EXT TRIG COMM and EXT TRIG INPUT connectors are joined. A PASS/FAIL message is displayed when the routine is done.

- h. Press the button at the completion of the self calibration routines to return to normal oscilloscope operation.

If a self calibration step fails, the currently stored calibration constants are not changed. Rerun the failed routine again.

If the failure persists, further information about the nature of the failure may be found by connecting the RS-232 interface port to a terminal or host computer and rerunning the failed self calibration routine. A coded error message is output when the error occurs.

An RS-232 interconnection cable for use with the 222 is available as an optional accessory. The cable wiring diagram is shown in Figure 4-1. Setting the communication baud rate is described in Section 4 of the Operators Manual.

Refer to "Troubleshooting" in the Maintenance section and the RS-232 Interfacing Guide for explanations of the error codes.

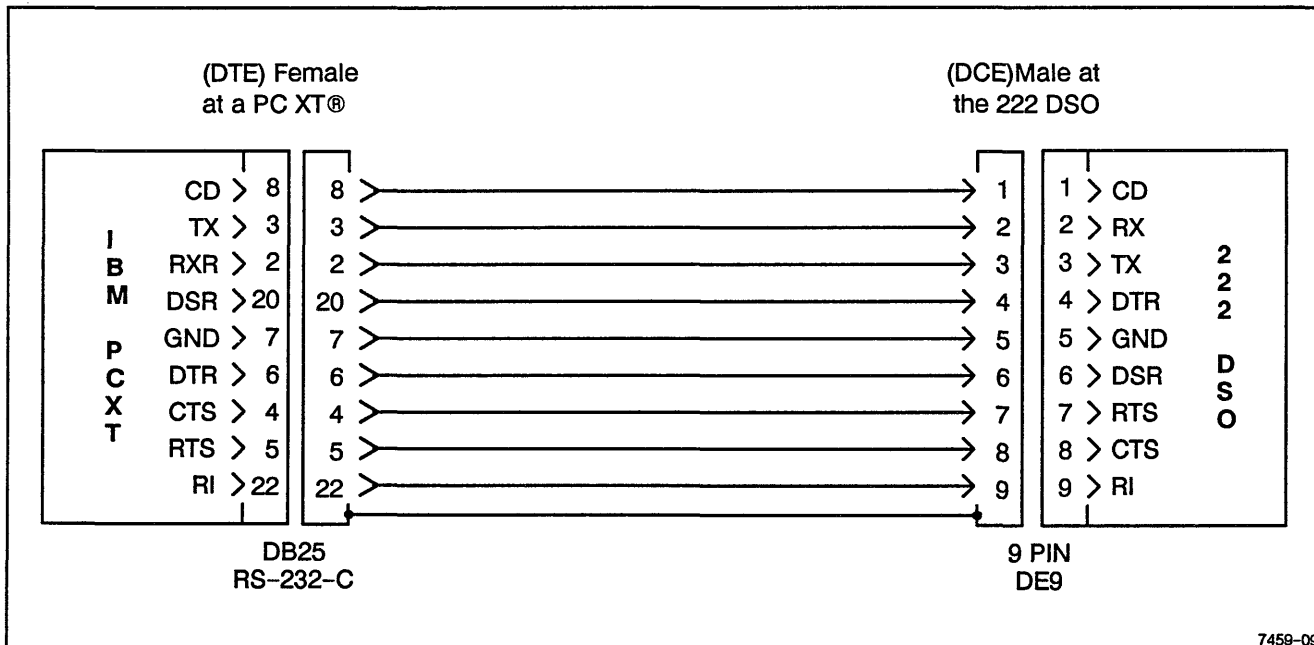

Figure 4-1. RS-232 interconnection cable wiring between a PC XT® (or compatible) and the 222.

INDEX TO PERFORMANCE CHECK PROCEDURE

DISPLAY CHECKS

Page

1. Check/Adjust INTENSITY Control 4-6
2. Adjust Focus Control 4-6
3. Check/Adjust Horizontal Alignment 4-6
4. Check/Adjust Vertical Alignment 4-6

VERTICAL

1. Check Input Current 4-7
2. Check Input Coupling 4-7
3. Check Vertical POSITION Range 4-8

4. Check Variable VOLTS/DIV Range 4-8
5. Check VOLTS/DIV Accuracy 4-8
6. Check Probe Compensation 4-9
7. Check Analog Bandwidth 4-9

HORIZONTAL

1. Check X1 SEC/DIV Accuracy 4-11

TRIGGER

1. Check Trigger Sensitivity 4-12
2. Check Trigger LEVEL Control 4-12
3. Check External Trigger Sensitivity 4-13
4. Check External Level Range 4-13
5. Check Trigger Jitter 4-14

DISPLAY CHECKS

Equipment Required (See Table 4-1)

Battery-Charger Adapter
(wall transformer)

Small Flat-blade Screwdriver

INITIAL CONTROL SETTINGS

Power and Display

External Power	ON
Power	ON

Front-Panel Controls

Auto Setup	Press for initial setup
------------	----------------------------

PROCEDURE

1. Check/Adjust INTENSITY Control

- Adjust the INTEN control (located on the rear panel) counterclockwise (CCW).
- CHECK—that the crt beam cuts off (no intensity).
- Adjust the INTEN control clockwise for normal viewing.

2. Adjust FOCUS Control

- Press the AUX FUNCT button on the top panel.
- Select the ALIGN menu choice.
- Adjust the FOCUS control (located on the rear panel) for the best definition of the ALIGN XY pattern.

3. Check/Adjust Horizontal Alignment

- CHECK—that the HORIZ ALIGN adjustment (accessible from the rear) will align the horizontal traces with the horizontal graticule lines.
- ADJUST—HORIZ ALIGN adjustment to align the horizontal traces with the horizontal graticule lines.

4. Check/Adjust Vertical Alignment

- CHECK—that the VERT ALIGN adjustment (accessible from the rear) will align the traces with the vertical lines.
- ADJUST—the VERT ALIGN adjustment to align the vertical traces with the vertical graticule lines.
- Press the CLEAR button to remove the display pattern and return to normal operation.

VERTICAL

Equipment Required (See Table 4-1)

Leveled Sine-Wave Generator	BNC-male-to-probe-tip Adapter
Calibration Generator	Battery-Charger Adapter (wall transformer)
50-Ω BNC Termination	

INITIAL CONTROL SETTINGS

Power and Display

External Power	ON
Power	ON

Vertical

CH 2 Input Coupling	GND
CH 2 VOLTS/DIV	5 mV
CH 2 Variable	CAL
CH 1 Input Coupling	GND
CH 1 VOLTS/DIV	5 mV
CH 1 Variable	CAL

Horizontal

SEC/DIV	1 ms
X10 MAG	OFF

Trigger

Trigger MODE	AUTOBL
Trigger SOURCE	VERT
Trigger SLOPE	+

Top Panel Controls

Trigger POS	POST
STORE/NON-STORE	STORE
CH 1 and CH 2 INVERT	OFF
XY MODE	OFF
READOUT	ON
ACQUISITION MODE	NORM

PROCEDURE

1. Check Input Current

- Connect the probe reference leads to their associated probe tips.

- Vertically position the CH 1 trace to the center horizontal graticule line.
- Set the CH 1 Coupling to DC.
- CHECK—for 0.5 division or less shift from center horizontal graticule line.
- Set CH 1 Coupling OFF.
- Repeat parts b, c, and d for CH 2.

2. Check Input Coupling

- SET:

CH 2 VOLTS/DIV	50 mV
SEC/DIV	0.5 ms
Trigger MODE	AUTOLVL
- CONNECT—the Calibration Generator AMPL output via a BNC-to-male probe-tip adapter to the CH 2 probe tip.
- Set the Calibration Generator for a STD AMPL output at 0.2 V.
- Vertically position the bottom of the signal to the center horizontal graticule line.
- Set the CH 2 Coupling to AC.
- CHECK—for the display to be vertically centered about the center horizontal graticule line.
- SET:

CH 2 Coupling	CH2 OFF
CH 1 Coupling	DC
CH 1 VOLTS/DIV	50 mV
- Disconnect the Channel 2 probe tip from the test equipment and connect the Channel 1 probe tip.
- Repeat parts d, e, and f for CH 1.

3. Check VERTICAL POSITION Range

- a. Set the CH 1 VOLTS/DIV setting to 0.2 V.
- b. Set the Calibration Generator to output a 5-V, standard-amplitude signal.
- c. Adjust the Vertical POSITION control fully clockwise.
- d. CHECK—for the bottom of the signal to be no more than 2 divisions below the center horizontal graticule line.
- e. Adjust the Vertical POSITION control fully counterclockwise.
- f. CHECK—for the top of the signal to be no more than 2 divisions above the center horizontal graticule line.
- g. SET:

CH 1 Coupling	CH1 OFF
CH 2 Coupling	AC
CH 2 VOLTS/DIV	0.2 V
- h. Disconnect the Channel 1 probe tip from the test equipment and connect the Channel 2 probe tip.
- i. Repeat parts c, d, e, and f for CH 2.

4. Check Variable VOLTS/DIV Range

- a. SET:

CH 2 Coupling	DC
CH 2 VOLTS/DIV	50 mV
- b. Set the Calibration Generator for a standard-amplitude output of 0.2 V.
- c. Position the bottom of the signal on the center vertical graticule line.
- d. Press in and rotate the Vertical POSITION knob (VAR VOLTS/DIV control when held in) counterclockwise until the display amplitude stops decreasing.
- e. CHECK—for less than 1.6 division of signal amplitude.

NOTE

The Variable knob must be held in as it is rotated or it reverts to its Vertical POSITION function.

- f. Set the CH 2 VAR VOLTS/DIV to CAL (press and hold in the Vertical POSITION knob and rotate it cw until an audible beep is heard and the uncal indicator is cleared from in front of the VOLTS/DIV readout).
- g. SET:

CH 2 Coupling	CH2 OFF
CH 1 Coupling	DC
CH 1 VOLTS/DIV	50 mV
- h. Disconnect the Channel 2 probe tip from the test equipment and connect the Channel 1 probe tip.
- i. Repeat parts c, d, e, and f for CH 1.

5. Check VOLTS/DIV Accuracy

- a. Set the CH 1 VOLTS/DIV to 5 mV.
- b. Set Calibration Generator for a standard-amplitude output signal of 20 mv.
- c. Vertically center the display.
- d. CHECK—all positions of the VOLTS/DIV settings for correct signal-to-graticule accuracy using the VOLTS/DIV and Calibration Generator settings and Amplitude Limits given in Table 4-2.
- e. Return the Calibration Generator output to 20 mV.
- f. SET:

CH 1 Coupling	CH1 OFF
CH 2 Coupling	DC
CH 2 VOLTS/DIV	5 mV
- g. Disconnect the Channel 1 probe tip from the test equipment and connect the Channel 2 probe tip.
- h. Repeat parts c and d for CH 2.
- i. Disconnect the test equipment from the oscilloscope and return the Calibration Generator output to 20 mV.

**Table 4-2
VOLTS/DIV Accuracy Settings**

VOLTS/DIV	CALIBRATION GENERATOR	AMPLITUDE LIMITS
5 mV	20 mV	3.88 div–4.12 div
10 mV	50 mV	4.85 div–5.15 div
20 mV	0.1 V	4.85 div–5.15 div
50 mV	0.2 V	3.88 div–4.12 div
0.1 V	0.5 V	4.85 div–5.15 div
0.2 V	1 V	4.85 div–5.15 div
0.5 V	2 V	3.88 div–4.12 div
1 V	5 V	4.85 div–5.15 div
2 V	10 V	4.85 div–5.15 div
5 V	20 V	3.88 div–4.12 div
10 V	50 V	4.85 div–5.15 div
20 V	100 V	4.85 div–5.15 div
50 V	100 V	1.94 div–2.06 div

6. Check Probe Compensation

- a. SET:
- | | |
|----------------|--------|
| CH 2 VOLTS/DIV | 50 mV |
| SEC/DIV | 0.2 ms |
| Trigger POS | MID |
- b. Connect the Calibration Generator positive-going, FAST-RISE output via a 50- Ω termination and a BNC-to-male probe-tip adapter to the CH 2 probe tip.
- c. Set the Calibration Generator to output a FAST RISE signal with a 1 ms period and a 4-division display amplitude.
- d. Vertically position the top of the square wave on the second horizontal graticule line above the center.
- e. Adjust the calibration output for a 5-division display amplitude.
- f. Position the rising edge at the trigger position to the center vertical graticule line.
- g. CHECK—for 0.1 division or less of rolloff or overshoot at the front corner.

h. SET:

CH 2 Coupling	CH2 OFF
CH 1 Coupling	DC
CH 1 VOLTS/DIV	50 mV

- i. Disconnect the Channel 2 probe tip from the test equipment and connect the Channel 1 probe tip.
- j. Vertically position the display.
- k. Repeat part g for CH 1.
- l. Disconnect the test equipment from the oscilloscope.

7. Check Analog Bandwidth

a. SET:

CH 1 VOLTS/DIV	0.5V
SEC/DIV	5 μ s

- b. Connect the Leveled Sine-Wave Generator output via a 50- Ω termination and BNC-to-male probe-tip adapter to the CH 1 Probe tip.

Performance Check Procedure – 222 Service

- c. Set the Leveled Sine-Wave Generator for a display amplitude of 6 divisions at 50 kHz.
- d. Set the SEC/DIV to 50 ns.
- e. Set the Leveled Sine-wave generator output frequency to 10 MHz.
- f. CHECK—for at least 4.2 divisions of display amplitude.
- g. Return the Sine-Wave Generator output frequency back to 50 kHz.

h. SET:

CH 1 Coupling	CH1 OFF
CH 2 Coupling	DC
CH 2 VOLTS/DIV	0.5 V
SEC/DIV	5 μ s

- i. Disconnect the Channel 1 probe tip from the test equipment and connect the Channel 2 probe tip.
- j. Vertically center the display.
- k. Repeat parts c, d, e, and f for CH 2.
- l. Disconnect the test equipment from the oscilloscope.

HORIZONTAL

Equipment Required (See Table 4-1)

Time-Mark Generator
50-Ω BNC Termination

BNC-male-to-probe-tip Adapter
Battery-Charger Adapter (wall transformer)

INITIAL CONTROL SETTINGS

Power and Display

External Power ON
Power ON

Vertical

CH 2 Input Coupling CH2 OFF
CH 1 Input Coupling DC
CH 1 VOLTS/DIV 0.1 V
CH 1 Variable CAL

Horizontal

SEC/DIV 1 ms
X10 MAG OFF

Trigger

Trigger MODE AUTOBL
Trigger SOURCE VERT
Trigger SLOPE +

Top Panel Controls

Trigger POS POST
STORE/NON-STORE STORE
CH 1 and CH 2 INVERT OFF
XY MODE OFF
READOUT ON
ACQUISITION MODE NORM

PROCEDURE

1. Check X1 SEC/DIV Accuracy

- a. Connect the Time Mark Generator via a 50-Ω termination and BNC-to-male probe-tip adapter to CH 1 probe tip.
- b. Set the Time Mark Generator to output 1 ms time markers.
- c. Vertically position the baseline of the time-marker signal to the center horizontal graticule line.
- d. Horizontally position the left time marker to the first vertical graticule line.
- e. CHECK—that the last time marker is aligned to the 11th vertical graticule line within 2% (± 0.2 division).

TRIGGER

Equipment Required (See Table 4-1)

Leveled Sine-Wave Generator	50-Ω BNC Termination
Calibration Generator	Battery-Charger Adapter (wall transformer)
BNC-to-dual-banana Adapter	BNC Coaxial Cable
Two, BNC-male-to-probe-tip Adapters	

INITIAL CONTROL SETTINGS

PROCEDURE

Power and Display

External Power	ON
Power	ON

Vertical

CH 2 Coupling	CH2 OFF
CH 2 Variable	CAL
CH 1 Coupling	DC
CH 1 VOLTS/DIV	5 mV
CH 1 Variable	CAL

Horizontal

X10 MAG	OFF
SEC/DIV	50 ns

Trigger

Trigger MODE	AUTOLVL
Trigger SLOPE	+
Trigger SOURCE	VERT

Top Panel Controls

Trigger POS	POST
STORE/NON-STORE	STORE
CH 1 and CH 2 INVERT	OFF
XY MODE	OFF
READOUT	ON
ACQUISITION MODE	NORM

1. Check Trigger Sensitivity

- Connect the Leveled Sine-Wave Generator via a 50-Ω termination and a BNC-to-male probe-tip adapter to the CH 1 probe tip.
- Set the Sine-Wave Generator for a 5-division display amplitude at 20 MHz.
- Set the CH 1 VOLTS/DIV to 50 mV for a 0.5-division display amplitude.
- CHECK—for a stably triggered display with the TRIG'D indicator on.

2. Check Trigger LEVEL Control

- SET:

CH 1 VOLTS/DIV	0.2 V
SEC/DIV	5 μs
Trigger MODE	AUTOBL
- Set the Sine-Wave Generator for a 5-division display amplitude at the 50 kHz reference frequency.
- Adjust the Trigger LEVEL control for a stable trigger.
- Check—that the signal remains triggered while the trigger point indicator “+” is on the positive slope when rotating the Trigger LEVEL control through its range.
- Set the Trigger SLOPE to “-.”
- Check—that the signal remains triggered while the trigger point indicator “+” is on the negative slope when rotating the Trigger LEVEL control through its range.

- g. Set the CH 1 VOLTS/DIV to 50 mV.
- h. Set the Trigger LEVEL control to position the trigger indicator (+) to 1 division below the positive peak of the signal. (Use the Vertical POSITION control to bring the peak of the signal on screen to see the trigger position on the waveform.)
- i. Position the waveform vertically to place the bottom of the signal on the center horizontal graticule line.
- j. CHECK—that the signal remains triggered with the TRIG'D indicator light on.
- k. Use the Trigger LEVEL control to place the trigger indicator 1 division above the negative peak of the signal.
- l. Position the waveform vertically to place the top of the signal 1 division below the center horizontal graticule line.
- m. CHECK—that the signal remains triggered with the TRIG'D indicator light on.
- n. Disconnect the CH 1 probe tip from the BNC-to-male probe-tip adapter and connect the CH 2 probe tip.
- o. SET:

CH 1 Coupling	CH1 OFF
CH 2 Coupling	DC
CH 2 VOLTS/DIV	0.2 V
Trigger SLOPE	+
Trigger LEVEL	For a stable display
- p. CHECK—that the signal remains triggered while the trigger point indicator “+” is on the positive slope when rotating the Trigger LEVEL control through its range.
- q. Set the Trigger SLOPE to “-.”
- r. CHECK—that the signal remains triggered while the trigger point indicator “+” is on the negative slope when rotating the Trigger LEVEL control through its range.
- s. Set the CH 2 VOLTS/DIV to 50 mV.
- t. Set the Trigger LEVEL control to position the trigger indicator (+) 1 division below the positive

peak of the signal. (Use the Vertical POSITION control to bring the peak of the signal on screen to see the trigger position on the waveform.)

- u. Position the waveform vertically to place the bottom of the signal 1 division above the center horizontal graticule line.
- v. CHECK—that the signal remains triggered with the TRIG'D indicator light on.
- w. Use the Trigger LEVEL control to place the trigger indicator 1 division above the negative peak of the signal.
- x. Position the waveform vertically to place the top of the signal 1 division below the center horizontal graticule line.
- y. CHECK—that the signal remains triggered with the TRIG'D indicator light on.
- z. Disconnect the test equipment from the CH 2 probe tip.

3. Check External Trigger Sensitivity

- a. SET:

CH 2 Coupling	GND
CH 1 Coupling	DC
CH 1 VOLTS/DIV	50 mV
Trigger SOURCE	EXT
SEC/DIV	50 ns
STORE/NONSTORE	NONSTORE
- b. Connect the Leveled Sine-Wave Generator output via a 50-Ω termination, a BNC T-connector, and a BNC-to-male probe-tip adapter to the CH 1 probe tip.
- c. Connect the other side of the T-connector via a 50-Ω coaxial cable and BNC-to-dual banana connector to the EXT TRIG and EXT TRIG COMM inputs.
- d. Vertically center the display.
- e. Set the Sine-Wave Generator for 5 divisions of amplitude at 10 MHz.
- f. CHECK—that the display can be stably triggered using the Trigger LEVEL control.

4. Check External Trigger Level Range

- a. SET:

CH 1 VOLTS/DIV	1 V
SEC/DIV	5 μ s
- b. Adjust the Leveled Sine-Wave Generator for maximum output at 50 kHz (just over a 5-division display amplitude).
- c. Vertically center the display and horizontally position the beginning of the sweep at the second vertical graticule line.
- d. CHECK – that the beginning of the signal moves at least 2.3 divisions below the center horizontal graticule line as the Trigger LEVEL control is rotated counterclockwise.
- e. CHECK – that the beginning of the signal moves at least 2.3 divisions above the center horizontal graticule line as the Trigger LEVEL control is rotated clockwise.

5. Check Trigger Jitter

- a. SET:

Trigger SOURCE	VERT
----------------	------
- b. Press the AUX FUNCT button on the top keypad.
- c. Select ALIGN to display the ALIGN menu with the XY choice.
- d. Press menu button 2 (next one down under the XY menu choice) to start the clock calibration procedure.
- e. CHECK – that the trigger position indicator (+) remains within the center two horizontal divisions (see Figure 4-2) An occasional jump outside the center two divisions is all right.
- f. Press CLEAR when finished with the trigger jitter check procedure.

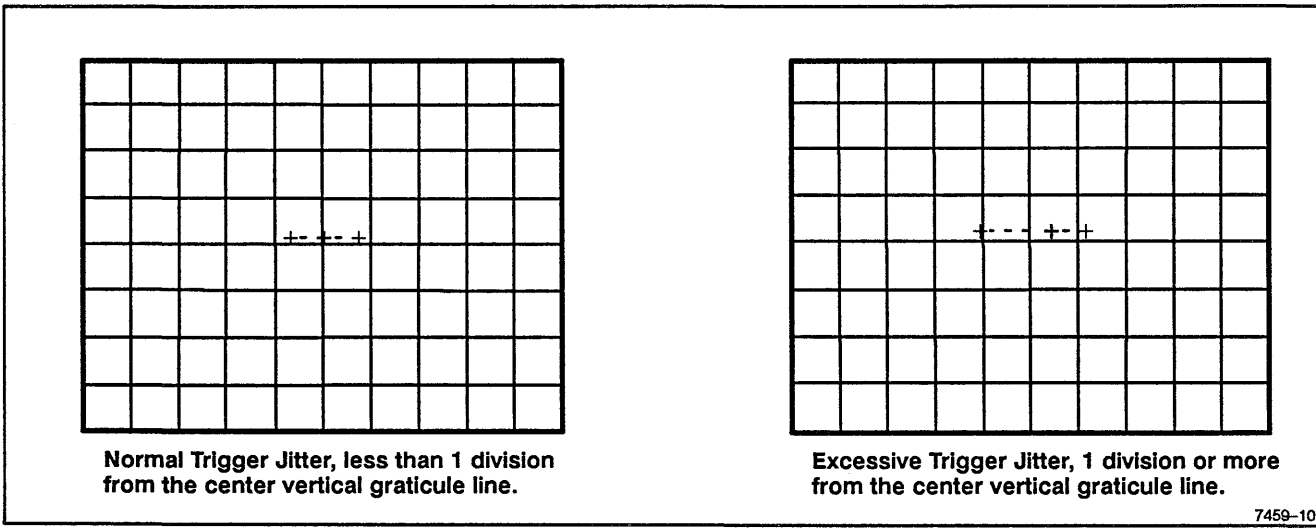

Figure 4-2. Trigger Jitter check.

ADJUSTMENT PROCEDURE

INTRODUCTION

The Adjustment Procedure is a set of sequenced instructions intended to return the instrument to conformance with the Performance Characteristics given in Section 1. Adjustments contained in this procedure should be done only after checks from the Performance Check Procedure, Section 4, have indicated a need for readjustment or after repairs have been made to the instrument.

TEST EQUIPMENT

Table 4-1 is a complete list of the test equipment required to accomplish both the Performance Check Procedure in Section 4 and the Adjustment Procedure in this section. To ensure accurate measurements, it is important that test equipment used for making the adjustments in this section meets or exceeds the specifications described in Table 4-1. When considering use of equipment other than that recommended, use the Minimum Specification column in Table 4-1 to determine whether available test equipment will work.

Detailed operating instructions for test equipment are not given in this procedure. If more operating information is required, refer to the appropriate test-equipment instruction manual.

LIMITS AND TOLERANCES

The limits and tolerances stated in this procedure are instrument specifications only if they are listed in the Performance Characteristics of Section 1. Tolerances given are applicable only to the instrument undergoing adjustment and do not include test equipment error. The instrument must have a warm-up period of at least 10 minutes before making adjustments.

The operating temperature range is between -10°C and $+55^{\circ}\text{C}$. To meet the stated Performance Specifications, the instrument must be operating at an ambient temperature within $\pm 5^{\circ}\text{C}$ of the last "Self Cal." A complete "Self Cal" is done as part of the adjustment procedure.

ADJUSTMENTS AFFECTED BY CIRCUIT BOARD REPLACEMENT

Replacement of a circuit board to repair an instrument may affect one or more adjustment settings. Due to the interactions possible between boards, it is recommended that a complete adjustment be done if boards are replaced.

PREPARATION FOR ADJUSTMENT

Before performing this procedure, do not preset any internal adjustments. Only change an internal adjustment setting if a Performance Characteristic cannot be met with the original setting.

PROCEDURE STEPS

Equipment Required (see Table 4-1)

Wall Transformer (Battery-Charger Adapter)	Alignment Tool
Calibration Generator	Torx Driver, T-15 Tip
50-Ω BNC Termination	Hex Wrench, 1/16 inch
BNC T-Connector	Open-end Wrench, 3/16 inch
BNC-to-probe-tip Adapter (2 required)	50-Ω BNC Coaxial Cable
Dual-Male-Banana-to-Female-BNC- Adapter	DMM Calibrator
	Shorting Jumper, Banana Tip Connectors

See Figures 5-2, 5-3, and 5-5 for the Adjustment Locations

PREPARATION

1. Remove the top case half and front panel from the instrument. (See the "Top Case Removal" procedure in Maintenance, Section 6.)
 2. Lay the top case half down on the right side of the 222 with the front of the case facing the instrument. Reconnect the top keypad cable to its front panel connector.
 3. Swing the front panel out from the left side to allow the crt to be viewed directly when the display adjustments are made.
 4. Connect the wall transformer to an appropriate source of ac power and connect the power supply cable to the EXT POWER connector.
 5. Apply external power to the instrument. Press the front-panel ON button to turn on the 222.
 6. Turn on the test equipment and allow a 10-minute warm-up period before beginning the procedure.
- c. Select XY to bring up the display test pattern.
 - d. ADJUST—INTEN control (R414, the larger control shaft located on the rear panel of the instrument) for a viewable display.
 - e. ADJUST—FOCUS control (R415, located on the rear panel) and ASTIG (R424) for the best focused display over the entire graticule area.
 - f. ADJUST—VPOS (R456) and HPOS (R448) to center the ALIGN XY calibration pattern on the crt.
 - g. ADJUST—HORIZ ALIGN (R426) and VERT ALIGN (R431) for best horizontal and vertical alignment of the box pattern to the graticule lines.
 - h. ADJUST—VGAIN (R455) for a display 4 vertical divisions high and HGAIN (R447) for a display 8 horizontal divisions wide on the outer box pattern.

ADJUSTMENTS

1. Display Adjust

- a. Press the AUX FUNCT button on the top keypad.
- b. Select the ALIGN menu choice to bring up the XY menu choice.

NOTE

Make sure the midpoint of each outside trace of the calibration pattern is exactly centered over its respective graticule line. See Figure 5-1.

- i. RECHECK—All the display controls for best adjustment.

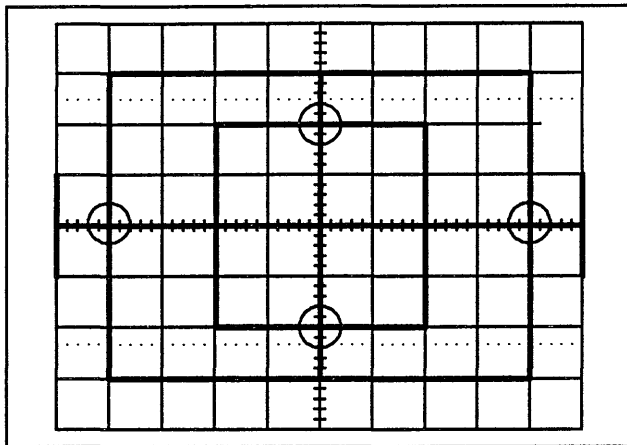

7459-11

Figure 5-1. Locations at which horizontal and vertical gains are adjusted.

2. Sweep Length and Vector Generator Adjust

- a. ADJUST – Swp Length (R255) to set the end of the sweep just to the vertical line on the right side of the ALIGN XY display pattern.

- b. ADJUST – XVECT (R259) and YVECT (R260) for the best corner at the lower left of the ALIGN XY display pattern.
- c. Press CLEAR to remove the display pattern.

3. CH1 and CH2 Reference Self Calibration

- a. Set up the DMM Calibrator to provide a 0.3 volt reference voltage.
- b. Connect a BNC T-connector and two BNC-to-probe tip adapters to the 0.3 volt output from the DMM calibrator via a 50-Ω BNC coaxial cable and BNC-female-to-dual-male-banana-tip adapter. Insert both 222 probe tips in the probe tip adapters.
- c. Press the AUX FUNCT button on the top keypad.
- d. Select SELF CAL to display the SELF CAL menu.

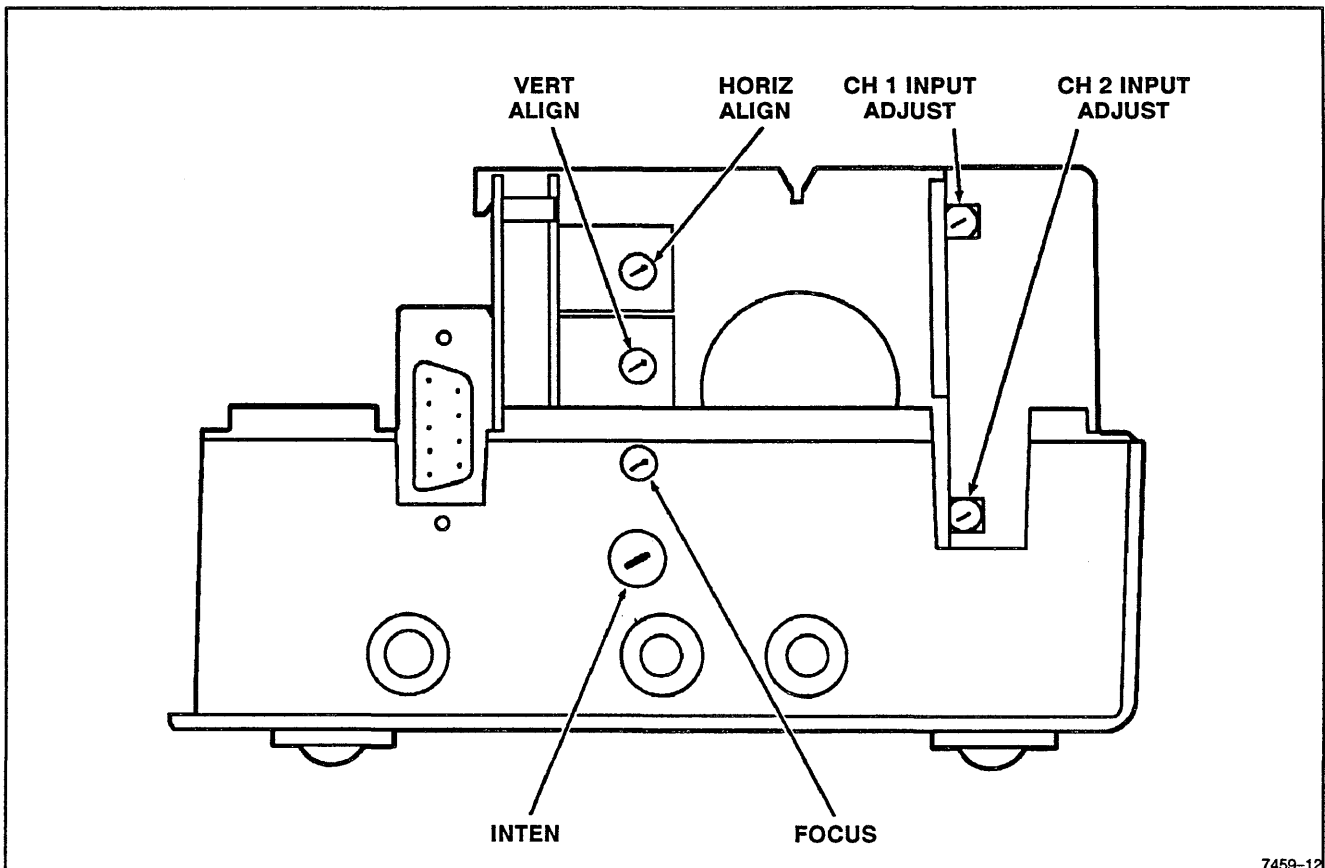

7459-12

Figure 5-2. Rear Panel adjustments.

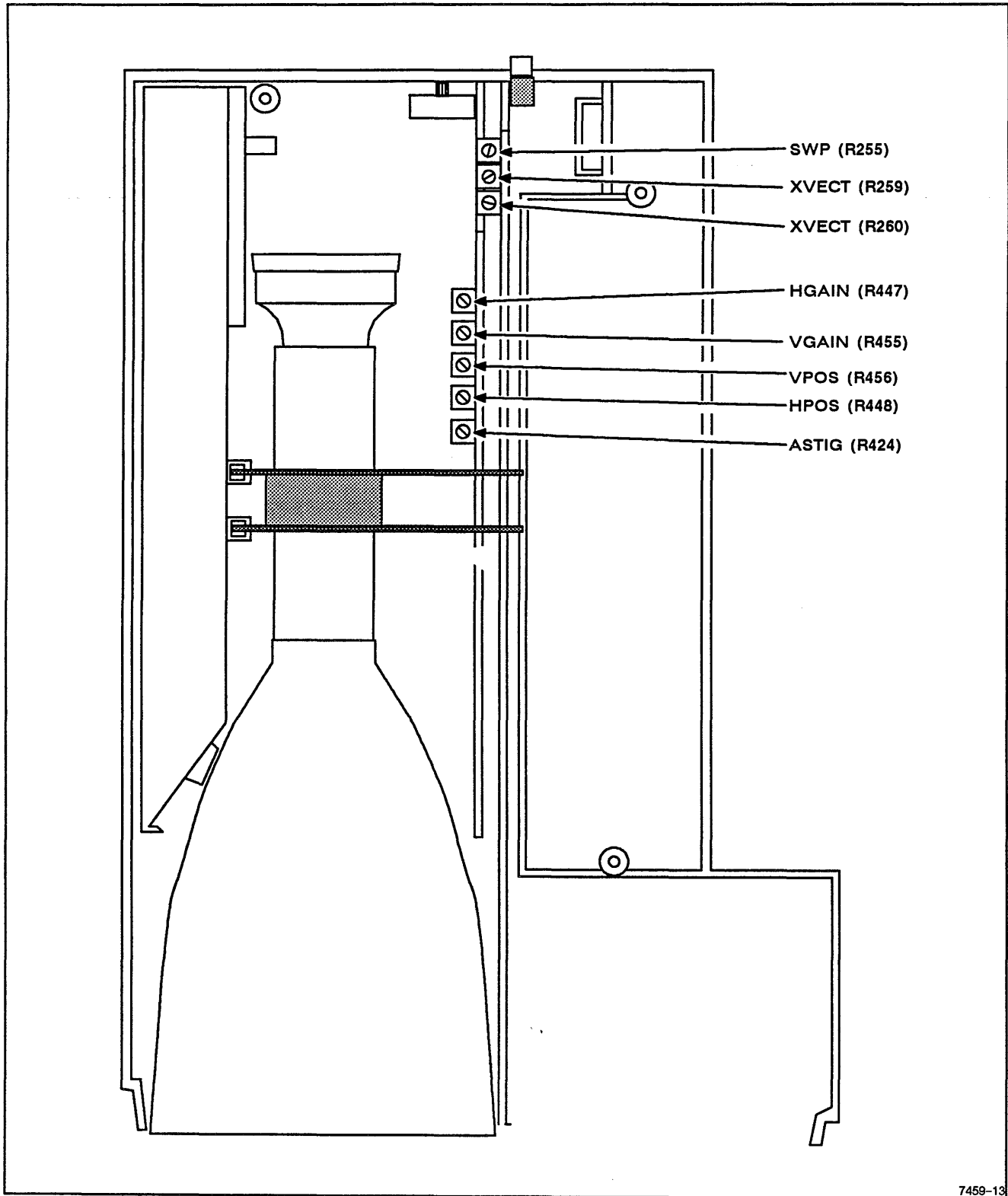

Figure 5-3. Top accessible adjustments.

- e. Press INIT to display the APPLY REF menu.
- f. Select CH 1 to run the CH 1 REFERENCE Self Cal.
- g. Select CH 2 to run the CH 2 REFERENCE Self Cal.
- h. When the calibration routine has finished, disconnect the T-connector, with the two probe tips remaining connected, from the 0.3 volt reference voltage.

4. CH 1 and CH 2 Gain Self Calibration

- a. Press the AUX FUNCT button on the top keypad.
- b. Press SELF CAL to call up the calibration menu.
- c. Press CH 1 to start the Channel 1 self calibration.
- d. When the PASS/FAIL message is displayed the first routine is done.
- e. Select CH 2 to start the Channel 2 self calibration.
- f. When the PASS/FAIL message is displayed the second routine is done.

NOTE

The PASS/FAIL message is not self-clearing and will remain on the display either until it is updated with the results of the next self cal process or until the CLEAR button is pressed.

5. Probe Compensation Adjust

- a. Connect the T-connector to a 50-ohm terminator on the FAST RISE (+) output of the Calibration Generator.
- b. Set the Calibration Generator for a FAST RISE output at a repetition rate of 1 ms and set the pulse amplitude control for maximum output.
- c. Press AUTO SETUP on the instruments front panel.
- d. Set:

CH 1 CPLG	DC
CH 2 CPLG	DC
STORE/NONSTORE	STORE
TRIG POS	MID

- e. ADJUST-CH1 Input capacitor on hybrid U110 (the top one) for the best flat corner on the displayed Channel 1 waveform (see Figure 5-4).
- f. ADJUST-CH2 Input capacitor on hybrid U160 (the lower one) for the best flat corner on the displayed Channel 2 waveform.
- g. Press CLEAR when finished.
- h. Disconnect the test equipment from the two probe tips.

6. Clock Delay Adjust

- a. Press the AUX FUNCT button on the top keypad.

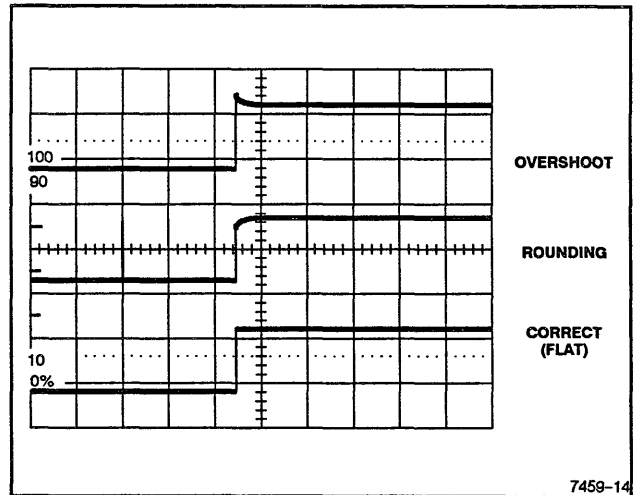

Figure 5-4. CH1 and CH2 Input Compensation.

- b. Select ALIGN to display the ALIGN menu with the XY choice.
- c. Press menu button 2 (the one below the XY menu choice) to start the clock calibration procedure.
- d. ADJUST-Clock Delay (R306, located below the front of the crt) until the trigger position indicator (+) remains within the center two horizontal divisions (an occasional jump outside the center divisions may occur).
- e. Press CLEAR when finished with the interactive portion of the CLOCK DELAY adjustment procedure.

7. External Trigger Offset Adjust

NOTE

The TRIG COM and EXT TRIG inputs must be connected together before running the External Trigger Offset self calibration.

- a. Use the Banana plug shorting fixture to short the two external trigger connectors together.
- b. Press the AUX FUNCT button on the top keypad.
- c. Select SELF CAL to display the SELF CAL menu.
- d. Select EXT TRIG to run the external trigger self calibration routine.
- e. When the routine finishes, disconnect the shorting fixture from the external trigger connectors.
- f. Disconnect the external power from the 222 and reassemble the instrument.

Check the instrument for proper operation after reassembling it.

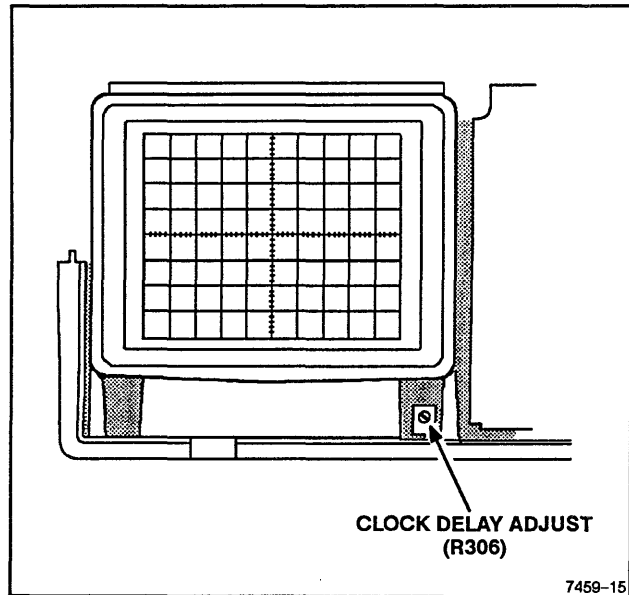

Figure 5-5. Clock Delay adjustment.

MAINTENANCE

This section of the manual contains information on static-sensitive components, preventive maintenance, troubleshooting, and corrective maintenance. General information regarding the care and handling of semiconductor devices is provided in "Static-Sensitive Components," and routine cleaning and inspection are

covered in "Preventive Maintenance." Internal testing capabilities and diagnostic test routines are included in the "Troubleshooting" subsection. The "Corrective Maintenance" part of this section includes circuit board removal procedures, maintenance aids, and soldering techniques.

STATIC-SENSITIVE COMPONENTS

The following precautions apply when performing any maintenance involving internal access to the instrument.



Static discharge can damage any semiconductor component in this instrument.

This instrument contains electrical components that are susceptible to damage from static discharge. Table 6-1 lists the relative susceptibility of various classes of semiconductors. Static voltages of 1 kV to 30 kV are common in unprotected environments.

When performing maintenance, observe the following precautions to avoid component damage:

1. Minimize handling of static-sensitive components.
2. Transport and store static-sensitive components or assemblies in their original containers or on a metal rail. Label any package that contains static-sensitive components or assemblies.
3. Discharge the static voltage from your body by wearing a grounded antistatic wrist strap while handling these components. Servicing static-sensitive components or assemblies should be performed only at a static-free work station by qualified service personnel.
4. Keep anything capable of generating or holding a static charge off the work station surface.
5. Keep the component leads shorted together whenever possible.
6. Pick up components by their bodies, never by their leads.
7. Do not slide the components over any surface.

8. Avoid handling components in areas that have a floor or work-surface covering capable of generating a static charge.
9. Use a soldering iron that is connected to earth ground.
10. Use only approved antistatic, vacuum-type desoldering tools for component removal.

Table 6-1
Relative Susceptibility to Static-Discharge Damage

Semiconductor Classes	Relative Susceptibility Levels ^a
MOS or CMOS microcircuits or discretes, or linear microcircuits with MOS inputs (Most Sensitive)	1
ECL	2
Schottky signal diodes	3
Schottky TTL	4
High-frequency bipolar transistors	5
JFET	6
Linear microcircuits	7
Low-power Schottky TTL	8
TTL (Least Sensitive)	9

^a Voltage equivalent for levels (voltage discharged from a 100-pF capacitor through a resistance of 100 Ω):

1 = 100 to 500 V	6 = 600 to 800 V
2 = 200 to 500 V	7 = 400 to 1000 V (est)
3 = 250 V	8 = 900 V
4 = 500 V	9 = 1200 V
5 = 400 to 600 V	

PREVENTIVE MAINTENANCE

INTRODUCTION

Preventive maintenance consists of cleaning, inspection, and checking instrument performance. Preventive maintenance on a regular basis may prevent instrument malfunction and improve instrument reliability. The required frequency of maintenance depends on the severity of the environment in which the instrument is used. A good time to do preventive maintenance is just before instrument adjustment.

INSPECTION AND CLEANING

Inspect and clean the 222 as often as operating conditions require. Accumulation of dirt in the instrument can cause overheating and component breakdown. Dirt on components acts as an insulating blanket, preventing efficient heat dissipation. It also provides an electrical conduction path that could result in instrument failure, especially under high-humidity conditions



Do not use chemical cleaning agents which might damage the plastics used in this instrument. Use a nonresidue-type cleaner, preferably isopropyl alcohol or a solution of 1% mild detergent and 99% water. Before using any other type of cleaner, consult your Tektronix Service Center or representative.

Exterior

INSPECTION. Inspect the external portions of the instrument for damage, wear, and missing parts; use Table 6-2 as a guide. Instruments that appear to have been dropped or otherwise abused should be checked thoroughly to verify correct operation and performance. Deficiencies that could cause personal injury or could lead to further instrument damage should be repaired immediately.

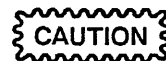

Do not allow moisture to get inside the instrument during external cleaning. Use only enough liquid to dampen the cloth or applicator.

CLEANING. Loose dust on the outside of the instrument can be removed with a soft cloth or small soft-bristle brush. The brush is particularly useful on and around the controls and connectors. Remove remaining dirt with a soft cloth dampened in a mild detergent-and-water solution. Do not use abrasive cleaners.

Clean the light filters and the crt face with a soft lint-free cloth dampened with either isopropyl alcohol or a mild detergent-and-water solution.

Interior

To clean or inspect the inside of the instrument, first refer to the Remove and Replace Procedures in this section.

**Table 6-2
External Inspection Checklist**

Item	Inspect For	Repair Action
Case and Front Panel	Cracks, scratches, deformations, damaged hardware or gaskets.	Touch up paint scratches and replace defective components.
Front-panel controls	Missing, damaged, or loose knobs, torn or damaged switch activators.	Repair or replace missing or defective items.
Connectors	Broken shells, cracked insulation, and deformed contacts. Dirt in connectors.	Replace defective parts. Clean or wash out dirt.
Accessories	Missing items or parts of items, bent pins, broken or frayed cables, and damaged connectors.	Replace damaged or missing items, frayed cables, and defective parts.

**Table 6-3
Internal Inspection Checklist**

Item	Inspect For	Repair Action
Circuit Boards	Loose, broken, or corroded solder connections. Burned circuit boards. Burned, broken, or cracked circuit-run plating.	Replace defective circuit board.
Resistors	Burned, cracked, broken, blistered, or separated from the circuit board.	Replace defective circuit board.
Solder Connections	Cold solder or rosin joints on connectors.	Resolder joint and clean with isopropyl alcohol.
Capacitors	Damaged or leaking cases. Corroded solder on leads or terminals, or separated from the circuit board.	Replace defective circuit board.
Semiconductors	Separated from circuit board or cracked.	Replace defective circuit board.
Wiring and Cables	Loose plugs or connectors. Burned, broken, or frayed wiring.	Firmly seat connectors. Repair or replace defective wires or cables.

INSPECTION. Inspect the internal parts of the 222 for damage and wear, using Table 6-3 as a guide. Repair any problems found immediately. The repair method for most visible defects is to replace the defective circuit board, but take particular care if heat-damaged components are found. Since overheating usually indicates other trouble in the instrument, the cause of overheating must be eliminated to prevent repeated damage.

If any circuit board is replaced, do a complete adjustment of the instrument (see Section 5 for the Adjustment Procedure).



To prevent damage from electrical arcing, ensure that circuit boards and components are dry before applying power to the instrument.

CLEANING. To clean the interior, blow off dust with dry, low-pressure air (approximately 9 psi). Remove any remaining dust with a soft brush or a cloth dampened with a solution of mild detergent and water. A cotton-tipped applicator is useful for cleaning in narrow spaces and on circuit boards. If these methods do not remove all the dust or dirt, the instrument may be spray

washed using a solution of 1% mild detergent and 99% water as follows:

1. Remove covers and shields to reach parts to be cleaned (see Removal and Replacement Instructions).
2. Spray wash dirty parts with the detergent-and-water solution; then use clean water to thoroughly rinse them.
3. Dry all parts with low-pressure air.
4. Dry all components and assemblies in an oven or drying compartment using low-temperature (125°F to 150°F) circulating air.

SWITCH CONTACTS. Switch contacts are permanently treated when assembled. Neither cleaning nor other preventive maintenance is necessary, unless the switch board had been contaminated during disassembly.

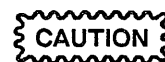

Do not touch the switch pad contacts or the carbon tipped actuators with your fingers. Residual body oils are corrosive to the contact material over time.

LUBRICATION

A regular lubrication program for the instrument is not necessary. The potentiometers used in this instrument are permanently sealed and do not require periodic lubrication. Rotary switches are sealed and do not require lubrication.

PERIODIC READJUSTMENT

To ensure accurate measurements, check the performance of this instrument every 2000 hours of

operation or, if used infrequently, once each year. If you replace any circuit boards it will be necessary to readjust the instrument because of possible interactions between the circuit boards.

Complete performance check instructions are given in Section 4 of this manual; adjustment instructions are given in Section 5. The Performance Check Procedure can be helpful in localizing certain troubles in the instrument. In some cases, minor problems may be revealed or corrected by readjustment.

TROUBLESHOOTING

INTRODUCTION

Preventive maintenance performed on a regular basis should reveal most potential problems before an instrument malfunctions. However, should troubleshooting be required, the following information is provided to aid in locating a fault. In addition, the material presented in the Block Diagram Description section of this manual may be helpful while troubleshooting.

TROUBLESHOOTING AIDS

Diagnostic Firmware

This instrument contains built-in diagnostic routines that can aid in localizing certain failures. If a failure is detected during power on or self-calibration, an error message is sent over the RS-232 interface to a terminal or host computer. See the RS-232 Interfacing Guide for complete information regarding the error messages.

Troubleshooting Chart

A troubleshooting chart is provided to help isolate problems to a circuit board.

Circuit Board Locations

The locations of circuit boards in the instrument are shown in "Removal and Replacement Procedures" in this section of the manual.

Circuit Board Interconnections

A circuit board interconnection diagram is provided to aid in tracing a signal path or power source between boards.

TROUBLESHOOTING TECHNIQUES

The following procedure is arranged in an order that enables checking simple trouble possibilities before requiring more extensive troubleshooting.



Before using any test equipment to make measurements on static-sensitive, current-sensitive, or voltage-sensitive components or assemblies, ensure that any voltage or current supplied by the test equipment does not exceed the limits of the component to be tested.

1. Power-up and Self Calibration Tests

When instrument power is applied, the contents of the microprocessor EEPROMs are checked for erroneous data that would indicate corrupted calibration constants. If the instrument fails the power-up tests, failure codes are sent via the RS-232 interface to a terminal or host computer. Refer to Table 6-4 for error codes, descriptions, and recommended corrective actions.

Table 6-4
Power Up Error Codes

Code	Bit Field	Description	Corrective Action
4001		EEPROM checksum bad.	Perform all self cal.
4002 FFFF		Initial self cal needed.	Perform all self cal.
4002 0001	0	CH 1 gain constant error.	Perform CH 1 GAIN self cal.
4002 0002	1	CH 2 gain constant error.	Perform CH 2 GAIN self cal.
4002 0004	2	CH 1 reference constant error.	Perform CH 1 REFERENCE self cal.
4002 0008	3	CH 2 reference constant error.	Perform CH 2 REFERENCE self cal.
4002 0010	4	CH 1 trigger constant error.	Perform CH 1 TRIGGER GAIN self cal.
4002 0020	5	CH 2 trigger constant error.	Perform CH 2 TRIGGER GAIN self cal.
4002 0040	6	External trigger constant error.	Perform EXT TRIG self cal.
4002 0080	7	Clock delay constant error.	Perform CLOCK DELAY self cal.

Any combination of power-up error codes may occur. The last two digits of the error code are a hexadecimal number that can be converted to an eight bit binary number. After converting to binary and determining which bits are high (set to 1), use Table 6-4 to determine which self cal procedures to perform.

For example, suppose the following error code is displayed on the crt:

4002 0021

Converting the hexadecimal value of 21 to binary format results in the following:

Binary Number							
Bit Field							
7	6	5	4	3	2	1	0
0	0	1	0	0	0	0	1

which is the binary number

0010 0001

The 0 bit and the 5th bit is high. Consult the Bit Field column in Table 6-4 and note that a CH 1 gain constant error and a CH 2 trigger constant error occurred. Perform the CH 1 GAIN and the CH 2 TRIGGER GAIN self calcs.

If there is a single failure, the description and corrective action may be determined directly from Table 6-4. For example, suppose the following error code appears on the display:

4002 0010

Referring to Table 6-4, it is noted that a CH 1 trigger constant error has occurred and that the CH 1 TRIGGER GAIN self cal should be performed.

At the end of a self cal process, the instrument will display a "PASS" or "FAIL" message near the center of the crt display area. If a process fails, the associated calibration constants are **not** updated. As the instrument is turned off and back on, it will continue to output calibration constant error codes. A successful self calibration will correct the calibration constants and eliminate the message.

When a self cal process fails, it immediately outputs an error code corresponding to the cause of the failure. Several error messages may be given before the process stops. The possible error codes descriptions and corrective actions are listed in Table 6-5.

**Table 6-5
Self Cal Error Codes**

Code	Description
8009 XXXX ¹	Trigger search error.
8013 XXXX	External trigger offset range error.
8014 XXXX	External trigger hysteresis error.
8015 XXXX	Clock delay error
8101 XXXX ²	CH 1 acquisition timeout error.
8102 XXXX	CH 1 mid position search error.
8103 XXXX	CH 1 mid position range error.
8104 XXXX	CH 1 offset search error.
8105 XXXX	CH 1 offset range error.
8106 XXXX	CH 1 offset gain error
8107 XXXX	CH 1 gain range error.
8108 XXXX	CH 1 gain search error.
8109 XXXX	CH 1 trigger search error.
8110 XXXX	CH 1 trigger offset range error.
8111 XXXX	CH 1 trigger gain error.
8112 XXXX	CH 1 trigger hysteresis error.
8116 XXXX	CH 1 acquisition delay error.
8201 XXXX ²	CH 2 acquisition timeout error.
8202 XXXX	CH 2 mid position search error.
8203 XXXX	CH 2 mid position range error.
8204 XXXX	CH 2 offset search error.
8205 XXXX	CH 2 offset range error.
8207 XXXX	CH 2 gain range error.
8208 XXXX	CH 2 gain search error.
8209 XXXX	CH 2 trigger search error.
8210 XXXX	CH 2 trigger offset range error.
8211 XXXX	CH 2 trigger gain error.
8212 XXXX	CH 2 trigger hysteresis error.
8216 XXXX	CH 2 acquisition delay error.

¹ To repair 80XX failures, first replace the Main circuit board. If the problem still exists, then replace the CPU circuit board.

² To repair 81XX and 82XX failures, replace the Acquisition circuit board.

A quick index to the self cal procedures is provided in Table 6-6.

**Table 6-6
Index To Self Cal Procedures**

Procedure	Page Number
CH 1 and CH 2 GAIN	5-3
CH 1 and CH 2 REFERENCE	5-4
CLOCK DELAY	5-6
EXT TRIG	5-7

Under unusual circumstances, functional processes may be disrupted during normal operation, resulting in the transmission of error messages out the RS-232 port. See Table 6-7 for error codes, descriptions, and corrective actions.

**Table 6-7
Error Codes Occurring During
Normal Operation**

Code	Description
8009 ¹	Auto level trigger search error.
F000 ²	COP timeout error.
F001	Illegal opcode execution.
F002	Interrupt exception.
F003	Task exception.

¹ Indicates a failure to locate and trigger on the signal. In Auto Level trigger mode, the error code will be output continuously until the signal can be located. If this condition occurs for all signals, perform the CH 1 and CH 2 self cal procedures. Most likely, one of them will indicate a trigger system failure which should be corrected by replacing the Acquisition circuit board. If the problem still occurs, replace the Main circuit board.

² The FXXX codes result in a system reset. If the front panel settings appear to be corrupted, they are returned to the default values. If these error codes occur frequently, it is likely that a failure has occurred on the CPU circuit board; replace it to correct the problem.

Incorrect control settings can give a false indication of instrument malfunction. If there is any question about the correct function or operation of any control, refer to the Operating Information in the 222 Operators Manual.

2. Check Associated Equipment

Before proceeding, ensure that any equipment used with the 222 is operating correctly. Verify that input signals are properly connected and that the interconnecting cables are not defective. Check that the ac-power-source voltage to all equipment is correct.

3. Visual Check



To avoid electrical shock, disconnect the instrument from the ac power source and remove the battery before making a visual inspection of the internal circuitry.

Perform a visual inspection for loose or broken connectors and wires, damaged circuit boards and components, or other clues to the cause of an instrument malfunction.

4. Check Instrument Performance and Adjustment

Check the performance of either those circuits where trouble appears to exist or the entire instrument. An apparent trouble may be caused by misadjustment. The complete performance check is in Section 4 of this manual and adjustment instructions are in Section 5.

5. Isolate Trouble to a Circuit Board

To isolate problems, use any symptoms noticed when checking the instrument's operation to help localize the trouble to a particular circuit board (i.e., no waveform acquisition, improper front-panel control operation, no display or improper display of the waveforms or readouts). The Troubleshooting Chart will help isolate the problem to a circuit board. Also, the block diagrams and the Interconnect Diagram may aid in determining signal flow and control line dependency for correct circuit operation.

6. Check Circuit Board Interconnections

After the trouble has been isolated to a particular circuit board, again check for loose or broken connections and improperly soldered or heat-damaged components. Damaged circuit boards must be replaced for repair of the instrument. (Refer to the appropriate instructions in the "Removal and Replacement Procedures" in this section.)

CORRECTIVE MAINTENANCE

INTRODUCTION

Corrective maintenance in the field consists of circuit board replacement by a qualified service person.

This instrument is covered by a standard Tektronix 3 year warranty. If it fails during the warranty period, it may be returned to Tektronix for free servicing (subject to the conditions of the warranty statement). For a detailed warranty statement, refer to the "Customer Information" section of the Tektronix product catalog.

To make arrangements for warranty service (or to get an estimate for out-of-warranty repairs) within the United States, call the following toll-free customer service number between 8:00 A.M. and 4:30 P.M. Pacific Time:

1-800-937-6007

To make arrangements for warranty service (or to get an estimate for out-of-warranty repairs) outside of the United States, call your local Tektronix Sales Office or Service Center. They are fully equipped to service your 222 DSO.

If it is necessary to return your instrument for repair or service, refer to the "Repackaging for Shipment" information below.

REPACKAGING FOR SHIPMENT

It is recommended that the original carton and packing material be saved in the event it is necessary for the instrument to be reshipped using a commercial transport carrier. If the original materials are unfit or not available, then repackage the instrument using the following procedure.

1. Use a corrugated cardboard shipping carton with a test strength of at least 275 pounds and an inside dimension at least six inches greater than the instrument dimensions.

2. Enclose the following information: owner's address, name and phone number of a contact person, serial number of the instrument, reason for returning, and a complete description of the service required.
3. Completely wrap the instrument with polyethylene sheeting or equivalent to protect the outside finish and keep harmful substances out of the instrument.
4. Cushion the instrument on all sides with three inches of padding material or urethane foam, tightly packed between the carton and the instrument.
5. Seal the shipping carton with an industrial stapler or strapping tape.
6. Mark the following address and your own return address on the shipping carton.

Tektronix, Inc.
4106 N. Vancouver Ave.
Portland, OR 97217

Attention: 222 Warranty Repair

NOTE

Most instruments will be returned within 24 hours of receipt at Tektronix, Inc.

MAINTENANCE PRECAUTIONS

To reduce the possibility of personal injury or instrument damage, observe the following precautions.

1. Disconnect the instrument from the ac-power source and remove the battery before removing or installing circuit boards.
2. Use care not to overtighten screws.

REMOVAL AND REPLACEMENT PROCEDURES

To prepare for calibration of the instrument and to further disassemble the instrument for circuit board replacement, the top half of the case must be removed.



All assembly and disassembly of the 222 must be done at an approved anti-static work station. The semiconductor devices in the 222 are highly susceptible to static discharge damage.

Top Case Removal

1. Use a 1/16 inch hexagonal wrench to remove the 6 front panel knobs.
2. Open the probe pouch and take the probes out of the pouch. This allows the battery compartment cover freedom to move away from the oscilloscope.
3. Place the oscilloscope on its right side and slide the battery compartment cover toward the rear to disengage the locking tabs. The hole for the probe leads makes a convenient place to apply the needed force with your finger.
4. Lift the battery compartment cover up and slide it down the probe leads far enough to lay down the cover.
5. Disconnect the 3-wire battery connector.
6. Lift the battery pack out of the battery compartment.
7. Place the 222 on its top on a flat anti-static work surface.
8. Use a T-15 torx head wrench to remove the 3 long and 2 short screws from the bottom of the case.
9. Use a 3/16 inch open-end wrench or nutdriver to remove the two hexagonal stand-off posts from the RS-232 connector on the rear panel.
10. Turn the 222 over and set it down with the front panel facing you.
11. Pull the bottom of the Front Panel assembly out until it clears the bottom case half. Then, disengage the top of the front panel from the top case half and pull the Front Panel assembly slightly away from the instrument (extending the connecting cable only about an inch or so).
12. Disconnect the 6-wire cable (coming from the top switch board) from the front-panel switch board. Note the orientation for reinstallation.
13. Lift the top case half off the instrument.

NOTE

If you are removing the top case half for calibration only or to change the probes, do not disassemble the instrument any further. Do not separate the front panel switch board or top panel switch board from their attachments unless you intend to change the boards or the rubber switch activators.

Probe Removal and Replacement

1. Remove the top case of the instrument (see the Top Case Removal procedure).
2. Separate the probe body from a defective probe cable by pulling the cable connector out of the probe body.
3. Pull the defective probe cable through the hole in the battery compartment cover.
4. Pull the probe cable retaining assembly out of the slots in the bottom case half.
5. Disconnect both probe cables from their Acquisition board connectors by pulling straight out on the probe cable connector. Rotating the probe connectors slightly may aid in getting it to release from the holder on the board.
6. Unsnap the clamp piece from the bracket on the retaining assembly.
7. Pull the probe cable to be replaced out of the bracket. Note orientation of the ferrite core and the strain relief grommet for reinstallation.

8. Install the new probe cable in the cable retaining bracket. Transfer the strain relief, grommet, and ferrite core to the new probe cable, observing the correct orientation of the ferrite core and grommet.
9. Reinstall the clamp piece on the bracket to hold the cables in place.
10. Slide the cable retaining assembly back into the slots in the bottom case half.



The probe connectors must be aligned correctly with the pins on the acquisition board to prevent damage to the connector pins when pushing the cable connectors into their holders.

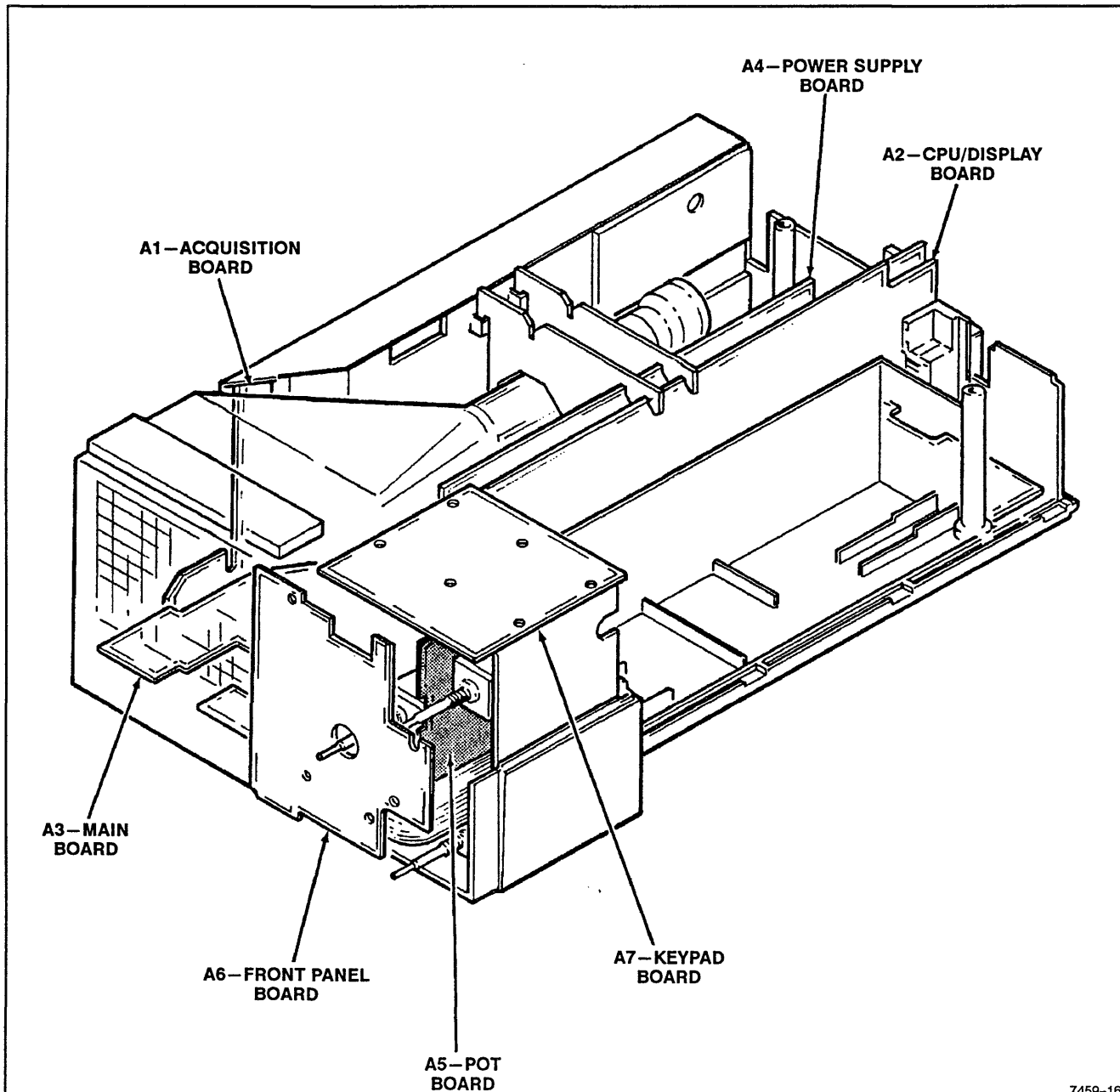

Figure 6-1. Circuit board locations.

11. Reconnect the probe cable connectors to the Acquisition board (Channel 1 cable to the top connector and Channel 2 cable to the bottom one).
12. Thread the probe cable through the hole in the battery compartment cover; reconnect the probe body to the probe cable.
13. Reconnect the battery to the instrument.
14. Perform the "Probe Compensation Adjust" procedure in Section 5 for both channels.
15. Reassemble the instrument and check for correct operation.

Front Panel Switch Board

1. Disconnect the two 14-pin ribbon-cable connectors from the Front Panel Switch board; lay the front panel face down on the work surface.



Do not melt the glue with a heat gun to remove it. Excess heat may damage the plastic front panel assembly.

2. The Front Panel Switch board is fastened in place using hot glue on the guide posts that protrude through the board. Gently break the glue off the board; remove the board from the front panel.

NOTE

Do not touch either the switch contact area on the Front Panel Switch Board or the carbon contact area on the rubber switch activators with bare fingers. Body oils can cause the contact surfaces to corrode over time.

3. The rubber switch-actuator sheet may now also be removed.
4. When reinstalling the rubber switch-actuator sheet, align all the switch activators with the appropriate holes in the Front Panel assembly.
5. Reinstall the Front Panel Switch board over the guide post and reglue the board to the Front Panel assembly using a small amount of hot glue.

Top Panel Switch Board

1. Lay the top instrument case down with the Top Panel Switch board visible.
2. Gently break the glue holding the board in place and remove the board from the instrument. The rubber switch-actuator sheet may now also be removed.

NOTE

Do not touch either the switch contact area on the Top Panel Switch board or the carbon contact area on the rubber switch activators with bare fingers. Body oils can cause the contact surfaces to corrode over time.

3. When reinstalling the rubber switch-actuator sheet, align all the switch activators with the appropriate holes in the top case with the text oriented correctly.
4. Reinstall the Top Panel Switch board over the guide posts. Reglue the board to the top case half at the guide posts. Do not glue the two guide posts nearest the side of the case.

Pot Board

1. The Pot board is mounted on a metal bracket. Once the top case half is removed and the connecting cable from the Front Panel Switch board is disconnected, lift the Pot board assembly out of the bottom case half. Note that there are slots in the bottom of the case that align with the metal bracket holding the Pot board.
2. Use a long, T-15 Torx tip to remove the mounting screw from the Pot board; separate the Pot board from the bracket.

CRT Removal

1. Remove the Front Panel assembly and top case half.
2. Pull the probe cable retaining assembly out of the slots in the bottom case half and push the probe cables back to provide more clearance.



The crt is a high-vacuum component. Wear the proper eye protection when handling the crt. Use care not to place excessive strain on the

neck or connector pins. Place the crt in a protected location while it is out of the instrument.

3. Raise the front of the crt out of the bottom case half, then raise the crt a little to allow you to reach the crt socket easily.
4. Gently disconnect the crt socket from the crt. Then, lift the crt and crt neck support bracket out of the instrument.
5. Place the crt in a safe place if it is to be reinstalled or dispose of it safely if it is defective. If replacing the crt, unsnap the bottom half of the support bracket and remove the bracket from the crt (the support bracket may remain assembled on the crt if the same crt is to be reinstalled).

Power Supply Board Removal

1. Remove the Front Panel assembly, top case half, and crt.

NOTE

You may leave the crt connected if you are not changing the Power Supply board.

2. Pull up on the front of the Power Supply board to disconnect it from the connectors on the Main board.
3. Lift the crt and Power Supply board out of the bottom case half.

CPU/Display Board

1. Remove the Front Panel assembly, top case half, crt, Power Supply board, and the Pot board assembly.
2. Hold down on Main board and pull up on the center of the CPU/Display board to disconnect it from the two connectors holding it to the Main board.
3. Lift the board up out of the bottom case half.

Acquisition Board and Main Board

The Main board and Acquisition board must be removed from the bottom case half as a unit. It must be reassembled as a complete unit before the two are reinstalled.

1. Remove the Front Panel assembly, the top case half, the crt, the Power Supply board, the Pot board assembly, and the CPU/Display board.

2. Disconnect both probe cables from their Acquisition board connectors by pulling straight out on the probe cable connector. Rotating a cable connector slightly may aid in releasing it from the holder on the acquisition board.
3. Remove the T-15 Torx head screw holding the Main board and External Trigger Input Connector housing to the bottom case half.
4. Grasp the square black component on the Main board with your right hand fingers and pull the Main board forward slightly while pulling on the back of the bottom case. This releases the External Trigger Input connector from the holes in the back of the case. Lift the Main board and Acquisition board as a unit straight up out of the bottom case half.
5. Disconnect the 4-wire connector from the top of the Acquisition board. Note orientation for reinstallation.
6. Pull firmly and evenly on the front and middle of the Acquisition board to separate it from the Main board connectors.

Acquisition Board Replacement

After the Acquisition board has been separated from the Main board, use the following procedure to replace the Acquisition board.

1. Separate the top and bottom of the Acquisition board shielding case.
2. Remove the two parts of the shielding case from the Acquisition board.

Acquisition Board and Main Board Reinstallation

1. Place the Acquisition board in the bottom half of the shielding case and replace the top half of the shielding case.
2. Align the connectors on the Acquisition board with the connectors on the left edge of the Main board and reconnect the two boards.
3. Reconnect the 4-wire connector to the top of the Acquisition board.
4. Position the Main board and Acquisition board assembly in the bottom case half.
5. Replace the T-15 Torx hold down screw in the External Trigger Input Connector housing at the rear of the Main board.

CPU/Display Board Reinstallation

1. Position the CPU/Display board into the bottom case half (the RS-232 connector is at the rear of the board).
2. Align the connectors at the front end of the CPU/Display board with the pins on the Main board. You may have to guide the foam board support on the back side of the board past the edge of the bottom case half to clear it.
3. Plug the CPU/Display board to the Main board.

Power Supply Board Reinstallation

1. Remove the INTENSITY knob extension from the intensity potentiometer shaft.
2. Position the Power Supply board into the bottom case half.
3. Align the Intensity knob with the hole through the rear of the bottom case half, and align the two connectors near the front of the Power Supply board with the pins on the Main board.
4. Press down on the Power Supply board to mate the connector pins.
5. Reinstall the INTENSITY knob extension on the intensity potentiometer shaft.

CRT Reinstallation



The crt is a high-vacuum component. Wear the proper eye protection when handling the crt. Use care not to place excessive strain on the neck or neck pins. Place the crt in a protected location while it is out of the instrument.

1. If installing a replacement crt, reassemble the crt neck support bracket on the new crt.
2. Position the crt in the bottom case half (top side up) and reconnect the socket to the crt pins.
3. Align the neck support bracket with the slots on the Power Supply and CPU/Display boards and the square holes on the Acquisition Board shielding case and lower the crt into place.



The probe connectors must be aligned correctly with the pins on the Acquisition board to prevent damage to the connector pins when pushing the cable connectors into their holders.

4. Reconnect the probe cable connectors to the Acquisition board.

Pot Board Reinstallation

1. Align the Pot board with the slot and mounting screw hole in the metal Pot board bracket.
2. Reinstall the T-15 Torx mounting screw to hold the Pot board to the bracket.
3. Position the Pot board assembly into the bottom case half, lining the bottom of the bracket up with the slots in the case.

Case Reassembly

1. Ensure that the probe leads and the circuit boards are all positioned correctly for reassembly of the case.
2. Position the top case half on the bottom case half, carefully aligning the two halves.

NOTE

Be sure the strap handle is properly captured between the top and bottom clips in the case halves.

3. Hold the two halves of the case together and turn it over.
4. Install the three long screws at the rear and center of the of the case. Do not overtighten.
5. Ensure that the blue implosion shield is seated in the front panel assembly, then position the Front Panel assembly in place
6. Reconnect the three connectors to the Front Panel Switch board. Dress the cables into the Pot board bracket as much as possible.
7. Guide the pot shafts through the Front Panel Switch board with the top of the Front Panel assembly

Maintenance – 222 Service

angled toward the top case half. The five slots on the top of the Front Panel assembly must catch on the five tabs on the top case half.

8. With the top of the Front Panel assembly caught, press the bottom of the Front Panel assembly over the front edge of the bottom case half.
9. Install the two, short screws that hold the Front Panel assembly to the bottom case half.
10. Reinstall the two hexagonal, stand-off posts in the RS-232 connector on the rear panel. Tighten only until snug.
11. Reinstall the battery; turn on the power to make sure the instrument works.
12. Turn off the power and reinstall the three larger Front Panel knobs.



Do not overtighten the hexagonal stand-off posts when reinstalling them in the RS-232 connector. The recommended torque is 3.5 in/lbs.

NOTE

Do not overtighten the set screws in the knobs. Excessive pressure can burr the shafts and make the knobs difficult to remove.

13. Reinstall the three smaller Front Panel knobs. Leave enough space between the large knobs and the smaller knobs so that positive switching occurs when the knobs are pressed.

OPTIONS

INTRODUCTION

This section contains a list of instrument options. Tektronix part numbers are provided. More information about instrument options and accessories can be obtained from the current Tektronix Product Catalog or your local Tektronix Field Office or representative. In the United States, instruments and accessories may also be ordered by calling the Tektronix National Marketing Center toll-free number, 1-800-427-2200.

OPTIONS

The following Battery-Charger Adapter Options are available:

	Description	Part Number
Option 02	Instrument supplied without the battery-charger adapter	
Option A1	European 220V	120-1826-00
Option A2	UK 240V	120-1827-00

*This Document is a complete Scan from the original
Tektronix manual*

*For enquiries about our complete
High quality line of technical Manuals in PDF*

mailto : Qservice@otenet.gr

**SEE
OTHER
SIDE**

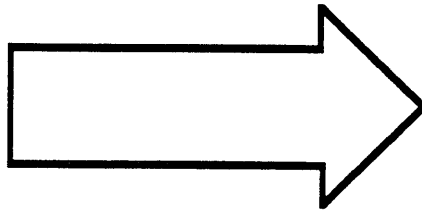

REPLACEABLE ELECTRICAL PARTS

PARTS ORDERING INFORMATION

Replacement parts are available from or through your local Tektronix, Inc. Field Office or representative.

When ordering parts, include the following information in your order: part number, instrument type or number, serial number, and modification number if applicable.

If a part you have ordered has been replaced with a new or improved part, your local Tektronix, Inc. Field Office or representative will contact you concerning any change in part number.

Change information, if any, is located at the rear of this manual.

LIST OF ASSEMBLIES

A list of assemblies can be found at the beginning of the electrical parts list. The assemblies are listed in numerical order.

CROSS INDEX-MFR. CODE NUMBER TO MANUFACTURER

The Mfg. Code Number to Manufacturer Cross Index for the electrical parts list is located immediately after this page. The cross index provides codes, names, and addresses of manufacturers of components listed in the electrical parts list.

ABBREVIATIONS

Abbreviations conform to American National Standard Y1.1.

COMPONENT NUMBER (column one of the parts list)

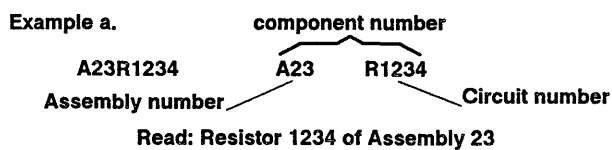

Assembly numbers are marked on the mechanical exploded views located in the mechanical parts list.

TEKTRONIX PART NO. (column two of the parts list)

Indicates part number to be used when ordering replacement part from Tektronix.

SERIAL NO. (columns three and four of the parts list)

Column three (3) indicates the serial number at which the part was first used. Column four (4) indicates the serial number at which the part was removed. No serial number entered indicates part is good for all serial numbers.

NAME & DESCRIPTION (column five of the parts list)

In the parts list, an item name is separated from the description by a colon (:). Because of space limitations, an item name may sometimes appear as incomplete. For further item name identification, the U.S. Federal Catalog handbook H6-1 can be utilized where possible.

MFR. CODE (column six of the parts list)

Indicates the code number of the actual manufacturer of the part. (Code to name and address cross reference can be found immediately after this page.)

MFR. PART NO. (column seven of the parts list)

Indicates actual manufacturer's part number.

CROSS INDEX - MFR. CODE NUMBER TO MANUFACTURER

Mfr. Code	Manufacturer	Address	City, State, Zip Code
80009	TEKTRONIX INC	14150 SW KARL BRAUN DR PO BOX 500	BEAVERTON OR 97077-0001

Replaceable Electrical Parts-222 Service

Component Number	Tektronix Part No.	Serial No.		Name & Description	Mfr. Code	Mfr. Part No.
		Effective	Dscont			
A1	671-0060-01			CIRCUIT BD ASSY:ACQUISITION	80009	671006001
A2	671-0062-00			CIRCUIT BD ASSY:CPU/DISPLAY	80009	671006200
A3	671-0059-00			CIRCUIT BD ASSY:MAIN	80009	671005900
A4	671-0061-00			CIRCUIT BD ASSY:POWER SUPPLY (w/o CRT)	80009	671006100
A5	671-0184-01			CIRCUIT BOARD ASSY:POT	80009	671018401
A6	671-0063-00			CIRCUIT BD ASSY:FRONT PANEL	80009	671006300
A7	671-0269-00			CIRCUIT BD ASSY:KEYPAD	80009	671026900

*This Document is a complete Scan from the original
Tektronix manual*

*For enquiries about our complete
High quality line of technical Manuals in PDF*

mailto : Qservice@otenet.gr

**SEE
OTHER
SIDE**

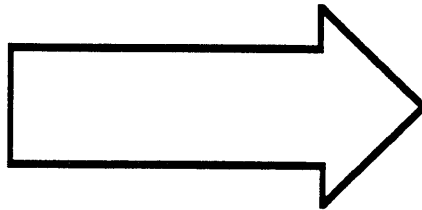

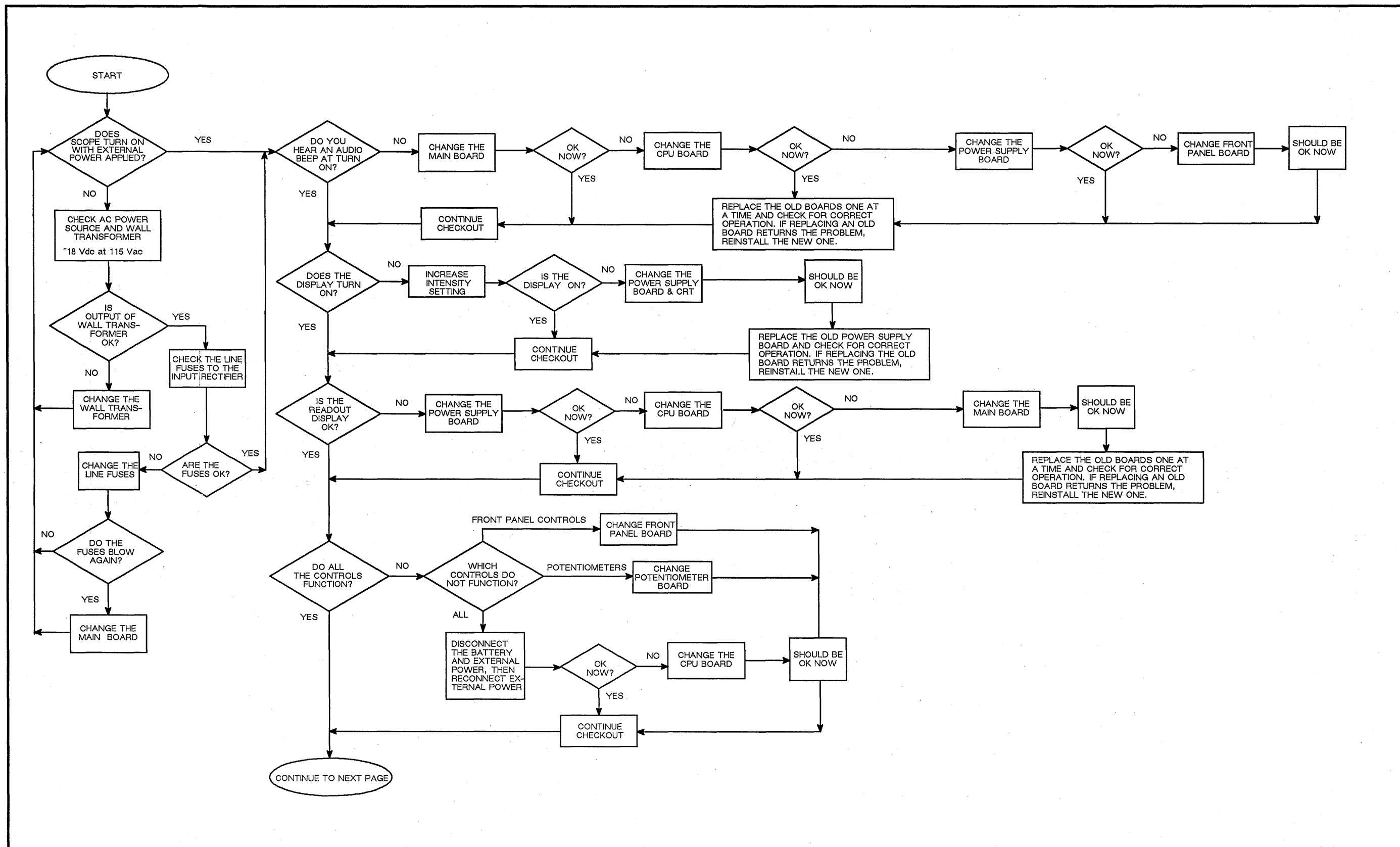

Figure 9-1. Troubleshooting chart.

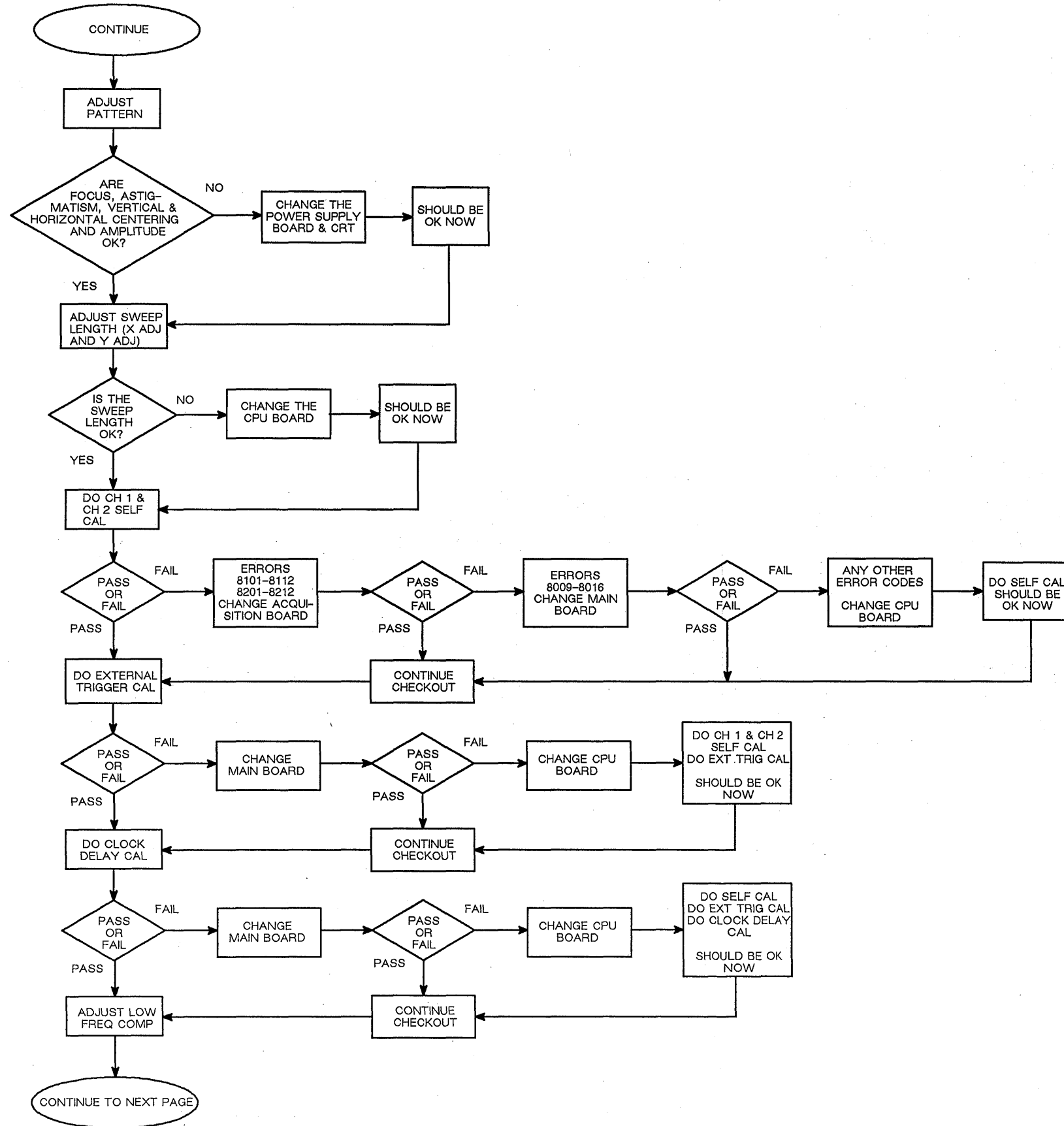

Figure 9-2. Troubleshooting chart (cont.)

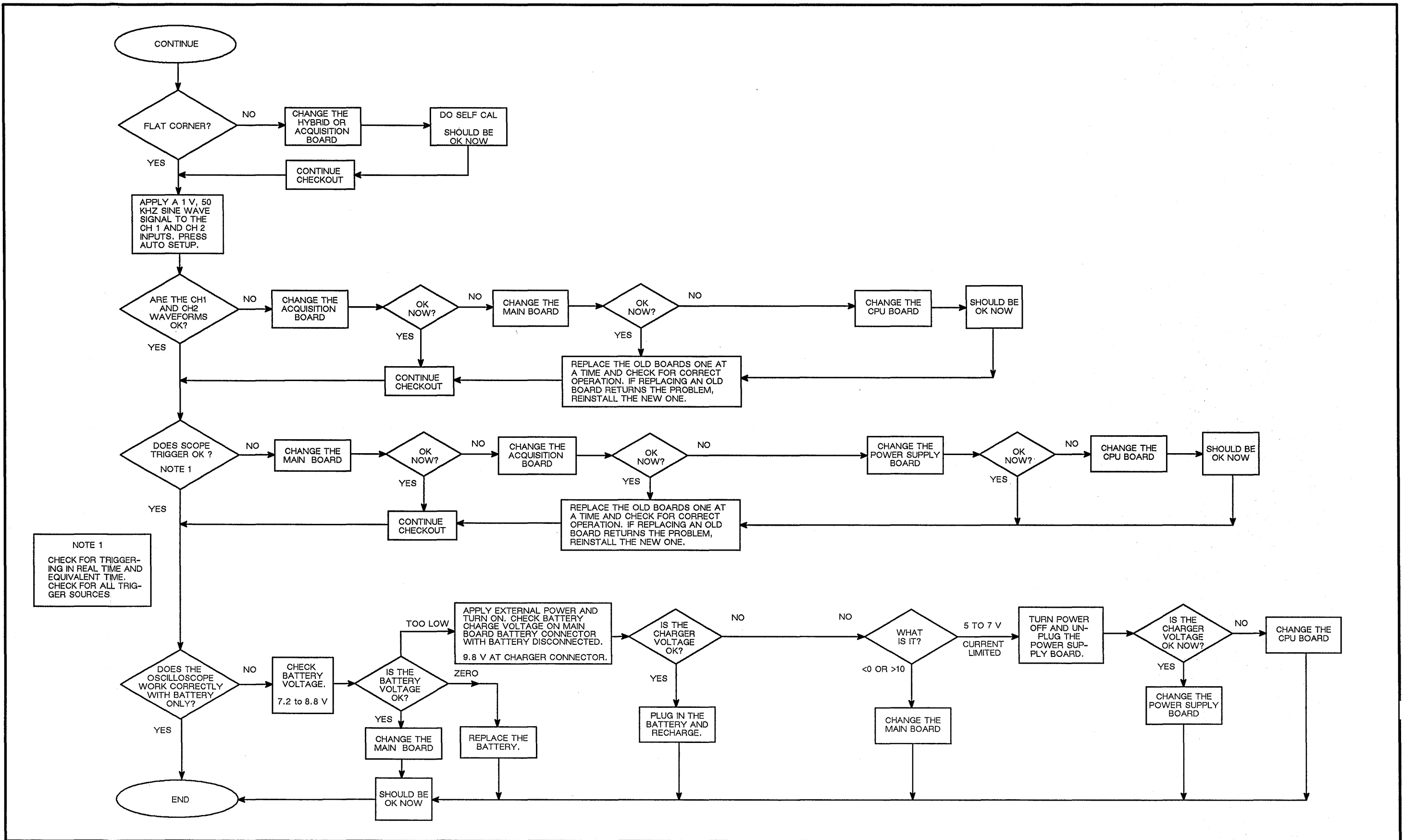

Figure 9-3. Troubleshooting chart (cont.)

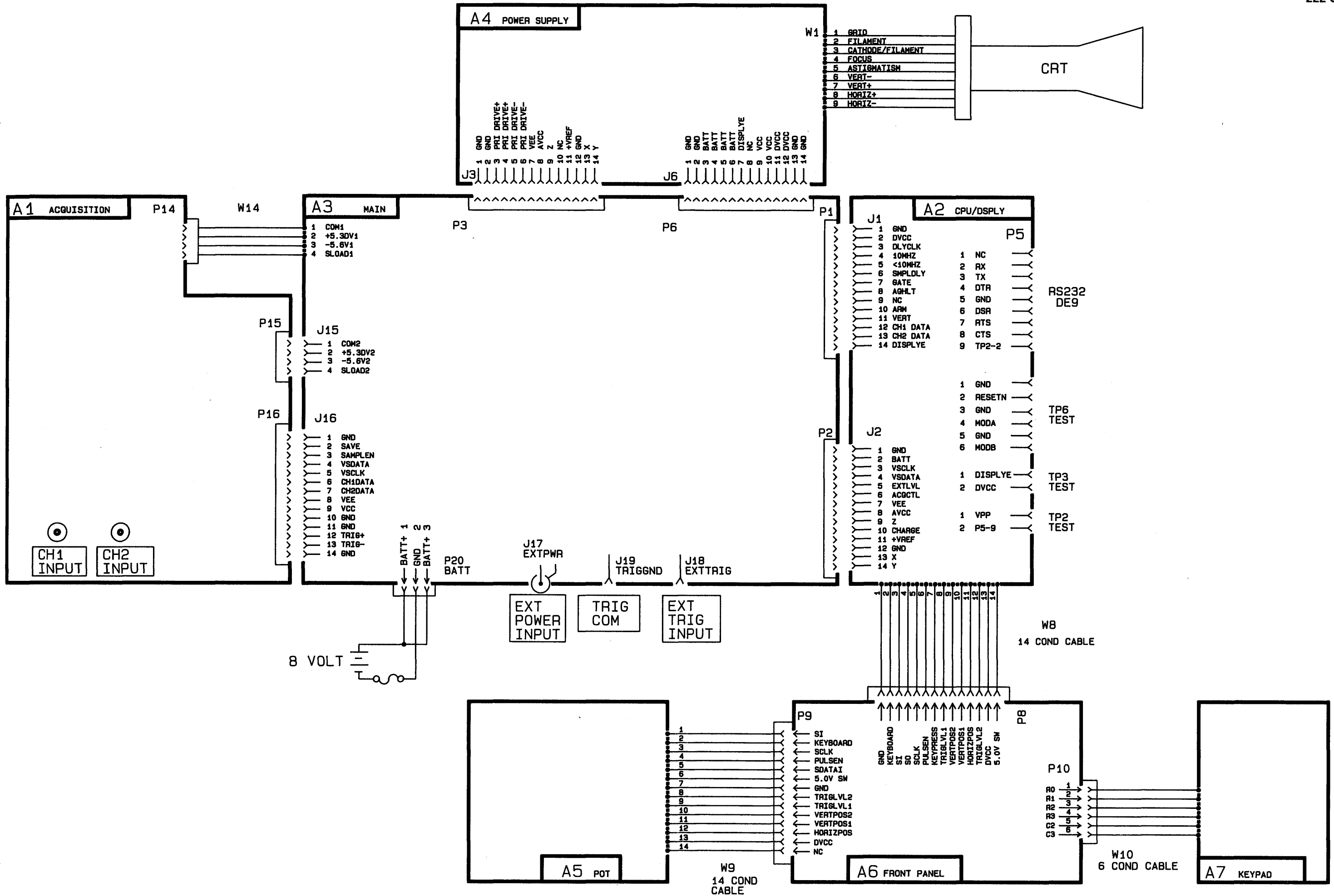

Figure 9-4. Interconnect diagram.

REPLACEABLE MECHANICAL PARTS

Replacement parts are available from or through your local Tektronix, Inc. Field Office or representative.

When ordering parts, include the following information in your order: part number, instrument type or number, serial number, and modification number if applicable.

If a part you have ordered has been replaced with a new or improved part, your local Tektronix, Inc. Field Office or representative will contact you concerning any change in part number.

Change information, if any, is located at the rear of this manual.

ITEM NAME

In the parts list, an item name is separated from the description by a colon(:). Because of space limitations, an item name may sometimes appear as incomplete. For further item name identification, the U.S. Federal Cataloging Handbook H6-1 can be utilized where possible.

FIGURE AND INDEX NUMBERS

Items in this section are referenced by figure and index numbers to the illustrations.

INDENTATION SYSTEM

This mechanical parts list is indented to indicate item relationships. Following is an example of the indentations system used in the description column.

1 2 3 4 5 *Name & Description*

Assembly and/or component

Attaching parts for assembly and/or component

END ATTACHING PARTS

Detail part of assembly and/or component

Attaching parts for detail part

END ATTACHING PARTS

Parts of detail part

Attaching parts for parts or detail part

END ATTACHING PARTS

Attaching parts always appear in the same indentation as the item it mounts, while the detail parts are indented to the right. Indented items are part of, and included with, the next higher indentation.

Attaching parts must be purchased separately, unless otherwise specified.

ABBREVIATIONS

Abbreviations conform to American National Standard Y1.1.

CROSS INDEX – MFR. CODE NUMBER TO MANUFACTURER

Mfr. Code	Manufacturer	Address	City, State, Zip Code
TK0IK	MODERN METALS	UNIT A/K, 5/F GOLD KING IND. BLDG NO. 35-41 TAI LIN ROAD	KWAI-CHUNG N.T. HONG KONG
TK0174	BADGLEY MFG CO	1620 NE ARGYLE	PORTLAND OR 97211
TK0435	LEWIS SCREW CO	4300 S RACINE AVE	CHICAGO IL 60609-3320
TK0588	UNIVERSAL PRECISION PRODUCTS	1775 NW 216TH	HILLSBORO OR 97123
TK0858	STAUFFER SUPPLY CO (DIST)	810 SE SHERMAN	PORTLAND OR 97214
TK1316	BOYD CORP	6136 NE 87TH AVE PO BOX 20038	PORTLAND OR 97220
TK1319	MORELLIS Q & D PLASTICS	1812 16-TH AVE	FOREST GROVE OR 97116
TK1903	MICRO POWER ELECTRONICS	7973 SW CIRRRUS DRIVE BLDG. #22	BEAVERTON OR 97005
TK1908	PLASTIC MOLDED PRODUCTS	4336 SO ADAMS	TACOMA WA 98409
TK2165	TRIQUEST CORP	3000 LEWIS AND CLARK HWY	VANCOUVER WA 98661-2999
TK2198	DEGUSSA	25932 EDEN LANDING RD	HAYWARD CA 94545
TK2278	COMTEK MANUFACTURING OF OREGON (METALS)	PO BOX 4200	BEAVERTON OR 97076-4200
TK2415	FRIWO FRIEMANN & WOLF	GERATEAU GMBH POSTFOCH 1209 B-4412	OSTBEVENERGERMANY
14310	AULT INC	1600-H FREEWAY BLVD	MINNEAPOLIS MN 55430-1706
80009	TEKTRONIX INC	14150 SW KARL BRAUN DR PO BOX 500	BEAVERTON OR 97077-0001
95760	PROTECTIVE CLOSURES CO INC	2150 ELMWOOD AVE	BUFFALO NY 14207-1910

Replaceable Mechanical Parts-222 Service

Fig. & Index No.	Tektronix Part No.	Serial No.		Qty	12345 Name & Description	Mfr. Code	Mfr. Part No.
		Effective	Dscont				
1	-1	390-1047-00		1	CABINET ASSY:FRONT,222	TK2198	ORDER BY DESCRI
	-2	366-2109-01		1	KNOB ASSEMBLY:AUTO LEVEL,DOVE GRAY W/5-40 SETSCREW	TK1908	ORDER BY DESCRI
	-3	366-2108-01		3	KNOB ASSEMBLY:VOLT/DIV,DOVE GRAY W/5-40 SETSCREW	TK1908	ORDER BY DESCRI
	-4	366-2107-01		2	KNOB ASSEMBLY:222 POSITION,DOVE GRAY W/5-40 SETSCREW	TK1908	ORDER BY DESCRI
	-5	337-3507-00		1	SHIELD,ELEC:IMPLOSION,LEXAN,LT BLUE	TK1316	ORDER BY DESCRI
	-6	348-1153-00		2	PAD,CUSHIONING:1.2 X 0.2 X 1.88,FOAM W/ACRYLIC ADHESIVE	TK1316	ORDER BY DESCRI
	-7	260-2423-00		1	SWITCH,PUSH:12 BUTTON,2 POLE	TK01K	ORDER BY DESCRI
	-8	390-1045-00		1	CABINET ASSY:TOP,222 ATTACHING PARTS	TK2198	ORDER BY DESCRI
	-9	211-0744-00		3	SCREW,MACHINE:6-32 X 2.0,PNH,TORX,STL,CD END ATTACHING PARTS	TK0435	ORDER BY DESCRI
	-10	200-3627-00		1	DOOR ASSEMBLY:222 BATTERY COVER W/PROBE POUCH	TK0174	ORDER BY DESCRI
	-11	346-0251-00		1	STRAP,HANDLE:HAND/CARRY GRIP ASSY	TK0174	ORDER BY DESCRI
	-12	260-2422-00		1	SWITCH,PUSH:8 BUTTON,2 POLE	TK01K	ORDER BY DESCRI
	-13	146-0075-00		1	BATTERY PACK AS:RECHARGABLE,2 X 4V	TK1903	ORDER BY DESCRI
	-14	348-1142-00		2	PAD,CUSHIONING:1.0 X 0.85 X 0.25,RUBBER W/ACRYLIC ADHESIVE	TK1316	ORDER BY DESCRI
	-15	342-0889-00		1	INSUL,CKT BOARD:POLYESTER,0.01 THK	TK1316	ORDER BY DESCRI
	-16	390-1046-00		1	CABINET ASSY:BOTTOM,222 ATTACHING PARTS	TK2198	ORDER BY DESCRI
	-17	211-0721-00		3	SCREW,MACHINE:6-32 X 0.375,PNH,STL END ATTACHING PARTS	TK0858	ORDER BY DESCRI
	-18	348-1059-00		1	STAND,TILT:POLYCARBONATE GLASS	TK1908	ORDER BY DESCRI

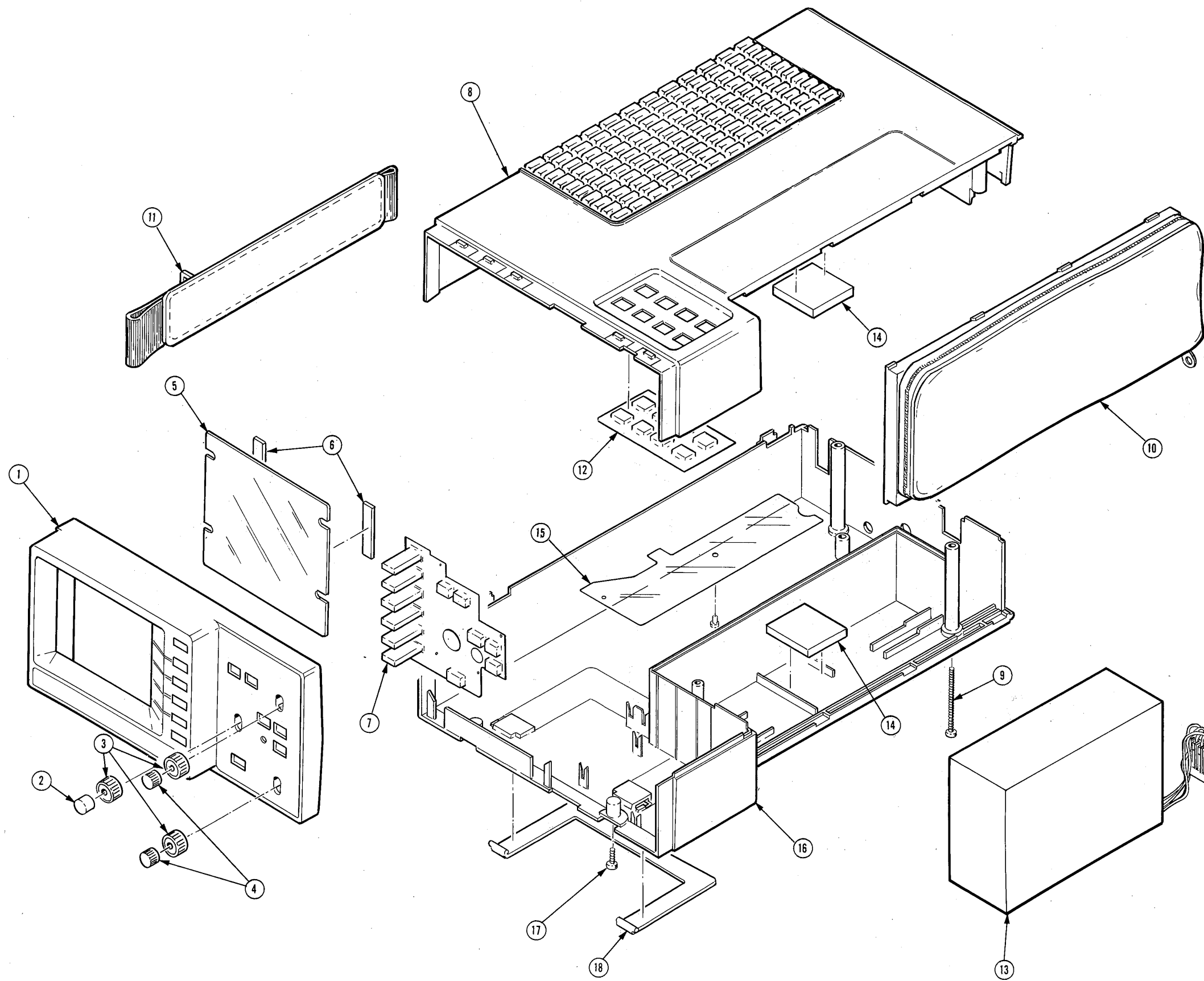

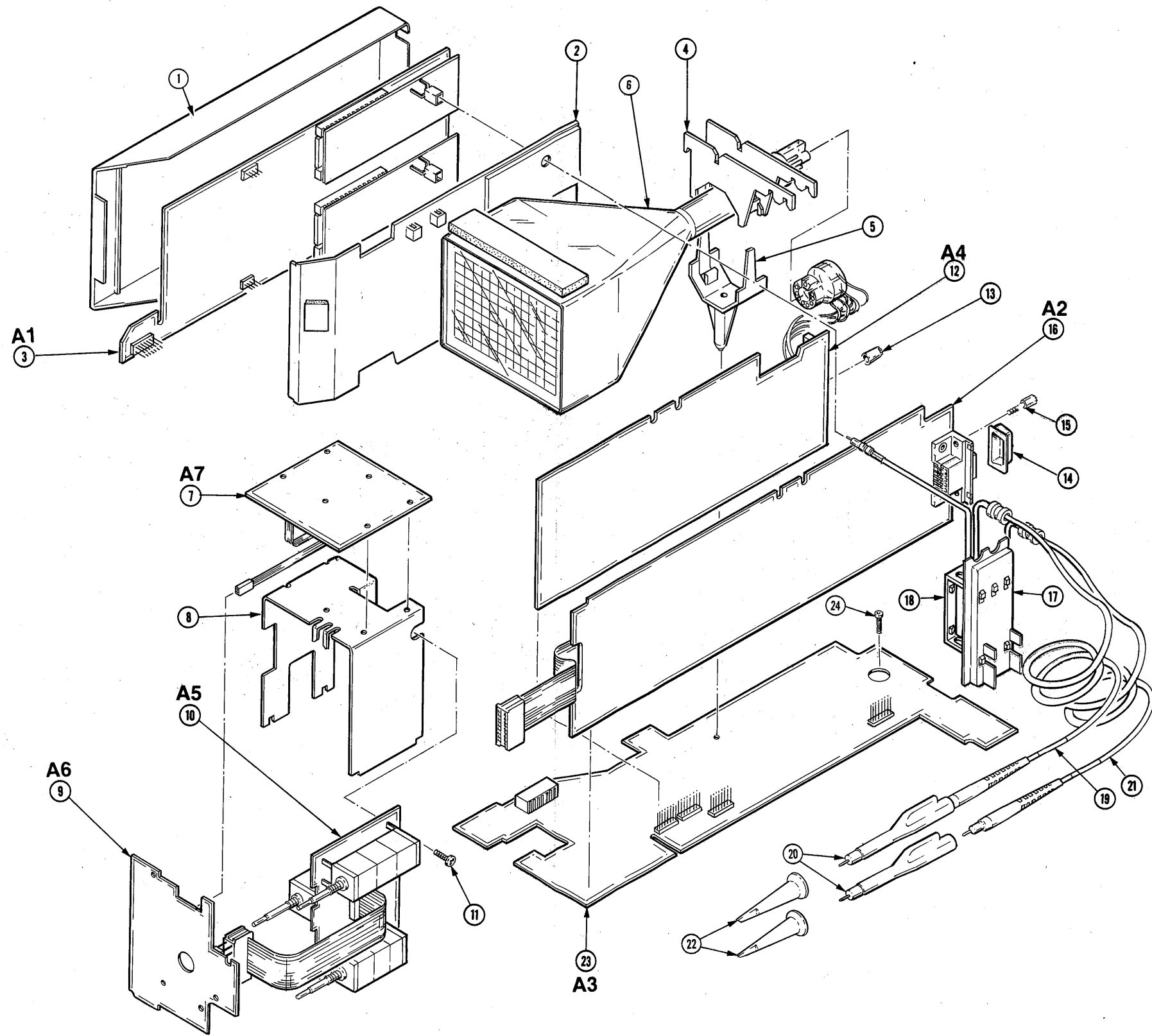

Replaceable Mechanical Parts-222 Service

Fig. & Index No.	Tektronix Part No.	Serial No.		Qty	12345 Name & Description	Mfr. Code	Mfr. Part No.
		Effective	Dscont				
2 -1	119-3548-01			1	HOUSING ASSY:ECB HOUSING W/EMI GASKET & LABEL	80009	119354801
-2	119-3549-00			1	COVER ASSEMBLY:222 CIRCUIT BOARD,W/EMI GASKET	80009	119354900
-3	_____			1	CICUIT BD ASSY:ACQUISITION (SEE A1)		
-4	386-5781-00			1	SUPPORT, TOP:POLYCARBONATE	TK1908	ORDER BY DESCRI
-5	386-5782-00			1	SUPPORT, BOTTOM:POLYCARBONATE	TK1908	ORDER BY DESCRI
-6	119-3547-00			1	CRT ASSEMBLY:222 CRT W/SHIELD & EMI GASKET	80009	119354700
-7	_____			1	CIRCUIT BD ASSY:KEYPAD (SEE A7)		
-8	407-3734-00			1	BRACKET,KEYPAD:ALUMINUM	TK2278	ORDER BY DESCRI
-9	_____			1	CIRCUIT BD ASSY:FRONT PANEL (SEE A6)		
-10	_____			1	CIRCUIT BD ASSY:POTENTIOMETER (SEE A5)		
-11	211-0721-00			1	ATTACHING PARTS SCREW,MACHINE:6-32 X 0.375,PNH,STL	TK0858	ORDER BY DESCRI
-12	_____			1	END ATTACHING PARTS CIRCUIT BD ASSY:PWR SPLY (SEE A4)		
-13	366-2110-00			1	KNOB,EXTENSION:INTENSITY,TEK BLUE,MONSANTO SANTOPRENE	TK1319	ORDER BY DESCRI
-14	200-3750-00			1	CAP,PROTECTIVE:POLYETHYLENE,BLACK,CONDUCTIVE, D SUB,9 PIN	95760	ORDER BY DESCRI
-15	129-1083-01			2	SPACER,POST:0.2 L,4-40,STEEL,0.188 HEX	TK0588	ORDER BY DESCRI
-16	_____			1	CIRCUIT BD ASSY:CPU/DSPLY (SEE A2)		
-17	352-0931-00			1	HOLDER,PROBE:LEXAN 940,SMOKE TAN	TK2165	ORDER BY DESCRI
-18	343-1431-00			1	CLAMP,PROBE:LEXAN 940,SMOKE TAN	TK2165	ORDER BY DESCRI
-19	174-1483-00			1	CABLE ASSY,RF:39 OHM COAX,1.5 METER	80009	174148300
-20	206-0402-00			2	PROBE HEAD:666.7K,40PF	80009	206040200
-21	174-1484-00			1	CABLE ASSY,RF:39 OHM COAX,1.5 METER	80009	174148400
-22	013-0107-06			2	TIP,PROBE:MINIATURE/COMPACT SIZE,RETRACTABLE HOOK ASSY	80009	013010706
-23	_____			1	CIRCUIT BD ASSY:MAIN (SEE A3)		
-24	211-0721-00			1	ATTACHING PARTS SCREW,MACHINE:6-32 X 0.375,PNH,STL END ATTACHING PARTS	TK0858	ORDER BY DESCRI
STANDARD ACCESSORIES							
	016-1024-00			1	CASE,CARRYING:BLACK CLOTH	TK0174	ORDER BY DESCRI
	020-1711-01			1	ACCESSORY PKG:STANDARD,222 PROBE	80009	020171101
	020-1752-00			1	ACCESSORY KIT:FOUR RUBBER FEET IN BAG W/ INSTRUCTION	TK1316	ORDER BY DESCRI
	070-7099-00			1	CARD,INFO:USERS,REFERENCE,222	80009	070709900
	070-7100-00			1	MANUAL,TECH:OPERATOR,222	80009	070710000
	070-7533-00			1	MANUAL,TECH:INTERFACE GUIDE,222	80009	070753300
	120-1807-00			AR	TRANSFORMER,PWR:16VA,WALL,WPWR PLUG (STANDARD)	14310	3281059001
	120-1826-00			AR	TRANSFORMER:220VAC/50HZ INPUT (OPTION A1)	TK2415	ORDER BY DESCRI
	120-1827-00			AR	TRANSFORMER:240VAC/50HZ INPUT (OPTION A2)	TK2415	ORDER BY DESCRI

*This Document is a complete Scan from the original
Tektronix manual*

*For enquiries about our complete
High quality line of technical Manuals in PDF*

mailto : Qservice@otenet.gr

**SEE
OTHER
SIDE**

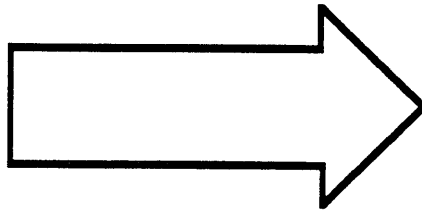

MANUAL CHANGE INFORMATION

At Tektronix, we continually strive to keep up with latest electronic developments by adding circuit and component improvements to our instruments as soon as they are developed and tested.

Sometimes, due to printing and shipping requirements, we can't get these changes immediately into printed manuals. Hence, your manual may contain new change information on following pages.

A single change may affect several sections. Since the change information sheets are carried in the manual until all changes are permanently entered, some duplication may occur. If no such change pages appear following this page, your manual is correct as printed.

*This Document is a complete Scan from the original
Tektronix manual*

*For enquiries about our complete
High quality line of technical Manuals in PDF*

mailto : Qservice@otenet.gr

**SEE
OTHER
SIDE**

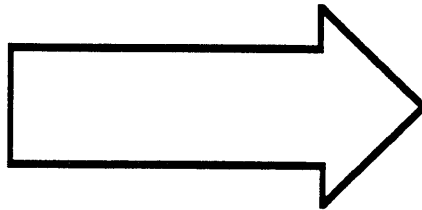

Date: 6-27-91

Change Reference: C1/0691

Product: 222 SERVICE MANUAL

Manual Part Number: 070-7459-00

DESCRIPTION

Product Group 41

REPLACEABLE ELECTRICAL PARTS LIST CHANGES

CHANGE TO:

A1	671-0060-02	B016226	CIRCUIT BOARD ASSY:ACQUISITION
A2	671-0062-01	B016226	CIRCUIT BOARD ASSY:CPU/DISPLAY
A3	671-0059-01	B016226	CIRCUIT BOARD ASSY:MAIN
A4	671-0061-01	B016226	CIRCUIT BOARD ASSY:POWER SUPPLY (W/O CRT)
A5	671-0184-02	B016226	CIRCUIT BOARD ASSY:POTENTIOMETER
A6	671-0063-01	B016226	CIRCUIT BOARD ASSY:FRONT PANEL
A7	671-0269-01	B016226	CIRCUIT BOARD ASSY:KEYPAD

REPLACEABLE MECHANICAL PARTS LIST CHANGES

Fig &
Index

Fig & Index No.	Part No.	Serial No. Effective	Dscont	Qty	NAME & DESCRIPTION
-----------------------	----------	-------------------------	--------	-----	--------------------

CHANGE TO:

1-1	390-1047-02	B018277		1	CABINET ASSY:222 FRONT,SMOKE TAN
1-2	366-2139-00	B017572		1	KNOB ASSEMBLY:AUTO LVL PUSH,0.26 ID X 0.42 OD X 0.3 H
1-3	366-2137-00	B017572		3	KNOB ASSEMBLY:5 ID X 0.62 OD X .3 H
1-4	366-2138-00	B017572		2	KNOB ASSEMBLY:POSITION,.42 OD X 0.26 ID X 0.3 H
1-8	390-1045-02	B018277		1	CABINET ASSY:TOP,BLUE
1-15	342-0889-01	B018277		1	INSUL,CKT BD:POLYESTER,0.010 THK
1-16	390-1046-02	B018277		1	CABINET ASSY:222,BOTTOM,BLUE
2-15	129-1390-00	B018186	B019191	2	SPACER,POST:0.250 L,4-40 THD,NI PL STEEL,0.188 X 0.2 L HEX
2-15	129-1230-01	B019192		2	SPACER,POST:4-40,0.302 L,NI PL BRASS,0.188 X 0.171 L,HEX
2-15	210-1494-00	B019192		2	WASHER,FLAT:0.122 ID X 0.228 OD X 0.016 THK,PASSIVATED SSTL

ADD:

	377-0612-00	B017572		3	0.128 ID X 0.518 OD X 0.270 H.W/4-40 SETSCREW
	377-0613-00	B017572		3	0.080 ID X 0.310 OD X 0.255 H.W/4-40 SETSCREW

STANDARD ACCESSORIES

REMOVE:

	070-7533-00	ALL		1	MANUAL,TECH:INTERFACE GUIDE,222 RS232
	070-7533-01	ALL		1	MANUAL,TECH:INTERFACE GUIDE,222 RS232

ADD:

	070-8099-00	ALL		1	MANUAL,TECH:INTERFACE GUIDE,222 SERIES,RS232
--	-------------	-----	--	---	--

*This Document is a complete Scan from the original
Tektronix manual*

*For enquiries about our complete
High quality line of technical Manuals in PDF*

mailto : Qservice@otenet.gr

**SEE
OTHER
SIDE**

