

0000263

**TEKTRONIX®**

7704A  
OSCILLOSCOPE  
SYSTEM  
SERVICE

INSTRUCTION MANUAL

**TEKTRONIX®**

**7704A  
OSCILLOSCOPE  
SYSTEM  
SERVICE**

**INSTRUCTION MANUAL**















**Tektronix, Inc.  
P.O. Box 500  
Beaverton, Oregon 97005**

**Serial Number** \_\_\_\_\_

**070-1260-00**

**373**

# TABLE OF CONTENTS

|  | Page |
|--|------|
| TABLE OF CONTENTS  | i    |
| LIST OF ILLUSTRATIONS  | iii  |
| LIST OF TABLES   | v    |
| <b>SECTION 1</b>   |      |
| <b>OPERATING INFORMATION</b>   |      |
| PRELIMINARY INFORMATION  |      |
| Operating Voltage  | 1-1  |
| CONTROLS AND CONNECTORS  | 1-1  |
| <b>SECTION 2</b>   |      |
| <b>CIRCUIT DESCRIPTION</b>   |      |
| BLOCK DIAGRAM  |      |
| Block Diagram Description  | 2-1  |
| CIRCUIT OPERATION  | 2-1  |
| LOGIC FUNDAMENTALS   |      |
| Symbols  | 2-3  |
| Logic Polarity   | 2-3  |
| Input/Output Tables  | 2-3  |
| Non-Digital Devices  | 2-3  |
| CALIBRATOR AND FRONT PANEL  | 2-6  |
| MAIN INTERFACE               | 2-7  |
| LOGIC CIRCUIT               | 2-9  |
| TRIGGER SELECTOR            | 2-25 |
| VERTICAL INTERFACE          | 2-28 |
| HORIZONTAL INTERFACE       | 2-30 |
| OUTPUT SIGNALS              | 2-31 |
| INVERTER/RECTIFIERS         | 2-33 |
| LOW-VOLTAGE REGULATORS    | 2-37 |
| READOUT SYSTEM              | 2-39 |
| MAIN INTERCONNECT           | 2-55 |
| VERTICAL AMPLIFIER         | 2-57 |
| HORIZONTAL AMPLIFIER       | 2-58 |
| CRT CIRCUIT                 | 2-59 |
| <b>SECTION 3</b>   |      |
| <b>MAINTENANCE</b>   |      |
| Panel Removal  | 3-1  |
| Power-Unit Removal   | 3-1  |
| PREVENTIVE MAINTENANCE   |      |
| Cleaning   | 3-2  |
| Lubrication  | 3-2  |
| Visual Inspection  | 3-2  |
| Semiconductor Checks   | 3-2  |
| Recalibration  | 3-2  |
| TROUBLESHOOTING  |      |
| Troubleshooting Equipment  | 3-3  |
| Troubleshooting Techniques   | 3-3  |

# TABLE OF CONTENTS (cont)

|   | Page |
|---|------|
| Special Adjustment Procedures                   | 3-5  |
| <b>CORRECTIVE MAINTENANCE</b>                   |      |
| Soldering Techniques                            | 3-10 |
| Component Replacement                           | 3-10 |
| Recalibration After Repair                      | 3-19 |
| Instrument Repackaging                          | 3-19 |
| <br>  |      |
| <b>SECTION 4</b>                                |      |
| <b>CALIBRATION</b>                              |      |
| Calibration Interval                            | 4-1  |
| Tektronix Field Services                        | 4-1  |
| Using This Procedure                            | 4-1  |
| <b>TEST EQUIPMENT REQUIRED</b>                  | 4-1  |
| Special Calibration Fixtures                    | 4-1  |
| Calibration Equipment Alternatives              | 4-1  |
| Signal Connections                              | 4-2  |
| <b>CALIBRATION PROCEDURE</b>                    |      |
| Index to Calibration Procedure                  | 4-3  |
| Preliminary Procedure for Calibration           | 4-4  |
| <b>POWER SUPPLY</b>                             | 4-5  |
| <b>Z-AXIS AND DISPLAY</b>                       | 4-7  |
| <b>VERTICAL SYSTEM</b>                          | 4-10 |
| <b>TRIGGERING</b>                               | 4-14 |
| <b>HORIZONTAL SYSTEM</b>                        | 4-16 |
| <b>CALIBRATOR</b>                               | 4-19 |
| <b>OUTPUT SIGNALS</b>                           | 4-21 |
| <b>READOUT SYSTEM</b>                           | 4-23 |
| <br>  |      |
| <b>SECTION 5</b>                                |      |
| <b>ELECTRICAL PARTS LIST</b>                    |      |
| <br>  |      |
| <b>SECTION 6</b>                                |      |
| <b>DIAGRAMS AND CIRCUIT BOARD ILLUSTRATIONS</b> |      |
| Symbols and Reference Designators               |      |
| <br>  |      |
| <b>SECTION 7</b>                                |      |
| <b>MECHANICAL PARTS LIST</b>                    |      |
| <br>  |      |
| <b>CHANGE INFORMATION</b>                       |      |

# LIST OF ILLUSTRATIONS

| Number | Page | Number | Page  |      |
|--------|------|--------|---|------|
|        |      | 2-22   | Input/output table for A and B Trigger Selector stages.   | 2-27 |
| 1-1    | 1-1  | 2-23   | Detailed block diagram of Vertical Interface circuit.   | 2-28 |
| 1-2A   | 1-2  | 2-24   | Input/output table for Vertical Plug-In Selector.   | 2-29 |
| 1-2B   | 1-3  | 2-25   | Input/output table for Vertical Trace Separation stage.   | 2-30 |
| 2-1    | 2-2  | 2-26   | Horizontal Interface circuit detailed block diagram.  | 2-30 |
| 2-2    | 2-7  | 2-27   | Input/output table for Horizontal Plug-In Selector.   | 2-31 |
| 2-3    | 2-8  | 2-28   | Output Signals detailed block diagram.  | 2-32 |
| 2-4    | 2-9  | 2-29   | Detailed block diagram of Inverter/Rectifiers circuit.  | 2-34 |
| 2-5    | 2-10 | 2-30   | Simplified schematic of Inverter, Regulator, and Inverter Control stages.   | 2-35 |
| 2-6    | 2-11 | 2-31   | Detailed block diagram of Low-Voltage Regulators circuit.   | 2-38 |
| 2-7    | 2-12 | 2-32   | Location of readout words on the CRT identifying the originating plug-in and channel (one complete frame shown, simulated readout). | 2-40 |
| 2-8    | 2-13 | 2-33   | Character Selection Matrix for 7704A Readout System.  | 2-41 |
| 2-9    | 2-14 | 2-34   | Typical readout display where only channel 1 of the Right Vertical and B Horizontal units is displayed.                             | 2-42 |
| 2-10   | 2-16 | 2-35   | Detailed block diagram of Readout System.   | 2-43 |
| 2-11   | 2-17 | 2-36   | Output waveforms of Timer stage.  | 2-45 |
| 2-12   | 2-18 | 2-37   | Detail of output at pins 12, 13, 14, and 16 of U3433.   | 2-45 |
| 2-13   | 2-19 | 2-38   | Timer stage operation when Display-Skip condition occurs.   | 2-46 |
| 2-14   | 2-20 | 2-39   | Time relationship of the time-slot (TS) pulses produced by U3445.   | 2-47 |
| 2-15   | 2-21 | 2-40   | Typical encoding scheme for voltage-sensing plug-in unit. Coding shown for deflection factor of 100 microvolts.                     | 2-49 |
| 2-16   | 2-22 | 2-41   | Idealized current waveforms of: (A) Row analog data, (B) Column analog data.  | 2-50 |
| 2-17   | 2-23 | 2-42   | Block representation of memory sequence in U3401.   | 2-52 |
| 2-18   | 2-24 | 2-43   | Typical output waveforms for Zeros Logic and Memory stage operation (at pin 7 of U3401).  | 2-54 |
| 2-19   | 2-25 |        |   |      |
| 2-20   | 2-26 |        |   |      |
| 2-21   | 2-27 |        |   |      |
|        |      |        |   |      |

## LIST OF ILLUSTRATIONS (cont)

| Number | Page  | Number | Page |
|--------|---|--------|------|
| 2-44   | Readout word relating 10 possible character locations to the decimal point instructions that can be encoded, and the resultant CRT display. | 2-55   |      |
| 2-45   | Flow chart for character generation by the Readout System.  | 2-56   |      |
| 2-46   | Vertical Amplifier circuit detailed block diagram.  | 2-57   |      |
| 2-47   | Horizontal Amplifier circuit detailed block diagram.  | 2-58   |      |
| 2-48   | Detailed block diagram of CRT Circuit.  | 2-60   |      |
| 3-1    | Power-unit securing screws.   | 3-1    |      |
| 3-2    | Troubleshooting chart for 7704A.  | 3-6    |      |
| 3-3    | Location of P4417 and P4418 on A44, Vertical Amplifier board.   | 3-8    |      |
| 3-4    | Location of adjustments on A22, Vertical Interface board.   | 3-9    |      |
| 3-5    | Location of P4315 and P4316 on A43, Horizontal Output board.  | 3-10   |      |
| 3-6    | Location of adjustments on A23, Horizontal Interface board.   | 3-11   |      |
| 3-7    | Disassembly and assembly of Display and Acquisition units.  | 3-12   |      |
| 3-8    | Exploded-view drawing of a portion of the power unit identifying several critical parts.  | 3-15   |      |
| 4-1    | Waveform showing correct high-frequency compensation of horizontal amplifier. Circle surrounds compensated portion of waveform.             | 4-18   |      |
| 4-2    | Typical display when checking X-Y phase shift.  | 4-18   |      |
| 4-3    | Readout display with Q3416 removed.   | 4-23   |      |
| 6-1    | Electrode configuration for semiconductors used in the 7704A.   | 6-1    |      |
| 6-2    | Location of circuit boards in the 7704A.  | 6-1    |      |
| 6-3    | A10—Calibrator circuit board.   | 6-2    |      |
| 6-4    | Electrode configuration for semiconductors shown on diagram 1.  | 6-3    |      |
| 1      | Calibrator and Front Panel  | 6-3    |      |
| 6-5    | A20—Main Interface circuit board.   | 6-4    |      |
| 2      | Main Interface  | 6-5    |      |
| 6-6    | A25—Logic circuit board.  | 6-6    |      |
| 6-7    | Electrode configuration for semiconductors shown on diagram 3.  | 6-7    |      |
| 3      | Logic Circuit   | 6-7    |      |
| 6-8    | A24—Trigger Selector circuit board.   | 6-8    |      |
| 4      | Trigger Selector  | 6-9    |      |
| 6-9    | A22—Vertical Interface circuit board (front view).  | 6-10   |      |
| 6-10   | A22—Vertical Interface circuit board (rear view).   | 6-10   |      |
| 5      | Vertical Interface  | 6-11   |      |
| 6-11   | A23—Horizontal Interface circuit board.   | 6-12   |      |
| 6      | Horizontal Interface  | 6-13   |      |
| 6-12   | A33—Signal Out circuit board.   | 6-14   |      |
| 7      | Output Signals  | 6-15   |      |
| 6-13   | A30—Power Supply Inverter circuit board.  | 6-16   |      |
| 6-14   | A31—Rectifier and Filter circuit board.   | 6-16   |      |
| 6-15   | Electrode configuration for semiconductors shown on diagram 8.  | 6-17   |      |
| 8      | Inverter/Rectifiers   | 6-17   |      |
| 6-16   | A32—Regulator circuit board.  | 6-18   |      |
| 6-17   | Electrode configuration for semiconductors shown on diagram 9.  | 6-19   |      |
| 9      | Low-Voltage Regulators.   | 6-19   |      |
| 6-18   | A34—Readout circuit board.  | 6-20   |      |
| 6-19   | Electrode configuration for semiconductors shown on diagram 10.   | 6-21   |      |
| 10     | Readout System  | 6-21   |      |
| 11     | Main Interconnect   | 6-23   |      |
| 6-20   | A44—Vertical Amplifier circuit board.   | 6-24   |      |
| 12     | Vertical Amplifier  | 6-25   |      |
| 6-21   | A43—Horizontal Output circuit board.  | 6-26   |      |
| 6-22   | Electrode configuration for semiconductors shown on diagram 13.   | 6-27   |      |
| 13     | Horizontal Amplifier  | 6-27   |      |
| 6-23   | A41—Z-Axis circuit board.   | 6-28   |      |
| 6-24   | A42—HV circuit board.   | 6-28   |      |

# LIST OF ILLUSTRATIONS (cont)

| Number   |   | Page | Number |  | Page |
|--|---|------|--------|--|------|
| 6-25   | Electrode configuration for semiconductors shown on diagram 14.                             | 6-29 | 6-35   | Location of Calibrator adjustments on A10—Calibrator board.              | 6-35 |
|  14 | CRT Circuit.  | 6-29 | 6-36   | Location of signal selector switches on A33—Output Signals board.        | 6-35 |
| 6-26   | +54-Volt test point location on A32—Regulator board (top of power unit).                    | 6-31 | 6-37   | Location of Readout System calibration adjustments on A34—Readout board. | 6-35 |
| 6-27   | +54-Volt adjustment, R3143, location in power unit.   | 6-31 |        |  |      |
| 6-28   | Power-supply test points and -50-Volt adjustment locations on A32—Regulator board.          | 6-31 |        |  |      |
| 6-29   | +150-Volt test point location on A43—Horizontal Output board.                               | 6-31 |        |  |      |
| 6-30   | TP 4222, high-voltage test point location.  | 6-33 |        |  |      |
| 6-31   | Location of Z-Axis and Display calibration adjustments and test points on A41—Z-Axis board. | 6-33 |        |  |      |
| 6-32   | Location of Vertical System calibration adjustments on A44—Vertical Amplifier board.        | 6-33 |        |  |      |
| 6-33   | Location of high-frequency compensation adjustments on A22—Vertical Interface board.        | 6-33 |        |  |      |
| 6-34   | Location of Horizontal System calibration adjustments on A43—Horizontal Output board.       | 6-35 |        |  |      |

## MECHANICAL PARTS LIST ILLUSTRATIONS

| Number |                    |
|--------|--------------------|
| 1      | D7704              |
| 2      | A7704 Front        |
| 3      | A7704 Rear         |
| 4      | Cabinet            |
| 5      | Accessories        |
| 6      | Instrument Options |
| 7      | Repackaging        |

# LIST OF TABLES

| Number |                                   | Page |
|--------|-----------------------------------|------|
| 2-1    | Basic Logic Reference             | 2-3  |
| 2-2    | Standard Readout Format           | 2-42 |
| 2-3    | Channel Address Code              | 2-48 |
| 3-1    | Power Supply Tolerance and Ripple | 3-4  |
| 3-2    | Fuse Ratings                      | 3-19 |
| 4-1    | Test Equipment                    | 4-2  |
| 4-2    | Power Supply Tolerance            | 4-6  |
| 4-3    | High-Frequency Compensation       | 4-11 |

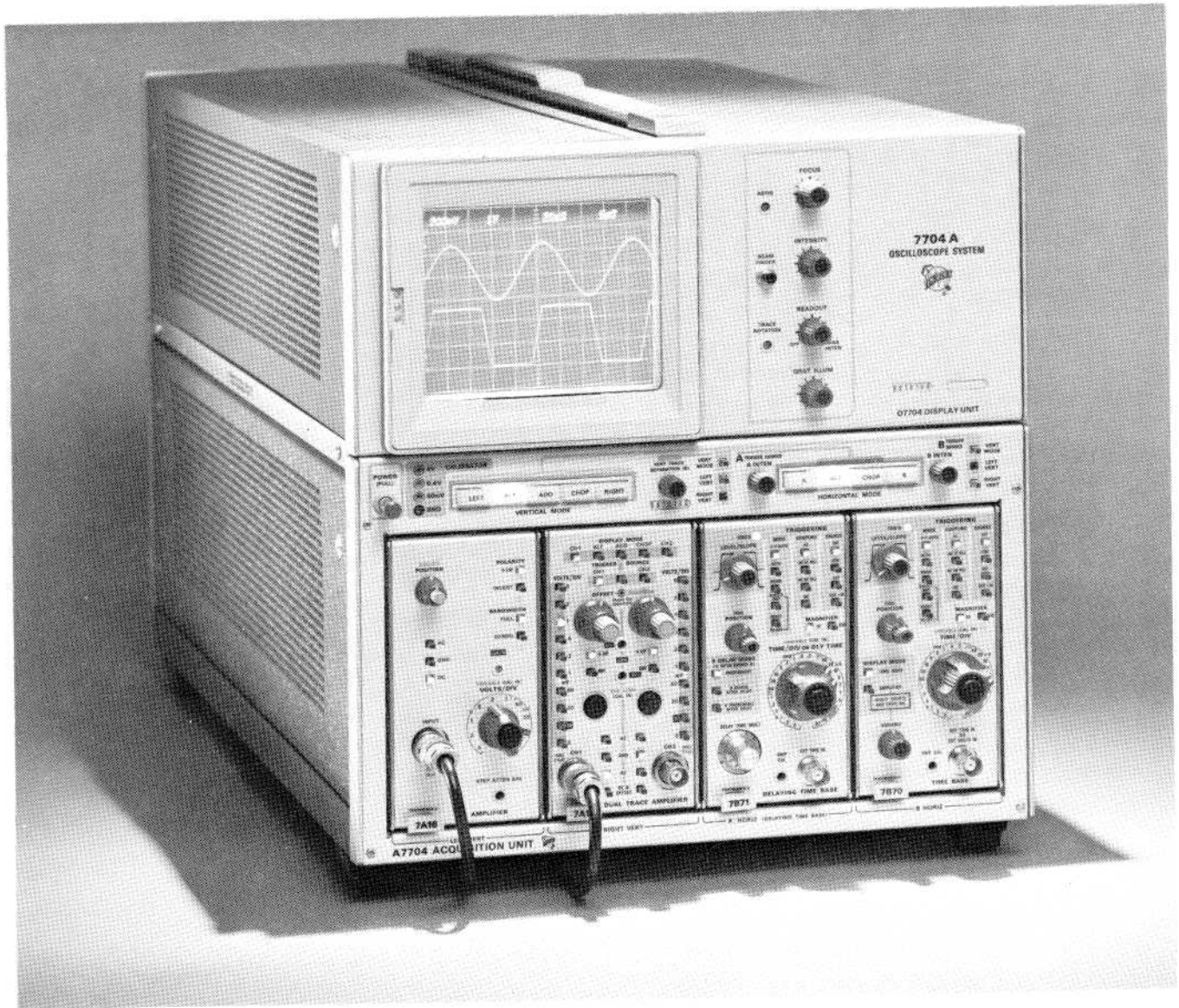

7704A Oscilloscope System.

## INTRODUCTION

The TEKTRONIX 7704A Oscilloscope System is a solid-state, high performance instrument designed for general applications. (For rise time and bandwidth specifications of oscilloscope systems using the 7704A, see the Operators manual). The system is composed of two individual units, the A7704 Acquisition Unit and the D7704 Display Unit.

The A7704 Acquisition Unit has four plug-in compartments. The left pair of plug-in units is connected to the vertical system; the right pair is connected to the horizontal system. Electronic switching between the plug-ins connected to each system allows a dual-trace vertical display or a dual-sweep horizontal display.

The D7704 Display Unit features a CRT with small spot size and high writing rate. In addition to the waveform, the CRT can also display alpha-numeric information from the plug-in units, such as deflection factor, sweep rate and other encoded parameters. Standard graticule size is 8 X 10 centimeters.

DC supplies in the Acquisition Unit supply power for the entire instrument. These supplies are regulated to assure that performance is not affected by variations in line voltage and frequency, or by changes in load due to the varying power requirements of the plug-in units.



# OPERATING INFORMATION

## PRELIMINARY INFORMATION

### Operating Voltage

The 7704A can be operated from either a 115-volt or a 230-volt nominal line voltage source. The Line Selector assembly on the rear panel converts this instrument from one operating voltage to the other. This assembly also includes line fuses. Use the following procedure to obtain correct instrument operation from the line voltage available.

### CAUTION

*This instrument is designed for operation from a power source with its neutral at or near earth (ground) potential with a separate safety-earth conductor. It is not intended for operation from two phases of a multi-phase system, or across the legs of a single-phase, three-wire system.*

1. Disconnect the instrument from the power source.
2. Loosen the two captive screws which hold the cover onto the selector assembly; then pull to remove the cover.
3. To convert from 115-volt to 230-volt nominal line voltage, or vice versa, pull out the Selector switch bar (see Fig. 1-1) and plug it back into the remaining hole. Change the line-cord power plug to match the power-source receptacle, or use a 115- to 230-volt adapter.

### Power Cord Conductor Identification

| Conductor            | Color        | Alternate Color |
|----------------------|--------------|-----------------|
| Ungrounded (Line)    | Brown        | Black           |
| Grounded (Neutral)   | Blue         | White           |
| Grounding (Earthing) | Green-Yellow | Green-Yellow    |

4. Install the cover and tighten the captive screws.

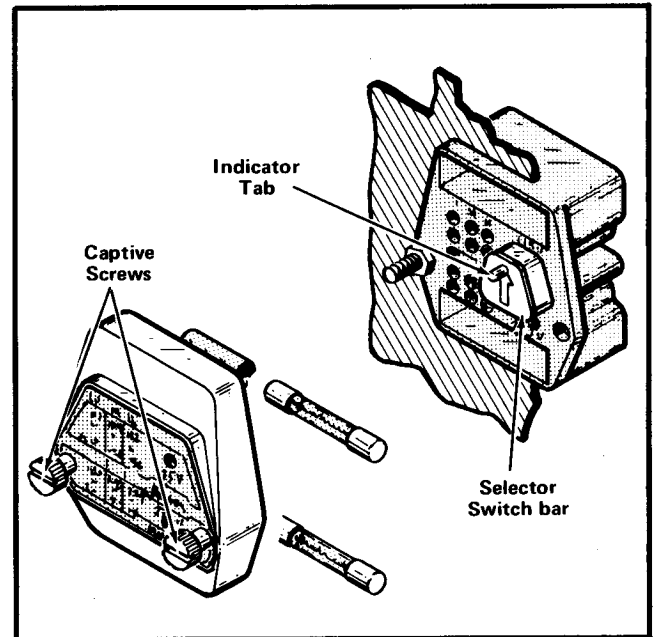

Fig. 1-1. Line Selector assembly on rear panel (shown with cover and fuses removed).

5. Before applying power to the instrument, check that the indicator tab on the switch bar is protruding through the correct hole for the desired line voltage range.

The 7704A is designed to be used with a three-wire AC power system. If the three- to two-wire adapter is used to connect this instrument to a two-wire AC power system, be sure to connect the ground lead of the adapter to earth (ground). Failure to complete the ground system may allow the chassis of this instrument to be elevated above ground potential and pose a shock hazard.

## CONTROLS AND CONNECTORS

The major controls and connectors are located on the front panel of the instrument. Several auxiliary functions are provided on the rear panel. Figure 1-2 shows the front and rear panels and provides brief descriptions of each control and connector. For more detailed operating information, refer to the 7704A Operators Manual.

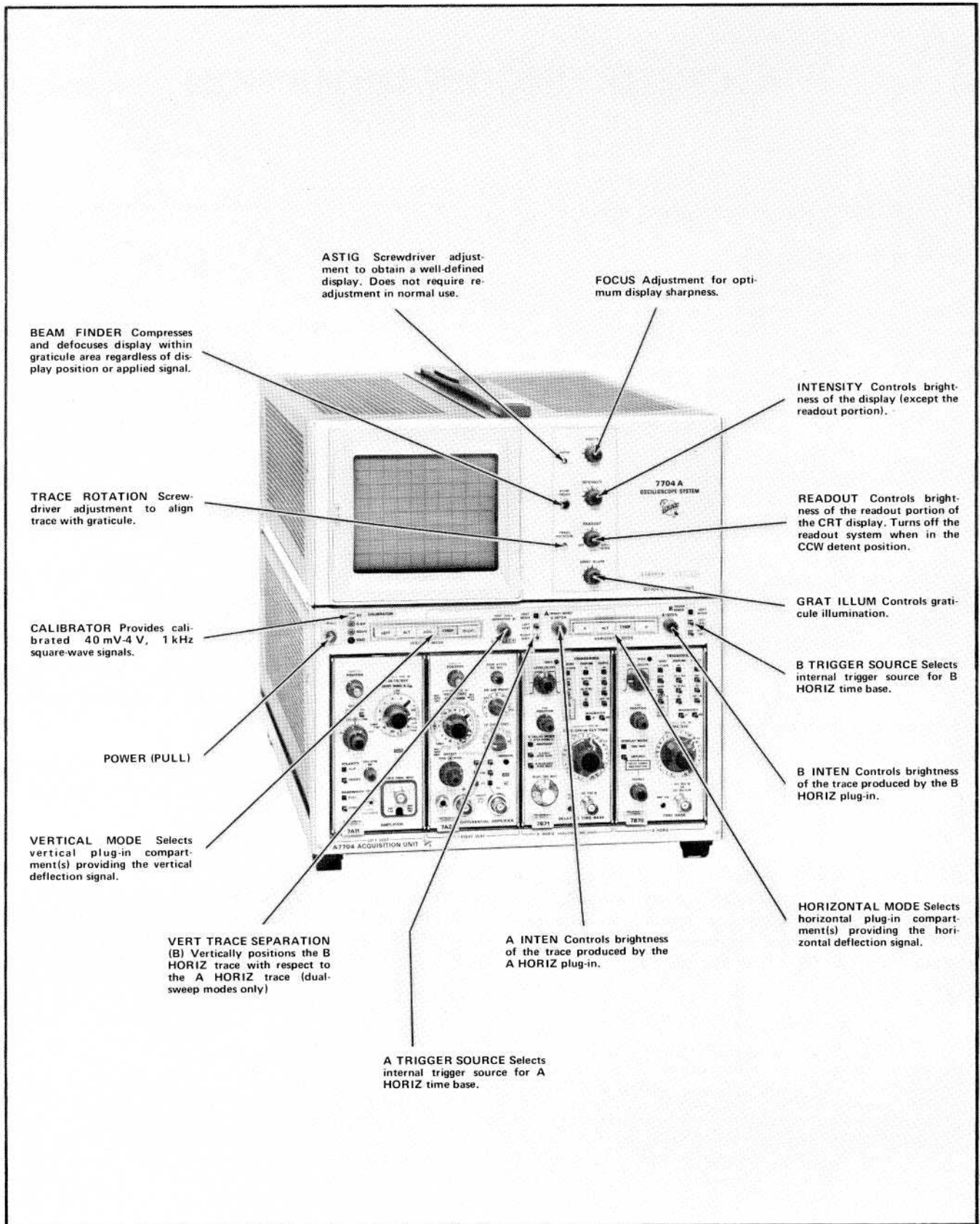

Fig. 1-2A. 7704A front-panel controls and connectors.

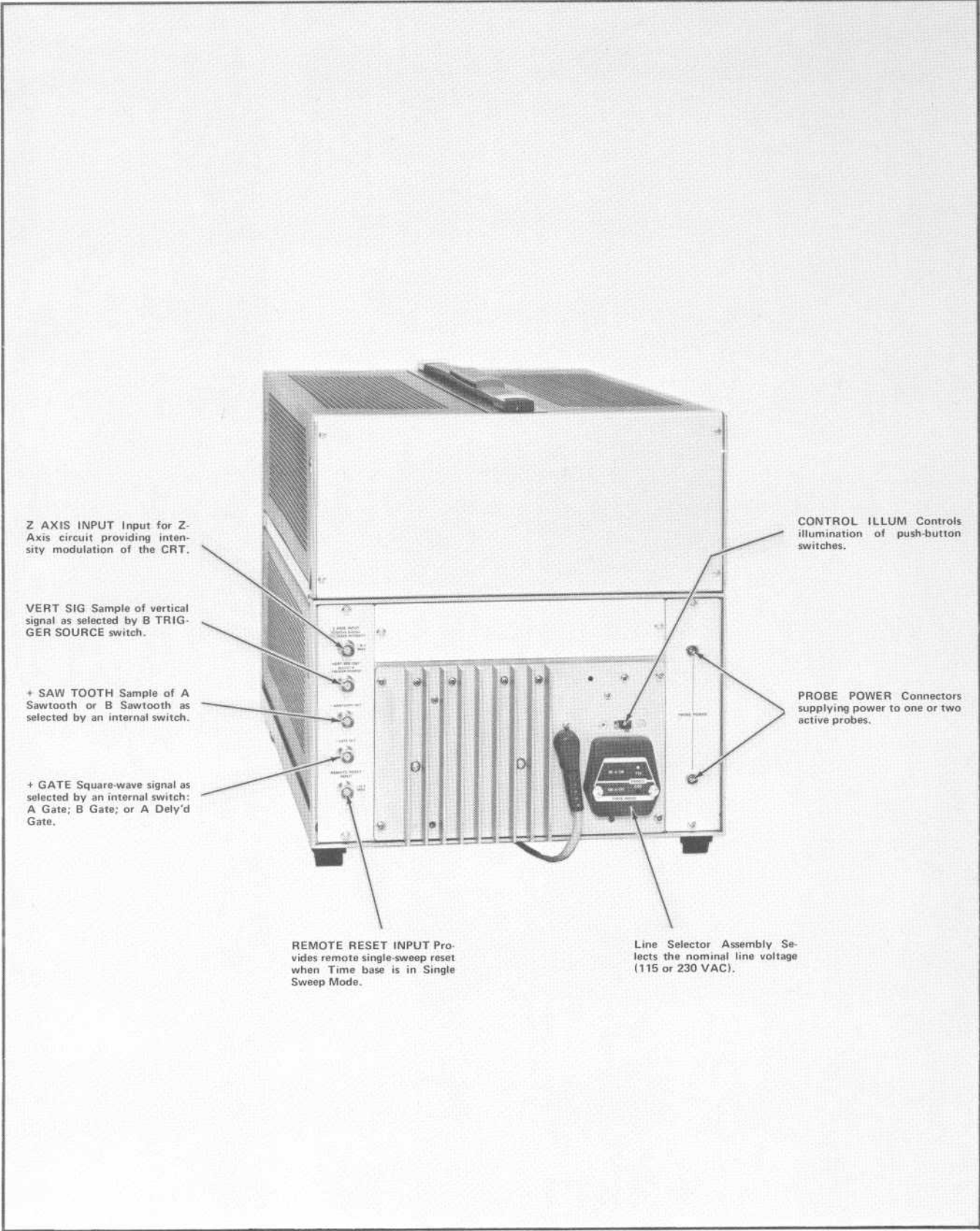

Fig. 1-2B. 7704A rear-panel controls and connectors.

# CIRCUIT DESCRIPTION

This section of the manual describes the circuitry used in the 7704A Oscilloscope System. The description begins with a discussion of the instrument, using the basic block diagram shown on Fig. 2-1. Next, each circuit is described in detail, using detailed block diagrams when appropriate, to show the relationship between the stages in each major circuit. Detailed schematics of each circuit are located in the Diagrams section at the back of this manual; refer to these schematics throughout the following circuit description for specific electrical values and relationships.

## BLOCK DIAGRAM

The basic block diagram in Fig. 2-1 shows the basic interconnections between the individual blocks; each block representing a major circuit within the instrument. The numbered diamond in each block refers to the circuit diagram (located at the rear of the manual) which covers that specific part of the instrument.

### Block Diagram Description

Vertical signals from both vertical plug-in compartments are applied to the Vertical Interface circuit. This circuit determines whether the signal from the left or right vertical plug-in unit is displayed. The selected vertical signal is then amplified by the Vertical Amplifier circuit to drive the vertical deflection plates of the CRT. The Vertical Amplifier circuit also accepts the Y-Readout signal from the Readout System to produce the vertical portion of the alpha-numeric readout display.

The Readout System provides an alpha-numeric display for information encoded by the plug-in units. This display is presented on the CRT on a time-shared basis with the analog waveform display.

Horizontal signals from both horizontal plug-in compartments are connected to the Horizontal Interface circuit. This circuit determines whether the signal from the A or B horizontal unit is displayed. The selected signal is connected to the Horizontal Amplifier circuit, where it is amplified to provide the horizontal deflection for the CRT beam. The Horizontal Amplifier circuit also accepts the X-Readout signal from the Readout System to produce the horizontal portion of the readout display.

The Logic Circuit develops control signals for use in other circuits within the instrument and plug-in units. These control signals automatically determine the correct operation of the instrument in relation to the plug-in installed or selected, the plug-in control settings, and the 7704A control settings.

The internal trigger signals from the vertical plug-in are connected to the Trigger Selector circuits. These circuits select the trigger signals to be applied to the sweep circuits in the horizontal plug-in units. The B Trigger Selector also supplies the drive signal for the Vertical Signal Output.

In addition to the Vertical Signal Output mentioned above, the Output Signals circuit also provides a +Sawtooth Out signal derived from the A or B horizontal sweep signals, and +Gate Out and readout triggering signals derived from the A or B horizontal gate signals.

The Calibrator circuit produces a one-kilohertz square-wave output. This signal is available as a voltage at the front-panel CALIBRATOR connectors or as a current through the 40 milliampere current-loop adapter available as an optional accessory.

The Inverter/Rectifiers circuit provides the low-voltage power necessary for operation of the entire instrument. The high voltages needed for the CRT are supplied by the CRT Circuit. The CRT Circuit also contains the Z-Axis Amplifier which provides the drive signal to control the intensity level of the display.

## CIRCUIT OPERATION

This section provides a detailed description of the electrical operation and relationship of the circuits in the 7704A. The theory of operation for circuits unique to this instrument is described in detail in this discussion. Circuits commonly used in the electronics industry are not described in detail. If more information is desired on these commonly used circuits, refer to the following textbooks (also see books under Logic Fundamentals):

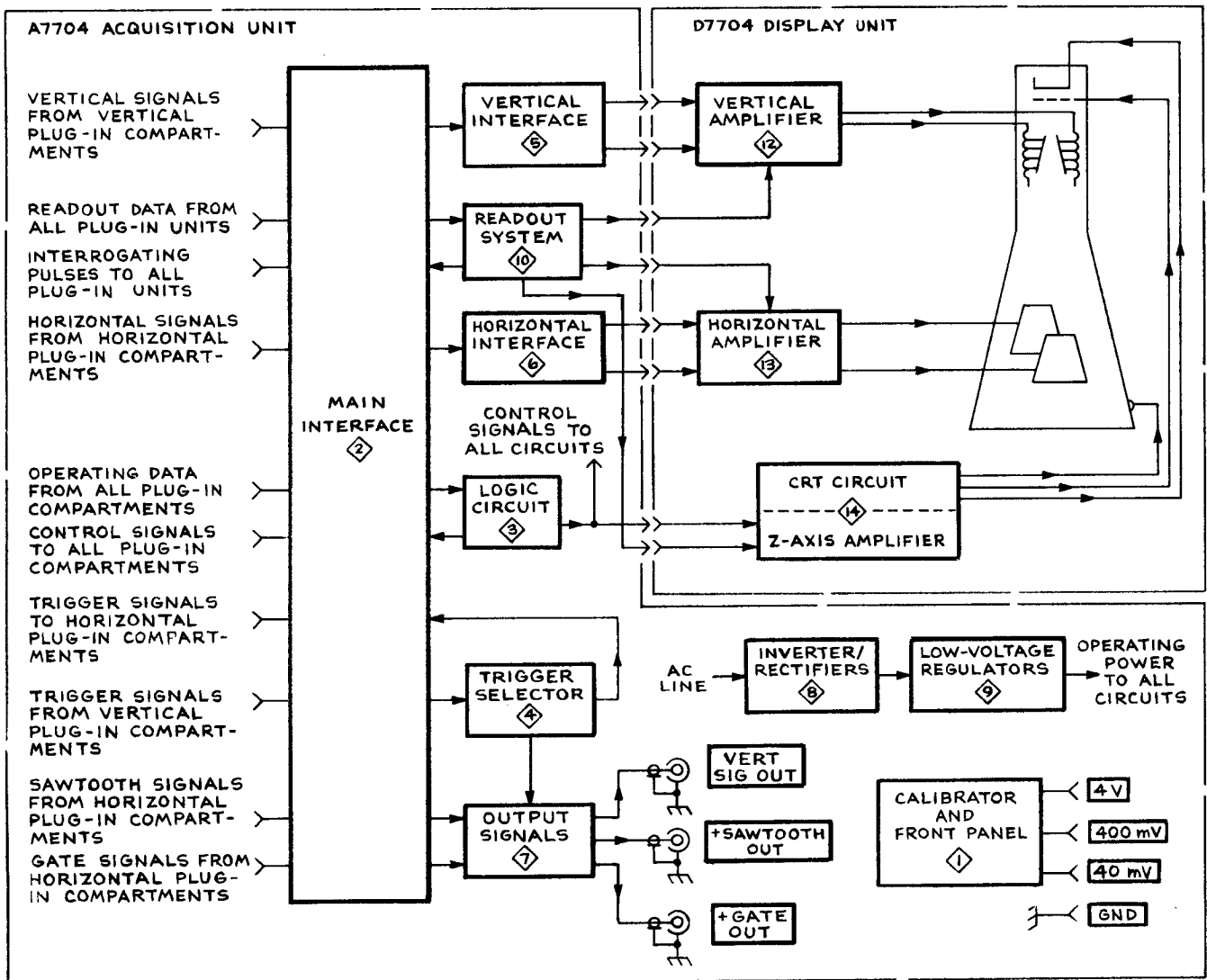

Fig. 2-1. 7704A block diagram.

Phillip Cutler, "Semiconductor Circuit Analysis", McGraw-Hill, New York, 1964.

Lloyd P. Hunter (Ed.), "Handbook of Semiconductor Electronics", second edition, McGraw-Hill, New York, 1962.

Jacob Millman and Herbert Taub, "Pulse, Digital, and Switching Waveforms", McGraw-Hill, New York, 1965.

The following circuit analysis is written around the detailed block diagrams which are given for each major circuit. These detailed block diagrams give the names of the individual stages within the major circuits and show how they are connected together to form the major circuit. The block diagrams also show the inputs and outputs for each circuit and the relationship of the front-panel controls to the individual stages. The circuit diagrams from which the detailed block diagrams are derived are shown in the Diagrams section.

NOTE

All references to direction of current in this manual are in terms of conventional current; i.e., from plus to minus.

## LOGIC FUNDAMENTALS

Digital logic techniques are used to perform many functions within this instrument. The function and operation of the logic circuits are described using logic symbology and terminology. This portion of the manual is provided to aid in the understanding of these symbols and terms. The following information is a basic introduction to logic concepts, not a comprehensive discussion of the subject. For further information on binary number systems and the associated Boolean Algebra concepts, the derivation of logic functions, a more detailed analysis of digital logic, etc., refer to the following textbooks:

Robert C. Baron and Albert T. Piccirilli, "Digital Logic and Computer Operation", McGraw-Hill, New York, 1967.

Thomas C. Bartee, "Digital Computer Fundamentals", McGraw-Hill, New York, 1966.

Yaohan Chu, "Digital Computer Design Fundamentals", McGraw-Hill, New York, 1962.

Joseph Millman and Herbert Taub, "Pulse, Digital, and Switching Waveforms", McGraw-Hill, New York, Chapters 9-11, 1965.

### Symbols

The operation of circuits in this instrument which use digital techniques is described using the graphic symbols set forth in military standard MIL-STD-806B. Table 2-1 provides a basic logic reference for the logic devices used within this instrument. Any deviations from the standard symbology, or devices not defined by the standard are described in the circuit description for the applicable device.

#### NOTE

*Logic symbols used on the diagrams depict the logic function as used in this instrument and may differ from the manufacturer's data.*

### Logic Polarity

All logic functions are described using the positive logic convention. Positive logic is a system of notation where the more positive of two levels (HI) is called the true or 1-state; the more negative level (LO) is called the false or 0-state. The HI-LO method of notation is used in this logic description. The specific voltages which constitute a HI or LO state vary between individual devices.

#### NOTE

*The HI-LO logic notation can be conveniently converted to 1-0 notation by disregarding the first letter of each step. Thus:*

$$\begin{aligned} HI &= 1 \\ LO &= 0 \end{aligned}$$

Wherever possible, the input and output lines are named to indicate the function that they perform when at the HI (true) state. For example, the line labeled "V-H Inhibit" means that the vertical and horizontal deflection function is inhibited or disabled when this line is HI.

### Input/Output Tables

Input/output (truth) tables are used in conjunction with the logic diagrams to show the input combinations important to a particular function, along with the resultant output conditions. This table may be given either for an individual device or for a complete logic stage. For examples of input/output tables for individual devices, see Table 2-1.

### Non-Digital Devices

Not all of the integrated circuit devices in this instrument are digital logic devices. The function of non-digital devices is described individually, using operating waveforms or other techniques to illustrate their function.

TABLE 2-1

Basic Logic Reference

| Device   | Symbol  | Description   | Input/Output Table |    |        |
|----------|---|---|--------------------|----|--------|
|          |   |   | Input              |    | Output |
| AND gate |  | A device with two or more inputs and one output. The output of the AND gate is HI if and only if all of the inputs are at the HI state. | A                  | B  | X      |
|          |   |   | LO                 | LO | LO     |
|          |   |   | LO                 | HI | LO     |
|          |   |   | HI                 | LO | LO     |
|          |   |   | HI                 | HI | HI     |

TABLE 2-1 (cont.)



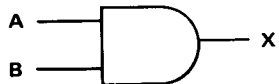

| Device             | Symbol  | Description  | Input/Output Table   |       |        |        |   |    |    |    |    |    |    |    |    |    |    |    |    |    |    |       |  |        |   |   |   |    |    |    |    |    |    |    |    |    |    |    |    |
|--------------------|---|--|--|-------|--------|--------|---|----|----|----|----|----|----|----|----|----|----|----|----|----|----|-------|--|--------|---|---|---|----|----|----|----|----|----|----|----|----|----|----|----|
| NAND gate          |    | A device with two or more inputs and one output. The output of the NAND gate is LO if and only if all of the inputs are at the HI state.   | <table border="1"> <thead> <tr> <th colspan="2">Input</th> <th>Output</th> </tr> <tr> <th>A</th> <th>B</th> <th>X</th> </tr> </thead> <tbody> <tr> <td>LO</td> <td>LO</td> <td>HI</td> </tr> <tr> <td>LO</td> <td>HI</td> <td>HI</td> </tr> <tr> <td>HI</td> <td>LO</td> <td>HI</td> </tr> <tr> <td>HI</td> <td>HI</td> <td>LO</td> </tr> </tbody> </table>  | Input |        | Output | A | B  | X  | LO | LO | HI | LO | HI | HI | HI | LO | HI | HI | HI | LO |       |  |        |   |   |   |    |    |    |    |    |    |    |    |    |    |    |    |
| Input              |   | Output   |  |       |        |        |   |    |    |    |    |    |    |    |    |    |    |    |    |    |    |       |  |        |   |   |   |    |    |    |    |    |    |    |    |    |    |    |    |
| A                  | B   | X  |  |       |        |        |   |    |    |    |    |    |    |    |    |    |    |    |    |    |    |       |  |        |   |   |   |    |    |    |    |    |    |    |    |    |    |    |    |
| LO                 | LO  | HI   |  |       |        |        |   |    |    |    |    |    |    |    |    |    |    |    |    |    |    |       |  |        |   |   |   |    |    |    |    |    |    |    |    |    |    |    |    |
| LO                 | HI  | HI   |  |       |        |        |   |    |    |    |    |    |    |    |    |    |    |    |    |    |    |       |  |        |   |   |   |    |    |    |    |    |    |    |    |    |    |    |    |
| HI                 | LO  | HI   |  |       |        |        |   |    |    |    |    |    |    |    |    |    |    |    |    |    |    |       |  |        |   |   |   |    |    |    |    |    |    |    |    |    |    |    |    |
| HI                 | HI  | LO   |  |       |        |        |   |    |    |    |    |    |    |    |    |    |    |    |    |    |    |       |  |        |   |   |   |    |    |    |    |    |    |    |    |    |    |    |    |
| OR gate            |    | A device with two or more inputs and one output. The output of the OR gate is HI if one or more of the inputs are at the HI state.   | <table border="1"> <thead> <tr> <th colspan="2">Input</th> <th>Output</th> </tr> <tr> <th>A</th> <th>B</th> <th>X</th> </tr> </thead> <tbody> <tr> <td>LO</td> <td>LO</td> <td>LO</td> </tr> <tr> <td>LO</td> <td>HI</td> <td>HI</td> </tr> <tr> <td>HI</td> <td>LO</td> <td>HI</td> </tr> <tr> <td>HI</td> <td>HI</td> <td>HI</td> </tr> </tbody> </table>  | Input |        | Output | A | B  | X  | LO | LO | LO | LO | HI | HI | HI | LO | HI | HI | HI | HI |       |  |        |   |   |   |    |    |    |    |    |    |    |    |    |    |    |    |
| Input              |   | Output   |  |       |        |        |   |    |    |    |    |    |    |    |    |    |    |    |    |    |    |       |  |        |   |   |   |    |    |    |    |    |    |    |    |    |    |    |    |
| A                  | B   | X  |  |       |        |        |   |    |    |    |    |    |    |    |    |    |    |    |    |    |    |       |  |        |   |   |   |    |    |    |    |    |    |    |    |    |    |    |    |
| LO                 | LO  | LO   |  |       |        |        |   |    |    |    |    |    |    |    |    |    |    |    |    |    |    |       |  |        |   |   |   |    |    |    |    |    |    |    |    |    |    |    |    |
| LO                 | HI  | HI   |  |       |        |        |   |    |    |    |    |    |    |    |    |    |    |    |    |    |    |       |  |        |   |   |   |    |    |    |    |    |    |    |    |    |    |    |    |
| HI                 | LO  | HI   |  |       |        |        |   |    |    |    |    |    |    |    |    |    |    |    |    |    |    |       |  |        |   |   |   |    |    |    |    |    |    |    |    |    |    |    |    |
| HI                 | HI  | HI   |  |       |        |        |   |    |    |    |    |    |    |    |    |    |    |    |    |    |    |       |  |        |   |   |   |    |    |    |    |    |    |    |    |    |    |    |    |
| NOR gate           |    | A device with two or more inputs and one output. The output of the NOR gate is LO if one or more of the inputs are at the HI state.  | <table border="1"> <thead> <tr> <th colspan="2">Input</th> <th>Output</th> </tr> <tr> <th>A</th> <th>B</th> <th>X</th> </tr> </thead> <tbody> <tr> <td>LO</td> <td>LO</td> <td>HI</td> </tr> <tr> <td>LO</td> <td>HI</td> <td>LO</td> </tr> <tr> <td>HI</td> <td>LO</td> <td>LO</td> </tr> <tr> <td>HI</td> <td>HI</td> <td>LO</td> </tr> </tbody> </table>  | Input |        | Output | A | B  | X  | LO | LO | HI | LO | HI | LO | HI | LO | LO | HI | HI | LO |       |  |        |   |   |   |    |    |    |    |    |    |    |    |    |    |    |    |
| Input              |   | Output   |  |       |        |        |   |    |    |    |    |    |    |    |    |    |    |    |    |    |    |       |  |        |   |   |   |    |    |    |    |    |    |    |    |    |    |    |    |
| A                  | B   | X  |  |       |        |        |   |    |    |    |    |    |    |    |    |    |    |    |    |    |    |       |  |        |   |   |   |    |    |    |    |    |    |    |    |    |    |    |    |
| LO                 | LO  | HI   |  |       |        |        |   |    |    |    |    |    |    |    |    |    |    |    |    |    |    |       |  |        |   |   |   |    |    |    |    |    |    |    |    |    |    |    |    |
| LO                 | HI  | LO   |  |       |        |        |   |    |    |    |    |    |    |    |    |    |    |    |    |    |    |       |  |        |   |   |   |    |    |    |    |    |    |    |    |    |    |    |    |
| HI                 | LO  | LO   |  |       |        |        |   |    |    |    |    |    |    |    |    |    |    |    |    |    |    |       |  |        |   |   |   |    |    |    |    |    |    |    |    |    |    |    |    |
| HI                 | HI  | LO   |  |       |        |        |   |    |    |    |    |    |    |    |    |    |    |    |    |    |    |       |  |        |   |   |   |    |    |    |    |    |    |    |    |    |    |    |    |
| Inverter           |    | A device with one input and one output. The output state is always opposite to the input state.  | <table border="1"> <thead> <tr> <th>Input</th> <th>Output</th> </tr> <tr> <th>A</th> <th>X</th> </tr> </thead> <tbody> <tr> <td>LO</td> <td>HI</td> </tr> <tr> <td>HI</td> <td>LO</td> </tr> </tbody> </table>   | Input | Output | A      | X | LO | HI | HI | LO |    |    |    |    |    |    |    |    |    |    |       |  |        |   |   |   |    |    |    |    |    |    |    |    |    |    |    |    |
| Input              | Output  |  |  |       |        |        |   |    |    |    |    |    |    |    |    |    |    |    |    |    |    |       |  |        |   |   |   |    |    |    |    |    |    |    |    |    |    |    |    |
| A                  | X   |  |  |       |        |        |   |    |    |    |    |    |    |    |    |    |    |    |    |    |    |       |  |        |   |   |   |    |    |    |    |    |    |    |    |    |    |    |    |
| LO                 | HI  |  |  |       |        |        |   |    |    |    |    |    |    |    |    |    |    |    |    |    |    |       |  |        |   |   |   |    |    |    |    |    |    |    |    |    |    |    |    |
| HI                 | LO  |  |  |       |        |        |   |    |    |    |    |    |    |    |    |    |    |    |    |    |    |       |  |        |   |   |   |    |    |    |    |    |    |    |    |    |    |    |    |
| LO-state indicator | <br><br><br><br> | <p>A small circle at the input or output of a symbol indicates that the LO state is the significant state. Absence of the circle indicates that the HI state is the significant state. Two examples follow:</p> <p>AND gate with LO-state indicator at the A input.</p> <p>The output of this gate is HI if and only if the A input is LO and the B input is HI.</p> <p>OR gate with LO-state indicator at the A input:</p> <p>The output of this gate is HI if either the A input is LO or the B input is HI.</p> | <table border="1"> <thead> <tr> <th colspan="2">Input</th> <th>Output</th> </tr> <tr> <th>A</th> <th>B</th> <th>X</th> </tr> </thead> <tbody> <tr> <td>LO</td> <td>LO</td> <td>LO</td> </tr> <tr> <td>LO</td> <td>HI</td> <td>HI</td> </tr> <tr> <td>HI</td> <td>LO</td> <td>LO</td> </tr> <tr> <td>HI</td> <td>HI</td> <td>LO</td> </tr> </tbody> </table><br><br><table border="1"> <thead> <tr> <th colspan="2">Input</th> <th>Output</th> </tr> <tr> <th>A</th> <th>B</th> <th>X</th> </tr> </thead> <tbody> <tr> <td>LO</td> <td>LO</td> <td>HI</td> </tr> <tr> <td>LO</td> <td>HI</td> <td>HI</td> </tr> <tr> <td>HI</td> <td>LO</td> <td>LO</td> </tr> <tr> <td>HI</td> <td>HI</td> <td>HI</td> </tr> </tbody> </table> | Input |        | Output | A | B  | X  | LO | LO | LO | LO | HI | HI | HI | LO | LO | HI | HI | LO | Input |  | Output | A | B | X | LO | LO | HI | LO | HI | HI | HI | LO | LO | HI | HI | HI |
| Input              |   | Output   |  |       |        |        |   |    |    |    |    |    |    |    |    |    |    |    |    |    |    |       |  |        |   |   |   |    |    |    |    |    |    |    |    |    |    |    |    |
| A                  | B   | X  |  |       |        |        |   |    |    |    |    |    |    |    |    |    |    |    |    |    |    |       |  |        |   |   |   |    |    |    |    |    |    |    |    |    |    |    |    |
| LO                 | LO  | LO   |  |       |        |        |   |    |    |    |    |    |    |    |    |    |    |    |    |    |    |       |  |        |   |   |   |    |    |    |    |    |    |    |    |    |    |    |    |
| LO                 | HI  | HI   |  |       |        |        |   |    |    |    |    |    |    |    |    |    |    |    |    |    |    |       |  |        |   |   |   |    |    |    |    |    |    |    |    |    |    |    |    |
| HI                 | LO  | LO   |  |       |        |        |   |    |    |    |    |    |    |    |    |    |    |    |    |    |    |       |  |        |   |   |   |    |    |    |    |    |    |    |    |    |    |    |    |
| HI                 | HI  | LO   |  |       |        |        |   |    |    |    |    |    |    |    |    |    |    |    |    |    |    |       |  |        |   |   |   |    |    |    |    |    |    |    |    |    |    |    |    |
| Input              |   | Output   |  |       |        |        |   |    |    |    |    |    |    |    |    |    |    |    |    |    |    |       |  |        |   |   |   |    |    |    |    |    |    |    |    |    |    |    |    |
| A                  | B   | X  |  |       |        |        |   |    |    |    |    |    |    |    |    |    |    |    |    |    |    |       |  |        |   |   |   |    |    |    |    |    |    |    |    |    |    |    |    |
| LO                 | LO  | HI   |  |       |        |        |   |    |    |    |    |    |    |    |    |    |    |    |    |    |    |       |  |        |   |   |   |    |    |    |    |    |    |    |    |    |    |    |    |
| LO                 | HI  | HI   |  |       |        |        |   |    |    |    |    |    |    |    |    |    |    |    |    |    |    |       |  |        |   |   |   |    |    |    |    |    |    |    |    |    |    |    |    |
| HI                 | LO  | LO   |  |       |        |        |   |    |    |    |    |    |    |    |    |    |    |    |    |    |    |       |  |        |   |   |   |    |    |    |    |    |    |    |    |    |    |    |    |
| HI                 | HI  | HI   |  |       |        |        |   |    |    |    |    |    |    |    |    |    |    |    |    |    |    |       |  |        |   |   |   |    |    |    |    |    |    |    |    |    |    |    |    |

TABLE 2-1 (cont.)

| Device                         | Symbol  | Description  | Input/Output Table  |       |        |        |   |                                |                               |                                |                               |    |    |           |    |    |    |    |    |    |    |    |    |    |    |               |  |
|--------------------------------|---|--|---|-------|--------|--------|---|--------------------------------|-------------------------------|--------------------------------|-------------------------------|----|----|-----------|----|----|----|----|----|----|----|----|----|----|----|---------------|--|
| Edge symbol                    |    | <p>Normally superimposed on an input line to a logic symbol. Indicates that this input (usually the trigger input of a flip-flop) responds to the indicated transition of the applied signal.</p>  |   |       |        |        |   |                                |                               |                                |                               |    |    |           |    |    |    |    |    |    |    |    |    |    |    |               |  |
| Triggered (toggle) Flip-Flop   |   | <p>A bistable device with one input and two outputs (either or both outputs may be used). When triggered, the outputs change from one stable state to the other stable state with each trigger. The outputs are complementary (i.e., when one output is HI the other is LO). The edge symbol on the trigger (T) input may be of either polarity depending on the device.</p>         | <table border="1"> <thead> <tr> <th colspan="2">Input</th> <th colspan="2">Output</th> </tr> <tr> <th>Condition before trigger pulse</th> <th>Condition after trigger pulse</th> <th>Condition before trigger pulse</th> <th>Condition after trigger pulse</th> </tr> </thead> <tbody> <tr> <td>X</td> <td>X</td> <td>X</td> <td>X</td> </tr> <tr> <td>LO</td> <td>HI</td> <td>HI</td> <td>LO</td> </tr> <tr> <td>HI</td> <td>LO</td> <td>LO</td> <td>HI</td> </tr> </tbody> </table> | Input |        | Output |   | Condition before trigger pulse | Condition after trigger pulse | Condition before trigger pulse | Condition after trigger pulse | X  | X  | X         | X  | LO | HI | HI | LO | HI | LO | LO | HI |    |    |               |  |
| Input                          |   | Output   |   |       |        |        |   |                                |                               |                                |                               |    |    |           |    |    |    |    |    |    |    |    |    |    |    |               |  |
| Condition before trigger pulse | Condition after trigger pulse   | Condition before trigger pulse   | Condition after trigger pulse   |       |        |        |   |                                |                               |                                |                               |    |    |           |    |    |    |    |    |    |    |    |    |    |    |               |  |
| X                              | X   | X  | X   |       |        |        |   |                                |                               |                                |                               |    |    |           |    |    |    |    |    |    |    |    |    |    |    |               |  |
| LO                             | HI  | HI   | LO  |       |        |        |   |                                |                               |                                |                               |    |    |           |    |    |    |    |    |    |    |    |    |    |    |               |  |
| HI                             | LO  | LO   | HI  |       |        |        |   |                                |                               |                                |                               |    |    |           |    |    |    |    |    |    |    |    |    |    |    |               |  |
| Set-Clear (J-K) Flip-Flop      |  | <p>A bistable device with two inputs and two outputs (either or both outputs may be used). The outputs change state in response to the states at the inputs. The outputs are complementary (i.e., when one output is HI the other is LO).</p>  | <table border="1"> <thead> <tr> <th colspan="2">Input</th> <th colspan="2">Output</th> </tr> <tr> <th>A</th> <th>B</th> <th>X</th> <th>X</th> </tr> </thead> <tbody> <tr> <td>LO</td> <td>LO</td> <td colspan="2">No change</td> </tr> <tr> <td>LO</td> <td>HI</td> <td>LO</td> <td>HI</td> </tr> <tr> <td>HI</td> <td>LO</td> <td>HI</td> <td>LO</td> </tr> <tr> <td>HI</td> <td>HI</td> <td colspan="2">Changes state</td> </tr> </tbody> </table>                                  | Input |        | Output |   | A                              | B                             | X                              | X                             | LO | LO | No change |    | LO | HI | LO | HI | HI | LO | HI | LO | HI | HI | Changes state |  |
| Input                          |   | Output   |   |       |        |        |   |                                |                               |                                |                               |    |    |           |    |    |    |    |    |    |    |    |    |    |    |               |  |
| A                              | B   | X  | X   |       |        |        |   |                                |                               |                                |                               |    |    |           |    |    |    |    |    |    |    |    |    |    |    |               |  |
| LO                             | LO  | No change  |   |       |        |        |   |                                |                               |                                |                               |    |    |           |    |    |    |    |    |    |    |    |    |    |    |               |  |
| LO                             | HI  | LO   | HI  |       |        |        |   |                                |                               |                                |                               |    |    |           |    |    |    |    |    |    |    |    |    |    |    |               |  |
| HI                             | LO  | HI   | LO  |       |        |        |   |                                |                               |                                |                               |    |    |           |    |    |    |    |    |    |    |    |    |    |    |               |  |
| HI                             | HI  | Changes state  |   |       |        |        |   |                                |                               |                                |                               |    |    |           |    |    |    |    |    |    |    |    |    |    |    |               |  |
| D (data) Type Flip-Flop        |  | <p>A bistable device with two inputs and two outputs (either or both outputs may be used). When triggered the state of the "1" output changes to the state at the data (D) input prior to the trigger. The outputs are complementary (i.e., when one output is HI the other is LO). The edge symbol on the trigger (T) input may be of either polarity, depending on the device.</p> | <table border="1"> <thead> <tr> <th>Input</th> <th colspan="2">Output</th> </tr> <tr> <th>A</th> <th>X</th> <th>X</th> </tr> </thead> <tbody> <tr> <td>LO</td> <td>LO</td> <td>HI</td> </tr> <tr> <td>HI</td> <td>HI</td> <td>LO</td> </tr> </tbody> </table> <p>Output conditions shown after trigger pulse</p>  | Input | Output |        | A | X                              | X                             | LO                             | LO                            | HI | HI | HI        | LO |    |    |    |    |    |    |    |    |    |    |               |  |
| Input                          | Output  |  |   |       |        |        |   |                                |                               |                                |                               |    |    |           |    |    |    |    |    |    |    |    |    |    |    |               |  |
| A                              | X   | X  |   |       |        |        |   |                                |                               |                                |                               |    |    |           |    |    |    |    |    |    |    |    |    |    |    |               |  |
| LO                             | LO  | HI   |   |       |        |        |   |                                |                               |                                |                               |    |    |           |    |    |    |    |    |    |    |    |    |    |    |               |  |
| HI                             | HI  | LO   |   |       |        |        |   |                                |                               |                                |                               |    |    |           |    |    |    |    |    |    |    |    |    |    |    |               |  |

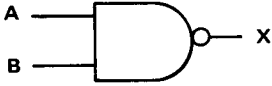
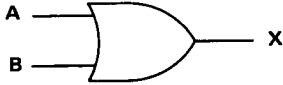

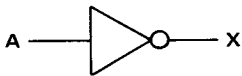
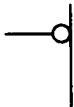
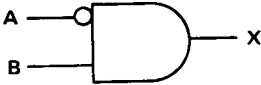
TABLE 2-1 (cont.)

| Device  | Symbol | Description  | Input/Output Table  |                        |    |        |  |        |   |   |   |    |    |           |   |    |    |    |    |                        |    |        |        |    |    |               |    |        |        |    |    |    |    |        |        |    |    |           |  |
|---|--------|--|---|------------------------|----|--------|--|--------|---|---|---|----|----|-----------|---|----|----|----|----|------------------------|----|--------|--------|----|----|---------------|----|--------|--------|----|----|----|----|--------|--------|----|----|-----------|--|
| Triggered Set-Clear (J-K) Flip-Flop                                       |        | <p>A bistable device with three or more inputs and two outputs (either or both outputs may be used). When triggered, the outputs change state in response to the states at the inputs prior to the trigger. The outputs are complementary (i.e., when one output is HI the other is LO). The edge symbol on the trigger (T) input may be of either polarity depending on the device.</p> | <table border="1"> <thead> <tr> <th colspan="2">Input</th> <th colspan="2">Output</th> </tr> <tr> <th>A</th> <th>B</th> <th>X</th> <th>X</th> </tr> </thead> <tbody> <tr> <td>LO</td> <td>LO</td> <td colspan="2">No change</td> </tr> <tr> <td>LO</td> <td>HI</td> <td>LO</td> <td>HI</td> </tr> <tr> <td>HI</td> <td>LO</td> <td>HI</td> <td>LO</td> </tr> <tr> <td>HI</td> <td>HI</td> <td colspan="2">Changes state</td> </tr> </tbody> </table> <p>Output conditions shown after trigger pulse</p>   | Input                  |    | Output |  | A      | B | X | X | LO | LO | No change |   | LO | HI | LO | HI | HI                     | LO | HI     | LO     | HI | HI | Changes state |    |        |        |    |    |    |    |        |        |    |    |           |  |
| Input   |        | Output   |   |                        |    |        |  |        |   |   |   |    |    |           |   |    |    |    |    |                        |    |        |        |    |    |               |    |        |        |    |    |    |    |        |        |    |    |           |  |
| A   | B      | X  | X   |                        |    |        |  |        |   |   |   |    |    |           |   |    |    |    |    |                        |    |        |        |    |    |               |    |        |        |    |    |    |    |        |        |    |    |           |  |
| LO  | LO     | No change  |   |                        |    |        |  |        |   |   |   |    |    |           |   |    |    |    |    |                        |    |        |        |    |    |               |    |        |        |    |    |    |    |        |        |    |    |           |  |
| LO  | HI     | LO   | HI  |                        |    |        |  |        |   |   |   |    |    |           |   |    |    |    |    |                        |    |        |        |    |    |               |    |        |        |    |    |    |    |        |        |    |    |           |  |
| HI  | LO     | HI   | LO  |                        |    |        |  |        |   |   |   |    |    |           |   |    |    |    |    |                        |    |        |        |    |    |               |    |        |        |    |    |    |    |        |        |    |    |           |  |
| HI  | HI     | Changes state  |   |                        |    |        |  |        |   |   |   |    |    |           |   |    |    |    |    |                        |    |        |        |    |    |               |    |        |        |    |    |    |    |        |        |    |    |           |  |
| Flip-Flop with Direct Inputs (may be applied to all triggered flip-flops) |        | <p>For devices with direct-set (<math>S_D</math>) or direct-clear (<math>C_D</math>) inputs, the indicated state at either of these inputs over-rides all other inputs (including trigger) to set the outputs to the states shown in the input/output table.</p>   | <table border="1"> <thead> <tr> <th colspan="4">Input</th> <th colspan="2">Output</th> </tr> <tr> <th>A</th> <th>B</th> <th>C</th> <th>D</th> <th>X</th> <th>X</th> </tr> </thead> <tbody> <tr> <td>1</td> <td>1</td> <td>LO</td> <td>LO</td> <td colspan="2">No change<sup>1</sup></td> </tr> <tr> <td><math>\Phi</math></td> <td><math>\Phi</math></td> <td>LO</td> <td>HI</td> <td>LO</td> <td>HI</td> </tr> <tr> <td><math>\Phi</math></td> <td><math>\Phi</math></td> <td>HI</td> <td>LO</td> <td>HI</td> <td>LO</td> </tr> <tr> <td><math>\Phi</math></td> <td><math>\Phi</math></td> <td>HI</td> <td>HI</td> <td colspan="2">Undefined</td> </tr> </tbody> </table> <p><math>\Phi</math> = Has no effect in this case<br/> <sup>1</sup>Output state determined by conditions at triggered inputs</p> | Input                  |    |        |  | Output |   | A | B | C  | D  | X         | X | 1  | 1  | LO | LO | No change <sup>1</sup> |    | $\Phi$ | $\Phi$ | LO | HI | LO            | HI | $\Phi$ | $\Phi$ | HI | LO | HI | LO | $\Phi$ | $\Phi$ | HI | HI | Undefined |  |
| Input   |        |  |   | Output                 |    |        |  |        |   |   |   |    |    |           |   |    |    |    |    |                        |    |        |        |    |    |               |    |        |        |    |    |    |    |        |        |    |    |           |  |
| A   | B      | C  | D   | X                      | X  |        |  |        |   |   |   |    |    |           |   |    |    |    |    |                        |    |        |        |    |    |               |    |        |        |    |    |    |    |        |        |    |    |           |  |
| 1   | 1      | LO   | LO  | No change <sup>1</sup> |    |        |  |        |   |   |   |    |    |           |   |    |    |    |    |                        |    |        |        |    |    |               |    |        |        |    |    |    |    |        |        |    |    |           |  |
| $\Phi$  | $\Phi$ | LO   | HI  | LO                     | HI |        |  |        |   |   |   |    |    |           |   |    |    |    |    |                        |    |        |        |    |    |               |    |        |        |    |    |    |    |        |        |    |    |           |  |
| $\Phi$  | $\Phi$ | HI   | LO  | HI                     | LO |        |  |        |   |   |   |    |    |           |   |    |    |    |    |                        |    |        |        |    |    |               |    |        |        |    |    |    |    |        |        |    |    |           |  |
| $\Phi$  | $\Phi$ | HI   | HI  | Undefined              |    |        |  |        |   |   |   |    |    |           |   |    |    |    |    |                        |    |        |        |    |    |               |    |        |        |    |    |    |    |        |        |    |    |           |  |

## CALIBRATOR AND FRONT PANEL 1

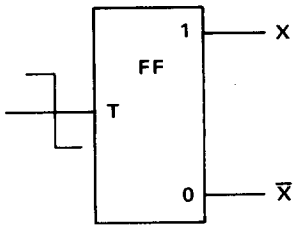
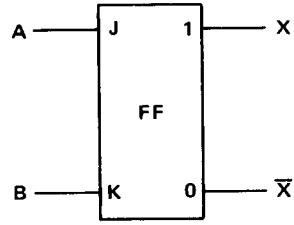
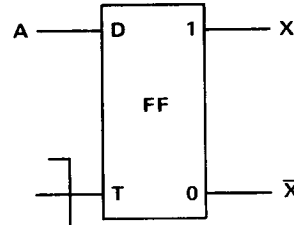
### Introduction

Diagram 1 shows the front-panel controls, the interconnections between these controls and the controlled circuits, and the Calibrator circuit. The circuitry associated with Q2080 and Q2090 is described in connection with the Trigger Selector circuit (diagram 4).

The Calibrator circuit provides a one-kilohertz square-wave signal at the front-panel CALIBRATOR pin-jacks. A block diagram of the Calibrator circuit is shown on Fig. 2-2.

### 2-kHz Oscillator

Q1001 and Q1003 are connected as a two-kilohertz, astable emitter-coupled multivibrator to provide the drive signal for the Calibrator Countdown stage. The repetition rate is determined by R1004, R1007, C1001, and the collector supply voltage for Q1001. The 1 kHz adjustment, R1001, sets the collector voltage of Q1001 so an accurate two-kilohertz square wave is produced at the collector of Q1003.

### Calibrator Countdown

C1004 and R1009 differentiate the two-kilohertz signal from the collector of Q1003 to produce positive- and negative-going pulses coincident with the rise and fall of the

square wave. The negative-going pulses have no effect on Q1011. The positive-going pulses turn on Q1011 to produce negative-going pulses at its collector, which are of sufficient level and amplitude to drive the Clock input of U1010.

U1010 is a triggered set-clear (J-K) flip-flop connected as a triggered (toggle) flip-flop. The negative-going pulses from Q1011 trigger U1010 so that the outputs change state with each negative input pulse to provide a one-kilohertz output.

### Output Amplifier

The one-kilohertz output of the Calibrator Countdown stage is connected through Q1021 and Q1023 to control the conduction of Q1025 and Q1027. Transistors Q1025 and Q1027 are connected as a comparator. The reference level at the base of Q1027 is determined by the network R1037-R1039-R1038-R1034-R1035-Q1031. The 0.4 Volts adjustment, R1037, is set to provide accurate output voltage at the 0.4 V Calibrator pin-jack. The voltage at the collector of Q1027 changes at a one-kilohertz repetition rate between zero volt and a level established by the reference level at its base.

### Output Voltage Divider

The output voltage divider, made up of resistors R1043 through R1058, is designed to provide a low-impedance output for all ranges except 40 V, while providing accurate output voltages between four millivolts and 40 volts. (Four-millivolt and 40-volt outputs are available on internal circuit-board pins.)

The output resistance at the 40 V pin is about 15 kilohms, as determined by R1041 and the equivalent resistance of the divider network. The remaining output voltages are accurate with a one-megohm load or, at reduced output, a 50-ohm load.

### Switch Logic

The VERTICAL MODE and HORIZONTAL MODE switches determine the operating mode of the Vertical Interface and Horizontal Interface circuits respectively. Each of these switches is self-canceling; i.e., only one button can be pressed at a time. Specific operation of these switches is described in connection with the circuits they control.

The A and B TRIGGER SOURCE switches control the operation of the Trigger Selector circuit. These switches are also self-canceling, so only one of the buttons can be pressed at a time. Operation of these switches is discussed in connection with the Trigger Selector circuit.

### Indicator Lights

The indicator lights shown in connection with the mode switches indicate which mode has been selected. When one of the pushbuttons is pressed, it completes the circuit between the associated bulb and the +5-Volt Lights supply. A separate bulb is used for each mode switch pushbutton.

The A and B TRIGGER SOURCE switches are also illuminated to indicate the trigger source, but only one bulb is used for each switch assembly. Light guides are used, so that the button pressed receives light, but the remaining buttons are not illuminated. The power for the indicator lights is controlled by the rear-panel CONTROL ILLUM switch (shown on diagram 9).

## MAIN INTERFACE 2

Diagram 2 shows the plug-in interface and the interconnections between the plug-in compartments, circuit boards, etc. of this instrument.

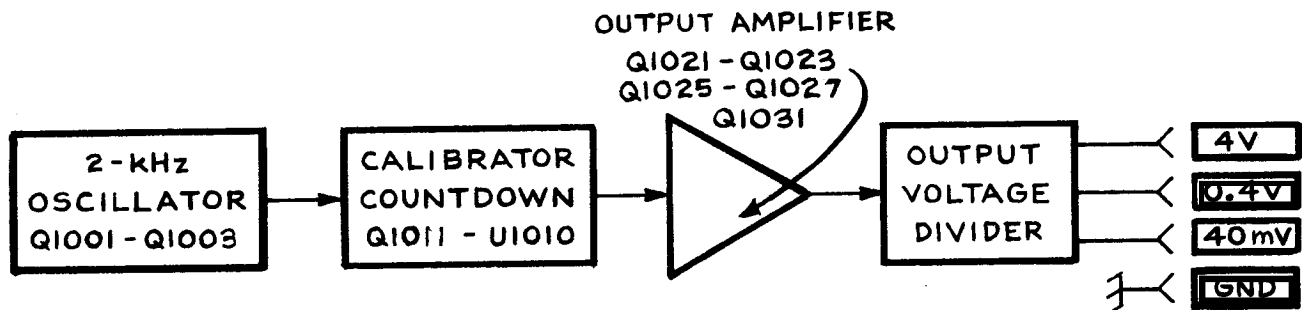

Fig. 2-2. Calibrator circuit detailed block diagram.

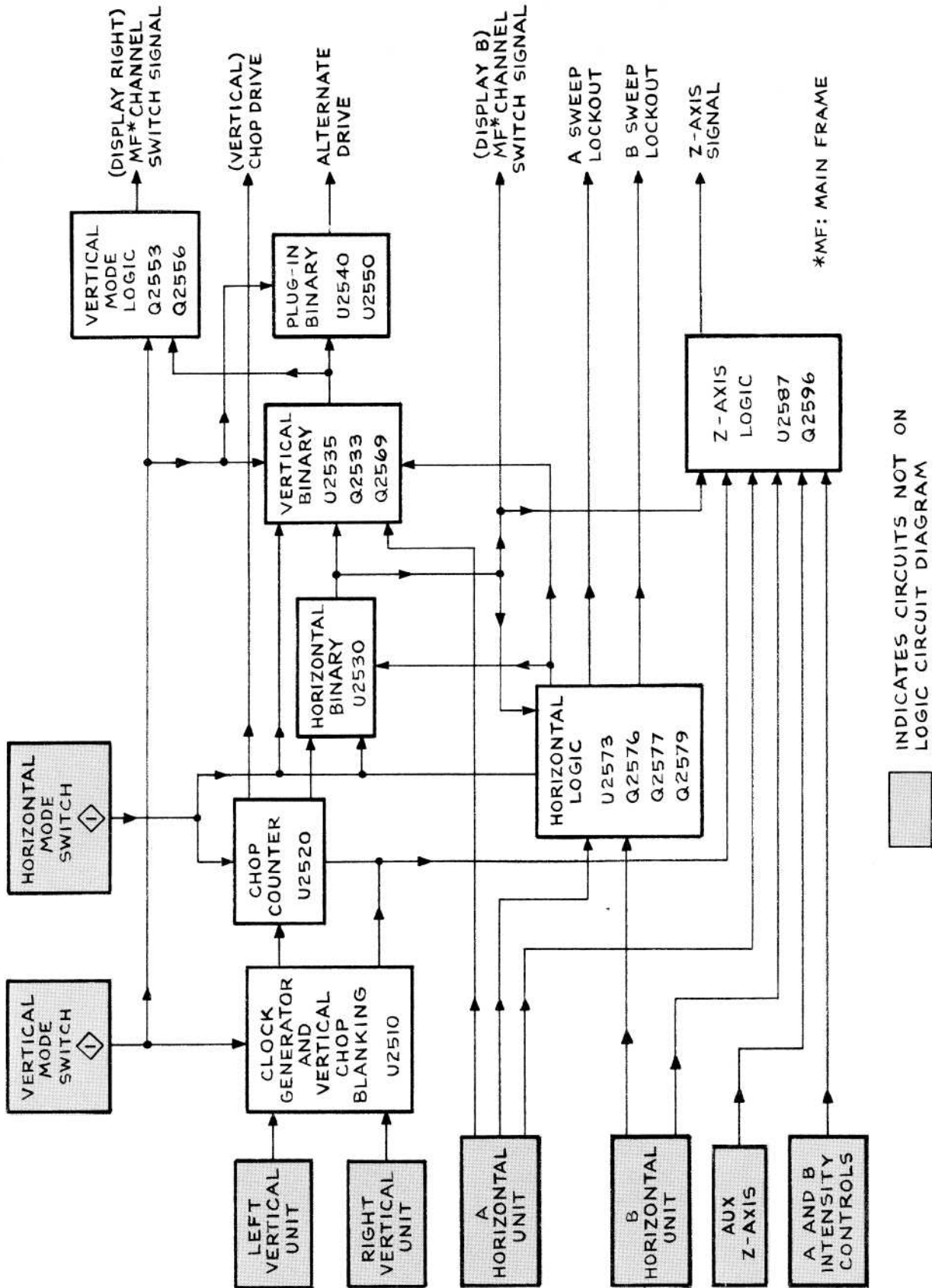

Fig. 2-3. Block diagram of Logic Circuit.

# LOGIC CIRCUIT 3

## General

The Logic Circuit develops control signals for use in other circuits within this instrument. These output signals automatically determine the correct instrument operation in relation to the plug-ins installed or selected, plug-in control settings, and 7704A control settings. A block diagram of the Logic Circuit is shown in Fig. 2-3. This diagram shows the source of the input control signals, the output signals produced by this stage, and the basic interconnections between blocks. The interconnections shown are intended only to indicate inter-relation between blocks and neither indicate a direct connection, nor that only a single connection is made between the given blocks. Details of the inter-relation between stages in this circuit are given in the circuit description which follows.

This circuit description for the Logic Circuit is written with the approach that each of the integrated circuits and its associated discrete components composes an individual stage as shown by the block diagram (Fig. 2-3). The operation of each of these stages is discussed, relating the

input signals or levels to the output, with consideration given to the various modes of operation that may affect the stage. A logic diagram is also provided for each stage. These diagrams are not discussed in detail, but are provided to aid in relating the function performed by a given stage to standard logic techniques. It should be noted that these logic diagrams are not an exact representation of the internal structure of the integrated circuit, but are only a logic diagram of the function performed by the stage. An input/output table is given, where applicable, for use along with the circuit description and logic diagram. These input/output tables document the combination of input conditions that are of importance to perform the prescribed function of an individual stage.

## Horizontal Logic

The Horizontal Logic stage performs three separate logic functions: A Sweep Lockout, B Sweep Lockout, and Alternate Pulse Generator. Figure 2-4 identifies the three individual stages and the input and output terminals associated with each. Notice that some of the input signals are connected internally to more than one of the individual stages.

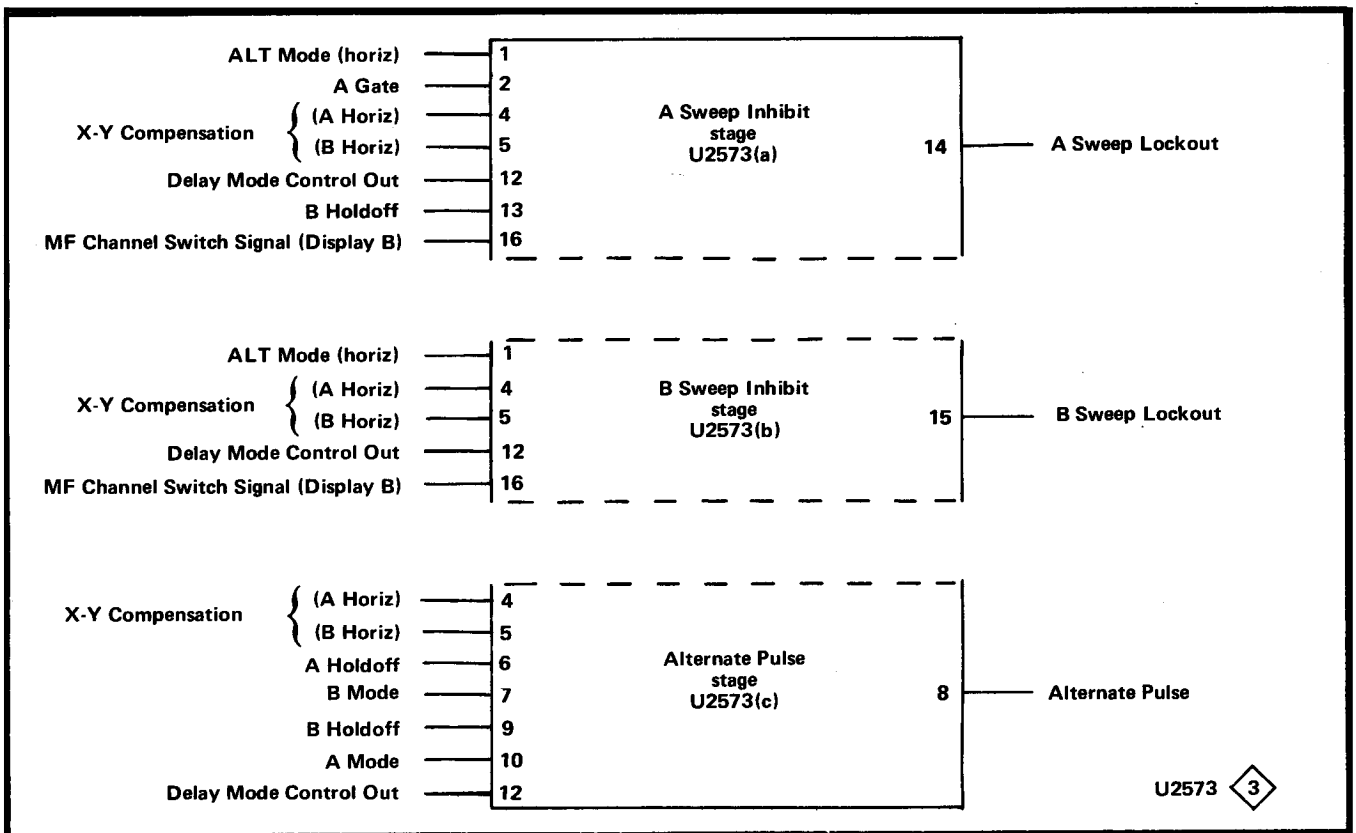

Fig. 2-4. Breakdown of separate stages within Horizontal Logic IC (U2573) showing inputs and outputs for each stage.

**Circuit Description—7704A Service**

**A Sweep Lockout.** The A Sweep Lockout stage produces an output level at the collector of Q2577 that determines if the A HORIZ time-base unit can produce a sweep. If this output is HI, the A HORIZ unit is locked out (disabled) so it cannot produce a sweep. If the level is LO, the A HORIZ unit is enabled and can produce a sweep when triggered.

The first combination disables the A sweep while the B sweep is being displayed in the ALT horizontal mode (both units must be in time-base mode) if non-delayed operation is being used. The second combination disables the A sweep during delayed-sweep operation so that the B sweep can complete its holdoff before the next A sweep begins.

As shown by the logic diagram and input/output table of Fig. 2-5, only two combinations of input conditions produce an A Sweep Lockout level (HI); if any one of the prescribed conditions is not met, the A Sweep Lockout level is LO and the A HORIZ time-base unit is enabled.

**B Sweep Lockout.** The B Sweep Lockout stage produces an output level at the collector of Q2579 that determines if the B HORIZ time-base unit can produce a sweep. A HI output level locks out (inhibits) the B HORIZ unit and a LO level enables the B HORIZ unit to produce a sweep.

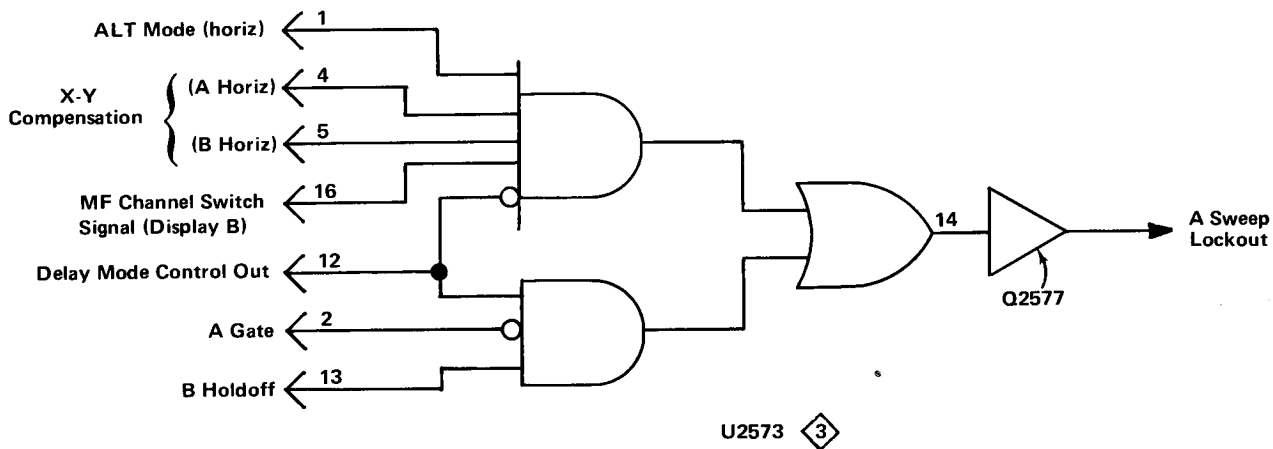

(A)

| Input                  |        |                  |         |                        |           |                                      | Output          |
|------------------------|--------|------------------|---------|------------------------|-----------|--------------------------------------|-----------------|
| ALT Mode (horiz)       | A Gate | X-Y Compensation |         | Delay Mode Control Out | B Holdoff | MF Channel Switch Signal (Display B) | A Sweep Lockout |
| 1                      | 2      | A Horiz          | B Horiz | 12                     | 13        | 16                                   |                 |
| HI                     | Φ      | HI               | HI      | LO                     | Φ         | HI                                   | HI              |
| Φ                      | LO     | Φ                | Φ       | HI                     | HI        | Φ                                    | HI              |
| All other combinations |        |                  |         |                        |           |                                      | LO              |

Φ = Has no effect in this case.

Fig. 2-5. (A) Logic diagram for A Sweep Lockout stage; (B) Table of input/output combinations.

As shown by Fig. 2-6B, the output of this stage is HI only under one set of input conditions. This set of conditions disables the B sweep while the A sweep is being displayed in the ALT horizontal mode if both units are in a time-base mode and non-delayed sweep is used. For any other combination of input conditions, the B Sweep Lockout level is LO. However, the lockout level to the B time-base unit is determined by both the Delay Gate from the A time-base unit and the B Sweep Lockout level produced by this stage. The B sweep is enabled only when both of these levels are LO.

Figure 2-6A shows the logic diagram of the B Sweep Lockout stage. The gate connected to the output of this stage is a phantom-OR gate located on the Main Interface diagram (a phantom-OR gate performs the OR-logic function merely by interconnection of the two signal lines).

**Alternate Pulse Generator.** The third function performed by the Horizontal Logic stage is to produce an Alternate Pulse signal for use by the Horizontal and Vertical Binary stages. The Alternate Pulse is produced at the end of either sweep, depending upon the operating conditions as shown in Fig. 2-7B. The holdoff gate produced at the end of the sweep by the respective time-base unit is differentiated by either C2575 or C2573 to provide a positive-going pulse to pin 6 or 9.

In Fig. 2-7A, note the resistors shown connected to pins 6 and 9. These resistors, which are internal to the IC, hold the levels at pins 6 and 9 LO unless a HI level is applied to the corresponding input. Since the holdoff gate is capacitively-coupled to pins 6 and 9, these inputs are at the LO level except when a differentiated A or B Holdoff gate is received.

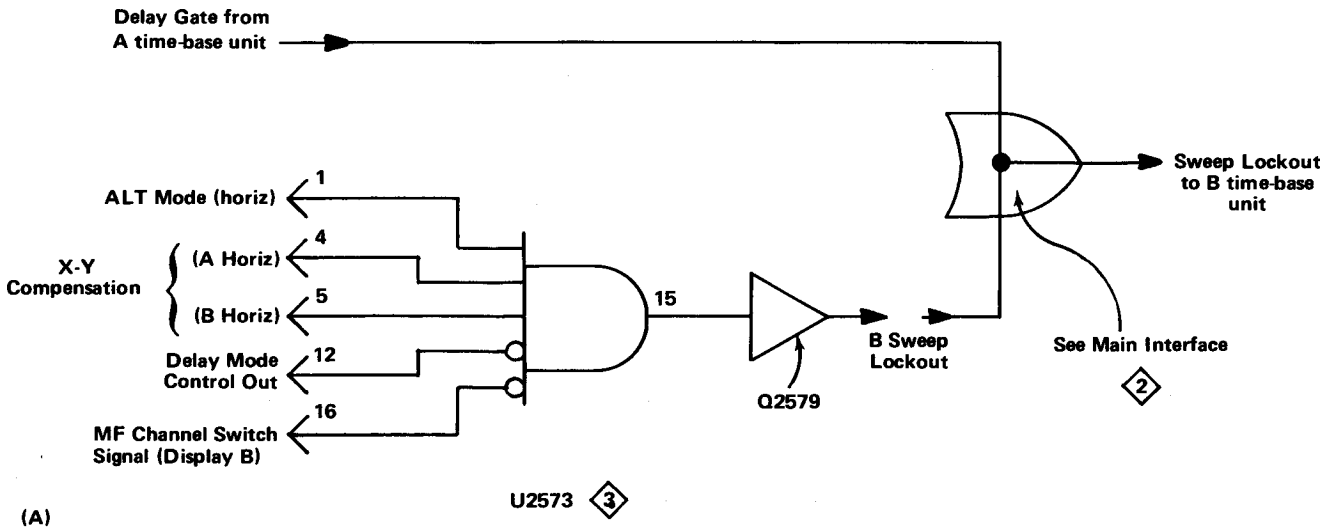

(A)

| Input                  |                  |         |                        |                                      | Output          |
|------------------------|------------------|---------|------------------------|--------------------------------------|-----------------|
| ALT Mode (horiz)       | X-Y Compensation |         | Delay Mode Control Out | MF Channel Switch Signal (Display B) | B Sweep Lockout |
| 1                      | A Horiz          | B Horiz | 12                     | 16                                   |                 |
| HI                     | HI               | HI      | LO                     | LO                                   | HI              |
| All other combinations |                  |         |                        |                                      | LO              |

(B)

Φ = Has no effect in this case

Fig. 2-6. (A) Logic diagram for B Sweep Lockout stage; (B) Table of input/output combinations.

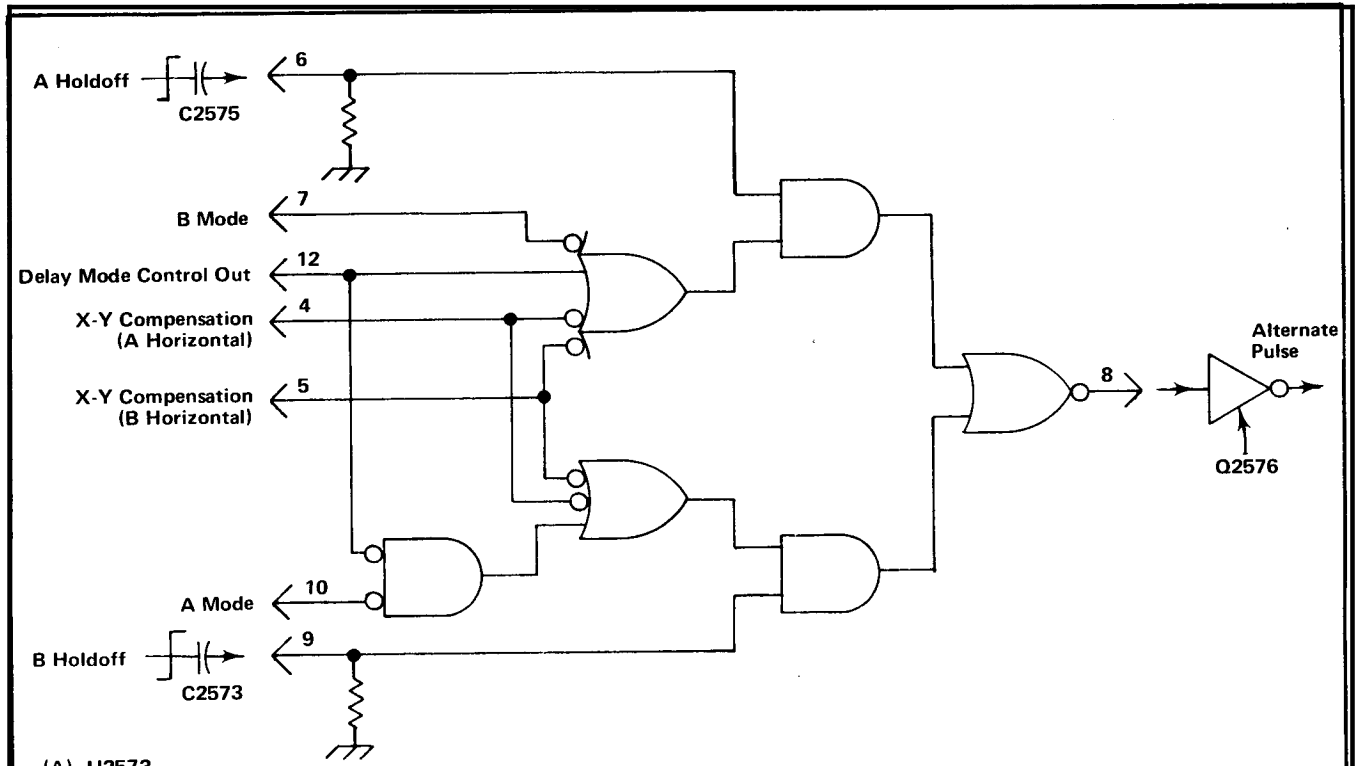

(A) U2573

| Input                                |                                      |                 |             |                 |              |                              | Output   |   |
|--------------------------------------|--------------------------------------|-----------------|-------------|-----------------|--------------|------------------------------|--|---|
| X-Y Compensation (A Horizontal)<br>4 | X-Y Compensation (B Horizontal)<br>5 | A Holdoff<br>6  | B Mode<br>7 | B Holdoff<br>9  | A Mode<br>10 | Delay Mode Control Out<br>12 | Time-Base which is source of Alternate Pulse<br>8 <sup>2</sup> | Horizontal Conditions                   |
| HI                                   | Φ                                    | HI <sup>1</sup> | LO          | Φ               | HI           | Φ                            | A  | A only                                  |
| Φ                                    | HI                                   | Φ               | HI          | HI <sup>1</sup> | LO           | LO                           | B  | B only                                  |
| HI                                   | HI                                   | HI <sup>1</sup> | LO          | HI <sup>1</sup> | LO           | LO                           | A and B  | ALT or CHOP                             |
| HI                                   | HI                                   | HI <sup>1</sup> | Φ           | Φ               | Φ            | HI                           | A  | A delays B                              |
| HI                                   | LO                                   | HI <sup>1</sup> | LO          | LO              | Φ            | Φ                            | A  | A with amplifier unit in B compartment. |
| LO                                   | HI                                   | LO              | Φ           | HI <sup>1</sup> | LO           | LO                           | B  | B with amplifier unit in A compartment. |
| All other combinations               |                                      |                 |             |                 |              |                              | No output pulse (LO at output)                                 |   |

Φ = Has no effect in this case

<sup>1</sup> Positive-going pulse. Where both A and B Holdoff are required to be HI, a HI at either input produces an Alternate Pulse.

<sup>2</sup> Negative-going pulse.

(B)

Fig. 2-7. (A) Logic diagram for Alternate Pulse Generator stage; (B) Table of input/output combinations.

The following discussions describe the operation of the Alternate Pulse Generator stage in relation to the various combinations of input conditions shown in Fig. 2-7B.

### 1. A (ONLY) MODE

An Alternate Pulse is produced at the end of each A sweep when the HORIZONTAL MODE switch is set to the A position.

### 2. B (ONLY) MODE

In the B position of the HORIZONTAL MODE switch, an Alternate Pulse is produced at the end of each B sweep (A time-base must be in independent, non-delayed mode).

### 3. ALT OR CHOP MODE

When the HORIZONTAL MODE switch is set to ALT or CHOP (A time-base unit must be in independent, non-delayed mode), an Alternate Pulse is produced at the end of each sweep. For example, an Alternate Pulse is produced at the end of the A sweep, then at the end of the B sweep, again at the end of the A sweep, etc. Although Alternate Pulses are produced in the CHOP horizontal mode, they are not used in this instrument.

### 4. DELAYED SWEEP (A DELAYS B)

When the A time-base unit is set for delayed operation, the operation of the Alternate Pulse Generator is changed so an Alternate Pulse is produced only at the end of the A sweep, even when the HORIZONTAL MODE switch is set to B. This is necessary since the A time-base establishes the amount of delay time for the B time-base unit whenever it is displayed.

### 5. AMPLIFIER UNIT IN HORIZONTAL COMPARTMENT

When an amplifier unit is installed in either of the horizontal plug-in compartments, the Alternate Pulse can be produced only from the remaining time-base unit. If amplifier units are installed in both horizontal compartments, an Alternate Pulse is not produced since there are no time-base units to produce a holdoff pulse.

## Z-Axis Logic

The Z-Axis Logic stage produces an output current which sets the intensity of the display on the CRT. The level of this output current is determined by the setting of the A or B INTENSITY controls, by a current added to provide an intensified zone on the A sweep for delayed-sweep operation, or by an external signal. The input current from the A and B INTENSITY controls is switched so that the output current matches the horizontal

display. The Chopped Blanking signals are applied to this stage to block the output current and blank the CRT display for vertical and horizontal chopping.

Figure 2-8 identifies the inputs to the Z-Axis Logic IC, U2587. This IC (integrated circuit) is current-driven at all inputs except pins 5 and 15. The current at pins 1, 2, 9, and 16 is variable from zero to four milliamperes and is determined by the applicable current source to control the output current at pin 8.

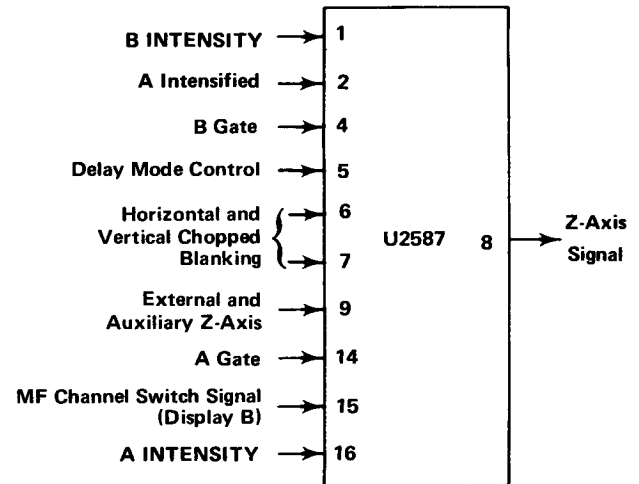

Fig. 2-8. Input and output pins for Z-Axis Logic IC.

The Chopped Blanking signal connected to pins 6 and 7 enables or disables this stage to control all output current. Quiescently, the level at pins 6 and 7 is HI so that the intensity current from pins 1, 2, 9, and 16 can pass to the output. However, pins 6 and 7 go LO during Vertical Chopped Blanking or Horizontal Chopped Blanking. This blocks the output current and the CRT is blanked. The Vertical Chopped Blanking signal is connected directly to U2587 from pin 4 of U2510. The Horizontal Chopped Blanking is connected to U2587 from pin 4 of U2520 through LR2523 and CR2524. CR2524 is normally reverse biased. When the Horizontal Chopped Blanking level goes LO, CR2524 is forward biased to produce a corresponding LO level at pins 6 and 7 of U2573.

The A INTENSITY control sets the output current level when the A Gate at pin 14 is HI and the MF (Main Frame) Channel Switch Signal at pin 15 is LO. The A INTENSITY current is blocked whenever the A Gate level goes LO (indicating that the A sweep is complete), or the MF Channel Switch Signal goes HI (indicating that the B sweep is being displayed). The current from the A INTENSITY control (see diagram 1) is connected to pin 16 through R2587.



Circuit Description—7704A Service

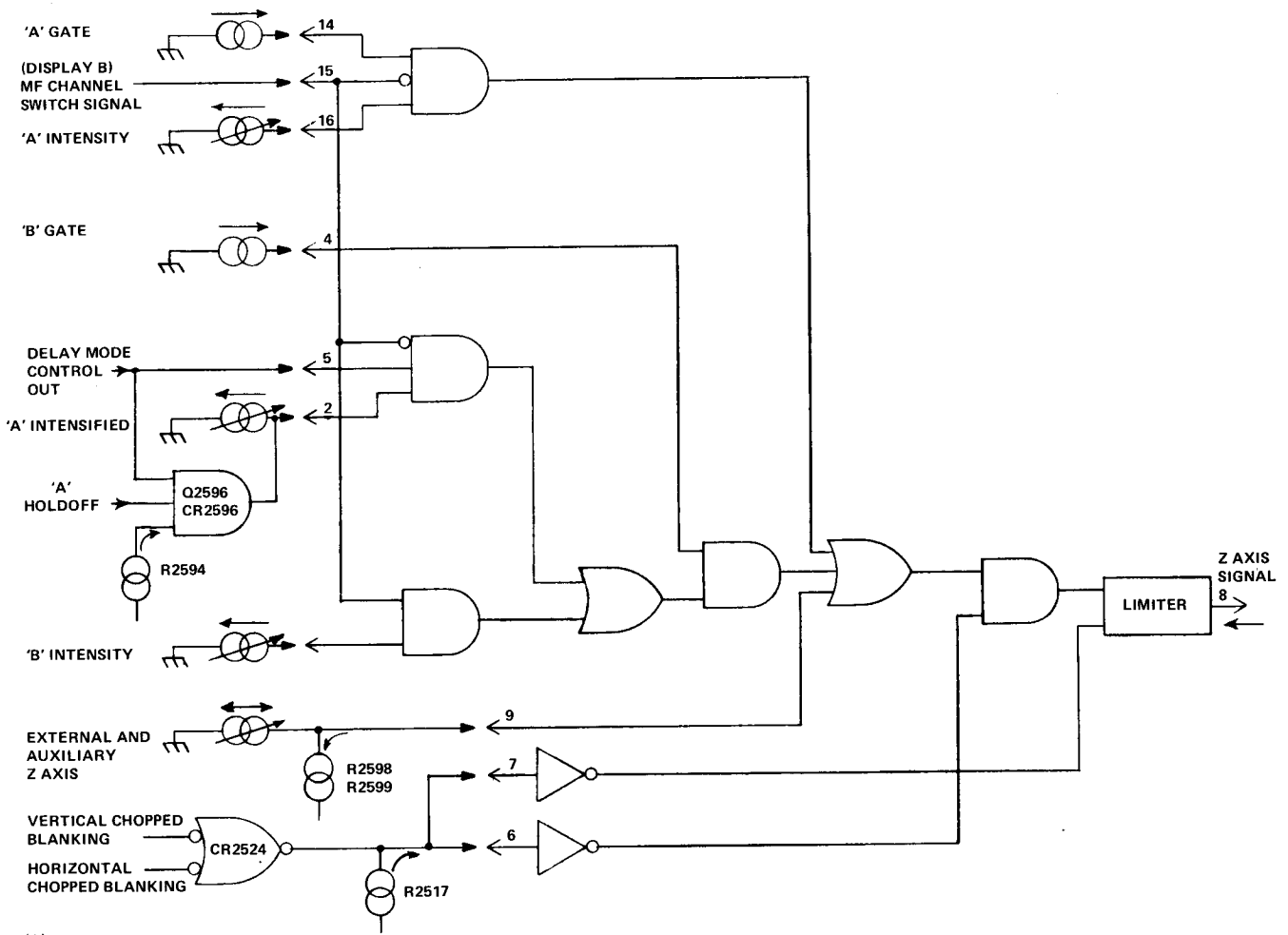

(A)

(B)

| Input                  |                |                |        |                        |   |                               |        |                          |                 |                | Output                                   |
|------------------------|----------------|----------------|--------|------------------------|---|-------------------------------|--------|--------------------------|-----------------|----------------|--|
| A Holdoff              | B INTENSITY    | A Intensified  | B Gate | Delay Mode Control Out | Vertical or Horizontal Chopped Blanking Inhibit | External and Auxiliary Z Axis | A Gate | MF Channel Switch Signal | A INTENSITY     | Z-Axis Signal  | Current source controlling Z-Axis Signal |
| $\Phi$                 | 1 <sup>1</sup> | 2 <sup>1</sup> | 4      | 5                      | 6   | 9 <sup>1</sup>                | 14     | 15                       | 16 <sup>1</sup> | 8 <sup>1</sup> |  |
| $\Phi$                 | $\Phi$         | $\Phi$         | $\Phi$ | LO                     | HI  | $\Phi^2$                      | HI     | LO                       | HI              | HI             | A INTENSITY                              |
| $\Phi$                 | HI             | $\Phi$         | HI     | $\Phi$                 | HI  | $\Phi^2$                      | $\Phi$ | HI                       | $\Phi$          | HI             | B INTENSITY                              |
| LO                     | $\Phi$         | HI             | HI     | HI                     | HI  | $\Phi^2$                      | HI     | LO                       | HI              | HI             | A INTENSITY and A Intensified            |
| $\Phi$                 | $\Phi$         | $\Phi$         | $\Phi$ | $\Phi$                 | HI  | HI                            | $\Phi$ | $\Phi$                   | $\Phi$          | HI             | External signal                          |
| All other combinations |                |                |        |                        |   |                               |        |                          |                 | LO             | No output signal                         |

LO = Minimum voltage or current.

HI = Maximum voltage or current.

$\Phi$  = Has no effect in this case

<sup>1</sup> Current level. LO = 0 mA  
HI = Variable from 0 to 4 mA

<sup>2</sup> Current can be added or subtracted for intensity modulation.

Fig. 2-9. (A) Logic diagram for Z-Axis Logic stage; (B) Table of input/output combinations.

In the delayed mode, current is added to the A INTENSITY current during the A sweep time to intensify a portion of the trace. This intensified portion is coincident with the B-sweep time to provide an indication of the portion of the A sweep that is displayed in the delayed mode. The A Intensified current is supplied to pin 2 of U2587 from the A INTENSITY control through R2586. With this configuration, the intensified current increases as the A INTENSITY control setting is advanced to provide a proportional intensity increase in the intensified zone as the overall A-sweep intensity increases. Therefore, the intensified zone is more readily visible at high intensity levels. The intensified current is added to the A INTENSITY current to produce an intensified zone on the A sweep under the following conditions: HI A Gate level at pin 14, LO MF Channel Switch Signal at pin 15, HI B Gate level at pin 4, HI Delay Mode Control Out level at pin 5 and the base of Q2596, and LO A Holdoff level at the emitter of Q2596.

The B INTENSITY control determines the output current when the B Gate level at pin 4 and the MF Channel Switch Signal at pin 15 are both HI. The current from the B INTENSITY control (see diagram 1) is connected to the Z-Axis Logic stage through R2588.

The current level established by the intensity controls can be altered by the External and Auxiliary Z-Axis current level at pin 9. The current at this pin can come from the Z AXIS INPUT connector on the rear panel through R2092 or from any of the plug-in compartments through R2090, R2080, R2012, or R2010 (see diagram 2). This current either increases or decreases (depending on polarity) the output current to modulate the intensity of the display. Input from the Z AXIS INPUT connector allows the trace to be modulated by external signals. The auxiliary Z-Axis inputs from the plug-in compartments allow special purpose plug-in units to modulate the display intensity. Diodes CR2585 and CR2594 limit the maximum voltage change at pin 9 to about + and -0.6 volt to protect the Z-Axis Logic stage if an excessive voltage is applied to the Z AXIS INPUT connector.

Figure 2-9A shows a logic diagram of the Z-Axis Logic stage. Notice the current-driven inputs as indicated by the current-generator symbols at the associated inputs. An input/output table for the Z-Axis Logic stage is given in Fig. 2-9B.

### Horizontal Binary

The MF (Main Frame) Channel Switch Signal (Display B) produced by the Horizontal Binary stage determines which horizontal unit provides the sweep display on the CRT. When this level is HI, the B HORIZ unit is displayed; when it is LO, the A HORIZ unit is displayed.

The MF Channel Switch Signal (Display B) is used in the following stages within the Logic Circuit: Horizontal Logic (for A and B Sweep Lockout), Z-Axis Logic (for blanking), and Vertical Binary (to synchronize vertical alternate switching with horizontal alternate switching). In addition, this signal is connected to the following circuits elsewhere in the instrument: Main Interface (to indicate which horizontal unit is to be displayed), Vertical Interface (for trace separation), and Horizontal Interface (for horizontal channel selection).

Notice that the levels at pins 3, 4, 7, and 10 are determined by the HORIZONTAL MODE switch (see diagram 1). This switch determines which horizontal mode has been selected by providing a HI level to only one of four output lines (the remaining lines are LO). Therefore, at any one time, either pin 3, pins 4 and 7 (notice that pins 4 and 7 are tied together), or pin 10 can be HI and the two unselected lines from the HORIZONTAL MODE switch remain LO.

The Horizontal Binary stage operates as follows for each position of the HORIZONTAL MODE switch (refer to Fig. 2-10B for input/output conditions):

#### 1. A MODE

When the HORIZONTAL MODE switch is set to A, the MF Channel Switch Signal (Display B) is LO to indicate to all circuits that the A HORIZ unit is to be displayed.

#### 2. B MODE

Selecting the B horizontal mode provides a HI MF Channel Switch Signal (Display B) to all circuits.

#### 3. CHOP MODE

In the CHOP position of the HORIZONTAL MODE switch, the MF Channel Switch Signal (Display B) switches between the HI and LO levels to produce a display that switches between the A HORIZ and B HORIZ units at a 200-kHz or 20-kHz rate, as selected by S2510. The repetition rate of the MF Channel Switch Signal (Display B) in this mode is determined by the Horizontal Chopped Blanking pulse (see Chop Counter description). Each time the Horizontal Chopped Blanking pulse at pin 1 drops LO, the output at pin 6 switches to the opposite state.

#### 4. ALT MODE

For ALT horizontal operation, the MF Channel Switch Signal (Display B) switches to the opposite state each time the negative portion of the Alternate Pulse is received from the Horizontal Logic stage. Repetition rate of the MF Channel Switch Signal (Display B) in this mode is one-half the repetition rate of the Alternate Pulse applied to pin 8.

**Circuit Description—7704A Service**

Figure 2-10A shows a logic diagram of the Horizontal Binary stage. An input/output table showing the conditions for each position of the HORIZONTAL MODE switch is shown in Fig. 2-10B.

RIGHT VERT unit is displayed and when it is LO, the LEFT VERT unit is displayed. In the ALT or CHOP positions of the HORIZONTAL MODE switch (non-delayed operation only), the output of this stage is slaved to the output of the Horizontal Binary stage so that the Display Right Command is always HI when the MF (Main Frame) Channel Switch Signal (Display B) is LO, and vice versa. This action allows sweep-slaving operation in the ALT position of the VERTICAL MODE switch and the ALT or CHOP positions of the HORIZONTAL MODE

**Vertical Binary**

The Vertical Binary stage produces the Display Right Command to determine which vertical unit is to be displayed on the CRT. When this output level is HI, the

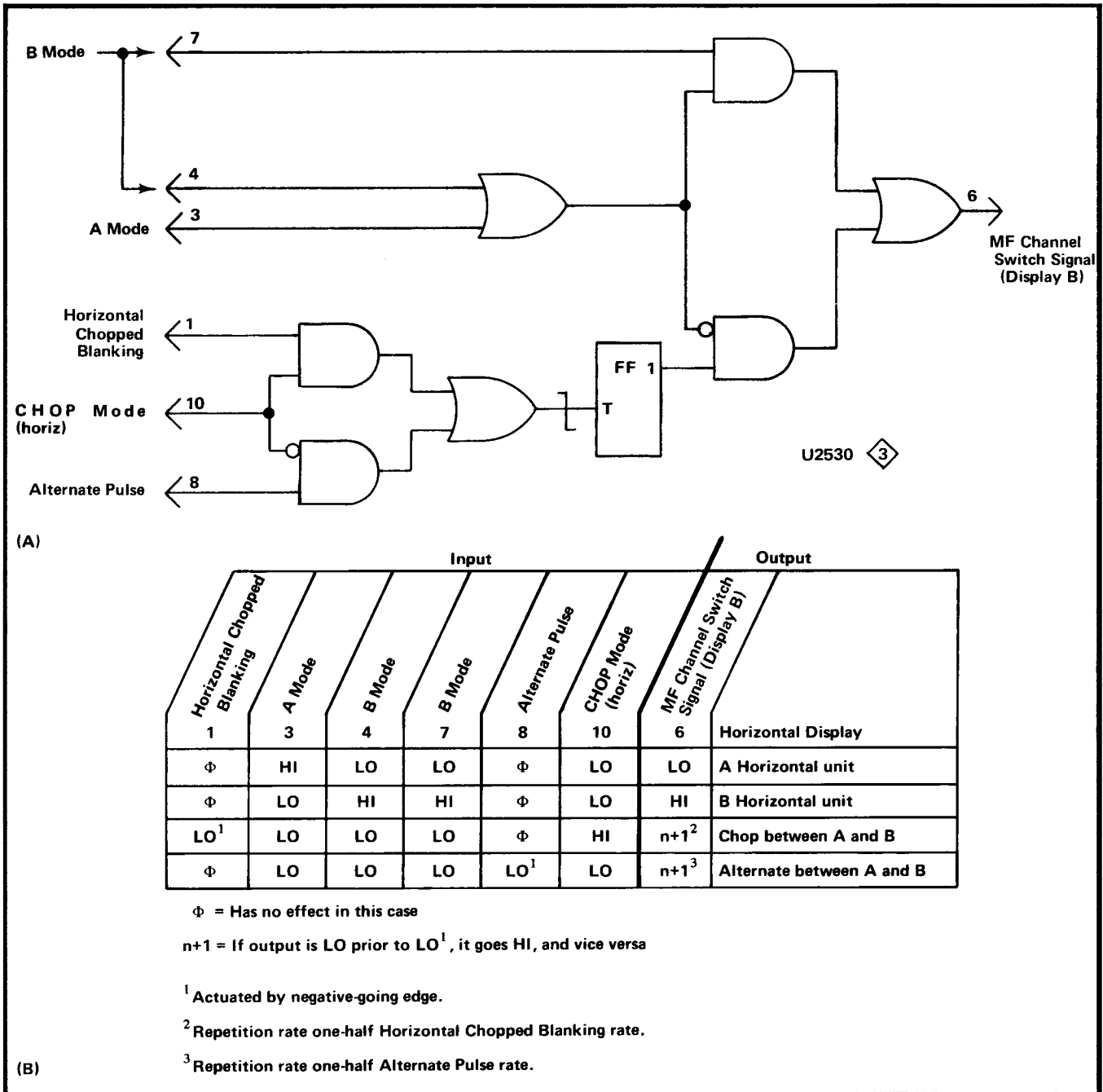

Fig. 2-10. (A) Logic diagram for Horizontal Binary stage; (B) Table of input/output combinations.

switch, whereby the LEFT VERT unit is always displayed at the sweep rate of the B time-base unit. When the A time-base unit is set to the delayed mode, the repetition rate of the Display Right Command is one-half the repetition rate of the MF Channel Switch Signal (Display B). This results in each vertical unit being displayed first against the A time-base unit (delaying), then the B time-base unit (delayed), before the display is switched to the other vertical unit.

The Display B Command is used in the following stages within the Logic Circuit: Plug-In Binary, Vertical Chopped Blanking, and Vertical Mode Logic. It is also connected to the following circuits elsewhere in the instrument to indicate which vertical unit is to be displayed (through Vertical Mode Logic stage; ALT vertical mode only): Main Interface, Trigger Selector, and Vertical Interface circuits.

The Vertical Binary stage uses the same type of IC as the Horizontal Binary stage. Figure 2-11 identifies the function of the input pins for U2535. Notice the Display A level at pin 7. This input is the inverse of the MF Channel Switch Signal (Display B) at pin 8. Therefore, the Display A level is always HI when the MF Channel Switch Signal (Display B) is LO, and vice versa. The following discussions describe the operation of the Vertical Binary stage in relation to the modes of operation that can occur.

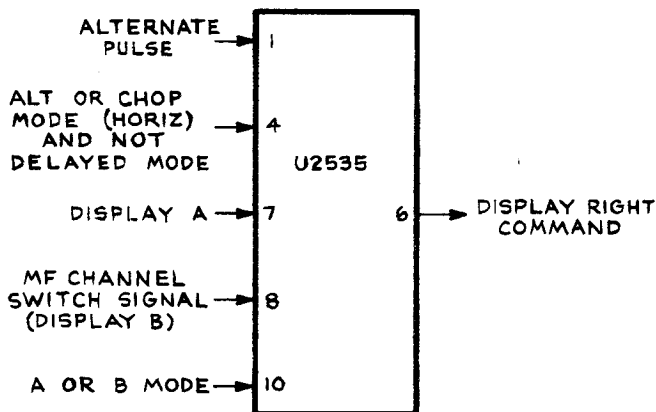

Fig. 2-11. Input and output pins for Vertical Binary IC.

#### NOTE

*Although the output at pin 6 of U2535 is always controlled by the HORIZONTAL MODE switch as described here, this level determines the MF Channel Switch Signal (Display Right) level at the collector of Q2556 only in the ALT position of the VERTICAL MODE switch due to AND gate CR2552-CR2553. See the discussion of the Vertical Mode Logic stage in this section for further information.*

#### 1. A OR B MODE

When the HORIZONTAL MODE switch is set to either A or B, the Display Right Command switches to the opposite state each time an Alternate Pulse is received from the Horizontal Logic stage. Repetition rate of the Display Right Command in this mode is one-half the repetition rate of the Alternate Pulse. The input conditions for these modes are:

Pin 1 LO—Alternate Pulse generated by Horizontal Logic stage goes negative.

Pin 4 LO—HORIZONTAL MODE switch in any position except ALT or CHOP, or the A time-base unit is set for delayed sweep.

Pin 10 HI—HORIZONTAL MODE switch set to A or B.

#### 2. ALT OR CHOP MODE (HORIZ)—NON-DELAYED

In the ALT or CHOP positions of the HORIZONTAL MODE switch, the output level at pin 6 is the same as the Display A level at pin 7. The Display A level is produced by inverting the MF Channel Switch Signal (Display B) from the Horizontal Binary stage. Therefore, the repetition rate of the output signal is the same as the MF Channel Switch Signal (Display B). The result, with the VERTICAL MODE switch set to ALT and the A time-base unit set for non-delayed operation, is that the RIGHT VERT unit is always displayed at the sweep rate of the A time-base unit, and the LEFT VERT unit at the sweep rate of the B time-base unit (sweep slaving). The input conditions to provide a HI output level so that the RIGHT VERT unit can be displayed at the A-sweep rate are:

Pin 4 HI—HORIZONTAL MODE switch set to ALT or CHOP with non-delayed sweep.

Pin 7 HI—A sweep is to be displayed; MF Channel Switch Signal (Display B) LO.

Pin 10 LO—HORIZONTAL MODE switch set to any position except A or B.

The input conditions to provide a LO output level so that the LEFT VERT unit can be displayed at the B-sweep rate are:

Pin 4 HI—HORIZONTAL MODE switch set to ALT or CHOP with non-delayed sweep.

Pin 7 LO—B sweep is to be displayed; MF Channel Switch Signal (Display B) HI.

Pin 10 LO—HORIZONTAL MODE switch set to any position except A or B.

**Circuit Description—7704A Service**

The Display Right Command switches from HI to LO along with the Display A level at pin 7 (inverse of MF Channel Switch Signal, Display B). However, notice that the Display Right Command changes from HI to LO as the MF Channel Switch Signal (Display B) changes from LO to HI, and vice versa.

**3. ALT OR CHOP MODE (HORIZ)—DELAYED**

If the A time-base unit is set to the delayed mode when the HORIZONTAL MODE switch is set to either ALT or

CHOP, the operation of the stage is changed from that discussed above. Now, the Display Right Command switches between the HI and LO states at a rate that is one-half the repetition rate of the MF Channel Switch Signal (Display B). The resultant CRT display allows the RIGHT VERT unit to be displayed first against the A sweep (delaying) and then against the B sweep (delayed). Then the display switches to the LEFT VERT unit and is displayed consecutively against the A and B sweeps in the same manner. The input conditions for this mode of operation are:

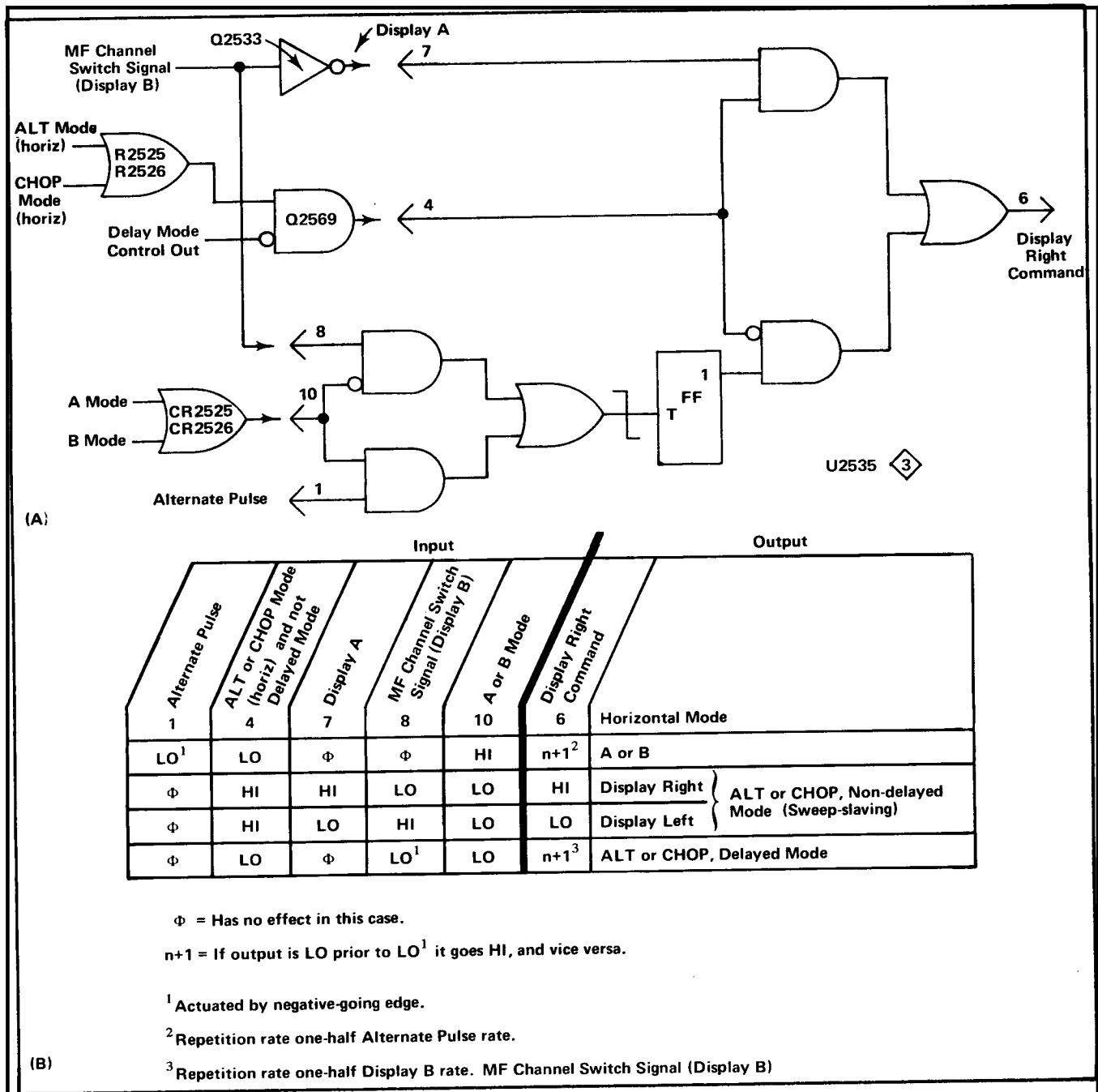

Fig. 2-12. (A) Logic diagram for Vertical Binary stage; (B) Table of input/output combinations.

Pin 4 LO—A time-base unit set for delayed operation.

Pin 8 LO—MF Channel Switch Signal (Display B) generated by Horizontal Binary stage goes negative.

Pin 10 LO—HORIZONTAL MODE switch set to any position except A or B.

A logic diagram of the Vertical Binary stage is shown in Fig. 2-12A. Several logic functions in this stage are performed by logic devices made up of discrete components. The components that make up these logic devices are identified on the Logic diagram. An input/output table for the Vertical Binary stage is given in Fig. 2-12B.

### Plug-In Binary

The Plug-In Binary stage produces the Alternate Drive signal to provide a plug-in alternate command to dual-trace plug-in units. This stage uses the same type of IC as the Horizontal Binary and Vertical Binary stages. Figure 2-13 identifies the function of the input pins for the Plug-In Binary IC, U2540.

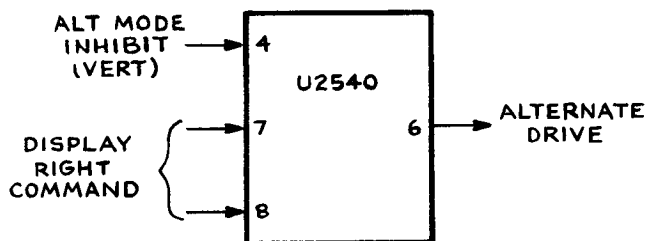

Fig. 2-13. Input and output pins for Plug-In Binary IC.

When the Alternate Drive level is HI and the plug-in unit is set for alternate operation, Channel 2 of the dual-trace unit is displayed. When it is LO, Channel 1 is displayed. The repetition rate of the Alternate Drive output is determined by the setting of the VERTICAL MODE switch. For all positions except ALT, the Alternate Drive level is the same as the Display Right Command from the Vertical Binary stage. Since the Display Right Command was derived directly from the MF (Main Frame) Channel Switch Signal (Display B), this allows the two channels of a dual-trace

vertical unit to be slaved to the time-base units (non-delayed, dual-sweep horizontal modes only) in the same manner as previously described for slaving between the vertical and time-base units. The resultant CRT presentation, when the dual-trace unit is set for alternate operation, displays the Channel 1 trace at the sweep rate of the B time-base unit and the Channel 2 trace at the sweep rate of the A time-base unit. Input conditions for a LO output so that Channel 1 of the vertical plug-in can be displayed at the B-sweep rate are:

Pin 4 HI—VERTICAL MODE switch set to any position except ALT.

Pin 7 HI—A sweep to be displayed.

The Alternate Drive switches from HI to LO as the MF Channel Switch Signal (Display B) from the Horizontal Binary stage switches from LO to HI, and vice versa.

When the VERTICAL MODE switch is set to ALT, the Display Right Command from the Vertical Binary stage switches the vertical display between the two vertical units. However, if either of the vertical plug-in units are dual-trace units, they can be operated in the alternate mode also. To provide a switching command to these units, the Plug-In Binary stage produces an output signal with a repetition rate that is one-half the repetition rate of the Display Right Command. The sequence of operation, when two dual-trace vertical units are installed in the vertical plug-in compartments and they are both set for alternate operation, is as follows (VERTICAL MODE and HORIZONTAL MODE switches set to ALT): 1. Channel 1 of LEFT VERT unit at sweep rate of B time-base unit, 2. Channel 1 of RIGHT VERT unit at sweep rate of A time-base unit, 3. Channel 2 of LEFT VERT unit at sweep rate of B time-base unit, 4. Channel 2 of RIGHT VERT unit at sweep rate of A time-base unit. Notice that under these conditions, both channels of the LEFT VERT unit are displayed at the B-sweep rate and that both channels of the RIGHT VERT unit are displayed at the A-sweep rate. The repetition rate at the output of this stage is one-half the Display Right Command rate. Input conditions, when the VERTICAL MODE switch is set to ALT, are:

Pin 4 LO—VERTICAL MODE switch set to ALT.

Pin 8 LO—Display Right Command generated by Vertical Binary stage goes negative.

Figure 2-14A shows a logic diagram of the Plug-In Binary stage. An input/output table for this stage is shown in Fig. 2-14B.

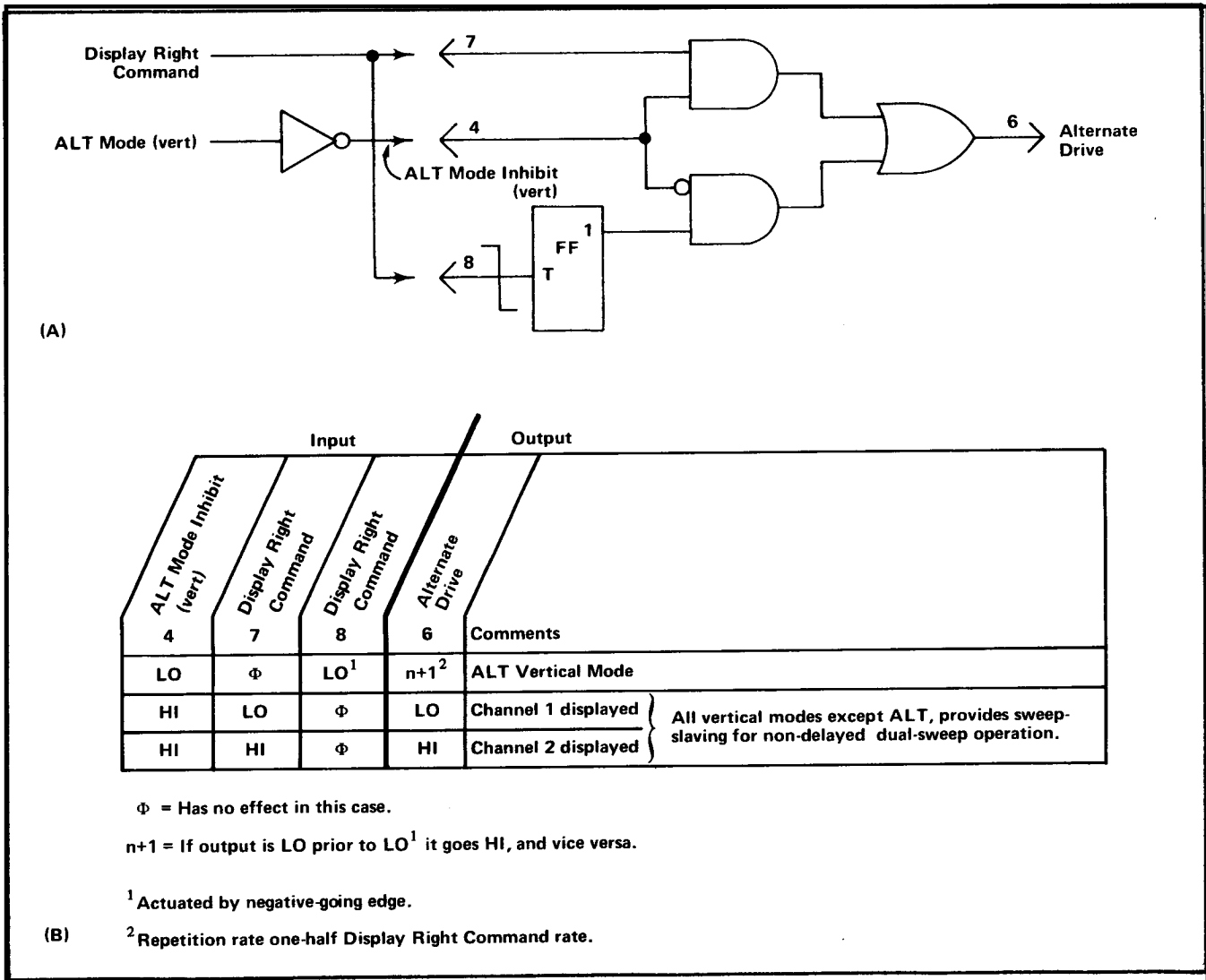

Fig. 2-14. (A) Logic diagram for Plug-In Binary stage; (B) Table of input/output combinations.

### Clock Generator

Part of integrated circuit U2510, along with the external components shown in Fig. 2-15A, make up the Clock Generator stage. R1, Q1, Q2, and Q3 represent an equivalent circuit within U2510. The output at pin 15 is a free-running timing (Clock) signal used to synchronize the vertical, horizontal, and plug-in chopping modes.

The frequency of the Clock signal is either 200 kilohertz or two megahertz, depending on the position of the internal Chop Frequency switch S2510. The 200-kilohertz output is provided for other systems using the A7704 Acquisition Unit (the bottom half of the 7704A). For normal operation of the 7704A, the Chop Frequency switch should be left in the 2-MHz position.

When the internal Chop Frequency switch is in the 200-kHz position, the stage operates as follows: At time  $T_0$  (see Fig. 2-15B), the collector current through Q2 is producing a voltage drop across R1 to cut off Q1. Since there is no current through Q1, C2510 and C2511 begin to charge towards -15 volts through R2510-R2511. This causes the emitter of Q1 to gradually go negative until it is about 0.6 volt more negative than the base. At this point ( $T_1$  on Fig. 2-15B), Q1 is forward biased into conduction and its emitter rapidly goes positive. Since the charge on C2510-C2511 cannot change instantaneously, the sudden change in voltage at the emitter of Q1 pulls the emitter of Q2 positive also, to reverse-bias it into cutoff. When the current through Q2 stops, its collector rises to produce a positive output level at pin 14 (time  $T_1$ ).

During time  $T_1$ - $T_2$ , conditions are reversed. Since Q2 is biased off, there is no current through it and C2510-C2511 begins to discharge through R2512-R2513. The emitter level of Q2 follows the discharge of C2510-C2511 until it is about 0.6 volt more negative than the base. This forward biases Q2 and its collector drops negative to reverse-bias Q1. The level at pin 14 drops negative also, to complete the cycle. Once again, C2510-C2511 begin to charge through R2510-R2511 to start the second cycle. When S2510 is set to the 2-MHz position, R2512 is bypassed and one end of C2511 is disconnected from the RC timing circuit. The decreased RC time allows C2510 to charge and discharge at a two-megahertz rate.

Two outputs are provided by this oscillator: The Delay Ramp signal from Q1 or Q2 is connected to the Vertical Chopped Blanking stage, and a square-wave output from pin 14. The square wave at pin 14 is connected to pin 16 through an external capacitor, C2510. C2510 differentiates the square wave from pin 14 to produce a negative-going pulse coincident with the falling edge of the square wave (see pin-16 waveform on Fig. 2-15B). This negative-going pulse is connected to pin 15 through an inverter-shaper which is part of U2510. The resulting output at pin 15 is a

positive-going Clock pulse at a repetition rate of either 200 kilohertz or two megahertz, depending on the position of S2510.

### Vertical Chopped Blanking

The Vertical Chopped Blanking stage is made up of the remainder of U2510. This stage determines if Vertical Chopped Blanking pulses are required, based upon the operating mode of the vertical system or the plug-in units (dual-trace units only). Vertical Chopped Blanking pulses are produced if: 1. VERTICAL MODE switch is set to CHOP; 2. Dual-trace vertical unit is operating in the chopped mode and that unit is being displayed; 3. Dual-trace vertical unit is operating in the chopped mode with the VERTICAL MODE switch set to ADD. The repetition rate of the negative-going Vertical Chopped Blanking pulse output at pin 4 is 0.2 or two megahertz for all of the above conditions (determined by the Clock Generator stage).

Figure 2-16 shows a logic diagram and an input/output table for the Vertical Chopped Blanking stage. Notice the comparator block on the diagram. The output of this comparator is determined by the relationship between the levels of its inputs. If pin 10 is more positive (HI) than the grounded input, the output is HI also; if it is more negative, the output is LO.

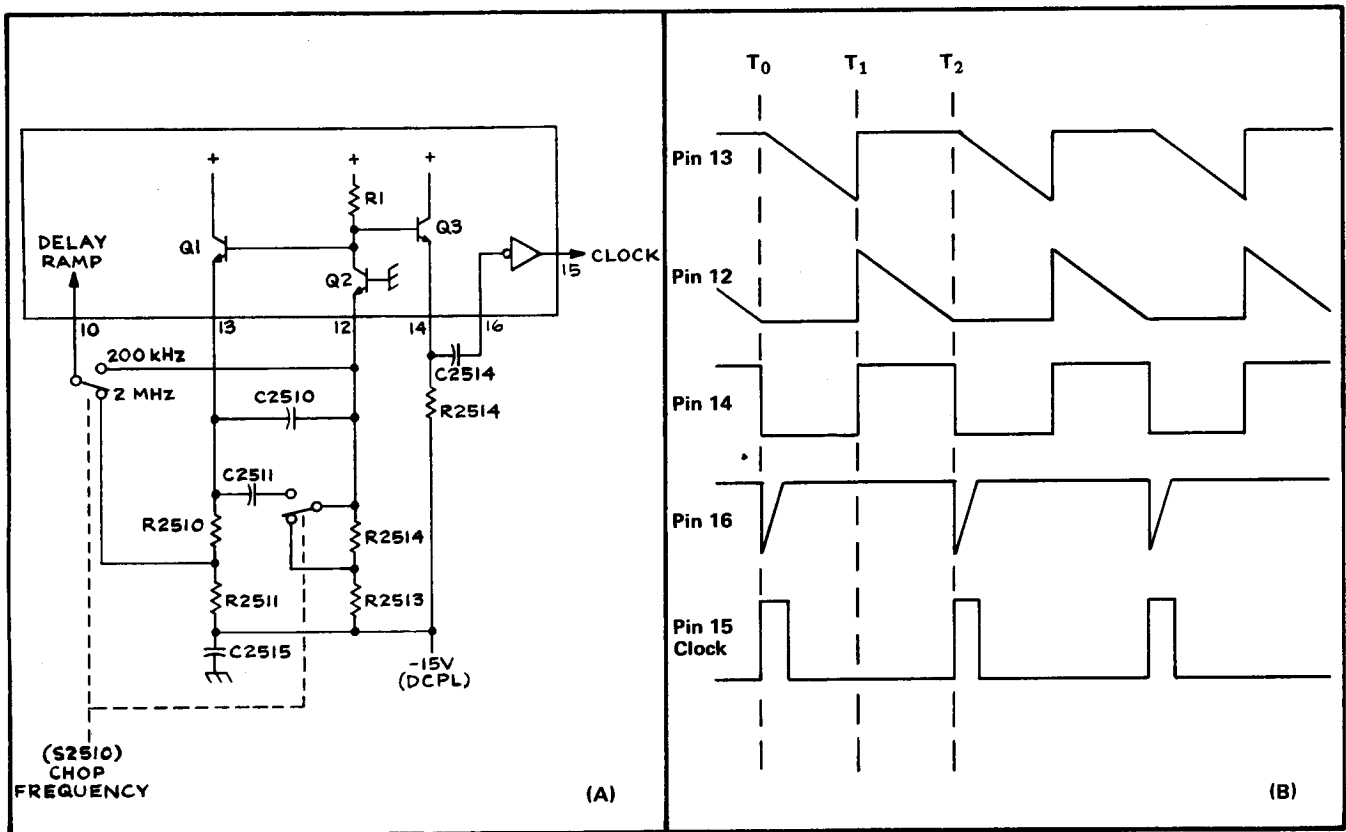

Fig. 2-15. (A) Diagram of Clock Generator stage; (B) Idealized waveforms for Clock Generator stage.



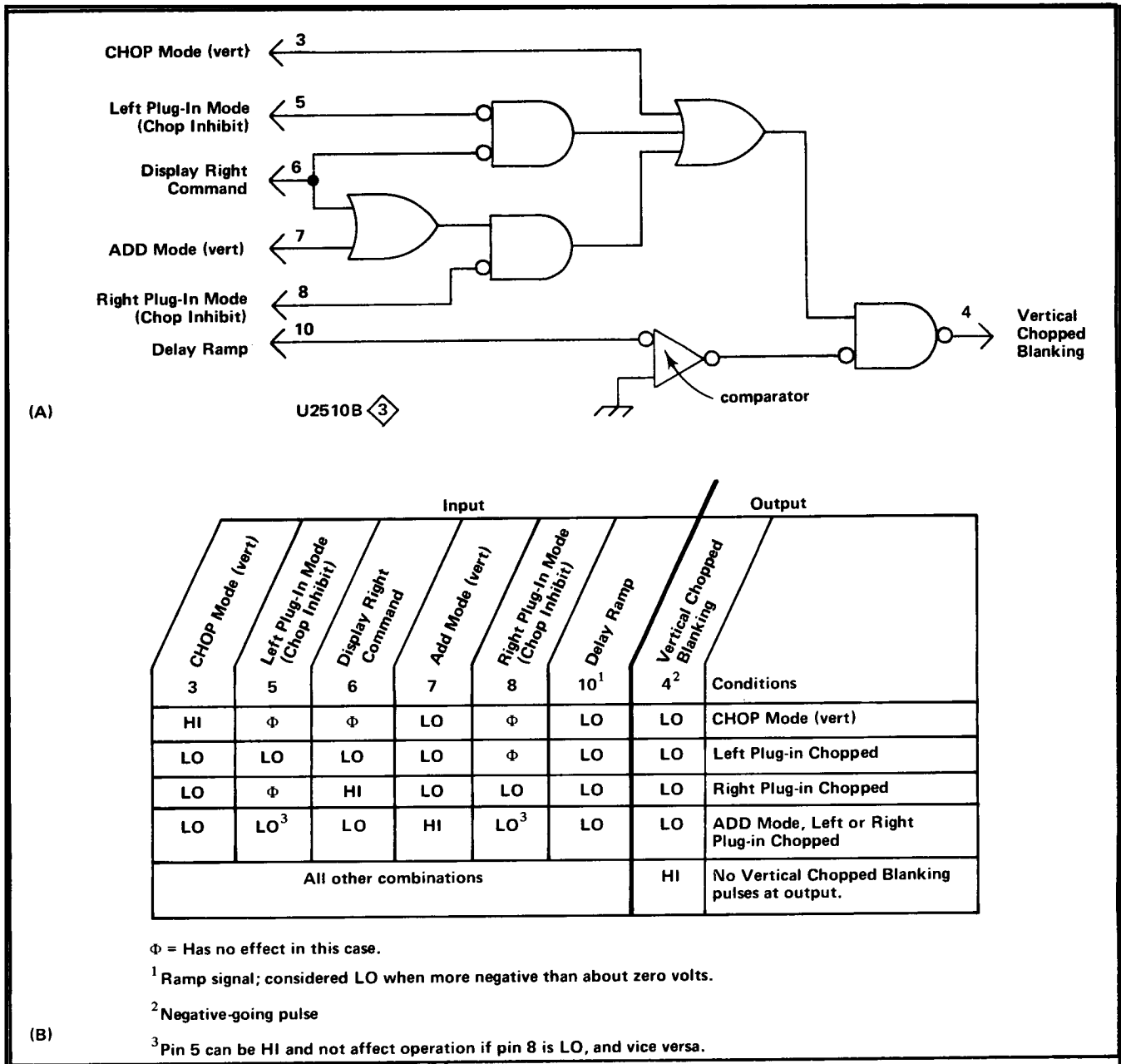

Fig. 2-16. (A) Logic diagram for Vertical Chopped Blanking stage; (B) Table of input/output combinations.

The Delay Ramp signal from the Clock Generator stage determines the repetition rate and pulse width of the Vertical Chopped Blanking pulses. The Delay Ramp applied to pin 10 starts to go negative from a level of about +1.1 volts coincident with the leading edge of the Clock pulse (see waveforms in Fig. 2-17). This results in a HI quiescent condition for the Vertical Chopped Blanking pulse. The slope of the negative-going Delay Ramp is determined by the Clock Generator stage. As it reaches a level slightly negative from ground, the Vertical Chopped Blanking pulse output level changes to the LO state and remains LO until the Delay Ramp goes HI again.

Notice the delay between the leading edge of the Clock pulse generated by U2510A, and the leading edge of the Vertical Chopped Blanking pulses. The amount of delay between the leading edges of these pulses is determined by the Delay Ramp applied to pin 10. This delay is necessary due to the delay line in the vertical deflection system. Otherwise, the trace blanking resulting from the Vertical Chopped Blanking pulse would not coincide with the switching between the displayed traces. The duty cycle of the square wave produced in the Clock Generator stage determines the pulse width of the Vertical Chopped Blanking pulses (see Clock Generator description for more information).

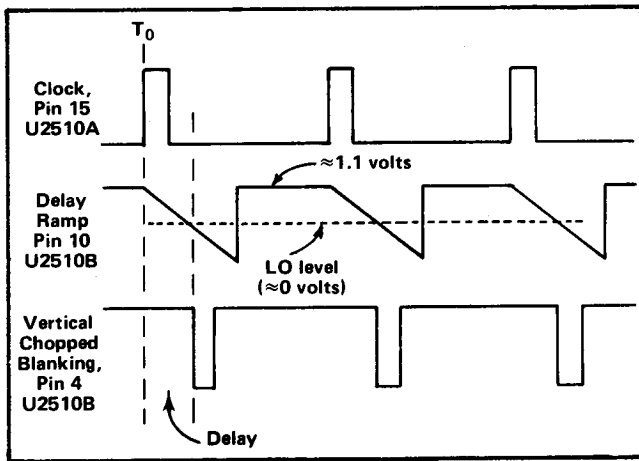

Fig. 2-17. Idealized waveforms for Vertical Chopped Blanking stage.

### Chop Counter

The Chop Counter stage of U2520 produces the Vertical Chopping Signal (pin 1), the (Vertical) Chop Drive (pin 8), and the Horizontal Chopped Blanking signal (pin 4). A logic diagram for U2520 is shown in Fig. 2-18, along with waveforms showing the timing relationship between the input and output signals for this stage.

When the HORIZONTAL MODE switch is set to any position except CHOP, pin 6 remains LO and the repetition rate of the Vertical Chopping Signal at pin 1 is one-half the Clock rate (see time  $T_0$  to  $T_1$ ). This determines the switching rate between the left and right vertical compartments when the VERTICAL MODE switch is set to CHOP.

At the same time, the repetition rate of the (Vertical) Chop Drive at pin 8 is one-fourth the Clock rate. This provides a chopping signal to dual-trace vertical units to provide switching between the two channels. During this time, the level at pin 4 will remain HI.

When the HORIZONTAL MODE switch is set to CHOP, the basic repetition rate of the Vertical Chopping Signal and the (Vertical) Chop Drive is altered. For example, if the HORIZONTAL MODE switch is changed at time  $T_1$  (see Fig. 2-18), a HI level is applied to pin 6. Outputs at pins 1 and 8 will be produced in the normal manner until both outputs are HI. (See time  $T_2$ ; this condition only occurs once every fifth Clock pulse and only when the HORIZONTAL MODE switch is set to CHOP.) When both of these outputs are at their HI level, the next Clock pulse (at time  $T_3$ ) switches both outputs LO, and at the same time, switches the Horizontal Chopped Blanking output to the LO level, where it remains until the start of the next Clock pulse.

This change at time  $T_3$  does not appear at pin 4 immediately, due to a delay network in the circuit. (The delay is necessary to make the Horizontal Chopped Blanking coincide with the Vertical Chopped Blanking produced by U2510A; compare bottom two waveforms of Fig. 2-18. Also, see Vertical Chopped Blanking description.) After the delay time, the output level at pin 4 goes LO to blank the display.

The Horizontal Chopped Blanking time must be longer than the Vertical Chopped Blanking time, since it takes more time for the display to switch between horizontal units than between vertical units. During the time that the level at pin 4 is LO, the CRT is blanked and the Vertical Chopping Signal and the (Vertical) Chop Drive cannot change levels. The Clock pulse at  $T_3$  changes only the Horizontal Chopped Blanking output. The level on pin 4 goes HI after the delay time to unblank the CRT.

For the next three Clock pulses, the Vertical Chopping Signal output and (Vertical) Chop Drive operate in the normal manner. However, at the fourth Clock pulse (Time  $T_4$ ) both outputs are again at their HI level. The fifth Clock pulse at  $T_5$  switches the output at pin 1, pin 8, and pin 4 (after delay) to the LO level to start the next cycle. Notice that a Horizontal Chopped Blanking pulse is produced at pin 4 with every fifth Clock pulse. Also notice that with the HORIZONTAL MODE switch set to CHOP, two complete cycles of the Vertical Chopping Signal are produced with each five Clock pulses (repetition rate, two-fifths Clock rate) and one complete cycle of the (Vertical) Chop Drive for every five Clock pulses (one-fifth Clock rate). Notice that the large shaded area produced by the Horizontal Chopped Blanking pulse (see Fig. 2-18) is not part of the display time (CRT display blanked). However, about the same time segment is displayed from the vertical signal source with or without Horizontal Chopped Blanking, due to the change in repetition rate when in the CHOP horizontal mode.

The Vertical Chopping Signal at pin 1 of U2520 is connected to the Vertical Mode Logic stage (see following description) through L2519-R2519. This signal is HI when the right vertical unit is to be displayed and LO when the left vertical unit is to be displayed. The (Vertical) Chop Drive at pin 8 is connected to the plug-in units in the vertical compartments through L2528-R2528 via the Main Interface board. When this signal is HI, Channel 2 of the plug-in units can be displayed; when this level is LO, Channel 1 is displayed. The Horizontal Chopped Blanking signal at pin 4 is connected through LR2523 to the Horizontal Binary stage U2530 and to the Z-Axis Logic stage U2573 by way of CR2524. When this signal is HI, the CRT is unblanked to display the selected signal. When it is LO, the CRT is blanked to allow switching between the horizontal units.

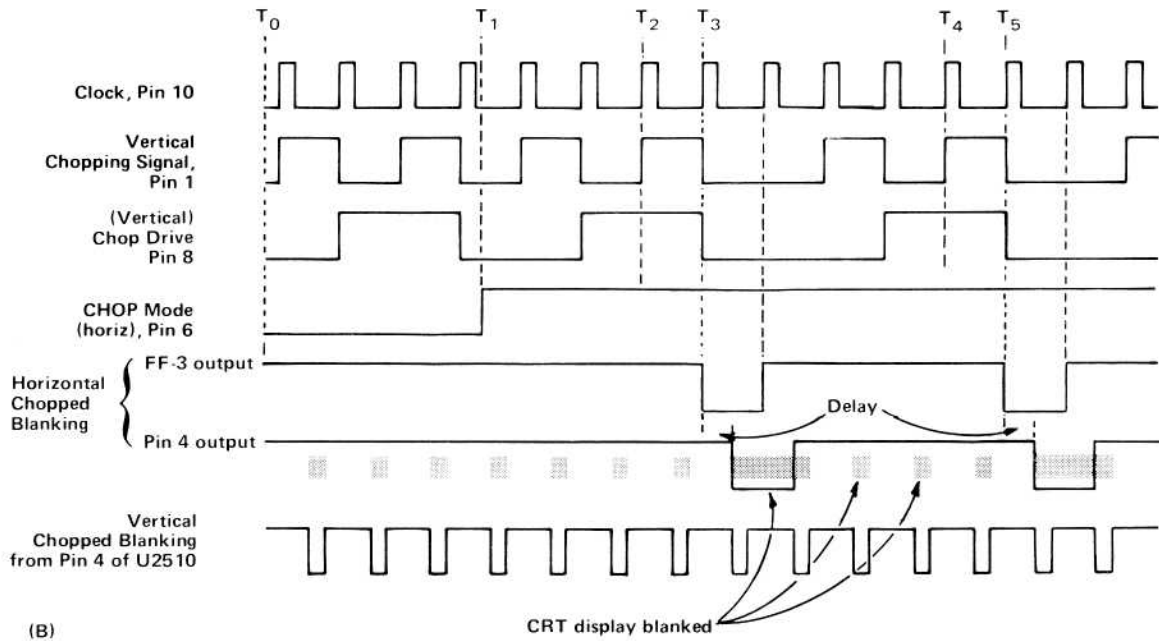
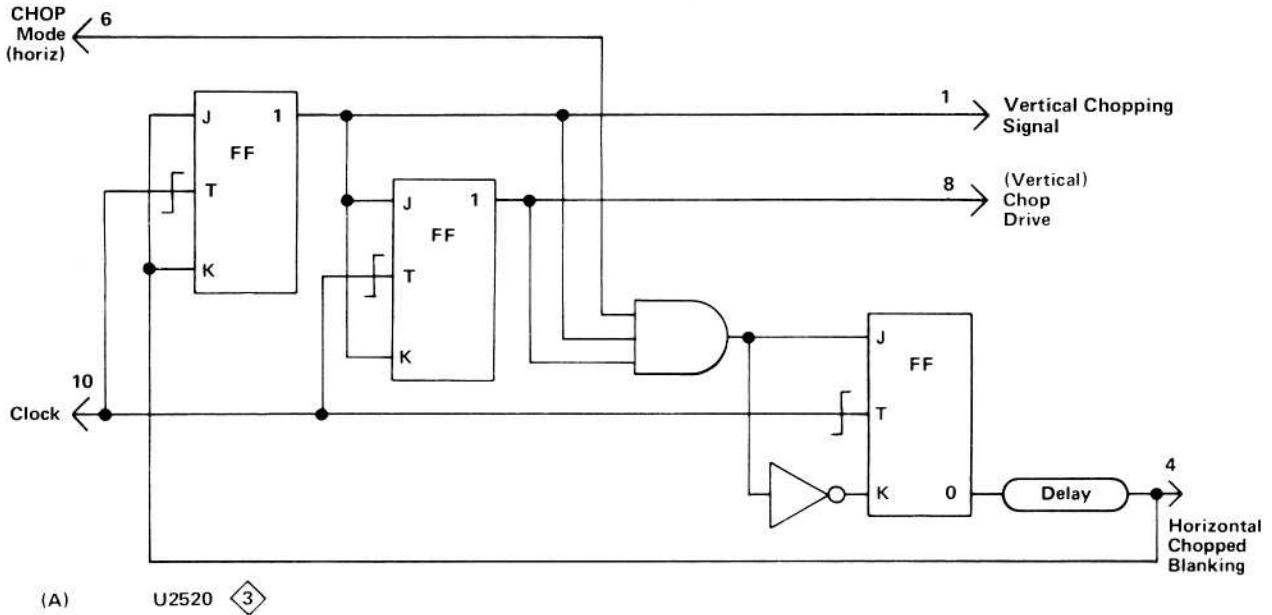

Fig. 2-18. (A) Logic diagram for Chop Counter stage; (B) Table of input/output combinations.

### Vertical Mode Logic

The Vertical Mode Logic stage is made up of discrete components CR2501-CR2502, CR2552-CR2553, and Q2553-Q2556. These components develop the MF (Main Frame) Channel Switch Signal (Display Right). This signal is connected to the Main Interface circuit (vertical plug-in compartments and trigger-selection circuitry) and to the

Vertical Interface circuit to indicate which vertical unit is to be displayed. When this output level is HI, the right vertical unit is displayed; when it is LO, the left vertical unit is displayed.

The VERTICAL MODE switch shown on diagram 1 provides control levels to this stage. This switch provides a

HI level on one of five output lines to indicate the selected vertical mode; the remaining lines are LO (notice that only four of the lines from the VERTICAL MODE switch are used on this schematic). Operation of this stage is as follows:

When the VERTICAL MODE switch is set to RIGHT, a HI level is connected to the base of Q2553 through R2501. This forward-biases Q2553, and the positive-going level at its emitter is connected to the emitter of Q2556. The collector of Q2556 goes HI to indicate that the right vertical unit is to be displayed. For the CHOP position of the VERTICAL MODE switch, a HI level is applied to the anodes of CR2501-CR2502 through R2502. Both diodes are forward biased so that the Vertical Chopping Signal from pin 1 of U2520 can pass to the base of Q2553. This signal switches between the HI and LO levels at the Clock Generator rate and produces a corresponding MF Channel Switch Signal (Display Right) output at the collector of Q2556. When this output is HI, the right vertical unit is displayed and when it switches to LO, the left vertical unit is displayed.

In the ALT position of the VERTICAL MODE switch, a HI level is applied to the anodes of CR2552-CR2553 through R2551. These diodes are forward biased so the Display Right Command from pin 6 of the Vertical Binary stage can pass to the base of Q2553 to determine the MF Channel Switch Signal (Display Right) level. The Display Right Command switches between its HI and LO levels at a rate determined by the Vertical Binary stage.

The control levels in the LEFT and ADD positions of the VERTICAL MODE switch are not connected to this stage. However, since only the selected line from the VERTICAL MODE switch can be HI, the RIGHT, CHOP, and ALT lines must remain at their LO level when either LEFT or ADD are selected. Therefore, the base of Q2553 remains LO to produce a LO MF Channel Switch Signal (Display Right) output level at the collector of Q2556.

A logic diagram of the Vertical Mode Logic stage is shown in Fig. 2-19.

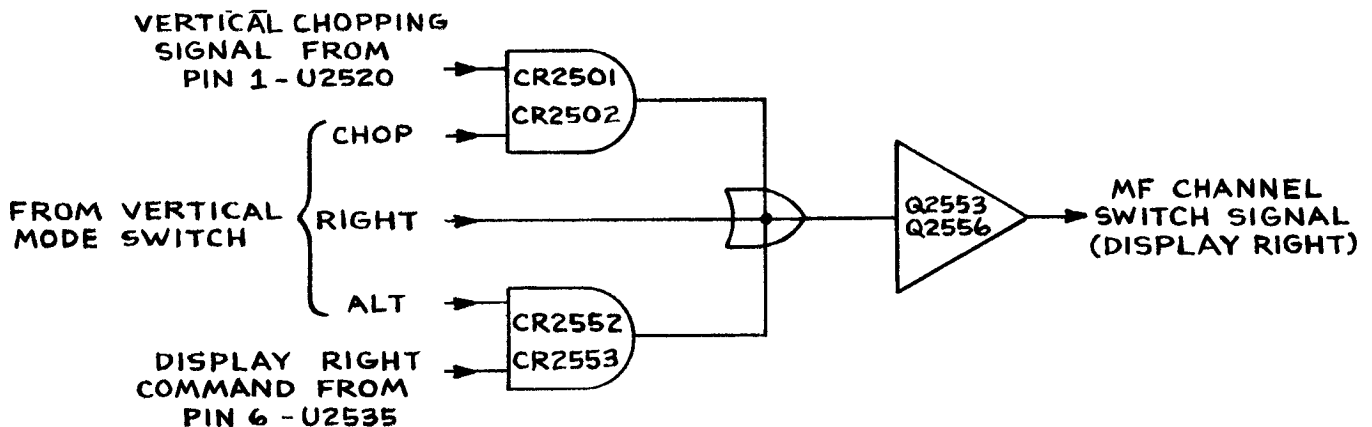

Fig. 2-19. Logic diagram of Vertical Mode Logic stage.

## TRIGGER SELECTOR 4

The Trigger Selector circuit determines the source of the triggering signals connected to the A HORIZ and B HORIZ plug-in compartments. In addition, the B Trigger Selector stage provides the drive for the Vertical Signal Out amplifier (see diagram 7). Figure 2-20 shows a simplified diagram of the Trigger Selector circuit.

### Trigger Modes

The switches shown on the left side of the diagram in Fig. 2-20 determine the operation of the Trigger Selector stages. When the A or B TRIGGER SOURCE switch is set to the LEFT VERT or RIGHT VERT position, the trigger signal is obtained from the indicated vertical compartment; when in the VERT MODE position, the VERTICAL MODE switch setting determines the trigger source. These switches are self-canceling; i.e., only one button on the switch can be pressed at a time.

The following discussion gives operating details for the A Trigger Selector stage; the operation of the B Trigger Selector stage is exactly the same except for the circuit numbers.

**VERT MODE.** In the VERT MODE position of the A or B TRIGGER SOURCE switch, the setting of the VERTICAL MODE switch determines the trigger source, as follows:

#### 1. LEFT VERTICAL MODE

In the LEFT vertical mode, Q2090 is not biased so pin 4 of U2404 is held LO by voltage divider R2093-R2094-R2095. Pin 14 of U2404 is held LO through CR1064 and CR1065. When pins 4 and 14 are both LO, the LEFT VERT unit supplies the trigger signal (see Fig. 2-21).

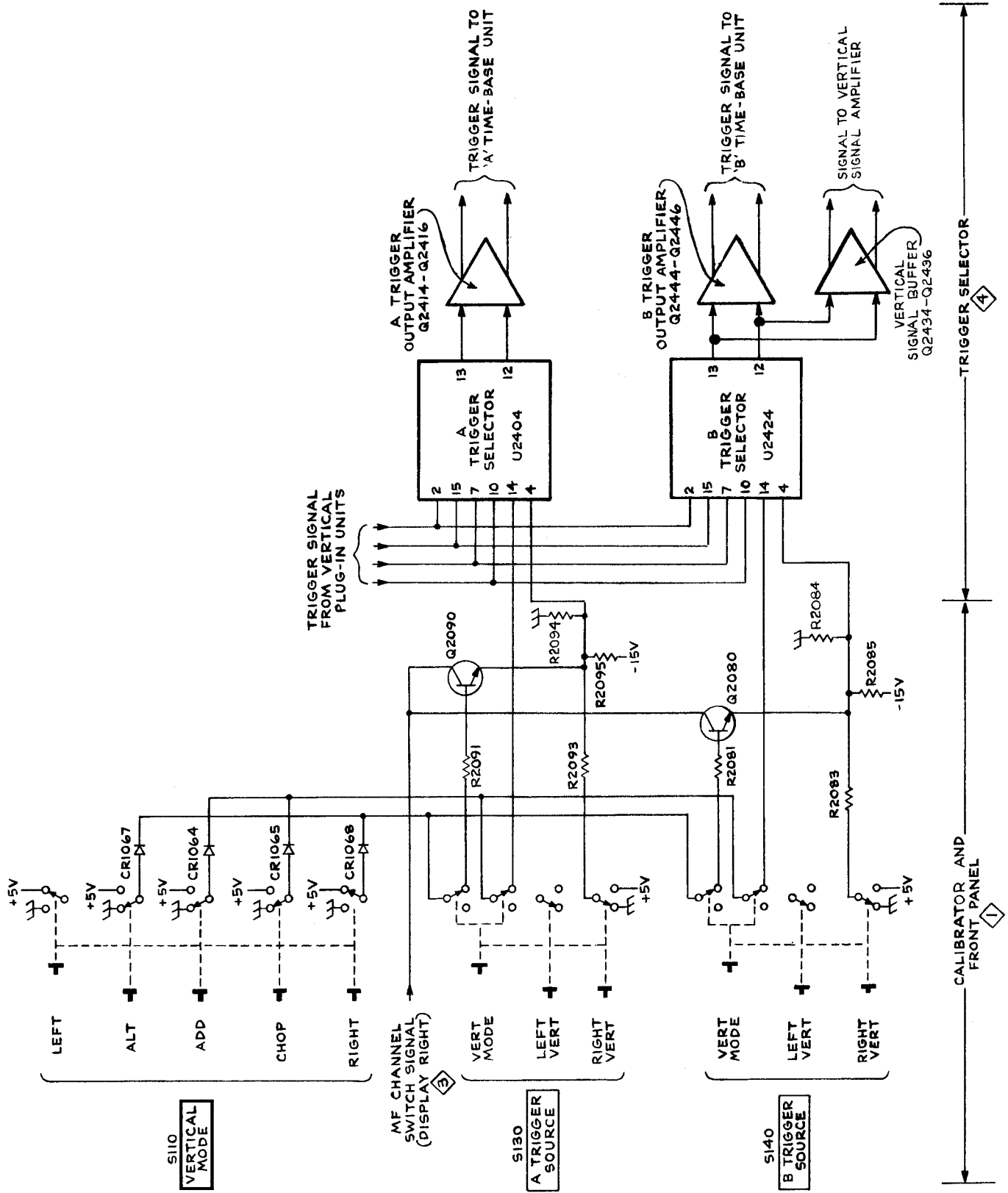

Fig. 2-20. Simplified schematic of trigger selection circuitry.

| VERTICAL MODE switch positions |   | A and B TRIGGER SOURCE switch positions → |                     |            |
|--------------------------------|---|---|---------------------|------------|
|                                |   | VERT MODE                                 | LEFT VERT           | RIGHT VERT |
| LEFT                           | LO (Left Vertical)  | ↑   | ↑                   |            |
| ALT                            | Switches from LO to HI, and vice versa, at end of each sweep (both; follows display)  | ↑   | ↑                   |            |
| ADD                            | LO at pin 4 of U2404 and U2424. HI at pin 14 <sup>1</sup> (both; added algebraically) | LO (Left Vertical)                        | HI (Right Vertical) |            |
| CHOP                           |   |   |                     |            |
| RIGHT                          | HI (Right Vertical)   | ↓   | ↓                   |            |

<sup>1</sup> Pin 14 LO for all other conditions.

Fig. 2-21. Input levels at pin 4 of U2404 and U2424 (source of triggering signal is shown in parentheses).

### 2. ALT VERTICAL MODE

Depressing the ALT button of the VERTICAL MODE switch applies +5 volts to the anode of CR1067 to turn it on. Current through CR1067 forward biases Q2090 into saturation, causing the voltage at pin 4 of U2404 to follow the MF (Main Frame) Channel Switch Signal (Display Right) as it switches between HI (RIGHT VERT display) and LO (LEFT VERT display) at the end of each sweep. At the same time, pin 14 is held LO through CR1064 and CR1065. As a result, the sweep for the RIGHT VERT display is triggered by the RIGHT VERT signal, and the sweep for the LEFT VERT display is triggered by the LEFT VERT signal.

### 3. ADD OR CHOP VERTICAL MODE

For these two modes, Q2090 is not biased on, so pin 4 of U2404 is held LO by the negative voltage applied through R2095. Pin 14 will be HI due to the positive voltage applied through CR1064 or CR1065.

As indicated by the input/output table, when pin 4 is LO and pin 14 is HI, the trigger output signal is the algebraic sum of the trigger input signals from the LEFT VERT and RIGHT VERT compartments. This prevents triggering on the vertical chopping transition of a CHOP display, and on only one signal of an ADD display.

### 4. RIGHT VERTICAL MODE

In this mode, Q2090 is biased into saturation by current through CR1068. The MF Channel Switch Signal (Display Right) is HI in this mode, so a HI is produced at pin 4 of U2404. The anodes of CR1064 and CR1065 are grounded to hold pin 14 of U2404 LO. Under these conditions (pin 4 HI, pin 14 LO), the RIGHT VERT unit supplies the trigger signal.

**LEFT VERT.** Since only one button of the trigger source switch can be pressed in at a time, pressing LEFT VERT opens the contacts in the VERT MODE section of the trigger source switch so pins 4 and 14 remain LO. As indicated by the input/output table of Fig. 2-22, this causes the LEFT VERT unit to supply the trigger signal.

| Input               |             | Output                     |
|---------------------|-------------|----------------------------|
| Trigger Mode Signal | Trigger ADD | Trigger Output Signal      |
| 4                   | 14          | 12, 13                     |
| LO                  | LO          | Left trigger signal        |
| HI                  | LO          | Right trigger signal       |
| LO                  | HI          | Both (added algebraically) |

Fig. 2-22. Input/output table for A and B Trigger Selector stages.

**RIGHT VERT.** In the RIGHT VERT position of the trigger source switch, +5 volts is connected to R2093 of the voltage divider. This causes pin 4 of U2404 to go HI. At the same time, pin 14 is disconnected from its voltage source, causing it to stay at a LO level. Under these input conditions, the RIGHT VERT unit supplies the trigger output signal.

### A and B Trigger Selector

The A and B Trigger Selector stages determine which input signal provides the trigger signal to the time-base units as controlled by the trigger mode and ADD signals from the trigger selection circuitry. Resistors R2401, R2402, R2421, and R2422 establish the input resistance of this stage and provide a load for the trigger output of the left and right vertical plug-in units. Resistors R2403-R2404-R2405 and R2406-R2407-R2408 establish the operating levels for the A Trigger Selector; R2403-R2405 and R2406-R2407 set the current gain for each channel. Resistors R2423-R2424-R2425 and R2427-R2428-R2429 establish

**Circuit Description—7704A Service**

the operating level for the B Trigger Selector; R2423-R2425 and R2427-R2429 set the current gain for each channel. These stages are made up primarily of integrated circuits U2404 and U2424. An input/output table for U2404 and U2424 is shown in Fig. 2-22. U2404-U2424 provide a high-impedance differential input for the trigger signal from the left vertical unit at pins 2 and 15 and for the trigger signal from the right vertical unit at pins 7 and 10. The output signal at pins 12 and 13 is a differential signal. The sum of the DC current at pins 12 and 13 is always equal to the sum of the DC currents at pins 1, 8, 9, and 16 in all modes. This provides a constant DC bias to the following stages as the A or B TRIGGER SOURCE switches or the VERTICAL MODE switch are changed.

**A Trigger Output Amplifier**

Transistors Q2414 and Q2416 provide a low-resistance load for the A Trigger Selector IC while providing a high output impedance to the following circuits. (The A HORIZ unit provides a 50-ohm differential load for this circuit; if it is removed from its compartment, the voltage swing at the collectors of Q2414-Q2416 will increase substantially.)

**B Trigger Output Amplifier**

Q2444-Q2446 provide a low-resistance load for the B Trigger Selector IC while providing a high output impedance to the trigger circuit, and isolation between the B HORIZ trigger circuits and the Vertical Signal Out Amplifier.

The B HORIZ plug-in provides a 50-ohm differential load for Q2444-Q2446. If this plug-in is removed from its compartment, the collector load for these transistors changes and the voltage swing at their collectors increases. CR2444-CR2449 clamp the collectors of Q2444-Q2446 at about +0.6 volt to prevent these transistors from saturating under this no-load condition.

**Vertical Signal Out Amplifier**

The trigger output signal at pins 12 and 13 of the B Trigger Selector IC is also connected through Q2434-Q2436 to the Vertical Signal Out circuit. R2437 through R2441 provide a differential output resistance of about 100 ohms.

**VERTICAL INTERFACE 5**

The Vertical Interface circuit selects the vertical deflection signal from the output of the LEFT VERT or RIGHT VERT plug-in compartments. It also accepts an input from the Readout System to block the vertical signal while readout information is displayed on the CRT. In addition, this circuit contains the Vertical Trace Separation stage to shift the vertical position of one sweep of a dual-sweep display. Figure 2-23 shows a detailed block diagram of the Vertical Interface circuit.

**Vertical Plug-In Selector**

The Vertical Plug-In Selector determines which input signal provides the vertical signal to the Vertical Buffer

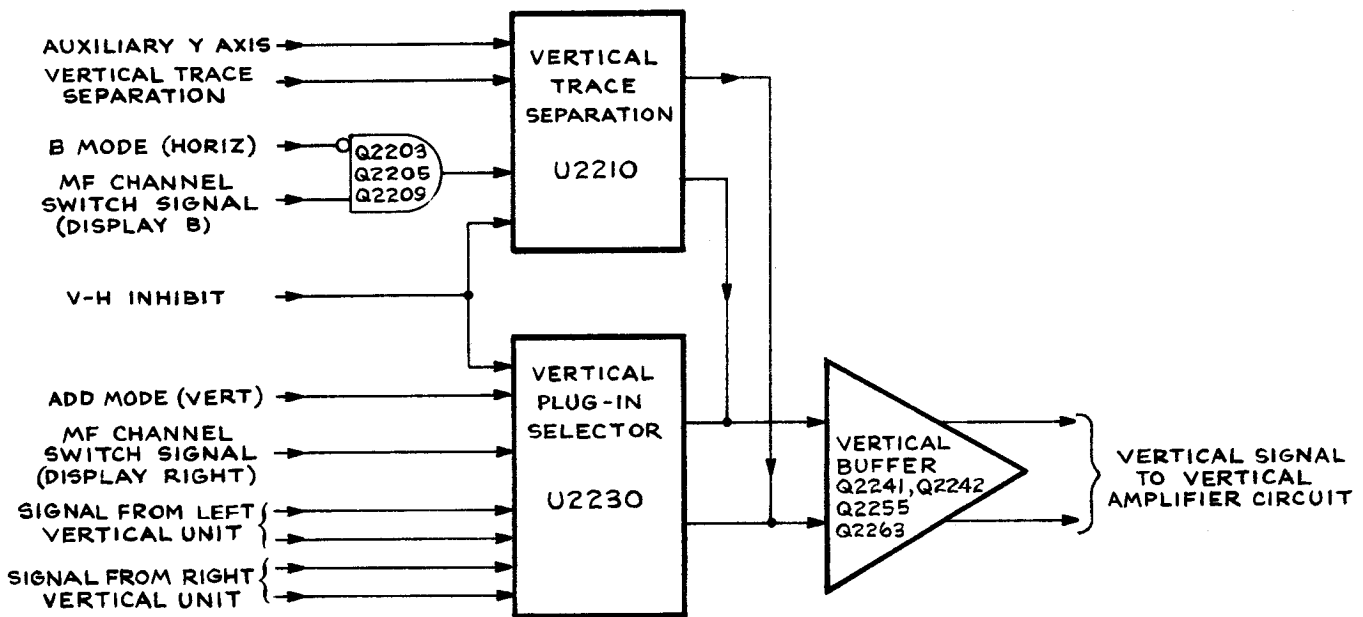

Fig. 2-23. Detailed block diagram of Vertical Interface circuit.

stage as controlled by the MF (Main Frame) Channel Switch Signal (Display Right) from the Logic Circuit. Resistors R2226-R2227 and R2228-R2229 establish the input resistance of this stage and provide a load for the left and right vertical plug-in units. Resistors R2237-R2239 and R2287-R2289 establish the operating levels for this stage. R2231 and R2281 set the current gain for each channel.

This stage is made up primarily of integrated circuit U2230, which is the same type as used for the Trigger Selector stages. An input/output table for U2230 is shown in Fig. 2-24. U2230 provides a high-impedance differential input for the signal from the left vertical unit at pins 2 and 15 and the signal from the right vertical unit at pins 7 and 10. The output signal at pins 12 and 13 is a differential signal, which is connected to the Vertical Buffer stage through R2241-R2242. The sum of the DC current at pins 12 and 13 is always equal to the sum of the DC currents at pins 1, 8, 9, and 16 in all modes. This provides a constant DC bias to the following stage as the VERTICAL MODE switch is changed.

When the VERTICAL MODE switch is set to LEFT, the level at pin 4 is LO. This level allows the signal from the left vertical unit to pass to the output while the signal from the right vertical unit is blocked. In the RIGHT position of the VERTICAL MODE switch, the level at pin 4 is HI. Now, the signal from the right vertical unit is connected to the output, while the signal from the left vertical unit is blocked.

When the VERTICAL MODE switch is set to either ALT or CHOP, the MF Channel Switch Signal (Display Right) at pin 4 switches between the LO and HI levels at a rate determined by either the Chop Counter or Vertical Binary stages (see Logic Circuit description). This action allows the signal from the left vertical unit to be displayed when the MF Channel Switch Signal (Display Right) is LO and the signal from the right vertical unit to be displayed when the MF Channel Switch Signal (Display Right) is HI. When ADD vertical mode operation is selected, a HI level is applied to pin 14 and the level at pin 4 is LO as determined by the Vertical Mode Logic stage in the Logic Circuit. This allows both the Right and Left Vertical signals to pass to the output pins. Now, the signal from both vertical units is algebraically added and the resultant signal determines the vertical deflection.

The V-H (Vertical-Horizontal) Inhibit signal from the Readout System that is applied to pin 6 has final control over the output signal from this stage. Quiescently, this signal is LO and the signal from the selected vertical unit can pass to output pins 12 and 13. However, when the Readout System is ready to display readout information, the level at pin 6 goes HI. This level blocks the signal from both vertical units, so there is no signal output from this stage under this condition.

| Input                    |                 |             | Output                              |
|--------------------------|-----------------|-------------|-------------------------------------|
| MF Channel Switch Signal | ADD Mode (Verr) | V-H Inhibit | Output signal                       |
| LO                       | LO              | LO          | Left vertical signal                |
| HI                       | LO              | LO          | Right vertical signal               |
| LO                       | HI              | LO          | Both (added algebraically)          |
| $\Phi$                   | $\Phi$          | HI          | Neither (blocked by Readout System) |

$\Phi$  = Has no effect in this case

Fig. 2-24. Input/output table for Vertical Plug-In Selector.

### Vertical Trace Separation

The Vertical Trace Separation stage determines if the Auxiliary Y Axis input or Vertical Trace Separation input are added to the vertical deflection signal. These inputs provide a variable positioning voltage to vertically offset one trace of a dual-sweep display. The Auxiliary Y Axis input originates in a dual time-base unit in either horizontal compartment. The Vertical Trace Separation input from the front panel (see diagram 1) provides a means to position the B-sweep display with respect to the A-sweep display for ALT or CHOP horizontal modes.

Integrated circuit U2210 in the Vertical Trace Separation stage is the same type as used for the Vertical Plug-In Selector stage. The output of this stage at pins 13 and 12 of U2210 is connected to the Vertical Buffer stage through R2221 and R2224. An input/output table for the Vertical Trace Separation stage is shown in Fig. 2-25.

As shown by the input/output table, the Auxiliary Y Axis input is connected to the output independent of the HORIZONTAL MODE switch setting. The Vertical Trace Separation input is connected to the output only when the MF Channel Switch Signal (Display B) is HI in the ALT or CHOP horizontal modes.

The V-H Inhibit signal from the Readout System, applied to pin 6, has final control over the output signal from this stage. Quiescently, this signal is LO and the selected input can pass to the output. However, when the Readout System is ready to display readout information, the level at pin 6 goes HI. This level blocks the offset inputs to this stage, so they have no effect on the position of the readout display.



**HORIZONTAL INTERFACE 6**

| Input                                |                |             | Output                              |
|--------------------------------------|----------------|-------------|-------------------------------------|
| MF Channel Switch Signal (Display B) | B Mode (Horiz) | V-H Inhibit | Aux Y Axis or Vert Trace Separation |
| LO                                   | LO             | LO          | Aux Y Axis                          |
| HI                                   | LO             | LO          | Both                                |
| Φ                                    | HI             | LO          | Aux Y Axis                          |
| Φ                                    | Φ              | HI          | Neither (Blocked By Readout System) |

Φ = Has no effect in this case

Fig. 2-25. Input/output table for Vertical Trace Separation stage.

**Vertical Buffer**

The outputs of the Vertical Plug-In Selector and Vertical Trace Separation stages are connected to the emitters of Q2241-Q2242. This transistor pair is connected in the common-base configuration to provide a low-impedance load to the previous stages. Centering adjustment R2222 sets the quiescent level on the base of Q2242 to adjust the trace position when no inputs are applied to this circuit. Gain adjustment R2247 sets the collector degeneration of Q2241-Q2242 to adjust the stage gain. Q2255-Q2263 are connected in the common-collector configuration (emitter follower) to provide a low-impedance reverse termination for the delay line.

The Horizontal Interface circuit determines whether the signal from the output of the A horizontal or B horizontal plug-in unit provides the horizontal deflection signal. This circuit also accepts as input from the Readout System to block the horizontal signal while readout information is displayed on the CRT. Figure 2-26 shows a detailed block diagram of the Horizontal Interface circuit.

**Horizontal Plug-In Selector**

The Horizontal Plug-In Selector determines which input signal provides the horizontal deflection signal to the Horizontal Amplifier as controlled by the MF (Main Frame) Channel Switch Signal (Display B) from the Logic Circuit. Resistors R2301-R2302 and R2303-R2304 establish the input resistance of this stage and provide a load for the A and B horizontal units. Resistors R2317-R2319 and R2327-R2329 establish the operating levels for this stage. R2311-R2313-R2315-RT2315 and R2321-R2323-R2325-RT2325 establish the current gain for each channel. R2313 and R2323 are adjustable to match the current gain of the two channels. Thermistors RT2315 and RT2325 provide temperature compensation to stabilize the current gain for each channel.

This stage is made up primarily of U2320, the same type of IC as used in the Trigger Selector and Vertical Interface circuits. An input/output table for U2320 is shown in Fig. 2-27. U2320 provides a high-impedance differential input for the signal from the A horizontal unit at pins 2 and 15 and the signal from the B horizontal unit at pins 7 and 10. The output signal at pins 12 and 13 is a differential signal to drive the Horizontal Amplifier circuit. The sum of the DC current at pins 12 and 13 is always equal to the sum of the DC currents at pins 1, 8, 9, and 16. This provides a constant DC output current level to the following stage as the HORIZONTAL MODE switch is changed.

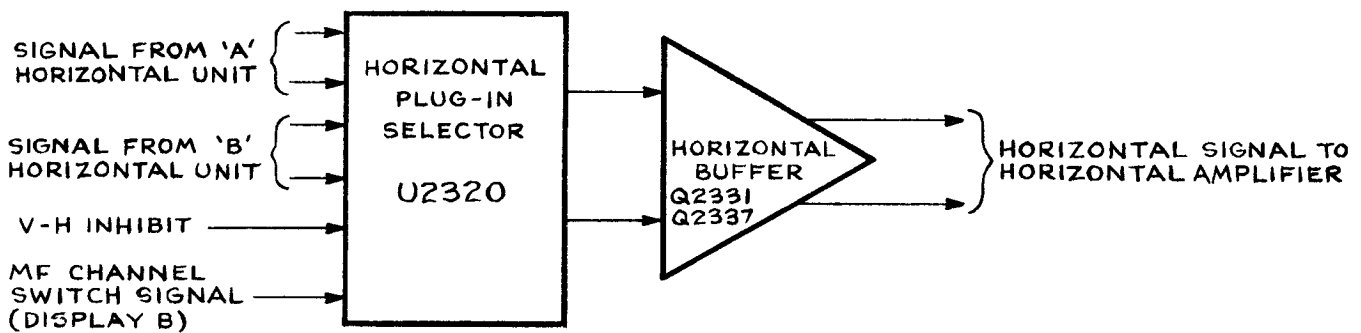

Fig. 2-26. Horizontal Interface circuit detailed block diagram.

OUTPUT SIGNALS 7

| Input                                |             | Output                              |
|--------------------------------------|-------------|-------------------------------------|
| MF Channel Switch Signal (Display B) | V-H Inhibit | Output Signal                       |
| 4                                    | 6           | 12,13                               |
| LO                                   | LO          | A Horizontal                        |
| HI                                   | LO          | B Horizontal                        |
| $\Phi$                               | HI          | Neither (blocked by readout system) |

$\Phi$  = Has no effect in this case.

Fig. 2-27. Input/output table for Horizontal Plug-In Selector.

When the HORIZONTAL MODE switch is set to A, the level at pin 4 is LO. This level allows the signal from the A horizontal unit to pass to the output while the signal from the B horizontal unit is blocked. In the B position of the HORIZONTAL MODE switch, the level at pin 4 is HI. Now, the signal from the B horizontal unit is connected to the output while the signal from the A horizontal unit is blocked.

For ALT or CHOP positions of the HORIZONTAL MODE switch, the MF Channel Switch Signal (Display B) at pin 4 switches between the LO and HI levels at a rate determined by the Horizontal Binary stage in the Logic Circuit. This action allows the signals from the A horizontal unit to be displayed when the MF Channel Switch Signal (Display B) is LO and the signal from the B horizontal unit to be displayed when the MF Channel Switch Signal (Display B) is HI.

The V-H (Vertical-Horizontal) Inhibit from the Readout System, applied to pin 6, has final control over the output signal from this stage. Quiescently, this signal is LO to allow the signal from the selected horizontal unit to pass to the output. However, when the Readout System is ready to display readout information, the level at pin 6 goes HI. This level blocks the signal from both horizontal units, so there is no signal output from this stage under this condition.

### Horizontal Buffer

The output signal from the Horizontal Plug-In Selector is connected to the Horizontal Amplifier circuit through the Horizontal Buffer stage. Transistors Q2331-Q2337 provide a low load impedance for U2320 as well as providing DC voltage matching between the Horizontal Interface and Horizontal Amplifier circuits.

The Output Signals circuit provides signals to the connectors located in the OUTPUTS section of the rear panel. These output signals are either generated within the instrument or are samples of signals from the associated plug-in units. In addition, this circuit contains the mode selection for the Readout System. Figure 2-28 shows a detailed block diagram of the Output Signals circuit.

### Vertical Signal Amplifier

The vertical signal selected by the B Trigger Selector (see Trigger Selector description for more information) is connected to the bases of transistors Q3306-Q3308. The amplified signal is connected to buffer Q3312-Q3315 through an RC network which provides thermal balance for the circuit. CR3315 and CR3317 protect this stage if high-level voltages are accidentally applied to the VERT SIG OUT connector. CR3315 provides protection from positive voltages and CR3317 provides protection from negative voltages.

### Sawtooth Amplifier

The sawtooth signals from the A and B time-base units are connected to the Sawtooth Amplifier stage through series resistors R2029 and R2019 respectively (See Diagram 2). Sweep Selector switch S3320 determines whether the A-sweep or the B-sweep sawtooth signal provides the +SAWTOOTH OUT signal. The unused sawtooth signal is terminated by R3320 to provide a constant load to the signal source.

Q3321-Q3323-Q3330 compose an inverting feedback amplifier. Gain of the stage is about two, as determined by the ratio of feedback resistor R3328 to the input resistance (made up of R3321 and either R2029 and R2019, depending on which sawtooth source is selected). RC network R3330-C3330 provides frequency-response stabilization for this stage.

CR3326 provides protection from high-amplitude positive voltages inadvertently connected to the output connector. This diode provides a current path to the +15-Volt supply through the collector-base junction of Q3330. When the diode is forward biased, it clamps the base of Q3330 at +15 volts. CR3333 provides protection from high-amplitude negative voltages at the SAWTOOTH OUT connector by clamping the output if it attempts to go more negative than about -15.6 volts.

### Gate Amplifier

The + GATE OUT signal is selected from three input gate signals by Gate Selector switch S3340. In the A position, the A Gate signal from the A HORIZ compart-

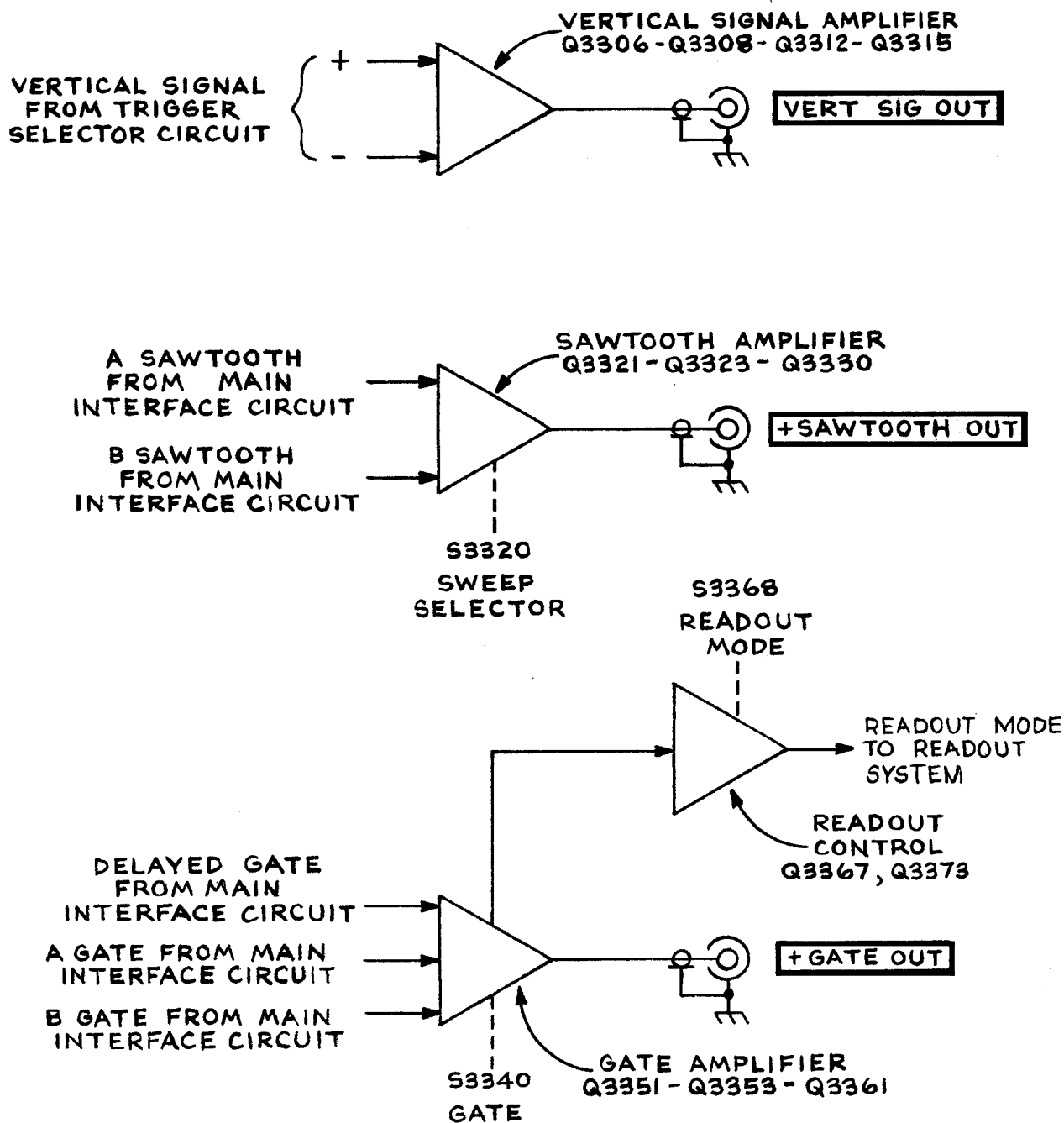

Fig. 2-28. Output Signals detailed block diagram.

ment is connected to the base of emitter-follower Q3351. The base of Q3353 is connected to ground by S3340 so the circuit operates as a common-base stage. Q3351 provides a high input impedance for the stage while the emitter coupling between the transistors provides temperature compensation. Operation is the same in the B position of the Gate Selector switch, except that the Gate signal from the B HORIZ compartment provides the input signal.

In the Dly'd position, the Gate Selector switch connects the base of Q3351 through R3349 to ground and

disconnects the A Gate and B Gate signals. The other section of the Gate Selector switch opens to allow the Delayed Gate signal from the delaying time-base unit to reach the base of Q3353. Q3353 inverts this negative-going Delayed Gate signal so that all three gate signals at the + GATE OUT connector are positive going.

CR3361 provides temperature compensation for Q3361. CR3363 protects Q3361 if a high-level positive voltage is applied to the + GATE OUT connector, and CR3364

clamps the collector of Q3361 at about  $-0.6$  volt if a negative voltage is applied to the output connector.

### Readout Control

Q3367 and Q3373, along with S3368, control the operating mode of the Readout System. When Readout Mode switch S3368 is in the Free-Run position, the Readout System runs continuously in a free-running manner. The emitter of Q3373 has no ground return, so Q3373 can not conduct and its collector rises positive (through circuitry in the Readout System) to enable the Readout System.

In the Gate Trig'd position, the emitter of Q3373 is connected to ground through R3373 and S3368 to produce a LO lockout level to the Readout System. At the end of the selected gate, a negative level is applied to the base of Q3367. This negative level is differentiated by C3368-R3368; the resulting negative-going pulse reverse biases Q3373 to momentarily allow its collector to go HI. This enables the Readout System so that it can produce one complete frame (eight words) each time the selected gate goes negative.

## INVERTER/RECTIFIERS

The Inverter/Rectifiers circuit provides the operating power for this instrument from an AC line-voltage source. This circuit includes a Line Selector assembly to permit selection of the nominal operating voltage for the instrument. Figure 2-29 shows a detailed block diagram of the Inverter/Rectifiers circuit.

### Line Input

Power is applied through the Line Filter, line fuse F3001, POWER switch S5020, and Line Selector switch S5022. The Line Filter is designed to keep power-line interference from entering the instrument and to keep the 25-kilohertz Inverter signal from entering the power line. L5020-L5022 provide common-mode EMI (electromagnetic interference) filtering with C5020-C5022, and differential filtering with C3005-C3006. R5020-R5022 provide common-mode resonance damping.

Line Selector switch S5022 allows the instrument to operate from either a 115-volt nominal or a 230-volt nominal line-voltage source. In the 115-volt position, rectifier CR3015 operates as a full-wave doubler with capacitors C3016-C3017 so the voltage across the two capacitors in series will be the peak-to-peak value of the line voltage. For 230-volt operation, CR3015 is connected as a bridge rectifier and C3016-C3017 operate as energy-storage filter capacitors. As a result, the output voltage applied to the Inverter stage is about the same for either 115-volt or 230-volt operation.

Thermistor RT3009 limits the surge current demanded by the power supply when it is first turned on. After the instrument is in operation, the thermistor resistance drops, so it has little effect on the operation of this stage. The stored charge on C3016 and C3017 limits the surge current if the POWER switch is turned off and back on after the resistance of RT3009 has dropped. If this occurs, the Inverter Control Line Stop stage will shut the Inverter off so that C3016 and C3017 will slowly discharge through R3021. The discharge time constant of C3016-C3017-R3021 is about equal but opposite to the thermistor thermal recovery time. This ensures sufficient thermistor resistance to limit the turn-on surge current to a safe level. Since C3016 and C3017 discharge slowly, dangerous potentials exist within the power supply for several minutes after the POWER switch is turned off. The presence of voltage in the circuit is indicated by the relaxation oscillator R3019-C3019-DS3019. Neon bulb DS3019 will blink until the potential across C3016-C3017 drops to about 80 volts.

DS3008-DS3013 are surge voltage protectors. When the Line Selector switch is in the 115-volt position, only DS3008 is connected across the line input. If a peak-voltage surge in excess of about 230 volts is present on the line (or if the instrument is accidentally connected to a 230-volt source), DS3008 will break down and demand high current. This excess current will quickly open line fuse F3001 to interrupt the input power before the instrument can be damaged. In the 230-volt position, DS3008 and DS3013 are connected in series across the line input to provide protection for peak voltages in excess of about 460 volts.

Transformer T3001 provides a sample of the line voltage to the plug-in connectors in the Main Interface circuit for internal triggering at line frequencies. This line-frequency signal is also connected to the Inverter Control Line Stop stage to indicate when line voltage is applied and the POWER switch is on.

The rectified output voltage from the Line Input stage is connected to the Start Network through Inverter fuse F3003. F3003 protects the Inverter stage if it demands excessive current due to a malfunction.

### Start Network

The input line voltage is connected to divider R3010-R3048. This voltage charges C3048 on each half cycle. When the charge on C3048 reaches about 32 volts, trigger diode CR3040 conducts to provide a turn-on trigger current to Q3047 through C3042. This current allows the Inverter stage to start operating. After the Inverter stage is operating, the recurrent waveform at the collector of Q3047 keeps C3048 discharged through CR3046. This disables the Start Network while the instrument is on.

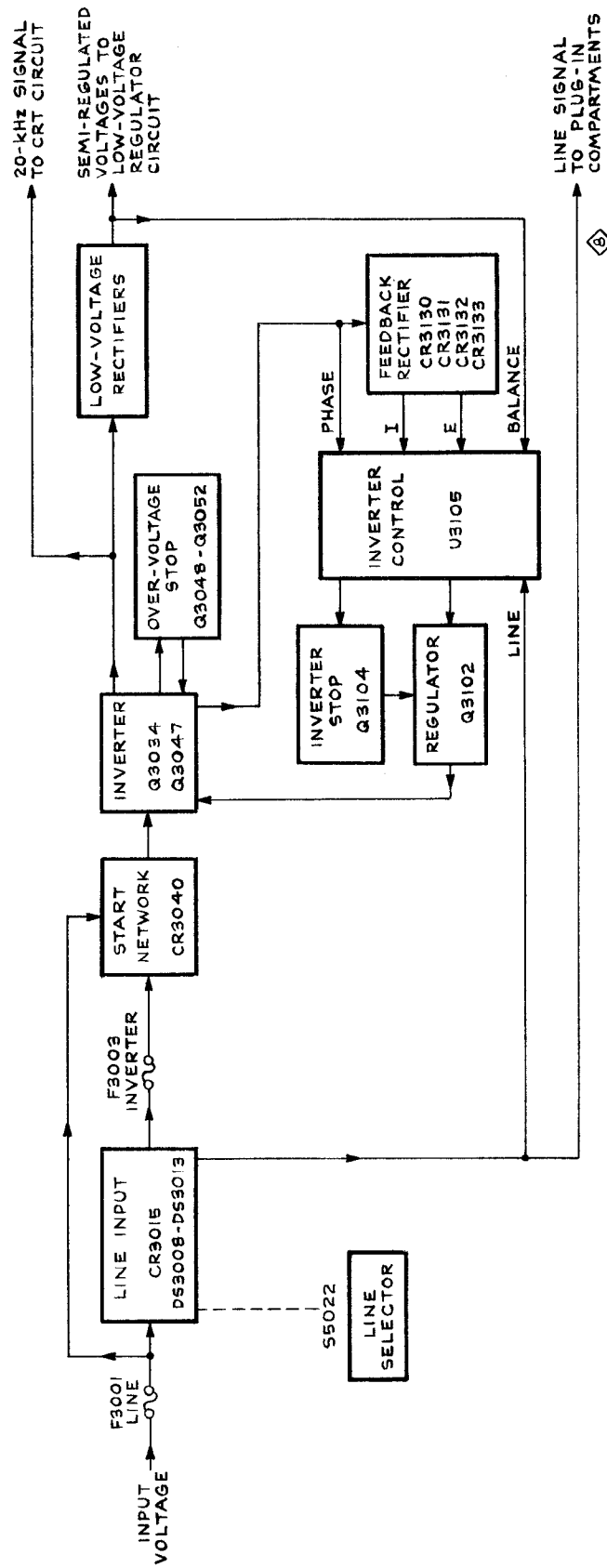

Fig. 2-29. Detailed block diagram of Inverter/Rectifiers circuit.

## Inverter

A simplified schematic of the Inverter, Regulator, and Inverter Control stages is shown in Fig. 2-30. Once the Inverter has been started by the Start Network, the Inverter is self-oscillating. Feedback required for oscillation is provided by base-drive transformer T1. Polarity of the windings causes Q1 and Q2 to conduct alternately. This generates a square-wave voltage at the emitter of Q1 with an amplitude approximately equal to the DC voltage at the input to this stage. The switching action of Q1 and Q2 supplies the drive necessary to maintain a sine-wave current in series resonant circuit L1-C1. Notice that this sine-wave current is also common to the primaries of T1, T2, and T3.

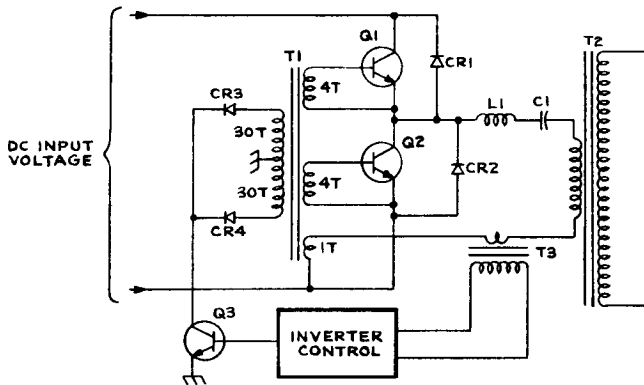

Fig. 2-30. Simplified schematic of Inverter, Regulator, and Inverter Control stages.

Q3 represents the Regulator stage, which is controlled by the Inverter Control stage. These stages are used to delay the turn-on of Q1 or Q2 to provide pre-regulation of the voltages induced in the secondary of T2. When Q3 is on, the voltages on all secondaries of T1 will be zero, and both Q1 and Q2 will be off. Current in the resonant circuit will flow through CR1 and CR2 when Q1 and Q2 are off. Transformer T3 samples the resonant-circuit current to provide current-phase information to the Pre-Regulator inputs of the Inverter Control stage to control the conduction of the Regulator stage.

The normal sequence of operation is as follows: Assume that the sine-wave current in the series resonant circuit is passing through zero and is increasing in the direction to cause CR1 to conduct. At zero crossing, Q3 turns on to hold Q2 off (CR1 will conduct as long as Q2 is off). At a controlled time after zero crossing, Q3 is turned off by the Inverter Control stage. Q2 then turns on, causing CR1 to be reverse biased. Q2 conducts as the current goes through its peak and back to zero.

At zero crossing, with current increasing in the opposite direction, Q3 turns on to hold Q1 off. During this Inverter

Control time, CR2 conducts while Q1 is off. When the Inverter Control stage turns Q3 off, Q1 will be turned on, causing CR2 to be reverse biased. Q1 conducts as the current goes through its peak and back to zero. The cycle then repeats with Q3 turning on to hold Q2 off.

Now, refer to the complete Inverter/Rectifiers diagram. The LC circuit is made up of L3037-C3037. After the circuit has been started by the Start Network, as discussed previously, L3037-C3037 resonates at a frequency of about 25 kilohertz. The feedback to the base circuits of Q3034-Q3047, through T3030, alternately turns Q3034 and Q3047 on. These transistors operate at a forced beta of four due to the turns ratio of T3030, and their output current sustains resonance in L3037-C3037. The 60-turn center-tapped winding of T3030 is used to delay the turn-on of Q3034 or Q3047 to provide pre-regulation of the voltages produced in the secondary of T3101. This operation will be discussed in more detail under Pre-Regulator. Diodes CR3034 and CR3045 provide reverse conduction paths across Q3034 and Q3047 respectively when these transistors are held off for pre-regulation purposes.

## Over-Voltage Stop

Q3048 and Q3052 provide a means to stop the Inverter whenever the voltage across the primary of T3101 exceeds a safe level. This stage is activated whenever the load on T3101 is removed or the normal voltage regulating path through Q3102 and T3030 is inoperative.

CR3057 charges C3049 to the peak of the voltage across the primary of T3101. If this voltage exceeds a safe level, VR3059 will conduct and turn on Q3052. C3049 will discharge through R3052, Q3052, and the base-emitter junction of Q3048. This current turns Q3048 on to cause Q3047 to be held off and stop the Inverter. The Inverter cannot restart until CR3050 has charged C3048 to about 32 volts (the breakdown voltage of CR3040) to energize the Start Network.

## Inverter Control

The Inverter Control stage, made up primarily of U3105, provides pre-regulation and fault protection for the low-voltage power supplies. For pre-regulation purposes, U3105 provides the Regulator output to the Regulator stage to vary the Inverter frequency. Fault protection is achieved through the Regulator output (as for pre-regulation) or by providing the Stop Trigger output to the Inverter Stop stage to turn the Inverter off.

U3105 includes a monostable multivibrator that is initially triggered by current-phase information fed back from the Inverter stage. The sensing inputs to U3105 determine the multivibrator pulse width. The multivibrator

## Circuit Description—7704A Service

Regulator output drives the Regulator stage through pin 9-U3105. Under normal operating conditions, only the E Sense input at pin 15 has control over the output pulse width for pre-regulation. However, an error detected by any of the sensing inputs will affect the output pulse width and will also produce a Stop Trigger to the Inverter Stop stage. The operation of each individual function of the Inverter Control stage is described in the following discussions.

### Pre-Regulator

The Pre-Regulator portion of U3105, in conjunction with the Regulator stage, maintains constant voltages at the outputs of the Low-Voltage Rectifiers.

Transformer T3035 provides Inverter power and phase information to U3105. The phase information is connected to the trigger input of the Inverter Control multivibrator via pins 10 and 11 through C3125 and C3126. Bridge rectifier CR3130-CR3131-CR3132-CR3133 provides positive and negative operating voltages to U3105. A shunt regulator in U3105 regulates the +7.5-volt output of the bridge rectifier connected to pin 6. The -2-volt (nominal) output connected to pin 7 is unregulated. VR3147 provides a stable reference voltage for the sensing-divider resistors R3142-R3143-R3144-R3146. In this divider, R3143 adjusts the voltage level at the E Sense input to the Pre-Regulator (pin 15-U3105) to set the output voltage of the Low-Voltage Rectifiers.

In the stable state of the Inverter Control multivibrator, the Regulator output at pin 9 is near ground to turn off the Regulator stage. After the Inverter current passes through zero, either pin 10 or pin 11 will go positive to trigger the Inverter Control multivibrator into its astable state. While the multivibrator is in the astable state, the Regulator output voltage level is positive to turn on the Regulator stage. The duration of the astable state is determined by the voltage level at the E Sense input at pin 15. If this voltage level is low, the duration is short. As this voltage level increases, the duration increases.

### Fault Protection

The fault-protection portions of U3105 protect the power-supply components from damage due to short circuits, turn-on surge currents, and other malfunctions. When a fault is detected at the Balance or I Sense inputs (pins 2 and 13 respectively), a current output from the Sample Period Timer output (pin 1) charges C3114. If the detected fault lasts longer than about 30 milliseconds, C3114 charges positive enough to produce a Stop Trigger output at pin 8 to turn the Inverter off. When the Inverter is shut off, the current charging C3114 is interrupted and C3114 will discharge. After about 450 milliseconds, the Stop Trigger output will return to a near zero-volt level to

allow the Inverter to run. This cycle repeats until the fault is corrected; the Inverter is on for about 30 milliseconds, then off for about 450 milliseconds.

**Inverter Current Limiter.** The Inverter Current Limiter provides protection for the Inverter components from damage due to excessive current. Operation of this stage is similar to the Pre-Regulator (voltage regulation). The Inverter Current Limiter takes control of the Inverter Control Regulator output pulse width during turn-on or whenever an overload causes the Inverter current to reach the limit value.

R3137 is the current-sensing resistor. The voltage at the junction of R3137-R3136-CR3138 is the negative rectified Inverter current. The I Sense input at pin 13 is normally held positive through R3135. If the Inverter current increases, the voltage at the I Sense input will become more negative. The Inverter Control Regulator output pulse width increases until the Inverter current reaches a value to hold pin 13 near the zero-volt level. If the voltage at pin 13 remains near zero for more than approximately 30 milliseconds, the Stop Trigger output at pin 8 will go positive to trigger the Inverter Stop stage.

**Balance.** The Balance portion of U3105 provides short-circuit protection for the +5-Volt and -17-Volt outputs of the Low-Voltage Rectifiers. Voltage divider R3152-R3154-R3155 biases the Balance Sense input at pin 2 of U3105 near a zero-volt level. If one of the output voltages changes sufficiently to cause the voltage level at pin 2 to vary approximately 200 millivolts (positive or negative), a positive Stop Trigger output is produced at pin 8 of U3105.

**Line Stop.** The Line Stop portion of U3105 protects the Line-Input components from damage due to turn-on surge current. This is achieved by triggering the Inverter Stop stage to stop the Inverter when the POWER switch is turned off. The Line Stop stage will also stop the Inverter if the AC line voltage falls below a minimum value. (For further information, refer to the discussion of the Line Input stage.)

The line-frequency signal from transformer T3001 is connected to the Line Stop Sense input of U3105 at pin 4. During normal operation, the line-frequency signal causes the Line Stop Timer terminal (pin 3) to be near a zero-volt level (ground). This zero-volt level keeps C3117 from being charged toward +7.5 volts through R3117. When the line-frequency signal is interrupted or falls below a minimum value, C3117 will begin to charge to +7.5 volts. When the voltage at pin 3 reaches approximately +0.7 volt, the Line Stop stage will produce a positive Stop Trigger output at pin 8 of U3105 to trigger the Inverter Stop stage.

## Regulator

The Regulator stage operates in conjunction with the Inverter Control and Inverter Stop stages to regulate the Inverter switching. Q3102 acts as a switch controlled by the Regulator output of U3105 (pin 9) or by the Inverter Stop stage. When Q3102 is turned on, CR3101 and CR3102 are forward biased. This effectively short circuits the 60-turn center-tapped winding of T3030 to shut off the Inverter. For further information, see the discussion of the Inverter stage.

## Inverter Stop

The Inverter Stop stage, Q3104, is controlled by the Stop Trigger output of U3105 (pin 8) to shut off the Inverter through the Regulator stage. During the start period, T3030 supplies current to charge C3106-C3108 through CR3106-CR3108. Also during this time, Q3104 is reverse biased by U3105. Once triggered on by a positive Stop Trigger, Q3104 will stay on while C3106-C3108 discharge through the base of Q3104. If U3105 is removed from its socket or is otherwise non-functional, the Inverter Stop stage will stop the Inverter after the first few cycles of operation. In this mode, the duty cycle will be much shorter because C3106-C3108 will not have sufficient time to charge.

## Low-Voltage Rectifiers

The rectifiers and filter components in the secondaries of T3101 provide rectified, pre-regulated voltages for further regulation by the Low-Voltage Regulators circuit. Error-sense voltages from the +54-Volt and lamp power (+5-Volt Lights) supplies are fed back to U3105 to control the amplitude of the Inverter drive to the Low-Voltage Rectifiers stage.

## LOW-VOLTAGE REGULATORS

The Low-Voltage Regulators circuit converts semi-regulated voltages from the Inverter/Rectifiers circuit to stabilized, low-ripple output voltages. The -50-Volt Supply is referenced to a zener diode; the remaining four supplies are referenced to the -50-Volt Supply. Each supply contains a short-protection circuit to prevent instrument damage if a supply is shorted to ground or to another supply. Figure 2-31 shows a detailed block diagram of the Low-Voltage Regulators circuit.

### -50-Volt Supply

The following discussion includes the description of the -50-V Series Regulator, -50-V Feedback Amplifier, -50-V Reference, and -50-V Current Limiting stages. Since these stages are closely related in the production of the -50-volt regulated output voltage, their operation is most easily understood when discussed as a unit.

Semi-regulated -54 volts from the Inverter/Rectifiers circuit provides the unregulated voltage source for this supply. Transistors Q32130-Q32115-Q32143 operate as a feedback-stabilized regulator circuit to maintain a constant -50-volt output level. Q32130 is connected as a differential amplifier to compare the feedback voltage at the base of Q32130B against the reference voltage at the base of Q32130A. The error output at the collector of Q32130B reflects the difference, if any, between these two inputs. The change in error-output level at the collector of Q32130B is always in the opposite direction to the change in the feedback input at the base of Q32130B (out of phase).

Zener diode VR32127 sets a reference level of about -9 volts at the base of Q32130A. A sample of the output voltage from this supply is connected to the base of Q32130B through divider R32132-R32133-R32134. R32133 in this divider is adjustable to set the output level of this supply. Notice that the feedback voltage to this divider is obtained from a line labeled -50 V Sense. If the feedback voltage were obtained at the supply, the voltage at the load would not stay constant, due to the inherent resistance of the interconnecting cable between the supply and its load (as the load current varies, the voltage drop along the cable also varies). The Sense configuration overcomes this problem by sensing the voltage at the load. Since the current in the Sense line is small and constant, the load voltage is held constant regardless of the load current.

Regulation occurs as follows: If the output level of this supply decreases (less negative) due to an increase in load or a decrease in input voltage (as a result of line-voltage changes or ripple), the voltage across divider R32132-R32133-R32134 decreases also. This results in a more positive feedback level at the base of Q32130B than that established by the -50-V Reference stage at the base of Q32130A. Since the transistor with the more positive base controls the conduction of the differential amplifier, the output current at the collector of Q32130B increases. This increase in output from Q32130B increases the current through Q32115. This allows more current to flow through Q32143 to result in increased conduction of the -50-V Series Regulator Q32139. The load current increases and the output voltage of this supply also increases (more negative). As a result, the feedback voltage from the -50-V Sense line increases and the base of Q32130B returns to the same level as the base of Q32130A. Similarly, if the output level of this supply increases (more negative), the output current of Q32130B decreases. The feedback through Q32115 and Q32143 reduces the conduction of the -50-V Series Regulator to decrease the output voltage of this supply. The -50 Volts adjustment R32133 determines the divider ratio to the base of Q32130B and thereby determines the feedback voltage.



Circuit Description—7704A Service

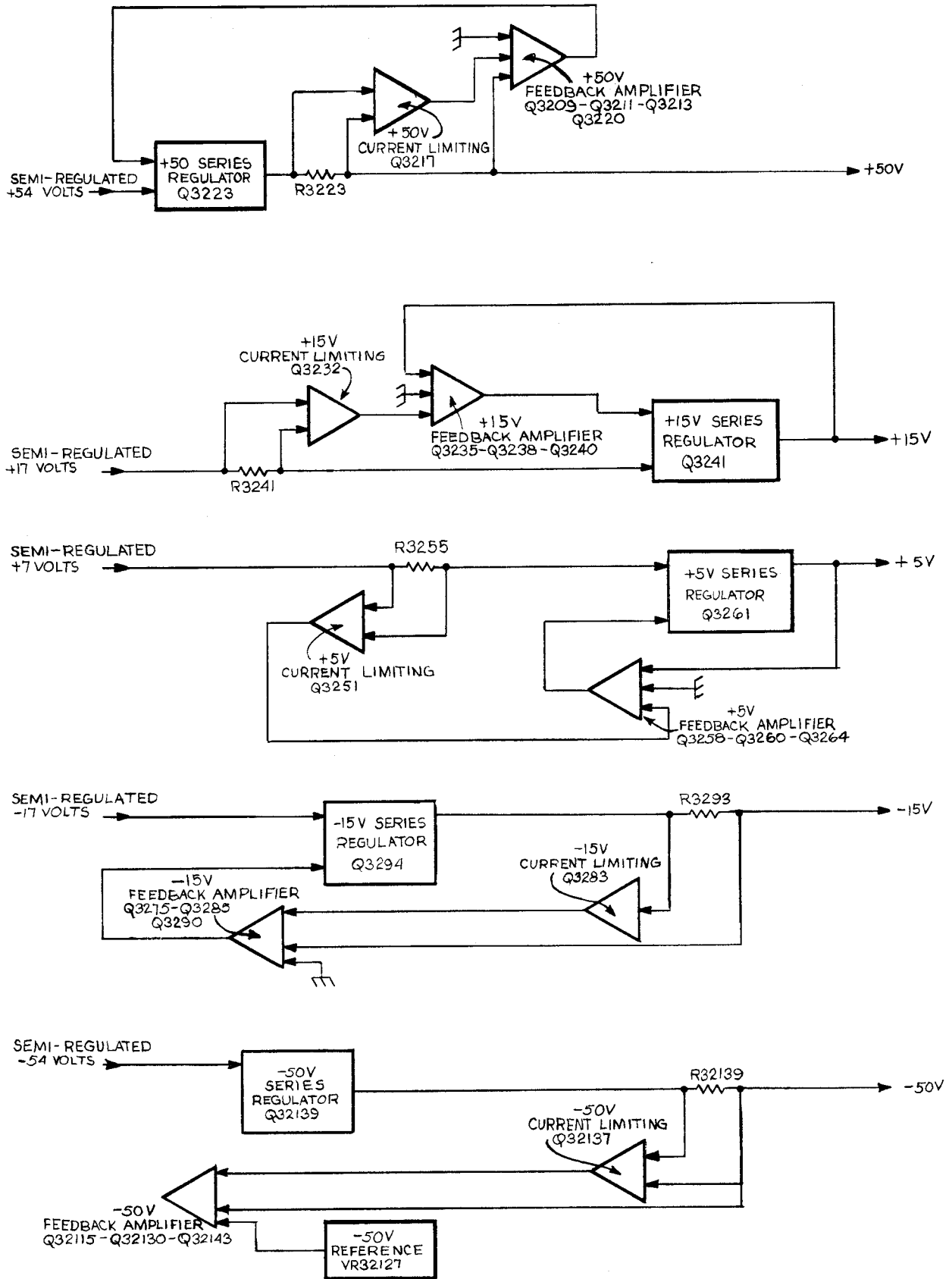

Fig. 2-31. Detailed block diagram of Low-Voltage Regulators circuit.

The -50-V Current Limiting stage Q32137 protects the -50-V Supply if excess current is demanded from this supply. Since the load is connected to this supply through R32139, all current from the -50-Volt Supply must flow through this resistor. Transistor Q32137 senses the voltage drop across R32139. Under normal operation, there is insufficient voltage drop across R32139 to forward bias Q32137. However, when excess current is demanded from the -50-V Series Regulator due to a short circuit or similar malfunction at the output of this supply, the voltage drop across R32139 increases until it is sufficient to forward bias Q32137. The collector current of Q32137 results in a reduction of current through Q32115 and Q32143 to limit the conduction of Q32139. This current limiting protects Q32139 from damage due to excess power dissipation.

Several protection diodes are also included in this circuit. CR32139 prevents the output of this supply from going more positive than about +0.6 volt if it is shorted to a positive supply. VR32121 and CR32123 supply a turn-on voltage for Q32130 to start the -50-Volt Supply when the instrument is first turned on. As soon as the -50-Volt Supply turns on, VR32121 and CR32123 turn off to disconnect the turn-on voltage from Q32130.

### -15-Volt Supply

Basic operation of all stages in the -15-Volt Supply is the same as for the -50-Volt Supply. Reference level for this supply is established by divider R3272-R3273 between ground and the -50 V Sense voltage. The divider ratio of R3272-R3273 sets a level of -15 volts at the base of Q3275A. The level on the -50 V Sense line is held stable by the -50-Volt Supply. Any change at the output of the -15-Volt Supply appears at the base of Q3275B as an error signal. The output voltage is regulated in the same manner as described for the -50-Volt Supply. CR3293 limits the output of this supply from going more positive than about +0.6 volt if it is shorted to one of the positive supplies. Diodes CR3274 and CR3275 provide reverse voltage protection for transistors Q3275B and Q3275A respectively.

### +5-Volt Supply

Basic operation of the +5-Volt Supply is the same as described for the previous supplies. The reference level for this supply is established by the ground connection at the base of Q3264A. Feedback voltage to the base of Q3264B is provided by divider R3264-R3267 between the -50 V Sense line and the +5 V Sense line. The divider ratio of R3265-R3267 is 10:1 so the base of Q3264B is at zero volt when the supply is operating properly. The level on the -50 V Sense line is held stable by the -50-Volt Supply. Therefore, any change at the output of the +5-Volt Supply appears at the base of Q3264B as an error signal. The

output voltage is regulated in the manner described previously for the -50-Volt Supply. Diode CR3261 limits the output of this supply to about -0.6 volt if it is shorted to one of the negative supplies.

### +15-Volt Supply

The +15-Volt Supply operates in the same manner as described for the previous supplies. The ground connection at the base of Q3235A provides the reference for this supply. Feedback voltage to the base of Q3235B is provided through divider R3236-R3239 between the -50 V Sense line and the +15 V Sense line. The divider ratio of R3236-R3239 sets the base of Q3235B at zero volt. Any change in the output level of the +15-Volt Supply appears at the base of Q3235B as an error signal. This results in an opposite change at the collector of Q3235B and at the base of Q3238. This change is connected to the +15-V Series Regulator stage through Q3240 to correct the error in the output voltage.

Diode CR3235 protects Q3235B against negative voltages if the +15-Volt Supply is shorted to ground. Diode CR3241 limits the output of this supply to about -0.6 volt if it is shorted to one of the negative supplies.

### +50-Volt Supply

Operation of the +50-Volt Supply is the same as described previously for the other supplies. Reference voltage for this supply is established by the ground connection through R3206 at the base of Q3209. Feedback voltage to the base of Q3209B is provided by divider R3208-R3214 between the -50 V Sense line and the +50 V Sense line. The divider ratio of R3208-R3214 sets the base level of Q3209B at zero volt when the output of this supply is correct. The protection diodes in this circuit operate similarly to the other supplies.

## READOUT SYSTEM

### INTRODUCTION TO READOUT SYSTEM

#### General

The Readout System provides alpha-numeric display of information encoded by the plug-in units. This display is presented on the CRT and is written by the CRT beam on a time-shared basis with the analog waveform display.

The definition of several terms follows:

**Character**—A character is a single number, letter, or symbol displayed on the CRT, either alone or in combination with other characters.

## Circuit Description—7704A Service

**Word**—A word is made up of a related group of characters. In the 7704A Readout System, a word can consist of up to ten characters.

**Frame**—A frame is a display of all words for a given operating mode and plug-in combination. Up to eight words can be displayed in one frame. Figure 2-32 shows the position of each word in a complete frame.

**Column**—One of the vertical lines in the Character Selection Matrix (see Fig. 2-33). Columns C-0 (column zero) to C-10 (column 10) can be addressed in the 7704A system.

**Row**—One of the horizontal lines in the Character Selection Matrix. Rows R-1 (row 1) through R-10 (row 10) and R-14 (row 14) can be addressed in the 7704A system.

**Time-Slot**—A location in a pulse train. In the 7704A Readout System, the pulse train consists of 10 negative-going pulses. Each time-slot pulse is assigned a number between one and ten. For example, the first time-slot is TS-1.

**Time-multiplexing**—Transmission of data from two or more sources over a common path by using different time intervals for different signals.

## Display Format

Up to eight words of readout information can be displayed on the CRT. The position of each word is fixed and is directly related to the plug-in unit from which it originated. Figure 2-32 shows the area of the graticule where the readout from each plug-in unit is displayed. Notice that Channel 1 of each plug-in unit is displayed within the top division of the CRT and Channel 2 is displayed directly below within the bottom division. Figure 2-34 shows a typical display where only Channel 1 of the Right Vertical and B Horizontal units is selected for display.

Each word in the readout display can contain up to 10 characters, although the typical display will contain between two and seven characters per word. The characters are selected from the Character Selection Matrix shown in Fig. 2-33. Any one of the 50 separate characters can be addressed and displayed on the CRT. In instruments above serial number B050000, a decimal-point character can be addressed and displayed. In addition, 12 operational addresses are provided for special instructions to the Readout System. The unused locations in the Matrix (shaded area) are available for future expansion of the Readout System. The method of addressing the locations in the Character Selection Matrix is described in the following discussion.

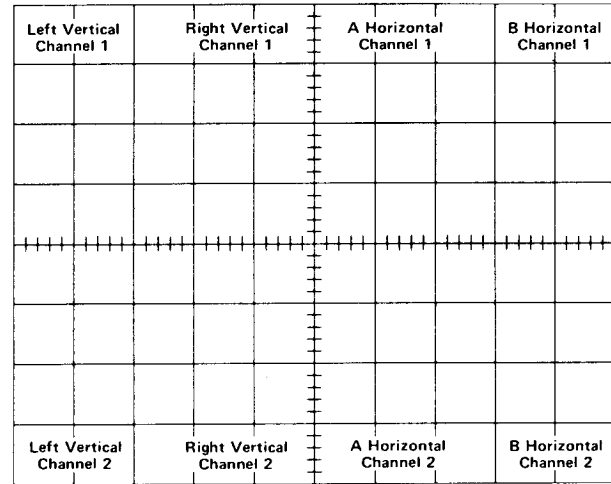

Fig. 2-32. Location of readout words on the CRT identifying the originating plug-in and channel (one complete frame shown, simulated readout).

## Developing the Display

The following basic description of the Readout System uses the block diagram shown in Fig. 2-35. This description is intended to relate the basic function of each stage to the operation of the overall Readout System. Detailed information on circuit operation is given later.

The key block in the Readout System is the Timer stage. This stage produces the basic signals which establish the timing sequences within the Readout System. Period of the timing signal is about 250 microseconds (drops to about 210 microseconds when Display-Skip is received; see detailed description of Timing stage for further information). This stage also produces control signals for other stages within this circuit and interrupt signals to the Vertical Interface, Horizontal Interface, and CRT Circuit, which allow a readout display to be presented. The Time-Slot Counter stage receives a trapezoidal voltage signal from the Timer stage and directs it to one of ten output lines. These output lines are labeled TS-1 through TS-10 (time-slots one through ten) and are connected to the vertical and horizontal plug-in compartments as well as to various stages within the Readout System. The output lines are energized sequentially, so there is a pulse on only one of the 10 lines during any 250-microsecond timing period. After the Time-Slot Counter stage has counted time-slot 10, it produces an End-of-Word pulse which advances the system to the next channel.

Two output lines, row and column, are connected from each channel of the plug-in unit back to the Readout System. Data is typically encoded on these output lines by connecting resistors between them and the time-slot input lines. The resultant output is a sequence of ten analog current levels which range from zero to one milliamperere (100 microamperes/step) on the row and column output

| Column Number → |                         |                                   |                               |                              |   |   |  |  |  |     |     |      |
|-----------------|-------------------------|-----------------------------------|-------------------------------|------------------------------|---|---|--|--|--|-----|-----|------|
| Row Number ↓    | Current (Milli-amperes) | C-0                               | C-1                           | C-2                          | C-3   | C-4   | C-5  | C-6  | C-7  | C-8 | C-9 | C-10 |
|                 | R-1                     | 0                                 | 0                             | 0                            | 0   | 0   | 0  | 0  | 0  | 0   | 0   | 0    |
| R-2             | 0.1                     | ↙                                 | <                             | μ                            | n   | /   | +  | -  | +  | C   | Δ   | >    |
| R-3             | 0.2                     | Add <sup>1</sup><br>one zero      | Add <sup>1</sup><br>two zeros | Shift <sup>1</sup><br>prefix | Shift <sup>1</sup><br>prefix and add one zero | Shift <sup>1</sup><br>prefix and add one zero | +  | -  | +  | C   | Δ   | >    |
| R-4             | 0.3                     | m                                 | μ                             | V                            | n   | P   | X  | K  | M  | G   | T   | R    |
| R-5             | 0.4                     | S                                 | V                             | A                            | A   | W   | H  | d  | B  | c   | Ω   | E    |
| R-6             | 0.5                     | U                                 | N                             | L                            | L   | Z   | Y  | P  | F  | J   | Q   | D    |
| R-7             | 0.6                     |                                   |                               |                              | Decimal <sup>1</sup><br>point location No. 3  | Decimal <sup>1</sup><br>point location No. 4  | Decimal <sup>1</sup><br>point location No. 5 | Decimal <sup>1</sup><br>point location No. 6 | Decimal <sup>1</sup><br>point location No. 7 |     |     |      |
| R-8             | 0.7                     |                                   |                               |                              |   |   |  |  |  |     |     |      |
| R-9             | 0.8                     |                                   |                               |                              |   |   |  |  |  |     |     |      |
| R-10            | 0.9                     | Add Space In Display <sup>1</sup> |                               |                              |   |   |  |  |  |     |     |      |

Fig. 2-33. Character Selection Matrix for 7704A Readout System.



Unused locations. Available for future expansion of Readout System

<sup>1</sup> Operational address.

<sup>2</sup> Decimal point character, instruments serial number B050000 and up. See Decimal-Point Character description in text.

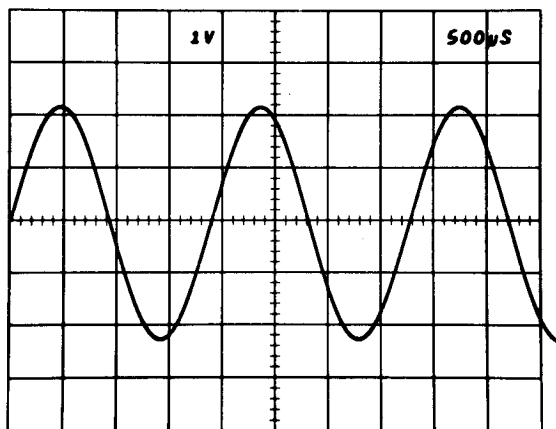

Fig. 2-34. Typical readout display where only channel 1 of the Right Vertical and B Horizontal units is displayed.

lines. This row and column correspond to the row and column of the Character Selection Matrix in Fig. 2-33. The standard format for encoding information onto the output lines is given in Table 2-2. (Special purpose plug-in units may have their own format for readout; these special formats will be defined in the manuals for these units.)

TABLE 2-2  
Standard Readout Format

| Time-Slot Number     | Description  |
|----------------------|--|
| TS-1                 | Determines decimal magnitude (number of zeros displayed or prefix change information) or the IDENTIFY function (no display during this time-slot).                       |
| TS-2                 | Indicates normal or inverted input (no display for normal).  |
| TS-3                 | Indicates calibrated or uncalibrated condition of plug-in variable control (no display for calibrated condition).  |
| TS-4                 | Scaling.   |
| TS-5<br>TS-6<br>TS-7 | Not encoded by plug-in unit. Left blank to allow addition of zeros by Readout System.  |
| TS-8                 | Defines the prefix which modifies the units of measurement.  |
| TS-9<br>TS-10        | Define the units of measurement of the plug-in unit. May be standard units of measurement (V, A, S, etc.) or special units selected from the Character Selection Matrix. |

The encoded column and row data from the plug-in units is selected by the Column Data Switch and Row Data

Switch stages respectively. These stages take the analog currents from the eight data lines (two channels from each of the four plug-in compartments) and produce a time-multiplexed analog voltage output containing all of the column or row information from the plug-ins. The Column Data Switch and Row Data Switch are sequenced by the binary Channel Address Code from the Channel Counter. The output of the data switches can be disconnected by an input from the Main Interconnect while the Main Interconnect provides the column and row data to the remainder of the Readout System.

The time-multiplexed output of the Column Data Switch is monitored by the Display-Skip Generator to determine if it represents valid information that should be displayed. Whenever information is not encoded in a time-slot, the Display-Skip Generator produces an output level to prevent the Timer stage from producing the control signals that normally interrupt the CRT display and present a character.

The analog outputs of the Column Data Switch and Row Data Switch are connected to the Column Decoder and Row Decoder stages respectively. These stages sense the magnitude of the analog voltage input and produce an output current on one of ten lines. The outputs of the Column Decoder stage are identified as C-1 through C-10 (column 1 through 10) corresponding to the encoded column information. Likewise, the outputs of the Row Decoder stage are identified as R-1 through R-10 (row 1 through 10) corresponding to the encoded row information. The primary function of the row and column outputs is to select a character from the Character Selection Matrix to be produced by the Character Generator stage. These outputs are also used at other points within the system to indicate when certain information has been encoded. One such stage is the Zeros Logic and Memory. During time-slot 1 (TS-1), this stage checks if zero-adding or prefix-shifting information has been encoded by the plug-in unit, and stores it in memory until time-slots 5, 6, or 8. After storing this information, it triggers the Display-Skip Generator stage so that there is no display during time-slot 1 (as defined by Standard Readout Format; see Table 2-2). When time-slots 5, 6, and 8 occur, the memory is addressed and any information stored there during time-slot 1 is transferred to the input of the Column Decoder stage to modify the analog data during the applicable time-slot.

Also, the Zeros Logic and Memory stage produces the IDENTIFY function. When time-slot 1 is encoded for IDENTIFY (column 10, row 3), this stage produces an output level, which connects the Column Data Switch and Row Data Switch to a coding network within the Readout System. Then, during time-slots 2 through 9, an analog current output is produced from the Column Data Switch and Row Data Switch which addresses the correct points in the Character Selection Matrix to display the word "IDENTIFY" on the CRT. The Zeros Logic and Memory stage is reset after each word by the Word Trigger pulse.

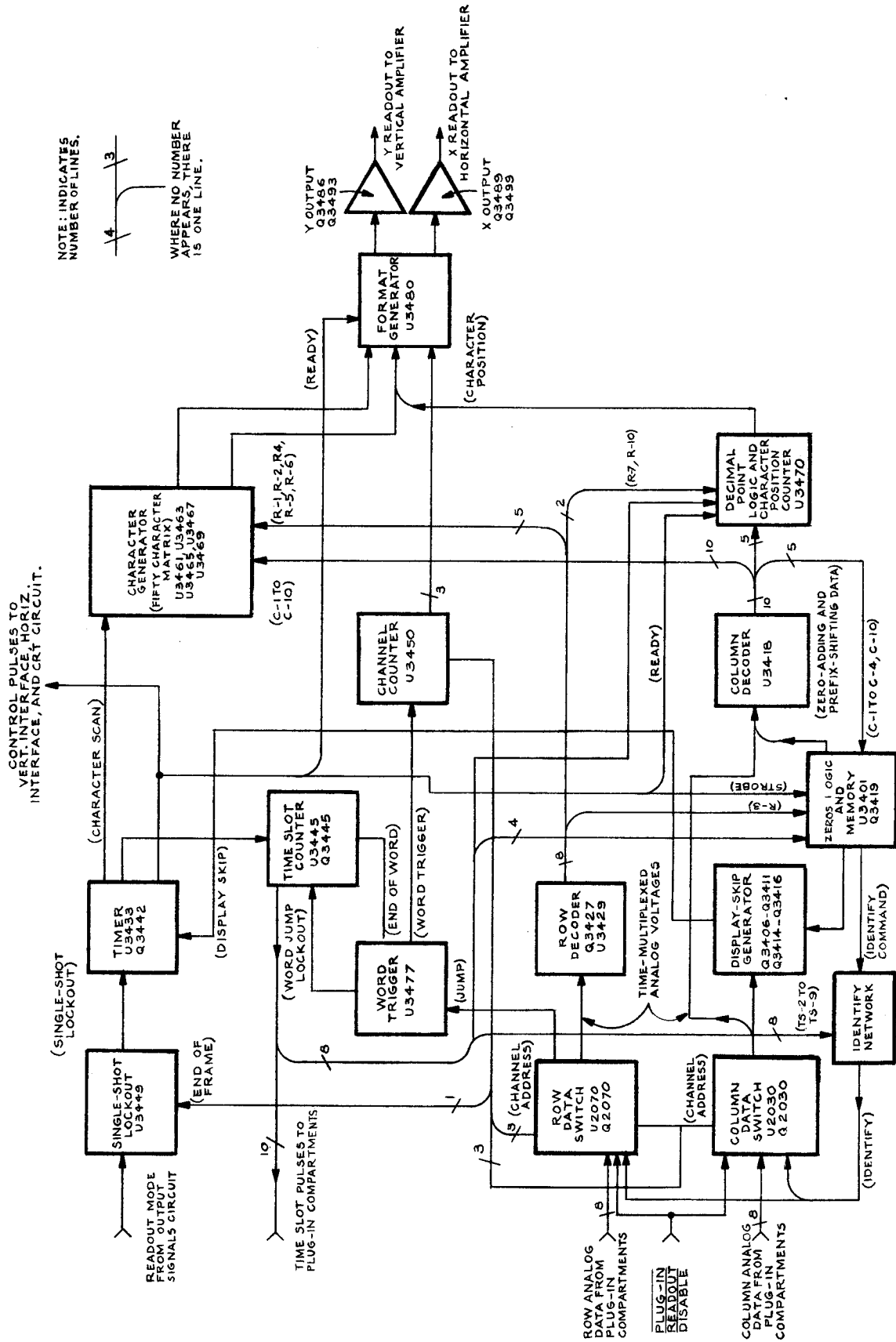

Fig. 2-35. Detailed block diagram of Readout System.

## Circuit Description—7704A Service

The Character Generator stages produce the characters which are displayed on the CRT. Any of the 50 characters shown on the Character Selection Matrix of Fig. 2-33 can be addressed by proper selection of the column and row currents. Only one character is addressable in any one time-slot; a space can be added into the displayed word by the Decimal Point Logic and Character Position Counter stage when encoded by the plug-in. The latter stage counts the number of characters generated and produces an output current to step the display one character position to the right for each character. In addition, the character position is advanced once during each of time-slots 1, 2, and 3, whether a character is generated during these time-slots or not. This action fixes the starting point of the standard-format display such that the first digit of the scaling factor always starts at the same point within each word regardless of the information encoded in time-slot 1, 2, or 3 preceding this digit. Also, by encoding row 10 and column 0 during any time-slot, a blank space can be added to the display. Decimal points can be added to the display at any time by addressing the appropriate row and column (see Character Selection Matrix for location of these decimal points). The Decimal Point Logic and Character Position Counter stage is reset after each word by the Word Trigger pulse.

The Format Generator stage provides the output signals to the vertical and horizontal deflection systems of the instrument to produce the character display. The binary Channel Address Code from the Channel Counter stage is connected to this stage, so that the display from each channel is positioned to the area of the CRT associated with the plug-in and channel originating the word (see Fig. 2-32). The positioning current or decimal point location current generated by the Decimal Point Logic and Character Position Counter stage is added to the Horizontal (X) signal at the input to the Format Generator stage to provide horizontal positioning of the characters within each word. The X- and Y-Readout signals are connected to the Horizontal Amplifier and Vertical Amplifier through the X- and Y-Buffer stages.

The Word Trigger stage produces a trigger from the End-of-Word pulse generated by the Time-Slot Counter stage after the tenth time-slot. This Word Trigger pulse advances the Channel Counter to display the information from the next channel or plug-in. It also provides a reset pulse to the Zeros Logic and Memory stage and the Decimal Point Logic and Character Position Counter stage. The Word Trigger stage can also be advanced to jump a complete word or a portion of a word when a Jump command is received from the Row Data Switch stage.

The Single-Shot Lockout stage allows the display sequence of the Readout System to be changed. Normally,

the Readout System operates in a free-running mode, so the waveform display is interrupted randomly to display characters. However, under certain conditions (such as single-shot photography), it is desirable that the Readout System operate in a triggered mode where the readout portion of the display is normally blanked out, but can be presented on command. The Readout Mode input from the Output Signals circuit determines the operating mode of the Readout System.

## Circuit Analysis of Readout System

The following analysis of the Readout System discusses the operation of each stage in detail. A complete schematic of the Readout System is shown on diagram 10 at the rear of this manual.

### Timer

Timer U3433 establishes the timing sequence for all circuits within the Readout System. This stage produces seven time-related output waveforms (see Fig. 2-36). The triangle waveform produced at pin 6 forms the basis for the remaining signals. The basic period of this triangle waveform is about 250 microseconds as controlled by RC network C3434-R3434. The triangle waveform is clipped and amplified by U3433 to form the trapezoidal output signal at pin 10. The amplitude of this output signal is exactly 15 volts as determined by U3433 (exact amplitude necessary to accurately encode data in plug-in units; see Encoding the Data). The Trigger output at pin 5 provides the switching signal for the Time-Slot Counter and Word Trigger stages.

The signals at pins 12, 13, 14, and 16 are produced only when the triangle waveform is on its negative slope and the trapezoidal waveform has reached the lower level. The timing sequence of these waveforms is important to the operation of the Readout System (see expanded waveforms in Fig. 2-37). The Z-Axis Inhibit at pin 14 is produced first. This negative-going signal provides a blanking pulse to the CRT Circuit (see diagram 14) to blank the CRT before the display is switched to the Readout System. It also produces the Strobe pulse through Q3442 and CR3442 to signal other stages within the Readout System to begin the sequence necessary to produce a character. The collector level of Q3442 is also connected to Character Generator No. 2, U3463, through CR3443. This activates U3463 during the quiescent period of the Strobe pulse (collector of Q3442 negative) and diverts the output current of Row Decoder U3429 to row 2. The purpose of this configuration is to prevent the Zeros Logic and Memory stage U3401 from storing incorrect data during the quiescent period of the Strobe pulse. When the Strobe pulse goes positive, CR3443 is reverse-biased to disconnect Q3442 from U3463 and allow the Row Decoder to operate in the normal manner.

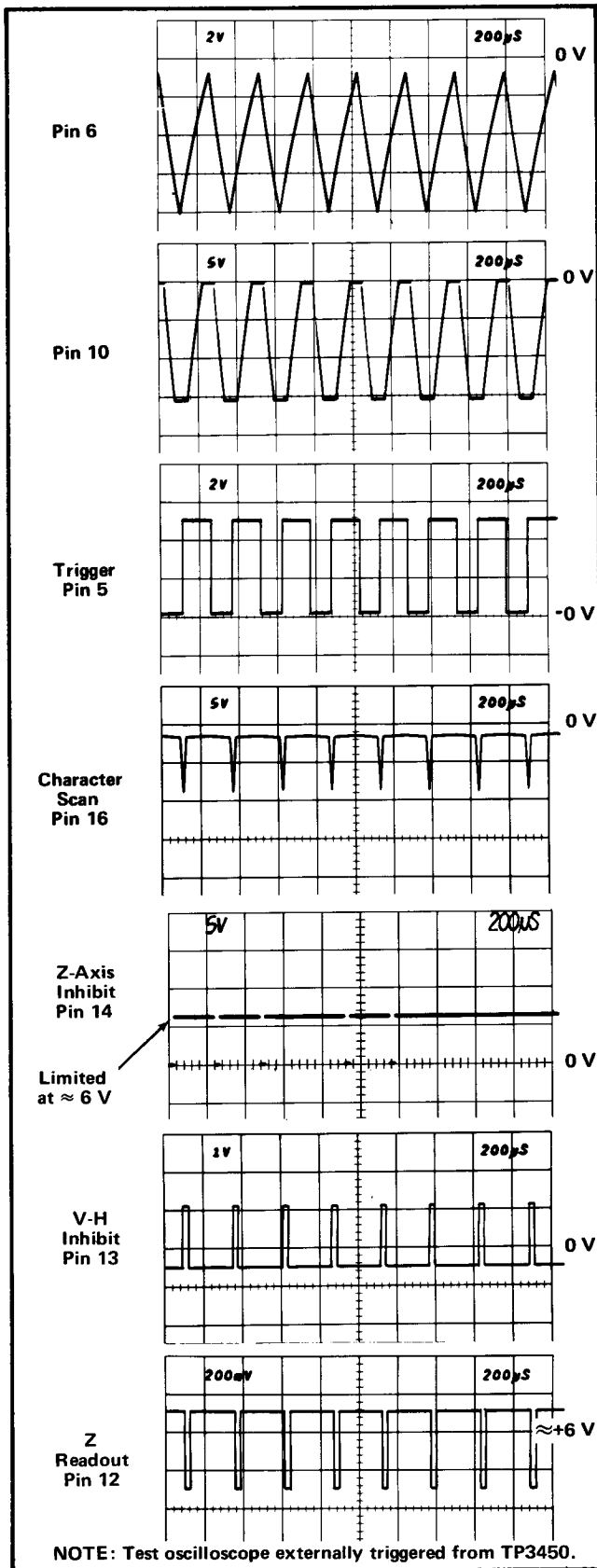

Fig. 2-36. Output waveforms of Timer stage.

The next signal to be produced is the V-H (Vertical-Horizontal) Inhibit at pin 13. This positive-going signal disconnects the plug-in signals from the vertical and horizontal deflection systems so the plug-in units do not control the position of the CRT beam during the readout display. The Ready signal derived from this output is connected to the Decimal Point Logic and Character Position Counter stage and the Format Generator stage.

The Z Readout output at pin 12 is produced next. This current is connected to the CRT Circuit to unblank the CRT to the intensity level determined by the READOUT intensity control. The Character Scan ramp at pin 16 started to go negative as this timing sequence began. However, character generation does not start until the readout intensity level has been established. The triangular Character Scan ramp runs from about  $-2$  volts to about  $-8.5$  volts, then returns back to the original level. This waveform provides the scanning signal for the Character Generator stages. Full Character Scan adjustment R3437 sets the DC level of the Character Scan ramp for complete characters on the display.

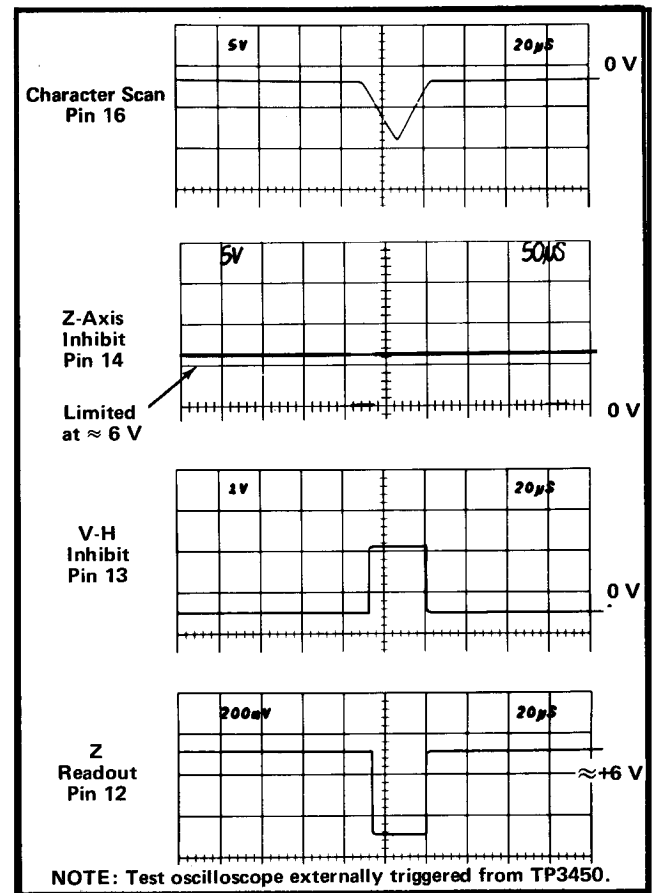

Fig. 2-37. Detail of output at pins 12, 13, 14, and 16 of U3433.



## Circuit Description—7704A Service

The Timer stage operates in one of two modes as controlled by the Display-Skip level at pin 4. The basic mode just described is a condition that does not occur unless all ten characters of each word (80 characters total) are displayed on the CRT. Under typical conditions only a few characters are displayed in each word. The Display-Skip level at pin 4 determines the period of the Timer output signal. When a character is to be generated, pin 4 is LO and the circuit operates as just described. However, when a character is not to be displayed, a HI level is applied to pin 4 of U3433 through CR3432 from the Display-Skip Generator stage. This signal causes the Timer to shorten its period of operation to about 210 microseconds. The waveforms in Fig. 2-38 show the operation of the Timer stage when the Display-Skip condition occurs for all positions in a word. Notice that there is no output at pins 12, 13, 14, and 16 under this condition. This means that the CRT display is not interrupted to display characters. Also notice that the triangle waveform at pin 6 does not go as far negative, and that the negative portion of the trapezoidal waveform at pin 10 is shorter. Complete details on operation of the Display-Skip Generator are given later.

The Timer operation is also controlled by the Single-Shot Lockout level at pin 2. If this level is LO, the Timer operates as just described. However, if the Single-Shot Lockout stage sets a HI level at this pin, the Timer stage is locked out and can not produce any output signals (see Single-Shot Lockout description for further information).

READOUT intensity control R5006 (see diagram 11) sets the intensity of the readout display independently of the A or B INTENSITY controls. The READOUT intensity control also provides a means of turning the Readout System off when a readout display is not desired. When R5006 is turned fully counterclockwise, switch S5006 opens. The current to pin 11 of U3433 is interrupted, and at the same time, a positive voltage is applied to pin 4 through CR3431. The positive voltage switches the stage to the same conditions as were present under the Display-Skip condition. Therefore, the CRT display is not interrupted to present characters. However, time-slot pulses continue to be generated.

### Time-Slot Counter

Time-Slot Counter U3445 is a sequential switch which directs the trapezoidal waveform input at pin 8 to one of its 10 output lines. These time-slot pulses are used to interrogate the plug-in units to obtain data for the Readout System. The Trigger pulse at pin 15 switches the Time-Slot Counter to the next output line; the output signal is sequenced consecutively from time-slot 1 through time-slot 10. Figure 2-39 shows the time relationship of the time-slot pulses. Notice that only one line carries a time-slot pulse at any given time. When time-slot 10 is completed, a negative-

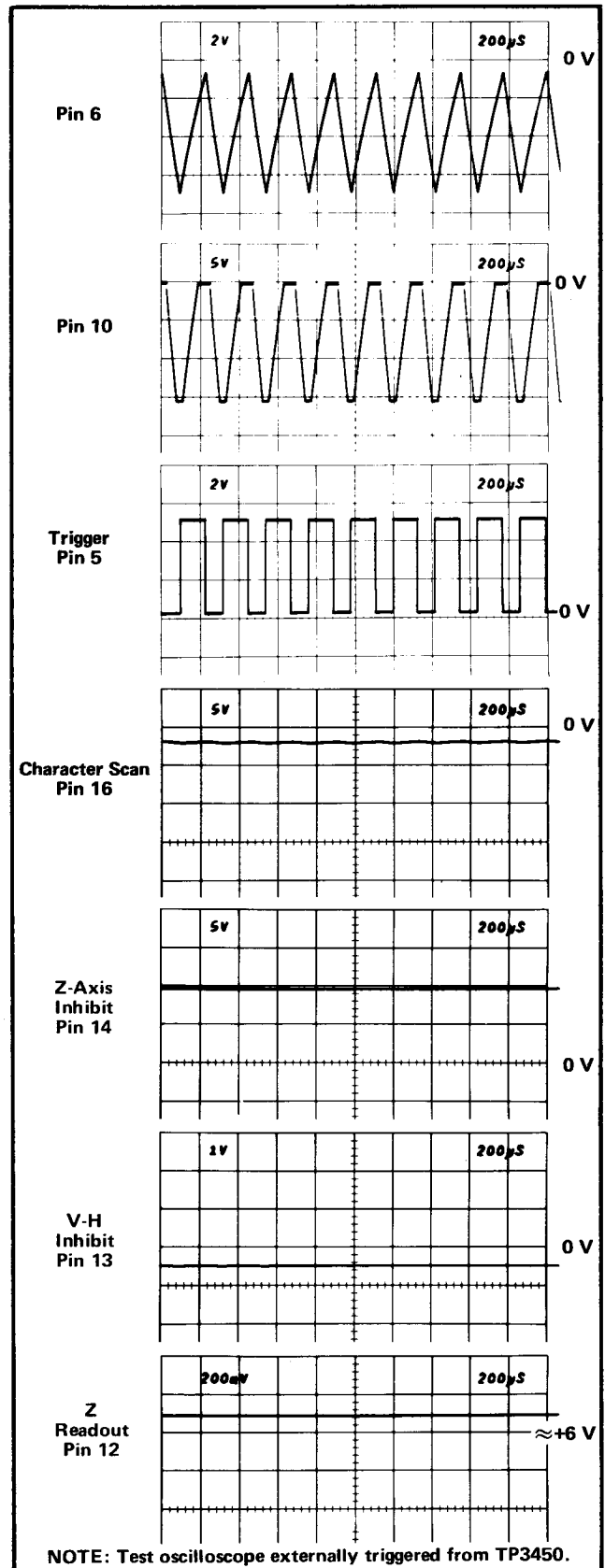

Fig. 2-38. Timer stage operation when Display-Skip condition occurs.

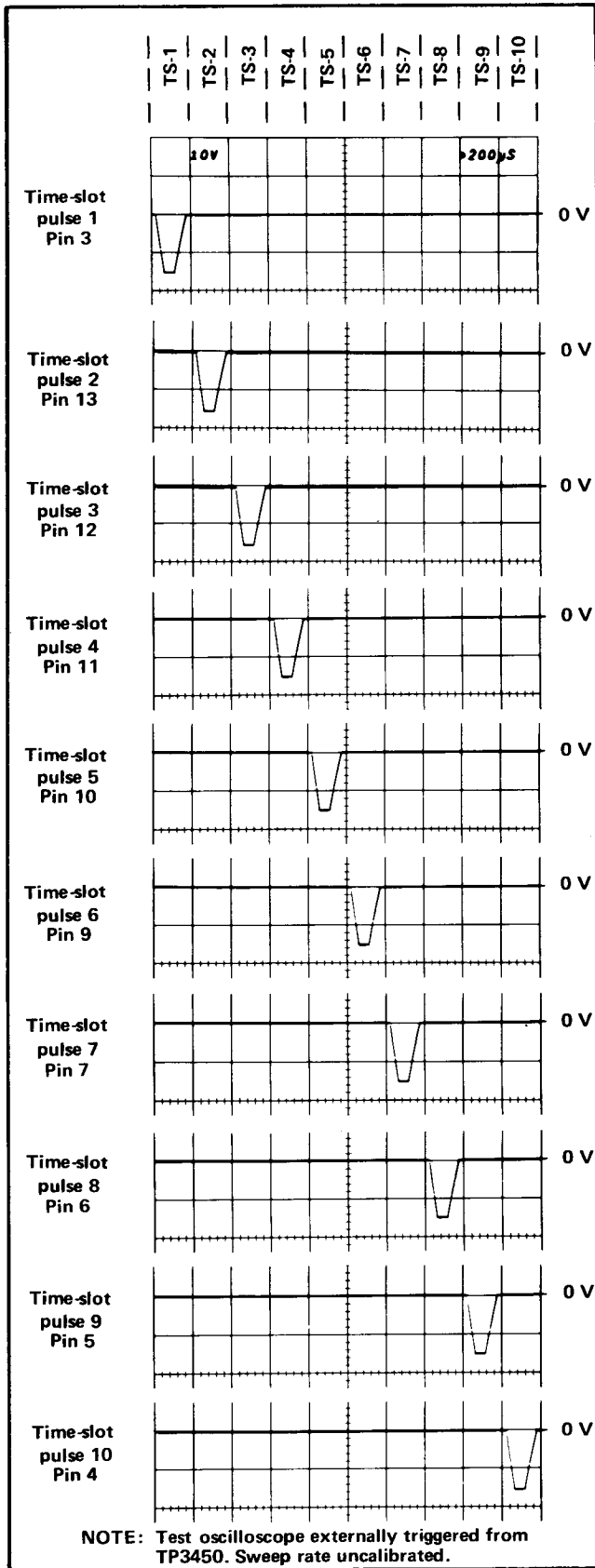

Fig. 2-39. Time relationship of the time-slot (TS) pulses produced by U3445.

going End-of-Word pulse is produced at pin 2. The End-of-Word pulse provides a drive pulse for the Word Trigger stage and also provides an enabling level to the Display-Skip Generator during time-slot 1 only.

Pin 16 is a reset input for the Time-Slot Counter. When this pin is held LO, the Time-Slot Counter resets to time-slot 1. The Time-Slot Counter can be reset in this manner only when a Jump Command is received by U3447A and B (see following discussion).

### Word Trigger

The Word Trigger stage is made up of U3447. Quietly, pin 8 of U3447C is LO as established by the operating conditions of U3447A-U3447B. Therefore, the LO End-of-Word pulse produced by the Time-Slot Counter results in a HI level at pin 10 of U3447C. This level is inverted by U3447D to provide a negative-going Word Trigger pulse to the Channel Counter.

A Word Trigger pulse is also produced by U3447D when a Jump Command is received at pin 5 of U3447B. This condition can occur during any time-slot (see Row Decoder for further information on origin of the Jump Command). U3447B and U3447A are connected as a bistable flip-flop. The positive-going Jump Command at pin 5 of U3447B produces a LO at pin 4. This LO is inverted by U3447A to produce a HI at pin 1, which allows pin 6 to be pulled HI through CR3447. The flip-flop has now been set and remains in this condition until reset, even though the Jump Command at pin 5 returns to its LO level. The HI output level at pin 1 turns on Q3445 to pull pin 16 of the Time-Slot Counter LO. This resets the Time-Slot Counter to time-slot 1 and holds it there until the Word Trigger is reset. At the same time, a HI level is applied to pin 4 of the Timer through CR3445 and CR3432. This HI level causes the Timer to operate in the Display-Skip mode, so a character is not generated.

The next Trigger pulse is not recognized by the Time-Slot Counter, since U3445 is locked in time-slot 1 by U3447. However, this Trigger pulse resets the Word Trigger stage through C3445. Pin 1 of U3447A goes LO to enable the Time-Slot Counter and Timer stages for the next time-slot pulse. Simultaneously, when U3447A switches output states, the resulting negative-going edge is connected to pin 8 of U3447C. This results in a negative-going Word Trigger output at pin 13 to advance the Channel Counter to the next word. When the next Trigger pulse is received at pin 15, the Time-Slot Counter returns to the normal sequence of operation and produces an output on the time-slot 1 line.

**Channel Counter**

Channel Counter U3450 is a binary counter which produces the Channel Address Code for the Column and Row Decoder stages and the Format Generator stage. This code instructs these stages to sequentially select and display the eight channels of data from the plug-ins. Table 2-3 gives the eight combinations of the Channel Address Code and the resultant channel selected with each combination.

**TABLE 2-3**  
**Channel Address Code**

| Pin 11<br>U3450 | Pin 8<br>U3450 | Pin 9<br>U3450 | Channel<br>Displayed        |
|-----------------|----------------|----------------|-----------------------------|
| LO              | LO             | LO             | Channel 2<br>Left Vertical  |
| LO              | LO             | HI             | Channel 1<br>Left Vertical  |
| LO              | HI             | LO             | Channel 2<br>Right Vertical |
| LO              | HI             | HI             | Channel 1<br>Right Vertical |
| HI              | LO             | LO             | Channel 2<br>A Horizontal   |
| HI              | LO             | HI             | Channel 1<br>A Horizontal   |
| HI              | HI             | LO             | Channel 2<br>B Horizontal   |
| HI              | HI             | HI             | Channel 1<br>B Horizontal   |

**Single-Shot Lockout**

U3449 makes up the Single-Shot Lockout stage. This stage allows a single readout frame (eight complete words) to be displayed on the CRT, after which the Readout System is locked out, so further readout displays are not presented until the circuit is reset. U3449C and U3449D are connected to form a bistable flip-flop. For normal operation, pin 8 of U3449C is pulled HI through R3449. This activates U3449C to result in a LO output level at pin 10, enabling the Timer stage to operate in the free-running manner described previously.

The output of the Single-Shot Lockout stage remains LO to allow U3433 to operate in the free-running mode until a LO is received at pin 8 of U3449C. When this occurs, the output level at pin 10 of U3449C does not change immediately. However, the Readout System is now enabled as far as the single-shot lockout function is concerned. If the Channel Counter has not completed word eight (Channel 1 of B Horizontal unit), the Readout System continues to operate in the normal manner. However, when word eight is completed, the positive-going End-of-Frame pulse is produced at pin 11 of U3450 as the Channel

Counter shifts to the code necessary to display word one. This pulse is coupled to pin 12 of U3449D. The momentary HI at pin 12 activates U3449D and its output goes LO to disable U3449C (pin 8 already LO). The output of U3449C goes HI to disable the Timer, so it operates in the Display-Skip mode. The HI at pin 10 of U3449C also holds U3449D enabled, so it maintains control of the flip-flop.

The Single-Shot Lockout stage remains in this condition until a positive-going trigger pulse is applied to pin 8 of U3449C. This trigger pulse produces a LO at pin 10 of U3449C to enable U3433 and disable U3449D. Now, the Timer can operate in the normal manner for another complete frame. When word eight is completed, the Channel Counter produces another End-of-Frame pulse to again lock out the Timer stage. (For further information on the Readout Mode, see the Output Signals description.)

**Encoding the Data**

Data is conveyed from the plug-in units to the Readout System in the form of an analog (current level) code. The characters that can be selected by the encoded data are shown on the Character Selection Matrix (see Fig. 2-33). Each character requires two currents to define it; these currents are identified as the column current and the row current, corresponding to the column and row of the matrix. The column and row data is encoded by programming the plug-in units. Figure 2-40 shows a typical encoding scheme using resistors for a voltage-sensing amplifier plug-in unit. Notice that the 10 time-slot (TS) pulses produced by the Time-Slot Counter stage are connected to the plug-in unit. However, time-slots 5, 6, 7, and 10 are not used by the plug-in unit to encode data when using the Standard Readout Format (see Table 2-2 for Standard Readout Format). The amplitude of the time-slot pulses is exactly -15 volts as determined by the Timer stage. Therefore, the resultant output current from the plug-in units can be accurately controlled by the programming resistors in the plug-in units.

For example, in Fig. 2-40 resistors R10 through R90 control the row analog data, which is connected back to the Readout System. Figure 2-41A shows an idealized output current waveform of row analog data, which results from the time-slot pulses. Each of the row levels of current shown in these waveforms corresponds to 100 microamperes of current. The row numbers on the left-hand side of the waveform correspond to the rows in the Character Selection Matrix (see Fig. 2-33). The row analog data is connected back to the Readout System via terminal B37 of the plug-in interface.

The Column analog data is defined by resistors R110 through R190. The program resistors are connected to the time-slot lines by switch closures to encode the desired data. The data as encoded by the circuit shown in Fig. 2-40

indicates a 100-microvolt sensitivity with the CRT display inverted and calibrated vertical deflection factors. This results in the idealized output current waveforms shown in Fig. 2-41B at the column analog data output, terminal A37 of the plug-in interface.

Resistor R111, connected between time-slot 1 and the column analog data output, encodes two units of current during time-slot 1. Referring to the Character Selection Matrix, two units of column current, along with the two units of row current encoded by resistor R10 (row 3), indicates that two zeros should be added to the display. Resistor R120 adds one unit of column current during time-slot 2 and, along with the one unit of current from the row output, the Readout System is instructed to add an invert arrow to the display. Resistor R130 is not connected to the time-slot 3 line, since the vertical deflection factors are calibrated. Therefore, there is no column current output during this time-slot and no display on the CRT (see Display-Skip Generator for further information).

During time-slot 4, two units of column current are encoded by R140. There is no row current encoded during this time-slot; this results in the numeral 1 being displayed on the CRT. Neither row nor column analog data is encoded during time-slots 5, 6, and 7 as defined by the Standard Readout Format. During time-slot 8, two units of column current and three units of row current are encoded by resistors R181 and R80, respectively. This addresses the  $\mu$  prefix in the Character Selection Matrix.

The final data output is provided from time-slot 9 by R190 connected to the column output and R90 to the row output. These resistors encode three units of column current and four units of row current to cause a V (volts) to be displayed. Time-slot 10 is not encoded in accordance with the Standard Readout Format. The resultant CRT readout will be  $\nabla 100 \mu V$ .

In the above example, the row analog data was programmed to define which row of the Character

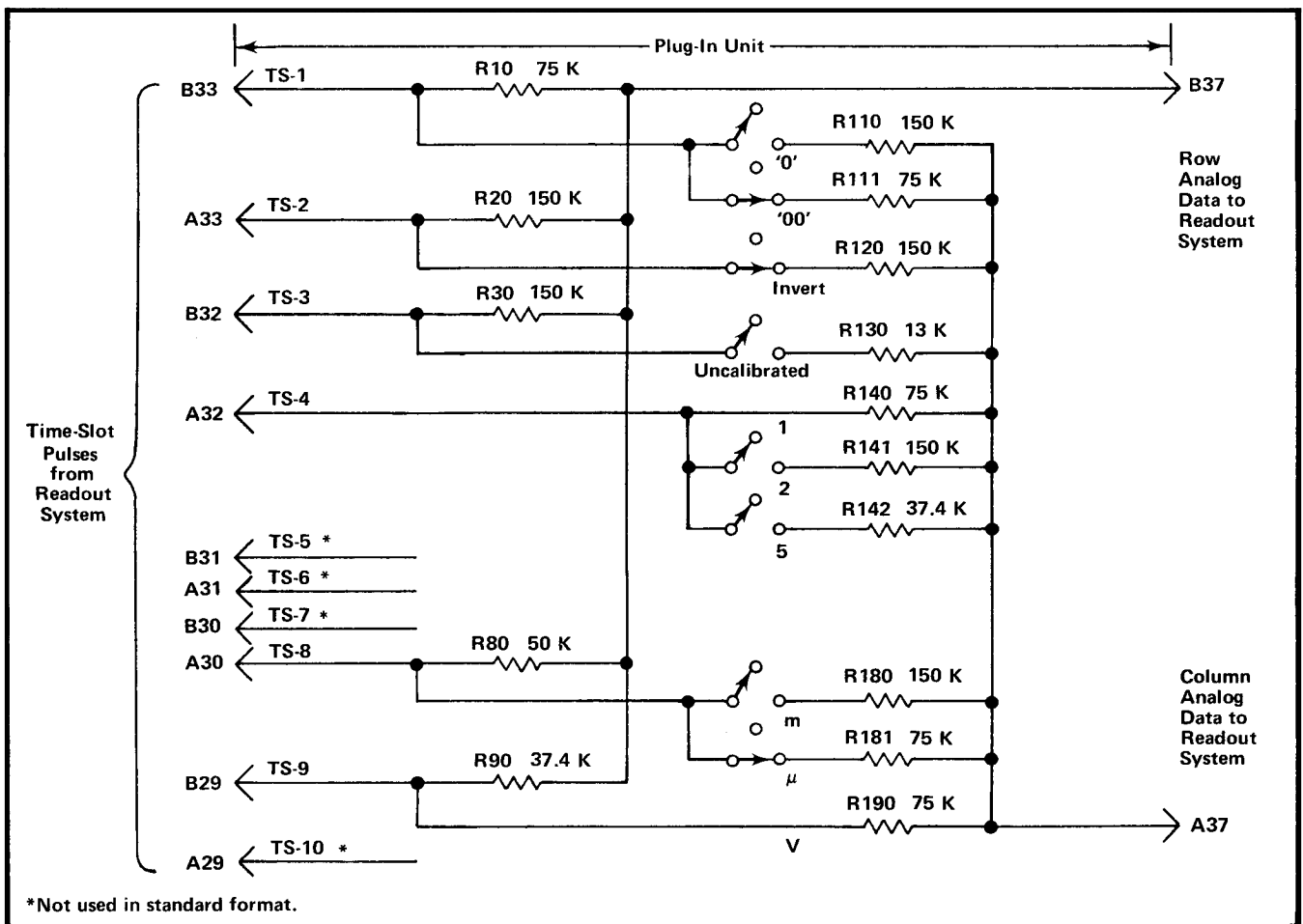

Fig. 2-40. Typical encoding scheme for voltage-sensing plug-in unit. Coding shown for deflection factor of 100 microvolts.

## Circuit Description—7704A Service

Selection Matrix was addressed to obtain information in each time-slot. The column data changes to encode the applicable readout data as the operating conditions change. For example, if the variable control of the plug-in unit was activated, R130 would be connected between time-slot 3 and the column analog data output line. This encodes 10 units of column current (see shaded area in time-slot 3 of the waveform shown in Fig. 2-41B). Since one unit of row current is also encoded during this time-slot by R30, a > symbol is added to the display. The CRT readout will now show  $\downarrow >100 \mu\text{V}$ . In a similar manner, the other switches can change the encoded data for the column output and thereby change the readout display. See the descriptions which follow for decoding this information.

The column analog data encoded by most plug-in units can be modified by attenuator probes connected to the input connectors of amplifier plug-in units. A special coding ring around the input connector of the plug-in unit senses the attenuation ratio of the probe (with readout-coded probes only). The probe contains a circuit which provides additional column current. For example, if a 10X attenuator probe is connected to a plug-in unit encoded for 100 microvolts as shown in Fig. 2-40, an additional unit of current is added to the column analog data during time-slot 1. Since two units of current were encoded by R111 (see Fig. 2-40), this additional current results in a total of three units of column analog current during this time-slot. Referring to the Character Selection Matrix, three units of column current, along with the two units of row current encoded by R10, indicates that the prefix should be shifted one column to the left. Since this instruction occurs in the same time-slot that previously indicated that two zeros should be added to the display and only one instruction can be encoded during a time-slot, the zeros do not appear in the display. The CRT readout will now be changed to 1 mV (readout program produced by plug-in same as for previous example).

Likewise, if a 100X readout-coded probe is connected to the input of the plug-in unit, the column current during time-slot 1 will be increased two units for a total of four units of column current. This addresses an instruction in the Character Selection Matrix to shift the prefix and add one zero to the display. The resultant CRT readout with the previous program is 10 mV.

Three other lines of information are connected from the plug-in compartments to the Readout System. The column and row analog data from Channel 2 of a dual-channel plug-in are connected to the Readout System through terminals A38 and B38 of the plug-in interface, respectively. Force readout information is encoded on terminal A35; the function of this input is described under Column and Row Data Switches.

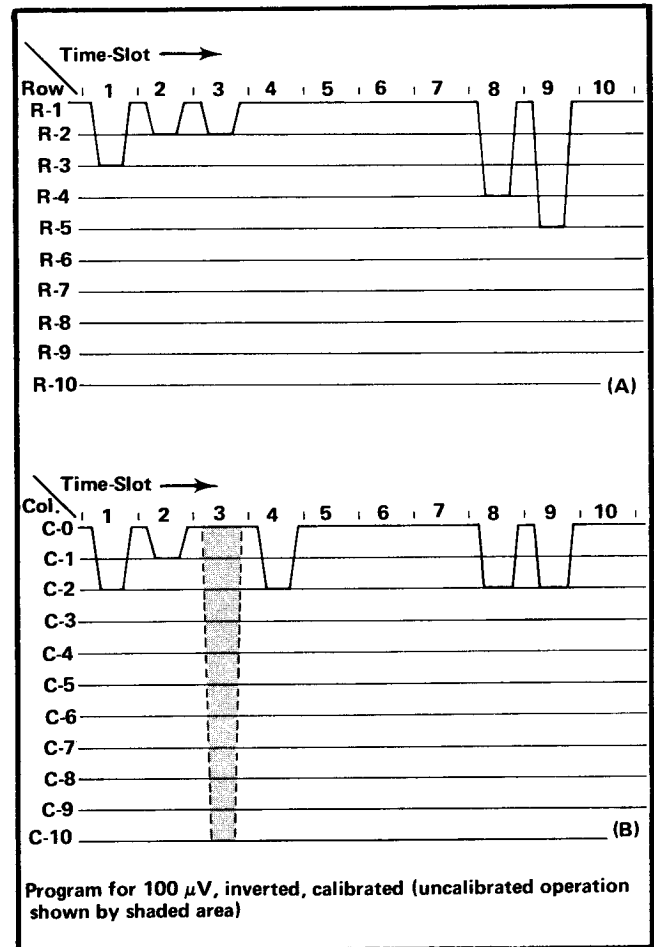

Fig. 2-41. Idealized current waveforms of: (A) Row analog data, (B) Column analog data.

The preceding information gave a typical example of encoding data from an amplifier plug-in unit. Specific encoding data and circuitry is shown in the individual plug-in unit manuals.

### Column and Row Data Switches

The encoding data from the plug-in units is connected to the Column and Row Data Switch stages. A column-data line and a row-data line convey analog data from each of the eight data sources (two channels from each of the four plug-in compartments).

The Column Data Switch U2030 and the Row Data Switch U2070 receive the Channel Address Code from the Channel Counter. This binary code directs the Column Data Switch and the Row Data Switch as to which channel should be the source of the encoding data. Table 2-3 gives the eight combinations of the Channel Address Code and the resultant channel selected with each combination. These stages have nine inputs and provide a

time-multiplexed output at pin 7, which includes the information from all of the input channels. Eight of the nine inputs to each stage originate in the plug-in units; the ninth input comes from a special data-encoding network composed of resistors R2058 through R2069 and R2070 through R2079 (see Zeros Logic and Memory description for further information on ninth channel).

In addition to the encoding data inputs from the plug-in units, inputs are provided to the Column Data Switch from the VERTICAL MODE and HORIZONTAL MODE switches to inhibit the readout for any plug-in unit(s) not selected for display. When a plug-in unit is selected, the respective mode input is HI to forward bias the associated diodes; CR2031-CR2033, CR2035-CR2037, CR2041-CR2043, or CR2045-CR2047. The forward-biased diodes cause the channel switches to bypass the encoded data from the opposite channel. However, since it may be desired to display information from special-purpose plug-in units (even though they do not produce a normal waveform display on the CRT), a feature is provided to over-ride the mode inhibit. This is done by applying a LO to the associated Force Readout input. The LO level diverts the HI mode-inhibit current and allows the data from this plug-in unit to reach the Column Data Switch, even though it has not been selected for display by the mode switches.

The outputs of U2070 and U2030 are connected to the rest of the Readout System through Q2070 and Q2030, respectively and through the Main Interconnect. Q2070 and Q2030 are normally forward biased by the positive voltage level established at their bases by divider R2051-CR2051-R2053. The Plug-In Readout Disable level from the Main Interconnect goes LO to reverse-bias CR2051-Q2030-Q2070. This disconnects U2030 and U2070 from the Readout System to allow the Main Interconnect to provide time-multiplexed analog voltages for the readout display.

Row Match adjustment R3422 sets the gain of the Row Data Switch to match the gain of the Row Decoder for correct output. Column Match adjustment R3407 performs the same function for the Column Data Switch stage.

#### Display-Skip Generator

The Display-Skip Generator is made up of Q3406, Q3411, Q3414, and Q3416. This stage monitors the time-multiplexed column data at the output of the Column Data Switch during each time-slot to determine if the information at this point is valid data that should result in a CRT display. Quiescently, there is about 100 microamperes of current flowing through R3407 from Q3419 and the Zeros Logic and Memory stage. (The purpose of this quiescent current will be discussed in connection with the Zeros Logic and Memory stage.) This current biases Q3406A so that its base is about 0.2 volt more positive

than the base of Q3406B in the absence of column data. Therefore, since Q3406A and Q3406B are connected as a comparator, Q3406A will remain on unless its base is pulled more negative than the base of Q3406B.

The analog data output from the Column Data Switch produces a 0.5-volt (approximately) change for each unit of column current that has been encoded by the plug-in unit. Whenever any information appears at the output of the Column Data Switch, the base of Q3406A is pulled more negative than the base of Q3406B, resulting in a negative (LO) Display-Skip output to the Timer stage through Q3416. Recall that a LO was necessary at the skip input of the Timer so it could perform the complete sequence necessary to display a character.

Q3411-Q3414 also provide Display-Skip action. The End-of-Word level connected to their emitters is LO only during time-slot 1. This means they are enabled only during this time-slot. These transistors allow the Zeros Logic and Memory stage to generate a Display-Skip signal during time-slot 1 when information that is not to be displayed on the CRT has been stored in memory (further information is given under Zeros Logic and Memory description).

#### Column and Row Decoders

The Column Decoder U3418 and Row Decoder U3429 sense the magnitude of the analog voltages at their inputs (pin 10) and produce a binary output on one of ten lines corresponding to the column or row data encoded by the plug-in unit. These outputs provide the Column Digital Data and Row Digital Data, which is used by the Character Generator stages to select the desired character for display on the CRT. The column and row data is also used throughout the Readout System to perform other functions.

The input current at pin 9 of the Column Decoder stage is steered to only one of the ten Column Digital Data outputs. The size of the displayed character is determined by the value of R3418. When a Display-Skip signal is present (collector of Q3416 HI), pin 9 is pulled HI through CR3416. This ensures that no current is connected to the Character Generator stage under this condition. Notice the corresponding input on the Row Decoder. This input is connected to ground and causes only one of the ten row outputs to saturate to ground.

The network at the input of the Row Decoder, made up of Q3427 and its associated components, is a Row-14 detector which produces the Jump Command. This row current is encoded by special-purpose plug-ins to cause all or part of a word to be jumped. Whenever row 14 (thirteen units of row current, 1.3 milliamperes) is encoded, the base of Q3427 is pulled negative enough so that this transistor is reverse biased to produce a HI Jump Command output at

**Circuit Description—7704A Service**

its collector. This Jump Command is connected to the Word Trigger stage to advance the Channel Counter to the next word and to reset the Time-Slot Counter to time-slot 1.

**Zeros Logic and Memory**

The Zeros Logic and Memory stage U3401 stores data encoded by the Plug-in units to provide zeros-adding and prefix-shifting logic for the Readout System. The Strobe pulse at pin 15 goes positive when the data has stabilized and can be inspected. This activates the Zeros Logic and Memory stage so that it can store the encoded data. A block representation of the memory sequence is shown in Fig. 2-42.

Typical output waveforms for the five possible input conditions that can occur are shown in Fig. 2-43. When time-slot 1 occurs, a store command is given to all of the memories. If the plug-in unit encoded data for column 1, 2, 3, 4, or 10 during time-slot 1, the appropriate memory (or memories) is set. Notice that row 3 information from the Row Decoder must also be present at pin 16 for data to be stored in the memory of U3401.

If data was encoded during time-slot 1, a negative-going output is produced at pin 7 while the memories are being set. This negative-going pulse is connected to the base of Q3414 in the Display-Skip Generator to produce a Display-Skip output. Since the information encoded during time-slot 1 was only provided to set the memories and not intended to be displayed on the CRT at this time, the Display-Skip output prevents a readout display during this time-slot.

During time-slot 5, memory A is interrogated. If information was stored in this memory, a positive-going output is produced at pin 7. This pulse is connected to pin 10 of the Column Decoder through Q3419 to add one unit of current at the input of the Column Decoder. This produces a zero after the character displayed during time-slot 4. During time-slot 6, memory B is interrogated to see if another zero should be added. If another zero is necessary, a second positive output is produced at pin 7, which again results in a column 1 output from the Column Decoder and a second zero in the CRT display.

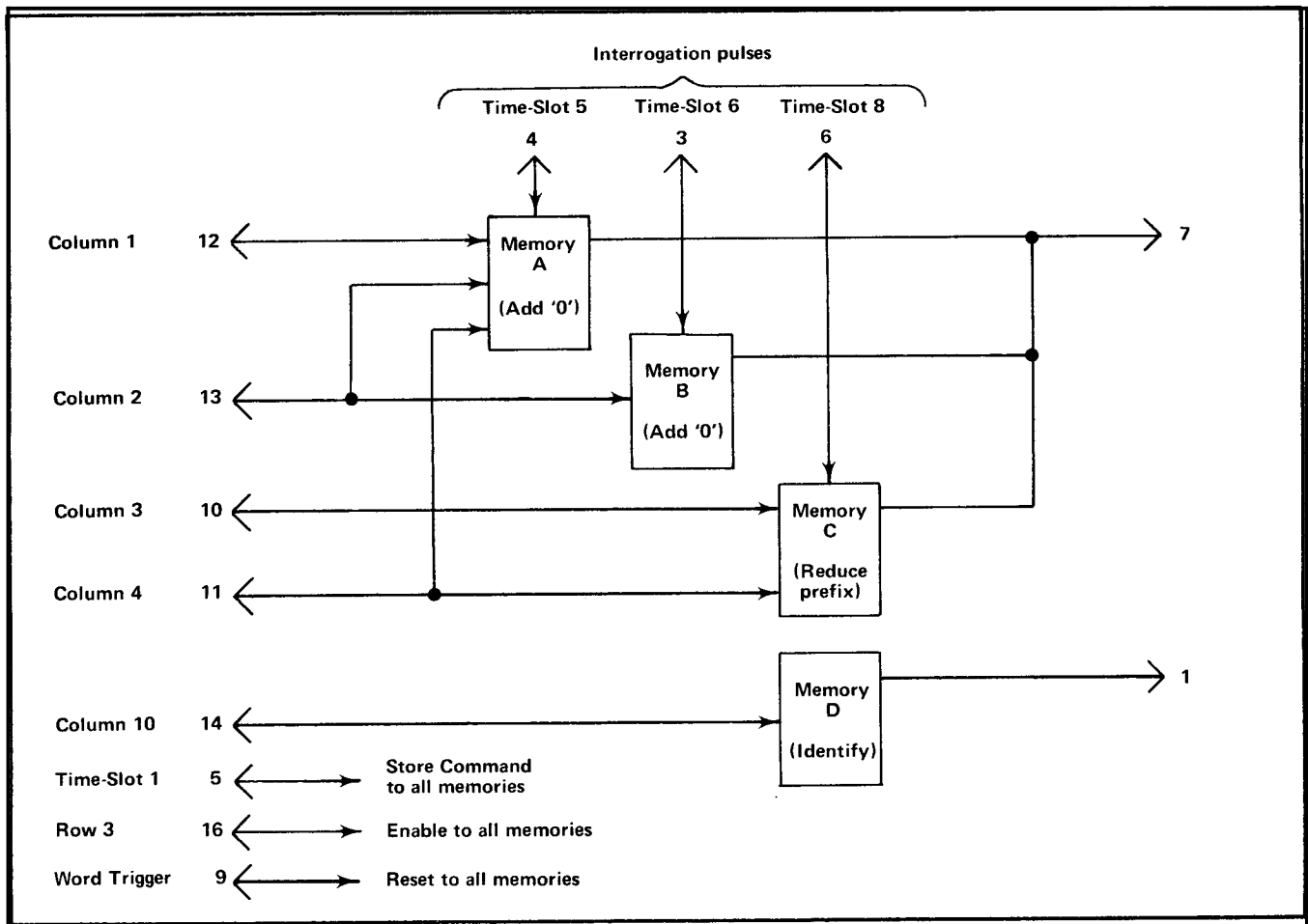

Fig. 2-42. Block representation of memory sequence in U3401.

Finally, memory C is interrogated during time-slot 8 to obtain information on whether the prefix should be changed, or left at the value that was encoded. If data has been encoded that calls for a shift in prefix, a negative-going output level is produced at pin 7. This negative level subtracts one unit of column current from the data at the input to the Column Decoder. Notice on the Character Selection Matrix of Fig. 2-33 that when row 4 is programmed, a reduction of one column results in a one-column shift of the prefix. For example, with the 100  $\mu$ V program shown in Fig. 2-40, if the data received from the plug-in called for a shift in prefix, the CRT readout would be changed to 1 mV (zeros deleted by program; see Encoding the Data).

The 100 microamperes of quiescent current through R3407 provided by Q3419 (see Display-Skip Generator) allows the prefix to be shifted from m (100 microamperes column current, column 1) to no prefix (zero column current, column zero) so only the unit of measurement encoded during time-slot 9 is displayed. Notice that reducing the prefix program from column 1 to column 0 programs the Readout System to not display a character at this readout location.

A further feature of the Zeros Logic and Memory is the Identify function. If 10 units of column current are encoded by the plug-in unit along with row 3 during time-slot 1, the Zeros Logic and Memory produces a negative-going output pulse at pin 1 to switch the Column Data Switch and Row Data Switch to the ninth channel. Then, time-slot pulses 2 through 9 encode an output current through resistors R2058-R2069 for column data and R2070-R2079 for row data. This provides the currents necessary to display the word IDENTIFY in the word position allotted to the channel that originated the Identify command. After completion of this word, the Column Data Switch and Row Data Switch continue with the next word in the sequence.

The Word Trigger signal from the Word Trigger stage is connected to pin 9 of U3401 through C3401. At the end of each word of readout information, this pulse goes LO. This erases the four memories in the Zeros Logic and Memory in preparation for the data to be received from the next channel.

#### Character Generators

The Character Generator stage consists of five similar integrated circuits (U3461 through U3469), which generate the X (horizontal) and Y (vertical) outputs at pins 16 and 1, respectively, to produce the character display on the CRT. Each integrated circuit can produce 10 individual characters. U3461 (designated "Numerals") can produce the numerals 0 through 9 shown in row 1 of the Character Selection Matrix (Fig. 2-33). U3463 can produce the

symbols shown in row 2 of the Character Selection Matrix and U3465 produces the prefixes and some letters, used as prefixes, shown in row 4. U3467 and U3469 produce the remaining letters shown in rows 5 and 6 of the Character Selection Matrix.

All of the Character Generator stages receive the Column Digital Data from the Column Decoder U3418 in parallel. However, only one of the Character Generators receives row data at a particular time and only the stage receiving this row data is activated. For example, if column 2 is encoded, the five Character Generators are enabled so that either a 1, <,  $\mu$ , V, or an N can be produced. If row 4 has been encoded at the same time, only the Prefix Character Generator U3465 will produce an output to result in a " $\mu$ " being displayed. The activated Character Generator provides current outputs for the Format Generator to produce the selected character on the CRT. In a similar manner, any of the characters shown in the Character Selection Matrix can be displayed by correct addressing of the row and column.

#### Decimal Point Logic and Character Position Counter

Decimal Point Logic and Character Position Counter U3470 performs two functions. The first function is to add a staircase current to the X (horizontal) signal to space the characters horizontally on the CRT. After each character is generated, the negative-going edge of the Ready signal at pin 5 advances the Character Position Counter. This produces a current step output at pin 3 which, when added to the X signal, causes the next character to be displayed one character space to the right. This stage can also be advanced when a Space instruction is encoded so a space is left between the displayed characters on the CRT. Row 10 information from the Row Decoder is connected to pin 4 of U3470. When row 10 and column 0 are encoded, the output of this stage advances one step to move the next character another space to the right. However, under this condition, no display is produced on the CRT during this time-slot, since the Character Generators are not activated.

Time-slot pulses 1, 2, and 3 are also connected to pin 4 of U3470 through VR3470, VR3471, and VR3472 respectively and R3470-R3473. This configuration adds a space to the displayed word during time-slots 1, 2, and 3 even if information is not encoded for display during these time-slots. With this feature, the information displayed during time-slot 4 (scaling data) always starts in the fourth character position whether data has been displayed in the previous time-slots or not. Therefore, the resultant CRT display does not shift position as normal-invert or cal-uncal information is encoded. The Word Trigger pulse connected to pin 8 resets the Character Position Counter to the first character position at the end of each word.



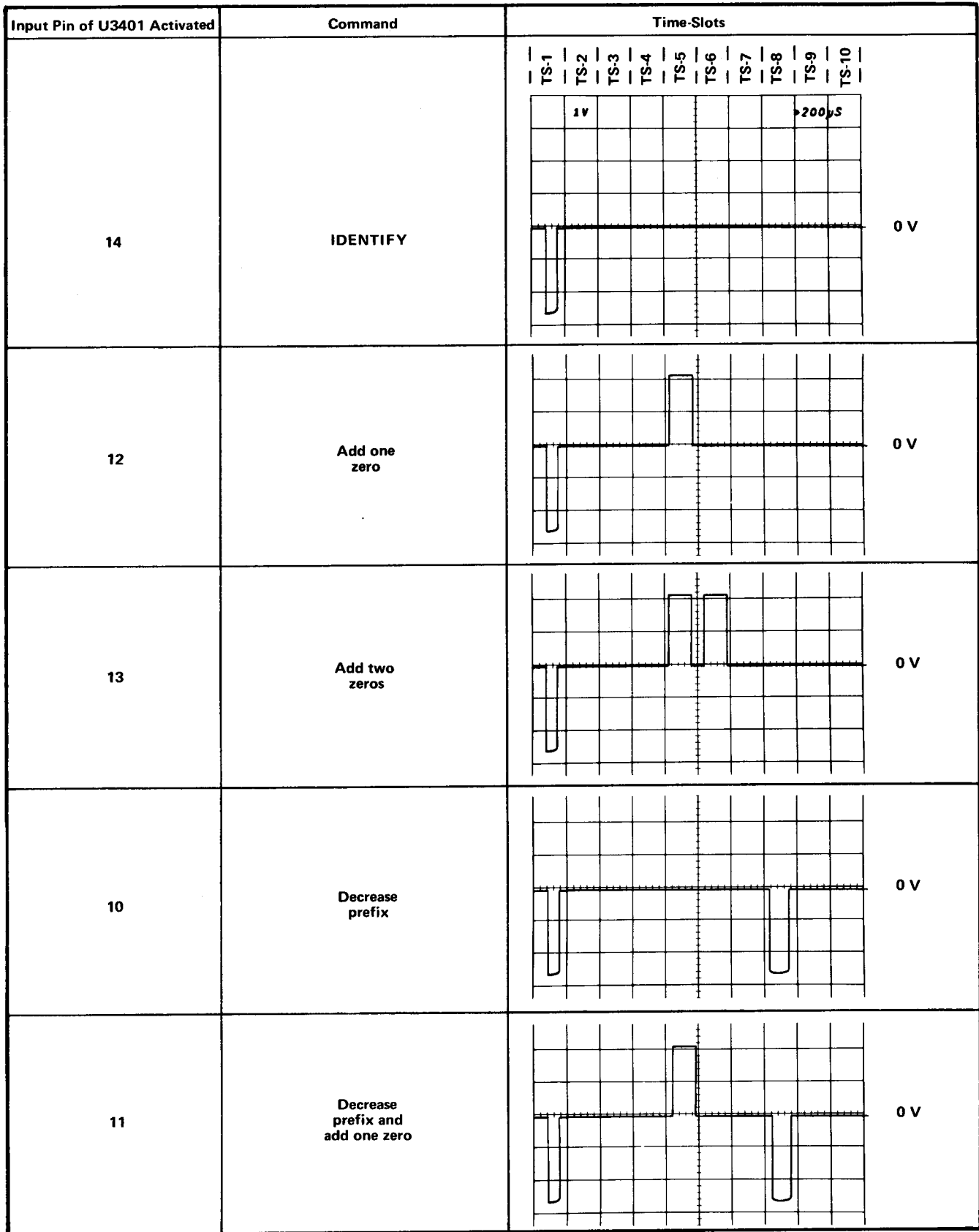

Fig. 2-43. Typical output waveforms for Zeros Logic and Memory stage operation (at pin 7 of U3401).

The Decimal Point Logic portion of this stage allows decimal points to be added to the CRT display. With the Standard Readout Format, row 7, encoded coincident with columns 3 through 7, addresses a decimal at one of the five locations identified in row 7 of the Character Selection Matrix (Fig. 2-33). This instruction refers to the decimal point location in relation to the total number of characters possible in one word (see Fig. 2-44). For example, column 3 encoded with row 7 during time-slot 1 places a decimal point in location No. 3. As shown in Fig. 2-44, this displays a decimal point after the third character that can be displayed on the CRT. (The first three time-slots produce a space whether data is encoded or not; see previous paragraph.) The simultaneous application of row-7 data to the Y-input of the Format Generator through R3477 raises the decimal point so it appears between the displayed characters.

When decimal-point data is encoded, the CRT is unblanked so a readout display is presented. However, since row 7 or row 8 does not activate any of the five Character Generators, the CRT beam is deflected vertically a fixed amount to display the decimal point between the characters along the bottom line of the readout word. After the

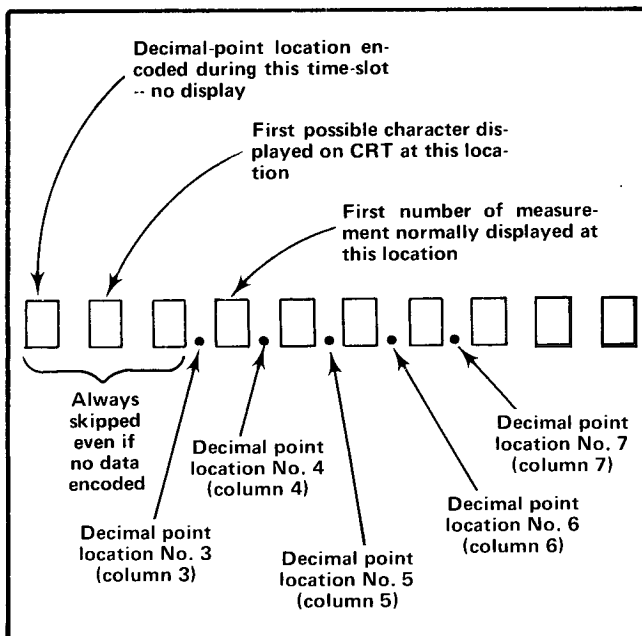

Fig. 2-44. Readout word relating 10 possible character locations to the decimal point instructions that can be encoded, and the resultant CRT display.

decimal point is produced in the addressed location, the CRT beam returns to the location indicated by the Character Position Counter to produce the remainder of the display.

#### Decimal-Point Character

In instruments serial number B050000 and higher, the addition of R3474-R3478-R3479 allows a decimal point to

be encoded for special formats. This decimal point can be placed in any character position by encoding column 9 with row 8 during the corresponding time slot. The application of row 8 data to the X and Y input of the Format Generator through R3478 and R3479 respectively, provides horizontal and vertical positioning current for the decimal points.

#### Format Generator

The X- and Y- deflection signals produced by the Character Generator stage are connected to pins 2 and 7, respectively, of Format Generator U3480. The Channel Address Code from the Channel Counter is also connected to pins 1, 8, and 15 of this stage. The Channel Address Code directs the Format Generator to add current to the X and Y signals to deflect the CRT beam to the area of the CRT associated with the plug-in channel that originated the information (see Fig. 2-32). The Channel Address Code and the resultant word positions are shown in Table 2-3. In addition, the character position current from the Decimal Point Logic and Character Position stage is added to the X (horizontal) input signal to space the characters horizontally on the CRT (see previous discussion). The Ready signal at pin 13 (coincident with the V-H Inhibit output) activates this stage when a character is to be displayed on the CRT.

#### Y-Output Amplifier

The Y-output signal at pin 6 of Format Generator U3480 is connected to the Y-Output Amplifier Q3486-Q3493. This stage provides a low impedance load for the Format Generator while providing isolation between the Readout System and the driven circuit(s). Vertical Separation adjustment R3490 changes the gain of this stage to control the vertical separation between the readout words displayed at the top and bottom of the graticule area.

#### X-Output Amplifier

The X-Output Amplifier Q3489-Q3499 operates like the Y-Output Amplifier, to provide the horizontal deflection from the readout signal available at pin 4 of U3480. The gain of this stage is fixed by the values of the resistors in the circuit.

#### Display Sequence

Figure 2-45 shows a flow chart for the Readout System. This chart illustrates the sequence of events that occurs in the Readout System each time a character is generated and displayed on the CRT.

### MAIN INTERCONNECT 11

The Main Interconnect diagram shows the signal and power interconnections between the Acquisition and Display Units.

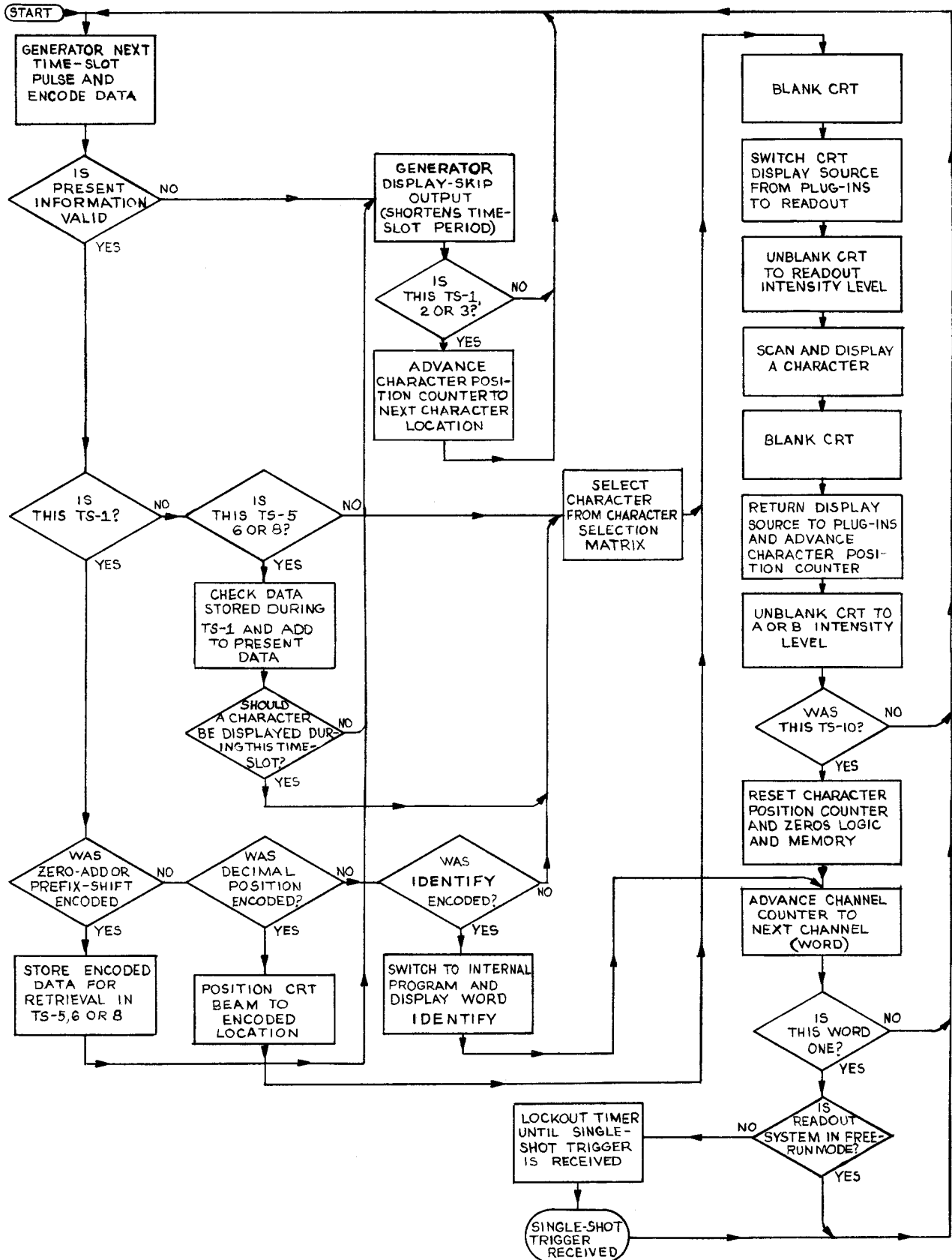

Fig. 2-45. Flow chart for character generation by the Readout System.

## VERTICAL AMPLIFIER

12

The Vertical Amplifier circuit provides final amplification for the vertical signal before it is applied to the vertical deflection plates of the CRT. This circuit includes the delay line and an input to produce the vertical portion of a readout display. The BEAM FINDER switch limits the dynamic range of this circuit to compress an over-scanned display within the CRT viewing area. Figure 2-46 shows a detailed block diagram of the Vertical Amplifier circuit.

## Delay Line

Delay Line DL5050 provides approximately 90 nanoseconds of delay for the vertical signal to allow the horizontal circuits time to initiate a sweep before the vertical signal reaches the vertical deflection plates of the CRT. This allows the instrument to display the leading edge of the signal when using internal triggering. The delay line is a coaxial type that does not produce preshoot or phase distortion in the CRT display.

## Input Balance

The Input Balance stage provides vertical trace centering and an input from the Readout System to the Vertical Amplifier circuit. Q4479-Q4485 are connected as a paraphase amplifier. Centering adjustment R4493 determines the voltage level at the base of Q4485 to set the quiescent DC levels at pins 2 and 4 of U4413. R4493 is adjusted to vertically center the trace when the inputs to this circuit are at the same potential. The Y-Readout signal from the

Readout System is connected to the base of Q4479 through common-base connected Q4470. The paraphase amplifier converts the single-ended Y-Readout signal to a push-pull signal to drive the Output Amplifier.

## Output Amplifier

The Output Amplifier stage is made up of integrated circuit U4413. The circuitry shown within the shaded area on diagram 12 is a representation of the internal circuitry of U4413. Notice that U4413 is made up of three similar push-pull stages. Each stage consists of a common-emitter transistor pair driving a pair of low input impedance, common-base transistors. R4439 sets the gain of the first stage. Thermistor RT4438 provides thermal compensation for the Vertical Amplifier circuit. RC network R4423-C4423-R4424-C4424-R4427-C4427 provides frequency compensation for the first stage. Gain adjustment R4406 sets the gain of the second stage to determine the overall gain of the Vertical Amplifier. C4401-L4401-R4404-L4410-L4411 provide fast-rise frequency compensation for the second amplifier stage. Bias adjustment R4415 sets the voltage level at pin 10 of U4413 to adjust the third amplifier stage for maximum voltage gain. RC networks R4455-C4455-R4453-C4453-R4451-C4451 and R4465-C4465-R4463-C4463-R4461-C4461 provide frequency compensation for the third stage.

BEAM FINDER switch S5007A disconnects the ground return for the third stage in U4413 to provide the beam finder function. This limits the dynamic range of this stage by limiting its current, so the display is compressed vertically within the graticule area.

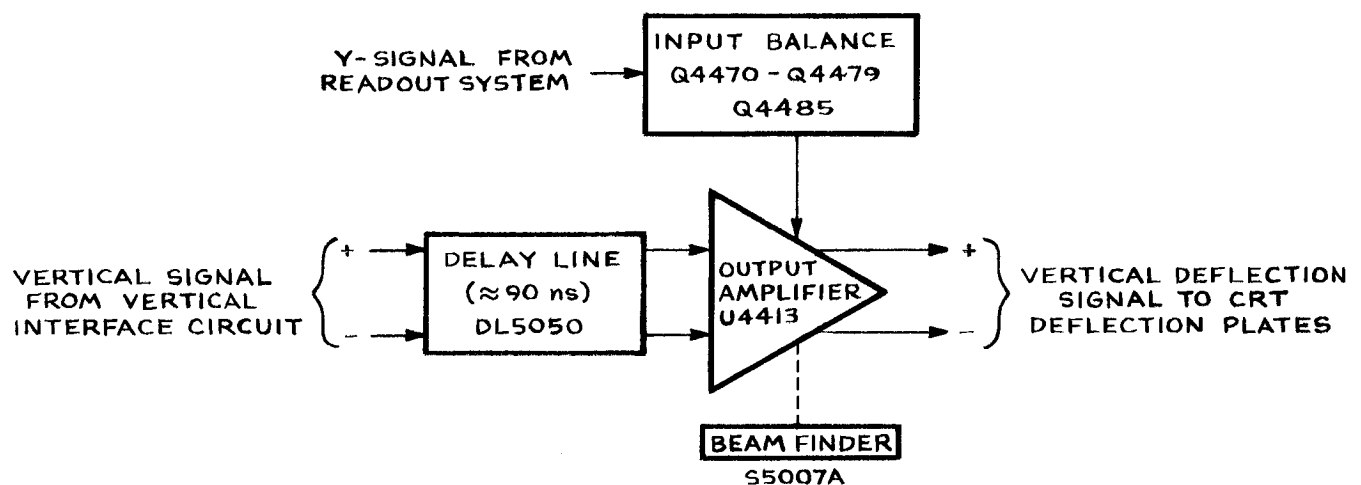

Fig. 2-46. Vertical Amplifier circuit detailed block diagram.

## HORIZONTAL AMPLIFIER 13

The Horizontal Amplifier circuit amplifies the push-pull horizontal deflection signal from the Horizontal Interface circuit and connects it to the horizontal deflection plates of the CRT. This circuit also receives the X Readout signal from the Readout System to produce the horizontal portion of the readout display. Figure 2-47 shows a detailed block diagram of the Horizontal Amplifier circuit.

### Input Amplifier

The horizontal signal from the Horizontal Interface circuit is connected to the bases of Q4321 and Q4331. The gain of this stage is controlled by the resistive network between the emitters of Q4321-Q4331. Horizontal Gain adjustment R4310 is variable to set the overall gain, and thermistor RT4313 provides thermal gain compensation. As the temperature goes up, the resistance of RT4313 goes down, resulting in less emitter degeneration. Therefore, the overall gain increases to compensate for the opposite temperature characteristic of the transistors in the Horizontal Amplifier circuit.

Transistor Q4304 normally supplies most of the emitter current of Q4321-Q4331. However, when the BEAM FINDER switch is actuated, Q4304 is no longer forward biased so the current through R4307-R4309 is determined by R4304 only. This results in less current to Q4321 and Q4331, so their dynamic range is limited. This reduces the effective gain of the horizontal system to keep the display

within the horizontal limits of the graticule, regardless of the setting of the horizontal positioning controls or the horizontal signal amplitude.

Horizontal Centering adjustment R4325 provides adjustment for differential unbalance in the Horizontal Amplifier circuit. The limiting network CR4323-CR4333-CR4340-CR4342 limits the input to the succeeding stages, so they always operate within their dynamic range and are not overdriven by excessive current from the Input Amplifier stage. Since the output from the Input Amplifier stage is a current signal, very little voltage change occurs across the limiting network. When horizontal deflection signals that produce an on-screen display are applied, CR4323 and CR4333 remain forward biased and CR4340-CR4342 are reverse biased. However, if high-amplitude signals are applied to this circuit as a result of sweep magnification or external signals, either CR4323 or CR4333 is reverse biased, depending on the polarity of the overdrive signal. This results in a sufficient voltage change at the anode of either CR4340 or CR4342 to forward bias it. The shunt diodes provide a current path for the signal current to limit the current change at the bases of Q4325-Q4335 during the overdrive condition.

For readout displays, the X Readout signal from the Readout System is connected to the base of Q4321 through R4300-R4322. The signal from the horizontal plug-in units is blocked in the Horizontal Interface circuit so the Readout System provides the only horizontal deflection. Q4321 and Q4331 operate as a paraphase amplifier to convert the single-ended readout signal at the base of Q4321 to a push-pull signal at the collectors of both Q4321 and Q4331.

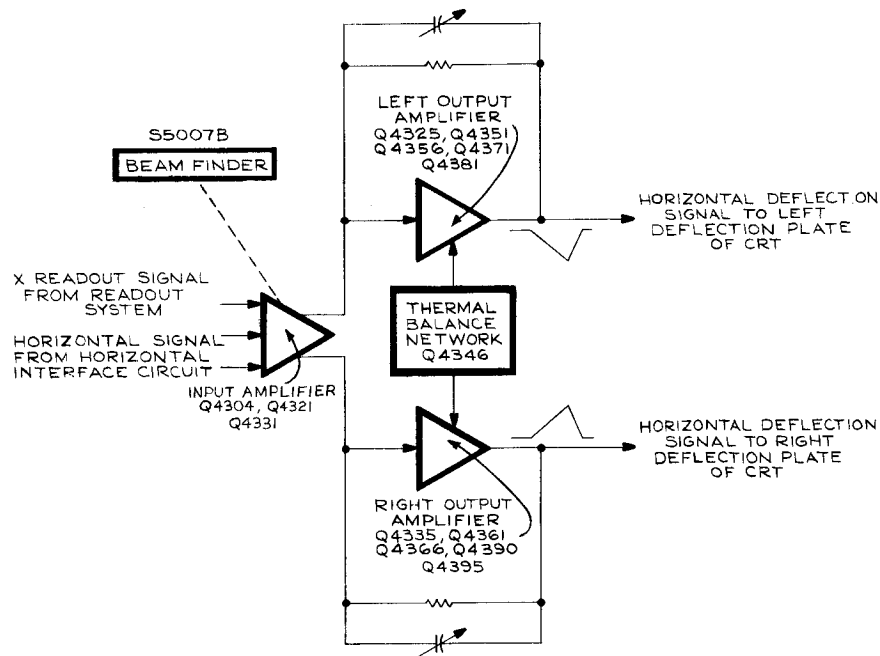

Fig. 2-47. Horizontal Amplifier circuit detailed block diagram.

CRT CIRCUIT **Left Output Amplifier**

Transistors Q4325, Q4351, Q4356, Q4371, and Q4381 are connected as a current-driven feedback amplifier. The input current is converted to a voltage output signal to drive the left horizontal deflection plate of the CRT. Input transistor Q4325, an NPN transistor, responds best to positive-going input signals. The signal at the collector of Q4325 is connected to the emitters of output transistors Q4356-Q4371 through two parallel paths. High-frequency signals are connected through capacitor C4325. Low-frequency signals are connected to the output transistors through R4324-Q4351-R4354. The output transistors Q4356 and Q4371 are connected in the complementary configuration to provide less resistive loading at the output. The output signal at the collector of Q4356-Q4371 is connected to the left deflection plate of the CRT through R4375.

Negative feedback is provided from the collectors of Q4356-Q4371 to the base of Q4325 through feedback network R4374-C4374-Q4381-R4329-C4329. Emitter follower Q4381 in the feedback network provides current gain for the feedback signal. With this configuration, the input impedance of the Left Output Amplifier is low since the feedback network beyond the emitter followers is effectively reduced in impedance as far as the input signal is concerned. Variable capacitor C4374 adjusts the transient response of the feedback network to provide good linearity at fast sweep rates. C4385-R4385 provide adjustment for correct high-frequency gain versus frequency response in the amplifier.

**Right Output Amplifier**

Basic operation of the Right Output Amplifier stage is the same as just described for the Left Output Amplifier stage. Notice that the input transistor in this stage is complementary to the corresponding transistor in the Left Output Amplifier stage. Therefore, this stage provides the best response to negative-going input signals. C4391 provides linearity adjustment for the Right Output Amplifier at fast sweep rates. The output signal at the collectors of Q4366-Q4395 is connected to the right deflection plate of the CRT through R4393.

**Thermal Balance Network**

Q4346 provides thermal balance for the Horizontal Amplifier circuit. The Thermal Balance adjustment R4346 sets the bias on Q4346 and thereby determines the operating voltage for Q4325-Q4335. This adjustment compensates for DC shift in the CRT display to reduce low-frequency signal cross talk. Diode CR4348 provides reverse-voltage breakdown protection for Q4346 when the instrument is first turned on. Diodes CR4346 and CR4344 establish the operating bias for Q4325-Q4335.

The CRT Circuit provides the control circuits and the high-voltage potentials necessary for the operation of the cathode-ray tube (CRT). This circuit includes the Z-Axis Amplifier stage to set the intensity of the CRT display and the Auto-Focus Amplifier stage to maintain optimum focus of the CRT display. The CRT Circuit also contains the Graticule-Light Supply. Figure 2-48 shows a detailed block diagram of the CRT Circuit.

**High-Voltage Transformer**

The High-Voltage Transformer, T4201, is driven by the 20-kilohertz square-wave voltage from the Inverter/Rectifiers circuit (secondary of Low-Voltage Transformer T3101 on diagram 8). Four secondary windings on T4201 provide power for the Graticule-Light Supply, +150-Volt Supply, CRT heater voltage, Anode Voltage Multiplier, and the CRT-Cathode Supply. The square-wave output of T4201 also drives the Control-Grid DC Restorer and Focus-Grid DC Restorer stages through R4217 and R4214 respectively.

**+150-Volt Supply**

The +150-Volt Supply provides a semi-regulated voltage for use in several circuits in the 7704A (semi-regulation is achieved by Inverter Regulator; see Inverter/Rectifiers description for further information). Bridge rectifier CR4201-CR4202-CR4203-CR4204 rectifies the voltage from the secondary of T4201. R4201-C4201 filter the rectified voltage.

**Graticule-Light Supply**

The graticule lights DS5001-DS5002-DS5003 are powered by the Graticule-Light Supply Q4250-Q4254. Rectified voltage for this supply is provided by CR4250 from a secondary winding of T4201. The setting of the front-panel GRAT ILLUM control R5000 determines the bias on the base of Q4254. The level on the collector of Q4254 then determines the current through Q4250 and the graticule lights.

**Cathode-Supply Regulator**

A sample of the output of the CRT-Cathode Supply is connected to the Cathode-Supply Regulator stage through divider R4123-R4240-R4241. Fast changes of the cathode-supply output are coupled to the Cathode-Supply Regulator through R4244-C4244. U4110 is connected as an error amplifier to sense any change in the voltage level at its non-inverting input (pin 3). The +50-Volt Supply, connected to R4123, and the ground connected to pin 2-U4110 through R4120 provide the reference for this stage. High Voltage adjustment R4123 sets the quiescent level at pin 3-U4110 for a -2.96-kilovolt operating potential at the

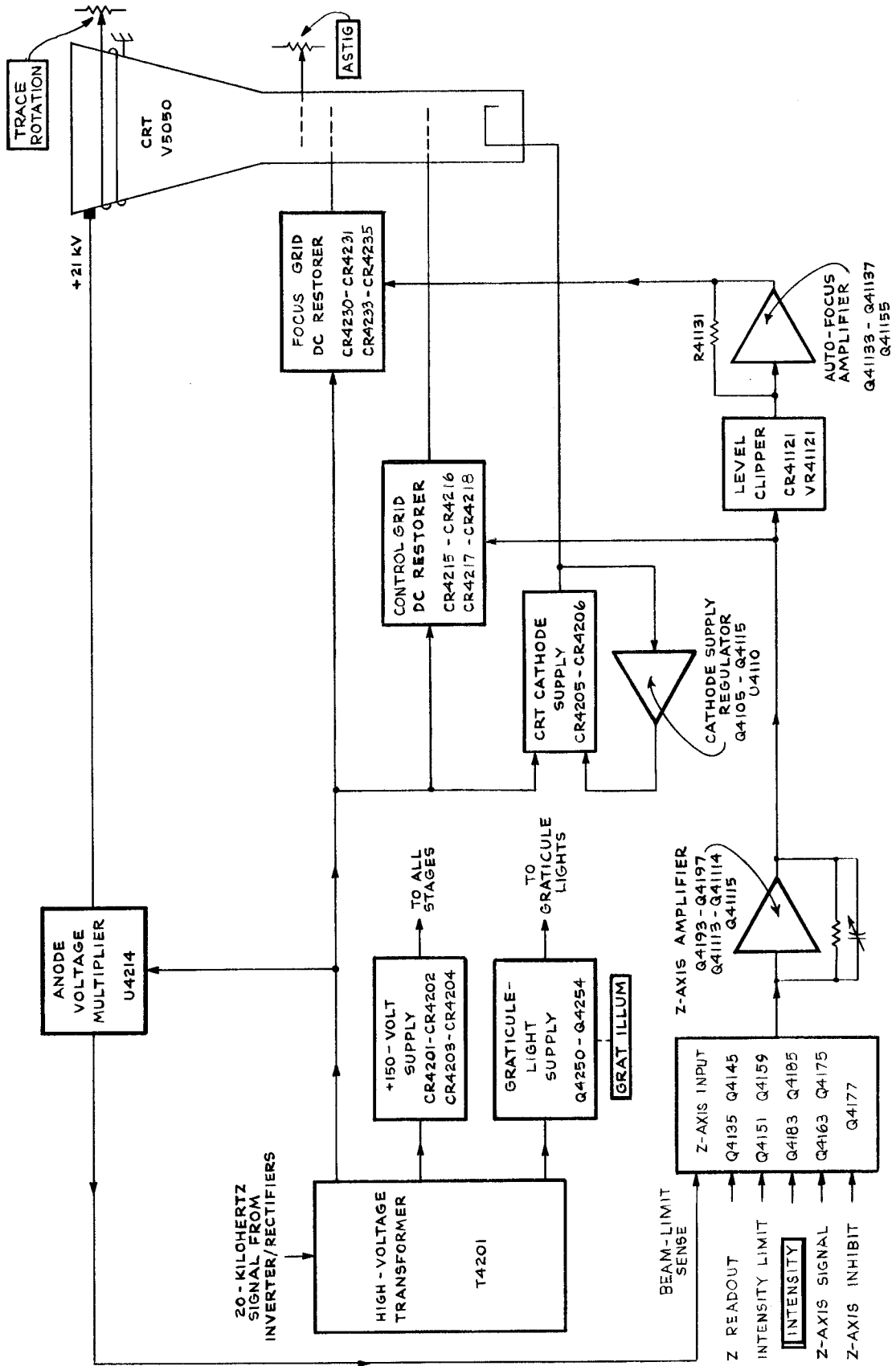

Fig. 2-48. Detailed block diagram of CRT Circuit.

CRT cathode. Q4105 and Q4115 are connected as a collector-coupled complementary amplifier driven by U4110 to correct the CRT-Cathode Supply for high- and low-frequency changes respectively.

Regulation occurs as follows: If the CRT cathode voltage becomes less negative, a positive-going change is coupled to the input of U4110 at pin 3 and results in a positive-going output at pin 6. This positive-going change is inverted by Q4105-Q4115 to a negative-going change at their collectors. This causes the voltage across C4205 to increase during the positive half cycle of the input waveform. During the negative half cycle, the increased voltage across C4205 increases the voltage at the output of the CRT-Cathode Supply to correct the original error. High-frequency correction signals are AC coupled to the CRT cathode through C4208.

### Control-Grid DC Restorer

The Control-Grid DC Restorer stage elevates the DC level of the Z-Axis Amplifier output to a potential more negative than the CRT cathode. This action allows the control grid to control the CRT beam current. The Control-Grid DC Restorer stage is driven by the square-wave output of T4201. CR4217 and CR4218 are forward biased during the positive and negative half cycles of the input square wave respectively to limit the square-wave amplitude at their junction. Grid Bias adjustment R4135 sets the voltage on the cathode of CR4217 to establish the forward-bias level and peak positive level at the anode of CR4217. The DC level of the Z-Axis Amplifier output determines the voltage on the anode of CR4218 to establish the forward-bias level and peak negative level at the cathode of CR4218. The limited-amplitude square wave at the junction of CR4217-CR4218 is coupled to the junction of CR4215-CR4216 through C4215. During the positive half cycle of the input square wave, CR4215 is forward biased to clamp its anode at the CRT-cathode voltage level. During the negative half cycle, C4216 is charged through CR4216 to a voltage level more negative than the CRT cathode by an amount equal to the difference between the Grid Bias adjustment setting and the Z-Axis Amplifier output level. High-frequency Z-Axis Amplifier signals are coupled to the control grid through C4219 and R4220-C4216.

### Focus-Grid DC Restorer

The operation of the Focus-Grid DC Restorer is similar to the operation of the Control-Grid DC Restorer. The limited-amplitude square wave at the junction of CR4230-CR4231 is coupled to the junction of CR4233-CR4235 through C4230. The amplitude of the positive half cycle of the input square wave is clamped at approximately +150 volts by CR4230. The peak negative amplitude is established by the DC level of the Auto-Focus Amplifier output through CR4231. During the positive half cycle, the focus-grid voltage is clamped to the voltage set by the FOCUS control R5001 through

R4235-CR4235-CR4233. During the negative half cycle, C4231 charges through CR4233 to establish the proper level at the focus-grid electrode.

### Z-Axis Input

The Z-Axis Input stage combines the various signals that affect the display intensity into one signal to provide the drive to the input of the Z-Axis Amplifier stage at the base of Q4197. For normal operation, the Z-Axis signal from the Logic Circuit determines the output of this stage. Other signals affecting the output include the front-panel (Display Unit) INTENSITY control R5004, the Intensity Limit input from the plug-in compartments, and the HV Sense signal from the Anode Voltage Multiplier. During readout displays, the Z-Axis Inhibit signal from the Readout System turns off Q4177 so the output of this stage is determined by the Z Readout input only.

### Z-Axis Amplifier

The Z-Axis Amplifier stage is a current driven, shunt-feedback amplifier with voltage output. The output voltage provides the drive signal to control the CRT intensity level through the Control-Grid DC Restorer stage. The output of the Z-Axis Amplifier is also connected to the Auto-Focus Amplifier stage to control the operation of the Auto-Focus Amplifier stage.

The base of Q4197 is the summing point (input) of the Z-Axis Amplifier stage. R41109-C41109 provide feedback from the output of this stage to the summing point. C41109 is adjustable to provide optimum step response with minimum overshoot or ringing. Otherwise, the CRT-display intensity would vary following sudden changes in intensity level. Z-Axis Peaking adjustment R4197 provides additional transient-response adjustment. The signal at the collector of Q4193 is DC-coupled to the base of Q41115 through R41101 to maintain good low-frequency response and to provide a fast falling edge on the output signal. The fast-changing portions of the input signal are coupled to the base of Q41113 through C41107.

Q41113-Q41114 are connected as a collector-coupled complementary amplifier. Q41113 is a PNP-type transistor, so it responds faster to negative-going changes at its base than to positive-going changes. This action provides a fast-rising edge on the output signal (fast-falling edge is provided by Q41115, an NPN-type transistor).

### Auto-Focus Amplifier

The Auto-Focus Amplifier stage develops control voltages to maintain optimum focus of the CRT display. When the FOCUS control is set for best definition of the CRT display at low to medium settings of the intensity



## Circuit Description—7704A Service

controls, this stage will maintain optimum focus for all portions of the display as it switches between readout, normal or intensified displays, slow or fast sweeps, and high- or low-intensity displays.

The Focus-Grid voltage required to maintain a focused display is fairly constant for low- and medium-intensity displays. However, for displays which require intensity control settings beyond midrange, the voltage requirement at the Focus Grid increases linearly with the increase in intensity drive at the output of the Z-Axis Amplifier stage. CR41121 and zener diode VR41121 clip the output level of the Z-Axis Amplifier stage, so the Auto-Focus Amplifier is not activated for low- or medium-intensity displays. Quiescently, the anode of VR41121 rests near zero volts. The positive voltage applied through R41121 sets the cathode of VR41121 at about +30 volts. Therefore, CR41121 is held reverse biased until its anode rises above about +30.5 volts. Then the portion of the Z-Axis drive signal that exceeds the 30-volt clipping level is coupled to the Auto-Focus Amplifier stage.

Q41133-Q41137-Q41155 are connected as an inverting operational amplifier to amplify the output of the Level Clipper and drive the Focus-Grid electrode. Auto-Focus Gain adjustment R41127 determines the amount of signal connected to the base of Q41133 to set the overall gain of

the Auto-Focus Amplifier. R41131 provides feedback from the output of this stage to the input. The capacitor shown next to R41131 (diagram 14) represents the gimmick-wire capacitor wrapped around the resistor body. This gimmick-wire capacitor is positioned to adjust the amount of AC feedback giving the best overall focus of displays with fast-changing intensity levels.

## CRT Control Circuit

The ASTIG adjustment R5002, used in conjunction with the FOCUS control to obtain a well-defined display, varies the level on the astigmatism grid. Geometry adjustment R41171 varies the positive level on the horizontal deflection plate shield to control the overall geometry of the display.

Two adjustments control the trace alignment by varying the magnetic field around the CRT. Y-Axis Align adjustment R41173 controls the current through L5007, which affects the CRT beam after vertical deflection but before horizontal deflection. Therefore, it affects only the vertical (Y) components of the display. TRACE ROTATION adjustment R5003 controls the current through L5003 and affects both the vertical and horizontal rotation of the beam.

# MAINTENANCE

This section of the manual contains maintenance information for use in preventive maintenance, corrective maintenance, or troubleshooting of the 7704A.

## Panel Removal

### WARNING

*Dangerous potentials exist at several points throughout this instrument. When the instrument is operated with the covers removed, do not touch exposed connections or components. Some transistors have voltages present on their cases. Disconnect power before cleaning the instrument or replacing parts.*

The side and bottom panels of the 7704A are held in place by slotted fasteners. To remove the panels, turn each fastener counterclockwise a quarter turn with a large screwdriver, coin, or similar device. Then, lift the panel away from the instrument. The panels protect this instrument from dust in the interior, and also provide protection to personnel from the operating potentials present. In addition, they reduce the EMI radiation from the instrument and EMI interference to the display due to other equipment.

## Power-Unit Removal

### WARNING

*Extreme caution must be used when troubleshooting in the power supply due to the line voltage, high voltage and high current potentials present. Refer to the discussion entitled Access to Components in Power Unit for information on how to remove the protective cover from the power unit.*

The power unit can be slid out of the rear of the 7704A to gain access to the Logic circuit board and for power-unit service. To remove the power unit, first disconnect the instrument from the power source. Remove the four screws which hold the power unit to the rear frame (see Fig. 3-1). Slide the power unit out of the rear of the instrument until it can be set on the work surface (guide the cables so they do not catch on other parts of the instrument). The power

unit remains connected to the rest of the instrument so it can be operated in this position for troubleshooting or calibration. Reverse this procedure when replacing the power unit; use care not to pinch the cables as the power unit is replaced. Be sure that all the securing screws are tight to hold the power unit in place properly.

## PREVENTIVE MAINTENANCE

Preventive maintenance consists of cleaning, visual inspection, lubrication, etc. Preventive maintenance performed on a regular basis may prevent instrument breakdown and will improve the reliability of this instrument. The severity of the environment to which the 7704A is subjected determines the frequency of maintenance. A convenient time to perform preventive maintenance is preceding recalibration of the instrument.

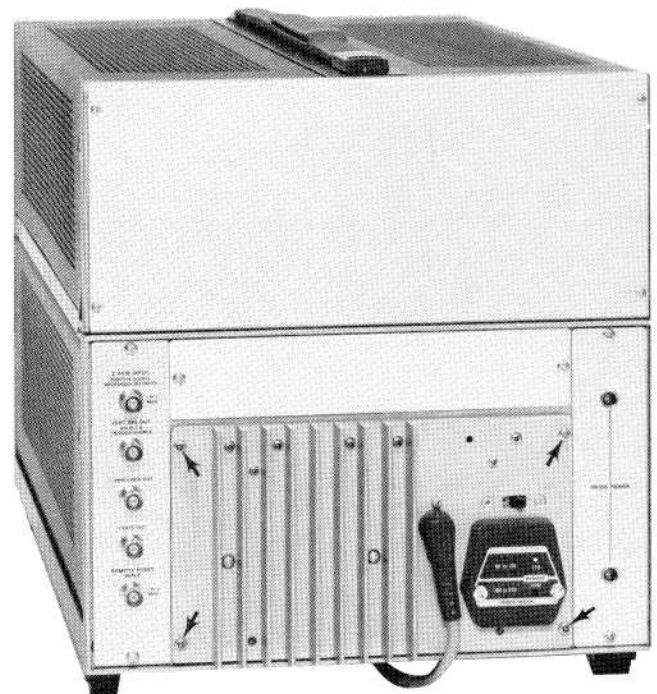

Fig. 3-1. Power-unit securing screws.

## Cleaning

**General.** The 7704A should be cleaned as often as operating conditions require. Accumulation of dirt in the instrument can cause overheating and component breakdown. Dirt on components acts as an insulating blanket and prevents efficient heat dissipation. It also provides an electrical conduction path which may result in instrument failure. The side panels provide protection against dust in the interior of the instrument. Operation without the panels in place necessitates more frequent cleaning.



*Avoid the use of chemical cleaning agents which might damage the plastics used in this instrument. In particular, avoid chemicals which contain benzene, toluene, xylene, acetone, or similar solvents.*

**Exterior.** Loose dust accumulated on the outside of the 7704A can be removed with a soft cloth or small brush. The brush is particularly useful for dislodging dirt on and around the front-panel controls. Dirt which remains can be removed with a soft cloth dampened in a mild detergent and water solution. Abrasive cleaners should not be used.

**CRT.** Clean the plastic light filter, faceplate protector, and the CRT face with a soft, lint-free cloth dampened with denatured alcohol.

The CRT mesh filter (furnished with Option 3 only) can be cleaned in the following manner:

1. Hold the mesh filter in a vertical position and brush lightly with a soft No. 7 water-color brush to remove light coatings of dust or lint.
2. Greasy residues or dried-on dirt can be removed with a solution of warm water and a neutral-pH liquid detergent. Use the brush to lightly scrub the filter.
3. Rinse the filter thoroughly in clean water and allow to air dry.
4. If any lint or dirt remains, use clean low-pressure air to remove it. Do not use tweezers or other hard cleaning tools on the filter, as the special finish may be damaged.
5. When not in use, store the mesh filter in a lint-free, dust-proof container such as a plastic bag.

**Interior.** Dust in the interior of the instrument should be removed occasionally due to its electrical conductivity under high-humidity conditions. The best way to clean the interior is to blow off the accumulated dust with dry, low-pressure air. Remove any dirt which remains with a soft brush or a cloth dampened with a mild detergent and water solution. A cotton-tipped applicator is useful for cleaning in narrow spaces or for cleaning ceramic terminal strips and circuit boards.

The high-voltage circuits, particularly parts located in the high-voltage compartment and the area surrounding the post-deflection anode leads, should receive special attention. Excessive dirt in these areas may cause high-voltage arcing and result in improper instrument operation.

## Lubrication

**General.** The reliability of potentiometers, switches, and other moving parts can be maintained if they are kept properly lubricated. However, over-lubrication is as detrimental as too little lubrication. A lubrication kit containing the necessary lubricants and instructions is available from Tektronix, Inc. Order Tektronix Part No. 003-0342-01.

## Visual Inspection

The 7704A should be inspected occasionally for such defects as broken connections, broken or damaged ceramic strips, improperly seated semiconductors, damaged or improperly installed circuit boards, and heat-damaged parts.

The corrective procedure for most visible defects is obvious; however, particular care must be taken if heat-damaged components are found. Overheating usually indicates other trouble in the instrument; therefore, it is important that the cause of overheating be corrected to prevent recurrence of the damage.

## Semiconductor Checks

Periodic checks of the semiconductors in the 7704A are not recommended. The best check of semiconductor performance is actual operation in the instrument. More details on checking semiconductor operation are given under troubleshooting.

## Recalibration

To assure accurate measurements, check the calibration of this instrument after each 1000 hours of operation or every six months if used infrequently. In addition, replacement of components may necessitate recalibration of the affected circuits. The calibration procedure can also be

helpful in localizing certain troubles in the instrument. In some cases, minor troubles may be revealed and/or corrected by recalibration.

## TROUBLESHOOTING

The following information is provided to facilitate troubleshooting of the 7704A. Information contained in other sections of this manual should be used along with the following information to aid in locating the defective component. An understanding of the circuit operation is very helpful in locating troubles, particularly where integrated circuits are used.

### Troubleshooting Equipment

The following equipment is useful for troubleshooting the 7704A.

#### 1. Transistor Tester

Description: Dynamic-type tester. Must be capable of measuring reverse breakdown voltages of at least 400 volts.

Purpose: To test the semiconductors used in this instrument.

Recommended type: Tektronix Type 576 Curve Tracer.

#### 2. Multimeter

Description: VTVM, 10 megohm input impedance and 0 to 500 volts range, AC and DC; ohmmeter, 0 to 50 megohms. Accuracy, within 3%. Test probes must be insulated to prevent accidental shorting.

Purpose: To check voltages and for general troubleshooting in this instrument.

#### NOTE

*A 20,000 ohms/volt VOM can be used to check the voltages in this instrument if allowances are made for the circuit loading of the VOM at high-impedance points.*

#### 3. Test Oscilloscope

Description: Frequency response, DC to 100 megahertz minimum; deflection factor, 5 millivolts to 5 volts/division and 1 milliampere to 1 ampere/division. A 10X, 10-megohm voltage probe should be used to reduce circuit loading for voltage measurements.

Purpose: To check operating waveforms in this instrument.

Recommended type: Tektronix 7603 Oscilloscope with 7A16A Amplifier, 7A14 Current Probe Amplifier, and

7B50 Time Base plug-in units. Use a P6053 10X probe and a P6021 Current Probe.

#### 4. Isolation Transformer

Description: 1:1 turns ratio, 500 volt-amperes minimum rating, 50-60 cycle. Must have three-wire power cord, plug, and receptacle with ground connection carried through from input to output.

Purpose: To isolate the 7704A from the line potential when troubleshooting in the power supply.

Recommended type: Stancor No. P6298 (for 115-volt line only) modified to include three-wire power cord, plug, and receptacle.

#### 5. Variable Autotransformer

Description: Output variable from 0 to 140 volts, 10 amperes minimum rating. Must have three-wire power cord, plug, and receptacle.

Purpose: To vary the input line voltage when troubleshooting in the power supply.

Recommended type: General Radio W10MT3W Variac Autotransformer.

### Troubleshooting Techniques

This troubleshooting procedure is arranged in an order which checks the simple trouble possibilities before proceeding with extensive troubleshooting. The first few checks assure proper connection, operation, and calibration. If the trouble is not located by these checks, the remaining steps aid in locating the defective component. When the defective component is located, it should be replaced following the replacement procedures given under Corrective Maintenance.

**1. Check Control Settings.** Incorrect control settings can indicate a trouble that does not exist. If there is any question about the correct function or operation of any control, see the Operators Manual.

**2. Check Associated Equipment.** Before proceeding with troubleshooting of the 7704A, check that the equipment used with this instrument is operating correctly. Check that the signal is properly connected and that the interconnecting cables are not defective. Also, check the power source. The associated plug-in units can be checked for proper operation by substituting other units which are known to be operating properly (preferably of the same types). If the trouble persists after substitution, the 7704A is probably at fault.

**3. Visual Check.** Visually check the portion of the instrument in which the trouble is located. Many troubles can be located by visual indications such as unsoldered connections, broken wires, damaged circuit boards, damaged components, etc.

**4. Check Instrument Calibration.** Check the calibration of this instrument, or the affected circuit if the trouble appears in one circuit. The apparent trouble may only be a result of misadjustment or may be corrected by calibration. Complete calibration instructions are given in the Calibration section.

**5. Isolate Trouble to a Circuit.** To isolate trouble to a particular circuit, note the trouble symptom. The symptom often identifies the circuit in which the trouble is located. For example, poor focus indicates that the CRT circuit (includes Auto Focus circuits) is probably at fault. When trouble symptoms appear in more than one circuit, check affected circuits by taking voltage and waveform readings. Also check for the correct output signals at the rear-panel output connectors with a test oscilloscope. If the signal is correct, the circuit is working correctly up to that point. For example, correct sawtooth output indicates that the time-base unit and sawtooth out portion of the Output Signals circuit is operating correctly. If a malfunction in the Readout System is suspected of causing trouble to appear in the Z-Axis Amplifier, Vertical Amplifier, or Horizontal Amplifier circuits, the trouble can be localized by removing the Readout System circuit board. This board can be removed without affecting the operation of other circuits in the instrument.

Incorrect operation of all circuits often indicates trouble in the power supply. Check first for correct voltage of the individual supplies. However, a defective component elsewhere in the instrument can appear as a power-supply trouble and may also affect the operation of other circuits.

If incorrect operation of the power supplies is suspected, connect the 7704A to a variable autotransformer. Then, check each power supply for correct regulation with a DC voltmeter (0.1% accuracy), and correct ripple with a test oscilloscope, while varying the autotransformer throughout the regulating range of this instrument (see rear-panel Line Selector for regulating range). Table 3-1 lists the tolerances of the power supplies in the 7704A. These voltages are measured between the power-supply test points and chassis ground. (P32G connects to the L.V. Regulator board in the power unit; P43 connects to the rear of the Horizontal Amplifier board.) Power-supply test points are shown on page 6-31 in the Diagrams section. If a power-supply voltage is within the listed tolerance, the supply can be assumed to be working correctly. If outside the tolerance, the supply may be misadjusted or operating incorrectly. Use the procedure given in the Calibration section to adjust the power supplies.

TABLE 3-1

Power Supply Tolerance and Ripple  
(referenced to chassis ground)

| Power Supply | Test Point | Tolerance  | Typical ripple (peak-to-peak) |
|--------------|------------|------------|-------------------------------|
| -50 Volt     | pin 6—P32G | ±0.20 volt | 2 millivolts                  |
| -15 Volt     | pin 1—P32G | ±0.15 volt | 2 millivolts                  |
| +5 Volt      | pin 2—P32G | ±0.10 volt | 2 millivolts                  |
| +15 Volt     | pin 4—P32G | ±0.15 volt | 2 millivolts                  |
| +50 Volt     | pin 5—P32G | ±0.50 volt | 5 millivolts                  |
| +155 Volt    | pin 1—P43  | ±5.0 volts | 500 millivolts                |

Figure 3-2 provides a guide for locating a defective circuit. Start at the top of the chart and perform the checks given on the left side of the page until a step is found that does not produce the indicated results. Further checks, or the circuit in which the trouble is probably located, are listed to the right of the step. This chart does not include checks for all possible defects; use steps 6 and 7 in such cases.

After the defective circuit has been located, proceed with steps 6 and 7 to locate the defective component(s).

**6. Check Voltages and Waveforms.** Often the defective component can be located by checking for the correct voltage or waveform in the circuit.

**7. Check Individual Components.** The following procedures describe methods of checking individual components in the 7704A. Components that are soldered in place are best checked by first disconnecting one end. This isolates the measurement from the effects of surrounding circuitry.

A. SEMICONDUCTORS.



*Power switch must be turned off before removing or replacing semiconductors.*

A good check of transistor operation is actual performance under operating conditions. A transistor can be most effectively checked by substituting a new component for it (or one which has been checked previously). However, be sure that circuit conditions are not such that a replacement transistor might also be damaged. If substitute transistors are not available, use a dynamic tester. Static-type testers are not recommended, since they do not check operation under simulated operating conditions.

IC's (integrated circuits) can be checked with a voltmeter, test oscilloscope, or by direct substitution. A good understanding of circuit operation is essential to troubleshooting circuits using IC's. Use care when checking voltages and waveforms around the IC's so that adjacent leads are not shorted together. A convenient means of clipping a test probe to the 14- and 16-pin IC's is with an IC test clip. This device also doubles as an extraction tool. The lead configuration for the semiconductors used in this instrument are shown on or adjacent to each diagram page.

## B. DIODES.

A diode can be checked for an open or for a short circuit by measuring the resistance between terminals with an ohmmeter set to the R X 1k scale. The diode resistance should be very high in one direction and very low when the meter leads are reversed. Do not check tunnel diodes or back diodes with an ohmmeter.

### CAUTION

*Do not use an ohmmeter scale that has a high internal current. High currents may damage the diode.*

The cathode end of each glass-encased diode is indicated by a stripe, a series of stripes, or a dot. For most silicon or germanium diodes with a series of stripes, the color-code identifies the three significant digits of the Tektronix Part Number using the resistor color-code system (e.g., a diode color-code pink-, or blue-, brown-gray-green indicates Tektronix Part Number 152-0185-00). The cathode and anode ends of metal-encased diodes can be identified by the diode symbol marked on the body.

## C. RESISTORS.

Check the resistors with an ohmmeter. See the Electrical Parts List for the tolerance of the resistors used in this instrument. Resistors normally do not need to be replaced unless the measured value varies widely from the specified value.

## D. INDUCTORS.

Check for open inductors by checking continuity with an ohmmeter. Shorted or partially shorted inductors can usually be found by checking the waveform response when high-frequency signals are passed through the circuit. Partial shorting often reduces high-frequency response (roll-off).

## E. CAPACITORS.

A leaky or shorted capacitor can best be detected by checking resistance with an ohmmeter on the highest scale.

Do not exceed the voltage rating of the capacitor. The resistance reading should be high after initial charge of the capacitor. An open capacitor can best be detected with a capacitance meter or by checking if the capacitor passes AC signals.

**8. Repair and Readjust the Circuit.** If any defective parts are located, follow the replacement procedures given in this section. Be sure to check the performance of any circuit that has been repaired or had any electrical components replaced.

## Special Adjustment Procedures

Several interface adjustments are provided in the Acquisition Unit to allow use with different Display Units. It is not usually necessary to perform these adjustments during recalibration of the complete system. However, if components are replaced in the interface circuits or if the Acquisition Unit is used in a different system, adjustment might be required. The need for adjustment is indicated if the vertical or horizontal adjustments in the Display Unit cannot be performed according to the Calibration procedure.

**Equipment Required.** The following equipment is required to calibrate the Acquisition Unit interface:

### 1. Test-oscilloscope system

Description: Differential inputs; frequency response, DC to 30 megahertz minimum; deflection factor, 50 millivolts/division.

Recommended type: Tektronix 7403N Oscilloscope with two 7A15A Amplifier units or one 7A18N Dual-Trace Amplifier and 7B50 Time-Base.

### 2. Signal Standardizer Calibration Fixture

Description: Produces gain-check and pulse-response waveforms.

Recommended type: Tektronix 067-0587-01 Calibration Fixture.

### 3. Adapter (two required)

Description: Adapts GR874 connector to Tektronix coaxial connector.

Recommended type: Tektronix Part No. 017-0093-00.

CIRCUIT ISOLATION TROUBLESHOOTING CHART

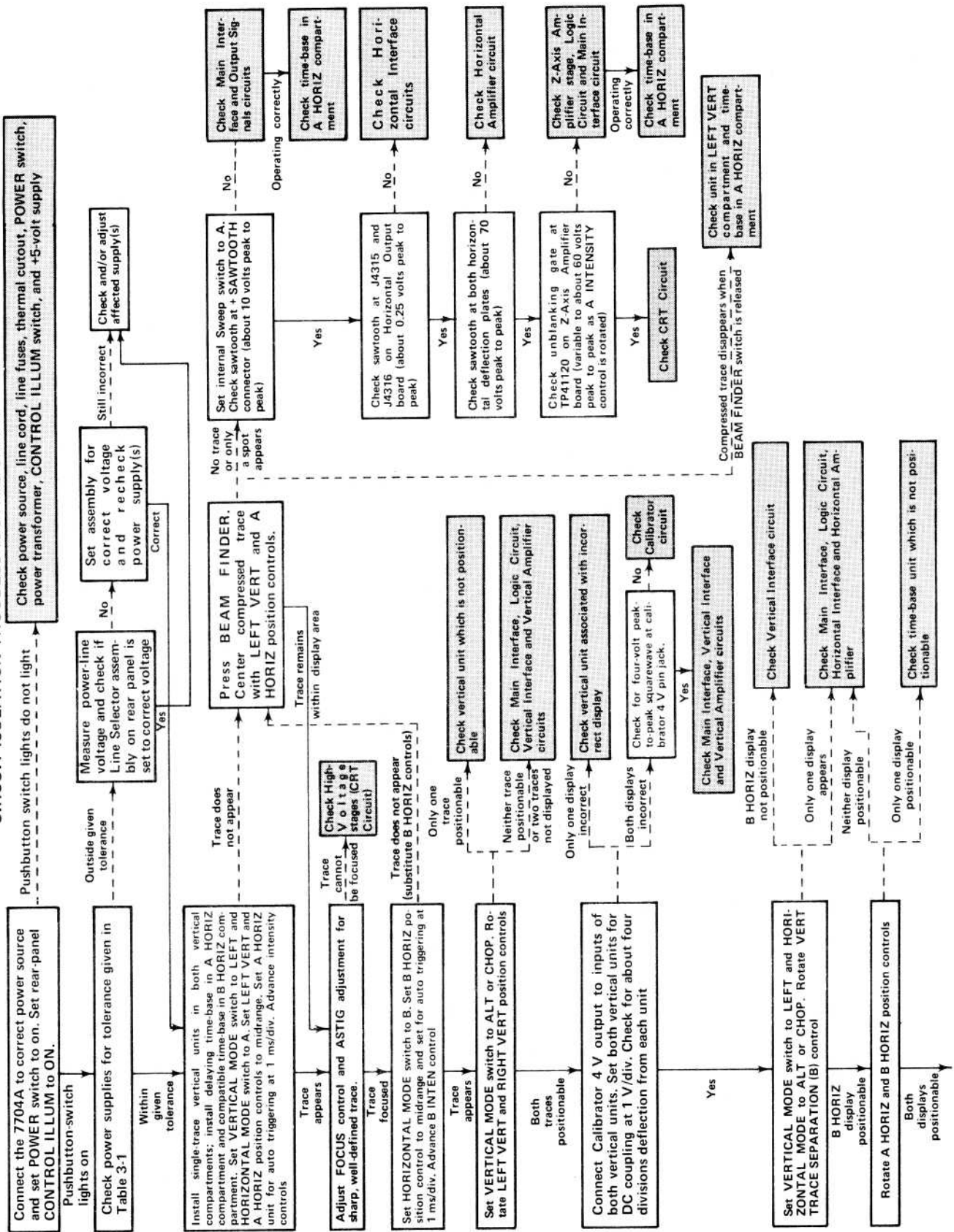

Fig. 3-2. Troubleshooting Chart for 7704A.

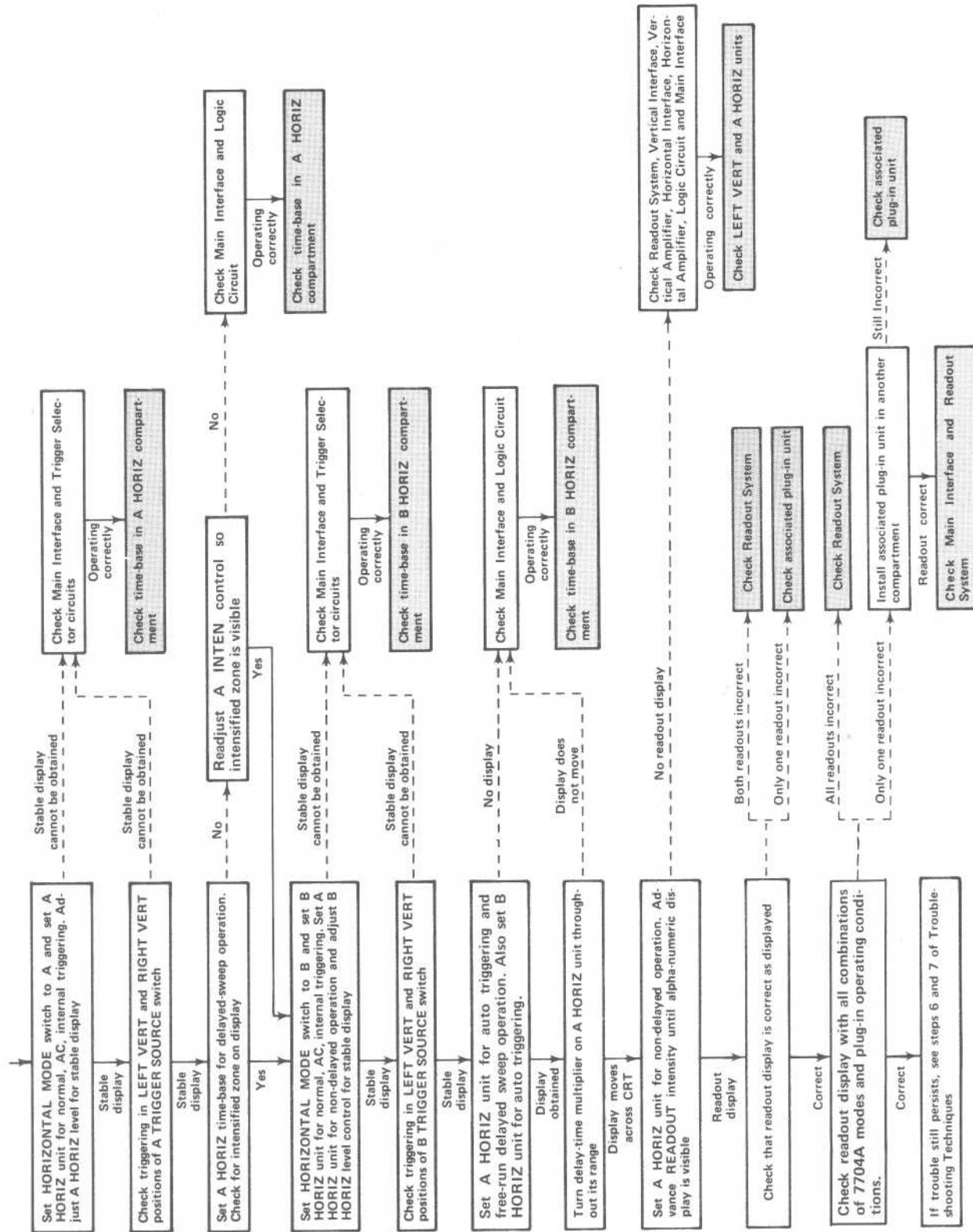

Fig. 3-2. (cont)



## Maintenance—7704A Service

**Control Settings.** Set the 7704A controls as follows:

|                           |           |
|---------------------------|-----------|
| POWER                     | OFF       |
| VERTICAL MODE             | RIGHT     |
| VERT TRACE SEPARATION (B) | Midrange  |
| A TRIGGER SOURCE          | VERT MODE |
| A INTEN                   | Midrange  |
| HORIZONTAL MODE           | A         |
| B INTEN                   | Midrange  |
| B TRIGGER SOURCE          | VERT MODE |
| READOUT                   | OFF       |

**Adjust Vertical Interface Centering and Gain.** To calibrate the Vertical Interface, set the controls as given under Control Settings and proceed as follows:

a. Disconnect coaxial connectors P4417 and P4418 from A44, Vertical Amplifier board (see Fig. 3-3).

b. Connect P4417 and P4418 to the vertical channels of the test oscilloscope with the adapters and cables. (If the test oscilloscope has a high input impedance, use 50-ohm terminations at the vertical-channel inputs.)

c. Set the POWER switch to on.

d. Set the test oscilloscope for differential operation between the vertical channels (added display mode with one channel inverted; invert the channel to which P4418 is connected), and a sweep rate of 100 microseconds/division.

e. Set the test-oscilloscope vertical channels for a deflection factor of 50 millivolts/division with the inputs grounded.

f. Establish a zero-volt reference level for the test-oscilloscope display by positioning the trace to the center horizontal line of the graticule. Do not change the test-oscilloscope position controls after setting this level.

g. Set the vertical channels of the test oscilloscope for DC input coupling.

h. ADJUST—Interface Centering adjustment R2222 (see Fig. 3-4) for a display DC level within 0.2 division (10 millivolts) of the zero-volt reference level in the LEFT and RIGHT positions of the VERTICAL MODE switch.

i. Install the signal standardizer calibration fixture in the RIGHT VERT compartment.

j. Set the VERTICAL MODE switch to RIGHT.

k. Set the calibration fixture Test switch to Vert or Horiz Gain and the Rep Rate switch to 10 kHz.

l. ADJUST—Interface Gain adjustment R2247 (see Fig. 3-4) for a test-oscilloscope display of nine traces with six divisions  $\pm 0.9$  division deflection between the second and eighth traces (300 millivolts within 45 millivolts).

m. Set the POWER switch to off.

n. Disconnect P4417 and P4418 from the test oscilloscope and connect them to their respective jacks on the Vertical Amplifier board.

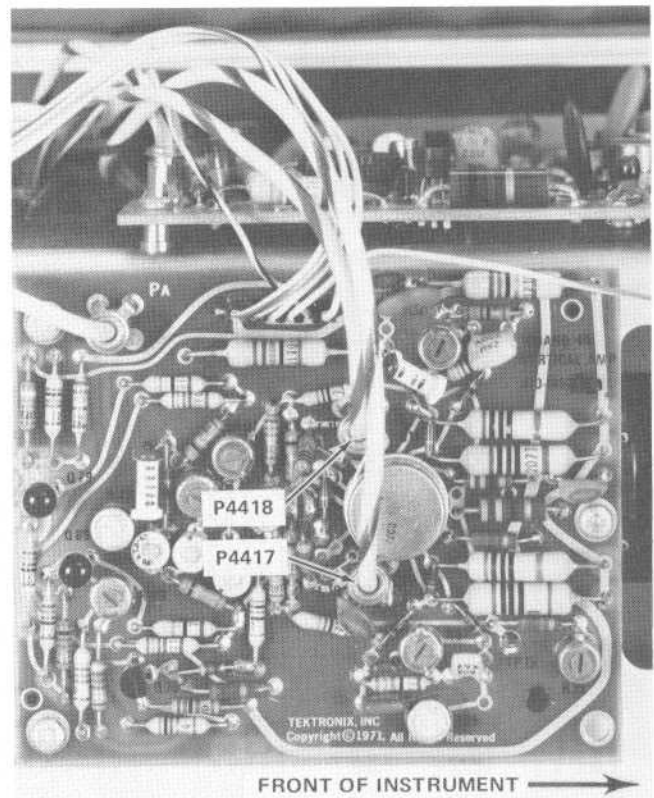

Fig. 3-3. Location of P4417 and P4418 on A44-Vertical Amplifier board.

**Adjust Horizontal Interface Gain.** To calibrate the Horizontal Interface, set the controls as given under Control Settings and proceed as follows:

- a. Disconnect coaxial connectors P4315 and P4316 from the Horizontal Output board (see Fig. 3-5).
- b. Connect P4315 and P4316 to the vertical channels of the test oscilloscope with the adapters and cables. (If the test oscilloscope has a high-impedance input, use 50-ohm terminations at the vertical-channel inputs.)
- c. Set the POWER switch to on.
- d. Set the test oscilloscope for differential operation between the vertical channels (added display mode with one channel inverted; invert the channel to which P4316 is connected), and a sweep rate of 100 microseconds/division. Free run the sweep.
- e. Set the test-oscilloscope vertical channels for a deflection factor of 50 millivolts/division with the inputs DC coupled.
- f. Remove the left side cover from the signal standardizer calibration fixture and install the calibration fixture in the A HORIZ compartment.
- g. Set the calibration fixture Test switch to Vert or Horiz Gain and the Rep Rate switch to 100 kHz.
- h. Position the test-oscilloscope display to align the bright center trace with the center horizontal line of the graticule.
- i. ADJUST—A Horiz Gain adjustment R2323 (see Fig. 3-6) for exactly six divisions of deflection between the second and eighth traces.
- j. Remove the calibration fixture and install it in the B HORIZ compartment.
- k. Set the HORIZONTAL MODE switch to B.
- l. Repeat parts h and i of this step; adjust B Horiz Gain adjustment R2313 (see Fig. 3-6) for the correct test-oscilloscope display.
- m. Set the POWER switch to off.
- n. Disconnect P4315 and P4316 from the test oscilloscope and connect each to its respective jack on the Horizontal Output board.

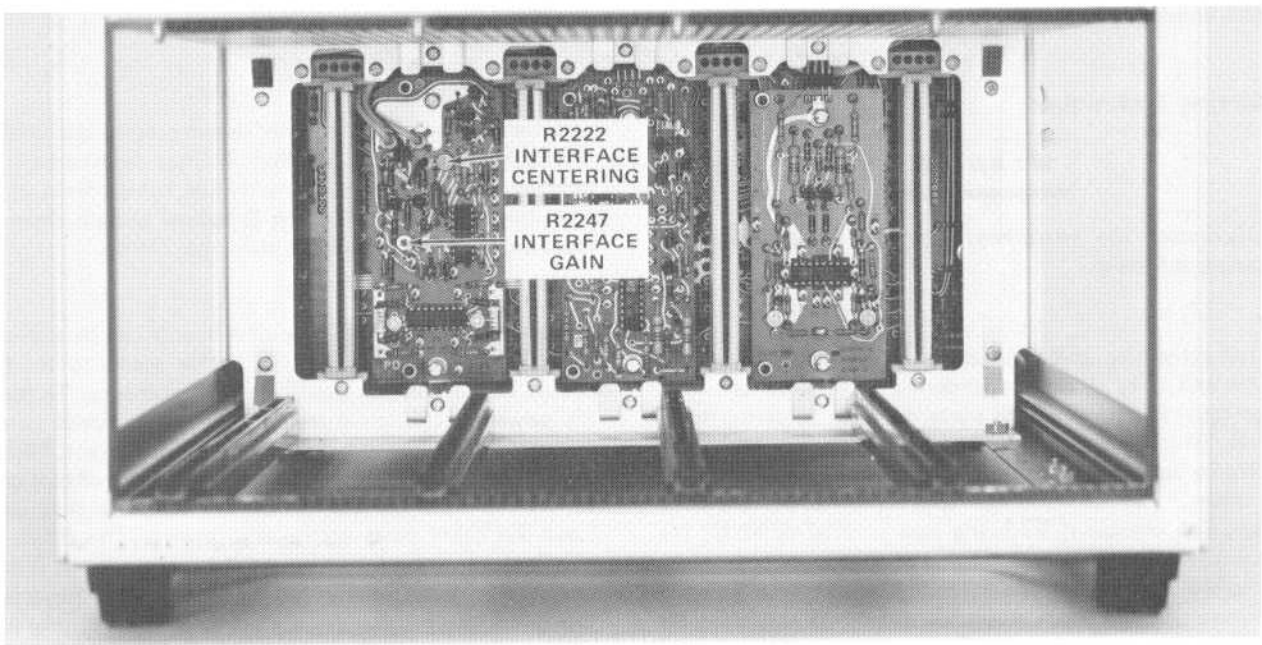

Fig. 3-4. Location of adjustments on A22, Vertical Interface board.

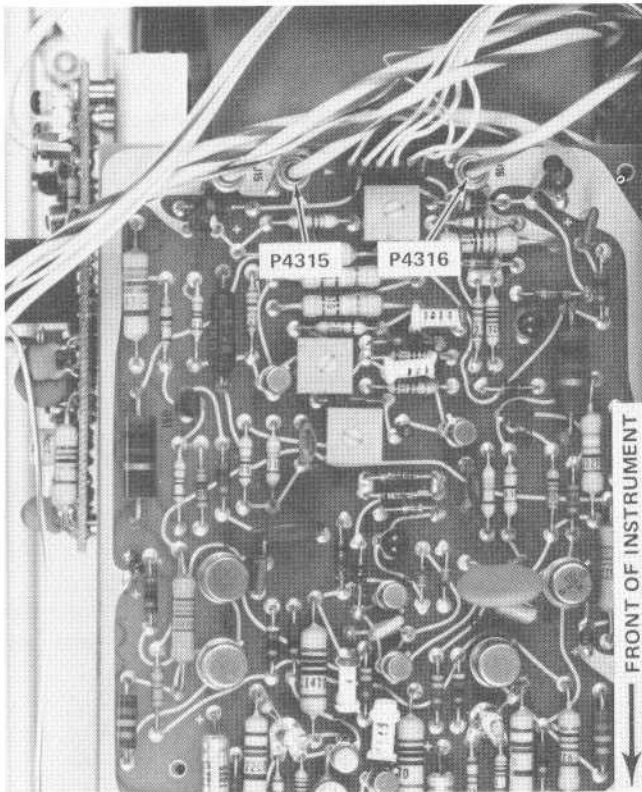

Fig. 3-5. Location of P4315 and P4316 on A43, Horizontal Output board.

### CORRECTIVE MAINTENANCE

Corrective maintenance consists of component replacement and instrument repair. Special techniques required to replace components in this instrument are given here.

### Soldering Techniques

**WARNING**

*Disconnect the instrument from the power source before soldering.*

The reliability and accuracy of this instrument can be maintained only if proper soldering techniques are used when repairing or replacing parts. General soldering techniques which apply to maintenance of any precision electronic equipment should be used when working on this instrument. Use only 60/40 rosin-core, electronic-grade solder. The choice of soldering iron is determined by the repair to be made. When soldering on circuit boards, use a 35- to 40-watt pencil-type soldering iron with a 1/8-inch wide, wedge-shaped tip. Keep the tip properly tinned for best heat transfer to the solder joint. A higher wattage soldering iron may separate the wiring from the base material. Avoid excessive heat; apply only enough heat to

remove the component or to make a good solder joint. Also, apply only enough solder to make a firm solder joint; do not apply too much solder.

**CAUTION**

*Several of the circuit boards in this instrument are multi-layer type boards with a conductive path (s) laminated between the top and bottom board layers. All soldering on these boards should be done with extreme care to prevent breaking the connections to the center conductor(s); only experienced maintenance personnel should attempt repair of these boards.*

For metal terminals (e.g., switch terminals, potentiometers, etc.), a higher wattage-rating soldering iron may be required. Match the soldering iron to the work being done. For example, if the component is connected to the chassis or other large heat-radiating surface, it will require a 75-watt or larger soldering iron. The pencil-type soldering iron used on the circuit board can be used for soldering to switch terminals, potentiometers, or metal terminals mounted in plastic holders.

### Component Replacement

**WARNING**

*Disconnect the instrument from the power source before replacing components.*

**General.** The exploded-view drawing associated with the Mechanical Parts List (Section 7) may be helpful in the removal or disassembly of individual components or sub-assemblies. Figure 6-2 in the Diagrams section shows the location of circuit boards within the 7704A.

**Power-Unit Removal.** The power unit can be slid out of the rear of the 7704A to gain better access to the Logic circuit board and for power-unit maintenance. To remove the power unit, first remove the four screws which hold the power unit to the rear frame of the instrument. Slide the power unit out of the rear of the instrument until it can be set on the work surface (guide the cables so they do not catch on other parts of the instrument). The power unit remains connected to the rest of the instrument so it can be operated in this position for troubleshooting. Reverse this procedure when replacing the power unit; be careful not to pinch the power cables as the power unit is replaced. Be sure that all the securing screws are tight to hold the power unit in place properly.

**WARNING**

*Extreme caution must be used when troubleshooting in the power supply due to the line voltage, high voltage and high current potentials present. Refer to the discussion entitled Access to Components in Power Unit for information on how to remove the protective cover from the power unit.*

**Access to Components in Power Unit.** To reach the components located inside the power unit for maintenance or repair, use the following procedure:

**WARNING**

*Disconnect the instrument from the power source before removing the power-unit cover. The primary storage capacitors, C3016 and C3017, remain charged with high voltage DC for several minutes after the line power is disconnected. A warning indicator (neon bulb), located on A30, Power Supply board, flashes when this stored voltage exceeds about 80 volts. Do not remove the power-unit cover while this light is flashing.*

1. Slide out the power unit as described previously.
2. Remove the four small screws that secure the cover to the rear heat sink.

3. Remove the two screws that attach each side of the cover to the power unit.
4. Disconnect the two coaxial connectors from J12 and J13 on A31, Rectifiers and Filter board.
5. Remove the cover from the power unit.
6. The power unit is now open for maintenance or repair. If the 7704A is to be operated with the cover removed, first reconnect the coaxial cables to A31, Rectifiers and Filter board.
7. Reverse the order of removal to replace the power-unit cover.

**Disassembly of Acquisition and Display Units.** The (A7704) Acquisition and (D7704) Display units can be disassembled to gain access to the front-panel controls. To disassemble the two units, first disconnect the instrument from the power source. Remove the side panels as described previously. Unplug the Interface Connector (located on the right side of 7704A; see Fig. 3-7) and place it on the storage fixture. Remove the two screws which attach the units on each side (see Fig. 3-7). The two units can now be separated. To assemble the units, reverse the disassembly procedure.

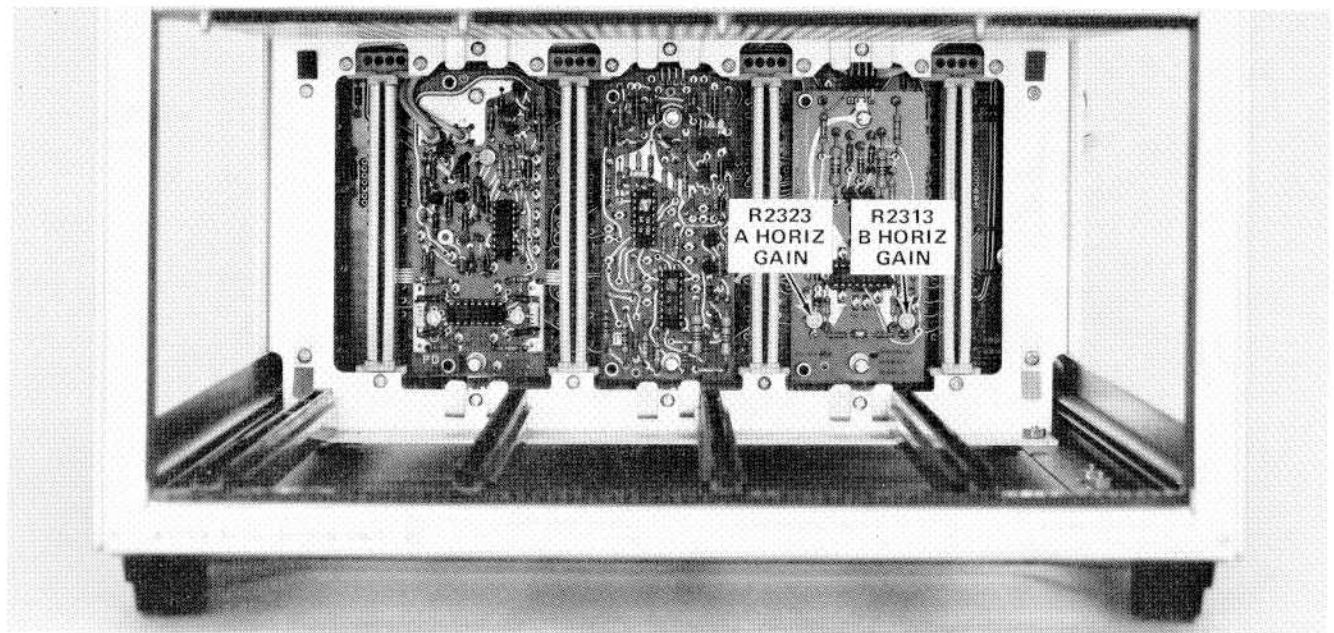

Fig. 3-6. Location of adjustments on A23, Horizontal Interface board.

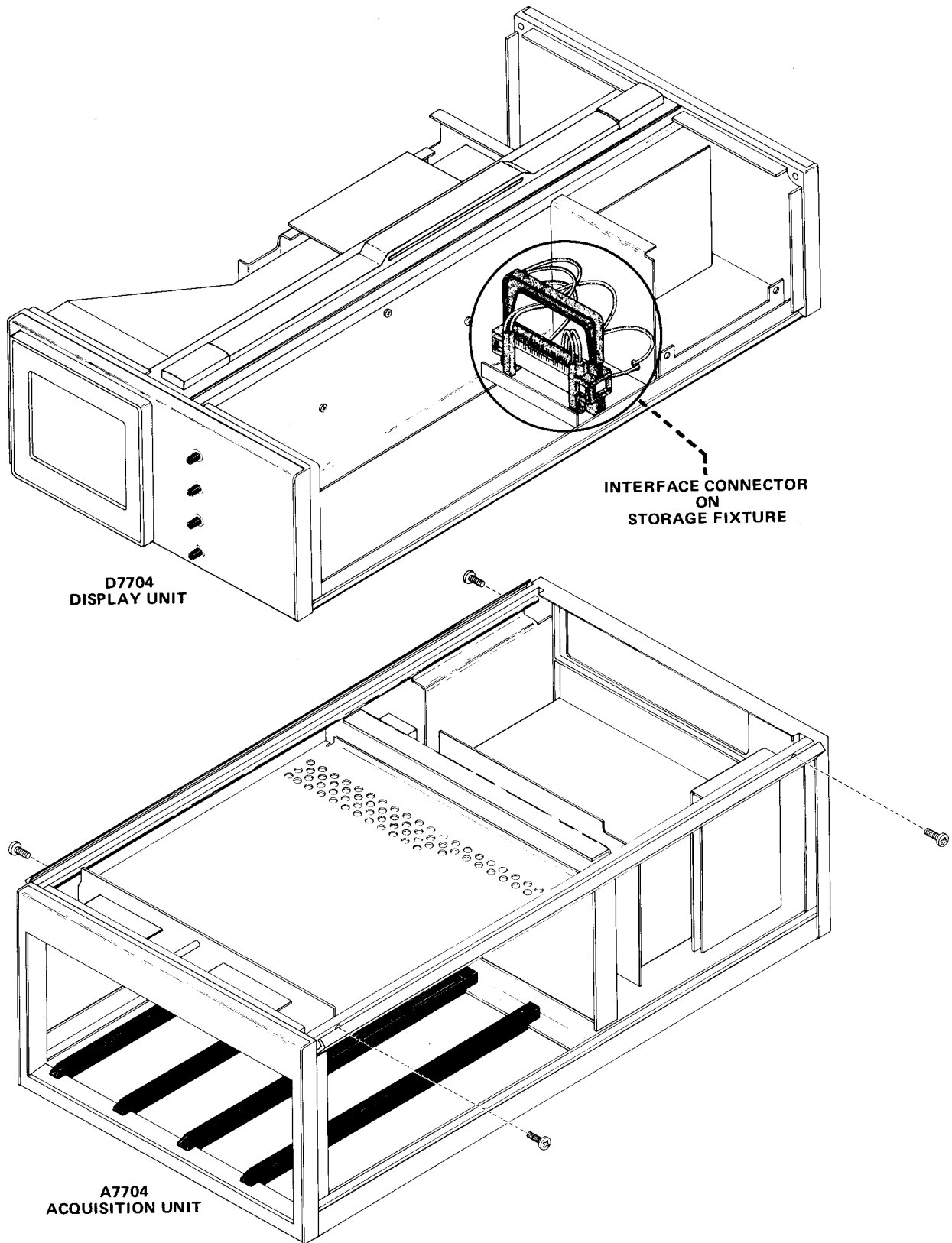

Fig. 3-7. Disassembly and assembly of Display and Acquisition units.

**Circuit Board Replacement.** If a circuit board is damaged beyond repair, replace the entire assembly including all soldered-on components. Part numbers for completely wired circuit boards are given in the Mechanical Parts List.

Most of the circuit boards in this instrument are mounted on the chassis; pin connectors are used for most interconnections with other circuit boards and components. Several boards plug onto the front and rear of the Main Interface board; feed-through connectors connect the plug-on boards to the Main Interface board. Use the following procedure to remove the chassis-mounted circuit boards (removal instructions for plug-on boards and boards requiring unique removal procedures will be given later).

The location of the pin connectors is shown on the circuit-board illustrations in the Diagrams section. Correct orientation of multi-pin connectors is indicated by an arrow molded into the connector housing (pin 1); a matching arrow is marked on the circuit board. Be sure these arrows are aligned as the multi-pin connector is replaced.

#### A. CHASSIS-MOUNTED BOARDS.

1. Disconnect all pin connectors or leads connected to the board or which connect the board to other portions of the instrument.
2. Remove the securing screws.
3. Remove the board.
4. To replace the board, reverse the order of removal. Match the arrows on the multi-pin connectors to the arrows on the board.

#### B. PLUG-ON BOARDS.

1. Remove plug-in units or slide out the power unit (as given previously) as necessary to gain access to boards mounted on the front or rear respectively of the Main Interface board.
2. Disconnect any coaxial end-lead or multi-pin connectors located on the board.
3. Loosen all of the securing screws on the board.

4. Pull out on the edges of the board until the board clears the feed-thru terminals. Hold the board parallel to the Main Interface board until the board is free, so as not to bend the feed-thru terminals.

5. To replace a plug-on circuit board, position it so the feed-thru pins and sockets mate properly.

6. Gently press the circuit board against the mounting surface. Be sure that all the feed-thru pins and sockets mate properly.

7. Uniformly tighten the securing screws. Recommended torque, four to six inch-pounds.

#### C. A20—MAIN INTERFACE CIRCUIT BOARD.

Use the following procedure to replace the Main Interface circuit board:

1. Disassemble the Display Unit from the Acquisition Unit (as given previously).

2. Slide out the power unit as described previously.

3. Remove all of the plug-on boards from the Main Interface board.

4. Disconnect all connectors which connect the Main Interface board to other portions of the Acquisition Unit.

5. Remove the screws from inside each plug-in compartment which hold the plug-in interface connectors to the chassis. Also, remove the screws which hold the ground straps to the chassis.

6. Slide the Main Interface board assembly to the rear and remove it through the top of the Acquisition Unit.

7. To replace the Main Interface board assembly, reverse the order of removal. Match the arrows on the pin connectors to the arrows on the board. Correct location of the pin connectors is shown in the circuit-board illustrations in the Diagrams section.

#### D. A10—CALIBRATOR BOARD.

To replace the Calibrator circuit board, proceed as follows:

1. Disassemble the Display Unit from the Acquisition Unit as described previously.

2. Loosen the setscrews securing the three front-panel knobs (use 1/16-inch hex-key wrench). Remove the knobs.

## Maintenance—7704A Service

3. Disconnect all pin connectors from the board.
4. Remove the screws which hold the Calibrator board to the spacers.
5. Remove the Calibrator board with the mode switches from the unit. The mode switches can be unplugged from the Calibrator board.
6. To replace the Calibrator board, first plug the mode switches into their sockets on the board.
7. Position the Calibrator board so the front-panel controls and switches align with the hole in the front panel.
8. Replace the securing screws and front-panel knobs.
9. Connect the pin connectors to the Calibrator board. Match the arrows on the connectors to the arrows on the board. Correct location of the connectors is shown in the circuit-board illustration in the Diagrams section.

### E. A34—READOUT BOARD OR A33—SIGNAL OUT BOARD.

The Readout and Signal Out boards are mounted on subassemblies. Either of these boards can be removed using the following procedure:

1. Disconnect the pin connectors from the circuit board.
2. Remove the two screws holding the subassembly to the rear panel of the Acquisition Unit.
3. Remove the entire subassembly from the unit.
4. To remove the board from the subassembly, disconnect the leads to the rear panel jacks and remove the securing screws.
5. To replace either board, reverse the removal procedure. Match the arrows on the connectors to the arrows on the board. Correct location of the pin connectors is shown in the circuit-board illustration in the Diagrams section.

### F. A32—REGULATOR BOARD

To remove and replace the Regulator board, use the following procedures:

#### REMOVAL:

1. Slide the power unit out of the rear of the instrument as described previously.
2. Disconnect the multi-pin connectors from the board.
3. Remove the mounting hardware securing the plastic-cased power transistors to the rear heat sink. Note the orientation of the lockwashers so they can be correctly replaced.
4. Remove the screws which hold the Regulator board to the top chassis.
5. Disconnect the leads soldered to the back of the circuit board. Note the location of these leads so they can be correctly replaced. Remove the excess solder from the board with a vacuum-type desoldering tool.
6. Remove the Regulator board along with the plastic-cased transistors.

#### REPLACEMENT:

1. Connect the leads to the back of the circuit board.
2. Apply a thin coat of silicone grease to the back (mounting surface) of each plastic power transistor case.
3. Place the Regulator board on the chassis. Replace the screws which hold the board to the chassis; do not tighten these screws at this time.
4. Check that the plastic-cased power transistors are aligned with their mounting holes and that the insulating washers are in place between the transistor case and the rear heat sink.
5. Secure the transistors to the heatsink with the mounting hardware. Do not over-tighten the nuts; recommended torque is four to six inch-pounds.
6. Tighten the screws holding the Regulator board to the chassis.

7. Connect the multi-pin connectors to the board. Match the arrows on the connectors to the arrows on the board.

8. Replace the power unit in the instrument.

#### G. A31—RECTIFIER AND FILTER BOARD.

To remove the Rectifier and Filter board, use the following procedure. An exploded-view drawing of the power unit is shown in the Mechanical Parts List. Also, several critical parts are identified in Fig. 3-8, an exploded-view drawing of a portion of the power unit.

1. Slide the power unit out of the instrument as described previously.

2. Remove the protective cover from the power unit as described under Access to Components in Power Unit.

3. Disconnect the multi-pin connectors from A32, Regulator board, and A31, Rectifier and Filter board.

4. Remove the two plastic screws which secure the circuit-board shield in place on A30, Power Supply Inverter board.

5. Unsolder the four power-transformer leads from A30, Power Supply Inverter board. These leads, which pass through holes in the board, are identified on the circuit-board illustration in the Diagrams section. Remove the excess solder from the board with a vacuum-type desoldering tool.

6. Remove the four screws securing A31, Rectifier and Filter board to the power unit.

7. Remove the circuit board along with the power transformer.

8. To replace A31, Rectifier and Filter board, reverse the removal procedure.

#### H. A30—POWER SUPPLY INVERTER BOARD.

To remove the Power Supply Inverter board, use the following procedure. An exploded-view drawing of the power unit is shown in the Mechanical Parts List. Several critical parts are identified in Fig. 3-8, an exploded-view drawing of a portion of the power unit.

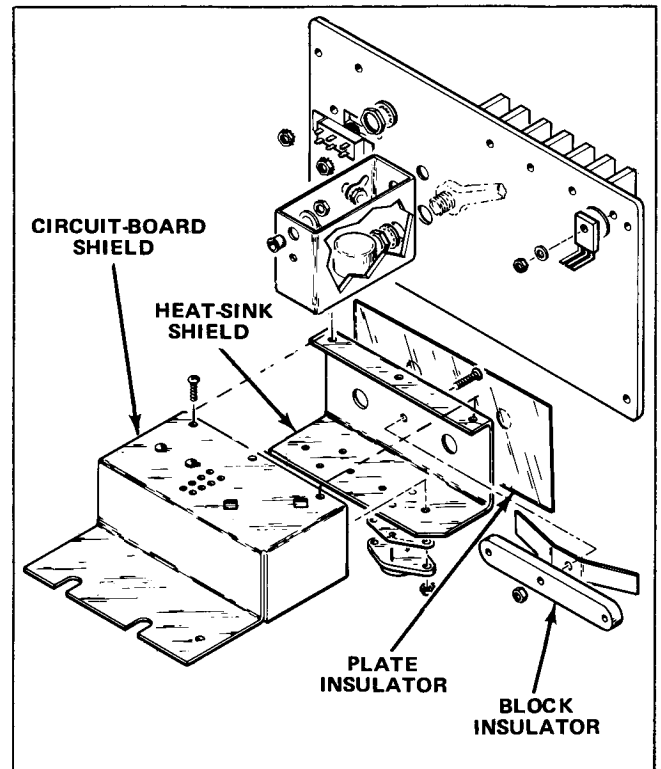

Fig. 3-8. Exploded-view drawing of a portion of the power unit identifying several critical parts.

### WARNING

*The power-unit assembly has been tested at the factory to assure safe operation. Improper repair of this unit can result in hazardous voltages on the chassis of this instrument. Do not remove the plate insulator, block insulator, or transistor shield from the rear heat sink (see Fig. 3-8).*

1. Remove A31, Rectifier and Filter board using the previous procedure.

2. Remove the screws which attach A30, Power Supply Inverter board, to the rest of the power unit.

3. Unsolder the line-input leads from the circuit board. These leads are identified on the circuit-board illustration in the Diagrams section. Remove the excess solder from the board with a vacuum-type desoldering tool.

4. Remove the two metal-cased power transistors by removing the securing nuts and pulling the transistors from their sockets.



## Maintenance—7704A Service

5. Move A30, Power Supply Inverter board, away from the heat sink shield until the transistor mounting studs clear the heat sink shield. Remove the Power Supply Inverter board from the power unit.

6. To replace the Power Supply Inverter board, reverse the removal procedure. Correct connection of the line-input leads is shown on the circuit-board illustration in the Diagrams section.

**Plug-In Interface Connectors.** The individual contacts of the plug-in interface connectors can be replaced. However, it is recommended that the entire Main Interface board be replaced if a large number of the contacts are damaged. An alternative solution is to refer the maintenance of the damaged Main Interface board to your local Tektronix Field Office or representative. Use the following procedure to replace an individual contact of the plug-in interface connector.

1. Remove the Main Interface circuit board from the instrument as described previously.
2. Snap the connector cover (white plastic) off the side of the plug-in interface connector which needs repair.
3. Unsolder and remove the damaged contact.
4. Install the replacement contact. Carefully form it to the required shape to fit against the connector body.
5. Snap the connector cover back onto the plug-in interface connector. Check that the contact which was replaced is aligned with the other contacts.
6. Replace the Main Interface board.

**Semiconductor Replacement.** Semiconductors should not be replaced unless actually defective. If removed from their sockets during routine maintenance, return them to their original sockets. Unnecessary replacement of semiconductors may affect the calibration of this instrument. When semiconductors are replaced, check the operation of the part of the instrument which may be affected.



*POWER switch must be turned off before removing or replacing semiconductors.*

Replacement semiconductors should be of the original type or a direct replacement. The lead configuration of the semiconductors used in this instrument are shown adjacent to or on each diagram page. Some plastic case transistors have lead configurations which do not agree with those shown here. If a replacement transistor is made by a different manufacturer than the original, check the manufacturer's basing diagram for correct basing. All transistor sockets in this instrument are wired for the standard basing used for metal-case transistors. Transistors which have heat radiators or are mounted on the chassis use silicone grease to increase heat transfer. Replace the silicone grease when replacing these transistors.

### WARNING

*Handle silicone grease with care. Avoid getting silicone grease in the eyes. Wash hands thoroughly after use.*

An extracting tool should be used to remove the 14- and 16-pin integrated circuits to prevent damage to the pins. This tool is available from Tektronix, Inc. Order Tektronix Part No. 003-0619-00. If an extracting tool is not available when removing one of these integrated circuits, pull slowly and evenly on both ends of the device. Try to avoid having one end of the integrated circuit disengage from the socket before the other, as the pins may be damaged.

To replace one of the power transistors mounted on the heat radiator on the rear of the power unit, first remove the mounting screws. Then, unsolder and remove the defective transistor. When replacing the transistor, be sure to install the insulating washer between the transistor and the heat radiator (use silicone grease as described previously). Tighten the mounting screw just tight enough to hold the transistor in place. Then solder the replacement transistor to the Regulator board.

**Interconnecting Pin Replacement.** Two methods of interconnection are used in this instrument to connect the circuit boards with other boards and components. When the interconnection is made with a coaxial cable, a special end-lead connector plugs into a socket on the board. Other interconnections are made with a pin soldered onto the board. Two types of mating connections are used for these interconnecting pins. If the mating connector is on the end of a lead, an end-lead pin connector is used which mates with the interconnecting pin. The following information provides the replacement procedure for the various types of interconnecting methods.

### A. COAXIAL-TYPE END-LEAD CONNECTORS.

Replacement of the coaxial-type end-lead connectors requires special tools and techniques; only experienced maintenance personnel should attempt replacement of these connectors. It is recommended that the cable or wiring harness be replaced as a unit. For cable or wiring harness part numbers, see the Mechanical Parts List. An alternative solution is to refer the replacement of the defective connector to your local Tektronix Field Office or representative.

### B. CIRCUIT-BOARD PINS.

#### NOTE

*A circuit-board pin replacement kit including necessary tools, instructions, and replacement pins is available from Tektronix, Inc. Order Tektronix Part No. 040-0542-00.*

To replace a pin which is mounted on a circuit board, first disconnect any pin connectors. Then, unsolder the damaged pin and pull it out of the circuit board with a pair of pliers. Be careful not to damage the wiring on the board with too much heat. Ream out the hole in the circuit board with a 0.031-inch drill. Remove the ferrule from the new interconnecting pin and press the new pin into the hole in the circuit board. Position the pin in the same manner as the old pin. Then, solder the pin on both sides of the circuit board. If the old pin was bent at an angle to mate with a connector, bend the new pin to match the associated pins.

### C. CIRCUIT-BOARD PIN SOCKETS.

The pin sockets on the circuit boards are soldered to the rear of the board. To replace one of these sockets, first unsolder the pin (use a vacuum-type desoldering tool to remove excess solder). Then straighten the tabs on the socket and remove it from the hole in the board. Place the new socket in the circuit-board hole and press the tabs down against the board. Solder the tabs of the socket to the circuit-board; be careful not to get solder into the socket.

#### NOTE

*The spring tension of the pin sockets ensures a good connection between the circuit board and the pin. This spring tension can be destroyed by using the pin sockets as a connecting point for spring-loaded probe tips, alligator clips, etc.*

### D. END-LEAD PIN CONNECTORS.

The pin connectors used to connect the wires to the interconnecting pins are clamped to the ends of the

associated leads. To replace damaged end-lead pin connectors, remove the old pin connector from the end of the lead and clamp the replacement connector to the lead.

Some of the pin connectors are grouped together and mounted in a plastic holder; the overall result is that these connectors are removed and installed as a multi-pin connector. To provide correct orientation of this multi-pin connector when it is replaced, an arrow is stamped on the circuit board and a matching arrow is molded into the plastic housing of the multi-pin connector. Be sure these arrows are aligned as the multi-pin connector is replaced. If the individual end-lead pin connectors are removed from the plastic holder, note the color of the individual wires for replacement.

**Cathode-Ray Tube Replacement.** To replace the cathode-ray tube, proceed as follows:

#### **WARNING**

*Use care when handling a CRT. Protective clothing and safety glasses should be worn. Avoid striking it on any object which might cause it to crack or implode. When storing a CRT, place it in a protective carton or set it face down in a protected location on a smooth surface with a soft mat under the faceplate to protect it from scratches.*

### A. REMOVAL:

1. Remove the plastic CRT mask, light filter, and metal light shield.
2. Remove the four screws securing the CRT bezel to the front panel. Disconnect the multi-pin connector from the left rear of the CRT bezel.
3. Release the CRT anode lead from the plastic fasteners near the top center of the instrument. Disconnect the anode plug from the jack on the high-voltage compartment. Ground this lead to the chassis to dissipate any stored charge.
4. Disconnect the deflection-plate connectors. Be careful not to bend these pins.
5. Remove the CRT base socket from the rear of the CRT.
6. Loosen the two screws located on each side of the CRT socket until the tension of the springs on these screws is released. Then, press in on the screws to be sure that the CRT clamp is loose.

## Maintenance—7704A Service

7. Hold one hand on the CRT faceplate and push forward on the CRT base with the other. As the CRT starts out of the shield, grasp it firmly. Guide the anode lead through the cutout in the CRT shield as the CRT is removed.

### B. REPLACEMENT:

1. Insert the CRT into the shield. Guide the anode lead through the hole in the CRT shield. Set the CRT firmly against the cushions mounted on each corner of the frame panel.

2. Clean the CRT faceplate, plastic faceplate protector, and the light filter with denatured alcohol.

3. Place the black plastic CRT mask over the CRT faceplate.

4. Reconnect the multi-pin connector to the CRT bezel (align arrow on connector with arrow on bezel). Hold the clear faceplate protector in position and install the CRT bezel. Firmly tighten the four screws.

5. Push forward on the CRT base to be certain that the CRT is as far forward as possible. Then tighten the two screws beside the CRT base socket until the springs on the screws are fully compressed.

6. Replace the CRT base socket.

7. Fasten the CRT anode lead into the plastic fasteners. Reconnect the CRT anode plug.

8. Carefully reconnect the deflection-plate connectors. After each connector is installed, lightly pull on its lead to be sure that it will remain in place.

9. Replace the metal light shield and the tinted filter. Then snap the plastic CRT mask into the CRT bezel.

10. Check the calibration of the complete instrument. Calibration procedure is given in Section 4.

**Switch Replacement.** Several types of switches are used in this instrument. The pull and slide switches should be replaced as a unit if damaged. Observe the soldering

precautions given previously in this section when replacing these switches. The following special maintenance information is provided for pushbutton switches.

The pushbutton switches are not repairable and should be replaced as a unit if defective. See the information under Light-Bulb Replacement for instructions on replacing the light bulbs. To replace a pushbutton switch, follow the procedure given for replacement of the Calibrator circuit board.

**Light-Bulb Replacement.** The following procedures describe replacement of the light bulbs in this instrument.

### A. MODE SWITCHES.

Use the following procedure to replace light bulbs in the VERTICAL MODE or HORIZONTAL MODE switches:

1. Remove the applicable mode switch as given previously.

2. Unsolder the leads of the bulb and plastic holder from the circuit board; remove these items from the switch assembly as a unit.

3. Remove the defective bulb from the plastic holder.

4. Install the new bulb in the plastic holder; install this unit in the switch assembly.

5. Solder the bulb and holder to the circuit board.

6. Replace the mode switch as described previously.

### B. TRIGGER SOURCE SWITCHES.

To replace light bulbs in the A TRIGGER SOURCE or B TRIGGER SOURCE switches, proceed as follows:

1. Remove the applicable trigger source switch, using the procedure described previously.

2. Unsolder the defective bulb from the circuit board.

3. Install the new bulb so it is positioned in the same manner as the original bulb.

4. Solder the bulb to the circuit board. If possible, use a heat sink to protect the bulb during soldering.

5. Install the switch using the procedure described previously.

**C. GRATICULE BULB REPLACEMENT.**

To replace the graticule bulbs, first remove the plastic CRT mask, light filter, and metal light shield. Pull on the white tabs to remove the graticule lamp assembly. Now, slide the lamp retaining strips to the side, off the bulb base. Pull the bulb out of the circuit board. Reverse the order of removal for replacement.

**Power Transformer Replacement.** Replace the power transformer only with a direct replacement Tektronix transformer. To replace the power transformer, proceed as follows:

1. Remove A31, Rectifier and Filter board, along with the power transformer as given under Circuit Board Replacement.

2. Unsolder the power-transformer leads from the Rectifier and Filter board. Remove the excess solder from the board with a vacuum-type desoldering tool.

3. Remove the brass spring retainers which hold the transformer windings and core in place and remove these items.

4. To replace the power transformer, reverse the order of removal.

**Fuse Replacement.** The fuses used in this instrument are as follows:

**TABLE 3-2**  
**Fuse Ratings**

| Circuit Number | Rating  | Function   | Location               |
|----------------|---------|------------|------------------------|
| F3001          | 4A Fast | Line Input | Line Selector Assembly |
| F3003          | 2A Fast | Inverter   | Line Selector Assembly |

**Recalibration After Repair**

After any electrical component has been replaced, the calibration of that particular circuit should be checked, as well as the calibration of other closely related circuits. Since the low-voltage supplies affect all circuits, calibration of the entire instrument should be checked if work has been done in the low-voltage supplies or if the power transformer has been replaced. See Section 4 for a complete calibration procedure.

**Instrument Repackaging**

If the Tektronix instrument is to be shipped to a Tektronix Service Center for service or repair, attach a tag showing: owner (with address) and the name of an individual at your firm that can be contacted, complete instrument serial number and a description of the service required.

Save and re-use the package in which your instrument was shipped. If the original packaging is unfit for use or not available, repackage the instrument as follows:

1. Obtain a carton of corrugated cardboard having inside dimensions of no less than six inches more than the instrument dimensions; this will allow for cushioning. Refer to the following table for carton test strength requirements.
2. Surround the instrument with polyethylene sheeting to protect the finish of the instrument.
3. Cushion the instrument on all sides by tightly packing dunnage or urethane foam between carton and instrument, allowing three inches on all sides.
4. Seal carton with shipping tape or industrial stapler.

**SHIPPING CARTON TEST STRENGTH**

| Gross Weight (lb) | Carton Test Strength (lb) |
|-------------------|---------------------------|
| 0-10              | 200                       |
| 10-30             | 275                       |
| 30-120            | 375                       |
| 120-140           | 500                       |
| 140-160           | 600                       |

# CALIBRATION

## Calibration Interval

To ensure instrument accuracy, check the calibration of the 7704A every 1000 hours of operation, or every six months if used infrequently. Before complete calibration, thoroughly clean and inspect this instrument.

## Tektronix Field Services

Tektronix, Inc. provides complete instrument repair and recalibration at local Field Service Centers and the Factory Service Center. Contact your local Tektronix Field Office or representative for further information.

## Using This Procedure

**General.** This procedure provides several features to facilitate calibration of the 7704A. These are:

**Index.** An index is given preceding the Calibration procedure to aid in locating steps.

**Performance Check.** The performance of this instrument can be checked by performing only the ✓ steps. The ✓ preceding a step indicates that performing this step checks the instrument against the tolerances listed as a Performance Requirement (see Specification section in 7704A Operators Manual). Limits and tolerances given in other check steps are calibration guides and should not be interpreted as instrument specifications. Operator front-panel adjustments are adjusted as part of the Performance Check procedure.

**Partial Calibration.** A partial calibration is often desirable after replacing components, or to touch up the adjustment of a portion of the instrument between major recalibrations. To calibrate only part of the instrument, start with the nearest Equipment Required list preceding the desired portion. To prevent unnecessary recalibration of other parts of the instrument, re-adjust only if the tolerance given in the CHECK — part of the step is not met. If re-adjustment is necessary, also check the calibration of any steps listed in the INTERACTION — part of the step.

**Complete Calibration Procedure.** Completion of each step in the Calibration procedure insures that this instrument is correctly adjusted and performing within all given tolerances.

## TEST EQUIPMENT REQUIRED

The following test equipment and accessories, or equivalent, is required for complete calibration of the 7704A. Specifications given for the test equipment are the minimum necessary for accurate calibration. Therefore, the specifications of any test equipment used must meet or exceed the listed specifications. All test equipment is assumed to be correctly calibrated and operating within the listed specifications. Detailed operating instructions for the test equipment are not given in this procedure. Refer to the instruction manual for the test equipment if more information is needed.

### Special Calibration Fixtures

Special Tektronix calibration fixtures are used in this procedure only where they facilitate instrument calibration. These calibration fixtures are available from Tektronix, Inc. Order by part number through your local Tektronix Field Office or representative.

### Calibration Equipment Alternatives

All of the listed test equipment, or its equivalent, is required to completely check and adjust this instrument. The Calibration procedure is based on the first item of equipment given as an example of applicable equipment. When other equipment is substituted, control settings or calibration setup may need to be altered to meet the requirements of the substituted equipment. If the exact item of test equipment given as an example in the Test Equipment list is not available, first check the Specifications column carefully to see if any other equipment is available which might suffice. Then check the Usage column to see what this item of test equipment is used for. If used for a check or adjustment which is of little or no importance to your measurement requirements, the item and corresponding step(s) can be deleted.

The following procedure is written to completely check and adjust the 7704A to the Performance Requirements listed in the Operators Manual and to allow interchangeability of 7000-series plug-in units between 7000-series mainframes without the need to completely recalibrate the instruments each time. If the applications for which you will use the 7704A do not require the full available

performance from the 7704A and plug-in combinations, this procedure and the required equipment list can be shortened accordingly. For example, the basic measurement capabilities of this instrument can be verified by just checking vertical deflection accuracy and basic horizontal timing with 7000-series real-time plug-in units and the 7704A Calibrator signal. Also, if the 7704A and plug-in combination is to be used as a fixed system without the need to interchange the plug-in units, all tests can be made by substituting vertical plug-in units and applicable test signals for the 067-0587-01 signal standardizer calibration fixture.

### Signal Connections

Detailed signal-connection information is not given in this procedure except when critical for a particular test. In general, the rear-panel output connectors should be connected to other equipment with 50-ohm BNC cables. The cable output should be terminated in 50 ohms; use a 50-ohm BNC termination if the other equipment has a high input impedance. Use a BNC T connector to simultaneously connect a signal to two inputs. Signal-connection and termination information for the test equipment should be available in the associated instruction manual.

TABLE 4-1  
Test Equipment

| Description                                | Minimum Specifications  | Usage  | Examples Of Applicable Test Equipment  |
|--|---|--|--|
| 1. Precision DC Voltmeter                  | Range, zero to 175 volts; accuracy, within 0.1%.  | Low-voltage power supply adjustment. Calibrator output voltage adjustment.   | a. Tektronix DM 501 Digital Multimeter. <sup>1</sup><br><br>b. Fluke Model 825A Differential DC Voltmeter.   |
| 2. DC Voltmeter (VOM)                      | Range, zero to 4000 volts; accuracy, checked to within 1% at -2960 volts.   | High-voltage power supply adjustment.  | a. Triplet Model 630-NA.<br><br>b. Simpson Model 262.<br><br>c. Item 1 used with a precision voltage divider.  |
| 3. Signal Standardizer Calibration Fixture | Produces gain-check and pulse-response waveforms.   | Used throughout procedure to standardize instrument so plug-in units can be interchanged without complete recalibration.           | a. Tektronix 067-0587-01 Calibration Fixture.<br><br>b. Calibrated 7000-series plug-in units with suitable signal sources may be substituted if lower performance is acceptable.   |
| 4. Time-Base Plug-In Unit (Two Required)   | Tektronix 7B-series. X10 magnifier and two nanosecond/division sweep rate required for complete procedure as written. | Used throughout procedure to provide sweep. Two nanosecond/division sweep required only for high-frequency timing (one unit only). | a. Tektronix 7B70 or 7B71 Time Base. May be shared with 7000-series test oscilloscope.<br><br>b. Any 7B-series plug-in unit (high-frequency timing cannot be checked if two nanosecond/division sweep rate not available). |
| 5. Test-Oscilloscope System with 10X Probe | Bandwidth, DC to 75 megahertz; minimum deflection factor, 50 millivolts/division; accuracy, within 3%.                | CRT grid bias adjustment. Z-axis transient response adjustment. Auto-focus adjustment. Output Signals checks.                      | a. Tektronix 7704A Oscilloscope with 7A15A Amplifier, 7B70 or 7B71 Time Base, and P6053 Probe.<br><br>b. Tektronix 454A Oscilloscope with P6054 Probe.   |
| 6. Time-Mark Generator                     | Marker outputs, two nanoseconds to one millisecond; marker accuracy, within 0.1%; trigger output, one millisecond.    | Geometry adjustment. High-frequency timing check. Calibrator 1 kHz repetition rate adjustment.                                     | a. Tektronix TG 501 Time-Mark Generator. <sup>1</sup><br><br>b. Tektronix Type 2901 Time-Mark Generator.   |
| 7. Low-Frequency Generator                 | Frequency, 50 kilohertz; output amplitude, variable from five millivolts to two volts peak-to-peak.                   | External Z-axis check. X-Y phase shift check.  | a. Tektronix SG 503 Signal Generator. <sup>1</sup><br><br>b. Tektronix Type 191 Constant Amplitude Signal Generator.<br><br>c. General Radio 1310-B Oscillator.  |

<sup>1</sup> Requires TM 500-Series Power Module.

TABLE 4-1 (cont)

| Description  | Minimum Specifications  | Usage   | Examples of Applicable Test Equipment  |
|--|---|---|--|
| 8. Amplifier Plug-In Unit (two identical units required) | Tektronix 7A-series. Bandwidth with 7704A, DC to 200 megahertz required for complete procedure as written.  | Used throughout procedure to provide vertical input to 7704A being calibrated. 200 megahertz bandwidth required only for vertical channel isolation check. Identical units required only for X-Y phasing check. | a. Tektronix 7A19 Amplifier.<br>b. Tektronix 7A16A Amplifier.<br>c. Any 7A-series plug-in (tolerances in some steps may be limited if low-frequency units are used). |
| 9. High Frequency Constant-Amplitude Signal Generator    | Frequency range, 100 megahertz to 250 megahertz (300 megahertz for Option 9); three megahertz; output amplitude, variable from 0.5 to four volts peak-to-peak; amplitude accuracy, constant within 1% of reference as output frequency changes. | Vertical channel isolation check. Vertical amplifier bandwidth check.   | a. Wavetek 1002 Sweep/Signal Generator.  |
| 10. Screwdriver  | Three-inch shaft. 3/32-inch bit.  | Used throughout procedure to adjust variable resistors.   | a. Xcelite R-3323.   |
| 11. Low-Capacitance Screwdriver                          | 1-1/2 shaft.  | Used throughout procedure to adjust variable capacitors.  | a. Tektronix Part Number 003-0000-00.  |
| 12. T Connector  | Connectors, BNC.  | Used to simultaneously connect a signal to two inputs.  | a. Tektronix Part Number 103-0030-00.  |
| 13. BNC to Pin-Jack Cable                                | Adapts pin jacks to BNC male connector.   | Used to connect calibrator output to BNC inputs.  | a. Tektronix Part Number 175-1178-00 (one supplied as standard accessory).   |

**CALIBRATION PROCEDURE**

7704A, Serial No. \_\_\_\_\_  
 Calibration Date \_\_\_\_\_  
 Calibrated By \_\_\_\_\_

**Introduction**

The following procedure returns the 7704A to correct calibration. All limits and tolerances given in this procedure are calibration guides, and should not be interpreted as instrument specifications except as listed as a Performance Requirement in the Operators manual.

**Index to Calibration Procedure**

|  | Page |
|--|------|
| <b>Power Supply</b>                      |      |
| 1. Adjust +54-Volt Supply                | 4-5  |
| 2. Adjust -50-Volt Power Supply          | 4-5  |
| 3. Check Remaining Power-Supply Voltages | 4-5  |

**Z-Axis and Display**

|                                      |     |
|--------------------------------------|-----|
| 4. Adjust High-Voltage Power Supply  | 4-7 |
| 5. Adjust CRT Grid Bias              | 4-7 |
| 6. Adjust Z-Axis Transient Response  | 4-8 |
| √7. Adjust Trace Alignment           | 4-8 |
| 8. Adjust Auto-Focus Operation       | 4-8 |
| 9. Adjust Geometry                   | 4-9 |
| √10. Check External Z-Axis Operation | 4-9 |

**Vertical System**

|   |      |
|---|------|
| 11. Adjust Vertical Amplifier Centering         | 4-10 |
| 12. Adjust Vertical Amplifier Bias              | 4-10 |
| √13. Adjust Vertical Amplifier Gain             | 4-10 |
| √14. Check Low-Frequency Linearity              | 4-11 |
| 15. Adjust Vertical High-Frequency Compensation | 4-11 |

## Calibration—7704A Service

|  | Page |
|--|------|
| √16. Check Vertical Amplifier Bandwidth        | 4-12 |
| √17. Check Vertical Channel Isolation          | 4-12 |
| √18. Check Vertical Display Modes              | 4-13 |
| √19. Check Vertical Trace Separation Operation | 4-13 |

### Triggering

|                                       |      |
|---------------------------------------|------|
| √20. Check Trigger Selector Operation | 4-14 |
|---------------------------------------|------|

### Horizontal System

|   |      |
|---|------|
| √21. Adjust Horizontal Amplifier Gain           | 4-16 |
| 22. Adjust Horizontal Amplifier Centering       | 4-17 |
| 23. Adjust Horizontal Amplifier Thermal Balance | 4-17 |
| √24. Check Low-Frequency Linearity              | 4-17 |
| √25. Adjust High-Frequency Timing               | 4-17 |
| √26. Check X-Y Phase Shift                      | 4-18 |

### Calibrator

|  |      |
|--|------|
| √27. Adjust Calibrator Output Voltage        | 4-19 |
| √28. Adjust Calibrator 1 kHz Repetition Rate | 4-19 |

### Output Signals

|                                    |      |
|------------------------------------|------|
| √29. Check Sawtooth Output Signals | 4-21 |
| √30. Check Gate Output Signals     | 4-21 |
| √31. Check Vertical Signal Output  | 4-22 |

### Readout System

|                                |      |
|--------------------------------|------|
| 32. Adjust Vertical Separation | 4-23 |
| 33. Adjust Full Character Scan | 4-24 |

|                                 | Page |
|---------------------------------|------|
| 34. Adjust Column and Row Match | 4-24 |
| √35. Check Readout Modes        | 4-24 |

## Preliminary Procedure for Calibration

### NOTE

*This instrument should be calibrated at an ambient temperature of  $+25^{\circ}\text{C} \pm 5^{\circ}\text{C}$  for best overall accuracy.*

1. Remove the side panels from the 7704A.

2. Connect the 7704A to a power source that meets the voltage and frequency requirements of this instrument. The applied voltage should be near the center of the voltage range selected by the Line Selector assembly (see Section 1 for information on converting this instrument from one operating voltage to another).

### NOTE

*If correct line voltage is not available, use a variable autotransformer to provide the correct input voltage.*

3. Set the controls as given under Control Settings preceding the desired section. Allow at least 20 minutes warmup before proceeding with the first section.

### NOTE

*Titles for external controls of this instrument are capitalized in this procedure (e.g., A INTENSITY). Internal adjustments are initial capitalized only (e.g., Vertical Amplifier Gain).*

### NOTE

*The assembly number is included as part of the circuit number of adjustments and test points used in this procedure. For example, R133 on assembly A32 is referred to as R32133.*



## POWER SUPPLY

## Equipment Required

1. Precision DC voltmeter

2. Three-inch screwdriver

## NOTE

The location of adjustments and test points for calibration is shown on a foldout, page 6-31, in the Diagrams section.

## Control Settings

Set the 7704A controls as follows:

|                  |           |
|------------------|-----------|
| POWER            | OFF       |
| VERTICAL MODE    | RIGHT     |
| VERT TRACE       |           |
| SEPARATION (B)   | Midrange  |
| A TRIGGER SOURCE | VERT MODE |
| A INTEN          | Midrange  |
| HORIZONTAL MODE  | A         |
| B INTEN          | Midrange  |
| B TRIGGER SOURCE | VERT MODE |
| INTENSITY        | Midrange  |
| FOCUS            | Midrange  |
| READOUT          | OFF       |
| GRAT ILLUM       | Midrange  |

## 1. Adjust +54-Volt Supply

a. Remove the screws securing the corners of the heat sink assembly to the rear of the instrument (the Line Selector assembly is mounted on the heat sink assembly). Slide the power unit out of the 7704A; the interconnecting cables remain connected.

**WARNING**

*Extreme caution must be used when operating the 7704A with the power-unit cover removed due to the line voltage and high-voltage/high-current potentials present.*

b. Return the POWER switch to on.

c. Connect the precision DC voltmeter between the +54 V test point (see Fig. 6-26) and ground.

d. CHECK—Meter reading; +54.2 volts  $\pm 0.25$  volt. (If the meter reading is within the given tolerance, do not re-adjust; otherwise, perform part e.)

e. ADJUST—+54-V adjustment R3143 (bottom of power supply, accessible through the cover near the front of the power unit; see Fig. 6-27) for a meter reading of +54.2 volts.

f. Disconnect the precision DC voltmeter.

g. INTERACTION—If the setting of R3143 is changed, check steps 2, 3, and 4.

## 2. Adjust -50 Volt Power Supply

a. Connect the precision DC voltmeter between the -50 V supply and chassis ground (pin 6-P32G; see Fig. 6-28).

b. CHECK—Meter reading; -50 volts  $\pm 0.2$  volt.

c. ADJUST -50 V adjustment R32133 (see Fig. 6-28) for a meter reading of -50 volts  $\pm 0.2$  volt.

d. INTERACTION—Any change in the setting of R32133 may affect operation of all circuits within the 7704A and plug-in units.

## 3. Check Remaining Power-Supply Voltages

a. CHECK—Table 4-2 lists the low-voltage power supplies in the instrument. Check each supply with the precision DC voltmeter for output voltage within the given tolerance.

## Calibration—7704A Service

b. Set the POWER switch to off and disconnect all test equipment.

c. Install the power unit in the instrument and return the POWER switch to on.

d. Connect the precision DC voltmeter to Pin 1 of P43 on rear of A43, Horizontal Output board; see Fig. 6-29.

e. CHECK—Meter reading +155 volts  $\pm$ 5 volts.

f. Disconnect all test equipment.

**TABLE 4-2**  
**Power Supply Tolerance**

| <b>Power Supply</b>         | <b>Output Voltage Tolerance</b> | <b>Test Point Location (see Fig. 6-28)</b> |
|-----------------------------|---------------------------------|--|
| -50 Volt                    | $\pm$ 0.20 volt                 | Pin 6—P32G                                 |
| -15 Volt                    | $\pm$ 0.15 volt                 | Pin 1—P32G                                 |
| +5 Volt                     | $\pm$ 0.10 volt                 | Pin 2—P32G                                 |
| +15 Volt                    | $\pm$ 0.15 volt                 | Pin 4—P32G                                 |
| +50 Volt                    | $\pm$ 0.50 volt                 | Pin 5—P32G                                 |
| Control Illum (+5 V Lights) | +0.2 to -0.5 volt               | Pin 9—P32G                                 |

## Z-AXIS AND DISPLAY

## Equipment Required

- |  |  |
|--|--|
| 1. DC voltmeter (VOM)                      | 5. Test oscilloscope system with 10X probe |
| 2. Signal standardizer calibration fixture | 6. Time-mark generator                     |
| 3. Time-base plug-in unit (two required)   | 7. Low-frequency signal generator          |
| 4. Amplifier plug-in unit                  | 8. Three-inch screwdriver                  |
|  | 9. Low-capacitance screwdriver             |

## NOTE

*The location of adjustments and test points for calibration is shown on a foldout, page 6-33, in the Diagrams section.*

## Control Settings

Set the 7704A controls as follows:

|                           |                        |
|---------------------------|------------------------|
| POWER                     | OFF                    |
| VERTICAL MODE             | RIGHT                  |
| VERT TRACE SEPARATION (B) | Midrange               |
| A TRIGGER SOURCE          | VERT MODE              |
| A INTEN                   | Fully clockwise        |
| HORIZONTAL MODE           | A                      |
| B INTEN                   | Fully clockwise        |
| B TRIGGER SOURCE          | VERT MODE              |
| INTENSITY                 | Fully counterclockwise |
| FOCUS                     | Midrange               |
| READOUT                   | OFF                    |
| GRAT ILLUM                | Midrange               |

## 4. Adjust High-Voltage Power Supply

a. Connect the DC voltmeter (VOM), set to measure at least 3000 volts, between TP4222 and chassis ground (see Fig. 6-30).

b. Set the POWER switch to on.

c. CHECK—Meter reading;  $-2960$  volts  $\pm 29.6$  volts.

d. ADJUST—High Voltage adjustment R4123 (see Fig. 6-31) for a meter reading of  $-2960$  volts.

e. Set the POWER switch to off and disconnect the voltmeter. Return the POWER switch to on.

## 5. Adjust CRT Grid Bias

a. Install the signal standardizer calibration fixture in the RIGHT VERT compartment and a time-base unit in the A HORIZ compartment.

b. Set the time-base unit for a free-running sweep at a rate of 0.2 second/division. Set the calibration fixture Test switch to Triggering Gain.

c. Connect the 10X probe to the input of the test oscilloscope. Check the probe compensation.

d. Set the test oscilloscope for a vertical deflection factor of 0.2 volt/division (two volts/division at probe tip) and a sweep rate of one millisecond/division.

e. Establish a ground reference level for the test oscilloscope by either grounding the probe tip or setting the input coupling to ground. Then, position the test oscilloscope trace to the bottom horizontal line of the graticule. Do not change the test-oscilloscope position control after setting this ground reference.

f. Connect the probe tip to TP41120 (see Fig. 6-31); connect the probe ground to chassis ground with a short grounding strap.

g. Note the DC level indicated by the test-oscilloscope trace.

h. Set the INTENSITY control for a DC level four volts more positive than the level noted in part g.

## Calibration—7704A Service

i. ADJUST—CRT Grid Bias adjustment R4135 (see Fig. 6-31) so the dot on the CRT screen is just extinguished.

j. Leave the 10X probe connected to TP 41120 for the next step.

### 6. Adjust Z-Axis Transient Response

a. Set the test oscilloscope for a vertical deflection factor of one volt/division (10 volts/division at probe tip) at a sweep rate of two microseconds/division.

b. Set the time-base unit for a free-running sweep at a rate of 0.02 microsecond/division.

c. Set the INTENSITY control for a pulse waveform with a peak-to-peak amplitude of 30 volts as displayed on the test oscilloscope.

d. Set the test oscilloscope for a sweep rate of 20 nanoseconds/division.

e. CHECK—Test oscilloscope for optimum square corner on displayed pulse.

f. ADJUST—Z-Axis Peaking adjustment R4197 and C41109 (see Fig. 6-31) for optimum square corner on displayed pulse.

g. Disconnect all test equipment.

### √7. Adjust Trace Alignment

a. Change the following control settings:

|                 |      |
|-----------------|------|
| VERTICAL MODE   | ALT  |
| HORIZONTAL MODE | CHOP |

b. Install a time-base unit in the LEFT VERT compartment and an amplifier unit in the B HORIZ compartment.

c. Set both time-base units for auto, external triggering at a sweep rate of 0.1 millisecond/division.

d. Set the calibration fixture Test switch to Vert or Horiz Freq Response.

e. Position the traces to the vertical and horizontal center lines of the graticule. Use the calibration fixture Position control to position the vertical trace and the amplifier unit position control to position the horizontal trace.

√f. CHECK—The vertical trace aligns with the center vertical line within 0.1 division and the horizontal trace aligns with the center horizontal line within 0.1 division.

√g. ADJUST—Front-panel TRACE ROTATION adjustment (horizontal alignment) and Y Axis Align adjustment (vertical alignment) R41173 (see Fig. 6-31) so the traces align with the vertical and horizontal center lines.

h. INTERACTION—Check step 8.

### 8. Adjust Auto-Focus Operation

a. Set the calibration fixture Test switch to Vert or Horiz + Step Resp, and the Rep Rate switch to 10 kHz.

b. Set the time-base unit for auto, internal triggering at a 0.1-microsecond/division sweep rate (left compartment).

c. Set the calibration fixture for a three-division display.

d. Set the INTENSITY control for a low-intensity display. Set the FOCUS control and ASTIG adjustment for a well-defined display.

e. Set the INTENSITY control for maximum display intensity.

f. ADJUST—Auto Focus Gain adjustment R41127 (see Fig. 6-31) for a well-defined, high-intensity display.

g. Set the INTENSITY control for a low-intensity display.

h. Connect the test oscilloscope 10X probe tip to the junction of R41131-CR41157-R41155-CR41155 (see Fig. 6-31).

i. Set the test oscilloscope for a vertical deflection factor of one volt/division (10 volts/division at probe tip), and a sweep rate of 200 nanoseconds/division.

j. While observing the test-oscilloscope display, rotate the INTENSITY control between the minimum and maximum display-intensity levels. If necessary, reposition the gimmick-capacitor wire located around R41131 (see Fig. 6-31) for best square corner on displayed pulse throughout the rotation of the INTENSITY control.

k. INTERACTION—Check step 6.

l. Disconnect the probe.

## 9. Adjust Geometry

a. Change the following control settings:

|                 |       |
|-----------------|-------|
| VERTICAL MODE   | RIGHT |
| HORIZONTAL MODE | A     |

b. Connect the marker output of the time-mark generator to the calibration fixture Aux In connector and the trigger output to the A time-base unit external trigger input.

c. Set the time-mark generator for one-millisecond markers and one-millisecond triggers.

d. Set the A time-base unit for auto triggering from the external source at a sweep rate of 0.5 millisecond/division.

e. Set the calibration fixture Test switch to Vert or Horiz Aux In. Set the Amplitude and Position controls so the time markers extend above and below the upper and lower graticule limits.

f. Set the time-base unit variable time/division control to obtain exactly one marker for each major graticule division.

g. Set the time-mark generator for both one- and 0.1-millisecond markers.

h. CHECK—Vertical bowing and tilt of the marker display is less than 0.1 division (each 0.1-millisecond marker represents 0.1 division).

i. ADJUST—Geometry adjustment R41171 (see Fig. 6-31) for minimum bowing of time markers. Adjustment might have to be compromised to obtain less than 0.1 division bowing and tilt everywhere within the graticule area.

j. Disconnect all test equipment.

## 9A. Adjust Shield Volts

a. Short the vertical deflection leads together with a jumper lead.

b. Connect the positive dc voltmeter lead to the deflection leads and note the reading.

c. Disconnect the positive voltmeter lead and remove the short.

d. Connect the positive dc voltmeter lead to pin 4 of P41U, on the Z-Axis board.

e. ADJUST—Shield Volts adjustment R41176 for approximately the same reading as obtained in part b of this step.

## ✓10. Check External Z-Axis Operation

### NOTE

*If the Signal-Buffer subassembly was deleted from this instrument (Option 7) omit this step.*

a. Remove the calibration fixture and install the amplifier unit in its place.

b. Connect the output of the low-frequency signal generator to the amplifier-unit input (use a BNC T connector at the amplifier input).

c. Set the amplifier unit for a calibrated deflection factor of 0.5 volt/division.

d. Set the A time-base unit for auto, internal triggering at a sweep rate of 10 microseconds/division.

e. Set the signal generator for a four-division display at 50 kilohertz.

f. Connect the signal from the output of the T connector at the amplifier input to the Z-AXIS INPUT connector on the rear panel.

✓g. CHECK—Top portion of displayed waveform is blanked out.

h. Disconnect all test equipment and remove the plug-in units.

## VERTICAL SYSTEM

### Equipment Required

- |  |   |
|--|---|
| 1. Signal standardizer calibration fixture | 4. High-frequency constant-amplitude signal generator |
| 2. Time-base plug-in unit (two required)   | 5. Three-inch screwdriver                             |
| 3. Amplifier plug-in unit (two required)   | 6. Low-capacitance screwdriver                        |

### NOTE

*The location of adjustments is shown on a pullout, page 6-33, in the Diagrams section.*

### Control Settings

Set the 7704A controls as follows:

|                  |                                   |
|------------------|-----------------------------------|
| POWER            | ON                                |
| VERTICAL MODE    | ALT                               |
| VERT TRACE       |                                   |
| SEPARATION (B)   | Midrange                          |
| A TRIGGER SOURCE | VERT MODE                         |
| A INTEN          | Midrange                          |
| HORIZONTAL MODE  | A                                 |
| B INTEN          | Midrange                          |
| B TRIGGER SOURCE | VERT MODE                         |
| INTENSITY        | Midrange                          |
| FOCUS            | Adjust for a well-defined display |
| READOUT          | OFF                               |
| GRAT ILLUM       | Midrange                          |

### NOTE

*The Vertical Interface Centering and Gain adjustments do not need to be checked during routine calibration. However, if components are replaced or if the Acquisition Unit is used in a different system, adjustment might be necessary. The need for adjustment is indicated if the Vertical System adjustments can not be performed according to the following procedure. Calibration information for the Vertical Interface is given under Special Adjustment Procedures in the Maintenance section.*

### 11. Adjust Vertical Amplifier Centering

a. Install a time-base unit in the A HORIZ compartment.

b. Set the time-base unit for a free-running sweep at a rate of 100 microseconds/division.

c. CHECK—CRT display; vertical position of alternating traces (might appear as a single trace) is within 0.2 division of the graticule center line.

d. ADJUST—Vertical Amplifier Centering adjustment R4493 (see Fig. 6-32) for equal spacing of the traces from the graticule center line. (If the traces appear as a single trace, adjust R4493 to position the trace to the graticule center line.)

### 12. Adjust Vertical Amplifier Bias

a. Set the VERTICAL MODE switch to RIGHT.

b. Install the signal standardizer calibration fixture in the RIGHT VERT compartment.

c. Set the calibration fixture Test switch to Vert or Horiz Gain and the Rep Rate to 1 kHz.

d. ADJUST—Vertical Amplifier Bias adjustment R4415 (see Fig. 6-32) for maximum deflection between the traces.

### √13. Adjust Vertical Amplifier Gain

a. Set the calibration fixture for a Rep Rate of 100 kHz. Position the display to align the bright center trace with the graticule center line.

√b. Check—Deflection between the second and eighth traces should be six divisions  $\pm$  0.06 division. Note the exact deflection for part f of this step.

c. ADJUST—Vertical Amplifier Gain adjustment R4406 (see Fig. 6-32) for exactly six divisions of deflection between the second and eighth traces.

d. Remove the calibration fixture from the RIGHT VERT compartment and install it in the LEFT VERT compartment.

e. Set the VERTICAL MODE switch to LEFT.

√f. CHECK—Deflection between the second and eighth traces should be the same as step 13b  $\pm 1\%$  (six divisions  $\pm 0.06$  division if R4406 was adjusted in step 13c).

g. ADJUST—If necessary, compromise the setting of R4406 for optimum gain for both vertical compartments. If re-adjustment is necessary, recheck parts b through f.

√14. Check Low-Frequency Linearity

a. Set the signal standardizer calibration fixture Test switch to Vert or Horiz +Step Resp with the Rep Rate switch set to 1 kHz.

b. Set the calibration fixture Amplitude control so the display is exactly two divisions in amplitude in the center of the graticule area.

√c. CHECK—Position the two-division display vertically and check for not more than 0.1 division of compression or expansion anywhere within the graticule area.

15. Adjust Vertical High-Frequency Compensation

a. Set the signal standardizer calibration fixture Rep Rate switch to 1 MHz. Set the Amplitude and Position controls for a six-division display, centered on the graticule.

b. Set the time-base unit for auto, internal triggering at a sweep rate of 100 nanoseconds/division. Set the triggering controls for a stable display triggered on the rising portion of the pulse.

c. CHECK—Check for optimum square corner and flat top on displayed pulse. Aberrations in the first 50 nanoseconds after the step are not to exceed +0.1 or -0.1 division with total peak-to-peak aberrations not to exceed 0.12 division; aberrations from 50 to 150 nanoseconds after the step are not to exceed 0.03 division peak-to-peak. (For Option 9: Aberrations in the first 50 nanoseconds after the step are not to exceed +0.3 or -0.3 division with total peak-to-peak aberrations not to exceed 0.3 division; aberrations from 50 to 150 nanoseconds after step are not to exceed 0.06 division peak-to-peak.)

d. ADJUST—High-frequency compensation as given in Table 4-3 for optimum square leading corner and flat top with minimum aberrations within limits given in part c. Location of the adjustments is shown in Figs. 6-32 and 6-33. Use the low-capacitance screwdriver to adjust variable capacitors. Adjust the inductors by changing their position in the sockets. Repeat the complete adjustment procedure as necessary to obtain optimum response.

e. Move the calibration fixture to the RIGHT VERT compartment and set the VERTICAL MODE switch to RIGHT.

f. CHECK—Check for optimum square corner and flat top on displayed pulse with aberrations within limits given in part c.

TABLE 4-3

High Frequency Compensation

| Calibration Fixture Rep Rate | Best Sweep Rate (time/division) | Adjustment  | Primary Area of Pulse Affected     |
|------------------------------|---------------------------------|-------------|------------------------------------|
| 100 Hz                       | 2 milliseconds                  | R4465       | First 10 microseconds (flat top)   |
| 1 kHz                        | 0.2 millisecond                 | R4453       | First five microseconds (flat top) |
| 10 kHz                       | 20 microseconds                 | R4461       | First one microsecond (flat top)   |
| 100 kHz                      | 2 microseconds                  | R4423       | First 400 nanoseconds              |
| 1 MHz                        | 100 nanoseconds                 | C4424       | First 50 nanoseconds               |
| 1 MHz                        | 50 nanoseconds                  | R4427-C4427 | Five to 15 nanoseconds             |
| 1 MHz                        | 20 nanoseconds                  | R4404-C4401 | 2 to 5 nanoseconds (leading edge)  |
| 1 MHz                        | 2 nanoseconds                   | L4410-L4411 | Front corner                       |
| 1 MHz                        | 2 nanoseconds                   | R2234-C2231 | Front corner                       |

## Calibration—7704A Service

g. ADJUST—Interface high-frequency compensation R2284-C2281 (see Fig. 6-33) for optimum square leading corner and flat top on displayed pulse with minimum aberrations within limits given in part c. If necessary, compromise the adjustments given in Table 4-3 (except for C2231) for optimum pulse response for both vertical compartments. If re-adjustment is necessary, recheck parts c through f.

### ✓16. Check Vertical Amplifier Bandwidth

a. Connect the output of the high-frequency constant-amplitude signal generator to the calibration fixture CW In connector.

b. Set the calibration fixture Test switch to Vert or Horiz Freq Resp.

c. Set the time-base unit for a free-running sweep at a rate of 200 nanoseconds/division.

d. Set the high-frequency generator for eight divisions of deflection at its reference frequency.

e. Without changing the output amplitude, increase the output frequency of the generator until the display amplitude is reduced to 5.6 divisions (−3 dB point).

✓f. CHECK—Generator output frequency must be 230 megahertz or higher (210 megahertz if checked outside the +20°C to +30°C temperature range). Actual frequency (RIGHT VERT) megahertz. (Option 9: Generator output frequency must be 280 megahertz or higher within the +20°C to +30°C temperature range, or 210 megahertz outside this range.)

g. Move the calibration fixture to the LEFT VERT compartment, and set the VERTICAL MODE switch to LEFT.

✓h. Repeat parts d through f. Actual frequency (LEFT VERT) megahertz.

### ✓17. Check Vertical Channel Isolation

a. Replace the signal standardizer calibration fixture with the amplifier unit.

b. Connect the output of the high-frequency signal generator to the amplifier unit input.

c. Set the amplifier unit and signal generator for an eight-division display at 100 megahertz.

d. Set the VERTICAL MODE switch to RIGHT.

✓e. CHECK—CRT display for not more than 0.1 division of 100-megahertz signal (channel isolation at least 100:1 at 100 megahertz).

f. Set the VERTICAL MODE switch to LEFT.

g. Set the generator for an eight-division display at 200 megahertz.

h. Set the VERTICAL MODE switch to RIGHT.

✓i. CHECK—CRT display for not more than 0.2 division of 200-megahertz signal (channel isolation at least 50:1 at 200 megahertz).

j. Move the amplifier unit to the RIGHT VERT compartment (leave signal connected).

k. Set the generator for an eight-division display at 200 megahertz.

l. Set the VERTICAL MODE switch to LEFT.

✓m. CHECK—CRT display for not more than 0.2 division of 200-megahertz signal (channel isolation at least 50:1 at 200 megahertz).

n. Set the VERTICAL MODE switch to RIGHT.

o. Set the generator for an eight-division display at 100 megahertz.

p. Set the VERTICAL MODE switch to LEFT.

✓q. CHECK—CRT display for not more than 0.1 division of 100-megahertz signal (channel isolation at least 100:1 at 100 megahertz).

r. Disconnect all test equipment.



✓18. Check Vertical Display Modes

a. Install another amplifier unit or the signal standardizer calibration fixture in the LEFT VERT compartment.

b. Position the trace to the upper half of the graticule area with the left-vertical unit position control.

c. Set the VERTICAL MODE switch to RIGHT and position the trace to the lower half of the graticule area with the right-vertical unit position control.

✓d. CHECK—CRT display for two traces in the ALT and CHOP positions of the VERTICAL MODE switch.

e. Set the VERTICAL MODE switch to ADD.

✓f. CHECK—CRT display for a single trace that can be positioned vertically with either vertical-unit position control.

✓19. Check Vertical Trace Separation Operation

a. Set the VERTICAL MODE switch to RIGHT.

b. Center the trace vertically with the right-vertical unit position control.

c. Install another time-base unit in the B HORIZ compartment.

d. Set both time-base units for a free-running sweep at a rate of 0.2 millisecond/division.

e. Set the HORIZONTAL MODE switch to CHOP.

✓f. CHECK—Turn the VERT TRACE SEPARATION (B) control throughout its range and check that the trace produced by the B time-base unit can be positioned above and below the trace produced by the A time-base unit. Also, check with the HORIZONTAL MODE switch set to ALT.

g. Remove all plug-in units.

## TRIGGER SYSTEM CALIBRATION

### Equipment Required

- |  |  |
|--|--|
| <ol style="list-style-type: none"> <li>1. Signal standardizer calibration fixture</li> <li>2. 7B92 time-base plug-in unit</li> <li>3. 7A19 vertical amplifier plug-in unit</li> <li>4. Plug-in extender calibration fixture</li> </ol> | <ol style="list-style-type: none"> <li>5. Test-oscilloscope (dual trace)</li> <li>6. Two 42-inch 50-ohm BNC cables</li> <li>7. Two 50-ohm terminations</li> <li>8. Seven-inch screwdriver</li> </ol> |
|--|--|

### Control Settings

Set the 7704A controls as follows:

|                  |                                |
|------------------|--------------------------------|
| POWER            | ON                             |
| VERTICAL MODE    | RIGHT                          |
| VERT TRACE       |                                |
| SEPARATION (B)   | Midrange                       |
| A TRIGGER SOURCE | VERT MODE                      |
| A INTEN          | Midrange                       |
| HORIZONTAL MODE  | A                              |
| B INTEN          | Midrange                       |
| B TRIGGER SOURCE | VERT MODE                      |
| INTENSITY        | Midrange                       |
| FOCUS            | Set for a well-defined display |
| READOUT          | OFF                            |
| GRAT ILLUM       | Midrange                       |

### ✓20. Check Trigger Selector Operation

- a. Remove all plug-in units. Install the plug-in extender fixture in the horizontal compartment.
  
- b. Connect the trigger lines from the plug-in extender (A20 and B20) to the test-oscilloscope. Use one 50-ohm BNC cable and 50-ohm termination from each trigger line to the test-oscilloscope vertical channels.
  
- c. Set both test-oscilloscope vertical channels for a deflection factor 50 millivolts/division ground input coupling. Set the test oscilloscope for differential operation between the two channels (added display mode with one channel inverted) at a sweep rate of 20 microseconds/division. Set input coupling to DC.
  
- d. CHECK—The test-oscilloscope display for a DC level within 0.5 division (25 millivolts) of the ground reference level in the LEFT, RIGHT, and ADD positions of the VERT MODE switch.

e. Install the signal standardizer calibration fixture in the left vertical compartment. Set the signal standardizer calibration fixture to triggering gain.

f. Set the VERT MODE switch to LEFT.

g. CHECK—Test-oscilloscope display for nine traces with the deflection between the second and eighth traces of six divisions  $\pm 0.9$  division (300 millivolts within 45 millivolts). Install the signal standardizer calibration fixture in the right vertical compartment. Set the VERT MODE switch to RIGHT.

h. CHECK—Trigger gain of the right vertical compartment.

### ✓21A. CHECK Trigger Selector Operation

- a. Install the time-base plug-in unit in the horizontal compartment and the vertical amplifier plug-in unit in the left vertical compartment. *(REMOVE EXTENDER IF STILL INSTALLED)*
  
- b. Set the left vertical amplifier plug-in unit for a deflection factor of 0.2 volt/division.
  
- c. Connect the 0.4 calibrator signal to input connector of the left vertical amplifier plug-in unit.
  
- d. Set the signal standardizer calibration fixture test switch to Vert or Horiz +Step Resp, and the Rep Rate switch to 1 kHz. Set the amplitude control for a two-division display.

e. Set the VERT MODE switch to ALT position, the left vertical display to bottom half of the graticule. Position the right vertical display to the upper half of the graticule.

f. Set the time-base plug-in unit for a sweep rate of 0.2 millisecond/division.

√g. CHECK—That both displays are triggered (stable display).

√h. CHECK—Press, in sequence, the VERT MODE switch push buttons. Check that a stable display is obtained in all switch positions. In the CHOP MODE a triggered display of the left or right Vertical should be obtained (depending on the position of the Level/Slope control of the time-base unit).

i. Press the LEFT TRIG SOURCE button.

√j. CHECK—Press, in sequence, the VERT MODE switch push buttons. Check that only the LEFT vertical display is triggered.

k. Press the RIGHT TRIG SOURCE button.

√l. CHECK—Press, in sequence, the VERT MODE switch push buttons. Check that only the right vertical display is triggered.

m. Disconnect all test equipment and remove the plug-in units.

## HORIZONTAL SYSTEM

### Equipment Required

- |  |                                   |
|--|-----------------------------------|
| 1. Signal standardizer calibration fixture | 5. Low-frequency signal generator |
| 2. Time-base plug-in unit (two required)   | 6. Three-inch screwdriver         |
| 3. Amplifier plug-in unit                  | 7. Low-capacitance screwdriver    |
| 4. Time-mark generator                     |                                   |

### NOTE

*The location of adjustments is shown on pullout page 6-35, in the Diagrams section.*

### Control Settings

Set the 7704A controls as follows:

|                  |                                |
|------------------|--------------------------------|
| POWER            | ON                             |
| VERTICAL MODE    | RIGHT                          |
| VERT TRACE       |                                |
| SEPARATION (B)   | Midrange                       |
| A TRIGGER SOURCE | VERT MODE                      |
| A INTEN          | Midrange                       |
| HORIZONTAL MODE  | B                              |
| B INTEN          | Midrange                       |
| B TRIGGER SOURCE | VERT MODE                      |
| INTENSITY        | Midrange                       |
| FOCUS            | Set for a well-defined display |
| GRAT ILLUM       | Midrange                       |

### NOTE

*The Horizontal Interface Gain adjustments do not need to be checked during routine calibration. However, if components are replaced or if the Acquisition Unit is used in a different system, adjustment might be necessary. The need for adjustment is indicated if the Horizontal System adjustments can not be performed according to the following procedure. Calibration information for the Horizontal Interface is given under Special Adjustment Procedures in the Maintenance section.*

### √21B. Adjust Horizontal Amplifier Gain

- a. Install a time-base unit in the RIGHT VERT compartment.
- b. Set the time-base unit for a free-running sweep at a rate of 0.1 millisecond/division.

c. Install the signal standardizer calibration fixture in the B HORIZ compartment.

d. Set the calibration fixture Test switch to Vert or Horiz Gain and the Rep Rate switch to 100 kHz.

e. Position the display to align the bright center trace with the center vertical line of the graticule.

√f. CHECK—Deflection between the second and tenth traces is eight divisions  $\pm 0.08$  division. Note the exact deflection for step 21j.

g. ADJUST—Horizontal Gain adjustment R4310 (see Fig. 6-34) for eight divisions of deflection between the second and tenth traces.

h. Move the calibration fixture to the A HORIZ compartment.

i. Set the HORIZONTAL MODE switch to A.

√j. CHECK—Deflection between the second and tenth traces is the same as in part f  $\pm 1\%$  (eight divisions  $\pm 0.08$  division, if R4310 was adjusted in part g).

k. ADJUST—If necessary, compromise the setting of R4310 for optimum gain for both horizontal compartments. If re-adjustment is necessary, recheck parts c through j.

## 22. Adjust Horizontal Amplifier Centering

a. Set the calibration fixture Test switch to Triggering Gain.

b. CHECK—Vertical trace should align with the vertical center line of the graticule within 0.2 division. Check also with the HORIZONTAL MODE switch in the CHOP position.

c. ADJUST—Horizontal Centering adjustment R4325 (see Fig. 6-34) to position the trace to the vertical center line. If necessary, adjust for best compromise in the A and CHOP positions of the HORIZONTAL MODE switch.

d. INTERACTION—If R4325 is adjusted, check step 21.

## 23. Adjust Horizontal Amplifier Thermal Balance

a. Install a time-base unit in the B HORIZ compartment.

b. Set the HORIZONTAL MODE switch to CHOP and the VERTICAL MODE switch to LEFT.

c. Set the B time-base unit for a free-running, magnified sweep at a rate of 50 milliseconds/division.

d. CHECK—CRT display for not more than 0.1-division movement of the dot. If this instrument contains a readout system, set the READOUT intensity control for visible characters; check that the displayed characters do not move more than 0.1 division.

e. ADJUST—Thermal Balance adjustment R4346 (see Fig. 6-34) for minimum movement of the dot or readout characters.

f. INTERACTION—If the setting of R4346 is changed, check steps 21 and 22.

## ✓ 24. Check Low-Frequency Linearity

a. Set the HORIZONTAL MODE switch to A and the VERTICAL MODE switch to RIGHT.

b. Set the calibration fixture Test switch to Vert or Horiz + Step Resp.

c. Set the calibration fixture Amplitude control for two divisions of deflection in the horizontal center of the graticule area.

✓d. CHECK—Horizontally position the two-division display and check for not more than 0.1 division of compression or expansion anywhere within the graticule area.

## ✓25. Adjust High-Frequency Timing

a. Install an amplifier unit in the LEFT VERT compartment.

b. Set the HORIZONTAL MODE switch to B and the VERTICAL MODE switch to LEFT.

c. Set the time-base unit for auto, internal triggering at a one-millisecond/division sweep rate.

d. Connect one-millisecond markers from the time-mark generator to the amplifier-unit input.

e. Position the first marker to the farthest left line of the graticule.

f. Set the time-base unit sweep-calibration adjustment for one marker at each major graticule division, between the second and tenth lines (center eight divisions).

✓g. CHECK—Refer to the time-base unit instruction manual for performance check or calibration procedures for checking high-frequency timing and linearity. Use the procedures and limits given for the three fastest sweep rates which do not exceed two nanoseconds/division. If the given limits are met, omit the remainder of this step.

h. Set the VERTICAL MODE switch to RIGHT and the HORIZONTAL MODE switch to A.

i. Set the RIGHT VERT time-base unit for auto, external triggering at a magnified sweep rate of 0.5 microsecond/division (use basic sweep rate of five microseconds/division, magnified ten times with X10 magnifier or delayed sweep to 0.5 microsecond/division).

j. Connect the calibration-fixture Trig Out connector to the external trigger input of the RIGHT VERT time-base unit.

## Calibration—7704A Service

k. Set the calibration fixture for an eight-division display with the Rep Rate switch set to 100 kHz. Horizontally center the display.

l. ADJUST—Horizontal Amplifier high-frequency compensation adjustments R4385, C4385, C4391, and C4374 (see Fig. 6-34) for optimum square-wave response. Check the leading edge of the pulse (lower right corner) for aberrations not to exceed +1.2 division with total peak-to-peak aberrations not to exceed 1.2 division. See Fig. 4-1 for a typical response waveform.

m. Repeat parts b through g of this step.

n. Disconnect all test equipment and remove the plug-in units.

### ✓ 26. Check X-Y Phase Shift

a. Install identical-type amplifier units in the RIGHT VERT and A HORIZ compartments.

b. Set both amplifier units for a deflection factor of ten millivolts/division with DC input coupling.

c. Connect the low-frequency signal generator to both amplifier units.

d. Set the signal generator for eight divisions of vertical and horizontal deflection at an output frequency of 50 kilohertz.

✓e. CHECK—CRT lissajous display for an opening at the center vertical line of 0.28 division or less (indicates  $2^\circ$  or less phase shift; see Fig. 4-2).

f. Move the A HORIZ unit to the B HORIZ compartment and set the HORIZONTAL MODE switch to B (leave signal connected).

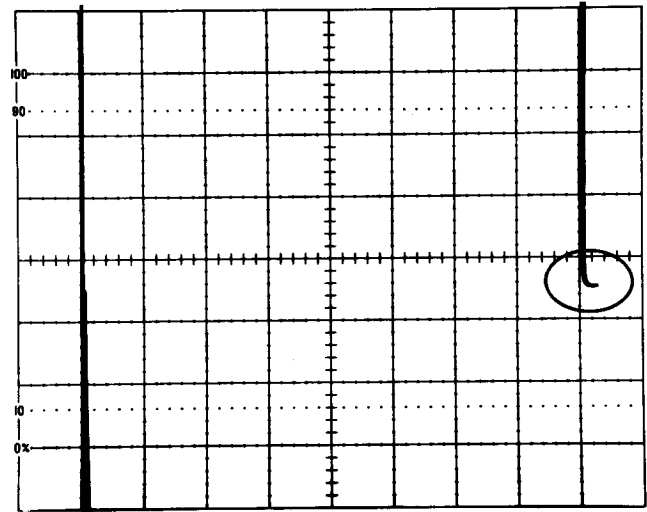

Fig. 4-1. Waveform showing correct high-frequency compensation of horizontal amplifier. Circle surrounds compensated portion of waveform.

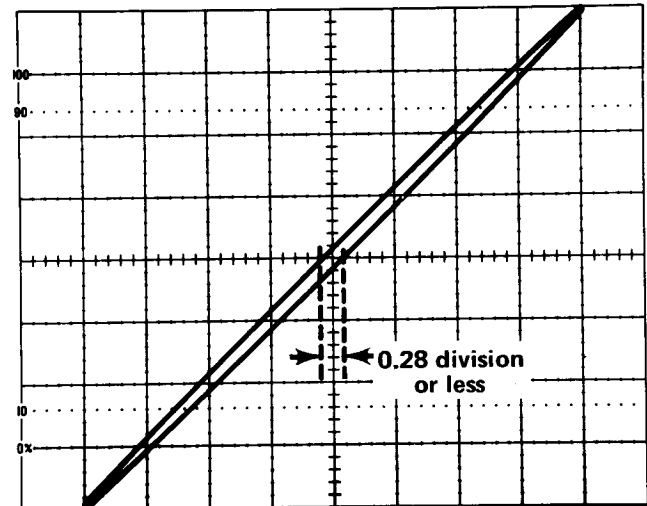

Fig. 4-2. Typical display when checking X-Y phase shift.

✓g. Repeat parts d and e.

h. Disconnect all test equipment and remove the plug-in units.

## CALIBRATOR

### Equipment Required

- |  |                           |
|--|---------------------------|
| 1. Precision DC voltmeter                | 4. Time-mark generator    |
| 2. Amplifier plug-in unit (two required) | 5. Three-inch screwdriver |
| 3. Time-base plug-in unit                |                           |

### NOTE

*The location of adjustments and test points for calibration is shown on a pullout, page 6-35, in the Diagrams section.*

### Control Settings

Set the 7704A controls as follows:

|                  |                                |
|------------------|--------------------------------|
| POWER            | ON                             |
| VERTICAL MODE    | RIGHT                          |
| VERT TRACE       |                                |
| SEPARATION (B)   | Midrange                       |
| A TRIGGER SOURCE | VERT MODE                      |
| A INTEN          | Midrange                       |
| HORIZONTAL MODE  | A                              |
| B INTEN          | Midrange                       |
| B TRIGGER SOURCE | VERT MODE                      |
| INTENSITY        | Midrange                       |
| FOCUS            | Set for a well-defined display |
| READOUT          | OFF                            |
| GRAT ILLUM       | Midrange                       |

### ✓27. Adjust Calibrator Output Voltage

a. Connect the inner lead of C1001 to chassis ground. (C1001 is the large, metal-cased capacitor located on the Calibrator Board behind the HORIZONTAL MODE switch circuit board; see Fig. 6-35.

b. Connect the precision DC voltmeter between the CALIBRATOR 0.4 V and GND pin jacks.

✓c. CHECK—Meter reading; 0.4 volt  $\pm 0.004$  volt within 0.008 volt if this measurement is made outside the  $+15^{\circ}\text{C}$  to  $+35^{\circ}\text{C}$  temperature range).

### NOTE

*If a zero-volt meter reading is obtained, momentarily remove the connection between C1001 and ground for a DC output.*

d. ADJUST—0.4 V adjustment R1037 (see Fig. 6-35) for a meter reading of exactly 0.4 volt.

e. Disconnect the precision DC voltmeter and the connection between C1001 and ground.

### ✓28. Adjust Calibrator 1 kHz Repetition Rate

### NOTE

*If a frequency counter with an accuracy of at least 0.1% is available (such as Tektronix 7D14 Digital Counter), it can be used to adjust the Calibrator repetition rate.*

a. Install an amplifier unit in both vertical compartments and a time-base unit in the A HORIZ compartment.

b. Set the VERTICAL MODE switch to ALT.

c. Connect the 0.4 V CALIBRATOR pin jack to the input of one of the amplifier units.

d. Connect one-millisecond markers from the time-mark generator to the other amplifier unit.

e. Set the amplifier units for a marker display of about two divisions and a square-wave display of about four divisions.

f. Set the time-base unit for a stable display of both waveforms in the normal, internal trigger mode at a 0.2-millisecond/division sweep rate.

## Calibration—7704A Service

g. Vertically position the displays so the tips of the markers fall just below the bottom of the square wave.

h. Set the VERTICAL MODE switch to ADD.

i. Set the time-base unit triggering so a stable square-wave display is presented only when the markers occur during the positive portion of the square wave.

j. Set the time-base unit triggering for AC low-frequency reject coupling, and a sweep rate of 0.2 second/division.

✓k. CHECK—The amount of time required for a time mark to drift across the positive level of the square wave, to the negative level and back to the positive level, must not

exceed 0.4 second (0.2 second if outside the +15°C to +35°C temperature range). This time can be measured directly from the display by observing the number of divisions that the marker moves across the display area before it returns to the positive level.

l. ADJUST—1 kHz adjustment R1001 (see Fig. 6-35) for a time not to exceed 0.4 second for a time mark to drift across the positive level of the square wave to the negative level and back to the positive level. (A preliminary adjustment can be made with the time-base unit triggered only on the squarewave at a 0.2-millisecond/division sweep rate; adjust R1001 for minimum drift of the markers.)

m. Disconnect all test equipment and remove the plug-in units.



## OUTPUT SIGNALS

### NOTE

If the Signal Buffer sub-assembly is deleted from this instrument (Option 7), delete this portion of the Calibration procedure.

### Equipment Required

- |  |  |
|--|--|
| 1. Amplifier plug-in unit (two required) | 2. Time-base plug-in unit (two required) |
|--|--|

### NOTE

The location of the signal selector switches is shown on a pullout, page 6-35, in the Diagrams section.

### Control Settings

Set the controls as follows:

|                  |                                |
|------------------|--------------------------------|
| POWER            | ON                             |
| VERTICAL MODE    | RIGHT                          |
| VERT TRACE       |                                |
| SEPARATION (B)   | Midrange                       |
| A TRIGGER SOURCE | VERT MODE                      |
| A INTEN          | Midrange                       |
| HORIZONTAL MODE  | A                              |
| B INTEN          | Midrange                       |
| B TRIGGER SOURCE | VERT MODE                      |
| INTENSITY        | Midrange                       |
| FOCUS            | Set for a well-defined display |
| READOUT          | OFF                            |
| GRAT ILLUM       | Midrange                       |

f. Set the Sweep Selector switch, S3320, to B. (S3320 is located behind the right side panel, near the rear of the instrument; see Fig. 6-36.)

√g. CHECK—CRT display for sawtooth waveform with an amplitude of five divisions  $\pm 0.75$  div (output amplitude into 50-ohm load, 0.5 volt or greater).

h. Set the HORIZONTAL MODE switch to B.

i. Set the Sweep Selector switch to A.

j. Set the B HORIZ time-base unit for auto, internal triggering at a sweep rate of two milliseconds/division.

k. Set the A HORIZ time-base unit for a free-running sweep at a rate of 0.5 millisecond/division.

√l. CHECK—CRT display for a sawtooth waveform with an amplitude of five divisions  $\pm 0.75$  div (output amplitude into 50-ohm load, 0.5 volt or greater).

m. Disconnect the + SAWTOOTH OUT connector from the amplifier unit.

### √29. Check Sawtooth Output Signals

a. Install amplifier units in both vertical compartments and time-base units in both horizontal compartments.

b. Connect the rear-panel + SAWTOOTH OUT connector to the RIGHT VERT amplifier unit.

c. Set the RIGHT VERT amplifier unit for a calibrated deflection factor of 0.1 volt/division with DC input coupling.

d. Set the A HORIZ time-base unit for auto, internal triggering at a sweep rate of two milliseconds/division.

e. Set the B HORIZ time-base unit for a free-running sweep at a rate of 0.5 millisecond/division.

### √30. Check Gate Output Signals

a. Connect the rear-panel + GATE OUT connector to the RIGHT VERT amplifier unit.

b. Set the RIGHT VERT amplifier unit for a calibrated deflection factor of 100 millivolts/division with DC input coupling.

## Calibration—7704A Service

c. Set the Gate Selector switch, S3340, to A. (S3340 is located behind the right side panel, near the rear of the instrument; see Fig. 6-36.)

√d. CHECK—CRT display for gate waveform five divisions  $\pm 0.5$  division in amplitude (output amplitude into 50-ohm load, 0.5 volt  $\pm 10\%$ ).

e. Set the HORIZONTAL MODE switch to A.

f. Set the Gate Selector switch to B.

g. Set the A HORIZ time-base unit for auto, internal triggering at a sweep rate of two milliseconds/division.

h. Set the B HORIZ time-base unit for a free-running sweep at a rate of 500 microseconds/division.

√i. CHECK—CRT display for gate waveform five divisions  $\pm 0.5$  division in amplitude (output amplitude into 50-ohm load, 0.5 volt  $\pm 10\%$ ).

j. Set the A HORIZ time-base unit for a 10-nanosecond/division sweep rate. Set the triggering to display the rising portion of the waveform. Set B Horiz to 100 nanosecond/division.

√k. CHECK—Displayed waveform for not more than two divisions between the 10% and 90% points (risetime, twenty nanoseconds or less).

l. Disconnect the + GATE OUT connector from the amplifier unit.

### √31. Check Vertical Signal Output

a. Connect the CALIBRATOR 0.4 V pin jack to the RIGHT VERT amplifier unit.

b. Set the A HORIZ time-base unit for auto, internal triggering at a sweep rate of 500 microseconds/division.

c. Set the RIGHT VERT amplifier unit for a four-division display.

d. Connect the rear-panel VERT SIG OUT connector to the LEFT VERT amplifier unit.

e. Set the LEFT VERT amplifier unit for a calibrated deflection factor of 20 millivolts/division with DC input coupling (10 millivolts/division with option 4 CRT).

f. Set the B TRIGGER SOURCE switch to RIGHT VERT and the VERTICAL MODE switch to LEFT.

√g. CHECK—CRT Display for waveform five divisions (2.5 divisions with Option 4 CRT)  $\pm 0.5$  division in amplitude (voltage output into 50-ohm load, 25 millivolts/division of display within 10%).

h. Disconnect all test equipment and remove the plug-in units.

### READOUT SYSTEM

*NOTE*

If the Readout System was deleted from the instrument being calibrated (Option 1), omit this section of the procedure.

| <b>Equipment Required</b>              |                           |
|--|---------------------------|
| 1. Amplifier plug-in unit (dual trace) | 3. Three-inch screwdriver |
| 2. Time-base plug-in unit              |                           |

*NOTE*

The location of adjustments for calibration is shown on a pullout, page 6-35, in the Diagrams section.

#### Control Settings

Set the 7704A controls as follows:

|                  |                                |
|------------------|--------------------------------|
| POWER            | OFF                            |
| VERTICAL MODE    | RIGHT                          |
| VERT TRACE       |                                |
| SEPARATION (B)   | Midrange                       |
| A TRIGGER SOURCE | VERT MODE                      |
| A INTEN          | Midrange                       |
| HORIZONTAL MODE  | A                              |
| B INTEN          | Midrange                       |
| B TRIGGER SOURCE | VERT MODE                      |
| INTENSITY        | Midrange                       |
| FOCUS            | Set for a well-defined display |
| READOUT          | OFF                            |
| GRAT ILLUM       | Midrange                       |

*NOTE*

These tolerances are provided as guides to correct instrument operation and are not instrument specifications.

e. ADJUST—Vertical Separation adjustment R4390 (see Fig. 6-37) to position the two rows of readout characters to the middle of the top and bottom divisions of the graticule.

*NOTE*

The Vertical Amplifier Centering adjustment must be correct before making this adjustment; see step 11.

f. Set the POWER switch to off and replace Q3416 (see Fig. 6-37) in its socket; return the POWER switch to on.

#### 32. Adjust Vertical Separation

a. Remove Q3416 from its socket on A34, Readout Board (see Fig. 6-37).

b. Set the POWER switch to on.

c. Set the READOUT control for visible characters (all zeros).

d. CHECK—CRT display for two rows of zeros, 40 zeros to a row with no overlap. The two rows of zeros should be located vertically in the middle of the top and bottom divisions of the graticule (see Fig. 4-3).

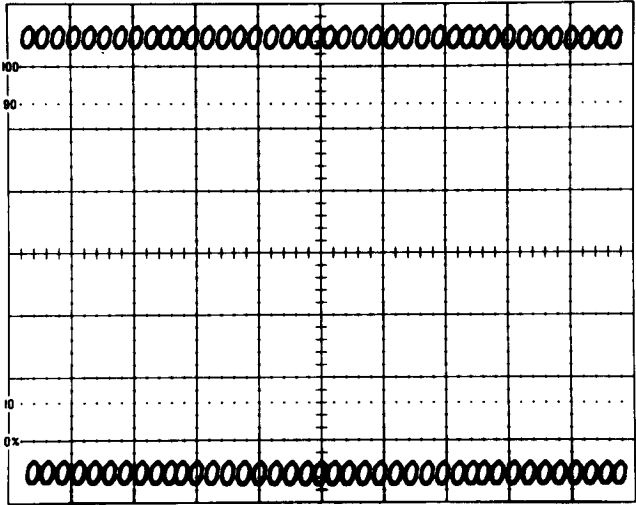

Fig. 4-3. Readout display with Q3416 removed.

### 33. Adjust Full Character Scan

- a. Install the dual-trace amplifier unit in the RIGHT VERT compartment.
- b. Set the amplifier unit for a deflection factor of 50 millivolts/division.
- c. CHECK—Displayed characters for completeness without overscanning (overscanning causes a bright dot where traces overlap).
- d. ADJUST—Full Character Scan adjustment R3437 (see Fig. 6-37) for fully scanned characters without overscanning. The m and the 5 will show the most change.

### 34. Adjust Column and Row Match

- a. Set the amplifier unit for a dual-trace display mode.
- b. Press and hold the amplifier unit trace-identify buttons.
- c. CHECK—Readout display for correct indication of "IDENTIFY". If the readout display blinks or is incorrect, adjustment is required.
- d. ADJUST—Column Match adjustment R3407 and Row Match adjustment R3422 (see Fig. 6-37) for correct readout of "IDENTIFY". Set these adjustments to the center of the adjustment range which provides correct readout indication. Release the amplifier unit trace-identify buttons.

### ✓ 35. Check Readout Modes

#### NOTE

*If the Signal Buffer sub-assembly is deleted from the instrument being calibrated (Option 7), omit this step.*

- a. Install a time-base unit in the A HORIZ compartment.
  - b. Set the time-base unit for a free-running sweep.
  - c. Set the Readout Mode switch to FR and the Gate Selector switch to A (see Fig. 6-36).
  - ✓d. CHECK—Set the time-base unit for several sweep rates throughout its range. Check that the readout characters are presented on a free-run basis, independent of the sweep rate.
  - e. Set the Readout Mode switch to Gated (see Fig. 6-36).
  - f. Set the time-base unit for a free-running sweep at a rate of 0.1 second/division.
  - ✓g. CHECK—Readout characters are blanked out while the sweep is running, and are displayed immediately after the end of the sweep; each character encoded by the plug-in units is displayed only once for each sweep.
- This completes the Calibration procedure for the 7704A. Disconnect all test equipment and replace the side panels.

# REPLACEABLE ELECTRICAL PARTS

## PARTS ORDERING INFORMATION

Replacement parts are available from or through your local Tektronix, Inc. Field Office or representative.

Changes to Tektronix instruments are sometimes made to accommodate improved components as they become available, and to give you the benefit of the latest circuit improvements developed in our engineering department. It is therefore important, when ordering parts, to include the following information in your order: Part number, instrument type or number, serial number, and modification number if applicable.

If a part you have ordered has been replaced with a new or improved part, your local Tektronix, Inc. Field Office or representative will contact you concerning any change in part number.

Change information, if any, is located at the rear of this manual.

## SPECIAL NOTES AND SYMBOLS

X000 Part first added at this serial number  
00X Part removed after this serial number

## ITEM NAME

In the Parts List, an Item Name is separated from the description by a colon (:). Because of space limitations, an Item Name may sometimes appear as incomplete. For further Item Name identification, the U.S. Federal Cataloging Handbook H6-1 can be utilized where possible.

## ABBREVIATIONS

|        |                      |          |                 |
|--------|----------------------|----------|-----------------|
| ACTR   | ACTUATOR             | PLSTC    | PLASTIC         |
| ASSY   | ASSEMBLY             | QTZ      | QUARTZ          |
| CAP    | CAPACITOR            | RECP     | RECEPTACLE      |
| CER    | CERAMIC              | RES      | RESISTOR        |
| CKT    | CIRCUIT              | RF       | RADIO FREQUENCY |
| COMP   | COMPOSITION          | SEL      | SELECTED        |
| CONN   | CONNECTOR            | SEMICOND | SEMICONDUCTOR   |
| ELCTLT | ELECTROLYTIC         | SENS     | SENSITIVE       |
| ELEC   | ELECTRICAL           | VAR      | VARIABLE        |
| INCAND | INCANDESCENT         | WW       | WIREWOUND       |
| LED    | LIGHT EMITTING DIODE | XFMR     | TRANSFORMER     |
| NONWIR | NON WIREWOUND        | XTAL     | CRYSTAL         |

## CROSS INDEX MFR. CODE NUMBER TO MANUFACTURER

| MFR.CODE | MANUFACTURER  | ADDRESS                     | CITY,STATE,ZIP          |
|----------|---|-----------------------------|-------------------------|
| 0000C    | Gettig Engineering and Manufacturing Co.                                  |                             | Springmill, PA 16875    |
| 0000D    | Corcom Incorporated   | 2857 N. Halsted St.         | Chicago, IL 60657       |
| 00853    | Sangamo Electric Co., S. Carolina Div.                                    | P. O. Box 128               | Pickens, SC 29671       |
| 01002    | General Electric Co., Industrial and Power Capacitor Products Dept.       | John St.                    | Hudson Falls, NY 12839  |
| 01121    | Allen-Bradley Co.   | 1201 2nd St. South          | Milwaukee, WI 53204     |
| 01295    | Texas Instruments, Inc., Semiconductor Group                              | P. O. Box 5012              | Dallas, TX 75222        |
| 02735    | RCA Corp., Solid State Division   | Route 202                   | Somerville, NY 08876    |
| 03877    | Transitron Electronic Corp.   | 168 Albion St.              | Wakefield, MA 01880     |
| 04713    | Motorola, Inc., Semiconductor Products Div.                               | 5005 E. McDowell Rd.        | Phoenix, AZ 85036       |
| 07263    | Fairchild Semiconductor, A Div. of Fairchild Camera and Instrument Corp.  | 464 Ellis St.               | Mountain View, CA 94042 |
| 07910    | Teledyne Semiconductor  | 12515 Chadron Ave.          | Hawthorne, CA 90250     |
| 08806    | General Electric Co., Miniature Lamp Products Dept.                       | Nela Pk.                    | Cleveland, OH 44112     |
| 11237    | CTS Keene, Inc.   | Commerce Drive              | Paso Robles, CA 93446   |
| 12040    | National Semiconductor Corp.  | Lower Washington St.        | Danbury, CT 06810       |
| 12697    | Clarostat Mfg. Co., Inc.  | 580 Pleasant St.            | Dover, NH 03820         |
| 12969    | Unitrode Corp.  |                             | Watertown, MA 02172     |
| 13715    | Fairchild Semiconductor, A Div. of Fairchild Camera and Instrument Corp.  | 4300 Redwood Hwy.           | San Rafael, CA 94903    |
| 14099    | Semtech Corp.   | 652 Mitchell Road           | Newbury Park, CA 91320  |
| 15454    | Rodan Industries, Inc.  | 2905 Blue Star St.          | Anaheim, CA 92806       |
| 24931    | Specialty Connector Co., Inc.   | 3560 Madison Ave.           | Indianapolis, IN 46227  |
| 25088    | Siemens Corp.   | 186 Wood Ave. S             | Iselin, NJ 08830        |
| 34553    | Amperex Electronic Corp., Component Div.                                  | 35 Hoffman Ave.             | Happauge, NY 11787      |
| 50157    | N. L. Industries, Inc., Electronics Dept.                                 | P. O. Box 787               | Muskegon, MI 49443      |
| 56285    | Sprague and Carleton  |                             | Avon Keene, NH 03431    |
| 56289    | Sprague Electric Co.  |                             | North Adams, MA 01247   |
| 63743    | Ward Leonard Electric Co., Inc.   | 31 South St.                | Mount Vernon, NY 10550  |
| 71400    | Bussman Mfg., Division of McGraw-Edison Co.                               | 2536 W. University St.      | St. Louis, MO 63107     |
| 71590    | Centralab Electronics, Div. of Globe-Union, Inc.                          | 5757 N. Green Bay Ave.      | Milwaukee, WI 53201     |
| 72136    | Electro Motive Corp., Sub of International Electronics Corp.              | South Park and John Streets | Willimantic, CT 06226   |
| 72982    | Erie Technological Products, Inc.   | 644 W. 12th St.             | Erie, PA 16512          |
| 73138    | Beckman Instruments, Inc., Helipot Div.                                   | 2500 Harbor Blvd.           | Fullerton, CA 92634     |
| 75042    | TRW Electronic Components, IRC Fixed Resistors, Philadelphia Division     | 401 N. Broad St.            | Philadelphia, PA 19108  |
| 78488    | Stackpole Carbon Co.  |                             | St. Marys, PA 15857     |
| 79727    | C-W Industries  | 550 Davisville Rd.          | Warminster, PA 18974    |
| 80009    | Tektronix, Inc.   | P. O. Box 500               | Beaverton, OR 97077     |
| 80294    | Bourns, Inc., Instrument Div.   | 6135 Magnolia Ave.          | Riverside, CA 92506     |
| 80740    | Beckman Instruments, Inc.   | 2500 Harbor Blvd.           | Fullerton, CA 92634     |
| 81483    | International Rectifier Corp.   | 9220 Sunset Blvd.           | Los Angeles, CA 90069   |
| 82389    | Switchcraft, Inc.   | 5555 N. Elston Ave.         | Chicago, IL 60630       |
| 83003    | Varo, Inc.  | 800 W. Garland Ave.         | Garland, TX 75040       |
| 84411    | TRW Electronic Components, TRW Capacitors                                 | 112 W. First St.            | Ogallala, NB 69153      |
| 90201    | Mallory Capacitor Co., Div. of P. R. Mallory Co., Inc.                    | 3029 E. Washington St.      | Indianapolis, IN 46206  |
| 91637    | Dale Electronics, Inc.  | P. O. Box 609               | Columbus, NB 68601      |
| 91929    | Honeywell, Inc., Micro Switch Div.  | Chicago & Spring Sts.       | Freeport, IL 61032      |
| 95238    | Continental Connector Corp.   | 34-63 56th St.              | Woodside, NY 11377      |
| 97979    | Reon Resistor Corp.   | 63 Lincoln Hwy.             | Fraser, PA 19355        |
| 99942    | Centralab Semiconductor, Centralab Electronics, Div. of Globe-Union, Inc. | 4501 N. Arden Dr.           | El Monte, CA 91734      |

| Ckt No. | Tektronix Part No. | Serial/Model No. Eff | Dscont  | Name & Description                     | Mfr Code | Mfr Part Number |
|---------|--------------------|----------------------|---------|--|----------|-----------------|
| A10     | 670-1879-00        |                      |         | CKT BOARD ASSY:CABLIBRATION            | 80009    | 670-1879-00     |
| A11     | 670-1877-00        |                      |         | CKT BOARD ASSY:VERTICAL MODE SWITCH    | 80009    | 670-1877-00     |
| A12     | 670-1878-00        |                      |         | CKT BOARD ASSY:HORIZONTAL MODE SWITCH  | 80009    | 670-1878-00     |
| A13     | 670-1876-00        |                      |         | CKT BOARD ASSY:A TRIGGER SOURCE SWITCH | 80009    | 670-1876-00     |
| A14     | 670-1876-00        |                      |         | CKT BOARD ASSY:B TRIGGER SOURCE SWITCH | 80009    | 670-1876-00     |
| A20     | 670-1880-00        |                      |         | CKT BOARD ASSY:MAIN INTERFACE          | 80009    | 670-1880-00     |
| A22     | 670-1881-00        |                      |         | CKT BOARD ASSY:VERTICAL INTERFACE      | 80009    | 670-1881-00     |
| A23     | 670-1883-00        |                      |         | CKT BOARD ASSY:HORIZONTAL INTERFACE    | 80009    | 670-1883-00     |
| A24     | 670-1882-00        |                      |         | CKT BOARD ASSY:TRIGGER SELECTOR        | 80009    | 670-1882-00     |
| A25     | 670-1884-00        | B010100              | B109999 | CKT BOARD ASSY:LOGIC                   | 80009    | 670-1884-00     |
| A25     | 670-1884-01        | B110000              | B132604 | CKT BOARD ASSY:LOGIC                   | 80009    | 670-1884-01     |
| A25     | 670-1884-02        | B132605              |         | CKT BOARD ASSY:LOGIC                   | 80009    | 670-1884-02     |
| A30     | 670-1985-00        | B010100              | B099999 | CKT BOARD ASSY:LINE INVERTER           | 80009    | 670-1985-00     |
| A30     | 670-1985-02        | B100000              |         | CKT BOARD ASSY:LINE INVERTER           | 80009    | 670-1985-02     |
| A31     | 670-1887-00        | B010100              | B079999 | CKT BOARD ASSY:RECTIFIER               | 80009    | 670-1887-00     |
| A31     | 670-1887-01        | B080000              |         | CKT BOARD ASSY:RECTIFIER               | 80009    | 670-1887-01     |
| A32     | 670-1888-00        | B010100              | B099999 | CKT BOARD ASSY:LV REGULATOR            | 80009    | 670-1888-00     |
| A32     | 670-1888-01        | B100000              |         | CKT BOARD ASSY:LV REGULATOR            | 80009    | 670-1888-01     |
| A33     | 670-1886-00        |                      |         | CKT BOARD ASSY:SIGNAL OUT              | 80009    | 670-1886-00     |
| A34     | 670-1885-00        | B010100              | B049999 | CKT BOARD ASSY:READOUT                 | 80009    | 670-1885-00     |
| A34     | 670-1885-02        | B050000              |         | CKT BOARD ASSY:READOUT                 | 80009    | 670-1885-02     |
| A41     | 670-1854-00        |                      |         | CKT BOARD ASSY:Z AXIS                  | 80009    | 670-1854-00     |
| A42     | 670-1855-00        | B010100              | B039999 | CKT BOARD ASSY:HIGH VOLTAGE            | 80009    | 670-1855-00     |
| A42     | 670-1855-01        | B040000              |         | CKT BOARD ASSY:HIGH VOLTAGE            | 80009    | 670-1855-01     |
| A43     | 670-1853-00        | B010100              | B109999 | CKT BOARD ASSY:HORIZONTAL AMPLIFIER    | 80009    | 670-1853-00     |
| A43     | 670-1853-01        | B110000              |         | CKT BOARD ASSY:HORIZONTAL AMPLIFIER    | 80009    | 670-1853-01     |
| A44     | 670-1852-00        | B010100              | B119999 | CKT BOARD ASSY:VERTICAL AMPLIFIER      | 80009    | 670-1852-00     |
| A44     | 670-1852-01        | B120000              | B139999 | CKT BOARD ASSY:VERTICAL AMPLIFIER      | 80009    | 670-1852-01     |
| A44     | 670-1852-02        | B140000              |         | CKT BOARD ASSY:VERTICAL AMPLIFIER      | 80009    | 670-1852-02     |
| A50     | 670-0702-00        |                      |         | CKT BOARD ASSY:GRATICULE LIGHTS        | 80009    | 670-0702-00     |
| A51     | 670-4347-00        | XB160000             |         | CKT BOARD ASSY:PROTECTION              | 80009    | 670-4347-00     |
| C1001   | 285-0756-01        |                      |         | CAP.,FXD,PLASTC:0.05UF,0.25%,400V      | 80009    | 285-0756-01     |
| C1004   | 283-0000-00        |                      |         | CAP.,FXD,CER DI:0.001UF,+100-0%,500V   | 72982    | 831-516E102P    |
| C1011   | 283-0003-00        |                      |         | CAP.,FXD,CER DI:0.01UF,+80-20%,150V    | 72982    | 855-547E103Z    |
| C1031   | 283-0003-00        |                      |         | CAP.,FXD,CER DI:0.01UF,+80-20%,150V    | 72982    | 855-547E103Z    |
| C2006   | 283-0000-00        |                      |         | CAP.,FXD,CER DI:0.001UF,+100-0%,500V   | 72982    | 831-516E102P    |
| C2081   | 290-0519-00        |                      |         | CAP.,FXD,ELCTLT:100UF,20%,20V          | 56289    | 196D107X0020MA3 |
| C2083   | 290-0531-00        |                      |         | CAP.,FXD,ELCTLT:100UF,20%,10V          | 90201    | TDC107M010WLC   |
| C2085   | 290-0519-00        |                      |         | CAP.,FXD,ELCTLT:100UF,20%,20V          | 56289    | 196D107X0020MA3 |
| C2087   | 290-0270-00        | B010100              | B142899 | CAP.,FXD,ELCTLT:8.2UF,20%,60V          | 56289    | 150D825X0060R2  |
| C2087   | 290-0716-00        | B142900              |         | CAP.,FXD,ELCTLT:8.2UF,20%,75V          | 05397    | T11C825M075AS   |
| C2089   | 290-0270-00        | B010100              | B142899 | CAP.,FXD,ELCTLT:8.2UF,20%,60V          | 56289    | 150D825X0060R2  |
| C2089   | 290-0716-00        | B142900              |         | CAP.,FXD,ELCTLT:8.2UF,20%,75V          | 05397    | T11C825M075AS   |
| C2201   | 281-0580-00        | XB194145             |         | CAP.,FXD,CER DI:470PF,10%,500V         | 04222    | 7001-1374       |
| C2231   | 281-0151-00        | B010100              | B079999 | CAP.,VAR,CER DI:1-3UF,100V             | 72982    | 518-600A1-3     |
| C2231   | 281-0184-00        | B080000              |         | CAP.,VAR,PLSTC:2-18PF,500VDC           | 34553    | 2222-809-05003  |
| C2235   | 281-0509-00        | B010100              | B079999 | CAP.,FXD,CER DI:15PF,+/-1.5PF,500V     | 72982    | 301-000C0G0150K |
| C2235   | 281-0609-00        | B080000              |         | CAP.,FXD,CER DI:1PF,+/-0.1PF,500V      | 72982    | 374-005C0K0109B |
| C2259   | 281-0547-00        | XB050000             |         | CAP.,FXD,CER DI:2.7PF,10%,500V         | 72982    | 301-000C0J0279C |
| C2267   | 281-0547-00        | XB050000             |         | CAP.,FXD,CER DI:2.7PF,10%,500V         | 72982    | 301-000C0J0279C |
| C2277   | 281-0670-00        |                      |         | CAP.,FXD,CER DI:1.8PF,+/-0.1PF,500V    | 72982    | 374-005C0K0189B |
| C2279   | 281-0540-00        |                      |         | CAP.,FXD,CER DI:51PF,5%,500V           | 72982    | 301-000U2J0510J |
| C2281   | 281-0151-00        | B010100              | B079999 | CAP.,VAR,CER DI:1-3UF,100V             | 72982    | 518-600A1-3     |
| C2281   | 281-0184-00        | B080000              |         | CAP.,VAR,PLSTC:2-18PF,500VDC           | 34553    | 2222-809-05003  |
| C2285   | 281-0509-00        | B010100              | B079999 | CAP.,FXD,CER DI:15PF,+/-1.5PF,500V     | 72982    | 301-000C0G0150K |
| C2285   | 281-0609-00        | B080000              |         | CAP.,FXD,CER DI:1PF,+/-0.1PF,500V      | 72982    | 374-005C0K0109B |
| C2403   | 281-0534-00        | XB080000             |         | CAP.,FXD,CER DI:3.3PF,+/-0.25PF,500V   | 72982    | 301-000C0J0339C |
| C2406   | 281-0534-00        | XB080000             |         | CAP.,FXD,CER DI:3.3PF,+/-0.25PF,500V   | 72982    | 301-000C0J0339C |

# Electrical Parts List—7704A

| Ckt No. | Tektronix Part No. | Serial/Model No. |          | Name & Description                    | Mfr Code | Mfr Part Number  |
|---------|--------------------|------------------|----------|---------------------------------------|----------|------------------|
|         |                    | Eff              | Dscont   |                                       |          |                  |
| C2423   | 281-0653-00        | XB040000         | B079999  | CAP.,FXD,CER DI:3.3PF,30%,200V        | 72982    | 374-001COK0109C  |
| C2423   | 281-0534-00        | B0800000         |          | CAP.,FXD,CER DI:3.3PF,+/-0.25PF,500V  | 72982    | 301-000C0J0339C  |
| C2427   | 281-0604-00        | XB080000         |          | CAP.,FXD,CER DI:2.2PF,(NOM VALUE),SEL | 72982    | 301-000C0J0229C  |
| C2444   | 283-0000-00        |                  |          | CAP.,FXD,CER DI:0.001UF,+100-0%,500V  | 72982    | 831-516E102P     |
| C2445   | 281-0601-00        | B010100          | B039999  | CAP.,FXD,CER DI:7.5PF,CER,500V        | 72982    | 301-000C0H0759D  |
| C2445   | 281-0544-00        | B0400000         | B163399  | CAP.,FXD,CER DI:5.6PF,10%,500V        | 72982    | 301-000C0H05     |
| C2445   | 281-0604-00        | B163400          |          | CAP.,FXD,CER DI:2.2PF,(NOM VALUE),SIL | 72982    | 301-000C0J0229C  |
| C2448   | 283-0000-00        |                  |          | CAP.,FXD,CER DI:0.001UF,+100-0%,500V  | 72982    | 831-516E102P     |
| C2510   | 283-0668-00        |                  |          | CAP.,FXD,MICA D:184PF,1%,500V         | 00853    | D155F1840F0      |
| C2511   | 283-0623-00        |                  |          | CAP.,FXD,MICA D:1200PF,1%,100V        | 72136    | DM19F122F0       |
| C2514   | 281-0564-00        |                  |          | CAP.,FXD,CER DI:24PF,5%,500V          | 72982    | 301-000C0G0240J  |
| C2515   | 283-0003-00        |                  |          | CAP.,FXD,CER DI:0.01UF,+80-20%,150V   | 72982    | 855-547E103Z     |
| C2518   | 281-0629-00        | B010100          | B079999X | CAP.,FXD,CER DI:33PF,5%,600V          | 72982    | 308-000COG0330G  |
| C2520   | 281-0525-00        |                  |          | CAP.,FXD,CER DI:470PF,+/-94PF,500V    | 72982    | 301-000X5U0471M  |
| C2521   | 281-0525-00        |                  |          | CAP.,FXD,CER DI:470PF,+/-94PF,500V    | 72982    | 301-000X5U0471M  |
| C2523   | 281-0543-00        |                  |          | CAP.,FXD,CER DI:270PF,10%,500V        | 72982    | 301-055X5P1271K  |
| C2524   | 281-0629-00        | XB120000         |          | CAP.,FXD,CER DI:33PF,5%,600V          | 72982    | 308-000C0G0330G  |
| C2529   | 281-0629-00        | B010100          | B079999X | CAP.,FXD,CER DI:33PF,5%,600V          | 72982    | 308-000COG0330G  |
| C2560   | 290-0534-00        |                  |          | CAP.,FXD,ELCTLT:1UF,20%,35V           | 56289    | 196D105X0035HAL  |
| C2562   | 290-0512-00        |                  |          | CAP.,FXD,ELCTLT:22UF,20%,15V          | 56285    | 196D226X0015KAL  |
| C2563   | 290-0534-00        |                  |          | CAP.,FXD,ELCTLT:1UF,20%,35V           | 56289    | 196D105X0035HAL  |
| C2565   | 290-0534-00        |                  |          | CAP.,FXD,ELCTLT:1UF,20%,35V           | 56289    | 196D105X0035HAL  |
| C2571   | 281-0589-00        |                  |          | CAP.,FXD,CER DI:170PF,5%,500V         | 72982    | 301-057Z5D0171J  |
| C2572   | 281-0589-00        |                  |          | CAP.,FXD,CER DI:170PF,5%,500V         | 72982    | 301-057Z5D0171J  |
| C2573   | 281-0603-00        |                  |          | CAP.,FXD,CER DI:39PF,5%,500V          | 72982    | 308-000C0G0390J  |
| C2575   | 281-0603-00        |                  |          | CAP.,FXD,CER DI:39PF,5%,500V          | 72982    | 308-000C0G0390J  |
| C2580   | 281-0523-00        |                  |          | CAP.,FXD,CER DI:100PF,+/-20PF,350V    | 72982    | 301-000U2M0101M  |
| C2585   | 283-0000-00        |                  |          | CAP.,FXD,CER DI:0.001UF,+100-0%,500V  | 72982    | 831-516E102P     |
| C2598   | 290-0534-00        |                  |          | CAP.,FXD,ELCTLT:1UF,20%,35V           | 56289    | 196D105X0035HAL  |
| C3005   | 283-0006-00        |                  |          | CAP.,FXD,CER DI:0.02UF,+80-20%,500V   | 71590    | DA049-2278       |
| C3006   | 283-0006-00        |                  |          | CAP.,FXD,CER DI:0.02UF,+80-20%,500V   | 71590    | DA049-2278       |
| C3016   | 290-0576-00        |                  |          | CAP.,FXD,ELCTLT:550UF,+50-10%,200V    | 56289    | 36D7135          |
| C3017   | 290-0576-00        |                  |          | CAP.,FXD,ELCTLT:550UF,+50-10%,200V    | 56289    | 36D7135          |
| C3019   | 283-0057-00        |                  |          | CAP.,FXD,CER DI:0.1UF,+80-20%,200V    | 56289    | 274C10           |
| C3027   | 283-0280-00        |                  |          | CAP.,FXD,CER DI:2200PF,10%,2000V      | 72982    | 818-002-Y550222K |
| C3028   | 283-0280-00        | B010100          | B020209X | CAP.,FXD,CER DI:2200PF,10%,2000V      | 72982    | 818-002-Y550222K |
| C3029   | 285-0939-00        |                  |          | CAP.,FXD,PLSTC:3UF,5%,400V            | 84411    | TEK111-305K4     |
| C3030   | 283-0279-00        |                  |          | CAP.,FXD,CER DI:0.001UF,20%,3000V     | 72982    | 878Y5S102M       |
| C3031   | 290-0395-00        |                  |          | CAP.,FXD,ELCTLT:4.7UF,20%,50V         | 56289    | 150D475X0050B2   |
| C3035   | 283-0000-00        | XB110000         | B139999X | CAP.,FXD,CER DI:0.001UF,+100-0%,500V  | 72982    | 831-516E102P     |
| C3035   | 283-0067-00        | XB173850         |          | CAP.,FXD,CER DI:0.001UF,10%,200V      | 72982    | 835-515B102K     |
| C3037   | 285-0938-00        |                  |          | CAP.,FXD,PLSTC:0.03UF,5%,600V         | 80009    | 285-0938-00      |
| C3039   | 283-0280-00        |                  |          | CAP.,FXD,CER DI:2200PF,10%,2000V      | 72982    | 818-002-Y550222K |
| C3040   | 283-0000-00        | B010100          | B020209X | CAP.,FXD,CER DI:0.001UF,+100-0%,500V  | 72982    | 831-516E102P     |
| C3042   | 290-0395-00        |                  |          | CAP.,FXD,ELCTLT:4.7UF,20%,50V         | 56289    | 150D475X0050B2   |
| C3048   | 283-0001-00        |                  |          | CAP.,FXD,CER DI:0.005UF,+100-0%,500V  | 72982    | 831-559E502P     |
| C3049   | 290-0159-00        |                  |          | CAP.,FXD,ELCTLT:2UF,+50-10%,150V      | 56289    | 30D205F150BB4    |
| C3050   | 290-0164-00        |                  |          | CAP.,FXD,ELCTLT:1UF,+50-10%,150V      | 56289    | 30D105F150BA4    |
| C3052   | 283-0003-00        |                  |          | CAP.,FXD,CER DI:0.01UF,+80-20%,150V   | 72982    | 855-547E103Z     |
| C3105   | 283-0003-00        |                  |          | CAP.,FXD,CER DI:0.01UF,+80-20%,150V   | 72982    | 855-547E103Z     |
| C3106   | 283-0003-00        |                  |          | CAP.,FXD,CER DI:0.01UF,+80-20%,150V   | 72982    | 855-547E103Z     |
| C3108   | 290-0523-00        |                  |          | CAP.,FXD,ELCTLT:2.2UF,20%,20V         | 56289    | 196D225X0025HAL  |
| C3113   | 283-0003-00        |                  |          | CAP.,FXD,CER DI:0.01UF,+80-20%,150V   | 72982    | 855-547E103Z     |
| C3114   | 290-0524-00        |                  |          | CAP.,FXD,ELCTLT:4.7UF,20%,10V         | 90201    | TDC475M010EL     |
| C3117   | 290-0523-00        |                  |          | CAP.,FXD,ELCTLT:2.2UF,20%,20V         | 56289    | 196D225X0025HAL  |



| Ckt No. | Tektronix Part No. | Serial/Model No. Eff | Dscont  | Name & Description                   | Mfr Code | Mfr Part Number |
|---------|--------------------|----------------------|---------|--------------------------------------|----------|-----------------|
| C3125   | 281-0523-00        |                      |         | CAP.,FXD,CER DI:100PF,+/-20PF,350V   | 72982    | 301-000U2M0101M |
| C3126   | 281-0523-00        |                      |         | CAP.,FXD,CER DI:100PF,+/-20PF,350V   | 72982    | 301-000U2M0101M |
| C3127   | 290-0572-00        |                      |         | CAP.,FXD,ELCTLT:0.1UF,20%,50V        | 56289    | 196D104X0050HAL |
| C3129   | 290-0572-00        |                      |         | CAP.,FXD,ELCTLT:0.1UF,20%,50V        | 56289    | 196D104X0050HAL |
| C3134   | 283-0092-00        |                      |         | CAP.,FXD,CER DI:0.03UF,+80-20%,200V  | 72982    | 845-534E303Z    |
| C3143   | 283-0028-00        |                      |         | CAP.,FXD,CER DI:0.0022UF,20%,50V     | 56289    | 19C606          |
| C3150   | 283-0594-00        |                      |         | CAP.,FXD,MICA D:0.001UF,1%,100V      | 00853    | D151F102F0      |
| C3153   | 283-0003-00        |                      |         | CAP.,FXD,CER DI:0.01UF,+80-20%,150V  | 72982    | 855-547E103Z    |
| C3154   | 283-0003-00        |                      |         | CAP.,FXD,CER DI:0.01UF,+80-20%,150V  | 72982    | 855-547E103Z    |
| C3168   | 290-0270-00        | B010100              | B142899 | CAP.,FXD,ELCTLT:8.2UF,20%,60V        | 56289    | 150D825X0060R2  |
| C3168   | 290-0716-00        | B142900              |         | CAP.,FXD,ELCTLT:8.2UF,20%,75V        | 05397    | T11C825M075AS   |
| C3169   | 290-0194-00        |                      |         | CAP.,FXD,ELCTLT:10UF,+50-10%,100V    | 56289    | 30D106F100DC4   |
| C3170   | 290-0270-00        | B010100              | B142899 | CAP.,FXD,ELCTLT:8.2UF,20%,60V        | 56289    | 150D825X0060R2  |
| C3170   | 290-0716-00        | B142900              |         | CAP.,FXD,ELCTLT:8.2UF,20%,75V        | 05397    | T11C825M075AS   |
| C3171   | 290-0194-00        |                      |         | CAP.,FXD,ELCTLT:10UF,+50-10%,100V    | 56289    | 30D106F100DC4   |
| C3172   | 290-0425-00        |                      |         | CAP.,FXD,ELCTLT:100UF,20%,20V        | 90201    | THF107M020P1G   |
| C3173   | 290-0519-00        |                      |         | CAP.,FXD,ELCTLT:100UF,20%,20V        | 56289    | 196D107X0020MA3 |
| C3174   | 290-0425-00        |                      |         | CAP.,FXD,ELCTLT:100UF,20%,20V        | 90201    | THF107M020P1G   |
| C3175   | 290-0519-00        |                      |         | CAP.,FXD,ELCTLT:100UF,20%,20V        | 56289    | 196D107X0020MA3 |
| C3178   | 290-0425-00        |                      |         | CAP.,FXD,ELCTLT:100UF,20%,20V        | 90201    | THF107M020P1G   |
| C3179   | 290-0531-00        |                      |         | CAP.,FXD,ELCTLT:100UF,20%,10V        | 90201    | TDC107M010CL    |
| C3181   | 290-0425-00        |                      |         | CAP.,FXD,ELCTLT:100UF,20%,20V        | 90201    | THF107M020P1G   |
| C3182   | 290-0531-00        |                      |         | CAP.,FXD,ELCTLT:100UF,20%,10V        | 90201    | TDC107M010CL    |
| C3213   | 281-0543-00        |                      |         | CAP.,FXD,CER DI:270PF,10%,500V       | 72982    | 301-055X5P1271K |
| C3214   | 283-0000-00        |                      |         | CAP.,FXD,CER DI:0.001UF,+100-0%,500V | 72982    | 831-516E102P    |
| C3228   | 283-0000-00        |                      |         | CAP.,FXD,CER DI:0.001UF,+100-0%,500V | 72982    | 831-516E102P    |
| C3236   | 290-0531-00        |                      |         | CAP.,FXD,ELCTLT:100UF,20%,10V        | 90201    | TDC107M010CL    |
| C3237   | 283-0000-00        |                      |         | CAP.,FXD,CER DI:0.001UF,+100-0%,500V | 72982    | 831-516E102P    |
| C3239   | 283-0000-00        |                      |         | CAP.,FXD,CER DI:0.001UF,+100-0%,500V | 72982    | 831-516E102P    |
| C3269   | 281-0523-00        |                      |         | CAP.,FXD,CER DI:100PF,+/-20PF,350V   | 72982    | 301-000U2M0101M |
| C3278   | 283-0000-00        | B010100              | B029999 | CAP.,FXD,CER DI:0.001UF,+100-0%,500V | 72982    | 831-516E102P    |
| C3278   | 283-0110-00        | B030000              |         | CAP.,FXD,CER DI:0.005UF,+80-20%,150V | 56289    | 19C242B         |
| C3289   | 283-0000-00        |                      |         | CAP.,FXD,CER DI:0.001UF,+100-0%,500V | 72982    | 831-516E102P    |
| C3309   | 281-0629-00        |                      |         | CAP.,FXD,CER DI:33PF,5%,600V         | 72982    | 308-000COG0330G |
| C3310   | 281-0540-00        |                      |         | CAP.,FXD,CER DI:51PF,5%,500V         | 72982    | 301-000U2J0510J |
| C3312   | 283-0000-00        |                      |         | CAP.,FXD,CER DI:0.001UF,+100-0%,500V | 72982    | 831-516E102P    |
| C3315   | 283-0000-00        |                      |         | CAP.,FXD,CER DI:0.001UF,+100-0%,500V | 72982    | 831-516E102P    |
| C3326   | 283-0024-00        |                      |         | CAP.,FXD,CER DI:0.1UF,+80-20%,30V    | 56289    | 273C16          |
| C3330   | 281-0510-00        |                      |         | CAP.,FXD,CER DI:22PF,+/-4.4PF,500V   | 72982    | 301-000COG0220M |
| C3354   | 283-0080-00        |                      |         | CAP.,FXD,CER DI:0.022UF,+80-20%,25V  | 56289    | 19C611          |
| C3356   | 283-0000-00        |                      |         | CAP.,FXD,CER DI:0.001UF,+100-0%,500V | 72982    | 831-516E102P    |
| C3364   | 281-0603-00        |                      |         | CAP.,FXD,CER DI:39PF,5%,500V         | 72982    | 308-000COG0390J |
| C3368   | 281-0546-00        |                      |         | CAP.,FXD,CER DI:330PF,10%,500V       | 72982    | 301-000X5P0331K |
| C3373   | 283-0003-00        |                      |         | CAP.,FXD,CER DI:0.01UF,+80-20%,150V  | 72982    | 855-547E103Z    |
| C3391   | 283-0024-00        |                      |         | CAP.,FXD,CER DI:0.1UF,+80-20%,30V    | 56289    | 273C16          |
| C3395   | 290-0523-00        |                      |         | CAP.,FXD,ELCTLT:2.2UF,20%,20V        | 56289    | 196D225X0025HAL |
| C3396   | 290-0523-00        |                      |         | CAP.,FXD,ELCTLT:2.2UF,20%,20V        | 56289    | 196D225X0025HAL |
| C3401   | 283-0000-00        |                      |         | CAP.,FXD,CER DI:0.001UF,+100-0%,500V | 72982    | 831-516E102P    |
| C3407   | 283-0597-00        |                      |         | CAP.,FXD,MICA D:470PF,10%,300V       | 00853    | D153E471K0      |
| C3418   | 283-0004-00        |                      |         | CAP.,FXD,CER DI:0.02UF,+80-20%,150V  | 72982    | 855016Z5V0203Z  |
| C3420   | 283-0597-00        |                      |         | CAP.,FXD,MICA D:470PF,10%,300V       | 00853    | D153E471K0      |
| C3429   | 283-0004-00        |                      |         | CAP.,FXD,CER DI:0.02UF,+80-20%,150V  | 72982    | 855016Z5V0203Z  |
| C3434   | 285-0698-00        |                      |         | CAP.,FXD,PLSTC:0.0082UF,5%,100V      | 01002    | 64F10AC682      |
| C3438   | 281-0612-00        |                      |         | CAP.,FXD,CER DI:5.6PF,+/-0.5PF,500V  | 72982    | 374-001COH0569D |
| C3443   | 283-0103-00        |                      |         | CAP.,FXD,CER DI:180PF,5%,500V        | 56289    | 40C638          |

# Electrical Parts List—7704A

| Ckt No. | Tektronix Part No. | Serial/Model No. Eff | Dscont  | Name & Description                   | Mfr Code | Mfr Part Number |
|---------|--------------------|----------------------|---------|--------------------------------------|----------|-----------------|
| C3445   | 283-0103-00        |                      |         | CAP.,FXD,CER DI:180PF,5%,500V        | 56289    | 40C638          |
| C3449   | 283-0000-00        |                      |         | CAP.,FXD,CER DI:0.001UF,+100-0%,500V | 72982    | 831-516E102P    |
| C3470   | 290-0523-00        |                      |         | CAP.,FXD,ELCTLT:2.2UF,20%,20V        | 56289    | 196D225X0025HA1 |
| C3471   | 290-0517-00        |                      |         | CAP.,FXD,ELCTLT:6.8UF,20%,35V        | 56289    | 196D685X0035KA1 |
| C3472   | 290-0523-00        |                      |         | CAP.,FXD,ELCTLT:2.2UF,20%,20V        | 56289    | 196D225X0025HA1 |
| C3475   | 283-0000-00        |                      |         | CAP.,FXD,CER DI:0.001UF,+100-0%,500V | 72982    | 831-516E102P    |
| C4101   | 283-0057-00        |                      |         | CAP.,FXD,CER DI:0.1UF,+80-20%,200V   | 56289    | 274C10          |
| C4104   | 283-0000-00        |                      |         | CAP.,FXD,CER DI:0.001UF,+100-0%,500V | 72982    | 831-516E102P    |
| C4106   | 283-0003-00        |                      |         | CAP.,FXD,CER DI:0.01UF,+80-20%,150V  | 72982    | 855-547E103Z    |
| C4120   | 283-0000-00        |                      |         | CAP.,FXD,CER DI:0.001UF,+100-0%,500V | 72982    | 831-516E102P    |
| C4135   | 283-0092-00        |                      |         | CAP.,FXD,CER DI:0.03UF,+80-20%,200V  | 72982    | 845-534E303Z    |
| C4140   | 283-0177-00        |                      |         | CAP.,FXD,CER DI:1UF,+80-20%,25V      | 72982    | 8131N039651105Z |
| C4142   | 283-0177-00        |                      |         | CAP.,FXD,CER DI:1UF,+80-20%,25V      | 72982    | 8131N039651105Z |
| C4157   | 283-0178-00        |                      |         | CAP.,FXD,CER DI:0.1UF,+80-20%,100V   | 72982    | 8131N145651104Z |
| C4167   | 283-0080-00        |                      |         | CAP.,FXD,CER DI:0.022UF,+80-20%,25V  | 56289    | 19C611          |
| C4193   | 283-0080-00        |                      |         | CAP.,FXD,CER DI:0.022UF,+80-20%,25V  | 56289    | 19C611          |
| C4197   | 281-0670-00        | XB040000             |         | CAP.,FXD,CER DI:1.8PF,+/-0.1PF,500V  | 72982    | 374-005COK0189B |
| C4201   | 290-0414-00        |                      |         | CAP.,FXD,ELCTLT:8UF,+50-10%,200V     | 90201    | TTBROT200C1C3P  |
| C4204   | 283-0105-00        |                      |         | CAP.,FXD,CER DI:0.01UF,+80-20%,2000V | 56289    | 41C316          |
| C4205   | 283-0105-00        |                      |         | CAP.,FXD,CER DI:0.01UF,+80-20%,2000V | 56289    | 41C316          |
| C4206   | 283-0272-00        |                      |         | CAP.,FXD,CER DI:0.0068UF,30%,4000V   | 72982    | 3888510Y5S682N  |
| C4207   | 283-0272-00        |                      |         | CAP.,FXD,CER DI:0.0068UF,30%,4000V   | 72982    | 3888510Y5S682N  |
| C4208   | 283-0272-00        |                      |         | CAP.,FXD,CER DI:0.0068UF,30%,4000V   | 72982    | 3888510Y5S682N  |
| C4215   | 283-0271-00        |                      |         | CAP.,FXD,CER DI:0.001UF,20%,4000V    | 72982    | 828552Y550102M  |
| C4216   | 283-0271-00        |                      |         | CAP.,FXD,CER DI:0.001UF,20%,4000V    | 72982    | 828552Y550102M  |
| C4217   | 283-0092-00        |                      |         | CAP.,FXD,CER DI:0.03UF,+80-20%,200V  | 72982    | 845-534E303Z    |
| C4219   | 283-0272-00        |                      |         | CAP.,FXD,CER DI:0.0068UF,30%,4000V   | 72982    | 3888510Y5S682N  |
| C4221   | 283-0272-00        |                      |         | CAP.,FXD,CER DI:0.0068UF,30%,4000V   | 72982    | 3888510Y5S682N  |
| C4230   | 283-0279-00        |                      |         | CAP.,FXD,CER DI:0.001UF,20%,3000V    | 72982    | 878Y5S102M      |
| C4231   | 283-0279-00        |                      |         | CAP.,FXD,CER DI:0.001UF,20%,3000V    | 72982    | 878Y5S102M      |
| C4244   | 283-0271-00        |                      |         | CAP.,FXD,CER DI:0.001UF,20%,4000V    | 72982    | 828552Y550102M  |
| C4250   | 290-0425-00        |                      |         | CAP.,FXD,ELCTLT:100UF,20%,20V        | 90201    | THF107M020P1G   |
| C4252   | 290-0531-00        |                      |         | CAP.,FXD,ELCTLT:100UF,20%,10V        | 90201    | TDCL07M010CL    |
| C4312   | 281-0540-00        | B010100              | B099999 | CAP.,FXD,CER DI:51PF,5%,500V         | 72982    | 301-000U2J0510J |
| C4312   | 281-0550-00        | B100000              | B109999 | CAP.,FXD,CER DI:120PF,10%,500V       | 72982    | 301-000X5P0121K |
| C4312   | 281-0524-00        | B110000              |         | CAP.,FXD,CER DI:150PF,+/-30PF,500V   | 72982    | 301-000X500151M |
| C4315   | 281-0542-00        |                      |         | CAP.,FXD,CER DI:18PF,10%,500V        | 72982    | 301-002C0G0180K |
| C4321   | 283-0000-00        |                      |         | CAP.,FXD,CER DI:0.001UF,+100-0%,500V | 72982    | 831-516E102P    |
| C4325   | 283-0083-00        |                      |         | CAP.,FXD,CER DI:0.0047UF,20%,500V    | 72982    | 811-565C472J    |
| C4329   | 281-0501-00        | B010100              | B109999 | CAP.,FXD,CER DI:4.7PF,+/-1PF,500V    | 72982    | 301-000S2H0479F |
| C4329   | 281-0504-00        | B110000              |         | CAP.,FXD,CER DI:10PF,+/-1PF,500V     | 72982    | 301-000C0G0100F |
| C4331   | 283-0000-00        |                      |         | CAP.,FXD,CER DI:0.001UF,+100-0%,500V | 72982    | 831-516E102P    |
| C4335   | 283-0041-00        |                      |         | CAP.,FXD,CER DI:0.0033UF,5%,500V     | 72982    | 841-541B332J    |
| C4339   | 281-0629-00        |                      |         | CAP.,FXD,CER DI:33PF,5%,600V         | 72982    | 308-000COG0330G |
| C4342   | 283-0092-00        |                      |         | CAP.,FXD,CER DI:0.03UF,+80-20%,200V  | 72982    | 845-534E303Z    |
| C4354   | 283-0178-00        | B010100              | B109999 | CAP.,FXD,CER DI:0.1UF,+80-20%,100V   | 72982    | 8131N145651104Z |
| C4354   | 283-0211-00        | B110000              |         | CAP.,FXD,CER DI:0.1UF,10%,200V       | 72982    | 814N227C104K    |
| C4356   | 290-0534-00        |                      |         | CAP.,FXD,ELCTLT:1UF,20%,35V          | 56289    | 196D105X0035HA1 |
| C4364   | 283-0178-00        | B010100              | B109999 | CAP.,FXD,CER DI:0.1UF,+80-20%,100V   | 72982    | 8131N145651104Z |
| C4364   | 283-0211-00        | B110000              |         | CAP.,FXD,CER DI:0.1UF,10%,200V       | 72982    | 814N227C104K    |
| C4366   | 290-0534-00        |                      |         | CAP.,FXD,ELCTLT:1UF,20%,35V          | 56289    | 196D105X0035HA1 |
| C4373   | 290-0305-00        |                      |         | CAP.,FXD,ELCTLT:3UF,20%,150V         | 56289    | 109D305X0150C2  |
| C4374   | 281-0064-00        |                      |         | CAP.,VAR,PLSTC:0.25-1.5PF,600V       | 72982    | 530-002         |

| Ckt No. | Tektronix Part No. | Serial/Model No. Eff | Dscont   | Name & Description                    | Mfr Code | Mfr Part Number |
|---------|--------------------|----------------------|----------|---------------------------------------|----------|-----------------|
| C4380   | 283-0080-00        |                      |          | CAP.,FXD,CER DI:0.022UF,+80-20%,25V   | 56289    | 19C611          |
| C4385   | 281-0123-00        |                      |          | CAP.,VAR,CER DI:5-25PF,100V           | 72982    | 518-000A5-25    |
| C4391   | 281-0064-00        |                      |          | CAP.,VAR,PLSTC:0.25-1.5PF,600V        | 72982    | 530-002         |
| C4394   | 290-0305-00        |                      |          | CAP.,FXD,ELCTLT:3UF,20%,150V          | 56289    | 109D305X0150C2  |
| C4397   | 283-0010-00        |                      |          | CAP.,FXD,CER DI:0.05UF,+100-20%,50V   | 56289    | 273C20          |
| C4398   | 290-0527-00        |                      |          | CAP.,FXD,ELCTLT:15UF,20%,20V          | 90201    | TDC156M020FL    |
| C4399   | 290-0527-00        |                      |          | CAP.,FXD,ELCTLT:15UF,20%,20V          | 90201    | TDC156M020FL    |
| C4401   | 281-0122-00        |                      |          | CAP.,VAR,CER DI:2.5-9PF,100V          | 72982    | 518-000A2.5-9   |
| C4417   | 283-0000-00        |                      |          | CAP.,FXD,CER DI:0.001UF,+100-0%,500V  | 72982    | 831-516E102P    |
| C4419   | 283-0000-00        |                      |          | CAP.,FXD,CER DI:0.001UF,+100-0%,500V  | 72982    | 831-516E102P    |
| C4423   | 281-0589-00        |                      |          | CAP.,FXD,CER DI:170PF,5%,500V         | 72982    | 301-057Z5D0171J |
| C4424   | 281-0158-00        |                      |          | CAP.,VAR,CER DI:7-45PF,50V            | 72982    | 518-000G7-45    |
| C4427   | 281-0122-00        |                      |          | CAP.,VAR,CER DI:2.5-9PF,100V          | 72982    | 518-000A2.5-9   |
| C4451   | 281-0580-00        |                      |          | CAP.,FXD,CER DI:470PF,10%,500V        | 72982    | 301-000Z5D0471K |
| C4453   | 283-0001-00        | B010100              | B010129  | CAP.,FXD,CER DI:0.005UF,+100-0%,500V  | 72982    | 831-559E502P    |
| C4453   | 283-0328-00        | B010130              |          | CAP.,FXD,CER DI:0.03UF,+80-20%,200V   | 72982    | 8131N225651303Z |
| C4455   | 283-0080-00        |                      |          | CAP.,FXD,CER DI:0.022UF,+80-20%,25V   | 56289    | 19C611          |
| C4458   | 283-0000-00        |                      |          | CAP.,FXD,CER DI:0.001UF,+100-0%,500V  | 72982    | 831-516E102P    |
| C4461   | 283-0119-00        | B010100              | B010129  | CAP.,FXD,CER DI:2200PF,5%,200V        | 72982    | 855-535B222J    |
| C4461   | 283-0238-00        | B010130              |          | CAP.,FXD,CER DI:0.01UF,10%,50V        | 72982    | 8121N071WR5103K |
| C4463   | 283-0003-00        | B010100              | B010129  | CAP.,FXD,CER DI:0.01UF,+80-20%,150V   | 72982    | 855-547E103Z    |
| C4463   | 283-0176-00        | B010130              |          | CAP.,FXD,CER DI:0.0022UF,20%,50V      | 72982    | 8121M050W5R222M |
| C4465   | 283-0111-00        | B010100              | B119999  | CAP.,FXD,CER DI:0.1UF,20%,50V         | 72982    | 8131N075651104M |
| C4465   | 283-0111-00        | B120000              |          | CAP.,FXD,CER DI:0.1UF,(NOM VALUE),SEL | 72982    | 8131N075651104M |
| C5013   | 283-0000-00        |                      |          | CAP.,FXD,CER DI:0.001UF,+100-0%,500V  | 72982    | 831-516E102P    |
| C5020   | 283-0044-00        | B010100              | B091620X | CAP.,FXD,CER DI:0.001UF,3000V         | 72982    | 390BW002Y5102M  |
| C5022   | 283-0044-00        | B010100              | B091620X | CAP.,FXD,CER DI:0.001UF,3000V         | 72982    | 390BW002Y5102M  |
| C32119  | 283-0067-00        | B010100              | B069999  | CAP.,FXD,CER DI:0.001UF,10%,200V      | 72982    | 835-515B102K    |
| C32119  | 283-0110-00        | B070000              | B099999  | CAP.,FXD,CER DI:0.005UF,+80-20%,150V  | 56289    | 19C242B         |
| C32119  | 283-0028-00        | B100000              |          | CAP.,FXD,CER DI:0.0022UF,20%,50V      | 56289    | 19C606          |
| C32127  | 283-0003-00        |                      |          | CAP.,FXD,CER DI:0.01UF,+80-20%,150V   | 72982    | 855-547E103Z    |
| C32134  | 283-0111-00        | B010100              | B099999  | CAP.,FXD,CER DI:0.1UF,20%,50V         | 72982    | 8131N075651104M |
| C32134  | 283-0208-00        | B100000              |          | CAP.,FXD,CER DI:0.22UF,10%,200V       | 72982    | 8151N230W5R224K |
| C32141  | 283-0000-00        |                      |          | CAP.,FXD,CER DI:0.001UF,+100-0%,500V  | 72982    | 831-516E102P    |
| C41105  | 283-0000-00        |                      |          | CAP.,FXD,CER DI:0.001UF,+100-0%,500V  | 72982    | 831-516E102P    |
| C41107  | 283-0110-00        |                      |          | CAP.,FXD,CER DI:0.005UF,+80-20%,150V  | 56289    | 19C242B         |
| C41109  | 281-0064-00        |                      |          | CAP.,VAR,PLSTC:0.25-1.5PF,600V        | 72982    | 530-002         |
| C41111  | 283-0178-00        | B010100              | B109999  | CAP.,FXD,CER DI:0.1UF,+80-20%,100V    | 72982    | 8131N145651104Z |
| C41111  | 283-0211-00        | B110000              |          | CAP.,FXD,CER DI:0.1UF,10%,200V        | 72982    | 8141N227C104K   |
| C41113  | 283-0178-00        | B010100              | B109999  | CAP.,FXD,CER DI:0.1UF,+80-20%,100V    | 72982    | 8131N145651104Z |
| C41113  | 283-0211-00        | B110000              |          | CAP.,FXD,CER DI:0.1UF,10%,200V        | 72982    | 8141N227C104K   |
| C41125  | 281-0526-00        |                      |          | CAP.,FXD,CER DI:1.5PF,+/-0.5PF,500V   | 72982    | 301-000S2K0159D |
| C41133  | 283-0178-00        |                      |          | CAP.,FXD,CER DI:0.1UF,+80-20%,100V    | 72982    | 8131N145651104Z |
| C41150  | 283-0092-00        |                      |          | CAP.,FXD,CER DI:0.03UF,+80-20%,200V   | 72982    | 845-534E303Z    |
| C41151  | 281-0629-00        |                      |          | CAP.,FXD,CER DI:33PF,5%,600V          | 72982    | 308-000COG0330G |
| C41163  | 290-0523-00        |                      |          | CAP.,FXD,ELCTLT:2.2UF,20%,20V         | 56289    | 196D225X0025HA1 |
| C41165  | 283-0178-00        |                      |          | CAP.,FXD,CER DI:0.1UF,+80-20%,100V    | 72982    | 8131N145651104Z |
| C41167  | 283-0178-00        |                      |          | CAP.,FXD,CER DI:0.1UF,+80-20%,100V    | 72982    | 8131N145651104Z |
| C41169  | 290-0523-00        |                      |          | CAP.,FXD,ELCTLT:2.2UF,20%,20V         | 56289    | 196D225X0025HA1 |
| C41171  | 283-0003-00        |                      |          | CAP.,FXD,CER DI:0.01UF,+80-20%,150V   | 72982    | 855-547E103Z    |
| C41175  | 283-0003-00        |                      |          | CAP.,FXD,CER DI:0.01UF,+80-20%,150V   | 72982    | 855-547E103Z    |
| C41179  | 283-0003-00        |                      |          | CAP.,FXD,CER DI:0.01UF,+80-20%,150V   | 72982    | 855-547E103Z    |
| C41185  | 283-0178-00        |                      |          | CAP.,FXD,CER DI:0.1UF,+80-20%,100V    | 72982    | 8131N145651104Z |



| Ckt No. | Tektronix Part No. | Serial/Model No. Eff Dscont | Name & Description                         | Mfr Code | Mfr Part Number |
|---------|--------------------|-----------------------------|--|----------|-----------------|
| CR2239  | 152-0333-00        | XB160000                    | SEMICON D DEVICE:SILICON, 55V, 200MA       | 80009    | 152-0333-00     |
| CR2240  | 152-0333-00        | XB160000                    | SEMICON D DEVICE:SILICON, 55V, 200MA       | 80009    | 152-0333-00     |
| CR2244  | 152-0141-02        |                             | SEMICON D DEVICE:SILICON, 30V, 150MA       | 07910    | 1N4152          |
| CR2444  | 152-0141-02        |                             | SEMICON D DEVICE:SILICON, 30V, 150MA       | 07910    | 1N4152          |
| CR2449  | 152-0141-02        |                             | SEMICON D DEVICE:SILICON, 30V, 150MA       | 07910    | 1N4152          |
| CR2501  | 152-0141-02        |                             | SEMICON D DEVICE:SILICON, 30V, 150MA       | 07910    | 1N4152          |
| CR2502  | 152-0141-02        |                             | SEMICON D DEVICE:SILICON, 30V, 150MA       | 07910    | 1N4152          |
| CR2524  | 152-0141-02        |                             | SEMICON D DEVICE:SILICON, 30V, 150MA       | 07910    | 1N4152          |
| CR2525  | 152-0141-02        |                             | SEMICON D DEVICE:SILICON, 30V, 150MA       | 07910    | 1N4152          |
| CR2526  | 152-0141-02        |                             | SEMICON D DEVICE:SILICON, 30V, 150MA       | 07910    | 1N4152          |
| CR2552  | 152-0141-02        |                             | SEMICON D DEVICE:SILICON, 30V, 150MA       | 07910    | 1N4152          |
| CR2553  | 152-0141-02        |                             | SEMICON D DEVICE:SILICON, 30V, 150MA       | 07910    | 1N4152          |
| CR2571  | 152-0141-02        |                             | SEMICON D DEVICE:SILICON, 30V, 150MA       | 07910    | 1N4152          |
| CR2572  | 152-0141-02        |                             | SEMICON D DEVICE:SILICON, 30V, 150MA       | 07910    | 1N4152          |
| CR2585  | 152-0141-02        |                             | SEMICON D DEVICE:SILICON, 30V, 150MA       | 07910    | 1N4152          |
| CR2594  | 152-0141-02        |                             | SEMICON D DEVICE:SILICON, 30V, 150MA       | 07910    | 1N4152          |
| CR2596  | 152-0141-02        |                             | SEMICON D DEVICE:SILICON, 30V, 150MA       | 07910    | 1N4152          |
| CR3015  | 152-0396-01        |                             | SEMICON D DEVICE:SILICON, 400V, 3A         | 12969    | 652-821         |
| CR3032  | 152-0107-00        |                             | SEMICON D DEVICE:SILICON, 375V, 400MA      | 80009    | 152-0107-00     |
| CR3034  | 152-0400-00        |                             | SEMICON D DEVICE:SILICON, 400V, 1A         | 80009    | 152-0400-00     |
| CR3040  | 152-0401-00        |                             | SEMICON D DEVICE:SILICON, 3-LAYER, TRIGGER | 04713    | MPT32           |
| CR3043  | 152-0107-00        |                             | SEMICON D DEVICE:SILICON, 375V, 400MA      | 80009    | 152-0107-00     |
| CR3045  | 152-0400-00        |                             | SEMICON D DEVICE:SILICON, 400V, 1A         | 80009    | 152-0400-00     |
| CR3046  | 152-0107-00        |                             | SEMICON D DEVICE:SILICON, 375V, 400MA      | 80009    | 152-0107-00     |
| CR3050  | 152-0061-00        |                             | SEMICON D DEVICE:SILICON, 175V, 100MA      | 80009    | 152-0061-00     |
| CR3057  | 152-0107-00        |                             | SEMICON D DEVICE:SILICON, 375V, 400MA      | 80009    | 152-0107-00     |
| CR3101  | 152-0061-00        |                             | SEMICON D DEVICE:SILICON, 175V, 100MA      | 80009    | 152-0061-00     |
| CR3102  | 152-0061-00        |                             | SEMICON D DEVICE:SILICON, 175V, 100MA      | 80009    | 152-0061-00     |
| CR3103  | 152-0141-02        |                             | SEMICON D DEVICE:SILICON, 30V, 150MA       | 07910    | 1N4152          |
| CR3106  | 152-0141-02        |                             | SEMICON D DEVICE:SILICON, 30V, 150MA       | 07910    | 1N4152          |
| CR3108  | 152-0141-02        |                             | SEMICON D DEVICE:SILICON, 30V, 150MA       | 07910    | 1N4152          |
| CR3130  | 152-0333-00        |                             | SEMICON D DEVICE:SILICON, 55V, 200MA       | 80009    | 152-0333-00     |
| CR3131  | 152-0333-00        |                             | SEMICON D DEVICE:SILICON, 55V, 200MA       | 80009    | 152-0333-00     |
| CR3132  | 152-0333-00        |                             | SEMICON D DEVICE:SILICON, 55V, 200MA       | 80009    | 152-0333-00     |
| CR3133  | 152-0333-00        |                             | SEMICON D DEVICE:SILICON, 55V, 200MA       | 80009    | 152-0333-00     |
| CR3138  | 152-0333-00        |                             | SEMICON D DEVICE:SILICON, 55V, 200MA       | 80009    | 152-0333-00     |
| CR3139  | 152-0333-00        |                             | SEMICON D DEVICE:SILICON, 55V, 200MA       | 80009    | 152-0333-00     |
| CR3140  | 152-0333-00        |                             | SEMICON D DEVICE:SILICON, 55V, 200MA       | 80009    | 152-0333-00     |
| CR3144  | 152-0141-02        |                             | SEMICON D DEVICE:SILICON, 30V, 150MA       | 07910    | 1N4152          |
| CR3163  | 152-0413-00        |                             | SEMICON D DEVICE:SILICON, 400V, 750MA      | 80009    | 152-0413-00     |
| CR3165  | 152-0413-00        |                             | SEMICON D DEVICE:SILICON, 400V, 750MA      | 80009    | 152-0413-00     |
| CR3167  | 152-0413-00        |                             | SEMICON D DEVICE:SILICON, 400V, 750MA      | 80009    | 152-0413-00     |
| CR3168  | 152-0413-00        |                             | SEMICON D DEVICE:SILICON, 400V, 750MA      | 80009    | 152-0413-00     |
| CR3172  | 152-0412-00        |                             | SEMICON D DEVICE:SILICON, 50V, 3A          | 04713    | SR1936          |
| CR3173  | 152-0412-00        |                             | SEMICON D DEVICE:SILICON, 50V, 3A          | 04713    | SR1936          |
| CR3174  | 152-0412-00        |                             | SEMICON D DEVICE:SILICON, 50V, 3A          | 04713    | SR1936          |
| CR3175  | 152-0412-00        |                             | SEMICON D DEVICE:SILICON, 50V, 3A          | 04713    | SR1936          |
| CR3178  | 152-0412-00        |                             | SEMICON D DEVICE:SILICON, 50V, 3A          | 04713    | SR1936          |
| CR3179  | 152-0412-00        |                             | SEMICON D DEVICE:SILICON, 50V, 3A          | 04713    | SR1936          |
| CR3181  | 152-0502-00        |                             | SEMICON D DEVICE:SILICON, 20V, 5A          | 04713    | 1N5823          |
| CR3182  | 152-0502-00        |                             | SEMICON D DEVICE:SILICON, 20V, 5A          | 04713    | 1N5823          |
| CR3202  | 152-0141-02        |                             | SEMICON D DEVICE:SILICON, 30V, 150MA       | 07910    | 1N4152          |
| CR3209  | 152-0141-02        |                             | SEMICON D DEVICE:SILICON, 30V, 150MA       | 07910    | 1N4152          |
| CR3211  | 152-0141-02        |                             | SEMICON D DEVICE:SILICON, 30V, 150MA       | 07910    | 1N4152          |
| CR3212  | 152-0141-02        |                             | SEMICON D DEVICE:SILICON, 30V, 150MA       | 07910    | 1N4152          |
| CR3221  | 152-0066-01        |                             | SEMICON D DEVICE:SILICON, 400V, 750MA      | 14099    | SM4             |
| CR3226  | 152-0141-02        |                             | SEMICON D DEVICE:SILICON, 30V, 150MA       | 07910    | 1N4152          |
| CR3235  | 152-0141-02        |                             | SEMICON D DEVICE:SILICON, 30V, 150MA       | 07910    | 1N4152          |
| CR3241  | 152-0066-01        |                             | SEMICON D DEVICE:SILICON, 400V, 750MA      | 14099    | SM4             |
| CR3245  | 152-0141-02        |                             | SEMICON D DEVICE:SILICON, 30V, 150MA       | 07910    | 1N4152          |
| CR3246  | 152-0141-02        |                             | SEMICON D DEVICE:SILICON, 30V, 150MA       | 07910    | 1N4152          |
| CR3261  | 152-0066-01        |                             | SEMICON D DEVICE:SILICON, 400V, 750MA      | 14099    | SM4             |
| CR3274  | 152-0141-02        |                             | SEMICON D DEVICE:SILICON, 30V, 150MA       | 07910    | 1N4152          |
| CR3275  | 152-0141-02        |                             | SEMICON D DEVICE:SILICON, 30V, 150MA       | 07910    | 1N4152          |

# Electrical Parts List—7704A

| Ckt No. | Tektronix Part No. | Serial/Model No. Eff | Dscont  | Name & Description                      | Mfr Code | Mfr Part Number |
|---------|--------------------|----------------------|---------|---|----------|-----------------|
| CR3277  | 152-0141-02        |                      |         | SEMICON D DEVICE: SILICON, 30V, 150MA   | 07910    | 1N4152          |
| CR3278  | 152-0141-02        |                      |         | SEMICON D DEVICE: SILICON, 30V, 150MA   | 07910    | 1N4152          |
| CR3281  | 152-0141-02        |                      |         | SEMICON D DEVICE: SILICON, 30V, 150MA   | 07910    | 1N4152          |
| CR3293  | 152-0066-01        |                      |         | SEMICON D DEVICE: SILICON, 400V, 750MA  | 14099    | SM4             |
| CR3315  | 152-0141-02        |                      |         | SEMICON D DEVICE: SILICON, 30V, 150MA   | 07910    | 1N4152          |
| CR3317  | 152-0141-02        |                      |         | SEMICON D DEVICE: SILICON, 30V, 150MA   | 07910    | 1N4152          |
| CR3326  | 152-0141-02        |                      |         | SEMICON D DEVICE: SILICON, 30V, 150MA   | 07910    | 1N4152          |
| CR3333  | 152-0141-02        |                      |         | SEMICON D DEVICE: SILICON, 30V, 150MA   | 07910    | 1N4152          |
| CR3361  | 152-0141-02        |                      |         | SEMICON D DEVICE: SILICON, 30V, 150MA   | 07910    | 1N4152          |
| CR3363  | 152-0141-02        |                      |         | SEMICON D DEVICE: SILICON, 30V, 150MA   | 07910    | 1N4152          |
| CR3364  | 152-0141-02        |                      |         | SEMICON D DEVICE: SILICON, 30V, 150MA   | 07910    | 1N4152          |
| CR3393  | 152-0141-02        |                      |         | SEMICON D DEVICE: SILICON, 30V, 150MA   | 07910    | 1N4152          |
| CR3416  | 152-0141-02        |                      |         | SEMICON D DEVICE: SILICON, 30V, 150MA   | 07910    | 1N4152          |
| CR3431  | 152-0141-02        |                      |         | SEMICON D DEVICE: SILICON, 30V, 150MA   | 07910    | 1N4152          |
| CR3432  | 152-0141-02        |                      |         | SEMICON D DEVICE: SILICON, 30V, 150MA   | 07910    | 1N4152          |
| CR3433  | 152-0141-02        |                      |         | SEMICON D DEVICE: SILICON, 30V, 150MA   | 07910    | 1N4152          |
| CR3438  | 152-0141-02        |                      |         | SEMICON D DEVICE: SILICON, 30V, 150MA   | 07910    | 1N4152          |
| CR3439  | 152-0141-02        |                      |         | SEMICON D DEVICE: SILICON, 30V, 150MA   | 07910    | 1N4152          |
| CR3441  | 152-0141-02        |                      |         | SEMICON D DEVICE: SILICON, 30V, 150MA   | 07910    | 1N4152          |
| CR3442  | 152-0141-02        |                      |         | SEMICON D DEVICE: SILICON, 30V, 150MA   | 07910    | 1N4152          |
| CR3443  | 152-0141-02        |                      |         | SEMICON D DEVICE: SILICON, 30V, 150MA   | 07910    | 1N4152          |
| CR3445  | 152-0141-02        |                      |         | SEMICON D DEVICE: SILICON, 30V, 150MA   | 07910    | 1N4152          |
| CR3447  | 152-0141-02        |                      |         | SEMICON D DEVICE: SILICON, 30V, 150MA   | 07910    | 1N4152          |
| CR4101  | 152-0066-01        |                      |         | SEMICON D DEVICE: SILICON, 400V, 750MA  | 14099    | SM4             |
| CR4110  | 152-0141-02        |                      |         | SEMICON D DEVICE: SILICON, 30V, 150MA   | 07910    | 1N4152          |
| CR4112  | 152-0141-02        |                      |         | SEMICON D DEVICE: SILICON, 30V, 150MA   | 07910    | 1N4152          |
| CR4121  | 152-0061-00        |                      |         | SEMICON D DEVICE: SILICON, 175V, 100MA  | 80009    | 152-0061-00     |
| CR4122  | 152-0061-00        |                      |         | SEMICON D DEVICE: SILICON, 175V, 100MA  | 80009    | 152-0061-00     |
| CR4145  | 152-0141-02        |                      |         | SEMICON D DEVICE: SILICON, 30V, 150MA   | 07910    | 1N4152          |
| CR4150  | 152-0141-02        |                      |         | SEMICON D DEVICE: SILICON, 30V, 150MA   | 07910    | 1N4152          |
| CR4151  | 152-0141-02        |                      |         | SEMICON D DEVICE: SILICON, 30V, 150MA   | 07910    | 1N4152          |
| CR4171  | 152-0141-02        |                      |         | SEMICON D DEVICE: SILICON, 30V, 150MA   | 07910    | 1N4152          |
| CR4175  | 152-0141-02        |                      |         | SEMICON D DEVICE: SILICON, 30V, 150MA   | 07910    | 1N4152          |
| CR4177  | 152-0141-02        |                      |         | SEMICON D DEVICE: SILICON, 30V, 150MA   | 07910    | 1N4152          |
| CR4195  | 152-0141-02        |                      |         | SEMICON D DEVICE: SILICON, 30V, 150MA   | 07910    | 1N4152          |
| CR4201  | 152-0413-00        |                      |         | SEMICON D DEVICE: SILICON, 400V, 750MA  | 80009    | 152-0413-00     |
| CR4202  | 152-0413-00        |                      |         | SEMICON D DEVICE: SILICON, 400V, 750MA  | 80009    | 152-0413-00     |
| CR4203  | 152-0413-00        |                      |         | SEMICON D DEVICE: SILICON, 400V, 750MA  | 80009    | 152-0413-00     |
| CR4204  | 152-0413-00        |                      |         | SEMICON D DEVICE: SILICON, 400V, 750MA  | 80009    | 152-0413-00     |
| CR4205  | 152-0409-00        |                      |         | SEMICON D DEVICE: SILICON, 12,000V, 5MA | 83003    | VG-12X          |
| CR4206  | 152-0409-00        |                      |         | SEMICON D DEVICE: SILICON, 12,000V, 5MA | 83003    | VG-12X          |
| CR4215  | 152-0242-00        |                      |         | SEMICON D DEVICE: SILICON, 225V, 200MA  | 12969    | NDP341          |
| CR4216  | 152-0242-00        |                      |         | SEMICON D DEVICE: SILICON, 225V, 200MA  | 12969    | NDP341          |
| CR4217  | 152-0242-00        |                      |         | SEMICON D DEVICE: SILICON, 225V, 200MA  | 12969    | NDP341          |
| CR4218  | 152-0242-00        |                      |         | SEMICON D DEVICE: SILICON, 225V, 200MA  | 12969    | NDP341          |
| CR4230  | 152-0242-00        |                      |         | SEMICON D DEVICE: SILICON, 225V, 200MA  | 12969    | NDP341          |
| CR4231  | 152-0242-00        |                      |         | SEMICON D DEVICE: SILICON, 225V, 200MA  | 12969    | NDP341          |
| CR4233  | 152-0242-00        |                      |         | SEMICON D DEVICE: SILICON, 225V, 200MA  | 12969    | NDP341          |
| CR4235  | 152-0242-00        |                      |         | SEMICON D DEVICE: SILICON, 225V, 200MA  | 12969    | NDP341          |
| CR4250  | 152-0413-00        |                      |         | SEMICON D DEVICE: SILICON, 400V, 750MA  | 80009    | 152-0413-00     |
| CR4256  | 152-0075-00        | B010100              | B109999 | SEMICON D DEVICE: GE, 25V, 40MA         | 80009    | 152-0075-00     |
| CR4256  | 152-0141-02        | B110000              |         | SEMICON D DEVICE: SILICON, 30V, 150MA   | 07910    | 1N4152          |
| CR4258  | 152-0141-02        | B010100              | B109999 | SEMICON D DEVICE: SILICON, 30V, 150MA   | 07910    | 1N4152          |
| CR4258  | 152-0075-00        | B110000              |         | SEMICON D DEVICE: GE, 25V, 40MA         | 80009    | 152-0075-00     |
| CR4323  | 152-0153-00        |                      |         | SEMICON D DEVICE: SILICON, 15V, 50MA    | 13715    | FD7003          |
| CR4333  | 152-0153-00        |                      |         | SEMICON D DEVICE: SILICON, 15V, 50MA    | 13715    | FD7003          |
| CR4340  | 152-0153-00        |                      |         | SEMICON D DEVICE: SILICON, 15V, 50MA    | 13715    | FD7003          |
| CR4342  | 152-0153-00        |                      |         | SEMICON D DEVICE: SILICON, 15V, 50MA    | 13715    | FD7003          |
| CR4344  | 152-0333-00        |                      |         | SEMICON D DEVICE: SILICON, 55V, 200MA   | 80009    | 152-0333-00     |
| CR4346  | 152-0333-00        |                      |         | SEMICON D DEVICE: SILICON, 55V, 200MA   | 80009    | 152-0333-00     |
| CR4348  | 152-0141-02        |                      |         | SEMICON D DEVICE: SILICON, 30V, 150MA   | 07910    | 1N4152          |
| CR4360  | 152-0141-02        |                      |         | SEMICON D DEVICE: SILICON, 30V, 150MA   | 07910    | 1N4152          |

| Ckt No. | Tektronix Part No. | Serial/Model No. |  | Name & Description                  | Mfr            |                 |
|---------|--------------------|------------------|--|-------------------------------------|----------------|-----------------|
|         |                    | Eff              | Dscont   |                                     | Code           | Mfr Part Number |
| CR4419  | 152-0141-02        | XB140000         |  | SEMICOND DEVICE:SILICON, 30V, 150MA | 07910          | 1N4152          |
| CR4473  | 152-0141-02        |                  | SEMICOND DEVICE:SILICON, 30V, 150MA                | 07910                               | 1N4152         |                 |
| CR32110 | 152-0141-02        |                  | SEMICOND DEVICE:SILICON, 30V, 150MA                | 07910                               | 1N4152         |                 |
| CR32113 | 152-0141-02        |                  | SEMICOND DEVICE:SILICON, 30V, 150MA                | 07910                               | 1N4152         |                 |
| CR32114 | 152-0141-02        |                  | SEMICOND DEVICE:SILICON, 30V, 150MA                | 07910                               | 1N4152         |                 |
| CR32123 | 152-0141-02        |                  | SEMICOND DEVICE:SILICON, 30V, 150MA                | 07910                               | 1N4152         |                 |
| CR32125 | 152-0141-02        |                  | SEMICOND DEVICE:SILICON, 30V, 150MA                | 07910                               | 1N4152         |                 |
| CR32128 | 152-0233-00        |                  | SEMICOND DEVICE:SILICON, 85V, 100MA                | 07910                               | CD61128        |                 |
| CR32130 | 152-0141-02        |                  | SEMICOND DEVICE:SILICON, 30V, 150MA                | 07910                               | 1N4152         |                 |
| CR32139 | 152-0066-01        |                  | SEMICOND DEVICE:SILICON, 400V, 750MA               | 14099                               | SM4            |                 |
| CR41103 | 152-0141-02        |                  | SEMICOND DEVICE:SILICON, 30V, 150MA                | 07910                               | 1N4152         |                 |
| CR41110 | 152-0141-02        |                  | SEMICOND DEVICE:SILICON, 30V, 150MA                | 07910                               | 1N4152         |                 |
| CR41111 | 152-0141-02        |                  |  | SEMICOND DEVICE:SILICON, 30V, 150MA | 07910          | 1N4152          |
| CR41121 | 152-0333-00        |                  |  | SEMICOND DEVICE:SILICON, 55V, 200MA | 80009          | 152-0333-00     |
| CR41129 | 152-0141-02        |                  |  | SEMICOND DEVICE:SILICON, 30V, 150MA | 07910          | 1N4152          |
| CR41137 | 152-0141-02        |                  |  | SEMICOND DEVICE:SILICON, 30V, 150MA | 07910          | 1N4152          |
| CR41155 | 152-0061-00        |                  | SEMICOND DEVICE:SILICON, 175V, 100MA               | 80009                               | 152-0061-00    |                 |
| CR41157 | 152-0107-00        |                  | SEMICOND DEVICE:SILICON, 375V, 400MA               | 80009                               | 152-0107-00    |                 |
| CR41183 | 152-0141-02        |                  | SEMICOND DEVICE:SILICON, 30V, 150MA                | 07910                               | 1N4152         |                 |
| DL5050  | 119-0337-00        |                  | DELAY LINE, ELEC:                                  | 80009                               | 119-0337-00    |                 |
| DS111   | 150-0057-03        |                  | LAMP ASSEMBLY: INCANDESCENT                        | 80009                               | 150-0057-03    |                 |
| DS112   | 150-0057-03        |                  | LAMP ASSEMBLY: INCANDESCENT                        | 80009                               | 150-0057-03    |                 |
| DS113   | 150-0057-03        |                  | LAMP ASSEMBLY: INCANDESCENT                        | 80009                               | 150-0057-03    |                 |
| DS114   | 150-0057-03        |                  | LAMP ASSEMBLY: INCANDESCENT                        | 80009                               | 150-0057-03    |                 |
| DS115   | 150-0057-03        |                  | LAMP ASSEMBLY: INCANDESCENT                        | 80009                               | 150-0057-03    |                 |
| DS121   | 150-0057-03        |                  | LAMP ASSEMBLY: INCANDESCENT                        | 80009                               | 150-0057-03    |                 |
| DS122   | 150-0057-03        |                  | LAMP ASSEMBLY: INCANDESCENT                        | 80009                               | 150-0057-03    |                 |
| DS123   | 150-0057-03        |                  | LAMP ASSEMBLY: INCANDESCENT                        | 80009                               | 150-0057-03    |                 |
| DS124   | 150-0057-03        |                  | LAMP ASSEMBLY: INCANDESCENT                        | 80009                               | 150-0057-03    |                 |
| DS131   | 150-0048-01        | XB010120         | LAMP, INCAND: NO. 683, SELECTED                    | 08806                               | 683AS15        |                 |
| DS141   | 150-0048-01        |                  | XB010120   | LAMP, INCAND: NO. 683, SELECTED     | 08806          | 683AS15         |
| DS3008  | 119-0181-00        |                  | SURGE VOLTAGE P: 230VAC, +/-15%                    | 80009                               | 119-0181-00    |                 |
| DS3013  | 119-0181-00        |                  | SURGE VOLTAGE P: 230VAC, +/-15%                    | 80009                               | 119-0181-00    |                 |
| DS3019  | 150-0035-00        |                  | LAMP, GLOW: 90V, 0.3MA                             | 08806                               | A1D-T          |                 |
| DS4216  | 150-0027-00        |                  | LAMP, GLOW: 90V, 3MA                               | 08806                               | 5AB-T          |                 |
| DS4218  | 150-0027-00        |                  | LAMP, GLOW: 90V, 3MA                               | 08806                               | 5AB-T          |                 |
| DS4237  | 150-0027-00        |                  | LAMP, GLOW: 90V, 3MA                               | 08806                               | 5AB-T          |                 |
| DS4239  | 150-0027-00        |                  | LAMP, GLOW: 90V, 3MA                               | 08806                               | 5AB-T          |                 |
| DS5001  | 150-0029-00        |                  | LAMP, INCAND: 6.3V, 0.20A                          | 08806                               | 349            |                 |
| DS5002  | 150-0029-00        |                  | LAMP, INCAND: 6.3V, 0.20A                          | 08806                               | 349            |                 |
| DS5003  | 150-0029-00        |                  | LAMP, INCAND: 6.3V, 0.20A                          | 08806                               | 349            |                 |
| F2020   | 159-0082-00        | B010100          | B019999X FUSE, CARTRIDGE: 1AG, 15A, 32V, FAST BLOW | 71400                               | GKN15          |                 |
| F3003   | 159-0021-00        |                  | FUSE, CARTRIDGE: 3AG, 2A, 250V, FAST-BLOW          | 71400                               | AGC 2          |                 |
| F5001   | 159-0017-00        |                  | FUSE, CARTRIDGE: 3AG, 4A, 250V, FAST BLOW          | 71400                               | MTH4           |                 |
| FL5020  | 119-0389-00        | XB091621         | FILTER, RAD INTE: 115/230V, 3A                     | 80009                               | 119-0389-00    |                 |
| J1      | 131-0767-02        | B010100          | B059999 CONNECTOR, RCPT, :76 CONTACT               | 80009                               | 131-0767-02    |                 |
| J1      | 131-0767-08        | B060000          | CONNECTOR, RCPT, :PLUG-IN CKT BD, 70 CONTACT       | 80009                               | 131-0767-08    |                 |
| J2      | 131-0767-02        | B010100          | B059999 CONNECTOR, RCPT, :76 CONTACT               | 80009                               | 131-0767-02    |                 |
| J2      | 131-0767-08        | B060000          | CONNECTOR, RCPT, :PLUG-IN CKT BD, 70 CONTACT       | 80009                               | 131-0767-08    |                 |
| J3      | 131-0767-00        | B010100          | B059999 CONNECTOR, RCPT, :76 CONTACT               | 80009                               | 131-0767-00    |                 |
| J3      | 131-0767-07        | B060000          | CONNECTOR, RCPT, :PLUG-IN CKT BD, 70 CONTACT       | 80009                               | 131-0767-07    |                 |
| J4      | 131-0767-00        | B010100          | B059999 CONNECTOR, RCPT, :76 CONTACT               | 80009                               | 131-0767-00    |                 |
| J4      | 131-0767-07        | B060000          | CONNECTOR, RCPT, :PLUG-IN CKT BD, 70 CONTACT       | 80009                               | 131-0767-07    |                 |
| J20     | 131-1250-00        | B010100          | B091620X CONNECTOR, RCPT, :60 CONTACT              | 95238                               | K60010060WA300 |                 |
| J2001   | 131-1003-00        |                  | CONNECTOR BODY, :CKT BD MT, 3 PRONG                | 80009                               | 131-1003-00    |                 |
| J2002   | 131-1003-00        |                  | CONNECTOR BODY, :CKT BD MT, 3 PRONG                | 80009                               | 131-1003-00    |                 |
| J2003   | 131-1003-00        |                  | CONNECTOR BODY, :CKT BD MT, 3 PRONG                | 80009                               | 131-1003-00    |                 |

# Electrical Parts List—7704A

| Ckt No.   | Tektronix Part No. | Serial/Model No. Eff Dscont | Name & Description                         | Mfr Code | Mfr Part Number |
|-----------|--------------------|-----------------------------|--|----------|-----------------|
| J2004     | 131-1003-00        |                             | CONNECTOR BODY, :CKT BD MT, 3 PRONG        | 80009    | 131-1003-00     |
| J2005     | 131-1003-00        |                             | CONNECTOR BODY, :CKT BD MT, 3 PRONG        | 80009    | 131-1003-00     |
| J2006     | 131-1003-00        |                             | CONNECTOR BODY, :CKT BD MT, 3 PRONG        | 80009    | 131-1003-00     |
| J2007     | 131-1003-00        |                             | CONNECTOR BODY, :CKT BD MT, 3 PRONG        | 80009    | 131-1003-00     |
| J2008     | 131-1003-00        |                             | CONNECTOR BODY, :CKT BD MT, 3 PRONG        | 80009    | 131-1003-00     |
| J2009     | 131-1003-00        |                             | CONNECTOR BODY, :CKT BD MT, 3 PRONG        | 80009    | 131-1003-00     |
| J2010     | 131-1003-00        |                             | CONNECTOR BODY, :CKT BD MT, 3 PRONG        | 80009    | 131-1003-00     |
| J2011     | 131-1003-00        |                             | CONNECTOR BODY, :CKT BD MT, 3 PRONG        | 80009    | 131-1003-00     |
| J2217     | 131-1003-00        |                             | CONNECTOR BODY, :CKT BD MT, 3 PRONG        | 80009    | 131-1003-00     |
| J2218     | 131-1003-00        |                             | CONNECTOR BODY, :CKT BD MT, 3 PRONG        | 80009    | 131-1003-00     |
| J2514     | 131-1003-00        |                             | CONNECTOR BODY, :CKT BD MT, 3 PRONG        | 80009    | 131-1003-00     |
| J3301     | 131-1003-00        |                             | CONNECTOR BODY, :CKT BD MT, 3 PRONG        | 80009    | 131-1003-00     |
| J3304     | 131-1003-00        |                             | CONNECTOR BODY, :CKT BD MT, 3 PRONG        | 80009    | 131-1003-00     |
| J3306     | 131-1003-00        |                             | CONNECTOR BODY, :CKT BD MT, 3 PRONG        | 80009    | 131-1003-00     |
| J3307     | 131-1003-00        |                             | CONNECTOR BODY, :CKT BD MT, 3 PRONG        | 80009    | 131-1003-00     |
| J3308     | 131-1003-00        |                             | CONNECTOR BODY, :CKT BD MT, 3 PRONG        | 80009    | 131-1003-00     |
| J3309     | 131-1003-00        |                             | CONNECTOR BODY, :CKT BD MT, 3 PRONG        | 80009    | 131-1003-00     |
| J3310     | 131-1003-00        |                             | CONNECTOR BODY, :CKT BD MT, 3 PRONG        | 80009    | 131-1003-00     |
| J3311     | 131-1003-00        |                             | CONNECTOR BODY, :CKT BD MT, 3 PRONG        | 80009    | 131-1003-00     |
| J3320     | 131-0955-00        |                             | CONNECTOR, RCPT, :BNC, FEMALE              | 24931    | 28JR200-1       |
| J3321     | 131-0955-00        |                             | CONNECTOR, RCPT, :BNC, FEMALE              | 24931    | 28JR200-1       |
| J3322     | 131-0955-00        |                             | CONNECTOR, RCPT, :BNC, FEMALE              | 24931    | 28JR200-1       |
| J3323     | 131-0955-00        |                             | CONNECTOR, RCPT, :BNC, FEMALE              | 24931    | 28JR200-1       |
| J3324     | 131-0955-00        |                             | CONNECTOR, RCPT, :BNC, FEMALE              | 24931    | 28JR200-1       |
| J3401     | 131-1003-00        |                             | CONNECTOR BODY, :CKT BD MT, 3 PRONG        | 80009    | 131-1003-00     |
| J3402     | 131-1003-00        |                             | CONNECTOR BODY, :CKT BD MT, 3 PRONG        | 80009    | 131-1003-00     |
| J3403     | 131-1003-00        |                             | CONNECTOR BODY, :CKT BD MT, 3 PRONG        | 80009    | 131-1003-00     |
| J3404     | 131-1003-00        |                             | CONNECTOR BODY, :CKT BD MT, 3 PRONG        | 80009    | 131-1003-00     |
| J3405     | 131-1003-00        |                             | CONNECTOR BODY, :CKT BD MT, 3 PRONG        | 80009    | 131-1003-00     |
| J4105     | 131-1003-00        |                             | CONNECTOR BODY, :CKT BD MT, 3 PRONG        | 80009    | 131-1003-00     |
| J4114     | 131-1003-00        |                             | CONNECTOR BODY, :CKT BD MT, 3 PRONG        | 80009    | 131-1003-00     |
| J4120     | 131-1003-00        |                             | CONNECTOR BODY, :CKT BD MT, 3 PRONG        | 80009    | 131-1003-00     |
| J4140     | 131-1003-00        |                             | CONNECTOR BODY, :CKT BD MT, 3 PRONG        | 80009    | 131-1003-00     |
| J4212     | 131-1003-00        |                             | CONNECTOR BODY, :CKT BD MT, 3 PRONG        | 80009    | 131-1003-00     |
| J4213     | 131-1003-00        |                             | CONNECTOR BODY, :CKT BD MT, 3 PRONG        | 80009    | 131-1003-00     |
| J4220     | 131-1003-00        |                             | CONNECTOR BODY, :CKT BD MT, 3 PRONG        | 80009    | 131-1003-00     |
| J4240     | 131-1003-00        |                             | CONNECTOR BODY, :CKT BD MT, 3 PRONG        | 80009    | 131-1003-00     |
| J4304     | 131-1003-00        |                             | CONNECTOR BODY, :CKT BD MT, 3 PRONG        | 80009    | 131-1003-00     |
| J4315     | 131-1003-00        |                             | CONNECTOR BODY, :CKT BD MT, 3 PRONG        | 80009    | 131-1003-00     |
| J4316     | 131-1003-00        |                             | CONNECTOR BODY, :CKT BD MT, 3 PRONG        | 80009    | 131-1003-00     |
| J4405     | 131-1003-00        |                             | CONNECTOR BODY, :CKT BD MT, 3 PRONG        | 80009    | 131-1003-00     |
| J4417     | 131-1003-00        |                             | CONNECTOR BODY, :CKT BD MT, 3 PRONG        | 80009    | 131-1003-00     |
| J4418     | 131-1003-00        |                             | CONNECTOR BODY, :CKT BD MT, 3 PRONG        | 80009    | 131-1003-00     |
| J5030     | 131-0771-00        |                             | CONNECTOR, RCPT, :4 CONT, QUICK DISCONNECT | 80009    | 131-0771-00     |
| J5033     | 131-0771-00        |                             | CONNECTOR, RCPT, :4 CONT, QUICK DISCONNECT | 80009    | 131-0771-00     |
| L2006 (4) | 276-0507-00        |                             | SHIELDING BEAD, :0.6UH                     | 78488    | 57-0180-7D      |
| L2016 (4) | 276-0507-00        |                             | SHIELDING BEAD, :0.6UH                     | 78488    | 57-0180-7D      |
| L2515     | 108-0245-00        |                             | COIL, RF: 3.9UH                            | 80009    | 108-0245-00     |
| L2519     | 108-0245-00        |                             | COIL, RF: 3.9UH                            | 80009    | 108-0245-00     |
| L2528     | 108-0245-00        |                             | COIL, RF: 3.9UH                            | 80009    | 108-0245-00     |
| L2560     | 108-0245-00        |                             | COIL, RF: 3.9UH                            | 80009    | 108-0245-00     |
| L2562     | 108-0245-00        |                             | COIL, RF: 3.9UH                            | 80009    | 108-0245-00     |
| L2563     | 108-0245-00        |                             | COIL, RF: 3.9UH                            | 80009    | 108-0245-00     |



| Ckt No. | Tektronix Part No. | Serial/Model No. Eff | Dscont   | Name & Description                      | Mfr Code | Mfr Part Number |
|---------|--------------------|----------------------|----------|---|----------|-----------------|
| L2565   | 108-0245-00        |                      |          | COIL,RF:3.9UH                           | 80009    | 108-0245-00     |
| L3029   | 108-0681-00        |                      |          | COIL,RF:140UH                           | 80009    | 108-0681-00     |
| L3037   | 108-0678-00        |                      |          | COIL,RF:1MH                             | 80009    | 108-0678-00     |
| L3168   | 108-0646-00        | B010100              | B139999  | COIL,RF:80UH                            | 80009    | 108-0646-00     |
| L3168   | 108-0681-00        | B140000              |          | COIL,RF:140UH                           | 80009    | 108-0681-00     |
| L3171   | 108-0646-00        |                      |          | COIL,RF:80UH                            | 80009    | 108-0646-00     |
| L3172   | 108-0680-00        |                      |          | COIL,RF:27UH                            | 80009    | 108-0680-00     |
| L3174   | 108-0680-00        |                      |          | COIL,RF:27UH                            | 80009    | 108-0680-00     |
| L3178   | 108-0679-00        |                      |          | COIL,RF:12UH                            | 80009    | 108-0679-00     |
| L3181   | 108-0679-00        |                      |          | COIL,RF:12UH                            | 80009    | 108-0679-00     |
| L3236   | 108-0337-00        |                      |          | COIL,RF:25UH                            | 80009    | 108-0337-00     |
| L3482   | 108-0331-00        |                      |          | COIL,RF:0.75UH                          | 80009    | 108-0331-00     |
| L4140   | 108-0065-00        |                      |          | COIL,RF:700UH                           | 80009    | 108-0065-00     |
| L4252   | 108-0680-00        |                      |          | COIL,RF:27UH                            | 80009    | 108-0680-00     |
| L4398   | 108-0245-00        |                      |          | COIL,RF:3.9UH                           | 80009    | 108-0245-00     |
| L4399   | 108-0245-00        |                      |          | COIL,RF:3.9UH                           | 80009    | 108-0245-00     |
| L4401   | 195-0048-00        |                      |          | LEAD,ELECTRICAL:0.018 DIA X 0.75" MIN L | 80009    | 195-0048-00     |
| L4410   | 195-0048-00        |                      |          | LEAD,ELECTRICAL:0.018 DIA X 0.75" MIN L | 80009    | 195-0048-00     |
| L4411   | 195-0048-00        |                      |          | LEAD,ELECTRICAL:0.018 DIA X 0.75" MIN L | 80009    | 195-0048-00     |
| L5003   | 108-0544-00        |                      |          | COIL,TUBE DEFLE:                        | 80009    | 108-0544-00     |
| L5007   | 108-0546-00        | B010100              | B039999  | COIL,TUBE DEFLE:                        | 80009    | 108-0546-00     |
| L5007   | 108-0605-00        | B040000              |          | COIL,TUBE DEFLE:Y AXIS ALIGNMENT        | 80009    | 108-0605-00     |
| L5020   | 108-0686-00        | B010100              | B091620X | COIL,RF:116UH                           | 80009    | 108-0686-00     |
| L5022   | 108-0686-00        | B010100              | B091620X | COIL,RF:116UH                           | 80009    | 108-0686-00     |
| LR2245  | 108-0328-00        |                      |          | COIL,RF:0.3UH                           | 80009    | 108-0328-00     |
| LR2523  | 108-0543-00        |                      |          | COIL,RF:1.1UH                           | 80009    | 108-0543-00     |
| LR2532  | 108-0543-00        |                      |          | COIL,RF:1.1UH                           | 80009    | 108-0543-00     |
| LR2536  | 108-0543-00        |                      |          | COIL,RF:1.1UH                           | 80009    | 108-0543-00     |
| LR2541  | 108-0543-00        |                      |          | COIL,RF:1.1UH                           | 80009    | 108-0543-00     |
| LR5010  | 108-0685-00        |                      |          | COIL,RF:80NH                            | 80009    | 108-0685-00     |
| LR5011  | 108-0685-00        |                      |          | COIL,RF:80NH                            | 80009    | 108-0685-00     |
| Q1001   | 151-0223-00        |                      |          | TRANSISTOR:SILICON,NPN                  | 07263    | S24848          |
| Q1003   | 151-0223-00        |                      |          | TRANSISTOR:SILICON,NPN                  | 07263    | S24848          |
| Q1011   | 151-0223-00        |                      |          | TRANSISTOR:SILICON,NPN                  | 07263    | S24848          |
| Q1021   | 151-0347-00        |                      |          | TRANSISTOR:SILICON,NPN                  | 80009    | 151-0347-00     |
| Q1023   | 151-0223-00        |                      |          | TRANSISTOR:SILICON,NPN                  | 07263    | S24848          |
| Q1025   | 151-0276-00        |                      |          | TRANSISTOR:SILICON,PNP                  | 04713    | 2N5087          |
| Q1027   | 151-0276-00        |                      |          | TRANSISTOR:SILICON,PNP                  | 04713    | 2N5087          |
| Q1031   | 151-0223-00        |                      |          | TRANSISTOR:SILICON,NPN                  | 07263    | S24848          |
| Q2030   | 151-0192-00        |                      |          | TRANSISTOR:SILICON,NPN,SEL FROM MPS6521 | 80009    | 151-0192-00     |
| Q2070   | 151-0192-00        |                      |          | TRANSISTOR:SILICON,NPN,SEL FROM MPS6521 | 80009    | 151-0192-00     |
| Q2080   | 151-0223-00        |                      |          | TRANSISTOR:SILICON,NPN                  | 07263    | S24848          |
| Q2090   | 151-0223-00        |                      |          | TRANSISTOR:SILICON,NPN                  | 07263    | S24848          |
| Q2203   | 151-0223-00        |                      |          | TRANSISTOR:SILICON,NPN                  | 07263    | S24848          |
| Q2205   | 151-0223-00        |                      |          | TRANSISTOR:SILICON,NPN                  | 07263    | S24848          |
| Q2209   | 151-0223-00        |                      |          | TRANSISTOR:SILICON,NPN                  | 07263    | S24848          |
| Q2241   | 151-0271-00        |                      |          | TRANSISTOR:SILICON,PNP                  | 01295    | SKA4504         |
| Q2242   | 151-0271-00        |                      |          | TRANSISTOR:SILICON,PNP                  | 01295    | SKA4504         |
| Q2255   | 151-0269-00        |                      |          | TRANSISTOR:SILICON,NPN,SEL FROM SE3005  | 80009    | 151-0269-00     |
| Q2263   | 151-0269-00        |                      |          | TRANSISTOR:SILICON,NPN,SEL FROM SE3005  | 80009    | 151-0269-00     |
| Q2331   | 151-0220-00        |                      |          | TRANSISTOR:SILICON,PNP                  | 80009    | 151-0220-00     |
| Q2337   | 151-0220-00        |                      |          | TRANSISTOR:SILICON,PNP                  | 80009    | 151-0220-00     |
| Q2414   | 151-0220-00        |                      |          | TRANSISTOR:SILICON,PNP                  | 80009    | 151-0220-00     |

# Electrical Parts List—7704A

| Ckt No.  | Tektronix Part No. | Serial/Model No. Eff | Dscont  | Name & Description                      | Mfr Code | Mfr Part Number |
|----------|--------------------|----------------------|---------|---|----------|-----------------|
| Q2416    | 151-0220-00        |                      |         | TRANSISTOR:SILICON,PNP                  | 80009    | 151-0220-00     |
| Q2434    | 151-0223-00        | B010100              | B039999 | TRANSISTOR:SILICON,NPN                  | 07263    | S24848          |
| Q2434    | 151-0192-00        | B040000              |         | TRANSISTOR:SILICON,NPN,SEL FROM MPS6521 | 80009    | 151-0192-00     |
| Q2436    | 151-0223-00        | B010100              | B039999 | TRANSISTOR:SILICON,NPN                  | 07263    | S24848          |
| Q2436    | 151-0192-00        | B040000              |         | TRANSISTOR:SILICON,NPN,SEL FROM MPS6521 | 80009    | 151-0192-00     |
| Q2444    | 151-0220-00        |                      |         | TRANSISTOR:SILICON,PNP                  | 80009    | 151-0220-00     |
| Q2446    | 151-0220-00        |                      |         | TRANSISTOR:SILICON,PNP                  | 80009    | 151-0220-00     |
| Q2533    | 151-0223-00        |                      |         | TRANSISTOR:SILICON,NPN                  | 07263    | S24848          |
| Q2550    | 151-0220-00        |                      |         | TRANSISTOR:SILICON,PNP                  | 80009    | 151-0220-00     |
| Q2553    | 151-0223-00        |                      |         | TRANSISTOR:SILICON,NPN                  | 07263    | S24848          |
| Q2556    | 151-0223-00        |                      |         | TRANSISTOR:SILICON,NPN                  | 07263    | S24848          |
| Q2569    | 151-0223-00        |                      |         | TRANSISTOR:SILICON,NPN                  | 07263    | S24848          |
| Q2576    | 151-0223-00        |                      |         | TRANSISTOR:SILICON,NPN                  | 07263    | S24848          |
| Q2577    | 151-0192-00        |                      |         | TRANSISTOR:SILICON,NPN,SEL FROM MPS6521 | 80009    | 151-0192-00     |
| Q2579    | 151-0192-00        |                      |         | TRANSISTOR:SILICON,NPN,SEL FROM MPS6521 | 80009    | 151-0192-00     |
| Q2596    | 151-0188-00        |                      |         | TRANSISTOR:SILICON,PNP                  | 04713    | 2N3906          |
| Q3034    | 151-0368-00        |                      |         | TRANSISTOR:SILICON,NPN                  | 02735    | 61577           |
| Q3047    | 151-0368-00        |                      |         | TRANSISTOR:SILICON,NPN                  | 02735    | 61577           |
| Q3048    | 151-0260-00        |                      |         | TRANSISTOR:SILICON,NPN                  | 02735    | 2N5189          |
| Q3052    | 151-0519-00        |                      |         | TRANSISTOR:SILICON,SCR                  | 04713    | 2N5063          |
| Q3102    | 151-0302-00        |                      |         | TRANSISTOR:SILICON,NPN                  | 04713    | 2N2222A         |
| Q3104    | 151-0302-00        |                      |         | TRANSISTOR:SILICON,NPN                  | 04713    | 2N2222A         |
| Q3209A,B | 151-0232-00        |                      |         | TRANSISTOR:SILICON,NPN,DUAL             | 12040    | NS7348          |
| Q3211    | 151-0350-00        |                      |         | TRANSISTOR:SILICON,PNP                  | 07263    | 2N5401          |
| Q3213    | 151-0347-00        |                      |         | TRANSISTOR:SILICON,NPN                  | 80009    | 151-0347-00     |
| Q3217    | 151-0190-01        |                      |         | TRANSISTOR:SILICON,NPN                  | 07910    | TE23652         |
| Q3220    | 151-0136-00        |                      |         | TRANSISTOR:SILICON,NPN                  | 02735    | 35495           |
| Q3223    | 151-0349-00        |                      |         | TRANSISTOR:SILICON,NPN SEL FROM MJE2801 | 04713    | SJE924          |
| Q3225    | 151-0350-00        |                      |         | TRANSISTOR:SILICON,PNP                  | 07263    | 2N5401          |
| Q3232A,B | 151-0232-00        |                      |         | TRANSISTOR:SILICON,NPN,DUAL             | 12040    | NS7348          |
| Q3235A,B | 151-0232-00        |                      |         | TRANSISTOR:SILICON,NPN,DUAL             | 12040    | NS7348          |
| Q3238    | 151-0347-00        |                      |         | TRANSISTOR:SILICON,NPN                  | 80009    | 151-0347-00     |
| Q3240    | 151-0260-00        |                      |         | TRANSISTOR:SILICON,NPN                  | 02735    | 2N5189          |
| Q3241    | 151-0349-00        |                      |         | TRANSISTOR:SILICON,NPN SEL FROM MJE2801 | 04713    | SJE924          |
| Q3251A,B | 151-0232-00        |                      |         | TRANSISTOR:SILICON,NPN,DUAL             | 12040    | NS7348          |
| Q3258    | 151-0192-00        |                      |         | TRANSISTOR:SILICON,NPN,SEL FROM MPS6521 | 80009    | 151-0192-00     |
| Q3260    | 151-0260-00        |                      |         | TRANSISTOR:SILICON,NPN                  | 02735    | 2N5189          |
| Q3261    | 151-0349-00        |                      |         | TRANSISTOR:SILICON,NPN SEL FROM MJE2801 | 04713    | SJE924          |
| Q3264A,B | 151-0232-00        |                      |         | TRANSISTOR:SILICON,NPN,DUAL             | 12040    | NS7348          |
| Q3275A,B | 151-0232-00        |                      |         | TRANSISTOR:SILICON,NPN,DUAL             | 12040    | NS7348          |
| Q3283A,B | 151-0232-00        |                      |         | TRANSISTOR:SILICON,NPN,DUAL             | 12040    | NS7348          |
| Q3285    | 151-0216-00        |                      |         | TRANSISTOR:SILICON,PNP                  | 04713    | MPS6523         |
| Q3290    | 151-0260-00        |                      |         | TRANSISTOR:SILICON,NPN                  | 02735    | 2N5189          |
| Q3294    | 151-0349-00        |                      |         | TRANSISTOR:SILICON,NPN SEL FROM MJE2801 | 04713    | SJE924          |
| Q3306    | 151-0220-00        |                      |         | TRANSISTOR:SILICON,PNP                  | 80009    | 151-0220-00     |
| Q3308    | 151-0220-00        |                      |         | TRANSISTOR:SILICON,PNP                  | 80009    | 151-0220-00     |
| Q3312    | 151-0220-00        |                      |         | TRANSISTOR:SILICON,PNP                  | 80009    | 151-0220-00     |
| Q3315    | 151-0220-00        |                      |         | TRANSISTOR:SILICON,PNP                  | 80009    | 151-0220-00     |
| Q3321    | 151-0223-00        |                      |         | TRANSISTOR:SILICON,NPN                  | 07263    | S24848          |
| Q3323    | 151-0223-00        |                      |         | TRANSISTOR:SILICON,NPN                  | 07263    | S24848          |
| Q3330    | 151-0220-00        |                      |         | TRANSISTOR:SILICON,PNP                  | 80009    | 151-0220-00     |
| Q3351    | 151-0223-00        |                      |         | TRANSISTOR:SILICON,NPN                  | 07263    | S24848          |
| Q3353    | 151-0223-00        |                      |         | TRANSISTOR:SILICON,NPN                  | 07263    | S24848          |

Electrical Parts List—7704A

| Ckt No.  | Tektronix Part No. | Serial/Model No. Eff | Dscont  | Name & Description                      | Mfr Code | Mfr Part Number |
|----------|--------------------|----------------------|---------|---|----------|-----------------|
| Q3361    | 151-0220-00        |                      |         | TRANSISTOR:SILICON,PNP                  | 80009    | 151-0220-00     |
| Q3367    | 151-0220-00        |                      |         | TRANSISTOR:SILICON,PNP                  | 80009    | 151-0220-00     |
| Q3373    | 151-0223-00        |                      |         | TRANSISTOR:SILICON,NPN                  | 07263    | S24848          |
| Q3406A,B | 151-0232-00        |                      |         | TRANSISTOR:SILICON,NPN,DUAL             | 12040    | NS7348          |
| Q3411    | 151-0223-00        |                      |         | TRANSISTOR:SILICON,NPN                  | 07263    | S24848          |
| Q3414    | 151-0223-00        |                      |         | TRANSISTOR:SILICON,NPN                  | 07263    | S24848          |
| Q3416    | 151-0220-00        |                      |         | TRANSISTOR:SILICON,PNP                  | 80009    | 151-0220-00     |
| Q3419    | 151-0223-00        |                      |         | TRANSISTOR:SILICON,NPN                  | 07263    | S24848          |
| Q3427    | 151-0192-00        |                      |         | TRANSISTOR:SILICON,NPN,SEL FROM MPS6521 | 80009    | 151-0192-00     |
| Q3442    | 151-0220-00        |                      |         | TRANSISTOR:SILICON,PNP                  | 80009    | 151-0220-00     |
| Q3445    | 151-0223-00        |                      |         | TRANSISTOR:SILICON,NPN                  | 07263    | S24848          |
| Q3486    | 151-0220-00        |                      |         | TRANSISTOR:SILICON,PNP                  | 80009    | 151-0220-00     |
| Q3489    | 151-0220-00        |                      |         | TRANSISTOR:SILICON,PNP                  | 80009    | 151-0220-00     |
| Q3493    | 151-0220-00        |                      |         | TRANSISTOR:SILICON,PNP                  | 80009    | 151-0220-00     |
| Q3499    | 151-0220-00        |                      |         | TRANSISTOR:SILICON,PNP                  | 80009    | 151-0220-00     |
| Q4105    | 151-0228-00        |                      |         | TRANSISTOR:SILICON,PNP,SEL FROM 2N4888  | 07263    | S21862          |
| Q4115    | 151-0279-00        |                      |         | TRANSISTOR:SILICON,NPN                  | 07263    | S25381          |
| Q4135    | 151-0223-00        |                      |         | TRANSISTOR:SILICON,NPN                  | 07263    | S24848          |
| Q4145    | 151-0216-00        |                      |         | TRANSISTOR:SILICON,PNP                  | 04713    | MPS6523         |
| Q4151    | 151-0220-00        |                      |         | TRANSISTOR:SILICON,PNP                  | 80009    | 151-0220-00     |
| Q4159    | 151-0220-00        |                      |         | TRANSISTOR:SILICON,PNP                  | 80009    | 151-0220-00     |
| Q4163    | 151-0223-00        |                      |         | TRANSISTOR:SILICON,NPN                  | 07263    | S24848          |
| Q4175    | 151-0223-00        |                      |         | TRANSISTOR:SILICON,NPN                  | 07263    | S24848          |
| Q4177    | 151-0220-00        |                      |         | TRANSISTOR:SILICON,PNP                  | 80009    | 151-0220-00     |
| Q4183    | 151-0223-00        |                      |         | TRANSISTOR:SILICON,NPN                  | 07263    | S24848          |
| Q4185    | 151-0223-00        |                      |         | TRANSISTOR:SILICON,NPN                  | 07263    | S24848          |
| Q4193    | 151-0220-00        | B010100              | B039999 | TRANSISTOR:SILICON,PNP                  | 80009    | 151-0220-00     |
| Q4193    | 151-0221-00        | B040000              |         | TRANSISTOR:SILICON,PNP                  | 07263    | S24849          |
| Q4197    | 151-0220-00        | B010100              | B039999 | TRANSISTOR:SILICON,PNP                  | 80009    | 151-0220-00     |
| Q4197    | 151-0221-00        | B040000              |         | TRANSISTOR:SILICON,PNP                  | 07263    | S24849          |
| Q4250    | 151-0324-00        |                      |         | TRANSISTOR:SILICON,PNP                  | 04713    | MJE-371         |
| Q4254    | 151-0192-00        |                      |         | TRANSISTOR:SILICON,NPN,SEL FROM MPS6521 | 80009    | 151-0192-00     |
| Q4304    | 151-0190-01        |                      |         | TRANSISTOR:SILICON,NPN                  | 07910    | TE23652         |
| Q4321    | 151-0127-00        |                      |         | TRANSISTOR:SILICON,NPN                  | 07263    | S6075           |
| Q4325    | 151-0127-00        |                      |         | TRANSISTOR:SILICON,NPN                  | 07263    | S6075           |
| Q4331    | 151-0127-00        |                      |         | TRANSISTOR:SILICON,NPN                  | 07263    | S6075           |
| Q4335    | 151-0301-00        |                      |         | TRANSISTOR:SILICON,PNP                  | 04713    | 2N2907A         |
| Q4346    | 151-0190-01        |                      |         | TRANSISTOR:SILICON,NPN                  | 07910    | TE23652         |
| Q4351    | 151-0220-00        |                      |         | TRANSISTOR:SILICON,PNP                  | 80009    | 151-0220-00     |
| Q4356    | 151-0274-00        |                      |         | TRANSISTOR:SILICON,NPN                  | 04713    | SS7394          |
| Q4361    | 151-0220-00        |                      |         | TRANSISTOR:SILICON,PNP                  | 80009    | 151-0220-00     |
| Q4366    | 151-0274-00        |                      |         | TRANSISTOR:SILICON,NPN                  | 04713    | SS7394          |
| Q4371    | 151-0270-00        |                      |         | TRANSISTOR:SILICON,PNP,SEL FROM 2N3495  | 03877    | ST30032         |
| Q4381    | 151-0127-00        |                      |         | TRANSISTOR:SILICON,NPN                  | 07263    | S6075           |
| Q4390    | 151-0127-00        |                      |         | TRANSISTOR:SILICON,NPN                  | 07263    | S6075           |
| Q4395    | 151-0270-00        |                      |         | TRANSISTOR:SILICON,PNP,SEL FROM 2N3495  | 03877    | ST30032         |
| Q4420    | 151-0188-00        | XB120000             |         | TRANSISTOR:SILICON,PNP                  | 04713    | 2N3906          |
| Q4470    | 151-0188-00        |                      |         | TRANSISTOR:SILICON,PNP                  | 04713    | 2N3906          |
| Q4479    | 151-0190-00        |                      |         | TRANSISTOR:SILICON,NPN                  | 04713    | 2N3904          |
| Q4485    | 151-0190-00        |                      |         | TRANSISTOR:SILICON,NPN                  | 04713    | 2N3904          |
| Q32115   | 151-0350-00        |                      |         | TRANSISTOR:SILICON,PNP                  | 07263    | 2N5401          |
| Q32130A, | 151-0232-00        |                      |         | TRANSISTOR:SILICON,NPN,DUAL             | 12040    | NS7348          |
| Q32130B  |                    |                      |         |   |          |                 |

# Electrical Parts List—7704A

| Ckt No. | Tektronix Part No. | Serial/Model No. Eff | Dscont   | Name & Description                       | Mfr Code | Mfr Part Number |
|---------|--------------------|----------------------|----------|--|----------|-----------------|
| Q32137  | 151-0347-00        |                      |          | TRANSISTOR:SILICON,NPN                   | 80009    | 151-0347-00     |
| Q32139  | 151-0349-00        |                      |          | TRANSISTOR:SILICON,NPN SEL FROM MJE2801  | 04713    | SJB924          |
| Q32143  | 151-0136-00        |                      |          | TRANSISTOR:SILICON,NPN                   | 02735    | 35495           |
| Q41113  | 151-0221-00        |                      |          | TRANSISTOR:SILICON,PNP                   | 07263    | S24849          |
| Q41114  | 151-0208-00        |                      |          | TRANSISTOR:SILICON,PNP                   | 12040    | 2N4036          |
| Q41115  | 151-0124-00        |                      |          | TRANSISTOR:SILICON,NPN,SEL FROM 2N3501   | 04713    | SM8138          |
| Q41133  | 151-0223-00        |                      |          | TRANSISTOR:SILICON,NPN                   | 07263    | S24848          |
| Q41137  | 151-0274-00        |                      |          | TRANSISTOR:SILICON,NPN                   | 04713    | SS7394          |
| Q41155  | 151-0274-00        |                      |          | TRANSISTOR:SILICON,NPN                   | 04713    | SS7394          |
| R1001   | 311-1224-00        |                      |          | RES.,VAR, NONWIR:500 OHM,20%,0.50W       | 80294    | 3389F-P31-501   |
| R1002   | 321-1234-02        |                      |          | RES.,FXD,FILM:2.71K OHM,0.5%,0.125W      | 75042    | CEAT2-2711D     |
| R1004   | 321-0364-00        |                      |          | RES.,FXD,FILM:60.4K OHM,1%,0.125W        | 75042    | CEAT0-6042F     |
| R1006   | 315-0472-00        |                      |          | RES.,FXD,COMP:4.7K OHM,5%,0.25W          | 01121    | CB4725          |
| R1007   | 321-0374-00        |                      |          | RES.,FXD,FILM:76.8K OHM,1%,0.125W        | 75042    | CEAT0-7682F     |
| R1009   | 315-0103-00        |                      |          | RES.,FXD,COMP:10K OHM,5%,0.25W           | 01121    | CB1035          |
| R1010   | 315-0103-00        |                      |          | RES.,FXD,COMP:10K OHM,5%,0.25W           | 01121    | CB1035          |
| R1012   | 315-0102-00        |                      |          | RES.,FXD,COMP:1K OHM,5%,0.25W            | 01121    | CB1025          |
| R1021   | 321-0315-00        |                      |          | RES.,FXD,FILM:18.7K OHM,1%,0.125W        | 75042    | CEAT0-1872F     |
| R1023   | 315-0153-00        |                      |          | RES.,FXD,COMP:15K OHM,5%,0.25W           | 01121    | CB1535          |
| R1025   | 321-0254-00        |                      |          | RES.,FXD,FILM:4.32K OHM,1%,0.125W        | 75042    | CEAT0-4321F     |
| R1026   | 321-0195-00        |                      |          | RES.,FXD,FILM:1.05K OHM,1%,0.125W        | 75042    | CEAT0-1051F     |
| R1027   | 321-1188-06        |                      |          | RES.,FXD,FILM:898 OHM,0.25%,0.125W       | 75042    | CEAT9-8980C     |
| R1031   | 315-0102-00        |                      |          | RES.,FXD,COMP:1K OHM,5%,0.25W            | 01121    | CB1025          |
| R1033   | 315-0103-00        |                      |          | RES.,FXD,COMP:10K OHM,5%,0.25W           | 01121    | CB1035          |
| R1034   | 321-0281-00        |                      |          | RES.,FXD,FILM:8.25K OHM,1%,0.125W        | 75042    | CEAT0-8251F     |
| R1035   | 321-0820-06        |                      |          | RES.,FXD,FILM:42K OHM,0.25%,0.125W       | 75042    | CEAT9-4202C     |
| R1037   | 311-1228-00        |                      |          | RES.,VAR, NONWIR:10K OHM,20%,0.50W       | 80294    | 3389F-P31-103   |
| R1038   | 315-0563-00        |                      |          | RES.,FXD,COMP:56K OHM,5%,0.25W           | 01121    | CB5635          |
| R1039   | 315-0393-00        |                      |          | RES.,FXD,COMP:39K OHM,5%,0.25W           | 01121    | CB3935          |
| R1041   | 301-0103-00        |                      |          | RES.,FXD,COMP:10K OHM,5%,0.50W           | 01121    | EB1035          |
| R1043   | 323-0761-07        |                      |          | RESISTOR:4.05K OHM, 0.50W, .1%           | 75042    | CECT9-4051B     |
| R1044   | 321-0815-07        |                      |          | RES.,FXD,FILM:4.1K OHM,0.1%,0.125W       | 75042    | CEAT9-4101B     |
| R1047   | 321-0812-07        |                      |          | RES.,FXD,FILM:455 OHM,0.1%,0.125W        | 75042    | CEAT9-4550B     |
| R1048   | 321-0811-07        |                      |          | RES.,FXD,FILM:56.3 OHM,0.1%,0.125W       | 75042    | CEAT9-56R30B    |
| R1051   | 321-0813-07        |                      |          | RES.,FXD,FILM:495 OHM,0.1%,0.125W        | 75042    | CEAT9-4950B     |
| R1052   | 321-0810-07        |                      |          | RES.,FXD,FILM:55 OHM,0.1%,0.125W         | 75042    | CEAT9-55R0B     |
| R1057   | 321-0816-07        |                      |          | RES.,FXD,FILM:5K OHM,0.1%,0.125W         | 75042    | CEAT9-5001B     |
| R1058   | 321-1068-07        |                      |          | RES.,FXD,FILM:50.5 OHM,0.1%,0.125W       | 75042    | CEAT9-50R50B    |
| R1063   | 311-1301-00        |                      |          | RES.,VAR, NONWIR:50K OHM,20%,0.5W        | 01121    | W-7917B         |
| R1065   | 311-1301-00        |                      |          | RES.,VAR, NONWIR:50K OHM,20%,0.5W        | 01121    | W-7917B         |
| R1067   | 311-1301-00        |                      |          | RES.,VAR, NONWIR:50K OHM,20%,0.5W        | 01121    | W-7917B         |
| R1068   | 131-0566-00        |                      |          | LINK,TERM.CONNE:0.086 DIA X 2.375 INCH L | 0000C    | L-2007-1        |
| R1069   | 315-0153-00        |                      |          | RES.,FXD,COMP:15K OHM,5%,0.25W           | 01121    | CB1535          |
| R2001   | 315-0511-00        | B010100              | B149999X | RES.,FXD,COMP:510 OHM,5%,0.25W           | 01121    | CB5115          |
| R2003   | 315-0511-00        | B010100              | B149999X | RES.,FXD,COMP:510 OHM,5%,0.25W           | 01121    | CB5115          |
| R2005   | 315-0511-00        | B010100              | B149999X | RES.,FXD,COMP:510 OHM,5%,0.25W           | 01121    | CB5115          |
| R2006   | 315-0392-00        | B010100              | B010159  | RES.,FXD,COMP:3.9K OHM,5%,0.25W          | 01121    | CB3925          |
| R2006   | 315-0362-00        | B010160              |          | RES.,FXD,COMP:3.6K OHM,5%,0.25W          | 01121    | CB3625          |
| R2007   | 315-0511-00        | B010100              | B149999X | RES.,FXD,COMP:510 OHM,5%,0.25W           | 01121    | CB5115          |
| R2009   | 315-0243-00        |                      |          | RES.,FXD,COMP:24K OHM,5%,0.25W           | 01121    | CB2435          |
| R2010   | 315-0510-00        |                      |          | RES.,FXD,COMP:51 OHM,5%,0.25W            | 01121    | CB5105          |
| R2011   | 315-0510-00        |                      |          | RES.,FXD,COMP:51 OHM,5%,0.25W            | 01121    | CB5105          |
| R2012   | 315-0510-00        |                      |          | RES.,FXD,COMP:51 OHM,5%,0.25W            | 01121    | CB5105          |

| Ckt No. | Tektronix Part No. | Serial/Model No. Eff Dscont | Name & Description                | Mfr Code | Mfr Part Number |
|---------|--------------------|-----------------------------|-----------------------------------|----------|-----------------|
| R2013   | 315-0510-00        |                             | RES.,FXD,COMP:51 OHM,5%,0.25W     | 01121    | CB5105          |
| R2015   | 315-0510-00        |                             | RES.,FXD,COMP:51 OHM,5%,0.25W     | 01121    | CB5105          |
| R2016   | 315-0510-00        |                             | RES.,FXD,COMP:51 OHM,5%,0.25W     | 01121    | CB5105          |
| R2017   | 315-0132-00        |                             | RES.,FXD,COMP:1.3K OHM,5%,0.25W   | 01121    | CB1325          |
| R2018   | 315-0202-00        |                             | RES.,FXD,COMP:2K OHM,5%,0.25W     | 01121    | CB2025          |
| R2019   | 321-0231-00        |                             | RES.,FXD,FILM:2.49K OHM,1%,0.125W | 75042    | CEATO-2491F     |
| R2020   | 315-0472-00        |                             | RES.,FXD,COMP:4.7K OHM,5%,0.25W   | 01121    | CB4725          |
| R2022   | 315-0202-00        |                             | RES.,FXD,COMP:2K OHM,5%,0.25W     | 01121    | CB2025          |
| R2023   | 315-0132-00        |                             | RES.,FXD,COMP:1.3K OHM,5%,0.25W   | 01121    | CB1325          |
| R2025   | 315-0202-00        |                             | RES.,FXD,COMP:2K OHM,5%,0.25W     | 01121    | CB2025          |
| R2026   | 315-0302-00        |                             | RES.,FXD,COMP:3K OHM,5%,0.25W     | 01121    | CB3025          |
| R2027   | 315-0132-00        |                             | RES.,FXD,COMP:1.3K OHM,5%,0.25W   | 01121    | CB1325          |
| R2029   | 321-0231-00        |                             | RES.,FXD,FILM:2.49K OHM,1%,0.125W | 75042    | CEATO-2491F     |
| R2030   | 315-0512-00        |                             | RES.,FXD,COMP:5.1K OHM,5%,0.25W   | 01121    | CB5125          |
| R2031   | 315-0102-00        |                             | RES.,FXD,COMP:1K OHM,5%,0.25W     | 01121    | CB1025          |
| R2033   | 315-0751-00        |                             | RES.,FXD,COMP:750 OHM,5%,0.25W    | 01121    | CB7515          |
| R2034   | 315-0751-00        |                             | RES.,FXD,COMP:750 OHM,5%,0.25W    | 01121    | CB7515          |
| R2036   | 315-0102-00        |                             | RES.,FXD,COMP:1K OHM,5%,0.25W     | 01121    | CB1025          |
| R2038   | 315-0751-00        |                             | RES.,FXD,COMP:750 OHM,5%,0.25W    | 01121    | CB7515          |
| R2039   | 315-0751-00        |                             | RES.,FXD,COMP:750 OHM,5%,0.25W    | 01121    | CB7515          |
| R2041   | 315-0102-00        |                             | RES.,FXD,COMP:1K OHM,5%,0.25W     | 01121    | CB1025          |
| R2043   | 315-0751-00        |                             | RES.,FXD,COMP:750 OHM,5%,0.25W    | 01121    | CB7515          |
| R2044   | 315-0751-00        |                             | RES.,FXD,COMP:750 OHM,5%,0.25W    | 01121    | CB7515          |
| R2046   | 315-0102-00        |                             | RES.,FXD,COMP:1K OHM,5%,0.25W     | 01121    | CB1025          |
| R2048   | 315-0751-00        |                             | RES.,FXD,COMP:750 OHM,5%,0.25W    | 01121    | CB7515          |
| R2049   | 315-0751-00        |                             | RES.,FXD,COMP:750 OHM,5%,0.25W    | 01121    | CB7515          |
| R2051   | 315-0242-00        |                             | RES.,FXD,COMP:2.4K OHM,5%,0.25W   | 01121    | CB2425          |
| R2053   | 315-0102-00        |                             | RES.,FXD,COMP:1K OHM,5%,0.25W     | 01121    | CB1025          |
| R2054   | 315-0511-00        |                             | RES.,FXD,COMP:510 OHM,5%,0.25W    | 01121    | CB5115          |
| R2056   | 315-0511-00        |                             | RES.,FXD,COMP:510 OHM,5%,0.25W    | 01121    | CB5115          |
| R2057   | 315-0511-00        |                             | RES.,FXD,COMP:510 OHM,5%,0.25W    | 01121    | CB5115          |
| R2058   | 315-0513-00        |                             | RES.,FXD,COMP:51K OHM,5%,0.25W    | 01121    | CB5135          |
| R2060   | 315-0133-00        |                             | RES.,FXD,COMP:13K OHM,5%,0.25W    | 01121    | CB1335          |
| R2061   | 315-0133-00        |                             | RES.,FXD,COMP:13K OHM,5%,0.25W    | 01121    | CB1335          |
| R2063   | 315-0753-00        |                             | RES.,FXD,COMP:75K OHM,5%,0.25W    | 01121    | CB7535          |
| R2064   | 321-0308-00        |                             | RES.,FXD,FILM:15.8K OHM,1%,0.125W | 75042    | CEATO-1582F     |
| R2066   | 315-0513-00        |                             | RES.,FXD,COMP:51K OHM,5%,0.25W    | 01121    | CB5135          |
| R2067   | 321-0319-00        |                             | RES.,FXD,FILM:20.5K OHM,1%,0.125W | 75042    | CEATO-2052F     |
| R2069   | 321-0335-00        |                             | RES.,FXD,FILM:30.1K OHM,1%,0.125W | 75042    | CEATO-3012F     |
| R2070   | 315-0154-00        |                             | RES.,FXD,COMP:150K OHM,5%,0.25W   | 01121    | CB1545          |
| R2071   | 321-0335-00        |                             | RES.,FXD,FILM:30.1K OHM,1%,0.125W | 75042    | CEATO-3012F     |
| R2073   | 321-0344-00        |                             | RES.,FXD,FILM:37.4K OHM,1%,0.125W | 75042    | CEATO-3742F     |
| R2074   | 321-0335-00        |                             | RES.,FXD,FILM:30.1K OHM,1%,0.125W | 75042    | CEATO-3012F     |
| R2076   | 315-0513-00        |                             | RES.,FXD,COMP:51K OHM,5%,0.25W    | 01121    | CB5135          |
| R2077   | 315-0154-00        |                             | RES.,FXD,COMP:150K OHM,5%,0.25W   | 01121    | CB1545          |
| R2078   | 321-0335-00        |                             | RES.,FXD,FILM:30.1K OHM,1%,0.125W | 75042    | CEATO-3012F     |
| R2079   | 321-0335-00        |                             | RES.,FXD,FILM:30.1K OHM,1%,0.125W | 75042    | CEATO-3012F     |
| R2080   | 315-0510-00        |                             | RES.,FXD,COMP:51 OHM,5%,0.25W     | 01121    | CB5105          |
| R2081   | 315-0103-00        |                             | RES.,FXD,COMP:10K OHM,5%,0.25W    | 01121    | CB1035          |
| R2083   | 315-0562-00        |                             | RES.,FXD,COMP:5.6K OHM,5%,0.25W   | 01121    | CB5625          |
| R2084   | 315-0302-00        |                             | RES.,FXD,COMP:3K OHM,5%,0.25W     | 01121    | CB3025          |
| R2085   | 315-0513-00        |                             | RES.,FXD,COMP:51K OHM,5%,0.25W    | 01121    | CB5135          |
| R2087   | 321-0260-00        |                             | RES.,FXD,FILM:4.99K OHM,1%,0.125W | 75042    | CEATO-4991F     |

# Electrical Parts List—7704A

| Ckt No. | Tektronix Part No. | Serial/Model No. Eff | Dscont  | Name & Description                   | Mfr Code | Mfr Part Number |
|---------|--------------------|----------------------|---------|--------------------------------------|----------|-----------------|
| R2088   | 321-0260-00        |                      |         | RES.,FXD,FILM:4.99K OHM,1%,0.125W    | 75042    | CEATO-4991F     |
| R2090   | 315-0510-00        |                      |         | RES.,FXD,COMP:51 OHM,5%,0.25W        | 01121    | CB5105          |
| R2091   | 315-0103-00        |                      |         | RES.,FXD,COMP:10K OHM,5%,0.25W       | 01121    | CB1035          |
| R2092   | 315-0241-00        |                      |         | RES.,FXD,COMP:240 OHM,5%,0.25W       | 01121    | CB2415          |
| R2093   | 315-0562-00        |                      |         | RES.,FXD,COMP:5.6K OHM,5%,0.25W      | 01121    | CB5625          |
| R2094   | 315-0302-00        |                      |         | RES.,FXD,COMP:3K OHM,5%,0.25W        | 01121    | CB3025          |
| R2095   | 315-0513-00        |                      |         | RES.,FXD,COMP:51K OHM,5%,0.25W       | 01121    | CB5135          |
| R2097   | 321-0260-00        |                      |         | RES.,FXD,FILM:4.99K OHM,1%,0.125W    | 75042    | CEATO-4991F     |
| R2098   | 321-0260-00        |                      |         | RES.,FXD,FILM:4.99K OHM,1%,0.125W    | 75042    | CEATO-4991F     |
| R2201   | 321-0068-00        |                      |         | RES.,FXD,FILM:49.9 OHM,1%,0.125W     | 75042    | CEATO-49R90F    |
| R2202   | 321-0068-00        |                      |         | RES.,FXD,FILM:49.9 OHM,1%,0.125W     | 75042    | CEATO-49R90F    |
| R2203   | 315-0153-00        |                      |         | RES.,FXD,COMP:15K OHM,5%,0.25W       | 01121    | CB1535          |
| R2205   | 315-0102-00        |                      |         | RES.,FXD,COMP:1K OHM,5%,0.25W        | 01121    | CB1025          |
| R2207   | 315-0511-00        |                      |         | RES.,FXD,COMP:510 OHM,5%,0.25W       | 01121    | CB5115          |
| R2208   | 315-0242-00        |                      |         | RES.,FXD,COMP:2.4K OHM,5%,0.25W      | 01121    | CB2425          |
| R2209   | 315-0511-00        |                      |         | RES.,FXD,COMP:510 OHM,5%,0.25W       | 01121    | CB5115          |
| R2210   | 321-0741-02        |                      |         | RES.,FXD,FILM:40.9 OHM,0.5%,0.125W   | 75042    | CEAT2-40R90D    |
| R2211   | 321-0741-02        |                      |         | RES.,FXD,FILM:40.9 OHM,0.5%,0.125W   | 75042    | CEAT2-40R90D    |
| R2212   | 321-0217-00        |                      |         | RES.,FXD,FILM:1.78K OHM,1%,0.125W    | 75042    | CEATO-1781F     |
| R2213   | 321-0741-02        |                      |         | RES.,FXD,FILM:40.9 OHM,0.5%,0.125W   | 75042    | CEAT2-40R90D    |
| R2214   | 321-0741-02        |                      |         | RES.,FXD,FILM:40.9 OHM,0.5%,0.125W   | 75042    | CEAT2-40R90D    |
| R2215   | 321-0217-00        |                      |         | RES.,FXD,FILM:1.78K OHM,1%,0.125W    | 75042    | CEATO-1781F     |
| R2216   | 315-0152-00        |                      |         | RES.,FXD,COMP:1.5K OHM,5%,0.25W      | 01121    | CB1525          |
| R2217   | 315-0152-00        |                      |         | RES.,FXD,COMP:1.5K OHM,5%,0.25W      | 01121    | CB1525          |
| R2221   | 317-0680-00        |                      |         | RES.,FXD,COMP:68 OHM,5%,0.125W       | 01121    | BB6805          |
| R2222   | 311-1007-00        |                      |         | RES.,VAR,NONWIR:20 OHM,20%,0.50W     | 80294    | 3329HG48-200    |
| R2223   | 323-0144-00        |                      |         | RES.,FXD,FILM:309 OHM,1%,0.50W       | 75042    | CECTO-3090F     |
| R2224   | 317-0680-00        |                      |         | RES.,FXD,COMP:68 OHM,5%,0.125W       | 01121    | BB6805          |
| R2225   | 323-0143-00        |                      |         | RES.,FXD,FILM:301 OHM,1%,0.50W       | 75042    | CECTO-3010F     |
| R2226   | 321-1068-01        |                      |         | RES.,FXD,FILM:50.5 OHM,0.5%,0.125W   | 75042    | CEATO-50R50D    |
| R2227   | 321-1068-01        |                      |         | RES.,FXD,FILM:50.5 OHM,0.5%,0.125W   | 75042    | CEATO-50R50D    |
| R2228   | 321-1068-01        |                      |         | RES.,FXD,FILM:50.5 OHM,0.5%,0.125W   | 75042    | CEATO-50R50D    |
| R2229   | 321-1068-01        |                      |         | RES.,FXD,FILM:50.5 OHM,0.5%,0.125W   | 75042    | CEATO-50R50D    |
| R2230   | 317-0101-00        | B010100              | B049999 | RES.,FXD,COMP:100 OHM,5%,0.125W      | 01121    | BB1015          |
| R2230   | 317-0510-00        | B050000              |         | RES.,FXD,COMP:51 OHM,(NOM VALUE),SEL | 01121    | BB5105          |
| R2231   | 321-0636-00        |                      |         | RES.,FXD,FILM:100 OHM,0.5%,0.125W    | 75042    | CEAT2-1000D     |
| R2233   | 317-0101-00        | B010100              | B049999 | RES.,FXD,COMP:100 OHM,5%,0.125W      | 01121    | BB1015          |
| R2233   | 317-0510-00        | B050000              |         | RES.,FXD,COMP:51 OHM,(NOM VALUE),SEL | 01121    | BB5105          |
| R2234   | 315-0302-00        | B010100              | B079999 | RES.,FXD,COMP:3K OHM,5%,0.25W        | 01121    | CB3025          |
| R2234   | 311-0634-00        | B080000              |         | RES.,VAR,NONWIR:500 OHM,10%,0.50W    | 80740    | 62-55-3         |
| R2235   | 315-0302-00        | B010100              | B079999 | RES.,FXD,COMP:3K OHM,5%,0.25W        | 01121    | CB3025          |
| R2235   | 317-0240-00        | B080000              |         | RES.,FXD,COMP:24 OHM,5%,0.125W       | 01121    | BB2405          |
| R2237   | 321-0219-02        |                      |         | RES.,FXD,FILM:1.87K OHM,0.5%,0.125W  | 75042    | CEAT2-1871D     |
| R2239   | 321-0219-02        |                      |         | RES.,FXD,FILM:1.87K OHM,0.5%,0.125W  | 75042    | CEAT2-1871D     |
| R2241   | 317-0270-00        |                      |         | RES.,FXD,COMP:27 OHM,5%,0.125W       | 01121    | BB2705          |
| R2242   | 317-0270-00        |                      |         | RES.,FXD,COMP:27 OHM,5%,0.125W       | 01121    | BB2705          |
| R2243   | 321-0173-00        |                      |         | RES.,FXD,FILM:619 OHM,1%,0.125W      | 75042    | CEATO-6190F     |
| R2244   | 315-0152-00        |                      |         | RES.,FXD,COMP:1.5K OHM,5%,0.25W      | 01121    | CB1525          |
| R2247   | 311-0605-00        |                      |         | RES.,VAR,NONWIR:200 OHM,10%,0.50W    | 80740    | 62-54-3         |
| R2250   | 315-0300-00        |                      |         | RES.,FXD,COMP:30 OHM,5%,0.25W        | 01121    | CB3005          |
| R2251   | 322-0237-00        |                      |         | RES.,FXD,FILM:2.87K OHM,1%,0.25W     | 75042    | CEBT0-2871F     |
| R2253   | 321-0126-00        |                      |         | RES.,FXD,FILM:200 OHM,1%,0.125W      | 75042    | CEATO-2000F     |
| R2255   | 315-0102-00        |                      |         | RES.,FXD,COMP:1K OHM,5%,0.25W        | 01121    | CB1025          |

| Ckt No. | Tektronix Part No. | Serial/Model No. |          | Name & Description                   | Mfr Code | Mfr Part Number |
|---------|--------------------|------------------|----------|--------------------------------------|----------|-----------------|
|         |                    | Eff              | Dscont   |                                      |          |                 |
| R2259   | 321-0067-00        |                  |          | RES.,FXD,FILM:48.7 OHM,1%,0.125W     | 75042    | CEATO-48R70F    |
| R2260   | 315-0300-00        |                  |          | RES.,FXD,COMP:30 OHM,5%,0.25W        | 01121    | CB3005          |
| R2261   | 322-0237-00        |                  |          | RES.,FXD,FILM:2.87K OHM,1%,0.25W     | 75042    | CEBTO-2871F     |
| R2263   | 321-0126-00        |                  |          | RES.,FXD,FILM:200 OHM,1%,0.125W      | 75042    | CEATO-2000F     |
| R2265   | 315-0102-00        |                  |          | RES.,FXD,COMP:1K OHM,5%,0.25W        | 01121    | CB1025          |
| R2267   | 321-0067-00        |                  |          | RES.,FXD,FILM:48.7 OHM,1%,0.125W     | 75042    | CEATO-48R70F    |
| R2275   | 315-0750-00        |                  |          | RES.,FXD,COMP:75 OHM,5%,0.25W        | 01121    | CB7505          |
| R2277   | 315-0131-00        |                  |          | RES.,FXD,COMP:130 OHM,5%,0.25W       | 01121    | CB1315          |
| R2279   | 317-0103-00        |                  |          | RES.,FXD,COMP:10K OHM,5%,0.125W      | 01121    | BB1035          |
| R2280   | 317-0101-00        | B010100          | B049999  | RES.,FXD,COMP:100 OHM,5%,0.125W      | 01121    | BB1015          |
| R2280   | 317-0510-00        | B050000          |          | RES.,FXD,COMP:51 OHM,(NOM VALUE),SEL | 01121    | BB5105          |
| R2281   | 321-0636-00        |                  |          | RES.,FXD,FILM:100 OHM,0.5%,0.125W    | 75042    | CEAT2-1000D     |
| R2283   | 317-0101-00        | B010100          | B049999  | RES.,FXD,COMP:100 OHM,5%,0.125W      | 01121    | BB1015          |
| R2283   | 317-0510-00        | B050000          |          | RES.,FXD,COMP:51 OHM,(NOM VALUE),SEL | 01121    | BB5105          |
| R2284   | 315-0302-00        | B010100          | B079999  | RES.,FXD,COMP:3K OHM,5%,0.25W        | 01121    | CB3025          |
| R2284   | 311-0634-00        | B080000          |          | RES.,VAR,NONWIR:500 OHM,10%,0.50W    | 80740    | 62-55-3         |
| R2285   | 315-0302-00        | B010100          | B079999  | RES.,FXD,COMP:3K OHM,5%,0.25W        | 01121    | CB3025          |
| R2285   | 317-0240-00        | B080000          |          | RES.,FXD,COMP:24 OHM,5%,0.125W       | 01121    | BB2405          |
| R2287   | 321-0219-02        |                  |          | RES.,FXD,FILM:1.87K OHM,0.5%,0.125W  | 75042    | CEAT2-1871D     |
| R2289   | 321-0219-02        |                  |          | RES.,FXD,FILM:1.87K OHM,0.5%,0.125W  | 75042    | CEAT2-1871D     |
| R2301   | 321-1068-01        |                  |          | RES.,FXD,FILM:50.5 OHM,0.5%,0.125W   | 75042    | CEATO-50R50D    |
| R2302   | 321-1068-01        |                  |          | RES.,FXD,FILM:50.5 OHM,0.5%,0.125W   | 75042    | CEATO-50R50D    |
| R2303   | 321-1068-01        |                  |          | RES.,FXD,FILM:50.5 OHM,0.5%,0.125W   | 75042    | CEATO-50R50D    |
| R2304   | 321-1068-01        |                  |          | RES.,FXD,FILM:50.5 OHM,0.5%,0.125W   | 75042    | CEATO-50R50D    |
| R2311   | 321-0085-00        |                  |          | RES.,FXD,FILM:75 OHM,1%,0.125W       | 75042    | CEATO-75R00F    |
| R2313   | 311-1007-00        |                  |          | RES.,VAR,NONWIR:20 OHM,20%,0.50W     | 80294    | 3329HG48-200    |
| R2315   | 315-0512-00        | B010100          | B079999X | RES.,FXD,COMP:5.1K OHM,5%,0.25W      | 01121    | CB5125          |
| R2317   | 321-0217-00        |                  |          | RES.,FXD,FILM:1.78K OHM,1%,0.125W    | 75042    | CEATO-1781F     |
| R2319   | 321-0217-00        |                  |          | RES.,FXD,FILM:1.78K OHM,1%,0.125W    | 75042    | CEATO-1781F     |
| R2320   | 321-0218-00        |                  |          | RES.,FXD,FILM:1.82K OHM,1%,0.125W    | 75042    | CEATO-1821F     |
| R2321   | 321-0085-00        |                  |          | RES.,FXD,FILM:75 OHM,1%,0.125W       | 75042    | CEATO-75R00F    |
| R2323   | 311-1007-00        |                  |          | RES.,VAR,NONWIR:20 OHM,20%,0.50W     | 80294    | 3329HG48-200    |
| R2325   | 315-0512-00        | B010100          | B079999X | RES.,FXD,COMP:5.1K OHM,5%,0.25W      | 01121    | CB5125          |
| R2327   | 321-0217-00        |                  |          | RES.,FXD,FILM:1.78K OHM,1%,0.125W    | 75042    | CEATO-1781F     |
| R2329   | 321-0217-00        |                  |          | RES.,FXD,FILM:1.78K OHM,1%,0.125W    | 75042    | CEATO-1781F     |
| R2330   | 315-0431-00        |                  |          | RES.,FXD,COMP:430 OHM,5%,0.25W       | 01121    | CB4315          |
| R2331   | 315-0200-00        |                  |          | RES.,FXD,COMP:20 OHM,5%,0.25W        | 01121    | CB2005          |
| R2333   | 323-0155-00        | B010100          | B049999  | RES.,FXD,FILM:402 OHM,1%,0.50W       | 75042    | CECTO-4020F     |
| R2333   | 323-0149-00        | B050000          |          | RES.,FXD,FILM:348 OHM,1%,0.50W       | 75042    | CECTO-3480F     |
| R2335   | 323-0155-00        | B010100          | B049999  | RES.,FXD,FILM:402 OHM,1%,0.50W       | 75042    | CECTO-4020F     |
| R2335   | 323-0149-00        | B050000          |          | RES.,FXD,FILM:348 OHM,1%,0.50W       | 75042    | CECTO-3480F     |
| R2337   | 315-0200-00        |                  |          | RES.,FXD,COMP:20 OHM,5%,0.25W        | 01121    | CB2005          |
| R2341   | 315-0241-00        |                  |          | RES.,FXD,COMP:240 OHM,5%,0.25W       | 01121    | CB2415          |
| R2343   | 322-0219-00        | B010100          | B049999  | RES.,FXD,FILM:1.87K OHM,1%,0.25W     | 75042    | CEBTO-1871F     |
| R2343   | 321-0210-00        | B050000          |          | RES.,FXD,FILM:1.5K OHM,1%,0.125W     | 75042    | CEATO-1501F     |
| R2345   | 322-0219-00        | B010100          | B049999  | RES.,FXD,FILM:1.87K OHM,1%,0.25W     | 75042    | CEBTO-1871F     |
| R2345   | 321-0210-00        | B050000          |          | RES.,FXD,FILM:1.5K OHM,1%,0.125W     | 75042    | CEATO-1501F     |
| R2347   | 315-0241-00        |                  |          | RES.,FXD,COMP:240 OHM,5%,0.25W       | 01121    | CB2415          |
| R2401   | 321-1068-01        |                  |          | RES.,FXD,FILM:50.5 OHM,0.5%,0.125W   | 75042    | CEATO-50R50D    |
| R2402   | 321-1068-01        |                  |          | RES.,FXD,FILM:50.5 OHM,0.5%,0.125W   | 75042    | CEATO-50R50D    |
| R2403   | 321-0741-02        | B010100          | B039999  | RES.,FXD,FILM:40.9 OHM,0.5%,0.125W   | 75042    | CEAT2-40R90D    |
| R2403   | 321-0058-00        | B040000          |          | RES.,FXD,FILM:39.2 OHM,1%,0.125W     | 75042    | CEATO-39R20F    |
| R2404   | 322-0184-00        |                  |          | RES.,FXD,FILM:806 OHM,1%,0.25W       | 75042    | CEBTO-8060F     |

# Electrical Parts List—7704A

| Ckt No. | Tektronix Part No. | Serial/Model No. Eff | Dscont  | Name & Description                 | Mfr Code | Mfr Part Number |
|---------|--------------------|----------------------|---------|------------------------------------|----------|-----------------|
| R2405   | 321-0741-02        | B010100              | B039999 | RES.,FXD,FILM:40.9 OHM,0.5%,0.125W | 75042    | CEAT2-40R90D    |
| R2405   | 321-0058-00        | B040000              |         | RES.,FXD,FILM:39.2 OHM,1%,0.125W   | 75042    | CEATO-39R20F    |
| R2406   | 321-0741-02        | B010100              | B039999 | RES.,FXD,FILM:40.9 OHM,0.5%,0.125W | 75042    | CEAT2-40R90D    |
| R2406   | 321-0058-00        | B040000              |         | RES.,FXD,FILM:39.2 OHM,1%,0.125W   | 75042    | CEATO-39R20F    |
| R2407   | 321-0741-02        | B010100              | B039999 | RES.,FXD,FILM:40.9 OHM,0.5%,0.125W | 75042    | CEAT2-40R90D    |
| R2407   | 321-0058-00        | B040000              |         | RES.,FXD,FILM:39.2 OHM,1%,0.125W   | 75042    | CEATO-39R20F    |
| R2408   | 322-0184-00        |                      |         | RES.,FXD,FILM:806 OHM,1%,0.25W     | 75042    | CEBT0-8060F     |
| R2409   | 321-0189-00        |                      |         | RES.,FXD,FILM:909 OHM,1%,0.125W    | 75042    | CEATO-9090F     |
| R2411   | 315-0560-00        | B010100              | B039999 | RES.,FXD,COMP:56 OHM,5%,0.25W      | 01121    | CB5605          |
| R2411   | 315-0430-00        | B040000              |         | RES.,FXD,COMP:43 OHM,5%,0.25W      | 01121    | CB4305          |
| R2412   | 315-0560-00        | B010100              | B039999 | RES.,FXD,COMP:56 OHM,5%,0.25W      | 01121    | CB5605          |
| R2412   | 315-0430-00        | B040000              |         | RES.,FXD,COMP:43 OHM,5%,0.25W      | 01121    | CB4305          |
| R2413   | 323-0155-00        |                      |         | RES.,FXD,FILM:402 OHM,1%,0.50W     | 75042    | CECT0-4020F     |
| R2414   | 323-0155-00        |                      |         | RES.,FXD,FILM:402 OHM,1%,0.50W     | 75042    | CECT0-4020F     |
| R2416   | 315-0331-00        |                      |         | RES.,FXD,COMP:330 OHM,5%,0.25W     | 01121    | CB3315          |
| R2418   | 321-0214-00        |                      |         | RES.,FXD,FILM:1.65K OHM,1%,0.125W  | 75042    | CEATO-1651F     |
| R2419   | 321-0214-00        |                      |         | RES.,FXD,FILM:1.65K OHM,1%,0.125W  | 75042    | CEATO-1651F     |
| R2421   | 321-1068-01        |                      |         | RES.,FXD,FILM:50.5 OHM,0.5%,0.125W | 75042    | CEATO-50R50D    |
| R2422   | 321-1068-01        |                      |         | RES.,FXD,FILM:50.5 OHM,0.5%,0.125W | 75042    | CEATO-50R50D    |
| R2423   | 321-0741-02        |                      |         | RES.,FXD,FILM:40.9 OHM,0.5%,0.125W | 75042    | CEAT2-40R90D    |
| R2424   | 322-0184-00        |                      |         | RES.,FXD,FILM:806 OHM,1%,0.25W     | 75042    | CEBT0-8060F     |
| R2425   | 321-0741-02        |                      |         | RES.,FXD,FILM:40.9 OHM,0.5%,0.125W | 75042    | CEAT2-40R90D    |
| R2427   | 321-0741-02        |                      |         | RES.,FXD,FILM:40.9 OHM,0.5%,0.125W | 75042    | CEAT2-40R90D    |
| R2428   | 322-0184-00        |                      |         | RES.,FXD,FILM:806 OHM,1%,0.25W     | 75042    | CEBT0-8060F     |
| R2429   | 321-0741-02        |                      |         | RES.,FXD,FILM:40.9 OHM,0.5%,0.125W | 75042    | CEAT2-40R90D    |
| R2431   | 321-0053-00        |                      |         | RES.,FXD,FILM:34.8 OHM,1%,0.125W   | 75042    | CEATO-34R80F    |
| R2432   | 321-0053-00        |                      |         | RES.,FXD,FILM:34.8 OHM,1%,0.125W   | 75042    | CEATO-34R80F    |
| R2435   | 315-0103-00        |                      |         | RES.,FXD,COMP:10K OHM,5%,0.25W     | 01121    | CB1035          |
| R2436   | 315-0331-00        |                      |         | RES.,FXD,COMP:330 OHM,5%,0.25W     | 01121    | CB3315          |
| R2437   | 321-0129-00        |                      |         | RES.,FXD,FILM:215 OHM,1%,0.125W    | 75042    | CEATO-2150F     |
| R2438   | 321-0129-00        |                      |         | RES.,FXD,FILM:215 OHM,1%,0.125W    | 75042    | CEATO-2150F     |
| R2439   | 321-0082-00        |                      |         | RES.,FXD,FILM:69.8 OHM,1%,0.125W   | 75042    | CEATO-69R80F    |
| R2440   | 321-0069-00        |                      |         | RES.,FXD,FILM:51.1 OHM,1%,0.125W   | 75042    | CEATO-51R10F    |
| R2441   | 321-0069-00        |                      |         | RES.,FXD,FILM:51.1 OHM,1%,0.125W   | 75042    | CEATO-51R10F    |
| R2443   | 321-0214-00        |                      |         | RES.,FXD,FILM:1.65K OHM,1%,0.125W  | 75042    | CEATO-1651F     |
| R2444   | 315-0101-00        |                      |         | RES.,FXD,COMP:100 OHM,5%,0.25W     | 01121    | CB1015          |
| R2445   | 315-0561-00        |                      |         | RES.,FXD,COMP:560 OHM,5%,0.25W     | 01121    | CB5615          |
| R2446   | 321-0050-00        |                      |         | RES.,FXD,FILM:32.4 OHM,1%,0.125W   | 75042    | CEATO-32R40F    |
| R2447   | 321-0050-00        |                      |         | RES.,FXD,FILM:32.4 OHM,1%,0.125W   | 75042    | CEATO-32R40F    |
| R2448   | 315-0101-00        |                      |         | RES.,FXD,COMP:100 OHM,5%,0.25W     | 01121    | CB1015          |
| R2449   | 321-0214-00        |                      |         | RES.,FXD,FILM:1.65K OHM,1%,0.125W  | 75042    | CEATO-1651F     |
| R2451   | 301-0220-00        |                      |         | RES.,FXD,COMP:22 OHM,5%,0.50W      | 01121    | EB2205          |
| R2501   | 315-0332-00        |                      |         | RES.,FXD,COMP:3.3K OHM,5%,0.25W    | 01121    | CB3325          |
| R2502   | 315-0202-00        |                      |         | RES.,FXD,COMP:2K OHM,5%,0.25W      | 01121    | CB2025          |
| R2503   | 315-0223-00        |                      |         | RES.,FXD,COMP:22K OHM,5%,0.25W     | 01121    | CB2235          |
| R2504   | 321-0193-00        |                      |         | RES.,FXD,FILM:1K OHM,1%,0.125W     | 75042    | CEATO-1001F     |
| R2505   | 315-0223-00        |                      |         | RES.,FXD,COMP:22K OHM,5%,0.25W     | 01121    | CB2235          |
| R2506   | 321-0193-00        |                      |         | RES.,FXD,FILM:1K OHM,1%,0.125W     | 75042    | CEATO-1001F     |
| R2510   | 315-0301-00        | B010100              | B079999 | RES.,FXD,COMP:300 OHM,5%,0.25W     | 01121    | CB3015          |
| R2510   | 315-0471-00        | B080000              | B139999 | RES.,FXD,COMP:470 OHM,5%,0.25W     | 01121    | CB4715          |
| R2510   | 315-0621-00        | B140000              |         | RES.,FXD,COMP:620 OHM,5%,0.25W     | 01121    | CB6215          |
| R2511   | 315-0302-00        | B010100              | B010139 | RES.,FXD,COMP:3K OHM,5%,0.25W      | 01121    | CB3025          |
| R2511   | 315-0392-00        | B010140              | B139999 | RES.,FXD,COMP:3.9K OHM,5%,0.25W    | 01121    | CB3925          |



| Ckt No. | Tektronix Part No. | Serial/Model No. Eff | Dscont   | Name & Description                | Mfr Code | Mfr Part Number |
|---------|--------------------|----------------------|----------|-----------------------------------|----------|-----------------|
| R2511   | 315-0472-00        | B140000              |          | RES.,FXD,COMP:4.7K OHM,5%,0.25W   | 01121    | CB4725          |
| R2512   | 315-0682-00        |                      |          | RES.,FXD,COMP:6.8K OHM,5%,0.25W   | 01121    | CB6825          |
| R2513   | 315-0912-00        |                      |          | RES.,FXD,COMP:9.1K OHM,5%,0.25W   | 01121    | CB9125          |
| R2514   | 315-0512-00        |                      |          | RES.,FXD,COMP:5.1K OHM,5%,0.25W   | 01121    | CB5125          |
| R2515   | 315-0101-00        |                      |          | RES.,FXD,COMP:100 OHM,5%,0.25W    | 01121    | CB1015          |
| R2517   | 321-0244-00        |                      |          | RES.,FXD,FILM:3.4K OHM,1%,0.125W  | 75042    | CEAT0-3401F     |
| R2518   | 315-0332-00        |                      |          | RES.,FXD,COMP:3.3K OHM,5%,0.25W   | 01121    | CB3325          |
| R2519   | 315-0271-00        |                      |          | RES.,FXD,COMP:2.7K OHM,5%,0.25W   | 01121    | CB2715          |
| R2520   | 315-0512-00        |                      |          | RES.,FXD,COMP:5.1K OHM,5%,0.25W   | 01121    | CB5125          |
| R2521   | 315-0101-00        |                      |          | RES.,FXD,COMP:100 OHM,5%,0.25W    | 01121    | CB1015          |
| R2524   | 315-0242-00        |                      |          | RES.,FXD,COMP:2.4K OHM,5%,0.25W   | 01121    | CB2425          |
| R2525   | 315-0512-00        |                      |          | RES.,FXD,COMP:5.1K OHM,5%,0.25W   | 01121    | CB5125          |
| R2526   | 315-0512-00        |                      |          | RES.,FXD,COMP:5.1K OHM,5%,0.25W   | 01121    | CB5125          |
| R2527   | 315-0332-00        |                      |          | RES.,FXD,COMP:3.3K OHM,5%,0.25W   | 01121    | CB3325          |
| R2528   | 315-0271-00        |                      |          | RES.,FXD,COMP:270 OHM,5%,0.25W    | 01121    | CB2715          |
| R2529   | 315-0332-00        | B010100              | B132604  | RES.,FXD,COMP:3.3K OHM,5%,0.25W   | 01121    | CB3325          |
| R2529   | 315-0182-00        | B132605              |          | RES.,FXD,COMP:1.8K OHM,5%,0.25W   | 01121    | CB1825          |
| R2530   | 315-0222-00        |                      |          | RES.,FXD,COMP:2.2K OHM,5%,0.25W   | 01121    | CB2225          |
| R2531   | 315-0332-00        |                      |          | RES.,FXD,COMP:3.3K OHM,5%,0.25W   | 01121    | CB3325          |
| R2533   | 315-0102-00        |                      |          | RES.,FXD,COMP:1K OHM,5%,0.25W     | 01121    | CB1025          |
| R2534   | 315-0222-00        |                      |          | RES.,FXD,COMP:2.2K OHM,5%,0.25W   | 01121    | CB2225          |
| R2535   | 315-0222-00        |                      |          | RES.,FXD,COMP:2.2K OHM,5%,0.25W   | 01121    | CB2225          |
| R2538   | 315-0332-00        |                      |          | RES.,FXD,COMP:3.3K OHM,5%,0.25W   | 01121    | CB3325          |
| R2540   | 315-0222-00        |                      |          | RES.,FXD,COMP:2.2K OHM,5%,0.25W   | 01121    | CB2225          |
| R2542   | 315-0332-00        |                      |          | RES.,FXD,COMP:3.3K OHM,5%,0.25W   | 01121    | CB3325          |
| R2550   | 315-0103-00        |                      |          | RES.,FXD,COMP:10K OHM,5%,0.25W    | 01121    | CB1035          |
| R2551   | 315-0202-00        |                      |          | RES.,FXD,COMP:2K OHM,5%,0.25W     | 01121    | CB2025          |
| R2552   | 315-0302-00        |                      |          | RES.,FXD,COMP:3K OHM,5%,0.25W     | 01121    | CB3025          |
| R2553   | 315-0303-00        |                      |          | RES.,FXD,COMP:30K OHM,5%,0.25W    | 01121    | CB3035          |
| R2555   | 315-0222-00        |                      |          | RES.,FXD,COMP:2.2K OHM,5%,0.25W   | 01121    | CB2225          |
| R2556   | 315-0332-00        |                      |          | RES.,FXD,COMP:3.3K OHM,5%,0.25W   | 01121    | CB3325          |
| R2558   | 315-0301-00        |                      |          | RES.,FXD,COMP:300 OHM,5%,0.25W    | 01121    | CB3015          |
| R2559   | 315-0102-00        |                      |          | RES.,FXD,COMP:1K OHM,5%,0.25W     | 01121    | CB1025          |
| R2565   | 315-0100-00        | B010100              | B109999X | RES.,FXD,COMP:10 OHM,5%,0.25W     | 01121    | CB1005          |
| R2569   | 315-0512-00        |                      |          | RES.,FXD,COMP:5.1K OHM,5%,0.25W   | 01121    | CB5125          |
| R2570   | 315-0201-00        |                      |          | RES.,FXD,COMP:200 OHM,5%,0.25W    | 01121    | CB2015          |
| R2571   | 321-0298-00        |                      |          | RES.,FXD,FILM:12.4K OHM,1%,0.125W | 75042    | CEAT0-1242F     |
| R2572   | 321-0298-00        |                      |          | RES.,FXD,FILM:12.4K OHM,1%,0.125W | 75042    | CEAT0-1242F     |
| R2573   | 315-0201-00        |                      |          | RES.,FXD,COMP:200 OHM,5%,0.25W    | 01121    | CB2015          |
| R2575   | 315-0153-00        |                      |          | RES.,FXD,COMP:15K OHM,5%,0.25W    | 01121    | CB1535          |
| R2577   | 321-0254-00        |                      |          | RES.,FXD,FILM:4.32K OHM,1%,0.125W | 75042    | CEAT0-4321F     |
| R2579   | 321-0254-00        |                      |          | RES.,FXD,FILM:4.32K OHM,1%,0.125W | 75042    | CEAT0-4321F     |
| R2580   | 315-0201-00        |                      |          | RES.,FXD,COMP:200 OHM,5%,0.25W    | 01121    | CB2015          |
| R2581   | 321-0201-00        | B010100              | B149999  | RES.,FXD,FILM:1.21K OHM,1%,0.125W | 75042    | CEAT0-1211F     |
| R2581   | 321-0199-00        | B150000              |          | RES.,FXD,FILM:1.15K OHM,1%,0.125W | 75042    | CEAT0-1151F     |
| R2582   | 315-0622-00        |                      |          | RES.,FXD,COMP:6.2K OHM,5%,0.25W   | 01121    | CB6225          |
| R2583   | 315-0622-00        |                      |          | RES.,FXD,COMP:6.2K OHM,5%,0.25W   | 01121    | CB6225          |
| R2586   | 315-0332-00        |                      |          | RES.,FXD,COMP:3.3K OHM,5%,0.25W   | 01121    | CB3325          |
| R2587   | 315-0392-00        | B010100              | B079999  | RES.,FXD,COMP:3.9K OHM,5%,0.25W   | 01121    | CB3925          |
| R2587   | 321-0253-00        | B080000              |          | RES.,FXD,FILM:4.22K OHM,1%,0.125W | 75042    | CEAT0-4221F     |
| R2588   | 315-0392-00        | B010100              | B079999  | RES.,FXD,COMP:3.9K OHM,5%,0.25W   | 01121    | CB3925          |
| R2588   | 321-0253-00        | B080000              |          | RES.,FXD,FILM:4.22K OHM,1%,0.125W | 75042    | CEAT0-4221F     |
| R2590   | 321-0279-00        |                      |          | RES.,FXD,FILM:7.87K OHM,1%,0.125W | 75042    | CEAT0-7871F     |
| R2591   | 321-0275-00        |                      |          | RES.,FXD,FILM:7.15K OHM,1%,0.125W | 75042    | CEAT0-7151F     |

# Electrical Parts List—7704A

| Ckt No. | Tektronix Part No. | Serial/Model No. Eff | Dscont  | Name & Description                 | Mfr Code | Mfr Part Number |
|---------|--------------------|----------------------|---------|------------------------------------|----------|-----------------|
| R2594   | 315-0683-00        |                      |         | RES.,FXD,COMP:68K OHM,5%,0.25W     | 01121    | CB6835          |
| R2595   | 315-0751-00        |                      |         | RES.,FXD,COMP:750 OHM,5%,0.25W     | 01121    | CB7515          |
| R2596   | 315-0103-00        |                      |         | RES.,FXD,COMP:10K OHM,5%,0.25W     | 01121    | CB1035          |
| R2597   | 315-0103-00        |                      |         | RES.,FXD,COMP:10K OHM,5%,0.25W     | 01121    | CB1035          |
| R2598   | 321-0247-00        | B010100              | B149999 | RES.,FXD,FILM:3.65K OHM,1%,0.125W  | 75042    | CEATO-3651F     |
| R2598   | 321-0243-00        | B150000              |         | RES.,FXD,FILM:3.32K OHM,1%,0.125W  | 75042    | CEATO-3321F     |
| R2599   | 315-0151-00        |                      |         | RES.,FXD,COMP:150 OHM,5%,0.25W     | 01121    | CB1515          |
| R3005   | 304-0270-00        |                      |         | RES.,FXD,COMP:27 OHM,10%,1W        | 01121    | GB2701          |
| R3008   | 304-0473-00        |                      |         | RES.,FXD,COMP:47K OHM,10%,1W       | 01121    | GB4731          |
| R3010   | 303-0304-00        |                      |         | RES.,FXD,COMP:300K OHM,5%,1W       | 01121    | GB3045          |
| R3013   | 304-0473-00        |                      |         | RES.,FXD,COMP:47K OHM,10%,1W       | 01121    | GB4731          |
| R3019   | 302-0565-00        |                      |         | RES.,FXD,COMP:5.6M OHM,10%,0.50W   | 01121    | EB5651          |
| R3021   | 304-0154-00        |                      |         | RES.,FXD,COMP:150K OHM,10%,1W      | 01121    | GB1541          |
| R3025   | 316-0471-00        |                      |         | RES.,FXD,COMP:470 OHM,10%,0.25W    | 01121    | CB4711          |
| R3031   | 307-0057-00        |                      |         | RES.,FXD,COMP:5.1 OHM,5%,0.50W     | 01121    | EB51G5          |
| R3032   | 316-0220-00        |                      |         | RES.,FXD,COMP:22 OHM,10%,0.25W     | 01121    | CB2201          |
| R3034   | 316-0684-00        |                      |         | RES.,FXD,COMP:680K OHM,10%,0.25W   | 01121    | CB6841          |
| R3039   | 316-0103-00        |                      |         | RES.,FXD,COMP:10K OHM,10%,0.25W    | 01121    | CB1031          |
| R3042   | 307-0057-00        |                      |         | RES.,FXD,COMP:5.1 OHM,5%,0.50W     | 01121    | EB51G5          |
| R3043   | 316-0220-00        |                      |         | RES.,FXD,COMP:22 OHM,10%,0.25W     | 01121    | CB2201          |
| R3048   | 315-0823-00        |                      |         | RES.,FXD,COMP:82K OHM,5%,0.25W     | 01121    | CB8235          |
| R3049   | 316-0184-00        |                      |         | RES.,FXD,COMP:25W 180K OHM,10%,0   | 01121    | CB1841          |
| R3050   | 316-0101-00        |                      |         | RES.,FXD,COMP:100 OHM,10%,0.25W    | 01121    | CB1011          |
| R3052   | 302-0332-00        |                      |         | RES.,FXD,COMP:3.3K OHM,10%,0.50W   | 01121    | EB3321          |
| R3054   | 316-0561-00        |                      |         | RES.,FXD,COMP:560 OHM,10%,0.25W    | 01121    | CB5611          |
| R3056   | 316-0101-00        |                      |         | RES.,FXD,COMP:100 OHM,10%,0.25W    | 01121    | CB1011          |
| R3057   | 316-0270-00        |                      |         | RES.,FXD,COMP:27 OHM,10%,0.25W     | 01121    | CB2701          |
| R3105   | 315-0473-00        |                      |         | RES.,FXD,COMP:47K OHM,5%,0.25W     | 01121    | CB4735          |
| R3106   | 315-0103-00        |                      |         | RES.,FXD,COMP:10K OHM,5%,0.25W     | 01121    | CB1035          |
| R3108   | 315-0103-00        |                      |         | RES.,FXD,COMP:10K OHM,5%,0.25W     | 01121    | CB1035          |
| R3109   | 315-0223-00        |                      |         | RES.,FXD,COMP:22K OHM,5%,0.25W     | 01121    | CB2235          |
| R3111   | 315-0104-00        |                      |         | RES.,FXD,COMP:100K OHM,5%,0.25W    | 01121    | CB1045          |
| R3117   | 315-0154-00        |                      |         | RES.,FXD,COMP:150K OHM,5%,0.25W    | 01121    | CB1545          |
| R3119   | 315-0224-00        |                      |         | RES.,FXD,COMP:220K OHM,5%,0.25W    | 01121    | CB2245          |
| R3120   | 315-0123-00        |                      |         | RES.,FXD,COMP:12K OHM,5%,0.25W     | 01121    | CB1235          |
| R3121   | 315-0201-00        |                      |         | RES.,FXD,COMP:200 OHM,5%,0.25W     | 01121    | CB2015          |
| R3122   | 315-0470-00        |                      |         | RES.,FXD,COMP:47 OHM,5%,0.25W      | 01121    | CB4705          |
| R3127   | 315-0560-00        |                      |         | RES.,FXD,COMP:56 OHM,5%,0.25W      | 01121    | CB5605          |
| R3129   | 315-0331-00        | B010100              | B109999 | RES.,FXD,COMP:330 OHM,5%,0.25W     | 01121    | CB3315          |
| R3129   | 315-0181-00        | B110000              |         | RES.,FXD,COMP:180 OHM,5%,0.25W     | 01121    | CB1815          |
| R3134   | 315-0471-00        |                      |         | RES.,FXD,COMP:470 OHM,5%,0.25W     | 01121    | CB4715          |
| R3135   | 321-0313-00        |                      |         | RES.,FXD,FILM:17.8K OHM,1%,0.125W  | 75042    | CEATO-1782F     |
| R3136   | 321-0193-00        |                      |         | RES.,FXD,FILM:1K OHM,1%,0.125W     | 75042    | CEATO-1001F     |
| R3137   | 321-0012-00        |                      |         | RES.,FXD,FILM:13 OHM,1%,0.125W     | 75042    | CEATO-13ROOF    |
| R3142   | 321-0388-00        |                      |         | RES.,FXD,FILM:107K OHM,0.125W,1%   | 91637    | MFF1816G10702F  |
| R3143   | 311-1239-00        |                      |         | RES.,VAR,NONWIR:2.5K OHM,10%,0.50W | 73138    | 72Y-26-0-252K   |
| R3144   | 321-0283-00        |                      |         | RES.,FXD,FILM:8.66K OHM,1%,0.125W  | 75042    | CEATO-8661F     |
| R3146   | 321-0282-00        |                      |         | RES.,FXD,FILM:8.45K OHM,1%,0.125W  | 75042    | CEATO-8451F     |
| R3147   | 315-0102-00        |                      |         | RES.,FXD,COMP:1K OHM,5%,0.25W      | 01121    | CB1025          |
| R3150   | 321-0356-00        |                      |         | RES.,FXD,FILM:49.9K OHM,1%,0.125W  | 75042    | CEATO-4992F     |
| R3152   | 315-0821-00        |                      |         | RES.,FXD,COMP:820 OHM,5%,0.25W     | 01121    | CB8215          |
| R3154   | 321-0286-00        |                      |         | RES.,FXD,FILM:9.31K OHM,1%,0.125W  | 75042    | CEATO-9311F     |
| R3155   | 321-0339-00        |                      |         | RES.,FXD,FILM:33.2K OHM,1%,0.125W  | 75042    | CEATO-3322F     |
| R3202   | 316-0471-00        | B010100              | B059999 | RES.,FXD,COMP:470 OHM,10%,0.25W    | 01121    | CB4711          |

| Ckt No. | Tektronix Part No. | Serial/Model No. Eff | Dscont  | Name & Description                | Mfr Code | Mfr Part Number |
|---------|--------------------|----------------------|---------|-----------------------------------|----------|-----------------|
| R3202   | 315-0471-00        | B060000              |         | RES.,FXD,COMP:470 OHM,5%,0.25W    | 01121    | CB4715          |
| R3204   | 316-0334-00        | B010100              | B059999 | RES.,FXD,COMP:330K OHM,10%,0.25W  | 01121    | CB3341          |
| R3204   | 315-0334-00        | B060000              |         | RES.,FXD,COMP:330K OHM,5%,0.25W   | 01121    | CB3345          |
| R3205   | 316-0221-00        | B010100              | B059999 | RES.,FXD,COMP:220 OHM,10%,0.25W   | 01121    | CB2211          |
| R3205   | 315-0221-00        | B060000              |         | RES.,FXD,COMP:220 OHM,5%,0.25W    | 01121    | CB2215          |
| R3206   | 316-0183-00        | B010100              | B059999 | RES.,FXD,COMP25W 18K OHM,10%,0.   | 01121    | CB1831          |
| R3206   | 315-0183-00        | B060000              |         | RES.,FXD,COMP:18K OHM,5%,0.25W    | 01121    | CB1835          |
| R3208   | 321-0924-07        |                      |         | RES.,FXD,FILM:40K OHM,0.1%,0.125W | 75042    | CEAT9-4002B     |
| R3209   | 316-0274-00        | B010100              | B059999 | RES.,FXD,COMP:270K OHM,10%,0.25W  | 01121    | CB2741          |
| R3209   | 315-0274-00        | B060000              |         | RES.,FXD,COMP:270K OHM,5%,0.25W   | 01121    | CB2745          |
| R3211   | 315-0621-00        |                      |         | RES.,FXD,COMP:620 OHM,5%,0.25W    | 01121    | CB6215          |
| R3212   | 315-0513-00        |                      |         | RES.,FXD,COMP:51K OHM,5%,0.25W    | 01121    | CB5135          |
| R3213   | 315-0272-00        |                      |         | RES.,FXD,COMP:2.7K OHM,5%,0.25W   | 01121    | CB2725          |
| R3214   | 321-0924-07        |                      |         | RES.,FXD,FILM:40K OHM,0.1%,0.125W | 75042    | CEAT9-4002B     |
| R3216   | 316-0102-00        | B010100              | B059999 | RES.,FXD,COMP:1K OHM,10%,0.25W    | 01121    | CB1021          |
| R3216   | 315-0102-00        | B060000              |         | RES.,FXD,COMP:1K OHM,5%,0.25W     | 01121    | CB1025          |
| R3217   | 315-0513-00        |                      |         | RES.,FXD,COMP:51K OHM,5%,0.25W    | 01121    | CB5135          |
| R3218   | 316-0681-00        | B010100              | B059999 | RES.,FXD,COMP:680 OHM,10%,0.25W   | 01121    | CB6811          |
| R3218   | 315-0681-00        | B060000              |         | RES.,FXD,COMP:680 OHM,5%,0.25W    | 01121    | CB6815          |
| R3220   | 316-0331-00        | B010100              | B059999 | RES.,FXD,COMP:330 OHM,10%,0.25W   | 01121    | CB3311          |
| R3220   | 315-0331-00        | B060000              |         | RES.,FXD,COMP:330 OHM,5%,0.25W    | 01121    | CB3315          |
| R3222   | 316-0471-00        | B010100              | B059999 | RES.,FXD,COMP:470 OHM,10%,0.25W   | 01121    | CB4711          |
| R3222   | 315-0471-00        | B060000              |         | RES.,FXD,COMP:470 OHM,5%,0.25W    | 01121    | CB4715          |
| R3223   | 308-0703-00        |                      |         | RES.,FXD,WW:1.8 OHM,5%,2W         | 75042    | BWH1R80J        |
| R3224   | 315-0753-00        |                      |         | RES.,FXD,COMP:75K OHM,5%,0.25W    | 01121    | CB7535          |
| R3225   | 315-0182-00        |                      |         | RES.,FXD,COMP:1.8K OHM,5%,0.25W   | 01121    | CB1825          |
| R3226   | 316-0334-00        | B010100              | B059999 | RES.,FXD,COMP:330K OHM,10%,0.25W  | 01121    | CB3341          |
| R3226   | 315-0334-00        | B060000              |         | RES.,FXD,COMP:330K OHM,5%,0.25W   | 01121    | CB3345          |
| R3228   | 315-0152-00        |                      |         | RES.,FXD,COMP:1.5K OHM,5%,0.25W   | 01121    | CB1525          |
| R3229   | 316-0153-00        | B010100              | B059999 | RES.,FXD,COMP:15K OHM,10%,0.25W   | 01121    | CB1531          |
| R3229   | 315-0153-00        | B060000              |         | RES.,FXD,COMP:15K OHM,5%,0.25W    | 01121    | CB1535          |
| R3230   | 315-0561-00        |                      |         | RES.,FXD,COMP:560 OHM,5%,0.25W    | 01121    | CB5615          |
| R3231   | 315-0182-00        |                      |         | RES.,FXD,COMP:1.8K OHM,5%,0.25W   | 01121    | CB1825          |
| R3232   | 315-0134-00        |                      |         | RES.,FXD,COMP:130K OHM,5%,0.25W   | 01121    | CB1345          |
| R3233   | 315-0512-00        |                      |         | RES.,FXD,COMP:5.1K OHM,5%,0.25W   | 01121    | CB5125          |
| R3234   | 315-0820-00        |                      |         | RES.,FXD,COMP:82 OHM,5%,0.25W     | 01121    | CB8205          |
| R3235   | 316-0184-00        | B010100              | B059999 | RES.,FXD,COMP.25W 180K OHM,10%,0  | 01121    | CB1841          |
| R3235   | 315-0184-00        | B060000              |         | RES.,FXD,COMP:180K OHM,5%,0.25W   | 01121    | CB1845          |
| R3236   | 321-0924-07        |                      |         | RES.,FXD,FILM:40K OHM,0.1%,0.125W | 75042    | CEAT9-4002B     |
| R3237   | 301-0103-00        | B010100              | B173849 | RES.,FXD,COMP:10K OHM,5%,0.50W    | 01121    | EB1035          |
| R3237   | 302-0392-00        | B173850              |         | RES.,FXD,COMP:3.9K OHM,10%,0.50W  | 01121    | EB3921          |
| R3238   | 315-0153-00        |                      |         | RES.,FXD,COMP:15K OHM,5%,0.25W    | 01121    | CB1535          |
| R3239   | 321-1296-07        |                      |         | RES.,FXD,FILM:12K OHM,0.1%,0.125W | 75042    | CEAT9-1202B     |
| R3240   | 316-0681-00        | B010100              | B059999 | RES.,FXD,COMP:680 OHM,10%,0.25W   | 01121    | CB6811          |
| R3240   | 315-0681-00        | B060000              |         | RES.,FXD,COMP:680 OHM,5%,0.25W    | 01121    | CB6815          |
| R3241   | 308-0701-00        |                      |         | RES.,FXD,WW:0.12 OHM,5%,2W        | 75042    | BWH-R1200J      |
| R3242   | 316-0151-00        | B010100              | B059999 | RES.,FXD,COMP:150 OHM,10%,0.25W   | 01121    | CB1511          |
| R3242   | 315-0151-00        | B060000              |         | RES.,FXD,COMP:150 OHM,5%,0.25W    | 01121    | CB1515          |
| R3245   | 316-0273-00        | B010100              | B059999 | RES.,FXD,COMP:27K OHM,10%,0.25W   | 01121    | CB2731          |
| R3245   | 315-0273-00        | B060000              |         | RES.,FXD,COMP:27K OHM,5%,0.25W    | 01121    | CB2735          |
| R3246   | 316-0273-00        | B010100              | B059999 | RES.,FXD,COMP:27K OHM,10%,0.25W   | 01121    | CB2731          |
| R3246   | 315-0273-00        | B060000              |         | RES.,FXD,COMP:27K OHM,5%,0.25W    | 01121    | CB2735          |
| R3248   | 315-0430-00        |                      |         | RES.,FXD,COMP:43 OHM,5%,0.25W     | 01121    | CB4305          |
| R3249   | 316-0562-00        | B010100              | B059999 | RES.,FXD,COMP:5.6K OHM,10%,0.25W  | 01121    | CB5621          |

**Electrical Parts List—7704A**

| Ckt No. | Tektronix Part No. | Serial/Model No. Eff | Dscont  | Name & Description                | Mfr Code | Mfr Part Number |
|---------|--------------------|----------------------|---------|-----------------------------------|----------|-----------------|
| R3249   | 315-0562-00        | B060000              |         | RES.,FXD,COMP:5.6K OHM,5%,0.25W   | 01121    | CB5625          |
| R3251   | 316-0223-00        | B010100              | B059999 | RES.,FXD,COMP:22K OHM,10%,0.25W   | 01121    | CB2231          |
| R3251   | 315-0223-00        | B060000              |         | RES.,FXD,COMP:22K OHM,5%,0.25W    | 01121    | CB2235          |
| R3253   | 315-0152-00        |                      |         | RES.,FXD,COMP:1.5K OHM,5%,0.25W   | 01121    | CB1525          |
| R3254   | 315-0750-00        |                      |         | RES.,FXD,COMP:75 OHM,5%,0.25W     | 01121    | CB7505          |
| R3255   | 308-0701-00        |                      |         | RES.,FXD,WW:0.12 OHM,5%,2W        | 75042    | BWH-R1200J      |
| R3258   | 316-0103-00        | B010100              | B059999 | RES.,FXD,COMP:10K OHM,10%,0.25W   | 01121    | CB1031          |
| R3258   | 315-0103-00        | B060000              |         | RES.,FXD,COMP:10K OHM,5%,0.25W    | 01121    | CB1035          |
| R3260   | 316-0681-00        | B010100              | B059999 | RES.,FXD,COMP:680 OHM,10%,0.25W   | 01121    | CB6811          |
| R3260   | 315-0681-00        | B060000              |         | RES.,FXD,COMP:680 OHM,5%,0.25W    | 01121    | CB6815          |
| R3262   | 316-0470-00        | B010100              | B059999 | RES.,FXD,COMP:47 OHM,10%,0.25W    | 01121    | CB4701          |
| R3262   | 315-0470-00        | B060000              |         | RES.,FXD,COMP:47 OHM,5%,0.25W     | 01121    | CB4705          |
| R3263   | 316-0470-00        | B010100              | B059999 | RES.,FXD,COMP:47 OHM,10%,0.25W    | 01121    | CB4701          |
| R3263   | 315-0470-00        | B060000              |         | RES.,FXD,COMP:47 OHM,5%,0.25W     | 01121    | CB4705          |
| R3264   | 316-0274-00        | B010100              | B059999 | RES.,FXD,COMP:270K OHM,10%,0.25W  | 01121    | CB2741          |
| R3264   | 315-0274-00        | B060000              |         | RES.,FXD,COMP:270K OHM,5%,0.25W   | 01121    | CB2745          |
| R3265   | 321-0924-07        |                      |         | RES.,FXD,FILM:40K OHM,0.1%,0.125W | 75042    | CEAT9-4002B     |
| R3267   | 321-0926-07        |                      |         | RES.,FXD,FILM:4K OHM,0.1%,0.125W  | 75042    | CEAT9-4001B     |
| R3268   | 316-0224-00        | B010100              | B059999 | RES.,FXD,COMP:220K OHM,10%,0.25W  | 01121    | CB2241          |
| R3268   | 315-0224-00        | B060000              |         | RES.,FXD,COMP:220K OHM,5%,0.25W   | 01121    | CB2245          |
| R3269   | 316-0103-00        | B010100              | B059999 | RES.,FXD,COMP:10K OHM,10%,0.25W   | 01121    | CB1031          |
| R3269   | 315-0103-00        | B060000              |         | RES.,FXD,COMP:10K OHM,5%,0.25W    | 01121    | CB1035          |
| R3272   | 321-1296-07        |                      |         | RES.,FXD,FILM:12K OHM,0.1%,0.125W | 75042    | CEAT9-1202B     |
| R3273   | 321-0332-07        |                      |         | RES.,FXD,FILM:28K OHM,0.1%,0.125W | 75042    | CEAT9-2802B     |
| R3275   | 316-0184-00        | B010100              | B059999 | RES.,FXD,COMP.25W 180K OHM,10%,0  | 01121    | CB1841          |
| R3275   | 315-0184-00        | B060000              |         | RES.,FXD,COMP:180K OHM,5%,0.25W   | 01121    | CB1845          |
| R3277   | 315-0124-00        |                      |         | RES.,FXD,COMP:120K OHM,5%,0.25W   | 01121    | CB1245          |
| R3278   | 316-0471-00        | B010100              | B059999 | RES.,FXD,COMP:470 OHM,10%,0.25W   | 01121    | CB4711          |
| R3278   | 315-0471-00        | B060000              |         | RES.,FXD,COMP:470 OHM,5%,0.25W    | 01121    | CB4715          |
| R3280   | 315-0272-00        |                      |         | RES.,FXD,COMP:2.7K OHM,5%,0.25W   | 01121    | CB2725          |
| R3283   | 301-0822-00        |                      |         | RES.,FXD,COMP:8.2K OHM,5%,0.50W   | 01121    | EB8225          |
| R3285   | 316-0222-00        | B010100              | B059999 | RES.,FXD,COMP:2.2K OHM,10%,0.25W  | 01121    | CB2221          |
| R3285   | 315-0222-00        | B060000              |         | RES.,FXD,COMP:2.2K OHM,5%,0.25W   | 01121    | CB2225          |
| R3287   | 316-0273-00        | B010100              | B059999 | RES.,FXD,COMP:27K OHM,10%,0.25W   | 01121    | CB2731          |
| R3287   | 315-0273-00        | B060000              |         | RES.,FXD,COMP:27K OHM,5%,0.25W    | 01121    | CB2735          |
| R3288   | 316-0391-00        | B010100              | B059999 | RES.,FXD,COMP:390 OHM,10%,0.25W   | 01121    | CB3911          |
| R3288   | 315-0391-00        | B060000              |         | RES.,FXD,COMP:390 OHM,5%,0.25W    | 01121    | CB3915          |
| R3289   | 316-0222-00        | B010100              | B059999 | RES.,FXD,COMP:2.2K OHM,10%,0.25W  | 01121    | CB2221          |
| R3289   | 315-0222-00        | B060000              |         | RES.,FXD,COMP:2.2K OHM,5%,0.25W   | 01121    | CB2225          |
| R3290   | 316-0681-00        | B010100              | B059999 | RES.,FXD,COMP:680 OHM,10%,0.25W   | 01121    | CB6811          |
| R3290   | 315-0681-00        | B060000              |         | RES.,FXD,COMP:680 OHM,5%,0.25W    | 01121    | CB6815          |
| R3293   | 308-0701-00        |                      |         | RES.,FXD,WW:0.12 OHM,5%,2W        | 75042    | BWH-R1200J      |
| R3294   | 316-0471-00        | B010100              | B059999 | RES.,FXD,COMP:470 OHM,10%,0.25W   | 01121    | CB4711          |
| R3294   | 315-0471-00        | B060000              |         | RES.,FXD,COMP:470 OHM,5%,0.25W    | 01121    | CB4715          |
| R3301   | 315-0241-00        |                      |         | RES.,FXD,COMP:240 OHM,5%,0.25W    | 01121    | CB2415          |
| R3302   | 321-0097-00        | B010100              | B089999 | RES.,FXD,FILM:100 OHM,1%,0.125W   | 75042    | CEATO-1000F     |
| R3302   | 321-0092-00        | B090000              |         | RES.,FXD,FILM:88.7 OHM,1%,0.125W  | 75042    | CEATO-88R70F    |
| R3304   | 321-0091-00        |                      |         | RES.,FXD,FILM:86.6 OHM,1%,0.125W  | 75042    | CEATO-86R60F    |
| R3306   | 321-0022-00        |                      |         | RES.,FXD,FILM:16.5 OHM,1%,0.125W  | 75042    | CEATO-16R50F    |
| R3308   | 321-0022-00        |                      |         | RES.,FXD,FILM:16.5 OHM,1%,0.125W  | 75042    | CEATO-16R50F    |
| R3310   | 315-0471-00        |                      |         | RES.,FXD,COMP:470 OHM,5%,0.25W    | 01121    | CB4715          |
| R3312   | 315-0151-00        |                      |         | RES.,FXD,COMP:150 OHM,5%,0.25W    | 01121    | CB1515          |
| R3313   | 321-0229-00        |                      |         | RES.,FXD,FILM:2.37K OHM,1%,0.125W | 75042    | CEATO-2371F     |

Electrical Parts List—7704A

| Ckt No. | Tektronix Part No. | Serial/Model No. Eff | Dscont  | Name & Description                 | Mfr Code | Mfr Part Number |
|---------|--------------------|----------------------|---------|------------------------------------|----------|-----------------|
| R3314   | 321-0244-00        |                      |         | RES.,FXD,FILM:3.4K OHM,1%,0.125W   | 75042    | CEATO-3401F     |
| R3315   | 315-0151-00        |                      |         | RES.,FXD,COMP:150 OHM,5%,0.25W     | 01121    | CB1515          |
| R3317   | 321-0224-00        |                      |         | RES.,FXD,FILM:2.1K OHM,1%,0.125W   | 75042    | CEATO-2101F     |
| R3318   | 321-0208-00        |                      |         | RES.,FXD,FILM:1.43K OHM,1%,0.125W  | 75042    | CEATO-1431F     |
| R3319   | 315-0101-00        |                      |         | RES.,FXD,COMP:100 OHM,5%,0.25W     | 01121    | CB1015          |
| R3320   | 315-0470-00        |                      |         | RES.,FXD,COMP:47 OHM,5%,0.25W      | 01121    | CB4705          |
| R3321   | 315-0101-00        |                      |         | RES.,FXD,COMP:100 OHM,5%,0.25W     | 01121    | CB1015          |
| R3323   | 315-0222-00        |                      |         | RES.,FXD,COMP:2.2K OHM,5%,0.25W    | 01121    | CB2225          |
| R3325   | 315-0241-00        |                      |         | RES.,FXD,COMP:240 OHM,5%,0.25W     | 01121    | CB2415          |
| R3326   | 315-0101-00        |                      |         | RES.,FXD,COMP:100 OHM,5%,0.25W     | 01121    | CB1015          |
| R3328   | 321-0260-00        | B010100              | B010159 | RES.,FXD,FILM:4.99K OHM,1%,0.125W  | 75042    | CEATO-4991F     |
| R3328   | 321-0262-00        | B010160              |         | RES.,FXD,FILM:5.23K OHM,1%,0.125W  | 75042    | CEATO-5231F     |
| R3330   | 315-0152-00        |                      |         | RES.,FXD,COMP:1.5K OHM,5%,0.25W    | 01121    | CB1525          |
| R3333   | 315-0272-00        |                      |         | RES.,FXD,COMP:2.7K OHM,5%,0.25W    | 01121    | CB2725          |
| R3334   | 321-0190-00        |                      |         | RES.,FXD,FILM:931 OHM,1%,0.125W    | 75042    | CEATO-9310F     |
| R3340   | 315-0181-00        |                      |         | RES.,FXD,COMP:180 OHM,5%,0.25W     | 01121    | CB1815          |
| R3341   | 315-0123-00        |                      |         | RES.,FXD,COMP:12K OHM,5%,0.25W     | 01121    | CB1235          |
| R3343   | 315-0181-00        |                      |         | RES.,FXD,COMP:180 OHM,5%,0.25W     | 01121    | CB1815          |
| R3344   | 315-0123-00        |                      |         | RES.,FXD,COMP:12K OHM,5%,0.25W     | 01121    | CB1235          |
| R3346   | 315-0201-00        |                      |         | RES.,FXD,COMP:200 OHM,5%,0.25W     | 01121    | CB2015          |
| R3347   | 315-0752-00        |                      |         | RES.,FXD,COMP:7.5K OHM,5%,0.25W    | 01121    | CB7525          |
| R3348   | 315-0101-00        |                      |         | RES.,FXD,COMP:100 OHM,5%,0.25W     | 01121    | CB1015          |
| R3349   | 315-0101-00        |                      |         | RES.,FXD,COMP:100 OHM,5%,0.25W     | 01121    | CB1015          |
| R3352   | 315-0102-00        |                      |         | RES.,FXD,COMP:1K OHM,5%,0.25W      | 01121    | CB1025          |
| R3354   | 315-0821-00        |                      |         | RES.,FXD,COMP:820 OHM,5%,0.25W     | 01121    | CB8215          |
| R3356   | 315-0561-00        |                      |         | RES.,FXD,COMP:560 OHM,5%,0.25W     | 01121    | CB5615          |
| R3358   | 321-0143-00        |                      |         | RES.,FXD,FILM:301 OHM,1%,0.125W    | 75042    | CEATO-3010F     |
| R3360   | 321-0226-00        |                      |         | RES.,FXD,FILM:2.21K OHM,1%,0.125W  | 75042    | CEATO-2211F     |
| R3361   | 321-0180-00        |                      |         | RES.,FXD,FILM:732 OHM,1%,0.125W    | 75042    | CEATO-7320F     |
| R3363   | 321-0189-00        |                      |         | RES.,FXD,FILM:909 OHM,1%,0.125W    | 75042    | CEATO-9090F     |
| R3364   | 315-0390-00        |                      |         | RES.,FXD,COMP:39 OHM,5%,0.25W      | 01121    | CB3905          |
| R3367   | 315-0102-00        |                      |         | RES.,FXD,COMP:1K OHM,5%,0.25W      | 01121    | CB1025          |
| R3368   | 315-0102-00        |                      |         | RES.,FXD,COMP:1K OHM,5%,0.25W      | 01121    | CB1025          |
| R3371   | 315-0510-00        |                      |         | RES.,FXD,COMP:51 OHM,5%,0.25W      | 01121    | CB5105          |
| R3372   | 315-0473-00        |                      |         | RES.,FXD,COMP:47K OHM,5%,0.25W     | 01121    | CB4735          |
| R3373   | 315-0221-00        |                      |         | RES.,FXD,COMP:220 OHM,5%,0.25W     | 01121    | CB2215          |
| R3391   | 315-0104-00        |                      |         | RES.,FXD,COMP:100K OHM,5%,0.25W    | 01121    | CB1045          |
| R3393   | 315-0152-00        |                      |         | RES.,FXD,COMP:1.5K OHM,5%,0.25W    | 01121    | CB1525          |
| R3401   | 315-0303-00        |                      |         | RES.,FXD,COMP:30K OHM,5%,0.25W     | 01121    | CB3035          |
| R3402   | 315-0203-00        |                      |         | RES.,FXD,COMP:20K OHM,5%,0.25W     | 01121    | CB2035          |
| R3403   | 315-0203-00        |                      |         | RES.,FXD,COMP:20K OHM,5%,0.25W     | 01121    | CB2035          |
| R3404   | 315-0203-00        |                      |         | RES.,FXD,COMP:20K OHM,5%,0.25W     | 01121    | CB2035          |
| R3405   | 315-0203-00        |                      |         | RES.,FXD,COMP:20K OHM,5%,0.25W     | 01121    | CB2035          |
| R3406   | 315-0134-00        |                      |         | RES.,FXD,COMP:130K OHM,5%,0.25W    | 01121    | CB1345          |
| R3407   | 311-1224-00        |                      |         | RES.,VAR, NONWIR:500 OHM,20%,0.50W | 80294    | 3389F-P31-501   |
| R3408   | 321-0300-00        |                      |         | RES.,FXD,FILM:13K OHM,1%,0.125W    | 75042    | CEATO-1302F     |
| R3409   | 321-0259-00        |                      |         | RES.,FXD,FILM:4.87K OHM,1%,0.125W  | 75042    | CEATO-4871F     |
| R3410   | 321-0181-00        |                      |         | RES.,FXD,FILM:750 OHM,1%,0.125W    | 75042    | CEATO-7500F     |
| R3411   | 321-0297-00        |                      |         | RES.,FXD,FILM:12.1K OHM,1%,0.125W  | 75042    | CEATO-1212F     |
| R3412   | 321-0212-00        |                      |         | RES.,FXD,FILM:1.58K OHM,1%,0.125W  | 75042    | CEATO-1581F     |
| R3414   | 315-0152-00        |                      |         | RES.,FXD,COMP:1.5K OHM,5%,0.25W    | 01121    | CB1525          |
| R3416   | 315-0222-00        |                      |         | RES.,FXD,COMP:2.2K OHM,5%,0.25W    | 01121    | CB2225          |
| R3418   | 321-0268-00        |                      |         | RES.,FXD,FILM:6.04K OHM,1%,0.125W  | 75042    | CEATO-6041F     |

# Electrical Parts List—7704A

| Ckt No. | Tektronix Part No. | Serial/Model No. Eff | Dscont | Name & Description                | Mfr Code | Mfr Part Number |
|---------|--------------------|----------------------|--------|-----------------------------------|----------|-----------------|
| R3419   | 321-0322-00        |                      |        | RES.,FXD,FILM:22.1K OHM,1%,0.125W | 75042    | CEATO-2212F     |
| R3420   | 321-0262-00        |                      |        | RES.,FXD,FILM:5.23K OHM,1%,0.125W | 75042    | CEATO-5231F     |
| R3422   | 311-1224-00        |                      |        | RES.,VAR,NONWIR:500 OHM,20%,0.50W | 80294    | 3389F-P31-501   |
| R3423   | 321-0372-00        |                      |        | RES.,FXD,FILM:73.2K OHM,1%,0.125W | 75042    | CEATO-7322F     |
| R3425   | 321-0403-00        |                      |        | RES.,FXD,FILM:154K OHM,1%,0.125W  | 75042    | CEATO-1543F     |
| R3427   | 315-0472-00        |                      |        | RES.,FXD,COMP:4.7K OHM,5%,0.25W   | 01121    | CB4725          |
| R3430   | 315-0432-00        |                      |        | RES.,FXD,COMP:4.3K OHM,5%,0.25W   | 01121    | CB4325          |
| R3431   | 315-0683-00        |                      |        | RES.,FXD,COMP:68K OHM,5%,0.25W    | 01121    | CB6835          |
| R3432   | 315-0153-00        |                      |        | RES.,FXD,COMP:15K OHM,5%,0.25W    | 01121    | CB1535          |
| R3433   | 315-0302-00        |                      |        | RES.,FXD,COMP:3K OHM,5%,0.25W     | 01121    | CB3025          |
| R3434   | 315-0393-00        |                      |        | RES.,FXD,COMP:39K OHM,5%,0.25W    | 01121    | CB3935          |
| R3435   | 315-0103-00        |                      |        | RES.,FXD,COMP:10K OHM,5%,0.25W    | 01121    | CB1035          |
| R3436   | 315-0183-00        |                      |        | RES.,FXD,COMP:18K OHM,5%,0.25W    | 01121    | CB1835          |
| R3437   | 311-1225-00        |                      |        | RES.,VAR,NONWIR:1K OHM,20%,0.50W  | 80294    | 3389F-P31-102   |
| R3438   | 315-0104-00        |                      |        | RES.,FXD,COMP:100K OHM,5%,0.25W   | 01121    | CB1045          |
| R3439   | 315-0152-00        |                      |        | RES.,FXD,COMP:1.5K OHM,5%,0.25W   | 01121    | CB1525          |
| R3440   | 315-0510-00        |                      |        | RES.,FXD,COMP:51 OHM,5%,0.25W     | 01121    | CB5105          |
| R3441   | 315-0752-00        |                      |        | RES.,FXD,COMP:7.5K OHM,5%,0.25W   | 01121    | CB7525          |
| R3442   | 315-0242-00        |                      |        | RES.,FXD,COMP:2.4K OHM,5%,0.25W   | 01121    | CB2425          |
| R3445   | 315-0152-00        |                      |        | RES.,FXD,COMP:1.5K OHM,5%,0.25W   | 01121    | CB1525          |
| R3447   | 315-0512-00        |                      |        | RES.,FXD,COMP:5.1K OHM,5%,0.25W   | 01121    | CB5125          |
| R3449   | 315-0512-00        |                      |        | RES.,FXD,COMP:5.1K OHM,5%,0.25W   | 01121    | CB5125          |
| R3450   | 315-0102-00        |                      |        | RES.,FXD,COMP:1K OHM,5%,0.25W     | 01121    | CB1025          |
| R3451   | 315-0102-00        |                      |        | RES.,FXD,COMP:1K OHM,5%,0.25W     | 01121    | CB1025          |
| R3452   | 315-0102-00        |                      |        | RES.,FXD,COMP:1K OHM,5%,0.25W     | 01121    | CB1025          |
| R3466   | 321-0153-00        |                      |        | RES.,FXD,FILM:383 OHM,1%,0.125W   | 75042    | CEATO-3830F     |
| R3468   | 321-0191-00        |                      |        | RES.,FXD,FILM:953 OHM,1%,0.125W   | 75042    | CEATO-9530F     |
| R3470   | 315-0102-00        |                      |        | RES.,FXD,COMP:1K OHM,5%,0.25W     | 01121    | CB1025          |
| R3472   | 315-0272-00        |                      |        | RES.,FXD,COMP:2.7K OHM,5%,0.25W   | 01121    | CB2725          |
| R3473   | 315-0512-00        |                      |        | RES.,FXD,COMP:5.1K OHM,5%,0.25W   | 01121    | CB5125          |
| R3474   | 315-0303-00        | XB050000             |        | RES.,FXD,COMP:30K OHM,5%,0.25W    | 01121    | CB3035          |
| R3475   | 315-0912-00        |                      |        | RES.,FXD,COMP:9.1K OHM,5%,0.25W   | 01121    | CB9125          |
| R3476   | 321-0296-00        |                      |        | RES.,FXD,FILM:11.8K OHM,1%,0.125W | 75042    | CEATO-1182F     |
| R3477   | 315-0823-00        |                      |        | RES.,FXD,COMP:82K OHM,5%,0.25W    | 01121    | CB8235          |
| R3478   | 315-0753-00        | XB050000             |        | RES.,FXD,COMP:75K OHM,5%,0.25W    | 01121    | CB7535          |
| R3479   | 315-0823-00        | XB050000             |        | RES.,FXD,COMP:82K OHM,5%,0.25W    | 01121    | CB8235          |
| R3480   | 321-0222-00        |                      |        | RES.,FXD,FILM:2K OHM,1%,0.125W    | 75042    | CEATO-2001F     |
| R3481   | 315-0223-00        |                      |        | RES.,FXD,COMP:22K OHM,5%,0.25W    | 01121    | CB2235          |
| R3482   | 321-0250-00        |                      |        | RES.,FXD,FILM:3.92K OHM,1%,0.125W | 75042    | CEATO-3921F     |
| R3483   | 315-0332-00        |                      |        | RES.,FXD,COMP:3.3K OHM,5%,0.25W   | 01121    | CB3325          |
| R3484   | 321-0216-00        |                      |        | RES.,FXD,FILM:1.74K OHM,1%,0.125W | 75042    | CEATO-1741F     |
| R3485   | 321-0245-00        |                      |        | RES.,FXD,FILM:3.48K OHM,1%,0.125W | 75042    | CEATO-3481F     |
| R3486   | 321-0199-00        |                      |        | RES.,FXD,FILM:1.15K OHM,1%,0.125W | 75042    | CEATO-1151F     |
| R3487   | 321-0273-00        |                      |        | RES.,FXD,FILM:6.81K OHM,1%,0.125W | 75042    | CEATO-6811F     |
| R3488   | 321-0193-00        |                      |        | RES.,FXD,FILM:1K OHM,1%,0.125W    | 75042    | CEATO-1001F     |
| R3489   | 321-0209-00        |                      |        | RES.,FXD,FILM:1.47K OHM,1%,0.125W | 75042    | CEATO-1471F     |
| R3490   | 311-1225-00        |                      |        | RES.,VAR,NONWIR:1K OHM,20%,0.50W  | 80294    | 3389F-P31-102   |
| R3491   | 321-0204-00        |                      |        | RES.,FXD,FILM:1.3K OHM,1%,0.125W  | 75042    | CEATO-1301F     |
| R3492   | 321-0245-00        |                      |        | RES.,FXD,FILM:3.48K OHM,1%,0.125W | 75042    | CEATO-3481F     |
| R3493   | 315-0152-00        |                      |        | RES.,FXD,COMP:1.5K OHM,5%,0.25W   | 01121    | CB1525          |
| R3494   | 315-0511-00        |                      |        | RES.,FXD,COMP:510 OHM,5%,0.25W    | 01121    | CB5115          |
| R3497   | 321-0241-00        |                      |        | RES.,FXD,FILM:3.16K OHM,1%,0.125W | 75042    | CEATO-3161F     |
| R3498   | 321-0255-00        |                      |        | RES.,FXD,FILM:4.42K OHM,1%,0.125W | 75042    | CEATO-4421F     |

| Ckt No. | Tektronix Part No. | Serial/Model No. |         | Name & Description                 | Mfr   |                 |
|---------|--------------------|------------------|---------|------------------------------------|-------|-----------------|
|         |                    | Eff              | Dscont  |                                    | Code  | Mfr Part Number |
| R3499   | 315-0152-00        |                  |         | RES.,FXD,COMP:1.5K OHM,5%,0.25W    | 01121 | CB1525          |
| R4101   | 315-0124-00        |                  |         | RES.,FXD,COMP:120K OHM,5%,0.25W    | 01121 | CB1245          |
| R4104   | 315-0332-00        |                  |         | RES.,FXD,COMP:3.3K OHM,5%,0.25W    | 01121 | CB3325          |
| R4105   | 315-0821-00        |                  |         | RES.,FXD,COMP:820 OHM,5%,0.25W     | 01121 | CB8215          |
| R4106   | 315-0392-00        |                  |         | RES.,FXD,COMP:3.9K OHM,5%,0.25W    | 01121 | CB3925          |
| R4108   | 315-0244-00        |                  |         | RES.,FXD,COMP:240K OHM,5%,0.25W    | 01121 | CB2445          |
| R4112   | 315-0331-00        |                  |         | RES.,FXD,COMP:330 OHM,5%,0.25W     | 01121 | CB3315          |
| R4114   | 315-0681-00        |                  |         | RES.,FXD,COMP:680 OHM,5%,0.25W     | 01121 | CB6815          |
| R4115   | 315-0150-00        |                  |         | RES.,FXD,COMP:15 OHM,5%,0.25W      | 01121 | CB1505          |
| R4120   | 315-0474-00        |                  |         | RES.,FXD,COMP:470K OHM,5%,0.25W    | 01121 | CB4745          |
| R4123   | 311-1235-00        |                  |         | RES.,VAR,NONWIR:100K OHM,20%,0.50W | 80294 | 3389F-P31-104   |
| R4131   | 315-0471-00        |                  |         | RES.,FXD,COMP:470 OHM,5%,0.25W     | 01121 | CB4715          |
| R4133   | 321-0258-00        |                  |         | RES.,FXD,FILM:4.75K OHM,1%,0.125W  | 75042 | CEAT0-4751F     |
| R4135   | 311-1232-00        |                  |         | RES.,VAR,NONWIR:50K OHM,20%,0.50W  | 80294 | 3389F-P31-503   |
| R4136   | 315-0273-00        |                  |         | RES.,FXD,COMP:27K OHM,5%,0.25W     | 01121 | CB2735          |
| R4137   | 321-0168-00        |                  |         | RES.,FXD,FILM:549 OHM,1%,0.125W    | 75042 | CEAT0-5490F     |
| R4142   | 315-0304-00        |                  |         | RES.,FXD,COMP:300K OHM,5%,0.25W    | 01121 | CB3045          |
| R4145   | 315-0473-00        |                  |         | RES.,FXD,COMP:47K OHM,5%,0.25W     | 01121 | CB4735          |
| R4151   | 315-0123-00        |                  |         | RES.,FXD,COMP:12K OHM,5%,0.25W     | 01121 | CB1235          |
| R4153   | 315-0102-00        |                  |         | RES.,FXD,COMP:1K OHM,5%,0.25W      | 01121 | CB1025          |
| R4157   | 315-0104-00        |                  |         | RES.,FXD,COMP:100K OHM,5%,0.25W    | 01121 | CB1045          |
| R4159   | 315-0513-00        |                  |         | RES.,FXD,COMP:51K OHM,5%,0.25W     | 01121 | CB5135          |
| R4161   | 315-0470-00        |                  |         | RES.,FXD,COMP:47 OHM,5%,0.25W      | 01121 | CB4705          |
| R4163   | 315-0152-00        | XB170000         |         | RES.,FXD,COMP:1.5K OHM,5%,0.25W    | 01121 | CB1525          |
| R4167   | 315-0511-00        |                  |         | RES.,FXD,CMPSN:510 OHM,5%,0.25W    | 01121 | CB5115          |
| R4171   | 315-0222-00        |                  |         | RES.,FXD,CMPSN:2.2K OHM,5%,0.25W   | 01121 | CB2225          |
| R4173   | 315-0102-00        |                  |         | RES.,FXD,COMP:1K OHM,5%,0.25W      | 01121 | CB1025          |
| R4175   | 315-0222-00        |                  |         | RES.,FXD,COMP:2.2K OHM,5%,0.25W    | 01121 | CB2225          |
| R4177   | 315-0153-00        |                  |         | RES.,FXD,COMP:15K OHM,5%,0.25W     | 01121 | CB1535          |
| R4183   | 321-0172-00        |                  |         | RES.,FXD,FILM:604 OHM,1%,0.125W    | 75042 | CEAT0-6040F     |
| R4185   | 321-0138-00        |                  |         | RES.,FXD,FILM:267 OHM,1%,0.125W    | 75042 | CEAT0-2670F     |
| R4187   | 321-0289-00        |                  |         | RES.,FXD,FILM:10K OHM,1%,0.125W    | 75042 | CEAT0-1002F     |
| R4191   | 321-0126-00        |                  |         | RES.,FXD,FILM:200 OHM,1%,0.125W    | 75042 | CEAT0-2000F     |
| R4193   | 321-0181-00        |                  |         | RES.,FXD,FILM:750 OHM,1%,0.125W    | 75042 | CEAT0-7500F     |
| R4195   | 303-0121-00        |                  |         | RES.,FXD,COMP:120 OHM,5%,1W        | 01121 | GB1215          |
| R4197   | 311-1223-00        |                  |         | RES.,VAR,NONWIR:250 OHM,10%,0.50W  | 80294 | 3389F-P32-251   |
| R4201   | 316-0101-00        |                  |         | RES.,FXD,COMP:100 OHM,10%,0.25W    | 01121 | CB1011          |
| R4205   | 302-0152-00        | B010100          | B039999 | RES.,FXD,COMP:1.5K OHM,10%,0.50W   | 01121 | EB1521          |
| R4205   | 301-0272-00        | B040000          |         | RES.,FXD,COMP:2.7K OHM,5%,0.50W    | 01121 | EB2725          |
| R4207   | 316-0472-00        |                  |         | RES.,FXD,COMP:4.7K OHM,10%,0.25W   | 01121 | CB4721          |
| R4208   | 316-0472-00        |                  |         | RES.,FXD,COMP:4.7K OHM,10%,0.25W   | 01121 | CB4721          |
| R4209   | 316-0472-00        |                  |         | RES.,FXD,COMP:4.7K OHM,10%,0.25W   | 01121 | CB4721          |
| R4211   | 302-0331-00        |                  |         | RES.,FXD,COMP:330 OHM,10%,0.50W    | 01121 | EB3311          |
| R4213   | 316-0124-00        |                  |         | RES.,FXD,COMP:120K OHM,10%,0.25W   | 01121 | CB1241          |
| R4214   | 302-0335-00        |                  |         | RES.,FXD,COMP:3.3M OHM,10%,0.50W   | 01121 | EB3351          |
| R4215   | 302-0183-00        |                  |         | RES.,FXD,COMP:18K OHM,10%,0.50W    | 01121 | EB1831          |
| R4216   | 302-0226-00        |                  |         | RES.,FXD,COMP:22M OHM,10%,0.50W    | 01121 | EB2261          |
| R4217   | 302-0335-00        |                  |         | RES.,FXD,COMP:3.3M OHM,10%,0.50W   | 01121 | EB3351          |
| R4218   | 302-0104-00        |                  |         | RES.,FXD,COMP:100K OHM,10%,0.50W   | 01121 | EB1041          |
| R4219   | 307-0113-00        |                  |         | RES.,FXD,COMP:5.1 OHM,5%,0.25W     | 01121 | CB51G5          |
| R4220   | 301-0103-00        |                  |         | RES.,FXD,COMP:10K OHM,5%,0.50W     | 01121 | EB1035          |
| R4221   | 316-0101-00        |                  |         | RES.,FXD,COMP:100 OHM,10%,0.25W    | 01121 | CB1011          |
| R4222   | 316-0104-00        |                  |         | RES.,FXD,COMP:100K OHM,10%,0.25W   | 01121 | CB1041          |
| R4235   | 302-0183-00        |                  |         | RES.,FXD,COMP:18K OHM,10%,0.50W    | 01121 | EB1831          |

# Electrical Parts List—7704A

| Ckt No. | Tektronix Part No. | Serial/Model No. Eff | Dscont   | Name & Description                | Mfr Code | Mfr Part Number |
|---------|--------------------|----------------------|----------|-----------------------------------|----------|-----------------|
| R4237   | 302-0104-00        |                      |          | RES.,FXD,COMP:100K OHM,10%,0.50W  | 01121    | EB1041          |
| R4239   | 302-0226-00        |                      |          | RES.,FXD,COMP:22M OHM,10%,0.50W   | 01121    | EB2261          |
| R4240   | 307-0290-02        | B010100              | B039999  | RES.,FXD,FILM:400.76K OHM,        | 80009    | 307-0290-02     |
| R4241   |                    |                      |          | RES.,FXD,FILM:24.5M OHM,          |          |                 |
| R4242   |                    |                      |          | RES.,FXD,FILM:23.4M OHM           |          |                 |
| R4243   |                    |                      |          | RES.,FXD,FILM:7.4M OHM,           |          |                 |
| R4240   | 307-0386-02        | B040000              |          | RES.,FXD,FILM:400.76K OHM,        | 80009    | 307-0386-02     |
| R4241   |                    |                      |          | RES.,FXD,FILM:24.5M OHM,          |          |                 |
| R4242   |                    |                      |          | RES.,FXD,FILM:20.4M OHM,          |          |                 |
| R4243   |                    |                      |          | RES.,FXD,FILM:7.37M OHM,          |          |                 |
| R4244   | 302-0102-00        |                      |          | RES.,FXD,COMP:1K OHM,10%,0.50W    | 01121    | EB1021          |
| R4251   | 316-0103-00        |                      |          | RES.,FXD,COMP:10K OHM,10%,0.25W   | 01121    | CB1031          |
| R4254   | 315-0243-00        |                      |          | RES.,FXD,COMP:24K OHM,5%,0.25W    | 01121    | CB2435          |
| R4255   | 316-0103-00        |                      |          | RES.,FXD,COMP:10K OHM,10%,0.25W   | 01121    | CB1031          |
| R4256   | 316-0562-00        |                      |          | RES.,FXD,COMP:5.6K OHM,10%,0.25W  | 01121    | CB5621          |
| R4257   | 316-0221-00        |                      |          | RES.,FXD,COMP:220 OHM,10%,0.25W   | 01121    | CB2211          |
| R4258   | 308-0702-00        |                      |          | RES.,FXD,WW:0.33 OHM,5%,2W        | 75042    | BWH-R3300J      |
| R4261   | 301-0304-00        |                      |          | RES.,FXD,COMP:300K OHM,5%,0.50W   | 01121    | EB3045          |
| R4263   | 301-0304-00        |                      |          | RES.,FXD,COMP:300K OHM,5%,0.50W   | 01121    | EB3045          |
| R4265   | 301-0304-00        |                      |          | RES.,FXD,COMP:300K OHM,5%,0.50W   | 01121    | EB3045          |
| R4267   | 301-0304-00        |                      |          | RES.,FXD,COMP:300K OHM,5%,0.50W   | 01121    | EB3045          |
| R4269   | 301-0304-00        |                      |          | RES.,FXD,COMP:300K OHM,5%,0.50W   | 01121    | EB3045          |
| R4271   | 301-0304-00        |                      |          | RES.,FXD,COMP:300K OHM,5%,0.50W   | 01121    | EB3045          |
| R4273   | 301-0304-00        |                      |          | RES.,FXD,COMP:300K OHM,5%,0.50W   | 01121    | EB3045          |
| R4275   | 301-0304-00        |                      |          | RES.,FXD,COMP:300K OHM,5%,0.50W   | 01121    | EB3045          |
| R4277   | 301-0304-00        |                      |          | RES.,FXD,COMP:300K OHM,5%,0.50W   | 01121    | EB3045          |
| R4279   | 301-0304-00        | B010100              | B109999X | RES.,FXD,COMP:300K OHM,5%,0.50W   | 01121    | EB3045          |
| R4300   | 321-0186-00        |                      |          | RES.,FXD,FILM:845 OHM,1%,0.125W   | 75042    | CEATO-8450F     |
| R4301   | 315-0302-00        |                      |          | RES.,FXD,COMP:3K OHM,5%,0.25W     | 01121    | CB3025          |
| R4302   | 321-0073-00        |                      |          | RES.,FXD,FILM:56.2 OHM,1%,0.125W  | 75042    | CEATO-56R20F    |
| R4303   | 315-0102-00        |                      |          | RES.,FXD,COMP:1K OHM,5%,0.25W     | 01121    | CB1025          |
| R4304   | 315-0221-00        | B010100              | B079999  | RES.,FXD,COMP:220 OHM,5%,0.25W    | 01121    | CB2215          |
| R4304   | 315-0101-00        | B080000              |          | RES.,FXD,COMP:100 OHM,5%,0.25W    | 01121    | CB1015          |
| R4305   | 321-0070-00        |                      |          | RES.,FXD,FILM:52.3 OHM,1%,0.125W  | 75042    | CEATO-52R30F    |
| R4307   | 323-0168-00        |                      |          | RES.,FXD,FILM:549 OHM,1%,0.50W    | 75042    | CECTO-5490F     |
| R4309   | 323-0168-00        |                      |          | RES.,FXD,FILM:549 OHM,1%,0.50W    | 75042    | CECTO-5490F     |
| R4310   | 311-1222-00        |                      |          | RES.,VAR,NONWIR:100 OHM,20%,0.50W | 80294    | 3389F-P31-101   |
| R4311   | 321-0098-00        | B010100              | B029999  | RES.,FXD,FILM:100 OHM,1%,0.125W   | 91637    | MFF1816G102R0F  |
| R4311   | 321-0093-00        | B030000              | B079999  | RES.,FXD,FILM:90.9 OHM,1%,0.125W  | 75042    | CEATO-90R90F    |
| R4311   | 321-0089-00        | B080000              |          | RES.,FXD,FILM:82.5 OHM,1%,0.125W  | 75042    | CEATO-82R50F    |
| R4312   | 315-0202-00        | B010100              | B099999  | RES.,FXD,COMP:2K OHM,5%,0.25W     | 01121    | CB2025          |
| R4312   | 315-0152-00        | B100000              | B109999  | RES.,FXD,COMP:1.5K OHM,5%,0.25W   | 01121    | CB1525          |
| R4312   | 315-0112-00        | B110000              |          | RES.,FXD,COMP:1.1K OHM,5%,0.25W   | 01121    | CB1125          |
| R4313   | 315-0511-00        | B010100              | B079999  | RES.,FXD,COMP:510 OHM,5%,0.25W    | 01121    | CB5115          |
| R4313   | 315-0102-00        | B080000              |          | RES.,FXD,COMP:1K OHM,5%,0.25W     | 01121    | CB1025          |
| R4315   | 321-0097-00        |                      |          | RES.,FXD,FILM:100 OHM,1%,0.125W   | 75042    | CEATO-1000F     |
| R4321   | 321-0096-00        |                      |          | RES.,FXD,FILM:97.6 OHM,1%,0.125W  | 75042    | CEATO-97R60F    |
| R4322   | 317-0510-00        | XB050000             |          | RES.,FXD,COMP:51 OHM,5%,0.125W    | 01121    | BB5105          |
| R4323   | 321-0178-00        | B010100              | B079999  | RES.,FXD,FILM:698 OHM,1%,0.125W   | 75042    | CEATO-6980F     |
| R4323   | 321-0168-00        | B080000              |          | RES.,FXD,FILM:549 OHM,1%,0.125W   | 75042    | CEATO-5490F     |
| R4324   | 321-0108-00        |                      |          | RES.,FXD,FILM:130 OHM,1%,0.125W   | 75042    | CEATO-1300F     |
| R4325   | 311-1224-00        | B010100              | B079999  | RES.,VAR,NONWIR:500 OHM,20%,0.50W | 80294    | 3389F-P31-501   |
| R4325   | 311-1222-00        | B080000              |          | RES.,VAR,NONWIR:100 OHM,20%,0.50W | 80294    | 3389F-P31-101   |



| Ckt No. | Tektronix Part No. | Serial/Model No. Eff | Dscont  | Name & Description                | Mfr Code | Mfr Part Number |
|---------|--------------------|----------------------|---------|-----------------------------------|----------|-----------------|
| R4327   | 323-0086-00        |                      |         | RES.,FXD,FILM:76.8 OHM,1%,0.50W   | 75042    | CECTO-76R80F    |
| R4328   | 308-0292-00        |                      |         | RES.,FXD,WW:2.2K OHM,5%,3W        | 63743    | 34824           |
| R4329   | 323-0126-00        |                      |         | RES.,FXD,FILM:200 OHM,1%,0.50W    | 75042    | CECTO-2000F     |
| R4331   | 321-0096-00        |                      |         | RES.,FXD,FILM:97.6 OHM,1%,0.125W  | 75042    | CEATO-97R60F    |
| R4332   | 317-0510-00        | XB050000             |         | RES.,FXD,COMP:51 OHM,5%,0.125W    | 01121    | BB5105          |
| R4333   | 321-0178-00        | B010100              | B079999 | RES.,FXD,FILM:698 OHM,1%,0.125W   | 75042    | CEATO-6980F     |
| R4333   | 321-0168-00        | B080000              |         | RES.,FXD,FILM:549 OHM,1%,0.125W   | 75042    | CEATO-5490F     |
| R4335   | 321-0120-00        |                      |         | RES.,FXD,FILM:174 OHM,1%,0.125W   | 75042    | CEATO-1740F     |
| R4339   | 323-0126-00        |                      |         | RES.,FXD,FILM:200 OHM,1%,0.50W    | 75042    | CECTO-2000F     |
| R4340   | 323-0101-00        |                      |         | RES.,FXD,FILM:110 OHM,1%,0.50W    | 75042    | CECTO-1100F     |
| R4342   | 323-0133-00        |                      |         | RES.,FXD,FILM:237 OHM,1%,0.50W    | 75042    | CECTO-2370F     |
| R4344   | 321-0190-00        | B010100              | B079999 | RES.,FXD,FILM:931 OHM,1%,0.125W   | 75042    | CEATO-9310F     |
| R4344   | 321-0185-00        | B080000              |         | RES.,FXD,FILM:825 OHM,1%,0.125W   | 75042    | CEATO-8250F     |
| R4346   | 311-1222-00        |                      |         | RES.,VAR,NONWIR:100 OHM,20%,0.50W | 80294    | 3389F-P31-101   |
| R4348   | 321-0177-00        |                      |         | RES.,FXD,FILM:681 OHM,1%,0.125W   | 75042    | CEATO-6810F     |
| R4351   | 321-0186-00        |                      |         | RES.,FXD,FILM:845 OHM,1%,0.125W   | 75042    | CEATO-8450F     |
| R4352   | 321-0244-00        |                      |         | RES.,FXD,FILM:3.4K OHM,1%,0.125W  | 75042    | CEATO-3401F     |
| R4354   | 315-0152-00        | B010100              | B109999 | RES.,FXD,COMP:1.5K OHM,5%,0.25W   | 01121    | CB1525          |
| R4354   | 315-0222-00        | B110000              |         | RES.,FXD,COMP:2.2K OHM,5%,0.25W   | 01121    | CB2225          |
| R4356   | 315-0820-00        |                      |         | RES.,FXD,COMP:82 OHM,5%,0.25W     | 01121    | CB8205          |
| R4358   | 303-0202-00        |                      |         | RES.,FXD,COMP:2K OHM,5%,1W        | 01121    | GB2025          |
| R4360   | 323-0178-00        |                      |         | RES.,FXD,FILM:698 OHM,1%,0.50W    | 75042    | CECTO-6980F     |
| R4361   | 321-0193-00        |                      |         | RES.,FXD,FILM:1K OHM,1%,0.125W    | 75042    | CEATO-1001F     |
| R4363   | 321-0251-00        |                      |         | RES.,FXD,FILM:4.02K OHM,1%,0.125W | 75042    | CEATO-4021F     |
| R4364   | 315-0681-00        | B010100              | B109999 | RES.,FXD,COMP:680 OHM,5%,0.25W    | 01121    | CB6815          |
| R4364   | 315-0102-00        | B110000              |         | RES.,FXD,COMP:1K OHM,5%,0.25W     | 01121    | CB1025          |
| R4366   | 315-0820-00        |                      |         | RES.,FXD,COMP:82 OHM,5%,0.25W     | 01121    | CB8205          |
| R4368   | 303-0202-00        |                      |         | RES.,FXD,COMP:2K OHM,5%,1W        | 01121    | GB2025          |
| R4370   | 301-0273-00        | B010100              | B109999 | RES.,FXD,COMP:27K OHM,5%,0.50W    | 01121    | EB2735          |
| R4370   | 303-0153-00        | B110000              |         | RES.,FXD,COMP:15K OHM,5%,1W       | 01121    | GB1535          |
| R4371   | 323-0233-00        |                      |         | RES.,FXD,FILM:2.61K OHM,1%,0.50W  | 75042    | CECTO-2611F     |
| R4373   | 315-0470-00        |                      |         | RES.,FXD,COMP:47 OHM,5%,0.25W     | 01121    | CB4705          |
| R4374   | 323-0316-00        |                      |         | RES.,FXD,FILM:19.1K OHM,1%,0.50W  | 75042    | CECTO-1912F     |
| R4375   | 315-0220-00        |                      |         | RES.,FXD,COMP:22 OHM,5%,0.25W     | 01121    | CB2205          |
| R4377   | 321-0282-00        |                      |         | RES.,FXD,FILM:8.45K OHM,1%,0.125W | 75042    | CEATO-8451F     |
| R4379   | 323-0335-00        |                      |         | RES.,FXD,FILM:30.1K OHM,1%,0.50W  | 75042    | CECTO-3012F     |
| R4380   | 315-0220-00        |                      |         | RES.,FXD,COMP:22 OHM,5%,0.25W     | 01121    | CB2205          |
| R4381   | 315-0332-00        |                      |         | RES.,FXD,COMP:3.3K OHM,5%,0.25W   | 01121    | CB3325          |
| R4382   | 321-0224-00        | B010100              | B079999 | RES.,FXD,FILM:2.1K OHM,1%,0.125W  | 75042    | CEATO-2101F     |
| R4382   | 321-0226-00        | B080000              |         | RES.,FXD,FILM:2.21K OHM,1%,0.125W | 75042    | CEATO-2211F     |
| R4384   | 321-0230-00        | B010100              | B079999 | RES.,FXD,FILM:2.43K OHM,1%,0.125W | 75042    | CEATO-2431F     |
| R4384   | 321-0228-00        | B080000              |         | RES.,FXD,FILM:2.32K OHM,1%,0.125W | 75042    | CEATO-2321F     |
| R4385   | 311-0633-00        |                      |         | RES.,VAR,NONWIR:5K OHM,10%,0.50W  | 80740    | 62-58-3         |
| R4387   | 321-0224-00        | B010100              | B079999 | RES.,FXD,FILM:2.1K OHM,1%,0.125W  | 75042    | CEATO-2101F     |
| R4387   | 321-0226-00        | B080000              |         | RES.,FXD,FILM:2.21K OHM,1%,0.125W | 75042    | CEATO-2211F     |
| R4389   | 321-0230-00        | B010100              | B079999 | RES.,FXD,FILM:2.43K OHM,1%,0.125W | 75042    | CEATO-2431F     |
| R4389   | 321-0228-00        | B080000              |         | RES.,FXD,FILM:2.32K OHM,1%,0.125W | 75042    | CEATO-2321F     |
| R4390   | 315-0332-00        |                      |         | RES.,FXD,COMP:3.3K OHM,5%,0.25W   | 01121    | CB3325          |
| R4391   | 323-0316-00        |                      |         | RES.,FXD,FILM:19.1K OHM,1%,0.50W  | 75042    | CECTO-1912F     |
| R4393   | 315-0220-00        |                      |         | RES.,FXD,COMP:22 OHM,5%,0.25W     | 01121    | CB2205          |
| R4394   | 315-0470-00        |                      |         | RES.,FXD,COMP:47 OHM,5%,0.25W     | 01121    | CB4705          |
| R4395   | 323-0233-00        |                      |         | RES.,FXD,FILM:2.61K OHM,1%,0.50W  | 75042    | CECTO-2611F     |
| R4396   | 301-0273-00        | B010100              | B109999 | RES.,FXD,COMP:27K OHM,5%,0.50W    | 01121    | EB2735          |

# Electrical Parts List—7704A

| Ckt No. | Tektronix Part No. | Serial/Model No. Eff | Dscont  | Name & Description                | Mfr Code | Mfr Part Number |
|---------|--------------------|----------------------|---------|-----------------------------------|----------|-----------------|
| R4396   | 303-0153-00        | B110000              |         | RES.,FXD,COMP:15K OHM,5%,1W       | 01121    | GB1535          |
| R4397   | 315-0201-00        |                      |         | RES.,FXD,COMP:200 OHM,5%,0.25W    | 01121    | CB2015          |
| R4401   | 321-0158-00        |                      |         | RES.,FXD,FILM:432 OHM,1%,0.125W   | 75042    | CEATO-4320F     |
| R4403   | 321-0158-00        |                      |         | RES.,FXD,FILM:432 OHM,1%,0.125W   | 75042    | CEATO-4320F     |
| R4404   | 311-0978-00        |                      |         | RES.,VAR,NONWIR:250 OHM,10%,0.50W | 80740    | 62-67-3         |
| R4405   | 321-0040-00        |                      |         | RES.,FXD,FILM:25.5 OHM,1%,0.125W  | 75042    | CEATO-25R5F     |
| R4406   | 311-0605-00        |                      |         | RES.,VAR,NONWIR:200 OHM,10%,0.50W | 80740    | 62-54-3         |
| R4407   | 321-0040-00        |                      |         | RES.,FXD,FILM:25.5 OHM,1%,0.125W  | 75042    | CEATO-25R5F     |
| R4410   | 321-0076-00        |                      |         | RES.,FXD,FILM:60.4 OHM,1%,0.125W  | 75042    | CEATO-60R40F    |
| R4411   | 321-0076-00        |                      |         | RES.,FXD,FILM:60.4 OHM,1%,0.125W  | 75042    | CEATO-60R40F    |
| R4413   | 321-0184-00        |                      |         | RES.,FXD,FILM:806 OHM,1%,0.125W   | 75042    | CEATO-8060F     |
| R4415   | 311-0634-00        |                      |         | RES.,VAR,NONWIR:500 OHM,10%,0.50W | 80740    | 62-55-3         |
| R4416   | 315-0222-00        |                      |         | RES.,FXD,COMP:2.2K OHM,5%,0.25W   | 01121    | CB2225          |
| R4417   | 315-0151-00        |                      |         | RES.,FXD,COMP:150 OHM,5%,0.25W    | 01121    | CB1515          |
| R4418   | 301-0330-00        |                      |         | RES.,FXD,COMP:33 OHM,5%,0.50W     | 01121    | EB3305          |
| R4419   | 315-0330-00        |                      |         | RES.,FXD,COMP:33 OHM,5%,0.25W     | 01121    | CB3305          |
| R4420   | 301-0562-00        | XB120000             |         | RES.,FXD,COMP:5.6K OHM,5%,0.50W   | 01121    | EB5625          |
| R4421   | 321-0771-03        |                      |         | RES.,FXD,FILM:50 OHM,0.25%,0.125W | 75042    | CEAT2-50R00C    |
| R4422   | 321-0260-00        | XB120000             |         | RES.,FXD,FILM:4.99K OHM,1%,0.125W | 75042    | CEATO-4991F     |
| R4423   | 311-0633-00        |                      |         | RES.,VAR,NONWIR:5K OHM,10%,0.50W  | 80740    | 62-58-3         |
| R4424   | 315-0182-00        |                      |         | RES.,FXD,COMP:1.8K OHM,5%,0.25W   | 01121    | CB1825          |
| R4425   | 321-0296-00        | XB1200000            |         | RES.,FXD,FILM:11.8K OHM,1%,0.125W | 75042    | CEATO-1182F     |
| R4427   | 311-0635-00        |                      |         | RES.,VAR,NONWIR:1K OHM,10%,0.50W  | 80740    | 62-56-3         |
| R4431   | 321-0076-00        |                      |         | RES.,FXD,FILM:60.4 OHM,1%,0.125W  | 75042    | CEATO-60R40F    |
| R4432   | 321-0076-00        |                      |         | RES.,FXD,FILM:60.4 OHM,1%,0.125W  | 75042    | CEATO-60R40F    |
| R4434   | 321-0228-00        |                      |         | RES.,FXD,FILM:2.32K OHM,1%,0.125W | 75042    | CEATO-2321F     |
| R4436   | 321-0228-00        |                      |         | RES.,FXD,FILM:2.32K OHM,1%,0.125W | 75042    | CEATO-2321F     |
| R4438   | 317-0511-00        |                      |         | RES.,FXD,COMP:510 OHM,5%,0.125W   | 01121    | BB5115          |
| R4439   | 321-0095-00        |                      |         | RES.,FXD,FILM:95.3 OHM,1%,0.125W  | 75042    | CEATO-95R30F    |
| R4441   | 321-0771-03        |                      |         | RES.,FXD,FILM:50 OHM,0.25%,0.125W | 75042    | CEAT2-50R00C    |
| R4450   | 317-0221-00        | XB010130             |         | RES.,FXD,COMP:220 OHM,5%,0.125W   | 01121    | BB2215          |
| R4451   | 321-0147-00        |                      |         | RES.,FXD,FILM:332 OHM,1%,0.125W   | 75042    | CEATO-3320F     |
| R4452   | 317-0180-00        |                      |         | RES.,FXD,COMP:18 OHM,5%,0.125W    | 01121    | BB1805          |
| R4453   | 321-0158-00        | B010100              | B010129 | RES.,FXD,FILM:432 OHM,1%,0.125W   | 75042    | CEATO-4320F     |
| R4453   | 311-0634-00        | B010130              | B029999 | RES.,VAR,NONWIR:500 OHM,10%,0.50W | 80740    | 62-55-3         |
| R4453   | 311-0635-00        | B030000              |         | RES.,VAR,NONWIR:1K OHM,10%,0.50W  | 80740    | 62-56-3         |
| R4454   | 317-0180-00        |                      |         | RES.,FXD,COMP:18 OHM,5%,0.125W    | 01121    | BB1805          |
| R4455   | 321-0169-00        |                      |         | RES.,FXD,FILM:562 OHM,1%,0.125W   | 75042    | CEATO-5620F     |
| R4456   | 323-0126-00        |                      |         | RES.,FXD,FILM:200 OHM,1%,0.50W    | 75042    | CECTO-2000F     |
| R4457   | 323-0126-00        |                      |         | RES.,FXD,FILM:200 OHM,1%,0.50W    | 75042    | CECTO-2000F     |
| R4458   | 323-0107-00        |                      |         | RES.,FXD,FILM:127 OHM,1%,0.50W    | 75042    | CECTO-1270F     |
| R4459   | 323-0012-00        |                      |         | RES.,FXD,FILM:13 OHM,1%,0.50W     | 91637    | MFF1226G13ROOF  |
| R4460   | 317-0221-00        | XB010130             |         | RES.,FXD,COMP:220 OHM,5%,0.125W   | 01121    | BB2215          |
| R4461   | 321-0145-00        | B010100              | B010129 | RES.,FXD,FILM:316 OHM,1%,0.125W   | 75042    | CEATO-3160F     |
| R4461   | 311-0635-00        | B010130              |         | RES.,VAR,NONWIR:1K OHM,10%,0.50W  | 80740    | 62-56-3         |
| R4462   | 317-0180-00        |                      |         | RES.,FXD,COMP:18 OHM,5%,0.125W    | 01121    | BB1805          |
| R4463   | 321-0170-00        |                      |         | RES.,FXD,FILM:576 OHM,1%,0.125W   | 75042    | CEATO-5760F     |
| R4464   | 317-0180-00        |                      |         | RES.,FXD,COMP:18 OHM,5%,0.125W    | 01121    | BB1805          |
| R4465   | 321-0174-00        | B010100              | B010129 | RES.,FXD,FILM:634 OHM,1%,0.125W   | 75042    | CEATO-6340F     |
| R4465   | 311-0635-00        | B010130              | B029999 | RES.,VAR,NONWIR:1K OHM,10%,0.50W  | 80740    | 62-56-3         |
| R4465   | 311-0633-00        | B030000              |         | RES.,VAR,NONWIR:5K OHM,10%,0.50W  | 80740    | 62-58-3         |
| R4467   | 323-0126-00        |                      |         | RES.,FXD,FILM:200 OHM,1%,0.50W    | 75042    | CECTO-2000F     |
| R4469   | 323-0126-00        |                      |         | RES.,FXD,FILM:200 OHM,1%,0.50W    | 75042    | CECTO-2000F     |

| Ckt No.            | Tektronix Part No. | Serial/Model No. Eff | Model No. Dscont | Name & Description                 | Mfr Code | Mfr Part Number |
|--------------------|--------------------|----------------------|------------------|------------------------------------|----------|-----------------|
| R4470              | 321-0239-00        |                      |                  | RES.,FXD,FILM:3.01K OHM,1%,0.125W  | 75042    | CEATO-3011F     |
| R4471              | 321-0277-00        |                      |                  | RES.,FXD,FILM:7.5K OHM,1%,0.125W   | 75042    | CEATO-7501F     |
| R4473              | 315-0752-00        |                      |                  | RES.,FXD,COMP:7.5K OHM,5%,0.25W    | 01121    | CB7525          |
| R4475              | 321-0206-00        |                      |                  | RES.,FXD,FILM:1.37K OHM,1%,0.125W  | 75042    | CEATO-1371F     |
| R4477              | 321-0274-00        |                      |                  | RES.,FXD,FILM:6.98K OHM,1%,0.125W  | 75042    | CEATO-6981F     |
| R4479              | 321-0223-00        |                      |                  | RES.,FXD,FILM:2.05K OHM,1%,0.125W  | 75042    | CEATO-2051F     |
| R4481              | 321-0122-00        |                      |                  | RES.,FXD,FILM:182 OHM,1%,0.125W    | 75042    | CEATO-1820F     |
| R4485              | 321-0122-00        |                      |                  | RES.,FXD,FILM:182 OHM,1%,0.125W    | 75042    | CEATO-1820F     |
| R4487              | 321-0196-00        |                      |                  | RES.,FXD,FILM:1.07K OHM,1%,0.125W  | 75042    | CEATO-1071F     |
| R4491              | 321-0288-00        |                      |                  | RES.,FXD,FILM:9.76K OHM,1%,0.125W  | 75042    | CEATO-9761F     |
| R4493              | 311-0634-00        |                      |                  | RES.,VAR,NONWIR:500 OHM,10%,0.50W  | 80740    | 62-55-3         |
| R4495              | 321-0256-00        |                      |                  | RES.,FXD,FILM:4.53K OHM,1%,0.125W  | 75042    | CEATO-4531F     |
| R4497              | 321-0161-00        |                      |                  | RES.,FXD,FILM:464 OHM,1%,0.125W    | 75042    | CEATO-4640F     |
| R4499              | 321-0161-00        |                      |                  | RES.,FXD,FILM:464 OHM,1%,0.125W    | 75042    | CEATO-4640F     |
| R5000              | 311-0546-00        |                      |                  | RES.,VAR,NONWIR:10K OHM,20%,0.75W  | 97979    | TK0546G         |
| R5001              | 311-0397-01        | B010100              | B039999          | RES.,VAR,NONWIR:2M OHM,10%,0.20W   | 71590    | BA173-002       |
| R5001              | 311-0254-00        | B040000              |                  | RES.,VAR,NONWIR:5M OHM,10%,0.20W   | 12697    | CM29709         |
| R5002              | 311-0467-00        |                      |                  | RES.,VAR,NONWIR:100K OHM,20%,0.50W | 11237    | 41334           |
| R5003              | 311-0964-00        |                      |                  | RES.,VAR,WW:2.5K OHM,10%           | 71590    | BAS105-036      |
| R5004              | 311-0310-00        |                      |                  | RES.,VAR,NONWIR:5K OHM,20%,0.50W   | 01121    | W-7350A         |
| R5005              | 315-0471-00        |                      |                  | RES.,FXD,COMP:470 OHM,5%,0.25W     | 01121    | CB4715          |
| R5006 <sup>1</sup> | 311-1104-00        |                      |                  | RES.,VAR,NONWIR:10K OHM,10%,0.50W  | 12697    | 381-CM40095     |
| R5007              | 301-0825-00        | XB040000             |                  | RES.,FXD,COMP:8.2M OHM,5%,0.50W    | 01121    | EB8255          |
| R5012 <sup>2</sup> | 307-0292-XX        |                      |                  | RESISTOR:THICK FILM                | 80009    | 307-0292-XX     |
| R5013 <sup>2</sup> | 307-0292-XX        |                      |                  | RESISTOR:THICK FILM                | 80009    | 307-0292-XX     |
| R5020              | 301-0271-00        | B010100              | B091620X         | RES.,FXD,COMP:270 OHM,5%,0.50W     | 01121    | EB2715          |
| R5022              | 301-0271-00        | B010100              | B091620X         | RES.,FXD,COMP:270 OHM,5%,0.50W     | 01121    | EB2715          |
| R32110             | 315-0472-00        |                      |                  | RES.,FXD,COMP:4.7K OHM,5%,0.25W    | 01121    | CB4725          |
| R32115             | 316-0222-00        | B010100              | B059999          | RES.,FXD,COMP:2.2K OHM,10%,0.25W   | 01121    | CB2221          |
| R32115             | 315-0222-00        | B060000              |                  | RES.,FXD,COMP:2.2K OHM,5%,0.25W    | 01121    | CB2225          |
| R32117             | 315-0124-00        |                      |                  | RES.,FXD,COMP:120K OHM,5%,0.25W    | 01121    | CB1245          |
| R32119             | 316-0471-00        | B010100              | B059999          | RES.,FXD,COMP:470 OHM,10%,0.25W    | 01121    | CB4711          |
| R32119             | 315-0471-00        | B060000              |                  | RES.,FXD,COMP:470 OHM,5%,0.25W     | 01121    | CB4715          |
| R32121             | 316-0393-00        | B010100              | B059999          | RES.,FXD,COMP:39K OHM,10%,0.25W    | 01121    | CB3931          |
| R32121             | 315-0393-00        | B060000              |                  | RES.,FXD,COMP:39K OHM,5%,0.25W     | 01121    | CB3935          |
| R32125             | 323-0264-00        |                      |                  | RES.,FXD,FILM:5.49K OHM,1%,0.50W   | 75042    | CECTO-5491F     |
| R32127             | 316-0562-00        | B010100              | B059999          | RES.,FXD,COMP:5.6K OHM,10%,0.25W   | 01121    | CB5621          |
| R32127             | 315-0562-00        | B060000              |                  | RES.,FXD,COMP:5.6K OHM,5%,0.25W    | 01121    | CB5625          |
| R32130             | 316-0224-00        | B010100              | B059999          | RES.,FXD,COMP:220K OHM,10%,0.25W   | 01121    | CB2241          |
| R32130             | 315-0224-00        | B060000              |                  | RES.,FXD,COMP:220K OHM,5%,0.25W    | 01121    | CB2245          |
| R32132             | 321-0272-00        |                      |                  | RES.,FXD,FILM:6.65K OHM,1%,0.125W  | 75042    | CEATO-6651F     |
| R32133             | 311-1237-00        |                      |                  | RES.,VAR,NONWIR:1K OHM,10%,0.50W   | 80294    | 3386H-T07-102   |
| R32134             | 321-0338-00        |                      |                  | RES.,FXD,FILM:32.4K OHM,1%,0.125W  | 75042    | CEATO-3242F     |
| R32137             | 301-0123-00        |                      |                  | RES.,FXD,COMP:12K OHM,5%,0.50W     | 01121    | EB1235          |
| R32138             | 315-0101-00        |                      |                  | RES.,FXD,COMP:100 OHM,5%,0.25W     | 01121    | CB1015          |
| R32139             | 308-0703-00        |                      |                  | RES.,FXD,WW:1.8 OHM,5%,2W          | 75042    | BWH1R80J        |
| R32140             | 316-0471-00        | B010100              | B059999          | RES.,FXD,COMP:470 OHM,10%,0.25W    | 01121    | CB4711          |
| R32140             | 315-0471-00        | B060000              |                  | RES.,FXD,COMP:470 OHM,5%,0.25W     | 01121    | CB4715          |
| R32141             | 316-0222-00        | B010100              | B059999          | RES.,FXD,COMP:2.2K OHM,10%,0.25W   | 01121    | CB2221          |
| R32141             | 315-0222-00        | B060000              |                  | RES.,FXD,COMP:2.2K OHM,5%,0.25W    | 01121    | CB2225          |
| R32143             | 316-0331-00        | B010100              | B059999          | RES.,FXD,COMP:330 OHM,10%,0.25W    | 01121    | CB3311          |
| R32143             | 315-0331-00        | B060000              |                  | RES.,FXD,COMP:330 OHM,5%,0.25W     | 01121    | CB3315          |
| R32145             | 301-0123-00        |                      |                  | RES.,FXD,COMP:12K OHM,5%,0.50W     | 01121    | EB1235          |

<sup>1</sup>Furnished as a unit with S5006.

<sup>2</sup>R5012 & R5013, Thick Film Hybrid resistors, are part of the CRT assembly and are selected at the Factory to match the impedance of the CRT Vertical Deflection Plates. Order the Tektronix P/N printed on the resistors.

# Electrical Parts List—7704A

| Ckt No.            | Tektronix Part No. | Serial/Model No. Eff | Dscont   | Name & Description                  | Mfr Code | Mfr Part Number  |
|--------------------|--------------------|----------------------|----------|-------------------------------------|----------|------------------|
| R41101             | 315-0131-00        |                      |          | RES.,FXD,COMP:130 OHM,5%,0.25W      | 01121    | CB1315           |
| R41103             | 303-0471-00        |                      |          | RES.,FXD,COMP:470 OHM,5%,1W         | 01121    | GB4715           |
| R41105             | 315-0470-00        |                      |          | RES.,FXD,COMP:47 OHM,5%,0.25W       | 01121    | CB4705           |
| R41107             | 315-0102-00        |                      |          | RES.,FXD,COMP:1K OHM,5%,0.25W       | 01121    | CB1025           |
| R41109             | 323-0309-00        | B010100              | B189999  | RES.,FXD,FILM:16.2K OHM,1%,0.50W    | 75042    | CECTO-1622F      |
| R41109             | 323-0315-00        | B190000              |          | RES.,FXD,FILM:18.7K OHM,1%,0.50W    | 75042    | CECTO-1872F      |
| R41111             | 315-0473-00        |                      |          | RES.,FXD,COMP:47K OHM,5%,0.25W      | 01121    | CB4735           |
| R41113             | 315-0620-00        |                      |          | RES.,FXD,COMP:62 OHM,5%,0.25W       | 01121    | CB6205           |
| R41115             | 303-0153-00        |                      |          | RES.,FXD,COMP:15K OHM,5%,1W         | 01121    | GB1535           |
| R41119             | 301-0101-00        |                      |          | RES.,FXD,COMP:100 OHM,5%,0.50W      | 01121    | EB1015           |
| R41120             | 308-0349-00        |                      |          | RES.,FXD,WW:3.6K OHM,1%,3W          | 63743    | 27988            |
| R41121             | 321-0385-00        |                      |          | RES.,FXD,FILM:100K OHM,1%,0.125W    | 75042    | CEATO-1003F      |
| R41123             | 315-0471-00        |                      |          | RES.,FXD,COMP:470 OHM,5%,0.25W      | 01121    | CB4715           |
| R41124             | 321-0349-00        |                      |          | RES.,FXD,FILM:42.2K OHM,1%,0.125W   | 75042    | CEATO-4222F      |
| R41125             | 321-0335-00        |                      |          | RES.,FXD,FILM:30.1K OHM,1%,0.125W   | 75042    | CEATO-3012F      |
| R41126             | 315-0682-00        |                      |          | RES.,FXD,COMP:6.8K OHM,5%,0.25W     | 01121    | CB6825           |
| R41127             | 311-1232-00        |                      |          | RES.,VAR,NONWIR:50K OHM,20%,0.50W   | 80294    | 3389F-P31-503    |
| R41129             | 321-0350-00        |                      |          | RES.,FXD,FILM:43.2K OHM,1%,0.125W   | 75042    | CEATO-4322F      |
| R41131             | 307-0272-00        |                      |          | RES.,FXD,COMP:130K OHM,1%,0.25W     | 80009    | 307-0272-00      |
| R41133             | 315-0821-00        | B010100              | B109999  | RES.,FXD,COMP:820 OHM,5%,0.25W      | 01121    | CB8215           |
| R41133             | 315-0101-00        | B110000              |          | RES.,FXD,COMP:100 OHM,5%,0.25W      | 01121    | CB1015           |
| R41137             | 315-0332-00        |                      |          | RES.,FXD,COMP:3.3K OHM,5%,0.25W     | 01121    | CB3325           |
| R41150             | 315-0181-00        |                      |          | RES.,FXD,COMP:180 OHM,5%,0.25W      | 01121    | CB1815           |
| R41151             | 303-0123-00        |                      |          | RES.,FXD,COMP:12K OHM,5%,1W         | 01121    | GB1235           |
| R41153             | 301-0562-00        |                      |          | RES.,FXD,COMP:5.6K OHM,5%,0.50W     | 01121    | EB5625           |
| R41154             | 315-0151-00        | XB110000             |          | RES.,FXD,COMP:150 OHM,5%,0.25W      | 01121    | CB1515           |
| R41155             | 315-0154-00        |                      |          | RES.,FXD,COMP:150K OHM,5%,0.25W     | 01121    | CB1545           |
| R41161             | 315-0102-00        |                      |          | RES.,FXD,COMP:1K OHM,5%,0.25W       | 01121    | CB1025           |
| R41171             | 311-1235-00        |                      |          | RES.,VAR,NONWIR:100K OHM,20%,0.50W  | 80294    | 3389F-P31-104    |
| R41173             | 311-1227-00        |                      |          | RES.,VAR,NONWIR:5K OHM,20%,0.50W    | 80294    | 3389F-P31-502    |
| R41175             | 321-0303-00        | B010100              | B069999  | RES.,FXD,FILM:14K OHM,1%,0.125W     | 75042    | CEATO-1402F      |
| R41175             | 321-0299-00        | B070000              |          | RES.,FXD,FILM:12.7K OHM,1%,0.125W   | 75042    | CEATO-1272F      |
| R41176             | 311-1466-00        | XB070000             |          | RES.,VAR,NONWIR:2K OHM,20%,0.50W    | 73138    | 72PM-08-0-202    |
| R41177             | 321-0343-00        | B010100              | B069999  | RES.,FXD,FILM:36.5K OHM,1%,0.125W   | 75042    | CEATO-3652F      |
| R41177             | 321-0342-00        | B070000              |          | RES.,FXD,FILM:35.7K OHM,1%,0.125W   | 75042    | CEATO-3572F      |
| R41181             | 315-0152-00        |                      |          | RES.,FXD,COMP:1.5K OHM,5%,0.25W     | 01121    | CB1525           |
| R41185             | 315-0104-00        |                      |          | RES.,FXD,COMP:100K OHM,5%,0.25W     | 01121    | CB1045           |
| RT2315             | 307-0124-00        | B010100              | B079999X | RES.,THERMAL:5K OHM,10%             | 50157    | 1D1618           |
| RT2325             | 307-0124-00        | B010100              | B079999X | RES.,THERMAL:5K OHM,10%             | 50157    | 1D1618           |
| RT3009             | 307-0350-00        |                      |          | RES.,THERMAL:7.5 OHM,10%,3.9%/DEG C | 15454    | 75DJ7R5R0220SS   |
| RT4313             | 307-0127-00        |                      |          | RES.,THERMAL:1K OHM,1%              | 50157    | 2D1596           |
| RT4438             | 307-0125-00        |                      |          | RES.,THERMAL:500 OHM,10%,25 DEG C   | 50157    | 2D1595           |
| S110 <sup>1</sup>  | 670-1877-00        |                      |          | SWITCH:PUSHBUTTON, VERTICAL MODE    | 80009    | 670-1877-00      |
| S120 <sup>1</sup>  | 670-1878-00        |                      |          | SWITCH:PUSHBUTTON, HORIZONTAL MODE  | 80009    | 670-1878-00      |
| S130 <sup>1</sup>  | 670-1876-00        |                      |          | SWITCH:PUSHBUTTON, A TRIGGER SOURCE | 80009    | 670-1876-00      |
| S140 <sup>1</sup>  | 670-1876-00        |                      |          | SWITCH:PUSHBUTTON, B TRIGGER SOURCE | 80009    | 670-1876-00      |
| S2510              | 260-0723-00        |                      |          | SWITCH,SLIDE:DPDT,0.5A,125VAC       | 80009    | 260-0723-00      |
| S3320              | 260-0723-00        |                      |          | SWITCH,SLIDE:DPDT,0.5A,125VAC       | 80009    | 260-0723-00      |
| S3340              | 260-0984-00        |                      |          | SWITCH,SLIDE:DP3POSN,0.5A,125VAC-DC | 79727    | G128S-FC/MOD7140 |
| S3368              | 260-0723-00        |                      |          | SWITCH,SLIDE:DPDT,0.5A,125VAC       | 80009    | 260-0723-00      |
| S5001              | 260-0449-00        |                      |          | SWITCH,SLIDE:SPDT,0.5A,125VA-DC     | 82389    | 11A1030          |
| S5006 <sup>2</sup> |                    |                      |          | SWITCH:READOUT                      |          |                  |
| S5007A,B           | 260-0688-00        |                      |          | SWITCH,PUSH:DPDT,1A,120VAC          | 82389    | 12S1025D         |

<sup>1</sup>See Mechanical Parts List for replacement parts.

<sup>2</sup>Furnished as a unit with R5006.

Electrical Parts List—7704A

| Ckt No. | Tektronix Part No. | Serial/Model No. Eff | Dscont  | Name & Description                         | Mfr Code | Mfr Part Number |
|---------|--------------------|----------------------|---------|--|----------|-----------------|
| S5020   | 260-1222-00        |                      |         | SWITCH,PUSH-PUL:10A,250VAC                 | 91929    | 2DM301          |
| S5022   | 1                  |                      |         |  |          |                 |
| T2279   | 120-0444-00        |                      |         | XFMR,TOROID:5 TURNS,BIFILAR                | 80009    | 120-0444-00     |
| T3001   | 120-0636-00        |                      |         | TRANSFORMER:LINE TRIGGER                   | 80009    | 120-0636-00     |
| T3025   | 120-0743-00        |                      |         | XFMR,TOROID:13 TURNS,BIFILAR               | 80009    | 120-0743-00     |
| T3030   | 120-0744-00        |                      |         | XFMR,TOROID:5 WINDINGS                     | 80009    | 120-0744-00     |
| T3035   | 120-0747-00        |                      |         | XFMR,TOROID:55 TURNS,SINGLE                | 80009    | 120-0747-00     |
| T3101   | 120-0763-00        |                      |         | TRANSFORMER:POWER                          | 80009    | 120-0763-00     |
| T4201   | 120-0762-00        |                      |         | TRANSFORMER:POWER HIGH VOLTAGE             | 80009    | 120-0762-00     |
| U1010   | 156-0038-00        |                      |         | MICROCIRCUIT,DI:J-K MASTER SLAVE FLIP-FLOP | 01295    | SN7472N         |
| U2030   | 155-0015-01        |                      |         | MICROCIRCUIT,DI:ML,ANALOG DATA SWITCH      | 80009    | 155-0015-01     |
| U2070   | 155-0015-01        |                      |         | MICROCIRCUIT,DI:ML,ANALOG DATA SWITCH      | 80009    | 155-0015-01     |
| U2210   | 155-0022-00        |                      |         | MICROCIRCUIT,DI:ML CHANNEL SWITCH          | 80009    | 155-0022-00     |
| U2230   | 155-0022-00        |                      |         | MICROCIRCUIT,DI:ML CHANNEL SWITCH          | 80009    | 155-0022-00     |
| U2320   | 155-0022-00        |                      |         | MICROCIRCUIT,DI:ML CHANNEL SWITCH          | 80009    | 155-0022-00     |
| U2404   | 155-0022-00        |                      |         | MICROCIRCUIT,DI:ML CHANNEL SWITCH          | 80009    | 155-0022-00     |
| U2424   | 155-0022-00        |                      |         | MICROCIRCUIT,DI:ML CHANNEL SWITCH          | 80009    | 155-0022-00     |
| U2510   | 155-0011-00        |                      |         | MICROCIRCUIT,DI:ML,CLOCK AND CHOP BLANKING | 80009    | 155-0011-00     |
| U2520   | 155-0010-00        |                      |         | MICROCIRCUIT,DI:ML,CHOP DIVIDER/BLANKING   | 80009    | 155-0010-00     |
| U2530   | 155-0013-00        |                      |         | MICROCIRCUIT,DI:ML,HORIZ CHOP ALTN BINARY  | 80009    | 155-0013-00     |
| U2535   | 155-0013-00        |                      |         | MICROCIRCUIT,DI:ML,HORIZ CHOP ALTN BINARY  | 80009    | 155-0013-00     |
| U2540   | 155-0013-00        |                      |         | MICROCIRCUIT,DI:ML,HORIZ CHOP ALTN BINARY  | 80009    | 155-0013-00     |
| U2573   | 155-0009-00        |                      |         | MICROCIRCUIT,DI:ML,HORIZ LOCKOUT LOGIC     | 80009    | 155-0009-00     |
| U2587   | 155-0012-00        |                      |         | MICROCIRCUIT,LI:ML,Z-AXIS ANDAMPLIFIER     | 80009    | 155-0012-00     |
| U3105   | 155-0067-02        |                      |         | MICROCIRCUIT,DI:ML,POWER SUPPLY REGULATOR  | 80009    | 155-0067-02     |
| U3401   | 155-0018-00        |                      |         | MICROCIRCUIT,DI:ZERO LOGIC                 | 80009    | 155-0018-00     |
| U3418   | 155-0014-01        |                      |         | MICROCIRCUIT,DI:ML,ANALOG TO DECIMAL CONV  | 80009    | 155-0014-01     |
| U3429   | 155-0014-01        |                      |         | MICROCIRCUIT,DI:ML,ANALOG TO DECIMAL CONV  | 80009    | 155-0014-01     |
| U3433   | 155-0021-00        |                      |         | MICROCIRCUIT,DI:ML,TIMING GENERATOR        | 80009    | 155-0021-00     |
| U3447   | 156-0043-00        |                      |         | MICROCIRCUIT DI:2-INPUT NOR GATE           | 01295    | SN7402N         |
| U3449   | 156-0043-00        |                      |         | MICROCIRCUIT DI:2-INPUT NOR GATE           | 01295    | SN7402N         |
| U3450   | 156-0032-00        |                      |         | MICROCIRCUIT,DI:4-BIT BINARY COUNTER       | 01295    | SN7493AN        |
| U3461   | 155-0023-00        |                      |         | MICROCIRCUIT,DI:ML,CHAR GEN NUMERALS       | 80009    | 155-0023-00     |
| U3463   | 155-0024-00        |                      |         | MICROCIRCUIT,DI:ML,CHAR GEN SPCL SYMBOLS   | 80009    | 155-0024-00     |
| U3465   | 155-0025-00        |                      |         | MICROCIRCUIT,DI:ML,CHAR GEN PREFIXES       | 80009    | 155-0025-00     |
| U3467   | 155-0026-00        |                      |         | MICROCIRCUIT,DI:ML,CHAR GEN LETTERS        | 80009    | 155-0026-00     |
| U3469   | 155-0027-00        |                      |         | MICROCIRCUIT,DI:ML,CHAR GEN SPCL ALPHA     | 80009    | 155-0027-00     |
| U3470   | 155-0019-00        |                      |         | MICROCIRCUIT,DI:ML,DECIMAL POINT SPACE     | 80009    | 155-0019-00     |
| U3480   | 155-0020-00        |                      |         | MICROCIRCUIT,DI:ML,CHANNEL SW OUTPUT ASSY  | 80009    | 155-0020-00     |
| U4110   | 156-0067-00        |                      |         | MICROCIRCUIT,LI:OPERATIONAL AMPLIFIER      | 07263    | U6T7741393      |
| U4214   | 152-0493-00        |                      |         | SEMICONV DEVICE:3KV P-P IN,+12KV OUT       | 80009    | 152-0493-00     |
| U4413   | 155-0077-00        |                      |         | MICROCIRCUIT,LI:HYBRID                     | 80009    | 155-0077-00     |
| V5050   | 154-0644-05        |                      |         | ELECTRON TUBE:CRT,P31 PHOSPHOR             | 80009    | 154-0644-05     |
| VR3059  | 152-0287-00        | B010100              | B099999 | SEMICONV DEVICE:ZENER,0.4W,110V,5%         | 04713    | 1N986B          |
| VR3059  | 152-0428-00        | B100000              |         | SEMICONV DEVICE:ZENER,0.4W,120V,5%         | 04713    | 1N987B          |
| VR3105  | 152-0243-00        |                      |         | SEMICONV DEVICE:ZENER,0.4W,15V,5%          | 81483    | 1N965B          |
| VR3129  | 152-0243-00        | B010100              | B059999 | SEMICONV DEVICE:ZENER,0.4W,15V,5%          | 81483    | 1N965B          |
| VR3129  | 152-0304-00        | B060000              |         | SEMICONV DEVICE:ZENER,0.4W,20V,5%          | 04713    | 1N968B          |
| VR3147  | 152-0212-00        |                      |         | SEMICONV DEVICE:ZENER,0.5W,9V,5%           | 04713    | SZ50646         |
| VR3201  | 152-0226-00        |                      |         | SEMICONV DEVICE:ZENER,0.4W,5.1V,5%         | 81483    | 69-6584         |
| VR3271  | 152-0226-00        |                      |         | SEMICONV DEVICE:ZENER,0.4W,5.1V,5%         | 81483    | 69-6584         |

<sup>1</sup>See Mechanical Parts List, Line Voltage Selector.

# Electrical Parts List—7704A

| Ckt No. | Tektronix Part No. | Serial/Model No. Eff | Dscont | Name & Description                 | Mfr Code | Mfr Part Number |
|---------|--------------------|----------------------|--------|------------------------------------|----------|-----------------|
| VR3470  | 152-0405-00        |                      |        | SEMICOND DEVICE:ZENER,1W,15V,5%    | 99942    | 1N5567B         |
| VR3471  | 152-0405-00        |                      |        | SEMICOND DEVICE:ZENER,1W,15V,5%    | 99942    | 1N5567B         |
| VR3472  | 152-0405-00        |                      |        | SEMICOND DEVICE:ZENER,1W,15V,5%    | 99942    | 1N5567B         |
| VR4142  | 152-0395-00        | XB150000             |        | SEMICOND DEVICE:ZENER,0.4W,4.3V,5% | 04713    | 1N749A          |
| VR4175  | 152-0175-00        |                      |        | SEMICOND DEVICE:ZENER,0.4W,5.6V,5% | 04713    | 1N752A          |
| VR32121 | 152-0127-00        |                      |        | SEMICOND DEVICE:ZENER,0.4W,7.5V,5% | 04713    | 1N755A          |
| VR32127 | 152-0212-00        |                      |        | SEMICOND DEVICE:ZENER,0.5W,9V,5%   | 04713    | SZ50646         |
| VR41111 | 152-0166-00        |                      |        | SEMICOND DEVICE:ZENER,0.4W,6.2V,5% | 81483    | 69-9035         |
| VR41120 | 152-0087-00        |                      |        | SEMICOND DEVICE:ZENER,1W,100V,5%   | 04713    | 1N3044B         |
| VR41121 | 152-0282-00        |                      |        | SEMICOND DEVICE:ZENER,0.4W,30V,5%  | 04713    | 1N972B          |

# SECTION 6

## DIAGRAMS AND CIRCUIT BOARD ILLUSTRATIONS

### Symbols and Reference Designators

Electrical components shown on the diagrams are in the following units unless noted otherwise:

Capacitors = Values one or greater are in picofarads (pF).  
 Values less than one are in microfarads ( $\mu$ F).  
 Resistors = Ohms ( $\Omega$ )

Symbols used on the diagrams are based on USA Standard Y32.2-1967.

Logic symbology is based on MIL-STD-806B in terms of positive logic. Logic symbols depict the logic function performed and may differ from the manufacturer's data.

The following special symbols are used on the diagrams:

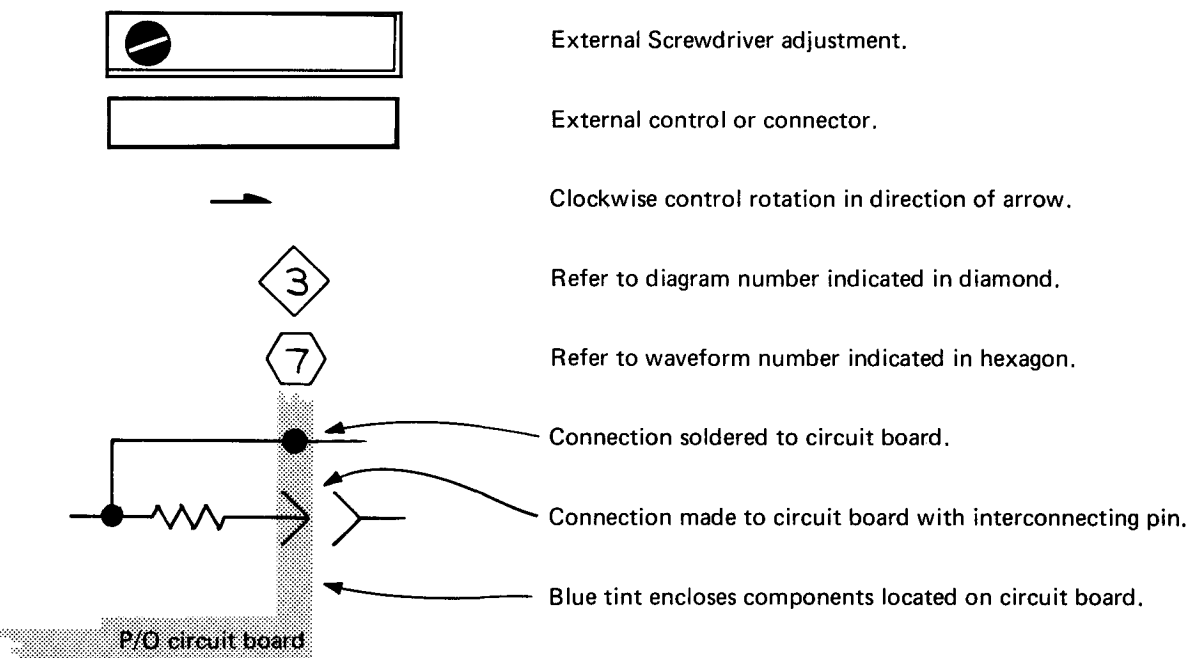

The following prefix letters are used as reference designators to identify components or assemblies on the diagrams.

|    |  |    |  |
|----|--|----|--|
| A  | Assembly, separable or repairable (circuit board, etc.)  | LR | Inductor/resistor combination                                      |
| AT | Attenuator, fixed or variable                            | M  | Meter  |
| B  | Motor  | Q  | Transistor or silicon-controlled rectifier                         |
| BT | Battery  | P  | Connector, movable portion   |
| C  | Capacitor, fixed or variable                             | R  | Resistor, fixed or variable  |
| CR | Diode, signal or rectifier                               | RT | Thermistor   |
| DL | Delay line   | S  | Switch   |
| DS | Indicating device (lamp)                                 | T  | Transformer  |
| F  | Fuse   | TP | Test point   |
| FL | Filter   | U  | Assembly, inseparable or non-repairable (integrated circuit, etc.) |
| H  | Heat dissipating device (heat sink, heat radiator, etc.) | V  | Electron tube  |
| HR | Heater   | VR | Voltage regulator (zener diode, etc.)                              |
| J  | Connector, stationary portion                            | Y  | Crystal  |
| K  | Relay  |    |  |
| L  | Inductor, fixed or variable                              |    |  |

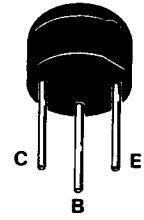
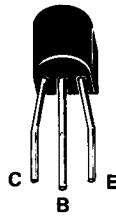

Plastic-Cased Transistors

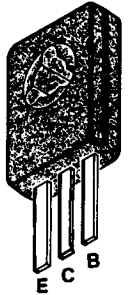
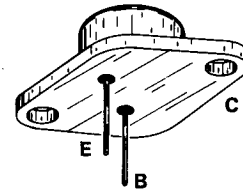
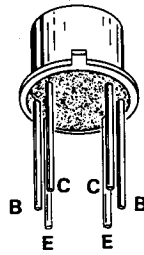
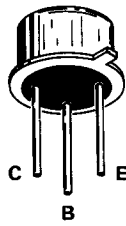

Metal-Cased Transistors

Plastic-Power Transistors

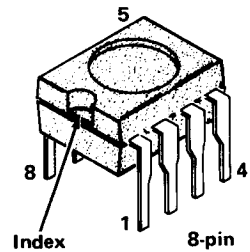
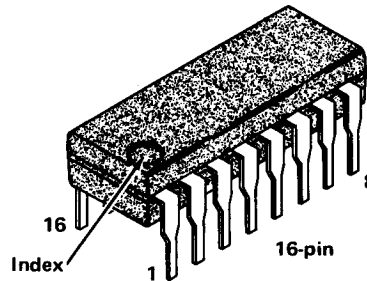
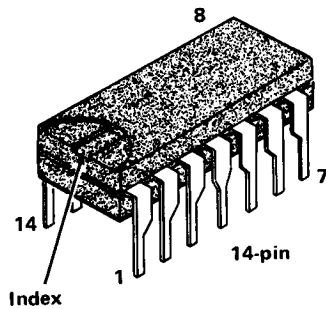
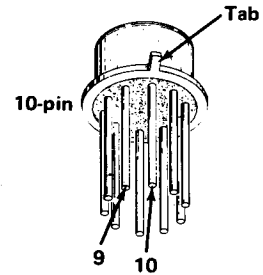
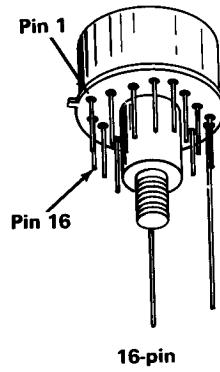

Integrated Circuits

NOTE: Circuit board is keyed with arrow ( ➤ ) or dot to locate either pin 1 or tab of integrated circuit.

Fig. 6-1. Electrode configuration for semiconductors used in the 7704A.



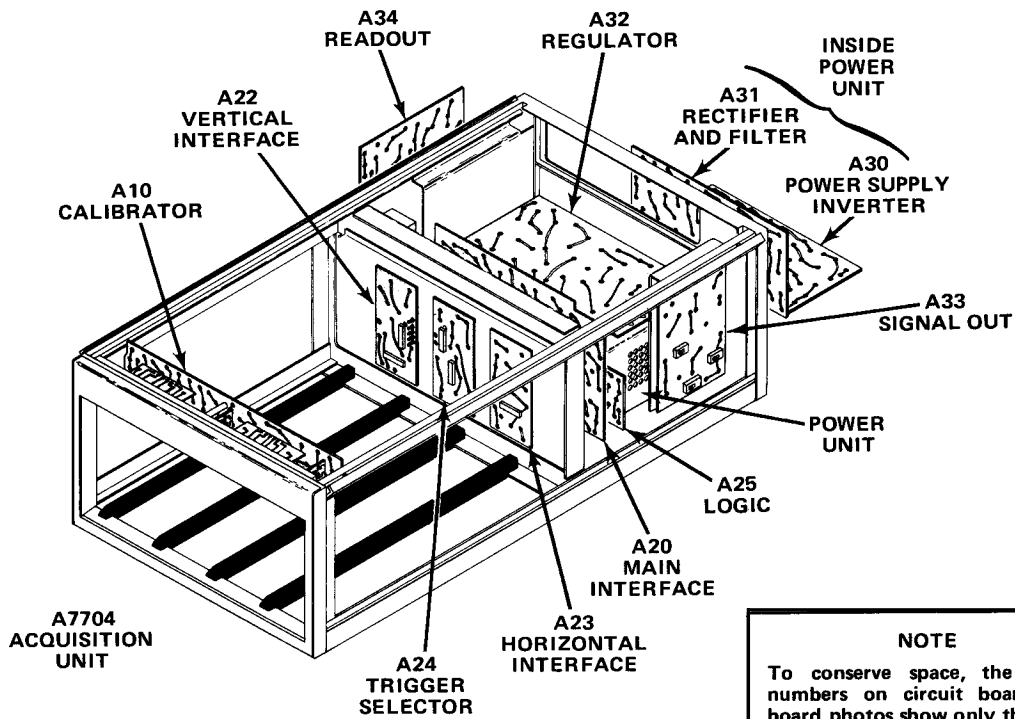
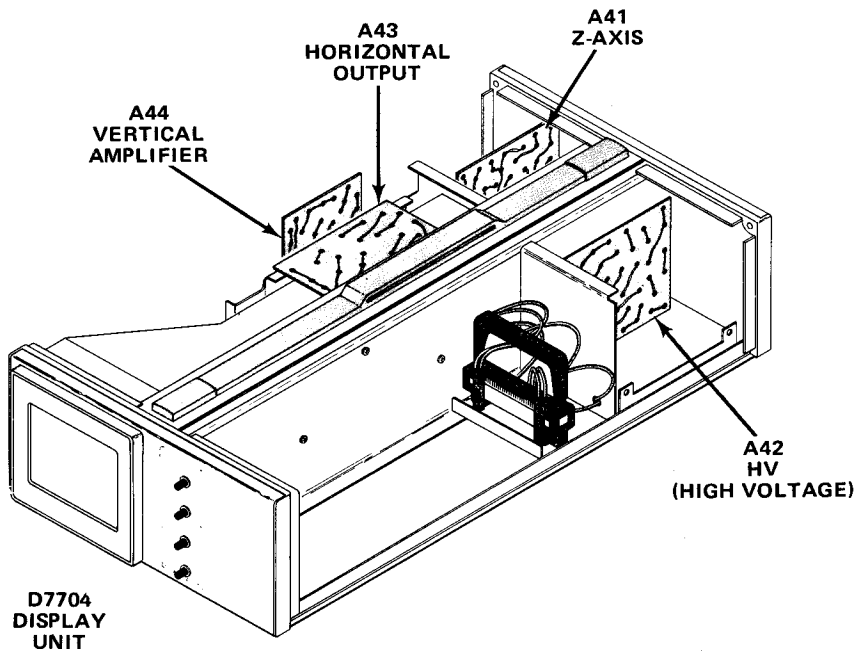

**NOTE**

To conserve space, the circuit numbers on circuit boards and board photos show only the letter prefix and last two digits of the complete circuit number shown in parts list and schematic (R69 = R1069, etc.).

Fig. 6-2. Location of circuit boards in the 7704A.

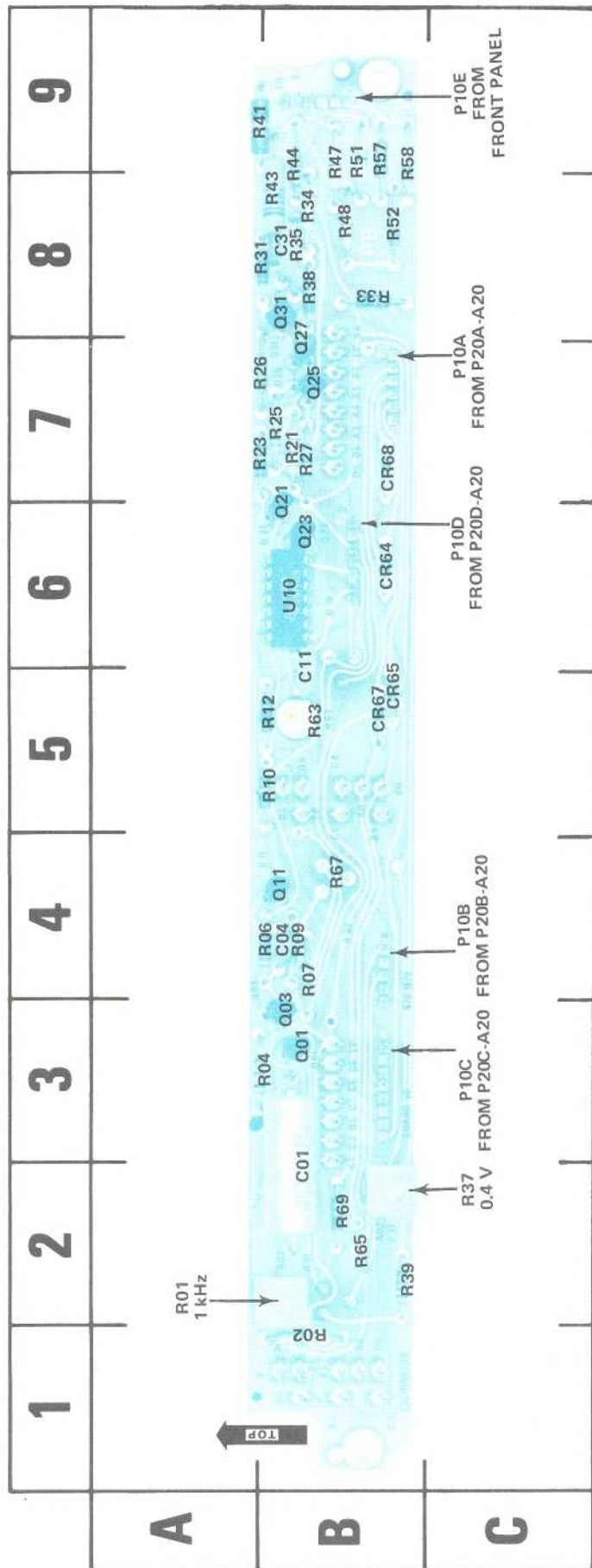
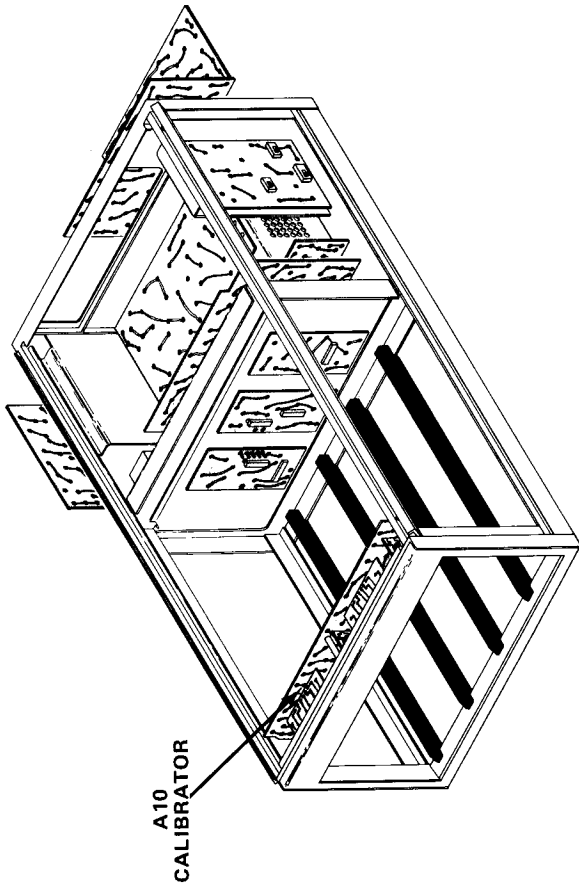

Fig. 6-3. A 10 — Calibrator circuit board.

| CKT NO | GRID/CKT LOC NO | GRID/CKT LOC NO | GRID/CKT LOC NO | GRID/CKT LOC NO | GRID/CKT LOC NO | GRID/CKT LOC NO | GRID/CKT LOC NO | GRID/CKT LOC NO | GRID/CKT LOC NO |     |    |     |    |     |    |
|--------|-----------------|-----------------|-----------------|-----------------|-----------------|-----------------|-----------------|-----------------|-----------------|-----|----|-----|----|-----|----|
| C01    | 2B              | P10A            | 7B              | Q11             | 4B              | R02             | 1B              | R21             | 7B              | R34 | 8B | R44 | 9B | R63 | 5B |
| C04    | 4B              | P10B            | 4B              | Q21             | 6B              | R04             | 3B              | R23             | 7B              | R35 | 8B | R47 | 9B | R65 | 2B |
| C11    | 6B              | P10C            | 3B              | Q23             | 6B              | R06             | 4B              | R25             | 7B              | R37 | 2B | R48 | 8B | R67 | 4B |
| C31    | 8B              | P10D            | 6B              | Q25             | 7B              | R07             | 4B              | R26             | 7B              | R38 | 8B | R51 | 9B | R69 | 2B |
| CR64   | 6B              | P10E            | 9B              | Q27             | 7B              | R09             | 4B              | R27             | 7B              | R39 | 2B | R52 | 8B | U10 | 6B |
| CR65   | 5B              | O01             | 3B              | Q31             | 8B              | R10             | 5B              | R31             | 8B              | R41 | 9B | R57 | 9B |     |    |
| CR67   | 5B              | O03             | 3B              | R01             | 2B              | R12             | 5B              | R33             | 8B              | R43 | 8B | R58 | 9B |     |    |
| CR68   | 7B              |                 |                 |                 |                 |                 |                 |                 |                 |     |    |     |    |     |    |



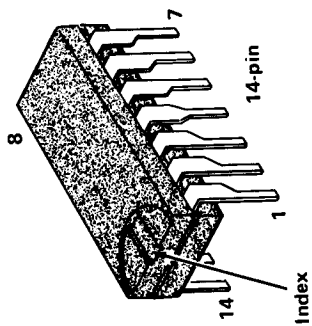
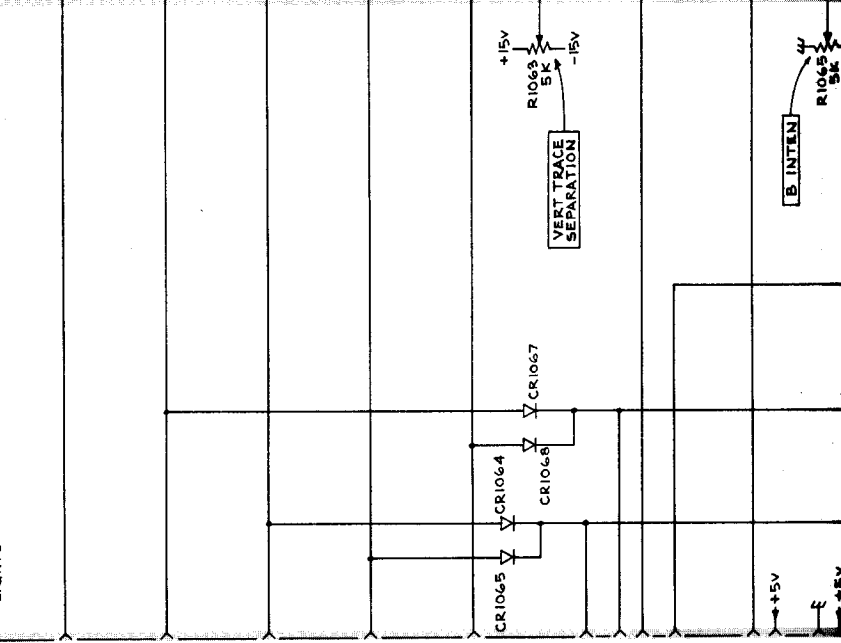
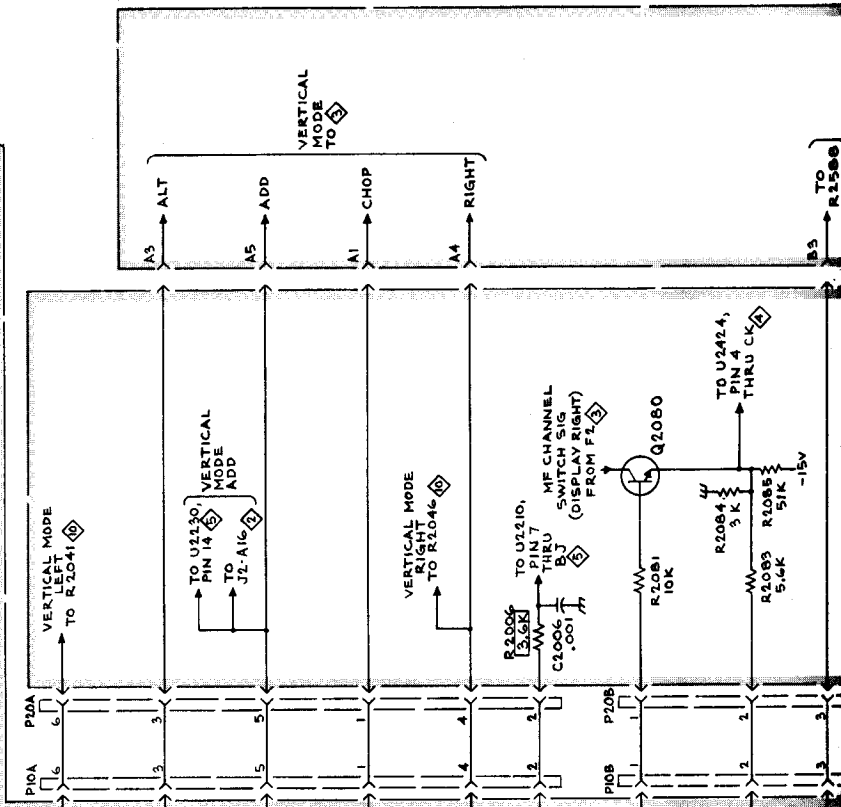
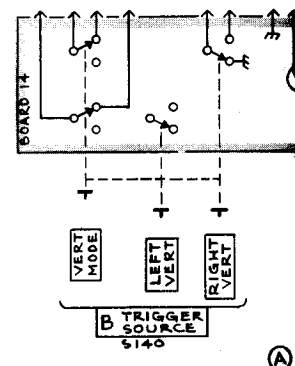
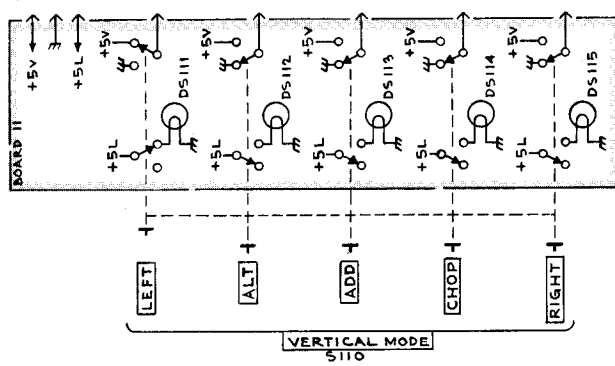
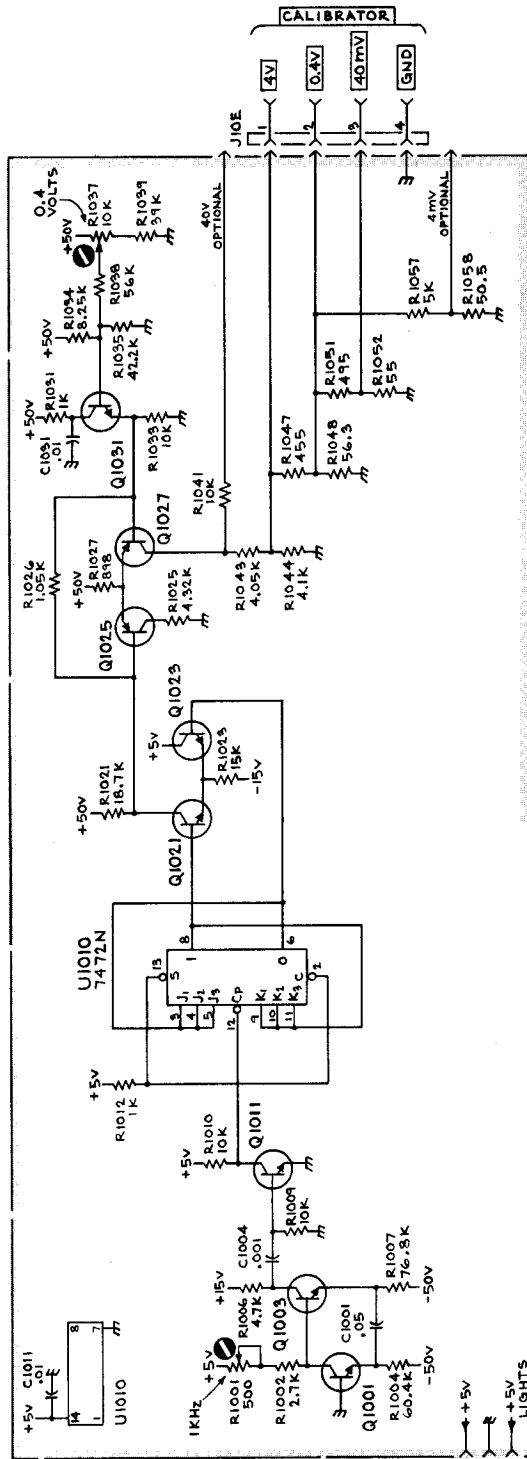

Fig. 6-4. Electrode configuration for semiconductors shown on diagram 1.



7704A (ACQUISITION UNIT)

VERTICAL MODE 510

B TRIGGER SOURCE 510

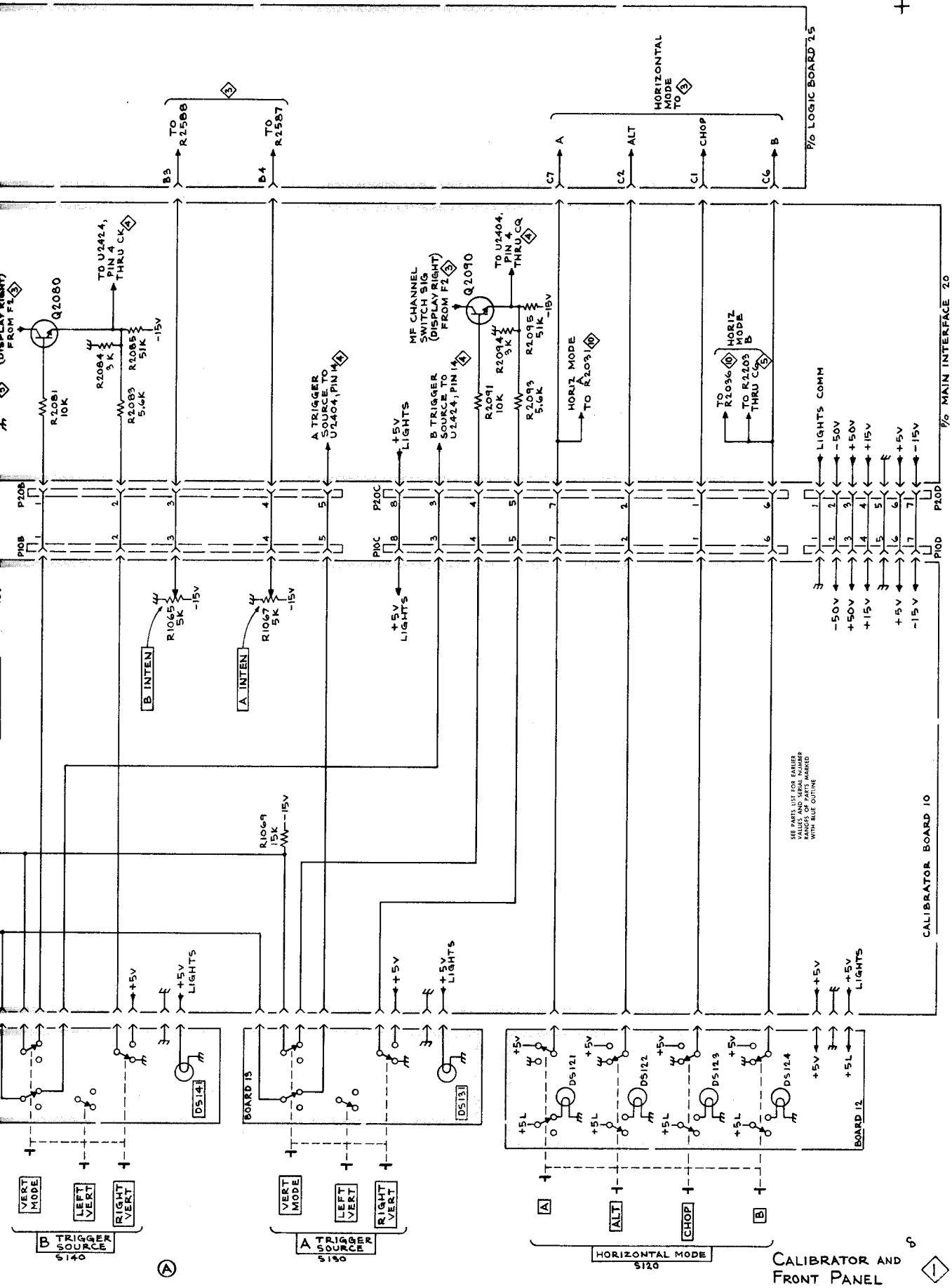

CALIBRATOR AND FRONT PANEL

1

ASSEMBLY A20

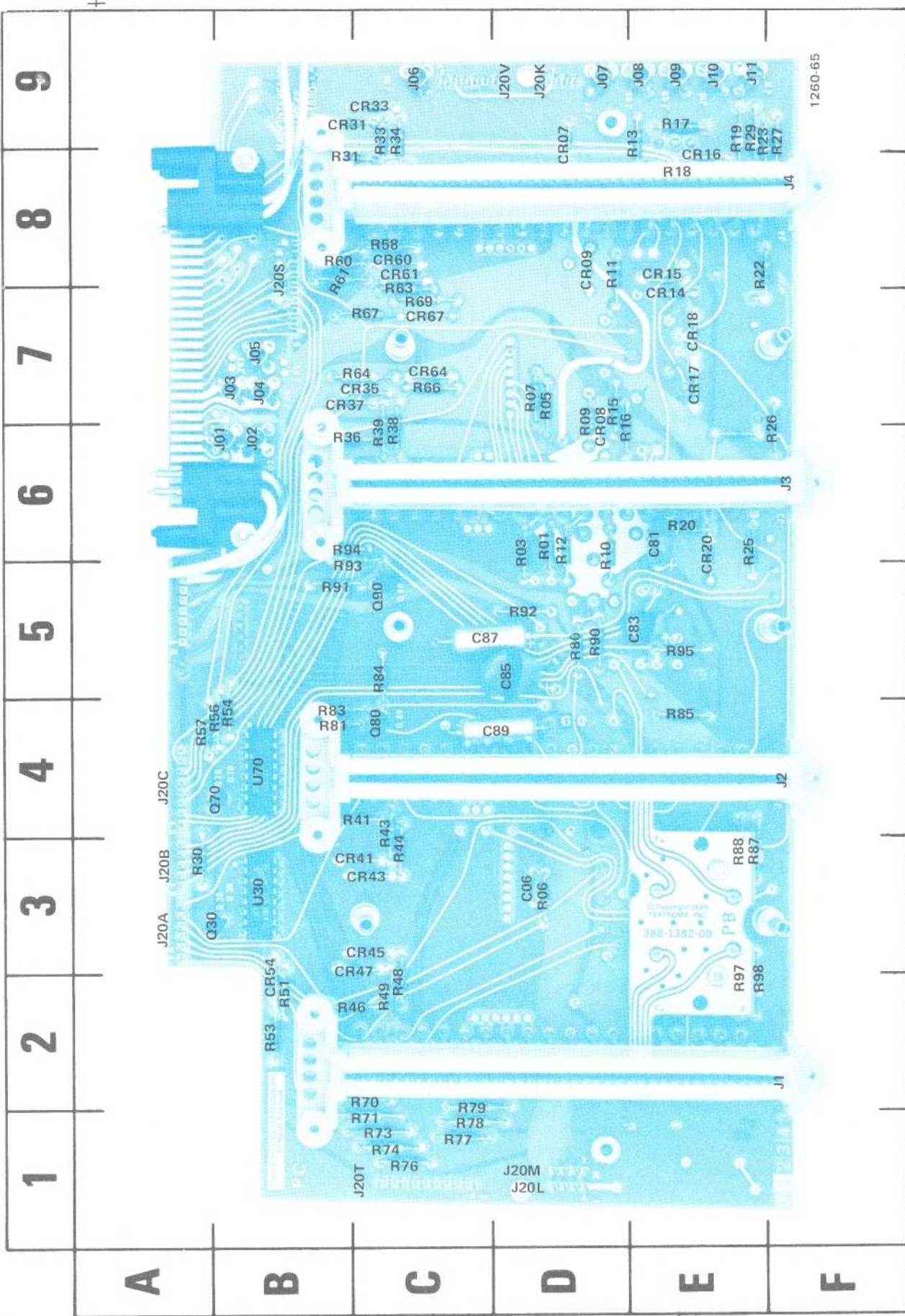
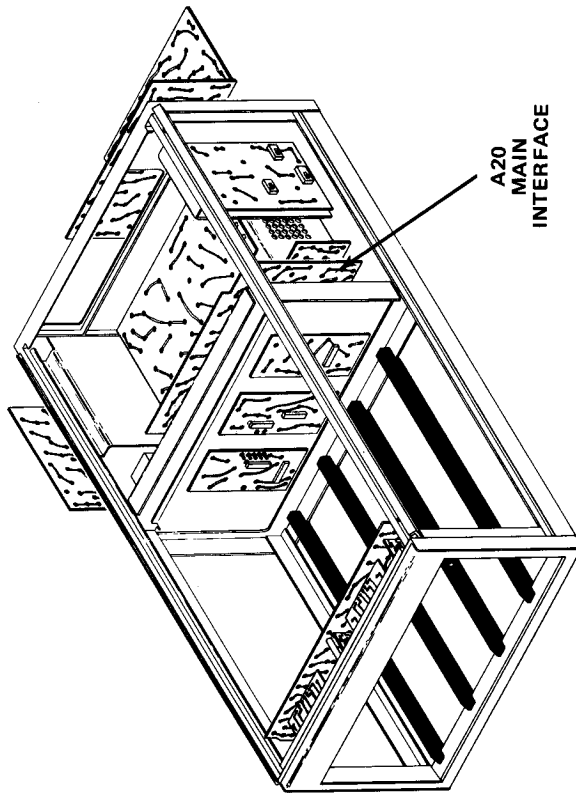

Fig. 6-5. A20 - Main Interface circuit board.

| CKT NO | GRID LOC | CKT NO | GRID LOC | CKT NO | GRID LOC | CKT NO | GRID LOC | CKT NO | GRID LOC | CKT NO | GRID LOC | CKT NO | GRID LOC | CKT NO | GRID LOC | CKT NO | GRID LOC |
|--------|----------|--------|----------|--------|----------|--------|----------|--------|----------|--------|----------|--------|----------|--------|----------|--------|----------|
| C06    | 3D       | CR37   | 7C       | J02    | 6B       | J20T   | 1C       | R12    | 6D       | R36    | 6B       | R61    | 8B       | R83    | 8B       | R83    | 4B       |
| C81    | 6E       | CR41   | 3C       | J03    | 7B       | J20V   | 9D       | R13    | 9E       | R38    | 6C       | R63    | 7C       | R84    | 7C       | R84    | 5C       |
| C83    | 5E       | CR43   | 3C       | J04    | 7B       |        |          | R15    | 7D       | R39    | 6C       | R64    | 7C       | R85    | 7C       | R85    | 4E       |
| C85    | 5D       | CR45   | 3C       | J05    | 7B       | Q30    | 3A       | R16    | 6E       | R41    | 4C       | R66    | 7C       | R87    | 7C       | R87    | 3E       |
| C87    | 5D       | CR47   | 3C       | J06    | 9C       | Q70    | 4A       | R17    | 9E       | R43    | 3C       | R67    | 7C       | R88    | 7C       | R88    | 3E       |
| C89    | 4D       | CR54   | 2B       | J08    | 9E       | Q80    | 4C       | R18    | 8E       | R44    | 3C       | R69    | 7C       | R90    | 7C       | R90    | 5D       |
|        |          | CR60   | 8C       | J09    | 9E       | Q90    | 5C       | R20    | 6E       | R46    | 3C       | R70    | 2C       | R91    | 2C       | R91    | 5B       |
| CR07   | 9D       | CR61   | 8C       | J10    | 9E       |        |          | R22    | 8F       | R48    | 3C       | R71    | 1C       | R92    | 1C       | R92    | 5D       |
| CR08   |          | CR64   | 7C       | J11    | 9E       | R01    | 6D       | R23    | 9E       | R49    | 3C       | R73    | 1C       | R93    | 1C       | R93    | 6C       |
| CR14   | 8E       | CR67   | 7C       | J20A   | 3A       | R03    | 6D       | R25    | 6E       | R51    | 2B       | R74    | 1C       | R94    | 1C       | R94    | 6C       |
| CR15   | 8E       |        |          | J20B   | 3A       | R05    | 7D       | R27    | 9F       | R53    | 2B       | R76    | 1C       | R95    | 1C       | R95    | 5E       |
| CR16   | 8E       | J1     | 2F       | J20C   | 4A       | R06    | 3D       | R29    | 9E       | R54    | 4B       | R77    | 1C       | R97    | 1C       | R97    | 2E       |
| CR20   | 6E       | J2     | 4F       | J20K   | 9D       | R07    | 7D       | R30    | 3A       | R56    | 4A       | R78    | 1C       | R98    | 1C       | R98    | 2E       |
| CR31   | 9C       | J3     | 6F       | J20L   | 1D       | R09    | 7D       | R31    | 8B       | R57    | 4A       | R79    | 2C       | U30    | 5D       | U30    | 3B       |
| CR33   | 9C       | J4     | 8F       | J20M   | 1D       | R10    | 5D       | R33    | 9C       | R58    | 8C       | R80    | 5D       | U70    | 4B       | U70    | 4B       |
| CR35   | 7C       | J01    | 6B       | J20S   | 8B       | R11    | 8D       | R34    | 9C       | R60    | 8B       | R81    | 4B       |        |          |        |          |

**NOTE**

To conserve space, the circuit numbers on circuit boards and board photos show only the letter prefix and last two digits of the complete circuit number shown in parts list and schematic (R69 = R1069, etc.).





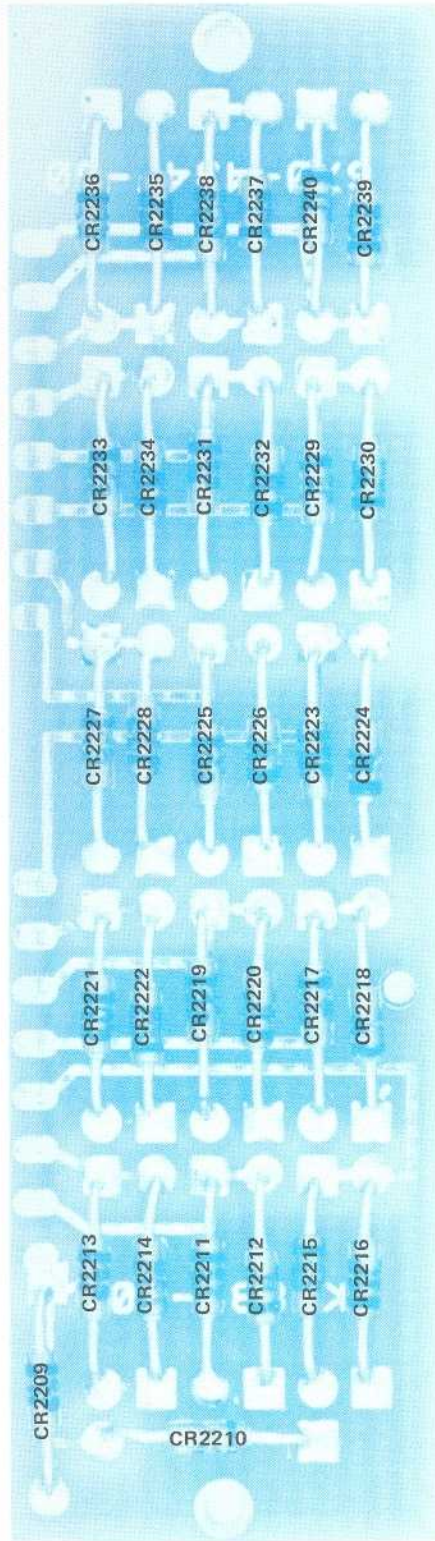

1260-111

Fig. 6-5A. A51—Protection circuit board assembly.  
(Eff. SN B160000 — up)

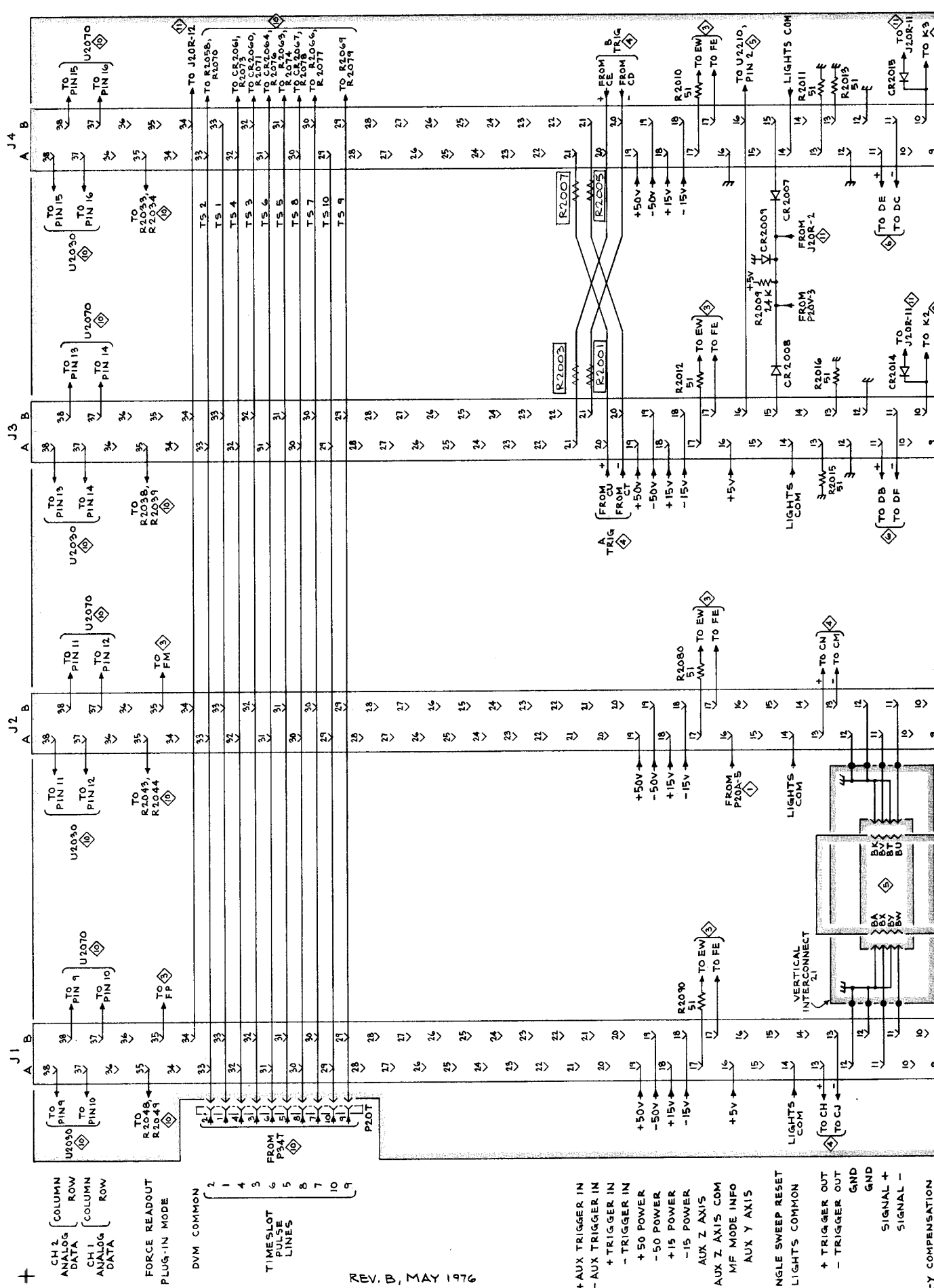

CH 2 COLUMN ANALOG DATA ROW  
 CH 1 COLUMN ANALOG DATA ROW  
 FORCE READOUT PLUG-IN MODE  
 DVM COMMON  
 TIMESLOT PULSE LINES  
 PLOT  
 FROM P541

REV. B, MAY 1976  
 1260-66

+ AUX TRIGGER IN  
 - AUX TRIGGER IN  
 + TRIGGER IN  
 - TRIGGER IN  
 +50 POWER  
 -50 POWER  
 +15 POWER  
 -15 POWER  
 AUX Z AXIS  
 AUX Z AXIS COM  
 MF MODE INFO  
 AUX Y AXIS  
 SINGLE SWEEP RESET  
 LIGHTS COMMON  
 + TRIGGER OUT  
 - TRIGGER OUT  
 GND  
 GND  
 SIGNAL +  
 SIGNAL -  
 X-Y COMPENSATION

7704A (ACQUISITION UNIT)

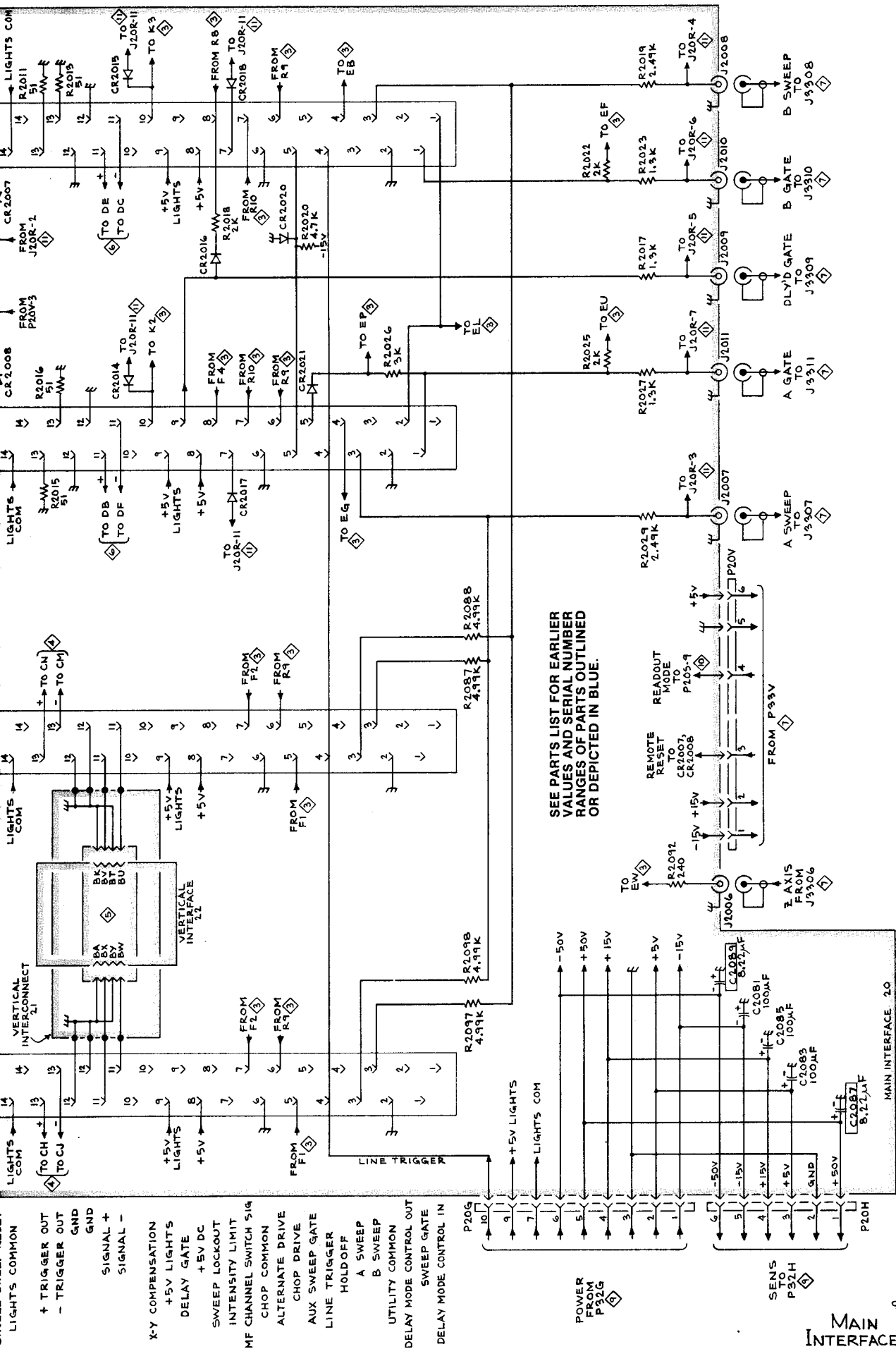

SEE PARTS LIST FOR EARLIER VALUES AND SERIAL NUMBER RANGES OF PARTS OUTLINED OR DEPICTED IN BLUE.

MAIN INTERFACE

2

MAIN INTERFACE 20

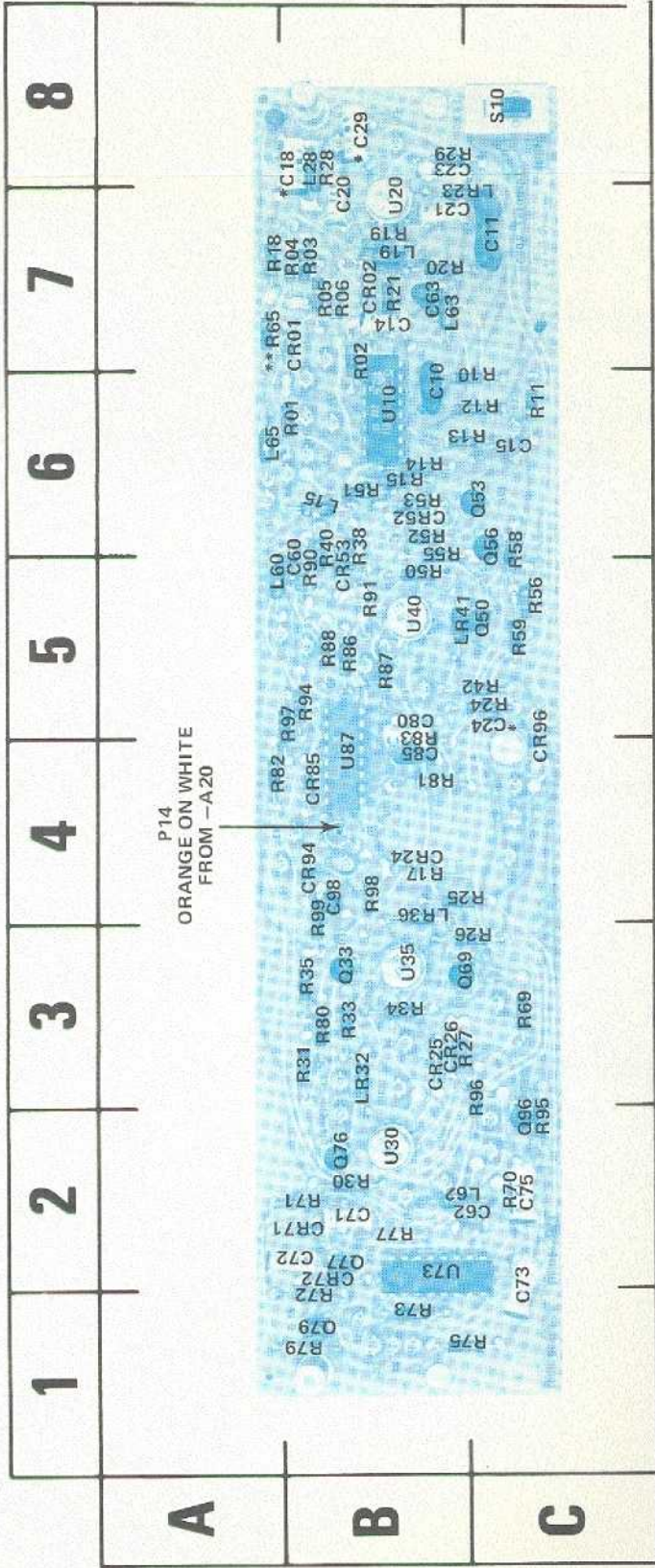
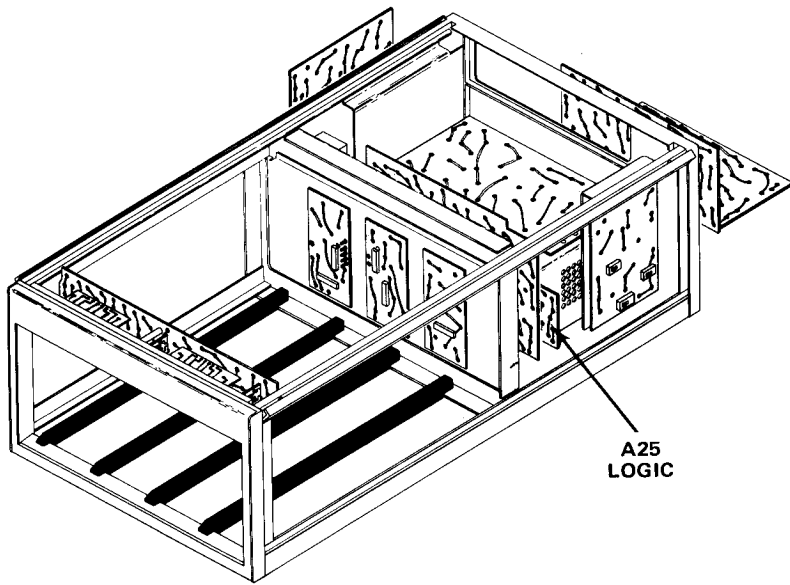

Fig. 6-6. A25 - Logic circuit board.

\*\* Relocated to back of board.

\* See Parts List for serial number ranges.

| CKT NO | GRID LOC | CKT NO | GRID LOC | CKT NO | GRID LOC | CKT NO | GRID LOC | CKT NO | GRID LOC | CKT NO | GRID LOC | CKT NO | GRID LOC | CKT NO | GRID LOC | CKT NO | GRID LOC | CKT NO | GRID LOC |  |  |
|--------|----------|--------|----------|--------|----------|--------|----------|--------|----------|--------|----------|--------|----------|--------|----------|--------|----------|--------|----------|--|--|
| C10    | 6B       | C85    | 4B       | L28    | 8B       | Q56    | 6C       | R14    | 6B       | R34    | 3B       | R71    | 2B       | R95    | 2C       |        |          |        |          |  |  |
| C11    | 7C       | C98    | 4B       | L60    | 5A       | Q69    | 3B       | R15    | 6B       | R35    | 3B       | R72    | 1B       | R96    | 3C       |        |          |        |          |  |  |
| C14    | 7B       |        |          | L62    | 2B       | Q76    | 2B       | R17    | 4B       | R38    | 6B       | R73    | 1B       | R97    | 5B       |        |          |        |          |  |  |
| C15    | 6C       |        |          | L63    | 7B       | Q77    | 2B       | R18    | 7A       | R40    | 6B       | R75    | 1B       | R98    | 4B       |        |          |        |          |  |  |
| C18    | 8B       |        |          | L65    | 6A       | Q79    | 1B       | R19    | 7B       | R42    | 5C       | R77    | 2B       | R99    | 4B       |        |          |        |          |  |  |
| C20    | 7B       |        |          |        |          | Q96    | 2C       | R20    | 7B       | R50    | 5B       | R79    | 1B       |        |          |        |          |        |          |  |  |
| C21    | 7B       |        |          | LR23   | 7B       |        |          | R21    | 7B       | R51    | 6B       | R80    | 3B       | S10    | 8C       |        |          |        |          |  |  |
| C23    | 8B       |        |          | LR32   | 3B       | R01    | 6B       | R24    | 5C       | R52    | 6B       | R81    | 4B       |        |          |        |          |        |          |  |  |
| C24    | 5C       |        |          | LR36   | 4B       | R02    | 7B       | R25    | 4B       | R53    | 6B       | R82    | 4A       | U10    | 6B       |        |          |        |          |  |  |
| C29    | 8B       |        |          | LR41   | 5B       | R03    | 7B       | R26    | 3C       | R55    | 6B       | R83    | 4B       | U20    | 7B       |        |          |        |          |  |  |
| C60    | 5B       |        |          |        |          | R04    | 7B       | R27    | 3B       | R56    | 5C       | R86    | 5B       | U30    | 2B       |        |          |        |          |  |  |
| C62    | 2B       |        |          | P14    | 4B       | R05    | 7B       | R28    | 8B       | R58    | 6C       | R87    | 5B       | U35    | 3B       |        |          |        |          |  |  |
| C63    | 7B       |        |          |        |          | R06    | 7B       | R29    | 8B       | R59    | 5C       | R88    | 5B       | U40    | 5B       |        |          |        |          |  |  |
| C65    | 8B       |        |          | Q33    | 3B       | R10    | 6C       | R30    | 2B       | R65    | 7A       | R90    | 5B       | U40    | 5B       |        |          |        |          |  |  |
| C71    | 2B       |        |          | Q50    | 5C       | R11    | 6C       | R31    | 3B       | R69    | 3C       | R91    | 5B       | U73    | 2B       |        |          |        |          |  |  |
| C72    | 2B       |        |          | Q63    | 6C       | R12    | 6C       | R33    | 3B       | R70    | 2C       | R94    | 5B       | U87    | 4B       |        |          |        |          |  |  |
| C73    | 2C       |        |          |        |          |        |          |        |          |        |          |        |          |        |          |        |          |        |          |  |  |
| C75    | 2C       |        |          |        |          |        |          |        |          |        |          |        |          |        |          |        |          |        |          |  |  |



A25  
LOGIC

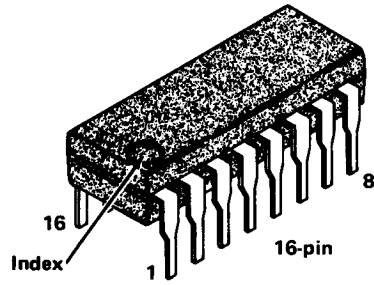
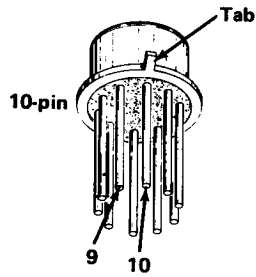
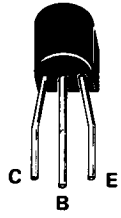

Fig. 6-7. Electrode configuration for semiconductors shown on diagram 3.

## VOLTAGE AND WAVEFORM CONDITIONS

The voltages and waveforms shown on this diagram were obtained with the test set-ups and equipment listed below. These measurements are not absolute and may vary slightly between instruments.

### Recommended Test Equipment

| Item  | Specifications  | Examples of Applicable Test Equipment  |
|---|---|--|
| Test oscilloscope                             | Frequency response, dc to 65 MHz; deflection factor (with 10X probe), 500 mV/division; fastest sweep rate, 500 ns/division. | a. Tektronix 7603 Oscilloscope with 7A15A Amplifier, 7B50 Time Base, and P6053A Probe, or equivalent.              |
| Dc voltmeter (non-loading digital multimeter) | Input impedance, 10 megohms; range, 0 to 20 volts dc.   | a. Tektronix 7D13 Digital Multimeter (test oscilloscope must have readout system).<br><br>b. Fairchild Model 7050. |

### Test Set-Up

**7704A Under Test:** Amplifier unit installed in LEFT VERT compartment. Time-base unit installed in B HORIZ compartment. Time-base unit set for free-running sweep at 0.1-ms/division sweep rate.

#### Front-Panel Controls

|                        |           |
|------------------------|-----------|
| Knob-type controls     | Midrange  |
| VERTICAL MODE          | LEFT      |
| A AND B TRIGGER SOURCE | VERT MODE |
| HORIZONTAL MODE        | B         |

**Test Equipment:** Voltmeter common is connected to 7704A chassis ground. Test oscilloscope is internally triggered.



**VOLTAGE & WAVEFORM CONDITIONS**

P/O MAIN INTERFACE 20

LEFT PLUG-IN MODE FROM J1-B35  
RIGHT PLUG-IN MODE FROM J2-B35

FROM J3-B10  
FROM J4-B10  
B HOLDOFF FROM J4-B4  
A HOLDOFF FROM J3-B4  
A GATE FROM R2016  
B GATE FROM R2022  
A GATE FROM R2025  
DELAY MODE CONTROL OUT FROM J3-B2  
AUX Z AXIS FROM: R2010, R2012, R2080, R2092  
AUX Z AXIS COMMON FROM B17-J1, J2, J3, J4

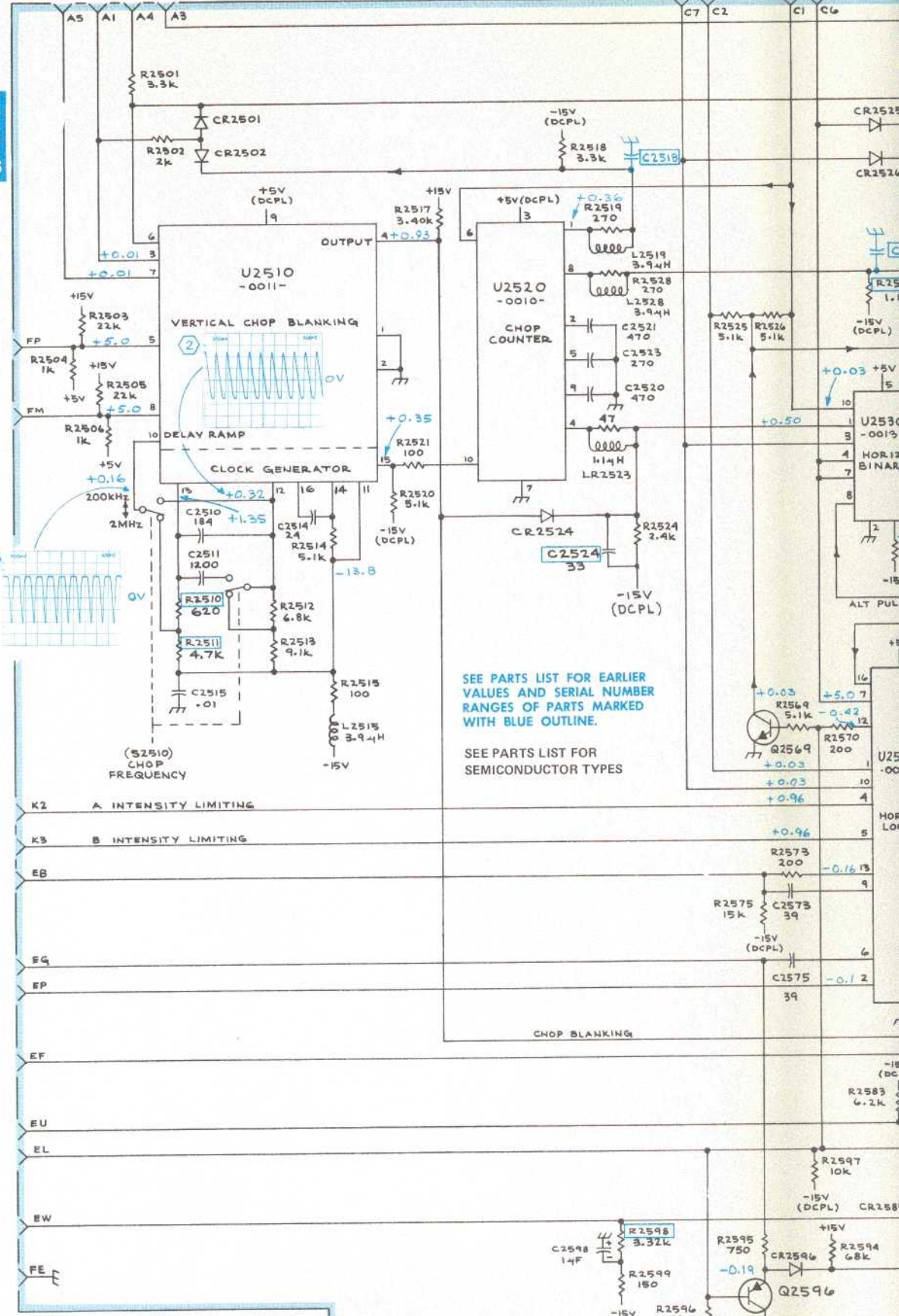

SEE PARTS LIST FOR EARLIER VALUES AND SERIAL NUMBER RANGES OF PARTS MARKED WITH BLUE OUTLINE.  
SEE PARTS LIST FOR SEMICONDUCTOR TYPES

7704A (ACQUISITION UNIT)



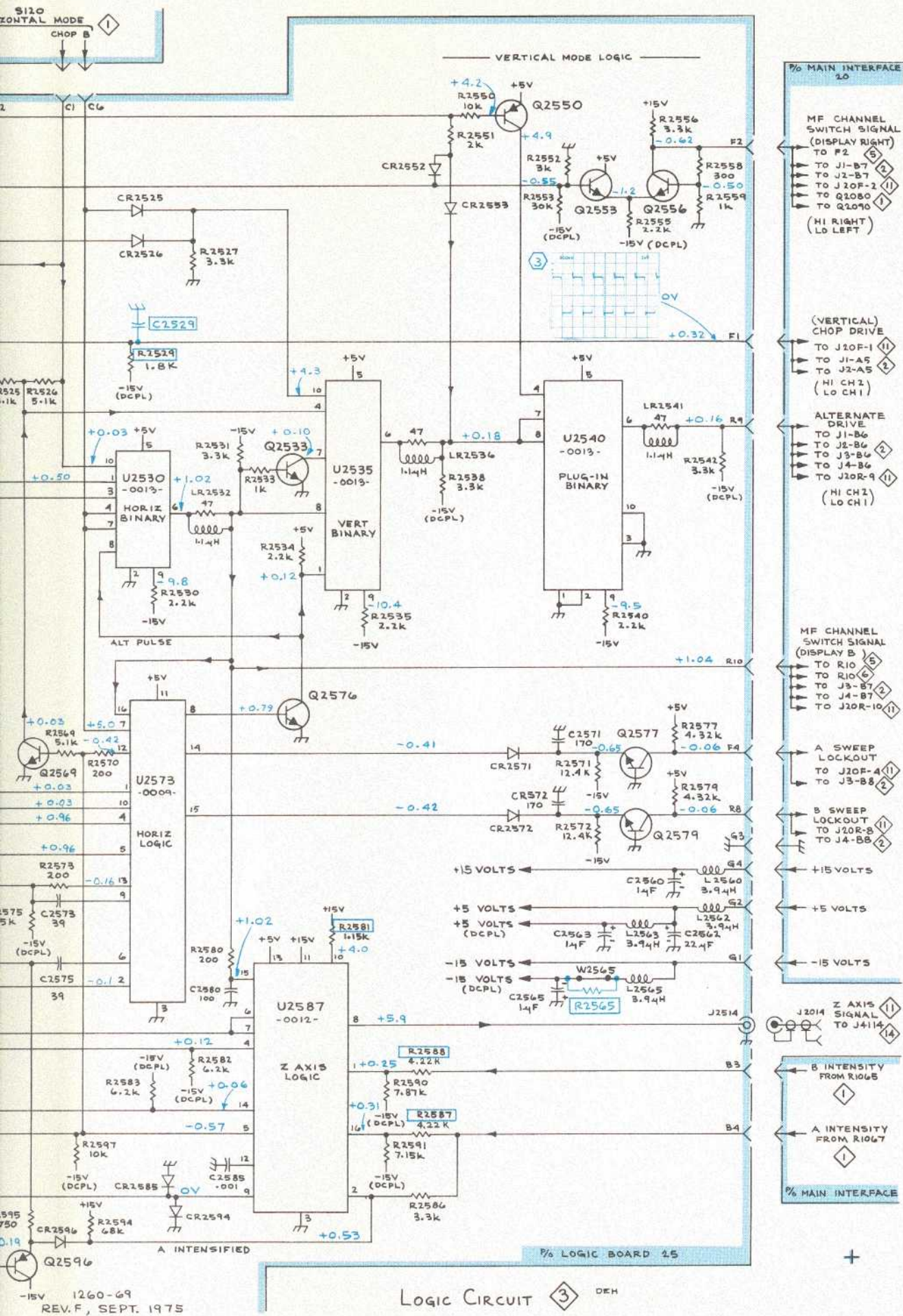

LOGIC CIRCUIT 3 DEH

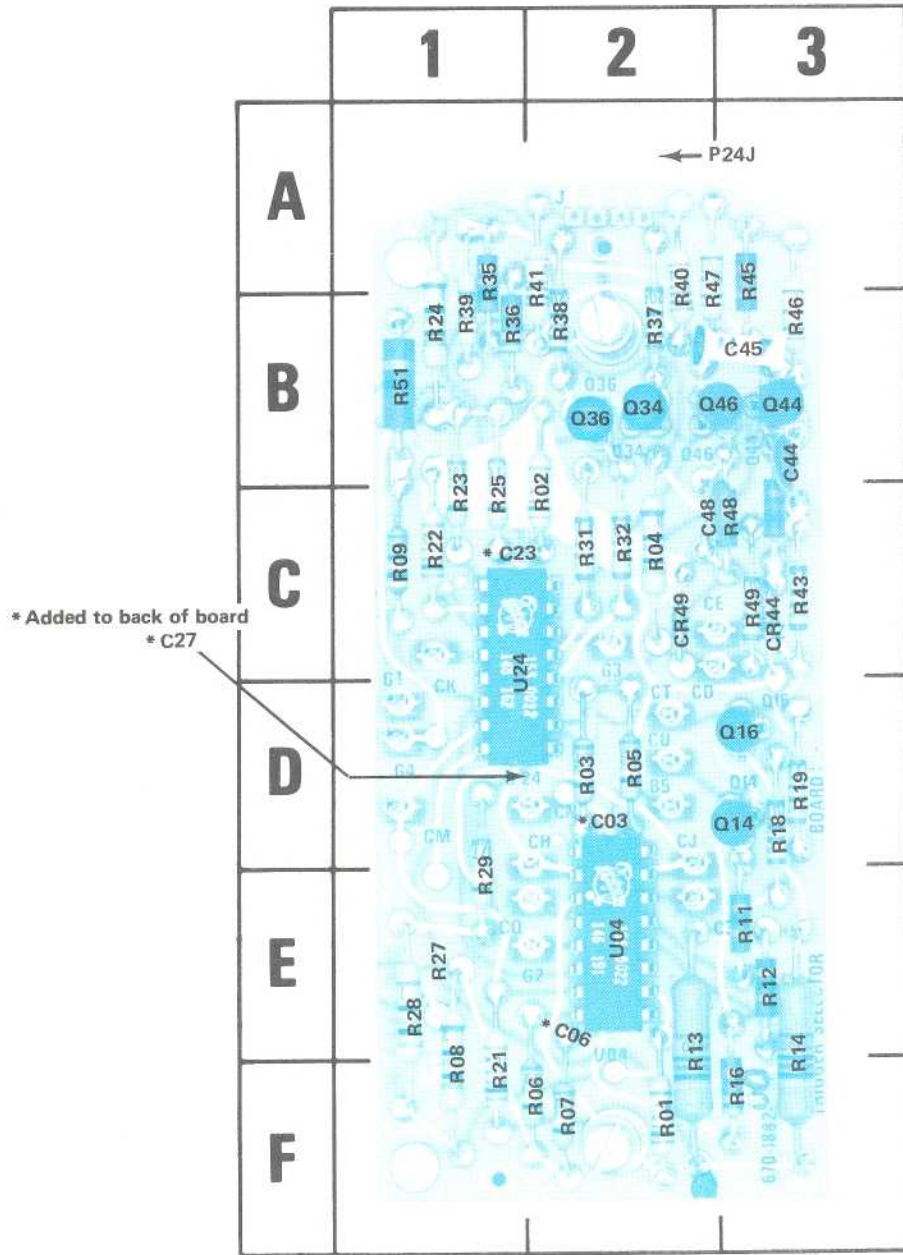
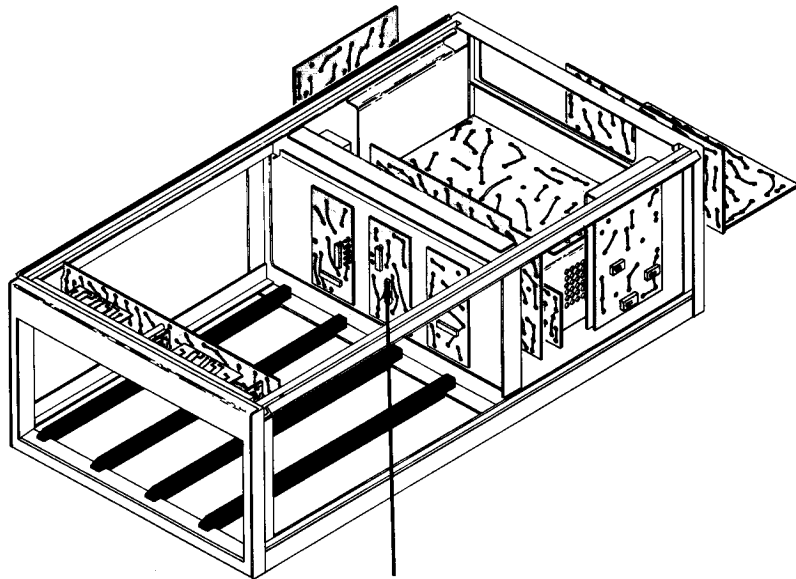

Fig. 6-8. A24 – Trigger Selector circuit board.

\*See Parts List for serial number ranges.

ASSEMBLY A24

| CKT NO | GRID LOC | CKT NO | GRID LOC | CKT NO | GRID LOC | CKT NO | GRID LOC | CKT NO | GRID LOC | CKT NO | GRID LOC | CKT NO | GRID LOC | CKT NO | GRID LOC |
|--------|----------|--------|----------|--------|----------|--------|----------|--------|----------|--------|----------|--------|----------|--------|----------|
| C03    | 2D       | Q14    | 3D       | R03    | 2D       | R11    | 3E       | R21    | 1F       | R29    | 1D       | R39    | 1B       | R48    | 3C       |
| C06    | 2F       | Q16    | 3D       | R04    | 2C       | R12    | 3E       | R22    | 1C       | R31    | 2C       | R40    | 2A       | R49    | 3C       |
| C23    | 1C       | Q34    | 2B       | R05    | 2D       | R13    | 2E       | R23    | 1C       | R32    | 2C       | R41    | 2A       | R51    | 1B       |
| C27    | 1D       | Q36    | 2B       | R06    | 2F       | R14    | 3E       | R24    | 1B       | R35    | 1B       | R43    | 3C       |        |          |
| C44    | 3B       | Q44    | 3B       | R07    | 2F       | R16    | 3F       | R25    | 1C       | R36    | 1B       | R45    | 3A       | U04    | 2E       |
| C48    | 2C       | Q46    | 3B       | R08    | 1E       | R18    | 3D       | R27    | 1E       | R37    | 2B       | R46    | 3B       | U24    | 1C       |
| C54    | 3B       |        |          | R09    | 1C       | R19    | 3D       | R28    | 1E       | R38    | 2B       | R47    | 2A       |        |          |
| CR44   | 3C       | R01    | 2F       |        |          |        |          |        |          |        |          |        |          |        |          |
| CR49   | 2C       | R02    | 2C       |        |          |        |          |        |          |        |          |        |          |        |          |



A24  
TRIGGER  
SELECTOR

## VOLTAGE CONDITIONS

The voltages shown on this diagram were obtained with the test set-up and equipment listed below. These measurements are not absolute and may vary slightly between instruments.

### Recommended Test Equipment

| Item  | Specifications  | Examples of Applicable Test Equipment  |
|---|---|--|
| Dc voltmeter (non-loading digital multimeter) | Input impedance, 10 megohms; range, 0 to 20 volts dc. | a. Tektronix 7D13 Digital Multimeter (test oscilloscope must have readout system).<br><br>b. Fairchild Model 7050. |

### Test Set-Up

**7704A Under Test:** No plug-in units installed.

**Front-Panel Controls**

|                        |           |
|------------------------|-----------|
| Knob-type controls     | Midrange  |
| VERTICAL MODE          | LEFT      |
| A AND B TRIGGER SOURCE | VERT MODE |
| HORIZONTAL MODE        | B         |

**Test Equipment:** Voltmeter common is connected to 7704A chassis ground.

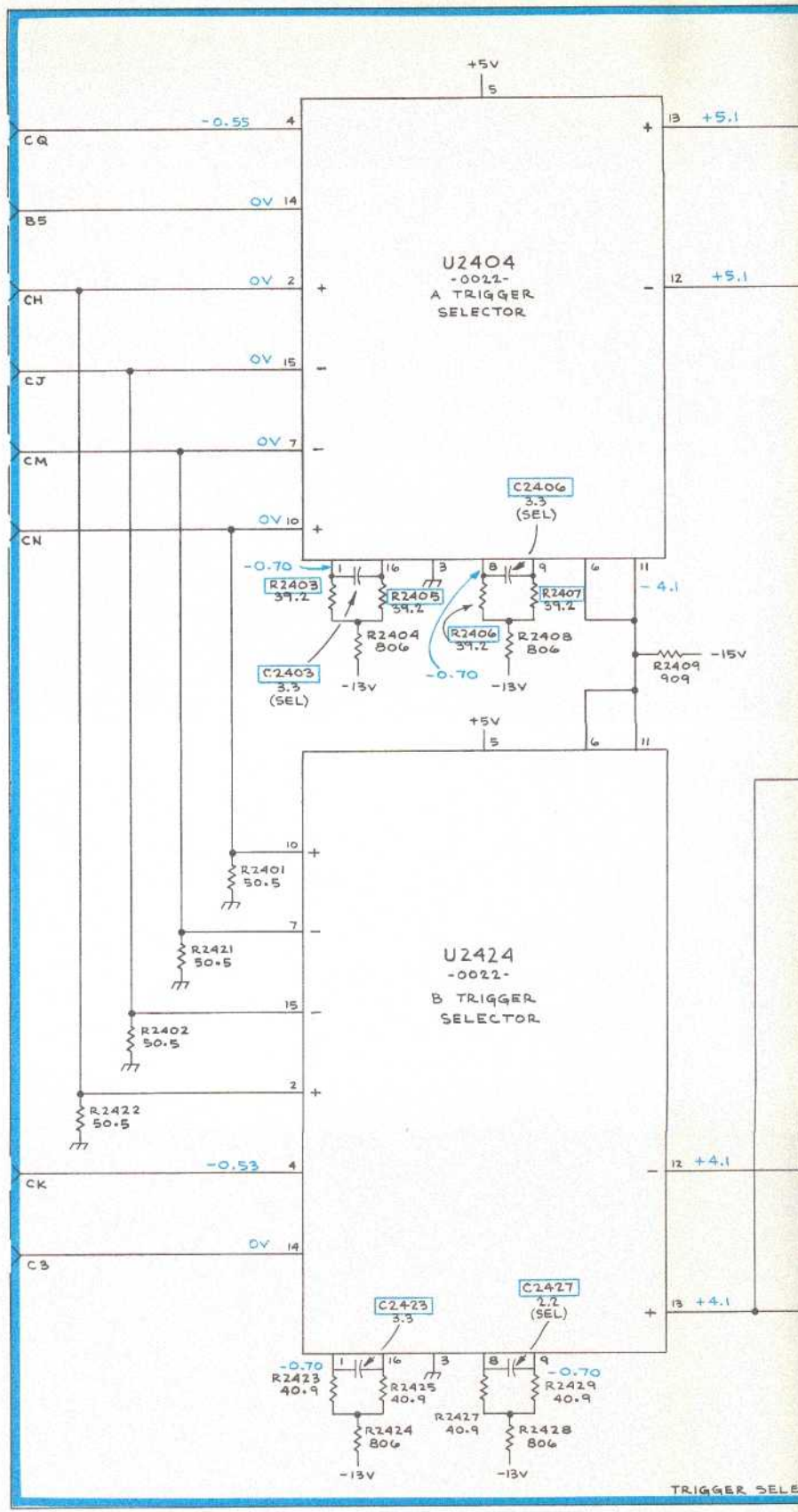
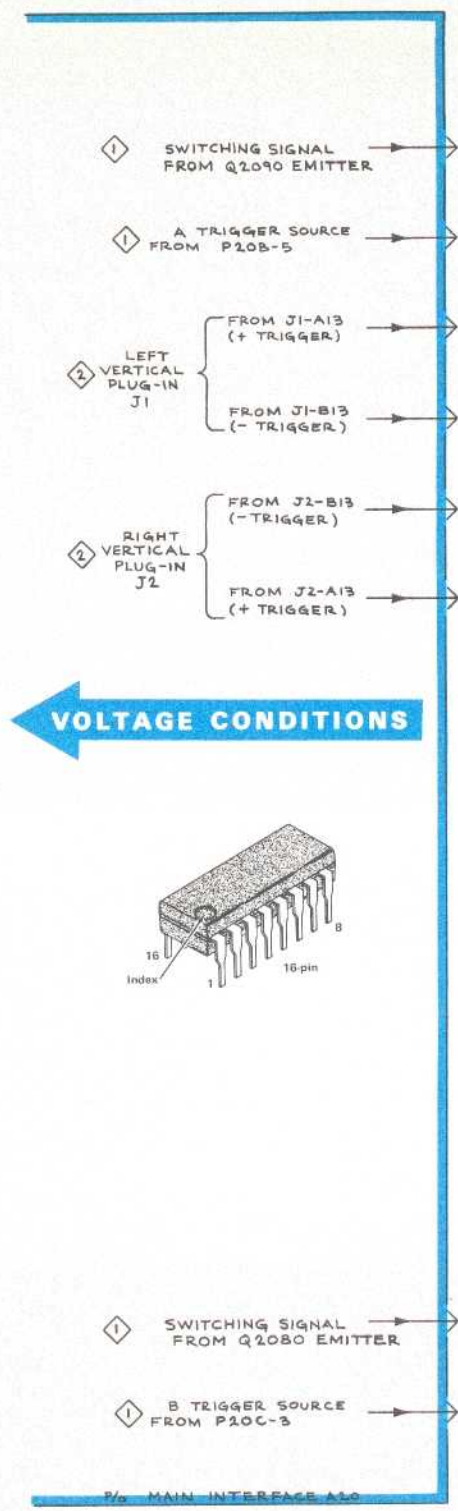

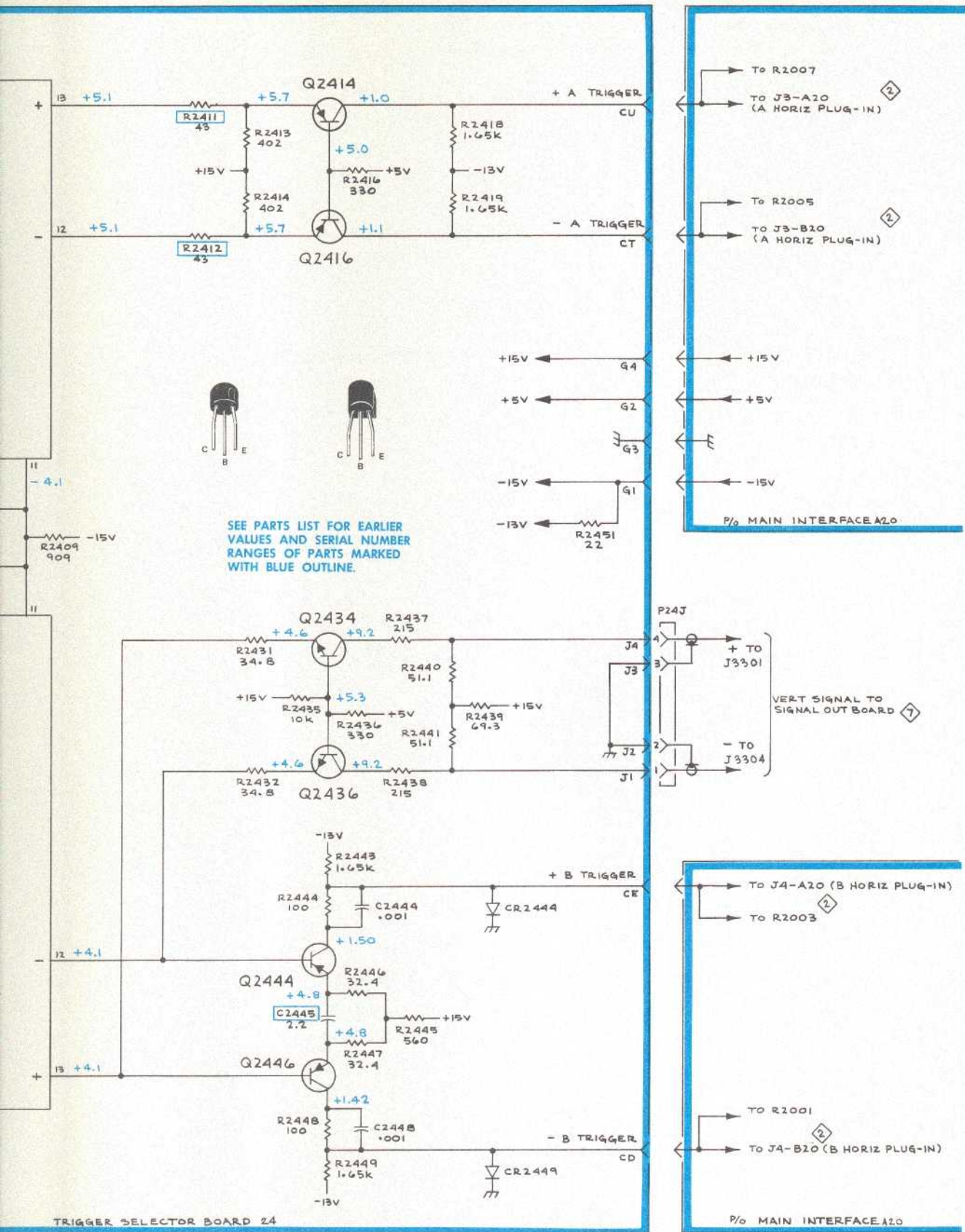

TRIGGER SELECTOR 4

DEH

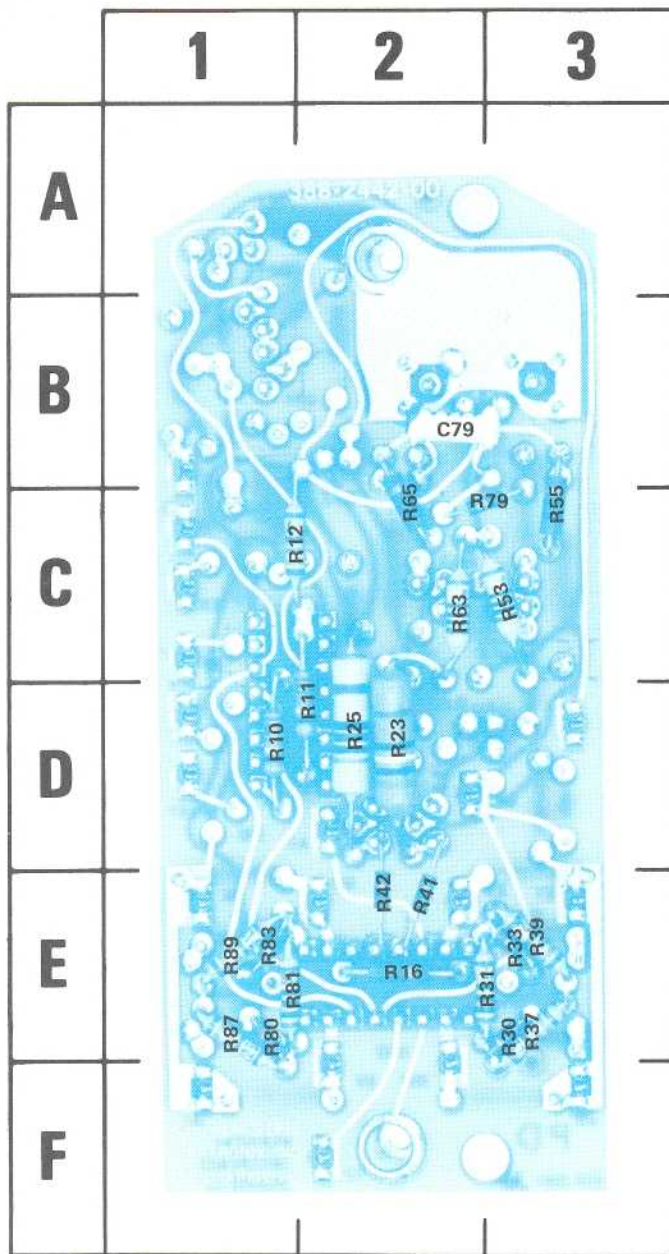
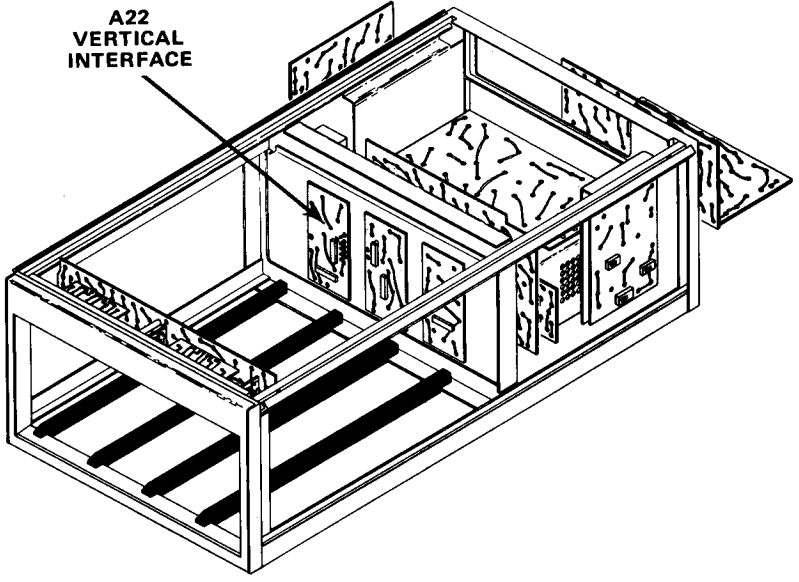

Fig. 6-10 A22 – Vertical Interface circuit board (rear view).

| CKT NO | GRID LOC | CKT NO | GRID LOC | CKT NO | GRID LOC | CKT NO | GRID LOC |
|--------|----------|--------|----------|--------|----------|--------|----------|
| C79    | 2B       | R25    | 2D       | R42    | 2E       | R81    | 1E       |
|        |          | R30    | 3E       | R53    | 3C       | R83    | 1E       |
| R10    | 1D       | R31    | 3E       | R55    | 3C       | R87    | 1E       |
| R11    | 2D       | R33    | 3E       | R63    | 2C       | R89    | 1E       |
| R12    | 1C       | R37    | 3E       | R65    | 2C       |        |          |
| R16    | 2E       | R39    | 3E       | R79    | 3C       |        |          |
| R23    | 2D       | R41    | 2E       | R80    | 1E       |        |          |

A22  
VERTICAL  
INTERFACE





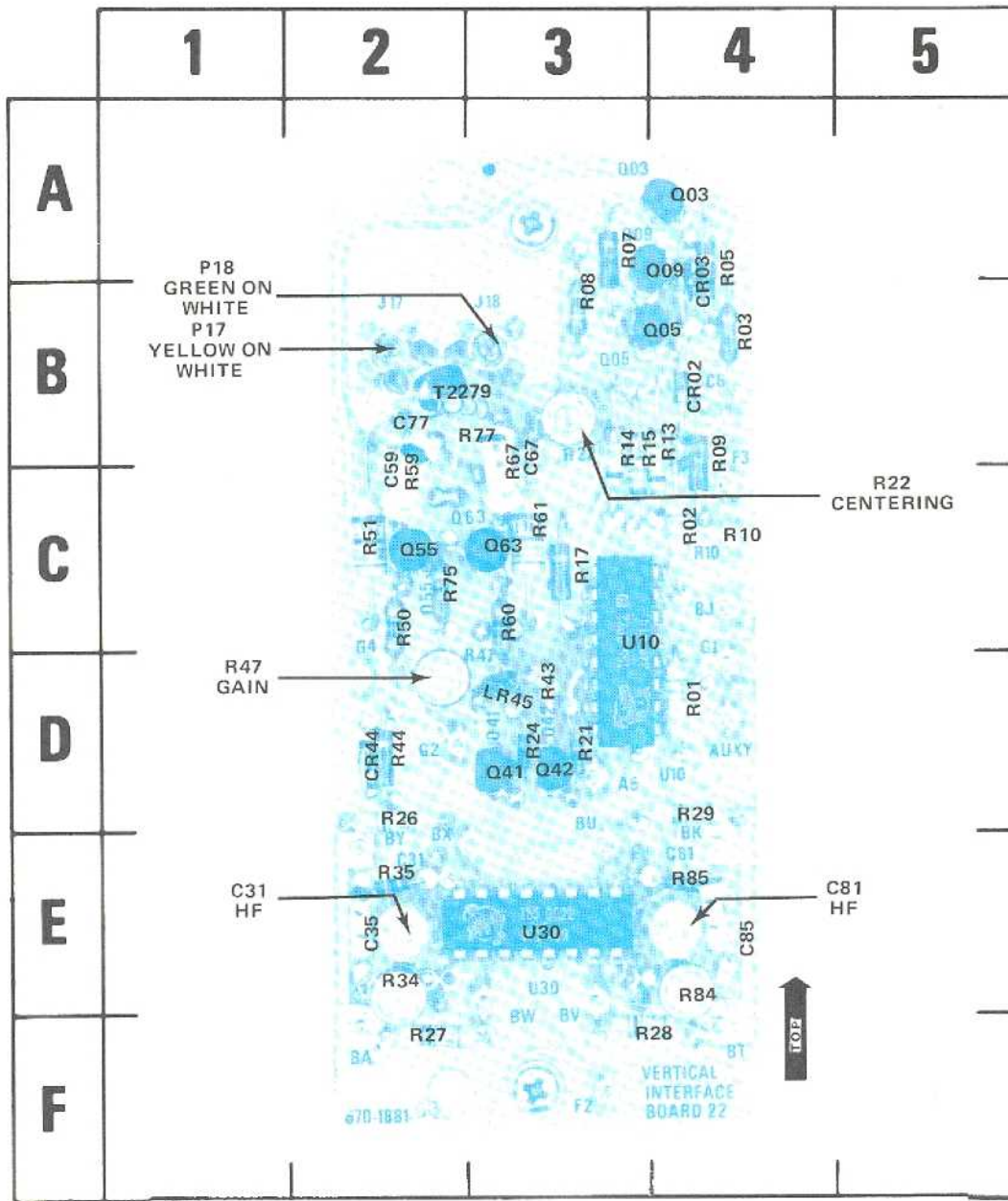

Fig. 6-9. A22 – Vertical Interface circuit board (front view).

| CKT NO | GRID LOC | CKT NO | GRID LOC | CKT NO | GRID LOC | CKT NO | GRID LOC | CKT NO | GRID LOC | CKT NO | GRID LOC | CKT NO | GRID LOC | CKT NO | GRID LOC |
|--------|----------|--------|----------|--------|----------|--------|----------|--------|----------|--------|----------|--------|----------|--------|----------|
| C31    | 2E       | CR44   | 2D       | Q41    | 3D       | R05    | 4A       | R17    | 3C       | R34    | 2E       | R60    | 3C       | T2279  | 2B       |
| C35    | 2E       | CR45   | 3D       | Q42    | 3D       | R07    | 3A       | R21    | 3D       | R35    | 2E       | R61    | 3C       |        |          |
| C59    | 2B       |        |          | Q55    | 2C       | R08    | 3A       | R22    | 3B       | R43    | 3D       | R67    | 3B       | U10    | 3C       |
| C67    | 3B       | P17    | 2B       | Q63    | 3C       | R09    | 4B       | R24    | 3D       | R44    | 2D       | R75    | 2C       | U30    | 3E       |
| C77    | 2B       |        |          |        |          | R10    | 4C       | R26    | 2D       | R47    | 2D       | R77    | 2B       |        |          |
| C81    | 4E       |        |          |        |          | R13    | 4B       | R27    | 2F       | R50    | 2C       | R84    | 4E       |        |          |
| C85    | 4E       | Q03    | 4A       | R01    | 4D       | R14    | 3B       | R28    | 4F       | R51    | 2C       | R85    | 4E       |        |          |
| CR02   | 4B       | Q05    | 4B       | R02    | 4C       | R15    | 4B       | R29    | 4D       | R59    | 2B       |        |          |        |          |
| CR03   | 4A       | Q09    | 4A       | R03    | 4B       |        |          |        |          |        |          |        |          |        |          |

## VOLTAGE CONDITIONS

The voltages shown on this diagram were obtained with the test set-up and equipment listed below. These measurements are not absolute and may vary slightly between instruments.

### Recommended Test Equipment

| Item  | Specifications  | Examples of Applicable Test Equipment  |
|---|---|--|
| Dc voltmeter (non-loading digital multimeter) | Input impedance, 10 megohms; range, 0 to 20 volts dc. | a. Tektronix 7D13 Digital Multimeter (test oscilloscope must have readout system).<br><br>b. Fairchild Model 7050. |

### Test Set-Up

7704A Under Test: No plug-in units installed.

#### Front-Panel Controls

|                        |           |
|------------------------|-----------|
| Knob-type controls     | Midrange  |
| VERTICAL MODE          | LEFT      |
| A AND B TRIGGER SOURCE | VERT MODE |
| HORIZONTAL MODE        | B         |

Test Equipment: Voltmeter common is connected to 7704A chassis ground.

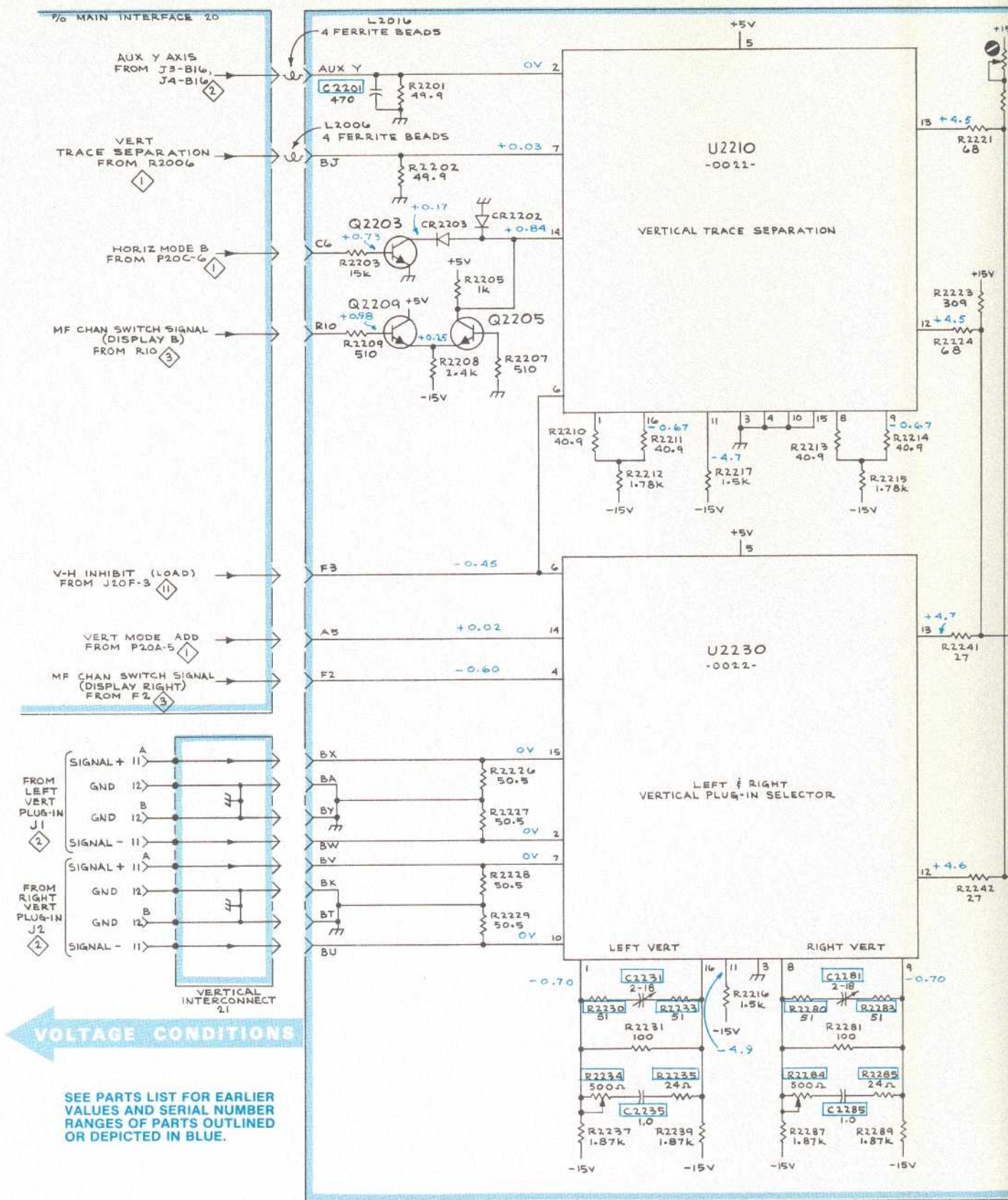

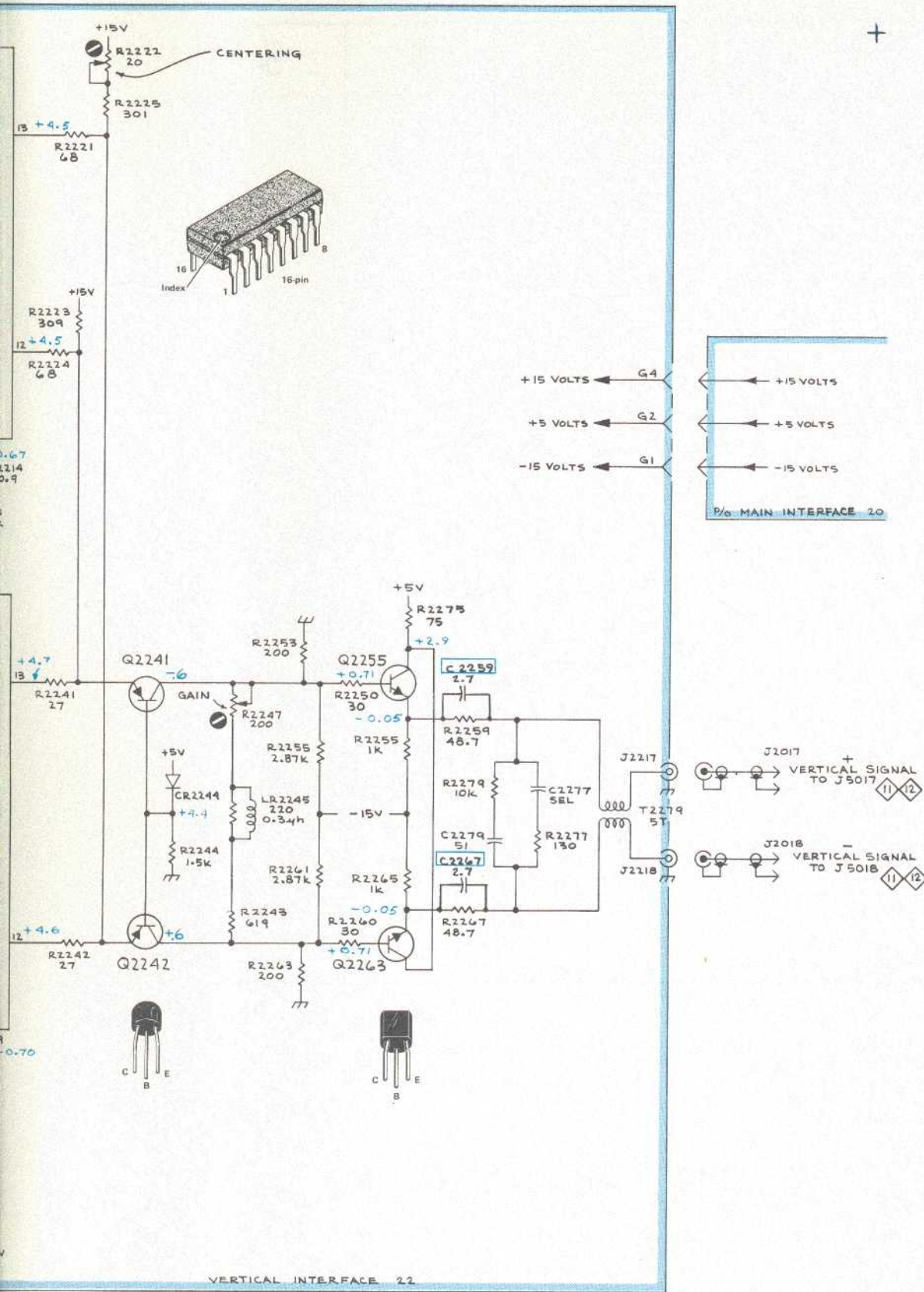

VERTICAL INTERFACE 5

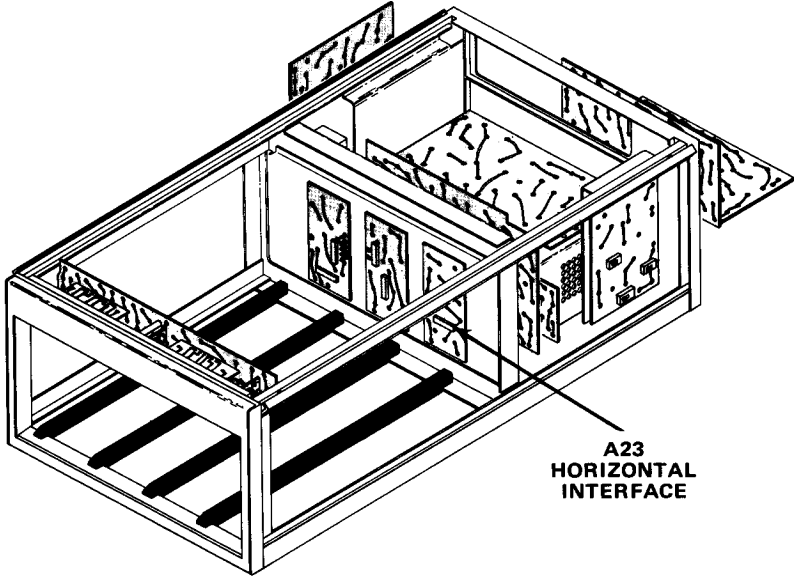

A23  
HORIZONTAL  
INTERFACE

ASSEMBLY A23

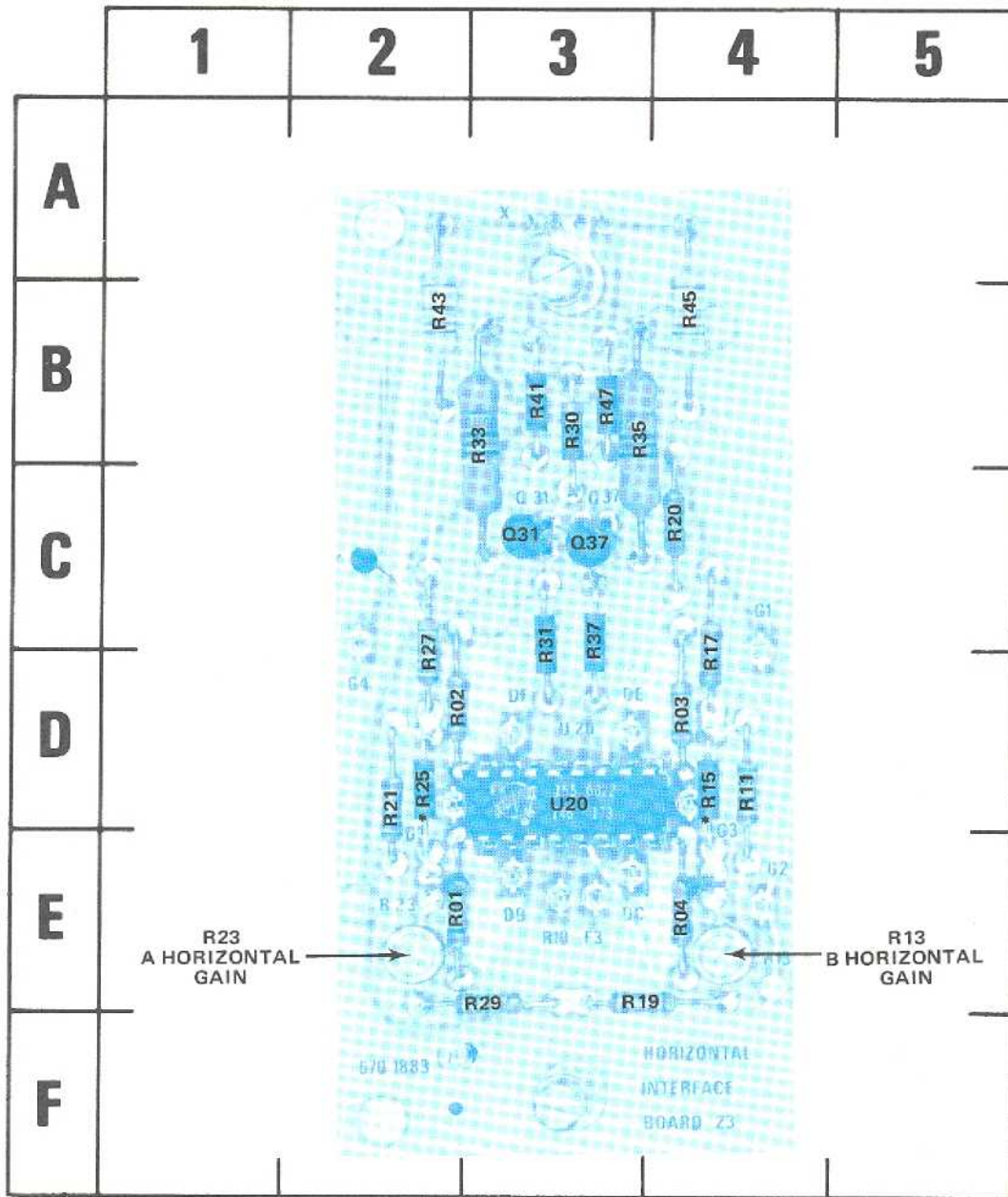

Fig. 6-11. A23 – Horizontal Interface circuit board.

\*See Parts List for serial number ranges.

| CKT NO | GRID LOC | CKT NO | GRID LOC | CKT NO | GRID LOC | CKT NO | GRID LOC |
|--------|----------|--------|----------|--------|----------|--------|----------|
| Q31    | 3C       | R11    | 4D       | R25    | 2D       | R37    | 3C       |
| Q37    | 3C       | R13    | 4E       | R27    | 2C       | R41    | 3B       |
|        |          | R15    | 4D       | R29    | 3E       | R43    | 2B       |
| R01    | 2E       | R17    | 4C       | R30    | 3B       | R45    | 4B       |
| R02    | 2D       | R19    | 3E       | R31    | 3C       | R47    | 3B       |
| R03    | 4D       | R20    | 4C       | R33    | 3B       |        |          |
| R04    | 4E       | R21    | 2D       | R35    | 3B       | U20    | 3D       |
|        |          | R23    | 2E       |        |          |        |          |

## VOLTAGE CONDITIONS

The voltages shown on this diagram were obtained with the test set-up and equipment listed below. These measurements are not absolute and may vary slightly between instruments.

### Recommended Test Equipment

| Item  | Specifications  | Examples of Applicable Test Equipment  |
|---|---|--|
| Dc voltmeter (non-loading digital multimeter) | Input impedance, 10 megohms; range, 0 to 20 volts dc. | a. Tektronix 7D13 Digital Multimeter (test oscilloscope must have readout system).<br>b. Fairchild Model 7050. |

### Test Set-Up

7704A Under Test: No plug-in units installed.

#### Front-Panel Controls

|                        |           |
|------------------------|-----------|
| Knob-type controls     | Midrange  |
| VERTICAL MODE          | LEFT      |
| A AND B TRIGGER SOURCE | VERT MODE |
| HORIZONTAL MODE        | B         |

Test Equipment: Voltmeter common is connected to 7704A chassis ground.

+

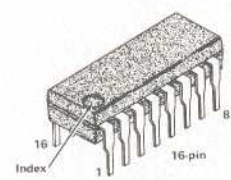
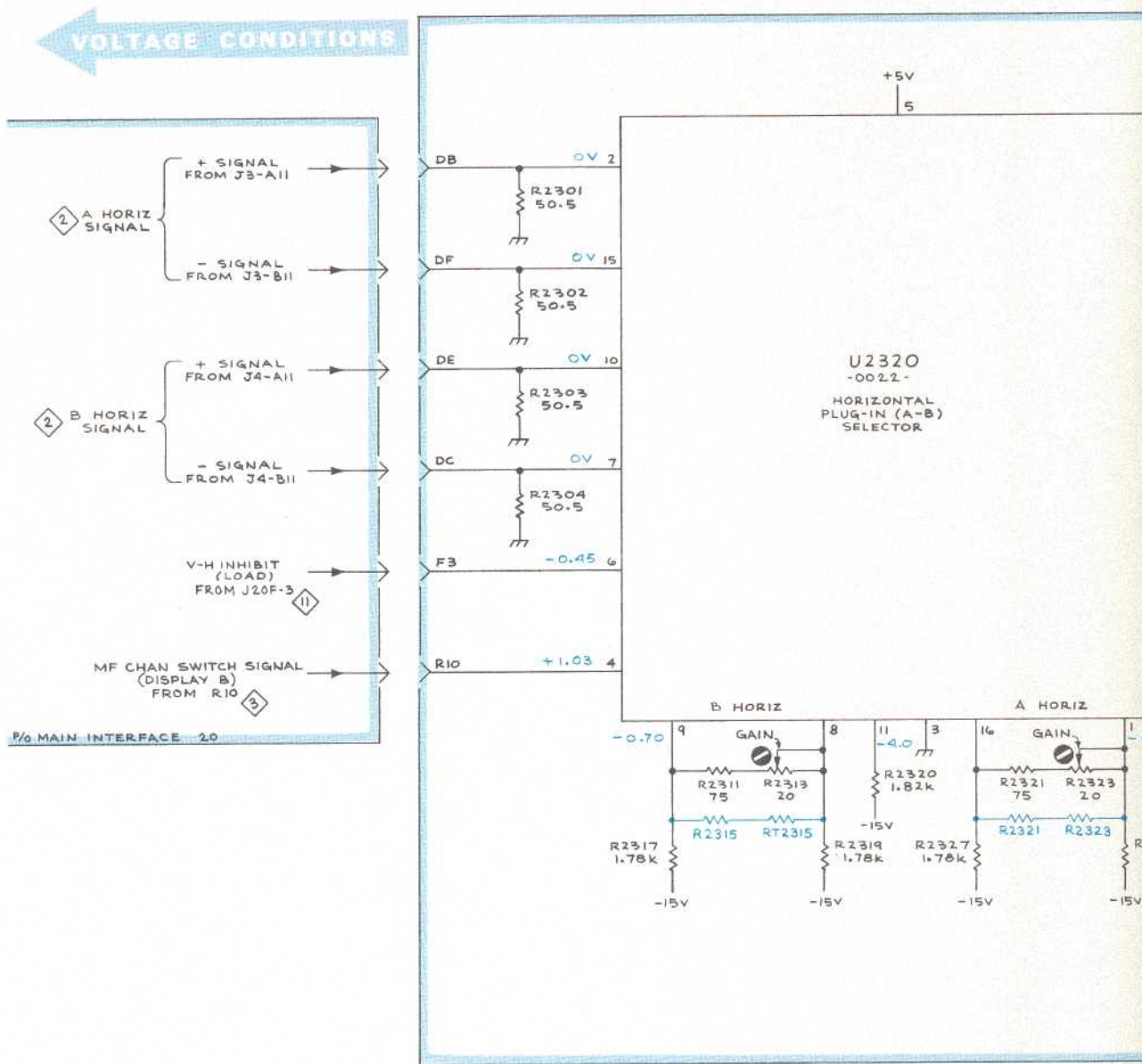



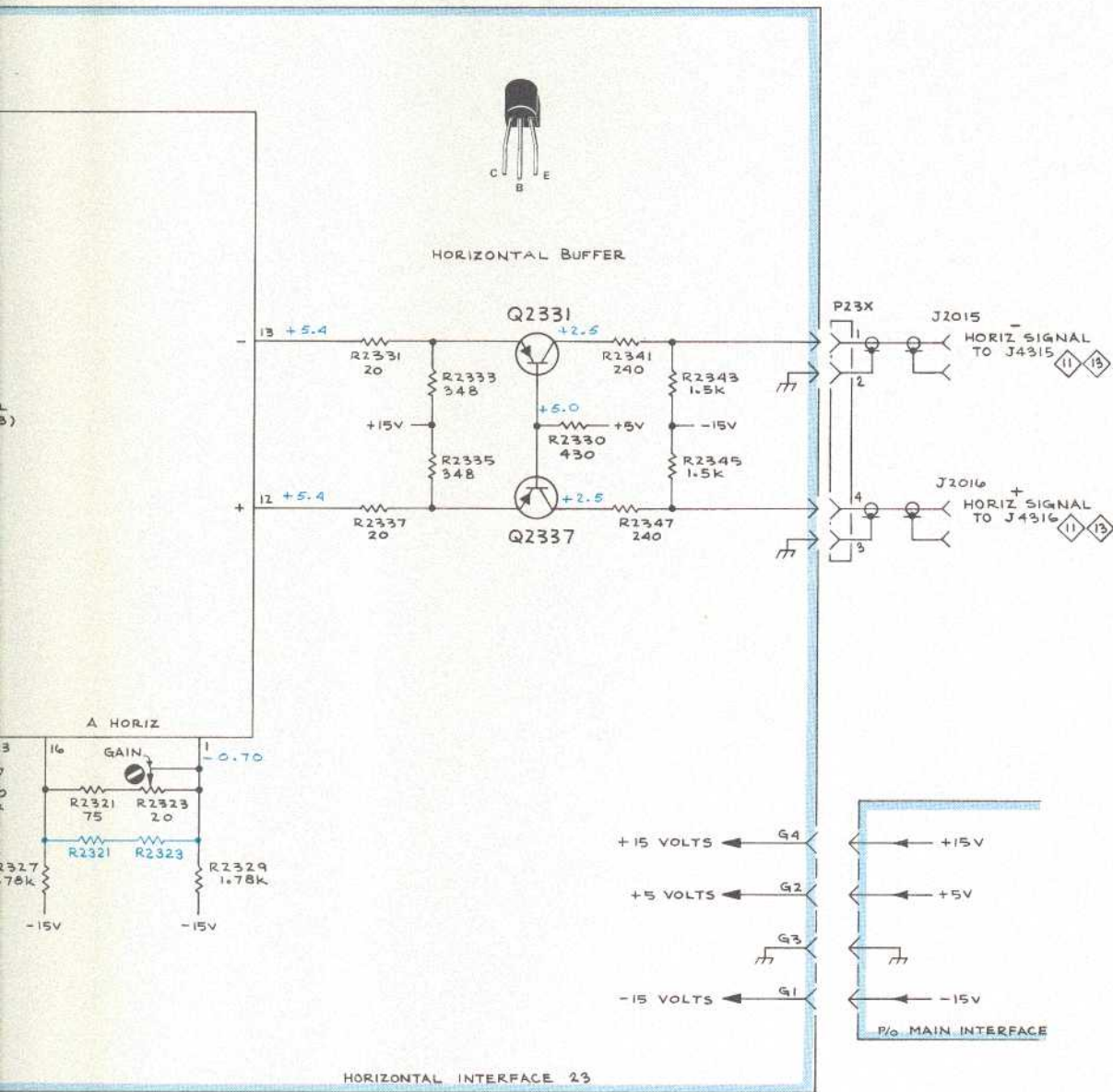

HORIZONTAL  
INTERFACE

6

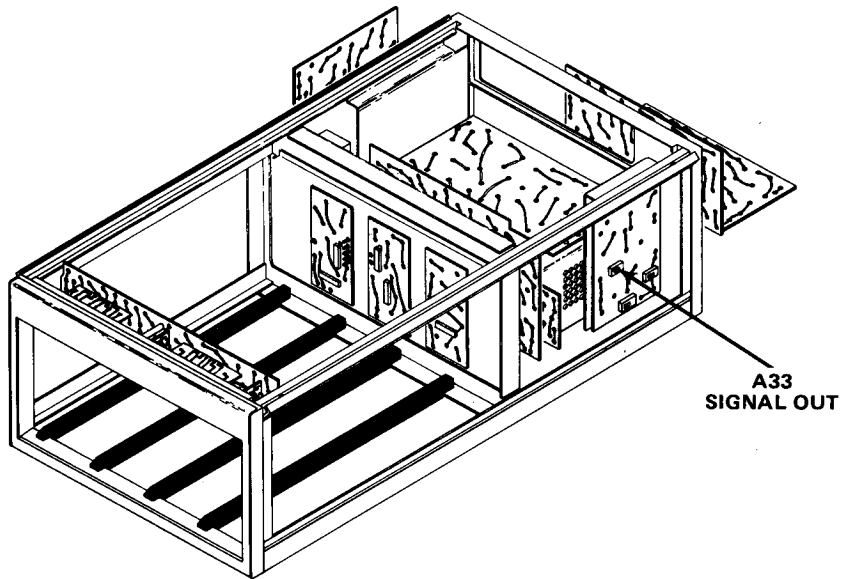

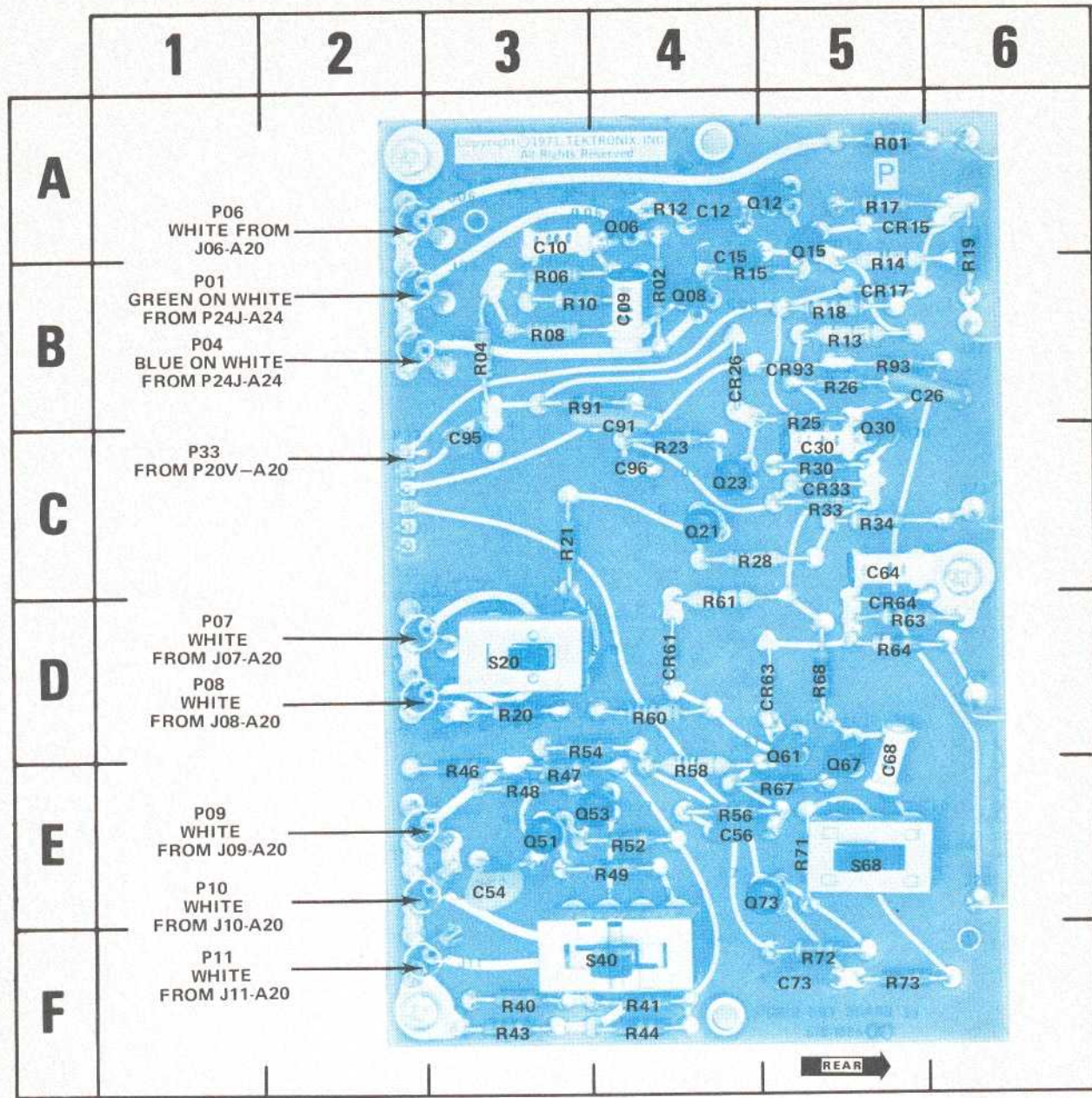

Fig. 6-12. A33 — Signal Out circuit board.

| CKT NO | GRID LOC | CKT NO | GRID LOC | CKT NO | GRID LOC | CKT NO | GRID LOC | CKT NO | GRID LOC | CKT NO | GRID LOC | CKT NO | GRID LOC | CKT NO | GRID LOC |
|--------|----------|--------|----------|--------|----------|--------|----------|--------|----------|--------|----------|--------|----------|--------|----------|
| C09    | 4B       | C95    | 3C       | P04    | 2B       | Q15    | 5A       | R03    | 3B       | R21    | 3C       | R46    | 3E       | R67    | 5E       |
| C10    | 3A       | C96    | 4C       | P06    | 2A       | Q21    | 4C       | R06    | 3B       | R23    | 4C       | R47    | 3E       | R68    | 5D       |
| C12    | 4A       |        |          | P07    | 2D       | Q23    | 4C       | R08    | 3B       | R25    | 5B       | R48    | 3E       | R71    | 5E       |
| C15    | 4A       | CR15   | 5A       | P08    | 2D       | Q30    | 5C       | R10    | 3B       | R26    | 5B       | R49    | 4E       | R72    | 5F       |
| C26    | 5B       | CR17   | 5B       | P09    | 2E       | Q51    | 3E       | R12    | 4A       | R28    | 4C       | R52    | 4E       | R73    | 5F       |
| C30    | 5C       | CR26   | 4B       | P10    | 2E       | Q53    | 3E       | R13    | 5B       | R30    | 5C       | R54    | 3D       | R91    | 3B       |
| C54    | 3E       | CR33   | 5C       | P11    | 2F       | Q61    | 5E       | R14    | 5B       | R33    | 5C       | R56    | 4E       | R93    | 5B       |
| C56    | 4E       | CR61   | 4D       | P33    | 2C       | Q67    | 5E       | R15    | 4B       | R34    | 5C       | R58    | 4E       |        |          |
| C64    | 5C       | CR63   | 5D       |        |          | Q73    | 5E       | R17    | 5A       | R40    | 3F       | R60    | 4D       | S20    | 3D       |
| C68    | 5E       | CR64   | 5D       |        |          |        |          | R18    | 5B       | R41    | 4F       | R61    | 4D       | S40    | 4F       |
| C73    | 5F       | CR93   | 5B       | Q06    | 4A       |        |          | R19    | 5B       | R43    | 3F       | R63    | 5D       | S68    | 5E       |
| C91    | 4C       |        |          | Q08    | 4B       | R01    | 5A       | R20    | 4B       | R44    | 4F       | R64    | 5D       |        |          |

## VOLTAGE AND WAVEFORM CONDITIONS

The voltages and waveforms shown on this diagram were obtained with the test set-ups and equipment listed below. These measurements are not absolute and may vary slightly between instruments.

### Recommended Test Equipment

| Item  | Specifications   | Examples of Applicable Test Equipment   |
|---|--|---|
| Test oscilloscope                             | Frequency response, dc to 65 MHz; deflection factor (with 10X probe), 100 mV/division to two V/division; fastest sweep rate, 500 $\mu$ s/division. | a. Tektronix 7603 Oscilloscope with 7A13 Differential Comparator, 7B50 Time Base, and P6053A Probe, or equivalent. (7A13 Differential Comparator used to obtain dc offset).<br><br>b. Use item (a) above with 7A15A Amplifier in place of 7A13. |
| Dc voltmeter (non-loading digital multimeter) | Input impedance, 10 megohms; range, 0 to 20 volts dc.  | a. Tektronix 7D13 Digital Multimeter (test oscilloscope must have readout system), or equivalent.<br><br>b. Fairchild Model 7050.   |

### Test Set-Up

**7704A Under Test:** Amplifier unit installed in LEFT VERT compartment. No signal applied for voltage measurements; trace is centered. For waveforms, the 7704A Calibrator signal is applied to the amplifier unit to obtain a centered, four-division display. A time-base unit is installed in the B HORIZ compartment. The time-base is set for auto triggering at a 0.1-ms/division sweep rate.

#### Front-Panel Controls

|                        |           |
|------------------------|-----------|
| Knob-type controls     | Midrange  |
| VERTICAL MODE          | LEFT      |
| A and B TRIGGER SOURCE | VERT MODE |
| HORIZONTAL MODE        | B         |

#### Internal Controls (on A33-Signal Output board)

|                |          |
|----------------|----------|
| Sweep Selector | B        |
| Gate Selector  | B        |
| Readout Mode   | Free-Run |

**Test Equipment:** Voltmeter common is connected to 7704A chassis ground. Test oscilloscope is externally triggered from 7704A +GATE OUT connector.

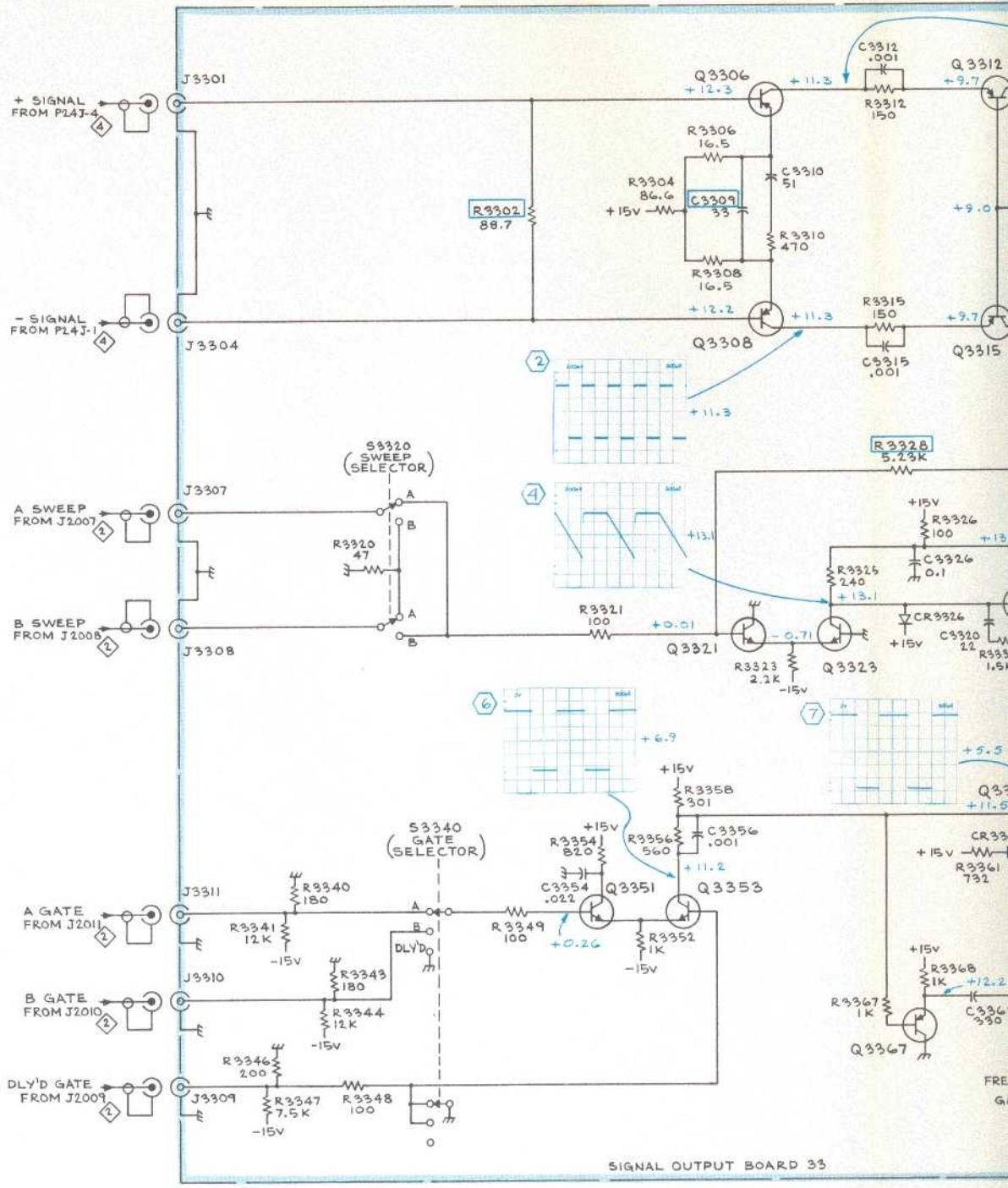

**VOLTAGE & WAVEFORM CONDITIONS**

SEE PARTS LIST FOR EARLIER VALUES AND SERIAL NUMBER RANGES OF PARTS OUTLINED OR DEPICTED IN BLUE.



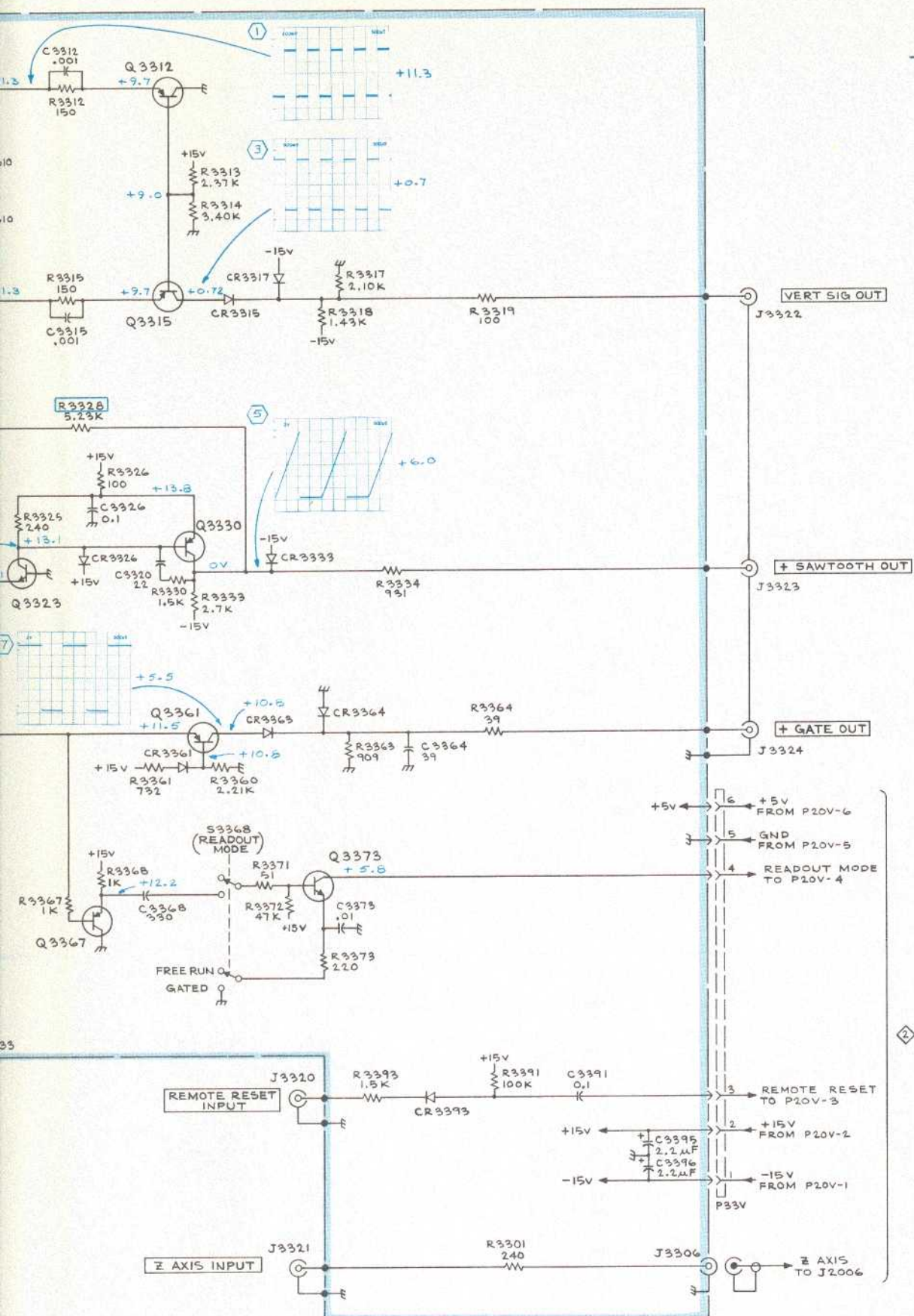

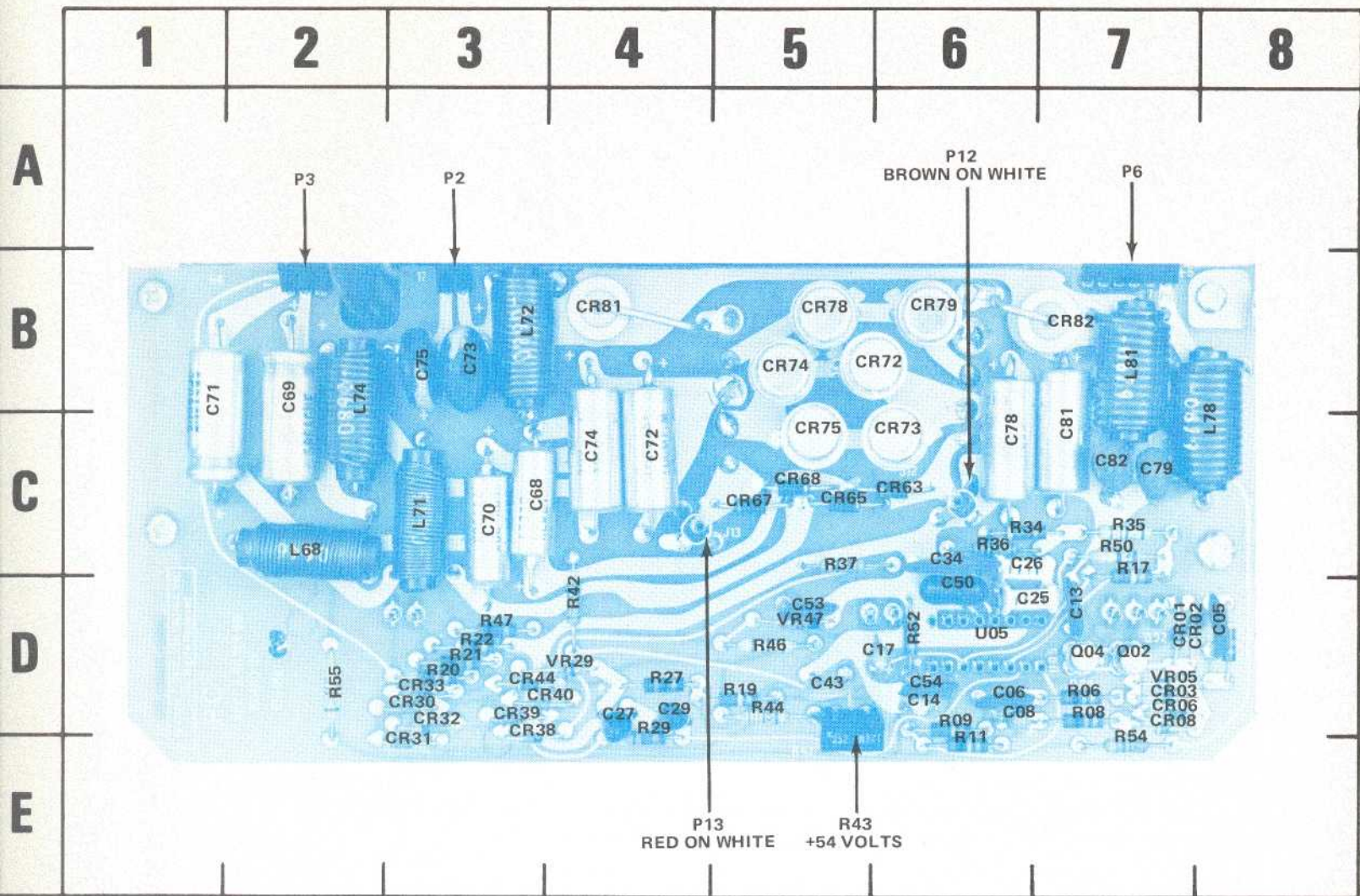
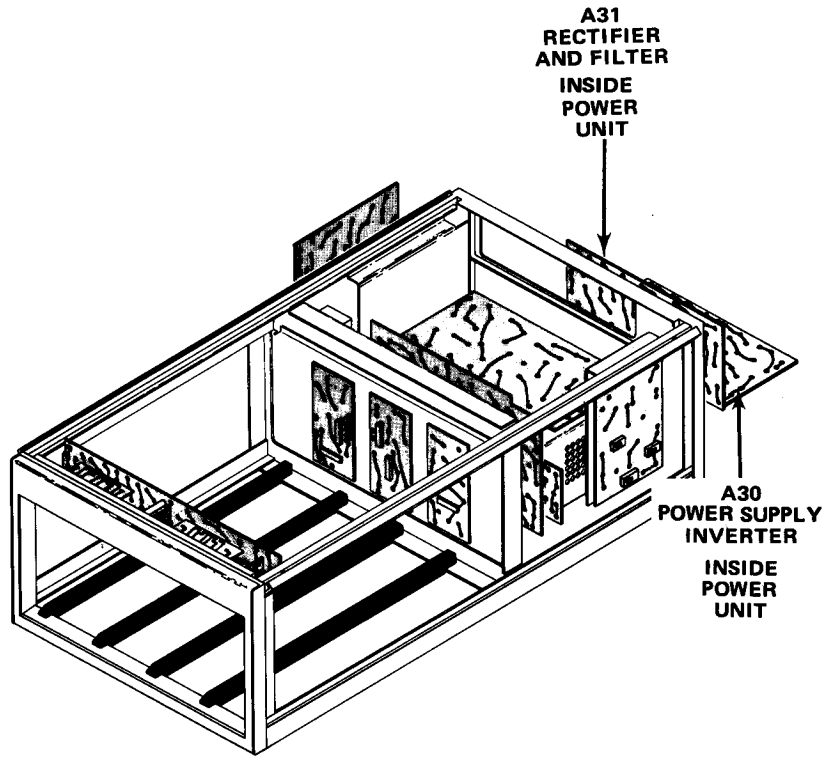
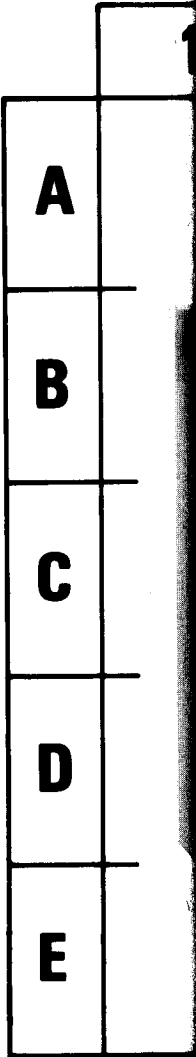
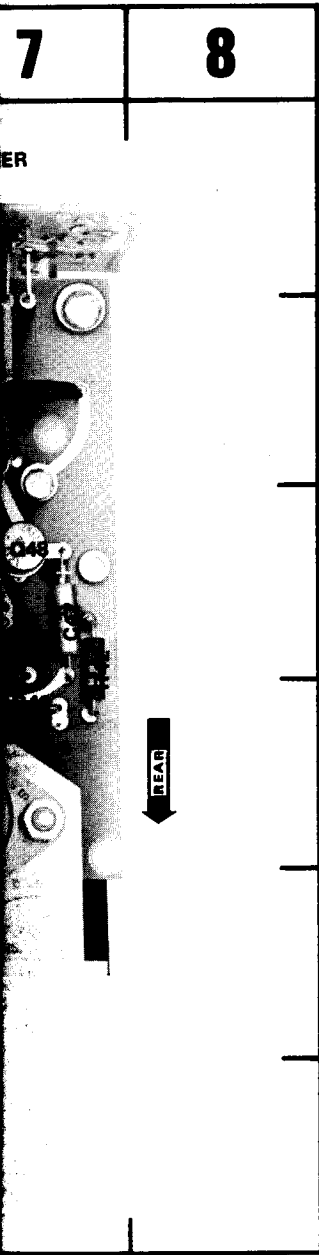

Fig. 6-14. A31 – Rectifier and Filter circuit board.

| CKT NO | GRID LOC | CKT NO | GRID LOC | CKT NO | GRID LOC | CKT NO | GRID LOC | CKT NO | GRID LOC | CKT NO | GRID LOC | CKT NO | GRID LOC | CKT NO | GRID LOC |
|--------|----------|--------|----------|--------|----------|--------|----------|--------|----------|--------|----------|--------|----------|--------|----------|
| C05    | 8D       | C54    | 6D       | CR01   | 7D       | CR63   | 6C       | L68    | 2C       | Q02    | 7D       | R22    | 3D       | R52    | 6D       |
| C06    | 6D       | C68    | 3C       | CR02   | 8D       | CR65   | 6C       | L71    | 3C       | Q04    | 7D       | R29    | 4D       | R54    | 7D       |
| C08    | 6D       | C69    | 2B       | CR03   | 7D       | CR67   | 5C       | L72    | 3B       |        |          | R34    | 6C       | R55    | 2D       |
| C13    | 7D       | C70    | 3C       | CR06   | 7D       | CR68   | 5C       | L74    | 2B       | R05    | 8D       | R35    | 7C       | R77    | 4D       |
| C14    | 6D       | C71    | 1B       | CR08   | 7D       | CR72   | 6B       | L78    | 8B       | R06    | 7D       | R36    | 6C       |        |          |
| C17    | 6D       | C72    | 4C       | CR30   | 3D       | CR73   | 6C       | L81    | 7B       | R08    | 7D       | R37    | 5C       | U05    | 6D       |
| C25    | 6D       | C73    | 3B       | CR31   | 3D       | CR74   | 5B       |        |          | R09    | 6D       | R42    | 4D       |        |          |
| C26    | 6C       | C74    | 4C       | CR32   | 3D       | CR75   | 5C       | P2     | 3B       | R11    | 6D       | R43    | 5D       | VR05   | 7D       |
| C27    | 4D       | C75    | 3B       | CR33   | 3D       | CR78   | 5B       | P3     | 2B       | R17    | 7C       | R44    | 5D       | VR29   | 4D       |
| C29    | 4D       | C78    | 6C       | CR38   | 3D       | CR79   | 6B       | P6     | 7B       | R19    | 5D       | R46    | 5D       | VR47   | 5D       |
| C34    | 6C       | C79    | 7C       | CR39   | 3D       | CR81   | 4B       | P12    | 6C       | R20    | 3D       | R47    | 3D       |        |          |
| C43    | 6C       | C81    | 7C       | CR40   | 4D       | CR82   | 7B       | P13    | 4C       | R21    | 3D       | R50    | 7C       |        |          |
| C50    | 6D       | C82    | 7C       | CR44   | 3D       |        |          |        |          |        |          |        |          |        |          |
| C53    | 5D       |        |          |        |          |        |          |        |          |        |          |        |          |        |          |



|    |      |
|----|------|
| KT | GRID |
| NO | LOC  |

|     |    |
|-----|----|
| R54 | 5B |
|-----|----|

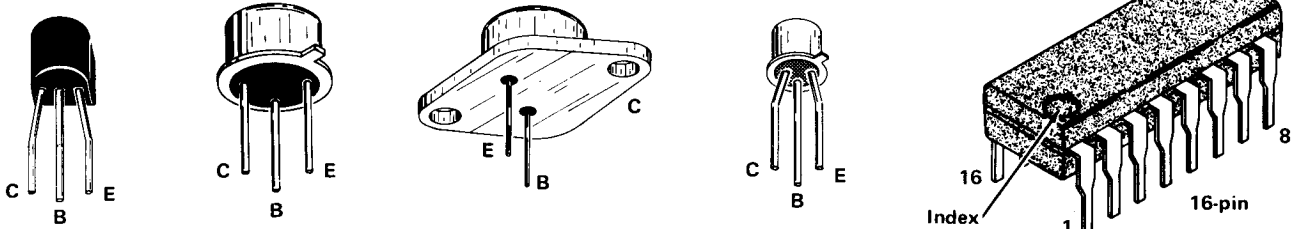
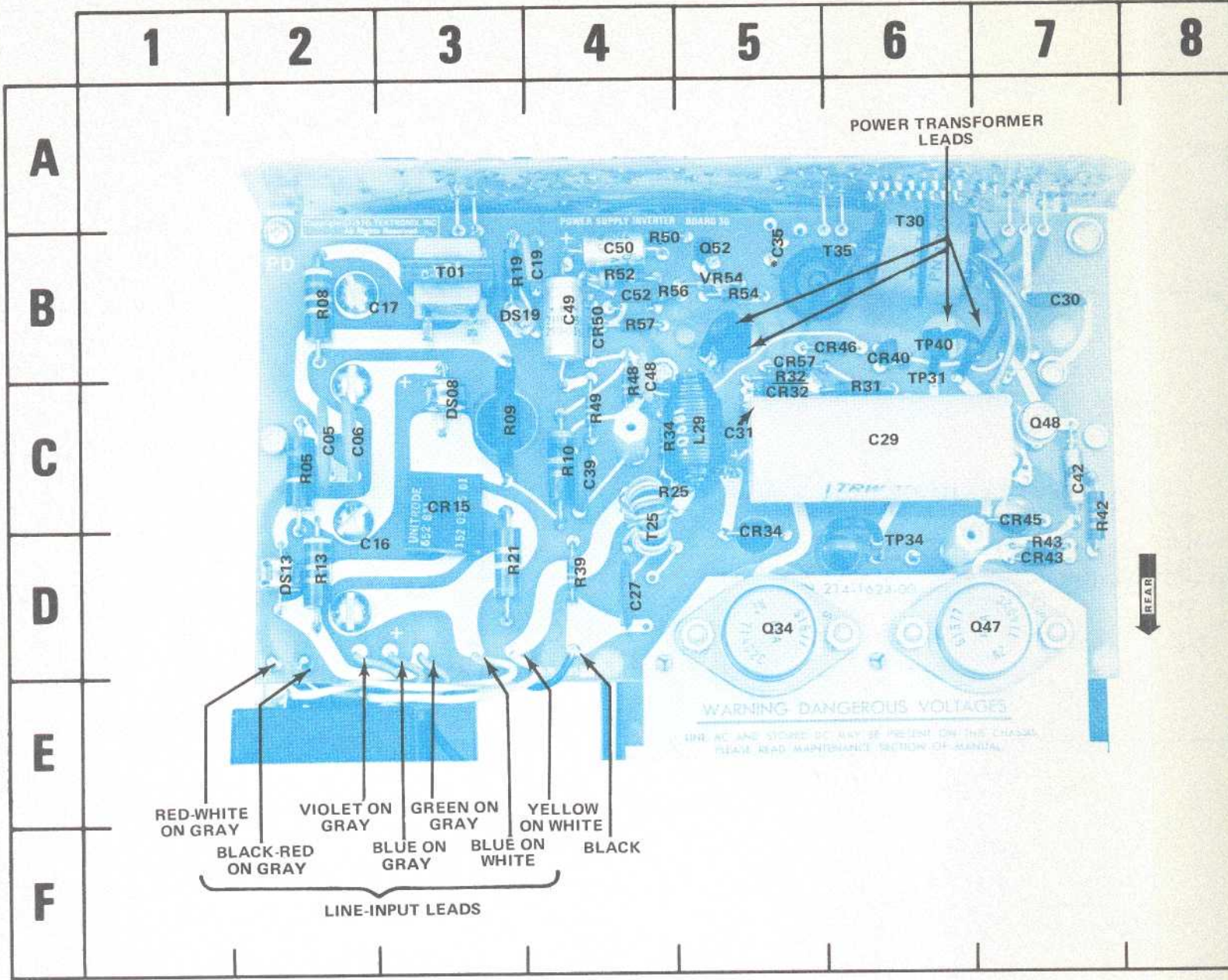

Fig. 6-15. Electrode configuration for semiconductors shown on diagram 8.





\*See Parts List for serial number ranges.

Fig. 6-13. A30 - Power Supply Inverter circuit board.

| CKT NO | GRID LOC | CKT NO | GRID LOC | CKT NO | GRID LOC | CKT NO | GRID LOC | CKT NO | GRID LOC | CKT NO | GRID LOC | CKT NO | GRID LOC | CKT NO | GRID LOC |
|--------|----------|--------|----------|--------|----------|--------|----------|--------|----------|--------|----------|--------|----------|--------|----------|
| C05    | 2C       | C42    | 7C       | CR43   | 6B       | Q34    | 5D       | R19    | 3B       | R43    | 7D       | T01    | 3B       | VR54   | 5B       |
| C06    | 2C       | C48    | 4B       | CR45   | 7C       | Q47    | 7D       | R21    | 3D       | R48    | 4C       | T25    | 4C       |        |          |
| C16    | 2D       | C49    | 4B       | CR46   | 6B       | Q48    | 7C       | R25    | 4C       | R49    | 4C       | T30    | 6A       |        |          |
| C17    | 3B       | C50    | 4B       | CR50   | 4B       | Q52    | 5B       | R31    | 6C       | R50    | 4B       | T35    | 6B       |        |          |
| C19    | 4B       | C52    | 4B       | CR57   | 5B       |        |          | R32    | 5B       | R52    | 4B       |        |          |        |          |
| C27    | 4D       |        |          | DS08   | 3C       | R05    | 2C       | R34    | 4C       | R54    | 5B       | TP31   | 6B       |        |          |
| C29    | 6C       | CR15   | 3C       | DS13   | 2D       | R08    | 2B       | R39    | 4D       | R56    | 4B       | TP34   | 6D       |        |          |
| C30    | 7B       | CR32   | 5C       | DS19   | 3B       | R09    | 3C       | R42    | 7C       | R57    | 4B       | TP40   | 6B       |        |          |
| C31    | 5C       | CR34   | 5D       |        |          | R10    | 3C       |        |          |        |          |        |          |        |          |
| C35    | 5B       | CR40   | 6B       | L29    | 5C       | R13    | 2D       |        |          |        |          |        |          |        |          |
| C39    | 4C       |        |          |        |          |        |          |        |          |        |          |        |          |        |          |

A30 & A31 ASSEMBLY

## VOLTAGE AND WAVEFORM CONDITIONS

The voltages and waveforms shown on this diagram were obtained with the test set-ups and equipment given below. These measurements are not absolute and may vary between instruments.

### Recommended Test Equipment

| Item  | Specifications   | Examples of Applicable Test Equipment   |
|---|--|---|
| Test oscilloscope                             | Frequency response, dc to 65 MHz; deflection factor (with 10X probe), 500 mV/division to five or 10 V/division; fastest sweep rate, 500 ns/division. | a. Tektronix 7603 Oscilloscope with 7A15A Amplifier or 7A13 Differential Comparator, 7B50 Time Base, and P6053A Probe, or equivalent. |
| Dc voltmeter (non-loading digital multimeter) | Input impedance, 10 megohm; range, 0 to 500 volts dc.  | a. Tektronix 7D13 Digital Multimeter (test oscilloscope must have readout system), or equivalent.<br><br>b. Fairchild Model 7050.     |

### Test Set-Up

7704A Under Test: Amplifier unit installed in LEFT VERT Compartment; no signal applied. Time-base unit installed in B HORIZ compartment. Time-base unit set for free-running sweep at 0.1-ms/division sweep rate. Line voltage source of 115 volts ac. Line Selector set for 90 to 132.

#### Front-Panel Controls

|                        |           |
|------------------------|-----------|
| Knob-type controls     | Midrange  |
| VERTICAL MODE          | LEFT      |
| A AND B TRIGGER SOURCE | VERT MODE |
| HORIZONTAL MODE        | B         |

Test Equipment: Voltmeter common is connected to 7704A chassis ground except for voltages marked \*; for \*, voltmeter is connected between the two points. Test Oscilloscope is internally triggered.

VOLTAGE & WAVEFORM CONDITIONS

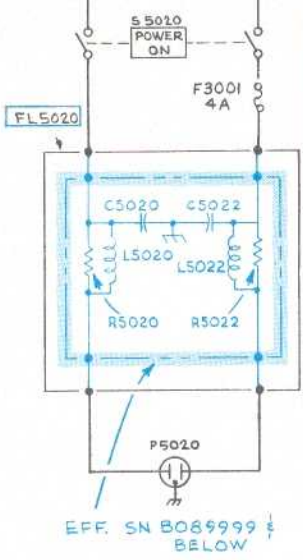
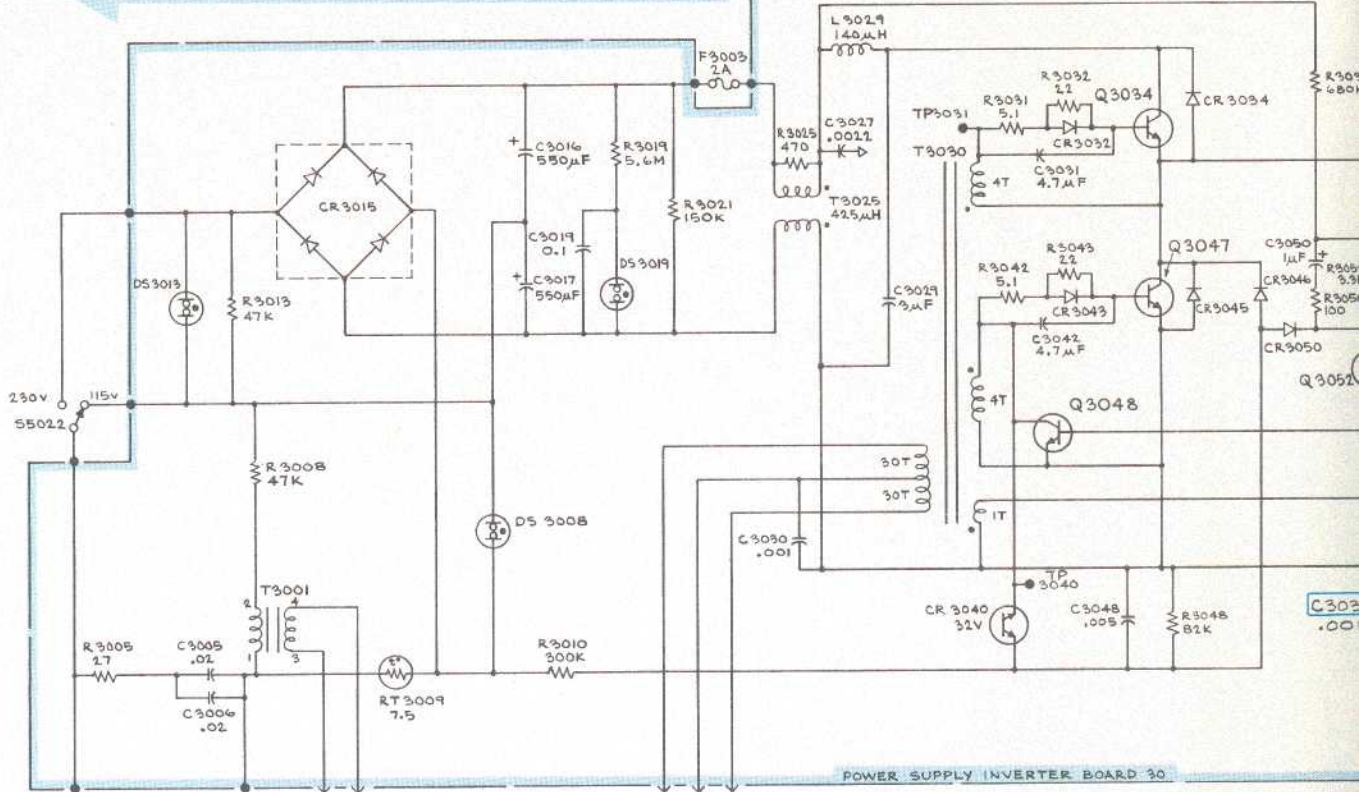

EFF. SN B089999 & BELOW

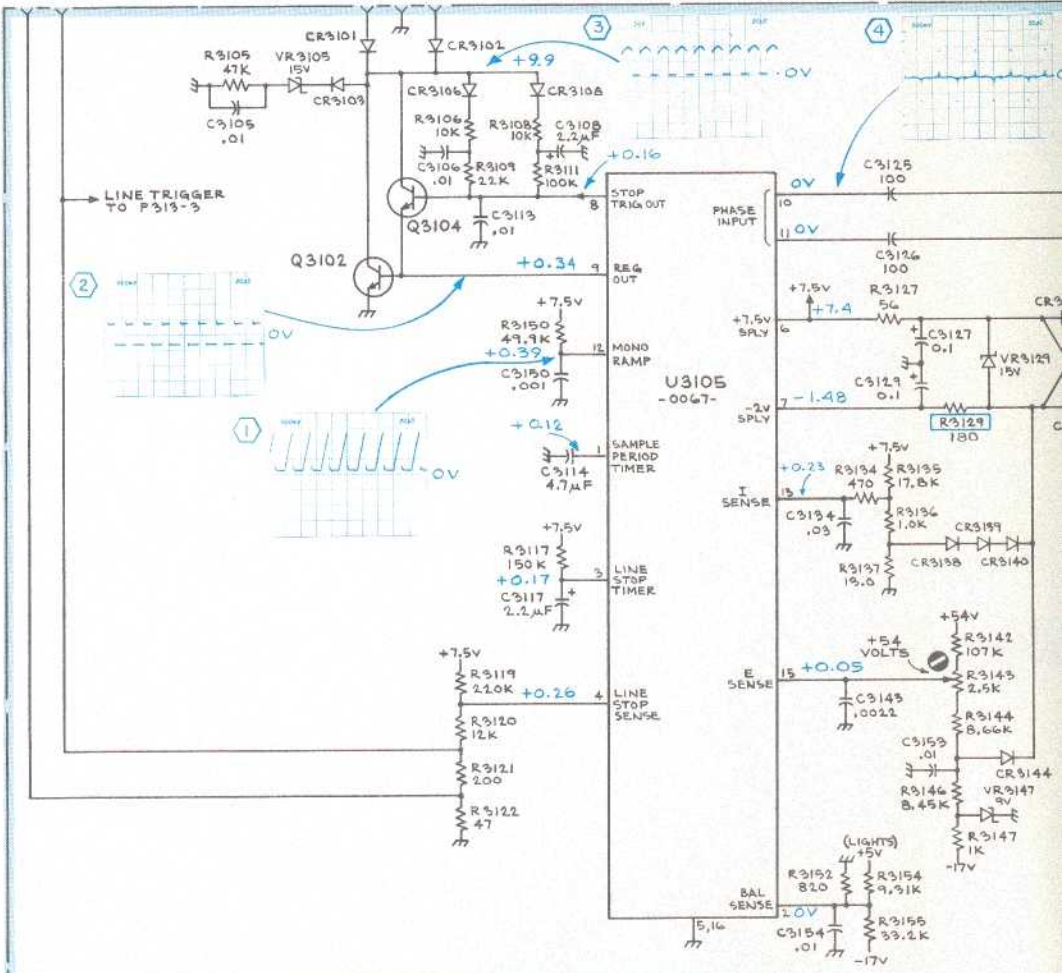

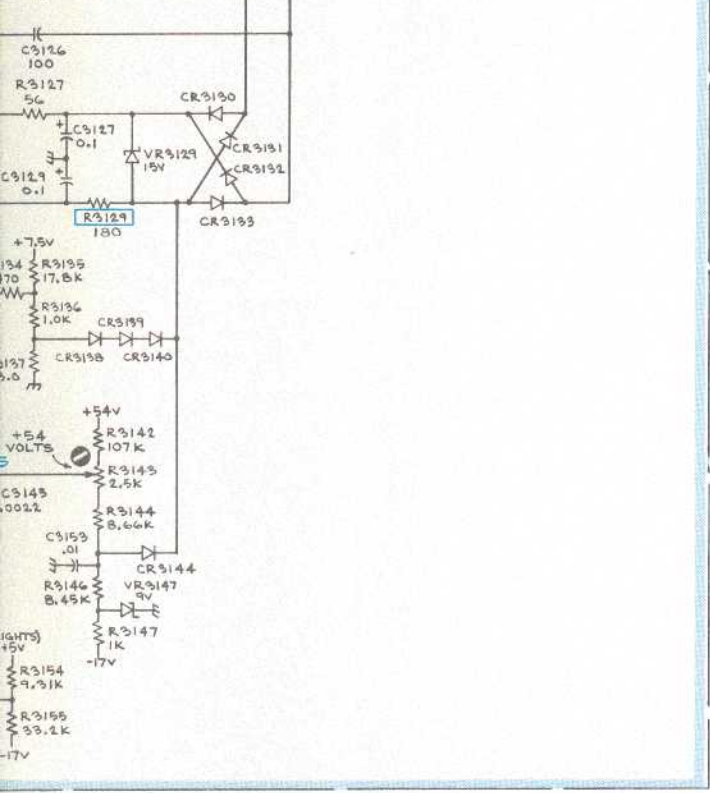
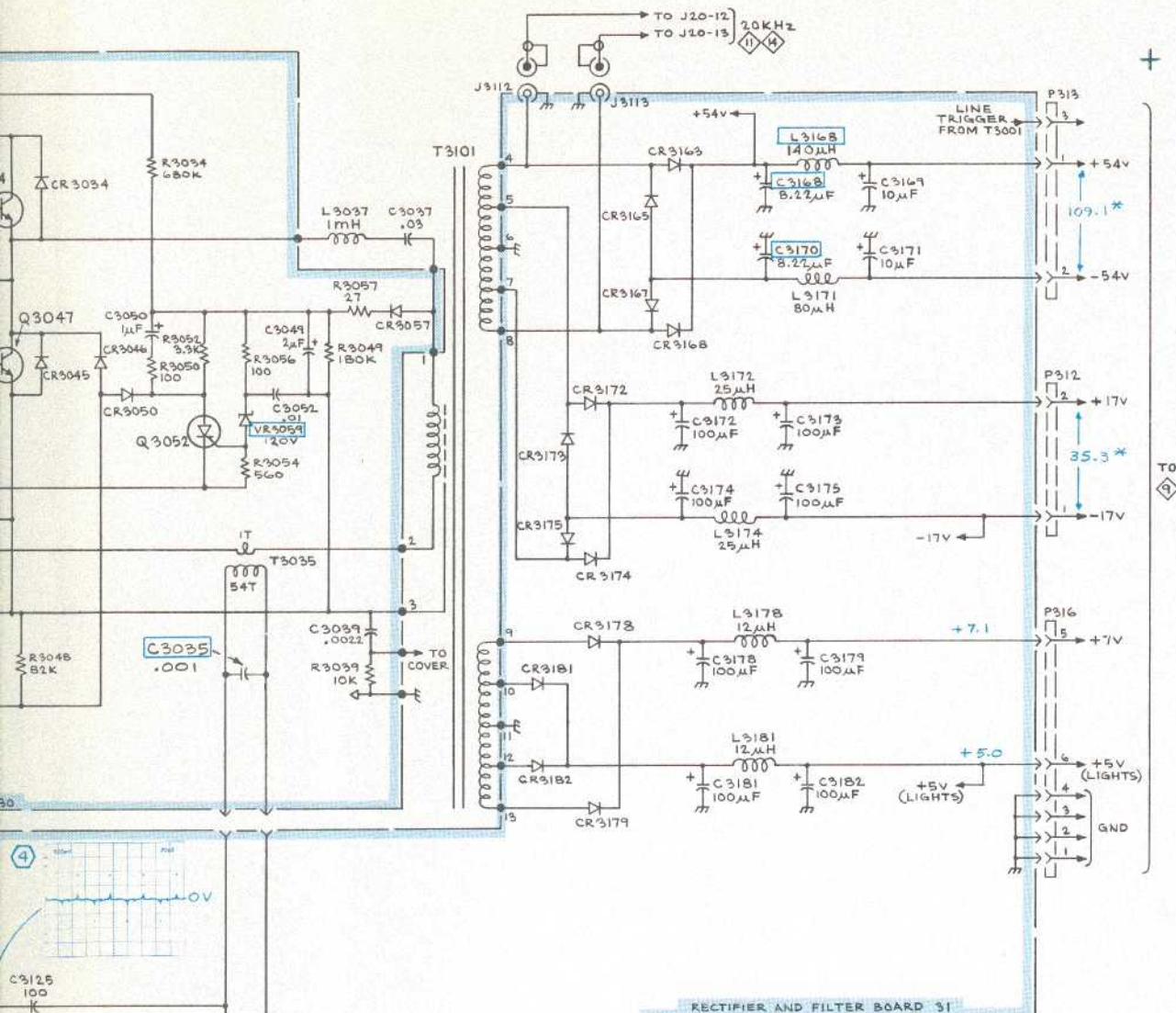

RECTIFIER AND FILTER BOARD 31

SEE PARTS LIST FOR SEMICONDUCTORS TYPES

SEE PARTS LIST FOR EARLIER VALUES AND SERIAL NUMBER RANGES OF PARTS OUTLINED OR DEPICTED IN BLUE.

**WARNING**

Extreme caution must be used when troubleshooting in the power supply due to the high-voltage and high-current potentials present. Refer to the Maintenance section for troubleshooting information.

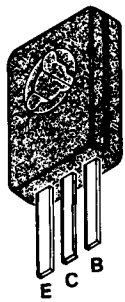
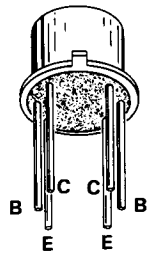
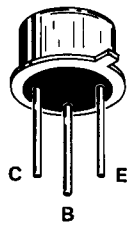
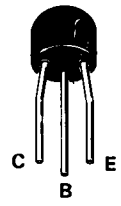
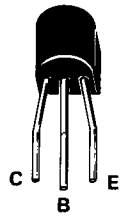
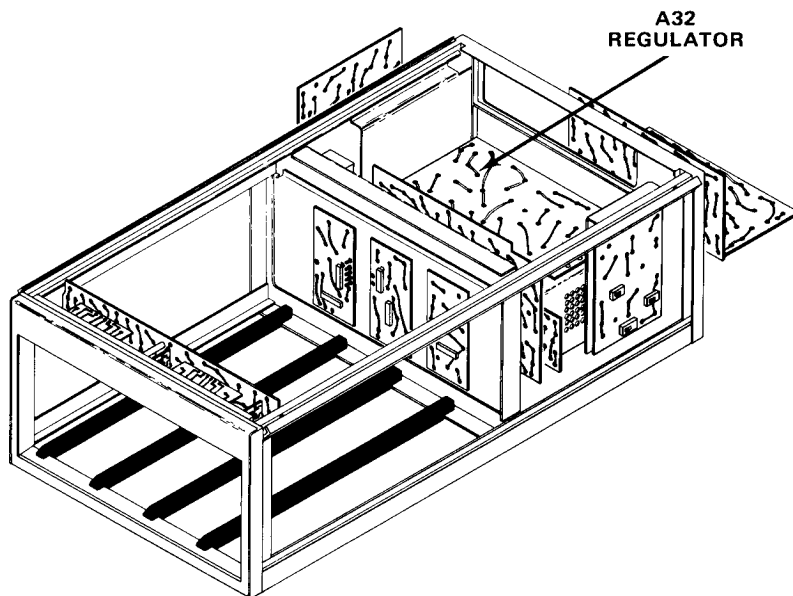

Fig. 6-17. Electrode configuration for semiconductors shown on diagram 9.

| CKT NO | GRID LOC | CKT NO | GRID LOC | CKT NO | GRID LOC | CKT NO | GRID LOC | CKT NO | GRID LOC | CKT NO | GRID LOC | CKT NO | GRID LOC | CKT NO | GRID LOC |
|--------|----------|--------|----------|--------|----------|--------|----------|--------|----------|--------|----------|--------|----------|--------|----------|
| C13    | 3D       | CR61   | 2B       | Q09    | 4D       | Q94    | 6B       | R20    | 4B       | R45    | 3B       | R77    | 6D       | R133   | 7E       |
| C14    | 3D       | CR74   | 5D       | Q11    | 4D       | Q115   | 7C       | R22    | 3E       | R46    | 3C       | R78    | 6D       | R134   | 7E       |
| C28    | 5B       | CR75   | 5D       | Q13    | 3D       | Q130   | 7D       | R23    | 3B       | R48    | 3D       | R80    | 6D       | R137   | 7C       |
| C34    | 7D       | CR77   | 6D       | Q17    | 4C       | Q137   | 7C       | R24    | 5C       | R49    | 3D       | R83    | 5D       | R138   | 7B       |
| C36    | 4E       | CR78   | 6D       | Q20    | 4C       | Q139   | 7B       | R25    | 4D       | R51    | 2D       | R85    | 6B       | R139   | 6C       |
| C37    | 4C       | CR81   | 6C       | Q23    | 4B       | Q143   | 7C       | R26    | 5D       | R53    | 2C       | R87    | 6C       | R140   | 7E       |
| C39    | 5C       | CR93   | 5C       | Q25    | 5D       |        |          | R28    | 5C       | R54    | 2C       | R88    | 6C       | R141   | 7B       |
| C69    | 3B       | CR110  | 7C       | Q32    | 5D       | R02    | 3C       | R29    | 5D       | R55    | 2B       | R89    | 6C       | R143   | 7B       |
| C78    | 5D       | CR113  | 7D       | Q35    | 5C       | R04    | 3D       | R30    | 5D       | R58    | 2B       | R90    | 6B       | R145   | 7C       |
| C89    | 6D       | CR114  | 7C       | Q40    | 5C       | R05    | 3C       | R31    | 6D       | R60    | 3B       | R93    | 6B       |        |          |
| C119   | 7D       | CR123  | 7D       | Q41    | 5B       | R06    | 4D       | R32    | 6D       | R62    | 3E       | R94    | 5E       | TP +7  | 2B       |
| C127   | 7D       | CR125  | 7D       | Q51    | 2C       | R08    | 3E       | R34    | 4C       | R63    | 2E       | R110   | 7C       | TP +17 | 5B       |
| C141   | 7C       | CR128  | 7D       | Q58    | 7C       | R09    | 3D       | R35    | 5D       | R64    | 2D       | R115   | 7B       | TP -17 | 6B       |
|        |          | CR130  | 7D       | Q60    | 2C       | R11    | 4D       | R36    | 5C       | R65    | 2D       | R117   | 7C       | TP +54 | 4B       |
| CR02   | 3C       | CR139  | 6C       | Q61    | 2B       | R12    | 3C       | R37    | 4C       | R67    | 2E       | R119   | 7C       | TP -54 | 7B       |
| CR09   | 3D       |        |          | Q64    | 2D       | R13    | 3D       | R38    | 4C       | R68    | 2C       | R121   | 7D       |        |          |
| CR11   | 4C       | L36    | 1D       | Q75    | 6D       | R14    | 4D       | R39    | 5C       | R69    | 3C       | R125   | 7D       | VR01   | 3C       |
| CR12   | 4C       |        |          | Q83    | 6C       | R16    | 3C       | R40    | 5B       | R72    | 6E       | R127   | 7D       | VR71   | 5D       |
| CR21   | 3B       | P32G   | 4E       | Q85    | 6D       | R17    | 4B       | R41    | 5B       | R73    | 6E       | R130   | 7D       | VR121  | 7C       |
| CR26   | 5D       | P32H   | 5E       | Q90    | 6C       | R18    | 4B       | R42    | 5E       | R75    | 6E       | R132   | 7E       | VR127  | 7E       |
| CR35   | 5D       |        |          |        |          |        |          |        |          |        |          |        |          |        |          |
| CR41   | 4B       |        |          |        |          |        |          |        |          |        |          |        |          |        |          |
| CR45   | 3B       |        |          |        |          |        |          |        |          |        |          |        |          |        |          |
| CR46   | 3C       |        |          |        |          |        |          |        |          |        |          |        |          |        |          |



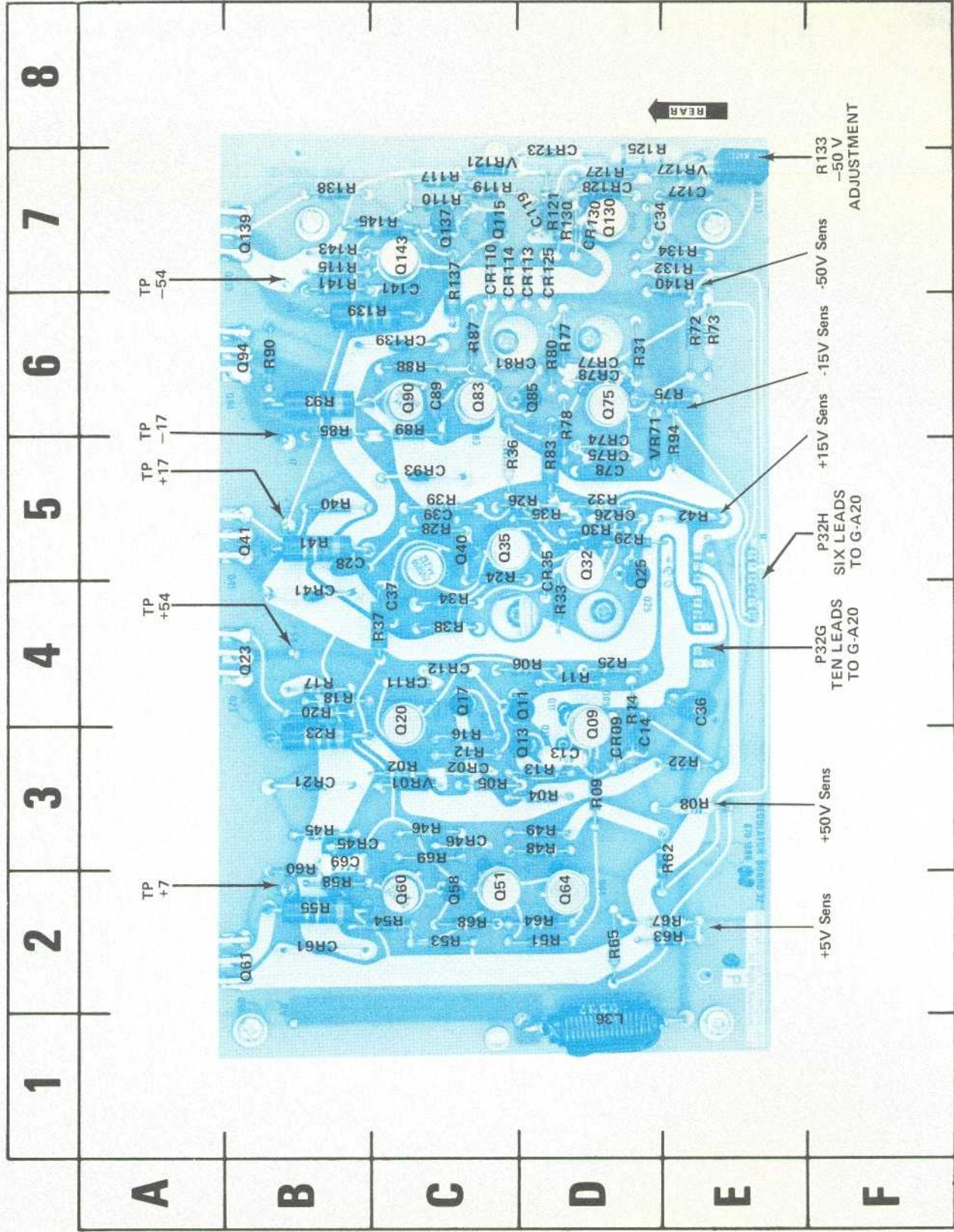

Fig. 6-16. A32-Regulator circuit board.

## VOLTAGE AND WAVEFORM CONDITIONS

The voltages and waveforms shown on this diagram were obtained with the test set-ups and equipment listed below. These measurements are not absolute and may vary slightly between instruments.

### Recommended Test Equipment

| Item   | Specifications   | Examples of Applicable Test Equipment   |
|--|--|---|
| Test oscilloscope                            | Frequency response, one Hz to 30 kHz; deflection factor (with 10X probe), one mV/division; sweep rate, five ms/division. | a. Tektronix 7603 Oscilloscope with 7A22 Differential Amplifier, 7B50 Time Base, and P6053A Probe, or equivalent.                 |
| Dc voltmeter (non-loading digital voltmeter) | Input impedance, 10 megohms; range, 0 to 100 volts dc.   | a. Tektronix 7D13 Digital Multimeter (test oscilloscope must have readout system), or equivalent.<br><br>b. Fairchild Model 7050. |

### Test Set-Up

**7704A Under Test:** Amplifier unit installed in LEFT VERT compartment; no signal applied. Time-base unit installed in B HORIZ compartment. Time-base unit set for free-running sweep at 0.1-ms/division sweep rate. Line-voltage source of 115 volts ac. Line Selector set for 90 to 132.

#### Front-Panel Controls

|                        |           |
|------------------------|-----------|
| Knob-type controls     | Midrange  |
| VERTICAL MODE          | LEFT      |
| A AND B TRIGGER SOURCE | VERT MODE |
| HORIZONTAL MODE        | B         |

**Test Equipment:** Voltmeter common is connected to 7704A chassis ground. Test oscilloscope is triggered from the internal Line source.

LOW-VOLTAGE  
REQUIREMENTS

9



# ← VOLTAGE & WAVEFORM CONDITIONS

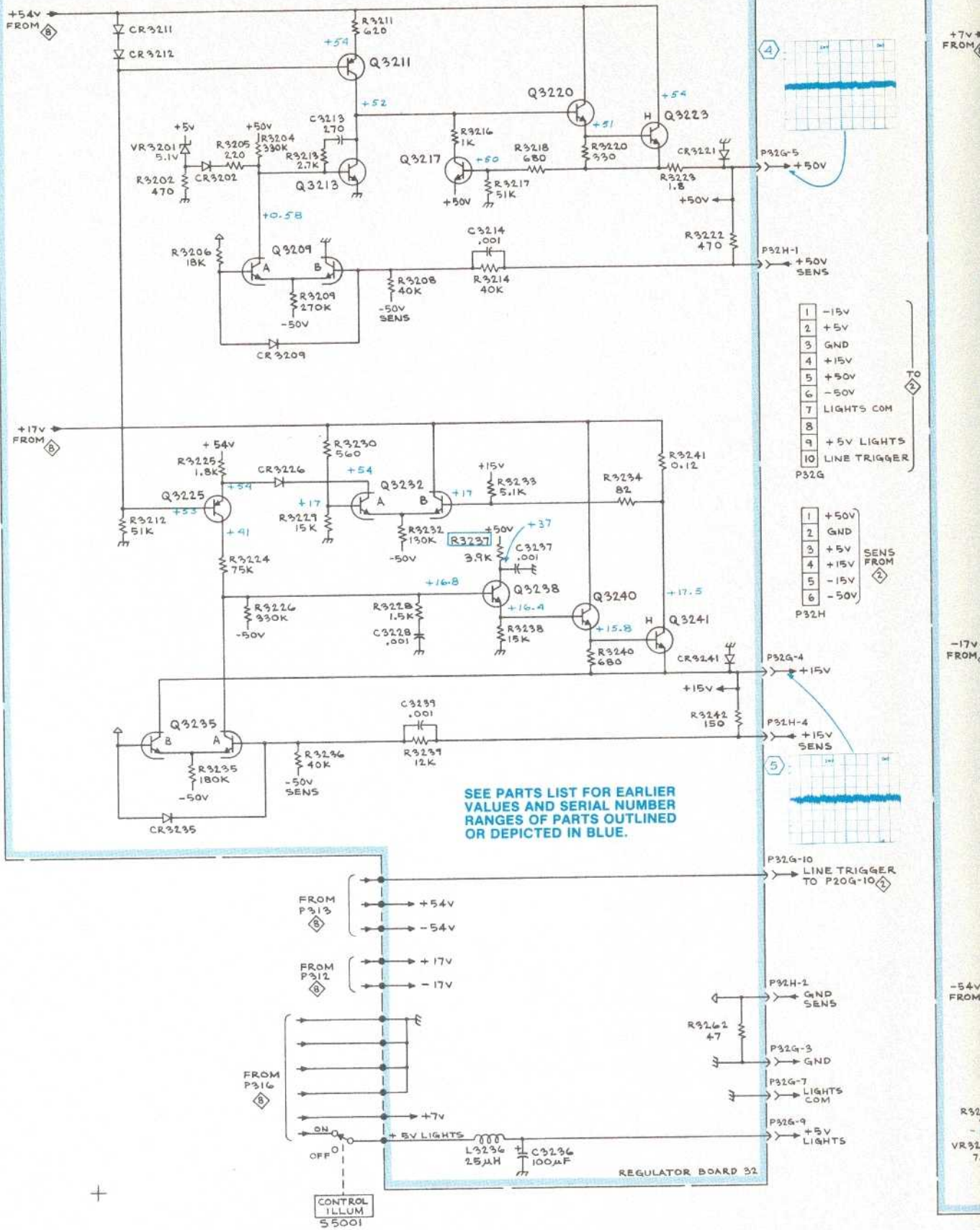

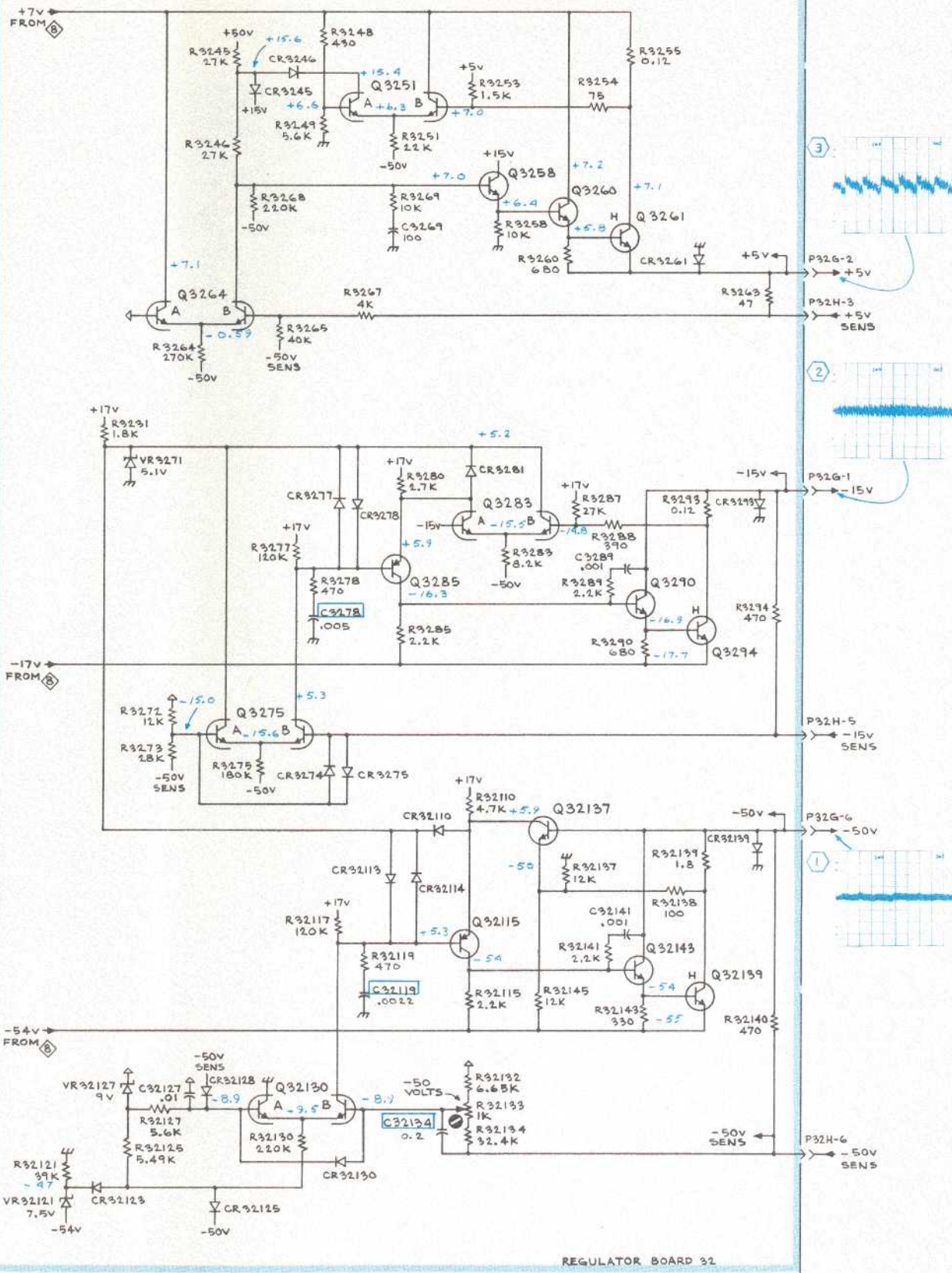

REGULATOR BOARD 32

| CKT NO | GRID LOC | CKT NO | GRID LOC | CKT NO | GRID LOC | CKT NO | GRID LOC | CKT NO | GRID LOC | CKT NO | GRID LOC | CKT NO | GRID LOC | CKT NO | GRID LOC |
|--------|----------|--------|----------|--------|----------|--------|----------|--------|----------|--------|----------|--------|----------|--------|----------|
| C01    | 6E       | CR33   | 6D       | P34S   | 5A       | R03    | 7E       | R27    | 5E       | R51    | 5B       | R88    | 3B       | U45    | 7D       |
| C05    | 3E       | CR38   | 6B       | P34T   | 7D       | R04    | 7E       | R30    | 6B       | R52    | 6B       | R89    | 4C       | U47    | 6D       |
| C18    | 3E       | CR39   | 6B       |        |          | R05    | 7E       | R31    | 6B       | R66    | 4D       | R90    | 3A       | U49    | 5D       |
| C20    | 3D       | CR41   | 7B       | Q06    | 3C       | R06    | 3C       | R32    | 7C       | R68    | 4D       | R91    | 3B       | U50    | 5C       |
| C29    | 4E       | CR42   | 7B       | Q11    | 3C       | R07    | 2E       | R33    | 6D       | R70    | 6E       | R92    | 3B       | U61    | 3F       |
| C34    | 6C       | CR43   | 6C       | Q14    | 3C       | R08    | 2B       | R34    | 6C       | R72    | 5E       | R93    | 3B       | U63    | 5F       |
| C38    | 7C       | CR45   | 5C       | Q16    | 2D       | R09    | 2E       | R35    | 6B       | R73    | 6E       | R94    | 3B       | U65    | 4F       |
| C43    | 6B       | CR47   | 6D       | Q19    | 3C       | R10    | 2C       | R36    | 5E       | R75    | 6E       | R97    | 4B       | U67    | 4F       |
| C45    | 6D       |        |          | Q27    | 3D       | R11    | 2C       | R37    | 6E       | R76    | 6G       | R98    | 4B       | U69    | 5F       |
| C49    | 5E       | J01    | 2E       | Q42    | 7B       | R12    | 2C       | R38    | 6C       | R77    | 4E       | R99    | 4B       | U70    | 6F       |
| C70    | 7F       | J02    | 2D       | Q45    | 7D       | R14    | 3C       | R39    | 6B       | R80    | 3D       |        |          | U80    | 5C       |
| C71    | 7F       |        |          | Q86    | 4B       | R16    | 2C       | R40    | 7B       | R81    | 4D       | TP45   | 7D       |        |          |
| C72    | 7F       | L82    | 4C       | Q89    | 4B       | R18    | 2E       | R41    | 6B       | R82    | 4C       | TP50   | 4B       | VR70   | 6E       |
| C75    | 6E       |        |          | Q93    | 3B       | R19    | 3C       | R42    | 7B       | R83    | 5C       |        |          | VR71   | 6E       |
|        |          | P03    | 7A       | Q99    | 4B       | R20    | 2D       | R45    | 7D       | R84    | 5B       | U01    | 7F       | VR72   | 7E       |
| CR16   | 2E       | P04    | 4A       |        |          | R22    | 3D       | R47    | 6C       | R85    | 5B       | U18    | 3F       |        |          |
| CR31   | 6B       | P05    | 3A       | R01    | 7E       | R23    | 3D       | R49    | 5C       | R86    | 4C       | U29    | 3E       |        |          |
| CR32   | 6C       | P34L   | 7F       | R02    | 7E       | R25    | 3D       | R50    | 6B       | R87    | 3B       | U33    | 6C       |        |          |

**NOTE**

To conserve space, the circuit numbers on circuit boards and board photos show only the letter prefix and last two digits of the complete circuit number shown in parts list and schematic (R69 = R1069, etc.).

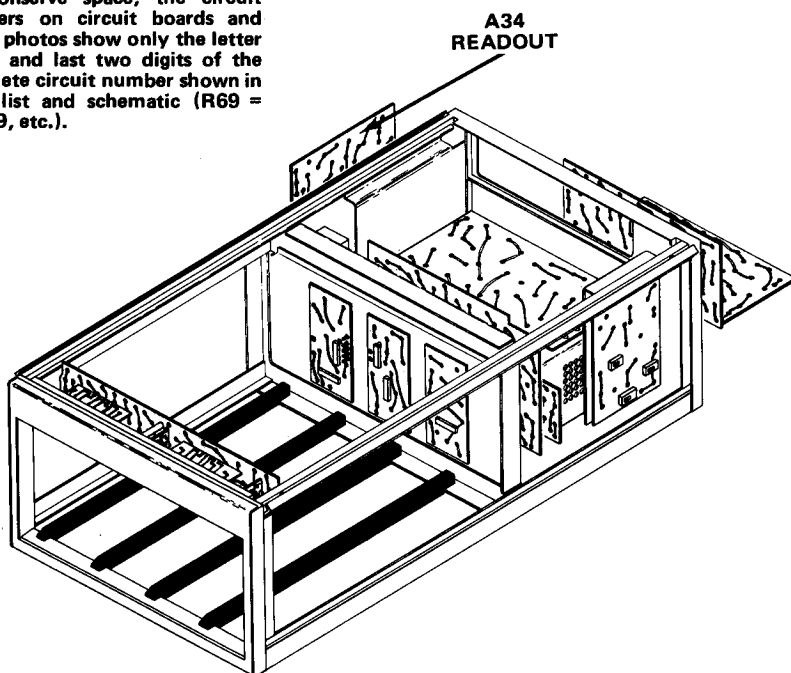



A34 ASSEMBLY

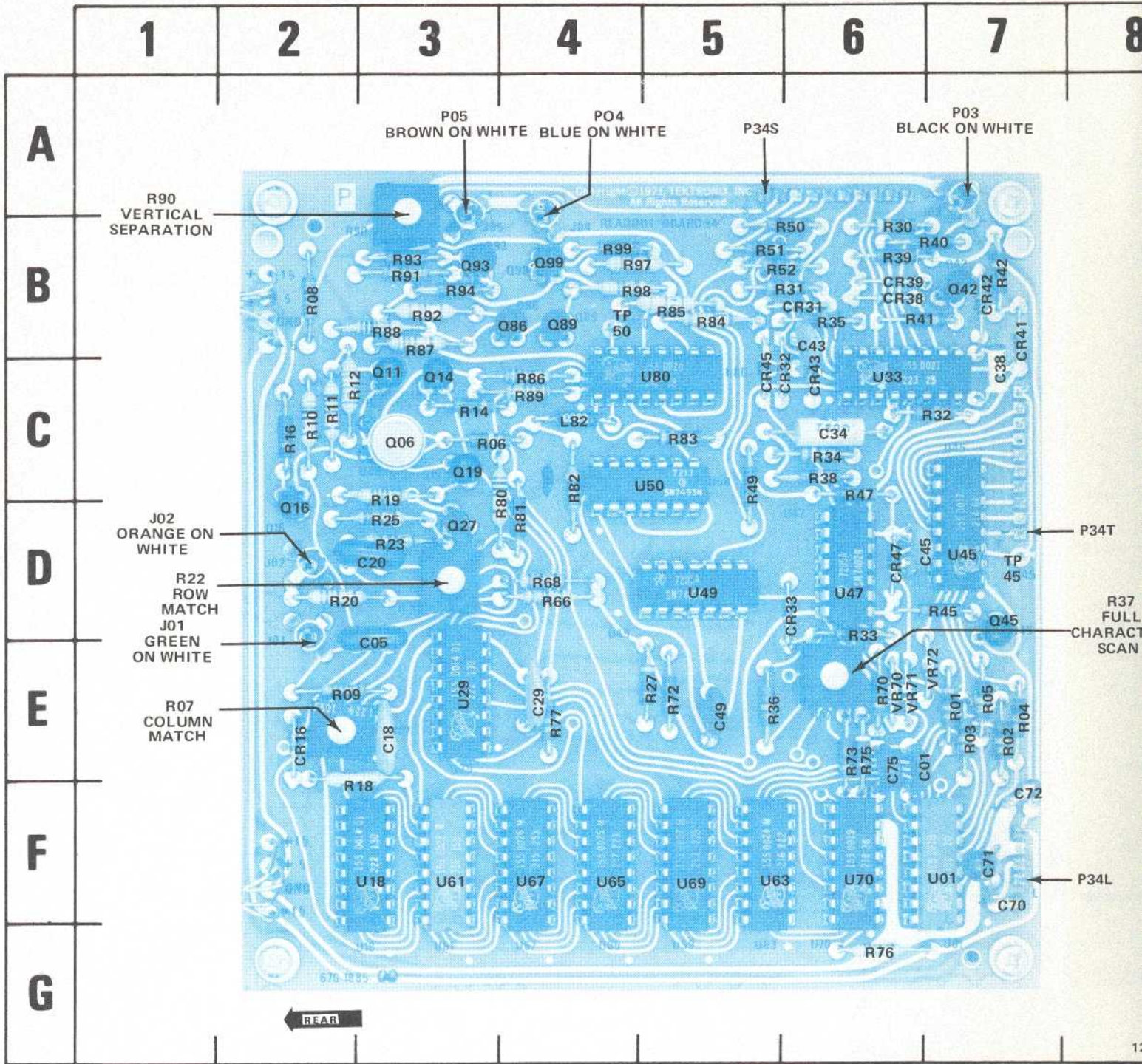

Fig. 6-18. A34-Readout circuit board.



## VOLTAGE AND WAVEFORM CONDITIONS

The voltages and waveforms shown on this diagram were obtained with the test set-ups and equipment given below. These measurements are not absolute and may vary between instruments.

### Recommended Test Equipment

| Item  | Specifications  | Examples of Applicable Test Equipment   |
|---|---|---|
| Test oscilloscope                             | Frequency response, dc to 65 MHz; deflection factor (with 10X probe), 20 mV to five V/division; fastest sweep rate, 100 $\mu$ s/division. | a. Tektronix 7603 Oscilloscope with 7A13 Differential Comparator, 7B50 Time Base, and P6053A Probe, or equivalent. (7A13 Differential Comparator used to obtain dc offset).<br><br>b. Use item (a) above with 7A15A Amplifier in place of 7A13. |
| Dc voltmeter (non-loading digital multimeter) | Input impedance, 10 megohms; range, 0 to 20 V dc.   | a. Tektronix 7D13 Digital Multimeter (test oscilloscope must have readout system), or equivalent.<br><br>b. Fairchild Model 7050.   |

### Test Set-Ups

7704A Under Test: No plug-in units installed.

#### Front-Panel Controls

|                        |           |
|------------------------|-----------|
| Knob-type controls     | Midrange  |
| VERTICAL MODE          | LEFT      |
| A AND B TRIGGER SOURCE | VERT MODE |
| HORIZONTAL MODE        | B         |

#### Internal Control (on A33—Signal Output board)

|              |          |
|--------------|----------|
| Readout Mode | Free-Run |
|--------------|----------|

Test Equipment: Voltmeter common is connected to 7704A chassis ground. Test oscilloscope is externally triggered from TP3450.

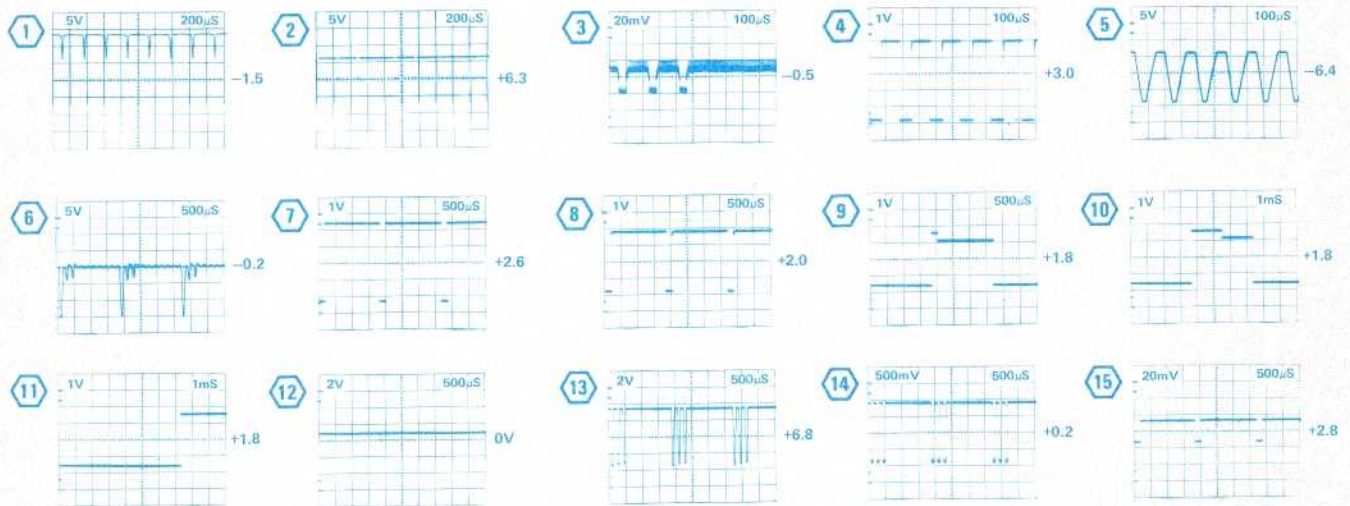

# VOLTAGE & WAVEFORM CONDITIONS

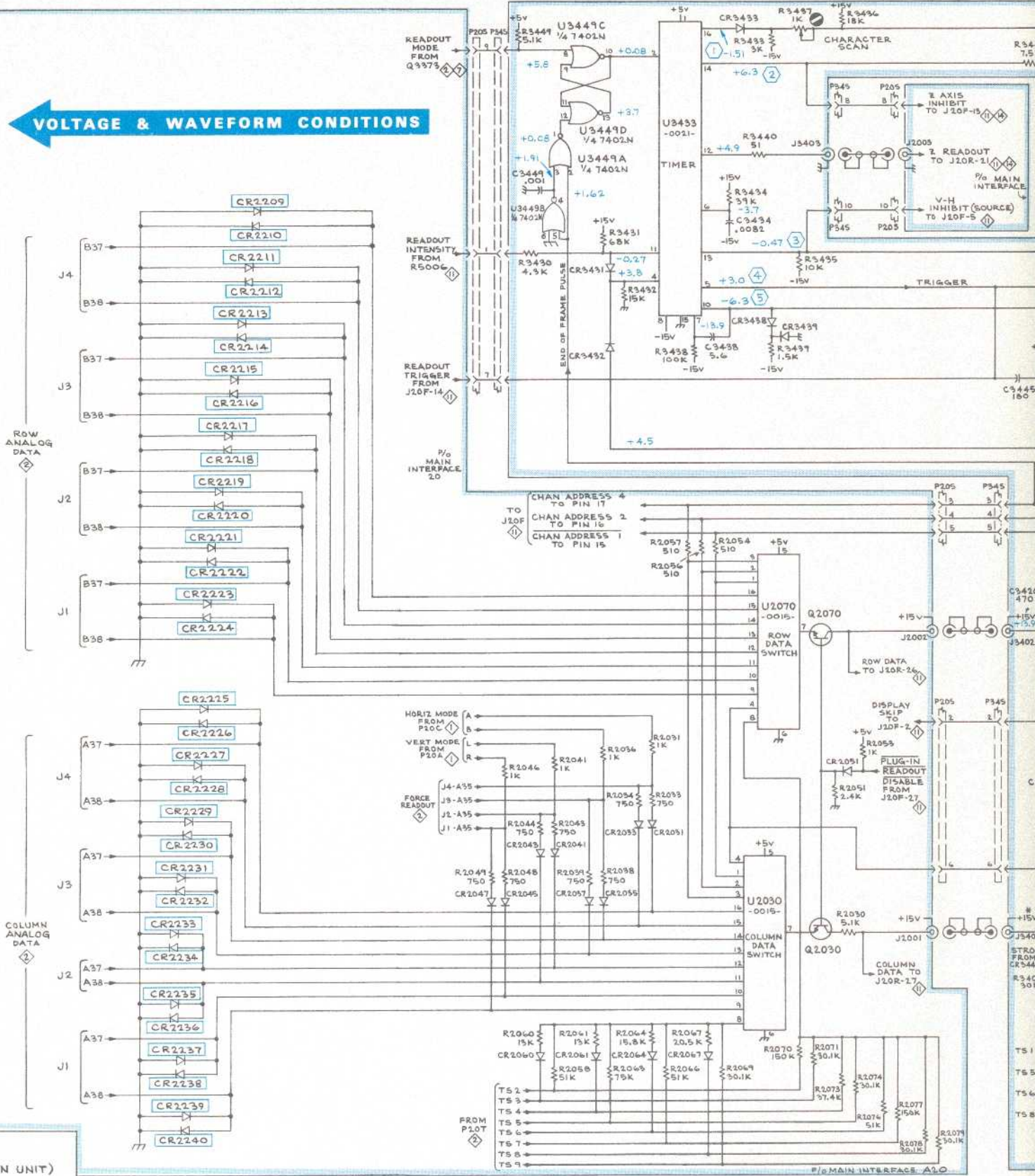

7704A  
(ACQUISITION UNIT)

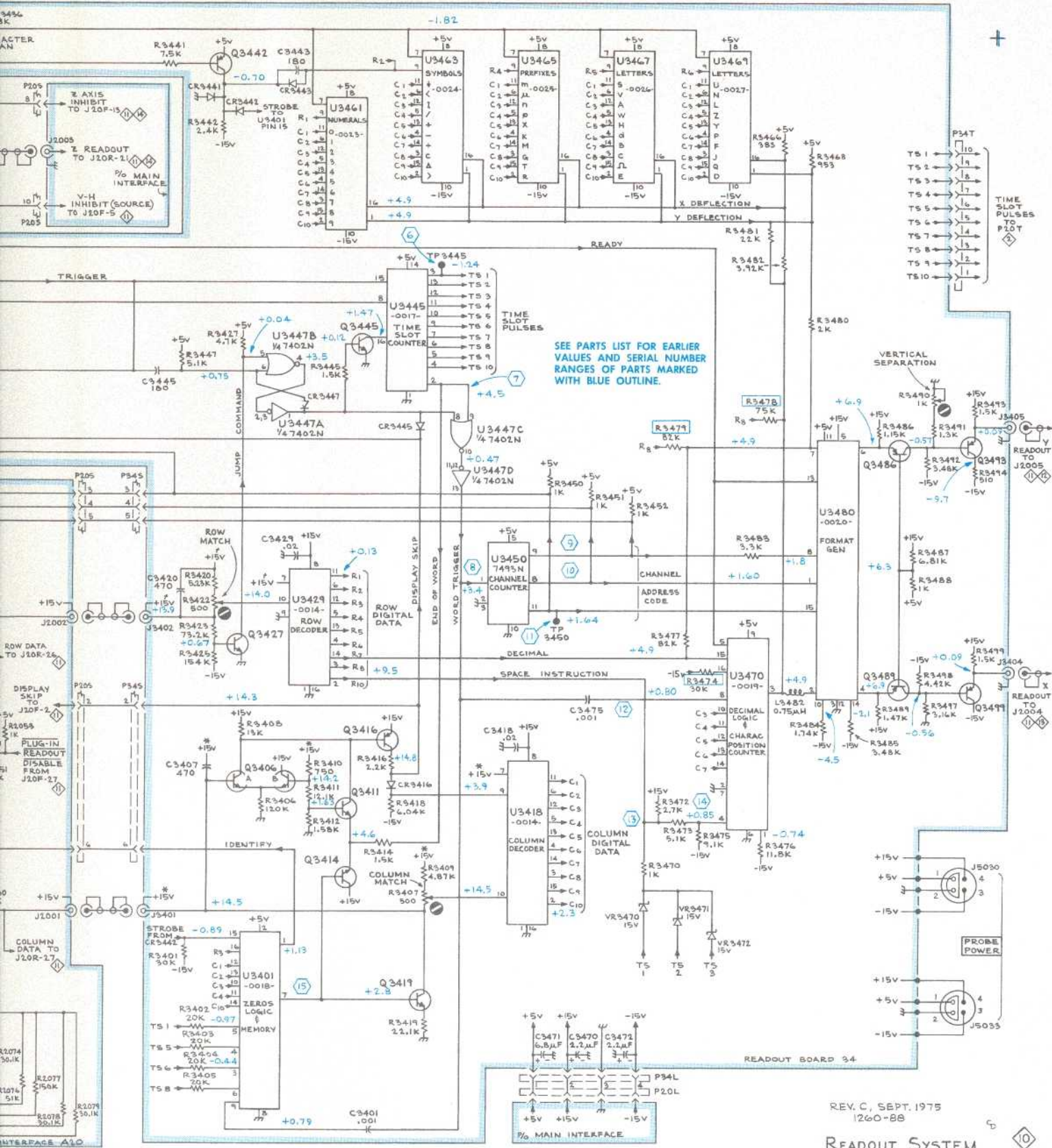

SEE PARTS LIST FOR EARLIER VALUES AND SERIAL NUMBER RANGES OF PARTS MARKED WITH BLUE OUTLINE.

REV. C, SEPT. 1975  
1260-88

READOUT SYSTEM

READOUT SYSTEM

10

10

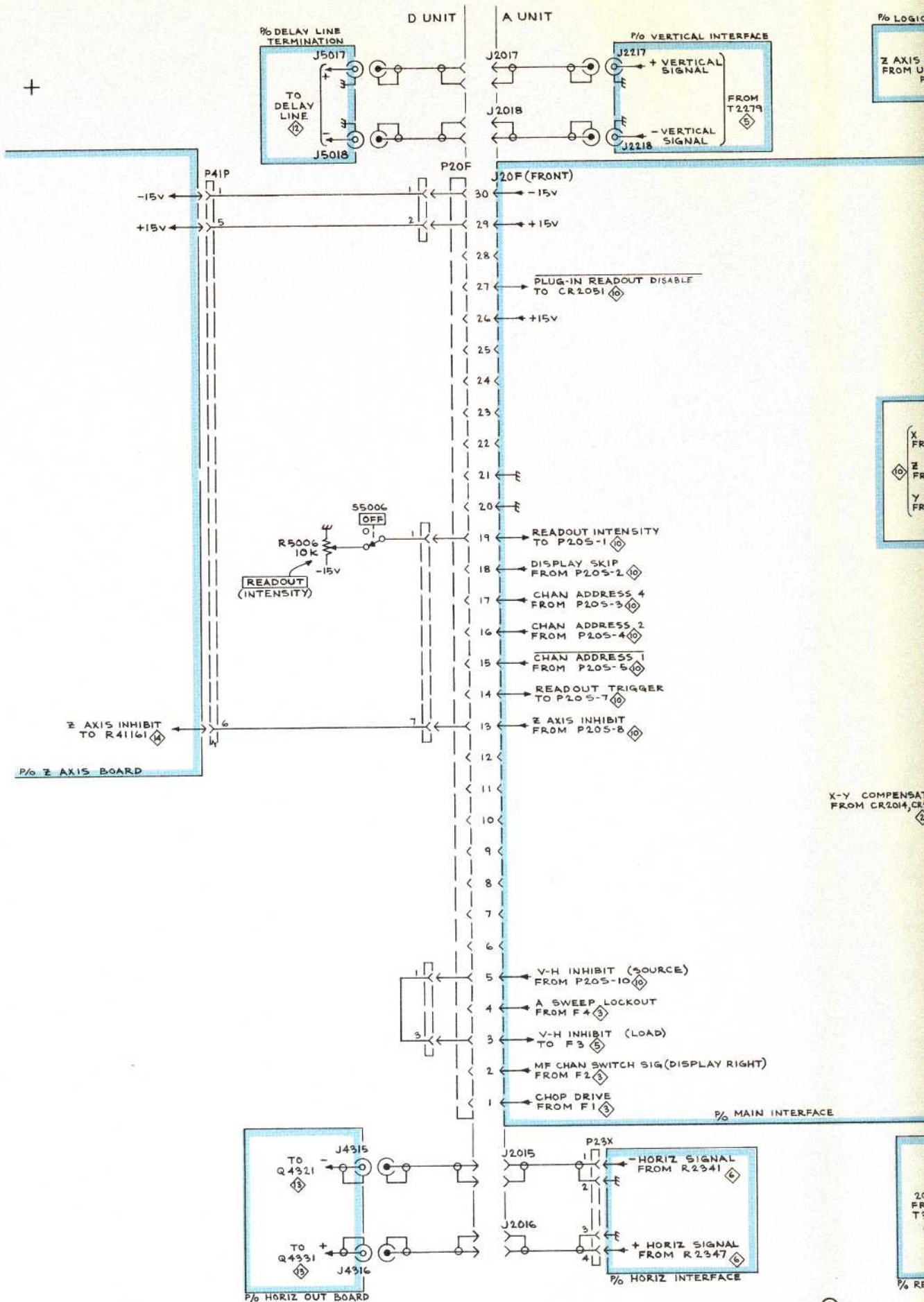



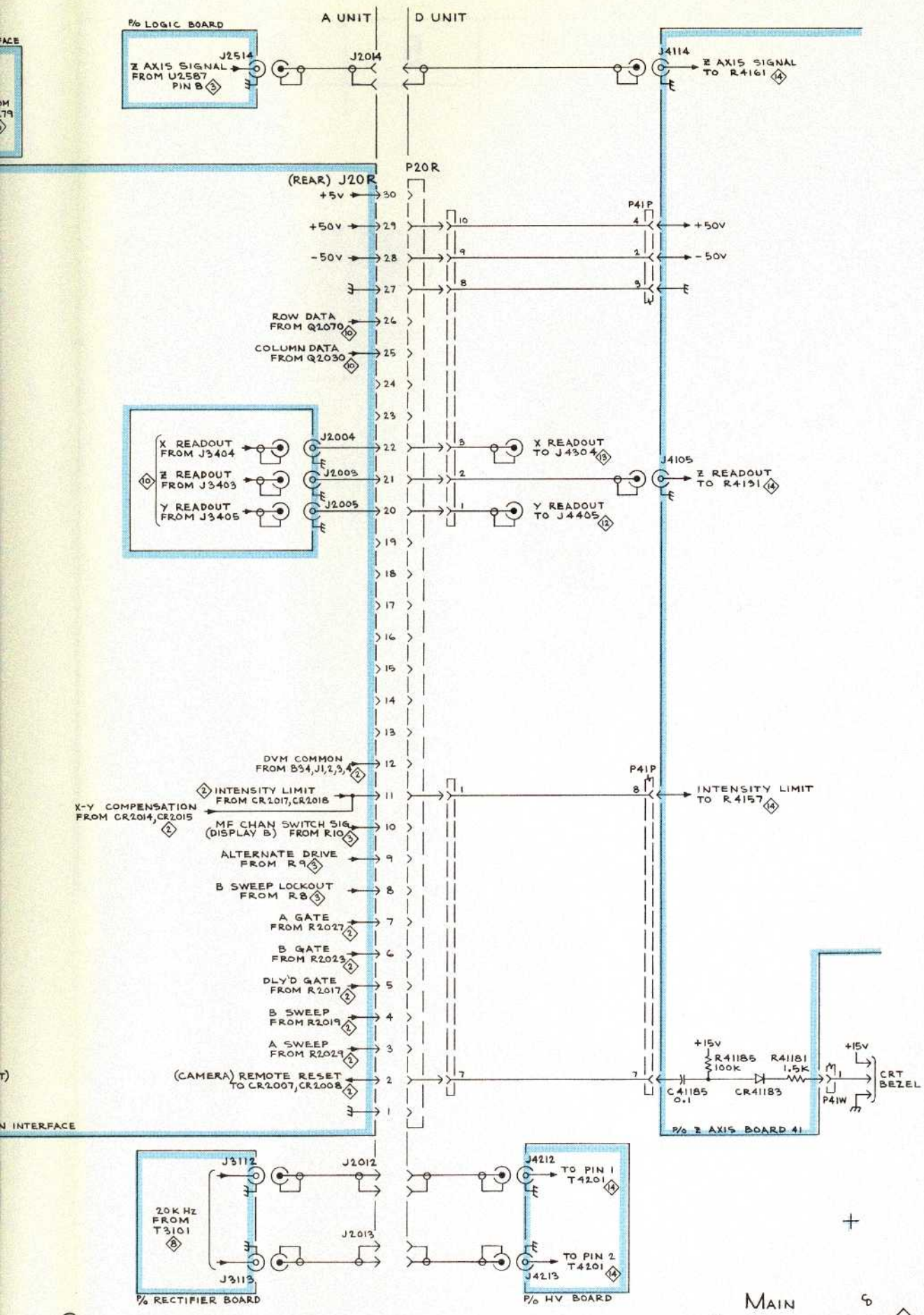

MAIN INTERCONNECT

MAIN INTERCONNECT

A44  
VERTICAL  
AMPLIFIER

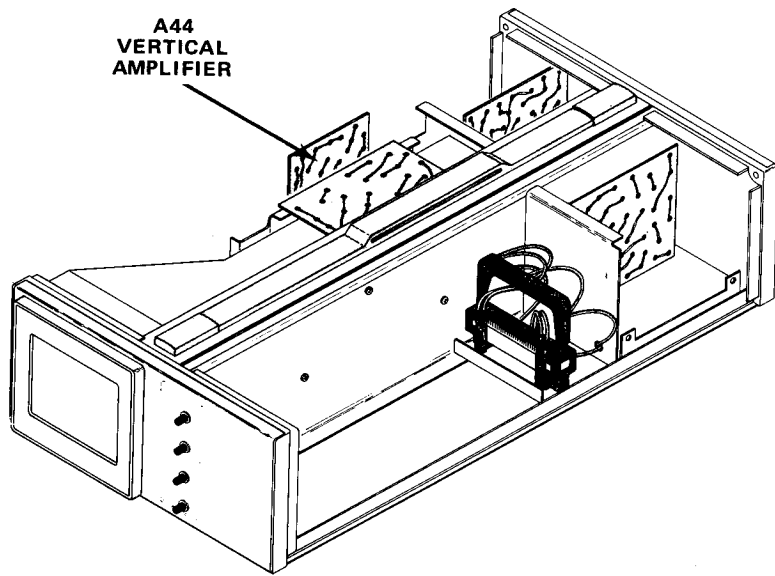

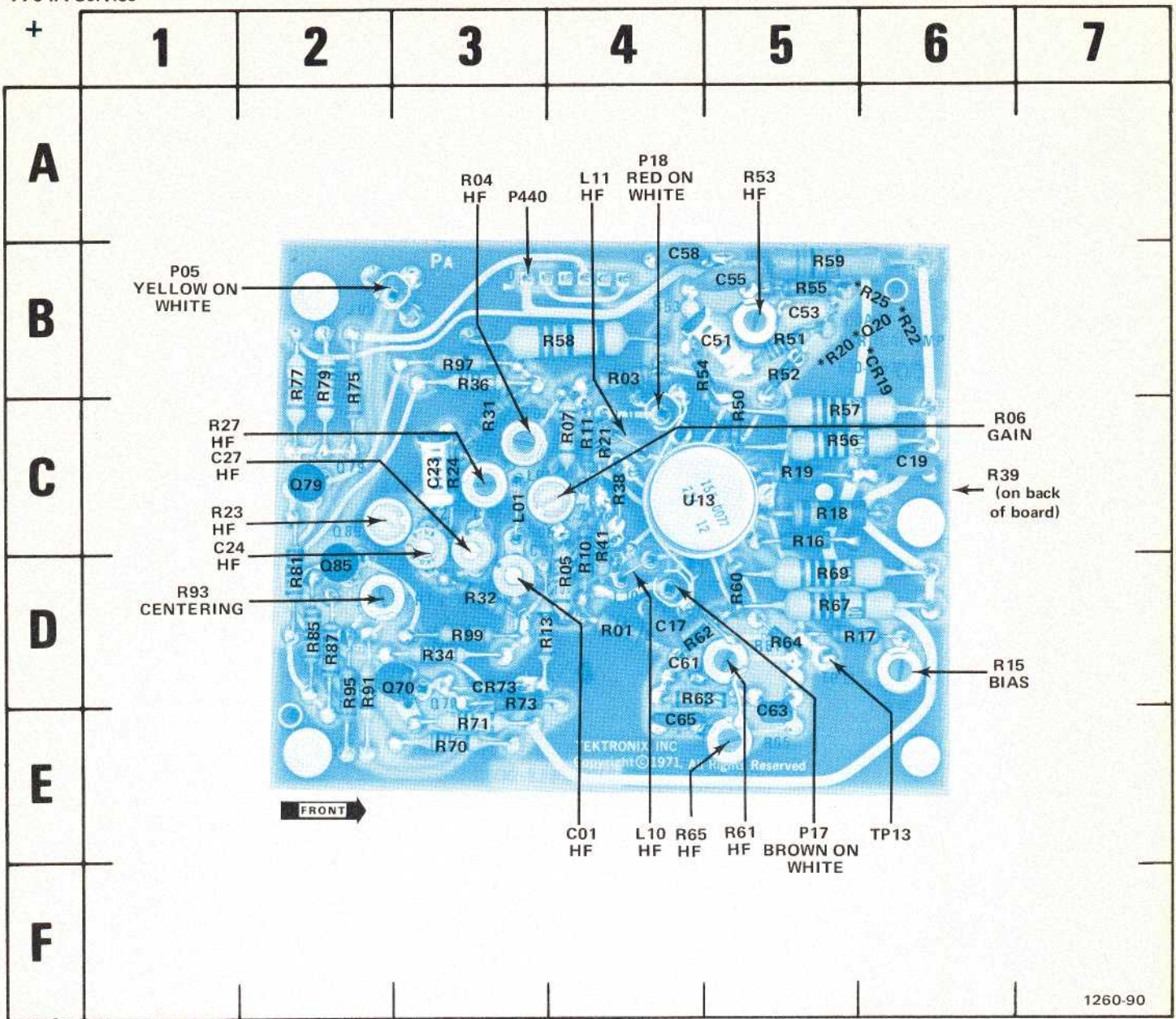

1260-90

\*See Parts List for serial number ranges.

Fig. 6-20. A44 – Vertical Amplifier circuit board.

REV. C, JUNE 1975

| CKT NO | GRID LOC | CKT NO | GRID LOC | CKT NO | GRID LOC | CKT NO | GRID LOC | CKT NO | GRID LOC | CKT NO | GRID LOC | CKT NO | GRID LOC | CKT NO | GRID LOC |
|--------|----------|--------|----------|--------|----------|--------|----------|--------|----------|--------|----------|--------|----------|--------|----------|
| C01    | 3D       | C63    | 5E       | P18    | 4C       | R06    | 4C       | R23    | 2C       | R52    | 5B       | R63    | 4D       | R81    | 2D       |
| C17    | 4D       | C65    | 4E       | P44D   | 3B       | R07    | 4C       | R24    | 3C       | R53    | 5B       | R64    | 5D       | R85    | 2D       |
| C19    | 6C       |        |          |        |          | R10    | 4C       | R27    | 3C       | R54    | 4B       | R65    | 5E       | R87    | 2D       |
| C23    | 3C       | CR73   | 3D       | Q70    | 3D       | R11    | 4C       | R31    | 3D       | R55    | 5B       | R67    | 5D       | R91    | 2D       |
| C24    | 3C       |        |          | Q79    | 2C       | R13    | 3D       | R32    | 3D       | R56    | 5C       | R69    | 5D       | R93    | 2D       |
| C27    | 3C       | L01    | 3C       | Q85    | 2D       | R15    | 6D       | R34    | 3D       | R57    | 5C       | R70    | 3E       | R95    | 2D       |
| C51    | 5B       | L10    | 4D       |        |          | R16    | 5C       | R36    | 3B       | R58    | 4B       | R71    | 3E       | R97    | 3B       |
| C53    | 5B       | L11    | 4C       | R01    | 4D       | R17    | 6D       | R38    | 4C       | R59    | 5B       | R73    | 3D       | R99    | 3D       |
| C55    | 5B       |        |          | R03    | 4B       | R18    | 5C       | R41    | 4C       | R60    | 5D       | R75    | 2B       |        |          |
| C58    | 4B       | P05    | 2B       | R04    | 3C       | R19    | 5C       | R50    | 5C       | R61    | 5D       | R77    | 2B       | TP13   | 5D       |
| C61    | 4D       | P17    | 4D       | R05    | 4D       | R21    | 4C       | R51    | 5B       | R62    | 4D       | R79    | 2B       | U13    | 4C       |

## VOLTAGE AND WAVEFORM CONDITIONS

The voltages and waveforms shown on this diagram were obtained with the test set-ups and equipment given below. These measurements are not absolute and may vary between instruments.

### Recommended Test Equipment

| Item  | Specifications  | Examples of Applicable Test Equipment  |
|---|---|--|
| Test oscilloscope                             | Frequency response, dc to 65 MHz and selectable reduced bandwidth to five or 10 MHz; deflection factor (with 10X probe), 20 mV to two V/division; sweep rate, 500 $\mu$ s/division. | <p>a. Tektronix 7603 Oscilloscope with 7A13 Differential Comparator, 7B50 Time Base, and P6053A Probe, or equivalent. (7A13 Differential Comparator used to obtain dc offset).</p> <p>b. Use item (a) above with 7A15A Amplifier in place of 7A13.</p> |
| Dc voltmeter (non-loading digital multimeter) | Input impedance, 10 megohms; range, 0 to 100 V dc.  | <p>a. Tektronix 7D13 Digital Multimeter (test oscilloscope must have readout system), or equivalent.</p> <p>b. Fairchild Model 7050.</p>   |

### Test Set-Up

7704A Under Test: Amplifier unit installed in LEFT VERT compartment. No signal applied for voltage measurements; trace is centered. For waveforms, the 7704A Calibrator signal is applied to the amplifier unit to obtain a centered, four-division display. A time-base unit is installed in the B HORIZ compartment. The time-base is set for auto triggering at a 0.1-ms/division sweep rate.

#### Front-Panel Controls

|                        |           |
|------------------------|-----------|
| Knob-type controls     | Midrange  |
| VERTICAL MODE          | LEFT      |
| A AND B TRIGGER SOURCE | VERT MODE |
| HORIZONTAL MODE        | B         |

Test Equipment: Voltmeter common is connected to 7704A chassis ground. Test oscilloscope is externally triggered from 7704A +GATE OUT connector. \* by waveform indicates that test oscilloscope was set for reduced bandwidth.

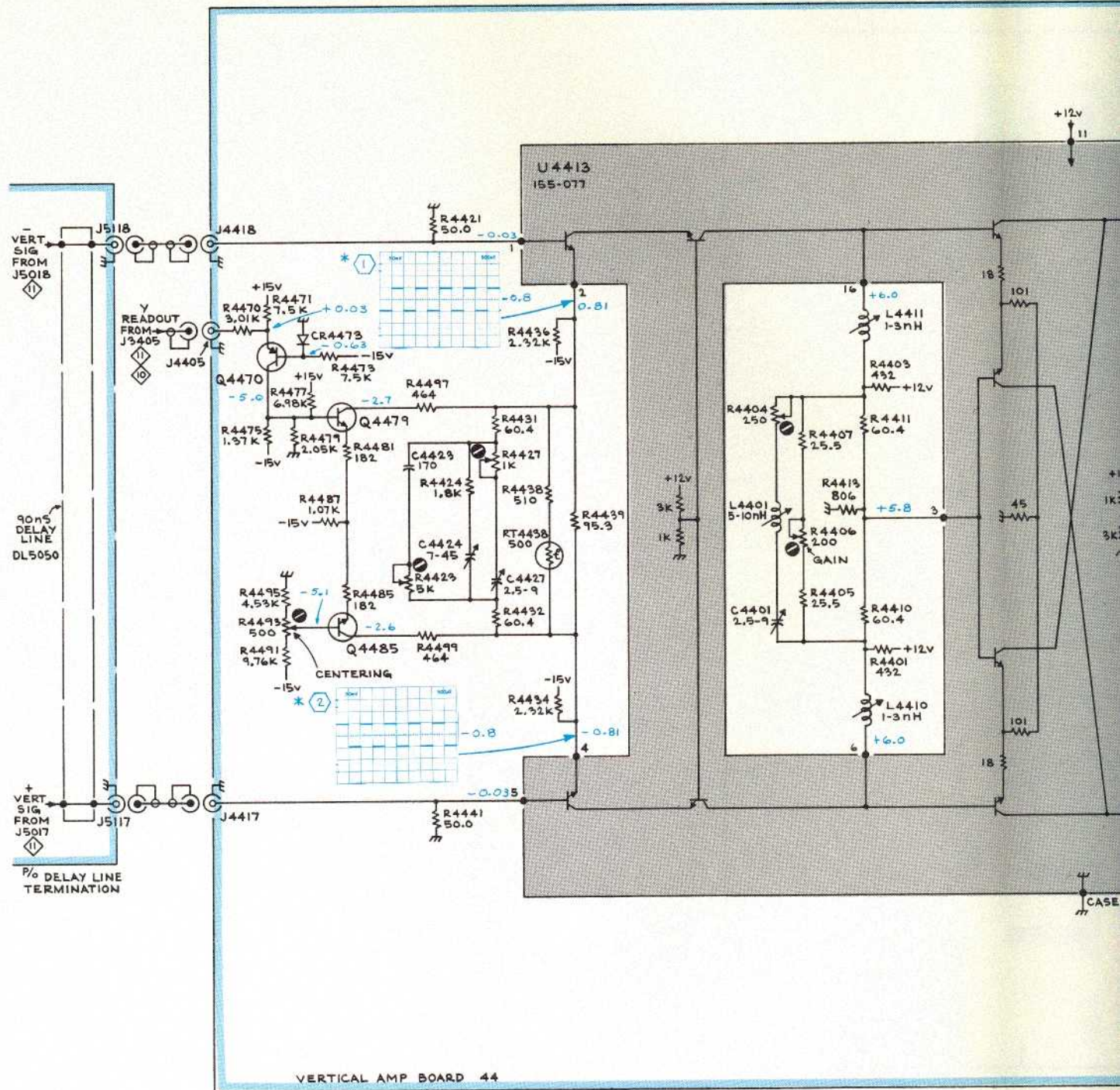

VOLTAGE & WAVEFORM CONDITIONS

+

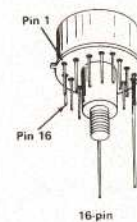

7704A (DISPLAY UNIT)

REV. C, NOV. 1971  
1260-91

S500  
BEAM

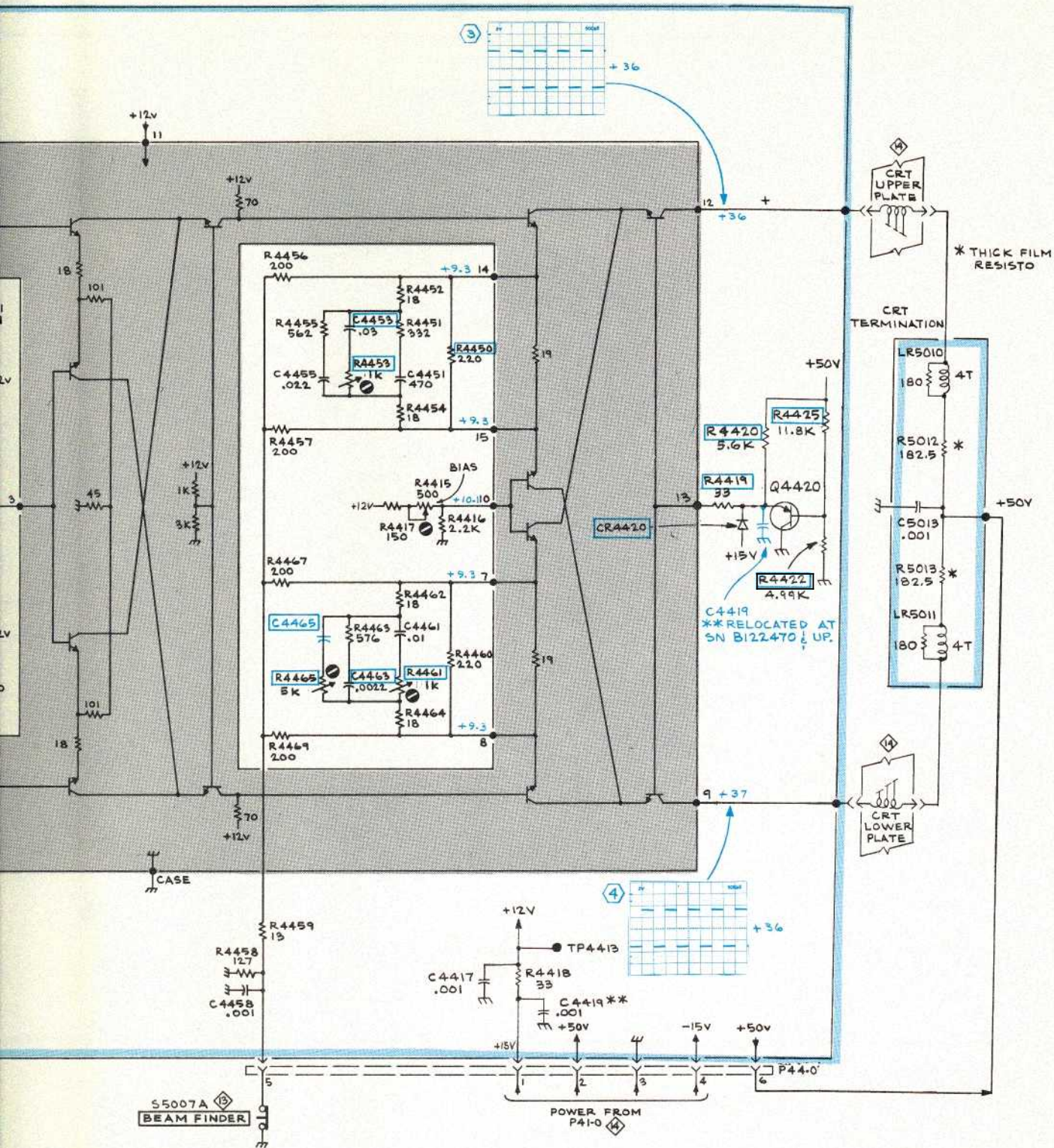

SEE PARTS LIST FOR EARLIER VALUES AND SERIAL NUMBER RANGES OF PARTS OUTLINED OR DEPICTED IN BLUE.



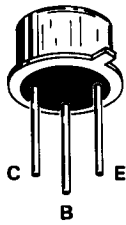
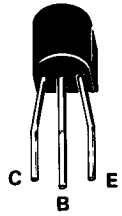
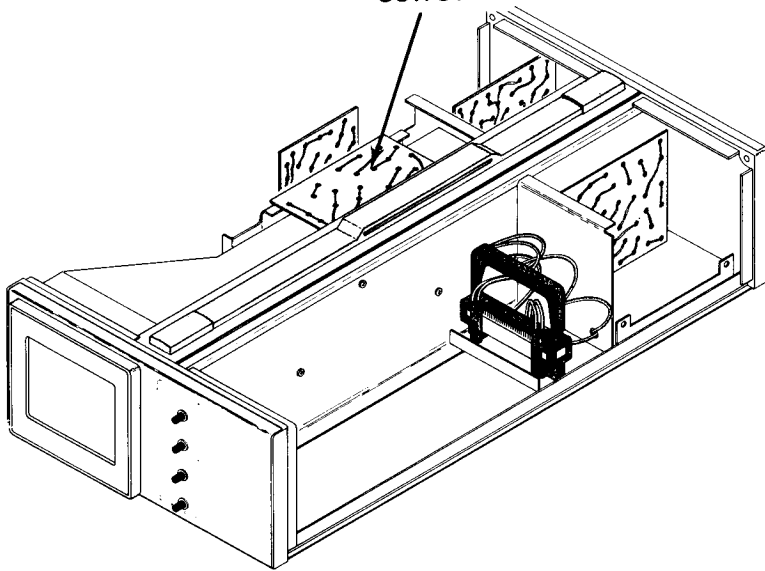

Fig. 6-22. Electrode configuration for semiconductors shown on diagram 13.

A43  
HORIZONTAL  
OUTPUT





1

2

3

4

5

6

7

8

A

B

C

D

E

F

G

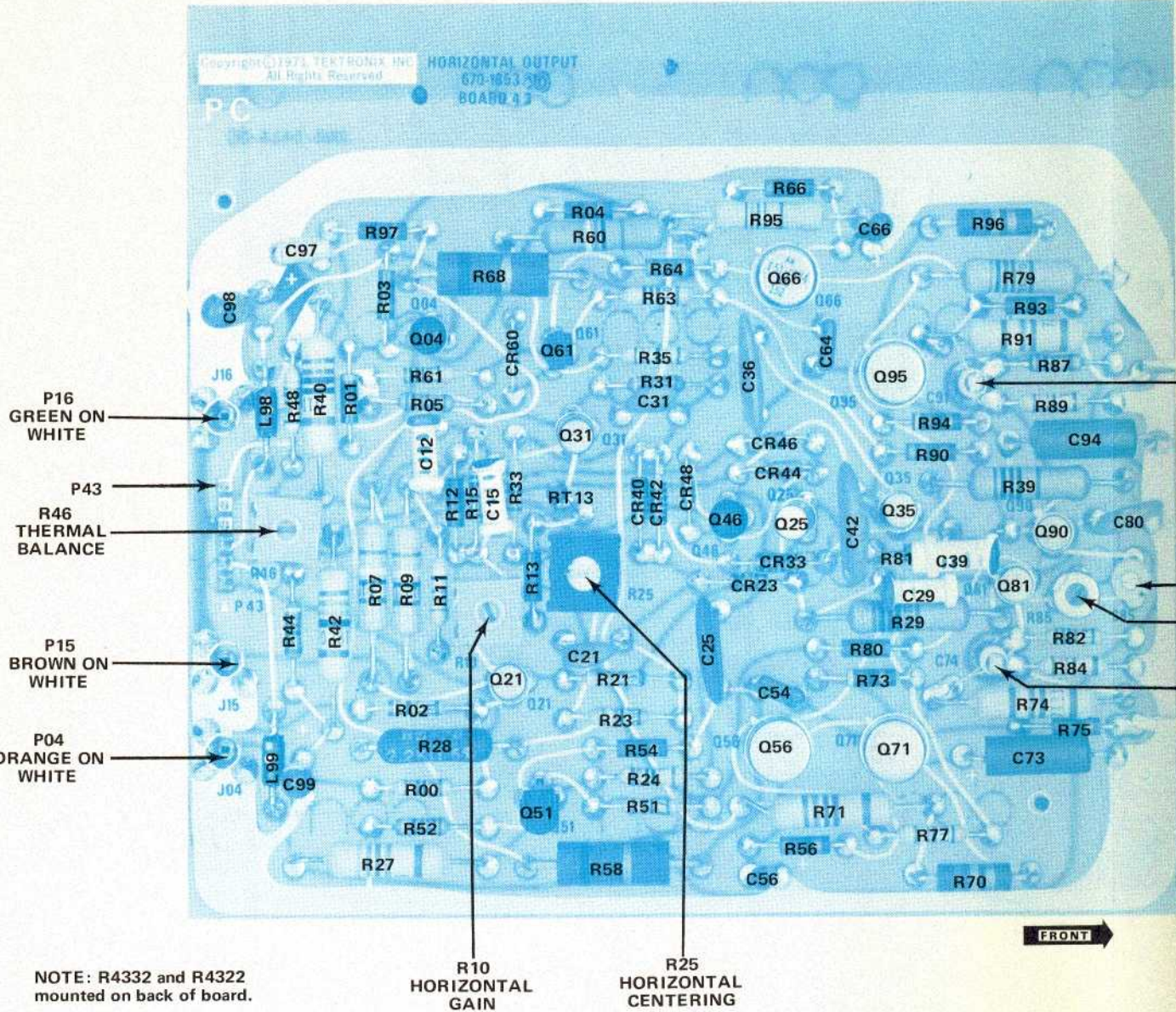
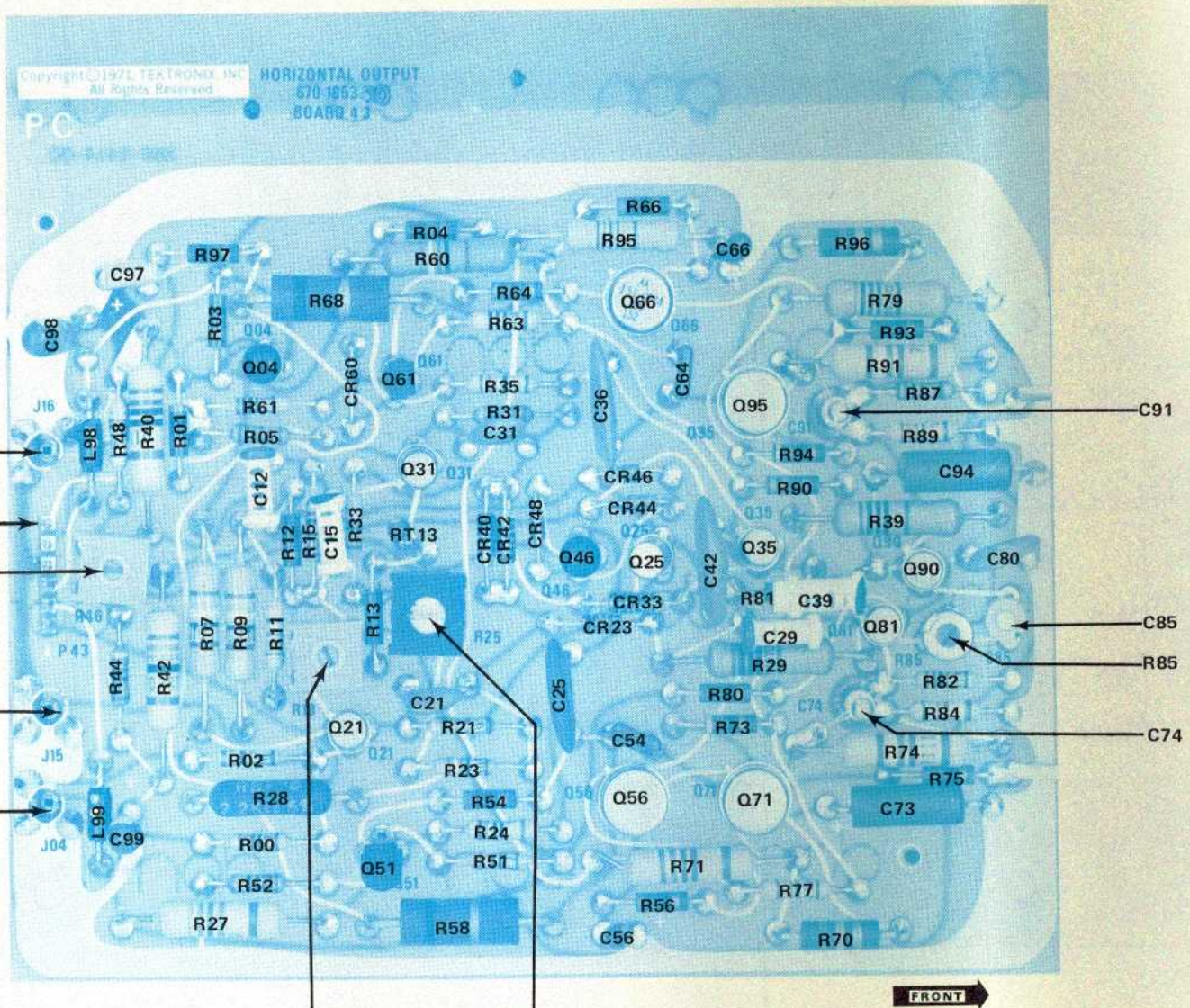

Fig. 6-21. A43—Horizontal Output circuit board.

| CKT NO | GRID LOC | CKT NO | GRID LOC | CKT NO | GRID LOC | CKT NO | GRID LOC | CKT NO | GRID LOC | CKT NO | GRID LOC | CKT NO | GRID LOC | CKT NO | GRID LOC |
|--------|----------|--------|----------|--------|----------|--------|----------|--------|----------|--------|----------|--------|----------|--------|----------|
| C12    | 3D       | C91    | 7C       | P04    | 2E       | R66    | 6C       | R10    | 4E       | R35    | 5C       | R63    | 5C       | R84    | 7E       |
| C15    | 4D       | C94    | 7D       | P15    | 2E       | Q71    | 6E       | R11    | 3D       | R39    | 7D       | R64    | 5C       | R85    | 7E       |
| C21    | 4E       | C97    | 3B       | P16    | 2C       | Q81    | 7D       | R12    | 4D       | R40    | 3C       | R66    | 6B       | R87    | 7C       |
| C25    | 5E       | C99    | 3F       | P43    | 2D       | Q90    | 7D       | R13    | 4D       | R42    | 3E       | R68    | 4C       | R89    | 7C       |
| C31    | 5C       |        |          |        |          | Q95    | 6C       | R14    | 4D       | R44    | 3E       | R70    | 7F       | R90    | 7D       |
| C36    | 5C       | CR23   | 5D       | Q04    | 3C       |        |          | R21    | 5E       | R46    | 2D       | R71    | 6F       | R91    | 7C       |
| C39    | 7D       | CR33   | 6D       | Q21    | 4E       | R00    | 3F       | R23    | 5E       | R48    | 3C       | R73    | 6E       | R93    | 7C       |
| C42    | 6D       | CR40   | 5D       | Q25    | 6D       | R01    | 3C       | R24    | 5F       | R51    | 5F       | R74    | 7E       | R94    | 7C       |
| C54    | 6E       | CR42   | 5D       | Q31    | 4C       | R02    | 3E       | R25    | 4D       | R52    | 3F       | R75    | 7E       | R95    | 5B       |
| C56    | 5F       | CR44   | 6D       | Q35    | 6D       | R03    | 3C       | R27    | 3F       | R54    | 5E       | R77    | 6F       | R96    | 7B       |
| C64    | 5F       | CR46   | 6D       | Q46    | 5D       | R04    | 4B       | R28    | 3E       | R56    | 6F       | R79    | 7C       | R97    | 3B       |
| C66    | 6B       | CR48   | 5D       | Q51    | 4F       | R05    | 3C       | R29    | 6E       | R58    | 5F       | R80    | 6E       |        |          |
| C73    | 7E       | CR60   | 4C       | Q56    | 6E       | R07    | 3D       | R31    | 5C       | R60    | 4B       | R81    | 6D       | RT13   | 4D       |
| C74    | 7E       |        |          | Q61    | 4C       | R09    | 3D       | R33    | 4D       | R61    | 3C       | R82    | 7E       |        |          |
| C80    | 8D       | L98    | 2C       |        |          |        |          |        |          |        |          |        |          |        |          |
| C85    | 8D       | L99    | 2F       |        |          |        |          |        |          |        |          |        |          |        |          |



NOTE: R4332 and R4322 mounted on back of board.

R10 HORIZONTAL GAIN  
R25 HORIZONTAL CENTERING

Fig. 6-21. A43-Horizontal Output circuit board.

| GRID LOC | CKT NO | GRID LOC | CKT NO | GRID LOC | CKT NO | GRID LOC | CKT NO | GRID LOC | CKT NO | GRID LOC | CKT NO | GRID LOC | CKT NO | GRID LOC |
|----------|--------|----------|--------|----------|--------|----------|--------|----------|--------|----------|--------|----------|--------|----------|
| 3D       | C91    | 7C       | P04    | 2E       | R66    | 6C       | R10    | 4E       | R35    | 5C       | R63    | 5C       | R84    | 7E       |
| 4D       | C94    | 7D       | P15    | 2E       | Q71    | 6E       | R11    | 3D       | R39    | 7D       | R64    | 5C       | R85    | 7E       |
| 4E       | C97    | 3B       | P16    | 2C       | Q81    | 7D       | R12    | 4D       | R40    | 3C       | R66    | 6B       | R87    | 7C       |
| 5E       | C99    | 3F       | P43    | 2D       | Q90    | 7D       | R13    | 4D       | R42    | 3E       | R68    | 4C       | R89    | 7C       |
| 5C       |        |          |        |          | Q95    | 6C       | R14    | 4D       | R44    | 3E       | R70    | 7F       | R90    | 7D       |
| 5C       | CR23   | 5D       | Q04    | 3C       |        |          | R21    | 5E       | R46    | 2D       | R71    | 6F       | R91    | 7C       |
| 7D       | CR33   | 6D       | Q21    | 4E       | R00    | 3F       | R23    | 5E       | R48    | 3C       | R73    | 6E       | R93    | 7C       |
| 6D       | CR40   | 5D       | Q25    | 6D       | R01    | 3C       | R24    | 5F       | R51    | 5F       | R74    | 7E       | R94    | 7C       |
| 6E       | CR42   | 5D       | Q31    | 4C       | R02    | 3E       | R25    | 4D       | R52    | 3F       | R75    | 7E       | R95    | 5B       |
| 5F       | CR44   | 6D       | Q35    | 6D       | R03    | 3C       | R27    | 3F       | R54    | 5E       | R77    | 6F       | R96    | 7B       |
| 5F       | CR46   | 6D       | Q46    | 5D       | R04    | 4B       | R28    | 3E       | R56    | 6F       | R79    | 7C       | R97    | 3B       |
| 6B       | CR48   | 5D       | Q51    | 4F       | R05    | 3C       | R29    | 6E       | R58    | 5F       | R80    | 6E       |        |          |
| 7E       | CR60   | 4C       | Q56    | 6E       | R07    | 3D       | R31    | 5C       | R60    | 4B       | R81    | 6D       | RT13   | 4D       |
| 7E       |        |          | Q61    | 4C       | R09    | 3D       | R33    | 4D       | R61    | 3C       | R82    | 7E       |        |          |
| 8D       | L98    | 2C       |        |          |        |          |        |          |        |          |        |          |        |          |
| 8D       | L99    | 2F       |        |          |        |          |        |          |        |          |        |          |        |          |

## VOLTAGE AND WAVEFORM CONDITIONS

The voltages and waveforms shown on this diagram were obtained with the test set-ups and equipment given below. These measurements are not absolute and may vary between instruments.

### Recommended Test Equipment

| Item  | Specifications   | Examples of Applicable Test Equipment  |
|---|--|--|
| Test oscilloscope                             | Frequency response, dc to 65 MHz; deflection factor (with 10X probe), 100 mV to 10 V/division; sweep rate, 500 $\mu$ s/division. | <p>a. Tektronix 7603 Oscilloscope with 7A13 Differential Comparator, 7B50 Time Base, and P6053A Probe, or equivalent. (7A13 Differential Comparator used to obtain dc offset).</p> <p>b. Use item (a) above with 7A15A Amplifier in place of 7A13.</p> |
| Dc voltmeter (non-loading digital multimeter) | Input impedance, 10 megohms; range, 0 to 200 V dc.   | <p>a. Tektronix 7D13 Digital Multimeter (test oscilloscope must have readout system), or equivalent.</p> <p>b. Fairchild Model 7050.</p>   |

### Test Set-Up

**7704A Under Test:** Amplifier unit installed in LEFT VERT compartment. No signal applied for voltage measurements. For waveforms, the 7704A Calibrator signal is applied to the amplifier unit to obtain a four-division display. A time-base unit is installed in the B HORIZ compartment. The time-base is set for auto triggering at a 0.1-ms/division sweep rate.

#### Front-Panel Controls

|                        |           |
|------------------------|-----------|
| Knob-type controls     | Midrange  |
| VERTICAL MODE          | LEFT      |
| A AND B TRIGGER SOURCE | VERT MODE |
| HORIZONTAL MODE        | B         |

**Test Equipment:** Voltmeter common is connected to 7704A chassis ground. Test oscilloscope is externally triggered from 7704A +GATE OUT connector.

# VOLTAGE & WAVEFORM CONDITIONS

SEE PARTS LIST FOR EARLIER VALUES AND SERIAL NUMBER RANGES OF PARTS MARKED WITH BLUE OUTLINE.

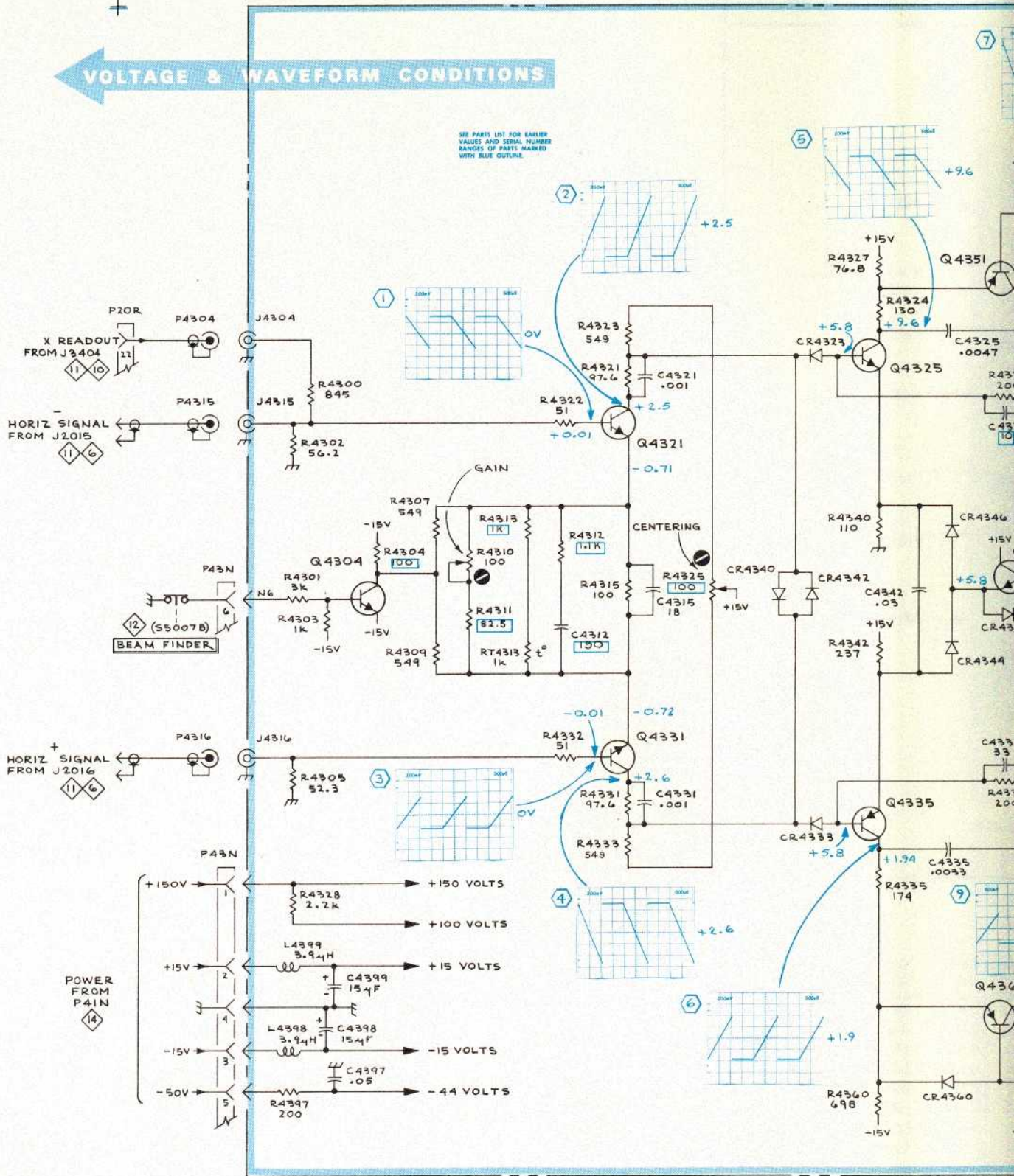

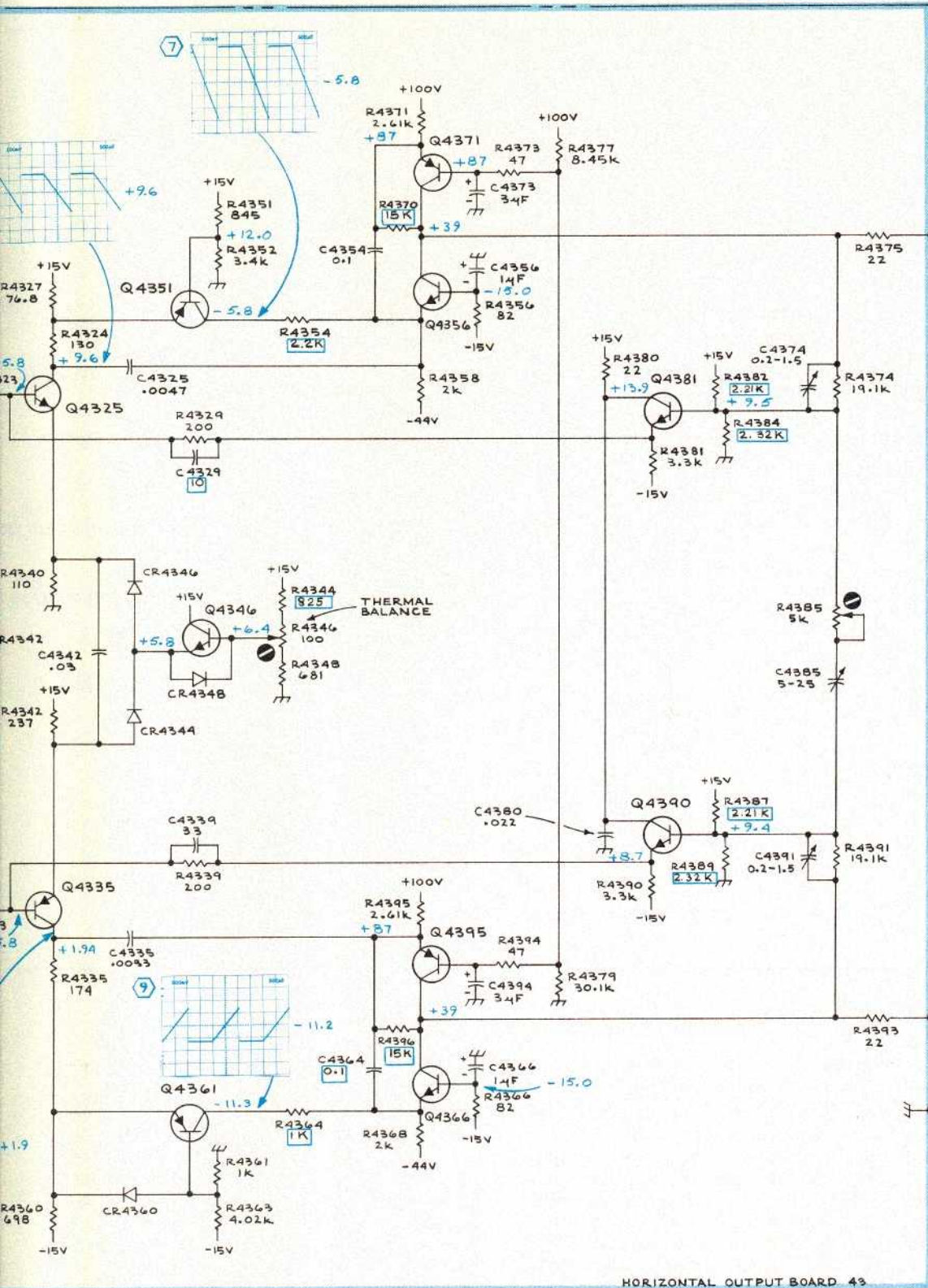

HORIZONTAL OUTPUT BOARD 43

2

3

4

5

6

7

8

9

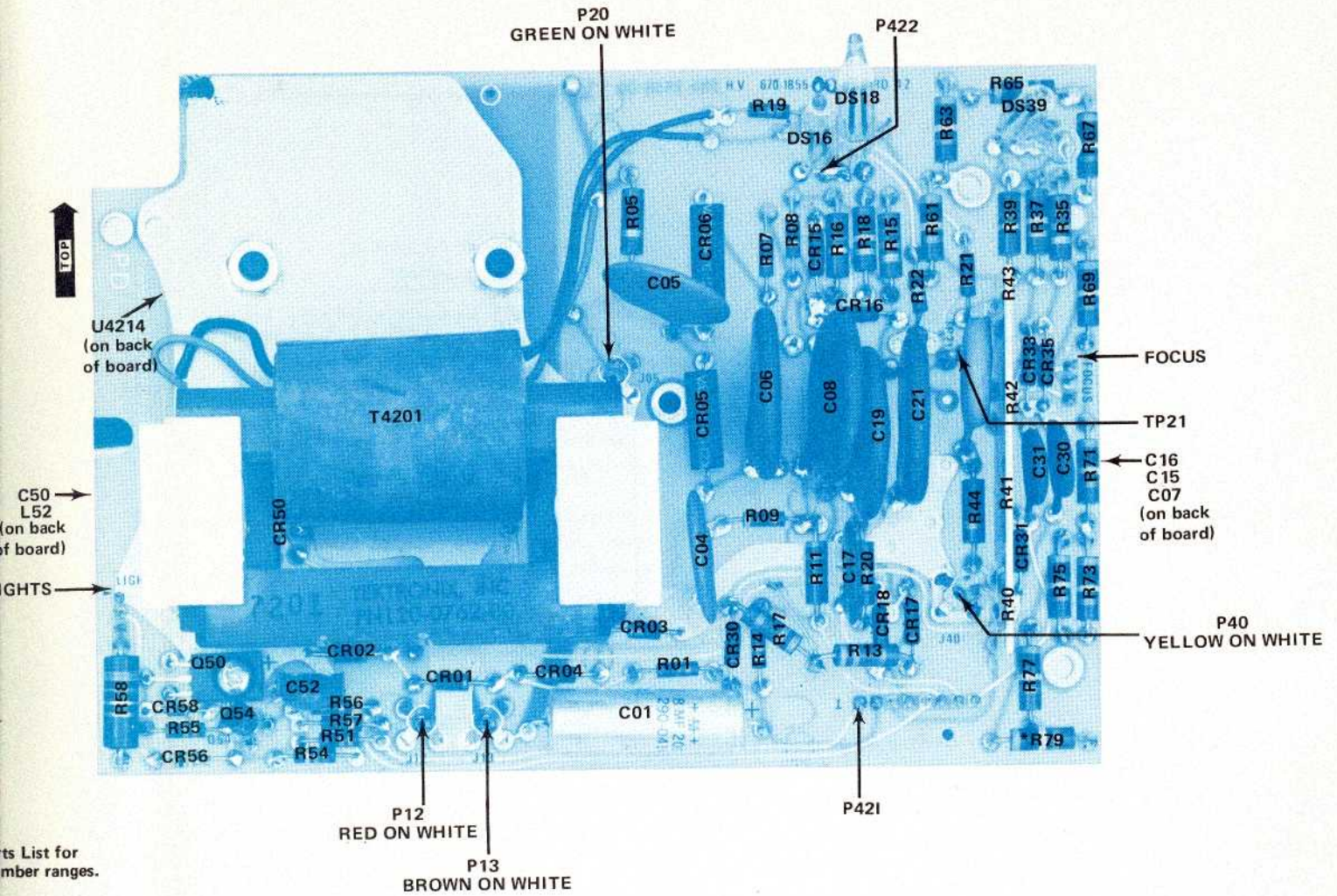

1260-96

Fig. 6-24. A42-HV circuit board.

| CKT NO | GRID LOC | CKT NO | GRID LOC | CKT NO | GRID LOC | CKT NO | GRID LOC | CKT NO | GRID LOC | CKT NO | GRID LOC | CKT NO | GRID LOC | CKT NO | GRID LOC |
|--------|----------|--------|----------|--------|----------|--------|----------|--------|----------|--------|----------|--------|----------|--------|----------|
| C01    | 5E       | CR01   | 4E       | CR31   | 7D       | P12    | 4E       | R05    | 5B       | R19    | 6A       | R44    | 7D       | R71    | 8D       |
| C04    | 5D       | CR02   | 3E       | CR33   | 7C       | P13    | 4E       | R07    | 6B       | R20    | 6D       | R51    | 3E       | R73    | 8D       |
| C05    | 5B       | CR03   | 5E       | CR35   | 7C       | P20    | 5C       | R08    | 6B       | R21    | 7B       | R54    | 3E       | R75    | 8D       |
| C06    | 6C       | CR04   | 5E       | CR50   | 3D       | P40    | 7D       | R09    | 6D       | R22    | 7C       | R55    | 2E       | R77    | 7E       |
| C08    | 6C       | CR05   | 5C       | CR56   | 2E       | P421   | 6E       | R11    | 6D       | R35    | 8B       | R56    | 3E       | R79    | 7E       |
| C17    | 6D       | CR06   | 5B       | CR58   | 2E       | P422   | 6B       | R13    | 6E       | R37    | 7B       | R57    | 3E       |        |          |
| C19    | 6C       | CR15   | 6B       |        |          |        |          | R14    | 6E       | R39    | 7B       | R58    | 2E       | T4201  | 4C       |
| C21    | 7C       | CR16   | 6C       |        |          |        |          | R15    | 7B       | R40    | 7D       | R61    | 7B       |        |          |
| C30    | 8D       | CR17   | 7E       |        |          |        |          | R16    | 6B       | R41    | 7D       | R63    | 7B       | TP21   | 7C       |
| C31    | 7D       | CR18   | 6E       |        |          |        |          | R17    | 6E       | R42    | 7C       | R65    | 7A       |        |          |
| C52    | 3E       | CR30   | 6E       |        |          |        |          | R18    | 6B       | R43    | 7C       | R67    | 8B       |        |          |



8-pin

1260-97

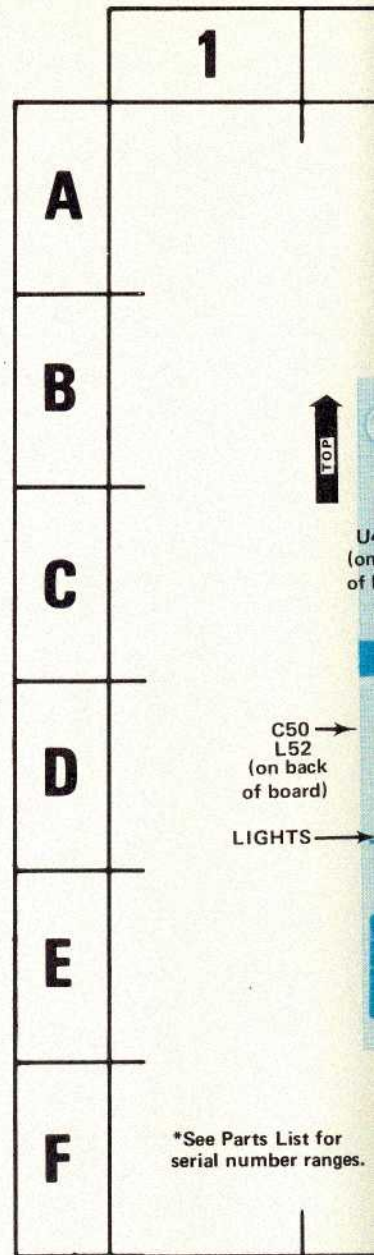
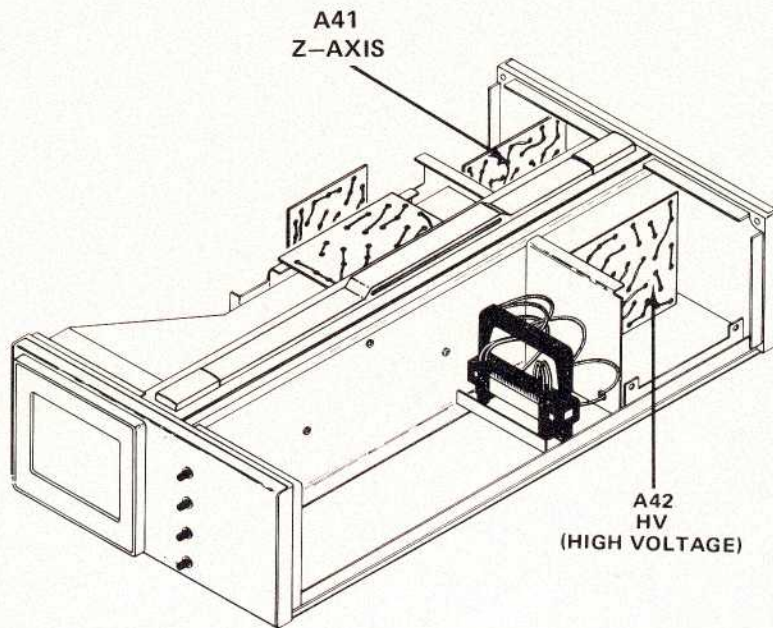
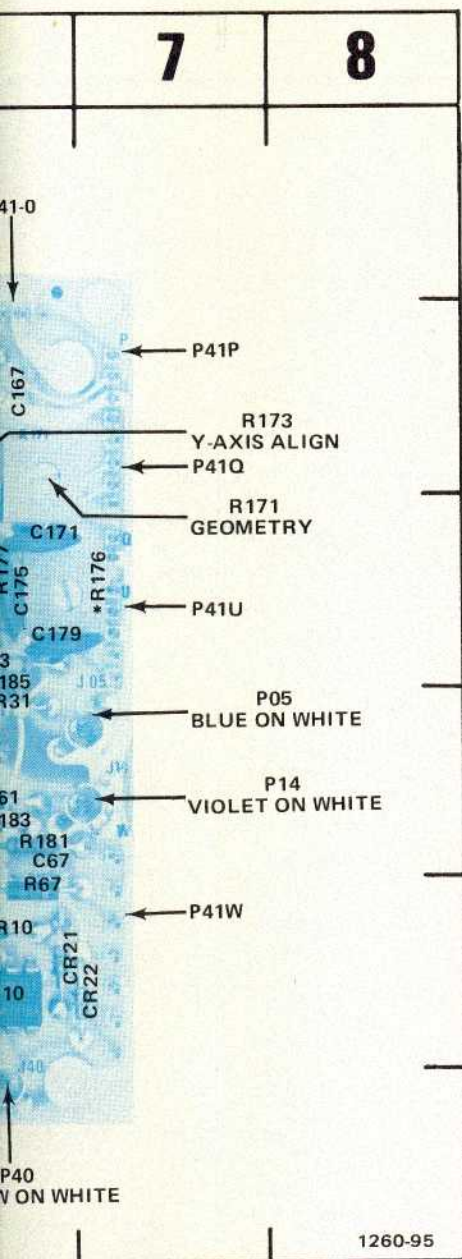

1260-95

**NOTE**

To conserve space, the circuit numbers on circuit boards and board photos show only the letter prefix and last two digits of the complete circuit number shown in parts list and schematic (R69 = R1069, etc.).

| GRID LOC | CKT NO | GRID LOC |
|----------|--------|----------|
| 5 4C     | R151   | 2D       |
| 7 4D     | R153   | 2D       |
| 9 4C     | R155   | 2E       |
| 1 3D     | R161   | 5C       |
| 3 3D     | R171   | 6B       |
| 5 3C     | R173   | 6B       |
| 9 3B     | R175   | 6C       |
| 0 4E     | R176   | 7C       |
| 1 3B     | R177   | 6C       |
| 3 3D     | R181   | 6D       |
| 4 3D     | R185   | 6C       |
| 5 2C     | TP120  | 3C       |
| 6 2C     |        |          |
| 7 2C     | U10    | 6E       |
| 9 2B     | VR42   | 3B       |
| 1 2D     | VR75   | 6D       |
| 3 2C     | VR107  | 3D       |
| 7 3E     | VR120  | 3E       |
| 0 3B     | VR121  | 3C       |

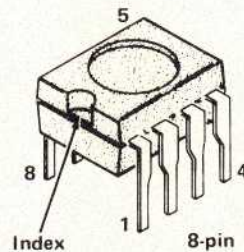
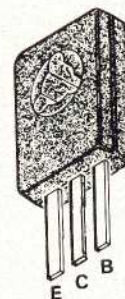
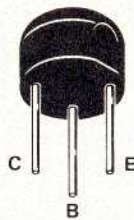

1260-97

Fig. 6-25. Electrode configuration for semiconductors shown on diagram 14.

A41 & A42 ASSEMBLY

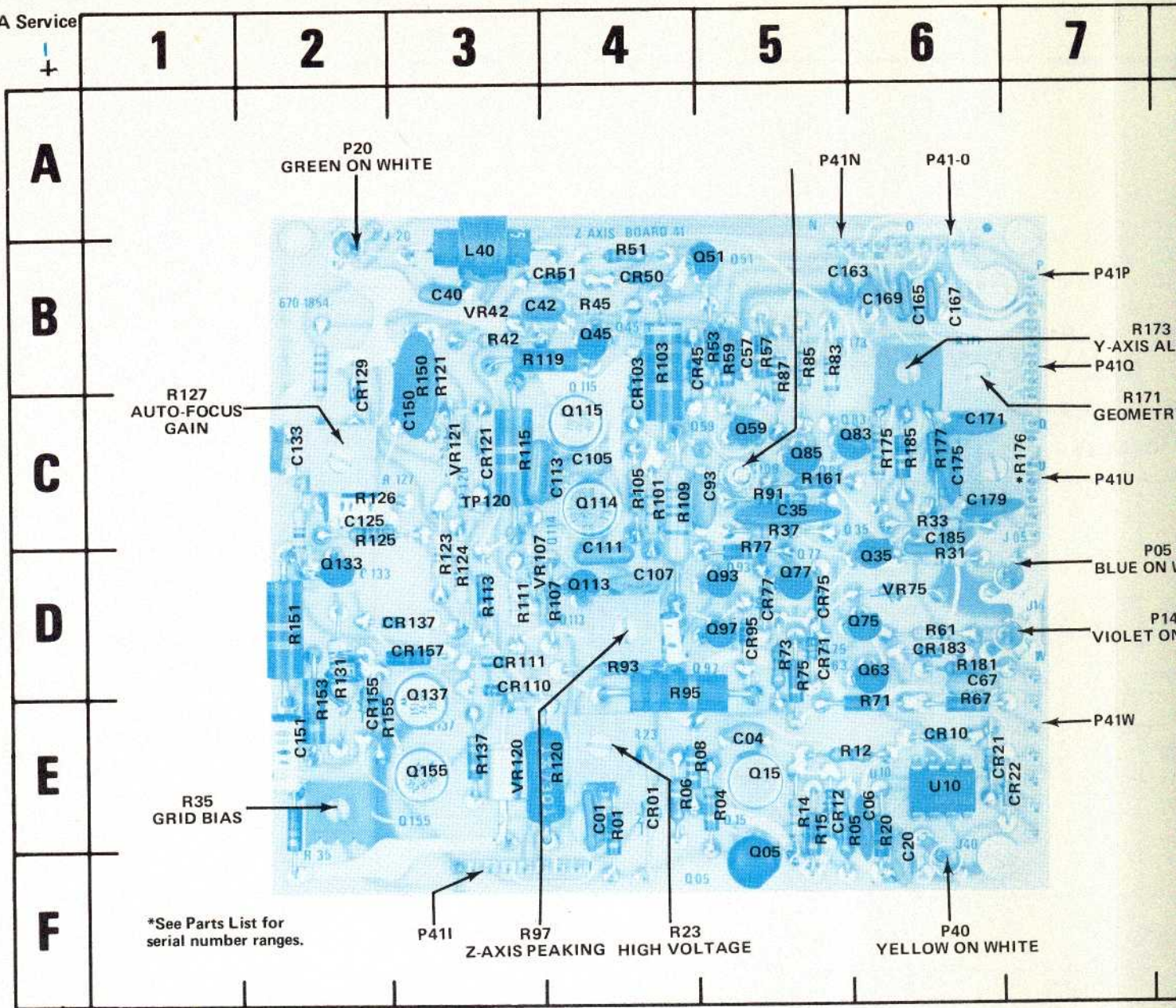

Added to back of board.

\*R63  
\*R154

Fig. 6-23. A41-Z-Axis circuit board.

| CKT NO | GRID LOC | CKT NO | GRID LOC | CKT NO | GRID LOC | CKT NO | GRID LOC | CKT NO | GRID LOC | CKT NO | GRID LOC | CKT NO | GRID LOC | CKT NO | GRID LOC |
|--------|----------|--------|----------|--------|----------|--------|----------|--------|----------|--------|----------|--------|----------|--------|----------|
| C01    | 4E       | C165   | 6B       | CR111  | 3D       | P41W   | 7E       | Q155   | 3E       | R51    | 4B       | R105   | 4C       | R151   | 2D       |
| C04    | 5E       | C167   | 6B       | CR121  | 3C       |        |          | R53    | 5B       | R107   | 4D       | R153   | 2D       |        |          |
| C06    | 6E       | C169   | 6B       | CR129  | 2B       | Q05    | 5E       | R01    | 4E       | R57    | 5B       | R109   | 4C       | R155   | 2E       |
| C20    | 6E       | C171   | 6C       | CR137  | 3D       | Q15    | 5E       | R04    | 5E       | R59    | 5B       | R111   | 3D       | R161   | 5C       |
| C35    | 5C       | C175   | 6C       | CR155  | 2E       | Q35    | 6D       | R05    | 5E       | R61    | 6D       | R113   | 3D       | R171   | 6B       |
| C40    | 3B       | C179   | 6C       | CR157  | 3D       | Q45    | 4B       | R06    | 4E       | R67    | 6E       | R115   | 3C       | R173   | 6B       |
| C42    | 3B       | C185   | 6C       | CR183  | 6D       | Q51    | 5B       | R08    | 4E       | R71    | 6E       | R119   | 3B       | R175   | 6C       |
| C57    | 5B       |        |          |        |          | Q59    | 5C       | R12    | 6E       | R73    | 5D       | R120   | 4E       | R176   | 7C       |
| C67    | 6D       | CR01   | 4E       | L40    | 3B       | Q63    | 6D       | R14    | 5E       | R75    | 5D       | R121   | 3B       | R177   | 6C       |
| C93    | 5C       | CR10   | 6E       |        |          | Q75    | 6D       | R15    | 5E       | R77    | 5D       | R123   | 3D       | R181   | 6D       |
| C105   | 4C       | CR12   | 5E       | P05    | 7D       | Q77    | 5D       | R20    | 6E       | R83    | 5B       | R124   | 3D       | R185   | 6C       |
| C107   | 4D       | CR21   | 6E       | P14    | 7D       | Q83    | 5C       | R23    | 4E       | R85    | 5B       | R125   | 2C       | TP120  | 3C       |
| C109   | 5C       | CR22   | 7E       | P20    | 2A       | Q85    | 5C       | R31    | 6D       | R87    | 5B       | R126   | 2C       |        |          |
| C111   | 4C       | CR45   | 4B       | P40    | 6F       | Q93    | 5D       | R33    | 6C       | R91    | 5C       | R127   | 2C       | U10    | 6E       |
| C113   | 4C       | CR50   | 4B       | P41I   | 3F       | Q97    | 5D       | R35    | 2E       | R93    | 4D       | R129   | 2B       | VR42   | 3B       |
| C125   | 2C       | CR71   | 5D       | P41N   | 5B       | Q113   | 4D       | R36    | 2E       | R95    | 4D       | R131   | 2D       | VR75   | 6D       |
| C133   | 2C       | CR75   | 5D       | P41O   | 6B       | Q114   | 4C       | R37    | 5C       | R97    | 4D       | R133   | 2C       | VR107  | 3D       |
| C150   | 3C       | CR77   | 5D       | P41P   | 7B       | Q115   | 4C       | R42    | 3B       | R101   | 4C       | R137   | 3E       | VR120  | 3E       |
| C151   | 2E       | CR95   | 5D       | P41Q   | 7B       | Q133   | 2D       | R45    | 4B       | R103   | 4B       | R150   | 3B       | VR121  | 3C       |
| C163   | 5B       | CR103  | 4B       | P41U   | 7C       | Q137   | 3D       |        |          |        |          |        |          |        |          |



## VOLTAGE AND WAVEFORM CONDITIONS

The voltages and waveforms shown on this diagram were obtained with the test set-ups and equipment given below. These measurements are not absolute and may vary between instruments.

### Recommended Test Equipment

| Item  | Specifications   | Examples of Applicable Test Equipment   |
|---|--|---|
| Test oscilloscope                             | Frequency response, dc to 65 MHz; deflection factor (with 10X probe), 100 mV to 10 V/division; sweep rate, 500 $\mu$ s/division. | a. Tektronix 7603 Oscilloscope with 7A13 Differential Comparator, 7B50 Time Base, and P6053A Probe, or equivalent. (7A13 Differential Comparator used to obtain dc offset).<br><br>b. Use item (a) above with 7A15A Amplifier in place of 7A13. |
| Dc voltmeter (non-loading digital multimeter) | Input impedance, 10 megohms; range, 0 to 200 V dc.   | a. Tektronix 7D13 Digital Multimeter (test oscilloscope must have readout system), or equivalent.<br><br>b. Fairchild Model 7050.   |

### Test Set-Up

7704A Under Test: Amplifier unit installed in LEFT VERT compartment. No signal applied for voltage measurements. For waveforms, the 7704A Calibrator signal is applied to the amplifier unit to obtain a four-division display. A time-base unit is installed in the B HORIZ compartment. The time-base is set for auto triggering at a 0.1-ms/division sweep rate.

#### Front-Panel Controls

|                        |           |
|------------------------|-----------|
| Knob-type controls     | Midrange  |
| VERTICAL MODE          | LEFT      |
| A AND B TRIGGER SOURCE | VERT MODE |
| HORIZONTAL MODE        | B         |

Test Equipment: Voltmeter common is connected to 7704A chassis ground. Test oscilloscope is externally triggered from 7704A +GATE OUT connector.

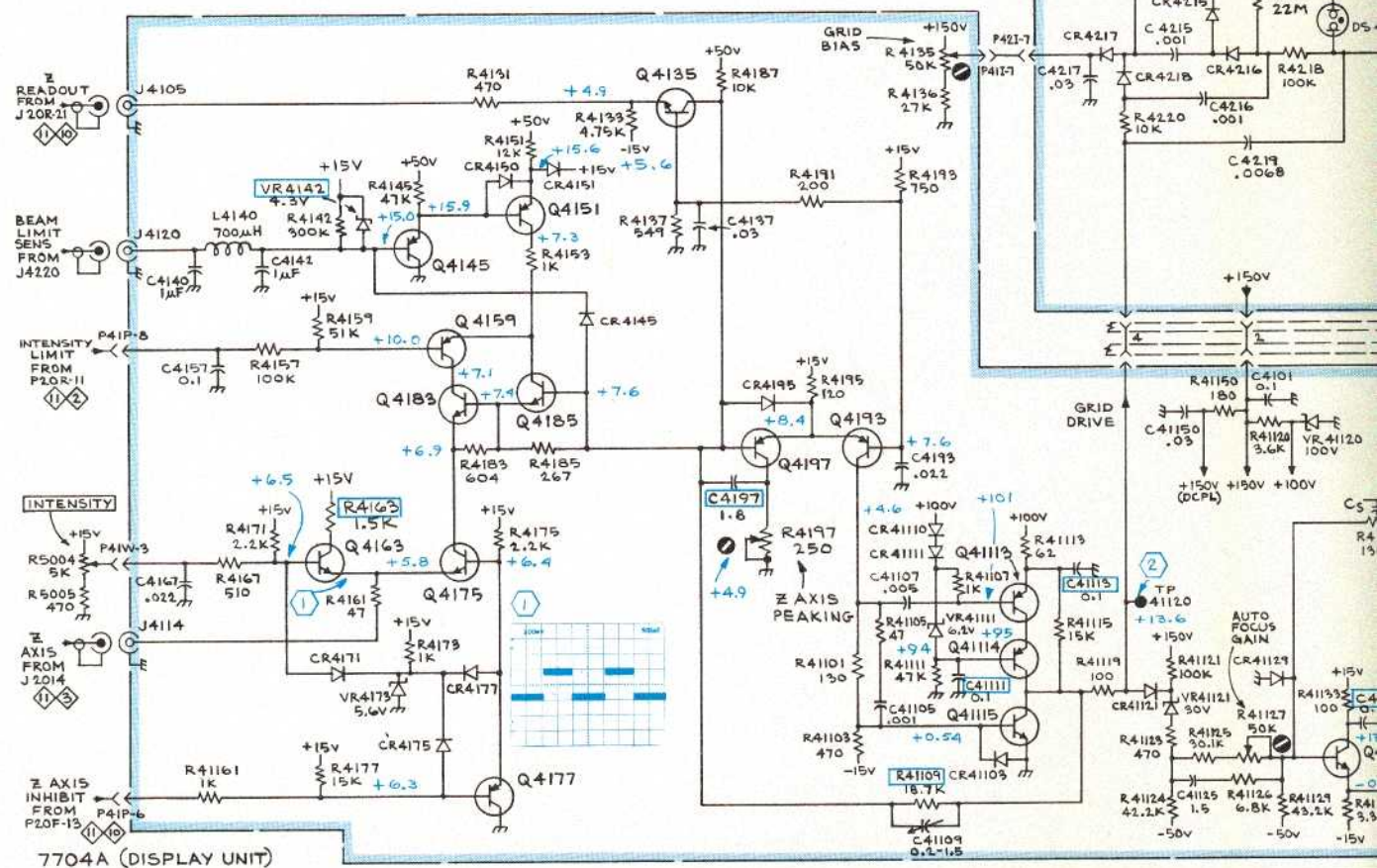
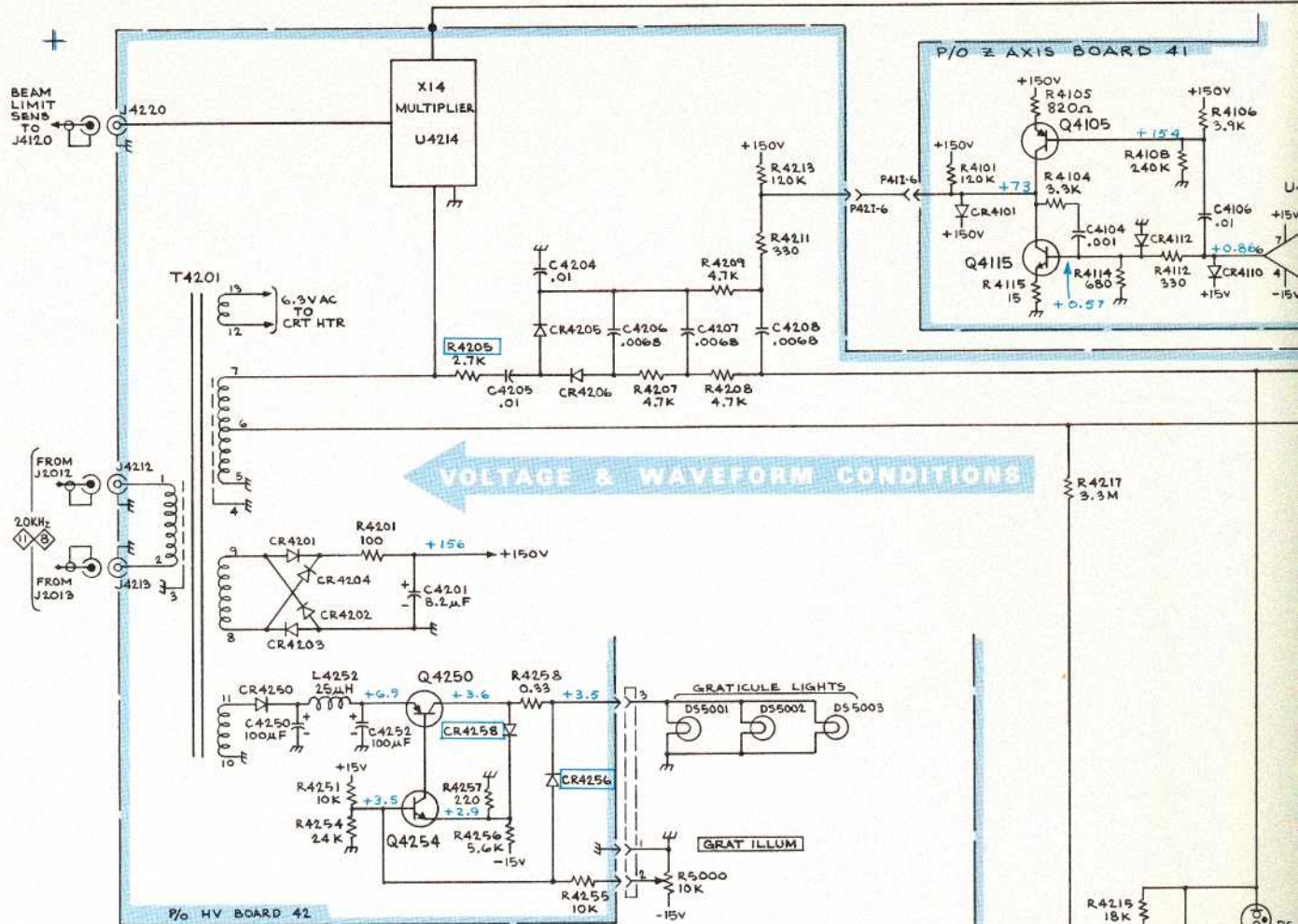

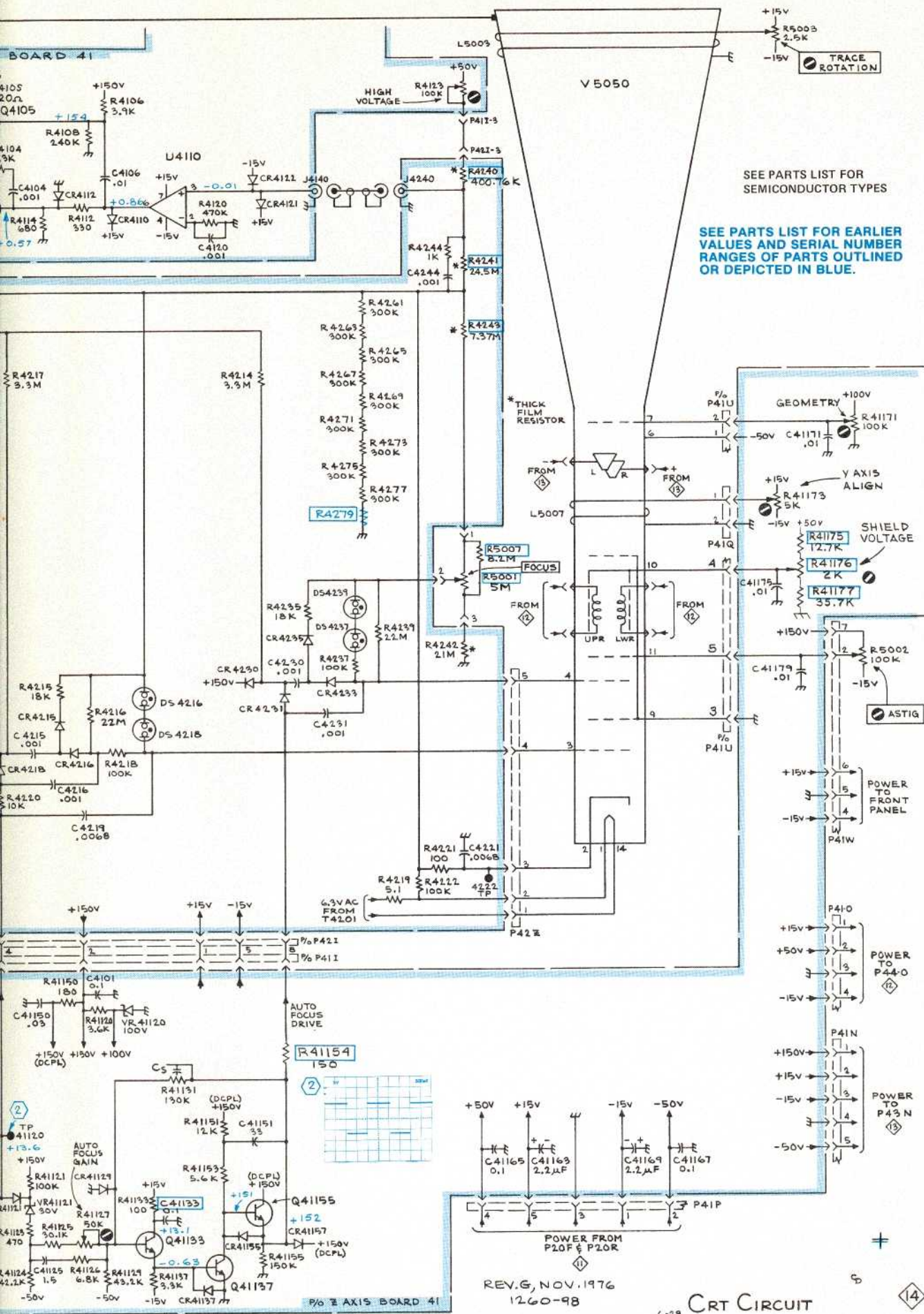

SEE PARTS LIST FOR SEMICONDUCTOR TYPES

SEE PARTS LIST FOR EARLIER VALUES AND SERIAL NUMBER RANGES OF PARTS OUTLINED OR DEPICTED IN BLUE.

CRT CIRCUIT

14

REV. G, NOV. 1976  
1260-98

6-29 CRT CIRCUIT

6-29

14

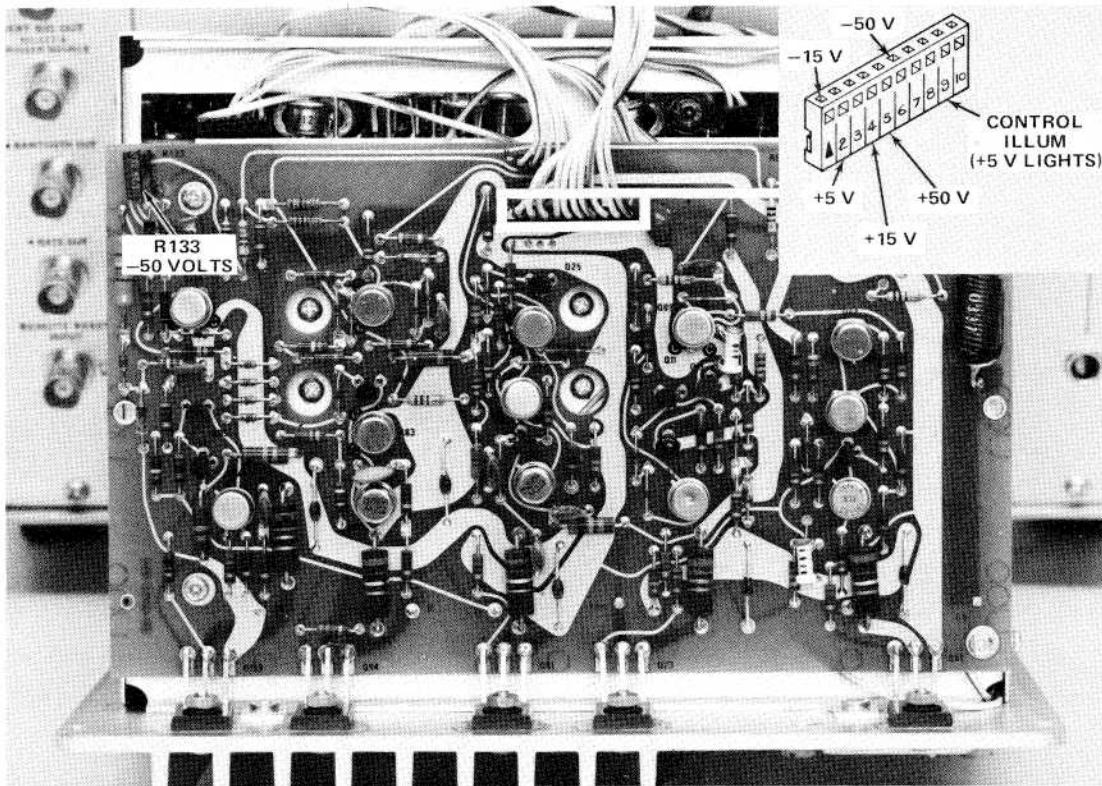

Fig. 6-28. Power-supply test points and -50 - Volt adjustment locations on A32 - Regulator board.

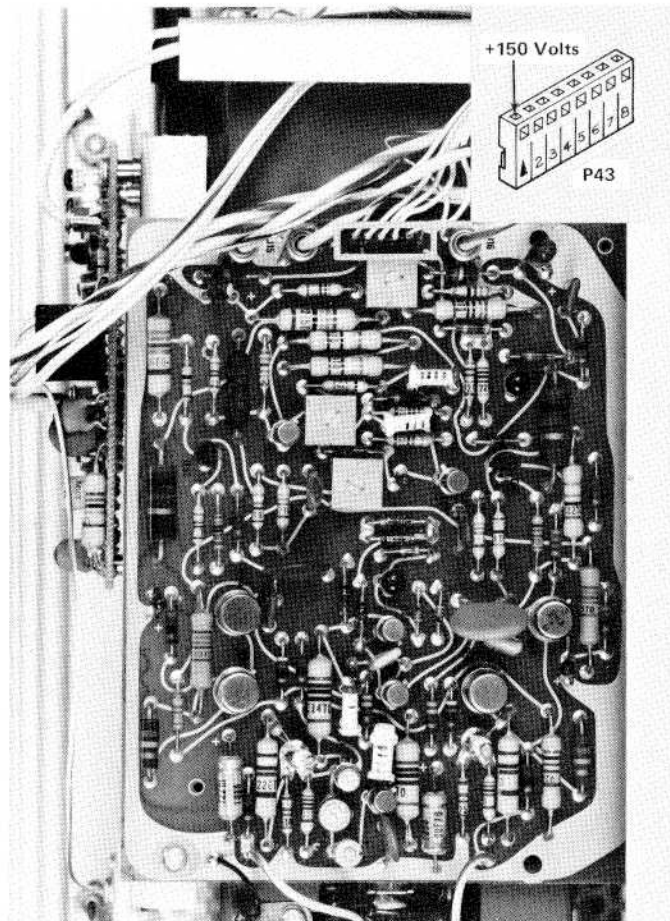

Fig. 6-29. +150-Volt test point location on A43 - Horizontal Output board.

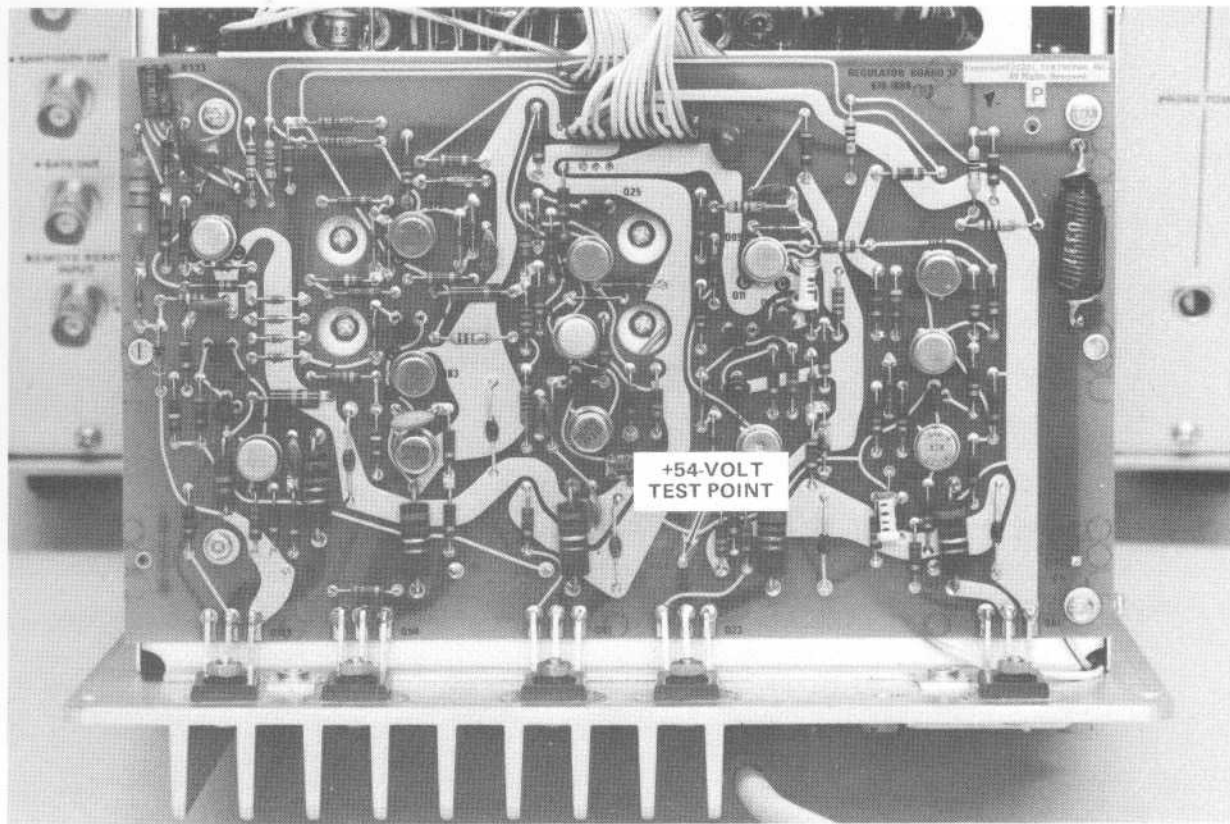

Fig. 6-26. +54-Volt test point location on A32 – Regulator board (top of power unit).

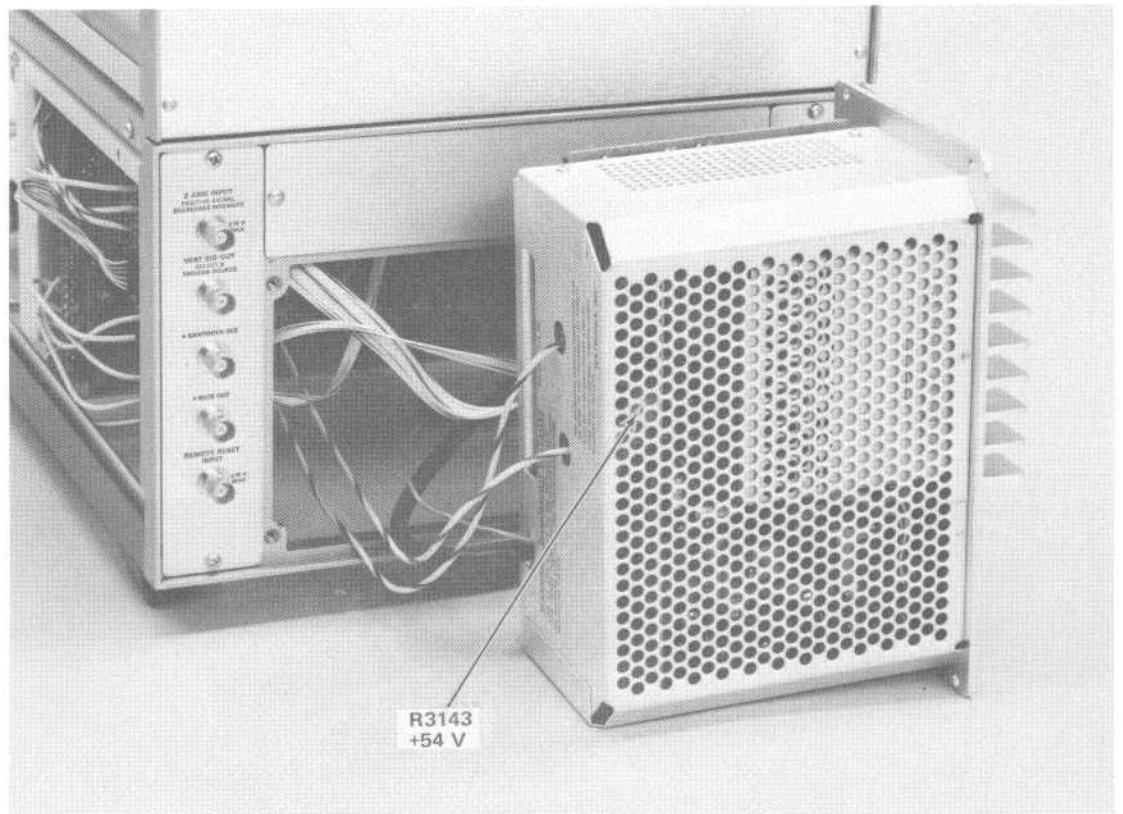

Fig. 6-27. +54-Volt adjustment, R3143, location in power unit.

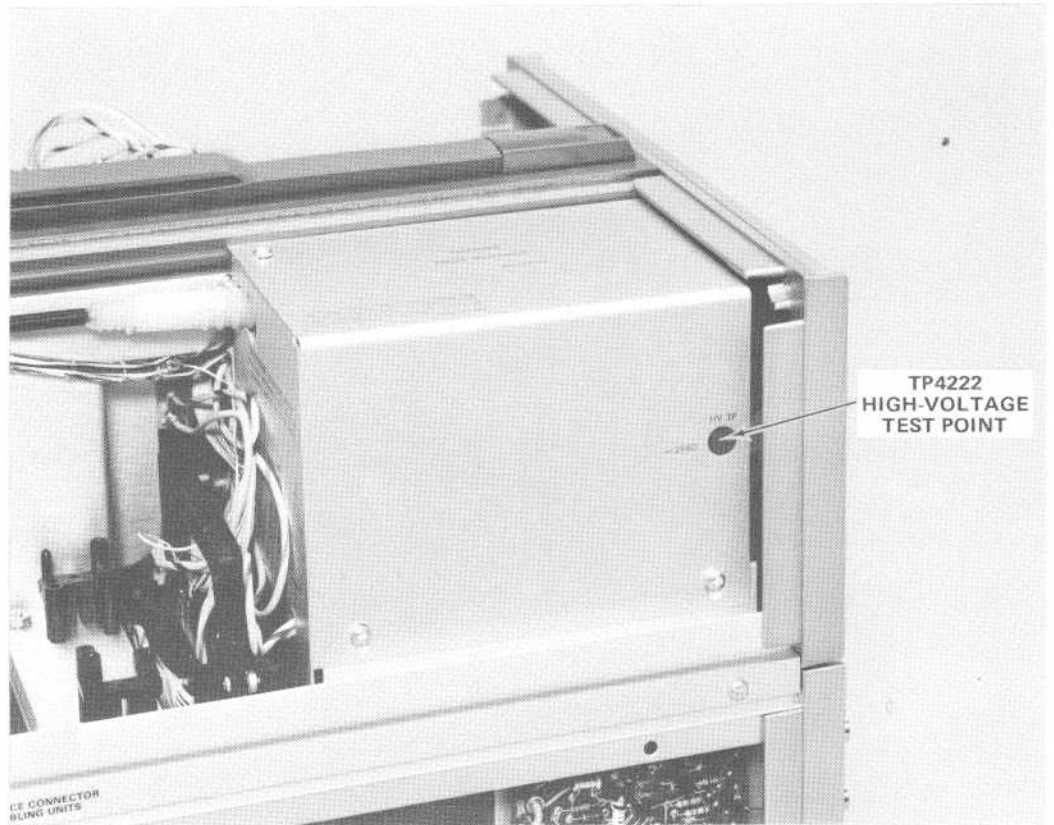

Fig. 6-30. TP4222, high-voltage test point location.

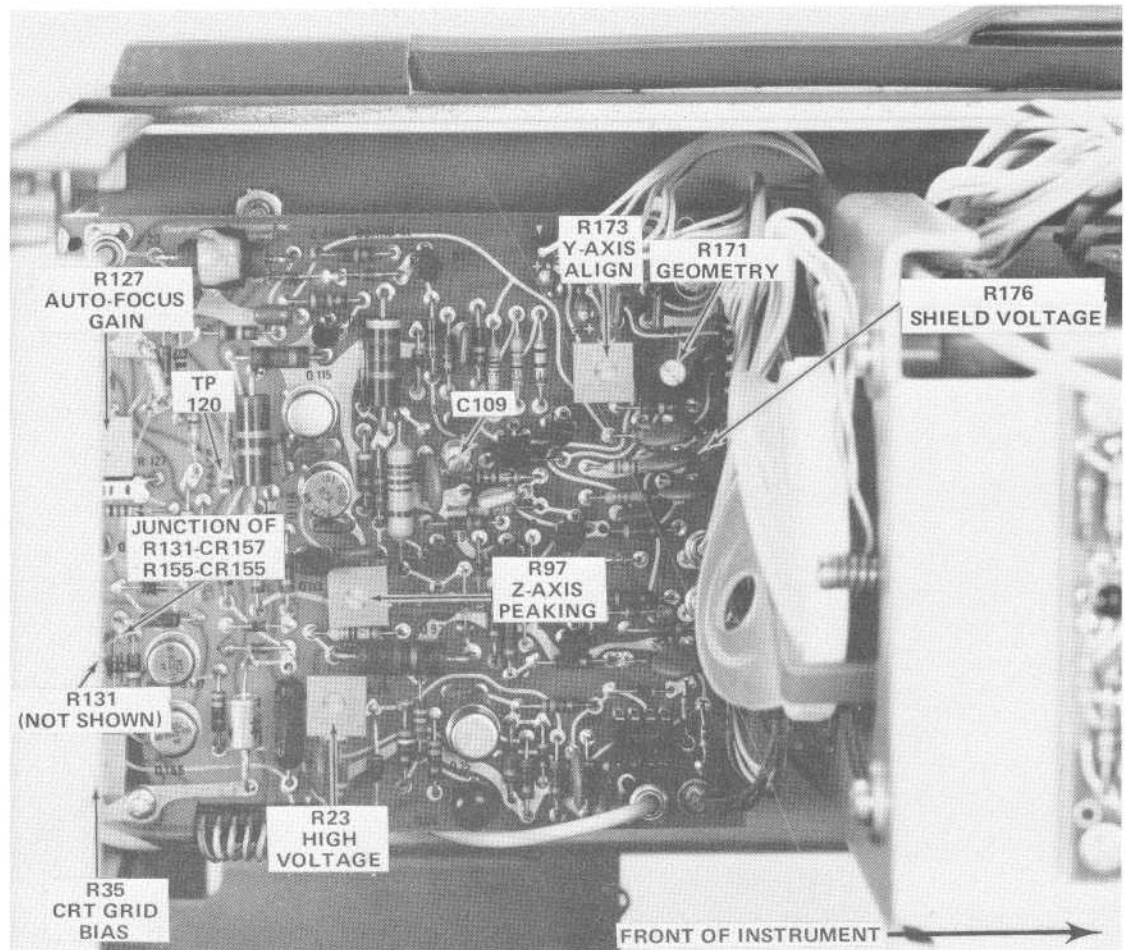

Fig. 6-31. Location of Z-Axis and Display calibration adjustments and test points on A41 - Z-Axis board.

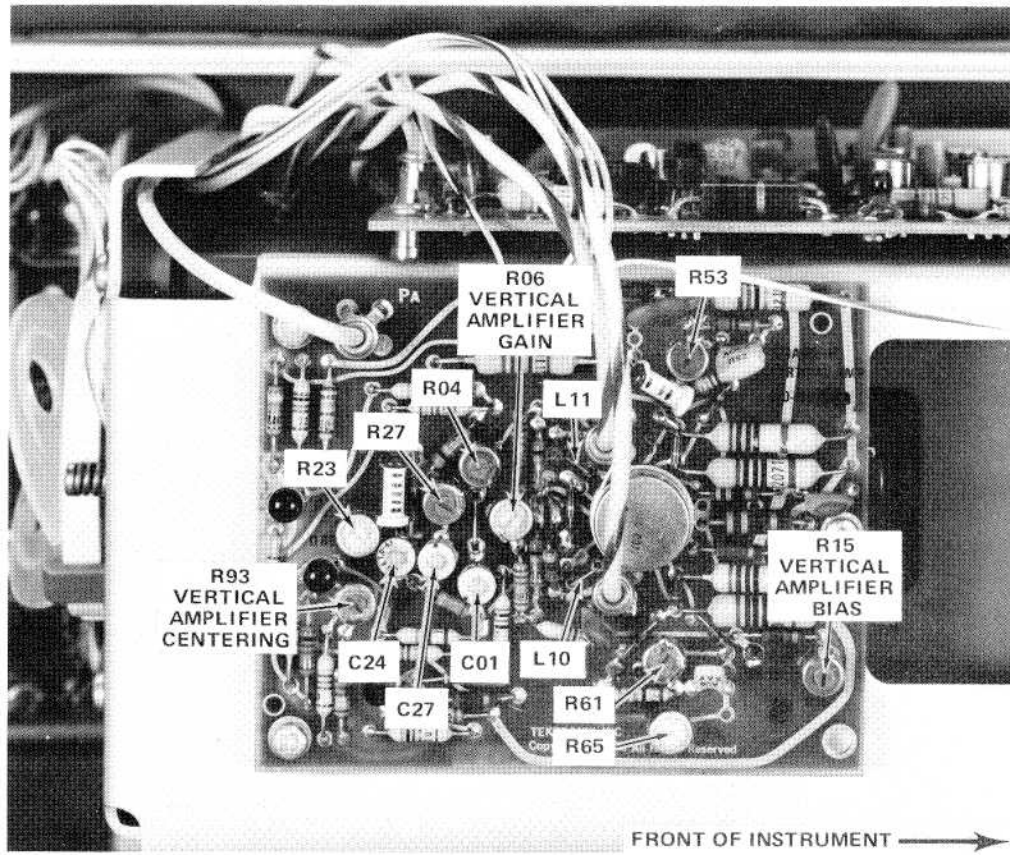

Fig. 6-32. Location of Vertical System calibration adjustments on A44 – Vertical Amplifier board.

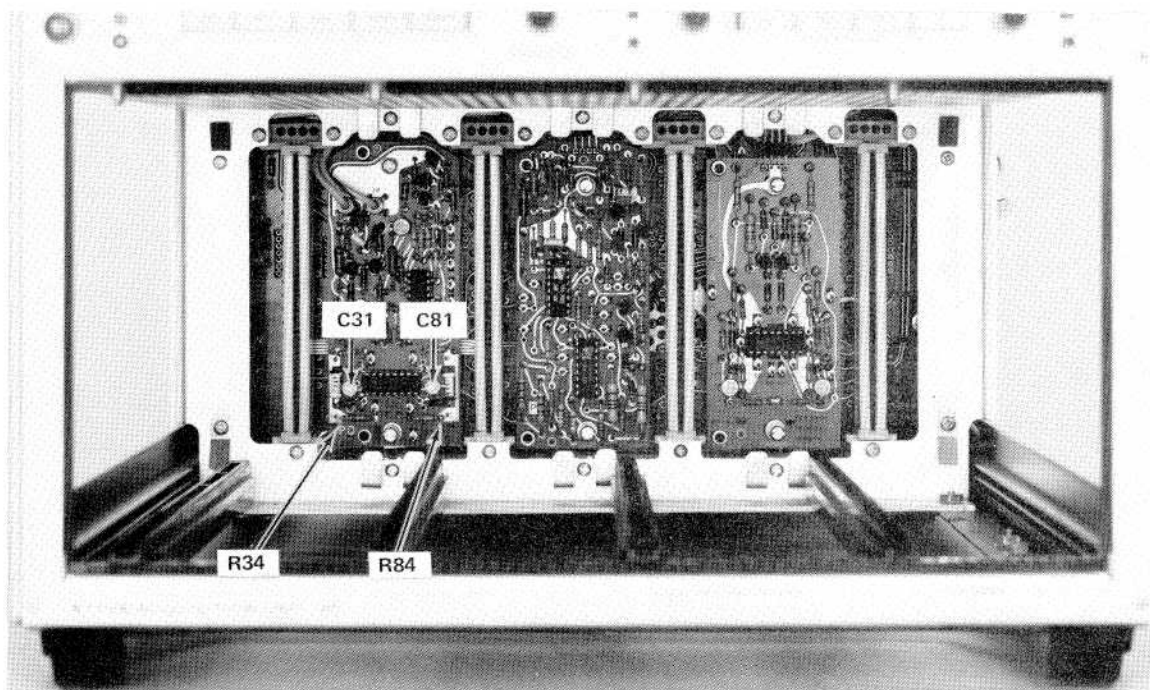

Fig. 6-33. Location of high-frequency compensation adjustments on A22 – Vertical Interface board.

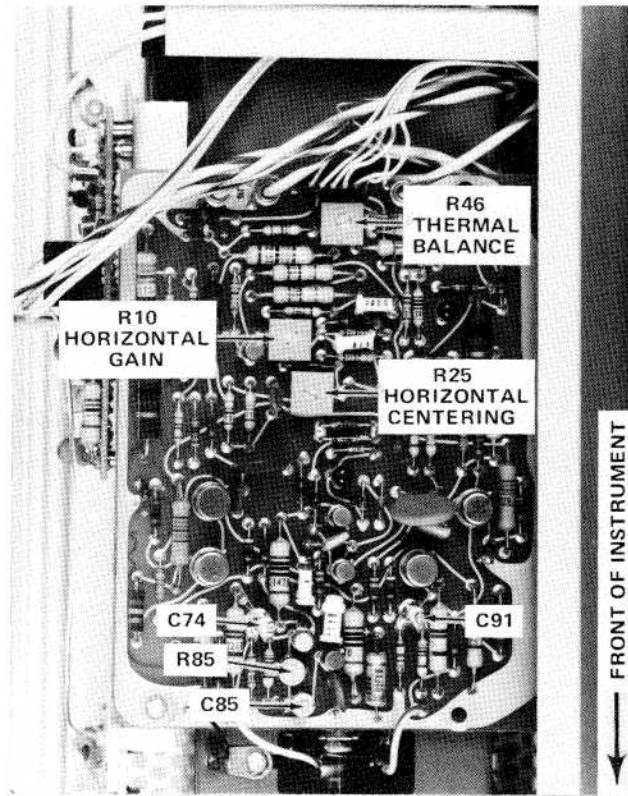

Fig. 6-34. Location of Horizontal System calibration adjustments on A43 – Horizontal Output board.

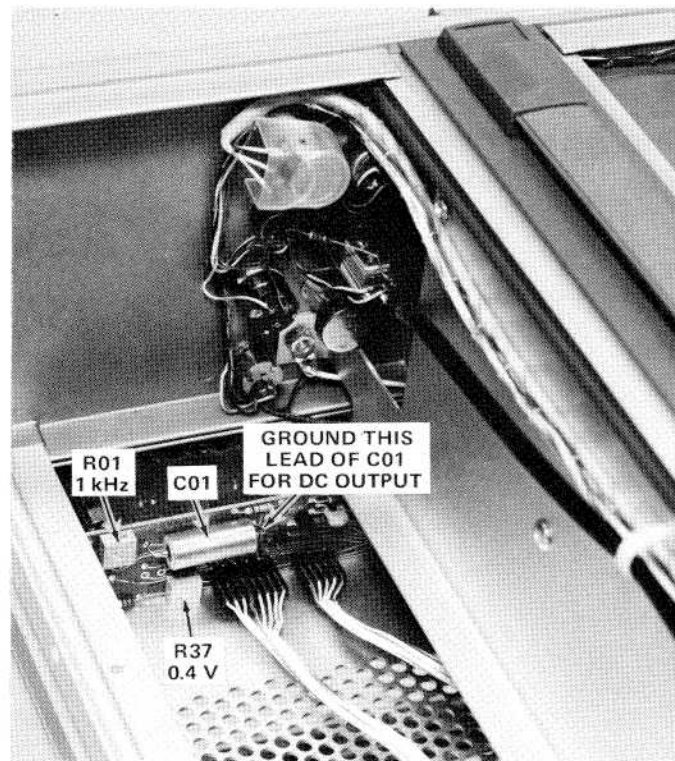
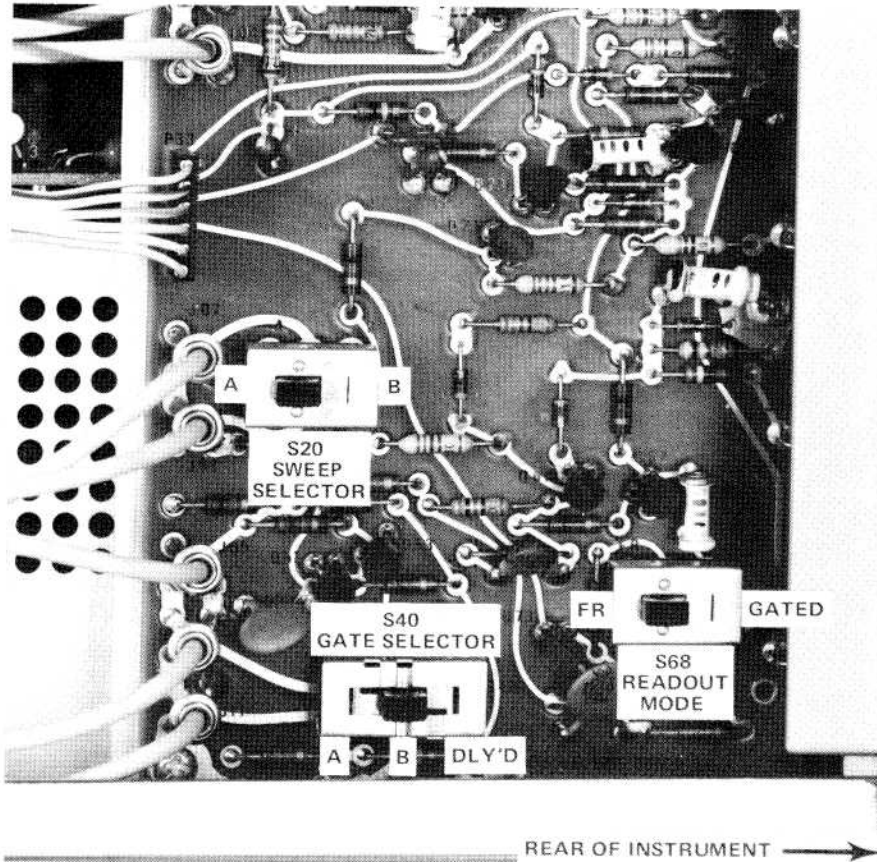

Fig. 6-35. Location of Calibrator adjustments on A10 – Calibrator board.





ADJUSTMENT LOCATIONS

Fig. 6-36. Location of signal selector switches on A33 – Output Signals board.

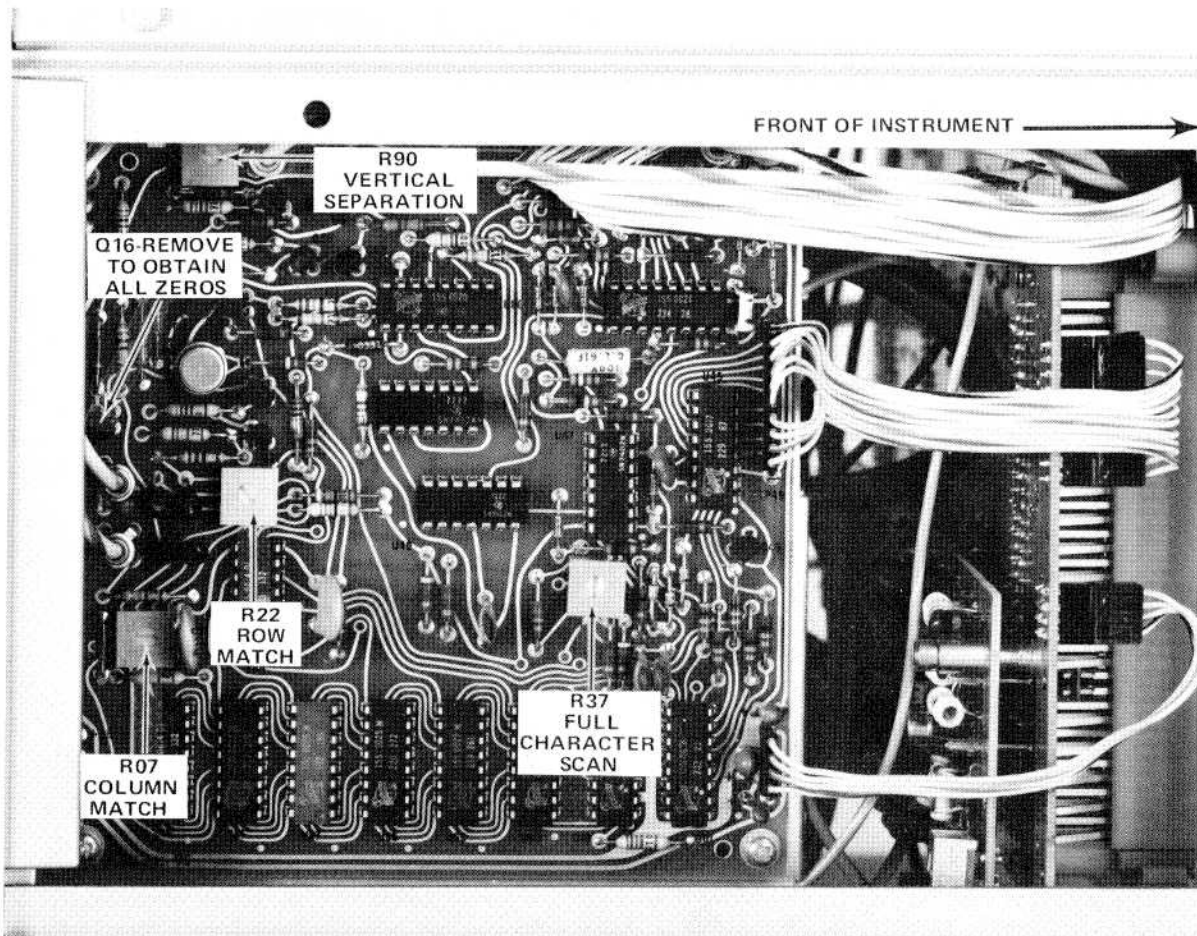

Fig. 6-37. Location of Readout System calibration adjustments on A34 – Readout board.

# REPLACEABLE MECHANICAL PARTS

## PARTS ORDERING INFORMATION

Replacement parts are available from or through your local Tektronix, Inc. Field Office or representative.

Changes to Tektronix instruments are sometimes made to accommodate improved components as they become available, and to give you the benefit of the latest circuit improvements developed in our engineering department. It is therefore important, when ordering parts, to include the following information in your order: Part number, instrument type or number, serial number, and modification number if applicable.

If a part you have ordered has been replaced with a new or improved part, your local Tektronix, Inc. Field Office or representative will contact you concerning any change in part number.

Change information, if any, is located at the rear of this manual.

## SPECIAL NOTES AND SYMBOLS

X000 Part first added at this serial number  
00X Part removed after this serial number

## FIGURE AND INDEX NUMBERS

Items in this section are referenced by figure and index numbers to the illustrations.

## INDENTATION SYSTEM

This mechanical parts list is indented to indicate item relationships. Following is an example of the indentation system used in the description column.

```

1 2 3 4 5           Name & Description
Assembly and/or Component
Attaching parts for Assembly and/or Component
-----
Detail Part of Assembly and/or Component
Attaching parts for Detail Part
-----
Parts of Detail Part
Attaching parts for Parts of Detail Part
-----

```

Attaching Parts always appear in the same indentation as the item it mounts, while the detail parts are indented to the right. Indented items are part of, and included with, the next higher indentation. The separation symbol ---\*--- indicates the end of attaching parts.

**Attaching parts must be purchased separately, unless otherwise specified.**

## ITEM NAME

In the Parts List, an Item Name is separated from the description by a colon (:). Because of space limitations, an Item Name may sometimes appear as incomplete. For further Item Name identification, the U.S. Federal Cataloging Handbook H6-1 can be utilized where possible.

## ABBREVIATIONS

|       |                    |         |                       |          |                      |          |                 |
|-------|--------------------|---------|-----------------------|----------|----------------------|----------|-----------------|
| "     | INCH               | ELCTRN  | ELECTRON              | IN       | INCH                 | SE       | SINGLE END      |
| #     | NUMBER SIZE        | ELEC    | ELECTRICAL            | INCAND   | INCANDESCENT         | SECT     | SECTION         |
| ACTR  | ACTUATOR           | ELECTLT | ELECTROLYTIC          | INSUL    | INSULATOR            | SEMICOND | SEMICONDUCTOR   |
| ADPTR | ADAPTER            | ELEM    | ELEMENT               | INTL     | INTERNAL             | SHLD     | SHIELD          |
| ALIGN | ALIGNMENT          | EPL     | ELECTRICAL PARTS LIST | LPHLDR   | LAMPHOLDER           | SHLDR    | SHOULDERED      |
| AL    | ALUMINUM           | EQPT    | EQUIPMENT             | MACH     | MACHINE              | SKT      | SOCKET          |
| ASSEM | ASSEMBLED          | EXT     | EXTERNAL              | MECH     | MECHANICAL           | SL       | SLIDE           |
| ASSY  | ASSEMBLY           | FIL     | FILLISTER HEAD        | MTG      | MOUNTING             | SLFLKG   | SELF-LOCKING    |
| ATTEN | ATTENUATOR         | FLEX    | FLEXIBLE              | NIP      | NIPPLE               | SLVG     | SLEEVING        |
| AWG   | AMERICAN WIRE GAGE | FLH     | FLAT HEAD             | NON WIRE | NOT WIRE WOUND       | SPR      | SPRING          |
| BD    | BOARD              | FLTR    | FILTER                | OBD      | ORDER BY DESCRIPTION | SQ       | SQUARE          |
| BRKT  | BRACKET            | FR      | FRAME or FRONT        | OD       | OUTSIDE DIAMETER     | SST      | STAINLESS STEEL |
| BRS   | BRASS              | FSTNR   | FASTENER              | OVH      | OVAL HEAD            | STL      | STEEL           |
| BRZ   | BRONZE             | FT      | FOOT                  | PH BRZ   | PHOSPHOR BRONZE      | SW       | SWITCH          |
| BSHG  | BUSHING            | FXD     | FIXED                 | PL       | PLAIN or PLATE       | T        | TUBE            |
| CAB   | CABINET            | GSKT    | GASKET                | PLSTC    | PLASTIC              | TERM     | TERMINAL        |
| CAP   | CAPACITOR          | HDL     | HANDLE                | PN       | PART NUMBER          | THD      | THREAD          |
| CER   | CERAMIC            | HEX     | HEXAGON               | PNH      | PAN HEAD             | THK      | THICK           |
| CHAS  | CHASSIS            | HEX HD  | HEXAGONAL HEAD        | PWR      | POWER                | TNSN     | TENSION         |
| CKT   | CIRCUIT            | HEX SOC | HEXAGONAL SOCKET      | ROPT     | RECEPTACLE           | TPG      | TAPPING         |
| COMP  | COMPOSITION        | HLCPS   | HELICAL COMPRESSION   | RES      | RESISTOR             | TRH      | TRUSS HEAD      |
| CONN  | CONNECTOR          | HLEXT   | HELICAL EXTENSION     | RGD      | RIGID                | V        | VOLTAGE         |
| COV   | COVER              | HV      | HIGH VOLTAGE          | RLF      | RELIEF               | VAR      | VARIABLE        |
| CPLG  | COUPLING           | IC      | INTEGRATED CIRCUIT    | RTNR     | RETAINER             | W/       | WITH            |
| CRT   | CATHODE RAY TUBE   | ID      | INSIDE DIAMETER       | SCH      | SOCKET HEAD          | WSHR     | WASHER          |
| DEG   | DEGREE             | IDNT    | IDENTIFICATION        | SCH      | OSCILLOSCOPE         | XFMR     | TRANSFORMER     |
| DWR   | DRAWER             | IMPLR   | IMPELLER              | SCR      | SCREW                | XSTR     | TRANSISTOR      |

CROSS INDEX MFR. CODE NUMBER TO MANUFACTURER

| MFR.CODE | MANUFACTURER   | ADDRESS                      | CITY,STATE,ZIP           |
|----------|--|------------------------------|--------------------------|
| 00779    | AMP, Inc.  | P. O. Box 3608               | Harrisburg, PA 17105     |
| 02768    | Illinois Tool Works, Inc., Fastex Div.                           | 195 Algonquin Rd.            | Des Plaines, IL 60016    |
| 07700    | Technical Wire and Products, Inc.                                | 129 Dermody St.              | Cranford, NJ 07016       |
| 08261    | Spectra-Strip Corp.  | 7100 Lampson Ave.            | Garden Grove, CA 92642   |
| 09422    | Plastic Stamping Corp.   | 2216 W. Armitage Ave.        | Chicago, IL 60647        |
| 12014    | Chicago Rivet and Machine Co.                                    | 950 S. 25th Ave.             | Bellwood, IL 60104       |
| 12327    | Freeway Corp.  | 9301 Allen Dr.               | Cleveland, OH 44125      |
| 22526    | Berg Electronics, Inc.   | Youk Expressway              | New Cumberland, PA 17070 |
| 23499    | Gavitt Wire and Cable, Division of RSC Industries, Inc.          | 455 N. Quince St.            | Escondido, CA 92025      |
| 24931    | Specialty Connector Co., Inc.                                    | 3560 Madison Ave.            | Indianapolis, IN 46227   |
| 26365    | Gries Reproducer Co., Div. of Coats and Clark Inc.               | 125 Beechwood Ave.           | New Rochelle, NY 10802   |
| 70485    | Atlantic India Rubber Works, Inc.                                | 571 W. Polk St.              | Chicago, IL 60607        |
| 71159    | Bristol Socket Screw, Div. of American Chain and Cable Co., Inc. | 40 Bristol St.               | Waterbury, CT 06720      |
| 71279    | Cambridge Thermionic Corp.                                       | 445 Concord Ave.             | Cambridge, MA 02138      |
| 71286    | Rexnord, Inc., Specialty Fastener Div.                           | 22 Spring Valley Rd.         | Paramus, NJ 07652        |
| 73743    | Fischer Special Mfg. Co.   | 446 Morgan St.               | Cincinnati, OH 45206     |
| 74445    | Holo-Krome Co.   | 31 Brook St. West            | Hartford, CT 06110       |
| 78189    | Illinois Tool Works, Inc. Shakeproof Division                    | St. Charles Road             | Elgin, IL 60120          |
| 79727    | C-W Industries   | 550 Davisville Rd.           | Warminster, PA 18974     |
| 79807    | Wrought Washer Mfg. Co.  | 2100 S. O Bay St.            | Milwaukee, WI 53207      |
| 80009    | Tektronix, Inc.  | P. O. Box 500                | Beaverton, OR 97077      |
| 80033    | Prestole Everlock, Inc.  | P. O. Box 278-1345 Miami St. | Toledo, OH 43605         |
| 82389    | Switchcraft, Inc.  | 5555 N. Elston Ave.          | Chicago, IL 60630        |
| 83385    | Central Screw Co.  | 2530 Crescent Dr.            | Broadview, IL 60153      |
| 87308    | N. L. Industries, Inc., Southern Screw Div.                      | P. O. Box 1360z              | Statesville, NC 28677    |
| 91929    | Honeywell, Inc., Micro Switch Div.                               | Chicago & Spring Sts.        | Freeport, IL 61032       |
| 95238    | Continental Connector Corp.                                      | 34-63 56th St.               | Woodside, NY 11377       |
| 98159    | Rubber Teck, Inc.  | 19115 Hamilton Ave.          | Gardena, CA 90247        |

FIGURE 1 D7704

| Fig. & Index No. | Tektronix Part No. | Serial/Model No. Eff | Dscnt   | Qty | 1 | 2 | 3 | 4 | 5 | Name & Description   | Mfr   |                  |
|------------------|--------------------|----------------------|---------|-----|---|---|---|---|---|--|-------|------------------|
|                  |                    |                      |         |     |   |   |   |   |   |  | Code  | Mfr Part Number  |
| 1-1              | 426-0514-00        |                      |         | 1   |   |   |   |   |   | FRAME, MASK: PLASTIC   | 80009 | 426-0514-00      |
| -2               | 337-1159-00        |                      |         | 1   |   |   |   |   |   | WINDOW, OBS: 4.78 X 3.93 X 0.07" PLSTC                       | 80009 | 337-1159-00      |
| -3               | 331-0258-03        |                      |         | 1   |   |   |   |   |   | MASK, CRT SCALE:   | 80009 | 331-0258-03      |
| -4               | 200-0939-01        |                      |         | 1   |   |   |   |   |   | BEZEL, CRT:  | 80009 | 200-0939-01      |
| -5               | 212-0023-00        | B010100              | B132652 | 4   |   |   |   |   |   | SCREW, MACHINE: 8-32 X 0.375 INCH, PNH STL                   | 83385 | OBD              |
|                  | 212-0008-00        | B132653              |         | 4   |   |   |   |   |   | SCREW, MACHINE: 8-32 X 0.312 INCH, PNH STL                   | 83385 | OBD              |
| -6               | 204-0380-00        |                      |         | 1   |   |   |   |   |   | BODY, TERMINAL:  | 80009 | 204-0380-00      |
| -7               | 131-0765-00        |                      |         | 3   |   |   |   |   |   | CONTACT, ELEC:   | 80009 | 131-0765-00      |
| -8               | 378-0625-00        |                      |         | 1   |   |   |   |   |   | FILTER, LT, CRT:   | 80009 | 378-0625-00      |
| -9               | 331-0245-00        |                      |         | 1   |   |   |   |   |   | MASK, CRT SCALE:   | 80009 | 331-0245-00      |
| -10              | 366-0494-00        |                      |         | 1   |   |   |   |   |   | KNOB: GRAY   | 80009 | 366-0494-00      |
|                  | 213-0153-00        |                      |         | 1   |   |   |   |   |   | . SETSCREW: 5-40 X 0.125 INCH, HEX SOC STL                   | 74445 | OBD              |
| -11              | 366-0494-00        |                      |         | 1   |   |   |   |   |   | KNOB: GRAY   | 80009 | 366-0494-00      |
|                  | 213-0153-00        |                      |         | 1   |   |   |   |   |   | . SETSCREW: 5-40 X 0.125 INCH, HEX SOC STL                   | 74445 | OBD              |
| -12              | 366-0494-00        |                      |         | 1   |   |   |   |   |   | KNOB: GRAY   | 80009 | 366-0494-00      |
|                  | 213-0153-00        |                      |         | 1   |   |   |   |   |   | . SETSCREW: 5-40 X 0.125 INCH, HEX SOC STL                   | 74445 | OBD              |
| -13              | 366-0494-00        |                      |         | 1   |   |   |   |   |   | KNOB: GRAY   | 80009 | 366-0494-00      |
|                  | 213-0153-00        |                      |         | 1   |   |   |   |   |   | . SETSCREW: 5-40 X 0.125 INCH, HEX SOC STL                   | 74445 | OBD              |
| -14              | 358-0301-02        |                      |         | 2   |   |   |   |   |   | BUSHING, SLEEVE: GRAY PLASTIC                                | 80009 | 358-0301-02      |
| -15              | - - - - -          |                      |         | 1   |   |   |   |   |   | CKT BOARD ASSY: GRATICULE LIGHT (SEE A50 EPL)                |       |                  |
| -16              | 378-0614-00        |                      |         | 1   |   |   |   |   |   | . REFLECTOR, LIGHT: MOLDED PLASTIC                           | 80009 | 378-0614-00      |
| -17              | 211-0062-00        |                      |         | 2   |   |   |   |   |   | . SCREW, MACHINE: 2-56 X 0.312 INCH, RDH STL                 | 83385 | OBD              |
| -18              | 344-0179-00        |                      |         | 2   |   |   |   |   |   | . CLIP, REFL RING: PLASTIC                                   | 80009 | 344-0179-00      |
| -19              | 333-1492-00        |                      |         | 1   |   |   |   |   |   | PANEL, FRONT: D7704  | 80009 | 333-1491-00      |
|                  | 200-0103-00        | XB130000             |         | 1   |   |   |   |   |   | NUT, PLAIN, KNURL: 0.25-28 X 0.375" OD, BRASS                | 80009 | 200-0103-00      |
|                  | 355-0507-00        | XB130000             |         | 1   |   |   |   |   |   | STUD, SHOULDERED: BINDING POST<br>(ATTACHING PARTS)          | 80009 | 355-0507-00      |
|                  | 210-0583-00        | XB130000             |         | 1   |   |   |   |   |   | NUT, PLAIN, HEX. : 0.25-32 X 0.312 INCH, BRS                 | 73743 | 2X20224-402      |
|                  | 210-0046-00        | XB130000             |         | 1   |   |   |   |   |   | WASHER, LOCK: INTL, 0.26 ID X 0.40" OD, STL<br>- - - * - - - | 78189 | 1214-05-00-0541C |
| -20              | - - - - -          |                      |         | 1   |   |   |   |   |   | RESISTOR: VARIABLE (SEE R5002 EPL)<br>(ATTACHING PARTS)      |       |                  |
| -21              | 358-0409-00        |                      |         | 1   |   |   |   |   |   | BSHG, MACH. THD: 0.25-32 X 0.159 ID X 0.24                   | 80009 | 358-0409-00      |
| -22              | 210-0046-00        |                      |         | 1   |   |   |   |   |   | WASHER, LOCK: INTL, 0.26 ID X 0.40" OD, STL                  | 78189 | 1214-05-00-0541C |
| -23              | 210-0471-00        |                      |         | 1   |   |   |   |   |   | NUT, SLEEVE: HEX. , 0.312 X 0.594 INCH LONG<br>- - - * - - - | 80009 | 210-0471-00      |
| -24              | 200-0608-00        |                      |         | 1   |   |   |   |   |   | COVER, VAR RES. : PLASTIC                                    | 80009 | 200-0608-00      |
| -25              | - - - - -          |                      |         | 1   |   |   |   |   |   | RESISTOR: VARIABLE (SEE R5001 EPL)<br>(ATTACHING PARTS)      |       |                  |
| -26              | 210-0583-00        |                      |         | 1   |   |   |   |   |   | NUT, PLAIN, HEX. : 0.25-32 X 0.312 INCH, BRS                 | 73743 | 2X20224-402      |
| -27              | 210-0046-00        |                      |         | 1   |   |   |   |   |   | WASHER, LOCK: INTL, 0.26 ID X 0.40" OD, STL                  | 78189 | 1214-05-00-0541C |
|                  | 210-0940-00        |                      |         | 1   |   |   |   |   |   | WASHER, FLAT: 0.25 ID X 0.375 INCH OD, STL<br>- - - * - - -  | 79807 | OBD              |
| -28              | 260-0688-00        |                      |         | 1   |   |   |   |   |   | SWITCH, PUSH: DPDT, 1A, 120VAC<br>(ATTACHING PARTS)          | 82389 | 12S1025D         |
| -29              | 210-0583-00        |                      |         | 2   |   |   |   |   |   | NUT, PLAIN, HEX. : 0.25-32 X 0.312 INCH, BRS                 | 73743 | 2X20224-402      |
|                  | 210-0940-00        |                      |         | 1   |   |   |   |   |   | WASHER, FLAT: 0.25 ID X 0.375 INCH OD, STL<br>- - - * - - -  | 79807 | OBD              |
| -30              | - - - - -          |                      |         | 1   |   |   |   |   |   | RESISTOR: VARIABLE (SEE R5004 EPL)<br>(ATTACHING PARTS)      |       |                  |
| -31              | 210-0583-00        |                      |         | 2   |   |   |   |   |   | NUT, PLAIN, HEX. : 0.25-32 X 0.312 INCH, BRS                 | 73743 | 2X20224-402      |
| -32              | 210-0046-00        |                      |         | 1   |   |   |   |   |   | WASHER, LOCK: INTL, 0.26 ID X 0.40" OD, STL<br>- - - * - - - | 78189 | 1214-05-00-0541C |
| -33              | - - - - -          |                      |         | 1   |   |   |   |   |   | RESISTOR: VARIABLE (SEE R5003 EPL)<br>(ATTACHING PARTS)      |       |                  |
| -34              | 358-0409-00        |                      |         | 1   |   |   |   |   |   | BSHG, MACH. THD: 0.25-32 X 0.159 ID X 0.24                   | 80009 | 358-0409-00      |
| -35              | 210-0046-00        |                      |         | 1   |   |   |   |   |   | WASHER, LOCK: INTL, 0.26 ID X 0.40" OD, STL                  | 78189 | 1214-05-00-0541C |
| -36              | 210-0471-00        |                      |         | 1   |   |   |   |   |   | NUT, SLEEVE: HEX. , 0.312 X 0.594 INCH LONG<br>- - - * - - - | 80009 | 210-0471-00      |
| -37              | - - - - -          |                      |         | 1   |   |   |   |   |   | RESISTOR: VARIABLE (SEE R5006 EPL)<br>(ATTACHING PARTS)      |       |                  |
| -38              | 210-0583-00        |                      |         | 1   |   |   |   |   |   | NUT, PLAIN, HEX. : 0.25-32 X 0.312 INCH, BRS                 | 73743 | 2X20224-402      |
| -39              | 210-0046-00        |                      |         | 1   |   |   |   |   |   | WASHER, LOCK: INTL, 0.26 ID X 0.40" OD, STL<br>- - - * - - - | 78189 | 1214-05-00-0541C |

**Mechanical Parts List—7704A**

FIGURE 1 D7704 (cont)

| Fig. & Index No. | Tektronix Part No. | Serial/Model No. Eff | Dscnt | Qty | Name & Description  |   |   |   |   | Mfr Code | Mfr Part Number  |
|------------------|--------------------|----------------------|-------|-----|---|---|---|---|---|----------|------------------|
|                  |                    |                      |       |     | 1   | 2 | 3 | 4 | 5 |          |                  |
| 1-40             | - - - - -          |                      |       | 1   | RESISTOR:VARIABLE (SEE R5000 EPL)<br>(ATTACHING PARTS)                |   |   |   |   |          |                  |
| -41              | 210-0583-00        |                      |       | 2   | NUT,PLAIN,HEX.:0.25-32 X 0.312 INCH,BRS                               |   |   |   |   | 73743    | 2X20224-402      |
| -42              | 210-0940-00        |                      |       | 1   | WASHER,FLAT:0.25 ID X 0.375 INCH OD,STL                               |   |   |   |   | 79807    | OBD              |
| -43              | 210-0046-00        |                      |       | 1   | WASHER,LOCK:INTL,0.26 ID X 0.40" OD,STL<br>- - - * - - -              |   |   |   |   | 78189    | 1214-05-00-0541C |
| -44              | 426-0808-01        |                      |       | 1   | FRAME PANEL,CAB:FRONT   |   |   |   |   | 80009    | 426-0808-01      |
| -45              | 386-1517-00        |                      |       | 4   | . SUPPORT,CRT:  |   |   |   |   | 80009    | 386-1517-00      |
| -46              | 348-0216-00        |                      |       | 1   | SHLD GSKT,ELECT:  |   |   |   |   | 07700    | 30-90042         |
|                  | 119-0337-00        |                      |       | 1   | DELAY LINE,ELEC:  |   |   |   |   | 80009    | 119-0337-00      |
| -47              | 200-1313-00        |                      |       | 1   | . COV,DELAY LINE:   |   |   |   |   | 80009    | 200-1313-00      |
| -48              | 213-0041-00        |                      |       | 4   | . SCR,TPG,THD CTG:6-32 X 0.375 INCH,TRH STL                           |   |   |   |   | 83385    | OBD              |
| -49              | 129-0215-00        |                      |       | 2   | . POST,NONMETALLI:1 DIA X 1.063 INCH LONG                             |   |   |   |   | 80009    | 129-0215-00      |
| -50              | 441-1045-00        |                      |       | 1   | . CHAS,DELAY LINE:<br>(ATTACHING PARTS)                               |   |   |   |   | 80009    | 441-1045-00      |
| -51              | 211-0559-00        |                      |       | 1   | SCREW,MACHINE:6-32 X 0.375"100 DEG,FLH STL                            |   |   |   |   | 83385    | OBD              |
| -52              | 210-0457-00        |                      |       | 4   | NUT,PLAIN,EXT W:6-32 X 0.312 INCH,STL                                 |   |   |   |   | 83385    | OBD              |
|                  | 211-0507-00        |                      |       | 3   | SCREW,MACHINE:6-32 X 0.312 INCH,PNH STL                               |   |   |   |   | 83385    | OBD              |
| -53              | 210-0202-00        |                      |       | 1   | TERMINAL,LUG:SE #6<br>- - - * - - -                                   |   |   |   |   | 78189    | 2104-06-00-2520N |
| -54              | 200-1319-00        |                      |       | 1   | COVER,CKT:UPPER<br>(ATTACHING PARTS)                                  |   |   |   |   | 80009    | 200-1319-00      |
| -55              | 211-0504-00        |                      |       | 3   | SCREW,MACHINE:6-32 X 0.25 INCH,PNH STL<br>- - - * - - -               |   |   |   |   | 83385    | OBD              |
| -56              | 200-1326-00        |                      |       | 1   | COVER,CKT:LOWER<br>(ATTACHING PARTS)                                  |   |   |   |   | 80009    | 200-1326-00      |
| -57              | 211-0507-00        |                      |       | 2   | SCREW,MACHINE:6-32 X 0.312 INCH,PNH STL                               |   |   |   |   | 83385    | OBD              |
| -58              | 210-0457-00        |                      |       | 2   | NUT,PLAIN,EXT W:6-32 X 0.312 INCH,STL                                 |   |   |   |   | 83385    | OBD              |
| -59              | 211-0504-00        |                      |       | 2   | SCREW,MACHINE:6-32 X 0.25 INCH,PNH STL<br>- - - * - - -               |   |   |   |   | 83385    | OBD              |
| -60              | -----              |                      |       | 1   | CKT BOARD ASSY:HIGH VOLTAGE(SEE A42 EPL)                              |   |   |   |   |          |                  |
| -61              | 131-0589-00        |                      |       | 5   | . CONTACT,ELEC:0.46 INCH LONG   |   |   |   |   | 22526    | 47350            |
|                  | 131-0608-00        |                      |       | 14  | . CONTACT,ELEC:0.365 INCH LONG  |   |   |   |   | 22526    | 47357            |
| -62              | - - - - -          |                      |       | 1   | . TRANSFORMER (SEE T4201 EPL)<br>(ATTACHING PARTS)                    |   |   |   |   |          |                  |
| -63              | 211-0008-00        |                      |       | 4   | . SCREW,MACHINE:4-40 X 0.25 INCH,PNH STL<br>- - - * - - -             |   |   |   |   | 83385    | OBD              |
| -64              | - - - - -          |                      |       | 1   | . HIGH VOLTAGE MULTIPLIER (U4214)<br>(ATTACHING PARTS)                |   |   |   |   |          |                  |
| -65              | 210-0409-00        |                      |       | 2   | . NUT,PLAIN,HEX.:8-32 X 0.312 INCH,BRS<br>- - - * - - -               |   |   |   |   | 73743    | 3046-402         |
| -66              | 131-1003-00        |                      |       | 4   | . CONNECTOR BODY,:CKT BD MT,3 PRONG                                   |   |   |   |   | 80009    | 131-1003-00      |
| -67              | 136-0252-04        |                      |       | 7   | . CONTACT,ELEC:0.188 INCH LONG  |   |   |   |   | 22526    | 75060            |
| -68              | - - - - -          |                      |       | 1   | TRANSISTOR (SEE Q4250 EPL)<br>(ATTACHING PARTS)                       |   |   |   |   |          |                  |
| -69              | 211-0012-00        |                      |       | 1   | . SCREW,MACHINE:4-40 X 0.375 INCH,PNH STL                             |   |   |   |   | 83385    | OBD              |
| -70              | 210-0921-00        |                      |       | 1   | . WASHER,MICA:0.50 X 0.141 X0.005 INCH THK<br>- - - * - - -           |   |   |   |   | 80009    | 210-0921-00      |
|                  | 131-0566-00        | XB110000             |       | 1   | . LINK,TERM.CONNE:0.086 DIA X 2.375 INCH L                            |   |   |   |   | 0000C    | L-2007-1         |
| -71              | 348-0090-00        |                      |       | 1   | CUSHION,CRT:<br>(ATTACHING PARTS)                                     |   |   |   |   | 80009    | 348-0090-00      |
| -72              | 211-0008-00        |                      |       | 4   | SCREW,MACHINE:4-40 X 0.25 INCH,PNH STL<br>- - - * - - -               |   |   |   |   | 83385    | OBD              |
| -73              | 129-0304-00        |                      |       | 4   | INSULATOR,STDF:0.25 OD X 1.23 INCH LONG<br>(ATTACHING PARTS FOR EACH) |   |   |   |   | 80009    | 129-0304-00      |
|                  | 211-0008-00        |                      |       | 1   | SCREW,MACHINE:4-40 X 0.25 INCH,PNH STL<br>- - - * - - -               |   |   |   |   | 83385    | OBD              |
| -74              | 129-0349-00        |                      |       | 1   | POST,ELEC-MECH:0.25 OD X 1.265 INCH LONG<br>(ATTACHING PARTS)         |   |   |   |   | 80009    | 129-0349-00      |
| -75              | 211-0008-00        |                      |       | 1   | SCREW,MACHINE:4-40 X 0.25 INCH,PNH STL<br>- - - * - - -               |   |   |   |   | 83385    | OBD              |
| -76              | 367-0156-00        |                      |       | 1   | HANDLE,CONN:<br>(ATTACHING PARTS)                                     |   |   |   |   | 80009    | 367-0156-00      |
| -77              | 211-0012-00        |                      |       | 2   | SCREW,MACHINE:4-40 X 0.375 INCH,PNH STL                               |   |   |   |   | 83385    | OBD              |
| -78              | 210-0586-00        |                      |       | 2   | NUT,PLAIN,EXT W:4-40 X 0.25 INCH,STL<br>- - - * - - -                 |   |   |   |   | 78189    | OBD              |
| -79              | 131-1250-00        |                      |       | 1   | CONNECTOR,RCPT,:60 CONTACT<br>(ATTACHING PARTS)                       |   |   |   |   | 95238    | K60010060WA300   |
| -80              | 213-0082-00        |                      |       | 2   | SCR,TPG,THD CTG:4-40 X 0.50 INCH,PNH STL<br>- - - * - - -             |   |   |   |   | 80009    | 213-0082-00      |

FIGURE 1 D7704 (cont)

| Fig. & Index No. | Tektronix Part No. | Serial/Model No. Eff | Dscnt   | Qty | 1 | 2 | 3 | 4 | 5 | Name & Description  | Mfr Code | Mfr Part Number  |             |
|------------------|--------------------|----------------------|---------|-----|---|---|---|---|---|---|----------|------------------|-------------|
|                  |                    |                      |         |     |   |   |   |   |   |   |          | Mfr              | Part Number |
| 1-81             | 175-1972-00        |                      |         | 1   |   |   |   |   |   | CABLE ASSY,RF:50 OHM COAX,UPPER LEFT                          | 80009    | 175-1972-00      |             |
|                  | 175-1971-00        |                      |         | 1   |   |   |   |   |   | CABLE ASSY,RF:50 OHM COAX,UPPER RIGHT                         | 80009    | 175-1971-00      |             |
| -82              | 175-1973-00        |                      |         | 1   |   |   |   |   |   | CABLE ASSY,RF:50 OHM COAX,LOWER RIGHT                         | 80009    | 175-1973-00      |             |
|                  | 175-1974-00        |                      |         | 1   |   |   |   |   |   | CABLE ASSY,RF:50 OHM COAX,LOWER LEFT<br>(ATTACHING PARTS)     | 80009    | 175-1974-00      |             |
| -83              | 213-0104-00        |                      |         | 2   |   |   |   |   |   | SCR,TPG,THD FOR:6-20 X 0.375 INCH,TRH STL                     | 83385    | OBD              |             |
| -84              | 407-1013-00        |                      |         | 1   |   |   |   |   |   | BRKT,CONN SPRT:   | 80009    | 407-1013-00      |             |
| -85              | 211-0507-00        |                      |         | 2   |   |   |   |   |   | SCREW,MACHINE:6-32 X 0.312 INCH,PNH STL                       | 83385    | OBD              |             |
| -86              | 210-0457-00        |                      |         | 2   |   |   |   |   |   | NUT,PLAIN,EXT W:6-32 X 0.312 INCH,STL<br>- - - * - - -        | 83385    | OBD              |             |
| -87              | 343-0089-00        |                      |         | 1   |   |   |   |   |   | CLAMP,LOOP:LARGE  | 80009    | 343-0089-00      |             |
| -88              | -----              |                      |         | 1   |   |   |   |   |   | CKT BOARD ASSY:Z-AXIS(SEE A41 EPL)                            |          |                  |             |
| -89              | 131-0589-00        |                      |         | 7   |   |   |   |   |   | . CONTACT,ELEC:0.46 INCH LONG                                 | 22526    | 47350            |             |
|                  | 131-0608-00        |                      |         | 32  |   |   |   |   |   | . CONTACT,ELEC:0.365 INCH LONG                                | 22526    | 47357            |             |
| -90              | 131-1003-00        |                      |         | 4   |   |   |   |   |   | . CONNECTOR BODY,:CKT BD MT,3 PRONG                           | 80009    | 131-1003-00      |             |
| -91              | 136-0252-04        | B010100              | B112459 | 69  |   |   |   |   |   | . CONTACT,ELEC:0.188 INCH LONG                                | 22526    | 75060            |             |
|                  | 136-0254-04        | B112460              |         | 7   |   |   |   |   |   | . CONTACT,ELEC:0.188 INCH LONG                                | 22526    | 75060            |             |
|                  | 136-0183-00        | B112460              |         | 18  |   |   |   |   |   | . SOCKET,PLUG-IN:3 PIN,ROUND                                  | 80009    | 136-0183-00      |             |
|                  | 136-0220-00        | B112460              |         | 12  |   |   |   |   |   | . SOCKET,PLUG-IN:3 PIN,SQUARE                                 | 71785    | 133-23-11-034    |             |
|                  | 136-0514-00        | B112460              |         | 1   |   |   |   |   |   | . SOCKET,PLUG-IN:MICROCIRCUIT,8 CONTACT                       | 82647    | C930802          |             |
| -92              | 214-0579-00        |                      |         | 1   |   |   |   |   |   | . TERM.,TEST PT:0.40 INCH LONG<br>(ATTACHING PARTS)           | 80009    | 214-0579-00      |             |
| -93              | 211-0008-00        |                      |         | 4   |   |   |   |   |   | SCREW,MACHINE:4-40 X 0.25 INCH,PNH STL<br>- - - * - - -       | 83385    | OBD              |             |
| -94              | 337-1460-00        |                      |         | 1   |   |   |   |   |   | SHLD,ELECTRON T:CRT   | 80009    | 337-1460-00      |             |
| -95              | -----              |                      |         | 1   |   |   |   |   |   | COIL (SEE L5007 EPL)<br>(ATTACHING PARTS)                     |          |                  |             |
| -96              | 343-0217-00        |                      |         | 1   |   |   |   |   |   | CLAMP,COIL:Y-AXIS   | 80009    | 343-0217-00      |             |
| -97              | 213-0138-00        |                      |         | 2   |   |   |   |   |   | SCR,TPG,THD FOR:4-40 X 0.188 INCH,PNH STL<br>- - - * - - -    | 83385    | OBD              |             |
| -98              | 214-0291-00        |                      |         | 1   |   |   |   |   |   | CONTACT,SPRING:1.188 X 0.375 X 0.25 INCH<br>(ATTACHING PARTS) | 80009    | 214-0291-00      |             |
| -99              | 211-0007-00        |                      |         | 1   |   |   |   |   |   | SCREW,MACHINE:4-40 X 0.188 INCH,PNH STL                       | 83385    | OBD              |             |
| -100             | 210-0586-00        |                      |         | 1   |   |   |   |   |   | NUT,PLAIN,EXT W:4-40 X 0.25 INCH,STL                          | 78189    | OBD              |             |
| -101             | 210-0201-00        |                      |         | 1   |   |   |   |   |   | TERMINAL,LUG:SE #4<br>- - - * - - -                           | 78189    | 2104-04-00-2520N |             |
| -102             | 348-0055-00        |                      |         | 2   |   |   |   |   |   | GROMMET,PLASTIC:0.25 INCH DIA                                 | 80009    | 348-0055-00      |             |
| -103             | 354-0347-00        |                      |         | 1   |   |   |   |   |   | RING,CLP,CRT RE:<br>(ATTACHING PARTS)                         | 80009    | 354-0347-00      |             |
| -104             | 211-0170-00        |                      |         | 2   |   |   |   |   |   | SCREW,MACHINE:4-40 X 2.75 INCH,PNH STL                        | 83385    | OBD              |             |
| -105             | 214-1333-00        |                      |         | 2   |   |   |   |   |   | SPRING,HLCPS:0.213 OD X 0.375 INCH LONG<br>- - - * - - -      | 80009    | 214-1333-00      |             |
| -106             | 343-0205-01        |                      |         | 1   |   |   |   |   |   | RTNR,ELECTRON T:<br>(ATTACHING PARTS)                         | 80009    | 343-0205-01      |             |
| -107             | 211-0507-00        |                      |         | 4   |   |   |   |   |   | SCREW,MACHINE:6-32 X 0.312 INCH,PNH STL                       | 83385    | OBD              |             |
| -108             | 210-0949-00        |                      |         | 4   |   |   |   |   |   | WASHER,FLAT:0.141 ID X 0.50 INCH OD,BRS<br>- - - * - - -      | 12327    | OBD              |             |
| -109             | 136-0493-00        |                      |         | 1   |   |   |   |   |   | SOCKET,PLUG-IN:CRT  | 80009    | 136-0493-00      |             |
| -110             | 136-0304-02        |                      |         | 1   |   |   |   |   |   | . SOCKET,PLUG-IN:CRT,14 PIN SOCKET,W/PINS                     | 80009    | 136-0304-02      |             |
| -111             | 200-0917-01        |                      |         | 1   |   |   |   |   |   | . COV,ELECTRON TU:2.052 OD X 0.291" THK,PLSTC                 | 80009    | 200-0917-01      |             |
| -112             | 343-0254-00        |                      |         | 1   |   |   |   |   |   | . CLAMP,CRT SKT:  | 80009    | 343-0254-00      |             |
| -113             | 367-0117-00        |                      |         | 1   |   |   |   |   |   | . PULL,SOC,PL-IN:   | 80009    | 367-0117-00      |             |
| -114             | 352-0163-00        |                      |         | 1   |   |   |   |   |   | . CONN BODY,PL,EL:5 WIRE BLACK                                | 80009    | 352-0163-00      |             |
| -115             | 352-0201-00        |                      |         | 1   |   |   |   |   |   | . CONN BODY,PL,EL:5 WIRE BLACK                                | 80009    | 352-0201-00      |             |
| -116             | 131-0707-00        |                      |         | 5   |   |   |   |   |   | . CONTACT,ELEC:0.48"L,22-26 AWG WIRE                          | 22526    | 47439            |             |
| -117             | 131-0621-00        |                      |         | 5   |   |   |   |   |   | . CONTACT,ELEC:0.577"L,22-26 AWG WIRE                         | 22526    | 46231            |             |
| -118             | 175-0828-00        |                      |         | IN  |   |   |   |   |   | . WIRE,ELECTRICAL2.833 FT 5 WIRE RIBBON                       | 23499    | TEK-175-0828-00  |             |
| -119             | 351-0322-00        |                      |         | 1   |   |   |   |   |   | GUIDE,CKT CARD:   | 80009    | 351-0322-00      |             |
| -120             | 210-0201-00        |                      |         | 1   |   |   |   |   |   | TERMINAL,LUG:SE #4<br>(ATTACHING PARTS)                       | 78189    | 2104-04-00-2520N |             |
| -121             | 211-0007-00        |                      |         | 1   |   |   |   |   |   | SCREW,MACHINE:4-40 X 0.188 INCH,PNH STL                       | 83385    | OBD              |             |
|                  | 210-0586-00        |                      |         | 1   |   |   |   |   |   | NUT,PLAIN,EXT W:4-40 X 0.25 INCH,STL<br>- - - * - - -         | 78189    | OBD              |             |
| -122             | -----              |                      |         | 1   |   |   |   |   |   | RESISTOR:THICK FILM(SEE R5012,R5013 EPL)<br>(ATTACHING PARTS) |          |                  |             |
| -123             | 211-0510-00        |                      |         | 2   |   |   |   |   |   | SCREW,MACHINE:6-32 X 0.312 INCH,PNH STL                       | 83385    | OBD              |             |
| -124             | 210-0457-00        |                      |         | 2   |   |   |   |   |   | NUT,PLAIN,EXT W:6-32 X 0.312 INCH,STL                         | 83385    | OBD              |             |

Mechanical Parts List—7704A

FIGURE 1 D7704 (cont)

| Fig. & Index No. | Tektronix Part No. | Serial/Model No. Eff | No. Dscont | Qty | 1 | 2 | 3 | 4 | 5 | Name & Description  | Mfr Code | Mfr Part Number  |
|------------------|--------------------|----------------------|------------|-----|---|---|---|---|---|---|----------|------------------|
| 1-125            | 210-0894-00        |                      |            | 2   |   |   |   |   |   | WASHER, NONMETAL: 0.19 ID X 0.438" OD, PLSTC<br>- - - * - - -         | 09422    | OBD              |
| -126             | 210-0202-00        |                      |            | 1   |   |   |   |   |   | TERMINAL, LUG: SE #6<br>(ATTACHING PARTS)                             | 78189    | 2104-06-00-2520N |
| -127             | 211-0507-00        |                      |            | 1   |   |   |   |   |   | SCREW, MACHINE: 6-32 X 0.312 INCH, PNH STL                            | 83385    | OBD              |
| -128             | 210-0457-00        |                      |            | 1   |   |   |   |   |   | NUT, PLAIN, EXT W: 6-32 X 0.312 INCH, STL<br>- - - * - - -            | 83385    | OBD              |
| -129             | -----              |                      |            | 1   |   |   |   |   |   | CKT BOARD ASSY: VERTICAL AMP (SEE A44 EPL)                            |          |                  |
| -130             | 131-0608-00        |                      |            | 6   |   |   |   |   |   | . CONTACT, ELEC: 0.365 INCH LONG                                      | 22526    | 47357            |
| -131             | 131-1003-00        |                      |            | 3   |   |   |   |   |   | . CONNECTOR BODY, :CKT BD MT, 3 PRONG                                 | 80009    | 131-1003-00      |
| -132             | 136-0252-01        |                      |            | 14  |   |   |   |   |   | . CONTACT, ELEC: 0.178 INCH LONG                                      | 00779    | 1-332095-2       |
|                  | 136-0252-04        |                      |            | 18  |   |   |   |   |   | . CONTACT, ELEC: 0.188 INCH LONG                                      | 22526    | 75060            |
| -133             | 214-0579-00        |                      |            | 1   |   |   |   |   |   | . TERM., TEST PT: 0.40 INCH LONG                                      | 80009    | 214-0579-00      |
| -134             | 346-0097-00        |                      |            | 1   |   |   |   |   |   | . STRAP, GROUNDING: INTEGRATED CIRCUIT                                | 80009    | 346-0097-00      |
| -135             | -----              |                      |            | 1   |   |   |   |   |   | . INTEGRATED CIRCUIT (SEE U4413 ELECTRICAL LIST)<br>(ATTACHING PARTS) |          |                  |
| -136             | 210-0407-00        |                      |            | 1   |   |   |   |   |   | NUT, PLAIN, HEX.: 6-32 X 0.25 INCH, BRS                               | 73743    | 3038-0228-402    |
| -137             | 210-0907-00        |                      |            | 1   |   |   |   |   |   | WASHER, RING: 0.25 INCH OD  | 71286    | 5S3-1            |
| -138             | 211-0008-00        |                      |            | 3   |   |   |   |   |   | SCREW, MACHINE: 4-40 X 0.25 INCH, PNH STL<br>- - - * - - -            | 83385    | OBD              |
| -139             | 348-0031-00        |                      |            | 3   |   |   |   |   |   | GROMMET, PLASTIC: 0.156 INCH DIA                                      | 80009    | 348-0031-00      |
| -140             | 134-0119-00        |                      |            | 1   |   |   |   |   |   | PLUG, PLASTIC: 0.17 OD X 0.144 INCH LONG                              | 80009    | 134-0119-00      |
| -141             | 348-0056-00        |                      |            | 1   |   |   |   |   |   | GROMMET, PLASTIC: 0.375 INCH DIA                                      | 80009    | 348-0056-00      |
| -142             | 441-1044-00        |                      |            | 1   |   |   |   |   |   | CHASSIS, SCOPE: HORIZ & VERT CKT<br>(ATTACHING PARTS)                 | 80009    | 441-1044-00      |
| -143             | 211-0507-00        |                      |            | 4   |   |   |   |   |   | SCREW, MACHINE: 6-32 X 0.312 INCH, PNH STL                            | 83385    | OBD              |
| -144             | 210-0457-00        |                      |            | 2   |   |   |   |   |   | NUT, PLAIN, EXT W: 6-32 X 0.312 INCH, STL                             | 83385    | OBD              |
| -145             | 210-0202-00        |                      |            | 1   |   |   |   |   |   | TERMINAL, LUG: SE #6<br>- - - * - - -                                 | 78189    | 2104-06-00-2520N |
| -146             | -----              |                      |            | 1   |   |   |   |   |   | CKT BOARD ASSY: HORIZONTAL AMPLIFIER (SEE A43 EPL)                    |          |                  |
| -147             | 131-0608-00        |                      |            | 6   |   |   |   |   |   | . CONTACT, ELEC: 0.365 INCH LONG                                      | 22526    | 47357            |
|                  | 166-0527-00        | XB050000             |            | 2   |   |   |   |   |   | . SLEEVE, SPACING: 0.15 INCH LONG                                     | 80009    | 166-0527-00      |
| -148             | 131-1003-00        |                      |            | 3   |   |   |   |   |   | . CONNECTOR BODY, :CKT BD MT, 3 PRONG                                 | 80009    | 131-1003-00      |
| -149             | 136-0252-04        |                      |            | 45  |   |   |   |   |   | . CONTACT, ELEC: 0.188 INCH LONG<br>(ATTACHING PARTS)                 | 22526    | 75060            |
| -150             | 211-0008-00        |                      |            | 2   |   |   |   |   |   | . SCREW, MACHINE: 4-40 X 0.25 INCH, PNH STL<br>- - - * - - -          | 83385    | OBD              |
| -151             | 426-0809-01        |                      |            | 1   |   |   |   |   |   | FRAME PANEL, CAB: REAR  | 80009    | 426-0809-01      |
| -152             | 386-2125-00        |                      |            | 1   |   |   |   |   |   | PANEL, REAR:<br>(ATTACHING PARTS)                                     | 80009    | 386-2125-00      |
| -153             | 211-0008-00        |                      |            | 4   |   |   |   |   |   | SCREW, MACHINE: 4-40 X 0.25 INCH, PNH STL<br>- - - * - - -            | 83385    | OBD              |
| -154             | 426-0815-00        |                      |            | 2   |   |   |   |   |   | FRAME SECT, CAB: BOTTOM<br>(ATTACHING PARTS FOR EACH)                 | 80009    | 426-0815-00      |
| -155             | 213-0270-00        |                      |            | 2   |   |   |   |   |   | SCR, TPG, THD FOR: 10-32 X 0.75 INCH FILH STL<br>- - - * - - -        | 83385    | OBD              |
| -156             | 352-0169-00        |                      |            | 2   |   |   |   |   |   | CONN BODY, PL, EL: 2 WIRE BLACK                                       | 80009    | 352-0169-00      |
| -157             | 352-0161-00        |                      |            | 1   |   |   |   |   |   | CONN BODY, PL, EL: 3 WIRE BLACK                                       | 80009    | 352-0161-00      |
| -158             | 352-0162-00        |                      |            | 1   |   |   |   |   |   | CONN BODY, PL, EL: 4 WIRE BLACK                                       | 80009    | 352-0162-00      |
| -159             | 352-0163-00        |                      |            | 2   |   |   |   |   |   | CONN BODY, PL, EL: 5 WIRE BLACK                                       | 80009    | 352-0163-00      |
| -160             | 352-0164-00        |                      |            | 2   |   |   |   |   |   | CONN BODY, PL, EL: 6 WIRE BLACK                                       | 80009    | 352-0164-00      |
| -161             | 352-0166-00        |                      |            | 3   |   |   |   |   |   | CONN BODY, PL, EL: 8 WIRE BLACK                                       | 80009    | 352-0166-00      |
| -162             | 352-0168-00        |                      |            | 3   |   |   |   |   |   | CONN BODY, PL, EL: 10 WIRE BLACK                                      | 80009    | 352-0168-00      |
| -163             | 131-0707-00        |                      |            | 56  |   |   |   |   |   | CONTACT, ELEC: 0.48" L, 22-26 AWG WIRE                                | 22526    | 47439            |
| -164             | 195-0121-00        |                      |            | 1   |   |   |   |   |   | LEAD SET, CRT DE:   | 80009    | 195-0121-00      |
| -165             | 210-0775-00        |                      |            | 12  |   |   |   |   |   | EYELET, METALLIC: 0.126 OD X 0.23 INCH L, BRS                         | 80009    | 210-0775-00      |
| -166             | 210-0774-00        |                      |            | 12  |   |   |   |   |   | EYELET, METALLIC: 0.152 OD X 0.245 INCH L, BRS                        | 80009    | 210-0774-00      |
| -167             | 179-1744-00        |                      |            | 1   |   |   |   |   |   | WIRING HARNESS: FRONT PANEL   | 80009    | 179-1744-00      |
| -168             | 175-0827-00        |                      |            | IN  |   |   |   |   |   | WIRE, ELECTRICAL: 4 WIRE RIBBON                                       | 08261    | TEK-175-0827-00  |
| -169             | 175-0828-00        |                      |            | IN  |   |   |   |   |   | WIRE, ELECTRICAL: 5 WIRE RIBBON                                       | 23499    | TEK-175-0828-00  |
| -170             | 175-0831-00        |                      |            | IN  |   |   |   |   |   | WIRE, ELECTRICAL: 8 WIRE RIBBON                                       | 08261    | TEK-175-0831-00  |

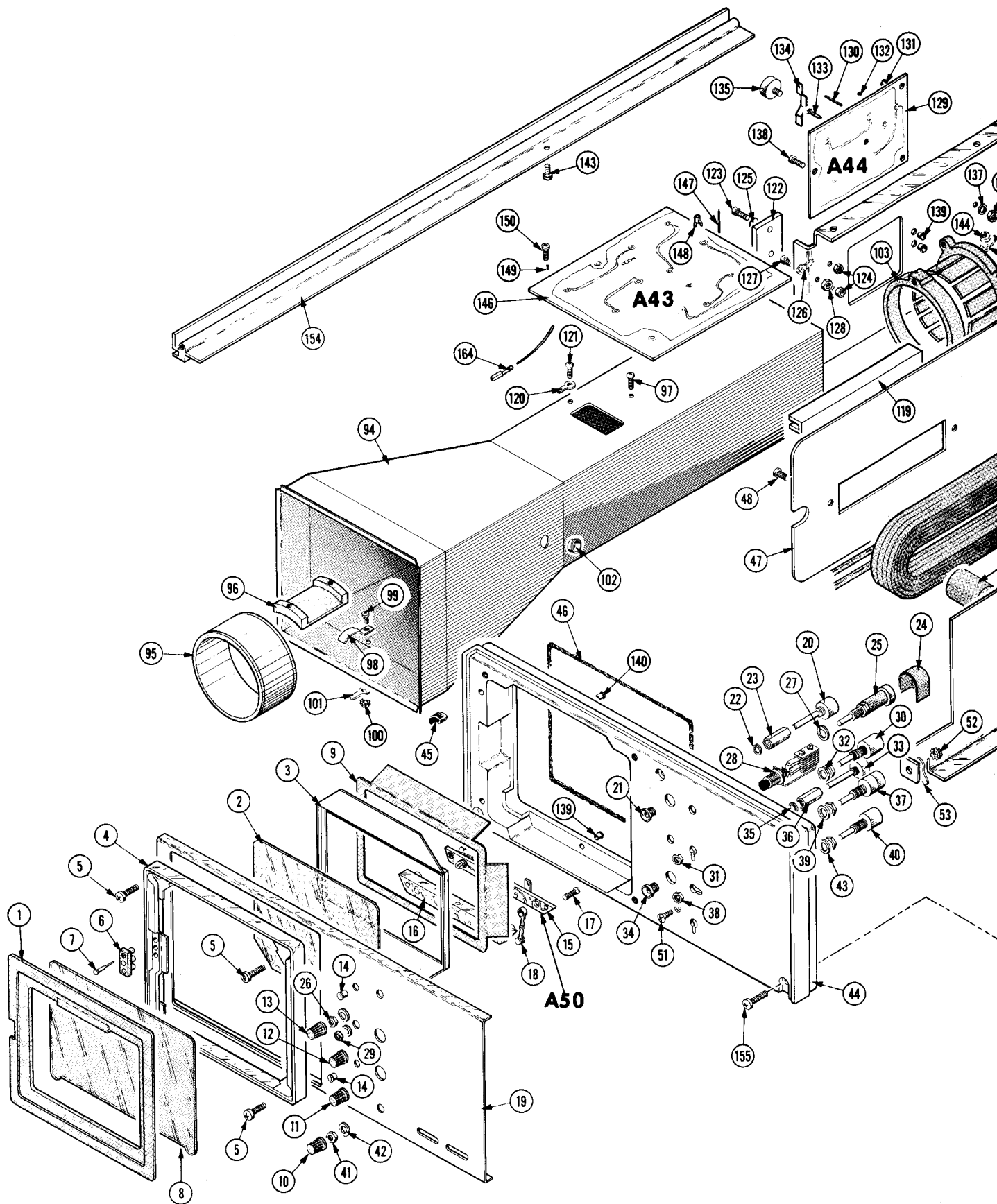



+

FIG. 1 01/04

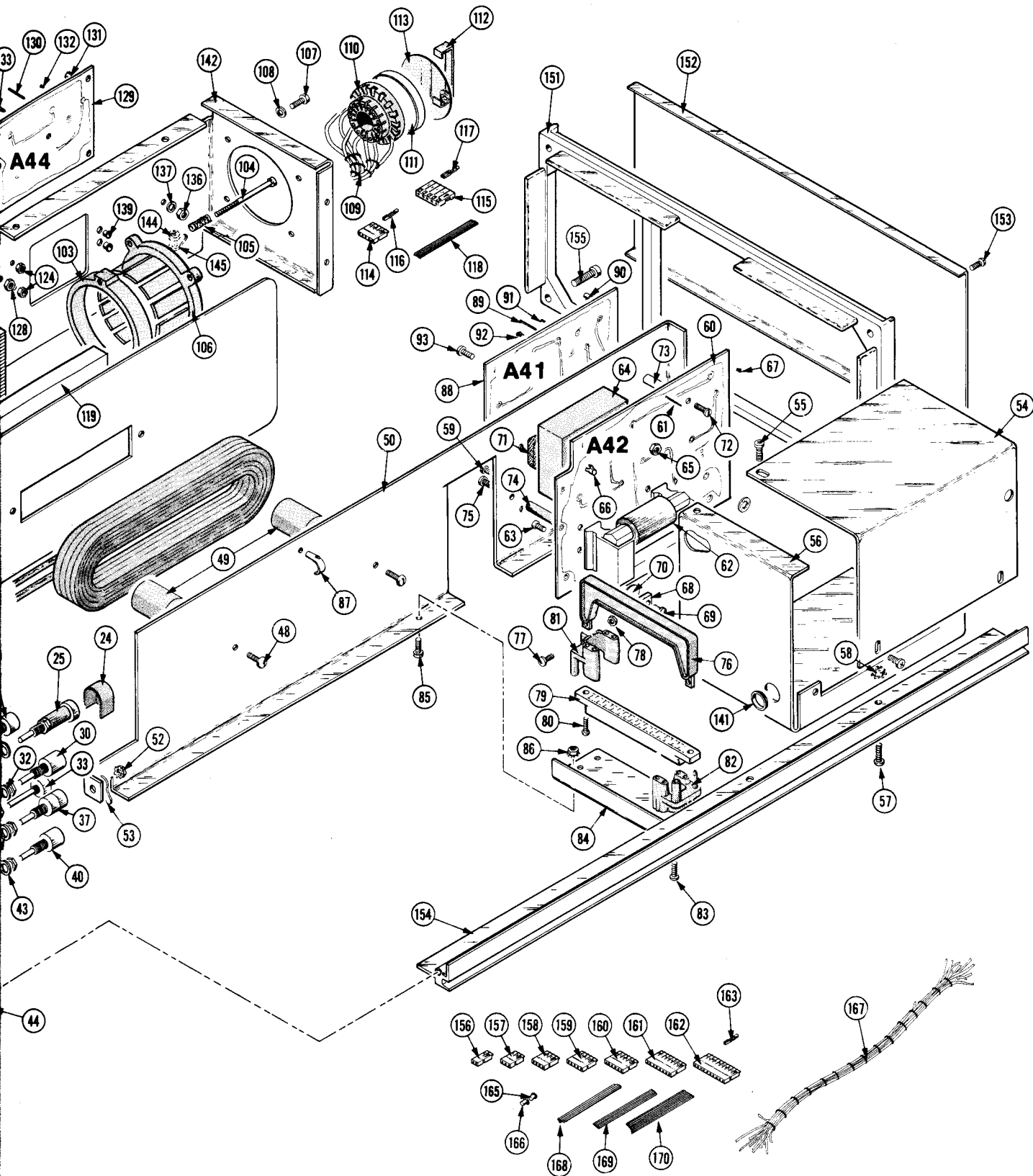

7704A OSCILLOSCOPE

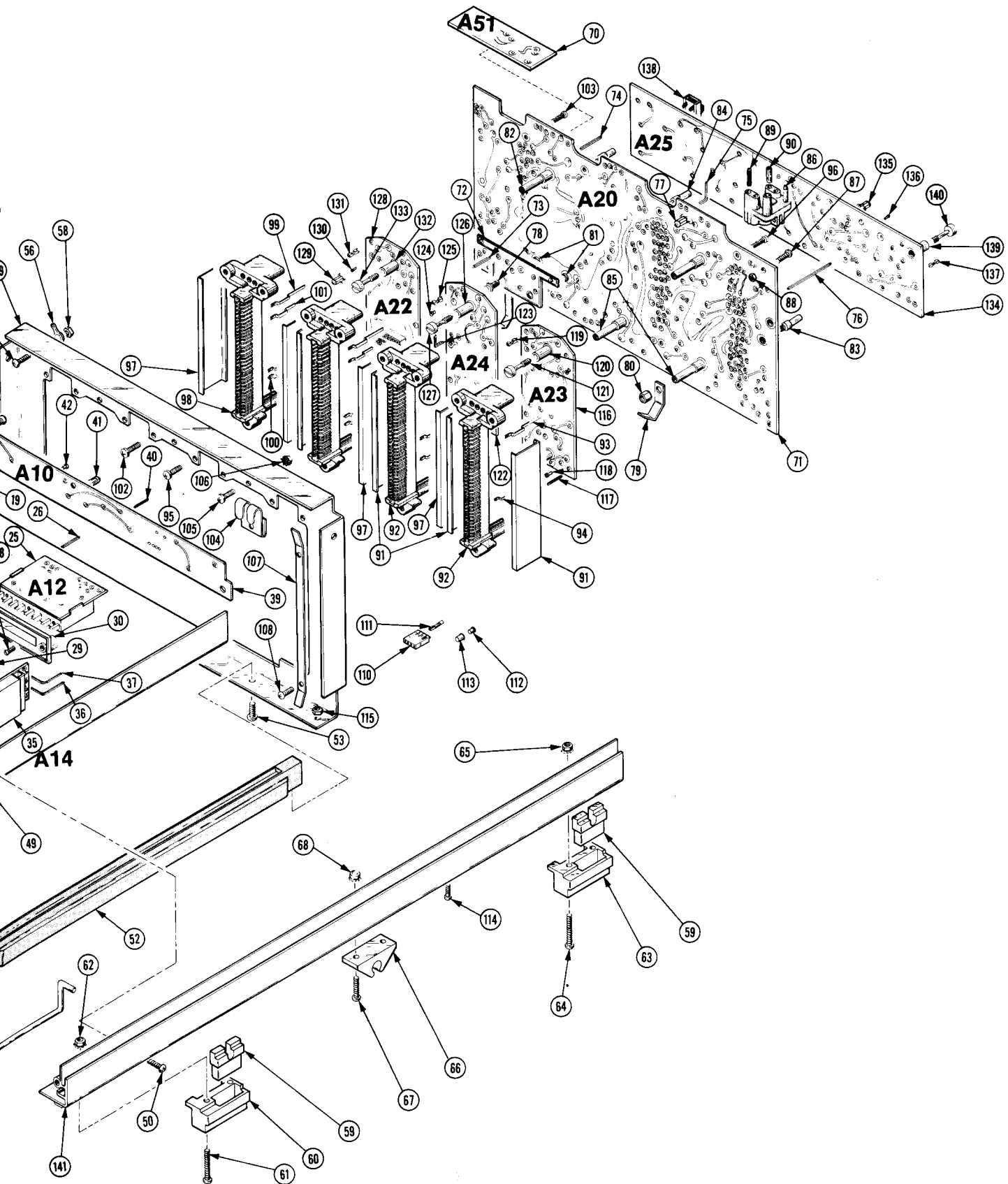
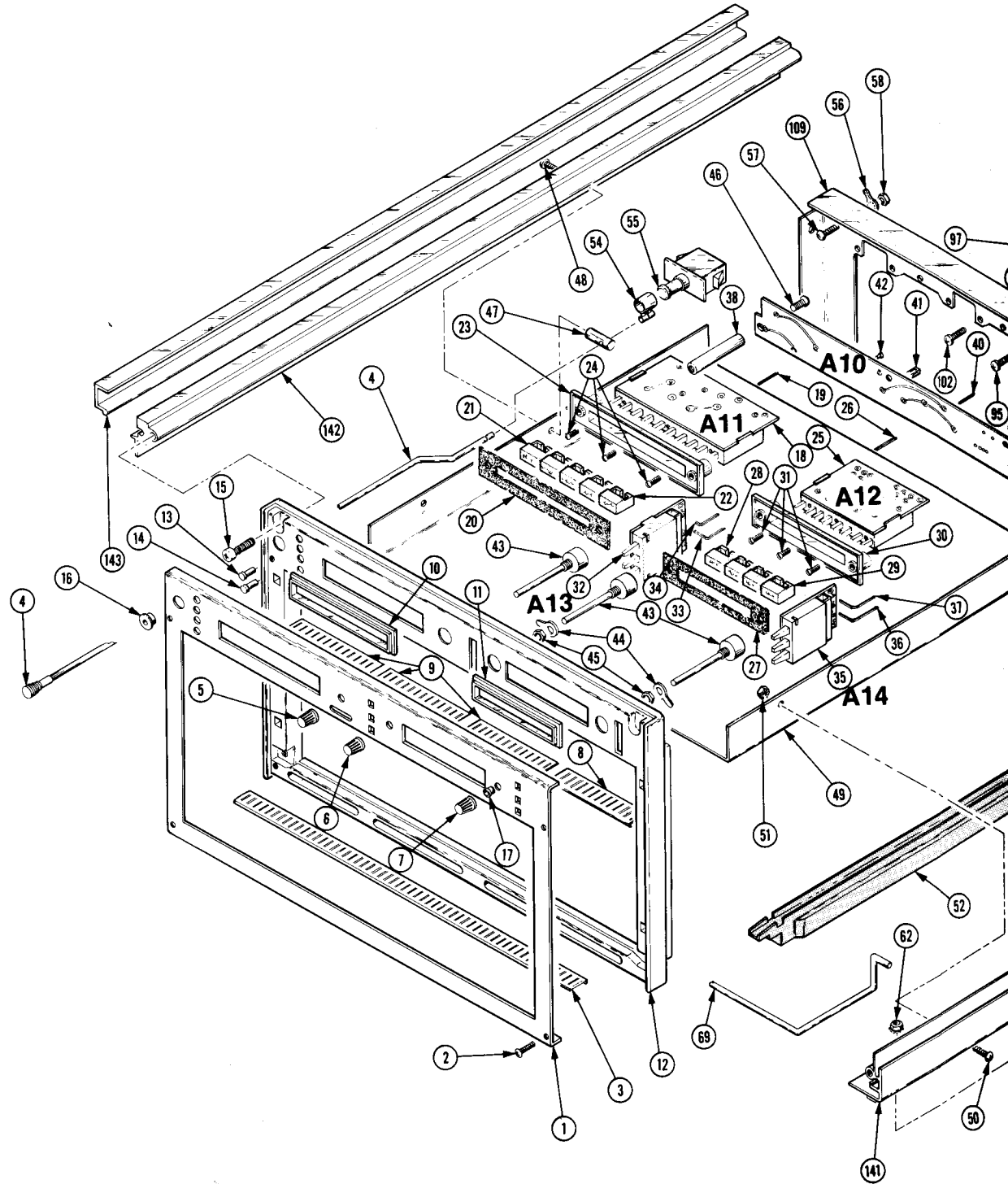

FIG. 2 A7704 FRONT

+



7704A OSCILLOSCOPE

FIGURE 2 A7704 FRONT

| Fig. & Index No. | Tektronix Part No. | Serial/Model No. Eff | No. Dscont | Qty | 1 2 3 4 5 | Name & Description  | Mfr Code | Mfr Part Number  |
|------------------|--------------------|----------------------|------------|-----|-----------|---|----------|------------------|
| 2-1              | 333-1491-00        |                      |            | 1   |           | PANEL:FRONT<br>(ATTACHING PARTS)                            | 80009    | 333-1491-00      |
| -2               | 213-0055-00        |                      |            | 4   |           | SCR,TPG,THD FOR:2-32 X 0.188 INCH,PNH STL<br>- - - * - - -  | 83385    | OBD              |
| -3               | 348-0204-00        |                      |            | 1   |           | SHLD GSKT,ELECT:  | 80009    | 348-0204-00      |
| -4               | 384-1122-00        |                      |            | 1   |           | EXTENSION SHAFT:POWER SWITCH                                | 80009    | 384-1122-00      |
| -5               | 366-1023-00        |                      |            | 1   |           | KNOB:GRAY   | 80009    | 366-1023-00      |
|                  | 213-0246-00        |                      |            | 1   |           | . SETSCREW:5-40 X 0.093 INCH L,HEX SOC                      | 71159    | OBD              |
| -6               | 366-1023-00        |                      |            | 1   |           | KNOB:GRAY   | 80009    | 366-1023-00      |
|                  | 213-0246-00        |                      |            | 1   |           | . SETSCREW:5-40 X 0.093 INCH L,HEX SOC                      | 71159    | OBD              |
| -7               | 366-1023-00        |                      |            | 1   |           | KNOB:GRAY   | 80009    | 366-1023-00      |
|                  | 213-0246-00        |                      |            | 1   |           | . SETSCREW:5-40 X 0.093 INCH L,HEX SOC                      | 71159    | OBD              |
| -8               | 337-1542-00        |                      |            | 1   |           | SHLD GSKT,ELECT:2.10 INCHES LONG                            | 80009    | 337-1542-00      |
| -9               | 337-1543-00        |                      |            | 3   |           | SHLD GSKT,ELECT:2.50 INCHES LONG                            | 80009    | 337-1543-00      |
| -10              | 200-0984-00        |                      |            | 1   |           | BEZEL:PLASTIC,5 BUTTON SWITCH                               | 80009    | 200-0984-00      |
| -11              | 200-0983-00        |                      |            | 1   |           | BEZEL:PLASTIC,4 BUTTON SWITCH                               | 80009    | 200-0983-00      |
| -12              | 426-0806-01        |                      |            | 1   |           | FRAME PANEL,CAB:FRONT                                       | 80009    | 426-0806-01      |
| -13              | 136-0387-00        |                      |            | 3   |           | . JACK,TIP:GRAY   | 71279    | 4352-1-0318      |
| -14              | 136-0387-01        |                      |            | 1   |           | . JACK,TIP:BLACK<br>(ATTACHING PARTS)                       | 71279    | 4352-1-0310      |
| -15              | 213-0270-00        |                      |            | 4   |           | SCR,TPG,THD FOR:10-32 X 0.75 INCH FILH STL<br>- - - * - - - | 83385    | OBD              |
| -16              | 358-0216-00        |                      |            | 1   |           | BUSHING,PLASTIC:0.257 ID X 0.412 INCH OD                    | 80009    | 358-0216-00      |
| -17              | 348-0031-00        |                      |            | 3   |           | GROMMET,PLASTIC:0.156 INCH DIA                              | 80009    | 348-0031-00      |
| -18              | -----              |                      |            | 1   |           | CKT BOARD ASSY:VERTICAL MODE(SEE All EPL)                   |          |                  |
| -19              | 131-0590-00        |                      |            | 8   |           | . CONTACT,ELEC:0.71 INCH LONG                               | 22526    | 47351            |
| -20              | 337-1157-00        |                      |            | 1   |           | . SHLD,ELECTRICAL:  | 80009    | 337-1157-00      |
| -21              | 366-1109-01        |                      |            | 1   |           | . PUSH BUTTON:LEFT  | 80009    | 366-1109-01      |
|                  | 366-1109-02        |                      |            | 1   |           | . PUSH BUTTON:ALT   | 80009    | 366-1109-02      |
|                  | 366-1109-03        |                      |            | 1   |           | . PUSH BUTTON:ADD   | 80009    | 366-1109-03      |
|                  | 366-1109-04        |                      |            | 1   |           | . PUSH BUTTON:CHOP  | 80009    | 366-1109-04      |
| -22              | 366-1109-05        |                      |            | 1   |           | . PUSH BUTTON:RIGHT   | 80009    | 366-1109-05      |
| -23              | 380-0147-00        |                      |            | 1   |           | . HOUSING,FRONT:<br>(ATTACHING PARTS)                       | 80009    | 380-0147-00      |
| -24              | 211-0125-00        |                      |            | 3   |           | . SCREW,MACHINE:1-72 X 0.25 INCH,PNH STL<br>- - - * - - -   | 83385    | OBD              |
| -25              | -----              |                      |            | 1   |           | CKT BOARD ASSY:HORIZONTAL MODE(SEE A12 EPL)                 |          |                  |
| -26              | 131-0590-00        |                      |            | 7   |           | . CONTACT,ELEC:0.71 INCH LONG                               | 22526    | 47351            |
| -27              | 337-1156-00        |                      |            | 1   |           | . SHLD,ELECTRICAL:  | 80009    | 337-1156-00      |
| -28              | 366-1109-06        |                      |            | 1   |           | . PUSH BUTTON:A   | 80009    | 366-1109-06      |
|                  | 366-1109-02        |                      |            | 1   |           | . PUSH BUTTON:ALT   | 80009    | 366-1109-02      |
|                  | 366-1109-04        |                      |            | 1   |           | . PUSH BUTTON:CHOP  | 80009    | 366-1109-04      |
| -29              | 366-1109-07        |                      |            | 1   |           | . PUSH BUTTON:B   | 80009    | 366-1109-07      |
| -30              | 380-0168-00        |                      |            | 1   |           | . HOUSING,FRONT:<br>(ATTACHING PARTS)                       | 80009    | 380-0168-00      |
| -31              | 211-0125-00        |                      |            | 3   |           | . SCREW,MACHINE:1-72 X 0.25 INCH,PNH STL<br>- - - * - - -   | 83385    | OBD              |
| -32              | -----              |                      |            | 1   |           | CKT BOARD ASSY:A TRIGGER SOURCE(SEE A13 EPL)                |          |                  |
| -33              | 131-0592-00        | B010100              | B010119    | 2   |           | . CONTACT,ELEC:0.885 INCH LONG                              | 22526    | 47353            |
|                  | 131-0592-00        | B010120              |            | 3   |           | . CONTACT,ELEC:0.885 INCH LONG                              | 22526    | 47353            |
| -34              | 131-0787-00        |                      |            | 5   |           | . CONTACT,ELEC:0.64 INCH LONG                               | 22526    | 47359            |
| -35              | -----              |                      |            | -   |           | CKT BOARD ASSY:B TRIGGER SOURCE(SEE A14 EPL)                |          |                  |
| -36              | 131-0592-00        | B010100              | B010119    | 2   |           | . CONTACT,ELEC:0.885 INCH LONG                              | 22526    | 47353            |
|                  | 131-0592-00        | B010120              |            | 3   |           | . CONTACT,ELEC:0.885 INCH LONG                              | 22526    | 47353            |
| -37              | 131-0787-00        |                      |            | 5   |           | . CONTACT,ELEC:0.64 INCH LONG                               | 22526    | 47359            |
| -38              | 166-0099-00        |                      |            | 3   |           | POST,ELEC-MECH:0.25 OD X 1.719 INCHES L                     | 80009    | 166-0099-00      |
| -39              | -----              |                      |            | 1   |           | CKT BOARD ASSY:CALIBRATOR(SEE A10 EPL)                      |          |                  |
| -40              | 131-0608-00        |                      |            | 32  |           | . CONTACT,ELEC:0.365 INCH LONG                              | 22526    | 47357            |
| -41              | 136-0263-03        | B010100              | B153439    | 31  |           | . CONTACT,ELEC:FOR 0.025 INCH SQUARE PIN                    | 00779    | 86250-2          |
|                  | 136-0263-04        | B153440              |            | 31  |           | . CONTACT,ELEC:FOR 0.025 INCH SQUARE PIN                    | 22526    | 75377-001        |
| -42              | 136-0252-04        | B010100              | B112459    | 38  |           | . CONTACT,ELEC:0.188 INCH LONG                              | 22526    | 75060            |
|                  | 136-0220-00        | B112460              |            | 8   |           | SOCKET,PLUG-IN:3 PIN,SQUARE                                 | 71785    | 133-23-11-034    |
|                  | 136-0292-02        | B112460              |            | 1   |           | SOCKET,PLUG-IN:14 CONTACT LOW CLEARANCE                     | 01295    | C931402          |
| -43              | -----              |                      |            | 3   |           | . RES.,VAR:(SEE R1063,R1065,R1067 EPL)                      |          |                  |
| -44              | 210-0223-00        | XB010210             |            | 2   |           | . TERMINAL,LUG:0.25 INCH DIA,SE<br>(ATTACHING PARTS)        | 78189    | 2101-14-03-2520N |
| -45              | 210-0583-00        | XB010210             |            | 1   |           | . NUT,PLAIN,HEX.:0.25-32 X 0.312 INCH,BRS<br>- - - * - - -  | 73743    | 2X20224-402      |

Mechanical Parts List—7704A

FIGURE 2 A7704 FRONT (cont)

| Fig. & Index No. | Tektronix Part No. | Serial/Model No. Eff | No. Dscont | Qty | Name & Description   |   |   |   |   | Mfr Code | Mfr Part Number  |
|------------------|--------------------|----------------------|------------|-----|--|---|---|---|---|----------|------------------|
|                  |                    |                      |            |     | 1  | 2 | 3 | 4 | 5 |          |                  |
| 2-46             | 211-0504-00        |                      |            | 3   | SCREW,MACHINE:6-32 X 0.25 INCH,PNH STL                                       |   |   |   |   | 83385    | OBD              |
| -47              | 385-0099-00        |                      |            | 1   | INS,STANDOFF:0.25 OD X 0.625 INCH LONG<br>(ATTACHING PARTS)                  |   |   |   |   | 80009    | 385-0099-00      |
| -48              | 211-0504-00        |                      |            | 1   | SCREW,MACHINE:6-32 X 0.25 INCH,PNH STL<br>- - - * - - -                      |   |   |   |   | 83385    | OBD              |
| -49              | 337-1558-00        |                      |            | 1   | SHLD,ELECTRICAL:<br>(ATTACHING PARTS)  |   |   |   |   | 80009    | 337-1558-00      |
| -50              | 211-0507-00        |                      |            | 3   | SCREW,MACHINE:6-32 X 0.312 INCH,PNH STL                                      |   |   |   |   | 83385    | OBD              |
| -51              | 210-0457-00        |                      |            | 3   | NUT,PLAIN,EXT W:6-32 X 0.312 INCH,STL<br>- - - * - - -                       |   |   |   |   | 83385    | OBD              |
| -52              | 351-0181-03        |                      |            | 4   | GUIDE,SLIDE:LWR,PLUG-IN UNIT<br>(ATTACHING PARTS FOR EACH)                   |   |   |   |   | 80009    | 351-0181-03      |
| -53              | 213-0054-00        |                      |            | 1   | SCR,TPG,THD FOR:6-32 X 0.312 INCH,PNH STL<br>- - - * - - -                   |   |   |   |   | 83385    | OBD              |
| -54              | 376-0127-00        |                      |            | 1   | COUPLER,SHAFT:PLASTIC  |   |   |   |   | 80009    | 376-0127-00      |
| -55              | 260-1222-00        |                      |            | 1   | SWITCH,PUSH-PUL:10A,250VAC   |   |   |   |   | 91929    | 2DM301           |
| -56              | 210-0202-00        |                      |            | 1   | TERMINAL,LUG:SE #6<br>(ATTACHING PARTS)                                      |   |   |   |   | 78189    | 2104-06-00-2520N |
| -57              | 211-0504-00        |                      |            | 1   | SCREW,MACHINE:6-32 X 0.25 INCH,PNH STL                                       |   |   |   |   | 83385    | OBD              |
| -58              | 210-0457-00        |                      |            | 1   | NUT,PLAIN,EXT W:6-32 X 0.312 INCH,STL<br>- - - * - - -                       |   |   |   |   | 83385    | OBD              |
| -59              | 377-0119-00        |                      |            | 4   | PAD,CUSHIONING::PLASTIC  |   |   |   |   | 80009    | 377-0119-00      |
| -60              | 348-0074-01        |                      |            | 2   | SPT PIVOT,FLIP:RIGHT FRONT LEFT REAR<br>(ATTACHING PARTS FOR EACH)           |   |   |   |   | 80009    | 348-0074-01      |
| -61              | 211-0532-00        |                      |            | 2   | SCREW,MACHINE:6-32 X 0.75 INCH,FILH STL                                      |   |   |   |   | 83385    | OBD              |
| -62              | 210-0457-00        |                      |            | 2   | NUT,PLAIN,EXT W:6-32 X 0.312 INCH,STL<br>- - - * - - -                       |   |   |   |   | 83385    | OBD              |
| -63              | 348-0073-01        |                      |            | 2   | SPT PIVOT,FLIP:LEFT FRONT RIGHT REAR<br>(ATTACHING PARTS FOR EACH)           |   |   |   |   | 80009    | 348-0073-01      |
| -64              | 211-0532-00        |                      |            | 2   | SCREW,MACHINE:6-32 X 0.75 INCH,FILH STL                                      |   |   |   |   | 83385    | OBD              |
| -65              | 210-0457-00        |                      |            | 2   | NUT,PLAIN,EXT W:6-32 X 0.312 INCH,STL<br>- - - * - - -                       |   |   |   |   | 83385    | OBD              |
| -66              | 343-0256-00        |                      |            | 2   | RTRN BLK,SCOPE:<br>(ATTACHING PARTS FOR EACH)                                |   |   |   |   | 80009    | 343-0256-00      |
| -67              | 213-0192-00        |                      |            | 2   | SCR,TPG,THD FOR:6-32 X 0.50 INCH,PNH STL                                     |   |   |   |   | 87308    | OBD              |
| -68              | 210-0457-00        |                      |            | 2   | NUT,PLAIN,EXT W:6-32 X 0.312 INCH,STL<br>- - - * - - -                       |   |   |   |   | 83385    | OBD              |
| -69              | 348-0193-00        |                      |            | 1   | FLIP-STAND:CABINET   |   |   |   |   | 80009    | 348-0193-00      |
|                  | 672-0571-00        | XB160000             |            | 1   | CKT BOARD ASSY:PROTECTION AND MAIN INTFC ASSY                                |   |   |   |   |          |                  |
| -70              | -----              | XB160000             |            | 1   | . CKT BOARD ASSY:PROTECTION(SEE A51 EPL)                                     |   |   |   |   |          |                  |
| -71              | -----              |                      |            | 1   | . CKT BOARD ASSY:MAIN INTERFACE(SEE A20 EPL)                                 |   |   |   |   |          |                  |
| -72              | 388-1382-01        |                      |            | 1   | . . . CIRCUIT BOARD--VERTICAL INTERCONNECT                                   |   |   |   |   | 80009    | 388-1382-01      |
| -73              | 131-0787-00        |                      |            | 8   | . . . CONTACT,ELEC:0.64 INCH LONG  |   |   |   |   | 22526    | 47359            |
| -74              | 131-0590-00        |                      |            | 27  | . . CONTACT,ELEC:0.71 INCH LONG  |   |   |   |   | 22526    | 47351            |
|                  | 131-0592-00        |                      |            | 31  | . . CONTACT,ELEC:0.885 INCH LONG   |   |   |   |   | 22526    | 47353            |
|                  | 131-0589-00        |                      |            | 10  | . . CONTACT,ELEC:0.46 INCH LONG  |   |   |   |   | 22526    | 47350            |
|                  | 131-0608-00        |                      |            | 54  | . . CONTACT,ELEC:0.365 INCH LONG   |   |   |   |   | 22526    | 47357            |
| -75              | 131-0827-00        |                      |            | 7   | . . CONTACT,ELEC:0.55 INCH LONG  |   |   |   |   | 22526    | 47349            |
| -76              | 131-0595-00        |                      |            | 6   | . . CONTACT,ELEC:1.37 INCH LONG  |   |   |   |   | 22526    | 47355            |
| -77              | 131-1003-00        |                      |            | 11  | . . CONNECTOR BODY,:CKT BD MT,3 PRONG  |   |   |   |   | 80009    | 131-1003-00      |
| -78              | 211-0008-00        |                      |            | 2   | . . SCREW,MACHINE:4-40 X 0.25 INCH,PNH STL                                   |   |   |   |   | 83385    | OBD              |
|                  | 136-0252-04        |                      |            | 55  | . . CONTACT,ELEC:0.188 INCH LONG   |   |   |   |   | 22526    | 75060            |
| -79              | 131-0805-00        |                      |            | 3   | . . LINK,TERM.CONNE:J-SHAPE,0.90X0.82 X 0.312"<br>(ATTACHING PARTS FOR EACH) |   |   |   |   | 80009    | 131-0805-00      |
| -80              | 220-0561-00        |                      |            | 1   | . . NUT,PLAIN,HEX.:10-32 X 0.25 INCH,BRS<br>- - - * - - -                    |   |   |   |   | 80009    | 220-0561-00      |
| -81              | 351-0213-00        |                      |            | 2   | . . GUIDE-POST,LOCK:0.285 INCH LONG  |   |   |   |   | 80009    | 351-0213-00      |
| -82              | 351-0188-00        |                      |            | 2   | . . GUIDE-POST,LOCK:0.65 INCH LONG   |   |   |   |   | 80009    | 351-0188-00      |
| -83              | 351-0186-00        |                      |            | 3   | . . GUIDE-POST,LOCK:0.84 INCH LONG   |   |   |   |   | 80009    | 351-0186-00      |
| -84              | 351-0185-00        |                      |            | 1   | . . GUIDE-POST,LOCK:0.65 INCH LONG   |   |   |   |   | 80009    | 351-0185-00      |

FIGURE 2 A7704 FRONT (CONT)

| Fig. & Index No. | Tektronix Part No. | Serial/Model No. Eff | Dscnt   | Qty | Name & Description |   |   |   |       | Mfr Code    | Mfr Part Number |        |
|------------------|--------------------|----------------------|---------|-----|--------------------|---|---|---|-------|-------------|-----------------|--------|
|                  |                    |                      |         |     | 1                  | 2 | 3   | 4 | 5     |             | Part            | Number |
| 2-85             | 351-0227-00        |                      |         | 3   | .                  | . | GUIDE-POST,LOCK:0.84 INCH LONG                                    |   | 80009 | 351-0227-00 |                 |        |
| -86              | 380-0262-00        |                      |         | 2   | .                  | . | HOUSING,CONN:<br>(ATTACHING PARTS FOR EACH)                       |   | 80009 | 380-0262-00 |                 |        |
| -87              | 211-0097-00        |                      |         | 2   | .                  | . | SCREW,MACHINE:4-40 X 0.312 INCH,PNH STL                           |   | 83385 | OBD         |                 |        |
| -88              | 210-0586-00        |                      |         | 2   | .                  | . | NUT,PLAIN,EXT W:4-40 X 0.25 INCH,STL<br>- - - * - - -             |   | 78189 | OBD         |                 |        |
| -89              | 131-1101-00        |                      |         | 4   | .                  | . | CONTACT,ELEC:MALE   |   | 00779 | 51563-1     |                 |        |
| -90              | 131-1102-00        |                      |         | 3   | .                  | . | CONTACT,ELEC:FEMALE   |   | 00779 | 51565-1     |                 |        |
|                  | 131-0767-00        | B010100              | B059999 | 2   | .                  | . | CONNECTOR,RCPT,:76 CONTACT  |   | 80009 | 131-0767-00 |                 |        |
|                  | 131-0767-07        | B060000              |         | 2   | .                  | . | CONNECTOR,RCPT,:PLUG-IN CKT BD,70 CONTACT                         |   | 80009 | 131-0767-07 |                 |        |
| -91              | 200-0950-00        |                      |         | 2   | .                  | . | COVER,ELEC CONN:PLASTIC   |   | 80009 | 200-0950-00 |                 |        |
| -92              | 204-0365-02        |                      |         | 1   | .                  | . | BODY,CONNECTOR:PLUG-IN CIRCUIT BOARD                              |   | 80009 | 204-0365-02 |                 |        |
| -93              | 131-0726-00        | B010100              | B059999 | 38  | .                  | . | CONTACT,ELEC:STRAIGHT   |   | 80009 | 131-0726-00 |                 |        |
|                  | 131-0726-00        | B060000              |         | 35  | .                  | . | CONTACT,ELEC:STRAIGHT   |   | 80009 | 131-0726-00 |                 |        |
| -94              | 131-0727-00        | B010100              | B059999 | 38  | .                  | . | CONTACT,ELEC:OFFSET   |   | 80009 | 131-0727-00 |                 |        |
|                  | 131-0727-00        | B060000              |         | 35  | .                  | . | CONTACT,ELEC:OFFSET<br>(ATTACHING PARTS FOR EACH)                 |   | 80009 | 131-0727-00 |                 |        |
| -95              | 213-0034-00        |                      |         | 3   | .                  | . | SCR,TPG,THD CTG:4-40 X 0.188 INCH,PNH STL                         |   | 83385 | OBD         |                 |        |
| -96              | 213-0232-00        |                      |         | 2   | .                  | . | SCR,TPG,THD FOR:2-32 X 0.312 INCH,PNH STL<br>- - - * - - -        |   | 83385 | OBD         |                 |        |
|                  | 131-0767-02        | B010100              | B059999 | 2   | .                  | . | CONNECTOR,RCPT,:76 CONTACT  |   | 80009 | 131-0767-02 |                 |        |
|                  | 131-0767-08        | B060000              |         | 2   | .                  | . | CONNECTOR,RCPT,:PLUG-IN CKT BD,70 CONTACT                         |   | 80009 | 131-0767-08 |                 |        |
| -97              | 200-0950-00        |                      |         | 2   | .                  | . | COVER,ELEC CONN:PLASTIC   |   | 80009 | 200-0950-00 |                 |        |
| -98              | 204-0365-00        |                      |         | 1   | .                  | . | BODY,CONNECTOR:PLUG-IN CIRCUIT BOARD                              |   | 80009 | 204-0365-00 |                 |        |
| -99              | 131-0726-00        | B010100              | B059999 | 36  | .                  | . | CONTACT,ELEC:STRAIGHT   |   | 80009 | 131-0726-00 |                 |        |
|                  | 131-0726-00        | B060000              |         | 33  | .                  | . | CONTACT,ELEC:STRAIGHT   |   | 80009 | 131-0726-00 |                 |        |
| -100             | 131-0727-00        | B010100              | B059999 | 36  | .                  | . | CONTACT,ELEC:OFFSET   |   | 80009 | 131-0727-00 |                 |        |
|                  | 131-0727-00        | B060000              |         | 33  | .                  | . | CONTACT,ELEC:OFFSET   |   | 80009 | 131-0727-00 |                 |        |
| -101             | 131-0899-00        |                      |         | 4   | .                  | . | CONTACT,ELEC:0.048 X 0.006 INCH THK<br>(ATTACHING PARTS FOR EACH) |   | 80009 | 131-0899-00 |                 |        |
| -102             | 213-0034-00        |                      |         | 3   | .                  | . | SCR,TPG,THD CTG:4-40 X 0.188 INCH,PNH STL                         |   | 83385 | OBD         |                 |        |
| -103             | 213-0232-00        |                      |         | 2   | .                  | . | SCR,TPG,THD FOR:2-32 X 0.312 INCH,PNH STL<br>- - - * - - -        |   | 83385 | OBD         |                 |        |
| -104             | 131-0930-00        |                      |         | 6   | .                  | . | CONTACT,ELEC:PLUG-IN GROUND<br>(ATTACHING PARTS FOR EACH)         |   | 80009 | 131-0930-00 |                 |        |
| -105             | 211-0008-00        |                      |         | 1   | .                  | . | SCREW,MACHINE:4-40 X 0.25 INCH,PNH STL                            |   | 83385 | OBD         |                 |        |
| -106             | 210-0586-00        |                      |         | 1   | .                  | . | NUT,PLAIN,EXT W:4-40 X 0.25 INCH,STL<br>- - - * - - -             |   | 78189 | OBD         |                 |        |
| -107             | 131-0800-00        |                      |         | 2   | .                  | . | CONTACT,ELEC:PLUG-IN GROUND<br>(ATTACHING PARTS FOR EACH)         |   | 80009 | 131-0800-00 |                 |        |
| -108             | 213-0138-00        |                      |         | 2   | .                  | . | SCR,TPG,THD FOR:4-40 X 0.188 INCH,PNH STL<br>- - - * - - -        |   | 83385 | OBD         |                 |        |
| -109             | 426-0813-00        |                      |         | 1   | .                  | . | FRAME,PLUG-IN H:  |   | 80009 | 426-0813-00 |                 |        |
| -110             | 352-0162-00        |                      |         | 1   | .                  | . | CONN BODY,PL,EL:4 WIRE BLACK                                      |   | 80009 | 352-0162-00 |                 |        |
| -111             | 131-0707-00        |                      |         | 2   | .                  | . | CONTACT,ELEC:0.48"L,22-26 AWG WIRE                                |   | 22526 | 47439       |                 |        |
|                  | 131-0708-00        |                      |         | 2   | .                  | . | CONTACT,ELEC:0.48"L,28-32 AWG WIRE                                |   | 22526 | 47437       |                 |        |
| -112             | 210-0775-00        |                      |         | 3   | .                  | . | EYELET,METALLIC:0.126 OD X 0.23 INCH L,BRS                        |   | 80009 | 210-0775-00 |                 |        |
| -113             | 210-0774-00        |                      |         | 3   | .                  | . | EYELET,METALLIC:0.152 OD X 0.245 INCH L,BRS<br>(ATTACHING PARTS)  |   | 80009 | 210-0774-00 |                 |        |
| -114             | 211-0504-00        |                      |         | 4   | .                  | . | SCREW,MACHINE:6-32 X 0.25 INCH,PNH STL                            |   | 83385 | OBD         |                 |        |
| -115             | 210-0457-00        |                      |         | 4   | .                  | . | NUT,PLAIN,EXT W:6-32 X 0.312 INCH,STL<br>- - - * - - -            |   | 83385 | OBD         |                 |        |
| -116             | -----              |                      |         | 1   | .                  | . | CKT BOARD ASSY:HORIZONTAL INTERFACE(SEE A23 EPL)                  |   |       |             |                 |        |
| -117             | 131-0787-00        |                      |         | 4   | .                  | . | CONTACT,ELEC:0.64 INCH LONG                                       |   | 22526 | 47359       |                 |        |
| -118             | 136-0252-04        |                      |         | 22  | .                  | . | CONTACT,ELEC:0.188 INCH LONG                                      |   | 22526 | 75060       |                 |        |
| -119             | 136-0263-03        | B010100              | B153439 | 11  | .                  | . | CONTACT,ELEC:FOR 0.025 INCHSQUARE PIN                             |   | 00779 | 86250-2     |                 |        |
|                  | 136-0263-04        | B153440              |         | 11  | .                  | . | CONTACT,ELEC:FOR 0.025 INCH SQUARE PIN                            |   | 22526 | 75377-001   |                 |        |
| -120             | 361-0238-00        |                      |         | 2   | .                  | . | SPACER,SLEEVE:0.25 OD X 0.34 INCH LONG                            |   | 80009 | 361-0238-00 |                 |        |
| -121             | 211-0155-00        |                      |         | 2   | .                  | . | SCREW,EXT,RLV B:4-40 X 0.375 INCH,SST                             |   | 80009 | 211-0155-00 |                 |        |
| -122             | -----              |                      |         | 1   | .                  | . | CKT BOARD ASSY:TRIGGER SELECTOR(SEE A24 EPL)                      |   |       |             |                 |        |

Mechanical Parts List—7704A

FIGURE 2 A7704A FRONT (CONT)

| Fig. &<br>Index<br>No. | Tektronix<br>Part No. | Serial/Model No.<br>Eff Dscont | Qty |   |   |   |   |   | Name & Description                             | Mfr<br>Code | Mfr Part Number |
|------------------------|-----------------------|--------------------------------|-----|---|---|---|---|---|--|-------------|-----------------|
|                        |                       |                                |     | 1 | 2 | 3 | 4 | 5 |  |             |                 |
| 2-123                  | 131-0787-00           |                                | 4   | . | . | . | . | . | CONTACT,ELEC:0.64 INCH LONG                    | 22526       | 47359           |
| -124                   | 136-0252-04           |                                | 50  | . | . | . | . | . | CONTACT,ELEC:0.188 INCH LONG                   | 22526       | 75060           |
| -125                   | 136-0263-03           | B010100 B153439                | 16  | . | . | . | . | . | CONTACT,ELEC:FOR 0.025 INCHSQUARE PIN          | 00779       | 86250-2         |
|                        | 136-0263-04           | B153440                        | 16  | . | . | . | . | . | CONTACT,ELEC:FOR 0.025 INCH SQUARE PIN         | 22526       | 75377-001       |
| -126                   | 361-0238-00           |                                | 2   | . | . | . | . | . | SPACER,SLEEVE:0.25 OD X 0.34 INCH LONG         | 80009       | 361-0238-00     |
| -127                   | 211-0155-00           |                                | 2   | . | . | . | . | . | SCREW,EXT,RLV B:4-40 X 0.375 INCH,SST          | 80009       | 211-0155-00     |
| -128                   | -----                 |                                | 1   | . | . | . | . | . | CKT BOARD ASSY:VERTICAL INTERFACE(SEE A22 EPL) |             |                 |
| -129                   | 131-1003-00           |                                | 2   | . | . | . | . | . | CONNECTOR BODY,:CKT BD MT,3 PRONG              | 80009       | 131-1003-00     |
| -130                   | 136-0252-04           |                                | 55  | . | . | . | . | . | CONTACT,ELEC:0.188 INCH LONG                   | 22526       | 75060           |
| -131                   | 136-0263-03           | B010100 B153439                | 18  | . | . | . | . | . | CONTACT,ELEC:FOR 0.025 INCHSQUARE PIN          | 00779       | 86250-2         |
|                        | 136-0263-04           | B153440                        | 18  | . | . | . | . | . | CONTACT,ELEC:FOR 0.025 INCH SQUARE PIN         | 22526       | 75377-001       |
| -132                   | 361-0238-00           |                                | 2   | . | . | . | . | . | SPACER,SLEEVE:0.25 OD X 0.34 INCH LONG         | 80009       | 361-0238-00     |
| -133                   | 211-0155-00           |                                | 2   | . | . | . | . | . | SCREW,EXT,RLV B:4-40 X 0.375 INCH,SST          | 80009       | 211-0155-00     |
| -134                   | -----                 |                                | 1   | . | . | . | . | . | CKT BOARD ASSY:LOGIC(SEE A25 EPL)              |             |                 |
| -135                   | 131-1003-00           |                                | 1   | . | . | . | . | . | CONNECTOR BODY,:CKT BD MT,3 PRONG              | 80009       | 131-1003-00     |
| -136                   | 136-0252-04           | B010100 B112459                | 115 | . | . | . | . | . | CONTACT,ELEC:0.188 INCH LONG                   | 22526       | 75060           |
|                        | 136-0220-00           | B112460                        | 9   | . | . | . | . | . | SOCKET,PLUG-IN:3 PIN,SQUARE                    | 71785       | 133-23-11-034   |
|                        | 136-0241-00           | B112460                        | 4   | . | . | . | . | . | SOCKET,PLUG-IN:10 CONTACT,ROUND                | 71785       | 133-99-12-064   |
|                        | 136-0260-02           | B112460                        | 3   | . | . | . | . | . | SOCKET,PLUG-IN:16 CONTACT,LOW CLEARANCE        | 01295       | C931602         |
| -137                   | 136-0263-03           | B010100 B153439                | 33  | . | . | . | . | . | CONTACT,ELEC:FOR 0.025 INCH SQUARE PIN         | 00779       | 86250-2         |
|                        | 136-0263-04           | B153440                        | 33  | . | . | . | . | . | CONTACT,ELEC:FOR 0.025 INCH SQUARE PIN         | 22526       | 75377-001       |
| -138                   | 260-0723-00           |                                | 1   | . | . | . | . | . | SWITCH,SLIDE:DPDT,0.5A,125VAC                  | 79727       | GF126-0028      |
| -139                   | 361-0238-00           |                                | 3   | . | . | . | . | . | SPACER,SLEEVE:0.25 OD X 0.34 INCH LONG         | 80009       | 361-0238-00     |
| -140                   | 211-0155-00           |                                | 3   | . | . | . | . | . | SCREW,EXT,RLV B:4-40 X 0.375 INCH,SST          | 80009       | 211-0155-00     |
|                        | 131-0566-00           | XB110000                       | 1   | . | . | . | . | . | LINK,TERM.CONNE:0.086 DIA X 2.375 INCH L       | 0000C       | L-2007-1        |
| -141                   | 426-0814-00           |                                | 2   | . | . | . | . | . | FRAME SECT,CAB:BOTTOM                          | 80009       | 426-0814-00     |
| -142                   | 426-0818-00           |                                | 2   | . | . | . | . | . | FRAME SECT,CAB:TOP                             | 80009       | 426-0818-00     |
| -143                   | 426-0849-00           |                                | 2   | . | . | . | . | . | FRAME SECT,CAB:COUPLING                        | 80009       | 426-0849-00     |

FIGURE 3 A7704 REAR

| Fig. & Index No. | Tektronix Part No. | Serial/Model No. Eff | Dscnt   | Qty |   |   |   |   |   | Name & Description | Mfr Code | Mfr Part Number  |  |
|------------------|--------------------|----------------------|---------|-----|---|---|---|---|---|--------------------|----------|------------------|--|
|                  |                    |                      |         |     | 1 | 2 | 3 | 4 | 5 |                    |          |                  |  |
| 3-1              | -----              |                      |         | 1   |   |   |   |   |   |                    |          |                  |  |
| -2               | 131-0608-00        |                      |         | 24  |   |   |   |   |   |                    | 22526    | 47357            |  |
| -3               | 131-0771-00        |                      |         | 2   |   |   |   |   |   |                    | 80009    | 131-0771-00      |  |
| -4               | 220-0551-00        |                      |         | 1   |   |   |   |   |   |                    | 80009    | 220-0551-00      |  |
| -5               | 131-1003-00        |                      |         | 5   |   |   |   |   |   |                    | 80009    | 131-1003-00      |  |
| -6               | 136-0252-04        | B010100              | B112459 | 273 |   |   |   |   |   |                    | 22526    | 75060            |  |
|                  | 136-0235-00        | B112460              |         | 1   |   |   |   |   |   |                    | 71785    | 133-96-12-062    |  |
|                  | 136-0220-00        | B112460              |         | 11  |   |   |   |   |   |                    | 71785    | 133-23-11-034    |  |
|                  | 136-0260-00        | B112460              |         | 12  |   |   |   |   |   |                    | 71785    | 133-51-92-008    |  |
|                  | 136-0269-02        | B112460              |         | 3   |   |   |   |   |   |                    | 01295    | C931402          |  |
| -7               | 214-0579-00        |                      |         | 2   |   |   |   |   |   |                    | 80009    | 214-0579-00      |  |
| -8               | 211-0097-00        |                      |         | 4   |   |   |   |   |   |                    | 83385    | OBD              |  |
| -9               | 441-1065-00        |                      |         | 1   |   |   |   |   |   |                    | 80009    | 441-1065-00      |  |
| -10              | 386-2153-00        |                      |         | 1   |   |   |   |   |   |                    | 80009    | 386-2153-00      |  |
| -11              | 352-0162-00        |                      |         | 2   |   |   |   |   |   |                    | 80009    | 352-0162-00      |  |
| -12              | 352-0168-00        |                      |         | 4   |   |   |   |   |   |                    | 80009    | 352-0168-00      |  |
| -13              | 131-0707-00        |                      |         | 48  |   |   |   |   |   |                    | 22526    | 47439            |  |
| -14              | 175-0827-00        |                      |         | IN  |   |   |   |   |   |                    | 08261    | TEK-175-0827-00  |  |
| -15              | 175-0833-00        |                      |         | IN  |   |   |   |   |   |                    | 23499    | TEK-175-0833-00  |  |
| -16              | 210-0775-00        |                      |         | 5   |   |   |   |   |   |                    | 80009    | 210-0775-00      |  |
| -17              | 210-0774-00        |                      |         | 5   |   |   |   |   |   |                    | 80009    | 210-0774-00      |  |
| -18              | 211-0507-00        |                      |         | 2   |   |   |   |   |   |                    | 83385    | OBD              |  |
| -19              | -----              |                      |         | 1   |   |   |   |   |   |                    |          |                  |  |
| -20              | 131-0955-00        |                      |         | 5   |   |   |   |   |   |                    | 24931    | 28JR200-1        |  |
| -21              | 131-1003-00        |                      |         | 8   |   |   |   |   |   |                    | 80009    | 131-1003-00      |  |
| -22              | 131-0608-00        |                      |         | 6   |   |   |   |   |   |                    | 22526    | 47357            |  |
| -23              | 136-0252-04        | B010100              | B112459 | 36  |   |   |   |   |   |                    | 22526    | 75060            |  |
|                  | 136-0220-00        | B112460              |         | 12  |   |   |   |   |   |                    | 71785    | 133-23-11-034    |  |
| -24              | 260-0723-00        |                      |         | 2   |   |   |   |   |   |                    | 79727    | GF126-0028       |  |
| -25              | 260-0984-00        |                      |         | 1   |   |   |   |   |   |                    | 79727    | G-128SPC/7140    |  |
| -26              | 441-1064-00        |                      |         | 1   |   |   |   |   |   |                    | 80009    | 441-1064-00      |  |
| -27              | 211-0097-00        |                      |         | 3   |   |   |   |   |   |                    | 83385    | OBD              |  |
| -28              | 210-0201-00        |                      |         | 1   |   |   |   |   |   |                    | 78189    | 2104-04-00-2520N |  |
| -29              | 386-2152-00        |                      |         | 1   |   |   |   |   |   |                    | 80009    | 386-2152-00      |  |
| -30              | 211-0507-00        |                      |         | 2   |   |   |   |   |   |                    | 83385    | OBD              |  |
| -31              | 386-2133-00        |                      |         | 1   |   |   |   |   |   |                    | 80009    | 386-2133-00      |  |
| -32              | 211-0507-00        |                      |         | 2   |   |   |   |   |   |                    | 83385    | OBD              |  |
| -33              | 426-0807-01        |                      |         | 1   |   |   |   |   |   |                    | 80009    | 426-0807-01      |  |
|                  | 213-0270-00        |                      |         | 4   |   |   |   |   |   |                    | 83385    | OBD              |  |
|                  | 620-0230-00        |                      |         | 1   |   |   |   |   |   |                    | 80009    | 620-0230-00      |  |
| -34              | -----              |                      |         | 1   |   |   |   |   |   |                    |          |                  |  |
| -35              | 131-0608-00        | B010100              | B194124 | 11  |   |   |   |   |   |                    | 22526    | 47357            |  |
|                  | 131-0589-00        | B194125              |         | 11  |   |   |   |   |   |                    | 22526    | 47350            |  |
| -36              | 131-1003-00        |                      |         | 2   |   |   |   |   |   |                    | 80009    | 131-1003-00      |  |
| -37              | 136-0252-04        | B010100              | B112459 | 22  |   |   |   |   |   |                    | 22526    | 75060            |  |
|                  | 136-0220-00        | B112460              |         | 12  |   |   |   |   |   |                    | 71785    | 133-23-11-034    |  |
|                  | 136-0260-02        | B112460              |         | 1   |   |   |   |   |   |                    | 01295    | C931602          |  |
| -38              | 136-0263-03        | B010100              | B153439 | 7   |   |   |   |   |   |                    | 00779    | 86250-2          |  |
|                  | 136-0263-04        | B153440              |         | 7   |   |   |   |   |   |                    | 22526    | 75377-001        |  |
| -39              | 210-0586-00        |                      |         | 4   |   |   |   |   |   |                    | 78189    | OBD              |  |
| -40              | 211-0008-00        |                      |         | 4   |   |   |   |   |   |                    | 83385    | OBD              |  |



# Mechanical Parts List—7704A

FIGURE 3 A7704 REAR (CONT)

| Fig. & Index No. | Tektronix Part No. | Serial/Model No. Eff | Dscont  | Qty | 1 | 2 | 3 | 4 | 5 | Name & Description   | Mfr Code | Mfr Part Number |
|------------------|--------------------|----------------------|---------|-----|---|---|---|---|---|--|----------|-----------------|
| 3-41             | 337-1490-00        |                      |         | 1   | . | . | . | . | . | SHLD,ELECTRICAL:CIRCUIT BOARD<br>(ATTACHING PARTS)             | 80009    | 337-1490-00     |
| -42              | 211-0040-00        |                      |         | 2   | . | . | . | . | . | SCREW,MACHINE:4-40 X 0.25",BDCH PLSTC<br>-----*                | 26365    | OBD             |
| -43              | -----              |                      |         | 1   | . | . | . | . | . | CKT BOARD ASSY:POWER SUPPLY INVERTER<br>(SEE A30 EPL)          |          |                 |
| -44              | 129-0323-00        |                      |         | 2   | . | . | . | . | . | POST,ELEC-MECH:HEX,0.25 X 1 INCH LONG<br>(ATTACHING PARTS)     | 80009    | 129-0323-00     |
| -45              | 211-0097-00        |                      |         | 1   | . | . | . | . | . | SCREW,MACHINE:4-40 X 0.312 INCH,PNH STL<br>-----*              | 83385    | OBD             |
|                  | 131-0591-00        |                      |         | 7   | . | . | . | . | . | CONTACT,ELEC:0.835 INCH LONG                                   | 22526    | 47352           |
| -46              | 136-0254-01        |                      |         | 4   | . | . | . | . | . | CONTACT,ELEC:0.145 INCH LONG                                   | 00779    | 1-331892-8      |
| -47              | 344-0230-00        |                      |         | 1   | . | . | . | . | . | CLIP,SPG,TNSN:   | 80009    | 344-0230-00     |
| -48              | -----              |                      |         | 2   | . | . | . | . | . | CAPACITOR:(SEE C3016,C3017 EPL)<br>(ATTACHING PARTS FOR EACH)  |          |                 |
| -49              | 212-0518-00        |                      |         | 2   | . | . | . | . | . | SCREW,MACHINE:10-32 X 0.312 INCH,PNH STL<br>-----*             | 83385    | OBD             |
| -50              | 214-0579-00        |                      |         | 3   | . | . | . | . | . | TERM.,TEST PT:0.40 INCH LONG                                   | 80009    | 214-0579-00     |
|                  | 348-0023-00        |                      |         | 6   | . | . | . | . | . | FOOT:  | 02768    | OBD             |
| -51              | -----              |                      |         | 2   | . | . | . | . | . | TRANSISTOR:(SEE Q3034,Q3037 EPL)<br>(ATTACHING PARTS FOR EACH) |          |                 |
| -52              | 211-0012-00        |                      |         | 2   | . | . | . | . | . | SCREW,MACHINE:4-40 X 0.375 INCH,PNH STL                        | 83385    | OBD             |
| -53              | 210-0586-00        |                      |         | 2   | . | . | . | . | . | NUT,PLAIN,EXT W:4-40 X 0.25 INCH,STL                           | 78189    | OBD             |
| -54              | 386-0978-00        |                      |         | 1   | . | . | . | . | . | INSULATOR,PLATE:0.002 INCH MICA,FOR TO-3<br>-----*             | 80009    | 386-0978-00     |
| -55              | 214-1624-00        |                      |         | 1   | . | . | . | . | . | HEATSINK-SHIELD  | 80009    | 214-1624-00     |
| -56              | 342-0103-00        |                      |         | 1   | . | . | . | . | . | INSULATOR,BLOCK:<br>(ATTACHING PARTS)                          | 80009    | 342-0103-00     |
| -57              | 211-0512-00        |                      |         | 1   | . | . | . | . | . | SCREW,MACHINE:6-32 X 0.50" 100 DEG,FLH STL                     | 83385    | OBD             |
| -58              | 210-0457-00        |                      |         | 1   | . | . | . | . | . | NUT,PLAIN,EXT W:6-32 X 0.312 INCH,STL                          | 83385    | OBD             |
| -59              | 213-0183-00        |                      |         | 2   | . | . | . | . | . | SCR,TPG,THD FOR:6-32 X 0.25 INCH,PNH STL<br>-----*             | 83385    | OBD             |
| -60              | 214-1625-00        |                      |         | 1   | . | . | . | . | . | SPRING:FLAT  | 80009    | 214-1625-00     |
| -61              | 337-1491-00        |                      |         | 1   | . | . | . | . | . | SHLD,ELECTRICAL:CIRCUIT BOARD                                  | 80009    | 337-1491-00     |
|                  | 344-0118-00        |                      |         | 2   | . | . | . | . | . | CLIP,SPG TENS:CAPACITOR MTG                                    | 80033    | E50008-041      |
|                  | 210-0623-00        |                      |         | 4   | . | . | . | . | . | RIVET:<br>(ATTACHING PARTS)                                    | 12014    | R-3682          |
| -62              | 211-0008-00        |                      |         | 3   | . | . | . | . | . | SCREW,MACHINE:4-40 X 0.25 INCH,PNH STL<br>-----*               | 83385    | OBD             |
| -63              | 346-0032-00        |                      |         | 1   | . | . | . | . | . | STRAP,RETAINING:   | 98159    | 2829-75-4       |
| -64              | 348-0005-00        |                      |         | 1   | . | . | . | . | . | GROMMET,RUBBER:0.50 INCH DIA<br>(ATTACHING PARTS)              | 70485    | 230             |
| -65              | 211-0008-00        |                      |         | 3   | . | . | . | . | . | SCREW,MACHINE:4-40 X 0.25 INCH,PNH STL                         | 83385    | OBD             |
| -66              | 210-0586-00        |                      |         | 1   | . | . | . | . | . | NUT,PLAIN,EXT W:4-40 X 0.25 INCH,STL                           | 78189    | OBD             |
| -67              | 211-0504-00        |                      |         | 1   | . | . | . | . | . | SCREW,MACHINE:6-32 X 0.25 INCH,PNH STL                         | 83385    | OBD             |
| -68              | 407-1014-00        |                      |         | 1   | . | . | . | . | . | BRACKET,CKT:<br>-----*   | 80009    | 407-1014-00     |
| -69              | 129-0318-00        |                      |         | 1   | . | . | . | . | . | INSULATOR,STDF:0.312 OD X 2.17 INCH LONG<br>(ATTACHING PARTS)  | 80009    | 129-0318-00     |
| -70              | 211-0504-00        |                      |         | 1   | . | . | . | . | . | SCREW,MACHINE:6-32 X 0.25 INCH,PNH STL<br>-----*               | 83385    | OBD             |
| -71              | 220-0623-00        |                      |         | 1   | . | . | . | . | . | NUT,BLOCK:<br>(ATTACHING PARTS)                                | 80009    | 220-0623-00     |
| -72              | 211-0504-00        |                      |         | 1   | . | . | . | . | . | SCREW,MACHINE:6-32 X 0.25 INCH,PNH STL<br>-----*               | 83385    | OBD             |
| -73              | -----              |                      |         | 1   | . | . | . | . | . | CKT BOARD ASSY:REGULATOR(SEE A32 EPL)                          |          |                 |
| -74              | 131-0608-00        |                      |         | 15  | . | . | . | . | . | CONTACT,ELEC:0.365 INCH LONG                                   | 22526    | 47357           |
| -75              | 136-0252-04        | B010100              | B112459 | 90  | . | . | . | . | . | CONTACT,ELEC:0.188 INCH LONG                                   | 22526    | 75060           |
|                  | 136-0235-00        | B112460              |         | 8   | . | . | . | . | . | SOCKET,PLUG-IN:6 CONTACT,ROUND                                 | 71785    | 133-96-12-062   |
|                  | 136-0220-00        | B112460              |         | 9   | . | . | . | . | . | SOCKET,PLUG-IN:3 PIN,SQUARE                                    | 71785    | 133-23-11-034   |
|                  | 136-0183-00        | B112460              |         | 5   | . | . | . | . | . | SOCKET,PLUG-IN:3 PIN,ROUND<br>(ATTACHING PARTS)                | 80009    | 136-0183-00     |
| -76              | 211-0008-00        |                      |         | 4   | . | . | . | . | . | SCREW,MACHINE:4-40 X 0.25 INCH,PNH STL<br>-----*               | 83385    | OBD             |

Mechanical Parts List—7704A

FIGURE 3 A7704 REAR (CONT)

| Fig. & Index No. | Tektronix Part No. | Serial/Model No. Eff | Model No. Dscont | Qty | 1 | 2 | 3 | 4 | 5 | Name & Description  | Mfr Code | Mfr Part Number   |
|------------------|--------------------|----------------------|------------------|-----|---|---|---|---|---|---|----------|-------------------|
| 3-77             | 337-1545-00        |                      |                  | 1   |   |   |   |   |   | . SHLD,ELECTRICAL:POWER SUPPLY<br>(ATTACHING PARTS)                     | 80009    | 337-1545-00       |
| -78              | 211-0008-00        |                      |                  | 2   |   |   |   |   |   | . SCREW,MACHINE:4-40 X 0.25 INCH,PNH STL<br>- - - * - - -               | 83385    | OBD               |
| -79              | -----              |                      |                  | 1   |   |   |   |   |   | . TRANSFORMER (SEE T4201 EPL)<br>(ATTACHING PARTS)                      |          |                   |
| -80              | 211-0008-00        |                      |                  | 4   |   |   |   |   |   | . SCREW,MACHINE:4-40 X 0.25 INCH,PNH STL<br>- - - * - - -               | 83385    | OBD               |
| -81              | -----              |                      |                  | 5   |   |   |   |   |   | . TRANSISTOR<br>(ATTACHING PARTS FOR EACH)                              |          |                   |
| -82              | 211-0578-00        |                      |                  | 1   |   |   |   |   |   | . SCREW,MACHINE:6-32 X 0.438 INCH,PNH STL                               | 83385    | OBD               |
| -83              | 210-0409-00        |                      |                  | 1   |   |   |   |   |   | . NUT,PLAIN,HEX.:8-32 X 0.312 INCH,BRS                                  | 73743    | 3046-402          |
| -84              | 210-0071-00        |                      |                  | 1   |   |   |   |   |   | . WASHER,SPR TNSN:0.146 ID X 0.323" OD,STL                              | 78189    | 4706-05-01-0531 . |
| -85              | 342-0136-00        |                      |                  | 1   |   |   |   |   |   | . INSULATOR,WSHR:0.812 OD X 0.0025 INCH THK<br>- - - * - - -            | 80009    | 342-0136-00       |
| -86              | 210-0201-00        | B010100              | B091620          | 3   |   |   |   |   |   | . TERMINAL,LUG:SE #4  | 78189    | 2104-04-00-2520N  |
|                  | 210-0201-00        | B091621              |                  | 1   |   |   |   |   |   | . TERMINAL,LUG:SE #4<br>(ATTACHING PARTS FOR EACH)                      | 78189    | 2104-04-00-2520N  |
| -87              | 211-0008-00        |                      |                  | 1   |   |   |   |   |   | . SCREW,MACHINE:4-40 X 0.25 INCH,PNH STL                                | 83385    | OBD               |
| -88              | 210-0586-00        |                      |                  | 1   |   |   |   |   |   | . NUT,PLAIN,EXT W:4-40 X 0.25 INCH,STL<br>- - - * - - -                 | 78189    | OBD               |
| -89              | 161-0033-06        | B010100              | B091620          | 1   |   |   |   |   |   | . CABLE ASSY,PWR,:  | 80009    | 161-0033-06       |
|                  | 161-0066-00        | B091621              |                  | 1   |   |   |   |   |   | . CABLE ASSY,PWR:3 WIRE,98 INCH LONG<br>(ATTACHING PARTS)               | 80009    | 161-0066-00       |
| -90              | 210-0413-00        |                      |                  | 1   |   |   |   |   |   | . NUT,PLAIN,HEX.:0.375-32 X 0.50 INCH,STL                               | 73743    | 3145-402          |
| -91              | 210-0012-00        |                      |                  | 1   |   |   |   |   |   | . WASHER,LOCK:INTL,0.375 ID X 0.50" OD STL<br>- - - * - - -             | 78189    | 1220-02-00-0541C  |
| -92              | -----              | B010100              | B091620          | 1   |   |   |   |   |   | . COIL:(SEE L5020/L5022 EPL)<br>(ATTACHING PARTS)                       |          |                   |
| -93              | 213-0138-00        | B010100              | B091620          | 1   |   |   |   |   |   | . SCR,TPG,THD FOR:4-40 X 0.188 INCH,PNH STL<br>- - - * - - -            | 83385    | OBD               |
| -94              | 348-0055-00        | B010100              | B091620          | 1   |   |   |   |   |   | . GROMMET,PLASTIC:0.25 INCH DIA   | 80009    | 348-0055-00       |
| -95              | 337-1666-00        | B010100              | B091620          | 1   |   |   |   |   |   | . SHLD,ELECTRICAL:  | 80009    | 337-1666-00       |
|                  | -----              | B091621              |                  | 1   |   |   |   |   |   | . FILTER,RFI:(SEE FL5020 EPL)<br>(ATTACHING PARTS)                      |          |                   |
|                  | 211-0012-00        | B091621              |                  | 2   |   |   |   |   |   | . SCREW,MACHINE:4-40 X 0.375 INCH,PNH STL<br>- - - * - - -              | 83385    | OBD               |
| -96              | 260-0449-00        |                      |                  | 1   |   |   |   |   |   | . SWITCH,SLIDE:SPDT,0.5A,125VA-DC<br>(ATTACHING PARTS)                  | 82389    | 11A-1030          |
| -97              | 211-0101-00        |                      |                  | 2   |   |   |   |   |   | . SCREW,MACHINE:4-40 X 0.25" 100 DEG,FLH STL                            | 83385    | OBD               |
| -98              | 210-0586-00        |                      |                  | 2   |   |   |   |   |   | . NUT,PLAIN,EXT W:4-40 X 0.25 INCH,STL<br>- - - * - - -                 | 78189    | OBD               |
| -99              | 386-2155-00        | B010100              | B091620          | 1   |   |   |   |   |   | . PANEL,HEATSINK:   | 80009    | 386-2155-00       |
|                  | 386-2155-01        | B091621              |                  | 1   |   |   |   |   |   | . PANEL,HEATSINK:   | 80009    | 386-2155-01       |
| -100             | 337-1546-00        |                      |                  | 1   |   |   |   |   |   | . SHLD ELECTRICAL:SHIELD,POWER SUPPLY<br>(ATTACHING PARTS)              | 80009    | 337-1546-00       |
| -101             | 211-0007-00        |                      |                  | 4   |   |   |   |   |   | . SCREW,MACHINE:4-40 X 0.188 INCH,PNH STL<br>- - - * - - -              | 83385    | OBD               |
| -102             | 200-0763-04        |                      |                  | 1   |   |   |   |   |   | . COV,LINE VOLTAG:  | 80009    | 200-0763-04       |
| -103             | 352-0102-00        |                      |                  | 2   |   |   |   |   |   | . FUSEHOLDER:0.262"ID TUBE FOR CRTG FUSE                                | 80009    | 352-0102-00       |
| -104             | 213-0088-00        |                      |                  | 4   |   |   |   |   |   | . SCR,TPG,THD CTG:4-24 X 0.25 INCH,PNH STL                              | 83385    | OBD               |
| -105             | 204-0278-01        |                      |                  | 1   |   |   |   |   |   | . BODY ASSY,LINE:<br>(ATTACHING PARTS)                                  | 80009    | 204-0278-01       |
| -106             | 210-0408-00        |                      |                  | 2   |   |   |   |   |   | . NUT,PLAIN,HEX.:6-32 X 0.312 INCH,BRS<br>- - - * - - -                 | 73743    | 3040-402          |
| -107             | 342-0104-00        |                      |                  | 1   |   |   |   |   |   | . INSULATOR,PLATE:2 X 4.40 INCHES<br>(ATTACHING PARTS FOR POWER SUPPLY) | 80009    | 342-0104-00       |
| -108             | 211-0507-00        |                      |                  | 4   |   |   |   |   |   | . SCREW,MACHINE:6-32 X 0.312 INCH,PNH STL<br>- - - * - - -              | 83385    | OBD               |

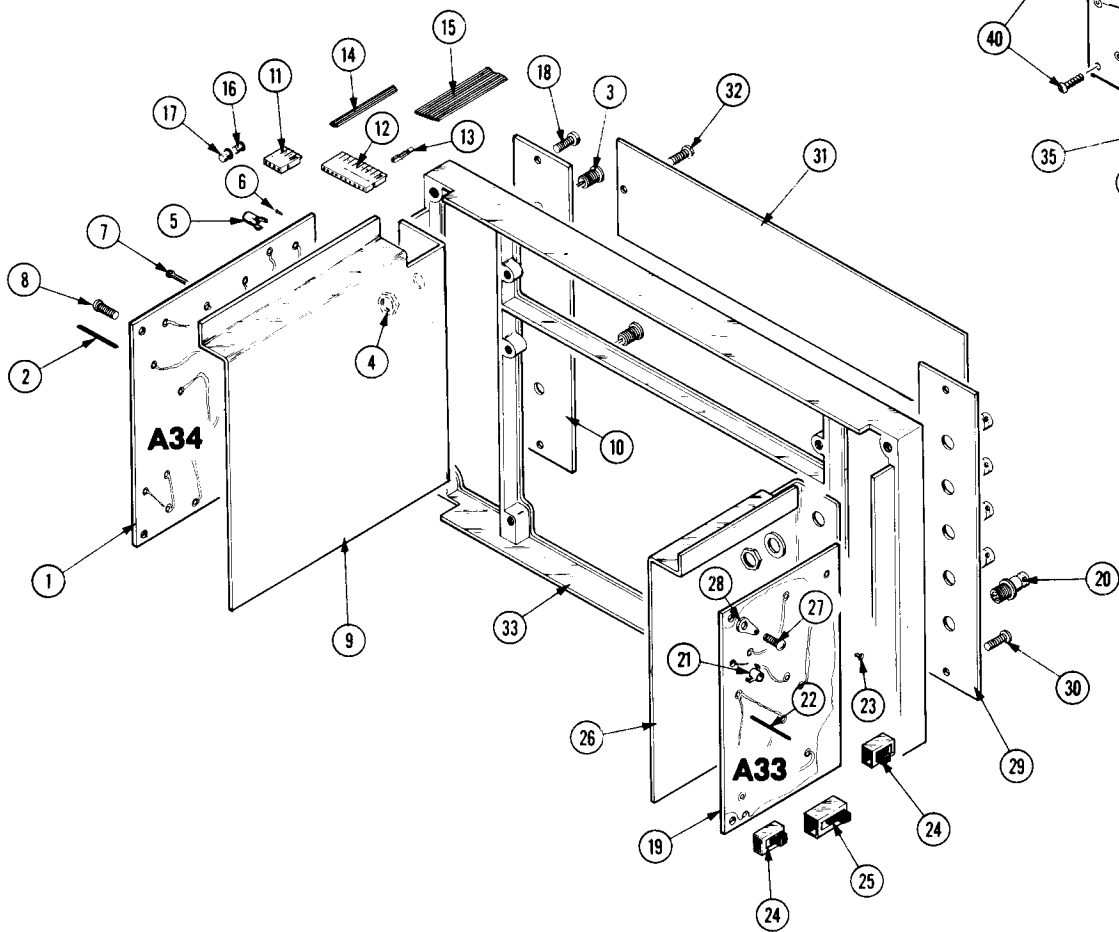

+

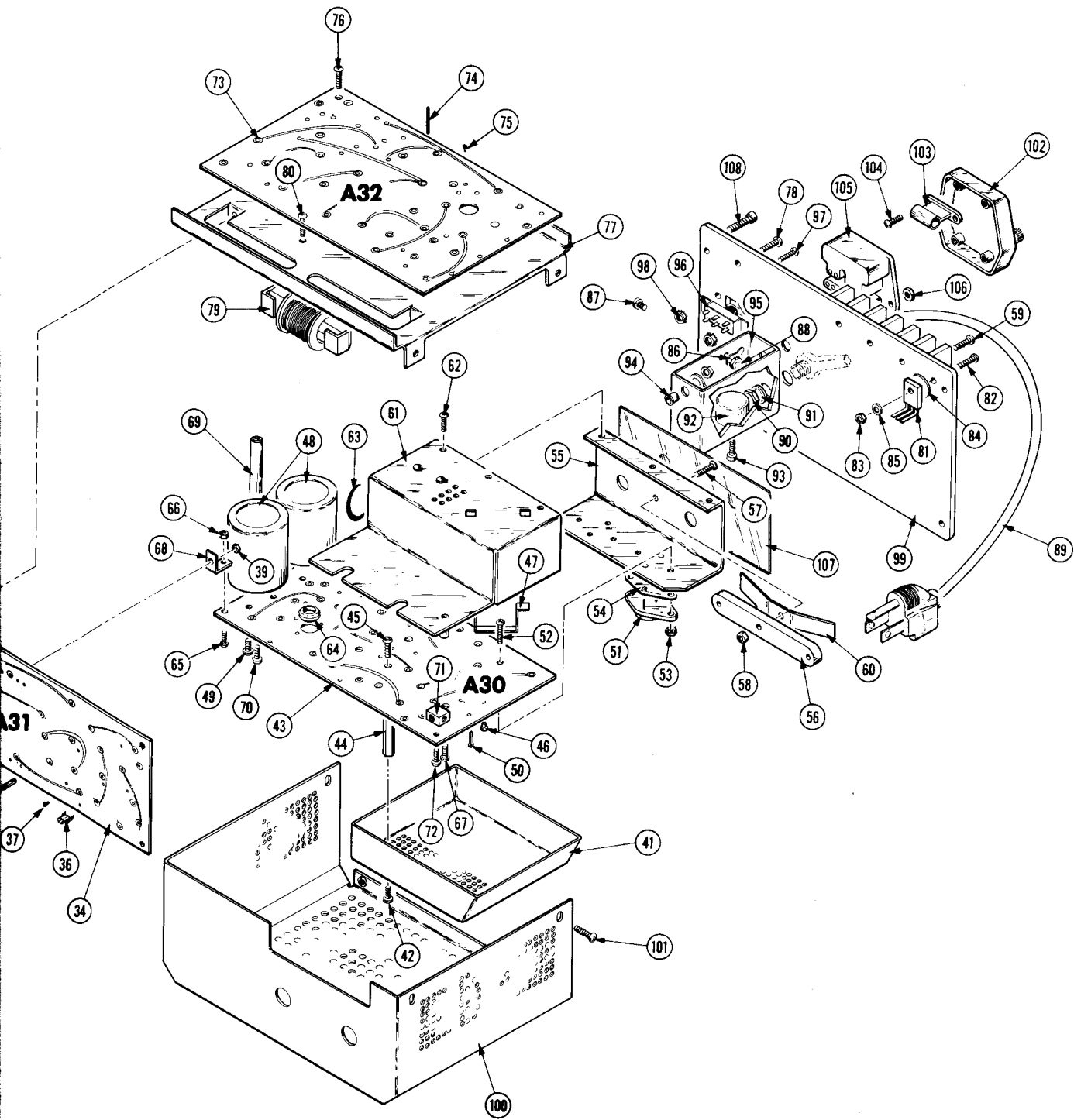
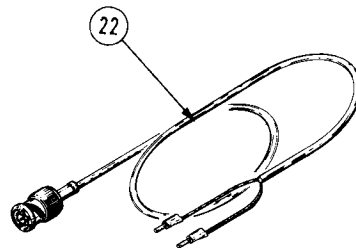
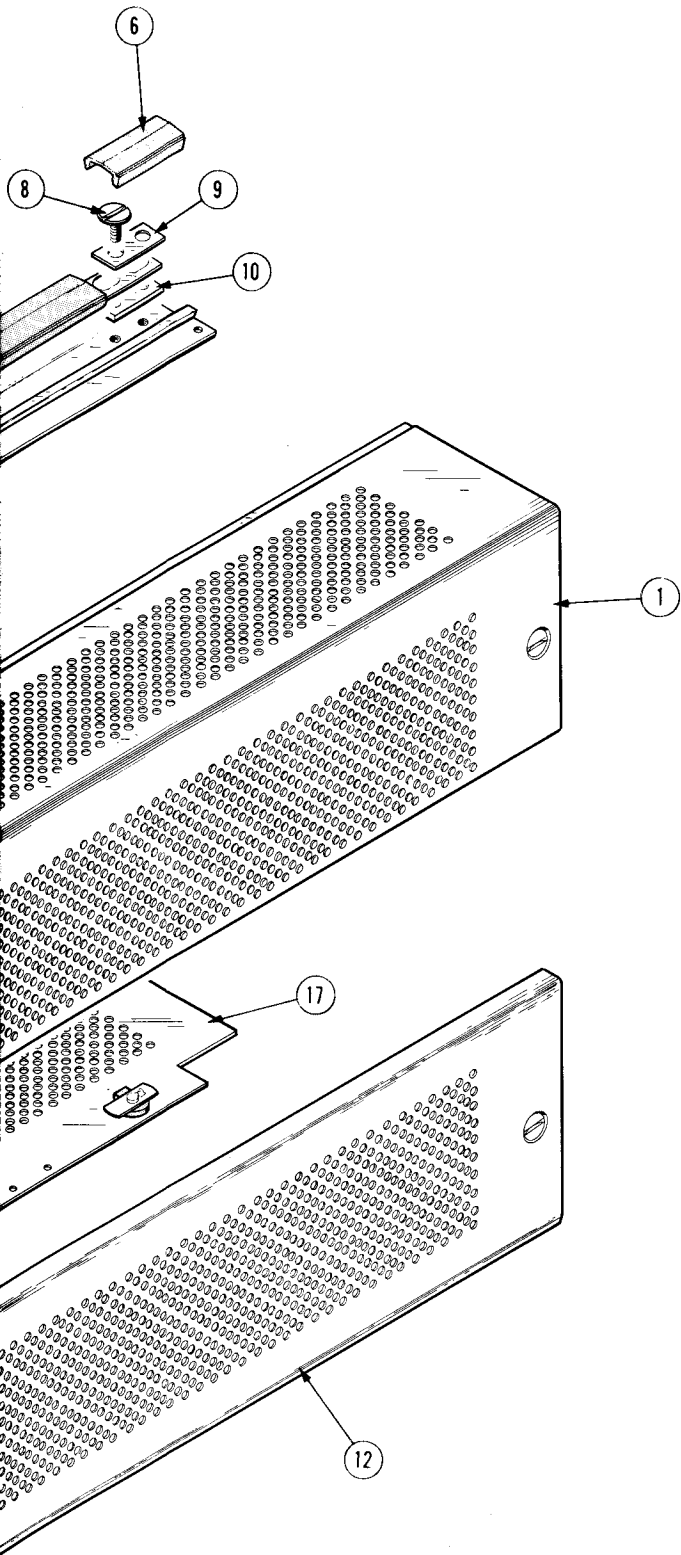
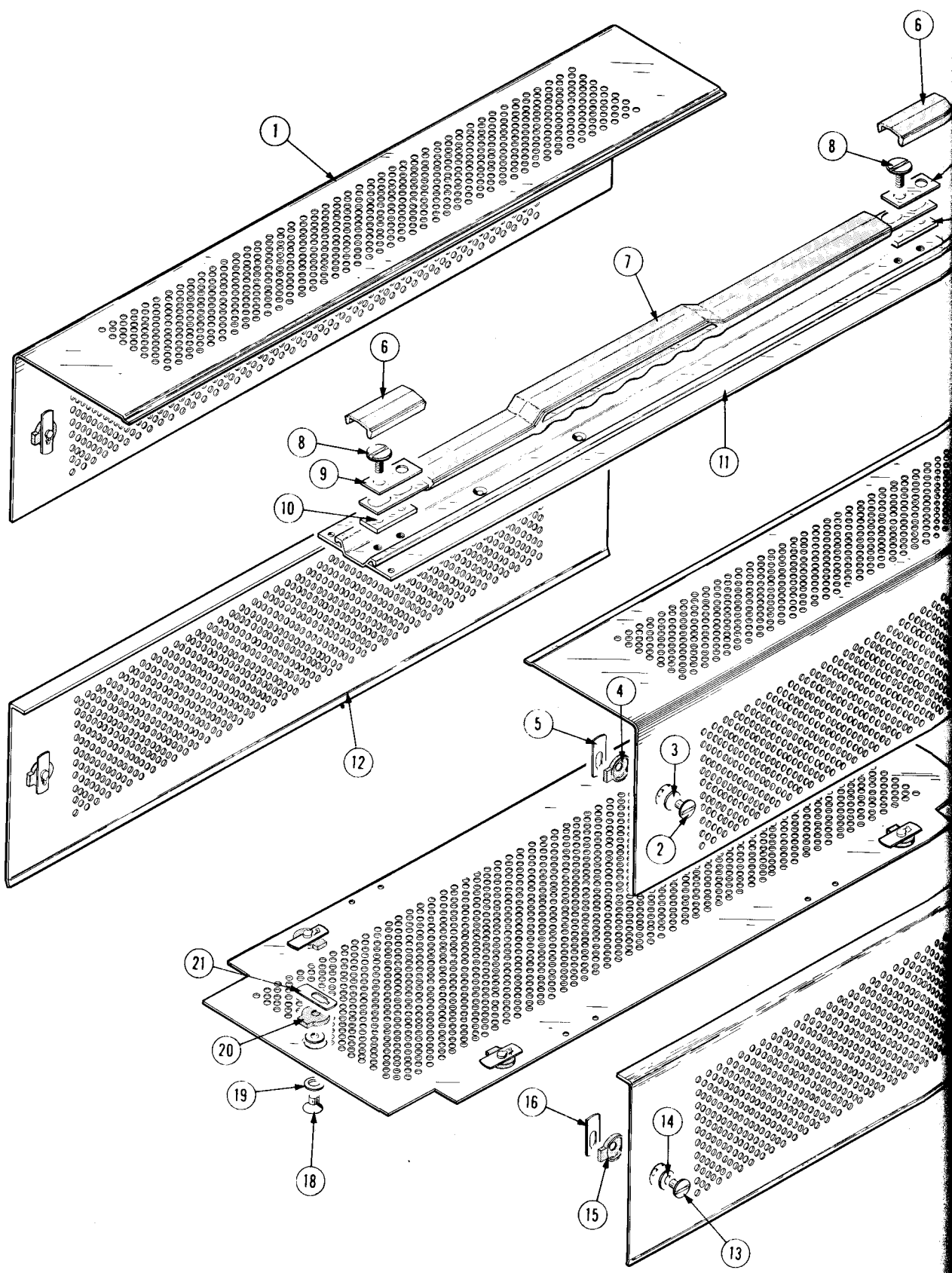

FIG. 3 A7704 REAR



+

FIG. 4 CABINET & ACCESSORIES



Mechanical Parts List—7704A

| Fig. &<br>Index<br>No. | Tektronix<br>Part No. | Serial/Model No.<br>Eff Dscont | Qty | Name & Description                                      |   |   |   |   | Mfr<br>Code | Mfr Part Number |             |
|------------------------|-----------------------|--------------------------------|-----|---|---|---|---|---|-------------|-----------------|-------------|
|                        |                       |                                |     | 1   | 2 | 3 | 4 | 5 |             | Mfr             | Part Number |
| 4-1                    | 390-0251-00           |                                | 2   | CAB SIDE,SCOPE:   |   |   |   |   | 80009       | 390-0251-00     |             |
|                        | 214-0816-00           |                                | 2   | . LATCH ASSEMBLY:                                       |   |   |   |   | 80009       | 214-0816-00     |             |
| -2                     | 214-0603-01           |                                | 1   | . . . PIN,SECURING:0.27 INCH LONG                       |   |   |   |   | 80009       | 214-0603-01     |             |
| -3                     | 214-0604-00           |                                | 1   | . . . WASH.,SPG TNSN:0.26 ID X 0.47 INCH OD             |   |   |   |   | 80009       | 214-0604-00     |             |
| -4                     | 386-0227-00           |                                | 1   | . . . PL,LATCH INDEX:                                   |   |   |   |   | 80009       | 386-0227-00     |             |
| -5                     | 386-1151-00           |                                | 1   | . . . PLATE,LATCH LKG:                                  |   |   |   |   | 80009       | 386-1151-00     |             |
| -6                     | 200-0728-00           |                                | 2   | COV,HANDLE END:   |   |   |   |   | 80009       | 200-0728-00     |             |
| -7                     | 367-0108-00           |                                | 1   | HANDLE,SCOPE:   |   |   |   |   | 80009       | 367-0108-00     |             |
|                        |                       |                                |     | (ATTACHING PARTS)                                       |   |   |   |   |             |                 |             |
| -8                     | 212-0597-00           |                                | 4   | SCREW,MACHINE:10-32 X 0.50 INCH,STL                     |   |   |   |   | 80009       | 212-0597-00     |             |
| -9                     | 386-1624-00           |                                | 2   | PL,RET.,HANDLE:   |   |   |   |   | 80009       | 386-1624-00     |             |
| -10                    | 386-1283-00           |                                | 2   | PLATE:HANDLE MOUNTING, PLASTIC                          |   |   |   |   | 80009       | 386-1283-00     |             |
|                        |                       |                                |     | - - - * - - -   |   |   |   |   |             |                 |             |
| -11                    | 426-0819-00           |                                | 1   | FRAME SECT,CAB:TOP CENTER                               |   |   |   |   | 80009       | 426-0819-00     |             |
|                        |                       |                                |     | (ATTACHING PARTS)                                       |   |   |   |   |             |                 |             |
|                        | 213-0270-00           |                                | 2   | SCR,TPG,THD FOR:10-32 X 0.75 INCH FILH STL              |   |   |   |   | 83385       | 0BD             |             |
|                        |                       |                                |     | - - - * - - -   |   |   |   |   |             |                 |             |
| -12                    | 390-0255-00           |                                | 2   | CAB SIDE,SCOPE:   |   |   |   |   | 80009       | 390-0255-00     |             |
|                        | 214-0816-00           |                                | 2   | . LATCH ASSEMBLY:                                       |   |   |   |   | 80009       | 214-0816-00     |             |
| -13                    | 214-0603-01           |                                | 1   | . . . PIN,SECURING:0.27 INCH LONG                       |   |   |   |   | 80009       | 214-0603-01     |             |
| -14                    | 214-0604-00           |                                | 1   | . . . WASH.,SPG TNSN:0.26 ID X 0.47 INCH OD             |   |   |   |   | 80009       | 214-0604-00     |             |
| -15                    | 386-0227-00           |                                | 1   | . . . PL,LATCH INDEX:                                   |   |   |   |   | 80009       | 386-0227-00     |             |
| -16                    | 386-1151-00           |                                | 1   | . . . PLATE,LATCH LKG:                                  |   |   |   |   | 80009       | 386-1151-00     |             |
| -17                    | 390-0256-00           |                                | 1   | CAB BOT,SCOPE:  |   |   |   |   | 80009       | 390-0256-00     |             |
|                        | 214-0816-00           |                                | 6   | . LATCH ASSEMBLY:                                       |   |   |   |   | 80009       | 214-0816-00     |             |
| -18                    | 214-0603-01           |                                | 1   | . . . PIN,SECURING:0.27 INCH LONG                       |   |   |   |   | 80009       | 214-0603-01     |             |
| -19                    | 214-0604-00           |                                | 1   | . . . WASH.,SPG TNSN:0.26 ID X 0.47 INCH OD             |   |   |   |   | 80009       | 214-0604-00     |             |
| -20                    | 386-0227-00           |                                | 1   | . . . PL,LATCH INDEX:                                   |   |   |   |   | 80009       | 386-0227-00     |             |
| -21                    | 386-1151-00           |                                | 1   | . . . PLATE,LATCH LKG:                                  |   |   |   |   | 80009       | 386-1151-00     |             |
|                        |                       |                                |     | ACCESSORIES   |   |   |   |   |             |                 |             |
|                        | 175-1178-00           |                                | 1   | CABLE,SP ELECT:   |   |   |   |   | 80009       | 175-1178-00     |             |
|                        | 070-1260-00           |                                | 1   | MANUAL:INSTRUCTION (NOT SHOWN)                          |   |   |   |   | 80009       | 070-1260-00     |             |
|                        | 016-0155-00           |                                | 1   | PLUG-IN PANEL:BLANK(OPTIONAL ACCESSORY FOR<br>OPTION 3) |   |   |   |   | 80009       | 016-0155-00     |             |

# REPLACEABLE PARTS FOR FACTOR

Fig. &  
Index  
No.

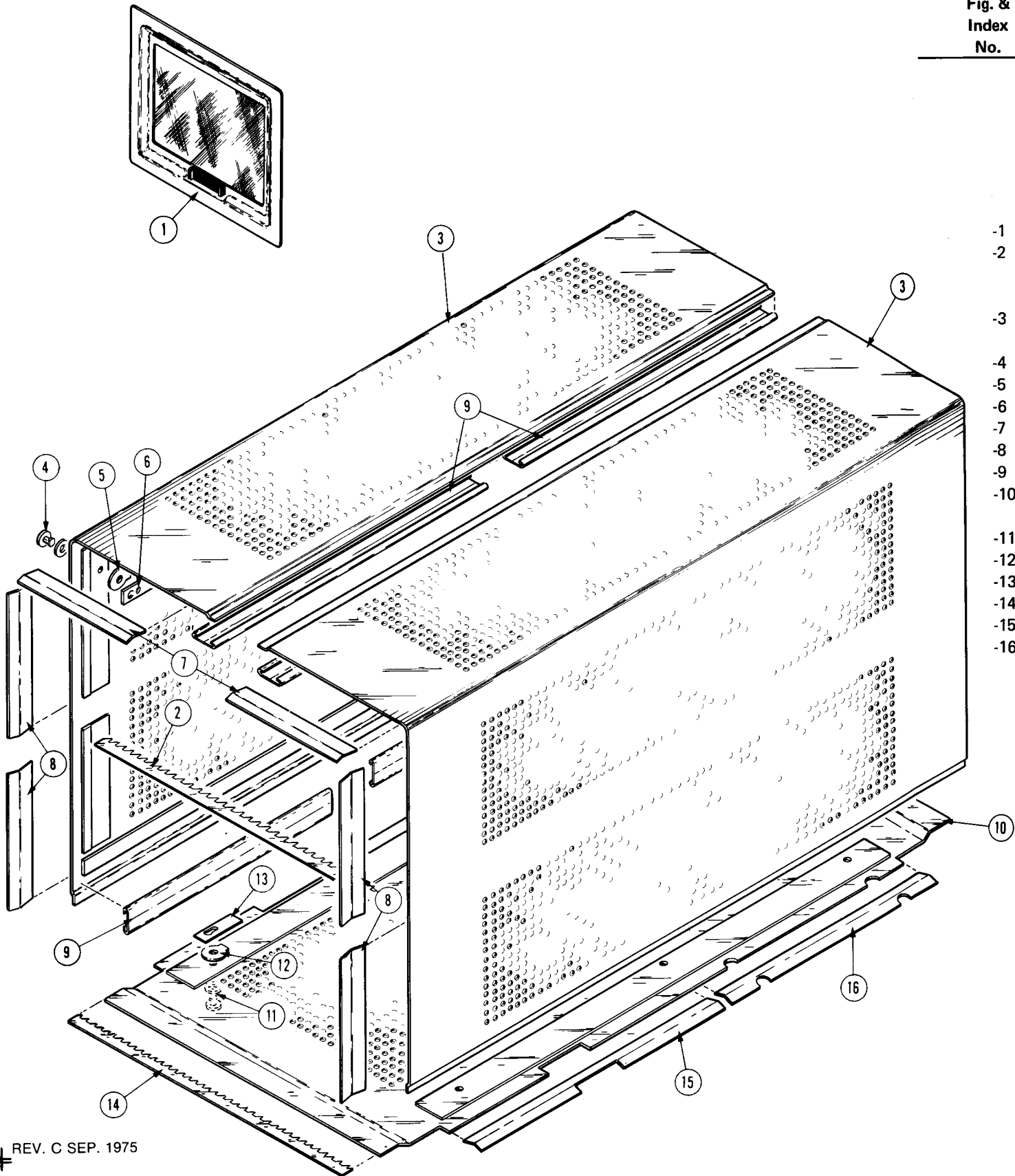

REV. C SEP. 1975





# OR FACTORY INSTALLED OPTIONS

| Fig. & Index No. | Tektronix Part No. | Serial/Model No. |      | Qty | Option |   |   |   |   | Description |
|------------------|--------------------|------------------|------|-----|--------|---|---|---|---|-------------|
|                  |                    | Eff              | Disc |     | 1      | 2 | 3 | 4 | 5 |             |

### OPTION 1 WITHOUT READOUT

|  |             |  |  |   |  |  |  |  |  |                         |
|--|-------------|--|--|---|--|--|--|--|--|-------------------------|
|  | 200-1352-00 |  |  | 1 |  |  |  |  |  | COVER, accessory cavity |
|--|-------------|--|--|---|--|--|--|--|--|-------------------------|

### OPTION 3 EMI MODIFICATION

|     |             |  |  |   |  |  |  |  |  |   |
|-----|-------------|--|--|---|--|--|--|--|--|---|
| -1  | 378-0603-00 |  |  | 1 |  |  |  |  |  | FILTER, mesh, CRT                               |
| -2  | 348-0274-00 |  |  | 1 |  |  |  |  |  | SHIELDING GASKET, electronic, 24 inches long    |
|     | 200-0678-00 |  |  | 5 |  |  |  |  |  | COVER, BNC connector, non-shorting              |
|     | 346-0045-00 |  |  | 5 |  |  |  |  |  | STRAP, connector cover, plastic                 |
| -3  | 390-0294-00 |  |  | 2 |  |  |  |  |  | CABINET SIDE                                    |
|     | -----       |  |  | - |  |  |  |  |  | each cabinet side includes:                     |
| -4  | 214-0603-02 |  |  | 4 |  |  |  |  |  | PIN, securing, w/spring                         |
| -5  | 386-1634-00 |  |  | 4 |  |  |  |  |  | PLATE, latch index                              |
| -6  | 386-1633-00 |  |  | 4 |  |  |  |  |  | PLATE, latch locking                            |
| -7  | 348-0332-00 |  |  | 2 |  |  |  |  |  | SHIELDING GASKET, electronic, 4.285 inches long |
| -8  | 348-0333-00 |  |  | 4 |  |  |  |  |  | SHIELDING GASKET, electronic, 4.80 inches long  |
| -9  | 348-0336-00 |  |  | 4 |  |  |  |  |  | SHIELDING GASKET, electronic, 9.625 inches long |
| -10 | 390-0295-00 |  |  | 1 |  |  |  |  |  | CABINET BOTTOM                                  |
|     | -----       |  |  | - |  |  |  |  |  | cabinet bottom includes:                        |
| -11 | 214-0603-02 |  |  | 6 |  |  |  |  |  | PIN, securing, w/spring                         |
| -12 | 386-1634-00 |  |  | 6 |  |  |  |  |  | PLATE, latch index                              |
| -13 | 386-1633-00 |  |  | 6 |  |  |  |  |  | PLATE, latch locking                            |
| -14 | 348-0274-01 |  |  | 2 |  |  |  |  |  | SHIELDING GASKET, electronic, 24 inches long    |
| -15 | 348-0335-00 |  |  | 2 |  |  |  |  |  | SHIELDING GASKET, electronic, 8.65 inches long  |
| -16 | 348-0334-00 |  |  | 2 |  |  |  |  |  | SHIELDING GASKET, electronic, 7.64 inches long  |
|     | 016-0155-00 |  |  | 1 |  |  |  |  |  | PANEL, BLANK, plug-in housing (not shown)       |

### OPTION 7 WITHOUT SIGNAL OUTPUT

|  |             |  |  |   |  |  |  |  |  |                         |
|--|-------------|--|--|---|--|--|--|--|--|-------------------------|
|  | 200-1352-00 |  |  | 1 |  |  |  |  |  | COVER, accessory cavity |
|--|-------------|--|--|---|--|--|--|--|--|-------------------------|

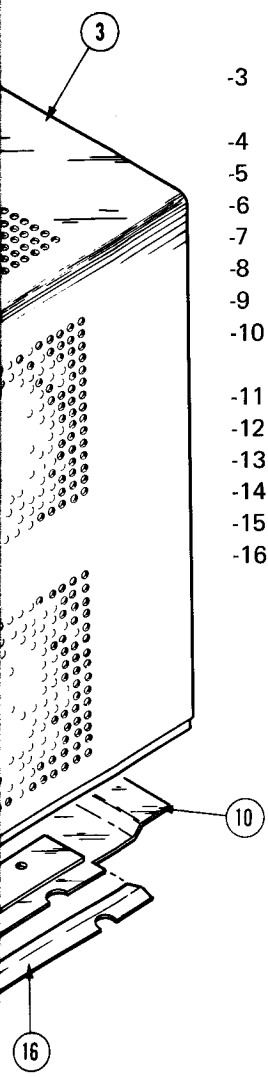

FIG. 5 INSTRUMENT OPTIONS

## **MANUAL CHANGE INFORMATION**

At Tektronix, we continually strive to keep up with latest electronic developments by adding circuit and component improvements to our instruments as soon as they are developed and tested.

Sometimes, due to printing and shipping requirements, we can't get these changes immediately into printed manuals. Hence, your manual may contain new change information on following pages.

A single change may affect several sections. Since the change information sheets are carried in the manual until all changes are permanently entered, some duplication may occur. If no such change pages appear following this page, your manual is correct as printed.

## **SERVICE NOTE**

Because of the universal parts procurement problem, some electrical parts in your instrument may be different from those described in the Replaceable Electrical Parts List. The parts used will in no way alter or compromise the performance or reliability of this instrument. They are installed when necessary to ensure prompt delivery to the customer. Order replacement parts from the Replaceable Electrical Parts List.

# CALIBRATION TEST EQUIPMENT REPLACEMENT

## Calibration Test Equipment Chart

This chart compares TM 500 product performance to that of older Tektronix equipment. Only those characteristics where significant specification differences occur, are listed. In some cases the new instrument may not be a total functional replacement. Additional support instrumentation may be needed or a change in calibration procedure may be necessary.

### Comparison of Main Characteristics

|                                 |   |   |
|---------------------------------|---|---|
| DM 501 replaces 7D13            |   |   |
| PG 501 replaces 107             | PG 501 - Risetime less than 3.5 ns into 50 $\Omega$ .   | 107 - Risetime less than 3.0 ns into 50 $\Omega$ .  |
| 108                             | PG 501 - 5 V output pulse; 3.5 ns Risetime.   | 108 - 10 V output pulse; 1 ns Risetime.   |
| 111                             | PG 501 - Risetime less than 3.5 ns; 8 ns Pretrigger pulse delay.  | 111 - Risetime 0.5 ns; 30 to 250 ns Pretrigger Pulse delay.   |
| 114                             | PG 501 - $\pm 5$ V output.  | 114 - $\pm 10$ V output. Short proof output.  |
| 115                             | PG 501 - Does not have Paired, Burst, Gated, or Delayed pulse mode; $\pm 5$ V dc Offset. Has $\pm 5$ V output.  | 115 - Paired, Burst, Gated, and Delayed pulse mode; $\pm 10$ V output. Short-proof output.  |
| PG 502 replaces 107             |   |   |
| 108                             | PG 502 - 5 V output   | 108 - 10 V output.  |
| 111                             | PG 502 - Risetime less than 1 ns; 10 ns Pretrigger pulse delay.   | 111 - Risetime 0.5 ns; 30 to 250 ns Pretrigger pulse delay.   |
| 114                             | PG 502 - $\pm 5$ V output   | 114 - $\pm 10$ V output. Short proof output.  |
| 115                             | PG 502 - Does not have Paired, Burst, Gated, Delayed & Undelayed pulse mode; Has $\pm 5$ V output.  | 115 - Paired, Burst, Gated, Delayed & Undelayed pulse mode; $\pm 10$ V output. Short-proof output.  |
| 2101                            | PG 502 - Does not have Paired or Delayed pulse. Has $\pm 5$ V output.   | 2101 - Paired and Delayed pulse; 10 V output.   |
| PG 506 replaces 106             | PG 506 - Positive-going trigger output signal at least 1 V; High Amplitude output, 60 V.  | 106 - Positive and Negative-going trigger output signal, 50 ns and 1 V; High Amplitude output, 100 V.   |
| 067-0502-01                     | PG 506 - Does not have chopped feature.   | 0502-01 - Comparator output can be alternately chopped to a reference voltage.  |
| SG 503 replaces 190, 190A, 190B |   |   |
| 191                             | SG 503 - Amplitude range 5 mV to 5.5 V p-p.   | 190B - Amplitude range 40 mV to 10 V p-p.   |
| 067-0532-01                     | SG 503 - Frequency range 250 kHz to 250 MHz.  | 191 - Frequency range 350 kHz to 100 MHz.   |
|                                 |   | 0532-01 - Frequency range 65 MHz to 500 MHz.  |
| TG 501 replaces 180, 180A       |   |   |
|                                 | TG 501 - Marker outputs, 5 sec to 1 ns. Sinewave available at 5, 2, and 1 ns. Trigger output - slaved to marker output from 5 sec through 100 ns. One time-mark can be generated at a time. | 180A - Marker outputs, 5 sec to 1 $\mu$ s. Sinewave available at 20, 10, and 2 ns. Trigger pulses 1, 10, 100 Hz; 1, 10, and 100 kHz. Multiple time-marks can be generated simultaneously.   |
| 181                             | TG 501 - Marker outputs, 5 sec to 1 ns. Sinewave available at 5, 2, and 1 ns.   | 181 - Marker outputs, 1, 10, 100, 1000, and 10,000 $\mu$ s, plus 10 ns sinewave.  |
| 184                             | TG 501 - Marker outputs, 5 sec to 1 ns. Sinewave available at 5, 2, and 1 ns. Trigger output - slaved to marker output from 5 sec through 100 ns. One time-mark can be generated at a time. | 184 - Marker outputs, 5 sec to 2 ns. Sinewave available at 50, 20, 10, 5, and 2 ns. Separate trigger pulses of 1 and .1 sec; 10, 1, and .1 ms; 10 and 1 $\mu$ s. Marker amplifier provides positive or negative time marks of 25 V min. Marker intervals of 1 and .1 sec; 10, 1, and .1 ms; 10 and 1 $\mu$ s. |
| 2901                            | TG 501 - Marker outputs, 5 sec to 1 ns. Sinewave available at 5, 2, and 1 ns. Trigger output - slaved to marker output from 5 sec through 100 ns. One time-mark can be generated at a time. | 2901 - Marker outputs, 5 sec to 0.1 $\mu$ s. Sinewave available to 50, 10, and 5 ns. Separate trigger pulses, from 5 sec to 0.1 $\mu$ s. Multiple time-marks can be generated simultaneously.   |

**NOTE: All TM 500 generator outputs are short-proof. All TM 500 plug-in instruments require TM 500-Series Power Module.**



**TEKTRONIX®**

committed to  
technical excellence

# MANUAL CHANGE INFORMATION

PRODUCT 7704A

CHANGE REFERENCE M31073

070-1260-00

DATE 1-6-77

| CHANGE: | DESCRIPTION |
|---------|-------------|
|---------|-------------|

EFF SN B194176

### ELECTRICAL PARTS LIST AND SCHEMATIC CHANGE

CHANGE TO:

C4157      283-0067-00      CAP.,FXD,CER DI:0.001UF, 10%,200V

R2570      315-0102-00      RES.,FXD,COMP:1K OHM,5%,0.25W

C4157 is located on the Z AXIS circuit board and shown on diagram 14 CRT CIRCUIT.

R2570 is located on the LOGIC circuit board and shown on diagram 3 LOGIC CIRCUIT.

**TEKTRONIX®**committed to  
technical excellence**MANUAL CHANGE INFORMATION**PRODUCT 7704A  
070-1260-00CHANGE REFERENCE M31390  
DATE 3-11-77

| CHANGE: | DESCRIPTION |
|---------|-------------|
|---------|-------------|

EFF SN B194278

## ELECTRICAL PARTS LIST AND SCHEMATIC CHANGES

## CHANGE TO:

|       |             |                                   |
|-------|-------------|-----------------------------------|
| A25   | 670-1884-03 | CKT BOARD ASSY:LOGIC              |
| R2587 | 321-0234-00 | RES.,FXD,FILM:2.67K OHM,1%,0.125W |
| R2588 | 321-0235-00 | RES.,FXD,FILM:2.74K OHM,1%,0.125W |

## REMOVE:

|       |             |                                   |
|-------|-------------|-----------------------------------|
| R2590 | 321-0279-00 | RES.,FXD,FILM:7.87K OHM,1%,0.125W |
| R2591 | 321-0275-00 | RES.,FXD,FILM:7.15K OHM,1%,0.125W |

The above parts are located on the LOGIC circuit board and shown on diagram 3.