

TEKTRONIX®

7B92 

DUAL TIME BASE

SERVICE

INSTRUCTION MANUAL

Tektronix, Inc.
P.O. Box 500
Beaverton, Oregon 97005

Serial Number

8064082



WARRANTY

All TEKTRONIX instruments are warranted against defective materials and workmanship for one year. Any questions with respect to the warranty should be taken up with your TEKTRONIX Field Engineer or representative.

All requests for repair and replacement parts should be directed to the TEKTRONIX Field Office or representative in your area. This will assure you the fastest possible service. Please include the instrument Type Number or Part Number and Serial Number with all requests for parts or service.

Specifications and price change privileges reserved.

Copyright © 1973 by Tektronix, Inc., Beaverton, Oregon. Printed in the United States of America. All rights reserved. Contents of this publication may not be reproduced in any form without permission of Tektronix, Inc.

U.S.A. and Foreign TEKTRONIX products covered by U.S. and foreign patents and/or patents pending.

TEKTRONIX is a registered trademark of Tektronix, Inc.

TABLE OF CONTENTS

SECTION 1	OPERATING INFORMATION	Page	Using This Procedure	4-1
	Preliminary Information	1-1	General	4-1
	Installation	1-1	Index	4-1
	Controls and Connectors	1-1	Performance Check	4-1
	General	1-1	Partial Calibration	4-1
	Main Triggering Controls	1-1	Complete Calibration Procedure	4-1
	Sweep Controls	1-4	Test Equipment Required	4-1
	Delayed Triggering Controls	1-5	General	4-1
	Front-Panel Inputs	1-5	Special Calibration Fixtures	4-1
			Calibration Equipment	
			Alternatives	4-1
SECTION 2	CIRCUIT DESCRIPTION		Test Equipment	4-2
	Block Diagram Description	2-1	Calibration Procedure	4-4
SECTION 3	MAINTENANCE		Introduction	4-4
	Preventive Maintenance	3-1	Index to Calibration Procedure	4-4
	General	3-1	Preliminary Procedure	4-5
	Cleaning	3-1	Trigger System Calibration	4-5
	Visual Inspection	3-1	Horizontal System Calibration	4-15
	Semiconductor Checks	3-1		
	Recalibration	3-1	SECTION 5	ELECTRICAL PARTS LIST
	Troubleshooting	3-1	SECTION 6	DIAGRAMS AND CIRCUIT BOARD ILLUSTRATIONS
	Introduction	3-1	SECTION 7	MECHANICAL PARTS LIST
	Troubleshooting Aids	3-2		
	Troubleshooting Equipment	3-2		
	Troubleshooting Techniques	3-3		
	Corrective Maintenance	3-4		
	General	3-4		
	Obtaining Replacement Parts	3-4		
	Component Replacement	3-4		
SECTION 4	CALIBRATION		CHANGE INFORMATION	
	Calibration Interval	4-1		
	Tektronix Field Service	4-1		
			NOTE	
			Refer to the 7B92 Operators manual for specifications and complete operating information.	

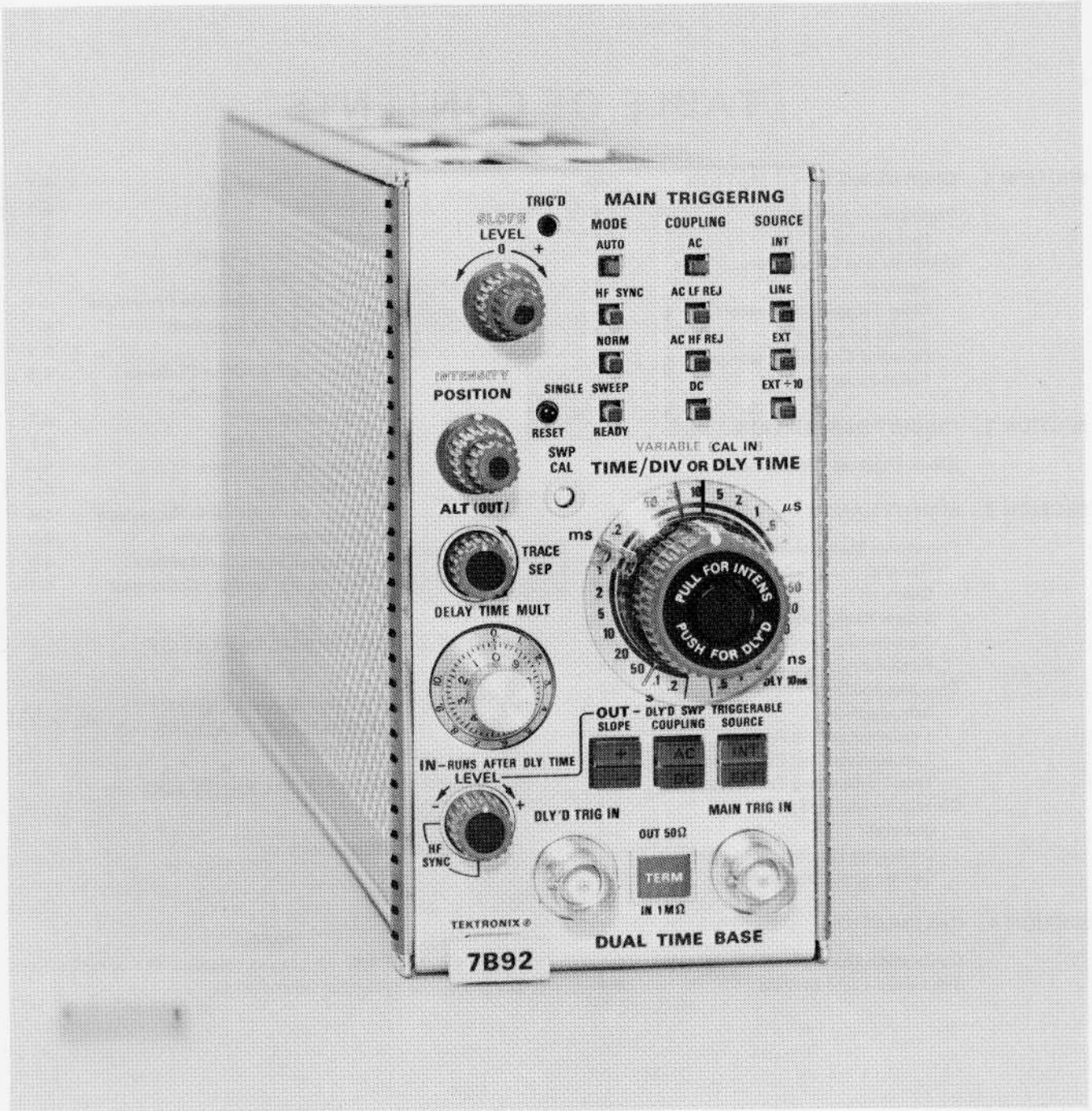

7B92 Features

The 7B92 Dual Time Base unit provides normal, intensified, delayed, and alternate sweep operation for Tektronix 7000-Series Oscilloscopes. Calibrated sweep rates from 0.2 second to 0.5 nanosecond and triggering to 500 megahertz are provided. The 7B92 is intended for use with high-frequency 7000-Series Oscilloscope systems; however, most 7B92 functions are compatible with all 7000-Series Oscilloscopes.

Other features include lighted pushbutton switches, compatibility with oscilloscopes having an alphanumeric readout system, and 0 to 9.9 times continuous sweep delay. A VARIABLE control allows continuously variable sweep rates between calibrated steps. Also, when operating in the AUTO MAIN TRIGGERING MODE, a bright base line is displayed in the absence of a trigger signal.

OPERATING INFORMATION

The 7B92 Dual Time Base unit operates with a Tektronix 7900-Series oscilloscope and a 7A-Series amplifier unit to form a complete high-frequency oscilloscope system. To effectively use the 7B92, its operation and capabilities should be known. Brief operating information is given in this section. For more detailed instructions, refer to the 7B92 Operators Manual.

PRELIMINARY INFORMATION

Installation

The 7B92 is designed to operate in the horizontal compartment of the oscilloscope. This instrument can also be installed in the vertical plug-in compartment to provide a sweep that runs vertically on the CRT. However, when used in this manner, there is no retrace blanking or internal triggering, and the unit may not meet the specifications given in the Operators Manual. The instructions in this manual are written for use of the 7B92 in the horizontal plug-in compartment.

Before proceeding with installation, check the settings of the Variable Selector multi-pin connector and the Mainframe Selector multi-pin connector (see Fig. 1-1). The Variable Selector determines whether the front-panel VARIABLE control operates in conjunction with the Delaying or Delayed Sweep. The Mainframe Selector determines the oscilloscope in which the 7B92 is to be operated; any 7900-Series Oscilloscope, or any other 7000-Series Oscilloscope.

CONTROLS AND CONNECTORS

General

All controls required for the operation of the 7B92, except the Variable Time/Division Selector and Mainframe Selector, are located on the front panel of the instrument. To make full use of the capabilities of this instrument, the operator should be familiar with the function and use of each control. A brief description of the front-panel controls and connectors is given here. More detailed information is given in the 7B92 Operators Manual. Fig. 1-2 shows the front-panel controls and connectors of the 7B92.

① Main Triggering Controls

LEVEL. Selects the amplitude point on the trigger signal where sweep triggering occurs when operating in the AUTO, NORM, or SINGLE SWEEP MAIN TRIGGERING MODE. When operating in the HF SYNC MAIN TRIGGERING MODE, the LEVEL control adjusts the frequency of the trigger generator to synchronize with the triggering signal to provide a stable display.

SLOPE. Permits triggering on the positive or negative-going portion of the trigger signal in all positions of the MAIN TRIGGERING MODE switch except HF SYNC.

TRIG'D Light. Indicates that the sweep is triggered and will produce a display with the correct setting of the POSITION control and the controls of the associated vertical units and oscilloscope.

MODE. Four pushbutton switches to select the desired triggering mode. Selected mode is indicated by lighted pushbutton.

AUTO. Triggered sweep is initiated by the applied trigger signal at a point selected by the LEVEL control and SLOPE switch when the trigger signal repetition rate is above 30 hertz and within the frequency range selected by the COUPLING switch. The sweep free-runs to provide a reference trace under the following conditions: When the LEVEL control is outside the amplitude range, the trigger repetition rate is outside the frequency range selected by the COUPLING switch, or the trigger signal is inadequate.

HF SYNC. Sweep initiated by trigger signals with repetition rates above 100 megahertz and within the range selected by the COUPLING switch. Stable displays can be obtained when the LEVEL control adjusts the frequency of the trigger generator to the frequency (or subharmonic) of the trigger signal frequency. When the LEVEL control is adjusted to frequencies between subharmonics, the sweep free-runs.

NORM. Sweep initiated by the applied trigger signal at a point selected by the LEVEL control and SLOPE switch over the frequency range selected by the COUPLING switch. Triggered sweep can be obtained only over the amplitude range of the applied trigger signal. When the LEVEL control is outside the amplitude range, the trigger repetition rate is outside the frequency range selected by the COUPLING switch, or the trigger signal is inadequate, there is no trace.

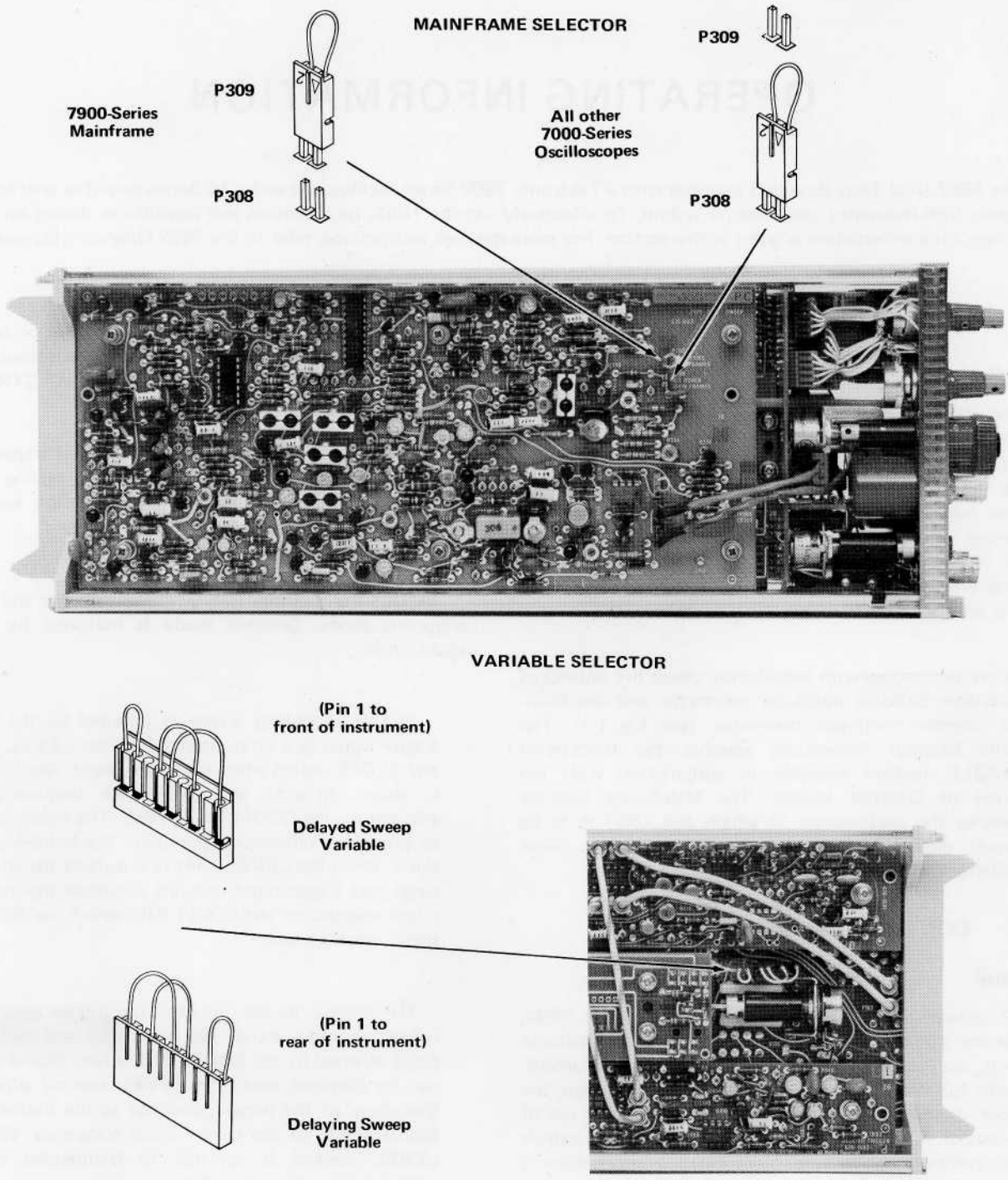

Fig. 1-1. Location of Variable Selector and Mainframe Selector multi-pin connectors.

SINGLE SWEEP—READY. After a sweep is displayed, further sweeps cannot be presented until the RESET button is pressed. Display is triggered as for NORM operation, using the MAIN TRIGGERING controls. The SINGLE SWEEP—READY light is illuminated when the RESET pushbutton is pressed, and remains on until a trigger is received and the sweep is completed.

RESET. When the RESET pushbutton is pressed (SINGLE SWEEP MODE), a single display is presented (with proper triggering) when the next trigger pulse is received. The SINGLE SWEEP—READY light remains on until a trigger is received and the sweep is completed. The RESET pushbutton must be pressed again before another sweep can be presented.

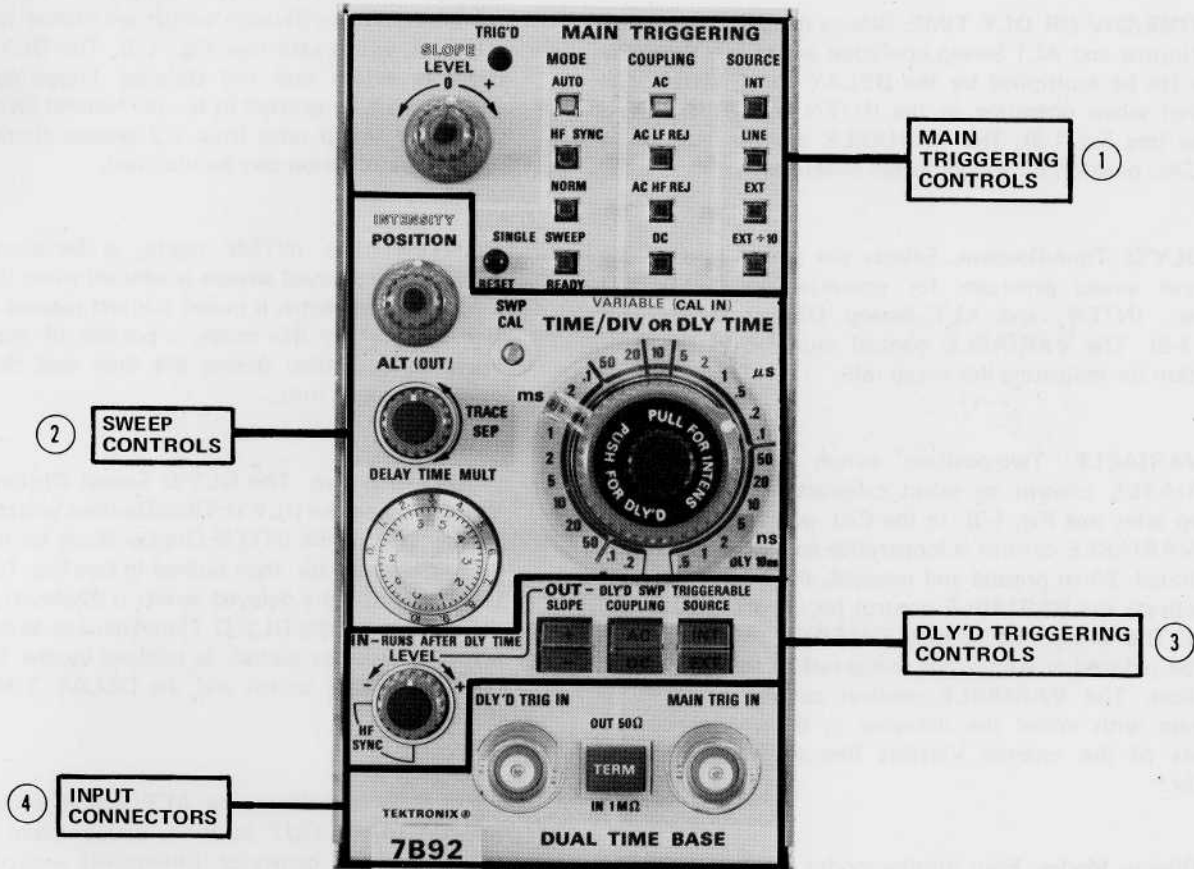

Fig. 1-2. Front-panel controls and connectors.

COUPLING. Four pushbutton switches to select trigger coupling. Selected coupling is indicated by lighted pushbutton.

AC. Rejects DC and attenuates AC signals below about 30 hertz. Accepts signals between 30 hertz and 500 megahertz.

AC LF REJ. Rejects DC and attenuates signals below about 30 kilohertz. Accepts signals between 30 kilohertz and 500 megahertz.

AC HF REJ. Rejects DC and attenuates signals above 50 kilohertz. Accepts signals from 30 hertz to 50 kilohertz.

DC. Accepts all signals from DC to 500 megahertz.

SOURCE. Four pushbutton switches that select the triggering source. Selected source is indicated by lighted pushbutton.

INT. Trigger signal obtained internally from vertical unit by way of associated oscilloscope.

LINE. Trigger signal obtained internally from a sample of the line voltage applied to the associated oscilloscope.

EXT. Trigger signal obtained from an external signal applied to the MAIN TRIG IN connector.

EXT ÷ 10. Trigger signal obtained from an external signal applied to the MAIN IN connector. In this position the external signal is attenuated 10 times before it is applied to the trigger circuit.

② Sweep Controls

TIME/DIV OR DLY TIME. Selects the basic sweep rate for Normal and ALT Sweep operation and selects the delay time (to be multiplied by the DELAY TIME MULT dial setting) when operating in the INTEN or DLY'D Sweep mode (see Fig. 1-3). The VARIABLE control must be in the CAL position for the indicated sweep rate.

DLY'D Time/Division. Selects the sweep rate of the delayed sweep generator for operation in the DLY'D Sweep, INTEN, and ALT Sweep Display Modes (see Fig. 1-3). The VARIABLE control must be in the CAL position for indicating the sweep rate.

VARIABLE. Two-position switch actuated by the VARIABLE control to select calibrated or uncalibrated sweep rates (see Fig. 1-3). In the CAL position (pressed in) the VARIABLE control is inoperative and the sweep rate is calibrated. When pressed and released, the knob moves out to activate the VARIABLE control for uncalibrated sweep rates. The sweep rate in each TIME/DIV switch position can be reduced at least to the sweep rate of the next slower position. The VARIABLE control can be switched to operate with either the delaying or delayed sweeps by means of the internal Variable Selector multi-pin connector.

Display Modes. Four display modes can be selected by the following switch settings:

NORMAL Sweep. A Normal Sweep (non-delayed) is selected when the TIME/DIV OR DLY TIME switch and the DLY'D Time/Division switch are locked together at the same sweep rate (see Fig. 1-3). The DLY'D Time/Division switch and the Delayed Triggering LEVEL control must be pressed in for the Normal Sweep Mode. Calibrated sweep rates from 0.2 second/division to 0.5 nanosecond/division can be obtained.

INTEN. The INTEN mode, a function of the delaying and delayed sweeps is selected when the DLY'D Time/Division switch is pulled out and rotated clockwise (see Fig. 1-3). In this mode, a portion of the delaying sweep is intensified during the time that the delayed sweep generator runs.

DLY'D Sweep. The DLY'D Sweep Display Mode is selected when the DLY'D Time/Division switch is pulled out, rotated in the INTEN Display Mode for the desired delayed sweep rate, then pushed in (see Fig. 1-3). In this Display Mode, the delayed sweep is displayed, at a rate determined by the DLY'D Time/Division switch, at the end of each delay period, as selected by the TIME/DIV OR DLY TIME switch and the DELAY TIME MULT dial settings.

ALT Sweep. When the ALT switch is pressed and released to the OUT position, sweeps from both the delaying sweep generator (intensified sweep) and delayed sweep generator (delayed sweep) are displayed.

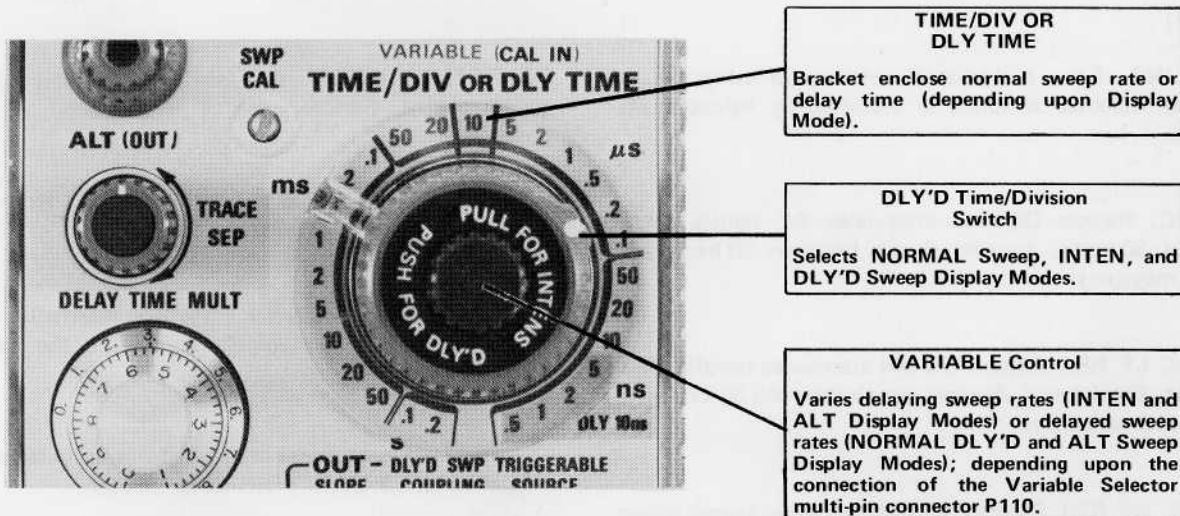

Fig. 1-3. Composite Time/Division switch.

The alternate sweep switches between generators at the end of each sweep. The TRACE SEP control is activated in this Display Mode.

TRACE SEP. When the ALT switch is OUT (ALT Sweep Display Mode), it serves as a trace separation control. This control vertically positions the trace (produced by the delaying sweep generator) up to four divisions with respect to the trace produced by the delayed sweep generator.

DELAY TIME MULT. Provides variable delay of 0 to 9.9 times the basic delay time selected by the TIME/DIV OR DLY TIME switch.

INTENSITY. Controls the intensity of the delaying sweep display only, when operating in the INTEN or ALT Sweep Display Modes.

SWP CAL. Screwdriver adjustment to set horizontal gain of unit. The SWP CAL is used to set the basic timing of the 7B92 and to compensate for differences in input sensitivity when changing oscilloscopes.

③ Delayed Triggering Controls

LEVEL. Control determines delayed sweep mode, delayed trigger mode and delayed trigger level.

IN-RUNS AFTER DLY TIME. The delayed sweep runs immediately following the delay time selected by TIME/DIV OR DLY TIME switch and the DELAY TIME MULT dial. Delayed SLOPE, COUPLING, SOURCE, and HF SYNC functions are inoperative.

OUT-DLY'D SWP TRIGGERABLE. When the Delayed Triggering LEVEL control is pressed and released, the delayed sweep is triggerable. The Delayed Triggering LEVEL control can now be rotated to select the amplitude point on the trigger signal at which the delayed sweep is triggered, or it can be rotated counterclockwise (as marked on the instrument front panel) to select the HF SYNC Delayed Triggering Mode. In the OUT-DLY'D SWP TRIGGERABLE mode, the delayed SLOPE, COUPLING, and SOURCE functions are activated.

HF SYNC. The HF SYNC Delayed Triggering Mode is selected when the Delayed Triggering LEVEL control is pressed and released to the OUT-DLY'D SWP TRIGGERABLE position and rotated counterclockwise to HF SYNC, as marked on the instrument front panel. Sweep is initiated by trigger signals with repetition rates above

100 megahertz and within the range selected by the COUPLING switch. Stable display can be obtained when the LEVEL control adjusts the frequency of the trigger generator to the frequency (or subharmonic of the trigger signal frequency). When the LEVEL control is adjusted to frequencies between subharmonics, the sweep free-runs.

SLOPE. Two-position switch to select the portion of the trigger signal which starts the delayed sweep.

+. The delayed sweep can be triggered from the positive slope of the trigger signal.

-. The delayed sweep can be triggered from the negative slope of the trigger signal.

COUPLING. Two-position switch that determines the method of coupling the delayed trigger signal to the delayed trigger circuit.

AC. Rejects DC and attenuates signals below about 30 hertz. Accepts delayed trigger signals from 30 hertz to 500 megahertz.

DC. Accepts trigger signals from DC to 500 Megahertz.

SOURCE. Two-position switch that selects the source of the delayed trigger signal.

INT. The delayed trigger signal is obtained from the vertical amplifier unit by way of the associated oscilloscope.

EXT. The delayed trigger signal is obtained from an external signal applied to the DLY'D TRIG IN connector.

④ Front-Panel Inputs

MAIN TRIG IN. When the SOURCE switch for MAIN TRIGGERING is set to EXT or $EXT \div 10$, this connector serves as an external trigger input for the main triggering circuit.

DLY'D TRIG IN. When the Delayed Triggering SOURCE switch is set to EXT, this connector serves as an external trigger input for the delayed triggering circuit.

TERM 50 Ω 1 M Ω . Two position switch to select 50 ohm or one megohm input impedance for the MAIN TRIG IN and DLY'D TRIG IN connectors.

CIRCUIT DESCRIPTION

The following discussion is provided to aid in understanding the overall concept of the 7B92. A basic block diagram of the 7B92 is shown in Fig. 2-1. Only the basic interconnections between the individual blocks are shown. The number on each block (enclosed in diamond) refers to the complete circuit diagram located at the rear of this manual.

Block Diagram Description

The Main Trigger Generator includes circuitry for selecting trigger source, type of coupling, triggering mode, and point on the trigger signal where triggering occurs. Also, regardless of the trigger signal, shape, or amplitude (within specification) the Main Trigger Generator provides a fast-rise uniform amplitude pulse to the Delaying Sweep Start Comparator. Termination of the gate pulse occurs at the rise of Delaying Sweep Holdoff.

The Delaying Sweep Start Comparator is activated by the positive gate from the Main Trigger Generator. The output gate, coupled to the Delaying Sweep Generator, is the same duration as the delaying sweep. This gate is also coupled to the Aux Sweep Gate connector and to Display Mode Switching for Alternate Sweep operation.

The delaying sweep sawtooth signal is generated when the gate from the Delaying Sweep Start Comparator is applied to the Delaying Sweep Generator. The sawtooth duration is determined by the gate duration; the rate of change of the sawtooth is set by Ct and Rt, selected by the TIME/DIV OR DLY TIME switch. The delaying sweep sawtooth signal is coupled to the Horizontal Output Amplifier, the Delaying Sweep Stop Comparator, the Delay Pickoff circuits, and the Delaying Sweep Out connector.

One side of the Delaying Sweep Stop Comparator is driven by the delaying sweep sawtooth signal and the other side is set by the Delaying Sweep Length adjustment. When the sawtooth waveform passes through the setting of the Delaying Sweep Length adjustment the output of the comparator switches to a positive level.

The positive level from the sweep stop comparator initiates the positive holdoff gate. The duration of the holdoff gate is variable, depending on the setting of the TIME/DIV switch. Holdoff timing capacitors are separate from sweep timing capacitors. Holdoff is longer for slower sweep rates. Output from the delaying sweep holdoff is coupled to the Main Trigger Generator, the Delayed Trigger Generator, and the Holdoff out connector. A sweep gate cannot be generated during the holdoff interval. When the holdoff falls, the trigger circuits are reset so that they are ready to receive a trigger signal.

The Lockout Amp processes mainframe logic signals (when operating the mainframe in the alternate or delaying Horizontal Modes) to provide a sweep disable pulse to the Main Trigger Generator.

The Horizontal Output amplifier provides positioning and amplification of the sawtooth signals. Display Mode Switching works in conjunction with the Horizontal Output to provide NORMAL Sweep, INTEN, DLY'D Sweep and ALT Sweep Display Modes.

The Delay Pickoff circuits produce a delay gate when the delaying sawtooth signal passes through the LEVEL selected by the DELAY TIME MULT dial. The gate ends with the delaying sawtooth signal. The output gate is coupled to the Delayed Trigger Generator.

The Delayed Trigger Generator includes circuitry for selecting delayed sweep mode, delayed trigger mode, delayed trigger source, type of coupling, and the point on the trigger signal where sweep triggering occurs. When the Delayed Trigger LEVEL is at the RUNS AFTER DLY TIME detent, the output sweep gate is generated as soon as the delay gate signal (from the Delay Pickoff circuits) is applied. When the Delayed Trigger LEVEL is in the DLY'D SWP TRIGGERABLE position, the output trigger is initiated by the next input trigger signal after the delay gate is applied. The delayed sweep trigger is terminated by the holdoff signal. The trigger signal is coupled to the Delayed Sweep Start Comparator.

The Delayed Sweep Start Comparator is activated by the signal from the Delayed Trigger Generator. The output gate coupled to the Delayed Sweep Generator, is the same duration as the delayed sweep. The delayed sweep gate signal is also coupled to the Sweep Gate Generator.

The delayed sweep sawtooth signal is developed by the Delayed Sweep Generator. The sawtooth is generated during the time that a gate is applied from the Delayed Sweep Start Comparator. Rate of change of the sawtooth is set by Ct and Rt, selected by the DLY'D TIME/DIV switch. The delayed sawtooth output is coupled to the Horizontal Output Amplifier and the Delayed Sweep Stop Comparator.

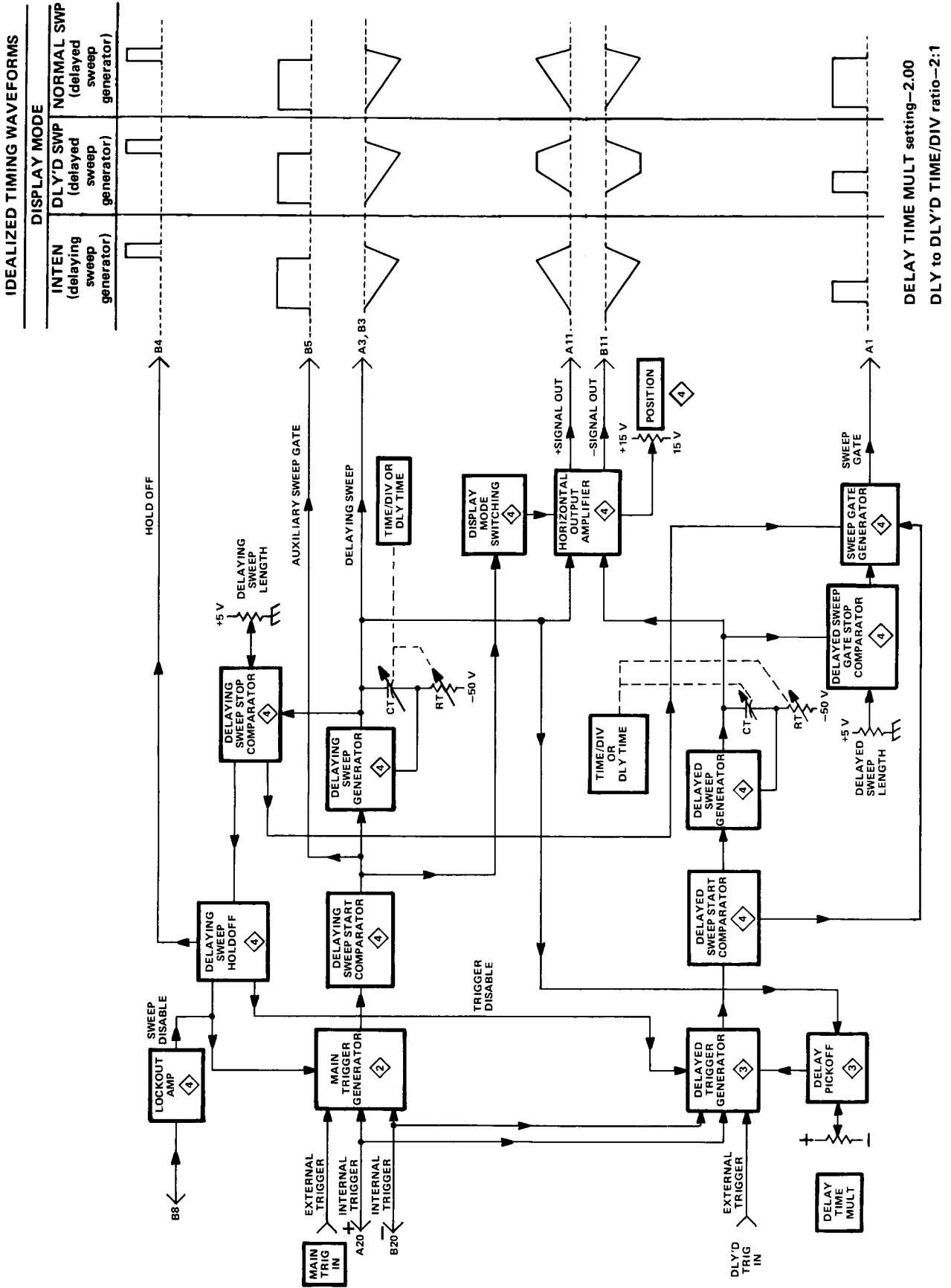

Fig. 2-1. 7B92 basic block diagram.

One side of the Delayed Sweep Stop Comparator is driven by the delaying sweep sawtooth signal; the other side is set by the Delayed Sweep Length Adjustment. When the delayed sawtooth waveform passes through the voltage set by the Delayed Sweep Length Adjustment, the comparator switches to a positive level. This positive level is coupled to the Sweep Gate Generator.

The Sweep Gate Generator produces an unblanking pulse for the associated oscilloscope. The Sweep Gate pulse is initiated by the gate from the Delayed Sweep Start Comparator and terminated by the pulse from the Delaying Sweep Stop Comparator or Delayed Sweep Stop Comparator (whichever occurs first).

MAINTENANCE

This section of the manual contains maintenance information for use in preventive maintenance, corrective maintenance, and troubleshooting of the 7B92.

PREVENTIVE MAINTENANCE

General

Preventive maintenance consists of cleaning, visual inspection, lubrication, etc. Preventive maintenance performed on a regular basis may prevent instrument breakdown and will improve the reliability of this instrument. The severity of the environment to which the 7B92 is subjected determines the frequency of maintenance. A convenient time to perform preventive maintenance is preceding recalibration of the instrument.

Cleaning

The 7B92 should be cleaned as often as operating conditions require. Accumulation of dirt in the instrument can cause overheating and component breakdown. Dirt on components acts as an insulating blanket and prevents efficient heat dissipation. It may also provide an electrical conduction path.

The covers of the oscilloscope reduce the amount of dust that reaches the interior of the 7B92. Operation of the system without the oscilloscope covers in place necessitates more frequent cleaning. When the 7B92 is not in use, it should be stored in a protected location, such as a dust-tight cabinet.

CAUTION

Avoid the use of chemical agents which might damage the plastics used in this instrument. Avoid chemicals which contain benzene, toluene, xylene, acetone, or similar solvents.

Exterior. Loose dust accumulated on the outside of the 7B92 can be removed with a soft cloth or small paint brush. The paint brush is particularly useful for dislodging dirt on and around the front-panel controls. Dirt that remains can be removed with a soft cloth dampened in a mild detergent and water solution. Abrasive cleaners should not be used.

Interior. Dust in the interior of the instrument should be removed occasionally, due to its electrical conductivity under high-humidity conditions. The best way to clean the interior is to blow off the accumulated dust with dry

low-velocity air. Remove any dirt that remains with a soft paint brush or a cloth dampened with a mild detergent and water solution. A cotton-tipped applicator is useful for cleaning in narrow spaces.

Visual Inspection

The 7B92 should be inspected occasionally for such defects as broken connections, broken or damaged circuit boards, improperly seated transistors or relays, and heat-damaged parts.

The corrective procedure for most visible defects is obvious; however, particular care must be taken if heat-damaged components are found. Overheating usually indicates other trouble in the instrument; therefore, it is important that the cause of overheating be corrected to prevent recurrence of the damage.

Semiconductor Checks

Periodic checks of the transistors, FET's, and IC's used in the 7B92 are not recommended. The best indication of performance is the actual operation of the device in the circuit. Performance of the circuits is thoroughly checked during recalibration; substandard semiconductors will usually be detected at that time.

Recalibration

To ensure accurate measurements, check the calibration of this instrument each 1000 hours of operation or every six months if used infrequently. In addition, replacement of components may necessitate recalibration of the affected circuits. Calibration instructions are given in Section 4.

TROUBLESHOOTING

Introduction

The following information is provided to facilitate troubleshooting of the 7B92. Information contained in other sections of this manual should be used along with the following information to aid in locating the defective component. An understanding of the circuit operation is very helpful in locating troubles. See the Circuit Description section.

Troubleshooting Aids

Diagrams. Circuit diagrams are given on foldout pages in Section 6. The component number and electrical value of each component in this instrument is shown on the diagrams.

Circuit Boards. Fig. 6-2 (located in the diagrams section) shows the location of the circuit boards within this instrument along with the assembly numbers. The assembly numbers are used on the diagrams to aid in locating the boards. Pictures of the circuit boards are shown in the Diagrams section, on the back of the page opposite the circuit diagram, to aid in cross-referencing between the diagrams and the circuit-board pictures. Each electrical component on the boards is identified by its circuit number, as well as the interconnecting wire or connectors. The diagrams are outlined with a blue line to show which portions of the circuit are located on a circuit board.

Switch Cam Identification. Switch cam numbers shown on the diagrams indicate the position of the cam in the complete switch assembly. The switch cams are numbered from front to rear.

Diode Color Code. The cathode end of each glass encased diode is identified by a stripe, a series of stripes, or a dot. For most silicon or germanium diodes with a series of stripes, the color code also indicates the type of diode or identifies the Tektronix Part Number using the resistor color-code system (e.g., a diode color coded blue-or pink-brown-gray-green indicates Tektronix Part Number 152-0185-00). The cathode and anode ends of a metal encased diode can be identified by the diode symbol marked on the body.

Wiring Color Code and Multi-Connector Identification. Insulated wire and cable used in the 7B92 is color coded to aid circuit tracing. Multi-connector holders are keyed with two triangles (or a triangle and a dot), one on the connector holder and one on the circuit board. The triangle on the multi-connector holder must match with the triangle on the circuit board for normal circuit operation. In special cases where multi-connector holders are used as a switch, the triangles may not match (see Operating Instructions for special multi-connector holder functions). The color of the multi-connector holder corresponds to the last numeral of the circuit number, using the EIA color code (e.g., P22 is red).

Interface Connector Pin Locations. The Interface circuit board couples the 7B92 to the associated oscilloscope. Fig. 3-1 illustrates the locations of pins on the interface connector as shown on the Voltage Distribution and Output Connectors schematic in the diagrams section.

Troubleshooting Equipment

The following equipment is useful for troubleshooting the 7B92.

1. Transistor Tester

Description: Tektronix Type 577 Transistor-Curve Tracer or a 7CT1N Curve Tracer plug-in unit and a 7000-Series Oscilloscope system.

Purpose: To test semiconductors used in this instrument.

2. Volt-ohmmeter

Description: 20,000 ohms/volt. 0-500 volts DC. Accurate within 3%

Purpose: To measure voltages and resistance.

3. Test Oscilloscope

Description: DC to 100 megahertz frequency response, five millivolts to five volts/division. Use a 10X probe.

Purpose: To check the waveforms in the instrument.

4. Plug-In Extender

Description: Rigid plug-in extender, Tektronix Part Number 067-0589-00.

Purpose: Permits operation of the 7B92 outside the plug-in compartment of the oscilloscope for better access during troubleshooting.

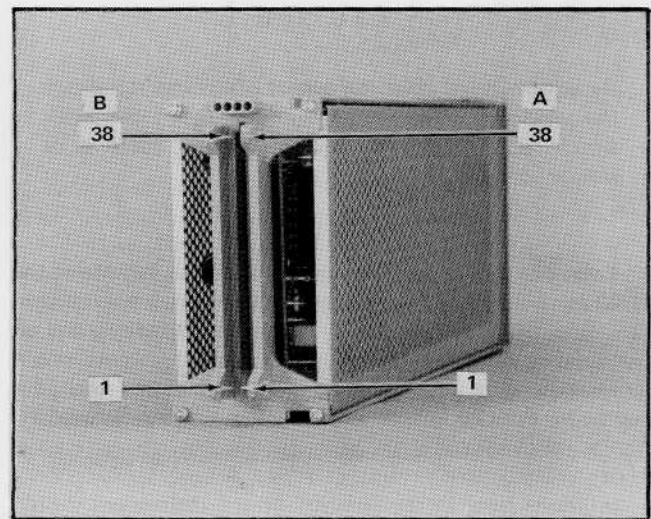

Fig. 3-1. Location of pins on Interface connector.

Troubleshooting Techniques

This troubleshooting procedure is arranged in an order which checks the simple trouble possibilities before proceeding with extensive troubleshooting. The first few checks ensure proper connection, operation, and calibration. If the trouble is not located by these checks, the remaining steps aid in locating the defective component. When the defective component is located, it should be replaced following the replacement procedures given under Corrective Maintenance.

1. Check Control Settings. Incorrect control settings can indicate a trouble that does not exist. If there is any question about the correct function or operation of any control, see the Operating Instructions.

2. Check Associated Equipment. Before proceeding with troubleshooting of the 7B92, check that the equipment used with this instrument is operating correctly. Check that the signal is properly connected and the probe (if used) is not defective. The oscilloscope and vertical plug-in unit can be checked for proper operation by substituting another time-base unit that is known to be operating properly (preferably another 7B92 or similar unit). If the trouble persists after substitution, the oscilloscope or vertical plug-in unit should be checked.

3. Check Instrument Calibration. Check the calibration of this instrument, or the affected circuit if the trouble exists in one circuit. The apparent trouble may only be a result of misadjustment that can be corrected by calibration. Complete calibration instructions are given in the Calibration section.

4. Visual Check. Visually check the portion of the instrument in which the trouble is located. Many troubles can be located by visual indications such as unsoldered connections, broken wires, damaged components, etc.

5. Isolate Trouble to a Circuit. To isolate a trouble to a particular circuit, note the trouble symptom. The symptom often indicates the circuit in which the trouble is located. For example, if stable triggering can be obtained in the INT position of the SOURCE switch and cannot be obtained in the EXT or LINE positions, the External Trigger Preamp or Trigger Source Switching circuits are probably at fault. When the trouble symptoms appear, use the front-panel controls and the CRT display to isolate the trouble to one circuit. Keep the amplifier unit and oscilloscope in mind when isolating the trouble. When trouble appears in more than one circuit, check all affected circuits by taking voltage and waveform measurements. Once the defective circuit has been located, proceed with steps 6 and 7 to locate the defective component(s).

6. Check Individual Components. The following procedures describe methods of checking individual components in the 7B92. Components that are soldered in place are best checked by disconnecting one end. This isolates the measurement from the effects of surrounding circuitry.

a. Relay. The eight pin relay used in the 7B92 is symmetrical and may be replaced in its socket facing either direction. This relay, which is plugged into the circuit board, may be removed and checked. Use an ohmmeter to check the 600 ohm resistance. The relay may also be actuated by placing the +15 volts across the coil. The internal connections are printed on the body of the relay.

b. Transistors. The best check of transistor operation is actual performance under operating conditions. If a transistor is suspected of being defective, it can best be checked by substituting a new component or one that has been checked previously. However, be sure that circuit conditions are not such that a replacement transistor might also be damaged. If substitute transistors are not available, use a dynamic tester (such as a Tektronix Type 577 or 7CT1N Curve Tracer plug-in unit and a 7000-Series Oscilloscope system).

c. Integrated Circuits. Integrated circuits should not be replaced unless they are actually defective. The best method for checking these devices is by direct substitution with a new component or one that is known to be good. Be sure that circuit conditions are not such that a replacement component might be damaged.

d. Diodes. A diode can be checked for an open or shorted condition by measuring the resistance between terminals. Using an ohmmeter scale having an internal source of between 800 millivolts and 3 volts, the resistance should be very high in one direction and very low when the leads are reversed.



Do not use an ohmmeter scale that has a high internal current. High currents may damage the diode.

e. Resistors. Resistors can be checked with an ohmmeter. Check the Electrical Parts List for the tolerance of the resistors used in this instrument. Resistors normally do not need to be replaced unless the measured value varies widely from the specified value.

f. Inductors. Check for open inductors by checking continuity with an ohmmeter. Shorted or partially shorted inductors can usually be found by checking the waveform response when high-frequency signals are passed through the circuit. Partial shorting often reduces high-frequency response.

g. Capacitors. A leaky or shorted capacitor can best be detected by checking the resistance with an ohmmeter on the highest scale. Do not exceed the voltage rating of the capacitor. The resistance should be high after the initial charge of the capacitor. An open capacitor can best be detected with a capacitance meter or by checking whether the capacitor passes AC signals.

7. Repair and Readjust the Circuit. If any defective parts are located, follow the replacement procedures given in this section. Be sure to check the performance of any circuit that has been repaired, or that has had any electrical components replaced.

CORRECTIVE MAINTENANCE

General

Corrective maintenance consists of component replacement and instrument repair. Special techniques required to replace components in the instrument are given here.

Obtaining Replacement Parts

All electrical and mechanical part replacements for the 7B92 can be obtained through your local Tektronix Field Office or representative. However, many of the standard electronic components can be obtained locally in less time than is required to order them from Tektronix, Inc. Before purchasing or ordering replacement parts, check the parts list for value, tolerance, rating, and description.

NOTE

When selecting replacement parts, it is important to remember that the physical size and shape of a component may affect the performance in the instrument, particularly at high frequencies. All replacement parts should be direct replacements unless it is known that a different component will not adversely affect instrument performance.

When ordering replacement parts from Tektronix, Inc., include the following information.

1. Instrument Type.
2. Instrument Serial Number.
3. A description of the part (if electrical, include circuit number).
4. Tektronix Part Number.

Component Replacement

WARNING

Disconnect the equipment from the power source before replacing components.

Relay Replacement. The relay in the 7B92 is manufactured by Tektronix, Inc. If the relay fails, a replacement may be ordered from your local Tektronix Field Office or representative. The eight-pin DPDT relay may be replaced in its socket either way, since this relay is symmetrical.

Semiconductor Replacement. Semiconductor devices used in this instrument should not be replaced unless actually defective. If removed from their sockets during routine maintenance, return them to their original sockets. Unnecessary replacement may affect the calibration of this instrument. When a semiconductor is replaced, check the operation of the part of the instrument that may be affected.

Replacement devices should be of the original type or direct replacement. Re-install in the same manner as the original. Fig. 6-1 (located in diagrams section) shows the lead configurations of the semiconductor devices used in this instrument. When replacing, check the manufacturer's basing diagram for correct basing.

Interconnecting Pin Replacement. Two methods of interconnection are used in this instrument to connect the circuit boards with other boards and components. When the interconnection is made with a coaxial cable, a special end-lead connector plugs into a socket on the board. Other interconnections are made with a pin soldered onto the board. Two types of mating connectors are used for these interconnecting pins. If the mating connector is mounted on a plug-on circuit board, a special socket is soldered into the board. If the mating connector is on the end of a lead, an end-lead pin connector is used that mates with the interconnecting pin. The following information provides the replacement procedure for the various interconnecting methods.

a. Coaxial-Type End-Lead Connectors.

Replacement of the coaxial-type end-lead connectors requires special tools and techniques; only experienced maintenance personnel should attempt replacement of these connectors. It is recommended that the cable or wiring harness be replaced as a unit. For cable or wiring harness part numbers, see the Mechanical Parts List. An alternate solution is to refer the replacement of the defective connector to your Tektronix Field Office or representative.

b. Circuit Board Pins and Pin Sockets.

CAUTION

The following procedures are recommended for single-layer circuit boards only. Pin and socket replacement on multi-layer circuit boards should be performed only by specialized service personnel. Refer to your local Tektronix Field Office or Service Center.

A circuit board pin replacement kit including necessary tools, instructions, and replacement pins is available from Tektronix, Inc. (Tektronix Part No. 040-0542-00). To replace a pin which is mounted on a circuit board, first disconnect any pin connectors. Then, unsolder the damaged pin and pull it out of the circuit board with a pair of pliers. Be careful not to damage the wiring on the board with too much heat.

Ream out the hole in the circuit board with a 0.031-inch drill. Remove the ferrule from the new interconnecting pin and press the new pin into the hole in the circuit board. Position the pin in the same manner as the old pin. Then, solder the pin on both sides of the circuit board. If the old pin was bent at an angle to mate with a connector, bend the new pin to match the associated pins.

The pin sockets on the circuit boards are soldered to the rear of the board. To replace one of these sockets, first unsolder the pin socket (use a vacuum-type desoldering tool to remove the excess solder). Then straighten the tabs on the socket and remove it from the hole in the board. Place the socket in the circuit board hole and press the tabs down against the board. Solder the tabs of the socket to the circuit board; be careful not to get solder into the socket.

NOTE

The spring tension of the pin sockets ensures a good connection between the circuit board and the pin. This spring tension can be destroyed by using the pin sockets as a connecting point for spring-loaded probe tips, alligator clips, etc.

c. End-Lead Pin Connectors.

The pin connectors used to connect the wires to the interconnecting pins are clamped to the ends of the associated leads. To replace damaged end-lead pin connectors, remove the old pin connector from the end of the lead and clamp the replacement connector to the lead.

Some of the pin connectors are grouped together and mounted in a plastic holder; the overall result is that these connectors are removed and installed as a multi-pin connector. To provide correct orientation of this multi-pin connector when it is replaced, an arrow (or dot) is stamped on the circuit board and a matching arrow is molded into the plastic housing of the multi-pin connector. Be sure that these arrows are aligned when the multi-pin connector is replaced. If the individual end-lead pin connectors are removed from the plastic holder, note the color of the individual wires for replacement.

Switch Replacement. Pushbutton switches and a cam-type switch are used in the 7B92. It is recommended that both switch types be replaced as a unit. Refer to Fig. 3-2 for cam-switch removal and to Fig. 3-3 for pushbutton switch removal.

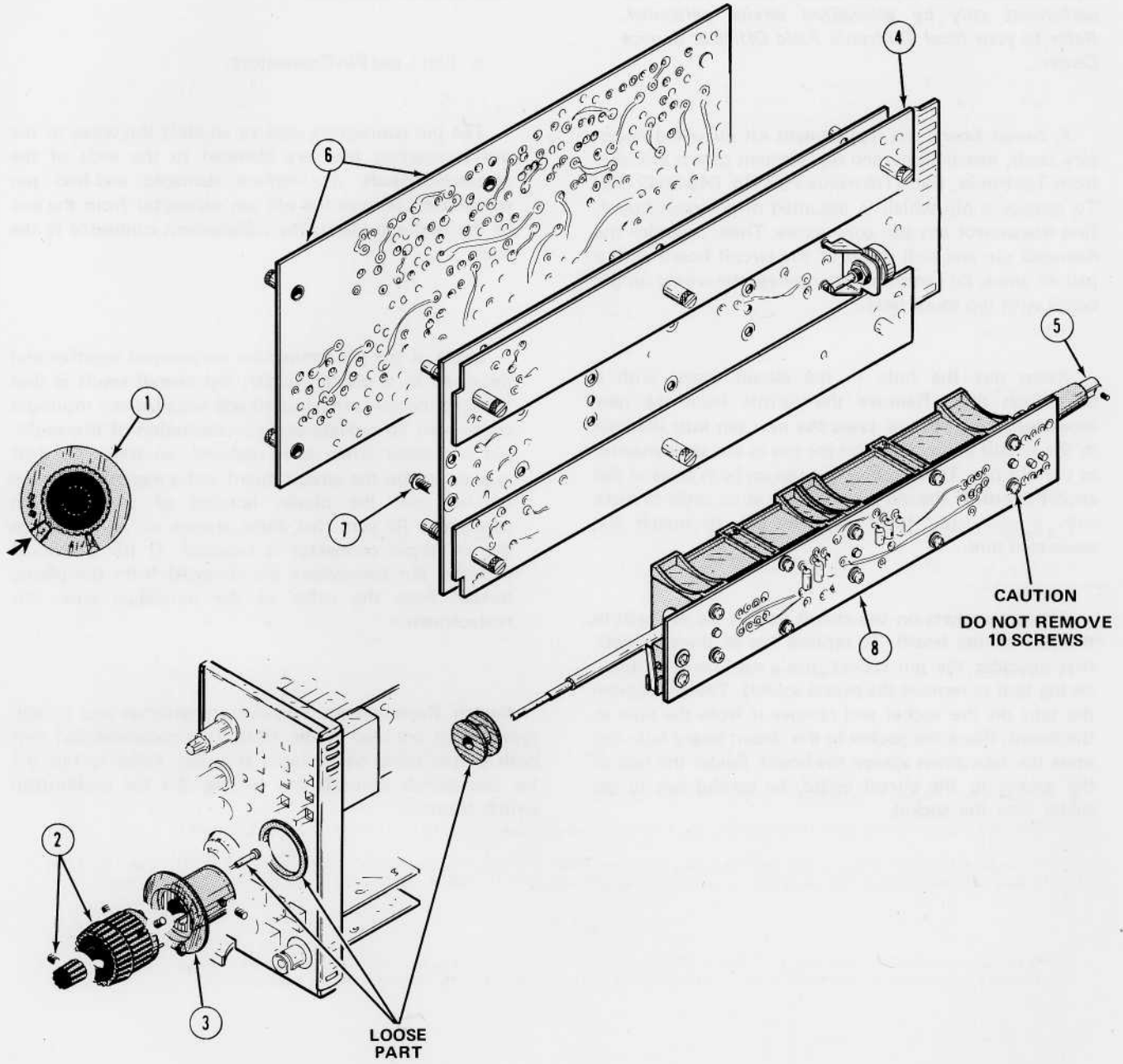

Fig. 3-2. Cam-switch removal.

CAUTION

Repair of the cam switch should only be undertaken by skilled maintenance personnel. Switch alignment and contact spacing must be carefully maintained for proper operation of the switch. The cam switch repair kit (Tektronix Part Number 040-0541-00) contains special alignment tools for use in repairing or replacing the cam and contacts. For information or assistance on maintenance of the cam switch, contact your local Tektronix Field Office or representative.

The cam switch (TIME/DIV OR DLY TIME and DLY'D Time/Division) consists of two rotating cams (front portion for TIME/DIV OR DLY TIME and rear portion for DLY'D Time/Division), which are turned by front-panel knobs and contacts mounted on the adjacent Interface board. These contacts are actuated by lobes on the cam as it is turned. The switch can be disassembled for inspection, cleaning, repair, or replacement; but it is recommended that the switch be removed from the instrument only as a unit.

NOTE

Before removing switch and control knobs, note the position of the knob to facilitate replacement and to assure proper alignment.

1. Set the TIME/DIV OR DLY TIME and DLY'D Time/Division switches to .2 s to provide easy access to the screw on the clear plastic flange (rear of subpanel) and to facilitate replacement of the switch.
2. Press in the DLY'D Time/Division switch. Loosen the set screws and remove the VARIABLE and DLY'D Time/Division knobs.
3. Remove the set screw from the rear of the front-subpanel and remove the clear plastic flange associated with the TIME/DIV OR DLY TIME assembly.
4. Disconnect the necessary cables from the Main Trigger circuit board to allow removal of the cam switch assembly.
5. Rotate the VARIABLE Time/Division switch to expose the set screw holding the shaft of R200. Loosen the set screw to allow cam switch removal.
6. Disconnect the two cables from the Sweep board and completely loosen the six screws holding the Sweep board. Carefully lift the sweep board from the instrument; do not bend pins from the Interface board to the Sweep board.
7. Remove the 10 set screws holding the cam switch to the Interface board. Hold the cam switch while removing the screws.

CAUTION

Do not remove ten screws holding Readout board to cam-switch.

8. Remove the cam switch assembly from the Interface board.
9. Follow the procedure as given in the switch repair kit to remove, replace, etc., the contacts on the Interface board.
10. To replace the cam switch, reverse the above procedure. Make sure that the clear plastic flange and the DLY'D Time/Division knob are replaced at the same switch position from which they were removed (.2 s/DIV with DLY'D Time/Division switch pushed in).

CAUTION

When replacing the 10 screws to the Interface board, tighten evenly. When replacing the Sweep board, do not apply much pressure until it is certain all pins from the Interface board have mated with the connectors on the Sweep board.

Fig. 3-2 (cont.)

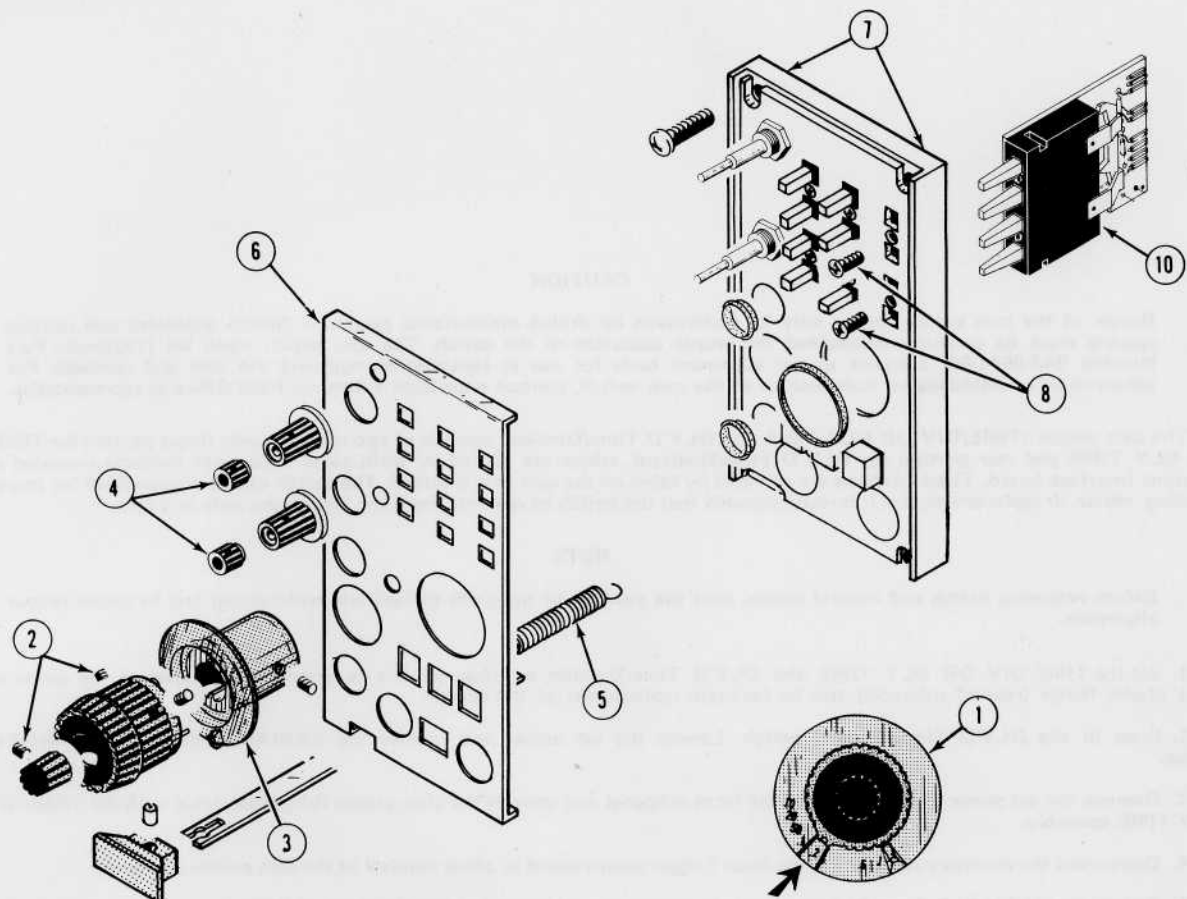

NOTE

Before removing switch and control knobs, note the position of the knob to facilitate replacement and to assure proper alignment.

1. Set the TIME/DIV OR DLY TIME and DLY'D Time/Division switches to .2 s to provide easy access to the set screw on the clear plastic flange and to facilitate replacement of the time/division switches.
2. Press in the DLY'D Time/Division switch. Loosen the set screws and remove the VARIABLE and DLY'D Time/Division knobs.
3. Remove the set screw from the rear of the front-subpanel and remove the clear plastic flange associated with the TIME/DIV OR DLY TIME assembly.
4. Loosen the set screws and remove the SLOPE, LEVEL, INTENSITY, and POSITION knobs.
5. Remove the spring from the 7B92 release latch.
6. Remove the front panel.
7. Remove the four set screws (one in each corner of the subpanel) holding the front-subpanel to the chassis. Pull out the front-subpanel to allow removal of the switches.
8. Loosen the screws holding the switch (to be replaced) to the front-subpanel.
9. Loosen any multipin connector(s) associated with the switch being replaced and unsolder leads or components where necessary.
10. When the switch is clear from external connection, remove the complete switch assembly from the front-subpanel.
11. To replace a pushbutton switch, reverse the above procedure. Make sure that all switch knobs are replaced in the same position as when they were removed.

Fig. 3-3. Pushbutton switch removal.

CALIBRATION

Calibration Interval

To assure instrument accuracy, check the calibration of the 7B92 every 1000 hours of operation, or every six months if used infrequently. Before complete calibration, thoroughly clean and inspect this instrument as outlined in the Maintenance section.

Tektronix Field Service

Tektronix, Inc. provides complete instrument repair and recalibration at local Field Service Centers and the Factory Service Center. Contact your local Tektronix Field Office or representative for further information.

Using This Procedure

General. This section provides several features to facilitate calibration of the 7B92. These are:

Index. An index is given preceding the calibration procedure to aid in locating steps.

Performance Check. The performance of this instrument can be checked by performing only the ✓ CHECK steps. The ✓ preceding a step indicates that performing this step checks the instrument against the tolerances listed as a Performance Requirement (see Specification section in Operators manual). Limits and tolerances given in other check steps are calibration guides and should not be interpreted as instrument specifications. Operator front-panel adjustments are adjusted as part of the Performance Check procedure.

Partial Calibration. A partial calibration is often desirable after replacing components, or to touch up the adjustment of a portion of the instrument between major recalibrations. To calibrate only part of the instrument, set the controls as given under Preliminary Control Settings and start with the nearest Equipment Required list preceding the desired portion. To prevent unnecessary recalibration of other parts of the instrument, readjust only if the tolerance given in the CHECK— part of the step is not met. If readjustment is necessary, also check the calibration of any steps listed in the INTERACTION or CALIBRATION part of the step.

Complete Calibration Procedure. Completion of each step in the complete Calibration procedure ensures that this instrument is correctly adjusted and performing within all given tolerances.

NOTE

All waveforms shown in this section were taken with a Tektronix oscilloscope camera system, unless otherwise stated.

TEST EQUIPMENT REQUIRED

General

The following test equipment and accessories, or its equivalent, is required for complete calibration of the 7B92. Specifications given for the test equipment are the minimum necessary for accurate calibration. Therefore, the specifications of any test equipment used must meet or exceed the listed specifications. All test equipment is assumed to be correctly calibrated and operating within the listed specifications. Detailed operating instructions for the test equipment are not given in this procedure. Refer to the instruction manual for the test equipment if more information is needed.

Special Calibration Fixtures

Special Tektronix calibration fixtures are used in this procedure only where they facilitate instrument calibration. These special calibration fixtures are available from Tektronix, Inc. Order by part number through your local Tektronix Field Office or representative.

Calibration Equipment Alternatives

All of the listed test equipment, or its equivalent, is required to completely check and adjust this instrument. The Calibration procedure is based on the first item of equipment given as an example of applicable equipment. When other equipment is substituted, control settings or calibration setup may need to be altered slightly to meet the requirements of the substitute equipment. If the exact item of test equipment is not available, first check the Specifications column carefully to see if any other equipment is available which might suffice.

TEST EQUIPMENT

Description	Minimum Specifications	Usage	Examples of Applicable Test Equipment
1. Calibration Oscilloscope	Tektronix 7000-Series. 500 megahertz bandwidth.	Used throughout procedure to provide a display.	a. Tektronix 7904 Oscilloscope.
2. Amplifier Plug-in Unit	Tektronix 7A-Series. 50 millivolts to five volts/div deflection factor.	External trigger level range checks. Delayed sweep baseline adjustment.	a. 7A15A, 7A16, 7A18 Amplifier Units. b. Other 7A-Series plug-in units may be used.
3. Wide-Band Amplifier Plug-in Unit	Tektronix 7A-Series. 500 megahertz bandwidth.	Used throughout procedure to provide vertical input to oscilloscope system.	a. Tektronix 7A19 Amplifier.
4. 10X Passive Probe	Compatible with 7A-Series Amplifiers.	Line triggering check. Delayed sweep baseline adjustment.	a. Tektronix P6053 Probe.
5. Differential Sampling System	System risetime at least 350 picoseconds; pulse amplitude, 200 millivolts input; differential sensitivity, 100 millivolts.	Delay Pickoff TD bias adjustment. High-frequency linearity checks and adjustments.	a. Tektronix 7S12 TDR/Sampler plug-in Unit with S-1 Sampling Head and S-52 Pulse Generator Head, and a 7S11 vertical sampling plug-in unit with a S-1 Sampling Head.
6. Fast-Rise Pulse Generator	Pulse output; positive-going pulse with 200 millivolts amplitude. Risetime equal to or less than 70 picoseconds.	Delay pickoff TD bias adjustment.	a. Tektronix S-52 Pulse Generator Head used with 7S12 TDR/Sampler or Type 285 Power Supply. b. Tektronix Type 284 Pulse Generator.
7. Time-Mark Generator	Marker outputs, two nanoseconds to 0.5 second; marker accuracy, within 0.1%.	Sweep timing checks and adjustments. Sweep delay checks and adjustments.	a. Tektronix 2901 Time-Mark Generator. b. Tektronix Type 184 Time-Mark Generator.
8. Low-Frequency Sine-wave Generator	Frequency, 30 hertz to 50 kilohertz; output amplitude, variable from 50 millivolts to 10 volts.	Low-frequency triggering checks.	a. General Radio 1310-B Oscillator.
9. Medium-Frequency Constant-Amplitude Signal Generator	Frequency, 20 megahertz to 100 megahertz; output amplitude variable from 100 millivolts to 500 millivolts.	20 megahertz triggering checks.	a. Tektronix Type 191 Constant Amplitude Signal Generator.
10. High-Frequency Constant-Amplitude Signal Generator	Frequency, 100 megahertz to 500 megahertz; reference frequency, 10 megahertz or lower; output amplitude, variable from 0.5 to four volts; amplitude accuracy, constant within 1% of reference as output frequency changes.	Trigger TD bias and runs after sensitivity adjustments. HF SYNC operation checks. Trigger jitter checks.	a. Tektronix 067-0532-01 Calibration Fixture. b. Tektronix 067-0650-00 Calibration Fixture. c. General Radio 1362 UHF Oscillator with 1263-C Amplitude-Regulation Power Supply. d. Wiltron Model 610B Swept Frequency Generator with Model 6108B, 10 to 1220 megahertz plug-in.

TEST EQUIPMENT (cont)

Description	Minimum Specifications	Usage	Examples of Applicable Test Equipment
11. Plug-In Extender	Provides access to 7B92 adjustments.	Used throughout procedure to provide access to internal adjustments and test points.	a. Tektronix 067-0589-00 Calibration Fixture.
12. Attenuator	Impedance, 50 ohms; attenuation, 5X; connector, GR874.	HF SYNC operation check.	a. Tektronix Part No. 017-0079-00.
13. T-Connector	Connectors, BNC.	External trigger checks. Trigger TD bias and runs after sensitivity adjustments. HF SYNC operation checks. Trigger jitter checks.	a. Tektronix Part No. 103-0030-00.
14. Cable (Three Required)	Impedance, 50 ohms; type RG-58/U; length, 42 inches; connectors, BNC.	Used throughout procedure for signal interconnection.	a. Tektronix Part No. 012-0057-01.
15. Adapter	Connectors, GR874 and BNC male.	Trigger TD bias and runs after sensitivity adjustments. HF SYNC operation checks. Trigger jitter checks.	a. Tektronix Part No. 017-0064-00.
16. Adapter (Two Required)	Connectors GR874 and BNC female.	20 megahertz triggering checks (one). High-frequency linearity checks and adjustments (two).	a. Tektronix Part No. 017-0063-00.
17. Adapter (Two Required)	Connectors, BNC female and BNC female.	High-frequency linearity checks and adjustments.	a. Tektronix Part No. 103-0028-00.
18. Adapter	Connectors, BSM female and BNC female.	High-frequency linearity checks and adjustments.	a. Tektronix Part No. 103-0036-00.
19. Adapter	SMA (3 mm) male to BNC female.	Delay pickoff TD bias adjustment.	a. Tektronix Part No. 015-1018-00.
20. Screwdriver	Three-inch shaft, 3/32 inch bit.	Used to adjust variable resistors.	a. Xcelite R-3323.
21. Low Capacitance Screwdriver	1-1/2 inch shaft.	Used to adjust variable capacitors.	a. Tektronix Part No. 003-0000-00.

N

CALIBRATION PROCEDURE

7B92 Serial No. _____

Calibration Date _____

Calibrated By _____

Introduction

The following procedure returns the 7B92 to correct calibration. All limits and tolerances given in this procedure are calibration guides, and should not be interpreted as instrument specifications except when listed as a performance requirement in the Specification section in the Operators Manual.

Index to Calibration Procedure

Trigger System Calibration

1. Preliminary Trigger Adjustments (R740, R750, R940, R950, and R364)	Page 4-6
2. Check/Adjust Main Trigger Level Sensitivity (R730)	Page 4-6
3. Check/Adjust Main Trigger Internal and External DC Centering (R647, R602)	Page 4-6
4. Check/Adjust Delayed Trigger Sensitivity (R920)	Page 4-7
5. Check/Adjust Delayed Triggering Internal and External DC Centering (R802)	Page 4-7
6. Check Main and Delayed Low-Frequency Triggering Operation	Page 4-8
7. Check Delayed and Main Triggering External Level Range	Page 4-9
8. Check Main Triggering AC LF REJ Operation	Page 4-10
9. Check Line Triggering Operation	Page 4-10
10. Check AUTO, NORM, and SINGLE SWEEP Modes	Page 4-10
11. Check/Adjust Main Triggering TD Bias and Runs After Sensitivity (R740, R750, and R959)	Page 4-11
12. Check Adjust Delayed Triggering TD Bias (R940, R950)	Page 4-12
13. Check HF SYNC Operation	Page 4-13

14. Check Main and Delayed Trigger Jitter	Page 4-14
15. Check 20 Megahertz Triggering	Page 4-14

Horizontal System Calibration

16. Check/Adjust Delayed Sweep Baseline (R452)	Page 4-16
17. Check/Adjust SWP CAL (Front panel)	Page 4-16
18. Check Display Modes	Page 4-16
19. Check/Adjust Delay Start and Delay Stop (R402, R350)	Page 4-17
20. Check/Adjust Position and Sweep Registration (R516, R560)	Page 4-18
21. Check/Adjust Delaying Sweep Calibration (R511)	Page 4-18
22. Check/Adjust Position Centering (R523)	Page 4-18
23. Check/Adjust Delaying and Delayed Sweep Length (R340, R465)	Page 4-19
24. Check/Adjust Delayed Sweep 20 Nanosecond Timing (C449)	Page 4-19
25. Check/Adjust One-Microsecond Timing (C414, C443)	Page 4-19
26. Check/Adjust Delay Pickoff TD Bias (R364)	Page 4-20
27. Check/Adjust High-Frequency Linearity (C557, C565, C572)	Page 4-20
28. Check/Adjust High-Frequency Timing (R244, R246, R567)	Page 4-22
29. Check Delaying and Delayed Sweep Timing Accuracy	Page 4-22
30. Check Delaying and Delayed Sweep Linearity	Page 4-23
31. Check Delaying and Delayed Sweep Variable Control Range	Page 4-24
32. Check Differential Delay Time Accuracy	Page 4-24
33. Check Absolute Delay Time Accuracy	Page 4-27
34. Check Delay Time Jitter	Page 4-27

Preliminary Procedure

1. Install the 7A19 Amplifier unit into the Left Vert Compartment of the 7904 Oscilloscope.
2. Remove the side covers from the 7B92 and install it into the 067-0589-00 plug-in extender. Install the 7B92 and the plug-in extender into the B Horiz compartment of the 7904 Oscilloscope.
3. Remove the right side panel from the 7904 Oscilloscope.
4. Turn on the oscilloscope and allow at least 20 minutes warm-up before proceeding with calibration.
5. Set the oscilloscope system controls as follows:

7904 Oscilloscope

Vertical Mode	Left
B Trigger Source	Vert Mode
A Trigger Source	Vert Mode
Horizontal Mode	B
Focus	Adjust for well defined display
Intensity	As desired
Grat Illum	As desired

7B92 Time Base

Main Triggering	
SLOPE	(+)
MODE	AUTO
COUPLING	AC
SOURCE	INT
TERM	OUT—50 Ω
Delayed Triggering	
SLOPE	(+)
COUPLING	AC
SOURCE	INT
LEVEL	IN—RUNS AFTER DLY TIME
DELAY TIME MULT	0.00
TIME/DIV OR	
DLY TIME	20 μs
DLY'D Time/Division	10 μs (pull out for INTEN Display Mode)
VARIABLE	CAL (press in)
Variable Selector (Internal)	Delaying Sweep Variable (see Operators Manual)
POSITION	For Centered Display
ALT	(press in)

7A19 Amplifier

Position	Midrange
Volts/Div	50 mV
Polarity	+Up
Input Coupling	DC

TRIGGER SYSTEM CALIBRATION

Equipment Required	
1. 7904 Oscilloscope	7. Constant amplitude signal generator (20 megahertz output)
2. 7A19 Amplifier	8. Constant amplitude signal generator (100 to 500 megahertz)
3. 7A15A Amplifier	9. 42-inch 50-ohm BNC cable (two)
4. Plug-in Extender	10. BNC T-connector
5. 10X probe	11. GR to BNC female adapter
6. Low-frequency sine-wave generator	12. GR to BNC male adapter
	13. GR 5X attenuator

NOTE

See Fig. 6-21 (located on pull-out page in the rear of the diagrams section) for location of Trigger System adjustments and test points.

Calibration—7B92 Service

Control Settings

Perform the Preliminary Procedure at the beginning of this section.

NOTE

If the 7B92 has been operating satisfactorily and it is desired to touch up instrument calibration for improved performance, complete steps 1(a) and 1(b), then proceed to calibration step 2. If the instrument has known operating problems, perform calibration steps 1(a) through 1(k), and then continue with calibration step 2.

1. Preliminary Trigger Adjustments (R740, R750, R940, R950, and R364)

a. Connect the low-frequency sine-wave generator to the 7A19 Input with a 42-inch 50-ohm BNC cable and BNC T-connector. Connect the output of the T-connector to the MAIN TRIG IN connector with a 42-inch BNC cable.

b. Set the low-frequency sine-wave generator for a two-division display at 50 kilohertz. Center the display vertically. Adjust the 7B92 INTENSITY control to view both the intensified and non-intensified portion of display.

c. Remove the 7B92 from the plug-in extender and install the 7B92 directly into the B Horiz compartment.

d. Preset the following control settings:

R364	Fully Counterclockwise
R750	Fully Counterclockwise
R940	Fully Counterclockwise
R950	Fully Counterclockwise

e. Rotate the MAIN TRIGGERING LEVEL control for a stable display. If a stable display cannot be obtained, adjust Intensity and Focus control for a well-defined free-running display and set the LEVEL control to 0.

f. ADJUST—R740, Main Arming TD Bias, fully counterclockwise, then adjust clockwise until a stable display is obtained. Adjust R740 an additional 10 degrees clockwise.

g. Press and release the Delayed Triggering LEVEL control to DLY'D SWP TRIGGERABLE (knob out). Rotate the Delayed Triggering LEVEL for a stable intensified display (do not rotate LEVEL control into HF SYNC area). Adjust the 7B92 and oscilloscope Intensity controls as necessary for an optimum intensified display.

h. ADJUST—R950, Delayed Sweep Start TD Bias, clockwise until the intensified portion of the sweep disappears. Adjust R950 an additional 10 degrees clockwise.

i. ADJUST—R940, Delayed Arming TD Bias, clockwise until a stable display of the intensified portion of the sweep appears. Rotate the Delayed Triggering LEVEL control as necessary.

j. Press the Delayed Triggering LEVEL control to the (knob in) RUNS AFTER DLY TIME position.

k. ADJUST—While rotating the DELAY TIME MULT dial, adjust R364, Delay Pickoff TD Bias, clockwise until the DELAY TIME MULT dial rotation affects the position of the intensified portion of the display.

l. Remove the 7B92 from the oscilloscope and install the 7B92 into the 067-0589-00 Plug-in extender. Install the 7B92 and the Plug-in extender into the B Horiz compartment.

2. Check/Adjust Main Trigger Level Sensitivity (R730)

a. Set the DELAY TIME MULT dial to 5.00.

b. CHECK—Rotate the MAIN TRIGGERING LEVEL control and check that the delaying sweep (non-intensified portion of the display) can be triggered at any point along the positive slope of the waveform.

c. ADJUST—R730, Trigger Level Sensitivity, to trigger the display (start of sweep) at any point along the positive slope of the waveform.

d. Change the MAIN TRIGGERING SLOPE switch to (—) and repeat steps b and c for the negative slope of the waveform.

3. Check/Adjust Main Triggering Internal and External DC Centering (R647, R602)

a. Set the low-frequency sine-wave generator for a 0.5 division display at 50 kilohertz. Vertically center the display.

b. Change the MAIN TRIGGERING MODE switch to NORM and rotate the MAIN TRIGGERING LEVEL

control for a stable display with the trigger point near the vertical center of the waveform (TRIG'D light on). Note the position of the sweep trigger point (start of non-intensified portion of sweep) with respect to CRT center.

c. Set the MAIN TRIGGERING COUPLING switch to DC.

d. CHECK—CRT for a triggered display with the position of the sweep trigger point the same as in part b.

e. ADJUST—R647, Internal DC Centering, for a triggered display with the position of the sweep trigger point the same as noted in part b.

f. Repeat the adjustment of R647 as necessary until the position of the sweep trigger remains the same in either the AC or DC positions of the MAIN TRIGGERING COUPLING switch. Return the COUPLING switch to AC.

g. Change the MAIN TRIGGERING SLOPE switch to (+). Repeat steps b through f for the positive slope of the waveform.

h. Set the low-frequency sine-wave generator for a two-division display (100 mV). Vertically center the display.

i. Rotate the MAIN TRIGGERING LEVEL control for a stable display with the trigger point of the non-intensified portion of the display near the center of the waveform. Note the position of the sweep trigger point with respect to CRT center.

j. Set the MAIN TRIGGERING SOURCE switch to EXT.

k. CHECK—CRT for triggered display with the position of the sweep trigger point the same as noted in part i.

l. ADJUST—R602, Main External DC Centering, for a triggered display with the position of the sweep trigger point the same as noted in part i.

m. Repeat the adjustment of R602 until the position of the sweep trigger point remains the same in either the INT or EXT positions of the MAIN TRIGGERING SOURCE switch. Return the MAIN TRIGGERING SOURCE switch to INT.

n. Change the MAIN TRIGGERING SLOPE switch to (–) and repeat steps i through m for the negative slope of the waveform.

4. Check/Adjust Delayed Trigger Sensitivity (R920)

a. Remove the BNC cable from the MAIN TRIG IN connector and connect it to the DLY'D TRIG IN connector.

b. Change the following control settings:

Main Triggering	
MODE	AUTO
LEVEL	Adjust for TRIG'D light on
TIME/DIV	
OR DLY TIME	20 μ s
DLY'D Time/Division	10 μ s (Press in for DLY'D Sweep Display Mode)

c. Press and release the Delayed Triggering LEVEL control and rotate for a triggered delayed sweep display (oscilloscope Intensity may need to be increased).

d. CHECK—Rotate the Delayed Triggering LEVEL control and check that display can be triggered at any point along the positive slope of the waveform. CHECK that the display cannot be triggered at either end of the Delayed Triggering LEVEL rotation (the negative end of the Delayed Triggering LEVEL does not include the HF SYNC area).

e. ADJUST—R920, Delayed Trigger Level Sensitivity, to trigger the display at any point along the positive slope of the waveform with no display at either end of the Delayed Triggering LEVEL rotation (the negative end of the Delayed Triggering LEVEL control does not include the HF SYNC area).

f. Change the Delayed Triggering SLOPE switch to (–) and repeat steps d and e for the negative slope of the waveform.

5. Check/Adjust Delayed Triggering Internal and External DC Centering (R802)

a. Set the Delayed Triggering COUPLING switch to DC. Rotate the Delayed Triggering LEVEL control to trigger the display near the vertical center of the waveform.

b. Note the position of the sweep trigger point with respect to display center.

Calibration—7B92 Service

- c. Set the Delayed Triggering SOURCE switch to EXT.
- d. CHECK—CRT for triggered display with the position of the sweep trigger point the same as noted in part b.
- e. ADJUST—R802, Delayed External DC Center, for a triggered display with the position of the sweep trigger point the same as noted in part b.
- f. Repeat the adjustment of R802 until the position of the sweep trigger point remains the same in either the INT or EXT positions of the Delayed Triggering SOURCE switch.
- g. Set the Delayed Triggering SOURCE switch to INT. Change the Delayed Triggering SLOPE switch to (+) and repeat parts a through f for the positive slope of the waveform.

√6. Check Main and Delayed Low-Frequency Triggering Operation

- a. Disconnect the BNC cable from the DLY'D TRIG IN connector and connect it to the MAIN TRIG IN connector.
- b. Change the following control settings:

Main Triggering	
COUPLING	AC
LEVEL	Adjust for TRIG'D light on
Delayed Triggering	
SLOPE	(+)
COUPLING	AC
SOURCE	INT
LEVEL	IN—RUNS AFTER DLY TIME
TIME/DIV OR	
DLY TIME	10 ms
DLY'D Time/Division	5 ms (Pull out for INTEN Display Mode)

- c. Set the low-frequency sine-wave generator for a 0.5 division display at 30 hertz.
- d. CHECK—Stable CRT display can be obtained with the MAIN TRIGGERING COUPLING switch set to AC, AC HF REJ, and DC for both the (+) and (–) SLOPE (MAIN TRIGGERING LEVEL control may be adjusted as necessary for a stable display).

- e. Change the MAIN TRIGGERING SOURCE switch to EXT. Set the low-frequency sine-wave generator for a two-division display (100 mV) at 30 hertz.
- f. CHECK—Stable CRT display can be obtained with the MAIN TRIGGERING COUPLING switch set to AC, AC HF REJ, and DC for both the (+) and (–) SLOPE (MAIN TRIGGERING LEVEL control may be adjusted as necessary for a stable display).
- g. CALIBRATION—If the 7B92 does not meet the requirement given in parts d and f, check the adjustment of the Main Trigger Level Sensitivity (R730—Calibration step 2).

- h. Disconnect the BNC cable from the MAIN TRIG IN connector and connect it to the DLY'D TRIG IN connector.
- i. Change the following control settings:

Main Triggering	
LEVEL	TRIG'D light on
SOURCE	INT
Delayed Triggering	
LEVEL	OUT—DLY'D SWP TRIGGERABLE
SOURCE	EXT
DLY'D Time/Division	Press in for DLY'D Sweep Display Mode

- j. CHECK—Stable CRT display can be obtained with the DLY'D TRIG COUPLING switch set to AC and DC for both the (+) and (–) SLOPE (Delayed Triggering LEVEL control may be adjusted as necessary for a stable display). It may be necessary to adjust the 7B92 and oscilloscope Intensity controls to view the delayed sweep trace.
- k. Change the Delayed Triggering SOURCE switch to INT.
- l. Press the Delayed Triggering LEVEL control to RUNS AFTER DLY TIME (knob inward). Set the low-frequency sine-wave generator for a 0.5 division display at 30 hertz. Return the Delayed Triggering LEVEL control to DLY'D SWP TRIGGERABLE (knob out).

- m. CHECK—Stable CRT display can be obtained with the Delayed Triggering COUPLING switch set to AC and DC for both the (+) and (–) SLOPE (Delayed Triggering LEVEL control may be adjusted as necessary for a stable display).

n. CALIBRATION—If the 7B92 does not meet the requirement given in parts j and m, check the adjustment of the Delayed Trigger Level Sensitivity (R920—Calibration step 4).

√7. Check Delayed and Main Triggering External Level Range

a. Install the 7A15A Amplifier into the Right Vert compartment of the 7904 oscilloscope. Set the oscilloscope Vertical Mode switch to Right.

b. Remove the BNC T-connector and connections from the 7A19 Input and connect it to the 7A15A Input.

c. Set the 7A15A Input Coupling switch to DC and the Volts/Div switch to 1 V.

d. Change the following control settings:

TIME/DIV OR	
DLY TIME	20 μ s
DLY'D Time/Division	10 μ s (Press in for DLY'D Sweep Display Mode)
Main Triggering	
LEVEL	Adjust for TRIG'D light on
SLOPE	(+)
TERM	IN—1 M Ω
Delayed Triggering	
SOURCE	EXT
SLOPE	(+)

e. Set the low-frequency sine-wave generator for a five division display (5 volts) at 50 kilohertz. Center the display vertically.

√f. CHECK—Rotate the Delayed Triggering LEVEL control throughout its range and check that all levels of the positive slope may be obtained (indicates an external delayed trigger level range of at least plus and minus 2.5 volts). CHECK that display is not triggered at either end of the LEVEL control rotation. (The negative end of the Delayed Triggering LEVEL does not include the HF SYNC area).

g. Change the Delayed Triggering ^{SLOPE} ~~SOURCE~~ switch to (-).

√h. CHECK—Repeat step f for the negative slope of the waveform.

i. CALIBRATION—If the 7B92 does not meet the requirements given in part f, check the adjustment of the Delayed Trigger Level Sensitivity (R920—Calibration step 4).

j. Remove the BNC connector from the DLY'D TRIG IN connector and connect it to the MAIN TRIG IN connector.

k. Press the Delayed Triggering LEVEL control to IN—RUNS AFTER DLY TIME and pull out the DLY'D Time/Division switch for the INTEN Display Mode. Set the MAIN TRIGGERING SOURCE switch to EXT.

l. Set the low-frequency sine-wave generator for a seven division display at 50 kilohertz. Center the display vertically.

√m. CHECK—Rotate the MAIN TRIGGERING LEVEL control throughout its range and check that all levels of the positive slope may be obtained (indicates an external main triggering level range of at least plus and minus 3.5 volts). Check that display is not triggered at either end of the LEVEL control rotation.

n. Change the MAIN TRIGGERING SLOPE switch to (-).

√o. CHECK—Repeat step m for the negative slope of the waveform.

p. CALIBRATION—If the 7B92 does not meet the requirements given in part m, check the adjustment of the Main Trigger Level Sensitivity (R730—Calibration step 2).

q. Change the MAIN TRIGGERING SOURCE switch to EXT \div 10.

r. To check EXT \div 10 external level range, apply a 70-volt peak to peak signal through an attenuator, to the 7A15A Input and to the MAIN TRIG IN connector (non-attenuated).

√s. CHECK—Rotate the MAIN TRIGGERING LEVEL control throughout its range and check that all levels of the negative slope may be selected (indicates EXT \div 10 external main triggering level range of at least plus and minus 35 volts). Check that display is not triggered at either extreme of LEVEL control rotation.

Calibration—7B92 Service

t. Change the MAIN TRIGGERING SLOPE switch to (+).

√u. CHECK—Repeat step s for the positive slope of the waveform.

v. If the 7B92 does not meet the requirements given in part s, check the adjustment of the Main Trigger Level Sensitivity (R730—Calibration step 2).

√8. Check Main Triggering AC LF REJ Operation

a. Change the following control settings:

7A15A Amplifier	
Volts/Div	1 V
7B92 Time Base	
Main Triggering SOURCE	EXT
TIME/DIV OR DLY TIME	10 ms
DLY'D Time/Division	10 ms (press in for NORMAL Sweep Display Mode)

b. Set the low-frequency sine-wave generator for a three-division display (three volts) at 60 hertz.

c. Rotate the MAIN TRIGGERING LEVEL control for a stable display (TRIG'D light on).

d. Change the MAIN TRIGGERING COUPLING switch to AC LF REJ.

√e. CHECK—Rotate the MAIN TRIGGERING LEVEL control throughout its range and check that a stable display cannot be obtained (TRIG'D light off).

f. Change the MAIN TRIGGERING SOURCE switch to INT and the COUPLING switch to AC LF REJ.

g. Set the low-frequency sine-wave generator for an eight-division display at 60 hertz. Center the display vertically.

√h. CHECK—Rotate the MAIN TRIGGERING LEVEL control throughout its range and check that a stable display cannot be obtained (TRIG'D light off).

i. Disconnect all test equipment from the oscilloscope system.

√9. Check Line Triggering Operation

a. Change the following control settings:

7A15A Amplifier	
Volts/Div	5 V
7B92 Time Base	
Main Triggering COUPLING SOURCE	AC LINE

b. Connect the 10X probe to the 7A15A Input and the probe tip to the same line-voltage source which is connected to the oscilloscope.

√c. CHECK—Rotate the MAIN TRIGGERING LEVEL control and check that a stable display can be obtained (TRIG'D light on) for both the (+) and (−) SLOPE.

d. Disconnect all test equipment from the oscilloscope system.

√10. Check AUTO, NORM, and SINGLE SWEEP Modes

a. Change the following control settings:

7A19 Amplifier	
Volts/Div	1 V
7904 Oscilloscope	
Vertical Mode	Left
7B92 Time Base	
Main Triggering SOURCE	INT
TIME/DIV OR DLY TIME	10 μs
DLY'D Time/Division	10 μs (press in for NORMAL Sweep Display Mode)

b. Connect the Output of the low-frequency sine-wave generator to the 7A19 Input with a 42-inch 50-ohm BNC cable. Set the low-frequency generator for a four-division display at 50 kilohertz.

c. Rotate the MAIN TRIGGERING LEVEL control for a free-running display (TRIG'D light off).

d. Set the MAIN TRIGGERING MODE switch to NORM.

✓e. CHECK—CRT for no display (TRIG'D light off).

f. Set the MODE switch to AUTO. Rotate the MAIN TRIGGERING LEVEL to just trigger the display.

g. Set the MODE switch to NORM.

✓h. CHECK—CRT for triggered display (TRIG'D light on).

i. Change the MAIN TRIGGERING MODE switch to SINGLE SWEEP.

✓j. CHECK—CRT for no display.

k. Press the MAIN TRIGGERING RESET button.

✓l. CHECK—CRT for one sweep as the RESET button is pressed (oscilloscope Intensity may need to be increased to view the single sweep display).

m. Remove the signal from the 7A19 Input, then press the RESET button.

✓n. CHECK—CRT for no display and READY light on.

✓o. CHECK—Reconnect the signal to the 7A19 Input. Check for one sweep as the signal is applied to the 7A19 and that the READY light is out after the completion of that sweep.

p. Disconnect all test equipment from the oscilloscope system.

✓11. Check/Adjust Main Triggering TD Bias and Runs After Sensitivity—(R740, R750 and R959)

a. Remove the 7B92 and plug-in extender from the oscilloscope. Install the 7B92 directly into the B Horiz compartment.

b. Change the following control settings:

Main Triggering	
MODE	AUTO
TIME/DIV OR	
DLY TIME	.5 ns
DLY'D Time/Division	.5 ns (press in for NORMAL Sweep Display Mode)
DELAY TIME MULT	1.00
TERM	OUT—50 Ω
Delayed Triggering	
LEVEL	IN—RUNS AFTER DLY TIME
SLOPE	(+)
COUPLING	AC
SOURCE	INT

c. Connect the Output of the high-frequency constant-amplitude signal generator to the 7A19 Input with a GR-to-BNC male adapter and BNC T-connector. Connect the output of the T-connector to the MAIN TRIG IN connector with a 42-inch 50-ohm BNC cable. Set the high-frequency sine-wave generator for a one-division display at 500 megahertz.

✓d. CHECK—Stable CRT display can be obtained with the MAIN TRIGGERING COUPLING switch set to AC, AC LF REJ, and DC for both the (+) and (−) SLOPE (MAIN TRIGGERING LEVEL control may be adjusted as necessary to obtain a stable display).

e. ADJUST—R740, Main Arming TD Bias, counter-clockwise until the sweep free-runs, then adjust clockwise until the sweep is triggered. Repeat part d.

f. Change the following control settings:

TIME/DIV OR	
DLY TIME	.1 μs
DLY'D Time/Division	.5 ns (press in for DLY'D Sweep Display Mode)
Main Triggering	
LEVEL	/ Adjust for TRIG'D light on

✓g. CHECK—Rotate the DELAY TIME MULT dial from 1.00 to 9.00 and check for no double triggering or defocusing of sine waves.

h. ADJUST—Rotate the DELAY TIME MULT dial from 1.00 to 9.00 and adjust R959, Runs After Delay Time Sensitivity, and R750, Delaying Sweep Start TD Bias, for no double triggering or defocusing.

✓i. CHECK—Vary the high frequency generator from 500 megahertz to 100 megahertz and from 100 megahertz to 500 megahertz. Check for stable CRT display with no

Calibration—7B92 Service

double triggering or defocusing of sine waves (MAIN TRIGGERING LEVEL control may be adjusted as necessary for a stable display).

j. ADJUST—Vary the high-frequency generator from 500 megahertz to 100 megahertz and from 100 megahertz to 500 megahertz. Repeat the adjustment of R740, R750, and R959 for a stable CRT display with no defocusing or double triggering.

→ k. INTERACTION—The adjustment of R959 may affect the adjustment of R940 and R950 (Calibration step 12) and R364 (Calibration steps 1 and 26).

l. Change the 7A19 Volts/Div switch to .1 V and set the MAIN TRIG SOURCE switch to EXT.

m. Set the high-frequency generator for a five-division display (500 millivolts) at 500 megahertz.

√n. CHECK—Stable CRT display can be obtained with the MAIN TRIGGERING COUPLING switch set to AC, AC LF REJ, and DC for both the (+) and (−) SLOPE.

√o. CHECK—Vary the high-frequency generator from 500 megahertz to 100 megahertz and from 100 megahertz to 500 megahertz. CHECK for stable CRT display with no double triggering or defocusing (MAIN TRIGGERING LEVEL control may be adjusted as necessary for a stable display).

p. CALIBRATION—If the 7B92 does not meet the requirements given in parts n and o, check the adjustments of R740, R750 and R959.

√12. Check/Adjust Delayed Triggering TD Bias (R940, R950)

a. Set the high-frequency generator and the 7A19 Volts/Division switch for a one-division display at 500 megahertz.

b. Change the following control settings:

7B92 Time Base

Main Triggering SOURCE LEVEL	INT Adjust for TRIG'D light on
Delayed Triggering LEVEL	OUT—DLY'D SWP TRIGGERABLE

c. Rotate the Delayed Triggering LEVEL control for a stable delayed sweep display.

NOTE

If a display cannot be obtained at any setting of the Delayed Triggering LEVEL control, check the preliminary adjustment of R940 and R950 (Calibration step 1) and R920 (Calibration step 4).

√d. CHECK—Stable delayed sweep display can be obtained with the Delayed Triggering COUPLING switch set to AC and DC for both the (+) and (−) SLOPE (Delayed Triggering LEVEL control may be adjusted as necessary for a stable display).

e. ADJUST—R950, Delayed Sweep Start TD Bias, to observe a slight shift or jump of the delayed sweep trace. Adjust R950 10 degrees clockwise from the observed shift.

f. ADJUST—R940, Delayed Arming TD Bias, to remove any double triggering or defocusing from the delayed sweep display.

√g. CHECK—Rotate the DELAY TIME MULT dial throughout its range and check for no double triggering or defocusing of sine waves.

h. INTERACTION—Repeat the adjustment of R940 and R950 as necessary. It may be necessary to check the adjustment of R920 Calibration step 4).

i. Remove the BNC cable from the MAIN TRIG IN connector and connect it to the DLY'D TRIG IN connector.

j. Set the 7A19 Volts/Division switch to .1 V. Set the high-frequency generator for a five-division display (500 mV) at 500 megahertz.

k. Change the Delayed Triggering SOURCE switch to EXT.

√l. CHECK—Stable delayed sweep display can be obtained with the Delayed Triggering COUPLING switch set to AC and DC for both the (+) and (−) SLOPE (Delayed Triggering LEVEL control may be adjusted as necessary for a stable display).

m. CALIBRATION—If the 7B92 does not meet the requirements given in part 1, check the adjustment of R940 and R950 (Calibration step 12) and R920 (Calibration step 4).

n. Disconnect all test equipment from the oscilloscope system.

✓13. Check HF SYNC Operation

a. Connect the output of the high-frequency constant-amplitude sine-wave generator to the 7A19 Input with a 5X GR attenuator, GR-to-BNC male adapter, and BNC T-connector. Connect the output of the T-connector to the MAIN TRIG IN connector with a 42-inch BNC cable.

b. Change the following control settings:

Main Triggering MODE	HF SYNC
TIME/DIV OR DLY TIME	10 ns
DLY'D Time/Division	10 ns (press in for NORMAL Sweep Display Mode)
Delayed Triggering LEVEL	IN—RUNS AFTER DLY TIME
SLOPE	(+)
COUPLING	DC
SOURCE	INT

c. Set the high-frequency sine-wave generator and the 7A19 Volts/Div switch for a 0.5 division display at 100 megahertz.

✓d. CHECK—Stable CRT display can be obtained with the MAIN TRIGGERING COUPLING switch set to AC, AC LF REJ, and DC (Rotate the MAIN TRIGGERING LEVEL control for optimum display).

e. Set the high-frequency sine-wave generator for 0.5 division display at 500 megahertz. Set the TIME/DIV OR DLY TIME and DLY'D Time/Division switches to .5 ns (press in DLY'D Time/Division switch for Normal Display Mode).

✓f. CHECK—Repeat part d.

g. Change the following control settings:

	7A19 Amplifier
Volts/Div	.1 V

7B92 Time Base

Main Triggering SOURCE	EXT
TIME/DIV OR DLY TIME	10 ns
DLY'D Time/Division	10 ns (press in for NORMAL Sweep Display Mode)

h. Set the high-frequency sine-wave generator for a one-division display (100 mV) at 100 megahertz.

✓i. CHECK—Repeat part d.

j. Change the TIME/DIV OR DLY TIME and DLY'D Time/Division switches to .5 ns (press in DLY'D Time/Division switch for the NORMAL Display Mode).

k. Set the high-frequency sine-wave generator for a one-division display (100 mV at 500 megahertz).

✓l. CHECK—Repeat part d.

m. CALIBRATION—If the 7B92 does not meet the requirements given in part d, check the adjustment of R740, R750, and R959 (Calibration step 11).

n. Remove the BNC cable from the MAIN TRIG IN connector and connect it to the DLY'D TRIG IN connector.

o. Change the following control settings:

Main Triggering SOURCE	INT
LEVEL	Adjust for TRIG'D light on
TIME/DIV OR DLY TIME	20 ns
DLY'D Time/Division	10 ns (press in for DLY'D Sweep Display Mode)

p. Set the high-frequency sine-wave generator and the 7A19 Volts/Div switch for a 0.5-division display at 100 megahertz. Press and release the Delayed Triggering LEVEL control to DLY'D SWP TRIGGERABLE (knob out).

✓q. CHECK—Rotate the Delayed Triggering LEVEL control into the HF SYNC area. Check that a stable display can be obtained with the Delayed Triggering COUPLING switch set to AC and DC (Rotate the Delayed Triggering

Calibration—7B92 Service

LEVEL control, within the HF SYNC area, as necessary for an optimum display).

r. Set the high-frequency sine-wave generator for a 0.5 division display at 500 megahertz. Set the TIME/DIV OR DLY TIME switch to .1 μ s and the DLY'D Time/Division switch to .5 ns (press in DLY'D Time/Division switch for the DLY'D Sweep Display Mode).

✓s. CHECK—Repeat part q.

t. Change the following control settings:

7A19 Amplifier

Volts/Div .1 V

7B92 Time Base

TIME/DIV OR DLY TIME .1 μ s
 DLY'D Time/Division 10 ns

u. Set the high-frequency generator for a one-division (100 mV) display at 100 megahertz. Set the Delayed Triggering SOURCE switch to EXT.

✓v. CHECK—Repeat part q.

w. Set the high-frequency sine-wave generator for a one-division display at 500 megahertz. Set the TIME/DIV OR DLY TIME switch to .1 μ s and the DLY'D Time/Division switch to .5 ns (press in DLY'D Time/Division switch for the DLY'D Display Mode).

✓x. CHECK—Repeat part q.

y. CALIBRATION—If the 7B92 does not meet the requirements given in part q, check the adjustment of R940 and R950 (Calibration step 12).

✓14. Check Main and Delayed Trigger Jitter

a. Change the following control settings:

Main Triggering MODE AUTO
 COUPLING AC
 TIME/DIV OR DLY TIME .5 ns

DLY'D Time/Division .5 ns (press in for NORMAL Sweep Display Mode)

Delayed Triggering SOURCE INT
 LEVEL IN—RUNS AFTER DLY TIME

b. Rotate the MAIN TRIGGERING LEVEL control for a stable display.

✓c. CHECK—CRT display for less than 0.1 division (50 picoseconds) of jitter. Disregard any slow drift.

d. Change the following control settings:

Main Triggering LEVEL Adjust for stable display
 TIME/DIV OR DLY TIME .1 μ s
 DLY'D Time/Division .5 ns (press in for DLY'D Sweep Display Mode)
 Delayed Triggering LEVEL OUT—DLY'D SWP TRIGGERABLE

e. Rotate the Delayed Triggering LEVEL control for a stable delayed sweep display.

✓f. CHECK—Delayed sweep display for no more than 0.1 division of jitter (50 picoseconds). Disregard any slow drift.

g. Disconnect all test equipment from the oscilloscope system.

✓15. Check 20 Megahertz Triggering

a. Change the following control settings:

7A19 Amplifier

Volts/Div .2 V

7B92 Time Base

TIME/DIV OR DLY TIME 50 ns
 DLY'D Time/Division 50 ns (press in for NORMAL Sweep Display Mode)
 Delayed Triggering LEVEL IN—RUNS AFTER DLY TIME

b. Connect the output of the medium-frequency constant amplitude signal generator to the 7A19 Input with a GR-to-BNC female adapter, 42-inch 50-ohm BNC cable and BNC T-connector. Connect the output of the T-connector to the MAIN TRIG IN connector. Set the Type 191 for a 0.5 division (100 mV) display at 20 megahertz.

√c. CHECK—Stable CRT display can be obtained with the MAIN TRIGGERING COUPLING switch set to AC, AC LF REJ, and DC for both the (+) and (−) SLOPE (MAIN TRIGGERING LEVEL control may be adjusted as necessary for a stable display).

↙ d. Change the MAIN TRIGGERING SOURCE switch to EXT.

√e. CHECK—Repeat part c.

f. CALIBRATION—If the 7B92 does not meet the requirements given in part c, check the adjustment of R730 (Calibration step 2).

g. Remove the BNC cable from the MAIN TRIG IN connector and connect it to the DLY'D TRIG IN connector.

h. Change the following control settings:

Main Triggering SOURCE	INT
LEVEL	Adjust for TRIG'D light on
TIME/DIV OR DLY TIME	.1 μs
DLY'D Time/Division	50 ns (press in for DLY'D Sweep Display Mode)
Delayed Triggering LEVEL	OUT—DLY'D SWP TRIGGERABLE
SOURCE	EXT

√i. CHECK—Stable delayed sweep display can be obtained with the Delayed Triggering COUPLING switch set to AC and DC for both the (+) and (−) SLOPE (Delayed Triggering LEVEL control may be adjusted as necessary for a stable display).

j. Change the Delayed Triggering SOURCE switch to INT.

√k. CHECK—Repeat part i.

l. CALIBRATION—If the 7B92 does not meet the requirements given in part i, check the adjustment of R920 (Calibration step 4).

m. Disconnect all test equipment from oscilloscope system.

HORIZONTAL SYSTEM CALIBRATION

Equipment Required	
1. 7904 Oscilloscope	8. S52 Pulse Generator Head
2. 7A19 Amplifier	9. Time-Mark Generator
3. 7A15A Amplifier	10. Plug-in extender
4. 10X probe	11. 42-inch 50-ohm BNC cable (three)
5. 7S11 Sampling Unit	12. GR to BNC female adapter (two)
6. 7S12 Sampling Unit	13. BNC female to BNC female adapter (two)
7. S1 Sampling Head (two)	14. BSM female to BNC female adapter
	15. SMA male to BNC female

NOTE

See Fig. 6-22 (located on pull-out page in the rear of the diagrams section) for location of Horizontal System adjustments and test points.

Calibration—7B92 Service

Control Settings

Set the controls as given in the Preliminary Procedure.

16. Check/Adjust Delayed Sweep Baseline (R452)

a. Install the 7A15A Amplifier unit into the Right Vert Compartment of the 7904 Oscilloscope.

b. Change the following control settings:

7904 Oscilloscope

Vert Mode Right

7B92 Time Base

TIME/DIV OR
DLY TIME 1 ms
DLY'D Time/Division 1 ms (pull out for
INTEN Display Mode)

c. To establish a ground reference, set the 7A15A input coupling to Gnd (7A15A installed in Right Vert compartment). Position the trace to start at CRT center with the 7A15A and 7B92 Position controls.

d. Connect a 10X probe from the 7A15A Input to (TP) 462.

e. Set the 7A15A input coupling to DC and adjust the Volts/Div to 50 mV.

f. CHECK—CRT trace must start at CRT center.

g. ADJUST—R452, Dly'd Swp Baseline, to start display at CRT center (see Fig. 4-1).

h. INTERACTION—The adjustment of R452 may affect the adjustment of R560 (Calibration step 20) and R364 (Preliminary adjustment Calibration step 1).

i. Disconnect all test equipment from the oscilloscope system.

17. Check/Adjust SWP CAL (front-panel) (1ms)

a. Set the 7904 Vertical Mode switch to Left.

b. Connect the marker output of the time-mark generator to the 7A19 Amplifier Input with a 42-inch

50-ohm BNC cable. Set the time-mark generator for one-millisecond markers and adjust the 7A19 Volts/Div switch for about two divisions of display.

c. Rotate the MAIN TRIGGERING LEVEL control for a stable display and rotate the POSITION control to horizontally center the trace.

d. CHECK—CRT display, for one-millisecond marker each major division over the center eight divisions of display.

e. ADJUST—Front-panel SWP CAL (screwdriver adjustment R260), for one-millisecond marker each division over the center eight divisions of display. Use the POSITION control as necessary to horizontally align the display with the vertical graticule lines.

✓18. Check Display Modes

a. Press in the DLY'D Time/Division switch for the NORMAL Sweep Display Mode.

✓b. Rotate the MAIN TRIGGERING LEVEL control for a stable display. Increase the oscilloscope Intensity as necessary. Rotate the DELAY TIME MULT dial and note that it has no effect on the display.

c. Pull out the DLY'D Time/Division switch for the INTEN Display Mode and rotate to .2 ms.

✓d. CHECK—CRT display for non-intensified trace (delaying sweep) with an intensified portion (delayed sweep). Adjust the 7B92 and oscilloscope Intensity controls for an optimum intensified trace.

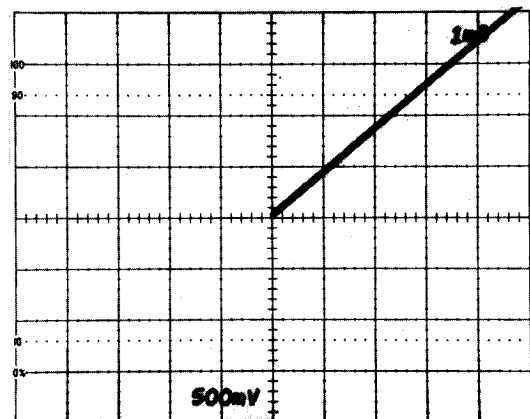

Fig. 4-1. Typical display for adjustment of Dly'd Swp Baseline (R452).

√e. CHECK—Rotate the DELAY TIME MULT dial and note that the amount of delay time before the intensified portion is controlled by the DELAY TIME MULT dial.

f. Press in the DLY'D Time/Division switch for the DLY'D Sweep Display Mode.

√g. CHECK—CRT for magnified display (one complete cycle in five divisions). The oscilloscope Intensity may need to be increased to view the delayed sweep display.

h. Press and release the ALT switch for ALT Sweep Display Mode and rotate (TRACE SEP) in a clockwise direction to separate the traces.

√i. CHECK—CRT display for both an intensified trace and a delayed sweep trace (vertically position the trace as necessary). The intensified trace provides an intensified portion on the delaying sweep (delaying sweep rate determined by the TIME/DIV OR DLY TIME switch) during the time that the delayed sweep runs. The delayed sweep trace displays the intensified portion, as viewed on the intensified trace, at the sweep rate indicated by the DLY'D Time/Division switch.

√j. CHECK—Rotate the TRACE SEP control fully clockwise and check that the intensified trace is positioned approximately four divisions vertically with respect to the delayed sweep trace.

√k. CHECK—Rotate the TRACE SEP control fully counterclockwise and check that the two traces are vertically positioned together. Rotate the TRACE SEP control fully clockwise.

l. Set the oscilloscope Intensity control to midrange.

√m. CHECK—Rotate the 7B92 INTENSITY control throughout its range. Check that the brightness of the non-intensified portion, of the intensified trace, can be varied with respect to the intensified portion.

19. Check/Adjust Delay Start and Delay Stop (R402, R350)

a. Change the following control settings:

TIME/DIV OR	
DLY TIME	1 ms
DLY'D Time/Division	10 μ s (pull out for INTEN Display Mode)
DELAY TIME MULT	1.00

b. Adjust the 7B92 and oscilloscope Intensity controls for the desired alternate trace display.

NOTE

Rough adjustments of the Delay Start and Delay Stop adjustments will be made by viewing the intensified trace, followed by fine adjustments viewing the delayed sweep trace.

c. CHECK—The intensified sweep starts on the second one-millisecond marker of the intensified trace (see Fig. 4-2).

d. ADJUST—R402, Dly Start, to start the intensified sweep on the second one-millisecond marker, then further adjust R402 to start the delayed sweep (delayed sweep trace) at the bottom of the marker (see Fig. 4-2).

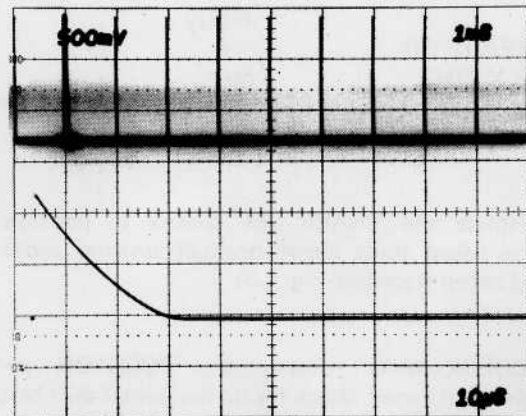

(a) Correct adjustment of Delay Start (R402)

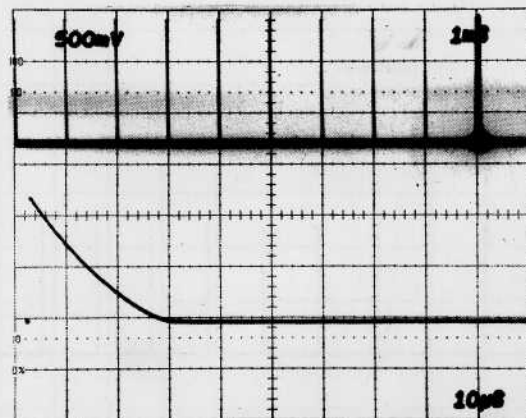

(b) Correct adjustment of Delay Stop (R350)

Fig. 4-2. Typical CRT display for adjustment of Dly Start and Dly Stop.

Calibration—7B92 Service

e. CHECK—Rotate the DELAY TIME MULT dial to 9.00 and check that the intensified sweep starts on the tenth one-millisecond marker (see Fig. 4-2).

f. ADJUST—R350, Dly Stop, to start the intensified sweep on the tenth one-millisecond marker, then further adjust R350 to start the delayed sweep (delayed sweep trace) at the bottom of the marker (see Fig. 4-2).

g. INTERACTION—Repeat the adjustment of R402 and R350 as necessary. The adjustment of R402 and R350 may affect the adjustment of R340 (Calibration step 23) and R364 (preliminary adjustment, Calibration step 1; final adjustment, Calibration step 26).

20. Check/Adjust Position and Sweep Registration (R516, R560)

a. Change the following control settings:

Main Triggering LEVEL	Adjust for stable display
TIME/DIV OR DLY TIME	1 ms
DLY'D Time/Division	1 ms
DELAY TIME MULT	0.00

b. Rotate the TRACE SEP control to position the delaying sweep trace about one-half division above the delayed sweep trace (see Fig. 4-3).

c. CHECK—While rotating the POSITION control throughout its range, check for no horizontal shift between traces.

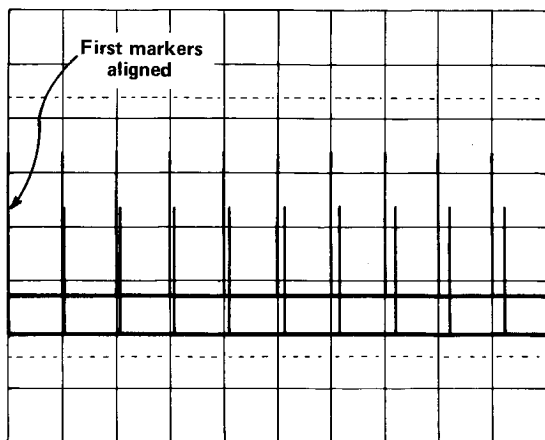

Fig. 4-3. Sweep Registration correctly adjusted (R560).

d. ADJUST—R516, Position Registration, for minimum shift between traces.

e. CHECK—First marker of both traces must be aligned.

f. ADJUST—R560, Sweep Registration, to align the first marker of both traces (see Fig. 4-3).

g. INTERACTION—Repeat the adjustment of R516 and R560 as necessary. The adjustment of R516 and R560 may affect the adjustment of R452 (Calibration step 16), R523 (Calibration step 22), and R364 (Preliminary adjustment in Calibration step 1, final adjustment in Calibration step 26).

21. Check/Adjust Delaying Sweep Calibration (R511)

a. CHECK—Rotate the POSITION control to view the tenth one-millisecond marker and check that the tenth marker of both traces are aligned.

b. ADJUST—R511, Delaying Sweep Cal, to align the tenth one-millisecond marker of both traces.

c. CHECK—CRT display for both traces horizontally aligned with one one-millisecond marker each graticule division over the center eight graticule divisions.

d. INTERACTION—Repeat the adjustment of R511 and the front-panel SWP CAL adjustment (Calibration step 17) as necessary.

22. Check/Adjust Position Centering (R523)

a. Rotate the front-panel POSITION control fully counterclockwise.

b. CHECK—That the second one-millisecond marker can be positioned to the left past the first graticule line.

c. ADJUST—R523, Position Centering, to position the second one-millisecond marker on the first graticule line.

d. CHECK—Rotate the POSITION control fully clockwise and check that the display can be positioned to the right of graticule center.

23. Check/Adjust Delaying and Delayed Sweep Length (R340, R465)

- a. Set the time-mark generator for one-millisecond and .1 millisecond markers.
- b. Adjust the MAIN TRIGGERING LEVEL control to trigger both traces on the one-millisecond markers.
- c. Rotate the TRACE SEP control fully clockwise and rotate the POSITION control to place the second one-millisecond marker on the first graticule line (see Fig. 4-4).
- d. CHECK—Delayed sweep trace for sweep length of 10.4 divisions (within 0.3 divisions) as shown by one to seven 0.1 millisecond markers to the right of the tenth vertical graticule line. The lower trace is the delayed sweep trace (see Fig. 4-4).
- e. ADJUST—R465, Delayed Sweep Length, for four 0.1 millisecond markers to the right of the tenth graticule line (see Fig. 4-4).
- f. CHECK—Delaying sweep trace for sweep length of 10.4 divisions (within 0.3 divisions) as shown by one to seven 0.1 millisecond markers to the right of the tenth vertical graticule line. The upper trace is the delaying sweep trace (see Fig. 4-4).
- g. ADJUST—R340, Delaying Sweep Length, for four 0.1 millisecond markers to the right of the tenth graticule line (see Fig. 4-4).
- h. INTERACTION—Repeat the adjustment of R340 and R465 as necessary. Check the adjustment of R402 (Calibration step 19) and R452 (Calibration step 16).

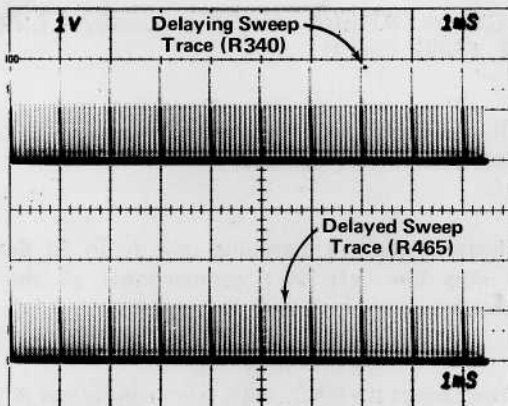

Fig. 4-4. Typical display when adjusting delaying and delayed sweep length (R340, R465).

24. Check/Adjust Delayed Sweep 20 Nanosecond Timing (C449)

- a. Set the time-mark generator for 10 nanosecond markers.
- b. Change the following control settings:

TIME/DIV OR	
DLY TIME	20 ns
DLY'D Time/Division	20 ns
POSITION	Adjust to horizontally center the display
Main Triggering	
LEVEL	Adjust for stable display
- c. CHECK—Delayed sweep trace (lower trace) for two complete cycles each graticule division over the center eight divisions.
- d. ADJUST—C449, Dly'd 20 ns Timing, for two complete cycles each graticule division over the center eight divisions of the delayed sweep trace.

25. Check/Adjust One-Microsecond Timing (C414, C443)

- a. Set the time-mark generator for one-microsecond markers.
- b. Change the following control settings:

TIME/DIV OR	
DLY TIME	1 μ s
DLY'D Time/Division	1 μ s
Main Triggering	
LEVEL	Adjust for a stable display
- c. CHECK—Delayed sweep trace (bottom trace) for one one-microsecond marker each graticule division.
- d. ADJUST—C443, Delayed One-Microsecond Timing, for one one-microsecond marker each graticule division of the delayed sweep trace (bottom trace).
- e. CHECK—Delaying sweep trace (upper trace) for one one-microsecond marker each graticule division.
- f. ADJUST—C414, Delaying One-Microsecond Timing, for one one-microsecond marker each graticule division of the delaying sweep trace (upper trace).

Calibration—7B92 Service

g. INTERACTION—Repeat the adjustment of C443, C414, and C449 (Calibration step 24) as necessary.

h. Change the following control settings:

TIME/DIV OR	
DLY TIME	1 μ s
DLY'D Time/Division	0.1 μ s
Main Triggering	
LEVEL	Adjust for a stable display

i. Rotate the DELAY TIME MULT dial to 1.00. If necessary, further rotate the dial to start the delayed sweep (lower trace) on the second 1 μ s marker.

j. Note the exact DELAY TIME MULT dial setting.

k. Rotate the DELAY TIME MULT dial exactly 8.00 divisions from the setting noted in part j.

l. CHECK—That the delayed sweep starts on the tenth 1 μ s marker.

m. ADJUST—C414, Delaying One Microsecond Timing, to start the delayed sweep trace on the tenth 1 μ s marker.

26. Check/Adjust Delay Pickoff TD Bias (R364)

a. Set the time-mark generator for two-nanosecond markers.

b. Change the following control settings:

DELAY TIME MULT	Fully counterclockwise
TIME/DIV OR	
DLY TIME	.1 μ s
DLY'D Time/Division	2 ns (press in for DLY'D Sweep Display Mode)
POSITION	Fully clockwise
ALT	(Press in)

c. Set the 7A19 Volts/Div switch for approximately two divisions of display. Position the display as necessary.

d. Rotate the MAIN TRIGGERING LEVEL control to trigger the display near the zero volt level. Do not change this LEVEL control setting.

e. Disconnect the time-mark signal from the 7A19 Input.

f. Remove the 7A15A Amplifier unit from the Right Vert compartment of the oscilloscope. Install the 7S12 TDR/Sampler (with S-1 Sampling Head and S-52 Pulse Generator Head) into the center two compartments of the oscilloscope.

g. Connect the Pulse Output of the S-52 Pulse Generator Head to the 7A19 Input with a SMA (3 mm) male-to-BNC female adapter and a 42-inch BNC cable.

h. Set the 7A19 Volts/Div switch for approximately two divisions of display.

i. CHECK—CRT display for leading edge of the pulse between the sixth and seventh graticule lines.

j. ADJUST—R364, Delay Pickoff TD Bias, fully counterclockwise. Then adjust R364 clockwise until the leading edge of the pulse is between the sixth and seventh graticule lines.

k. Remove the 7B92 and plug-in extender from the oscilloscope, then install the 7B92 directly into the B Horizontal compartment.

l. CHECK—CRT display for leading edge of the pulse between the seventh and eighth graticule lines.

m. INTERACTION—If the requirements in step l cannot be met, install the 7B92 and plug-in extender into the B Horizontal compartment and repeat steps i through l. The adjustment of R364, given in step j, may need to be varied slightly to meet requirements given in step l.

27. Check/Adjust High-Frequency Linearity (C557, C565, C572)

a. Remove the 7A19 Amplifier unit and the 7B92 Time Base unit from the oscilloscope.

b. Install the 7S11 Sampling unit (with S1 Sampling Head) into the Left Vert compartment of the 7904 Oscilloscope.

c. Disconnect the BNC cables from connectors A 11 and B 11 of the 067-0589-00 plug-in extender. Install the 7B92 and plug-in extender into the B Horizontal compartment of the oscilloscope.

d. Connect the + and – outputs of the 7B92 (plug-in extender cables A 11 and B 11) differentially to the sampling system inputs. Specifically, connect the + signal from plug-in extender cable A 11 to the 7S12 Input (by way of S-1 Sampling Head) with a BNC female-to-female adapter, 42-inch BNC cable, and BNC female-to-GR adapter. Connect the – signal from plug-in extender cable B 11 to the 7S11 Input (by way of S-1 Sampling Head) with a BNC female-to-female adapter, 42-inch BNC cable, and BNC female-to-GR adapter. Install a 42-inch BNC cable, with BSM female-to-BNC female adapter, from the S-52 Pretrig Out connector (S-52 pulse generator head is installed in the 7S12 TDR Sampler) to the 7B92 MAIN TRIG IN connector.

e. Change the following control settings:

7904 Oscilloscope

Vertical Mode	Add
Horizontal Mode	A

7B92 Time Base

Main Triggering SOURCE	EXT
TIME/DIV OR DLY TIME	.1 μ s
DLY'D Time/Division	50 ns (press in for DLY'D Sweep Display Mode)

7S11 Sampling Unit

+ Up/Invert	Invert
mVolts/Div	100
Variable	Cal In
Dot Response	Normal

7S12 TDR/Sampler

mV/mp (pushbutton)	mV
mVolts/Div	100
Variable Volts/Div	Cal In
Time/Div	.1 μ s
REP (pushbutton)	(Press in for repetitive scan display)

f. Rotate the 7B92 MAIN TRIGGERING LEVEL control for the TRIG'D light on.

g. Rotate the 7S11 and 7S12 DC Offset controls to vertically position the display on the CRT.

h. Set the 7904 Vertical Mode to Chop. Rotate the 7S11 and 7S12 DC Offset controls and the 7S11 Delay Control to position both traces together.

i. Repeat steps g and h until the display is vertically positioned on the CRT when the 7904 is in the Add Vertical Mode, and both traces are positioned together when the 7904 is in the Chop Vertical Mode.

j. Set the 7904 Vertical Mode to ADD.

k. Press and release the 7S12 Time/Division Variable control for variable sweep rates, and adjust for a ramp display of five vertical divisions in five horizontal divisions. Rotate the DELAY TIME MULT dial to approximately midrange and rotate the 7S12 Time Distance control to horizontally position the trace.

NOTE

The sampling system display is now calibrated to the 50 nanosecond sweep rate of the 7B92 under calibration. Do not change the 7S12 Time/Div Variable and Time Distance control.

l. Change the following control settings:

7B92 Time Base

TIME/DIV OR DLY TIME	.1 μ s
DLY'D Time/Division	2 ns (press in for DLY'D Sweep Display Mode)

7S11 Sampling Unit

mVolts/Div	200
------------	-----

7S12 Sampling Unit

mVolts/Div	200
Time/Div	10 ns

n. Rotate the 7B92 DELAY TIME MULT dial to horizontally position the trace.

o. CHECK—CRT display for a smooth and linear ramp with slight preshoot (see Fig. 4-5).

p. ADJUST—C557, Sweep Linearity, for peak amplitude on leading edge, C565 and C572 for a slight preshoot with as smooth and linear ramp as possible.

q. INERACTION—Repeat the adjustment of C557, C565, and C572 as necessary.

r. Disconnect all test equipment and remove all plug-in units from the oscilloscope.

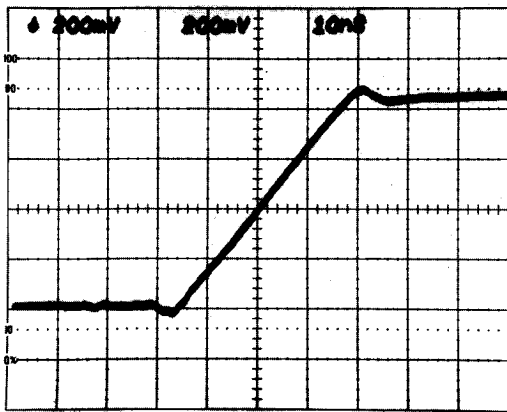

Fig. 4-5. Typical CRT display when adjusting high-frequency linearity (C557, C565, C572).

28. Check/Adjust High-Frequency Timing (R244, R246, R567)

a. Install the 7A19 Amplifier directly into the Left Vert compartment of the 7904 Oscilloscope and 7B92 Time Base directly into the B Horiz compartment.

b. Connect the output of the time-mark generator to the 7A19 Input with a 42-inch 50-ohm BNC cable. Set the time-mark generator for 2 ns markers.

c. Change the following control settings:

7904 Oscilloscope

Vertical Mode Left Vert
Horizontal Mode B

7B92 Time Base

Main Triggering
SOURCE INT
LEVEL Adjust for stable display

TIME/DIV OR
DLY TIME .1 μ s
DLY'D Time/Division .5 ns (press in for DLY'D Sweep Display Mode)

d. Adjust the 7A19 Volts/Division switch for about two divisions of display. Adjust the 7B92 and oscilloscope Intensity controls as necessary. Center the display on the CRT with the 7A19 and 7B92 POSITION controls.

NOTE

Timing checks must be made with the 7B92 installed directly into the oscilloscope. Adjustment of R567

can be made by reaching into the center two compartments of the oscilloscope (be certain that the 7A19 side covers are on). R244 and R246 can be adjusted through the top plug-in housing or by removing the 7B92 from the oscilloscope.

e. CHECK—CRT display for two complete cycles over the center eight graticule divisions.

f. ADJUST—R567, .5 ns Timing, for two complete cycles over the center eight graticule divisions.

g. Change the DLY'D Time/Division switch to 1 ns.

h. CHECK—CRT display for one complete cycle in two graticule divisions.

i. ADJUST—R246, 1 ns Timing, for one complete cycle in two graticule divisions.

j. Change the DLY'D Time/Division switch to 2 ns.

k. CHECK—CRT display for one complete cycle each division over the center eight divisions of the graticule.

l. ADJUST—R244 for one complete cycle each division over the center eight divisions of the graticule.

NOTE

If R244, R246, or R567 cannot be adjusted to the given tolerances, repeat calibration step 27.

√29. Check Delaying and Delayed Sweep Timing Accuracy

NOTE

The tolerance in steps 29 and 30 are for an ambient temperature range of +15°C to +35°C. If outside this range, see Specifications in the 7B92 Operator's Manual for applicable tolerances.

a. Change the following control settings:

ALT OUT (TRACE SEP fully clockwise)
DELAY TIME MULT 0.00

b. Set the 7B92 and oscilloscope Intensity controls for an optimum ALT Sweep Display. Position the display as necessary.

✓c. CHECK—Using the Time/Division switch settings and the time-mark generator settings given in Table 4-1, check delaying and delayed sweep timing to the tolerance given in Table 4-1. Make timing checks in the ALT Sweep Display Mode. The upper trace is the delaying sweep trace and the lower trace is the delayed sweep trace.

d. CALIBRATION—If the 7B92 does not meet the requirements given in part c, check the adjustment of the front-panel SWP CAL (Calibration step 17) and R511 (Calibration step 21). If the adjustment of R511 and the front-panel SWP CAL does not correct the 7B92 timing accuracy, check Calibration steps 24 through 28.

✓30. Check Delaying and Delayed Sweep Linearity

a. Change the following settings:

TIME/DIV OR DLY TIME 1 ms
 DLY'D Time/Division 1 ms (Pull out for INTEN Display Mode)
 ALT IN

b. Set the time-mark generator for one-millisecond markers. Center the display vertically and rotate the MAIN TRIGGERING LEVEL control for a stable display.

c. Position the second marker to the second graticule line.

TABLE 4-1
 Delaying and Delayed Sweep Timing

TIME/DIV OR DLY TIME	DLY'D Time/Division	Time Markers	CRT Display (markers/division)	Tolerance (+15°C to +35°C)	
				Delaying Sweep	Delayed Sweep
.2 s	.2 s	.1 s	2	±0.32 div	±0.32 div
.1 s	.1 s	.1 s	1	±0.24 div	±0.24 div
50 ms	50 ms	50 ms	1		
20 ms	20 ms	10 ms	2		
10 ms	10 ms	10 ms	1		
5 ms	5 ms	5 ms	1		
2 ms	2 ms	1 ms	2		
1 ms	1 ms	1 ms	1		
.5 ms	.5 ms	.5 ms	1		
.2 ms	.2 ms	.1 ms	2		
.1 ms	.1 ms	.1 ms	1		
50 μs	50 μs	50 μs	1		
20 μs	20 μs	10 μs	2		
10 μs	10 μs	10 μs	1		
5 μs	5 μs	5 μs	1		
2 μs	2 μs	1 μs	2		
1 μs	1 μs	1 μs	1		
.5 μs	.5 μs	.5 μs	1		
.2 μs	.2 μs	.1 μs	2		
.1 μs	.1 μs	.1 μs	1		
50 ns	50 ns	50 ns	1	±0.32 div (Exclude the first 2 div of delayed sweep)	
20 ns	20 ns	10 ns	2		
10 ns	10 ns	10 ns	1		
10 ns	5 ns	5 ns	1		
	2 ns	2 ns	1		
	1 ns	2 ns	1 cycle/2 div		±0.32 div (Exclude the first 5 div of delayed sweep)
	.5 ns	2 ns	1 cycle/4 div		±0.4 div (Exclude the first 10 divisions of delayed sweep)

Calibration—7B92 Service

√d. CHECK—Fourth marker is within 0.1 division (5%) of the fourth graticule line.

e. Position the third marker to the third graticule line.

√f. CHECK—Fifth marker is within 0.1 division (5%) of the fifth graticule line.

√g. CHECK—Continue linearity check for each two division portion of the sweep within the center eight divisions of display.

h. Change the TIME/DIV OR DLY TIME and DLY'D Time/Division switches to 10 ns (INTEN Display Mode). Set the time-mark generator for 10 nanosecond markers.

√i. CHECK—Using the procedure outlined in steps c through g, check that delaying sweep linearity is within 0.1 division (5%).

j. Set the TIME/DIV OR DLY TIME and DLY'D Time/Division switches to 1 ms (press in DLY'D Time/Division switch for NORMAL Sweep Display Mode). Set the time-mark generator for one-millisecond markers.

√k. CHECK—Using the procedure outlined in steps c through g, check that delayed sweep linearity is within 0.1 division (5%).

l. Set the TIME/DIV OR DLY TIME and DLY'D Time/Division switches to 10 ns (press in DLY'D Time/Division switch for NORMAL Sweep Display Mode). Set the time-mark generator for ten nanosecond markers.

√m. CHECK—Using the procedure outlined in steps c through g, check that delayed sweep linearity is within 0.2 division (10%).

n. Set the TIME/DIV OR DLY TIME and DLY'D Time/Division switches to 2 ns (press in DLY'D Time/Division switch for NORMAL Sweep Display Mode). Set the time-mark generator for two nanosecond markers.

√o. CHECK—Using the procedure outlined in steps c through g, check that delayed sweep linearity is within 0.2 division (10%). Exclude the first two divisions of delayed sweep.

√31. Check Delaying and Delayed Sweep Variable Control Range

a. Set the time-mark generator for ten-microsecond markers.

b. Change the following control settings:

TIME/DIV OR	
DLY TIME	2 μ s
DLY'D Time/Division	2 μ s (pull out for INTEN Display Mode)
Variable	Set for Delaying
Time/Division	Sweep Variable (see Operator's Manual)
Selector (P110)	

c. Adjust the MAIN TRIGGERING LEVEL control for a stable display. Press and release the VARIABLE Time/Division control for variable delaying sweep rates.

√d. CHECK—Rotate the VARIABLE control fully counterclockwise. Check CRT display for no more than two major divisions between ten-microsecond markers. (This indicates continuously variable sweep rates between calibrated steps.)

e. Set the Variable Time/Division Selector for variable delayed sweep rates. Press in the DLY'D Time/Division switch for the DLY'D Sweep Display Mode.

√f. CHECK—Repeat part d.

√32. Check Differential Delay Time Multiplier Accuracy

a. Set the time-mark generator for 1 ms markers.

b. Change the following control settings:

TIME/DIV OR	
DLY TIME	1 ms
DLY'D Time/Division	10 μ s (press in for DLY'D Sweep Display Mode)
VARIABLE	CAL (IN)
MAIN TRIGGERING	
LEVEL	Set for stable display

NOTE

The following steps check delay time multiplier accuracy. Two factors must be determined: the maximum error allowable to be within the specifications, and the actual error of the measurement.

c. Rotate the DELAY TIME MULT dial to 1.00. If necessary, further rotate the dial to place a 1 ms marker on the CRT. To provide a reference point, position the 1 ms marker to graticule center with the 7B92 POSITION control (see Fig. 4-6). Note the exact DELAY TIME MULT dial setting.

Measurement Error as Viewed from CRT Display

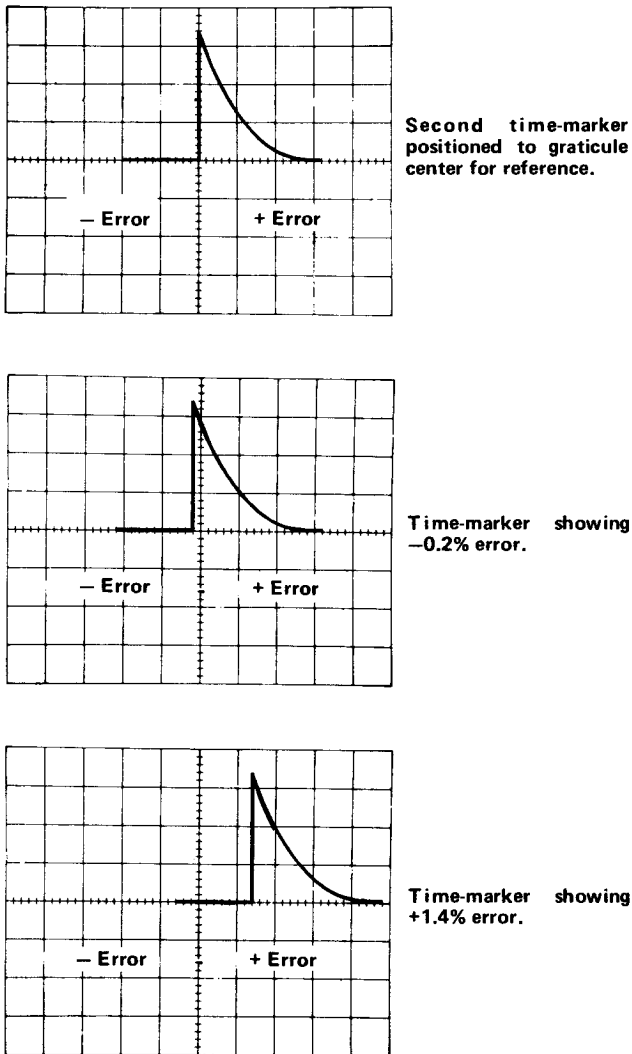

NOTE

With the delayed sweep rate 1/100 of the main sweep rate (e.g. TIME/DIV or DLY TIME switch at 1 ms; DLY'D Time/division switch at 10 μ s), each major horizontal graticule division represents 1% error.

Fig. 4-6. Typical delay time error measurement.

d. Rotate the DELAY TIME MULT dial to major division points from the dial setting noted in part c (e.g. if the DELAY TIME MULT dial setting noted in part c is 1.02, major division points will be 2.02, 3.02, 4.02 through 9.02). Check and record the position of each time marker

(with respect to the reference point established to graticule center) at each major division over the center eight divisions. See Fig. 4-6 for error measurement and Fig. 4-7 for typical delay time error figures.

√e. CHECK—Scan the figures recorded in step d for all difference readings over the center eight divisions (see Fig. 4-7). Find the maximum error over any one division measurement. Check that it is within the allowable error (see Fig. 4-8).

Example. Refer to the curve in Fig. 4-8 for the 0.1 s/DIV to 0.1 μ s/DIV delay time range. For any one-division measurement the allowable error is 3.7%. At the same delay time range, for any five division measurement the allowable error is 1.3%.

√f. CHECK—Scan the figures recorded in step d for difference reading over the center eight divisions of display (see Fig. 4-7). Find the maximum error over any two-division measurement, divider by two, and check that it is within the allowable error given in Fig. 4-8.

√g. CHECK—Scan the figures recorded in step d for difference readings over the center eight divisions (see Fig. 4-7). Find the maximum error over any four division measurement, divide by four, and check that it is within the allowable error given in Fig. 4-8.

√h. CHECK—Scan the figures recorded in step d (see Fig. 4-7). Find the maximum error over an eight-division measurement, divide by eight, and check that it is within the allowable error given in Fig. 4-8.

i. Set the time-mark generator for .1 s markers.

j. Change the following control settings:

TIME/DIV OR	
DLY TIME	.2 s
DLY'D Time/Division	2 ms (press in for DLY'D Sweep Display Mode)
Main Triggering	
LEVEL	Set for stable display

√k. CHECK—Repeat steps c through h. Refer to the curve in Fig. 4-8 for .2 s accuracy.

l. Set the TIME/DIV OR DLY TIME and DLY'D Time/Division switches to 50 ns.

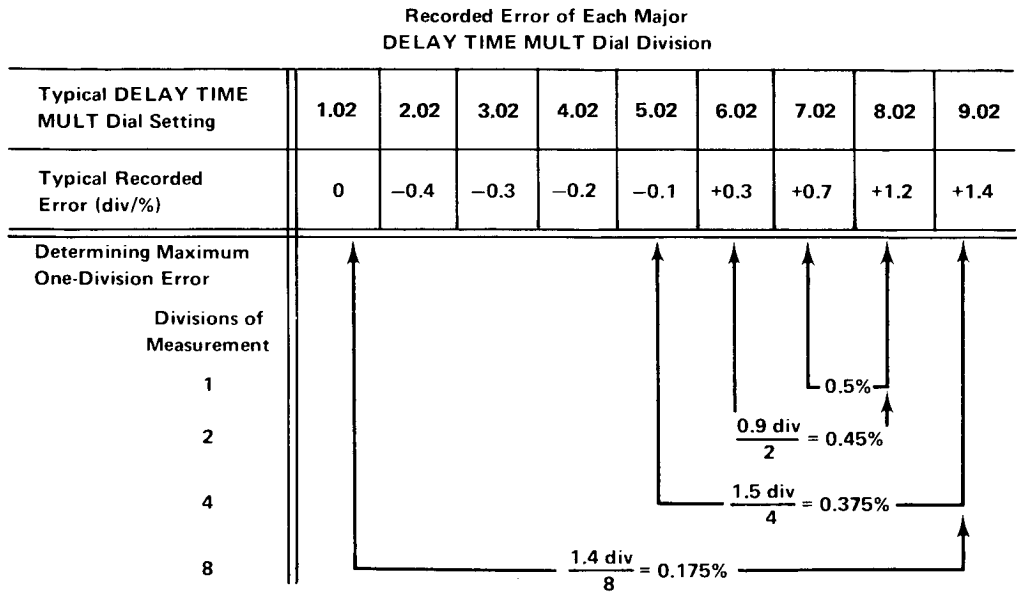

NOTE : Percentage figures apply only when delayed sweep rate is 1/100 of the main sweep rate.

Fig. 4-7. Typical delay time error figures.

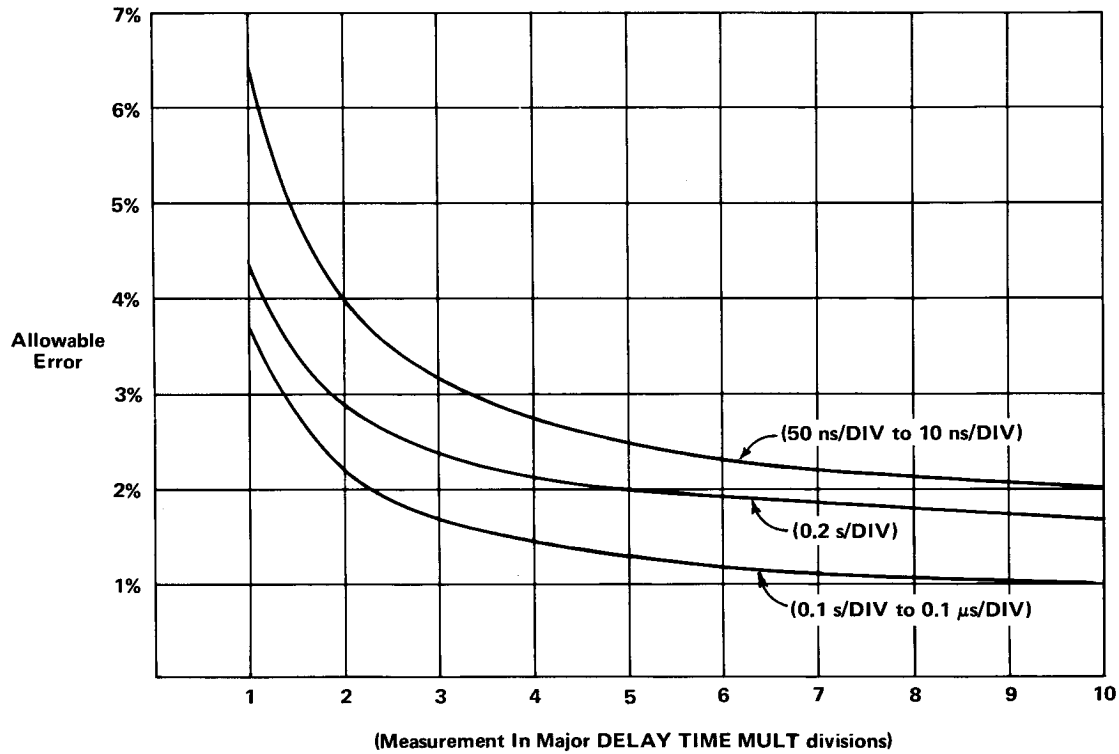

Fig. 4-8. Allowable delay time error.

m. Set the time-mark generator for 50 ns markers. Center the display vertically on the CRT. Do not change the Amplifier unit Position control for the remainder of this step.

n. Set the TIME/DIV OR DLY TIME switch to 50 ns and the DLY'D Time/Division switch to .5 ns (press in the DLY'D Time/Division switch for the DLY'D Sweep Display Mode).

o. Rotate the DELAY TIME MULT dial to 1.00. If necessary, further rotate the dial to place the positive slope of the time-mark waveform at CRT center (see Fig. 4-9). Note the exact DELAY TIME MULT dial setting.

NOTE

The point that the positive slope of the time mark crosses graticule center, provides a timing reference point.

√p. CHECK—Repeat parts c through h. Refer to Fig. 4-9 for error measurement of the 50 ns time mark and refer to the curve in Fig. 4-8 for 50 ns/DIV to 10 ns/DIV accuracy.

√33. Check Absolute Delay Time Accuracy

a. Press and release the ALT pushbutton for the ALT Sweep Display Mode and rotate fully clockwise (TRACE SEP).

b. Adjust the 7A19 Volts/Division switch for approximately a two-division display of each trace. Center the display vertically.

√c. CHECK—Using the TIME/DIV OR DLY TIME switch settings, DLY'D Time/Division switch settings, and time-mark generator settings given in Table 4-2, check absolute delay time accuracy. Set the DELAY TIME MULT dial to 0.00. Rotate the 7B92 POSITION control to reference a point on the delayed sweep waveform (lower trace) to the center vertical graticule line. Rotate the DELAY TIME MULT dial to move the waveform (delayed sweep trace) one or two complete cycles (number of cycles given in Table 4-2) to the left with the same point referenced to the center vertical graticule line. Check that the DELAY TIME MULT dial setting is 1.00 within the tolerance given in Table 4-2.

NOTE

The delayed sweep trace (lower trace) provides the best indication of the sweep starting point while the intensified trace indicates the marker on which the sweep starts.

√34. Check Delay-Time Jitter

a. Set the time-mark generator for 1 millisecond markers.

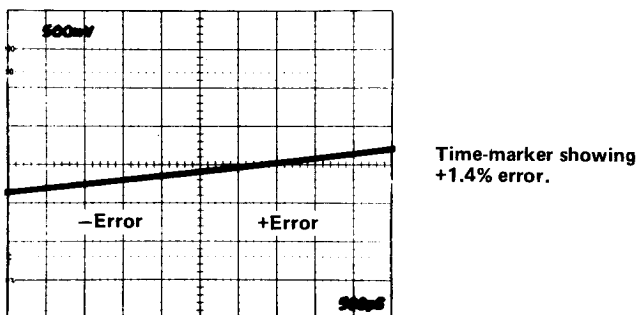
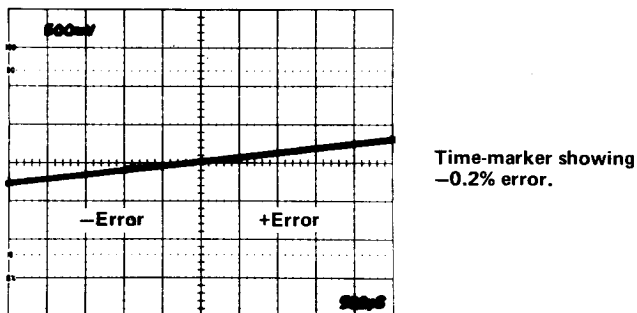
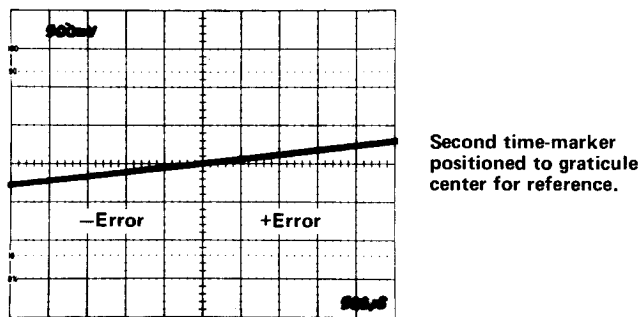

NOTE

With the delayed sweep rate 1/100 of the main sweep rate (e.g. TIME/DIV or DLY TIME switch at 50 ns DLY'D Time/division switch at .5 ns), each major horizontal graticule division represents 1% error.

Fig. 4-9. Typical delay time error measurement.

TABLE 4-2
Absolute Delay Time Measurements

TIME/DIV OR DLY TIME Switch	DLY'D Time/ Division Switch (DLY'D SWP Display Mode)	Time-Mark Generator Setting	Measurement (cycles or markers)	Allowable Error
.2 s	2 ms	.1 s	2	±8 minor dial divisions
.1 s	10 ms	.1 s	1	±7.5 minor dial divisions
50 ms	5 ms	50 ms	1	
20 ms	2 ms	10 ms	2	
10 ms	1 ms	10 ms	1	
5 ms	.5 ms	5 ms	1	
2 ms	.2 ms	1 ms	2	
1 ms	.1 ms	1 ms	1	
.5 ms	50 μs	.5 ms	1	
.2 ms	20 μs	.1 ms	2	
.1 ms	10 μs	.1 ms	1	
50 μs	5 μs	50 μs	1	
20 μs	2 μs	10 μs	2	
10 μs	1 μs	10 μs	1	
5 μs	.5 μs	5 μs	1	
2 μs	.2 μs	1 μs	2	
1 μs	.1 μs	1 μs	1	
.5 μs	50 ns	.5 μs	1	
.2 μs	20 ns	.1 μs	2	±32.5 minor dial divisions
.1 μs	20 ns	.1 μs	1	±57.5 minor dial divisions
50 ns	20 ns	50 ns	1	±31 minor dial divisions
20 ns	5 ns	10 ns	2	±61 minor dial divisions
10 ns	5 ns	10 ns	1	±111 minor dial divisions

b. Change the following control settings:

TIME/DIV OR DLY TIME 1 ms
 DLY'D Time/Division 1 μs (press in for DLY'D Sweep Display Mode)
 ALT IN
 DELAY TIME MULT 1.00

c. Position the pulse to the center of CRT display area with the DELAY TIME MULT dial.

√d. CHECK—Jitter in the leading edge of the pulse should not exceed 0.2 division (one part in 50,000). Disregard any slow drift.

e. Rotate the DELAY TIME MULT dial to about 9.00 and adjust the pulse to the center of the CRT display area.

√f. CHECK—Jitter on the leading edge of the pulse should not exceed 0.2 division (one part in 50,000). Disregard any slow drift.

REPLACEABLE ELECTRICAL PARTS

PARTS ORDERING INFORMATION

Replacement parts are available from or through your local Tektronix, Inc. Field Office or representative.

Changes to Tektronix instruments are sometimes made to accommodate improved components as they become available, and to give you the benefit of the latest circuit improvements developed in our engineering department. It is therefore important, when ordering parts, to include the following information in your order: Part number, instrument type or number, serial number, and modification number if applicable.

If a part you have ordered has been replaced with a new or improved part, your local Tektronix, Inc. Field Office or representative will contact you concerning any change in part number.

Change information, if any, is located at the rear of this manual.

SPECIAL NOTES AND SYMBOLS

- X000 Part first added at this serial number
00X Part removed after this serial number

ITEM NAME

In the Parts List, an Item Name is separated from the description by a colon (:). Because of space limitations, an Item Name may sometimes appear as incomplete. For further Item Name identification, the U.S. Federal Cataloging Handbook H6-1 can be utilized where possible.

ABBREVIATIONS

ACTR	ACTUATOR	PLSTC	PLASTIC
ASSY	ASSEMBLY	QTZ	QUARTZ
CAP	CAPACITOR	RECP	RECEPTACLE
CER	CERAMIC	RES	RESISTOR
CKT	CIRCUIT	RF	RADIO FREQUENCY
COMP	COMPOSITION	SEL	SELECTED
CONN	CONNECTOR	SEMICOND	SEMICONDUCTOR
ELCTLT	ELECTROLYTIC	SENS	SENSITIVE
ELEC	ELECTRICAL	VAR	VARIABLE
INCAND	INCANDESCENT	WW	WIREWOUND
LED	LIGHT EMITTING DIODE	XFMR	TRANSFORMER
NONWIR	NON WIREWOUND	XTAL	CRYSTAL

CROSS INDEX MFR. CODE NUMBER TO MANUFACTURER

MFR.CODE	MANUFACTURER	ADDRESS	CITY,STATE,ZIP
00853	Sangamo Electric Co., S. Carolina Div.	P. O. Box 128	Pickens, SC 29671
01121	Allen-Bradley Co.	1201 2nd St. South	Milwaukee, WI 53204
01295	Texas Instruments, Inc., Components Group	P. O. Box 5012	Dallas, TX 75222
03508	General Electric Co., Semi-Conductor Products Dept.	Electronics Park	Syracuse, NY 13201
04713	Motorola, Inc., Semiconductor Products Div.	5005 E. McDowell Rd.	Phoenix, AZ 85008
07263	Fairchild Semiconductor, A Div. of Fairchild Camera and Instrument Corp.	464 Ellis St.	Mountain View, CA 94040
07910	Teledyne Semiconductor	12515 Chadron Ave.	Hawthorne, CA 90250
12697	Clarostat Mfg. Co., Inc.	Lower Washington St.	Dover, NH 03820
13715	Fairchild Semiconductor, A Div. of Fairchild Camera and Instrument Corp.	4300 Redwood Hwy.	San Rafael, CA 94903
14936	General Instrument Corp., Semiconductor Products Group	600 W. John St.	Hicksville, NY 11802
22229	Solitron Devices, Inc.	8808 Balboa Ave.	San Diego, CA 92123
27014	National Semi-Conductor Corp.	2900 San Ysidro Way	Santa Clara, CA 95051
28480	Hewlett-Packard Co., Corporate Hq.	1501 Page Mill Rd.	Palo Alto, CA 94304
56289	Sprague Electric Co.		North Adams, MA 01247
71590	Centralab Electronics, Div. of Globe-Union, Inc.	5757 N. Green Bay Ave.	Milwaukee, WI 53201
72982	Erie Technological Products, Inc.	644 W. 12th St.	Erie, PA 16512
73138	Beckman Instruments, Inc., Helipot Div.	2500 Harbor Blvd.	Fullerton, CA 92634
74970	Johnson, E. F., Co.	299 10th Ave. S. W.	Waseca, MN 56093
75042	TRW Electronic Components, IRC Fixed Resistors, Philadelphia Division	401 N. Broad St.	Philadelphia, PA 19108
76493	Bell Industries, Inc., Miller, J. W., Div.	P. O. Box 5825	Compton, CA 90224
78488	Stackpole Carbon Co.		St. Marys, PA 15857
80009	Tektronix, Inc.	P. O. Box 500	Beaverton, OR 97077
80294	Bourns, Inc., Instrument Div.	6135 Magnolia Ave.	Riverside, CA 92506
80740	Beckman Instruments, Inc.	2500 Harbor Blvd.	Fullerton, CA 92634
81483	International Rectifier Corp.	9220 Sunset Blvd.	Los Angeles, CA 90069
90201	Mallory Capacitor Co., Div. of P. R. Mallory Co., Inc.	3029 E. Washington St.	Indianapolis, IN 46206

Ckt No.	Tektronix Part No.	Serial/Model No. Eff	Dscont	Name & Description	Mfr Code	Mfr Part Number
A1	670-1588-00			CKT BOARD ASSY:MODE SWITCH	80009	670-1588-00
A2	670-1587-00			CKT BOARD ASSY:COUPLING SWITCH	80009	670-1587-00
A3	670-1589-00			CKT BOARD ASSY:SOURCE SWITCH	80009	670-1589-00
A4	670-1585-00			CKT BOARD ASSY:DELAYED TRIGGER SWITCH	80009	670-1585-00
A5	670-1593-00			CKT BOARD ASSY:DISTRIBUTION	80009	670-1593-00
A6	670-1584-00	B010100	B039999	CKT BOARD ASSY:MAIN INTERFACE	80009	670-1584-00
A6	670-1584-01	B040000	B059999	CKT BOARD ASSY:MAIN INTERFACE	80009	670-1584-01
A6	670-1584-02	B060000		CKT BOARD ASSY:MAIN INTERFACE	80009	670-1584-02
A7	670-1586-00			CKT BOARD ASSY:EXT INPUT	80009	670-1586-00
A8	670-1591-00			CKT BOARD ASSY:MAIN TRIGGER	80009	670-1591-00
A9	670-1592-00			CKT BOARD ASSY:DELAYED TRIGGER	80009	670-1592-00
A10	670-1583-00			CKT BOARD ASSY:SWEEP	80009	670-1583-00
A11	670-1590-00			CKT BOARD ASSY:READOUT	80009	670-1590-00
C3	283-0068-00			CAP.,FXD,CER DI:0.01UF,+100-0%,500V	56289	19C241
C9	290-0246-00			CAP.,FXD,ELCTLT:3.3UF,10%,15V	56289	162D335X9015C02
C30	283-0000-00			CAP.,FXD,CER DI:0.001UF,+100-0%,500V	72982	831-516E102P
C54	283-0160-00			CAP.,FXD,CER DI:1.5PF,10%,50V	72982	8101A058COK159B
C57	283-0140-00			CAP.,FXD,CER DI:4.7PF,5%,50V	72982	8101-003C0H479C
C59	283-0140-00			CAP.,FXD,CER DI:4.7PF,5%,50V	72982	8101-003C0H479C
C62	281-0544-00			CAP.,FXD,CER DI:5.6PF,10%,500V	72982	301-000C0H0569D
C63	281-0633-00			CAP.,FXD,CER DI:910PF,5%,500V	72982	308-000T2H0880J
C73	281-0544-00			CAP.,FXD,CER DI:5.6PF,10%,500V	72982	301-000C0H0569D
C78	281-0653-00			CAP.,FXD,CER DI:3.3PF,30%,200V	72982	374-001C0K0109C
C79	283-0068-00			CAP.,FXD,CER DI:0.01UF,+100-0%,500V	56289	19C241
C84	283-0160-00			CAP.,FXD,CER DI:1.5PF,10%,50V	72982	8101A058COK159B
C86	281-0618-00			CAP.,FXD,CER DI:4.7PF,+/-0.5PF,200V	72982	374-001C0H0479D
C141	283-0111-00			CAP.,FXD,CER DI:0.1UF,20%,50V	72982	8131N075651104M
C150	290-0246-00			CAP.,FXD,ELCTLT:3.3UF,10%,15V	56289	162D335X9015C02
C151	281-0605-00			CAP.,FXD,CER DI:200PF,10%,500V	72982	301-000Y5D0201K
C161	283-0239-00			CAP.,FXD,CER DI:0.022UF,10%,50V	72982	8131N075WR5223K
C207	283-0164-00			CAP.,FXD,CER DI:2.2UF,20%,25V	72982	8141N038651225M
C208	283-0239-00			CAP.,FXD,CER DI:0.022UF,10%,50V	72982	8131N075WR5223K
C212	290-0525-00	B010100	B019999	CAP.,FXD,ELCTLT:4.7UF,20%,50V	56289	196D475X0050KA1
C212	283-0212-00	B020000		CAP.,FXD,CER DI:2UF,20%,50V	72982	8141050651205M
C216 ¹	295-0145-00			CAP.,MATCHED:0.01UF		
C217 ¹				CAP.,MATCHED:1UF		
C248	290-0525-00	B010100	B019999	CAP.,FXD,ELCTLT:4.7UF,20%,50V	56289	196D475X0050KA1
C248	283-0212-00	B020000		CAP.,FXD,CER DI:2UF,20%,50V	72982	8141050651205M
C255 ¹	295-0145-00			CAP.,MATCHED:0.01UF		
C256 ¹				CAP.,MATCHED:1UF		
C267	290-0522-00			CAP.,FXD,ELCTLT:1UF,20%,50V	56289	196D105X0050HA1
C277	281-0630-00			CAP.,FXD,CER DI:390PF,5%,500V	72982	301-000Y5D0391J
C278	281-0580-00			CAP.,FXD,CER DI:470PF,10%,500V	72982	301-000Z5D0471K
C280	283-0000-00			CAP.,FXD,CER DI:0.001UF,+100-0%,500V	72982	831-516E102P
C281	283-0111-00			CAP.,FXD,CER DI:0.1UF,20%,50V	72982	8131N075651104M
C284	283-0000-00			CAP.,FXD,CER DI:0.001UF,+100-0%,500V	72982	831-516E102P
C285	283-0111-00			CAP.,FXD,CER DI:0.1UF,20%,50V	72982	8131N075651104M
C293	283-0111-00			CAP.,FXD,CER DI:0.1UF,20%,50V	72982	8131N075651104M
C294	283-0000-00			CAP.,FXD,CER DI:0.001UF,+100-0%,500V	72982	831-516E102P
C295	283-0111-00	XB020000		CAP.,FXD,CER DI:0.1UF,20%,50V	72982	8131N075651104M
C297	283-0111-00			CAP.,FXD,CER DI:0.1UF,20%,50V	72982	8131N075651104M
C298	283-0000-00			CAP.,FXD,CER DI:0.001UF,+100-0%,500V	72982	831-516E102P
C300	290-0522-00			CAP.,FXD,ELCTLT:1UF,20%,50V	56289	196D105X0050HA1
C304	290-0522-00			CAP.,FXD,ELCTLT:1UF,20%,50V	56289	196D105X0050HA1

¹Furnished as a unit with C255 and C256.

²Furnished as a unit with C216 and C217.

³Individual timing capacitors in this assembly must be ordered by the 9 digit part number, letter suffix and tolerance printed on the timing capacitor to be replaced. The letter suffix and the tolerance should be the same for all of the timing capacitors in the assembly: EXAMPLE ————|285-XXXX-XX F-|—————

Electrical Parts List—7B92

Ckt No.	Tektronix Part No.	Serial/Model No. Eff	Dscont	Name & Description	Mfr Code	Mfr Part Number
C307	283-0054-00			CAP.,FXD,CER DI:150PF,5%,200V	72982	855-535U2J151J
C308	283-0108-00			CAP.,FXD,CER DI:220PF,10%,200V	56289	272C13
C309	290-0536-00			CAP.,FXD,ELCTLT:10UF,20%,25V	90201	TDC106M025FL
C314	290-0535-00			CAP.,FXD,ELCTLT:33UF,20%,10V	56289	196D336X0010KA1
C330	290-0519-00			CAP.,FXD,ELCTLT:100UF,20%,20V	56289	196D107X0020MA3
C335	281-0605-00			CAP.,FXD,CER DI:200PF,10%,500V	72982	301-000Y5D0201K
C337	281-0523-00			CAP.,FXD,CER DI:100PF,+/-20PF,350V	72982	301-000U2M0101M
C349	281-0524-00	B010100	B029999	CAP.,FXD,CER DI:150PF,+/-30PF,500V	72982	301-000X5U0151M
C349	281-0543-00	B030000		CAP.,FXD,CER DI:270PF,10%,500V	72982	301-055X5P1271K
C351	290-0522-00			CAP.,FXD,ELCTLT:1UF,20%,50V	56289	196D105X0050HA1
C356	290-0536-00			CAP.,FXD,ELCTLT:10UF,20%,25V	90201	TDC106M025FL
C361	290-0517-00			CAP.,FXD,ELCTLT:6.8UF,20%,35V	56289	196D685X0035KA1
C370	281-0504-00			CAP.,FXD,CER DI:10PF,+/-1PF,500V	72982	301-000C0G0100F
C380	290-0522-00			CAP.,FXD,ELCTLT:1UF,20%,50V	56289	196D105X0050HA1
C382	290-0532-00			CAP.,FXD,ELCTLT:150UF,20%,6V	90201	TDC157M006CL
C383	281-0523-00			CAP.,FXD,CER DI:100PF,+/-20PF,350V	72982	301-000U2M0101M
C390	281-0658-00			CAP.,FXD,CER DI:6.2PF, /-0.25PF,500V	72982	301-000C0H0629C
C400	281-0523-00			CAP.,FXD,CER DI:100PF,+/-20PF,350V	72982	301-000U2M0101M
C408	283-0111-00			CAP.,FXD,CER DI:0.1UF,20%,50V	72982	8131N075651104M
C409	290-0522-00			CAP.,FXD,ELCTLT:1UF,20%,50V	56289	196D105X0050HA1
C413	283-0632-00			CAP.,FXD,MICA D:87PF,1%,100V	00853	D151E870F0
C414	281-0166-00			CAP.,VAR,AIR DI:1.9-15.7PF,250V	74970	187-0109-005
C425	281-0519-00			CAP.,FXD,CER DI:47PF,+/-4.7PF,500V	72982	308-000C0G0470K
C432	281-0524-00			CAP.,FXD,CER DI:150PF,+/-30PF,500V	72982	301-000X5U0151M
C441	281-0550-00			CAP.,FXD,CER DI:120PF,10%,500V	72982	301-000X5P0121K
C443	281-0166-00			CAP.,VAR,AIR DI:1.9-15.7PF,250V	74970	187-0109-005
C444	283-0633-00			CAP.,FXD,MICA D:77PF,1%,100V	00853	D151E770F0
C448	281-0519-00			CAP.,FXD,CER DI:47PF,+/-4.7PF,500V	72982	308-000C0G0470K
C449	281-0166-00			CAP.,VAR,AIR DI:1.9-15.7PF,250V	74970	187-0109-005
C452	290-0517-00			CAP.,FXD,ELCTLT:6.8UF,20%,35V	56289	196D685X0035KA1
C457	290-0522-00			CAP.,FXD,ELCTLT:1UF,20%,50V	56289	196D105X0050HA1
C460	283-0111-00			CAP.,FXD,CER DI:0.1UF,20%,50V	72982	8131N075651104M
C462	290-0522-00			CAP.,FXD,ELCTLT:1UF,20%,50V	56289	196D105X0050HA1
C463	290-0517-00			CAP.,FXD,ELCTLT:6.8UF,20%,35V	56289	196D685X0035KA1
C472	281-0544-00			CAP.,FXD,CER DI:5.6PF,10%,500V	72982	301-000C0H0569D
C475	281-0651-00			CAP.,FXD,CER DI:47PF,5%,200V	72982	374-001T2H0470J
C484	281-0523-00			CAP.,FXD,CER DI:100PF,+/-20PF,350V	72982	301-000U2M0101M
C486	290-0517-00			CAP.,FXD,ELCTLT:6.8UF,20%,35V	56289	196D685X0035KA1
C488	283-0079-00			CAP.,FXD,CER DI:0.01UF,20%,250V	72982	8151B202C103M
C506	281-0519-00			CAP.,FXD,CER DI:47PF,+/-4.7PF,500V	72982	308-000C0G0470K
C508	281-0542-00			CAP.,FXD,CER DI:18PF,10%,500V	72982	301-002C0G0180K
C528	281-0519-00			CAP.,FXD,CER DI:47PF,+/-4.7PF,500V	72982	308-000C0G0470K
C541	281-0525-00			CAP.,FXD,CER DI:470PF,+/-94PF,500V	72982	301-000X5U0471M
C557	281-0158-00			CAP.,VAR,CER DI:7-45PF,50V	72982	518-000G7-45
C565	281-0158-00			CAP.,VAR,CER DI:7-45PF,50V	72982	518-000G7-45
C572	281-0122-00			CAP.,VAR,CER DI:2.5-9PF,100V	72982	518-000A2.5-9
C581	290-0536-00			CAP.,FXD,ELCTLT:10UF,20%,25V	90201	TDC106M025FL
C582	283-0001-00			CAP.,FXD,CER DI:0.005UF,+100-0%,500V	72982	831-559E502P
C584	290-0536-00			CAP.,FXD,ELCTLT:10UF,20%,25V	90201	TDC106M025FL
C585	283-0001-00			CAP.,FXD,CER DI:0.005UF,+100-0%,500V	72982	831-559E502P
C590	290-0536-00			CAP.,FXD,ELCTLT:10UF,20%,25V	90201	TDC106M025FL
C591	283-0001-00			CAP.,FXD,CER DI:0.005UF,+100-0%,500V	72982	831-559E502P
C601	290-0522-00			CAP.,FXD,ELCTLT:1UF,20%,50V	56289	196D105X0050HA1
C609	281-0658-00			CAP.,FXD,CER DI:6.2PF, /-0.25PF,500V	72982	301-000C0H0629C
C612	283-0186-00			CAP.,FXD,CER DI:27PF,5%,50V	72982	8121B070C0G270J

Kit No.	Tektronix Part No.	Serial/Model No.		Name & Description	Mfr Code	Mfr Part Number
		Eff	Dscont			
C654	283-0191-00			CAP.,FXD,CER DI:0.022UF,20%,50V	72982	8121N063651223M
C658	283-0191-00			CAP.,FXD,CER DI:0.022UF,20%,50V	72982	8121N063651223M
C672	283-0001-00			CAP.,FXD,CER DI:0.005UF,+100-0%,500V	72982	831-559E502P
C683	283-0000-00			CAP.,FXD,CER DI:0.001UF,+100-0%,500V	72982	831-516E102P
C702	281-0524-00			CAP.,FXD,CER DI:150PF,+/-30PF,500V	72982	301-000X5U0151M
C706	281-0504-00			CAP.,FXD,CER DI:10PF,+/-1PF,500V	72982	301-000C0G0100F
C710	283-0116-00			CAP.,FXD,CER DI:820PF,5%,500V	72982	801-547B821J
C712	283-0116-00			CAP.,FXD,CER DI:820PF,5%,500V	72982	801-547B821J
C739	290-0522-00			CAP.,FXD,ELCTLT:LUF,20%,50V	56289	196D105X0050HAL
C741	281-0523-00			CAP.,FXD,CER DI:100PF,+/-20PF,350V	72982	301-000U2M0101M
C744	283-0139-00			CAP.,FXD,CER DI:150PF,20%,50V	72982	8101-050X5F151M
C746	283-0204-00			CAP.,FXD,CER DI:0.01UF,20%,50V	72982	8121N058651103M
C749	290-0517-00			CAP.,FXD,ELCTLT:6.8UF,20%,35V	56289	196D685X0035KAL
C755	283-0116-00			CAP.,FXD,CER DI:820PF,5%,500V	72982	801-547B821J
C760	283-0156-00			CAP.,FXD,CER DI:1000PF,+100-0%,200V	72982	8111A208E102Z
C761	283-0156-00			CAP.,FXD,CER DI:1000PF,+100-0%,200V	72982	8111A208E102Z
C791	290-0522-00			CAP.,FXD,ELCTLT:LUF,20%,50V	56289	196D105X0050HAL
C793	290-0522-00			CAP.,FXD,ELCTLT:LUF,20%,50V	56289	196D105X0050HAL
C795	290-0522-00			CAP.,FXD,ELCTLT:LUF,20%,50V	56289	196D105X0050HAL
C801	290-0522-00			CAP.,FXD,ELCTLT:LUF,20%,50V	56289	196D105X0050HAL
C804	290-0534-00			CAP.,FXD,ELCTLT:LUF,20%,35V	56289	196D105X0035HAL
C807	281-0717-00			CAP.,FXD,CER DI:7.8PF,+/-0.1PF,500V	72982	374-005COG789F
C812	281-0512-00			CAP.,FXD,CER DI:27PF,+/-2.7PF,500V	72982	308-000C0G0270K
C836	283-0108-00	B010100	B010468	CAP.,FXD,CER DI:220PF,10%,200V	56289	272C13
C836	281-0523-00	B010469		CAP.,FXD,CER DI:100PF,+/-20PF,350V	72982	301-000U2M0101M
C838	283-0191-00			CAP.,FXD,CER DI:0.022UF,20%,50V	72982	8121N063651223M
C841	283-0108-00	B010100	B010468	CAP.,FXD,CER DI:220PF,10%,200V	56289	272C13
C841	281-0523-00	B010469		CAP.,FXD,CER DI:100PF,+/-20PF,350V	72982	301-000U2M0101M
C848	283-0191-00			CAP.,FXD,CER DI:0.022UF,20%,50V	72982	8121N063651223M
C885	283-0000-00			CAP.,FXD,CER DI:0.001UF,+100-0%,500V	72982	831-516E102P
C912	283-0156-00			CAP.,FXD,CER DI:1000PF,+100-0%,200V	72982	8111A208E102Z
C939	290-0517-00			CAP.,FXD,ELCTLT:6.8UF,20%,35V	56289	196D685X0035KAL
C941	281-0564-00			CAP.,FXD,CER DI:24PF,5%,500V	72982	301-000C0G0240J
C945	283-0139-00			CAP.,FXD,CER DI:150PF,20%,50V	72982	8101-050X5F151M
C947	283-0204-00			CAP.,FXD,CER DI:0.01UF,20%,50V	72982	8121N058651103M
C949	290-0517-00			CAP.,FXD,ELCTLT:6.8UF,20%,35V	56289	196D685X0035KAL
C961	283-0204-00			CAP.,FXD,CER DI:0.01UF,20%,50V	72982	8121N058651103M
C991	290-0522-00			CAP.,FXD,ELCTLT:LUF,20%,50V	56289	196D105X0050HAL
C993	290-0522-00			CAP.,FXD,ELCTLT:LUF,20%,50V	56289	196D105X0050HAL
C995	290-0522-00			CAP.,FXD,ELCTLT:LUF,20%,50V	56289	196D105X0050HAL
CR9	152-0141-02			SEMICOND DEVICE:SILICON,30V,150MA	07910	1N4152
CR10	152-0141-02	XB010200		SEMICOND DEVICE:SILICON,30V,150MA	07910	1N4152
CR102	152-0141-02			SEMICOND DEVICE:SILICON,30V,150MA	07910	1N4152
CR135	152-0141-02			SEMICOND DEVICE:SILICON,30V,150MA	07910	1N4152
CR140	152-0141-02			SEMICOND DEVICE:SILICON,30V,150MA	07910	1N4152
CR145	152-0141-02			SEMICOND DEVICE:SILICON,30V,150MA	07910	1N4152
CR146	152-0141-02			SEMICOND DEVICE:SILICON,30V,150MA	07910	1N4152
CR147	152-0141-02			SEMICOND DEVICE:SILICON,30V,150MA	07910	1N4152
CR150	152-0141-02			SEMICOND DEVICE:SILICON,30V,150MA	07910	1N4152
CR198	152-0141-02			SEMICOND DEVICE:SILICON,30V,150MA	07910	1N4152
CR205	152-0322-00			SEMICOND DEVICE:SILICON,15V	28480	5082-2672
CR219	152-0075-00			SEMICOND DEVICE:GE,25V,40MA	14936	GD238
CR257	152-0075-00			SEMICOND DEVICE:GE,25V,40MA	14936	GD238
CR259	152-0141-02			SEMICOND DEVICE:SILICON,30V,150MA	07910	1N4152
CR271	152-0141-02			SEMICOND DEVICE:SILICON,30V,150MA	07910	1N4152

Electrical Parts List—7B92

Ckt No.	Tektronix Part No.	Serial/Model No. Eff	Dscont	Name & Description	Mfr Code	Mfr Part Number
CR309	152-0141-02			SEMICON D DEVICE:SILICON,30V,150MA	07910	1N4152
CR310	152-0141-02			SEMICON D DEVICE:SILICON,30V,150MA	07910	1N4152
CR311	152-0141-02			SEMICON D DEVICE:SILICON,30V,150MA	07910	1N4152
CR312	152-0141-02			SEMICON D DEVICE:SILICON,30V,150MA	07910	1N4152
CR315	152-0141-02			SEMICON D DEVICE:SILICON,30V,150MA	07910	1N4152
CR319	152-0141-02			SEMICON D DEVICE:SILICON,30V,150MA	07910	1N4152
CR322	152-0141-02			SEMICON D DEVICE:SILICON,30V,150MA	07910	1N4152
CR323	152-0141-02			SEMICON D DEVICE:SILICON,30V,150MA	07910	1N4152
CR334	152-0141-02			SEMICON D DEVICE:SILICON,30V,150MA	07910	1N4152
CR345	152-0141-02			SEMICON D DEVICE:SILICON,30V,150MA	07910	1N4152
CR348	152-0075-00			SEMICON D DEVICE:GE,25V,40MA	14936	GD238
CR358	152-0141-02			SEMICON D DEVICE:SILICON,30V,150MA	07910	1N4152
CR359	152-0141-02			SEMICON D DEVICE:SILICON,30V,150MA	07910	1N4152
CR364	152-0182-00			SEMICON D DEVICE:TUNNEL		
CR365	152-0141-02	B010100	B029999X	SEMICON D DEVICE:SILICON,30V,150MA	07910	1N4152
CR381	152-0141-02			SEMICON D DEVICE:SILICON,30V,150MA	07910	1N4152
CR388	152-0075-00			SEMICON D DEVICE:GE,25V,40MA	14936	GD238
CR390	152-0141-02			SEMICON D DEVICE:SILICON,30V,150MA	07910	1N4152
CR404	152-0141-02			SEMICON D DEVICE:SILICON,30V,150MA	07910	1N4152
CR406	152-0141-02			SEMICON D DEVICE:SILICON,30V,150MA	07910	1N4152
CR444	152-0141-02	XB010200		SEMICON D DEVICE:SILICON,30V,150MA	07910	1N4152
CR445	152-0322-00			SEMICON D DEVICE:SILICON,15V	28480	5082-2672
CR446	152-0322-00			SEMICON D DEVICE:SILICON,15V	28480	5082-2672
CR451	152-0141-02			SEMICON D DEVICE:SILICON,30V,150MA	07910	1N4152
CR456	152-0141-02			SEMICON D DEVICE:SILICON,30V,150MA	07910	1N4152
CR457	152-0153-00			SEMICON D DEVICE:SILICON,15V,50MA	13715	FD7003
CR471	152-0141-02			SEMICON D DEVICE:SILICON,30V,150MA	07910	1N4152
CR474	152-0141-02			SEMICON D DEVICE:SILICON,30V,150MA	07910	1N4152
CR487	152-0141-02			SEMICON D DEVICE:SILICON,30V,150MA	07910	1N4152
CR488	152-0153-00			SEMICON D DEVICE:SILICON,15V,50MA	13715	FD7003
CR489	152-0153-00			SEMICON D DEVICE:SILICON,15V,50MA	13715	FD7003
CR490	152-0141-02			SEMICON D DEVICE:SILICON,30V,150MA	07910	1N4152
CR494	152-0141-02			SEMICON D DEVICE:SILICON,30V,150MA	07910	1N4152
CR495	152-0141-02	XB030000		SEMICON D DEVICE:SILICON,30V,150MA	07910	1N4152
CR498	152-0141-02			SEMICON D DEVICE:SILICON,30V,150MA	07910	1N4152
CR499	152-0141-02			SEMICON D DEVICE:SILICON,30V,150MA	07910	1N4152
CR501	152-0141-02			SEMICON D DEVICE:SILICON,30V,150MA	07910	1N4152
CR502	152-0322-00			SEMICON D DEVICE:SILICON,15V	28480	5082-2672
CR504	152-0322-00			SEMICON D DEVICE:SILICON,15V	28480	5082-2672
CR505	152-0322-00			SEMICON D DEVICE:SILICON,15V	28480	5082-2672
CR512	152-0141-02			SEMICON D DEVICE:SILICON,30V,150MA	07910	1N4152
CR526	152-0141-02			SEMICON D DEVICE:SILICON,30V,150MA	07910	1N4152
CR565	152-0141-02			SEMICON D DEVICE:SILICON,30V,150MA	07910	1N4152
CR600	152-0141-02	XB010200		SEMICON D DEVICE:SILICON,30V,150MA	07910	1N4152
CR631	152-0141-02			SEMICON D DEVICE:SILICON,30V,150MA	07910	1N4152
CR632	152-0141-02			SEMICON D DEVICE:SILICON,30V,150MA	07910	1N4152
CR660	152-0141-02			SEMICON D DEVICE:SILICON,30V,150MA	07910	1N4152
CR684	152-0141-02			SEMICON D DEVICE:SILICON,30V,150MA	07910	1N4152
CR720	152-0177-00	B010100	B019999	SEMICON D DEVICE:SILICON,10MA		
CR720	152-0177-02	B020000		SEMICON D DEVICE:SILICON,10MA		
CR736	152-0141-02			SEMICON D DEVICE:SILICON,30V,150MA	07910	1N4152
CR740	152-0177-00	B010100	B019999	SEMICON D DEVICE:SILICON,10MA		
CR740	152-0177-02	B020000		SEMICON D DEVICE:SILICON,10MA		
CR750	152-0177-00	B010100	B019999	SEMICON D DEVICE:SILICON,10MA		
CR750	152-0177-02	B020000		SEMICON D DEVICE:SILICON,10MA		

'kt No.	Tektronix Part No.	Serial/Model No.		Name & Description	Mfr Code	Mfr Part Number
		Eff	Dscont			
CR752	152-0141-02			SEMICON D DEVICE : SILICON , 30V , 150MA	07910	1N4152
CR821	152-0141-02			SEMICON D DEVICE : SILICON , 30V , 150MA	07910	1N4152
CR824	152-0141-02			SEMICON D DEVICE : SILICON , 30V , 150MA	07910	1N4152
CR827	152-0141-02			SEMICON D DEVICE : SILICON , 30V , 150MA	07910	1N4152
CR828	152-0141-02			SEMICON D DEVICE : SILICON , 30V , 150MA	07910	1N4152
CR833	152-0141-02			SEMICON D DEVICE : SILICON , 30V , 150MA	07910	1N4152
CR861	152-0141-02			SEMICON D DEVICE : SILICON , 30V , 150MA	07910	1N4152
CR880	152-0141-02			SEMICON D DEVICE : SILICON , 30V , 150MA	07910	1N4152
CR883	152-0141-02			SEMICON D DEVICE : SILICON , 30V , 150MA	07910	1N4152
CR920	152-0177-00	B010100	B019999	SEMICON D DEVICE : SILICON , 10MA		
CR920	152-0177-02	B020000		SEMICON D DEVICE : SILICON , 10MA		
CR924	152-0141-02			SEMICON D DEVICE : SILICON , 30V , 150MA	07910	1N4152
CR940	152-0177-00	B010100	B019999	SEMICON D DEVICE : SILICON , 10MA		
CR940	152-0177-02	B020000		SEMICON D DEVICE : SILICON , 10MA		
CR950	152-0177-00	B010100	B019999	SEMICON D DEVICE : SILICON , 10MA		
CR950	152-0177-02	B020000		SEMICON D DEVICE : SILICON , 10MA		
CR952	152-0141-02			SEMICON D DEVICE : SILICON , 30V , 150MA	07910	1N4152
CR968	152-0141-02			SEMICON D DEVICE : SILICON , 30V , 150MA	07910	1N4152
CR969	152-0141-02			SEMICON D DEVICE : SILICON , 30V , 150MA	07910	1N4152
CR1000	152-0141-02			SEMICON D DEVICE : SILICON , 30V , 150MA	07910	1N4152
CR1003	152-0075-00			SEMICON D DEVICE : GE , 25V , 40MA	14936	GD238
CR1005	152-0075-00			SEMICON D DEVICE : GE , 25V , 40MA	14936	GD238
CR1007	152-0075-00			SEMICON D DEVICE : GE , 25V , 40MA	14936	GD238
CR1009	152-0075-00			SEMICON D DEVICE : GE , 25V , 40MA	14936	GD238
CR1011	152-0075-00			SEMICON D DEVICE : GE , 25V , 40MA	14936	GD238
CR1013	152-0075-00			SEMICON D DEVICE : GE , 25V , 40MA	14936	GD238
CR1015	152-0075-00			SEMICON D DEVICE : GE , 25V , 40MA	14936	GD238
CR1023	152-0075-00			SEMICON D DEVICE : GE , 25V , 40MA	14936	GD238
CR1025	152-0075-00			SEMICON D DEVICE : GE , 25V , 40MA	14936	GD238
CR1027	152-0075-00			SEMICON D DEVICE : GE , 25V , 40MA	14936	GD238
CR1029	152-0075-00			SEMICON D DEVICE : GE , 25V , 40MA	14936	GD238
CR1031	152-0075-00			SEMICON D DEVICE : GE , 25V , 40MA	14936	GD238
CR1033	152-0075-00			SEMICON D DEVICE : GE , 25V , 40MA	14936	GD238
DS1	150-0048-01			LAMP , INCAND : NO . 683 , SELECTED	80009	150-0048-01
DS2	150-0048-01			LAMP , INCAND : NO . 683 , SELECTED	80009	150-0048-01
DS3	150-0048-01			LAMP , INCAND : NO . 683 , SELECTED	80009	150-0048-01
DS5	150-0048-01			LAMP , INCAND : NO . 683 , SELECTED	80009	150-0048-01
DS7	150-0048-01			LAMP , INCAND : NO . 683 , SELECTED	80009	150-0048-01
DS8	150-0048-01			LAMP , INCAND : NO . 683 , SELECTED	80009	150-0048-01
DS9	150-0048-01			LAMP , INCAND : NO . 683 , SELECTED	80009	150-0048-01
DS11	150-0048-01			LAMP , INCAND : NO . 683 , SELECTED	80009	150-0048-01
J50	131-0106-02			CONNECTOR , RCPT , : BNC	80009	131-0106-02
J70	131-0106-02			CONNECTOR , RCPT , : BNC	80009	131-0106-02
J601	131-1003-00			CONNECTOR BODY , : CKT BD MT , 3 PRONG	80009	131-1003-00
J613	131-1003-00			CONNECTOR BODY , : CKT BD MT , 3 PRONG	80009	131-1003-00
J614	131-1003-00			CONNECTOR BODY , : CKT BD MT , 3 PRONG	80009	131-1003-00
J683	131-1003-00			CONNECTOR BODY , : CKT BD MT , 3 PRONG	80009	131-1003-00
J684	131-1003-00			CONNECTOR BODY , : CKT BD MT , 3 PRONG	80009	131-1003-00
J801	131-1003-00			CONNECTOR BODY , : CKT BD MT , 3 PRONG	80009	131-1003-00
J863	131-1003-00			CONNECTOR BODY , : CKT BD MT , 3 PRONG	80009	131-1003-00
J864	131-1003-00			CONNECTOR BODY , : CKT BD MT , 3 PRONG	80009	131-1003-00
K10	108-0358-00			RELAY , REED :		
K10S1	260-0721-00			SWITCH , REED :		
K445	148-0034-00			RELAY , ARMATURE : DPDT , 15VDC , 600 OHM	80009	148-0034-00

Electrical Parts List—7B92

Ckt No.	Tektronix Part No.	Serial/Model No. Eff	Dscont	Name & Description	Mfr Code	Mfr Part Number
K600	148-0034-00			RELAY,ARMATURE:DPDT,15VDC,600 OHM	80009	148-0034-00
L52	108-0170-01			COIL,RF:0.5UH	80009	108-0170-01
L82	108-0170-01			COIL,RF:0.5UH	80009	108-0170-01
L190	276-0507-00			SHIELDING BEAD,:0.6UH	78488	57-0180-7D
L280	120-0382-00			XFMR,TOROID:14 TURNS,SINGLE	80009	120-0382-00
L282	108-0538-00			COIL,RF:2.7UH	76493	70F276A1
L283	108-0538-00			COIL,RF:2.7UH	76493	70F276A1
L285	120-0382-00			XFMR,TOROID:14 TURNS,SINGLE	80009	120-0382-00
L287	108-0538-00			COIL,RF:2.7UH	76493	70F276A1
L288	108-0538-00			COIL,RF:2.7UH	76493	70F276A1
L291	108-0538-00			COIL,RF:2.7UH	76493	70F276A1
L292	108-0538-00			COIL,RF:2.7UH	76493	70F276A1
L293	120-0382-00			XFMR,TOROID:14 TURNS,SINGLE	80009	120-0382-00
L298	120-0382-00			XFMR,TOROID:14 TURNS,SINGLE	80009	120-0382-00
L449	108-0369-00			COIL,RF:0.12UH		
L462	276-0507-00			SHIELDING BEAD,:0.6UH	78488	57-0180-7D
L514	276-0507-00			SHIELDING BEAD,:0.6UH	78488	57-0180-7D
L555	276-0507-00			SHIELDING BEAD,:0.6UH	78488	57-0180-7D
L557	276-0507-00			SHIELDING BEAD,:0.6UH	78488	57-0180-7D
L558	276-0507-00			SHIELDING BEAD,:0.6UH	78488	57-0180-7D
L559	276-0507-00			SHIELDING BEAD,:0.6UH	78488	57-0180-7D
L626	108-0331-00			COIL,RF:0.75UH	80009	108-0331-00
L627	276-0543-02	XB010469		CORE,FERRITE:		
L628	108-0331-00			COIL,RF:0.75UH	80009	108-0331-00
L639	108-0331-00			COIL,RF:0.75UH	80009	108-0331-00
L640	108-0331-00			COIL,RF:0.75UH	80009	108-0331-00
L641	276-0543-02	XB030000		CORE,FERRITE:		
L654	108-0170-01			COIL,RF:0.5UH	80009	108-0170-01
L656	108-0537-00			COIL,RF:200UH	80009	108-0537-00
L658	108-0170-01			COIL,RF:0.5UH	80009	108-0170-01
L660	108-0331-00			COIL,RF:0.75UH	80009	108-0331-00
L661	276-0543-02	XB050000		CORE,FERRITE:		
L662	108-0331-00			COIL,RF:0.75UH	80009	108-0331-00
L663	276-0543-02	XB050000		CORE,FERRITE:		
L714	108-0057-00			COIL,RF:8.8UH	80009	108-0057-00
L720	276-0507-00			SHIELDING BEAD,:0.6UH	78488	57-0180-7D
L722	276-0543-02			CORE,FERRITE:		
L727	276-0507-00			SHIELDING BEAD,:0.6UH	78488	57-0180-7D
L728	276-0507-00			SHIELDING BEAD,:0.6UH	78488	57-0180-7D
L760	276-0557-00			CORE,FERRITE:0.23 ID X 0.12 ID X 0.125	78488	57-0131
L824	108-0331-00			COIL,RF:0.75UH	80009	108-0331-00
L825	108-0331-00			COIL,RF:0.75UH	80009	108-0331-00
L826	276-0543-00			SHIELDING BEAD,:	80009	276-0543-00
L833	108-0331-00			COIL,RF:0.75UH	80009	108-0331-00
L834	108-0331-00			COIL,RF:0.75UH	80009	108-0331-00
L835	276-0543-02	XB030000		CORE,FERRITE:		
L836	276-0507-00	XB010469		SHIELDING BEAD,:0.6UH	78488	57-0180-7D
L840	276-0543-02	XB063640		CORE,FERRITE:		
L841	276-0507-00	XB010469		SHIELDING BEAD,:0.6UH	78488	57-0180-7D
L842	276-0543-02	XB063640		CORE,FERRITE:		
L859	108-0331-00			COIL,RF:0.75UH	80009	108-0331-00
L860	276-0543-02	XB050000		CORE,FERRITE:		
L861	108-0331-00			COIL,RF:0.75UH	80009	108-0331-00
L862	276-0543-02	XB050000		CORE,FERRITE:		

Kt No.	Tektronix		Serial/Model No.		Name & Description	Mfr	
	Part No.	Eff	Dscont			Code	Mfr Part Number
L890	108-0557-00				COIL,RF:35NH	80009	108-0557-00
L910	276-0507-00				SHIELDING BEAD,:0.6UH	78488	57-0180-7D
L922	276-0543-02				CORE,FERRITE:		
L934	276-0507-00				SHIELDING BEAD,:0.6UH	78488	57-0180-7D
L935	276-0507-00				SHIELDING BEAD,:0.6UH	78488	57-0180-7D
L961	276-0557-00				CORE,FERRITE:0.23 ID X 0.12 ID X 0.125	78488	57-0131
L963	276-0507-00				SHIELDING BEAD,:0.6UH	78488	57-0180-7D
LR295	108-0520-00				COIL,RF:2.2UH		
P163	131-1003-00				CONNECTOR BODY,:CKT BD MT,3 PRONG	80009	131-1003-00
P164	131-1003-00				CONNECTOR BODY,:CKT BD MT,3 PRONG	80009	131-1003-00
Q102	151-0220-00				TRANSISTOR:SILICON,PNP	80009	151-0220-00
Q104	151-0220-00				TRANSISTOR:SILICON,PNP	80009	151-0220-00
Q106	151-0190-01				TRANSISTOR:SILICON,NPN	07910	TE23652
Q108	151-0190-01				TRANSISTOR:SILICON,NPN	07910	TE23652
Q132	151-0221-00				TRANSISTOR:SILICON,PNP	07263	S24849
Q134	151-0216-00				TRANSISTOR:SILICON,PNP	04713	MPS6523
Q144	151-0223-00				TRANSISTOR:SILICON,NPN	80009	151-0223-00
Q146	151-0190-01				TRANSISTOR:SILICON,NPN	07910	TE23652
Q148	151-0207-00				TRANSISTOR:SILICON,NPN	03508	GET3415
Q152	151-0192-00				TRANSISTOR:SILICON,NPN,SEL FROM MPS6521	80009	151-0192-00
Q154	151-0192-00				TRANSISTOR:SILICON,NPN,SEL FROM MPS6521	80009	151-0192-00
Q162	151-0192-00				TRANSISTOR:SILICON,NPN,SEL FROM MPS6521	80009	151-0192-00
Q164	151-0192-00				TRANSISTOR:SILICON,NPN,SEL FROM MPS6521	80009	151-0192-00
Q172	151-0188-00				TRANSISTOR:SILICON,PNP	04713	2N3906
Q174	151-0188-00				TRANSISTOR:SILICON,PNP	04713	2N3906
Q182	151-0192-00				TRANSISTOR:SILICON,NPN,SEL FROM MPS6521	80009	151-0192-00
Q184	151-0192-00				TRANSISTOR:SILICON,NPN,SEL FROM MPS6521	80009	151-0192-00
Q188	151-0192-00				TRANSISTOR:SILICON,NPN,SEL FROM MPS6521	80009	151-0192-00
Q192	151-0188-00				TRANSISTOR:SILICON,PNP	04713	2N3906
Q194	151-0192-00				TRANSISTOR:SILICON,NPN,SEL FROM MPS6521	80009	151-0192-00
Q202	151-0207-00				TRANSISTOR:SILICON,NPN	03508	GET3415
Q304	151-0301-00				TRANSISTOR:SILICON,PNP	04713	2N2907A
Q312	151-0221-00				TRANSISTOR:SILICON,PNP	07263	S24849
Q314	151-0223-00				TRANSISTOR:SILICON,NPN	80009	151-0223-00
Q315	151-0198-00				TRANSISTOR:SILICON,NPN,SEL FROM MPS918	80009	151-0198-00
Q322	151-0223-00				TRANSISTOR:SILICON,NPN	80009	151-0223-00
Q326	151-0223-00				TRANSISTOR:SILICON,NPN	80009	151-0223-00
Q330	151-0225-00				TRANSISTOR:SILICON,NPN	07910	CS23365
Q336	151-0220-00				TRANSISTOR:SILICON,PNP	80009	151-0220-00
Q343	151-0220-00				TRANSISTOR:SILICON,PNP	80009	151-0220-00
Q346	151-0190-00				TRANSISTOR:SILICON,NPN	04713	2N3904
Q348	151-0219-00				TRANSISTOR:SILICON,PNP		
Q349	151-0190-00				TRANSISTOR:SILICON,NPN	04713	2N3904
Q359A,B	151-0353-00				TRANSISTON:SILICON,NPN,DUAL MONOLITH	80009	151-0353-00
Q363	151-0190-00				TRANSISTOR:SILICON,NPN	04713	2N3904
Q368	151-0198-00				TRANSISTOR:SILICON,NPN,SEL FROM MPS918	80009	151-0198-00
Q374	151-0223-00				TRANSISTOR:SILICON,NPN	80009	151-0223-00
Q376	151-0220-00				TRANSISTOR:SILICON,PNP	80009	151-0220-00
Q378	151-0220-00				TRANSISTOR:SILICON,PNP	80009	151-0220-00
Q382	151-0220-00				TRANSISTOR:SILICON,PNP	80009	151-0220-00
Q392	151-0221-00				TRANSISTOR:SILICON,PNP	07263	S24849
Q395	151-0220-00				TRANSISTOR:SILICON,PNP	80009	151-0220-00
Q398	151-0223-00				TRANSISTOR:SILICON,NPN	80009	151-0223-00

Electrical Parts List—7B92

Ckt No.	Tektronix Part No.	Serial/Model No. Eff	Dscont	Name & Description	Mfr Code	Mfr Part Number
Q402 } Q404 }	151-1042-00			SEMICON DVC SE:MATCHED PAIR FET	80009	151-1042-00
Q406	151-0222-00			TRANSISTOR:SILICON,NPN		
Q408	151-0222-00			TRANSISTOR:SILICON,NPN		
Q422	151-0223-00			TRANSISTOR:SILICON,NPN	80009	151-0223-00
Q424	151-0190-00	B010100	B010449	TRANSISTOR:SILICON,NPN	04713	2N3904
Q424	151-0190-02	B010450		TRANSISTOR:SILICON,NPN	04713	2N3904
Q426	151-0223-00			TRANSISTOR:SILICON,NPN	80009	151-0223-00
Q432	151-0325-00			TRANSISTOR:SILICON,PNP,SEL FROM 2N4258	80009	151-0325-00
Q434	151-0325-00			TRANSISTOR:SILICON,PNP,SEL FROM 2N4258	80009	151-0325-00
Q440	151-0223-00			TRANSISTOR:SILICON,NPN	80009	151-0223-00
Q450 } Q454 }	151-1042-00			SEMICON DVC SE:MATCHED PAIR FET	80009	151-1042-00
Q456	151-0222-00			TRANSISTOR:SILICON,NPN		
Q462	151-0222-00			TRANSISTOR:SILICON,NPN		
Q468	151-0221-00			TRANSISTOR:SILICON,PNP	07263	S24849
Q472	151-0221-00			TRANSISTOR:SILICON,PNP	07263	S24849
Q475	151-0223-00			TRANSISTOR:SILICON,NPN	80009	151-0223-00
Q480	151-0221-00			TRANSISTOR:SILICON,PNP	07263	S24849
Q486	151-0269-00			TRANSISTOR:SILICON,NPN,SEL FROM SE3005	80009	151-0269-00
Q494	151-0190-00			TRANSISTOR:SILICON,NPN	04713	2N3904
Q498	151-0190-00			TRANSISTOR:SILICON,NPN	04713	2N3904
Q501	151-0190-00			TRANSISTOR:SILICON,NPN	04713	2N3904
Q503	151-0223-00			TRANSISTOR:SILICON,NPN	80009	151-0223-00
Q508	151-0223-00			TRANSISTOR:SILICON,NPN	80009	151-0223-00
Q514	151-0325-00			TRANSISTOR:SILICON,PNP,SEL FROM 2N4258	80009	151-0325-00
Q517	151-0220-00			TRANSISTOR:SILICON,PNP	80009	151-0220-00
Q520	151-0190-00	B010100	B029999	TRANSISTOR,SILICON,NPN	04713	2N3904
Q520	151-0190-01	B030000		TRANSISTOR:SILICON,NPN	07910	TE23652
Q524	151-0190-00			TRANSISTOR:SILICON,NPN	04713	2N3904
Q530	151-0220-00			TRANSISTOR:SILICON,PNP	80009	151-0220-00
Q533	151-0325-00			TRANSISTOR:SILICON,PNP,SEL FROM 2N4258	80009	151-0325-00
Q546	151-0190-00	B010100	B029999	TRANSISTOR:SILICON,NPN	04713	2N3904
Q546	151-0190-01	B030000		TRANSISTOR:SILICON,NPN	07910	TE23652
Q550	151-0220-00			TRANSISTOR:SILICON,PNP	80009	151-0220-00
Q552	151-0220-00			TRANSISTOR:SILICON,PNP	80009	151-0220-00
Q555	151-0271-00			TRANSISTOR:SILICON,PNP	01295	SKA4504
Q559	151-0271-00			TRANSISTOR:SILICON,PNP	01295	SKA4504
Q562	151-0223-00			TRANSISTOR:SILICON,NPN	80009	151-0223-00
Q568	151-0192-00			TRANSISTOR:SILICON,NPN,SEL FROM MPS6521	80009	151-0192-00
Q594	151-0190-00			TRANSISTOR:SILICON,NPN	04713	2N3904
Q596	151-0216-00			TRANSISTOR:SILICON,PNP	04713	MPS6523
Q600A,B	151-1011-00			TRANSISTOR:SILICON,JFE,N-CHANNEL,DUAL	22229	FD1167
Q602	151-0333-00			TRANSISTOR:SILICON,NPN,SEL FROM MPS918	80009	151-0333-00
Q604	151-0333-00			TRANSISTOR:SILICON,NPN,SEL FROM MPS918	80009	151-0333-00
Q614	151-0333-00			TRANSISTOR:SILICON,NPN,SEL FROM MPS918	80009	151-0333-00
Q618	151-0333-00			TRANSISTOR:SILICON,NPN,SEL FROM MPS918	80009	151-0333-00
Q684	151-0188-00			TRANSISTOR:SILICON,PNP	04713	2N3906
Q702	151-0198-00			TRANSISTOR:SILICON,NPN,SEL FROM MPS918	80009	151-0198-00
Q704	151-0192-00			TRANSISTOR:SILICON,NPN,SEL FROM MPS6521	80009	151-0192-00
Q708	151-0192-00			TRANSISTOR:SILICON,NPN,SEL FROM MPS6521	80009	151-0192-00
Q714	151-0269-00			TRANSISTOR:SILICON,NPN,SEL FROM SE3005	80009	151-0269-00
Q718	151-0269-00			TRANSISTOR:SILICON,NPN,SEL FROM SE3005	80009	151-0269-00
Q722	151-0294-00			TRANSISTOR:SILICON,PNP		

Jkt No.	Tektronix		Serial/Model No.		Name & Description	Mfr	
	Part No.	Eff	Dscont	Eff		Code	Mfr Part Number
Q724	151-0269-00				TRANSISTOR:SILICON,NPN,SEL FROM SE3005	80009	151-0269-00
Q726	151-0269-00				TRANSISTOR:SILICON,NPN,SEL FROM SE3005	80009	151-0269-00
Q728	151-0188-00				TRANSISTOR:SILICON,PNP	04713	2N3906
Q744	151-0293-00				TRANSISTOR:SILICON,NPN		
Q748	151-0223-00				TRANSISTOR:SILICON,NPN	80009	151-0223-00
Q754	151-0223-00				TRANSISTOR:SILICON,NPN	80009	151-0223-00
Q755	151-0221-00				TRANSISTOR:SILICON,PNP	07263	S24849
Q800A,B	151-1011-00				TRANSISTOR:SILICON,JFE,N-CHANNEL,DUAL	22229	FD1167
Q802	151-0333-00				TRANSISTOR:SILICON,NPN,SEL FROM MPS918	80009	151-0333-00
Q804	151-0333-00				TRANSISTOR:SILICON,NPN,SEL FROM MPS918	80009	151-0333-00
Q814	151-0333-00				TRANSISTOR:SILICON,NPN,SEL FROM MPS918	80009	151-0333-00
Q818	151-0333-00				TRANSISTOR:SILICON,NPN,SEL FROM MPS918	80009	151-0333-00
Q908	151-0190-00				TRANSISTOR:SILICON,NPN	04713	2N3904
Q910	151-0188-00				TRANSISTOR:SILICON,PNP	04713	2N3906
Q914	151-0269-00				TRANSISTOR:SILICON,NPN,SEL FROM SE3005	80009	151-0269-00
Q918	151-0269-00				TRANSISTOR:SILICON,NPN,SEL FROM SE3005	80009	151-0269-00
Q922	151-0294-00				TRANSISTOR:SILICON,PNP		
Q932	151-0269-00				TRANSISTOR:SILICON,NPN,SEL FROM SE3005	80009	151-0269-00
Q934	151-0269-00				TRANSISTOR:SILICON,NPN,SEL FROM SE3005	80009	151-0269-00
Q944	151-0293-00				TRANSISTOR:SILICON,NPN		
Q948	151-0223-00				TRANSISTOR:SILICON,NPN	80009	151-0223-00
Q954	151-0223-00				TRANSISTOR:SILICON,NPN	80009	151-0223-00
Q954	151-0223-00				TRANSISTOR:SILICON,NPN	80009	151-0223-00
R2	311-1068-00				RES.,VAR, NONWIR:5K OHM,10%,0.50W	01121	W-7682
R3	317-0244-00				RES.,FXD,COMP:24K OHM,5%,0.125W	01121	BB2445
R4	311-1068-00				RES.,VAR, NONWIR:5K OHM,10%,0.50W	01121	W-7682
R5	317-0103-00				RES.,FXD,COMP:10K OHM,5%,0.125W	01121	BB1035
R6 ¹	311-1192-00				RES.,VAR, NONWIR:10K OHM,20%,1W	12697	CM39695
R7	317-0682-00				RES.,FXD,COMP:6.8K OHM,5%,0.125W	01121	BB6825
R8	317-0331-00				RES.,FXD,COMP:330 OHM,5%,0.125W	01121	BB3315
R10	317-0103-00				RES.,FXD,COMP:10K OHM,5%,0.125W	01121	BB1035
R14	315-0622-00				RES.,FXD,COMP:6.2K OHM,5%,0.25W	01121	CB6225
R16	315-0123-00	B010100	B029999		RES.,FXD,COMP:12K OHM,5%,0.25W	01121	CB1235
R16	315-0123-00	B030000			RES.,FXD,COMP:12K OHM,5%,0.25W	01121	CB1235
R20	311-1191-00				RES.,VAR, NONWIR:2 X 10K OHM,10%,0.50W		
R22							
R25	311-0946-00				RES.,VAR, WW:50K OHM,3%,2W		
R50	303-0680-00				RES.,FXD,COMP:68 OHM,5%,1W	01121	GB6805
R52	315-0201-00				RES.,FXD,COMP:200 OHM,5%,0.25W	01121	CB2015
R54	317-0680-00				RES.,FXD,COMP:68 OHM,5%,0.125W	01121	BB6805
R55	315-0361-00				RES.,FXD,COMP:360 OHM,5%,0.25W	01121	CB3615
R57	317-0911-00				RES.,FXD,COMP:910 OHM,5%,0.125W	01121	BB9115
R58	317-0101-00				RES.,FXD,COMP:100 OHM,5%,0.125W	01121	BB1015
R60	317-0201-00				RES.,FXD,COMP:200 OHM,5%,0.125W	01121	BB2015
R63	317-0153-00				RES.,FXD,COMP:15K OHM,5%,0.125W	01121	BB1535
R65	315-0754-00				RES.,FXD,COMP:750K OHM,5%,0.25W	01121	CB7545
R71	317-0201-00				RES.,FXD,COMP:200 OHM,5%,0.125W	01121	BB2015
R73	315-0754-00				RES.,FXD,COMP:750K OHM,5%,0.25W	01121	CB7545
R75	317-0103-00				RES.,FXD,COMP:10K OHM,5%,0.125W	01121	BB1035
R76	317-0103-00				RES.,FXD,COMP:10K OHM,5%,0.125W	01121	BB1035
R78	317-0153-00				RES.,FXD,COMP:15K OHM,5%,0.125W	01121	BB1535
R81	303-0680-00				RES.,FXD,COMP:68 OHM,5%,1W	01121	GB6805
R82	315-0201-00				RES.,FXD,COMP:200 OHM,5%,0.25W	01121	CB2015
R84	317-0680-00				RES.,FXD,COMP:68 OHM,5%,0.125W	01121	BB6805

¹Furnished as a unit with S6.

Electrical Parts List—7B92

Ckt No.	Tektronix Part No.	Serial/Model No.		Name & Description	Mfr	
		Eff	Dscont		Code	Mfr Part Number
R86	315-0361-00			RES.,FXD,COMP:360 OHM,5%,0.25W	01121	CB3615
R102	315-0431-00			RES.,FXD,COMP:430 OHM,5%,0.25W	01121	CB4315
R104	315-0362-00			RES.,FXD,COMP:3.6K OHM,5%,0.25W	01121	CB3625
R105	315-0751-00			RES.,FXD,COMP:750 OHM,5%,0.25W	01121	CB7515
R106	315-0751-00			RES.,FXD,COMP:750 OHM,5%,0.25W	01121	CB7515
R107	315-0821-00	B010100	B059999	RES.,FXD,COMP:820 OHM,5%,0.25W	01121	CB8215
R107	315-0621-00	B060000		RES.,FXD,COMP:620 OHM,5%,0.25W	01121	CB6215
R108	321-0229-00	B010100	B059999	RES.,FXD,FILM:2.37K OHM,1%,0.125W	75042	CEAT0-2371F
R108	322-0215-00	B060000		RES.,FXD,FILM:1.69K OHM,1%,0.25W	75042	CEBT0-1691F
R109	315-0361-00			RES.,FXD,COMP:360 OHM,5%,0.25W	01121	CB3615
R110	315-0153-00			RES.,FXD,COMP:15K OHM,5%,0.25W	01121	CB1535
R131	315-0102-00			RES.,FXD,COMP:1K OHM,5%,0.25W	01121	CB1025
R133	315-0242-00			RES.,FXD,COMP:2.4K OHM,5%,0.25W	01121	CB2425
R135	315-0431-00			RES.,FXD,COMP:430 OHM,5%,0.25W	01121	CB4315
R137	321-0229-00			RES.,FXD,FILM:2.37K OHM,1%,0.125W	75042	CEAT0-2371F
R138	321-0222-00			RES.,FXD,FILM:2K OHM,1%,0.125W	75042	CEAT0-2001F
R141	315-0101-00			RES.,FXD,COMP:100 OHM,5%,0.25W	01121	CB1015
R142	315-0362-00			RES.,FXD,COMP:3.6K OHM,5%,0.25W	01121	CB3625
R144	315-0202-00			RES.,FXD,COMP:2K OHM,5%,0.25W	01121	CB2025
R145	315-0153-00			RES.,FXD,COMP:15K OHM,5%,0.25W	01121	CB1535
R146	315-0472-00			RES.,FXD,COMP:4.7K OHM,5%,0.25W	01121	CB4725
R147	315-0392-00			RES.,FXD,COMP:3.9K OHM,5%,0.25W	01121	CB3925
R148	315-0103-00			RES.,FXD,COMP:10K OHM,5%,0.25W	01121	CB1035
R149	315-0241-00			RES.,FXD,COMP:240 OHM,5%,0.25W	01121	CB2415
R151	315-0302-00			RES.,FXD,COMP:3K OHM,5%,0.25W	01121	CB3025
R153	315-0161-00			RES.,FXD,COMP:160 OHM,5%,0.25W	01121	CB1615
R154	315-0161-00			RES.,FXD,COMP:160 OHM,5%,0.25W	01121	CB1615
R156	315-0752-00			RES.,FXD,COMP:7.5K OHM,5%,0.25W	01121	CB7525
R157	315-0911-00			RES.,FXD,COMP:910 OHM,5%,0.25W	01121	CB9115
R158	315-0511-00			RES.,FXD,COMP:510 OHM,5%,0.25W	01121	CB5115
R159	315-0272-00			RES.,FXD,COMP:2.7K OHM,5%,0.25W	01121	CB2725
R161	315-0472-00			RES.,FXD,COMP:4.7K OHM,5%,0.25W	01121	CB4725
R165	315-0472-00			RES.,FXD,COMP:4.7K OHM,5%,0.25W	01121	CB4725
R166	315-0303-00			RES.,FXD,COMP:30K OHM,5%,0.25W	01121	CB3035
R167	315-0512-00			RES.,FXD,COMP:5.1K OHM,5%,0.25W	01121	CB5125
R171	315-0102-00			RES.,FXD,COMP:1K OHM,5%,0.25W	01121	CB1025
R173	315-0272-00			RES.,FXD,COMP:2.7K OHM,5%,0.25W	01121	CB2725
R176	315-0202-00			RES.,FXD,COMP:2K OHM,5%,0.25W	01121	CB2025
R177	315-0622-00			RES.,FXD,COMP:6.2K OHM,5%,0.25W	01121	CB6225
R180	315-0302-00			RES.,FXD,COMP:3K OHM,5%,0.25W	01121	CB3025
R183	315-0161-00			RES.,FXD,COMP:160 OHM,5%,0.25W	01121	CB1615
R184	315-0331-00			RES.,FXD,COMP:330 OHM,5%,0.25W	01121	CB3315
R185	315-0161-00			RES.,FXD,COMP:160 OHM,5%,0.25W	01121	CB1615
R186	315-0752-00			RES.,FXD,COMP:7.5K OHM,5%,0.25W	01121	CB7525
R188	315-0103-00			RES.,FXD,COMP:10K OHM,5%,0.25W	01121	CB1035
R189	315-0112-00			RES.,FXD,COMP:1.1K OHM,5%,0.25W	01121	CB1125
R191	315-0392-00			RES.,FXD,COMP:3.9K OHM,5%,0.25W	01121	CB3925
R192	315-0303-00			RES.,FXD,COMP:30K OHM,5%,0.25W	01121	CB3035
R194	315-0152-00			RES.,FXD,COMP:1.5K OHM,5%,0.25W	01121	CB1525
R195	315-0202-00			RES.,FXD,COMP:2K OHM,5%,0.25W	01121	CB2025
R196	315-0112-00			RES.,FXD,COMP:1.1K OHM,5%,0.25W	01121	CB1125
R198	315-0562-00			RES.,FXD,COMP:5.6K OHM,5%,0.25W	01121	CB5625
R199	315-0472-00			RES.,FXD,COMP:4.7K OHM,5%,0.25W	01121	CB4725
R200	311-0959-00			RES.,VAR,WW10K OHM,5%,1.5W	71590	BA165-007
R201	315-0103-00			RES.,FXD,COMP:10K OHM,5%,0.25W	01121	CB1035

Ckt No.	Tektronix Part No.	Serial/Model No.		Name & Description	Mfr	
		Eff	Dscont		Code	Mfr Part Number
R203	315-0242-00			RES.,FXD,COMP:2.4K OHM,5%,0.25W	01121	CB2425
R204	315-0242-00			RES.,FXD,COMP:2.4K OHM,5%,0.25W	01121	CB2425
R207	315-0103-00			RES.,FXD,COMP:10K OHM,5%,0.25W	01121	CB1035
R208	317-0101-00	XB010310	B039999X	RES.,FXD,COMP:100 OHM,5%,0.125W	01121	BB1015
R211	315-0472-00			RES.,FXD,COMP:4.7K OHM,5%,0.25W	01121	CB4725
R212	315-0101-00			RES.,FXD,COMP:100 OHM,5%,0.25W	01121	CB1015
R215A	323-0794-07			RES.,FXD,FILM:11.17K OHM,0.1%,0.50W		
R215B	323-0795-07			RES.,FXD,FILM:22.34K OHM,0.1%,0.50W		
R215C	323-0785-07			RES.,FXD,FILM:55.85K OHM,0.1%,0.50W		
R215D	323-0786-07			RES.,FXD,FILM:111.7K OHM,0.1%,0.50W		
R215E	323-0787-07			RES.,FXD,FILM:223.4K OHM,0.1%,0.50W		
R215F	323-0788-07			RES.,FXD,FILM:558.5K OHM,0.1%,0.50W		
R215G	323-0789-07			RES.,FXD,FILM:1.117M OHM,0.1%,0.50W		
R215H	323-0789-07			RES.,FXD,FILM:1.117M OHM,0.1%,0.50W		
R215J	325-0080-00			RES.,FXD,FILM:3.351M OHM,1%,0.50W		
R215K	325-0081-00			RES.,FXD,FILM:11.17M OHM,1%,0.50W		
R215L	325-0081-00			RES.,FXD,FILM:11.17M OHM,1%,0.50W		
R216	315-0470-00			RES.,FXD,COMP:47 OHM,5%,0.25W	01121	CB4705
R219	315-0133-00			RES.,FXD,COMP:13K OHM,5%,0.25W	01121	CB1335
R221	315-0154-00			RES.,FXD,COMP:150K OHM,5%,0.25W	01121	CB1545
R222	321-0344-00			RES.,FXD,FILM:37.4K OHM,1%,0.125W	75042	CEAT0-3742F
R223	315-0154-00			RES.,FXD,COMP:150K OHM,5%,0.25W	01121	CB1545
R224	321-0344-00			RES.,FXD,FILM:37.4K OHM,1%,0.125W	75042	CEAT0-3742F
R226	315-0154-00			RES.,FXD,COMP:150K OHM,5%,0.25W	01121	CB1545
R227	315-0513-00			RES.,FXD,COMP:51K OHM,5%,0.25W	01121	CB5135
R228	315-0154-00			RES.,FXD,COMP:150K OHM,5%,0.25W	01121	CB1545
R229	315-0513-00			RES.,FXD,COMP:51K OHM,5%,0.25W	01121	CB5135
R231	315-0753-00			RES.,FXD,COMP:75K OHM,5%,0.25W	01121	CB7535
R232	315-0753-00			RES.,FXD,COMP:75K OHM,5%,0.25W	01121	CB7535
R233	315-0154-00			RES.,FXD,COMP:150K OHM,5%,0.25W	01121	CB1545
R234	315-0154-00			RES.,FXD,COMP:150K OHM,5%,0.25W	01121	CB1545
R235	315-0154-00			RES.,FXD,COMP:150K OHM,5%,0.25W	01121	CB1545
R236	315-0154-00			RES.,FXD,COMP:150K OHM,5%,0.25W	01121	CB1545
R238	315-0753-00			RES.,FXD,COMP:75K OHM,5%,0.25W	01121	CB7535
R239	315-0753-00			RES.,FXD,COMP:75K OHM,5%,0.25W	01121	CB7535
R242A	325-0081-00			RES.,FXD,FILM:11.17M OHM,1%,0.50W		
R242B	325-0081-00			RES.,FXD,FILM:11.17M OHM,1%,0.50W		
R242C	325-0080-00			RES.,FXD,FILM:3.351M OHM,1%,0.50W		
R242D	323-0789-07			RES.,FXD,FILM:1.117M OHM,0.1%,0.50W		
R242E	323-0789-07			RES.,FXD,FILM:1.117M OHM,0.1%,0.50W		
R242F	323-0788-07			RES.,FXD,FILM:558.5K OHM,0.1%,0.50W		
R242G	323-0787-07			RES.,FXD,FILM:223.4K OHM,0.1%,0.50W		
R242H	323-0786-07			RES.,FXD,FILM:111.7K OHM,0.1%,0.50W		
R242J	323-0785-07			RES.,FXD,FILM:55.85K OHM,0.1%,0.50W		
R242K	323-0317-00			RES.,FXD,FILM:19.6K OHM,1%,0.50W	75042	CECT0-1962F
R242L	323-0280-00			RES.,FXD,FILM:8.06K OHM,1%,0.50W	75042	CECT0-8061F
R244	311-1282-00			RES.,VAR,NONWIR:5K OHM,10%,0.50W	80294	3329W-L58-502
R246	311-1281-00			RES.,VAR,NONWIR:2.5K OHM,10%,0.5W	73138	62PAS-337-0
R248	315-0101-00			RES.,FXD,COMP:100 OHM,5%,0.25W	01121	CB1015
R251	315-0512-00			RES.,FXD,COMP:5.1K OHM,5%,0.25W	01121	CB5125
R252	315-0432-00			RES.,FXD,COMP:4.3K OHM,5%,0.25W	01121	CB4325
R255	315-0470-00			RES.,FXD,COMP:47 OHM,5%,0.25W	01121	CB4705
R257	315-0753-00			RES.,FXD,COMP:75K OHM,5%,0.25W	01121	CB7535
R258	315-0753-00			RES.,FXD,COMP:75K OHM,5%,0.25W	01121	CB7535
R259	315-0362-00			RES.,FXD,COMP:3.6K OHM,5%,0.25W	01121	CB3625

Electrical Parts List—7B92

Ckt No.	Tektronix Part No.	Serial/Model No. Eff	Dscont	Name & Description	Mfr Code	Mfr Part Number
R260	311-1300-00			RES.,VAR,NONWIR:200 OHM,10%,1W		
R261	315-0752-00			RES.,FXD,COMP:7.5K OHM,5%,0.25W	01121	CB7525
R262	321-0097-00			RES.,FXD,FILM:100 OHM,1%,0.125W	75042	CEAT0-1000F
R263	315-0752-00			RES.,FXD,COMP:7.5K OHM,5%,0.25W	01121	CB7525
R267	315-0512-00			RES.,FXD,COMP:5.1K OHM,5%,0.25W	01121	CB5125
R269	315-0822-00			RES.,FXD,COMP:8.2K OHM,5%,0.25W	01121	CB8225
R271	315-0752-00			RES.,FXD,COMP:7.5K OHM,5%,0.25W	01121	CB7525
R274	315-0470-00			RES.,FXD,COMP:47 OHM,5%,0.25W	01121	CB4705
R277	315-0203-00			RES.,FXD,COMP:20K OHM,5%,0.25W	01121	CB2035
R278	315-0203-00			RES.,FXD,COMP:20K OHM,5%,0.25W	01121	CB2035
R280	315-0101-00			RES.,FXD,COMP:100 OHM,5%,0.25W	01121	CB1015
R285	315-0101-00			RES.,FXD,COMP:100 OHM,5%,0.25W	01121	CB1015
R293	315-0101-00			RES.,FXD,COMP:100 OHM,5%,0.25W	01121	CB1015
R296	315-0202-00			RES.,FXD,COMP:2K OHM,5%,0.25W	01121	CB2025
R298	315-0101-00			RES.,FXD,COMP:100 OHM,5%,0.25W	01121	CB1015
R300	315-0124-00	B010100	B010468	RES.,FXD,COMP:120K OHM,5%,0.25W	01121	CB1245
R300	315-0184-00	B010469		RES.,FXD,COMP:180K OHM,5%,0.25W	01121	CB1845
R302	315-0102-00			RES.,FXD,COMP:1K OHM,5%,0.25W	01121	CB1025
R303	315-0103-00			RES.,FXD,COMP:10K OHM,5%,0.25W	01121	CB1035
R304	315-0100-00			RES.,FXD,COMP:10 OHM,5%,0.25W	01121	CB1005
R305	315-0301-00	XB010200		RES.,FXD,COMP:300 OHM,5%,0.25W	01121	CB3015
R306	315-0472-00			RES.,FXD,COMP:4.7K OHM,5%,0.25W	01121	CB4725
R307	315-0241-00			RES.,FXD,COMP:240 OHM,5%,0.25W	01121	CB2415
R308	315-0184-00			RES.,FXD,COMP:180K OHM,5%,0.25W	01121	CB1845
R309	315-0393-00			RES.,FXD,COMP:39K OHM,5%,0.25W	01121	CB3935
R310	315-0622-00			RES.,FXD,COMP:6.2K OHM,5%,0.25W	01121	CB6225
R311	315-0472-00			RES.,FXD,COMP:4.7K OHM,5%,0.25W	01121	CB4725
R312	315-0472-00			RES.,FXD,COMP:4.7K OHM,5%,0.25W	01121	CB4725
R313	315-0103-00			RES.,FXD,COMP:10K OHM,5%,0.25W	01121	CB1035
R314	315-0100-00			RES.,FXD,COMP:10 OHM,5%,0.25W	01121	CB1005
R315	315-0472-00			RES.,FXD,COMP:4.7K OHM,5%,0.25W	01121	CB4725
R317	315-0472-00			RES.,FXD,COMP:4.7K OHM,5%,0.25W	01121	CB4725
R320	315-0471-00			RES.,FXD,COMP:470 OHM,5%,0.25W	01121	CB4715
R321	315-0390-00			RES.,FXD,COMP:39 OHM,5%,0.25W	01121	CB3905
R322	315-0202-00			RES.,FXD,COMP:2K OHM,5%,0.25W	01121	CB2025
R323	315-0102-00	B010100	B019999	RES.,FXD,COMP:1K OHM,5%,0.25W	01121	CB1025
R323	315-0122-00	B020000		RES.,FXD,COMP:1.2K OHM,5%,0.25W	01121	CB1225
R324	323-0190-00			RES.,FXD,FILM:931 OHM,1%,0.50W	75042	CECT0-9310F
R325	315-0332-00			RES.,FXD,COMP:3.3K OHM,5%,0.25W	01121	CB3325
R326	315-0241-00			RES.,FXD,COMP:240 OHM,5%,0.25W	01121	CB2415
R327	315-0153-00			RES.,FXD,COMP:15K OHM,5%,0.25W	01121	CB1535
R328	321-0146-00			RES.,FXD,FILM:324 OHM,1%,0.125W	75042	CEAT0-3240F
R330	315-0101-00			RES.,FXD,COMP:100 OHM,5%,0.25W	01121	CB1015
R332	315-0822-00			RES.,FXD,COMP:8.2K OHM,5%,0.25W	01121	CB8225
R333	315-0471-00			RES.,FXD,COMP:470 OHM,5%,0.25W	01121	CB4715
R334	315-0362-00			RES.,FXD,COMP:3.6K OHM,5%,0.25W	01121	CB3625
R337	315-0471-00			RES.,FXD,COMP:470 OHM,5%,0.25W	01121	CB4715
R339	315-0202-00			RES.,FXD,COMP:2K OHM,5%,0.25W	01121	CB2025
R340	311-0634-00			RES.,VAR,NONWIR:500 OHM,10%,0.50W	80740	62-55-3
R341	315-0202-00			RES.,FXD,COMP:2K OHM,5%,0.25W	01121	CB2025
R343	315-0332-00			RES.,FXD,COMP:3.3K OHM,5%,0.25W	01121	CB3325
R345	315-0153-00			RES.,FXD,COMP:15K OHM,5%,0.25W	01121	CB1535
R346	315-0153-00			RES.,FXD,COMP:15K OHM,5%,0.25W	01121	CB1535
R347	315-0471-00			RES.,FXD,COMP:470 OHM,5%,0.25W	01121	CB4715
R348	315-0203-00			RES.,FXD,COMP:20K OHM,5%,0.25W	01121	CB2035

Ckt No.	Tektronix		Serial/Model No.		Name & Description	Mfr	
	Part No.	Eff	Dscont			Code	Mfr Part Number
R349	315-0472-00				RES.,FXD,COMP:4.7K OHM,5%,0.25W	01121	CB4725
R349A	315-0392-00				RES.,FXD,COMP:3.9K OHM,5%,0.25W	01121	CB3925
R350	311-0607-00				RES.,VAR,NONWIR:10K OHM,10%,0.50W	80740	62-59-3
R351	321-0306-00				RES.,FXD,FILM:15K OHM,1%,0.125W	75042	CEATO-1502F
R352	321-0198-00				RES.,FXD,FILM:1.13K OHM,1%,0.125W	75042	CEATO-1131F
R354	315-0102-00				RES.,FXD,COMP:1K OHM,5%,0.25W	01121	CB1025
R356	315-0102-00				RES.,FXD,COMP:1K OHM,5%,0.25W	01121	CB1025
R357	315-0301-00				RES.,FXD,COMP:300 OHM,5%,0.25W	01121	CB3015
R358	315-0301-00				RES.,FXD,COMP:300 OHM,5%,0.25W	01121	CB3015
R360	321-0239-00				RES.,FXD,FILM:3.01K OHM,1%,0.125W	75042	CEATO-3011F
R361	321-0331-00				RES.,FXD,FILM:27.4K OHM,1%,0.125W	75042	CEATO-2742F
R362	321-0271-00				RES.,FXD,FILM:6.49K OHM,1%,0.125W	75042	CEATO-6491F
R363	315-0201-00	XB030000			RES.,FXD,COMP:200 OHM,5%,0.25W	01121	CB2015
R364	311-0607-00	B010100	B029999		RES.,VAR,NONWIR:10K OHM,10%,0.50W	80740	62-59-3
R364	311-0609-00	B030000			RES.,VAR,NONWIR:2K OHM,10%,0.50W	80740	62-57-3
R365	315-0302-00	B010100	B029999		RES.,FXD,COMP:3K OHM,5%,0.25W	01121	CB3025
R365	315-0182-00	B030000			RES.,FXD,COMP:1.8K OHM,5%,0.25W	01121	CB1825
R366	315-0151-00	XB030000			RES.,FXD,COMP:150 OHM,5%,0.25W	01121	CB1515
R367	315-0151-00				RES.,FXD,COMP:150 OHM,5%,0.25W	01121	CB1515
R368	315-0331-00	B010100	B029999		RES.,FXD,COMP:330 OHM,5%,0.25W	01121	CB3315
R368	315-0910-00	B030000			RES.,FXD,COMP:91 OHM,5%,0.25W	01121	CB9105
R370	315-0102-00				RES.,FXD,COMP:1K OHM,5%,0.25W	01121	CB1025
R371	315-0102-00				RES.,FXD,COMP:1K OHM,5%,0.25W	01121	CB1025
R373	315-0242-00				RES.,FXD,COMP:2.4K OHM,5%,0.25W	01121	CB2425
R374	315-0681-00				RES.,FXD,COMP:680 OHM,5%,0.25W	01121	CB6815
R375	321-0280-00				RES.,FXD,FILM:8.06K OHM,1%,0.125W	75042	CEATO-8061F
R376	315-0101-00				RES.,FXD,COMP:100 OHM,5%,0.25W	01121	CB1015
R377	321-0222-00				RES.,FXD,FILM:2K OHM,1%,0.125W	75042	CEATO-2001F
R379	321-0280-00				RES.,FXD,FILM:8.06K OHM,1%,0.125W	75042	CEATO-8061F
R380	315-0102-00				RES.,FXD,COMP:1K OHM,5%,0.25W	01121	CB1025
R381	315-0102-00				RES.,FXD,COMP:1K OHM,5%,0.25W	01121	CB1025
R382	315-0100-00				RES.,FXD,COMP:10 OHM,5%,0.25W	01121	CB1005
R383	315-0471-00				RES.,FXD,COMP:470 OHM,5%,0.25W	01121	CB4715
R385	315-0102-00				RES.,FXD,COMP:1K OHM,5%,0.25W	01121	CB1025
R386	315-0102-00				RES.,FXD,COMP:1K OHM,5%,0.25W	01121	CB1025
R388	315-0103-00				RES.,FXD,COMP:10K OHM,5%,0.25W	01121	CB1035
R389	315-0102-00				RES.,FXD,COMP:1K OHM,5%,0.25W	01121	CB1025
R390	315-0103-00				RES.,FXD,COMP:10K OHM,5%,0.25W	01121	CB1035
R392	315-0822-00				RES.,FXD,COMP:8.2K OHM,5%,0.25W	01121	CB8225
R393	315-0391-00				RES.,FXD,COMP:390 OHM,5%,0.25W	01121	CB3915
R395	315-0390-00				RES.,FXD,COMP:39 OHM,5%,0.25W	01121	CB3905
R396	315-0153-00				RES.,FXD,COMP:15K OHM,5%,0.25W	01121	CB1535
R397	315-0201-00				RES.,FXD,COMP:200 OHM,5%,0.25W	01121	CB2015
R398	315-0151-00				RES.,FXD,COMP:150 OHM,5%,0.25W	01121	CB1515
R400	315-0330-00				RES.,FXD,COMP:33 OHM,5%,0.25W	01121	CB3305
R402	311-1035-00				RES.,VAR,NONWIR:50K OHM,10%,0.50W	80740	62-62-3
R403	315-0153-00				RES.,FXD,COMP:15K OHM,5%,0.25W	01121	CB1535
R406	301-0152-00				RES.,FXD,COMP:1.5K OHM,5%,0.50W	01121	EB1525
R408	315-0101-00				RES.,FXD,COMP:100 OHM,5%,0.25W	01121	CB1015
R409	315-0510-00				RES.,FXD,COMP:51 OHM,5%,0.25W	01121	CB5105
R410	301-0202-00				RES.,FXD,COMP:2K OHM,5%,0.50W	01121	EB2025
R412	315-0201-00				RES.,FXD,COMP:200 OHM,5%,0.25W	01121	CB2015
R420	315-0390-00				RES.,FXD,COMP:39 OHM,5%,0.25W	01121	CB3905
R422	322-0210-00				RES.,FXD,FILM:1.5K OHM,1%,0.25W	75042	CEBTO-1501F
R424	315-0122-00				RES.,FXD,COMP:1.2K OHM,5%,0.25W	01121	CB1225

Electrical Parts List—7B92

Ckt No.	Tektronix Part No.	Serial/Model No. Eff	Dscont	Name & Description	Mfr Code	Mfr Part Number
R425	315-0331-00			RES.,FXD,COMP:330 OHM,5%,0.25W	01121	CB3315
R427	315-0472-00			RES.,FXD,COMP:4.7K OHM,5%,0.25W	01121	CB4725
R428	315-0301-00			RES.,FXD,COMP:300 OHM,5%,0.25W	01121	CB3015
R430	315-0390-00			RES.,FXD,COMP:39 OHM,5%,0.25W	01121	CB3905
R432	315-0201-00			RES.,FXD,COMP:200 OHM,5%,0.25W	01121	CB2015
R433	315-0201-00			RES.,FXD,COMP:200 OHM,5%,0.25W	01121	CB2015
R434	322-0193-00			RES.,FXD,FILM:1K OHM,1%,0.25W	75042	CEBT0-1001F
R436	315-0103-00			RES.,FXD,COMP:10K OHM,5%,0.25W	01121	CB1035
R437	315-0301-00			RES.,FXD,COMP:300 OHM,5%,0.25W	01121	CB3015
R438	315-0201-00			RES.,FXD,COMP:200 OHM,5%,0.25W	01121	CB2015
R439	315-0102-00			RES.,FXD,COMP:1K OHM,5%,0.25W	01121	CB1025
R441	315-0300-00			RES.,FXD,COMP:30 OHM,5%,0.25W	01121	CB3005
R447	321-0126-00			RES.,FXD,FILM:200 OHM,1%,0.125W	75042	CEAT0-2000F
R448	315-0390-00			RES.,FXD,COMP:39 OHM,5%,0.25W	01121	CB3905
R451	315-0153-00			RES.,FXD,COMP:15K OHM,5%,0.25W	01121	CB1535
R452	311-1035-00			RES.,VAR,NONWIR:50K OHM,10%,0.50W	80740	62-62-3
R455	301-0431-00			RES.,FXD,COMP:430 OHM,5%,0.50W	01121	EB4315
R457	315-0392-00			RES.,FXD,COMP:3.9K OHM,5%,0.25W	01121	CB3925
R458	315-0392-00			RES.,FXD,COMP:3.9K OHM,5%,0.25W	01121	CB3925
R460	315-0101-00			RES.,FXD,COMP:100 OHM,5%,0.25W	01121	CB1015
R461	315-0470-00			RES.,FXD,COMP:47 OHM,5%,0.25W	01121	CB4705
R462	315-0390-00			RES.,FXD,COMP:39 OHM,5%,0.25W	01121	CB3905
R463	315-0152-00			RES.,FXD,COMP:1.5K OHM,5%,0.25W	01121	CB1525
R465	311-0634-00			RES.,VAR,NONWIR:500 OHM,10%,0.50W	80740	62-55-3
R466	315-0202-00			RES.,FXD,COMP:2K OHM,5%,0.25W	01121	CB2025
R467	315-0102-00			RES.,FXD,COMP:1K OHM,5%,0.25W	01121	CB1025
R468	315-0332-00			RES.,FXD,COMP:3.3K OHM,5%,0.25W	01121	CB3325
R470	315-0202-00			RES.,FXD,COMP:2K OHM,5%,0.25W	01121	CB2025
R471	315-0102-00			RES.,FXD,COMP:1K OHM,5%,0.25W	01121	CB1025
R472	315-0102-00			RES.,FXD,COMP:1K OHM,5%,0.25W	01121	CB1025
R473	315-0202-00			RES.,FXD,COMP:2K OHM,5%,0.25W	01121	CB2025
R474	315-0202-00			RES.,FXD,COMP:2K OHM,5%,0.25W	01121	CB2025
R475	315-0102-00			RES.,FXD,COMP:1K OHM,5%,0.25W	01121	CB1025
R476	315-0391-00			RES.,FXD,COMP:390 OHM,5%,0.25W	01121	CB3915
R477	315-0561-00			RES.,FXD,COMP:560 OHM,5%,0.25W	01121	CB5615
R478	315-0101-00			RES.,FXD,COMP:100 OHM,5%,0.25W	01121	CB1015
R480	315-0202-00			RES.,FXD,COMP:2K OHM,5%,0.25W	01121	CB2025
R482	315-0822-00			RES.,FXD,COMP:8.2K OHM,5%,0.25W	01121	CB8225
R483	315-0202-00			RES.,FXD,COMP:2K OHM,5%,0.25W	01121	CB2025
R484	315-0161-00			RES.,FXD,COMP:160 OHM,5%,0.25W	01121	CB1615
R486	315-0471-00			RES.,FXD,COMP:470 OHM,5%,0.25W	01121	CB4715
R487	315-0471-00			RES.,FXD,COMP:470 OHM,5%,0.25W	01121	CB4715
R488	315-0152-00			RES.,FXD,COMP:1.5K OHM,5%,0.25W	01121	CB1525
R489	315-0470-00			RES.,FXD,COMP:47 OHM,5%,0.25W	01121	CB4705
R490	315-0243-00			RES.,FXD,COMP:24K OHM,5%,0.25W	01121	CB2435
R491	315-0472-00			RES.,FXD,COMP:4.7K OHM,5%,0.25W	01121	CB4725
R492	315-0203-00			RES.,FXD,COMP:20K OHM,5%,0.25W	01121	CB2035
R494	315-0302-00			RES.,FXD,COMP:3K OHM,5%,0.25W	01121	CB3025
R495	315-0152-00	XB030000		RES.,FXD,COMP:1.5K OHM,5%,0.25W	01121	CB1525
R496	315-0152-00			RES.,FXD,COMP:1.5K OHM,5%,0.25W	01121	CB1525
R497	315-0102-00			RES.,FXD,COMP:1K OHM,5%,0.25W	01121	CB1025
R498	315-0472-00			RES.,FXD,COMP:4.7K OHM,5%,0.25W	01121	CB4725
R500	315-0102-00			RES.,FXD,COMP:1K OHM,5%,0.25W	01121	CB1025
R501	315-0102-00			RES.,FXD,COMP:1K OHM,5%,0.25W	01121	CB1025
R504	315-0102-00			RES.,FXD,COMP:1K OHM,5%,0.25W	01121	CB1025

'kt No.	Tektronix	Serial/Model No.		Name & Description	Mfr	
	Part No.	Eff	Dscont		Code	Mfr Part Number
R506	315-0102-00			RES.,FXD,COMP:1K OHM,5%,0.25W	01121	CB1025
R508	315-0681-00			RES.,FXD,COMP:680 OHM,5%,0.25W	01121	CB6815
R510	321-0168-00			RES.,FXD,FILM:549 OHM,1%,0.125W	75042	CEATO-5490F
R511	311-0622-00			RES.,VAR,NONWIR:100 OHM,10%,0.50W	80740	62-53-5
R512	321-0115-00			RES.,FXD,FILM:154 OHM,1%,0.125W	75042	CEATO-1540F
R513	321-0246-00			RES.,FXD,FILM:3.57K OHM,1%,0.125W	75042	CEATO-3571F
R515	321-0089-00			RES.,FXD,FILM:82.5 OHM,1%,0.125W	75042	CEATO-82R50F
R516	311-1007-00			RES.,VAR,NONWIR:20 OHM,20%,0.50W	80294	3329HG48-200
R518	315-0162-00			RES.,FXD,COMP:1.6K OHM,5%,0.25W	01121	CB1625
R519	315-0821-00			RES.,FXD,COMP:820 OHM,5%,0.25W	01121	CB8215
R521	315-0102-00			RES.,FXD,COMP:1K OHM,5%,0.25W	01121	CB1025
R523	311-0609-00			RES.,VAR,NONWIR:2K OHM,10%,0.50W	80740	62-57-3
R524	321-0614-00			RES.,FXD,FILM:10.1K OHM,1%,0.125W	75042	CEATO-1012F
R526	315-0103-00			RES.,FXD,COMP:10K OHM,5%,0.25W	01121	CB1035
R528	321-0224-00			RES.,FXD,FILM:2.1K OHM,1%,0.125W	75042	CEATO-2101F
R530	315-0302-00			RES.,FXD,COMP:3K OHM,5%,0.25W	01121	CB3025
R532	315-0102-00			RES.,FXD,COMP:1K OHM,5%,0.25W	01121	CB1025
R534	315-0620-00			RES.,FXD,COMP:62 OHM,5%,0.25W	01121	CB6205
R536	322-0202-00			RES.,FXD,FILM:1.24K OHM,1%,0.25W	75042	CEBTO-1241F
R538	322-0202-00			RES.,FXD,FILM:1.24K OHM,1%,0.25W	75042	CEBTO-1241F
R540	321-0143-00			RES.,FXD,FILM:301 OHM,1%,0.125W	75042	CEATO-3010F
R542	321-0260-00			RES.,FXD,FILM:4.99K OHM,1%,0.125W	75042	CEATO-4991F
R543	321-0260-00			RES.,FXD,FILM:4.99K OHM,1%,0.125W	75042	CEATO-4991F
R545	315-0102-00			RES.,FXD,COMP:1K OHM,5%,0.25W	01121	CB1025
R547	315-0821-00			RES.,FXD,COMP:820 OHM,5%,0.25W	01121	CB8215
R548	315-0162-00			RES.,FXD,COMP:1.6K OHM,5%,0.25W	01121	CB1625
R552	315-0102-00			RES.,FXD,COMP:1K OHM,5%,0.25W	01121	CB1025
R553	315-0302-00			RES.,FXD,COMP:3K OHM,5%,0.25W	01121	CB3025
R555	315-0620-00			RES.,FXD,COMP:62 OHM,5%,0.25W	01121	CB6205
R558	321-0094-00			RES.,FXD,FILM:93.1 OHM,1%,0.125W	75042	CEATO-93R10F
R560	311-0635-00			RES.,VAR,NONWIR:1K OHM,10%,0.50W	80740	62-56-3
R561	321-0233-00			RES.,FXD,FILM:2.61K OHM,1%,0.125W	75042	CEATO-2611F
R563	315-0222-00			RES.,FXD,COMP:2.2K OHM,5%,0.25W	01121	CB2225
R565	321-0122-00			RES.,FXD,FILM:182 OHM,1%,0.125W	75042	CEATO-1820F
R566	321-0230-00			RES.,FXD,FILM:2.43K OHM,1%,0.125W	75042	CEATO-2431F
R567	311-0635-00			RES.,VAR,NONWIR:1K OHM,10%,0.50W	80740	62-56-3
R568	315-0472-00			RES.,FXD,COMP:4.7K OHM,5%,0.25W	01121	CB4725
R569	321-0193-00			RES.,FXD,FILM:1K OHM,1%,0.125W	75042	CEATO-1001F
R571	315-0183-00			RES.,FXD,COMP:18K OHM,5%,0.25W	01121	CB1835
R572	321-0172-00			RES.,FXD,FILM:604 OHM,1%,0.125W	75042	CEATO-6040F
R592	321-0260-00			RES.,FXD,FILM:4.99K OHM,1%,0.125W	75042	CEATO-4991F
R593	321-0289-00			RES.,FXD,FILM:10K OHM,1%,0.125W	75042	CEATO-1002F
R595	315-0103-00			RES.,FXD,COMP:10K OHM,5%,0.25W	01121	CB1035
R600	317-0101-00	XB010302		RES.,FXD,COMP:100 OHM,5%,0.125W	01121	BB1015
R601	315-0331-00			RES.,FXD,COMP:330 OHM,5%,0.25W	01121	CB3315
R602	311-0635-00			RES.,VAR,NONWIR:1K OHM,10%,0.50W	80740	62-56-3
R603	315-0561-00			RES.,FXD,COMP:560 OHM,5%,0.25W	01121	CB5615
R604	317-0101-00	XB010302		RES.,FXD,COMP:100 OHM,5%,0.125W	01121	BB1015
R605	315-0910-00			RES.,FXD,COMP:91 OHM,5%,0.25W	01121	CB9105
R606	315-0512-00			RES.,FXD,COMP:5.1K OHM,5%,0.25W	01121	CB5125
R607	315-0224-00			RES.,FXD,COMP:220K OHM,5%,0.25W	01121	CB2245
R608	315-0243-00			RES.,FXD,COMP:24K OHM,5%,0.25W	01121	CB2435
R610	315-0242-00			RES.,FXD,COMP:2.4K OHM,5%,0.25W	01121	CB2425
R612	315-0750-00			RES.,FXD,COMP:75 OHM,5%,0.25W	01121	CB7505
R614	315-0242-00			RES.,FXD,COMP:2.4K OHM,5%,0.25W	01121	CB2425

Electrical Parts List—7B92

Ckt No.	Tektronix Part No.	Serial/Model No. Eff	Dscont	Name & Description	Mfr Code	Mfr Part Number
R616	315-0151-00			RES.,FXD,COMP:150 OHM,5%,0.25W	01121	CB1515
R617	315-0510-00			RES.,FXD,COMP:51 OHM,5%,0.25W	01121	CB5105
R618	315-0510-00			RES.,FXD,COMP:51 OHM,5%,0.25W	01121	CB5105
R619	315-0151-00			RES.,FXD,COMP:150 OHM,5%,0.25W	01121	CB1515
R621	315-0101-00			RES.,FXD,COMP:100 OHM,5%,0.25W	01121	CB1015
R623	315-0101-00			RES.,FXD,COMP:100 OHM,5%,0.25W	01121	CB1015
R624	315-0510-00			RES.,FXD,COMP:51 OHM,5%,0.25W	01121	CB5105
R629	315-0510-00	B010100	B049999	RES.,FXD,COMP:51 OHM,5%,0.25W	01121	CB5105
R629	315-0101-00	B050000		RES.,FXD,COMP:100 OHM,5%,0.25W	01121	CB1015
R630	315-0203-00			RES.,FXD,COMP:20K OHM,5%,0.25W	01121	CB2035
R631	315-0203-00			RES.,FXD,COMP:20K OHM,5%,0.25W	01121	CB2035
R633	315-0241-00			RES.,FXD,COMP:240 OHM,5%,0.25W	01121	CB2415
R634	315-0241-00			RES.,FXD,COMP:240 OHM,5%,0.25W	01121	CB2415
R636	317-0753-00			RES.,FXD,COMP:75K OHM,5%,0.125W	01121	BB7535
R637	317-0471-00			RES.,FXD,COMP:470 OHM,5%,0.125W	01121	BB4715
R641	317-0753-00			RES.,FXD,COMP:75K OHM,5%,0.125W	01121	BB7535
R642	317-0471-00			RES.,FXD,COMP:470 OHM,5%,0.125W	01121	BB4715
R644	315-0201-00			RES.,FXD,COMP:200 OHM,5%,0.25W	01121	CB2015
R645	315-0201-00			RES.,FXD,COMP:200 OHM,5%,0.25W	01121	CB2015
R647	311-0613-00			RES.,VAR,NONWIR:100K OHM,10%,0.50W	80740	62-63-3
R648	315-0274-00			RES.,FXD,COMP:270K OHM,5%,0.25W	01121	CB2745
R650	315-0202-00			RES.,FXD,COMP:2K OHM,5%,0.25W	01121	CB2025
R652	315-0202-00			RES.,FXD,COMP:2K OHM,5%,0.25W	01121	CB2025
R654	315-0510-00			RES.,FXD,COMP:51 OHM,5%,0.25W	01121	CB5105
R655	315-0100-00			RES.,FXD,COMP:10 OHM,5%,0.25W	01121	CB1005
R657	315-0100-00			RES.,FXD,COMP:10 OHM,5%,0.25W	01121	CB1005
R658	315-0510-00			RES.,FXD,COMP:51 OHM,5%,0.25W	01121	CB5105
R660	315-0133-00			RES.,FXD,COMP:13K OHM,5%,0.25W	01121	CB1335
R662	315-0472-00			RES.,FXD,COMP:4.7K OHM,5%,0.25W	01121	CB4725
R664	315-0472-00			RES.,FXD,COMP:4.7K OHM,5%,0.25W	01121	CB4725
R665	315-0111-00			RES.,FXD,COMP:110 OHM,5%,0.25W	01121	CB1115
R666	315-0111-00			RES.,FXD,COMP:110 OHM,5%,0.25W	01121	CB1115
R668	315-0431-00			RES.,FXD,COMP:430 OHM,5%,0.25W	01121	CB4315
R669	315-0431-00			RES.,FXD,COMP:430 OHM,5%,0.25W	01121	CB4315
R671	315-0102-00			RES.,FXD,COMP:1K OHM,5%,0.25W	01121	CB1025
R673	315-0102-00			RES.,FXD,COMP:1K OHM,5%,0.25W	01121	CB1025
R680	315-0512-00			RES.,FXD,COMP:5.1K OHM,5%,0.25W	01121	CB5125
R682	315-0512-00			RES.,FXD,COMP:5.1K OHM,5%,0.25W	01121	CB5125
R683	315-0244-00			RES.,FXD,COMP:240K OHM,5%,0.25W	01121	CB2445
R685	315-0152-00			RES.,FXD,COMP:1.5K OHM,5%,0.25W	01121	CB1525
R687	315-0823-00			RES.,FXD,COMP:82K OHM,5%,0.25W	01121	CB8235
R700	317-0151-00			RES.,FXD,COMP:150 OHM,5%,0.125W	01121	BB1515
R701	315-0202-00			RES.,FXD,COMP:2K OHM,5%,0.25W	01121	CB2025
R703	315-0621-00			RES.,FXD,COMP:620 OHM,5%,0.25W	01121	CB6215
R705	315-0103-00			RES.,FXD,COMP:10K OHM,5%,0.25W	01121	CB1035
R706	315-0302-00			RES.,FXD,COMP:3K OHM,5%,0.25W	01121	CB3025
R707	315-0820-00			RES.,FXD,COMP:82 OHM,5%,0.25W	01121	CB8205
R708	315-0122-00			RES.,FXD,COMP:1.2K OHM,5%,0.25W	01121	CB1225
R709	315-0122-00			RES.,FXD,COMP:1.2K OHM,5%,0.25W	01121	CB1225
R711	315-0102-00			RES.,FXD,COMP:1K OHM,5%,0.25W	01121	CB1025
R712	315-0102-00			RES.,FXD,COMP:1K OHM,5%,0.25W	01121	CB1025
R714	315-0332-00			RES.,FXD,COMP:3.3K OHM,5%,0.25W	01121	CB3325
R715	317-0101-00			RES.,FXD,COMP:100 OHM,5%,0.125W	01121	BB1015
R717	315-0512-00			RES.,FXD,COMP:5.1K OHM,5%,0.25W	01121	CB5125
R718	315-0561-00			RES.,FXD,COMP:560 OHM,5%,0.25W	01121	CB5615

Kit No.	Tektronix		Serial/Model No.		Name & Description	Mfr	
	Part No.	Eff	Dscont	Code		Mfr Part Number	
R719	315-0330-00				RES.,FXD,COMP:33 OHM,5%,0.25W	01121	CB3305
R721	317-0152-00				RES.,FXD,COMP:1.5K OHM,5%,0.125W	01121	BB1525
R722	317-0101-00				RES.,FXD,COMP:100 OHM,5%,0.125W	01121	BB1015
R724	317-0510-00				RES.,FXD,COMP:51 OHM,5%,0.125W	01121	BB5105
R725	315-0241-00				RES.,FXD,COMP:240 OHM,5%,0.25W	01121	CB2415
R726	315-0102-00				RES.,FXD,COMP:1K OHM,5%,0.25W	01121	CB1025
R727	315-0241-00				RES.,FXD,COMP:240 OHM,5%,0.25W	01121	CB2415
R729	315-0391-00				RES.,FXD,COMP:390 OHM,5%,0.25W	01121	CB3915
R730	311-0609-00				RES.,VAR,NONWIR:2K OHM,10%,0.50W	80740	62-57-3
R731	315-0112-00				RES.,FXD,COMP:1.1K OHM,5%,0.25W	01121	CB1125
R732	321-0242-00				RES.,FXD,FILM:3.24K OHM,1%,0.125W	75042	CEAT0-3241F
R733	321-0222-00				RES.,FXD,FILM:2K OHM,1%,0.125W	75042	CEAT0-2001F
R734	315-0103-00				RES.,FXD,COMP:10K OHM,5%,0.25W	01121	CB1035
R736	317-0101-00				RES.,FXD,COMP:100 OHM,5%,0.125W	01121	BB1015
R738	317-0510-00				RES.,FXD,COMP:51 OHM,5%,0.125W	01121	BB5105
R739	315-0220-00				RES.,FXD,COMP:22 OHM,5%,0.25W	01121	CB2205
R740	311-0634-00				RES.,VAR,NONWIR:500 OHM,10%,0.50W	80740	62-55-3
R741	315-0102-00				RES.,FXD,COMP:1K OHM,5%,0.25W	01121	CB1025
R742	317-0391-00				RES.,FXD,COMP:390 OHM,5%,0.125W	01121	BB3915
R744	317-0510-00				RES.,FXD,COMP:51 OHM,5%,0.125W	01121	BB5105
R745	317-0153-00				RES.,FXD,COMP:15K OHM,5%,0.125W	01121	BB1535
R746	317-0101-00				RES.,FXD,COMP:100 OHM,5%,0.125W	01121	BB1015
R748	315-0102-00				RES.,FXD,COMP:1K OHM,5%,0.25W	01121	CB1025
R749	315-0101-00				RES.,FXD,COMP:100 OHM,5%,0.25W	01121	CB1015
R750	311-0634-00				RES.,VAR,NONWIR:500 OHM,10%,0.50W	80740	62-55-3
R751	315-0132-00				RES.,FXD,COMP:1.3K OHM,5%,0.25W	01121	CB1325
R752	317-0101-00				RES.,FXD,COMP:100 OHM,5%,0.125W	01121	BB1015
R754	315-0102-00				RES.,FXD,COMP:1K OHM,5%,0.25W	01121	CB1025
R755	315-0102-00				RES.,FXD,COMP:1K OHM,5%,0.25W	01121	CB1025
R756	315-0471-00				RES.,FXD,COMP:470 OHM,5%,0.25W	01121	CB4715
R757	315-0471-00				RES.,FXD,COMP:470 OHM,5%,0.25W	01121	CB4715
R759	317-0201-00				RES.,FXD,COMP:200 OHM,5%,0.125W	01121	BB2015
R763	317-0510-00				RES.,FXD,COMP:51 OHM,5%,0.125W	01121	BB5105
R765	317-0510-00				RES.,FXD,COMP:51 OHM,5%,0.125W	01121	BB5105
R800	317-0101-00	XB010302			RES.,FXD,COMP:100 OHM,5%,0.125W	01121	BB1015
R801	315-0331-00				RES.,FXD,COMP:330 OHM,5%,0.25W	01121	CB3315
R802	311-0635-00				RES.,VAR,NONWIR:1K OHM,10%,0.50W	80740	62-56-3
R803	315-0561-00				RES.,FXD,COMP:560 OHM,5%,0.25W	01121	CB5615
R804	317-0101-00	XB010302			RES.,FXD,COMP:100 OHM,5%,0.125W	01121	BB1015
R805	315-0910-00				RES.,FXD,COMP:91 OHM,5%,0.25W	01121	CB9105
R807	315-0274-00				RES.,FXD,COMP:270K OHM,5%,0.25W	01121	CB2745
R810	315-0242-00				RES.,FXD,COMP:2.4K OHM,5%,0.25W	01121	CB2425
R812	315-0750-00				RES.,FXD,COMP:75 OHM,5%,0.25W	01121	CB7505
R814	315-0242-00				RES.,FXD,COMP:2.4K OHM,5%,0.25W	01121	CB2425
R816	315-0151-00				RES.,FXD,COMP:150 OHM,5%,0.25W	01121	CB1515
R817	315-0510-00				RES.,FXD,COMP:51 OHM,5%,0.25W	01121	CB5105
R818	315-0510-00				RES.,FXD,COMP:51 OHM,5%,0.25W	01121	CB5105
R819	315-0151-00				RES.,FXD,COMP:150 OHM,5%,0.25W	01121	CB1515
R821	315-0272-00				RES.,FXD,COMP:2.7K OHM,5%,0.25W	01121	CB2725
R823	315-0510-00	B010100	B049999		RES.,FXD,COMP:51 OHM,5%,0.25W	01121	CB5105
R823	315-0101-00	B050000			RES.,FXD,COMP:100 OHM,5%,0.25W	01121	CB1015
R826	315-0510-00				RES.,FXD,COMP:51 OHM,5%,0.25W	01121	CB5105
R828	315-0101-00				RES.,FXD,COMP:100 OHM,5%,0.25W	01121	CB1015
R829	315-0101-00				RES.,FXD,COMP:100 OHM,5%,0.25W	01121	CB1015
R831	315-0241-00				RES.,FXD,COMP:240 OHM,5%,0.25W	01121	CB2415

Electrical Parts List—7B92

Ckt No.	Tektronix	Serial/Model No.		Name & Description	Mfr	Mfr Part Number
	Part No.	Eff	Dscont		Code	
R832	315-0241-00			RES.,FXD,COMP:240 OHM,5%,0.25W	01121	CB2415
R833	315-0272-00			RES.,FXD,COMP:2.7K OHM,5%,0.25W	01121	CB2725
R835	315-0753-00			RES.,FXD,COMP:75K OHM,5%,0.25W	01121	CB7535
R836	315-0471-00			RES.,FXD,COMP:470 OHM,5%,0.25W	01121	CB4715
R837	315-0560-00			RES.,FXD,COMP:56 OHM,5%,0.25W	01121	CB5605
R840	315-0753-00			RES.,FXD,COMP:75K OHM,5%,0.25W	01121	CB7535
R841	315-0471-00			RES.,FXD,COMP:470 OHM,5%,0.25W	01121	CB4715
R842	315-0560-00			RES.,FXD,COMP:56 OHM,5%,0.25W	01121	CB5605
R844	315-0201-00			RES.,FXD,COMP:200 OHM,5%,0.25W	01121	CB2015
R846	315-0201-00			RES.,FXD,COMP:200 OHM,5%,0.25W	01121	CB2015
R851	315-0431-00			RES.,FXD,COMP:430 OHM,5%,0.25W	01121	CB4315
R853	315-0431-00			RES.,FXD,COMP:430 OHM,5%,0.25W	01121	CB4315
R854	315-0101-00			RES.,FXD,COMP:100 OHM,5%,0.25W	01121	CB1015
R855	315-0101-00			RES.,FXD,COMP:100 OHM,5%,0.25W	01121	CB1015
R856	315-0472-00			RES.,FXD,COMP:4.7K OHM,5%,0.25W	01121	CB4725
R858	315-0472-00			RES.,FXD,COMP:4.7K OHM,5%,0.25W	01121	CB4725
R862	315-0133-00			RES.,FXD,COMP:13K OHM,5%,0.25W	01121	CB1335
R881	315-0823-00			RES.,FXD,COMP:82K OHM,5%,0.25W	01121	CB8235
R883	315-0302-00			RES.,FXD,COMP:3K OHM,5%,0.25W	01121	CB3025
R885	315-0244-00			RES.,FXD,COMP:240K OHM,5%,0.25W	01121	CB2445
R887	315-0512-00			RES.,FXD,COMP:5.1K OHM,5%,0.25W	01121	CB5125
R889	315-0512-00			RES.,FXD,COMP:5.1K OHM,5%,0.25W	01121	CB5125
R890	315-0332-00			RES.,FXD,COMP:3.3K OHM,5%,0.25W	01121	CB3325
R905	315-0473-00			RES.,FXD,COMP:47K OHM,5%,0.25W	01121	CB4735
R907	321-0242-00			RES.,FXD,FILM:3.24K OHM,1%,0.125W	75042	CEAT0-3241F
R908	321-0222-00			RES.,FXD,FILM:2K OHM,1%,0.125W	75042	CEAT0-2001F
R913	315-0330-00			RES.,FXD,COMP:33 OHM,5%,0.25W	01121	CB3305
R914	315-0561-00			RES.,FXD,COMP:560 OHM,5%,0.25W	01121	CB5615
R916	315-0512-00			RES.,FXD,COMP:5.1K OHM,5%,0.25W	01121	CB5125
R919	317-0101-00			RES.,FXD,COMP:100 OHM,5%,0.125W	01121	BB1015
R920	311-0609-00			RES.,VAR,NONWIR:2K OHM,10%,0.50W	80740	62-57-3
R921	315-0152-00			RES.,FXD,COMP:1.5K OHM,5%,0.25W	01121	CB1525
R922	317-0101-00			RES.,FXD,COMP:100 OHM,5%,0.125W	01121	BB1015
R924	317-0101-00			RES.,FXD,COMP:100 OHM,5%,0.125W	01121	BB1015
R926	315-0241-00			RES.,FXD,COMP:240 OHM,5%,0.25W	01121	CB2415
R927	315-0102-00			RES.,FXD,COMP:1K OHM,5%,0.25W	01121	CB1025
R928	315-0241-00			RES.,FXD,COMP:240 OHM,5%,0.25W	01121	CB2415
R930	317-0510-00			RES.,FXD,COMP:51 OHM,5%,0.125W	01121	BB5105
R932	315-0152-00			RES.,FXD,COMP:1.5K OHM,5%,0.25W	01121	CB1525
R935	315-0103-00			RES.,FXD,COMP:10K OHM,5%,0.25W	01121	CB1035
R937	317-0510-00			RES.,FXD,COMP:51 OHM,5%,0.125W	01121	BB5105
R939	315-0220-00			RES.,FXD,COMP:22 OHM,5%,0.25W	01121	CB2205
R940	311-0634-00			RES.,VAR,NONWIR:500 OHM,10%,0.50W	80740	62-55-3
R941	315-0102-00			RES.,FXD,COMP:1K OHM,5%,0.25W	01121	CB1025
R943	317-0391-00			RES.,FXD,COMP:390 OHM,5%,0.125W	01121	BB3915
R944	317-0201-00			RES.,FXD,COMP:200 OHM,5%,0.125W	01121	BB2015
R945	317-0510-00			RES.,FXD,COMP:51 OHM,5%,0.125W	01121	BB5105
R946	317-0153-00			RES.,FXD,COMP:15K OHM,5%,0.125W	01121	BB1535
R947	315-0101-00			RES.,FXD,COMP:100 OHM,5%,0.25W	01121	CB1015
R949	315-0101-00			RES.,FXD,COMP:100 OHM,5%,0.25W	01121	CB1015
R950	311-0634-00			RES.,VAR,NONWIR:500 OHM,10%,0.50W	80740	62-55-3
R951	315-0162-00			RES.,FXD,COMP:1.6K OHM,5%,0.25W	01121	CB1625
R952	317-0101-00			RES.,FXD,COMP:100 OHM,5%,0.125W	01121	BB1015
R953	315-0681-00			RES.,FXD,COMP:680 OHM,5%,0.25W	01121	CB6815
R954	315-0152-00			RES.,FXD,COMP:1.5K OHM,5%,0.25W	01121	CB1525

Ckt No.	Tektronix		Serial/Model No.		Name & Description	Mfr	
	Part No.	Eff	Dscont	Code		Mfr Part Number	
R955	315-0102-00				RES.,FXD,COMP:1K OHM,5%,0.25W	01121	CB1025
R957	315-0751-00				RES.,FXD,COMP:750 OHM,5%,0.25W	01121	CB7515
R958	315-0151-00				RES.,FXD,COMP:150 OHM,5%,0.25W	01121	CB1515
R959	311-0634-00				RES.,VAR,NONWIR:500 OHM,10%,0.50W	80740	62-55-3
R963	317-0510-00				RES.,FXD,COMP:51 OHM,5%,0.125W	01121	BB5105
R967	315-0471-00				RES.,FXD,COMP:470 OHM,5%,0.25W	01121	CB4715
R968	315-0471-00				RES.,FXD,COMP:470 OHM,5%,0.25W	01121	CB4715
R1001	315-0332-00				RES.,FXD,COMP:3.3K OHM,5%,0.25W	01121	CB3325
R1003	315-0154-00				RES.,FXD,COMP:150K OHM,5%,0.25W	01121	CB1545
R1005	315-0753-00				RES.,FXD,COMP:75K OHM,5%,0.25W	01121	CB7535
R1007	315-0154-00				RES.,FXD,COMP:150K OHM,5%,0.25W	01121	CB1545
R1009	321-0344-00				RES.,FXD,FILM:37.4K OHM,1%,0.125W	75042	CEAT0-3742F
R1011	315-0154-00				RES.,FXD,COMP:150K OHM,5%,0.25W	01121	CB1545
R1013	315-0753-00				RES.,FXD,COMP:75K OHM,5%,0.25W	01121	CB7535
R1015	315-0513-00				RES.,FXD,COMP:51K OHM,5%,0.25W	01121	CB5135
R1021	315-0332-00				RES.,FXD,COMP:3.3K OHM,5%,0.25W	01121	CB3325
R1023	315-0753-00				RES.,FXD,COMP:75K OHM,5%,0.25W	01121	CB7535
R1025	315-0154-00				RES.,FXD,COMP:150K OHM,5%,0.25W	01121	CB1545
R1027	321-0344-00				RES.,FXD,FILM:37.4K OHM,1%,0.125W	75042	CEAT0-3742F
R1029	315-0154-00				RES.,FXD,COMP:150K OHM,5%,0.25W	01121	CB1545
R1031	315-0753-00				RES.,FXD,COMP:75K OHM,5%,0.25W	01121	CB7535
R1033	315-0154-00				RES.,FXD,COMP:150K OHM,5%,0.25W	01121	CB1545
S1 ¹	670-1588-00				PUSH BUTTON:MODE		
S2	260-0516-00				SWITCH,PUSH:ALT		
S3 ¹	670-1587-00				PUSH BUTTON:COUPLING		
S4	260-0516-00				SWITCH,PUSH:TRIGGER LEVEL		
S5 ¹	670-1589-00				PUSH BUTTON:SOURCE		
S6 ²							
S7 ³	260-1133-00				SWITCH,PUSH:DLY'D TRIGGER COUPLING		
S8	260-0735-01				SWITCH,PUSH:RESET		
S9 ⁴	260-1133-00				SWITCH,PUSH:DLY'D TRIGGER COUPLING		
S10	260-1132-00				SWITCH,PUSH:1 BUTTON,DOUBLE POLE	80009	260-1132-00
S11 ⁵	260-1133-00				SWITCH,PUSH:DLY'D TRIGGER SOURCE		
S140	260-0960-01				SWITCH,SLIDE:0.5A,120VDC,CKT BD MT	80009	260-0960-01
S200	214-1136-00				SWITCH,SLIDE:CAL IN		
S240A	105-0267-00				ACTR ASSY,CAM S:TIME/DIV OR DLY TIME		
S240B	105-0266-00				ACTR ASSY,CAM S:DLY'D TIME/DIV		
S352	260-1309-00				SWITCH,PUSH:SWEEP COINCIDENCE		
S1000	260-0960-01				SWITCH,SLIDE:0.5A,120VDC,CKT BD MT	80009	260-0960-01
U277	156-0067-00				MICROCIRCUIT,LI:OPERATIONAL AMPLIFIER	07263	U6T7741393
U310	155-0049-00	B010100	B039999		MICROCIRCUIT,DI:SWEEP CONTROL	80009	155-0049-00
U310	155-0049-01	B040000			MICROCIRCUIT,DI:MONOLITHIC,SWEEP CONTROL	80009	155-0049-01
U355	156-0067-00				MICROCIRCUIT,LI:OPERATIONAL AMPLIFIER	07263	U6T7741393
U380	156-0041-00				MICROCIRCUIT,DI:DUAL D-TYPE FLIP-FLOP	27014	DM7474N
U620	155-0061-01				MICROCIRCUIT:CHANNEL SWITCH,SELECTED	80009	155-0061-01
U640	155-0061-01				MICROCIRCUIT:CHANNEL SWITHC,SELECTED	80009	155-0061-01
U660	155-0061-02				MICROCIRCUIT:CHANNEL SWITHC,SELECTED	80009	155-0061-02
U680	156-0067-00				MICROCIRCUIT,LI:OPERATIONAL AMPLIFIER	07263	U6T7741393
U820	155-0061-01				MICROCIRCUIT:CHANNEL SWITCH,SELECTED	80009	155-0061-01
U840	155-0061-01				MICROCIRCUIT:CHANNEL SWITCH,SELECTED	80009	155-0061-01
U860	155-0061-01				MICROCIRCUIT:CHANNEL SWITCH,SELECTED	80009	155-0061-01
U880	156-0067-00				MICROCIRCUIT,LI:OPERATIONAL AMPLIFIER	07263	U6T7741393
VR1	152-0166-00				SEMICONV DEVICE:ZENER,0.4W,6.2V,5%	81483	69-9035

¹See Mechanical Parts List for replacement parts.

²Furnished as a unit with R6.

³Furnished as a unit with S9 and S11.

⁴Furnished as a unit with S7 and S11.

⁵Furnished as a unit with S7 and S9.

Electrical Parts List—7B92

Ckt No.	Tektronix Part No.	Serial/Model No. Eff	Dscont	Name & Description	Mfr Code	Mfr Part Number
VR2	152-0166-00			SEMICON D DEVICE:ZENER,0.4W,6.2V,5%	81483	69-9035
VR200	152-0149-00			SEMICON D DEVICE:ZENER,0.4W,10V,5%	04713	1N961B
VR210	152-0166-00			SEMICON D DEVICE:ZENER,0.4W,6.2V,5%	81483	69-9035
VR352	152-0461-00			SEMICON D DEVICE:ZENER,0.4W,6.2V,5%	04713	1N821
VR408	152-0278-00			SEMICON D DEVICE:ZENER,400MA,3V,5%	07910	1N4372A
VR462	152-0278-00			SEMICON D DEVICE:ZENER,400MA,3V,5%	07910	1N4372A
VR473	152-0243-00			SEMICON D DEVICE:ZENER,0.4W,15V,5%	81483	1N965B
VR600	152-0166-00			SEMICON D DEVICE:ZENER,0.4W,6.2V,5%	81483	69-9035
VR660	152-0326-00			SEMICON D DEVICE:ZENER,0.4W,7.5V,5%		
VR800	152-0166-00			SEMICON D DEVICE:ZENER,0.4W,6.2V,5%	81483	69-9035
VR860	152-0326-00			SEMICON D DEVICE:ZENER,0.4W,7.5V,5%		

SECTION 6

DIAGRAMS AND CIRCUIT BOARD ILLUSTRATIONS

Symbols and Reference Designators

Electrical components shown on the diagrams are in the following units unless noted otherwise:

Capacitors = Values one or greater are in picofarads (pF).
 Values less than one are in microfarads (μ F).
 Resistors = Ohms (Ω)

Symbols used on the diagrams are based on USA Standard Y32.2-1967.

Logic symbology is based on MIL-STD-806B in terms of positive logic. Logic symbols depict the logic function performed and may differ from the manufacturer's data.

The following special symbols are used on the diagrams:



External Screwdriver adjustment.

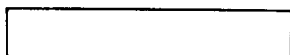

External control or connector.



Clockwise control rotation in direction of arrow.



Refer to diagram number indicated in diamond.



Refer to waveform number indicated in hexagon.

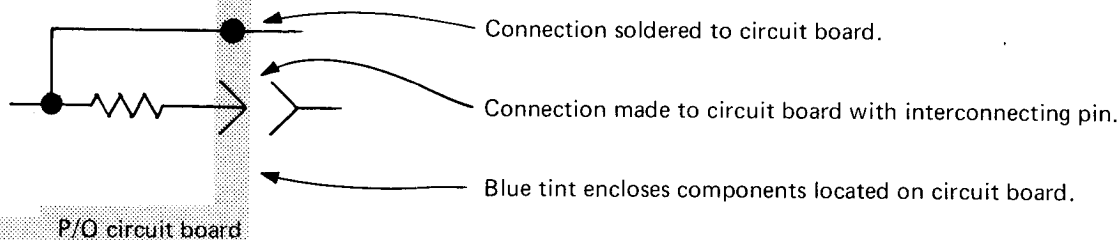

The following prefix letters are used as reference designators to identify components or assemblies on the diagrams.

A	Assembly, separable or repairable (circuit board, etc.)	LR	Inductor/resistor combination
AT	Attenuator, fixed or variable	M	Meter
B	Motor	Q	Transistor or silicon-controlled rectifier
BT	Battery	P	Connector, movable portion
C	Capacitor, fixed or variable	R	Resistor, fixed or variable
CR	Diode, signal or rectifier	RT	Thermistor
DL	Delay line	S	Switch
DS	Indicating device (lamp)	T	Transformer
F	Fuse	TP	Test point
FL	Filter	U	Assembly, inseparable or non-repairable (integrated circuit, etc.)
H	Heat dissipating device (heat sink, heat radiator, etc.)	V	Electron tube
HR	Heater	VR	Voltage regulator (zener diode, etc.)
J	Connector, stationary portion	Y	Crystal
K	Relay		
L	Inductor, fixed or variable		

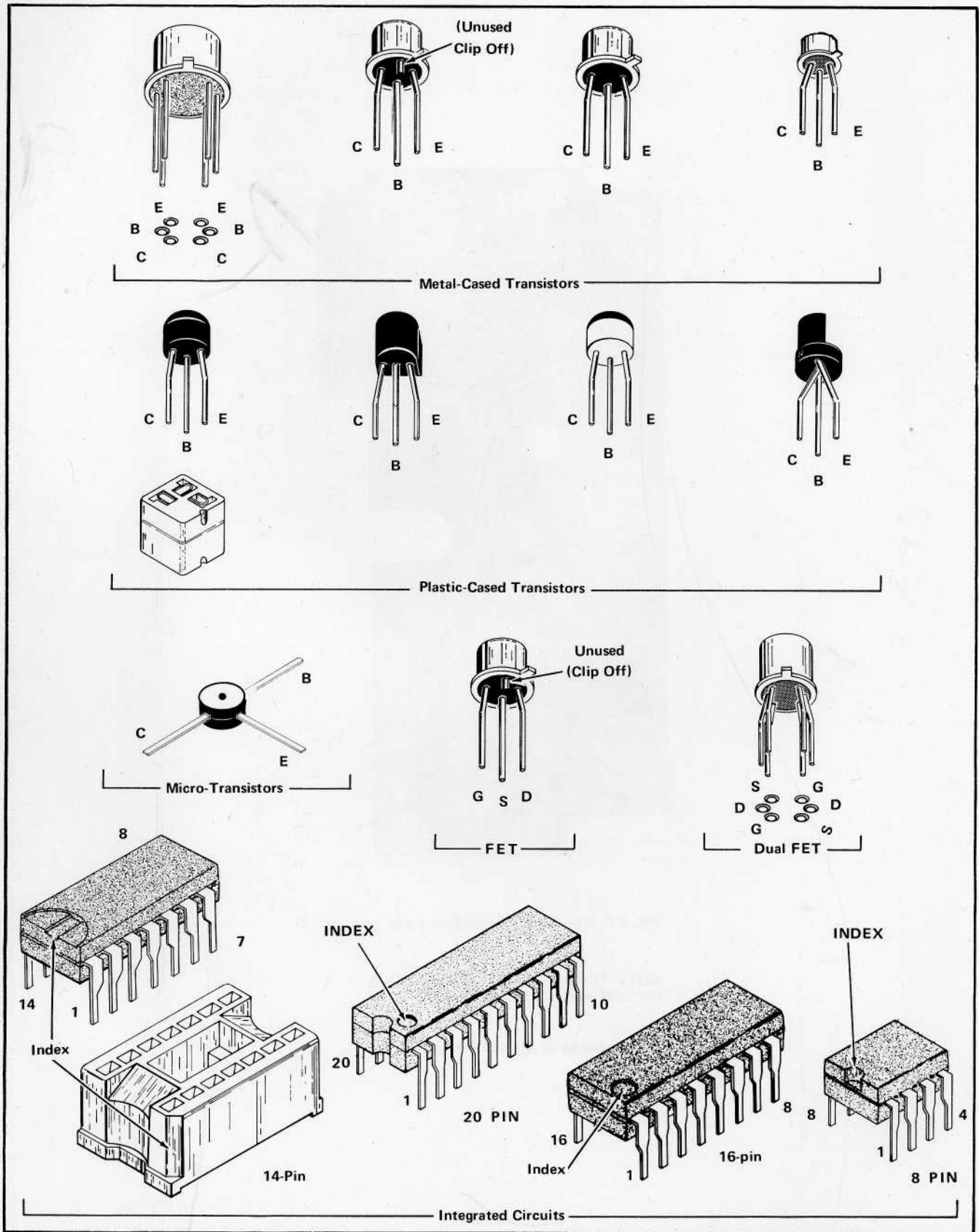

Fig. 6-1. Electrode configuration for semiconductors in this instrument.

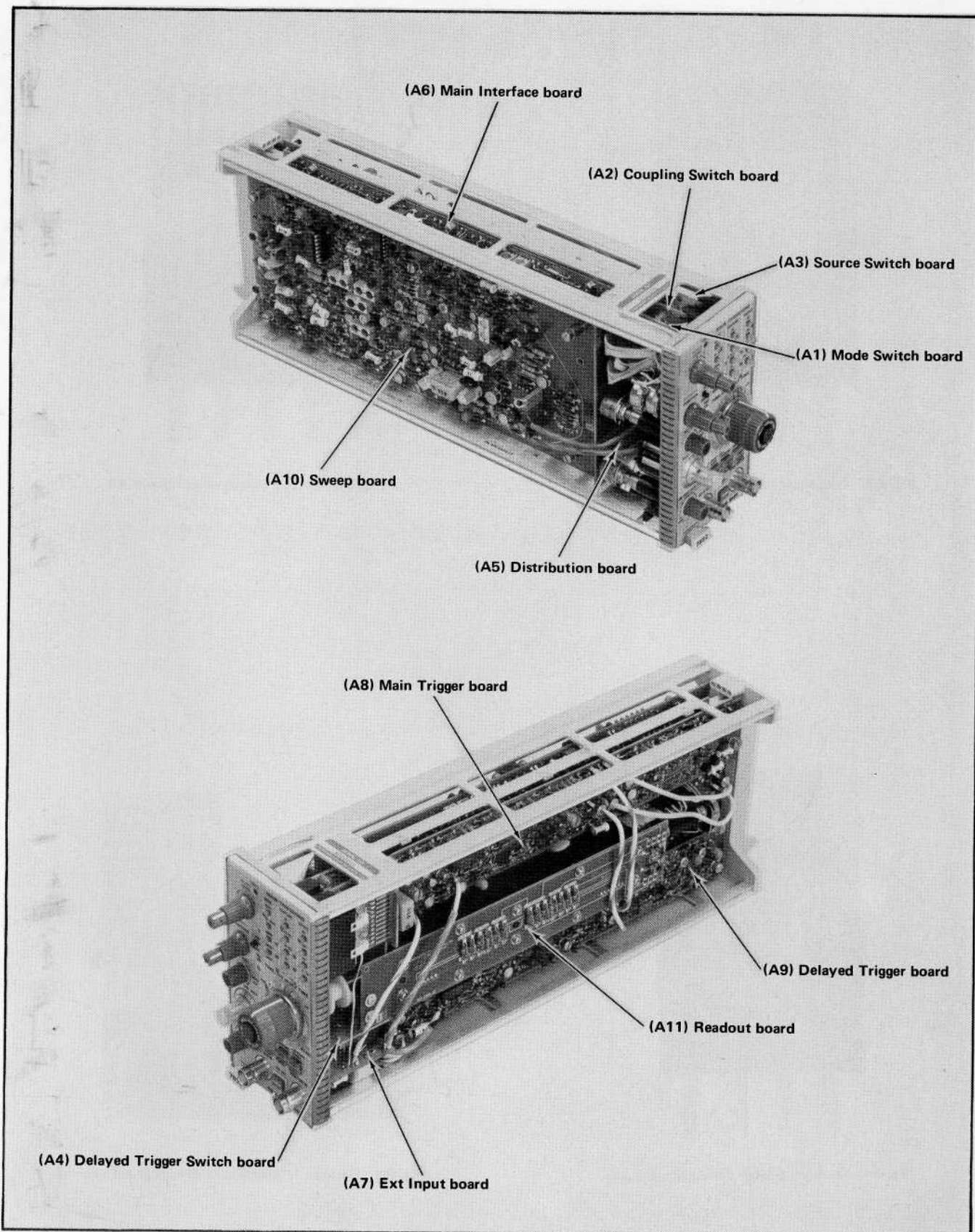

Fig. 6-2. Location of circuit boards in the 7B92.



Fig. 6-3. Trigger Mode Switch circuit board A1.

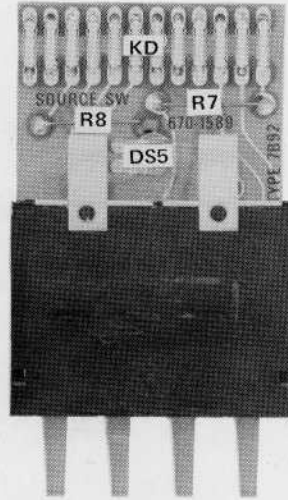

Fig. 6-5. Source Switch circuit board A3.

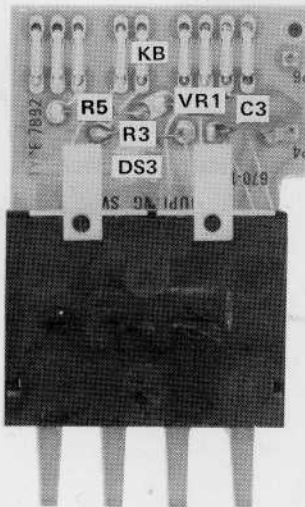

Fig. 6-4. Coupling Switch circuit board A2.

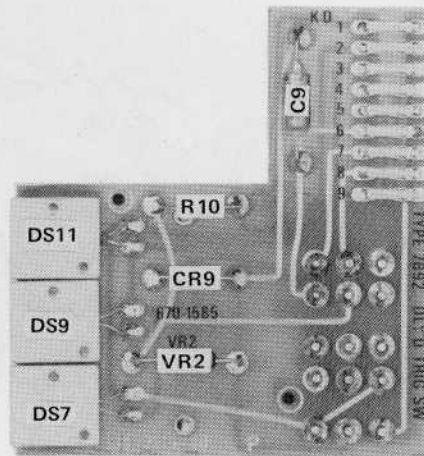

Fig. 6-6. Delayed Trigger Switch circuit board A4.

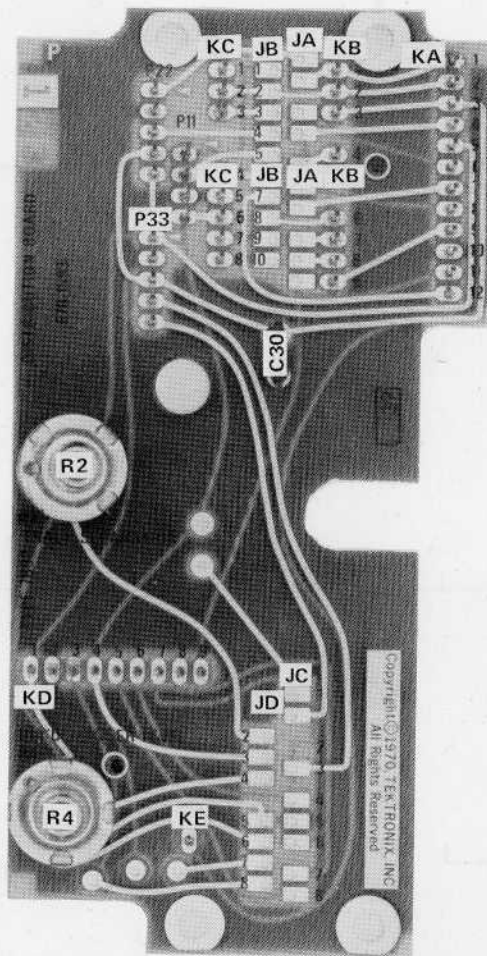

Fig. 6-7. Distribution circuit board A5.

NOTE: *CR10, *CR600, R16, and R14 are mounted on rear of circuit board.

*Added Serial Number B010200

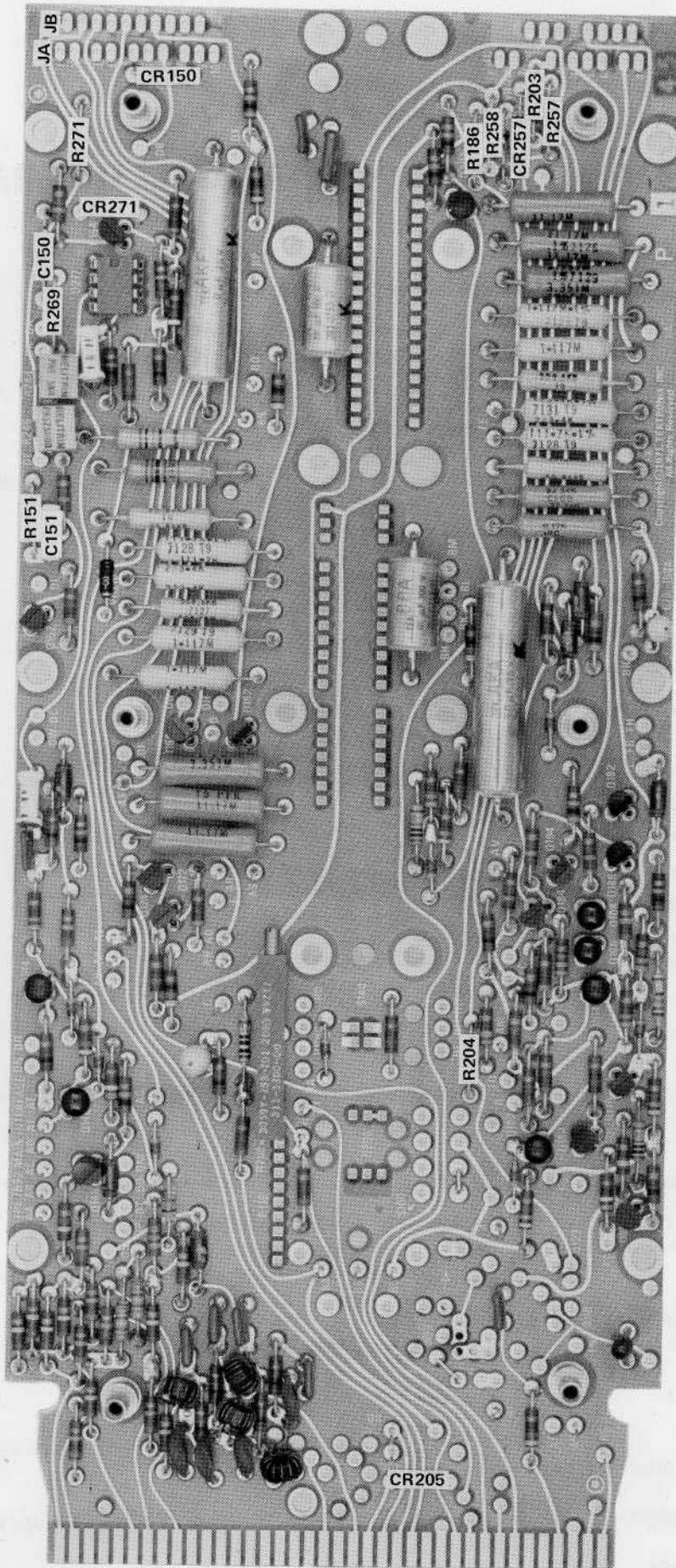
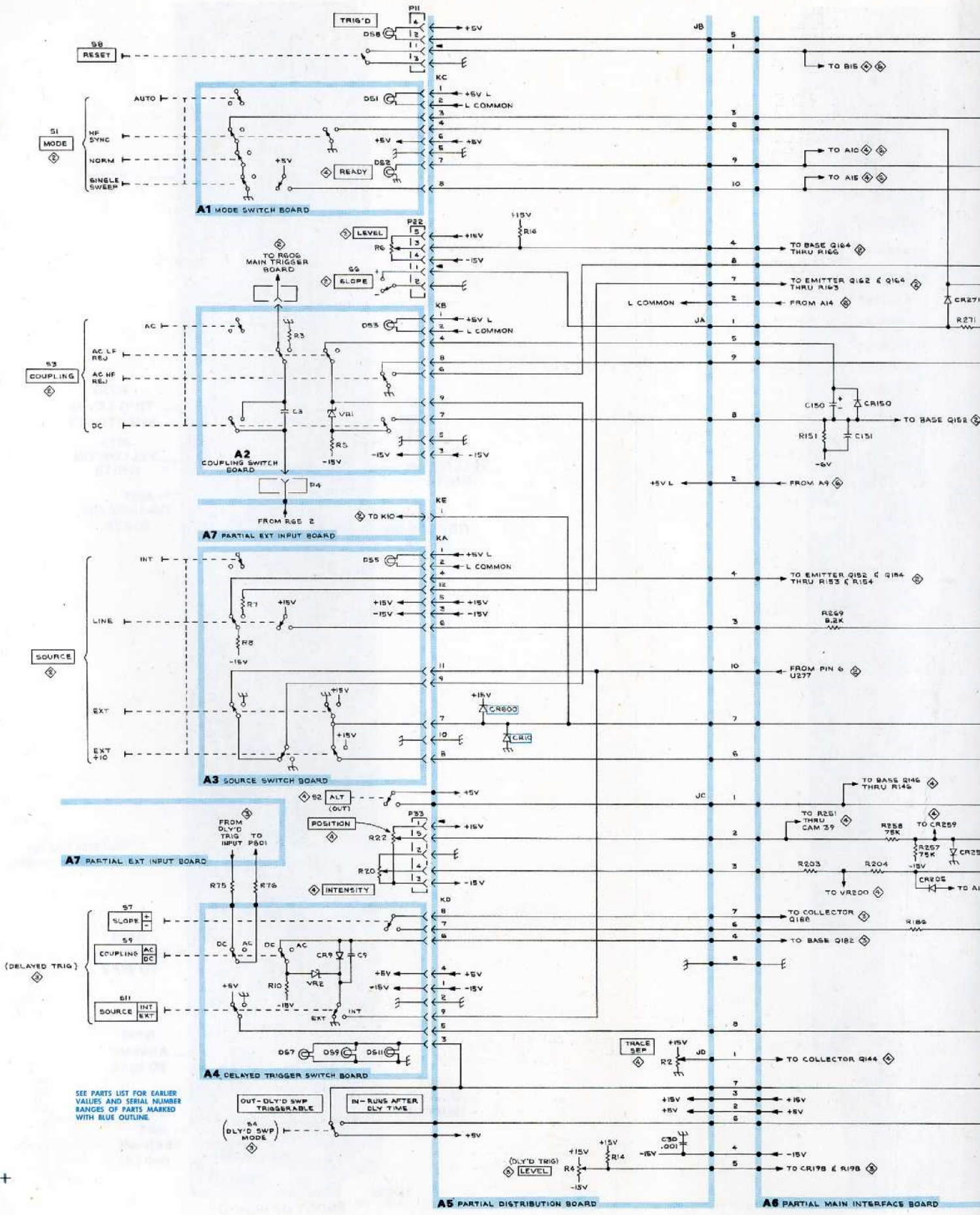
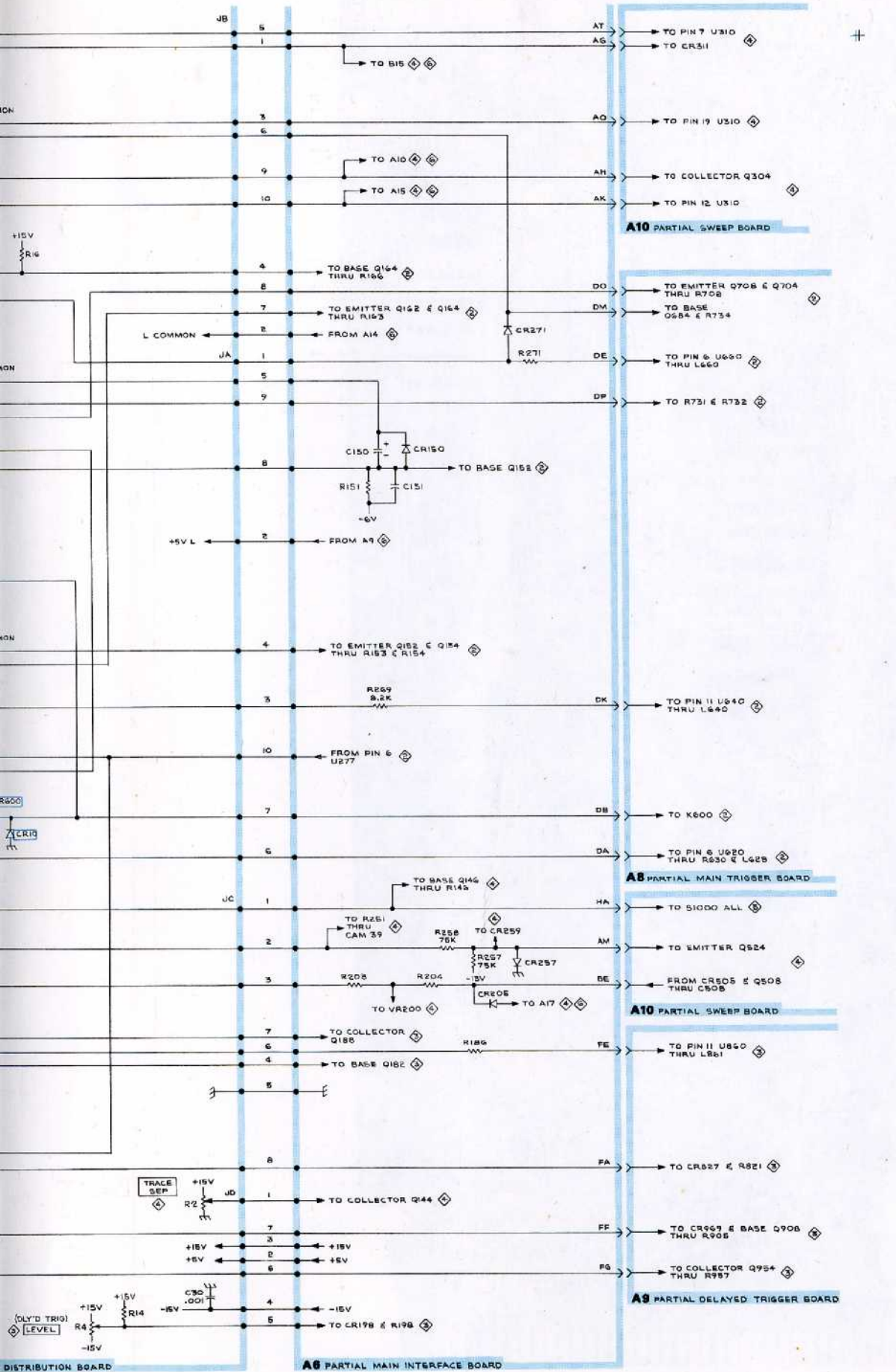

Fig. 6-8. Partial Main Interface circuit board A6.



SEE PARTS LIST FOR EARLIER VALUES AND SERIAL NUMBER RANGES OF PARTS MARKED WITH BLUE OUTLINE



(A)

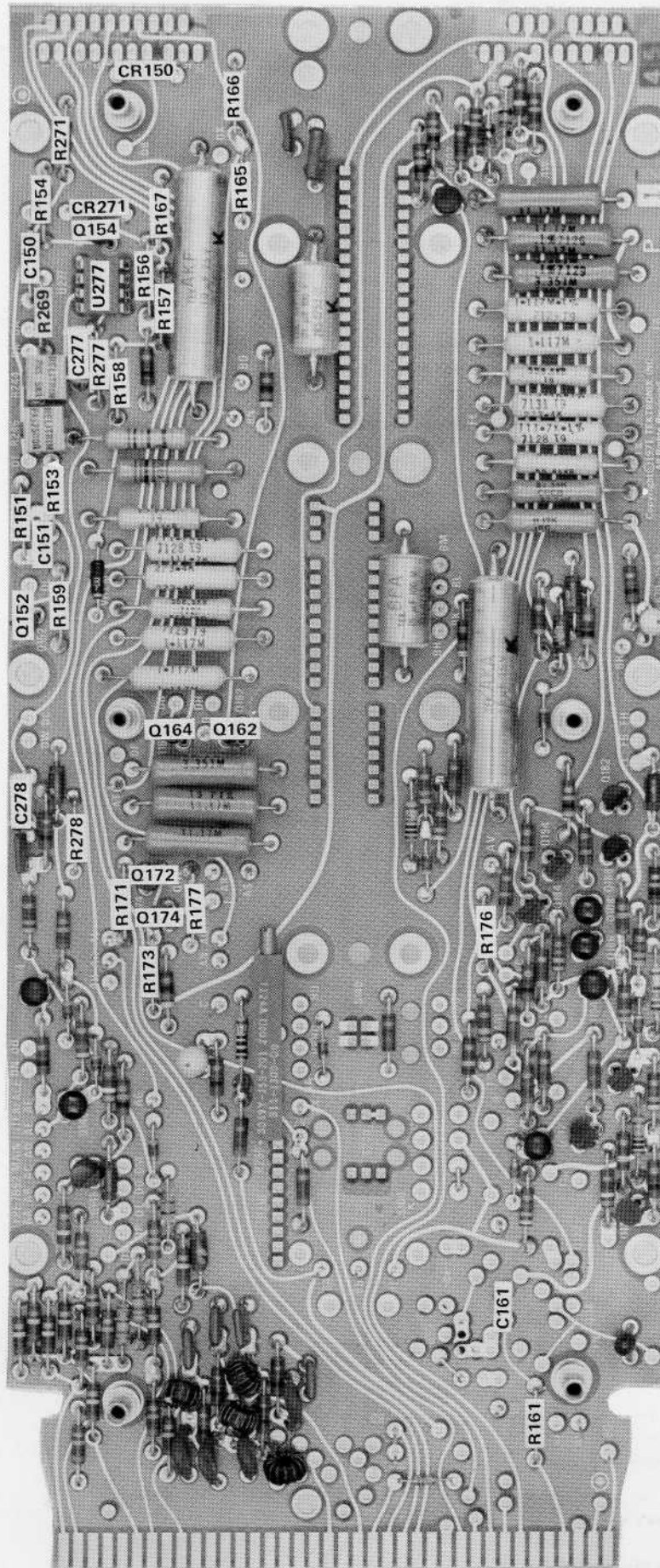
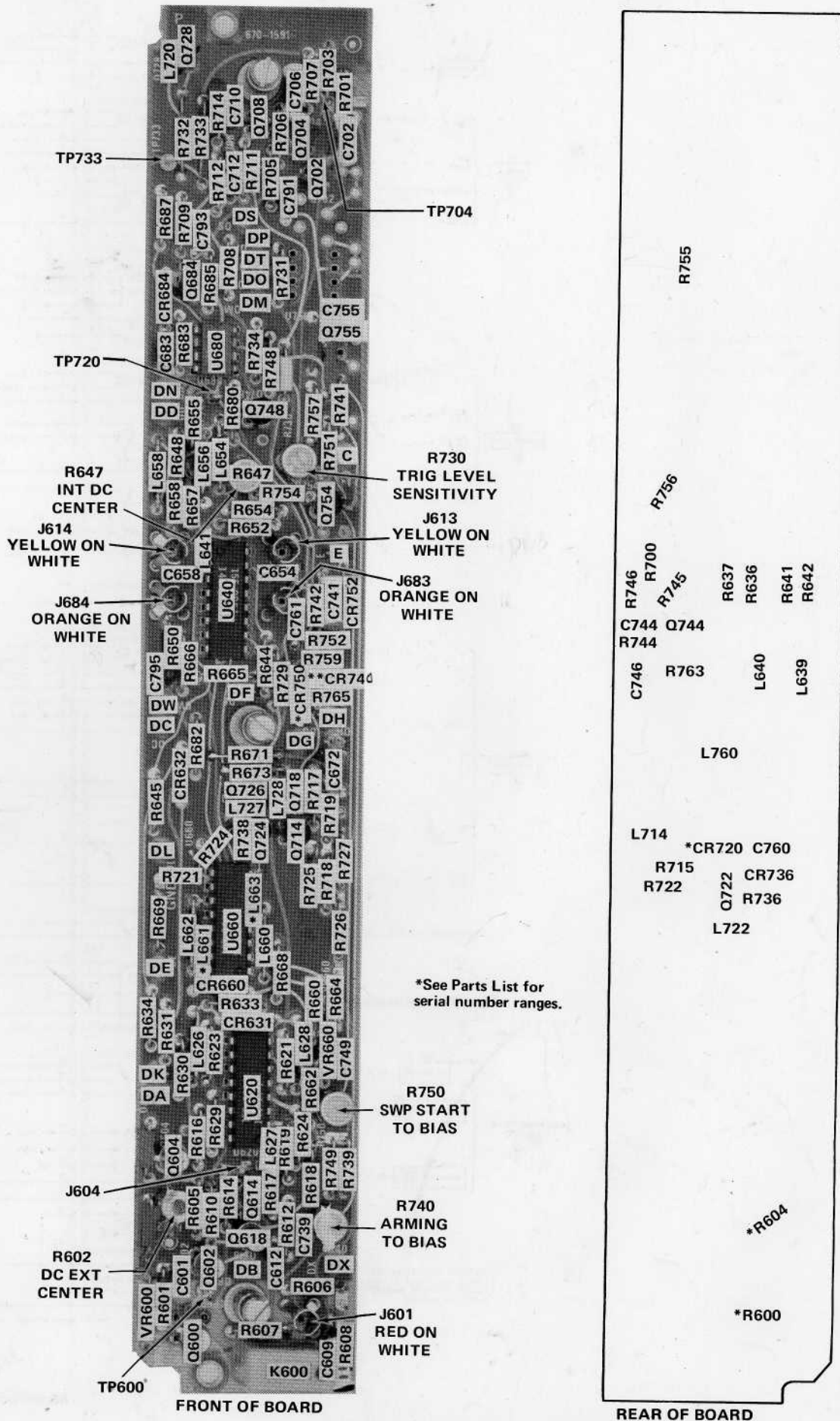

Fig. 6-9. Partial Main Interface circuit board A6.



FRONT OF BOARD

REAR OF BOARD

Fig. 6-10. Main Trigger circuit board A8.

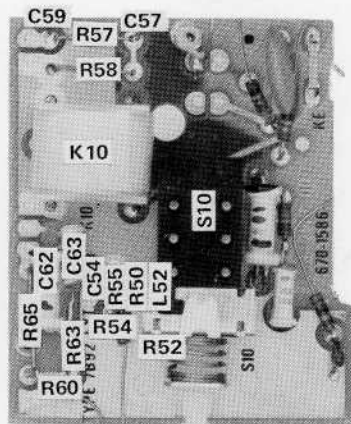

NOTE: See Figs. 6-3, 6-4, and 6-5 for parts not identified here.

Fig. 6-11. Partial Ext Input circuit board A7.

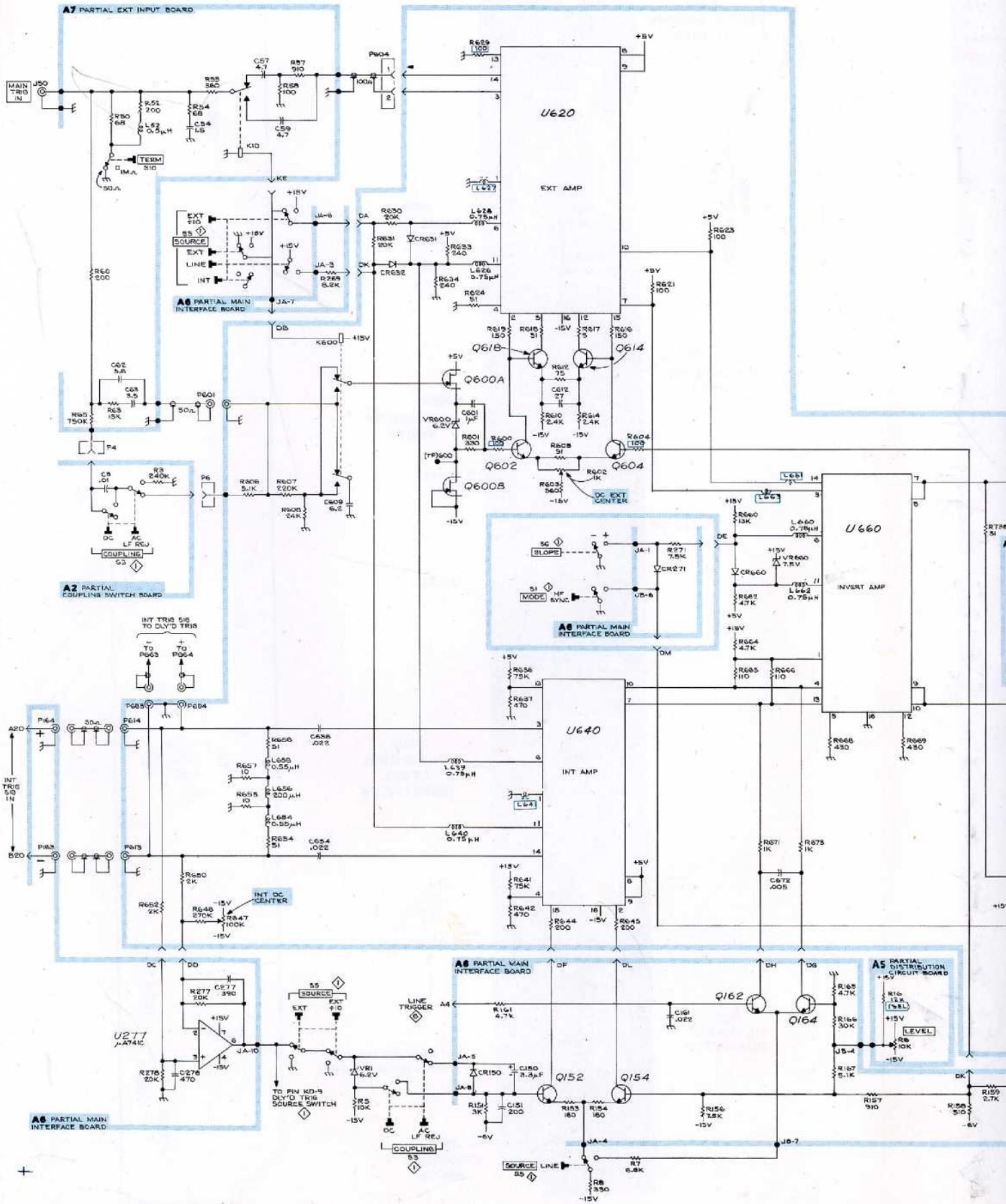

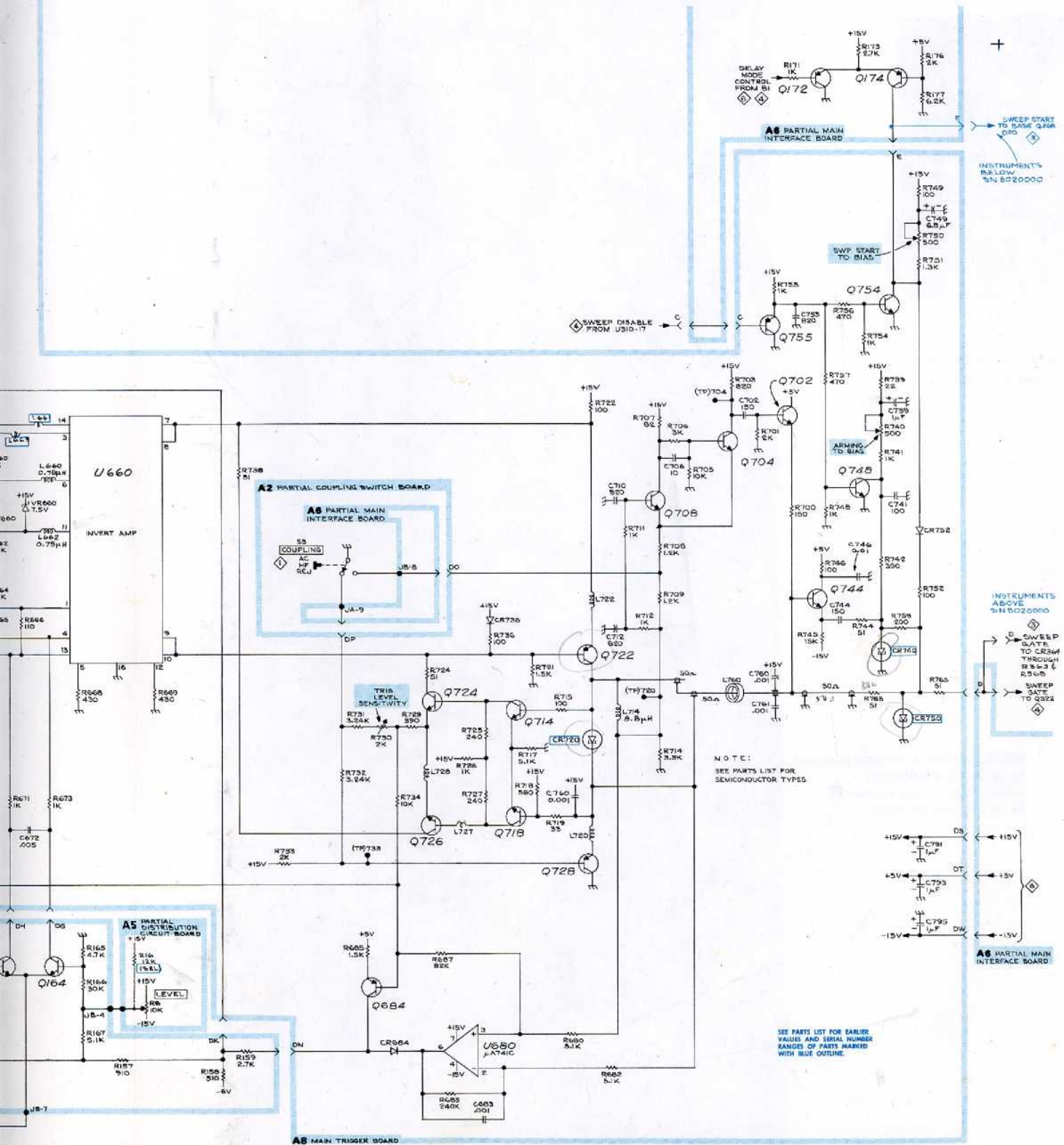

NOTE:
SEE PARTS LIST FOR SEMICONDUCTOR TYPES

SEE PARTS LIST FOR EARLIER VALUES AND SERIAL NUMBER RANGES OF PARTS MARKED WITH BLUE OUTLINE.

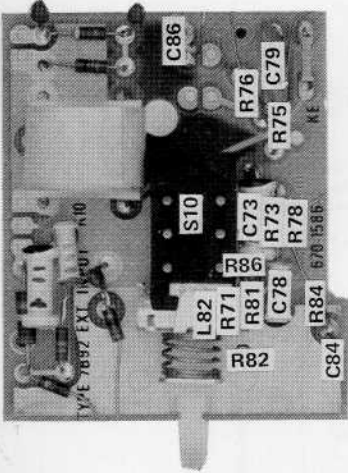

Fig. 6-12. Partial Ext Input circuit board A7.

Ⓐ

NOTE: CR365 and Q368 removed
Serial Number B030000.
R363 added to rear of board
Serial Number B030000.

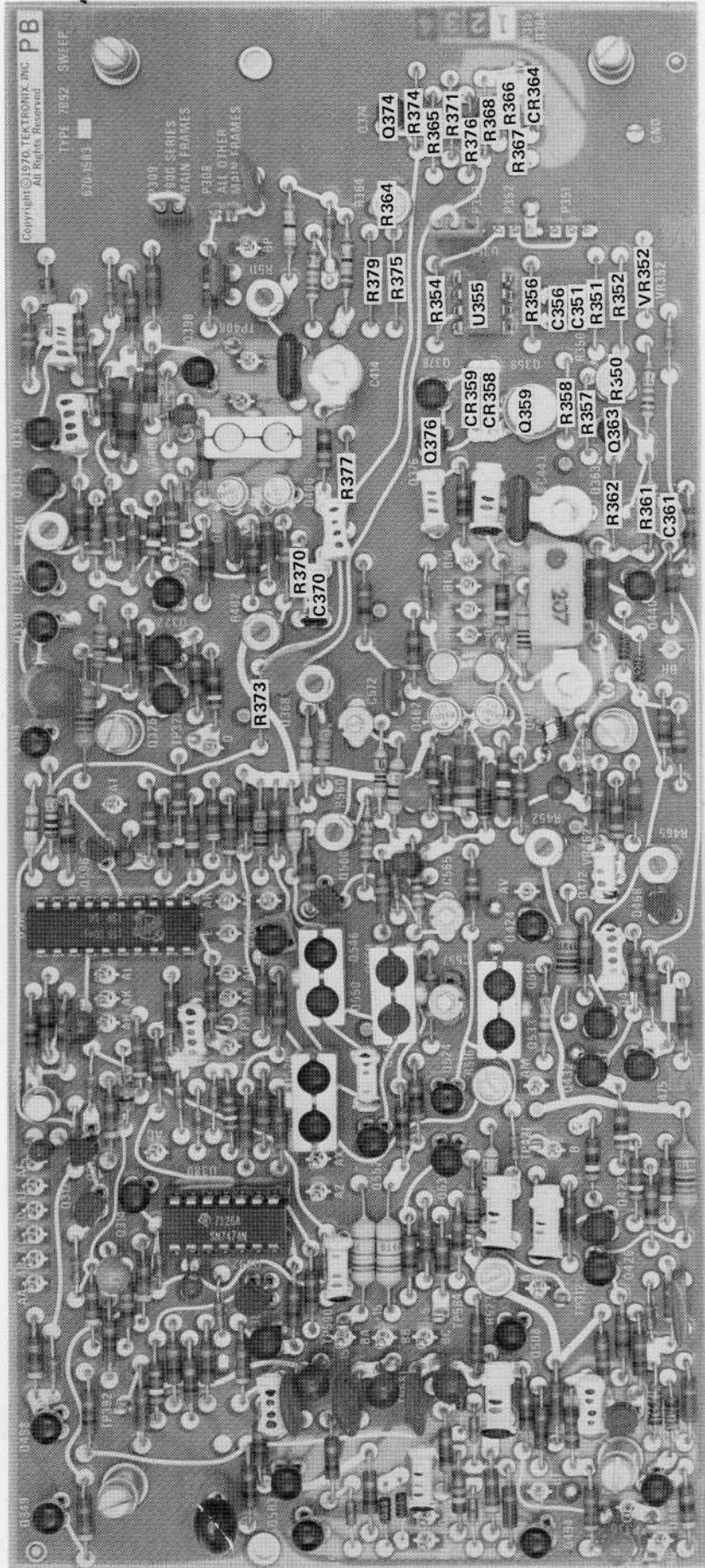

Fig. 6-13. Partial Sweep circuit board A10.

Ⓐ

R940
DLY'D ARMING
TO BIAS

R950
DLY'D SWP START
TO BIAS

J864
ORANGE ON
WHITE

*L840

R802
DLY'D EXT
DC CENTER

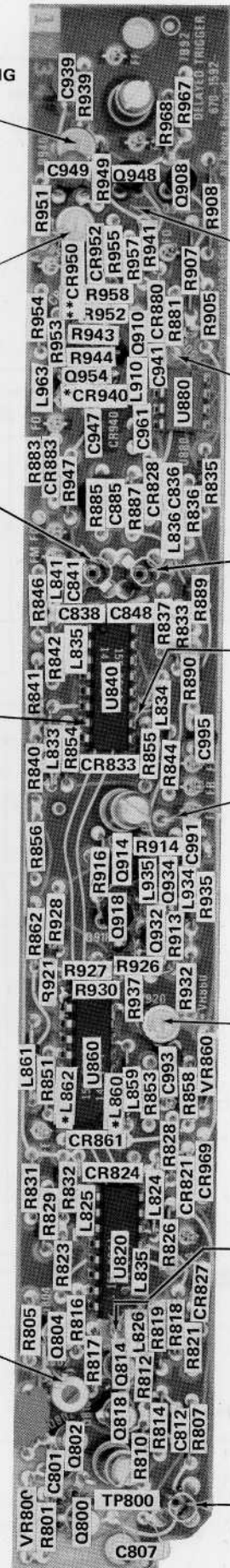

FRONT OF BOARD

R959
RUNS AFTER
SENSITIVITY

TP908

J863
ORANGE ON
WHITE

*L842

TP920

R920
DLY'D TRIG
LEVEL
SENSITIVITY

J804

*See Parts List for
serial number ranges.

J801
BROWN ON
WHITE

CR968

R963

R945
C945
Q944

R946

L961

R919 L890
C912 CR924
R922 *CR920 Q922 R924
L922

C804

R804

*R800 *R803

REAR OF BOARD

Fig. 6-14. Delayed Trigger circuit board A9.

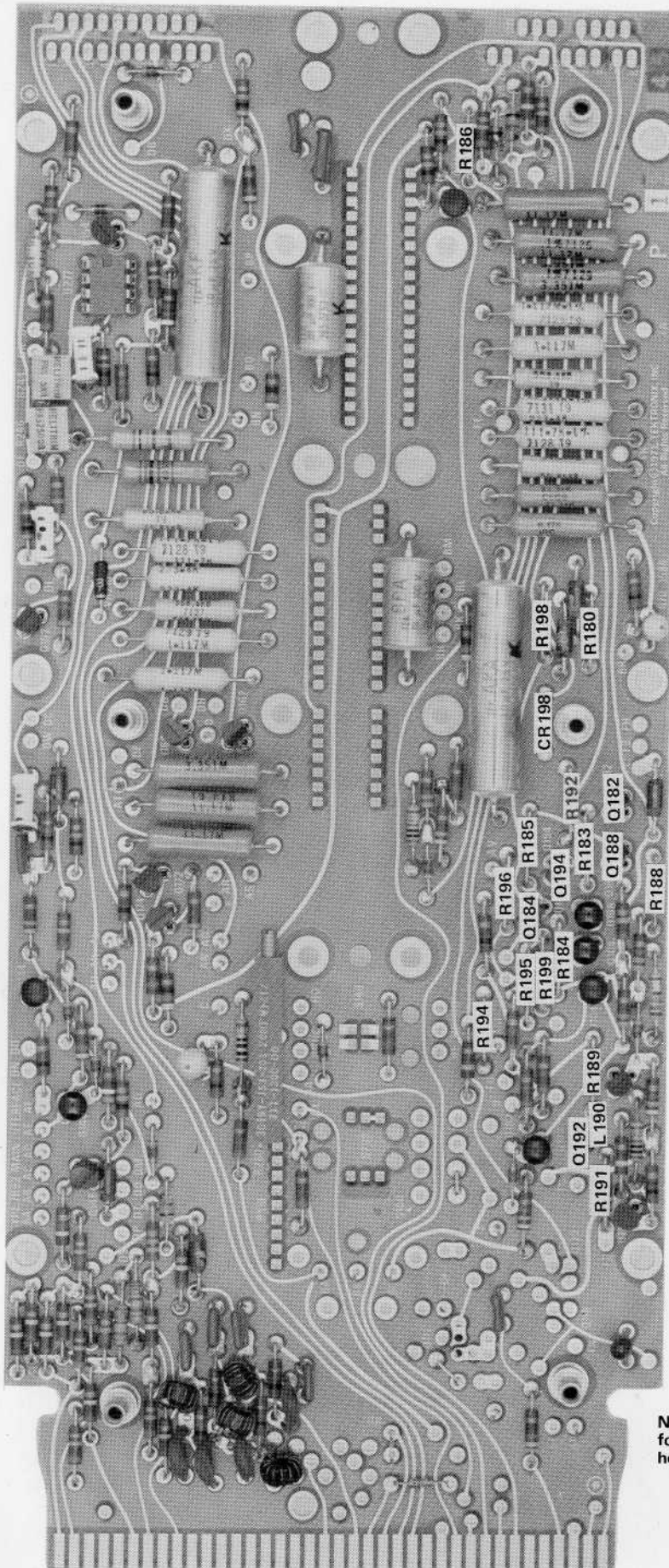

NOTE: See Figs. 6-4, 6-5, and 6-7 for location of parts not identified here.

Fig. 6-15. Partial Main Interface circuit board A6.

SWEEP GATE
FROM Q7B
BEFORE
SWEEP GATE
FROM Q7B
THROUGH R7C

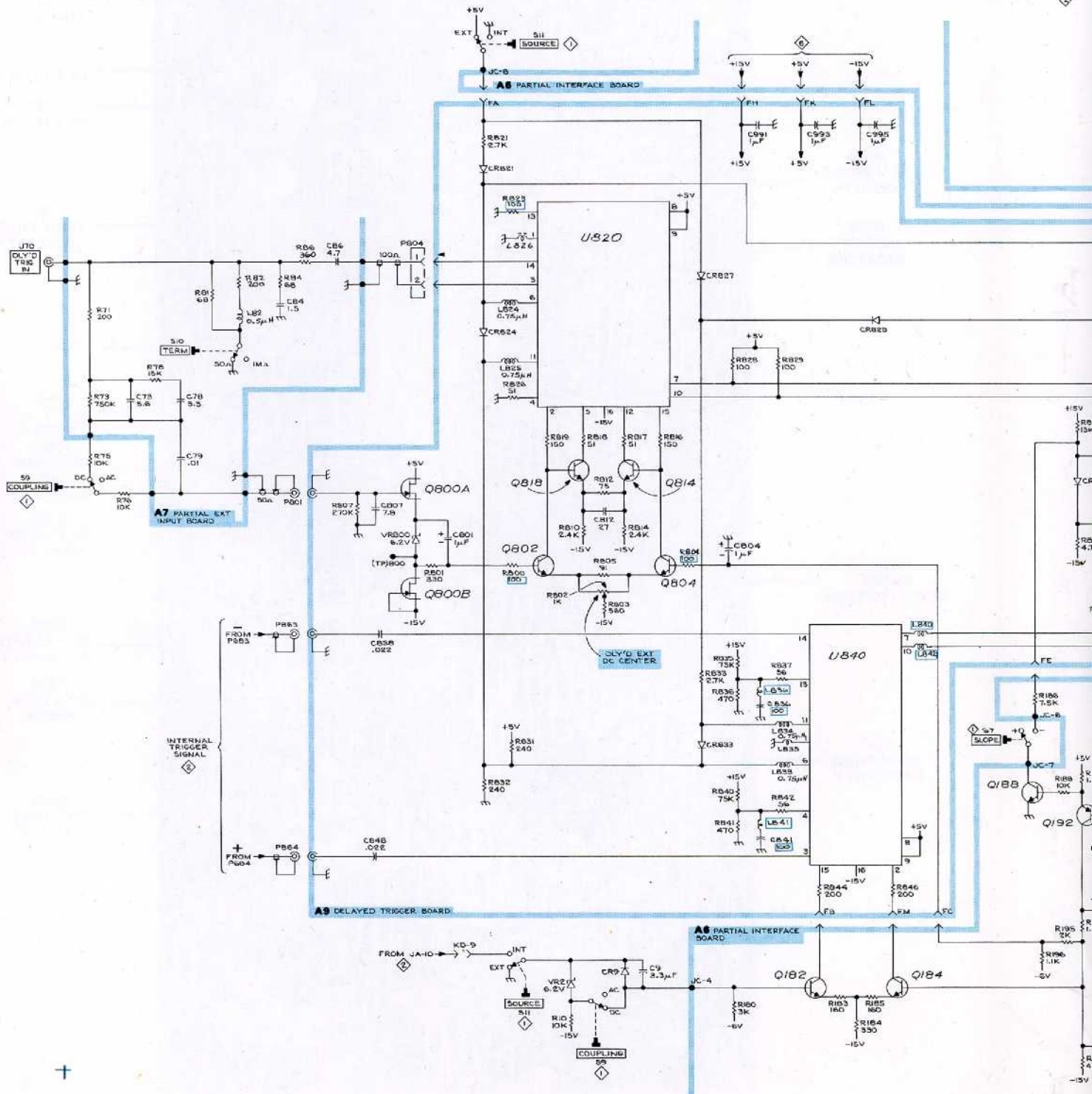

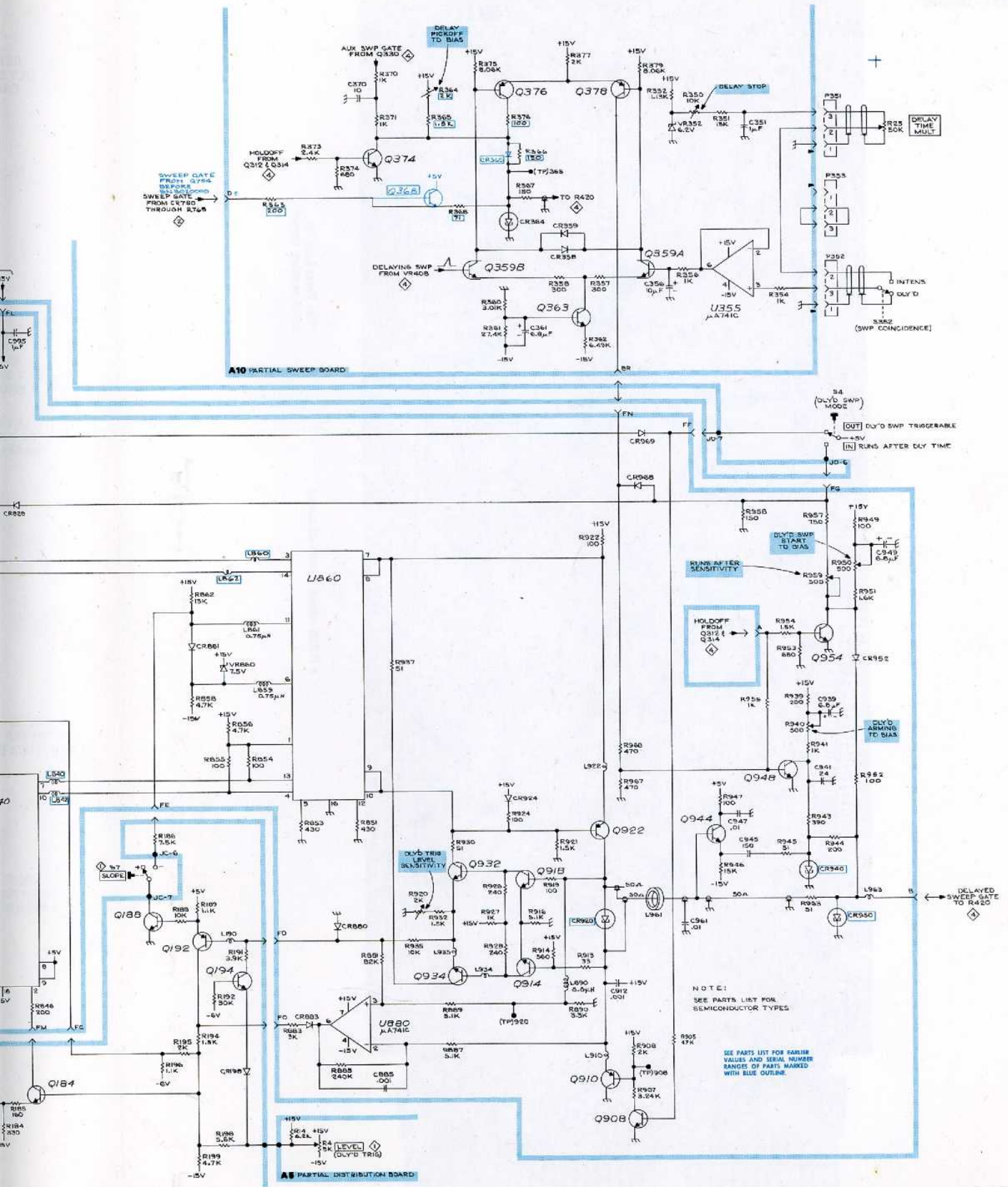

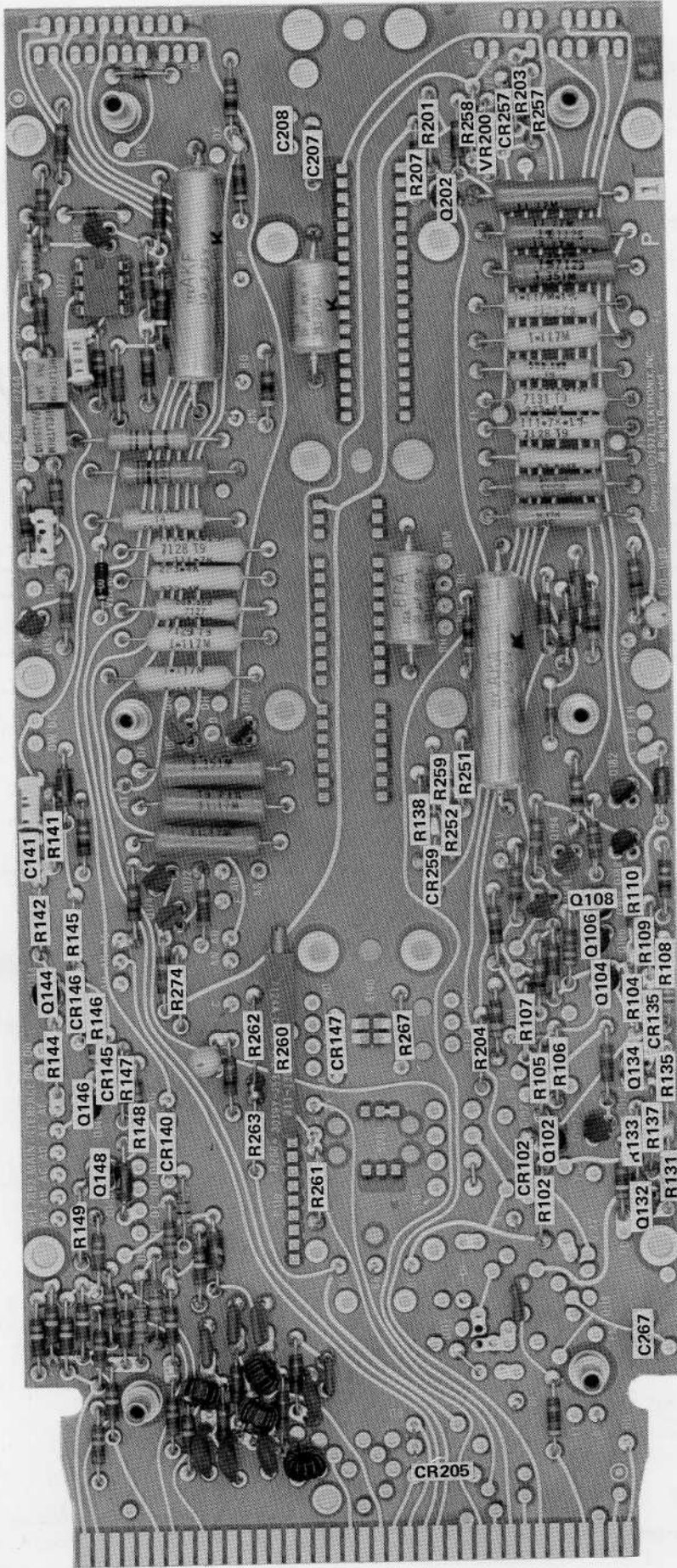
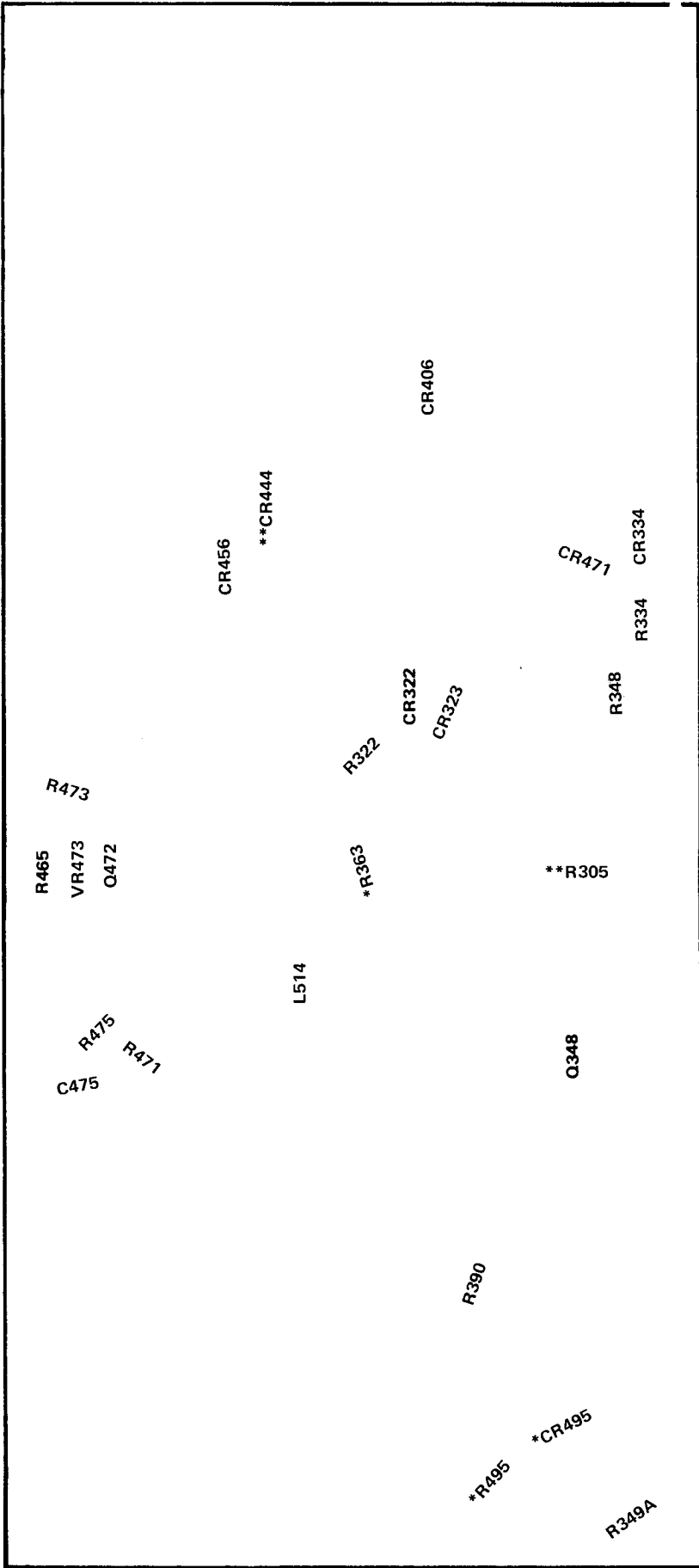

Fig. 6-16. Partial Main Interface circuit board A6.

*See Parts List for serial number ranges.

* R208 added to rear of board



REAR OF BOARD

*Added Serial Number B030000

**Added Serial Number B010200

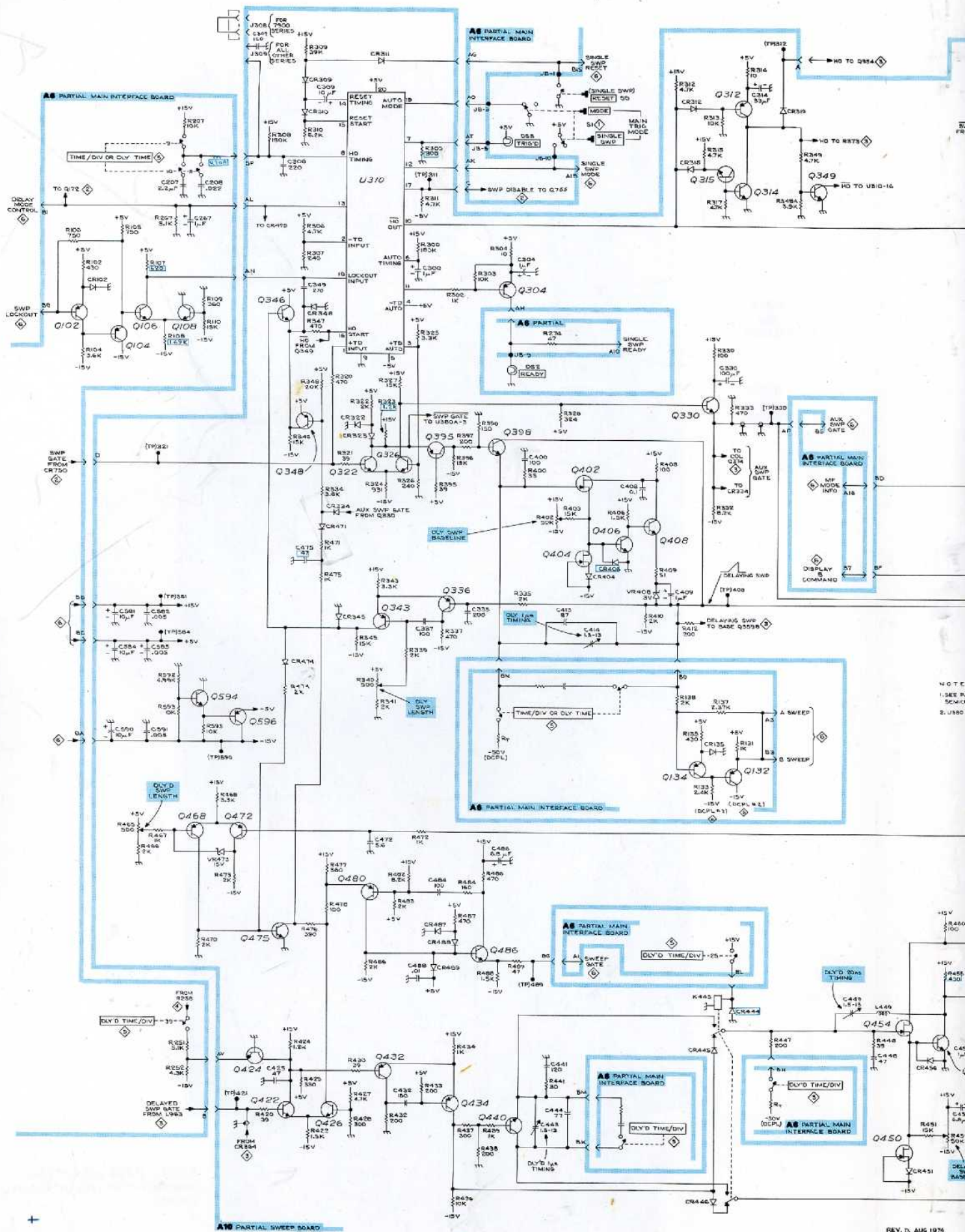

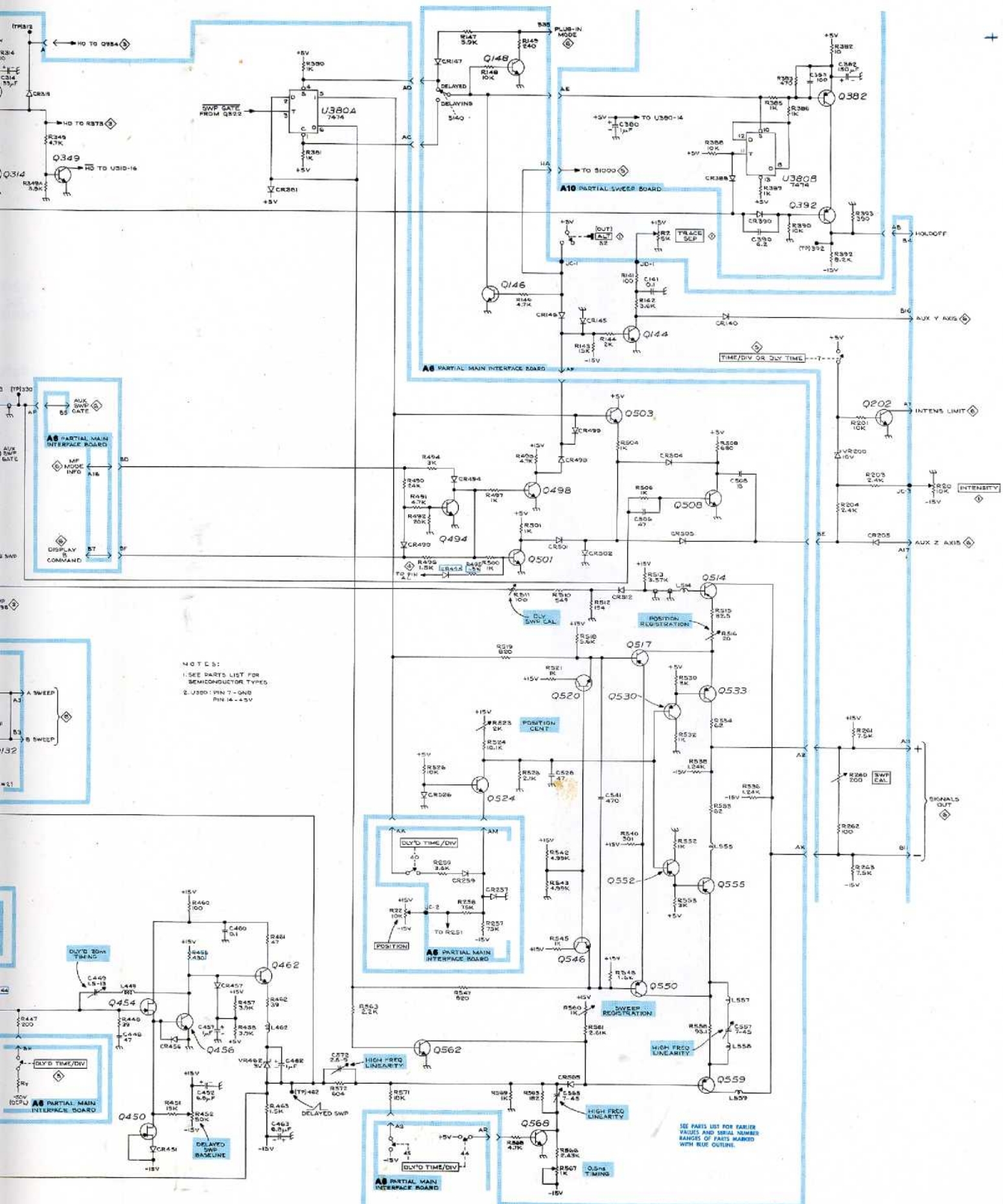

NOTES:
 1. SEE PARTS LIST FOR SEMICONDUCTOR TYPES.
 2. U3801 PIN 7 - GND
 PIN 14 - +5V

SEE PARTS LIST FOR EARLIER TRACES AND SERIAL NUMBERS. RANGES OF PARTS MARKED WITH BLUE OUTLINE.

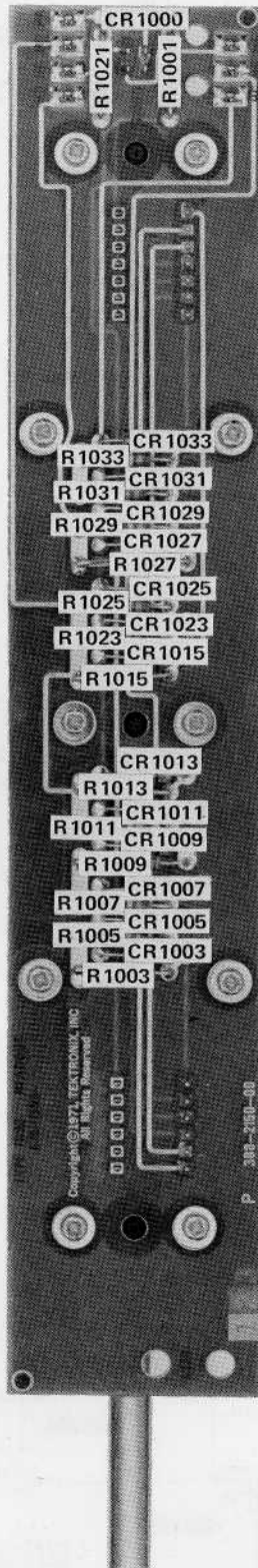
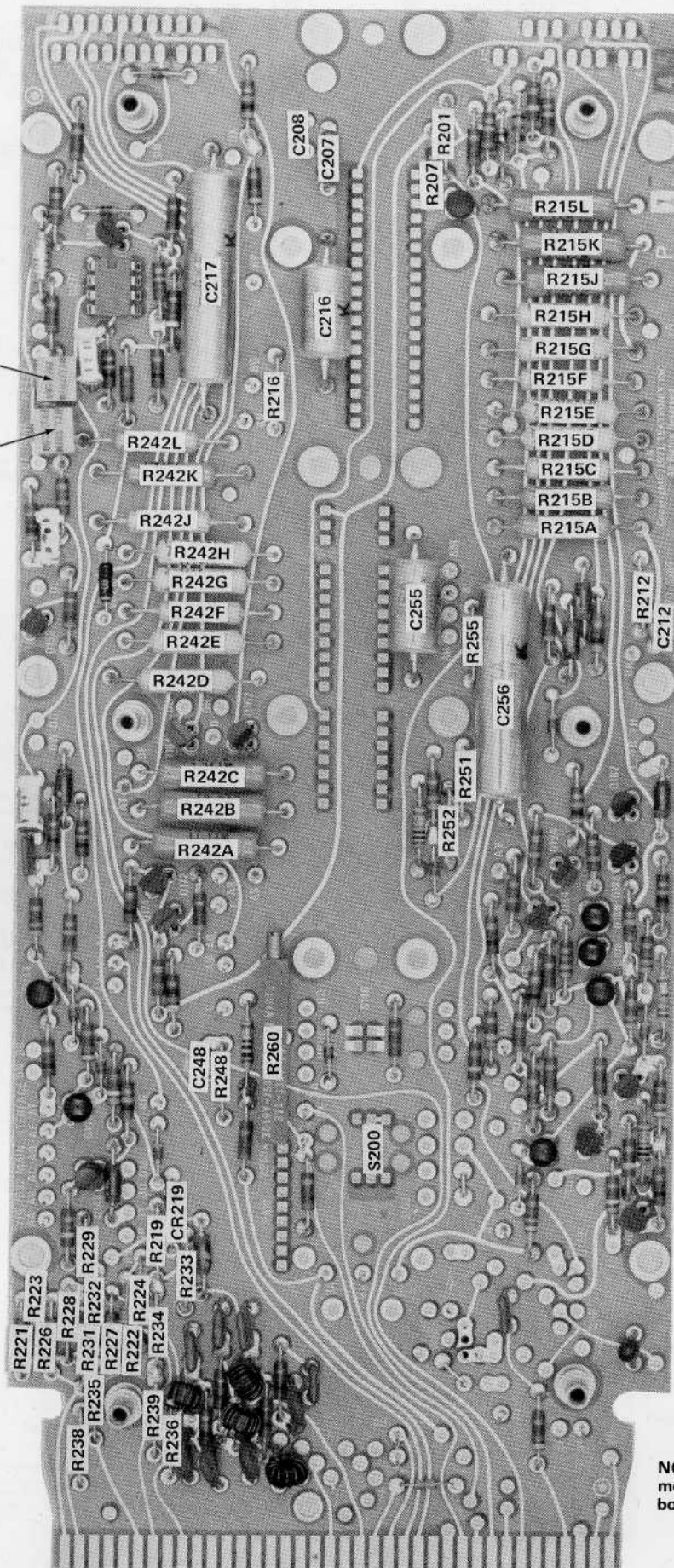

Fig. 6-18. Readout circuit board A11.

R244
2ns
TIMING

R246
.5ns
TIMING



NOTE: R200 and R211 are
mounted on the rear of circuit
board.

Fig. 6-19. Partial Main Interface circuit board A6.

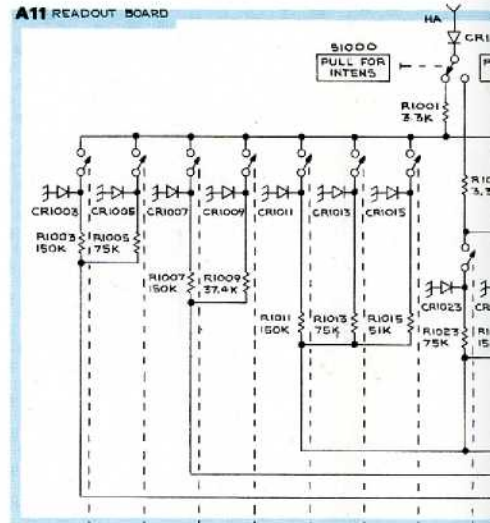
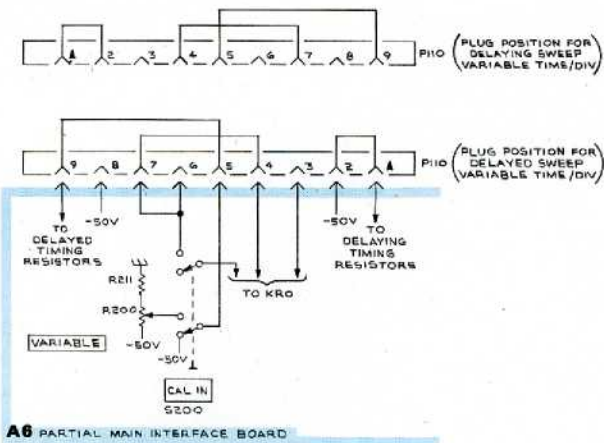

SEE PARTS LIST FOR EARLIER VALUES AND SERIAL NUMBER RANGES OF PARTS MARKED WITH BLUE OUTLINE.

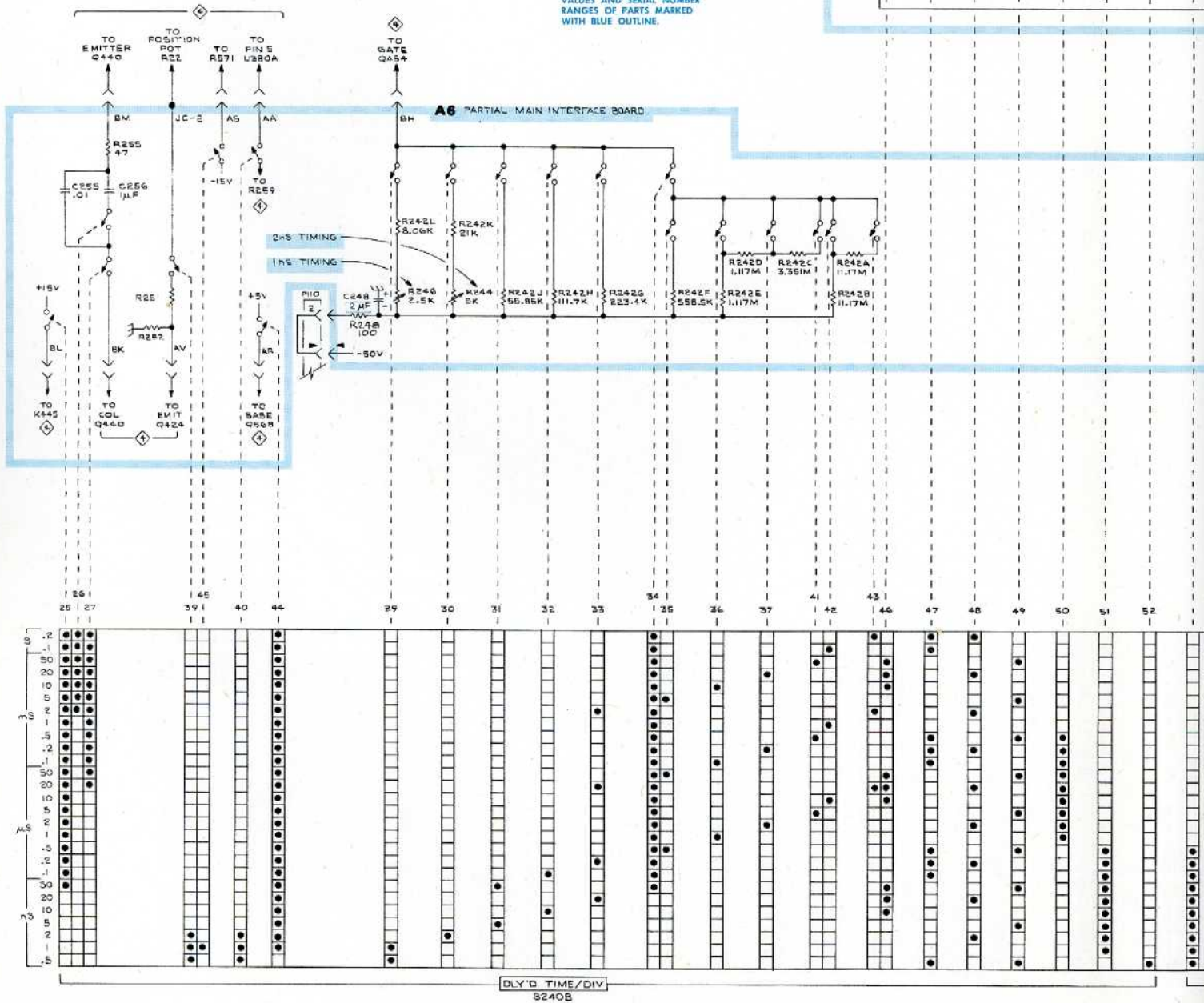

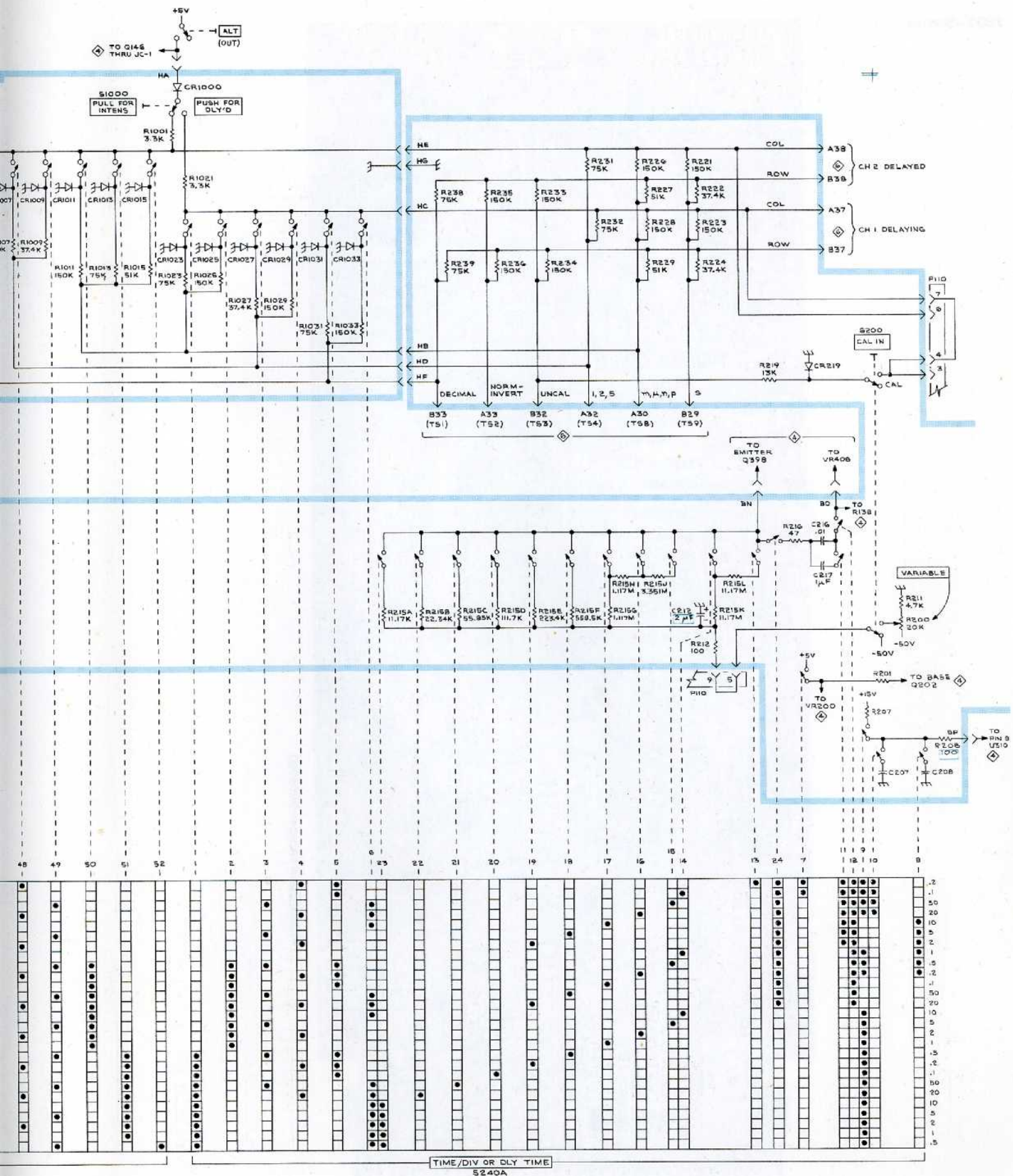

(A)

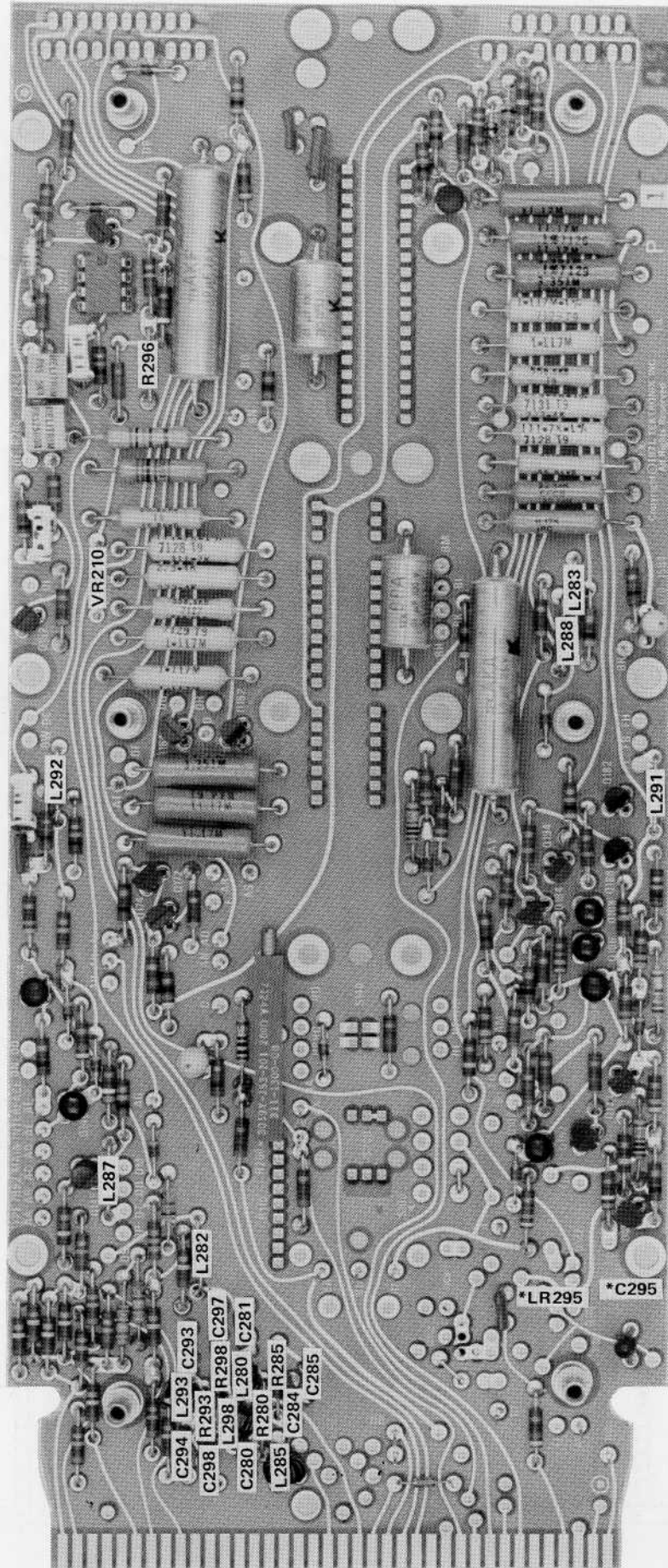

*Added Serial Number B030000

Fig. 6-20. Partial Main Interface circuit board A6.

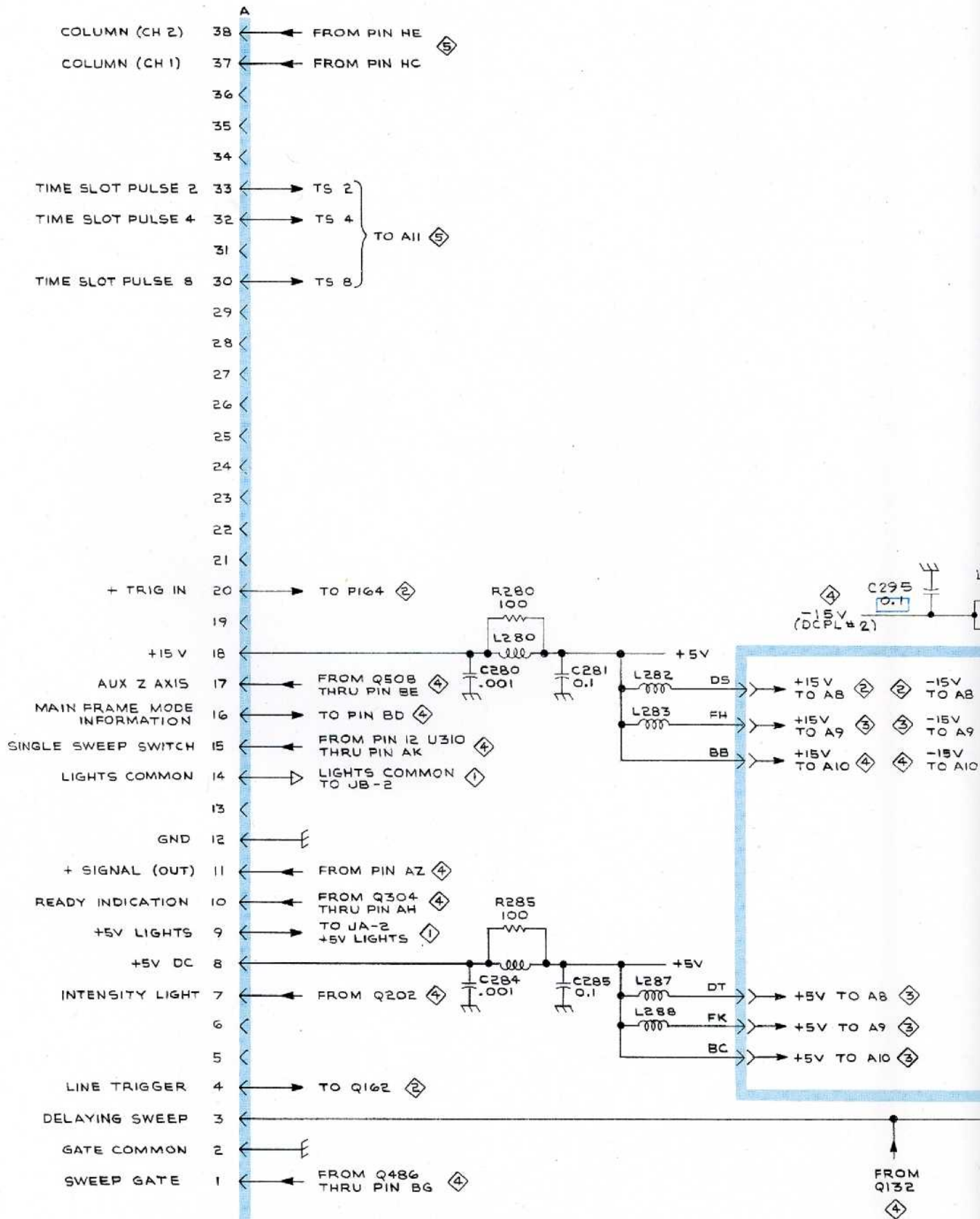

A6 PARTIAL MAIN INTERFACE BOARD

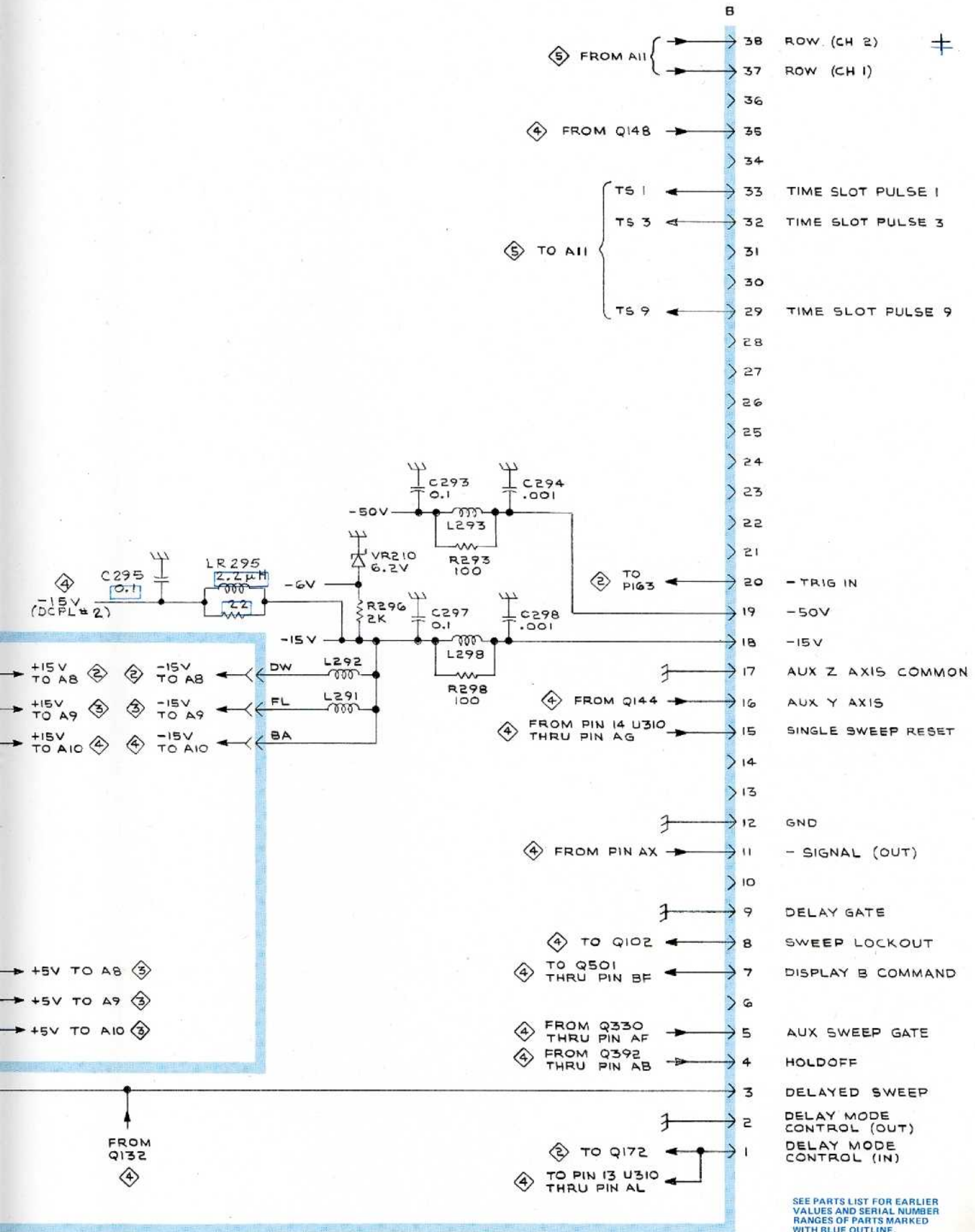

SEE PARTS LIST FOR EARLIER VALUES AND SERIAL NUMBER RANGES OF PARTS MARKED WITH BLUE OUTLINE.

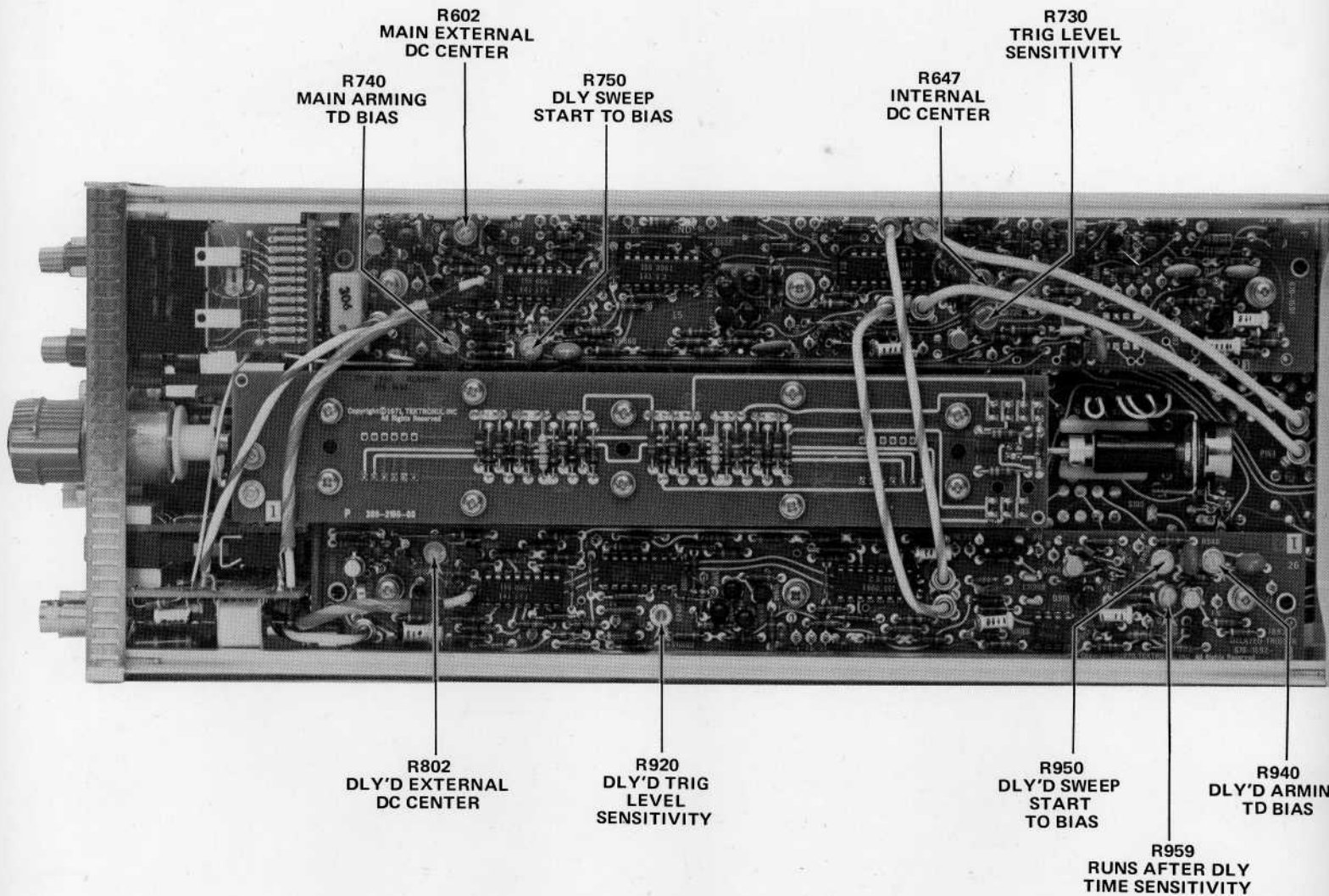

Fig. 6-21. Location of Trigger System adjustments.

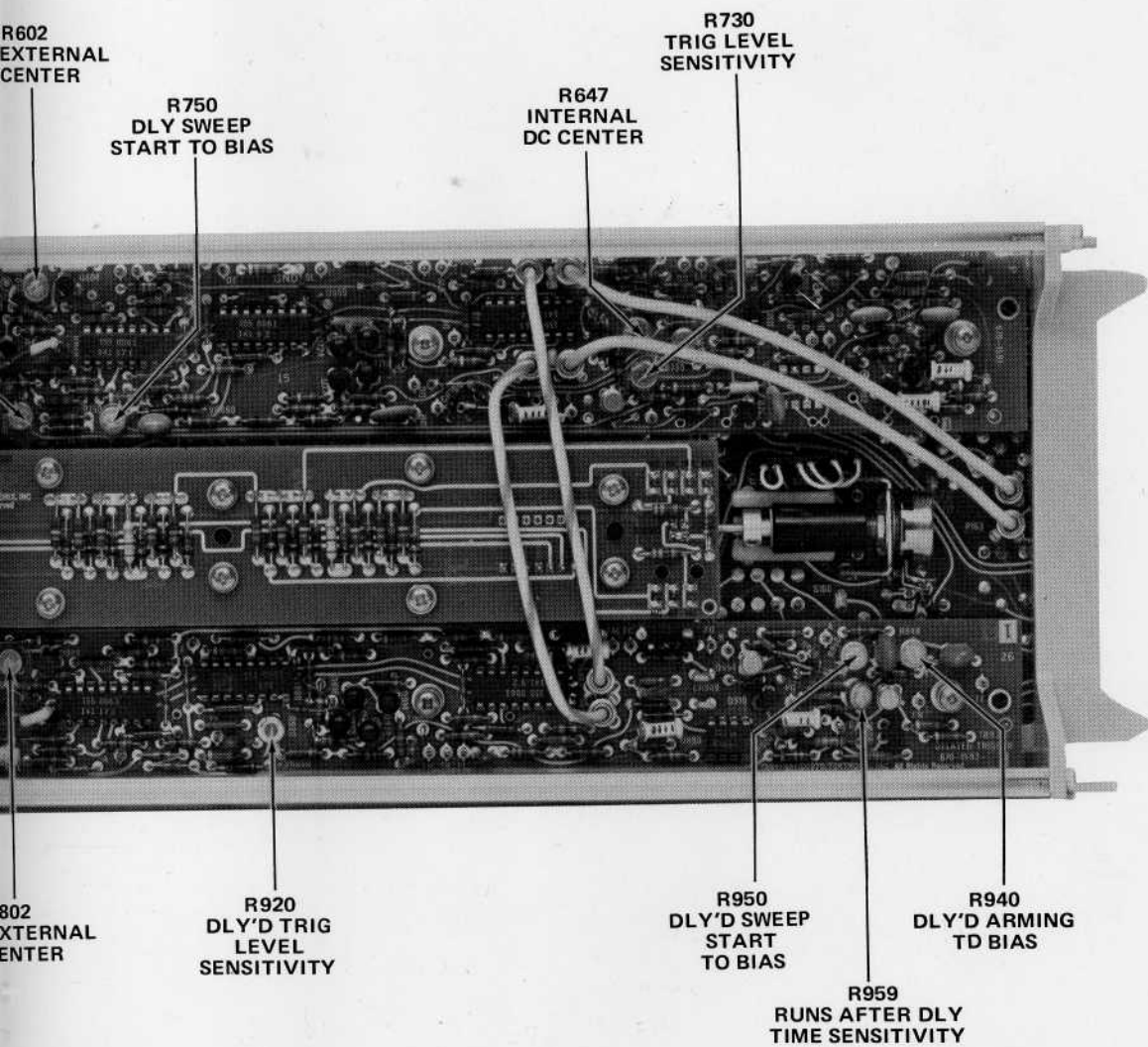

Fig. 6-21. Location of Trigger System adjustments.

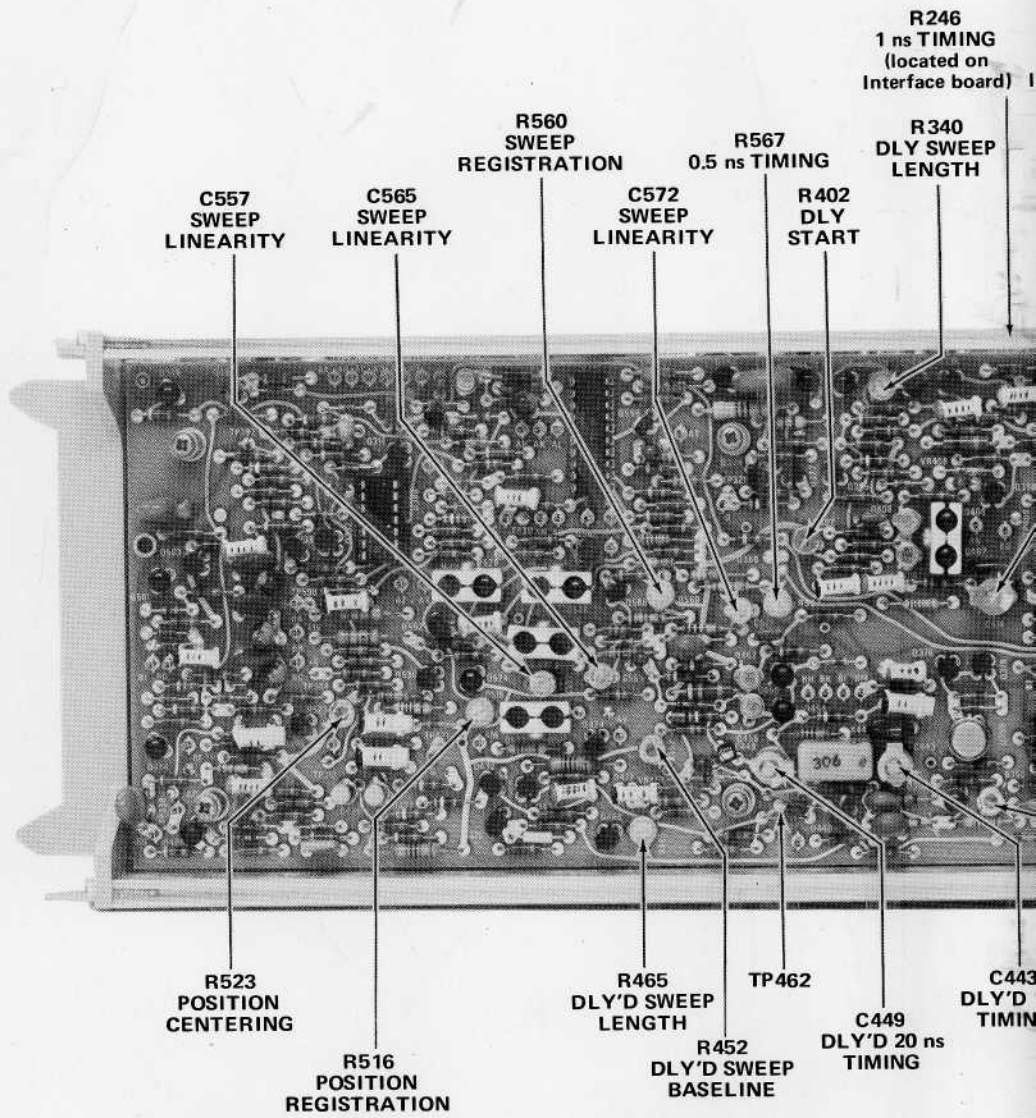
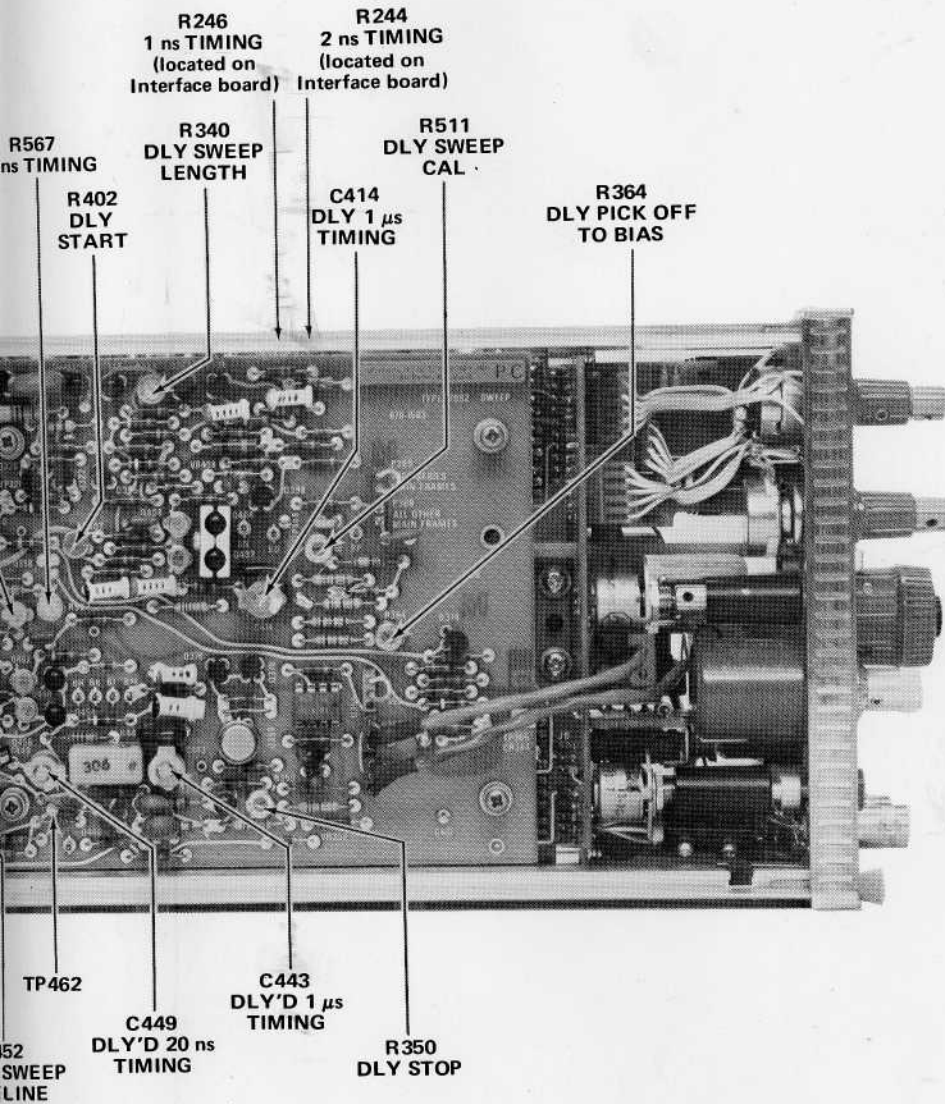

Fig. 6-22. Location of Horizontal System



2. Location of Horizontal System adjustments.

REPLACEABLE MECHANICAL PARTS

PARTS ORDERING INFORMATION

Replacement parts are available from or through your local Tektronix, Inc. Field Office or representative.

Changes to Tektronix instruments are sometimes made to accommodate improved components as they become available, and to give you the benefit of the latest circuit improvements developed in our engineering department. It is therefore important, when ordering parts, to include the following information in your order: Part number, instrument type or number, serial number, and modification number if applicable.

If a part you have ordered has been replaced with a new or improved part, your local Tektronix, Inc. Field Office or representative will contact you concerning any change in part number.

Change information, if any, is located at the rear of this manual.

SPECIAL NOTES AND SYMBOLS

X000 Part first added at this serial number
00X Part removed after this serial number

FIGURE AND INDEX NUMBERS

Items in this section are referenced by figure and index numbers to the illustrations.

INDENTATION SYSTEM

This mechanical parts list is indented to indicate item relationships. Following is an example of the indentation system used in the description column.

```

1 2 3 4 5           Name & Description
Assembly and/or Component
Attaching parts for Assembly and/or Component
    ---*---
Detail Part of Assembly and/or Component
Attaching parts for Detail Part
    ---*---
Parts of Detail Part
Attaching parts for Parts of Detail Part
    ---*---
  
```

Attaching Parts always appear in the same indentation as the item it mounts, while the detail parts are indented to the right. Indented items are part of, and included with, the next higher indentation. The separation symbol ---*--- indicates the end of attaching parts.

Attaching parts must be purchased separately, unless otherwise specified.

ITEM NAME

In the Parts List, an Item Name is separated from the description by a colon (:). Because of space limitations, an Item Name may sometimes appear as incomplete. For further Item Name identification, the U.S. Federal Cataloging Handbook H6-1 can be utilized where possible.

ABBREVIATIONS

"	INCH	ELCTRN	ELECTRON	IN	INCH	SE	SINGLE END
#	NUMBER SIZE	ELEC	ELECTRICAL	INCAND	INCANDESCENT	SECT	SECTION
ACTR	ACTUATOR	ELCLTL	ELECTROLYTIC	INSUL	INSULATOR	SEMICOND	SEMICONDUCTOR
ADPTR	ADAPTER	ELEM	ELEMENT	INTL	INTERNAL	SHLD	SHIELD
ALIGN	ALIGNMENT	EPL	ELECTRICAL PARTS LIST	LPHLDR	LAMPHOLDER	SHLDR	SHOULDERED
AL	ALUMINUM	EQPT	EQUIPMENT	MACH	MACHINE	SKT	SOCKET
ASSEM	ASSEMBLED	EXT	EXTERNAL	MECH	MECHANICAL	SL	SLIDE
ASSY	ASSEMBLY	FIL	FILLISTER HEAD	MTG	MOUNTING	SLFLKG	SELF-LOCKING
ATTEN	ATTENUATOR	FLEX	FLEXIBLE	NIP	NIPPLE	SLVG	SLEEVING
AWG	AMERICAN WIRE GAGE	FLH	FLAT HEAD	NON WIRE	NOT WIRE WOUND	SPR	SPRING
BD	BOARD	FLTR	FILTER	OBD	ORDER BY DESCRIPTION	SQ	SQUARE
BRKT	BRACKET	FR	FRAME or FRONT	OD	OUTSIDE DIAMETER	SST	STAINLESS STEEL
BRS	BRASS	FSTNR	FASTENER	OVH	OVAL HEAD	STL	STEEL
BRZ	BRONZE	FT	FOOT	PH BRZ	PHOSPHOR BRONZE	SW	SWITCH
BSHG	BUSHING	FXD	FIXED	PL	PLAIN or PLATE	T	TUBE
CAB	CABINET	GSKT	GASKET	PLSTC	PLASTIC	TERM	TERMINAL
CAP	CAPACITOR	HDL	HANDLE	PN	PART NUMBER	THD	THREAD
CER	CERAMIC	HEX	HEXAGON	PNH	PAN HEAD	THK	THICK
CHAS	CHASSIS	HEX HD	HEXAGONAL HEAD	PWR	POWER	TNSN	TENSION
CKT	CIRCUIT	HEX SOC	HEXAGONAL SOCKET	RCPT	RECEPTACLE	TPG	TAPPING
COMP	COMPOSITION	HLCPS	HELICAL COMPRESSION	RES	RESISTOR	TRH	TRUSS HEAD
CONN	CONNECTOR	HLEXT	HELICAL EXTENSION	RGD	RIGID	V	VOLTAGE
COV	COVER	HV	HIGH VOLTAGE	RLF	RELIEF	VAR	VARIABLE
COPLG	COUPLING	IC	INTEGRATED CIRCUIT	RTNR	RETAINER	W/	WITH
CRT	CATHODE RAY TUBE	ID	INSIDE DIAMETER	SCH	SOCKET HEAD	WSHR	WASHER
DEG	DEGREE	IDNT	IDENTIFICATION	SCOPE	OSCILLOSCOPE	XFMR	TRANSFORMER
DWR	DRAWER	IMPLR	IMPELLER	SCR	SCREW	XSTR	TRANSISTOR

CROSS INDEX MFR. CODE NUMBER TO MANUFACTURER

MFR.CODE	MANUFACTURER	ADDRESS	CITY,STATE,ZIP
0000C	Gettig Engineering and Manufacturing Co.		Springmill, PA 16875
00779	AMP, Inc.	P. O. Box 3608	Harrisburg, PA 17105
05129	Kilo Engineering Co.	2015 D	La Verne, CA 91750
08261	Spectra-Strip Corp.	7100 Lampson Ave.	Garden Grove, CA 92642
13257	Esna, Ltd.	10 Esna Park Dr.	Markham, Ontario, Canada
22526	Berg Electronics, Inc.	Youk Expressway	New Cumberland, PA 17070
23499	Gavitt Wire and Cable, Division of Amerace Esna Corp.	455 N. Quince St.	Escondido, CA 92025
70276	Allen Mfg. Co.	P. O. Drawer 570	Hartford, CT 06101
71785	TRW Electronic Components, Cinch Connector Operations	1501 Morse Ave.	Elk Grove Village, IL 60007
73743	Fischer Special Mfg. Co.	446 Morgan St.	Cincinnati, OH 45206
74445	Holo-Krome Co.	31 Brook St. West	Hartford, CT 06110
77250	Pheoll Manufacturing Co., Division of Allied Products Corp.	5700 W. Roosevelt Rd.	Chicago, IL 60650
78189	Illinois Tool Works, Inc. Shakeproof Division	St. Charles Road	Elgin, IL 60126
79727	Continental-Wirt Electronics Corp.		Warminster, PA 18974
80009	Tektronix, Inc.	P. O. Box 500	Beaverton, OR 97077
83385	Central Screw Co.	2530 Crescent Dr.	Broadview, IL 60153
87308	N. L. Industries, Inc., Southern Screw Div.	P. O. Box 1360	Statesville, NC 28677
97464	Industrial Retaining Ring Co.	57 Cordier St.	Irvington, NJ 07111

FIGURE 1 EXPLODED

Fig. & Index No.	Tektronix Part No.	Serial/Model No. Eff	Dscnt	Qty	1 2 3 4 5	Name & Description	Mfr	
							Code	Mfr Part Number
1-1	366-1168-00			1		KNOB:BLACK CAP AND RED BODY W/SETSCREW	80009	366-1168-00
	213-0153-00			1		. SETSCREW:5-40 X 0.125 INCH,HEX SOC STL	74445	OBD
-2	366-1321-00			1		KNOB:CHARCOAL--TIME/DIV OR DLY TIME		
	213-0243-00			2		. SETSCREW:5-40 X 0.25 INCH,HEX SOC STL	70276	NOTE
-3	354-0410-00			1		RING:KNOB SKIRT		
	213-0153-00			1		. SETSCREW:5-40 X 0.125 INCH,HEX SOC STL	74445	OBD
-4	384-1087-00			1		SHAFT:PUSH, ACTUATOR		
-5	401-0126-00			1		BEARING:KNOB SKIRT		
-6	366-1391-00			1		KNOB:GRAY W/SETSCREW	80009	366-1391-00
	213-0140-00			1		. SETSCREW:2-56 X 0.094 INCH,HEX SOC STL	70276	OBD
-7	366-1077-00			1		KNOB:GRAY W/SETSCREW	80009	366-1077-00
	213-0153-00			1		. SETSCREW:5-40 X 0.125 INCH,HEX SOC STL	74445	OBD
-8	366-1391-00			1		KNOB:GRAY W/SETSCREW	80009	366-1391-00
	213-0140-00			1		. SETSCREW:2-56 X 0.094 INCH,HEX SOC STL	70276	OBD
-9	366-1077-00			1		KNOB:GRAY W/SETSCREW	80009	366-1077-00
	213-0153-00			1		. SETSCREW:5-40 X 0.125 INCH,HEX SOC STL	74445	OBD
-10	366-1023-01			1		KNOB:GRAY	80009	366-1023-01
	213-0153-00			1		. SETSCREW:5-40 X 0.125 INCH,HEX SOC STL	74445	OBD
-11	331-0247-00			1		DIAL,CONTROL:10 TURN	05129	77131
-12	366-1023-01			1		KNOB:GRAY	80009	366-1023-01
	213-0153-00			1		. SETSCREW:5-40 X 0.125 INCH,HEX SOC STL	74445	OBD
-13	214-1597-00			1		ACTUATOR:SWITCH		
-14	131-0106-02			2		CONNECTOR,RCPT,:BNC	80009	131-0106-02
-15	366-1214-01			1		PUSH BUTTON:LIGHT GRAY--INT-EXT		
-16	366-1214-02			1		PUSH BUTTON:LIGHT GRAY--AC-DC		
-17	366-1214-03			1		PUSH BUTTON:LIGHT GRAY-- + -		
-18	366-1328-01			1		PUSH BUTTON:CHARCOAL--TERM		
-19	426-0681-00			1		FR,PUSH BUTTON:GRAY PLASTIC	80009	426-0681-00
-20	366-1058-26			1		KNOB:LATCH		
						(ATTACHING PARTS)		
-21	214-1095-00			1		PIN,SPG,SPLIT:0.094 OD X 0.187 INCH LONG	13257	52-022-094-0187
						- - - - * - - - -		
-22	105-0076-00			1		REL BAR,LATCH:PLUG-IN UNIT	80009	105-0076-00
-23	214-1280-00			1		SPRING,HLCPS:0.14 OD X 1.126"L,0.16"DIA W	80009	214-1280-00
-24	358-0378-00			1		BUSHING,SLEEVE:PRESS MOUNT	80009	358-0378-00
-25	333-1447-00			1		PANEL:FRONT		
-26	337-1064-00			1		SHLD,SIDE,ELEC:PLUG-IN	80009	337-1064-00
-27	337-1435-01			1		SHIELD:ELECTRICAL,RIGHT		
-28	358-0408-00			2		BUSHING:SLEEVE		
-29	200-0935-00			1		BASE,LAMPHOLDER:0.29 OD X 0.19" L,BK PLSTC	80009	200-0935-00
-30	378-0602-00			1		LENS,LIGHT:GREEN	80009	378-0602-00
-31	352-0157-00			1		LAMPHOLDER:WHITE PLASTIC	80009	352-0157-00
-32	-----			1		RESISTOR, VARIABLE:		
						(ATTACHING PARTS)		
-33	210-0583-00			1		NUT,PLAIN,HEX.:0.25-32 X 0.312 INCH,BRS	73743	2X20319-402
						- - - - * - - - -		
-34	-----			1		RESISTOR,VARIABLE:		
						(ATTACHING PARTS)		
-35	210-0583-00			1		NUT,PLAIN,HEX.:0.25-32 X 0.312 INCH,BRS	73743	2X20319-402
						- - - - * - - - -		
-36	260-0735-01			1		SWITCH:PUSH,W/HARDWARE		
						(ATTACHING PARTS)		
-37	210-0008-00			1		WASHER,LOCK:INTL,0.172 ID X 0.331"OD,STL	78189	1208-00-00-0541C
						- - - - * - - - -		
-38	-----			1		CKT BOARD ASSY:TRIGGER MODE(SEE A1 EPL)		
	136-0328-02			8		. CONTACT,ELEC:HORIZONTAL	00779	86282-2
						(ATTACHING PARTS FOR CKT BD)		
-39	211-0156-00			2		SCREW,MACHINE:1-72 X 0.25",82 DEG,FLH STL	77250	OBD
						- - - - * - - - -		
-40	-----			1		CKT BOARD ASSY:TRIGGER COUPLING(SEE A2 EPL)		
	131-0608-00			2		. CONTACT,ELEC:0.365 INCH LONG	22526	47357
	136-0328-02			9		. CONTACT,ELEC:HORIZONTAL	00779	86282-2
						(ATTACHING PARTS FOR CKT BD)		
	211-0156-00			2		SCREW,MACHINE:1-72 X 0.25",82 DEG,FLH STL	77250	OBD
						- - - - * - - - -		

Mechanical Parts List—7B92

FIGURE 1 EXPLODED (CONT)

Fig. & Index No.	Tektronix Part No.	Serial/Model No. Eff	No. Dscont	Qty	1 2 3 4 5					Name & Description	Mfr Code	Mfr Part Numb
1-41	-----	-----		1								
-42	136-0328-02			12						00779	86282-2	
									(ATTACHING PARTS FOR CKT BD)			
	211-0156-00			2					SCREW,MACHINE:1-72 X 0.25",82 DEG,FLH STL	77250	OBD	
									- - - - * - - - -			
-43	380-0200-00			3					HOUSING:PUSH BUTTON			
-44	-----	-----		1					CKT BOARD ASSY:DELAYED TRIGGER(SEE A3 EPL)			
-45	136-0328-02			9					. CONTACT,ELEC:HORIZONTAL	00779	86282-2	
-46	352-0239-00			3					. LAMPHOLDER:			
									(ATTACHING PARTS)			
-47	213-0098-00			2					. SCREW:0-80 X 0.125 INCH,82 DEG CSK,FHS			
									- - - - * - - - -			
-48	260-1133-00			1					. SWITCH:PUSH,SET OF 3--SLOPE,COUPLING,SOURCE			
									(ATTACHING PARTS FOR CKT BD)			
-49	211-0541-00			3					SCREW,MACHINE:6-32 X 0.25"100 DEG,FLH STL	83385	OBD	
									- - - - * - - - -			
-50	-----	-----		1					CKT BOARD ASSY:EXTERNAL INPUT(SEE A7 EPL)			
-51	136-0328-00			1					. SOCKET:PIN TERMINAL			
-52	260-1132-00			1					. SWITCH,PUSH:1 BUTTON,DOUBLE POLE	80009	260-1132-00	
									(ATTACHING PARTS FOR CKT BD)			
-53	211-0001-00			2					SCREW,MACHINE:2-56 X 0.25 INCH,PNH STL	83385	OBD	
									- - - - * - - - -			
-54	220-0616-00			1					NUT BLOCK:			
									(ATTACHING PARTS)			
-55	211-0105-00			2					SCREW,MACHINE:4-40 X 0.188"100 DEG,FLH STL	83385	OBD	
									- - - - * - - - -			
-56	348-0235-00			2					SHLD GSKT,ELEC:4.734 INCH LONG	80009	348-0235-00	
-57	386-1447-56			1					SUBPANEL:FRONT			
									(ATTACHING PARTS)			
-58	213-0192-00			4					SCR,TPG,THD FOR:6-32 X 0.50 INCH,PNH STL	87308	OBD	
									- - - - * - - - -			
-59	384-1009-00			2					SHAFT:EXTENSION,0.56 INCH LONG			
-60	214-1190-00			2					EXTENDER-RETRACTER:KNOB			
	213-0075-00			1					. SETSCREW:4-40 X 0.094 INCH,HEX SOC STL	70276	OBD	
	213-0140-00			1					. SETSCREW:4-40 X 0.094 INCH,HSS	70276	OBD	
-61	260-0516-00			1					SWITCH:SENSITIVE--ALT(OUT)			
									(ATTACHING PARTS)			
-62	211-0159-00			2					SCREW,MACHINE:2-56 X 0.375 INCH,PNH STL	83385	OBD	
-63	210-0001-00			2					WASHER,LOCK:INTL,0.092 ID X 0.18"OD,STL	78189	1202-00-00-0541C	
-64	210-0405-00			2					NUT,PLAIN,HEX.:2-56 X 0.188 INCH,BRS	73743	2X12157-402	
									- - - - * - - - -			
-65	260-0516-00			1					SWITCH:SENSITIVE--IN-RUNS AFTER DLY TIME			
									(ATTACHING PARTS)			
-66	211-0159-00			2					SCREW,MACHINE:2-56 X 0.375 INCH,PNH STL	83385	OBD	
-67	210-0001-00			2					WASHER,LOCK:INTL,0.092 ID X 0.18"OD,STL	78189	1202-00-00-0541C	
-68	210-0405-00			2					NUT,PLAIN,HEX.:2-56 X 0.188 INCH,BRS	73743	2X12157-402	
									- - - - * - - - -			
-69	407-0749-00			2					BRACKET:COMPONENT MOUNTING			
									(ATTACHING PARTS FOR EACH)			
-70	210-0583-00			1					NUT,PLAIN,HEX.:0.25-32 X 0.312 INCH,BRS	73743	2X20319-402	
-71	210-0046-00			1					WASHER,LOCK:INTL,0.26 ID X 0.40" OD,STL	78189	1214-05-00-0541C	
									- - - - * - - - -			
-72	386-1402-00			1					PANEL,REAR:	80009	386-1402-00	
									(ATTACHING PARTS)			
-73	213-0192-00			4					SCR,TPG,THD FOR:6-32 X 0.50 INCH,PNH STL	87308	OBD	
-74	361-0326-00			1					SPACER,SLEEVE:0.18 ID X 0.25 OD X 0.10"L	80009	361-0326-00	
									- - - - * - - - -			
-75	220-0547-01			10					NUT,BLOCK:0.38 X 0.25 X 0.282"OA	80009	220-0547-01	
									(ATTACHING PARTS FOR EACH)			
-76	211-0105-00			1					SCREW,MACHINE:4-40 X 0.188"100 DEG,FLH STL	83385	OBD	
									- - - - * - - - -			

FIGURE 1 EXPLODED (CONT)

Fig. & Index No.	Tektronix Part No.	Serial/Model No. Eff Dscont	Qty	1 2 3 4 5					Name & Description	Mfr Code	Mfr Part Number
1-77	-----	-----	1								CKT BOARD ASSY:SWEEP(SEE A10 EPL)
-78	131-0608-00		11						22526	47357	. CONTACT,ELEC:0.365 INCH LONG
-79	136-0220-00		1						71785	133-23-11-034	. SOCKET,PLUG-IN:3 PIN
-80	136-0269-00		1						71785	133-59-02-073	. SOCKET,PLUG-IN:14 PIN DUAL INLINE
-81	136-0252-04		212						22526	75060	. CONTACT,ELEC:0.188 INCH LONG
-82	136-0263-03		39						00779	86250-2	. CONTACT,ELEC:FOR 0.025 INCH SQUARE PIN
-83	200-0945-00		5						80009	200-0945-00	. COVER,HALF XSTR:FOR DUAL TO-18CASE
-84	200-0945-01		5						80009	200-0945-01	. COVER,HALF XSTR:FOR DUAL TO-18 CS,2-56 THD
-85	211-0001-00		5						83385	OBD	. SCREW,MACHINE:2-56 X 0.25 INCH,PNH STL
-86	214-0579-00		13						80009	214-0579-00	. TERM.,TEST PT:0.40 INCH LONG
-87	352-0228-00		4						80009	352-0228-00	. HOLDER,CABLE:FOR 0.125"DIA CABLE,PLASTIC
-88	211-0155-00		6						80009	211-0155-00	. SCREW,EXT,RLV B:4-40 X 0.375 INCH,SST
-89	361-0238-00		6						80009	361-0238-00	. SPACER,SLEEVE:0.25 OD X 0.34 INCH LONG
-90	-----	-----	1								CKT BOARD ASSY:DELAYED TRIGGER(SEE A9 EPL)
-91	131-0608-00		2						22526	47357	. CONTACT,ELEC:0.365 INCH LONG
-92	131-1003-00		3						80009	131-1003-00	. CONNECTOR BODY,:CKT BD MT,3 PRONG
-93	136-0252-04		104						22526	75060	. CONTACT,ELEC:0.188 INCH LONG
-94	136-0263-03		15						00779	86250-2	. CONTACT,ELEC:FOR 0.025 INCH SQUARE PIN
-95	214-0579-00		3						80009	214-0579-00	. TERM.,TEST PT:0.40 INCH LONG
-96	352-0213-00		1						80009	352-0213-00	. HOLDER,CABLE:FOR 0.16 X 0.08"CABLE,PLASTIC
-97	352-0228-00		2						80009	352-0228-00	. HOLDER,CABLE:FOR 0.125"DIA CABLE,PLASTIC
-98	352-0238-00		1						80009	352-0238-00	. HOLDER,COAXIAL:GROUNDING,FOR 0.125"DIA COA
-99	211-0155-00		3						80009	211-0155-00	. SCREW,EXT,RLV B:4-40 X 0.375 INCH,SST
-100	361-0238-00		3						80009	361-0238-00	. SPACER,SLEEVE:0.25 OD X 0.34 INCH LONG
-101	-----	-----	1								CKT BOARD ASSY:MAIN TRIGGER(SEE A8 EPL)
-102	131-0566-00		1						0000C	L-2007-1	. LINK,TERM.CONNE:0.086 DIA X 2.375 INCH L
-103	131-0608-00		3						22526	47357	. CONTACT,ELEC:0.365 INCH LONG
-104	131-1003-00		5						80009	131-1003-00	. CONNECTOR BODY,:CKT BD MT,3 PRONG
-105	136-0252-04		112						22526	75060	. CONTACT,ELEC:0.188 INCH LONG
-106	136-0337-00		1								. SOCKET:RELAY,8 PIN
-107	136-0263-03		21						00779	86250-2	. CONTACT,ELEC:FOR 0.025 INCH SQUARE PIN
-108	214-0579-00		4						80009	214-0579-00	. TERM.,TEST PT:0.40 INCH LONG
-109	352-0213-00		2						80009	352-0213-00	. HOLDER,CABLE:FOR 0.16 X 0.08"CABLE,PLASTIC
-110	352-0228-00		1						80009	352-0228-00	. HOLDER,CABLE:FOR 0.125"DIA CABLE,PLASTIC
-111	352-0238-00		2						80009	352-0238-00	. HOLDER,COAXIAL:GROUNDING,FOR 0.125"DIA COA
-112	211-0155-00		3						80009	211-0155-00	. SCREW,EXT,RLV B:4-40 X 0.375 INCH,SST
-113	361-0238-00		3						80009	361-0238-00	. SPACER,SLEEVE:0.25 OD X 0.34 INCH LONG
-114	384-1082-00		1								SHAFT:EXTENSION,8.53 INCH LONG
-115	376-0101-00		1								COUPLING:SHAFT
	213-0075-00		2						70276	OBD	. SETSCREW:4-40 X 0.094 INCH,HEX SOC STL
-116	131-0963-00		1						80009	131-0963-00	CONTACT,ELEC:GROUNDING
-117	214-1136-00		1								ACTUATOR:SLIDE SWITCH
-118	214-1190-00		1								EXTENDER-RETRACTOR:KNOB
	213-0075-00		1						70276	OBD	. SETSCREW:4-40 X 0.094 INCH,HEX SOC STL
	213-0140-00		1						70276	OBD	. SETSCREW:2-56 X 0.094 INCH,HEX SOC STL
-119	214-1630-00		1								DETENT ASSY:SWITCH
-120	260-0960-01		1						80009	260-0960-01	SWITCH,SLIDE:0.5A,120VDC,CKT BD MT
-121	384-1102-00		1								SHAFT:EXTENSION,10.85 INCH LONG
-122	-----	-----	1								RESISTOR,VARIABLE: (ATTACHING PARTS)
-123	210-0583-00		1						73743	2X20319-402	NUT,PLAIN,HEX.:0.25-32 X 0.312 INCH,BRS
-124	210-0046-00		1						78189	1214-05-00-0541C	WASHER,LOCK:INTL,0.26 ID X 0.40" OD,STL
-125	210-1027-00		1								WASHER:FLAT,0.252 ID X 0.406 INCH OD - - - * - - -
-126	407-0803-00		1						80009	407-0803-00	BRKT,COMPONENT:
	672-0474-00	B010100 B039999	1								CKT BOARD ASSY:INTERFACE/DIST
	672-0474-01	B040000	1								CKT BOARD ASSY:INTERFACE/DIST
-127	-----	-----	1								CKT BOARD ASSY:DISTRIBUTION(SEE A5 EPL)
-128	131-0589-00		49						22526	47350	. . CONTACT,ELEC:0.46 INCH LONG
	131-0590-00		4						22526	47351	. . CONTACT,ELEC:0.71 INCH LONG
-129	-----	-----	2								. . RESISTOR,VARIABLE: (ATTACHING PARTS)
-130	211-0116-00		4						83385	OBD	. . SCR,ASSEM WSHR:4-40 X 0.312 INCH,PNH BRS - - - * - - -

Mechanical Parts List—7B92

FIGURE 1 EXPLODED (CONT)

Fig. & Index No.	Tektronix Part No.	Serial/Model No. Eff	Model No. Dscont	Qty	1	2	3	4	5	Name & Description	Mfr Code	Mfr Part Numbe
1-131	-----	-----		1	.					CKT BOARD ASSY:INTERFACE(SEE A6 EPL)		
-132	131-0589-00			17	.	.				CONTACT,ELEC:0.46 INCH LONG	22526	47350
	131-0590-00			31	.	.				CONTACT,ELEC:0.71 INCH LONG	22526	47351
	131-0591-00			18	.	.				CONTACT,ELEC:0.835 INCH LONG	22526	47352
	131-0592-00			33	.	.				CONTACT,ELEC:0.885 INCH LONG	22526	47353
-133	131-0593-00			7	.	.				CONTACT,ELEC:1.15 INCH LONG	22526	47354
	131-0595-00			5	.	.				CONTACT,ELEC:1.37 INCH LONG	22526	47355
-134	131-0604-00			40	.	.				CONTACT,ELEC:0.025 SQ X 0.365 INCH LONG	80009	131-0604-00
	131-0608-00			9	.	.				CONTACT,ELEC:0.365 INCH LONG	22526	47357
-135	131-1003-00			2	.	.				CONNECTOR BODY,:CKT BD MT,3 PRONG	80009	131-1003-00
-136	136-0252-04			70	.	.				CONTACT,ELEC:0.188 INCH LONG	22526	75060
-137	260-0984-00			1	.	.				SWITCH,SLIDE:DP3POSN,0.5A,125VAC-DC	79727	G128S-PC/MOD7140
-138	-----	-----		1	.	.				RESISTOR,VARIABLE:(SEE R260 EPL)		
-139	131-0707-00			6	.	.				CONTACT,ELEC:0.48"L,22-26 AWG WIRE	22526	47439
-140	352-0167-00			1	.	.				HOLDER,TERM.CON:9 WIRE BLACK	80009	352-0167-00
-141	352-0274-00			1	.	.				HOLDER,TERMINAL:FOR 8 SQUARE PINS	80009	352-0274-00
-142	351-0180-00			1	.	.				SLIDE,GUIDE:SWITCH ACTUATOR	80009	351-0180-00
-143	351-0185-00			6	.	.				GUIDE-POST,LOCK:0.65 INCH LONG	80009	351-0185-00
-144	351-0186-00			6	.	.				GUIDE-POST,LOCK:0.84 INCH LONG	80009	351-0186-00
										(ATTACHING PARTS FOR CKT BD)		
-145	211-0116-00			6	SCR,ASSEM	WSHR:4-40	X	0.312	INCH,PNH	BRS	83385	OBD
										* - - - -		
-146	-----	-----		1	CKT BOARD ASSY:READOUT(SEE A11 EPL)					(ATTACHING PARTS)		
-147	211-0182-00			10	SCREW:SEMS,2-56	X	0.312	INCH,PHB				
-148	210-0405-00			10	NUT,PLAIN,HEX.:2-56	X	0.188	INCH,BRS			73743	2X12157-402
										* - - - -		
-149	376-0129-01			1	COUPLER:CAM SWITCH							
-150	384-0806-00			1	SHAFT:CAM SWITCH							
-151	200-1255-00			2	COVER:CAM SWITCH							
										(ATTACHING PARTS FOR EACH)		
-152	211-0116-00			1	SCR,ASSEM	WSHR:4-40	X	0.312	INCH,PNH	BRS	83385	OBD
-153	210-0591-00			1	NUT:HEX.,4-40	X	0.188	INCH				
										* - - - -		
-154	200-1256-00			2	COVER:CAM SWITCH							
										(ATTACHING PARTS FOR EACH)		
	211-0116-00			1	SCR,ASSEM	WSHR:4-40	X	0.312	INCH,PNH	BRS	83385	OBD
-155	210-0591-00			1	NUT:HEX.,4-40	X	0.188	INCH				
										* - - - -		
-156	354-0391-00			2	RING,RETAINING:0.395"FREE ID	X	0.025" STL				97464	3100-43-CD
-157	214-1139-00 ¹			-	SPRING,FLAT:GOLD COLORED						80009	214-1139-00
	214-1139-02 ¹			-	SPRING,FLAT:GREEN COLORED						80009	214-1139-02
	214-1139-03 ¹			-	SPRING,FLAT:RED COLORED						80009	214-1139-03
-158	214-1127-00			4	ROLLER,DETENT:0.125 DIA	X	0.125	INCH L			80009	214-1127-00
-159	401-0081-02			2	BEARING,CAM SW:FRONT						80009	401-0081-02
										(ATTACHING PARTS FOR EACH)		
-160	211-0116-00			2	SCR,ASSEM	WSHR:4-40	X	0.312	INCH,PNH	BRS	83385	OBD
-161	210-0591-00			2	NUT:HEX.,4-40	X	0.188	INCH				
										* - - - -		
-162	401-0083-00			1	BEARING:CENTER							
										(ATTACHING PARTS)		
	211-0116-00			2	SCR,ASSEM	WSHR:4-40	X	0.312	INCH,PNH	BRS	83385	OBD
	210-0591-00			2	NUT:HEX.,4-40	X	0.188	INCH				
										* - - - -		
-163	105-0267-00			1	DRUM:CAM SWITCH,REAR							
-164	105-0266-00			1	DRUM:CAM SWITCH,FRONT							
-165	131-0604-00			13	CONTACT,ELEC:0.025 SQ	X	0.365	INCH LONG			80009	131-0604-00
-166	260-0960-01			1	SWITCH,SLIDE:0.5A,120VDC,CKT	BD	MT				80009	260-0960-01
-167	136-0327-01			7	CONTACT,ELEC:0.067	INCH	DIA				00779	86281-2
-168	260-1309-00			1	SWITCH:PUSH							
										(ATTACHING PARTS)		
-169	211-0185-00			2	SCREW:4-40	X	0.175	INCHES,PHS				
-170	210-0850-00			2	WASHER:FLAT,0.093	ID	X	0.281	INCH OD			
-171	220-0619-00			1	NUT PLATE:							
										* - - - -		

¹Replace only with part bearing the same color as the original part in your instrument.

FIGURE 1 EXPLODED (CONT)

Fig. & Index No.	Tektronix Part No.	Serial/Model No. Eff Dscont	Qty						Name & Description	Mfr Code	Mfr Part Number
				1	2	3	4	5			
1-172	214-1061-00		1						SPRING,GROUND:FLAT	80009	214-1061-00
-173	426-0505-11		1						FR SECT,PLUG-IN:TOP	80009	426-0505-11
-174	214-1054-00		1						SPRING,DETENT:LATCH	80009	214-1054-00
-175	105-0075-00		1						PAWL:0.475 X 0.21 X 0.184 INCH,PLSTC	80009	105-0075-00
-176	426-0499-11		1						FR SECT,PLUG IN:BOTTOM	80009	426-0499-11
-177	352-0161-01		1						HOLDER,TERM.CON:3 WIRE BROWN	80009	352-0161-01
	352-0161-02		1						HOLDER,TERM.CON:3 WIRE RED	80009	352-0161-02
-178	352-0162-01		1						HOLDER,TERM.CON:4 WIRE BROWN	80009	352-0162-01
-179	352-0163-02		1						HOLDER,TERM.CON:5 WIRE RED	80009	352-0163-02
	352-0163-03		1						HOLDER,TERM.CON:5 WIRE ORANGE	80009	352-0163-03
-180	352-0169-00		1						HOLDER,TERM.CON:2 WIRE BLACK	80009	352-0169-00
-181	131-0622-00		2						CONTACT,ELEC:0.577"L,28-32 AWG WIRE	22526	46241
	131-0707-00		24						CONTACT,ELEC:0.48"L,22-26 AWG WIRE	22526	47439
	131-0792-00		2						CONTACT,ELEC:0.577"L,18-20AWG WIRE	22526	46221
-182	210-0774-00		6						EYELET,METALLIC:0.152 OD X 0.245 INCH L,BRS	80009	210-0774-00
-183	210-0775-00		6						EYELET,METALLIC:0.126 OD X 0.23 INCH L,BRS	80009	210-0775-00
-184	175-0827-00		FT						WIRE,ELECTRICAL:4 WIRE RIBBON,3 INCH LONG	08261	TEK-175-0827-00
-185	175-0828-00		FT						WIRE,ELECTRICAL:5 WIRE RIBBON,5.75 INCH L	23499	TEK-175-0828-00
-186	-----		1						RESISTOR,VARIABLE:W/HARDWARE(SEE R25 EPL)		

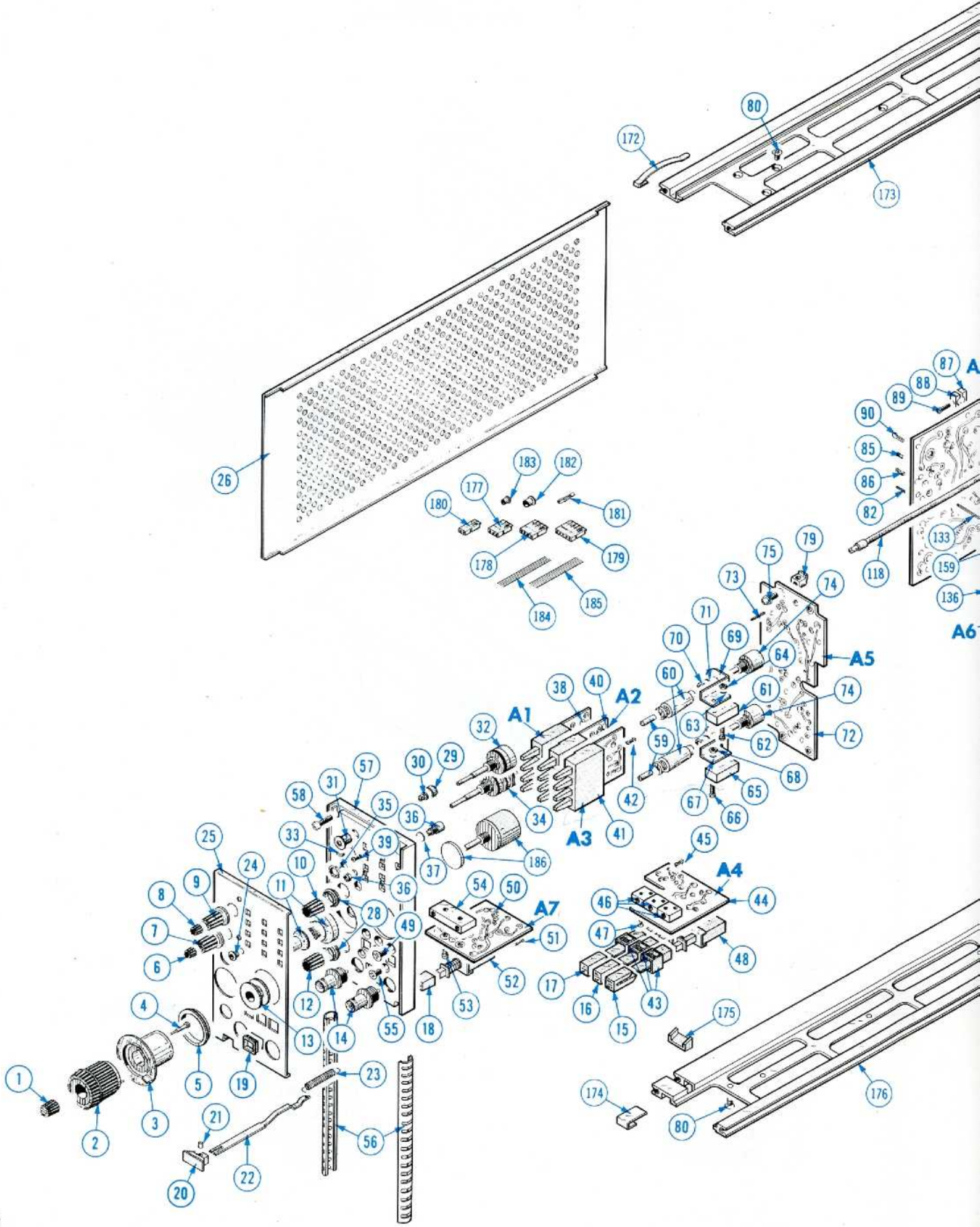

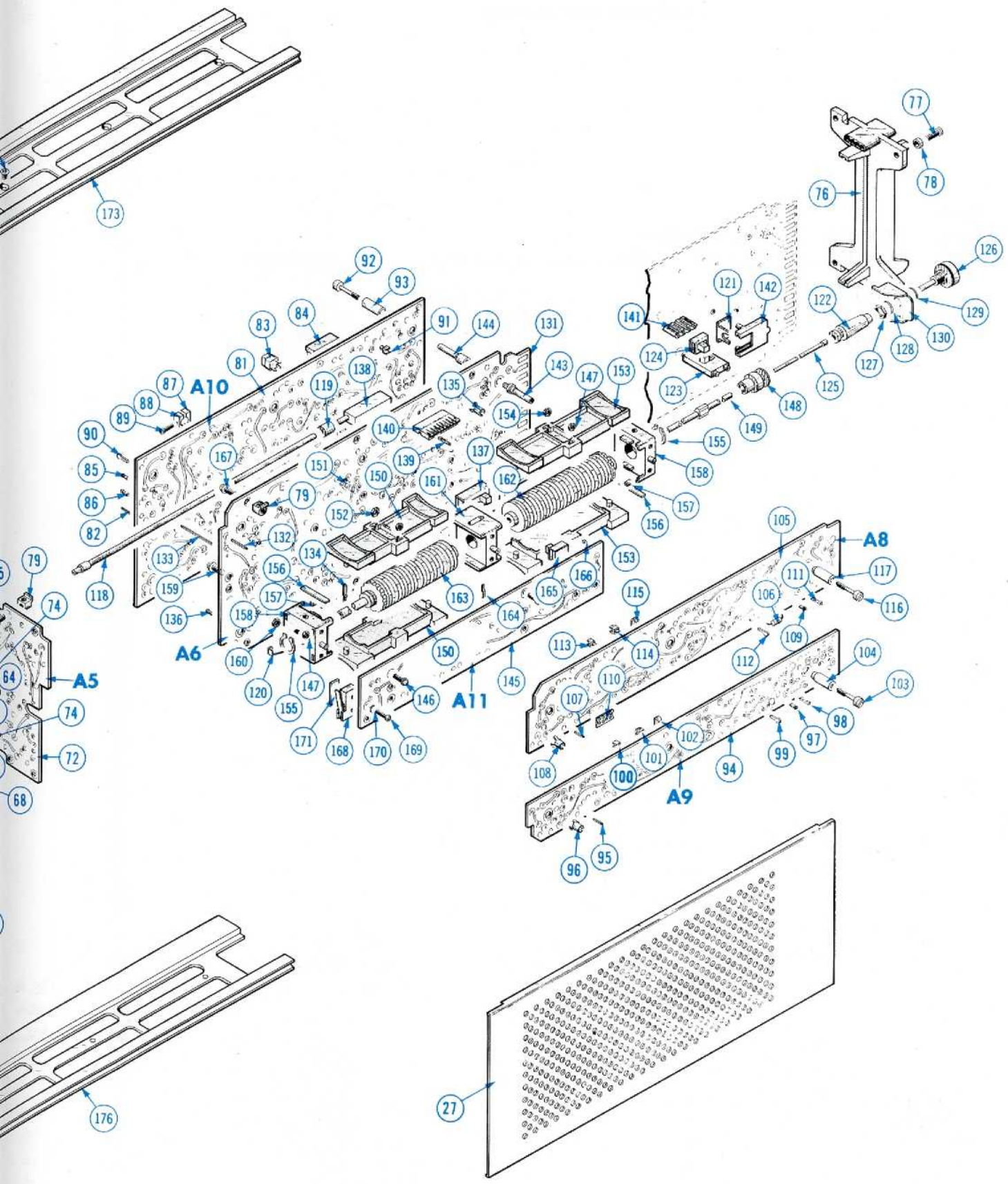

7B92 DUAL TIME BASE

+

STANDARD ACCESSORIES

Fig. & Index No.	Tektronix Part No.	Serial/Model No.		Q t y						Description
		Eff	Disc		1	2	3	4	5	
	070-1192-00			1						MANUAL, service
	070-1401-00			1						MANUAL, operators
	070-1630-00			1						CIRCUIT DESCRIPTION SUPPLEMENT

Fig. &
Index
No.

2-
-1
-2
-3
-4

CARTON ASSEMBLY
(Part No. 065-0125-00)

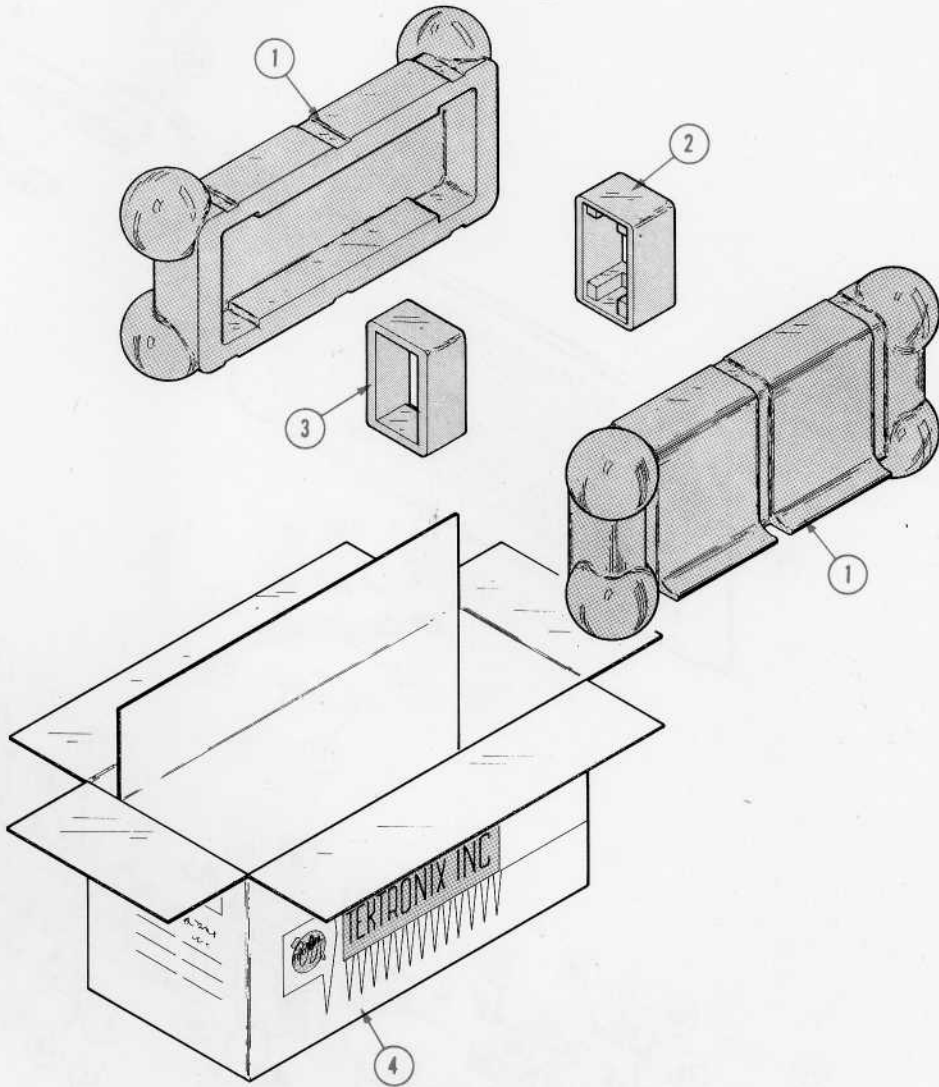

Fig. & Index No.	Tektronix Part No.	Serial/Model No.		Q t y	1	2	3	4	5	Description
		Eff	Disc							
2-	065-0125-00			1						CARTON ASSEMBLY
	-----			-						carton assembly includes:
-1	004-0241-00			2						CASE HALF
-2	004-0242-00			1						END CAP, rear
-3	004-0243-00			1						END CAP, front
-4	004-0748-00			1						CARTON