

Service Manual



AWG2005 Arbitrary Waveform Generator 070-8962-50

Warning

The servicing instructions are for use by qualified personnel only. To avoid personal injury, do not perform any servicing unless you are qualified to do so. Refer to all safety summaries prior to performing service.

www.tektronix.com

Copyright © Tektronix Japan, Ltd. All rights reserved.

Copyright © Tektronix, Inc. All rights reserved.

Tektronix products are covered by U.S. and foreign patents, issued and pending. Information in this publication supercedes that in all previously published material. Specifications and price change privileges reserved.

Tektronix Japan, Ltd., 5-9-31 Kitashinagawa, Shinagawa-ku, Tokyo 141-0001 Japan

Tektronix, Inc., P.O. Box 500, Beaverton, OR 97077

TEKTRONIX and TEK are registered trademarks of Tektronix, Inc.

WARRANTY

Tektronix warrants that the products that it manufactures and sells will be free from defects in materials and workmanship for a period of one (1) year from the date of shipment. If a product proves defective during this warranty period, Tektronix, at its option, either will repair the defective product without charge for parts and labor, or will provide a replacement in exchange for the defective product.

In order to obtain service under this warranty, Customer must notify Tektronix of the defect before the expiration of the warranty period and make suitable arrangements for the performance of service. Customer shall be responsible for packaging and shipping the defective product to the service center designated by Tektronix, with shipping charges prepaid. Tektronix shall pay for the return of the product to Customer if the shipment is to a location within the country in which the Tektronix service center is located. Customer shall be responsible for paying all shipping charges, duties, taxes, and any other charges for products returned to any other locations.

This warranty shall not apply to any defect, failure or damage caused by improper use or improper or inadequate maintenance and care. Tektronix shall not be obligated to furnish service under this warranty a) to repair damage resulting from attempts by personnel other than Tektronix representatives to install, repair or service the product; b) to repair damage resulting from improper use or connection to incompatible equipment; c) to repair any damage or malfunction caused by the use of non-Tektronix supplies; or d) to service a product that has been modified or integrated with other products when the effect of such modification or integration increases the time or difficulty of servicing the product.

THIS WARRANTY IS GIVEN BY TEKTRONIX IN LIEU OF ANY OTHER WARRANTIES, EXPRESS OR IMPLIED. TEKTRONIX AND ITS VENDORS DISCLAIM ANY IMPLIED WARRANTIES OF MERCHANTABILITY OR FITNESS FOR A PARTICULAR PURPOSE. TEKTRONIX' RESPONSIBILITY TO REPAIR OR REPLACE DEFECTIVE PRODUCTS IS THE SOLE AND EXCLUSIVE REMEDY PROVIDED TO THE CUSTOMER FOR BREACH OF THIS WARRANTY. TEKTRONIX AND ITS VENDORS WILL NOT BE LIABLE FOR ANY INDIRECT, SPECIAL, INCIDENTAL, OR CONSEQUENTIAL DAMAGES IRRESPECTIVE OF WHETHER TEKTRONIX OR THE VENDOR HAS ADVANCE NOTICE OF THE POSSIBILITY OF SUCH DAMAGES.

Preface

This is the service manual for the AWG2005 Arbitrary Waveform Generator. The manual contains information needed to service the AWG2005 to the module level.

Manual Structure

This manual is divided into sections, such as *Specifications* and *Theory of Operation*. Further, some sections are divided into subsections, such as *Product Description* and *Removal and Installation Procedures*.

Sections containing procedures also contain introductions to those procedures. Be sure to read these introductions because they provide information needed to do the service correctly and efficiently. The following contains a brief description of each manual section.

- *Specifications* — contains a description of the AWG2005 and the characteristics that apply to it.
- *Operating Information* — includes general information and operating instructions at the level needed to safely power on and service the AWG2005.
- *Theory of Operation* — contains circuit descriptions that support general service to the module level.
- *Performance Verification* — contains a collection of procedures for confirming that the AWG2005 functions properly and meets warranted limits.
- *Adjustment Procedures* — contains a collection of procedures for internal calibration the AWG2005 to meet warranted limits.
- *Maintenance* — contains information and procedures for performing preventive and corrective maintenance of the AWG2005. These instructions include cleaning, module removal and installation, and fault isolation to the module.
- *Options* — contains information on servicing any of the factory-installed options that your AWG2005 includes.
- *Electrical Parts List* — contains a statement referring you to *Mechanical Parts List*, where both electrical and mechanical modules are listed. See below.
- *Diagrams* — contains block diagrams and an interconnection diagram useful in isolating failed modules.
- *Mechanical Parts List* — includes a table of all replaceable modules, their descriptions, and their Tektronix part numbers.

Manual Conventions

This manual uses certain conventions that you should become familiar with.

Some sections of the manual contain procedures for you to perform. To keep those instructions clear and consistent, this manual uses the following conventions:

- Instructions for menu selection follow this format: **FRONT PANEL BUTTON→Main Menu Button→Side Menu Button**. For example, “Press **UTILITY→Misc→Config...→Reset to Factory→O.K.**”
- Names of front panel controls and menus appear in the same case (initial capitals, all uppercase, etc.) in the manual as is used on the AWG2005 front panel and menus. Front panel names are all upper-case letters; for example, **MODE MENU, CH 1**, etc.
- Instruction steps are numbered unless there is only one step.

Modules

Throughout this manual, any replaceable component, assembly, or part of the AWG2005 is referred to generically as a module. In general, a module is an assembly (like a circuit board), rather than a component (like a resistor or an integrated circuit). Sometimes a single component is a module; for example, the chassis of the AWG2005 is a module.

Safety

Symbols and terms related to safety appear in the *Safety Summary* near the beginning of this manual.

Finding Other Information

Other documentation for the AWG2005 Arbitrary Waveform Generator includes:

- The *AWG2005 User Manual* contains a tutorial to quickly describe how to operate the AWG2005. It also includes an in-depth discussion on how to more completely use AWG2005 features.
- The *AWG2000 series Programmer Manual* explains how to control the AWG2005 with a computer through the GPIB or RS-232-C interface.

Table of Contents

List of Figures	vii
List of Tables	xi
General Safety Summary	xiii
Service Safety Summary	xvii
Introduction	xix
Adjustment Interval	xix
Strategy for Servicing	xix
Tektronix Service Offerings	xix
Warranty Repair Service	xx
Repair or Calibration Service	xx
Self Service	xx

Specifications

Product Description	1-1
Nominal Traits	1-3
Warranted Characteristics	1-11
Performance Conditions	1-11
Typical Characteristics	1-19

Operating Information

Preparation for Use	2-1
Operating Environment	2-1
Operating Temperature	2-1
Ventilation Requirements	2-1
Supplying Power	2-2
Power Cord Information	2-2
Rear Panel Controls	2-3
Fuse Type and Rating	2-4
Applying and Interrupting Power	2-5
Power-on Cycle	2-5
Power-off Cycle	2-5
Memory Backup Power	2-6
Installed Options	2-6
Instructions for Operation	2-7

How to Power On	2-7
Internal Diagnostics Routines	2-7
User Interface	2-8
Display	2-8
Menus	2-11
Waveform Files	2-11
Waveform Storage and I/O	2-12
Loading Files	2-12
Setting Output Parameters	2-13
Operation Mode Settings	2-15

Theory of Operation

Theory of Operation	3-1
Module Overview	3-1
Clock Oscillator (A1 Clock Board)	3-1
Clock Sweep Oscillator (A31 Clock Sweep Board)	3-1
Sequencer (A2 AWG Board)	3-1
Waveform Memory (A2 AWG Board)	3-1
Digital-to-Analog Converter (DAC) (A11 D/A Board)	3-2
Analog Processing (A3/A23 Analog Board)	3-2
CPU and Memory (A6 CPU Board)	3-2
GPIB (A6 CPU Board)	3-2
RS-232-C (A6 CPU Board)	3-2
Display Control (A6 CPU Board)	3-2
Display Monitor	3-3
Front Panel (A12 Key Board)	3-3
Floppy Disk Drive	3-3
Low Voltage Power Supply	3-3
Fan	3-3
Options	3-4

Performance Verification

Before Verification	4-1
Preparation	4-1
Conventions	4-1
Self Tests	4-3
Diagnostics	4-3
Calibration	4-5
Performance Tests	4-7
Prerequisites	4-7
Related Information	4-8
Equipment Required	4-8

Performance Check Files	4-9
Operating Mode Checks	4-12
Check Cont Mode	4-12
Check Triggered Mode	4-14
Check Gated Mode	4-16
Check Waveform Advance Mode	4-18
Check Autostep Mode	4-20
Arithmetic Operation Checks	4-22
Check External AM Operation	4-22
Check Internal AM Operation	4-25
Check External ADD Operation	4-25
Check Internal Add Operation	4-26
Clock Frequency and Amplitude Checks	4-27
Check Clock Frequency Accuracy	4-27
Check Clock Amplitude	4-29
Gain Accuracy Check	4-30
Offset Accuracy Check	4-32
Pulse Response Check	4-34
MARKER OUT Amplitude Check	4-36
.....	4-36
CONTROL SIG OUT Amplitude Check	4-38
.....	4-38
External Trigger Level Accuracy Check	4-39
External CLOCK IN Check	4-42
Optional Check –	
Master-Slave Operation Check	4-44
DIGITAL DATA OUT Check (Option 04)	4-46
Floating Point Processor Check (Option 09)	4-49

Adjustment Procedures

Adjustments	5-1
--------------------------	------------

Maintenance

Before Maintenance	6-1
Prerequisites	6-1
Preventing ESD	6-2
Precautions	6-2
Susceptibility to ESD	6-2
Inspection and Cleaning	6-5
General Care	6-5
Inspection and Cleaning Procedures	6-5
Inspection — Exterior	6-6
Cleaning Procedure — Exterior	6-7

Inspection — Interior	6-7
Cleaning Procedure — Interior	6-8
Lubrication	6-8
Removal and Installation Procedures	6-9
Preparation	6-9
List of Mechanical Parts	6-9
General Instructions	6-10
Summary of Procedures	6-10
Equipment Required	6-10
AWG2005 Orientation	6-12
Access Procedure	6-13
Procedures for External Modules	6-16
Front-panel Knob	6-17
Line Fuse and Line Cord	6-18
Rear Cover and Cabinet	6-20
EMI Gaskets	6-22
Front Cover, Trim Ring, and Menu Buttons	6-22
Front-panel Module	6-24
Procedures for Internal Modules	6-28
A23 Analog Board or A3 Analog Board (Option 02)	6-29
Connector Module	6-31
Fan and Fan Frame	6-33
Rear Shield Cover	6-35
Rear BNC Connectors	6-37
Power Supply Module	6-38
AUX Power Board and AC Inlet	6-39
Monitor Module and CRT Frame	6-42
Circuit Boards	6-45
A5 Backplane Board	6-49
Lithium Battery	6-51
Floppy-disk Drive Module	6-53
Repackaging	6-55
Repackaging Instructions	6-55
Troubleshooting	6-57
Troubleshooting Procedures	6-57
AWG2005 Diagnostics	6-58
Checking Diagnostics Tests	6-58

Options

Options and Accessories	7-1
List of Options	7-1
Options A1–A5	7-2
Option 02	7-2
Option 04	7-2

Data Output	7-2
Clock Output	7-2
Output Connector Configuration	7-3
Operation	7-4
Output Circuit and Output Waveform	7-5
Cable	7-7
Application Suggestions	7-8
Option 05	7-9
Option 09	7-9
Option 1R	7-9
Option 1S	7-9
Option 95	7-9
Accessories	7-10
Standard Accessories	7-10
Optional Accessories	7-10

Electrical Parts List

Electrical Parts List	8-1
-----------------------------	-----

Diagrams

Diagrams	9-1
----------------	-----

Mechanical Parts List

Replaceable Mechanical Parts	10-1
Parts Ordering Information	10-1
Using the Replaceable Mechanical Parts List	10-2

Table of Contents

List of Figures

Figure 2-1: Optional Power Cords	2-3
Figure 2-2: Rear Panel Controls	2-4
Figure 2-3: Display Features	2-10
Figure 2-4: LOAD Menu	2-13
Figure 2-5: SETUP Menu	2-14
Figure 2-6: MODE Menu	2-16
Figure 4-1: Diagnostics Menu	4-4
Figure 4-2: Calibrations Menu	4-6
Figure 4-3: Cont Mode Initial Test Hookup	4-12
Figure 4-4: Triggered Mode Initial Test Hookup	4-14
Figure 4-5: Gated Mode Initial Test Hookup	4-16
Figure 4-6: Relationship between 1 Volt or Greater Gate Signal and Waveform Output Signal	4-18
Figure 4-7: Waveform Advance Mode Initial Test Hookup	4-19
Figure 4-8: Autostep Mode Initial Test Hookup	4-21
Figure 4-9: External AM Operation Initial Test Hookup	4-23
Figure 4-10: MODE Menu Autostep Setting	4-24
Figure 4-11: Clock Frequency Accuracy Initial Test Hookup	4-27
Figure 4-12: Clock Amplitude Initial Test Hookup	4-29
Figure 4-13: Gain Accuracy Initial Test Hookup	4-31
Figure 4-14: Offset Accuracy Initial Test Hookup	4-33
Figure 4-15: Pulse Response Initial Test Hookup	4-34
Figure 4-16: Initial Test Hookup	4-36
Figure 4-17: Initial Test Hookup	4-38
Figure 4-18: External Trigger Level Accuracy Initial Test Hookup ...	4-40
Figure 4-19: External CLOCK IN Initial Test Hookup	4-42
Figure 4-20: Slave Operation Initial Test Hookup	4-44
Figure 4-21: Digital Data Out Initial Test Hookup	4-47
Figure 4-22: Output Pins on the Digital Data Out Cable	4-48

Figure 6-1: AWG2005 Orientation	6-12
Figure 6-2: Guide to Removal Procedures	6-13
Figure 6-3: External Modules	6-14
Figure 6-4: Internal Modules	6-15
Figure 6-5: Front-panel Knob Removal	6-17
Figure 6-6: Line Fuse and Line Cord Removal	6-19
Figure 6-7: Rear Cover and Cabinet Removal	6-21
Figure 6-8: Front Cover, Trim Ring, and Menu Button Removal (Front Cover not Shown)	6-23
Figure 6-9: Front-panel Module Removal	6-25
Figure 6-10: A12 Keyboard Removal	6-26
Figure 6-11: Disassembly of Front-panel Module	6-27
Figure 6-12: A23/A3 Analog Board Removal	6-30
Figure 6-13: Connector Module Removal	6-32
Figure 6-14: Fan and Fan Frame Removal	6-34
Figure 6-15: Rear Shield Cover Removal	6-36
Figure 6-16: Rear BNC Connectors Removal	6-37
Figure 6-17: Power Supply Module Removal	6-39
Figure 6-18: AUX Power Board and AC Inlet Removal	6-41
Figure 6-19: Monitor Module Removal	6-43
Figure 6-20: CRT Frame Removal	6-44
Figure 6-21: Board Removal	6-46
Figure 6-22: A5 Backplane Board Removal	6-50
Figure 6-23: Battery Location on the A5 Backplane Board	6-52
Figure 6-24: Floppy-disk Drive Module Removal	6-54
Figure 6-25: Primary Troubleshooting Procedure	6-59
Figure 6-26: CPU Board	6-60
Figure 6-27: Troubleshooting Procedure 1 — Power Supply Module	6-61
Figure 6-28: AUX Power Board	6-62
Figure 6-29: Power Supply Module	6-62
Figure 6-30: Troubleshooting Procedure 2 — A6 CPU Board or Front-panel Module	6-63
Figure 6-31: Key Board	6-64
Figure 6-32: Troubleshooting Procedure 3 — Monitor Module	6-65
Figure 6-33: Monitor Module	6-66
Figure 6-34: Horizontal and Vertical Sync Signals	6-66
Figure 6-35: A Video Signal with White and Black Levels	6-67
Figure 6-36: Troubleshooting Procedure 4 — Module Isolation	6-68

Figure 7-1: Option 04 Block Diagram	7-3
Figure 7-2: Option 04 Output Connector	7-3
Figure 7-3: Generation of Excess Output	7-5
Figure 7-4: Output Circuit	7-5
Figure 7-5: Output Waveform	7-6
Figure 7-6: Data Latching	7-6
Figure 7-7: Digital Data Out Cable	7-7
Figure 7-8: Waveform Reproduction Circuit Example	7-8
Figure 9-1: Block Diagram	9-3
Figure 9-2: Interconnect Diagram	9-5
Figure 10-1: Cabinet	10-5
Figure 10-2: Main Chassis and CRT	10-7
Figure 10-3: Main Chassis and Circuit Boards	10-9
Figure 10-4: Circuit Boards	10-11
Figure 10-5: Front Panel Assembly	10-13
Figure 10-6: Option 02	10-15
Figure 10-7: Option 04	10-16
Figure 10-8: Option 05	10-17
Figure 10-9: Option 09	10-18

List of Figures

List of Tables

Table 1-1: Period Jitter (CH1 Marker Out)	1-7
Table 1-2: Cycle to Cycle Jitter (CH1 Marker Out)	1-7
Table 1-3: Period Jitter (Clock Out)	1-7
Table 1-4: Cycle to Cycle Jitter (Clock Out)	1-7
Table 2-1: Power-cord Conductor Identification	2-2
Table 2-2: Fuse Type and Rating	2-4
Table 4-1: Test Equipment	4-8
Table 4-2: Test Equipment For Optional Check	4-9
Table 4-3: File List for Performance Check Disk	4-10
Table 4-4: Clock Frequency Accuracy	4-29
Table 6-1: Relative Susceptibility to Static-discharge Damage	6-3
Table 6-2: External Inspection Check List	6-6
Table 6-3: Internal Inspection Check List	6-7
Table 6-4: Equipment Required	6-11
Table 7-1: International Power Cords	7-2
Table 7-2: Option 04 Digital Output Signals	7-4
Table 7-3: Standard Accessories List	7-10
Table 7-4: Optional Accessories List	7-10
Table 7-5: Maintenance Kit Contents	7-11

General Safety Summary

Review the following safety precautions to avoid injury and prevent damage to this product or any products connected to it.

Only qualified personnel should perform service procedures.

Injury Precautions

Use Proper Power Cord

To avoid fire hazard, use only the power cord specified for this product.

Avoid Electric Overload

To avoid electric shock or fire hazard, do not apply a voltage to a terminal that is outside the range specified for that terminal.

Ground the Product

This product is grounded through the grounding conductor of the power cord. To avoid electric shock, the grounding conductor must be connected to earth ground. Before making connections to the input or output terminals of the product, ensure that the product is properly grounded.

Do Not Operate Without Covers

To avoid electric shock or fire hazard, do not operate this product with covers or panels removed.

Use Proper Fuse

To avoid fire hazard, use only the fuse type and rating specified for this product.

Do Not Operate in Wet/Damp Conditions

To avoid electric shock, do not operate this product in wet or damp conditions.

Do Not Operate in Explosive Atmosphere

To avoid injury or fire hazard, do not operate this product in an explosive atmosphere.

Product Damage Precautions

Use Proper Power Source

Do not operate this product from a power source that applies more than the voltage specified.

Provide Proper Ventilation

To prevent product overheating, provide proper ventilation.

Do Not Operate With Suspected Failures

If you suspect there is damage to this product, have it inspected by qualified service personnel.

Safety Terms and Symbols

Terms in This Manual

These terms may appear in this manual:



WARNING. Warning statements identify conditions or practices that could result in injury or loss of life.



CAUTION. Caution statements identify conditions or practices that could result in damage to this product or other property.

Terms on the Product

These terms may appear on the product:

DANGER indicates an injury hazard immediately accessible as you read the marking.

WARNING indicates an injury hazard not immediately accessible as you read the marking.

CAUTION indicates a hazard to property including the product.

Symbols on the Product

The following symbols may appear on the product:



DANGER
High Voltage



Protective Ground
(Earth) Terminal



ATTENTION
Refer to
Manual



Double
Insulated

Certifications and Compliances

CSA Certified Power Cords

CSA Certification includes the products and power cords appropriate for use in the North America power network. All other power cords supplied are approved for the country of use.

General Safety Summary

Service Safety Summary

Only qualified personnel should perform service procedures. Read this *Service Safety Summary* and the *General Safety Summary* before performing any service procedures.

Do Not Service Alone

Do not perform internal service or adjustments of this product unless another person capable of rendering first aid and resuscitation is present.

Disconnect Power

To avoid electric shock, disconnect the main power by means of the power cord or, if provided, the power switch.

Use Caution When Servicing the CRT

To avoid electric shock or injury, use extreme caution when handling the CRT. Only qualified personnel familiar with CRT servicing procedures and precautions should remove or install the CRT.

CRTs retain hazardous voltages for long periods of time after power is turned off. Before attempting any servicing, discharge the CRT by shorting the anode to chassis ground. When discharging the CRT, connect the discharge path to ground and then the anode. Rough handling may cause the CRT to implode. Do not nick or scratch the glass or subject it to undue pressure when removing or installing it. When handling the CRT, wear safety goggles and heavy gloves for protection.

Use Care When Servicing With Power On

Dangerous voltages or currents may exist in this product. Disconnect power, remove battery (if applicable), and disconnect test leads before removing protective panels, soldering, or replacing components.

To avoid electric shock, do not touch exposed connections.

X-Radiation

To avoid x-radiation exposure, do not modify or otherwise alter the high-voltage circuitry or the CRT enclosure. X-ray emissions generated within this product have been sufficiently shielded.

Service Safety Summary

Introduction

This manual contains information needed to properly service the AWG2005 Arbitrary Waveform Generator, as well as general information critical to safe and effective servicing.

To prevent personal injury or damage to the AWG2005, consider the following before attempting service:

- The procedures in this manual should be performed only by a qualified service person
- Read the *Safety Summary* found at the beginning of this manual
- Read *Preparation for Use* in section 2, *Operating Information*

When using this manual for servicing, be sure to follow all warnings, cautions and notes.

Adjustment Interval

Generally, the internal calibration described in section 5, *Adjustment Procedures*, should be done every 12 months. In addition, internal calibration is recommended after module replacement or temperature changes.

Strategy for Servicing

Throughout this manual the term "module" refers to any field-replaceable component, assembly, or part of the AWG2005.

This manual contains all the information needed for periodic maintenance of the AWG2005. (Examples of such information are procedures for checking performance and for readjustment.)

Further, it contains all information for corrective maintenance down to the module level. To isolate a failure to a module, use the fault isolation procedures found in *Troubleshooting*, part of section 6, *Maintenance*. To remove and replace any failed module, follow the instructions in *Removal and Installation Procedures*, also part of section 6. After isolating a faulty module, replace it with a fully-tested module obtained from the factory. Section 10, *Mechanical Parts List*, contains part number and ordering information for all replaceable modules.

Tektronix Service Offerings

Tektronix provides service to cover repair under warranty as well as other services that may provide a cost-effective answer to your service needs.

Whether providing warranty repair service or any of the other services listed below, Tektronix service technicians are well equipped to service the AWG2005. Tektronix technicians train on Tektronix products; they have access to the latest information on improvements to the AWG2005 as well as the latest new options.

Warranty Repair Service

Tektronix warrants this product for one year from date of purchase. (The warranty appears on the back of the title page in this manual.) Tektronix technicians provide warranty service at most Tektronix service locations worldwide. The Tektronix product catalog lists all service locations worldwide.

Repair or Calibration Service

The following services can be purchased to tailor repair and/or calibration of the AWG2005 to fit your requirements.

At-depot Service — Tektronix offers several standard-priced adjustment (calibration) and repair services:

- A single repair and/or adjustment
- Calibrations using equipment and procedures that meet the traceability standards specific to the local area
- Annual maintenance agreements that provide for either calibration and repair or calibration only of the AWG2005

Of these services, the annual maintenance agreement offers a particularly cost-effective approach to service for many owners of the AWG2005.

Self Service

Tektronix supports repair to the module level by providing *Module Exchange*.

Module Exchange — This service reduces down-time for repair by allowing you to exchange most modules for remanufactured ones. Tektronix ships an updated and tested exchange module from the Beaverton, Oregon service center, typically within 24 hours. Each module comes with a 90-day service warranty.

For More Information — Contact your local Tektronix service center or sales engineer for more information on any of the repair or adjustment services just described.

Product Description

The AWG2005 is a portable arbitrary waveform generator capable of generating both arbitrary waveforms and standard function waveforms. Key features include:

- Arbitrary waveform generation from waveform data files that you:
 - Create using the graphical waveform editor
 - Generate from equations you create using the equation editor
 - Transfer from GPIB or RS-232-C interfaces
 - Directly transfer from a Tektronix TDS Digitizing Oscilloscope, 2200 Series, 2400 Series or 11000 Series Digital Storage Oscilloscope (DSO), DSA Series Digitizing Analyzer, RTD710A Transient Digitizer, AFG2020 Arbitrary Function Generator, or from another AWG2000 Series Arbitrary Waveform Generator
- Continuous generation of arbitrary waveform data files you specify in a sequence file
- Stepped arbitrary waveform generation of waveform data files and/or sequence files you specify in an autostep file (Autostep mode)
- 2 Channel or 4 channel waveform output to 10 V_{p-p} (the 4 channels are Option 02)
- Point clock rate from 0.01 Hz to 20 MHz
- Continuous, triggered or gated trigger modes
- Waveform advance and autostep modes
- Amplitude modulation (CH2 or external signal to CH1)
- Output waveform Add function (CH 2 or external signal to CH1)
- Internal waveform memory of 64K × 12 bits for each channel
- Internal catalog memory of 4 M
- Waveform file storage in internal nonvolatile memory (512 K) or on disk
- Waveform marker (per channel)
- Rear-panel waveform output in digital format (Option 04)
- Editing the clock sweep (Option 05)
- Editing in frequency domain (floating point processor, Option 09)
- Sample waveform library and GPIB programming examples on disk
- Standard function waveforms
- Internal diagnostic/calibration

Product Description

Nominal Traits

This section contains tables that list the various *nominal traits* that describe the AWG2005 Arbitrary Waveform Generator. Electrical and mechanical traits are included.

Nominal traits are described not by equipment performance, but by parameters like memory capacity.

Electrical Characteristics

Characteristics	Description
Arbitrary Waveforms	
Memory	
Waveform	64K x 12 bits The Waveform can position 256 data point boundary in the waveform memory. The maximum waveforms in the waveform memory is 256.
Marker	64 K x 1 bit
Minimum Data Length	16 points for the Waveform and the Marker.
Sequence	32 K x 16 bits A Sequence requires minimum 7 words.
Scan Counter	
Waveform	1 to 64 K (16 bits)
Sequence	1 to 64 K (16 bits)
Catalog Memory	4 M bytes
Clock Generator	
Frequency Range	0.01 Hz to 20 MHz
Resolution	4 digits (The maximum Resolution 0.01% is obtained at the value "9999".)
Reference Oscillator	
Nominal Frequency	12.8 MHz

Characteristics

Electrical Characteristics

Characteristics	Description
Clock Generator (Option 05)	
Frequency Range	0.01 Hz to 20 MHz
Resolution	Up to 7 digits
Sweep	
Type	Linear, Log, Arbitrary
Mode	Continuous, Triggered, Gated
Update Rate	1 μ s to 65.535 ms
Points per sweep	8 Kwords
Frequency Resolution	0.0298 Hz
Reference Oscillator	
Nominal Frequency	12.8 MHz
Main Output	
DA Converter	
Resolution	12 bits
Amplitude	
Range	0.05 to 10 Vp-p into 50 Ω The amplitude range expands about 2 times (20 Vp-p) into open circuit. It's actual value is two times the displayed value. The absolute peak Amplitude plus the Offset is limited to +10 V or -10V.
Resolution	1 mV
Offset	
Range	-5.0 to 5.0 V into 50 Ω The offset range expands about 2 times (-10 V to 10V) into open circuit. It's actual value is two times the displayed value. The absolute peak Amplitude plus the Offset is limited to +10 V or -10V. -200 mA to 200 mA (Current source output)
Resolution	5 mV
Impedance	50 Ω

Electrical Characteristics

Characteristics	Description	Performance Test
Operating Modes		
Continuous	Generates the waveform or sequence continuously.	Check Cont Mode, page 4-12.
Triggered	Output quiescent until triggered by an GPIB, external, or manual trigger; then generates a waveform or sequence only one time.	Check Triggered Mode, page 4-14.
Gated	Same as Continuous mode, except waveforms or sequences are output for the duration of the gated signal.	Check Gated Mode page 4-16.
Waveform Advance		
Continuous	Continuously generates the waveform or sequence in the Sequence file; the next trigger advances to the next waveform/sequence.	Check Waveform Advance Mode, page 4-18.
Step	Output quiescent until triggered by an GPIB, external, or manual trigger; then generates the waveform/sequence in the Sequence file. When the scan count reaches its value, then stops output and waits for the next trigger.	
Autostep		
Continuous	Similar operation to the Waveform Advance : Continuous , but the Autostep file is used instead of the Sequence file and the output parameters (Amplitude, Offset, etc.) are changed.	Check Autostep Mode, page 4-20.
Step	Similar operation to the Waveform Advance : Step , but the Autostep file is used instead of the Sequence file and the output parameters (Amplitude, Offset, etc.) are changed.	
Master	Provide the Clock and the Trigger to the Slave AWG2005 for the parallel operation.	
Slave	Receive the Clock and the Trigger from the Master AWG2005 for the parallel operation.	

Characteristics

Electrical Characteristics

Characteristics	Description
Filters	
Type	Low Pass (–24 dB/Oct) 5MHz 2MHz 1MHz 500kHz
Auxiliary Output	
MARKER	
Amplitude	>2V into 50Ω
Impedance	50Ω
Period Jitter	Refer to Table 1-1 (Measured by TDS694C–1MHD with TDSJIT1)
Cycle to Cycle Jitter	Refer to Table 1-2 (Measured by TDS694C–1MHD with TDSJIT1)
CLOCK	
Amplitude	>2V into 50Ω
Impedance	50Ω
Period Jitter	Refer to Table 1-3 (Measured by TDS694C–1MHD with TDSJIT1)
Cycle to Cycle Jitter	Refer to Table 1-4 (Measured by TDS694C–1MHD with TDSJIT1)
CONTROL SIG	
Amplitude	>2V into 50Ω
Impedance	50Ω
SWEEP (Option 05)	
Amplitude	0 V to 5 V (Same waveform as selected sweep. Amplitude is dependent on start and stop frequencies and a 5 V limit.)
Impedance	600Ω
Digital Data Out (option 04)	
Output Signals	
CH1	Data (D0 to D11), Clock
CH2	Data (D0 to D11), Clock
Amplitude	>2 V into 50Ω
Impedance	50Ω
Connector	28 pin Header

Table 1-1: Period Jitter (CH1 Marker Out)

Clock=20MS/s		Clock=10MS/s	
StdDev	Pk-Pk	StdDev	Pk-Pk
24.0 ps	140.0 ps	24.0 ps	120.0 ps

Table 1-2: Cycle to Cycle Jitter (CH1 Marker Out)

Clock=20MS/s		Clock=10MS/s	
StdDev	Pk-Pk	StdDev	Pk-Pk
40.0 ps	220.0 ps	40.0 ps	200.0 ps

Table 1-3: Period Jitter (Clock Out)

Clock=20MS/s		Clock=10MS/s	
StdDev	Pk-Pk	StdDev	Pk-Pk
24.0 ps	140.0 ps	24.0 ps	120.0 ps

Table 1-4: Cycle to Cycle Jitter (Clock Out)

Clock=20MS/s		Clock=10MS/s	
StdDev	Pk-Pk	StdDev	Pk-Pk
40.0 ps	220.0 ps	40.0 ps	200.0 ps

Characteristics

Electrical Characteristics

Characteristics	Description
Auxiliary Input	
TRIGGER	
Threshold Level	-5 V to 5V
Resolution	0.1V
Impedance	10k Ω
AM	
Range	2 Vp-p (-1V to 1V) for 100% modulation
Impedance	10k Ω
Add	
Range	10 Vp-p (-5 V to 5V)
Impedance	50 Ω
CONTROL SIG	
Threshold Level	0.8 V to 2.0 V
Impedance	10k Ω
CLOCK	
Threshold Level	0.8 V to 2.0 V
Impedance	330 Ω (Master mode), 10k Ω (Slave mode)
Function Generator	
Waveform Shape	Sine, Triangle, Square, Ramp, Pulse (1 MHz filter is inserted when Sine is selected.)
Output Parameter	All of these values with the exception of frequency can be set independently for each channel. Frequency settings apply to all channels.
Frequency	1.000 Hz to 200 kHz
Amplitude	Can be set between 50 mV and 10 V in 1 mV increments
Offset	Can be set between ± 5 V in 5 mV increments
Polarity	Normal, Invert
Duty	0% to 100% Pulse only. Can be set in 1% increments
Operating Mode	Continuous mode
Auxiliary Output	
Marker	2V into 50 Ω , generated at the starting point of the waveform. The pulse width will vary depending on the frequency.

Electrical Characteristics

Characteristics	Description
Display	
CRT	
Display Area	132mm (5.2 inches) horizontally by 99mm (3.9 inches) vertically
Resolution	640 (H) x 480 (V) pixels
AC Power Source	
AC Line Power	
Fuse Rating	6A first blow, 250 V, UL198G(3AG) or 5 A (T), 250 V, IEC127
Battery	
Type	Li3 V, 650 mAH

Mechanical Characteristics

Characteristics	Description
Net Weight	
Standard	10.7 kg
Size	
Height	16cm (6.4 inches) with feet
Width	36cm (14.3 inches) with handle
Length	49cm (19.25 inches) with front cover 56cm (22.2 inches) with handle extended

Characteristics

Warranted Characteristics

This section will describe the warranted characteristics of the AWG2005. These can be divided into two main categories: electrical characteristics and environmental characteristics.

Performance Conditions

The electrical characteristics are valid under the following conditions:

- 1) The instrument must have been calibrated at an ambient temperature between +20° C to +30° C.
- 2) The instrument must be in an environment whose limits are described in Environmental Characteristics.
- 3) All tolerance limits apply after a 20 minute warm up and an execution of the self calibration.
- 4) The instrument is operating at an ambient temperature between +10° C to +40° C, unless otherwise noted.

Electrical Characteristics

Characteristics	Description	Performance Test
Clock Generator		
Accuracy		Check Clock Frequency Accuracy, page 4-27.
+15° C to +30° C	0.005%	
+10° C to +40° C	0.01%	
Reference Oscillator		
Accuracy	± 1ppm	
Stability	± 1 ppm/year (20° C to 30° C)	
Clock Generator (Option 05)		
Accuracy		Check Clock Frequency Accuracy, page 4-27.
+15° C to +30° C	0.0005%	
+10° C to +40° C	0.001%	
Reference Oscillator		
Accuracy	± 1ppm	
Stability	± 1 ppm/year (20° C to 30° C)	

Characteristics

Electrical Characteristics

Characteristics	Description	Performance Test
Main Output		
Amplitude	Except multiply(AM) and add(Add) operation Clock 1 MHz, Waveform data; 000 and FFF, Norm, No Filter, No Offset	Check Gain Accuracy, page 4-30.
DC Accuracy		
0.050 V to 0.999 V	± (0.5% of amplitude + 5 mV)	
1.000 V to 10.000 V	± (1% of amplitude + 50 mV)	
Offset	Clock 1 MHz, Waveform data; FFF, Norm, No Filter, Amplitude 0.05V.	Check Offset Accuracy, page 4-32.
Accuracy	± (1% of Offset + 10 mV)	
Pulse Response	Clock 20 MHz, Waveform Data; 000 (16 points) and FFF (16 points), Norm, No Filter, Amplitude 5 V, No Offset.	Pulse Response Check, page 4-34.
Rise/Fall Time	<35 ns	
Flatness	within <3% (After 150 ns from rise/fall edges)	
Aberration	within <7%	
Cross talk between Channels	Sine (512 points), 20 MHz Clock, Norm, No Filter, Amplitude 5 V, No Offset < -70 dBc	
Noise Floor	Clock 20 MHz, Waveform Data; 7FF, Norm, No Filter, No Offset.	
0.5V	< -110 dBm/Hz (at 1 MHz)	
5.0V	< -95 dBm/Hz (at 1 MHz)	
Sine Wave Characteristics	F.G mode, 100 Hz to 200 kHz, No Offset	
Flatness	within ± 4% Amplitude 1 V, 1 kHz reference	
T.H.D	Including up to 4th Harmonics	
5.0V	< -55 dBc	

Electrical Characteristics

Characteristics	Description	Performance Test
AM and Add		
AM	CH1 : Sine (512 points), Clock 20 MHz, AM , No Filter, Amplitude 5 V, No Offset CH2 : Waveform Data; FFF, No Filter, Amplitude 10 V	
Internal Amplitude Accuracy	Add 5% to the Amplitude Specification *CH1 Out = CH1 x CH2,	Check Internal AM Operation, page 4-25.
Frequency Response	DC to 10 MHz (–3 dB)	
External Sensitivity	2 V _{p-p} (± 5%) signal causes 100% modulation. *CH1 Out = CH1 x Ext Signal Ext Signal 1V, 100% modulation 0V, 50% modulation –1V, 0% modulation	Check External AM Operation, page 4-22.
Frequency Response	DC to 10 MHz (–3 dB)	
Add	CH1 : sine (512 points), Clock 20 MHz, Add , No Filter, Amplitude 5 V, No Offset CH2 : Waveform Data; FFF, No Filter, Amplitude 2 V	
Internal Amplitude Accuracy	Add 5% to the Amplitude Specification *CH1 Out = CH1 + CH2	Check Internal Add Operation, page 4-26.
Frequency Response	DC to 10 MHz (–3 dB)	
External Amplitude Accuracy	Add 5% to the Amplitude Specification *CH1 Out = CH1 + Ext Signal	Check External ADD Operation, page 4-25.
Frequency Response	DC to 10 MHz (–3 dB)	

*Note: Output Amplitude can't exceed 10 V_{p-p} (into 50Ω)

Characteristics

Electrical Characteristics

Characteristics	Description	Performance Test
Filter		
Aberration	within $\pm 7\%$	
Rise Time		
5MHz	70ns $\pm 20\%$	
2MHz	175ns $\pm 20\%$	
1MHz	350ns $\pm 20\%$	
500kHz	700ns $\pm 20\%$	
Auxiliary Output		
MARKER		
Amplitude	>2 V into 50 Ω	MARKER OUT Amplitude Check, page 4-36.
CLOCK		
Amplitude	>2 V into 50 Ω	Clock Amplitude Check, page 4-29.
CONTROL SIG		
Amplitude	>2 V into 50 Ω	CONTROL SIG OUT Amplitude Check, page 4-38.
Digital Data Out (Option 04)		
Amplitude	>2 V into 50 Ω	DIGITAL DATA OUT Check, page 4-46.
Skew Between Data	within 15 ns	
Clock to Data Delay	Within 15 ns	

Electrical Characteristics

Characteristics	Description	
Auxiliary Input		
TRIGGER		External Trigger Level Accuracy Check, page 4-39.
Accuracy	± (5% of Level + 0.1 V)	
Pulse Width	150 ns minimum	
Input Swing	0.2 Vp-p minimum	
Maximum Input Volts	± 10 V (DC + peak AC)	
Trigger Hold Off	2 μs + 1 Clock (Excluding Autostep mode)	
AM	Sine (512 points), Clock 20 MHz, AM , No Filter, Amplitude 5 V, No Offset	
Amplitude Accuracy	within 5% (1.9 Vp-p to 2.1 Vp-p for 100% modulation)	
Maximum Input Volts	± 5 V (DC + peak AC)	
Add	Sine (512 points), Clock 20 MHz, Add , No filter, Amplitude 5 V, No Offset	
Amplitude Accuracy	Add 5% to the Amplitude Specification	
Maximum Input Volts	± 5 V (DC + peak AC)	
CONTROL SIG		Master–Slave Operation Check, page 4-44.
Threshold Level	TTL Level (0.8 V to 2.0 V)	
Pulse Width	40 ns minimum	
Input Volts	0 V to 5 V	
CLOCK		External CLOCK IN Check, page 4-42.
Threshold Level	TTL Level (0.8V to 2.0 V)	
Rise/Fall Time	within 1 μs	
Pulse Width	20 ns minimum	
Input Volts	0 V to 5 V	
Frequency Range	1 Hz to 20 MHz	

Characteristics

Electrical Characteristics

Characteristics	Description
Voltage	
AC Power Source	
Rating Voltage	100 VAC to 240 VAC Continuous range, CAT II
Range	
90 VAC to 250 VAC	48 Hz to 63 Hz
90 VAC to 127 VAC	48 Hz to 440 Hz
Maximum Power Consumption	300W
Maximum Current	4A
Grounding Impedance	The impedance for the chassis ground and power plug ground pins is 0.1 Ω at 30A.
Primary Circuit Dielectric Voltage withstand Test	1500 V rms, 50 Hz for 15 seconds, without breakdown.

Environmental Characteristics

Characteristics	Description
Temperature	
Operating	+10°C to + 40°C
Non operating	-20°C to + 60°C
Relative Humidity	
Operating	20% to 80% (No condensation) Maximum wet-bulb temperature 29.4°C
Non operating	5% to 90% (No condensation) Maximum wet-bulb temperature 40.0°C
Altitude	
Operating	To 4.5 km (15000 ft). Maximum operating temperature decreases 1°C each 300 m above 1.5 km.
Non operating	To 15 km (50000 ft).

Environmental Characteristics

Characteristics	Description
Dynamics	
Vibration Operating	0.33 mmp-p, 10 to 55 Hz, 15 minutes
Shock Non operating	294 m/s ² (30 G), half-sine, 11 ms duration.
Installation Requirements	
Power Consumption (Fully Loaded)	300 watts max. Maximum line current is 4 A rms at 50 Hz, 90 V line.
Surge Current	30 A peak for < 5 line cycles, after product has been off for at least 30 s.
Cooling Clearance	
Top Clearance	7.6cm (3 inches)
Side Clearance	15cm (6 inches)
Rear Clearance	7.6cm (3 inches)

Typical Characteristics

This section will describe the typical characteristics for the AWG2005. These values represent typical or average performance and are not absolutely guaranteed.

Characteristics	Description
Main Output	
DA Converter	
Integral Non Linearity	1LSB
Differential Non Linearity	1LSB
Skew between channels	5 ns
Delay Master to Slave	5 ns
Filters	
Delay	
5MHz	80ns
2MHz	190ns
1MHz	400ns
500kHz	800ns
Auxiliary Output	
MARKER	
Marker to Signal Delay	35ns
Auxiliary Input	
TRIGGER	
Trigger to Signal delay	
Internal Clock	400 ns (Excluding Clock Sweep mode)
External Clock	400 ns + 2 Clock
Power Supply	
Battery	
Back Up Time	4 years

Certifications and compliances

Category	Standards or description														
EC Declaration of Conformity – EMC	<p>Meets intent of Directive 89/336/EEC for Electromagnetic Compatibility. Compliance was demonstrated to the following specifications as listed in the Official Journal of the European Communities:</p> <p>EMC Directive 89/336/EEC:</p> <table border="0"> <tr> <td>EN 55022</td> <td>Class B Radiated and Conducted Emissions</td> </tr> <tr> <td>EN 50081-1 Emissions:</td> <td></td> </tr> <tr> <td>EN60555-2</td> <td>AC Power Line Harmonic Emissions</td> </tr> <tr> <td>EN 50082-1 Immunity:</td> <td></td> </tr> <tr> <td>IEC801-2</td> <td>Electrostatic Discharge Immunity</td> </tr> <tr> <td>IEC801-3</td> <td>RF Electromagnetic Field Immunity</td> </tr> <tr> <td>IEC801-4</td> <td>Electrical Fast Transient/Burst Immunity</td> </tr> </table>	EN 55022	Class B Radiated and Conducted Emissions	EN 50081-1 Emissions:		EN60555-2	AC Power Line Harmonic Emissions	EN 50082-1 Immunity:		IEC801-2	Electrostatic Discharge Immunity	IEC801-3	RF Electromagnetic Field Immunity	IEC801-4	Electrical Fast Transient/Burst Immunity
EN 55022	Class B Radiated and Conducted Emissions														
EN 50081-1 Emissions:															
EN60555-2	AC Power Line Harmonic Emissions														
EN 50082-1 Immunity:															
IEC801-2	Electrostatic Discharge Immunity														
IEC801-3	RF Electromagnetic Field Immunity														
IEC801-4	Electrical Fast Transient/Burst Immunity														
Australian/New Zealand declaration of Conformity - EMC	<p>Complies with EMC provision of Radio–communications Act per the following standard:</p> <table border="0"> <tr> <td>AS/NZS 2064.1/2</td> <td>Industrial, Scientific, and Medical Equipment: 1992</td> </tr> </table>	AS/NZS 2064.1/2	Industrial, Scientific, and Medical Equipment: 1992												
AS/NZS 2064.1/2	Industrial, Scientific, and Medical Equipment: 1992														
EC Declaration of Conformity – Low Voltage	<p>Compliance was demonstrated to the following specification as listed in the Official Journal of the European Communities:</p> <p>Low Voltage Directive 73/23/EEC, amended by 93/68/EEC</p> <table border="0"> <tr> <td>EN 61010-1/A1:1992</td> <td>Safety requirements for electrical equipment for measurement, control and laboratory use.</td> </tr> </table>	EN 61010-1/A1:1992	Safety requirements for electrical equipment for measurement, control and laboratory use.												
EN 61010-1/A1:1992	Safety requirements for electrical equipment for measurement, control and laboratory use.														
Approvals	<p>Complies with the following safety standards:</p> <table border="0"> <tr> <td>UL3111–1, First Edition</td> <td>Standard for electrical measuring and test equipment.</td> </tr> <tr> <td>CAN/CSA C22.2 No.1010.1-92</td> <td>Safety requirements for electrical equipment for measurement, control and laboratory use.</td> </tr> </table>	UL3111–1, First Edition	Standard for electrical measuring and test equipment.	CAN/CSA C22.2 No.1010.1-92	Safety requirements for electrical equipment for measurement, control and laboratory use.										
UL3111–1, First Edition	Standard for electrical measuring and test equipment.														
CAN/CSA C22.2 No.1010.1-92	Safety requirements for electrical equipment for measurement, control and laboratory use.														
Installation Category Description	<p>Terminals on this product may have different installation (over–voltage) category designations. The installation categories are:</p> <table border="0"> <tr> <td>Category</td> <td>Examples of products in this category</td> </tr> <tr> <td>CAT III</td> <td>Distribution-level mains (usually permanently connected). Equipment at this level is typically in a fixed industrial location.</td> </tr> <tr> <td>CAT II</td> <td>Local-level mains (wall sockets). Equipment at this level includes appliances, portable tools, and similar products. Equipment is usually cord-connected.</td> </tr> <tr> <td>CAT I</td> <td>Secondary (signal level) or battery operated circuits of electronic equipment.</td> </tr> </table>	Category	Examples of products in this category	CAT III	Distribution-level mains (usually permanently connected). Equipment at this level is typically in a fixed industrial location.	CAT II	Local-level mains (wall sockets). Equipment at this level includes appliances, portable tools, and similar products. Equipment is usually cord-connected.	CAT I	Secondary (signal level) or battery operated circuits of electronic equipment.						
Category	Examples of products in this category														
CAT III	Distribution-level mains (usually permanently connected). Equipment at this level is typically in a fixed industrial location.														
CAT II	Local-level mains (wall sockets). Equipment at this level includes appliances, portable tools, and similar products. Equipment is usually cord-connected.														
CAT I	Secondary (signal level) or battery operated circuits of electronic equipment.														
Pollution Degree	<p>A measure of the contaminates that could occur in the environment around and within a product. Typically the internal environment inside a product is considered to be the same as the external. Products should be used only in the environment for which they are rated.</p> <table border="0"> <tr> <td>Pollution Degree 2</td> <td>Normally only dry, nonconductive pollution occurs. Occasionally a temporary conductivity that is caused by condensation must be expected. This location is a typical office/home environment. Temporary condensation occurs only when the product is out of service.</td> </tr> </table>	Pollution Degree 2	Normally only dry, nonconductive pollution occurs. Occasionally a temporary conductivity that is caused by condensation must be expected. This location is a typical office/home environment. Temporary condensation occurs only when the product is out of service.												
Pollution Degree 2	Normally only dry, nonconductive pollution occurs. Occasionally a temporary conductivity that is caused by condensation must be expected. This location is a typical office/home environment. Temporary condensation occurs only when the product is out of service.														

Certifications and compliances (cont.)

Category	Standards or description
Conditions of Approval	Safety Certifications/Compliances are made for the following conditions: Altitude (maximum operation): 2000 meters
IEC Characteristics	Equipment type: Test and Measuring Installation Category II (as defined in IEC 61010-1, Annex J) Pollution Degree 2 (as defined in IEC 61010-1) Safety Class I (as defined in IEC 61010-1, Annex H)

Preparation for Use

This subsection describes how to prepare the AWG2005 Arbitrary Waveform Generator for use. The information describes these items:

- Proper operating environment
- Checking power cord and line voltage configurations
- Checking the fuse
- Power-on and power-off cycles

Operating Environment

To ensure proper AWG2005 operation and long life, note these environmental requirements.

Operating Temperature

The AWG2005 operates in an environment with an ambient air temperature between +10° C and +40° C. The AWG2005 storage temperature ranges from –20° C to +60° C. After storage at temperatures outside the operating limits, allow the AWG2005 chassis to stabilize at a safe operating temperature before applying power.

Ventilation Requirements

Air drawn in and exhausted through the cabinet side and bottom panels cools AWG2005 internal circuits. To ensure proper cooling, allow the following clearances:

Top and back	7.6 cm (3 in.)
Left and right	15 cm (6 in.)

The feet on the bottom of the AWG2005 cabinet provide the required clearance when it is set on a flat surface. The top of the AWG2005 does not require ventilation clearance.



To prevent temporary shutdown of the AWG2005, do not restrict air flow through the chassis. If the AWG2005 shuts down unexpectedly, improve ventilation around the AWG2005 and wait a few minutes to allow it to cool down; then switch the power on again.

Supplying Power

Before installing the AWG2005, note these precautions:

WARNING

To avoid equipment failure and potential fire or personal shock hazards, do not exceed the maximum rated operating voltage of 250 V between the voltage-to-ground (earth) and either pole of the power source. The AWG2005 operates from a single-phase power source and has a three-wire power cord with a two-pole, three-terminal grounding plug. Also, before making connection to the power source, be sure the AWG2005 has a suitable two-pole, three-terminal grounding-type plug.

To avoid personal shock hazard, do not contact conductive parts. All accessible conductive parts are directly connected through the grounding conductor of the power cord to the grounded (earthing) contact of the power plug. The AWG2005 is safety Class 1 equipment (IEC designation).

To avoid personal shock hazard, do not defeat the grounding connection. Insert the power input plug only in a mating receptacle with a grounding contact where earth ground has been verified by a qualified service person. Also, for electrical-shock protection, make the grounding connection before making connection to the AWG2005 input or output terminals.

Power Cord Information

The AWG2005 ships with the required power cord as ordered by the customer. Table 2-1 gives the color-coding of the conductors in the power cord. Figure 2-1 shows information on the available power cords.

Table 2-1: Power-cord Conductor Identification

Conductor	Color	Alternate Color
Ungrounded (Line)	Brown	Black
Grounding (Neutral)	Light Blue	White
Grounding (Earthing)	Green/Yellow	Green

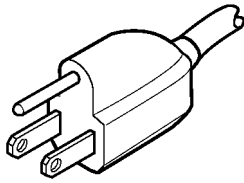

Standard*
North American
115V

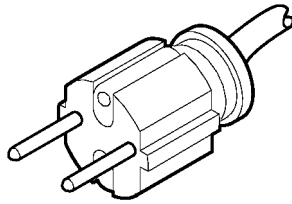

Option A1
Universal Euro
230V

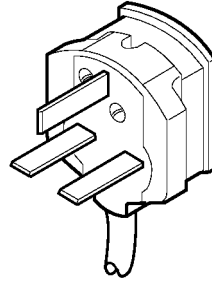

Option A2
UK
230V

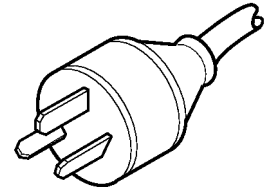

Option A3
Australian
230V

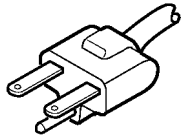

Option A4*
North American
230V

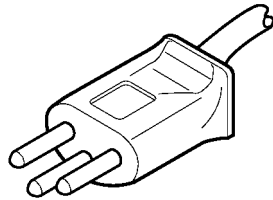

Option A5
Switzerland
230V

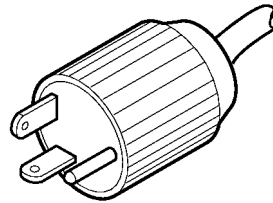

Option 1A*
North American
115V/High Power

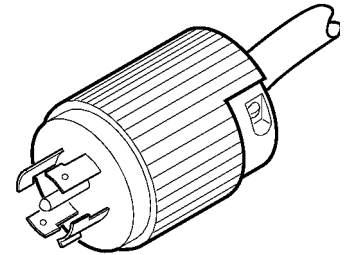

Option 1B
North American
3-Phase

* Canadian Standards Association certification includes these power plugs for use in the North American power network

Figure 2-1: Optional Power Cords

Rear Panel Controls

Section 1, *Specifications*, lists the line voltage and frequency ranges over which the AWG2005 operates.

Figure 2-2 shows the rear panel controls for the AWG2005.

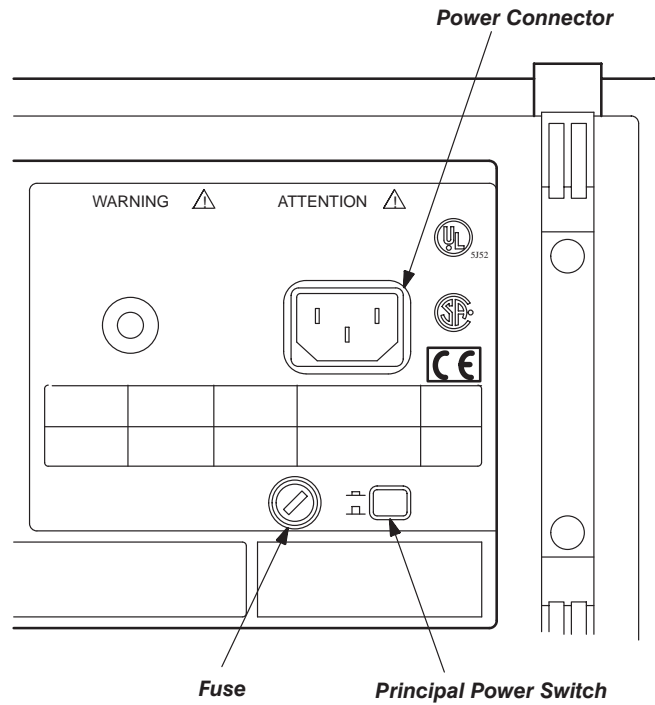

Figure 2-2: Rear Panel Controls

Fuse Type and Rating

The AWG2005 uses the same fuse for all operating line voltage range. There are two types of fuses provided. Here is the fuse type and rating.

Table 2-2: Fuse Type and Rating

Fuse	Fuse Part Number	Fuse Cap Part Number
6mm(0.25 inch) x 32mm(1.25 inch) (UL 198G,3AG):6A FAST,250V	159-0239-00	200-2264-00
5 mm x 20 mm (IEC 127): 5A(T),250V	159-0210-00	200-2265-00

WARNING

To avoid electrical shock, always unplug the power cord from the socket before checking the line fuse.

To check the fuse, remove the fuse holder on the rear panel. Refer to Figure 2-2 for the location of the fuse holder. To remove the fuse holder, turn it counter-clockwise with a screwdriver while pushing it in. Then remove the fuse from the fuse holder.

Applying and Interrupting Power

Consider the following information when you power on or power off the AWG2005 or when external power loss occurs.

Power-on Cycle

At power-on, the start-up diagnostics check the AWG2005 operation. The start-up diagnostics take about 30 seconds. If all diagnostic items complete without error, the AWG2005 displays PASS on the screen and then changes to the SETUP menu.

If the diagnostics detect an error, the AWG2005 displays FAIL and the error code. To exit the diagnostics menu, press any key; then the system displays the SETUP menu. See section 6, *Maintenance*, for information on diagnostics and fault isolation.

NOTE

If the ambient temperature goes outside the specified operating temperature range, an error occurs during the diagnostics at power-on. If this happens, power off the AWG2005 and wait until the chassis temperature is appropriate; then switch the power on again.

Power-off Cycle



*To prevent loss of internally stored adjustment constants, DO NOT power off the AWG2005 when doing the internal calibration described in section 5, *Adjustment Procedures*.*

Wait for the AWG2005 to finish the operation when doing internal calibration or saving waveform or sequence files. Improper power-off or unexpected loss of power to the AWG2005 can result in the corruption of data stored in nonvolatile memory.

Memory Backup Power

A lithium battery maintains internal nonvolatile memory, allowing the AWG2005 to retain waveform and sequence files if AC power is lost. This battery has a shelf life of about three years. Partial or total loss of stored information at power-on may indicate that the battery needs to be replaced.

WARNING

To avoid risk of fire or explosion, replace the AWG2005 battery with a lithium battery having the part number listed in section 10, Mechanical Parts List. This battery is a safety-controlled part.

To avoid risk of fire or explosion, do not recharge, rapidly discharge, or disassemble the battery; and do not incinerate the battery or heat it above 100° C. Also, dispose of used batteries promptly. Small quantities of used batteries can be disposed of in normal refuse. Keep lithium batteries away from children.

Installed Options

Your AWG2005 may include one or more options. To determine which options are installed, power on the AWG2005 and look at the display during the power-on sequence. The AWG2005 lists the installed options after Options, near the top of the display.

Table 2-1 of this subsection gives information about line cord options. Section 7, *Options*, lists other options and optional accessories. For further information and prices of options, see your Tektronix Products catalog or contact a Tektronix Field Office.

Instructions for Operation

Before servicing the AWG2005, read the following operating instructions. These instructions are at the level appropriate for servicing the AWG2005. The user manual contains complete operator instructions.

In addition, section 4, *Performance Verification*, includes instructions for making the front-panel settings required to check AWG2005 characteristics.

How to Power On

To power-on the AWG2005, follow these steps:

1. Set the PRINCIPAL POWER SWITCH (on the back of the AWG2005) to the ON position. This switch is the main power switch; it routes power to the standby circuit in the AWG2005.
2. Then, press the ON/STBY (standby) switch on the front (lower-left corner) of the AWG2005. This switch applies power to the remaining circuits of the AWG2005. Allow at least 20 minutes for the AWG2005 to warm up.

WARNING

To avoid personal shock hazard, turn off both the ON/STBY switch and the PRINCIPAL POWER SWITCH before servicing. The PRINCIPAL POWER SWITCH on the rear panel is the true power disconnect switch. The ON/STBY (standby) switch simply toggles operation on and off. When connected to a power source and when the PRINCIPAL POWER SWITCH is on, the internal power supplies and much of the other circuitry of the AWG2005 remain energized regardless of the setting of the ON/STBY switch.

To avoid personal shock hazard, set the PRINCIPAL POWER SWITCH off before connecting or disconnecting the line cord to or from the power source.

Internal Diagnostics Routines

At power-on, the AWG2005 performs internal start-up diagnostics. These diagnostics check internal circuit function and report any failures. In addition, you can initiate internal diagnostics; these diagnostics differ from the start-up diagnostics in that they do more extensive memory checking.

The AWG2005 also contains internal calibration routines, which check internal circuit function and adjust calibration constants. Run these calibration routines whenever the AWG2005 undergoes a temperature change. For

instance, run the calibration routines after the AWG2005 warms up at power-on. This warmup period and subsequent calibration assures AWG2005 operation at optimum performance levels.

User Interface

The AWG2005 uses a combination of front-panel buttons, keys, a knob, and on-screen menus to control generator functions. Some front-panel controls select menus and manipulate menu items. Others enter values and units, allow manual triggering, and turn on/off AWG2005 output. On-screen graphics show various aspects of the current AWG2005 configuration.

On-screen menus set all AWG2005 functions except manual triggering and output control. Main menus provide access to lower-level nested submenus. Buttons in the center of the front panel select the main menus.

When you select a menu, the display shows the items controlled by that menu and numeric values currently in effect. Buttons around the display select lower-level menus, change menu selections, modify numeric values and units, and execute functions.

Display

Figure 2-3 contains two examples of AWG2005 displays. To see the first display on the AWG2005, press **Edit** in the MENU column; then press **New Waveform** in the side menu. The second display shows an example of the message area. Text after the illustration describes each display feature.

Status Area — The status of the AWG2005 always appears in the status line. Status information includes the interface status (refer to Programmer manual), operating mode status, trigger status (refer to User manual), and busy icon (a clock) which appears while loading or saving waveform or sequence files.

Date & Time Display — This area displays the date and time set in the UTILITY menu. The date and time display can be set to on or off.

Error Display Area — If an error occurs during operation, this area displays an error message.

Side Menu Label — This area displays a label that matches the bottom menu that was selected.

Side Menu — When you select an item from the bottom menu, the corresponding side menu appears on the right side of the screen. To select an item, input numerals, or execute functions, push the soft button corresponding to the side menu item.

Button Operation — This area includes an explanation of front panel operation.

Knob Icon — The knob icon appears next to an item that is selected. To change the value of the item use the general purpose knob or press the numeric and units keys.

Message Area — This area displays messages for the user.

Bottom Menu — Pushing any button of the MENU column or the F.G button displays the corresponding bottom menu in the lower part of the screen. To select an item from a bottom menu, push the corresponding soft button.

Instructions for Operation

Status Area → GPIB | Continuous mode | Master Stopped
Error Display Area → Undo Buffer empty.
 Date & Time Display → 11-Nov-93 11:11:16
Side Menu Label → Operation
Side Menu → Cut, Copy to Buffer, Paste from Buffer, Draw..., More 1 of 3
Button Operation → CURSOR: Switch Cursor
 Select/ Open | **Operation** | Zoom | Setting | Undo | Standard Waveform | Close/ Write

GPIB | Continuous mode | Master Stopped
 Date & Time Display → 11-Nov-93 11:12:02
 Free : 2480KB
Knob Icon → [Knob icon]
Message Area → Are you sure you want to delete "SAMPLE-1.WFM" ?
 Cancel
 O.K.
Bottom Menu → Rename | Comment | Copy | **Delete** | Delete All | Lock On Off

Name	Type	Size	Date & Time	Comment
SAMPLE-1	WFM	2948	93-11-11 12:00	
SAMPLE-2	WFM	2948	93-11-11 12:03	
SAMPLE-3	WFM	2948	93-11-11 12:09	
SAMPLE-4	EQU	296	93-11-11 12:11	
SAMPLE-4	WFM	2948	93-11-11 12:10	
SAMPLE-5	SEQ	960	93-11-11 12:13	
SAMPLE-6	AST	554	93-11-11 12:15	

Figure 2-3: Display Features

Menus

The AWG2005 operation is primarily controlled by means of menus that correspond to the SETUP, MODE, EDIT, LOAD/SAVE and UTILITY buttons in the MENU column. To display one of these main menus on the screen, push the corresponding button. The button LED indicates which menu is currently selected. Refer to the User Manual for more details concerning these menus. The F.G button under the MENU column selects function generator operation.

- **SETUP Menu** — The SETUP menu sets the following waveform output parameters for each channel: clock source and frequency, waveform or sequence file selection, operation, filter, amplitude, and offset.
- **MODE Menu** — This menu sets the operation output mode. The operation modes are the trigger modes (Cont, Triggered and Gated) and the modes which display a waveform in sequence for each trigger (Waveform Advance and Autostep modes). This menu also has an item for setting the system configure to either master or slave.
- **EDIT Menu** — The EDIT menu allows you to edit an existing file saved in internal memory or to create a new file. To modify files in internal memory, use one of the four editors, depending on the waveform file type: waveform edit, sequence edit, equation edit, and autostep edit. Instruments with Option 05 installed also have a clock sweep editor which provides linear, log and arbitrary sweep output for clock frequencies. Instrument with Option 09 installed have an FFT editor to permit editing in the frequency domain and a convolution editor to operate the waveforms convolution in high speed.
- **LOAD/SAVE Menu** — Here are the functions for this menu:
 - **LOAD menu** — loads files from the AWG2005 floppy disk drive or nonvolatile internal memory into internal memory.
 - **SAVE menu** — saves files from the AWG2005 internal memory onto a floppy disk or into nonvolatile internal memory.
- **UTILITY Menu** — Use this menu to rename or delete files saved in the floppy disk or internal nonvolatile memory, to set the parameters of GPIB or RS-232-C, to set AWG2005 date and time, to change display brightness, to set the catalog order, to set the system configure, to set the hardcopy port and format, to check interface status, and to execute internal diagnosis and calibration routines.

Waveform Files

The AWG2005 generates waveform output from four different types of waveform files:

- *Waveform data file (filename.WFM)*. This is the basic waveform data file. It contains the waveform data that the AWG2005 loads into memory and reads when generating waveform output. The data in this kind of file can be created using the waveform editor, generated from equations made using the equation editor, transferred in over an interface, or directly transferred in from certain Tektronix instruments. In addition, the waveform editor displays the data in a waveform data file in three formats: graphical, table, and timing.
- *Waveform equation file (filename.EQU)*. The waveform equation file contains equations that express waveform characteristics. Compilation of the waveform equation file generates a waveform data file. The AWG2005 generates the waveform output from this file.
- *Waveform sequence file (filename.SEQ)*. The waveform sequence file specifies a series of waveform data files. When the AWG2005 executes a waveform sequence file, it sequentially generates waveforms from each waveform data file, in the order specified.
- *Waveform autostep file (filename.AST)*. The waveform autostep file specifies a series of waveform data files and/or waveform sequence files. When the AWG2005 executes a waveform autostep file, it generates the waveform for the first file specified. Then it waits for a trigger before generating from the next specified file. The autostep file includes output conditions for each channel.

Waveform Storage and I/O

The AWG2005 has both internal memory and internal nonvolatile memory (NVRam) for waveform file storage. The AWG2005 generates waveforms from files residing in internal memory. To save a file that is in internal memory, copy it to nonvolatile memory or floppy disk. Only nonvolatile memory retains files at power-off.

The AWG2005 also has a floppy-disk drive for loading files from floppy disk into internal memory or internal nonvolatile memory and for saving files from either memory to floppy disk. The disk drive accepts 3.5-inch MS-DOS-formatted floppy disks.

Loading Files

The following steps explain how to load files from a floppy disk into internal memory.

1. Push the **LOAD/SAVE** button in the MENU column.
2. Turn the disk so the side with the arrow is on top; insert the disk into the AWG2005 floppy disk drive.

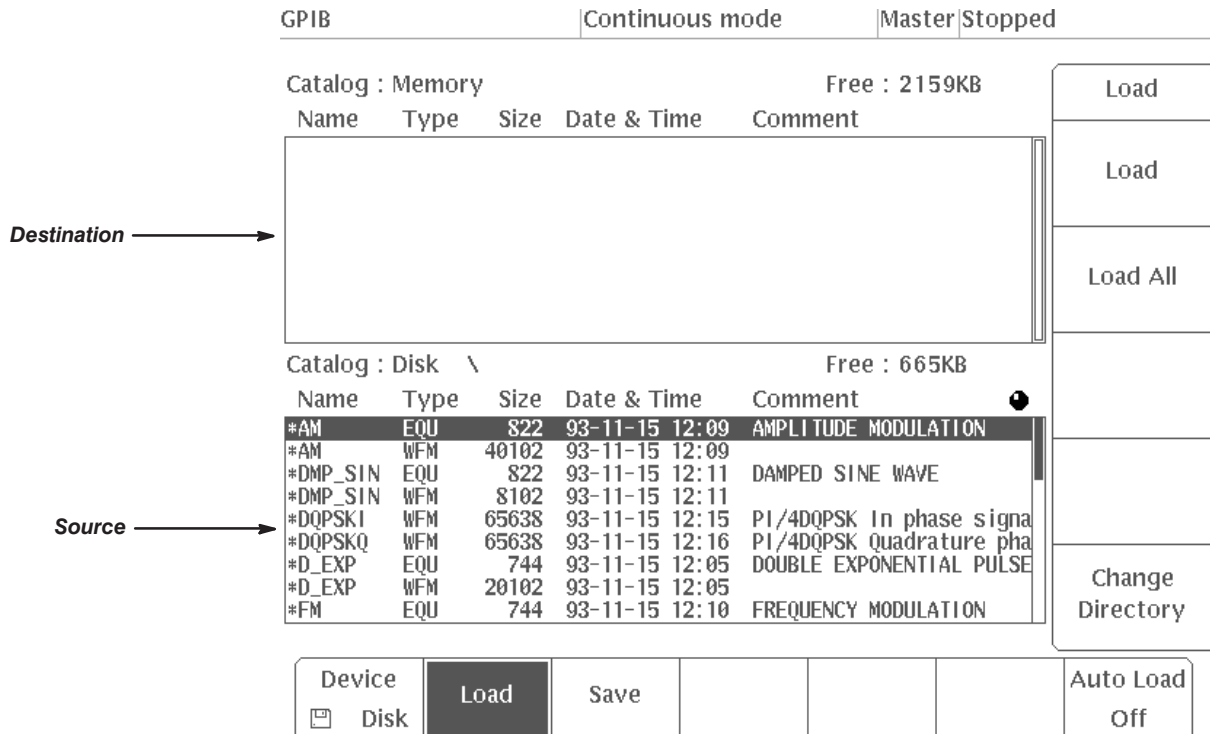

Figure 2-4: LOAD Menu

3. Push the **Device** button along the bottom menu to select **Disk**. The menu in Figure 2-4 appears.
4. Select the **Load All** button along the side menu to load all files in the root directory on the disk into the AWG2005 internal (volatile) memory. Or, turn the general-purpose knob to highlight the file you want to load and select **Load**. The display indicates which file it is loading. When loading is complete, the clock disappears.
5. Push the floppy drive button and remove the disk from the floppy drive.
6. Push any button in the MENU column (other than LOAD/SAVE) to exit the menu.

Setting Output Parameters

The SETUP menu allows you to set various output parameters for outputting a waveform or sequence waveform. To set the output parameters, select a waveform or sequence file (that is already loaded into memory) as the active file.

When you select a file, the AWG2005 changes to the output parameters associated with the file and displays these parameters on the SETUP menu. If you modify the displayed output parameters and later save the file, the modified output parameters are saved with the file. (if the file is locked, you cannot modify the file contents.)

The following steps go through the process of selecting a file and modifying individual output parameters.

1. Push the **SETUP** button in the MENU column. The SETUP menu in Figure 2-5 appears.

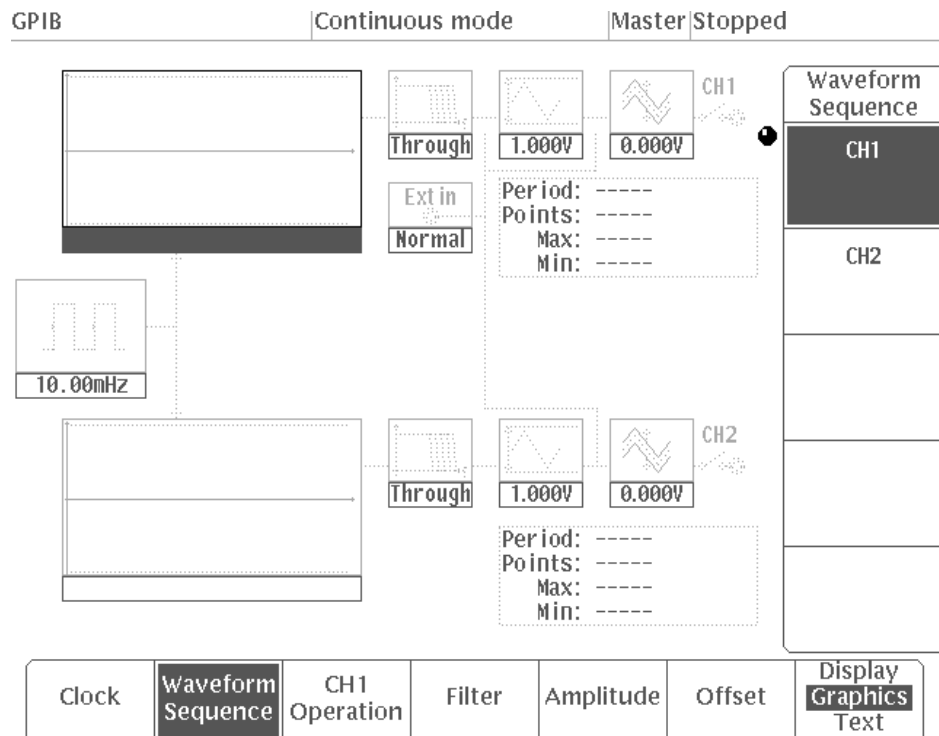

Figure 2-5: SETUP Menu

2. Select **Waveform Sequence** from the bottom menu. Waveform Sequence toggles between the CH1 files (upper list) and the CH2 files (lower list).
3. Turn the general purpose knob to highlight a file in the displayed list of files; these are the files currently in internal memory. Then, push **ENTER** to select the file; the AWG2005 changes to the output parameters associated with the file you selected.
4. After the file is selected, push the front panel **VALUE** button. Now you can modify output waveform parameters.
5. Setting individual parameters:
 Push the **SETUP** button in the MENU column (if the button is not selected). Now select the appropriate item from the bottom menu; then use the numeric keys or general purpose knob to modify the parameter setting.

The following explains each item in the bottom menu.

- **Clock** — This item sets the clock source and clock frequency. The clock source can be set to either internal or external.

The clock period is the time between the data points for the waveform created. Therefore, the product of the clock period and the number of waveform points is the waveform or sequence period. For example, if the clock frequency is 1 MHz (period of 1 μ s) and there are 100 waveform points, the waveform period is displayed as 100 μ s.

The clock source and clock frequency setting will be applied to all channels.

- **Operation** — This item performs an arithmetic operation between the CH1 waveform and CH2 waveform or external waveform, and outputs the result at the CH1 output connector. The operations are addition (Add, External Add) and multiplication (AM, External AM).
- **Filter** — This item selects a filter that restricts the frequency band for the output channel. Choose a 5, 2, 1 MHz, or 500 kHz filter, or you can select Through (no filter).
- **Ampl** — This selection sets the voltage value for the 12-bit, full-scale, output amplitude on the vertical scale. The amplitude can be set in steps of 1 mV within the range from 0.05 V to 10 V.
- **Offset** — This item sets the offset level of the output waveform. The offset can be set in steps of 5 mV within the range ± 5 V.

Operation Mode Settings

The MODE menu initiates the waveform output with the output conditions set using the SETUP menu.

1. Push the **MODE** button in the MENU column. The MODE menu in Figure 2-6 appears.
2. Select the operation mode from the bottom menu. The operation modes are Cont, Triggered, Gated, Waveform Advance, and Autostep.

In all modes except Cont, the trigger or gate signal source can be the external signal applied to the TRIGGER INPUT connector or can be generated by pushing the front panel TRIGGER MANUAL button. The following text describes the individual modes.

- **Cont Mode** — When you push the Cont button, the AWG2005 immediately outputs the specified waveform or sequence waveform continuously.

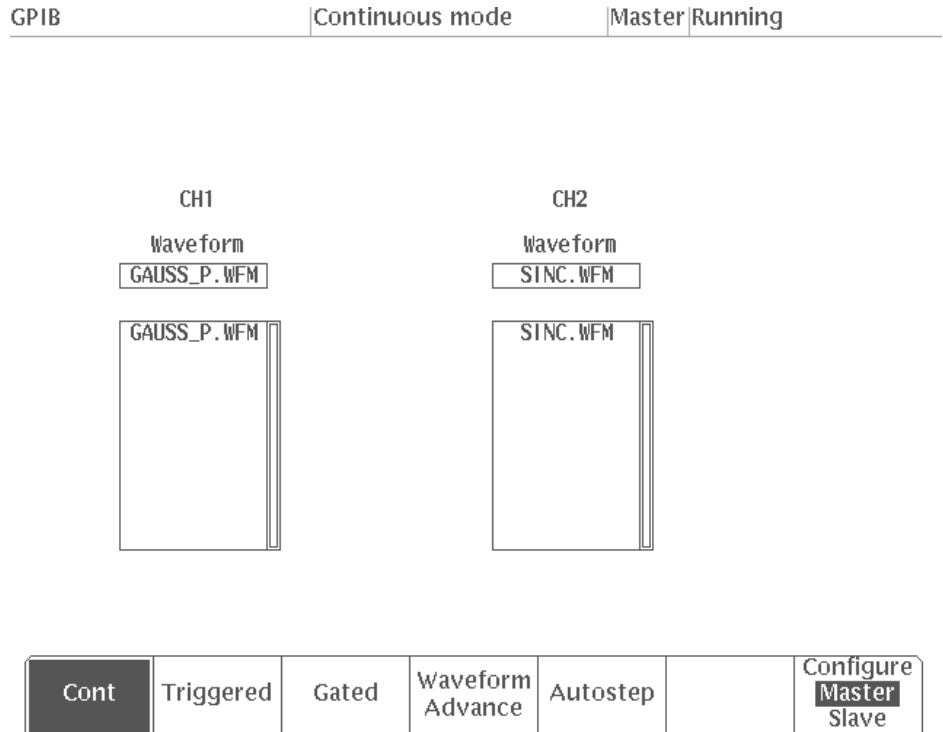

Figure 2-6: MODE Menu

- **Triggered Mode** — In triggered mode, the AWG2005 outputs the specified waveform or sequence waveform once, when a trigger occurs.
- **Gated Mode** — In gated mode, the gate signal controls the waveform or sequence output.

As long as the front panel MANUAL button is pushed, (or the gating signal is high) the AWG2005 outputs the specified waveform or sequence. When the MANUAL button is released (or the gating signal goes low), the waveform output stops. When the MANUAL button is pushed again, the output resumes from the level at which the waveform or sequence output stopped.

- **Waveform Advance Mode** — When a sequence file has been designated in the SETUP menu, Waveform Advance mode is used to advance a waveform in sequence each time a trigger is received.

The waveform output conditions in waveform advance mode can be set to either **Continuous** or **Step** depending on the selection for the **Run** side menu item.

Continuous — In this mode, the first waveform is output over and over again for each channel when a trigger signal is received. When the next trigger signal is received, output of the first waveform stops after the end point of that waveform and then the second waveform is output in the same manner. The next waveform is not started at the moment a trigger is received, but rather at the completion of the previous waveform.

In this way, waveforms are output for each channel one by one in sequence each time a trigger signal is received. When a trigger signal is received while output of the last waveform is in progress, the output stops at the end point of that waveform and then the process begins again from output of the first waveform.

Step — In this mode, the first waveform is output on each channel when a trigger signal is received, but only for the number of times set with **Repeat** in the sequence editor. The next waveform is output when the next trigger signal is received. Other operations are the same as **Continuous** output.

- **Autostep Mode** — Use Autostep mode to start an Autostep file created with the EDIT menu Autostep editor. An Autostep file stores a program that specifies a waveform or sequence file (including output parameters) for each channel for each step.

Autostep mode resembles Waveform Advance mode in which each time a trigger is received, the display advances one waveform. However, in this mode the output parameters for each waveform change as well. The operating mode for each step can be set with the waveform output conditions to either **Continuous** or **Step**, as in the case of Waveform Advance mode. Just as in other operating modes, the Autostep mode trigger signal can be generated from the external trigger signal or by pressing the front panel MANUAL button.

Continuous — In this mode the programmed **Step:1** waveform is output over and over again when a trigger signal is received. When the next trigger signal is received output of the **Step:1** waveform stops after the end point of that waveform and then the **Step:2** waveform is output in the same manner. The waveform is started at the moment a trigger is received.

In this way, the current waveforms advance for each channel one by one in sequence each time a trigger signal is received. When a trigger signal is received while output of the last waveform in the step is in progress, the output stops at the end point of that waveform and then the process begins again from output of the **Step:1** waveform.

Step — When a trigger signal is received, the **Step:1** waveform for each channel is output once. When the next trigger signal is received, the **Step:2** waveform is output (once). When the next trigger signal is received while waveform output is in progress, output stops after the end point of that waveform and then the waveform for the next step is output.

3. Set the trigger (gate) conditions for the external trigger (gate) source.

The external trigger (gate) signal is input from the TRIGGER INPUT connector on the front panel. The input impedance is 10 k Ω and the maximum input voltage is ± 10 V.

When an operating mode other than Cont is selected, the AWG2005 displays a side menu for selecting the trigger (gate) conditions for the external trigger (gate) source. The following describes each of these items.

- **Slope** — This item sets the slope for external trigger signals. To select a positive or negative slope, push the side menu Slope button. For a positive slope, the AWG2005 applies the trigger at the rising edge of the external trigger signal; for a negative slope, the trigger is applied at the falling edge of the external trigger signal.
- **Polarity (Gated Mode)** — This item sets the polarity for the gate that outputs the waveform or sequence based on the level of the external gate signal. To set the polarity, push the side menu Polarity button. For a positive polarity, the AWG2005 outputs the waveform or sequence waveform while the gate signal level is higher than the gate level parameter set with the side menu Level item. For negative polarity, waveform output occurs while the gate signal level is lower.
- **Level** — This item sets the external trigger (gate) signal level. To set this parameter push the side menu Level button, then use the numeric keys or the general purpose knob to change the value. The trigger (gate) level can be set in steps of 0.1 V within the range from -5.0 V to 5.0 V.

Theory of Operation

This section describes the basic operation of the major circuit blocks or modules in the AWG2005. Section 9, *Diagrams*, includes two block diagrams and an interconnect diagram. Figure 9-1 shows the modules and functional blocks of the AWG2005 with Option 02, 04, 05 and 09 installed. Figure 9-2 shows how the modules interconnect.

Module Overview

The module overview describes the basic operation of each functional circuit block.

The AWG2005 Arbitrary Waveform Generator is a portable, two- or four-channel instrument. For each channel, the AWG2005 reads the digital waveform data loaded into its waveform memory. The point rate clock determines the rate at which the data is read. The AWG2005 converts the data from digital to analog format and outputs the resulting arbitrary waveform.

Clock Oscillator (A1 Clock Board)

The clock circuit is a PLL oscillator that uses a 12.8 MHz reference crystal. It supplies a point rate clock that is adjustable from 20 MHz to 0.01 Hz for reading data from channel waveform memory.

When an external clock source is selected, the external clock signal is passed directly through to the Clock board and used for reading waveform data in memory.

Clock Sweep Oscillator (A31 Clock Sweep Board)

In addition to the description for the Clock Sweep Oscillator, it provides the clock sweep from 20 MHz to 0.03 Hz.

Sequencer (A2 AWG Board)

This sequencer block controls the waveform memory addresses read out according to the contents of a sequence file.

Waveform Memory (A2 AWG Board)

This functional block contains the memory that holds the waveform digital data. There are 12 bits for waveform data and one bit for waveform markers (for each channel).

Digital-to-Analog Converter (DAC) (A11 D/A Board)

This functional block is a 12-bit high-speed digital-to-analog converter. It converts the digital data from the waveform memory into analog signals.

Analog Processing (A3/A23 Analog Board)

This analog processing block amplifies the analog signals from the DAC to the necessary amplitude. If an offset is specified, this circuit adds that offset and outputs the result at the output connector for that channel. This circuit also contains a filter, an AM modulator, and other elements that modify waveform output. Its output impedance is 50 Ω .

CPU and Memory (A6 CPU Board)

This functional block directs operation of all internal circuits, based on front panel control operation and commands received over the GPIB or RS-232-C interface. This circuit includes the 68000 CPU, DRAM, EPROM, SRAM. Data in memory is retained by a lithium battery on the A5 Backplane board.



To avoid losing waveform data files stored in NVRam, save the files to a floppy disk before removing the A6 CPU board or A5 Backplane board. Then restore the files from floppy disk to AWG2005 NVRam after reinstalling the board(s).

GPIB (A6 CPU Board)

This functional block is the General Purpose Interface Bus (GPIB) interface driver, which controls communication with external devices over the parallel interface. The GPIB connector is on the rear panel.

RS-232-C (A6 CPU Board)

This functional block is the RS-232-C interface circuit which controls serial communication with external devices over the RS-232-C interface. The RS-232-C interface connector is on the rear panel.

Display Control (A6 CPU Board)

The display control block processes the test and waveform information based on commands from the processor. The block sends the text and waveform information to the display monitor as video signals with vertical and horizontal sync control.

Display Monitor

The display monitor takes in the video signals and displays them on a 17.8 cm (7 in.) CRT screen. The display resolution is 480 × 640 pixels.

Front Panel (A12 Key Board)

The front panel block includes the buttons, keys, knobs, and so on, for entering selections. User selections from the front panel are sent to the processor. The buttons at the bottom and side of the display are also included in this block. Commands from the processor control the LED in the buttons.

Floppy Disk Drive

The 3.5-inch floppy disk drive supports both 2DD and 2HD MS-DOS formats.

Low Voltage Power Supply

This functional block is a switching-type power supply that converts the line voltage into the various voltages required for internal circuit operation.

Fan

The fan prevents heat build-up inside the cabinet; it pulls air into the right (floppy-disk) side of the AWG2005 and exhausts it out the left side.

Options

The following four options which modify AWG2005 operation are available.

- **Option 02: CH3 and CH4 Output Channels**

This option adds CH3 and CH4 waveform output channels. It includes an AWG board, a D/A board and an Analog board for Channel 3 and 4.

- **Option 04: Digital Data Out**

This option directly outputs the digital data in the waveform memory without passing it through the digital-to-analog converter. This option and Option 09 cannot both be installed.

- **Option 05: Clock Sweep**

This option provides an additional function: the clock sweep editor. In addition to performing linear sweep and log sweep for the clock frequency, the clock sweep editor enables you to easily create arbitrary sweep. The Clock board for the AWG2005 standard type is replaced by the Clock Sweep board.

- **Option 09: Floating Point Processor**

This option is a card dedicated to floating point processing. It provides the capability to edit in the frequency domain and it speeds up internal calculations.

For more information about these and other options, see section 7, *Options*.

Before Verification

This subsection describes the kind of verification procedures that can be followed, it indicates when to use the procedures, and gives conventions used in their structure. The procedures in this section are:

- Self Tests
- Performance Tests

Preparation

These procedures verify the AWG2005 Arbitrary Waveform Generator functionality. Which procedure to follow depends on your goal:

- To quickly confirm that the AWG2005 functions correctly and was adjusted properly, do the procedures under *Self Tests*, which begin on page 4-3.

Advantages: These procedures are short, require no external equipment, and perform extensive functional and accuracy testing. Use them to quickly determine if the AWG2005 is suitable for putting into service, such as when it is first received.

- For a more extensive confirmation of performance, do the *Performance Tests*, beginning on page 4-7 after doing the *Self Tests*.

Advantages: These procedures involve direct checking of warranted specifications. They require more time and suitable test equipment. (See *Equipment Required* on page 4-8.)

Before starting any of these procedures, read *Instructions for Operation* in section 2 of this manual. These instructions briefly describe the AWG2005 front-panel controls and menu system. The user manual contains detailed information on operating the AWG2005.

Conventions

Throughout the procedures in this section the following conventions apply:

- Each test procedure uses the following general format:
 - Title of Test
 - Equipment Required
 - Prerequisites
 - Procedure

Before Verification

- Each procedure consists of as many steps, substeps, and subparts as required to do the test. Steps, substeps, and subparts are sequenced as follows:
 1. First Step
 - a. First Substep
 - First Subpart
 - Second Subpart
 - b. Second Substep
 2. Second Step
- Instructions for menu selection follow this format: **FRONT PANEL BUTTON→Main Menu Button→Side Menu Button**. For example, “Press **UTILITY→Misc→Config...→Reset to Factory→O.K.**”
- Where instructed to use a front-panel button, key, or knob, or select from the MENU column, or from a bottom or side menu, the name of the item appears in boldface type: “push **MODE**, ” or “select **Triggered** in the bottom menu.”

Self Tests

This subsection describes how to use AWG2005 internal self-test routines. No equipment is required to do these procedures. The self tests include these internal routines:

- **Diagnostics**

This self-test procedure uses internal routines to verify that the AWG2005 functions, and passes the internal circuit tests.

- **Calibration**

The second procedure checks the AWG2005 internal calibration constants and changes them if needed.

Diagnostics

The internal diagnostic routines check AWG2005 characteristics such as amplitude, offset, trigger level, clock, filters and attenuation.

The AWG2005 automatically performs the internal diagnostics at power-on; you can also run the internal diagnostics using the menu selections described in this procedure. The difference between these two methods of initiating the diagnostics is that the menu method does more detailed memory checking than the power-on method.

Equipment Required: None.

Prerequisites: Power on the AWG2005 and allow a twenty-minute warmup period before doing this procedure.

Procedure:

1. *Verify that internal diagnostics pass:* Do the following substeps to verify passing internal diagnostics.
 - a. *Display the diagnostics menu and select all tests:* Push **UTILITY**→**Diag/Cal**→**Diagnostics xxxx**→**All**. See the menu in Figure 4-1.

The Diagnostics column on the left shows the tests available for diagnostics. In addition to selecting all of the tests shown for Diagnostics, you can select only the test(s) you want to run using the general purpose knob. In Figure 4-1, the symbol to the left of Cpu indicates that test is one of the tests selected.

GPIB Continuous mode Master Stopped

Diagnostics	Result	Code
* Cpu	Pass	
* Clock	Pass	
* Display	Pass	
FPP	----	
* FrontPanel	Pass	
* Trigger	Pass	
* Setup CH1	Pass	
* Setup CH2	Pass	
Setup CH3	----	
Setup CH4	----	
* Waveform Memory CH1	Pass	
* Waveform Memory CH2	Pass	
Waveform Memory CH3	----	
Waveform Memory CH4	----	

Diag/Cal

Diagnostics
All

Calibrations
All

Interactive
Test
Front Panel

Execute



Disk

NVRam

GPIB

RS232C

Date Time

Misc



Diag/Cal

Figure 4-1: Diagnostics Menu

- b. *Run the diagnostics:* Select **Execute** from the side menu. This executes all the AWG2005 diagnostics automatically.
 - c. *Wait:* The internal diagnostics do an extensive verification of AWG2005 functions. While this verification progresses, the screen displays the clock icon. When finished, the resulting status appears on the screen.
 - d. *Confirm that no failures are found:* Verify that no failures are found and reported on-screen. If the diagnostics displays FAIL as the result of any test, use the instructions in section 6, *Troubleshooting*, to identify the faulty module. If the diagnostics display an error code, contact your nearest representative.
2. *Return to regular service:* Push a button (other than UTILITY) in the MENU column to exit the diagnostic menu.

Calibration

The AWG2005 includes internal calibration routines that check electrical characteristics such as amplitude, offset, trigger level, clock, filters and attenuation and adjust internal calibration constants as necessary. This procedure describes how to do the internal calibration.

Equipment Required: None.

Prerequisites: Power on the AWG2005 and allow a 20 minute warmup period at an ambient temperature between +15°C and +25°C before doing this procedure.

Procedure:

NOTE

If the AWG2005 is powered off while the calibration is executed the calibration data in the memory may be loss.

1. *Verify that internal adjustments pass:* Do the following substeps to verify internal adjustments have passed.
 - a. *Display the calibrations menu and select all tests:* Push **UTILITY**→**Diag/Cal**→**Calibrations xxx**→**All**. See the menu in Figure 4-2.

The Calibrations column on the left shows the tests available for calibration. In addition to selecting all of the tests shown, you can select only the test(s) you want to run using the general purpose knob. In Figure 4-2, the symbol to the left of Trigger indicates the tests selected.

Performance Tests

This subsection contains a series of procedures for checking that the AWG2005 Arbitrary Waveform Generator performs as warranted.

The procedures are arranged in eleven logical groupings, presented in the following order:

- Operating Mode Checks
- Arithmetic Operation Checks
- Clock Frequency and Amplitude Checks
- Gain Accuracy Check
- Offset Accuracy Check
- Pulse Response Check
- MARKER OUT Amplitude Check
- CONTROL SIG OUT Amplitude Check
- External Trigger Level Accuracy Check
- External CLOCK IN Check
- Master–Slave Operation Check (Optional Check)
- DIGITAL DATA OUT Check

These procedures extend the confidence level provided by the internal diagnostic and calibration routines described on page 4-3.

Prerequisites

The tests in this subsection comprise an extensive, valid confirmation of performance and functionality, when the following requirements are met:

- You must have performed and passed the calibration procedure described in *Self Tests*, the previous subsection.

NOTE

For operation to specified accuracy, allow the AWG2005 to warm up at least 20 minutes before doing the performance tests.

- Load all the files from the Performance Check disk (063-1706-XX) that comes with this manual into AWG2005 internal memory. For instructions on loading files, see *Loading Files* on page 2-12 in the *Instructions for Operation* subsection in section 2.

Related Information

Read *Preparation and Conventions* on page 4-1. Also, if you are not familiar with operating the AWG2005, read the subsection, *Instructions for Operation*, in section 2 before doing any of these procedures.

Equipment Required

The following equipment is required to check the performance of the AWG2005.

Table 4-1: Test Equipment

Item Description	Minimum Requirements	Example	Purpose
Precision termination	Impedance: 50 Ω , 0.1% Connectors: BNC	Tektronix Part 011-0129-XX	Signal termination.
Adapter	Connectors: BNC female-to-dual banana	Tektronix Part 103-0090-XX	Signal interconnection.
BNC dual input (TEE) adapter	Connectors: BNC	Tektronix Part 103-0030-XX	Signal interconnection.
BNC cable (4 required)	Impedance 50 Ω Connectors: BNC Length: 43 inches	Tektronix Part 012-0057-XX	Signal interconnection.
Digital Data Out Cable (Option 04)	Must use example equipment	Tektronix Part 174-3192-XX	Used to check digital data output .
2 X13 header (Option 04)	Must use example equipment	Tektronix Part 131-3847-XX	Used to check digital data output.
Probe, 10X (Option 04)	10X probe	Tektronix Part P6139A	Used to check digital data output.
Test oscilloscope	Bandwidth: >250 MHz	Tektronix TDS500 Series Digitizing Oscilloscope or 2400 Series Digitizing Oscilloscope	Checks output signals. Used in many procedures.
Frequency counter	Frequency range: 10 Hz to 250 MHz	Tektronix DC 5010 Programmable Universal Counter/Timer*	Used to check clock frequency.
Digital multimeter	DC volts range: 0.05 V to 10 V Accuracy: $\pm 0.1\%$	Fluke 8842A	Used throughout the checks to measure voltage.
Function generator	Output voltage: -5 V to 5 V	Tektronix FG 5010 Programmable Function Generator*	Used to input the trigger signal.
Performance Check disk	Must use example listed	Tektronix Part 063-1706-XX	Used throughout the checks to provide waveform files.

* Requires a TM 5000 Series Power Module Mainframe

Table 4-2: Test Equipment For Optional Check

Item Description	Minimum Requirements	Example	Purpose
Arbitrary Waveform Generator	Must use example listed	Tektronix AWG2005 Arbitrary Waveform Generator	Used to check master–slave operation.

Performance Check Files

Table 4-3 lists the waveform files on the Performance Check disk (063-1706-XX) that are used in these performance tests, the AWG2005 front-panel settings that each file sets up, and the performance test that uses each file.

NOTE

*The files on the Performance Check disk are locked (the files names are displayed with *), so the data in these files cannot be changed unless the lock is opened. The file data includes not only waveform data, but also output parameters.*

When you select a file with the Waveform Sequence item, the AWG2005 output parameters change to those specified in the file, and the waveform output reflects waveform data in the file. After selecting a file, do not change an output parameter with the SETUP menu unless a procedure instructs you to do so. During the procedures, if you are unsure that the AWG2005 settings still match the file's settings, select the waveform again using the Waveform Sequence item on the SETUP menu.

Table 4-3: File List for Performance Check Disk





No.	File Name	EDIT Menu		SETUP Menu					Usage
		Wfm Shape	Wfm Point	Clock	Operation	Filter	Ampl	Offset	
1	MODE.WFM		1000	10 MHz	Normal	Through	1 V	0 V	Cont Mode, Triggered Mode, Gated Mode
2	MODE_ADV.SEQ ADV-1.WFM ADV-2.WFM		1200 1000 200	10 MHz	Normal	Through	1 V	0 V	Waveform Advance Mode
3	MODE_AST.AST Step: 1 AST-1.WFM		1000	10 MHz	Normal	Through	3 V	0 V	Autostep Mode
	Step: 2 AST-2.WFM		200	5 MHz	Normal	Through	1.5 V	0 V	
	Step: 3 AST-3.WFM		200	20 MHz	Normal	Through	0.5 V	0 V	
4	OPE.AST Step: 1 EXT_AM.WFM (CH1)		1000	1 MHz	Ext AM	Through	5 V	0 V	External AM Operation
	Step: 1 ----- (CH2)								
	Step: 2 AM-1.WFM (CH1)		1000	1 MHz	AM	Through	5 V	0 V	Internal AM Operation
	Step:2 AM-2.WFM (CH2)		1000	1 MHz	---	Through	10 V	0 V	
	Step: 3 AM-1.WFM (CH1)		1000	1 MHz	AM	Through	5 V	0 V	
	Step:3 AM-3.WFM (CH2)		1000	1 MHz	---	Through	10 V	0 V	
	Step: 4 ADD.WFM (CH1)		1000	1 MHz	Ext ADD	Through	5 V	0 V	External ADD Operation
	Step: 4 ----- (CH2)								
	Step: 5 ADD.WFM (CH1)		1000	1 MHz	Add	Through	5 V	0 V	Internal Add Operation
	Step:5 ADD.WFM (CH2)		1000	1 MHz	---	Through	5 V	0 V	

Table 4-3: File List for Performance Check Disk (Cont.)



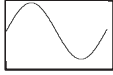
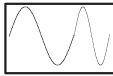
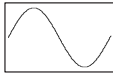
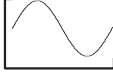



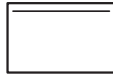
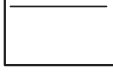
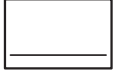
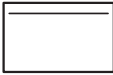
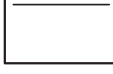
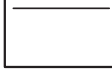



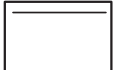

No.	File Name	EDIT Menu		SETUP Menu					Usage
		Wfm Shape	Wfm Point	Clock	Operation	Filter	Ampl	Offset	
5	CLK_FREQ.WFM		1000	20 MHz	Normal	Through	1 V	0 V	Clock Frequency Accuracy
6	CLK_AMPL.WFM		1000	1 MHz	Normal	Through	1 V	0 V	Clock Amplitude
7	GAIN.AST (CH1 – CH4) Step: 1 GAIN-1.WFM		1000	1 MHz	Normal	Through	0.999 V	0 V	Gain Accuracy
	Step: 2 GAIN-2.WFM		1000	1 MHz	Normal	Through	-0.999 V	0 V	
	Step: 3 GAIN-3.WFM		1000	1 MHz	Normal	Through	10 V	0 V	
	Step: 4 GAIN-4.WFM		1000	1 MHz	Normal	Through	-10 V	0 V	
8	OFF.AST (CH1 – CH4) Step: 1 OFFSET-1.WFM		1000	1 MHz	Normal	Through	0.05 V	5 V	Offset Accuracy
	Step: 2 OFFSET-2.WFM		1000	1 MHz	Normal	Through	0.05 V	0 V	
	Step: 3 OFFSET-3.WFM		1000	1 MHz	Normal	Through	0.05 V	-5 V	
9	PULSE.WFM		64	20 MHz	Normal	Through	0.5 V	0 V	Pulse Response
10	MKR.WFM		200	1 MHz	Normal	Through	1 V	0 V	MARKER OUT Amplitude
11	CNTRL.WFM		200	1 MHz	Normal	Through	1 V	0 V	CONTROL SIG OUT Amplitude
12	TRG_IN.WFM		1000	20 MHz	Normal	Through	1 V	0 V	External Trigger Level Accuracy
13	EXT_CLK.WFM		1000	External Clock	Normal	Through	1 V	0 V	External CLOCK IN

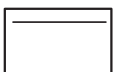
Table 4-3: File List for Performance Check Disk (Cont.)

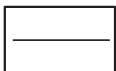
No.	File Name	EDIT Menu		SETUP Menu					Usage
		Wfm Shape	Wfm Point	Clock	Operation	Filter	Ampl	Offset	
14	MS_SL.WFM		200	1 MHz	Normal	Through	1 V	0 V	Master–Slave Operation Check (Optional Check)
15	DIGI_OUT.WFM		4096	1 MHz	Normal	Through	1 V	0 V	DIGITAL DATA OUT Check (Option 04)

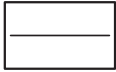
Operating Mode Checks

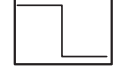
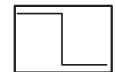
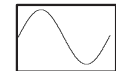
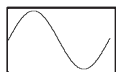
These procedures check operation of the Cont, Triggered, Gated, Waveform Advance, and Autostep modes.

Check Cont Mode

Electrical Characteristic Checked: Operating modes, Continuous, on page 1-5.

Equipment Required: A 50 Ω coaxial cable and an oscilloscope.

Prerequisites: The AWG2005 must meet the prerequisites listed on page 4-7.

Procedure:

1. *Install the test hookup and set test equipment controls:*
 - a. *Hook up the oscilloscope:* Connect the AWG2005 CH1 output connector through the coaxial cable to the CH1 vertical input connector on the oscilloscope (see Figure 4-3).

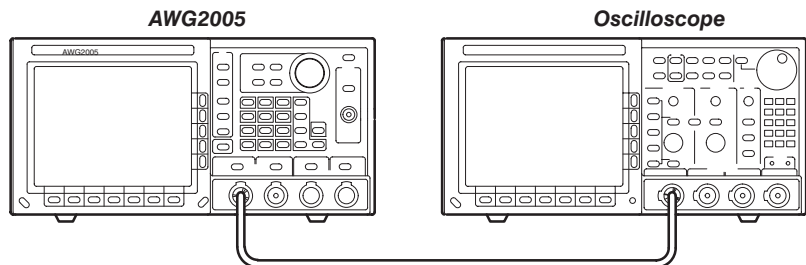

Figure 4-3: Cont Mode Initial Test Hookup

b. *Set the oscilloscope controls:*

Vertical:	CH1
CH1 coupling:	DC
CH1 scale	0.2 V/div.
CH1 input impedance:	50 Ω
Horizontal	
Sweep	50 μ s/div.
Trigger	
Source	CH1
Coupling	DC
Slope	Positive
Level	-100 mV
Mode	Auto

2. *Set the AWG2005 controls and select the waveform file:*

a. *Initialize AWG2005 controls:* Push **UTILITY**→**Misc**→**Config...**→**Reset to Factory**→**O.K.**

b. *Select the file:*

- Push **SETUP**→**Waveform Sequence**, if necessary, to select a waveform file for CH1. Waveform Sequence toggles between the CH1 files (upper list) and the CH2 files (lower list).
- Turn the general purpose knob to display the list of waveform files and highlight the **MODE.WFM** file.
- Push **ENTER** to select the file. This button is located to the lower-right of the numeric keypad.
- Select the **MODE.WFM** file for CH2 same as CH1.

3. *Turn on the AWG2005 CH1 output:* Push the **CH1** button so that the LED above the CH1 output connector is on.

4. *Check against limits:* Check that the amplitude of the sine wave displayed on the oscilloscope is 5 vertical divisions and that 5 cycles of the waveform are displayed.

5. Move the connection for the coaxial cable from the AWG2005 CH1 output to AWG2005 CH2 output connector.

6. *Turn on the AWG2005 CH2 output:* Push the **CH2** button so that the LED above the CH2 output connector is on.

7. Repeat procedure 2.

8. *If Option 02 is installed (adds CH3 and CH4 output channels):* Repeat this procedure for CH3 and CH4 outputs.

9. *End procedure:* Disconnect the oscilloscope.

Check Triggered Mode

Electrical Characteristic Checked: Operating modes, Triggered, on page 1-5.

Equipment Required: Two 50 Ω coaxial cables, a function generator, and an oscilloscope.

Prerequisites: The AWG2005 meets the prerequisites listed on page 4-7.

Procedure:

1. *Install the test hookup and set test equipment controls:*
 - a. *Hook up the oscilloscope:* Connect the AWG2005 CH1 output connector through the coaxial cable to the CH1 vertical input connector on the oscilloscope.
 - b. *Hook up the function generator:*
 - Connect the AWG2005 TRIGGER INPUT connector through a coaxial cable to the function generator output connector (see Figure 4-4).

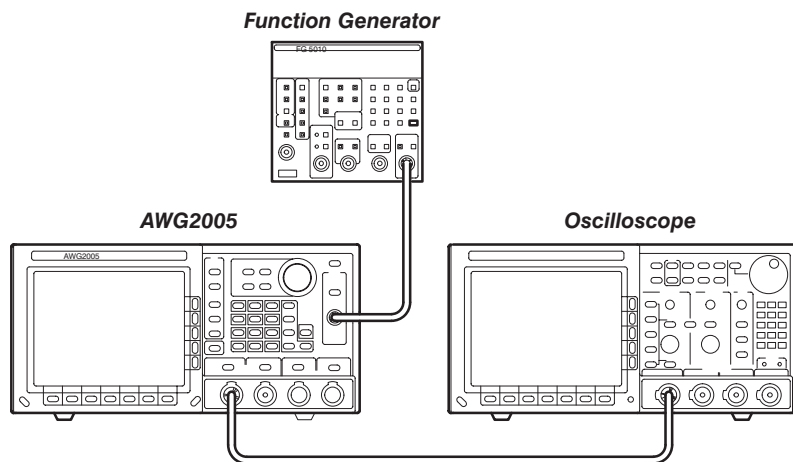

Figure 4-4: Triggered Mode Initial Test Hookup

- c. *Set the oscilloscope controls:*

Vertical:	CH1
CH1 coupling:	DC
CH1 scale	0.2 V/div.
CH1 input impedance:	50 Ω
Horizontal	
Sweep	50 μ s/div.

Trigger	
Source	CH1
Coupling	DC
Slope	Positive
Level	– 100 mV
Mode	Auto

d. *Set the function generator controls:*

Function	Square
Mode	Continuous
Parameter	
Frequency	1 kHz
Amplitude	4 V
Offset	2 V
Output	Off

2. *Set AWG2005 controls and select the waveform file:*

a. *Initialize AWG2005 controls:* Push **UTILITY**→**Misc**→**Config...**→**Reset to Factory**→**O.K.**

b. *Modify the AWG2005 default settings:*

- Push **MODE**→**Triggered**→**Slope** to select **Positive** slope.
- Select **Level** from the side menu and turn the general purpose knob to select a 1 V trigger level.

c. *Select the file:*

- Push **SETUP**→**Waveform Sequence**, if necessary, to select a waveform file for CH1. Waveform Sequence toggles between the CH1 files (upper list) and the CH2 files (lower list).
- Highlight the **MODE.WFM** file using the general purpose knob.
- Push **ENTER** to select the file.

3. *Turn on the AWG2005 CH1 output:* Push the **CH1** button so that the LED above the CH1 output connector is on.

4. *Check triggered mode with manual triggering:* Push the AWG2005 **MANUAL TRIGGER** button and check that when the button is pushed, the oscilloscope displays a one-cycle sine wave.

5. *Check triggered mode with external triggering:*

- a. Change the oscilloscope trigger mode to Normal.
- b. *Enable function generator output:* Turn on the function generator output.
- c. *Check triggering:* Check that for each trigger supplied by the function generator, the oscilloscope displays a one-cycle sine wave.

6. *End procedure:* Turn off the function generator output, and disconnect the function generator and oscilloscope.

Check Gated Mode

Electrical Characteristic Checked: Operating modes, Gated, on page 1-5.

Equipment Required: Three 50 Ω coaxial cables, a 50 Ω precision termination, a function generator, and an oscilloscope.

Prerequisites: The AWG2005 meets the prerequisites listed on page 4-7.

Procedure:

1. *Install test hookup and set test equipment controls:*
 - a. *Hook up the oscilloscope:* Connect the AWG2005 CH1 output connector through the coaxial cable to the CH1 vertical input connector on the oscilloscope.
 - b. *Hook up the function generator:* Connect the function generator output to both the AWG2005 TRIGGER INPUT and the oscilloscope CH2 input through a coaxial cable and a dual input coupler (see Figure 4-5).

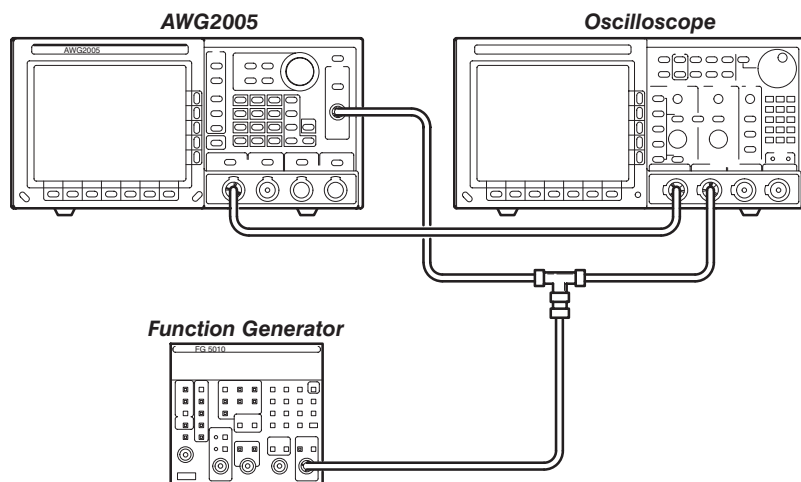

Figure 4-5: Gated Mode Initial Test Hookup

- c. *Set oscilloscope controls:*

Vertical	CH1
CH1 coupling	DC
CH1 scale	0.5 V/div.
CH1 input impedance	50 Ω

Horizontal	
Sweep	200 μ s/div.
Trigger	
Source	CH1
Coupling	DC
Slope	Positive
Level	500 mV
Mode	Auto

d. *Set function generator controls:*

Function	Square
Mode	Continuous
Parameter	
Frequency	1 kHz
Amplitude	4.0 V
Offset	2.0 V
Output	Off

2. *Set the AWG2005 controls and select the waveform file:*

a. *Initialize AWG2005 controls:* Push **UTILITY**→**Misc**→**Config...**→**Reset to Factory**→**O.K.**

b. *Modify the AWG2005 default settings:*

- Push **MODE**→**Gated**→**Polarity** to highlight **Positive**.

c. *Select the file:*

- Push **SETUP**→**Waveform Sequence**, if necessary, to select a waveform file for CH1. Waveform Sequence toggles between the CH1 files (upper list) and the CH2 files (lower list).
- Highlight the **MODE.WFM** file, using the general purpose knob.
- Push **ENTER** to select the file.

3. *Turn on the AWG2005 CH1 output:* Push the **CH1** button so that the LED above the CH1 output connector is on.

4. *Check gated mode with manual trigger:* Push and hold the AWG2005 **MANUAL TRIGGER** button, and check that the oscilloscope continuously displays a sine wave while the **MANUAL TRIGGER** button is pushed.

5. *Check gated mode with gate signal:*

a. *Change the oscilloscope controls:*

Vertical	CH1
CH1 coupling	DC
CH1 scale	0.5 V/div.
CH1 input impedance	50 Ω

Trigger Source CH1

- b. *Apply gate signal:* Turn function generator output on.
- c. *Check gated mode with positive gate signal:* Check that the oscilloscope displays a sine wave while the function generator gate signal level is in upper portion of the display (see Figure 4-6).

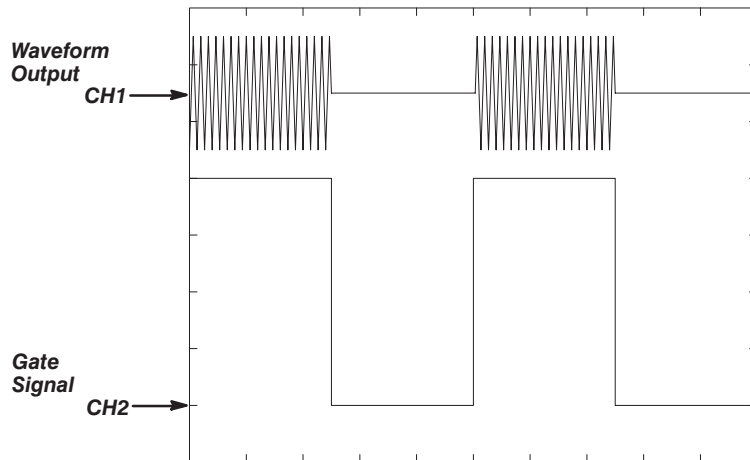

Figure 4-6: Relationship between 1 Volt or Greater Gate Signal and Waveform Output Signal

- d. *Change the AWG2005 trigger polarity to negative:* Push **MODE**→**Polarity** to change the polarity to **Negative**.
 - e. *Check gated mode with a negative gate signal:* Check that the oscilloscope displays a sine wave while the function generator gate signal level is in the lower portion of the display.
6. *End procedure:* Turn the function generator output off and disconnect the function generator.

Check Waveform Advance Mode

Electrical Characteristic Checked: Operating modes, Waveform Advance, on page 1-5.

Equipment Required: A 50 Ω coaxial cable and an oscilloscope.

Prerequisites: The AWG2005 meets the prerequisites listed on page 4-7.

Procedure:

1. *Install test hookup and set test equipment controls:*
 - a. *Hook up the oscilloscope:* Connect the AWG2005 CH1 output connector through the coaxial cable to the CH1 vertical input connector on the oscilloscope (see Figure 4-7).

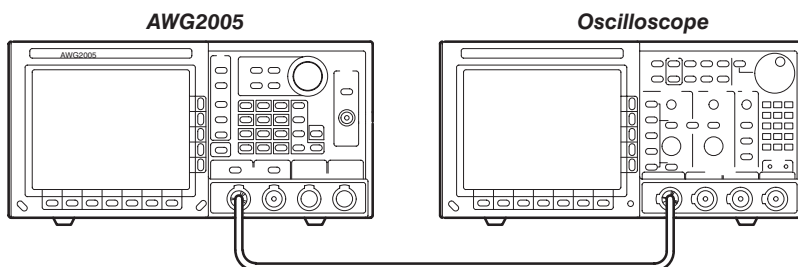
**Figure 4-7: Waveform Advance Mode Initial Test Hookup**

- b. *Set oscilloscope controls:*

Vertical	CH1
CH1 coupling	DC
CH1	0.2 V/div.
CH1 input impedance	50 Ω
Horizontal	
Sweep	50 μ s/div.
Trigger	
Source	CH1
Coupling	DC
Slope	Positive
Level	0 V
Mode	Auto

2. *Set the AWG2005 controls and select the waveform file:*
 - a. *Initialize AWG2005 controls:* Push **UTILITY**→**Misc**→**Config...**→**Reset to Factory**→**O.K.**
 - b. *Set AWG2005 controls:*
 - Push **MODE**→**Waveform Advance**→**Slope** to highlight **Positive**.
 - Select **Level** from the side menu, and turn the general purpose knob to select a 1.0 V level.
 - Check that the side menu **Run** highlights **Continuous**. If necessary, push **Run** to select **Continuous**.
 - c. *Select waveform file:*

- Push **SETUP**→**Waveform Sequence**, if necessary, to select a waveform file for CH1. Waveform Sequence toggles between the CH1 files (upper list) and the CH2 files (lower list).
 - Highlight the **MODE_ADV.SEQ** file using the general purpose knob.
 - Push **ENTER** to select the file.
3. *Turn on the AWG2005 CH1 output:* Push the **CH1** button so that the LED above the CH1 output connector is on.
 4. *Check waveform advance:* Repeatedly push the AWG2005 **MANUAL TRIGGER** button, and check that the oscilloscope displays a continuous sine wave that switches between two frequencies at each manual trigger.
 5. *End procedure:* Disconnect the oscilloscope.

Check Autostep Mode

Electrical Characteristic Checked: Operating mode, Autostep, on page 1-5.

Equipment Required: Two 50 Ω coaxial cables and an oscilloscope.

Prerequisites: The AWG2005 meets the prerequisites listed on page 4-7.

Procedure:

1. *Install test hookup and set test equipment controls:*
 - a. *Hook up the oscilloscope:*
 - Connect the AWG2005 CH1 output through a coaxial cable to the oscilloscope CH1 vertical input.
 - Connect the AWG2005 rear-panel CH1 MARKER OUT output through a coaxial cable to the oscilloscope CH2 vertical input (see Figure 4-8). The CH1 MARKER OUT signal will serve as an external trigger signal for the oscilloscope.

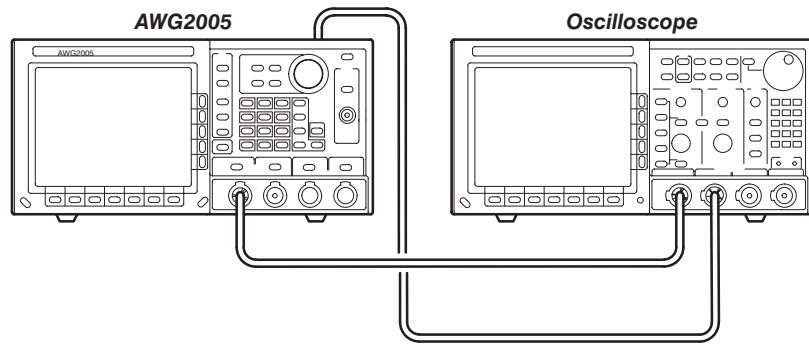

Figure 4-8: Autostep Mode Initial Test Hookup

b. *Set the oscilloscope controls:*

Vertical	CH1
CH1 coupling	DC
CH1 scale	0.5 V/div.
CH1 input impedance	50 Ω
Horizontal	
Sweep	50 μ s/div.
Trigger	
Source	CH2
Coupling	DC
Slope	Positive
Level	100 mV
Mode	Auto

2. *Set the AWG2005 controls and select the waveform file:*

a. *Initialize AWG2005 controls:* Push **UTILITY**→**Misc**→**Config...**→**Reset to Factory**→**O.K.**

b. *Modify AWG2005 default settings:*

- Push **MODE**→**Autostep**→**Slope** to highlight **Positive**.
- Push **Run** from the side menu to highlight **Continuous**.
- Select **Level** from the side menu, and turn the general purpose knob to select 1 V.
- Select **Select Autostep File** from the side menu.
- Turn the general purpose knob to highlight the **MODE_AST.AST** file.
- Push **ENTER** to select the file.

3. *Check autostep mode:* Push the AWG2005 **MANUAL TRIGGER** button and check that the oscilloscope momentarily displays a sine wave with a different frequency and amplitude each time you push the button.

4. *End procedure:* Disconnect the oscilloscope.

Arithmetic Operation Checks

These procedures check operation of external AM, external ADD, internal AM and internal Add arithmetic functions.

NOTE

The arithmetic operation checks are structured as a continuous series of tests. After Check External AM Operation, each test uses the control settings from the last test and uses the next step in the autostep file.

Check External AM Operation

Electrical Characteristic Checked: External amplitude modulation, page 1-13.

Equipment Required: Two 50 Ω coaxial cables, a 50 Ω terminator, a function generator, and a digital multimeter (DMM).

Prerequisites: The AWG2005 meets the prerequisites listed on page 4-7.

Procedure:

1. *Install test hookup and set test equipment controls:*
 - a. *Hook up DMM:* Connect the AWG2005 CH1 output through a coaxial cable, the 50 Ω terminator, and BNC-to-dual banana connector to the DMM INPUT connector.
 - b. *Hook up function generator:* Connect the AWG2005 rear-panel CH1 AM IN input through a coaxial cable to the function generator output (see Figure 4-9).

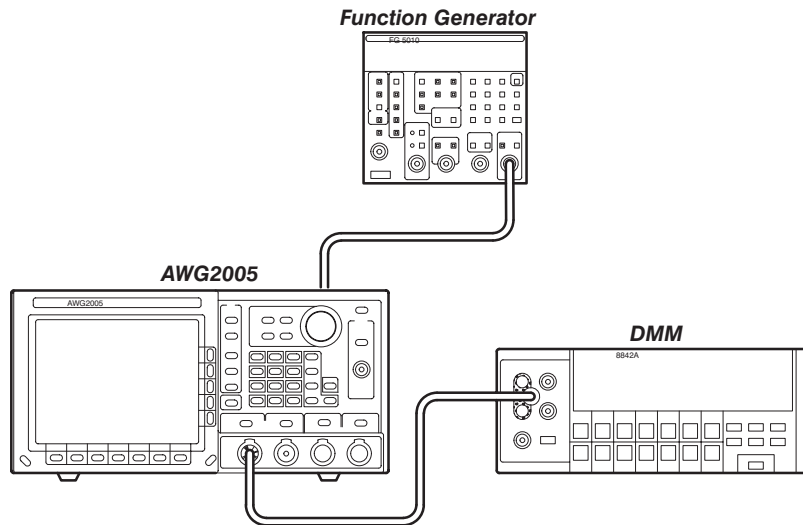

Figure 4-9: External AM Operation Initial Test Hookup

c. *Set DMM controls:*

Mode	VDC
Range	20
Inputs	Front

d. *Set function generator controls:*

Function	Square
Mode	Continuous
Parameter	
Frequency	1 kHz
Amplitude	0 V
Offset	1 V
Output	Off

2. *Set the AWG2005 controls and select the waveform file:*

a. *Initialize AWG2005 controls:* Push **UTILITY**→**Misc**→**Config...**→**Re-set to Factory**→**O.K.**

b. *Modify AWG2005 default settings:*

- Push **MODE**→**Autostep**.

c. *Select waveform file:*

- Select **Select Autostep File** from the side menu.
- Turn the general purpose knob to highlight the **OPE.AST** file.
- Push **ENTER** to select the file.

3. *Enable the function generator output:* Turn on the function generator output.
4. *Check external AM operation:*
 - Check that the step number displayed on the AWG2005 MODE menu is **Step: 1** (see Figure 4-10). If it is not, push **MANUAL TRIGGER** to step through the autostep file steps until Step 1 is displayed.

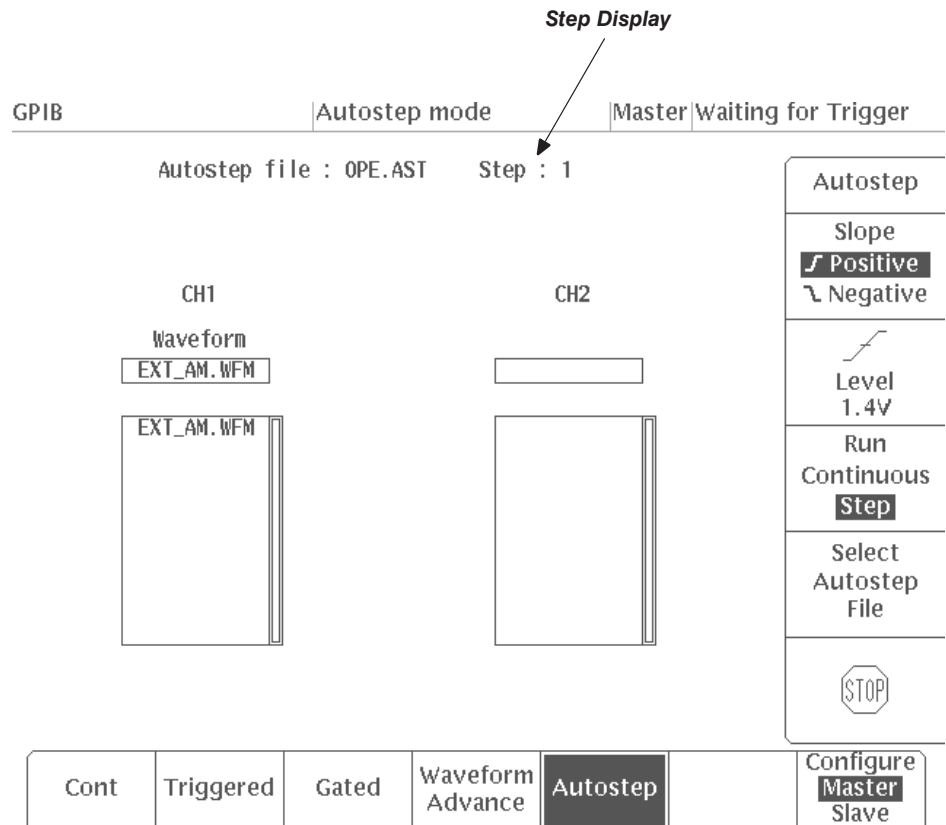

Figure 4-10: MODE Menu Autostep Setting

- Check that the DMM reading is in the range from 2.375 to 2.625 V (100% modulation).
 - Set the function generator offset value to 0 V. Check that the DMM reading is in the range from 1.125 to 1.375 V (50% modulation).
 - Set the function generator offset value to -1 V. Check that the DMM voltage reading is in the range from -0.125 to 0.125 V (0% modulation).
5. *End procedure:* Keep the test connections and instrument settings for the next check.

Check Internal AM Operation

Electrical Characteristic Checked: Arithmetic Operation, Amplitude Modulation, on page 1-13.

Equipment Required: Two 50 Ω coaxial cables, a function generator, and a digital multimeter (DMM).

Prerequisites: The AWG2005 meets the prerequisites listed on page 4-7.

Procedure:

1. *Use test hookup and control settings from previous check.*
2. *Check internal AM operation:*
 - a. *Check Autostep Step 2:*
 - Push the AWG2005 **MANUAL TRIGGER** button, and check that the step changes to Step 2 on the MODE menu.
 - Check that the DMM reading is in the range from 2.375 to 2.625 VDC.
 - b. *Check Autostep Step 3:*
 - Push the AWG2005 **MANUAL TRIGGER** button, and check that the Autostep changes to Step 3 on the MODE menu.
 - Check that the DMM reading is in the range from -2.625 to -2.375 V.
3. *End procedure:* Retain the test hookup and settings for the next check.

Check External ADD Operation

Electrical Characteristic Checked: Arithmetic Operation, Ext Add, on page 1-13.

Equipment Required: Two 50 Ω coaxial cables, a function generator, and a digital multimeter (DMM).

Prerequisites: The AWG2005 meets the prerequisites listed on page 4-7.

Procedure:

1. *Install test hookup and set test equipment controls:*
 - a. *Hook up function generator:* Move the connection for the coaxial cable from rear-panel CH1 AM IN to CH1 ADD IN connector. (see Figure 4-9).

b. *Set function generator controls:*

Function	Square
Mode	Continuous
Parameter	
Frequency	1 kHz
Amplitude	0 V
Offset	5.0 V
	(The actual voltage out is $1/2$ of what is displayed.)
Output	Off

2. *Enable the function generator output:* Turn on the function generator output.
3. *Check external ADD operation:*
 - a. *Check Autostep Step 4:*
 - Push the AWG2005 **MANUAL TRIGGER** button, and check that the step changes to Step 4 on the MODE menu.
 - Check that the DMM reading is in the range from 4.750 to 5.250 V.
4. *Disable function generator output:* Turn the function generator output off.
5. *End procedure:* Keep the test connections and instrument settings for the next check.

Check Internal Add Operation

Electrical Characteristic Checked: Arithmetic Operation, Add, on page 1-13.

Equipment Required: Two 50 Ω coaxial cables, a function generator, and a digital multimeter (DMM).

Prerequisites: The AWG2005 meets the prerequisites listed on page 4-7.

Procedure:

1. *Use test hookup and control settings from previous check.*
2. *Check internal ADD operation:*
 - a. *Check Autostep Step 5:*
 - Push the AWG2005 **MANUAL TRIGGER** button, and check that the step changes to Step 5 on the MODE menu.
 - Check that the DMM reading is in the range from 4.750 to 5.250 V.

3. *End procedure: Remove equipment:* Disconnect connections to the test equipment.

Clock Frequency and Amplitude Checks

These procedures check the accuracy of the AWG2005 clock frequency and the waveform output amplitude.

Check Clock Frequency Accuracy

Electrical Characteristic Checked: Clock Generator, Accuracy, on page 1-11.

Equipment Required: A 50 Ω coaxial cable and a frequency counter.

Prerequisites: The AWG2005 meets the prerequisites listed on page 4-7.

Procedure:

1. *Install test hookup and set test equipment controls:*
 - a. *Hook up frequency counter:* Connect the AWG2005 rear panel CLOCK OUT connector to the frequency counter input through a coaxial cable (see Figure 4-11).

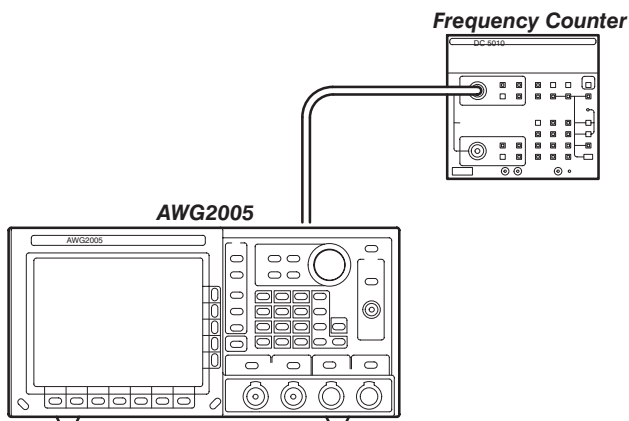

Figure 4-11: Clock Frequency Accuracy Initial Test Hookup

- b. *Set frequency counter controls:*

CHANNEL A	
Termination	50 Ω
Slope	Negative
Attenuation	X5
Coupling	DC

FREQ A

2. *Set AWG2005 controls and select the waveform:*
 - a. *Initialize AWG2005 controls:* Push **UTILITY**→**Misc**→**Config...**→**Reset to Factory**→**O.K.**
 - b. *Select the waveform file:*
 - Push **SETUP**→**Waveform Sequence**, if necessary, to select a waveform file for CH1. Waveform Sequence toggles between the CH1 files (upper list) and the CH2 files (lower list).
 - Turn the general purpose knob to select the **CLK_FREQ.WFM** file.
 - Push **ENTER** to select the file.
3. *Check clock frequency accuracy:*
 - a. *Check clock frequency accuracy at current clock frequency setting:* Check that the frequency counter reading falls between 19.9999 MHz and 20.001 MHz (between 19.9999 MHz and 20.0001 MHz for the instrument with Option 05).
 - b. *Check clock frequency accuracy for different clock frequency settings:*
 - Select **Clock** from the bottom of the **SETUP** menu.
 - Push **Source** from the side menu to highlight **Internal**.
 - Select **Internal Clock** from the side menu.
 - Turn the general purpose knob (or press the numeric and units keys, and push **ENTER**) to select the first clock frequency listed in Table 4-4.
 - Check that the frequency counter reading is within the frequency range listed in the table for the clock frequency setting (refer to right column in the table for the instrument with Option 05).
 - Repeat this step for each clock frequency and frequency range listed in Table 4-4.

Table 4-4: Clock Frequency Accuracy

Clock Frequency	Frequency Range	Frequency Range (Option 05)
10 MHz	9.9995 MHz – 10.0005 MHz	9.99995 MHz – 10.00005 MHz
1 MHz	0.99995 MHz – 1.00005 MHz	0.999995 MHz – 1.000005 MHz
1 kHz	0.99995 kHz – 1.00005 kHz	0.999995 kHz – 1.000005 kHz
10 Hz	9.9995 Hz – 10.0005 Hz	9.99995 Hz – 10.00005 Hz

4. *End procedure:* Disconnect the frequency counter.

Check Clock Amplitude

Electrical Characteristic Checked: Auxiliary Outputs, Clock, Amplitude, on page 1-14.

Equipment Required: A 50 Ω coaxial cable and an oscilloscope.

Prerequisites: The AWG2005 meets the prerequisites listed on page 4-7.

Procedure:

1. *Install test hookup and set test equipment controls:*
 - a. *Hook up oscilloscope:* Connect the AWG2005 rear-panel CLOCK OUT connector through a coaxial cable to the oscilloscope CH1 vertical input (see Figure 4-12).

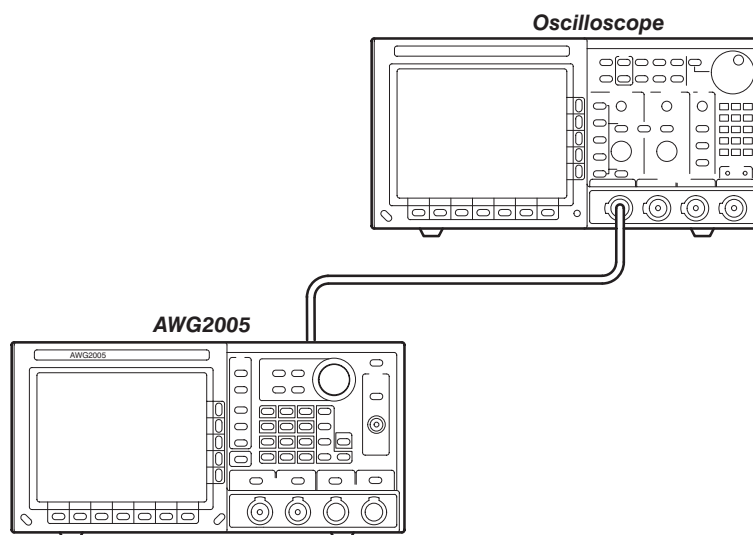

Figure 4-12: Clock Amplitude Initial Test Hookup

b. *Set oscilloscope controls:*

Vertical	CH1
Coupling	DC
Scale	500 mV/div.
Input impedance	50 Ω
Horizontal	
Sweep	500 ns/div.
Trigger	
Source	CH1
Coupling	DC
Slope	Positive
Level	500 mV
Mode	Auto

2. *Set the AWG2005 controls and select the waveform file:*

a. *Initialize AWG2005 controls:* Push **UTILITY**→**Misc**→**Config...**→**Reset to Factory**→**O.K.**

b. *Select the waveform file:*

- Push **SETUP**→**Waveform Sequence**, if necessary, to select a waveform file for CH1. Waveform Sequence toggles between the CH1 files (upper list) and the CH2 files (lower list).
- Turn the general purpose knob to select the **CLK_AMPL.WFM** file.
- Push **ENTER** to select the file.

3. *Turn on the AWG2005 CH1 output:* Push the **CH1** button so that the LED above the CH1 output connector is on.

4. *Check clock amplitude accuracy:* Check that the pulse amplitude of the displayed waveform is 2 V_{p-p} or greater.

5. *End procedure:* Disconnect the oscilloscope.

Gain Accuracy Check

This procedure checks the accuracy of the AWG2005 gain.

Electrical Characteristic Checked: Main Output, Amplitude, DC Accuracy, on page 1-12.

Equipment Required: A 50 Ω coaxial cable, a 50 Ω termination, a BNC-to-dual banana adapter, and a digital multimeter (DMM).

Prerequisites: The AWG2005 meets the prerequisites listed on page 4-7.

Procedure:

1. *Install test hookup and set controls:*
 - a. *Hook up DMM:* Connect the AWG2005 CH1 output through a 50 Ω coaxial cable, a 50 Ω termination, and a dual banana connector to the DMM INPUT connector (see Figure 4-13).

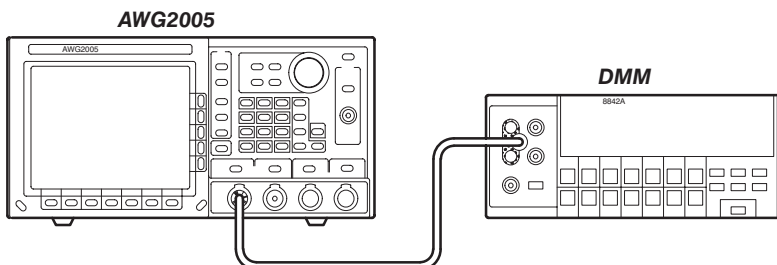
**Figure 4-13: Gain Accuracy Initial Test Hookup**

- b. *Set DMM controls:*

Mode	VDC
Range	20
Input	Front
2. *Set the AWG2005 controls and select the waveform file:*
 - a. *Initialize AWG2005 controls:* Push **UTILITY**→**Misc**→**Config...**→**Reset to Factory**→**O.K.**
 - b. *Select the AWG2005 waveform file:*
 - Push **MODE**→**Autostep**→**Select Autostep Fil.**
 - Turn the general purpose knob to select the **GAIN.AST** file.
 - Push **ENTER** to select the file.
3. *Check gain accuracy:*
 - Check that the displayed step is Step 1 on the MODE menu. If it is not, select the side menu **STOP** button to return to Step 1.
 - Note the DMM reading as "A" for this value.
 - Push the AWG2005 **MANUAL TRIGGER** button, and check that the displayed step is Step 2.
 - Note the DMM reading as "B" for this value.
 - Do the following calculation.

$$A - B$$
 - Check that the calculated value is in the range from 0.990 V to 1.010 V.

- Push the AWG2005 **MANUAL TRIGGER** button, and check that the displayed step is Step 3.
- Note the DMM reading as "C" for this value.
- Push the AWG2005 **MANUAL TRIGGER** button, and check that the displayed step is Step 4.
- Record the DMM reading as "D" for this value.
- Do the following calculation.

$$C - D$$

- Check that the calculated value is in the range from 9.850 V to 10.15 V.
4. Move the connection for the coaxial cable from the AWG2005 CH1 output to AWG2005 CH2 output connector.
 5. Repeat procedure 3.
 6. *If Option 02 is installed (adds CH3 and CH4 output channels):* Repeat above procedure for CH3 and CH4 outputs.
 7. *End procedure:* Retain the test hookup and control settings.

Offset Accuracy Check

This procedure checks the accuracy of the AWG2005 offset.

Electrical Characteristic Checked: Main Output, Offset, Accuracy, on page 1-12.

Equipment Required: A 50 Ω coaxial cable, a 50 Ω termination, BNC-to-dual banana adapter, and a digital multimeter (DMM).

Prerequisites: The AWG2005 meets the prerequisites listed on page 4-7.

Procedure:

1. *Install test hookup and set controls:*
 - a. *Hook up DMM:* Connect the AWG2005 CH1 output through a 50 Ω coaxial cable, a 50 Ω termination, and a dual banana connector to the DMM INPUT connector (see Figure 4-14).

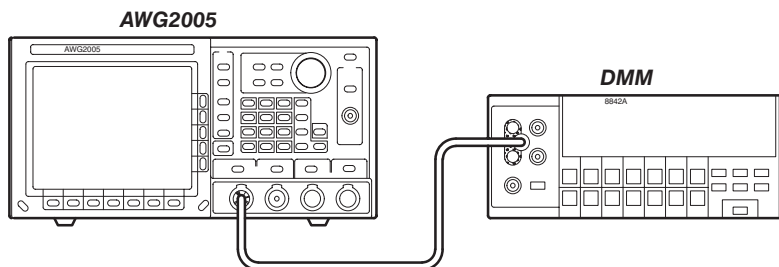

Figure 4-14: Offset Accuracy Initial Test Hookup

- b. Set DMM controls:

Mode	VDC
Range	20
Input	Front
2. Set the AWG2005 controls and select the waveform file:
 - a. Initialize AWG2005 controls: Push **UTILITY**→**Misc**→**Config...**→**Reset to Factory**→**O.K.**
 - b. Select the AWG2005 waveform file:
 - Push **MODE**→**Autostep**→**Select Autostep File**.
 - Turn the general purpose knob to select the **OFF.AST** file.
 - Push **ENTER** to select the file.
3. Check offset accuracy:
 - Check that the displayed step is Step 1 on the MODE menu. If it is not, select the side menu **STOP** button to return to Step 1.
 - Check that the DMM voltage reading is in the range from 4.940 to 5.060 V.
 - Push the AWG2005 **MANUAL TRIGGER** button, and check that the displayed step is Step 2.
 - Check that the DMM voltage reading is in the range from -0.010 to 0.010 V.
 - Push the AWG2005 **MANUAL TRIGGER** button, and check that the displayed step is Step 3.
 - Check that the DMM voltage reading is in the range from -5.060 to -4.940 V.
4. Move the connection for the coaxial cable from the AWG2005 CH1 output to AWG2005 CH2 output connector.
5. Repeat procedure 3.
6. If Option 02 is installed (adds CH3 and CH4 output channels): Repeat above procedure for CH3 and CH4 outputs.

7. *End procedure:* Disconnect the DMM.

Pulse Response Check

This procedure checks the pulse response characteristics of the AWG2005 output waveforms at amplitudes of 0.5 and 1 V.

Electrical Characteristic Checked: Main Output, Pulse Response, on page 1-12.

Equipment Required: A 50 Ω coaxial cable and an oscilloscope.

Prerequisites: The AWG2005 meets the prerequisites listed on page 4-7.

Procedure:

1. *Install test hookup and set test equipment controls:*
 - a. *Hook up the oscilloscope:* Connect the AWG2005 CH1 output connector through the coaxial cable to the CH1 vertical input connector on the oscilloscope (see Figure 4-15).

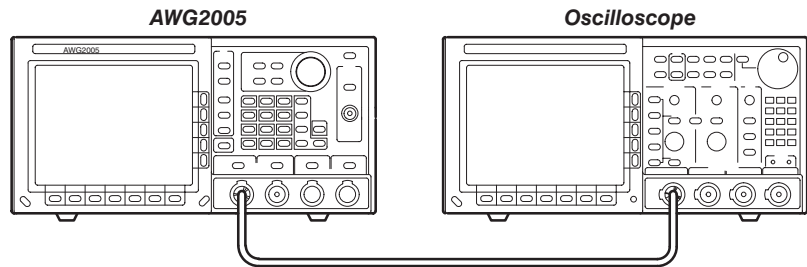

Figure 4-15: Pulse Response Initial Test Hookup

- b. *Set oscilloscope controls:*

Vertical	CH1
Coupling	DC
Scale	0.1 V/div.
Input impedance	50 Ω
Horizontal	
Sweep	20 ns/div.
Trigger	
Source	CH1
Coupling	DC
Slope	Positive
Level	0 V
Mode	Auto

2. *Set the AWG2005 controls and select the waveform file:*
 - a. *Initialize AWG2005 controls:* Push **UTILITY**→**Misc**→**Config...**→**Reset to Factory**→**O.K.**
 - b. *Select waveform file:*
 - Push **SETUP**→**Waveform Sequence**, if necessary, to select a waveform file for CH1. Waveform Sequence toggles between the CH1 files (upper list) and the CH2 files (lower list).
 - Turn the general purpose knob to select the **PULSE.WFM** file.
 - Push **ENTER** to select the file.
 - Select the **PULSE.WFM** file for CH2 same as CH1.
3. *Turn on the AWG2005 CH1 output:* Push the **CH1** button so that the LED above the CH1 output connector is on.
4. *Check pulse response at 0.5 V amplitude:*
 - a. *Check rise time:* Check that the rise time of the waveform displayed on the oscilloscope from the 10% point to the 90% point is 35 ns or less.
 - b. *Check aberrations:* Check that the aberrations of the displayed waveform is within 0.35 div.
 - c. *Check flatness:* Check that the flatness of the displayed waveform is within 0.15 div. after 20 ns from the rising edge.
 - d. *Change the oscilloscope controls:*

Trigger	Negative
Slope	
 - e. *Check fall time:* Check that the fall time of the displayed waveform from the 10% point to the 90% point is 35 ns or less.
5. *Check pulse response at 10 V amplitude:*
 - a. *Change the oscilloscope controls:*

Vertical	CH1
CH1 scale	2 V/div.
Trigger	
Slope	Positive
 - b. *Change the AWG2005 controls:*
 - Push **SETUP**→**Amplitude** to change the amplitude for CH1.
 - Press the numeric key **1, 0** and press the units key **V** to select an amplitude of 10 V.
 - c. *Repeat substeps 4a through 4e, checking to the follow limits:*

Rise time	35 ns, maximum
Aberrations	0.35 div., maximum

Flatness	0.15 div., maximum
Fall time	35 ns, maximum

6. Move the connection for the coaxial cable from the AWG2005 CH1 output to AWG2005 CH2 output connector.
7. *Turn on the AWG2005 CH2 output:* Push the **CH2** button so that the LED above the CH2 output connector is on.
8. Repeat procedures 4 through 5.
9. *If Option 02 is installed (add CH3 and CH4 output channels:* Repeat above procedure for the AWG2005 CH3 and CH4 output channels.
10. *End procedure:* Remove the connections.

MARKER OUT Amplitude Check

This procedure checks the amplitude of the MARKER OUT signal.

Electrical Characteristic Checked: Auxiliary Output, MARKER, Amplitude, on page 1-14.

Equipment Required: A 50 Ω coaxial cable and an oscilloscope.

Prerequisites: The AWG2005 meets the prerequisites listed on page 4-7.

Procedure:

1. *Install test hookup and set test equipment controls:*
 - a. *Hook up the oscilloscope:* Connect the AWG2005 rear-panel CH1 MARKER OUT connector through the coaxial cable to the CH1 vertical input connector on the oscilloscope (see Figure 4-16).

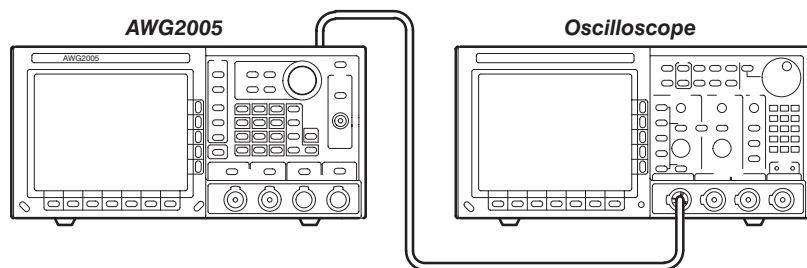

Figure 4-16: Initial Test Hookup

- b. *Set oscilloscope controls:*

Vertical	CH1
CH1 Coupling	DC
CH1 Scale	500 mV/div.
CH1 Input Impedance	50 Ω
Horizontal	
Sweep	50 μ s/div.
Trigger	
Source	CH1
Coupling	DC
Slope	Positive
Level	500 mV
Mode	Auto

2. *Set the AWG2005 controls and select the waveform file:*
 - a. *Initialize AWG2005 controls:* Push **UTILITY**→**Misc**→**Config...**→**Reset to Factory**→**O.K.**
 - b. *Select waveform file:*
 - Push **SETUP**→**Waveform Sequence**, if necessary, to select a waveform file for CH1. Waveform Sequence toggles between the CH1 files (upper list) and the CH2 files (lower list).
 - Turn the general purpose knob to highlight the **MRK.WFM** file.
 - Push **ENTER** to select the file.
3. *Check rear-panel CH1 MARKER OUT amplitude:*
 - a. *Check CH1 MARKER OUT pulse amplitude:*
 - Check that the pulse amplitude of the displayed waveform is 2 V_{p-p} or greater.
4. *Check rear-panel CH2 MARKER OUT pulse amplitude:*
 - a. *Check CH2 MARKER OUT pulse amplitude:*
 - Move the coaxial cable from the AWG2005 rear-panel CH1 MARKER OUT connector to the rear-panel CH2 MARKER OUT connector.
 - Check that the pulse amplitude of the displayed waveform is 2 V or greater.
5. *Check Option 02:* If the AWG2005 has CH3 and CH4, repeat this entire test, selecting the AWG2005 waveform and setting controls for CH3 and CH4 and checking:
 - Rear-panel CH3 MARKER pulse amplitude
 - Rear-panel CH4 MARKER pulse amplitude
6. *End procedure:* Disconnect the oscilloscope.

CONTROL SIG OUT Amplitude Check

This procedure checks the amplitude of the CONTROL SIG OUT signal.

Electrical Characteristic Checked: Auxiliary Output, CONTROL SIG, Amplitude, on page 1-14 .

Equipment Required: A 50 Ω coaxial cable and an oscilloscope.

Prerequisites: The AWG2005 meets the prerequisites listed on page 4-7.

Procedure:

1. *Install test hookup and set test equipment controls:*
 - a. *Hook up the oscilloscope:* Connect the AWG2005 rear-panel CONTROL SIG OUT connector through the coaxial cable to the CH1 vertical input connector on the oscilloscope (see Figure 4-17).

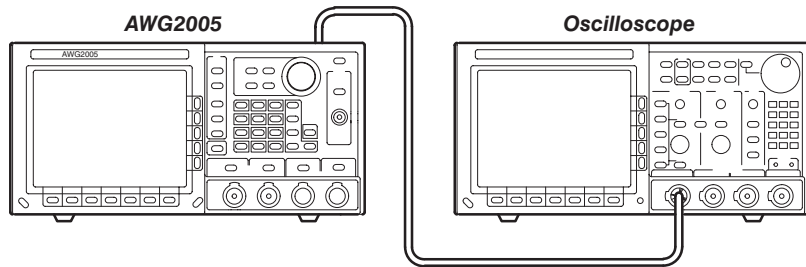

Figure 4-17: Initial Test Hookup

- b. *Set oscilloscope controls:*

Vertical	CH1
CH1 Coupling	DC
CH1 Scale	1 V/div.
CH1 Input Impedance	50 Ω
Horizontal	
Sweep	50 ns/div.
Trigger	
Source	CH1
Coupling	DC
Slope	Positive
Level	500 mV
Mode	Auto

2. *Set the AWG2005 controls and select the waveform file:*
 - a. *Initialize AWG2005 controls:* Push **UTILITY**→**Misc**→**Config...**→**Reset to Factory**→**O.K.**

- b. *Select waveform file:*
 - Push **SETUP**→**Waveform Sequence**, if necessary, to select a waveform file for CH1. Waveform Sequence toggles between the CH1 files (upper list) and the CH2 files (lower list).
 - Turn the general purpose knob to highlight the **CNTRL.WFM** file.
 - Push **ENTER** to select the file.
3. *Check rear-panel CONTROL SIG OUT amplitude:*
 - a. *Check CONTROL SIG OUT pulse amplitude:*
 - Push **Mode**→**Gated**.
 - Push the AWG2005 **MANUAL TRIGGER** button.
 - Check that the pulse upper level of the displayed waveform is 2 V or greater.
 - Check that the pulse lower level of the displayed waveform is 0.8 V or less.
4. *End procedure:* Disconnect the oscilloscope.

External Trigger Level Accuracy Check

This procedure checks the external trigger level accuracy of the AWG2005.

Electrical Characteristic Checked: Auxiliary Input, TRIGGER, Accuracy, on page 1-15.

Equipment Required: Two 50 Ω coaxial cables, a function generator, and an oscilloscope.

Prerequisites: The AWG2005 meets the prerequisites listed on page 4-7.

Procedure:

1. *Install test hookup and set test equipment controls:*
 - a. *Hook up oscilloscope:* Connect the AWG2005 CH1 output through a coaxial cable to the oscilloscope CH1 vertical input.
 - b. *Hook up function generator:* Connect the AWG2005 TRIGGER INPUT through a coaxial cable to the function generator output (see Figure 4-18).

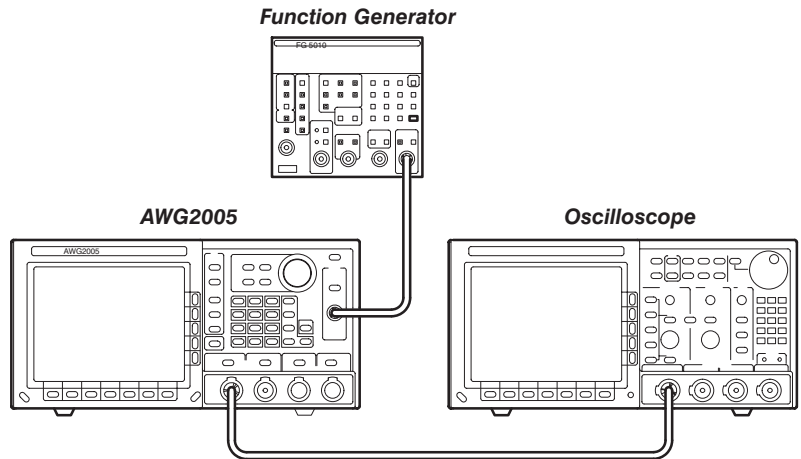

Figure 4-18: External Trigger Level Accuracy Initial Test Hookup

c. Set oscilloscope controls:

Vertical	CH1
CH1 Coupling	DC
CH1 Scale	0.2 V/div.
CH1 Input Impedance	50 Ω
Horizontal	
Sweep	50 μs/div.
Trigger	
Source	CH1
Coupling	DC
Slope	Positive
Level	0 V
Mode	Auto

d. Set function generator controls:

Function	Square
Mode	Continuous
Parameter	
Frequency	1 kHz
Amplitude	0 V
Offset	0.6 V
Output	Off

2. Select the AWG2005 waveform file and set AWG2005 controls:

- a. Initialize AWG2005 controls: Push **UTILITY**→**Misc**→**Config...**→**Reset to Factory**→**O.K.**
- b. Modify AWG2005 default settings:
 - Push **MODE**→**Gated**→**Polarity** to highlight **Positive**.

6. *End procedure:* Turn off the function generator output and disconnect the function generator.

External CLOCK IN Check

This procedure checks the AWG2005 response to an external CLOCK IN signal.

Electrical Characteristic Checked: Auxiliary Input, CLOCK, Threshold level, on page 1-15.

Equipment Required: Two 50 Ω coaxial cables, a function generator, and an oscilloscope.

Prerequisites: The AWG2005 meets the prerequisites listed on page 4-7.

Procedure:

1. *Install test hookup and set test equipment controls:*
 - a. *Hook up oscilloscope:* Connect the AWG2005 CH1 output through a coaxial cable to the oscilloscope CH1 vertical input.
 - b. *Hook up function generator:* Connect the AWG2005 rear-panel **CLOCK IN** through a coaxial cable to the function generator output (see Figure 4-19).

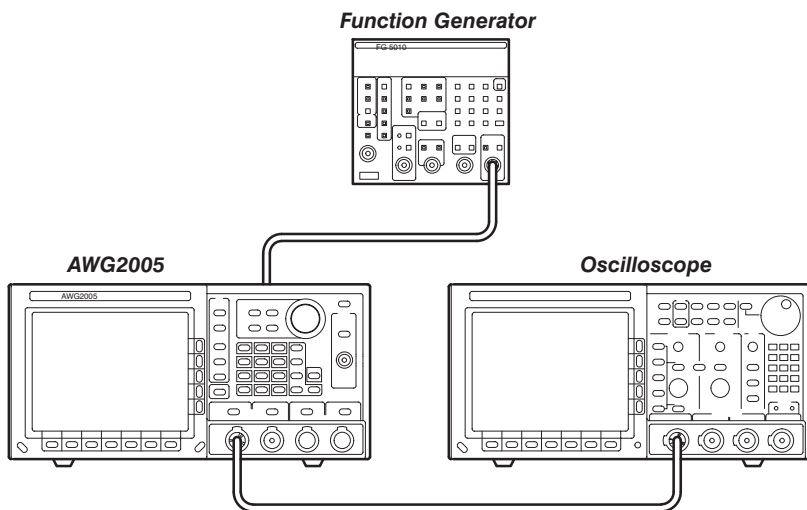

Figure 4-19: External CLOCK IN Initial Test Hookup

- c. *Set oscilloscope controls:*

Vertical	CH1
Coupling	DC
Scale	0.2 V/div.
Input Impedance	50 Ω
Horizontal	
Sweep	500 μ s/div.
Trigger	
Source	CH1
Coupling	DC
Slope	Positive
Level	0 mV
Mode	Auto

d. *Set function generator controls:*

Function	Square
Mode	Continuous
Parameter	
Frequency	1 MHz
Amplitude	2.0 V
Offset	1.0 V
Output	Off

2. *Select the AWG2005 waveform file and set AWG2005 controls:*

a. *Initialize AWG2005 controls:* Push **UTILITY**→**Misc**→**Config...**→**Reset to Factory**→**O.K.**

b. *Select waveform file:*

- Push **SETUP**→**Waveform Sequence**, if necessary, to select a waveform file for CH1. Waveform Sequence toggles between the CH1 files (upper list) and the CH2 files (lower list).
- Turn the general purpose knob to highlight the **EXT_CLK.WFM** file.
- Push **ENTER** to select the file.

3. *Turn on the AWG2005 CH1 output:* Push the **CH1** button so that the LED above the CH1 output connector is on.

4. *Check the external CLOCK IN threshold level:*

- a. *Enable function generator output:* Turn on function generator output.
- b. *Check the level:* Check that the waveform displayed on the oscilloscope has an amplitude of 5 divisions and a stable display of 5 cycles.

5. *Turn off equipment output and disconnect test hookup:*

- a. *Disable function generator output:* Turn off function generator output.
- b. *Remove connections:* Disconnect all connections to the AWG2005.

Optional Check – Master-Slave Operation Check

This procedure checks operation of the AWG2005 slave mode.

NOTE

This Slave Operation check has been factory verified. The check is performed only as necessary or only after a failure.

Electrical Characteristic Checked: Auxiliary Input, CONTROL SIG IN, Threshold level, Pulse Width, Input Volts, on page 1-15.

Equipment Required: Two 50 Ω coaxial cables, a function generator, and an oscilloscope.

Prerequisites: The AWG2005 meets the prerequisites listed on page 4-7.

Procedure:

1. *Install test hookup and set test equipment controls:*
 - a. *Hook up master AWG2005:* Connect the slave AWG2005 (device under test) rear-panel **CONTROL SIG IN** and **CLOCK IN** connectors to the master AWG2005 **CONTROL SIG OUT** and **CLOCK OUT** connectors using the two coaxial cables.
 - b. *Hook up oscilloscope:* Connect the master AWG2005 CH1 output and slave AWG2005 CH1 output to the oscilloscope CH1 and CH2 vertical inputs using the two coaxial cables (see Figure 4-20).

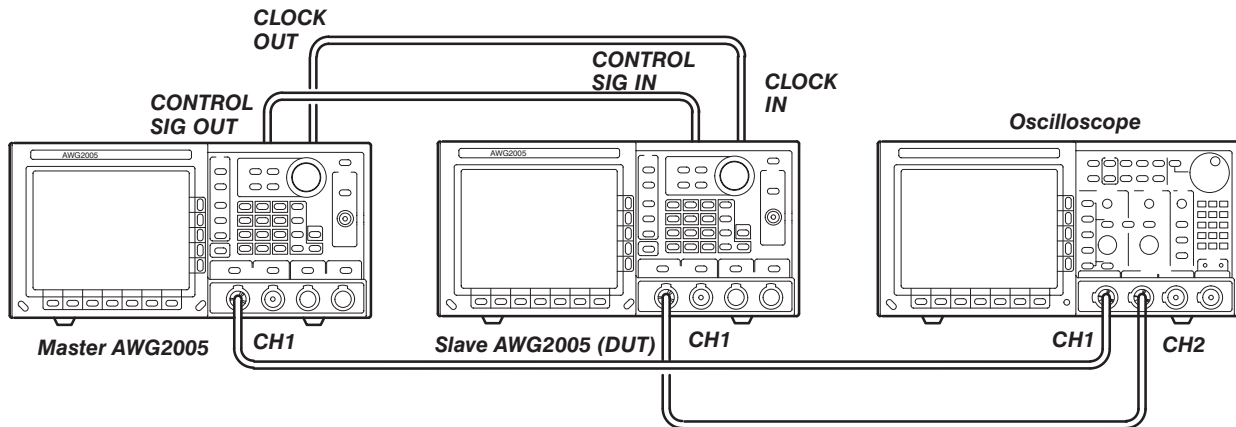

Figure 4-20: Slave Operation Initial Test Hookup

- c. *Set oscilloscope controls:*

Vertical	CH1 and CH2
Coupling	DC
Scale	0.2 V/div.
Input Impedance	50 Ω
Horizontal	
Sweep	500 μ s/div.
Trigger	
Source	CH1
Coupling	DC
Slope	Positive
Level	0 mV
Mode	Auto
Output	Off

2. *Select the master AWG2005 waveform file and set master AWG2005 controls:*
 - a. *Initialize master AWG2005 controls:* Push **UTILITY**→**Misc**→**Config...**→**Reset to Factory**→**O.K.**
 - b. *Load waveform file:* Load the **CNTRL_IN.WFM** file only to the master AWG2005 using the performance check disk. For details on how to load a file, see the Instruction for Operation in the section 2.
 - c. *Set waveform file:*
 - Push **SETUP**→**Waveform Sequence**, if necessary, to select a waveform file for CH1. Waveform Sequence toggles between the CH1 files (upper list) and the CH2 files (lower list).
 - Turn the general purpose knob to display the list of waveform files and highlight the **SLAVE.WFM** file.
 - Push **ENTER** to select the file.
 - Push **MODE**→**Triggered**.
 - Press the bottom **Configure** button to select **Master**.
3. *Select the slave AWG2005 waveform file and set slave AWG2005 controls:*
 - a. *Initialize slave AWG2005 controls:* Push **UTILITY**→**Misc**→**Config...**→**Reset to Factory**→**O.K.**
 - b. *Select waveform file:*
 - Push **SETUP**→**Waveform Sequence**, if necessary, to select a waveform file for CH1. Waveform Sequence toggles between the CH1 files (upper list) and the CH2 files (lower list).
 - Turn the general purpose knob to highlight the **SLAVE.WFM** file.
 - Push **ENTER** to select the file.
 - Push **MODE**→**Cont**.

- Press the bottom **Configure** button to select **Slave**.
- 4. *Turn on CH1 output on both AWG2005 instruments* : Push the **CH1** button so that the LED above the CH1 output connector is on.
- 5. *Check the slave operation:*
 - a. Change the master AWG2005 operation mode from **Triggered** to **Cont**.
 - b. *Check the operation:* Check that the two waveforms displayed on the oscilloscope have a same timing relation and a stable display.
- 6. *Disconnect test hookup:*
 - a. *Remove connections:* Disconnect all connections to the both AWG2005 instruments and oscilloscope.

DIGITAL DATA OUT Check (Option 04)

This procedure checks the AWG2005 DIGITAL DATA OUT at the rear panel.

NOTE

This check requires that the AWG2005 has Option 04 installed.

Electrical Characteristic Checked: Auxiliary Output, DIGITAL DATA OUT, Level, on page 1-14.

Equipment Required: Digital data out cable, 2 X13 header, probe and oscilloscope.

Prerequisites: The AWG2005 meets the prerequisites listed on page 4-7.

Procedure:

1. *Install test hookup and set test equipment controls:*
 - a. *Hook up termination board:* Connect a digital data output cable to the AWG2005 rear-panel **CH1 DIGITAL DATA OUT** output (see Figure 4-21).
 - b. *Hook up oscilloscope:*
 - Connect the oscilloscope probe to the CH1 vertical input.
 - Connect the probe ground-clip to the GND pin of 2 X13 header.

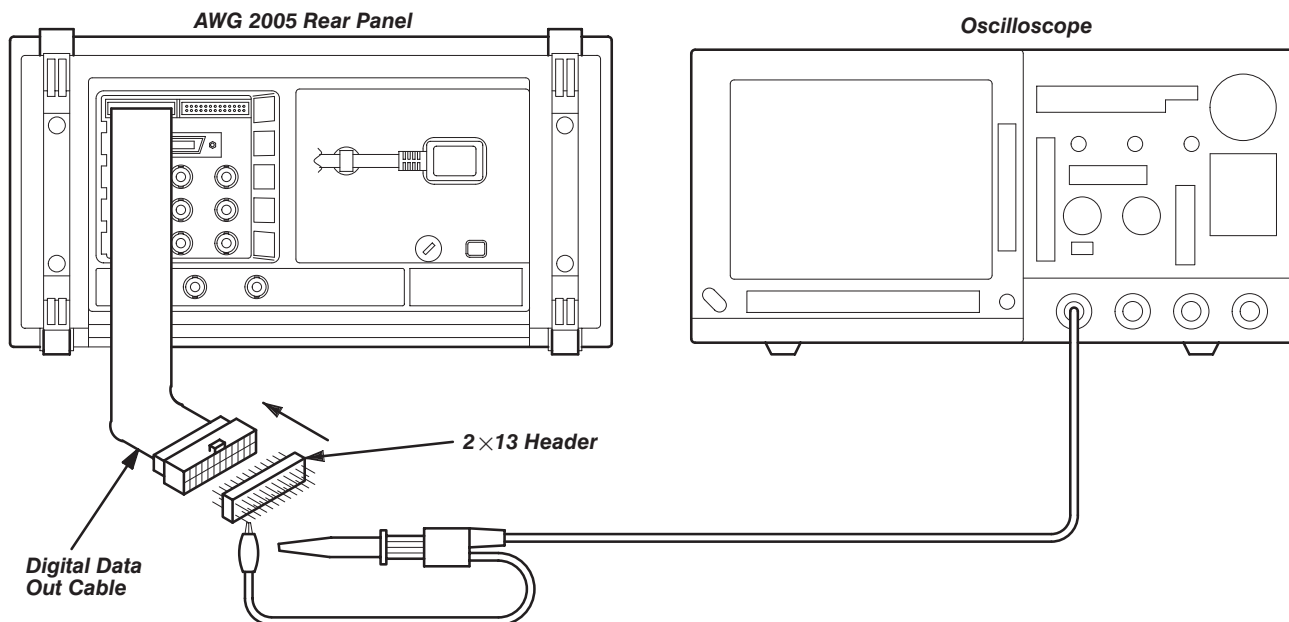

Figure 4-21: Digital Data Out Initial Test Hookup

c. Set oscilloscope controls:

Vertical	CH1
Scale	1 V/div.
Input Impedance	1 M Ω
Horizontal	
Sweep	Adjust as needed
Trigger	
Mode	Auto

2. Create the AWG2005 waveform file, select waveform file, and set AWG2005 controls:

a. Initialize AWG2005 controls: Push **UTILITY**→**Misc**→**Config...**→**Reset to Factory**→**O.K.**

b. Select waveform file:

- Push **SETUP**→**Waveform Sequence**, if necessary, to select a waveform file for CH1. Waveform Sequence toggles between the CH1 files (upper list) and the CH2 files (lower list).
- Turn the general purpose knob to highlight the **DIGI_OUT.WFM** file.
- Push **ENTER** to select the file.

c. Set AWG2005 controls:

- Push **MODE**→**Cont**

3. Check the CH1 digital data output signals:

a. *Check the signal levels:*

- Contact the oscilloscope probe to the pins on 2 X13 header (see Figure 4-22). Check that the oscilloscope display shows these signals:
 - Data signals D0-D11 and CLK (Clock) are TTL level output.
 - All other pins are ground.

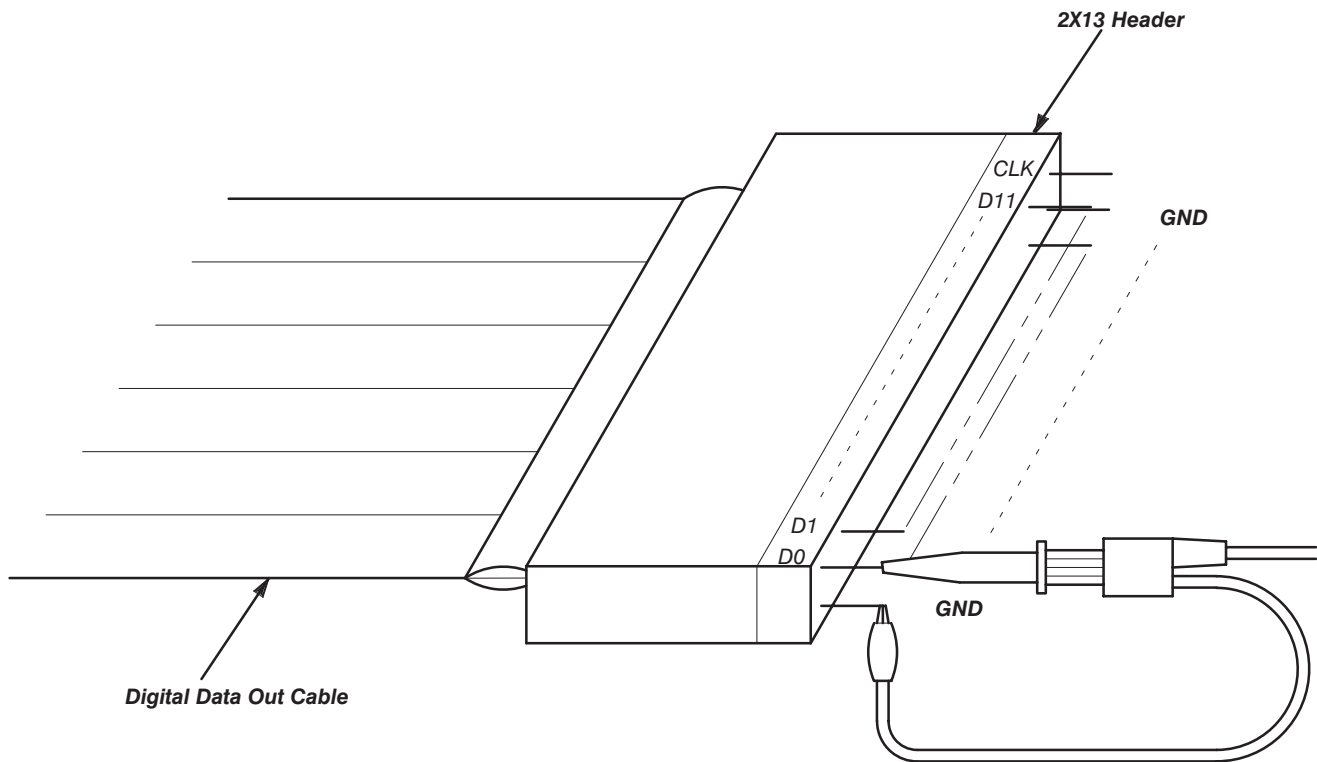

Figure 4-22: Output Pins on the Digital Data Out Cable

4. *Check the CH2 digital data output signals:*

- a. *Change connection:* Change the connection for the digital data out cable from CH1 DIGITAL DATA OUT connector to CH2 DIGITAL DATA OUT connector.
- b. Repeat the step 2 and 3 to check the CH2 digital data output signals.

5. *Turn off equipment output and disconnect test hookup:*

- a. *Disable power supply output:* Turn off power supply output.
- b. *Remove connections:* Disconnect all connections to the AWG2005.

Floating Point Processor Check (Option 09)

This procedure checks the AWG2005 floating point processor.

NOTE

This check requires that the AWG2005 has Option 09 installed.

Equipment Required: None.

Prerequisites: The AWG2005 meets the prerequisites listed on page 4-7.

Procedure:

1. *Check that floating point processor test in internal diagnostics passes:*
 - a. *Run the AWG2005 internal diagnostics:* Push the AWG2005 **ON/STBY** switch two times so that the AWG2005 runs the power-on diagnostics.
 - b. *Check the FPP test results:* When the AWG2005 finishes the FPP test, check that the test result is Pass.

This completes the performance tests for the AWG2005.

Adjustments

The AWG2005 doesn't need manual adjustment since it is equipped with a self calibration system.. This internal calibration enables the instrument to automatically adjust the gain and offset of the pre-amp, the gain error of filter, the attenuation rate of attenuator, as well as several other parameters.

Perform the internal calibration to return the AWG2005 to conformance with performance specified in section 1, *Specifications*. As for the internal calibration, see the subsection, *Self Tests*, in section 4.

Adjustment Interval — Generally, this internal calibration should be done every 12 months.

Adjustment After Repair — Perform the internal calibration after the removal and replacement of a module due to electrical failure.

Before Adjustments

Before Maintenance

This section contains the information needed to do periodic and corrective maintenance on the AWG2005 Arbitrary Waveform Generator. Specifically, the following subsections are included:

- *Before Maintenance* — This subsection includes general information on preventing damage to internal modules when doing maintenance.
- *Inspection and Cleaning* — Information and procedures for inspecting the AWG2005 and cleaning its external and internal modules.
- *Removal and Installation Procedures* — How to remove defective modules and replace new or repaired modules.
- *Repackaging* — Information on packaging the AWG2005 properly for shipment.
- *Troubleshooting* — Information on isolating failed modules. Included are instructions on operating the AWG2005 internal diagnostic routines and troubleshooting flowcharts for fault isolation. Most of the flowcharts use the internal diagnostic routines to speed fault isolation to a specific module.

Prerequisites

Before performing any of the procedures in the *Maintenance* section, note the following:

- Only trained service technicians should perform these procedures.
- Read the *Safety Summary* located near the beginning of this manual.
- Read the *Strategy for Servicing* in the frontmatter introduction.
- Read section 2, *Operating Information*.

Preventing ESD



Static discharge can damage any semiconductor component in the AWG2005.

Precautions

When performing service which requires internal access to the AWG2005, follow these precautions to avoid damaging internal modules and their components due to electrostatic discharge (ESD).

1. Minimize handling of static-sensitive modules.
2. Transport and store static-sensitive modules in their static-protected containers or on a metal rail. Label any package that contains static-sensitive modules.
3. Discharge the static voltage from your body by wearing a grounded antistatic wrist strap while handling these modules. Only service static-sensitive modules at a static-free work station.
4. Do not remove the AWG2005 cabinet unless you have met precaution number 3, above. Consider all internal modules static-sensitive.
5. Do not allow anything capable of generating or holding a static charge on the work station surface.
6. Handle circuit boards by the edges when possible.
7. Do not slide the modules over any surface.
8. Avoid handling modules in areas that have a floor or work-surface covering capable of generating a static charge.
9. Do not use high-velocity compressed air when cleaning dust from modules.

Susceptibility to ESD

Table 6-1 lists the relative susceptibility of various classes of semiconductors. Static voltages of 1 kV to 30 kV are common in unprotected environments.

Table 6-1: Relative Susceptibility to Static-discharge Damage

Semiconductor Classes	Relative Susceptibility Levels¹
MOS or CMOS microcircuits or discrete circuits, or linear microcircuits with MOS inputs (most sensitive)	1
ECL	2
Schottky signal diodes	3
Schottky TTL	4
High-frequency bipolar transistors	5
JFET	6
Linear microcircuits	7
Low-power Schottky TTL	8
TTL (least sensitive)	9

¹Voltage equivalent for levels (voltage discharged from a 100 pF capacitor through resistance of 100 Ω):

1 = 100 to 500 V	6 = 600 to 800 V
2 = 200 to 500 V	7 = 400 to 1000 V (est.)
3 = 250 V	8 = 900 V
4 = 500 V	9 = 1200 V
5 = 400 to 600 V	

Before Maintenance

Inspection and Cleaning

This subsection describes how to determine whether the AWG2005 needs cleaning, and how to do the cleaning. Inspection and cleaning are preventive maintenance procedures. When done regularly, preventive maintenance may prevent AWG2005 malfunction and enhance reliability.

Preventive maintenance consists of visually inspecting and cleaning the AWG2005 and using general care when operating it.

How often to do maintenance depends on the severity of the environment in which the AWG2005 operates.

General Care

The cabinet helps keep dust out of the AWG2005 and is a major component of the instrument cooling system. The cabinet should normally be in place when operating the AWG2005. The AWG2005 front cover (optional accessory) protects the front panel and display from dust and damage. Install it when storing or transporting the instrument.

Inspection and Cleaning Procedures

Inspect and clean the AWG2005 as operating conditions require. The collection of dirt on components inside can cause them to overheat and break down. (Dirt acts as an insulating blanket, preventing efficient heat dissipation.) Dirt also provides an electrical conduction path that can cause an instrument failure, especially under high-humidity conditions.

WARNING

To avoid personal injury or death due to electric shock, unplug the power cord from the line voltage source before cleaning the AWG2005.



To prevent damaging the plastics used in the AWG2005 do not use chemical cleaning agents. Use only deionized water when cleaning the menu buttons or front-panel buttons. Use a ethyl alcohol solution as a cleaner, and rinse with deionized water.

To prevent damaging AWG2005 components, do not use high-pressure compressed air when cleaning dust from the interior of the AWG2005. (High pressure air can cause electrostatic discharge.) Instead, use low pressure compressed air (about 9 psi).

Inspection — Exterior

Inspect the outside of the AWG2005 for damage, wear, and missing parts, using Table 6-2 as a guide. If the AWG2005 appears to have been dropped or otherwise abused, check it thoroughly to verify correct operation and performance. Repair any defects that may cause personal injury or lead to further damage to the AWG2005.

Table 6-2: External Inspection Check List

Item	Inspect For	Repair Action
Cabinet, front panel, and cover	Cracks, scratches, deformations, damaged hardware or gaskets.	Replace defective module.
Front-panel knobs	Missing, damaged, or loose knobs.	Repair or replace missing or defective knobs.
Connectors	Broken shells, cracked insulation, and deformed contacts. Dirt in connectors.	Replace defective modules. Clear or wash out dirt.
Carrying handle, cabinet, feet	Correct operation.	Replace defective module.
Accessories	Missing items or parts of items, bent pins, broken or frayed cables, and damaged connectors.	Replace damaged or missing items, frayed cables, and defective modules.

Cleaning Procedure — Exterior

WARNING

To avoid potential electric shock hazard or damage to the AWG2005 circuits, do not allow any moisture inside the AWG2005 during external cleaning; use only enough liquid to dampen the cloth or applicator.

1. Remove loose dust on the outside of the AWG2005 with a lint free cloth.
2. Remove remaining dirt with a lint free cloth dampened in a general purpose detergent-and-water solution. Do not use abrasive cleaners.
3. Clean the light filter protecting the monitor screen with a lint-free cloth dampened with either ethyl alcohol or, preferably, a gentle general-purpose detergent-and-water solution.

Inspection — Interior

To access the inside of the AWG2005 for inspection and cleaning, refer to the *Removal and Installation Procedures* in this section.

Inspect the internal portions of the AWG2005 for damage and wear, using Table 6-3 as a guide. Repair any defects immediately.

CAUTION

To prevent damage from electrical arcing, ensure that circuit boards and components are dry before applying power to the AWG2005.

Table 6-3: Internal Inspection Check List

Item	Inspect For	Repair Action
Circuit boards	Loose, broken or corroded solder connections. Burned circuit boards. Burned, broken, or cracked circuit-run plating.	Remove failed modules and replace with a new module.
Resistors	Burned, cracked, broken blistered condition.	Replace failed module and replace with a new module.
Solder connections	Cold solder or rosin joints.	Resolder joint and clean with ethyl alcohol.

Resolder joint and clean with ethyl alcohol.

Table 6-3: Internal Inspection Check List (Cont.)

Item	Inspect For	Repair Action
Capacitors	Damaged or leaking cases. Corroded solder on leads or terminals.	Remove damaged module and replace with a new module from the factory.
Semiconductors	Loosely inserted in sockets. Distorted pins.	Firmly seat loose semiconductors. Remove devices that have distorted pins. Carefully straighten pins (as required to fit the socket), using long-nose pliers, and reinsert firmly. Ensure that straightening action does not crack pins, causing them to break off.
Wiring and cables	Loose plugs or connectors. Burned, broken, or frayed wiring.	Firmly seat connectors. Repair or replace modules with defective wires or cables.
Chassis	Dents, deformations, and damaged hardware.	Straighten, repair, or replace defective hardware.

Cleaning Procedure — Interior

If, after doing steps 1 and 2, a module is clean upon inspection, skip the remaining steps.

1. Blow off dust with dry, low-pressure, deionized air (approximately 9 psi).
2. Remove any remaining dust with a lint-free cloth dampened in ethyl alcohol, and rinse with a warm deionized water. (A cotton-tipped applicator is useful for cleaning in narrow spaces and on circuit boards.)
3. If steps 1 and 2 do not remove all the dust or dirt, the AWG2005 may be spray washed using a solution of ethyl alcohol by doing step 4 through 8.
4. Gain access to the parts to be cleaned by removing easily accessible shields and panels (see *Removal and Installation Procedures* in this section).
5. Spray wash dirty parts with the ethyl alcohol, and wait 60 seconds for the majority of the alcohol to evaporate.
6. Use hot (120° F to 140° F) deionized water to thoroughly rinse them.
7. Dry all parts with low-pressure, deionized air.
8. Dry all components and assemblies in an oven or drying compartment using low-temperature (125° F to 150° F) circulating air.

Lubrication

There is no periodic lubrication required for the AWG2005.

Removal and Installation Procedures

This subsection describes removing and installing the mechanical and electrical modules in the AWG2005.

Preparation

This subsection contains the following:

- Preparatory information
- A list of equipment required in removing modules
- Module locator diagrams for finding each module in the AWG2005
- Procedures for removing and reinstalling electrical and mechanical modules

WARNING

To avoid possible personal injury or damage to AWG2005 components, read the Preparation for Use subsection in section 2, and Preventing ESD in the subsection, Before Maintenance. Read the Safety Summary found near the beginning of this manual before doing any procedure in this manual.

To avoid possible personal injury or death, disconnect the power cord from the line voltage source before doing any procedures in this section.

List of Mechanical Parts

Section 10, *Mechanical Parts List*, lists all mechanical parts in the AWG2005.

General Instructions

NOTE

Read these general instructions before removing a module.

First read the *Summary of Procedures* to understand how the procedures are organized. Then read *Equipment Required* to find out the tools needed to remove and install modules.

To remove a module, begin by doing the *Access Procedure* (on page 6-13). By following the instructions in that procedure, you can remove the desired module without unnecessarily removing other modules.

Summary of Procedures

The *Access Procedure* on page 6-13 identifies the procedure for removing each module. These categories separate the procedures based on their location in the AWG2005.

- *Procedures for External Modules* on page 6-16 describes how to remove modules without internal access to the AWG2005.
- *Procedures for Internal Modules* on page 6-28 describes how to remove modules which require internal access to the AWG2005.

Equipment Required

The removal of most modules in the AWG2005 requires only a screwdriver handle mounted with a size T-15, Torx® screwdriver tip. Use this tool whenever a procedure step instructs you to remove or install a screw, unless a different size screwdriver is specified in that step. The first step of a module procedure lists all equipment required to remove and reinstall the module.

Table 6-4: Equipment Required

Name	Description	Part Number
Screwdriver handle	Accepts Torx-driver bits	003-0524-00
T-9 Torx tip	Torx-driver bit for T-9 size screw heads	003-0965-00
T-10 Torx tip	Torx-driver bit for T-10 size screw heads	003-0815-00
T-15 Torx tip	Torx-driver bit for T-15 size screw heads	003-0966-00
#1 Phillips tip	Phillips-driver bit for #1 size screw heads	003-0335-00
Flat-bladed screwdriver	Screwdriver for removing standard-headed screws	
Hex wrench, 0.050 inch	Standard tool	
Hex wrench, $\frac{1}{16}$ inch	Standard tool	
Needle-nose pliers	Standard tool	
Nut driver, $\frac{1}{2}$ inch	Standard tool	
Nut driver, $\frac{1}{4}$ inch	Standard tool	
Nut driver, $\frac{5}{16}$ inch	Standard tool	
Nut driver, 5 mm	Standard tool	
Open-end wrench $\frac{1}{2}$ inch	Standard tool	
Soldering iron	Standard tool	

AWG2005 Orientation

In this manual, procedures refer to “front,” “back,” “top,” etc. of the AWG2005. Figure 6-1 shows how the sides are referenced.

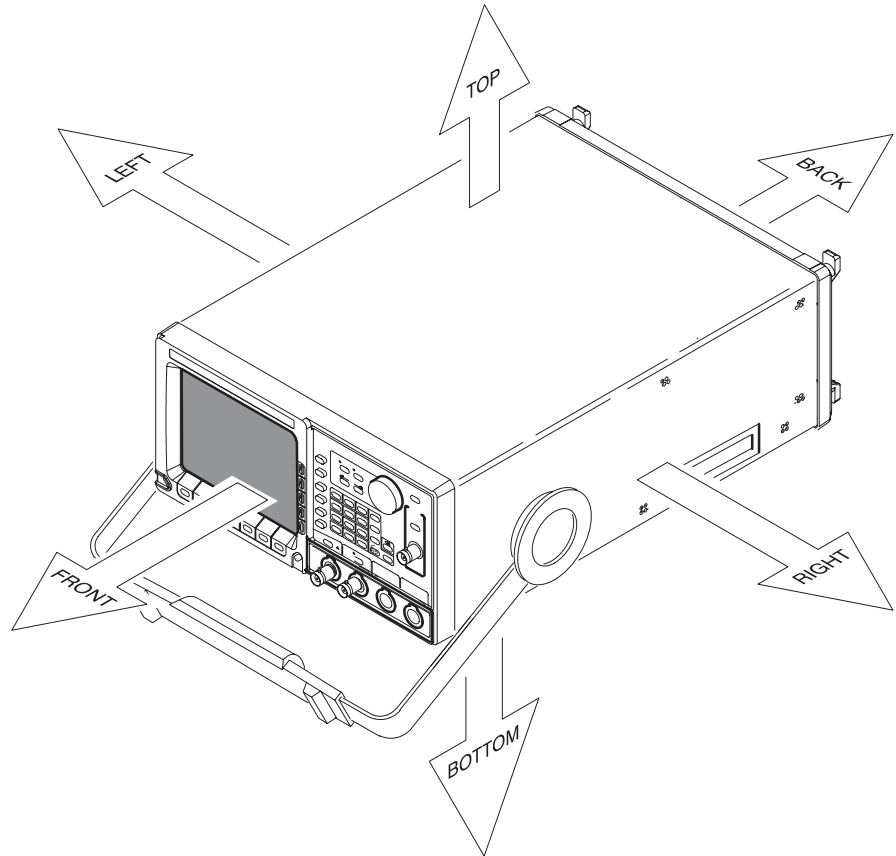

Figure 6-1: AWG2005 Orientation

Access Procedure

When you have identified the module to be removed for service, read *General Instructions* found earlier in this section. Then use the flowchart in Figure 6-2 to determine which procedures to use for removing the module. The removal procedures end with reinstallation instructions.

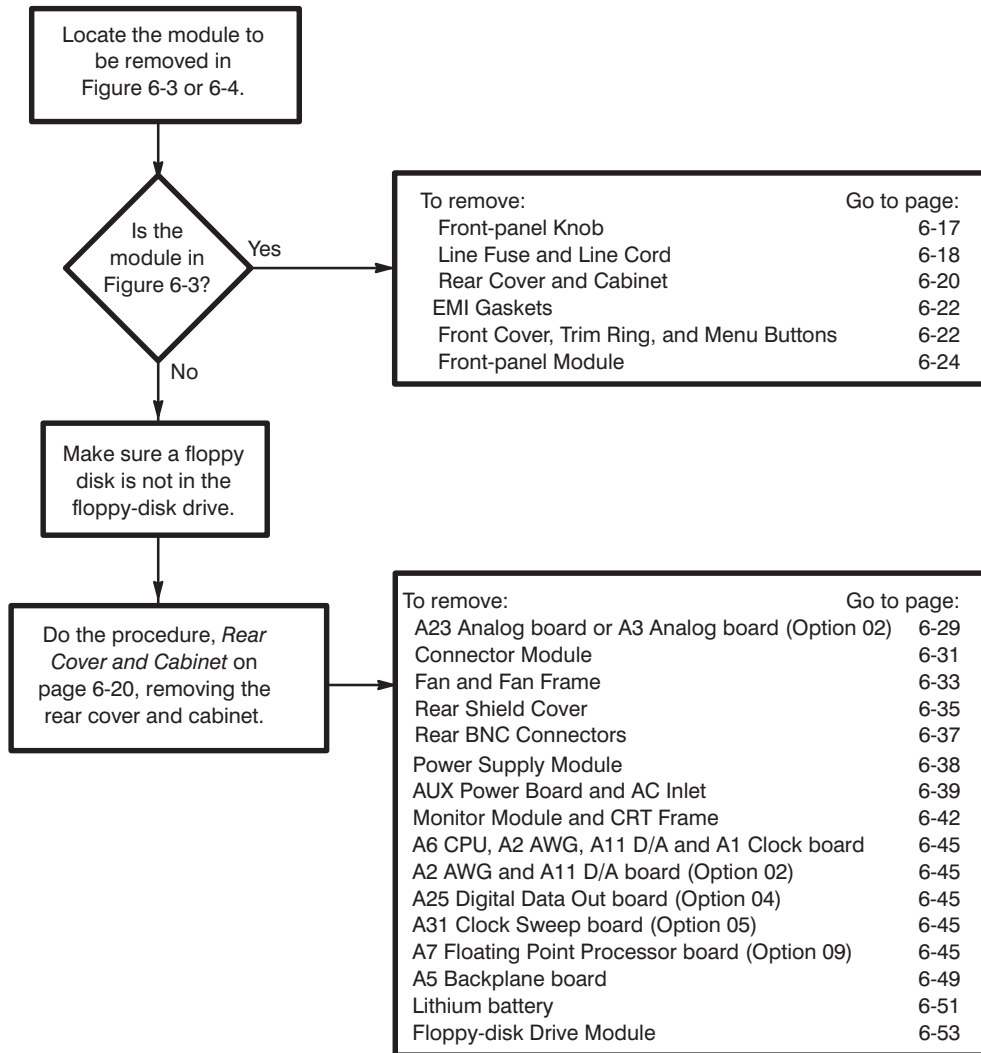

Figure 6-2: Guide to Removal Procedures

Removal and Installation Procedures

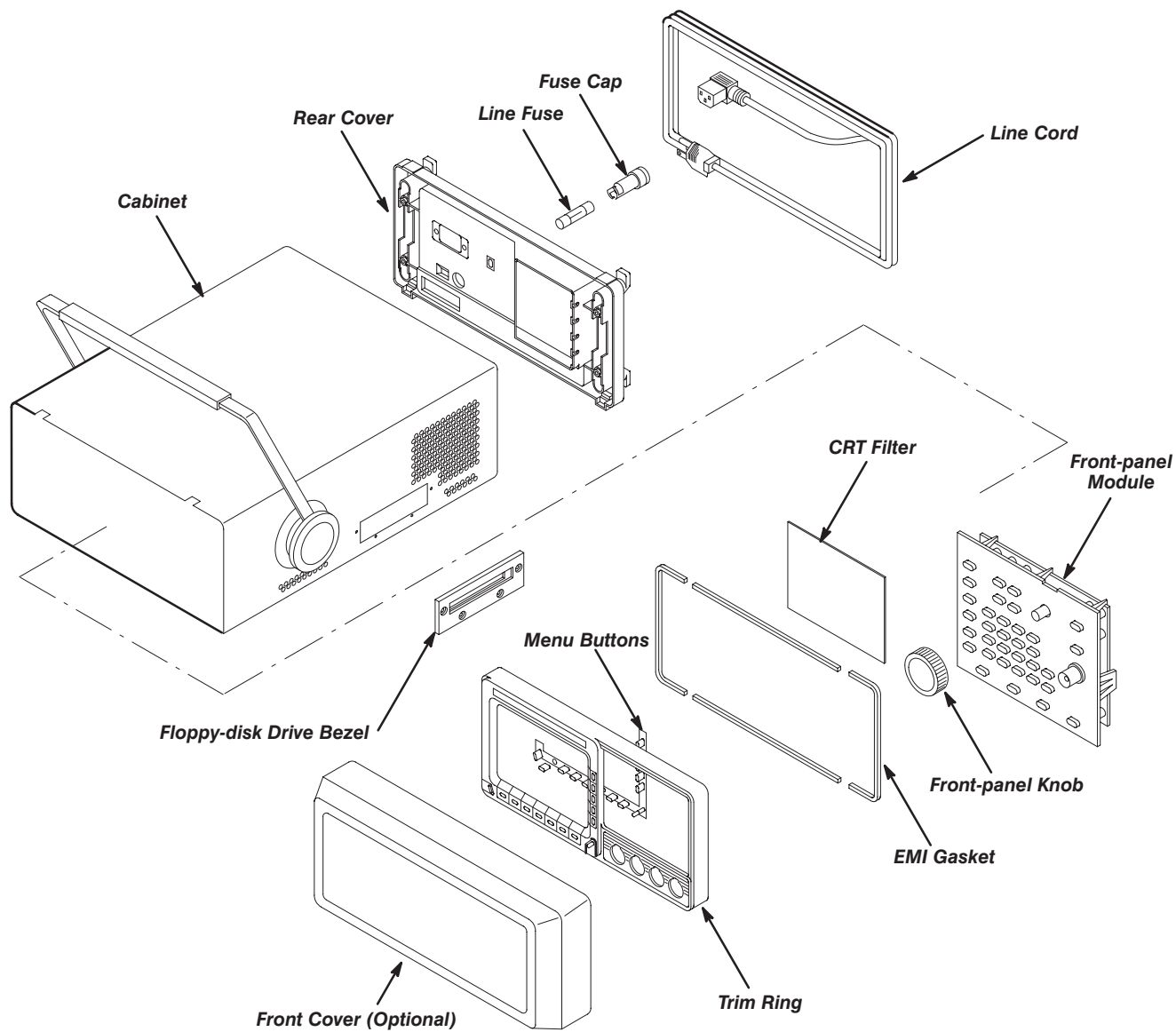

Figure 6-3: External Modules

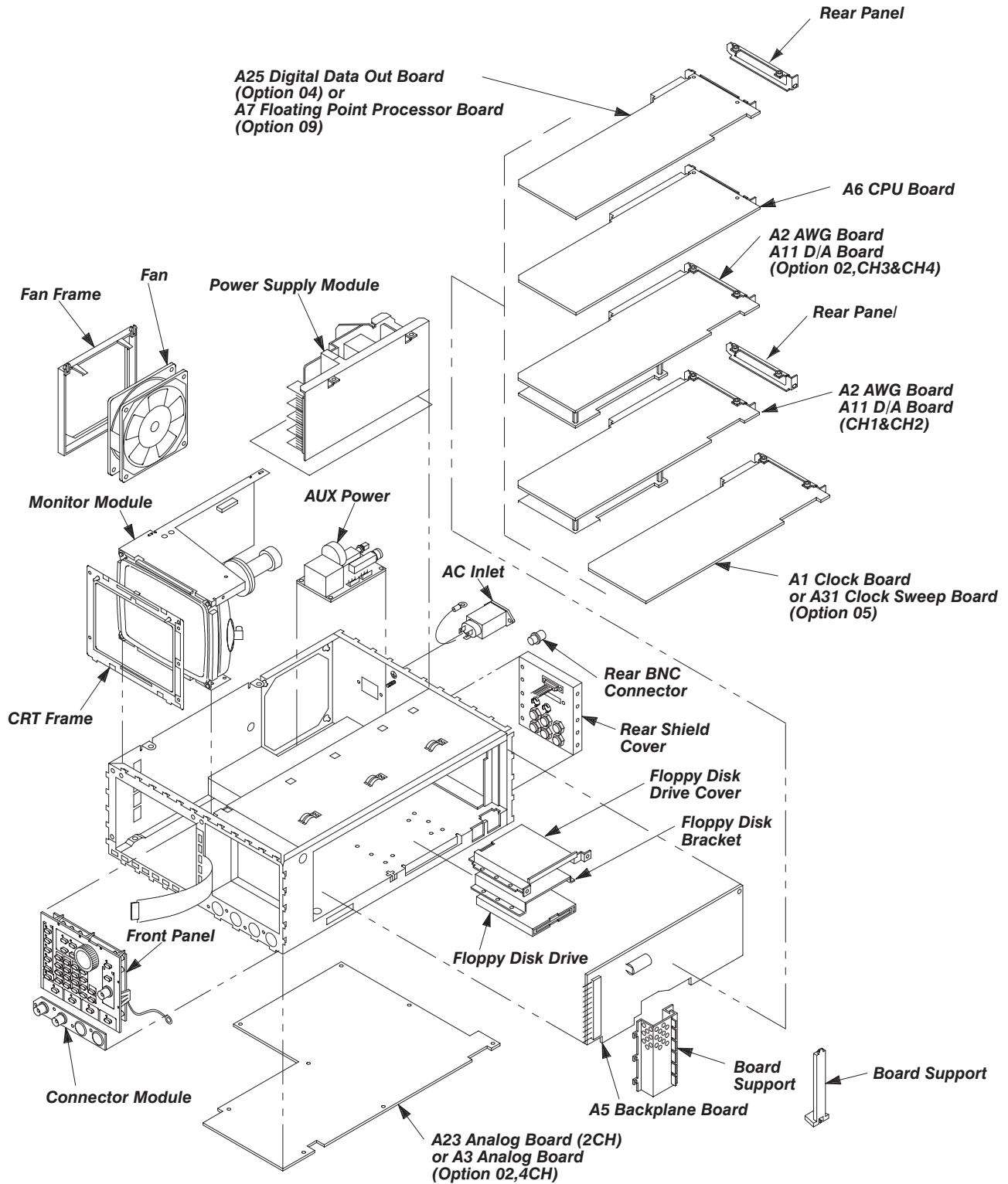

Figure 6-4: Internal Modules

Procedures for External Modules

Do the *Access Procedure* (page 6-13) before doing any procedure in this group.

This group contains the following procedures:

- Front-panel Knob
- Line Fuse and Line Cord
- Rear Cover and Cabinet
- EMI Gaskets
- Front Cover, Trim Ring, and Menu Buttons
- Front-panel Module

Front-panel Knob

1. *Assemble equipment and locate modules to be removed:* You will need a $\frac{1}{16}$ -inch hex wrench to do this procedure. Find the front-panel knob on the front panel in the locator diagram, *External Modules*, Figure 6-3.
2. *Orient instrument:* Set the AWG2005 with the bottom down on the work surface and the front facing you (see Figure 6-5).
3. *Remove front cover:* If the optional front cover is installed, grasp the front cover by the left and right edges and snap it off of the trim ring. (When reinstalling, align and snap back on.)
4. *Remove knob:* Loosen the setscrew securing the knob using the $\frac{1}{16}$ -inch hex wrench. Pull the knob toward you to remove it.
5. *Reinstallation:* Place the knob onto the shaft, and tighten the setscrew using the $\frac{1}{16}$ -inch hex wrench.

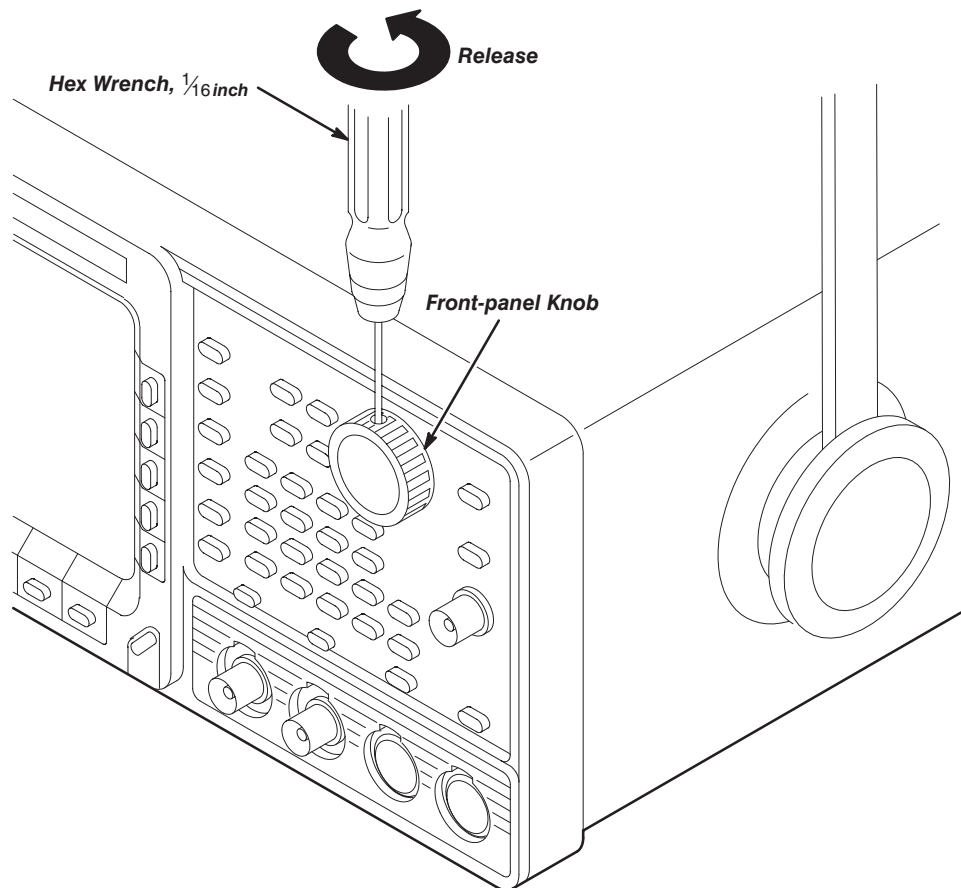

Figure 6-5: Front-panel Knob Removal

Line Fuse and Line Cord

1. *Assemble equipment and locate modules to be removed:* You will need a flat-bladed screwdriver to do this procedure. Locate the line fuse and line cord in the locator diagram, *External Modules*, Figure 6-3.
2. *Orient instrument:* Set the AWG2005 with the bottom down on the work surface and the back facing you. If you are servicing the line fuse, do the next step; if you are servicing the line cord, skip to step 4.
3. *Remove line fuse:* Find the fuse cap on the rear panel. See Figure 6-6. Remove the fuse cap by turning it counter-clockwise using a flat-bladed screwdriver, and remove the line fuse. Reverse the procedure to reinstall.
4. *Remove line cord:* Find the line cord on the rear cover. See Figure 6-6. Remove the line-cord retaining clamp by first unplugging the line cord from the line cord receptacle (1). Grasp both the line cord and the retaining clamp and rotate it 90 degrees counter-clockwise (2). Pull the line cord and clamp away to complete the removal (3). Reverse the procedure to reinstall.
5. *Reinstallation:* Do steps 3 and 4 in reverse order to reinstall the line cord, and then the line fuse.

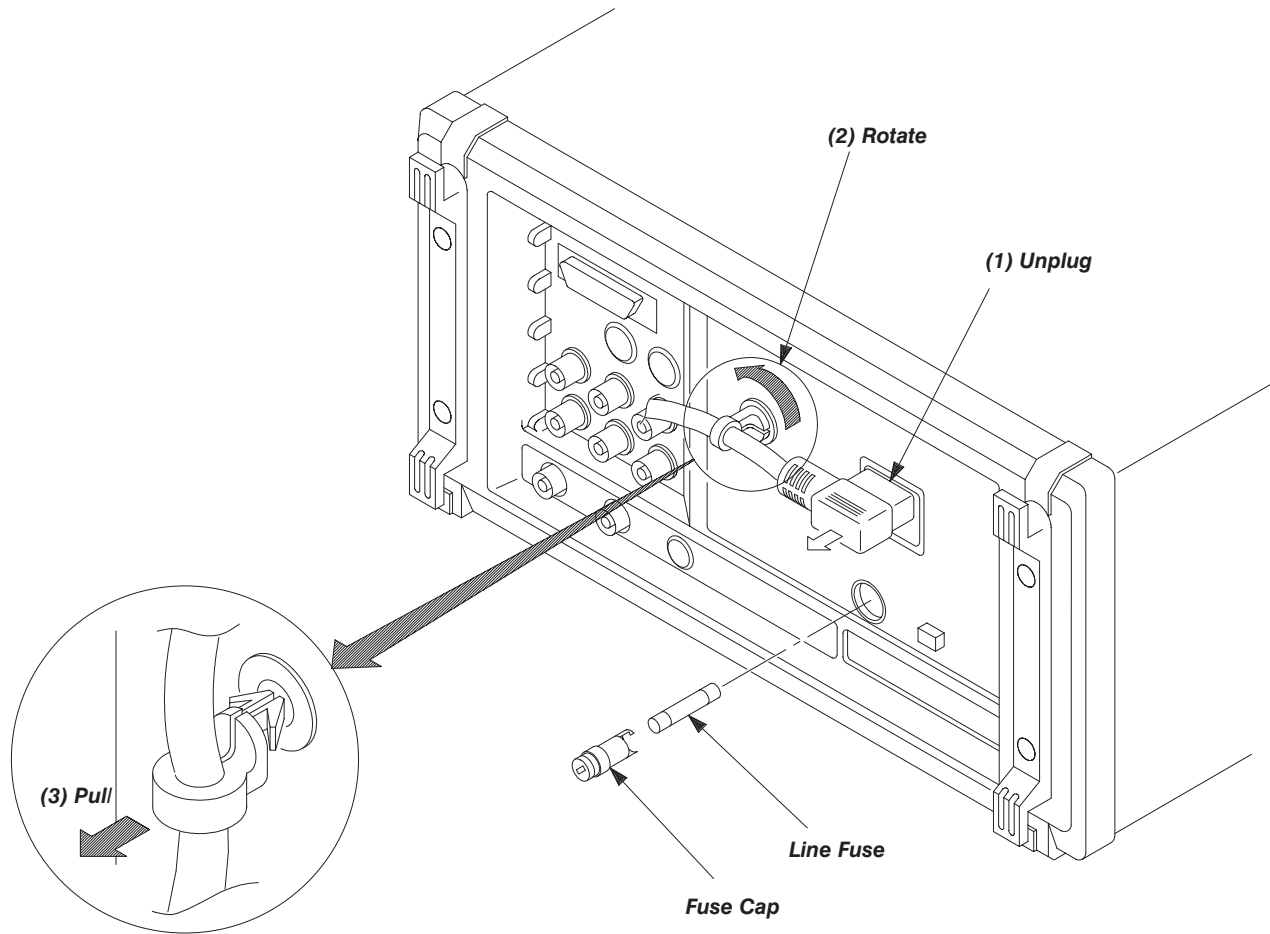

Figure 6-6: Line Fuse and Line Cord Removal

Rear Cover and Cabinet

1. *Assemble equipment and locate modules to be removed:*
 - a. You will need a screwdriver with size T-9 and T-15 Torx tips to do this procedure.
 - b. Make sure the AWG2005 front cover (optional accessory) is installed. If it is not, install it by snapping the edges of the front cover over the trim ring.
 - c. Locate the rear cover and cabinet in the locator diagram, *External Modules*, Figure 6-3.
2. *Orient instrument:* Set the AWG2005 face down, with the front cover on the work surface and the instrument bottom facing you (see Figure 6-7).
3. *Disconnect line cord:* Do the *Line Fuse and Line Cord* procedure on page 6-18, removing only the line cord.
4. *Remove rear cover:* Using a screwdriver with a size T-15 Torx tip, remove the four screws securing the rear cover to the instrument. Lift off the rear cover.
5. *Orient instrument:* Set the AWG2005 face down, with the front cover on the work surface and right side facing you.
6. *Remove floppy disk drive bezel:* Using a screwdriver with a size T-9 Torx tip, remove the four screws securing the floppy-disk drive bezel to the cabinet. Lift off the floppy-disk drive bezel.
7. *Remove cabinet:*



To prevent damaging the eject button, make sure floppy disk is not inserted in the floppy disk drive before removing the cabinet from the AWG2005.

- a. Using a screwdriver with a size T-15 Torx tip, remove the screw securing the left side of the cabinet to the instrument.
 - b. Grasp the right and left edges of the cabinet toward the back.
 - c. Pull upward to slide the cabinet off the instrument. Take care not to bind or snag the cabinet on internal cabling as you remove it.
8. *Reinstall cabinet and rear cover:*
 - a. Do steps 3 through 7 in reverse order to reinstall the cabinet.
 - b. Take care not to bind or snag the cabinet on internal cabling; re-dress cables as necessary.

- c. When sliding the cabinet, be sure that the front edge of the cabinet aligns with the groove containing the four EMI shields on the trim ring.
- d. When reinstalling the four screws at the rear panel, tighten them to a torque of 16 kg/cm (6 in/lbs).
- e. See the procedure, *Line Fuse and Line Cord*, on page 6-18 to reinstall the line cord. This completes the AWG2005 reassembly.

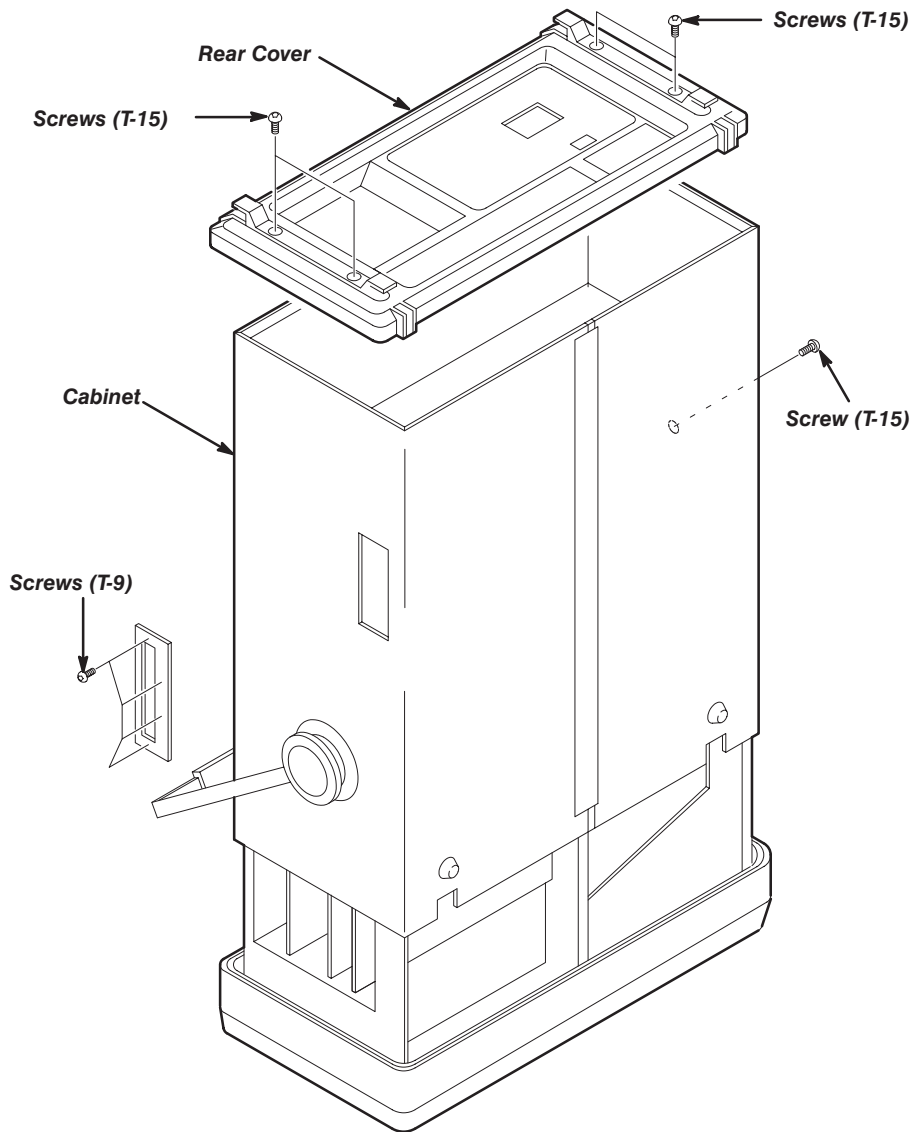

Figure 6-7: Rear Cover and Cabinet Removal

EMI Gaskets

1. *Remove front cover and trim ring:* Do the *Front Cover, Trim Ring, and Menu Buttons* procedure on page 6-22, removing only the front cover and trim ring.



When reinstalling the EMI gaskets and/or the AWG2005 cabinet carefully follow the instructions given to prevent exceeding the environmental characteristics for EMI.

2. *Remove EMI gaskets:*
 - a. You will need needle-nose pliers to do this part of the procedure.
 - b. Locate the EMI gaskets in the locator diagram, *External Modules*, in Figure 6-3.
 - c. Use a pair of needle-nose pliers to remove the four sections of EMI gaskets from the groove in the trim ring.
3. *Reinstall EMI gaskets:* Press the EMI gaskets back into the groove in the trim ring.

Front Cover, Trim Ring, and Menu Buttons

1. *Assemble equipment and locate modules to be removed:* No tools are needed. Locate the modules to be removed in the locator diagram, *External Modules*, in Figure 6-3.
2. *Orient instrument:* Set the AWG2005 with the back down on the work surface and bottom facing you (see Figure 6-8).
3. *Remove front cover:* If the optional front cover is installed, grasp the front cover by the left and right edges and snap it off of the trim ring. (When reinstalling, align and snap back on.)
4. *Remove front-panel knob:* Do the *Front-panel Knob* procedure, on page 6-17.

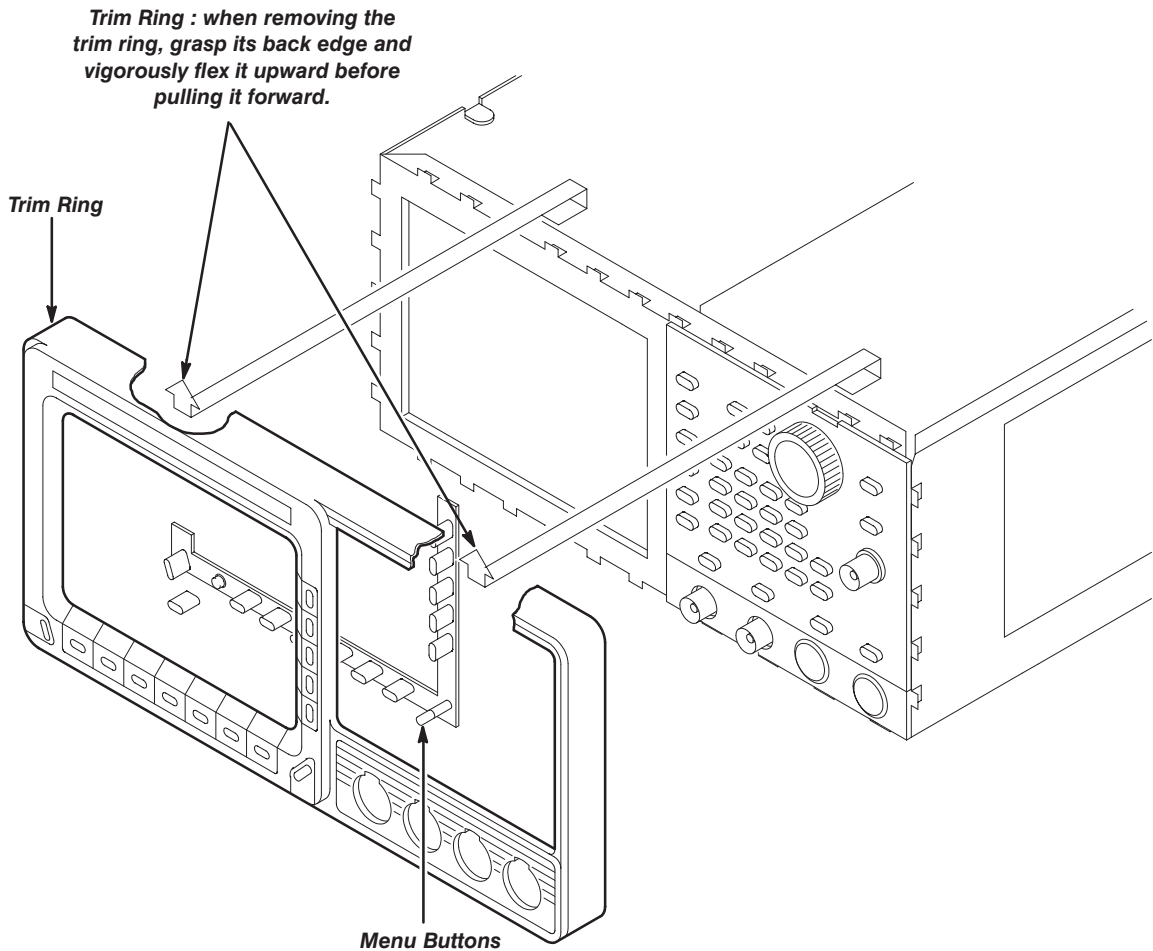

**Figure 6-8: Front Cover, Trim Ring, and Menu Button Removal
(Front Cover not Shown)**

CAUTION

To prevent contaminating AWG2005 parts, do not touch the carbon contact points on the menu buttons installed in the trim ring. Also, do not touch the contacts on the flex circuit exposed when you remove the trim ring.

5. *Remove trim ring:* Grasp the trim ring by the top edge and pry it up and lift it forward to snap it off of the trim ring. If servicing the menu buttons, lift them out of the trim ring. (When reinstalling, reinsert the menu buttons, align the trim ring to the chassis and press it back on.)
6. *Reinstallation:* Do steps 3–5 in reverse order to reinstall the menu buttons, trim ring and the front cover, following the reinstallation instructions found in each step.

Front-panel Module

NOTE

This procedure includes removal and reinstallation instructions for the front-panel module and front-panel buttons. Unless either of those modules are being serviced, do not do step 6, "Further disassembly of Front-panel Module."

1. *Assemble equipment and locate modules to be removed:*
 - a. You will need a flat-bladed screwdriver and a 0.05-inch and $\frac{1}{16}$ -inch hex wrench to do this procedure.
 - b. Locate the modules to be removed in the locator diagram, *External Modules*, in Figure 6-3.
 - c. Do the procedure, *Front Cover, Trim Ring, and Menu Buttons*, steps 1–6 (immediately preceding this procedure).
2. *Remove front-panel knob:* Do the *Front-panel Knob* procedure, on page 6-17.
3. *Remove front cover, trim ring, and menu buttons:* Do the *Front Cover, Trim Ring, and Menu Buttons* procedure on page 6-22 removing only the module(s) you want to service.
4. *Orient instrument:* Set the AWG2005 with the bottom down on the work surface and the front facing you.
5. *Remove front-panel module:*
 - a. As shown in Figure 6-9, release the snap at the right of the front-panel module using a flat-bladed screwdriver. Lift the front-panel module out of the chassis until you can reach the interconnect cable.
 - b. Disconnect the ribbon interconnect cable at J101 and flexible board connector at JP301 on the A12 Keyboard assembly. Disconnect the interconnect cable at the TRIGGER INPUT connector.
 - c. Finally, lift the front-panel module out of the chassis to complete the removal.

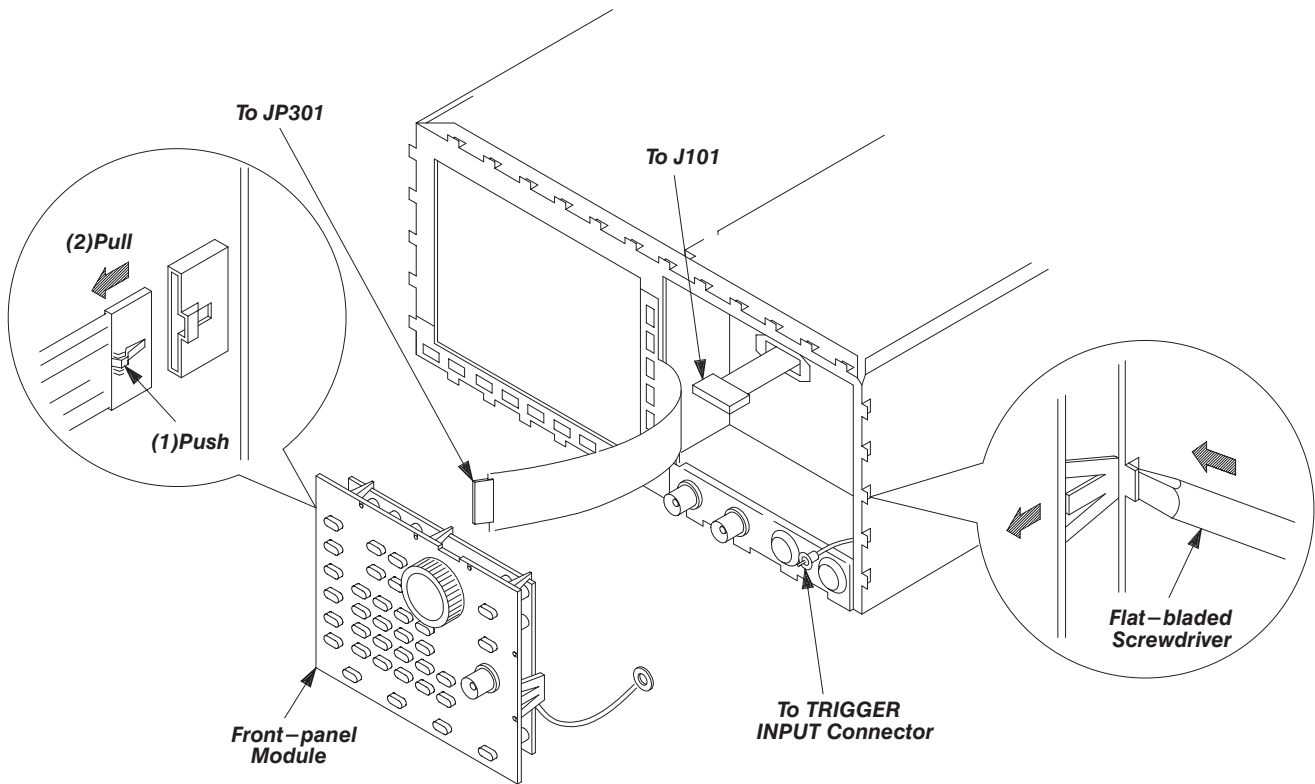

Figure 6-9: Front-panel Module Removal

6. *Further disassembly of front-panel module:* If the front-panel module or the front-panel buttons are to be serviced, do the following substeps:
 - a. Remove the front-panel knob from the front-panel module using the method described in the procedure, *Front-panel Knob*, on page 6-17.
 - b. Remove the setscrew completely from the extension using the 0.05-inch hex wrench, and then remove the extension from the shaft of the rotary switch.
 - c. As shown in Figure 6-10, release the four hooks, and then remove the A12 Keyboard from the chassis.

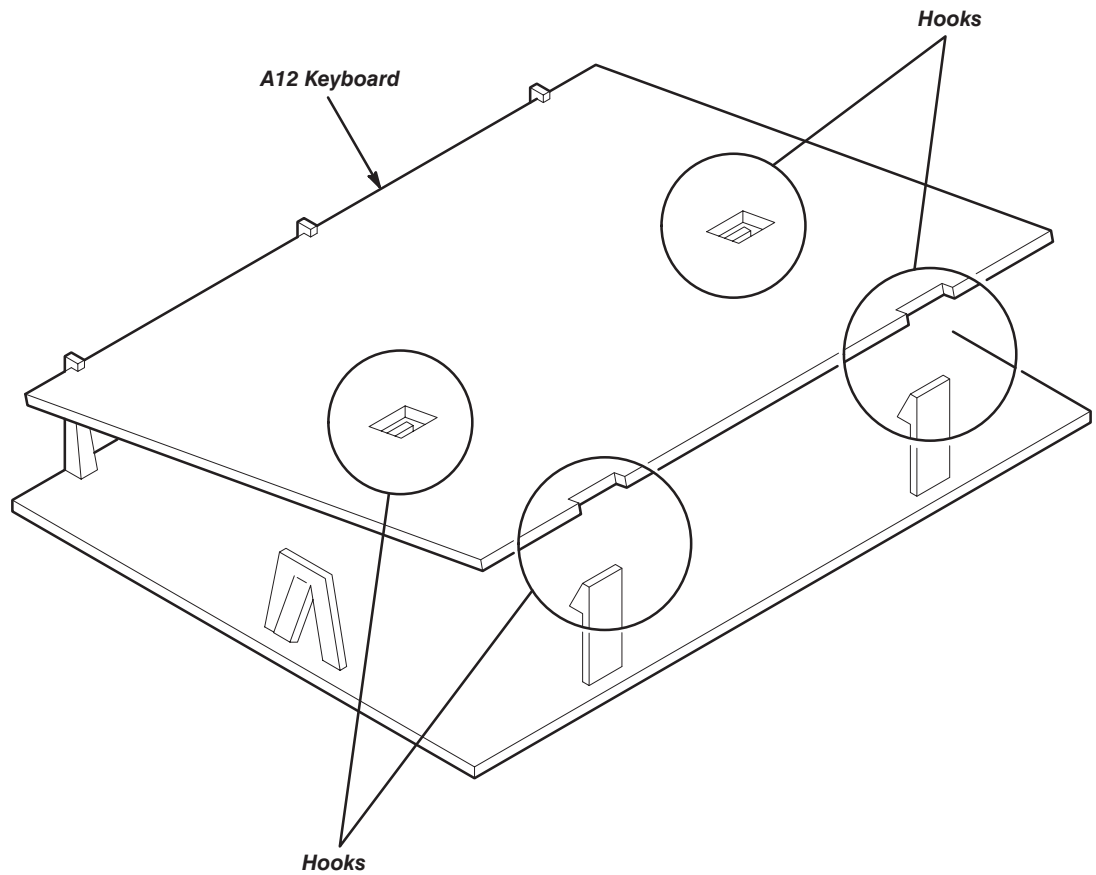

Figure 6-10: A12 Keyboard Removal

- d. Now hand disassemble the front-panel module components using Figure 6-11 as a guide. Reverse the procedure to reassemble.

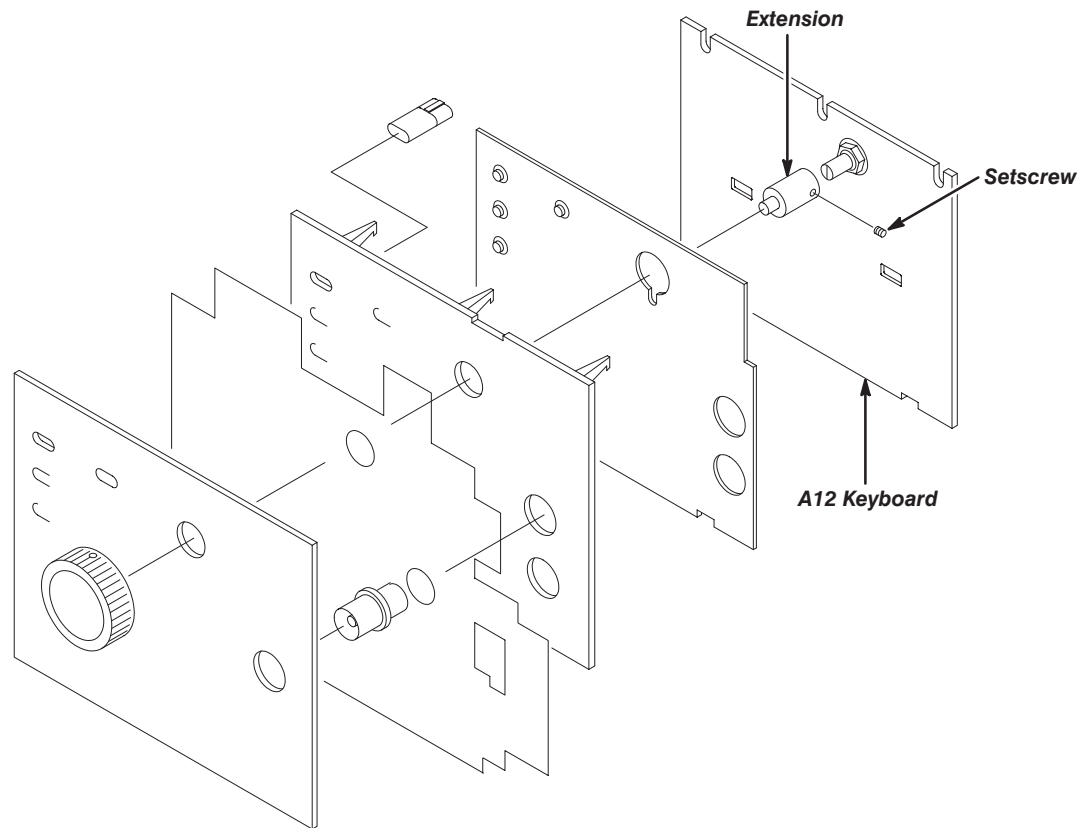

Figure 6-11: Disassembly of Front-panel Module

7. *Reinstallation:* If the front-panel module was further disassembled in step 6, then reverse substeps 6a–6d to reassemble, using Figure 6-11 as a guide. Then do the substeps in step 3 in reverse order, reversing the order of the items in each substep. Last, reinstall the trim ring and, if desired, the front cover, referring to the procedure, *Front Cover, Trim Ring, and Menu Buttons* (page 6-22).

Procedures for Internal Modules

Do the *Access Procedure* (on page 6-13) before doing any procedure in this group.

This part contains the following removal and installation procedures; the procedures are presented in the order listed:

- A23 Analog Board or A3 Analog Board (Option 02)
- Connector Module
- Fan and Fan Frame
- Rear Shield Cover
- Rear BNC Connector
- Power Supply Module
- AUX Power Board and AC Inlet
- Monitor Module and CRT Frame
- Circuit Boards:
 - A6 CPU Board
 - A2 AWG Board
 - A11 D/A Board
 - A1 Clock Board
 - For Option 02: A2 AWG Board and A11 D/A Board
 - For Option 04: A25 Digital Data Out Board
 - For Option 05: A31 Clock Sweep Board
 - For Option 09: A7 Floating Point Processor Board
- A5 Backplane Board
- Lithium Battery
- Floppy Disk Drive Module

A23 Analog Board or A3 Analog Board (Option 02)

1. *Assemble equipment and locate modules to be removed:*
 - a. You will need a screwdriver with a size T-15 Torx tip to do this procedure.
 - b. Locate the modules to be removed in the locator diagram, *Internal Modules*, Figure 6-4.
2. *Orient instrument:* Set the AWG2005 with the top down on the work surface and the right side facing you.
3. *Remove A23 Analog board:*
 - a. Disconnect the six interconnect cables at J100, J198, J200, J298, J500 and J550 on the A23 Analog board. See Figure 6-12.
 - b. Using a screwdriver with a size T-15 Torx tip, remove the eight screws attaching the A23 Analog board to the chassis.
 - c. Lift the A23 Analog board up and away from the chassis to complete the removal.

J800 on the A23 Analog board is connected to J7 on the A5 Back-plane board. Grasp the both ends of the A23 Analog board and pull upward slowly to remove it.
4. *Remove A3 Analog board (Option 02):*
 - a. Disconnect the ten interconnect cables at J100, J198, J200, J298, J300, J398, J400, J498, J500 and J550 on the A3 Analog board. See Figure 6-12.
 - b. Using a screwdriver with a size T-15 Torx tip, remove the eight screws attaching the A3 Analog board to the chassis.
 - c. Lift the A3 Analog board up and away from the chassis to complete the removal.

J800 on the A3 Analog board is connected to J7 on the A5 Back-plane board. Grasp the both ends of the A3 Analog board and pull upward slowly to remove it.

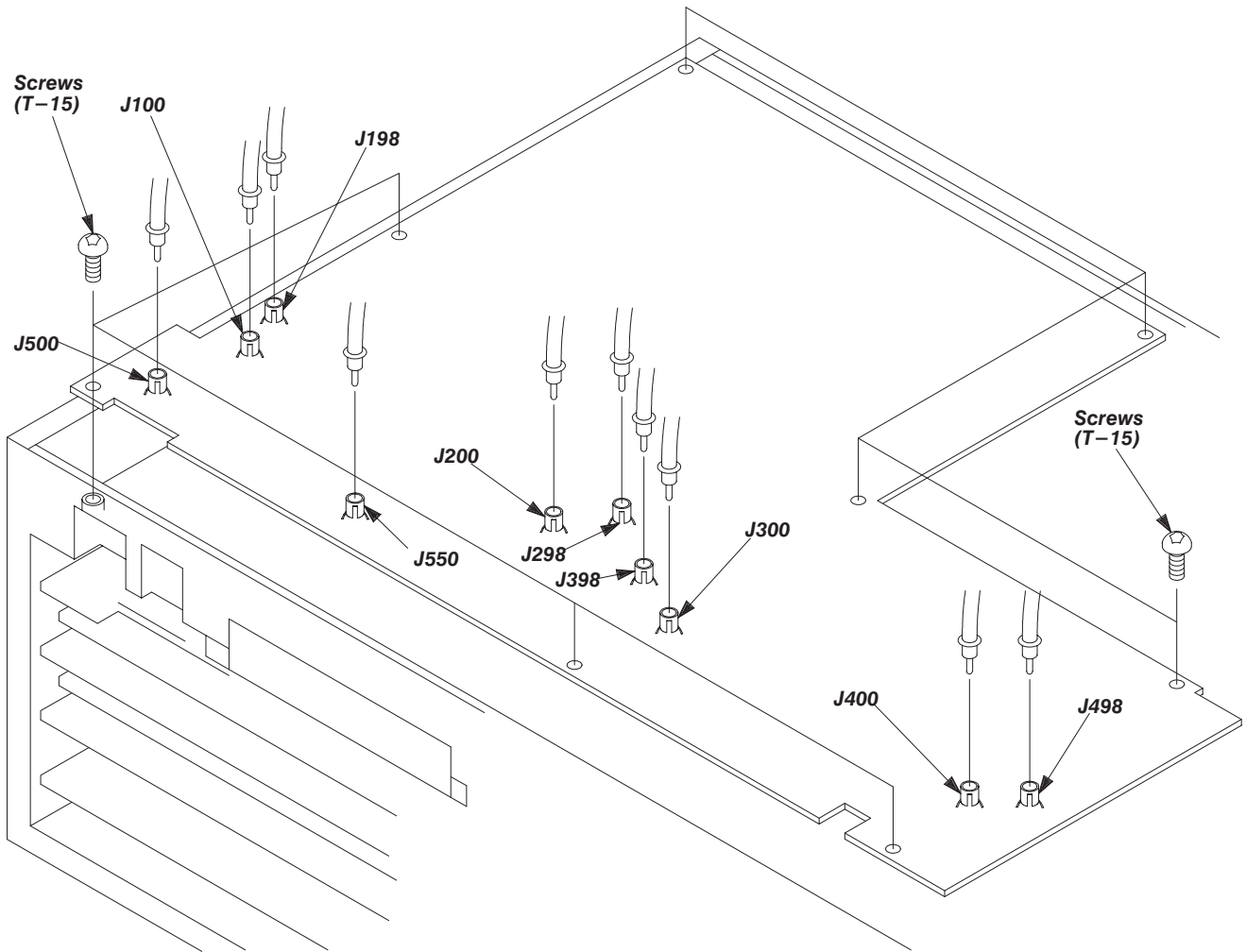

Figure 6-12: A23/A3 Analog Board Removal

5. *Reinstallation:* If the AWG2005 includes Option 02, do substeps 4a–4c in reverse order to reinstall the A3 Analog board. Do substeps 3a–3c in reverse order to reinstall the A23 Analog board.

Connector Module

1. *Assemble equipment and locate modules to be removed:*
 - a. You will need a screwdriver with a size T-9 Torx tip and a 1/2-inch nut driver to do this procedure.
 - b. Locate the modules to be removed in the locator diagram, *Internal Modules*, in Figure 6-4.
2. *Remove front-panel knob:* Do the *Front-panel Knob* procedure, on page 6-17.
3. *Remove front cover, trim ring, and menu buttons:* Do the *Front Cover, Trim Ring, and Menu Buttons* procedure on page 6-22.
4. *Orient instrument:* Set the AWG2005 with the top down on the work surface and the right side facing you.
5. *Remove connector module:*
 - a. Disconnect the interconnect cables at the CH1 and CH2 Waveform Output connectors. For an AWG2005 with Option 02, disconnect the interconnect cables at the CH3 and CH4 Waveform Output connectors.
 - b. Using the screwdriver with a size T-9 Torx tip, remove the four screws attaching the connector module to the chassis. See Figure 6-13.
6. *Remove BNC connector:*
 - a. To remove a BNC connector, remove the nut attaching the BNC connector to the panel using a 1/2-inch nut driver, and then remove the BNC connector from the panel.
7. *Reinstallation:*
 - a. *Install BNC connector:* Do substep 6a, reversing the order of the items in the substep.
 - b. *Install connector module:* Install the connector module by doing substeps 5a–5b in reverse order.

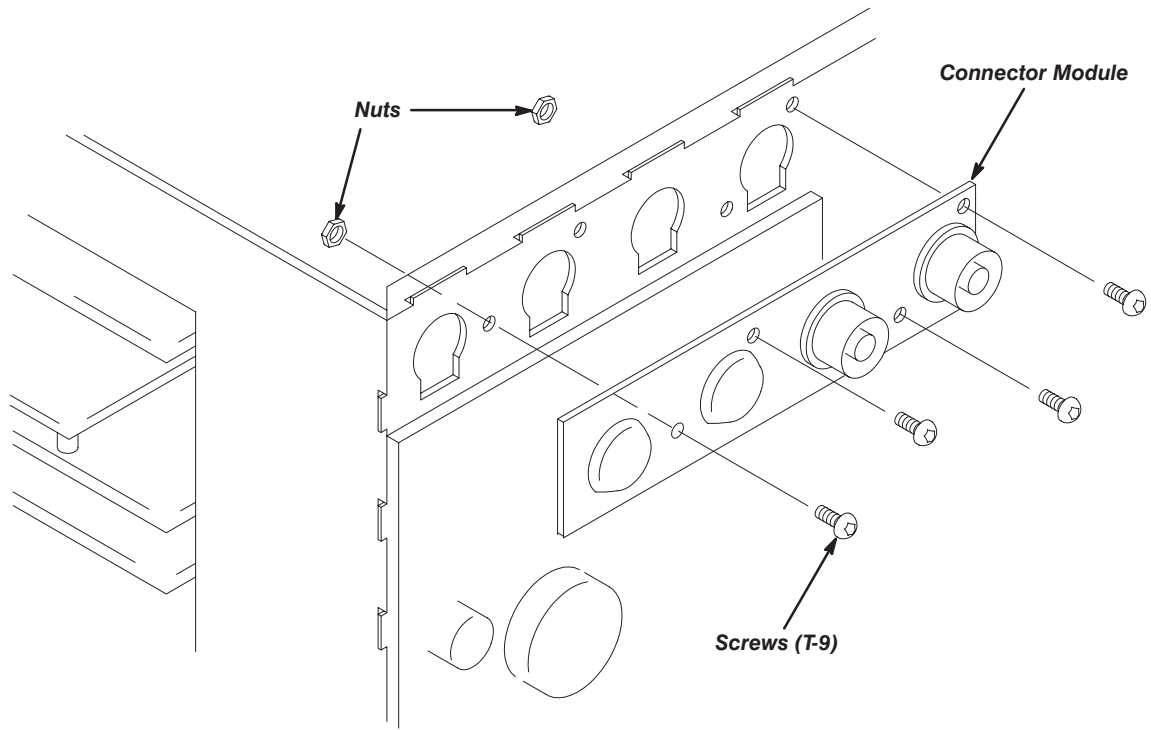

Figure 6-13: Connector Module Removal

Fan and Fan Frame

1. *Assemble equipment and locate modules to be removed:*
 - a. No tools are needed to do this procedure.
 - b. Locate the modules to be removed in the locator diagram, *Internal Modules*, in Figure 6-4.
2. *Orient instrument:* Set the AWG2005 with the bottom down on the work surface and the left side facing you.
3. *Remove fan and fan frame:*
 - a. Disconnect the ribbon interconnect cable from J3 of the power supply module. See Figure 6-14.
 - b. As shown in Figure 6-14, slide (2) in the direction indicated by arrow (1) while pushing it, and then remove the fan and fan frame.
 - c. Release the four hooks securing the fan, separate the fan and fan frame.

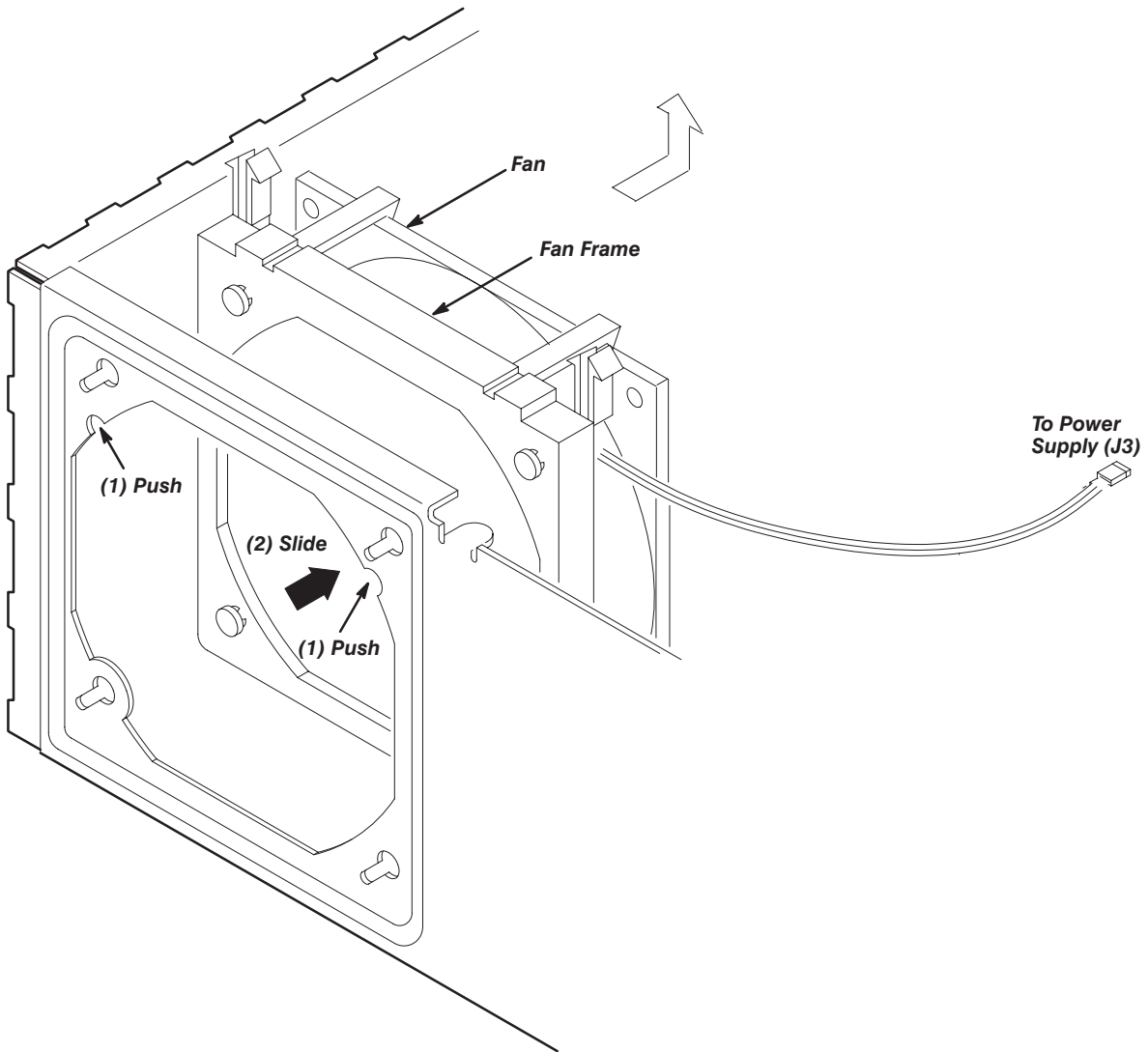

Figure 6-14: Fan and Fan Frame Removal

4. *Reinstallation:*

- a. Secure the fan to the fan frame.
- b. Connect the cable (J3) to power supply module.
- c. Align the four protrusions of the fan frame with the holes of the chassis, slide the fan and fan frame to the lower left, and then install them.

Rear Shield Cover

1. *Assemble equipment and locate modules to be removed:*
 - a. You will need a screwdriver with a size T-15 Torx tip, a $\frac{1}{4}$ -inch nut driver, a 5 mm nut driver and a $\frac{1}{2}$ -inch nut driver to do this procedure.
 - b. Locate the modules to be removed in the locator diagram, *Internal Modules*, Figure 6-4.
2. *Orient instrument:* Set the AWG2005 with the bottom down on the work surface and the back facing you (see Figure 6-15).
3. *Remove rear shield cover:*
 - a. Disconnect the ribbon interconnect cable from J30 on the A6 CPU board. See Figure 6-21.
 - b. Using a screwdriver with a size T-15 Torx tip, remove the five screws securing the rear shield cover to the chassis from the back side.
 - c. Using a screwdriver with a size T-15 Torx tip, remove the five screws securing the rear shield cover to the chassis from the left side.
 - d. Using a $\frac{1}{4}$ -inch nut driver, remove the IEEE STD 488 PORT cover by removing the two spacer posts.
 - e. Grasp the serial interface connector, pull the rear shield cover toward you taking care not to damage the cable.
 - f. Disconnect the interconnect cables at the CH1/CH2 MARKER OUT, CLOCK IN/OUT and CONTROL SIG IN/OUT BNC connectors. For an AWG2005 with Option 02, disconnect the interconnect cables at the CH3 and CH4 MARKER OUT BNC connectors.
 - g. You can remove the rear panel of a slot in which no board is mounted.
4. *Remove BNC connector:* Use a $\frac{1}{2}$ -inch nut driver to remove the nut attaching the BNC connector to the panel; then, remove the BNC connector from the panel.
5. *Remove serial interface connector:* Use a 5 mm nut driver to remove the nut attaching the connector to the rear shield cover; then, remove the connector.
6. *Reinstallation:*
 - a. Install the serial interface connector if you removed it by reversing the items in step 5.
 - b. Install the BNC connector if you removed it by reversing the items in step 4.
 - c. Install the rear shield cover by doing substeps 3a-3g in reverse order.

Removal and Installation Procedures

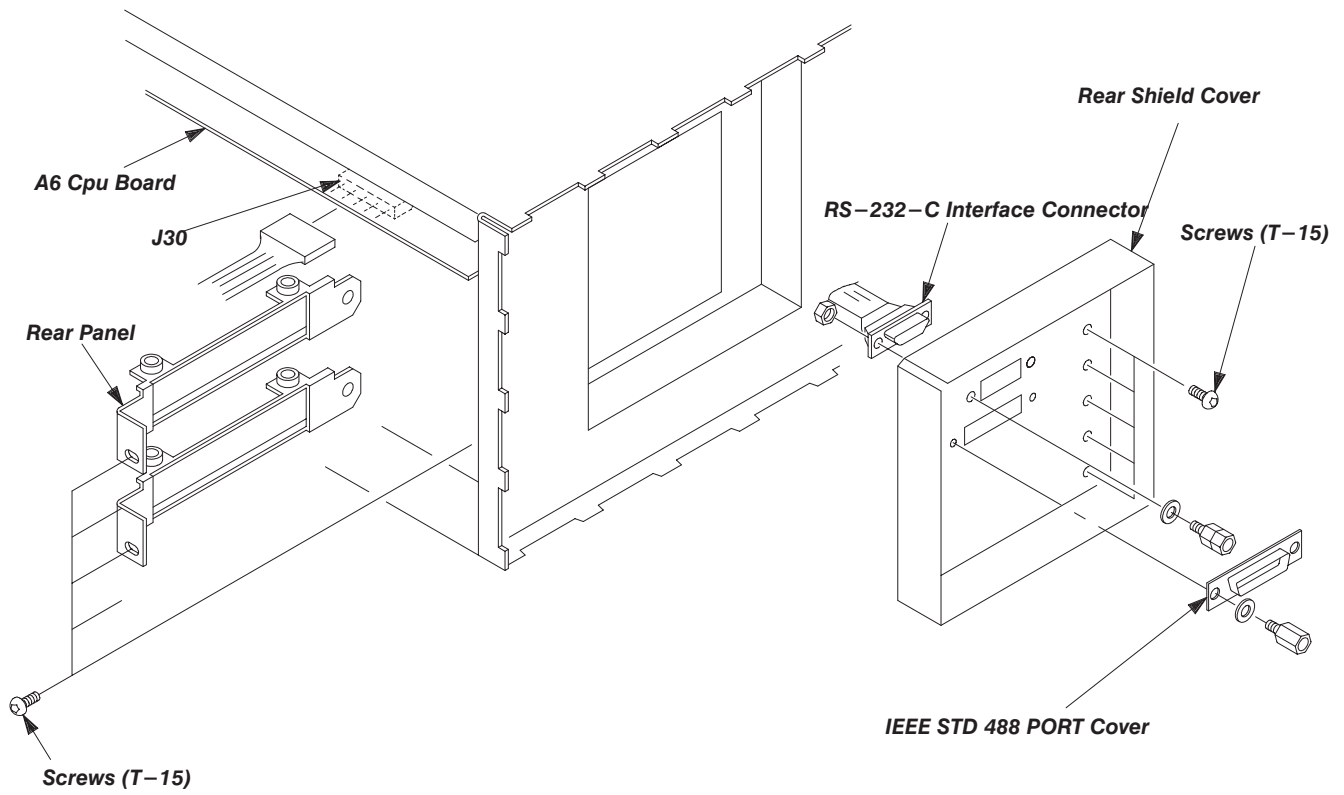

Figure 6-15: Rear Shield Cover Removal

Rear BNC Connectors

1. *Assemble equipment and locate modules to be removed:*
 - a. You will need a $\frac{1}{2}$ -inch open-end wrench to do this procedure.
 - b. Locate the modules to be removed in the locator diagram, *Internal Modules*, in Figure 6-4. (An instrument with Option 05 has an additional BNC connector.)
2. *Orient instrument:* Set the AWG2005 with the top down on the work surface and the left side facing you (see Figure 6-16).
3. *Remove rear BNC connectors:*
 - a. Disconnect the interconnect cables at the CH1 AM IN and CH1 ADD IN connectors.
 - b. Using the open-end wrench, remove the nut securing the BNC connectors to the chassis. Then, lift the BNC connectors out of the chassis to complete the removal.
 - c. For an instrument with Option 05, remove the SWEEP OUT connector using the same procedure.
4. *Reinstallation:* Install the rear BNC connectors by doing substeps 3a and 3b in reverse order.

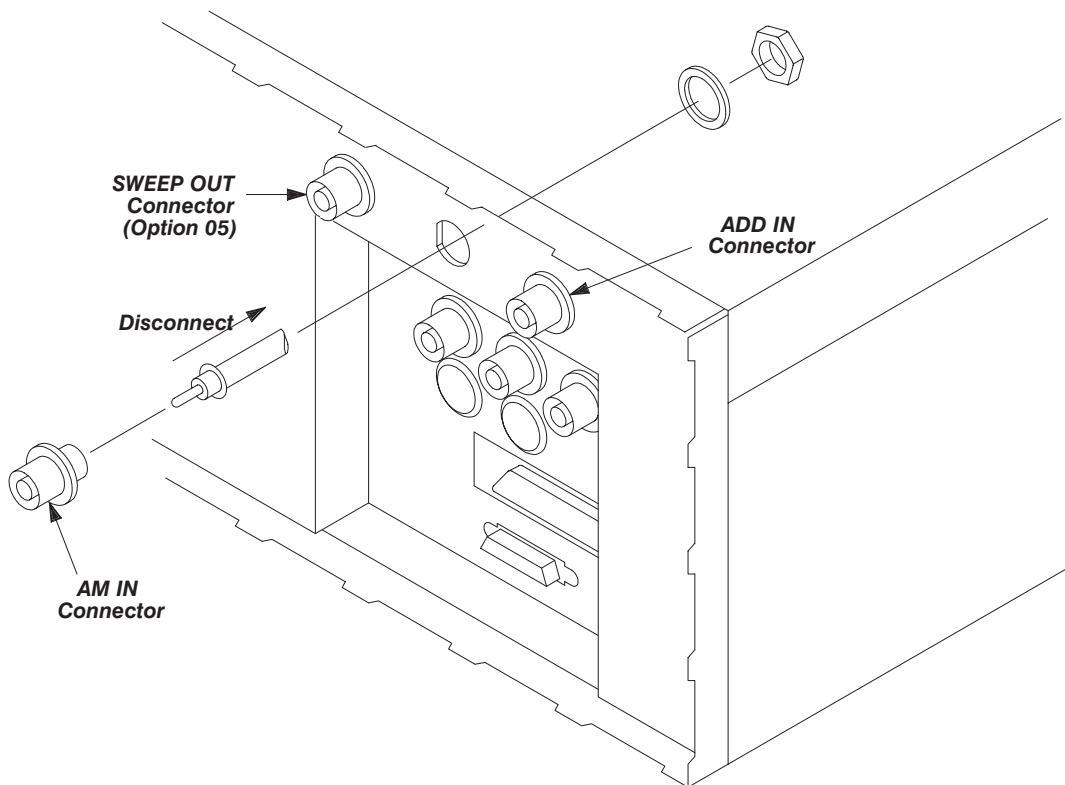

Figure 6-16: Rear BNC Connectors Removal

Power Supply Module

1. *Assemble equipment and locate modules to be removed:* You will need a screwdriver with a size T-15 Torx tip to do this procedure. Locate the modules to be removed in the locator diagram, *Internal Modules*, in Figure 6-4.
2. *Orient instrument:* Set the AWG2005 with the bottom down on the work surface and the left side facing you.
3. *Remove power supply module:*
 - a. Disconnect the ribbon interconnect cable at J1, J3, J4, and J5 on the power supply module. See Figure 6-17.
 - b. Disconnect the flat cable at J2 on the power supply module.
 - c. Using a screwdriver with a size T-15 Torx tip, remove the two screws attaching the power supply module to chassis.

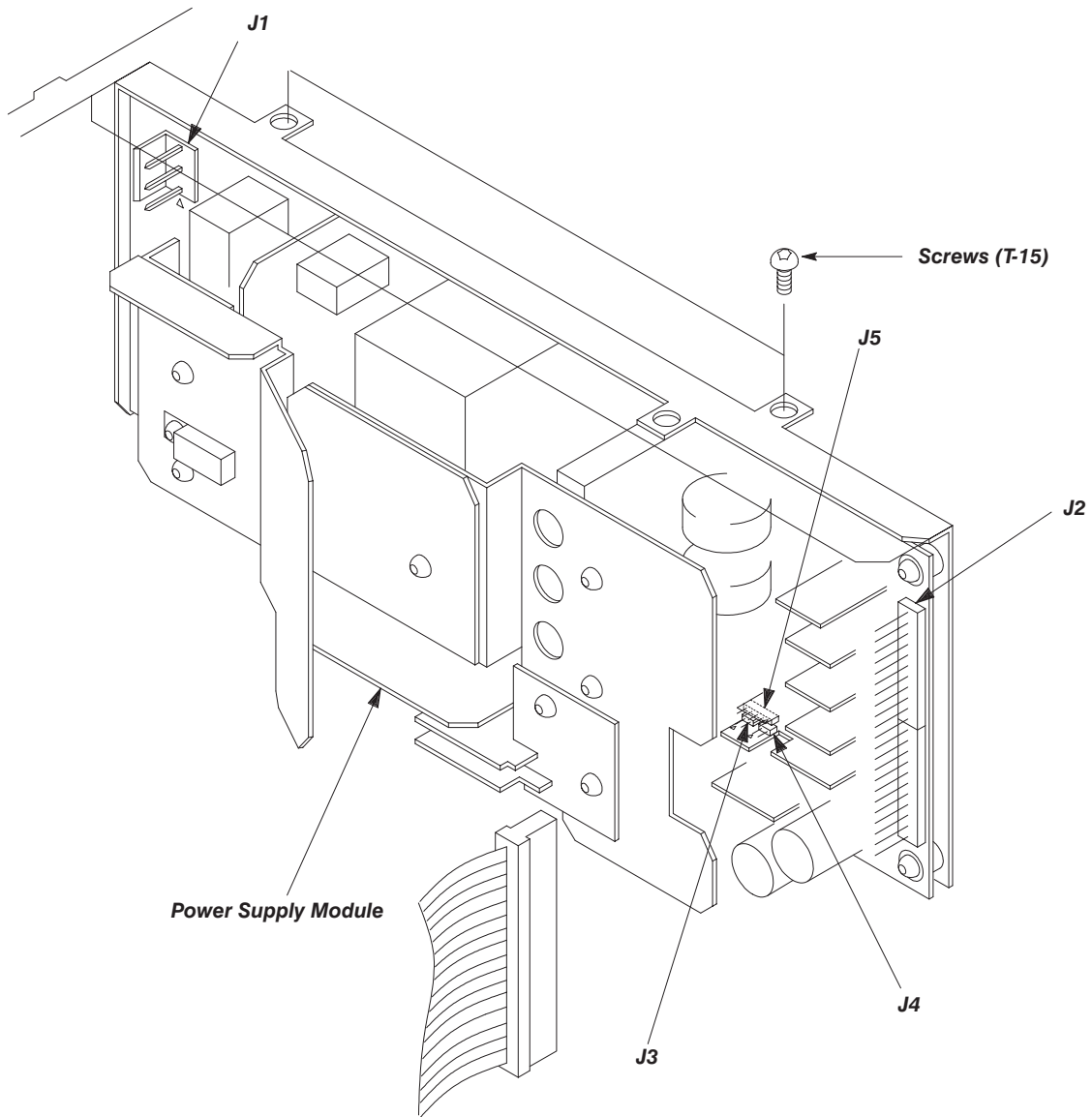

Figure 6-17: Power Supply Module Removal

4. *Reinstallation:* Do substeps 3a–3c in reverse order to reinstall the power supply module.

AUX Power Board and AC Inlet

1. *Assemble equipment and locate modules to be removed:*
 - a. You will need a screwdriver with a size T-15 Torx tip, a $\frac{5}{16}$ -inch nut driver and a soldering iron to do this procedure.
 - b. Locate the modules to be removed in the locator diagram, *Internal Modules*, in Figure 6-4.

Removal and Installation Procedures

2. *Remove fan and fan frame:* Do the *Fan and Fan Frame* procedure on page 6-33.
3. *Orient instrument:* Set the AWG2005 with the bottom down on the work surface and the back facing you (see Figure 6-18).
4. *Remove the power supply module:* Do the procedure, *Power Supply Module*, on page 6-38.
5. *Remove AC inlet:*
 - a. Disconnect the interconnect cable at CN1 on the AUX Power board.
 - b. Using a $\frac{5}{16}$ -inch nut driver, remove the nut attaching the ground wire to the chassis.
 - c. Remove the two insulating tubes of cables attached to the AC inlet.
 - d. Unsolder the three interconnect cables attached to the AC inlet.
 - e. Using a screwdriver with a size T-15 Torx tip, remove the two screws securing the AC inlet to the chassis.
6. *Remove AUX Power board:*
 - a. Disconnect the interconnect cable at CN2 on the AUX Power board.
 - b. Remove the three screws attaching the AUX Power board to the chassis.
 - c. Lift the AUX Power board up and away from the chassis to complete the removal.

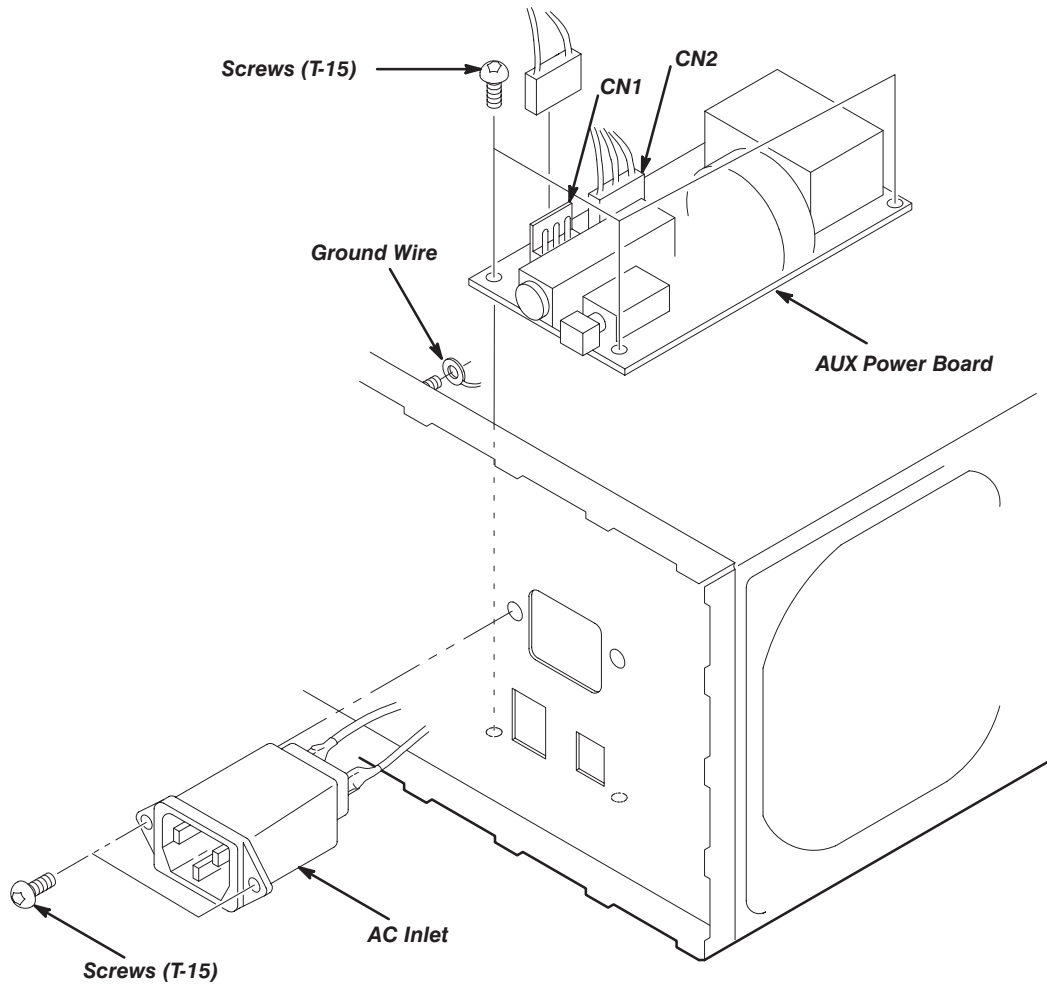

Figure 6-18: AUX Power Board and AC Inlet Removal

7. Reinstallation:

- a. Install the AUX Power board by doing substeps 6a and 6c in reverse order.
- b. Install the AC Inlet by doing substeps 5a–5e in reverse order.

Monitor Module and CRT Frame

1. *Assemble equipment and locate modules to be removed:*
 - a. You will need a screwdriver with a size T-15 Torx tip to do this procedure.
 - b. Locate the modules to be removed in the locator diagram, *Internal Modules*, in Figure 6-4.
2. *Remove front cover, trim ring, and menu buttons:* Do the *Front Cover, Trim Ring, and Menu Buttons* procedure on page 6-22.
3. *Orient instrument:* Set the AWG2005 with the bottom down on the work surface and the left side facing you.
4. *Remove monitor module:*

NOTE

Take care not to damage the CRT surface when installing or removing the monitor module.

- a. Disconnect the ribbon interconnect cable at J901 on the monitor module. See Figure 6-19.
- b. Remove the five screws securing the monitor module top and bottom to the chassis.
- c. Release the snap at the right of the front-panel module and shift the assembly. Insert the screwdriver with a size T-15 Torx tip into the right hole of the chassis, and then remove the screw securing the monitor module.
- d. Lift the monitor module up and away from the chassis to complete the removal.

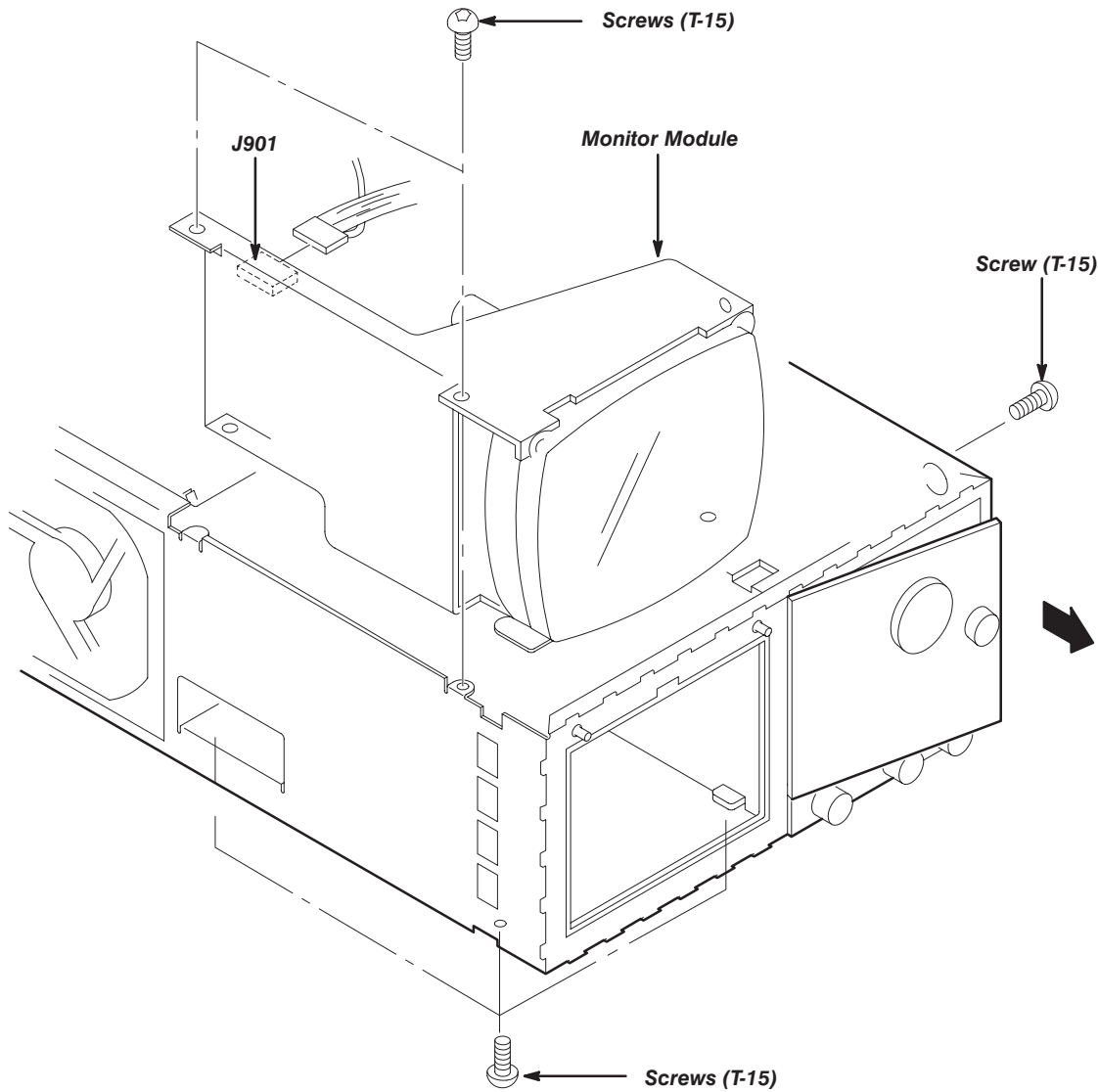

Figure 6-19: Monitor Module Removal

5. *Remove CRT frame:* Grasp the upper part of the CRT frame and take it out as shown in Figure 6-20.

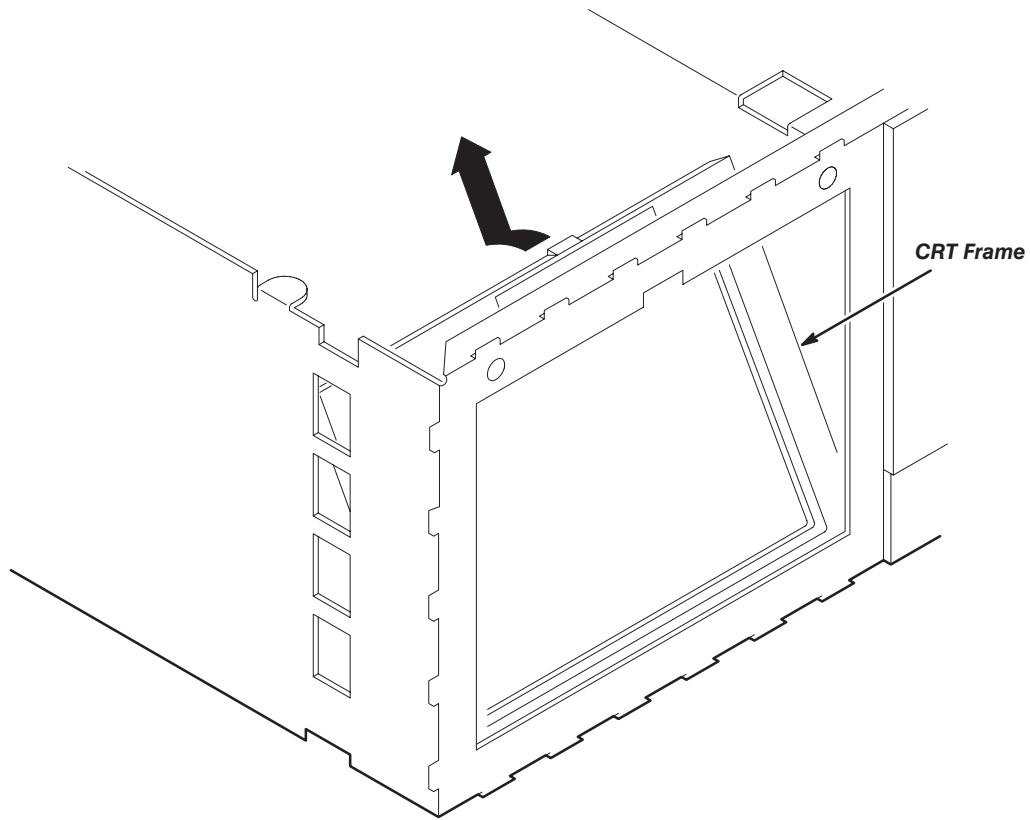

Figure 6-20: CRT Frame Removal

6. *Reinstallation:*

- a. Grasp the upper part of the CRT frame, align the notch of the chassis with the protrusion of the CRT frame, and place the CRT frame in the chassis.
- b. Install the monitor module by doing substeps 4a–4d in reverse order.

Circuit Boards

This procedure describes how to remove these circuit boards:

- A6 CPU Board
 - A2 AWG Board
 - A11 D/A Board
 - A1 Clock Board
 - For Option 02: A2 AWG Board and A11 D/A Board
 - For Option 04: A25 Digital Data Out Board
 - For Option 05: A31 Clock Sweep Board
 - For Option 09: A7 Floating Point Processor Board
1. *Assemble equipment and locate modules to be removed:* No tools are needed; however, the maintenance kit includes an ejector that is useful in removing circuit boards from the chassis. Locate the modules to be removed in the locator diagram, *Internal Modules*, in Figure 6-4.
 2. *Remove the rear shield cover:* Do the procedure, *Rear Shield Cover*, on page 6-35.
 3. *Orient instrument:* Set the AWG2005 with the left side down on the work surface and the bottom facing you.
 4. *Remove board support:* Remove the board support upward while pushing its hook to the inside.
 5. *Remove A6 CPU board:* This circuit board is installed in the second slot from the top.



To avoid permanent loss of waveform files, note the following: A lithium battery which maintains the nonvolatile memory during power-off time is located on the A5 Backplane board. The nonvolatile memory that contains the waveforms and their setup parameter data is located on the A6 CPU board. Removing either board will cause the waveform files, sequence files, and autostep files in nonvolatile memory to be permanently lost. Before removing either the A6 CPU board or the A5 Backplane board, save the waveform files, sequence files, and autostep files in the instrument nonvolatile memory to a floppy disk. Then, after reinstalling the board(s), reload the files into nonvolatile memory.

- a. Disconnect the ribbon interconnect cable at J50 and J64 on the A6 CPU board (see Figure 6-21).

Removal and Installation Procedures

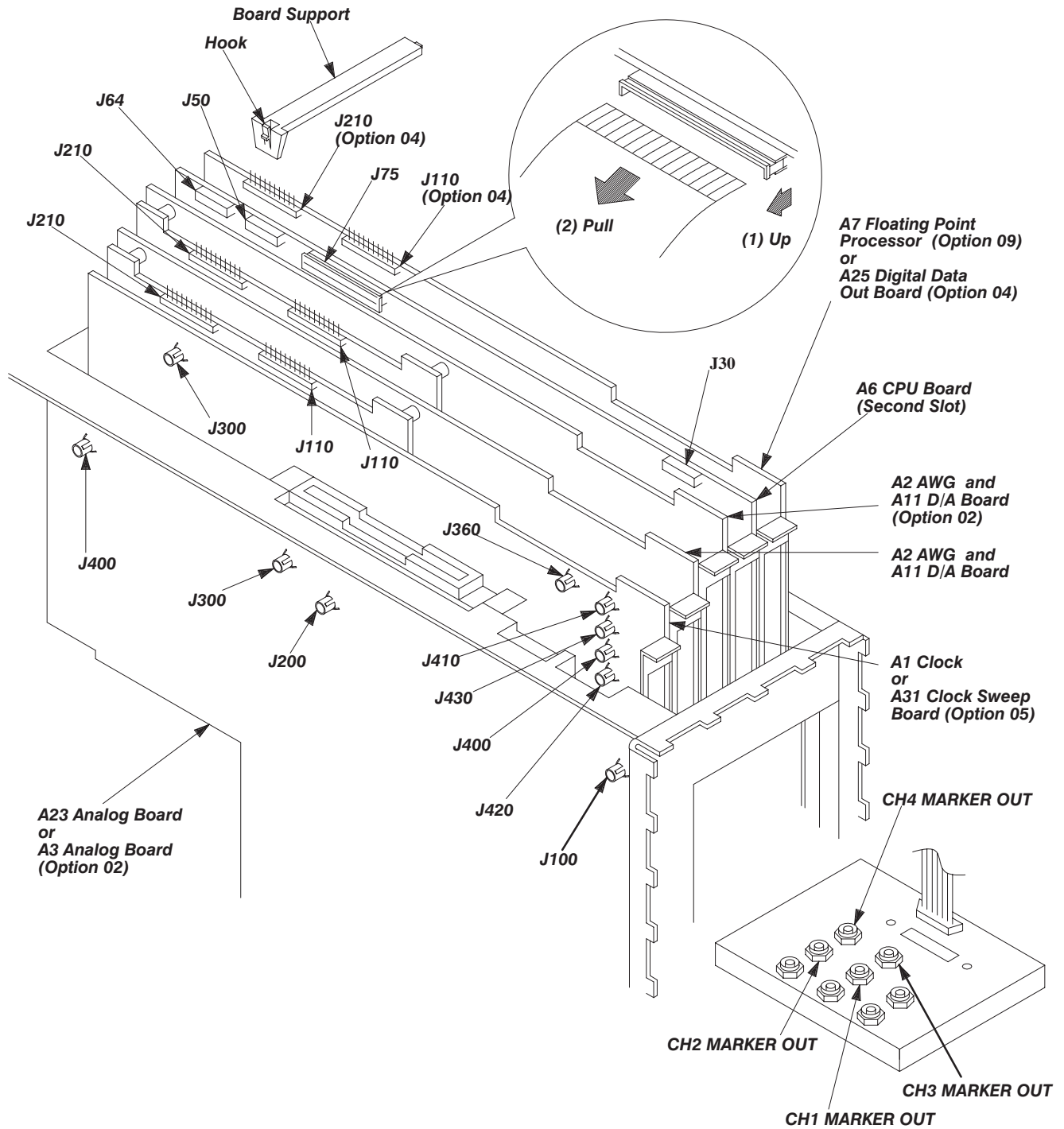

Figure 6-21: Board Removal

- b. Disconnect the flat cable at J75 on the A6 CPU board. Remove the flat cable as shown in Figure 6-21.
- c. Grasp the upper part of the A6 CPU board, and pull upward to remove it.

6. *Remove A2 AWG board and A11 D/A board:* This circuit board is installed in fourth slot from the top.
 - a. Disconnect the interconnect cables at J100 and J200 on the A23 Analog board (see Figure 6-21).
 - b. Disconnect the interconnect cables at the CH1 MARKER OUT and CH2 MARKER OUT connectors.
 - c. For the instrument with Option 04 installed, disconnect the flat cables at J110 and J210 on the A11 D/A board.
 - d. Grasp the upper part of the A2 AWG board and the A11 D/A board and pull upward to remove them.
7. *Remove A1 Clock board:* This circuit board is installed in the fifth slot from the top.
 - a. Disconnect the interconnect cables at J300, J400, J410, J420 and J430 on the A1 Clock board (see Figure 6-21).
 - b. Grasp the upper part of the A1 Clock board and pull upward to remove it.
8. *Remove A2 AWG board and A11 D/A board (Option 02):* The option adds the A2 AWG board and A11 D/A board in the third slot from the top.
 - a. Disconnect the interconnect cables at J300 and J400 on the A3 Analog board (see Figure 6-21).
 - b. Disconnect the interconnect cables at the CH3 MARKER OUT and CH4 MARKER OUT connectors.
 - c. Grasp the upper part of the A2 AWG board and the A11 D/A board and pull upward to remove them.
9. *Remove A25 Digital Data Out board (Option 04):* The option adds the A25 Digital Data Out board in the first slot from the top.
 - a. Disconnect the flat cables at J110 and J210 on the A25 Digital Data Out board (see Figure 6-21).
 - b. Grasp the upper part of the A25 Digital Data Out board, and pull it upward to remove it.
10. *Remove A31 Clock Sweep board (Option 05):* This option replaces A1 Clock board with A31 Clock Sweep board.
 - a. Disconnect the interconnect cables at J300, J360, J400, J410, J420 and J430 on the A31 Clock board (see Figure 6-21).
 - b. Grasp the upper part of the A31 Clock board and pull upward to remove it.

Removal and Installation Procedures

11. *Remove A7 Floating Point Processor board (Option 09):* The option adds the A7 Floating Point Processor board in the first slot from the top.
 - a. Grasp the upper part of the A7 Floating Point Processor board and pull it upward to remove it (see Figure 6-21).
12. *Reinstallation:* Do the board removal procedures in reverse order, reversing the order of the items in each procedure.

A5 Backplane Board



To avoid the permanent loss of waveform files, note the following: A lithium battery which maintains the nonvolatile memory during power-off time is located on the A5 Backplane board. The nonvolatile memory that contains the waveforms and their setup parameter data is located on the A6 CPU board. Removing either board will cause the waveform files, sequence files, and autostep files in nonvolatile memory to be permanently lost. Before removing either the A6 CPU board or the A5 Backplane board, save the waveform files, sequence files, and autostep files in the instrument nonvolatile memory to a floppy disk. Then, after reinstalling the board(s), reload the files into nonvolatile memory.

1. *Assemble equipment and locate modules to be removed:*
 - a. You will need a screwdriver with a size T-15 Torx tip and a 1/4-inch nut driver to do this procedure.
 - b. Locate the modules to be removed in the locator diagram, *Internal Modules*, in Figure 6-4.
2. *Orient instrument:* Set the AWG2005 with the left side down on the work surface and the top facing you.
3. *Remove A23 Analog board or A3 Analog board (Option 02):* Do the procedure, *A23 Analog board or A3 Analog board*, on page 6-29.
4. *Remove all circuit boards:* Do the procedure, *Circuit Boards*, on page 6-45.
5. *Remove A5 Backplane board:*
 - a. Remove the five screws and a nut securing the shield cover (see Figure 6-22).
 - b. Grasp the shield cover, and take it out.
 - c. Disconnect the ribbon interconnect cables at J8 on the A5 Backplane board (see Figure 6-22).
 - d. Disconnect the flat cable at J6 on the A5 Backplane board.
 - e. Remove the remaining four screws securing the A5 Backplane board to the chassis.
 - f. Lift the A5 Backplane board sideways, and then take it out.
6. *Reinstallation:*
 - a. *Install the A5 Backplane board:* Do substeps 5a–5f in reverse order to install the board.

Removal and Installation Procedures

- b. *Install the other boards:* Do the procedure, *Circuit Boards*, on page 6-45, in reverse order, reversing the items in each step.

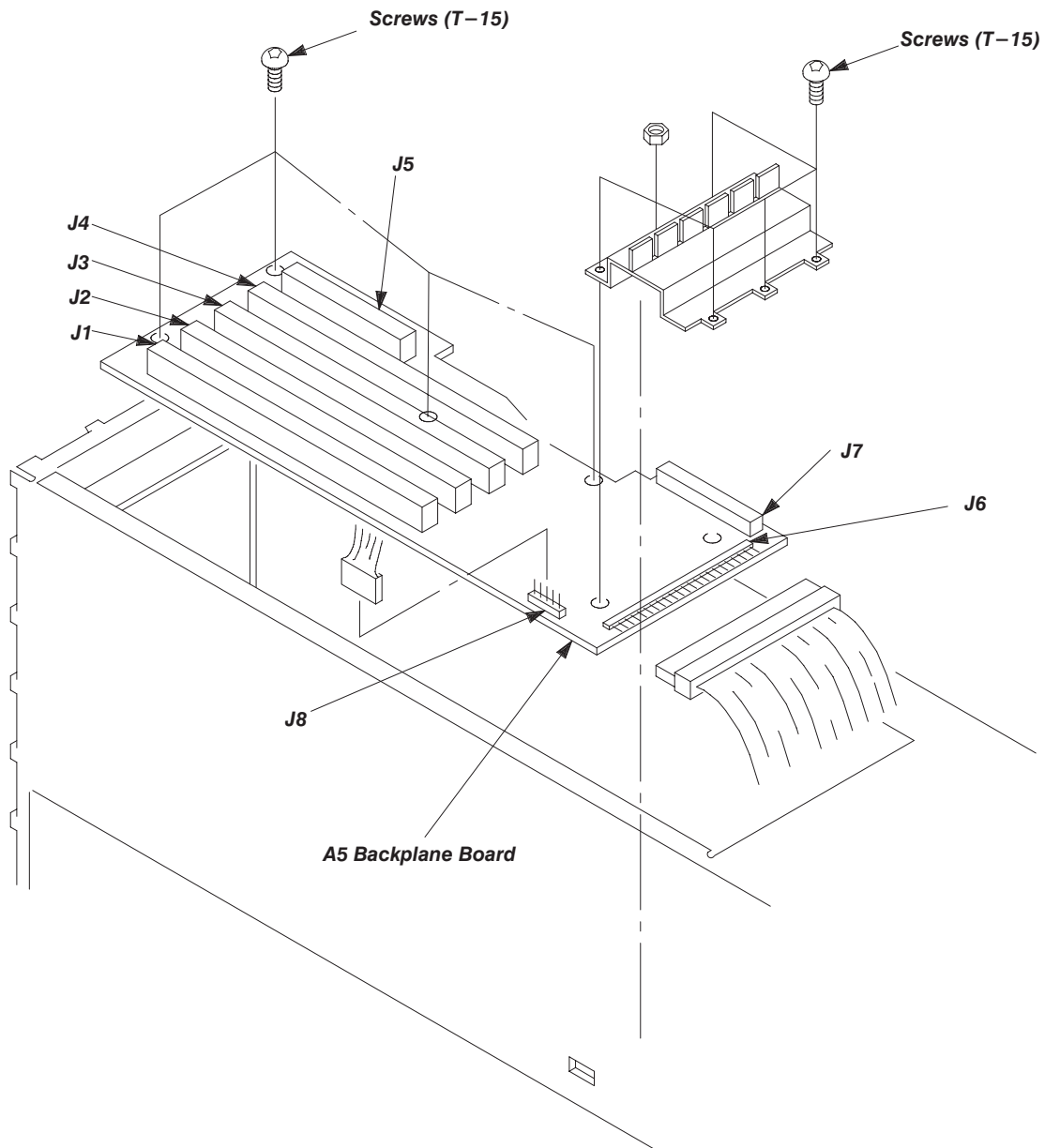

Figure 6-22: A5 Backplane Board Removal

Lithium Battery

WARNING

To avoid the risk of fire or explosion, install a new battery that has the same part number as listed in section 10, Mechanical Parts List, for a replacement battery.

To avoid the risk of fire or explosion, do not recharge, rapidly discharge, or disassemble the battery, heat it above 100° C, or incinerate it.

Dispose of used batteries promptly. Small quantities of used batteries may be disposed of in normal refuse. Keep lithium batteries away from children.

1. *Assemble equipment and locate modules to be removed:*
 - a. You will need a soldering iron to do this procedure.
 - b. You will also need a replacement lithium battery having the part number listed in section 10, *Mechanical Parts List*.
 - c. Locate the battery to be removed in the locator diagram, *Internal Modules*, in Figure 6-4.
2. *Remove A5 Backplane board:* Do the *A5 Backplane Board* procedure on page 6-49.
3. *Orient board:* Set the A5 Backplane board on an insulating surface.
4. *Remove used battery:*
 - a. Unsolder the tabs at the ends of the battery, taking care not to heat the battery (see Figure 6-23).
 - b. Grasp the battery, and lift it away from the board.
5. *Install new battery:*
 - a. Place the new battery on the board with the negative tab of the battery closest to the board edge connector.
 - b. Solder the tabs to the board.

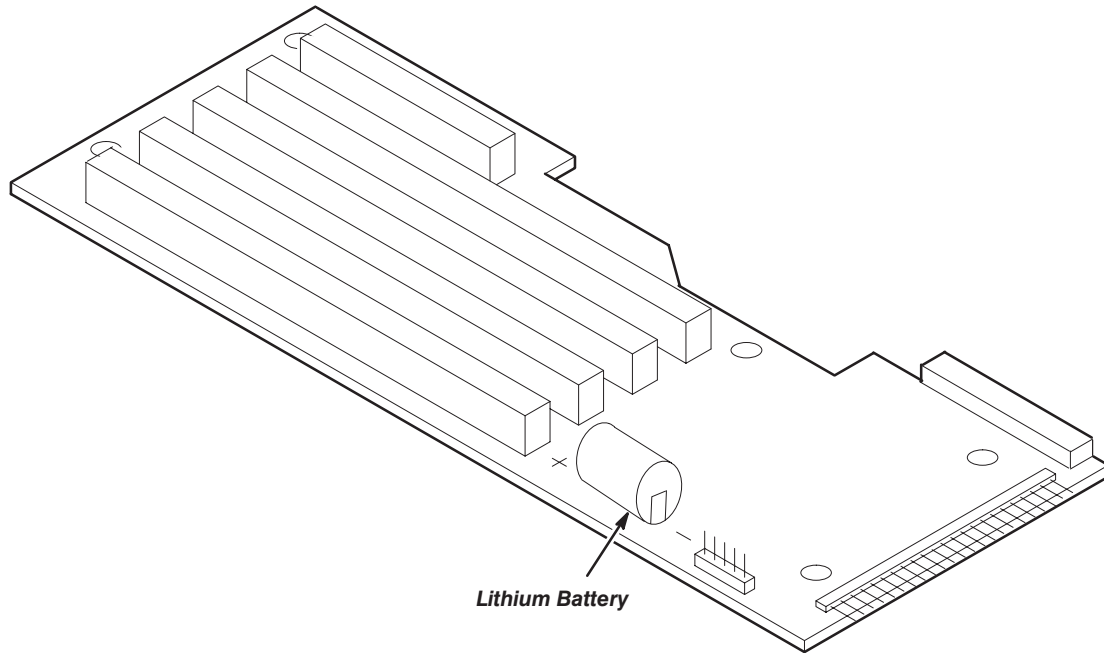

Figure 6-23: Battery Location on the A5 Backplane Board

Floppy-disk Drive Module

1. *Assemble equipment and locate modules to be removed:*
 - a. You will need a screwdriver with a size T-10 Torx tip and a size #1 Phillips tip to do this procedure.
 - b. Locate the modules to be removed in the locator diagram, *Internal Modules*, in Figure 6-4.
2. *Remove rear shield cover:* Do the *Rear Shield Cover* procedure on page 6-35.
3. *Remove A23 Analog board or A3 Analog board (Option 02):* Do the *A23 Analog board or A3 Analog board* procedure on page 6-29, removing the A23 Analog board or A3 Analog board.
4. *Orient instrument:* Set the AWG2005 with the left side down on the work surface and the bottom facing you.
5. *Remove all circuit boards:* Do the procedure, *Circuit Boards*, on page 6-45.
6. *Remove floppy-disk drive module:*
 - a. Using a screwdriver with a size T-10 Torx tip, remove the six screws securing the floppy-disk drive cover to the chassis (see Figure 6-24).
 - b. Disconnect the flat cable of the floppy disk drive.
 - c. Using a screwdriver with a size #1 Phillips tip, remove the three screws securing the floppy-disk drive to the bracket.
 - d. Using a screwdriver with a size #1 Phillips tip, remove the three screws securing the spacer to floppy-disk drive.
 - e. Grasp the upper part of the floppy-disk, and pull it upward to remove it.
7. *Reinstallation:*
 - a. *Install floppy-disk drive module:* Do substeps 6a–6e in reverse order.
 - b. *Install circuit boards:* Do the procedure, *Circuit Boards*, on page 6-45, in reverse order.
 - c. *Install A23 Analog board:* Do the part on removing the A23 Analog board on page 6-29 in reverse order. This completes the reinstallation.

Removal and Installation Procedures

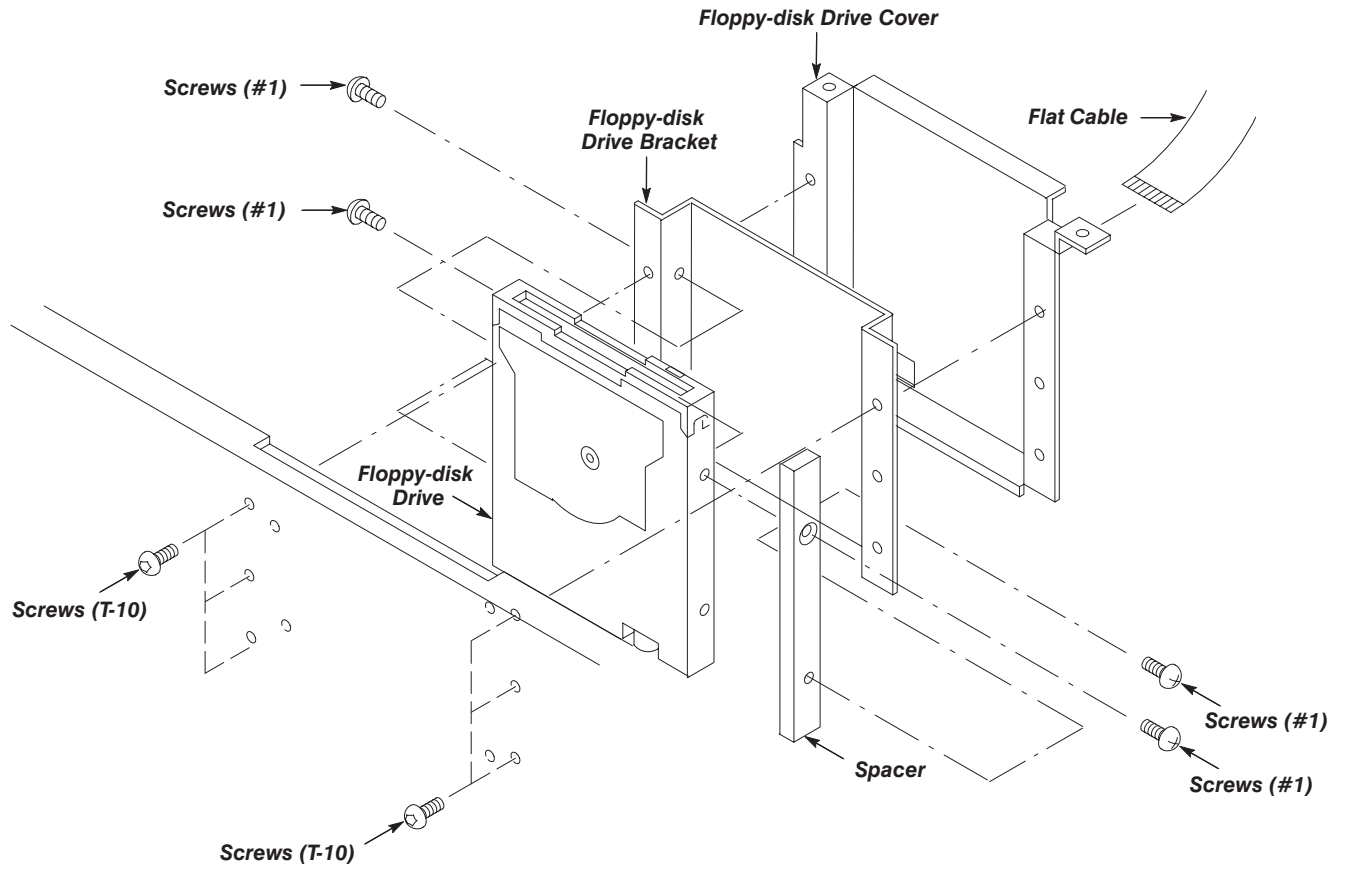

Figure 6-24: Floppy-disk Drive Module Removal

Repackaging

This subsection contains information about repackaging the AWG2005 for shipment.

Repackaging Instructions

Use a corrugated cardboard shipping carton having a test strength of at least 275 pounds and with an inside dimension at least six inches greater than the AWG2005 dimensions. (If available, use the original shipping carton, which meets these requirements.)

If the AWG2005 is shipped to a Tektronix Service Center, enclose the following information:

- The owner's address
- Name and phone number of a contact person
- Type and serial number of the AWG2005
- Reason for returning
- A complete description of the service required

Seal the shipping carton with an industrial stapler or strapping tape.

Mark the address of the Tektronix Service Center and your own return address on the shipping carton in two prominent locations.

Troubleshooting

This subsection contains information and procedures designed to isolate faulty modules in the AWG2005 Arbitrary Waveform Generator. If these procedures indicate a module needs to be replaced, follow the *Removal and Installation Procedures*, preceding.

Troubleshooting Procedures

The troubleshooting procedures consist of these flowcharts.

- Figure 6-25: Primary Troubleshooting Procedure
- Figure 6-27: Troubleshooting Procedure 1 — Power Supply Module
- Figure 6-30: Troubleshooting Procedure 2 — A6 CPU Board or Front-panel Module
- Figure 6-32: Troubleshooting Procedure 3 — Monitor Module
- Figure 6-36: Troubleshooting Procedure 4 — Module Isolation

To use these procedures, begin with the Primary Troubleshooting Procedure. It prompts you to check various indications of AWG2005 functionality and directs you to the other troubleshooting procedures.

AWG2005 Diagnostics

The AWG2005 has internal diagnostics that verify circuit functionality. The AWG2005 automatically executes the internal diagnostics at power-on. You can also run the internal diagnostics by using the UTILITY menu. See *Checking Diagnostics Tests* below. The difference between the two methods of running the internal diagnostics routine is that the power-on method does not do as much memory checking.

If the internal diagnostics indicate a test in the internal diagnostics failed, use the troubleshooting procedures in this subsection to determine which module to replace.

Checking Diagnostics Tests

Prerequisites — Power on the AWG2005 and allow a 20 minute warmup before doing this procedure.

1. Push the **UTILITY**→**Diag/Cal**→**Diagnostics**
2. Select **All** with the general purpose knob.
3. Select **Execute** from the side menu. This executes all the diagnostics automatically. As each test finishes, the result is displayed on the screen.
4. Check the diagnostic test results. If any test failed, go to *Troubleshooting Procedure 4 — Module Isolation* on page 6-68. The table in the flowchart shows which module is related to each diagnostic test. If the tests pass but there is still a problem, go to the *Primary Troubleshooting Procedure* on page 6-59.

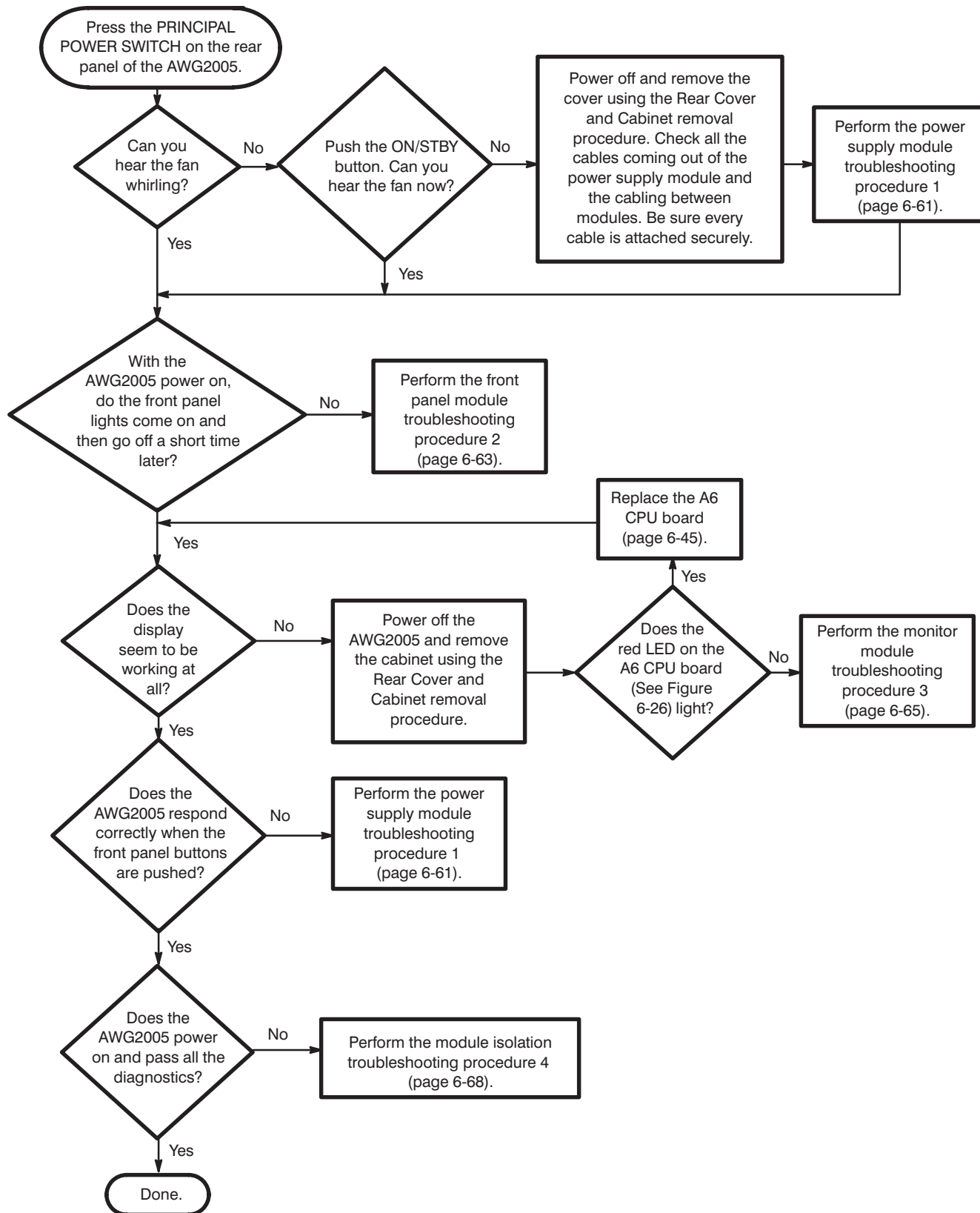

Figure 6-25: Primary Troubleshooting Procedure

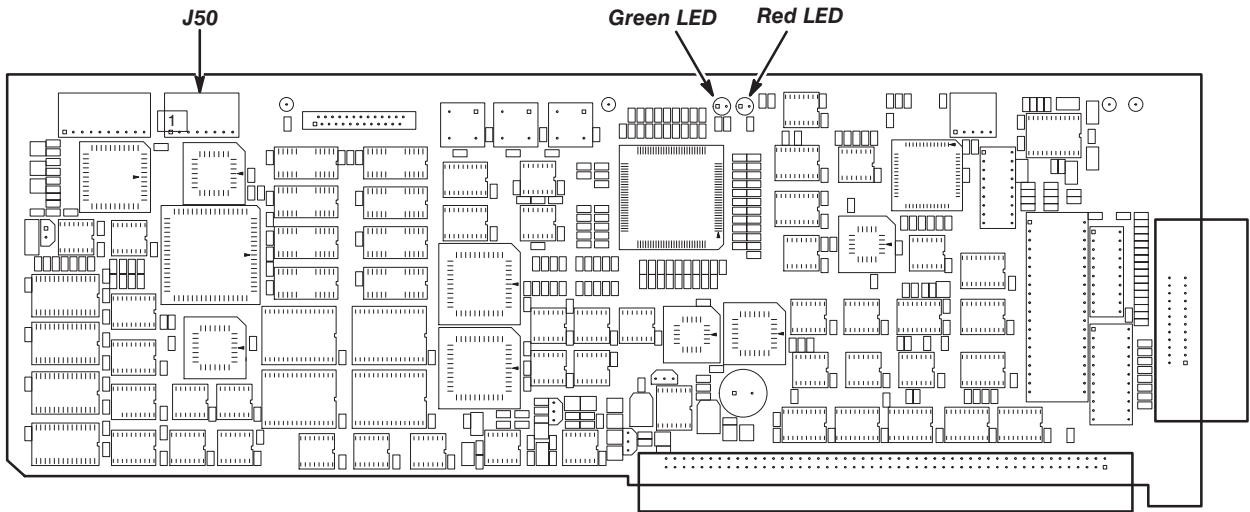

Figure 6-26: CPU Board

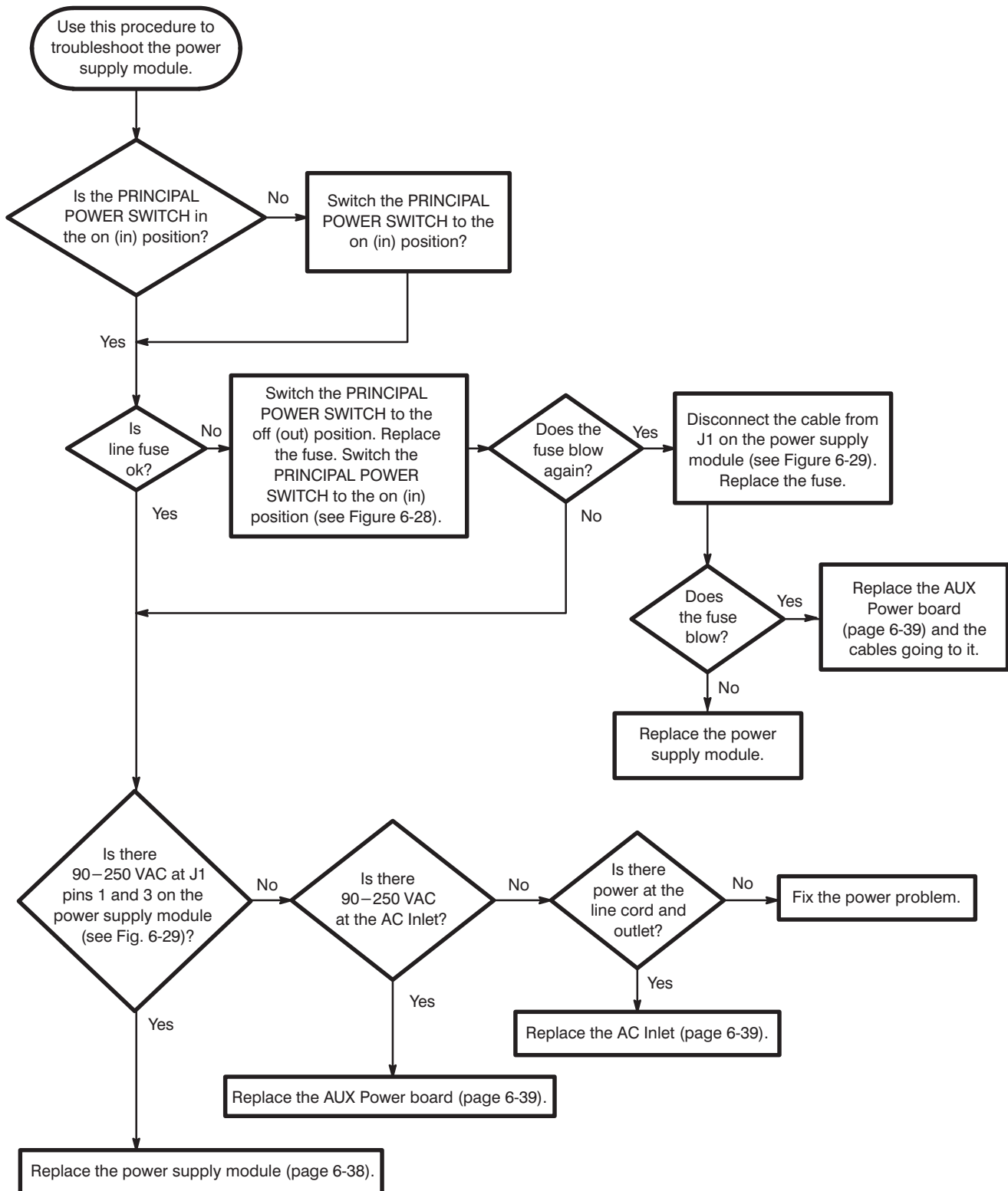

Figure 6-27: Troubleshooting Procedure 1 — Power Supply Module

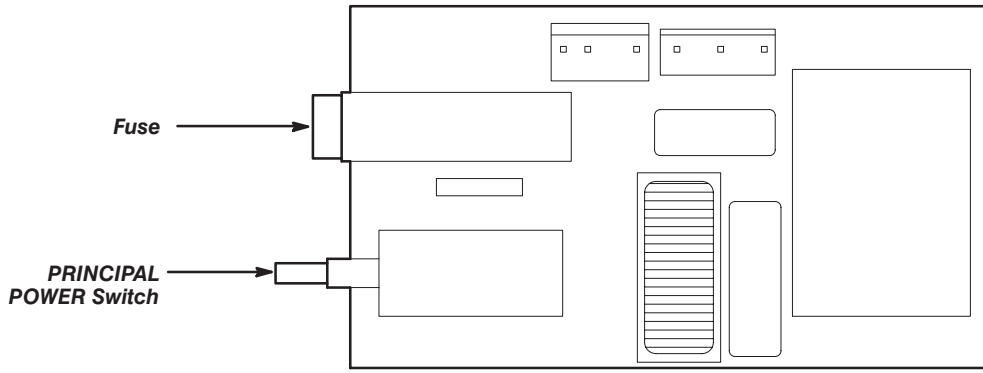

Figure 6-28: AUX Power Board

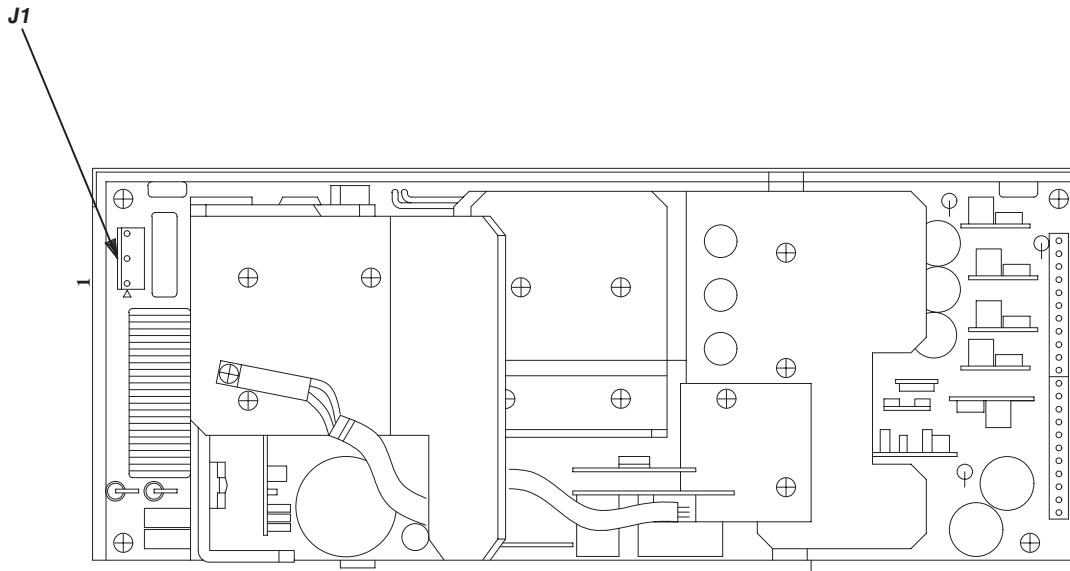

Figure 6-29: Power Supply Module

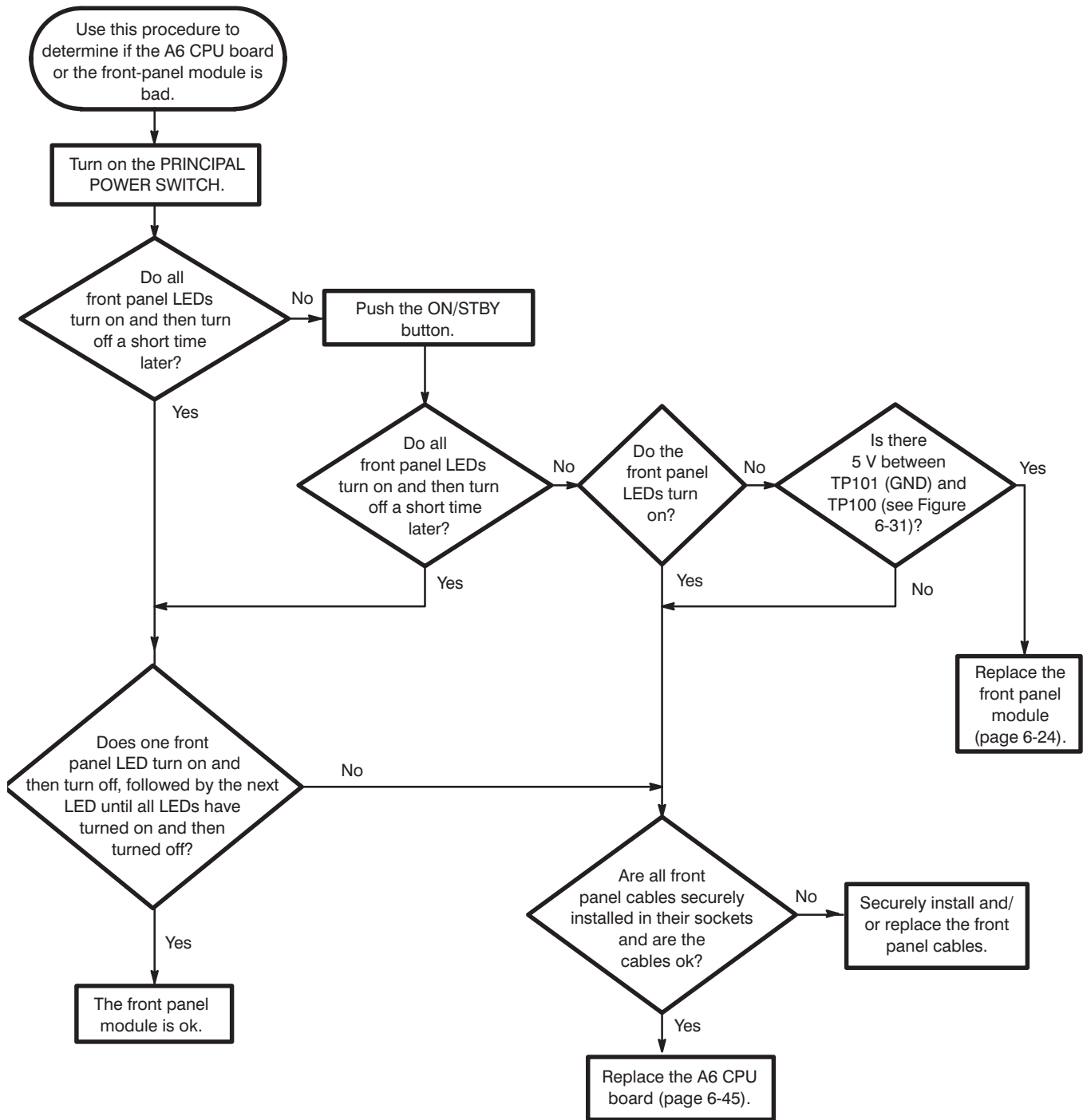

Figure 6-30: Troubleshooting Procedure 2 — A6 CPU Board or Front-panel Module

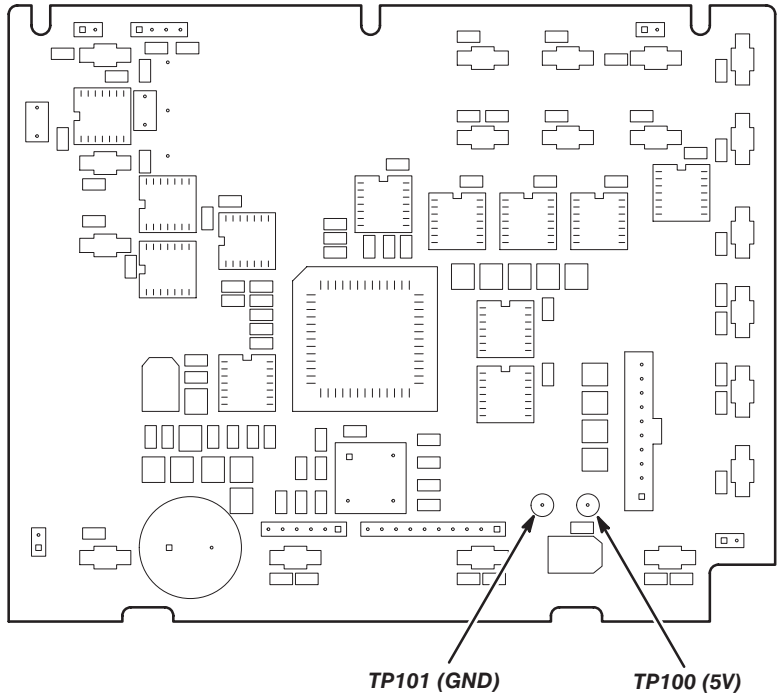

Figure 6-31: Key Board

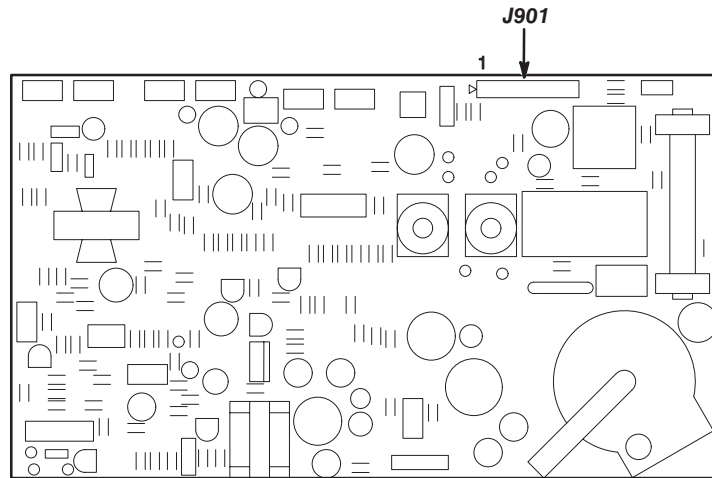

Figure 6-33: Monitor Module

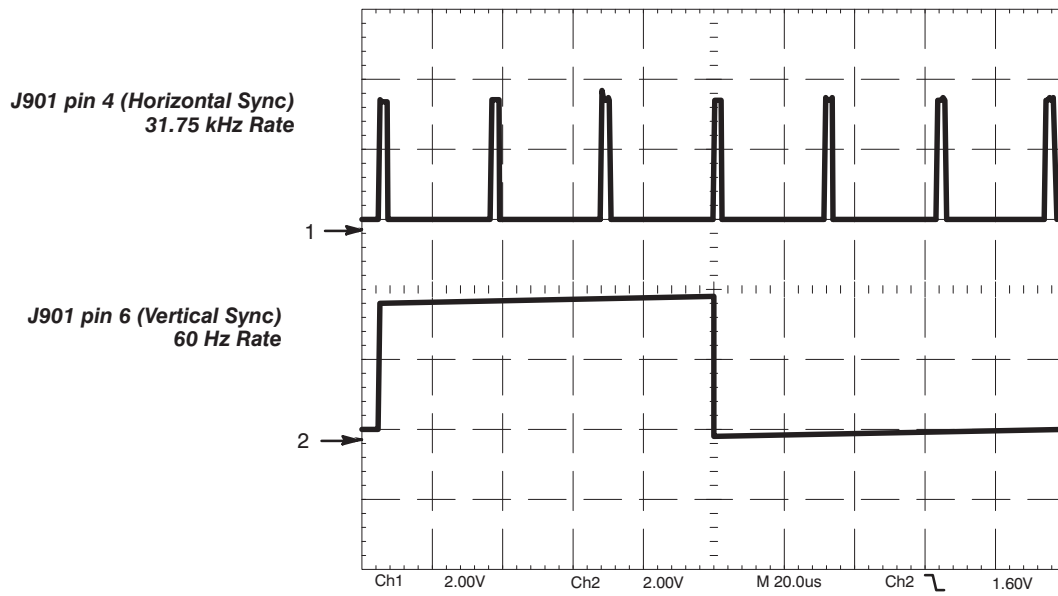

Figure 6-34: Horizontal and Vertical Sync Signals

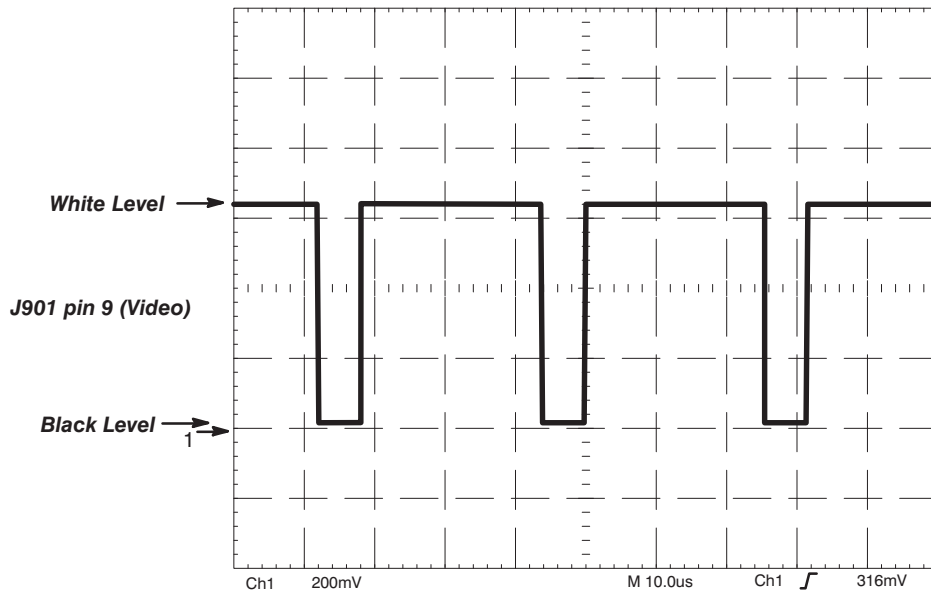

Figure 6-35: A Video Signal with White and Black Levels

Troubleshooting

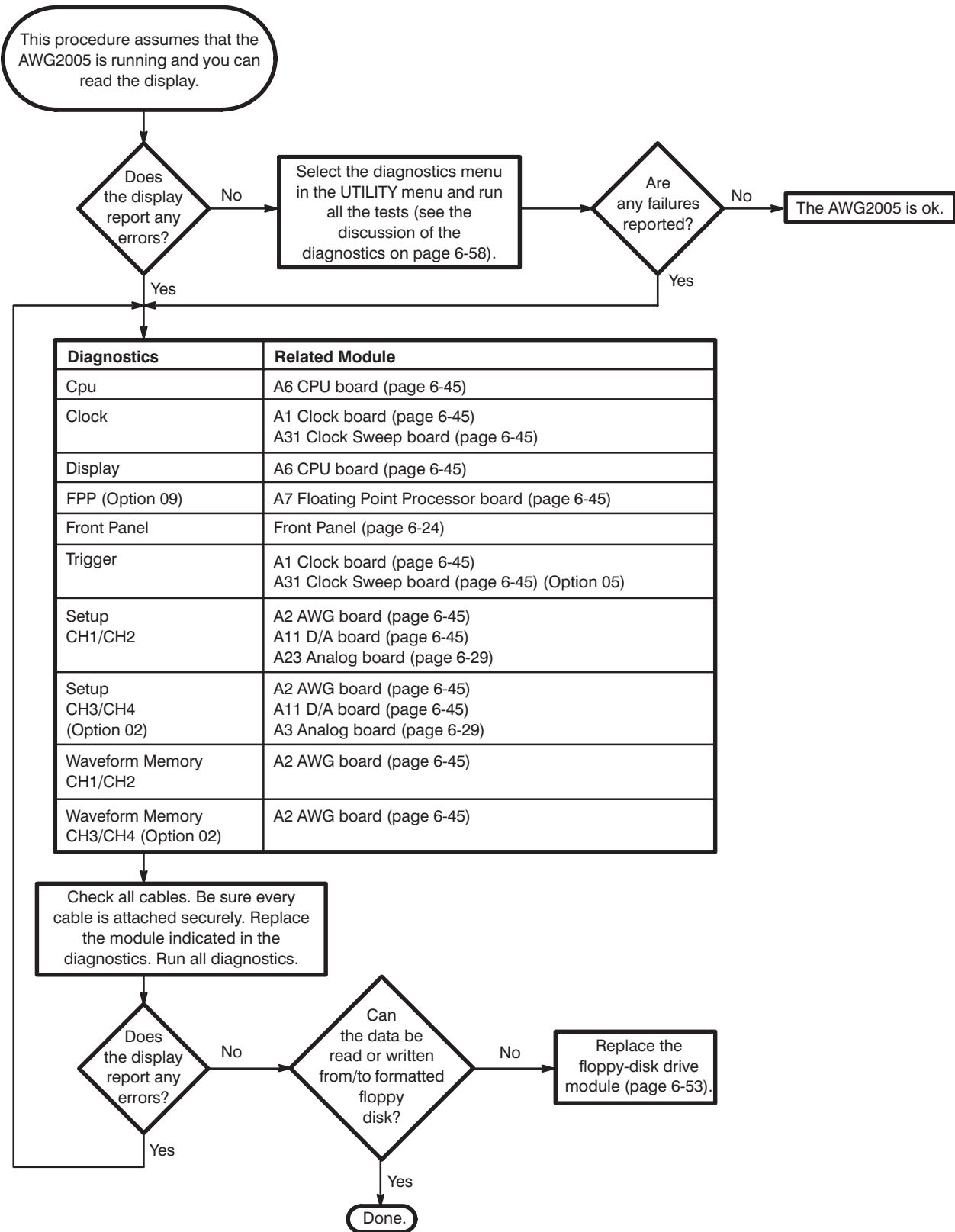

Figure 6-36: Troubleshooting Procedure 4 — Module Isolation

Options and Accessories

This section describes the various options as well as the standard and optional accessories that are available for the AWG2005 Arbitrary Waveform Generator.

List of Options

Options include:

- **Option 02** — adds CH3 and CH4 output.
- **Option 04** — makes digital waveform data available at the rear panel. See note, below.
- **Option 05** — adds a clock sweep editor.
- **Option 09** — adds a FFT editor, a convolution waveform editor and floating-point processor. See note, below.
- **Option 1R** — ships the waveform generator configured for installation in an instrument rack.
- **Option 1S** — adds the WaveWriter S3FT400.
- **Option 95** — ships with a test result report.
- **Option A1–A5** — changes the standard power cord to one of five alternate power cord configurations.
- **Option B1** — adds the service manual and the Performance Check disk.

NOTE

Options 04 and 09 are mutually exclusive.

Each option is described more fully in the following pages.

Options A1 – A5

In place of the standard North American, 110 V, 60 Hz power cord, Tektronix ships any of five alternate power cord configurations with the waveform generator, as ordered by the customer.

Table 7-1: International Power Cords

Option	Power Cord
Option A1	Universal European — 220 V, 50 Hz
Option A2	United Kingdom — 240 V, 50 Hz
Option A3	Australian — 240 V, 50 Hz
Option A4	North American — 240 V, 60 Hz
Option A5	Switzerland — 220 V, 50 Hz

Option 02

This option provides two additional channels (channel 3 and channel 4). Also, two additional connectors are added on the rear panel (**CH3 MARKER OUT** and **CH4 MARKER OUT**). The instrument with Option 02 allows you to simultaneously output four different waveforms.

Option 04

With Option 04, the waveform generator can provide the following digital signals at the rear panel output connector. This option and Option 09 cannot both be installed.

Data Output

The data (D0–D11) fed to this instrument's internal D/A converter is buffered and connected to the output connector. At the same time that the analog waveform is output, the digital output can be obtained. Output will be at the TTL level.

Clock Output

The same clock that is fed to this instrument's internal D/A converter is buffered in the same way as the data and connected to the connector. As in the case of data output, clock output will be at the TTL level.

Figure 7-1 is a block diagram of the digital data output Option 04.

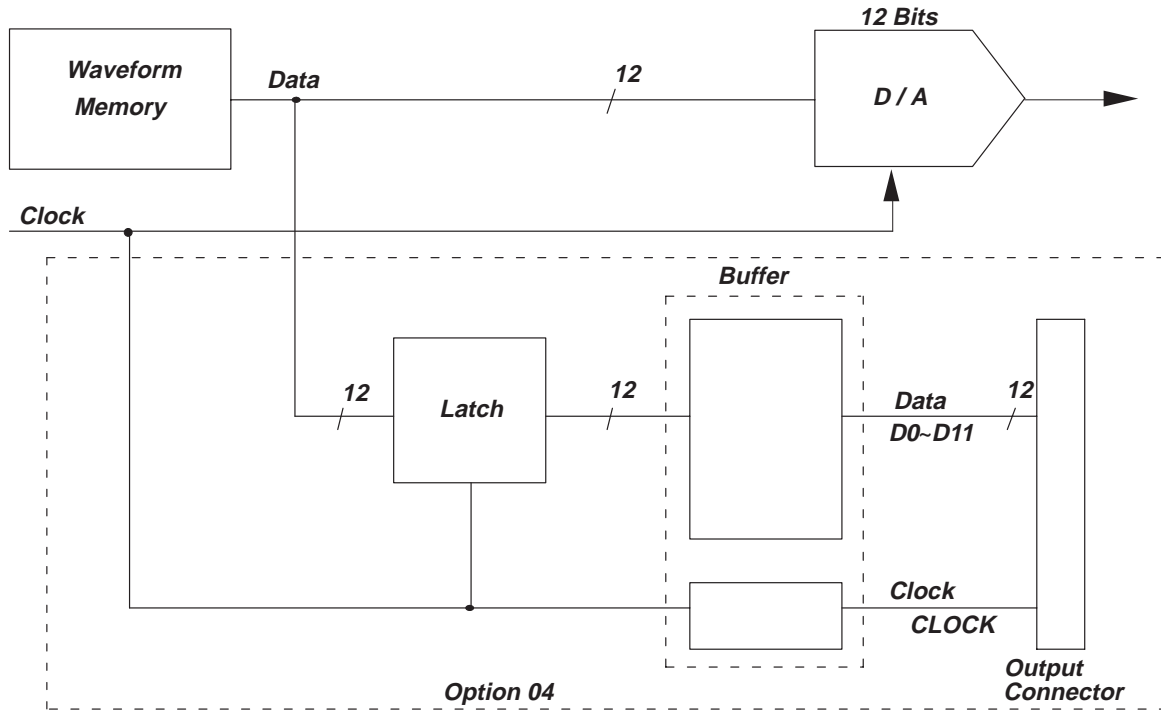

Figure 7-1: Option 04 Block Diagram

Output Connector Configuration

Figure 7-2 shows the shape of the output connector and its pin locations. Table 7-2 lists the output signal for each pin.

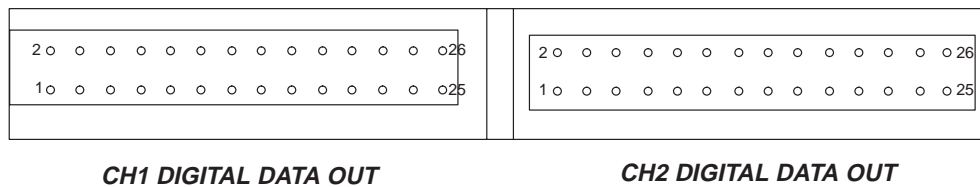

Figure 7-2: Option 04 Output Connector

Table 7-2: Option 04 Digital Output Signals

Pin Number	Signal	Pin Number	Signal
1	Data bit 0 (LSB)	15	Data bit 7
3	Data bit 1	17	Data bit 8
5	Data bit 2	19	Data bit 9
7	Data bit 3	21	Data bit 10
9	Data bit 4	23	Data bit 11 (MSB)
11	Data bit 5	24	Clock
13	Data bit 6		

Pins other than above are connected to ground. The pin assignments are identical for both CH1 and CH2.

Operation

Basically, operations are in correspondence with analog output for the AWG2005 arbitrary waveform generator. When a waveform is not being output, the waveform's initial data may be output to the connector. At this time, the clock is not generated.

When starting the waveform output, the clock is generated and the data is updated.

NOTE

Excess output can be generated in the data clock (see Figure 7-3) when loading a new waveform into waveform memory, when resetting the waveform memory, or during the hold off.

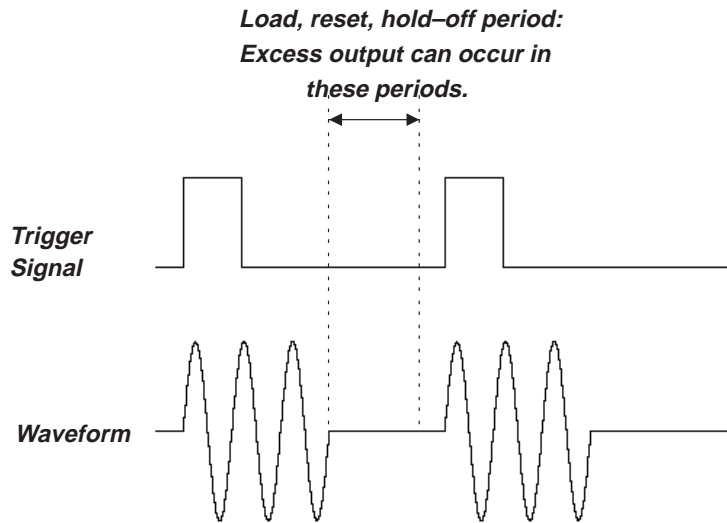

Figure 7-3: Generation of Excess Output

Output Circuit and Output Waveform

Figure 7-4 shows a diagram of the output circuit. After first passing through an output resistance of $50\ \Omega$, the buffer output proceeds to the output connectors. The AWG2005 can be used without terminating the receiving (user) side with a resistance of $50\ \Omega$, but when waveform distortion is greater the $50\ \Omega$ termination is required.

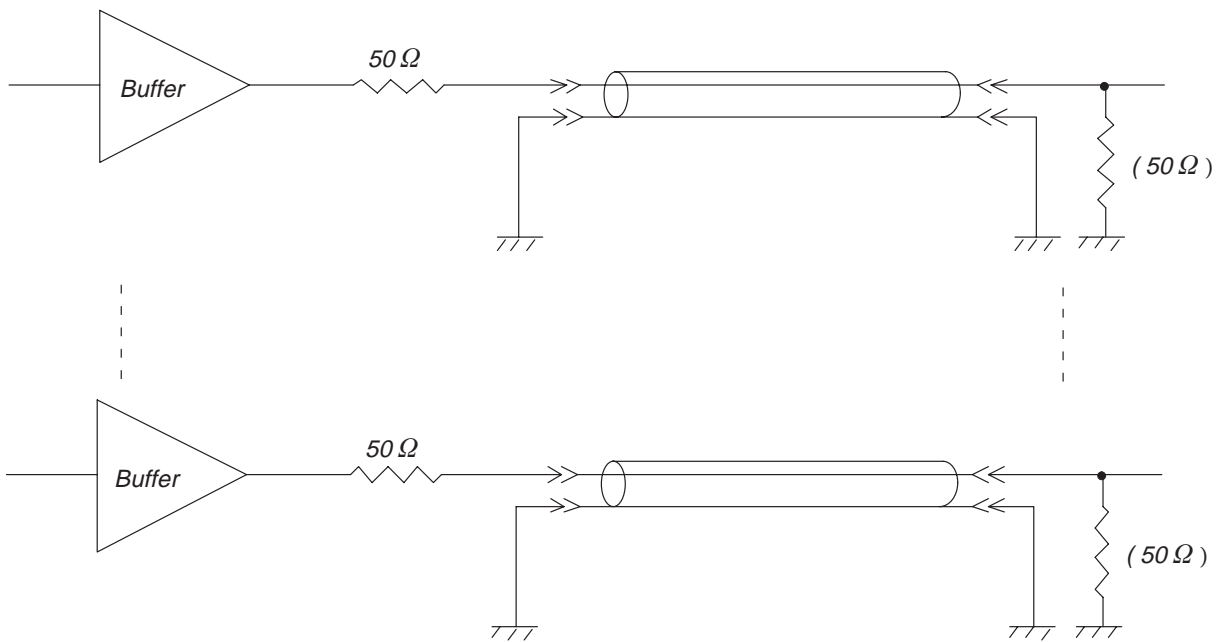

Figure 7-4: Output Circuit

The skew of the data output is held to ± 15 ns. The rising and falling times will depend on the buffer ICs, but neither is greater than 4 ns. See Figure 7-5. This figure shows the specifications for the waveform at the output connector when a cable is not being used.

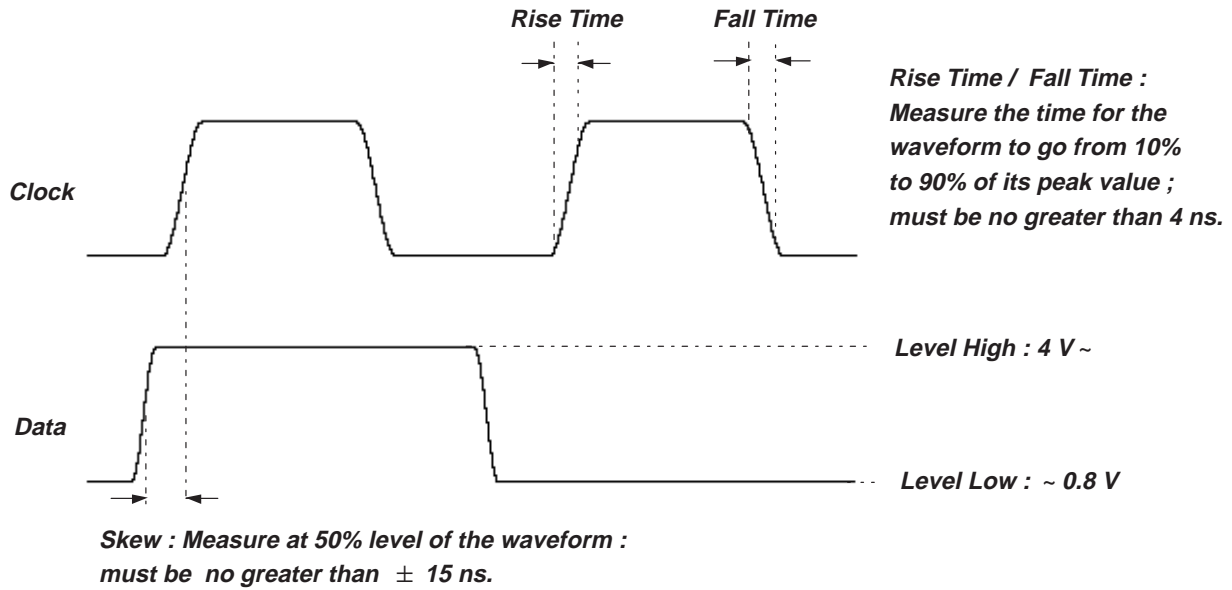

Figure 7-5: Output Waveform

If a cable is used these waveforms have transmission distortion. It is necessary to latch the data with a clock before using the waveform in actual circuits at the cable receiving side (user side) and to reproduce the waveform. Delay the clock with the delay line in order to reproduce the data reliably (see Figure 7-6).

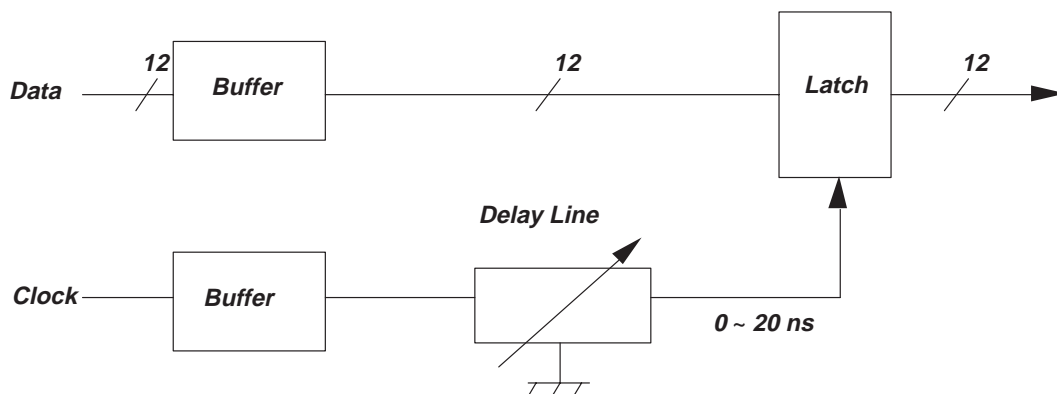

Figure 7-6: Data Latching

Cable

Option 04 comes with a digital data out cable. The cable connecting the AWG2005 rear panel output connectors and the user circuit is extremely critical for operation at the maximum clock frequency. Figure 7-7 shows the digital data out cable provided as a standard accessory and the receiving connector.

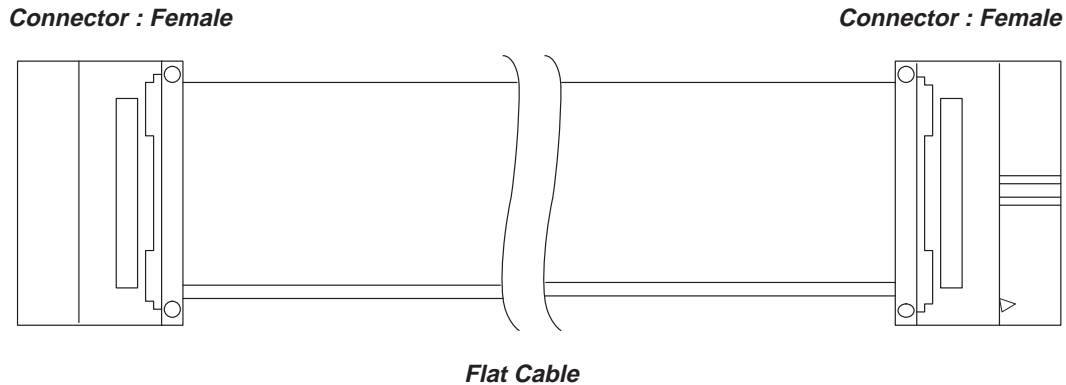

Figure 7-7: Digital Data Out Cable

If you use a cable other than the one provided as the standard accessory the cable must meet the following conditions.

- It must be a coaxial cable with a characteristic impedance of $50\ \Omega$ for all DATA and CLOCK lines.
- Keep cables as short as possible. The acceptable length depends on the characteristics of the coaxial cable used, but lengths under 1 meter are preferable.

Application Suggestions

Waveform Regeneration — In some cases even a cable that has been carefully made will create transmission distortion. Figure 7-8 shows an example of a circuit used to regenerate the waveform.

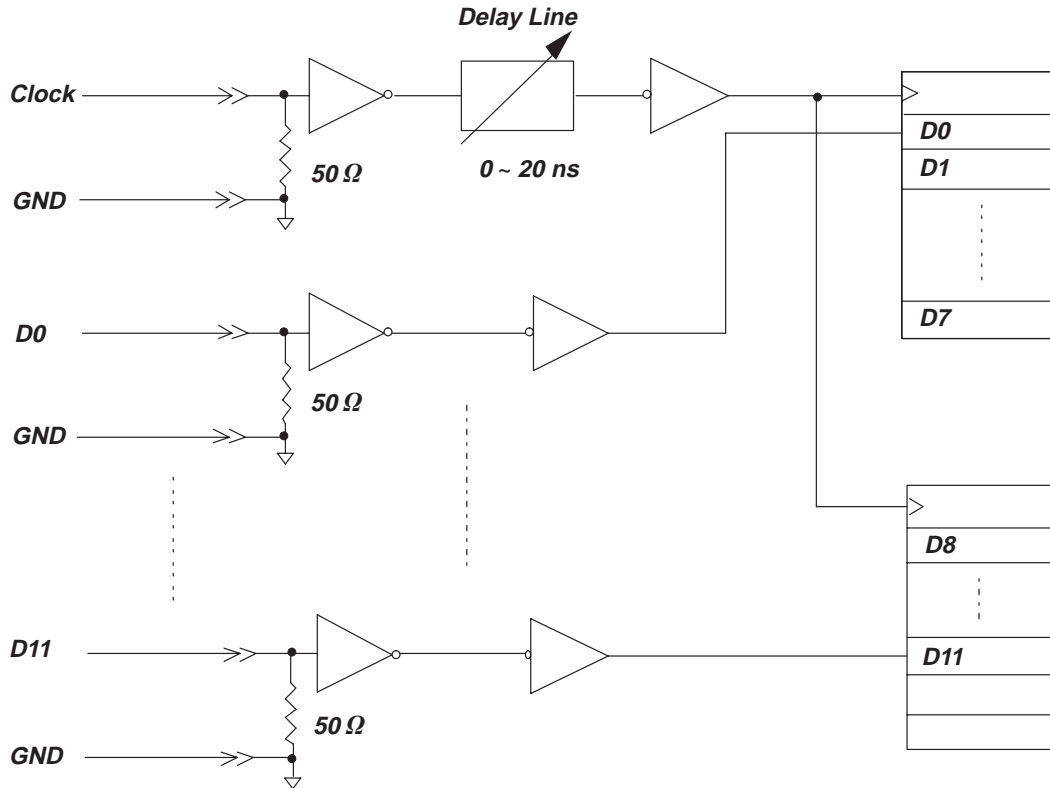

Figure 7-8: Waveform Reproduction Circuit Example

NOTE

Tektronix cannot be responsible for the infringement of any third-party industrial proprietary rights, copyrights, or other rights arising from the use of these circuits.

NOTE

The ECB is a multi-layer board. One layer is used as ground and the other as the power supply. The data lines are wired to the same length so that their delay times will be the same.

Option 05

This option provides a clock sweep editor. In addition to performing linear sweep and log sweep for the clock frequency, the clock sweep editor enables you to easily create arbitrary sweep.

Option 09

This option provides increased internal calculation speed and two additional editors: an FFT editor and a convolution editor.

Option 1R

For Option 1R, the waveform generator is configured for installation in a 19-inch wide instrument rack. In this configuration, the floppy disk drive is mounted on the front panel. To change an AWG2005 into a rackmount version, contact your closest Tektronix representative.

Option 1S

WaveWriter is an application program used to create waveforms for advanced signal generating and processing instruments. Many Tektronix instruments, such as arbitrary waveform generators and oscilloscopes with the "save-on-delta" feature, are enhanced by this program. WaveWriter helps users configure waveforms with a minimum of effort.

With the WaveWriter package, you can create new waveforms or edit waveforms acquired from various instrument sources. WaveWriter gives you interactive control of the waveform generating process. WaveWriter operates within the Microsoft Windows™ environment.

Option 95

A test result report will be provided with the AWG2005 when this option is specified.

Accessories

Standard Accessories

The following standard accessories are provided with each instrument:

Table 7-3: Standard Accessories List

Qty	Description	Part Number
1	User manual	070-8958-50
1	Programmer manual	070-8657-XX
1	GPIB Programming Examples Disk, 3.5-inch media	063-1708-XX
1	Sample Waveform Library Disk, 3.5-inch media	063-1704-XX
1	Power cable	161-0230-01
1	Fuse (6 A, 250 V, fast-blow) (UL 198G/3AG)	159-0239-XX
1	Fuse cap	200-2264-XX
1	Fuse 5 A (T) (IEC127)	159-0210-XX
1	Fuse cap	200-2265-XX
1	Certificate of Calibration	

Optional Accessories

The following optional accessories are recommended for use with the instrument:

Table 7-4: Optional Accessories List

Qty	Description	Part Number
1	Service manual	070-8962-50
1	Performance check disk	063-1706-XX
1	Front cover	200-3232-XX
1	Accessory pouch	016-1159-XX
1	GPIB cable	012-0991-XX
1	50 Ω BNC cable	012-1342-XX
1	50 Ω BNC terminator	011-0049-XX
1	Maintenance kit (see Table 7-5)	067-1396-XX

Table 7-5: Maintenance Kit Contents

Qty	Description	Part Number
1	Extender-A board (for slot 1, 2, 3, 4)	671-2331-XX
1	Extender-B board (for slot 5)	671-2487-XX
1	Cable kit	198-5802-XX
1	Ejector	003-1315-XX
1	Header	131-5537-XX
1	Connector (PELTOLA-to-BNC)	131-1315-XX

Electrical Parts List

The modules that make up this instrument are often a combination of mechanical and electrical subparts. Therefore, all replaceable modules are listed in section 10, *Mechanical Parts List*. Refer to that section for part numbers when using this manual.

Diagrams

This section contains a block diagram and an interconnect diagram. The block diagram shows the modules and functional blocks in an AWG2005 with Option 02, the CH3 and CH4, and Option 04, Digital Data Out, and Option 05, Clock Sweep, and Option 09, Floating Point Processor. The interconnect diagram shows how the modules in the AWG2005 connect.

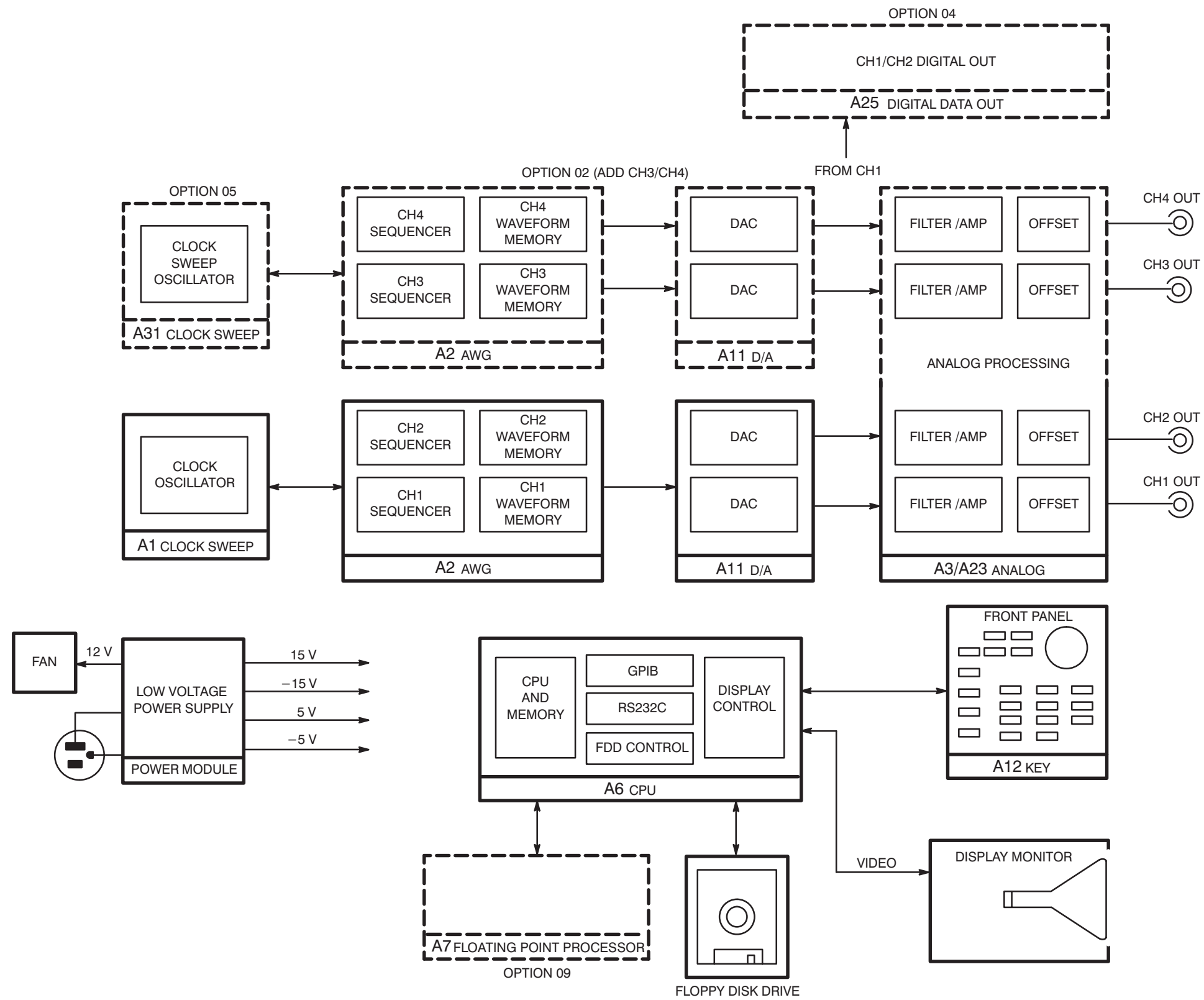

Figure 9-1: Block Diagram

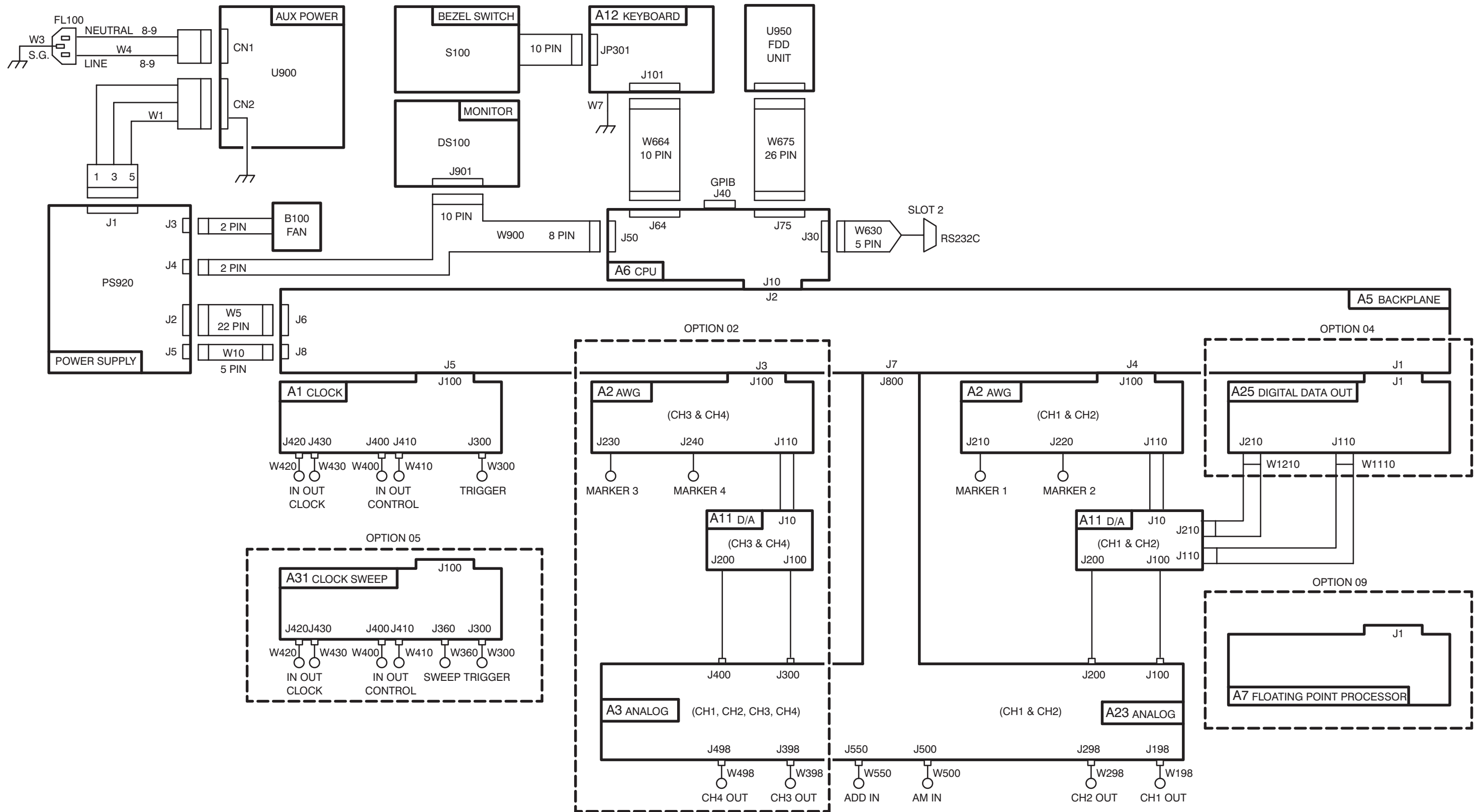

Figure 9-2: Interconnect Diagram

Replaceable Mechanical Parts

This section contains a list of the replaceable mechanical components for the AWG2005. Use this list to identify and order replacement parts.

Parts Ordering Information

Replacement parts are available through your local Tektronix field office or representative.

Changes to Tektronix products are sometimes made to accommodate improved components as they become available and to give you the benefit of the latest improvements. Therefore, when ordering parts, it is important to include the following information in your order.

- Part number (see Part Number Revision Level below)
- Instrument type or model number
- Instrument serial number
- Instrument modification number, if applicable

If you order a part that has been replaced with a different or improved part, your local Tektronix field office or representative will contact you concerning any change in part number.

Change information, if any, is located at the rear of this manual.

Part Number Revision Level

Tektronix part numbers contain two digits that show the revision level of the part. For most parts in this manual, you will find the letters XX in place of the revision level number.



When you order parts, Tektronix will provide you with the most current part for your product type, serial number, and modification (if applicable). At the time of your order, Tektronix will determine the part number revision level needed for your product, based on the information you provide.

Using the Replaceable Mechanical Parts List

The tabular information in the Replaceable Mechanical Parts List is arranged for quick retrieval. Understanding the structure and features of the list will help you find all of the information you need for ordering replacement parts. The following table describes the content of each column in the parts list.

Parts List Column Descriptions

Column	Column Name	Description
1	Figure & Index Number	Items in this section are referenced by figure and index numbers to the exploded view illustrations that follow.
2	Tektronix Part Number	Use this part number when ordering replacement parts from Tektronix.
3 and 4	Serial Number	Column three indicates the serial number at which the part was first effective. Column four indicates the serial number at which the part was discontinued. No entries indicates the part is good for all serial numbers.
5	Qty	This indicates the quantity of parts used.
6	Name & Description	An item name is separated from the description by a colon (:). Because of space limitations, an item name may sometimes appear as incomplete. Use the U.S. Federal Catalog handbook H6-1 for further item name identification.
7	Mfr. Code	This indicates the code of the actual manufacturer of the part.
8	Mfr. Part Number	This indicates the actual manufacturer's or vendor's part number.

Abbreviations Abbreviations conform to American National Standard ANSI Y1.1–1972.

Chassis Parts Chassis-mounted parts and cable assemblies are located at the end of the Replaceable Electrical Parts List.

Mfr. Code to Manufacturer Cross Index The table titled Manufacturers Cross Index shows codes, names, and addresses of manufacturers or vendors of components listed in the parts list.

Manufacturers Cross Index

Mfr. Code	Manufacturer	Address	City, State, Zip Code
S3109	FELLER	72 VERONICA AVE UNIT 4	SUMMERSET NJ 08873
TK0191	TEKTRONIX JAPAN Ltd.	PO BOX 5209 TOKYO INTERNATIONAL	TOKYO JAPAN 100-31
TK0392	NORTHWEST FASTENER SALES INC	8058 SW NIMBUS AVENUE	BEAVERTON OR 97008
TK0435	LEWIS SCREW CO	4300 S RACINE AVE	CHICAGO IL 60609-3320
TK1163	POLYCAST INC	9898 SW TIGARD ST	TIGARD OR 97223
TK1287	ENOCH MFG CO	14242 SE 82ND DR PO BOX 98	CLACKAMAS OR 97015
TK1908	PLASTIC MOLDED PRODUCTS	4336 SO ADAMS	TACOMA WA 98409
TK1918	SHIN-ETSU POLYMER AMERICA INC	1181 NORTH 4TH ST	SAN JOSE CA 95112
TK2058	TDK CORPORATION OF AMERICA	1600 FEEHANVILLE DRIVE	MOUNT PROSPECT, IL 60056
TK2432	UNION ELECTRIC	15/F #1, FU-SHING N. ROAD	TAIPEI, TAIWAN ROC
TK2548	XEROX BUSINESS SERVICES DIV OF XEROX CORPORATION	14181 SW MILLIKAN WAY	BEAVERTON OR 97077
0JR05	TRIQUEST CORP	3000 LEWIS AND CLARK HWY	VANCOUVER WA 98661-2999
0KB01	STAUFFER SUPPLY	810 SE SHERMAN	PORTLAND OR 97214
00779	AMP INC	2800 FULLING MILL PO BOX 3608	HARRISBURG PA 17105
07416	NELSON NAME PLATE CO	3191 CASITAS	LOS ANGELES CA 90039-2410
2W733	BELDEN CORPORATION	2200 US HIGHWAY 27 SOUTH PO BOX 1980	RICHMOND IN 47375-0010
24931	SPECIALTY CONNECTOR CO INC	2100 EARLYWOOD DR PO BOX 547	FRANKLIN IN 46131
6D224	HARBOR TRI-TEC A BERG ELECTRONICS COMPANY	14500 SOUTH BROADWAY	GARDENA, CA 90248
61058	MATSUSHITA ELECTRIC CORP OF AMERICA PANASONIC INDUSTRIAL CO DIV	TWO PANASONIC WAY	SECAUCUS NJ 07094
61857	SAN-0 INDUSTRIAL CORP	91-3 COLIN DRIVE	HOLBROOK NY 11741
61935	SCHURTER INC	1016 CLEGG COURT	PETALUMA CA 94952-1152
64537	KDI/TRIANGLE ELECTRONICS	60 S JEFFERSON ROAD	WHIPPANY, NJ 07981
73743	FISCHER SPECIAL MFG CO	111 INDUSTRIAL RD	COLD SPRING KY 41076-9749
78189	ILLINOIS TOOL WORKS INC SHAKEPROOF DIV	ST CHARLES ROAD	ELGIN IL 60120
80009	TEKTRONIX INC	14150 SW KARL BRAUN DR PO BOX 500	BEAVERTON OR 97077-0001
86928	SEASTROM MFG CO INC	701 SONORA AVE	GLENDALE CA 91201-2431

Mechanical Parts List

Fig. & Index Number	Tektronix Part Number	Serial No. Effective	Serial No. Discont'd	Qty	Name & Description	Mfr. Code	Mfr. Part Number
10-1-1	343-1213-XX			1	CLAMP,PWR CORD:POLYIMIDE	TK1163	ORDER BY DESC
-2	161-0230-01			1	CABLE ASSY,PWR,;3, 18 AWG,92 L,SVT,TAN (STANDARD ACCESSORY)	TK2432	ORDER BY DESC
-3	334-3388-XX			1	MARKER,IDENT:MKD,SONY/TEKTRONIX	80009	3343388XX
-4	334-8410-XX	J300101	J310231	1	MARKER,IDENT:BLANK,POLYESTER	80009	3348410XX
-5	334-8705-XX			1	MARKER,IDENT:MKD WARRNING/FUSE DATA,PC,W/CE	80009	3348705XX
-6	334-8697-XX			1	MARKER,IDENT:MKD I/O SIGNALS,POLYCARBONATE	TK0191	334-8697-XX
-7	211-0691-XX			4	SCR,ASSEM WSHR:6-32 X 0.625,PNH,STL,,T-15	0KB01	ORDER BY DESC
-8	200-3991-XX			1	COVER,REAR:HARD,POLYCARBONATE,LEXAN	TK1163	200-3991-XX
-9	390-1138-XX	J300101	J310326	1	CABINET,SCOPE:TEK BLUE,0.04 AL	80009	3901138XX
	390-1145-XX	J310327		1	CABINET,SCOPE:TEK BLUE,0.04 AL	80009	3901145XX
-10	211-0378-XX			4	SCR,ASSEM WSHR:4-40 X 0.375,PNH,STL,T9	0KB01	ORDER BY DESC
-11	200-3983-XX			1	BEZEL:FDD,AL	80009	2003983XX
-12	348-1276-XX			1	GASKET,SHIELD:CONDUCTIVE FORM STRIP	80009	3481276XX
-13	334-8708-XX	J300101	J310243	1	MARKER,IDENT:MKD AWG,HANDLE,POLYCARBONATE	TK0191	334-8708-XX
-14	260-2539-XX			1	SWITCH,SET,;ELASTOMERIC BEZEL	TK1918	260-2539-XX
-15	366-2164-XX			14	PUSH BUTTON:SMOKE TAN	80009	3662164XX
-16	354-0709-XX			1	RING,TRIM:LEXAN 940	80009	3540709XX
-17	334-8696-XX			1	MARKER,IDENT:MKD AWG2005,POLYCARBONATE	TK0191	334-8696-XX
-18	378-0404-XX			1	FILTER,LT,CRT:BULE SMOKE,112MM X 145MM X1MM THK	80009	3780404XX
-19	348-1289-XX			1	SHLD GSKT,ELEK:MESH TYPE,3.2MM X 4.7MM	80009	3481289XX
-20	211-0722-XX			1	SCREW,MACHINE:6-32 X 0.250,PNH,STL,T-15	0KB01	ORDER BY DESC

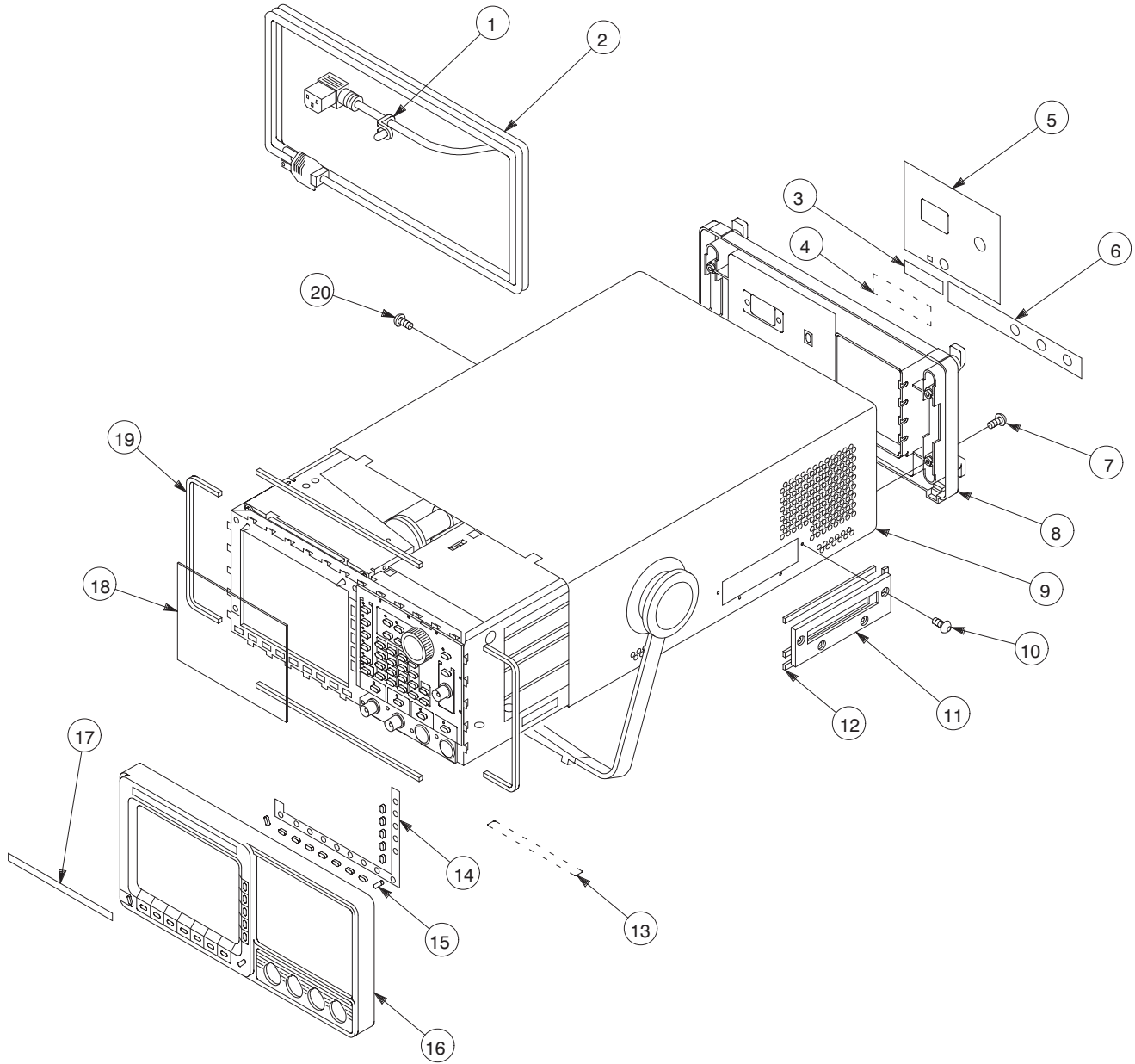

Figure 10-1: Cabinet

Mechanical Parts List

Fig. & Index Number	Tektronix Part Number	Serial No. Effective	Serial No. Discont'd	Qty	Name & Description	Mfr. Code	Mfr. Part Number
10-2-1	213-0882-XX			6	SCREW,TPG,TR:6-32 X 0.437,PNH,T-15	0KB01	ORDER BY DESC
-2	119-4322-XX			1	FAN,TUBAXIAL:12VDC,2.4M/M,5.8MM HZO,6W (B100)	80009	1194322XX
-3	252-0571-XX			1	PLASTIC SHEET:EXTR CHAN,5MM X 3.3MM,NYLON	80009	2520571XX
-4	342-0993-XX			1	INSULATOR,FILM:PWR SPLY,POLYCARBONATE	TK0191	342-0993-XX
-5	211-0722-XX			2	SCREW,MACHINE:6-32 X 0.250,PNH,STL,T-15	0KB01	ORDER BY DESC
-6	620-0058-XX			1	POWER SUPPLY:185W;SWITCHING,15V/4A,12V/0.5A (PS920)	80009	6200058XX
-7	213-0882-XX			3	SCREW,TPG,TR:6-32 X 0.437,PNH,STL,T-15	0KB01	ORDER BY DESC
-8	366-1480-XX			1	PUSH BUTTON:GRAY,0.328 X 0.253 X 0.43	0JR05	ORDER BY DESC
-9	-----			1	CAP,FUSEHOLDER:(P/O TABLE 2-2)		
-10	-----			1	FUSE,CARTRIDGE:(P/O TABLE 2-2)		
-11	671-3351-XX			1	CIRCUIT BD ASSY:AUX,POWER SUPPLY (A900)	80009	6713351XX
-12	213-0882-XX			2	SCREW,TPG,TR:6-32 X 0.437,PNH,STL,T-15	0KB01	ORDER BY DESC
-13	119-2683-XX			1	FILTER,RFI:50/60HZ,250VAC,6A (FL100)	TK2058	ZUB2206H-F
-14	426-2426-XX			1	FRAME,FAN MTG:POLYCARBONATE	TK1163	426-2426-XX
-15	210-0457-XX			1	NUT,PL,ASSEM WA:6-32 X 0.312,STL	TK0435	ORDER BY DESC
-16	334-3379-XX			1	MARKER,IDENT:MARKED GROUND SYMBOL	07416	ORDER BY DESC
-17	441-2054-XX			1	CHASSIS ASSY:ALUMINUM,W/GASKET	TK0191	441-2054-XX
-18	210-0586-XX			2	NUT,PL,ASSEM WA:4-40 X 0.25,STL	TK0435	ORDER BY DESC
-19	344-0472-XX			1	CLIP,CABLE:NYLON,GRAY	80009	3440472XX
-20	407-4087-XX	J300101	J310290	1	BRKT,CMPNT,BNC:ALUMINUM,5.250 X 1.050	80009	4074087XX
	407-4394-XX	J310291		1	BRKT,CMPNT,BNC:ALUMINUM,5.250 X 1.050	80009	4073494XX
-21	211-0325-XX			4	SCR,ASSEM WSHR:4-40 X 0.250,PNH,STL,T-9	0KB01	ORDER BY DESC
-22	134-0218-XX			2	BUTTON,PLUG:0.625 DIA,PLASTIC,TAN	80009	1340218XX
-23	210-0005-XX			1	WASHER,LOCK:#6 EXT,0.02 THK,STL	78189	1106-00
-24	211-0722-XX			1	SCREW,MACHINE:6-32 X 0.250,PNH,STL,T-15	0KB01	ORDER BY DESC
-25	131-1315-XX			2	CONN,RF JACK:BNC/PNL,;50 OHM,FEMALE (J198,J298)	24931	28JR306-1
-26	259-0086-XX			1	FLEX CIRCUIT:BEZEL BUTTON (S100)	07416	ORDER BY DESC
-27	348-1313-XX			1	GASKET,SHIELD:CONDUCTIVE URETHANE FOAM	80009	3481313XX
-28	426-2436-XX			1	FRAME,CRT FLTR:POLYCARBONATE,BLACK	80009	4262436XX
-29	348-1302-XX			1	GASKET,SHIELD:CONDUCTIVE URETHANE FORM STRIP,W/ADHESIVE TAPE,1M L,AWG2020	80009	3481302XX
-30	640-0079-XX	J300101	J310100	1	DISPLAY MONITOR:7 INCH,480 X 640 PIXEL	80009	6400079X
	640-0081-XX	J310101		1	DISPLAY MONITOR:7 INCH,480 X 640 PIXEL (DS100)	80009	6400081XX

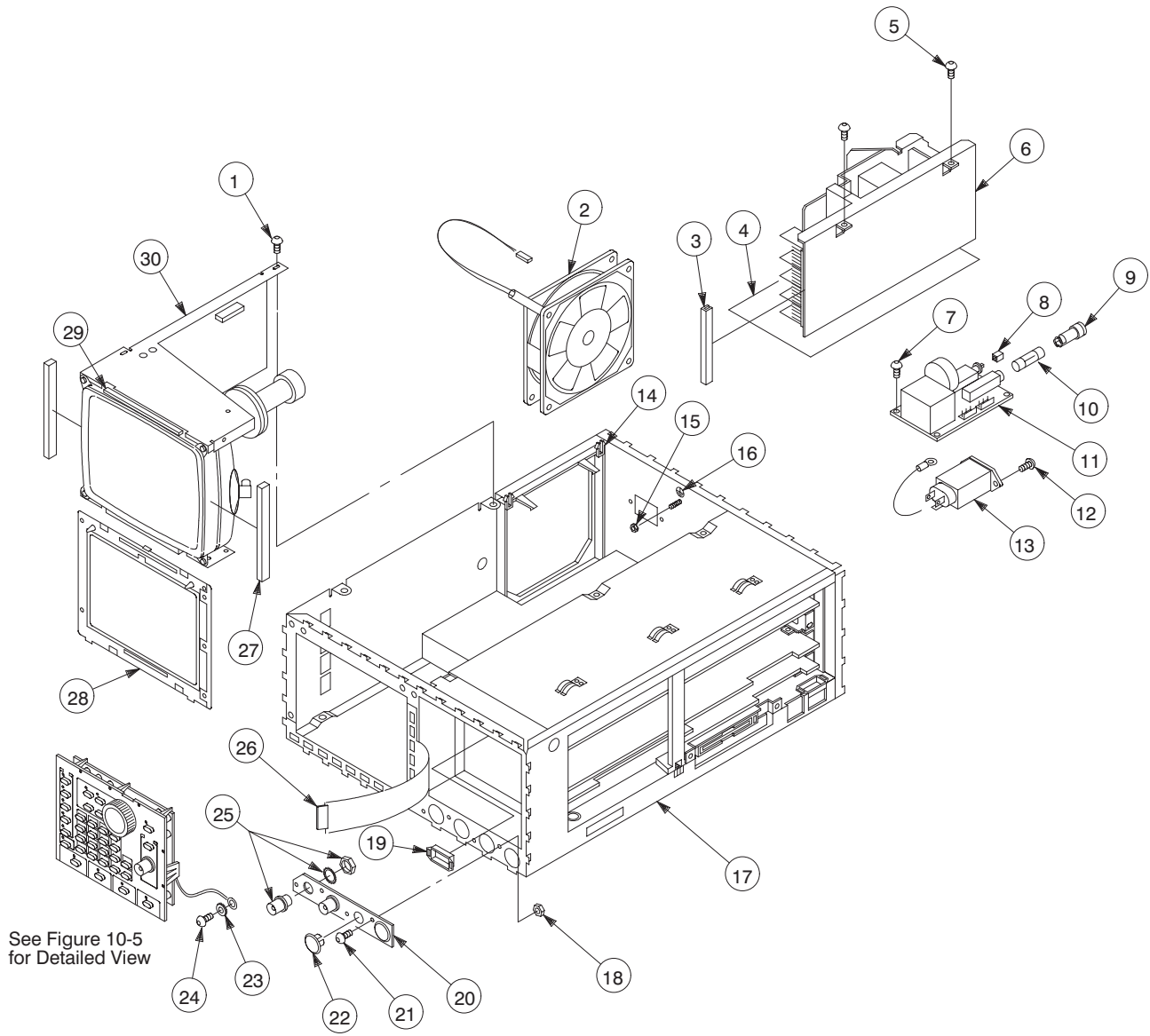

Figure 10-2: Main Chassis and CRT

Mechanical Parts List

Fig. & Index Number	Tektronix Part Number	Serial No. Effective	Serial No. Discont'd	Qty	Name & Description	Mfr. Code	Mfr. Part Number
10-3-1	134-0218-XX			1	BUTTON,PLUG:0.625 DIA,PLASTIC,TAN	80009	1340218XX
-2	131-1315-XX			2	CONN,RF JACK:BNC/PNL,,50 OHM,FEMALE (J500,J550)	24931	28JR306-1
-3	348-1314-XX			1	GASKET,SHIELD:FINGER RYPE,BE-CU,609.6MM L	80009	3481314XX
-4	211-0722-XX	J300101	J310231	5	SCREW,MACHINE:6-32 X 0.250,PNH,STL,T-15	0KB01	ORDER BY DESC
	211-0722-XX	J310232		3	SCREW,MACHINE:6-32 X 0.250,PNH,STL,T-15	0KB01	ORDER BY DESC
-5	129-1051-XX			2	SPACER,POST:12.5 MM L,W/4-40 INT/ 4-40 EXT THD,AL	80009	1291051XX
-6	134-0218-XX			1	BUTTON,PLUG:0.625 DIA,PLASTIC,TAN	80009	1340218XX
-7	334-8698-XX			1	MARKER,IDENT:MKD CH 1,2,3,4,POLYCARBONATE	TK0191	3348698XX
-8	131-1315-XX			6	CONN,RF JACK:BNC/PNL,,50 OHM,FEMALE (J210,J220,J400,J410,J420,J430)	24931	28JR306-1
-9	210-0978-XX	J300313		6	WASHER,FLAT:0.375 ID X 0.5 OD X 0.024,STL	0KB01	ORDER BY DESC
-10	129-1107-XX			2	SPACER,POST:0.98 L,6-32 EXT & M3.5 INTTHD	TK1287	1291107XX
-11	210-0056-XX			2	WASHER,LOCK:#10 SPLIT,0.047 THK,SI BRZ	86928	ORDER BY DESC
-12	337-3964-XX			1	SHIELD,ELEC:REAR,CH 1,2,3,4,BRASS	TK0191	3373964XX
-13	344-0472-XX			2	CLIP,CABLE:NYLON,GRAY	80009	3440472XX
-14	252-0571-XX			1	PLASTIC SHEET:EXTR CHAN,5MM X 3.3MM,NYLON	80009	2520571XX
-15	342-0302-XX			1	INSULATOR,FILM:CHASSIS,MYLAR	80009	3420302XX
-16	343-1639-XX			3	CLAMP,CABLE:9-13MM ID NYLON W/CUSHION	TK0191	3431639XX
-17	337-3983-XX	J300101	J310496	1	SHIELD,ELEC:FDD,AL	TK0191	3373983XX
	337-4088-XX	J310497		1	SHIELD,ELEC:FDD,AL	TK0191	3374088XX
-18	407-4643-XX			1	BRACKET,FDD,STL	80009	4074639XX
-19	348-1276-XX			2	GASKET,SHIELD:CONDUCTIVE FORM STRIP	80009	3481276XX
-20	119-4404-XX			1	DISK DRIVE:FLOPPY,3.5 INCH W/INTERFACE (U950)	80009	1194404XX
-21	105-1081-XX			1	BRACKET,SPACER	TK1163	1051081XX
-22	211-1032-XX			1	SCREW,MACHINE:M2.6 X 8MM L,PNH,STL,MFZN-D,CROSS REC	TK0191	2111032XX
-23	211-1033-XX			3	SCREW,MACHINE:M2.6 X 3MM L,PNH,STL,MFZN-D,CROSS REC	TK0191	2111033XX
-24	211-0325-XX			4	SCR,ASSEM WSHR:4-40 X 0.250,PNH,STL,T-9	0KB01	ORDER BY DESC
-25	671-3072-XX			1	CIRCUIT BD ASSY:BACKPLANE (A5)	TK0191	6713072XX
-26	146-0055-XX			1	BATTERY,DRY:3.0V,1200 MAH,LITHIUM (A5BT001)	61058	BR-2/3A-E2P
-27	252-0571-XX			1	PLASTIC SHEET:EXTR CHAN,5MM X 3.3MM,NYLON	80009	2520571XX
-28	210-0586-XX			1	NUT,PL,ASSEM WA:4-40 X 0.25,STL	TK0435	ORDER BY DESC
-29	211-0722-XX			5	SCREW,MACHINE:6-32 X 0.250,PNH,STL,T-15	0KB01	ORDER BY DESC
-30	337-3963-XX			1	SHIELD,ELEC:CENTER,ALUMINUM	TK0191	3373963XX
-31	211-0373-XX			6	SCREW,MACHINE:4-40 X 0.250,PNH,STL,T-10	0KB01	2110373XX
-32	343-1084-XX			1	CLAMP,CABLE:NYLON	80009	3431084XX
-33	348-0948-XX			2	GROMMET,PLASTIC:BLACK,RING,9.5MM ID	80009	3480948XX
-34	671-3070-XX			1	CIRCUIT BD ASSY:ANALOG,2 CH (A23)	TK0191	6713070XX
-35	211-0722-XX			8	SCREW,MACHINE:6-32 X 0.250,PNH,STL,T-15	0KB01	ORDER BY DESC
-36	252-0571-XX			1	PLASTIC SHEET:EXTR CHAN,5MM X 3.3MM,NYLON	80009	2520571XX

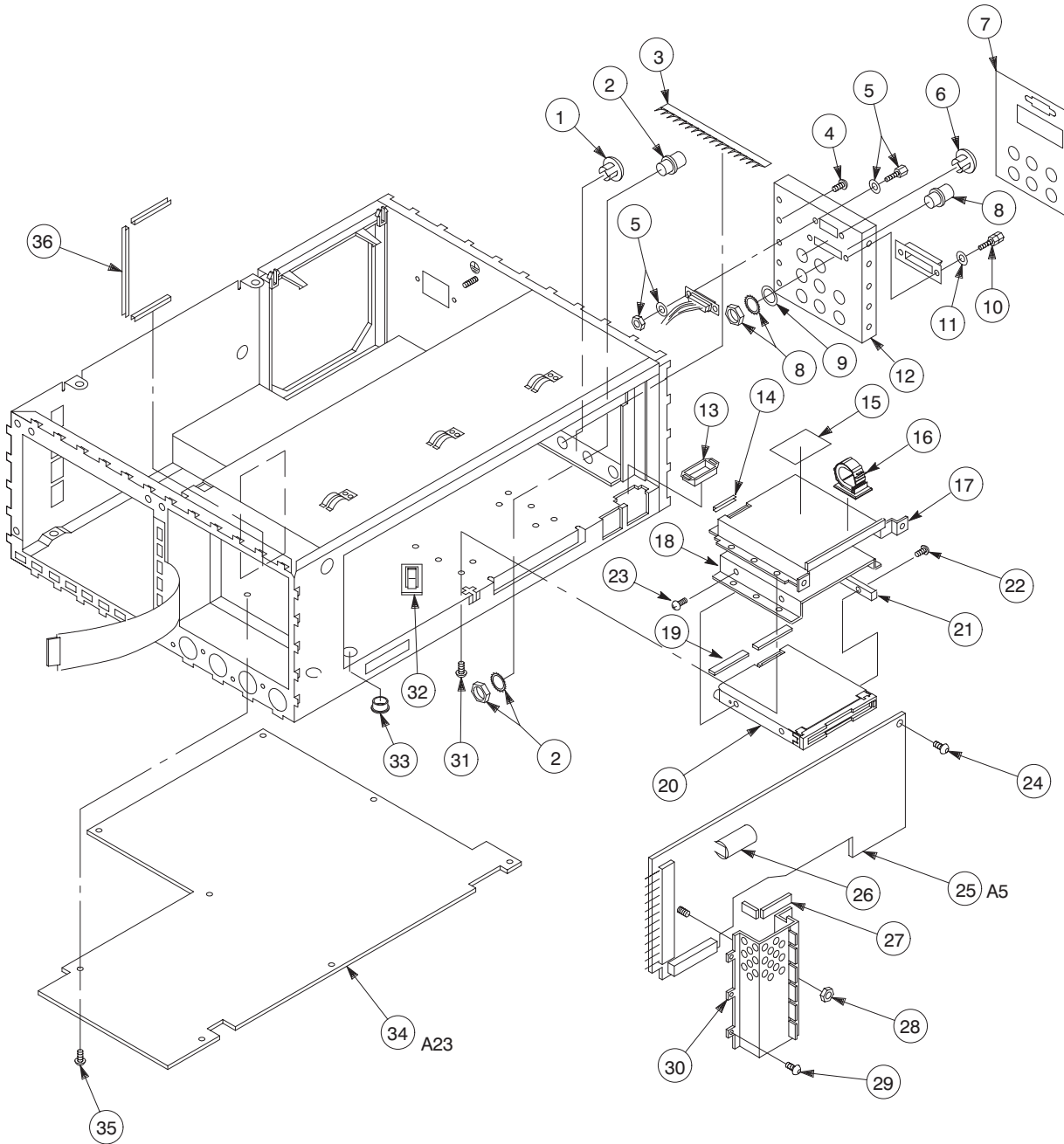

Figure 10-3: Main Chassis and Circuit Boards

Mechanical Parts List

Fig. & Index Number	Tektronix Part Number	Serial No. Effective	Serial No. Discont'd	Qty	Name & Description	Mfr. Code	Mfr. Part Number
10-4-1	671-3089-XX	J300101	J310100	1	CIRCUIT BD ASSY:A06 CPU	TK0191	671-3089-XX
	671-4000-XX	J310101		1	CIRCUIT BD ASSY:A06 CPU	80009	6714000XX
	671-5193-00				CIRCUIT BD ASSY:A06 CPU	80009	671519300
	671-B264-00				CIRCUIT BD ASSY:A06 CPU (A6)	80009	671B26400
-2	160-9788-XX	J300101	J310100	1	IC, MEMORY:CMOS, EPROM; 256K X 16, 100NS, PRGM	TK0191	160-9788-XX
	163-0378-XX	J310101		1	IC, MEMORY:CMOS, EPROM; 256K X 16, 120NS, PRGM	80009	1630378XX
	163-1449-00				IC, MEMORY:CMOS, EPROM; 256K X 16, 120NS, PRGM	80009	163144900
	160-M392-00				IC, MEMORY:CMOS, EPROM; 256K X 16, 120NS, PRGM (A6U305)	80009	160M39200
-3	160-9787-XX	J300101	J310100	1	IC, MEMORY:CMOS, EPROM; 256K X 16, 100NS, PRGM	TK0191	160-9787-XX
	163-0377-XX	J310101		1	IC, MEMORY:CMOS, EPROM; 256K X 16, 120NS, PRGM	80009	1630377XX
	163-1448-00				IC, MEMORY:CMOS, EPROM; 256K X 16, 120NS, PRGM	80009	163144800
	160-M391-00				IC, MEMORY:CMOS, EPROM; 256K X 16, 120NS, PRGM (A6U300)	80009	160M39100
-4	131-5165-XX			1	CONN, RIBBON::PCB,; FEMALE, RTANG, 24 POS, 0.085CTR (A6J40)	00779	555139-1
-5	333-4123-XX	J300101	J310231	2	PANEL, REAR: BRASS	TK0191	333-4123-XX
-6	211-0722-XX			5	SCREW, MACHINE: 6-32 X 0.250, PNH, STL, T-15	0KB01	ORDER BY DESC
-7	211-0001-XX			6	SCREW, MACHINE: 2-56 X 0.25, PNH, STL	TK0435	ORDER BY DESC
-8	671-3073-XX			1	CIRCUIT BD ASSY: CLOCK (A1)	TK0191	671-3073-XX
-9	211-0325-XX			12	SCR, ASSEM WSHR: 4-40 X 0.250, PNH, STL, T-9	0KB01	ORDER BY DESC
-10	129-1409-XX			4	SPACER, POST: 10.0MM L, 4-40 INT THD BOTH ENDS, BRS	80009	1291409XX
-11	671-3069-XX			1	CIRCUIT BD ASSY: D/A (A11)	TK0191	671-3069-XX
-12	671-3074-XX			1	CIRCUIT BD ASSY: AWG (A2)	TK0191	671-3074-XX

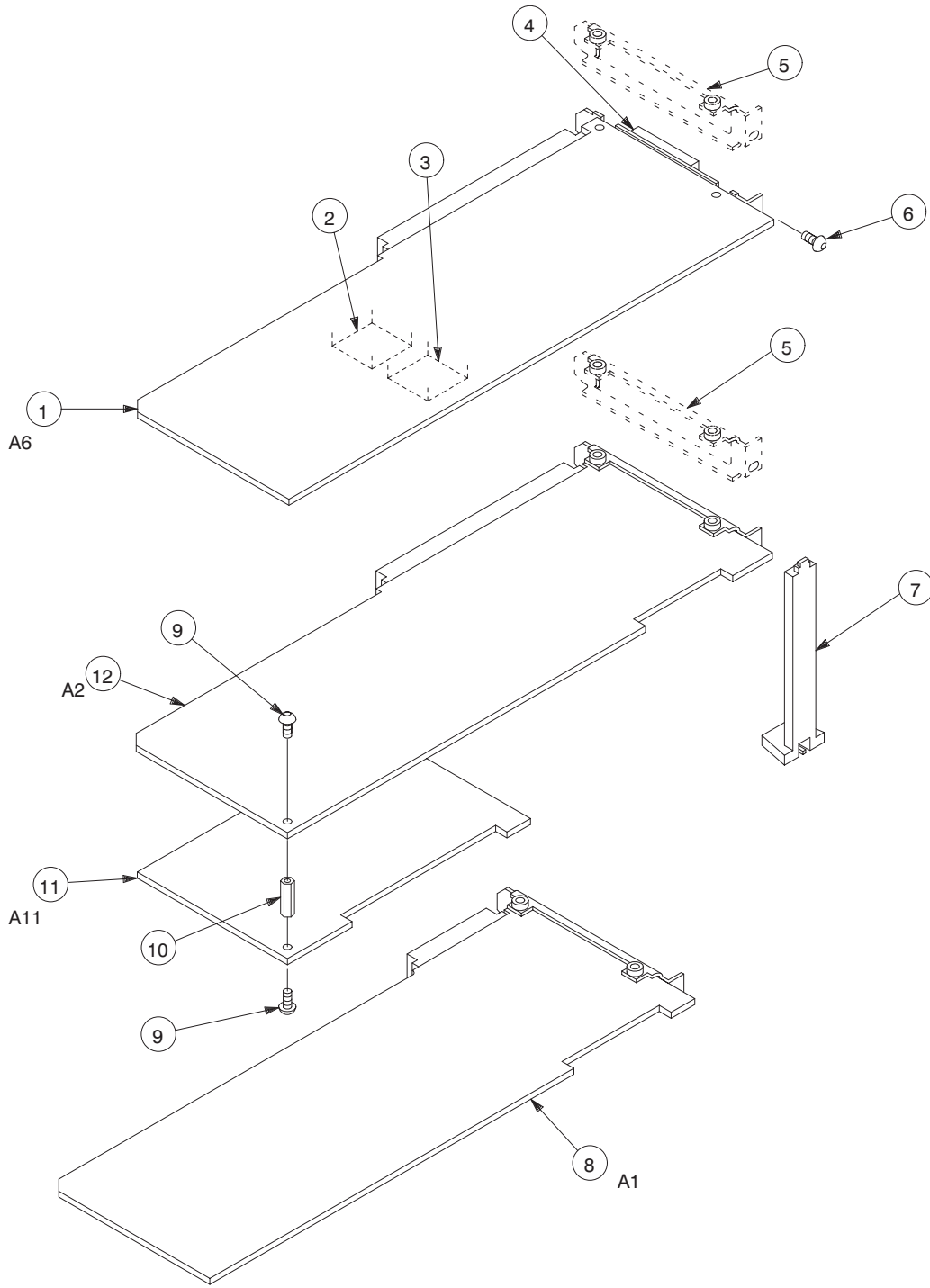

Figure 10-4: Circuit Boards

Mechanical Parts List

Fig. & Index Number	Tektronix Part Number	Serial No. Effective	Serial No. Discont'd	Qty	Name & Description	Mfr. Code	Mfr. Part Number
10-5-1	671-2520-XX			1	CIRCUIT BD ASSY:KEYBOARD (A12)	TK0191	671-2520-XX
-2	213-0048-XX			1	SETSCREW:4-40 X 0.125,STL	TK0392	ORDER BY DESC
-3	260-2497-XX	J300101	J300XXX	1	SWITCH,ROTARY:ENCODER,5VDC,70MA,INCREMENTAL (A12S103)	80009	2602497XX
	260-2666-XX	J300XXX		1	SWITCH,ROTARY:ENCODER,5VDC,70MA,INCREMENTAL (A12S103)	80009	2602666XX
-4	384-1686-XX			1	EXTENSION SHAFT:0.790 L X 0.500 DIA,PLASTIC	80009	3841686XX
-5	160-7853-XX			1	IC,PROCESSOR:CMOS,MICROCOMPUTER (A12U101)	80009	1607853XX
-6	210-0413-XX			2	NUT,PLAIN,HEX:0.375-32 X 0.5,BRS	73743	3145-402
-7	210-0840-XX			1	WASHER,FLAT:0.39 ID X 0.562 OD X 0.02,STL	86928	ORDER BY DESC
-8	348-1276-XX			1	GASKET,SHIELD:CONDUCTIVE FORM STRIP	80009	3481276XX
-9	131-1315-XX			1	CONN,RF JACK:BNC/PNL,,50 OHM,FEMALE (J970)	24931	28JR306-1
-10	366-2159-XX			1	KNOB:IVORY GRAY,SCROLL,1.243 IDX 1.4 OD X 0.4 H	TK1163	ORDER BY DESC
-11	213-0153-XX			1	SETSCREW:5-40 X 0.125,STL	TK0392	ORDER BY DESC
-12	333-4122-XX			1	PANEL,FRONT:MAIN KEY,POLYCARBONATE	TK0191	333-4122-XX
-13	337-3962-XX	J300101	J310231	1	SHIELD,ELEC:FRONT PANEL,EMI,ALUMINUM FOIL	TK0191	337-3962-XX
-14	380-1060-XX			1	HOUSING,SWITCH:POLYCARONATE,W/METALLIZED	80009	3801060XX
-15	260-2552-XX			1	SWITCH,PUSH:50 BUTTON,SP/ST	80009	2602552XX
-16	366-2163-XX			34	PUSH BUTTON:IVORY GRAY,OVAL	80009	3662163XX

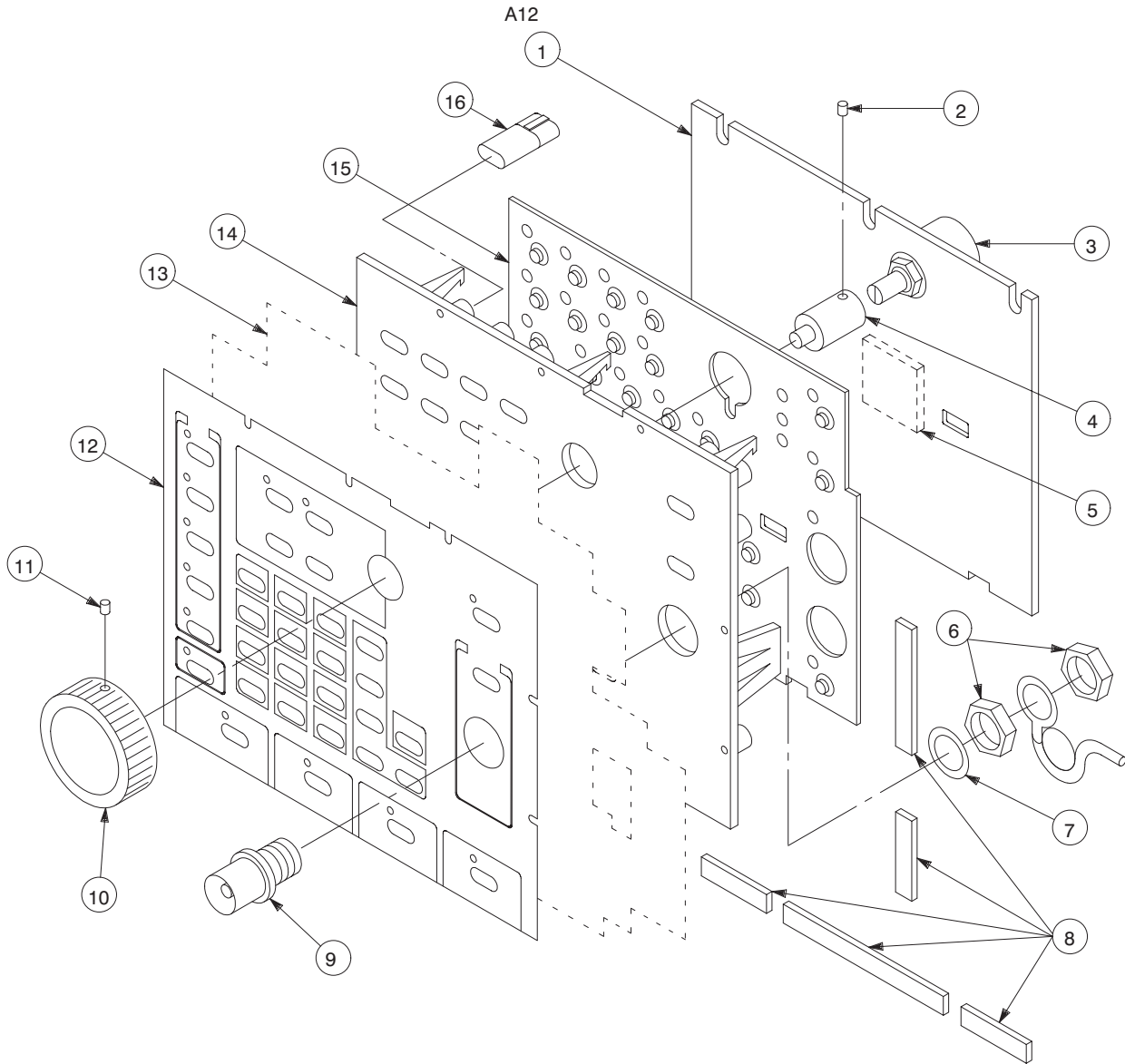

Figure 10-5: Front Panel Assembly

Mechanical Parts List

Fig. & Index Number	Tektronix Part Number	Serial No. Effective	Serial No. Discont'd	Qty	Name & Description	Mfr. Code	Mfr. Part Number
OPTION 02							
10-6-1	131-1315-XX			2	CONN,RF JACK:BNC/PNL,;50 OHM,FEMALE (J230,J240)	24931	28JR306-1
-2	210-0978-XX	J300313		2	WASHER,FLAT:0.375 ID X 0.5 OD X 0.024,STL	0KB01	ORDER BY DESC
-3	671-3074-XX			1	CIRCUIT BD ASSY:AWG (A2)	TK0191	671-3074-XX
-4	671-3069-XX			1	CIRCUIT BD ASSY:D/A (A11)	TK0191	671-3069-XX
-5	129-1409-XX			4	SPACER,POST:10.0MM L,4-40 INT THD BOTH ENDS,BRS	80009	1291409XX
-6	211-0325-XX			8	SCR,ASSEM WSHR:4-40 X 0.250,PNH,STL,T-9	0KB01	ORDER BY DESC
-7	671-3071-XX			1	CIRCUIT BD ASSY:ANALOG,4 CH (A3)	TK0191	671-3071-XX
-8	131-1315-XX			2	CONN,RF JACK:BNC/PNL,;50 OHM,FEMALE (J398,J498)	24931	28JR306-1

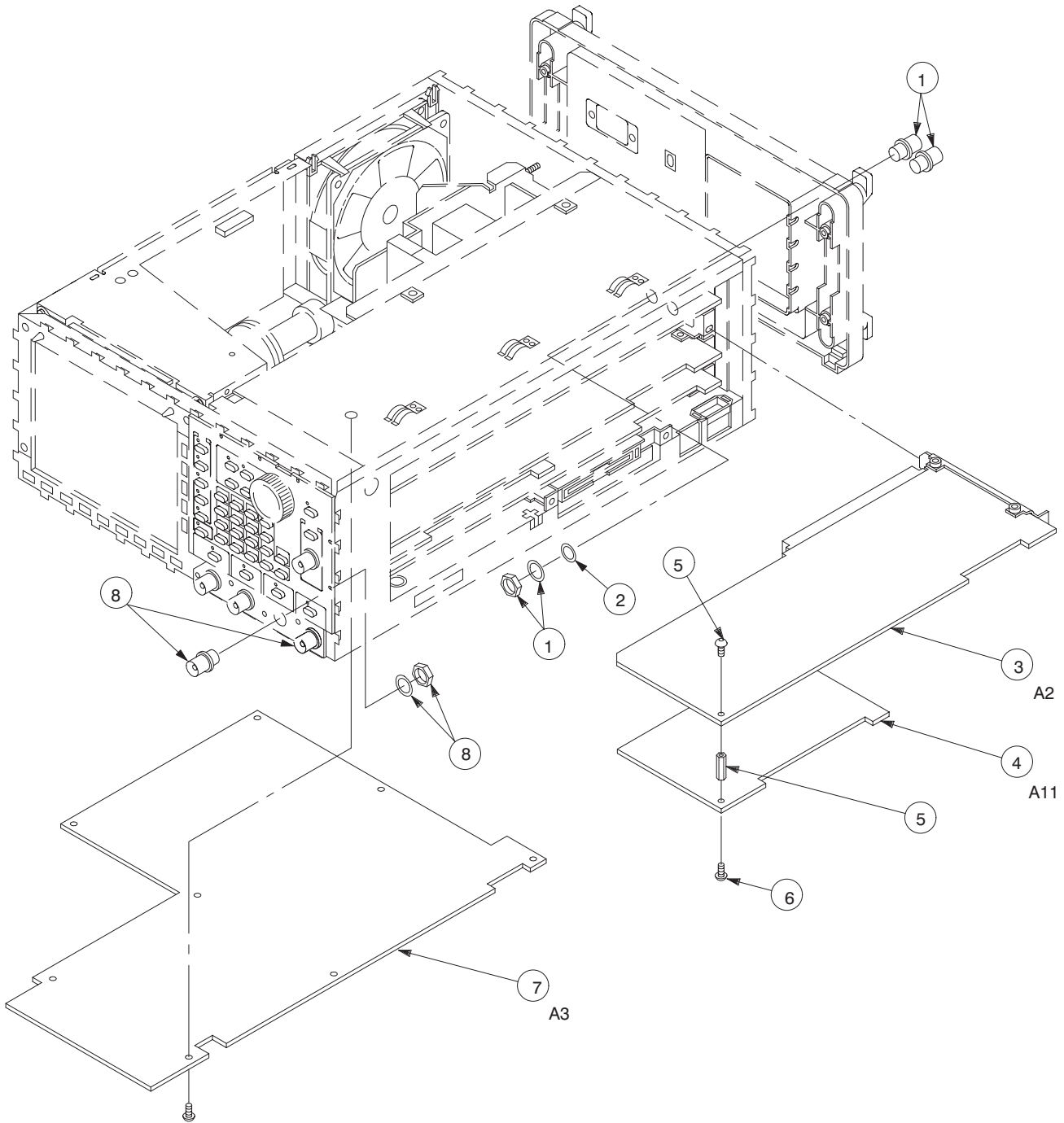

Figure 10-6: Option 02

Mechanical Parts List

Fig. & Index Number	Tektronix Part Number	Serial No. Effective	Serial No. Discont'd	Qty	Name & Description	Mfr. Code	Mfr. Part Number
OPTION 04							
10-7-1	337-3965-XX			1	SHIELD,ELEC:REAR,DDO,BRASS	TK0191	337-3965-XX
-2	334-8699-XX			1	MARKER,IDENT:MKD DDO,POLYCARBONATE	TK0191	334-8699-XX
-3	131-5778-XX			2	CONN,HDR:PCB,;MALE,RTANG,2 X 13,0.1 CTR	TK0191	131-5778-XX
-4	671-3068-XX			1	CKT BD ASSY:AWG (A25)	80009	671306801

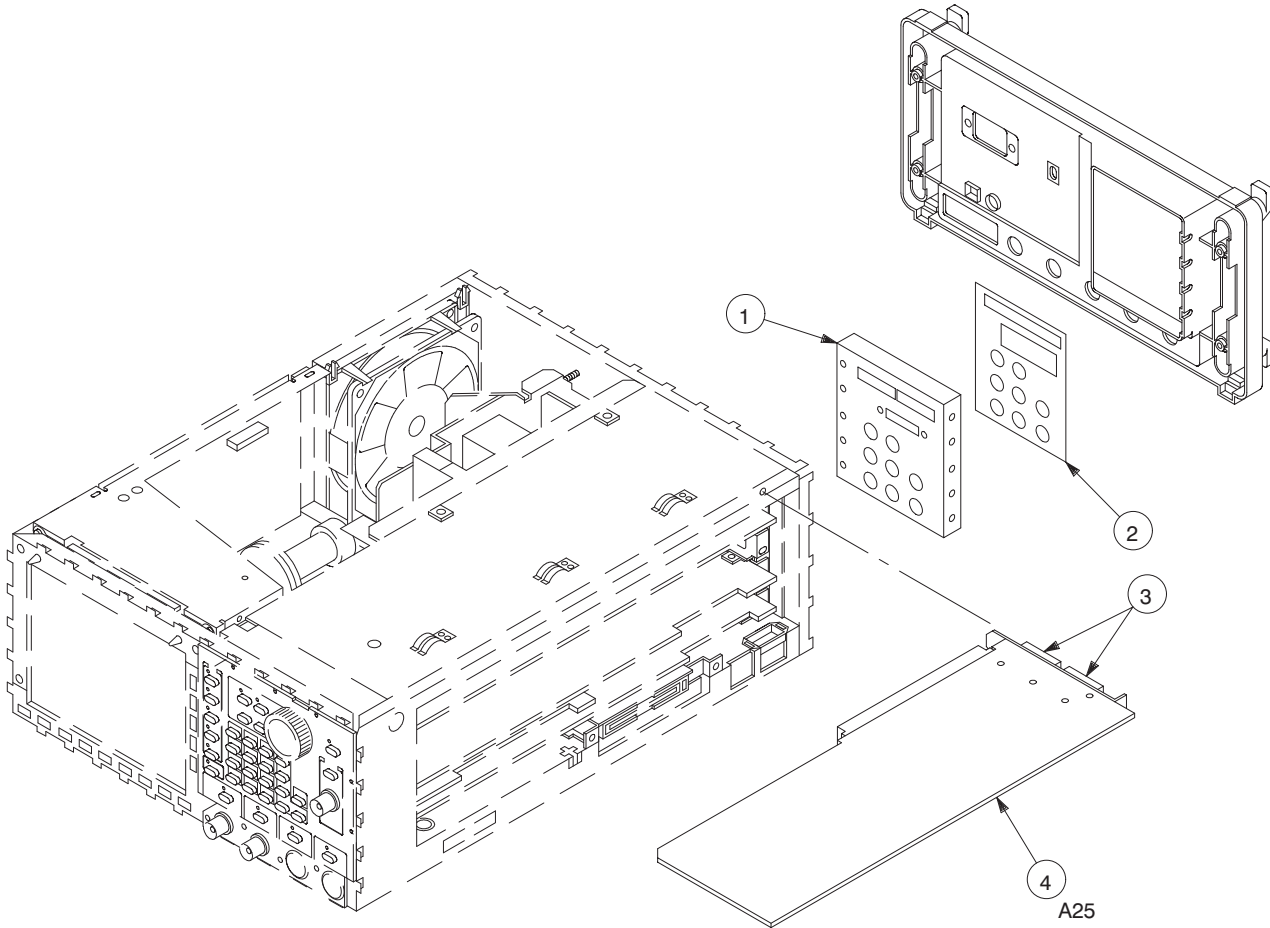

Figure 10-7: Option 04

Fig. & Index Number	Tektronix Part Number	Serial No. Effective	Serial No. Discont'd	Qty	Name & Description	Mfr. Code	Mfr. Part Number
OPTION 05							
10-8-1	131-1315-XX			1	CONN,RF JACK:BNC/PNL,,50 OHM,FEMALE (J360)	24931	28JR306-1
-2	671-3067-XX			1	CIRCUIT BD ASSY:CLOCK SWEEP (A31)	80009	6713067XX

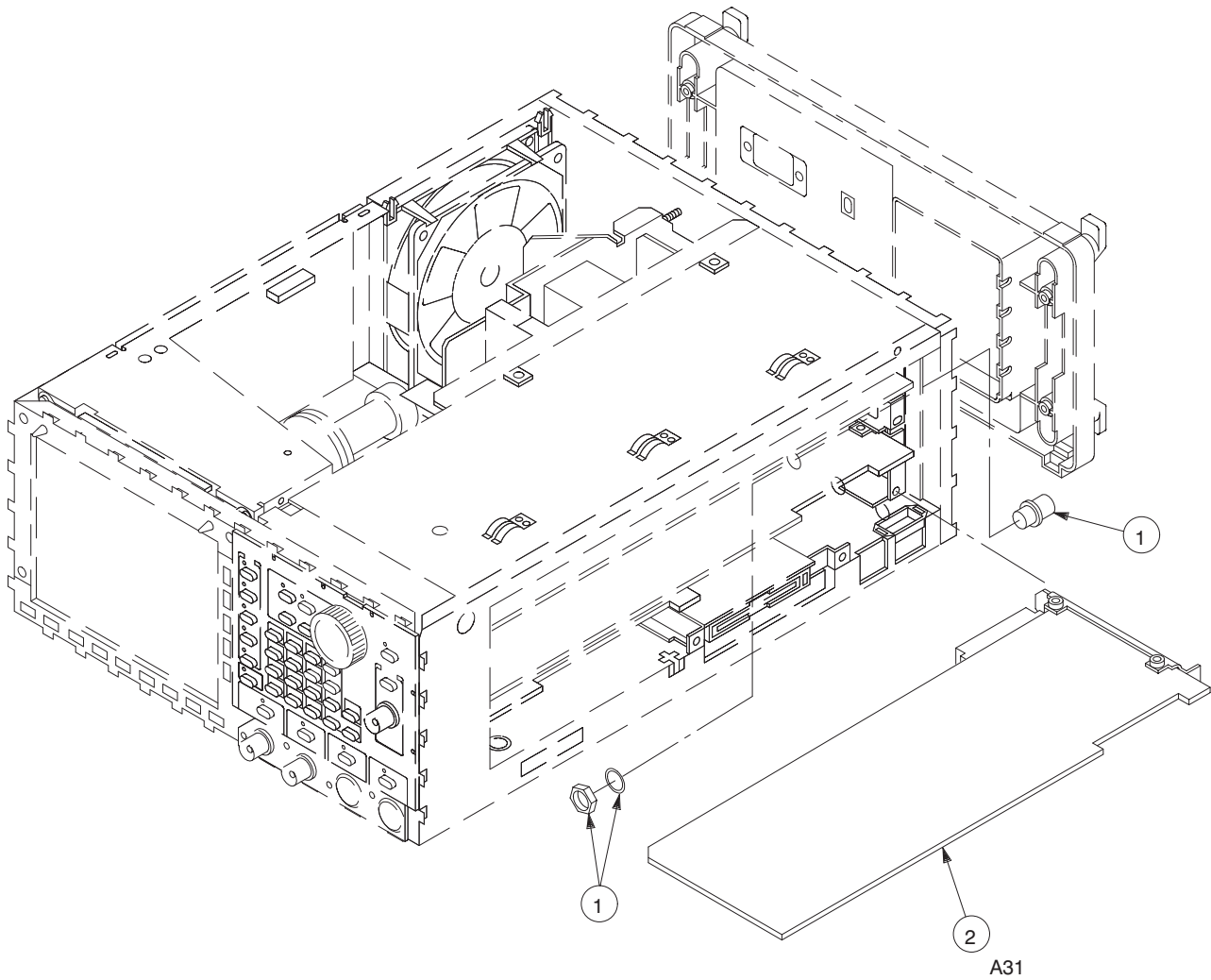

Figure 10-8: Option 05

Mechanical Parts List

Fig. & Index Number	Tektronix Part Number	Serial No. Effective	Serial No. Discont'd	Qty	Name & Description	Mfr. Code	Mfr. Part Number
---------------------	-----------------------	----------------------	----------------------	-----	--------------------	-----------	------------------

OPTION 09							
10-9-1	671-3179-XX			1	CIRCUIT BD ASSY:FLOATING PROCESSOR (A7)	TK0191	671-3179-XX

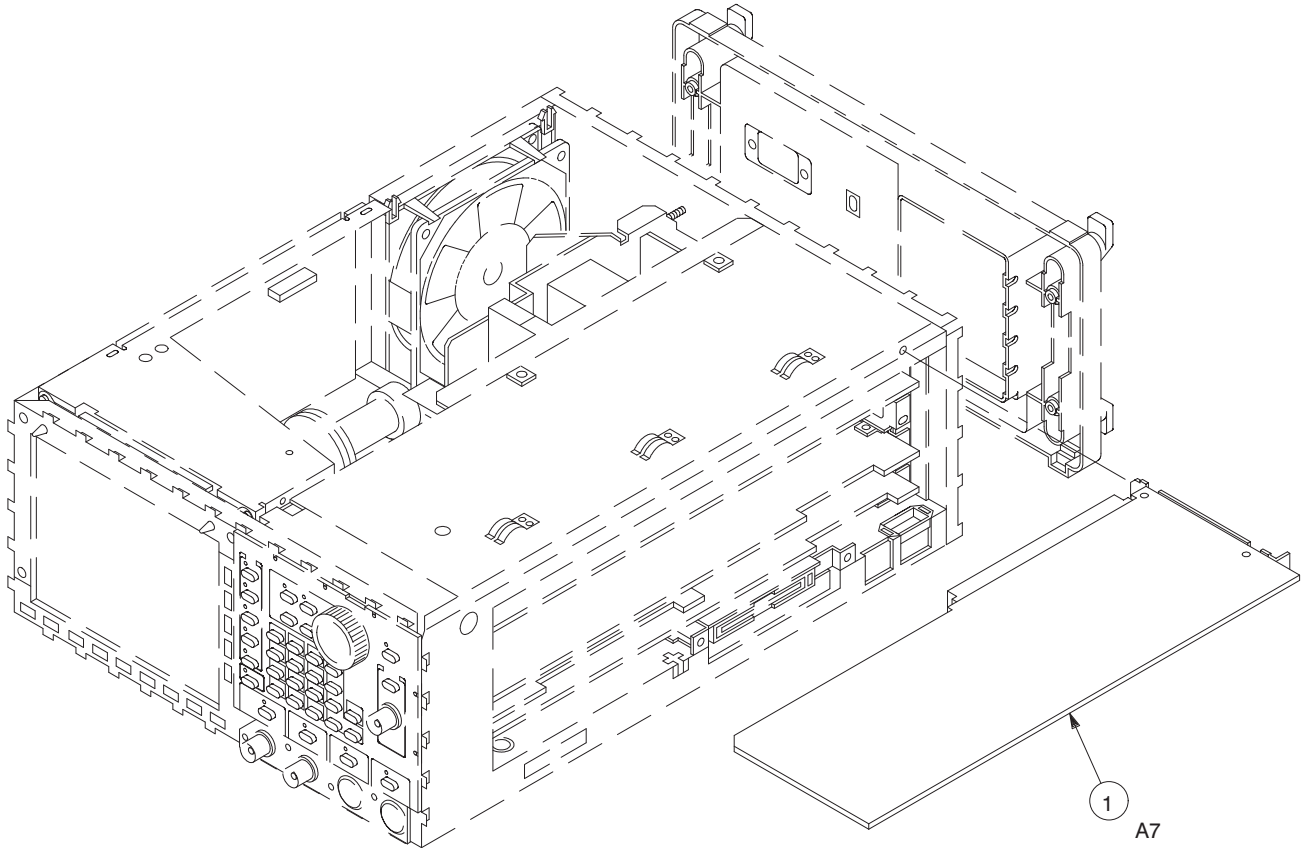

Figure 10-9: Option 09

Mechanical Parts List

Component Number	Tektronix Part Number	Serial No. Effective	Serial No. Discont'd	Name & Description	Mfr. Code	Mfr. Part Number
W1	174-2934-XX			CA ASSY,SP,ELEC:3,18 AWG,18CM L,AWG2020	80009	1742934XX
W3	196-3112-XX			LEAD,ELECTRICAL:18 AWG,6.0 L,5-4	80009	1963112XX
W4	174-2935-XX	J300100	J310248	CA ASSY,SP,ELEC:2.18 AWG,12CM L,W/CONN	80009	1742935XX
	174-2803-XX	J310249		CA ASSY,SP,ELEC:2.18 AWG,12CM L,W/CONN	80009	1742803XX
W6	174-2971-XX			CA ASSY,SP,ELEC:22,18 AWG,10CM L,AFG2020	80009	1742971XX
W7	196-3389-XX			LEAS,ELECTRICAL:18 AWG,15CM L,5-4,W/TERM LUG	80009	1963389XX
W10	174-2936-XX			CA ASSY,SP,ELEC:5,26 AWG,26CM L,RIBBON	80009	1742936XX
W198	174-3206-XX			CA ASSY,RF:50 OHM COAX,65CM L,9-1,W/PELTOLA	TK0191	174-3206-XX
W298	174-2938-XX			CABLE ASSY,RF:50 OHM COAX,42CM L,9-1,W/PELTOLA	80009	1742938XX
W300	174-3205-XX			CA ASSY,RF:50 OHM COAX,20CM L,9-5,W/PELTOLA	TK0191	174-3205-XX
W360	174-3200-XX			CA ASSY,RF:50 OHM COAX,26CM L,9-1,W/PELTOLA (OPTION 05 ONLY)	TK0191	174-3200-XX
W398	174-3209-XX			CA ASSY,RF:50 OHM COAX,32CM L,9-1,W/PELTOLA (OPTION 02 ONLY)	TK0191	174-3209-XX
W400	174-3203-XX			CA ASSY,RF:50 OHM COAX,20CM L,9-3,W/PELTOLA	TK0191	174-3203-XX
W410	174-3204-XX			CA ASSY,RF:50 OHM COAX,20CM L,9-4,W/PELTOLA	TK0191	174-3204-XX
W420	174-3201-XX			CA ASSY,RF:50 OHM COAX,20CM L,9-1,W/PELTOLA	TK0191	174-3201-XX
W430	174-3202-XX			CA ASSY,RF:50 OHM COAX,20CM L,9-2,W/PELTOLA	TK0191	174-3202-XX
W498	174-3210-XX			CA ASSY,RF:50 OHM COAX,15CM L,9-1,W/PELTOLA (OPTION 02 ONLY)	TK0191	174-3210-XX
W500	174-3208-XX	J300100	J310231	CA ASSY,RF:50 OHM COAX,18CM L,9-1,W/PELTOLA	TK0191	174-3208-XX
	174-3201-XX	J310232		CA ASSY,RF:50 OHM COAX,18CM L,9-1,W/PELTOLA	TK0191	174-3201-XX
W550	174-3200-XX			CA ASSY,RF:50 OHM COAX,26CM L,9-1,W/PELTOLA	TK0191	174-3200-XX
W630	174-2933-XX			CA ASSY,SP,ELEC:5,26 AWG,15CM L,RIBBON W/O-SUB	80009	1742933XX
W664	174-2945-XX			CA ASSY,SP,ELEC:10,26 AWG,23CM L,RIBBON	80009	1742945XX
W675	174-2775-XX			CA ASSY,SP,ELEC:26,350MM L,FLAT FLEX	80009	1742775XX
W900	174-2770-XX			CA ASSY,SP,ELEC:10,26 AWG,390MM L,RIBBON	80009	1742770XX
W1110	174-3239-XX			CA ASSY,SP:30,30 AWG,80CM L,FLAT (OPTION 04 ONLY)	TK0191	174-3239-XX
W1210	174-3239-XX			CA ASSY,SP:30,30 AWG,80CM L,FLAT (OPTION 04 ONLY)	TK0191	174-3239-XX

Mechanical Parts List

Fig. & Index Number	Tektronix Part Number	Serial No. Effective	Serial No. Discont'd	Qty	Name & Description	Mfr. Code	Mfr. Part Number
STANDARD ACCESSORIES							
	063-1704-XX			1	SOFTWARE PKG:3.5 DISK,AWG2005 WAVEFORM LIBRARY	TK0191	063-1704-XX
	063-1706-XX	J310248		1	SOFTWARE PKG:3.5 DISK,AWG2005 PERF CHECK/ADJ	TK0191	063-1706-XX
	063-1708-XX			1	SOFTWARE PKG:3.5 DISK,AWG2000 SERIES SAMPLE PRGM	TK0191	063-1708-XX
	070-8958-XX			1	MANUAL,TECH:USERS,AWG2005,DP	TK2548	0708958XX
	070-8657-XX			1	MANUAL,TECH:PROGRAMMER,ENGLISH VER,AWG SERIES	TK2548	0708657XX
	174-3192-XX			1	CA ASSY,SP:13,COAX,50 OHM,FLAT (OPTION 04 ONLY)	TK0191	174-3192-XX
	-----			1	CABLE ASSY,PWR:,3,18 AWG,92 L,SVT,TAN (SEE FIGURE 1-2)		
	161-0104-05			1	CA ASSY,PWR:3,1.0MM SQ,250V/10A,2.5 METER (OPTION A3 - AUSTRALIAN)	S3109	198-010
	161-0104-06			1	CA ASSY,PWR:3,1.0MM SQ,250V/10A,2.5 METER (OPTION A1 - EUROPEAN)	S3109	198-010
	161-0104-07			1	CA ASSY,PWR:3,1.0MM SQ,240V/10A,2.5 METER (OPTION A2 - UNITED KINGDOM)	S3109	209010
	161-0104-08			1	CA ASSY,PWR:3,18 AWG,250/10A,98 INCH L (OPTION A4 - NORTH AMERICAN)	2W733	ORDER BY DESC
	161-0167-00			1	CA ASSY,PWR:3,0.75MM SQ,250V/10A,2.5 METER (OPTION A5 - SWITZERLAND)	S3109	ORDER BY DESC
OPTIONAL ACCESSORIES							
	011-0049-XX			1	TERMN,COAXIAL:50 OHM,2W,BNC	64537	T132DS
	012-0991-XX			1	CABLE,INTCON:SHLD CMPST,GPIB;CRC,12 TW PR	6D224	81190-020
	012-1342-XX			1	CA ASSY,RF:COAXIAL,;RFD,50 OHM,24 L,BNC,MALE	80009	0121342XX
	016-1159-XX			1	POUCH:POUCH & PLATE,GPS SIZE	80009	0161159XX
	067-1396-XX			1	FIXTURE,CAL:AWG2005	TK0191	067-1396-XX
	070-8962-50			1	MANUAL,TECH:SERVICE,AWG2005,DP	80009	0708962XX
	200-3232-XX			1	COVER,FRONT:ABS	TK1908	ORDER BY DESC
	159-0239-XX			1	FUSE,CARTRIDGE:3AG,6A,250V,MEDIUM	80009	1590239XX
	159-0210-XX			1	FUSE,CARTRIDGE:DIN 5 X 20MM,5AMP,250V	61857	ET 5 AMP
	200-2264-XX			1	CAP,FUSEHOLDER:3AG FUSES (FOR 159-0239-XX)	61935	FEK 031 1666
	200-2265-XX			1	CAP,FUSEHOLDER:5 X 20MM FUSES (FOR 159-0210-XX)	61935	FEK 031.1663