



product modification

040-0276-00

Type 575

INCREASED COLLECTOR VOLTS

For the TEKTRONIX® Type 575 Oscilloscopes:
All Serial Numbers

Modification Kit, PN 040-0276-00, converts the Type 575 to Type 575 Mod 122C, providing the following features:

- a) A maximum Collector Sweep voltage of 400V (instead of 200V), rated at 0.5 amp maximum.
- b) Three more sensitivities (50, 100 and 200V/Div) on the HORIZONTAL VOLTS/DIV switch.
- c) A ± 1.5 kV supply for checking peak inverse voltage of rectifiers. The high voltage is accessible at the Collector test terminals, and the supply current is limited by an internal impedance of 1.8 meg.

NOTE: The output voltage (Collector terminal voltage) of the 1.5kV supply varies directly with the line voltage and inversely with the load current (i.e., at 117V (234V) line voltage is approximately 1.8kV; with a load current of 1mA, the output voltage is zero).

PARTS INCLUDED IN MODIFICATION KIT:

Ckt.No.	Quantity	Part Number	Description
	(1 ea)		Assembly, Switch, PEAK VOLTS RANGE (262-0496-00), consisting of:
	1 ea	210-0012-00	Lockwasher, int. 3/8 x 1/2, small pot
	1 ea	210-0413-00	Nut, hex 3/8-32 x 1/2
	1 ea	210-0840-00	Washer, flat, 0.390 x 9/16
## SW706	1 ea	260-0403-01	Switch, raw
			Wire, #22 solid, 175-0522-00 wht-vio 4-1/4"
			Wire, #22 solid, 175-0522-00 wht-blu 3-1/4"
			Wire, #22 solid, 175-0522-00 wht 2-1/2"
	(1 ea)		Assembly, Switch, HORIZ. VOLTS/DIV (262-0633-00), consisting of:
	4 ea	210-0001-00	Lockwasher, int. #2
	2 ea	210-0006-00	Lockwasher, int. #6
	4 ea	210-0438-00	Nut, 1-72
	2 ea	210-0449-00	Nut, hex, 5-40 x 1/4
	4 ea	210-0801-00	Washer, flat, #5S
## SW305	1 ea	260-0591-01	Switch, raw
## C318	1 ea	281-0010-00	Capacitor, cer, 4.5-25pF var.
## R300, R301	2 ea	302-0105-00	Resistor, comp, 1meg 1/2W 10%
## R319	1 ea	309-0001-00	Resistor, prec, 433k 1/2W 1%
## *R250, R258	4 ea	309-0020-00	Resistor, prec, 1.8meg 1/2W 1%
## R333	1 ea	309-0030-00	Resistor, prec, 1.8k 1/2W 1%
## R315, R323	2 ea	309-0041-00	Resistor, prec, 60k 1/2W 1%
## R317, R325	2 ea	323-0414-00	Resistor, prec, 200k 1/2W 1%
## R332	1 ea	309-0098-00	Resistor, prec, 2k 1/2W 1%
## R312, R313	4 ea	309-0100-00	Resistor, prec, 10k 1/2W 1%
## R320, R321			
## R314, R322	2 ea	309-0153-00	Resistor, prec, 20k 1/2W 1%
## R331	1 ea	309-0180-00	Resistor, prec, 1.063k 1/2W 1%
## R330	1 ea	309-0191-00	Resistor, prec, 4.535k 1/2W 1%
## R329	1 ea	309-0192-00	Resistor, prec, 11.48k 1/2W 1%
## R328	1 ea	309-0194-00	Resistor, prec, 32.31k 1/2W 1%
## R316, R324	2 ea	309-0260-00	Resistor, prec, 100k 1/2W 1%
## R307, R308	2 ea	309-0400-00	Resistor, prec, 80Ω 1/2W 1/2%
## R302	1 ea	309-0405-00	Resistor, prec, 116k 1/2W 1/2%
## R306	1 ea	309-0406-00	Resistor, prec, 240Ω 1/2W 1/2%
## R305	1 ea	309-0407-00	Resistor, prec, 400Ω 1/2W 1/2%
## R304	1 ea	309-0408-00	Resistor, prec, 800Ω 1/2W 1/2%
## R303	1 ea	309-0409-00	Resistor, prec, 2.4k 1/2W 1/2%
## R334, R434	2 ea	311-0056-00	Potentiometer, comp. 500Ω minipot 20%
	1 ea	388-0523-00	Board, etched circuit
			Tubing, plastic, #20, 162-0504-00 blk 1"
			Wire, #22 solid, 175-0517-00 orn 4-1/2"
			Wire, #22 solid, 175-0522-00 wht-red 3"

*R250 & R258 are 3.6 Meg resistors consisting of 2 ea. 1.8 Meg resistors connected in series.

PARTS INCLUDED IN MODIFICATION KIT: Continued

Ckt.No.	Quantity	Part Number	Description
	(1 ea)		Assembly, Switch, HORIZ. VOLTS/DIV (262-0633-00), consisting of: (continued)
			Wire, #22 solid, 175-0522-00 wht-red 3-1/2"
			Wire, #22 solid, 175-0522-00 wht-gry 3"
			Wire, #22 solid, 175-0522-00 wht-grn 3-1/2"
			Wire, #22 solid, 175-0522-00 wht-grn 4-1/2"
			Wire, #22 solid, 175-0522-00 wht-blk 3-1/4"
			Wire, #22 solid, 175-0522-00 wht-blk 4"
			Wire, #22 solid, 175-0522-00 wht-vi. 2-1/2"
	2 ea		Wire, #22 solid, 175-0522-00 wht-orn 3-1/2"
			Wire, #22 solid, 175-0522-00 wht-yel 3"
			Wire, #22 solid, 175-0522-00 wht-orn-blk-brn 4-3/4"
			Wire, #22 solid, 175-0544-00 gry
	(2 ea)		• Assembly, Capacitor, consisting of:
	2 ea	166-0025-00	Spacer, tube mech.
	2 ea	210-0406-00	Nut, hex, 4-40 x 3/16
	4 ea	210-0906-00	Washer, fiber
	2 ea	211-0017-00	Screw, 4-40 x 3/4 RHS
##	C706B, C706C	1 ea	281-0010-00 Capacitor, cer, 4.5-25pF var.
	(1 ea)		Assembly, Transformer bracket, consisting of:
	1 ea	120-0226-00	Transformer, 2KV
	2 ea	124-0106-00	Strip, cer, 7/16 X 11 notches, clip-mounted
	4 ea	166-0025-00	Spacer, tube mech.
	4 ea	210-0004-00	Lockwasher, int. #4
	7 ea	210-0010-00	Lockwasher, int. #10
	1 ea	210-0206-00	Lug, solder, #10
	4 ea	210-0406-00	Nut, hex, 4-40 x 3/16
	4 ea	210-0410-00	Nut, hex, 10-32 x 5/16
	8 ea	210-0906-00	Washer, fiber
	4 ea	211-0017-00	Screw, 4-40 x 3/4 RHS
	4 ea	212-0553-00	Screw, 10-32 x 1-1/2 RHS
	1 ea	281-0007-00	Capacitor, cer, 3-12pF var.
	1 ea	281-0010-00	Capacitor, cer, 4.5-25pF var.
#	C706A		
#	C706D		
#	R729, A, B, C, D	4 ea	306-0474-00 Resistor, comp, 470k 2W 10%
	4 ea	361-0C39-00	Spacer, nylon molded, 13/32
	1 ea	406-0743-00	Bracket, 2KV transformer mounting
			Tubing, plastic, #20, 162-0504-00 blk 11/16"
			Wire, #22 solid, 175-0522-00 wht-blk 11"
			Wire, #22 solid, 175-0522-00 wht-yel 4-1/2"
			Wire, #20 str., HV ins. 175-0513-00 wht-yel 5-1/2"
			Wire, #20 str., HV ins. 175-0513-00 wht-yel 2-1/2"
	(1 ea)		Assembly, Switch, pushbutton and cable, PRESS
			TO CHECK, consisting of:
	(1 ea)		Cable, harness (179-0668-00), consisting of:
			Wire, #22 solid, 175-0522-00 wht 16-3/4"
			Wire, #18 solid, 175-0504-00 yel-brn-grn-brn 19"
			Wire, #18 solid, 175-0504-00 yel-brn-orn-brn 16-1/4"

PARTS INCLUDED IN MODIFICATION KIT: Continued

Ckt.No.	Quantity	Part Number	Description
	(1 ea)		Assembly, Switch, pushbutton and cable, PRESS TO CHECK, consisting of: (continued)
	1 ea	210-0013-00	Lockwasher, 3/8 x 11/16
	2 ea	210-0202-00	Lug, solder, SE6 w/2 wire holes
	1 ea	210-0207-00	Lug, solder, pot, 3/8
	2 ea	210-0413-00	Nut, hex, 3/8-32 x 1/2
	1 ea	210-0840-00	Washer, flat, 0.390 x 1/2
## SW700	1 ea	260-0017-00	Switch, raw
			Wire, #18 solid, 175-0503-00 yel-brn-orn-brn 4-1/2"
	(1 ea)		Assembly, Rectifier, Germanium, consisting of:
## GR707	1 ea	106-0060-00	Rectifier, Germanium stack
	2 ea	210-0457-00	Nut, Keps, 6-32 x 5/16
	2 ea	210-0802-00	Washer, flat, #6S
	2 ea	211-0507-00	Screw, 6-32 x 5/16 BHS
			Wire, #22 solid, 175-0522-00 wht-orn 24"
			Wire, #22 solid, 175-0522-00 wht-brn 20"
			Wire, #22 solid, 175-0522-00 wht-brn 3"
			Wire, #22 solid, 175-0522-00 wht-blu 24"
	(1 ea)		Assembly, Switch, Transistor Selector, consisting of:
	2 ea	210-0021-00	Lockwasher, int. 3/8 x 1/2
	1 ea	210-0845-00	Washer, 5/8 x 1/2 x 0.020"
## SW735	1 ea	260-0463-00	Switch, lever, locking
## R731	1 ea	302-0101-00	Resistor, comp, 100Ω 1/2W 10%
	1 ea	361-0048-00	Spacer, toggle switch, 5/8 x 0.130L
			Wire, HyRad, 175-0549-00 5-1/2"
			Wire, #22 solid, 175-0522-00 wht-yel 6-1/2"
			Wire, #22 solid, 175-0522-00 wht-grn 5"
			Wire, #22 solid, 175-0522-00 wht 2-1/2"
	(1 ea)		Assembly, Switch, POLARITY, consisting of:
	1 ea	210-0312-00	Lockwasher, int. 3/8 x 1/2, small pot
	1 ea	210-0413-00	Nut, hex, 3/8 x 1/2
	1 ea	210-0840-00	Washer, flat, 0.390 x 9/16
## SW708	1 ea	260-0404-01	Switch, raw
## R705	1 ea	304-0274-00	Resistor, comp. 270k 1W 10%
			Wire, #18 solid, 175-0504-00 wht-brn 11"
			Wire, #20 stranded, HV ins. 175-0513-00 wht-yel 4-1/4"

PARTS INCLUDED IN MODIFICATION KIT:

Ckt.No.	Quantity	Part Number	Description	
	1 ea	003-0220-00	Template	
##	2 ea	124-0120-00	Strip, cer, 7/16 X 4 notches, clip-mounted	
	2 ea	166-0030-00	Spacer, 3/16 (for transformer mounting bracket)	
	2 ea	210-0006-00	Lockwasher, int, #6	
	1 ea	210-0205-00	Lug, solder, SE-8	
	2 ea	210-0206-00	Lug, solder, #10	
	2 ea	210-0407-00	Nut, 6-32 x 1/4	
	1 ea	210-0505-00	Nut, 3/8-27 x 1/2	
	2 ea	210-0803-00	Washer, flat, #6L	
	1 ea	210-0812-00	Washer, fiber #10	
	1 ea	210-0813-00	Washer, fiber #10 shouldered	
	6 ea	210-0869-00	Washer, nylon, insulating	
	6 ea	211-0504-00	Screw, 6-32 x 1/4 PHS, Phillips	
	2 ea	211-0507-00	Screw, 6-32 x 5/16 PHS, Phillips	
	2 ea	211-0511-00	Screw, 6-32 x 1/2 PHS, Phillips	
##	SW602	1 ea	260-0249-00	Switch, circuit breaker, 0.8 amp
##	C239	1 ea	281-0044-00	Capacitor, mica, 80-480pF var.
##	C734	1 ea	283-0555-00	Capacitor, mica, 0.002μF 500V
##	*R730	4 ea	309-0025-00	Resistor, prec, 2.5M 1/2W 1%
##	R732	1 ea	309-0125-00	Resistor, prec, 300k 1/2W 1%
##	R732A	1 ea	311-0126-00	Potentiometer, comp. 1M minipot var.
		1 ea	333-0690-00	Panel, (for Mod 122C)
##		2 ea	334-1529-00	Insert, (for Mod 122C and serial number)
		1 ea	334-0820-00	Tag, overlay
		1 ea	337-0476-00	Shield, Collector Sweep side
		2 ea	343-0002-00	Clamp, cable, 3/16
##		4 ea	361-0392-00	Spacer, nylon molded, 0.593
		1 ea	366-0033-00	Knob, small black
		2 ea		Tubing, plastic, #16, 162-0502-00 blk 1-7/8"

*R730 is composed of 4 2.5M resist rs connected in series.

PARTS INCLUDED IN MODIFICATION KIT:

Ckt.No.	Quantity	Part Number	Description	
			Wire, HyRad, high voltage, 175-0549-00	13"
			Wire, HyRad, high voltage, 175-0549-00	24"
			Wire, #22 solid, 175-0522-00, wht	3-1/2"
			Wire, #22 solid, 175-0522-00, wht	7-1/2"
			Wire, #22 solid, 175-0522-00, wht-orn	5-1/4"
			Wire, #22 solid, 175-0522-00, wht-orn	3"
			Wire, #22 solid, 175-0522-00, wht-gry	5-1/2"
			Wire, #22 solid, 175-0522-00, wht-gry	4"
			Wire, #22 solid, 176-0122-00, bare	12"
			Wire, #16 solid, 176-0124-00, bare	12"
			Wire, solder, silver-bearing	

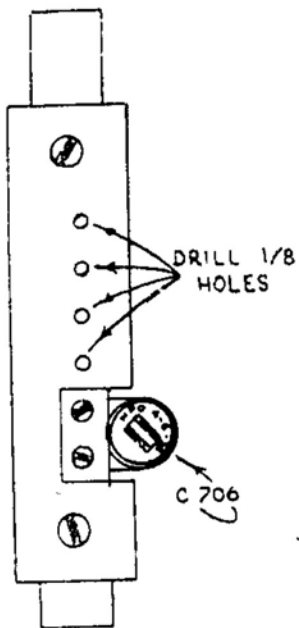

FIG. 1

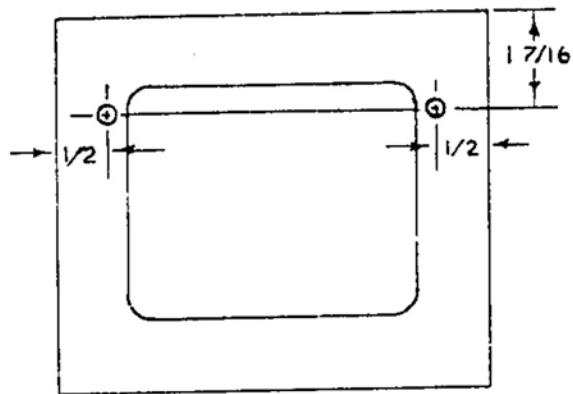

FIG. 2

INSTRUCTIONS

IMPORTANT: When soldering to the ceramic strips, use the silver-bearing solder supplied with this kit.

- () 1. Remove the cabinet sides and bottom.
- () 2. Remove the side shield covering the Collector Sweep (C.S.) box at left of instrument.

NOTE: Save all hardware until the modification is completed.

- () 3. Unsolder the five wires connected to the Collector Sweep transformer (T702). (Terminals accessible inside C.S. box.)
- () 4. Unsolder and remove the ground strap connecting C706 (small trimmer capacitor, at rear of C.S. box) to ground lug on the resistor stack.
- () 5. Turn the instrument upside down and locate the white-red wire which is dressed through the grommet in the front of the C.S. box, through a grommet in the lower main chassis, and connects to the Transistor Selector (TRANSISTOR A - TRANSISTOR B) switch mounted on the Transistor Test Panel.
- () Unsolder this wire from the Transistor Selector switch and pull it back through the grommet in the lower chassis.
- () 6. Remove the four nuts and insulated spacers holding the C.S. box to the lower chassis.
- () 7. Turn the instrument right side up and locate the white-brown wire which comes from the C.S. box and connects to the lower side of the VERTICAL CURRENT OR VOLTAGE PER DIVISION switch.
- () Unsolder this wire from switch and pull it down toward the C.S. box.

NOTE: In some instruments, this wire will be secured with a cable clamp. If so, pull the wire back through the clamp.

- () 8. Loosen the allen setscrews at the back side of the flexible couplers which connect the PEAK VOLTS RANGE, POLARITY and the DISSIPATION LIMITING RESISTOR controls to the C.S. box.
- () Slide the shafts of these controls all the way forward.
- () 9. Remove the cable clamp (not in all instruments), secured to the right side (as viewed from front) of the C.S. box.
- () 10. Carefully lift up the C.S. box and remove it from the instrument.
- () 11. Mount the drilling template (from kit) on the rear edge of C.S. box, as shown in Fig. 1. If not already present, drill four 1/8 inch holes as indicated. Remove template.
- () 12. If not already present, mark and drill two 5/32 inch holes in the back of the C.S. box, as shown in Fig. 2.

INSTRUCTIONS (continued)

- () 13. If not already present, mark and drill three 5/32 inch holes in the right side of the C.S. box, as shown in Fig. 3. To locate the support plate mounting holes, temporarily place transformer support plate assembly over the top outside edge of the C.S. box and mark the two 5/32 inch mounting holes. DO NOT DRILL THROUGH HOLES IN PLATE.

CAUTION: Remove any metal shaving made by drilling!

FIG. 3

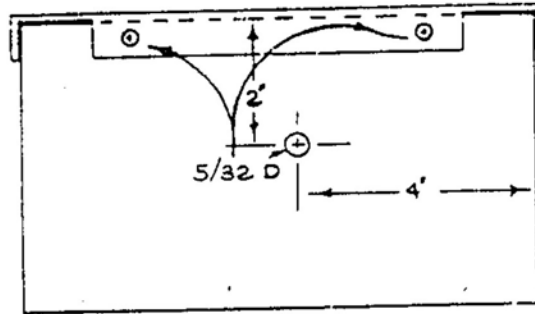

- () 14. Mount the cable assembly* (from kit) on the side of the C.S. box with the two cable clamps (from kit). See Fig. 5. Use the 6-32 PHS screws, flat washers, lockwashers and nuts from the kit.

DO NOT MOUNT TRANSFORMER SUPPORT PLATE AT THIS TIME.

- () 15. Mount the Germanium rectifier (GR707) assembly (from kit), using the holes drilled in step 12.

NOTE: The assembly mounts directly over the existing rectifiers, with the contacts facing downward.

- () 16. Mount the two 4.5-25pF variable capacitors from the kit. Use the four holes drilled in step 11 and mount in the same manner as the two capacitors mounted on the transformer support plate, from the kit. DO NOT OVER TIGHTEN!
- () 17. Unsolder all the wires from the POLARITY and PEAK VOLTS RANGE switches.
- () Remove these two switches from the C.S. box.
- () 18. Mark and drill a 5/32 inch keyway hole in the front of the C.S. box for the PEAK VOLTS RANGE switch, as shown in Fig. 4.

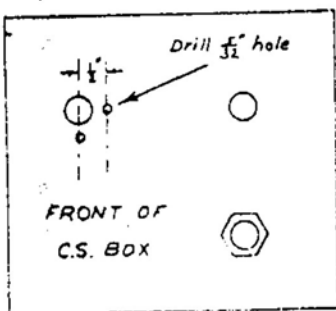

FIG. 4

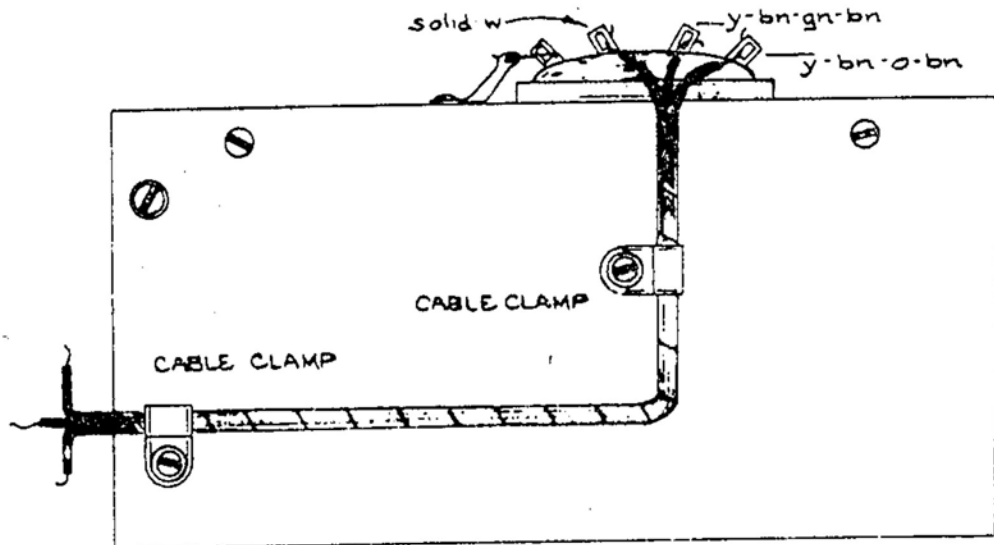

FIG. 5

INSTRUCTIONS (continued)

- () 19. Install the new POLARITY switch (from kit) and solder the wires to it, as shown in Fig. 6.

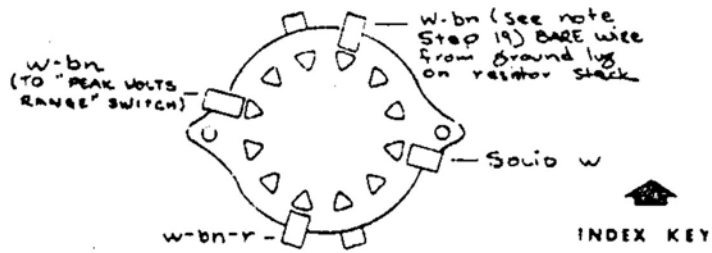

FIG. 6

NOTE: There were two white-brown wires previously connected to the POLARITY switch. Connect only the one which is dressed through the grommet in the front of the C.S. box (check with ohmmeter) to the new POLARITY switch. The other one will connect to the PEAK VOLTS RANGE switch, as called out in Fig. 7.

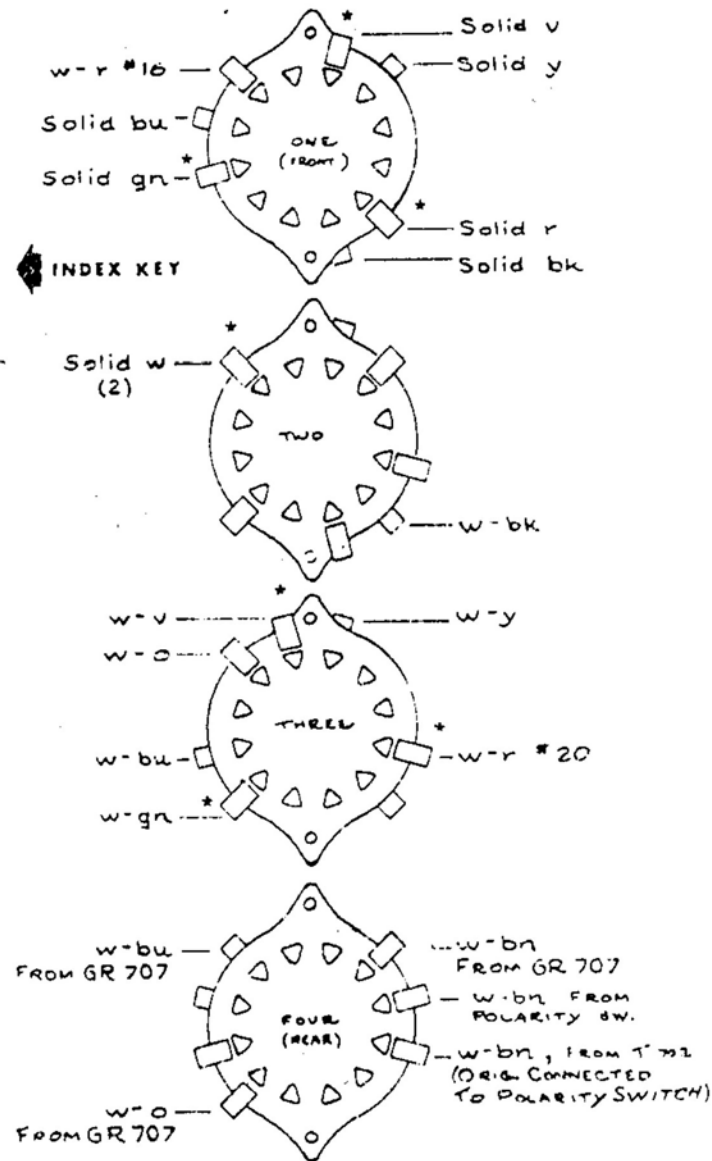

FIG. 7

*These are double contacts; one on the front of the wafer and the other on the rear. Solder the wire to both contacts.

INSTRUCTIONS (continued)

- () 20. Dress the three wires (white-blue, white-brown and white-orange) from the Germanium rectifier (GR707, mounted in step 15) down along the cable toward the front of the C.S. box.
- () 21. Locate the white-red wire which is dressed through the grommet in the front of the C.S. box and connects to the wiper contact on the front wafer of the DISSIPATION LIMITING RESISTOR switch.
() Replace this wire with the 13 inch length of Hyper high voltage wire from the kit. (Cut off the white-red wire where it enters the cable, and also where it leaves the C.S. box.)
- () 22. Install the new PEAK VOLTS RANGE switch (from kit) and solder the wires to it as shown in Fig. 7.
- () 23. Solder the rear terminals (terminals nearest rear of instrument) of C706B, C and E together. Leave about 3 inches of extra wire coming from C706C. (This point will later be grounded outside of the C.S. box.)

NOTE: Determine the C numbers by looking at the new C.S. box side shield in the kit.

- () 24. Solder the short length of white-brown wire from GR707 to the front terminal of C706B (the upper trimmer capacitor).
- () 25. THIS COMPLETES THE REWORK OF THE C.S. BOX. Recheck wiring for accuracy. It is easier to check it now, before it is put back into the instrument.
- () 26. Remove the bottom cover from the Transistor Test Panel assembly.

NOTE: There may be four white-yellow wires soldered to the Transistor Selector switch. If 050-0070-00 has been installed, remove only the two white-yellow wires that are connected to the same contact.

- () 27. Unsolder the two shielded cables and the white-yellow wires from the Transistor Selector switch.
- () 28. Unsolder the white-brown wire from the ground point inside the test panel.
- () 29. Remove the Test Panel assembly from the instrument. (It is held with the four nuts at the back of the sub-panel.)

NOTE: If the TRANSISTOR SELECTOR switch in your instrument is the same type as the switch from the kit, omit steps 30 through 37.

- () 30. Unsolder the wires from the Transistor Selector switch and remove it from the Test Panel assembly.
- () 31. Unsolder the two white-green wires from the ground lug on the Test Panel.

NOTE: Some instruments have a ground buss soldered between two ground lugs. If your Test Panel is wired this way, unsolder only one white-green wire from buss.

INSTRUCTIONS (continued)

- () 32. Enlarge the Transistor Selector switch mounting hole in the Test Panel to 1/2 inch, using a drill or reamer.
- () Install the Transistor Selector switch (from kit) as shown in Fig. 8. Orient switch so that the white-green wire comes out to the TRANSISTOR B side.

NOTE: On some older instruments it may be necessary to file away a small portion of the frame to make the switch mount straight.

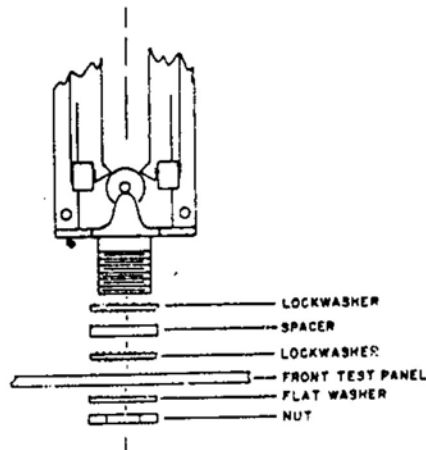

FIG. 8

- () 33. Add a ground lug, a no. 16 buss wire and two lengths of tubing (from kit), as shown in Fig. 9. (Disregard this step for instruments which already have a ground buss.)
- () 34. Solder the white-green wire from the Transistor Selector switch to the center of the ground buss (see Fig. 9).

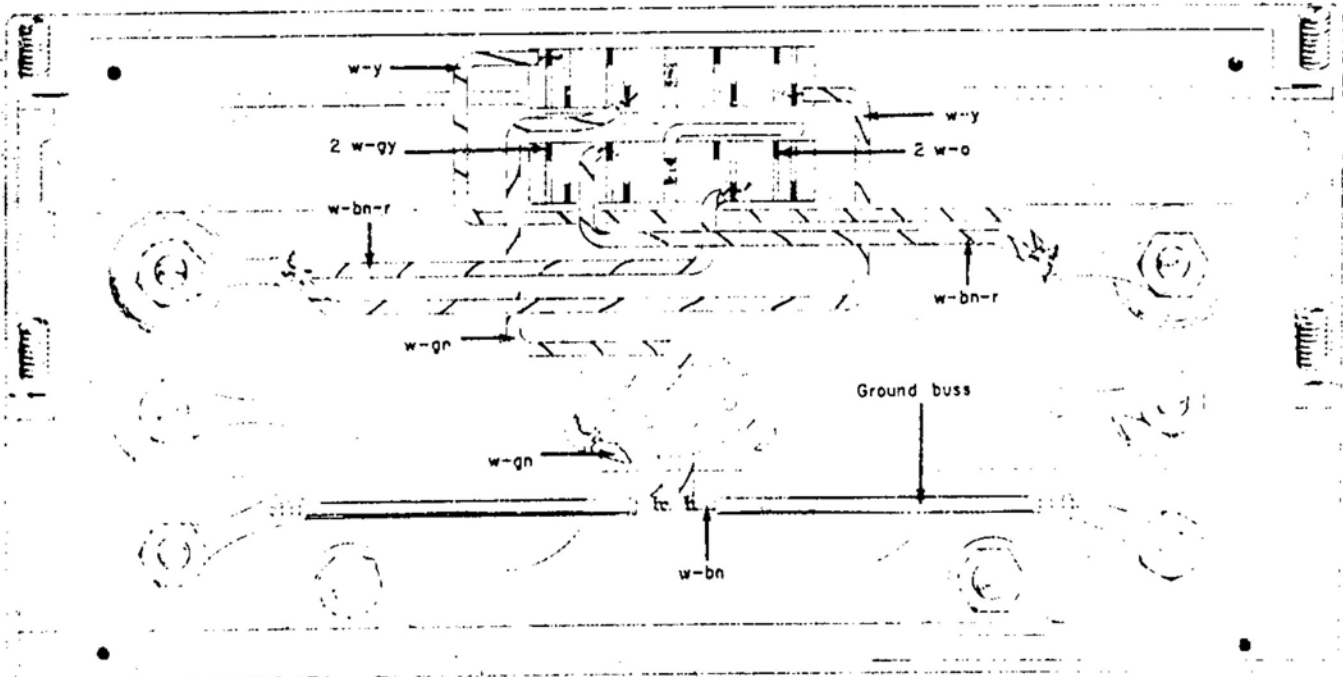

FIG. 9

INSTRUCTIONS (continued)

- () 35. Solder the white-green wire from EMITTER GROUNDED - BASE GROUNDED switch to the center of the ground buss (see Fig. 9).

NOTE: Omit this step for instruments which already have a bare wire connected here.

- () 36. Solder the two white-yellow wires from the Selector switch to the Collector Test terminals, as shown in Fig. 9. (Some instruments already have two white-yellow wires connected to the test terminals. If so, remove and discard them.)
- () 37. Solder the two white-gray, the two white-orange and the two white-brown-red wires to the Selector switch, as shown in Fig. 9.

NOTE: If any white-gray or white-orange wire is too short, replace it with a longer one from the kit.

The white-brown wire, called out to center of the ground buss, will be connected at a later step --- after the Test Panel is re-installed.

- () 38. Replace the front panel with the new one from the kit. BE SURE THAT THE TWO INSERT TABS ARE IN PLACE AND THAT THE SERIAL NUMBER IS CORRECT.

NOTE: If your instrument is below SN 861, and does not have the Collector Current multiplier pushbuttons, apply the small panel decal (from kit) to cover the holes.

- () 39. FOR INSTRUMENTS BELOW SERIAL NUMBER 861 ONLY:
Replace the Collector Sweep fuse holder (not in instrument above SN 860) with the Circuit Breaker from the kit.
- () 40. Turn the instrument upside down and remount the Transistor Test Panel assembly.
- () 41. Locate the white-brown wire, previously grounded inside the Test Panel. Solder it to the center of the ground buss, as indicated in Fig. 9.
- () Replace the bottom cover on the Test Panel assembly.
- () 42. Turn the instrument right side up.
- () 43. Center-punch and drill a 3/8 inch hole through the front sub-panel for the PRESS TO CHECK pushbutton switch.

CAUTION: Blow out any metal shavings made by drilling!

- () 44. Reinstall the C.S. box in the instrument using old mounting hardware.
- () (SN 101-4769 ONLY) place a solder lug under the nut holding the C.S. box, nearest to the power transformer, T601.
- () Resolder the six wires (unsoldered in step 3) to the Collector Sweep transformer (T702).

INSTRUCTIONS (continued)

NOTE: Replace cable clamp (removed in step 9) on the side of the C.S. box.

- () 45. Install the pushbutton switch in the hole drilled in step 43.
- () 46. Dress the white-brown wire from the C.S. box, up to the VERTICAL CURRENT OR VOLTAGE PER DIVISION switch.
- () Solder it to the terminal on the rear wafer, from which it was disconnected in step 7.
- () 47. Solder the short yellow-brown-orange-brown wire from the PRESS TO CHECK pushbutton switch to fused side of the CIRCUIT BREAKER.

NOTE: You can find the fused side by connecting an ohmmeter (use the lowest range) between terminal 3 (center arm) of the PERCENT OF PEAK VOLTS RANGE auto transformer and the CIRCUIT BREAKER. The terminal on the CIRCUIT BREAKER which indicates the highest resistance (approximately 1Ω higher) is the fused side.

- () 48. Solder the yellow-brown-green-brown wire from the cable mounted on the side of the C.S. box (step 14) to terminal 1 of the PERCENT OF PEAK VOLTS RANGE auto transformer.
- () 49. Dress the high voltage lead, from the C.S. box, through the grommet hole in the lower chassis.
- () 50. Mount the Transformer Support Plate assembly (from kit) on top of the C.S. box, using two 6-32 x 1/4 PHS screws.

NOTE: Instruments BELOW SN 359 have a wider C.S. box. For these instruments, use the 3/16 inch spacers (from kit) between the inside edge (edge nearest center of instrument) of the C.S. box and the support plate. Mount with the 6-32 x 1/2 PHS screws from the kit.

- () 51. Solder the three wires to the transformer terminals, as shown in Fig. 5.
- () 52. Solder the white-blue wire from the PEAK VOLTS RANGE switch to the lower terminal of C706A.
- () 53. Solder the white-violet wire from the PEAK VOLTS RANGE switch to the lower terminal of C706D.
- () 54. Solder the no. 22 white-yellow solid wire from the 11-notch ceramic strip, on the support plate, to C706E.
- () 55. Solder the white-yellow stranded wire from the support plate assembly to the POLARITY switch, as shown in Fig. 10.
- () Solder the white-yellow stranded wire from the POLARITY switch to terminal 8 of T703.

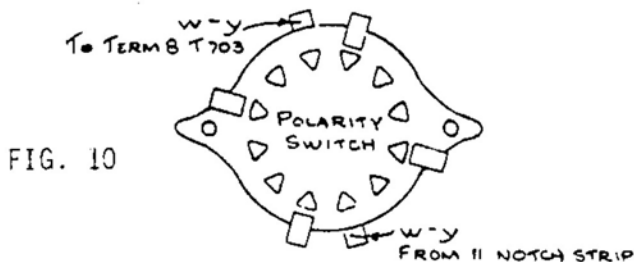

INSTRUCTIONS (continued)

- () 56. Dress the white-black wire from C706A and C706D along the inside edge of the transformer support plate towards the rear of the C.S. box, down the back of the box to a point near C706B, C and E.
- () Solder this wire, along with the bare wire connecting C706B, C and E together, to the ground lug on the resistor stack outside and to the rear of the C.S. box.
- () Remove the rubber bumper from the Collector Sweep shield and install in new cover.
- () 57. Install the C.S. side shield from the kit. The additional 6-32 x 1/4 BHS screws and insulating washers are provided in the kit.
- () Reconnect the switch shaft couplers to the C.S. box.
- () 58. If your instrument has a PEAK VOLTS RANGE knob with two white dots, replace it with the new one from the kit.
- () 59. Turn the instrument upside down.
- () 60. If not already present, mark and drill four 5/32 inch holes, as shown in Fig. 11.

FIG. 11

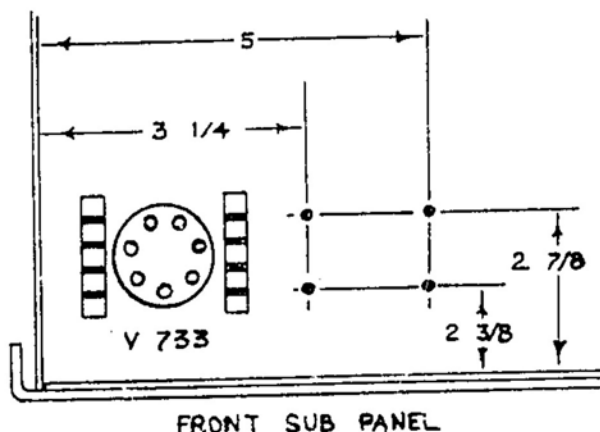

- () 61. Insert four nylon spacers (from kit) in the holes just drilled and press the two 4-slot ceramic strips (from kit) into them. (See Fig. 12).
- () 62. Unsolder and remove all the components on the 4-slot ceramic strips mounted over the V733 tube socket. SAVE THE 100k, 1W RESISTOR FOR RE-USE.
- () 63. Remove C735 (variable ceramic capacitor).
- () 64. Unsolder the solid orange, the two white-yellow wires, and the bare jumper wire from CSB (see Fig. 12).
- () Unsolder the bare wire from CSA to -in-1 of V733.
- () 65. Unlace the three wires (just unsoldered) back to the grommet.
- () Discard the short white-yellow wire, which is now free.
- () 66. Unsolder the black-brown-green-brown wire from CSB and resolder it, as shown in Fig. 12.

INSTRUCTIONS (continued)

- () 67. Resolder the solid orange wire to the point vacated by the black-brown-green-brown wire in step 66 (see Fig. 12).

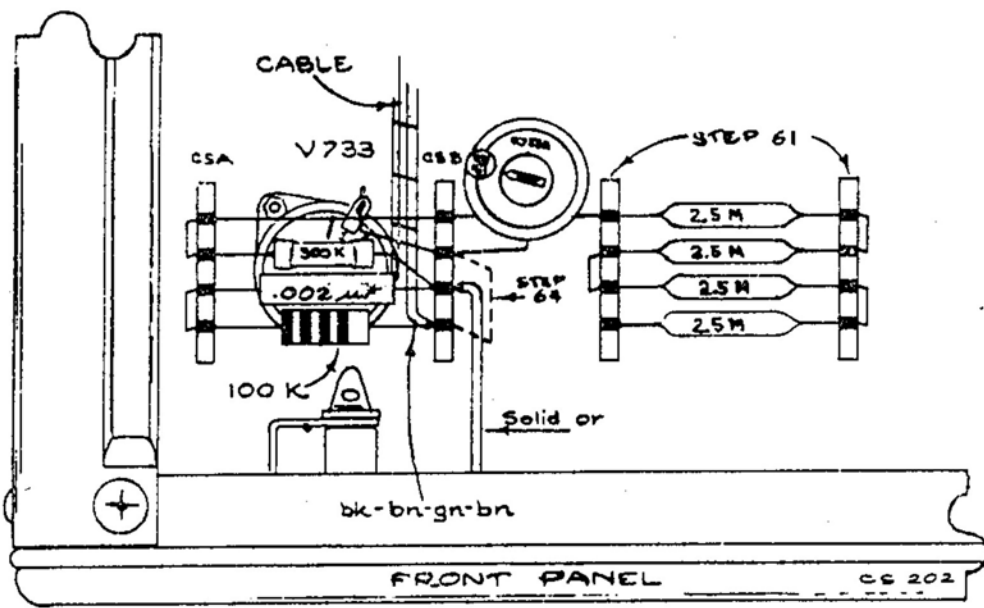

FIG. 12

- () 68. Replace the white-yellow wire (unsoldered in step 64) with the 24 inch length of high voltage wire from the kit.

NOTE: First, unsolder the white-yellow wire from the HORIZONTAL VOLTS/DIV switch, then pull it out of the cable from the bottom of the instrument. It is not necessary for the high voltage wire to go into the cable.

DO NOT SOLDER THE HIGH VOLTAGE WIRE AT EITHER END AT THIS TIME.

- () 69. Wire all four ceramic strips, as shown in Fig. 12.
- () 70. Wire the Transistor Selector switch and connect the two high voltage leads to the ceramic strips, as shown in Fig. 13.

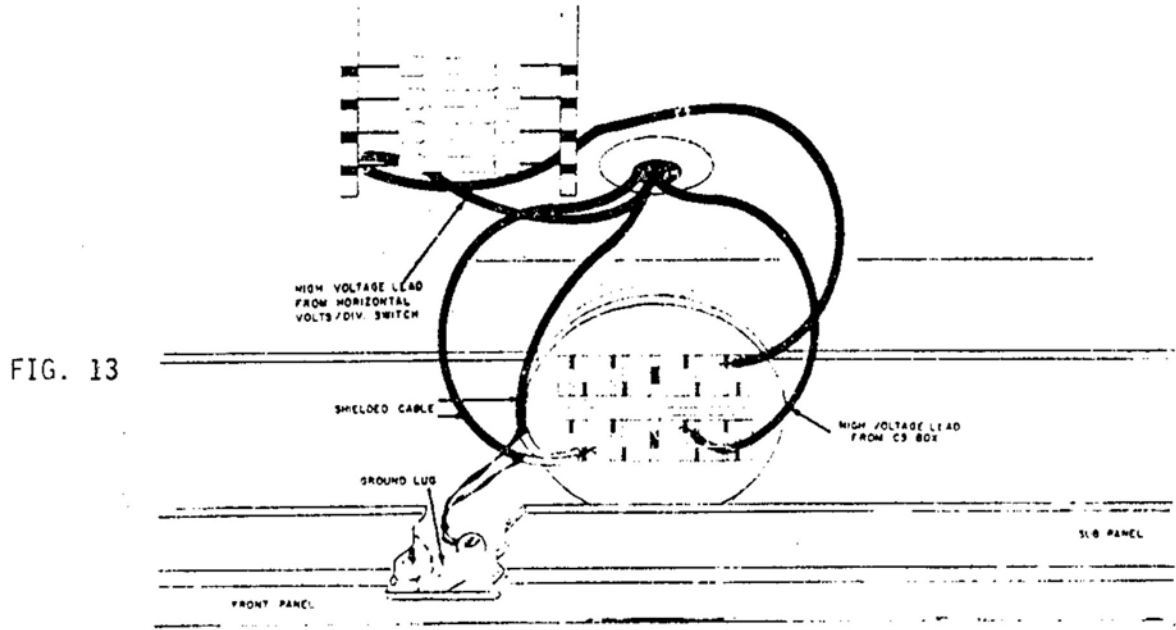

FIG. 13

INSTRUCTIONS (continued)

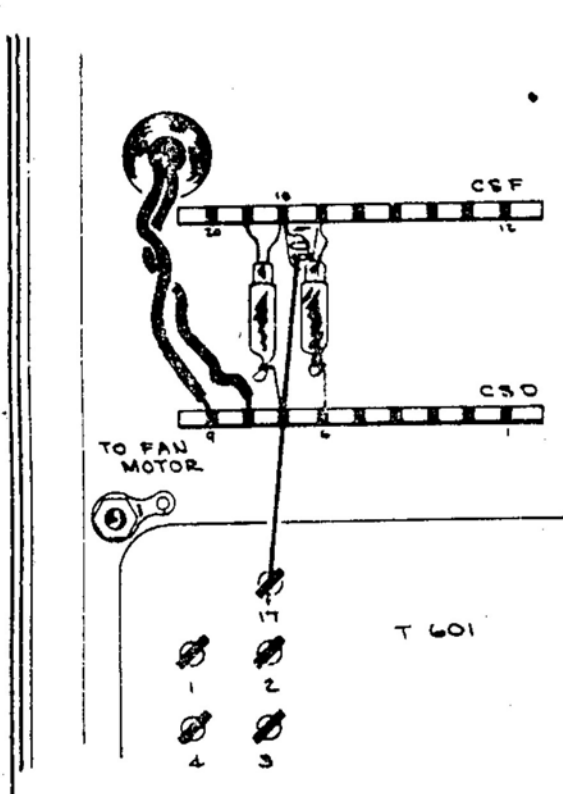

Fig. 14A BEFORE

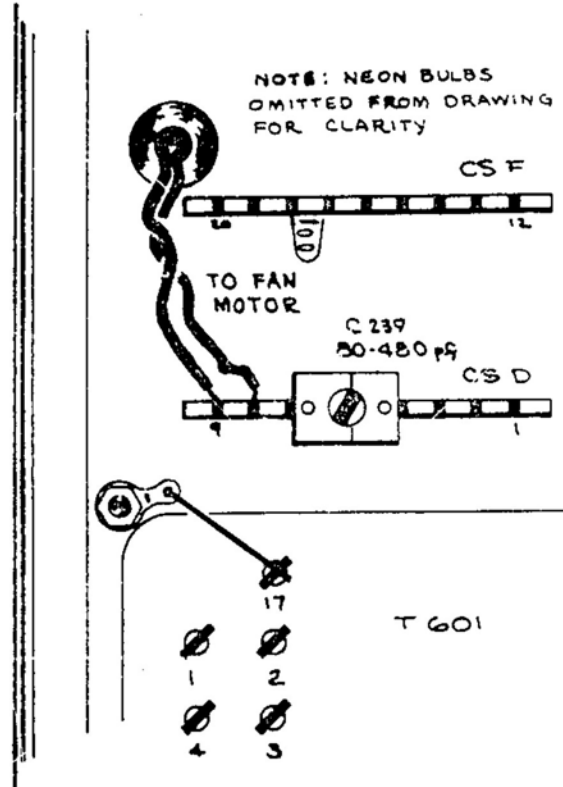

Fig. 14B AFTER

NOTE: Fan motor leads may be connected differently than shown.

INSTRUCTIONS (continued)

PERFORM STEPS 71 AND 72 FOR SN 101-4769 ONLY

- () 71. Move the neon holder from CSD-7 to CSD-6. See Fig. 14A for locations.
- () If a bare wire is connected from terminal 17 of T601 to CSD-7 to the ground lug indicated in Fig. 14A, remove this wire completely; instead, install a #16 bare wire (from kit) between terminal 17 and the ground lug shown in Fig. 14B. (If no lug is present, install a #10 solder lug from the kit.)
- () 72. Connect a 7-1/2 inch length of #22 solid white wire (from kit) from CSD-4 to the solder lug installed in step 44.
- () Connect a 3-1/2 inch length of #22 solid white wire (from kit) from terminal 14 of T601 to CSD-7. See recalibration instructions.
- () Install C239, an 80-480pF capacitor (from kit) between CSD-4 and CSD-7. See Fig. 14B.
- () 73. Carefully unsolder all the wires from the HORIZONTAL VOLTS/DIV switch.
- () FOR INSTRUMENTS ABOVE SERIAL NUMBER 821 ONLY:
Unsolder the wires connected to the potentiometers (R434 and R334) on the rear bracket at the potentiometer terminals.
- () 74. Remove the switch from the instrument.
- () 75. Re-install the HORIZONTAL VOLTS/DIV switch and secure with the pot nut and washer.
- () 76. Install the HORIZONTAL VOLTS/DIV knob.
- () 77. Solder the wires to the switch as shown in Fig. 15.

NOTE: Potentiometers R334 and R434, previously mounted on rear bracket of HORIZONTAL VOLTS/DIV switch, are now mounted on the printed circuit board attached to rear of switch. In instruments BELOW SN 822, R334 was mounted on HORIZONTAL VOLTS/DIV switch and R434 was mounted on VERTICAL CURRENT OR VOLTAGE PER DIVISION switch.

- () 78. FOR INSTRUMENTS BELOW SERIAL NUMBER 822 ONLY:
Remove potentiometer R434 from VERTICAL CURRENT OR VOLTAGE PER DIVISION switch. Note switch terminals used and solder the white-black and white-red wires from the new R434 to these terminals. The white-red wire is soldered to the switch terminal nearest to the outside of the instrument.
- () 79. FOR INSTRUMENTS ABOVE SERIAL NUMBER 821 ONLY:
Solder the white-black and the white-red wires from R434 to the terminals on the VERTICAL CURRENT OR VOLTAGE PER DIVISION switch that this potentiometer was previously connected to. Discard the old white-red and white-black wires.

INSTRUCTIONS (continued)

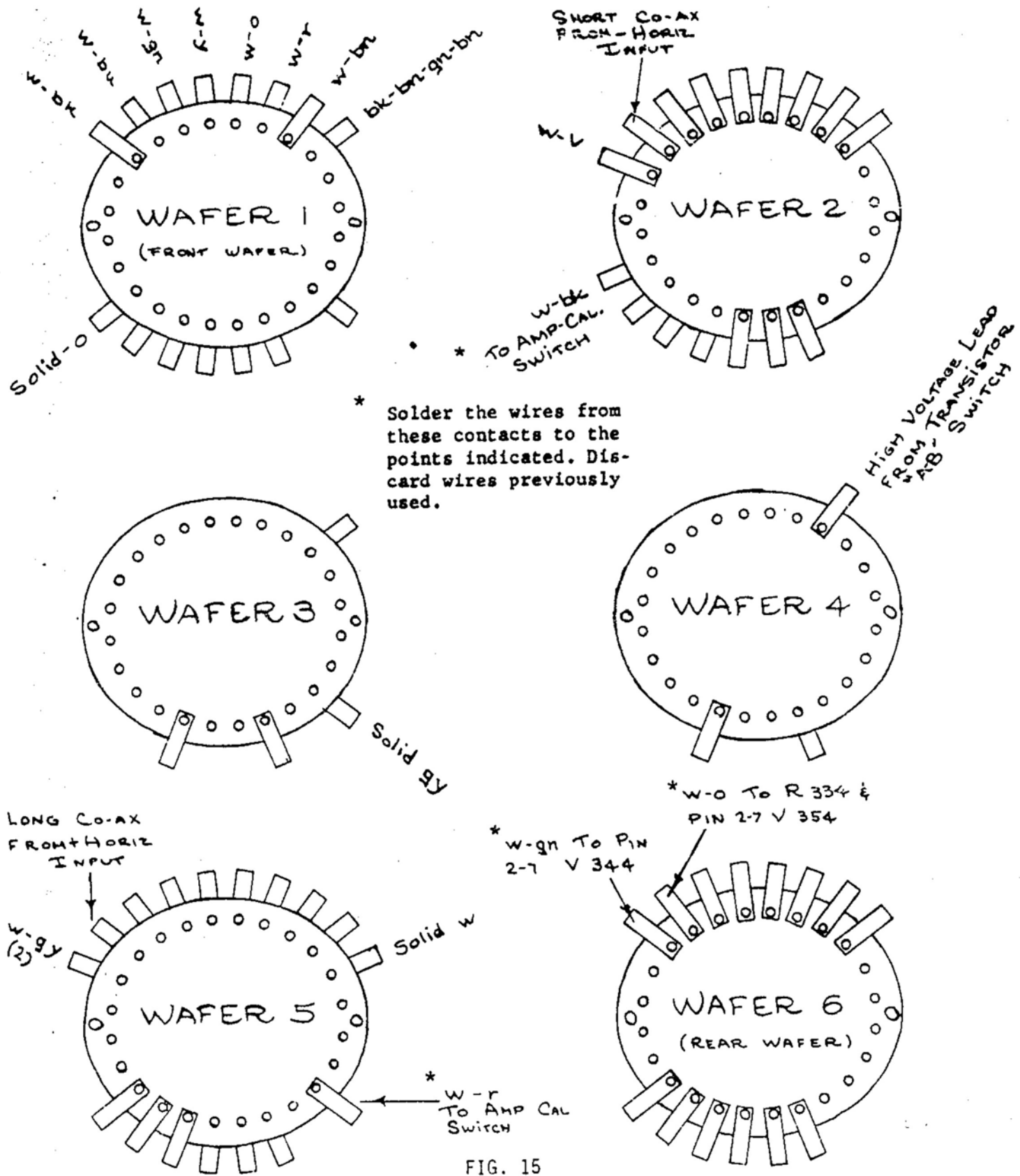

FIG. 15

INSTRUCTIONS (continued)

- () 80. For instruments which have Horizontal and Vertical coaxial inputs on the rear panel, remove the 1 Meg 1/2W resistor on the Horizontal inputs.
- () 81. Turn instrument upside down and refer to Fig. 16 while performing steps 82 through 84.
- () 82. Remove the frame brace that is bolted to the side rails and the Collector Sweep Transformer (T702) support post. Save the hardware.
- () 83. Enlarge the support post mounting hole to 17/64 inch diameter.
- () 84. Reinstall the frame brace, using the insulating washers for the support post as shown in the drawing.
- () Recheck wiring for accuracy.

CAUTION: Blow out all shavings made from drilling!

- () Refer to the Manual insert pages for recalibration procedure.
- () Fasten the Manual insert pages in your Instruction Manual.

JT:ljs

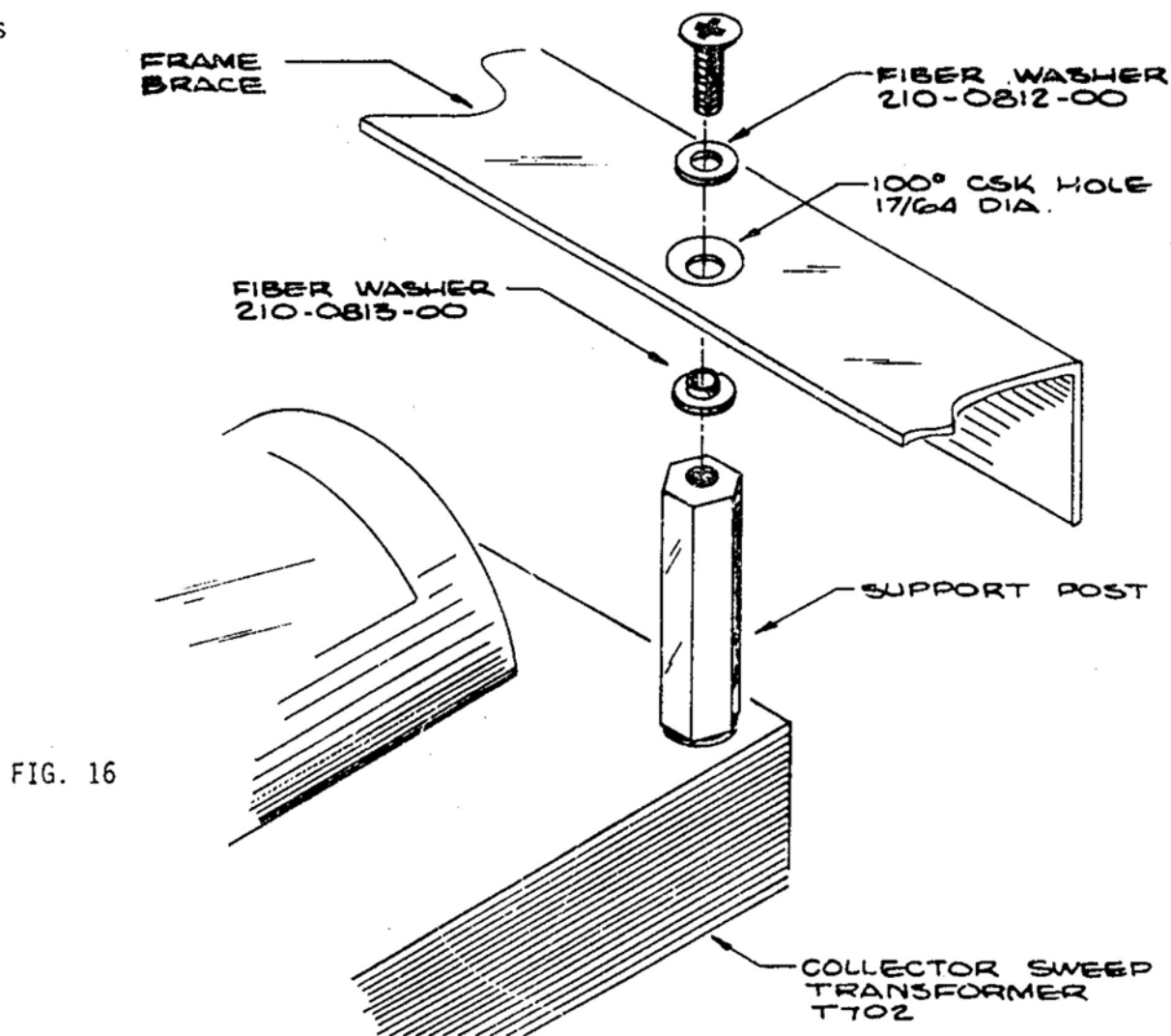

FIG. 16

INSTRUCTION MANUAL

MODIFICATION INSERT

INCREASED COLLECTOR VOLTS

Type 575 -- All Serial Numbers

Installed in Type 575 SN _____ Date _____

This insert has been written to supplement the Instruction Manual for this instrument. The information given in this insert will supersede that given in the manual.

This Insert Material Copyright © 1964 by Tektronix, Inc., Beaverton, Oregon. Printed in the United States of America. All rights reserved. Contents of this insert may not be reproduced in any form without the permission of the copyright owner.

GENERAL INFORMATION

Modification Kit, PN 040-0276-00, converted the Type 575 to Type 575 Mod 122C, and provided the following features:

- a) A maximum Collector Sweep voltage of 400V (instead of 200V), rated at 0.5 amp maximum.
- b) Three more sensitivities (50, 100 and 200V/Div) on the HORIZONTAL VOLTS/DIV switch.
- c) At ± 1.5 kV supply for checking peak inverse voltage of rectifiers. The high voltage is accessible at the Collector test terminals, and the supply current is limited by an internal impedance of 1.8 meg.

NOTE: The output voltage (Collector terminal voltage) of the 1.5kV supply varies directly with the line voltage and inversely with the load current (i.e., at 117V (234V) line voltage is approximately 1.8kV; with a load current of 1mA, the output voltage is zero).

OPERATING INSTRUCTIONS

For operating purposes, several important front panel changes have been made in the Type 575 by the addition of the Increased Collector Volts Mod. The HORIZONTAL VOLTS/DIV switch has three additional positions, 50, 100, and 200 VOLTS/DIV, added to the Collector Volts Range.

There are also changes in the COLLECTOR SWEEP switching, with an added 0-400 position on the PEAK VOLTS RANGE switch and a third position on the POLARITY switch. This third position, labeled $\pm 1.5\text{kV}$, 1mA MAX is brought to the Collector terminal posts, on the front Test Panel, by turning the POLARITY switch fully clockwise and pressing the PRESS TO CHECK button, which energizes the primary of the High Voltage Transformer. The high voltage can be varied by turning the PER CENT OF PEAK VOLTS RANGE control.

RECALIBRATION

When recalibrating your instrument, use the following procedure in lieu of step 9 in your Manual.

NOTE: If this Mod has just been installed and the instrument does not need a complete recalibration, it will be necessary to use only this procedure plus steps 4 and 5 in your Manual, which refer to Vertical Gain (R434) and Horizontal gain (R334).

STEP 9 -- ADJUST COLLECTOR SWEEP BALANCE

Set controls:

VERTICAL COLL MA/DIV	-- 0.01
HORIZ COLL VOLTS/DIV	-- 20
PEAK VOLTS RANGE	-- 0-200
PEAK VOLTS PER CENT	-- 80
POLARITY	-- MINUS (-)
TRANSISTOR A-B SWITCH	-- B

With controls set as noted above, adjust R732A, *C239 (under lower chassis) and C706A for minimum trace separation. If trace separation is greater than 2 or 3mm, change the white wire added in step 7 to terminal 16 of T601, and adjust for minimum separation as indicated in steps a through e on the following page.

(Complications will arise if a 575 Mod 122C is used on a 3-wire power Source and the hot and common leads are revised. The 60 cycle line voltage appears mixed with the collector sweep wave form, and it becomes impossible to adjust R732A and C706A for a satisfactory minimum trace separation.

Normally, one primary lead to T703 is connected to the common lead in the instrument and the other primary lead is switched to the hot side of the line through the 'PRESS TO CHECK' switch. If the primary lead normally connected to the common side becomes hot, a large 60 cycle AC signal is coupled into the Collector Sweep supply via the electrostatic shield at the secondary of T703.

RECALIBRATION (continued)

If this problem is encountered, first check the power Source at the 3-wire connector. The "hot" terminal should show the full line voltage (see drawing below).

*Effective SN 101-4769 only

If the Source is okay, check the wiring of the instrument against the schematics. The "hot" side should be the only side switched or fused.

- a. Set PEAK VOLTS RANGE to 0-400, and adjust C706B.
- b. Set POLARITY to PLUS (+), and adjust C706C.
- c. Turn PEAK VOLTS RANGE to 0-200, and adjust C706D. Then turn PEAK VOLTS RANGE to 0-400.
- d. Set HORIZONTAL to 50 COLLECTOR VOLTS/DIV, and adjust C318 (on etched circuit board at rear of HORIZONTAL VOLTS/DIV switch).
- e. Set PEAK VOLTS RANGE to 0-20, POLARITY to $\pm 1.5\text{kV}$, and depress the PRESS TO CHECK button. While holding the button depressed, adjust C706E.

If all adjustments are made carefully and in proper sequence, there should be no need to repeat any step, since there is then a minimum of inter-action between adjustments.

ELECTRICAL PARTS LIST

Values fixed unless marked variable. Only new parts and circuit numbers listed.

Ckt.No. Part Number Description

CAPACITORS

Tolerance ±20% unless otherwise indicated.

*C239	281-0044-00	80-480pF	Mica	Var.
C318	281-0010-00	4.5-25pF	Cer.	Var.
C706A	281-0007-00	3-12pF	Cer.	Var.
C706B	281-0010-00	4.5-25pF	Cer.	Var.
C706C	281-0010-00	4.5-25pF	Cer.	Var.
C706D	281-0010-00	4.5-25pF	Cer.	Var.
C706E	281-0010-00	4.5-25pF	Cer.	Var.
C734	283-0555-00	0.002μF	Mica	

RECTIFIERS

GR707	106-0060-00	6 Germanium rectifier cells, each cell rated at 0.5 amp, 300V peak inverse
-------	-------------	--

RESISTORS

Resistors are 10% composition unless otherwise indicated.

R250	309-0020-00	3.6 Meg	--	1.8 Meg	1/2W	prec.	1%
	309-0020-00			1.8 Meg	1/2W	prec.	1%
R258	309-0020-00	3.6 Meg	--	1.8 Meg	1/2W	prec.	1%
	309-0020-00			1.8 Meg	1/2W	prec.	1%
R319	309-0001-00	433k			1/2W	prec.	1%
R705	304-0274-00	270k			1W	prec.	10%
R729A	306-0474-00	470k			2W		
R729B	306-0474-00	470k			2W		
R729C	306-0474-00	470k			2W		
R729D	306-0474-00	470k			2W		
R730	309-0025-00	10 Meg	--	2.5 Meg	1/2W	prec.	1%
	309-0025-00			2.5 Meg	1/2W	prec.	1%
	309-0025-00			2.5 Meg	1/2W	prec.	1%
	309-0025-00			2.5 Meg	1/2W	prec.	1%
R732	309-0125-00	300k			1/2W	prec.	1%
R732A	311-0126-00	1 Meg			minipot	Var.	

SWITCHES

SW305	260-0591-01(unwired)	262-0633-00(wired)	Rotary	HORIZONTAL VOLTS/DIV
SW700	260-0017-00(unwired)		SPST Push	PRESS TO CHECK
SW706	260-0403-00(unwired)	262-0496-00(wired)	Rotary	PEAK VOLTS RANGE
SW708	260-0404-01(unwired)		Rotary	POLARITY
SW735	260-0463-01(unwired)		Lever	TRANSISTOR SELECTOR

TRANSFORMERS

T703	120-0226-00	High Voltage for Diode Test
------	-------------	-----------------------------

NOTE: The following circuit numbers should be deleted from the Standard Manual parts list: C706, C730, C735.

*Effective SN 101-4769 ONLY.

MECHANICAL PARTS LIST

Part Number	Description
388-0523-00	Board, etched circuit
406-0743-00	Bracket, 2kV transformer mounting
179-0668-00	Cable, harness, power for 2kV transformer
343-0002-00	Clamp, cable, 3/16
366-0033-00	Knob, small, black
210-0001-00	Lockwasher, int. no. 2
210-0004-00	Lockwasher, int. no. 4
210-0006-00	Lockwasher, int. no. 6
210-0010-00	Lockwasher, int. no. 10
210-0012-00	Lockwasher, int. 3/8 x 1/2, small potentiometer
210-0013-00	Lockwasher, int. 3/8 x 11/16, large potentiometer
210-0202-00	Lug, solder, SE6 w/2 wire holes
210-0205-00	Lug, solder, SE8
210-0206-00	Lug, solder, no. 10
210-0207-00	Lug, solder, 3/8, potentiometer
210-0406-00	Nut, hex, 4-40 x 3/16
210-0407-00	Nut, hex, 6-32 x 1/4
210-0410-00	Nut, hex, 10-32 x 5/16
210-0413-00	Nut, hex, 3/8-32 x 1/2
210-0438-00	Nut, 1-72
210-0449-00	Nut, hex, 5-40 x 1/4
210-0457-00	Nut, Keps, 6-32 x 5/16
210-0505-00	Nut, hex, 3/8-27 x 1/2
333-0690-00	Panel, (for Mod 122C)
211-0017-00	Screw, 4-40 x 3/4 RHS
211-0504-00	Screw, 6-32 x 1/4 BHS, Phillips
211-0507-00	Screw, 6-32 x 5/16 BHS, Phillips
211-0511-00	Screw, 6-32 x 1/2 BHS, Phillips
212-0553-00	Screw, 10-32 x 1-1/2 RHS
337-0476-00	Shield, Collector Sweep side
166-0025-00	Spacer, tube, mech.
166-0030-00	Spacer, 3/16 (for transformer mounting bracket)
361-0007-00	Spacer, nylon molded, 0.063
361-0009-00	Spacer, nylon molded, 0.313
361-0048-00	Spacer, toggle switch, 5/8 x 0.130L
124-0088-00	Strip, cer, 3/4 x 4 notches, clip-mounted
124-0091-00	Strip, cer, 3/4 x 11 notches, clip-mounted
334-0820-00	Tag, overlay
003-0220-00	Template
210-0801-00	Washer, flat, no. 5S
210-0802-00	Washer, flat, no. 6S
210-0803-00	Washer, flat, no. 6L
210-0840-00	Washer, flat, 0.390 x 9/16
210-0869-00	Washer, nylon, insulating
210-0906-00	Washer, fiber
210-0812-00	Washer, fiber #10
210-0813-00	Washer, fiber #10, shouldered

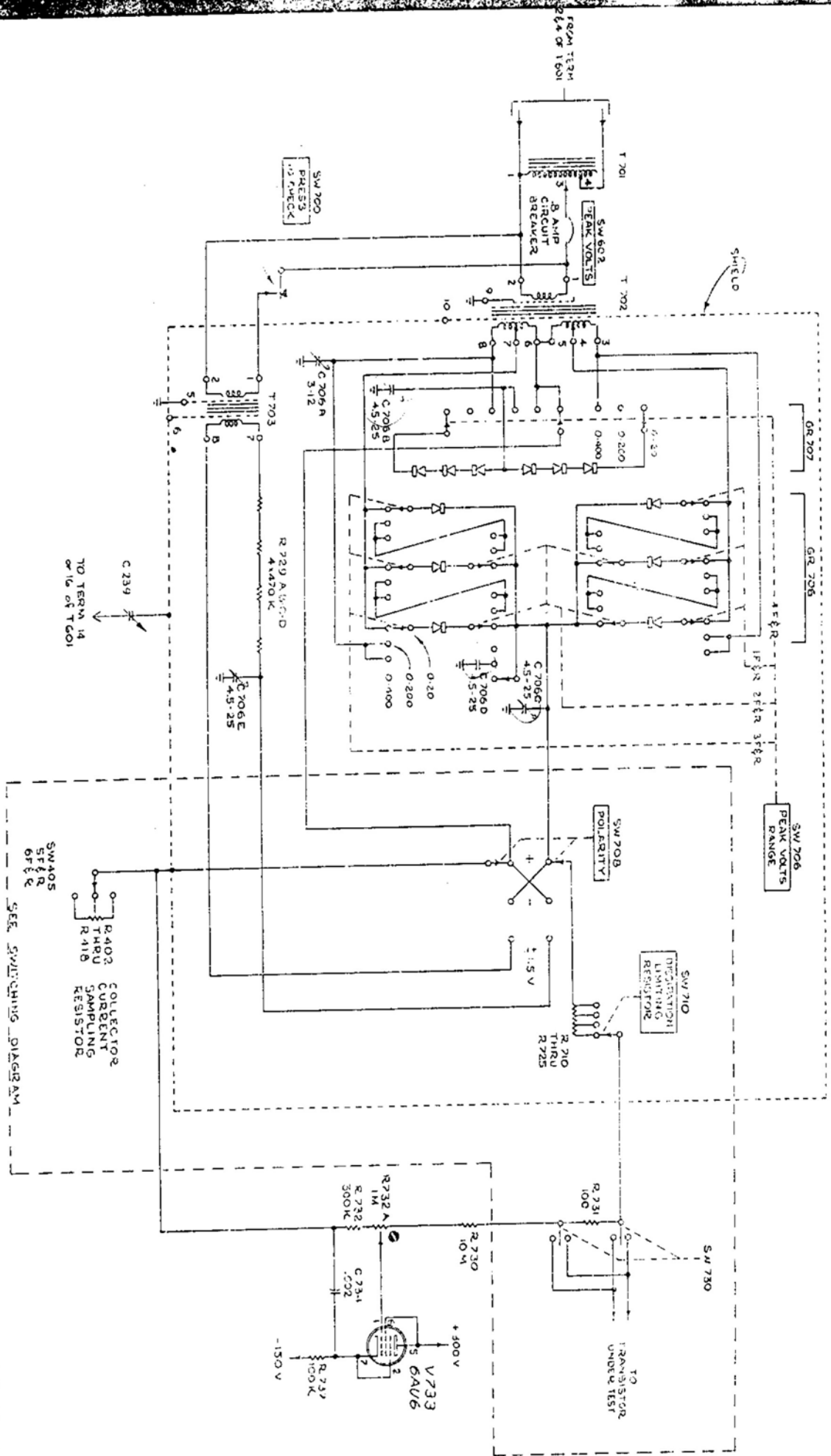

COLLECTOR SV

JFN
1-12-62 CS 20
100-0-1-12 B

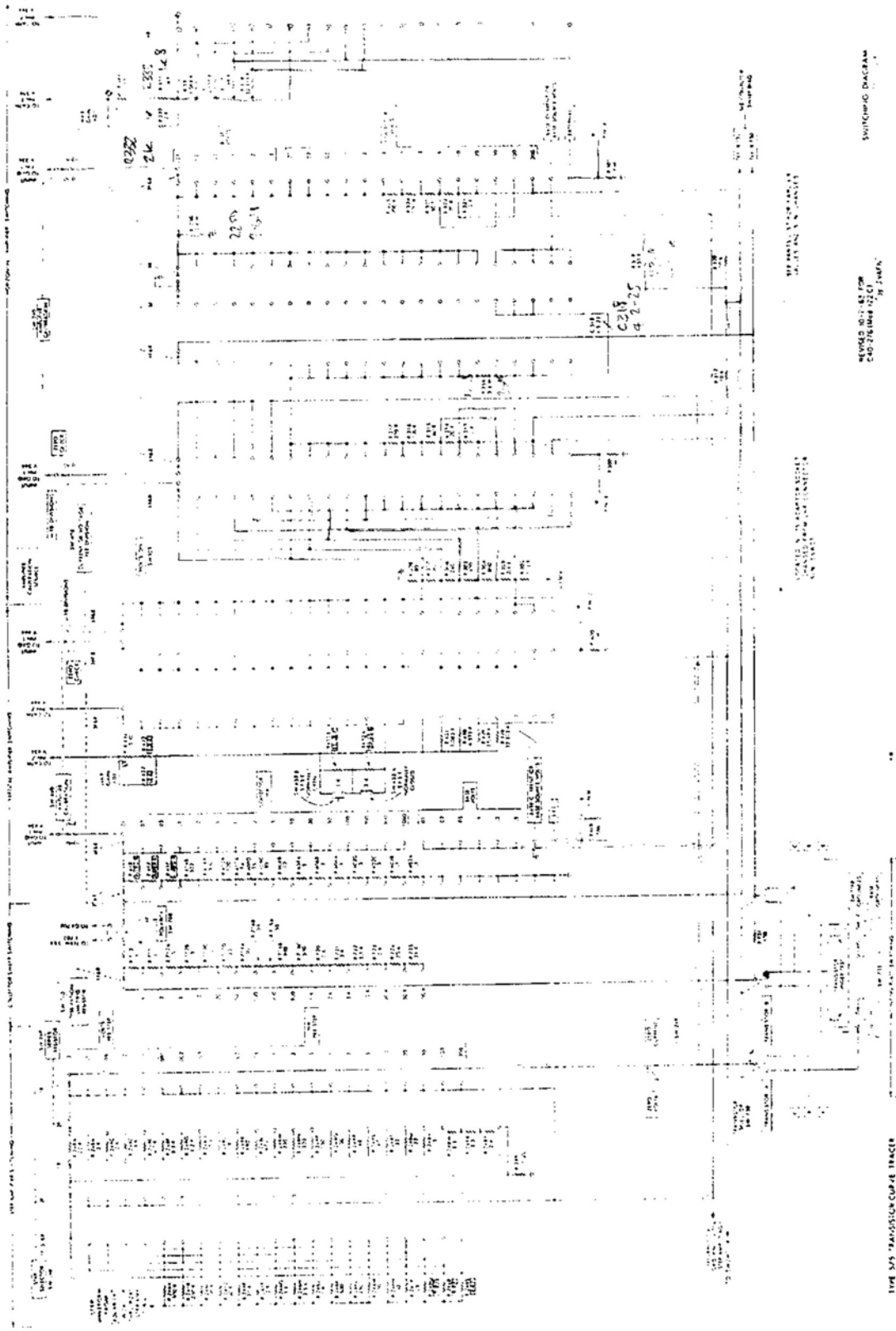

SWITCHING DIAGRAM

REVISED 001-85 1700
040-276-00-01
BY JAFK

TYPE S45 TRANSISTOR CURVE TRACER