

608 MONITOR WITH OPTIONS

*Please Check for
CHANGE INFORMATION
at the Rear of This Manual*

Copyright © 1977 Tektronix, Inc. All rights reserved.
Contents of this publication may not be reproduced in any
form without the written permission of Tektronix, Inc.

Products of Tektronix, Inc. and its subsidiaries are
covered by U.S. and foreign patents and/or pending
patents.

TEKTRONIX, TEK, SCOPE-MOBILE, and  are reg-
istered trademarks of Tektronix, Inc. TELEQUIPMENT is
a registered trademark of Tektronix U.K. Limited.

Printed in U.S.A. Specification and price change
privileges are reserved.

TABLE OF CONTENTS

	PAGE
LIST OF ILLUSTRATIONS	ii
LIST OF TABLES	ii
OPERATORS SAFETY INFORMATION	iii
SERVICE SAFETY INFORMATION	v

SECTION 1 GENERAL INFORMATION

INTRODUCTION	1-1
OPERATORS MANUAL	1-1
INSTRUCTION MANUAL	1-1
SPECIFICATION	1-2
STANDARD ACCESSORIES	1-5
INSTRUMENT PACKAGING	1-7

SECTION 2 OPERATING INSTRUCTIONS

AMBIENT TEMPERATURE CONSIDERATIONS	2-1
CONTROLS AND CONNECTORS	2-1
DETAILED OPERATING INFORMATION	2-1
INPUT SIGNAL REQUIREMENTS	2-1
FUNCTIONAL CHECK	2-4
TEST EQUIPMENT REQUIRED	2-4
PRELIMINARY SET UP	2-4
DISPLAY FUNCTIONS	2-4
DEFLECTION AND Z-AXIS FUNCTIONS	2-5

WARNING

THE REMAINING PORTION OF THIS TABLE OF CONTENTS LISTS THE SERVICING INSTRUCTIONS. THESE SERVICING INSTRUCTIONS ARE FOR USE BY QUALIFIED PERSONNEL ONLY. TO AVOID ELECTRICAL SHOCK, DO NOT PERFORM ANY SERVICING OTHER THAN THAT CALLED OUT IN THE OPERATING INSTRUCTIONS UNLESS QUALIFIED TO DO SO.

SECTION 3 INSTALLATION

OPERATING POWER INFORMATION	3-1
POWER CORD INFORMATION	3-1
LINE-VOLTAGE AND REGULATING RANGE SELECTION	3-2
INSTALLATION IN PATIENT-CARE FACILITIES	3-2
Z-AXIS INPUT ATTENUATION SELECTION	3-2
RACKMOUNTING INFORMATION	3-2
CABINET-TO-RACKMOUNT CONVERSION	3-4
RACKMOUNT-TO-CABINET CONVERSION	3-4
INSTRUMENT DIMENSIONS	3-4

SECTION 4 THEORY OF OPERATION

BLOCK DIAGRAM	4-1
DETAILED CIRCUIT OPERATION	4-1
VERTICAL (Y) DEFLECTION AMPLIFIER	4-1
HORIZONTAL (X) DEFLECTION AMPLIFIER	4-3
Z-AXIS AMPLIFIER	4-3
DYNAMIC FOCUS	4-4
HIGH-VOLTAGE POWER SUPPLY	4-5
LOW-VOLTAGE POWER SUPPLY	4-9

SECTION 5 MAINTENANCE

PREVENTIVE MAINTENANCE	5-1
CLEANING	5-1
EXTERIOR	5-1
CRT	5-1
INTERIOR	5-1

	PAGE
VISUAL INSPECTION	5-1
SEMICONDUCTOR CHECKS	5-2
PERIODIC ELECTRICAL ADJUSTMENT	5-2
TROUBLESHOOTING	5-2
TROUBLESHOOTING AIDS	5-2
DIAGRAMS	5-2
CIRCUIT BOARD ILLUSTRATIONS	5-2
TROUBLESHOOTING CHART	5-2
TEST POINT AND ADJUSTMENT LOCATIONS	5-2
COMPONENT COLOR CODING	5-2
SEMICONDUCTOR LEAD CONFIGURATIONS	5-5
MULTI-CONNECTOR HOLDERS	5-5
TROUBLESHOOTING EQUIPMENT	5-5
TROUBLESHOOTING TECHNIQUES	5-5
1. CHECK CONTROL SETTINGS	5-5
2. CHECK ASSOCIATED EQUIPMENT	5-5
3. VISUAL CHECK	5-6
4. CHECK INSTRUMENT ADJUSTMENT	5-6
5. ISOLATE TROUBLE TO A CIRCUIT	5-6
6. CHECK VOLTAGES AND WAVEFORMS	5-6
7. CHECK INDIVIDUAL COMPONENTS	5-6
8. REPAIR AND READJUST THE CIRCUIT	5-8
CORRECTIVE MAINTENANCE	5-8
OBTAINING REPLACEMENT PARTS	5-8
STANDARD PARTS	5-8
SPECIAL PARTS	5-8
ORDERING PARTS	5-8
SOLDERING TECHNIQUES	5-8
COMPONENT REMOVAL AND REPLACEMENT	5-9
CATHODE-RAY TUBE REMOVAL	5-9
CATHODE-RAY TUBE REPLACEMENT	5-11
CIRCUIT BOARDS	5-11
SEMICONDUCTORS	5-13
CIRCUIT-BOARD PIN REPLACEMENT	5-13
END-LEAD PIN CONNECTORS	5-14

SECTION 6 PERFORMANCE CHECK AND ADJUSTMENT

PRELIMINARY INFORMATION	6-1
USING THIS PROCEDURE	6-1
ADJUSTMENT INTERVAL	6-3
TEKTRONIX FIELD SERVICE	6-3
TEST EQUIPMENT REQUIRED	6-6
SPECIAL FIXTURES	6-6
TEST EQUIPMENT ALTERNATIVES	6-6
PERFORMANCE CHECK AND ADJUSTMENT PROCEDURE	6-9
INDEX	6-9
POWER UP SEQUENCE	6-9
A. POWER SUPPLY	6-10
B. CRT CIRCUIT AND DYNAMIC FOCUS	6-12
C. HORIZONTAL (X) AMPLIFIER	6-15
D. VERTICAL (Y) AMPLIFIER	6-18
E. Z-AXIS AMPLIFIER	6-21

SECTION 7 REPLACEABLE ELECTRICAL PARTS

SECTION 8 DIAGRAMS AND CIRCUIT BOARD ILLUSTRATIONS

SECTION 9 INSTRUMENT OPTIONS

SECTION 10 REPLACEABLE MECHANICAL PARTS

CHANGE INFORMATION

LIST OF ILLUSTRATIONS

FIGURE NO.	PAGE	FIGURE NO.	PAGE
Frontis-piece	608 Features.	vi	
1-1	608 Overall dimensional drawing	1-6	
2-1	Front-panel controls and indicators.	2-2	
2-2	Rear-panel controls and connectors.	2-3	
3-1	Location of line-voltage selector plugs, regulating-range pins, and line fuse	3-3	
3-2	Typical method for modifying Z-Axis input impedance and attenuation	3-4	
4-1	608 Block Diagram	4-2	
4-2	Simplified illustration of geometric defocusing	4-4	
4-3	Typical correction-voltage curve applied to the crt focus element (correction voltage applied for both vertical and horizontal deflection)	4-5	
4-4	Simplified diagram of Control-Grid DC Restorer	4-7	
4-5	Simplified diagram of Focus-Element DC Restorer	4-8	
5-1	Color code for resistors and capacitors	5-3	
5-2	Semiconductor lead configurations	5-4	
5-3	Orientation of multi-connector holders	5-5	
5-4	Location and rating of power-supply fuses.	5-7	
5-5	Cathode-ray tube (crt) removal and replacement	5-10	
5-6	Location of screws securing A1 Deflection Amplifier and A2 Z-Axis Amplifier boards	5-11	
5-7	Location of screws securing A3 Dynamic Focus and A5 Low-Voltage Power Supply boards	5-12	
5-8	Location of screws securing A4 High-Voltage Power Supply board	5-13	
5-9	Exploded view of circuit-board pin and ferrule	5-14	
6-1	How to perform a partial Performance Check and Adjustment Procedure.	6-2	
6-2	Focus adjustments corresponding to the appropriate area of the dot display	6-14	
6-3	Typical crt display for adjustment of horizontal (x) compensation and gain	6-15	
6-4	Typical crt display for horizontal settling-time measurement (settling time includes corner distortion)	6-16	
6-5	Typical crt display for adjustment of vertical (Y) compensation and gain	6-18	
6-6	Typical horizontal and vertical phase difference display	6-19	
6-7	Typical crt display for vertical settling-time measurement (settling time includes other distortion)	6-20	
The illustrations in section 8 are located near their associated diagrams on the foldout page.			
8-1	Semiconductor Lead Configurations.		
8-2	Circuit Board Locations.		
8-3	A1—Vertical (Y) Amplifier components and waveform test points locator.		
8-4	A1—Horizontal (X) Amplifier components and waveform test points locator.		
8-5	A2—Z-Axis Amplifier components and waveform test points locator.		
8-6	A3—Dynamic Focus Components and waveform test points locator.		
8-7	A4—High-Voltage Power Supply components and waveform test points locator.		
8-8	A5—Low-Voltage Power Supply components locator.		
8-9	608 Troubleshooting Chart.		
8-10	Location of test points and adjustments.		
8-11	Detailed dimensional drawing.		

LIST OF TABLES

TABLE NO.	PAGE
1-1	Electrical Characteristics. 1-2
1-2	Environmental Characteristics. 1-5
1-3	Physical Characteristics. 1-5
3-1	Power-Cord Conductor Identification 3-1
3-2	Location of Power-Cord Configuration Information 3-2
5-1	Power Supply Output Voltage. 5-6
6-1	Performance Check Summary 6-3
6-2	Test Equipment 6-7
6-3	Low-Voltage Supply Accuracy 6-10
9-1	Option Information Locator. 9-2

OPERATORS SAFETY INFORMATION



The following general safety information applies to all operators and service personnel. Specific warnings will be found throughout the manual where they apply and should be followed in each instance.

WARNING statements identify conditions or practices which could result in personal injury or loss of life.

CAUTION statements identify conditions or practices which could result in damage to the equipment or other property.

The word **DANGER** on the equipment identifies areas of immediate hazard which could result in personal injury or loss of life.

The following safety symbols may appear on the equipment:

-  **CAUTION**—Refer to manual
-  **DANGER**—High voltage
-  Protective ground (earth) terminal

Other warning symbols where they apply.

WARNING

AC POWER SOURCE AND CONNECTION

This instrument operates from a single-phase power source and has a three-wire power cord with a two-pole, three-terminal grounding-type connector. The voltage to ground (earth) from either pole of the power source must not exceed the maximum rated operating voltage, 250 volts.

Before making connection to the power source, a qualified service person should verify that the instrument is set to match the voltage of the power source and has a suitable two-pole, three-terminal grounding-type connector.

GROUNDING THE INSTRUMENT

This instrument is safety class I equipment (IEC designation). All accessible conductive parts are directly connected through the grounding conductor of the power cord to the grounding contact of the power connector. Before making external connections to this instrument, always ground the instrument first.*

For electric-shock protection, the power-input plug must be inserted only into a mating receptacle with a grounding contact. Do not defeat the grounding connection. Any interruption of the grounding connection can create an electric-shock hazard. Qualified service personnel should verify proper grounding of this instrument. For medical-dental applications (to assure grounding integrity) the hospital-grade input plug must be inserted only into a mating hospital-grade receptacle with a grounding contact.

DANGER ARISING FROM LOSS OF GROUND

Upon loss of the protective-ground connection, all accessible conductive parts (including knobs and controls that may appear to be insulating) can render an electric shock.

*IEC: International Electrotechnical Commission

MEDICAL-DENTAL APPLICATIONS

Do not use the amplifier INPUTs for direct patient connection. Signal currents at these connectors, as well as leakage currents, may exceed values considered non-hazardous for direct patient connection.

Although this instrument is not to be used for direct patient connection, interconnecting this Monitor with other equipment can result in application of excess current to the patient. It is extremely important that the equipment be interconnected in accordance with NFPA 76B-T, Tentative Standard for the Safe Use of Electricity in Patient Care Areas of Health Care Facilities, section 3038, "Signal Transmission Between Appliances".

Do not operate this instrument in the presence of flammable gases or anesthetics. Explosion can result from operation in such an environment.

USE THE PROPER FUSE

Refer fuse replacement to qualified service personnel only. To avoid electric shock and fire hazard, use only the fuse specified in the parts list for your instrument and which is identical in the following respects:

- A. Type—Slow blow, fast blow, etc.*
- B. Voltage rating—250 V, etc.*
- C. Current rating.*

DO NOT REMOVE INSTRUMENT COVERS

High-voltage is present inside the instrument. To avoid electric shock, operating personnel must not remove protective instrument covers. Component replacement and internal adjustments must be made by qualified service personnel only.

LIMIT INPUT SIGNAL VOLTAGE

To avoid electric-shock hazard, do not apply input signals of more than 25 volts (dc + peak ac). Should fault conditions occur however, the instrument is protected for application of input signals up to 100 volts (dc + peak ac).



EXERCISE CARE WITH INTENSITY LEVEL

Exercise care in establishing the correct display intensity; a high-amplitude Z-Axis input signal, combined with an excessively high setting of the INTENSITY control, may damage the crt phosphor. Therefore, set the INTENSITY control for just enough display intensity for good visibility.



This equipment generates, uses, and can radiate radio frequency energy and may cause interference to radio communications if not installed and used in accordance with the instruction manual. It has been tested and found to comply with the limits for Class B computing devices pursuant to Subpart J of Part 15 of FCC Rules, which are designed to provide reasonable protection against such interference when this equipment is operated in a commercial environment. Operation in a residential area is likely to cause interference in which case the users at their own expense must take whatever measures may be required to correct the interference.

SERVICE SAFETY INFORMATION

FOR QUALIFIED SERVICE PERSONNEL ONLY

The following are safety precautions which appear in the servicing information sections of this manual. This Service Safety Information is in addition to the Operators Safety Information given previously.

WARNING

DO NOT SERVICE ALONE

Do not attempt internal service or adjustment of this instrument unless another person, capable of rendering first aid and resuscitation, is present.

AC POWER SOURCE AND CONNECTION

This instrument is intended to be operated from a single-phase earth-referenced power source having one current-carrying conductor (the Neutral Conductor) near earth potential. Operation from power sources where both current-carrying conductors are live with respect to earth (such as phase-to-phase on a three-wire system) is not recommended, since only the Line conductor has over-current (fuse) protection within the instrument.

EXERCISE CARE WHEN OPERATING INSTRUMENT WITHOUT COVERS

Dangerous potentials exist at several points throughout this instrument. When the instrument is operated without protective covers, do not touch exposed connections or components.

DISCONNECT INSTRUMENT POWER

To avoid electric shock, disconnect the Monitor from the power source before removing protective panels, soldering, or replacing components.

CRT HANDLING

Use care when handling a crt. Breakage of the crt causes a high-velocity scattering of glass fragments (implosion). Protective clothing and safety glasses should be worn. Avoid striking the crt on any object which might cause it to crack or implode. When storing a crt, place it in a protective carton or set it face down in a protected location on a smooth surface with a soft mat under the faceplate.

SILICONE GREASE HANDLING

Handle silicone grease with care. Avoid getting the silicone grease in your eyes. Wash hands thoroughly after use.

CAUTION

APPLY PROPER LINE VOLTAGE

To prevent damage to the instrument, always check the line-voltage information recorded on the rear panel before applying power to the instrument. Incorrect placement of the line-voltage selector plug may damage the instrument. Verify correct placement of the line-voltage selector plug.

AVOID EXCESSIVE MOISTURE

Circuit boards and components must be dry before applying power to prevent damage from electrical arcing.

EXERCISE CARE WHEN CHECKING DIODES

When checking diodes, do not use an ohmmeter scale that has a high internal current, since high currents may damage the diodes under test.

USE PROPER CLEANING AGENTS

Avoid the use of chemical cleaning agents which might damage the plastics used in this instrument. Use a non-residue type of cleaner, preferably isopropyl alcohol, totally denatured ethyl alcohol, or TP35. Before using any other type of cleaner, consult your Tektronix Service Center or representative.

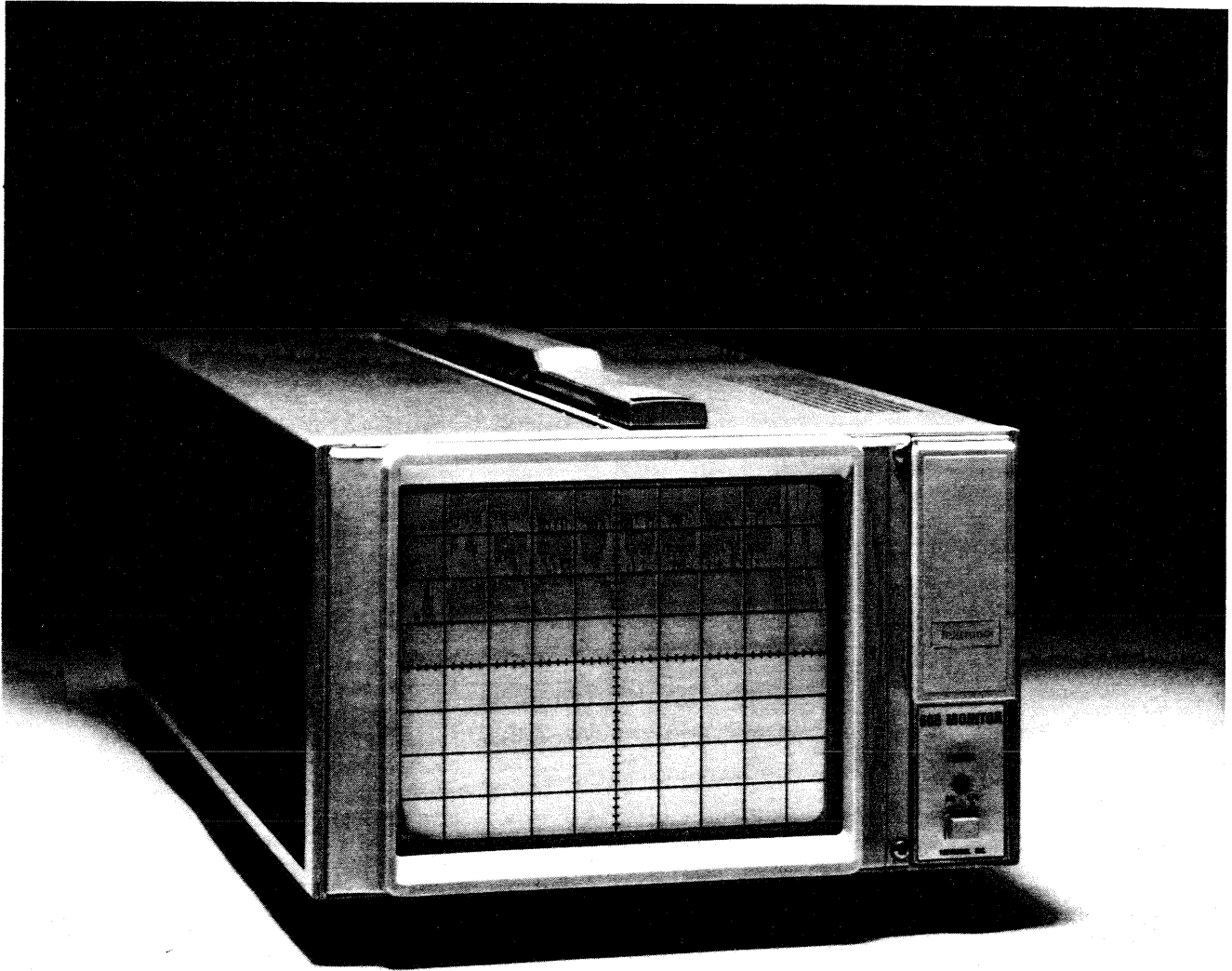

608 FEATURES

The 608 Monitor is a general purpose, high-brightness, high-resolution, X-Y display monitor providing a clear, bright, display of analog data on a large screen area. This instrument is designed for display applications as in ultrasonic detection systems, electron microscope systems, volume and vibration analysis, auger probes, and medical biophysical systems. The 608 Monitor may also be used to provide displays of alphanumeric and graphic information from computers and other data transmission systems. Resolution of the large screen crt (cathode-ray tube) in this instrument is excellent. (Monitor is shown with Option 23.)

2305-4

GENERAL INFORMATION

INTRODUCTION

OPERATORS MANUAL

The Operators Manual contains information necessary to effectively operate the 608 Monitor and is divided into three sections: Section 1 provides a basic description of the 608 with instrument specifications and accessories. Section 2 contains operating information for the instrument. Information on the options available for the 608 Monitor is located in section 3 of the manual.

INSTRUCTION MANUAL

The Instruction Manual provides both operating and servicing information for the 608 Monitor. The Instruction Manual is divided into ten sections. Operating information is covered in the first two sections; servicing information for use by qualified service personnel is contained in the remaining eight sections of the manual. Schematic diagrams are located at the rear of the manual and can be unfolded for reference while reading other parts of the manual. The reference designators and symbols used on the schematics are defined on the first page of the Diagrams and Circuit Board Illustrations section. All abbreviations used in this manual, with the exception of the parts lists and schematic diagrams, comply with the American National Institute Y1.1-1972 publication. The parts lists are computer printouts and use computer-supplied abbreviations. Information on the options available for the 608 Monitor is located in section 9 of the Instruction Manual.

INSTRUMENT DESCRIPTION

The 608 Monitor is a compact, solid-state instrument with excellent resolution, providing accurate displays of information from the X, Y, and Z signal inputs.

WARNING

High voltage is present inside the instrument. To avoid electric shock, operating personnel must not remove protective instrument covers. Component replacement and internal adjustments must be made by qualified service personnel only.

Vertical and horizontal signals to be displayed on the crt are supplied to the Deflection Amplifiers through the appropriate X and Y INPUT connectors. The Deflection Amplifiers process the input signals and provide push-pull outputs to drive the deflection plates of the crt. Both Deflection Amplifiers contain position and gain controls.

The Z-Axis Amplifier controls the display intensity by providing a voltage to drive the crt control grid. Input signals are applied to the Z INPUT connector.

The Dynamic Focus circuit provides focus correction for the display when the crt beam is deflected from the crt center. Thus, by varying the voltage to the crt focus element, the Dynamic Focus circuit compensates for geometric defocusing.

The High-Voltage and Low-Voltage Power Supplies provide all the voltages necessary for operation of this instrument.

SPECIFICATION

The electrical specifications listed in Table 1-1 apply when the following conditions are met: (1) The instrument must have been adjusted at an ambient temperature between +15° and +25° C (+59° and +77° F), (2) the instrument must be operating in an ambient temperature between 0° and +50° C (+32° and +122° F) and (3) the instrument must have been operating for at least 20 minutes.

NOTE

Electrical specifications for the available options are located in the Instrument Options section of this manual.

TABLE 1-1
Electrical Characteristics

Characteristic	Performance Requirement
VERTICAL AND HORIZONTAL AMPLIFIERS	
Deflection Factor Vertical (Y)	Adjustable from 0.5 V, or less, to at least 2.5 V full scale.
Horizontal (X)	Adjustable from 0.5 V, or less, to at least 2.5 V full scale.
Polarity +Y INPUT	Positive signal applied deflects beam up; negative signal deflects beam down.
+X INPUT	Positive signal applied deflects beam to the right; negative signal deflects beam to the left.
Settling Time	Spot must reach new writing position, within 0.05 cm (0.02 in), within 300 ns of deflection from any on-screen position.
Bandwidth (With 80% Full-Screen Reference Signal)	Dc to at least 5 MHz at -3 dB point.
Rise Time	70 ns or less.
Phase Difference (DC to 1.5 MHz)	1° or less between X and Y amplifiers. X and Y amplifier gain (V/div) must be set for the same deflection factor.
Position Stability	0.5 mm or less of drift per hour (after 20 minute warm-up).
Gain Stability	1% or less of drift (after 20 minute warm-up).
Displayed Noise (Tangentially Measured)	0.05 mm, or less, with all inputs terminated into 1 kΩ or less.
Input RC (Both Inputs)	1 MΩ, within 1%, paralleled by 60 pF or less.
Maximum Nondestructive Input Voltage (Fault Condition Only)	+100 V or -100 V (dc + peak ac).
Position Range (With No Input Signals Applied)	Front panel controls allow spot to be set anywhere within the viewing area.
Dynamic Range	At least 1.5 screen diameters from center screen.

TABLE 1-1 (CONT.)
Electrical Characteristics

Characteristic	Performance Requirement
Crosstalk Between X and Y Amplifiers At 500 kHz	0.25 mm, or less, of deflection on the grounded channel (X or Y) with a 1 V signal applied on the other channel (Y or X).
At 5 MHz	0.38 mm, or less, of deflection on the grounded channel (X or Y) with a 1 V signal applied on the other channel (Y or X).

Z-AXIS AMPLIFIER

Useful Input Voltage Range (+Z INPUT)	Adjustable. With Z Gain at maximum, no more than +1 V will provide full intensity. With Z Gain at minimum, at least +5 V is required to produce full intensity. (-1 V input signal cuts off visible intensity.)
Useful Frequency Range	Dc to at least 10 MHz at -3 dB point.
Rise Time	35 ns or less.
Noise	No visible intensity modulation with Z INPUT terminated into 1 k Ω or less.
Input RC	1 M Ω , within 1%, paralleled by 60 pF or less.
Maximum Nondestructive Input Voltage (Fault Condition Only)	+100 V or -100 V (dc + peak ac) with crt beam positioned off the viewing area.
Crosstalk Between Z-Axis Amplifier and X or Y Amplifier 0 to 500 kHz	0.25 mm or less, with X and Y INPUTS grounded and a 1 V signal applied to the Z-Axis Amplifier. (Z-Axis Gain set for maximum.)
500 kHz to 5 MHz	0.38 mm or less, with X and Y INPUTS grounded and a 1 V signal applied to the Z-Axis Amplifier. (Z-Axis Gain set at minimum.)
Light Output (Option 24 only)	Linear function of Z-Axis input voltage between 2% and 100% of maximum brightness, $\pm 20\%$ of maximum brightness.

CATHODE-RAY TUBE DISPLAY

Usable Screen Area	9.8 X 12.2 centimeters.
Quality Area	9 X 11 centimeters.
Geometry (Within Graticule Area)	Bowing or tilt is 0.1 division or less.
Orthogonality (Within Graticule Area)	90° within 0.7°.
Accelerating Potential	22.5 kV.
Phosphor	P31 standard.
Deflection	Electrostatic.

**TABLE 1-1 (CONT.)
Electrical Characteristics**

Characteristic	Performance Requirement
Brightness	Light output is at least 240 cd/m ² (70 fL) with a 0.33 mm, or less, centered spot size. Measured with the crt screen area flooded by a raster, 60 Hz refresh rate, 308 horizontal lines.
Uniformity	Light output does not vary more than 20% in the crt quality area, at moderate intensity 34 cd/m ² (10 fL). Measured with the quality area flooded by a raster, 60 Hz refresh rate, 320 horizontal lines.
Spot Size #1	0.031 cm (0.012 in) or less, anywhere inside the quality area, with the intensity set to produce 170 cd/m ² (50 fL) brightness, with a full screen raster refreshed at a 60 Hz rate. Measured with the shrinking raster method.
#2	0.026 cm (0.010 in) or less, at 0.5 μA beam current. Measured with the shrinking raster method.
Resolution	Spot size does not vary more than 10% in the quality area at a constant intensity.

POWER SOURCE

Line Voltage (ac, rms) Low Range, P951 Low (100 V ac)	90 to 110 V ac.
Medium (110 V ac)	99 to 121 V ac.
High (120 V ac)	108 to 132 V ac.
High Range, P952 Low (200 V ac)	180 to 220 V ac.
Medium (220 V ac)	198 to 242 V ac.
High (240 V ac)	216 to 250 V ac.
Line Frequency	48 to 440 Hz.
Maximum Power Consumption (120 V ac, 60 Hz)	61 watts; 0.7 ampere.

TABLE 1-2
Environmental Characteristics

Characteristic	Information
NOTE	
<i>This instrument will meet the electrical characteristics given in the Performance Requirement column of Table 1-1 over the following environmental limits.</i>	
Temperature	
Operating	0° to +50° C (+32° to +122° F).
Nonoperating	-40° to +70° C (-40° to +158° F).
Altitude	
Operating	To 4.6 km (15,000 ft.).
Nonoperating	To 12.6 km (50,000 ft.).
Humidity	To 95% at 40° C.
Transportation	Qualified under National Safe Transit Committee Test Procedure 1A, Category II.

TABLE 1-3
Physical Characteristics

Characteristic	Information
Net Weight	About 8.2 kg (18 pounds).
Overall Dimensions	See Figure 1-1.

STANDARD ACCESSORIES

- 1 ea Operators Manual
- 1 ea Instruction Manual
- 1 ea Lined Crt Implosion Shield
(8 X 10 division graticule)

For more detailed information, refer to tabbed Accessories page in the 608 Instruction Manual.

OVERALL DIMENSIONS
(MEASURED AT MAXIMUM POINTS)

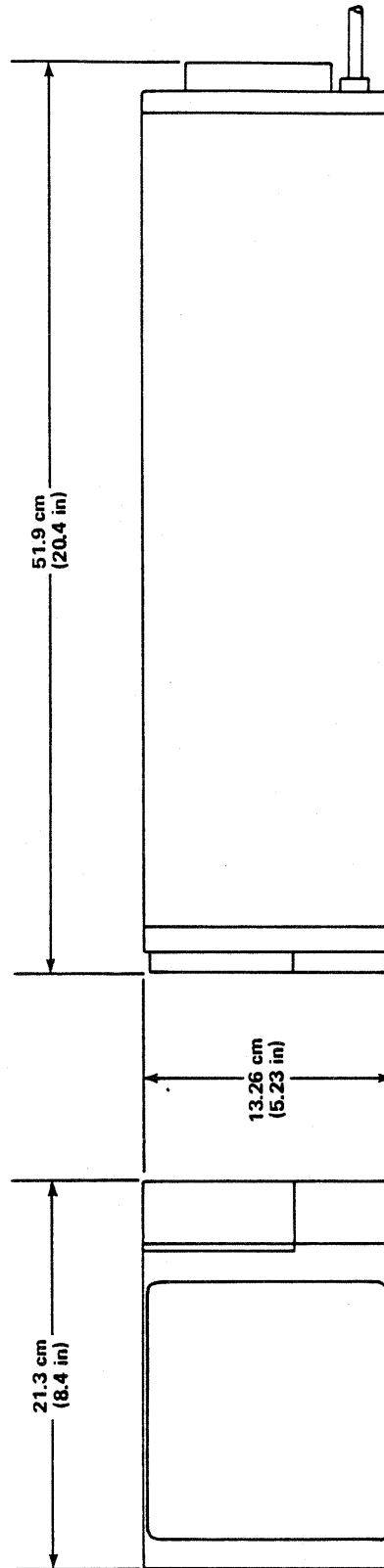

NOTE: DIMENSIONS ARE GIVEN WITH TOP FIGURE
IN CENTIMETERS AND BOTTOM FIGURE
IN INCHES.

REFER TO DIAGRAMS AND CIRCUIT BOARD
ILLUSTRATIONS FOR A DETAILED DIMEN-
SIONAL DRAWING.

2305-5

Figure 1-1. 608 Overall dimensional drawing.

INSTRUMENT PACKAGING

If the instrument is to be shipped to a Tektronix Service Center for service or repair, attach a tag showing the following: Owner (with address) and the name of an individual at your firm who can be contacted, complete instrument type and serial number, and a description of the service required.

Save and re-use the package in which your 608 Monitor was shipped to you. If the original packaging is unfit for use or is not available, repackage the instrument as follows:

1. Obtain a carton of corrugated cardboard with a 275 pound test strength, and having inside dimensions of no less than six inches more than the instrument dimensions; this allows for cushioning.
2. Surround the instrument with polyethylene sheeting to protect the finish.
3. Cushion the instrument on all sides by tightly packing dunnage or urethane foam between the carton and the instrument, allowing three inches on all sides.
4. Seal the carton with shipping tape or with an industrial stapler.

OPERATING INSTRUCTIONS

AMBIENT TEMPERATURE CONSIDERATIONS

This instrument can be operated where the ambient air temperature is between 0° and +50° C (+32° and +122° F), and can be stored in ambient temperatures between -40° and +70° C (-40° and +158° F). After being stored in temperatures beyond the above operating limits, allow the chassis temperature to return to within the operating limits before applying power. Allowing the Monitor to operate at an ambient temperature substantially higher than that specified may result in poor reliability as well as inaccurate performance.

When the 608 is mounted in a rack with other equipment, it is important that the ambient temperature surrounding the Monitor does not exceed +50° C (+122° F). Additional clearance or forced ventilation methods (fan) may be needed to maintain ambient temperatures below +50° C (+122° F). Reliability and performance of the 608 will be affected if the ventilation holes in the protective panels are obstructed, or if the 608 is operated at an ambient temperature higher than +50° C (+122° F). Other environments and mounting configurations may require additional cooling measures.

CONTROLS AND CONNECTORS

Controls and connectors necessary for operation of the 608 Monitor are located on the front and rear panels of the instrument. To make full use of the capabilities of this instrument, the operator should be familiar with the function and use of each external control and connector. The front-panel controls are shown and described in Figure 2-1. Brief descriptions of the rear-panel controls and connectors are given in Figure 2-2.

NOTE

Information on controls and connectors for the available options is located in the Instrument Options section of this manual.

DETAILED OPERATING INFORMATION

INPUT SIGNAL REQUIREMENTS

The horizontal (X) and vertical (Y) deflection factors are set at the factory to one volt for eight divisions of deflection on each axis. Thus, as shipped, the input signal required for each division of deflection is 0.125 volt.

NOTE

The Functional Check procedure may be used to determine if the horizontal and vertical deflection factors of your particular instrument meet those set at the factory, as stated above.

The best transient response from the 608 Monitor is achieved when the input signal amplitude to the vertical or horizontal INPUT is no greater than that sufficient to provide full-screen deflection.

WARNING

To avoid electric shock, do not apply input signals of more than 25 volts (dc plus peak ac). Should fault conditions occur however, the instrument is protected for application of input signals up to 100 volts (dc plus peak ac).

With no signals applied to the +Z INPUT connector, the intensity of the display is controlled only by the front-panel INTENSITY control. To control the display intensity with an externally applied signal, set the INTENSITY control to about midrange, and apply the input signal to the +Z INPUT connector.

CAUTION

Exercise care in establishing the correct display intensity; a high-amplitude Z-Axis input signal, combined with an excessively high setting of the INTENSITY control, may damage the crt phosphor.

The input signal required for maximum display intensity, through the +Z INPUT connector, is set at the factory for +1 volt, or less. The input signal required to visually cut off the display intensity is set at the factory for -1 volt, or less. The best transient response of the Z-Axis Amplifier is achieved when the input signal is the minimum required to provide the desired intensity change.

NOTE

Detailed Operating Information for the available options is located in the Instrument Options section of this manual.

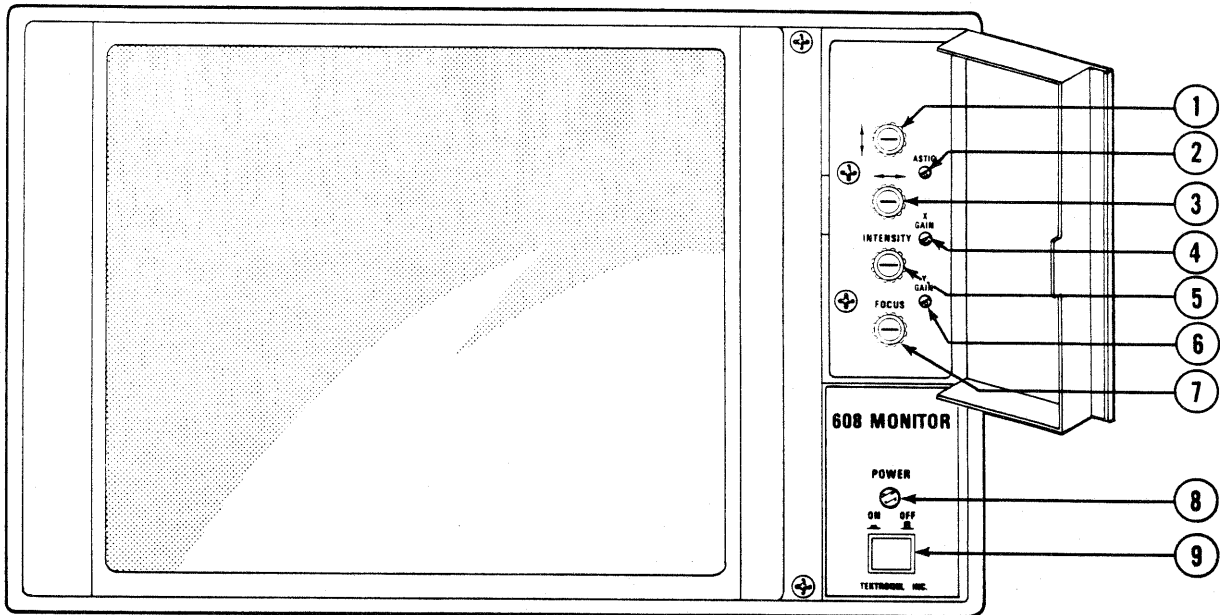

- ① **Vertical (Y) Position**—Positions the crt beam in the Y axis.
- ② **ASTIG**—Screwdriver adjustment to be used in conjunction with the FOCUS control to provide a well-defined display.
- ③ **Horizontal (X) Position**—Positions the crt beam in the X axis.
- ④ **X GAIN**—Provides an adjustable amplification factor for crt full-screen deflection of at least 0.5 volt to 2.5 volts.
- ⑤ **INTENSITY**—Controls brightness of the crt display and is the offset control for the Z-Axis INPUTS.
- ⑥ **Y GAIN**—Provides an adjustable amplification factor for crt full-screen deflection of at least 0.5 volt to 2.5 volts.
- ⑦ **FOCUS**—Provides adjustment to obtain a well-defined display.
- ⑧ **POWER (Indicator)**—Illuminates when instrument is on.
- ⑨ **ON/OFF**—Controls power to the Monitor. Instrument is on when pushbutton is in.

2305-1

Figure 2-1. Front-panel controls and indicators.

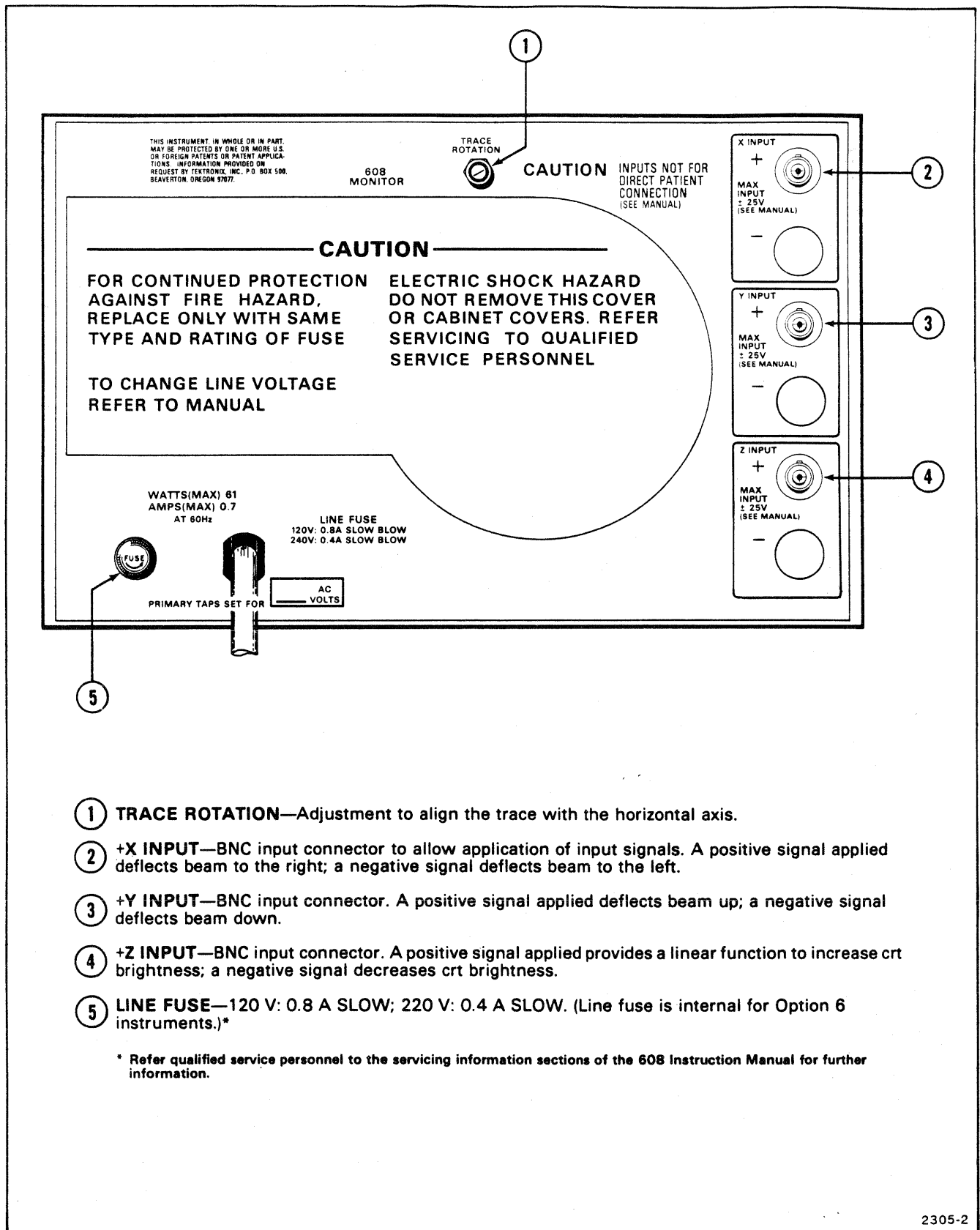

- ① **TRACE ROTATION**—Adjustment to align the trace with the horizontal axis.
- ② **+X INPUT**—BNC input connector to allow application of input signals. A positive signal applied deflects beam to the right; a negative signal deflects beam to the left.
- ③ **+Y INPUT**—BNC input connector. A positive signal applied deflects beam up; a negative signal deflects beam down.
- ④ **+Z INPUT**—BNC input connector. A positive signal applied provides a linear function to increase crt brightness; a negative signal decreases crt brightness.
- ⑤ **LINE FUSE**—120 V: 0.8 A SLOW; 220 V: 0.4 A SLOW. (Line fuse is internal for Option 6 instruments.)*

* Refer qualified service personnel to the servicing information sections of the 608 Instruction Manual for further information.

2305-2

Figure 2-2. Rear-panel controls and connectors.

FUNCTIONAL CHECK

The following procedure is provided to aid in obtaining a display on the 608 Monitor and may be used as a check of basic instrument operation. The procedure may be used for incoming inspection to verify proper operation, and may also be used by the operator for instrument familiarization. Only instrument functions, and not measurement quantities or specifications, are checked in these procedures. Therefore, a minimum amount of test equipment is required. If performing the Functional Check procedure reveals improper performance or instrument malfunction, first check the operation of associated equipment; then refer to qualified service personnel for repair or adjustment of the instrument.

NOTE

Functional Check Procedures for the available options are located in the Instrument Options section of this manual.

TEST EQUIPMENT REQUIRED

The following test equipment was used as a basis to write the Functional Check procedure. Other test equipment, which meets these requirements, may be substituted. When other equipment is substituted, the control settings or set up may need to be altered.

1. Power Module

Description: Tektronix TM 500-series power module with one or more plug-in compartments.

Type Used: TEKTRONIX TM 501 (used with the FG 503 Function Generator).

2. Function Generator

Description: Frequency range, one hertz to 50 kilohertz; output amplitude, one volt peak-to-peak into 50 ohms, waveform output, sine wave.

Type Used: TEKTRONIX FG 503 (used with TM 501 Power Module).

3. Cables (2 Required)

Description: Length, 42 inches (1 required), 18 inches (1 required); connectors, BNC.

Type Used: Type RG-58/U, 50-ohm coaxial, Tektronix Part 012-0057-01 (42 inch), Tektronix Part 012-0076-00 (18 inch).

4. T Connector

Description: Connectors, BNC-to-BNC.

Type Used: BNC-to-BNC T connector, Tektronix Part 103-0030-00.

5. 50-Ohm Termination

Description: Impedance, 50 ohm; connectors, BNC.

Type Used: Tektronix Part 011-0049-01.

PRELIMINARY SET UP

1. Install the function generator in the power module and turn on the power module.
2. Connect the 608 power cord to a suitable power source.

NOTE

Check the line voltage information recorded on the rear panel. If the source voltage is not within this range, refer qualified service personnel to the servicing information sections of the 608 Instruction Manual.

3. Open the access door on the front panel and set the controls as follows:

Vertical and
Horizontal Position Midrange

INTENSITY Fully counterclockwise

FOCUS Midrange

ON/OFF ON (pushbutton in)

4. Allow at least one minute for the instrument to warm up.

DISPLAY FUNCTIONS

1. Perform the Preliminary Set Up procedure.
2. Notice that a spot will appear on the crt, increasing in brightness as you slowly turn the INTENSITY control clockwise.

CAUTION

A high intensity level combined with a stationary spot will damage the crt phosphor. Therefore, set the INTENSITY control to the minimum necessary for good visibility.

3. Adjust the FOCUS and ASTIG controls for a sharp, well-defined display.

4. Turn the Vertical and Horizontal Position controls and notice that the spot position can be controlled by both controls.

5. Set the function generator for a 1-volt (peak-to-peak), 50-kilohertz sine-wave output.
6. Connect the function generator output to the rear-panel +X INPUT connector via the 50-ohm termination and 42-inch cable.
7. Center the display with the Horizontal Position control, and position the trace on the center horizontal graticule line.
8. Check that the rear-panel TRACE ROTATION control will align the trace with the center horizontal graticule line.

DEFLECTION AND Z-AXIS FUNCTIONS

1. Perform the Preliminary Set Up procedure.
2. Set the function generator for a 2-volt (peak-to-peak), 50-kilohertz sine-wave output.
3. Connect the function generator output to the rear-panel +X INPUT connector via the 50-ohm termination and 42-inch cable.

4. Center the display with the Horizontal Position control and check that the X GAIN control will adjust for 8 divisions of horizontal deflection.
5. Disconnect the signal from the +X INPUT connector and apply it to the +Y INPUT connector.
6. Center the display with the Vertical Position control and check that the Y GAIN control will adjust for 8 divisions of vertical deflection.
7. Adjust the INTENSITY control for a barely-visible display.
8. Disconnect the signal from the +Y INPUT connector and apply it to the +X INPUT and +Z INPUT connectors via the 50-ohm termination, 42-inch cable, BNC T connector, and the 18-inch cable.
9. Notice that the right end of the crt display becomes bright, and that the left end disappears.
10. Disconnect the function generator.

This completes the Functional Check procedure for the 608 Monitor.

WARNING

THE FOLLOWING SERVICING INSTRUCTIONS ARE FOR USE BY QUALIFIED PERSONNEL ONLY. TO AVOID PERSONAL INJURY, DO NOT PERFORM ANY SERVICING OTHER THAN THAT CONTAINED IN OPERATING INSTRUCTIONS UNLESS YOU ARE QUALIFIED TO DO SO. REFER TO OPERATORS SAFETY SUMMARY AND SERVICE SAFETY SUMMARY PRIOR TO PERFORMING ANY SERVICE.



INSTALLATION

OPERATING POWER INFORMATION

This instrument can be operated from either a 120-volt or 220-volt nominal line-voltage source, 48 to 440 hertz. In addition, three regulating ranges are provided for each nominal line-voltage source.

CAUTION

To prevent damage to the instrument, always check the line-voltage information recorded on the rear panel before applying power to the instrument.

POWER CORD INFORMATION

WARNING

This instrument is intended to be operated from a single-phase earth-referenced power source having one current-carrying conductor (the Neutral Conductor) near earth potential. Operation from power sources where both current-carrying conductors are live with respect to earth (such as phase-to-phase on a three-wire system) is not recommended, since only the Line conductor has over-current (fuse) protection within the instrument.

This instrument has a three-wire power cord with a polarized two-pole, three-terminal plug for connection to the power source and safety-earth. The safety-earth terminal of the plug is directly connected to the instrument frame. For electric-shock protection, insert this plug only in a mating outlet with a safety-earth contact.

Do not defeat the grounding connection. Any interruption of the grounding connection can create an electric-shock hazard. Before making external connections to this instrument, always ground the instrument first by connecting the power cord to a properly mated power outlet.

TABLE 3-1

Power-Cord Conductor Identification

Conductor	Color	Alternate Color
Line	Brown	Black
Neutral	Light Blue*	White
Safety Earth	Green/Yellow	Green/Yellow

*Tinned copper conductor.

The power-cord plug required depends upon the ac input voltage and the country in which the instrument is to be used. Should you require a power-cord plug other than that supplied with your instrument, refer to the standards listed in Table 3-2.

TABLE 3-2

Location of Power-Cord Configuration Information

Nominal Line Voltage	Reference Standards
120 V ac	¹ ANSI C73.11
	² NEMA 5-15P (Hospital Grade)
220 V ac	ANSI C73.20
	³ AS C112
	⁴ BS 1363
	⁵ CEE 7, sheets IV, VI and VII
	NEMA 6-15-P

¹ANSI—American National Standard Institute

²NEMA—National Electrical Manufacturer's Association

³AS—Standards Association of Australia

⁴BS—British Standards Institution

⁵CEE—International Commission on Rules for the Approval of Equipment

For medical-dental applications, use NEMA 5-15-P (Hospital Grade) plug for 120-volt operation, or NEMA 6-15-P plug for 220-volt operation.

LINE-VOLTAGE AND REGULATING-RANGE SELECTION

CAUTION

Damage to the instrument may result from incorrect placement of the line-voltage selector plug.

To select the correct nominal line voltage and regulating range, proceed as follows:

1. Disconnect the instrument from the power source.
2. Insert the proper line-voltage selector plug (the brown plug for 120-volt operation or the red plug for 220-volt operation) on the line-voltage selector pins (located on the Low-Voltage Power Supply board) labeled for the desired nominal line-voltage range. Refer to Figure 3-1 for location and additional information.
3. Remove the line fuse from the fuse holder and check for the correct rating. Replace it with one having the correct rating, if necessary. Refer to Figure 3-1 for fuse information and location.

NOTE

An alternate line fuse, intended for the line-voltage source for which the Monitor was not set when shipped from the factory, is clipped to the Low-Voltage Power Supply board (see Fig. 3-1).

4. Change the nominal line-voltage information recorded on the 608 rear panel. Use a non-abrasive eraser to remove previous data, and mark on the new data with a pencil.
5. Apply power to the Monitor.

INSTALLATION IN PATIENT-CARE FACILITIES

WARNING

Do not use the amplifier INPUTS for direct-patient connection. Signal currents at these connectors, as well as leakage currents, may exceed values considered non-hazardous for direct-patient connection.

WARNING

Although this Monitor is not to be connected directly to a patient, interconnecting this Monitor to other equipment can result in the application of excessive current to a patient. It is extremely important that the interconnection is made in accordance with NFPA 76B-T, Tentative Standard for the Safe Use of Electricity in Patient Care Areas of Health Care Facilities, section 3038, "Signal Transmission Between Appliances".

Among the situations involving the above-mentioned patient hazard is one in which two or more pieces of interconnected equipment are grounded at locations remote from one another. The standard mentioned in the preceding warning describes both this hazard and the appropriate corrective measures.

Z-AXIS INPUT ATTENUATION SELECTION

CAUTION

Exercise care in establishing the correct display intensity; a high-amplitude Z-Axis input signal, combined with an excessively high setting of the INTENSITY control, may damage the crt phosphor.

The Z-Axis Amplifier is shipped from the factory with 1X input attenuation and 1 megohm input impedance. However, the attenuation and input impedance can be modified to suit a specific application. Posts, on the Z-Axis Amplifier board, allow components to be changed without damage to the circuit board. Figure 3-2 illustrates the method used to modify input attenuation and input impedance of the +Z INPUT. Refer to the Test Point and Adjustment Locations foldout page in section 8, Diagrams and Circuit Board Illustrations, for location of the Z-Axis attenuation components. Refer to your Tektronix Field Office or representative for additional information.

RACKMOUNTING INFORMATION

The 608 can be operated in a standard 19-inch instrument rack with front and rear holes that conform to universal hole spacing. Kits are available to convert the 608 from the cabinet to a rackmounted configuration, and vice versa. Complete instructions are included in the kits. A brief description of each available conversion kit is given here. Consult your Tektronix Field Office or representative for additional information.

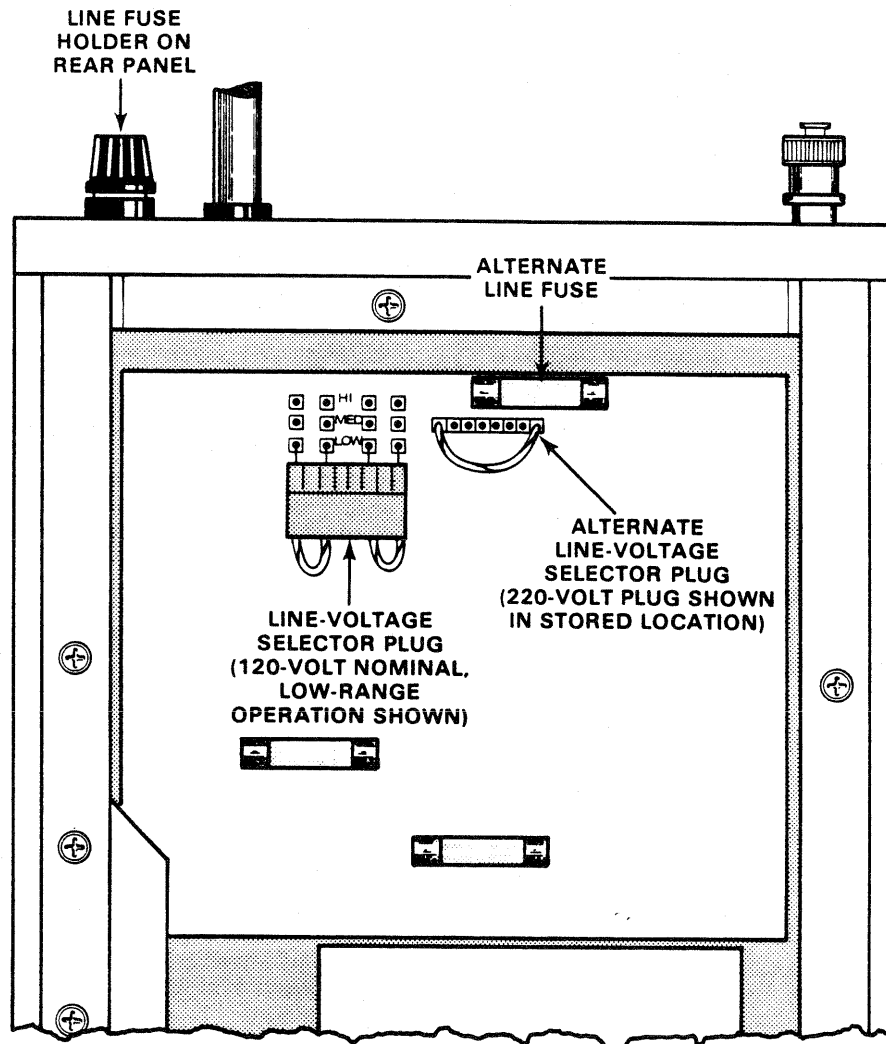

Regulating Ranges

Line-Voltage Selector Position	Regulating Range and Fuse Data	
	120 Volts (Nominal)	220 Volts (Nominal)
LO	90 V ac to 110 V ac	180 V ac to 220 V ac
MED	99 V ac to 121 V ac	198 V ac to 242 V ac
HI	108 V ac to 132 V ac	216 V ac to 250 V ac
Line Fuse Data	0.8 A slow-blowing type	0.4 A slow-blowing type

2305-7

Figure 3-1. Location of line-voltage selector plugs, regulating-range pins, and line fuse.

CAUTION

Reliability and performance of the 608 will be affected if the ventilation holes in the protective panels are obstructed, or if the 608 is operated in an ambient temperature higher than +50° C. Forced ventilation methods may be needed.

1X ATTENUATION WITH 1 MΩ INPUT (STANDARD FROM FACTORY)

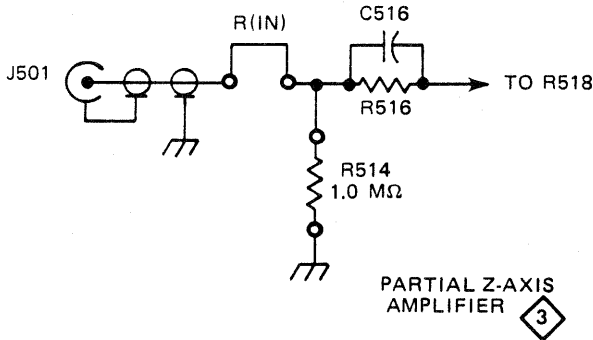

FORMULAS FOR DETERMINING INPUT IMPEDANCE AND ATTENUATION (10X ATTENUATION SHOWN)

$$R (IN) + R514 = \text{INPUT IMPEDANCE}$$

$$900k + 100 k = 1M\Omega \text{ INPUT IMPEDANCE}$$

$$\frac{R(IN) + R514}{R514} = \text{ATTENUATION}$$

$$\frac{100 k\Omega + 900 k\Omega}{100 k\Omega} = 10X \text{ ATTENUATION}$$

EXAMPLE OF 10X ATTENUATION (MODIFICATION REQUIRED BY CUSTOMER)

NOTE

THE ELECTRICAL VALUES ARE GIVEN ONLY TO ILLUSTRATE THE RATIO OF RESISTANCE NEEDED FOR X10 ATTENUATION.

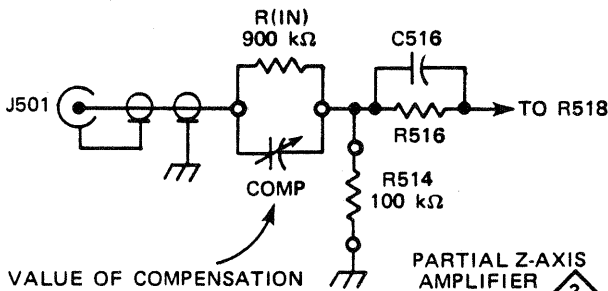

VALUE OF COMPENSATION CAPACITANCE VARIES WITH ATTENUATION DESIRED AND FREQUENCY RANGE.

(2025-32)2305-8

CABINET-TO-RACKMOUNT CONVERSION

Tektronix Part 040-0601-00. Mounts one 608 Monitor in a standard 19-inch wide rack. The kit is equipped with a slide-out assembly, securing hardware, and a blank front panel to cover the second instrument opening in the rack. Complete rackmounting instructions are included in each kit.

Tektronix Part 040-0624-01. Converts one TM 503 Power Module and one 608 Monitor to mount side-by-side in a standard 19-inch wide instrument rack. The kit includes slide-out assembly and securing hardware. Complete rackmounting instructions are included with each kit.

RACKMOUNT-TO-CABINET CONVERSION

Tektronix Part 040-0602-00. Converts one 608 Monitor from a rackmount configuration to a cabinet configuration. Complete instructions are included in each kit.

INSTRUMENT DIMENSIONS

A drawing showing the major dimensions of the 608 is shown in Figure 1-1 (General Information section). Further details and tolerances are shown on the Detailed Dimensional Drawing foldout page in section 8, Diagrams and Circuit Board Illustrations.

Figure 3-2. Typical method for modifying Z-Axis input impedance and attenuation.

THEORY OF OPERATION

This section of the manual describes the circuitry in the 608 Monitor. The description begins with a discussion of the instrument using the block diagram on Figure 4-1, and then continues in detail, showing the relationships between the stages in each major circuit. Schematics of all major circuits are given in Section 8, Diagrams and Circuit Board Illustrations. Stages are outlined on the schematics with wide shaded lines; the stage names are in shaded boxes. Refer to these schematics throughout the following discussions for specific electrical values and relationships.

NOTE

The Theory of Operation for available electrical options is located in Section 9, Instrument Options, at the rear of this manual.

BLOCK DIAGRAM

The following discussion is provided to aid in understanding the overall concept of the 608 before the individual circuits are discussed in detail. A basic block diagram is shown in Figure 4-1.

Vertical and horizontal signals to be displayed on the crt are supplied to the Deflection Amplifiers through the appropriate Y and X INPUT connectors. The Deflection Amplifiers process the input signals and provide push-pull outputs to drive the deflection plates of the crt. Both Deflection Amplifiers contain position and gain controls.

The Z-Axis Amplifier controls the display intensity by providing a voltage to drive the crt control grid. Input signals are applied to the Z INPUT connector.

The Dynamic Focus circuit provides focus correction for the display when it is deflected from the crt center. Thus, by varying the voltage to the crt focus element, the Dynamic Focus circuit compensates for geometric defocusing.

The High-Voltage and Low-Voltage Power Supplies provide all the voltages necessary for operation of this instrument.

DETAILED CIRCUIT OPERATION

Complete schematic diagrams are provided in Section 8, Diagrams and Circuit Board Illustrations. The numbers inside the diamond after a heading in the following discussions refer to the schematic diagram for that circuit. The schematic diagrams contain wide shaded borders around the major stages of the circuits to conveniently locate the components mentioned in the following discussions. The name of each stage, given in a shaded box on the diagram, matches the subheading in the discussion of that schematic diagram.

VERTICAL (Y) DEFLECTION AMPLIFIER

The Vertical (Y) Deflection Amplifier processes the Y input signals and provides final amplification to drive the vertical deflection plates of the crt. A schematic diagram of the Vertical (Y) Deflection Amplifier is

shown on diagram 1. A detailed block diagram, showing each major stage of the Vertical (Y) Deflection Amplifier, is superimposed on the schematic with wide shaded lines to conveniently locate the components mentioned here. The stage names (given as sub-headings in the following discussion) can be found in the shaded boxes on diagram 1.

Y PREAMPLIFIER

Signals to be displayed are applied to J101 (+Y INPUT). The Y Preamplifier employs a matched pair of FETs to provide a high input impedance and temperature stability. This stage consists of two identical and inverting feedback amplifiers, Q120A-Q130-Q134 and Q120B-Q230-Q234, which operate as a paraphase amplifier. A push-pull signal is produced at the collectors of Q134 and Q234. The FET gates are diode-clamped on negative-going overdrive signals to protect the field-effect transistors from excessive

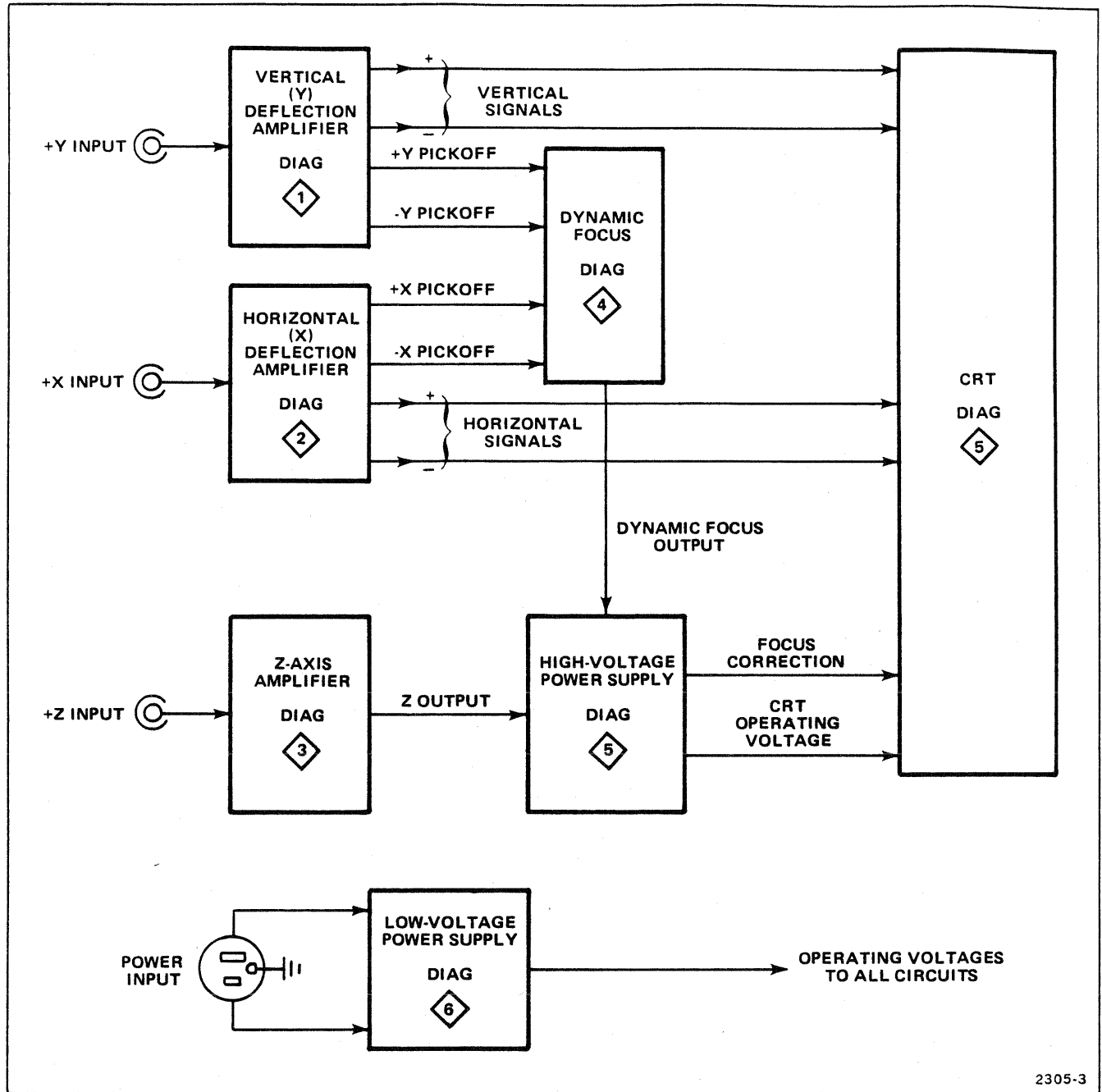

Figure 4-1. 608 Block Diagram.

input voltages. Front-panel screwdriver adjustment Y Gain (R125) provides an adjustable amplification factor to allow crt full-screen deflection range of at least 0.5 to 2.5 volt. This control is normally set to a nominal 1 volt for 8 divisions of deflection.

VERTICAL POSITIONING & LIMITER

Vertical positioning is provided by front-panel control R147, through the current sources of Q142-Q242. The

push-pull signals from the Y Pre-amplifier are applied to the Y Output Amplifier after being offset by this stage. Diodes CR140 and CR240 prevent overdriving the Y Output Amplifier by limiting the Y Pre-amplifier signals to within about 4 volts of each other.

Y FOCUS-CORRECTION PICKOFF

Samples of the +Y and -Y signals are coupled from the Y Pre-amplifier to the Dynamic Focus circuit

(diagram 4) for focus correction in the Y axis. A sampling of the +Y voltage signal is converted to a current signal by Q295, and the -Y voltage signal by Q195, before being applied to the Dynamic Focus circuit.

Y OUTPUT AMPLIFIER

The Y Output Amplifier consists of two identical and non-inverting operational amplifiers connected in a differential configuration. For ease of explanation, only the + side will be discussed.

Transistors Q270-Q272-Q276-Q284-Q286-Q290 make up the active components of the +Y Output Amplifier. Transistor Q290 provides bias current for input transistor Q270. The signal from the Y Preamplifier stage is amplified by Q270 and fed to emitter followers Q272-Q276. The emitter followers drive output transistors Q286 and Q284. The output transistors (Q286-Q284) are connected as a collector-coupled complementary amplifier to provide a fast linear output signal while consuming minimum quiescent power.

The output signal at the collectors of Q286 and Q284 causes a change in the current through feedback resistor R288 that, due to the input signal, will just balance the current through R163. Thus the current in Q270 is held nearly constant. Variable capacitor C167 and potentiometer R161 (HF Comp) provide a means of adjusting the amplifier response.

HORIZONTAL (X) DEFLECTION AMPLIFIER

The Horizontal (X) Deflection Amplifier processes the X input signals and provides final amplification to drive the horizontal deflection plates of the crt. A schematic diagram of the Horizontal (X) Deflection Amplifier is shown in diagram 2. A detailed block diagram, showing each major stage of the Horizontal (X) Deflection Amplifier, is superimposed on the schematic with wide shaded lines to conveniently locate the components mentioned here. The stage names (given as sub-headings in the following discussion) can be found in the shaded boxes on diagram 2.

X PREAMPLIFIER

Signals to be displayed are applied to J301 (+X INPUT). The X Preamplifier employs a matched pair of FETs to provide a high input impedance and temperature stability. This stage consists of two identical and inverting feedback amplifiers, Q320A-Q330-Q334 and Q320B-Q430-Q434, which operate as a paraphase amplifier. A push-pull signal is produced at the collectors of Q334 and Q434. The FET gates are diode-clamped on negative-going overdrive signals to protect the field-effect transistors from excessive input voltages. Front-panel screwdriver adjustment R325 (X GAIN) provides an adjustable amplification

factor to allow a crt full-screen deflection range of at least 0.5 volt to 2.5 volts. This control is normally set to a nominal 1 volt for 8 divisions of deflection.

HORIZONTAL POSITIONING AND LIMITER

Horizontal positioning is provided by front-panel control R347, through the current sources of Q342-Q442. The push-pull signals from the X Preamplifier are applied to the X Output Amplifier after being offset by this stage. Diodes CR340 and CR440 prevent overdriving the X Output Amplifier by limiting the X Preamplifier signals to within about 4 volts of each other.

X FOCUS-CORRECTION PICKOFF

Samples of the +X and -X signals are coupled from the X Preamplifier to the Dynamic Focus circuit (diagram 4) for focus correction in the X axis. A sampling of the +X voltage signal is converted to a current signal by Q495, and the -X voltage signal by Q395, before being applied to the Dynamic Focus circuit.

X OUTPUT AMPLIFIER

The X Output Amplifier consists of two identical and non-inverting operational amplifiers connected in a differential configuration. For ease of explanation, only the + side will be discussed.

Transistors Q470-Q472-Q476-Q484-Q486-Q490 make up the active components of the +X Output Amplifier. Transistor Q490 provides bias current for input transistor Q470. The signal from the X Preamplifier stage is amplified by Q470 and fed to emitter followers Q472-Q476. The emitter followers drive output transistors Q486 and Q484. The output transistors (Q484-Q486) are connected as a collector-coupled complementary amplifier to provide a fast linear output signal while consuming minimum quiescent power.

The output signal at the collectors of Q486 and Q484 causes a change in the current through feedback resistor R488 that, due to the input signal, will just balance the current through R363. Thus the current in Q470 is held nearly constant. Variable capacitor C367 and potentiometer R361 (HF Comp) provide a means of adjusting the amplifier response.

Z-AXIS AMPLIFIER

The Z-Axis Amplifier circuit provides the drive signal to control the crt intensity. A schematic diagram of the Z-Axis Amplifier is shown on diagram 3 at the rear of this manual. A detailed block diagram, showing each major stage, is superimposed on the schematic diagram with wide shaded lines. The stage names (given as sub-headings in the following discussion) can be found in the shaded boxes on diagram 3.

Z PREAMPLIFIER

Input signals are applied to J501 (+Z INPUT). Provisions are made on the input line to permit installation of an attenuating resistor and to change the input impedance (see Z-Axis Input Attenuation Selection in Section 3, Installation).

The Z Preamp amplifier employs a matched pair of FETs to provide a high input impedance and temperature stability. This stage consists of two identical and inverting feedback amplifiers, Q520A-Q530-Q534 and Q520B-Q630-Q634, which operate as a paraphase amplifier. A push-pull signal is produced at the collectors of Q534 and Q634. The FET gates are diode-clamped on negative-going overdrive signals to protect the field-effect transistors from excessive input voltages. Potentiometer R525 (Z Gain) allows an adjustable amplification factor to provide maximum crt grid drive when a signal of at least +1 volt to +5 volts is applied to the +Z INPUT connector, and R547 (INTENSITY) is set to about midrange. Under this condition, a zero-volt input cuts off the display intensity to below the visible level.

INTENSITY AND LIMITER

Display intensity is varied by front-panel control R547 (INTENSITY) through the current sources of Q542 and Q642. The push-pull signals from the Z Preamp amplifier are applied to the Z Output Amplifier after being offset by this stage. Diodes CR565 and CR540 prevent overdriving the Z Output Amplifier by limiting the Z Preamp amplifier signals to within 3.4 volts of each other.

Z OUTPUT AMPLIFIER

The push-pull signals from the Z Preamp amplifier stage are applied to the bases of Q570 and Q670. These two transistors are voltage-to-current converters which, with Q576, produce a single-ended current signal.

Transistors Q580-Q680-Q590-Q690-Q596-Q696 are connected as an operational amplifier, with the feedback path provided through R692. High-current, low-impedance drive is provided by the complementary configuration of emitter followers Q580-Q680. The dc and low-frequency signals from Q580-Q680 are coupled through R584 to the base of Q690; the high-frequency signals are capacitively coupled through C585 and C586 to the base of Q590. Complementary amplifiers Q590-Q690 provide the final gain for the Z output signals, with emitter followers Q596-Q696 supplying the high current necessary to drive the capacitive load. High-frequency compensation is provided by C693-R693 (HF Comp).

DYNAMIC FOCUS 4

The Dynamic Focus circuit provides focus correction as the crt beam is deflected to the edges of the display area in both the vertical (Y) and horizontal (X) axis. A schematic diagram of the Dynamic Focus circuit is shown in diagram 4. A detailed block diagram, showing the major stages of this circuit, is superimposed on the schematic diagram with wide shaded lines. The stage names (given as sub-headings in the following discussion) can be found in the shaded boxes on diagram 4.

Geometric defocusing, a contributing factor to overall crt defocusing, occurs when the beam is deflected from the crt center. The electron beam, at center screen, is focused for a particular beam length. When the beam is deflected, either vertically or horizontally, the beam length changes. However, the focusing voltage remains the same. As a result, the display is defocused, appearing larger at the edges of the screen than at crt center (see Fig. 4-2).

The Dynamic Focus circuit varies the voltage to the focus element of the crt depending upon the vertical

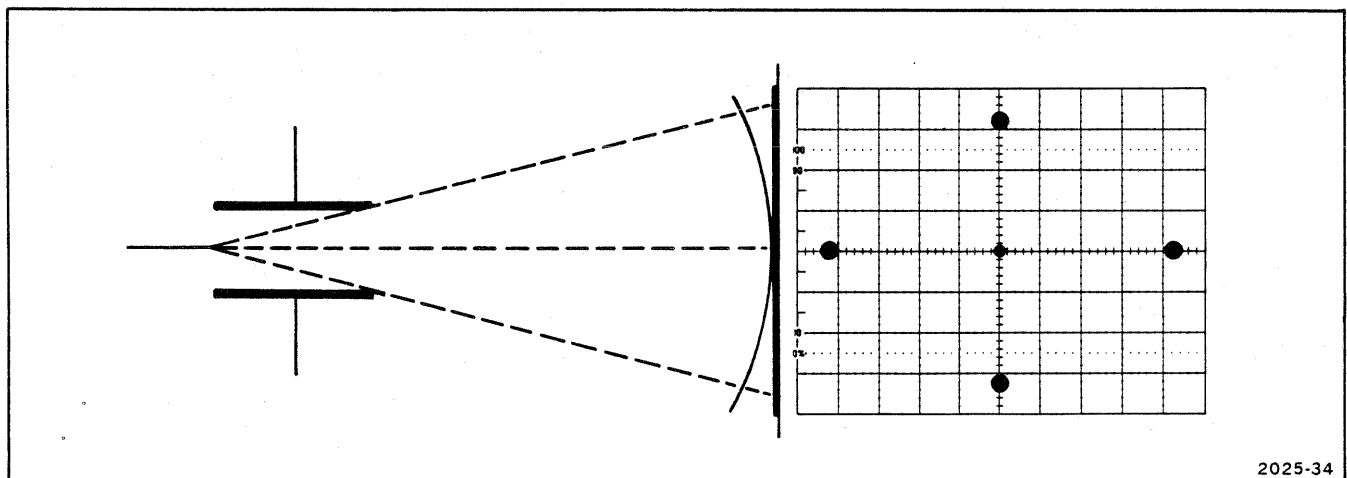

Figure 4-2. Simplified illustration of geometric defocusing.

and horizontal positions of the electron beam. Therefore, overall focus is improved over the crt display area. Figure 4-3 illustrates the typical correction-voltage curve as the beam is deflected over the crt display area. The correction-voltage curves for vertical and horizontal deflection are not identical; however, the theory is the same.

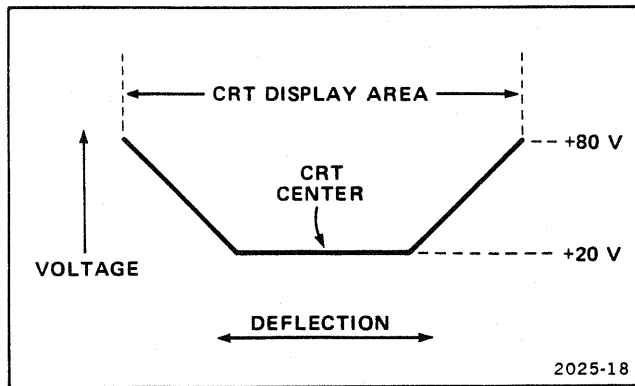

Figure 4-3. Typical correction-voltage curve applied to the crt focus element (correction voltage applied for both vertical and horizontal deflection).

X FOCUS-CORRECTION SHAPER

Samples of the +X and -X horizontal signals, from the X Focus-Correction Pickoff stage shown on diagram 2, are coupled to the X Focus-Correction Shaper stage of the Dynamic Focus circuit. Quiescently, with the crt beam horizontally deflected within about 3 divisions of center screen, Q710-Q720 are conducting and CR710-CR720 are reverse biased. The voltage level at the anodes of CR710 and CR720 is approximately +5.1 volts, as determined by zener diode VR750 and transistor Q750.

As the beam is deflected to the right side of the crt display area, the output of Q710 falls below +4.5 volts, forward biasing CR710 (CR720 is reverse biased). The signal is coupled through R715 (Right) and applied to the Summing and Output Amplifier at the emitter of Q750.

As the beam is deflected to the left side of the crt display area, the output of Q720 falls below +4.5 volts, forward biasing CR720 (CR710 is reverse biased). The signal is coupled through R725 (Left) and applied to the Summing and Output Amplifier at the emitter of Q750.

Y FOCUS-CORRECTION SHAPER

Samples of the +Y and -Y vertical signals, from the Y Focus-Correction Pickoff stage shown on diagram 1, are coupled to the Y Focus-Correction Shaper stage of the Dynamic Focus circuit. Quiescently, with the crt beam vertically deflected within about 3 divisions of

center screen, Q730-Q740 are conducting and CR730-CR740 are reverse biased. The voltage level at the anodes of CR730 and CR740 is approximately +5.1 volts, as determined by zener diode VR750 and transistor Q750.

As the beam is deflected to the bottom region of the crt display area, the output of Q730 falls below +4.5 volts, forward biasing CR730 (CR740 is reverse biased). The signal is coupled through R735 (Bottom) and applied to the Summing and Output Amplifier at the emitter of Q750.

As the beam is deflected to the top region of the crt display area, the output of Q740 falls below +4.5 volts, forward biasing CR740 (CR730 is reverse biased). The signal is coupled through R745 (Top) and applied to the Summing and Output Amplifier at the emitter of Q750.

SUMMING AND OUTPUT AMPLIFIER

Outputs from both the X and Y Focus-Correction Shapers are added in the Summing and Output Amplifier stage. The focus-correction signals are coupled to common-base transistor Q750. Diode CR753 limits the output of Q750 to prevent overdriving the Output Amplifier. The Output Amplifier of this stage, consisting of transistors Q760-Q765-Q770-Q776, is an inverting operation amplifier. The input signal to this amplifier is developed across R753. The feedback network for the Output Amplifier consists of R789 and C789-C788. Emitter followers Q760 and Q765 provide current amplification for Q770 and Q776, which are connected in a collector-coupled complementary amplifier configuration. The composite correction signal is coupled to the Focus-Element DC Restorer stage of the High-Voltage Power Supply circuit (diagram 5).

HIGH-VOLTAGE POWER SUPPLY 5

The High-Voltage Power Supply provides the voltage levels and control circuits necessary for operation of the cathode-ray tube (crt). A schematic diagram of the High-Voltage Power Supply is shown on diagram 5. A detailed block diagram, showing each major stage of this circuit, is superimposed on the schematic diagram with wide shaded lines. The stage names (given as sub-headings in the following discussion) can be found in the shaded boxes on diagram 5.

HIGH-VOLTAGE OSCILLATOR

A repetitive, sinusoidal signal is produced by a regenerative feedback oscillator in the primary of T850 and induced into the secondary. Current drive for the primary winding is furnished by Q816-Q818-Q810-Q814. The conduction of the High-Voltage Oscillator transistors is controlled by the output voltage of the Error Amplifier.

CATHODE SUPPLY

The Cathode Supply voltage, -4500 volts, is produced by voltage doubler C852-CR852-CR853. It is then filtered by C854, R856, and C858, before being applied to the crt cathode (pin 2 of V950). The Cathode Supply is regulated by the Error Amplifier.

ERROR AMPLIFIER

Regulation of the Cathode Supply voltage is accomplished by applying a sample of the -4500 volts, from voltage divider R920A-R920B, to the positive input (pin 3) of U832. If the output level of the Cathode Supply exceeds the normal -4500 volts (becomes more negative), the voltage at pin 3 of U832 goes negative from its quiescent zero-volt level. This results in a reduced output voltage from U832. A lower potential from the Error Amplifier reduces the conduction of the High-Voltage Oscillator, resulting in a smaller peak-to-peak amplitude of the signal in the secondary of T850 and returning the Cathode Supply to -4500 volts.

CURRENT LIMITER

Transistor Q826 protects the High-Voltage Oscillator transistors if excess current is demanded from the secondary of T850, due to a short circuit or abnormal load, by limiting the maximum current drawn by the High-Voltage Oscillator.

CONTROL-GRID DC RESTORER

The Control-Grid DC Restorer couples the dc and low-frequency components of the Z-Axis Amplifier output signal to the crt control grid (pin 3 of V950). This allows the Z-Axis Amplifier to control the crt beam intensity. The potential difference between the Z-Axis Amplifier output level and the crt control grid (about -4500 volts) prohibits direct coupling.

The Control-Grid DC Restorer is actually a cathode-referenced bias supply for the crt control grid. Quiescently, its output voltage is more negative than the crt cathode by an amount determined by the Z-Axis Amplifier output level and the setting of the Crt Bias adjustment, R862. (The cutoff voltage at the crt control grid is typically about 85 volts more negative than the crt cathode level.)

NOTE

A simplified diagram of the Control-Grid DC Restorer is shown in Figure 4-4. The voltages given on this diagram are idealized levels and will not necessarily be the same as those found in the actual instrument.

The Control-Grid DC Restorer is divided into two sections for ease of explanation. The first section can be considered a modulator at low-voltage potentials, and the remaining section as a demodulator at high-voltage potentials (see Fig. 4-4).

Modulator

When the secondary winding output of T850 (pin 10) swings positive, C872 charges through R860 and C860 to a voltage level determined by the setting of the Crt Bias adjustment, R862. At this voltage level (approximately +85 volts), diode CR872 conducts, preventing any additional increase in the positive voltage across C872. When the secondary-winding output swings negative, diode CR872 turns off. Then CR860 conducts and clamps the negative excursion at C872 to the voltage level of the Z-Axis Amplifier output. The result is a square-wave output from the Modulator; the output amplitude is determined by the difference between the Z-Axis Amplifier output level and the Crt Bias adjustment setting. (See waveform 2 on Fig. 4-4.) This square wave is coupled through C872 to the Demodulator.

Demodulator

The Demodulator rectifies the signal from the Modulator and references it to the crt Cathode Supply level. The positive swing of waveform 3, Figure 4-4, is limited by CR874 to the level of the Cathode Supply; the negative excursion is coupled through CR876 to C879. Quiescently, C879 will charge to about -4500 volts through R876. After repetitive cycles from C872, C879 will charge to the negative level of waveform 3. Capacitor C879 filters the output of the Demodulator, and also provides a path for the high-frequency portions of the Z-Axis Amplifier output signal to be coupled to the crt control grid.

The remainder of the components not shown on the simplified diagram in Figure 4-4 provide circuit protection in the event of a high-voltage arc, or other malfunction.

FOCUS-ELEMENT DC RESTORER

The Focus-Element DC Restorer couples the dc and low-frequency components of the Dynamic Focus correction signals (diagram 4) to the crt focus element of V950. This allows the Dynamic Focus circuit to control the focus-element potential. The potential difference between the Dynamic Focus output and the focus element (approximately 3250 volts) prohibits direct coupling.

The Focus-Element DC Restorer is divided into 2 sections for ease of explanation. The first section can be considered a modulator at low-voltage potentials and the remaining section a demodulator at high-voltage potentials (see Fig. 4-5).

Modulator

When the secondary-winding output at T850 pin 10 swings positive, C929 charges through R927 and C927 to a voltage level determined by the output level from the Summing and Output Amplifier stage of the Dynamic Focus circuit (diagram 4). At this voltage level (approximately +15 volts for center-screen deflection) CR925 conducts, preventing any additional

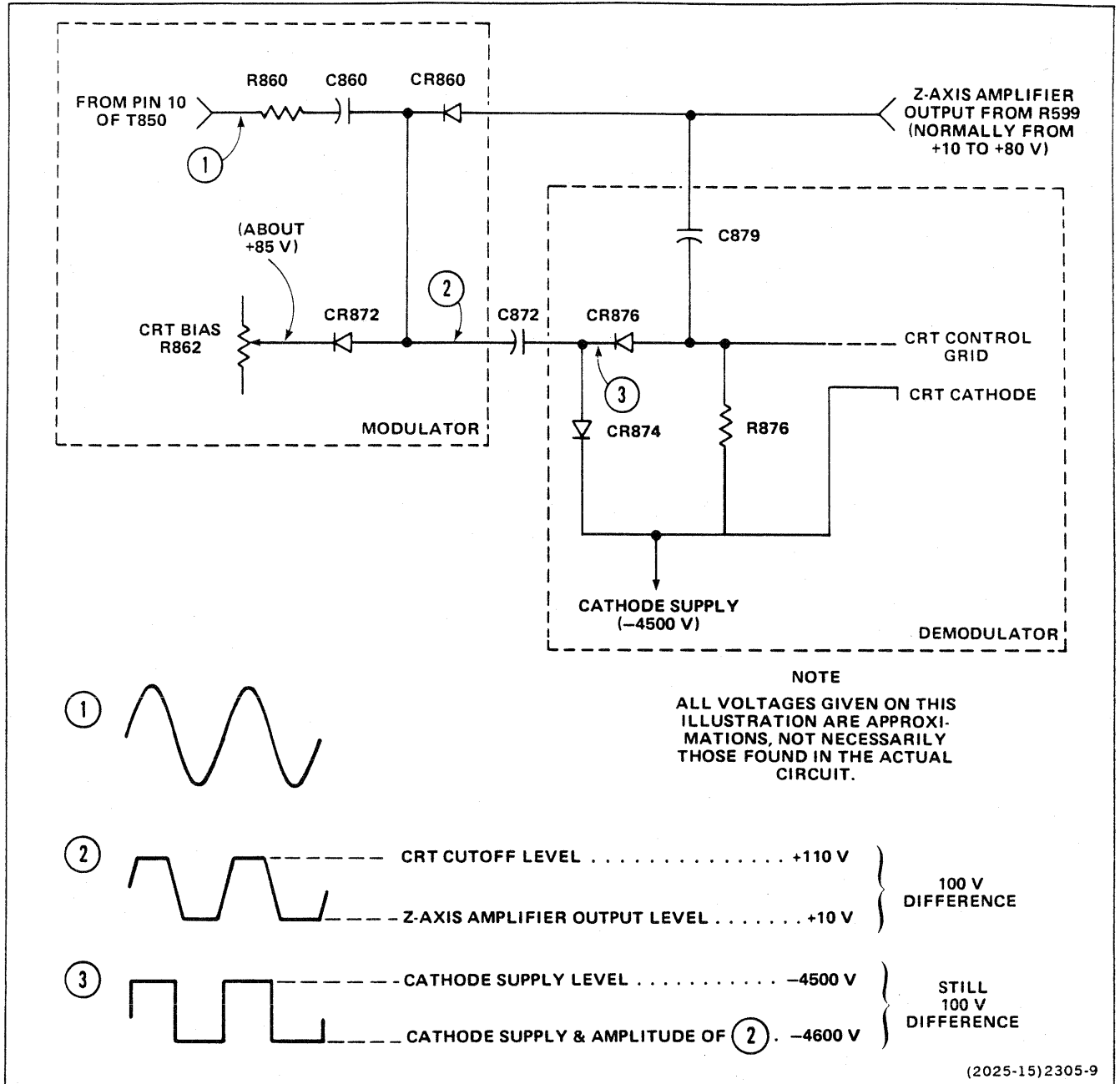

Figure 4-4. Simplified diagram of Control-Grid DC Restorer.

increase in positive voltage across C929. When the secondary-winding output swings negative, CR925 turns off. Then, CR927 conducts and clamps the negative excursion at C929 a diode drop below ground. The result is a square-wave output from the Modulator, with the output amplitude determined by the difference between the level of the Dynamic Focus circuit (diagram 4) and approximately ground (see waveform 2 on Fig. 4-5). The Modulator output is coupled through C929 to the Demodulator.

Demodulator

The Demodulator rectifies the signal from the Modulator and references it to the potential on C934. The potential on C934 is determined by voltage divider R920D, R920C, and FOCUS control R844. The negative swing of waveform 3 in Figure 4-5 is limited by CR929 to the level of C934; the positive excursion is coupled through CR930 to C930. Quiescently, C930 will charge to about -3250 volts through R930. After

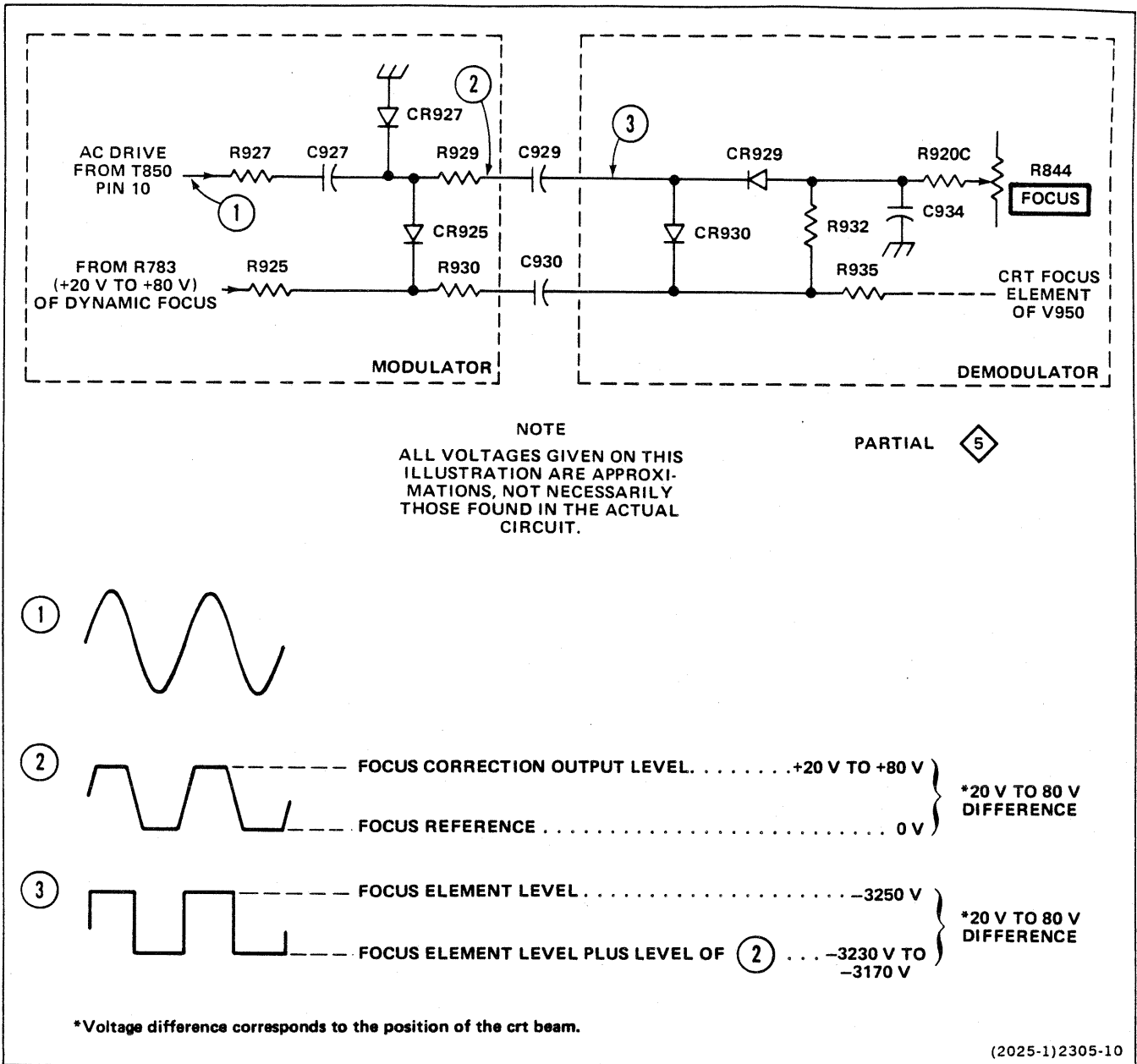

Figure 4-5. Simplified diagram of Focus-Element DC Restorer.

repetitive cycles from C929, C930 will charge to the positive level of waveform 3. Capacitor C930 filters the output of the Demodulator, and also provides a path for the high-frequency portions of the focus-correction signal to be coupled to the crt focus element at V950.

The remainder of the components not shown on the simplified diagram in Figure 4-5 provides circuit protection in the event of a high-voltage arc or other malfunction.

+100-VOLT REGULATED SUPPLY

The ac voltage from pin 2 of T850 is half-wave rectified by CR888 to provide unregulated power for the +100-Volt Regulated Supply. Filtering is provided by C889, L889, and C890.

The regulator for this supply is a feedback amplifier system. Current to the load is delivered by series-pass transistor Q900, which is located in the output side of the supply. The supply voltage is established by the

drop across resistive-divider network R904-R906. The feedback through this network and R907 is compared to the reference level established at the base of Q911. Any variation in output voltage of the supply (due to ripple, change of current through the load, etc.), is immediately transmitted through error amplifier Q907-Q911-Q914 to the base of Q900, changing its conduction and nullifying the original output variation.

Transistor Q895 protects the +100-volt series regulator (Q900) if excess current is demanded from this supply. Essentially, all current from this supply flows through R896. When excess current is demanded from the +100-volt series regulator, due to a short circuit or similar malfunction at the output of this supply, the voltage drop across R896 increases, causing Q895 to increase conduction. The resulting current through Q895 reduces the conduction of Q900 to limit the supply current to a safe level.

CRT INTERCONNECTS

The ASTIG screwdriver adjustment, R841, which is used in conjunction with the front-panel FOCUS control to provide a well-defined display, varies the positive level on the astigmatism element of the crt. Geometry adjustment R943 varies the positive level on the geometry element to control the overall geometry of the display. TRACE ROTATION adjustment R949 controls the current through L980 to provide adjustment of the display alignment.

LOW-VOLTAGE POWER SUPPLY

The Low-Voltage Power Supply provides the operating power for the Monitor. Electronic regulation is used to provide stable, low-ripple output voltages. A schematic diagram of the Low-Voltage Power Supply is shown on diagram 6 at the rear of this manual. A detailed block diagram, showing each major stage of this circuit, is superimposed on the schematic with wide shaded lines. The stage names (given as sub-headings in the following discussion) can be found in the shaded blocks on diagram 6.

POWER INPUT

Power is applied to the primary of transformer T950 through fuse F950, thermal cutout S960, ON/OFF switch S950, and Line-Voltage Selector plug P951 or P952. The Line-Voltage Selector plugs allow changing the primary winding taps of T950 to meet different line-voltage and regulating range requirements. Line fuse F950 should be changed for each nominal line voltage (current rating of fuse for 220-volt operation must be 0.4 A slow-blowing type; for 120-volt operation the current rating of the fuse must be 0.8 A slow-blowing type).

Thermal cutout S960 provides thermal protection for this instrument. If the internal temperature of the

instrument exceeds a safe operating level, S960 opens to interrupt the applied power. When the temperature returns to a safe level, S960 automatically closes to re-apply the power.

RECTIFIER AND FILTER

A full-wave bridge circuit, composed of CR951-CR952-CR953-CR954 rectifies the ac voltage from the secondary of T950. Filtering is provided by C951 and C952.

+18-VOLT UNREGULATED SUPPLY

The +18-Volt Unregulated Supply provides unregulated power for the high-voltage transformer (T850) on diagram 5. Fuse F951 provides circuit protection in the event of an overload.

+15-VOLT REGULATED SUPPLY

The +15-Volt Regulated Supply, in addition to providing power to circuitry throughout the instrument, provides a reference-voltage source to establish the operating level for the feedback regulator of the -15-Volt Regulated Supply. The regulator for the +15-Volt Regulated Supply is a feedback amplifier system that operates between ground and the +18-Volt Unregulated Supply. Current to the load is delivered by series-pass transistor Q955, which is located in the output side of the supply. The supply voltage is established by the drop across resistive-divider network R959-R958-R957. The feedback through this network is compared to the reference level established at the base of Q965 by the voltage drop across VR968. Any variation in output voltage of the supply (due to ripple, change of current through the load, etc.), is immediately transmitted to the base of Q955 and nullified by a change in Q955 conduction, maintaining a steady output.

The output of the supply is set to exactly +15 volts by adjustment of R958, the +15-V Adjust.

Transistor Q970 protects the +15-volt series regulator (Q955) if excess current is demanded from this supply. Essentially, all current from this supply flows through R954. When excess current is demanded from the +15-volt series regulator, due to a short circuit or similar malfunction at the output of this supply, the voltage drop across R954 increases enough to turn on Q970. The resulting current through Q970 reduces the conduction of Q955 to limit the supply current to a safe level. Fuse F953 provides circuit protection in the event of an overload or regulator malfunction.

-15-VOLT REGULATED SUPPLY

The regulator for the -15-Volt Regulated Supply consists of series-pass transistor Q976 and error amplifier Q987-Q944-Q981. This is a feedback

Theory of Operation—608

amplifier system similar to that just described for the +15-Volt Regulated Supply.

The center of resistive-divider network R978-R979 is set by the error amplifier to be zero volts, with respect to ground, during normal operation. Any variation in output from the -15-Volt Regulated Supply is coupled to the error amplifier, which changes the bias of the -15-volt series regulator (Q976). This change in bias, and resulting change in conduction of the regulator, nullifies the output variation to maintain a steady level from the supply.

Diode CR993 protects the -15-volt series regulator (Q976) if excess current is demanded from this supply. Essentially, all current from this supply flows through R975. When excess current is demanded from the -15-volt series regulator, due to a short circuit or similar malfunction at the output of this supply, the voltage drop across R954 increases enough to forward bias CR993. This increases the conduction of Q994, which then reduces the conduction of Q976 to limit the supply current to a safe level. Fuse F955 provides circuit protection in the event of an overload or regulator malfunction.