

## WARNING

THE FOLLOWING SERVICING INSTRUCTIONS ARE FOR USE BY QUALIFIED PERSONNEL ONLY. TO AVOID PERSONAL INJURY, DO NOT PERFORM ANY SERVICING OTHER THAN THAT CONTAINED IN OPERATING INSTRUCTIONS UNLESS YOU ARE QUALIFIED TO DO SO.

**PLEASE CHECK FOR CHANGE INFORMATION  
AT THE REAR OF THIS MANUAL.**



# 2336 OSCILLOSCOPE SERVICE

## INSTRUCTION MANUAL

Tektronix, Inc.  
P.O. Box 500  
Beaverton, Oregon 97077  
070-4118-00  
Product Group 40

Serial Number \_\_\_\_\_

First Printing MAY 1981  
Revised NOV 1981

# Scans By *Artek Media*

Artek Media  
1042 Plummer Cir. SW  
Rochester, MN 55902

[www.artekmedia.com](http://www.artekmedia.com)

“High resolution scans of obsolete technical manuals”

If you are looking for a quality scanned technical manual in PDF format please visit our WEB site at [www.artekmedia.com](http://www.artekmedia.com) or drop us an email at [manuals@artekmedia.com](mailto:manuals@artekmedia.com) and we will be happy to email you a current list of the manuals we have available.

If you don't see the manual you need on the list drop us a line anyway we may still be able to point you to other sources. If you have an existing manual you would like scanned please write for details, This can often be done very reasonably in consideration for adding your manual to our library.

Typically the scans in our manuals are done as follows;

- 1) Typed text pages are typically scanned in black and white at 300 dpi.
- 2) Photo pages are typically scanned in gray scale mode at 600 dpi
- 3) Schematic diagram pages are typically scanned in black and white at 600 dpi unless the original manual had colored high lighting (as is the case for some 70's vintage Tektronix manuals).

If you purchased this manual from us (typically through our Ebay name of ArtekMedia) thank you very much. If you received this from a well-meaning “friend” for free we would appreciate your treating this much like you would “share ware”. By that we mean a donation of at least \$5-10 per manual is appreciated in recognition of the time (a manual can take as much as 40 hours to reproduce, book, link etc.), energy and quality of effort that went into preserving this manual. Donations via PayPal go to: [manuals@artekmedia.com](mailto:manuals@artekmedia.com) or can be mailed to us the address above.

Thanks



Dave & Lynn Henderson  
Artek Media

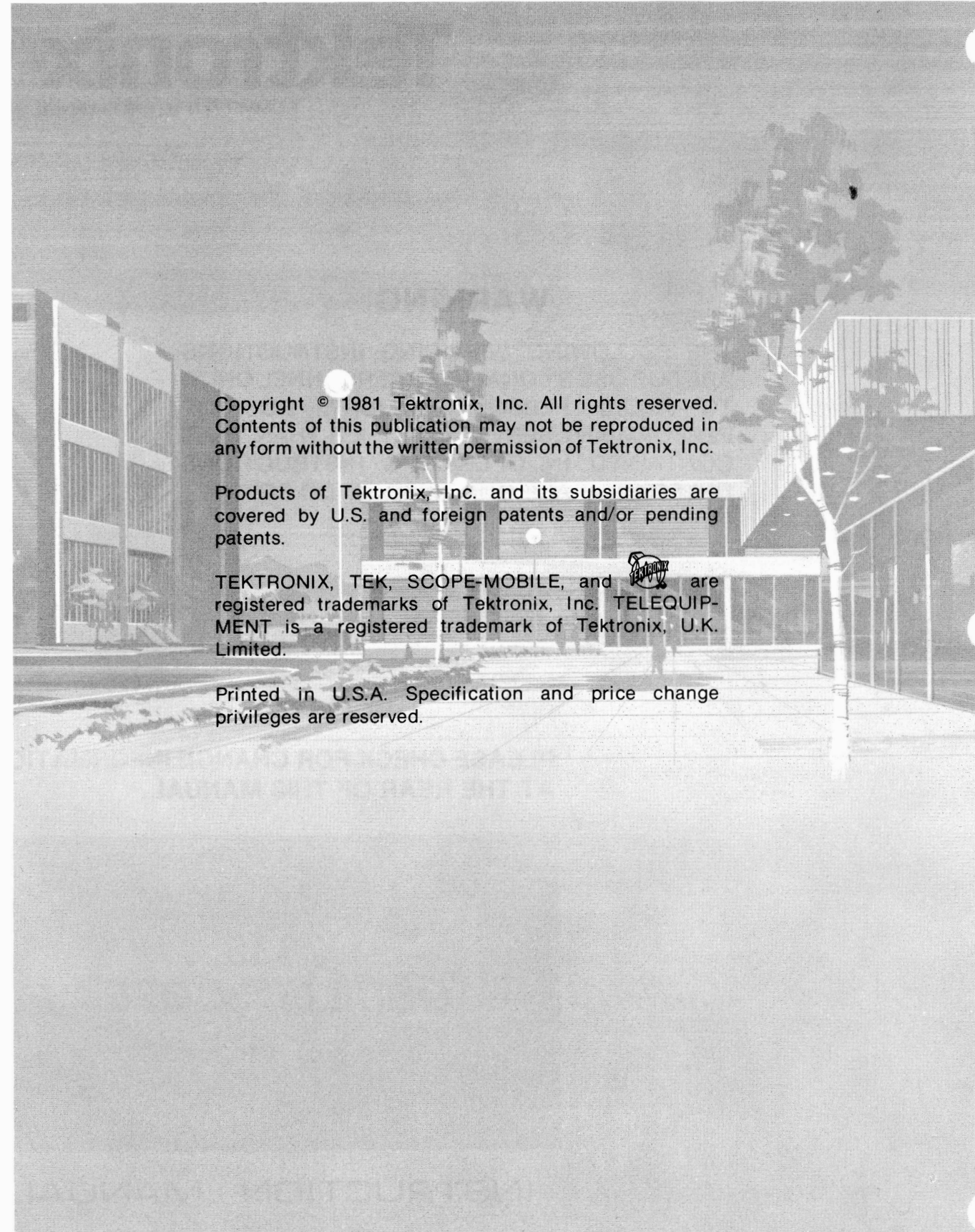

Copyright © 1981 Tektronix, Inc. All rights reserved.  
Contents of this publication may not be reproduced in  
any form without the written permission of Tektronix, Inc.

Products of Tektronix, Inc. and its subsidiaries are  
covered by U.S. and foreign patents and/or pending  
patents.

TEKTRONIX, TEK, SCOPE-MOBILE, and  are  
registered trademarks of Tektronix, Inc. TELEQUIP-  
MENT is a registered trademark of Tektronix, U.K.  
Limited.

Printed in U.S.A. Specification and price change  
privileges are reserved.

# TABLE OF CONTENTS

	Page		Page
<b>LIST OF ILLUSTRATIONS</b> . . . . .	iii	<b>SECTION 3 THEORY OF OPERATION</b>	
<b>LIST OF TABLES</b> . . . . .	v	INTRODUCTION . . . . .	3-1
<b>OPERATORS SAFETY SUMMARY</b> . . . . .	vi	GENERAL DESCRIPTION . . . . .	3-2
<b>SERVICING SAFETY SUMMARY</b> . . . . .	vii	DETAILED CIRCUIT	
		DESCRIPTION . . . . .	3-6
<b>SECTION 1 SPECIFICATION</b>		CHANNEL 1 AND CHANNEL 2	
INTRODUCTION . . . . .	1-1	ATTENUATORS . . . . .	3-6
ACCESSORIES . . . . .	1-1	VERTICAL PREAMPLIFIERS,	
AVAILABLE OPTION . . . . .	1-1	DIODE GATES, AND DELAY	
PERFORMANCE CONDITIONS . . . . .	1-1	LINE DRIVER . . . . .	3-7
		VERTICAL OUTPUT	
<b>SECTION 2 OPERATING INSTRUCTIONS</b>		AMPLIFIER . . . . .	3-10
PREPARATION FOR USE . . . . .	2-1	VERTICAL SWITCHING LOGIC	
SAFETY CONSIDERATIONS . . . . .	2-1	AND CHOP BLANKING . . . . .	3-11
LINE VOLTAGE SELECTION . . . . .	2-1	TRIGGER . . . . .	3-13
LINE FUSE . . . . .	2-1	SWEEP . . . . .	3-19
POWER CORD . . . . .	2-2	A AND B TIMING SWITCHES . . . . .	3-26
CONTROLS, CONNECTORS,		HORIZONTAL AMPLIFIER . . . . .	3-26
AND INDICATORS . . . . .	2-3	CRT CIRCUIT . . . . .	3-29
POWER AND DISPLAY . . . . .	2-3	LOW-VOLTAGE POWER SUPPLY . . . . .	3-33
VERTICAL . . . . .	2-3	FAN CIRCUIT . . . . .	3-35
HORIZONTAL . . . . .	2-5	CALIBRATOR . . . . .	3-35
A TRIGGER . . . . .	2-6	DELTA TIME . . . . .	3-36
B TRIGGER . . . . .	2-7		
REAR PANEL . . . . .	2-8	<b>SECTION 4 PERFORMANCE CHECK</b>	
OPERATING CONSIDERATIONS . . . . .	2-9	<b>PROCEDURE</b>	
GRATICULE . . . . .	2-9	INTRODUCTION . . . . .	4-1
GROUNDING . . . . .	2-10	TEST EQUIPMENT REQUIRED . . . . .	4-1
SIGNAL CONNECTIONS . . . . .	2-10	PERFORMANCE CHECK	
INPUT COUPLING CAPACITOR		INTERVAL . . . . .	4-1
PRECHARGING . . . . .	2-10	LIMITS AND TOLERANCES . . . . .	4-1
INSTRUMENT COOLING . . . . .	2-10	SPECIAL FIXTURES . . . . .	4-1
<b>OSCILLOSCOPE DISPLAYS</b> . . . . .	2-11	PREPARATION . . . . .	4-1
INTRODUCTION . . . . .	2-11	INDEX TO PERFORMANCE	
NORMAL SWEEP DISPLAY . . . . .	2-11	CHECK STEPS . . . . .	4-4
SIGNAL DISPLAY . . . . .	2-11	VERTICAL . . . . .	4-5
MAGNIFIED-SWEEP DISPLAY . . . . .	2-12	TRIGGERING . . . . .	4-13
DELAYED-SWEEP DISPLAY . . . . .	2-12	HORIZONTAL . . . . .	4-18
DELAYED-SWEEP		EXTERNAL Z-AXIS AND	
MEASUREMENTS . . . . .	2-12	CALIBRATOR . . . . .	4-23
SINGLE-SWEEP DISPLAY . . . . .	2-12		
X-Y DISPLAY . . . . .	2-13		

# TABLE OF CONTENTS (cont)

	Page		Page
<b>SECTION 5 ADJUSTMENT PROCEDURE</b>		<b>CORRECTIVE MAINTENANCE (cont)</b>	
INTRODUCTION . . . . .	5-1	TRANSISTORS AND	
TEST EQUIPMENT REQUIRED . . .	5-1	INTEGRATED CIRCUITS . . . . .	6-14
LIMITS AND TOLERANCES . . . .	5-1	SOLDERING TECHNIQUES . . . . .	6-14
PARTIAL PROCEDURES . . . . .	5-1	REMOVAL AND REPLACEMENT	
INTERNAL ADJUSTMENTS AND		INSTRUCTIONS . . . . .	6-15
ADJUSTMENT INTERACTION . . .	5-2	Cabinet . . . . .	6-16
PREPARATION FOR		Lid Cover . . . . .	6-16
ADJUSTMENT . . . . .	5-2	A30—Delta Time Logic	
INDEX TO ADJUSTMENT		Circuit Board . . . . .	6-16
PROCEDURE . . . . .	5-4	B Trigger Panel . . . . .	6-17
MAIN POWER SUPPLY . . . . .	5-5	Delta Time Interconnect Cable. . .	6-17
DISPLAY AND Z-AXIS . . . . .	5-7	Cathode-Ray Tube . . . . .	6-18
VERTICAL . . . . .	5-9	A15—Vert Out/H.V. Power	
TRIGGERING . . . . .	5-19	Supply Circuit Board . . . . .	6-19
HORIZONTAL . . . . .	5-26	A10—Vert Preamp/L.V. Power	
EXTERNAL Z-AXIS AND		Supply Circuit Board . . . . .	6-20
CALIBRATOR . . . . .	5-35	A11—Negative Regulator	
		Circuit Board . . . . .	6-22
		A12—Positive Regulator	
		Circuit Board . . . . .	6-22
<b>SECTION 6 MAINTENANCE</b>		A23—Trigger Circuit Board . . . . .	6-22
STATIC-SENSITIVE COMPONENTS . .	6-1	A24—Sweep/Horiz Amp/Opt	
PREVENTIVE MAINTENANCE . . . .	6-2	Circuit Board . . . . .	6-23
INTRODUCTION . . . . .	6-2	Timing Switch Assembly . . . . .	6-23
GENERAL CARE . . . . .	6-2	Attenuators . . . . .	6-27
INSPECTION AND CLEANING . . .	6-2	REPACKAGING FOR SHIPMENT . .	6-31
LUBRICATION . . . . .	6-5	SELECTABLE COMPONENTS . . . .	6-31
SEMICONDUCTOR CHECKS . . . .	6-5		
PERIODIC READJUSTMENT . . . .	6-5	<b>SECTION 7 OPTIONS</b>	
TROUBLESHOOTING . . . . .	6-5	INTRODUCTION . . . . .	7-1
INTRODUCTION . . . . .	6-5	OPTION 03 . . . . .	7-1
TROUBLESHOOTING AIDS . . . .	6-5		
TROUBLESHOOTING		<b>SECTION 8 REPLACEABLE ELECTRICAL PARTS</b>	
EQUIPMENT . . . . .	6-7		
TROUBLESHOOTING		<b>SECTION 9 DIAGRAMS</b>	
TECHNIQUES . . . . .	6-7		
CORRECTIVE MAINTENANCE . . . .	6-12	<b>SECTION 10 REPLACEABLE MECHANICAL PARTS</b>	
INTRODUCTION . . . . .	6-12		
MAINTENANCE PRECAUTIONS . .	6-12	<b>ACCESSORIES</b>	
OBTAINING REPLACEMENT			
PARTS . . . . .	6-12	<b>CHANGE INFORMATION</b>	
MAINTENANCE AIDS . . . . .	6-12		
INTERCONNECTIONS . . . . .	6-12		

# LIST OF ILLUSTRATIONS

Figure		Page
	The 2336 Oscilloscope	viii
2-1	LINE VOLTAGE SELECTOR switch, line fuse, and power cord . . . . .	2-2
2-2	Optional power cords. . . . .	2-2
2-3	Power and display controls and indicators . . . . .	2-3
2-4	Vertical controls, connectors, and indicators and calibrator output . . . . .	2-4
2-5	Horizontal controls and indicator . . . . .	2-5
2-6	A TRIGGER controls, connector, and indicator . . . . .	2-6
2-7	B TRIGGER controls, connector, and LCD readout. . . . .	2-8
2-8	Rear-panel connectors . . . . .	2-9
2-9	Graticule measurement markings . . . . .	2-9
3-1	Basic block diagram of the 2336 Oscilloscope . . . . .	3-3
3-2	Channel 1 Vertical Attenuator, simplified block diagram. . . . .	3-6
3-3	Vertical Preamplifier, Diode Gate, and Delay Line Driver, simplified block diagram . . . . .	3-8
3-4	Diode Gate biasing for Channel 1 display . . . . .	3-9
3-5	Simplified illustration of Multiplexer U215 switching operation . . . . .	3-11
3-6	Trigger circuitry, detailed block diagram . . . . .	3-14
3-7	Trigger signal slow path (low frequency) . . . . .	3-15
3-8	Trigger signal fast path (high frequency) . . . . .	3-16
3-9	Simplified diagram of the B Trigger Generator and B Source and B Slope switching circuitry. . . . .	3-18
3-10	Sweep operation in the A Sweep Mode . . . . .	3-23
3-11	Sweep circuit waveform relationships . . . . .	3-24
3-12	Sweep operation in the B Sweep Mode . . . . .	3-25
3-13	Horizontal Amplifier, detailed block diagram . . . . .	3-27
3-14	High-Voltage Oscillator waveform relationships. . . . .	3-29
3-15	DC Restorer circuit, simplified diagram . . . . .	3-33
3-16	Foldover circuit action . . . . .	3-34
3-17	Typical waveforms in the Fan Motor three-stage inverter circuit. . . . .	3-35
3-18	Simplified diagram of the Delay Time Switching and Prescaling circuit . . . . .	3-38
3-19	Exclusive-OR gate switching action. . . . .	3-41
4-1	Test setup for external trigger and jitter checks. . . . .	4-15
5-1	Areas affected by high-frequency compensation adjustments. . . . .	5-15
6-1	Multipin connector orientation . . . . .	6-7
6-2	Attenuator contact pressure check . . . . .	6-11
6-3	Attenuator contact alignment . . . . .	6-11
6-4	SEC/DIV switch exploded view . . . . .	6-24
6-5	Vertical attenuator exploded view . . . . .	6-28

# LIST OF ILLUSTRATIONS (cont)

## Figure

- 9-1 Color codes for resistors and capacitors.
- 9-2 Semiconductor lead configurations.
- 9-3 Locating components on schematic diagrams and circuit board illustrations.
- 9-4 2336 main block diagram.
- 9-5 2336 Delta Time block diagram.
- 9-6 A19—Attenuator exploded view.
- 9-7 A11—Negative Regulator, A12—Positive Regulator, and A10—Vertical Preamp/L.V. Power Supply boards.
- 9-8 A15—Vertical Output/H.V. Power Supply board.
- 9-9 A23—Trigger board.
- 9-10 A24—Sweep/Horizontal Amplifier/Option board.
- 9-11 A16—B Timing and A17—A Timing boards.
- 9-12 Timing Switch exploded view.
- 9-13 A30—Delta Time Logic and A31—B Timing Slope Switch boards.

# LIST OF TABLES

Table		Page
1-1	Electrical Characteristics . . . . .	1-2
1-2	Environmental Characteristics . . . . .	1-10
1-3	Physical Characteristics . . . . .	1-11
1-4	Option Electrical Characteristics . . . . .	1-11
2-1	Line Voltage and Fuse Selection . . . . .	2-1
2-2	Option 03 Line Voltage and Fuse Selection . . . . .	2-1
3-1	PROM U38 Logic Table . . . . .	3-37
4-1	Test Equipment Required . . . . .	4-2
4-2	DC Accuracy Limits . . . . .	4-7
4-3	Low-Frequency Compensation Setup . . . . .	4-8
4-4	Switch Combinations for A Trigger Checks (CH 1) . . . . .	4-13
4-5	Switch Combinations for B Trigger Checks . . . . .	4-14
4-6	Switch Combinations for A Trigger Checks (CH 2) . . . . .	4-14
4-7	Settings for Timing Accuracy Checks . . . . .	4-19
4-8	$\Delta$ Time Readout Accuracy . . . . .	4-20
5-1	Adjustment Interactions . . . . .	5-3
5-2	Main Power Supply Tolerances and p-p Ripple . . . . .	5-6
5-3	Vertical DC Accuracy Checks . . . . .	5-13
5-4	Switch Combinations for A Trigger Checks (CH 1) . . . . .	5-21
5-5	Switch Combinations for B Trigger Checks . . . . .	5-21
5-6	Switch Combinations for A Trigger Checks (CH 2) . . . . .	5-21
5-7	$\Delta$ Time Linearity . . . . .	5-28
5-8	Settings for Timing Accuracy Checks . . . . .	5-30
5-9	$\Delta$ Time Readout Accuracy . . . . .	5-31
5-10	A Trigger Holdoff Time . . . . .	5-34
6-1	Relative Susceptibility to Static-Discharge Damage . . . . .	6-1
6-2	External Inspection Checklist . . . . .	6-3
6-3	Internal Inspection Checklist . . . . .	6-3
6-4	Suggested Troubleshooting Equipment . . . . .	6-8
6-5	Maintenance Aids . . . . .	6-13



# OPERATORS SAFETY SUMMARY

*The general safety information in this part of the summary is for both operating and servicing personnel. Specific warnings and cautions will be found throughout the manual where they apply and do not appear in this summary.*

## Terms in This Manual

CAUTION statements identify conditions or practices that could result in damage to the equipment or other property.

WARNING statements identify conditions or practices that could result in personal injury or loss of life.

## Terms as Marked on Equipment

CAUTION indicates a personal injury hazard not immediately accessible as one reads the markings, or a hazard to property, including the equipment itself.

DANGER indicates a personal injury hazard immediately accessible as one reads the marking.

## Symbols in This Manual



This symbol indicates where applicable cautionary or other information is to be found. For maximum input voltage see Table 1-1.

## Symbols as Marked on Equipment



DANGER – High voltage.



Protective ground (earth) terminal.



ATTENTION – Refer to manual.

## Power Source

This product is intended to operate from a power source that does not apply more than 250 volts rms between the supply conductors or between either supply conductor and ground. A protective ground connection by way of the grounding conductor in the power cord is essential for safe operation.

## Grounding the Product

This product is grounded through the grounding conductor of the power cord. To avoid electrical shock, plug the power cord into a properly wired receptacle before connecting to the product input or output terminals. A protective ground connection by way of the grounding conductor in the power cord is essential for safe operation.

## Danger Arising From Loss of Ground

Upon loss of the protective-ground connection, all accessible conductive parts (including knobs and controls that may appear to be insulating) can render an electric shock.

## Use the Proper Power Cord

Use only the power cord and connector specified for your product.

Use only a power cord that is in good condition.

For detailed information on power cords and connectors see Figure 2-2.

## Use the Proper Fuse

To avoid fire hazard, use only a fuse of the correct type, voltage rating and current rating as specified in the parts list for your product.

## Do Not Operate in Explosive Atmospheres

To avoid explosion, do not operate this product in an explosive atmosphere unless it has been specifically certified for such operation.

## Do Not Remove Covers or Panels

To avoid personal injury, do not remove the product covers or panels. Do not operate the product without the covers and panels properly installed.

# SERVICING SAFETY SUMMARY

## FOR QUALIFIED SERVICE PERSONNEL ONLY

*Refer also to the preceding Operators Safety Summary.*

### **Do Not Service Alone**

Do not perform internal service or adjustment of this product unless another person capable of rendering first aid and resuscitation is present.

### **Use Care When Servicing With Power On**

Dangerous voltages exist at several points in this product. To avoid personal injury, do not touch exposed connections or components while power is on.

Disconnect power before removing protective panels, soldering, or replacing components.

### **Power Source**

This product is intended to operate from a power source that does not apply more than 250 volts rms between the supply conductors or between either supply conductor and ground. A protective ground connection by way of the grounding conductor in the power cord is essential for safe operation.



4118-01

The 2336 Oscilloscope.

# SPECIFICATION

This section of the manual contains a general description of instrument features, identifies standard accessories, provides option information, and lists the instrument specification.

## INTRODUCTION

The TEKTRONIX 2336 Oscilloscope is a rugged, lightweight, dual-channel, 100-MHz instrument having a compact crt that provides a sharply defined trace. Its vertical system supplies calibrated deflection factors from 5 mV per division to 5 V per division. Sensitivity can be increased to at least 2 mV per division by the variable VOLTS/DIV VAR control. Trigger circuits enable stable triggering over the full bandwidth of the vertical system. The horizontal system provides calibrated sweep speeds from 0.5 s per division to 50 ns per division, along with delayed-sweep features, thus accommodating accurate relative-time measurements. A X10 magnifier circuit extends the maximum sweep speed to 5 ns per division when the SEC/DIV switch is set to 0.05  $\mu$ s per division.

A 3 1/2-digit LCD (liquid-crystal display) readout enables rapid measurement of time difference between any two points on the oscilloscope display. Both time measurement points are displayed simultaneously on the crt screen.

## ACCESSORIES

The instrument is shipped with the following standard accessories:

- 2 Probe packages
- 1 Accessory pouch
- 1 Operators manual
- 1 Service manual
- 1 Accessory pouch, zip lock
- 1 Crt filter, clear plastic
- 2 1.0-A AGC fast-blow fuses
- 1 0.5-A AGC fast-blow fuse

For part numbers and further information about accessories, refer to the "Accessories" page at the back of this manual. Your Tektronix representative or local Tektronix Field Office can also provide accessories information.

## AVAILABLE OPTION

Option 03 (100-V/200-V Power Transformer) permits operation of the instrument from either a 100-V or a 200-V nominal ac-power-input source at a line frequency from 48 Hz to 440 Hz.

## PERFORMANCE CONDITIONS

The following electrical characteristics (Table 1-1) are valid for the 2336 when it has been adjusted at an ambient temperature between +20°C and +30°C, has had a warmup period of at least 20 minutes, and is operating at an ambient temperature between -15°C and +55°C (unless otherwise noted).

Items listed in the "Performance Requirements" column are verifiable qualitative or quantitative limits that may be checked by procedures contained in the "Performance Check" section of the manual (see Section 4), except as noted. Performance check procedures for items listed in the "Supplemental Information" column are not provided; items in this column are either explanatory notes, performance characteristics for which no absolute limits are specified, or characteristics that are impractical to check in routine maintenance.

Environmental characteristics of the 2336 are given in Table 1-2. All environmental tests performed meet the requirements of MIL-T-28800B, Type III, Class 3 equipment, except where otherwise noted.

Physical characteristics of the instrument are listed in Table 1-3, and option electrical characteristics are presented in Table 1-4.

Table 1-1  
Electrical Characteristics

Characteristics	Performance Requirements	Supplemental Information
<b>VERTICAL DEFLECTION SYSTEM</b>		
Deflection Factor Range	5 mV per division to 5 V per division in a 1, 2, 5 sequence.	
Accuracy	±3% on all ranges when VOLTS/DIV is calibrated at 5 mV per division; add 0.05% per °C deviation from 25°C.	
Uncalibrated (VAR) Range	Continuously variable between VOLTS/DIV switch settings. Reduces deflection factor at least 2.5 to 1 on all VOLTS/DIV switch settings.	Reduces deflection factor to at least 2 mV per division with VOLTS/DIV switch set to 5 mV.
Frequency Response		6-division reference signal from a 25-Ω source; centered vertically, with VOLTS/DIV VAR control in calibrated detent.
-15°C to +40°C	Dc to at least 100 MHz. Reduces to 88 MHz at 2 mV per division. <sup>a</sup>	
+40°C to +55°C	Dc to at least 85 MHz. <sup>a</sup> Reduces to 70 MHz at 2 mV per division. <sup>a</sup>	
Ac Coupled Lower -3 dB Point 1X Probe	10 Hz or less. <sup>a</sup>	
10X Probe	1 Hz or less. <sup>a</sup>	
Step Response		5-division reference signal, dc coupled at all deflection factors, from a 25-Ω source; centered vertically with VOLTS/DIV VAR control in calibrated detent. BW LIMIT push button must be out for full bandwidth operation.
Rise Time (5 mV per division to 5 V per division)		Rise time is calculated from the formula:
-15°C to +40°C	3.5 ns or less.	Rise Time = $\frac{0.35}{\text{BW (in MHz)}}$
+40°C to +55°C	4.15 ns or less. <sup>a</sup>	
Aberrations Positive-Going Step (Excluding ADD Mode) 5 mV per division to 0.2 V per division	+3%, -3%, 3% p-p or less.	



<sup>a</sup>Performance Requirement not checked in manual.

Table 1-1 (cont)

Characteristics	Performance Requirements	Supplemental Information
<b>VERTICAL DEFLECTION SYSTEM (cont)</b>		
Aberrations (cont) Negative-Going Step		Add 2% to all positive-going step specifications; checked at 5 mV per division.
ADD Mode		Add 4% to all positive-going step specifications; checked at 5 mV per division.
Position Effect		Total aberrations less than +5%, -5%, 5% p-p; checked at 5 mV per division.
Temperature Effect		Add 0.15% per °C deviation to aberrations specifications from 25°C.
Common-Mode Rejection Ratio	At least 10 to 1 at 50 MHz for common-mode signals of 6 divisions or less.	VAR control adjusted for best CMRR at 10 mV per division at 50 kHz; checked at 10 mV per division.
Channel 2 Invert Trace Shift	Less than 0.4 division from center screen when switching from normal to inverted.	
Input Gate Current -15°C to +30°C	0.5 nA or less.	0.1-division trace shift when moving Input Coupling switch from GND to AC at 5 mV per division.
+30°C to +55°C	4.0 nA or less. <sup>a</sup>	0.8-division trace shift when moving Input Coupling switch from GND to AC at 5 mV per division.
Attenuator Isolation (CH 1 to CH 2)	At least 100 to 1.	With one vertical input set at 0.5 V per division, apply 4-V p-p 25-MHz signal; set the other vertical input to 10 mV per division. Check for less than 4 divisions of signal.
POSITION Control Range	At least +12 and -12 divisions from graticule center.	
Step Attenuator Balance	Less than or equal to 0.2-division trace shift when rotated from 5 mV per division to 5 V per division.	Double for each 10°C deviation from 25°C.
Chop Frequency	275 kHz ±30%.	
Input Characteristics Resistance	1 MΩ ±2%. <sup>a</sup>	
Capacitance	20 pF ±10%. <sup>a</sup>	

<sup>a</sup>Performance Requirement not checked in manual.

Table 1-1 (cont)

Characteristics	Performance Requirements	Supplemental Information
<b>VERTICAL DEFLECTION SYSTEM (cont)</b>		
Maximum Input Voltage  DC Coupled	400 V (dc + peak ac) or 500 V p-p ac at 1 kHz or less. <sup>a</sup>	
AC Coupled	400 V (dc + peak ac) or 500 V p-p ac at 1 kHz or less. <sup>a</sup>	
<b>TRIGGER SYSTEM</b>		
Sensitivity		With VOLTS/DIV VAR control in calibrated detent. In EXT ÷ 10, multiply input requirements by 10.
<b>A TRIGGER</b> AC Coupled Signal	0.3 division internal or 50 mV external from 20 Hz to 20 MHz; increasing to 1.1 divisions internal or 150 mV external at 100 MHz.	
LF REJ Coupled Signal	0.3 division internal or 50 mV external from 50 kHz ±10 kHz to 20 MHz; increasing to 1.1 divisions internal or 150 mV external at 100 MHz.	Attenuates signals below 50 kHz ±10 kHz (–3 dB at 50 kHz).
HF REJ Coupled Signal	0.3 division internal or 50 mV external from 20 Hz ±4 Hz to 50 kHz ±10 kHz.	Attenuates signals below 20 Hz ±4 Hz and above 50 kHz ±10 kHz (–3 dB at 20 Hz and 50 kHz).
DC Coupled Signal	0.3 division internal or 50 mV external from dc to 20 MHz; increasing to 1.1 divisions internal or 150 mV external at 100 MHz.	
<b>B TRIGGER</b> (Ac Coupled Signal)	0.3 division internal or 50 mV external from 30 Hz to 20 MHz; increasing to 1.1 divisions internal or 150 mV external at 100 MHz.	
Trigger Jitter	0.2 division or less at 5 ns per division (X10 MAG on) with 100 MHz applied and at the rated trigger sensitivity.	VOLTS/DIV VAR control must be in calibrated detent.
<b>External Trigger Inputs</b>		
Maximum Input Voltage 	400 V (dc + peak ac) or 500 V p-p ac at 1 kHz or less. <sup>a</sup>	
Input Resistance	1 MΩ ±10%. <sup>a</sup>	
Input Capacitance	20 pF ±30%. <sup>a</sup>	

<sup>a</sup>Performance Requirement not checked in manual.

Table 1-1 (cont)

Characteristics	Performance Requirements	Supplemental Information
<b>TRIGGER SYSTEM (cont)</b>		
LEVEL Control Range EXT	At least $\pm 1$ V, 2 V p-p.	
EXT $\div 10$	At least $\pm 10$ V, 20 V p-p. <sup>a</sup>	
Trigger View (A Trigger) Deflection Factor EXT	100 mV per division $\pm 40\%$ .	
EXT $\div 10$	1 V per division $\pm 40\%$ .	
Centering of Trigger Point		Within 1 division of center screen.
Bandwidth	To at least 80 MHz.	4-division reference signal from a 25- $\Omega$ source; centered vertically.
Delay Difference	3 ns $\pm 2$ ns.	5-division signal with 5-ns rise time or less from 25- $\Omega$ source, centered vertically; equal cable length from signal source to vertical channel and external trigger inputs, terminated in 50 $\Omega$ at each input.
<b>HORIZONTAL DEFLECTION SYSTEM</b>		
Sweep Rate Calibrated Range A Sweep	0.5 s per division to 0.05 $\mu$ s per division in a 1, 2, 5 sequence. X10 MAG extends maximum sweep speed to 5 ns per division.	
B Sweep	50 ms per division to 0.05 $\mu$ s per division in a 1, 2, 5 sequence. X10 MAG extends maximum sweep speed to 5 ns per division.	
Accuracy	<b>Unmagnified</b>	Accuracy specification applies over the full 10 divisions with X10 MAG on and off. Exclude the first and last 40 ns of the sweep on all sweep speeds with X10 MAG on and off.
+20°C to +30°C	$\pm 2\%$	
-15°C to +55°C	$\pm 3\%$ <sup>a</sup>	
	<b>Magnified</b>	
		$\pm 3\%$
		$\pm 4\%$ <sup>a</sup>
Linearity	$\pm 5\%$ .	Over any 2-division portion of the full 10 divisions, displayed at all sweep speeds. Exclude the first and last displayed divisions of the 5- and 10-ns per division sweep speeds with X10 MAG on.

<sup>a</sup>Performance Requirement not checked in manual.



Table 1-1 (cont)

Characteristics	Performance Requirements	Supplemental Information
<b>HORIZONTAL DEFLECTION SYSTEM (cont)</b>		
Variable Range (VAR)	Continuously variable between calibrated settings of the SEC/DIV switches.	Extends maximum A Sweep speed to at least 1.25 s per division.
A Sweep Length	10.5 to 11.5 divisions.	Checked at 1 ms per division.
A Trigger Holdoff (VAR)	At least 2.5 times the minimum holdoff at any sweep speed. <sup>a</sup>	
Magnifier Registration	±0.2 division from graticule center (X10 MAG on to X10 MAG off).	
POSITION Control Range	Start of sweep must position to right of graticule center. End of sweep must position to left of graticule center.	Checked at 1 ms per division.
Differential Time Measurement Accuracy		Exclude delayed operation when knobs are locked at any sweep speed or when the A SEC/DIV switch is at either 0.1 μs per division or 0.05 μs per division. Exclude the first 0.25 division on all A Sweep speeds.
+15°C to +35°C	±1% of reading ±1 count.	
-15°C to +55°C	±2.5% of reading ±1 count. <sup>a</sup>	
Delay Time Jitter	±0.005% of 10 times the A SEC/DIV switch setting (less than one part in 20,000) over the full delay time range.	
<b>X-Y OPERATION</b>		
Deflection Factor Range	5 mV per division to 5 V per division in a 1, 2, 5 sequence.	No X-axis variable.
Bandwidth		
X-Axis	Dc to at least 2 MHz.	
Y-Axis	Dc to at least 100 MHz.	
Input Characteristics		
Resistance	1 MΩ ±2%. <sup>a</sup>	
Capacitance	20 pF ±10%. <sup>a</sup>	

<sup>a</sup>Performance Requirement not checked in manual.

Table 1-1 (cont)

Characteristics	Performance Requirements	Supplemental Information
<b>X-Y OPERATION (cont)</b>		
Phase Difference Between X- and Y-Axis Amplifiers	$\leq 3^\circ$ from dc to 200 kHz.	
Accuracy		
X-Axis		
$0^\circ\text{C}$ to $+40^\circ\text{C}$	$\pm 5\%$ of indicated deflection.	
$-15^\circ\text{C}$ to $+55^\circ\text{C}$	$\pm 8\%$ of indicated deflection. <sup>a</sup>	
<b>CALIBRATOR</b>		
Waveshape		Positive-going square wave.
Duty Cycle		$50\% \pm 10\%$ .
Output Voltage		
$0^\circ\text{C}$ to $+40^\circ\text{C}$	$0.2\text{ V} \pm 1\%$ .	
$-15^\circ\text{C}$ to $+55^\circ\text{C}$	$0.2\text{ V} \pm 1.5\%$ . <sup>a</sup>	
Repetition Rate		$1\text{ kHz} \pm 25\%$ .
Output Impedance		$200\ \Omega \pm 1\%$ .
<b>Z-AXIS INPUT</b>		
Sensitivity	5 V p-p signal referenced to ground causes noticeable modulation of display at normal intensity.	Positive-going signal decreases intensity; negative-going signal increases intensity.
Usable Frequency Range	Dc to 20 MHz.	
Input Resistance		$10\text{ k}\Omega \pm 6\%$ .
Input Capacitance		Less than 15 pF.
Maximum Input Voltage	$\pm 25\text{ V}$ (dc + peak ac) dc to 10 MHz, derate above 10 MHz. <sup>a</sup>  $V\text{ (dc + peak ac)} = \frac{250}{f\text{ (in MHz)}}$	
Input Coupling	Dc.	

<sup>a</sup>Performance Requirement not checked in manual.

Table 1-1 (cont)

Characteristics	Performance Requirements	Supplemental Information
<b>POWER SOURCE</b>		
Voltage Ranges, AC rms 115 V Nominal	100 V to 132 V.	
230 V Nominal	200 V to 250 V. <sup>a</sup>	
Line Frequency	48 Hz to 440 Hz. <sup>a</sup>	
Power Consumption Typical	35 W at 115 V, 60 Hz. <sup>a</sup>	
Maximum	60 W at 132 V, 48 Hz. <sup>a</sup>	Measured at worst-case load and frequency.
VA Maximum	75 VA. <sup>a</sup>	
<b>CATHODE-RAY TUBE</b>		
Display Area	8- by 10-divisions with 0.8-centimeter divisions; internal, nonilluminated, rise time graticule. <sup>a</sup>	
Trace Rotation Range	Adequate to align trace with horizontal graticule lines.	
Standard Phosphor	P31. <sup>a</sup>	
Raster Distortion Geometry		Less than 0.1 division of bowing or tilt, horizontal and vertical.
Nominal Accelerating Voltage	18 kV. <sup>a</sup>	
Electrode Voltages to Ground Heater Voltage Between CRT Pins 1 and 14		6.3 Vrms ±0.3 V; elevated to -1960 V.

<sup>a</sup>Performance Requirement not checked in manual.

Table 1-1 (cont)

Characteristics	Supplemental Information		
	Initial Setting	Maximum p-p Ripple	High-Voltage Oscillator Frequency, p-p Ripple
<b>INTERNAL POWER SUPPLIES</b>			
Low-Voltage Supply Accuracy (+20°C to +30°C)			
-10 V	±1.2%	1 mV	
-5 V	±0.9%	1 mV	
+5 V	±0.7%	1 mV	
+10 V	±0.9%	1 mV	
+40 V	±0.2%	1 mV	
+102 V	±2.0%	1 V	
High-Voltage Supply Accuracy (+20°C to +30°C)			
-1960 V (cathode)	±1.0%	2 V	400 mV
+16 kV (anode)	±4.0%	5 V	500 mV

**Table 1-2**  
**Environmental Characteristics**

Characteristics	Description
	<p style="text-align: center;"><b>NOTE</b></p> <p style="text-align: center;"><i>All of the environmental tests performed meet the requirements of MIL-T-28800B, Type III, Class 3 equipment, except storage temperature and humidity requirements, which are reduced to prevent potential damage to the LCD readout. All other instrument characteristics in this table meet the full requirement of Class 3 testing.</i></p>
Temperature Operating	-15°C to +55°C.
Nonoperating (Storage)	-40°C to +80°C.
Altitude Operating	To 15,000 ft. Maximum operating temperature decreased 1°C per 1,000 ft above 5,000 ft.
Nonoperating (Storage)	To 50,000 ft.
Humidity Operating	+55°C, 90% relative humidity, for at least 72 hours.
Nonoperating (Storage)	+60°C, 90% relative humidity, for at least 72 hours.
Vibration (Operating)	15 minutes along each of 3 major axes at a total displacement of 0.025 inch p-p (4 g at 55 Hz), with frequency varied from 10 Hz to 55 Hz to 10 Hz in 1-minute sweeps. Hold 10 minutes at each major resonance, or if none exists, hold 10 minutes at 55 Hz (procedure differs from MIL-T-28800B).
Shock (Operating and Nonoperating)	50 g, half-sine, 11-ms duration, 3 shocks per axis in each direction, for a total of 18 shocks.
EMI	Will meet MIL-STD-461A requirements using procedures outlined in MIL-STD-462, except use 10 Volts/Meter in place of 1 Volt/Meter for RS-03; use 500 Hz to 30 kHz in place of 30 Hz to 30 kHz for RE-01.
Transportation	Meets the limits of National Safe Transit Association test procedure 1A-B with a 36-inch drop.

**Table 1-3**  
**Physical Characteristics**

Characteristics	Description
Weight	
With Accessories and Accessory Pouch	8.8 kg (19.5 lb).
Without Accessories and Accessory Pouch	7.9 kg (17.5 lb).
Shipping Weight	
Domestic	10.9 kg (24.0 lb).
Export	15.0 kg (33.0 lb).
Height	
With Feet and Pouch	210 mm (8.3 in).
Without Pouch	135 mm (5.3 in).
Width	
With Handle	315 mm (12.4 in).
Without Handle	274 mm (10.8 in).
Depth	
With Front Cover	432 mm (17.0 in).
With Handle Extended	527 mm (20.8 in).

**Table 1-4**  
**Option Electrical Characteristics**

Characteristics	Performance Requirements	Supplemental Information
<b>100-V/200-V POWER TRANSFORMER (OPTION 03)</b>		
Voltage Ranges, AC rms		
100 V Nominal	90 V to 115 V. <sup>a</sup>	
200 V Nominal	180 V to 230 V. <sup>a</sup>	
Line Frequency	48 Hz to 440 Hz. <sup>a</sup>	
Power Consumption		
Typical	35 W at 100 V, 60 Hz. <sup>a</sup>	
Maximum	60 W at 115 V, 48 Hz. <sup>a</sup>	Measured at worst-case load and frequency.
VA Maximum	75 VA. <sup>a</sup>	

<sup>a</sup>Performance Requirement not checked in manual.

# OPERATING INSTRUCTIONS

This section of the manual provides information on instrument installation and power requirements, and the functions of controls, connectors, and indicators are described. Operating considerations and procedures intended to familiarize the operator with obtaining basic oscilloscope displays are included. For more complete operating information, refer to the 2336 Operators Manual.

## PREPARATION FOR USE

### SAFETY CONSIDERATIONS

Refer to the Safety Summary at the front of this manual for power source, grounding, and other safety considerations pertaining to the use of the 2336. Before connecting the instrument to a power source, read the following information, then verify that the LINE VOLTAGE SELECTOR switch is properly set for the ac power source being used and that the proper power-input fuse is installed.

**CAUTION**

*This instrument may be damaged if operated with the LINE VOLTAGE SELECTOR switch set for the wrong applied ac power input source voltage or if the wrong line fuse is installed.*

### LINE VOLTAGE SELECTION

The 2336 operates from either a 115-V or a 230-V nominal ac power input source with a line frequency ranging from 48 Hz to 440 Hz. Before connecting the power cord to a power input source, verify that the LINE VOLTAGE SELECTOR switch, located on the rear panel (see Figure 2-1), is set for the correct nominal ac power input source voltage. To convert the instrument for operation from one line-voltage range to the other, move the LINE VOLTAGE SELECTOR switch to the correct nominal ac source voltage position (see Table 2-1). If your instrument is equipped with Option 03 (100-V/200-V Power Transformer), use Table 2-2. The detachable power cord may have to be changed to match the power source outlet.

Table 2-1

Line Voltage and Fuse Selection

Line Voltage Selector Switch Position	Voltage Range	Fuse Data
115 V Nominal	100 to 132 V	1.0 A, 250 V, Fast-blow
250 V Nominal	200 to 250 V	0.5 A, 250 V, Fast-blow

Table 2-2

Option 03 Line Voltage and Fuse Selection

Line Voltage Selector Switch Position	Voltage Range	Fuse Data
100 V Nominal	90 to 115 V	1.0 A, 250 V, Fast-blow
200 V Nominal	180 to 230 V	0.5 A, 250 V, Fast-blow

### LINE FUSE

To verify that the instrument power-input fuse is of proper value for the nominal ac source voltage, perform the following procedure:

1. Press in the fuse holder cap and release it with a slight counterclockwise rotation.

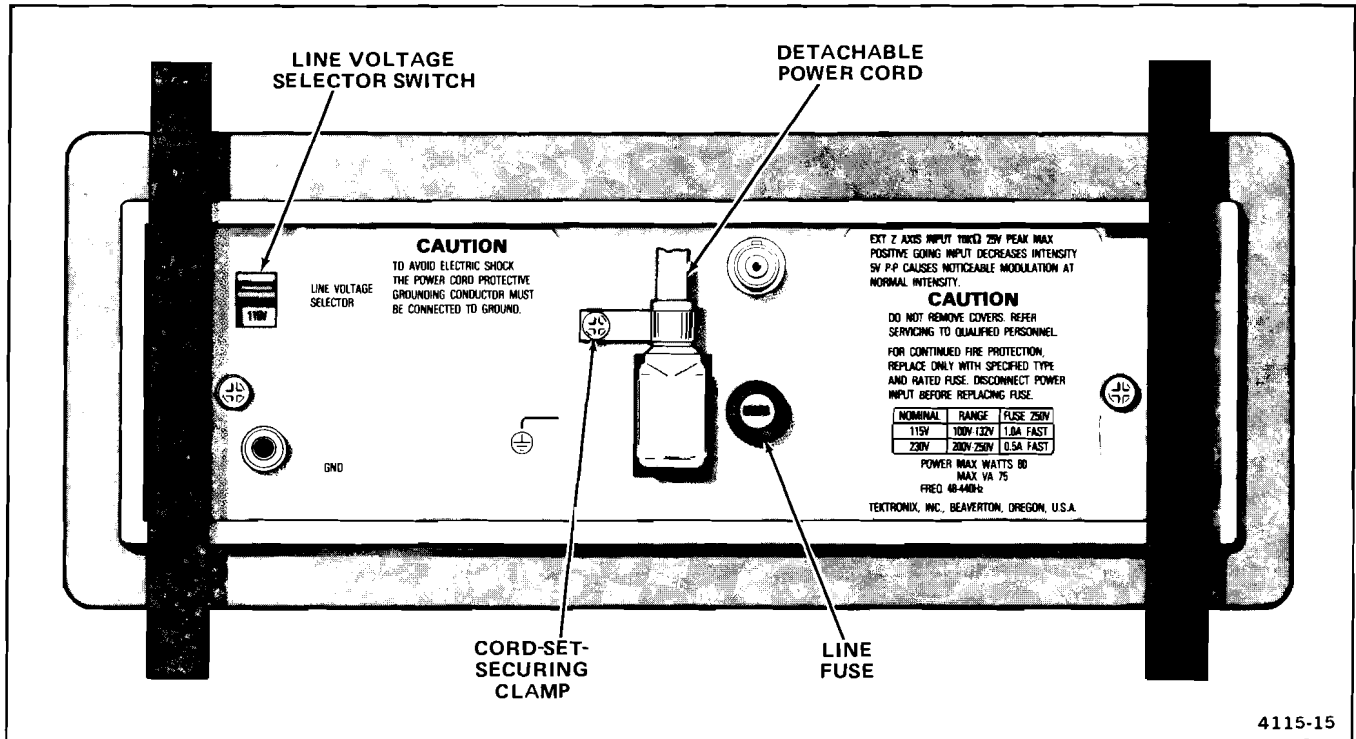

Figure 2-1. LINE VOLTAGE SELECTOR switch, line fuse, and power cord.

2. Pull the cap (with the attached fuse inside) out of the fuse holder.
3. Verify proper fuse value (see Tables 2-1 and 2-2).

## POWER CORD

This instrument has a detachable, three-wire power cord with a three-contact plug for connection to both the power source and protective ground. Its power cord is secured to the rear panel by a cord-set-securing clamp. The plug protective-ground contact connects (through the power-cord protective grounding conductor) to the accessible metal parts of the instrument. For electrical-shock protection, insert this plug into a power source outlet that has a properly grounded protective-ground contact.

Instruments are shipped with the required power cord as ordered by the customer. Available power cord options are illustrated in Figure 2-2. Contact your Tektronix representative or local Tektronix Field Office for additional power-cord information.

Plug Configuration	Usage	Nominal Line-Voltage (AC)	Reference Standards	Option #
	North American 120V/ 15A	120V	ANSI C73.11 <sup>a</sup> NEMA 5-15-P <sup>b</sup> IEC 83 <sup>c</sup>	Standard
	Universal Euro 240V/ 10-16A	240V	CEE (7), II, IV, VII <sup>d</sup> IEC 83 <sup>c</sup>	A1
	UK 240V/ 13A	240V	BS 1363 <sup>e</sup> IEC 83 <sup>c</sup>	A2
	Australian 240V/ 10A	240V	AS C112 <sup>f</sup>	A3
	North American 240V/ 15A	240V	ANSI C73.20 <sup>a</sup> NEMA 6-15-P <sup>b</sup> IEC 83 <sup>c</sup>	A4

<sup>a</sup>ANSI—American National Standards Institute  
<sup>b</sup>NEMA—National Electrical Manufacturer's Association  
<sup>c</sup>IEC—International Electrotechnical Commission  
<sup>d</sup>CEE—International Commission on Rules for the Approval of Electrical Equipment  
<sup>e</sup>BS—British Standards Institution  
<sup>f</sup>AS—Standards Association of Australia

2931-05

Figure 2-2. Optional power cords.



# CONTROLS, CONNECTORS, AND INDICATORS

This part of the manual will familiarize the operator with the location and operation of instrument controls, connectors, and indicators.

## POWER AND DISPLAY

Refer to Figure 2-3 for location of items 1 through 8.

- ① **POWER Switch**—Turns instrument power on and off. Press in for ON; press again for OFF.
- ② **FOCUS Control**—Adjusts for optimum display definition.
- ③ **ASTIG Control**—Screwdriver control used in conjunction with the FOCUS control to obtain a well-defined display over the entire graticule area. It does not require readjustment during normal operation of the instrument.

- ④ **INTEN Control**—Determines the brightness of the crt display (has no effect when BEAM FIND switch is pressed in).
- ⑤ **BEAM FIND Switch**—When held in, compresses the display to within the graticule area and provides a visible viewing intensity to aid in locating off-screen displays.
- ⑥ **TRACE ROTATION Control**—Screwdriver control used to align the crt trace with the horizontal graticule lines.
- ⑦ **Internal Graticule**—Eliminates parallax viewing error between the trace and graticule lines. Rise-time amplitude measurement points are indicated at the left edge of the graticule.
- ⑧ **SERIAL and Mod Slots**—The SERIAL slot is imprinted with the instrument's serial number. The Mod slot contains the option number that has been installed in the instrument.

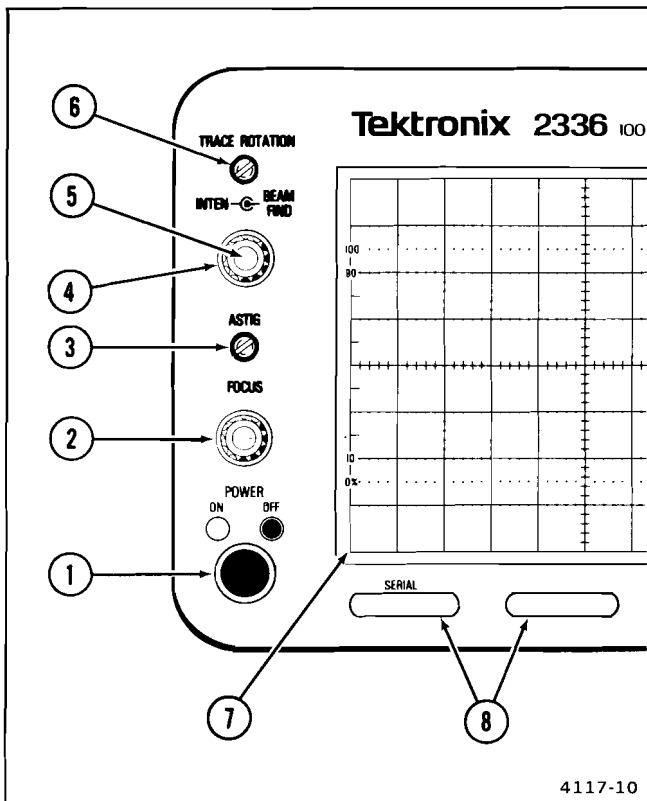

Figure 2-3. Power and display controls and indicators.

## VERTICAL

Refer to Figure 2-4 for location of items 9 through 19.

- ⑨ **AMPL CAL Connector**—Provides a 0.2-V, positive-going square-wave voltage (at approximately 1 kHz) that permits the operator to compensate voltage probes and to check oscilloscope vertical operation. It is not intended to verify time-base calibration.
- ⑩ **CH 1 OR X and CH 2 OR Y Connectors**—Provide for application of external signals to the inputs of the vertical deflection system or for an X-Y display. In the X-Y mode, the signal connected to the CH 1 OR X connector provides horizontal deflection, and the signal connected to the CH 2 OR Y connector provides vertical deflection.
- ⑪ **Input Coupling Switches (AC-GND-DC)**—Select the method of coupling input signals to the vertical deflection system.

AC—Input signal is capacitively coupled to the vertical amplifier. The dc component of the

**Operating Instructions—2336 Service**

input signal is blocked. Low-frequency limit (−3 db point) is approximately 10 Hz.

**GND**—The input of the vertical amplifier is grounded to provide a zero (ground) reference voltage display (does not ground the input signal). Allows precharging the input coupling capacitor.

**DC**—All frequency components of the input signal are coupled to the vertical deflection system.

- 12 **CH 1 VOLTS/DIV and CH 2 VOLTS/DIV Switches**—Select the vertical deflection factor in a 1-2-5 sequence. VAR control must be in detent to obtain a calibrated deflection factor.

**1X PROBE**—Indicates the deflection factor selected when using either a 1X probe or coaxial cable.

**10X PROBE**—Indicates the deflection factor selected when using a 10X probe.

- 13 **VAR Controls**—Provide continuously variable uncalibrated deflection factors between the calibrated settings of the VOLTS/DIV switches when rotated

clockwise out of the detent position. Channel 1 VOLTS/DIV VAR control is inoperative when X-Y VERTICAL MODE is selected.

- 14 **UNCAL Indicator**—LED illuminates to indicate that either Channel 1 or Channel 2 VOLTS/DIV VAR control is out of calibrated detent (vertical deflection factor is uncalibrated).

- 15 **VERTICAL MODE Switches**—Five push-button switches that select the mode of operation for the vertical amplifier system.

**CH 1**—Selects only the Channel 1 input signal for display.

**ALT**—The display alternates between Channel 1 and Channel 2 vertical input signals. The alternation occurs during retrace at the end of each sweep. This mode is useful for viewing both vertical input signals at sweep speeds from 0.2 ms per division to 0.05 μs per division.

**CHOP**—The display switches between the Channel 1 and Channel 2 vertical input signals during the sweep. The switching rate is approximately 275 kHz. This mode is useful for viewing both Channel 1 and Channel 2 vertical inputs at sweep speeds from 0.5 ms per division to 0.5 s per division.

**ADD**—Selects the algebraic sum of the Channel 1 and Channel 2 input signals for display.

**CH 2**—Selects only the Channel 2 input signal for display.

**AUTO**—Press in both ALT and CHOP buttons. The A Sweep circuitry automatically selects the most useful switching method (ALT or CHOP) for dual displays.

**X-Y**—Press in both CH 1 and CH 2 buttons. The X-signal is applied through the Channel 1 input connector, and the Y-signal is applied through the Channel 2 input connector.

- 16 **CH 2 INVERT Switch**—Inverts Channel 2 display when button is pressed in. Push button must be pressed in a second time to release it and regain a noninverted display.

- 17 **POSITION Controls**—Determine the vertical position of the displays on the crt. When X-Y VERTICAL MODE is selected, the Channel 2 POSITION control

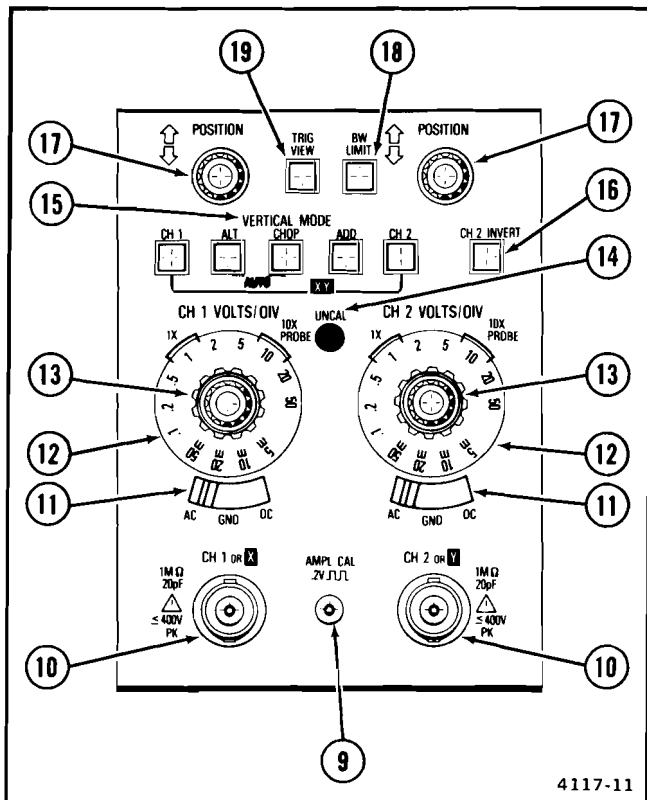

Figure 2-4. Vertical controls, connectors, and indicators and calibrator output.

moves the display vertically (Y-axis), and the Horizontal POSITION control moves the display horizontally (X-axis).

- 18 **BW LIMIT Switch**—Limits the bandwidth of the vertical amplifier to approximately 20 MHz when pressed in. Push button must be pressed a second time to release it and regain full 100-MHz bandwidth operation. Provides a method for reducing interference from unwanted high-frequency signals when viewing low-frequency signals.

- 19 **TRIG VIEW Switch**—Press in and hold this push button to display a sample of the signal present in the A Trigger amplifier (for all A TRIGGER SOURCE switch settings except VERT MODE). All other signal displays are removed while the TRIG VIEW push button is held in.

## HORIZONTAL

Refer to Figure 2-5 for location of items 20 through 26.

- 20 **B DELAY TIME POSITION and  $\Delta$  TIME POSITION Controls**—Select the amount of delay time between start of the A Sweep and start of the B Sweep. Delay time is variable to at least 10 times the A SEC/DIV switch setting. The B DELAY TIME POSITION (outer knob) controls the reference point when the B TRIGGER SOURCE switch is set to either  $\Delta$  TIME or RUNS AFTER DLY. The  $\Delta$  TIME (inner knob) controls the time-measurement point only when the B TRIGGER SOURCE switch is set to  $\Delta$  TIME. When the time-measurement point is to the left of the reference point, the LCD readout indicates a negative time difference.

- 21 **A AND B SEC/DIV Switches**—Selects the sweep speed for the A and B Sweep generators in a 1-2-5 sequence. The A SEC/DIV switch sets the time between the B Sweeps (delay time). For calibrated sweep rates, the TIME (PULL) VAR control must be in the calibrated detent (fully clockwise position).

**A SEC/DIV**—The A Sweep speed is shown between the two black lines on the clear plastic skirt. This switch also selects the delay time (used in conjunction with the B DELAY TIME POSITION control) for delayed sweep operation.

**B SEC/DIV**—The B Sweep speed is set by pulling the inner knob and rotating it to a setting shown by the white line scribed on the knob. The B Sweep circuit is used for delayed sweep operation only.

- 22 **TIME (PULL) VAR Control**—Provides continuously variable, uncalibrated A Sweep speeds between SEC/DIV switch settings to at least 2.5 times the calibrated setting (extends slowest sweep speed to at least 1.25 s per division). To operate this control, pull out the VAR knob and rotate it counterclockwise out of the detent.

- 23 **UNCAL Indicator LED**—Illuminates to indicate that the A Sweep speed is uncalibrated when the TIME (PULL) VAR control is rotated out of the calibrated detent.

- 24 **HORIZ MODE Switches**—Three push-button switches that select the mode of operation for the horizontal deflection system.

**A**—Horizontal deflection is provided by the A Sweep generator at a sweep speed determined by the setting of the A SEC/DIV switch.

**A INTEN**—Horizontal deflection is provided by the A Sweep generator at a speed determined by the A SEC/DIV switch. The B Sweep generator provides an intensified zone on the display. The length of the intensified zone is determined by

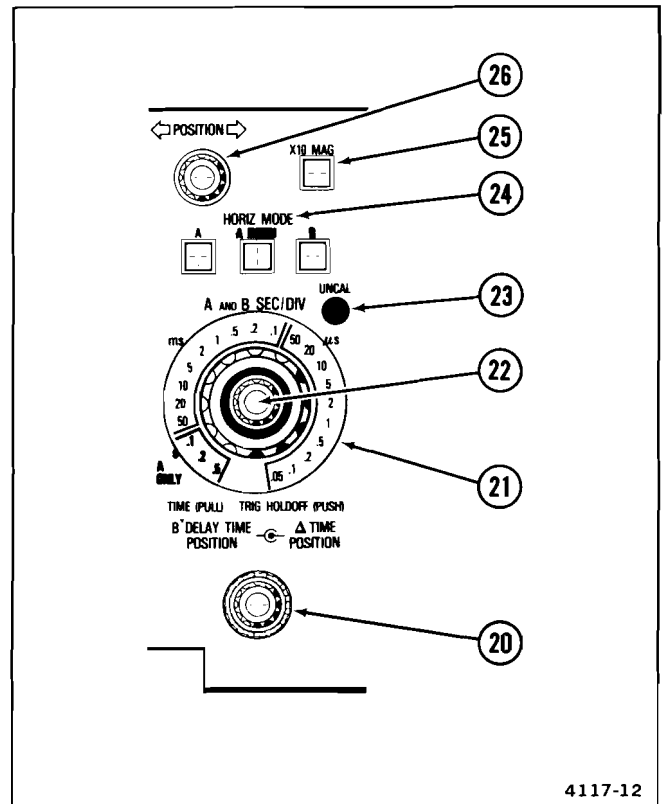

Figure 2-5. Horizontal controls and indicator.

the setting of the B SEC/DIV switch. The location of the intensified zone is determined by the setting of the B DELAY TIME POSITION and  $\Delta$  TIME POSITION controls.

**B**—Horizontal deflection is provided by the B Sweep generator at a sweep speed determined by the setting of the B SEC/DIV switch. The start of the B Sweep is delayed from the start of the A Sweep by a time determined by the settings of the A SEC/DIV switch and the B DELAY TIME POSITION and  $\Delta$  TIME POSITION controls.

- 25 **X10 MAG Switch**—When pressed in, increases the displayed sweep speed by a factor of 10. Extends fastest sweep speed to 5 ns per division. Push button must be pressed in a second time to release it and regain the X1 sweep speed.
- 26 **POSITION Control**—Positions the display horizontally in all modes. Provides both coarse and fine control action. Reverse the direction of rotation to actuate fine positioning feature. When X-Y VERTICAL MODE is selected, the Horizontal POSITION control moves the display horizontally (X-axis).

### A TRIGGER

Refer to Figure 2-6 for location of items 27 through 34.

- 27 **SLOPE Switch**—Selects the slope of the signal that triggers the sweep.
  - + (plus)—When push button is released out, sweep is triggered from the positive-going slope of the trigger signal.
  - (minus)—When push button is pressed in, sweep is triggered from the negative-going slope of the trigger signal.
- 28 **LEVEL Control**—Selects the amplitude point on the trigger signal at which the sweep is triggered. The LEVEL control is usually adjusted for the desired display after trigger SLOPE, COUPLING, and SOURCE switch settings have been selected.
- 29 **Trigger Mode Switches**—Three push-button switches that determine the trigger mode for the A Sweep.

**AUTO**—Permits triggering on waveforms with repetition rates down to approximately 10 Hz. Sweep free runs and provides a baseline trace

either in the absence of an adequate trigger signal or when the repetition rate of the trigger signal is below approximately 10 Hz.

**NORM**—Sweep is initiated when an adequate trigger signal is applied. In the absence of a trigger signal, no baseline trace will be present.

**SGL SWP**—Press in the spring-return push button momentarily to arm the A Sweep circuit for a single sweep display. This mode operates the same as NORM, except only one sweep is displayed for each trigger signal. Another single sweep cannot be displayed until the SGL SWP push button is momentarily pressed in again to reset the A Sweep circuit. This mode is useful for displaying and photographing either nonrepetitive signals or signals that cause unstable conventional displays (e.g., signals that vary in amplitude, shape, or time).

- 30 **TRIG'D-READY Indicator LED**—Illuminates when either AUTO or NORM Trigger Mode is selected to indicate that the A Sweep is triggered (TRIG'D). When SGL SWP Trigger Mode is selected, the LED illuminates to indicate that the trigger circuit is armed (READY) for a single sweep display.

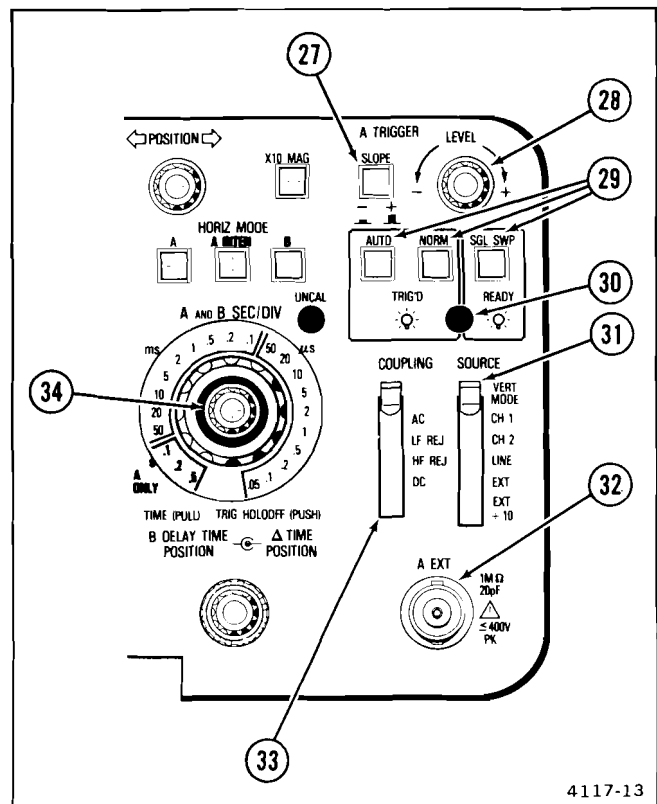

Figure 2-6. A TRIGGER controls, connector, and indicator.

- ③① **SOURCE Switch**—Determines the source of the trigger signals coupled to the input of the trigger circuit.

**VERT MODE**—The internal trigger source is determined by the signals selected for display by the VERTICAL MODE switches.

**CH 1**—The signal applied to the CH 1 input connector is the source of the trigger signal.

**CH 2**—The signal applied to the CH 2 input connector is the source of the trigger signal.

**LINE**—Provides a trigger signal from a sample of the ac-power-source waveform. This trigger source is useful when channel input signals are time related (multiple or submultiple) to the frequency of the power-input source voltage.

**EXT**—Permits triggering on signals applied to the External Trigger Input connector (A EXT).

**EXT÷10**—External trigger signals are attenuated by a factor of 10.

- ③② **A EXT Connector**—Provides a means of applying external signals to the trigger circuit.

- ③③ **COUPLING Switch**—Determines the method used to couple the trigger signal to the input of the trigger circuit.

**AC**—Signals above 20 Hz are capacitively coupled, blocking any dc components of the signal. Signals below 20 Hz are attenuated.

**LF REJ**—Signals are capacitively coupled. The dc component is blocked, and signals below approximately 50 kHz are attenuated. This position is useful for providing a stable display of the high-frequency components of a complex waveform.

**HF REJ**—Signals are capacitively coupled. The dc component is blocked, and signals below approximately 20 Hz and above approximately 50 kHz are attenuated. This position is useful for providing a stable display of the low-frequency components of a complex waveform.

**DC**—All components of the signal are coupled to the A Trigger circuitry. This position is useful for displaying low-frequency or low-repetition-rate signals.

- ③④ **TRIG HOLDOFF (PUSH) VAR Control**—Provides continuous control of holdoff time between sweeps. This control improves the ability to trigger on aperiodic signals (such as complex digital waveforms) and increases the minimum holdoff time to at least 2.5 times at any sweep speed.

## B TRIGGER

Refer to Figure 2-7 for location of items 35 through 39.

- ③⑤ **LEVEL Control**—Selects the amplitude point on the trigger signal at which the sweep is triggered. This control is usually adjusted for the desired display after Trigger SLOPE and SOURCE switch settings have been selected.

- ③⑥ **SOURCE Switch**—Determines the mode of operation for the B Sweep and the signal source for the B Trigger.

**Δ TIME**—Provides two intensified zones on the crt trace for differential time measurements. The time difference between the two intensified zones is determined by the B DELAY TIME POSITION and Δ TIME POSITION controls. Time difference is displayed on the LCD Readout. With the HORIZ MODE set to A INTEN, alternation of the reference intensified zone and measurement intensified zone occurs at the end of each sweep. With the HORIZ MODE set to B, the start of the B Sweep alternates between the setting of the reference intensified zone and the setting of the measurement intensified zone.

**RUNS AFTER DLY**—The B Sweep starts immediately after the delay time selected by the B DELAY TIME POSITION control and is independent of the B Trigger signal.

**VERT MODE**—Allows the internal trigger source to be determined by the vertical mode of operation.

**CH 1**—The signal applied to the CH 1 input connector is the source of the trigger signal.

**CH 2**—The signal applied to the CH 2 input connector is the source of the trigger signal.

**EXT**—Permits triggering on signals applied to the External Trigger Input (B EXT) connector.

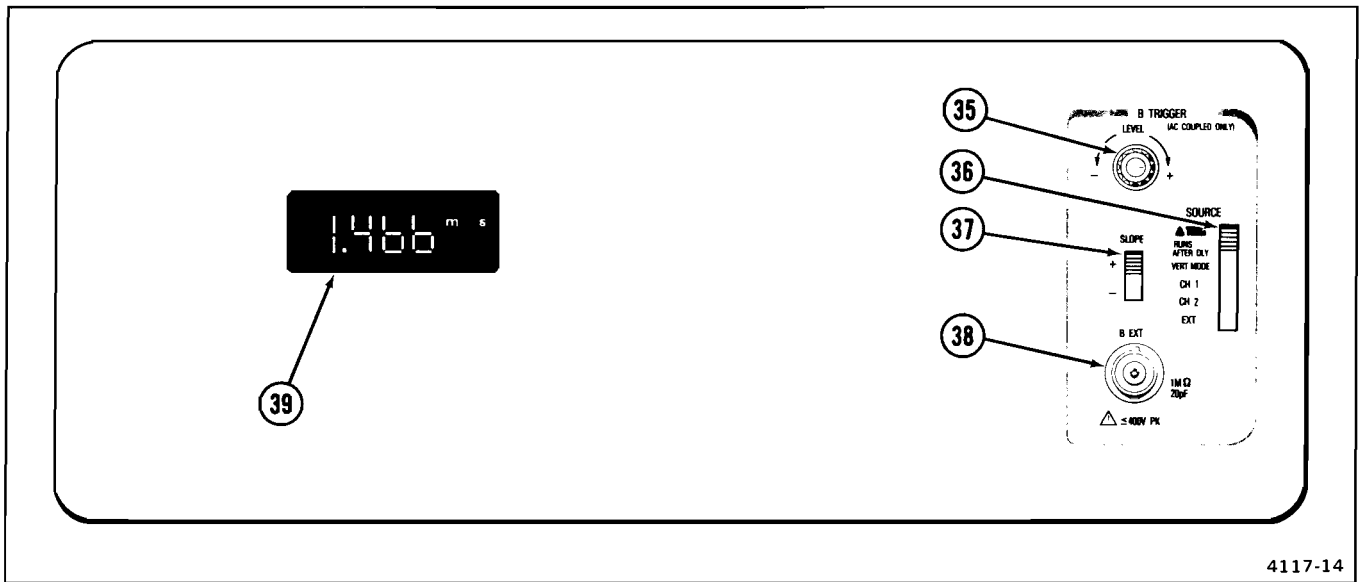

Figure 2-7. B TRIGGER controls, connector, and LCD readout.

**37) SLOPE Switch**—Selects the slope of the signal that triggers the sweep.

+ (plus)—Sweep is triggered on the positive-going portion of the trigger signal.

– (minus)—Sweep is triggered on the negative-going portion of the trigger signal.

**38) B EXT Connector**—Provides a means of introducing external signals into the B Trigger Generator.

**39) Readout**—Consists of a 3 1/2-digit LCD unit which is used when the B TRIGGER SOURCE switch is set to Δ TIME. Negative polarity indication is automatic for negative time measurements. No polarity indication is displayed for positive values. The decimal point location is controlled by the A SEC/DIV switch, B DELAY TIME POSITION, and Δ TIME POSITION controls. The readout displays UNCAL when the TIME (PULL) VAR control is out of calibrated detent. It indicates units of time

difference between the two intensified zones on the crt display in seconds (s), milliseconds (ms), microseconds (μs), or nanoseconds (ns).

## REAR PANEL

Refer to Figure 2-8 for location of items 40 and 41.

**40) GND Connector**—Provides direct connection to instrument chassis ground.

**41) EXT Z AXIS INPUT Connector**—Provides a means of connecting external signals to the Z-Axis amplifier to intensity modulate the crt display. Applied signals do not affect display waveshape. Signals with fast rise time and fall time provide the most abrupt intensity change. Positive-going signals decrease the intensity, and a 5-V p-p signal will produce noticeable modulation. Z-axis signals must be time-related to the display to obtain a stable presentation on the crt.

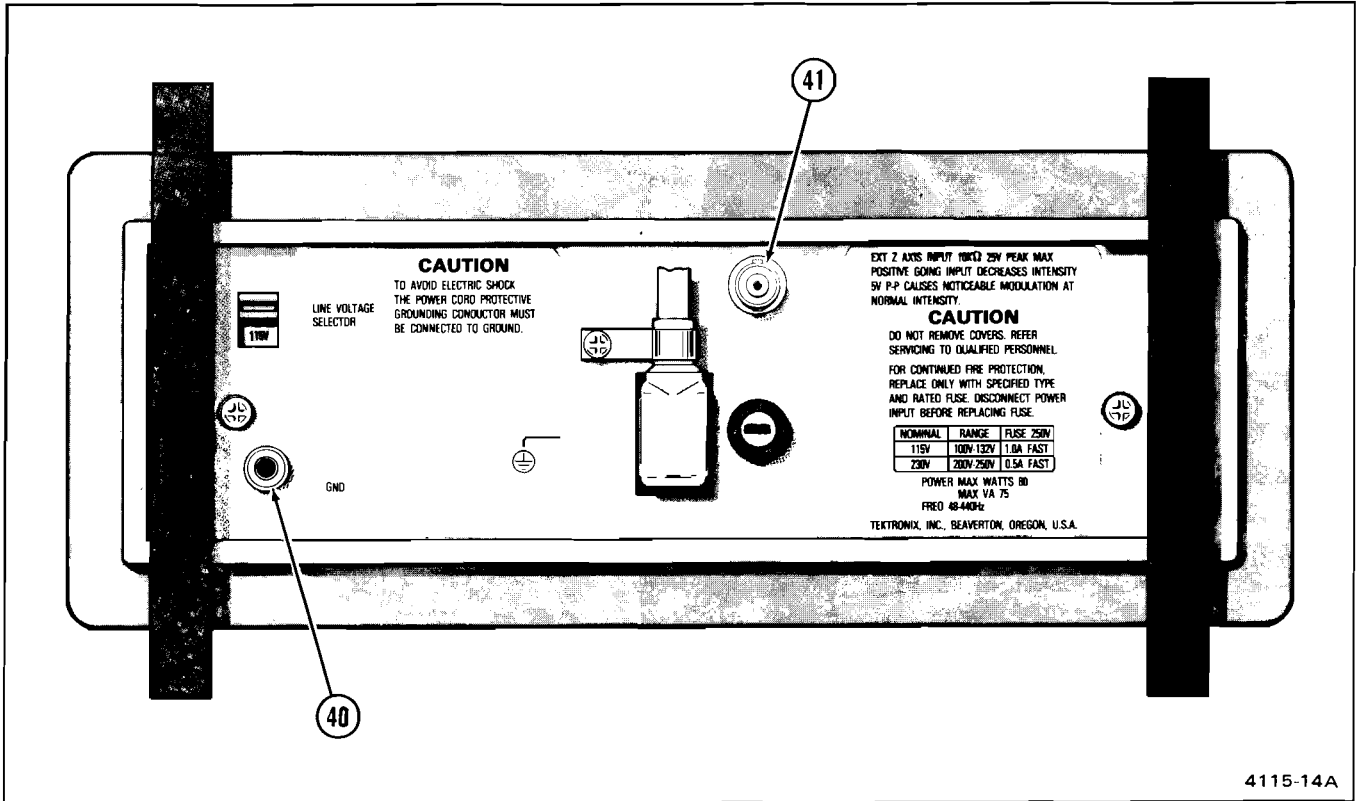

Figure 2-8. Rear-panel connectors.

## OPERATING CONSIDERATIONS

This part contains basic operating information and techniques that should be considered before attempting any measurements.

### GRATICULE

The graticule is internally marked on the faceplate of the crt to enable accurate measurements without parallax error (see Figure 2-9). It is marked with eight vertical and ten horizontal major divisions. In addition, each major division is divided into five subdivisions. The vertical deflection factors and horizontal timing are calibrated to the graticule so that accurate measurements can be made directly from the crt. Also, percentage marks for the measurement of rise and fall times are located on the left side of the graticule.

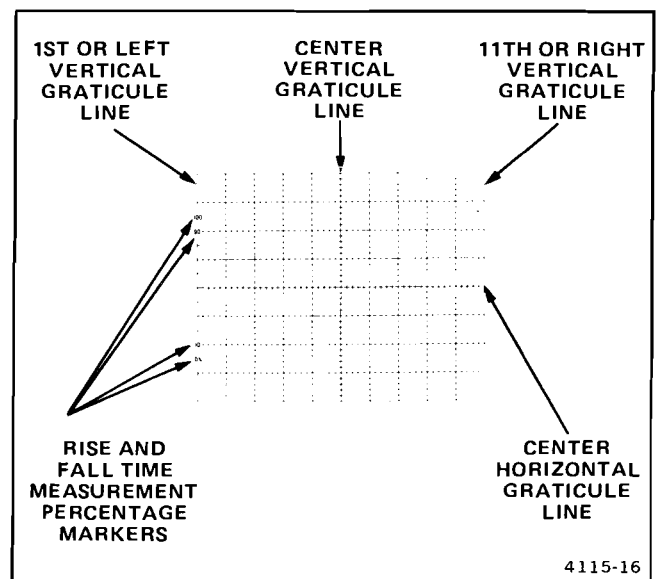

Figure 2-9. Graticule measurement markings.

## GROUNDING

The most reliable signal measurements are made when the 2336 and the unit under test are connected by a common reference (ground lead) in addition to the signal lead or probe. The probe's ground lead provides the best grounding method for signal interconnection and ensures the maximum amount of signal-lead shielding in the probe cable. A separate ground lead can also be connected from the unit under test to the oscilloscope GND connector located on the rear panel.

## SIGNAL CONNECTIONS

### Probes

Generally, probes offer the most convenient means of connecting an input signal to the instrument. They are shielded to prevent pickup of electromagnetic interference, and the supplied 10X probe offers a high input impedance that minimizes circuit loading. This allows the circuit under test to operate with a minimum of change from the normal condition of the circuit when measurements are being made.

### Coaxial Cables

Cables may also be used to connect signals to the input connectors, but they may have considerable effect on the accuracy of a displayed waveform. To maintain the original frequency characteristics of an applied signal, only high-quality, low-loss coaxial cables should be used. Coaxial cables should be terminated at both ends in their characteristic impedance. If this is not possible, use suitable impedance-matching devices.

## INPUT COUPLING CAPACITOR PRECHARGING

When the input coupling switch is set to GND, the input signal is connected to ground through the input coupling capacitor in series with an 800-k $\Omega$  resistor to form a pre-charging network. This network allows the input coupling capacitor to charge to the average dc-voltage level of the signal applied to the probe. Thus, any large voltage

transients that may accidentally be generated will not be applied to the amplifier input when input coupling is switched from GND to AC. The precharging network also provides a measure of protection to the external circuitry by reducing the current levels that can be drawn from the external circuitry during capacitor charging.

The following procedure should be used whenever the probe tip is connected to a signal source having a different dc level than that previously applied, especially if the dc-level difference is more than 10 times the VOLTS/DIV switch setting:

1. Set the AC-GND-DC switch to GND before connecting the probe tip to a signal source.

### NOTE

*The outer shells of the A EXT, CH 1 OR X, and CH 2 OR Y connectors are attached to the 2336 chassis ground.*

2. Touch the probe tip to the oscilloscope chassis ground.

3. Wait several seconds for the input coupling capacitor to discharge.

4. Connect the probe tip to the signal source.

5. Wait several seconds for the input coupling capacitor to charge.

6. Set the AC-GND-DC switch to AC. The display will remain on the screen, and the ac component of the signal can be measured in the normal manner.

## INSTRUMENT COOLING

To maintain adequate instrument cooling, the ventilation holes on both sides of the equipment cabinet must remain free of obstructions.



# OSCILLOSCOPE DISPLAYS

## INTRODUCTION

The procedures in this section will allow you to set up and operate your instrument to obtain the most commonly used oscilloscope displays. Before proceeding with these instructions, verify that the LINE VOLTAGE SELECTOR switch is placed in the proper position and that the correct line fuse is installed for the available ac-power-input source voltage. Refer to the "Preparation for Use" instructions in this section for this information and for procedures relating to ac-power-input source voltage and fuse selection. Verify that the POWER switch is OFF (push button out).

## NORMAL SWEEP DISPLAY

Obtain a Normal Sweep Display (baseline trace), using the following procedure.

1. Preset the instrument front-panel controls as follows:

### Display

INTEN	Fully counterclockwise (minimum)
ASTIG	Midrange
FOCUS	Midrange

### Vertical (both CH 1 and CH 2 if applicable)

AC-GND-DC	AC
VOLTS/DIV	50 m (1X)
VOLTS/DIV VAR	Calibrated detent (fully counterclockwise)
VERTICAL MODE	Select CH 1
CH 2 INVERT	Off (push button out)
BW LIMIT	Not limited (push button out)
POSITION	Midrange

### Horizontal

A AND B SEC/DIV TIME (PULL) VAR	Locked together at 0.5 ms Pull out the VAR knob and set it to the calibrated detent (fully clockwise), then push in the VAR knob.
HORIZ MODE	Select A
X10 MAG	Off (push button out)
POSITION	Midrange
B DELAY TIME POSITION	Fully counterclockwise
Δ TIME POSITION	Midrange

### A Trigger

SLOPE	+ (push button out)
LEVEL	Midrange
Trigger Mode	Select AUTO
COUPLING	AC
SOURCE	VERT MODE
TRIG HOLDOFF (PUSH) VAR	Fully clockwise and pushed in

### B Trigger

SLOPE	+ (up)
LEVEL	Midrange
SOURCE	Δ TIME

2. Press in the POWER switch button (ON) and allow the instrument to warm up for 20 minutes.

3. Adjust the INTEN control for desired display brightness.

4. Adjust the Vertical and Horizontal POSITION controls to center the trace on the screen.

## SIGNAL DISPLAY

1. Obtain a Normal Sweep Display.

2. Apply a signal to either vertical-channel input connector and set the VERTICAL MODE switch to display the channel used. To display two time-related input signals, use both vertical-channel input connectors and select either ALT or CHOP VERTICAL MODE, depending on the frequency of input signals (or select AUTO VERTICAL MODE, if automatic selection is desired).

3. Adjust the INTEN control for desired display brightness. If the display is not visible with the INTEN control at midrange, press the BEAM FIND push button and hold it in while adjusting the appropriate VOLTS/DIV switch(es) to reduce the vertical display size. Center the compressed display within the graticule area using the Vertical and Horizontal POSITION controls; release the BEAM FIND push button.

4. Adjust the A TRIGGER LEVEL control if necessary to obtain a stable display.

## Operating Instructions—2336 Service

5. Set the appropriate VOLTS/DIV switch(es) and readjust the Vertical and Horizontal POSITION controls to center the display within the graticule area.

6. Set the A SEC/DIV switch for the desired number of cycles of displayed signal. Then adjust the FOCUS control (and ASTIG, if necessary) for the best-defined display.

### MAGNIFIED-SWEEP DISPLAY

1. Obtain a Signal Display (see preceding instructions).
2. Adjust the Horizontal POSITION control to move the trace area to be magnified to within the center graticule division of the crt (0.5 division on each side of the center vertical graticule line). Change the A SEC/DIV switch setting as required.
3. Press in the X10 MAG push button (on) and adjust the Horizontal POSITION control for precise positioning of the magnified display.
4. To calculate the magnified sweep speed, divide the A SEC/DIV switch setting by 10.

### DELAYED-SWEEP DISPLAY

1. Obtain a Signal Display.
2. Set the B TRIGGER SOURCE SWITCH to RUN AFTER DLY.
3. Select A INTEN HORIZ MODE and set the B SEC/DIV switch until the intensified zone is the desired length. Adjust the INTEN control as needed to make the intensified zone distinguishable from the remainder of the display.
4. Adjust the B DELAY TIME POSITION control to move the intensified zone to cover that portion of the A trace that is to be displayed on the B trace.
5. Select the B HORIZ MODE. The intensified zone adjusted in steps 3 and 4 is now displayed as the B trace.

The delayed sweep speed is indicated by the white stripe on the B SEC/DIV knob.

### DELAYED-SWEEP MEASUREMENTS

1. Obtain a Signal Display.
2. Select the A INTEN HORIZ MODE and set the B SEC/DIV switch until the two intensified zones are the desired length. Adjust the INTEN control as needed to make the intensified zones distinguishable from the remainder of the display.
3. Adjust the B DELAY TIME POSITION control to move the reference point to the first pulse of interest.
4. Adjust the  $\Delta$  TIME POSITION control to move the measurement point to the second pulse of interest.
5. Select the B HORIZ MODE and adjust the  $\Delta$  TIME POSITION control to superimpose the waveforms.
6. Read the time difference on the LCD readout.

### SINGLE-SWEEP DISPLAY

1. Obtain a Signal Display. For random signals, set the A TRIGGER LEVEL control to trigger the sweep on a signal that is approximately the same amplitude as the random signal.
2. Press in the A TRIGGER SGL SWP push button momentarily for single-sweep operation. The next trigger pulse will initiate the sweep, and a single trace will be displayed. If no trigger signal is present, the TRIG'D-READY light should illuminate to indicate that the A Sweep Generator circuit is set to initiate a sweep when a trigger signal is received.
3. When the single sweep has been triggered and the sweep is completed, the Sweep-Logic circuitry is locked out. Another sweep cannot be generated until the A TRIGGER SGL SWP push button is again pressed in to set the A Sweep Generator to the READY condition.

## X-Y DISPLAY

1. Obtain a Normal Sweep Display.
2. Use equal length coaxial cables, or the two supplied 10X probes, to apply the horizontal signal (X-axis) to the CH 1 OR X input connector and the vertical signal (Y-axis) to the CH 2 OR Y input connector.
3. Select X-Y VERT MODE by simultaneously pressing in the CH 1 and CH 2 push buttons.

4. Advance the INTEN control setting until two dots are displayed. The display can be positioned horizontally with the Horizontal POSITION control and vertically with the Channel 2 POSITION control.

### NOTE

*The display obtained when sinusoidal signals are applied to the X- and Y-axis is called a Lissajous Figure. This display is commonly used to compare the frequency and phase relationship of two input signals. The frequency relationship of the two input signals determines the pattern seen. The pattern will be stable only if a common divisor exists between the two frequencies.*

# THEORY OF OPERATION

## INTRODUCTION

### SECTION ORGANIZATION

This section contains a functional description of the 2336 Oscilloscope circuitry. The discussion begins with an overview of instrument functions and continues with detailed explanations of each major circuit. Reference is made to supporting schematic and block diagrams which will facilitate understanding of the text. These diagrams show interconnections between parts of the circuitry, identify circuit components, list specific component values, and indicate interrelationships with front-panel controls.

The detailed block diagram and the schematic diagrams are located in the tabbed "Diagrams" section at the rear of this manual, while smaller functional diagrams are contained within this section near their respective text. The particular schematic diagram associated with each circuit description is identified in the text, and the diagram number is shown (enclosed within a diamond symbol) on the tab of the appropriate foldout page. For optimum understanding of the circuit being described, refer to both the applicable schematic diagram and the functional block diagram.

### INTEGRATED CIRCUIT DESCRIPTIONS

#### Digital Logic Conventions

Digital logic circuits perform many functions within this instrument. The operation of these circuits is represented by specific logic symbology and terminology. Most logic-function descriptions contained in this manual use the positive-logic convention. Positive logic is a system of notation whereby the more positive of two levels is the TRUE (or 1) state; the more negative level is the FALSE (or 0) state. In the logic descriptions, the TRUE state is referred to as HI, and the FALSE state is referred to as LO. The specific voltages which constitute a HI or a LO state vary between individual devices. For specific device characteristics, refer to the manufacturer's data book.

#### Linear Devices

The functioning of individual linear integrated circuit devices is described in this section using waveforms or other graphic techniques to illustrate their operation.

# GENERAL DESCRIPTION

## OVERALL OPERATION

In the following overview of the 2336 Oscilloscope circuitry, refer to the basic block diagram shown in Figure 3-1 and to the detailed block diagrams located in the "Diagrams" section of this manual. Each major block in the detailed block diagram represents a major circuit within the instrument. In Figure 3-1, the numbered diamond symbol shown inside each block refers to the appropriate schematic diagram number.

Signals to be displayed on the crt may be applied to either the CH 1 OR X input connector or the CH 2 OR Y input connector. Separate input-coupling and deflection-factor selections are provided for each input signal. These input signals are attenuated to the selected display amplitude by precision attenuator circuits. Included in the attenuator circuitry is a buffer amplifier used to match impedances between the input high-impedance attenuator and the output low-impedance attenuator. The attenuated input signals are then applied to the Vertical Preamplifier circuit.

Each Vertical Preamplifier input stage is a hybrid circuit that provides signal amplification, variable deflection factor, and a sample of the input signal for use during internal triggering. Succeeding stages of the Vertical Preamplifier provide for vertical positioning of the display and additional gain. In the final stage of the Channel 2 Vertical Preamplifier, additional circuitry is used to provide for the selectable Channel 2 Invert feature. This circuit allows the operator either to invert the Channel 2 signal display as seen on the crt (when CH 2 INVERT is selected) or to subtract the Channel 2 signal from the Channel 1 signal (when ADD VERTICAL MODE is in use).

The outputs of both Vertical Preamplifier circuits are applied to a Diode Gate network that, under control of the Vertical Switching Logic circuitry, selects appropriate channel signals to be passed to the Vertical Output Amplifier. Selected channel signals are applied to the Delay Line via the Delay Line Driver stage. When the TRIG VIEW push button is pressed in, channel signals do not pass through the Diode Gate; instead, the Trig View signal (supplied from the A Trigger Generator) is applied to the Delay Line Driver input.

After passing through the Delay Line, the vertical signal is applied to the Vertical Output Amplifier input stage. Also included at this point is the Bandwidth Limit circuitry that, when BW LIMIT is selected, reduces the upper

frequency-response limit of the vertical deflection system. Three stages of amplification are contained in the input amplifier. The vertical portion of the Beam Find circuitry acts on the third stage of amplification in the integrated circuit. When the Beam Find function is activated (by pressing in the BEAM FIND button), the gain of the amplifier is reduced to limit vertical deflection to within the graticule viewing area. This feature aids the operator in locating off-screen or overscanned displays. The horizontal and intensity portions of the Beam Find circuitry are discussed in the Horizontal and Z-Axis circuit descriptions respectively.

A final hybrid stage in the Vertical Output Amplifier converts the current signal to a voltage signal that is then applied to the crt vertical deflection plates.

The vertical mode of operation is controlled by the Vertical Switching Logic and Chop Blanking circuit. Front-panel VERTICAL MODE push-button switches determine circuitry operation. Control signals from the Vertical Switching Logic circuit select either the Channel 1 signal or the Channel 2 signal for a single-trace display. When either ALT or CHOP VERTICAL MODE is selected, both channel signals are displayed; these signals are displayed either alternately (one complete sweep per channel) or chopped (one sweep switched between channels at a fixed rate). If ADD VERTICAL MODE is selected, the two channel signals are either algebraically added (when the CH 2 INVERT feature is not activated) or algebraically subtracted (when the CH 2 INVERT button is pressed in).

The Chop Blanking circuit produces a blanking signal which is fed to the input of the Z-Axis Amplifier. This signal blanks the transients that occur when switching between channel signals during the chopped mode of operation. An external Z-Axis signal input is also provided at this point via the EXT Z-AXIS input connector located on the instrument rear panel. External Z-Axis signals are summed with all other Z-Axis input signals to produce the final display intensity.

The A Trigger Generator circuit produces an output gate that initiates the triggered A Sweep ramp. Input triggering signals can be obtained from any of the following sources: Channel 1 signal, Channel 2 signal, signal(s) displayed on the crt (VERT MODE), the signal connected to the A EXT TRIGGER input connector, or a signal derived from the ac-power source waveform (LINE). The Trigger Generator circuit contains level, slope, coupling, and source control switches for controlling the circuit operation.

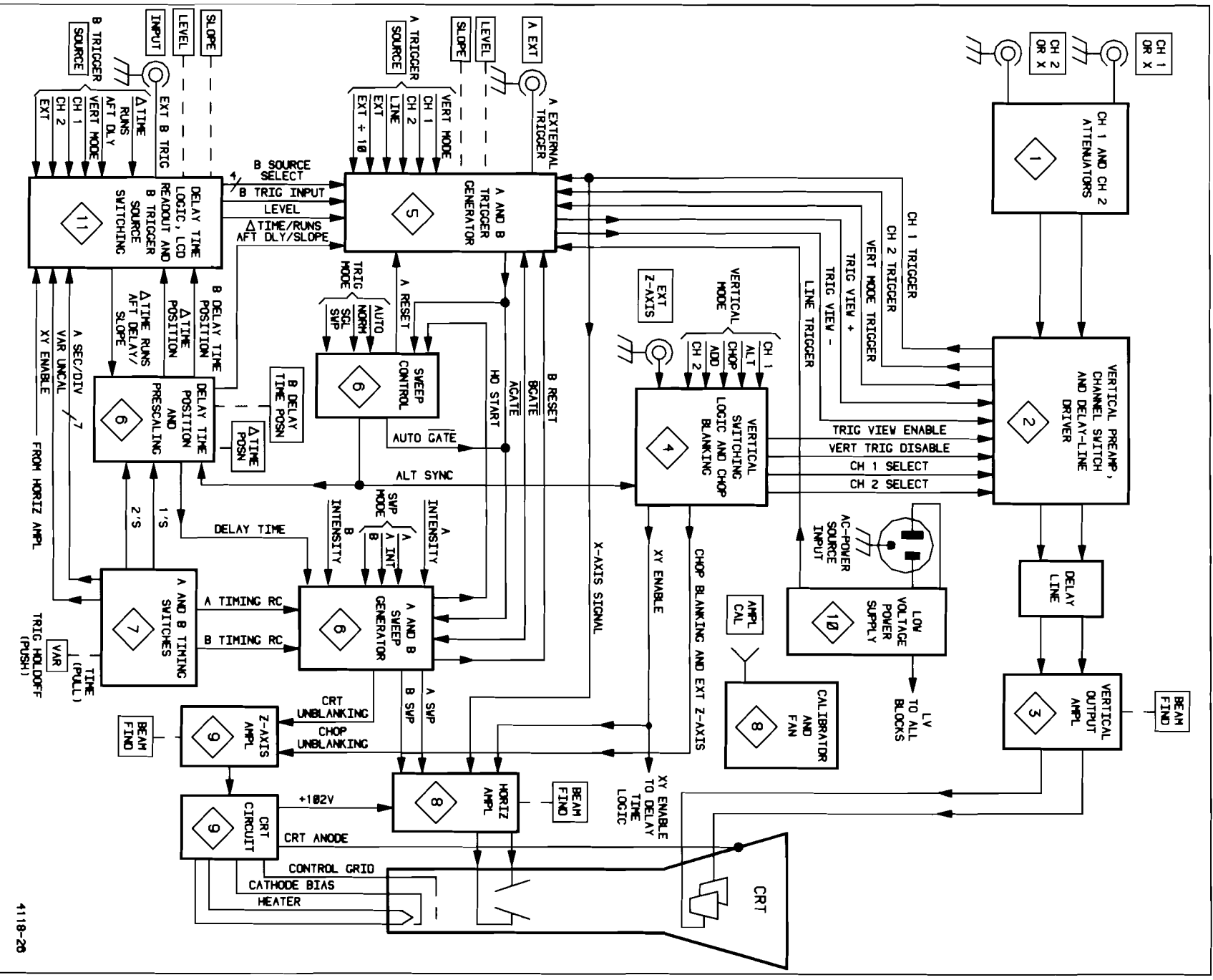

Figure 3-1. Basic block diagram of the 2336 Oscilloscope.

## Theory of Operation—2336 Service

When the TRIG VIEW switch is activated, the trigger view output signal is supplied to the Trigger View Amplifier circuitry in the Vertical Preamplifier circuit for viewing on the crt.

When activated by the A Trigger Generator sweep-gate output, the A Sweep Generator starts an internal linear A Sweep ramp. Either an A Sweep signal, a Crt Unblanking signal, or both, will be produced as determined by the selected HORIZ MODE switch. When either the A or A INTEN HORIZ MODE is selected, both a Sweep signal and an Unblanking signal will be produced. In the B HORIZ MODE, neither an A Sweep output nor an Unblanking signal will be produced, but the A Sweep Generator continues operating to establish the B Sweep delay timing.

The triggered B Sweep ramps are initiated by an output gate from the B Trigger Generator. Input triggering signals for the B Sweep can be obtained from the same sources that are available for the A Sweep with the exception of LINE. Two additional B SOURCE switch positions provide the  $\Delta$  TIME and RUNS AFTER DLY triggering modes. In these two additional triggering modes, the B Sweep Generator starts an internal B Sweep ramp only when a Delayed Gate signal is generated by the A Sweep Generator.

In  $\Delta$  TIME, Delayed Gates are generated from the A Sweep Generator at different delay times on alternate sweeps. One Delayed Gate corresponds to the delay time set by the B DELAY TIME POSITION control; the other corresponds to the delay time set by the  $\Delta$  TIME POSITION control. The resulting display appears as either two intensified zones on the A Sweep (A INTEN HORIZ MODE) or as separate B Sweeps (B HORIZ MODE) for each Delayed Gate signal.

In RUNS AFTER DLY, only one Delayed Gate is generated, and the delay time is established by the B DELAY TIME POSITION control only.

Several sweep functions are controlled by the Sweep Control IC. Among these functions are holdoff timing, trigger mode, and sweep resetting. When AUTO Trigger Mode is selected, absence of an adequate trigger signal for about 100 ms after the end of holdoff causes an Auto Gate signal to the A Sweep Generator. The Auto Gate initiates the A Sweep ramp in lieu of the A Gate normally produced by the Trigger Generator. When NORM Trigger Mode is selected, the Auto Gate is not produced, and an A Sweep is generated only if the A Trigger Generator circuit receives an adequate triggering signal. Pushing the SGL SWP push button sets the Sweep Control IC to allow

only one sweep after a triggering signal is received. Following the single sweep, a reset is held on the Trigger Generator to disable it until the SGL SWP push button is pressed again.

The A Gate output from the Sweep Control IC is used to produce an Alt Sync signal. This signal synchronizes vertical switching when ALT VERTICAL MODE is used to display both Channel 1 and Channel 2 signals.

The Alt Sync signal also drives the switching IC that selects either the B DELAY TIME POSITION control voltage or the  $\Delta$  TIME POSITION control voltage, for application to the A Sweep Generator Delay Time input pin. Switching between the two levels occurs only when the  $\Delta$  TIME measurement mode is selected.

Sweep signals from either the A or the B Sweep Generator are amplified by the Horizontal Amplifier circuit to produce horizontal deflection on the crt. When the X-Y display feature is selected (by pressing in both CH 1 and CH 2 VERTICAL MODE push buttons), the A and the B Sweeps are disabled, and the Channel 1 signal is supplied to the Horizontal Amplifier for use as the X-Axis deflection signal. The Y-Axis deflection signal is supplied from the CH 2 OR Y input connector.

The Horizontal Amplifier contains a X10 magnifier feature that may be selected to increase the displayed sweep rate by a factor of 10 for any A or B SEC/DIV switch setting. The display is magnified from the middle of the trace toward both ends. This feature enables the operator to align the portion of the display to be magnified with the center vertical graticule line prior to pressing the X10 MAG push button; then, when the X10 MAG push button is pressed in, the centered portion remains near the center of the graticule area.

The horizontal portion of the Beam Find circuitry acts to reduce the Horizontal Amplifier gain, limiting the horizontal deflection to within the graticule viewing area.

The Z-Axis Amplifier circuit sets the crt display intensity and blanking levels. Input current(s) supplied from either the A or the B Sweep Generator (unblanking and intensity), the Chop Blanking circuit, and the External Z-Axis input connector are summed in the Z-Axis Amplifier. The resulting signal level determines crt display intensity. The Beam Find circuitry overrides all the other Z-Axis Amplifier input signals to produce a fixed intensity level that is unaffected by the INTENSITY control position.

Included in the CRT circuitry are the High-Voltage Oscillator, the High-Voltage Multiplier, and the High-Voltage Regulator. The regulator controls oscillator drive current to maintain a correct level of high-voltage output. Alternating oscillator current flows through the primary winding of the high-voltage transformer. Transformer secondary windings supply drive current to the High-Voltage Multiplier, the DC Restorer circuit, the +102-V power supply, the crt heater, and the crt cathode and focus power supply.

The High-Voltage Multiplier, the DC Restorer, and the cathode and focus voltage supply circuits are contained in a sealed high-voltage module. High voltage from the multiplier is supplied directly to the crt anode.

DC restoration is used to raise the dc output level of the Z-Axis Amplifier. This allows the signal to be coupled to the crt intensity grid. Direct coupling of the Z-Axis signal to the intensity grid is not possible due to the elevated voltage on both the crt cathode and grid.

Remaining operating voltages for the 2336 are provided by the Low-Voltage Power Supply. Power is distributed throughout the instrument to supply required circuit operating voltages.

Fan-drive voltage is produced by a three-stage switching circuit. The Fan's speed is determined by both the ambient temperature and the line-voltage level (via the -5-V unregulated voltage source).

The Amplitude Calibrator circuit provides a square-wave output signal with accurate voltage amplitude. This signal is useful both for checking the instrument vertical calibration and compensating voltage probes.

The Delay Time Position and Prescaling circuit performs the task of switching between the outputs of the B DELAY TIME POSITION control and the  $\Delta$  TIME POSITION control when  $\Delta$  TIME measurements are made. In addition, the circuit prescales the voltage difference between the output of the two controls to match the time setting of the A SEC/DIV switch.

The Delta Time Logic circuitry is contained in the instrument's lid along with the B Trigger SOURCE and SLOPE switching and the B External Trigger Amplifier.

The Delta Time Logic circuit has an A/D Converter IC that converts the equivalent-time voltage difference from the B DELAY TIME POSITION and  $\Delta$  TIME POSITION controls into time difference output data. The digital output of the A/D Converter drives the segments of a 3 1/2-digit liquid-crystal display (LCD). Scale factors and decimal points for the display are controlled by the position of the A SEC/DIV switch.



## DETAILED CIRCUIT DESCRIPTION

### CHANNEL 1 AND CHANNEL 2 ATTENUATORS

The Vertical Attenuator circuitry is shown on schematic diagram 1. Since the Channel 1 and Channel 2 circuits are nearly identical, only the Channel 1 Attenuator is discussed. A simplified block diagram of the Channel 1 Attenuator circuitry is shown in Figure 3-2.

#### Input Coupling

Signals applied to the input connector can be ac coupled, dc coupled, or internally disconnected from the attenuator input. When input coupling switch S2 is set to DC, the input signal is coupled directly to the attenuator input via R3. When it is set to AC, the input signal passes through input coupling capacitor C15. The coupling capacitor prevents the dc component of the input signal from passing to the attenuator input. With switch S2 in the GND position, the direct signal path is opened and the input of the attenuator is grounded. The input signal from C15 is connected to ground via R2. Resistor R2 has a high resistance value and is used to allow precharging of input coupling capacitor C15 when the input coupling switch is set to GND. With C15 precharged, the trace will remain

within the graticule area of the crt whenever the input coupling switch is moved from GND to AC. The GND position of S2 provides a ground reference without the need to disconnect the applied signal from the input connector.

#### Input Attenuator

The effective overall deflection factor of each vertical channel is determined by the setting of the associated Channel VOLTS/DIV switch. The basic deflection factor (with no attenuation) of the vertical deflection system is 5 mV per division of crt deflection.

For VOLTS/DIV switch settings above 5 mV, frequency-compensated voltage-divider sections (precision attenuators) are switched into the signal path to produce the vertical deflection factors indicated on the instrument front panel. Each channel has a 2X, a 4X, and three 10X attenuators which may be selected in various combinations. The selected combination provides constant attenuation for all frequencies within the bandwidth range of the instrument. The vertical attenuators maintain the same input characteristics (1 MΩ and approximately 20 pF) for each setting of the VOLTS/DIV switch.

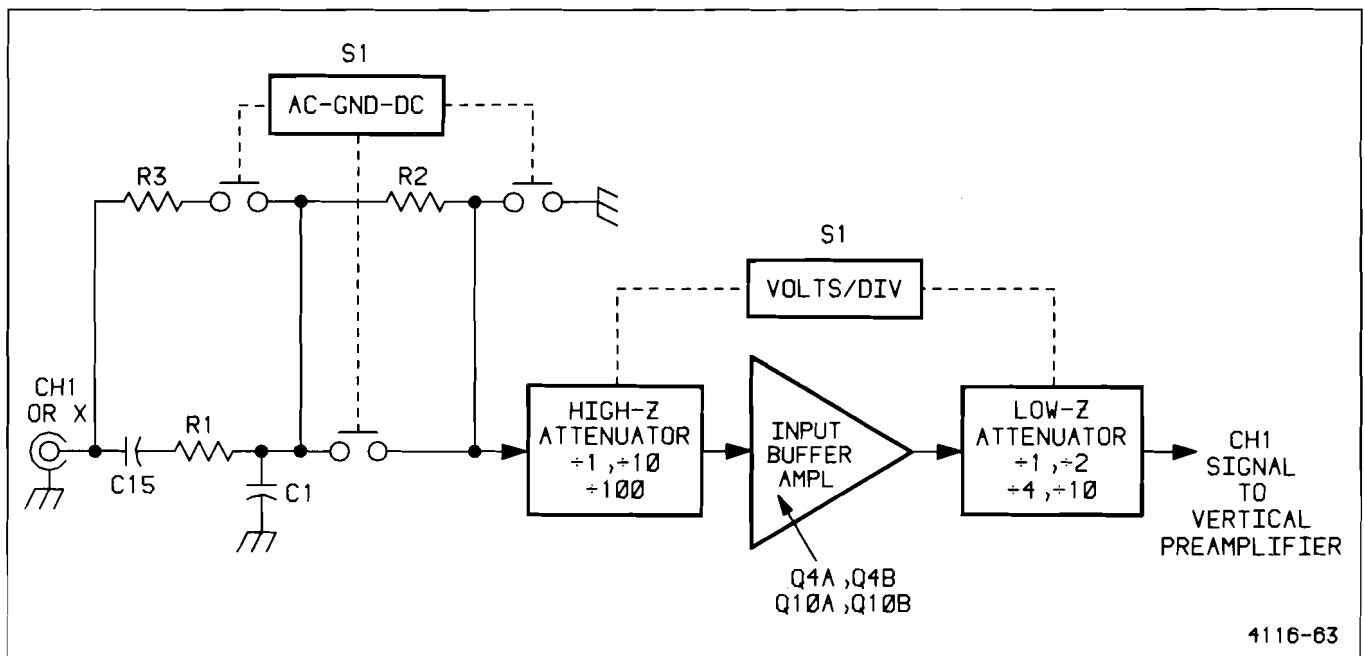

Figure 3-2. Channel 1 Vertical Attenuator, simplified block diagram.

Each channel attenuator circuit is composed of an input high-impedance attenuator (two divide-by-ten sections), an input buffer amplifier, and a low-impedance output attenuator (divide-by-two, -four, or -ten). The attenuator precision components are located on hybrid ceramic chips.

The high-impedance input attenuator produces minimum circuit loading for the signal applied to the vertical input connector. Each channel's input attenuator divide-by-ten sections may be cascaded to produce an attenuation factor of 100. For VOLTS/DIV switch settings of 5 mV up to 50 mV, the input attenuator is a straight-through signal path with no attenuation of the signal. For 100-mV to 500-mV settings, the signal is attenuated by ten; and for the 1-V, 2-V, and 5-V settings, the signal is attenuated by 100.

### Buffer Amplifier

The Channel 1 output signal from the input attenuator is connected through C900 and R900 to Source Follower Q4A. Resistor R900 provides the input resistance, and resistor R13 (in the attenuator hybrid) acts as a damping resistor. Transistors Q4B and Q10A provide a constant-current source for Q4A.

In the event that excessively high amplitude signals are applied to Source Follower Q4A, succeeding circuitry is protected by CR1, CR2, CR3, and the gate-source junction of Q4A (along with CR8) which limit the signal amplitude to a safe level. If excessive negative signal amplitude causes CR1 and CR2 to become forward biased, the Q4A gate will be clamped to about  $-2$  V. Excessive positive-signal amplitude will forward bias the gate-source junction of Q4A. As soon as gate current flows in Q4A, the gate voltage will cease increasing. Gate current is limited to a safe value by the high resistance of R900.

Source Follower Q4A drives Emitter Follower Q10B. Attenuator Balance potentiometer R10 (in the Q10A emitter circuit) is used to adjust the emitter-follower output voltage to zero volts with no signal applied.

The low-impedance emitter-follower output drives a  $75\text{-}\Omega$  hybrid output attenuator.

### Output Attenuator

The low-impedance output attenuator is switchable to produce attenuation factors of 1, 2, 4, or 10. Since a portion of R20 (the attenuator voltage divider) remains in the signal path for all attenuation factors, capacitors C15 and C20 compensate the divider network to maintain a  $75\text{-}\Omega$  output impedance for all VOLTS/DIV switch settings. The signal from the Output Attenuator is fed to the Vertical Preamplicifier via a  $75\text{-}\Omega$  transmission line.

## VERTICAL PREAMPLIFIERS, DIODE GATES, AND DELAY LINE DRIVER

Channel 1 and Channel 2 Vertical Preamplicifiers are shown on schematic diagram 2. They are identical with the exception of the added inverting feature in the Channel 2 circuitry. Complete Channel 1 circuit operation is described, along with the Channel 2 differences. A simplified block diagram of the Vertical Preamplicifier circuitry is shown in Figure 3-3.

### Input Preamplicifier

Channel 1 Input Preamplicifier U30 is a hybrid amplifier circuit that produces a differential output signal from the single-ended input signal. The Channel 1 gain is adjustable via R47 to establish the calibrated deflection factors.

A single-ended trigger output signal, available at U30 pin 16, supplies the Channel 1 internal trigger signal to the Trigger Generator. Positive-going vertical signals produce positive-going output trigger signals, amplified by a voltage gain of six.

The circuit composed of U41B and Q36 eliminates common-mode signals from the differential output signal. Any common-mode signal present appears at the junction of R42 and R43 (connected between U30 pins 13 and 11) and is applied to pin 5 of U41B. Common-mode signals vary the base voltage on Current Source transistor Q36. Transistor Q36 inverts the common-mode signal and produces negative feedback that cancels the common-mode output signal from U30.

Compensating networks, connected between U30 pins 4 and 6, provide both high- and low-frequency compensation for square-wave input signals. Variable Balance control R22 is adjustable to reduce trace shift when the VAR VOLTS/DIV control is rotated through its range.

The Variable-gain circuit is composed of VAR GAIN control R902 and FET Q49. This circuit increases the 5-mV-per-division gain of U30 to obtain a deflection factor of 2 mV per division or less at the fully clockwise rotation of R902. The VAR GAIN control provides continuously variable deflection factors between each calibrated deflection factor setting of the VOLTS/DIV switch.

Gain compensation for U30 over varying ambient temperature is provided by thermistor RT46 and R46.

### Channel 1 Positioning

Hybrid circuit U55 provides balanced current sources for producing at least  $\pm 12$  divisions of vertical positioning for the displayed signal. POSITION control R903 varies the amount of dc-offset current added to the vertical signal current at U55 pins 2 and 6. The sum of the dc-offset current and the vertical-signal current establishes the vertical position of the crt display. Diodes CR53 and CR54, connected between U55 pins 2 and 6, limit the range of the Channel 1 positioning circuit to prevent it from affecting the horizontal-display position when the X-Y feature is in use. Corresponding diodes are not included in the Channel 2 circuitry.

### Channel 1 Common-Base Output Stage

A common-base output stage composed of Q55 and Q57 provides current-summing nodes for the vertical positioning and Channel 1 signal currents. When the TRIG VIEW

feature is used, the output of the common-base stage is blocked by a diode gate to prevent the vertical input signal from reaching the Delay Line Driver.

### Channel 2 Invert Operation

The Channel 2 common-base output stage is composed of two transistor pairs. In the noninverting mode, transistors Q132 and Q134 are biased on to carry the signal current. When the INVERT push-button switch is pressed in, Q132 and Q134 become biased off; and Q133 and Q135 are biased on. The collectors of Q133 and Q135 are cross-connected to the stage output points; consequently, the Channel 2 signal current becomes inverted.

### Diode Gates

Channel 1 Diode Gate is composed of CR55, CR56, CR57, and CR58. The Diode Gate acts as a switch that is

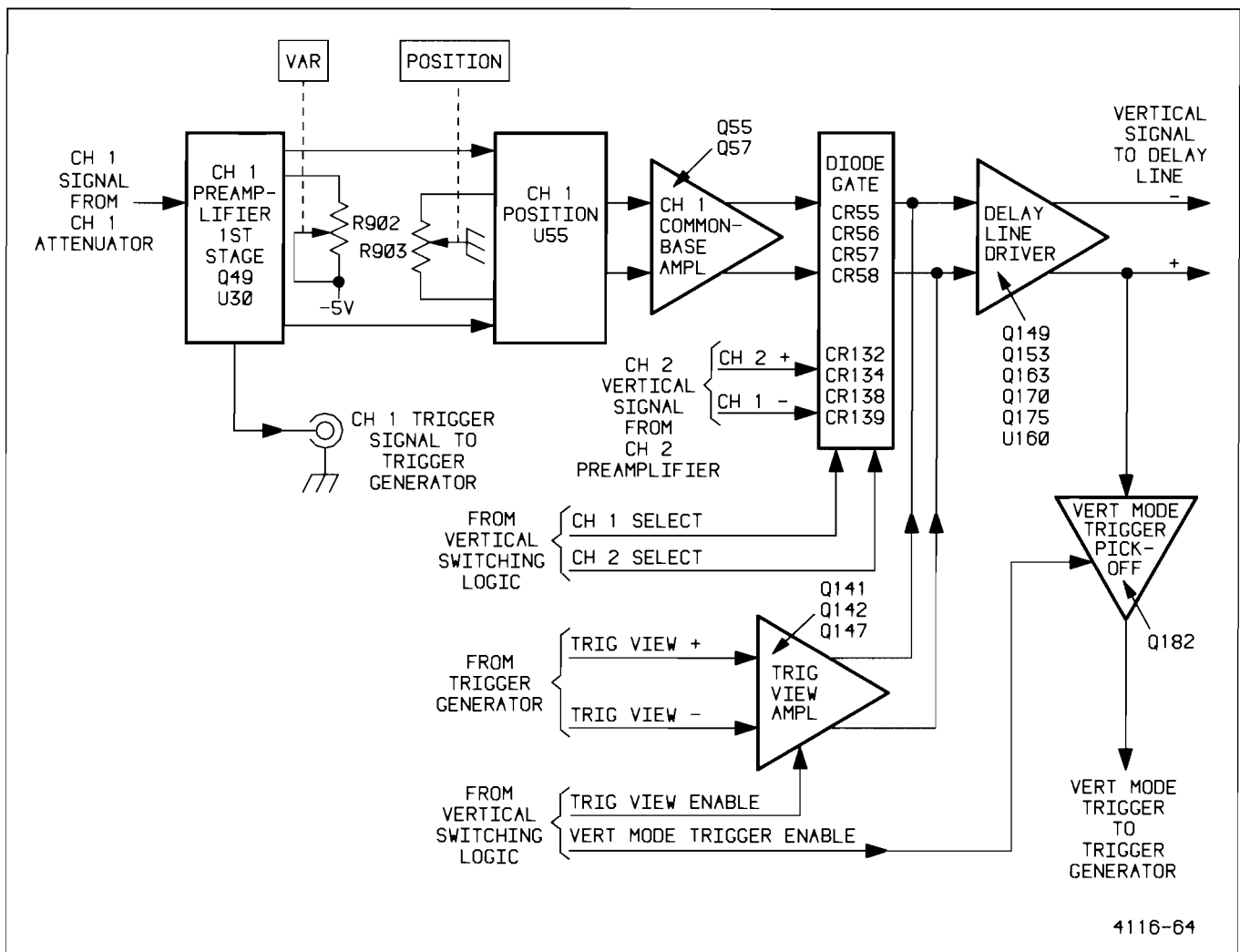

Figure 3-3. Vertical Preamplifier, Diode Gate, and Delay Line Driver, simplified block diagram.

controlled by the Vertical Switching Logic circuit. Channel 2 Diode Gate is identical in operation.

**CHANNEL 1 DISPLAY ONLY.** To display only the Channel 1 signal, the CH 1 Select signal is HI and the CH 2 Select signal is LO. With CH 1 Select HI, diodes CR56 and CR58 are reverse biased (see Figure 3-4). Series diodes CR55 and CR57 are forward biased, and the Channel 1 vertical signal is allowed to pass to the Delay Line Driver. In the Channel 2 Diode Gate (with the CH 2 Select signal LO) CR138 and CR139 are forward biased, and the Channel 2 vertical-signal current is shunted away from series diodes CR132 and CR134. The series diodes are reverse biased, and the Channel 2 signal current is prevented from reaching the Delay Line Driver.

**CHANNEL 2 DISPLAY ONLY.** When CH 2 VERTICAL MODE is selected, the CH 1 Select signal goes LO and the CH 2 Select signal goes HI. The Channel 1 signal is blocked by the Diode Gate, and the Channel 2 signal reaches the Delay Line Driver.

**ADD DISPLAY.** Both Diode Gates are biased on to pass the Channel 1 and Channel 2 vertical signals. Both channel-signal currents are summed at the input to the Delay Line Driver to produce the ADD display signal.

**ALTERNATE AND CHOPPED DISPLAY.** The Diode Gates are switched on and off by the channel select signals from the Vertical Switching Logic circuit. When ALT VERTICAL MODE is selected, the Diode Gates are switched at the end of each sweep. When CHOP VERTICAL MODE is selected, the Diode Gates are switched at a rate of about 275 kHz. See the "Vertical Switching Logic" discussion for a description of how the channel selection signals are obtained.

**TRIG VIEW DISPLAY.** While the TRIG VIEW push button is pressed in, both Diode Gates are biased off, and the Trigger View Amplifier (shown in Figure 3-3) is enabled to pass the A Trigger View signal to the Delay Line Driver.

**X-Y DISPLAY.** Pressing in both the CH 1 and CH 2 VERTICAL MODE push buttons activates the instrument's

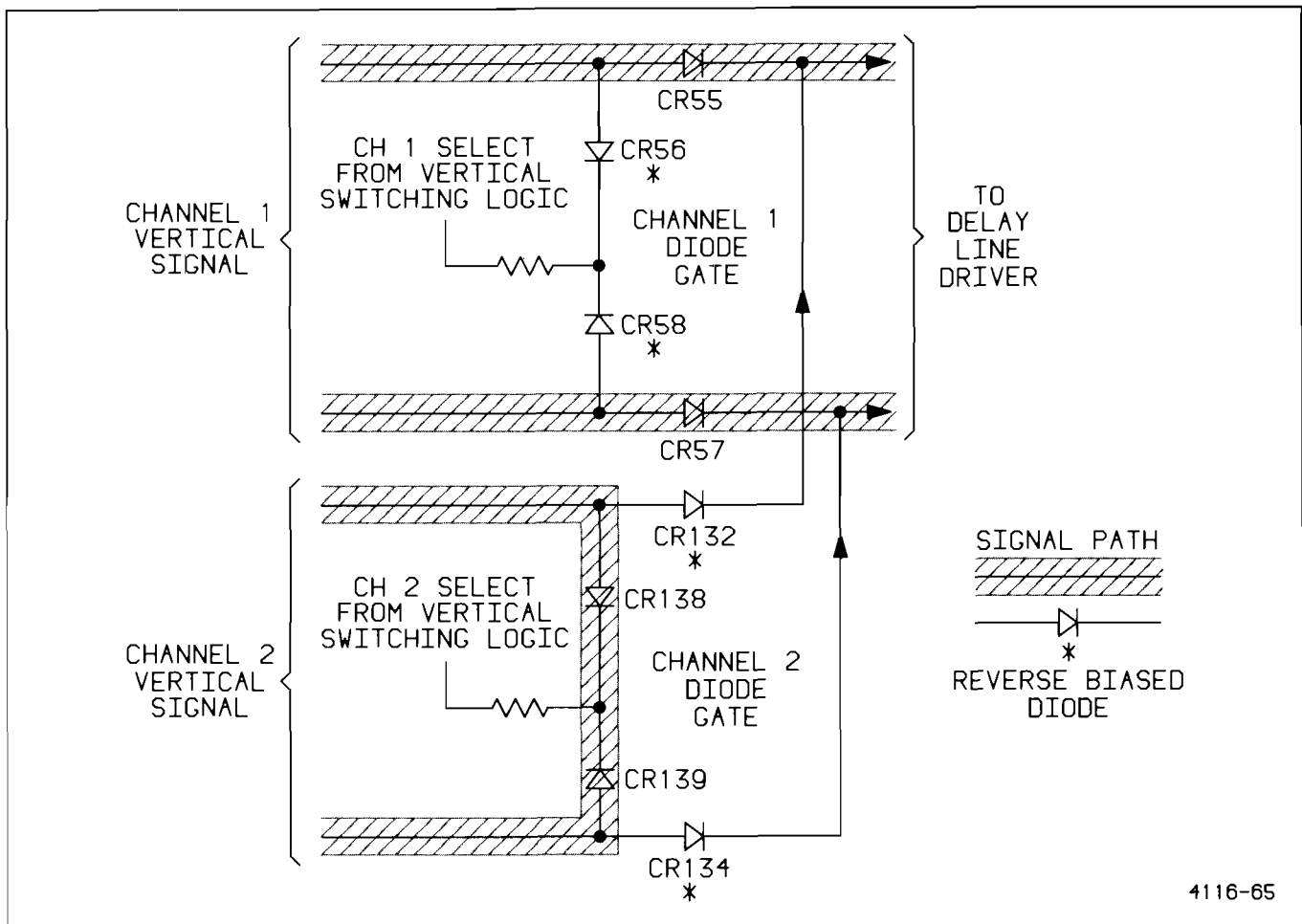

Figure 3-4. Diode Gate biasing for Channel 1 display.

## Theory of Operation—2336 Service

X-Y display feature. The Channel 1 Diode Gate is held off, and the Channel 2 Diode Gate is biased on. The Channel 2 signal is passed to the Delay Line Driver and ultimately to the crt to provide the Y-Axis display deflection. The X-Axis deflection signal is supplied to the Horizontal Preamp from the Channel 1 trigger-signal output of the Channel 1 Vertical Preamp (U30).

### Delay Line Driver

The Delay Line Driver is arranged as a cascaded, common-emitter, feedback amplifier. Differential input-signal current is converted to differential voltage at the input to the Delay Line. Feedback elements are R154 (between Q163 emitter and Q153 base in the negative-signal path) and R173 (between Q175 emitter and Q170 base in the positive-signal path).

A circuit composed of U160 and Q149 supplies negative feedback from the common-mode point at the junction of R168 and R176 (in the Delay Line Driver output) to the common-mode point at the junction of R148 and R169 (in the Delay Line Driver input). The negative feedback eliminates common-mode signals from the Delay Line, and it balances both sides of the amplifier when ADD VERTICAL MODE is selected. The resulting output signal level to the Delay Line is then centered at zero volts.

Components R162 and C162, connected between the base of Q163 and the base of Q175, supply high-frequency damping of the Delay Line Driver frequency response.

### Vert Mode Trigger Pickoff Amplifier

The trigger signal for the VERT MODE position of the SOURCE switch is obtained from emitter-follower Q182. The Vert Mode Trigger Enable signal (−5 V dc) is applied to the emitter of Q182. This signal is the emitter-current source for the transistor, and it is supplied from the Vertical Switching Logic circuit (diagram 4). The enabling voltage is removed when the TRIG VIEW push button is pressed in. This action opens the feedback loop that would otherwise occur between the Vert Mode Trigger output and the Trig View input. Diode CR180 provides thermal compensation of the Q182 base-to-emitter junction voltage.

### Delay Line

Delay Line DL900 provides about 90 ns of delay in the vertical signal. When using internal triggering (VERT MODE, CH 1, or CH 2) the delay time allows the Sweep Generator circuits sufficient time to initiate a sweep before the vertical signal reaches the crt deflection plates. This feature permits the leading edge of the internal signal that originates the trigger pulse to be displayed.

## VERTICAL OUTPUT AMPLIFIER

The Vertical Output Amplifier circuit, shown on schematic diagram 3, provides the final amplification of the vertical deflection signal. This circuit includes the bandwidth limiting components, part of the Beam Find circuitry, an input IC amplifier, and a hybrid-circuit crt driver.

### Bandwidth Limiting

The upper-frequency response limit of the Vertical Output Amplifier may be reduced to eliminate high-frequency interference from a lower-frequency signal display. Pressing in the front-panel BW LIMIT switch forward biases a diode bridge composed of CR8, CR9, CR24, and CR25. This action also connects capacitors C8 and C25 to ground through the diode bridge, R17, and C18; and the upper-frequency signals are shunted to ac ground.

Proper termination for the Delay Line is provided by R8 and T9 (in the negative-signal side) and by R25 and T24 (in the positive-signal side). The signal is tapped off T9 and T24 at the correct impedance point to match the input impedance of Input Amplifier U43. Resistors R9 and R24 damp the signal slightly to eliminate high-frequency oscillation.

### Input Amplifier

Input Amplifier U43 is a three-stage IC amplifier. Frequency compensation for the Delay Line and first amplifier stage is provided by compensating networks connected between U43 pins 12 and 9. Also connected between these pins is Gain adjustment R44 and Vertical Balance adjustment R18. The Vertical Balance adjustment centers the vertical POSITION control range to obtain equal positive and negative positioning limits.

Compensating components connected between U43 pins 17 and 18 and between U43 pins 3 and 4 provide for thermal compensation of the amplifier. Common-mode signals are balanced by amplifier U58 controlling the third amplifier stage bias current.

The vertical portion of the Beam Find circuit acts on the third amplifier stage. When BEAM FIND switch S900 is pressed in, the amplifier gain is reduced by limiting the current available to the third stage.

### Vertical Output Amplifier

Vertical Output Amplifier U54 is a current-driven, common-base, hybrid-circuit amplifier. The signal current from U43 pins 2 and 19 is converted to a crt deflection

voltage (nominally 3 V per division of deflection). Approximately 2.5 watts of power is dissipated by this IC, and it must be properly heat sunk when operating.

The parallel coil and resistor components (L913 and L915) at the output pins of U54 compensate the crt deflection-plate capacitance.

### VERTICAL SWITCHING LOGIC AND CHOP BLANKING

The Vertical Switching Logic portion of this circuit, shown on schematic diagram 4, controls the channel switching to obtain the appropriate display for each selected VERTICAL MODE switch. During chopped operation, the Chop Blanking portion of the circuit supplies a blanking signal to the Z-Axis Amplifier. When switching between channels, this blanking signal turns off the Z-Axis Amplifier to prevent transients from appearing in the display.

### Vertical Mode Selection

The front-panel VERTICAL MODE switches provide the logic levels that control the channel-enabling-signal selection. Dual Multiplexer U215 switches the channel Diode Gates on and off by selecting either the Alt Sync signal or the outputs from flip-flop U211A. The Q and  $\bar{Q}$  output levels from U211A are used for selecting CHOP, ADD, CH 1, or CH 2 VERTICAL MODE.

**CHANNEL 1 DISPLAY.** When only the CH 1 push button is pressed in, the remaining VERTICAL MODE switches are released. The Reset input of U211A (pin 1) goes LO, and the Set input (pin 4) is pulled HI through pull-up resistor R203. Flip-flop U211A resets, and the  $\bar{Q}$  output (pin 6) goes HI while the Q output (pin 5) goes LO. The HI is placed on pin 12 of Multiplexer U215, and the LO is placed on pin 4.

The A and B select inputs of U215 determine the input pins that are switched to the output pins (see Figure 3-5). Input A is a permanent LO, and the B input is controlled by the ALT and CHOP VERTICAL MODE switches. When

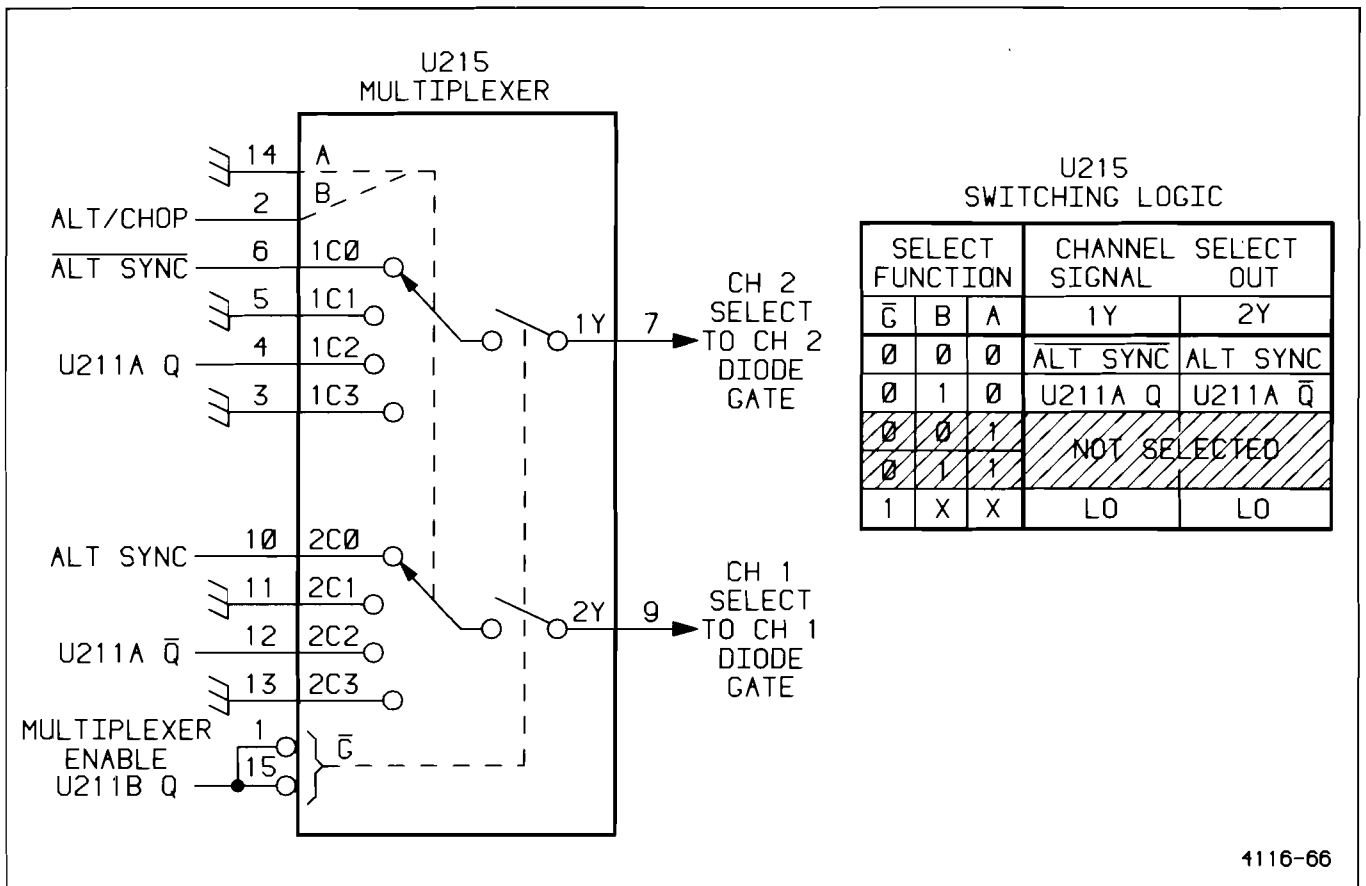

Figure 3-5. Simplified illustration of Multiplexer U215 switching operation.

## Theory of Operation—2336 Service

CH 1 VERTICAL MODE is selected, the U215 B input (pin 2) will be held HI through pull-up resistor R215. With the A input LO and the B input HI, the 1C2 input (from the Q output of U211A) will be connected to the 1Y output (CH 2 Select), and the 2C2 input (from the  $\bar{Q}$  output of U211A) will be connected to the 2Y output (CH 1 Select).

The output state of flip-flop U211A is also determined by the input logic levels set up by the VERTICAL MODE switches. For a Channel 1 display, the Reset input of U211A (pin 1) will be held LO by a ground connected through the CH 1 and CH 2 VERTICAL MODE switches. The  $\bar{Q}$  output will be reset HI, and the Q output will be LO. The HI from U211A pin 6 is applied to U215 pin 12 (2C2 input) and is connected through U215 to pin 9 (2Y output). A HI on pin 9 turns on the Channel 1 Diode Gate to allow the Channel 1 signal to pass to the Delay Line Driver. The LO on U211A pin 5 is applied to U215 pin 4 (1C2 input) and is connected through U215 to pin 7 (1Y output). A LO on pin 7 turns off the Channel 2 Diode Gate.

**CHANNEL 2 DISPLAY.** When CH 2 VERTICAL MODE switch is pressed in, the condition of Multiplexer U215 remains unchanged from the Channel 1 selection previously discussed. The change occurs in the state of flip-flop U211A. With CH 2 push button pressed in, the Set input of U211A is grounded for a LO, and the Reset input is pulled HI through pull-up resistor R202. The U211A Q output becomes HI, and the  $\bar{Q}$  output becomes LO. The states of the CH 1 Select and CH 2 Select lines are therefore reversed from the Channel 1 display states, and Channel 2 Diode Gate is biased on while the Channel 1 Diode Gate is biased off.

**ADD DISPLAY.** Again, the condition of Multiplexer U215 does not change from the Channel 1 display state for an ADD display. The Set and Reset inputs of flip-flop U211A are both switched LO by pressing in the ADD VERTICAL MODE switch, and both the Q and  $\bar{Q}$  outputs of U211A become HI. The CH 1 and CH 2 Select signals from U215 are thus both HI, and both channel Diode Gates are switched on.

**CHOP DISPLAY.** To obtain the required channel switching and chop blanking for the Chop display, the Chop Clock Oscillator must be enabled. In the circuit composed of U196A, U196B, and Q209, an oscillator circuit (operating at a nominal frequency of 500 kHz) is formed by NAND gate U196A and the associated RC network connected between pins 2 and 3.

For VERTICAL MODE switch selections other than CHOP, U196A pin 1 is grounded to make it LO. The

U196A output at pin 3 is then HI, and C197 charges through CR201 and R201 to make U196A pin 2 HI. At the moment the CHOP VERTICAL MODE switch is pressed in, U196A pin 1 becomes HI, and U196A pin 3 is then switched LO. Capacitor C197 begins discharging through parallel resistor R197 toward the LO threshold of U196A. When the LO input threshold is reached, U196A pin 3 is switched HI to start charging C197 back to the HI threshold. The selected time constants of the charge and discharge paths, along with the threshold switching levels of U196A, produce an asymmetrical Chop Clock pulse that is HI 20% of the time and LO 80% of the time at U196A pin 3.

The Chop Clock signal is applied to U211A pin 3 (Clock input) to switch the flip-flop at the chop rate. Every positive-going transition clocks the level at U211A pin 2 onto the Q output (pin 5). With the U211A  $\bar{Q}$  output connected to pin 2, each Chop Clock pulse causes the U211A outputs to toggle (change state). Each change of the output state of U211A is connected through Multiplexer U215 to produce the Channel Select signals that drive the Channel Diode Gates. Thus, the Diode Gates are switched on and off at the chop rate to present a dual-channel display.

The Chop Clock signal is also applied to NAND gate U196B pin 4 to drive Chop Blanking Amplifier Q209. Chop blanking is used to prevent display of the switching transients that occur with chopping. During chop operation, U196B pin 5 is held HI by pull-up resistor R196. Positive transitions of the Chop Clock signal (corresponding to the channel switching time) switch U196B pin 6 to a LO state. This LO is applied to the base of Q209, turning it on. Chop Blanking Amplifier Q209 supplies blanking current to the Z-Axis Amplifier (diagram 9) until the Chop Clock signal goes LO again. At that time, U196B pin 6 will switch HI, biasing off Q209. The Z-Axis Amplifier then is able to respond to the remaining Z-Axis signals setting the display intensity. Diode CR209 clips any negative portion of the blanking waveform.

**ALT DISPLAY.** During the time that ALT VERTICAL MODE is selected, the Chop Clock Oscillator is disabled by a fixed LO on pin 1 of NAND gate U196A. Multiplexer U215 is switched by a LO on pin 2 (the B Select input) to select the 1C0 and 2C0 inputs ( $\bar{\text{Alt Sync}}$  and  $\text{Alt Sync}$ ) to be connected to the 1Y and 2Y outputs. The  $\text{Alt Sync}$  signal is supplied from Q108 in the Sweep circuit (diagram 6) and is inverted by U196C to produce the  $\bar{\text{Alt Sync}}$  signal at U215 pin 6. At the end of each sweep, the  $\text{Alt Sync}$  signal changes state. The change of state (applied through U215 to the CH 1 and CH 2 Select lines) switches the Channel 1 and Channel 2 Diode Gates to alternately allow first one and then the other channel signal to reach the Delay Line Driver.

**AUTO ALT/CHOP SELECT.** By pressing in both the ALT and CHOP VERTICAL MODE push buttons simultaneously, an automatic Alt/Chop selection circuit is enabled. When in use, the Auto Alt/Chop feature will automatically switch a dual-channel display mode to either ALT or CHOP for the best display presentation. The circuit is composed of Q194 (diagram 4) and a diode-switching network (diagram 6). The diode switches are under control of the A SEC/DIV switch. The A SEC/DIV switch settings from 0.5 s to 0.5 ms will select CHOP (no diode switches on). The remaining switch positions (0.2 ms to 0.05  $\mu$ s) turn on one of the diode switches to produce an Auto Sel signal.

In the ALT selection range, the Auto Sel signal is applied through R195 and the CHOP and ALT VERTICAL MODE switches to bias on Q194. At the collector of Q194, a LO is produced and applied to U215 pin 2 (B Select input) to switch the Multiplexer to the Alt Sync inputs. This LO is also applied to U196A pin 1 to disable the Chop Clock Oscillator.

When the A SEC/DIV switch is set to any position in the CHOP select range, the Auto Sel signal is removed. Transistor Q194 is biased off, and pull-up resistor R215 places a HI on both U215 pin 2 and U196A pin 1. Multiplexer U215 switches to the Q and  $\bar{Q}$  outputs of U211A, and the Chop Clock Oscillator is enabled for CHOP operation.

**TRIG VIEW DISPLAY.** Pressing in the front-panel TRIG VIEW push button performs three functions:

1. The  $-5$ -V Vert Mode Trig Enable signal is removed from Vert Mode Trigger transistor Q182 (diagram 2). This action disables the pickoff circuit.
2. The ground is removed from the base leads of Trigger View Amplifier transistors Q141 and Q147 (diagram 2). Transistor Q142 is biased on, and diodes CR140 and CR146 are reverse biased. This action allows the A Trig View signal to pass to the Delay Line Driver.
3. A LO is placed on the Set input of U211B, causing pin 9 (Q output) to go HI. This action disables both outputs of Multiplexer U215, and both channel-select signals become LO (see Figure 3-5). The Channel 1 and Channel 2 Diode Gates are biased off by the LO signals to prevent either channel signal from passing to the Delay Line Driver.

**X-Y DISPLAY.** To obtain an X-Y display, both CH 1 and CH 2 VERTICAL MODE push buttons are pressed in simultaneously. A LO is placed on the Set input of U211A

by the CH 2 VERTICAL MODE switch, and the Channel 2 Diode Gate is biased on. The Channel 2 signal is then applied to the Vertical Output Amplifier to provide Y-Axis (vertical) crt deflection. The X-Axis deflection signal is supplied by the Channel 1 input signal via the CH 1 Trigger signal output of Channel 1 Vertical Preamplifier U30.

A separate section of VERTICAL MODE switch S194 (see diagram 8) applies an X-Y Enable signal to both the Horizontal Preamplifier (U128 pin 12) and the A Sweep Generator (U43 pin 14, diagram 6). The Horizontal Preamplifier is switched to amplify the X (Channel 1) signal for the X-Axis crt deflection, and the A Sweep Generator is prevented from producing an output sweep signal.

## TRIGGER

The Trigger circuitry, shown on schematic diagram 5, is composed of the A trigger-source and A trigger-coupling switching stages, the A External Trigger Amplifier, and the A and B Trigger Generator integrated circuits. Figure 3-6 is a detailed block diagram of the A Trigger circuitry.

### A Trigger Source

The A Trigger Generator circuit produces a sweep Gate signal that is used to initiate the A Sweep from a choice of five sources of the input trigger signal. A Trigger SOURCE switches S22A and S22B select trigger signals from the following sources:

**VERT MODE:** Signals displayed on the crt. Obtained from Vert Mode Trigger Pickoff Q182 following the Delay Line Driver (diagram 2).

**CH 1:** Channel 1 vertical signals. Obtained from Channel 1 Vertical Preamplifier U30 (diagram 2).

**CH 2:** Channel 2 vertical signals. Obtained from Channel 2 Vertical Preamplifier U100 (diagram 2).

**LINE:** Ac-power-source waveform. Obtained from the 5-V secondary winding of Power Transformer T900 (diagram 10).

**EXT:** External trigger signals. Obtained from the signal applied to the A EXT input connector.

**EXT $\div$ 10:** External trigger signals attenuated by a factor of ten.

The EXT and EXT $\div$ 10 trigger signals are buffered by an amplifier circuit composed of Q15, Q16, and Q21. Source-follower Q15 drives emitter-follower Q21 to buffer the trigger signal and to isolate the Trigger Generator IC from the A EXT input connector.



**Theory of Operation—2336 Service**

Field-effect transistor Q16 acts as a constant-current source for Q15 and also provides thermal compensation for the input amplifier. The gate of Q15 is protected from accidental application of large-amplitude triggering signals by clamp diodes CR10 and CR14.

A portion of the A COUPLING switch (S67A) selects either AC or DC coupling to apply the external triggering signal to the A External Trigger Amplifier. When set to DC coupling, all components of the input signal are passed in

AC coupling, series capacitor C9 is placed in the trigger signal path to block the dc component of the input signal.

**A Trigger Switching**

Input triggering signals to be applied to A Trigger Generator U81 are selected by the A Trigger SOURCE switch. The frequency range of the applied signals is determined by the A Trigger COUPLING switch. Signals are applied to the Trigger Generator via two different signal paths:

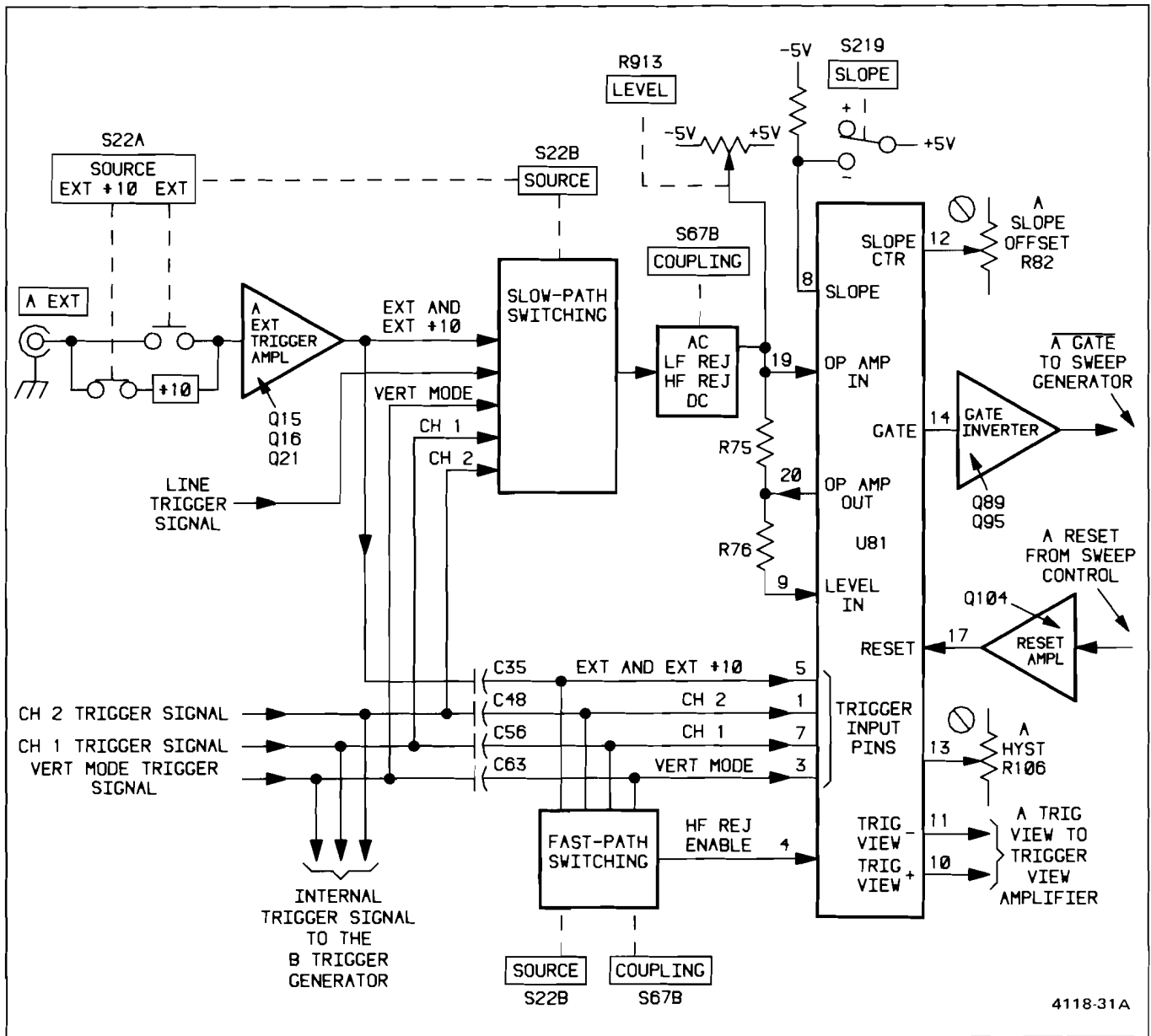

Figure 3-6. Trigger circuitry, detailed block diagram.

the fast path (high-frequency) connects directly to the trigger input pins of U81; the slow path (low-frequency) connects to U81 pin 19 via the A Trigger SOURCE switch.

**SLOW-PATH SWITCHING.** Figure 3-7 illustrates the trigger signal slow path. As shown, the A Trigger SOURCE switch is selecting the CH 1 slow-path signal, and the A Trigger COUPLING switch is set for AC coupling. The slow-path signal is fed through C67 when either AC or HF REJ coupling is selected. The DC coupling path is directly connected, and no signal path is established when LF REJ coupling is selected.

It is at this point that dc voltage from the A Trigger LEVEL control (R913) is added to the slow-path trigger signal. The resulting sum is then applied to U81 pin 19, the internal operational amplifier inverting input.

The inverted trigger signal (with the added LEVEL control dc voltage) at U81 pin 20 is applied from the Op Amp output to U81 pin 9, the Level input. This signal is applied to an internal trigger-level comparator (contained in U81) for use in determining the signal level at which the Gate output signal will be produced.

**FAST-PATH SWITCHING.** Figure 3-8 illustrates the trigger signal fast path (high-frequency). The dc and low-frequency components of the trigger signal are blocked by capacitors (C35, C48, C56, and C63) in series with each signal path. High-frequency components are passed and applied to the U81 trigger inputs (pins 5, 1, 7, and 3).

One of the possible trigger signals is selected as an input signal by a portion of the A Trigger SOURCE switch. This switch controls the Trigger Generator input pins using enabling voltages rather than by directly switching trigger signals. Each signal is applied to a separate internal emitter follower in U81. When 0 V is applied to the input pin (by grounding out the pull-down voltage) the emitter follower associated with that pin will conduct, thus passing the trigger signal applied to that pin. The U81 internal emitter followers are disabled to prevent the signal from passing by applying a negative voltage (about  $-2$  V) through a pull-down resistor.

Trigger input pin 4 is not used to apply a trigger signal, but it is biased on whenever none of the other fast-path inputs are selected. This switching is required because one of the U81 internal emitter followers must be conducting to enable proper operation of the internal trigger-level comparator. Switching of the pin 4 voltage is accomplished by a portion of the A Trigger COUPLING switch.

In Figure 3-8, note that when HF REJ coupling is selected, pin 4 of U81 is enabled by grounding the pull-down voltage. The remaining contacts (AC, LF REJ, and DC) are open, so none of the other fast-path inputs are enabled. The trigger signal used for HF REJ coupling is obtained from the signal selected by the slow-path A Trigger SOURCE switching.

When the COUPLING switch is set to any other position than HF REJ, pin 4 is disabled by the pull-down voltage applied from R56G. The trigger signal input selected

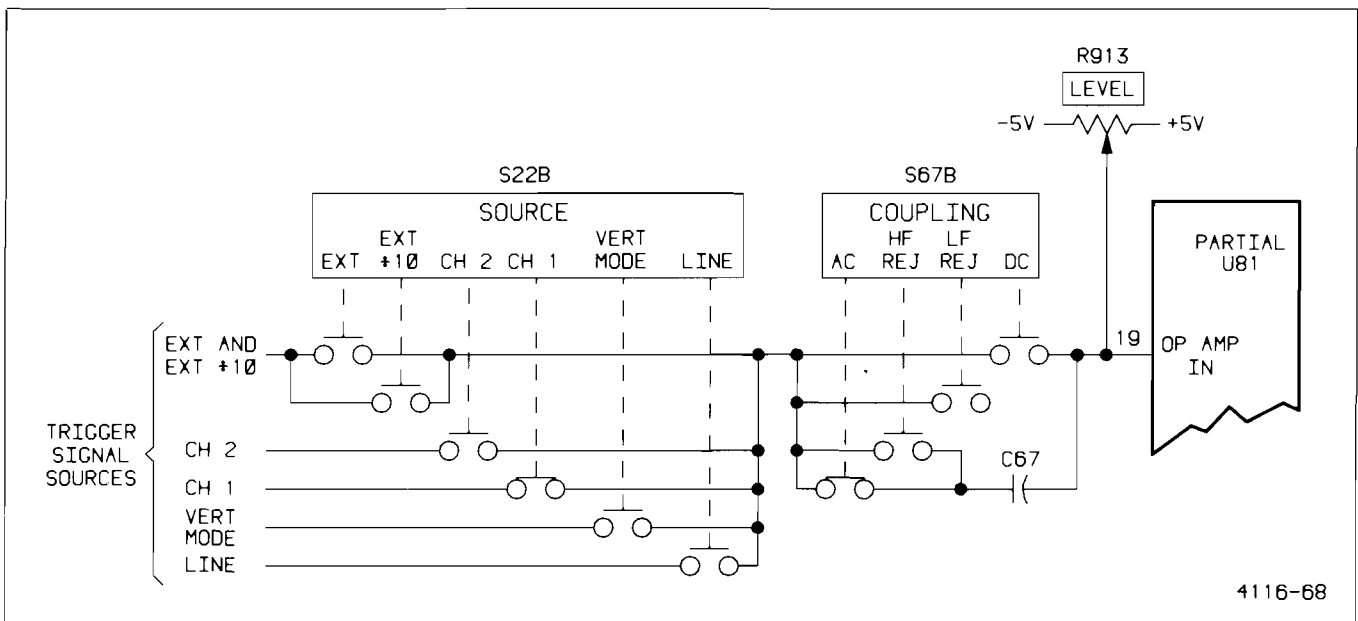

Figure 3-7. Trigger signal slow path (low frequency).

**Theory of Operation—2336 Service**

by the A Trigger SOURCE switch is enabled by grounding out the pull-down voltage on the selected trigger input pin via the A Trigger COUPLING switch.

When LINE SOURCE is selected, a slightly different switching path is set up, and pin 4 of U81 will be enabled regardless of the A Trigger COUPLING switch setting. For the AC, LF REJ, and DC positions, pin 4 is enabled by the ground applied to R56G through the LINE contacts of the A Trigger SOURCE switch. In the HF REJ position, a ground is applied to R56G through the HF REJ contacts of the A Trigger COUPLING switch.

The LINE trigger signal is a low-frequency signal and is applied through slow-path switching to U81 pin 19. All of the fast-path inputs are disabled when LINE SOURCE is selected.

**A Trigger Generator**

The A Trigger Generator consists of integrated circuit U81 and associated components. Contained within U81 is the necessary circuitry to generate the Gate output signal (at U81 pin 14) that is used to start the A Sweep Generator (diagram 6).

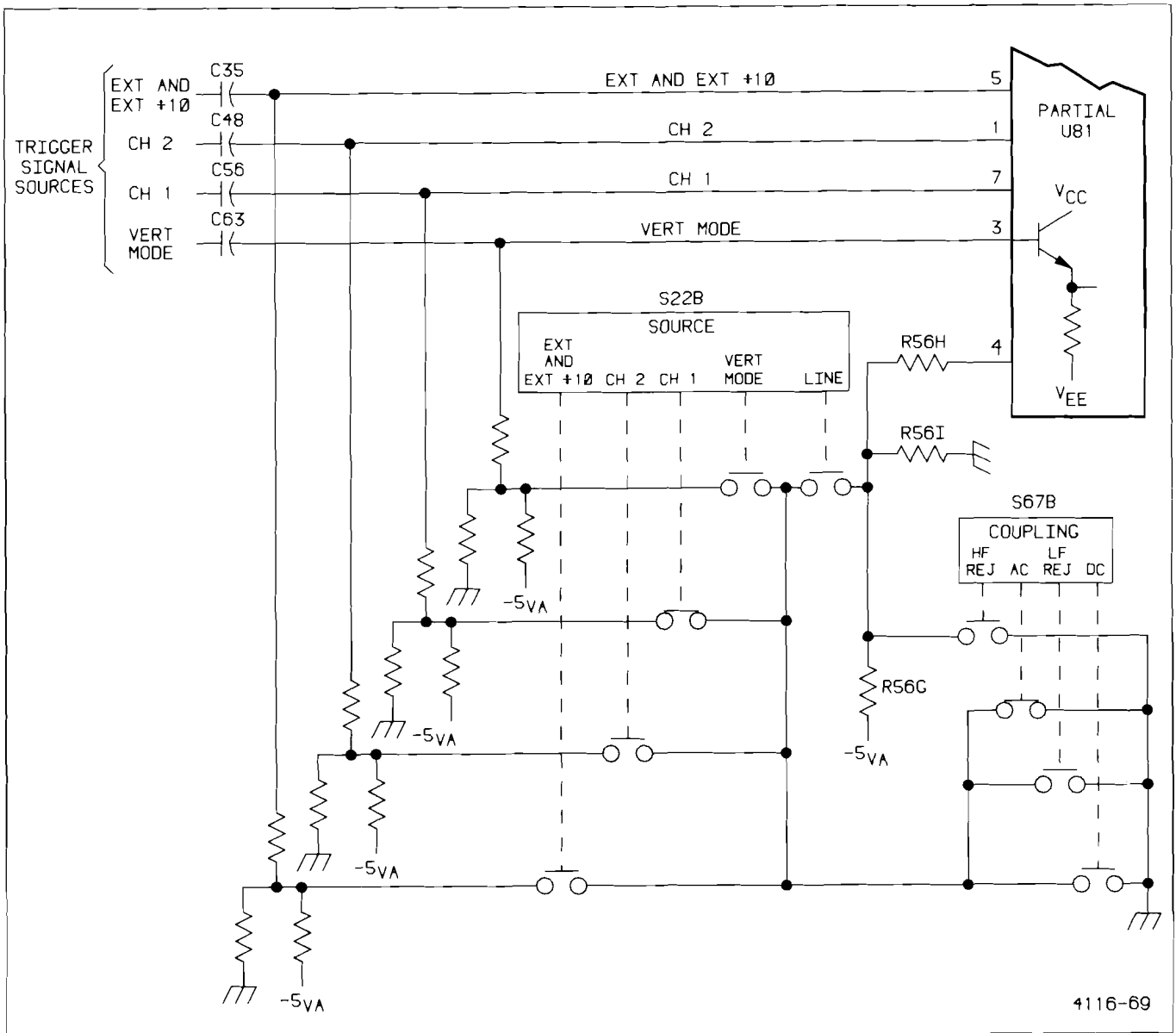

**Figure 3-8. Trigger signal fast path (high frequency).**

External control voltages applied to U81 set the trigger level, trigger slope, slope centering, and trigger threshold level.

The A Sweep Gate is generated when the input trigger signal reaches the amplitude determined by the setting of LEVEL control R913. The Gate signal at pin 14 remains HI for the duration of one cycle of the A Sweep. When the A Sweep ends, the A Reset signal at pin 9 of Sweep Control IC U87 (diagram 6) is applied to U81 pin 17 to reset the Trigger Generator IC internal circuitry. The A Reset signal remains on pin 17 until the end of sweep holdoff time (determined by the Sweep Control IC). When the holdoff time has passed, the A Reset signal is removed, and Trigger Generator U81 is enabled to respond to the next triggering signal.

The slope of the input signal that triggers the A Sweep Generator is determined by the setting of SLOPE switch S219. When the SLOPE switch is set to the + (plus) position, the Gate signal output (U81 pin 14) will switch HI only on a positive slope of the input triggering signal. When the SLOPE switch is set to the – (minus) position, the output Gate signal will switch HI only on a negative slope of the input triggering signal.

The A Slope Offset adjustment, R82, balances the U81 internal trigger amplifier so that a Gate signal output occurs at the same level on both the negative and positive slopes of the triggering signal. The A Hyst adjustment, R106, adjusts the built-in hysteresis in the U81 internal threshold comparator to prevent triggering on low-level noise at the Trigger Generator inputs.

Transistors Q89 and Q95 are arranged in a differential amplifier circuit. The Gate signal is inverted, and the dc level is shifted to the correct level for application to the Sweep Control and A Sweep Generator IC (diagram 6). Peak-to-peak amplitude of the A Gate output signal is clamped to about 1.4 V (–0.7 to +0.7 V) by diodes CR90 and CR91 in the Q89 collector circuit.

Transistor Q104 converts the incoming A Reset current signal (from the Sweep Control IC) back into a voltage signal of the correct level for application to the Reset input (pin 17) of Trigger Generator U81.

A differential Trig View signal is available at U81 pins 10 and 11. The Trig View signal is applied to the Trigger View Amplifier (diagram 2). When the front-panel TRIG VIEW switch is pressed in, the Trigger View Amplifier is enabled to pass the Trig View signal on to the Delay Line Driver for display on the crt.

## B Trigger Source Switching

In addition to the A Trigger sources (VERT MODE, CH 1, CH 2, and EXT), the B SOURCE switch has a  $\Delta$  TIME and a RUNS AFTER DLY position. The  $\Delta$  TIME position provides for delta time measurements. The RUNS AFTER DLY position enables the B Sweep to commence immediately after the delay time established by the B DELAY TIME POSITION control.

The B SOURCE switching circuitry is included in the components located in the lid of the instrument. A simplified schematic of the B SOURCE switching and the External B Trigger Amplifier is shown in Figure 3-9.

For each of the triggered sweep selections (VERT MODE, CH 1, CH 2, and EXT), a portion of the B SOURCE switch (S2, diagram 11) controls the source selection voltages to the B Trigger Generator (U122, diagram 5). Switching transistors on the Source Select lines (U365A, B, C, and D) are forward biased whenever the B SOURCE associated with that select line is not selected. The transistors conduct and apply the –5-V emitter voltage to the Trigger Input pins of the B Trigger Generator (U122, diagram 5). The negative voltage keeps the B Trigger Generator IC emitter followers reverse biased to keep the Trigger Input pins inactive.

When the B SOURCE switch is set to VERT MODE, CH 1, CH 2, or EXT, –10 V is applied to the base of the associated switching transistor. The negative voltage will reverse bias the selected transistor to shut it off. The Trigger Select line of the off transistor goes to 0 V, and the associated Trigger Input pin of U122 becomes active.

$\Delta$  TIME/RUNS AFTER DLY/SLOPE. A second set of contacts on the B SOURCE switch controls the  $\Delta$  Time/Runs After Dly/Slope signal line. The voltage levels applied to this signal line control the Delay Time Position switching, the B Reset signal line, and both the Slope and Free Run inputs of U122 (the B Trigger Generator). Delay Time Position switching and the B Reset signal are discussed in the text pertaining to those circuits.

A simplified diagram of the Slope and  $\Delta$  Time/Runs After Dly switching is included in Figure 3-9.

In both the  $\Delta$  TIME and RUNS AFTER DLY switch positions, the B Trigger Generator Free Run input (pin 2) is held HI. Selecting RUNS AFTER DLY applies +5 V to the signal line. Diode CR50 (diagram 11) becomes reverse biased, and the SLOPE switch is isolated from the signal line. Diode CR63 (diagram 6) also becomes reverse biased,

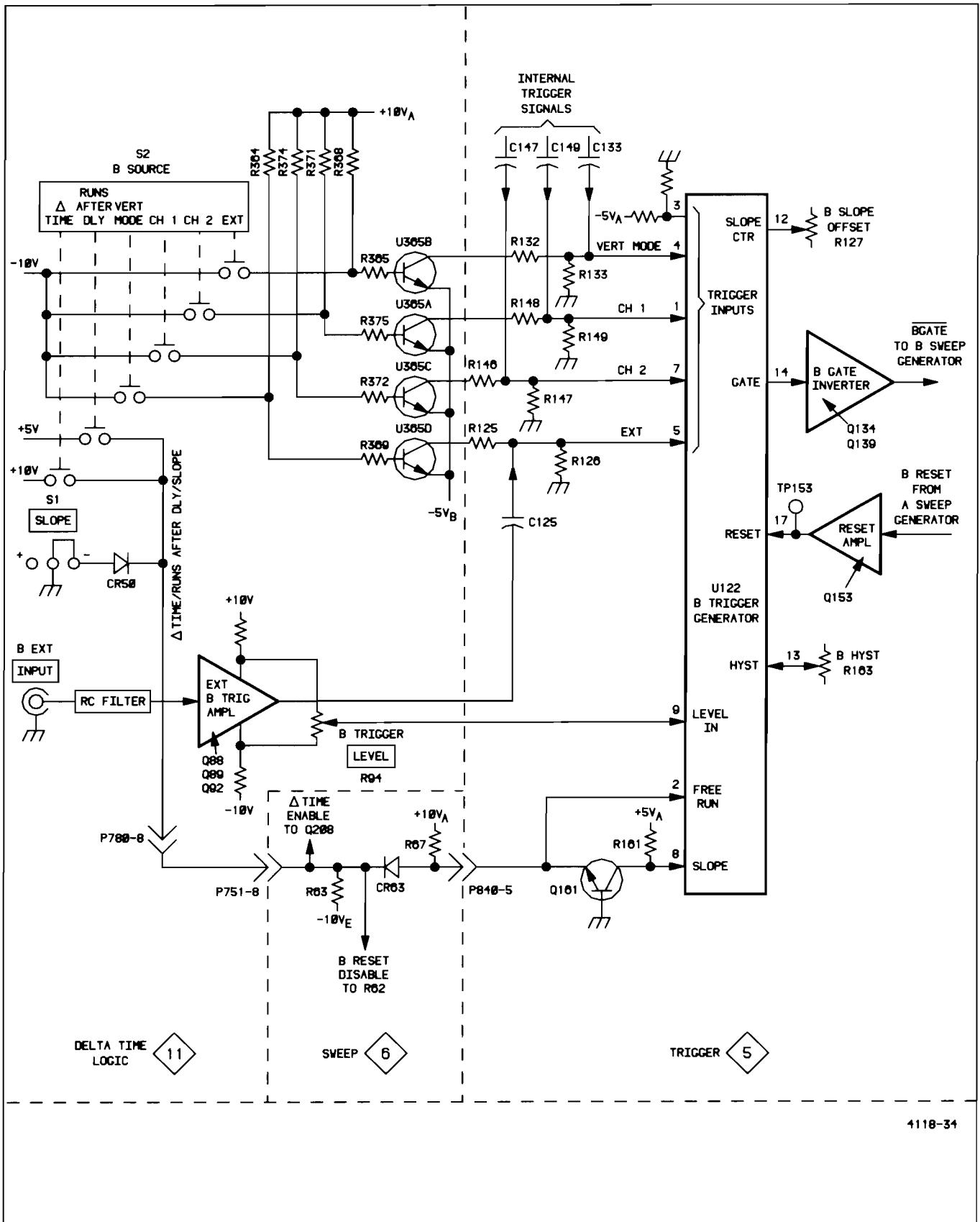

Figure 3-9. Simplified diagram of the B Trigger Generator and B Source and B Slope switching circuitry.

and that allows the Free Run input pin of U122 to be pulled HI from the +10-V level applied to the signal line via R67.

Selecting the  $\Delta$  TIME position of the B SOURCE switch applies +10 V to the signal line. Diode CR63 remains reverse biased so the added voltage does not change the conditions at the B Trigger Generator on pins 2 and 8. The additional voltage serves to control the bias on Q208 (diagram 6). Transistor Q208 controls the enabling voltage on CMOS bilateral switch U216B in the B Delay Time Position and  $\Delta$  Time Position switching circuit. Further discussion of this circuit is contained in the description of the B Delay Time Position and Prescaling circuit.

SLOPE switch S1 is functional when any trigger source other than  $\Delta$  TIME or RUNS AFTER DLY is selected. Both the +5 V and the +10 V are removed from the signal line, and the SLOPE switch then either grounds the line (–SLOPE) or leaves it open (+SLOPE). When the signal line is grounded, diode CR50 is forward biased by the –10 V applied via R63. The cathode voltage of CR63 is then approximately –0.7 V (the drop across CR50), and diode CR63 is forward biased by the +10 V applied via R67. With an additional 0.7 V dropped across CR63, the voltage applied to the Free Run input of U122 is approximately 0 V. The Trigger Generator does not free run, and transistor Q161 is held off. Pin 8 of U122 is pulled HI by the +5 V applied via pull-up resistor R161. With pin 8 HI, an output gate from U122 will be produced during the negative slope of the input trigger signal.

When the SLOPE switch is set to the + position, the signal line becomes open through CR50. This allows the cathode end of CR63 to be pulled down to –10 V via R63. The anode end of the forward-biased diode also moves more negative, and Q161 is biased on. Pin 8 of U122 is pulled LO, and now an output gate is produced from U122 during the positive slope of the input trigger signal.

### B External Trigger Amplifier

A trigger signal applied to the B Trigger External INPUT connector is ac coupled to the B External Trigger Amplifier via an RC bandwidth filter. The filter response limits the B External Trigger bandwidth to a range of 30 Hz to 20 MHz. Protection diodes CR85 and CR86 prevent excessive amplitude trigger signals from being accidentally applied to the gate of source-follower Q88.

The amplifier is composed of source-follower Q88, constant-current source Q89, and emitter-follower Q92. In addition to acting as a constant-current source for Q88, FET Q89 also provides thermal compensation for the amplifier stage. The output trigger signal is taken from the

emitter circuit of Q92 and fed to the B Trigger Generator (diagram 5), where it is available for selection as the B Trigger signal.

B Trigger LEVEL control R94 is connected between the +10-V and –10-V supplies of the Trigger Amplifier. The triggering level of the B Trigger Generator is set by the dc level established by the LEVEL control.

### B Trigger Generator

B Trigger Generator IC U122 operates in a manner similar to the A Trigger Generator IC. Integrated circuit U122 generates the Gate signal used to control the B Sweep Generator (U24, diagram 6). When the Gate signal at U122 pin 14 is LO, the B Sweep Generator will not be enabled to produce a sweep signal.

When the B sweep is triggered (VERT MODE, CH 1, CH 2, or EXT), the first triggering signal that occurs after the delay time has elapsed will cause the Gate signal at pin 14 to go HI, and the B Sweep Generator will initiate a sweep signal. When either the  $\Delta$  TIME or RUNS AFTER DLY B Trigger SOURCE is selected, the Free Run input of U122 is held HI. In this condition, the Gate signal at pin 14 is also held HI. Inverter circuit Q134 and Q139 inverts the Gate signal to  $\overline{\text{B GATE}}$  and applies it to the B Gate input pin of U24 (pin 13). With a LO on U24 pin 13, the B Sweep Generator will initiate a B Sweep signal on receipt of a Delayed Gate signal from the A Sweep Generator (U43).

## SWEEP

The Sweep circuitry, shown on schematic diagram 6, is composed of the A and B Sweep Generator IC, the Sweep Control IC, the Miller Sweep circuit, and the B DELAY TIME POSITION control circuitry. Logic levels necessary to control the sequence of events associated with sweep generation, both A and B Sweep signals, and crt unblanking signals are produced by the Sweep circuitry.

### A and B Sweep Generators

The A and B Sweep Generators produce linear sawtooth voltages which are amplified by the Horizontal Amplifier circuit to produce the crt display horizontal deflection. Both Sweep Generator integrated circuits also produce Z-Axis signals that unblank the crt during the appropriate sweep time and establish the display intensity. The A and B Sweep Generator circuits are contained in two identical 16-pin integrated circuits, U43 and U24 respectively.

The following is a brief description of the function associated with each of the pins of the IC device used for U43 and U24.

## Theory of Operation—2336 Service

Pin 1: Delay Time In (used in the A Sweep Generator IC only). In RUNS AFTER DLY, this pin connects to the B DELAY TIME POSITION control. The dc level from this control is used to vary the time between the start of the A Sweep and the start of the Delayed Gate output at pin 16. In  $\Delta$  TIME, the Delay Time input voltage will alternate between the level set by the B DELAY TIME POSITION control and that set by the  $\Delta$  TIME POSITION control. For  $\Delta$  TIME measurements, either two intensified zones (A INTEN HORIZ MODE) or two alternated B Sweeps (B HORIZ MODE) will be displayed.

Pin 2: Miller Out. Connects to the ramp output signal from the Miller Sweep circuit.

Pin 3: Current Source. Sets the internal operating current levels.

Pin 4: Miller Null Retrace Current. Supplies retrace current and feedback to set the sweep-start voltage on the Miller Sweep circuit.

Pin 5: Sweep Out. The sweep output signal is present on this pin; it is applied to the Horizontal Amplifier circuit. The output can be switched off and on by the logic level on pin 7.

Pin 6: Start Level Current In. Sets current levels that determine the Miller Sweep start voltage.

Pin 7: Sweep Switch In. Enables the sweep output signal at pin 5. When pin 7 is LO, a sweep output can occur; when HI, the sweep output is disabled and pin 5 is held at  $-3$  V.

Pin 8:  $V_{EE}$ . Connects to the  $-5$ -V supply.

Pin 9: Ground. Ground connection point for the IC.

Pin 10: Holdoff Start Out. Provides an output pulse to U87 to start the holdoff timing ramp when the sweep ramp reaches its maximum negative level.

Pin 11: Intensity In. Current from Q218, controlled by the front-panel INTEN potentiometer, is supplied to this point to establish the level of unblanking current produced at pin 12.

Pin 12: Crt Unblanking Out. Z-Axis unblanking current supplied from this pin to the Z-Axis Amplifier determines the display intensity during sweep times. During nonsweep times, the crt is blanked by the absence of the unblanking current.

Pin 13: A Gate In (U43) and B Gate In (U24). The logic level on this pin is used in conjunction with the logic level on pin 14 (Sweep Disable on U43; Delayed Gate In on U24) to start and stop the sweep. A negative-going gate pulse applied to pin 13 starts the sweep if pin 14 is LO. Also, a negative-going gate pulse applied to pin 14 starts the sweep if pin 13 is LO. When either  $\Delta$  TIME or RUNS AFTER DLY is selected, pin 13 of B Sweep Generator U24 is held LO by the B Gate signal from B Trigger Generator U122. In this condition, the Delayed Gate signal on pin 14 controls the start and stop of the B Sweep. In the triggered B Sweep modes (VERT MODE, CH 1, CH 2, or EXT), after the delay time has elapsed, the Delayed Gate is applied to U24 pin 14 to enable the next triggering signal received at the B Trigger Generator to initiate a B Sweep.

Pin 14: Delayed Gate In (U24) or Sweep Disable (U43). See "Pin 13" discussion for the use of pin 14 in conjunction with pin 13. In the A Sweep Generator IC, when X-Y VERTICAL MODE is selected, pin 14 (Sweep Disable) is switched HI to prevent any sweep from being generated. Horizontal deflection of the display is accomplished using the signal applied to the CH 1 OR X input connector. In the B Sweep Generator IC, the Delayed Gate produced from pin 16 of the A Sweep Generator IC is applied to this pin to control the B Sweep as described in the "Pin 13" discussion.

Pin 15:  $V_{CC}$ . Connects to the  $+5$ -V supply.

Pin 16: Delayed Gate Out (used in the A Sweep Generator IC only). A Delayed Gate pulse produced at this pin is applied to pin 14 (Delayed Gate In) of the B Sweep Generator IC. The delay time between the start of the A Sweep and the generation of the Delayed Gate is determined by the B DELAY TIME POSITION control setting in RUNS AFTER DLY. In  $\Delta$  TIME the delay time is alternated between that set by the B DELAY TIME POSITION control and that set by the  $\Delta$  TIME POSITION control.

In addition, the B Reset signal is derived from the logic level at U43 pin 16. For triggered B Sweep modes, the B Reset signal coincides with the end of the Delayed Gate. In RUNS AFTER DLY and  $\Delta$  TIME, the B Reset signal is held LO by U365E, and the B Trigger Generator is not reset. Thus, the B Gate signal to U24 pin 13 is held LO, and the Delayed Gate from U43 pin 16 controls the start and stop of the B Sweep.

## B Delay Time Position and $\Delta$ Time Position Circuit

The B DELAY TIME POSITION control, R918A, and the  $\Delta$  TIME POSITION control, R918B, set dc levels at U43 pin 1 (Delay Time In). The voltage levels from these two controls are multiplexed when the B SOURCE switch is set to  $\Delta$  TIME. Otherwise, only the B DELAY TIME POSITION control voltage is used to establish the delay time.

The dc level (between +2 V and -2 V) is compared with the A Sweep ramp level in a delay pickoff comparator within U43. When the A Sweep ramp crosses the dc level set by either the B DELAY TIME POSITION control or the  $\Delta$  TIME POSITION control, a Delayed Gate is produced at U43 pin 16.

The voltage levels applied to the ends of potentiometers R918A and B are produced by two operational amplifiers, U198A and U198B. The two amplifiers are biased to produce stable voltages of +2 V and -2 V respectively when either A INTEN or B HORIZ MODE is selected.

Pressing in the A HORIZ MODE push button places +5 V on the anode end of both CR195 and CR193. Amplifiers U198A and U198B are then biased to produce outputs of -4 V to both ends of R918A and B, and the delay pickoff comparator within U43 is disabled. A Delayed Gate is not generated at U43 pin 16; therefore, a B Sweep is not started by the B Sweep Generator.

Buffer amplifiers U197A and U197B amplify the dc voltage level from the delay time position controls and provide the drive level to the Prescaling circuit for use when delta time measurements are being made. Further discussion of the Prescaling circuit is located in the "Delta Time" circuit description. CMOS switch U216B is switched when the two dc voltage levels are multiplexed.

In all B Trigger Modes except  $\Delta$  TIME, Q208 is biased on. With Q208 conducting, +5 V is applied to U216B pin 9, and pin 3 of the bilateral switch is connected to pin 4. Therefore, only the B DELAY TIME POSITION control voltage level is passed to the A Sweep Generator. When the A HORIZ MODE is selected, +5 V is applied from S218 to pin 9 of U216B via CR202 to prevent U216B from switching to the  $\Delta$  TIME POSITION control output voltage even if  $\Delta$  TIME B SOURCE is selected.

When  $\Delta$  TIME B SOURCE is selected, +10 V is applied to the  $\Delta$  Time/Runs After Div/Slope signal line. This voltage level causes Q208 to become reverse biased, and the +5 V from Q208 to U216B pin 9 is removed. If either A INTEN or B HORIZ MODE is also selected, CR202 is

reverse biased and the Alt Sync signal applied to U216B pin 9 via CR208 is enabled to drive U216B.

In this condition, the dc level applied to the Delay Time In pin of U43 alternates between the output voltage of U197A and the output voltage of U197B. On one A Sweep the Delayed Gate to the B Trigger Generator will be generated at a delay time set by the B DELAY TIME POSITION control, and on the next A Sweep the Delayed Gate will be generated at a delay time set by the  $\Delta$  TIME POSITION control. The result is either two intensified zones on the A Sweep (if A INTEN HORIZ MODE is selected) or two alternating B Sweeps (if B HORIZ MODE is selected).

## +35-V Regulator

A stable voltage source is required for proper operation of the Miller Sweep circuits. Regulator IC U3 develops the +34-V charging voltage that is applied to the Miller Sweep timing capacitors. The Regulator develops the +34 V from the +40-V supply.

## Miller Sweep Generator

Transistors Q80, Q81, Q83, and the selected RC timing elements (determined by the A SEC/DIV switch position) make up the A Miller Sweep Generator. Both the A Sweep and B Sweep circuits operate in a similar manner. The A Sweep circuit is discussed to explain circuit operation. Any differences in circuit operation between the A Sweep and the B Sweep are also discussed.

When both pins 13 and 14 of U43 are LO, the minus input of the internal Sweep Start Comparator is pulled LO, and the Comparator output at pin 4 of U43 becomes a high impedance. Timing capacitor  $C_t$  then begins to charge toward +32 V through  $R_t$ . The gate of Q80 (connected to the junction of  $C_t$  and  $R_t$ ) begins to go positive as it follows the charge on  $C_t$ . The resulting increase in current through Q80 decreases the current through Q81 to produce a positive-going voltage rise at the base of Q83. The Q83 collector voltage decreases, and the negative side of  $C_t$  follows. This action results in a negative-going voltage applied across  $C_t$  that maintains a constant charging current through  $C_t$ . The linear charging current produces a linear, rather than exponential, rate of fall to the sawtooth output signal.

The sawtooth output voltage continues to fall until it reaches -2.4 V. At that point, the End-of-Sweep Comparator contained in U43 initiates the Holdoff Start pulse at U43 pin 10. The Holdoff Start pulse starts the sweep holdoff time and resets the A Sweep IC by removing the A Gate from U43 pin 13.



## Theory of Operation—2336 Service

When the A Sweep IC resets, the Delayed  $\overline{\text{Gate}}$  signal from U43 pin 16 goes HI to reset the B Sweep Generator. In the triggered B Sweep modes, the B Trigger Generator is also reset by U43 pin 16 going HI. When either the  $\Delta$  TIME or RUNS AFTER DLY B Sweep mode is selected, the B Trigger Generator is not reset when the A Sweep ends, and the B  $\overline{\text{Gate}}$  signal remains LO at U24 pin 13.

In X-Y VERTICAL MODE, the X-Y Enable signal is applied to U43 pin 14 (Sweep Disable input) to prevent the A Sweep from being generated.

Delay Start potentiometer R74 and B Time potentiometer R10 permit adjustment of the quiescent current levels of Q81 and Q16 in the A and B Sweep circuits respectively. These current levels set the starting points for the sweep output signals.

### Sweep Control Integrated Circuit

The Sweep Control integrated circuit is U87. Several functions are performed in this stage, depending on the mode of operation of the instrument. The following list is a brief explanation of the function associated with each pin of the IC.

**Pin 1: NORM Mode.** When this pin is grounded through the A Trigger Mode switch, S210, the sweep operates in the single-sweep mode. When the ground is removed from this pin (by pressing in the NORM push button), the sweep operates in the repetitive mode.

**Pin 2: Single Sweep Reset.** Pressing in and releasing the SGL SWP push button prepares the single-sweep circuitry to respond to the next triggering event. The READY LED will illuminate and remain on until a trigger occurs.

**Pin 3: Auto Timing.** With AUTO Trigger Mode selected, R100 and C100 determine the amount of time between the end of holdoff and the generation of the AUTO  $\overline{\text{Gate}}$  when no triggering signal is received. If no triggering signal is received within about 100 ms, the charge on C100 will be sufficient to place a HI on pin 3, thus causing the Auto Gate signal to occur.

**Pin 4: Auto Mode.** Grounding this pin through Trigger Mode switch S210 enables automatic sweep mode operation.

**Pin 5: Logic  $\overline{\text{Gate}}$ .** The A  $\overline{\text{Gate}}$  from the A Trigger Generator is applied here to prevent an Auto  $\overline{\text{Gate}}$  from occurring and to control the TRIG'D and READY LED.

**Pin 6: Auto  $\overline{\text{Gate}}$ .** When in the automatic sweep mode, the gate output from this pin triggers the sweep if a trigger signal does not occur within about 100 ms after holdoff ends.

**Pin 7: A Gate.** The gate provided from this pin synchronizes alternate trace switching in the Vertical Switching Logic circuitry.

**Pin 8: Ground connection for the IC.**

**Pin 9: Holdoff Out.** The gate level present here is LO during sweep holdoff time and HI otherwise. This gate is used to reset the Trigger Generator circuitry. While this pin is LO, a triggering signal cannot be generated from the Trigger Generator circuitry.

**Pin 10: Holdoff Timing.** The RC timing networks selected by the A SEC/DIV switch are connected between this pin and pin 11. The TRIG HOLDOFF (PUSH) VAR control (on diagram 7) may be used to vary the amount of holdoff time from that produced by the fixed holdoff timing components.

**Pin 11: Holdoff Ramp.** A negative-going holdoff ramp is present on this pin. The slope of the ramp determines the sweep holdoff time.

**Pin 12: Holdoff Start.** A positive-going end-of-sweep pulse is applied to this pin. The pulse terminates any Sweep Control output gates, starts the holdoff ramp, and initiates the A Reset pulse to the A Trigger Generator.

**Pins 13 and 15: Triggered and Ready Light.** In NORM or AUTO Trigger Mode, pin 13 illuminates the TRIG'D-READY LED to indicate that a triggered gate has occurred. In SGL SWP Trigger Mode, pin 15 illuminates the TRIG'D-READY LED to indicate that the Sweep Control IC is prepared to generate a single sweep when a triggering signal occurs.

**Pin 14: Light Ground.** Provides a ground point for the TRIG'D-READY LED.

**Pin 16: The +5-V supply to the IC.**

### A Horizontal Mode

When an adequate triggering signal is applied to the A Trigger Generator (U81, diagram 5), a gate signal is produced at U81 pin 14 (see Figures 3-10 and 3-11). The

gate in inverted and its level shifted by Q89 to become the A Gate signal. This signal is applied via CR87 to U87 pin 5 (the Logic Gate input of the Sweep Control IC) and via CR88 to U43 pin 13 (the A Gate input of the A Sweep Generator IC). In response to the application of A Gate, U43 starts a negative-going A Sweep ramp at U43 pin 5.

In Sweep Control IC U87, application of the A Gate signal at pin 5 prevents the generation of an Auto Gate output at pin 6. Output gates automatically occur at pin 6

in the AUTO Trigger Mode if a triggering signal does not occur within about 100 ms after holdoff has ended.

When the A Sweep ramp reaches a predetermined level (within U43), a Holdoff Start signal is produced at U43 pin 10. Holdoff Start is applied to Sweep Control IC U87 at pin 12 to cause the A Reset signal at U87 pin 9 to go HI. The HI A Reset signal is then applied to Trigger Generator U81 at pin 17 via Q104 to reset U81, and the A Gate signal (applied to U43 at pin 13) goes HI.

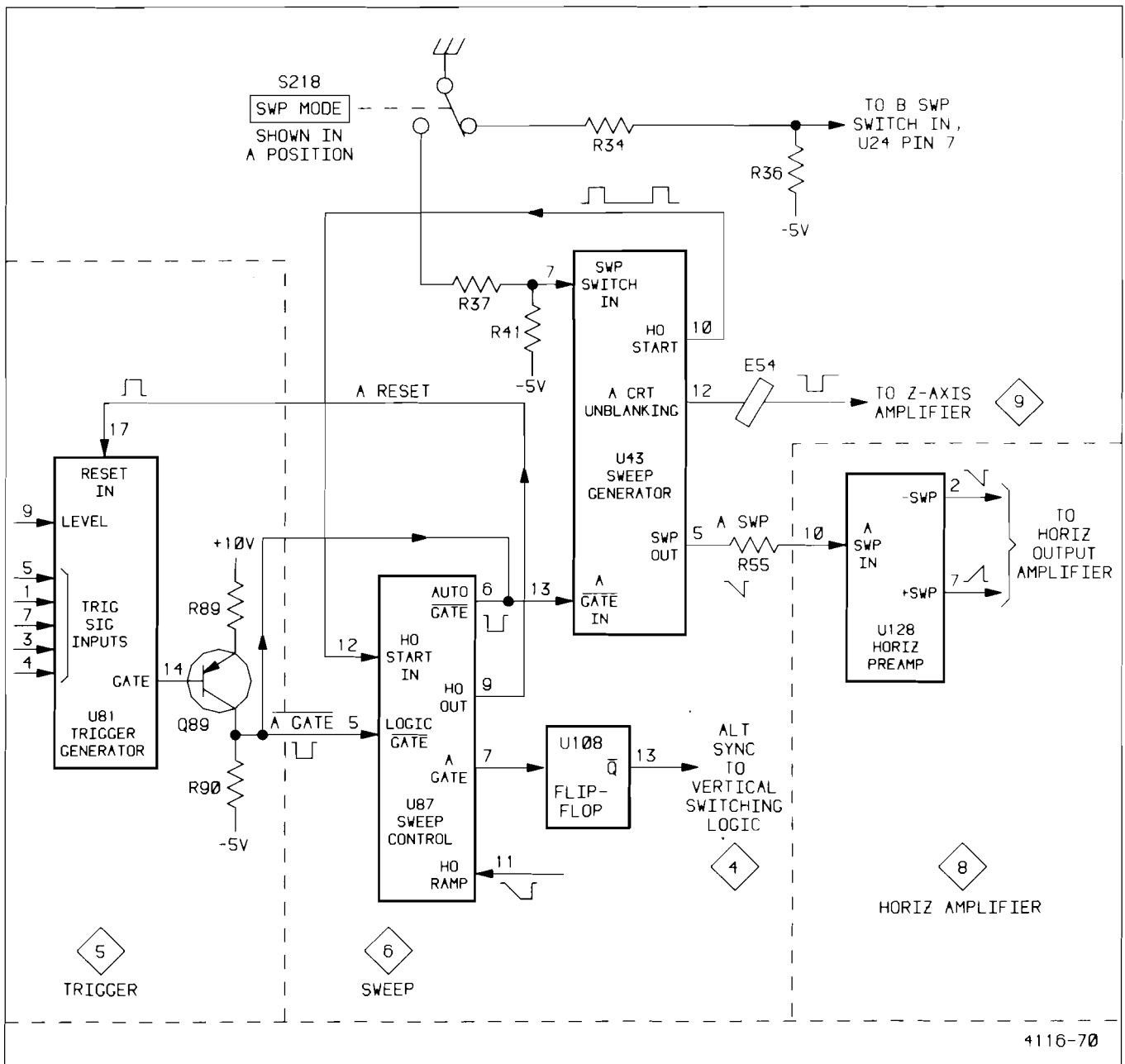

Figure 3-10. Sweep operation in the A Sweep Mode.

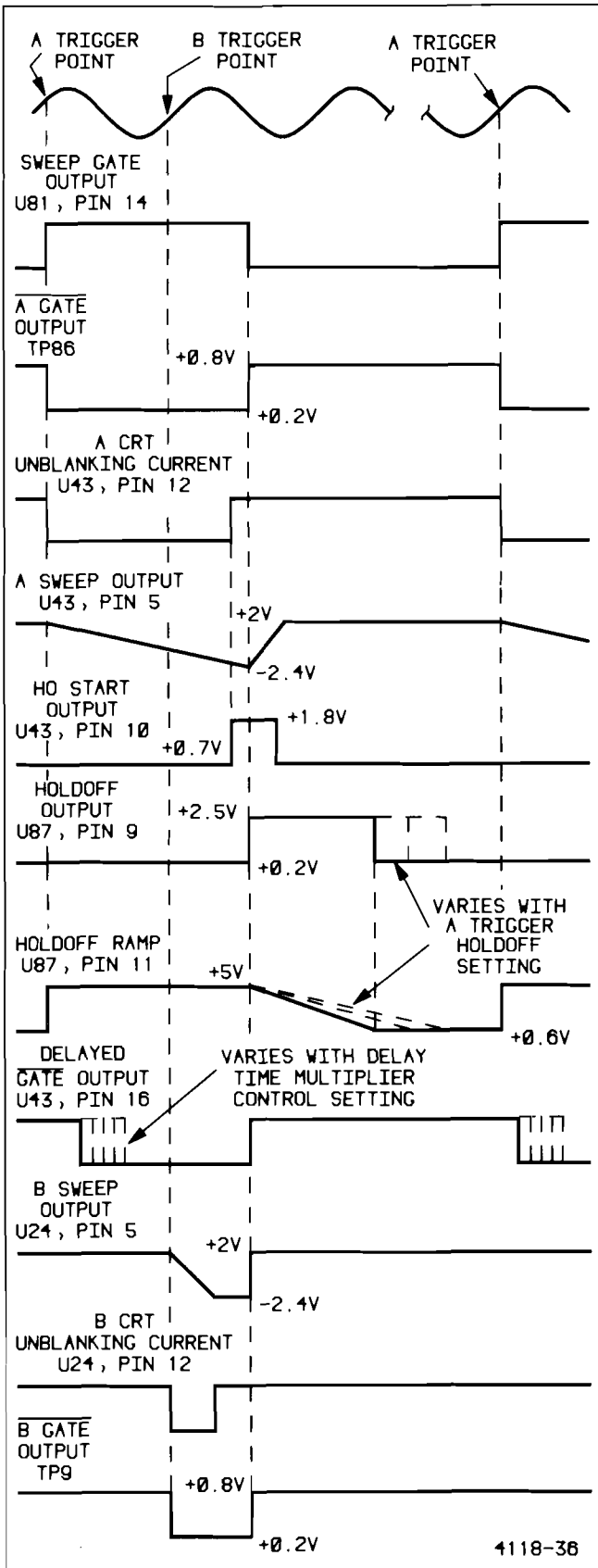

Figure 3-11. Sweep circuit waveform relationships.

At that point, Holdoff Start at U43 pin 10 goes LO and is applied to U87 pin 12. With Holdoff Start LO, the negative-going Holdoff ramp at U87 pin 11 starts. When the ramp level reaches about  $-2\text{ V}$ , the A Reset signal at U87 pin 9 returns LO to remove the reset signal from the Trigger Generator. Trigger Generator U81 is now able to respond to another triggering signal.

The Holdoff ramp at U87 pin 11 stays LO until another triggering signal occurs. When either the A Gate is generated by U81 or an Auto Gate is generated by U87, the Holdoff ramp is reset HI in preparation for the next Holdoff timing period.

From U87 pin 7, the A Gate signal is used to clock Alt Sync Flip-flop U108. The output pulse from U108 pin 13 (the  $\bar{Q}$  output pin) is applied to the Vertical Switching Logic circuitry to synchronize vertical switching between channel displays when ALT VERTICAL MODE is selected.

When  $\Delta$  TIME is selected, the Alt Sync pulse is also applied to CMOS switch U216B via CR208. The Alt Sync pulse switches the delay time between that set by the B DELAY TIME POSITION control and that set by the  $\Delta$  TIME POSITION control.

When either A or A INTEN HORIZ MODE is selected, U43 pin 7 is held LO to enable the A Sweep output signal at U43 pin 5; and pin 7 of U24 (the B Sweep Generator) is held HI to prevent a B Sweep signal output from occurring. For the A INTEN HORIZ MODE however, the B Crt Unblanking output signal continues to be provided to the Z-Axis Amplifier to intensify the A Sweep during the B Sweep period.

In the A INTEN HORIZ MODE, selecting  $\Delta$  TIME B Trigger SOURCE, will present two intensified zones alternated on the A Sweep. One corresponds to the delay set by the B DELAY TIME POSITION control; the other corresponds to the delay set by the  $\Delta$  TIME POSITION control.

### B Horizontal Mode

In the B HORIZ MODE (Figure 3-12), the A Sweep Generator continues to operate much the same as it does in the A HORIZ MODE. However, both the A Sweep output at U43 pin 5 and the Crt Unblanking output at U43 pin 12 are disabled to prevent any A trace display. The A Sweep ramp continues to be generated within U43 to control the delay timing and sweep resetting functions required for the B HORIZ MODE.

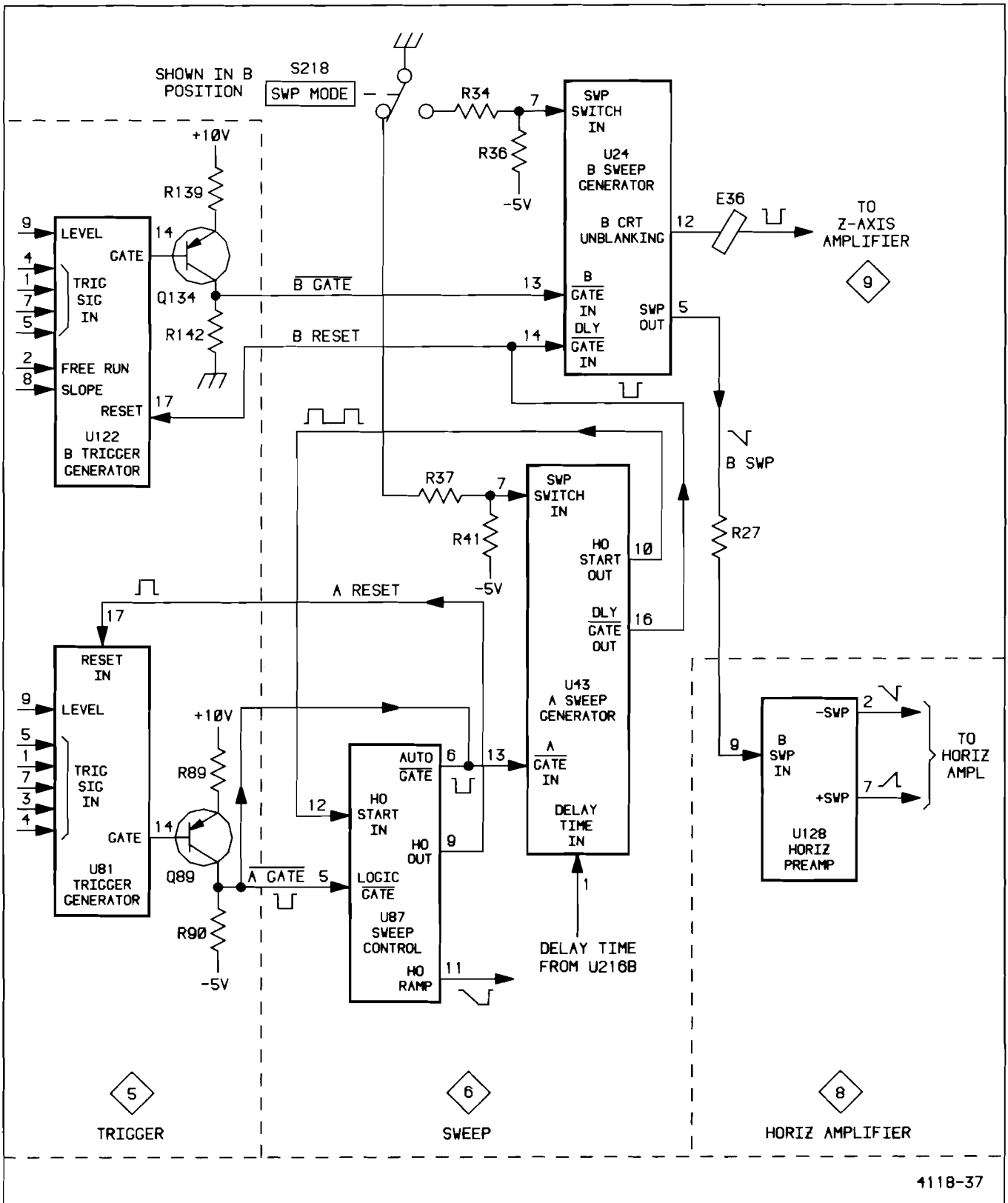

Figure 3-12. Sweep operation in the B Sweep Mode.

## Theory of Operation—2336 Service

The B Sweep runs only once per A Sweep, and it is initiated by one of two gate signals. Both the Delayed Gate at U24 pin 14 and the B Gate at U24 pin 13 interact to control the actual sweep start.

If one of the triggered B Sweep modes is in use, the B Sweep is initiated by the first triggering signal that occurs after the delay time set by the B DELAY TIME POSITION control has elapsed. When the A Sweep ramp within U43 reaches the level set at U43 pin 1, a Delayed Gate is generated at U43 pin 16. This gate signal does two things: first, it sets U24 pin 14 LO to enable the B Sweep Generator; and second, it removes the B Reset signal from the B Trigger Generator to enable the B Trigger Generator (U122, diagram 5).

The next triggering signal received by U122 will cause the B Gate signal at U24 pin 13 to go LO and a B Sweep is initiated. At the end of the A Sweep ramp, the Delayed Gate at U43 pin 16 goes HI again, and both the B Trigger Generator and the B Sweep Generator become reset.

The sequence of events is altered when either  $\Delta$  TIME or RUNS AFTER DLY B Trigger SOURCE is selected. In either of these cases, the Free Run input of B Trigger Generator U122 is held HI (in the Free Run mode), and the B Gate signal to the B Sweep Generator is held LO. In this condition, a B Sweep will be initiated immediately upon receipt of the Delayed Gate from U43 pin 16.

At the end of the A Sweep ramp, when the Delayed Gate goes HI, pin 14 of U24 is allowed to go HI to reset the B Sweep Generator. However, the B Reset signal is held LO by U365E being forward biased, and the B Trigger Generator is not reset.

The crt is unblanked for the duration of the B Sweep by a B Crt Unblanking signal produced at U24 pin 12. When the B Sweep ramp reaches a predetermined level within U24, the Crt Unblanking signal current drops to zero, and the crt becomes blanked again. The B Sweep ramp finishes its rundown but remains LO until it is reset by the removal of the Delayed Gate signal from U24 pin 14 (see Figure 3-11).

### A INTEN Horizontal Mode

In the A INTEN HORIZ MODE, both the A and B Sweep Generators operate, but the B Sweep output at U24 pin 5 is disabled by a HI placed on U24 pin 7 via the HORIZ MODE switch. The B Crt Unblanking signal (produced at U24 pin 12 during the B Sweep time) adds to the A Crt Unblanking signal to produce the intensified zone(s) on the crt display trace.

### X-Y Mode

When both CH 1 and CH 2 VERTICAL MODE push buttons are pressed in, the X-Y display is enabled. The X-Y Enable signal is applied to U43 pin 14 to disable both the A and B Sweep outputs to the Horizontal Amplifier. However, the X-Y Enable signal is also supplied to the Intensity inputs of both Sweep Generators to produce a fixed crt unblanking output level to the Z-Axis Amplifier. The X-Y Enable signal is applied to both Sweep Generators at pin 11 (via CR29 and R29 to U43; via CR47 and R47 to U24) so that the crt can be unblanked regardless of the Horizontal Mode selected. Additional intensity signal current from Q218 (required to set the crt display intensity to the desired viewing brightness) is added to the fixed X-Y level via HORIZ MODE switch S218.

## A AND B TIMING SWITCHES

The switching circuitry shown in schematic diagram 7 includes the switching contacts and timing components for each position of the A and B SEC/DIV switches. Also shown is the Variable Time and Variable Trigger Holdoff control circuitry. Switch contacts for the holdoff timing are included in diagram 7, but the holdoff timing components are shown in diagram 6.

Contacts on the A SEC/DIV switch supply setting information to both the Prescaling circuit (diagram 6) and the Scale Factor Decoding circuit (diagram 11). The position information sets the Prescaling voltage divider for the appropriate dividing ratio and determines the scale factor to be displayed in the LCD readout when  $\Delta$  TIME measurements are made.

## HORIZONTAL AMPLIFIER

The Horizontal Amplifier circuit, shown on schematic diagram 8, provides the output signals that drive the horizontal crt deflection plates. The signal that is applied to the Horizontal Preamplifier IC (U128) is determined by the HORIZ MODE and VERTICAL MODE switches. Horizontal deflection signals can come from either of the Sweep Generators or from the CH 1 OR X input connector (X-Y display). See Figure 3-13 for a detailed block diagram of the Horizontal Amplifier.

### Horizontal Preamplifier

Horizontal Preamplifier IC U128 converts single-ended input signals into the differential output signals necessary for proper crt deflection. Horizontal positioning, magnifier registration, X10 magnification, and X-Axis signal amplification (X-Y mode) are also accomplished in U128.

The following is a brief description of the function associated with each pin of U128.

**Pin 1: Magnifier Registration.** This pin is used in conjunction with pin 8 to provide for registration adjustment between normal and magnified sweeps. The Horizontal Beam Find voltage is also applied between pins 1 and 8 to reduce the horizontal deflection of a signal to within the graticule area.

**Pin 2: Horizontal I (-).** Negative differential signal current at this pin is applied to the Horizontal Output Amplifier.

**Pin 3: Gain Set.** The amplifier gain setting circuitry is connected between this pin and pin 6. Relay K127 is actuated by the front-panel X10 MAG push button to switch either the X1 or X10 gain-setting components into the circuit.

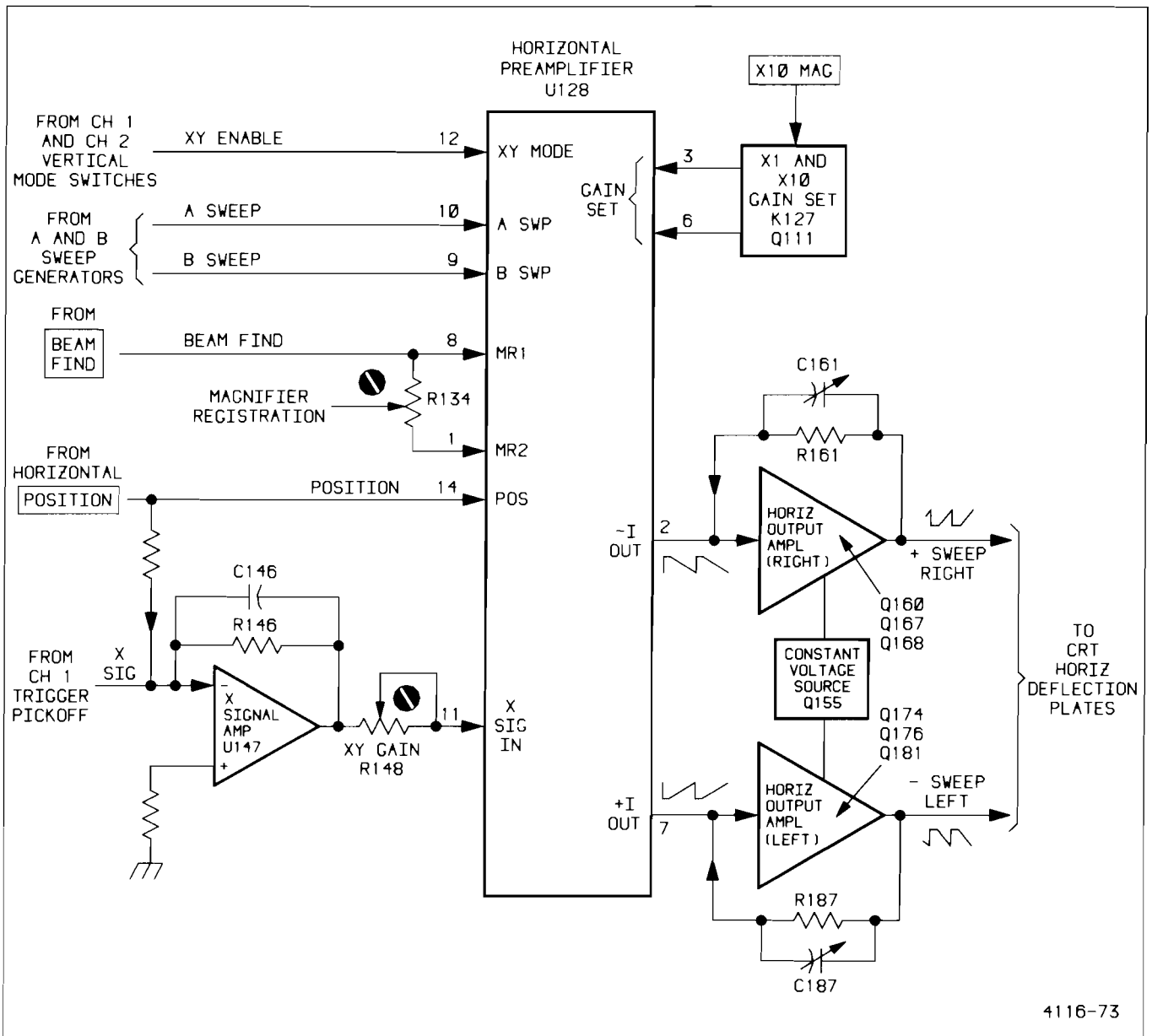

Figure 3-13. Horizontal Amplifier, detailed block diagram.

## Theory of Operation—2336 Service

Pin 4:  $V_{EE}$ . The  $-5\text{-V}$  supply is applied to the IC at this pin.

Pin 5: Bias. The internal biasing current is supplied to this pin from the  $+40\text{-V}$  supply via R149.

Pin 6: Gain Set. This pin is used in conjunction with pin 3 for connection of the amplifier gain-setting components.

Pin 7: Horizontal I (+). Positive differential signal current at this pin is applied to the Horizontal Output Amplifier.

Pin 8: Magnifier Registration. See Pin 1 discussion.

Pin 9: B Sweep. Input pin for the B Sweep signal.

Pin 10: A Sweep. Input pin for the A Sweep signal.

Pin 11: X Signal. Input pin for the X-Axis signal from Channel 1 when the X-Y display feature is in use.

Pin 12: X-Y Mode. Switches the amplifier circuitry to amplify the signal connected to pin 11. A LO on pin 12 is normal for A or B Sweep amplification.

Pin 13: Frequency Compensation. Connects to frequency compensating capacitor C149.

Pin 14: Horizontal Position. Input pin for the Horizontal POSITION control signal.

Pin 15:  $V_{CC}$ . The  $+5\text{-V}$  supply is applied to the IC at this pin.

Pin 16: Ground. This pin provides the ground connection point for the IC.

### X-Signal Amplifier

A circuit composed of U147 and associated components performs several signal-processing functions on the X-Axis signal prior to its application to the Horizontal Preamplifier.

The X-Axis signal is derived from the CH 1 Trigger signal output of the Channel 1 Vertical Preamplifier (U30,

diagram 2). The CH 1 Trigger signal is thermally compensated in the Channel 1 Preamplifier. Effects of the thermal compensation are eliminated from the X-Axis signal by the RC network composed of R142, C141, and R141. The network also supplies the input impedance for U147.

Horizontal positioning from the Horizontal POSITION control is added to the X-Axis signal via R139. The resulting signal is applied to the inverting input of U147 to establish the correct signal polarity for application to Horizontal Preamplifier U128.

Stage gain of U147 is approximately two and is set by both R146 and the input resistance to U147. Capacitor C146 provides high-frequency compensation for U147. The calibrated X-Axis signal gain is adjustable by X-Y Gain potentiometer R148.

### Horizontal Output Amplifier

The Horizontal Output Amplifier circuit consists of two complementary, feedback-amplifier halves. One half amplifies the negative-going current signal from the Horizontal Preamplifier (U128 pin 2), and the other half amplifies the positive-going current signal at U128 pin 7.

The negative-going signal amplifier is composed of Q160, Q167, and Q168; the positive-going signal amplifier is composed of Q174, Q176, and Q181. Transistor Q155 is a constant-voltage source which is common to both input transistors (Q160 and Q174).

Input transistors Q160 and Q174 are common-emitter, inverting amplifiers with low input impedance. The base voltage on the transistors varies only a small amount during the change in signal current. Quiescent base voltages of Q160 and Q174 are held to nearly the same dc level by the action of constant-voltage-source transistor Q155 along with CR160 and CR175.

The inverted signal current at the collectors of Q160 and Q174 drive the emitters of a pair of complementary common-base amplifiers. Transistor pair Q167 and Q168 (driven by Q160) provides the voltage to the right horizontal deflection plate, and transistor pair Q176 and Q181 (driven by Q174) provides the voltage to the left horizontal deflection plate.

The transistors in a complementary pair (Q167 and Q168 in the right side, and Q176 and Q181 in the left side) share a common current path. The pairs are arranged so that the signal current has the opposite effect on the forward biasing of each transistor in the pair.

In the pair of Q167 and Q168, both transistors are forward biased. The incoming positive-going signal reduces the forward bias on Q167 and increases the voltage drop across it. However, a positive-going signal increases the forward bias on Q168, thereby reducing the voltage drop across it. This action continues as the sweep signal rises linearly, and the collector voltage of Q167 and Q168 rises toward the +102-V supply level. At the end of the sweep, the transition back to the sweep quiescent level is started quickly by the ac-signal coupling through C167 to the emitter of Q168.

The left side transistor pair (Q176 and Q181) operates in a manner similar to that described for the right side. Zener diode VR174 in the left side provides the correct bias level for Q176, and C174 is a fast signal path around VR174.

Resistors R163 (in the right side) and R190 (in the left side) dampen the deflection signal slightly to prevent oscillation.

## CRT CIRCUIT

The CRT circuit, shown on schematic diagram 9, provides the voltage levels and control circuits for operation of the cathode-ray tube. The circuitry consists of the Z-Axis Amplifier, High-Voltage Oscillator, High-Voltage Regulator, +102-V Low-Voltage Power Supply, High-Voltage Rectifier, High-Voltage Multiplier, and the Crt controls.

### High-Voltage Oscillator

Transistors Q161 and Q163 and associated components compose a High-Voltage Oscillator that produces drive for High-Voltage Transformer T167. The frequency of oscillation is determined by the resonant frequency of T167 (approximately 38 kHz). Waveform relationships in the circuit are illustrated in Figure 3-14.

When ac power is applied to the instrument, R176B supplies start-up current to turn on Q178 and Q184. Initially, with zero feedback from the -1.96-kV supply, both Q178 and Q184 turn on at full conduction. Capacitor C183 becomes positively charged with respect to ground, and the base of Q161 becomes forward biased and begins conducting. As Q161 collector current starts flowing through T168 (pins 1 and 2) and T167 (pins 4 and 5), a positive-feedback voltage is induced in T167 between pins 3 and 6 and in T168 between pins 3 and 4. The sum of the two feedback voltages is applied to the base of Q161 to quickly turn on Q161 at full conduction; drive current is also supplied to the T167 primary winding (pins 4 and 5).

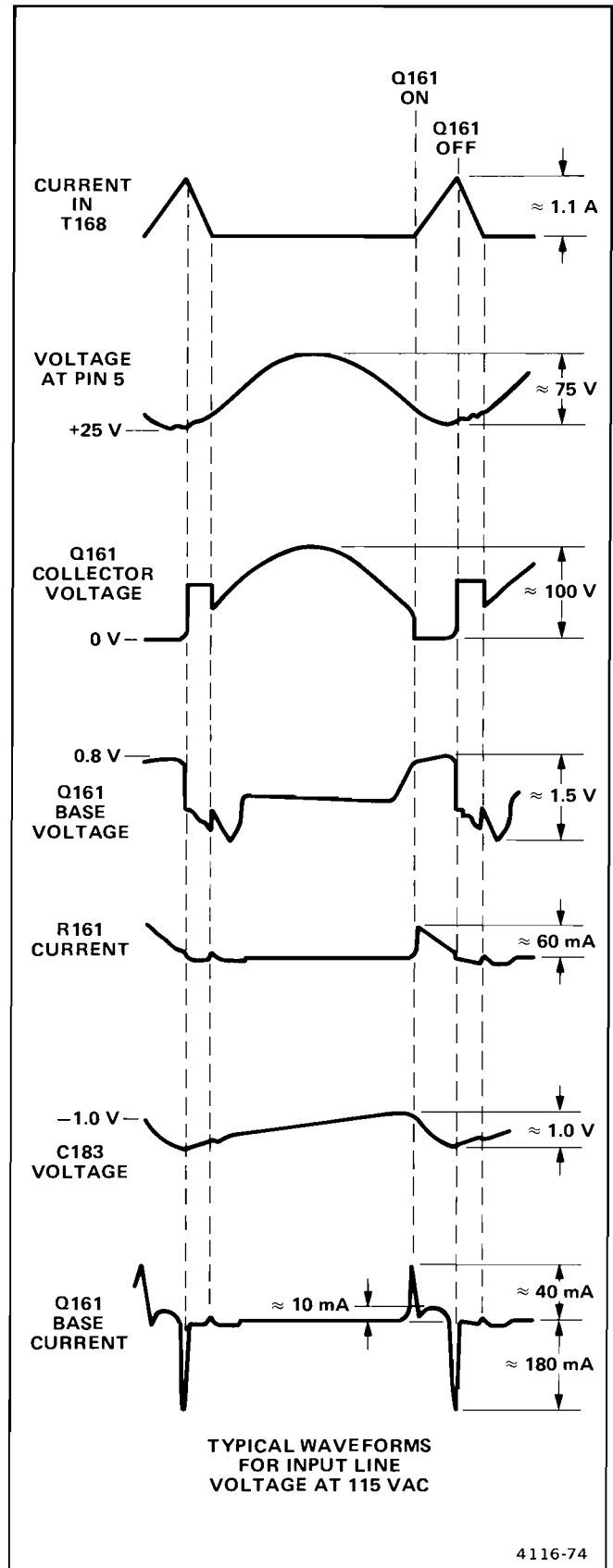

Figure 3-14. High-Voltage Oscillator waveform relationships.



## Theory of Operation—2336 Service

Capacitor C183 is in the base current path for Q161, and due to the base current flow through it, C183 loses its positive charge and becomes negatively charged with respect to ground. The voltage level developed across C183 during this cycle determines the point at which Q161 will turn on during the next resonant cycle.

After the voltage in the T167 feedback winding peaks, it begins to decrease. The base drive to Q161 decreases, and Q161 starts to turn off. At this point, the current through Q161 will start to fall. The feedback voltage across T168 reverses polarity as the magnetic field begins to collapse, and Q161 is rapidly turned off.

The reversed polarity voltage across T168 pins 1 and 2 forward biases CR165 in the base circuit of Q163, and Q163 begins to conduct. This action places the inductance of T168 in parallel with the inductance of T167, and the energy stored in the magnetic field around T168 is coupled to T167 instead of being dissipated as heat in the transformer. Transistor Q163 turns off when the magnetic field of T168 collapses to a point that no longer sustains the base current to Q163.

Transistor Q161 remains off until the magnetic field around T167 reverses again due to the flywheel effect of the resonant transformer. When the feedback voltage induced in T167 at pin 3 becomes positive enough with respect to pin 6 to overcome the negative voltage level retained on C183 from the previous cycle, Q161 will become forward biased again.

The sequence of events just described occurs repetitively as the circuit continues to oscillate.

### High-Voltage Regulation

Regulation of the high-voltage supply is controlled by feedback from the  $-1.96\text{-kV}$  crt cathode voltage supply. When power is first applied, the feedback signal is zero, and both Q178 and Q184 conduct heavily. As the operating level is reached, the negative feedback applied to the base of Q178 reduces the forward bias on Q178. Current through Q184, used to charge C183 in a positive direction (less negative), is also reduced. Thus Q161 turns on later in the resonant cycle than during start up. Drive current is supplied to High-Voltage Transformer T167 for a shorter time during the resonant cycle, and the amplitude of the sinusoidal oscillation is reduced.

If the crt cathode voltage becomes more negative due to less loading of the high-voltage supply, the charging current to C183 through Q184 is reduced even more to hold the

voltage across C183 at a more negative level. The feedback voltage at T167 pin 3 must rise to a higher positive level to overcome the voltage on C183, and Q161 will turn on later in the resonant cycle. The reduction in oscillation amplitude in T167 will return the  $-1.96\text{-kV}$  supply to the correct operating level. High voltage is thus regulated by controlling the amplitude of the  $-1.96\text{-kV}$  supply.

Decoupling components C167 and L167 prevent oscillator current from disturbing the  $+40\text{-V}$  unregulated supply.

### High-Voltage Over-Voltage Shutdown Circuit

In the event that a high-voltage over-voltage condition occurs, a shutdown circuit composed of Q148, Q155, Q156, and associated components acts to stop drive current to the High-Voltage Transformer.

The  $+102\text{-V}$  supply level (developed in the High-Voltage Transformer secondary circuit) is proportional to both the high voltage ( $+16\text{ kV}$ ) and the crt cathode voltage ( $-1.96\text{ kV}$ ). An over-voltage condition of the  $+102\text{-V}$  supply can therefore be used to sense a high-voltage over-voltage condition.

In the base circuit of Q148, the  $+102\text{ V}$  is divided down by R149 and R150 to provide the Q148 base-bias voltage. Reference diode VR148, in the emitter lead of Q148, holds a voltage level on the emitter that must be exceeded by the base-bias voltage before Q148 can become forward biased. When an over-voltage condition exists, the Q148 base-bias voltage becomes high enough to cause Q148 to conduct.

Transistor Q155 then becomes forward biased by the voltage drop across R147 (in the Q148 collector circuit). Collector current through Q155 supplies base current to Q148, and both Q148 and Q155 will be latched on. Transistor Q155 also supplies base current to Q156 via R155 to bias Q156 into conduction. With Q156 on, base current to Q161 (main oscillator transistor) is shunted to ground to prevent Q161 from being biased into conduction. Drive current to the High-Voltage Transformer is removed, and the over-voltage condition is eliminated.

To unlatch Q148 and Q155, the instrument power must be turned off.

### High-Voltage Circuitry

Secondary windings of High-Voltage Transformer T167 provide crt heater current, source voltage for the  $+102\text{-V}$  supply, and three  $38\text{-kHz}$  sine-wave voltages:  $150\text{ V}$  at terminal 7,  $980\text{ V}$  at terminal 8, and  $2700\text{ V}$  at terminal 9.

The three 38-kHz sine-wave voltages are supplied to High-Voltage Module U130. This module houses a high-voltage multiplier (used to produce the +16-kV crt anode voltage), a dc-restorer circuit (to couple the Z-Axis Amplifier output to the crt intensity grid), and a rectifier and filter circuit used to produce the remaining crt operating voltages (grid bias, focus, cathode voltage, and mesh voltage).

Focus voltage is adjustable over a range of approximately  $-1400\text{ V}$  to  $-1700\text{ V}$  by R940, the front-panel FOCUS control. The grid-bias voltage is adjusted (by R140) to set the level at which the Z-Axis Amplifier output voltage blanks the crt display.

### CRT Control Circuits

Crt focus is controlled by FOCUS control R940 in conjunction with ASTIG adjustment R945. The ASTIG adjustment varies the voltage level on the astigmatism grid and is used to obtain a well-defined display over the face of the crt. Geometry adjustment R202 varies the voltage level on the horizontal deflection-plate shields to control the overall geometry of the display (minimizes bowing of the display).

Two controls align the trace with the graticule lines. Y-Axis adjustment R203 controls the current through one of the two coils wound on the crt neck and aligns the vertical display components only. Front-panel TRACE ROTATION adjustment R942 controls the current through the other coil. The Trace Rotation coil is located between the crt face and the vertical and horizontal deflection plates, and it affects both the vertical and horizontal display components.

### +102-V Supply

A secondary winding of T167 (pin 1 to pin 2) supplies drive to a voltage-doubler circuit composed of C197, C190, CR197, and CR190. Filtering of the +102-V supply is accomplished by L191 and C191. Diode CR191 protects the output load from any negative transients that may occur during turn on or shut down.

### Z-Axis Amplifier

The Z-Axis Amplifier controls the crt intensity level via several input signal sources. The effect of these input signals is to either increase or decrease the trace intensity or to completely blank portions of the display.

Unblanking signal current from the Sweep IC (U43 for A Sweep or U24 for B Sweep, diagram 6) is applied through R92 to the emitter of input buffer transistor Q93. Signal current flow in the unblanking signal line ranges from 0 (for

no intensity) to approximately 3 mA (for full intensity). The amplitude of the unblanking signal current is determined by the setting of the front-panel INTEN control (R909, diagram 3).

Input transistor Q93 also acts as a buffer amplifier for two of the remaining Z-Axis Amplifier input signals: chop blanking and external Z-Axis signals.

When the instrument is operating in the Chop mode (switching between CH 1 display and CH 2 display), Chop Blanking Amplifier Q209 (diagram 4) is turned on, and current of opposite polarity to the unblanking signal current is drawn through R92. The unblanking signal current is completely cancelled, and additional current is drawn from the emitter current available to Q93. Less current flows through Q93, and the collector voltage rapidly rises toward the +40-V supply voltage level. This increase in collector voltage is limited to +4.9 V plus the forward-bias drop across CR94. Diode CR100 becomes reverse biased, and signal current to Q100 is shut off, thereby eliminating chopping switching transients from the display.

External Z-Axis signals are also applied on the chop blanking line via R210 (diagram 4). These signals either add or subtract from the unblanking signal current. The algebraic sum of all the signal current inputs determines the overall trace intensity on the crt.

The BEAM FIND switch (diagram 3) acts on the Z-Axis Amplifier in two ways. First, the unblanking signal current level is raised enough to drive the Q93 emitter positive with respect to the base, and Q93 becomes reverse biased. Thus all signal inputs to the Z-Axis Amplifier are over-ridden. Secondly, the BEAM FIND switch grounds the left end of R91 in the collector circuit of Q93. A fixed level of current flows through R91 into the collector circuit of Q93 and on through CR100 to the base of Q100. This fixed level of current provides a visible trace intensity to aid the operator in locating the trace position regardless of the INTEN control setting.

Signal current from the collector of Q93 is applied via CR100 to the input of a high-speed feedback amplifier at the base of Q100. The feedback amplifier is composed of Q100, Q107, Q114, Q115, and Q116. The feedback path includes gain-controlling resistors R101, R102, and R128, connected between the amplifier output and input at the base of Q100.

The combination of resistor values and the feedback circuit arrangement have the effect of a single  $20\text{-}\Omega$  feedback resistor. Given the full-intensity input current of 3 mA,

## Theory of Operation—2336 Service

the total output-voltage swing may be calculated as 60 V (3 mA x 20 k $\Omega$ ).

Transistor Q100 changes the input signal current to a signal voltage at the bases of Q107 and Q116. Shunt feedback resistor R99 (from the collector to the base of Q100) holds the gain of Q100 low, and there is minimum collector voltage swing.

The remaining portion of the Z-Axis Amplifier is divided into two signal paths: a fast path for the positive-going leading edges of the unblanking signal, and a fast path for the negative-going trailing edges. Transistors Q107 and Q114 provide the positive-going edge amplification. The ac-coupling capacitor (C108) between Q107 and Q114 produces a rapid turn on of the trace at the high sweep speed.

Emitter follower Q107 feeds Q114, connected as a common-base amplifier. The voltage gain of Q107 is less than 1, but it has a large current gain. Common-base output transistor Q114 produces the large voltage swing necessary to drive the crt intensity grid.

Transistors Q116 and Q115 provide the fast path for the negative-going edges of the unblanking signal. The direct coupling between Q116 and Q115 enables them to also provide the dc and low-frequency amplification of the unblanking signal.

A clamp circuit composed of CR127, VR123, and C123 limits the Z-Axis positive output voltage to prevent excessive crt intensity. If the output voltage level reaches 82 V, CR127 begins to conduct. Reference diode VR123 then limits the output level to +82 V by shunting additional current to ground. Capacitor C123 bypasses fast crt surges around VR123.

Z-Axis signal voltage is fed to the crt grid-bias circuit via R130 and CR130. The signal is coupled to the crt intensity grid by a dc-restorer circuit that is housed in High-Voltage Module U130.

### DC Restorer

The DC Restorer circuit provides crt control-grid bias and couples both dc and low-frequency components of the Z-Axis Amplifier unblanking signal to the crt control grid. This circuit allows the Z-Axis Amplifier output to control the intensity of the crt display. The potential difference between the Z-Axis output and the control grid (about 2 kV) prevents direct signal coupling. Refer to Figure 3-15 during the following circuit description.

Ac drive to the DC Restorer circuit is obtained from pin 7 of T167. The voltage on pin 7 is approximately 150 V peak at 38 kHz. This sinusoidal voltage is coupled through C136 and R136 into the DC Restorer circuit. Crt Grid Bias adjustment R140 sets the voltage level on the cathode of CR140 to approximately +100 V. When the ac-drive voltage rises to +100 V, CR140 becomes forward biased and clamps the junction of R135, R134, R136, and CR130 to approximately +100 V.

The Z-Axis Amplifier output signal voltage is applied to the DC Restorer via R130 and CR130. The Z-Axis signal voltage level varies between +10 V and +80 V, depending on the setting of the INTEN control. The ac-drive voltage will hold CR130 reverse biased until the voltage falls below the Z-Axis Amplifier output voltage level. At that point, CR130 becomes forward biased and clamps the junction of CR130, R134, R135, and R136 to the Z-Axis output level. The ac-drive voltage is thus clamped on both the positive and negative peaks to produce an approximate square-wave signal with a positive dc offset level.

The DC Restorer circuit is referenced to the crt cathode voltage inside U130. Capacitor C, connected to pin 6 of U130, initially charges to a level determined by the difference between the Z-Axis Amplifier output level and the cathode reference voltage. The charging path is from the crt cathode, through the DC Restorer components internal to U130 (diode A, resistor E, and capacitor C) to U130 pin 6; then to R134, CR130, and R130 to the Z-Axis Amplifier output. Initially, capacitor D (connected to U130 pin 5) will be charged to approximately the same dc level as on capacitor C.

When the ac-drive voltage starts its positive transition from the lower clamped level (+10 V to +80 V) toward the higher clamped level (+100 V), the charge on capacitor C increases. The additional charge acquired is proportional to the amplitude of the positive transition of the clamped ac-drive voltage.

When the clamped ac-drive voltage starts its negative transition from the upper clamped level back to the lower clamped level, diode A becomes reverse biased. Diode B becomes forward biased, and the added charge on capacitor C is transferred to capacitor D through diode B. The added charge that is transferred depends on the setting of the INTEN control, since this control sets the lower clamping level for the ac-drive voltage.

The added charge also determines the control-grid bias voltage with respect to the cathode voltage. If more charge is added to the charge already on capacitor D, the control grid becomes more negative, and less crt writing-beam current flows. Conversely, if less charge is added, the

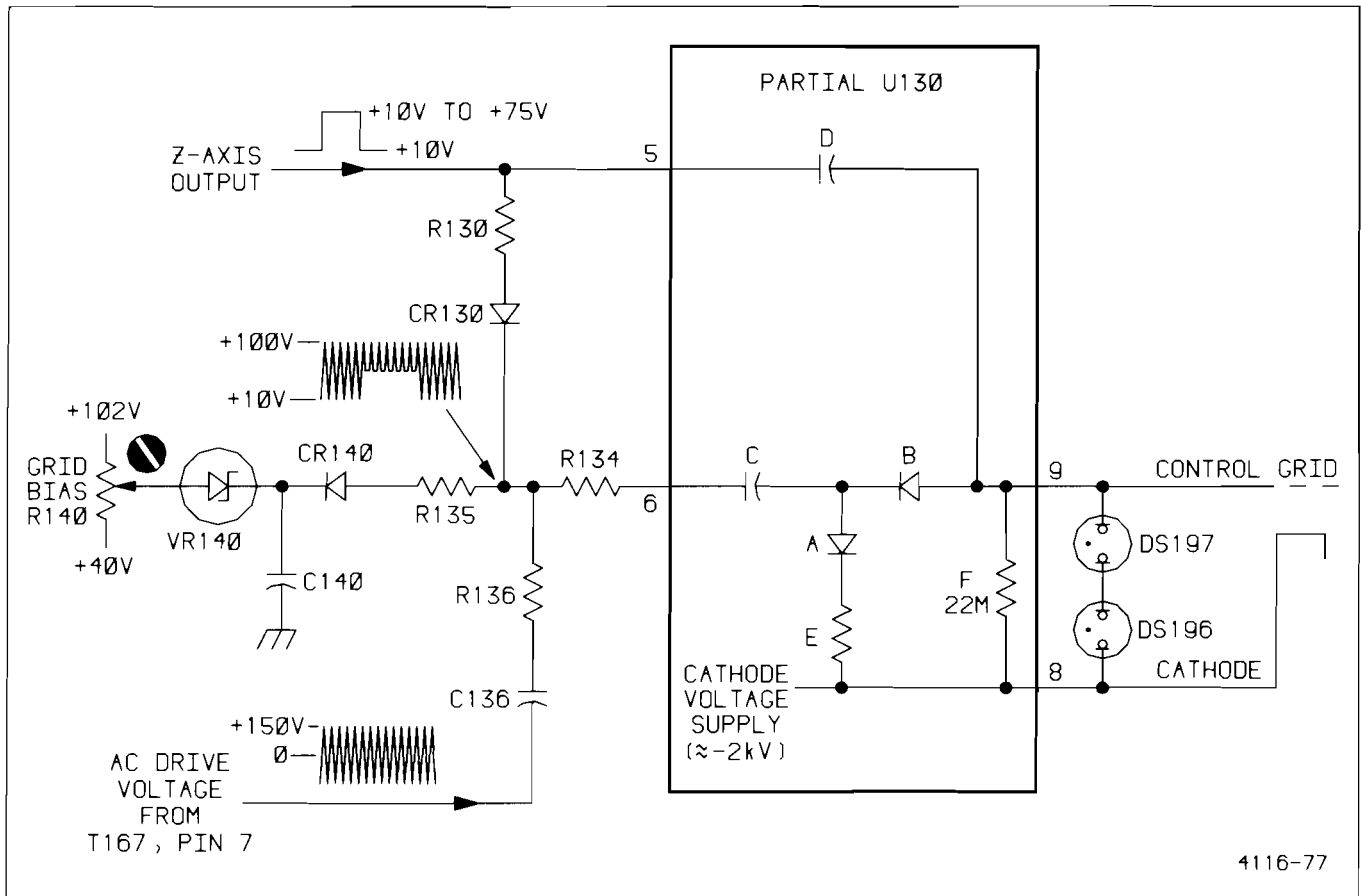

Figure 3-15. DC Restorer circuit, simplified diagram.

control-grid voltage will become closer to the same amplitude as the cathode voltage, and more crt writing-beam current will flow.

During periods that capacitor C is charging, the crt control-grid voltage is held constant by the long time-constant discharge path of capacitor D through resistor F. Any charge that is leaked off capacitor D during the positive transitions of the ac-drive voltage will be replaced by capacitor C when the ac-drive voltage makes its negative transitions.

The fast-rise and fast-fall transitions of the unblanking pulses are coupled to the crt control grid through capacitor D to U130 pin 9. The fast-path signal starts the crt writing beam toward the new intensity level. The DC Restorer output level then follows the Z-Axis output voltage level to set the new bias voltage for the crt control grid.

Neon lamps DS196 and DS197 prevent arcing in the crt if the potential on either the control grid or the cathode is lost for any reason.

## LOW-VOLTAGE POWER SUPPLY

The Low-Voltage Power Supply circuit, shown on schematic diagram 10, includes five regulated supplies to provide the operating power for this instrument. Regulation provides stable, low-ripple output voltages. Two unregulated output voltages are supplied for circuit applications where regulation is unnecessary.

### Power Input

Ac-source power is supplied to the primary of transformer T900 through Line Fuse F900, POWER switch S903, and Line Voltage Selector switch S901. LINE VOLTAGE SELECTOR switch S901 connects the split primaries of T900 either in parallel (for 115-V nominal operation) or in series (for 230-V nominal operation). Line Fuse F900 value is selected to provide the protection required for each nominal ac-source voltage. Refer to "Replaceable Electrical Parts" list of this manual for correct fuse values.

**Secondary Circuits**

The following power supplies are series-regulated supplies: +5 V, -5 V, +10 V, -10 V, and +40 V. Amplifiers U237, U3A, U3B, U8A, and U8B are two-channel, high-gain amplifier cells with differential inputs. These amplifiers monitor variations in the output voltages and supply correction information to the series-regulating transistors. The +40-V supply is the reference voltage source for the remaining supplies, and its output must be correct to enable the other supplies to operate within their regulating limits.

Current-limiting circuits provide short-circuit protection for each of the regulated supplies. The following description applies only to the +40-V current-limiting circuit; the other current-limiting circuits operate in a similar manner.

In the +40-V supply, Q239 is normally biased off. Under normal power-supply-loading conditions, the base voltage of Q239 is about +40 V. When additional power-supply loading occurs, the supply current increases, and the voltage drop across R246 (in the emitter circuit of Q246) increases. The increasing emitter voltage level is coupled through the base of Q246 to a voltage divider (composed of R244 and R245) thereby causing the base of Q239 to go more positive. If the +40-V supply is loaded down sufficiently, Q239 will turn on. The collector of Q239 then moves in the negative direction, and Q244 and Q246 begin turning off to limit the output current. Even though the supply is limited, transistor Q246 will continue to conduct current in order to produce enough voltage drop across R246 to keep Q239 biased on. The limited output voltage can be any value between the supply's regulated value and zero, depending on the extra load current it is trying to supply (see Figure 3-16). The current-limiting transistors for the other supplies are as follows:

On the Positive Regulator circuit board (A12):

Supply	Limiting Transistor
+10 V	Q9
+5 V	Q16

On the Negative Regulator circuit board (A11):

Supply	Limiting Transistor
-5 V	Q9
-10 V	Q21

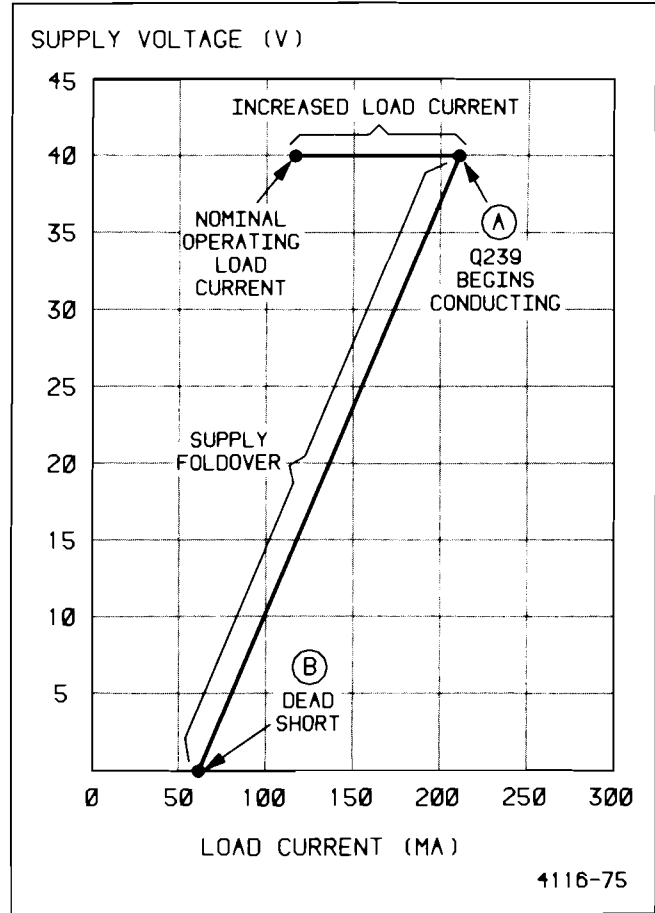

Figure 3-16. Foldover circuit action.

Figure 3-16 also illustrates the action of the current-limiting (foldover) circuit. At point A, Q239 begins conducting. At point B, the supply is directly shorted to ground through a milliammeter.

In the event that a power supply problem occurs, service jumpers (circuit number prefix is W) may be removed to isolate the supply from the load. In this manner, the problem can be narrowed to either a loading condition or a malfunction in the supply involved.

Short-circuit protection for each of the power supplies is also provided by fuses located in each secondary winding of the power transformer.

The unregulated +40 V is supplied to the High-Voltage Oscillator circuit, and the unregulated -5 V is used in the Fan Inverter circuit.

A sample of the ac-voltage waveform (present in the secondary of T900) is provided as the Line Trigger signal from a voltage-divider network composed of R257 and R258 from P714 pin 7 to ground.

## FAN CIRCUIT

The Fan motor in this instrument is a three-phase, brushless motor. A three-phase inverter circuit, shown on schematic diagram 8, provides drive to the three motor-field windings.

Fan motor speed is controlled by the emitter voltage of Darlington transistor Q289. As ambient temperature changes, a voltage-dividing network (composed of RT295, R295, and R296) in the base lead of Q289 varies the amount of forward bias on Q289. A temperature increase causes the resistance of thermistor RT295 to decrease, thus increasing the forward bias on Q289. The available current supply to each of the three inverter stages increases, causing the switching frequency to increase and drive the Fan motor at a faster speed. Conversely, a temperature decrease will cause the Fan motor to go slower.

The three-phase inverter consists of three basically identical driver sections. However, resistors R265, R273, and R284 in each driver input have different resistance values. Each of these resistors is in parallel with one of three equal-value capacitors: C265, C273, and C284 respectively. These parallel RC combinations produce a slightly different time-constant circuit to each of the three driver circuits to ensure that the start-up sequence is in the correct order for proper direction of Fan rotation.

Only one of the driver sections is on at any one time. Negative feedback to the other sections holds them off during the period of time that the conducting stage is supplying field current to the Fan motor. As the fan rotates, a voltage is induced in its windings. This voltage is fed back to the "off" sections of the inverter. When the feedback voltage reaches the "on" switching level of the next inverter stage to be turned on, the transistor being turned on (Q267, Q281, or Q288) causes a voltage drop on the emitters of the other two transistors on the common supply bus. This voltage drop completes the turn off of the on transistor and holds the remaining transistor off.

Typical collector, base, and emitter waveforms of the operating circuit are illustrated in Figure 3-17.

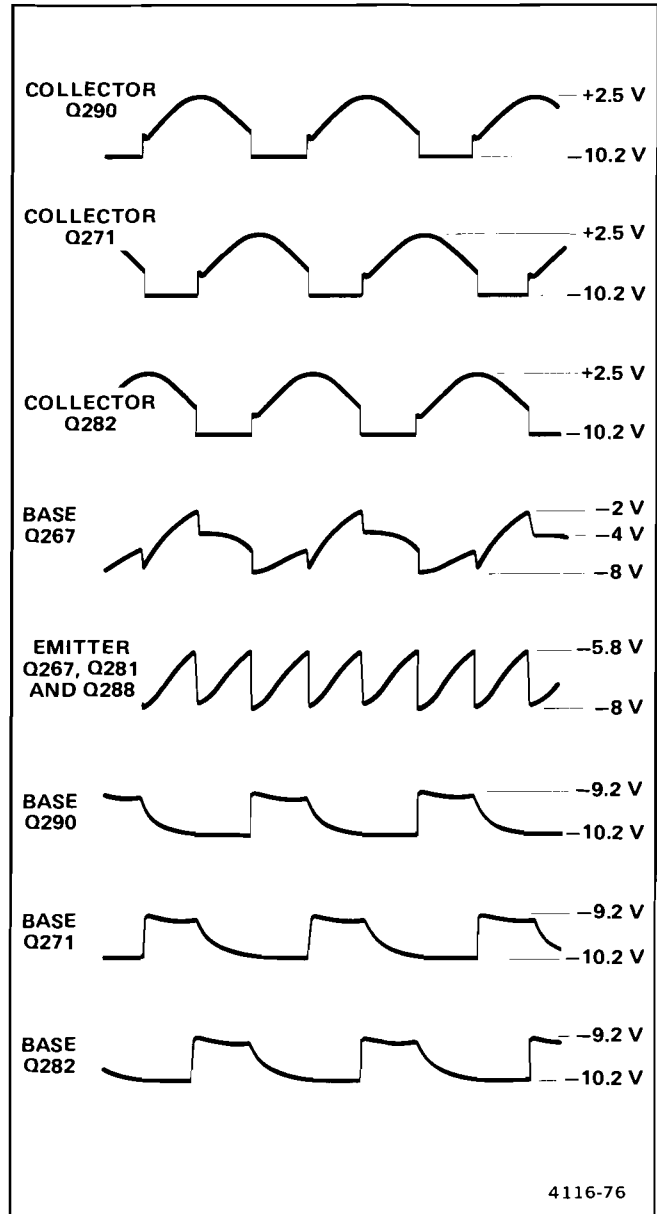

Figure 3-17. Typical waveforms in the Fan Motor three-stage inverter circuit.

## CALIBRATOR

The Calibrator circuit, shown on schematic diagram 8, produces an accurate 0.2-V peak-to-peak square-wave output that is useful for checking the instrument's vertical deflection accuracy and for compensating voltage probes. This circuit consists of a dual-feedback, astable multi-vibrator circuit followed by a transistor output amplifier.

## Multivibrator

The astable multivibrator is composed of U238 and associated components. The basic multivibrator circuit comprises U238D and the parallel arrangement of U238A, U238B, U238C, and U238E. Added components (U238F, R245 and R239) form a second feedback path that eliminates the effect of varying threshold levels found between CMOS devices of the same type. The duty cycle of the symmetrical square-wave signal thus produced is virtually independent of variations in threshold levels.

Nominal frequency of oscillation is 1 kHz, and it is determined by the RC time constant of feedback components R244 and C244. The resistance and capacitance value of R244 and C244 are selected to account for stray and input capacitance of the circuit.

A second negative-feedback path around U238D is provided by inverter U238F. The negative-feedback signal is added to the inverted U238F threshold voltage and injected into U238D through R239. The gain of U238F is set to cancel the effect of the U238 threshold level on the duty cycle.

Inverters U238A, U238B, U238C, and U238E are connected in parallel to supply the output drive to Q250.

### CAUTION

*Integrated circuit U238 is a CMOS device and is subject to static discharge damage. See the "Maintenance" section of this manual for handling of static-sensitive components.*

## Output Amplifier

The square-wave output from the multivibrator switches output transistor Q250 between cutoff and saturation. During the periods that Q250 is cutoff, the highly accurate +40 V collector-supply voltage is divided down by precision resistors R250, R252, and R253 to produce a 0.2-V peak signal amplitude at the front-panel AMPL CAL output terminal. When transistor Q250 is conducting, the collector voltage (and the AMPL CAL output voltage) drops to near 0 V, thus producing a zero-to-peak calibrator signal of +0.2 V.

## DELTA TIME

A Delta Time Logic circuit, contained in the lid of the instrument, provides the time-measuring capability of the 2336. In the  $\Delta$  TIME position of the B Trigger SOURCE switch, two intensified zones will appear on the A INTEN HORIZ MODE Sweep display. These two zones mark the timing set by the B DELAY TIME POSITION control and

the  $\Delta$  TIME POSITION control. An A/D Converter circuit converts the voltage output of the two controls into the digital signal necessary to drive the Liquid-Crystal Display (LCD). The equivalent time of the voltage difference, with appropriate decimal point and scale factor, will be displayed in the 3 1/2 digit readout. Refer to schematic diagram 8 and detailed block diagram Figure 9-5 during the following discussion.

## Prescaling Circuit

The voltage levels from the B DELAY TIME POSITION and  $\Delta$  TIME POSITION controls are applied to a Prescaling circuit before going to the A/D Converter. This circuit, shown in Figure 3-18, is required because the equivalent time of the voltage difference between the two dc levels is not the same for each A TIME/DIV switch setting. In other words, 10-division spacing between the two intensified zones for a 1-ms-per-division setting is not the same at 2 ms or 5 ms per division. However, the dc-voltage difference of the outputs of U197A and U197B for a 10-division spacing is exactly the same in each TIME/DIV setting.

The Prescaling circuit is a switchable voltage divider that produces the correct equivalent-time voltage for each A TIME/DIV switch setting. The switching sequence is set up in groups of three positions (see Table 3-1). As an example of the Prescaling circuit switching, consider the group of 20 ms, 10 ms, and 5 ms. A full 10-division difference at 20 ms per division is 200 ms, while it is 100 ms at 10 ms per division and only 50 ms at 5 ms per division. To obtain the correct equivalent-time voltage for each range to be applied to the A/D Converter, the voltage divider must be switched. Enabling voltages from the A TIME/DIV switch are applied to CMOS switches U216A and U216C in the correct order to select the correct division factor.

CMOS switches U216A and U216C are connected across a resistive voltage divider composed of R214, R216, R215, and R210. When one of the "2" sequence positions (0.2 s, 20 ms, 2 ms, etc.) is selected, the A TIME/DIV switch applies the enabling voltage to U216A at pin 10. The junction of R214 and R216 is then connected to the output line to the A/D Converter. This point in the divider produces a division factor of two.

The full-scale voltage difference from the B DELAY TIME POSITION and  $\Delta$  TIME POSITION controls is 4 V. The Prescaling voltage divider reduces this level to the A/D Converter full-scale input voltage of 2 V.

A "1" sequence A TIME/DIV switch position (0.1 s, 10 ms, 1 ms, etc.) applies the enabling voltage to CMOS switch U216C pin 11. CMOS switch U216A has the enabling voltage removed, so it switches back to internally

Table 3-1  
PROM U38 Logic Table

U38 Input Address					U38 Output Data								A SEC/DIV Setting
A <sub>4</sub>	A <sub>3</sub>	A <sub>2</sub>	A <sub>1</sub>	A <sub>0</sub>	O <sub>8</sub>	O <sub>7</sub>	O <sub>6</sub>	O <sub>5</sub>	O <sub>4</sub>	O <sub>3</sub>	O <sub>2</sub>	O <sub>1</sub>	
0	0	0	0	0	0	1	0	0	0	0	0	0	0.5 s
0	0	0	0	1	0	0	1	0	0	0	0	1	
0	0	0	1	0	0	0	1	0	0	0	0	0	0.2 s 0.1 s 50 ms
0	0	0	1	1	1	0	0	0	0	1	0	1	
0	0	1	0	0	1	0	0	0	0	1	0	0	20 ms 10 ms 5 ms
0	0	1	0	1	0	1	0	0	0	1	0	1	
0	0	1	1	0	0	1	0	0	0	1	0	0	2 ms 1 ms 0.5 ms
0	0	1	1	1	0	0	1	0	0	1	0	1	
0	1	0	0	0	0	0	1	0	0	1	0	0	0.2 ms 0.1 ms 50 μs
0	1	0	0	1	1	0	0	0	0	0	1	1	
0	1	0	1	0	1	0	0	0	0	0	1	0	20 μs 10 μs 5 μs
0	1	0	1	1	0	1	0	0	0	0	1	1	
0	1	1	0	0	0	1	0	0	0	0	1	0	2 μs 1 μs 0.5 μs
0	1	1	0	1	0	0	1	0	0	0	1	1	
0	1	1	1	0	0	0	1	0	0	0	1	0	0.2 μs 0.1 μs 0.05 μs
0	1	1	1	1	0	0	1	0	0	0	1	0	
1	0	1	1	0	0	0	0	0	0	0	0	0	UNCAL
z	y	x	w	Auto Range	RDP	CDP	LDP	NC	NC	m	μ	Auto Range	

connect pin 2 to pin 15. With U216C switched, the junction of R216 and R215 is connected to the output line via both U216C and U216A. This point in the voltage divider produces a division factor of four.

No enabling voltage is applied to either U216C or U216A in the "5" sequence positions (50 ms, 5 ms, 0.5 ms, etc.) of the A TIME/DIV switch. CMOS switch U216C internally connects pin 12 to pin 14, and the junction of R215 and R210 is connected to the output line via U216C and U216A. This connection point produces a division factor of eight for the input signal.

The circuit composed of Q222, Q213, and associated components shunts a small compensating current away from the voltage divider for sweep speeds from 5 μs/division through 0.5 s/division. When the A SEC/DIV switch is set to .05 μs division through 2 μs/division, +10 V is applied to the base of Q222 either through R223 or R224. Transistor Q222 becomes forward biased and -10 V is applied to the

gate of Q213 to bias it off. This removes the shunting resistance of R212 from across R214 and improves the linearity for the faster time measurements.

### A/D Converter

The prescaled voltage difference between the B DELAY TIME POSITION and Δ TIME POSITION controls is applied to pins 30 and 31 of U10, a 3 1/2 digit A/D Converter (diagram 11). The digital output from the A/D Converter drives the segments of the Liquid-Crystal Display.

Positive supply voltage to U10 is developed by Operational Amplifier U2 which is referenced back to U10 pin 30, the negative input pin. The developed voltage maintains a constant difference between the signal voltage applied to pin 30 and pin 1 (the positive supply input pin). The action of this circuit reduces linearity errors in the A/D Converter that would occur if large common-mode voltages were allowed to approach a fixed positive supply voltage level. The negative supply is less sensitive to common-mode voltages and is fixed at -10 V.



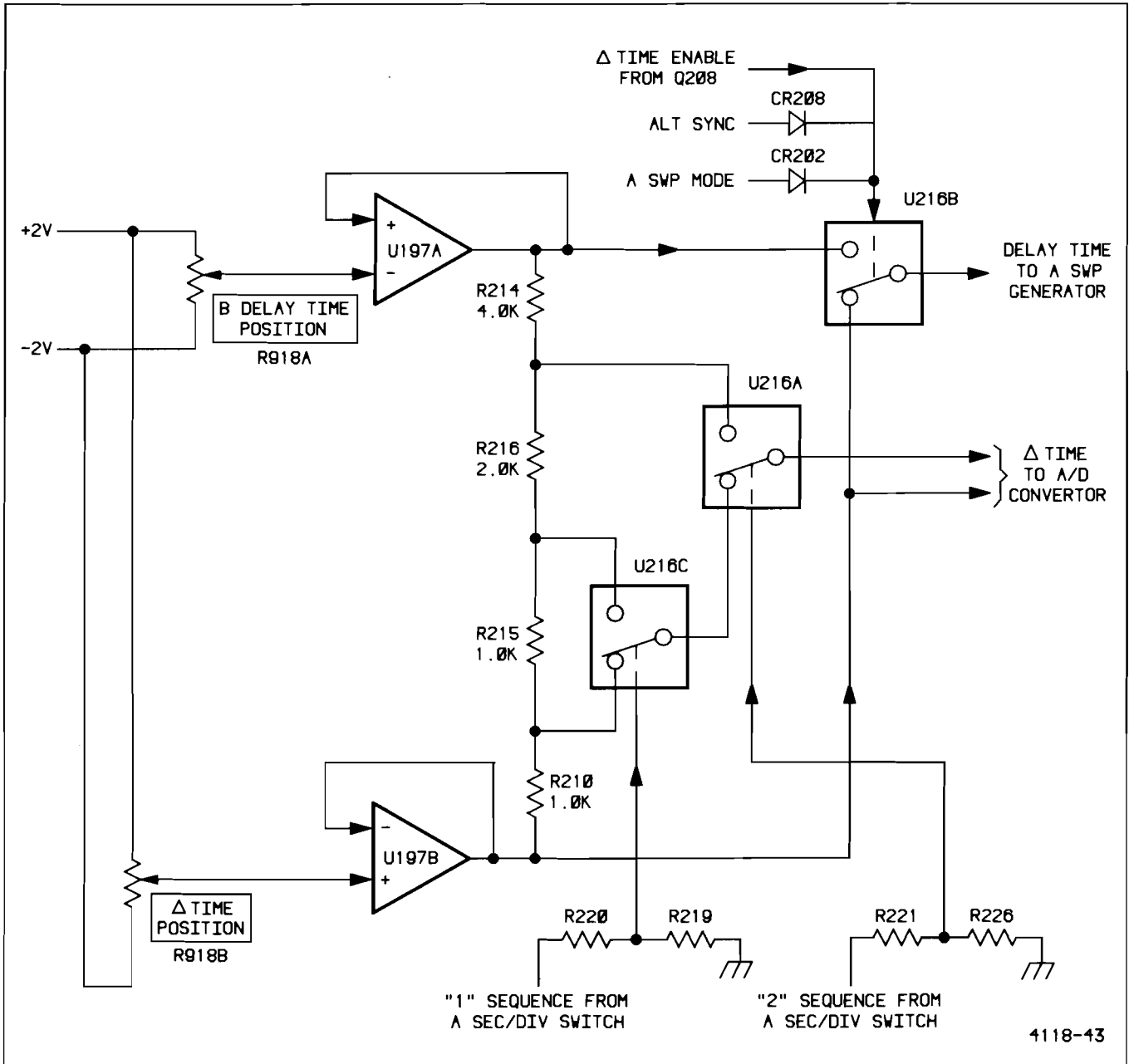

Figure 3-18. Simplified diagram of the Delay Time Switching and Prescaling circuit.

An Auto Ranging circuit selects one of two reference voltage levels to apply to the A/D Converter HI reference voltage input pin U10 pin 36. Part of the A/D Converter digitizing process compares the reference voltage with the input voltage being measured. The selected reference voltage is applied to U10 pin 36 via U9C, a CMOS switch controlled by the Auto Range bit.

### Auto Range Bit

The Auto Range bit is decoded from the segment drive output data of A/D Converter U10. The decoded bit becomes the  $A_0$  bit applied to PROM U38. This PROM is addressed on its remaining input pins by the A TIME/DIV switch to provide the data that drives the scale factors and decimal points of the LCD. The  $A_0$  bit controls the Auto Range circuit. If the prescaled input voltage to the A/D Converter is large (due to a larger time difference between the B DELAY TIME and  $\Delta$  TIME control settings), the  $A_0$  bit will be decoded as a 0 logic level (LO). From Table 3-1, it can be seen that whenever  $A_0$  is a 1, the  $O_1$  output data from U38 is also a 1 except for the three fastest settings of the A SEC/DIV switch.

From the U38  $O_1$  output pin, the logic level is applied to the Auto Range circuitry to control both the integrating resistors (R15 and R16) and HI reference levels to the A/D Converter. In addition to auto ranging the A/D Converter, the Auto Range bit addresses data from PROM U38 that automatically switches the decimal point in the LCD readout to the appropriate location in the display.

### Auto Range Bit Decoder

Output drive for the  $b_1$ ,  $g_1$  and  $f_1$  segments and the 1 digit from the A/D Converter is logically compared to determine the necessity to either uprange or downrange the A/D Converter. The particular segments tested are chosen so that when logically compared in the decoder circuitry (shown in diagram 11), the overrange and underrange A/D Converter outputs are detected.

The drive logic for the  $b_1$  and  $g_1$  segments and the 1 digit are applied to exclusive-OR gates along with the BP (Back Plane drive) signal. Whenever the segment drive is  $180^\circ$  out of phase with the 60-Hz, square-wave BP signal, that segment is illuminated in the display. The  $f_1$  segment drive is applied to exclusive-OR gate U22D along with the inverted BP signal (inverted by U40C). The logic combination of the  $b_1$  and  $g_1$  segments is obtained from OR gate U23A, and the logic combination of the  $g_1$  segment and the 1 digit is obtained from OR gate U23D. The output

of U23D is further combined with the  $f_1$  segment through OR gate U23C.

The Auto Range circuit will uprange when the output from U23A goes LO. This condition occurs when both the  $b_1$  and the  $g_1$  segments are off. These segments are off simultaneously only when the A/D Converter over-ranges. In overrange, the 1 digit is turned on and the remaining segments are turned off.

Downranging occurs when the output of U23C goes LO. The output of U23C will go LO when the  $f_1$  segment is on and both the 1 digit and the  $g_1$  segment are off. This occurs when the second digit displayed is a 0 and the first digit is off.

The decoder output logic levels applied to the + (plus) inputs of U25B and U25C are derived from the floating supply voltage developed by U2. These levels follow the input voltage that is applied to U10 pin 30 to be measured. Comparators U25B and U25C are used to compare the logic levels with the floating supply common level. The output signals from U25B and U25C are then used to develop the proper logic levels for use in the TTL circuits that follow.

The output of comparators U25B and U25C switches between high impedance for a HI input and  $-10$  V for a LO input. In the output of U25B, a voltage divider composed of R25 and R27 reduces the voltage levels at pin 1 of U32A to TTL logic levels. An output of  $-10$  V from U25B produces an input to U32A of approximately 0 V. When the output of U25B is a high impedance, the input of U32A is pulled HI through R27 to the +5-V supply. Segment switching transients are filtered by a capacitor (C25) that is connected from U32A pin 1 to ground.

In the output of U25C, added components are used to slow down the switching time when downranging occurs. This added time ensures that the output signals from A/D Converter U10 have all settled and that the Auto Range circuit will not switch back and forth between uprange and downrange during the transition period.

When the output of U25C is open, CR30 is forward biased and C30 quickly charges to the U32 HI switching level. Thus, the circuit allows an uprange to occur rapidly. However, when the output of U25C switches to  $-10$  V, CR30 is reverse biased and C30 must discharge down to the LO switching threshold through R30. The high resistance value of R30 produces a longer time constant for discharging, thereby ensuring that the U10 segment output drive signals have settled.

## Theory of Operation—2336 Service

Cross-coupled NAND gates U32A and U32D form a latch circuit that holds the  $A_0$  input to PROM U38 at a constant potential between uprange and downrange switching points. Buffer U55E supplies the required drive current to the U38  $A_0$  input pin.

### Scale Factor Switching Matrix

The scale factor for the readout is determined by the A SEC/DIV switch setting. A diode decoding matrix, shown in diagram 11, uses eight positions of the A SEC/DIV switch to produce either a HI or a LO on the matrix output lines (w, x, y, and z). The output of the matrix forms a four-bit address (part of the five-bit address applied to the Scale Factor Decoder PROM, U38).

In addition to controlling the scale factor, the diode matrix produces an output to blank the LCD display whenever the X-Y Mode is selected, whenever the SEC/DIV VAR control is out of its detent, and when the HORIZ DISPLAY switch is set to A.

The A SEC/DIV switch positions are divided into seven groups of three positions each and one switch position (0.5 s) by itself (see diagram 7) to establish the switching points of the scale-factor display. As an example of the decoder operation, assume that the A SEC/DIV switch is set to 0.5 ms per division. In this case, +10 V is applied from the A SEC/DIV switch (diagram 7) to the anodes of CR316 and CR317 in the diode matrix (diagram 11). Diodes CR316 and CR317 become forward biased. On the output lines, CR357 (w) and CR354 (x) become reverse biased. Both the y and z output line diodes (CR360 and CR362 respectively) remain forward biased from the -5 V applied to their cathodes through pull-down resistors.

With the w and x diodes reverse biased, the signal lines connected to their anodes are allowed to go HI through pull-up resistors R374 and R371 to the +10-V supply potential. The four-bit address decoded is therefore 0011. The address levels are applied to four additional switching diodes in the B SOURCE select line (CR67 for w, CR62 for x, CR55 for y, and CR71 for z). Both CR67 and CR62 will become forward biased while CR55 and CR71 will remain reverse biased. The additional switching diodes are used to allow the B SOURCE select lines to be bidirectional. The scale-factor information passes in one direction, and the B SOURCE select information passes in the opposite direction on the signal lines.

The logic levels produced are buffered by U55A, B, C, and D and then applied to the address inputs ( $A_1$  through  $A_4$ ) of PROM U38. The output data from the address

selected (0011) may be determined from the logic listing for U38 in Table 3-1.

### Scale Factor Decoder PROM

The  $A_0$  through  $A_4$  bits applied to the input pins of PROM U38 address memory locations within the PROM. Each addressed location produces a different data output on the PROM output pins (see Table 3-1 for the U38 logic table). The  $O_2$ ,  $O_3$ ,  $O_6$ ,  $O_7$ , and  $O_8$  output bits drive the LCD scale factors and decimal points. The  $O_1$  output bit controls the Auto Ranging circuit for upranging and downranging A/D Converter U10.

### LCD Scale Factor Driver

Output data from U38 is first applied to comparators U25D and U39A, B, C, and D. The comparators convert the TTL logic level outputs from U38 back into floating logic levels required to drive the LCD. The segment drive voltages are referenced to the input voltage being measured by the A/D Converter, and the scale factors and decimal points must use the same reference level. Therefore, each of the comparator outputs is returned to the A/D Converter positive supply voltage level through pull-up resistors. When a particular scale factor or decimal point is selected for display, a HI is placed on one input pin of the associated exclusive-OR gate. With a HI on one pin, the Back Plane signal on the other input produces an inverted, out-of-phase output signal (see Figure 3-19). As indicated previously, when the driven segment is  $180^\circ$  out of phase with the BP signal, that segment is on.

When a scale factor or decimal point is not to be displayed, a LO is placed on input pin of the associated exclusive-OR gate. The BP signal then produces an in-phase output signal, and that scale factor or decimal point is not displayed.

The "s" is switched on or off by the z input signal to PROM U38. When the z signal line is LO (as it is except for UNCAL and blanked conditions), U32C inverts the level to a HI at pin 5 of comparator U25A. The HI is converted to the correct voltage level at the output of U25A to produce a HI on pin 9 of exclusive-OR gate U42C. As before, when one pin of the gate is held HI, the BP signal produces an inverted (out-of-phase) signal, and the "s" in the LCD display is illuminated.

"UNCAL" is displayed whenever the VAR SEC/DIV control is out of the detent position. The z input line to PROM U38 is pulled HI from the Scale-Factor Diode Switching Matrix. Inverter U32C changes the HI to a LO

that is applied to U40A pin 2, and the inverted Back Plane signal is applied to U40A pin 1. The resulting output signal from exclusive-OR gate U40A is in phase with the BP signal on pin 1, and "UNCAL" is displayed in the LCD readout. In addition, all of the decimal points and scale factors will remain unilluminated.

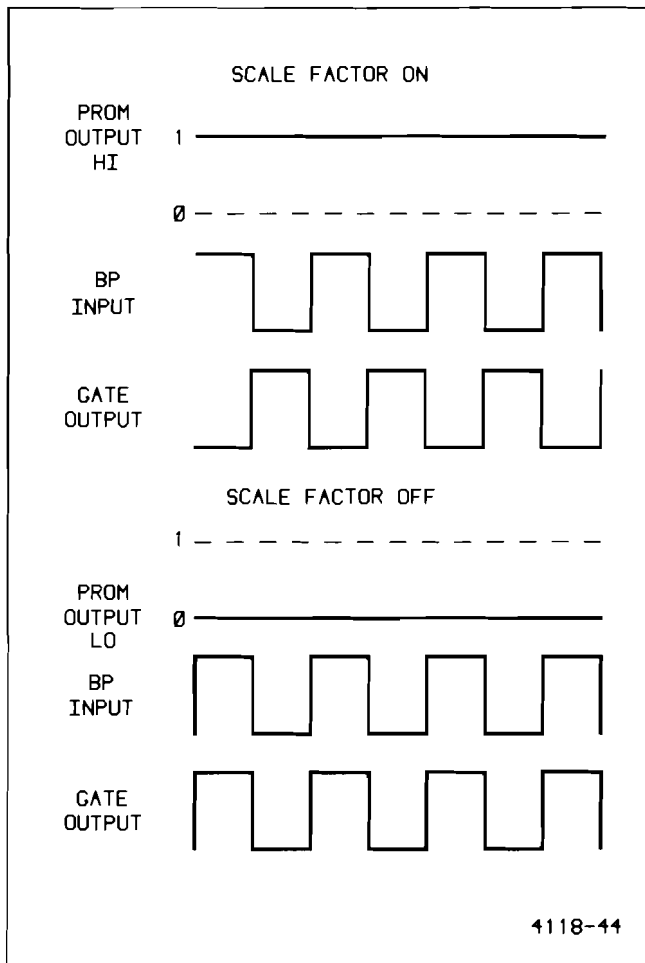

Figure 3-19. Exclusive-OR gate switching action.

The display is blanked except when a time measurement display mode is in use. The TRIG MODE control must be set to  $\Delta$  TIME, the HORIZ MODE switch must be set to either A INTEN or B, and the X-Y display mode must be disabled before the LCD will be illuminated.

Blanking is accomplished when both the y and z input lines to PROM U38 are forced HI. The two signal lines are connected to a NAND gate (U32B) that controls one section of CMOS switch U9B. When both the y and the z lines are HI, the output of U32B goes LO, and two things happen: first, the  $-10$ -V supply line to A/D Converter U10 is opened to shut that device off; and second, the  $-10$  V is applied to the comparators at the output of PROM U38 to ensure that the display is blanked.

Setting the y and z signal lines HI is accomplished via different pairs of switching diodes for each of the previously mentioned blanked conditions. For each of the B SOURCE switch positions except  $\Delta$  TIME,  $+5$  V is applied via CR51 and CR52 to the y and z signal lines prior to the signal-line buffer amplifiers (U55C and U55D). The  $+5$  V pulls the lines HI to activate NAND gate U32B and blank the display.

When X-Y display mode is selected, the X-Y Enable signal ( $+5$  V) is applied to a pair of diodes (CR319 and CR334) in the Scale Factor Diode Switching Matrix. Diodes CR319 and CR334 are forward biased, and the  $+5$  V is fed to CR360 on the y signal line and CR362 on the z signal line. Both CR360 and CR362 are then reverse biased, removing the  $-5$ -V pull-down voltage from the y and z signal lines. The signal lines are then pulled HI by the base bias voltage of U365B and U365D. As before, with a HI on both the y and z signal lines, the LCD is blanked.

Similarly, when the A HORIZ MODE is selected,  $+5$  V is applied to diodes CR330 and CR323. The  $+5$ -V level is applied to CR360 and CR323 to reverse bias them as before and again the LCD is blanked.

# PERFORMANCE CHECK PROCEDURE

## INTRODUCTION

The "Performance Check Procedure" is used to verify the instrument's Performance Requirements as listed in the "Specification" (Section 1) and to determine the need for readjustment. These checks may also be used as an acceptance test and as a preliminary troubleshooting aid.

This procedure does not check every facet of instrument operation; rather it is concerned with those portions of the 2336 that are essential to measurement accuracy. Removing the instrument's cover is not necessary to perform this procedure. All checks are made using the operator-accessible front- and rear-panel controls and connectors.

### TEST EQUIPMENT REQUIRED

The test equipment listed in Table 4-1 is a complete list of the equipment required to accomplish both the "Performance Check Procedure" in this section and the "Adjustment Procedure" in Section 5. Test equipment specifications described in Table 4-1 are the minimum necessary to provide accurate results. Therefore, equipment used must meet or exceed the listed specifications. Detailed operating instructions for test equipment are not given in this procedure. If more operating information is required, refer to the appropriate test equipment instruction manual.

When equipment other than that recommended is used, control settings of the test setup may need to be altered. If the exact item of equipment given as an example in Table 4-1 is not available, first check the "Purpose" column to verify use of this item. If it is used for a check that is of little or no importance to your measurement requirements, the item and corresponding steps may be deleted. If the check is important, use the "Minimum Specification" column carefully to determine if any other available test equipment might suffice.

### PERFORMANCE CHECK INTERVAL

To ensure instrument accuracy, check its performance after every 2000 hours of operation or once each year, if used infrequently.

### LIMITS AND TOLERANCES

The limits and tolerances given in this procedure are valid for an instrument that has been calibrated at an ambient temperature between +20°C and +30°C, is operating at an ambient temperature between -15°C and +55°C (unless otherwise noted), and has had a warm-up period of at least 20 minutes. The stated limits and tolerances are instrument specifications only if they are listed in the "Performance Requirements" column of the "Specification" (Section 1). Tolerances given are applicable to the 2336 and do not include test-equipment error.

### SPECIAL FIXTURES

Special fixtures are used only where they simplify the test setup and procedure. These fixtures are available from Tektronix, Inc. and can be ordered by part number through your local Tektronix Field Office or representative.

### PREPARATION

Test equipment items 1 through 17 in Table 4-1 are required to accomplish a complete Performance Check. Specific items of equipment required to perform each subsection in this procedure are listed at the beginning of the subsection. The item number shown in parentheses with each piece of equipment refers to the equipment item number presented in Table 4-1.

Before performing this procedure, ensure that the LINE VOLTAGE SELECTOR switch is set for the ac-power-input source voltage being used (see "Preparation for Use" in Section 2). Connect the test equipment and the instrument to be checked to an appropriate ac-power-input source.

This procedure is structured in subsections to permit checking individual sections of the instrument whenever a complete Performance Check is not required. At the beginning of each subsection is a list of all the front-panel control settings required to prepare the instrument for performing Step 1 in that subsection. Each succeeding step within a subsection should then be performed both in the sequence presented and in its entirety to ensure that control-setting changes will be correct for ensuing steps.

**Table 4-1**  
**Test Equipment Required**

Item No. and Description	Minimum Specification	Purpose	Examples of Suitable Test Equipment
1. Test Oscilloscope with 10X probe and 1X probe (1X probe is optional accessory)	Bandwidth: dc to 100 MHz. Minimum deflection factor: 5 mV/div. Accuracy: $\pm 3\%$ . Dual trace. Probe: 10X scale-factor switching.	Power supply ripple check. Crt Z-axis compensation. Vertical gain adjustment. Trigger holdoff check.	a. TEKTRONIX 465B Oscilloscope with 2 (included) 10X probes. b. TEKTRONIX P6101 Probe (1X). Part Number 010-6101-03.
2. Calibration Generator	Standard-amplitude accuracy: $\pm 0.25\%$ . Signal amplitude: 2 mV to 50 V. Output signal: 1-kHz square wave. Fast-rise repetition rate: 1 to 100 kHz. Rise time: 1 ns or less. Fast-rise signal amplitude: 100 mV to 1 V. Aberrations: $\pm 2\%$ . Flatness: $\pm 0.5\%$ . High-amplitude output: variable to 60 V; supplying at least 10 mA.	Vertical checks and adjustments. Trigger view checks and adjustments. X-gain adjustment. Z-axis check.	TEKTRONIX PG 506 Calibration Generator. <sup>a</sup>
3. Sine-Wave Generator	Frequency: 350 kHz to above 100 MHz. Output amplitude: variable from 0.5 to 5.5 V p-p. Output impedance: 50 $\Omega$ . Reference frequency: 50 to 350 kHz. Amplitude accuracy: constant within 3% of reference frequency as output frequency changes.	Vertical centering checks and adjustments. Bandwidth and isolation checks. Trigger checks and adjustments. X-Y phase difference check. X-Y bandwidth check.	TEKTRONIX SG 503 Leveled Sine-Wave Generator. <sup>a</sup>
4. Time-Mark Generator	Marker outputs: 2 ns to 0.5 s. Marker accuracy: $\pm 0.1\%$ . Trigger output: 1 ms to 0.1 $\mu$ s, time-coincident with markers.	Crt Y-axis and geometry adjustments. Horizontal timing checks and adjustments.	TEKTRONIX TG 501 Time-Mark Generator. <sup>a</sup>
5. 50- $\Omega$ Signal Pickoff	Frequency response: 50 kHz to 100 MHz. Impedance: 50 $\Omega$ for signal input, signal output, and trigger output.	Trigger checks and adjustments.	TEKTRONIX CT-3 Signal Pickoff. Part Number 017-0061-00.
6. Cable (2 required)	Impedance: 50 $\Omega$ . Length: 42 in. Connectors: bnc.	Signal interconnection.	Tektronix Part Number 012-0057-01.
7. Adapter	Connectors: bnc male-to-miniature probe tip.	Signal interconnection.	Tektronix Part Number 013-0084-01.
8. Dual-Input Coupler	Connectors: bnc female-to-dual-bnc male.	Vertical checks. Trigger checks and adjustments. X-Y phase check.	Tektronix Part Number 067-0525-01.

<sup>a</sup>Requires a TM 500-series power-module mainframe.

Table 4-1 (cont)

Item No. and Description	Minimum Specification	Purpose	Examples of Suitable Test Equipment
9. T-Connector	Connectors: bnc.	Signal interconnection.	Tektronix Part Number 103-0030-00.
10. 10X Attenuator	Ratio: 10X. Impedance: 50 $\Omega$ . Connectors: bnc.	Vertical compensation. Vertical bandwidth check. Trigger adjustments.	Tektronix Part Number 011-0059-02.
11. 5X Attenuator	Ratio: 5X. Impedance: 50 $\Omega$ . Connectors: bnc.	Vertical compensation. Trigger adjustments.	Tektronix Part Number 011-0060-02.
12. 2X Attenuator	Ratio: 2X. Impedance: 50 $\Omega$ . Connectors: bnc.	Vertical compensation. Trigger adjustments.	Tektronix Part Number 011-0069-02.
13. Termination (2 required)	Impedance: 50 $\Omega$ . Connectors: bnc.	Signal termination.	Tektronix Part Number 011-0049-01.
14. Precision Cable	Impedance: 50 $\Omega$ . Length: 36 in. Connectors: bnc.	Signal interconnection.	Tektronix Part Number 012-0482-00.
15. Adapter	Connectors: GR-to-bnc male.	Signal interconnection.	Tektronix Part Number 017-0064-00.
16. Adapter	Connectors: GR-to-bnc female.	Signal interconnection.	Tektronix Part Number 017-0063-00.
17. Low-Frequency Generator	Frequency: 60 Hz to 1 kHz. Output amplitude: variable from 30 mV to 4 V p-p.	Low-frequency trigger checks.	TEKTRONIX FG 502 Function Generator. <sup>a</sup>
18. Variable Auto-transformer	Capable of supplying 1.5 A over a range of 108 to 132 V.	Power-supply regulation check.	General Radio W8WT3VM Variac Autotransformer.
19. Digital Voltmeter	Range: 0 to 140 V. Dc voltage accuracy: $\pm 0.15\%$ . 4 1/2-digit display.	Low-voltage power supply checks and adjustments. Crt grid bias adjustment. Vertical and horizontal centering adjustments.	TEKTRONIX DM 501A Digital Multimeter. <sup>a</sup>
20. DC Voltmeter	Range: 0 to 2500 V, calibrated to 1% accuracy at -1960 V.	High-voltage power supply check.	Triplett Model 630-NA.
21. Screwdriver	Length: 3-in shaft. Bit size: 3/32 in.	Adjust variable resistors.	Xcelite R-3323.
22. Shorting Strap		Power supply adjustment.	
23. Low-Capacitance Alignment Tool	Length: 1-in shaft. Bit size: 3/32 in.	Adjust variable capacitors.	J.F.D. Electronics Corp. Adjustment Tool Number 5284.

<sup>a</sup>Requires a TM 500-series power-module mainframe.

## INDEX TO PERFORMANCE CHECK STEPS

Vertical	Page
1. Check Trace Alignment and Astigmatism . . . . .	4-5
2. Check ALT Mode Operation . . . . .	4-5
3. Check CHOP Mode Operation . . . . .	4-6
4. Check CH 2 INVERT Trace Shift . . . . .	4-6
5. Check CH 1 Attenuator Balance . . . . .	4-6
6. Check CH 2 Attenuator Balance . . . . .	4-6
7. Check Vertical POSITION Range and Centering . . . . .	4-6
8. Check BEAM FIND Operation . . . . .	4-6
9. Check CH 1 and CH 2 DC Accuracy . . . . .	4-7
10. Check CH 1 and CH 2 VOLTS/DIV VAR Range . . . . .	4-7
11. Check CH 1 and CH 2 Input Gate Current . . . . .	4-7
12. Check ADD Mode Operation . . . . .	4-8
13. Check CH 1 and CH 2 Gain Balance . . . . .	4-8
14. Check Vertical Low-Frequency Compensation . . . . .	4-8
15. Check CH 1 and CH 2 VOLTS/DIV Compensation . . . . .	4-8
16. Check CH 1 and CH 2 Transient Response . . . . .	4-9
17. Check Signal Isolation . . . . .	4-9
18. Check CH 1 and CH 2 Bandwidth . . . . .	4-9
19. Check Trigger View Gain . . . . .	4-10
20. Check Trigger View Centering . . . . .	4-10
21. Check Trigger View Low-Frequency Compensation . . . . .	4-10
22. Check Trigger View High-Frequency Compensation . . . . .	4-11
23. Check Trigger View Delay . . . . .	4-11
24. Check Common-Mode Rejection Ratio . . . . .	4-11
25. Check Trigger View Bandwidth . . . . .	4-12

Triggering	Page
1. Check A and B Internal Triggering . . . . .	4-13
2. Check A and B External Triggering and Jitter . . . . .	4-15
3. Check NORM Triggering Mode Operation . . . . .	4-16
4. Check SGL SWP Mode Operation . . . . .	4-17
5. Check A and B External Trigger Ranges . . . . .	4-17

Horizontal	Page
1. Check A and B Timing Accuracy and Linearity . . . . .	4-18
2. Check $\Delta$ Time Readout Accuracy . . . . .	4-19
3. Check Delay Jitter . . . . .	4-20
4. Check X10 MAG Registration . . . . .	4-20
5. Check A Sweep Length . . . . .	4-20
6. Check A SEC/DIV VAR Range . . . . .	4-21
7. Check A and B Sweep Horizontal POSITION Range . . . . .	4-21
8. Check X-Y Gain . . . . .	4-21
9. Check X-Y Bandwidth . . . . .	4-21
10. Check X-Y Phase Differential . . . . .	4-22

External Z-Axis and Calibrator	Page
1. Check External Z-Axis Operation . . . . .	4-23
2. Check AMPL CAL Operation . . . . .	4-23



# VERTICAL

## Equipment Required (see Table 4-1):

10X Probe (part of Item 1)	10X Attenuator (Item 10)
Calibration Generator (Item 2)	5X Attenuator (Item 11)
Leveled Sine-Wave Generator (Item 3)	2X Attenuator (Item 12)
Two 50-Ω BNC Cables (Item 6)	Two 50-Ω BNC Terminations (Item 13)
BNC-to-Probe-Tip Adapter (Item 7)	Precision 50-Ω BNC Cable (Item 14)
Dual-Input Coupler (Item 8)	Low-Frequency Generator (Item 17)
BNC T-Connector (Item 9)	

## 2336 CONTROL SETTINGS

POWER	ON (button in)
<b>CRT</b>	
INTEN	As required for visible trace
FOCUS	Best focused display
<b>Vertical (Both Channels)</b>	
VERTICAL MODE	CH 1
POSITION	Midrange
VOLTS/DIV	5 m
VOLTS/DIV VAR	Calibrated detent
AC-GND-DC	GND
CH 2 INVERT	Normal (button out)
BW LIMIT	Full bandwidth (button out)
<b>Trigger (A and B, if applicable)</b>	
COUPLING	AC
LEVEL	Midrange
SLOPE	+
SOURCE	VERT MODE
Mode	AUTO
TRIG HOLDOFF (PUSH) VAR	Off (in detent)
<b>Sweep</b>	
HORIZ MODE	A
A and B SEC/DIV	1 ms (knobs locked)
TIME (PULL) VAR	Pulled out and in calibrated detent
B DELAY TIME	
POSITION	Fully counterclockwise
Δ TIME POSITION	Fully counterclockwise
X10 MAG	Off (button out)
POSITION	Midrange

## 1. Check Trace Alignment and Astigmatism

a. Position the baseline trace to the center horizontal graticule line.

b. CHECK—Trace is parallel with the center horizontal graticule line. If necessary, readjust the TRACE ROTATION potentiometer (front-panel screwdriver adjustment) to align trace exactly with the center horizontal graticule line.

c. CHECK—All portions of the trace are well defined and uniform over its entire length. If necessary, readjust the ASTIG potentiometer (front-panel screwdriver adjustment).

## 2. Check ALT Mode Operation

a. Set:

A and B SEC/DIV	50 ms (knobs locked)
VERTICAL MODE	ALT
A TRIGGER SOURCE	EXT

b. Use the CH 1 and CH 2 Vertical POSITION controls to separate the two traces about 2 divisions apart.

c. CHECK—Sweep alternates in all positions of the A and B SEC/DIV switch.

### NOTE

*At sweep speeds of 2 ms per division or faster, the trace alternations occur too rapidly to be seen.*

### 3. Check CHOP Mode Operation

a. Set:

A and B SEC/DIV	1 $\mu$ s
VERTICAL MODE	CHOP
A TRIGGER SOURCE	VERT MODE

b. Use the CH 1 and CH 2 Vertical POSITION controls to separate the two traces about 4 divisions apart.

c. Adjust the A TRIGGER LEVEL control for a stable display of the CHOP frequency.

d. CHECK—Period of one cycle is 2.8 to 5.2  $\mu$ s (approximately 4 horizontal divisions).

### 4. Check CH 2 INVERT Trace Shift

a. Select CH 2 VERTICAL MODE.

b. Position the trace to the center horizontal graticule line.

c. Press in the CH 2 INVERT push button.

d. CHECK—Trace shift is 0.4 division or less when switching between normal (button out) and invert (button in).

e. Return the CH 2 INVERT push button to normal (button out).

### 5. Check CH 1 Attenuator Balance

a. Set:

VERTICAL MODE	CH 1
CH 1 VOLTS/DIV	0.1
CH 1 AC-GND-DC	DC
A and B SEC/DIV	1 ms

b. Position the trace to the center horizontal graticule line.

c. Set CH 1 VOLTS/DIV to 50 m.

d. CHECK—For 0.2 division or less trace shift from the center horizontal graticule line.

### 6. Check CH 2 Attenuator Balance

a. Set:

VERTICAL MODE	CH 2
CH 2 VOLTS/DIV	0.1
CH 2 AC-GND-DC	DC

b. Position the trace to the center horizontal graticule line.

c. Set CH 2 VOLTS/DIV to 50 m.

d. CHECK—For 0.2 division or less trace shift from the center horizontal graticule line.

### 7. Check Vertical POSITION Range and Centering

a. Set:

CH 1 VOLTS/DIV	10 m
A TRIGGER LEVEL	Fully clockwise

b. Connect the leveled sine-wave generator output to the CH 2 OR Y input via a precision 50- $\Omega$  cable and a 50- $\Omega$  termination. Set the generator frequency to 50 kHz and adjust the output for a vertical display of 4.8 divisions.

c. Set CH 2 VOLTS/DIV to 10 m.

d. CHECK—Top of display can be positioned down to the center horizontal graticule line and bottom of the display can be positioned up to the center horizontal graticule line.

e. Move the signal to the CH 1 OR X input.

f. Select CH 1 VERTICAL MODE.

g. Repeat part d for CH 1.

### 8. Check BEAM FIND Operation

a. Push in and hold the BEAM FIND push button.

b. CHECK—Compressed display is visible regardless of the settings of the following controls:

CH 1 POSITION
INTEN
Horizontal POSITION

c. Return both the Horizontal POSITION and the INTEN controls to midrange.

d. Set CH 1 AC-GND-DC switch to GND.

e. While still holding in the BEAM FIND button, vertically position the trace to the center horizontal graticule line.

f. Release the BEAM FIND button.

g. CHECK—Trace remains in the graticule area.

h. Return CH 1 AC-GND-DC switch to DC and disconnect the test equipment.

## 9. Check CH 1 and CH 2 DC Accuracy

a. Set CH 1 VOLTS/DIV to 5 m.

b. Connect a 20-mV standard-amplitude signal to the CH 1 OR X input connector via a 50- $\Omega$  cable. Do not use a termination.

c. CHECK—CH 1 dc accuracy is within the limits (Vertical Deflection) given in Table 4-2.

d. Repeat part c for each CH 1 VOLTS/DIV switch setting and corresponding standard-amplitude signal in Table 4-2.

e. Select CH 2 VERTICAL MODE and set CH 2 VOLTS/DIV switch to 5.

f. Move the signal to the CH 2 OR Y input connector.

g. CHECK—CH 2 dc accuracy is within the limits given in Table 4-2.

h. Repeat part g for each CH 2 VOLTS/DIV switch setting and corresponding standard-amplitude signal in Table 4-2. For greater efficiency, reverse the order of checks (from bottom to top).

Table 4-2

DC Accuracy Limits

VOLTS/DIV Switch Setting	Standard Amplitude Signal	Vertical Deflection (Divisions)	3% Accuracy (Divisions)
5 m	20 mV	4	3.88 to 4.12
10 m	50 mV	5	4.85 to 5.15
20 m	0.1 V	5	4.85 to 5.15
50 m	0.2 V	4	3.88 to 4.12
0.1	0.5 V	5	4.85 to 5.15
0.2	1.0 V	5	4.85 to 5.15
0.5	2.0 V	4	3.88 to 4.12
1	5.0 V	5	4.85 to 5.15
2	10.0 V	5	4.85 to 5.15
5	20.0 V	4	3.88 to 4.12

## 10. Check CH 1 and CH 2 VOLTS/DIV VAR Range

a. Set:

VOLTS/DIV (both)	5 m
AC-GND-DC (both)	DC

b. Change the generator output to 10 mV.

c. CHECK—Display increases to at least 5 divisions when the CH 2 VOLTS/DIV VAR control is rotated to its extreme clockwise rotation.

d. Move the signal to the CH 1 OR X input connector and select CH 1 VERTICAL MODE.

e. CHECK—Repeat part c using the CH 1 VOLTS/DIV VAR control.

f. Return both VOLTS/DIV VAR controls to their calibrated detents and disconnect the input signal.

## 11. Check CH 1 and CH 2 Input Gate Current

a. Set both CH 1 and CH 2 AC-GND-DC switches to GND.

**Performance Check Procedure—2336 Service**

b. CHECK—For 0.5 nA or less (0.1 division or less) vertical shift in display while switching CH 1 AC-GND-DC switch from GND to AC.

c. Select CH 2 VERTICAL MODE.

d. CHECK—For 0.5 nA or less (0.1 division or less) vertical shift in display while switching CH 2 AC-GND-DC switch from GND to AC.

**12. Check ADD Mode Operation**

a. Set:

AC-GND-DC (both)	DC
VERTICAL MODE	ADD

b. Connect a 10-mV standard-amplitude signal to both the CH 1 and CH 2 input connectors via a 50-Ω cable and a dual-input coupler.

c. CHECK—Displayed signal is approximately 4 divisions in amplitude.

**13. Check CH 1 and CH 2 Gain Balance**

a. Press in CH 2 INVERT push button.

b. CHECK—Displayed vertical amplitude is approximately zero division.

c. Return the CH 2 INVERT push button to normal (button out) and disconnect the test equipment.

**14. Check Vertical Low-Frequency Compensation**

a. Set:

VERTICAL MODE	CH 1
A and B SEC/DIV	0.2 ms (knobs locked)
VOLTS/DIV (both)	10 m

b. Connect a 1-kHz fast-rise, positive-going, square-wave signal to the CH 1 OR X input connector via a 50-Ω cable, a 10X attenuator, and a 50-Ω termination.

c. Adjust generator output to obtain a 5-division display. Adjust the A TRIGGER LEVEL control for a stable triggered display.

d. CHECK—Rolloff or overshoot is within 3% (±0.15 division) at each of the generator frequencies and corresponding SEC/DIV switch settings listed in Table 4-3.

e. Move the signal to the CH 2 OR Y input connector and select CH 2 VERTICAL MODE.

f. CHECK—Repeat part d for CH 2.

g. Disconnect the input signal.

**Table 4-3**  
**Low-Frequency Compensation Setup**

Calibration Generator Frequency	SEC/DIV Switch Setting
1 kHz	0.2 ms
10 kHz	20 μs
100 kHz	2 μs

**15. Check CH 1 and CH 2 VOLTS/DIV Compensation**

a. Set both A and B SEC/DIV to 0.2 ms (knobs locked).

b. Connect a 10X probe to the CH 2 OR Y input.

c. Connect a 1-kHz high-amplitude, square-wave signal through a 2X, 5X, or 10X 50-Ω attenuator (depending on generator output amplitude) to a 50-Ω termination that is connected to a bnc-to-probe-tip adapter. Insert the probe tip into the probe-tip adapter.

d. Adjust the generator output and select attenuators as necessary to obtain a 5-division display.

e. Adjust probe compensation for the best flat-top waveform.

**NOTE**

*Do not readjust probe compensation during the remainder of this step.*

f. CHECK—Rolloff or overshoot of the waveform is within 3% ( $\pm 0.15$  division) at all settings of the VOLTS/DIV switch between 5 m and 5. Add or remove attenuators and/or termination as required and adjust the generator output amplitude as necessary to maintain a 5-division display at each VOLTS/DIV switch setting.

g. Move the test setup to the CH 1 OR X input connector and select CH 1 VERTICAL MODE.

h. Repeat part f for CH 1.

i. Disconnect the test setup.

## 16. Check CH 1 and CH 2 Transient Response

a. Set:

VERTICAL MODE	CH 2
A and B SEC/DIV	0.5 $\mu$ s (knobs locked)
VOLTS/DIV (both)	5 m
A TRIGGER SLOPE	+ (button out)

b. Connect a 100-kHz fast-rise, positive-going, square-wave signal via a 50- $\Omega$  cable, a 10X attenuator, and a 50- $\Omega$  termination to the CH 2 OR Y input connector. Set the generator output for a 5-division vertical display.

c. Vertically center the display using the CH 2 POSITION control.

d. CHECK—Flat-top waveform is within 3% (4.85 to 5.15 divisions).

e. Repeat parts c and d for each of the following CH 2 VOLTS/DIV switch settings: 10 m, 20 m, 50 m, 0.1 and 0.2. Adjust the generator output and select attenuators as necessary to maintain a 5-division display at each VOLTS/DIV switch setting.

f. Disconnect the test signal from the CH 2 OR Y input connector. Re-connect the 10X attenuator (if previously removed) and reduce the generator amplitude to minimum.

g. Set VERTICAL MODE to CH 1 and connect the test signal to the CH 1 OR X input connector. Set the generator output amplitude for a 5-division vertical display.

h. Vertically center the display using the CH 1 POSITION control.

i. CHECK—Repeat parts d and e for CH 1.

j. Disconnect the test setup.

## 17. Check Signal Isolation

a. Set:

CH 1 VOLTS/DIV	0.5
CH 2 VOLTS/DIV	10 m
VERTICAL MODE	CH 1
AC-GND-DC (both)	DC
A TRIGGER SOURCE	VERT MODE

b. Connect a 25-MHz leveled sine-wave signal to the CH 1 OR X input connector via a precision 50- $\Omega$  cable and a 50- $\Omega$  termination.

c. Adjust generator for an 8-division vertical display.

d. Select CH 2 VERTICAL MODE.

e. CHECK—Display amplitude is 4 divisions or less.

f. Move the test setup to the CH 2 OR Y input connector.

g. Set:

CH 1 VOLTS/DIV	10 m
CH 2 VOLTS/DIV	0.5
VERTICAL MODE	CH 1

h. CHECK—Display amplitude is 4 divisions or less.

i. Disconnect the test setup.

## 18. Check CH 1 and CH 2 Bandwidth

a. Set:

A and B SEC/DIV	0.2 ms (knobs locked)
A TRIGGER LEVEL	Fully clockwise
CH 1 VOLTS/DIV	5 m

b. Connect a 50-kHz leveled sine-wave signal to the CH 1 OR X input connector via a precision 50- $\Omega$  cable, a 10X attenuator, and a 50- $\Omega$  termination.

c. Set generator output for a vertical display of 5 divisions; then change its output frequency to 100 MHz.

## Performance Check Procedure—2336 Service

- d. CHECK—Display amplitude is 3.5 divisions or greater.

### NOTE

*Attempting to check the VOLTS/DIV settings beyond 0.5 will exceed the power-handling capability at the 50- $\Omega$  termination and the output power of the recommended calibration equipment.*

e. Repeat parts c and d for all CH 1 VOLTS/DIV switch settings from 5 m to 0.5. Adjust generator output amplitude and either add or remove attenuators as necessary to maintain a 5-division, 50-kHz reference-signal display.

f. Move the leveled sine-wave signal to the CH 2 OR Y input connector and select CH 2 VERTICAL MODE.

g. Repeat parts c and d for all CH 2 VOLTS/DIV switch settings from 0.5 to 5 m. Adjust the generator output and either add or remove attenuators as needed to maintain a 5-division, 50-kHz reference-signal display.

- h. Disconnect the test setup.

## 19. Check Trigger View Gain

- a. Set:

A and B SEC/DIV	0.2 ms (knobs locked)
A TRIGGER COUPLING	DC
A TRIGGER SOURCE	EXT
A TRIGGER LEVEL	Midrange

b. Connect a 0.2-V standard-amplitude signal to the A EXT input connector via a 50- $\Omega$  cable. Use no termination.

c. While holding in the TRIG VIEW push button, use the A TRIGGER LEVEL control to vertically center the displayed signal.

d. CHECK—Display signal amplitude is 2 divisions  $\pm 40\%$  (1.2 divisions to 2.8 divisions) while holding in the TRIG VIEW push button.

e. Set the A TRIGGER SOURCE switch to EXT $\div 10$  and change the generator output to 2 V. While holding in the TRIG VIEW push button, use the A TRIGGER LEVEL control to vertically center the displayed signal.

f. CHECK—Display signal amplitude is 2 divisions  $\pm 40\%$  (1.2 divisions to 2.8 divisions) while holding in the TRIG VIEW push button.

- g. Disconnect the test signal.

## 20. Check Trigger View Centering

- a. Set the A TRIGGER SOURCE switch to EXT.

b. Connect a 1-kHz sine-wave signal to the A EXT input connector via a 50- $\Omega$  cable. Use no termination.

c. While holding in the TRIG VIEW push button, set the generator output to obtain a 4-division vertical display and use the A TRIGGER LEVEL control to vertically center the displayed signal.

d. CHECK—Start of sweep is within  $\pm 1$  vertical division of the center horizontal graticule line.

- e. Disconnect the test signal.

## 21. Check Trigger View Low-Frequency Compensation

- a. Set:

A and B SEC/DIV	0.1 ms (knobs locked)
A TRIGGER SLOPE	+ (button out)

b. Connect a 1-kHz high-amplitude, square-wave signal to the A EXT input connector via a 50- $\Omega$  cable, a 10X attenuator, and a 50- $\Omega$  termination.

c. While holding in the TRIG VIEW push button, set the generator output for a 4-division vertical display and use the A TRIGGER LEVEL control to vertically center the displayed signal.

d. CHECK—Square-wave leading edge has less than 20% rolloff or overshoot (3.2 to 4.8 divisions), while holding in the TRIG VIEW push button.

- e. Set the A TRIGGER SOURCE switch to EXT $\div 10$ .

f. While holding in the TRIG VIEW push button, adjust the generator output for a signal display of 4 vertical divisions and use the A TRIGGER LEVEL control to vertically center the displayed signal.

g. CHECK—Square-wave leading edge has less than 20% rolloff or overshoot (3.2 to 4.8 divisions) while holding in the TRIG VIEW push button.

h. Disconnect the test signal.

## 22. Check Trigger View High-Frequency Compensation

a. Set:

A TRIGGER SOURCE	EXT
A and B SEC/DIV	0.2 $\mu$ s (knobs locked)

b. Connect a 100-kHz fast-rise, positive-going, square-wave signal to the A EXT input connector via a 50- $\Omega$  cable and a 50- $\Omega$  termination.

c. While holding in the TRIG VIEW push button, adjust the generator output for a signal display of 2 vertical divisions and use the A TRIGGER LEVEL control to vertically center the displayed signal.

d. CHECK—Square-wave front-corner overshoot or rolloff is less than 20% (1.6 to 2.4 divisions) while holding in the TRIG VIEW push button.

e. Disconnect the test setup.

## 23. Check Trigger View Delay

a. Set:

VERTICAL MODE	CH 2
A and B SEC/DIV	0.05 $\mu$ s
X10 MAG	On (button in)
A TRIGGER COUPLING	AC
A TRIGGER SLOPE	+ (button out)
A TRIGGER LEVEL	Midrange
A TRIGGER SOURCE	EXT
CH 2 VOLTS/DIV	0.1

b. Connect a 100-kHz fast-rise, positive-going square-wave signal via a 50- $\Omega$  cable, a 50- $\Omega$  termination, and a dual-input coupler to the CH 2 OR Y and A EXT input connectors.

c. Use the CH 2 POSITION control to vertically center the trace on the graticule and use the Horizontal POSITION control to center the rising portion of the signal on the center vertical graticule line.

d. While holding in the TRIG VIEW push button, adjust the generator output for a 5-division vertical display of the Trigger View signal.

e. Adjust the CH 2 VOLTS/DIV and VAR controls to match the amplitude of the displayed signal to the amplitude of the Trigger View signal.

f. While holding in the TRIG VIEW push button, use the A TRIGGER LEVEL control to vertically center the Trigger View display. Use the CH 2 POSITION control to vertically center the CH 2 display.

g. CHECK—Time difference between the CH 2 and Trigger View signals (by alternately pressing in the TRIG VIEW push button and releasing it) is 3 ns  $\pm$  2 ns (0.2 to 1 horizontal graticule division or less).

h. Disconnect the test setup.

## 24. Check Common-Mode Rejection Ratio

a. Set:

VOLTS/DIV (both)	10 m
AC-GND-DC (both)	DC
A TRIGGER SOURCE	VERT MODE
CH 2 INVERT	Inverted (button in)

b. Connect a 50-MHz, leveled sine-wave signal to the CH 1 OR X and the CH 2 OR Y input connectors via a precision 50- $\Omega$  cable, a 10X attenuator, a 50- $\Omega$  termination, and a dual-input coupler.

c. Set the generator amplitude for a 6-division display.

d. Select ADD VERTICAL MODE.

e. CHECK—Display amplitude is 0.6 division or less.

f. If the check in part e meets the requirement, skip to part m. If it does not, continue with part g.

## Performance Check Procedure—2336 Service

- g. Set VERTICAL MODE to display CH 1.
- h. Change the generator frequency to 50 kHz and adjust the output to obtain a 6-division display.
- i. Set VERTICAL MODE to ADD.
- j. Adjust CH 2 VOLTS/DIV VAR for minimum display amplitude (best CMRR).
- k. Change the generator frequency to 50 MHz.
- l. CHECK—Display amplitude is 0.6 division or less.
- m. Press the CH 2 INVERT button to release it and disconnect the test setup.

## 25. Check Trigger View Bandwidth

- a. Set:

VERTICAL MODE	CH 1
X10 MAG	Off (button out)
A and B SEC/DIV	50 $\mu$ s
A TRIGGER SOURCE	EXT

- b. Connect a 50-kHz leveled sine-wave signal to the A EXT input connector via a precision 50- $\Omega$  cable and a 50- $\Omega$  termination.
- c. Press in the TRIG VIEW push button and adjust the generator output for a 4-division vertical display. Vertically center the display using the A TRIGGER LEVEL control.
- d. Set the generator output frequency to 80 MHz.
- e. CHECK—For a display amplitude of 2.8 divisions or more with the TRIG VIEW button held in.
- f. Disconnect the test setup.



# TRIGGERING

Equipment Required (see Table 4-1):	
Leveled Sine-Wave Generator (Item 3)	Two 50-Ω Terminations (Item 13)
50-Ω Signal Pickoff (Item 5)	50-Ω Precision Cable (Item 14)
Two 50-Ω Cables (Item 6)	GR-to-BNC Male Adapter (Item 15)
Dual-Input Coupler (Item 8)	GR-to-BNC Female Adapter (Item 16)
10X Attenuator (Item 10)	Low-Frequency Generator (Item 17)
2X Attenuator (Item 12)	

## 2336 CONTROL SETTINGS

POWER	ON (button in)
<b>CRT</b>	
INTEN	As required for visible trace
FOCUS	Best focused display

### Vertical

VERTICAL MODE	CH 1
POSITION (both)	Midrange
CH 1 VOLTS/DIV	10 m
CH 2 VOLTS/DIV	0.2
VOLTS/DIV VAR (both)	Calibrated detent
AC-GND-DC (both)	DC
CH 2 INVERT	Normal (button out)
BW LIMIT	Full bandwidth (button out)

### Trigger (A and B, if applicable)

COUPLING	AC
LEVEL	Midrange
SLOPE	+
SOURCE	VERT MODE
Mode	AUTO
TRIG HOLDOFF (PUSH) VAR	Off (in detent)

### Sweep

HORIZ MODE	A
A and B SEC/DIV	5 ms (knobs locked)
TIME (PULL) VAR	Pulled out and in calibrated detent
B DELAY TIME	Fully counterclockwise
POSITION	Off (button out)
X10 MAG	Midrange
POSITION	

## 1. Check A and B Internal Triggering

a. Connect a low-frequency 60-Hz sine-wave signal to the CH 1 OR X input connector via a 50-Ω cable, a 10X attenuator, a 2X attenuator, and a 50-Ω termination.

b. Adjust the generator output for a 6-division vertical display.

c. Set the CH 1 VOLTS/DIV switch to 0.2 to obtain a 0.3-division vertical signal display.

d. CHECK—Stable display can be obtained and the TRIG'D LED is illuminated by adjusting the A TRIGGER LEVEL control for each of the switch combinations listed in Table 4-4, except as noted in Table 4-4 footnotes.

Table 4-4

Switch Combinations for A Trigger Checks (CH 1)

A TRIGGER COUPLING	A TRIGGER SOURCE	A TRIGGER SLOPE
AC	VERT MODE CH 1	+ and – – and +
LF REJ <sup>a</sup>	CH 1 VERT MODE	+ and – – and +
HF REJ <sup>b</sup>	VERT MODE CH 1	+ and – – and +
DC	CH 1 VERT MODE	+ and – – and +

<sup>a</sup>Will not trigger at 60 Hz in A HORIZ MODE.

<sup>b</sup>Will not trigger at 20 MHz and 100 MHz in A HORIZ MODE.

**Performance Check Procedure—2336 Service**

e. CHECK—Stable display cannot be obtained for any position of the A TRIGGER COUPLING switch excepted in Table 4-4.

f. Set the A TRIGGER COUPLING switch to AC and obtain a stable display using the A TRIGGER LEVEL control.

g. Set HORIZ MODE to B.

h. CHECK—Stable display can be obtained by adjusting the B TRIGGER LEVEL control for each of the switch combinations listed in Table 4-5.

**Table 4-5**

**Switch Combinations for B Trigger Checks**

B TRIGGER SOURCE	B TRIGGER SLOPE
VERT MODE	+ and –
CH 1	+ and –

i. Move the input signal from the CH 1 OR X input connector to the CH 2 OR Y input connector.

j. Set:

VERTICAL MODE            CH 2  
 HORIZ MODE                A  
 A TRIGGER SOURCE        CH 2  
 B TRIGGER SOURCE        CH 2

k. CHECK—Stable display can be obtained and the TRIG'D LED is illuminated by adjusting the A TRIGGER LEVEL control for each of the switch combinations listed in Table 4-6, except as noted in Table 4-6 footnotes.

**Table 4-6**

**Switch Combinations for A Trigger Checks (CH 2)**

AC TRIGGER COUPLING	A TRIGGER SLOPE
AC	+ and –
LF REJ <sup>a</sup>	– and +
HF REJ <sup>b</sup>	+ and –
DC	– and +

<sup>a</sup>Will not trigger at 60 Hz in A HORIZ MODE.

<sup>b</sup>Will not trigger at 20 MHz and 100 MHz in A HORIZ MODE.

l. CHECK—Stable display cannot be obtained for any position of the A TRIGGER COUPLING switch excepted in Table 4-6.

m. Set the A TRIGGER COUPLING switch to AC and obtain a stable display using the A TRIGGER LEVEL control.

n. Set HORIZ MODE to B.

o. CHECK—Stable display can be obtained by adjusting the B TRIGGER LEVEL with B TRIGGER SLOPE at either + or –.

p. Disconnect the test equipment from the instrument.

q. Set:

VERTICAL MODE            CH 1  
 CH 1 VOLTS/DIV            10 m  
 HORIZ MODE                A  
 A and B SEC/DIV            0.05  $\mu$ s  
 A TRIGGER SOURCE        VERT MODE  
 B TRIGGER SOURCE        VERT MODE

r. Connect a 10-MHz leveled sine-wave signal to the CH 1 OR X input connector via a 50- $\Omega$  cable and a 50- $\Omega$  termination.

s. Repeat parts b through o for the 20-MHz signal.

t. Set:

VERTICAL MODE            CH 1  
 HORIZ MODE                A  
 X10 MAG                    On (button in)  
 A TRIGGER SOURCE        VERT MODE  
 B TRIGGER SOURCE        VERT MODE

u. Set the generator to produce a 100-MHz, 1.1-division vertical display.

v. Repeat parts d through o for the 100-MHz signal.

w. Disconnect the test equipment from the instrument.

2. Check A and B External Triggering and Jitter

a. Set:

CH 1 VOLTS/DIV	10 m
X10 MAG	Off (button out)
A and B SEC/DIV	5 ms
A TRIGGER COUPLING	AC
A TRIGGER SOURCE	EXT
B TRIGGER SOURCE	EXT

b. Connect a 60-Hz sine-wave signal to the CH 1 OR X and the A EXT input connectors via a 50-Ω cable, a 10X attenuator, a 2X attenuator, a 50-Ω termination, and a dual-input coupler.

c. Set the generator output for a 5-division vertical display.

d. Repeat Step 1, parts k and l.

e. Set the A TRIGGER COUPLING switch to AC and obtain a stable display using the A TRIGGER LEVEL control.

f. Set HORIZ MODE to B and move the signal from the A EXT input connector to the B EXT input connector.

g. CHECK—Stable display can be obtained by adjusting the B TRIGGER LEVEL control with the B TRIGGER SLOPE switch in either + or -.

h. Remove the 10X attenuator from the test setup and move the signal from the B EXT input connector to the A EXT input connector.

i. Set:

CH 1 VOLTS/DIV	0.1
HORIZ MODE	A
A TRIGGER SOURCE	EXT÷10

j. Repeat Step 1, parts k and l.

k. Connect the test setup as shown in Figure 4-1.

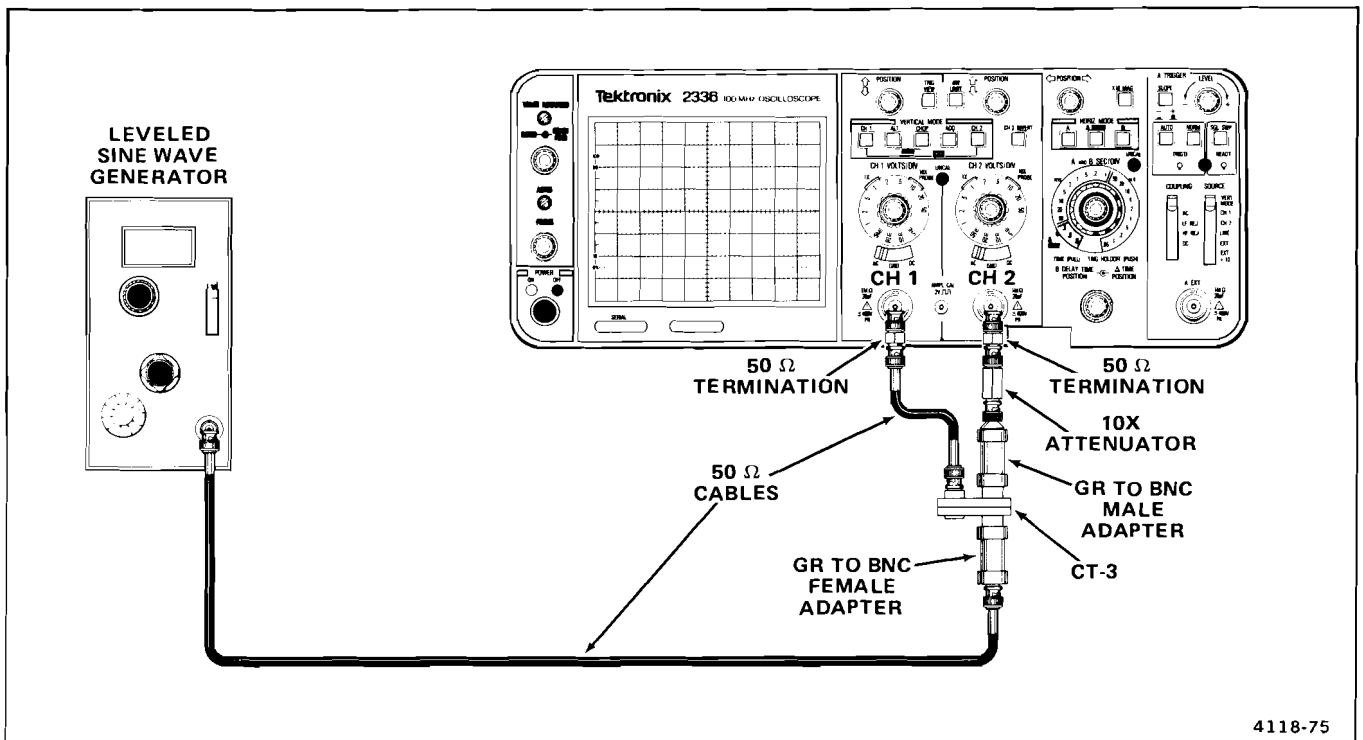

Figure 4-1. Test setup for external trigger and jitter checks.

**Performance Check Procedure—2336 Service**

l. Set:

VERTICAL MODE	CH 2
VOLTS/DIV (both)	10 m
A and B SEC/DIV	20 $\mu$ s
A TRIGGER COUPLING	AC
A TRIGGER SOURCE	VERT MODE

m. Set the leveled sine-wave generator for a 50-kHz, 5-division display.

n. Set:

VERTICAL MODE	CH 1
A and B SEC/DIV	0.05 $\mu$ s
A TRIGGER SOURCE	EXT

o. Set the generator to 20 MHz.

p. Move the signal from the CH 2 OR Y input connector to the A EXT input connector.

q. Repeat Step 1, parts k and l.

r. Repeat parts e through h of this step.

s. Set:

HORIZ MODE	A
A TRIGGER SOURCE	EXT $\div$ 10

t. Repeat Step 1, parts k and l.

u. Reconnect the test setup as shown in Figure 4-1.

v. Set:

VERTICAL MODE	CH 2
VOLTS/DIV (both)	50 m
A and B SEC/DIV	20 $\mu$ s
A TRIGGER COUPLING	AC
A TRIGGER SOURCE	VERT MODE

w. Set the leveled sine-wave generator for a 50-kHz, 3-division display.

x. Set:

VERTICAL MODE	CH 1
A and B SEC/DIV	0.05 $\mu$ s
X10 MAG	On (button in)
A TRIGGER SOURCE	EXT

y. Set the generator to 100 MHz.

z. Move the signal from the CH 2 OR Y input connector to the A EXT input connector.

aa. Repeat Step 1, parts k and l.

ab. Repeat parts e through h of this step.

ac. Set:

HORIZ MODE	A
A TRIGGER SOURCE	EXT $\div$ 10

ad. Repeat Step 1, parts k and l.

ae. Set the A TRIGGER COUPLING switch to AC and adjust the A TRIGGER LEVEL control for a stable display.

af. CHECK—For less than 0.2 division of horizontal waveform jitter.

ag. Set the A TRIGGER SOURCE switch to EXT and reinsert the 10X attenuator into the test setup.

ah. CHECK—For less than 0.2 division of horizontal waveform jitter.

**3. Check NORM Triggering Mode Operation**

a. Set the A TRIGGER SOURCE switch to VERT MODE.

b. Adjust the A TRIGGER LEVEL control for a stable display.

c. Set the A TRIGGER Mode to NORM.

d. CHECK—Stable display is visible.

- e. Set CH 1 AC-GND-DC switch to GND.
- f. CHECK—For no visible display.

**4. Check SGL SWP Mode Operation**

a. Set:

CH 1 AC-GND-DC	DC
X10 MAG	Off (button out)
A and B SEC/DIV	20 $\mu$ s

b. Adjust the output of the leveled sine-wave generator for a 50-kHz, 2-division vertical display.

c. Adjust the A TRIGGER LEVEL control until the display just triggers.

d. Set the CH 1 AC-GND-DC switch to GND.

e. Press in the SGL SWP push button. The READY LED should illuminate and remain on.

f. Set CH 1 AC-GND-DC switch to DC.

g. CHECK—READY LED goes out and a single sweep occurs.

**NOTE**

*The INTEN control may require adjustment to observe the single-sweep trace.*

h. Press in the SGL SWP push button several times.

i. CHECK—Single-sweep trace occurs, and READY LED illuminates briefly every time the SGL SWP push button is pressed in and released.

j. Disconnect the test setup.

**5. Check A and B External Trigger Ranges**

a. Set:

CH 1 VOLTS/DIV	0.5
TRIGGER SLOPE (both)	+
TRIGGER SOURCE (both)	EXT
A TRIGGER Mode	AUTO

b. Connect a 50-kHz sinewave signal to the CH 1 OR X and A EXT input connectors via a precision 50- $\Omega$  cable, a 50- $\Omega$  termination, and a dual-input coupler.

c. Set the generator output for a 4-division vertical display.

d. CHECK—Display is triggered along the entire positive slope of the waveform as the A TRIGGER LEVEL control is rotated.

e. CHECK—Display is not triggered (free runs) at either extreme of rotation.

f. Set A TRIGGER SLOPE switch to —.

g. CHECK—Display is triggered along the entire negative slope of the waveform as the A TRIGGER LEVEL control is rotated.

h. CHECK—Display is not triggered (free runs) at either extreme of rotation.

i. Move the input signal from the A EXT input connector to the B EXT input connector.

j. Set:

A TRIGGER LEVEL	Fully counterclockwise
HORIZ MODE	B

k. Repeat parts d through i for the B Sweep using the B TRIGGER LEVEL control and the B TRIGGER SLOPE switch.

l. Disconnect the test setup.

# HORIZONTAL

**Equipment Required (see Table 4-1):**

Calibration Generator (Item 2)	Dual-Input Coupler (Item 8)
Leveled Sine-Wave Generator (Item 3)	50-Ω Termination (Item 13)
Time-Mark Generator (Item 4)	Precision Cable (Item 14)
50-Ω Cable (Item 6)	Low-Frequency Generator (Item 17)

## 2336 CONTROL SETTINGS

POWER ON (button in)

### CRT

INTEN As required for visible display  
 FOCUS Best focused display

### Vertical (Both Channels)

VERTICAL MODE CH 1  
 POSITION Midrange  
 VOLTS/DIV 0.2  
 VOLTS/DIV VAR Calibrated detent  
 AC-GND-DC DC  
 CH 2 INVERT Normal (button out)  
 BW LIMIT Full bandwidth (button out)

### Trigger (A and B, if applicable)

COUPLING AC  
 LEVEL As needed for a stable display  
 SLOPE +  
 A SOURCE VERT MODE  
 B SOURCE VERT MODE  
 Mode AUTO  
 TRIG HOLDOFF (PUSH) VAR Off (in detent)

### Sweep

HORIZ MODE A  
 A and B SEC/DIV 0.05 μs (knobs locked)  
 TIME (PULL) VAR Pulled out and in calibrated detent  
 B DELAY TIME Fully counterclockwise  
 POSITION Midrange  
 POSITION

### 1. Check A and B Timing Accuracy and Linearity

a. Connect 50-ns time markers from the time-mark generator via a 50-Ω cable and a 50-Ω termination to the CH 1 OR X input connector.

b. Adjust the A TRIGGER LEVEL control for a stable display and vertically center the display using the CH 1 POSITION control.

c. Use the Horizontal POSITION control to align the first time marker with the first vertical graticule line.

d. CHECK—The SEC/DIV timing accuracy is within 2% (0.2 division at the 11th time marker), and linearity is within 5% (0.1 division over any 2-division portion of the graticule).

e. Repeat part d for A SEC/DIV switch settings of 0.1 μs to 0.5 s given in Table 4-7. Readjust the A TRIGGER LEVEL and Horizontal POSITION controls as necessary.

**NOTE**

*For the A SEC/DIV settings from 50 ms to 0.5 s per division, watch the time-marker tips only at the 1st and 11th graticule lines while adjusting the Horizontal POSITION control and checking the timing accuracy.*

f. Set:

X10 MAG                      On (button in)  
A TRIGGER Mode              AUTO

g. CHECK—The A Magnified timing accuracy and linearity using the SEC/DIV switch settings and the time-mark generator settings given in Table 4-7 under the “X10 MAG” column. At each setting combination, timing must be accurate to within 3% (0.3 division at the 11th time marker). When checking accuracy, exclude the first and last 40 ns of the sweep. Linearity must be within 5% (0.1 division) over any 2-division portion of the graticule. When checking linearity, exclude the first- and last-displayed divisions for the A and B SEC/DIV switch settings of 0.05  $\mu$ s and 0.1  $\mu$ s.

h. Set:

HORIZ MODE                      B  
B SEC/DIV                          0.05  $\mu$ s  
A SEC/DIV                          0.1  $\mu$ s  
X10 MAG                              Off (button out)  
A TRIGGER Mode                  AUTO

i. Select 50-ns time markers from the time-mark generator and adjust the A and B TRIGGER LEVEL controls (if necessary) for a stable display.

j. CHECK—Repeat parts d through g for the B Sweep.

**Table 4-7**  
**Settings for Timing Accuracy Checks**

A and B SEC/DIV Switch Setting	Time-Mark Generator Output	
	Normal	X10 MAG
0.05 $\mu$ s	50 ns	5 ns
0.1 $\mu$ s	0.1 $\mu$ s	10 ns
0.2 $\mu$ s	0.2 $\mu$ s	20 ns
0.5 $\mu$ s	0.5 $\mu$ s	50 ns
1 $\mu$ s	1 $\mu$ s	0.1 $\mu$ s
2 $\mu$ s	2 $\mu$ s	0.2 $\mu$ s
5 $\mu$ s	5 $\mu$ s	0.5 $\mu$ s
10 $\mu$ s	10 $\mu$ s	1 $\mu$ s
20 $\mu$ s	20 $\mu$ s	2 $\mu$ s
50 $\mu$ s	50 $\mu$ s	5 $\mu$ s
0.1 ms	0.1 ms	10 $\mu$ s
0.2 ms	0.2 ms	20 $\mu$ s
0.5 ms	0.5 ms	50 $\mu$ s
1 ms	1 ms	0.1 ms
2 ms	2 ms	0.2 ms
5 ms	5 ms	0.5 ms
10 ms <sup>a</sup>	10 ms	1 ms
20 ms <sup>a</sup>	20 ms	2 ms
50 ms <sup>a</sup>	50 ms	5 ms
<b>A Sweep Only</b>		
0.1 s <sup>a</sup>	0.1 s	10 ms
0.2 s <sup>a</sup>	0.2 s	20 ms
0.5 s <sup>a</sup>	0.5 s	50 ms

<sup>a</sup>For SEC/DIV switch settings slower than 5 ms, set the A TRIGGER Mode to NORM.

**2. Check  $\Delta$  Time Readout Accuracy**

a. Set:

A SEC/DIV                          0.2  $\mu$ s  
B SEC/DIV                          0.05  $\mu$ s  
HORIZ MODE                      A INTEN  
A TRIGGER Mode                  AUTO  
B TRIGGER SOURCE               $\Delta$  TIME  
X10 MAG                              Off (button out)

b. Select 0.2- $\mu$ s time markers from the time-mark generator.

c. Use the B DELAY TIME POSITION control to position the start of one intensified zone to the left of the second vertical graticule line. Use the  $\Delta$  TIME POSITION control to position the start of the other intensified zone just to the left of the tenth vertical graticule line ( $\Delta$  Time readout should be about 1.600  $\mu$ s).

d. Set HORIZ MODE to B and use the  $\Delta$  TIME POSITION control to superimpose the time markers.

e. CHECK— $\Delta$  Time readout is within the range of values specified in Table 4-8 for the SEC/DIV switches and time-marker settings used.

f. Repeat part e for the remaining A and B SEC/DIV switch settings and time-marker combinations listed in Table 4-8. Use the  $\Delta$  TIME POSITION control to superimpose the time markers at each SEC/DIV switch setting before checking the  $\Delta$  Time readout accuracy.

**Table 4-8**  
**Δ Time Readout Accuracy**

A SEC/DIV Switch Setting	B SEC/DIV Switch Setting	Time Markers	Δ Time Readout
0.2 μs 0.5 μs	0.05 μs 0.05 μs	0.2 μs 0.5 μs	1.583 μs to 1.617 μs 3.95 μs to 4.05 μs
1 μs 2 μs 5 μs	0.1 μs 0.1 μs 0.5 μs	1 μs 2 μs 5 μs	7.91 μs to 8.09 μs 15.83 μs to 16.17 μs 39.5 μs to 40.5 μs
10 μs 20 μs 50 μs	1 μs 1 μs 5 μs	10 μs 20 μs 50 μs	79.1 μs to 80.9 μs 158.3 μs to 161.7 μs .395 ms to .405 ms
0.1 ms 0.2 ms 0.5 ms	10 μs 10 μs 50 μs	0.1 ms 0.2 ms 0.5 ms	.791 ms to .809 ms 1.583 ms to 1.617 ms 3.95 ms to 4.05 ms
1 ms 2 ms 5 ms	0.1 ms 0.1 ms 0.5 ms	1 ms 2 ms 5 ms	7.91 ms to 8.09 ms 15.83 ms to 16.17 ms 39.5 ms to 40.5 ms
10 ms <sup>a</sup> 20 ms <sup>a</sup> 50 ms <sup>a</sup>	1 ms 1 ms 5 ms	10 ms 20 ms 50 ms	79.1 ms to 80.9 ms 158.3 ms to 161.7 ms .395 s to .405 s
0.1 s <sup>a</sup> 0.2 s <sup>a</sup> 0.5 s <sup>a</sup>	10 ms 10 ms 50 ms	0.1 s 0.2 s 0.5 s	.791 s to .809 s 1.583 s to 1.617 s 3.95 s to 4.05 s

<sup>a</sup>For SEC/DIV switch settings slower than 5 ms, set the A TRIGGER Mode to NORM.

### 3. Check Delay Jitter

a. Set:

A SEC/DIV                    1 ms  
B SEC/DIV                    0.5 μs  
HORIZ MODE                 A INTEN

b. Select 1-ms time markers from the time-mark generator.

c. Align the intensified zones with the second time marker using the B DELAY TIME POSITION and Δ TIME POSITION controls.

d. Set HORIZ MODE to B.

e. Align the rising edges of the time markers with the center vertical graticule line using the B DELAY TIME POSITION and Δ TIME POSITION controls.

f. CHECK—For 1 division or less of horizontal jitter on the rising edges of the time markers.

g. Rotate the Δ TIME POSITION control clockwise to bring each succeeding time marker within the graticule viewing area (up to a Δ Time readout of 9 ms) and CHECK for 1 division or less of pulse jitter on the rising edge of each time marker.

h. Rotate the B DELAY TIME POSITION control clockwise to bring each succeeding time marker within the graticule viewing area (down to a Δ Time readout of 0 ms) and CHECK for 1 division or less of pulse jitter on the rising edges of the time markers.

### 4. Check X10 MAG Registration

a. Set:

HORIZ MODE                 A  
X10 MAG                        On (button in)

b. Position the time-marker baseline to the bottom horizontal graticule line using the CH 1 POSITION control.

c. Use the Horizontal POSITION control to position the displayed time marker to the center vertical graticule line.

d. Release the X10 MAG push button (button out).

e. CHECK—Time marker remains centered within 0.2 division of the center vertical graticule line.

### 5. Check A Sweep Length

a. Use the Horizontal POSITION control to position the third time marker to the first vertical graticule line.

b. CHECK—Horizontal trace extends at least 0.5 division, but not more than 1.5 divisions, past the 9th vertical graticule line.



## 6. Check A SEC/DIV VAR Range

a. Set:

A and B SEC/DIV	2 ms (knobs locked)
TIME (PULL) VAR	Pulled out and in calibrated detent

b. Select 5-ms time markers from the time-mark generator.

c. Use the Horizontal POSITION control to align the first time marker with the first vertical graticule line.

d. CHECK—At least one time marker per division can be obtained by rotating the TIME (PULL) VAR control counterclockwise.

e. Return the TIME (PULL) VAR control to its calibrated detent.

## 7. Check A and B Sweep Horizontal POSITION Range

a. Set:

A and B SEC/DIV	1 ms (knobs locked)
Horizontal POSITION	Fully counterclockwise

b. CHECK—Sweep ends to the left of the center vertical graticule line.

c. Rotate the Horizontal POSITION control fully clockwise.

d. CHECK—Sweep begins to the right of the center vertical graticule line.

e. Set:

HORIZ MODE	B
Horizontal POSITION	Fully counterclockwise

f. Repeat parts b through d for the B Sweep.

g. Disconnect the test equipment from the instrument.

## 8. Check X-Y Gain

a. Set:

VERTICAL MODE	X-Y
VOLTS/DIV (both)	10 m
CH 2 AC-GND-DC	GND
HORIZ MODE	A

b. Connect a 50-mV standard-amplitude signal from the calibration generator to the CH 1 OR X input connector via a 50- $\Omega$  cable.

c. CHECK—For a display of 5 divisions  $\pm 0.25$  division (4.75 to 5.25 divisions).

d. Disconnect the test setup.

## 9. Check X-Y Bandwidth

a. Connect a 50 kHz leveled sine-wave signal via a precision 50- $\Omega$  cable, and a 50- $\Omega$  termination to the CH 1 OR X input connector.

b. Set the generator for a 6-division horizontal display.

c. Without changing the generator amplitude, adjust generator output frequency to 2 MHz.

d. CHECK—Display is at least 4.2 divisions in length.

## Performance Check Procedure—2336 Service

e. Disconnect the test equipment from the instrument.

### 10. Check X-Y Phase Differential

a. Connect a 200-kHz sine-wave signal to the CH 1 OR X and CH 2 OR Y input connectors via a 50- $\Omega$  cable, a 50- $\Omega$  termination, and a dual-input coupler.

b. Adjust the generator output amplitude for 6 divisions of horizontal deflection.

c. Set CH 2 AC-GND-DC switch to DC.

d. Vertically center the display using the channel 2 POSITION control, and horizontally center the display using the horizontal POSITION control.

e. CHECK—Opening is 0.3 division or less, measured horizontally.

f. Disconnect the test setup.

# EXTERNAL Z-AXIS AND CALIBRATOR

## Equipment Required (see Table 4-1):

Calibration Generator (Item 2)  
Two 50- $\Omega$  Cables (Item 6)

T-Connector (Item 9)

## 2336 CONTROL SETTINGS

POWER ON (button in)

### CRT

INTEN As required for visible trace  
FOCUS Best focused display

### Vertical (Both Channels)

VERTICAL MODE CH 1  
POSITION Midrange  
VOLTS/DIV 2  
VOLTS/DIV VAR Calibrated detent  
AC-GND-DC DC  
CH 2 INVERT Normal (button out)  
BW LIMIT Full bandwidth (button out)

### Trigger (A and B, if applicable)

COUPLING AC  
LEVEL Fully clockwise  
SLOPE + (button out)  
SOURCE VERT MODE  
Mode AUTO  
TRIG HOLDOFF (PUSH) Off (in detent)

### Sweep

HORIZ MODE A  
A and B SEC/DIV 2 ms (knobs locked)  
TIME (PULL) VAR Pulled out and in calibrated detent  
  
B DELAY TIME Fully counterclockwise  
POSITION Off (button out)  
X10 MAG Midrange  
POSITION

## 1. Check External Z-Axis Operation

a. Connect a 5-V standard-amplitude, square-wave signal to the CH 2 OR Y input connector and to the EXT Z-AXIS input connector (located on the rear panel) via a 50- $\Omega$  T-connector and two 50- $\Omega$  cables.

b. CHECK—For noticeable intensity modulation of the trace when the INTEN control is set for normal-viewing brightness. Adjust the TIME (PULL) VAR control, if necessary, to observe the modulation. Return the TIME (PULL) VAR control to the calibrated detent.

c. Disconnect the test setup.

## 2. Check AMPL CAL Operation

a. Set:

CH 1 VOLTS/DIV 5 m  
A and B SEC/DIV 1 ms (knobs locked)

b. Connect the 10X probe (supplied with the 2336) to the CH 1 OR X input connector. Insert the probe tip into the AMPL CAL connector.

c. CHECK—For a 4-division vertical display of the AMPL CAL square-wave signal (square-wave period is typically 1 ms, within 25%).

d. Disconnect all test equipment.

# ADJUSTMENT PROCEDURE

## INTRODUCTION

### IMPORTANT—PLEASE READ BEFORE USING THIS PROCEDURE

The "Adjustment Procedure" is used to return the instrument to conformance with its "Performance Requirements" as listed in the "Specification" (Section 1). These adjustments should be performed only after the checks in the "Performance Check Procedure" (Section 4) have indicated a need for adjustment of the instrument.

### TEST EQUIPMENT REQUIRED

The test equipment listed in Table 4-1 is a complete list of the equipment required to accomplish both the "Adjustment Procedure" in this section and the "Performance Check Procedure" in Section 4. Test equipment specifications described in Table 4-1 are the minimum necessary to provide accurate results. Therefore, equipment used must meet or exceed the listed specifications. Detailed operating instructions for test equipment are not given in this procedure. If more operating information is required, refer to the appropriate test equipment instruction manual.

When equipment other than that recommended is used, control settings of the test setup may need to be altered. If the exact item of equipment given as an example in Table 4-1 is not available, first check the "Purpose" column to verify use of this item. If it is used for a check or adjustment that is of little or no importance to your measurement requirements, the item and corresponding steps may be deleted. If the check or adjustment is important, use the "Minimum Specification" column to determine if any other available test equipment might suffice.

### LIMITS AND TOLERANCES

The limits and tolerances stated in this procedure are instrument specifications only if they are listed in the "Performance Requirements" column of the "Specification" (Section 1). Tolerances given are applicable only to the instrument undergoing adjustment and do not include test equipment error. Adjustment of the instrument must be accomplished at an ambient temperature between +20°C and +30°C, and the instrument must have had a warm-up period of at least 20 minutes.

### PARTIAL PROCEDURES

This procedure is structured in subsections to permit adjustment of individual sections of the instrument (except the Power Supply) whenever a complete readjustment is not required. For example, if only the Vertical section fails to meet the Performance Requirements (or has had repairs made or components replaced), it can be readjusted with little or no effect on other sections of the instrument. However, if the Power Supply section has undergone repairs or adjustments that change the absolute value of any of the supply voltages, a complete readjustment of the instrument may be required.

At the beginning of each subsection is a list of all the front-panel control settings required to prepare the instrument for performing Step 1 in that subsection. Each succeeding step within a subsection should then be performed both in the sequence presented and in its entirety to ensure that control settings will be correct for ensuing steps.

## INTERNAL ADJUSTMENTS AND ADJUSTMENT INTERACTION

Do not preset any internal controls or change the +40-V Power-Supply adjustment, since that will typically necessitate a complete readjustment of the instrument, when only a partial readjustment might otherwise be required. To avoid unnecessary readjustment, change an internal control setting only when a Performance Characteristic cannot be met with the original setting. When it is necessary to change the setting of any internal control, always check Table 5-1 for possible interacting adjustments that might be required.

The use of Table 5-1 is particularly important if only a partial procedure is performed or if a circuit requires readjustment due to a component replacement. To use this table, first find the adjustment that was made (extreme left column). Then move to the right, across the row, until you come to a darkened square. From the darkened square, move up the table and check the accuracy of the adjustment found at the heading of that column. Readjust if necessary.

Specific interactions are called out within certain adjustment steps to indicate that the adjustments must be repeated until no further improvement is noted.

## PREPARATION FOR ADJUSTMENT

It is necessary to remove the instrument cabinet to perform the Adjustment Procedure. See the "Cabinet" removal instructions located in the "Maintenance" section of the manual.

Before performing this procedure, ensure that the LINE VOLTAGE SELECTOR switch is set for the ac-power-input source voltage being used (see "Preparation for Use" in Section 2). This procedure is written for the instrument to be operated from a 115-V ac-power-input source. Operating from other input-source voltages will require setting the LINE VOLTAGE SELECTOR switch to the appropriate setting for the available ac-power-input source.

All test equipment items described in Table 4-1 are required to accomplish a complete Adjustment Procedure. The specific items of equipment needed to perform each subsection in this procedure are listed at the beginning of the subsection. The item number shown in parentheses with each piece of equipment refers to the equipment item number presented in Table 4-1.

Connect the test equipment to an appropriate ac-power-input source and connect the 2336 to a variable auto-transformer (Item 18 in Table 4-1) that is set for 115 V ac. Apply power and allow a 20-minute warm-up period before commencing any adjustments.

### Display

The most accurate display adjustments are made with a stable, well-focused, low-intensity display. Unless otherwise noted, adjust the INTEN, ASTIG, FOCUS, and TRIGGER LEVEL controls as needed to view the display.

### Step and Part Titles

Where possible in this procedure, instrument performance is checked before an adjustment is made. Steps containing both checks and adjustments are titled "Check/Adjust." Those steps with only checks are titled "Check."

If a part is titled "CHECK/ADJUST," first perform a check to determine whether the instrument meets the requirement. If it does, the adjustment is not required.

**Table 5-1**  
Adjustment Interactions

Adjustments or Replacements Made	Adjustments Affected																															
	TRACE ROTATION	Y-AXIS ALIGNMENT	GEOMETRY	CRT GRID BIAS	Z-AXIS COMP	5ns TIMING	X1 HORIZ GAIN	X10 HORIZ GAIN	X-Y GAIN	MAG REGISTRATION	A HIGH SPEED TIMING	B HIGH SPEED TIMING	B TIME	DELAY START	DELAY STOP	A HYSTERESIS	A SLOPE OFFSET	B HYSTERESIS	B SLOPE OFFSET	VERT MODE LEVEL	DC EXT LEVEL	VERTICAL OUTPUT GAIN	VERTICAL BALANCE	CH1 GAIN	CH2 GAIN	CH1 VAR BAL	CH2 VAR BAL	CH1 ATTENUATOR BAL	CH2 ATTENUATOR BAL	+40-V ADJ		
TRACE ROTATION	■																															
Y-AXIS ALIGNMENT	■																															
GEOMETRY	■																															
CRT GRID BIAS		■																														
Z-AXIS COMP			■																													
5ns TIMING				■																												
X1 HORIZ GAIN					■																											
X10 HORIZ GAIN						■																										
X-Y GAIN							■																									
MAG REGISTRATION								■																								
A HIGH SPEED TIMING						■																										
B HIGH SPEED TIMING							■																									
B TIME								■																								
DELAY START									■																							
DELAY STOP										■																						
A HYSTERESIS											■																					
A SLOPE OFFSET												■																				
B HYSTERESIS													■																			
B SLOPE OFFSET														■																		
VERT MODE LEVEL															■																	
DC EXT LEVEL																■																
VERTICAL OUTPUT GAIN																	■															
VERTICAL BALANCE																		■														
CH1 GAIN																			■													
CH2 GAIN																				■												
CH1 VAR BAL																					■											
CH2 VAR BAL																						■										
CH1 ATTENUATOR BAL																							■									
CH2 ATTENUATOR BAL																								■								
CRT REPLACEMENT	■	■	■	■	■	■	■	■	■	■	■	■	■	■	■	■	■	■	■	■	■	■	■	■	■	■	■	■	■	■	■	■
+40-V ADJ	■	■	■	■	■	■	■	■	■	■	■	■	■	■	■	■	■	■	■	■	■	■	■	■	■	■	■	■	■	■	■	■

4118-63A

## INDEX TO ADJUSTMENT PROCEDURE

	Page
<b>Main Power Supply</b>	
1. Check/Adjust Power Supply DC Levels, Regulation, and Ripple (R231) . . . . .	5-5
2. Check High-Voltage Overdrive . . . . .	5-6
<b>Display and Z-Axis</b>	
1. Check/Adjust CRT Grid Bias (R140). . . . .	5-7
2. Check/Adjust Trace Alignment . . . . .	5-7
3. Check/Adjust Y-Axis Alignment (R203) . . . . .	5-8
4. Check/Adjust Geometry (R202). . . . .	5-8
5. Check/Adjust Z-Axis Compensation (C101 and C128). . . . .	5-8
<b>Vertical</b>	
1. Check Input Coupling Switches . . . . .	5-9
2. Check ALT Mode Operation . . . . .	5-10
3. Check CHOP Mode Operation . . . . .	5-10
4. Check AUTO Vertical Mode Operation . . . . .	5-10
5. Check BEAM FIND Operation. . . . .	5-10
6. Check/Adjust CH 1 VOLTS/DIV VAR Balance (R22) and UNCAL LED. . . . .	5-11
7. Check/Adjust CH 1 Attenuator Balance (R10) . . . . .	5-11
8. Check/Adjust CH 2 VOLTS/DIV VAR Balance (R83) and UNCAL LED. . . . .	5-11
9. Check/Adjust CH 2 Attenuator Balance (R74) . . . . .	5-12
10. Check/Adjust CH 1 Vertical Output Gain (R44) . . . . .	5-12
11. Check/Adjust Vertical Balance (R18) . . . . .	5-12
12. Check/Adjust CH 1 and CH 2 Vertical Gain (R47 and R114) . . . . .	5-12
13. Check CH 1 and CH 2 VOLTS/DIV VAR Range . . . . .	5-13
14. Check CH 1 and CH 2 Input Gate Current . . . . .	5-13
15. Check ADD Mode Operation. . . . .	5-13
16. Check Compression and Expansion. . . . .	5-13
17. Check Low-Frequency Transient Response. . . . .	5-14
18. Check/Adjust CH 1 and CH 2 Low-Frequency Compensation (R66, R73, R31, and R92) . . . . .	5-14
19. Check/Adjust Vertical Output High-Frequency Compensation (R29, R32, R33, and C36) and CH 1 and CH 2 Preamplifier High-Frequency Compensation (R33, C33, R95, and C95) . . . . .	5-14
20. Check CH 1 and CH 2 Transient Response . . . . .	5-15
21. Check Bandwidth . . . . .	5-16
22. Check Trigger View Gain . . . . .	5-16
23. Check Trigger View Centering . . . . .	5-16
24. Check Trigger View Low-Frequency Compensation. . . . .	5-17

	Page
<b>Vertical (cont)</b>	
25. Check Trigger View High-Frequency Compensation. . . . .	5-17
26. Check Trigger View Delay. . . . .	5-17
27. Check Trigger View Bandwidth . . . . .	5-17
28. Check Channel Isolation. . . . .	5-18
29. Check Common-Mode Rejection Ratio . . . . .	5-18
30. Check Bandwidth Limit Operation . . . . .	5-18

<b>Triggering</b>	
1. Adjust A Trigger Slope Offset (R82) and A Hysteresis (R106). . . . .	5-19
2. Adjust B Trigger Slope Offset (R127) and B Hysteresis (R163). . . . .	5-20
3. Adjust Vert Mode DC Level (R29) . . . . .	5-20
4. Check A and B Internal Triggering . . . . .	5-20
5. Adjust A External Trigger DC Level (R41) . . . . .	5-22
6. Check A and B External Triggering and Jitter . . . . .	5-22
7. Check NORM Triggering Mode Operation . . . . .	5-23
8. Check SGL SWP Mode Operation. . . . .	5-24
9. Check A and B External Trigger Level Ranges. . . . .	5-24
10. Check Line Triggers. . . . .	5-25

<b>Horizontal</b>	
1. Check A INTEN Operation . . . . .	5-26
2. Adjust A Sweep Start and Sweep Stop (R74 and R6) . . . . .	5-27
3. Check $\Delta$ Time Readout Linearity . . . . .	5-27
4. Check Delay Jitter. . . . .	5-28
5. Check/Adjust X1 and X10 Horizontal Gain (R126 and R127) . . . . .	5-28
6. Check/Adjust X10 MAG Registration (R134) . . . . .	5-29
7. Check/Adjust B Time (R10) . . . . .	5-29
8. Check A and B Timing Accuracy and Linearity . . . . .	5-29
9. Adjust A and B Timing Accuracy and Linearity (C84, C22, C161, and C187) . . . . .	5-30
10. Check $\Delta$ Time Readout Accuracy. . . . .	5-31
11. Check A and B Sweep Length . . . . .	5-32
12. Check A SEC/DIV VAR Range . . . . .	5-32
13. Check A and B Sweep Horizontal POSITION Range . . . . .	5-32
14. Check AUTO Recovery . . . . .	5-33
15. Check/Adjust X-Y Gain (R148) . . . . .	5-33
16. Check X-Y Bandwidth and Phasing. . . . .	5-33
17. Check A Trigger Holdoff. . . . .	5-33

<b>External Z-Axis and Calibrator</b>	
1. Check External Z-Axis Operation . . . . .	5-35
2. Check AMPL CAL Operation. . . . .	5-36

# MAIN POWER SUPPLY

## Equipment Required (see Table 4-1):

Test Oscilloscope with 1X Probe (Item 1)	Screwdriver (Item 21)
Variable Autotransformer (Item 18)	Shorting Strap (Item 22)
Digital Voltmeter (Item 19)	

See **ADJUSTMENT LOCATIONS 1** and **ADJUSTMENT LOCATIONS 4**

at the back of this manual for test point and adjustment locations.

## 2336 CONTROL SETTINGS

LINE VOLTAGE  
SELECTOR  
POWER

115 V  
ON (button in)

### CRT

INTEN As required for visible trace  
FOCUS Best focused display

### Vertical (Both Channels)

VERTICAL MODE X-Y (CH 1 and CH 2 buttons in)  
POSITION Midrange  
VOLTS/DIV 5 m  
VOLTS/DIV VAR Calibrated detent  
AC-GND-DC GND  
CH 2 INVERT Normal (button out)  
BW LIMIT Full bandwidth (button out)

### Trigger

COUPLING LEVEL AC  
As required for stable display  
SLOPE + (button out)  
SOURCE VERT MODE  
Mode AUTO  
TRIG HOLDOFF (PUSH) VAR Off (in detent)

### Sweep

HORIZ MODE A  
A and B SEC/DIV 1 ms (knobs locked)  
TIME (PULL) VAR Pulled out and in calibrated detent  
B DELAY TIME  
POSITION Fully counterclockwise  
X10 MAG Off (button out)  
POSITION Midrange

### 1. Check/Adjust Power Supply DC Levels, Regulation, and Ripple (R231)

#### NOTE

Review the information at the beginning of this section before starting this step.

a. Connect the digital voltmeter low lead to chassis ground and connect the volts lead to the first test point listed in Table 5-2.

b. CHECK—Voltage reading is within the range given in Table 5-2.

c. Repeat parts a and b for each test point in Table 5-2.

d. If all voltages are within tolerance, skip to part g. If they are not, continue with part e.

#### NOTE

Adjustment of the +40-V Power Supply may require a complete readjustment of the instrument. Do not adjust the +40-V Power Supply if it is within tolerance, unless a complete adjustment procedure is to be performed.



**Table 5-2**  
**Main Power Supply Tolerances and p-p Ripple**

Power Supply	Test Point (+ Lead)	Reading	Tolerance	Typical p-p Ripple
+40 V	TP247	+39.92 to +40.08	±0.2%	1 mV
+10 V	TP252	+9.91 to +10.09	±0.9%	1 mV
-10 V	TP265	-9.88 to -10.12	±1.2%	1 mV
+5 V	TP255	+4.97 to +5.04	±0.7%	1 mV
-5 V	TP264	-4.95 to -5.05	±0.9%	1 mV
+102 V	TP320	+100 to +104	±2.0%	1 V

e. Connect the digital voltmeter low lead to chassis ground and connect the volts lead to TP247.

f. ADJUST—+40-V Supply (R231) for +40 V and again CHECK all power supply dc levels according to Table 5-2.

g. Disconnect the voltmeter.

h. Set test oscilloscope controls as follows:

A and B Sec/Div	5 ms
Ac-Gnd-Dc (both)	Ac
Trigger controls	As required for a stable display

i. Connect the test oscilloscope to the first test point given in Table 5-2 via a 1X probe and cascaded gain on the oscilloscope. This will obtain the necessary vertical resolution for measuring ripple amplitude.

j. CHECK—Ripple amplitude of the dc supply while varying the autotransformer output voltage between 100 V and 132 V. Ripple amplitude should be within the typical value given in Table 5-2.

k. Repeat part j for each test point in Table 5-2.

l. Return the autotransformer output voltage to 115 V and disconnect the test setup.

## 2. Check High-Voltage Overdrive

a. Connect the digital voltmeter low lead to chassis ground and connect the volts lead to TP320 (+102 V supply). Set the autotransformer to zero output.

b. Connect a shorting strap between TP184 and TP185.

c. CHECK—While slowly increasing the autotransformer output, that the voltage level increases to 112 V ± 4 V, then drops to approximately 13 V. Note that a buzzing sound is heard just before the voltage drops. Reset the autotransformer for a 115 V output.

d. Set POWER switch to OFF, remove the shorting strap, and disconnect the voltmeter. Set POWER switch to ON.

# DISPLAY AND Z-AXIS

## Equipment Required (see Table 4-1):

Test Oscilloscope with 10X Probe (Item 1)	Digital Voltmeter (Item 19)
Time-Mark Generator (Item 4)	Screwdriver (Item 21)
50-Ω BNC Cable (Item 6)	Low-Capacitance Alignment Tool (Item 23)
50-Ω BNC Termination (Item 13)	

See **ADJUSTMENT LOCATIONS 4** at the back of this manual for test point and adjustment locations.

## 2336 CONTROL SETTINGS

LINE VOLTAGE SELECTOR POWER	115 V ON (button in)
-----------------------------------	-------------------------

### CRT

INTEN	As required for visible trace
FOCUS	Best focused display

### Vertical (Both Channels)

VERTICAL MODE	X-Y (CH 1 and CH 2 buttons in)
POSITION	Midrange
VOLTS/DIV	5 m
VOLTS/DIV VAR	Calibrated detent
AC-GND-DC	GND
CH 2 INVERT	Normal (button out)
BW LIMIT	Full bandwidth (button out)

### Trigger

COUPLING LEVEL	AC As required for stable display
SLOPE	+ (button out)
SOURCE Mode	VERT MODE AUTO
TRIG HOLDOFF (PUSH) VAR	Off (in detent)

### Sweep

HORIZ MODE	A
A and B SEC/DIV TIME (PULL) VAR	1 ms (knobs locked) Pulled out and in calibrated detent
B DELAY TIME POSITION	Fully counterclockwise
X10 MAG POSITION	Off (button out) Midrange

### 1. Check/Adjust CRT Grid Bias (R140)

a. Connect the digital voltmeter low lead to chassis ground and the volts lead to TP130.

b. Set the INTEN control for a digital voltmeter reading of +20 V.

c. CHECK—Display for a well-defined, low-intensity dot. Adjust the FOCUS and ASTIG controls as necessary.

d. ADJUST—CRT Grid Bias (R140) for a dot, then back off the control until the dot is just visible.

e. Disconnect the test setup.

### 2. Check/Adjust Trace Alignment

a. Set:

VERTICAL MODE	CH 1
A and B SEC/DIV	0.5 ms
INTEN	As required for visible trace

## Adjustment Procedure—2336 Service

b. Use the CH 1 POSITION control to move the trace to the center horizontal graticule line.

c. CHECK—Trace is parallel with the center horizontal graticule line.

d. ADJUST—TRACE ROTATION control (front-panel screwdriver adjustment) to align the trace parallel with the center horizontal graticule line.

### 3. Check/Adjust Y-Axis Alignment (R203)

a. Set:

VERTICAL MODE	X-Y (CH 1 and CH 2 buttons in)
CH 2 AC-GND-DC	DC
CH 2 VOLTS/DIV	0.1
CH 2 POSITION	Fully counterclockwise

b. Connect 0.5-ms time markers from the time-mark generator to the CH 2 OR Y input connector via a 50- $\Omega$  cable and a 50- $\Omega$  termination.

c. Use the Horizontal POSITION control to move the display to the center vertical graticule line.

d. CHECK—Display for 0.1 division of tilt or less when compared to the center vertical graticule line.

e. ADJUST—Y-Axis Alignment (R203) to align the display parallel with the center vertical graticule line.

f. INTERACTION—TRACE ROTATION adjustment. Repeat Steps 2 and 3 for best display alignment.

### 4. Check/Adjust Geometry (R202)

a. Set:

VERTICAL MODE	CH 2
A TRIGGER SOURCE	CH 2
A TRIGGER LEVEL	For a stable display

b. CHECK—Display for 0.1 division or less of bowing of the time markers across the graticule area from top to bottom.

c. ADJUST—Geometry (R202) for minimum bowing of the time markers across the graticule area (especially at the left and right vertical graticule lines).

d. INTERACTION—Y-Axis Alignment adjustment. Repeat Steps 3 and 4 for best display alignment.

e. Disconnect the test setup from the instrument.

### 5. Check/Adjust Z-Axis Compensation (C101 and C128)

a. Set:

VERTICAL MODE	CH 1
A and B SEC/DIV	0.05 $\mu$ s
A TRIGGER LEVEL	Fully clockwise

b. Set test oscilloscope controls as follows:

Volts/Div	0.2 V (with 10X probe)
A and B Sec/Div	0.1 $\mu$ s
AC-Gnd-DC (both)	DC
Trigger controls	As required for a stable display

c. Connect the 10X probe from the test oscilloscope to TP127 and connect the probe ground clip to TP92 (GND 2).

d. Adjust the 2336 INTEN control for a 5-division (5-V) vertical display (on the test oscilloscope) of the unblanking gate.

e. ADJUST—Z-Axis Compensation (C101), using a low-capacitance alignment tool, for the best square front corner on the unblanking pulse displayed on the test oscilloscope. Also adjust C128 for the best flat top just after the front corner.

f. CHECK—The p-p aberration is less than  $\pm 5\%$  (0.25 division).

g. Disconnect the test equipment from the instrument.

# VERTICAL

## Equipment Required (see Table 4-1):

Test Oscilloscope with 10X Probe (Item 1)	2X Attenuator (Item 12)
Calibration Generator (Item 2)	Two 50-Ω BNC Terminations (Item 13)
Leveled Sine-Wave Generator (Item 3)	Precision 50-Ω BNC Cable (Item 14)
Two 50-Ω BNC Cables (Item 6)	Low-Frequency Generator (Item 17)
Bnc-to-Probe-Tip Adapter (Item 7)	Digital Voltmeter (Item 19)
Dual-Input Coupler (Item 8)	Screwdriver (Item 21)
10X Attenuator (Item 10)	Low-Capacitance Alignment Tool (Item 23)
5X Attenuator (Item 11)	

See **ADJUSTMENT LOCATIONS 1** and **ADJUSTMENT LOCATIONS 4** at the back of this manual for test point and adjustment locations.

## 2336 CONTROL SETTINGS

LINE VOLTAGE  
SELECTOR POWER 115 V  
ON (button in)

### CRT

INTEN As required for visible trace  
FOCUS Best focused display

### Vertical (Both Channels)

VERTICAL MODE CH 1  
POSITION Midrange  
VOLTS/DIV 5 m  
VOLTS/DIV VAR Calibrated detent  
AC-GND-DC DC  
CH 2 INVERT Normal (button out)  
BW LIMIT Full bandwidth  
(button out)

### Trigger

COUPLING LEVEL AC  
As required for stable display  
SLOPE + (button out)  
SOURCE VERT MODE  
Mode AUTO  
TRIG HOLDOFF (PUSH) VAR Off (in detent)

### Sweep

HORIZ MODE A  
A and B SEC/DIV 1 ms (knobs locked)  
TIME (PULL) VAR Pulled out and in calibrated detent  
B DELAY TIME  
POSITION Fully counterclockwise  
X10 MAG Off (button out)  
POSITION Midrange

### 1. Check Input Coupling Switches

a. Connect a 20-mV, standard-amplitude square-wave signal to the CH 1 OR X input connector via a 50-Ω cable.

b. Position the bottom of the display to the center horizontal graticule line and set the CH 1 AC-GND-DC switch to GND.

c. CHECK—Trace is at the center horizontal graticule line with no vertical deflection.

d. Set the CH 1 AC-GND-DC switch to AC.

e. CHECK—Display is centered about the center horizontal graticule line.

f. Set VERTICAL MODE to CH 2 and move the test signal to the CH 2 OR Y input connector.

## Adjustment Procedure—2336 Service

g. Position the bottom of the display to the center horizontal graticule line and set the CH 2 AC-GND-DC switch to GND.

h. CHECK—Trace is at the center horizontal graticule line with no vertical deflection.

i. Set CH 2 AC-GND-DC switch to AC.

j. CHECK—Display is centered about the center horizontal graticule line.

k. Disconnect the test equipment from the instrument.

b. Vertically spread the CH 1 and CH 2 traces about 4 divisions apart using the CH 1 and CH 2 POSITION controls and adjust the A TRIGGER LEVEL control for a stable display.

c. CHECK—Vertical switching transients are completely blanked between horizontal chopped segments for normal viewing intensity.

d. CHECK—Period of one complete square-wave cycle is 2.8 to 5.2  $\mu$ s (approximately 4 horizontal divisions).

e. Rotate the A TRIGGER LEVEL control fully clockwise.

f. CHECK—Two traces are visible for all B SEC/DIV switch settings.

g. Set HORIZ MODE to A and repeat part f for the A sweeps.

## 2. Check ALT Mode Operation

a. Set:

A and B SEC/DIV	50 ms (knobs locked)
VERTICAL MODE	ALT
A TRIGGER LEVEL	Fully clockwise

b. Position CH 1 and CH 2 traces about 2 divisions apart.

c. CHECK—Sweeps alternate for all A SEC/DIV switch settings.

### NOTE

*At sweep speeds of 2 ms per division or faster, the trace alternations occur rapidly and cannot be observed.*

d. Set HORIZ MODE to B and repeat part c for the B sweeps.

## 3. Check CHOP Mode Operation

a. Set:

A and B SEC/DIV	1 $\mu$ s
VERTICAL MODE	CHOP
AC-GND-DC (both)	GND
A TRIGGER Mode	AUTO
A TRIGGER COUPLING	AC
A TRIGGER SOURCE	VERT MODE

## 4. Check AUTO Vertical Mode Operation

a. Set:

VERTICAL MODE	AUTO (ALT and CHOP buttons in)
A and B SEC/DIV	0.2 ms

b. Set test oscilloscope controls as follows:

Volts/Div	1 V (with 10X probe)
Time/Div	0.5 ms
Ac-Gnd-Dc	Dc
Trigger controls	As required for a stable display

c. Connect a 10X probe from the test oscilloscope to TP61 (CH 1).

d. Verify that the display is a square-wave signal with a period of approximately 4.8 ms.

e. Set the A and B SEC/DIV controls to 0.5 ms.

f. CHECK—Display on the test oscilloscope becomes a square-wave signal with a period of approximately 2  $\mu$ s (adjust the test oscilloscope Time/Div control as necessary to view the signal).

- g. Disconnect the test equipment from the instrument.

## 5. Check BEAM FIND Operation

- a. Push in and hold the BEAM FIND push button.
- b. CHECK—Display remains entirely in the graticule area regardless of the settings of the Vertical and Horizontal POSITION controls, with the X10 MAG push button both in and out.
- c. CHECK—Trace intensity remains constant and visible regardless of the INTEN control setting.
- d. Set VERTICAL MODE to CH 1 and center the CH 1 trace both vertically and horizontally while holding in the BEAM FIND push button.
- e. Release the BEAM FIND button.
- f. CHECK—Trace remains centered within the graticule area.

## 6. Check/Adjust CH 1 Attenuator Balance (R10)

- a. Set:
- |                |     |
|----------------|-----|
| CH 1 VOLTS/DIV | 0.1 |
| CH 1 AC-GND-DC | DC  |
- b. Position the trace to the center horizontal graticule line.
- c. Set the CH 1 VOLTS/DIV control to 50 m.

### NOTE

*CH 1 Attenuator Balance (R10) is adjusted while the CH 1 VOLTS/DIV control is set to 0.1.*

- d. CHECK/ADJUST—CH 1 Attenuator Balance (R10) for no discernable trace shift from the center horizontal graticule line when the CH 1 VOLTS/DIV control is switched between 0.1 and 50 m.

## 7. Check/Adjust CH 1 VOLTS/DIV VAR Balance (R22) and UNCAL LED

- a. Set:
- |                  |                     |
|------------------|---------------------|
| A and B SEC/DIV  | 1 ms (knobs locked) |
| VOLTS/DIV (both) | 10 m                |
| CH 1 AC-GND-DC   | GND                 |
- b. Position the trace to the center horizontal graticule line.
- c. Rotate the CH 1 VOLTS/DIV VAR control clockwise out of its calibrated detent.
- d. CHECK—UNCAL LED is illuminated.
- e. CHECK/ADJUST—CH 1 Var Balance (R22) for no discernable trace shift when rotating the VOLTS/DIV VAR control from fully counterclockwise to fully clockwise.
- f. Return the CH 1 VOLTS/DIV VAR control to its calibrated detent (fully counterclockwise).

## 8. Check/Adjust CH 2 Attenuator Balance (R74)

- a. Set:
- |                |     |
|----------------|-----|
| CH 2 VOLTS/DIV | 0.1 |
| CH 2 AC-GND-DC | DC  |
- b. Position the trace to the center horizontal graticule line.
- c. Set the CH 2 VOLTS/DIV control to 50 m.

### NOTE

*CH 2 Attenuator Balance (R74) is adjusted while the CH 2 VOLTS/DIV control is set to 0.1.*

- d. CHECK/ADJUST—CH 2 Attenuator Balance (R74) for no discernable trace shift from the center horizontal graticule line when the CH 2 VOLTS/DIV control is switched between 0.1 and 50 m.

**9. Check/Adjust CH 2 VOLTS/DIV VAR Balance (R83) and UNCAL LED**

a. Set:

VERTICAL MODE	CH 2
VOLTS/DIV (both)	10 m
CH 2 AC-GND-DC	GND

b. Position the trace to the center horizontal graticule line.

c. Rotate the CH 2 VOLTS/DIV VAR control clockwise out of its calibrated detent.

d. CHECK—UNCAL LED is illuminated.

e. CHECK/ADJUST—CH 2 Var Balance (R83) for no discernable trace shift when rotating the CH 2 VOLTS/DIV VAR control from fully counterclockwise to fully clockwise.

f. Return the CH 2 VOLTS/DIV VAR control to its calibrated detent (fully counterclockwise).

**10. Check/Adjust Vertical Output Gain (R44)**

a. Connect the digital voltmeter leads between TP156 and TP176, set voltmeter scale to 200 mV and adjust the CH 2 Vertical POSITION control for a voltmeter indication of 0 V.

b. Adjust Vertical Balance (R18) to position the trace on the center horizontal graticule line.

c. Adjust the CH 2 Vertical POSITION control for a voltmeter indication of 150 mV.

d. ADJUST—Vertical Output Gain (R44) to position the trace 2 divisions above the center horizontal graticule line.

**NOTE**

*If the trace does not reach exactly 2 full divisions above the center horizontal graticule line, set R44 to maximum or minimum to position the trace as closely as possible to 2 divisions above the center horizontal graticule line.*

e. Disconnect the test equipment from the instrument.

**11. Check/Adjust Vertical Balance (R18)**

a. Set the CH 2 AC-GND-DC switch to GND.

b. Rotate the channel 2 POSITION control while alternately pressing in and releasing the CH 2 INVERT button until a point is reached where there is no trace movement.

c. CHECK/ADJUST—Vertical Balance (R18) to vertically position the trace within  $\pm 0.4$  division of the center horizontal graticule line.

d. Repeat parts b and c as necessary.

**12. Check/Adjust CH 1 and CH 2 Vertical Gain (R47 and R114)**

a. Set:

VOLTS/DIV (both)	5 m
AC-GND-DC (both)	DC
CH 2 INVERT	Normal (button out)

b. Connect a 20-mV, standard-amplitude square-wave signal to the CH 2 OR Y input connector via a 50- $\Omega$  cable.

c. CHECK/ADJUST—CH 2 Vertical Gain (R114) for a display amplitude of 4 divisions  $\pm 3\%$  (3.88 to 4.12 divisions).

d. CHECK—Dc accuracies are within display limits at each CH 2 VOLTS/DIV switch setting and standard-amplitude signal as listed in Table 5-3.

e. Set VERTICAL MODE to CH 1.

f. Set the generator to 20 mV and move the input signal to the CH 1 OR X input connector.

g. CHECK/ADJUST—CH 1 Vertical Gain (R47) for display amplitude of 4 divisions  $\pm 3\%$  (3.88 to 4.12 divisions).

h. CHECK—Dc accuracies are within display limits at each CH 1 VOLTS/DIV switch setting and standard-amplitude signal as listed in Table 5-3.

i. Set the generator output for a 10-mV signal.

Table 5-3  
Vertical DC Accuracy Checks

VOLTS/DIV Switch Setting	Standard Amplitude Signal	Deflection for 3% Accuracy (divisions)	Display Limits (divisions)
10 m	50 mV	5	4.85 to 5.15
20 m	0.1 V	5	4.85 to 5.15
50 m	0.2 V	4	3.88 to 4.12
0.1	0.5 V	5	4.85 to 5.15
0.2	1 V	5	4.85 to 5.15
0.5	2 V	4	3.88 to 4.12
1	5 V	5	4.85 to 5.15
2	10 V	5	4.85 to 5.15
5	20 V	4	3.88 to 4.12

### 13. Check CH 1 and CH 2 VOLTS/DIV VAR Range

a. Set:

VOLTS/DIV (both)	5 m
AC-GND-DC (both)	DC

b. Rotate the CH 1 VOLTS/DIV VAR control fully clockwise.

c. CHECK—Display increases to 5 divisions or more in amplitude.

d. Move the test signal to the CH 2 OR X input connector and set VERTICAL MODE to CH 2.

e. Rotate the CH 2 VOLTS/DIV VAR control fully clockwise.

f. CHECK—Display increases to 5 divisions or more in amplitude.

g. Return both VAR controls to their calibrated detents.

h. Disconnect the test equipment from the instrument.

### 14. Check CH 1 and CH 2 Input Gate Current

a. Set both AC-GND-DC switches to GND.

b. CHECK—For 0.1 division or less vertical shift in display (0.5 nA or less input gate current) while alternating the CH 2 AC-GND-DC switch between AC and GND.

c. Set VERTICAL MODE to CH 1.

d. CHECK—For 0.1 division or less vertical shift in display (0.5 nA or less input gate current) while alternating the CH 1 AC-GND-DC switch between AC and GND.

### 15. Check ADD Mode Operation

a. Set:

VERTICAL MODE	ADD
AC-GND-DC (both)	DC

b. Connect a 10-mV, standard-amplitude square-wave signal to both CH 1 OR X and CH 2 OR Y input connectors via a 50-Ω cable and a dual-input coupler.

c. CHECK—Display amplitude is 4 divisions  $\pm 3\%$  (3.88 to 4.12 divisions).

### 16. Check Compression and Expansion

a. Set:

CH 2 AC-GND-DC	GND
VERTICAL MODE	CH 1

b. Adjust the CH 1 VOLTS/DIV VAR control (if necessary) for an exact 2-division vertical display centered within the graticule area.

c. Position the top of the display to the top graticule line.

d. CHECK—For display compression or expansion of 0.1 division or less.

e. Position the bottom of the display to the bottom graticule line.



## Adjustment Procedure—2336 Service

f. CHECK—For display compression or expansion of 0.1 division or less.

g. Return the CH 1 VOLTS/DIV VAR control to its calibrated detent.

h. Disconnect the test setup from the instrument.

### 17. Check/Adjust CH 1 and CH 2 Low-Frequency Transient Response and Compensation (R66, R73, R31 and R92)

a. Set:

VERTICAL MODE	CHOP
AC-GND-DC (both)	DC
VOLTS/DIV (both)	5 m
A TRIGGER SOURCE	CH 1
A SEC/DIV	1 ms
A TRIGGER LEVEL	For a stable display

b. Connect a 1-kHz signal from the square-wave generator's fast-rise, positive-going output via a precision 50- $\Omega$  cable, a X10 attenuator, and a 50- $\Omega$  termination to the CH 1 OR X input connector.

c. Adjust the generator output to obtain a 5-division vertical display.

d. Position the CH 2 trace on the center horizontal graticule line, center the CH 1 display, and adjust the A TRIGGER LEVEL control for a stable display.

e. CHECK—Display overshoot or rounding is within  $\pm 3\%$  (4.85 to 5.15 divisions) for each CH 1 VOLTS/DIV switch setting from 5 m to 0.2 and waveform flatness is within  $\pm 2\%$  (0.1 division) at all settings. Adjust the generator output and/or remove the attenuator as necessary to maintain a 5-division vertical display throughout this step. If not within tolerance proceed to part f; if within tolerance skip to part j.

f. Set CH 1 and CH 2 VOLTS/DIV to 10 m and adjust the generator output for a 5-division vertical display.

g. Repeat part d.

h. ADJUST —Low-frequency Compensation (R66 and R73) for no vertical deflection on the CH 2 trace.

i. ADJUST—Low-frequency Compensation (R31) for the best flat-top square wave on the CH 1 display.

j. Set generator output to minimum amplitude and move the test signal to the CH 2 OR Y input connector.

k. Set:

VOLTS/DIV (CH 2)	5 m
VERTICAL MODE	CH 2
A TRIGGER SOURCE	CH 2
A TRIGGER LEVEL	For a stable display

l. Vertically center the CH 2 display and repeat parts c and e for CH 2. If within tolerance skip to Step 18; if not, proceed to part m.

m. Reduce generator output to minimum, reinstall the attenuator, and set CH 2 VOLTS/DIV to 10 m.

n. ADJUST—Low-frequency compensation (R92) for the best flat-top square wave on the CH 2 display.

o. Repeat all of Step 17 as necessary, then proceed to Step 18.

### 18. Check/Adjust CH 1 and CH 2 20 pf Compensation (C1 and C62 on A10 Board)

a. Reduce generator output to minimum and reinstall the attenuator.

b. Set:

VERTICAL MODE	CH2
VOLTS/DIV (both)	10 m
A TRIGGER SOURCE	VERT MODE
A TRIGGER LEVEL	For a stable display

c. Adjust generator output for a 5-division vertical display and set A TRIGGER LEVEL for a stable display.

d. Note shape of displayed waveform.

e. Set CH 2 VOLTS/DIV to 0.1 and readjust generator output for a 5-division vertical display (remove attenuator if necessary).

f. CHECK—Displayed waveform shape matches that noted in part d. If so skip to part h, if not proceed to part g.

g. ADJUST—C62 for waveform shape to match the waveform noted in part d.

h. Set CH 2 VOLTS/DIV to 0.2 and set generator for a 5-division display. Check that waveform shape matches that noted in part d. If not, repeat all of Steps 17 and 18. (If still not correct a circuit malfunction is indicated)

- i. Set generator for minimum output.
- j. Move the test signal to the CH 1 or X input connector.
- k. Set VERTICAL MODE to CH 1.
- l. Repeat parts c through e for channel 1.
- m. CHECK—Displayed waveform shape matches the waveform noted in part d for channel 1. If so, skip to Step 19, if not, proceed to part n.
- n. ADJUST—C1 for waveform shape to match the waveform noted in part d for channel 1.
- o. Repeat part h for channel 1.

### 19. Check/Adjust Vertical Output High-Frequency Compensation (R29, R32, C33, C36, R39 and C39) and CH 1 and CH 2 Preamp High-Frequency Compensation (R33, C33, C58, R95, and C95)

- a. Set:
 

VERTICAL MODE	CH 1
VOLTS/DIV	10 m
A TRIGGER SOURCE	VERT MODE
A SEC/DIV	1 $\mu$ s
BW LIMIT	Full Bandwidth (button out)
- b. Set generator for minimum output amplitude and connect a fast-rise, positive-going 100 kHz signal from the square-wave generator output via a precision 50  $\Omega$  cable a 10X attenuator and a 50- $\Omega$  termination to the CH 2 OR Y input connector.
- c. Adjust the generator output for a 5-division vertical signal display.
- d. CHECK—Flat-top display aberrations are within  $\pm 3\%$  (0.15 division or less). See Figure 5-1 for a typical display.
- e. ADJUST—Vertical Output Amplifier HF Compensation (R29, R32, and C33) for the best flat-top display (see Figure 5-1).
- f. Set the A SEC/DIV switch to 0.2 $\mu$ s.

- g. ADJUST—Vertical Output Amplifier HF Compensation (C36) for the best flat-top display (see Figure 5-1).
- h. Set the A SEC/DIV switch to 0.5  $\mu$ s.
- i. ADJUST—CH 2 Preamp HF Compensation (R95 and C95) and Vertical Output Amplifier HF Compensation (R39 and C39) for best front corner (see Figure 5-1).

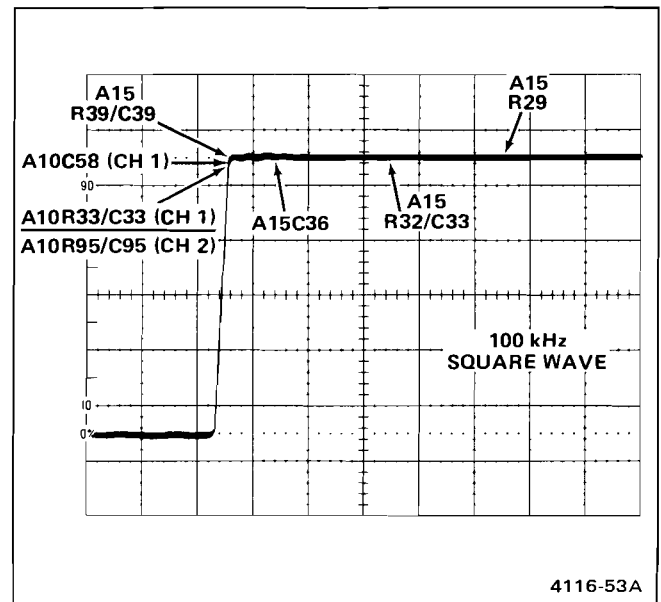

Figure 5-1. Areas affected by high-frequency compensation adjustments.

- j. Set VERTICAL MODE to CH 1 and move the test signal to the CH 1 OR X input connector.
- k. ADJUST—CH 1 Preamp HF Compensation (R33, C33 and C58) for best front corner (see Figure 5-1) NOTE: C58 affects the same area on the waveform as C33 and R33 do. C58 is located just to the right of Q57 (see ADJUSTMENT LOCATIONS 1 and Figure 9-7).

l. INTERACTION—It may be necessary to compromise the Vertical Output Amplifier and CH 1 Preamp adjustments made in part k to obtain the best high-frequency match between CH 1 and CH 2.

### 20. Check CH 1 and CH 2 Transient Response

- a. Set:
 

VERTICAL MODE	CH 1
VOLTS/DIV	5 m
- b. Set the generator output for a 5-division vertical display.

**Adjustment Procedure—2336 Service**

c. Vertically center the display using the channel 1 POSITION control.

d. CHECK—Flat-top waveform is within  $\pm 3\%$  (4.85 to 5.15 divisions).

e. Position the top of the display to the bottom horizontal graticule line.

f. CHECK—Flat-top waveform is within  $\pm 5\%$  (4.75 to 5.25 divisions).

g. Repeat parts c and d for each of the following CH 1 VOLTS/DIV switch settings: 10 m, 20 m, 50 m, 0.1 and 0.2. Adjust the generator output and select attenuators as necessary to maintain a 5-division display at each VOLTS/DIV switch settings.

h. Reduce the generator output and set VERTICAL MODE to CH 2 then move the test signal to the CH 2 OR Y input connector.

i. Repeat parts b through g for CH 2.

j. Set:

VOLTS/DIV (both)	5 m
A TRIGGER SLOPE	—(button in)

k. Connect a 100 kHz fast-rise, negative-going squarewave signal from the generator via a precision 50- $\Omega$  cable, a 10X attenuator and a 50- $\Omega$  termination to the CH 2 OR Y input connector, and adjust the generator output for a 5-division vertical display.

l. Vertically center the display using the CH 2 POSITION control.

m. CHECK—Flat-bottom waveform is within  $\pm 5\%$  (4.75 to 5.25 divisions).

n. Position the bottom of the display to the top horizontal graticule line.

o. CHECK—Flat-bottom waveform is within  $\pm 7\%$  (4.65 to 5.35 divisions).

p. Set VERTICAL MODE to CH 1 and move the test signal to the CH 1 OR X input connector.

q. Repeat parts l through o for CH 1.

r. Disconnect the test equipment from the instrument.

**21. Check Bandwidth**

a. Set:

VERTICAL MODE	CH 1
A SEC/DIV	0.2 ms
TRIGGER SLOPE	+ (button out)

b. Connect the leveled sine-wave generator reference-signal frequency (50 kHz) via a precision 50- $\Omega$  cable, a 10X attenuator, and a 50- $\Omega$  termination to the CH 1 OR X input connector.

c. Adjust the generator output for a 5-division vertical display of the generator reference-signal frequency.

d. Set the generator frequency to 100 MHz; do not readjust the generator output amplitude.

e. CHECK—Display amplitude is 3.5 divisions or more.

f. Repeat parts c, d, and e of this step for the following positions of the CH 1 VOLTS/DIV switch: 5 m through 1.

g. Set VERTICAL MODE to CH 2 and move the test signal to the CH 2 OR Y input connector.

h. Repeat parts c, d, and e for the following positions of the CH 2 VOLTS/DIV switch: 5 m through 1.

i. Disconnect the test equipment from the instrument.

**22. Check Trigger View Gain**

a. Set:

A TRIGGER SOURCE	EXT
A TRIGGER LEVEL	Midrange

b. Connect a 0.2-V standard-amplitude signal to the A EXT input connector via a 50- $\Omega$  cable. Use no termination.

c. Hold in the TRIG VIEW push button and use the A TRIGGER LEVEL control to vertically center the display.

d. CHECK—Displayed signal amplitude is 2 divisions  $\pm 40\%$  (1.2 divisions to 2.8 divisions) while holding in the TRIG VIEW push button.

e. Set the A TRIGGER SOURCE switch to EXT÷10 and change the generator output to 2 V.

f. CHECK—Repeat parts c and d.

g. Disconnect the test equipment from the instrument.

### 23. Check Trigger View Centering

a. Set the A TRIGGER SOURCE switch to EXT.

b. Connect a 1-kHz, low-frequency sine-wave signal to the A EXT input connector via a 50-Ω cable. Use no termination.

c. Hold in the TRIG VIEW push button and set the generator output to obtain a 4-division vertical display. Use the A TRIGGER LEVEL control to vertically center the display.

d. CHECK—Start of sweep is within  $\pm 1$  vertical division of the center horizontal graticule line.

e. Disconnect the test equipment from the instrument.

### 24. Check Trigger View Low-Frequency Compensation

a. Set:

A and B SEC/DIV	0.1ms (knobs locked)
A TRIGGER SLOPE	+ (button out)
A TRIG COUPLING	DC

b. Connect a 1-kHz, high-amplitude square-wave signal to the A EXT input connector via a 50-Ω cable, a 2X attenuator, and a 50-Ω termination.

c. Hold in the TRIG VIEW push button and set the generator output for a 4-division vertical display. Use the A TRIGGER LEVEL control to vertically center the display.

d. CHECK—Square-wave leading-edge rolloff or overshoot is  $\pm 20\%$  or less (0.8 division or less) while holding in the TRIG VIEW push button.

e. Set the A TRIGGER SOURCE switch to EXT÷10.

f. CHECK—Repeat parts c and d.

g. Disconnect the test equipment from the instrument.

### 25. Check Trigger View High-Frequency Compensation

a. Set:

A TRIGGER SOURCE	EXT
A and B SEC/DIV	0.2 $\mu$ s (knobs locked)

b. Connect a 100-kHz fast-rise, positive-going square-wave signal to the A EXT input connector via a 50-Ω cable and a 50-Ω termination.

c. Hold in the TRIG VIEW push button and adjust the generator output for a signal display of 4 vertical divisions. Use the A TRIGGER LEVEL control to vertically center the display.

d. CHECK—Square-wave front-corner overshoot or roll-off is  $\pm 20\%$  or less (3.2 to 4.8 divisions) while holding in the TRIG VIEW push button.

e. Disconnect the test equipment from the instrument.

### 26. Check Trigger View Delay

a. Set:

VERTICAL MODE	CH 2
A and B SEC/DIV	0.05 $\mu$ s
X10 MAG	On (button in)
A TRIGGER COUPLING	AC
A TRIGGER SLOPE	+ (button out)
A TRIGGER LEVEL	Midrange
A TRIGGER SOURCE	EXT
CH 2 VOLTS/DIV	0.1

b. Connect a 100-kHz fast-rise, positive-going square-wave signal via a 50-Ω cable, a 50-Ω termination and a dual-input coupler to the CH 2 OR Y input connector and the A EXT input connector.

c. Use the CH 2 POSITION control to vertically center the trace on the graticule and use the Horizontal POSITION control to center the rising portion of the signal on the center vertical graticule line.

d. Hold in the TRIG VIEW push button and adjust the generator output for a 5-division vertical display of the Trigger View signal. Vertically center the display using the A TRIGGER LEVEL control.

e. Release the TRIG VIEW push button and adjust the CH 2 VOLTS/DIV and VAR controls to match the amplitude of the displayed signal to the amplitude of the Trigger View signal. Vertically center the CH 2 display using the CH 2 POSITION control.

## Adjustment Procedure—2336 Service

f. CHECK—Time difference between the CH 2 and Trigger View signals (by alternately pressing in the TRIG VIEW push button and releasing it) is  $3 \text{ ns} \pm 2 \text{ ns}$  (0.2 to 1 horizontal graticule division).

g. Disconnect the test equipment from the instrument.

### 27. Check Trigger View Bandwidth

a. Set:

A and B SEC/DIV	50 $\mu\text{s}$
X10 MAG	Off (button out)

b. Connect a leveled sine-wave generator's reference signal frequency via a precision  $50\text{-}\Omega$  cable and a  $50\text{-}\Omega$  termination to the A EXT input connector.

c. Press in the TRIG VIEW push button and adjust the generator output for a 4-division vertical display. Center the display vertically using the A TRIGGER LEVEL control.

d. Set the generator output frequency to 80 MHz; do not readjust the generator output amplitude.

e. CHECK—For a display amplitude of 2.8 divisions or more with the TRIG VIEW button held in.

f. Release the TRIG VIEW push button and move the test signal from the A EXT input connector to the CH 2 OR Y input connector.

### 28. Check Channel Isolation

a. Set:

A and B SEC/DIV	0.05 $\mu\text{s}$
CH 1 VOLTS/DIV	10 m
CH 2 VOLTS/DIV	0.5
AC-GND-DC (both)	DC

b. Change the generator frequency to 25 MHz and adjust the generator amplitude for an 8-division vertical display.

c. Set:

VERTICAL MODE	CH 1
A TRIGGER SOURCE	CH 2
A TRIGGER LEVEL	As required for stable display

d. CHECK—CH 1 display amplitude is 4 divisions or less.

e. Move the test signal to the CH 1 OR X input connector.

f. Set:

CH 1 VOLTS/DIV	0.5
CH 2 VOLTS/DIV	10 m
VERTICAL MODE	CH 2
A TRIGGER SOURCE	CH 1
A TRIGGER LEVEL	As required for stable display

g. CHECK—CH 2 display amplitude is 4 divisions or less.

h. Disconnect the test equipment from the instrument.

### 29. Check Common-Mode Rejection Ratio

a. Set:

VOLTS/DIV (both)	10 m
A TRIGGER SOURCE	VERT MODE
CH 2 INVERT	Inverted (button in)

b. Connect a 20-MHz leveled sine-wave signal via a precision  $50\text{-}\Omega$  cable, a 10X attenuator, a  $50\text{-}\Omega$  termination, and a dual-input coupler to the CH 1 OR X and the CH 2 OR Y input connectors.

c. Set the generator amplitude for a 6-division vertical display.

d. Set VERTICAL MODE to ADD.

e. CHECK—ADD display amplitude is 0.6 division or less.

f. Press the CH 2 INVERT button to release it, then disconnect the test equipment from the instrument.

### 30. Check Bandwidth Limit Operation

a. Set:

BW LIMIT	Limited bandwidth (button in)
VERTICAL MODE	CH 1

b. Connect the leveled sine-wave generator's reference-frequency signal via a precision  $50\text{-}\Omega$  cable and a  $50\text{-}\Omega$  termination to the CH 1 OR X input connector.

c. Set the generator output amplitude for a 6-division vertical display.

d. Increase the generator output frequency until the display decreases to 4.2 vertical divisions.

e. CHECK—Generator output frequency is set to 20 MHz,  $\pm 5$  MHz.

f. Disconnect the test equipment from the instrument.

# TRIGGERING

## Equipment Required (see Table 4-1):

Calibration Generator (Item 2)	Precision 50- $\Omega$ BNC Cable (Item 14)
Leveled Sine-Wave Generator (Item 3)	GR-to-BNC-Male Adapter (Item 15)
50- $\Omega$ Signal Pickoff (Item 5)	GR-to-BNC-Female Adapter (Item 16)
Two 50- $\Omega$ BNC Cables (Item 6)	Low-Frequency Generator (Item 17)
Dual-Input Coupler (Item 8)	Screwdriver (Item 21)
10X Attenuator (Item 10)	Low-Capacitance Alignment Tool (Item 23)
Two 50- $\Omega$ BNC Terminations (Item 13)	

See **ADJUSTMENT LOCATIONS 2** at the back of this manual for test point and adjustment locations.

## 2336 CONTROL SETTINGS

LINE VOLTAGE SELECTOR	115 V
POWER	ON (button in)

### CRT

INTEN	As required for visible display
FOCUS	Best focused display

### Vertical

VERTICAL MODE	CH 1
POSITION (both)	Midrange
CH 1 VOLTS/DIV	10 m
CH 2 VOLTS/DIV	0.2
VOLTS/DIV VAR (both)	Calibrated detent
AC-GND-DC (both)	DC
CH 2 INVERT	Normal (button out)
BW LIMIT	Full bandwidth (button out)

### Trigger (A and B, if applicable)

COUPLING	AC
LEVEL	As required for stable display
SLOPE	+ (button out)
SOURCE	CH 1
A TRIGGER Mode	AUTO
TRIG HOLDOFF (PUSH) VAR	Off (in detent)

### Sweep

HORIZ MODE	A
A and B SEC/DIV	20 $\mu$ s (knobs locked)
TIME (PULL) VAR	Pulled out
B DELAY TIME	
POSITION	Fully counterclockwise
$\Delta$ TIME POSITION	Fully counterclockwise
X10 MAG	Off (button out)
POSITION	Midrange

### 1. Adjust A Trigger Slope Offset (R82) and A Hysteresis (R106)

a. Connect a leveled sine-wave generator via a precision 50- $\Omega$  cable and a 50- $\Omega$  termination to the CH 1 OR X input connector.

b. Set the leveled sine-wave generator for a 50-kHz 4-division display, then switch the CH 1 VOLTS/DIV control to 0.2.

c. Rotate Hysteresis adjustment R106 fully counterclockwise, then adjust the A TRIGGER LEVEL control for a stable display.

d. Set the CH 1 VOLTS/DIV switch to 0.5.

e. ADJUST—Hysteresis (R106) clockwise just until any setting of the A TRIGGER LEVEL control will not obtain a stable display of a 0.08-division vertical signal.

## Adjustment Procedure—2336 Service

f. Set the CH 1 VOLTS/DIV switch to 0.2 and check that adjusting the A TRIGGER LEVEL control will obtain a stable display on a 0.2-division vertical signal.

g. Repeat parts e and f until a stable display can be obtained with a 0.2-division signal, but not with a 0.08-division signal.

h. Set the CH 1 VOLTS/DIV switch to 10 m and set the A and B SEC/DIV switches to 10  $\mu$ s.

i. ADJUST—A Trigger Slope Offset (R82) so that the display triggers at the same point on the waveform for both the + (plus) and – (minus) SLOPE switch positions.

j. Repeat parts e through i until no improvement is noted.

### 2. Adjust B Trigger Slope Offset (R127) and B Hysteresis (R163)

a. Set:

A and B SEC/DIV	20 $\mu$ s (knobs locked)
HORIZ MODE	B
CH 1 VOLTS/DIV	0.2

b. Rotate B Hysteresis adjustment R163 fully counter-clockwise, then adjust the B TRIGGER LEVEL control for a stable display.

c. Set the CH 1 VOLTS/DIV switch to 0.5.

d. ADJUST—B Hysteresis (R163) clockwise just until any setting of the B TRIGGER LEVEL control will not obtain a stable display of a 0.08-division vertical signal.

e. Set the CH 1 VOLTS/DIV switch to 0.2 and check that adjusting the B TRIGGER LEVEL control will obtain a stable display on a 0.2-division vertical signal.

f. Repeat parts b through e until a stable display can be obtained with a 0.2-division signal but not with a 0.08-division signal.

g. Set the CH 1 VOLTS/DIV switch to 10 m and set the A and B SEC/DIV switches to 10  $\mu$ s.

h. ADJUST—B Trigger Slope Offset (R127) so that the display triggers at the same point on the waveform for both the + (plus) and – (minus) SLOPE switch positions.

### 3. Adjust Vert Mode DC Level (R29)

a. Set:

A TRIGGER SOURCE	VERT MODE
HORIZ MODE	A
A TRIGGER SLOPE	+ (button out)

b. Center the display vertically and use the A TRIGGER LEVEL control to obtain a stable display with the waveform starting at the center horizontal graticule line.

c. Set the A TRIGGER COUPLING switch to DC.

d. ADJUST—Vert Mode DC Level (R29) for a stable triggered display which starts at the center horizontal graticule line.

e. Disconnect the test equipment from the instrument.

### 4. Check A and B Internal Triggering

a. Connect a 60-Hz low-frequency sine-wave signal to the CH 1 OR X input connector via a 50- $\Omega$  cable, a 10X attenuator, a 2X attenuator, and a 50- $\Omega$  termination.

b. Set the A and B SEC/DIV switches to 5 ms.

c. Adjust the generator output for a 6-division vertical display. Then set the CH 1 VOLTS/DIV switch to 0.2 to obtain a 0.3-division vertical signal display.

d. CHECK—Stable display can be obtained and the TRIG'D LED is illuminated by adjusting the A TRIGGER LEVEL control for each of the switch combinations listed in Table 5-4, except as noted in Table 5-4 footnotes.

e. CHECK—Stable display cannot be obtained for any position of the A TRIGGER COUPLING switch excepted in Table 5-4.

**Table 5-4**  
Switch Combinations for A Trigger Checks (CH 1)

A TRIGGER COUPLING	A TRIGGER SOURCE	A TRIGGER SLOPE
AC	VERT MODE CH 1	+ and – – and +
LF REJ <sup>a</sup>	CH 1 VERT MODE	+ and – – and +
HF REJ <sup>b</sup>	VERT MODE CH 1	+ and – – and +
DC	CH 1 VERT MODE	+ and – – and +

<sup>a</sup>Will not trigger at 60 Hz in A HORIZ MODE.

<sup>b</sup>Will not trigger at 20 MHz and 100 MHz in A HORIZ MODE.

f. Set the A TRIGGER COUPLING switch to AC and obtain a stable display using the A TRIGGER LEVEL control.

g. Set HORIZ MODE to B.

h. CHECK—Stable display can be obtained by adjusting the B TRIGGER LEVEL control for each of the switch combinations listed in Table 5-5.

**Table 5-5**  
Switch Combinations for B Trigger Checks

B TRIGGER SOURCE	B TRIGGER SLOPE
VERT MODE	+ and –
CH 1	+ and –

i. Move the input signal from the CH 1 OR X input connector to the CH 2 OR Y input connector.

j. Set:

VERTICAL MODE	CH 2
HORIZ MODE	A
A TRIGGER SOURCE	CH 2
B TRIGGER SOURCE	CH 2

k. CHECK—Stable display can be obtained, and the TRIG'D LED is illuminated by adjusting the A TRIGGER LEVEL control for each of the switch combinations listed in Table 5-6, except as noted in Table 5-6 footnotes.

l. CHECK—Stable display cannot be obtained for any position of the A TRIGGER COUPLING switch excepted in Table 5-6.

**Table 5-6**  
Switch Combinations for A Trigger Checks (CH 2)

AC TRIGGER COUPLING	A TRIGGER SLOPE
AC	+ and –
LF REJ <sup>a</sup>	– and +
HF REJ <sup>b</sup>	+ and –
DC	– and +

<sup>a</sup>Will not trigger at 60 Hz in A HORIZ MODE.

<sup>b</sup>Will not trigger at 20 MHz and 100 MHz in A HORIZ MODE.

m. Set the A TRIGGER COUPLING switch to AC and obtain a stable display using the A TRIGGER LEVEL control.

n. Set HORIZ MODE to B.

o. CHECK—Stable display can be obtained by adjusting the B TRIGGER LEVEL with B TRIGGER SLOPE at either + or –.

p. Disconnect the test equipment from the instrument.

q. Set:

VERTICAL MODE	CH 1
CH 1 VOLTS/DIV	10 m
HORIZ MODE	A
A and B SEC/DIV	0.05 $\mu$ s
A TRIGGER SOURCE	VERT MODE
B TRIGGER SOURCE	VERT MODE

r. Connect a 20-MHz leveled sine-wave signal to the CH 1 OR X input connector via a 50- $\Omega$  cable and a 50- $\Omega$  termination.



## Adjustment Procedure—2336 Service

s. Repeat parts b through o for the 20-MHz signal.

t. Set:

VERTICAL MODE	CH 1
HORIZ MODE	A
X10 MAG	On (button in)
A TRIGGER SOURCE	VERT MODE
B TRIGGER SOURCE	VERT MODE

u. Set the generator to produce a 100-MHz, 1.1-division vertical display.

v. Repeat parts d through o for the 100-MHz signal.

### 5. Adjust A External Trigger DC Level (R41)

a. Set:

A TRIGGER COUPLING	AC
A and B SEC/DIV	20 $\mu$ s
X10 MAG	Off (button out)
HORIZ MODE	A
A TRIGGER SOURCE	EXT

b. Move the input signal to the A EXT input connector.

c. Set the leveled sine-wave generator to 50 kHz. Hold in the TRIG VIEW push button and adjust the generator output to obtain a 4-division vertical display.

d. Vertically center the display using the A TRIGGER LEVEL control. Readjust the generator output amplitude (if necessary) for a 4-division display.

e. Set the A TRIGGER COUPLING switch to DC.

f. ADJUST—A External Trigger Level (R41) to vertically center the display.

g. Disconnect the test equipment from the instrument.

### 6. Check A and B External Triggering and Jitter

a. Set:

CH 1 VOLTS/DIV	10 m
A and B SEC/DIV	5 ms
A TRIGGER COUPLING	AC
A TRIGGER SOURCE	EXT
B TRIGGER SOURCE	EXT

b. Connect a 60-Hz sine-wave signal to the CH 1 OR X and the A EXT input connectors via a 50- $\Omega$  cable, a 10X attenuator, a 2X attenuator, a 50- $\Omega$  termination, and a dual-input coupler.

c. Set the generator output for a 5-division vertical display.

d. Repeat Step 4, parts k and l.

e. Set the A TRIGGER COUPLING switch to AC and obtain a stable display using the A TRIGGER LEVEL control.

f. Set HORIZ MODE to B and move the signal from the A EXT input connector to the B EXT input connector.

g. CHECK—Stable display can be obtained by adjusting the B TRIGGER LEVEL control with the B TRIGGER SLOPE switch in either + or —.

h. Remove the 10X attenuator from the test setup and move the signal from the B EXT input connector to the A EXT input connector.

i. Set:

CH 1 VOLTS/DIV	0.1
HORIZ MODE	A
A TRIGGER SOURCE	EXT $\div$ 10

j. Repeat Step 4, parts k and l.

k. Connect the test setup as shown in Figure 4-1.

l. Set:

VERTICAL MODE	CH 2
VOLTS/DIV (both)	10 m
A and B SEC/DIV	20 $\mu$ s
A TRIGGER COUPLING	AC
A TRIGGER SOURCE	VERT MODE

m. Set the leveled sine-wave generator for a 50-kHz, 5-division display.

n. Set:

VERTICAL MODE	CH 1
A and B SEC/DIV	0.05 $\mu$ s
A TRIGGER SOURCE	EXT

o. Set the generator to 20 MHz.

p. Move the signal from the CH 2 OR Y input connector to the A EXT input connector.

q. Repeat Step 4, parts k and l.

r. Repeat parts e through h of this step.

s. Set:

HORIZ MODE	A
A TRIGGER SOURCE	EXT $\div$ 10

t. Repeat Step 4, parts k and l.

u. Reconnect the test setup as shown in Figure 4-1.

v. Set:

VERTICAL MODE	CH 2
VOLTS/DIV (both)	50 m
A and B SEC/DIV	20 $\mu$ s
A TRIGGER COUPLING	AC
A TRIGGER SOURCE	VERT MODE

w. Set the leveled sine-wave generator for a 50-kHz, 3-division display.

x. Set:

VERTICAL MODE	CH 1
A and B SEC/DIV	0.05 $\mu$ s
X10 MAG	On (button in)
A TRIGGER SOURCE	EXT

y. Set the generator to 100 MHz.

z. Move the signal from the CH 2 OR Y input connector to the A EXT input connector.

aa. Repeat Step 4, parts k and l.

ab. Repeat parts e through h of this step.

ac. Set:

HORIZ MODE	A
A TRIGGER SOURCE	EXT $\div$ 10

ad. Repeat Step 4, parts k and l.

ae. Set the A TRIGGER COUPLING switch to AC and adjust the A TRIGGER LEVEL control for a stable display.

af. CHECK—For less than 0.2 division horizontal waveform jitter.

ag. Set the A TRIGGER SOURCE switch to EXT and reinsert the 10X attenuator into the test setup.

ah. CHECK—For less than 0.2 division horizontal waveform jitter.

## 7. Check NORM Triggering Mode Operation

a. Set the A TRIGGER SOURCE switch to VERT MODE.

b. Adjust the A TRIGGER LEVEL control for a stable display.

c. Set A TRIGGER Mode to NORM.

d. CHECK—For a visible, stable display.

## Adjustment Procedure—2336 Service

- e. Set the CH 1 AC-GND-DC switch to GND.
- f. CHECK—For no visible display.

### 8. Check SGL SWP Mode Operation

- a. Set:

CH 1 AC-GND-DC	DC
X10 MAG	Off (button in)
A and B SEC/DIV	20 $\mu$ s

b. Adjust the leveled sine-wave generator output for a 50-kHz, 2-division vertical display.

c. Adjust the A TRIGGER LEVEL control until the display just triggers.

d. Set the CH 1 AC-GND-DC switch to GND.

e. Press in the SGL SWP push button. The READY LED should illuminate and remain on.

f. Set the CH 1 AC-GND-DC switch to DC.

g. CHECK—READY LED goes out, and a single sweep occurs.

#### NOTE

*The INTEN control may require adjustment to observe the single-sweep trace.*

h. Press in the SGL SWP push button several times.

i. CHECK—Single-sweep trace occurs, and READY LED illuminates briefly every time the SGL SWP push button is pressed in and released.

j. Disconnect the test equipment from the instrument.

### 9. Check A and B External Trigger Level Ranges

- a. Set:

A TRIGGER COUPLING	AC
TRIGGER SLOPE (both)	+
CH 1 VOLTS/DIV	0.5
A TRIGGER Mode	AUTO
TRIGGER SOURCE (both)	EXT

b. Connect a leveled sine-wave reference-frequency signal via a precision 50- $\Omega$  cable, a 50- $\Omega$  termination, and a dual-input coupler to the CH 1 OR X and A EXT input connectors.

c. Set the generator output for a 4-division vertical display.

d. CHECK—Display is triggered along the entire positive slope of the waveform as the A TRIGGER LEVEL control is rotated.

e. CHECK—Display is not triggered (free runs) at either extreme of rotation.

f. Set the A TRIGGER SLOPE switch to —.

g. CHECK—Display is triggered along the entire negative slope of the waveform as the A TRIGGER LEVEL control is rotated.

h. CHECK—Display is not triggered (free runs) at either extreme of rotation.

i. Move the input signal from the A EXT input connector to the B EXT input connector.

- j. Set:

A TRIGGER LEVEL	Fully counterclockwise
HORIZ MODE	B

k. CHECK—Display is triggered along the entire positive slope of the waveform as the B TRIGGER LEVEL control is rotated.

l. CHECK—Display is not triggered (not visible) at either extreme of rotation.

m. Set the B TRIGGER SLOPE switch to —.

n. CHECK—Display is triggered along the entire negative slope of the waveform as the B TRIGGER LEVEL control is rotated.

o. CHECK—Display is not triggered (not visible) at either extreme of rotation.

p. Disconnect the test setup.

q. Set:

HORIZ DISPLAY	A
A TRIGGER SOURCE	EXT÷10
CH 1 VOLTS/DIV	5
CH 1 VAR	Fully counterclockwise
A TRIGGER COUPLING	AC
A and B SEC/DIV	0.2 m

r. Connect the calibration generator standard-amplitude output to the A EXT input connector via a 50-Ω cable. Adjust the generator output to 20 volts.

s. Press in and hold the TRIG VIEW push button.

t. CHECK—Display is triggered along the entire negative slope of the waveform as the A TRIGGER LEVEL control is rotated.

u. Set the A TRIGGER SLOPE switch to +.

v. CHECK—Display is triggered along the entire positive slope of the waveform as the A TRIGGER LEVEL control is rotated.

w. Disconnect the test equipment from the instrument.

## 10. Check Line Triggers

a. Set:

A TRIGGER Mode	AUTO
CH 1 VOLTS/DIV	10 m
A TRIGGER SOURCE	LINE
A TRIGGER SLOPE	+ (button out)
A SEC/DIV	5 ms
CH 1 AC-GND-DC	DC

b. Connect a 10X probe to the CH 1 OR X input connector and place the probe tip next to the line cord.

c. Set the CH 1 VOLTS/DIV switch to obtain a display amplitude of about 3 to 4 divisions.

d. CHECK—A stable display can be obtained by adjusting the A TRIGGER LEVEL control, with the A TRIGGER SLOPE switch set to either + or –.

e. Disconnect the 10X probe from the instrument.

# HORIZONTAL

## Equipment Required (see Table 4-1):

Test Oscilloscope with 10X Probe (Item 1)	50- $\Omega$ BNC Termination (Item 13)
Calibration Generator (Item 2)	Precision 50- $\Omega$ BNC Cable (Item 14)
Leveled Sine-Wave Generator (Item 3)	Low-Frequency Generator (Item 17)
Time-Mark Generator (Item 4)	Screwdriver (Item 21)
50- $\Omega$ BNC Cable (Item 6)	Low-Capacitance Alignment Tool (Item 23)
Dual-Input Coupler (Item 8)	

See **ADJUSTMENT LOCATIONS 3** at the back of this manual for test point and adjustment locations.

## 2336 CONTROL SETTINGS

LINE VOLTAGE SELECTOR POWER	115 V ON (button in)
<b>CRT</b>	
INTEN	As required for visible display
FOCUS	Best focused display

### Vertical (Both Channels)

VERTICAL MODE	CH 1
POSITION	Midrange
VOLTS/DIV	0.2
VOLTS/DIV VAR	Calibrated detent
AC-GND-DC	DC
CH 2 INVERT	Normal (button out)
BW LIMIT	Full bandwidth (button out)

### Trigger

COUPLING	AC
LEVEL	As required for stable display + (button out)
SLOPE (both)	CH 1
A SOURCE	$\Delta$ TIME
B SOURCE	AUTO
Mode	
TRIG HOLDOFF (PUSH) VAR	Off (in detent)

### Sweep

HORIZ MODE	A INTEN
A and B SEC/DIV	1 ms (knobs locked)
TIME (PULL) VAR	Pulled out and in calibrated detent
B DELAY TIME	
POSITION	Fully counterclockwise
$\Delta$ TIME POSITION	Fully clockwise
X10 MAG	Off (button out)
POSITION	Midrange

### 1. Check A INTEN Operation

a. Vertically center the trace using the CH 1 POSITION control.

b. Use the Horizontal POSITION control to align the start of the intensified zone with the first (extreme left) vertical graticule line.

c. Set the LCD readout to 10.00 ms using the  $\Delta$  TIME POSITION control.

d. CHECK—Intensified portion of the trace decreases one graticule division as the B DELAY TIME POSITION dial is rotated clockwise to each whole number LCD readout (9.00, 8.00, etc.) down to zero.

## 2. Adjust A Sweep Start and Sweep Stop (R74 and R6)

a. Set:

A SEC/DIV	2 ms
B SEC/DIV	5 $\mu$ s
B DELAY TIME POSITION	Fully Counterclockwise
B TRIGGER SOURCE	RUNS AFTER DLY

b. Connect 0.1-ms time markers from the time-mark generator via a 50- $\Omega$  cable and a 50- $\Omega$  termination to the CH 1 OR X input connector.

c. Use the Horizontal POSITION control to align the start of the trace with the center vertical graticule line.

d. Press in the X10 MAG push button.

e. ADJUST—A Sweep Start (R74) so the intensified zone is on the third time marker.

f. Set:

X10 MAG	Off (button out)
B SEC/DIV	20 $\mu$ s
B TRIGGER SOURCE	$\Delta$ TIME

g. Select 2-ms time markers from the time-mark generator and use the B DELAY TIME POSITION control to set the B Delay intensified zone on the second time marker.

h. Use the  $\Delta$  TIME POSITION control to obtain a  $\Delta$  Time readout of 16.00 ms.

i. Set the HORIZ MODE to B and use the Horizontal POSITION control to center the display.

j. ADJUST—Sweep Stop (R6) to superimpose the time markers.

## 3. Check $\Delta$ Time Readout Linearity

a. Set:

A SEC/DIV	1 ms
B SEC/DIV	10 $\mu$ s
HORIZ MODE	A INTEN

b. Select 1-ms time markers from the time-mark generator and use the Horizontal POSITION control to align the first time marker with the first vertical graticule line. Set the B DELAY TIME POSITION control to place the intensified zone at the second graticule line. Set the  $\Delta$  TIME POSITION control for a  $\Delta$  TIME digital readout of 8.00 ms. Set HORIZ MODE to B and set the time-mark generator variable timing control to superimpose the displayed time marks. Do not change the time mark generator settings for the remainder of Step 3.

c. Set HORIZ MODE to A INTEN and align both intensified zones with the second vertical graticule line using both the B DELAY TIME POSITION and the  $\Delta$  TIME POSITION controls.

d. Set HORIZ MODE to B.

e. Use the  $\Delta$  TIME POSITION control to superimpose the time markers.

f. CHECK— $\Delta$  Time readout is  $-.001$  to  $.001$  ms.

g. Rotate the  $\Delta$  TIME POSITION control clockwise until the next time marker that appears is aligned with the reference time marker (positioned by the B DELAY TIME POSITION control).

h. CHECK— $\Delta$  Time readout is  $.998$  to  $1.002$  ms.

### NOTE

*The position of the  $\Delta$  Time marker with respect to the reference may be determined by setting HORIZ MODE to A INTEN. Then return HORIZ MODE to B and align the time markers.*

i. Rotate the  $\Delta$  TIME POSITION control clockwise, past the next time marker that appears, and align the succeeding time marker with the reference.

j. CHECK— $\Delta$  Time readout is within the limits shown in Table 5-7, under the column heading "Reference Time Marker at 2nd Vertical Graticule."

k. Repeat parts i and j for the 7th, 9th, and 11th time markers.

l. Set the HORIZ MODE to A INTEN.

m. Rotate the B DELAY TIME POSITION control clockwise until the two intensified zones are aligned at the 11th vertical graticule line.

**Table 5-7**  
**Δ Time Linearity**

Time Marker Aligned With Vertical Graticule	Reference Time Marker at:	
	2nd Vertical Graticule	11th Vertical Graticule
5	2.96 to 3.04 ms	−5.93 to −6.07 ms
7	4.94 to 5.05 ms	−3.95 to −4.05 ms
9	6.92 to 7.08 ms	−1.97 to −2.03 ms
11	8.90 to 9.10 ms	−.001 to .001 ms

n. Rotate the Δ TIME POSITION control counterclockwise until the intensified zone is aligned with the 3rd vertical graticule line.

o. Set HORIZ MODE to B.

p. Use the Δ TIME POSITION control to superimpose the time markers.

q. CHECK—Δ Time readout is −7.91 to −8.09 ms.

r. Rotate the Δ TIME POSITION control clockwise, past the next time marker that appears, and align the succeeding time marker with the reference.

s. CHECK—Δ Time readout is within the limits shown in Table 5-7, under the column heading "Reference Time Marker at 11th Vertical Graticule."

t. Repeat parts r and s for the 7th, 9th, and 11th time markers.

u. Set the time-mark generator for calibrated time marks (set variable to off).

#### 4. Check Delay Jitter

a. Set:

A SEC/DIV	1 ms
B SEC/DIV	0.5 μs
B TRIGGER SOURCE	Δ TIME
HORIZ MODE	A INTEN

b. Select 1-ms time markers from the time-mark generator.

c. Align the intensified zones with the second time marker using the B DELAY TIME POSITION and Δ TIME POSITION controls.

d. Set HORIZ MODE to B.

e. Align the rising edges of the time markers with the center vertical graticule line using the B DELAY TIME POSITION and Δ TIME POSITION controls.

f. CHECK—For 1 division or less of horizontal jitter on the rising edges of the time markers.

g. Rotate the Δ TIME POSITION control clockwise to bring each succeeding time marker within the graticule viewing area (up to a Δ Time readout of 9 ms) and CHECK for 1 division or less of pulse jitter on the rising edge of each time marker.

h. Rotate the B DELAY TIME POSITION control clockwise to bring each succeeding time marker within the graticule viewing area (down to a Δ Time readout of .000 ms) and CHECK for 1 division or less of pulse jitter on the rising edges of the time markers.

#### 5. Check/Adjust X1 and X10 Horizontal Gain (R126 and R127)

a. Set HORIZ MODE to A.

b. Use the Horizontal POSITION control to align the first time marker with the first vertical graticule line (extreme left edge).

c. CHECK—For 1 time marker per division across the full 10 divisions (within 0.2 division at the 11th time marker).

d. ADJUST—X1 Gain (R126) for exactly 1 time marker per division.

e. Press in the X10 MAG push button and select 0.1-ms time markers from the time-mark generator.

f. Align the nearest time marker with the first vertical graticule line.

g. CHECK—For 1 time marker per division across the full 10 divisions (within 0.3 division at the 11th time marker).

h. ADJUST—X10 Gain (R127) for exactly 1 time marker per division.

### 6. Check/Adjust X10 MAG Registration (R134)

a. Position the time-marker baseline to the bottom horizontal graticule line using the CH 1 POSITION control.

b. Use the Horizontal POSITION control to position the displayed time marker to the center vertical graticule line.

c. Release the X10 MAG push button (button out).

d. CHECK—Time marker remains centered within 0.2 division of the center vertical graticule line.

e. Use the Horizontal POSITION control to position the trace while switching between X10 MAG On and X10 MAG Off. (It is not necessary to latch the X10 MAG button On. It need only be pressed in enough to display the magnified sweep.) Position the trace horizontally until no shift is observed between the center unmagnified time marker and the magnified time marker.

f. ADJUST—Mag Registration (R134) to align the center unmagnified time marker with the center vertical graticule line.

### 7. Check/Adjust B Time (R10)

a. Set:

X10 MAG	On (button in)
B TRIGGER SOURCE	RUNS AFTER DLY
A and B SEC/DIV	1 ms (knobs locked)
CH 1 AC-GND-DC	GND

b. Use the CH 1 POSITION control to vertically center the trace and use the Horizontal POSITION control to align the start of the A Sweep with the center vertical graticule line.

c. Set HORIZ MODE to B.

d. CHECK—The B Sweep starts at the center vertical graticule line.

e. ADJUST—B Time (R10) to move the start of the B Sweep to the center vertical graticule line.

### 8. Check A and B Timing Accuracy and Linearity

a. Set:

A and B SEC/DIV	0.05 $\mu$ s (knobs locked)
HORIZ MODE	A
CH 1 AC-GND-DC	DC
X10 MAG	Off (button out)

b. Select 50-ns time markers from the time-mark generator.

c. Adjust the A TRIGGER LEVEL control for a stable display and vertically center the display using the CH 1 POSITION control.

d. Use the Horizontal POSITION control to align the first time marker with the first vertical graticule line.

e. CHECK—The SEC/DIV timing accuracy is within 2% (0.2 division at the 11th time marker), and linearity is within 5% (0.1 division over any 2-division portion of the graticule).

f. Repeat part e for A SEC/DIV switch settings of 0.1  $\mu$ s to 2  $\mu$ s in Table 5-8. Readjust the A TRIGGER LEVEL and Horizontal POSITION control as necessary. If the timing accuracy and linearity at any one of these settings are not within tolerance, perform Step 9 immediately. If they are all within tolerance, complete the CHECK for the 5- $\mu$ s to 0.5-s settings of the A SEC/DIV switch.

#### NOTE

*For the A SEC/DIV settings from 50 ms to 0.5 s per division, watch the time marker tips only at the 1st and 11th graticule lines while adjusting the Horizontal POSITION control and checking the timing accuracy.*

g. Set:

X10 MAG	On (button in)
A TRIGGER Mode	AUTO



**Table 5-8**  
**Settings for Timing Accuracy Checks**

A and B SEC/DIV Switch Setting	Time-Mark Generator Output	
	Normal	X10 MAG
0.05 $\mu$ s	50 ns	5 ns
0.1 $\mu$ s	0.1 $\mu$ s	10 ns
0.2 $\mu$ s	0.2 $\mu$ s	20 ns
0.5 $\mu$ s	0.5 $\mu$ s	50 ns
1 $\mu$ s	1 $\mu$ s	0.1 $\mu$ s
2 $\mu$ s	2 $\mu$ s	0.2 $\mu$ s
5 $\mu$ s	5 $\mu$ s	0.5 $\mu$ s
10 $\mu$ s	10 $\mu$ s	1 $\mu$ s
20 $\mu$ s	20 $\mu$ s	2 $\mu$ s
50 $\mu$ s	50 $\mu$ s	5 $\mu$ s
0.1 ms	0.1 ms	10 $\mu$ s
0.2 ms	0.2 ms	20 $\mu$ s
0.5 ms	0.5 ms	50 $\mu$ s
1 ms	1 ms	0.1 ms
2 ms	2 ms	0.2 ms
5 ms	5 ms	0.5 ms
10 ms <sup>a</sup>	10 ms	1 ms
20 ms <sup>a</sup>	20 ms	2 ms
50 ms <sup>a</sup>	50 ms	5 ms
<b>A Sweep Only</b>		
0.1 s <sup>a</sup>	0.1 s	10 ms
0.2 s <sup>a</sup>	0.2 s	20 ms
0.5 s <sup>a</sup>	0.5 s	50 ms

<sup>a</sup>For SEC/DIV switch settings slower than 5 ms, set the A TRIGGER Mode to NORM.

h. CHECK—The A Magnified timing accuracy and linearity using the SEC/DIV switch settings and the time-mark generator settings given in Table 5-8 under the "X10 MAG" column. At each setting combination, timing must be accurate to within 3% (0.3 division at the 11th time marker). When checking accuracy, exclude the first and last 40 ns of the sweep. Linearity must be within 5% (0.1 division) over any 2-division portion of the graticule. When checking linearity, exclude the first- and last-displayed divisions for the A and B SEC/DIV switch settings of 0.05  $\mu$ s and 0.1  $\mu$ s.

i. Set:

HORIZ MODE	B
B SEC/DIV	0.05 $\mu$ s
A SEC/DIV	0.1 $\mu$ s
X10 MAG	Off (button out)
A TRIGGER Mode	AUTO

j. Select 50-ns time markers from the time-mark generator and adjust the A TRIGGER LEVEL control (if necessary) for a stable display.

k. CHECK—Repeat parts e through h for the B Sweep.

l. Skip to Step 10 if either the accuracy and linearity checks are within tolerance or if Step 9 has been previously completed.

### 9. Adjust A and B Timing Accuracy and Linearity (C84, C22, C161, and C187)

a. Set:

A SEC/DIV	1 $\mu$ s
B SEC/DIV	0.05 $\mu$ s
HORIZ MODE	A
X10 MAG	Off (button out)
B TRIGGER SOURCE	$\Delta$ TIME

b. Select 1- $\mu$ s time markers from the time-mark generator and use the Horizontal POSITION control to align the first time marker with the first vertical graticule line.

c. ADJUST—The A Sweep High-Speed Timing (C84) to obtain one time marker per division across the graticule area.

d. Set HORIZ MODE to A INTEN and rotate the B DELAY TIME POSITION control to position one intensified zone on the second time marker. Use the  $\Delta$  TIME POSITION control to position the other intensified zone until the LCD readout is 8.00  $\mu$ s.

e. Set HORIZ MODE to B.

f. ADJUST—The A Sweep High-Speed Timing (C84) to superimpose the two displayed time markers.

g. Set:

B SEC/DIV                    0.2  $\mu$ s  
B TRIGGER SOURCE        RUNS AFTER DLY

h. Select 0.2- $\mu$ s time markers from the time-mark generator.

i. ADJUST—The B Sweep High-Speed Timing (C22) to obtain one time marker per division across the graticule area.

j. Set:

A SEC/DIV                    0.5  $\mu$ s  
HORIZ MODE                A  
CH 1 VOLTS/DIV        0.1 V  
X10 MAG                    On (button in)

k. Select 10-ns time markers from the time-mark generator.

#### NOTE

*In the next part, keep the adjustment screws for C161 and C187 as close to the same length as possible.*

l. ADJUST—The 5-ns Timing (C161 and C187 alternately) for one time marker every two divisions over the center 10 divisions of the magnified sweep.

m. Repeat Steps 8 and 9 as necessary until all timing ranges are within tolerance.

## 10. Check $\Delta$ Time Readout Accuracy

a. Set:

CH 1 VOLTS/DIV        0.2 V  
A SEC/DIV                0.2  $\mu$ s  
B SEC/DIV                0.05  $\mu$ s  
HORIZ MODE            A INTEN  
A TRIGGER Mode        AUTO  
B TRIGGER SOURCE      $\Delta$  TIME  
X10 MAG                Off (button out)

b. Select 0.2- $\mu$ s time markers from the time-mark generator.

c. Use the B DELAY TIME POSITION control to position the start of one intensified zone to the left of the second vertical graticule line. Use the  $\Delta$  TIME POSITION control to position the start of the other intensified zone just to the left of the tenth vertical graticule line ( $\Delta$  Time readout should be about 1.600  $\mu$ s).

d. Set HORIZ MODE to B and use the  $\Delta$  TIME POSITION control to superimpose the time markers.

e. CHECK— $\Delta$  Time readout is within the range of values specified in Table 5-9 for the SEC/DIV switches and time-marker settings used.

f. Repeat part e for the remaining A and B SEC/DIV switch settings and time-marker combinations listed in Table 5-9. Use the  $\Delta$  TIME POSITION control to superimpose the time markers at each SEC/DIV switch setting before checking the  $\Delta$  Time readout accuracy.

**Table 5-9**  
 **$\Delta$  Time Readout Accuracy**

A SEC/DIV Switch Setting	B SEC/DIV Switch Setting	Time Markers	$\Delta$ Time Readout
0.2 $\mu$ s 0.5 $\mu$ s	0.05 $\mu$ s 0.05 $\mu$ s	0.2 $\mu$ s 0.5 $\mu$ s	1.583 $\mu$ s to 1.617 $\mu$ s 3.95 $\mu$ s to 4.05 $\mu$ s
1 $\mu$ s 2 $\mu$ s 5 $\mu$ s	0.1 $\mu$ s 0.1 $\mu$ s 0.5 $\mu$ s	1 $\mu$ s 2 $\mu$ s 5 $\mu$ s	7.91 $\mu$ s to 8.09 $\mu$ s 15.83 $\mu$ s to 16.17 $\mu$ s 39.5 $\mu$ s to 40.5 $\mu$ s
10 $\mu$ s 20 $\mu$ s 50 $\mu$ s	1 $\mu$ s 1 $\mu$ s 5 $\mu$ s	10 $\mu$ s 20 $\mu$ s 50 $\mu$ s	79.1 $\mu$ s to 80.9 $\mu$ s 158.3 $\mu$ s to 161.7 $\mu$ s .395 ms to .405 ms
0.1 ms 0.2 ms 0.5 ms	10 $\mu$ s 10 $\mu$ s 50 $\mu$ s	0.1 ms 0.2 ms 0.5 ms	.791 ms to .809 ms 1.583 ms to 1.617 ms 3.95 ms to 4.05 ms
1 ms 2 ms 5 ms	0.1 ms 0.1 ms 0.5 ms	1 ms 2 ms 5 ms	7.91 ms to 8.09 ms 15.83 ms to 16.17 ms 39.5 ms to 40.5 ms
10 ms <sup>a</sup> 20 ms <sup>a</sup> 50 ms <sup>a</sup>	1 ms 1 ms 5 ms	10 ms 20 ms 50 ms	79.1 ms to 80.9 ms 158.3 ms to 161.7 ms .395 s to .405 s
0.1 s <sup>a</sup> 0.2 s <sup>a</sup> 0.5 s <sup>a</sup>	10 ms 10 ms 50 ms	0.1 s 0.2 s 0.5 s	.791 s to .809 s 1.583 s to 1.617 s 3.95 s to 4.05 s

<sup>a</sup>For SEC/DIV switch settings slower than 5 ms, set the A TRIGGER Mode to NORM.

### 11. Check A and B Sweep Length

a. Set:

A and B SEC/DIV	1 ms (knobs locked)
B TRIGGER SOURCE	VERT MODE
B DELAY TIME	
POSITION	Fully counterclockwise
A TRIGGER Mode	AUTO

b. Select 1-ms time markers from the time-mark generator.

c. Use the Horizontal POSITION control to position the second time marker to the first vertical graticule line.

d. CHECK—Horizontal trace extends at least 0.5 division, but not more than 1.5 divisions, past the 11th time marker. Use the Horizontal POSITION control to position the trace farther to the left if necessary.

e. Set:

A SEC/DIV	2 ms
B SEC/DIV	1 ms
HORIZ MODE	B

f. Use the B DELAY TIME POSITION control to align the nearest time marker with the first vertical graticule line.

g. CHECK—Repeat part d for the B Sweep.

### 12. Check A SEC/DIV VAR Range

a. Set:

HORIZ MODE	A
A and B SEC/DIV	2 ms (knobs locked)
TIME (PULL) VAR	Pulled out and in calibrated detent

b. Select 5-ms time markers from the time-mark generator.

c. Use the Horizontal POSITION control to align the first time marker with the first vertical graticule line.

d. CHECK—At least one time marker per division can be obtained by rotating the TIME (PULL) VAR control counterclockwise.

e. Return the TIME (PULL) VAR control to its calibrated detent.

### 13. Check A and B Sweep Horizontal POSITION Range

a. Set the A and B SEC/DIV switches to 1 ms and rotate the Horizontal POSITION control fully counterclockwise.

b. CHECK—Sweep ends to the left of the center vertical graticule line.

c. Rotate the Horizontal POSITION control fully clockwise.

d. CHECK—Sweep begins to the right of the center vertical graticule line.

e. Set:

HORIZ MODE	B
Horizontal POSITION	Fully counterclockwise

f. CHECK—Repeat parts b through d for the B Sweep.

g. Press in the X10 MAG push button.

h. Rotate the Horizontal POSITION control counterclockwise to position a time marker to the second vertical graticule line. If the marker moves past the line, continue rotating counterclockwise until the next time marker reaches the second vertical graticule line.

i. Gently rotate the Horizontal POSITION control clockwise until the coarse position potentiometer is engaged and stop. Note the trace starting point on the graticule.

j. CHECK—Trace begins 4 to 9 divisions to the right of the second vertical graticule line.

**14. Check AUTO Recovery**

a. Set:

A and B SEC/DIV	1 ms (knobs locked)
HORIZ MODE	A
Horizontal POSITION	Midrange
A TRIGGER Mode	AUTO
X10 MAG	Off (button out)

b. Select 0.1-s time markers from the time-mark generator and adjust the A TRIGGER LEVEL control for a stable display.

c. Select 0.5-s time markers.

d. CHECK—Display cannot be triggered (free runs).

e. Disconnect the test equipment from the instrument.

**15. Check/Adjust X-Y Gain (R148)**

a. Set:

A and B SEC/DIV	1 ms (knobs locked)
VERTICAL MODE	X-Y (both CH 1 and CH 2 buttons in)
VOLTS/DIV (both)	10 m
CH 1 AC-GND-DC	DC
CH 2 AC-GND-DC	GND
HORIZ MODE	A
X10 MAG	Off (button out)

b. Connect a 50-mV standard-amplitude signal from the calibration generator to the CH 1 OR X input connector via a 50- $\Omega$  cable.

c. CHECK—Spacing between the two dots is 5 divisions  $\pm 0.25$  division (4.75 to 5.25 divisions).

d. ADJUST—X-Y Gain (R148) for a 5-division horizontal spacing between the dots.

e. Disconnect the test equipment from the instrument.

**16. Check X-Y Bandwidth and Phasing**

a. Connect a 50-kHz leveled sine-wave signal via a precision 50- $\Omega$  cable, a 50- $\Omega$  termination, and a dual-input coupler to the CH 1 OR X and the CH 2 OR Y input connectors.

b. Set the generator output amplitude to obtain a 6-division horizontal display.

c. Adjust the generator output frequency to 2 MHz; do not change the generator output amplitude control setting.

d. CHECK—For 4.2 divisions or more horizontal deflection at 2 MHz.

e. Set the CH 1 and CH 2 VOLTS/DIV to 0.2.

f. Disconnect the leveled sine-wave generator from the test setup and connect a low-frequency sine-wave generator. Set the generator output frequency to 200 kHz and adjust the output amplitude for 6 divisions of horizontal deflection.

g. Set the CH 2 AC-GND-DC switch to DC.

h. Vertically center the display using the CH 2 POSITION control.

i. CHECK—For a horizontal ellipse opening of 0.3 division or less.

j. Disconnect the test equipment from the instrument.

**17. Check A Trigger Holdoff**

a. Connect the test oscilloscope 10X probe tip to TP55 and connect the probe ground lead to TP194.

**Adjustment Procedure—2336 Service**

b. Set test oscilloscope controls initially as follows:

Volts/Div	2 V
Sec/Div	1 $\mu$ s
Trig Mode	Norm

c. Set VERT MODE to CH 1 and A TRIGGER SOURCE to EXT.

d. CHECK—Trigger holdoff time corresponds approximately to the times listed in Table 5-10 for each range of A SEC/DIV switch settings. Trigger holdoff is defined as the +2-V level of the sweep waveform after recovery but before it starts a negative-going ramp. Set test oscilloscope Sec/Div control as required to make the time measurements.

e. Set A SEC/DIV to 0.5 ms and rotate VAR TRIG HOLDOFF fully counterclockwise.

**Table 5-10**  
**A Trigger Holdoff Time**

<b>A SEC/DIV Switch Settings</b>	<b>Approximate Holdoff Time</b>
0.05 $\mu$ s to 0.2 $\mu$ s	2 $\mu$ s
0.5 $\mu$ s to 2 $\mu$ s	4 $\mu$ s
5 $\mu$ s to 20 $\mu$ s	13 $\mu$ s
50 $\mu$ s to 0.2 ms	175 $\mu$ s
0.5 ms to 2 ms	1.3 ms
5 ms to 20 ms	8 ms
50 ms to 0.5 s	50 ms

f. CHECK—That holdoff time increases by a factor of at least 2.5.

# EXTERNAL Z-AXIS AND CALIBRATOR

## Equipment Required (see Table 4-1):

Calibration Generator (Item 2)	Two 50- $\Omega$ BNC Terminations (Item 13)
Leveled Sine-Wave Generator (Item 3)	Digital Voltmeter (Item 19)
Two 50- $\Omega$ BNC Cables (Item 6)	Shorting Strap (Item 22)
BNC T-Connector (Item 9)	

See **ADJUSTMENT LOCATIONS 3** at the back of this manual for test point and adjustment locations.

## 2336 CONTROL SETTINGS

LINE VOLTAGE SELECTOR POWER	115 V ON (button in)
-----------------------------------	-------------------------

### CRT

INTEN	As required for visible trace
FOCUS	Best focused display

### Vertical (Both Channels)

VERTICAL MODE	CH 1
POSITION	Midrange
VOLTS/DIV	2
VOLTS/DIV VAR	Calibrated detent
AC-GND-DC	DC
CH 2 INVERT	Normal (button out)
BW LIMIT	Full bandwidth (button out)

### Trigger

COUPLING	AC
LEVEL	As required for stable display
SLOPE	+ (button out)
SOURCE	VERT MODE
Mode	AUTO
TRIG HOLDOFF (PUSH) VAR	Off (in detent)

### Sweep

HORIZ MODE	A
A and B SEC/DIV TIME (PULL) VAR	2 ms (knobs locked) Pulled out and in calibrated detent
B DELAY TIME POSITION	Fully counterclockwise
X10 MAG POSITION	Off (button out) Midrange

## 1. Check External Z-Axis Operation

a. Connect a 5-V standard-amplitude square-wave signal to the CH 1 OR X input connector and the EXT Z-AXIS input connector (located on the rear panel) via a 50- $\Omega$  T-connector and two 50- $\Omega$  cables.

b. CHECK—For noticeable intensity modulation of the trace when the INTEN control is set for normal-viewing brightness. Adjust the TIME (PULL) VAR control, if necessary, to observe the modulation. Return the TIME (PULL) VAR control to the calibrated detent.

c. Disconnect the test setup.

d. Set the A SEC/DIV switch to 0.05  $\mu$ s.

e. Connect a 5-V, 20-MHz leveled sine-wave signal to the CH 1 OR X input connector and the EXT Z-AXIS input connector via a 50- $\Omega$  T-connector, two 50- $\Omega$  cables, and two 50- $\Omega$  terminations.

## Adjustment Procedure—2336 Service

f. CHECK—Repeat part b.

g. Disconnect the test equipment from the instrument.

## 2. Check AMPL CAL Operation

a. Set:

CH 1 VOLTS/DIV	10 m
A and B SEC/DIV	1 ms (knobs locked)

b. Connect the 10X probe (supplied with the 2336) to the CH 1 OR X input connector. Insert the probe tip into the AMPL CAL connector.

c. CHECK—For a 2-division vertical display of the AMPL CAL square-wave signal with a period of  $1 \text{ ms} \pm 25\%$  (0.75 to 1.25 ms).

d. Connect the digital voltmeter LO lead to chassis ground and connect the HI lead to the AMPL CAL connector center pin.

e. Connect a shorting strap between TP246 and TP250.

f. CHECK—AMPL CAL output voltage is  $200 \text{ mV} \pm 1\%$  (198 to 202 mV).

g. Disconnect all test equipment from the instrument.

# MAINTENANCE

This section of the manual contains information for conducting preventive maintenance, troubleshooting, and corrective maintenance on the 2336 Oscilloscope.

## STATIC-SENSITIVE COMPONENTS

The following precautions are applicable when performing any maintenance involving internal access to the instrument.



*Static discharge can damage any semiconductor component in this instrument.*

This instrument contains electrical components that are susceptible to damage from static discharge. Table 6-1 lists the relative susceptibility of various classes of semiconductors. Static voltages of 1 kV to 30 kV are common in unprotected environments.

When performing maintenance observe the following precautions to avoid component damage:

1. Minimize handling of static-sensitive components.
2. Transport and store static-sensitive components or assemblies in their original containers or on a metal rail. Label any package that contains static-sensitive components or assemblies.
3. Discharge the static voltage from your body by wearing a grounded antistatic wrist strap while handling these components. Servicing static-sensitive components or assemblies should be performed only at a static-free work station by qualified service personnel.
4. Nothing capable of generating or holding a static charge should be allowed on the work station surface.

5. Keep the component leads shorted together whenever possible.

6. Pick up components by their bodies, never by their leads.

Table 6-1

Relative Susceptibility to  
Static-Discharge Damage

Semiconductor Classes	Relative Susceptibility Levels <sup>a</sup>
MOS or CMOS microcircuits or discretes, or linear microcircuits with MOS inputs (Most Sensitive)	1
ECL	2
Schottky signal diodes	3
Schottky TTL	4
High-frequency bipolar transistors	5
JFET	6
Linear microcircuits	7
Low-power Schottky TTL	8
TTL (Least Sensitive)	9

<sup>a</sup>Voltage equivalent for levels (voltage discharged from a 100-pF capacitor through a resistance of 100  $\Omega$ ):

1 = 100 to 500 V	4 = 500 V	7 = 400 to 1000 V (est)
2 = 200 to 500 V	5 = 400 to 600 V	8 = 900 V
3 = 250 V	6 = 600 to 800 V	9 = 1200 V



7. Do not slide the components over any surface.
8. Avoid handling components in areas that have a floor or work-surface covering capable of generating a static charge.
9. Use a soldering iron that is connected to earth ground.
10. Use only approved antistatic, vacuum-type desoldering tools for component removal.

## PREVENTIVE MAINTENANCE

### INTRODUCTION

Preventive maintenance consists of cleaning, visual inspection, lubrication, and checking instrument performance. When accomplished regularly, it may prevent instrument malfunction and enhance instrument reliability. The severity of the environment in which the instrument is used determines the required frequency of maintenance. An appropriate time to accomplish preventive maintenance is just before instrument adjustment.

### GENERAL CARE

The cabinet minimizes accumulation of dust inside the instrument and should normally be in place when operating the 2336. The lid provides both dust and damage protection for the front panel and crt face, and it should be closed whenever the instrument is stored or is being transported.

### INSPECTION AND CLEANING

The 2336 should be visually inspected and cleaned as often as operating conditions require. Accumulation of dirt in the instrument can cause overheating and component breakdown. Dirt on components acts as an insulating blanket, preventing efficient heat dissipation. It also provides an electrical conduction path that could result in instrument failure, especially under high-humidity conditions.



*Avoid the use of chemical cleaning agents which might damage the plastics used in this instrument. Use a nonresidue-type cleaner, preferably isopropyl alcohol, denatured ethyl alcohol, or a solution of 1% mild detergent with 99% water. Before using any other type of cleaner, consult your Tektronix Service Center or representative.*

### Exterior

**INSPECTION.** Inspect the external portions of the instrument for damage, wear, and missing parts; use Table 6-2 as a guide. Instruments that appear to have been dropped or otherwise abused should be checked thoroughly to verify correct operation and performance. Deficiencies found that could cause personal injury or could lead to further damage to the instrument should be repaired immediately.



*To prevent getting moisture inside the instrument during external cleaning, use only enough liquid to dampen the cloth or applicator.*

**CLEANING.** Loose dust on the outside of the instrument can be removed with a soft cloth or small soft-bristle brush. The brush is particularly useful for dislodging dirt on and around the controls and connectors. Dirt that remains can be removed with a soft cloth dampened in a mild detergent-and-water solution. Do not use abrasive cleaners.

Two plastic light filters, one blue and one clear, are provided with the oscilloscope. Clean the light filters and the crt face with a soft lint-free cloth dampened with either denatured alcohol or a mild detergent-and-water solution.

### Interior

To gain access to internal portions of the instrument for inspection and cleaning, refer to the "Removal and Replacement Instructions" in the "Corrective Maintenance" part of this section.

**INSPECTION.** Inspect the internal portions of the 2336 for damage and wear, using Table 6-3 as a guide. Deficiencies found should be repaired immediately. The

**Table 6-2**  
**External Inspection Checklist**

<b>Item</b>	<b>Inspect For</b>	<b>Repair Action</b>
Cabinet, Lid, Front Panel	Cracks, scratches, deformations, and damaged hardware or gaskets.	Touch up paint scratches and replace defective parts.
Front-panel Controls	Missing, damaged, or loose knobs, buttons, and controls.	Repair or replace missing or defective items.
Connectors	Broken shells, cracked insulation, and deformed contacts. Dirt in connectors.	Replace defective parts. Clean or wash out dirt.
Carrying Handle	Correct operation.	Replace defective parts.
Accessories	Missing items or parts of items, bent pins, broken or frayed cables, and damaged connectors.	Replace damaged or missing items, frayed cables, and defective parts.

**Table 6-3**  
**Internal Inspection Checklist**

<b>Item</b>	<b>Inspect For</b>	<b>Repair Action</b>
Circuit Boards	Loose, broken, or corroded solder connections. Burned circuit boards. Burned, broken, or cracked circuit-run plating.	Clean solder corrosion with an eraser and flush with isopropyl alcohol. Resolder defective connections. Determine cause of burned items and repair. Repair defective circuit runs.
Resistors	Burned, cracked, broken, or blistered.	Replace defective resistors. Check for cause of burned component and repair as necessary.
Solder Connections	Cold solder or rosin joints.	Resolder joint and clean with isopropyl alcohol.
Capacitors	Damaged or leaking cases. Corroded solder on leads or terminals.	Replace defective capacitors. Clean solder connections and flush with isopropyl alcohol.
Semiconductors	Loosely inserted in sockets. Distorted pins.	Firmly seat loose semiconductors. Remove devices having distorted pins. Carefully straighten pins (as required to fit the socket), using long-nose pliers, and reinsert firmly. Ensure that straightening action does not crack pins, causing them to break off.
Wiring and Cables	Loose plugs or connectors. Burned, broken, or frayed wiring.	Firmly seat connectors. Repair or replace defective wires or cables.
Chassis	Dents, deformations, and damaged hardware.	Straighten, repair, or replace defective hardware.

## Maintenance—2336 Service

corrective procedure for most visible defects is obvious; however, particular care must be taken if heat-damaged components are found. Overheating usually indicates other trouble in the instrument; therefore, it is important that the cause of overheating be corrected to prevent recurrence of the damage.

If any electrical component is replaced, conduct a Performance Check for the affected circuit and for other closely related circuits (see Section 4). If repair or replacement work is done on any of the power supplies, conduct a complete Performance Check and, if so indicated, an instrument readjustment (see Sections 4 and 5).

### CAUTION

*To prevent damage from electrical arcing, ensure that circuit boards and components are dry before applying power to the instrument.*

**CLEANING.** To clean the interior, blow off dust with dry, low-pressure air (approximately 9 psi). Remove any remaining dust with a soft brush or a cloth dampened with a solution of mild detergent and water. A cotton-tipped applicator is useful for cleaning in narrow spaces and on circuit boards.

If these methods do not remove all the dust or dirt, the instrument may be spray washed using a solution of 5% mild detergent and 95% water as follows:

1. Gain access to the parts to be cleaned by removing easily accessible shields and panels.
2. Spray wash dirty parts with the detergent-and-water solution; then use clean water to thoroughly rinse them.
3. Dry all parts with low-pressure air.

### NOTE

*Refer to "Switch Contacts" (next paragraph) prior to performing step 4.*

4. Clean switch contacts with Isopropanol or Fotocol and wait for 60 seconds. Then dry with low-pressure air.

5. Dry all components and assemblies in an oven or compartment using low-temperature (125°F to 150°F) circulating air.

6. Lubricate the circuit-board-mounted switch contacts for the A and B SEC/DIV switches and the TRIGGER COUPLING and SOURCE switches. Use only a light film of No-Noise lubricant.

**SWITCH CONTACTS.** Most of the switches in the 2336 are circuit-board mounted with cam-actuated contacts. Care must be exercised to preserve the high-frequency characteristics of these switches. Switch maintenance is seldom necessary, but if it is required, use the following cleaning methods and observe the stated precautions.

### CAUTION

*The A and B SEC/DIV and the TRIGGER COUPLING and SOURCE switches are factory lubricated with No-Noise spray cleaner. If disassembly, repair, or cleaning of these switches is necessary, do not overlubricate them before reassembly. Only lubricate the contact surfaces on the circuit board with a very light film of No-Noise cleaner (or one with similar characteristics).*

1. Clean switch contacts only with isopropyl alcohol or denatured ethyl alcohol, especially in the area of the vertical attenuator boards.
2. Apply the cleaning solution with a camel-hair brush. Do not use cotton-tipped applicators, since they tend to snag on contacts and could possibly cause damage. Strands of cotton caught by the contacts may cause intermittent electrical contact.

Some film deposits may not be completely removed by the preceding procedure. For these cases, use an Eberhard Fabre "Pink Pearl" eraser to gently remove remaining film from switch contacts. Do not use typewriter or fiber-glass erasers, since they are too abrasive and will remove excessive amounts of the gold plating. After removing film with an eraser, clean the contacts again with alcohol and a soft brush to assure removal of all contamination.

## LUBRICATION

The fan motor and most of the potentiometers used in the 2336 are permanently sealed and generally do not require periodic lubrication. The switches used in the 2336, both cam- and lever-type, are installed with proper lubrication applied where necessary and will rarely require any additional lubrication. A regular periodic lubrication program for the instrument is not recommended.

## SEMICONDUCTOR CHECKS

Periodic checks of the transistors and other semiconductors in the oscilloscope are not recommended. The best check of semiconductor performance is actual operation in the instrument.

## PERIODIC READJUSTMENT

To ensure accurate measurements, check the performance of this instrument after every 2000 hours of operation, or if used infrequently, once each year. In addition, replacement of components may necessitate readjustment of the affected circuits.

Complete Performance Check and Adjustment instructions are given in Sections 4 and 5. The Performance Check Procedure can also be helpful in localizing certain trouble in the instrument. In some cases, minor troubles may be revealed or corrected by readjustment. If only a partial adjustment is performed, see the interaction chart, Table 5-1, for possible interactions with circuits not adjusted.

# TROUBLESHOOTING

## INTRODUCTION

Preventive maintenance performed on a regular basis should reveal most potential problems before an instrument malfunctions. However, should troubleshooting be required, the following information is provided to facilitate location of a fault. In addition, the material presented in the "Theory of Operation" and "Diagrams" sections of this manual may be helpful while troubleshooting.

## TROUBLESHOOTING AIDS

### Schematic Diagrams

Complete schematic diagrams are located on tabbed foldout pages in the "Diagrams" section. The portions of circuitry that are mounted on each circuit board are enclosed within heavy black lines. Also within the black lines, near either the top or the bottom edge, are the assembly number and name of the circuit board.

Component numbers and electrical values of components in this instrument are shown on the schematic diagrams. Refer to the first page of the "Diagrams" section for definitions of the reference designators and symbols used to identify components. Important voltages and waveform reference numbers (enclosed in hexagonal-shaped boxes) are also shown on each diagram. Waveform illustrations are located adjacent to their respective schematic diagram, and the physical location of each waveform test point is shown on the appropriate circuit board illustration.

### Circuit Board Illustrations

Circuit board illustrations (showing the physical location of each component) are provided for use in conjunction with each schematic diagram. Each board illustration is found in the "Diagrams" section on the back of a foldout page, preceding the schematic diagram(s) to which it relates. If more than one schematic diagram is associated with a particular circuit board, the board illustration is located on a left-hand page that precedes the diagram with which the board is first associated.

Waveform test-point locations are also identified on the circuit board illustration by hexagonal-outlined numbers that correspond to the waveform numbers appearing on both the schematic diagram and the waveform illustration.

### Circuit Board Locations

The location of a circuit board within the instrument is shown on the foldout page along with the circuit board illustration.

### Circuit Board Interconnection Diagram

A circuit board interconnection diagram is provided in the "Diagrams" section to aid in tracing a signal path or power source between boards. The entire oscilloscope is illustrated, with plug and jack numbers shown along with associated pin numbers. The off-board components are also shown, and the schematic diagram numbers on which components are located are identified.

## Power Distribution Diagram

A Power Distribution diagram is also provided in the "Diagrams" section to aid in troubleshooting power-supply problems. This diagram shows service jumpers used to remove power from the various circuit boards. Excessive loading on a power supply by a circuit board can be isolated to the faulty board by disconnecting appropriate service jumpers.

## Grid Coordinate System

Each schematic diagram and circuit board illustration has a grid border along its left and top edges. A table located adjacent to each schematic diagram lists the grid coordinates of each component shown on that diagram. To aid in physically locating a component on the circuit board, this table also lists the grid coordinates of each component on the circuit board illustration.

Adjacent to each circuit board illustration is an alphanumeric listing of every component mounted on that board. A second column in this listing identifies the schematic diagram in which each component can be found. These component-locator tables are especially useful when more than one schematic diagram is associated with a particular circuit board.

## Troubleshooting Charts

The troubleshooting charts contained in the "Diagrams" section are to be used as an aid in locating malfunctioning circuitry. To use the charts, begin with the Troubleshooting Index. This index chart will help identify a particular problem area and will direct you to other appropriate charts for further troubleshooting of that area.

Note that some troubleshooting-procedure boxes on each chart contain numbers along their lower edges. These numbers identify the applicable schematic diagram(s) and circuit board illustration(s) to be used when performing the action specified in the box (see Troubleshooting Index chart, General Notes). The diagram and illustration identified at the start of a troubleshooting path remain applicable to downstream steps in the path until a different diagram or illustration is specified.

Both General and Specific notes may be called out in the troubleshooting-procedure boxes. These notes are located on the inner panels of the foldout pages. Specific Notes contain procedures or additional information to be used in performing the particular troubleshooting step called for in that box. General Notes contain information that pertains to the overall troubleshooting procedure.

Some malfunctions, especially those involving multiple simultaneous failures, may require more elaborate troubleshooting approaches with references to circuit descriptions in the "Theory of Operation" section of this manual.

## Component Color Coding

Information regarding color codes and markings of resistors and capacitors is located in the color-coding illustration (Figure 9-1) at the beginning of the "Diagrams" section.

**RESISTOR COLOR CODE.** Resistors used in this instrument are carbon-film, composition, or precision metal-film types. They are color coded with the EIA color code; however, some metal-film resistors may have the value printed on the body. The color code is interpreted starting with the stripe that is nearest to one end of the resistor. Composition resistors have four stripes; these represent two significant figures, a multiplier, and a tolerance value. Metal-film resistors have five stripes which represent three significant figures, a multiplier, and a tolerance value.

**CAPACITOR MARKINGS.** Capacitance values of common disc capacitors and small electrolytics are marked on the side of the capacitor body. White ceramic capacitors are color coded in picofarads, using a modified EIA code.

Dipped tantalum capacitors are color coded in microfarads. The color dot indicates both the positive lead and the voltage rating. Since these capacitors are easily destroyed by reversed or excessive voltage, be careful to observe the polarity and voltage rating.

**DIODE COLOR CODE.** The cathode end of each glass-encased diode is indicated by either a stripe, a series of stripes, or a dot. For most silicon or germanium diodes marked with a series of stripes, the color combination of the stripes identifies three digits of the Tektronix Part Number, using the resistor color-code system (e.g., a diode having either a pink or a blue stripe at the cathode end, then a brown-gray-green stripe combination, indicates Tektronix Part Number 152-0185-00). The cathode and anode ends of a metal-encased diode can be identified by the diode symbol marked on its body.

## Semiconductor Lead Configurations

Figure 9-2 in the "Diagrams" section shows the lead configurations for semiconductor devices used in the instrument. These lead configurations and case styles are typical of those available at completion of the design of the instrument. Vendor changes and performance improvement changes may result in changes in case styles or lead

configurations. If the device in question does not appear to match the configuration in Figure 9-2, examine the associated circuitry or consult a semiconductor manufacturer's data sheet.

### Multipin Connectors

Multipin connector orientation is indicated by two triangles: one on the holder and one on the circuit board. Slot numbers are usually molded into the holder. When a connection is made to circuit-board pins, ensure that the triangle on the holder and the triangle on the circuit board are aligned with each other (see Figure 6-1).

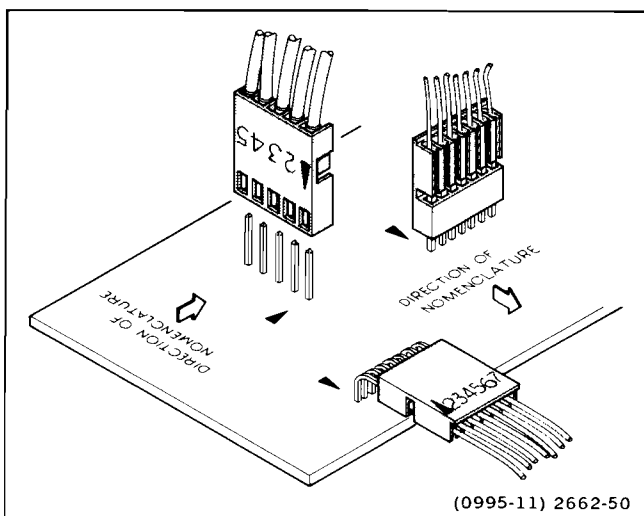

Figure 6-1. Multipin connector orientation.

## TROUBLESHOOTING EQUIPMENT

The equipment listed in Table 6-4 and in Table 4-1, or equivalent equipment, may be useful when troubleshooting this instrument.

## TROUBLESHOOTING TECHNIQUES

The following procedure is arranged in an order that enables checking simple trouble possibilities before requiring more extensive troubleshooting. The first four checks ensure proper control settings, connections, operation, and adjustment. If the trouble is not located by these checks, the remaining steps will aid in locating the defective component. When the defective component is located, replace it, using the appropriate replacement procedure given under "Corrective Maintenance" in this section.

### CAUTION

*Before using any test equipment to make measurements on static-sensitive, current-sensitive, or voltage-sensitive components or assemblies, ensure that any voltage or current supplied by the test equipment does not exceed the limits of the component to be tested.*

### 1. Check Control Settings

Incorrect control settings can give a false indication of instrument malfunction. If there is any question about the correct function or operation of any control, refer to either the "Operating Instructions" (Section 2) in this manual or to the 2336 Operators Manual.

### 2. Check Associated Equipment

Before proceeding, ensure that any equipment used with the 2336 is operating correctly. Verify that input signals are properly connected and that the interconnecting cables are not defective. Check the power input source voltages.

### 3. Visual Check

Perform a visual inspection. This check may reveal broken connections or wires, damaged components, semiconductors not firmly mounted, damaged circuit boards, or other clues.

### 4. Check Instrument Performance and Adjustment

Check the performance of either those circuits where trouble appears to exist or the entire instrument. The apparent trouble may be the result of misadjustment. Complete performance check and adjustment instructions are given in Sections 4 and 5 of this manual.

### 5. Isolate Trouble to a Circuit

To isolate problems to a particular area, use the trouble symptom to help identify the circuit in which the trouble is located. Refer to the troubleshooting charts in the "Diagrams" section as an aid in locating a faulty circuit.

When trouble symptoms appear in more than one circuit, first check the power supplies; then check the affected circuits by taking voltage and waveform readings. Check first for the correct output voltage of each individual supply. These voltages are measured between the power-supply test points and ground (see schematic diagrams 9 and 10 and associated circuit board illustrations in the "Diagrams" section). If power-supply voltages and ripple are within the listed ranges, the supply can be assumed to

be working correctly. If they are outside the range, the supply may be either misadjusted or operating incorrectly.

If the trouble has been isolated to a power supply, follow the troubleshooting chart for that supply. The Low-Voltage Power Supply levels are interdependent. All the low-voltage supplies depend on the +40-V supply for a reference. If more than one of the low-voltage supplies appears defective, repair them in the following order: +40 V, +10 V, +5 V, -10 V, -5 V, then +102 V. To adjust the +40-V Power Supply, refer to the "Adjustment Procedure" (Section 5).

A defective component elsewhere in the instrument can create the appearance of a power-supply problem and may also affect the operation of other circuits.

## 6. Check Circuit Board Interconnections

After the trouble has been isolated to a particular circuit, again check for loose or broken connections, improperly seated semiconductors, and heat-damaged components.

## 7. Check Voltages and Waveforms

Often the defective component can be located by checking the appropriate voltage or waveform in the circuit. Typical voltages are listed on the schematic diagrams. Waveforms are shown adjacent to the diagrams, and waveform test points are indicated on the schematic and circuit board illustrations by a hexagonal-outlined number.

**Table 6-4**  
Suggested Troubleshooting Equipment

Equipment	Minimum Specification	Usage	Examples
1. Test Oscilloscope with 10X Voltage Probe	Frequency response: dc to 100 MHz. Deflection factor: 20 mV to 100 V/div. A 10X, 10-M $\Omega$ probe should be used to reduce circuit loading.	Check operating waveforms.	TEKTRONIX 465B Oscilloscope with included P6105 Probes.
2. Signal Generator	Repetition rate: 250 kHz to 100 MHz with 50 kHz reference.	Check bandwidth.	TEKTRONIX SG 503 Signal Generator. <sup>a</sup>
3. Calibration Generator	Rise time: 1 ns or less. Output amplitude: 0 to 10 V.	Check rise time and gain.	TEKTRONIX PG 506 Calibration Generator. <sup>a</sup>
4. Digital Multimeter	Voltmeter: input impedance, 10 M $\Omega$ ; range, 0 to 200 V dc; voltage accuracy, within 0.15%; display, 4 1/2 digits. Ohmmeter: 0 to 20 M $\Omega$ . Test probes should be insulated to prevent accidental shorting.	Measure voltages and resistances.	TEKTRONIX DM 501A Digital Multimeter. <sup>a</sup>
5. Variable Auto-transformer	Variable ac output from 0 to 140 V, 1.2 A. Equipped with 3-wire power cord, plug, and receptacle.	Vary input line voltage when troubleshooting power supply.	General Radio W8MT3VM or W10MT3W Metered Variac Autotransformer.
6. Semiconductor Tester	Dynamic-type tester. Measure reverse breakdown voltages up to at least 400 V.	Test semiconductors.	TEKTRONIX 576 Curve Tracer.

<sup>a</sup>Requires a TM 500-Series power module.

**NOTE**

*Voltages and waveforms given on the schematic diagrams are not absolute and may vary slightly between instruments. To establish operating conditions similar to those used to obtain these readings, see the voltage and waveform setup conditions in the "Diagrams" section for the preliminary equipment setup. Note the recommended test equipment, front-panel control settings, voltage and waveform conditions, and cable-connection instructions. The oscilloscope control settings required to obtain the given waveforms and voltages are located adjacent to the waveform diagrams. Changes to the control settings from the preliminary setup, other than those given, are usually not required.*

**8. Check Individual Components**

The following procedures describe methods of checking individual components. Two-lead components that are soldered in place are most accurately checked by first disconnecting one end from the circuit board. This isolates the measurement from the effects of surrounding circuitry. See Figure 9-1 for value identification or Figure 9-2 for semiconductor lead configuration.

**WARNING**

*To avoid electric shock, always disconnect the instrument from the power input source before removing or replacing components.*

**CAUTION**

*When checking semiconductors, observe the static-sensitivity precautions located at the beginning of this section.*

**TRANSISTORS.** A good check of transistor operation is actual performance under operating conditions. A transistor can most effectively be checked by substituting a known good component. However, be sure that circuit conditions are not such that a replacement transistor might also be damaged. If substitute transistors are not available, use a dynamic tester. Static-type testers are not recommended, since they do not check operation under simulated operating conditions.

When troubleshooting transistors in the circuit with a voltmeter, measure both the emitter-to-base and emitter-to-collector voltages to determine whether they are consistent with normal circuit voltages. Voltages across a transistor may vary with the type of device and its circuit function.

Some of these voltages are predictable. The emitter-to-base voltage for a conducting silicon transistor will normally range from 0.6 to 0.8 V, and the emitter-to-base voltage for a conducting germanium transistor ranges from 0.2 to 0.4 V. The emitter-to-collector voltage for a saturated transistor is about 0.2 V. Because these values are small, the best way to check them is by connecting a sensitive voltmeter across the junction rather than comparing two voltages taken with respect to ground. If the former method is used, both leads of the voltmeter must be isolated from ground.

If values less than these are obtained, either the device is shorted or no current is flowing in the external circuit. If values exceed the emitter-to-base values given, either the junction is reverse biased or the device is defective. Voltages exceeding those given for typical emitter-to-collector values could indicate either a nonsaturated device operating normally or a defective (open-circuited) transistor. If the device is conducting, voltage will be developed across the resistors in series with it; if it is open, no voltage will be developed across the resistors in series with it, unless current is being supplied by a parallel path.

**CAUTION**

*When checking emitter-to-base junctions, do not use an ohmmeter range that has a high internal current. High current can damage the transistor. Reverse biasing the emitter-to-base junction with a high current may degrade the transistor's current-transfer ratio (Beta).*

A transistor emitter-to-base junction also can be checked for an open or shorted condition by measuring the resistance between terminals with an ohmmeter set to a range having a low internal source current, such as the R X 1 k $\Omega$  range. The junction resistance should be very high in one direction and very low when the meter leads are reversed.

When troubleshooting a field-effect transistor, the voltage across its elements can be checked in the same manner as previously described for other transistors. However, remember that in the normal depletion mode of operation, the gate-to-source junction is reverse biased; in the enhanced mode, the junction is forward biased.

**INTEGRATED CIRCUITS.** An integrated circuit (IC) can be checked with a voltmeter, test oscilloscope, or by direct substitution. A good understanding of circuit operation is essential to troubleshooting a circuit having an IC. Use care when checking voltages and waveforms around the IC so that adjacent leads are not shorted



together. An IC test clip provides a convenient means of clipping a test probe to an IC.



*When checking a diode, do not use an ohmmeter scale that has a high internal current. High current can damage a diode. Checks on diodes can be performed in much the same manner as on transistor emitter-to-base junctions. Do not check tunnel diodes or back diodes with an ohmmeter; use a dynamic tester, such as the TEKTRONIX 576 Curve Tracer.*

**DIODES.** A diode can be checked for either an open or a shorted condition by measuring the resistance between terminals with an ohmmeter set to a range having a low internal source current, such as the R X 1 k $\Omega$  range. The diode resistance should be very high in one direction and very low when the meter leads are reversed.

Silicon diodes should have 0.6 to 0.8 V across their junctions when conducting. Higher readings indicate that they are either reverse biased or defective, depending on polarity.

**RESISTORS.** Check resistors with an ohmmeter. Refer to the "Replaceable Electrical Parts" list for the tolerances of resistors used in this instrument. A resistor normally does not require replacement unless its measured value varies widely from its specified value and tolerance.

**INDUCTORS.** Check for open inductors by checking continuity with an ohmmeter. Shorted or partially shorted inductors can usually be found by checking the waveform response when high-frequency signals are passed through the circuit.

**CAPACITORS.** A leaky or shorted capacitor can best be detected by checking resistance with an ohmmeter set to one of the highest ranges. Do not exceed the voltage rating of the capacitor. The resistance reading should be high after the capacitor is charged to the output voltage of the ohmmeter. An open capacitor can be detected with a capacitance meter or by checking whether the capacitor passes ac signals.

**ATTENUATORS.** The thick-film attenuators are best checked by substitution. If only one channel of the 2336 is not operating properly and there is reason to believe the attenuator is defective, replace the suspected attenuator

with the attenuator from the other channel and recheck instrument operation. If proper operation results, either order a new attenuator or replace the defective contact set or hybrid circuit in the malfunctioning attenuator as described in the "Removal and Replacement Instructions" of this section.

Improper contact pressure on a contact pad can either cause or contribute to attenuator switch failure. Contact pressure can be determined by visually inspecting cam-to-contact-arm height and contact-arm shape. Sometimes a previously defective switch contact will operate satisfactorily after it is installed on either a new or freshly cleaned hybrid circuit board. Make visual inspections of switch contacts by rotating the switch shaft and observing all contacts in both their open and closed positions. Also check that the contacts are correctly aligned with each other. Refer to Figure 6-2 and Figure 6-3.

When a contact is open, its lobe should ride on the cam. A gap means either a defective contact arm or excessive cam clearance. Contact-to-pad gaps should be even. Variations may indicate defective contacts or actuator problems.

As a contact closes, contact should be made while the contact lobe is still on the cam ramp (before the logic lobe is over the contact lobe). Excessive cam clearance or a defective contact arm can cause improper contact closure. All contact fingers on any arm should touch the pads at the same time. If they do not, either the contact arm or the fingers are defective.

When contacts are closed, their fingers should be centered squarely on their respective pads. If they are not, either the contact arms or fingers are defective. If the cam does not supply sufficient pressure on the arm to produce good finger-to-pad contact, an intermittent connection can result. This condition can be produced by either a defective contact arm or actuator problems.

## 9. Repair and Adjust the Circuit

If any defective parts are located, follow the replacement procedures given under "Corrective Maintenance" in this section. After any electrical component has been replaced, the performance for that particular circuit should be checked, as well as the performance of other closely related circuits. Since the power supplies affect all circuits, performance of the entire instrument should be checked if work has been done in the power supplies or if the power transformer has been replaced. Readjustment of the affected circuitry may be necessary. Refer to the "Performance Check" and "Adjustment Procedure" (Sections 4 and 5) and to Table 5-1 (Adjustment Interactions).

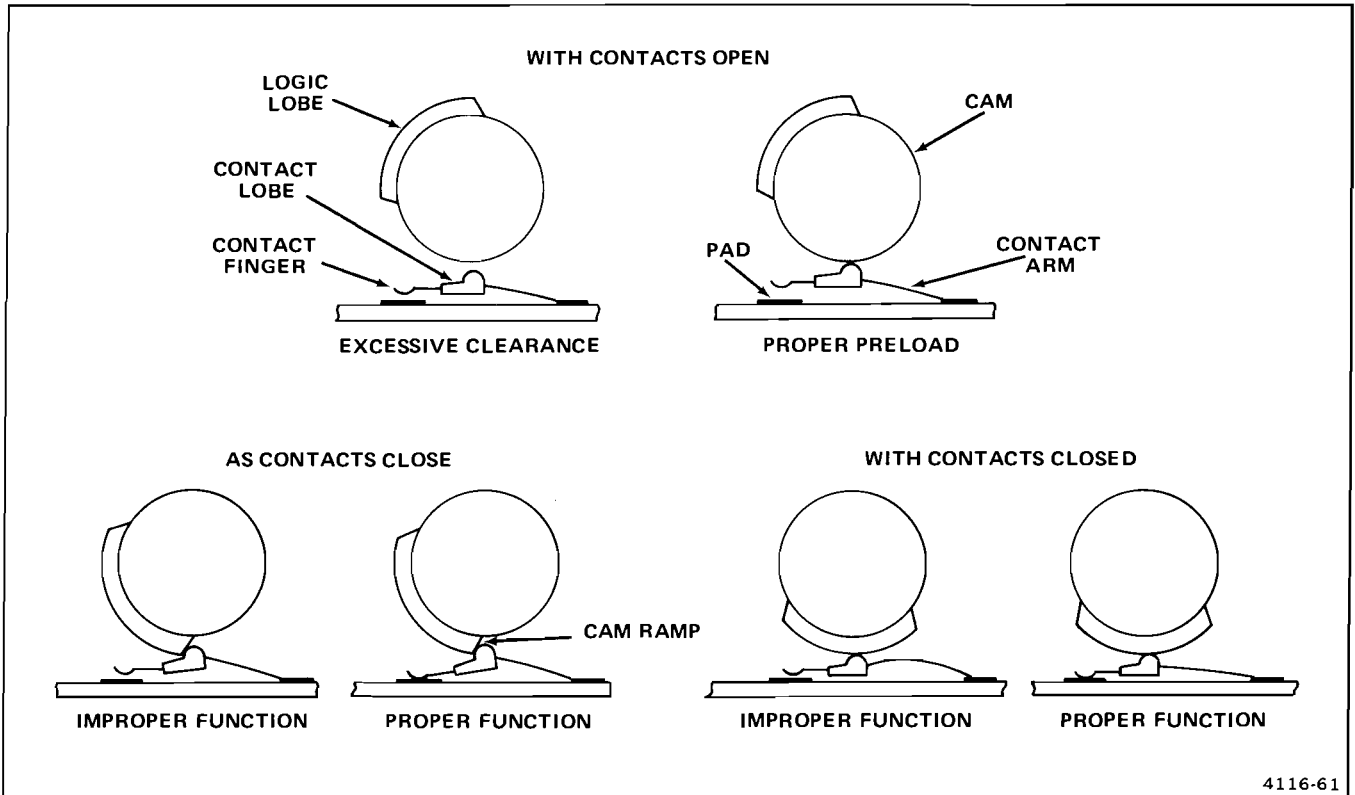

4116-61

Figure 6-2. Attenuator contact pressure check.

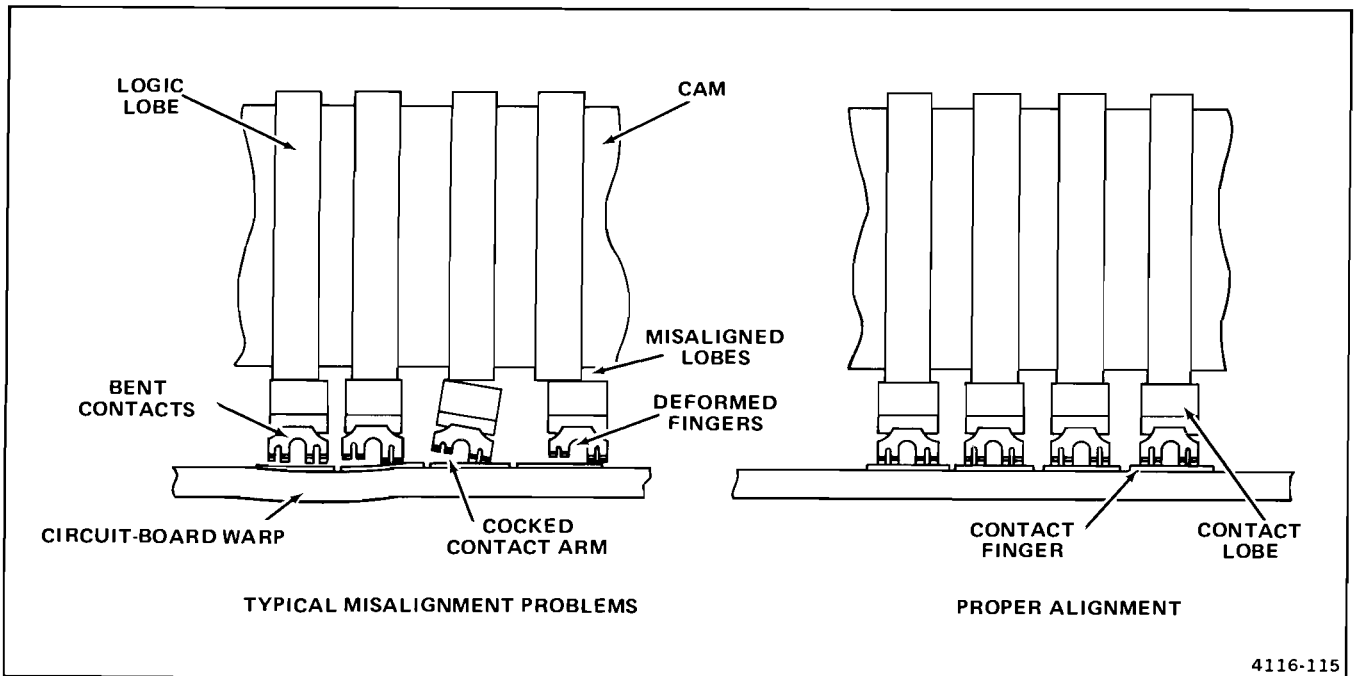

4116-115

Figure 6-3. Attenuator contact alignment.

# CORRECTIVE MAINTENANCE

## INTRODUCTION

Corrective maintenance consists of component replacement and instrument repair. This part of the manual describes special techniques and procedures required to replace components in this instrument. If it is necessary to ship your instrument to a Tektronix Service Center for repair or service, refer to the "Instrument Repackaging Instructions" at the end of this section.

## MAINTENANCE PRECAUTIONS

To reduce the possibility of personal injury or instrument damage, observe the following precautions.

1. Disconnect the instrument from the ac power input source before removing or installing components.
2. Use care not to interconnect instrument grounds which may be at different potentials (cross grounding).
3. When soldering on circuit boards or small insulated wires, use only a 15-watt, pencil-type soldering iron.

## OBTAINING REPLACEMENT PARTS

Most electrical and mechanical parts can be obtained through your local Tektronix Field Office or representative. However, many of the standard electronic components can usually be obtained from a local commercial source. Before purchasing or ordering a part from a source other than Tektronix, Inc., please check the "Replaceable Electrical Parts" list for the proper value, rating, tolerance, and description.

### NOTE

*Physical size and shape of a component may affect instrument performance, particularly at high frequencies. Always use direct-replacement components, unless it is known that a substitute will not degrade instrument performance.*

### Special Parts

In addition to the standard electronic components, some special parts are used in the 2336. These components are manufactured or selected by Tektronix, Inc. to meet specific performance requirements, or are manufactured for Tektronix, Inc. in accordance with our specifications.

The various manufacturers can be identified by referring to the "Cross Index—Manufacturer's Code Number to Manufacturer" at the beginning of the "Replaceable Electrical Parts" list. Most of the mechanical parts used in this instrument were manufactured by Tektronix, Inc. Order all special parts directly from your local Tektronix Field Office or representative.

### Ordering Parts

When ordering replacement parts from Tektronix, Inc., be sure to include all of the following information:

1. Instrument type (include modification or option numbers).
2. Instrument serial number.
3. A description of the part (if electrical, include its component number).
4. Tektronix part number.

## MAINTENANCE AIDS

The maintenance aids listed in Table 6-5 include items required for performing most of the maintenance procedures in this instrument. Equivalent products may be substituted for the examples given, provided their characteristics are similar.

## INTERCONNECTIONS

Two methods of interconnection are used in this instrument to connect the circuit boards with other boards and components. When the interconnection is made with a coaxial cable, a special end-lead connector plugs into a socket on the board. Other interconnections are made with pins soldered onto the board. Several types of mating connectors are used for these interconnecting pins. The following information provides the replacement procedures for the various interconnecting methods.

### Coaxial-Type End-Lead Connectors

Replacement of the coaxial-type end-lead connectors requires special tools and techniques; only maintenance personnel familiar with the specialized techniques should attempt replacement of these connectors. It is recommended that the cable or wiring harness and connector be replaced as a unit. For cable or wiring harness part numbers, see the "Replaceable Mechanical Parts" list. An

**Table 6-5**  
**Maintenance Aids**

Description	Specifications	Usage	Example
1. Soldering Iron	15 to 25 W.	General soldering and unsoldering.	Antex Precision Model C.
2. Phillips Screwdrivers	#1 tip, #2 tip.	Assembly and disassembly.	Xcelite Models X108 and X102.
3. Flat-bit Screwdriver	3-inch shaft, 3/32-inch bit.	Assembly and disassembly.	Xcelite Model R3323.
4. Torque Screwdriver	3 inch-pounds.	Assembly of crt and SEC/DIV and VOLTS/DIV switches.	Sturtevant-Richmont Torque Products Model PM-5 Roto-Torq.
5. Nutdrivers	3/16 inch, 1/4 inch.	Assembly and disassembly.	Xcelite #6 and #8.
6. Open-end Wrenches	1/4 inch, 5/16 inch, 7/16 inch.	Assembly and disassembly.	
7. Allen Wrenches	0.050 inch, 1/16 inch, 1/8 inch.	Assembly and disassembly.	
8. Long-nose Pliers		Component removal and replacement.	
9. Diagonal Cutters		Component removal and replacement.	
10. Vacuum Solder Extractor	No static charge retention.	Unsoldering static-sensitive devices and components on multilayer boards.	Pace Model PC-10.
11. Lubricant	Versilube (silicone grease).	Switch lubrication.	Tektronix Part Number 006-1353-01.
12. Spray Cleaner	No-Noise.	Switch pad cleaning.	Tektronix Part Number 006-0442-02.
13. Pin-replacement Kit		Replace circuit board connector pins.	Tektronix Part Number 040-0542-00.
14. IC-Removal Tool		Removing DIP IC packages.	Augat T114-1.

alternative solution is to refer the replacement of the defective connector to your local Tektronix Field Office or representative.

### End-Lead Pin Connectors

Pin connectors used to connect the wires to the inter-connecting pins are factory assembled. They consist of machine-inserted pin connectors mounted in plastic holders. If the connectors are faulty, the entire wire assembly should be replaced.

### Multipin Connectors

When pin connectors are grouped together and mounted in a plastic holder, they are removed, reinstalled, or replaced as a unit. If any individual wire or connector in the assembly is faulty, the entire cable assembly should be replaced. To provide correct orientation of this multipin connector when it is reconnected to its mating pins, an arrow is stamped on the circuit board, and a matching arrow is molded into the plastic housing of the multipin connector. Be sure these arrows are aligned with each other when the multipin connector is reinstalled.

## TRANSISTORS AND INTEGRATED CIRCUITS

Transistors and integrated circuits should not be replaced unless they are actually defective. If removed from their sockets or unsoldered from the circuit board during routine maintenance, return them to their original sockets or board locations. Unnecessary replacement or transposing of semiconductor devices may affect the adjustment of the instrument. When a semiconductor is replaced, check the performance of any instrument circuit that may be affected.

Any replacement component should be of the original type or a direct replacement. Bend transistor leads to fit their circuit board holes and cut the leads to the same length as the original component. See Figure 9-2 for lead-configuration illustrations.

To remove socketed dual-in-line packaged (DIP) integrated circuits, pull slowly and evenly on both ends of the device. Avoid disengaging one end of the integrated circuit from the socket before the other, since this may damage the pins.

To remove a soldered DIP IC, do not heat adjacent conductors consecutively. Apply heat to pins at alternate sides and ends of the IC as solder is removed. Allow a moment for the circuit board to cool before proceeding to the next pin.

The heat-sink-mounted power supply transistors are insulated from the heat sink. In addition, a heat-sink compound is used to increase heat transfer capabilities. Reinstall the insulators and replace the heat-sink compound when replacing these transistors. The compound should be applied to both sides of the insulators and should be applied to the bottom side of the transistor where it comes in contact with the insulator.

### NOTE

*After replacing a power transistor, check that the collector is not shorted to the heat sink before applying power to the instrument.*

## SOLDERING TECHNIQUES

The reliability and accuracy of this instrument can be maintained only if proper soldering techniques are used to remove or replace parts. General soldering techniques, which apply to maintenance of any precision electronic equipment, should be used when working on this instrument.

### WARNING

*To avoid an electric-shock hazard, observe the following precautions before attempting any soldering: turn the instrument off, disconnect it from the ac power source, and allow approximately three minutes for the power-supply capacitors to discharge.*

Use rosin-core wire solder containing 63% tin and 37% lead. Contact your local Tektronix Field Office or representative to obtain the names of approved solder types.

When soldering on circuit boards or small insulated wires, use only a 15-watt, pencil-type soldering iron. A higher wattage soldering iron can cause etched circuit conductors to separate from the board base material and melt the insulation on small wires. Always keep the soldering-iron tip properly tinned to ensure best heat transfer from the iron tip to the solder joint. To protect heat-sensitive components, either hold the component lead with long-nose pliers or place a heat block between the component body and the solder joint. Apply only enough solder to make a firm joint. After soldering, clean the area around the solder connection with an approved flux-removing solvent (such as isopropyl alcohol) and allow it to air dry.

Circuit boards in this instrument may have as many as three conductive layers. Conductive paths between the top and bottom board layers may connect to one or more inner layers. If any inner-layer conductive path becomes broken due to poor soldering practices, the board becomes unusable and must be replaced. Damage of this nature can void the instrument warranty.

### CAUTION

*Only an experienced maintenance person, proficient in the use of vacuum-type desoldering equipment, should attempt repair of any circuit board in this instrument. The following multilayer board assemblies are particularly susceptible to heat damage: A23—Trigger, A16—B Timing Switch, and A17—A Timing Switch.*

Desoldering parts from multilayer circuit boards is especially critical. Many of the integrated circuits are static sensitive and can be damaged by a static charge that can be generated by some types of solder extractors. Perform work involving static-sensitive devices only at a static-free work station while wearing a grounded antistatic wrist strap and use only an antistatic vacuum-type solder extractor approved by a Tektronix Service Center.

**CAUTION**

*Attempts to unsolder, remove, and resolder leads from the component side of a circuit board may cause damage to the reverse side of the circuit board.*

The following techniques should be used to replace a component on any of the circuit boards:

1. Touch the vacuum desoldering tool to the lead at the solder connection. Never place the iron directly on the board; doing this may damage the board.

**NOTE**

*Some components are difficult to remove from the circuit board due to a bend placed in each lead during machine insertion of the component. The purpose of the bent leads is to hold the component in place during a solder-flow manufacturing process that solders all the components at once. To make removal of machine-inserted components easier, straighten the component leads on the reverse side of the circuit board with a small screwdriver or pliers. It may be necessary to remove the circuit board to gain access to the component leads on the reverse side of the circuit board. Circuit-board removal and reinstallation procedures are discussed later in this section.*

2. When removing a multipin component, especially an IC, do not heat adjacent pins consecutively. Apply heat to pins at alternate sides and ends of the IC as solder is removed. Allow a moment for the circuit board to cool before proceeding to the next pin.

**CAUTION**

*Excessive heat can cause the etched circuit conductors to separate from the circuit board. Never allow the solder extractor tip to remain at one place on the board for more than three seconds. Solder wick, spring-actuated or squeeze-bulb solder suckers, and heat blocks (for desoldering multipin components) must not be used. Damage caused by poor soldering techniques can void the instrument warranty.*

3. Bend the leads of the replacement component to fit the holes in the circuit board. If the component is replaced while the board is installed in the instrument, cut the leads so they protrude only a small amount through the reverse side of the circuit board. Excess lead length may cause shorting to other conductive parts.

4. Insert the leads into the holes of the board so that the replacement component is positioned the same as the original component. Most components should be firmly seated against the circuit board.

**CAUTION**

*Do not allow either solder or flux to flow beneath etched circuit board switches. The etched switch contacts on the circuit board are an integral part of the switch, and intermittent operation can occur if the contacts become contaminated.*

5. Touch the soldering iron to the connection and apply enough solder to make a firm solder joint. Do not move the component while the solder hardens.

6. Cut off any excess lead protruding through the circuit board (if not clipped to size in step 3).

7. Clean the area around the solder connection with an approved flux-removing solvent. Be careful not to remove any of the printed information from the circuit board.

When soldering to the ceramic strips in the instrument, a slightly larger soldering iron can be used. It is recommended that a solder containing about 3% silver be used when soldering to these strips to avoid destroying the bond to the ceramic material. This bond can be broken by repeated use of ordinary tin-lead solder or by the application of too much heat; however, occasional use of ordinary solder will not break the bond, provided excessive heat is not applied.

If it becomes necessary to solder in the general area of any of the high-frequency contacts of this instrument, clean the contacts immediately upon completion of soldering. Refer to the "Switch Contacts" paragraph in the "Preventive Maintenance" part of this section for the recommended cleaners and procedures.

## REMOVAL AND REPLACEMENT INSTRUCTIONS

**WARNING**

*To avoid electric shock, disconnect the instrument from the power input source before removing or replacing any component or assembly.*

The exploded view drawings in the "Replaceable Mechanical Parts" list may be helpful during the removal

## Maintenance—2336 Service

and reinstallation of individual components or sub-assemblies. Circuit board and component locations are shown in the "Diagrams" section.

Read these instructions completely before attempting any corrective maintenance.

### Cabinet

Removal and reinstallation of the instrument cabinet is accomplished by the following steps:

1. Remove one Phillips-head screw holding the power-cord securing clamp. Remove the clamp and disconnect the power cord.

2. Remove two Phillips-head retaining screws from the rear of the cabinet assembly (one near each of the bottom feet).

3. Loosen six Phillips-head retaining screws on the rim band around the front panel (three across the top and three across the bottom).

4. Close and latch the lid, place the cabinet handle against the bottom of the cabinet, and set the instrument face down on a flat surface.

5. Carefully lift up on the cabinet until the ground lug, ac-power-input jack, and fuse holder are free of the perforations in the rear of the cabinet; then slide the cabinet up off of the instrument chassis.

To reinstall the cabinet:

6. Place the instrument face down on a flat surface (with the lid latched).

7. Align the cabinet to allow the ground lug, ac-power-input jack, and fuse holder to pass through the perforation in the rear of the cabinet and carefully slide the cabinet down over the instrument chassis to its original position.

8. Open the lid and tighten six retaining screws around the rim band (loosened in step 3).

9. Reinstall two Phillips-head screws (removed in step 2).

10. Reconnect the power cord and reinstall the securing clamp and screw removed in step 1.

### Lid Cover

Removal and reinstallation of the lid cover is accomplished by the following steps:

1. Shut and latch the lid; set the instrument vertically, on its rear feet, on a flat working surface.

2. Remove two Phillips-head screws at the end of the two rubber bumper strips (one for each bumper strip).

3. Remove two Phillips-head screws under each bumper strip (on the top of the lid cover).

4. Note the orientation of the lid cover and pull it free from the lid assembly.

To reinstall the lid cover:

5. Slide the cover over the lid assembly, oriented as noted in step 4.

6. Reinstall four Phillips-head screws, two under each bumper strip (removed in step 3).

7. Reinstall two Phillips-head screws retaining the bumper strips (removed in step 2).

### A30—Delta Time Logic Circuit Board

Removal and reinstallation of the Delta Time Logic circuit board is accomplished by the following steps:

1. Remove the lid cover, using the preceding procedure.

2. Disconnect J780 from P780 on the Delta Time Logic circuit board.

3. Use a 1/16-inch Allen wrench to loosen the set screw in the B TRIGGER LEVEL knob and remove the knob.

4. Use a 1/4-inch nutdriver to remove four hexagonal standoffs retaining the Delta Time Logic circuit board and lift out the board.

To reinstall the Delta Time Logic circuit board:

5. Set the circuit board into place in the lid and secure it with four hexagonal standoffs (removed in step 4).

6. Reinstall the B TRIGGER LEVEL knob (removed in step 3).

7. Reconnect J780 to P780 (disconnected in step 2).

8. Reinstall the lid cover, using the preceding procedure.

### B Trigger Panel

Removal and reinstallation of the B Trigger panel is accomplished by the following steps:

1. Remove both the lid cover and the Delta Time Logic circuit board, using the preceding procedures.

2. Use a 1/4-inch nutdriver to remove two nuts retaining the flange which holds down the Delta Time Interconnect cable boot. Lift the flange off of the two mounting studs.

3. Use a 7/16-inch open-end wrench to remove the nut and flat washer retaining the flex ground tab and carefully lift the tab off of its grounding stud.

4. Remove six Phillips-head screws retaining the B Trigger panel and lift out the panel.

To reinstall the B Trigger panel:

5. Set the panel into place in the lid and secure it with six Phillips-head screws (removed in step 4).

6. Place the flex ground tab onto its grounding stud and use a 7/16-inch open-end wrench to reinstall the nut and flat washer removed in step 3.

7. Reinstall the flange which holds down the Delta Time interconnect cable boot and secure it with two nuts (removed in step 2).

8. Reinstall the Delta Time Logic circuit board and the lid cover, using the preceding procedures.

### Delta Time Interconnect Cable

Removal and reinstallation of the Delta Time Interconnect cable is accomplished by the following steps:

1. Remove the lid cover, the Delta Time Logic circuit board, and the B Trigger panel (in that order), using the preceding procedures.

2. Remove six Phillips-head screws retaining the gray rim band around the instrument front panel. Remove the gray rim band from the instrument.

3. Remove four Phillips-head screws retaining the now-exposed black rim band, but do not remove the black rim band from the instrument.

4. Disconnect the Delta Time Interconnect cable from P751 on the Sweep/Horiz Amp/Opt circuit board.

5. Use a flat-bit screwdriver to lift the black rim band away from the front casting in the area of the Delta Time Interconnect cable and remove the right-angle edge of the boot from the notch in the casting.

6. Gently pull forward on the Delta Time Interconnect cable (along with its boot and flex ground strap) until the complete cable assembly is clear of the instrument.

To install a new Delta Time Interconnect cable:

7. Use a flat-bit screwdriver to lift up the black rim band in the area of the notch in the edge of the front casting. Insert the cable assembly (J751 towards the Sweep/Horiz Amp/Opt circuit board) between the black rim band and the casting.

8. Insert the right-angle edge of the boot into the notch (facing towards the top of the instrument) and insert the flex ground over the edge of the casting (facing towards the bottom of the instrument).

9. Connect J751 and P751 on the Sweep/Horiz Amp/Opt circuit board.

10. Reinstall four screws securing the black rim band to the front casting (removed in step 3).

11. Reinstall the gray rim band (with the hinge edge along the bottom edge of the instrument) and secure it with six screws (removed in step 2).

12. Reinstall the B Trigger panel, the Delta Time Logic circuit board, and the lid cover (in that order).



**NOTE**

*For all of the following procedures, the cabinet must first be removed in accordance with the foregoing removal and replacement instructions.*

**Cathode-Ray Tube**

**WARNING**

*Use care when handling a crt. Breaking the crt can cause high-velocity scattering of glass fragments. Protective clothing and safety glasses should be worn. Avoid striking the crt on any object which might cause it to crack or implode. When storing a crt, either place it in a protective carton or set it face down on a smooth surface in a protected location with a soft mat under the faceplate.*

Removal and replacement of the crt is accomplished by the following steps:

1. Disconnect P768 from the Vert Out/H.V. Power Supply circuit board.

2. Use long-nose pliers to disconnect the two vertical deflection connectors from the pins on the neck of the crt (these wires come from the Vert Out/H.V. Power Supply circuit board). Pull straight out on these connectors to prevent placing strain on the metal-to-glass seal. Note wire colors and positions for reinstallation reference.

3. Raise the front of the instrument and disconnect the two horizontal deflection pin connectors from the neck of the crt (these wires come from the Sweep/Horiz Amp/Opt circuit board). Pull straight out on these connectors to prevent placing strain on the metal-to-glass seal. Note wire color and location for reinstallation reference.

**WARNING**

*The crt anode and the output terminal of the High-Voltage Multiplier will retain a high-voltage charge after the instrument is turned off. To avoid electrical shock, ground both the output terminal and the crt high-voltage lead to the main instrument chassis.*

4. Disconnect the crt anode lead from the High-Voltage Multiplier lead by carefully pulling the anode plug out of the jack. Discharge the plug tip to the chassis.

5. Disconnect the socket from the base of the crt, gripping the tabs on the socket cover to pull it free.

6. Disconnect the Delay Line electrical connector from J878 on the Vert Out/H.V. Power Supply circuit board.

7. Pull the Delay Line cable free from the two retaining clips on the Vert Out/H.V. Power Supply circuit board.

8. Remove three Phillips-head screws retaining the Delay Line assembly.

9. Lift the Delay Line assembly up and set it on top of the Vert Preamp/L.V Power Supply circuit board.

10. Remove the Phillips-head screw retaining the ground lug to the bottom rear of the crt shield.

11. Support the crt with one hand and use a 1/8-inch Allen wrench to loosen one of four set screws (located at each corner of the crt face), counting the turns, until the tip of the screw is flush with its mounting tab. Then loosen the remaining three set screws the same number of turns as the first one.

**NOTE**

*It may be necessary to remove some of the rear panel screws in the area of the crt and to pull back slightly on the rear chassis panel when performing the next step.*

12. Slide the crt and the surrounding metal shield back and lift them out of the instrument. The implosion shield will remain in the front casting. Note the alignment of the graticule for reinstallation reference.

13. Remove the metal mask and EMI gasket from around the front of the crt.

14. Remove the metal shield from the crt by sliding the shield to the rear. Exercise care not to damage the high-voltage lead, neck pins, and cable connecting to the two coils.

**NOTE**

*It may be necessary to remove the rubber grommet from the metal shield before sliding the shield off of the crt.*

To install a replacement crt:

15. Insert the crt into its metal shield (removed in step 14), passing the high-voltage lead and the cable connected to the two coils through the appropriate holes in the shield. Reinstall the rubber grommet, if it was previously removed.



*The EMI gasket must be installed correctly to ensure both a proper ground to the shield and a cushion for the front of the crt.*

16. Set the metal mask (removed in step 13) on a flat surface with its back edges facing upward.

17. Drape the EMI gasket over the edges of the mask so that the gasket material is partially inside and partially outside the mask.

18. Press the front of the crt into the mask.

19. Verify that the EMI gasket makes even contact with the mask and the crt shield on all four sides when viewed from the rear.

20. Verify that the EMI gasket also makes even contact between the mask and the front of the crt on all four sides when viewed from the front (graticule).

21. Carefully place the assembled crt and mask into the instrument, ensuring that the index guide and graticule are aligned as noted in step 12.

22. Support the crt with one hand and use a 1/8-inch Allen wrench to alternately tighten each of the four retaining screws about one to two turns less than counted in step 11. Then use a torque screwdriver to alternately torque each screw to 1.5 inch-pounds.

23. Align the index slot of the crt socket with the index guide on the crt base and press the socket firmly into place.

### WARNING

*The High-Voltage Multiplier can again build up a high-voltage charge after it is first discharged to ground. To avoid electrical shock, ground its output terminal to the main instrument chassis before reconnecting the crt anode lead.*

24. Reconnect the crt anode-lead plug to the jack from the High-Voltage Multiplier.

25. Reinstall the screw securing the ground lug to the crt shield (removed in step 10).

26. Reinstall the Delay Line assembly (removed in step 9), using three retaining screws (removed in step 8).

27. Press the Delay Line cable into its two retaining clips on the Vert Out/H.V. Power Supply circuit board.

28. Reconnect the Delay Line electrical connector to J878 (disconnected in step 6).

29. Raise the front of the instrument and use long-nose pliers to reconnect the two horizontal deflection pin connectors (from the Sweep/Horiz Amp/Opt circuit board) to the neck of the crt at the positions noted in step 3.

30. Reconnect the two vertical deflection pin connectors (from the Vert Out/H.V. Power Supply circuit board) to the neck of the crt at the positions noted in step 2.

31. Reconnect P768 (disconnected in step 1) to the Vert Out/H.V. Power Supply circuit board.

### A15—Vert Out/H.V. Power Supply Circuit Board

Removal and reinstallation of the Vert Out/H.V. Power Supply circuit board is accomplished by the following steps:

1. Use a 1/16-inch Allen wrench to loosen the set screw on the FOCUS control knob. Note its position for reinstallation reference and remove the knob from the instrument.

2. Use a 5/16-inch open-end wrench to remove the retaining nut from the FOCUS control shaft and push the control shaft through the front panel until it hangs free.

## Maintenance—2336 Service

3. Disconnect P763, P759, and P765 at the front edge of the circuit board.

4. Disconnect the Delay Line electrical connector from J878.

5. Pull the Delay Line cable free from the two retaining clips on the circuit board.

6. Disconnect P756, P768, and P758 at the rear of the circuit board.

7. Disconnect the socket from the base of the crt, gripping the tabs on the socket cover to pull it free.

8. Use long-nose pliers to disconnect the two vertical deflection pin connectors from the neck of the crt (these wires come from the Vert Out/H.V. Power Supply circuit board). Pull straight out on these connectors to prevent placing strain on the metal-to-glass seal. Note their positions for reinstallation reference.

9. Remove five Phillips-head screws retaining the circuit board (four around the outer edges and one near the center of the board).

10. Remove the Vert Out/H.V. Power Supply circuit board from the instrument, taking care not to damage L913 and L915.

To reinstall the Vert Out/H.V. Power Supply circuit board:

11. Carefully reposition the board into place, taking care not to damage L913 and L915.

12. Reinstall five retaining screws (removed in step 9).

13. Use long-nose pliers to reconnect the two vertical deflection pin connectors to the neck of the crt at the positions noted in step 8.

14. Align the index slot of the crt socket with the index guide on the crt base and press the socket firmly into place.

15. Press the Delay Line cable into its two retaining clips.

16. Reconnect P756, P768, and P758 at the rear of the circuit board (disconnected in step 6).

17. Reconnect the Delay Line electrical connector to J878 (disconnected in step 4).

18. Reconnect P763, P759, and P765 at the front edge of the circuit board (disconnected in step 3).

19. Insert the FOCUS control shaft through the front panel and reinstall the retaining nut (removed in step 2).

20. Reinstall the FOCUS control knob, noting its position in step 1, and tighten the set screw.

## A10—Vert Preamp/L.V. Power Supply Circuit Board

Removal and reinstallation of the Vert Preamp/L.V. Power Supply circuit board is accomplished by the following steps:

1. Use a 1/16-inch Allen wrench to loosen both VOLTS/DIV VAR control-knob set screws. Note their positions for reinstallation reference and remove the knobs.

2. Pull both VOLTS/DIV control knobs from their shafts, noting their positions for reinstallation references.

3. Disconnect P703 and P704, located near the middle of the circuit board. These lead to the CH 1 and CH 2 POSITION controls respectively.

4. Disconnect P733 from the Trigger circuit board (from the LEVEL control) and remove its rubber grommet from the slot in the edge of the Vert Preamp/L.V. Power Supply circuit board.

5. Disconnect P730 and P732 from the Trigger circuit board.

6. Disconnect the two miniature coaxial connectors (P830 for Channel 1 and P831 for Channel 2) from the Trigger circuit board. Note the color and location of each for reinstallation reference.

7. Disconnect the following connectors from the Vert Preamp/L.V. Power Supply circuit board, noting their locations for reinstallation reference:

- a. P710 (from the Vert Out/H.V. Power Supply circuit board).
- b. P714 (from the transformer).
- c. P702 (from the EXT Z AXIS connector).



*Exercise care not to damage the center conductors of the miniature coaxial connectors while performing the next step.*

8. Tip the instrument up, exposing the bottom, and use long-nose pliers to disconnect the miniature coaxial connectors from the CH 1 and CH 2 input bnc connectors.

9. Remove two Phillips-head screws retaining the attenuators (one for each attenuator).

10. Remove the following nine Phillips-head retaining screws from the Vert Preamp/L.V. Power Supply circuit board and the preamplifier circuit shield:

- a. One near each end of the Negative Regulator board (A11).
- b. Two connecting the preamplifier circuit shield to the front casting (do not remove the four screws securing the hexagonal standoffs).
- c. One on the edge of the board, adjacent to Q194.
- d. Two under the preamplifier circuit shield.
- e. One toward the rear of the circuit board, adjacent to U215 and to which the grounding lug is attached.
- f. One toward the rear of the circuit board, located between C225 and C250.

11. Gently lift up on the rear of the Vert Preamp/L.V. Power Supply circuit board to disengage it from the pins of P808 on the Trigger circuit board.

12. With the rear of the circuit board raised approximately one inch, use long-nose pliers to disconnect the Delay Line electrical connector from the bottom of the board. Use a screwdriver to carefully pry the Delay Line cable from its retaining clip.

13. Remove the Vert Preamp/L.V. Power Supply circuit board from the instrument by lifting the rear of the board and pulling it toward the rear of the instrument.

#### NOTE

*The attenuators are now accessible for servicing. Their contacts are factory lubricated. If preventive-maintenance cleaning is to be performed, lubricate the switch contacts after cleaning with a thin film of No-Noise lubricant, or the equivalent. Lubricate only the gold-plated contact surfaces of the hybrid circuit boards, not the cam-switch assembly. Attenuator disassembly and reassembly instructions are presented later in this section of the manual.*

*Power-supply pass transistors Q246, Q253, Q264, Q252, and Q256 are mounted on a heat sink. Thermal-transfer compound is used on the insulator between each transistor and the heat sink. If any of these transistors are replaced, be sure to replace both the insulator and the thermal-transfer compound.*

To reinstall the Vert Preamp/L.V. Power Supply circuit board:

14. Press the Delay Line cable back into its retaining clip and reconnect its electrical connector (disconnected in step 12).

15. Position the Vert Preamp/L.V. Power Supply circuit board into the instrument, aligning all the extension shafts with their respective holes in the front panel and aligning the pins of J808 with connector P808. Carefully press P808 onto the pins of J808 until the board is firmly seated.

16. Reinstall nine Phillips-head screws (removed in Step 10).



*Exercise care not to damage the center conductors of the miniature coaxial connectors while performing the next step.*

17. Place the instrument on its side, exposing the rear of the input bnc connectors, and use long-nose pliers to insert the miniature coaxial connectors into the CH 1 and CH 2 input bnc connectors.

18. Reinstall two Phillips-head screws retaining the attenuators (removed in step 9).

## Maintenance—2336 Service

19. Place the instrument right side up and reconnect the following cables and connectors (disconnected in steps 7, 6, 5, 4, and 3).

- a. P702 (from the EXT Z AXIS connector).
- b. P714 (from the transformer).
- c. P710 (from the Vert Out/H.V. Power Supply circuit board).
- d. P830 (for Channel 1) and P831 (for Channel 2) (from the Trigger circuit board).
- e. P730 and P732 (from the Trigger circuit board).
- f. P733 (from the Trigger circuit board). Reinstall the rubber grommet removed in step 4.
- g. P703 and P704 (from the CH 1 and CH 2 POSITION controls respectively).

20. Reinstall both VOLTS/DIV control knobs onto their shafts in the positions noted in step 2.

21. Reinstall both VOLTS/DIV VAR control knobs in the positions noted in step 1 and tighten their set screws.

### A11—Negative Regulator Circuit Board

Removal and replacement of the Negative Regulator circuit board is accomplished by the following steps:



*The following procedure destroys the circuit board being removed. Perform this procedure only if a new board is available for replacement.*

1. Cut five pins at J803 and six pins at J804 on the Vert Preamp/L.V. Power Supply circuit board and remove the Negative Regulator circuit board.

2. Use a vacuum-type desoldering tool to clean the 11 pin holes.

3. Insert the pins of P803 and P804 into the appropriate holes on the Vert Preamp/L.V. Power Supply circuit board. Hold the Negative Regulator board in place and solder the 11 pins.

### A12—Positive Regulator Circuit Board

Removal and replacement of the Positive Regulator circuit board is accomplished by the following steps:



*The following procedure destroys the circuit board being removed. Perform this procedure only if a new board is available for replacement.*

1. Note board orientation and cut four pins at J801 and four pins at J802 on the Vert Preamp/L.V. Power Supply circuit board and remove the Positive Regulator circuit board.

2. Use a vacuum-type desoldering tool to clean the 8 pin holes.

3. Orient the replacement Positive Regulator board as noted in step 1 and insert the pins of the replacement Positive Regulator circuit board into the appropriate holes on the Vert Preamp/L.V. Power Supply circuit board. Hold the Positive Regulator board in place and solder the 8 pins.

### A23—Trigger Circuit Board

Removal and reinstallation of the Trigger circuit board is accomplished by the following steps:

1. Disconnect the following connectors and cables from the Trigger circuit board (note colors and locations for reinstallation reference):

- a. P733 (from the LEVEL control).
- b. Two miniature coaxial connectors, J830 and J831. Note their color and position for reinstallation reference.
- c. P732 (from the Vert Preamp/L.V. Power Supply circuit board).
- d. Miniature coaxial connector P829 (from the Sweep/Horiz Amp/Opt circuit board).

2. Loosen, but do not completely remove, nine Phillips-head screws retaining the Vert Preamp/L.V. Power Supply circuit board.

3. Remove four Phillips-head screws retaining the Trigger circuit board.

4. Gently pry up on the rear of the Vert Preamp/L.V. Power Supply circuit board until the top edge-connector receptacle of J808 disengages from P808 pins on the Trigger circuit board. Then gently pull the Trigger circuit board away from the instrument until the bottom edge-connector pins of P840, on the Sweep/Horiz Amp/Opt circuit board, disengage from J840.

5. Remove the Trigger circuit board from the instrument, taking care not to damage the COUPLING and SOURCE switch control levers and the pins of P808 and P840.

To reinstall the Trigger circuit board:

6. Position the board into place, inserting the COUPLING and SOURCE switch levers into their respective slots in the front panel and aligning the pins of P808 with J808 and the pins of P840 with J840.

7. Gently press J840 (on the Trigger board) onto the pins of P840 (on the Sweep/Horiz Amp/Opt board); then press J808 (on the Vert Preamp/L.V. Power Supply board) onto the pins of P808 (on the Trigger board).

8. Reinstall four Phillips-head screws (removed in step 3).

9. Tighten nine screws on the Vert Preamp/L.V. Power Supply circuit board (loosened in step 2).

10. Reconnect the five cables and connectors that were disconnected in step 1.

## A24—Sweep/Horiz Amp/Opt Circuit Board

Removal and reinstallation of the Sweep/Horiz Amp/Opt circuit board is accomplished by the following steps:

1. Place the instrument on its side so that the Sweep/Horiz Amp/Opt circuit board is accessible and disconnect the following cables and connectors from the board:

- a. P842 (from the Trigger circuit board).
- b. P745 (from the Vert Out/H.V. Power Supply circuit board).
- c. P750 (from the B DELAY TIME POSITION control).
- d. P751 (the Delta Time Interconnect cable).

2. Remove six Phillips-head screws retaining the Sweep/Horiz Amp/Opt circuit board.

3. Gently pull the circuit board away from the instrument until connectors J871 and J876 (from the A and B Timing Switch circuit boards) are disengaged.

To reinstall the Sweep/Horiz Amp/Opt circuit board:

4. Position the board into place, aligning J871 and J876 with pins P871 and P876 on the A and B Timing Switch circuit boards.

5. Press gently on the Sweep/Horiz Amp/Opt circuit board until P871 and P876 are fully engaged with J871 and J876.

6. Reinstall six Phillips-head screws (removed in step 2).

7. Reconnect the four cables and connectors that were disconnected in step 1.

## Timing Switch Assembly

The Timing Switch assembly is a unit consisting of the A and B Timing switches, the VAR potentiometer, the A Timing Switch circuit board (A17), and the B Timing Switch circuit board (A16). Replacing a complete Timing Switch assembly with a new or rebuilt unit is the recommended procedure. However, should it become necessary to disassemble and repair the assembly, replacement parts (as well as complete replacement units) can be ordered from your local Tektronix Field Office or representative.

The following procedure not only describes removal and replacement of the Timing Switch assembly as a complete unit, but also explains how to disassemble and reassemble the unit to facilitate repair and cleaning. Both Figure 6-4 and the exploded view drawings in the "Replaceable Mechanical Parts" list (Section 10) are useful in performing switch disassembly and reassembly.

It is recommended that this procedure be read completely before starting any disassembly.

1. Remove the Vert Preamp/L.V. Power Supply circuit board using the procedure previously described in this part of the manual.

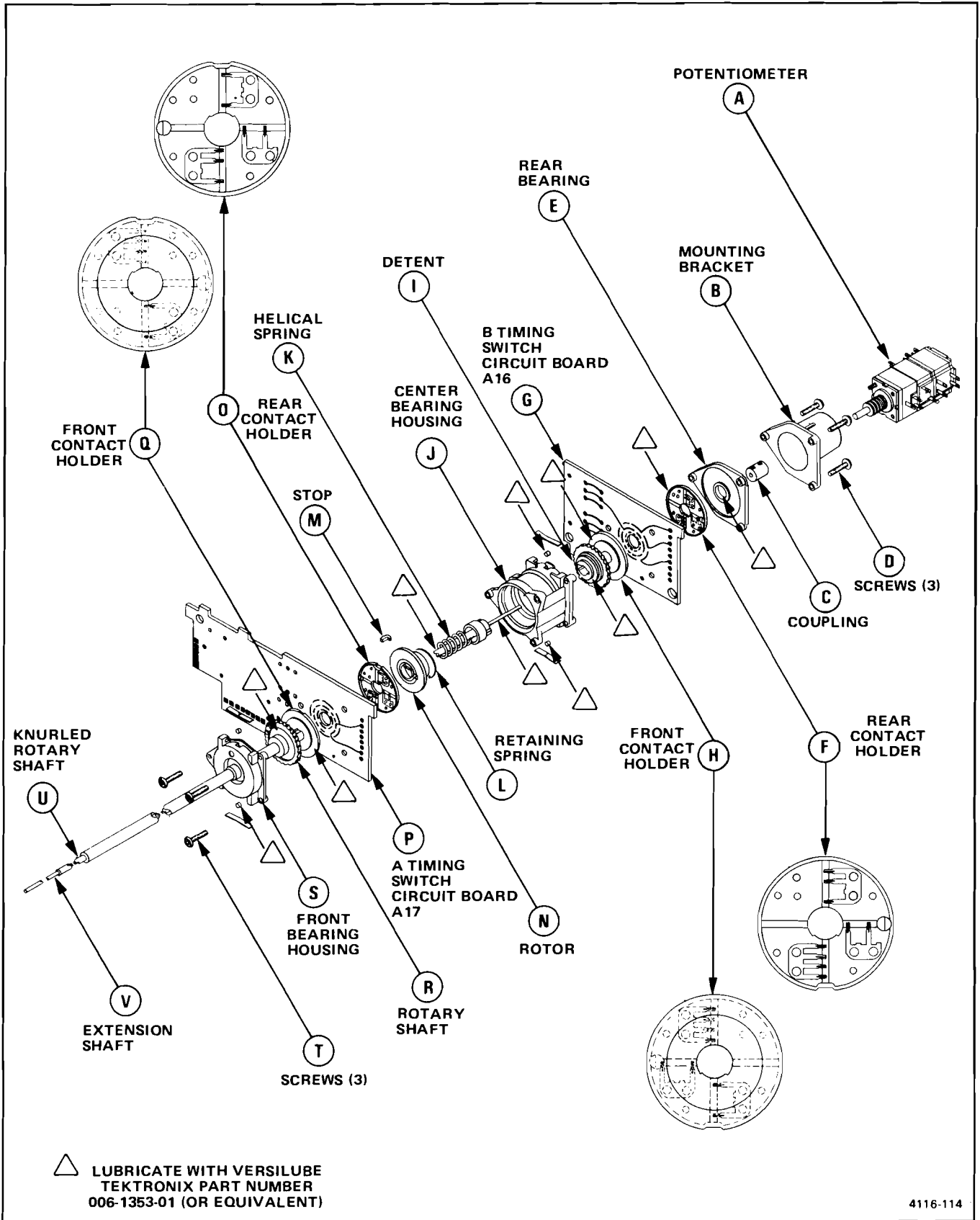

Figure 6-4. SEC/DIV switch exploded view.

2. Rotate the A and B SEC/DIV switch fully counterclockwise.

3. Use a 0.050-inch Allen wrench to loosen the set screw on the SEC/DIV VAR control knob. Note its position for reinstallation reference and remove the knob.

4. Use a 1/16-inch Allen wrench to loosen the set screws on the control knobs for the A and B SEC/DIV switches. Note their positions for reinstallation reference and remove the knobs.

5. Use a 7/16-inch open-end wrench to remove the retaining nut for the control-shaft housing of the A and B SEC/DIV switches. Note its position for reinstallation reference.

6. Pull up on the Timing Switch assembly until the pins on the A and B Timing Switch circuit boards disengage from connectors J871 and J876 on the Sweep/Horiz Amp/Opt circuit board.

7. Continue lifting up on the Timing Switch assembly while guiding it to the rear of the instrument until the assembly is clear.

#### NOTE

*As this point resistors, capacitors, diodes and transistors may be replaced on the Timing Switch circuit boards without further disassembly. After replacing circuit-board components, proceed to step 50 for reinstallation instructions.*

8. If mechanical or electrical components of the Timing Switch assembly are to be replaced, proceed to step 9. If the entire assembly is to be replaced, proceed to step 50.

9. Disconnect P774 from the A Timing Switch circuit board, A17.

#### NOTE

*In steps 10 through 48, the capital letters enclosed within parentheses refer to the like-lettered components in Figure 6-4.*

*Before each component is removed, note its position and/or orientation for reinstallation reference. To facilitate reassembly, it is recommended that all parts be laid out in the order in which they are removed.*

*Steps 10 through 14 are necessary only if the potentiometer (A) requires replacement.*

10. Remove the mounting screw from the potentiometer (A).

11. Rotate the extension shaft (V) counterclockwise until the set screws in the coupling (C) line up with the slot in the clear plastic mounting bracket.

12. Use a 0.050-inch Allen wrench to loosen the rear-most set screw in the coupling (C).

13. Unscrew the potentiometer from its mounting bracket (B).

14. If only the potentiometer is being replaced, proceed to step 45.



*The knurled rotary shaft (U) is spring loaded and must be held in place while performing steps 15 through 21 to prevent possible damage to the electrical contacts. Two of the ways that this can be accomplished are: (1) placing the shaft in a vise, or (2) temporarily reinstalling the VAR knob and gripping it to hold the shaft in place.*

15. Remove three Phillips-head screws (D) retaining the mounting bracket (B).

16. Pull the coupling (C), with extension shaft (V) attached, out through the rear of the assembly.

17. Remove the rear bearing (E).



*Contact holders are mechanically, but not electrically, interchangeable.*

*Do not touch switch contacts and their corresponding circuit-board runs with your hands. This will avoid contamination, preserve high-frequency characteristics, and avoid possible damage.*

18. Remove the rear contact holder (F).

19. Remove the B Timing Switch circuit board (G).



## Maintenance—2336 Service

20. Remove the detent (I) along with the front contact holder (H). Separate them both from the B Timing Switch circuit board and from each other.

21. Gradually release the knurled rotary shaft (U) from the tension of the helical spring (K). Remove the VAR knob (if it was reinstalled for holding), then remove the shaft through the rear of the assembly.

22. Remove three Phillips-head screws (T) while holding both the front bearing (S) and the center bearing housing (J) between your thumb and forefinger.

23. Remove the center bearing housing (J).

### NOTE

*Steps 24 through 26 should be performed only if the rotor, stop, and/or retaining spring parts are worn and require replacement. Otherwise proceed to step 27.*

24. Remove rotor (N), stop (M), and retaining spring (L) together.

25. Carefully remove the retaining spring (stretch it as little as possible) from the rotor.

26. Remove the stop (M) from the rotor.

27. Remove the front bearing housing (S).

28. Remove the rear contact holder (O).

29. Remove the rotary shaft with detent (R) and the front contact holder (Q).

30. Separate the front contact holder from the rotary shaft.

### NOTE

*During reassembly, if any cleaning has been done or if the switch assembly was previously difficult to rotate, lubricate the points indicated by a triangle symbol on Figure 6-4 with a very small amount of Versilube (or equivalent) silicone grease. All places indicated may not require lubrication. A general guide is to lubricate only the mechanical parts that rub together. See "Switch Contacts" in the "Preventive Maintenance" part of this section.*

To reassemble the Timing Switch assembly (refer to Figure 6-4):

31. Install the front contact holder (Q) on the rotary shaft (R).

32. Reinstall the rotary shaft (R), with contact holder (Q), facing the component side of the A Timing Switch circuit board (P).

33. Reinstall the front bearing housing (S).

34. Reinstall the stop (M) and retaining spring (L) on the rotor (N).

35. Reinstall the rotor assembly.

36. Reinstall the center bearing housing (J) and front bearing (S); hold them in place with your thumb and forefinger.

37. Reinstall the three screws (T) removed in step 22.



*The knurled rotary shaft (U) is spring loaded. To prevent possible damage to the electrical contacts, it must be held in place while performing steps 38 through 44 (see CAUTION preceding step 15).*

38. Reinstall the knurled rotary shaft (U), with helical spring (K), through the rear of the assembly.

39. Reinsert detent (I) into front contact holder (H) and insert them both into the center bearing housing (J).

40. Reinstall the B Timing Switch circuit board, A16.

41. Reinstall the rear contact holder (F).

42. Reinstall the rear bearing (E).

43. Reinstall the extension shaft (V), with coupling (C), through the rear of the assembly.

44. Reinstall bracket (B) using the three Phillips-head screws (D).

45. If applicable, screw the replacement potentiometer (A) into the rear of the mounting bracket (B) while inserting its shaft into the coupling (C).

46. Rotate the extension shaft (V) to align the rear-most set screw on coupling (C) with the slot in the clear plastic bracket (B).

47. Tighten the set screw using a 0.050-inch Allen wrench.

48. Rotate the Potentiometer (A) clockwise to its proper orientation and reinstall its mounting screw.

49. Reconnect P774 to the A Timing Switch circuit board, A17.

50. Position the Timing Switch assembly into the instrument by first inserting the control shaft (with housing) through the front panel.

51. Align the edge-connector pins of the A and B Timing Switch circuit boards with connectors J871 and J876 on the Sweep/Horiz Amp/Opt circuit board and press them firmly into place.

52. Reinstall the control-shaft housing for the A and B SEC/DIV switches at the position noted in step 5 and tighten the retaining nut with a 7/16-inch open-end wrench.

53. Reinstall the control knobs for the A and B SEC/DIV switches in the positions noted in step 4 and tighten the set screws with a 1/16-inch Allen wrench.

54. Reinstall the VAR control knob in the position noted in step 3 and tighten its set screw with a 0.050-inch Allen wrench.

55. Reinstall the Vert Preamp/L.V. Power Supply circuit board using the procedure previously described.

## Attenuators

Replacing a complete Attenuator assembly with a new or rebuilt unit is the recommended procedure. However, should it become necessary to disassemble and repair an Attenuator, replacement parts (as well as complete replacement units) can be ordered from your local Tektronix Field Office or representative.

The following procedure not only describes removal and installation of an Attenuator as a complete unit, but also explains how to disassemble and reassemble the unit to facilitate repair and cleaning. Both Figure 6-5 and the exploded view drawing in the "Replaceable Mechanical Parts" list (Section 10) are useful when performing attenuator disassembly and reassembly.

It is recommended that this procedure be read completely before starting any disassembly.

1. Remove the Vert Preamp/L.V. Power Supply circuit board using the procedure previously described in this part of the manual.

2. Disconnect the following connectors from the Vert Preamp/L.V. Power Supply circuit board:

- a. J700 (from the rear of the Channel 1 Attenuator).
- b. J705 (from the rear of the Channel 2 Attenuator).

3. Unsolder the wire connecting the two potentiometers at the rear of the attenuators and unsolder the wire from the Channel 2 potentiometer which leads to J712 on the Vert Preamp/L.V. Power Supply circuit board. Note wire color and location for reinstallation reference.



*If the Channel 1 Attenuator is to be replaced or repaired, the Channel 2 Attenuator must first be removed. Attempting to unsolder the resistor-capacitor network from the Channel 1 Attenuator without first removing the Channel 2 Attenuator can result in heat damage to both attenuators.*

## NOTE

*In the remainder of this procedure, the capital letters enclosed within parentheses refer to the like-lettered components in Figure 6-5.*

4. Unsolder the resistor-capacitor network (adjacent to the Channel 2 Attenuator) from the shielded hybrid circuit board (E) in the Channel 2 Attenuator assembly.

5. On the component side of the circuit board, use a 3/16-inch nutdriver to remove the two hexagonal standoffs retaining the Channel 2 Attenuator.

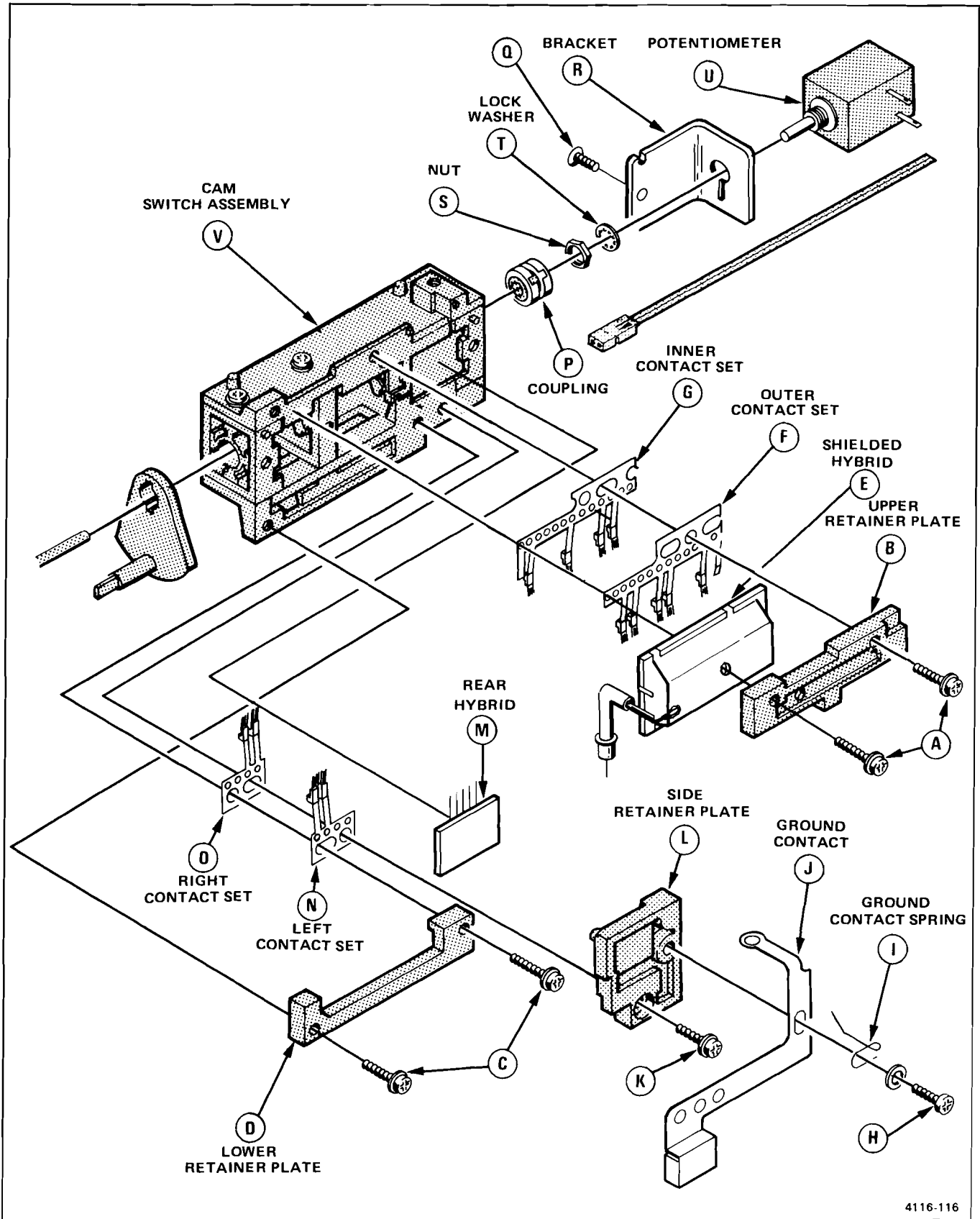

4116-116

Figure 6-5. Vertical attenuator exploded view.

6. Gently pull the Channel 2 Attenuator straight away from the circuit board to avoid damaging the rear hybrid circuit module (M) that plugs into the circuit board.

7. Repeat steps 4 through 6 for the Channel 1 Attenuator, if it is to be removed.

8. If a replacement Attenuator assembly is to be installed as a complete unit, proceed to step 45.

#### NOTE

*Steps 9 through 44 describe how to disassemble and reassemble an attenuator to accomplish replacement of one or more of the following parts: shielded hybrid (E) and its associated contact sets, rear hybrid (M) and its associated contact sets, and the potentiometer (U).*

*Before any component is removed during disassembly, carefully note its position and/or orientation for reinstallation reference. To facilitate reassembly, it is recommended that all parts be laid out in the order in which they are removed.*

9. If the shielded hybrid (E) or its associated contact sets require replacement, proceed to step 10. To replace the rear hybrid (M) or its associated contact sets, go to step 16. To replace the potentiometer (U), go to step 21.

10. Remove the two screws (A) and the upper retainer plate (B).

11. Remove the two screws (C) and the lower retainer plate (D).



*Prior to performing the next step, note the exact location and orientation of the shielded hybrid (E) to prevent damage during reinstallation.*

12. Unsolder the shielded hybrid (two places) from the ground contact (J) and remove the shielded hybrid.

13. Remove the outer contact set (F); it has five contacts and a ground tab.

14. Remove the inner contact set (G); it has four contacts and a ground tab.

15. If no other components are to be replaced, proceed to step 39 for reinstallation instructions.

#### NOTE

*To ensure proper grounding after reinstallation, note the positioning of the ground contact spring against the shaft before removing it in the next step.*

16. Remove the screw (H) and ground contact spring (I). Unsolder the ground contact (J) in two places and remove it (if not previously unsoldered in step 12).

17. Remove the side retaining plate (L).

18. Remove the rear hybrid (M). Note its exact location and orientation to prevent damage during reinstallation.

19. Remove both the left contact set (N) and the right contact set (O).

20. If no other components are to be replaced, proceed to step 32 for reinstallation instructions.

21. Use a 0.050-inch Allen wrench and loosen, but do not remove, the two set screws on the coupling (P) which are nearest to the potentiometer (U).

22. Remove the screw (Q) and remove the bracket (R), with the potentiometer attached, from the Attenuator cam-switch assembly.

23. Use a 5/16-inch open-end wrench to remove the nut (S) and the lockwasher (T) retaining the potentiometer.

24. Remove the potentiometer (U) from the bracket.

25. Unsolder the wires connected to the potentiometer, noting their color and location for reinstallation reference.

26. To install a replacement potentiometer, resolder the wires (removed in step 25) at the locations noted.

27. Insert the potentiometer into the bracket (R) and orient it as noted in step 24.

28. Reinstall the nut and lockwasher (removed in step 23).

## Maintenance—2336 Service

29. Mount the bracket (R) to the cam-switch assembly with the screw (Q) removed in step 22. Use a torque screwdriver to tighten it to 3 inch-pounds.

30. Use a 0.050-inch Allen wrench to tighten the two set screws (loosened in step 21) on the coupling (P).

31. If no other parts require reassembly, proceed to step 45.

32. To reinstall the rear hybrid (M) and its associated contact sets, first insert the left contact set (N) into the cam-switch assembly. Then insert the right contact set (O). Position them both as noted in step 19.

33. Place the rear hybrid (M) in the exact location and orientation noted in step 18.

34. Place the side retaining plate (L) over the hybrid.

35. Place the ground contact (J) over the side retaining plate. Insert the ground contact spring (I) through the hole in the ground contact so that the end of the spring is against the same side of the shaft.

36. Reinstall the screw (H) removed in step 16; use a torque screwdriver to tighten it to 3 inch-pounds.

37. Check contact pressure and alignment (refer to Figure 6-2 and Figure 6-3).

38. If no other components are to be reinstalled, proceed to step 44.

39. To reinstall the shielded hybrid (E), insert the inner contact set (G) into the cam-switch assembly. Then insert the outer contact set (F). Position them as noted in steps 14 and 13.

40. Reinstall the shielded hybrid (E) at the exact location and orientation noted in step 12.

41. Reinstall the lower retaining plate (D) with the two screws (C) removed in step 11. Use a torque screwdriver to tighten the screws to 3 inch-pounds.

42. Reinstall the upper retaining plate (B) with the two screws (A) removed in step 10. Use a torque screwdriver to tighten the screws to 3 inch-pounds.

43. Check contact pressure and alignment (refer to Figure 6-2 and Figure 6-3).

44. Solder the ground contact (J) to the shielded hybrid (E) in two places.

45. Reinstall the Channel 1 Attenuator (if applicable) by carefully plugging the pins of the rear hybrid (M) into the Vert Preamp/L.V. Power Supply circuit board.

46. Use a 3/16-inch nutdriver to reinstall the two hexagonal standoffs securing the Channel 1 Attenuator (if removed in step 5).

47. Resolder the resistor-capacitor network lead (unsoldered in step 4) to the shielded hybrid (E) on the Channel 1 Attenuator (if applicable).

48. Repeat steps 45 through 47 for the Channel 2 Attenuator.

49. Resolder the wire connecting the two potentiometers and resolder the wire leading to J712 (unsoldered in step 3).

50. Reconnect the following connectors to the Vert Preamp/L.V. Power Supply circuit board (disconnected in step 2):

- a. J700 (from the Channel 1 Attenuator).
- b. J705 (from the Channel 2 Attenuator).

51. Reinstall the Vert Preamp/L.V. Power Supply circuit board.

## REPACKAGING FOR SHIPMENT

If the Tektronix instrument is to be shipped to a Tektronix Service Center for service or repair, attach a tag showing: owner (with address) and the name of an individual at your firm that can be contacted. Include complete instrument serial number and a description of the service required.

Save and reuse the package in which your instrument was shipped. If the original packaging is unfit for use or not available, repackage the instrument as follows:

Surround the instrument with polyethylene sheeting to protect the finish of the instrument. Obtain a carton of corrugated cardboard of the correct carton strength and having inside dimensions of no less than six inches more than the instrument dimensions. Cushion the instrument by tightly packing three inches of dunnage or urethane foam between carton and instrument, on all sides. Seal carton with shipping tape or industrial stapler.

The carton test strength for your instrument is 275 pounds.

## SELECTABLE COMPONENTS

### A10R50 A10R122

If U55 or U125 is replaced, the position pots may no longer have sufficient range (+ and -12 div), in which case R50 or R122 respectively will need to be removed by clipping the leads.

### A13R11

If the transient response is too large for the External Trigger View when in  $\div 10$  mode, R11 may be changed to a higher value. The nominal value is  $43 \Omega$  and selected values are:  $51 \Omega$ ,  $62 \Omega$ ,  $75 \Omega$ , or  $910 \Omega$  which are all 0.125W, 5% resistors.

# OPTIONS

## INTRODUCTION

There is presently only one option available for the 2336. A brief description of this option is given in the following paragraph. For further information about instrument options, see your Tektronix Catalog or contact your Tektronix Field Office or representative.

## OPTION 03

Option 03 (100-V/200-V Power Transformer) permits operation of the instrument from either a 100-V or a 200-V nominal ac-power-input source at a line frequency from 48 Hz to 440 Hz. This option does not affect the basic instrument operating and servicing information presented in this manual.

# REPLACEABLE ELECTRICAL PARTS

## PARTS ORDERING INFORMATION

Replacement parts are available from or through your local Tektronix, Inc. Field Office or representative.

Changes to Tektronix instruments are sometimes made to accommodate improved components as they become available, and to give you the benefit of the latest circuit improvements developed in our engineering department. It is therefore important, when ordering parts, to include the following information in your order: Part number, instrument type or number, serial number, and modification number if applicable.

If a part you have ordered has been replaced with a new or improved part, your local Tektronix, Inc. Field Office or representative will contact you concerning any change in part number.

Change information, if any, is located at the rear of this manual.

### LIST OF ASSEMBLIES

A list of assemblies can be found at the beginning of the Electrical Parts List. The assemblies are listed in numerical order. When the complete component number of a part is known, this list will identify the assembly in which the part is located.

### CROSS INDEX-MFR. CODE NUMBER TO MANUFACTURER

The Mfr. Code Number to Manufacturer index for the Electrical Parts List is located immediately after this page. The Cross Index provides codes, names and addresses of manufacturers of components listed in the Electrical Parts List.

### ABBREVIATIONS

Abbreviations conform to American National Standard Y1.1.

### COMPONENT NUMBER (column one of the Electrical Parts List)

A numbering method has been used to identify assemblies, subassemblies and parts. Examples of this numbering method and typical expansions are illustrated by the following:

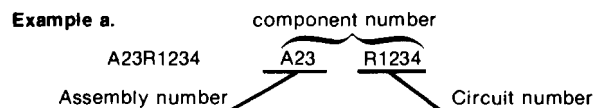

**Read: Resistor 1234 of Assembly 23**

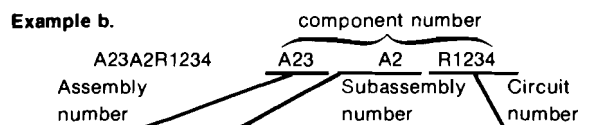

**Read: Resistor 1234 of Subassembly 2 of Assembly 23**

Only the circuit number will appear on the diagrams and circuit board illustrations. Each diagram and circuit board illustration is clearly marked with the assembly number. Assembly numbers are also marked on the mechanical exploded views located in the Mechanical Parts List. The component number is obtained by adding the assembly number prefix to the circuit number.

The Electrical Parts List is divided and arranged by assemblies in numerical sequence (e.g., assembly A1 with its subassemblies and parts, precedes assembly A2 with its subassemblies and parts).

Chassis-mounted parts have no assembly number prefix and are located at the end of the Electrical Parts List.

### TEKTRONIX PART NO. (column two of the Electrical Parts List)

Indicates part number to be used when ordering replacement part from Tektronix.

### SERIAL/MODEL NO. (columns three and four of the Electrical Parts List)

Column three (3) indicates the serial number at which the part was first used. Column four (4) indicates the serial number at which the part was removed. No serial number entered indicates part is good for all serial numbers.

### NAME & DESCRIPTION (column five of the Electrical Parts List)

In the Parts List, an Item Name is separated from the description by a colon (:). Because of space limitations, an Item Name may sometimes appear as incomplete. For further Item Name identification, the U.S. Federal Cataloging Handbook H6-1 can be utilized where possible.

### MFR. CODE (column six of the Electrical Parts List)

Indicates the code number of the actual manufacturer of the part. (Code to name and address cross reference can be found immediately after this page.)

### MFR. PART NUMBER (column seven of the Electrical Parts List)

Indicates actual manufacturers part number.



CROSS INDEX—MFR. CODE NUMBER TO MANUFACTURER

Mfr. Code	Manufacturer	Address	City, State, Zip
000AX	BUEHLER PRODUCTS INC.	PO BOX A,HIGHWAY 70 EAST	KINGSTON, NC 28501
000FJ	MARCOM SWITCHES INC.	67 ALBANY STREET	CAZENOVIA, N.Y. 13035
000HX	SAN-O INDUSTRIAL CORP.	170 WILBER PLACE	BOHEMIA, LONG ISLAND, NY. 117
01121	ALLEN-BRADLEY COMPANY	1201 2ND STREET SOUTH	MILWAUKEE, WI 53204
01295	TEXAS INSTRUMENTS, INC., SEMICONDUCTOR GROUP	P O BOX 5012, 13500 N CENTRAL EXPRESSWAY	DALLAS, TX 75222
02111	SPECTROL ELECTRONICS CORPORATION	17070 EAST GALE AVENUE	CITY OF INDUSTRY, CA 91745
02114	FERROXCUBE CORPORATION	PO BOX 359, MARION ROAD	SAUGERTIES, NY 12477
02735	RCA CORPORATION, SOLID STATE DIVISION	ROUTE 202	SOMERVILLE, NY 08876
03508	GENERAL ELECTRIC COMPANY, SEMI-CONDUCTOR PRODUCTS DEPARTMENT	ELECTRONICS PARK	SYRACUSE, NY 13201
04222	AVX CERAMICS, DIVISION OF AVX CORP.	P O BOX 867, 19TH AVE. SOUTH	MYRTLE BEACH, SC 29577
04713	MOTOROLA, INC., SEMICONDUCTOR PROD. DIV.	5005 E MCDOWELL RD,PO BOX 20923	PHOENIX, AZ 85036
05245	CORCOM INC.	2635 N KILDARE AVENUE	CHICAGO, IL 60639
07263	FAIRCHILD SEMICONDUCTOR, A DIV. OF FAIRCHILD CAMERA AND INSTRUMENT CORP.	464 ELLIS STREET	MOUNTAIN VIEW, CA 94042
07716	TRW ELECTRONIC COMPONENTS, IRC FIXED RESISTORS, BURLINGTON DIV.	2850 MT. PLEASANT	BURLINGTON, IA 52601
12697	CLAROSTAT MFG. CO., INC.	LOWER WASHINGTON STREET	DOVER, NH 03820
12969	UNITRODE CORPORATION	580 PLEASANT STREET	WATERTOWN, MA 02172
14193	CAL-R, INC.	1601 OLYMPIC BLVD.	SANTA MONICA, CA 90404
14433	ITT SEMICONDUCTORS	3301 ELECTRONICS WAY P O BOX 3049	WEST PALM BEACH, FL 33402
14552	MICRO SEMICONDUCTOR CORP.	2830 E FAIRVIEW ST.	SANTA ANA, CA 92704
14936	GENERAL INSTRUMENT CORP., SEMICONDUCTOR PRODUCTS GROUP	P.O. BOX 600,600 W. JOHN ST.	HICKSVILLE, NY 11802
15238	ITT SEMICONDUCTORS, A DIVISION OF INTER NATIONAL TELEPHONE AND TELEGRAPH CORP.	P.O. BOX 168, 500 BROADWAY	LAWRENCE, MA 01841
18324	SIGNETICS CORP.	811 E. ARQUES	SUNNYVALE, CA 94086
19396	ILLINOIS TOOL WORKS, INC. PAKTRON DIV.	900 FOLLIN LANE, SE	VIENNA, VA 22180
20932	EMCON DIV OF ILLINOIS TOOL WORKS INC.	11620 SORRENTO VALLEY RD P O BOX 81542	SAN DIEGO, CA 92121
22229	SOLITRON DEVICES, INC., SEMICONDUCTOR GROUP	8808 BALBOA AVENUE	SAN DIEGO OPERS, CA 92123
24546	CORNING GLASS WORKS, ELECTRONIC COMPONENTS DIVISION	550 HIGH STREET	BRADFORD, PA 16701
27014	NATIONAL SEMICONDUCTOR CORP.	2900 SEMICONDUCTOR DR.	SANTA CLARA, CA 95051
31918	IEE/SCHADOW INC.	8081 WALLACE ROAD	EDEN PRAIRIE, MN 55343
32293	INTERSIL, INC.	10900 N. TANTAU AVE.	CUPERTINO, CA 95014
32997	BOURNS, INC., TRIMPOT PRODUCTS DIV.	1200 COLUMBIA AVE.	RIVERSIDE, CA 92507
50157	MIDWEST COMPONENTS INC.	P. O. BOX 787	MUSKEGON, MI 49443
50434	HEWLETT-PACKARD COMPANY	1981 PORT CITY BLVD.	PALO ALTO, CA 94304
51642	CENTRE ENGINEERING INC.	640 PAGE MILL ROAD	STATE COLLEGE, PA 16801
52306	HIGH VOLTAGE DEVICES, INC.	2820 E COLLEGE AVENUE	VISALIA, CA 93277
52648	PLESSEY SEMICONDUCTORS	7485 AVENUE 304	IRVINE, CA 92714
54473	MATSUSHITA ELECTRIC, CORP. OF AMERICA	1641 KAISER	SECAUCUS, NJ 07094
55210	GETTIG ENG. AND MFG. COMPANY	1 PANASONIC WAY	SPRING MILLS, PA 16875
56289	SPRAGUE ELECTRIC CO.	PO BOX 85, OFF ROUTE 45	NORTH ADAMS, MA 01247
59660	TUSONIX INC.	87 MARSHALL ST.	TUCSON, AZ 85705
71400	BUSSMAN MFG., DIVISION OF MCGRAW-EDISON CO.	2155 N FORBES BLVD	
72619	DIALIGHT, DIV. AMPEREX ELECTRONIC	2536 W. UNIVERSITY ST.	ST. LOUIS, MO 63107
72982	ERIE TECHNOLOGICAL PRODUCTS, INC.	203 HARRISON PLACE	BROOKLYN, NY 11237
73138	BECKMAN INSTRUMENTS, INC., HELIPOT DIV.	644 W. 12TH ST.	ERIE, PA 16512
73899	JFD ELECTRONICS COMPONENTS CORP.	2500 HARBOR BLVD.	FULLERTON, CA 92634
74276	SIGNALITE DIV., GENERAL INSTRUMENT CORP.	PINETREE ROAD	OXFORD, NC 27565
74970	JOHNSON, E. F., CO.	1933 HECK AVE.	NEPTUNE, NJ 07753
75042	TRW ELECTRONIC COMPONENTS, IRC FIXED RESISTORS, PHILADELPHIA DIVISION	299 10TH AVE. S. W.	WASECA, MN 56093
75915	LITTELFUSE, INC.	401 N. BROAD ST.	PHILADELPHIA, PA 19108
76493	BELL INDUSTRIES, INC., MILLER, J. W., DIV.	800 E. NORTHWEST HWY	DES PLAINES, IL 60016
78488	STACKPOLE CARBON CO.	19070 REYES AVE., P O BOX 5825	COMPTON, CA 90224
80009	TEKTRONIX, INC.	P O BOX 500	ST. MARYS, PA 15857
82104	STANDARD GRIGSBY CO., DIV. OF SUN CHEMICAL CORPORATION		BEAVERTON, OR 97077
90201	MALLORY CAPACITOR CO., DIV. OF P. R. MALLORY AND CO., INC.	920 RATHBONE AVENUE	AURORA, IL 60507
91637	DALE ELECTRONICS, INC.	3029 E. WASHINGTON STREET	INDIANAPOLIS, IN 46206
95348	GORDOS CORPORATION	P. O. BOX 372	COLUMBUS, NE 68601
		P. O. BOX 609	BLOOMFIELD, NJ 07003
		250 GLENWOOD AVENUE	

Component No.	Tektronix Part No.	Serial/Model No. Eff Dscnt	Name & Description	Mfr Code	Mfr Part Number
A10	670-6526-00		CKT BOARD ASSY:VERT PREAMP/LV POWER	80009	670-6526-00
A11	670-6532-00		CKT BOARD ASSY:NEGATIVE RGLTR	80009	670-6532-00
A12	670-6533-00		CKT BOARD ASSY:POSITIVE RGLTR	80009	670-6533-00
A15	670-6529-00		CKT BOARD ASSY:VERT OUT/HV POWER	80009	670-6529-00
A16	670-6531-00		CKT BOARD ASSY:B TIMING SWITCH	80009	670-6531-00
A17	670-6530-00		CKT BOARD ASSY:A TIMING SWITCH	80009	670-6530-00
A19	119-1193-00		ATTENUATOR,VAR:5MV TO 5V,1 MEG OHM HYBRID	80009	119-1193-00
A23	670-6527-01		CKT BOARD ASSY:A & B TRIGGER	80009	670-6527-01
A24	670-6528-00		CKT BOARD ASSY:SWEEEP/HORIZ AMP	80009	670-6528-00
A30	670-6535-00		CKT BOARD ASSY:DELTA TIME LOGIC	80009	670-6535-00
A31	670-6590-00		CKT BOARD ASSY:B TRIGGER SWITCH	80009	670-6590-00
A10	-----		CKT BOARD ASSY:VERT PREAMP/LV POWER		
A10C1	281-0151-00		CAP.,VAR,CER DI:1-3PF,100V	72982	518-600A1-3
A10C3	281-0786-00		CAP.,FXD,CER DI:150PF,10%,100V	72982	8035D2AADX5P151K
A10C6	281-0862-00		CAP.,FXD,CER DI:0.001UF,+80-20%,100V	20932	401-ES-100-AD102
A10C7	281-0862-00		CAP.,FXD,CER DI:0.001UF,+80-20%,100V	20932	401-ES-100-AD102
A10C10	281-0862-00		CAP.,FXD,CER DI:0.001UF,+80-20%,100V	20932	401-ES-100-AD102
A10C11	281-0862-00		CAP.,FXD,CER DI:0.001UF,+80-20%,100V	20932	401-ES-100-AD102
A10C12	281-0862-00		CAP.,FXD,CER DI:0.001UF,+80-20%,100V	20932	401-ES-100-AD102
A10C14	290-0523-00		CAP.,FXD,ELCLTLT:2.2UF,20%,20V	56289	196D225X0020HA1
A10C15	283-0140-00		CAP.,FXD,CER DI:4.7PF,5%,50V	72982	8101E003A479C
A10C16	281-0786-00		CAP.,FXD,CER DI:150PF,10%,100V	72982	8035D2AADX5P151K
A10C20	283-0140-00		CAP.,FXD,CER DI:4.7PF,5%,50V	72982	8101E003A479C
A10C27	281-0815-00		CAP.,FXD,CER DI:0.027UF,20%,50V	72982	8005D9AABW5R273M
A10C30	283-0164-00		CAP.,FXD,CER DI:2.2UF,20%,25V	72982	8141N037Z5U0225M
A10C31	283-0339-00		CAP.,FXD,CER DI:0.22UF.10%,50V	72982	8131N075W5R224K
A10C33	281-0158-00		CAP.,VAR,CER DI:7-45PF,50V	73899	DVJ-5006
A10C52	281-0862-00		CAP.,FXD,CER DI:0.001UF,+80-20%,100V	20932	401-ES-100-AD102
A10C53	281-0862-00		CAP.,FXD,CER DI:0.001UF,+80-20%,100V	20932	401-ES-100-AD102
A10C54	281-0862-00		CAP.,FXD,CER DI:0.001UF,+80-20%,100V	20932	401-ES-100-AD102
A10C55	281-0862-00		CAP.,FXD,CER DI:0.001UF,+80-20%,100V	20932	401-ES-100-AD102
A10C56	281-0862-00		CAP.,FXD,CER DI:0.001UF,+80-20%,100V	20932	401-ES-100-AD102
A10C58	281-0151-00		CAP.,VAR,CER DI:1-3PF,100V	72982	518-600A1-3
A10C62	281-0151-00		CAP.,VAR,CER DI:1-3PF,100V	72982	518-600A1-3
A10C67	281-0786-00		CAP.,FXD,CER DI:150PF,10%,100V	72982	8035D2AADX5P151K
A10C75	281-0862-00		CAP.,FXD,CER DI:0.001UF,+80-20%,100V	20932	401-ES-100-AD102
A10C76	281-0786-00		CAP.,FXD,CER DI:150PF,10%,100V	72982	8035D2AADX5P151K
A10C77	283-0140-00		CAP.,FXD,CER DI:4.7PF,5%,50V	72982	8101E003A479C
A10C81	283-0140-00		CAP.,FXD,CER DI:4.7PF,5%,50V	72982	8101E003A479C
A10C88	281-0815-00		CAP.,FXD,CER DI:0.027UF,20%,50V	72982	8005D9AABW5R273M
A10C89	283-0164-00		CAP.,FXD,CER DI:2.2UF,20%,25V	72982	8141N037Z5U0225M
A10C92	283-0339-00		CAP.,FXD,CER DI:0.22UF.10%,50V	72982	8131N075W5R224K
A10C95	281-0158-00		CAP.,VAR,CER DI:7-45PF,50V	73899	DVJ-5006
A10C120	281-0862-00		CAP.,FXD,CER DI:0.001UF,+80-20%,100V	20932	401-ES-100-AD102
A10C121	281-0862-00		CAP.,FXD,CER DI:0.001UF,+80-20%,100V	20932	401-ES-100-AD102
A10C124	281-0862-00		CAP.,FXD,CER DI:0.001UF,+80-20%,100V	20932	401-ES-100-AD102
A10C125	281-0862-00		CAP.,FXD,CER DI:0.001UF,+80-20%,100V	20932	401-ES-100-AD102
A10C126	281-0862-00		CAP.,FXD,CER DI:0.001UF,+80-20%,100V	20932	401-ES-100-AD102
A10C133	281-0862-00		CAP.,FXD,CER DI:0.001UF,+80-20%,100V	20932	401-ES-100-AD102
A10C134	281-0862-00		CAP.,FXD,CER DI:0.001UF,+80-20%,100V	20932	401-ES-100-AD102
A10C135	281-0862-00		CAP.,FXD,CER DI:0.001UF,+80-20%,100V	20932	401-ES-100-AD102
A10C143	290-0524-00		CAP.,FXD,ELCLTLT:4.7UF,20%,10V	90201	TDC475M010EL
A10C145	290-0523-00		CAP.,FXD,ELCLTLT:2.2UF,20%,20V	56289	196D225X0020HA1
A10C147	281-0862-00		CAP.,FXD,CER DI:0.001UF,+80-20%,100V	20932	401-ES-100-AD102
A10C150	290-0524-00		CAP.,FXD,ELCLTLT:4.7UF,20%,10V	90201	TDC475M010EL
A10C160	281-0862-00		CAP.,FXD,CER DI:0.001UF,+80-20%,100V	20932	401-ES-100-AD102
A10C162	281-0615-00		CAP.,FXD,CER DI:3.9PF,+/-0.5PF,200V	59660	374001C0J0399D

**Replaceable Electrical Parts—2336 Service**

Component No.	Tektronix Part No.	Serial/Model No. Eff Dscont	Name & Description	Mfr Code	Mfr Part Number
A10C181	281-0862-00		CAP., FXD, CER DI:0.001UF,+80-20%,100V	20932	401-ES-100-AD102
A10C182	281-0862-00		CAP., FXD, CER DI:0.001UF,+80-20%,100V	20932	401-ES-100-AD102
A10C183	281-0862-00		CAP., FXD, CER DI:0.001UF,+80-20%,100V	20932	401-ES-100-AD102
A10C197	283-0051-00		CAP., FXD, CER DI:0.0033UF,5%,100V	72982	8131N145C0G0332J
A10C224	290-0524-00		CAP., FXD, ELCTLT:4.7UF,20%,10V	90201	TDC475M010EL
A10C225	290-0915-00		CAP., FXD, ELCTLT:440UF,+50-10%,100V	56289	39DX1281
A10C226	281-0773-00		CAP., FXD, CER DI:0.01UF,10%,100V	04222	GC70-1C103K
A10C231	281-0814-00		CAP., FXD, CER DI:100PF,10%,100V	04222	GC70-1-A101K
A10C232	290-0573-00		CAP., FXD, ELCTLT:2.7UF,20%,50V	56289	196D275X0050JA1
A10C237	281-0813-00		CAP., FXD CER DI:0.047UF,20%,50V	04222	GC705-E-473M
A10C238	281-0773-00		CAP., FXD, CER DI:0.01UF,10%,100V	04222	GC70-1C103K
A10C246	290-0768-00		CAP., FXD, ELCTLT:10UF,+50-10%,100V	54473	ECE-A100V10L
A10C248	281-0775-00		CAP., FXD, CER DI:0.1UF,20%,50V	72982	8005D9AABZ5U104M
A10C249	281-0775-00		CAP., FXD, CER DI:0.1UF,20%,50V	72982	8005D9AABZ5U104M
A10C250	290-0913-00		CAP., FXD, ELCTLT:3200UF,+75-10%,25V	56289	39DX1207
A10C251	290-0913-00		CAP., FXD, ELCTLT:3200UF,+75-10%,25V	56289	39DX1207
A10C252	290-0770-00		CAP., FXD, ELCTLT:100UF,+50-10%,25V	56289	502D230
A10C253	290-0770-00		CAP., FXD, ELCTLT:100UF,+50-10%,25V	56289	502D230
A10C257	281-0775-00		CAP., FXD, CER DI:0.1UF,20%,50V	72982	8005D9AABZ5U104M
A10C258	281-0775-00		CAP., FXD, CER DI:0.1UF,20%,50V	72982	8005D9AABZ5U104M
A10C259	290-0914-00		CAP., FXD, ELCTLT:6200UF,+75-10%,15V	56289	39DX1210
A10C260	290-0914-00		CAP., FXD, ELCTLT:6200UF,+75-10%,15V	56289	39DX1210
A10C264	290-0770-00		CAP., FXD, ELCTLT:100UF,+50-10%,25V	56289	502D230
A10C265	290-0770-00		CAP., FXD, ELCTLT:100UF,+50-10%,25V	56289	502D230
A10CR1	119-1429-00		COMPONENT ASSY:(2) DIODES	80009	119-1429-00
A10CR2	119-1429-00		COMPONENT ASSY:(2) DIODES	80009	119-1429-00
A10CR3	152-0141-02		SEMICONV DEVICE:SILICON,30V,150MA	01295	1N4152R
A10CR8	152-0141-02		SEMICONV DEVICE:SILICON,30V,150MA	01295	1N4152R
A10CR53	152-0141-02		SEMICONV DEVICE:SILICON,30V,150MA	01295	1N4152R
A10CR54	152-0141-02		SEMICONV DEVICE:SILICON,30V,150MA	01295	1N4152R
A10CR55	152-0141-02		SEMICONV DEVICE:SILICON,30V,150MA	01295	1N4152R
A10CR56	152-0141-02		SEMICONV DEVICE:SILICON,30V,150MA	01295	1N4152R
A10CR57	152-0141-02		SEMICONV DEVICE:SILICON,30V,150MA	01295	1N4152R
A10CR58	152-0141-02		SEMICONV DEVICE:SILICON,30V,150MA	01295	1N4152R
A10CR62	119-1429-00		COMPONENT ASSY:(2) DIODES	80009	119-1429-00
A10CR63	119-1429-00		COMPONENT ASSY:(2) DIODES	80009	119-1429-00
A10CR64	152-0141-02		SEMICONV DEVICE:SILICON,30V,150MA	01295	1N4152R
A10CR69	152-0141-02		SEMICONV DEVICE:SILICON,30V,150MA	01295	1N4152R
A10CR132	152-0141-02		SEMICONV DEVICE:SILICON,30V,150MA	01295	1N4152R
A10CR134	152-0141-02		SEMICONV DEVICE:SILICON,30V,150MA	01295	1N4152R
A10CR138	152-0141-02		SEMICONV DEVICE:SILICON,30V,150MA	01295	1N4152R
A10CR139	152-0141-02		SEMICONV DEVICE:SILICON,30V,150MA	01295	1N4152R
A10CR140	152-0141-02		SEMICONV DEVICE:SILICON,30V,150MA	01295	1N4152R
A10CR142	152-0141-02		SEMICONV DEVICE:SILICON,30V,150MA	01295	1N4152R
A10CR146	152-0141-02		SEMICONV DEVICE:SILICON,30V,150MA	01295	1N4152R
A10CR149	152-0141-02		SEMICONV DEVICE:SILICON,30V,150MA	01295	1N4152R
A10CR180	152-0141-02		SEMICONV DEVICE:SILICON,30V,150MA	01295	1N4152R
A10CR201	152-0141-02		SEMICONV DEVICE:SILICON,30V,150MA	01295	1N4152R
A10CR209	152-0141-02		SEMICONV DEVICE:SILICON,30V,150MA	01295	1N4152R
A10CR225	152-0488-00		SEMICONV DEVICE:SILICON,200V,1500MA	04713	3N55 FAMILY
A10CR237	152-0141-02		SEMICONV DEVICE:SILICON,30V,150MA	01295	1N4152R
A10CR239	152-0141-02		SEMICONV DEVICE:SILICON,30V,150MA	01295	1N4152R
A10CR250	152-0462-00		SEMICONV DEVICE:RECT,SI,200V,2.5A	04713	SDA10228
A10CR259	152-0462-00		SEMICONV DEVICE:RECT,SI,200V,2.5A	04713	SDA10228
A10E6	276-0532-00		SHIELDING BEAD,:	02114	56-590-65/4A6
A10E7	276-0532-00		SHIELDING BEAD,:	02114	56-590-65/4A6
A10E11	276-0532-00		SHIELDING BEAD,:	02114	56-590-65/4A6

Component No.	Tektronix Part No.	Serial/Model No. Eff Dscont	Name & Description	Mfr Code	Mfr Part Number
A10E12	276-0532-00		SHIELDING BEAD, :	02114	56-590-65/4A6
A10F225	159-0185-00		FUSE, CARTRIDGE:5.2 X 20MM,0.75A,125V	000HX	TSC.75
A10F250	159-0184-00		FUSE, CARTRIDGE:5 X 20MM,1.25A,125V	000HX	TSC 1.25
A10F251	159-0184-00		FUSE, CARTRIDGE:5 X 20MM,1.25A,125V	000HX	TSC 1.25
A10F257	159-0186-00		FUSE, CARTRIDGE:5.2 X 20MM,1.5A,125V	000HX	TSC 1.5
A10F259	159-0186-00		FUSE, CARTRIDGE:5.2 X 20MM,1.5A,125V	000HX	TSC 1.5
A10L6	119-1486-00		COMPONENT ASSY:SHIELDING BEAD/BARE WIRE	80009	119-1486-00
A10L7	119-1486-00		COMPONENT ASSY:SHIELDING BEAD/BARE WIRE	80009	119-1486-00
A10L11	119-1486-00		COMPONENT ASSY:SHIELDING BEAD/BARE WIRE	80009	119-1486-00
A10L12	119-1486-00		COMPONENT ASSY:SHIELDING BEAD/BARE WIRE	80009	119-1486-00
A10Q4	151-1090-04		TRANSISTOR:MONOLITHIC, DUAL, FIELD, EFFECT	32293	OBD
A10Q10	151-0725-00		TRANSISTOR:SILICON, NPN, DUAL	52648	SL360C
A10Q36	151-0712-00		TRANSISTOR:SILICON, NPN	04713	SPS8223
A10Q49	151-1124-00		TRANSISTOR:JFE, N-CHAN, SI, SEL	22229	F2942
A10Q55	151-0712-00		TRANSISTOR:SILICON, NPN	04713	SPS8223
A10Q57	151-0712-00		TRANSISTOR:SILICON, NPN	04713	SPS8223
A10Q68	151-1090-04		TRANSISTOR:MONOLITHIC, DUAL, FIELD, EFFECT	32293	OBD
A10Q74	151-0725-00		TRANSISTOR:SILICON, NPN, DUAL	52648	SL360C
A10Q106	151-0712-00		TRANSISTOR:SILICON, NPN	04713	SPS8223
A10Q119	151-1124-00		TRANSISTOR:JFE, N-CHAN, SI, SEL	22229	F2942
A10Q132	151-0712-00		TRANSISTOR:SILICON, NPN	04713	SPS8223
A10Q133	151-0712-00		TRANSISTOR:SILICON, NPN	04713	SPS8223
A10Q134	151-0712-00		TRANSISTOR:SILICON, NPN	04713	SPS8223
A10Q135	151-0712-00		TRANSISTOR:SILICON, NPN	04713	SPS8223
A10Q141	151-0711-00		TRANSISTOR:SILICON, NPN	04713	SPS8224
A10Q142	151-0190-05		TRANSISTOR:SILICON, NPN	80009	151-0190-05
A10Q147	151-0711-00		TRANSISTOR:SILICON, NPN	04713	SPS8224
A10Q149	151-0190-05		TRANSISTOR:SILICON, NPN	80009	151-0190-05
A10Q153	151-0369-00		TRANSISTOR:SILICON, PNP	01295	SKA6664
A10Q163	151-0472-00		TRANSISTOR:SILICON, NPN	80009	151-0472-00
A10Q170	151-0369-00		TRANSISTOR:SILICON, PNP	01295	SKA6664
A10Q175	151-0472-00		TRANSISTOR:SILICON, NPN	80009	151-0472-00
A10Q182	151-0711-00		TRANSISTOR:SILICON, NPN	04713	SPS8224
A10Q194	151-0190-05		TRANSISTOR:SILICON, NPN	80009	151-0190-05
A10Q209	151-0199-02		TRANSISTOR:SILICON, PNP, PRESTRESSED	80009	151-0199-02
A10Q218	151-0190-05		TRANSISTOR:SILICON, NPN	80009	151-0190-05
A10Q239	151-0347-01		TRANSISTOR:SILICON, NPN, PRESTRESSED	80009	151-0347-01
A10Q244	151-0347-01		TRANSISTOR:SILICON, NPN, PRESTRESSED	80009	151-0347-01
A10Q246	151-0476-00		TRANSISTOR:SILICON, NPN	02735	68430
A10Q252	151-0323-00		TRANSISTOR:SILICON, NPN, SEL FROM MJE521	04713	SJE916
A10Q253	151-0323-00		TRANSISTOR:SILICON, NPN, SEL FROM MJE521	04713	SJE916
A10Q264	151-0324-00		TRANSISTOR:SILICON, PNP	04713	SJE915
A10Q265	151-0324-00		TRANSISTOR:SILICON, PNP	04713	SJE915
A10R1	315-0471-00		RES., FXD, CMPSN:470 OHM, 5%, 0.25W	01121	CB4715
A10R2	315-0103-00		RES., FXD, CMPSN:10K OHM, 5%, 0.25W	01121	CB1035
A10R3	315-0101-00		RES., FXD, CMPSN:100 OHM, 5%, 0.25W	01121	CB1015
A10R4	315-0160-00		RES., FXD, CMPSN:16 OHM, 5%, 0.25W	01121	CB1605
A10R7	307-0109-00		RES., FXD, CMPSN:8.2 OHM, 5%, 0.25W	01121	CB82G5
A10R8	317-0201-00		RES., FXD, CMPSN:200 OHM, 5%, 0.125W	01121	BB2015
A10R9	317-0240-00		RES., FXD, CMPSN:24 OHM, 5%, 0.125W	01121	BB2405
A10R10	311-2098-00		RES., VAR, NONWIR:TRMR, 100 OHM, 10%, 0.5W	73138	72-265-0
A10R11	315-0152-00		RES., FXD, CMPSN:1.5K OHM, 5%, 0.25W	01121	CB1525
A10R13	315-0160-00		RES., FXD, CMPSN:16 OHM, 5%, 0.25W	01121	CB1605
A10R14	315-0100-00		RES., FXD, CMPSN:10 OHM, 5%, 0.25W	01121	CB1005
A10R15	315-0132-00		RES., FXD, CMPSN:1.3K OHM, 5%, 0.25W	01121	CB1325
A10R16	315-0361-00		RES., FXD, CMPSN:360 OHM, 5%, 0.25W	01121	CB3615
A10R21	321-0173-00		RES., FXD, FILM:619 OHM, 1%, 0.125W	91637	MFF1816G619ROF

Replaceable Electrical Parts—2336 Service

Component No.	Tektronix Part No.	Serial/Model No. Eff Dscont	Name & Description	Mfr Code	Mfr Part Number
A10R22	311-0643-00		RES.,VAR, NONWIR:50 OHM,10%,0.50W	73138	82-33-2
A10R23	321-0099-00		RES.,FXD,FILM:105 OHM,1%,0.125W	91637	MFF1816G105ROF
A10R24	321-0099-00		RES.,FXD,FILM:105 OHM,1%,0.125W	91637	MFF1816G105ROF
A10R27	315-0431-00		RES.,FXD,CMPSN:430 OHM,5%,0.25W	01121	CB4315
A10R28	321-0099-00		RES.,FXD,FILM:105 OHM,1%,0.125W	91637	MFF1816G105ROF
A10R29	321-0099-00		RES.,FXD,FILM:105 OHM,1%,0.125W	91637	MFF1816G105ROF
A10R30	315-0561-00		RES.,FXD,CMPSN:560 OHM,5%,0.25W	01121	CB5615
A10R31	311-0609-00		RES.,VAR, NONWIR:2K OHM,10%,0.50W	73138	82-26-1
A10R33	311-0643-00		RES.,VAR, NONWIR:50 OHM,10%,0.50W	73138	82-33-2
A10R34	321-0050-00		RES.,FXD,FILM:32.4 OHM,1%,0.125W	91637	MFF1816G32R40F
A10R36	315-0130-00		RES.,FXD,CMPSN:13 OHM,5%,0.25W	01121	CB1305
A10R37	315-0103-00		RES.,FXD,CMPSN:10K OHM,5%,0.25W	01121	CB1035
A10R42	315-0332-00		RES.,FXD,CMPSN:3.3K OHM,5%,0.25W	01121	CB3325
A10R43	315-0332-00		RES.,FXD,CMPSN:3.3K OHM,5%,0.25W	01121	CB3325
A10R46	317-0272-00		RES.,FXD,CMPSN:2.7K OHM,5%,0.125W	01121	BB2725
A10R47	311-0978-00		RES.,VAR, NONWIR:250 OHM,10%,0.50W	73138	82-4-2
A10R48	317-0301-00		RES.,FXD,CMPSN:300 OHM,5%,0.125W	01121	BB3015
A10R49	315-0104-00		RES.,FXD,CMPSN:100K OHM,5%,0.25W	01121	CB1045
A10R50	315-0152-00		RES.,FXD,CMPSN:1.5K OHM,5%,0.25W	01121	CB1525
A10R53	315-0822-00		RES.,FXD,CMPSN:8.2K OHM,5%,0.25W	01121	CB8225
A10R54	315-0750-00		RES.,FXD,CMPSN:75 OHM,5%,0.25W	01121	CB7505
A10R56	321-0266-00		RES.,FXD,FILM:5.76K OHM,1%,0.125W	91637	MFF1816G57600F
A10R57	315-0390-00		RES.,FXD,CMPSN:39 OHM,5%,0.25W	01121	CB3905
A10R58	317-0221-00	B010100 B010419	RES.,FXD,CMPSN:220 OHM,5%,0.125W	01121	BB2215
A10R58	317-0301-00	B010420	RES.,FXD,CMPSN:300 OHM,5%,0.125W	01121	BB3015
A10R60	321-0251-00		RES.,FXD,FILM:4.02K OHM,1%,0.125W	91637	MFF1816G40200F
A10R61	315-0470-00		RES.,FXD,CMPSN:47 OHM,5%,0.25W	01121	CB4705
A10R62	315-0471-00		RES.,FXD,CMPSN:470 OHM,5%,0.25W	01121	CB4715
A10R63	315-0103-00		RES.,FXD,CMPSN:10K OHM,5%,0.25W	01121	CB1035
A10R67	315-0101-00		RES.,FXD,CMPSN:100 OHM,5%,0.25W	01121	CB1015
A10R68	317-0160-00		RES.,FXD,CMPSN:16 OHM,5%,0.125W	01121	BB1605
A10R69	317-0201-00		RES.,FXD,CMPSN:200 OHM,5%,0.125W	01121	BB2015
A10R70	317-0240-00		RES.,FXD,CMPSN:24 OHM,5%,0.125W	01121	BB2405
A10R72	307-0109-00		RES.,FXD,CMPSN:8.2 OHM,5%,0.25W	01121	CB82G5
A10R73	315-0152-00		RES.,FXD,CMPSN:1.5K OHM,5%,0.25W	01121	CB1525
A10R74	311-2098-00		RES.,VAR, NONWIR:TRMR,100 OHM,10%,0.5W	73138	72-265-0
A10R75	315-0100-00		RES.,FXD,CMPSN:10 OHM,5%,0.25W	01121	CB1005
A10R76	315-0361-00		RES.,FXD,CMPSN:360 OHM,5%,0.25W	01121	CB3615
A10R77	315-0132-00		RES.,FXD,CMPSN:1.3K OHM,5%,0.25W	01121	CB1325
A10R78	315-0160-00		RES.,FXD,CMPSN:16 OHM,5%,0.25W	01121	CB1605
A10R82	321-0173-00		RES.,FXD,FILM:619 OHM,1%,0.125W	91637	MFF1816G619ROF
A10R83	311-0643-00		RES.,VAR, NONWIR:50 OHM,10%,0.50W	73138	82-33-2
A10R84	321-0099-00		RES.,FXD,FILM:105 OHM,1%,0.125W	91637	MFF1816G105ROF
A10R85	321-0099-00		RES.,FXD,FILM:105 OHM,1%,0.125W	91637	MFF1816G105ROF
A10R88	315-0431-00		RES.,FXD,CMPSN:430 OHM,5%,0.25W	01121	CB4315
A10R89	315-0561-00		RES.,FXD,CMPSN:560 OHM,5%,0.25W	01121	CB5615
A10R90	321-0099-00		RES.,FXD,FILM:105 OHM,1%,0.125W	91637	MFF1816G105ROF
A10R91	321-0099-00		RES.,FXD,FILM:105 OHM,1%,0.125W	91637	MFF1816G105ROF
A10R92	311-0609-00		RES.,VAR, NONWIR:2K OHM,10%,0.50W	73138	82-26-1
A10R95	311-0643-00		RES.,VAR, NONWIR:50 OHM,10%,0.50W	73138	82-33-2
A10R96	321-0050-00		RES.,FXD,FILM:32.4 OHM,1%,0.125W	91637	MFF1816G32R40F
A10R106	315-0130-00		RES.,FXD,CMPSN:13 OHM,5%,0.25W	01121	CB1305
A10R107	315-0103-00		RES.,FXD,CMPSN:10K OHM,5%,0.25W	01121	CB1035
A10R112	315-0332-00		RES.,FXD,CMPSN:3.3K OHM,5%,0.25W	01121	CB3325
A10R113	315-0332-00		RES.,FXD,CMPSN:3.3K OHM,5%,0.25W	01121	CB3325
A10R114	311-0978-00		RES.,VAR, NONWIR:250 OHM,10%,0.50W	73138	82-4-2
A10R115	317-0272-00		RES.,FXD,CMPSN:2.7K OHM,5%,0.125W	01121	BB2725

Component No.	Tektronix Part No.	Serial/Model No. Eff Dscont	Name & Description	Mfr Code	Mfr Part Number
A1OR118	317-0301-00		RES.,FXD,CMPSN:300 OHM,5%,0.125W	01121	BB3015
A1OR119	315-0104-00		RES.,FXD,CMPSN:100K OHM,5%,0.25W	01121	CB1045
A1OR120	315-0822-00		RES.,FXD,CMPSN:8.2K OHM,5%,0.25W	01121	CB8225
A1OR121	315-0750-00		RES.,FXD,CMPSN:75 OHM,5%,0.25W	01121	CB7505
A1OR122	315-0152-00		RES.,FXD,CMPSN:1.5K OHM,5%,0.25W	01121	CB1525
A1OR126	315-0390-00		RES.,FXD,CMPSN:39 OHM,5%,0.25W	01121	CB3905
A1OR127	321-0242-00		RES.,FXD,FILM:3.24K OHM,1%,0.125W	91637	MFF1816G32400F
A1OR128	321-0231-00		RES.,FXD,FILM:2.49K OHM,1%,0.125W	91637	MFF1816G24900F
A1OR132	321-0242-00		RES.,FXD,FILM:3.24K OHM,1%,0.125W	91637	MFF1816G32400F
A1OR133	315-0390-00		RES.,FXD,CMPSN:39 OHM,5%,0.25W	01121	CB3905
A1OR134	321-0251-00		RES.,FXD,FILM:4.02K OHM,1%,0.125W	91637	MFF1816G40200F
A1OR135	321-0251-00		RES.,FXD,FILM:4.02K OHM,1%,0.125W	91637	MFF1816G40200F
A1OR139	315-0470-00		RES.,FXD,CMPSN:47 OHM,5%,0.25W	01121	CB4705
A1OR140	321-0136-00		RES.,FXD,FILM:255 OHM,1%,0.125W	91637	MFF1816G255R0F
A1OR141	321-0230-00		RES.,FXD,FILM:2.43K OHM,1%,0.125W	91637	MFF1816G24300F
A1OR142	315-0751-00		RES.,FXD,CMPSN:750 OHM,5%,0.25W	01121	CB7515
A1OR145	317-0560-00		RES.,FXD,CMPSN:560 OHM,5%,0.125W	01121	BB5605
A1OR146	321-0136-00		RES.,FXD,FILM:255 OHM,1%,0.125W	91637	MFF1816G255R0F
A1OR147	321-0230-00		RES.,FXD,FILM:2.43K OHM,1%,0.125W	91637	MFF1816G24300F
A1OR148	321-0174-00		RES.,FXD,FILM:634 OHM,1%,0.125W	91637	MFF1816G634R0F
A1OR149	315-0751-00		RES.,FXD,CMPSN:750 OHM,5%,0.25W	01121	CB7515
A1OR153	321-0143-00		RES.,FXD,FILM:301 OHM,1%,0.125W	91637	MFF1816G301R0F
A1OR154	321-0168-00		RES.,FXD,FILM:549 OHM,1%,0.125W	91637	MFF1816G549R0F
A1OR155	321-0107-00		RES.,FXD,FILM:127 OHM,1%,0.125W	91637	MFF1816G127R0F
A1OR156	321-0231-00		RES.,FXD,FILM:2.49K OHM,1%,0.125W	91637	MFF1816G24900F
A1OR160	315-0103-00		RES.,FXD,CMPSN:10K OHM,5%,0.25W	01121	CB1035
A1OR161	321-0102-00		RES.,FXD,FILM:113 OHM,1%,0.125W	91637	MFF1816G113R0F
A1OR162	317-0431-00		RES.,FXD,CMPSN:430 OHM,5%,0.125W	01121	BB4315
A1OR163	321-0087-00		RES.,FXD,FILM:78.7 OHM,1%,0.125W	91637	MFF1816G78R70F
A1OR167	321-0115-00		RES.,FXD,FILM:154 OHM,1%,0.125W	91637	CMF55116G154R0F
A1OR168	315-0203-00		RES.,FXD,CMPSN:20K OHM,5%,0.25W	01121	CB2035
A1OR169	321-0174-00		RES.,FXD,FILM:634 OHM,1%,0.125W	91637	MFF1816G634R0F
A1OR170	321-0143-00		RES.,FXD,FILM:301 OHM,1%,0.125W	91637	MFF1816G301R0F
A1OR173	321-0168-00		RES.,FXD,FILM:549 OHM,1%,0.125W	91637	MFF1816G549R0F
A1OR174	321-0107-00		RES.,FXD,FILM:127 OHM,1%,0.125W	91637	MFF1816G127R0F
A1OR175	321-0087-00		RES.,FXD,FILM:78.7 OHM,1%,0.125W	91637	MFF1816G78R70F
A1OR176	315-0203-00		RES.,FXD,CMPSN:20K OHM,5%,0.25W	01121	CB2035
A1OR180	315-0510-00		RES.,FXD,CMPSN:51 OHM,5%,0.25W	01121	CB5105
A1OR181	321-0224-00		RES.,FXD,FILM:2.1K OHM,1%,0.125W	91637	MFF1816G21000F
A1OR182	315-0271-00		RES.,FXD,CMPSN:270 OHM,5%,0.25W	01121	CB2715
A1OR183	315-0132-00		RES.,FXD,CMPSN:1.3K OHM,5%,0.25W	01121	CB1325
A1OR184	315-0911-00		RES.,FXD,CMPSN:910 OHM,5%,0.25W	01121	CB9115
A1OR185	315-0752-00		RES.,FXD,CMPSN:7.5K OHM,5%,0.25W	01121	CB7525
A1OR186	315-0112-00		RES.,FXD,CMPSN:1.1K OHM,5%,0.25W	01121	CB1125
A1OR187	315-0620-00		RES.,FXD,CMPSN:62 OHM,5%,0.25W	01121	CB6205
A1OR188	315-0362-00		RES.,FXD,CMPSN:3.6K OHM,5%,0.25W	01121	CB3625
A1OR189	315-0750-00		RES.,FXD,CMPSN:75 OHM,5%,0.25W	01121	CB7505
A1OR190	315-0202-00		RES.,FXD,CMPSN:2K OHM,5%,0.25W	01121	CB2025
A1OR193	315-0271-00		RES.,FXD,CMPSN:270 OHM,5%,0.25W	01121	CB2715
A1OR194	315-0103-00		RES.,FXD,CMPSN:10K OHM,5%,0.25W	01121	CB1035
A1OR195	315-0393-00		RES.,FXD,CMPSN:39K OHM,5%,0.25W	01121	CB3935
A1OR196	315-0103-00		RES.,FXD,CMPSN:10K OHM,5%,0.25W	01121	CB1035
A1OR197	315-0561-00		RES.,FXD,CMPSN:560 OHM,5%,0.25W	01121	CB5615
A1OR201	315-0101-00		RES.,FXD,CMPSN:100 OHM,5%,0.25W	01121	CB1015
A1OR202	315-0103-00		RES.,FXD,CMPSN:10K OHM,5%,0.25W	01121	CB1035
A1OR203	315-0103-00		RES.,FXD,CMPSN:10K OHM,5%,0.25W	01121	CB1035
A1OR208	315-0472-00		RES.,FXD,CMPSN:4.7K OHM,5%,0.25W	01121	CB4725

Replaceable Electrical Parts—2336 Service

Component No.	Tektronix Part No.	Serial/Model No. Eff Dscont	Name & Description	Mfr Code	Mfr Part Number
A10R209	315-0821-00		RES., FXD, CMPSN: 820 OHM, 5%, 0.25W	01121	CB8215
A10R210	315-0103-00		RES., FXD, CMPSN: 10K OHM, 5%, 0.25W	01121	CB1035
A10R211	315-0103-00		RES., FXD, CMPSN: 10K OHM, 5%, 0.25W	01121	CB1035
A10R215	315-0103-00		RES., FXD, CMPSN: 10K OHM, 5%, 0.25W	01121	CB1035
A10R216	321-0318-00		RES., FXD, FILM: 20K OHM, 1%, 0.125W	91637	MFF1816G20001F
A10R217	315-0101-00		RES., FXD, CMPSN: 100 OHM, 5%, 0.25W	01121	CB1015
A10R218	321-0218-00		RES., FXD, FILM: 1.82K OHM, 1%, 0.125W	91637	MFF1816G18200F
A10R219	315-0682-00		RES., FXD, CMPSN: 6.8K OHM, 5%, 0.25W	01121	CB6825
A10R222	315-0392-00		RES., FXD, CMPSN: 3.9K OHM, 5%, 0.25W	01121	CB3925
A10R223	315-0102-00		RES., FXD, CMPSN: 1K OHM, 5%, 0.25W	01121	CB1025
A10R224	307-0113-00		RES., FXD, CMPSN: 5.1 OHM, 5%, 0.25W	01121	CB51G5
A10R225	315-0513-00		RES., FXD, CMPSN: 51K OHM, 5%, 0.25W	01121	CB5135
A10R229	303-0472-00		RES., FXD, CMPSN: 4.7K OHM, 5%, 1W	01121	GB4725
A10R230	321-0293-03		RES., FXD, FILM: 11K OHM, 0.25%, 0.125W	24546	NC55C1102C
A10R231	311-2101-00		RES., VAR, NONWIR: TRMR, 2K OHM, 10%, 0.5W	73138	72-268-0
A10R232	321-0966-03		RES., FXD, FILM: 40K OHM, 0.25%, 0.125W	91637	MFF1816G40001C
A10R236	303-0472-00		RES., FXD, CMPSN: 4.7K OHM, 5%, 1W	01121	GB4725
A10R237	315-0912-00		RES., FXD, CMPSN: 9.1K OHM, 5%, 0.25W	01121	CB9125
A10R238	315-0511-00		RES., FXD, CMPSN: 510 OHM, 5%, 0.25W	01121	CB5115
A10R239	315-0472-00		RES., FXD, CMPSN: 4.7K OHM, 5%, 0.25W	01121	CB4725
A10R243	315-0204-00		RES., FXD, CMPSN: 200K OHM, 5%, 0.25W	01121	CB2045
A10R244	321-0174-00		RES., FXD, FILM: 634 OHM, 1%, 0.125W	91637	MFF1816G634ROF
A10R245	321-0337-00		RES., FXD, FILM: 31.6K OHM, 1%, 0.125W	91637	MFF1816G31601F
A10R246	308-0739-00		RES., FXD, WW: 40 OHM, 1%, 3W	91637	RS2B4R00F
A10R250	315-0103-00		RES., FXD, CMPSN: 10K OHM, 5%, 0.25W	01121	CB1035
A10R251	315-0103-00		RES., FXD, CMPSN: 10K OHM, 5%, 0.25W	01121	CB1035
A10R252	308-0703-00		RES., FXD, WW: 1.8 OHM, 5%, 2W	75042	BWH-1R800J
A10R253	308-0677-00		RES., FXD, WW: 1 OHM, 5%, 2W	75042	BWH-1R000J
A10R257	315-0393-00		RES., FXD, CMPSN: 39K OHM, 5%, 0.25W	01121	CB3935
A10R258	315-0102-00		RES., FXD, CMPSN: 1K OHM, 5%, 0.25W	01121	CB1025
A10R259	315-0272-00		RES., FXD, CMPSN: 2.7K OHM, 5%, 0.25W	01121	CB2725
A10R260	315-0272-00		RES., FXD, CMPSN: 2.7K OHM, 5%, 0.25W	01121	CB2725
A10R264	308-0677-00		RES., FXD, WW: 1 OHM, 5%, 2W	75042	BWH-1R000J
A10R265	308-0703-00		RES., FXD, WW: 1.8 OHM, 5%, 2W	75042	BWH-1R800J
A10RT46	307-0477-00		RES., THERMAL: 1K OHM, 10%, 6MW/DEG C	14193	1013-10000K
A10RT115	307-0477-00		RES., THERMAL: 1K OHM, 10%, 6MW/DEG C	14193	1013-10000K
A10S134	260-1771-00		SWITCH, PUSH: DPDT, 1 BUTTON, 2 POLE	80009	260-1771-00
A10S190	260-2018-00		SWITCH, PUSH: SGL BUTTON, 2 PLE	80009	260-2018-00
A10S194	260-2060-00		SWITCH, PUSH: 5 BUTTON, 2 POLE, VERT MODE	80009	260-2060-00
A10S210	260-1720-01		SWITCH, PUSH: 3 BUTTON, IL & MR 2 POLE	80009	260-1720-01
A10S211A & B	260-2019-00		SWITCH, PUSH: 2 BUTTON, 2 POLE	80009	260-2019-00
A10S218	260-1544-01		SWITCH, PUSH: 3 STA, 2 POLE, W/O MTG EARS	82104	0BD
A10S219	260-2018-00		SWITCH, PUSH: SGL BUTTON, 2 PLE	80009	260-2018-00
A10TP1	214-0579-00		TERM, TEST POINT: BRS CD PL	80009	214-0579-00
A10TP30	214-0579-00		TERM, TEST POINT: BRS CD PL	80009	214-0579-00
A10TP61	214-0579-00		TERM, TEST POINT: BRS CD PL	80009	214-0579-00
A10TP62	214-0579-00		TERM, TEST POINT: BRS CD PL	80009	214-0579-00
A10TP139	214-0579-00		TERM, TEST POINT: BRS CD PL	80009	214-0579-00
A10TP156	214-0579-00		TERM, TEST POINT: BRS CD PL	80009	214-0579-00
A10TP176	214-0579-00		TERM, TEST POINT: BRS CD PL	80009	214-0579-00
A10TP247	214-0579-00		TERM, TEST POINT: BRS CD PL	80009	214-0579-00
A10TP252	214-0579-00		TERM, TEST POINT: BRS CD PL	80009	214-0579-00
A10TP254	214-0579-00		TERM, TEST POINT: BRS CD PL	80009	214-0579-00
A10TP255	214-0579-00		TERM, TEST POINT: BRS CD PL	80009	214-0579-00
A10TP264	214-0579-00		TERM, TEST POINT: BRS CD PL	80009	214-0579-00
A10TP265	214-0579-00		TERM, TEST POINT: BRS CD PL	80009	214-0579-00
A10TP266	214-0579-00		TERM, TEST POINT: BRS CD PL	80009	214-0579-00

Component No.	Tektronix Part No.	Serial/Model No. Eff Dscont	Name & Description	Mfr Code	Mfr Part Number
A10U30	155-0220-00		MICROCIRCUIT,LI:VERTICAL PREAMP	80009	155-0220-00
A10U41	156-0158-03		MICROCIRCUIT,LI:DUAL OPNL AMPL,CHK	80009	156-0158-03
A10U55	155-0231-00		MICROCIRCUIT,LI:VERTICAL PREAMP	80009	155-0231-00
A10U100	155-0220-00		MICROCIRCUIT,LI:VERTICAL PREAMP	80009	155-0220-00
A10U125	155-0231-00		MICROCIRCUIT,LI:VERTICAL PREAMP	80009	155-0231-00
A10U160	156-0067-12		MICROCIRCUIT,LI:OPERATIONAL AMPLIFIER	04713	MC1741CU
A10U196	156-0721-02		MICROCIRCUIT,DI:QUAD 2-IN NAND SCHMITT TRI	04713	SN74LS132NDS
A10U211	156-0388-03		MICROCIRCUIT,DI:DUAL D FLIP-FLOP	07263	74LS74A
A10U215	156-0798-02		MICROCIRCUIT,DI:DUAL 14 TO 1 LINE SEL/MUX	01295	SN74LS153
A10U237	156-0067-12		MICROCIRCUIT,LI:OPERATIONAL AMPLIFIER	04713	MC1741CU
A10VR229	152-0411-00		SEMICONV DEVICE:ZENER,0.25W,9V,5%	04713	SZ12483KRL
A10VR236	152-0405-00		SEMICONV DEVICE:ZENER,1W,15V,5%	80009	152-0405-00
A10VR238	152-0241-00		SEMICONV DEVICE:ZENER,0.4W,33V,5%	80009	152-0241-00
A10VR246	152-0756-00		SEMICONV DEVICE:ZENER,SI,47V,5%,1W	04713	1N4756A
A10VR252	152-0520-00		SEMICONV DEVICE:ZENER,1W,12V,5%	14433	1N4742A
A10VR253	152-0757-00		SEMICONV DEVICE:ZENER,SI,6.2V,5%,1W	04713	1N4735A
A10VR264	152-0757-00		SEMICONV DEVICE:ZENER,SI,6.2V,5%,1W	04713	1N4735A
A10VR265	152-0520-00		SEMICONV DEVICE:ZENER,1W,12V,5%	14433	1N4742A
A10W1	131-0566-00		BUS CONDUCTOR:DUMMY RES,2.375,22 AWG	55210	L-2007-1
A10W2	131-0566-00		BUS CONDUCTOR:DUMMY RES,2.375,22 AWG	55210	L-2007-1
A10W143	131-0566-00		BUS CONDUCTOR:DUMMY RES,2.375,22 AWG	55210	L-2007-1
A10W146	131-0566-00		BUS CONDUCTOR:DUMMY RES,2.375,22 AWG	55210	L-2007-1
A10W211	131-0566-00		BUS CONDUCTOR:DUMMY RES,2.375,22 AWG	55210	L-2007-1
A10W215	131-0566-00		BUS CONDUCTOR:DUMMY RES,2.375,22 AWG	55210	L-2007-1
A10W244	131-0566-00		BUS CONDUCTOR:DUMMY RES,2.375,22 AWG	55210	L-2007-1
A10W246	131-0566-00		BUS CONDUCTOR:DUMMY RES,2.375,22 AWG	55210	L-2007-1
A10W247	131-0566-00		BUS CONDUCTOR:DUMMY RES,2.375,22 AWG	55210	L-2007-1
A10W248	131-0566-00		BUS CONDUCTOR:DUMMY RES,2.375,22 AWG	55210	L-2007-1
A10W251	131-0566-00		BUS CONDUCTOR:DUMMY RES,2.375,22 AWG	55210	L-2007-1
A10W252	131-0566-00		BUS CONDUCTOR:DUMMY RES,2.375,22 AWG	55210	L-2007-1
A10W253	131-0566-00		BUS CONDUCTOR:DUMMY RES,2.375,22 AWG	55210	L-2007-1
A10W255	131-0566-00		BUS CONDUCTOR:DUMMY RES,2.375,22 AWG	55210	L-2007-1
A10W263	131-0566-00		BUS CONDUCTOR:DUMMY RES,2.375,22 AWG	55210	L-2007-1
A10W264	131-0566-00		BUS CONDUCTOR:DUMMY RES,2.375,22 AWG	55210	L-2007-1
A10W265	131-0566-00		BUS CONDUCTOR:DUMMY RES,2.375,22 AWG	55210	L-2007-1



# Replaceable Electrical Parts—2336 Service

Component No.	Tektronix Part No.	Serial/Model No. Eff Dscont	Name & Description	Mfr Code	Mfr Part Number
A11	-----		CKT BOARD ASSY:NEGATIVE REG		
A11C1	281-0775-00		CAP., FXD, CER DI:0.1UF, 20%, 50V	72982	8005D9AABZ5U104M
A11C2	281-0775-00		CAP., FXD, CER DI:0.1UF, 20%, 50V	72982	8005D9AABZ5U104M
A11C8	281-0765-00		CAP., FXD, CER DI:100PF, 5%, 100V	51642	G1710100X5P101J
A11C9	281-0775-00		CAP., FXD, CER DI:0.1UF, 20%, 50V	72982	8005D9AABZ5U104M
A11C15	281-0765-00		CAP., FXD, CER DI:100PF, 5%, 100V	51642	G1710100X5P101J
A11C21	281-0775-00		CAP., FXD, CER DI:0.1UF, 20%, 50V	72982	8005D9AABZ5U104M
A11CR9	152-0141-02		SEMICONV DEVICE:SILICON, 30V, 150MA	01295	1N4152R
A11CR14	152-0141-02		SEMICONV DEVICE:SILICON, 30V, 150MA	01295	1N4152R
A11CR21	152-0141-02		SEMICONV DEVICE:SILICON, 30V, 150MA	01295	1N4152R
A11CR23	152-0141-02		SEMICONV DEVICE:SILICON, 30V, 150MA	01295	1N4152R
A11Q9	151-0188-03		TRANSISTOR:SILICON, PNP, SEL	80009	151-0188-03
A11Q10	151-0188-03		TRANSISTOR:SILICON, PNP, SEL	80009	151-0188-03
A11Q21	151-0188-03		TRANSISTOR:SILICON, PNP, SEL	80009	151-0188-03
A11Q22	151-0188-03		TRANSISTOR:SILICON, PNP, SEL	80009	151-0188-03
A11R1	315-0201-00		RES., FXD, CMPSN:200 OHM, 5%, 0.25W	01121	CB2015
A11R2	315-0201-00		RES., FXD, CMPSN:200 OHM, 5%, 0.25W	01121	CB2015
A11R3	321-0289-03		RES., FXD, FILM:10K OHM, 0.25%, 0.125W	91637	MFF1816D10001C
A11R4	321-0289-03		RES., FXD, FILM:10K OHM, 0.25%, 0.125W	91637	MFF1816D10001C
A11R8	315-0512-00		RES., FXD, CMPSN:5.1K OHM, 5%, 0.25W	01121	CB5125
A11R9	315-0202-00		RES., FXD, CMPSN:2K OHM, 5%, 0.25W	01121	CB2025
A11R10	321-0198-00		RES., FXD, FILM:1.13K OHM, 1%, 0.125W	91637	MFF1816G11300F
A10R211	315-0103-00		RES., FXD, CMPSN:10K OHM, 5%, 0.25W	01121	CB1035
A11R14	321-0262-00		RES., FXD, FILM:5.23K OHM, 1%, 0.125W	91637	MFF1816G52300F
A11R15	321-0289-03		RES., FXD, FILM:10K OHM, 0.25%, 0.125W	91637	MFF1816D10001C
A11R16	321-0289-03		RES., FXD, FILM:10K OHM, 0.25%, 0.125W	91637	MFF1816D10001C
A11R20	315-0512-00		RES., FXD, CMPSN:5.1K OHM, 5%, 0.25W	01121	CB5125
A11R21	315-0132-00		RES., FXD, CMPSN:1.3K OHM, 5%, 0.25W	01121	CB1325
A11R22	321-0198-00		RES., FXD, FILM:1.13K OHM, 1%, 0.125W	91637	MFF1816G11300F
A11R23	321-0289-00		RES., FXD, FILM:10K OHM, 1%, 0.125W	91637	MFF1816G10001F
A11U8	156-0158-03		MICROCIRCUIT, LI:DUAL OPNL AMPL, CHK	80009	156-0158-03
A11VR9	152-0195-00		SEMICONV DEVICE:ZENER, 0.4W, 5.1V, 5%	04713	SZ11755
A11VR21	152-0306-00		SEMICONV DEVICE:ZENER, 0.4W, 9.1V, 5%	15238	25409

Component No.	Tektronix Part No.	Serial/Model No. Eff Dscont	Name & Description	Mfr Code	Mfr Part Number
A12	-----		CKT BOARD ASSY:POSITIVE REG		
A12C1	281-0775-00		CAP.,FXD,CER DI:0.1UF,20%,50V	72982	8005D9AABZ5U104M
A12C8	281-0765-00		CAP.,FXD,CER DI:100PF,5%,100V	51642	G1710100X5P101J
A12C9	281-0775-00		CAP.,FXD,CER DI:0.1UF,20%,50V	72982	8005D9AABZ5U104M
A12C15	281-0765-00		CAP.,FXD,CER DI:100PF,5%,100V	51642	G1710100X5P101J
A12CR9	152-0141-02		SEMICOND DEVICE:SILICON,30V,150MA	01295	1N4152R
A12CR14	152-0141-02		SEMICOND DEVICE:SILICON,30V,150MA	01295	1N4152R
A12Q9	151-0190-05		TRANSISTOR:SILICON,NPN	80009	151-0190-05
A12Q10	151-0190-05		TRANSISTOR:SILICON,NPN	80009	151-0190-05
A12Q16	151-0190-05		TRANSISTOR:SILICON,NPN	80009	151-0190-05
A12Q20	151-0190-05		TRANSISTOR:SILICON,NPN	80009	151-0190-05
A12R1	315-0201-00		RES.,FXD,CMPSN:200 OHM,5%,0.25W	01121	CB2015
A12R2	321-0761-03		RES.,FXD,FILM:35K OHM,0.25%,0.125W	91637	MFF1816D35001C
A12R3	321-0816-03		RES.,FXD,FILM:5K OHM,0.25%,0.125W	91637	MFF1816D50000C
A12R4	321-1310-03		RES.,FXD,FILM:16.7K OHM,0.25%,0.125W	91637	MFF1816D16701C
A12R8	321-1310-03		RES.,FXD,FILM:16.7K OHM,0.25%,0.125W	91637	MFF1816D16701C
A12R9	315-0153-00		RES.,FXD,CMPSN:15K OHM,5%,0.25W	01121	CB1535
A12R10	321-0198-00		RES.,FXD,FILM:1.13K OHM,1%,0.125W	91637	MFF1816G11300F
A12R14	321-0289-00		RES.,FXD,FILM:10K OHM,1%,0.125W	91637	MFF1816G10001F
A12R15	315-0822-00		RES.,FXD,CMPSN:8.2K OHM,5%,0.25W	01121	CB8225
A12R16	315-0153-00		RES.,FXD,CMPSN:15K OHM,5%,0.25W	01121	CB1535
A12R20	321-0198-00		RES.,FXD,FILM:1.13K OHM,1%,0.125W	91637	MFF1816G11300F
A12R21	321-0262-00		RES.,FXD,FILM:5.23K OHM,1%,0.125W	91637	MFF1816G52300F
A12U3	156-0158-03		MICROCIRCUIT,LI:DUAL OPNL AMPL,CHK	80009	156-0158-03
A12VR9	152-0195-00		SEMICOND DEVICE:ZENER,0.4W,5.1V,5%	04713	SZ11755

Replaceable Electrical Parts—2336 Service

Component No.	Tektronix Part No.	Serial/Model No. Eff Dscont	Name & Description	Mfr Code	Mfr Part Number
A15	-----		CKT BOARD ASSY:VERT OUT/HV POWER		
A15C1	290-0522-00		CAP.,FXD,ELCTLT:1UF,20%,50V	56289	196D105X0050HA1
A15C3	290-0523-00		CAP.,FXD,ELCTLT:2.2UF,20%,20V	56289	196D225X0020HA1
A15C5	290-0524-00		CAP.,FXD,ELCTLT:4.7UF,20%,10V	90201	TDC475M010EL
A15C8	281-0809-00		CAP.,FXD,CER DI:200PF,5%,100V	72982	8013T2ADDC1G201J
A15C10	281-0773-00		CAP.,FXD,CER DI:0.01UF,10%,100V	04222	GC70-1C103K
A15C18	281-0862-00		CAP.,FXD,CER DI:0.001UF,+80-20%,100V	20932	401-ES-100-AD102
A15C25	281-0809-00		CAP.,FXD,CER DI:200PF,5%,100V	72982	8013T2ADDC1G201J
A15C26	281-0862-00		CAP.,FXD,CER DI:0.001UF,+80-20%,100V	20932	401-ES-100-AD102
A15C29	283-0330-00		CAP.,FXD,CER DI:100PF,5%,50V	51642	150-050-NP0-101J
A15C32	283-0115-00		CAP.,FXD,CER DI:47PF,5%,200V	59660	805-519-C0G0470J
A15C33	281-0123-00		CAP.,VAR,CER DI:5-25PF,100V	72982	518-000A5-25
A15C36	281-0167-00		CAP.,VAR,CER DI:9-45PF,200V	72982	538-011-D 9-45
A15C39	281-0123-00		CAP.,VAR,CER DI:5-25PF,100V	72982	518-000A5-25
A15C54	281-0862-00		CAP.,FXD,CER DI:0.001UF,+80-20%,100V	20932	401-ES-100-AD102
A15C57	281-0862-00		CAP.,FXD,CER DI:0.001UF,+80-20%,100V	20932	401-ES-100-AD102
A15C58	281-0770-00		CAP.,FXD,CER DI:0.001UF,20%,100V	72982	8035D9AADX5R102M
A15C66	281-0774-00		CAP.,FXD,CER DI:0.022UF,20%,100V	12969	GGE223MEZ
A15C73	281-0772-00		CAP.,FXD,CER DI:0.0047UF,10%,100V	04222	GC701C472K
A15C80	281-0862-00		CAP.,FXD,CER DI:0.001UF,+80-20%,100V	20932	401-ES-100-AD102
A15C86	281-0775-00		CAP.,FXD,CER DI:0.1UF,20%,50V	72982	8005D9AABZ5U104M
A15C87	281-0775-00		CAP.,FXD,CER DI:0.1UF,20%,50V	72982	8005D9AABZ5U104M
A15C94	281-0775-00		CAP.,FXD,CER DI:0.1UF,20%,50V	72982	8005D9AABZ5U104M
A15C100	281-0775-00		CAP.,FXD,CER DI:0.1UF,20%,50V	72982	8005D9AABZ5U104M
A15C101	281-0138-00		CAP.,VAR,PLSTC:0.4-1.2PF,600V	74970	273-0051-001
A15C108	285-1062-00		CAP.,FXD,PLSTC:0.005UF,0.1%,200V	19396	502F02PP460
A15C109	281-0775-00		CAP.,FXD,CER DI:0.1UF,20%,50V	72982	8005D9AABZ5U104M
A15C110	281-0775-00		CAP.,FXD,CER DI:0.1UF,20%,50V	72982	8005D9AABZ5U104M
A15C116	281-0775-00		CAP.,FXD,CER DI:0.1UF,20%,50V	72982	8005D9AABZ5U104M
A15C121	281-0773-00		CAP.,FXD,CER DI:0.01UF,10%,100V	04222	GC70-1C103K
A15C122	285-1101-00		CAP.,FXD,PLSTC:0.022UF,10%,200V	19396	223K02PT485
A15C123	281-0783-00		CAP.,FXD,CER DI:0.1UF,20%,100V	72982	8045-D-25U104M
A15C128	281-0151-00		CAP.,VAR,CER DI:1-3PF,100V	72982	518-600A1-3
A15C136	281-0760-00		CAP.,FXD,CER DI:22PF,10%,500V	72982	0314021 C0G0220K
A15C140	285-1099-00		CAP.,FXD,PLSTC:0.047UF,20%,200V	19396	473M02PT605
A15C148	281-0773-00		CAP.,FXD,CER DI:0.01UF,10%,100V	04222	GC70-1C103K
A15C150	283-0177-00		CAP.,FXD,CER DI:1UF,+80-20%,25V	56289	273C5
A15C156	281-0876-00		CAP.,FXD,CER DI:5.6PF,+/-0.5PF,500WVDC	04222	GC106A569D
A15C167	290-0939-00		CAP.,FXD,ELCTLT:10UF,+100-10%,100V	56289	672D106H100CG2C
A15C168	281-0783-00		CAP.,FXD,CER DI:0.1UF,20%,100V	72982	8045-D-25U104M
A15C174	283-0167-00		CAP.,FXD,CER DI:0.1UF,10%,100V	72982	8131N145X5R0104K
A15C175	285-1040-00		CAP.,FXD,PLSTC:0.0012UF,10%,4000V	56289	430P522
A15C182	281-0775-00		CAP.,FXD,CER DI:0.1UF,20%,50V	72982	8005D9AABZ5U104M
A15C183	285-1119-00		CAP.,FXD,PLSTC:0.082UF,10%,200V	19396	PP680C823K
A15C185	281-0775-00		CAP.,FXD,CER DI:0.1UF,20%,50V	72982	8005D9AABZ5U104M
A15C190	285-0892-00		CAP.,FXD,PLSTC:0.22UF,10%,200V	56289	LP66A1C224K002
A15C191	290-0159-00		CAP.,FXD,ELCTLT:2UF,+50-10%,150V	56289	30D205F150BB9
A15C196	285-1040-00		CAP.,FXD,PLSTC:0.0012UF,10%,4000V	56289	430P522
A15C197	285-0892-00		CAP.,FXD,PLSTC:0.22UF,10%,200V	56289	LP66A1C224K002
A15C198	285-1095-00		CAP.,FXD,PLSTC:3300PF,10%,400V	19396	273-M-12PA1350
A15C202	285-1101-00		CAP.,FXD,PLSTC:0.022UF,10%,200V	19396	223K02PT485
A15C205	281-0773-00		CAP.,FXD,CER DI:0.01UF,10%,100V	04222	GC70-1C103K
A15C209	285-1101-00		CAP.,FXD,PLSTC:0.022UF,10%,200V	19396	223K02PT485
A15C210	281-0773-00		CAP.,FXD,CER DI:0.01UF,10%,100V	04222	GC70-1C103K
A15C211	281-0783-00		CAP.,FXD,CER DI:0.1UF,20%,100V	72982	8045-D-25U104M
A15CR8	152-0141-02		SEMICOND DEVICE:SILICON,30V,150MA	01295	1N4152R
A15CR9	152-0141-02		SEMICOND DEVICE:SILICON,30V,150MA	01295	1N4152R

Component No.	Tektronix Part No.	Serial/Model No. Eff Dscont	Name & Description	Mfr Code	Mfr Part Number
A15CR24	152-0141-02		SEMICON D DEVICE:SILICON,30V,150MA	01295	1N4152R
A15CR25	152-0141-02		SEMICON D DEVICE:SILICON,30V,150MA	01295	1N4152R
A15CR91	152-0141-02		SEMICON D DEVICE:SILICON,30V,150MA	01295	1N4152R
A15CR92	152-0061-00		SEMICON D DEVICE:SILICON,175V,100MA	07263	FDH2161
A15CR94	152-0141-02		SEMICON D DEVICE:SILICON,30V,150MA	01295	1N4152R
A15CR100	152-0141-02		SEMICON D DEVICE:SILICON,30V,150MA	01295	1N4152R
A15CR123	152-0061-00		SEMICON D DEVICE:SILICON,175V,100MA	07263	FDH2161
A15CR127	152-0061-00		SEMICON D DEVICE:SILICON,175V,100MA	07263	FDH2161
A15CR130	152-0061-00		SEMICON D DEVICE:SILICON,175V,100MA	07263	FDH2161
A15CR140	152-0061-00		SEMICON D DEVICE:SILICON,175V,100MA	07263	FDH2161
A15CR148	152-0141-02		SEMICON D DEVICE:SILICON,30V,150MA	01295	1N4152R
A15CR154	152-0061-00		SEMICON D DEVICE:SILICON,175V,100MA	07263	FDH2161
A15CR156	152-0141-02		SEMICON D DEVICE:SILICON,30V,150MA	01295	1N4152R
A15CR157	152-0107-04		SEMICON D DEVICE:SILICON,400V,400MA,SEL	14936	GPD-011
A15CR161	152-0061-00		SEMICON D DEVICE:SILICON,175V,100MA	07263	FDH2161
A15CR163	152-0141-02		SEMICON D DEVICE:SILICON,30V,150MA	01295	1N4152R
A15CR165	152-0107-04		SEMICON D DEVICE:SILICON,400V,400MA,SEL	14936	GPD-011
A15CR167	152-0398-00		SEMICON D DEVICE:SILICON,200V,1A	04713	SR3609RL
A15CR168	152-0061-00		SEMICON D DEVICE:SILICON,175V,100MA	07263	FDH2161
A15CR174	152-0141-02		SEMICON D DEVICE:SILICON,30V,150MA	01295	1N4152R
A15CR175	152-0141-02		SEMICON D DEVICE:SILICON,30V,150MA	01295	1N4152R
A15CR177	152-0141-02		SEMICON D DEVICE:SILICON,30V,150MA	01295	1N4152R
A15CR190	152-0061-00		SEMICON D DEVICE:SILICON,175V,100MA	07263	FDH2161
A15CR191	152-0066-00		SEMICON D DEVICE:SILICON,400V,750MA	14433	LG4016
A15CR197	152-0061-00		SEMICON D DEVICE:SILICON,175V,100MA	07263	FDH2161
A15DS195	150-0030-00		LAMP,GLOW:NEON,T-2,60 TO 90 VOLTS	74276	NE2V-T
A15DS196	150-0030-00		LAMP,GLOW:NEON,T-2,60 TO 90 VOLTS	74276	NE2V-T
A15DS197	150-0030-00		LAMP,GLOW:NEON,T-2,60 TO 90 VOLTS	74276	NE2V-T
A15F89	159-0183-00		FUSE,CARTRIDGE:5.2 X 20MM,0.25A,125V	000HX	TSC.25
A15L54	108-0440-00		COIL,RF:8UH,TOROIDAL INDUCTOR	80009	108-0440-00
A15L167	108-0237-00		COIL,RF:80UH	80009	108-0237-00
A15L191	108-0691-00		COIL,RF:1.8MH	76493	02279
A15Q93	151-0192-03		TRANSISTOR:SILICON,NPN	80009	151-0192-03
A15Q100	151-0188-03		TRANSISTOR:SILICON,PNP,SEL	80009	151-0188-03
A15Q107	151-0190-05		TRANSISTOR:SILICON,NPN	80009	151-0190-05
A15Q114	151-0350-01		TRANSISTOR:PNP,SI PRESTRESSED & TESTED	80009	151-0350-01
A15Q115	151-0347-01		TRANSISTOR:SILICON,NPN,PRESTRESSED	80009	151-0347-01
A15Q116	151-0199-02		TRANSISTOR:SILICON,PNP,PRESTRESSED	80009	151-0199-02
A15Q148	151-0347-01		TRANSISTOR:SILICON,NPN,PRESTRESSED	80009	151-0347-01
A15Q155	151-0350-01		TRANSISTOR:PNP,SI PRESTRESSED & TESTED	80009	151-0350-01
A15Q156	151-0190-05		TRANSISTOR:SILICON,NPN	80009	151-0190-05
A15Q161	151-0701-00		TRANSISTOR:SILICON,NPN	80009	151-0701-00
A15Q163	151-0364-00		TRANSISTOR:SILICON,PNP	80009	151-0364-00
A15Q178	151-0126-01		TRANSISTOR:SILICON,NPN,PRESTRESSED	80009	151-0126-01
A15Q184	151-0188-03		TRANSISTOR:SILICON,PNP,SEL	80009	151-0188-03
A15R8	321-0086-00		RES.,FXD,FILM:76.8 OHM,1%,0.125W	91637	MFF1816G76R80F
A15R9	317-0220-00		RES.,FXD,CMPSN:22 OHM,5%,0.125W	01121	BB2205
A15R10	315-0220-00		RES.,FXD,CMPSN:22 OHM,5%,0.25W	01121	CB2205
A15R17	315-0111-00		RES.,FXD,CMPSN:110 OHM,5%,0.25W	01121	CB1115
A15R18	311-2082-00		RES.,VAR,NONWIR:TRMR,200 OHM,10%,0.5W	73138	72-256-0
A15R22	321-0134-00		RES.,FXD,FILM:243 OHM,1%,0.125W	91637	MFF1816G243R0F
A15R23	321-0134-00		RES.,FXD,FILM:243 OHM,1%,0.125W	91637	MFF1816G243R0F
A15R24	317-0220-00		RES.,FXD,CMPSN:22 OHM,5%,0.125W	01121	BB2205
A15R25	321-0086-00		RES.,FXD,FILM:76.8 OHM,1%,0.125W	91637	MFF1816G76R80F
A15R26	315-0111-00		RES.,FXD,CMPSN:110 OHM,5%,0.25W	01121	CB1115
A15R29	311-1560-00		RES.,VAR,NONWIR:5K OHM,20%,0.50W	73138	91-82-0
A15R30	315-0471-00		RES.,FXD,CMPSN:470 OHM,5%,0.25W	01121	CB4715

Replaceable Electrical Parts—2336 Service

Component No.	Tektronix Part No.	Serial/Model No. Eff Dscont	Name & Description	Mfr Code	Mfr Part Number
A15R31	315-0101-00		RES., FXD, CMPSN:100 OHM, 5%, 0.25W	01121	CB1015
A15R32	311-1564-00		RES., VAR, NONWIR:TRMR, 500 OHM, 0.5W	73138	91-86-0
A15R37	315-0181-00		RES., FXD, CMPSN:180 OHM, 5%, 0.25W	01121	CB1815
A15R38	315-0181-00		RES., FXD, CMPSN:180 OHM, 5%, 0.25W	01121	CB1815
A15R39	311-0605-00		RES., VAR, NONWIR:TRMR, 200 OHM, 0.5W	73138	82-23-2
A15R43	321-0106-00		RES., FXD, FILM:124 OHM, 1%, 0.125W	91637	MFF1816G124R0F
A15R44	311-0643-00		RES., VAR, NONWIR:50 OHM, 10%, 0.50W	73138	82-33-2
A15R50	321-0157-00		RES., FXD, FILM:422 OHM, 1%, 0.125W	91637	MFF1816G422R0F
A15R51	321-0083-00		RES., FXD, FILM:71.5 OHM, 1%, 0.125W	91637	MFF1816G71R50F
A15R52	321-0083-00		RES., FXD, FILM:71.5 OHM, 1%, 0.125W	91637	MFF1816G71R50F
A15R53	321-0157-00		RES., FXD, FILM:422 OHM, 1%, 0.125W	91637	MFF1816G422R0F
A15R57	315-0470-00		RES., FXD, CMPSN:47 OHM, 5%, 0.25W	01121	CB4705
A15R58	315-0331-00		RES., FXD, CMPSN:330 OHM, 5%, 0.25W	01121	CB3315
A15R59	315-0203-00		RES., FXD, CMPSN:20K OHM, 5%, 0.25W	01121	CB2035
A15R60	315-0203-00		RES., FXD, CMPSN:20K OHM, 5%, 0.25W	01121	CB2035
A15R64	315-0203-00		RES., FXD, CMPSN:20K OHM, 5%, 0.25W	01121	CB2035
A15R65	315-0203-00		RES., FXD, CMPSN:20K OHM, 5%, 0.25W	01121	CB2035
A15R66	311-1560-00		RES., VAR, NONWIR:5K OHM, 20%, 0.50W	73138	91-82-0
A15R67	315-0391-00		RES., FXD, CMPSN:390 OHM, 5%, 0.25W	01121	CB3915
A15R71	322-0147-00		RES., FXD, FILM:332 OHM, 1%, 0.25W	24546	NA60D3320F
A15R72	322-0147-00		RES., FXD, FILM:332 OHM, 1%, 0.25W	24546	NA60D3320F
A15R73	311-1561-00		RES., VAR, NONWIR:2.5K OHM, 20%, 0.50W	73138	91-83-0
A15R74	315-0391-00		RES., FXD, CMPSN:390 OHM, 5%, 0.25W	01121	CB3915
A15R75	322-0147-00		RES., FXD, FILM:332 OHM, 1%, 0.25W	24546	NA60D3320F
A15R78	322-0147-00		RES., FXD, FILM:332 OHM, 1%, 0.25W	24546	NA60D3320F
A15R79	315-0221-00		RES., FXD, CMPSN:220 OHM, 5%, 0.25W	01121	CB2215
A15R80	307-0105-00		RES., FXD, CMPSN:3.9 OHM, 5%, 0.25W	01121	CB39G5
A15R85	315-0100-00		RES., FXD, CMPSN:10 OHM, 5%, 0.25W	01121	CB1005
A15R86	315-0100-00		RES., FXD, CMPSN:10 OHM, 5%, 0.25W	01121	CB1005
A15R87	315-0100-00		RES., FXD, CMPSN:10 OHM, 5%, 0.25W	01121	CB1005
A15R90	315-0102-00		RES., FXD, CMPSN:1K OHM, 5%, 0.25W	01121	CB1025
A15R91	315-0511-00		RES., FXD, CMPSN:510 OHM, 5%, 0.25W	01121	CB5115
A15R92	315-0240-00		RES., FXD, CMPSN:24 OHM, 5%, 0.25W	01121	CB2405
A15R93	321-0227-00		RES., FXD, FILM:2.26K OHM, 1%, 0.125W	91637	MFF1816G22600F
A15R94	322-0287-00		RES., FXD, FILM:9.53K OHM, 1%, 0.25W	24546	NA60D9531F
A15R99	321-0258-00		RES., FXD, FILM:4.75K OHM, 1%, 0.125W	91637	MFF1816G47500F
A15R100	321-0030-00		RES., FXD, FILM:20 OHM, 1%, 0.125W	91637	MFF1816G20R00F
A15R101	321-0286-00		RES., FXD, FILM:9.31K OHM, 1%, 0.125W	91637	MFF1816G93100F
A15R102	321-0294-00		RES., FXD, FILM:11.3K OHM, 1%, 0.125W	91637	MFF1816G11301F
A15R106	321-0144-00		RES., FXD, FILM:309 OHM, 1%, 0.125W	91637	MFF1816G309R0F
A15R107	315-0122-00		RES., FXD, CMPSN:1.2K OHM, 5%, 0.25W	01121	CB1225
A15R108	315-0330-00		RES., FXD, CMPSN:33 OHM, 5%, 0.25W	01121	CB3305
A15R109	315-0331-00		RES., FXD, CMPSN:330 OHM, 5%, 0.25W	01121	CB3315
A15R113	315-0162-00		RES., FXD, CMPSN:1.6K OHM, 5%, 0.25W	01121	CB1625
A15R114	301-0273-00		RES., FXD, CMPSN:27K OHM, 5%, 0.50W	01121	EB2735
A15R115	315-0200-00		RES., FXD, CMPSN:20 OHM, 5%, 0.25W	01121	CB2005
A15R116	315-0331-00		RES., FXD, CMPSN:330 OHM, 5%, 0.25W	01121	CB3315
A15R120	315-0513-00		RES., FXD, CMPSN:51K OHM, 5%, 0.25W	01121	CB5135
A15R121	315-0113-00		RES., FXD, CMPSN:11K OHM, 5%, 0.25W	01121	CB1135
A15R122	315-0101-00		RES., FXD, CMPSN:100 OHM, 5%, 0.25W	01121	CB1015
A15R123	315-0103-00		RES., FXD, CMPSN:10K OHM, 5%, 0.25W	01121	CB1035
A15R127	315-0101-00		RES., FXD, CMPSN:100 OHM, 5%, 0.25W	01121	CB1015
A15R128	321-0277-00		RES., FXD, FILM:7.5K OHM, 1%, 0.125W	91637	MFF1816G75000F
A15R130	315-0102-03		RES., FXD, CMPSN:1K OHM, 5%, 0.25W	01121	CB1025
A15R134	315-0103-03		RES., FXD, CMPSN:10K OHM, 5%, 0.25W	01121	CB1035
A15R135	315-0102-03		RES., FXD, CMPSN:1K OHM, 5%, 0.25W	01121	CB1025
A15R136	315-0224-01		RES., FXD, CMPSN:240K OHM, 5%, 0.25W	01121	CB2245

Component No.	Tektronix Part No.	Serial/Model No. Eff Dscont	Name & Description	Mfr Code	Mfr Part Number
A15R140	311-1164-00		RES.,VAR, NONWIR:50K OHM,20%	32997	3386M-T07-503
A15R147	315-0203-00		RES.,FXD,CMPSN:20K OHM,5%,0.25W	01121	CB2035
A15R148	315-0203-00		RES.,FXD,CMPSN:20K OHM,5%,0.25W	01121	CB2035
A15R149	321-0982-00		RES.,FXD,FILM:450K OHM,1%,0.125W	91637	MFF1816G45002F
A15R150	321-0756-00		RES.,FXD,FILM:50K OHM,1%,0.125W	24546	NA55D5002F
A15R154	315-0473-00		RES.,FXD,CMPSN:47K OHM,5%,0.25W	01121	CB4735
A15R155	315-0622-00		RES.,FXD,CMPSN:6.2K OHM,5%,0.25W	01121	CB6225
A15R156	315-0102-00		RES.,FXD,CMPSN:1K OHM,5%,0.25W	01121	CB1025
A15R157	315-0101-00		RES.,FXD,CMPSN:100 OHM,5%,0.25W	01121	CB1015
A15R161	315-0120-00		RES.,FXD,CMPSN:12 OHM,5%,0.25W	01121	CB1205
A15R163	315-0101-00		RES.,FXD,CMPSN:100 OHM,5%,0.25W	01121	CB1015
A15R168	315-0511-00		RES.,FXD,CMPSN:510 OHM,5%,0.25W	01121	CB5115
A15R176	307-0687-00		RES,NTWK,FXD FI:HIGH VOLTAGE DIVIDER	80009	307-0687-00
A15R177	315-0393-00		RES.,FXD,CMPSN:39K OHM,5%,0.25W	01121	CB3935
A15R178	315-0474-00		RES.,FXD,CMPSN:470K OHM,5%,0.25W	01121	CB4745
A15R182	315-0123-00		RES.,FXD,CMPSN:12K OHM,5%,0.25W	01121	CB1235
A15R183	315-0101-00		RES.,FXD,CMPSN:100 OHM,5%,0.25W	01121	CB1015
A15R184	315-0101-00		RES.,FXD,CMPSN:100 OHM,5%,0.25W	01121	CB1015
A15R185	315-0822-00		RES.,FXD,CMPSN:8.2K OHM,5%,0.25W	01121	CB8225
A15R191	315-0101-00		RES.,FXD,CMPSN:100 OHM,5%,0.25W	01121	CB1015
A15R202	311-1148-00		RES.,VAR, NONWIR:100K OHM,20%,0.50W	32997	3386M-T07-104
A15R203	311-1137-00		RES.,VAR, NONWIR:5K OHM,20%,0.50W	73138	72PX-67-0-502M
A15R204	315-0623-00		RES.,FXD,CMPSN:62K OHM,5%,0.25W	01121	CB6235
A15R205	315-0104-00		RES.,FXD,CMPSN:100K OHM,5%,0.25W	01121	CB1045
A15R210	315-0101-00		RES.,FXD,CMPSN:100 OHM,5%,0.25W	01121	CB1015
A15R211	315-0101-00		RES.,FXD,CMPSN:100 OHM,5%,0.25W	01121	CB1015
A15R940	311-2118-00		RES.,VAR, NONWIR:PNL,5M OHM,20%,0.5W	12697	CM41759
A15T9	108-0570-00		COIL,RF:75NH	80009	108-0570-00
A15T24	108-0570-00		COIL,RF:75NH	80009	108-0570-00
A15T167	120-1311-00		XFMR,PWR,STU:HIGH VOLTAGE	80009	120-1311-00
A15T168	108-1066-00		COIL,RF:FIXED,95UH	80009	108-1066-00
A15U43	155-0218-00		MICROCIRCUIT,LI:VERTICAL OUTPUT AMPL	80009	155-0218-00
A15U54	155-0219-00		MICROCIRCUIT,LI:VERTICAL OUTPUT DR	80009	155-0219-00
A15U58	156-0067-12		MICROCIRCUIT,LI:OPERATIONAL AMPLIFIER	04713	MC1741CU
A15U130	152-0767-00		SEMICONV DEVICE:HV MULTR,SI,8KV PP INP	52306	HVG126E
A15VR51	152-0395-00		SEMICONV DEVICE:ZENER,0.4W,4.3V,5%	14552	TD332317
A15VR123	152-0749-00		SEMICONV DEVICE:ZEN,SI,82V,5%,5W	04713	SZP40096
A15VR140	152-0284-00		SEMICONV DEVICE:ZENER,0.4W,47V,5%	80009	152-0284-00
A15VR148	152-0514-00		SEMICONV DEVICE:ZENER,0.4W,10V,1%	80009	152-0514-00
A15VR155	152-0166-00		SEMICONV DEVICE:ZENER,0.4W,6.2V,5%	04713	SZ11738
A15VR198	152-0247-00		SEMICONV DEVICE:ZENER,0.4W,150V,5%	04713	SZG275K1RL
A15W1	131-0566-00		BUS CONDUCTOR:DUMMY RES,2.375,22 AWG	55210	L-2007-1
A15W88	131-0566-00		BUS CONDUCTOR:DUMMY RES,2.375,22 AWG	55210	L-2007-1
A15W163	131-0566-00		BUS CONDUCTOR:DUMMY RES,2.375,22 AWG	55210	L-2007-1
A15W209	131-0566-00		BUS CONDUCTOR:DUMMY RES,2.375,22 AWG	55210	L-2007-1

**Replaceable Electrical Parts—2336 Service**

Component No.	Tektronix Part No.	Serial/Model No. Eff Dscont	Name & Description	Mfr Code	Mfr Part Number
A16	-----		CKT BOARD ASSY:B TIMING SWITCH		
A16C1 } A16C2 } A16C3 }	295-0193-00		CAP SET,MATCHED:10UF,1UF,0.0099UF,900PF	80009	295-0193-00
A16C4 } A16R1 }	307-0693-00		(FURN. AS A MATCHED SET WITH A17C1,C2,C3) RES,NTWK,FXD FI:TIMING	80009	307-0693-00
A16R2	315-0332-00		RES.,FXD,CMPSN:3.3K OHM,5%,0.25W	01121	CB3325
A16R3	315-0472-00		RES.,FXD,CMPSN:4.7K OHM,5%,0.25W	01121	CB4725
A16R4	315-0752-00		RES.,FXD,CMPSN:7.5K OHM,5%,0.25W	01121	CB7525
A16R5	315-0153-00		RES.,FXD,CMPSN:15K OHM,5%,0.25W	01121	CB1535
A16R6	315-0273-00		RES.,FXD,CMPSN:27K OHM,5%,0.25W	01121	CB2735
A16R7	315-0563-00		RES.,FXD,CMPSN:56K OHM,5%,0.25W	01121	CB5635
A17	-----		CKT BOARD ASSY:A TIMING SWITCH		
A17C1 } A17C2 } A17C3 }	295-0193-00		CAP SET,MATCHED:10UF,1UF,0.0099UF,900PF	80009	295-0193-00
A17Q10 } A17R1A }	151-0190-05		(FURN. AS A MATCHED SET WITH A16C1,C2,C3,C4) TRANSISTOR:SILICON,NPN	80009	151-0190-05
A17R1B } A17R1C } A17R1D } A17R1E } A17R1F } A17R1G }	307-0693-00		RES,NTWK,FXD FI:TIMING	80009	307-0693-00
A17R2	315-0332-00		RES.,FXD,CMPSN:3.3K OHM,5%,0.25W	01121	CB3325
A17R3	315-0472-00		RES.,FXD,CMPSN:4.7K OHM,5%,0.25W	01121	CB4725
A17R4	315-0752-00		RES.,FXD,CMPSN:7.5K OHM,5%,0.25W	01121	CB7525
A17R5	315-0153-00		RES.,FXD,CMPSN:15K OHM,5%,0.25W	01121	CB1535
A17R6	315-0273-00		RES.,FXD,CMPSN:27K OHM,5%,0.25W	01121	CB2735
A17R7	315-0563-00		RES.,FXD,CMPSN:56K OHM,5%,0.25W	01121	CB5635
A17R10	315-0621-00		RES.,FXD,CMPSN:620 OHM,5%,0.25W	01121	CB6215
A19	-----		ATTENUATOR,VAR:5MV TO 5V,1 MEG OHM		
A19R20	307-0692-00		RES,NTWK,FXD FI:ATTENUATOR	80009	307-0692-00
A19R30	307-0682-00		RES,NTWK,FXD FI:ATTENUATOR	80009	307-0682-00
A19R902	311-2089-00		RES.,VAR,NONWIR:PNL,10K OHM,20%,0.5W (CHANNEL 1 ONLY)	01121	20M156
A19R906	311-2089-00		RES.,VAR,NONWIR:PNL,10K OHM,20%,0.5W (CHANNEL 2 ONLY)	01121	20M156
A19S1A & B   A19S2 }	263-1188-00		SW CAM ACTR AS:ATTENUATOR	80009	263-1188-00

Component No.	Tektronix Part No.	Serial/Model No. Eff Dscont	Name & Description	Mfr Code	Mfr Part Number
A23	-----		CKT BOARD ASSY:A & B TRIGGER		
A23C2	281-0874-00		CAP.,FXD,CER DI:10F,5%,500V	04222	GC106A100J
A23C3	281-0874-00		CAP.,FXD,CER DI:10F,5%,500V	04222	GC106A100J
A23C4	281-0873-00		CAP.,FXD,CER DI:2.2PF,5%,500V	72982	314021C0J0229D
A23C8	281-0872-00		CAP.,FXD,CER DI:91PF,5%,100V	04222	MC101A910J
A23C9	283-0414-00		CAP.,FXD,CER DI:0.022UF,20%,500V	51642	300-500X7R223M
A23C15	281-0775-00		CAP.,FXD,CER DI:0.1UF,20%,50V	72982	8005D9AABZ5U104M
A23C21	281-0775-00		CAP.,FXD,CER DI:0.1UF,20%,50V	72982	8005D9AABZ5U104M
A23C27	281-0775-00		CAP.,FXD,CER DI:0.1UF,20%,50V	72982	8005D9AABZ5U104M
A23C35	281-0812-00		CAP.,FXD,CER DI:1000PF,10%,100V	72982	8035D9AADX7R102K
A23C36	281-0775-00		CAP.,FXD,CER DI:0.1UF,20%,50V	72982	8005D9AABZ5U104M
A23C48	281-0812-00		CAP.,FXD,CER DI:1000PF,10%,100V	72982	8035D9AADX7R102K
A23C56	281-0812-00		CAP.,FXD,CER DI:1000PF,10%,100V	72982	8035D9AADX7R102K
A23C63	281-0812-00		CAP.,FXD,CER DI:1000PF,10%,100V	72982	8035D9AADX7R102K
A23C67	290-0245-00		CAP.,FXD,ELCTLT:1.5UF,10%,10V	56289	150D155X9010A2
A23C70	281-0775-00		CAP.,FXD,CER DI:0.1UF,20%,50V	72982	8005D9AABZ5U104M
A23C74	281-0797-00		CAP.,FXD,CER DI:15PF,10%,100V	72982	8035D9AADCOG150K
A23C77	281-0812-00		CAP.,FXD,CER DI:1000PF,10%,100V	72982	8035D9AADX7R102K
A23C80	119-1484-00		COMPONENT ASSY:CAPACITOR/RESISTOR	80009	119-1484-00
A23C81	281-0775-00		CAP.,FXD,CER DI:0.1UF,20%,50V	72982	8005D9AABZ5U104M
A23C82	281-0775-00		CAP.,FXD,CER DI:0.1UF,20%,50V	72982	8005D9AABZ5U104M
A23C91	281-0775-00		CAP.,FXD,CER DI:0.1UF,20%,50V	72982	8005D9AABZ5U104M
A23C106	281-0775-00		CAP.,FXD,CER DI:0.1UF,20%,50V	72982	8005D9AABZ5U104M
A23C114	281-0775-00		CAP.,FXD,CER DI:0.1UF,20%,50V	72982	8005D9AABZ5U104M
A23C122	281-0775-00		CAP.,FXD,CER DI:0.1UF,20%,50V	72982	8005D9AABZ5U104M
A23C125	290-0246-00		CAP.,FXD,ELCTLT:3.3UF,10%,15V	56289	162D335X9015CD2
A23C127	281-0775-00		CAP.,FXD,CER DI:0.1UF,20%,50V	72982	8005D9AABZ5U104M
A23C133	290-0246-00		CAP.,FXD,ELCTLT:3.3UF,10%,15V	56289	162D335X9015CD2
A23C147	290-0246-00		CAP.,FXD,ELCTLT:3.3UF,10%,15V	56289	162D335X9015CD2
A23C149	119-1485-00		COMPONENT ASSY:CAPACITOR/RESISTOR	80009	119-1485-00
A23C156	281-0775-00		CAP.,FXD,CER DI:0.1UF,20%,50V	72982	8005D9AABZ5U104M
A23C162	281-0775-00		CAP.,FXD,CER DI:0.1UF,20%,50V	72982	8005D9AABZ5U104M
A23C163	281-0775-00		CAP.,FXD,CER DI:0.1UF,20%,50V	72982	8005D9AABZ5U104M
A23C170	281-0775-00		CAP.,FXD,CER DI:0.1UF,20%,50V	72982	8005D9AABZ5U104M
A23C171	281-0775-00		CAP.,FXD,CER DI:0.1UF,20%,50V	72982	8005D9AABZ5U104M
A23CR10	152-0141-02		SEMIGOND DEVICE:SILICON,30V,150MA	01295	1N4152R
A23CR14	152-0141-02		SEMIGOND DEVICE:SILICON,30V,150MA	01295	1N4152R
A23CR90	152-0322-00		SEMIGOND DEVICE:SILICON,15V,HOT CARRIER	50434	5082-2672
A23CR91	152-0141-02		SEMIGOND DEVICE:SILICON,30V,150MA	01295	1N4152R
A23Q15	151-1042-00		SEMIGOND DVC SE:MATCHED PAIR FET	27014	SF50031
A23Q16					
A23Q21	151-0188-03		TRANSISTOR:SILICON,PNP,SEL	80009	151-0188-03
A23Q89	151-0199-02		TRANSISTOR:SILICON,PNP,PRESTRESSED	80009	151-0199-02
A23Q95	151-0199-02		TRANSISTOR:SILICON,PNP,PRESTRESSED	80009	151-0199-02
A23Q104	151-0190-05		TRANSISTOR:SILICON,NPN	80009	151-0190-05
A23Q134	151-0188-03		TRANSISTOR:SILICON,PNP,SEL	80009	151-0188-03
A23Q139	151-0188-03		TRANSISTOR:SILICON,PNP,SEL	80009	151-0188-03
A23Q153	151-0190-05		TRANSISTOR:SILICON,NPN	80009	151-0190-05
A23Q161	151-0190-05		TRANSISTOR:SILICON,NPN	80009	151-0190-05
A23R2	315-0105-00		RES.,FXD,CMPSN:1M OHM,5%,0.25W	01121	CB1055
A23R3	315-0514-00		RES.,FXD,CMPSN:510K OHM,5%,0.25W	01121	CB5145
A23R4	315-0335-00		RES.,FXD,CMPSN:3.3M OHM,5%,0.25W	01121	CB3355
A23R7	315-0220-00		RES.,FXD,CMPSN:22 OHM,5%,0.25W	01121	CB2205
A23R8	315-0913-00		RES.,FXD,CMPSN:91K OHM,5%,0.25W	01121	CB9135
A23R9	315-0470-00		RES.,FXD,CMPSN:47 OHM,5%,0.25W	01121	CB4705
A23R10	315-0470-00		RES.,FXD,CMPSN:47 OHM,5%,0.25W	01121	CB4705
A23R11	317-0620-00	B010100 B010344	RES.,FXD,CMPSN:62 OHM,5%,0.125W	01121	BB6205



**Replaceable Electrical Parts—2336 Service**

Component No.	Tektronix Part No.	Serial/Model No. Eff Dscont	Name & Description	Mfr Code	Mfr Part Number
A23R11	317-0430-00	B010345	RES., FXD, CMPSN:43 OHM, 5%, 0.125W (NOMINAL VALUE, SELECTED)	01121	BB4305
A23R14	315-0105-00		RES., FXD, CMPSN:1M OHM, 5%, 0.25W	01121	CB1055
A23R15	315-0470-00		RES., FXD, CMPSN:47 OHM, 5%, 0.25W	01121	CB4705
A23R16	315-0101-00		RES., FXD, CMPSN:100 OHM, 5%, 0.25W	01121	CB1015
A23R20	315-0470-00		RES., FXD, CMPSN:47 OHM, 5%, 0.25W	01121	CB4705
A23R21	315-0102-00		RES., FXD, CMPSN:1K OHM, 5%, 0.25W	01121	CB1025
A23R22	315-0103-00		RES., FXD, CMPSN:10K OHM, 5%, 0.25W	01121	CB1035
A23R23	321-0289-00		RES., FXD, FILM:10K OHM, 1%, 0.125W	91637	MFF1816G10001F
A23R24	307-0113-00		RES., FXD, CMPSN:5.1 OHM, 5%, 0.25W	01121	CB51G5
A23R27	315-0104-00		RES., FXD, CMPSN:100K OHM, 5%, 0.25W	01121	CB1045
A23R28	315-0473-00		RES., FXD, CMPSN:47K OHM, 5%, 0.25W	01121	CB4735
A23R29	311-2103-00		RES., VAR, NONWIR:TRMR, 20K OHM, 10%, 0.5W	73138	72-270-0
A23R30	321-0289-00		RES., FXD, FILM:10K OHM, 1%, 0.125W	91637	MFF1816G10001F
A23R34	321-0289-00		RES., FXD, FILM:10K OHM, 1%, 0.125W	91637	MFF1816G10001F
A23R35	321-0289-00		RES., FXD, FILM:10K OHM, 1%, 0.125W	91637	MFF1816G10001F
A23R36	315-0104-00		RES., FXD, CMPSN:100K OHM, 5%, 0.25W	01121	CB1045
A23R37	315-0473-00		RES., FXD, CMPSN:47K OHM, 5%, 0.25W	01121	CB4735
A23R41	311-2103-00		RES., VAR, NONWIR:TRMR, 20K OHM, 10%, 0.5W	73138	72-270-0
A23R56	307-0694-00		RES, NTWK, FXD FI:TRIGGER PICK-OFF	80009	307-0694-00
A23R61	315-0301-00		RES., FXD, CMPSN:300 OHM, 5%, 0.25W	01121	CB3015
A23R67	315-0124-00		RES., FXD, CMPSN:120K OHM, 5%, 0.25W	01121	CB1245
A23R70	315-0222-00		RES., FXD, CMPSN:2.2K OHM, 5%, 0.25W	01121	CB2225
A23R74	315-0332-00		RES., FXD, CMPSN:3.3K OHM, 5%, 0.25W	01121	CB3325
A23R75	321-0289-00		RES., FXD, FILM:10K OHM, 1%, 0.125W	91637	MFF1816G10001F
A23R76	321-0241-00		RES., FXD, FILM:3.16K OHM, 1%, 0.125W	91637	MFF1816G31600F
A23R77	315-0101-00		RES., FXD, CMPSN:100 OHM, 5%, 0.25W	01121	CB1015
A23R80	119-1484-00	XB010424	COMPONENT ASSY:CAPACITOR/RESISTOR	80009	119-1484-00
A23R81	307-0113-00		RES., FXD, CMPSN:5.1 OHM, 5%, 0.25W	01121	CB51G5
A23R82	311-2102-00		RES., VAR, NONWIR:TRMR, 10K OHM, 1%, 0.5W	73138	72-269-0
A23R83	315-0222-00		RES., FXD, CMPSN:2.2K OHM, 5%, 0.25W	01121	CB2225
A23R84	315-0620-00		RES., FXD, CMPSN:62 OHM, 5%, 0.25W	01121	CB6205
A23R88	315-0222-00		RES., FXD, CMPSN:2.2K OHM, 5%, 0.25W	01121	CB2225
A23R89	315-0391-00		RES., FXD, CMPSN:390 OHM, 5%, 0.25W	01121	CB3915
A23R90	315-0331-00		RES., FXD, CMPSN:330 OHM, 5%, 0.25W	01121	CB3315
A23R91	315-0220-00		RES., FXD, CMPSN:22 OHM, 5%, 0.25W	01121	CB2205
A23R95	315-0102-00		RES., FXD, CMPSN:1K OHM, 5%, 0.25W	01121	CB1025
A23R96	315-0222-00		RES., FXD, CMPSN:2.2K OHM, 5%, 0.25W	01121	CB2225
A23R103	315-0122-00		RES., FXD, CMPSN:1.2K OHM, 5%, 0.25W	01121	CB1225
A23R104	315-0302-00		RES., FXD, CMPSN:3K OHM, 5%, 0.25W	01121	CB3025
A23R106	311-1137-00		RES., VAR, NONWIR:5K OHM, 20%, 0.50W	73138	72PX-67-0-502M
A23R107	315-0132-00		RES., FXD, CMPSN:1.3K OHM, 5%, 0.25W	01121	CB1325
A23R111	315-0472-00		RES., FXD, CMPSN:4.7K OHM, 5%, 0.25W	01121	CB4725
A23R112	315-0242-00		RES., FXD, CMPSN:2.4K OHM, 5%, 0.25W	01121	CB2425
A23R113	315-0560-00		RES., FXD, CMPSN:56 OHM, 5%, 0.25W	01121	CB5605
A23R114	315-0100-00		RES., FXD, CMPSN:10 OHM, 5%, 0.25W	01121	CB1005
A23R118	315-0242-00		RES., FXD, CMPSN:2.4K OHM, 5%, 0.25W	01121	CB2425
A23R119	315-0560-00		RES., FXD, CMPSN:56 OHM, 5%, 0.25W	01121	CB5605
A23R120	315-0473-00		RES., FXD, CMPSN:47K OHM, 5%, 0.25W	01121	CB4735
A23R121	315-0473-00		RES., FXD, CMPSN:47K OHM, 5%, 0.25W	01121	CB4735
A23R122	307-0113-00		RES., FXD, CMPSN:5.1 OHM, 5%, 0.25W	01121	CB51G5
A23R124	315-0101-00		RES., FXD, CMPSN:100 OHM, 5%, 0.25W	01121	CB1015
A23R125	315-0302-00		RES., FXD, CMPSN:3K OHM, 5%, 0.25W	01121	CB3025
A23R126	315-0302-00		RES., FXD, CMPSN:3K OHM, 5%, 0.25W	01121	CB3025
A23R127	311-2102-00		RES., VAR, NONWIR:TRMR, 10K OHM, 1%, 0.5W	73138	72-269-0
A23R128	315-0222-00		RES., FXD, CMPSN:2.2K OHM, 5%, 0.25W	01121	CB2225
A23R131	315-0470-00	XB010513	RES., FXD, CMPSN:47 OHM, 5%, 0.25W	01121	CB4705

Component No.	Tektronix Part No.	Serial/Model No. Eff Dscont	Name & Description	Mfr Code	Mfr Part Number
A23R132	315-0302-00		RES., FXD, CMPSN:3K OHM, 5%, 0.25W	01121	CB3025
A23R133	315-0302-00		RES., FXD, CMPSN:3K OHM, 5%, 0.25W	01121	CB3025
A23R134	315-0620-00		RES., FXD, CMPSN:62 OHM, 5%, 0.25W	01121	CB6205
A23R135	315-0222-00		RES., FXD, CMPSN:2.2K OHM, 5%, 0.25W	01121	CB2225
A23R139	315-0391-00		RES., FXD, CMPSN:390 OHM, 5%, 0.25W	01121	CB3915
A23R140	315-0102-00		RES., FXD, CMPSN:1K OHM, 5%, 0.25W	01121	CB1025
A23R141	315-0222-00		RES., FXD, CMPSN:2.2K OHM, 5%, 0.25W	01121	CB2225
A23R142	315-0101-00		RES., FXD, CMPSN:100 OHM, 5%, 0.25W	01121	CB1015
A23R145	315-0470-00	XB010513	RES., FXD, CMPSN:47 OHM, 5%, 0.25W	01121	CB4705
A23R146	315-0302-00		RES., FXD, CMPSN:3K OHM, 5%, 0.25W	01121	CB3025
A23R147	315-0302-00		RES., FXD, CMPSN:3K OHM, 5%, 0.25W	01121	CB3025
A23R148	315-0302-00		RES., FXD, CMPSN:3K OHM, 5%, 0.25W	01121	CB3025
A23R149	315-0302-00		RES., FXD, CMPSN:3K OHM, 5%, 0.25W	01121	CB3025
A23R150	119-1485-00		COMPONENT ASSY:CAPACITOR/RESISTOR	80009	119-1485-00
A23R153	315-0302-00		RES., FXD, CMPSN:3K OHM, 5%, 0.25W	01121	CB3025
A23R154	315-0132-00		RES., FXD, CMPSN:1.3K OHM, 5%, 0.25W	01121	CB1325
A23R155	315-0223-00		RES., FXD, CMPSN:22K OHM, 5%, 0.25W	01121	CB2235
A23R156	315-0102-00		RES., FXD, CMPSN:1K OHM, 5%, 0.25W	01121	CB1025
A23R160	315-0101-00		RES., FXD, CMPSN:100 OHM, 5%, 0.25W	01121	CB1015
A23R161	315-0752-00		RES., FXD, CMPSN:7.5K OHM, 5%, 0.25W	01121	CB7525
A23R162	315-0100-00		RES., FXD, CMPSN:10 OHM, 5%, 0.25W	01121	CB1005
A23R163	311-1137-00		RES., VAR, NONWIR:5K OHM, 20%, 0.50W	73138	72PX-67-0-502M
A23R164	315-0132-00		RES., FXD, CMPSN:1.3K OHM, 5%, 0.25W	01121	CB1325
A23R167	321-0193-00		RES., FXD, FILM:1K OHM, 1%, 0.125W	91637	MFF1816G10000F
A23S22	263-0075-00		SW LEVER ASSY:4 POSN, 14 DEG, A COUPLING	80009	263-0075-00
A23S67	263-0076-00		SW LEVER ASSY:A SOURCE	80009	263-0076-00
A23U81	155-0196-00		MICROCKT, INTFC:TRIGGER	80009	155-0196-00
A23U122	155-0196-00		MICROCKT, INTFC:TRIGGER	80009	155-0196-00

**Replaceable Electrical Parts—2336 Service**

Component No.	Tektronix Part No.	Serial/Model No. Eff Dscont	Name & Description	Mfr Code	Mfr Part Number
A24	-----		CKT BOARD ASSY:SWEEP/HORIZ AMP		
A24C1	290-0136-00		CAP.,FXD,ELCLTLT:2.2UF,20%,20V	56289	162D225X0020CD2
A24C2	281-0775-00		CAP.,FXD,CER DI:0.1UF,20%,50V	72982	8005D9AABZ5U104M
A24C6	281-0809-00		CAP.,FXD,CER DI:200PF,5%,100V	72982	8013T2ADDC1G201J
A24C15	281-0775-00		CAP.,FXD,CER DI:0.1UF,20%,50V	72982	8005D9AABZ5U104M
A24C19	281-0811-00		CAP.,FXD,CER DI:10PF,10%,100V	72982	8035D2AADC1G100K
A24C20	281-0816-00		CAP.,FXD,CER DI:82PF,5%,100V	20932	201-E0-100AT820J
A24C21	281-0775-00		CAP.,FXD,CER DI:0.1UF,20%,50V	72982	8005D9AABZ5U104M
A24C22	281-0160-00		CAP.,VAR,CER DI:7-25PF,350V	72982	538-011B7-25
A24C23	281-0763-00		CAP.,FXD,CER DI:47PF,10%,100V	72982	8035D9AADC1G470K
A24C54	281-0785-00		CAP.,FXD,CER DI:68PF,10%,100V	72982	8035D2AADC0G680K
A24C68	281-0763-00		CAP.,FXD,CER DI:47PF,10%,100V	72982	8035D9AADC1G470K
A24C76	290-0136-00		CAP.,FXD,ELCLTLT:2.2UF,20%,20V	56289	162D225X0020CD2
A24C80	281-0797-00		CAP.,FXD,CER DI:15PF,10%,100V	72982	8035D9AADC0G150K
A24C82	281-0816-00		CAP.,FXD,CER DI:82PF,5%,100V	20932	201-E0-100AT820J
A24C83	281-0775-00		CAP.,FXD,CER DI:0.1UF,20%,50V	72982	8005D9AABZ5U104M
A24C84	281-0160-00		CAP.,VAR,CER DI:7-25PF,350V	72982	538-011B7-25
A24C87	281-0775-00		CAP.,FXD,CER DI:0.1UF,20%,50V	72982	8005D9AABZ5U104M
A24C89	281-0775-00		CAP.,FXD,CER DI:0.1UF,20%,50V	72982	8005D9AABZ5U104M
A24C90	281-0775-00		CAP.,FXD,CER DI:0.1UF,20%,50V	72982	8005D9AABZ5U104M
A24C100	290-0264-00		CAP.,FXD,ELCLTLT:0.22UF,10%,35V	56289	162D224X9035BC2
A24C108	281-0775-00		CAP.,FXD,CER DI:0.1UF,20%,50V	72982	8005D9AABZ5U104M
A24C128	281-0775-00		CAP.,FXD,CER DI:0.1UF,20%,50V	72982	8005D9AABZ5U104M
A24C140	281-0775-00		CAP.,FXD,CER DI:0.1UF,20%,50V	72982	8005D9AABZ5U104M
A24C141	281-0775-00		CAP.,FXD,CER DI:0.1UF,20%,50V	72982	8005D9AABZ5U104M
A24C145	281-0775-00		CAP.,FXD,CER DI:0.1UF,20%,50V	72982	8005D9AABZ5U104M
A24C146	281-0810-00		CAP.,FXD,CER DI:5.6PF,0.5%,100V	72982	1035D2ADC0G569D
A24C147	281-0775-00		CAP.,FXD,CER DI:0.1UF,20%,50V	72982	8005D9AABZ5U104M
A24C148	281-0775-00		CAP.,FXD,CER DI:0.1UF,20%,50V	72982	8005D9AABZ5U104M
A24C149	281-0809-00		CAP.,FXD,CER DI:200PF,5%,100V	72982	8013T2ADDC1G201J
A24C153	281-0775-00		CAP.,FXD,CER DI:0.1UF,20%,50V	72982	8005D9AABZ5U104M
A24C155	281-0775-00		CAP.,FXD,CER DI:0.1UF,20%,50V	72982	8005D9AABZ5U104M
A24C159	281-0775-00		CAP.,FXD,CER DI:0.1UF,20%,50V	72982	8005D9AABZ5U104M
A24C160	281-0775-00		CAP.,FXD,CER DI:0.1UF,20%,50V	72982	8005D9AABZ5U104M
A24C161	281-0138-00		CAP.,VAR,PLSTC:0.4-1.2PF,600V	74970	273-0051-001
A24C167	285-1100-00		CAP.,FXD,PLSTC:0.022UF,5%,200V	19396	223J02PT485
A24C169	281-0771-00		CAP.,FXD,CER DI:0.0022UF,20%,200V	56289	292C Z5U222M200B
A24C173	281-0775-00		CAP.,FXD,CER DI:0.1UF,20%,50V	72982	8005D9AABZ5U104M
A24C174	281-0775-00		CAP.,FXD,CER DI:0.1UF,20%,50V	72982	8005D9AABZ5U104M
A24C180	285-1100-00		CAP.,FXD,PLSTC:0.022UF,5%,200V	19396	223J02PT485
A24C182	281-0771-00		CAP.,FXD,CER DI:0.0022UF,20%,200V	56289	292C Z5U222M200B
A24C187	281-0138-00		CAP.,VAR,PLSTC:0.4-1.2PF,600V	74970	273-0051-001
A24C190	285-0695-00		CAP.,FXD,PLSTC:0.01UF,10%,200V	56289	292P10392
A24C194	290-0136-00		CAP.,FXD,ELCLTLT:2.2UF,20%,20V	56289	162D225X0020CD2
A24C197	281-0775-00		CAP.,FXD,CER DI:0.1UF,20%,50V	72982	8005D9AABZ5U104M
A24C200	281-0775-00		CAP.,FXD,CER DI:0.1UF,20%,50V	72982	8005D9AABZ5U104M
A24C201	281-0775-00		CAP.,FXD,CER DI:0.1UF,20%,50V	72982	8005D9AABZ5U104M
A24C205	283-0212-00		CAP.,FXD,CER DI:2UF,20%,50V	72982	8141N064Z5U205M
A24C206	283-0212-00		CAP.,FXD,CER DI:2UF,20%,50V	72982	8141N064Z5U205M
A24C209	281-0775-00		CAP.,FXD,CER DI:0.1UF,20%,50V	72982	8005D9AABZ5U104M
A24C240	281-0775-00		CAP.,FXD,CER DI:0.1UF,20%,50V	72982	8005D9AABZ5U104M
A24C244	285-1100-00		CAP.,FXD,PLSTC:0.022UF,5%,200V	19396	223J02PT485
A24C250	290-0164-00		CAP.,FXD,ELCLTLT:1UF,+50-10%,150V	56289	500D105F150BA7
A24C265	290-0290-00		CAP.,FXD,ELCLTLT:10UF,20%,25V	56289	30D472
A24C266	290-0264-00		CAP.,FXD,ELCLTLT:0.22UF,10%,35V	56289	162D224X9035BC2
A24C267	290-0121-00		CAP.,FXD,ELCLTLT:2UF,+75-10%,25V	56289	30D205G025BA9
A24C273	290-0290-00		CAP.,FXD,ELCLTLT:10UF,20%,25V	56289	30D472

Component No.	Tektronix Part No.	Serial/Model No. Eff Dscont	Name & Description	Mfr Code	Mfr Part Number
A24C281	290-0264-00		CAP., FXD, ELCTLT: 0.22UF, 10%, 35V	56289	162D224X9035BC2
A24C282	290-0121-00		CAP., FXD, ELCTLT: 2UF, +75-10%, 25V	56289	30D205G025BA9
A24C284	290-0290-00		CAP., FXD, ELCTLT: 10UF, 20%, 25V	56289	30D472
A24C288	290-0264-00		CAP., FXD, ELCTLT: 0.22UF, 10%, 35V	56289	162D224X9035BC2
A24C290	290-0121-00		CAP., FXD, ELCTLT: 2UF, +75-10%, 25V	56289	30D205G025BA9
A24C340	281-0765-00		CAP., FXD, CER DI: 100PF, 5%, 100V	51642	G1710100X5P101J
A24C343	281-0820-00		CAP., FXD, CER DI: 680PF, 10%, 50V	12969	CGB681KDX
A24C345	281-0773-00		CAP., FXD, CER DI: 0.01UF, 10%, 100V	04222	GC70-1C103K
A24C347	290-0188-00		CAP., FXD, ELCTLT: 0.1UF, 10%, 35V	56289	162D104X9035BC2
A24C349	290-0283-00		CAP., FXD, ELCTLT: 0.47UF, 10%, 35V	56289	162D474X9035BC2
A24C351	290-0246-00		CAP., FXD, ELCTLT: 3.3UF, 10%, 15V	56289	162D335X9015CD2
A24C355	281-0765-00		CAP., FXD, CER DI: 100PF, 5%, 100V	51642	G1710100X5P101J
A24CR21	152-0141-02		SEMICONV DEVICE: SILICON, 30V, 150MA	01295	1N4152R
A24CR28	152-0141-02		SEMICONV DEVICE: SILICON, 30V, 150MA	01295	1N4152R
A24CR29	152-0141-02		SEMICONV DEVICE: SILICON, 30V, 150MA	01295	1N4152R
A24CR45	152-0141-02		SEMICONV DEVICE: SILICON, 30V, 150MA	01295	1N4152R
A24CR47	152-0141-02		SEMICONV DEVICE: SILICON, 30V, 150MA	01295	1N4152R
A24CR63	152-0141-02		SEMICONV DEVICE: SILICON, 30V, 150MA	01295	1N4152R
A24CR83	152-0141-02		SEMICONV DEVICE: SILICON, 30V, 150MA	01295	1N4152R
A24CR87	152-0141-02		SEMICONV DEVICE: SILICON, 30V, 150MA	01295	1N4152R
A24CR88	152-0141-02		SEMICONV DEVICE: SILICON, 30V, 150MA	01295	1N4152R
A24CR111	152-0141-02		SEMICONV DEVICE: SILICON, 30V, 150MA	01295	1N4152R
A24CR128	152-0141-02		SEMICONV DEVICE: SILICON, 30V, 150MA	01295	1N4152R
A24CR133	152-0141-02		SEMICONV DEVICE: SILICON, 30V, 150MA	01295	1N4152R
A24CR135	152-0141-02		SEMICONV DEVICE: SILICON, 30V, 150MA	01295	1N4152R
A24CR160	152-0141-02		SEMICONV DEVICE: SILICON, 30V, 150MA	01295	1N4152R
A24CR161	152-0141-02		SEMICONV DEVICE: SILICON, 30V, 150MA	01295	1N4152R
A24CR175	152-0141-02		SEMICONV DEVICE: SILICON, 30V, 150MA	01295	1N4152R
A24CR193	152-0141-02		SEMICONV DEVICE: SILICON, 30V, 150MA	01295	1N4152R
A24CR195	152-0141-02		SEMICONV DEVICE: SILICON, 30V, 150MA	01295	1N4152R
A24CR202	152-0141-02		SEMICONV DEVICE: SILICON, 30V, 150MA	01295	1N4152R
A24CR208	152-0141-02		SEMICONV DEVICE: SILICON, 30V, 150MA	01295	1N4152R
A24CR300	152-0141-02		SEMICONV DEVICE: SILICON, 30V, 150MA	01295	1N4152R
A24CR301	152-0141-02		SEMICONV DEVICE: SILICON, 30V, 150MA	01295	1N4152R
A24CR302	152-0141-02		SEMICONV DEVICE: SILICON, 30V, 150MA	01295	1N4152R
A24CR303	152-0141-02		SEMICONV DEVICE: SILICON, 30V, 150MA	01295	1N4152R
A24CR308	152-0141-02		SEMICONV DEVICE: SILICON, 30V, 150MA	01295	1N4152R
A24CR311	152-0141-02		SEMICONV DEVICE: SILICON, 30V, 150MA	01295	1N4152R
A24CR313	152-0141-02		SEMICONV DEVICE: SILICON, 30V, 150MA	01295	1N4152R
A24CR314	152-0141-02		SEMICONV DEVICE: SILICON, 30V, 150MA	01295	1N4152R
A24CR315	152-0141-02		SEMICONV DEVICE: SILICON, 30V, 150MA	01295	1N4152R
A24CR316	152-0141-02		SEMICONV DEVICE: SILICON, 30V, 150MA	01295	1N4152R
A24CR317	152-0141-02		SEMICONV DEVICE: SILICON, 30V, 150MA	01295	1N4152R
A24CR318	152-0141-02		SEMICONV DEVICE: SILICON, 30V, 150MA	01295	1N4152R
A24CR319	152-0141-02		SEMICONV DEVICE: SILICON, 30V, 150MA	01295	1N4152R
A24CR321	152-0141-02		SEMICONV DEVICE: SILICON, 30V, 150MA	01295	1N4152R
A24CR322	152-0141-02		SEMICONV DEVICE: SILICON, 30V, 150MA	01295	1N4152R
A24CR323	152-0141-02		SEMICONV DEVICE: SILICON, 30V, 150MA	01295	1N4152R
A24CR324	152-0141-02		SEMICONV DEVICE: SILICON, 30V, 150MA	01295	1N4152R
A24CR325	152-0141-02		SEMICONV DEVICE: SILICON, 30V, 150MA	01295	1N4152R
A24CR327	152-0141-02		SEMICONV DEVICE: SILICON, 30V, 150MA	01295	1N4152R
A24CR329	152-0141-02		SEMICONV DEVICE: SILICON, 30V, 150MA	01295	1N4152R
A24CR330	152-0141-02		SEMICONV DEVICE: SILICON, 30V, 150MA	01295	1N4152R
A24CR334	152-0141-02		SEMICONV DEVICE: SILICON, 30V, 150MA	01295	1N4152R
A24CR336	152-0141-02		SEMICONV DEVICE: SILICON, 30V, 150MA	01295	1N4152R
A24CR340	152-0141-02		SEMICONV DEVICE: SILICON, 30V, 150MA	01295	1N4152R
A24CR341	152-0141-02		SEMICONV DEVICE: SILICON, 30V, 150MA	01295	1N4152R

Replaceable Electrical Parts—2336 Service

Component No.	Tektronix Part No.	Serial/Model No. Eff Dscnt	Name & Description	Mfr Code	Mfr Part Number
A24CR342	152-0141-02		SEMICON D DEVICE:SILICON,30V,150MA	01295	1N4152R
A24CR343	152-0141-02		SEMICON D DEVICE:SILICON,30V,150MA	01295	1N4152R
A24CR344	152-0141-02		SEMICON D DEVICE:SILICON,30V,150MA	01295	1N4152R
A24CR345	152-0141-02		SEMICON D DEVICE:SILICON,30V,150MA	01295	1N4152R
A24CR346	152-0141-02		SEMICON D DEVICE:SILICON,30V,150MA	01295	1N4152R
A24CR347	152-0141-02		SEMICON D DEVICE:SILICON,30V,150MA	01295	1N4152R
A24CR348	152-0141-02		SEMICON D DEVICE:SILICON,30V,150MA	01295	1N4152R
A24CR349	152-0141-02		SEMICON D DEVICE:SILICON,30V,150MA	01295	1N4152R
A24CR350	152-0141-02		SEMICON D DEVICE:SILICON,30V,150MA	01295	1N4152R
A24CR351	152-0141-02		SEMICON D DEVICE:SILICON,30V,150MA	01295	1N4152R
A24CR353	152-0141-02		SEMICON D DEVICE:SILICON,30V,150MA	01295	1N4152R
A24CR357	152-0141-02		SEMICON D DEVICE:SILICON,30V,150MA	01295	1N4152R
A24CR358	152-0141-02		SEMICON D DEVICE:SILICON,30V,150MA	01295	1N4152R
A24CR359	152-0141-02		SEMICON D DEVICE:SILICON,30V,150MA	01295	1N4152R
A24CR360	152-0141-02		SEMICON D DEVICE:SILICON,30V,150MA	01295	1N4152R
A24CR362	152-0141-02		SEMICON D DEVICE:SILICON,30V,150MA	01295	1N4152R
A24E36	119-1487-00		COMPONENT ASSY:SHIELDING BEAD/BARE WIRE	80009	119-1487-00
A24E54	119-1487-00		COMPONENT ASSY:SHIELDING BEAD/BARE WIRE	80009	119-1487-00
A24E85	276-0507-00		SHIELDING BEAD ; FERRITE	78488	57-3443
A24K127	148-0076-00		RELAY, REED: 1 FORM A, 5V, 0.25A, 100V	95348	F81-1447
A24L36	119-1487-00		COMPONENT ASSY:SHIELDING BEAD/BARE WIRE	80009	119-1487-00
A24L54	119-1487-00		COMPONENT ASSY:SHIELDING BEAD/BARE WIRE	80009	119-1487-00
A24Q16	151-1042-00		SEMICON D VC SE:MATCHED PAIR FET	27014	SF50031
A24Q20	151-1042-00		SEMICON D VC SE:MATCHED PAIR FET	27014	SF50031
A24Q21	151-0188-03		TRANSISTOR:SILICON,PNP,SEL	80009	151-0188-03
A24Q24	151-0190-05		TRANSISTOR:SILICON,NPN	80009	151-0190-05
A24Q28	151-0188-03		TRANSISTOR:SILICON,PNP,SEL	80009	151-0188-03
A24Q80	151-1042-00		SEMICON D VC SE:MATCHED PAIR FET	27014	SF50031
A24Q81	151-1042-00		SEMICON D VC SE:MATCHED PAIR FET	27014	SF50031
A24Q83	151-0188-03		TRANSISTOR:SILICON,PNP,SEL	80009	151-0188-03
A24Q108	151-0190-05		TRANSISTOR:SILICON,NPN	80009	151-0190-05
A24Q111	151-0188-03		TRANSISTOR:SILICON,PNP,SEL	80009	151-0188-03
A24Q155	151-0190-05		TRANSISTOR:SILICON,NPN	80009	151-0190-05
A24Q160	151-0188-03		TRANSISTOR:SILICON,PNP,SEL	80009	151-0188-03
A24Q167	151-0347-01		TRANSISTOR:SILICON,NPN,PRESTRESSED	80009	151-0347-01
A24Q168	151-0350-01		TRANSISTOR:PNP,SI PRESTRESSED & TESTED	80009	151-0350-01
A24Q174	151-0460-00		TRANSISTOR:SILICON,NPN	80009	151-0460-00
A24Q176	151-0347-01		TRANSISTOR:SILICON,NPN,PRESTRESSED	80009	151-0347-01
A24Q181	151-0350-01		TRANSISTOR:PNP,SI PRESTRESSED & TESTED	80009	151-0350-01
A24Q208	151-0188-03		TRANSISTOR:SILICON,PNP,SEL	80009	151-0188-03
A24Q213	151-1025-00		TRANSISTOR:SILICON,JFE,N-CHANNEL	01295	SFB8129
A24Q222	151-0190-05		TRANSISTOR:SILICON,NPN	80009	151-0190-05
A24Q250	151-0190-05		TRANSISTOR:SILICON,NPN	80009	151-0190-05
A24Q267	151-0216-02		TRANSISTOR:PNP,SI PRESTRESSED & TESTED	80009	151-0216-02
A24Q271	151-0736-00		TRANSISTOR:SILICON,NPN	04713	SPS8317
A24Q281	151-0216-02		TRANSISTOR:PNP,SI PRESTRESSED & TESTED	80009	151-0216-02
A24Q282	151-0736-00		TRANSISTOR:SILICON,NPN	04713	SPS8317
A24Q288	151-0216-02		TRANSISTOR:PNP,SI PRESTRESSED & TESTED	80009	151-0216-02
A24Q289	151-0405-03		TRANSISTOR:SILICON,NPN,CHK	80009	151-0405-03
A24Q290	151-0736-00		TRANSISTOR:SILICON,NPN	04713	SPS8317
A24Q327	151-0190-05		TRANSISTOR:SILICON,NPN	80009	151-0190-05
A24R1	315-0223-00		RES.,FXD,CMPSN:22K OHM,5%,0.25W	01121	CB2235
A24R3	315-0470-00		RES.,FXD,CMPSN:47 OHM,5%,0.25W	01121	CB4705
A24R4	321-0385-00		RES.,FXD,FILM:100K OHM,1%,0.125W	91637	MFF1816G10002F
A24R6	311-1943-00		RES.,VAR, NONWIR:10K OHM,10%,0.50W	73138	68-10-0
A24R8	321-0327-00		RES.,FXD,FILM:24.9K OHM,1%,0.125W	91637	MFF1816G24901F
A24R10	311-0607-00		RES.,VAR, NONWIR:10K OHM,10%,0.50W	73138	82-25-2

Component No.	Tektronix Part No.	Serial/Model No. Eff Dscont	Name & Description	Mfr Code	Mfr Part Number
A24R14	315-0203-00		RES.,FXD,CMPSN:20K OHM,5%,0.25W	01121	CB2035
A24R15	315-0203-00		RES.,FXD,CMPSN:20K OHM,5%,0.25W	01121	CB2035
A24R16	315-0303-00		RES.,FXD,CMPSN:30K OHM,5%,0.25W	01121	CB3035
A24R17	315-0153-00		RES.,FXD,CMPSN:15K OHM,5%,0.25W	01121	CB1535
A24R20	315-0272-00		RES.,FXD,CMPSN:2.7K OHM,5%,0.25W	01121	CB2725
A24R21	315-0220-00		RES.,FXD,CMPSN:22 OHM,5%,0.25W	01121	CB2205
A24R23	315-0824-00		RES.,FXD,CMPSN:820K OHM,5%,0.25W	01121	CB8245
A24R24	315-0103-00		RES.,FXD,CMPSN:10K OHM,5%,0.25W	01121	CB1035
A24R25	315-0103-00		RES.,FXD,CMPSN:10K OHM,5%,0.25W	01121	CB1035
A24R26	315-0220-00		RES.,FXD,CMPSN:22 OHM,5%,0.25W	01121	CB2205
A24R27	315-0101-00		RES.,FXD,CMPSN:100 OHM,5%,0.25W	01121	CB1015
A24R28	315-0471-00		RES.,FXD,CMPSN:470 OHM,5%,0.25W	01121	CB4715
A24R29	315-0102-00		RES.,FXD,CMPSN:1K OHM,5%,0.25W	01121	CB1025
A24R30	315-0912-00		RES.,FXD,CMPSN:9.1K OHM,5%,0.25W	01121	CB9125
A24R34	315-0912-00		RES.,FXD,CMPSN:9.1K OHM,5%,0.25W	01121	CB9125
A24R35	315-0912-00		RES.,FXD,CMPSN:9.1K OHM,5%,0.25W	01121	CB9125
A24R36	315-0332-00		RES.,FXD,CMPSN:3.3K OHM,5%,0.25W	01121	CB3325
A24R37	315-0912-00		RES.,FXD,CMPSN:9.1K OHM,5%,0.25W	01121	CB9125
A24R38	315-0106-00		RES.,FXD,CMPSN:10M OHM,5%,0.25W	01121	CB1065
A24R41	315-0332-00		RES.,FXD,CMPSN:3.3K OHM,5%,0.25W	01121	CB3325
A24R42	315-0103-00		RES.,FXD,CMPSN:10K OHM,5%,0.25W	01121	CB1035
A24R43	315-0512-00		RES.,FXD,CMPSN:5.1K OHM,5%,0.25W	01121	CB5125
A24R47	315-0102-00		RES.,FXD,CMPSN:1K OHM,5%,0.25W	01121	CB1025
A24R49	315-0302-00		RES.,FXD,CMPSN:3K OHM,5%,0.25W	01121	CB3025
A24R53	315-0122-00		RES.,FXD,CMPSN:1.2K OHM,5%,0.25W	01121	CB1225
A24R54	315-0390-00		RES.,FXD,CMPSN:39 OHM,5%,0.25W	01121	CB3905
A24R55	315-0101-00		RES.,FXD,CMPSN:100 OHM,5%,0.25W	01121	CB1015
A24R56	315-0392-00		RES.,FXD,CMPSN:3.9K OHM,5%,0.25W	01121	CB3925
A24R61	315-0103-00		RES.,FXD,CMPSN:10K OHM,5%,0.25W	01121	CB1035
A24R62	315-0912-00		RES.,FXD,CMPSN:9.1K OHM,5%,0.25W	01121	CB9125
A24R63	315-0472-00		RES.,FXD,CMPSN:4.7K OHM,5%,0.25W	01121	CB4725
A24R67	315-0153-00		RES.,FXD,CMPSN:15K OHM,5%,0.25W	01121	CB1535
A24R68	315-0824-00		RES.,FXD,CMPSN:820K OHM,5%,0.25W	01121	CB8245
A24R73	315-0683-00		RES.,FXD,CMPSN:68K OHM,5%,0.25W	01121	CB6835
A24R74	311-1943-00		RES.,VAR, NONWIR:10K OHM,10%,0.50W	73138	68-10-0
A24R75	315-0203-00		RES.,FXD,CMPSN:20K OHM,5%,0.25W	01121	CB2035
A24R76	315-0203-00		RES.,FXD,CMPSN:20K OHM,5%,0.25W	01121	CB2035
A24R77	315-0334-00		RES.,FXD,CMPSN:330K OHM,5%,0.25W	01121	CB3345
A24R81	315-0183-00		RES.,FXD,CMPSN:18K OHM,5%,0.25W	01121	CB1835
A24R82	315-0272-00		RES.,FXD,CMPSN:2.7K OHM,5%,0.25W	01121	CB2725
A24R83	315-0220-00		RES.,FXD,CMPSN:22 OHM,5%,0.25W	01121	CB2205
A24R85	317-0220-00		RES.,FXD,CMPSN:22 OHM,5%,0.125W	01121	BB2205
A24R88	315-0122-00		RES.,FXD,CMPSN:1.2K OHM,5%,0.25W	01121	CB1225
A24R89	315-0104-00		RES.,FXD,CMPSN:100K OHM,5%,0.25W	01121	CB1045
A24R90	315-0474-00		RES.,FXD,CMPSN:470K OHM,5%,0.25W	01121	CB4745
A24R100	315-0624-00		RES.,FXD,CMPSN:620K OHM,5%,0.25W	01121	CB6245
A24R104	315-0682-00		RES.,FXD,CMPSN:6.8K OHM,5%,0.25W	01121	CB6825
A24R105	315-0621-00	B010100 B010512	RES.,FXD,CMPSN:620 OHM,5%,0.25W	01121	CB6215
A24R105	315-0241-00	B010513	RES.,FXD,CMPSN:240 OHM,5%,0.25W	01121	CB2415
A24R106	315-0302-00		RES.,FXD,CMPSN:3K OHM,5%,0.25W	01121	CB3025
A24R107	315-0102-00		RES.,FXD,CMPSN:1K OHM,5%,0.25W	01121	CB1025
A24R108	315-0472-00		RES.,FXD,CMPSN:4.7K OHM,5%,0.25W	01121	CB4725
A24R109	315-0102-00		RES.,FXD,CMPSN:1K OHM,5%,0.25W	01121	CB1025
A24R110	315-0100-00		RES.,FXD,CMPSN:10 OHM,5%,0.25W	01121	CB1005
A24R111	315-0202-00		RES.,FXD,CMPSN:2K OHM,5%,0.25W	01121	CB2025
A24R112	315-0242-00		RES.,FXD,CMPSN:2.4K OHM,5%,0.25W	01121	CB2425
A24R124	321-0108-00		RES.,FXD,FILM:130 OHM,1%,0.125W	91637	MFF1816G130R0F

**Replaceable Electrical Parts—2336 Service**

Component No.	Tektronix Part No.	Serial/Model No. Eff Dscont	Name & Description	Mfr Code	Mfr Part Number
A24R125	321-0213-00		RES., FXD, FILM:1.62K OHM,1%,0.125W	91637	MFF1816G16200F
A24R126	311-2100-00		RES., VAR, NONWIR:TRMR,1K OHM,10%,0.5W	73138	72-267-0
A24R127	311-0622-00		RES., VAR, NONWIR:100 OHM,10%,0.50W	32997	3329H-G48-101
A24R128	307-0106-00		RES., FXD, CMPSN:4.7 OHM,5%,0.25W	01121	CB47G5
A24R132	315-0182-00		RES., FXD, CMPSN:1.8K OHM,5%,0.25W	01121	CB1825
A24R133	321-0307-00		RES., FXD, FILM:15.4K OHM,1%,0.125W	91637	MFF1816G15401F
A24R134	311-1137-00		RES., VAR, NONWIR:5K OHM,20%,0.50W	73138	72PX-67-0-502M
A24R135	321-0307-00		RES., FXD, FILM:15.4K OHM,1%,0.125W	91637	MFF1816G15401F
A24R139	315-0223-00		RES., FXD, CMPSN:22K OHM,5%,0.25W	01121	CB2235
A24R140	315-0101-00		RES., FXD, CMPSN:100 OHM,5%,0.25W	01121	CB1015
A24R141	315-0753-00		RES., FXD, CMPSN:75K OHM,5%,0.25W	01121	CB7535
A24R142	321-0222-07		RES., FXD, FILM:2K OHM,0.1%,0.125W	91637	MFF1816C20000B
A24R146	321-0268-00		RES., FXD, FILM:6.04K OHM,1%,0.125W	91637	MFF1816G60400F
A24R147	315-0103-00		RES., FXD, CMPSN:10K OHM,5%,0.25W	01121	CB1035
A24R148	311-2099-00		RES., VAR, NONWIR:TRMR,500 OHM,10%,0.5W	73138	72-266-0
A24R149	321-0337-00		RES., FXD, FILM:31.6K OHM,1%,0.125W	91637	MFF1816G31601F
A24R153	307-0106-00		RES., FXD, CMPSN:4.7 OHM,5%,0.25W	01121	CB47G5
A24R154	315-0470-00		RES., FXD, CMPSN:47 OHM,5%,0.25W	01121	CB4705
A24R155	321-0260-00		RES., FXD, FILM:4.99K OHM,1%,0.125W	91637	MFF1816G49900F
A24R156	321-0306-00		RES., FXD, FILM:15K OHM,1%,0.125W	91637	MFF1816G15001F
A24R163	315-0470-00		RES., FXD, CMPSN:47 OHM,5%,0.25W	01121	CB4705
A24R167	301-0223-00		RES., FXD, CMPSN:22K OHM,5%,0.50W	01121	EB2235
A24R168	321-0189-00		RES., FXD, FILM:909 OHM,1%,0.125W	91637	MFF1816G9090RF
A24R169	315-0470-00		RES., FXD, CMPSN:47 OHM,5%,0.25W	01121	CB4705
A24R170	315-0562-00		RES., FXD, CMPSN:5.6K OHM,5%,0.25W	01121	CB5625
A24R173	315-0470-00		RES., FXD, CMPSN:47 OHM,5%,0.25W	01121	CB4705
A24R174	315-0241-00		RES., FXD, CMPSN:240 OHM,5%,0.25W	01121	CB2415
A24R175	315-0431-00		RES., FXD, CMPSN:430 OHM,5%,0.25W	01121	CB4315
A24R176	315-0681-00		RES., FXD, CMPSN:680 OHM,5%,0.25W	01121	CB6815
A24R181	321-0189-00		RES., FXD, FILM:909 OHM,1%,0.125W	91637	MFF1816G9090RF
A24R182	315-0470-00		RES., FXD, CMPSN:47 OHM,5%,0.25W	01121	CB4705
A24R183	315-0913-00		RES., FXD, CMPSN:91K OHM,5%,0.25W	01121	CB9135
A24R187	323-0312-00		RES., FXD, FILM:17.4K OHM,1%,0.50W	91637	MFF1226G17401F
A24R190	315-0470-00		RES., FXD, CMPSN:47 OHM,5%,0.25W	01121	CB4705
A24R193	315-0473-00		RES., FXD, CMPSN:47K OHM,5%,0.25W	01121	CB4735
A24R194	321-0432-00		RES., FXD, FILM:309K OHM,1%,0.125W	91637	MFF1816G30902F
A24R195	315-0622-00		RES., FXD, CMPSN:6.2K OHM,5%,0.25W	01121	CB6225
A24R196	321-0309-00		RES., FXD, FILM:16.2K OHM,1%,0.125W	91637	MFF1816G16201F
A24R197	321-0310-00		RES., FXD, FILM:16.5K OHM,1%,0.125W	91637	MFF1816G16501F
A24R198	321-0306-00		RES., FXD, FILM:15K OHM,1%,0.125W	91637	MFF1816G15001F
A24R201	315-0103-00		RES., FXD, CMPSN:10K OHM,5%,0.25W	01121	CB1035
A24R203	315-0363-00		RES., FXD, CMPSN:36K OHM,5%,0.25W	01121	CB3635
A24R204	315-0433-00		RES., FXD, CMPSN:43K OHM,5%,0.25W	01121	CB4335
A24R205	315-0470-00		RES., FXD, CMPSN:47 OHM,5%,0.25W	01121	CB4705
A24R206	315-0470-00		RES., FXD, CMPSN:47 OHM,5%,0.25W	01121	CB4705
A24R208	315-0103-00		RES., FXD, CMPSN:10K OHM,5%,0.25W	01121	CB1035
A24R209	315-0103-00		RES., FXD, CMPSN:10K OHM,5%,0.25W	01121	CB1035
A24R210	321-0193-07		RES., FXD, FILM:1K OHM,0.1%,0.125W	91637	MFF1816C10000B
A24R212	315-0394-00		RES., FXD, CMPSN:390K OHM,5%,0.25W	01121	CB3945
A24R213	315-0105-00		RES., FXD, CMPSN:1M OHM,5%,0.25W	01121	CB1055
A24R214	321-0926-07		RES., FXD, FILM:4K OHM,0.1%,0.125W	91637	MFF1816C40000B
A24R215	321-0193-07		RES., FXD, FILM:1K OHM,0.1%,0.125W	91637	MFF1816C10000B
A24R216	321-0222-07		RES., FXD, FILM:2K OHM,0.1%,0.125W	91637	MFF1816C20000B
A24R219	315-0103-00		RES., FXD, CMPSN:10K OHM,5%,0.25W	01121	CB1035
A24R220	315-0103-00		RES., FXD, CMPSN:10K OHM,5%,0.25W	01121	CB1035
A24R221	315-0103-00		RES., FXD, CMPSN:10K OHM,5%,0.25W	01121	CB1035
A24R222	315-0102-00		RES., FXD, CMPSN:1K OHM,5%,0.25W	01121	CB1025

Component No.	Tektronix Part No.	Serial/Model No. Eff Dscont	Name & Description	Mfr Code	Mfr Part Number
A24R223	315-0103-00		RES., FXD, CMPSN:10K OHM, 5%, 0.25W	01121	CB1035
A24R224	315-0103-00		RES., FXD, CMPSN:10K OHM, 5%, 0.25W	01121	CB1035
A24R226	315-0103-00		RES., FXD, CMPSN:10K OHM, 5%, 0.25W	01121	CB1035
A24R238	321-0323-00		RES., FXD, FILM:22.6K OHM, 1%, 0.125W	91637	MFF1816G22601F
A24R239	321-0323-00		RES., FXD, FILM:22.6K OHM, 1%, 0.125W	91637	MFF1816G22601F
A24R240	315-0101-00		RES., FXD, CMPSN:100 OHM, 5%, 0.25W	01121	CB1015
A24R243	315-0563-00		RES., FXD, CMPSN:56K OHM, 5%, 0.25W	01121	CB5635
A24R244	321-0358-00		RES., FXD, FILM:52.3K OHM, 1%, 0.125W	91637	MFF1816G52301F
A24R245	321-0358-00		RES., FXD, FILM:52.3K OHM, 1%, 0.125W	91637	MFF1816G52301F
A24R246	315-0103-00		RES., FXD, CMPSN:10K OHM, 5%, 0.25W	01121	CB1035
A24R250	321-1289-07		RES., FXD, FILM:10.1K OHM, 0.1%, 0.125W	91637	MFF1816C10101B
A24R251	315-0100-00		RES., FXD, CMPSN:10 OHM, 5%, 0.25W	01121	CB1005
A24R252	321-0685-07		RES., FXD, FILM:30K OHM, 0.1%, 0.125W	91637	MFF1816C30001B
A24R253	321-0829-07		RES., FXD, FILM:202 OHM, 0.1%, 0.125W	91637	MFF1816C202R0B
A24R264	315-0223-00		RES., FXD, CMPSN:22K OHM, 5%, 0.25W	01121	CB2235
A24R265	315-0333-00		RES., FXD, CMPSN:33K OHM, 5%, 0.25W	01121	CB3335
A24R267	315-0681-00		RES., FXD, CMPSN:680 OHM, 5%, 0.25W	01121	CB6815
A24R271	315-0163-00		RES., FXD, CMPSN:16K OHM, 5%, 0.25W	01121	CB1635
A24R272	315-0223-00		RES., FXD, CMPSN:22K OHM, 5%, 0.25W	01121	CB2235
A24R273	315-0393-00		RES., FXD, CMPSN:39K OHM, 5%, 0.25W	01121	CB3935
A24R274	315-0104-00		RES., FXD, CMPSN:100K OHM, 5%, 0.25W	01121	CB1045
A24R281	315-0681-00		RES., FXD, CMPSN:680 OHM, 5%, 0.25W	01121	CB6815
A24R282	315-0163-00		RES., FXD, CMPSN:16K OHM, 5%, 0.25W	01121	CB1635
A24R283	315-0223-00		RES., FXD, CMPSN:22K OHM, 5%, 0.25W	01121	CB2235
A24R284	315-0473-00		RES., FXD, CMPSN:47K OHM, 5%, 0.25W	01121	CB4735
A24R287	315-0104-00		RES., FXD, CMPSN:100K OHM, 5%, 0.25W	01121	CB1045
A24R288	315-0681-00		RES., FXD, CMPSN:680 OHM, 5%, 0.25W	01121	CB6815
A24R289	315-0151-00		RES., FXD, CMPSN:150 OHM, 5%, 0.25W	01121	CB1515
A24R290	315-0163-00		RES., FXD, CMPSN:16K OHM, 5%, 0.25W	01121	CB1635
A24R294	321-0291-00		RES., FXD, FILM:10.5K OHM, 1%, 0.125W	91637	MFF1816G10501F
A24R295	315-0203-00		RES., FXD, CMPSN:20K OHM, 5%, 0.25W	01121	CB2035
A24R296	321-0260-00		RES., FXD, FILM:4.99K OHM, 1%, 0.125W	91637	MFF1816G49900F
A24R326	315-0202-00		RES., FXD, CMPSN:2K OHM, 5%, 0.25W	01121	CB2025
A24R327	315-0153-00		RES., FXD, CMPSN:15K OHM, 5%, 0.25W	01121	CB1535
A24R340	315-0273-00		RES., FXD, CMPSN:27K OHM, 5%, 0.25W	01121	CB2735
A24R343	315-0333-00		RES., FXD, CMPSN:33K OHM, 5%, 0.25W	01121	CB3335
A24R345	315-0333-00		RES., FXD, CMPSN:33K OHM, 5%, 0.25W	01121	CB3335
A24R347	315-0333-00		RES., FXD, CMPSN:33K OHM, 5%, 0.25W	01121	CB3335
A24R349	315-0333-00		RES., FXD, CMPSN:33K OHM, 5%, 0.25W	01121	CB3335
A24R350	315-0431-00		RES., FXD, CMPSN:430 OHM, 5%, 0.25W	01121	CB4315
A24R351	315-0333-00		RES., FXD, CMPSN:33K OHM, 5%, 0.25W	01121	CB3335
A24R353	315-0562-00		RES., FXD, CMPSN:5.6K OHM, 5%, 0.25W	01121	CB5625
A24R355	315-0154-00		RES., FXD, CMPSN:150K OHM, 5%, 0.25W	01121	CB1545
A24R357	315-0752-00		RES., FXD, CMPSN:7.5K OHM, 5%, 0.25W	01121	CB7525
A24R359	315-0752-00		RES., FXD, CMPSN:7.5K OHM, 5%, 0.25W	01121	CB7525
A24R360	315-0752-00		RES., FXD, CMPSN:7.5K OHM, 5%, 0.25W	01121	CB7525
A24R362	315-0752-00		RES., FXD, CMPSN:7.5K OHM, 5%, 0.25W	01121	CB7525
A24R364	315-0163-00		RES., FXD, CMPSN:16K OHM, 5%, 0.25W	01121	CB1635
A24R365	315-0473-00		RES., FXD, CMPSN:47K OHM, 5%, 0.25W	01121	CB4735
A24R368	315-0163-00		RES., FXD, CMPSN:16K OHM, 5%, 0.25W	01121	CB1635
A24R369	315-0473-00		RES., FXD, CMPSN:47K OHM, 5%, 0.25W	01121	CB4735
A24R371	315-0163-00		RES., FXD, CMPSN:16K OHM, 5%, 0.25W	01121	CB1635
A24R372	315-0473-00		RES., FXD, CMPSN:47K OHM, 5%, 0.25W	01121	CB4735
A24R374	315-0163-00		RES., FXD, CMPSN:16K OHM, 5%, 0.25W	01121	CB1635
A24R375	315-0473-00		RES., FXD, CMPSN:47K OHM, 5%, 0.25W	01121	CB4735
A24RT295	307-0124-00		RES., THERMAL:5K OHM, 10%	50157	1D1618
A24TP2	214-0579-00		TERM, TEST POINT: BRS CD PL	80009	214-0579-00



Replaceable Electrical Parts—2336 Service

Component No.	Tektronix Part No.	Serial/Model No. Eff Dscont	Name & Description	Mfr Code	Mfr Part Number
A24TP3	214-0579-00		TERM,TEST POINT:BRS CD PL	80009	214-0579-00
A24TP9	214-0579-00		TERM,TEST POINT:BRS CD PL	80009	214-0579-00
A24TP27	214-0579-00		TERM,TEST POINT:BRS CD PL	80009	214-0579-00
A24TP49	214-0579-00		TERM,TEST POINT:BRS CD PL	80009	214-0579-00
A24TP55	214-0579-00		TERM,TEST POINT:BRS CD PL	80009	214-0579-00
A24TP85	214-0579-00		TERM,TEST POINT:BRS CD PL	80009	214-0579-00
A24TP86	214-0579-00		TERM,TEST POINT:BRS CD PL	80009	214-0579-00
A24TP87	214-0579-00		TERM,TEST POINT:BRS CD PL	80009	214-0579-00
A24TP89	214-0579-00		TERM,TEST POINT:BRS CD PL	80009	214-0579-00
A24TP106	214-0579-00		TERM,TEST POINT:BRS CD PL	80009	214-0579-00
A24TP127	214-0579-00		TERM,TEST POINT:BRS CD PL	80009	214-0579-00
A24TP190	214-0579-00		TERM,TEST POINT:BRS CD PL	80009	214-0579-00
A24TP194	214-0579-00		TERM,TEST POINT:BRS CD PL	80009	214-0579-00
A24TP210	214-0579-00		TERM,TEST POINT:BRS CD PL	80009	214-0579-00
A24TP216	214-0579-00		TERM,TEST POINT:BRS CD PL	80009	214-0579-00
A24TP246	214-0579-00		TERM,TEST POINT:BRS CD PL	80009	214-0579-00
A24TP250	214-0579-00		TERM,TEST POINT:BRS CD PL	80009	214-0579-00
A24TP327	214-0579-00		TERM,TEST POINT:BRS CD PL	80009	214-0579-00
A24U3	156-0053-00		MICROCIRCUIT,LI:VOLTAGE REGULATOR	07263	SL21721
A24U24	155-0123-00		MICROCIRCUIT,LI:A AND B SWP/PICKOFF	80009	155-0123-00
A24U43	155-0123-00		MICROCIRCUIT,LI:A AND B SWP/PICKOFF	80009	155-0123-00
A24U87	155-0122-00		MICROCIRCUIT,DI:A & B LOGIC	80009	155-0122-00
A24U108	156-0387-02		MICROCIRCUIT,DI:DUAL J-K FF,BURN IN	01295	SN74LS73
A24U128	155-0124-00		MICROCIRCUIT,LI:HORIZONTAL PREAMPL	80009	155-0124-00
A24U147	156-1338-00		MICROCIRCUIT,LI:OPERATIONAL AMPLIFIER	18324	NE5534N
A24U197	156-0158-03		MICROCIRCUIT,LI:DUAL OPNL AMPL,CHK	80009	156-0158-03
A24U198	156-0158-03		MICROCIRCUIT,LI:DUAL OPNL AMPL,CHK	80009	156-0158-03
A24U216	156-0515-03	B010100 B010274	MICROCIRCUIT,DI:TPL 2 CHAN MUX,SCR	80009	156-0515-03
A24U216	156-0515-02	B010275	MICROCIRCUIT,DI:TRIPLE 3-CHANMUX,SEL	80009	156-0515-02
A24U238	156-0494-02		MICROCIRCUIT,DI:HEX INV/BUFF,SELECTED	80009	156-0494-02
A24U365	156-0197-01		MICROCIRCUIT,LI:5-TRANSISTOR ARRAY	80009	156-0197-01
A24VR111	152-0149-00		SEMICONV DEVICE:ZENER,0.4W,10V,5%	04713	SZG35009K3
A24VR174	152-0217-00		SEMICONV DEVICE:ZENER,0.4W,8.2V,5%	04713	SZG20
A24W5	131-0566-00		BUS CONDUCTOR:DUMMY RES,2.375,22 AWG	55210	L-2007-1
A24W6	131-0566-00		BUS CONDUCTOR:DUMMY RES,2.375,22 AWG	55210	L-2007-1
A24W7	131-0566-00		BUS CONDUCTOR:DUMMY RES,2.375,22 AWG	55210	L-2007-1
A24W8	131-0566-00		BUS CONDUCTOR:DUMMY RES,2.375,22 AWG	55210	L-2007-1
A24W9	131-0566-00		BUS CONDUCTOR:DUMMY RES,2.375,22 AWG	55210	L-2007-1
A24W85	131-0566-00		BUS CONDUCTOR:DUMMY RES,2.375,22 AWG	55210	L-2007-1
A24W88	131-0566-00		BUS CONDUCTOR:DUMMY RES,2.375,22 AWG	55210	L-2007-1
A24W109	131-0566-00		BUS CONDUCTOR:DUMMY RES,2.375,22 AWG	55210	L-2007-1
A24W208	131-0566-00		BUS CONDUCTOR:DUMMY RES,2.375,22 AWG	55210	L-2007-1
A24W235	131-0566-00		BUS CONDUCTOR:DUMMY RES,2.375,22 AWG	55210	L-2007-1
A24W240	131-0566-00		BUS CONDUCTOR:DUMMY RES,2.375,22 AWG	55210	L-2007-1

Replaceable Electrical Parts—2336 Service

Component No.	Tektronix Part No.	Serial/Model No. Eff Dscont	Name & Description	Mfr Code	Mfr Part Number
A30	-----		CKT BOARD ASSY:DELTA TIME LOGIC		
A30C2	281-0773-00		CAP.,FXD,CER DI:0.01UF,10%,100V	04222	GC70-1C103K
A30C4	281-0775-00		CAP.,FXD,CER DI:0.1UF,20%,50V	72982	8005D9AABZ5U104M
A30C11	281-0814-00		CAP.,FXD,CER DI:100PF,10%,100V	04222	GC70-1-A101K
A30C12	285-0809-00		CAP.,FXD,PLSTC:1UF,10%,50V	56289	LP66A1A105K
A30C15	285-1098-00		CAP.,FXD,PLSTC:0.22UF,10%,80V	56289	192P2249R8
A30C16	285-1098-00		CAP.,FXD,PLSTC:0.22UF,10%,80V	56289	192P2249R8
A30C20	281-0775-00		CAP.,FXD,CER DI:0.1UF,20%,50V	72982	8005D9AABZ5U104M
A30C25	281-0814-00		CAP.,FXD,CER DI:100PF,10%,100V	04222	GC70-1-A101K
A30C30	290-0136-00		CAP.,FXD,ELCTLT:2.2UF,20%,20V	56289	162D225X0020CD2
A30C80	283-0414-00		CAP.,FXD,CER DI:0.022UF,20%,500V	51642	300-500X7R223M
A30C81	281-0797-00		CAP.,FXD,CER DI:15PF,10%,100V	72982	8035D9AADCOG150K
A30C83	281-0763-00		CAP.,FXD,CER DI:47PF,10%,100V	72982	8035D9AADC1G470K
A30C91	281-0775-00		CAP.,FXD,CER DI:0.1UF,20%,50V	72982	8005D9AABZ5U104M
A30C92	281-0775-00		CAP.,FXD,CER DI:0.1UF,20%,50V	72982	8005D9AABZ5U104M
A30CR30	152-0141-02		SEMICONV DEVICE:SILICON,30V,150MA	01295	1N4152R
A30CR50	152-0141-02		SEMICONV DEVICE:SILICON,30V,150MA	01295	1N4152R
A30CR51	152-0141-02		SEMICONV DEVICE:SILICON,30V,150MA	01295	1N4152R
A30CR52	152-0141-02		SEMICONV DEVICE:SILICON,30V,150MA	01295	1N4152R
A30CR55	152-0141-02		SEMICONV DEVICE:SILICON,30V,150MA	01295	1N4152R
A30CR62	152-0141-02		SEMICONV DEVICE:SILICON,30V,150MA	01295	1N4152R
A30CR67	152-0141-02		SEMICONV DEVICE:SILICON,30V,150MA	01295	1N4152R
A30CR71	152-0141-02		SEMICONV DEVICE:SILICON,30V,150MA	01295	1N4152R
A30CR85	152-0246-00		SEMICONV DEVICE:SW,SI,40V,200MA	03508	DE140
A30CR86	152-0246-00		SEMICONV DEVICE:SW,SI,40V,200MA	03508	DE140
A30CR89	152-0141-02		SEMICONV DEVICE:SILICON,30V,150MA	01295	1N4152R
A30DS41	150-1078-00		LT EMITTING DIO:GREEN,565NM,20MA	50434	HLMP 1502
A30Q88 }	151-1042-02	B010100 B010536	SEMICONV DVC SE:MATCHED PAIR FET	80009	151-1042-02
A30Q89 }					
A30Q88 }	151-1042-00	B010537	SEMICONV DVC SE:MATCHED PAIR FET	27014	SF50031
A30Q89 }					
A30Q92	151-0199-02		TRANSISTOR:SILICON,PNP,PRESTRESSED	80009	151-0199-02
A30R1	315-0105-00		RES.,FXD,CMPSN:1M OHM,5%,0.25W	01121	CB1055
A30R2	315-0105-00		RES.,FXD,CMPSN:1M OHM,5%,0.25W	01121	CB1055
A30R4	315-0153-00		RES.,FXD,CMPSN:15K OHM,5%,0.25W	01121	CB1535
A30R5	321-0268-00		RES.,FXD,FILM:6.04K OHM,1%,0.125W	91637	MFF1816G60400F
A30R7	321-0227-00		RES.,FXD,FILM:2.26K OHM,1%,0.125W	91637	MFF1816G22600F
A30R8A-B	307-0765-00		RES.,FXD,FILM:1K OHM & 9K OHM,5% EA,0.1W	07716	1168
A30R11	321-0385-00		RES.,FXD,FILM:100K OHM,1%,0.125W	91637	MFF1816G10002F
A30R15	321-0450-00		RES.,FXD,FILM:475K OHM,1%,0.125W	91637	MFF1816G47502F
A30R16	321-0354-00		RES.,FXD,FILM:47.5K OHM,1%,0.125W	91637	MFF1816G47501F
A30R18	315-0104-00		RES.,FXD,CMPSN:100K OHM,5%,0.25W	01121	CB1045
A30R21	315-0473-00		RES.,FXD,CMPSN:47K OHM,5%,0.25W	01121	CB4735
A30R25	315-0185-00		RES.,FXD,CMPSN:1.8M OHM,5%,0.25W	01121	CB1855
A30R27	315-0105-00		RES.,FXD,CMPSN:1M OHM,5%,0.25W	01121	CB1055
A30R28	315-0105-00		RES.,FXD,CMPSN:1M OHM,5%,0.25W	01121	CB1055
A30R29	315-0153-00		RES.,FXD,CMPSN:15K OHM,5%,0.25W	01121	CB1535
A30R30	315-0185-00		RES.,FXD,CMPSN:1.8M OHM,5%,0.25W	01121	CB1855
A30R31	315-0471-00		RES.,FXD,CMPSN:470 OHM,5%,0.25W	01121	CB4715
A30R34	315-0383-00		RES.,FXD,CMPSN:33K OHM,5%,0.25W	01121	CB3335
A30R35	315-0104-00		RES.,FXD,CMPSN:100K OHM,5%,0.25W	01121	CB1045
A30R36	315-0474-00		RES.,FXD,CMPSN:470K OHM,5%,0.25W	01121	CB4745
A30R37	315-0153-00		RES.,FXD,CMPSN:15K OHM,5%,0.25W	01121	CB1535
A30R38	315-0104-00		RES.,FXD,CMPSN:100K OHM,5%,0.25W	01121	CB1045
A30R39	315-0474-00		RES.,FXD,CMPSN:470K OHM,5%,0.25W	01121	CB4745
A30R40	315-0392-00		RES.,FXD,CMPSN:3.9K OHM,5%,0.25W	01121	CB3925
A30R41	315-0201-00		RES.,FXD,CMPSN:200 OHM,5%,0.25W	01121	CB2015

Replaceable Electrical Parts—2336 Service

Component No.	Tektronix Part No.	Serial/Model No. Eff Dscont	Name & Description	Mfr Code	Mfr Part Number
A30R42	315-0104-00		RES.,FXD,CMPSN:100K OHM,5%,0.25W	01121	CB1045
A30R43	315-0474-00		RES.,FXD,CMPSN:470K OHM,5%,0.25W	01121	CB4745
A30R45	315-0104-00		RES.,FXD,CMPSN:100K OHM,5%,0.25W	01121	CB1045
A30R46	315-0474-00		RES.,FXD,CMPSN:470K OHM,5%,0.25W	01121	CB4745
A30R48	315-0104-00		RES.,FXD,CMPSN:100K OHM,5%,0.25W	01121	CB1045
A30R49	315-0474-00		RES.,FXD,CMPSN:470K OHM,5%,0.25W	01121	CB4745
A30R51	315-0104-00		RES.,FXD,CMPSN:100K OHM,5%,0.25W	01121	CB1045
A30R52	315-0474-00		RES.,FXD,CMPSN:470K OHM,5%,0.25W	01121	CB4745
A30R53	315-0471-00		RES.,FXD,CMPSN:470 OHM,5%,0.25W	01121	CB4715
A30R55	315-0104-00		RES.,FXD,CMPSN:100K OHM,5%,0.25W	01121	CB1045
A30R57	315-0104-00		RES.,FXD,CMPSN:100K OHM,5%,0.25W	01121	CB1045
A30R62	315-0104-00		RES.,FXD,CMPSN:100K OHM,5%,0.25W	01121	CB1045
A30R64	315-0104-00		RES.,FXD,CMPSN:100K OHM,5%,0.25W	01121	CB1045
A30R67	315-0104-00		RES.,FXD,CMPSN:100K OHM,5%,0.25W	01121	CB1045
A30R69	315-0104-00		RES.,FXD,CMPSN:100K OHM,5%,0.25W	01121	CB1045
A30R71	315-0104-00		RES.,FXD,CMPSN:100K OHM,5%,0.25W	01121	CB1045
A30R73	315-0104-00		RES.,FXD,CMPSN:100K OHM,5%,0.25W	01121	CB1045
A30R80	315-0270-01		RES.,FXD,CMPSN:27 OHM,5%,0.25W	01121	CB2705
A30R81	315-0754-00		RES.,FXD,CMPSN:750K OHM,5%,0.25W	01121	CB7545
A30R83	315-0244-00		RES.,FXD,CMPSN:240K OHM,5%,0.25W	01121	CB2445
A30R85	315-0470-00		RES.,FXD,CMPSN:47 OHM,5%,0.25W	01121	CB4705
A30R88	315-0470-00		RES.,FXD,CMPSN:47 OHM,5%,0.25W	01121	CB4705
A30R89	315-0101-00		RES.,FXD,CMPSN:100 OHM,5%,0.25W	01121	CB1015
A30R90	315-0470-00		RES.,FXD,CMPSN:47 OHM,5%,0.25W	01121	CB4705
A30R92	315-0102-00		RES.,FXD,CMPSN:1K OHM,5%,0.25W	01121	CB1025
A30R94	311-2124-00		RES.,VAR, NONWIR:20K OHM,20%,0.5W	32997	35405-694-103
A30U2	156-1149-01		MICROCIRCUIT,LI:OPER AMPL,JFET,BURN-IN	27014	LF351N/A+
A30U6	156-1490-00		MICROCIRCUIT,LI:VOLTAGE REFERENCE	32293	ICL8069CCQ
A30U9	156-0515-02		MICROCIRCUIT,DI:TRIPLE 3-CHANMUX,SEL	80009	156-0515-02
A30U10	156-1483-00		MICROCIRCUIT,LI:A/D CONVERTER	32293	ICL7106CPL
A30U22	156-0786-02		MICROCIRCUIT,DI:QUAD EXCLUSIVE OR GATE	80009	156-0786-02
A30U23	156-1340-01		MICROCIRCUIT,DI:QUAD 2-INP ORGATE	02735	CD4071BFX
A30U25	156-0411-02		MICROCIRCUIT,LI:QUAD COMPARATOR,SEL	04713	MLM339LDS
A30U32	156-0961-02		MICROCIRCUIT,DI:QUAD 2-INP NAND ST,BURN-IN	80009	156-0961-02
A30U37	150-1094-00		DSPL,LIQ XTAL:3.5 DIGIT	73138	1739-12-0
A30U38	160-0885-00		MICROCIRCUIT,DI:32 X 8 PROM,PRGM	80009	160-0885-00
A30U39	156-0411-02		MICROCIRCUIT,LI:QUAD COMPARATOR,SEL	04713	MLM339LDS
A30U40	156-0786-02		MICROCIRCUIT,DI:QUAD EXCLUSIVE OR GATE	80009	156-0786-02
A30U42	156-0786-02		MICROCIRCUIT,DI:QUAD EXCLUSIVE OR GATE	80009	156-0786-02
A30U55	156-0330-02		MICROCIRCUIT,DI:HEX BUFFER	04713	MC14050BCLD
A30VR20	152-0395-00		SEMICONV DEVICE:ZENER,0.4W,4.3V,5%	14552	TD332317
A31	-----		CKT BOARD ASSY:B TRIGGER SWITCH		
A31S1	263-0083-00		SWITCH,SL ASSY:B TRIGGER SLOPE	80009	263-0083-00
A31S2	263-0084-00		SWITCH,SL ASSY:B TRIGGER SOURCE	80009	263-0084-00

Replaceable Electrical Parts—2336 Service

Component No.	Tektronix Part No.	Serial/Model No. Eff Dscont	Name & Description	Mfr Code	Mfr Part Number
CHASSIS PARTS					
B924	119-0830-02		FAN,TUBEAXIAL:12VDC,2.4W,5250 RPM	000AX	OBD
C900	283-0000-00		CAP.,FXD,CER DI:0.001UF,+100-0%,500V	59660	831-519-25U-102P
C901	283-0000-00		CAP.,FXD,CER DI:0.001UF,+100-0%,500V	59660	831-519-25U-102P
C911	281-0876-00		CAP.,FXD,CER DI:5.6PF,+/-0.5PF,500WVDC	04222	GC106A569D
CR931	152-0141-02		SEMICONV DEVICE:SILICON,30V,150MA	01295	1N4152R
CR932	152-0141-02		SEMICONV DEVICE:SILICON,30V,150MA	01295	1N4152R
DL900	119-1309-00		DELAY LINE,ELEC:90NS,75 OHM	80009	119-1309-00
DS900	150-1054-01		LT EMITTING DIO:GREEN,560NM,35MA MAX	72619	558-0201-802
DS902	150-1093-01		LT EMITTING DIO:RED,655NM 50MA MAX	72619	558-0101-804
DS910	150-1093-00		LT EMITTING DIO:RED,655NM 50MA MAX	72619	558-0101-003
F900	159-0022-00		FUSE,CARTRIDGE:3AG,1A,250V,FAST-BLOW	71400	AGC 1
F900	159-0182-00		FUSE,CARTRIDGE:5 X 20MM,0.5A,250V,30 MIN (OPTION A1,A2 & A3 ONLY)	75915	212-500
F900	159-0025-00		FUSE,CARTRIDGE:3AG,0.5A,250V,FAST-BLOW (OPTION A4 ONLY)	71400	AGC 1/2
FL900	119-1359-00		FILTER,RFI:3AMP,115-240VAC,60HZ	05245	3EF1
L913	119-1366-00		COMPONENT ASSY:RF COIL,W/CONNECTOR	80009	119-1366-00
L915	119-1366-00		COMPONENT ASSY:RF COIL,W/CONNECTOR	80009	119-1366-00
R900	315-0474-00		RES.,FXD,CMPSN:470K OHM,5%,0.25W	01121	CB4745
R901	315-0474-00		RES.,FXD,CMPSN:470K OHM,5%,0.25W	01121	CB4745
R903	311-2121-00		RES.,VAR,NONWIR:PNL,500 OHM,10%,0.5W	01121	WAIG040S501UZ
R904	321-0227-00		RES.,FXD,FILM:2.26K OHM,1%,0.125W	91637	MFF1816G22600F
R905	321-0227-00		RES.,FXD,FILM:2.26K OHM,1%,0.125W	91637	MFF1816G22600F
R907	311-2121-00		RES.,VAR,NONWIR:PNL,500 OHM,10%,0.5W	01121	WAIG040S501UZ
R909	311-2123-00		RES.,VAR,NONWIR:PNL,5K OHM,20%,0.5W	01121	20M904
R911	315-0270-00		RES.,FXD,CMPSN:27 OHM,5%,0.25W	01121	CB2705
R913	311-2120-00		RES.,VAR,NONWIR:PNL,20K OHM,20%,0.5W	01121	WA1G040S203MZ
R918A & B	311-2142-00		RES.,VAR,WW:10K OHM,5%,2W	02111	534-7213
R930	311-2091-00		RES.,VAR,NONWIR:PNL,10K OHM,20%,0.5W	01121	20M157
R931	315-0102-00		RES.,FXD,CMPSN:1K OHM,5%,0.25W	01121	CB1025
R935A & B	311-2117-00		RES.,VAR,NONWIR:PNL,10K X 2.5K OHM,20%	12697	CM41783
R942	311-2119-00		RES.,VAR,NONWIR:PNL,5K OHM,20%,0.5W	01121	WA4G032S502MZ
R945	311-2122-00		RES.,VAR,NONWIR:PNL,100K OHM,20%,0.5W	12697	CM41785
S901	260-1967-00		SWITCH,SLIDE:DPDT,5A/250V,10A/125V MKD	000FJ	4021.0512
S903	260-2047-00		SWITCH,PUSH:DPST,4A,250V	31918	NE1611
T900	120-1314-00		XFMR,PWR,STPDN:LF	80009	120-1314-00
V940	154-0832-00		ELECTRON TUBE:CRT,T2330	80009	154-0832-00

# DIAGRAMS AND CIRCUIT BOARD ILLUSTRATIONS

## Symbols

Graphic symbols and class designation letters are based on ANSI Standard Y32.2-1975.

Logic symbology is based on ANSI Y32.14-1973 in terms of positive logic. Logic symbols depict the logic function performed and may differ from the manufacturer's data.

The overline on a signal name indicates that the signal performs its intended function when it is in the low state.

Abbreviations are based on ANSI Y1.1-1972.

Other ANSI standards that are used in the preparation of diagrams by Tektronix, Inc. are:

Y14.15, 1966 Drafting Practices.  
 Y14.2, 1973 Line Conventions and Lettering.  
 Y10.5, 1968 Letter Symbols for Quantities Used in Electrical Science and Electrical Engineering.

American National Standard Institute  
 1430 Broadway  
 New York, New York 10018

## Component Values

Electrical components shown on the diagrams are in the following units unless noted otherwise:

Capacitors = Values one or greater are in picofarads (pF).  
 Values less than one are in microfarads ( $\mu$ F).

Resistors = Ohms ( $\Omega$ ).

———— The information and special symbols below may appear in this manual. ————

## Assembly Numbers and Grid Coordinates

Each assembly in the instrument is assigned an assembly number (e.g., A20). The assembly number appears on the circuit board outline on the diagram, in the title for the circuit board component location illustration, and in the lookup table for the schematic diagram and corresponding component locator illustration. The Replaceable Electrical Parts list is arranged by assemblies in numerical sequence; the components are listed by component number \*(see following illustration for constructing a component number).

The schematic diagram and circuit board component location illustration have grids. A lookup table with the grid coordinates is provided for ease of locating the component. Only the components illustrated on the facing diagram are listed in the lookup table. When more than one schematic diagram is used to illustrate the circuitry on a circuit board, the circuit board illustration may only appear opposite the first diagram on which it was illustrated; the lookup table will list the diagram number of other diagrams that the circuitry of the circuit board appears on.

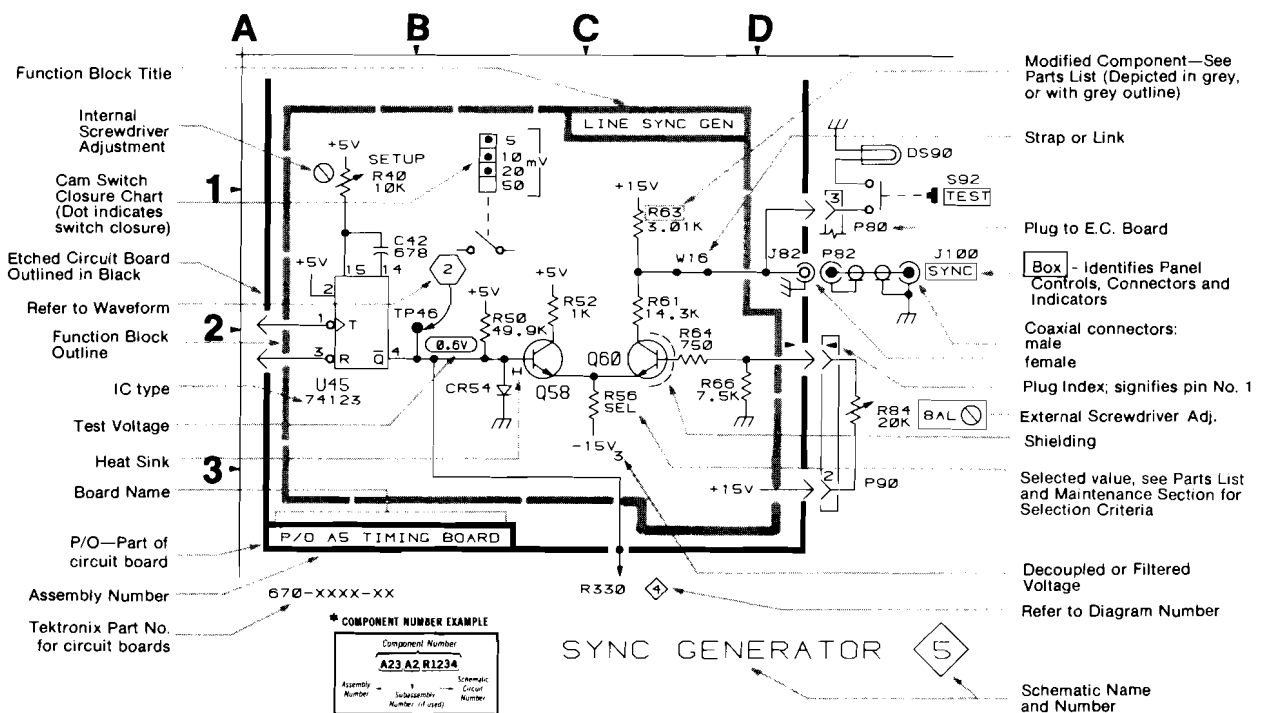

COLOR CODE

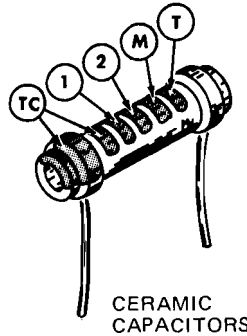
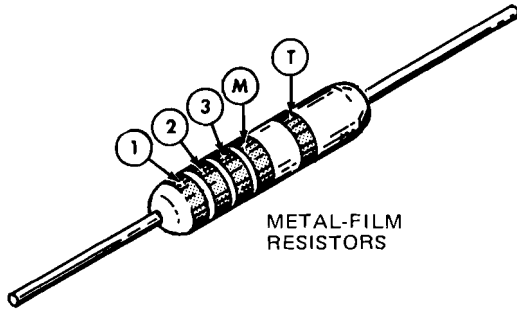
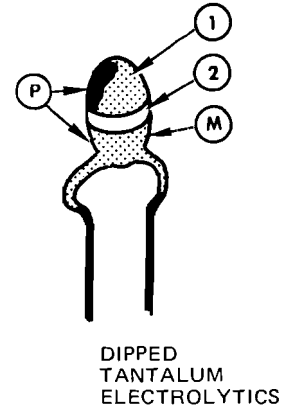
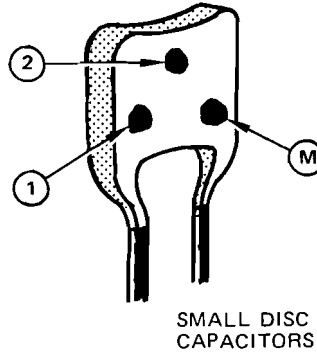
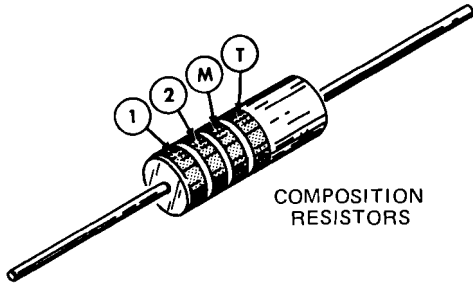

① ② and ③ – 1st, 2nd, and 3rd significant figures

Ⓜ – multiplier      Ⓣ – tolerance

ⓉⓈ – temperature coefficient

Ⓟ – polarity and voltage rating

Ⓣ and/or ⓉⓈ color code may not be present on some capacitors

COLOR	SIGNIFICANT FIGURES	RESISTORS		CAPACITORS			DIPPED TANTALUM VOLTAGE RATING
		MULTIPLIER	TOLERANCE	MULTIPLIER	TOLERANCE		
					over 10 pF	under 10 pF	
BLACK	0	1	----	1	±20%	±2 pF	4 VDC
BROWN	1	10	±1%	10	±1%	±0.1 pF	6 VDC
RED	2	10 <sup>2</sup> or 100	±2%	10 <sup>2</sup> or 100	±2%	----	10 VDC
ORANGE	3	10 <sup>3</sup> or 1 K	±3%	10 <sup>3</sup> or 1000	±3%	----	15 VDC
YELLOW	4	10 <sup>4</sup> or 10 K	±4%	10 <sup>4</sup> or 10,000	+100% -9%	----	20 VDC
GREEN	5	10 <sup>5</sup> or 100 K	±½%	10 <sup>5</sup> or 100,000	±5%	±0.5 pF	25 VDC
BLUE	6	10 <sup>6</sup> or 1 M	±¼%	10 <sup>6</sup> or 1,000,000	----	----	35 VDC
VIOLET	7	----	±1/10%	----	----	----	50 VDC
GRAY	8	----	----	10 <sup>-2</sup> or 0.01	+80% -20%	±0.25 pF	----
WHITE	9	----	----	10 <sup>-1</sup> or 0.1	±10%	±1 pF	3 VDC
GOLD	-	10 <sup>-1</sup> or 0.1	±5%	----	----	----	----
SILVER	-	10 <sup>-2</sup> or 0.01	±10%	----	----	----	----
NONE	-	----	±20%	----	±10%	±1 pF	----

Figure 9-1. Color codes for resistors and capacitors.

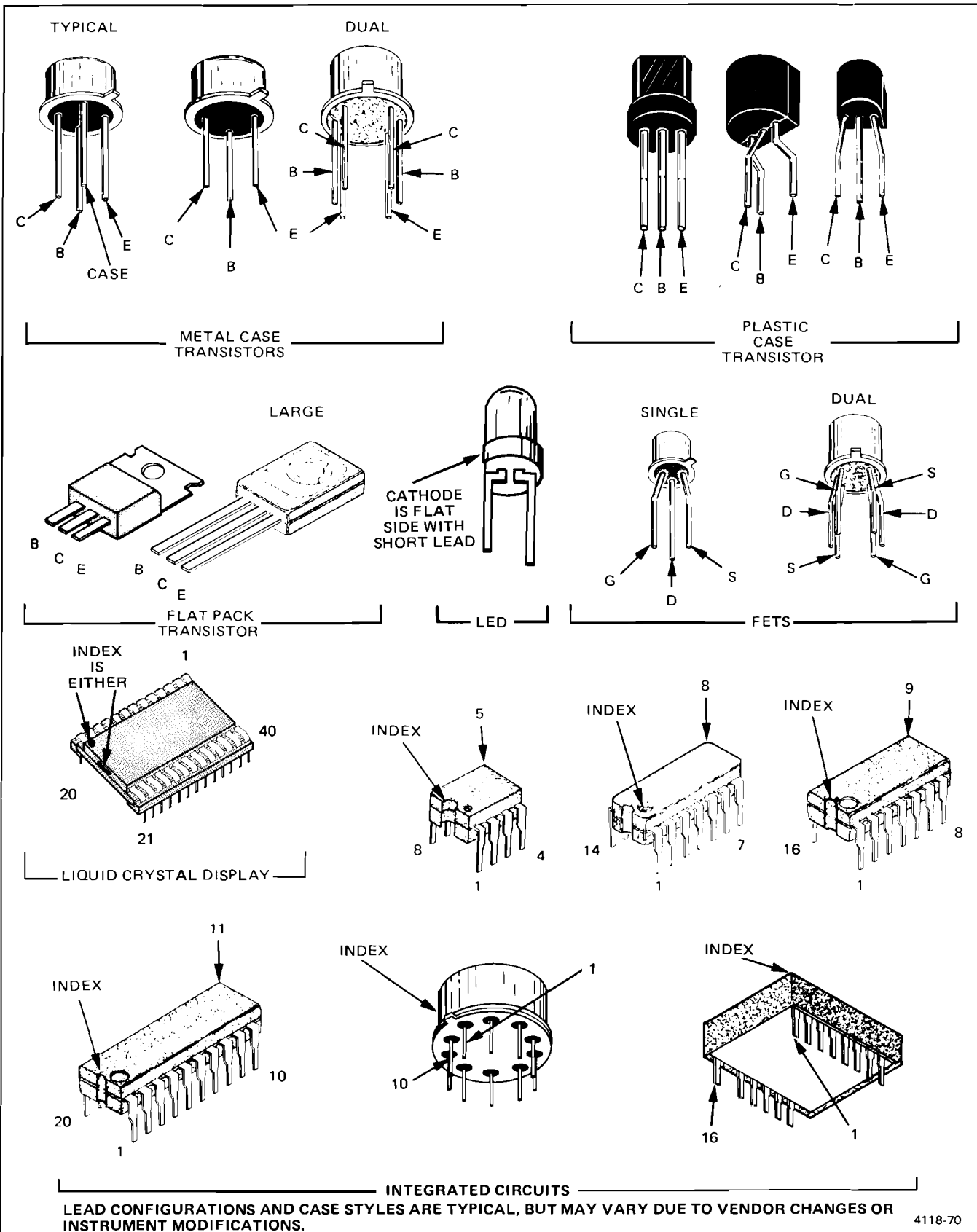

4118-70

Figure 9-2. Semiconductor lead configurations.

2336 Service

To identify any component mounted on a circuit board and to locate that component in the appropriate schematic diagram

1. Locate the Circuit Board Illustration
  - a. In the instrument identify the Assembly Number of the circuit board in question. The Assembly Number is usually printed on the upper left corner of the circuit board on the component side.
  - b. In the manual locate and pull out tabbed page whose title corresponds with the Assembly Number of the circuit board. Circuit board assembly numbers and board nomenclature are printed on the back side of the tabs (facing the rear of the manual).

2. Determine the Circuit Number
  - a. Compare the circuit board with its illustration and locate the desired component by area and shape on the illustration.
  - b. Scan the table adjacent to the Circuit Board Illustration and find the Circuit Number of the desired component.
  - c. Determine the Schematic Diagram Number in which the component is located.

3. Locate the Component
  - a. Locate and identify the component on the schematic diagram and determine its circuit number (facing the front of the manual).
  - b. Scan the Component Location Table for the Assembly Number just determined and find the Circuit Number of the desired component.

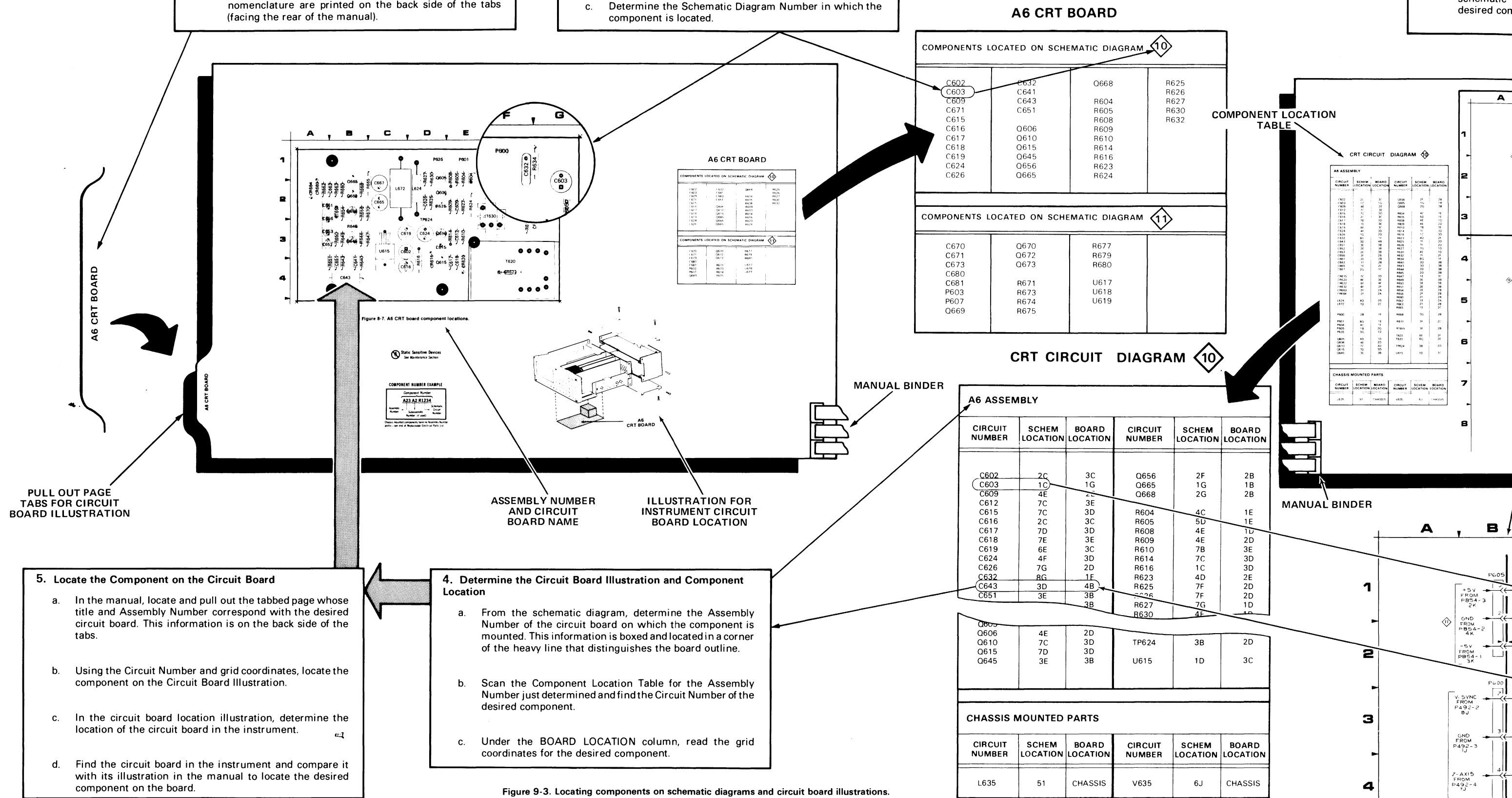

**A6 CRT BOARD**

COMPONENTS LOCATED ON SCHEMATIC DIAGRAM 10

C602	Q632	Q668	R625
C603	C641	R626	R626
C609	C643	R627	R627
C671	C651	R605	R630
C615	Q606	R608	R632
C616	Q610	R609	
C617	Q615	R610	
C618	Q645	R614	
C619	Q656	R616	
C624	Q665	R623	
C626		R624	

COMPONENTS LOCATED ON SCHEMATIC DIAGRAM 11

C670	Q670	R677	
C671	Q672	R679	
C673	Q673	R680	
C680			
C681	R671	U617	
P603	R673	U618	
P607	R674	U619	
Q669	R675		

**COMPONENT LOCATION TABLE**

CRT CIRCUIT DIAGRAM 10

ASSEMBLY	CIRCUIT NUMBER	SCHEM LOCATION	BOARD LOCATION	CIRCUIT NUMBER	SCHEM LOCATION	BOARD LOCATION
P600	2C	3C	Q632	2F	2B	
P601	1C	1G	Q665	1G	1B	
P602	4E	2C	Q668	2G	2B	
P603	7C	3E				
P604	7C	3D	R604	4C	1E	
P605	2C	3C	R605	5D	1E	
P606	7D	3D	R608	4E	1D	
P607	7E	3E	R609	4E	2D	
P608	6E	3C	R610	7B	3E	
P609	4F	3D	R614	7C	3D	
P610	7G	2D	R616	1C	3D	
P611	8G	1F	R623	4D	2E	
P612	3D	4B	R625	7F	2D	
P613	3E	3B	R626	7F	2D	
P614			R627	7G	1D	
P615			R630	4E	1D	

CHASSIS MOUNTED PARTS

CIRCUIT NUMBER	SCHEM LOCATION	BOARD LOCATION	CIRCUIT NUMBER	SCHEM LOCATION	BOARD LOCATION
L635	51	CHASSIS	V635	6J	CHASSIS

5. Locate the Component on the Circuit Board
  - a. In the manual, locate and pull out the tabbed page whose title and Assembly Number correspond with the desired circuit board. This information is on the back side of the tabs.
  - b. Using the Circuit Number and grid coordinates, locate the component on the Circuit Board Illustration.
  - c. In the circuit board location illustration, determine the location of the circuit board in the instrument.
  - d. Find the circuit board in the instrument and compare it with its illustration in the manual to locate the desired component on the board.

4. Determine the Circuit Board Illustration and Component Location
  - a. From the schematic diagram, determine the Assembly Number of the circuit board on which the component is mounted. This information is boxed and located in a corner of the heavy line that distinguishes the board outline.
  - b. Scan the Component Location Table for the Assembly Number just determined and find the Circuit Number of the desired component.
  - c. Under the BOARD LOCATION column, read the grid coordinates for the desired component.

Figure 9-3. Locating components on schematic diagrams and circuit board illustrations.

FIG. 9-3 LOCATING COMPONENTS EXAMPLE



**Determine the Circuit Number**

Compare the circuit board with its illustration and locate the desired component by area and shape on the illustration.

Scan the table adjacent to the Circuit Board Illustration and find the Circuit Number of the desired component.

Determine the Schematic Diagram Number in which the component is located.

**3. Locate the Component on the Schematic Diagram**

- a. Locate and pull out tabbed page whose number and title correspond with the Schematic Diagram Number just determined in the table. Schematic diagram nomenclature and numbers are printed on the front side of the tabs (facing the front of the manual).
- b. Scan the Component Location Table adjacent to the schematic diagram and find the Circuit Number of the desired component.
- c. Under the SCHEM LOCATION column, read the grid coordinates for the desired component.
- d. Using the Circuit Number and grid coordinates, locate the component on the schematic diagram.

**A6 CRT BOARD**

COMPONENTS LOCATED ON SCHEMATIC DIAGRAM 10			
C602	C632	Q668	R625
C603	C641	R626	R626
C609	C643	R627	R627
C671	C651	R605	R630
C615		R608	R609
C616	Q606	R610	R614
C617	Q610	R616	R623
C618	Q615	R616	R623
C619	Q645	R623	R624
C624	Q656		
C626	Q665		

COMPONENTS LOCATED ON SCHEMATIC DIAGRAM 11			
C670	Q670	R677	
C671	Q672	R679	
C673	Q673	R680	
C680			
C681	R671	U617	
P603	R673	U618	
P607	R674	U619	
Q669	R675		

**COMPONENT LOCATION TABLE**

AN ASSEMBLY					
CIRCUIT NUMBER	SCHEM LOCATION	BOARD LOCATION	CIRCUIT NUMBER	SCHEM LOCATION	BOARD LOCATION
C602	2C	3C	Q668	2F	2B
C603	1C	1G	Q665	1G	1B
C609	4E	2D	Q668	2G	2B
C615	7C	3E	R604	4C	1E
C616	7C	3D	R605	5D	1E
C617	7D	3D	R608	4E	1D
C618	7E	3E	R609	4E	2D
C619	6E	3C	R610	7B	3E
C624	4F	3D	R614	7C	3D
C626	7G	2D	R616	1C	3D
C632	8G	1F	R623	4D	2E
C643	3D	4B	R625	7F	2D
C651	3E	3B	R627	7F	2D
			R627	7G	1D
			R630	4E	1D

CHASSIS MOUNTED PARTS					
CIRCUIT NUMBER	SCHEM LOCATION	BOARD LOCATION	CIRCUIT NUMBER	SCHEM LOCATION	BOARD LOCATION
L635	51	CHASSIS	V635	6J	CHASSIS

**CRT CIRCUIT DIAGRAM 10**

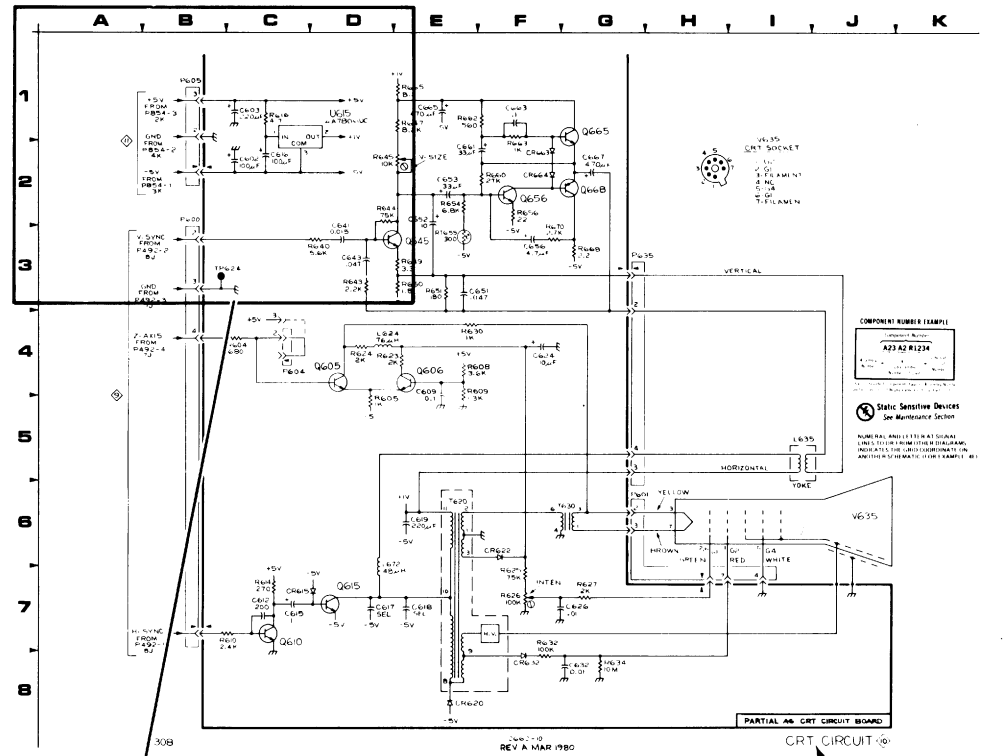

PULL OUT PAGE TABS FOR SCHEMATIC DIAGRAMS

CRT CIRCUIT 10

**A6 ASSEMBLY**

CIRCUIT NUMBER	SCHEM LOCATION	BOARD LOCATION	CIRCUIT NUMBER	SCHEM LOCATION	BOARD LOCATION
C602	2C	3C	Q656	2F	2B
C603	1C	1G	Q665	1G	1B
C609	4E	2D	Q668	2G	2B
C612	7C	3E			
C615	7C	3D	R604	4C	1E
C616	2C	3D	R605	5D	1E
C617	7D	3D	R608	4E	1D
C618	7E	3E	R609	4E	2D
C619	6E	3C	R610	7B	3E
C624	4F	3D	R614	7C	3D
C626	7G	2D	R616	1C	3D
C632	8G	1F	R623	4D	2E
C643	3D	4B	R625	7F	2D
C651	3E	3B	R627	7F	2D
			R627	7G	1D
			R630	4E	1D

CIRCUIT NUMBER	SCHEM LOCATION	BOARD LOCATION	CIRCUIT NUMBER	SCHEM LOCATION	BOARD LOCATION
Q606	4E	2D	TP624	3B	2D
Q610	7C	3D			
Q615	7D	3D			
Q645	3E	3B	U615	1D	3C

CHASSIS MOUNTED PARTS					
CIRCUIT NUMBER	SCHEM LOCATION	BOARD LOCATION	CIRCUIT NUMBER	SCHEM LOCATION	BOARD LOCATION
L635	51	CHASSIS	V635	6J	CHASSIS

MANUAL BINDER

PARTIAL A6 CRT CIRCUIT BOARD

CRT CIRCUIT 10

SCHEMATIC DIAGRAM NAME AND NUMBER

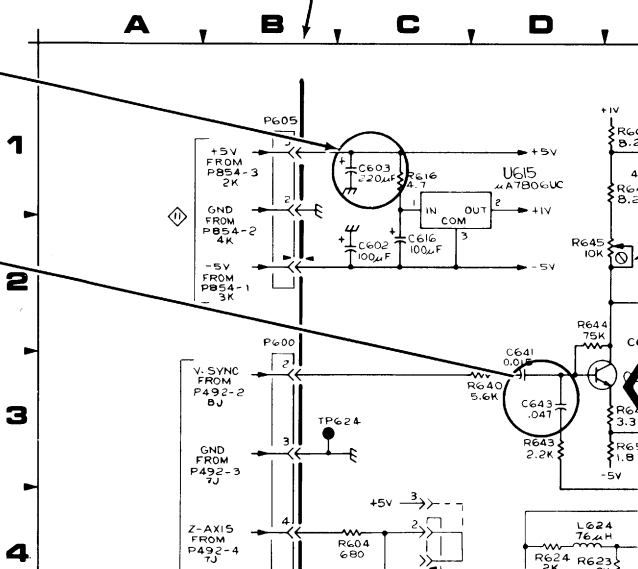

To identify any component in a schematic diagram and to locate that component on its respective circuit board.

ILLUSTRATION FOR INSTRUMENT CIRCUIT BOARD LOCATION

Diagram, determine the Assembly board on which the component is located and find the Circuit Number of the component.

Component Location Table for the Assembly board and find the Circuit Number of the component.

Under the SCHEM LOCATION column, read the grid coordinates for the desired component.

Locate components on schematic diagrams and circuit board illustrations.

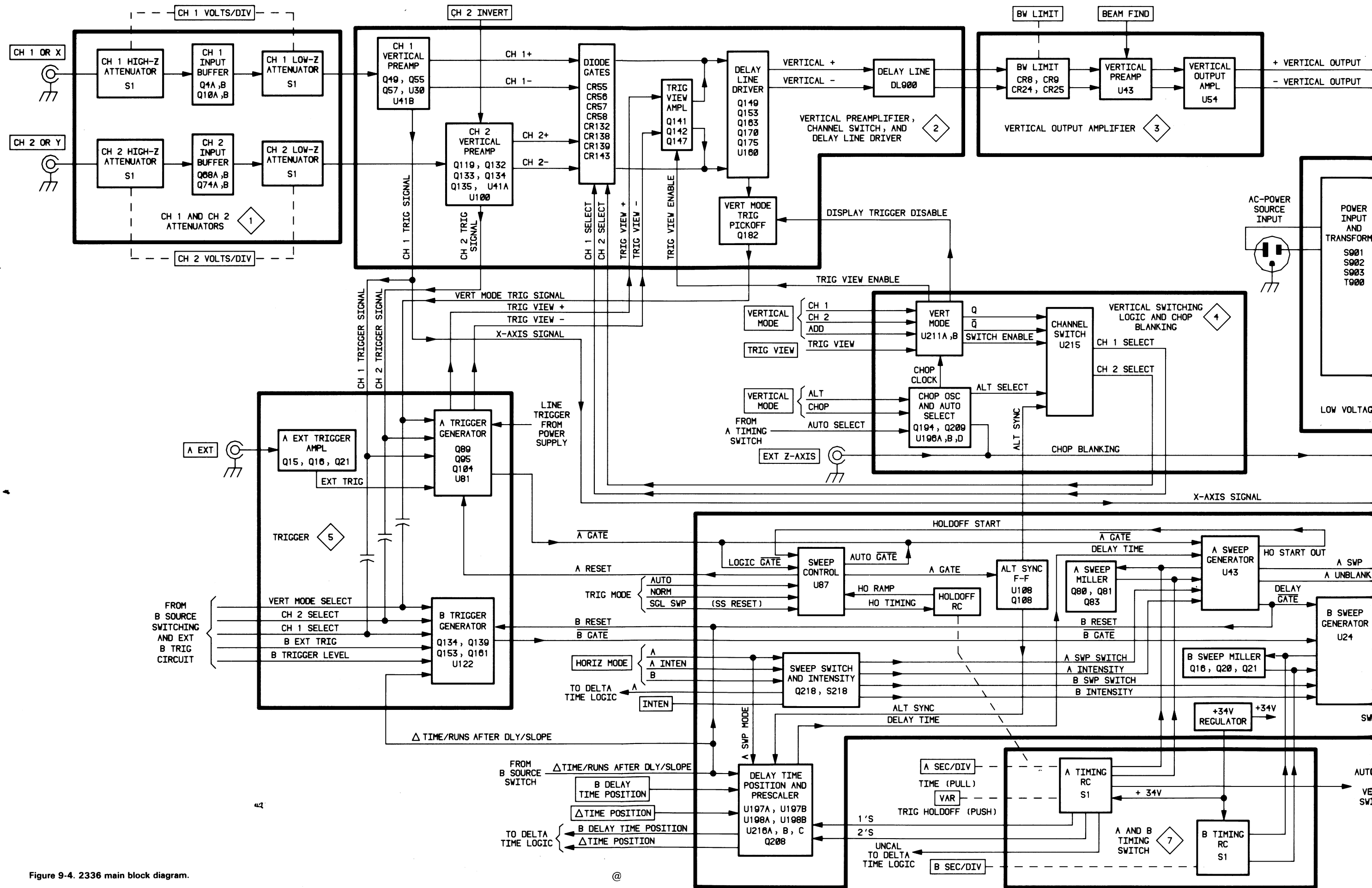

Figure 9-4. 2336 main block diagram.

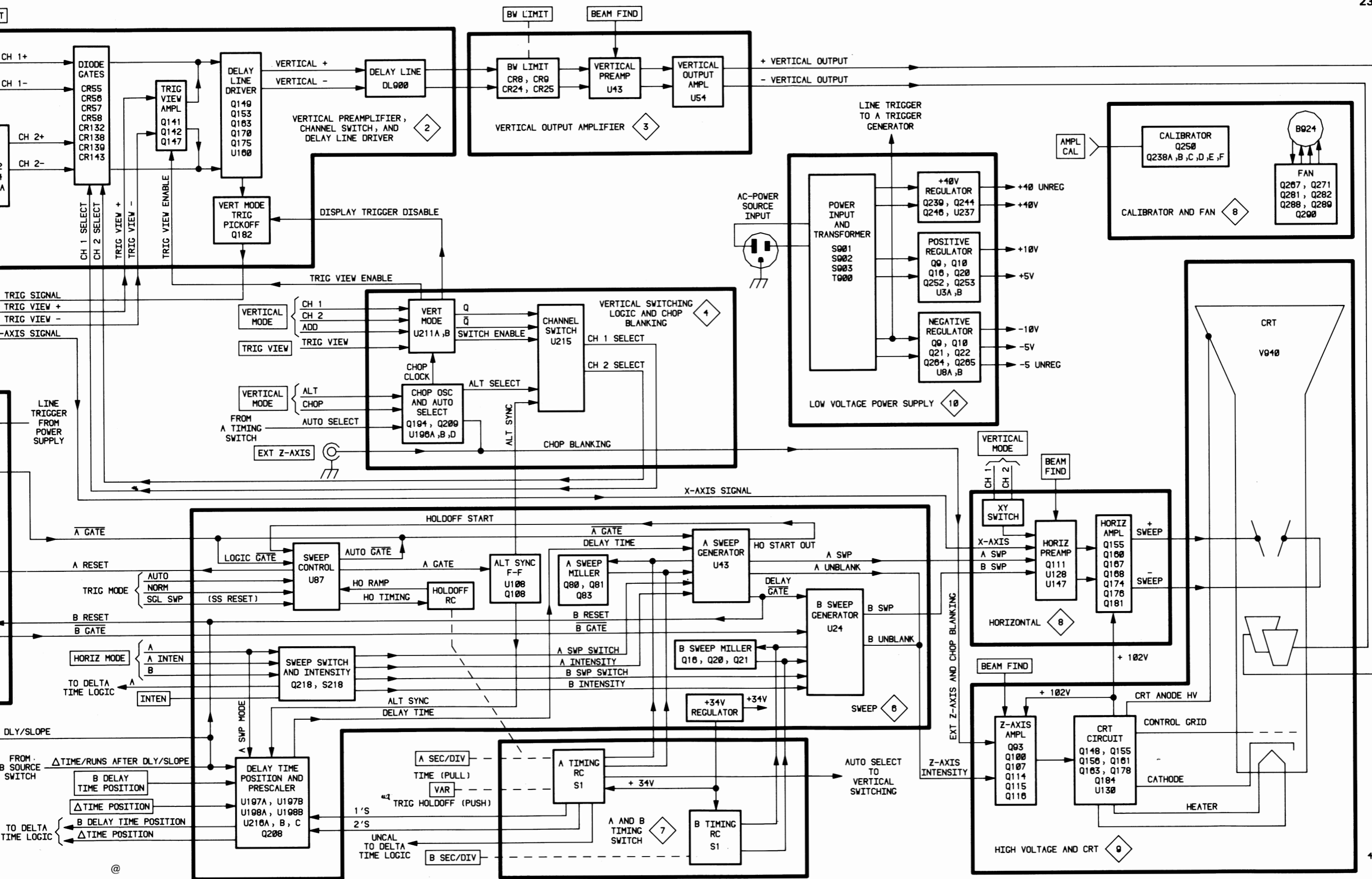
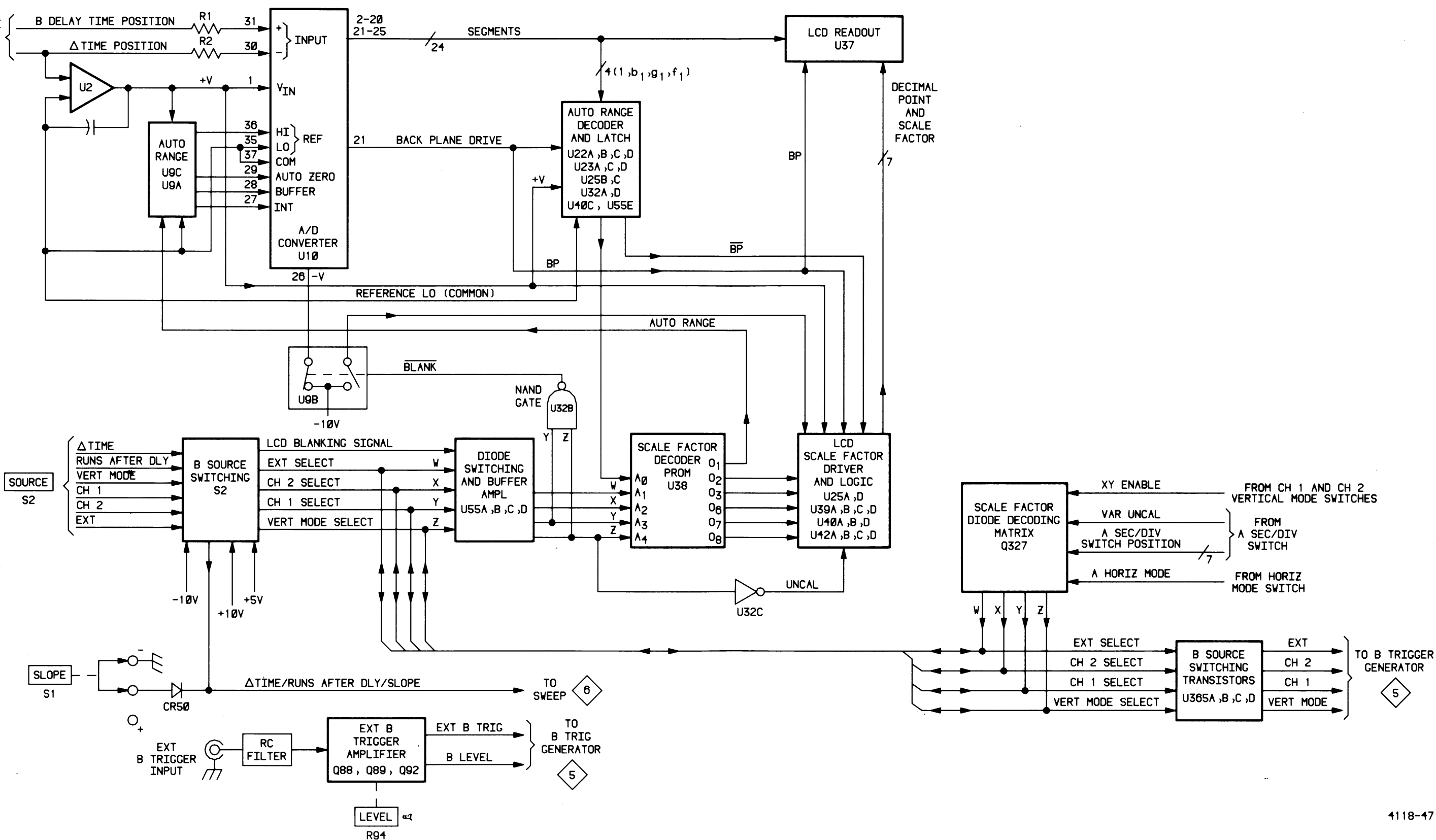

FIG. 9-4



2336 DELTA TIME BLOCK DIAGRAM  
FIG. 9-5

Figure 9-5. 2336 Delta Time block diagram.

CIRCUIT BOARD INTERCONNECTIONS

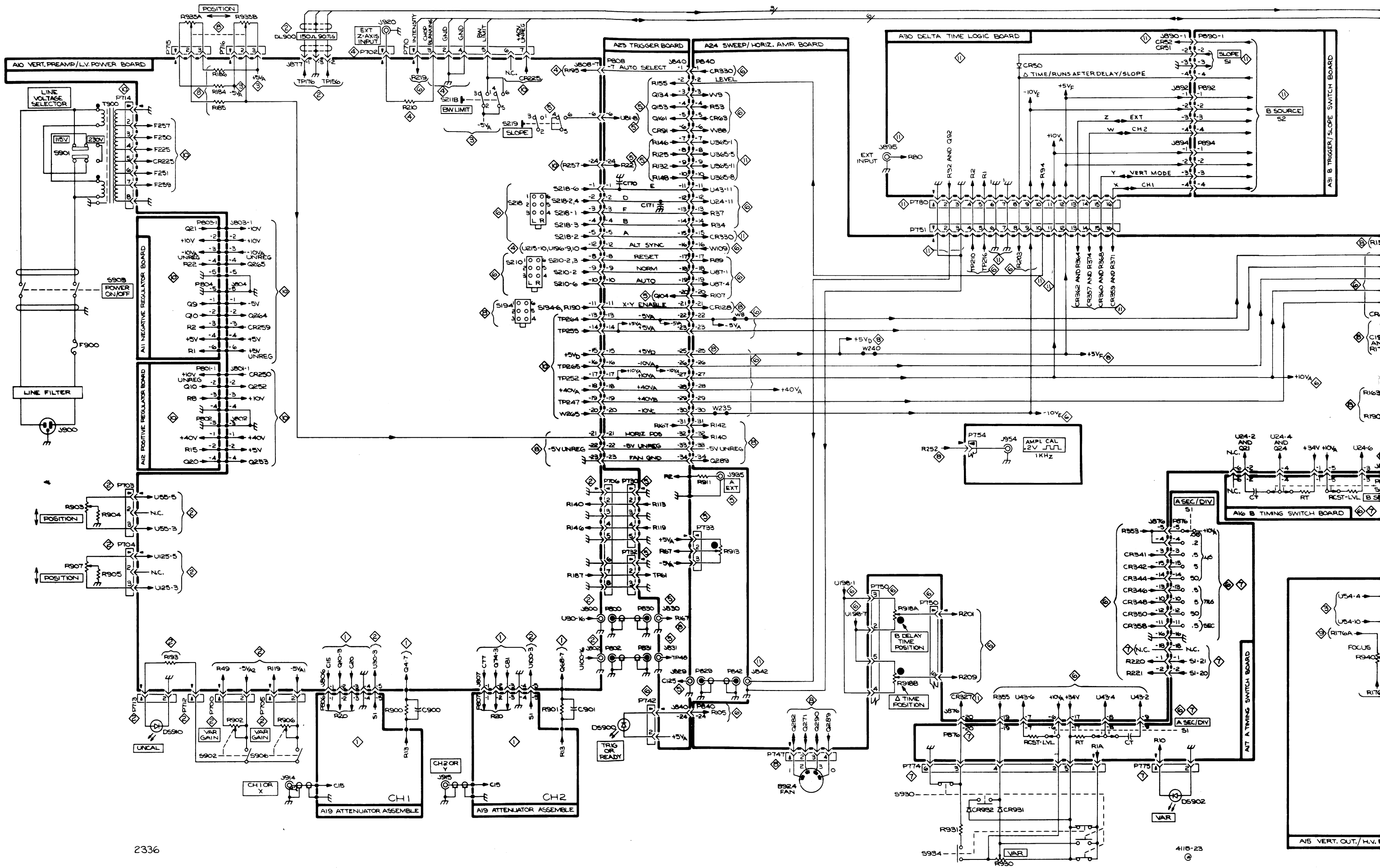

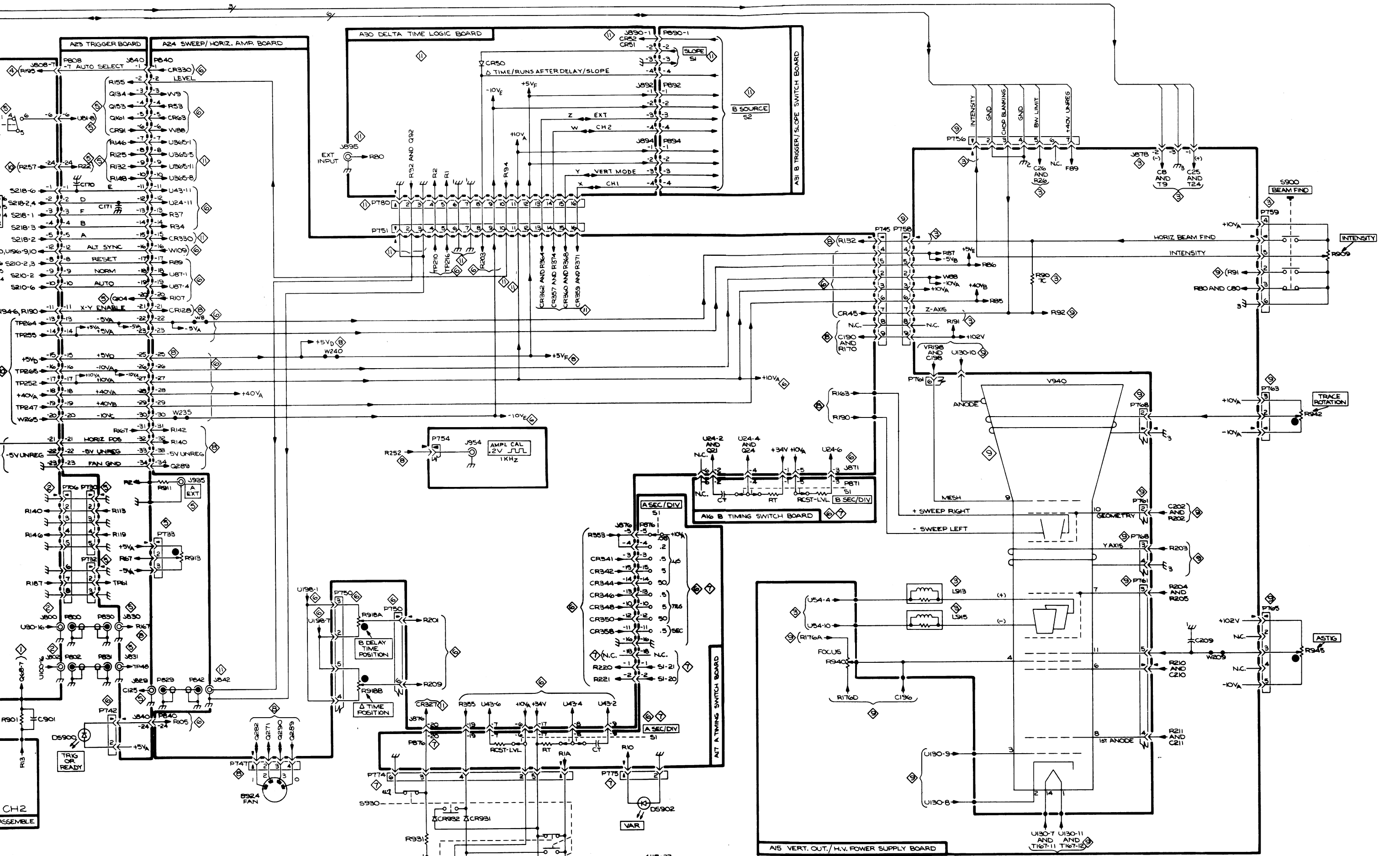

CIRCUIT BOARD INTERCONNECTIONS

418-23

### CHASSIS MOUNTED PARTS

CIRCUIT NUMBER	SCHEM NUMBER	SCHEM LOCATION	CIRCUIT NUMBER	SCHEM NUMBER	SCHEM LOCATION	CIRCUIT NUMBER	SCHEM NUMBER	SCHEM LOCATION
B924	8	7N	J915	1	7A	R913	5	1I
			J920	4	7E	R918A	6	8G
C900	1	2G	J935	5	2A	R918B	6	9G
C901	1	7G	J954	8	8F	R930	7	2D
C911	5	2A				R931	7	1E
			L913	3	3J	R935A	8	3A
CR931	7	2E	L915	3	4J	R935B	8	4A
CR932	7	2E				R940	9	4J
			P708	2	8E	R942	9	1N
DL900	2	5N	P800	2	4E	R945	9	4N
			P829	5	8B			
DS195	9	6J	P830	5	4B	S900	3	5A
DS196	9	5J	P831	5	4B	S901	10	3B
DS197	9	5J				S902	2	3G
DS900	6	4B	R900	1	2G	S903	10	5B
DS902	7	1F	R901	1	7G	S906	2	6G
DS910	2	4E	R902	2	3G	S930	7	3F
			R903	2	3G	S934	7	1E
F900	10	6B	R904	2	3G			
			R905	2	7G	T900	10	1B
FL900	10	6A	R906	2	7G			
			R907	2	7G			
J900	10	6B	R909	3	6A			
J914	1	2A	R911	5	2A			

# TEST WAVEFORM AND VOLTAGE SETUPS

On the left-hand pages preceding the schematic diagrams are illustrations of test waveforms that are intended to aid in troubleshooting the instrument. To test the instrument for these waveforms, make the initial control settings and connect the initial test setup as specified in these setup instructions.

## RECOMMENDED TEST EQUIPMENT

Item	Specification	Example
Test Oscilloscope with 10X probe and 1X probe (1X probe is optional accessory).	Frequency response: Dc to 100 MHz. Deflection factor: 50 mV to 50 V/div (to 5 V/div with 1X probe). Input impedance: 1 M $\Omega$ , 20 pF.	a. TEKTRONIX 465B Oscilloscope with two (included) 10X probes.  b. TEKTRONIX P6101 Probe (1X), Part Number 010-6101-03.
Calibration Generator	Standard-amplitude accuracy: $\pm 0.3\%$ . Signal amplitude: at least 50 mV. Output signal: Square wave. Repetition rate: 1 to 100 kHz. Rise time: 1 ns or less.	TEKTRONIX PG 506 Calibration Generator. <sup>a</sup>
Dual-input Coupler	Connectors: Bnc female-to-dual-bnc male.	Tektronix Part Number 067-0525-01
Cable	Impedance: 50 $\Omega$ . Connectors: bnc. Length: 42 in.	Tektronix Part Number 012-0057-01.
Digital Multimeter (for dc voltages up to 1 kV)	Range: 0 to 1 kV. Input impedance: 10 M $\Omega$ .	TEKTRONIX DM 501A Digital Multimeter.
DC Voltmeter (for dc voltages above 1 kV)	Range: 0 to 1500 V. Input impedance: 20 k $\Omega$ /V.	Triplet Model 630NA

<sup>a</sup> Requires TM 500 power-module mainframe.

## 2336 INITIAL CONTROL SETTINGS

### NOTE

*Changes to 2336 initial control settings applicable to specific waveforms or sets of waveforms are identified near the top of the page on which the waveforms are located.*

## Vertical (Both Channels, if applicable)

BW LIMIT	Full bandwidth (button out)
VERTICAL MODE	Set to channel being measured; change setting as indicated for specific waveforms
CH 2 INVERT	Off (button out)
VOLTS/DIV	10 mV
VAR	Calibrated detent
AC-GND-DC	DC
POSITION	As required to center the baseline trace



**Horizontal**

POSITION	Midrange
X10 MAG	Off (button out)
HORIZ MODE	A
A and B SEC/DIV	.5 ms
VAR	Calibrated detent
B DELAY TIME POSITION	Fully counterclockwise

**CALIBRATION GENERATOR  
INITIAL CONTROL SETTINGS**

Std Ampl-Fast Rise-High Ampl	Std Ampl
Period	0.1 ms
Pulse Amplitude	50 mV

**Trigger**

SLOPE	+ (button out)
LEVEL	Midrange
Mode	AUTO
COUPLING	DC
SOURCE	VERT MODE

**INITIAL TEST SETUP**

On the 2336, align the Channel 1 and Channel 2 baseline traces with the center horizontal graticule line. For waveforms on schematic diagrams 1, 2, 3, and 5, connect a 50-mV pp standard-amplitude square-wave signal to the 2336 CH 1 OR X and CH 2 OR Y input connectors via a dual input coupler and 50- $\Omega$  cable. An input signal is not required for waveforms on schematic diagrams 4 and 6 through 11. Connect a 10X probe to the test oscilloscope Channel 1 input.

**TEST OSCILLOSCOPE  
INITIAL CONTROL SETTINGS****NOTE**

*Changes to test oscilloscope initial control settings applicable to specific waveforms are listed on the respective waveform illustration.*

If applicable, make control-setting changes to the test oscilloscope as indicated on each specific waveform. If applicable, make control setting changes to the 2336 as indicated near the top of the waveform illustration page. Apply the probe tip to the component lead or test point indicated on both the schematic diagram and the circuit board illustration associated with that schematic. The waveforms illustrated are typical for troubleshooting purposes only.

All controls as needed for best display, except as follows:

Volts/Division (Channel 1)	As specified on each waveform illustration.
Ac-Gnd-Dc (Channel 1)	Dc
Position (Channel 1)	Midrange
Vertical Mode	Channel 1
Time/Division	As specified on each waveform illustration.
Trigger Mode	Auto
Source	Normal
Coupling	Dc
Slope	+ (plus)
Level	Midrange

**DC VOLTAGE MEASUREMENTS**

Typical voltage measurements were obtained with the 2336 operating under the conditions specified in the preceding setups, with control-setting changes noted on each waveform page. These measurements were taken with reference to chassis ground and are rounded to the nearest  $\pm 5\%$ .

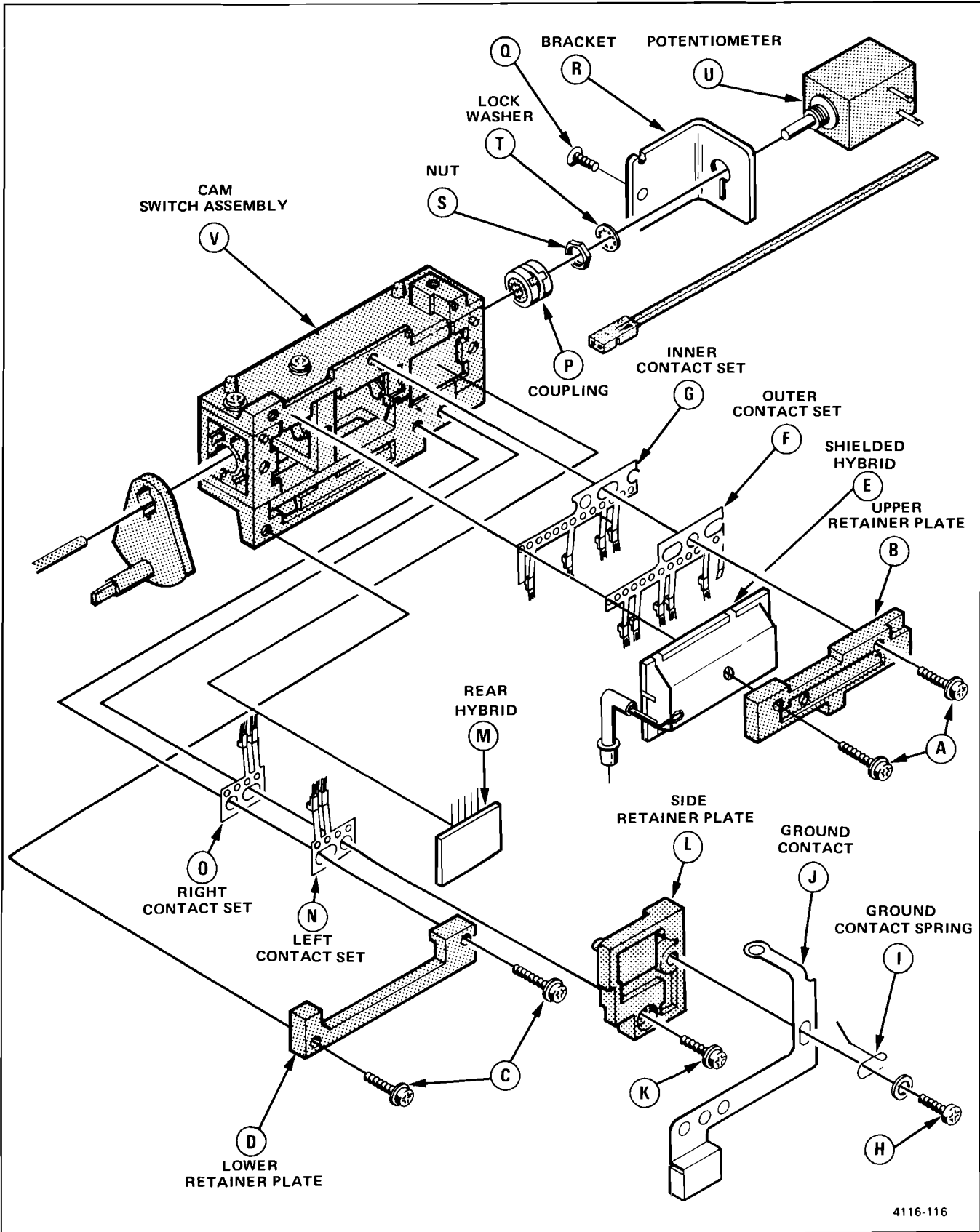

4116-116

Figure 9-6. A19—Attenuator exploded view.

A19 — ATTENUATORS ARE SHOWN IN SCHEMATIC DIAGRAM 1.

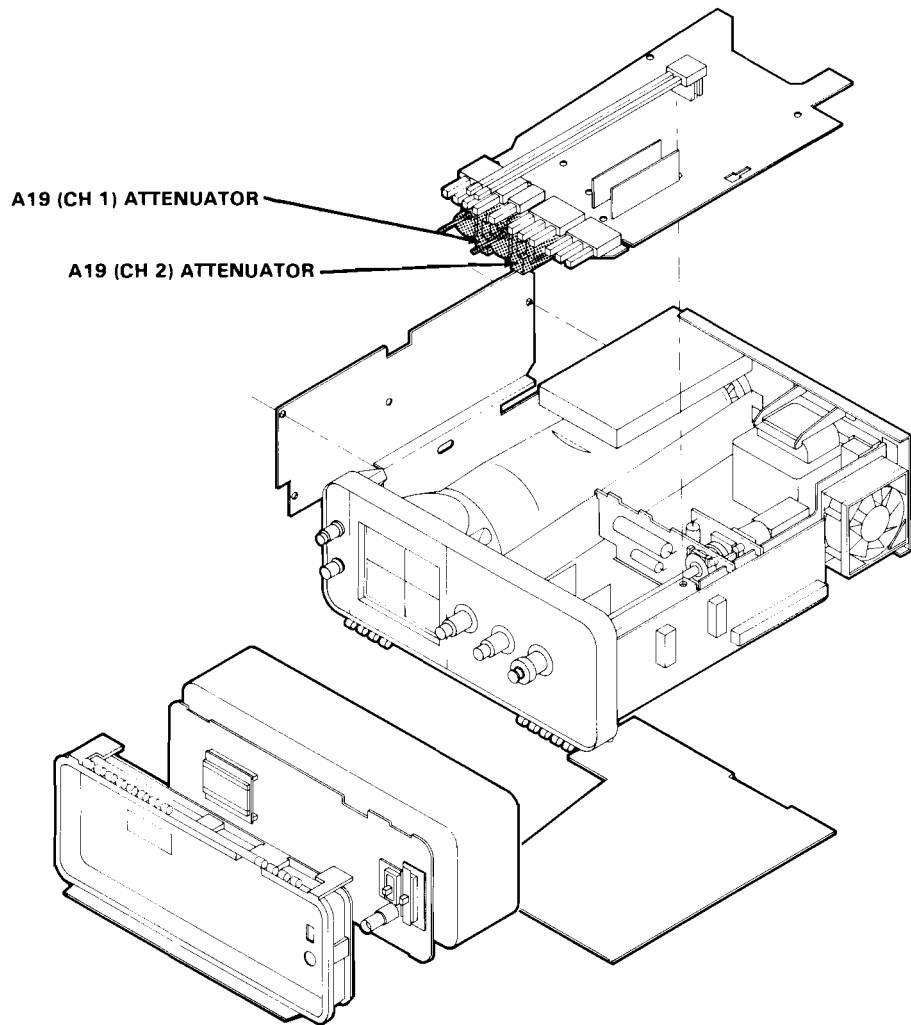

@

TEST WAVEFORMS FOR DIAGRAM 1

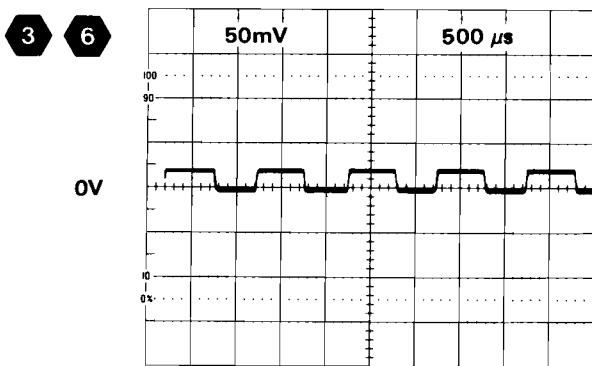
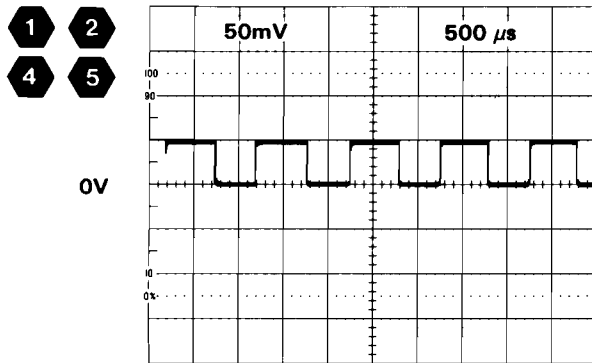

4116-80

# CH1 & CH2 ATTENUATORS DIAGRAM



ASSEMBLY A10								
CIRCUIT NUMBER	SCHEM LOCATION	BOARD LOCATION	CIRCUIT NUMBER	SCHEM LOCATION	BOARD LOCATION	CIRCUIT NUMBER	SCHEM LOCATION	BOARD LOCATION
C1	2G	5C	JB06	1J	4D	R13	4H	4D
C3	2H	4C	JB06	3N	4D	R14	5H	5C
C10	4I	4D	JB07	5J	6D	R15	3I	4D
C14	1I	5C	JB07	7N	6D	R16	2I	4C
C15	1J	4D				R62	6G	6D
C16	2I	4C	Q4A	2H	4C	R63	6H	6C
C20	1J	4D	Q4B	3H	4C	R67	6H	6C
C62	6G	6C	Q10A	4H	4D	R68	7H	5C
C67	6H	6C	Q10B	3I	4D	R69	7H	5C
C75	9I	6D	Q68A	7H	6C	R70	8H	5D
C76	7I	5C	Q68B	8H	6C	R72	9I	5D
C77	5J	6D	O74A	8H	5D	R73	8I	5D
CB1	6J	6D	O74B	7I	5D	R74	9I	4D
						R75	9H	6C
CR1	2H	4C	R1	2G	5D	R76	7I	5C
CR2	2H	5D	R2	2H	5C	R77	8I	5D
CR3	2H	5C	R3	2H	4C	R78	9H	5D
CR8	3H	4C	R4	3H	4C			
CR62	7H	6C	R7	4I	4D	TP1	2G	5D
CR63	6H	6D	R8	3H	4C			
CR64	6H	6C	R9	4H	4D	W1	1I	6C
CR69	8H	5C	R10	4I	3D	W2	1I	6B
			R11	4I	3D			
<i>Partial A10 also shown on diagrams 2, 3, 4, 5, 6, 8 and 10.</i>								
ASSEMBLY A19								
CIRCUIT NUMBER	SCHEM LOCATION	BOARD LOCATION	CIRCUIT NUMBER	SCHEM LOCATION	BOARD LOCATION	CIRCUIT NUMBER	SCHEM LOCATION	BOARD LOCATION
C1	2B	**	P807	7M	**	R10	2F	**
C1	7B	**				R10	6F	**
C2	2C	**	R1	2B	**	R11	1F	**
C2	6C	**	R1	7B	**	R11	6F	**
C3	1D	**	R2	2C	**	R12	2F	**
C3	6D	**	R2	6C	**	R12	7F	**
C4	2E	**	R3	2B	**	R13	2F	**
C4	6E	**	R3	6B	**	R13	7F	**
C5	2E	**	R4	2E	**	R20	1K	**
C5	6E	**	R4	6E	**	R20	8K	**
C6	1F	**	R5	1D	**	R30	3E	**
C6	6F	**	R5	6D	**	R30	7E	**
C7	2F	**	R6	2E	**			
C7	6F	**	R6	6E	**	S1A	4E	**
C15	2B	**	R7	2E	**	S1A	9E	**
C15	7B	**	R7	6E	**	S1B	4L	**
			R8	2F	**	S1B	9L	**
P806	1J	**	R8	6F	**	S2	3C	**
P806	3M	**	R9	1F	**	S2	8C	**
P807	5J	**	R9	6F	**			
CHASSIS MOUNTED PARTS								
CIRCUIT NUMBER	SCHEM LOCATION	BOARD LOCATION	CIRCUIT NUMBER	SCHEM LOCATION	BOARD LOCATION	CIRCUIT NUMBER	SCHEM LOCATION	BOARD LOCATION
C900	2G	CHASSIS	J914	2A	CHASSIS	R900	2G	CHASSIS
C901	7G	CHASSIS	J915	7A	CHASSIS	R901	7G	CHASSIS

A B C D E F G H I J K L M N

1  
2  
3  
4  
5  
6  
7  
8  
9  
0

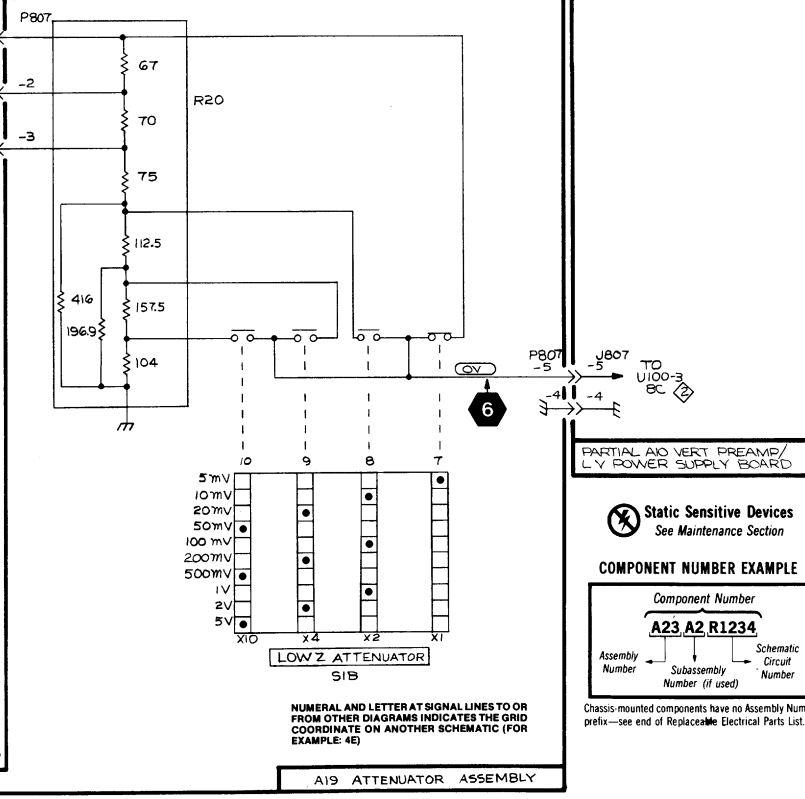
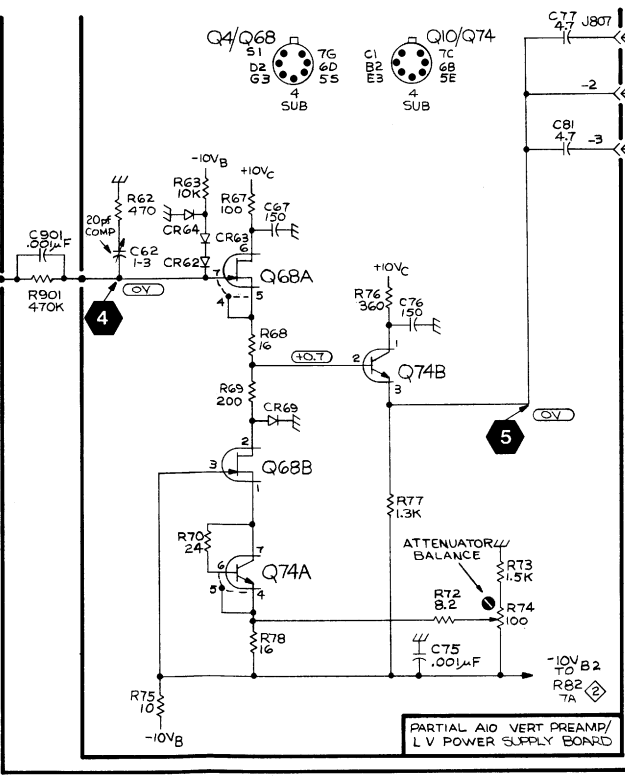
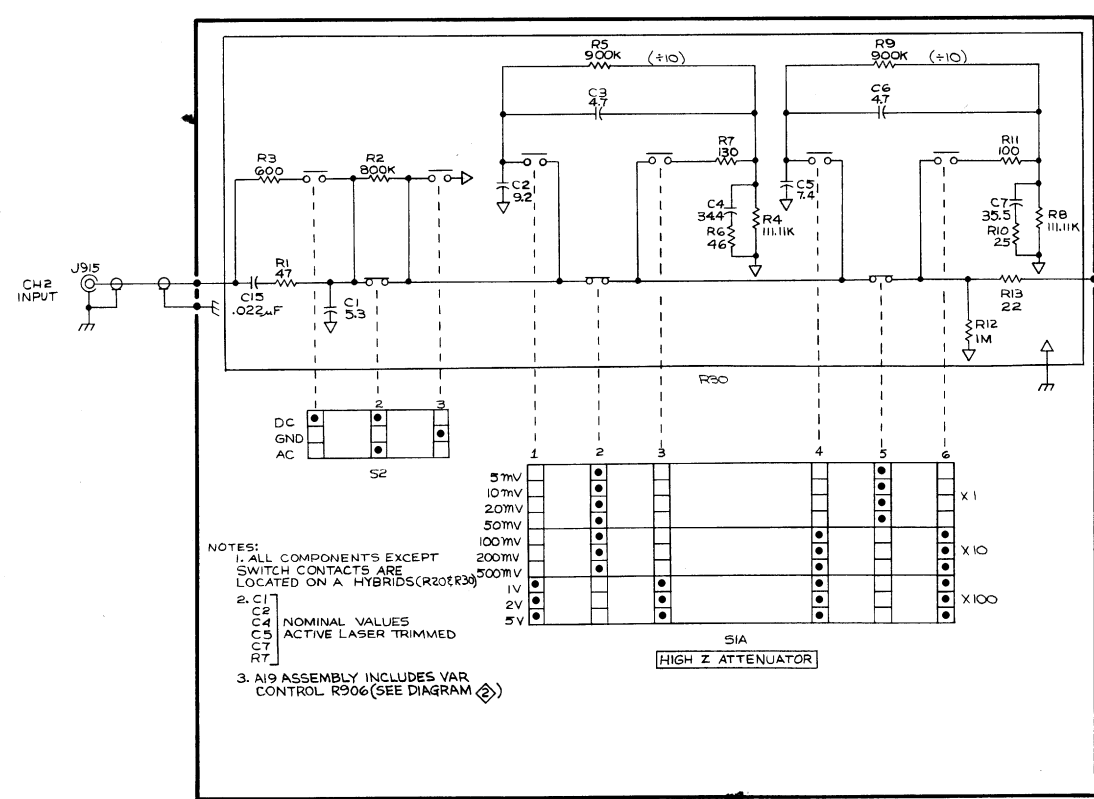
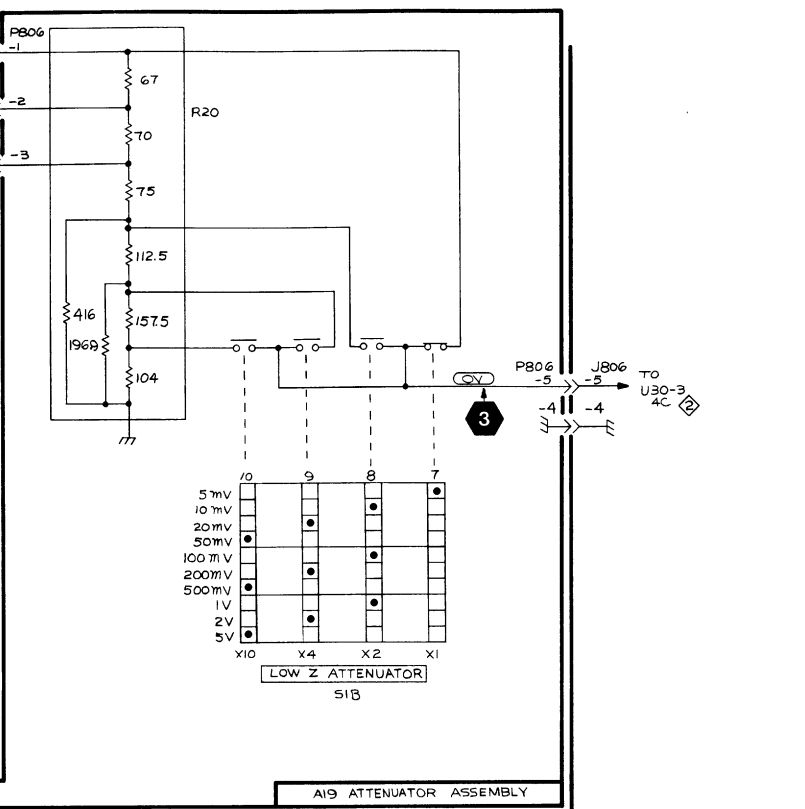
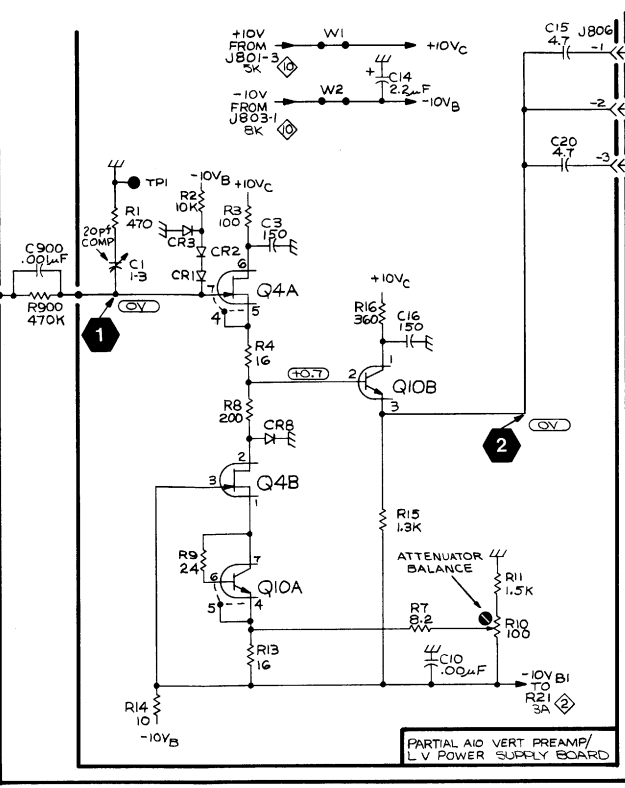
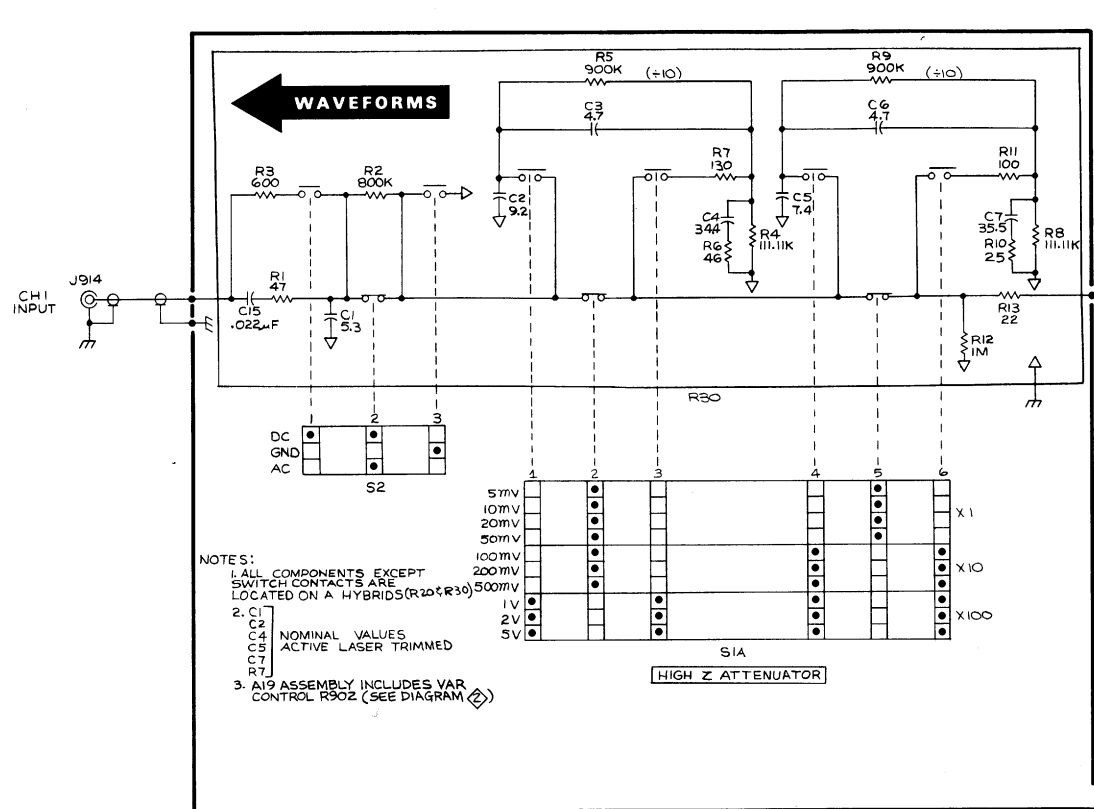

Static Sensitive Devices See Maintenance Section

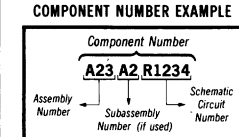

Chassis-mounted components have no Assembly Number prefix—see end of Replaceable Electrical Parts List.

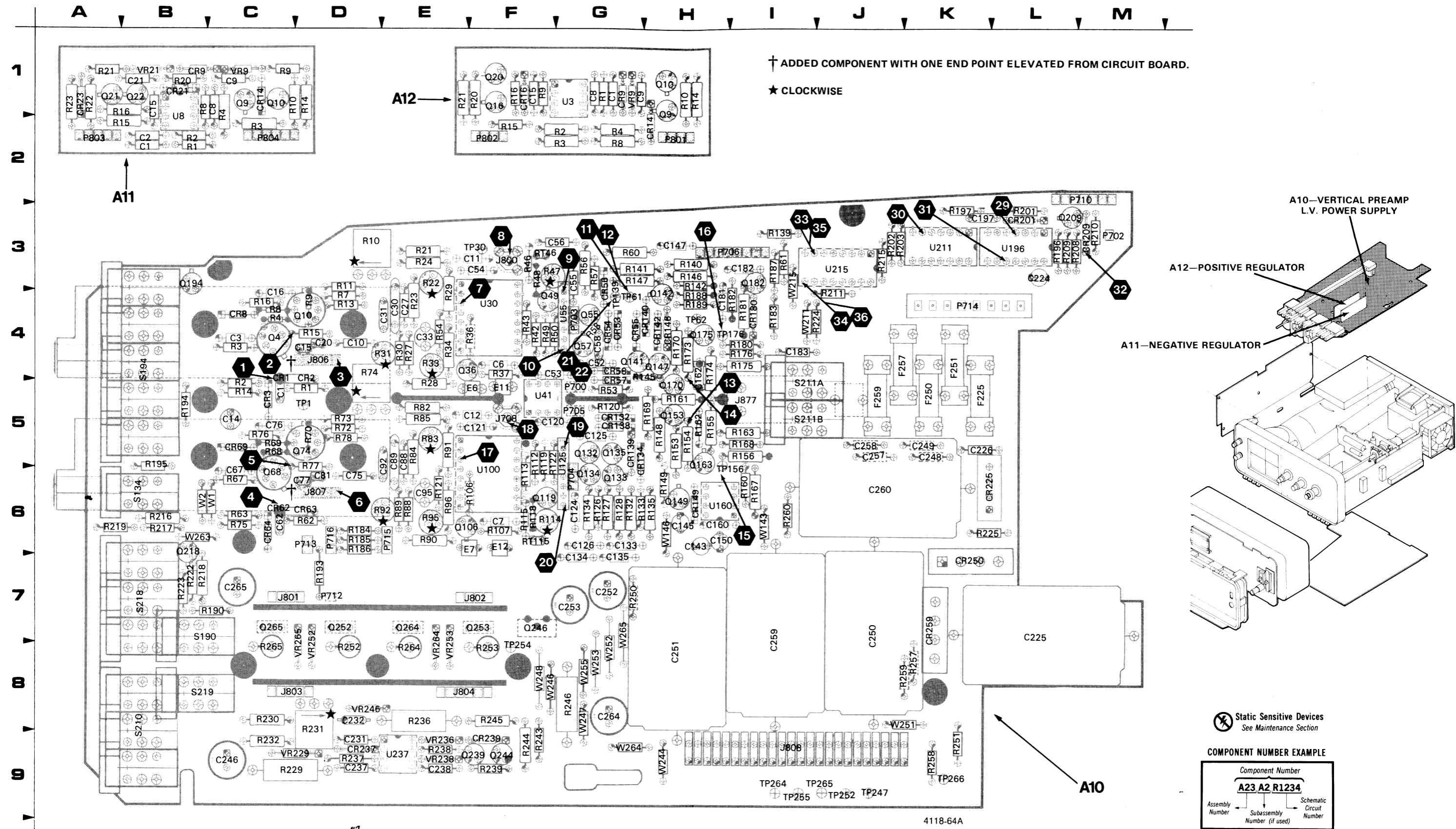

Figure 9-7. A11—Negative Regulator, A12—Positive Regulator, and A10—Vertical Preamp/L.V. Power Supply boards.

REV JUL 1981

**A10-VERT PREAMP /L.V. POWER SUPPLY BOARD**

CIRCUIT NUMBER	SCHEM NUMBER	CIRCUIT NUMBER	SCHEM NUMBER	CIRCUIT NUMBER	SCHEM NUMBER	CIRCUIT NUMBER	SCHEM NUMBER	CIRCUIT NUMBER	SCHEM NUMBER	CIRCUIT NUMBER	SCHEM NUMBER
C1	1	C259	10	P710	6	R37	2	R153	2	R258	10
C3	1	C260	10	P710	10	R42	2	R154	2	R259	10
C6	2	C264	10	P712	2	R43	2	R155	2	R260	10
C7	2	C265	10	P713	2	R46	2	R156	2	R264	10
C10	1	CR1	1	P714	10	R47	2	R160	2	R265	10
C11	2	CR2	1	P715	8	R48	2	R161	2	RT46	2
C12	2	CR3	1	P716	8	R49	2	R162	2	RT115	2
C14	1	CR8	1	Q4	1	R50	2	R163	2	S134	2
C15	1	CR53	2	Q10	1	R53	2	R167	2	S190	8
C16	1	CR54	2	Q36	2	R54	2	R168	2	S194	4
C20	2	CR55	2	Q49	2	R56	2	R169	2	S194	8
C27	2	CR56	2	Q55	2	R57	2	R170	2	S210	6
C30	2	CR57	2	Q57	2	R58	2	R173	2	S211	3
C31	2	CR58	2	Q68	1	R60	2	R174	2	S211	4
C33	2	CR62	1	Q74	1	R61	2	R175	2	S218	6
C52	2	CR63	1	Q106	2	R62	1	R176	2	S219	5
C53	2	CR64	1	Q119	2	R63	1	R180	2	TP1	1
C54	2	CR69	1	Q132	2	R67	1	R181	2	TP30	2
C55	2	CR132	2	Q133	2	R68	1	R182	2	TP61	2
C56	2	CR134	2	Q134	2	R69	1	R183	2	TP62	2
C58	2	CR138	2	Q135	2	R70	1	R184	8	TP139	2
C62	1	CR139	2	Q141	2	R72	1	R185	8	TP156	2
C67	1	CR140	2	Q142	2	R73	1	R186	8	TP176	2
C75	1	CR142	2	Q147	2	R74	1	R187	2	TP247	10
C76	1	CR146	2	Q149	2	R75	1	R188	2	TP252	10
C77	1	CR149	2	Q153	2	R76	1	R189	2	TP254	10
C81	1	CR180	2	Q163	2	R77	1	R190	8	TP255	10
C88	2	CR201	4	Q170	2	R78	1	R193	2	TP264	10
C89	2	CR209	4	Q175	2	R82	2	R194	4	TP265	10
C92	2	CR225	10	Q182	2	R83	2	R195	4	TP266	10
C95	2	CR237	10	Q194	4	R84	2	R196	4	U30	2
C120	2	CR239	10	Q209	4	R85	2	R197	4	U41	2
C121	2	CR250	10	Q218	6	R88	2	R201	4	U55	2
C124	2	CR259	10	Q239	10	R89	2	R202	4	U100	2
C125	2	E6	2	Q244	10	R90	2	R203	4	U125	2
C126	2	E7	2	Q246	10	R91	2	R208	4	U160	2
C133	2	E11	2	Q252	10	R92	2	R209	4	U196	4
C134	2	E12	2	Q253	10	R95	2	R210	4	U211	4
C135	2	F225	10	Q264	10	R96	2	R211	4	U215	4
C143	2	F250	10	Q265	10	R106	2	R215	4	U237	10
C145	2	F251	10	R1	1	R107	2	R216	6	VR229	10
C147	2	F257	10	R2	1	R112	2	R217	6	VR236	10
C150	2	F259	10	R3	1	R113	2	R218	6	VR238	10
C160	2	J708	2	R4	1	R114	2	R219	6	VR246	10
C162	2	J800	2	R7	1	R115	2	R222	6	VR252	10
C181	2	J801	10	R8	1	R118	2	R223	6	VR253	10
C182	2	J802	10	R9	1	R119	2	R224	4	VR264	10
C183	2	J803	10	R10	1	R120	2	R225	10	VR265	10
C197	4	J804	10	R11	1	R121	2	R229	10	W1	1
C224	4	J806	1	R13	1	R122	2	R230	10	W2	1
C225	10	J807	1	R14	1	R126	2	R231	10	W143	2
C226	10	J808	4	R15	1	R127	2	R232	10	W146	2
C231	10	J808	5	R16	1	R128	2	R236	10	W211	4
C232	10	J808	6	R21	2	R132	2	R237	10	W215	4
C237	10	J808	8	R22	2	R133	2	R238	10	W244	10
C238	10	J808	10	R23	2	R134	2	R239	10	W246	10
C246	10	J877	2	R24	2	R135	2	R243	10	W247	10
C248	10	P700	2	R27	2	R139	2	R244	10	W248	10
C249	10	P702	4	R28	2	R140	2	R245	10	W251	10
C250	10	P703	2	R29	2	R141	2	R246	10	W252	10
C251	10	P704	2	R30	2	R142	2	R250	10	W253	10
C252	10	P705	2	R31	2	R145	2	R251	10	W255	10
C253	10	P706	2	R33	2	R146	2	R252	10	W263	10
C257	10	P710	3	R34	2	R147	2	R253	10	W264	10
C258	10	P710	4	R36	2	R148	2	R257	10	W265	10
						R149	2				

**ALL COMPONENTS MOUNTED ON A11-NEGATIVE REGULATOR  
AND A12-POSITIVE REGULATOR CIRCUIT BOARDS ARE SHOWN  
IN SCHEMATIC DIAGRAM .**



TEST WAVEFORMS FOR DIAGRAM **2**

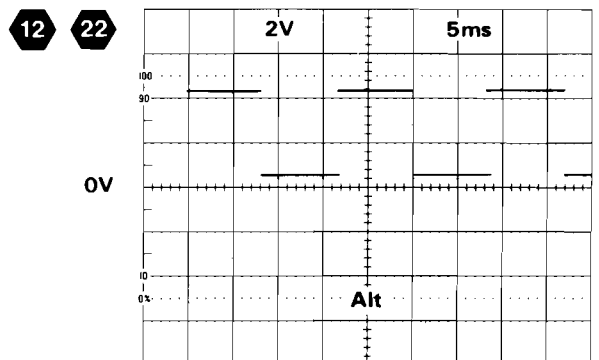
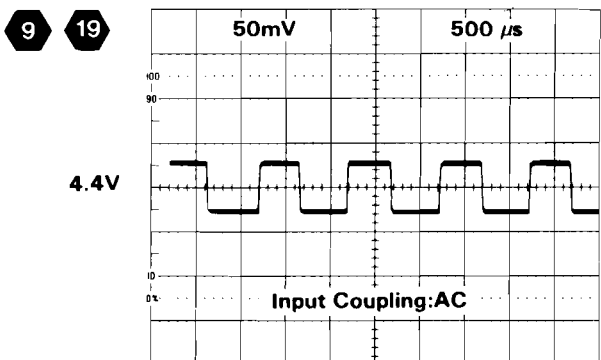
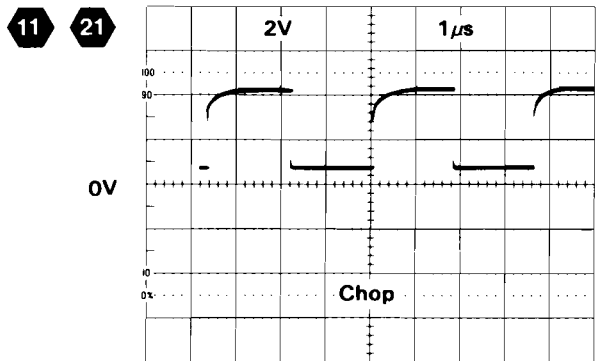
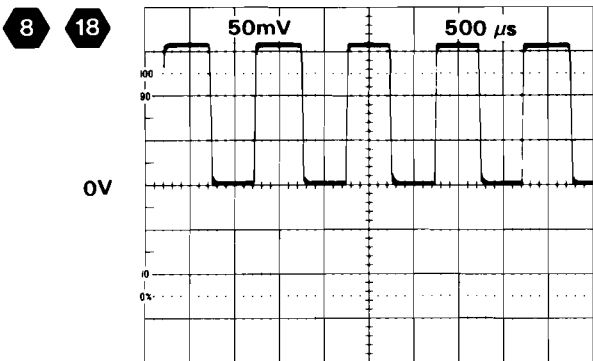
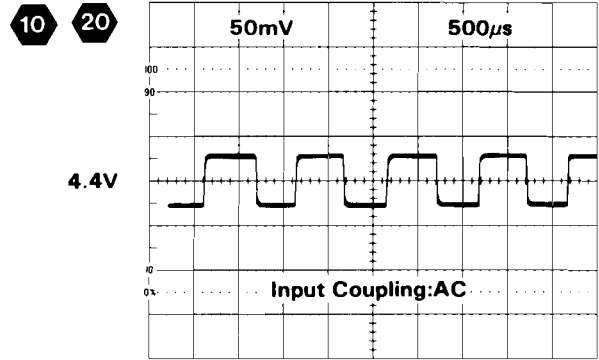
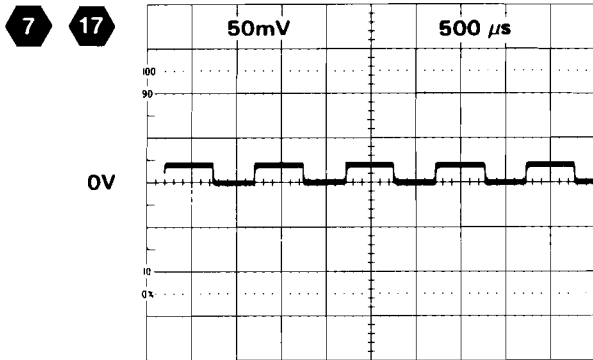

4116-81

(CONT)

TEST WAVEFORMS FOR DIAGRAM 2 (CONT)

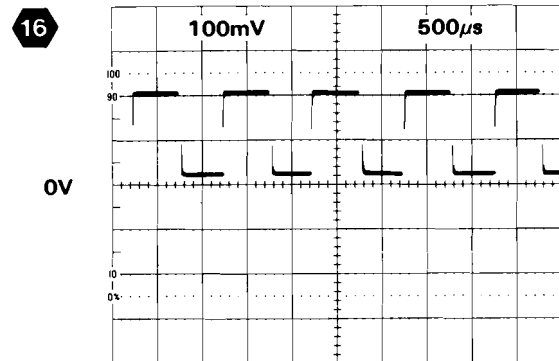
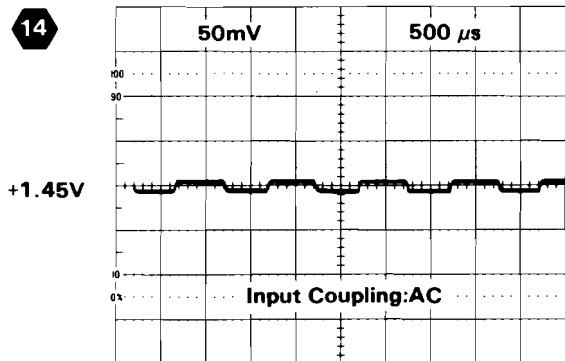
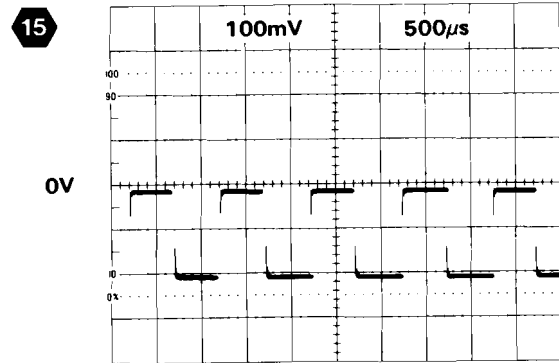
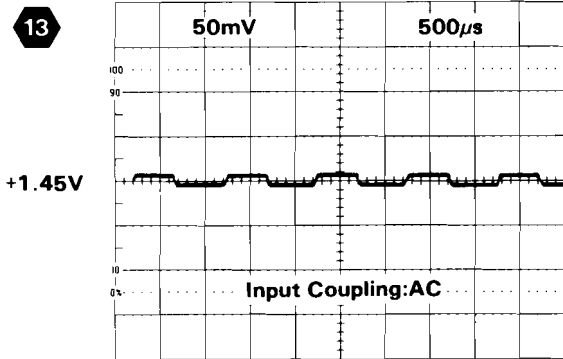

4116-82

## CH1 & CH2 VERT PREAMP & DELAY LINE DRIVER DIAGRAM



<b>ASSEMBLY A10</b>											
CIRCUIT NUMBER	SCHEM LOCATION	BOARD LOCATION	CIRCUIT NUMBER	SCHEM LOCATION	BOARD LOCATION	CIRCUIT NUMBER	SCHEM LOCATION	BOARD LOCATION	CIRCUIT NUMBER	SCHEM LOCATION	BOARD LOCATION
C6	8B	4F	E6	8B	5F	R36	2D	4F	R147	6L	3G
C7	8B	6F	E7	8B	6F	R37	2D	4F	R148	4M	5H
C11	9B	3F	E11	9B	5F	R42	3D	4F	R149	1M	6H
C12	9B	5F	E12	9B	6F	R43	3D	4F	R153	2M	5H
C27	3B	4E				R46	3E	3F	R154	2M	5H
C30	3B	4E	J708	8E	5F	R47	3E	3F	R155	1N	5H
C31	3B	4E	J800	4E	3F	R48	3E	3F	R156	2N	5I
C33	3B	4E	J877	2N	5I	R49	3F	4F	R160	1N	6I
C52	4H	4G	J877	5N	5I	R50	3H	4F	R161	5M	5H
C53	3F	4F	J877	8N	5I	R53	3F	5G	R162	5M	5H
C54	2C	3F				R54	2C	4E	R163	3N	5I
C55	3H	3G	P700	3F	5G	R56	3I	3G	R167	5N	6I
C56	4J	3G	P703	3H	4G	R57	3J	3G	R168	4N	5I
C58	4J	4G	P704	6H	6G	R58	3J	4G	R169	5M	5H
C88	6B	5E	P705	7F	5G	R60	4I	3G	R170	8M	4H
C89	6B	5E	P706	3K	3I	R61	3J	3I	R173	9M	4H
C92	6B	5E	P706	8N	3I	R82	6A	5E	R174	9M	4H
C95	6B	6E	P712	4F	7D	R83	6A	5E	R175	7M	4I
C120	7F	5F	P713	4E	6D	R84	7A	5E	R176	5N	4I
C121	6C	5F				R85	6A	5E	R180	8N	4I
C124	7H	6G	Q36	2D	4F	R88	7B	6E	R181	8N	4I
C125	6H	5G	Q49	3F	4F	R89	7B	6E	R182	8N	4I
C126	5I	6G	Q55	2J	4G	R90	7B	6E	R183	9N	4I
C133	7J	6G	Q57	4J	4G	R91	6B	5E	R187	9N	3I
C134	8I	7G	Q106	5D	6F	R92	7B	6E	R188	5L	4H
C135	8J	7G	Q119	6F	6F	R95	7C	6E	R189	4L	4H
C143	8A	6H	Q132	5J	5G	R96	7C	6E	R193	4F	7D
C145	8B	6H	Q133	6J	6G	R106	5D	6F			
C147	7L	3H	Q134	8J	6G	R107	5D	6F	RT46	3E	3F
C150	9A	6H	Q135	7J	5G	R112	6D	5F	RT115	6E	6F
C160	1N	6H	Q141	4L	4G	R113	7D	6F			
C162	5M	4H	Q142	5L	4H	R114	6E	6F	S134	9I	6B
C181	8N	4H	Q147	6L	4H	R115	7E	6F			
C182	8N	3I	Q149	1M	6H	R118	7E	6F	TP30	2C	3F
C183	9N	4I	Q153	2M	5H	R119	7F	5F	TP61	3K	4G
			Q163	2M	5H	R120	6F	5G	TP62	8M	4H
CR53	3I	4G	Q170	8M	5H	R121	6C	6E	TP139	7K	4G
CR54	3I	4G	Q175	8M	4H	R122	7H	5F	TP156	2N	6I
CR55	2K	4G	Q182	8N	3I	R126	5I	6G	TP176	8N	4I
CR56	3K	3G				R127	6I	6G			
CR57	4K	5G	R21	3A	3E	R128	6J	6G	U30	4D	4F
CR58	4K	4G	R22	3A	3E	R132	6J	6G	U41A	5D	5F
CR132	5K	5G	R23	4A	4E	R133	7J	6G	U41B	2D	5F
CR134	8K	5G	R24	3A	3E	R134	8I	6G	U55	2I	4G
CR138	6K	5G	R27	3B	4E	R135	8I	6H	U100	8C	6F
CR139	7K	5G	R28	4B	5E	R139	7J	3I	U125	5I	5G
CR140	4L	4H	R29	3B	4E	R140	4L	3H	U160	1N	6H
CR142	5L	4H	R30	3B	4E	R141	4L	3G			
CR146	6L	4H	R31	3B	4D	R142	5L	3H	W143	8A	6I
CR149	1M	6H	R33	3C	4E	R145	6L	4H	W146	8A	6H
CR180	8N	4I	R34	3C	4E	R146	6L	3H			

*Partial A10 also shown on diagrams 1, 3, 4, 5, 6, 8 and 10*

### CHASSIS MOUNTED PARTS

CIRCUIT NUMBER	SCHEM LOCATION	BOARD LOCATION	CIRCUIT NUMBER	SCHEM LOCATION	BOARD LOCATION	CIRCUIT NUMBER	SCHEM LOCATION	BOARD LOCATION	CIRCUIT NUMBER	SCHEM LOCATION	BOARD LOCATION
DL900	5N	CHASSIS	P800	4E	CHASSIS	R905	7G	CHASSIS	S906	6G	CHASSIS
DS910	4E	CHASSIS	R902	3G	CHASSIS	R906	7G	CHASSIS			
			R903	3G	CHASSIS	R907	7G	CHASSIS			
P708	8E	CHASSIS	R904	3G	CHASSIS	S902	3G	CHASSIS			

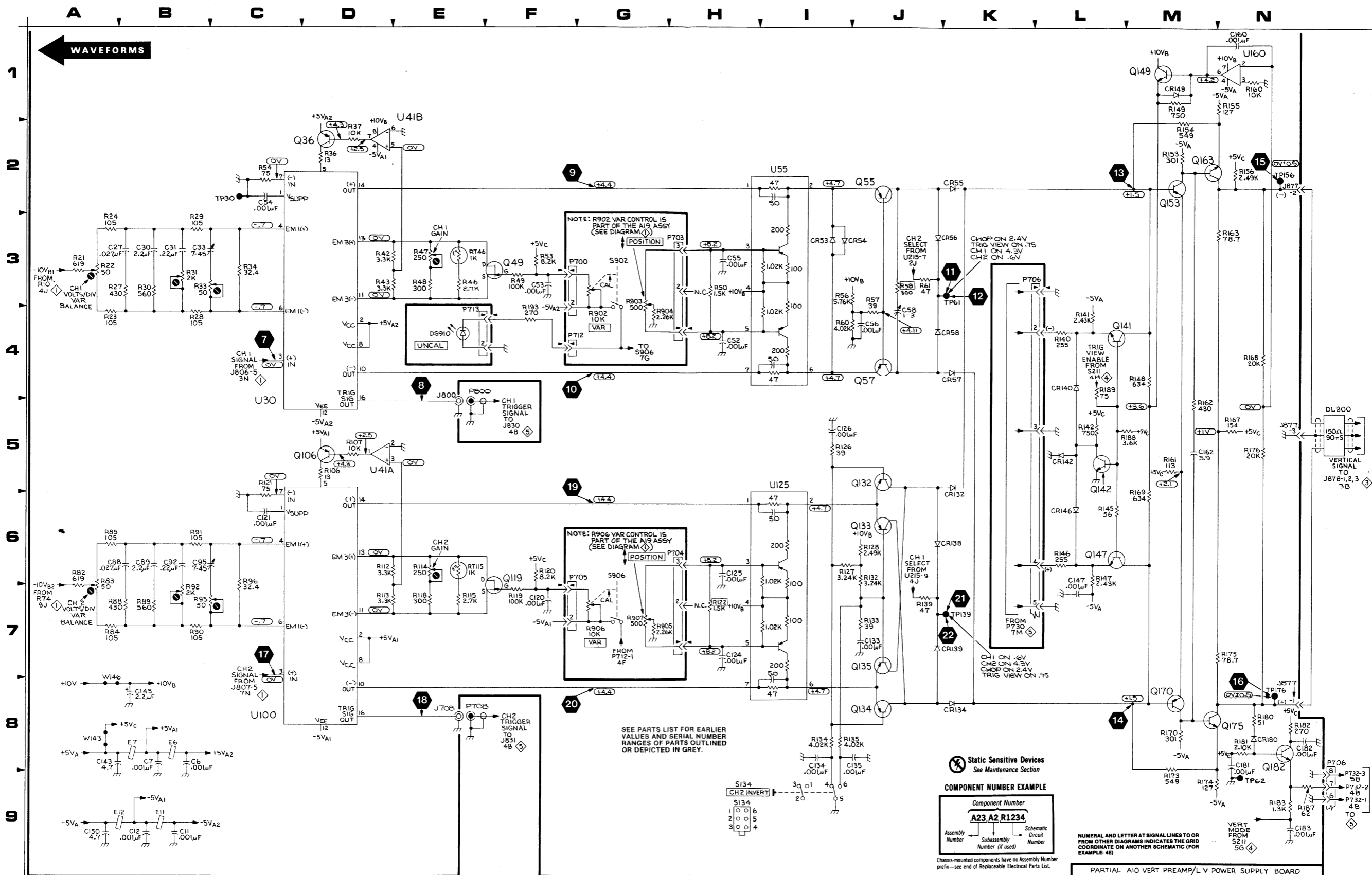

SEE PARTS LIST FOR EARLIER VALUES AND SERIAL NUMBER RANGES OF PARTS OUTLINED OR DEPICTED IN GREY.

Static Sensitive Devices  
See Maintenance Section

COMPONENT NUMBER EXAMPLE

Component Number		
A23	A2	R1234
Assembly Number	Subassembly Number (if used)	Schematic Circuit Number

NUMERAL AND LETTER AT SIGNAL LINES TO OR FROM OTHER DIAGRAMS INDICATES THE GRID COORDINATE ON ANOTHER SCHEMATIC (FOR EXAMPLE 4E)

VERT MODE FROM 5211 5G

A15—VERT OUT/H.V. PWR SPLY BD FIG. 9-8 & WAVEFORMS

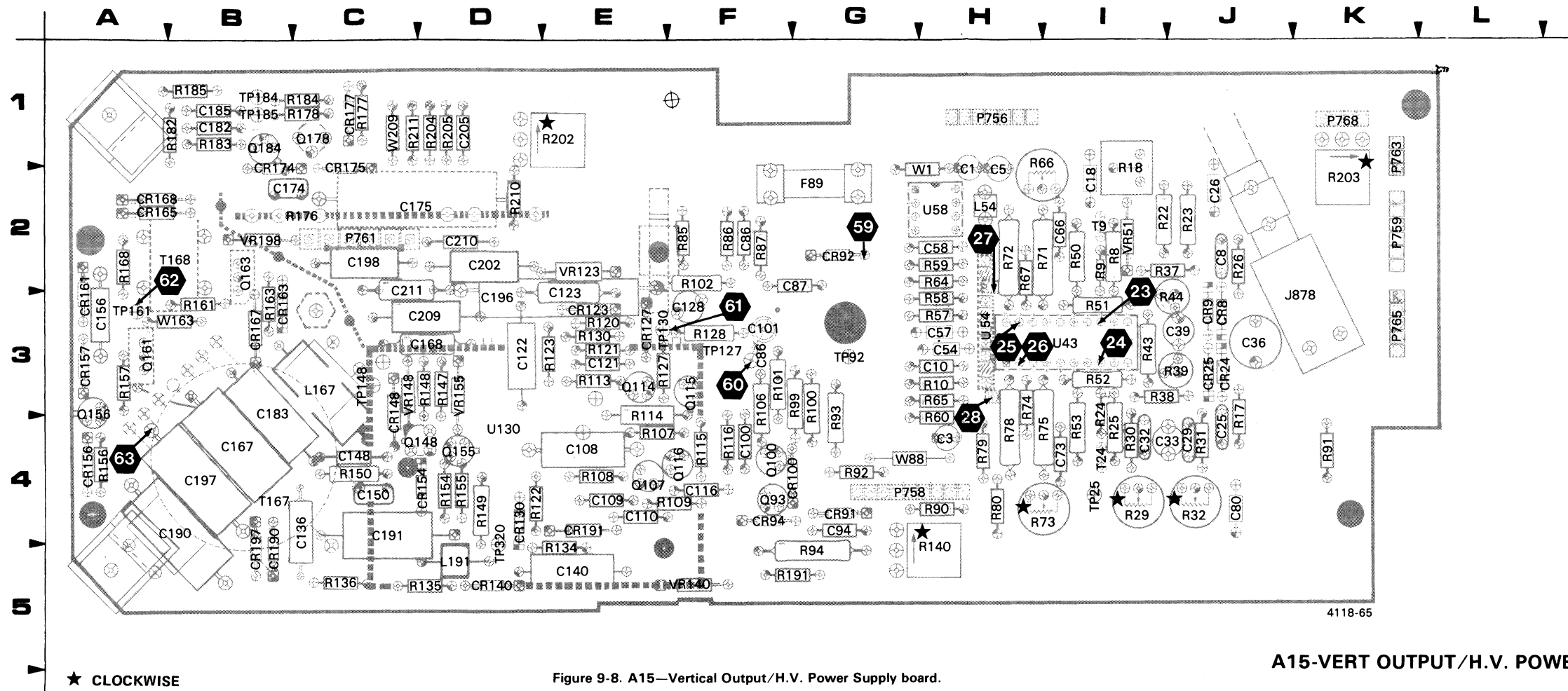
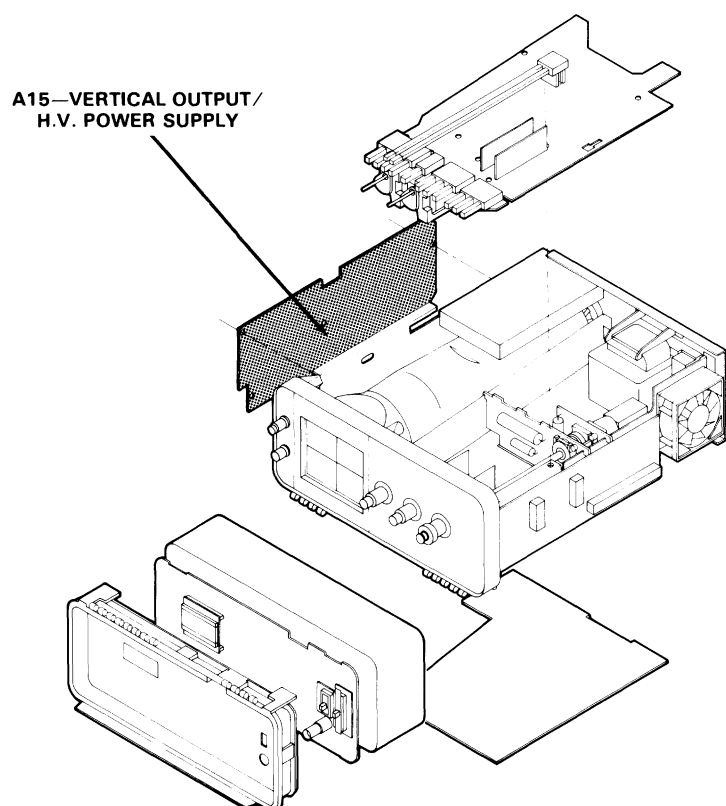
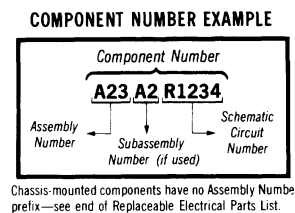

Figure 9-8. A15—Vertical Output/H.V. Power Supply board.

**A15-VERT OUTPUT/H.V. POWER SUPPLY BOARD**

Static Sensitive Devices  
See Maintenance Section



CIRCUIT NUMBER	SCHEM NUMBER	CIRCUIT NUMBER	SCHEM NUMBER	CIRCUIT NUMBER	SCHEM NUMBER	CIRCUIT NUMBER	SCHEM NUMBER	CIRCUIT NUMBER	SCHEM NUMBER	CIRCUIT NUMBER	SCHEM NUMBER
C1	3	C174	9	CR190	9	R26	3	R100	9	R185	9
C3	9	C175	9	CR191	9	R29	3	R101	9	R191	9
C5	9	C182	9	CR197	9	R30	3	R102	9	R202	9
C8	3	C183	9	F89	9	R31	3	R106	9	R203	9
C10	3	C185	9	J878	3	R32	3	R107	9	R204	9
C18	3	C190	9	L54	3	R37	3	R108	9	R205	9
C25	3	C191	9	L167	9	R38	3	R109	9	R210	3
C26	3	C196	9	L191	9	R39	3	R113	9	R211	9
C29	3	C197	9	P756	3	R43	3	R114	9	T9	3
C32	3	C198	9	P756	9	R44	3	R115	9	T24	3
C33	3	C202	9	P758	3	R50	3	R116	9	T167	9
C36	3	C205	9	P758	9	R51	3	R120	9	T168	9
C39	3	C209	9	P759	3	R52	3	R121	9	TP25	3
C54	3	C210	9	P761	9	R53	3	R122	9	TP92	9
C57	3	C211	9	P763	9	R57	3	R123	9	TP127	9
C58	3	CR8	3	P765	9	R58	3	R127	9	TP130	9
C66	3	CR9	3	P768	9	R59	3	R128	9	TP148	9
C73	3	CR24	3	Q93	9	R60	3	R130	9	TP161	9
C80	3	CR25	3	Q100	9	R64	3	R134	9	TP184	9
C86	9	CR91	9	Q107	9	R65	3	R135	9	TP185	9
C87	9	CR92	9	Q114	9	R66	3	R136	9	TP320	9
C94	9	CR94	9	Q115	9	R67	3	R140	9	U43	3
C100	9	CR100	9	Q116	9	R71	3	R147	9	U54	3
C101	9	CR123	9	Q148	9	R72	3	R148	9	U58	3
C108	9	CR127	9	Q155	9	R73	3	R149	9	U130	9
C109	9	CR130	9	Q156	9	R74	3	R150	9	VR51	3
C110	9	CR140	9	Q161	9	R75	3	R154	9	VR123	9
C116	9	CR148	9	Q163	9	R78	3	R155	9	VR140	9
C121	9	CR154	9	Q178	9	R79	3	R156	9	VR148	9
C122	9	CR156	9	Q184	9	R80	3	R157	9	VR155	9
C123	9	CR157	9	R8	3	R85	9	R161	9	VR198	9
C128	9	CR161	9	R9	3	R86	9	R163	9	W1	3
C136	9	CR163	9	R10	3	R87	9	R168	9	W88	9
C140	9	CR165	9	R17	3	R90	3	R176	9	W163	9
C148	9	CR167	9	R18	3	R91	9	R177	9	W209	9
C150	9	CR168	9	R22	3	R92	9	R178	9		
C156	9	CR174	9	R23	3	R93	9	R182	9		
C167	9	CR175	9	R24	3	R94	9	R183	9		
C168	9	CR177	9	R25	3	R99	9	R184	9		

## TEST WAVEFORMS FOR DIAGRAM 3

For waveforms 25 through 28, center the 2335 trace about the center horizontal graticule line.

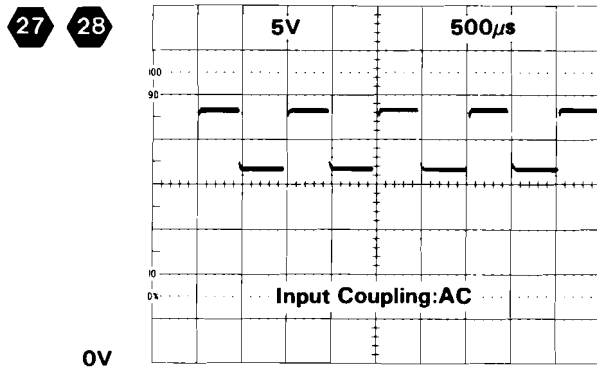
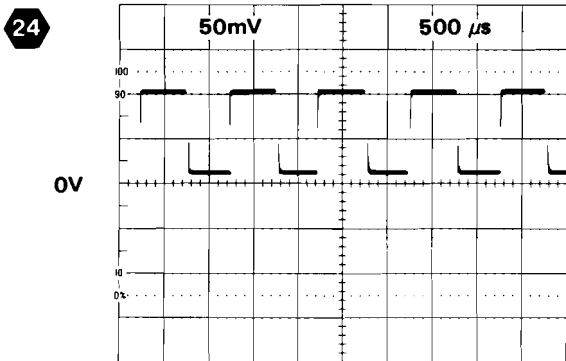
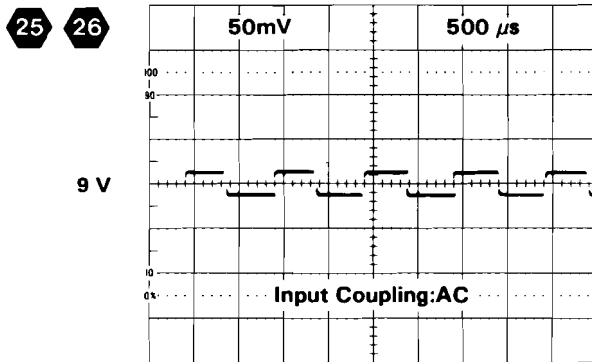
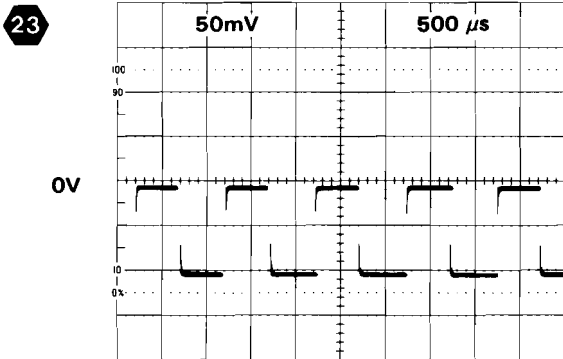

4116-83

## VERTICAL OUTPUT AMPLIFIER DIAGRAM



<b>ASSEMBLY A10</b>								
CIRCUIT NUMBER	SCHEM LOCATION	BOARD LOCATION	CIRCUIT NUMBER	SCHEM LOCATION	BOARD LOCATION	CIRCUIT NUMBER	SCHEM LOCATION	BOARD LOCATION
P710	2B	3M	S211B	1A	5I			
<i>Partial A10 also shown on diagrams 1, 2, 4, 5, 6, 8 and 10</i>								
<b>ASSEMBLY A15</b>								
CIRCUIT NUMBER	SCHEM LOCATION	BOARD LOCATION	CIRCUIT NUMBER	SCHEM LOCATION	BOARD LOCATION	CIRCUIT NUMBER	SCHEM LOCATION	BOARD LOCATION
C1	2I	2H	P756	8B	1H	R59	5F	2H
C8	3C	2J	P758	8C	4G	R60	6E	4H
C10	2G	3H	P759	6B	2K	R64	6F	2H
C18	3D	2I				R65	7F	3H
C25	4C	4J	R8	2C	2I	R66	5E	2H
C26	2C	2J	R9	2D	2I	R67	6E	2H
C29	4E	4J	R10	2G	3H	R71	5E	2I
C32	3E	4I	R17	4D	4J	R72	6E	2H
C33	3E	4I	R18	3E	2I	R73	6E	4I
C36	3F	3J	R22	3E	2I	R74	7E	4H
C39	3F	3J	R23	4E	2J	R75	6E	4H
C54	4I	3H	R24	5D	4I	R78	7E	4H
C57	6G	3H	R25	5C	4I	R79	7D	4H
C58	5F	2H	R26	2C	2J	R80	7D	4H
C66	5E	2I	R29	3E	4I	R90	7C	4H
C73	6E	4I	R30	3E	4I			
C80	7D	4J	R31	4E	4J	T9	2C	2I
			R32	3E	4J	T24	5C	4I
CR8	3C	3J	R37	3F	2I			
CR9	3C	3J	R38	4F	3I	TP25	5C	4I
CR24	4C	3J	R39	4F	3J			
CR25	4C	3J	R43	4G	3I	U43	1H	3I
			R44	3F	3J	U54	4I	3H
J87B	3C	3K	R50	2H	2I	U58	5F	2H
J878	4C	3K	R51	2H	3I			
			R52	3H	3I	VR51	2I	2I
L54	3I	2H	R53	3H	4I			
			R57	5G	3H	W1	2I	2H
P756	2B	1H	R58	5F	3H			
<i>Partial A15 also shown on diagram 9</i>								
<b>CHASSIS MOUNTED PARTS</b>								
CIRCUIT NUMBER	SCHEM LOCATION	BOARD LOCATION	CIRCUIT NUMBER	SCHEM LOCATION	BOARD LOCATION	CIRCUIT NUMBER	SCHEM LOCATION	BOARD LOCATION
L913	3J	CHASSIS	R909	6A	CHASSIS			
L915	4J	CHASSIS	S900	5A	CHASSIS			

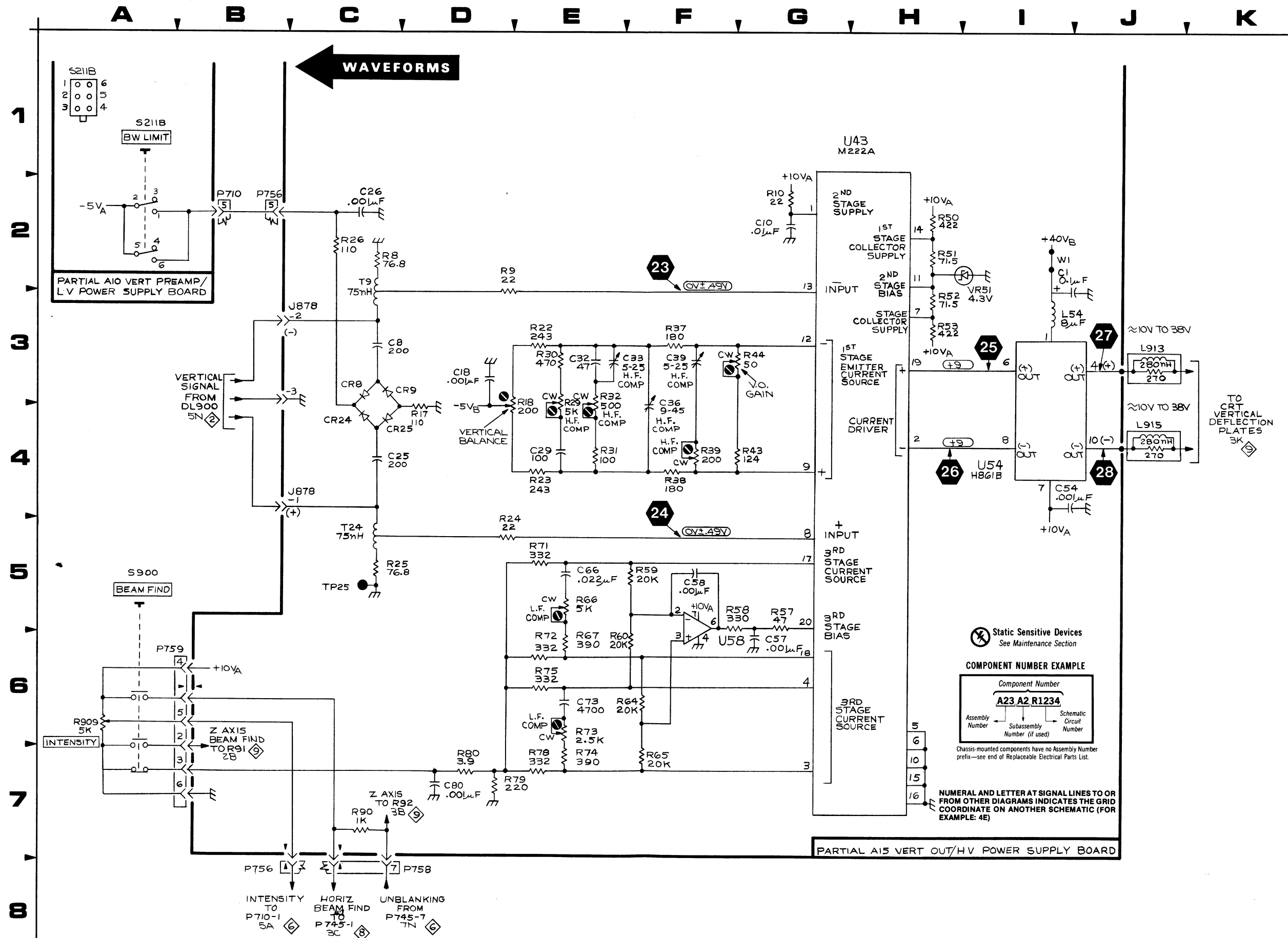

VERTICAL OUTPUT AMPLIFIER 3



TEST WAVEFORMS FOR DIAGRAM 4

For waveforms 29, 30, 32, 33, and 34, set the 2335 VERTICAL MODE to CHOP. For waveforms 31, 35, and 36, set the 2335 VERTICAL MODE to ALT and the SEC/DIV to .5ms.

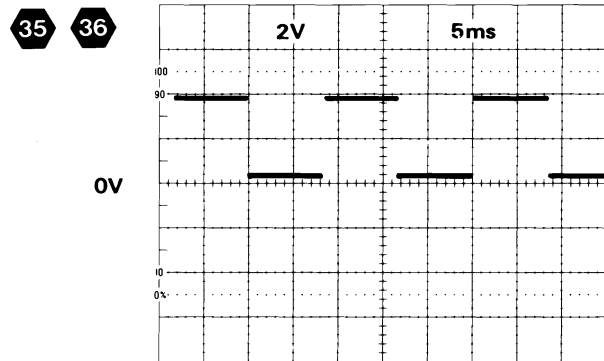
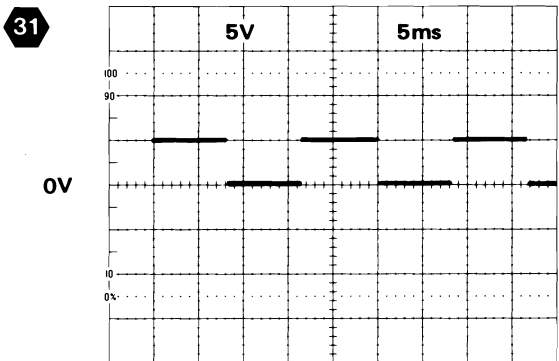
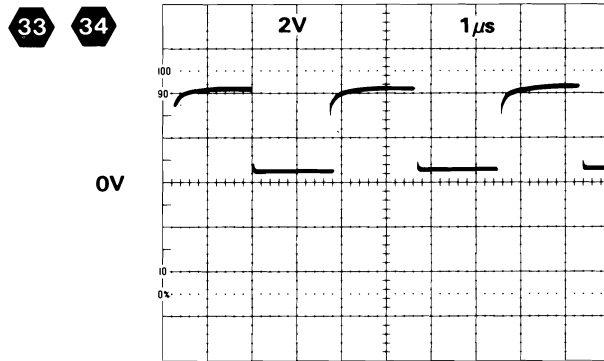
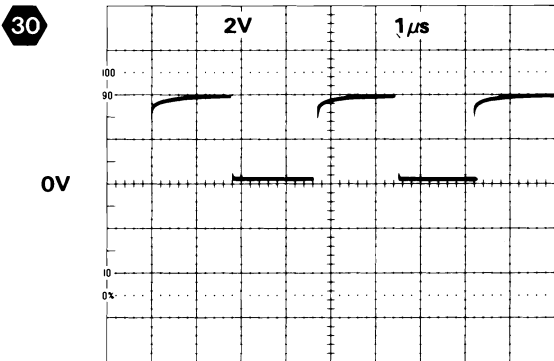
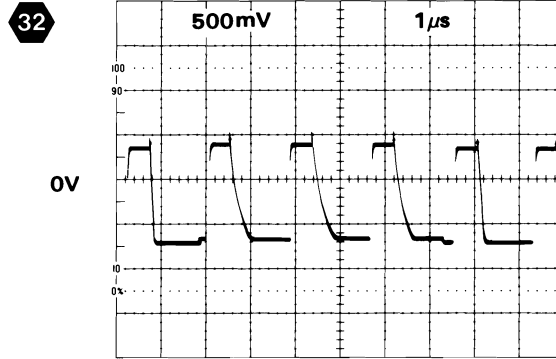
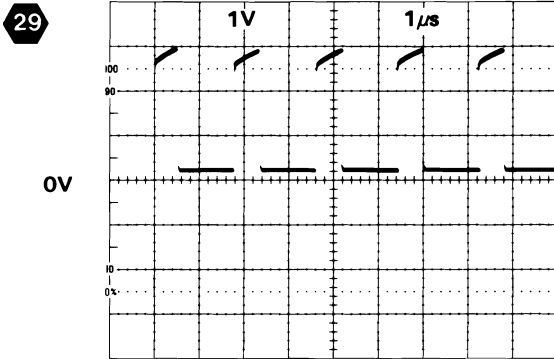

4116-84

# VERT SWITCHING LOGIC & CHOP BLANKING DIAGRAM



<b>ASSEMBLY A10</b>								
CIRCUIT NUMBER	SCHEM LOCATION	BOARD LOCATION	CIRCUIT NUMBER	SCHEM LOCATION	BOARD LOCATION	CIRCUIT NUMBER	SCHEM LOCATION	BOARD LOCATION
C197	6E	3K	R194	2C	5B	S194	4A	4B
C224	7B	3L	R195	7C	5B	S211A	5F	5I
CR201	6E	3L	R196	6D	3L			
CR209	7G	3M	R197	6D	3K	U196A	6E	3L
			R201	6E	3L	U196B	6F	3L
			R202	3F	3J	U196C	2H	3L
JB08	1H	9I	R203	3F	3J	U196D	5E	3L
			R208	6G	3L	U211A	3F	3K
P702	7F	3M	R209	6G	3L	U211B	5H	3K
P710	7K	3M	R210	7G	3M	U215	1I	3J
			R211	4H	4J			
Q194	2C	3B	R215	2F	3J	W211	5H	4I
Q209	6G	3L	R224	7B	4J	W215	2I	3I
<i>Partial A10 also shown on diagrams 1, 2, 3, 5, 6, 8 and 10.</i>								
<b>ASSEMBLY A23</b>								
CIRCUIT NUMBER	SCHEM LOCATION	BOARD LOCATION	CIRCUIT NUMBER	SCHEM LOCATION	BOARD LOCATION	CIRCUIT NUMBER	SCHEM LOCATION	BOARD LOCATION
JB40	1G	3I	P808	1H	1I			
<i>Partial A23 also shown on diagrams 5, 6 and 8.</i>								
<b>ASSEMBLY A24</b>								
CIRCUIT NUMBER	SCHEM LOCATION	BOARD LOCATION	CIRCUIT NUMBER	SCHEM LOCATION	BOARD LOCATION	CIRCUIT NUMBER	SCHEM LOCATION	BOARD LOCATION
P840	1G	1G						
<i>Partial A24 also shown on diagrams 6, 7, 8 and 11.</i>								
<b>CHASSIS MOUNTED PARTS</b>								
CIRCUIT NUMBER	SCHEM LOCATION	BOARD LOCATION	CIRCUIT NUMBER	SCHEM LOCATION	BOARD LOCATION	CIRCUIT NUMBER	SCHEM LOCATION	BOARD LOCATION
J920	7E	CHASSIS						

A B C D E F G H I J K

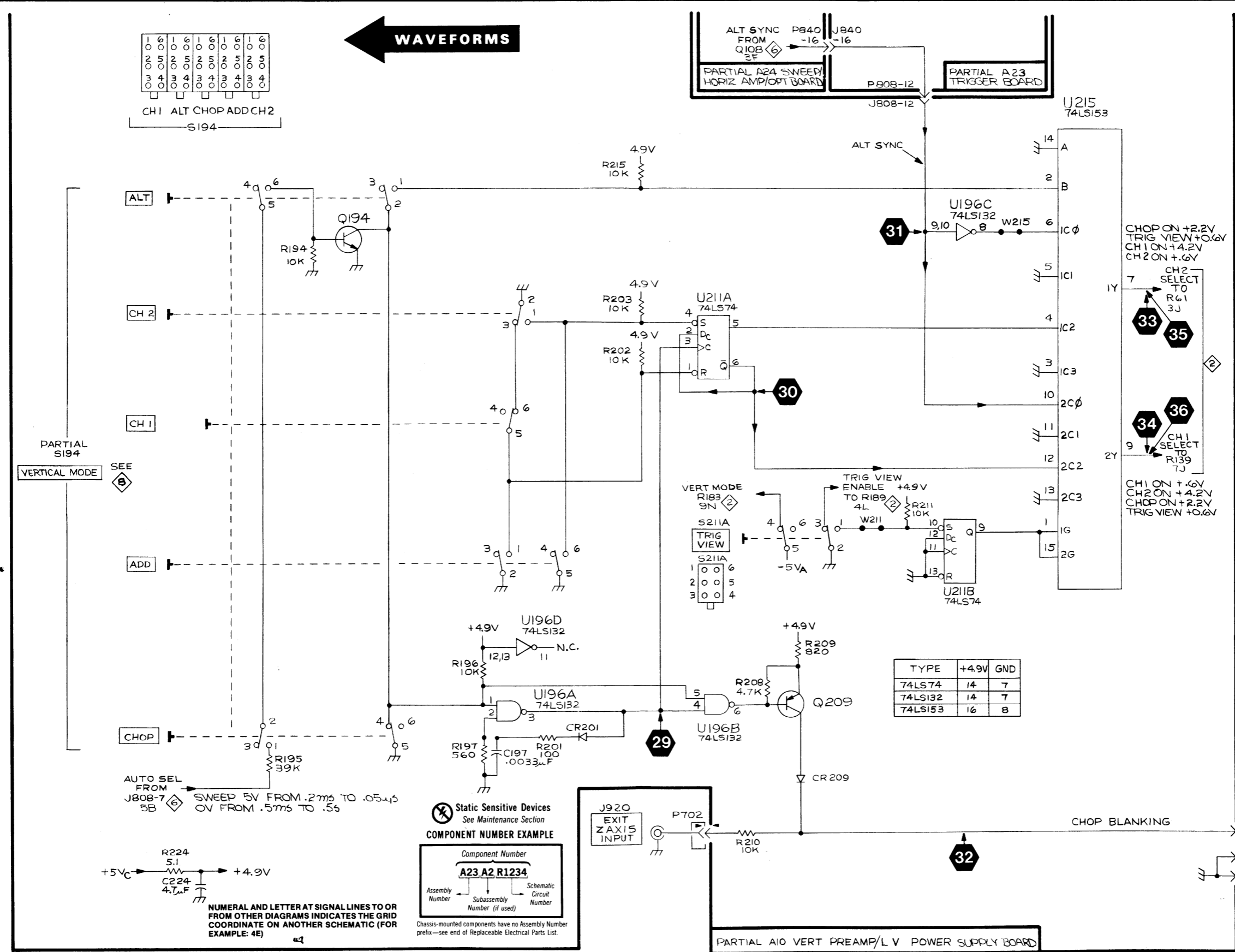

1	0	6	1	0	6	1	0	6	1	0	6
2	0	5	2	0	5	2	0	5	2	0	5
3	4	3	4	3	4	3	4	3	4	3	4
0	0	0	0	0	0	0	0	0	0	0	0

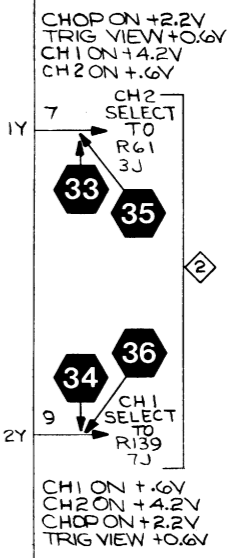
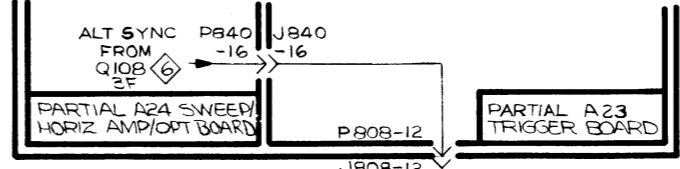

TYPE	+4.9V	GND
74LS74	14	7
74LS132	14	7
74LS153	16	8

**Static Sensitive Devices**  
See Maintenance Section

**COMPONENT NUMBER EXAMPLE**

Component Number		
A23	A2	R1234
Assembly Number	Subassembly Number (if used)	Schematic Circuit Number

Chassis-mounted components have no Assembly Number prefix—see end of Replaceable Electrical Parts List.

PARTIAL A10 VERT PREAMP/L V POWER SUPPLY BOARD

VERTICAL SWITCHING LOGIC & CHOP BLANKING 4

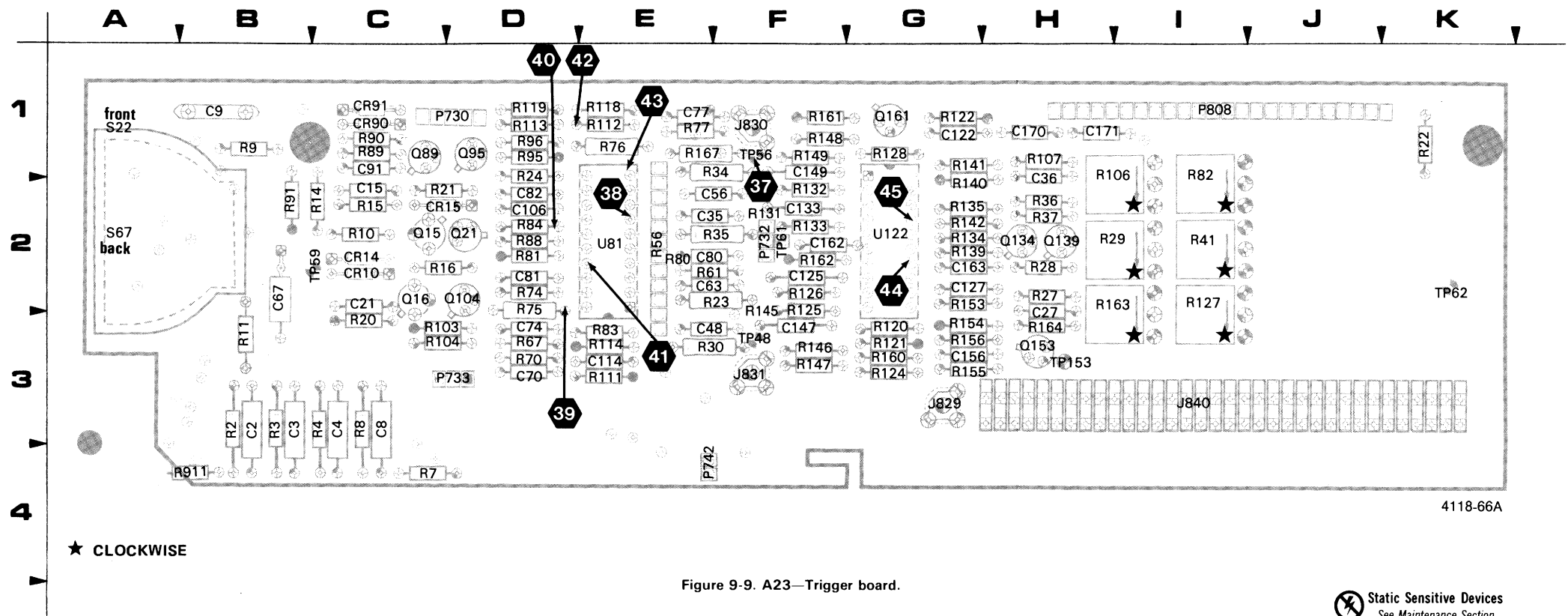

4118-66A

Figure 9-9. A23—Trigger board.

Static Sensitive Devices  
See Maintenance Section

COMPONENT NUMBER EXAMPLE

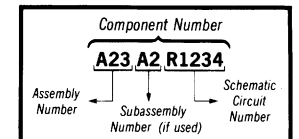

Chassis-mounted components have no Assembly Number prefix—see end of Replaceable Electrical Parts List.

A23-TRIGGER BOARD

CIRCUIT NUMBER	SCHEM NUMBER	CIRCUIT NUMBER	SCHEM NUMBER	CIRCUIT NUMBER	SCHEM NUMBER	CIRCUIT NUMBER	SCHEM NUMBER	CIRCUIT NUMBER	SCHEM NUMBER
C2	5	C170	6	R2	5	R77	5	R135	5
C3	5	C171	6	R3	5	R80*	5	R139	5
C4	5	CR10	5	R4	5	R81	5	R140	5
C8	5	CR14	5	R7	5	R82	5	R141	5
C9	5	CR15	5	R8	5	R83	5	R142	5
C15	5	CR90	5	R9	5	R84	5	R145*	5
C21	5	CR91	5	R10	5	R88	5	R146	5
C27	5	J829	5	R11	5	R89	5	R147	5
C35	5	J830	5	R14	5	R90	5	R148	5
C36	5	J831	5	R15	5	R91	5	R149	5
C48	5	J840	4	R16	5	R95	5	R150	5
C56	5	J840	5	R20	5	R96	5	R153	5
C63	5	J840	6	R21	5	R103	5	R154	5
C67	5	J840	8	R22	5	R104	5	R155	5
C70	5	P730	5	R23	5	R106	5	R156	5
C74	5	P732	5	R24	5	R107	5	R160	5
C77	5	P733	5	R27	5	R111	5	R161	5
C80	5	P742	6	R28	5	R112	5	R162	5
C81	5	P808	4	R29	5	R113	5	R163	5
C82	5	P808	5	R30	5	R114	5	R164	5
C91	5	P808	6	R34	5	R118	5	R167	8
C106	5	P808	8	R35	5	R119	5	S22	5
C114	5	Q15	5	R36	5	R120	5	S67	5
C122	5	Q16	5	R37	5	R121	5	TP48	5
C125	5	Q21	5	R41	5	R122	5	TP56	5
C127	5	Q89	5	R56	5	R124	5	TP61	5
C133	5	Q95	5	R61	5	R125	5	TP153	5
C147	5	Q104	5	R67	5	R126	5	U81	5
C149	5	Q134	5	R70	5	R127	5	U122	5
C156	5	Q139	5	R74	5	R128	5		
C162	5	Q153	5	R75	5	R131*	5		
C163	5	Q161	5	R76	5	R132	5		
						R133	5		
						R134	5		

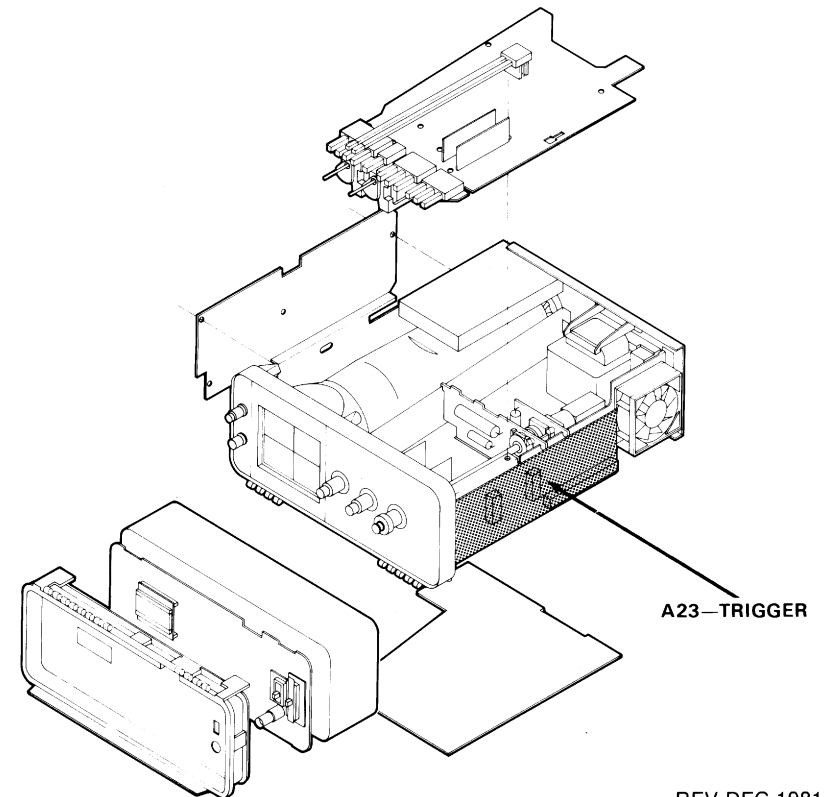

REV DEC 1981

FIG. 9-9

A23-TRIGGER BD & WAVEFORMS

# TEST WAVEFORMS FOR DIAGRAM 5

42

For waveforms 37 through 45, connect a 1X probe to the test oscilloscope External Trigger input and set the test scope Trigger Source switch to External. Apply the tip of the 1X probe to TP56 and set the 2336 SEC/DIV to .2ms. For waveforms 39, 42, and 43, the 0-V level is determined by the 2336 A TRIGGER LEVEL control.

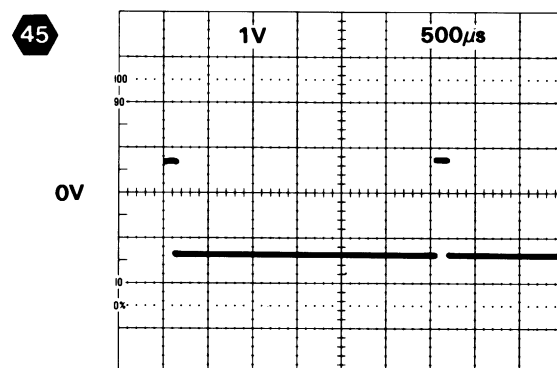
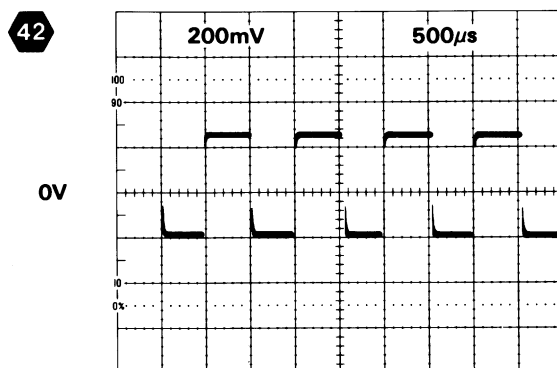
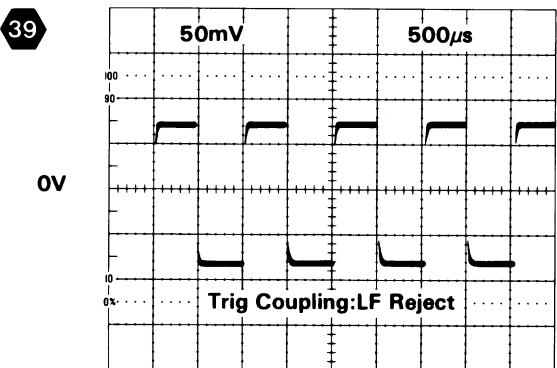
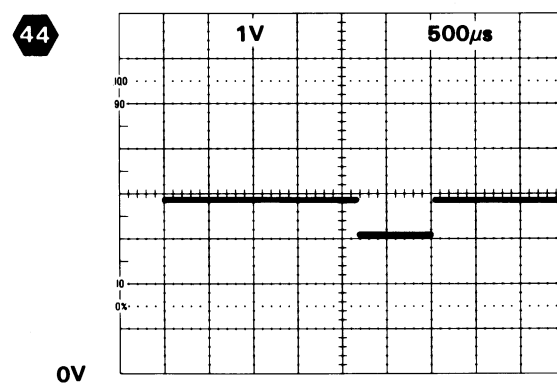
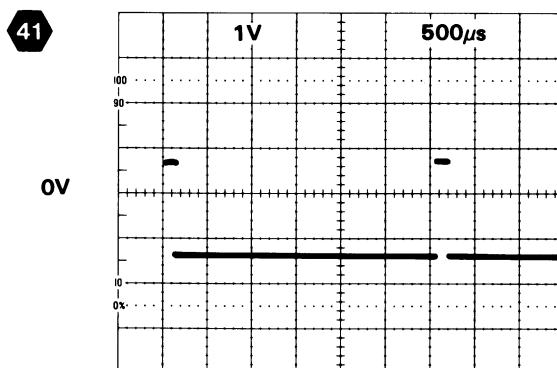
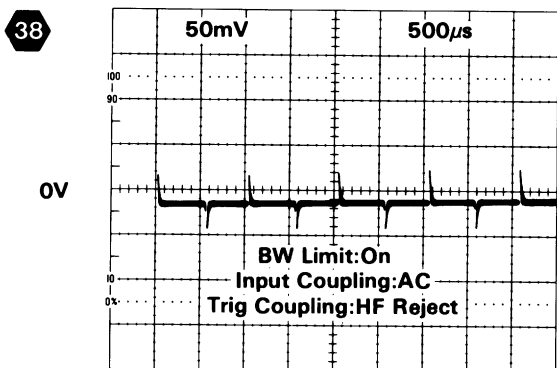
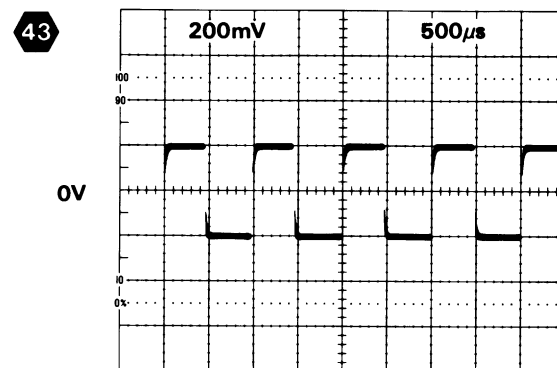
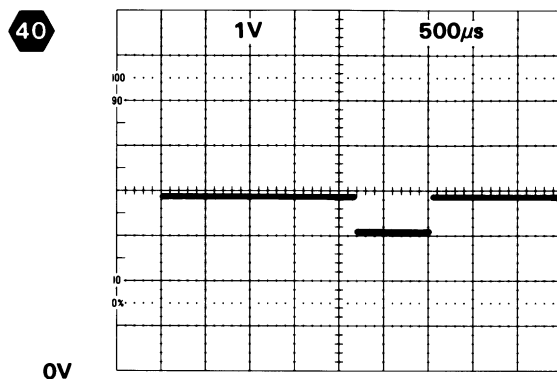
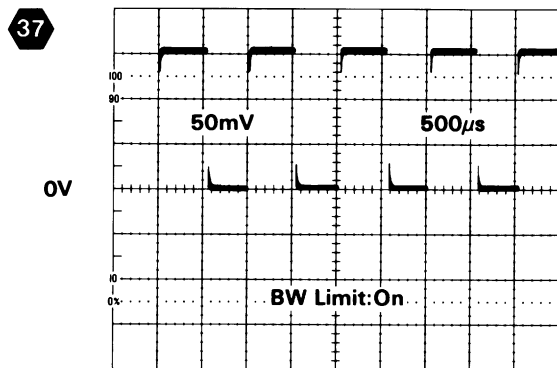

# TRIGGER DIAGRAM



<b>ASSEMBLY A10</b>											
CIRCUIT NUMBER	SCHEM LOCATION	BOARD LOCATION	CIRCUIT NUMBER	SCHEM LOCATION	BOARD LOCATION	CIRCUIT NUMBER	SCHEM LOCATION	BOARD LOCATION	CIRCUIT NUMBER	SCHEM LOCATION	BOARD LOCATION
J808	1J	9I	S219	1J	8B						

*Partial A10 also shown on diagrams 1, 2, 3, 4, 6, 8 and 10.*

<b>ASSEMBLY A23</b>											
CIRCUIT NUMBER	SCHEM LOCATION	BOARD LOCATION	CIRCUIT NUMBER	SCHEM LOCATION	BOARD LOCATION	CIRCUIT NUMBER	SCHEM LOCATION	BOARD LOCATION	CIRCUIT NUMBER	SCHEM LOCATION	BOARD LOCATION
C2	2B	3B	J840	8B	3I	R41	2E	2I	R121	6I	3G
C3	2B	3B	J840	8M	3I	R56A	5E	2E	R122	6J	1G
C4	2B	3C				R56B	4E	2E	R124	8C	3G
C8	2B	3C	P730	4M	1D	R56C	5D	2E	R125	8C	2F
C9	2C	1B	P732	4B	2F	R56D	5E	2E	R126	8D	2F
C15	2D	2C	P733	1I	3D	R56E	4E	2E	R127	6K	3I
C21	3D	2C	P808	1J	1I	R56F	5E	2E	R128	6K	1G
C27	6G	2H	P808	3B	1I	R56G	5H	2E	R131*		3F
C35	2E	2E				R56H	5I	2E	R132	6C	2F
C36	2E	1H	Q15	2D	2C	R56I	5I	2E	R133	6D	2F
C48	4D	3E	Q16	2D	2C	R56J	5E	2E	R134	7K	2G
C56	4D	2E	Q21	2D	2D	R56K	4E	2E	R135	7K	2G
C63	4D	2E	Q89	3K	1C	R56L	5D	2E	R139	7L	2G
C67	3I	2B	Q95	3L	1D	R56M	5E	2E	R140	7L	1G
C70	2I	3D	Q104	4L	2D	R56N	4E	2E	R141	7L	1G
C74	2I	3D	Q134	7K	2H	R56O	5E	2E	R142	7K	2G
C77	3I	1E	Q139	7L	2H	R61	4D	2E	R145*		3F
C80	5I	2E	Q153	8K	3H	R67	2I	3D	R146	7C	3F
C81	2J	2D	Q161	9I	1G	R70	2I	3D	R147	7C	3F
C82	2K	2D				R74	2I	2D	R148	7C	1F
C91	3K	1C	R2	2B	3B	R75	2J	2D	R149	7C	1F
C106	4K	2D	R3	2B	3B	R76	3J	1E	R150	6C	1F
C114	5J	3E	R4	2B	3C	R77	3J	1E	R153	8K	2G
C122	6J	1G	R7	3B	4C	R80*	5I	2E	R154	8L	3G
C125	8C	2F	R8	3B	3C	R81	2J	2D	R155	8I	3G
C127	6K	2G	R9	2C	1B	R82	2K	1I	R156	8I	3G
C133	6D	2F	R10	2C	2C	R83	2K	3E	R160	8I	3G
C147	7C	3F	R11	2B	3B	R84	3K	2D	R162	9J	2F
C149	6C	1F	R14	2C	2C	R88	3K	2D	R163	8K	3I
C156	8I	3G	R15	2D	2C	R89	2L	1C	R164	9K	3H
C162	9J	2F	R16	2D	2C	R90	3K	1C			
C163	8K	2G	R20	3D	3C	R91	3K	2B	S22A	1C	1A
CR10	2D	2C	R21	2D	2C	R95	2L	1D	S22B	1G	1A
CR14	2D	2C	R22	3F	1K	R96	3L	1D	S67A	1C	2A
CR15	2D	2C	R23	3F	2E	R103	4L	3C	S67B	1H	2A
CR90	3L	1C	R24	2D	1D	R104	4L	3C			
CR91	3L	1C	R27	6G	2H	R106	4K	1I	TP48	4C	3F
			R28	6G	2H	R107	4K	1H	TP56	4D	1F
			R29	6G	2I	R111	2J	3E	TP59	2D	2B
J829	8B	3G	R30	3F	3E	R112	5K	1E	TP61	4D	2F
J830	4B	1F	R34	3F	1E	R113	5L	1D	TP62	2D	2K
J831	4B	3F	R35	2E	2E	R114	5J	3E	TP153	8K	3H
J840	4M	3I	R36	2E	2H	R118	5K	1E			
J840	6B	3I	R37	2E	2H	R119	5L	1D	U81	5K	2E
						R120	6I	3G	U122	9K	2G

*Partial A23 also shown on diagrams 4, 6 and 8.*

<b>CHASSIS MOUNTED PARTS</b>											
CIRCUIT NUMBER	SCHEM LOCATION	BOARD LOCATION	CIRCUIT NUMBER	SCHEM LOCATION	BOARD LOCATION	CIRCUIT NUMBER	SCHEM LOCATION	BOARD LOCATION	CIRCUIT NUMBER	SCHEM LOCATION	BOARD LOCATION
C911	2A	CHASSIS	P829	8B	CHASSIS	R911	2A	CHASSIS			
J935	2A	CHASSIS	P830	4B	CHASSIS	R913	1I	CHASSIS			
			P831	4B	CHASSIS						

\*See Parts List for  
serial number ranges.

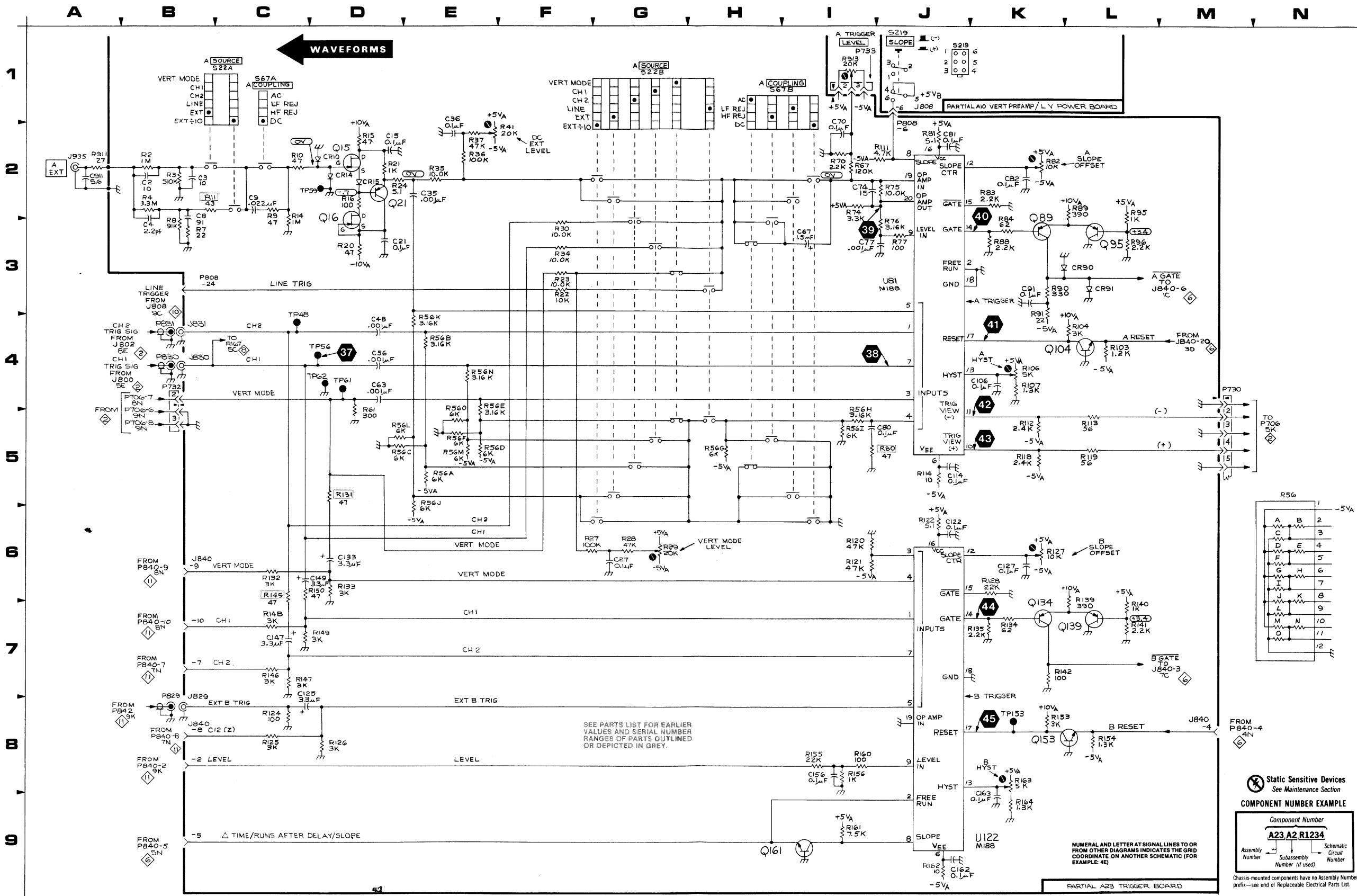

2336

4110-15  
REV DEC 1981

TRIGGER

Static Sensitive Devices  
See Maintenance Section

COMPONENT NUMBER EXAMPLE

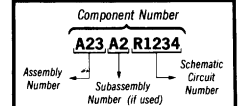

Chassis-mounted components have no Assembly Number prefix—see end of Replaceable Electrical Parts List.

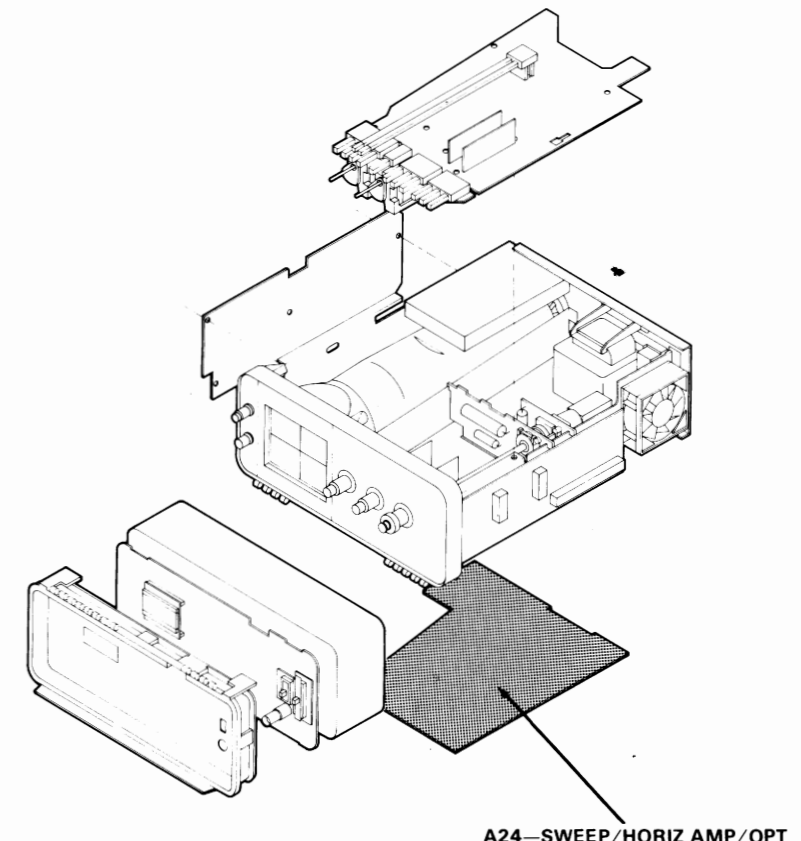
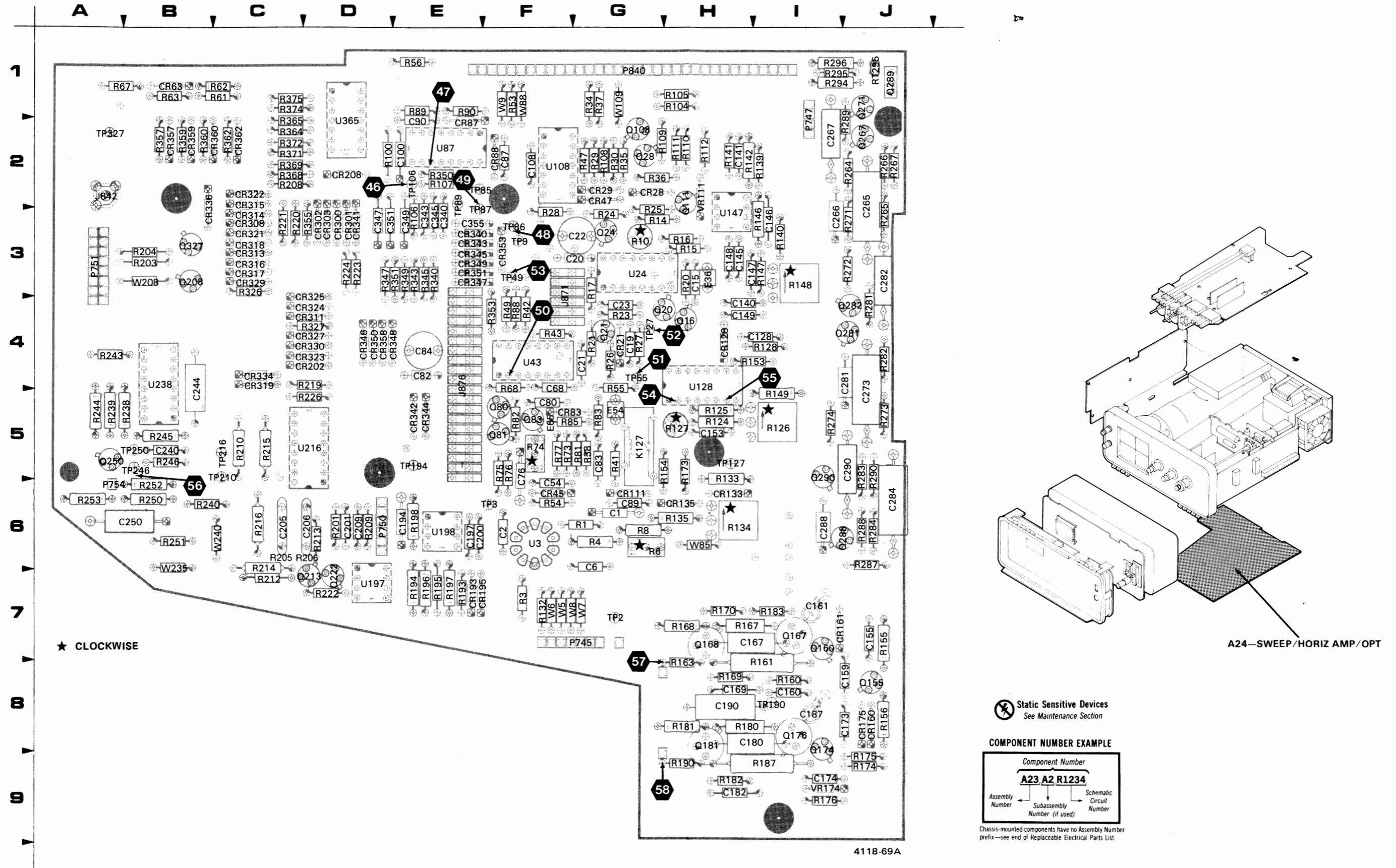

Figure 9-10. A24—Sweep/Horizontal Amplifier/Option board.

REV JUL 1981



## A24-SWEEP/HORIZ AMP/OPT BOARD

CIRCUIT NUMBER	SCHEM NUMBER	CIRCUIT NUMBER	SCHEM NUMBER	CIRCUIT NUMBER	SCHEM NUMBER	CIRCUIT NUMBER	SCHEM NUMBER	CIRCUIT NUMBER	SCHEM NUMBER	CIRCUIT NUMBER	SCHEM NUMBER
C1	6	C355	6	J876	6	R37	6	R174	8	R345	6
C2	6	CR21	6	J876	7	R38	6	R175	8	R347	6
C6	6	CR28	6	K127	8	R41	6	R176	8	R349	6
C15	6	CR29	6	P745	6	R42	6	R180	8	R350	6
C19	6	CR45	6	P745	8	R43	6	R181	8	R351	6
C20	6	CR47	6	P747	8	R47	6	R182	8	R353	6
C21	6	CR63	6	P750	6	R49	6	R183	8	R355	6
C22	6	CR83	6	P751	6	R53	6	R187	8	R357	11
C23	6	CR87	6	P751	8	R54	6	R190	8	R359	11
C54	6	CR88	6	P751	11	R55	6	R193	6	R360	11
C68	6	CR111	8	P754	8	R56	6	R194	6	R362	11
C76	6	CR128	8	P840	4	R61	6	R195	6	R364	11
C80	6	CR133	8	P840	6	R62	6	R196	6	R365	11
C82	6	CR135	8	P840	8	R63	6	R197	6	R368	11
C83	6	CR160	8	P840	11	R67	6	R198	6	R369	11
C84	6	CR161	8	Q16	6	R68	6	R201	6	R371	11
C87	6	CR175	8	Q20	6	R73	6	R203	6	R372	11
C89	6	CR193	6	Q21	6	R74	6	R204	6	R374	11
C90	6	CR195	6	Q24	6	R75	6	R205	6	R375	11
C100	6	CR202	6	Q28	6	R76	6	R206	6	RT295	8
C108	6	CR208	6	Q80	6	R77	6	R208	6	TP2	6
C128	8	CR300	6	Q81	6	R81	6	R209	6	TP3	6
C140	8	CR301	6	Q83	6	R82	6	R210	6	TP9	6
C141	8	CR302	6	Q108	6	R83	6	R212	6	TP27	6
C145	8	CR303	6	Q111	8	R85	6	R213	6	TP49	6
C146	8	CR308	11	Q155	8	R88	6	R214	6	TP55	6
C147	8	CR311	11	Q160	8	R89	6	R215	6	TP85	6
C148	8	CR313	11	Q167	8	R90	6	R216	6	TP86	6
C149	8	CR314	11	Q168	8	R100	6	R219	6	TP87	6
C153	8	CR315	11	Q174	8	R104	6	R220	6	TP89	6
C155	8	CR316	11	Q176	8	R105	6	R221	6	TP106	6
C159	8	CR317	11	Q181	8	R106	6	R222	6	TP127	8
C160	8	CR318	11	Q208	6	R107	6	R223	6	TP190	8
C161	8	CR319	11	Q213	6	R108	6	R224	6	TP194	6
C167	8	CR321	11	Q222	6	R109	6	R226	6	TP196	6
C169	8	CR322	11	Q250	8	R110	8	R238	8	TP210	6
C173	8	CR323	11	Q267	8	R111	8	R239	8	TP216	6
C174	8	CR324	11	Q271	8	R112	8	R240	8	TP246	8
C180	8	CR325	11	Q281	8	R124	8	R243	8	TP250	8
C182	8	CR327	11	Q282	8	R125	8	R244	8	TP327	11
C187	8	CR329	11	Q288	8	R126	8	R245	8	U3	6
C190	8	CR330	11	Q289	8	R127	8	R246	8	U24	6
C194	6	CR334	11	Q290	8	R128	8	R250	8	U43	6
C197	6	CR336	11	Q327	11	R132	8	R251	8	U87	6
C200	6	CR340	6	R1	6	R133	8	R252	8	U108	6
C201	6	CR341	6	R3	6	R134	8	R253	8	U128	8
C205	6	CR342	6	R4	6	R135	8	R264	8	U147	8
C206	6	CR343	6	R6	6	R139	8	R265	8	U197	6
C209	6	CR344	6	R8	6	R140	8	R266	8	U198	6
C240	8	CR345	6	R10	6	R141	8	R267	8	U216	6
C244	8	CR346	6	R14	6	R142	8	R271	8	U238	8
C250	8	CR347	6	R15	6	R146	8	R272	8	U365	6
C265	8	CR348	6	R16	6	R147	8	R273	8	U365	11
C266	8	CR349	6	R17	6	R148	8	R274	8	VR111	8
C267	8	CR350	6	R20	6	R149	8	R281	8	VR174	8
C273	8	CR351	6	R21	6	R153	8	R282	8	W5	6
C281	8	CR353	6	R23	6	R154	8	R283	8	W6	6
C282	8	CR357	11	R24	6	R155	8	R284	8	W7	6
C284	8	CR358	6	R25	6	R156	8	R287	8	W8	6
C288	8	CR359	11	R26	6	R160	8	R288	8	W9	6
C290	8	CR360	11	R27	6	R161	8	R289	8	W85	6
C340	6	CR362	11	R28	6	R163	8	R290	8	W88	6
C343	6	E36	6	R29	6	R167	8	R294	8	W109	6
C345	6	E54	6	R30	6	R168	8	R295	8	W208	6
C347	6	E85	6	R34	6	R169	8	R296	8	W235	6
C349	6	J842	11	R35	6	R170	8	R326	11	W240	8
C351	6	J871	6	R36	6	R173	8	R327	11		
		J871	7					R340	6		
								R343	6		

## TEST WAVEFORMS FOR DIAGRAM 6

For waveforms 46 through 53, set 2336 SEC/DIV to 1 ms. For waveforms 52 and 53, set 2336 HORIZ MODE to B.

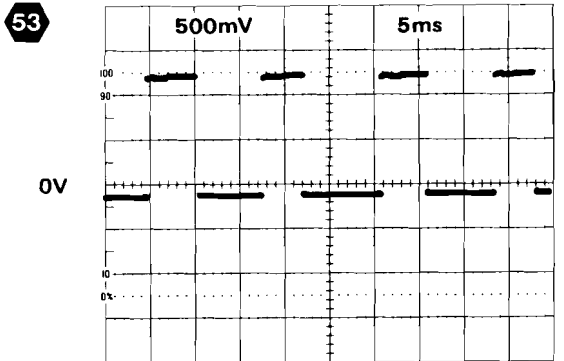
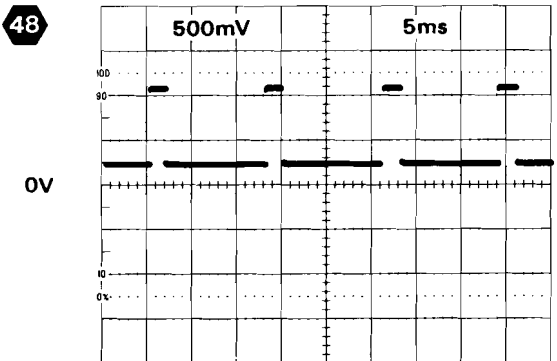
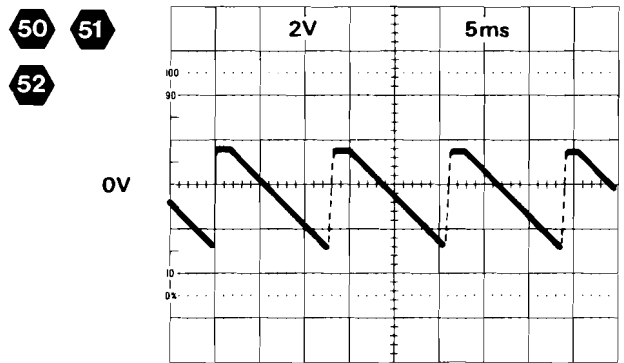
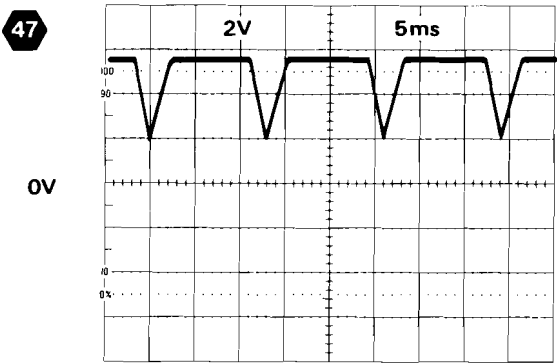
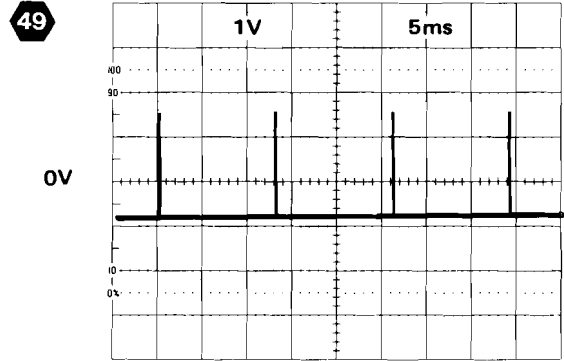
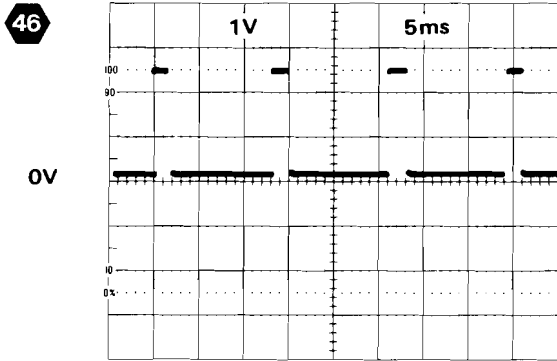

**SWEEP DIAGRAM**



<b>ASSEMBLY A10</b>											
CIRCUIT NUMBER	SCHEM LOCATION	BOARD LOCATION	CIRCUIT NUMBER	SCHEM LOCATION	BOARD LOCATION	CIRCUIT NUMBER	SCHEM LOCATION	BOARD LOCATION	CIRCUIT NUMBER	SCHEM LOCATION	BOARD LOCATION
J80B	2B	9I	Q218	6A	6B	R218	6A	7B	S210	2A	8B
J80B	5B	9I				R219	6A	6A	S218	5B	7B
P710	5A	3M	R216	6A	6B	R222	6A	7B			
			R217	6A	6B	R223	6B	7B			
<i>Partial A10 also shown on diagrams 1, 2, 3, 4, 5, 8 and 10.</i>											
<b>ASSEMBLY A23</b>											
CIRCUIT NUMBER	SCHEM LOCATION	BOARD LOCATION	CIRCUIT NUMBER	SCHEM LOCATION	BOARD LOCATION	CIRCUIT NUMBER	SCHEM LOCATION	BOARD LOCATION	CIRCUIT NUMBER	SCHEM LOCATION	BOARD LOCATION
C170	6C	1H	J840	1C	3I	P742	4B	4E			
C171	6C	1H	J840	2C	3I	P808	2C	1I			
						P808	5C	1I			
<i>Partial A23 also shown on diagrams 4, 5 and 8</i>											

TABLE (CONT)



**SWEEP DIAGRAM**



<b>ASSEMBLY A24</b>											
CIRCUIT NUMBER	SCHEM LOCATION	BOARD LOCATION	CIRCUIT NUMBER	SCHEM LOCATION	BOARD LOCATION	CIRCUIT NUMBER	SCHEM LOCATION	BOARD LOCATION	CIRCUIT NUMBER	SCHEM LOCATION	BOARD LOCATION
C1	8J	6F	CR345	4E	3E	R28	5M	3F	R215	5H	5C
C2	7J	6F	CR346	4F	4D	R29	6L	2G	R216	4H	6C
C6	8J	6F	CR347	4E	3E	R30	5K	2G	R219	5H	4D
C15	8K	3H	CR348	4F	4D	R34	5K	1G	R220	5H	3C
C19	7L	4G	CR349	4E	3E	R35	5K	2G	R221	5I	3C
C20	8L	3G	CR350	5F	4D	R36	6L	2G	R222	3G	7D
C21	7M	4G	CR351	5E	3E	R37	6K	1G	R223	3G	3D
C22	8L	3G	CR353	3E	3F	R38	4K	5G	R224	3G	3D
C23	8N	4G	CR358	5F	4D	R41	4L	5G	R226	5I	5D
C54	3N	6F				R42	5N	4F	R340	4F	3E
C68	2N	5F	E36	7N	3H	R43	4N	4F	R343	4F	3E
C76	4K	5F	E54	3N	5G	R47	6L	2G	R345	4F	3E
C80	3L	5F	E85	3L	5F	R49	4N	4F	R347	4F	3D
C82	3L	4E	J871	9K	4F	R53	4N	1F	R349	4F	3E
C83	2L	5G	J876	1K	5E	R54	3N	6F	R350	5E	2E
C84	3L	4E	J876	3G	5E	R55	3N	4G	R351	5F	3E
C87	2D	2F	J876	5H	5E	R56	5N	1E	R353	3F	4F
C89	4K	6F	J876	9J	5E	R61	5N	1C	R355	5F	3D
C90	3D	2E				R62	5N	1C			
C100	4D	2E	P745	7D	7G	R63	5N	1B	TP2	7J	7G
C108	3E	2F	P745	7N	7G	R67	5N	1A	TP3	7K	6F
C194	8E	6E	P750	7G	6D	R68	2N	4F	TP9	6L	3F
C197	8F	6E	P750	8G	6D	R73	3J	5F	TP27	8N	4G
C200	9F	6E	P751	4J	3A	R74	3J	5F	TP49	5M	3F
C201	8H	6D	P840	1C	1G	R75	3K	5F	TP55	2N	4G
C205	9I	6C	P840	2C	1G	R76	4K	5F	TP85	4D	2E
C206	8I	6D	P840	4N	1G	R77	3K	5F	TP86	2E	3F
C209	9H	6D				R81	3K	5G	TP87	1E	2E
C340	4E	3E	Q16	8L	4H	R82	4L	5F	TP89	3E	2E
C343	4E	3E	Q20	8L	4H	R83	2L	5G	TP106	3D	2E
C345	4E	3E	Q21	7M	4G	R85	3L	5F	TP194	9F	5E
C347	4E	3D	Q24	8M	3G	R88	1E	4F	TP210	4I	5C
C349	4E	3E	Q28	5M	2G	R89	2C	1E	TP216	4I	5C
C351	5E	3D	Q80	3L	5F	R90	2D	1E			
C355	4E	3E	Q81	3K	5F	R100	3D	2D	U3	8J	6F
			Q83	3L	5F	R104	4C	1H	U24	7N	3G
CR21	7L	4G	Q108	3F	2G	R105	4D	1H	U43	3N	4F
CR28	5N	2G	Q208	5I	3B	R106	3D	3E	U87	4D	2E
CR29	6L	2G	Q213	3I	7D	R107	3C	2E	U108	3E	2F
CR45	7N	6F	Q222	2H	7D	R108	3E	2G	U197A	8H	7D
CR47	6L	2G				R109	2F	2G	U197B	9H	7D
CR63	5N	1B	R1	7J	6G	R193	8F	7E	U198A	7F	6E
CR83	3L	5F	R3	7J	7F	R194	7E	7E	U198B	9F	6E
CR87	2D	2E	R4	7K	6G	R195	7F	7E	U216A	4I	5D
CR88	1D	2F	R6	8K	6G	R196	8F	7E	U216B	8I	5D
CR193	8E	7E	R8	8K	6G	R197	8F	7E	U216C	4H	5D
CR195	7E	7E	R10	8K	3G	R198	7F	6E	U365E	6N	2D
CR202	7I	4D	R14	8K	3G	R201	8H	6D			
CR208	6I	2D	R15	8K	3H	R203	5I	3B	W5	8D	7F
CR300	3G	3D	R16	8K	3H	R204	5I	3B	W6	9D	7F
CR301	4G	3D	R17	7L	3G	R205	9H	6C	W7	8D	7G
CR302	4G	3D	R20	8L	3H	R206	8H	6D	W8	8D	7G
CR303	4G	3D	R21	7L	4G	R208	5I	2C	W9	7D	1F
CR340	3E	3E	R23	8N	4G	R209	9H	6D	W85	4K	6H
CR341	3F	3D	R24	8M	3G	R210	5H	5C	W88	1C	1F
CR342	4F	5E	R25	8M	3G	R212	2I	7C	W109	2F	1G
CR343	4E	3E	R26	7M	4G	R213	3I	6D	W208	4I	3B
CR344	4F	5E	R27	8N	4G	R214	4H	7C	W235	8C	6B

*Partial A24 also shown on diagrams 4, 7, 8 and 11*

**CHASSIS MOUNTED PARTS**

CIRCUIT NUMBER	SCHEM LOCATION	BOARD LOCATION	CIRCUIT NUMBER	SCHEM LOCATION	BOARD LOCATION	CIRCUIT NUMBER	SCHEM LOCATION	BOARD LOCATION	CIRCUIT NUMBER	SCHEM LOCATION	BOARD LOCATION
DS900	4B	CHASSIS	R918A R918B	8G 9G	CHASSIS CHASSIS						



**TABLE (CONT)**

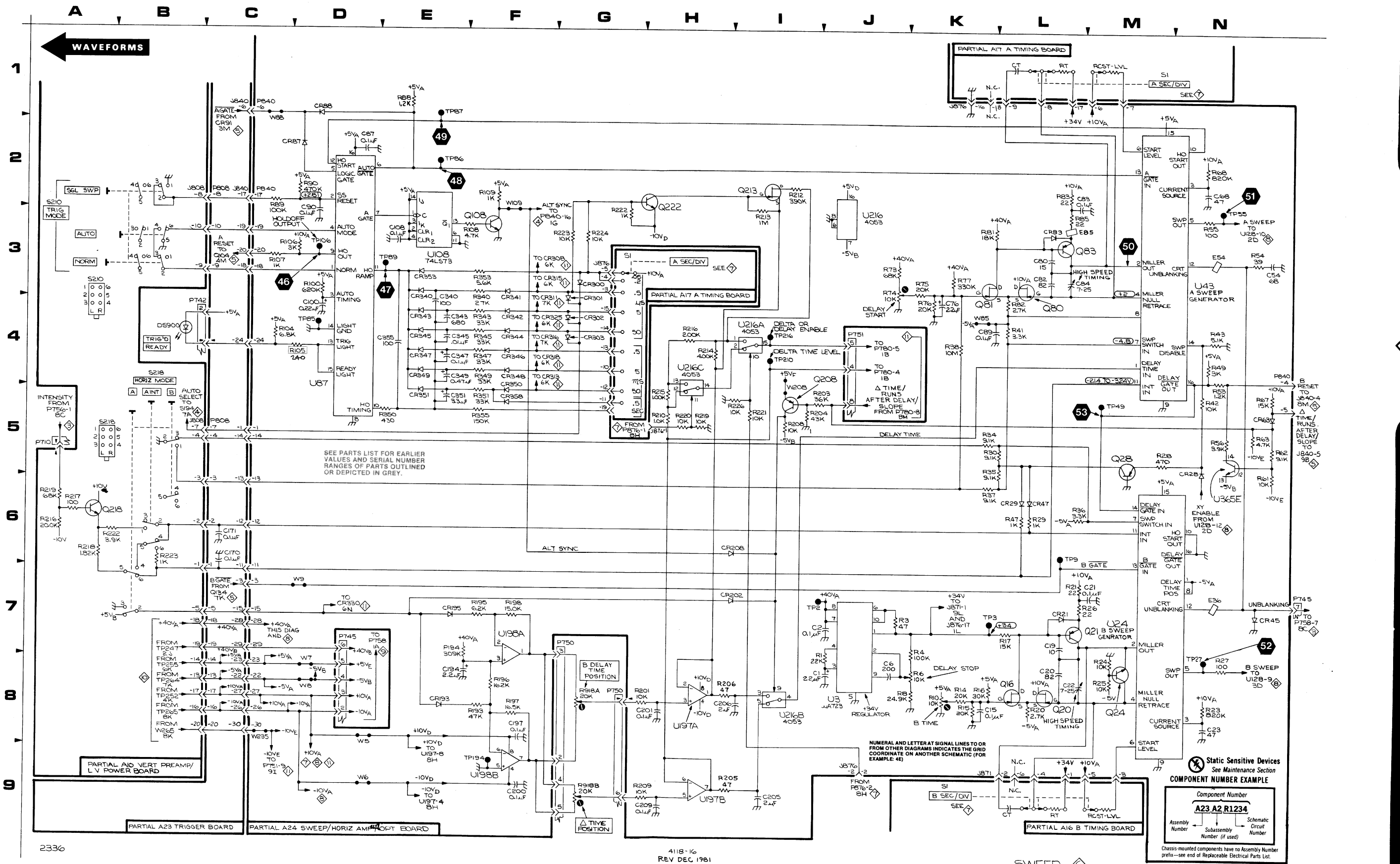

SEE PARTS LIST FOR EARLIER VALUES AND SERIAL NUMBER RANGES OF PARTS OUTLINED OR DEPICTED IN GREY.

NUMERAL AND LETTER AT SIGNAL LINES TO OR FROM OTHER DIAGRAMS INDICATES THE GRID COORDINATE ON ANOTHER SCHEMATIC (FOR EXAMPLE: 4E)

**Static Sensitive Devices**  
See Maintenance Section

**COMPONENT NUMBER EXAMPLE**

Component Number			
A23	A2	R1234	
Assembly Number	Subassembly Number (if used)	Schematic Circuit Number	

Chassis-mounted components have no Assembly Number prefix—see end of Replaceable Electrical Parts List.

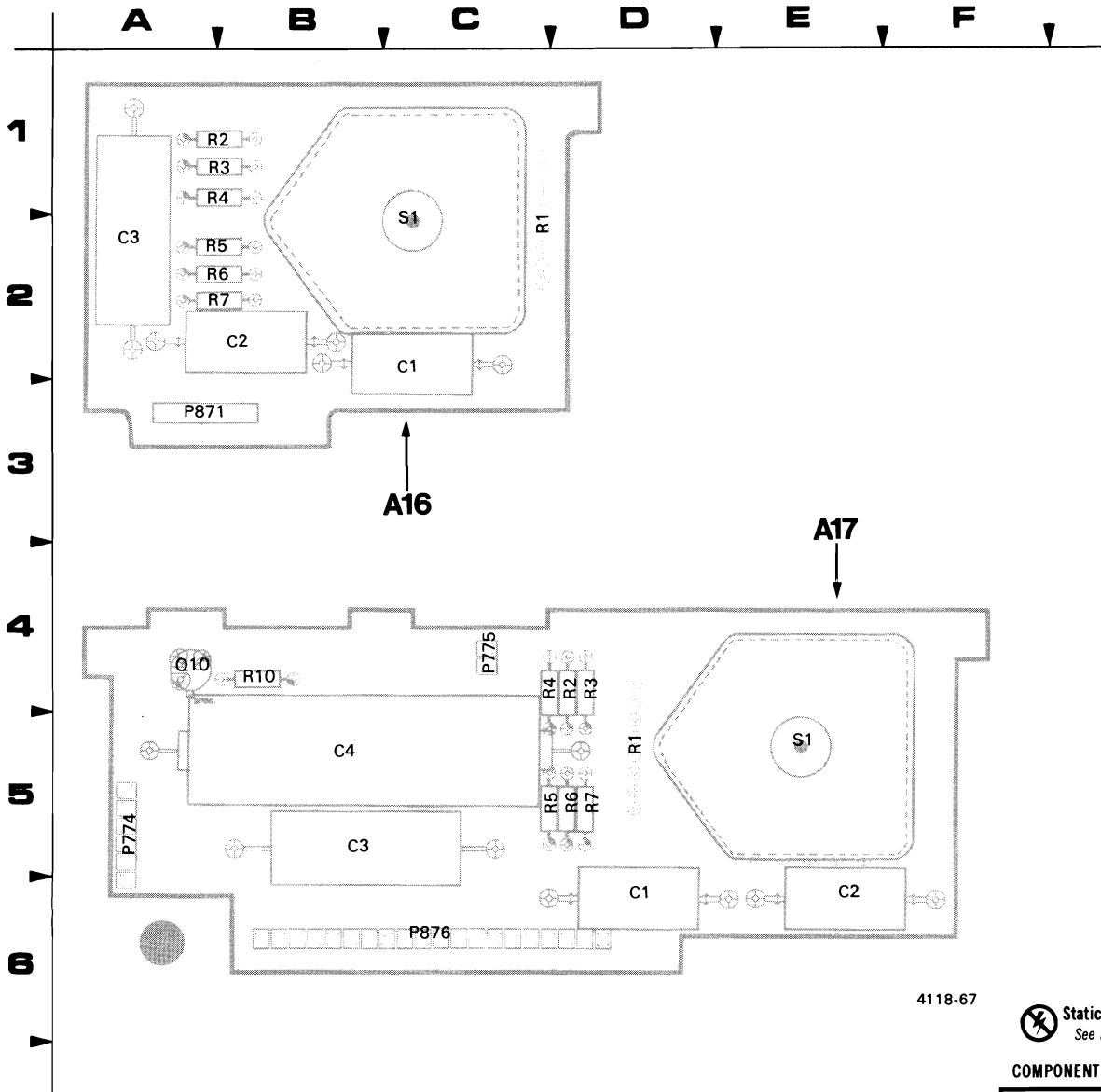
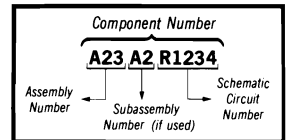

Figure 9-11. A16—B Timing and A17—A Timing boards.

4118-67

 **Static Sensitive Devices**  
See Maintenance Section

**COMPONENT NUMBER EXAMPLE**



Chassis-mounted components have no Assembly Number prefix—see end of Replaceable Electrical Parts List.

ALL COMPONENTS MOUNTED ON A16—B TIMING AND  
A17—A TIMING CIRCUIT BOARDS ARE SHOWN IN SCHEMATIC  
DIAGRAM .

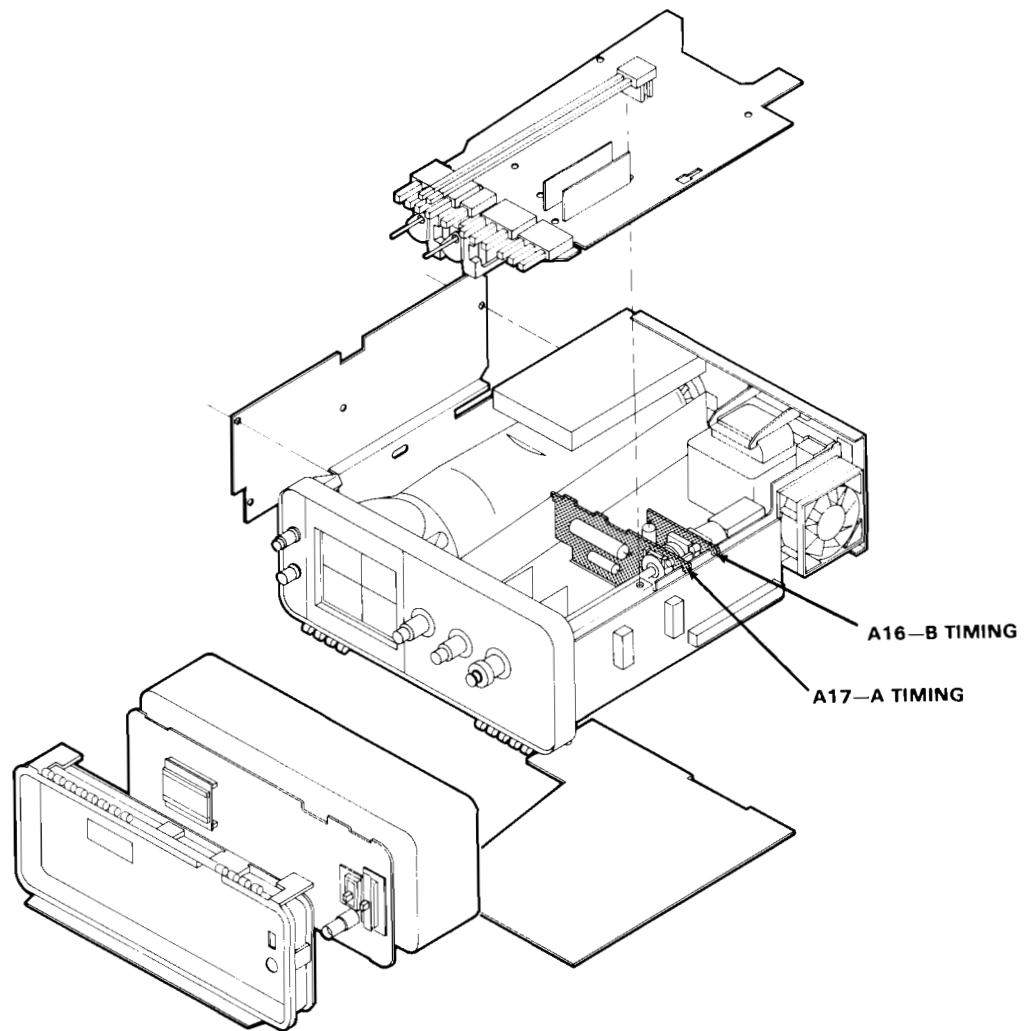

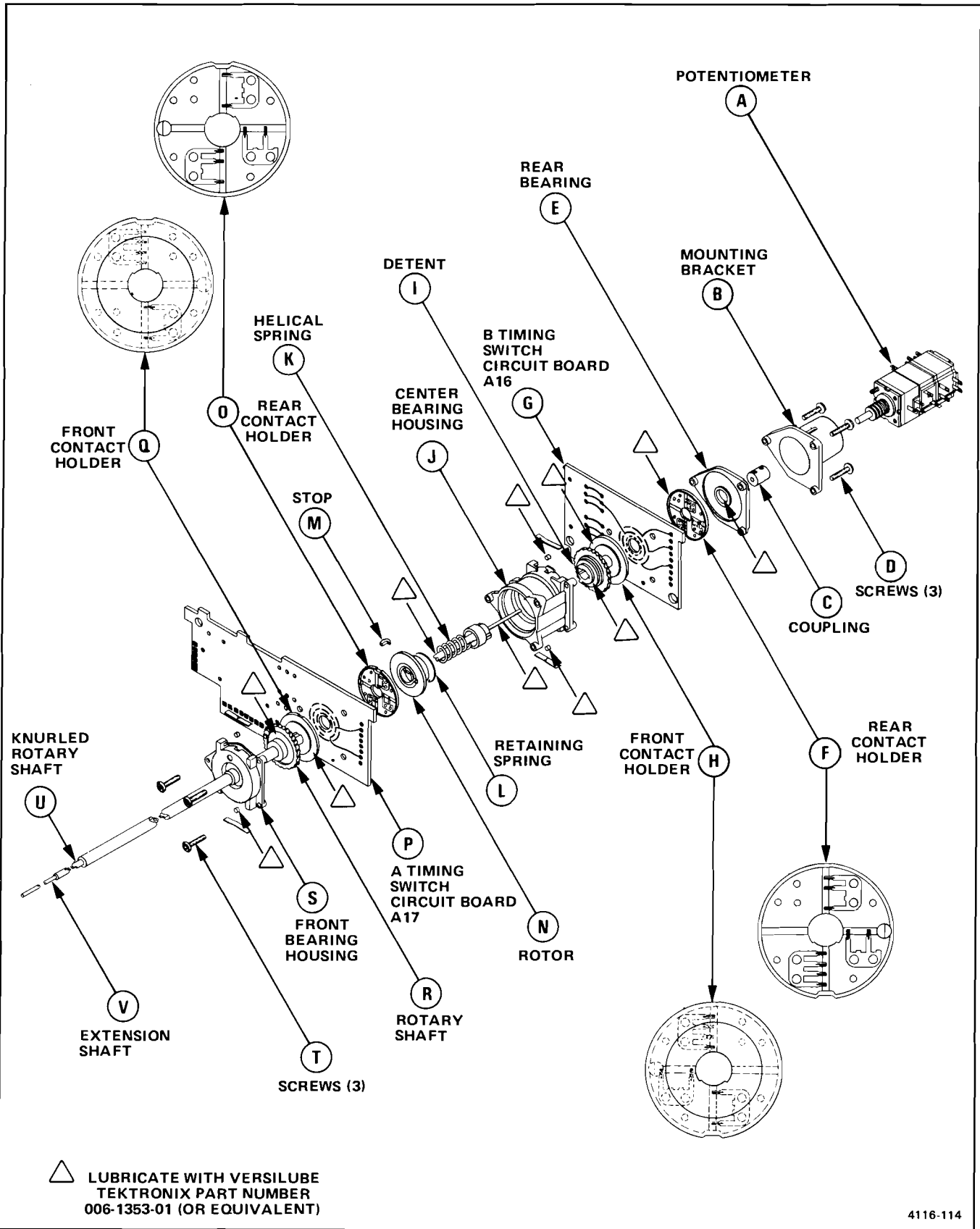

Figure 9-12. Timing Switch exploded view.



## A & B TIMING SWITCHES DIAGRAM



<b>ASSEMBLY A16</b>								
CIRCUIT NUMBER	SCHEM LOCATION	BOARD LOCATION	CIRCUIT NUMBER	SCHEM LOCATION	BOARD LOCATION	CIRCUIT NUMBER	SCHEM LOCATION	BOARD LOCATION
C1	5K	2C	R1A	9L	2C	R3	4N	1A
C2	6K	2B	R1B	9L	2C	R4	4N	1A
C3	8K	2A	R1C	9L	2C	R5	4N	2A
			R1D	9L	2C	R6	4N	2A
P871	2K	3A	R1E	8L	2C	R7	4N	2A
P871	3N	3A	R1F	8L	2C			
P871	8K	3A	R1G	8L	2C	S1	3K	2C
P871	9N	3A	R2	3N	1A			

<b>ASSEMBLY A17</b>								
CIRCUIT NUMBER	SCHEM LOCATION	BOARD LOCATION	CIRCUIT NUMBER	SCHEM LOCATION	BOARD LOCATION	CIRCUIT NUMBER	SCHEM LOCATION	BOARD LOCATION
C1	5B	6D	P876	8A	6C	R2	6D	4D
C2	6B	6E				R3	6D	4D
C3	7B	5B	Q10	1G	4A	R4	7D	4D
C4	8B	5B				R5	8E	5D
			R1A	3C	5D	R6	8E	5D
P774	1F	5A	R1B	3C	5D	R7	8E	5D
P774	3D	5A	R1C	4C	5D	R10	1F	4B
P775	1F	4C	R1D	4C	5D			
P876	1G	6C	R1E	4C	5D	S1	3D	5E
P876	3A	6C	R1F	4C	5D			
P876	3G	6C	R1G	5C	5D			

  

<b>ASSEMBLY A24</b>								
CIRCUIT NUMBER	SCHEM LOCATION	BOARD LOCATION	CIRCUIT NUMBER	SCHEM LOCATION	BOARD LOCATION	CIRCUIT NUMBER	SCHEM LOCATION	BOARD LOCATION
JB71	2K	4F	JB71	9N	4F	JB76	3H	5E
JB71	3N	4F	JB76	1H	5E	JB76	8A	5E
JB71	8J	4F	JB76	3A	5E			

*Partial A24 also shown on diagrams 4, 6, 8 and 11.*

<b>CHASSIS MOUNTED PARTS</b>								
CIRCUIT NUMBER	SCHEM LOCATION	BOARD LOCATION	CIRCUIT NUMBER	SCHEM LOCATION	BOARD LOCATION	CIRCUIT NUMBER	SCHEM LOCATION	BOARD LOCATION
CR931	2E	CHASSIS	R930	2D	CHASSIS	S934	1E	CHASSIS
CR932	2E	CHASSIS	R931	1E	CHASSIS			
DS902	1F	CHASSIS	S930	3F	CHASSIS			

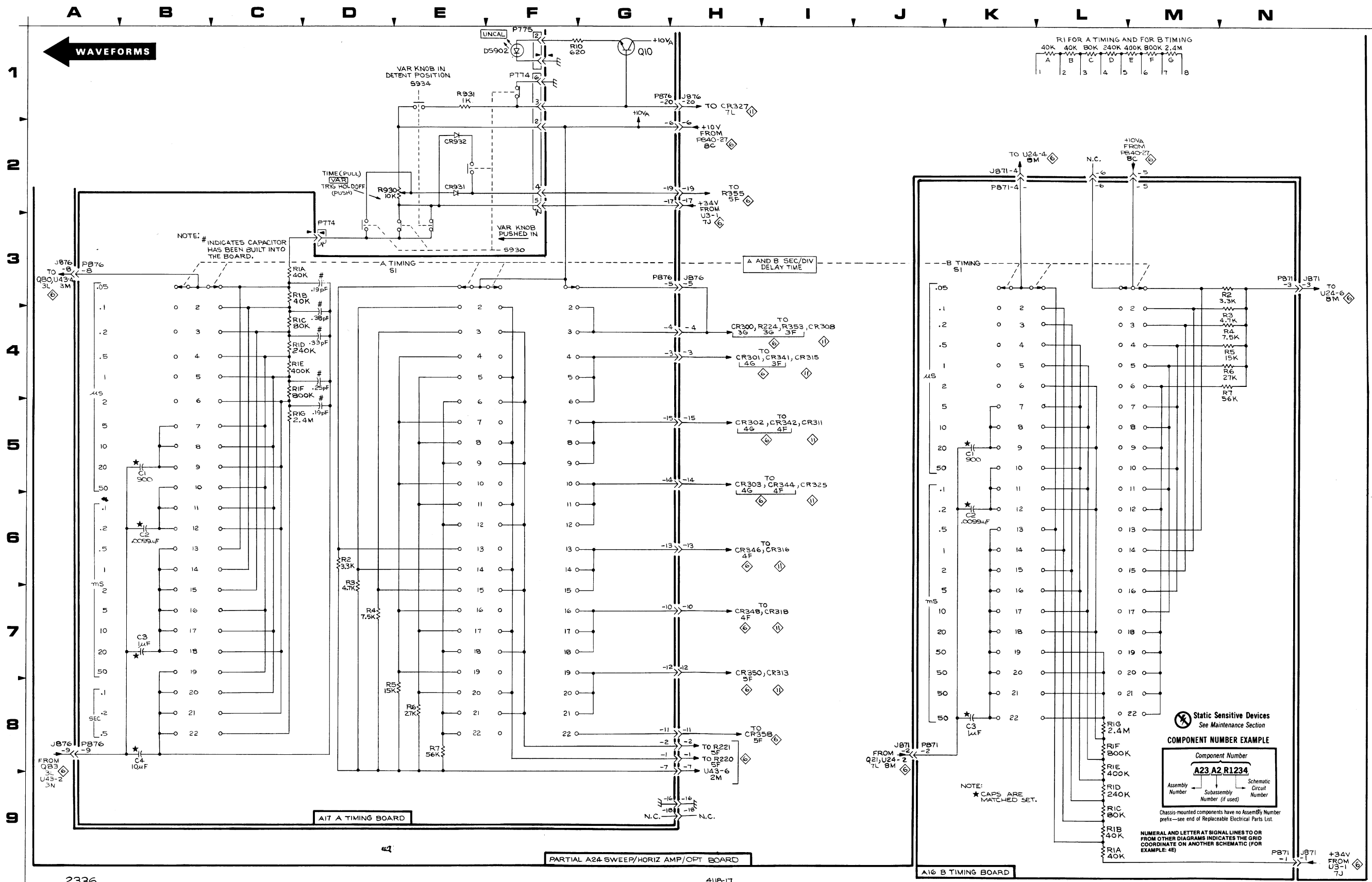

2336

4118-17  
©

A & B TIMING SWITCHES

A & B TIMING SWITCHES

7

# TEST WAVEFORMS FOR DIAGRAM 8

For waveforms 57 and 58, set 2336 SEC/DIV to 1 ms.

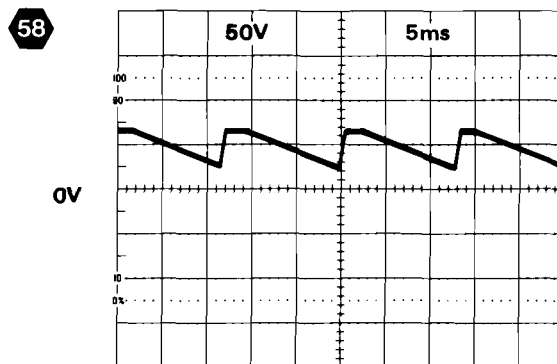
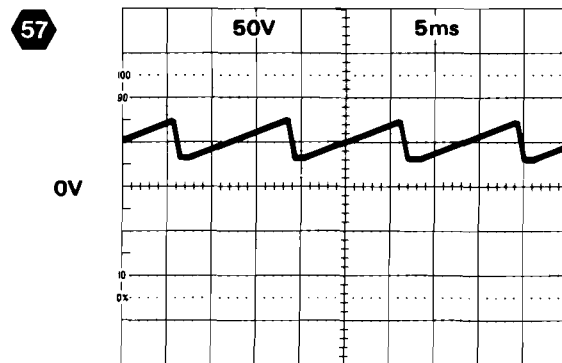
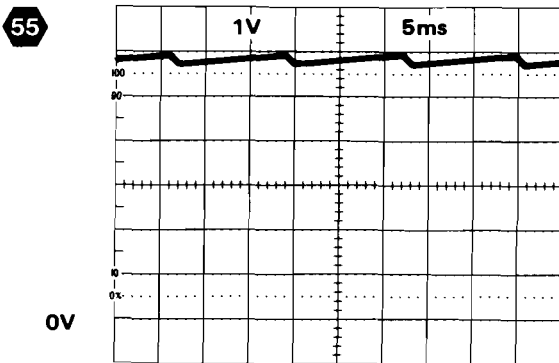
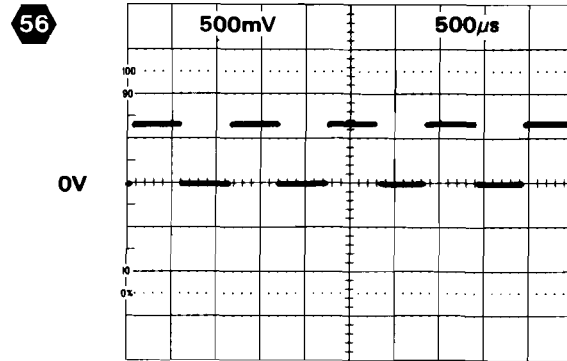
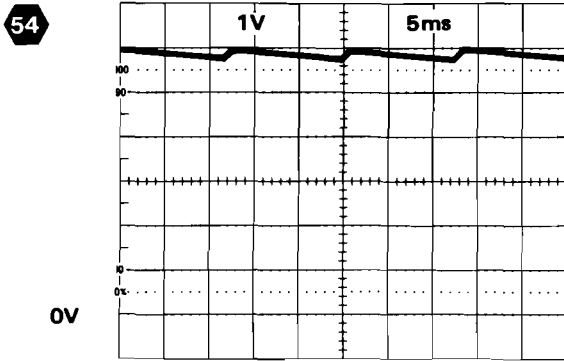

## HORIZONTAL, PROBE COMP AND FAN DIAGRAM



<b>ASSEMBLY A10</b>											
CIRCUIT NUMBER	SCHEM LOCATION	BOARD LOCATION	CIRCUIT NUMBER	SCHEM LOCATION	BOARD LOCATION	CIRCUIT NUMBER	SCHEM LOCATION	BOARD LOCATION	CIRCUIT NUMBER	SCHEM LOCATION	BOARD LOCATION
J808	1B	9I	P715	3A	6E	R184	3B	6D	S190	1B	7B
J808	5B	9I	P716	3A	6D	R185	3B	6D	S194	2B	4B
						R186	3B	6D			
<i>Partial A10 also shown on diagrams 1, 2, 3, 4, 5, 6 and 10.</i>											
<b>ASSEMBLY A23</b>											
CIRCUIT NUMBER	SCHEM LOCATION	BOARD LOCATION	CIRCUIT NUMBER	SCHEM LOCATION	BOARD LOCATION	CIRCUIT NUMBER	SCHEM LOCATION	BOARD LOCATION	CIRCUIT NUMBER	SCHEM LOCATION	BOARD LOCATION
J840	1C	3I	J840	9N	3I	P808	6B	1I	R167	5C	1E
J840	4C	3I				P808	9N	1I			
J840	6B	3I	P808	1C	1I						
<i>Partial A23 also shown on diagrams 4, 5 and 6.</i>											

TABLE (CONT)



# HORIZONTAL, PROBE COMP AND FAN DIAGRAM



<b>ASSEMBLY A24</b>											
CIRCUIT NUMBER	SCHEM LOCATION	BOARD LOCATION	CIRCUIT NUMBER	SCHEM LOCATION	BOARD LOCATION	CIRCUIT NUMBER	SCHEM LOCATION	BOARD LOCATION	CIRCUIT NUMBER	SCHEM LOCATION	BOARD LOCATION
C128	1F	4I	K127	2G	5G	R139	4D	2I	R265	8I	3J
C140	4E	4H				R140	4D	3I	R266	9I	2J
C141	4D	2H	P745	3D	7G	R141	4D	2H	R267	9I	2J
C145	4E	3H	P745	4N	7G	R142	5D	2H	R271	8I	3J
C146	4E	3I	P747	7N	2I	R146	4E	3I	R272	8J	3J
C147	5E	3H	P751	7F	3A	R147	5D	3I	R273	8J	5J
C148	5E	3H	P754	8F	6A	R148	5E	3I	R274	9J	5I
C149	6E	4H	P840	1D	1G	R149	5E	5I	R281	9K	4J
C153	6F	5H	P840	4D	1G	R153	6F	4H	R282	8K	4J
C155	4H	7J	P840	6B	1G	R154	3G	5H	R283	8K	5J
C159	4H	8J	P840	9M	1G	R155	4G	7J	R284	8K	6J
C160	3H	8I				R156	4G	8J	R287	9K	6J
C161	2I	7I	Q111	1G	2H	R160	3H	8I	R288	9L	6J
C167	3J	7H	Q155	4H	8J	R161	2I	8H	R289	8M	2J
C169	4K	8H	Q160	3H	7I	R163	3K	8H	R290	8L	5J
C173	5H	8J	Q167	3J	7I	R167	3J	7H	R294	8M	1I
C174	5I	9I	Q168	3K	7H	R168	4K	7H	R295	6M	1I
C180	5J	8H	Q174	6H	8I	R169	3K	8H	R296	6M	1I
C182	5K	9H	Q176	6J	8I	R170	3L	7H			
C187	7I	8I	Q181	5K	8H	R173	5G	5H	RT295	6M	1J
C190	4L	8H	Q250	8E	5A	R174	6H	9J			
C240	8C	5B	Q267	9I	2J	R175	5H	9J	TP127	2G	5H
C244	9C	4B	Q271	9J	1J	R176	6J	9I	TP190	5L	8I
C250	8E	6B	Q281	9K	4J	R180	5J	8H	TP246	8D	5B
C265	8I	2J	Q282	9K	4J	R181	5K	8H	TP250	8D	5B
C266	8I	3I	Q288	9L	6J	R182	5K	9H			
C267	9I	2I	Q289	7L	1J	R183	5K	7I	U128	4F	4H
C273	8J	4J	Q290	9L	5I	R187	6I	9I	U147	5E	3H
C281	8J	4J				R190	6K	9H	U238A	9D	4B
C282	9K	3J	R110	1G	2H	R238	9A	5A	U238B	9D	4B
C284	8L	6J	R111	1E	2H	R239	9B	5A	U238C	8D	4B
C288	8L	6I	R112	2E	2H	R240	8B	6B	U238D	9C	4B
C290	9L	5J	R124	3G	5H	R243	9B	4A	U238E	9D	4B
			R125	2F	5H	R244	9C	5A	U238F	9A	4B
CR111	1G	6G	R126	3F	5I	R245	9A	5B			
CR128	2E	4H	R127	3G	5H	R246	8D	5B	VR111	1E	2H
CR133	3E	6H	R128	1F	4I	R250	8E	6B	VR174	6I	9I
CR135	3E	6H	R132	3D	7F	R251	8E	6B			
CR160	4H	8J	R133	3E	5H	R252	8E	6B	W240	7B	6C
CR161	3H	7J	R134	3E	6H	R253	8E	6A			
CR175	4H	8J	R135	3E	6H	R264	8I	2J			

*Partial A24 also shown on diagrams 4, 6, 7 and 11.*

<b>CHASSIS MOUNTED PARTS</b>											
CIRCUIT NUMBER	SCHEM LOCATION	BOARD LOCATION	CIRCUIT NUMBER	SCHEM LOCATION	BOARD LOCATION	CIRCUIT NUMBER	SCHEM LOCATION	BOARD LOCATION	CIRCUIT NUMBER	SCHEM LOCATION	BOARD LOCATION
B924	7N	CHASSIS	J954	8F	CHASSIS	R935A	3A	CHASSIS			
						R935B	4A	CHASSIS			



**TABLE (CONT)**

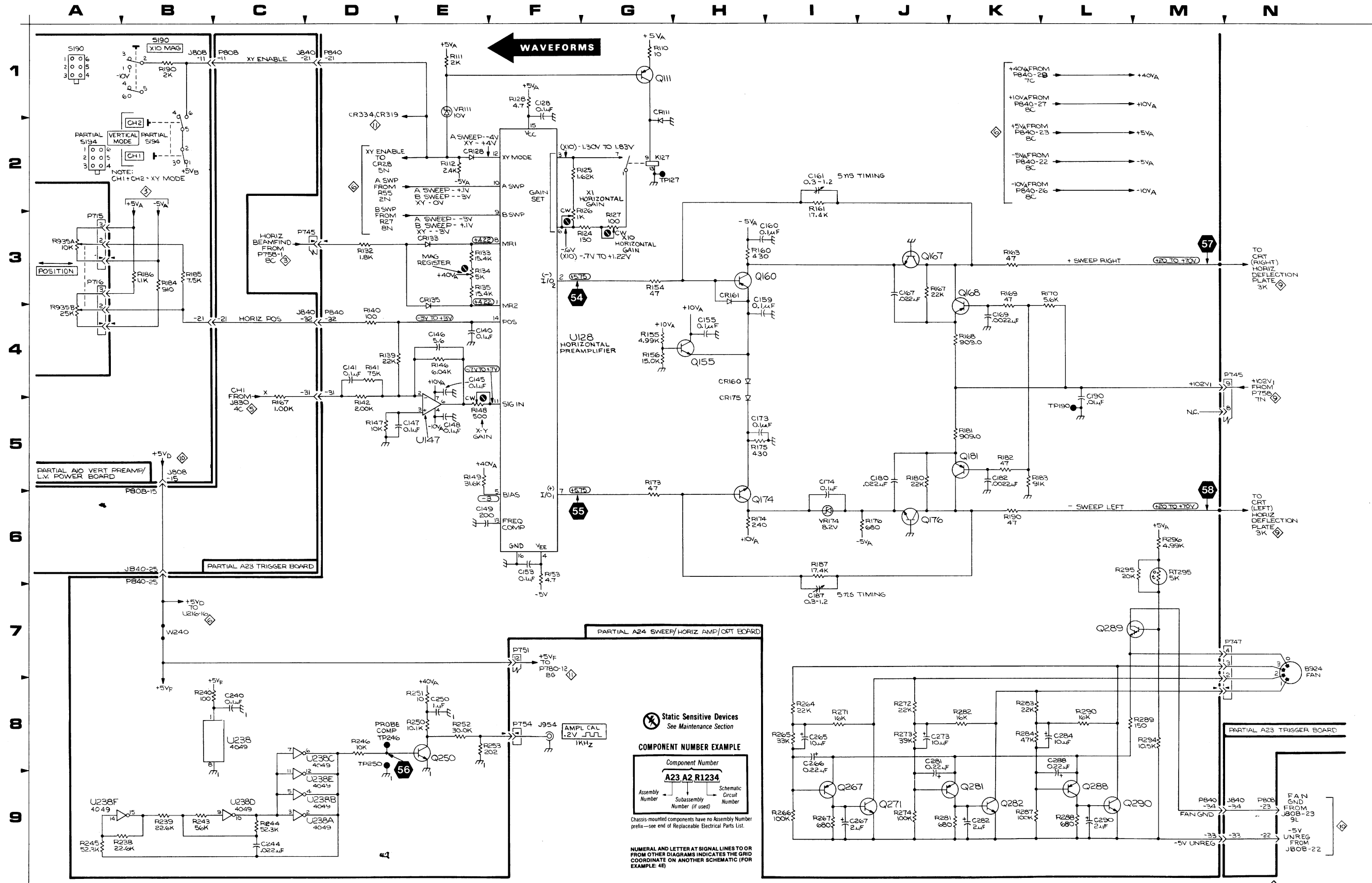

2336

4118-16  
©

HORIZONTAL, PROBE COMP AND FAN

HORIZONTAL, PROBE COMP & FAN

TEST WAVEFORMS FOR DIAGRAM 9

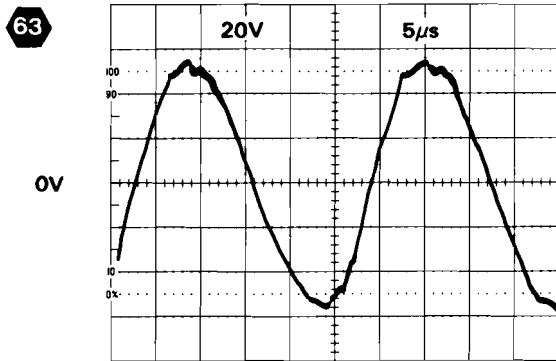
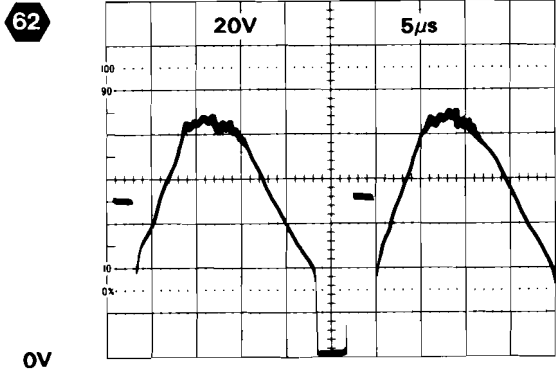
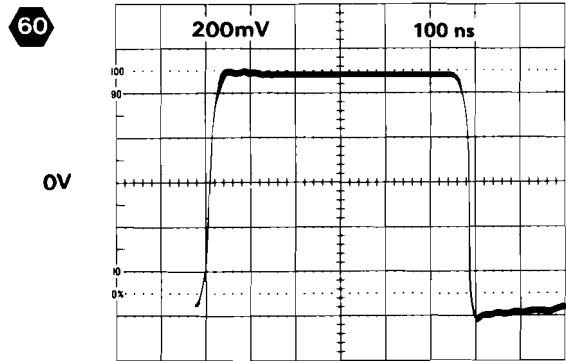
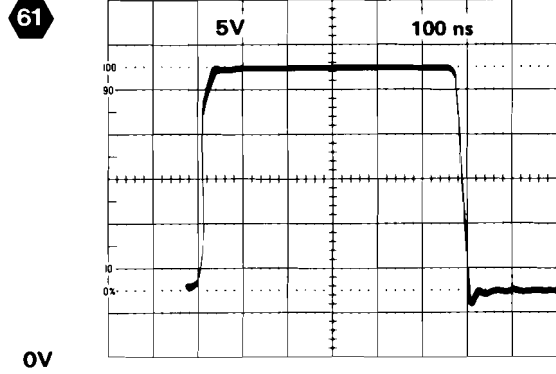
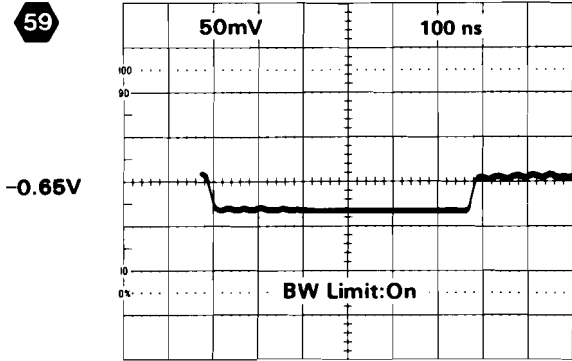

4118-62

@

# HIGH VOLTAGE & CRT DIAGRAM



ASSEMBLY A15								
CIRCUIT NUMBER	SCHEM LOCATION	BOARD LOCATION	CIRCUIT NUMBER	SCHEM LOCATION	BOARD LOCATION	CIRCUIT NUMBER	SCHEM LOCATION	BOARD LOCATION
C3	1B	4H	CR191	7I	4E	R128	3G	3F
C5	2A	2H	CR197	7H	5B	R130	3G	3E
C86	2B	3F				R134	4G	5E
C87	2B	2F	F89	5B	2G	R135	4G	5D
C94	2C	4G				R136	4G	5C
C100	2D	4F	L167	5D	3C	R140	4E	5H
C101	4D	3F	L191	7I	5D	R147	6B	3D
C108	2E	4E				R148	7B	3D
C109	1E	4E	P756	3A	1H	R149	7B	4D
C110	1D	4E	P756	4A	1H	R150	7B	4C
C116	3E	4F	P758	1A	4G	R154	7C	4D
C121	2F	3E	P758	4A	4G	R155	7C	4D
C122	1F	3D	P758	7N	4G	R156	7D	4A
C123	2G	3E	P761	2J	2C	R157	6E	3A
C128	3F	3F	P761	2L	2C	R161	6E	3B
C136	5G	4C	P761	3L	2C	R163	6D	3B
C140	4F	5E	P763	1N	1K	R168	5D	2A
C148	7A	4C	P765	3N	3K	R176A	3J	2C
C150	7B	4C	P768	1L	1K	R176B	9I	2C
C156	7D	3A	P768	2L	1K	R176C	9J	2C
C167	5D	4B				R176D	4J	2C
C168	5C	3D	Q93	3B	4F	R177	9H	1C
C174	9I	2B	Q100	3D	4F	R178	8H	1C
C175	9J	2C	Q107	1D	4E	R182	9H	1B
C182	9H	1B	Q114	2E	3E	R183	9F	1B
C183	9F	3B	Q115	3E	3F	R184	8G	1C
C185	9G	1B	Q116	3E	4F	R185	9G	1B
C190	7H	4B	Q148	7A	4D	R191	7N	5G
C191	7I	4C	Q155	6C	4D	R202	2M	1E
C196	4J	3D	Q156	7E	3A	R203	2M	2K
C197	7G	4B	Q161	6E	3A	R204	3M	1D
C198	2J	2C	Q163	6C	2B	R205	3M	1D
C202	2M	2D	Q178	9H	1C	R210	4M	2D
C205	3M	1D	Q184	9G	1B	R211	4M	1D
C209	4M	3C						
C210	4M	2D	R85	1B	2F	T167	5F	4B
C211	5M	2C	R86	1B	2F	T168	6E	2B
			R87	2B	2F			
CR91	2B	4G	R91	2B	4K	TP92	3B	3G
CR92	3B	2G	R92	3B	4G	TP127	2G	3F
CR94	3C	4F	R93	3B	4G	TP130	2G	3E
CR100	3C	4F	R94	2B	5G	TP148	8A	3C
CR123	2F	3E	R99	3D	3G	TP161	6D	3A
CR127	2F	3E	R100	2D	3G	TP184	8G	1B
CR130	4G	4D	R101	4D	3F	TP185	9G	1B
CR140	4F	5D	R102	3D	2F	TP320	7L	4D
CR148	7B	3C	R106	3D	3F			
CR154	7B	4D	R107	2D	4E	U130	1G	4D
CR156	7E	4A	R108	2E	4E			
CR157	6E	3A	R109	1D	4F	VR123	2G	2E
CR161	6E	3A	R113	2E	3E	VR140	4F	5F
CR163	6D	3B	R114	2E	4E	VR148	7B	3C
CR165	6C	2A	R115	3E	4F	VR155	6C	3D
CR167	5C	3B	R116	3E	4F	VR198	2J	2B
CR168	5C	2A	R120	2F	3E			
CR174	9I	1B	R121	2F	3E	W88	4B	4G
CR175	9I	1C	R122	1F	4D	W163	6D	3B
CR177	9H	1C	R123	2F	3E	W209	4N	1C
CR190	7H	5B	R127	2G	3E			

*Partial A15 also shown on diagram 3.*

CHASSIS MOUNTED PARTS								
CIRCUIT NUMBER	SCHEM LOCATION	BOARD LOCATION	CIRCUIT NUMBER	SCHEM LOCATION	BOARD LOCATION	CIRCUIT NUMBER	SCHEM LOCATION	BOARD LOCATION
DS195	6J	CHASSIS	R940	4J	CHASSIS	V940	1K	CHASSIS
DS196	5J	CHASSIS	R942	1N	CHASSIS			
DS197	5J	CHASSIS	R945	4N	CHASSIS			



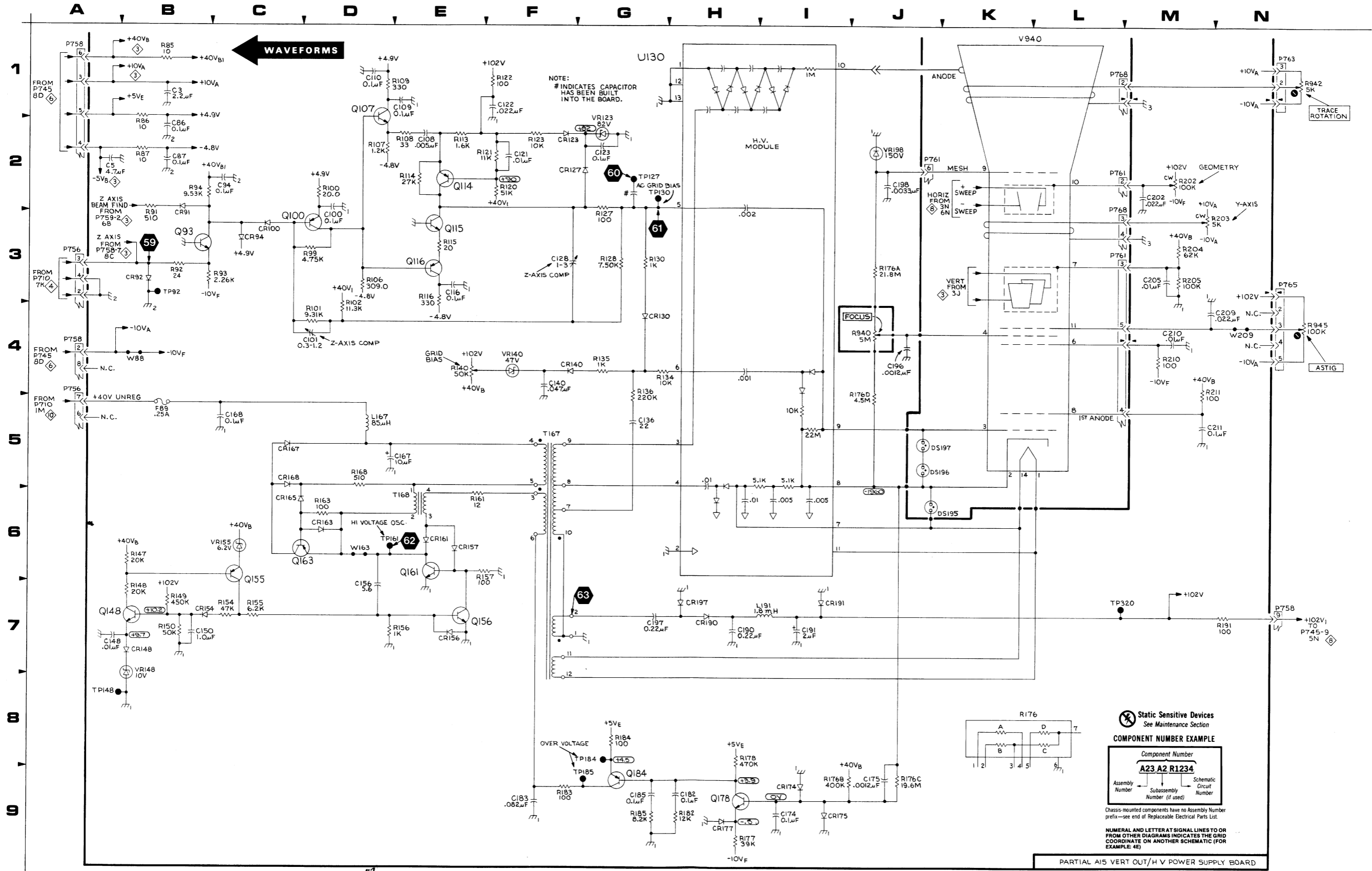

# LOW VOLTAGE POWER SUPPLY DIAGRAM



<b>ASSEMBLY A10</b>											
CIRCUIT NUMBER	SCHEM LOCATION	BOARD LOCATION	CIRCUIT NUMBER	SCHEM LOCATION	BOARD LOCATION	CIRCUIT NUMBER	SCHEM LOCATION	BOARD LOCATION	CIRCUIT NUMBER	SCHEM LOCATION	BOARD LOCATION
C225	1D	7L	F257	7C	4K	R225	1E	6K	TP265	8L	9J
C226	1C	5K	F259	6C	5J	R229	1E	9C	TP266	8C	9K
C231	2G	9D				R230	3F	8C			
C232	2F	8D	J801	3E	7C	R231	3F	8D	U237	1F	9E
C237	1F	9D	J801	4J	7C	R232	3F	9C			
C238	1G	9E	J801	5E	7C	R236	3F	8E	VR229	1E	9D
C246	2I	9C	J802	5E	7F	R237	1F	9D	VR236	2F	9E
C248	4C	5K	J802	5E	7F	R238	1G	9E	VR238	1G	9E
C249	3C	5K	J802	5J	7F	R239	1H	9F	VR246	2I	8D
C250	3D	7J	J803	7E	8C	R243	2H	9F	VR252	5J	8D
C251	4D	8H	J803	8E	8C	R244	2I	9F	VR253	6J	8E
C252	5J	7G	J803	8E	8C	R245	2I	8F	VR264	6K	8E
C253	6J	7G	J803	8J	8C	R246	2J	8G	VR265	8K	8D
C257	7C	5J	J804	7E	8E	R250	3E	7G			
C258	7C	5J	J804	7E	8E	R251	3E	9K	W244	1I	9H
C259	7D	8I	J804	7J	8E	R252	4K	8D	W246	1I	8F
C260	7D	6J	J808	8C	9I	R253	6K	8F	W247	2J	8G
C264	6K	8G	J808	9K	9I	R257	7C	8K	W248	2I	8F
C265	8K	7C				R258	8C	9K	W251	4D	8J
			P710	1M	3M	R259	7E	8K	W252	5K	8G
CR225	1D	6K	P714	1B	4K	R260	7D	6I	W253	6K	8G
CR237	1F	9D				R264	7K	8E	W255	6K	8G
CR239	2H	9F	Q239	2H	9F	R265	8K	8C	W263	6L	6B
CR250	3D	7K	Q244	1H	9F				W264	7K	9G
CR259	6D	7K	Q246	2J	7F	TP247	2K	9J	W265	8K	7G
			Q252	4K	7D	TP252	4L	9J			
F225	1C	5K	Q253	5K	7F	TP254	6J	8F			
F250	3C	5K	Q264	7K	7E	TP255	6L	9I			
F251	3C	4K	Q265	8K	7C	TP264	7L	9I			

*Partial A10 also shown on diagrams 1, 2, 3, 4, 5, 6 and 8*

<b>ASSEMBLY A11</b>											
CIRCUIT NUMBER	SCHEM LOCATION	BOARD LOCATION	CIRCUIT NUMBER	SCHEM LOCATION	BOARD LOCATION	CIRCUIT NUMBER	SCHEM LOCATION	BOARD LOCATION	CIRCUIT NUMBER	SCHEM LOCATION	BOARD LOCATION
C1	7F	2B	P803	7E	2A	R1	7F	2B	R22	8H	1A
C2	8F	2B	P803	8E	2A	R2	8F	2B	R23	8H	1A
C8	8G	1C	P803	8E	2A	R3	7F	2C			
C9	7H	1C	P803	8J	2A	R4	8F	1C	U8A	9G	1B
C15	9G	1B	P804	7E	2C	R8	8G	1B	U8B	7G	1B
C21	8H	1B	P804	7E	2C	R9	8I	1C			
			P804	7J	2C	R10	7H	1C	VR9	7H	1C
CR9	7G	1B				R14	7H	1D	VR21	9H	1B
CR14	7I	1C	Q9	7I	1C	R15	9F	2A			
CR21	9G	1B	Q10	7I	1C	R16	9F	1A			
CR23	8I	1A	Q21	8I	1A	R20	9G	1B			
			Q22	9I	1B	R21	9I	1A			

<b>ASSEMBLY A12</b>											
CIRCUIT NUMBER	SCHEM LOCATION	BOARD LOCATION	CIRCUIT NUMBER	SCHEM LOCATION	BOARD LOCATION	CIRCUIT NUMBER	SCHEM LOCATION	BOARD LOCATION	CIRCUIT NUMBER	SCHEM LOCATION	BOARD LOCATION
C1	3F	1G	P801	4J	2H	R1	3F	1G	R20	6I	1F
C8	4G	1G	P801	5E	2H	R2	3F	2G	R21	6I	1E
C9	3H	1H	P802	5E	2F	R3	5G	2G			
C15	6G	1F	P802	5E	2F	R4	5G	2G	U3A	5G	1G
			P802	5J	2F	R8	5G	2G	U3B	4G	1G
CR9	4G	1G				R9	4H	1F			
CR14	4I	2H	Q9	4H	1H	R10	4I	1H	VR9	4H	1G
CR16	5H	1F	Q10	4I	1H	R14	4I	1H			
			Q16	6H	1F	R15	6G	2F			
P801	3E	2H	Q20	5I	1F	R16	5H	1F			

<b>CHASSIS MOUNTED PARTS</b>											
CIRCUIT NUMBER	SCHEM LOCATION	BOARD LOCATION	CIRCUIT NUMBER	SCHEM LOCATION	BOARD LOCATION	CIRCUIT NUMBER	SCHEM LOCATION	BOARD LOCATION	CIRCUIT NUMBER	SCHEM LOCATION	BOARD LOCATION
F900	6B	CHASSIS	J900	6B	CHASSIS	S903	5B	CHASSIS			
FL900	6A	CHASSIS	S901	3B	CHASSIS	T900	1B	CHASSIS			

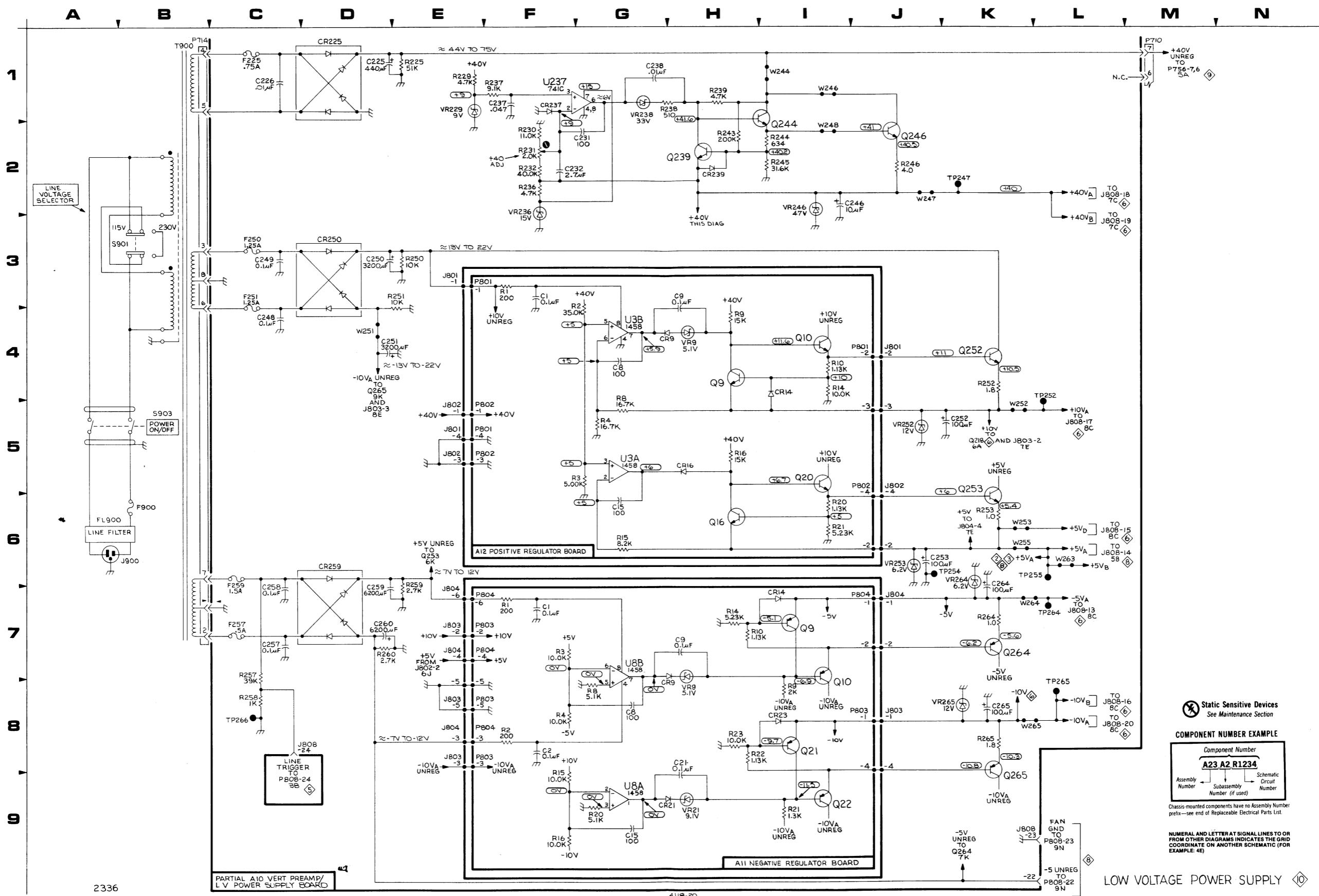

2336

PARTIAL A10 VERT PREAMP/  
L.V. POWER SUPPLY BOARD

AI1 NEGATIVE REGULATOR BOARD

AI2 POSITIVE REGULATOR BOARD

Static Sensitive Devices  
See Maintenance Section

COMPONENT NUMBER EXAMPLE

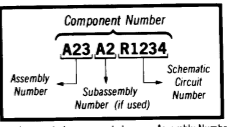

Chassis-mounted components have no Assembly Number prefix—see end of Replaceable Electrical Parts List.

NUMERAL AND LETTER AT SIGNAL LINES TO OR FROM OTHER DIAGRAMS INDICATES THE GRID COORDINATE ON ANOTHER SCHEMATIC (FOR EXAMPLE: 4E)

LOW VOLTAGE POWER SUPPLY

LOW VOLTAGE POWER SUPPLY



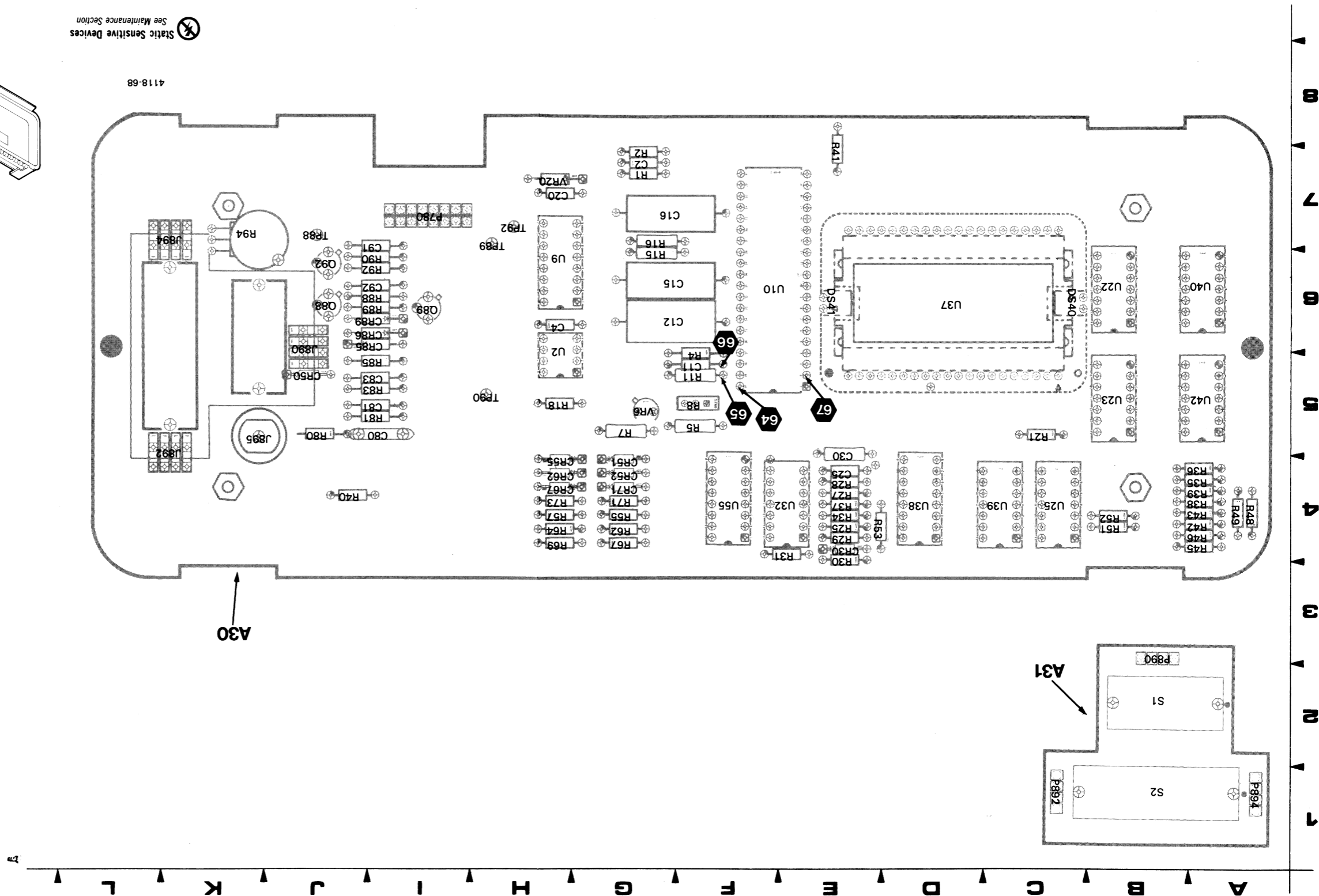

4118-68

⚡ Static Sensitive Devices  
See Maintenance Section

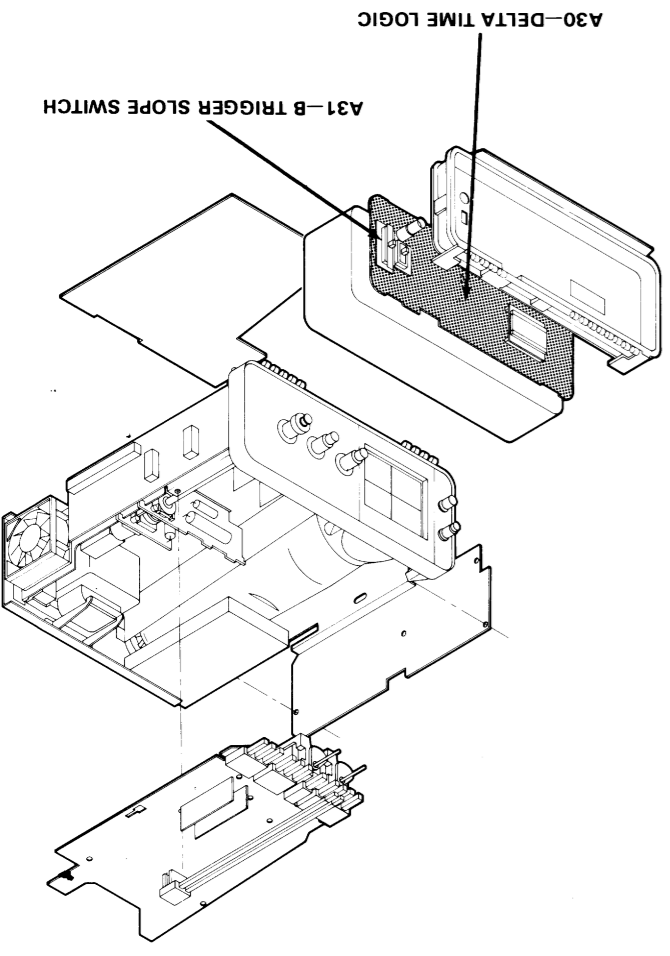
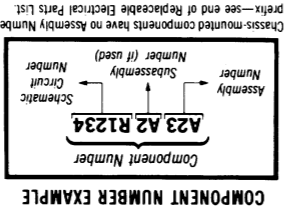

IN SCHEMATIC DIAGRAM ALL COMPONENTS MOUNTED ON A30-DELTA TIME AND A31-B TRIGGER SLOPE SWITCH CIRCUIT BOARDS ARE SHOWN

Figure 9-13. A30-Delta Time Logic and A31-B Timing Slope Switch boards.

### TEST WAVEFORMS FOR DIAGRAM

11

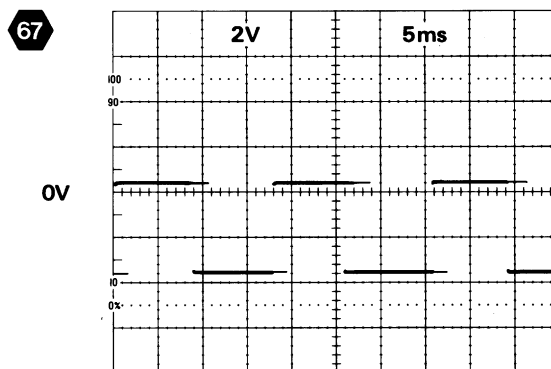
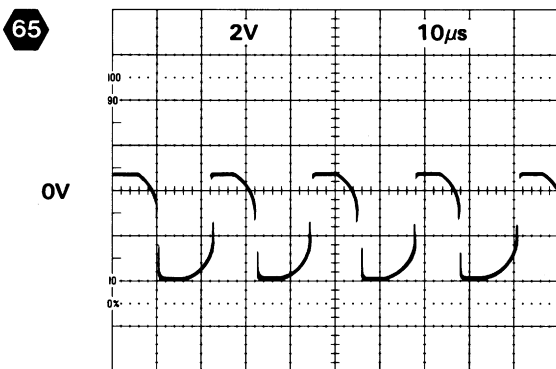
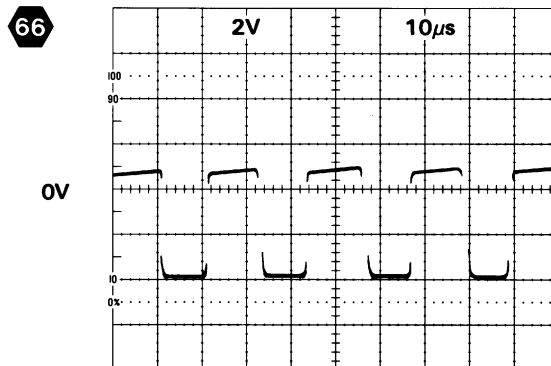
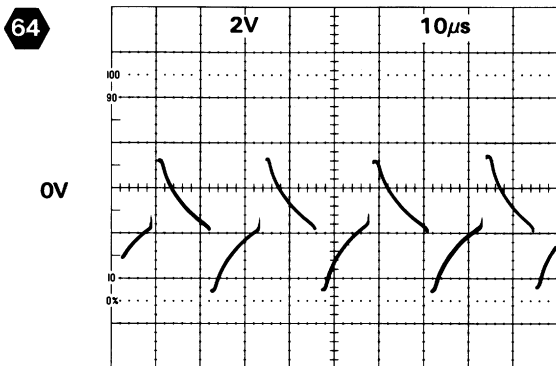

4118-46

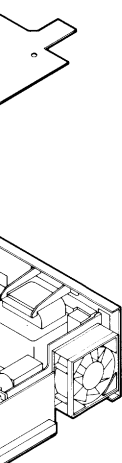

SWITCH

# DELTA TIME LOGIC DIAGRAM



ASSEMBLY A24											
CIRCUIT NUMBER	SCHEM LOCATION	BOARD LOCATION	CIRCUIT NUMBER	SCHEM LOCATION	BOARD LOCATION	CIRCUIT NUMBER	SCHEM LOCATION	BOARD LOCATION	CIRCUIT NUMBER	SCHEM LOCATION	BOARD LOCATION
CR00308	6K	3C	CR327	6L	4D	P840	9J	1G	R369	8N	2C
CR311	7K	4D	CR329	7L	3C				R371	8N	2C
CR313	7K	3C	CR330	6M	4D	Q327	7L	3B	R372	8N	2C
CR314	6K	3C	CR334	6M	4C				R374	8N	1C
CR315	6L	2C	CR336	7M	3B	R326	7M	3C	R375	8N	1C
CR316	7K	3C	CR357	7K	2B	R327	7L	4D			
CR317	7K	3C	CR359	7L	2B	R357	7K	2B	TP327	7L	2A
CR318	6K	3C	CR360	7M	2B	R357	7L	2B			
CR319	6M	4C	CR362	7M	2C	R359	7L	2B	U365A	8N	2D
CR321	6M	3C				R360	7M	2B	U365B	7N	2D
CR322	6M	2C	J842	9J	2A	R362	7M	2C	U365C	8N	2D
CR323	7M	4D				R364	7N	2C	U365D	8N	2D
CR324	6M	4D	P751	7I	3A	R365	7N	2C			
CR325	6M	4D	P840	7N	1G	R368	8N	2C			

Partial A24 also shown on diagrams 4, 6, 7 and 8

ASSEMBLY A30											
CIRCUIT NUMBER	SCHEM LOCATION	BOARD LOCATION	CIRCUIT NUMBER	SCHEM LOCATION	BOARD LOCATION	CIRCUIT NUMBER	SCHEM LOCATION	BOARD LOCATION	CIRCUIT NUMBER	SCHEM LOCATION	BOARD LOCATION
C2	1D	7G	J895	9B	5K	R45	4M	4A	U22C	3H	6B
C4	2C	6H				R46	4M	4A	U22D	3H	6B
C11	3D	5F	P780	1B	7I	R48	4M	4A	U23A	3I	5B
C12	3D	6G	P780	7H	7I	R49	4M	4A	U23C	3I	5B
C15	3D	6G				R51	5M	4B	U23D	3I	5B
C16	4D	7G	Q88	9E	6J	R52	5M	4B	U25A	5M	4C
C20	5E	7H	Q89	9E	6I	R53	4K	4E	U25B	3J	4C
C25	3J	4E	Q92	9E	6J	R55	6F	4G	U25C	3J	4C
C30	4J	4E				R57	6F	4H	U25D	3M	4C
C80	9C	5I	R1	1D	7G	R62	6F	4G	U32A	3K	4E
C81	9C	5I	R2	1D	7G	R64	6F	4H	U32B	5F	4E
C83	9D	5I	R4	2C	5F	R67	6F	4G	U32C	5K	4E
C91	9F	6I	R5	2C	5F	R69	6F	4H	U32D	3K	4E
C92	9F	6I	R7	2C	5G	R71	7F	4G	U37	1I	6D
			R8A	2C	5F	R73	7F	4H	U38	3L	4D
CR30	3J	4E	R8B	2C	5F	R80	9C	5J	U39A	3M	4C
CR50	5C	5J	R11	3D	5F	R81	9C	5I	U39B	4M	4C
CR51	7D	4G	R15	4D	6G	R83	9D	5I	U39C	4M	4C
CR52	7D	4G	R16	4D	7G	R85	9D	5I	U39D	4M	4C
CR55	6D	4H	R18	5C	5H	R88	9E	6I	U40A	5N	6A
CR62	6D	4H	R21	5E	5C	R89	9E	6I	U40B	3N	6A
CR67	6D	4H	R25	3J	4E	R90	9E	6I	U40C	4G	6A
CR71	7D	4G	R27	3J	4E	R92	9E	6I	U40D	4N	6A
CR85	9D	6I	R28	3J	4E	R94	9F	7K	U42A	4N	5A
CR86	9E	6I	R29	3J	4E				U42B	4N	5A
CR89	9E	6I	R30	3J	3E	TP88	8G	7J	U42C	5N	5A
			R31	3K	4E	TP89	8G	7H	U42D	3N	5A
DS40	7B	6C	R34	3L	4E	TP90	8G	5H	U55A	6G	4F
DS41	7B	6E	R35	3M	4A	TP92	8G	7H	U55B	6G	4F
			R36	3M	4A				U55C	6G	4F
J890	4B	6J	R37	5L	4E	U2	1C	5H	U55D	7G	4F
J890	5B	6J	R38	3M	4A	U9A	4D	6H	U55E	3K	4F
J890	7B	6J	R39	3M	4A	U9B	5E	6H			
J892	6B	5K	R40	7B	4J	U9C	2D	6H	VR6	2C	5G
J892	7B	5K	R41	7B	7E	U10	1E	6F	VR20	5E	7H
J894	5B	7K	R42	3M	4A	U22A	3H	6B			
J894	6B	7K	R43	4M	4A	U22B	3H	6B			

ASSEMBLY A31											
CIRCUIT NUMBER	SCHEM LOCATION	BOARD LOCATION	CIRCUIT NUMBER	SCHEM LOCATION	BOARD LOCATION	CIRCUIT NUMBER	SCHEM LOCATION	BOARD LOCATION	CIRCUIT NUMBER	SCHEM LOCATION	BOARD LOCATION
P890	4B	3B	P892	6B	1C	P894	6B	1A	S2	4A	1B
P890	5B	3B	P892	7B	1C						
P890	7B	3B	P894	5B	1A	S1	4B	2B			

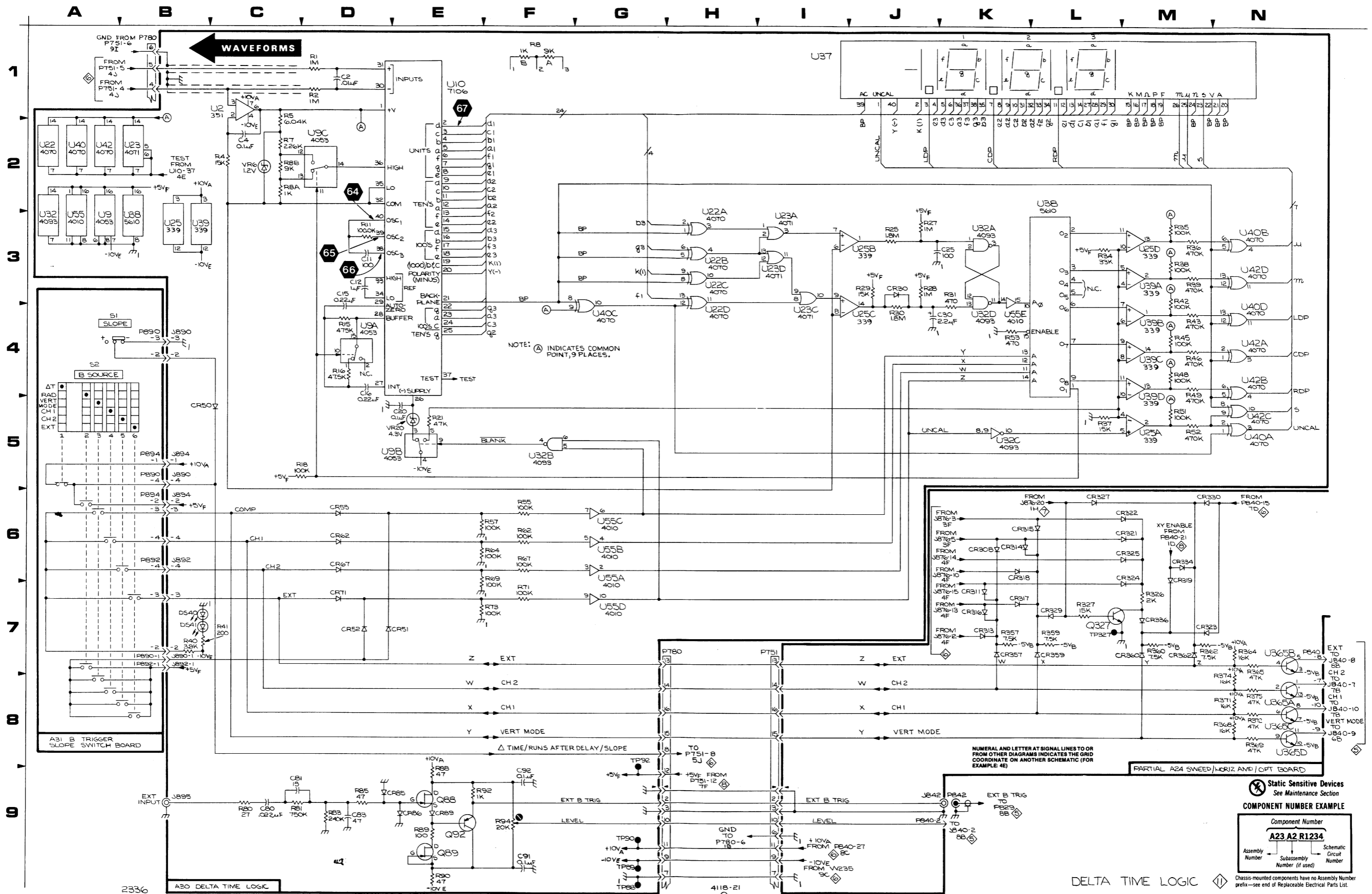

DELTA TIME LOGIC



Static Sensitive Devices See Maintenance Section

COMPONENT NUMBER EXAMPLE

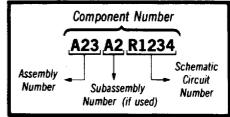

Chassis-mounted components have no Assembly Number prefix—see end of Replaceable Electrical Parts List.

DELTA TIME LOGIC

## POWER SUPPLY ISOLATION PROCEDURE

Each regulated supply has numerous feed points to external loads throughout the instrument. The power distribution diagram is used in conjunction with the schematic diagrams to determine those loads that can be isolated by removing service jumpers and those that cannot.

The power distribution diagram is divided into circuit boards. Each power supply feed to a circuit board is indicated by the schematic diagram number on which the voltage appears. The schematic diagram grid location of a service jumper or component is given adjacent to the component number on the power distribution diagram.

If a power supply comes up after lifting a service jumper or other component to isolate a circuit, it is very probable that the problem is in that circuit. This can sometimes, however, lead to erroneous conclusions. A supply may pass through one circuit to another circuit. For instance, the +5V<sub>B</sub> supply goes through both the CH 1 and CH 2 VERT MODE switches (for XY MODE), across the A13 Trigger board from P808-11 to J840-21, and onto the A14 Sweep/Horiz Amp board. It is no longer identified as +5V<sub>B</sub>, but is now labeled XY Enable. The XY Enable signal appears on both diagram 8 and on diagram 6. Watch for this type of condition when trying to localize a loading problem.

Typical resistance values to ground from the regulated supplies output as measured at the supply test points are:

+40 V	4 K $\Omega$ at TP247
+10 V	210 $\Omega$ at TP252
+5 V	110 $\Omega$ at TP255
-10 V	400 $\Omega$ at TP265
-5 V	160 $\Omega$ at TP264

Resistance values significantly lower may indicate shorted components in the load. Values will vary between instruments.

Always set the POWER switch to OFF before soldering or unsoldering service jumpers or other components and before attempting to measure component resistance values.



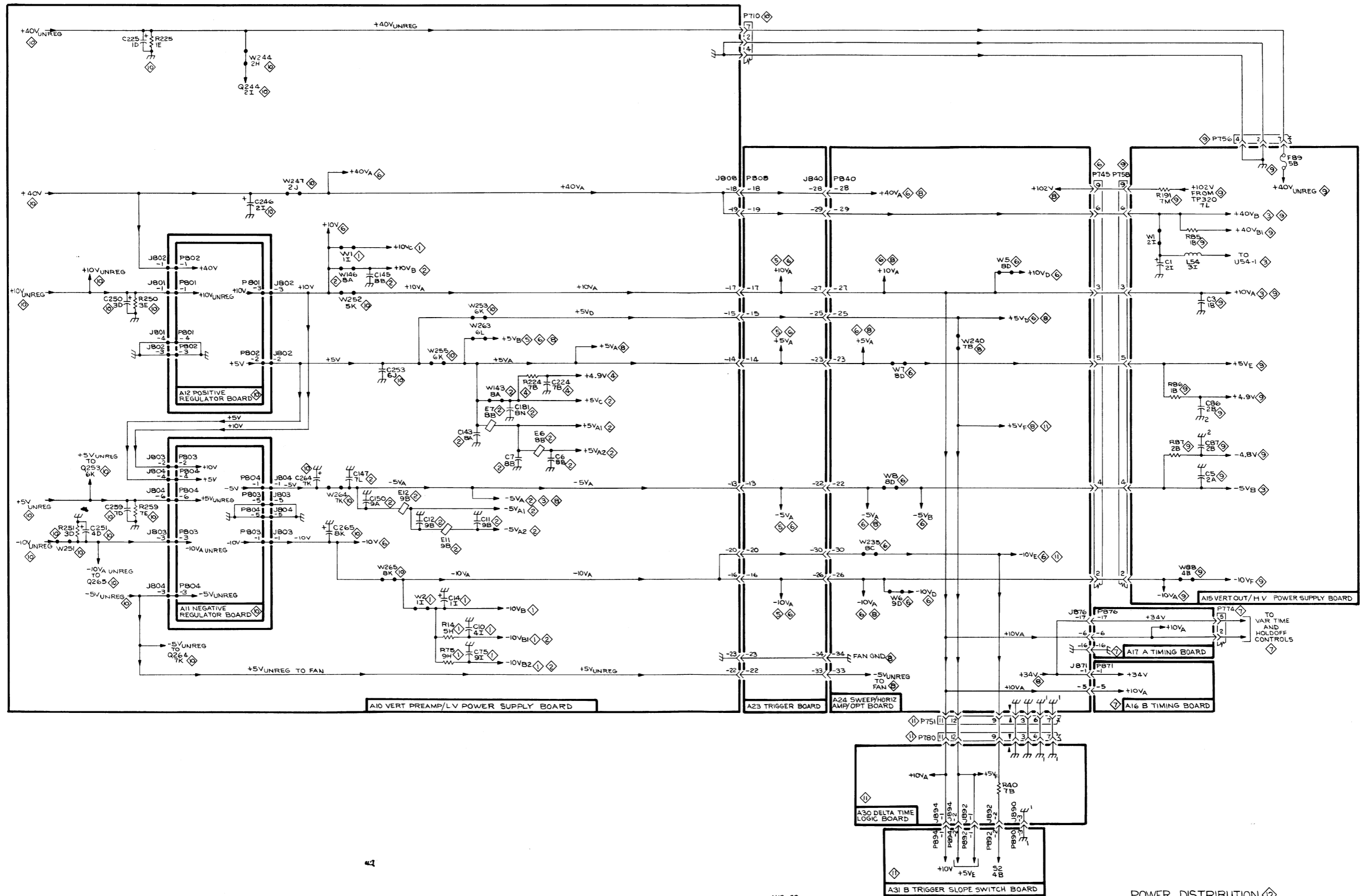

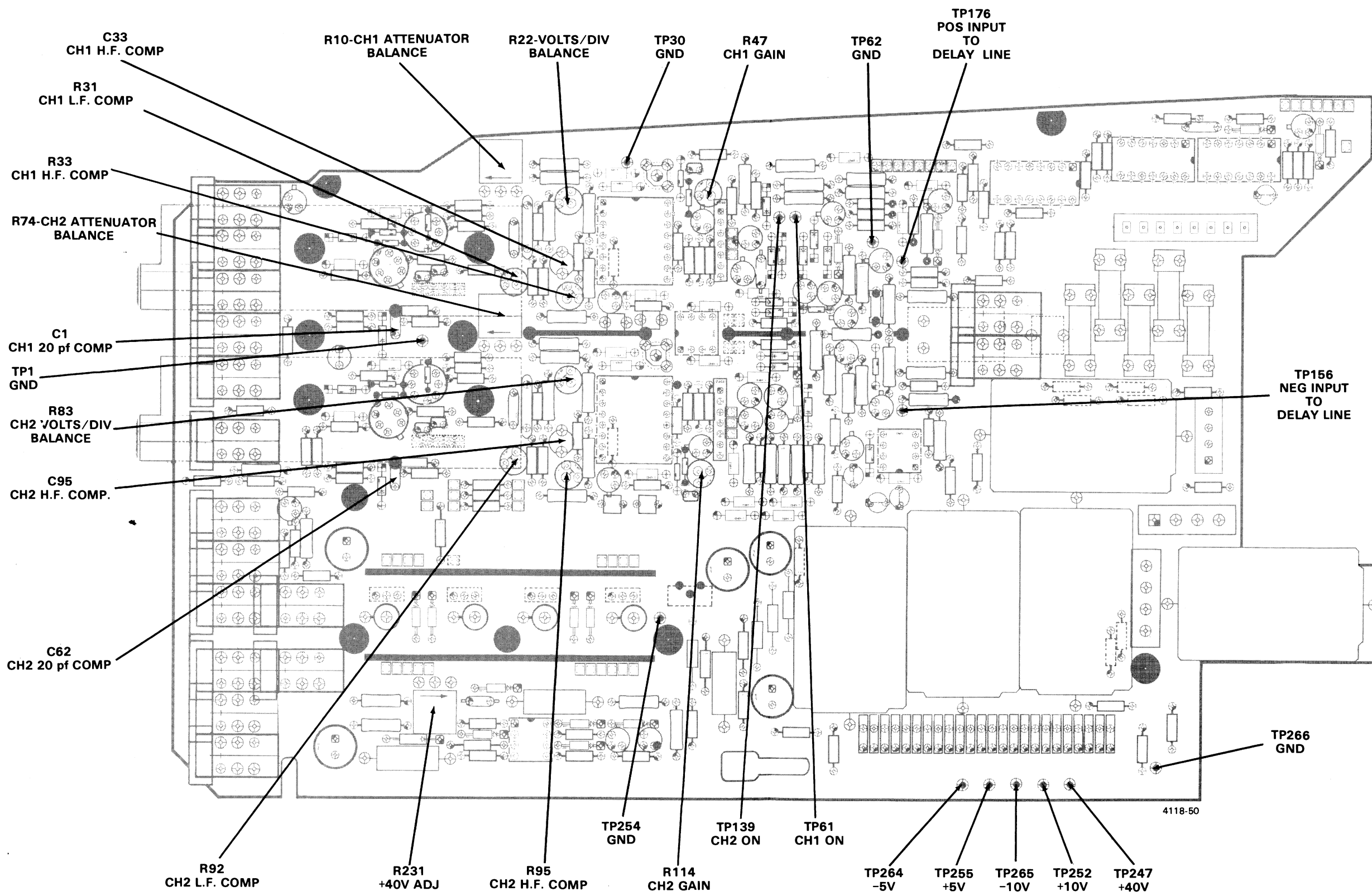

A10—VERTICAL PREAMP/LOW VOLTAGE POWER SUPPLY, ADJUSTMENT LOCATIONS

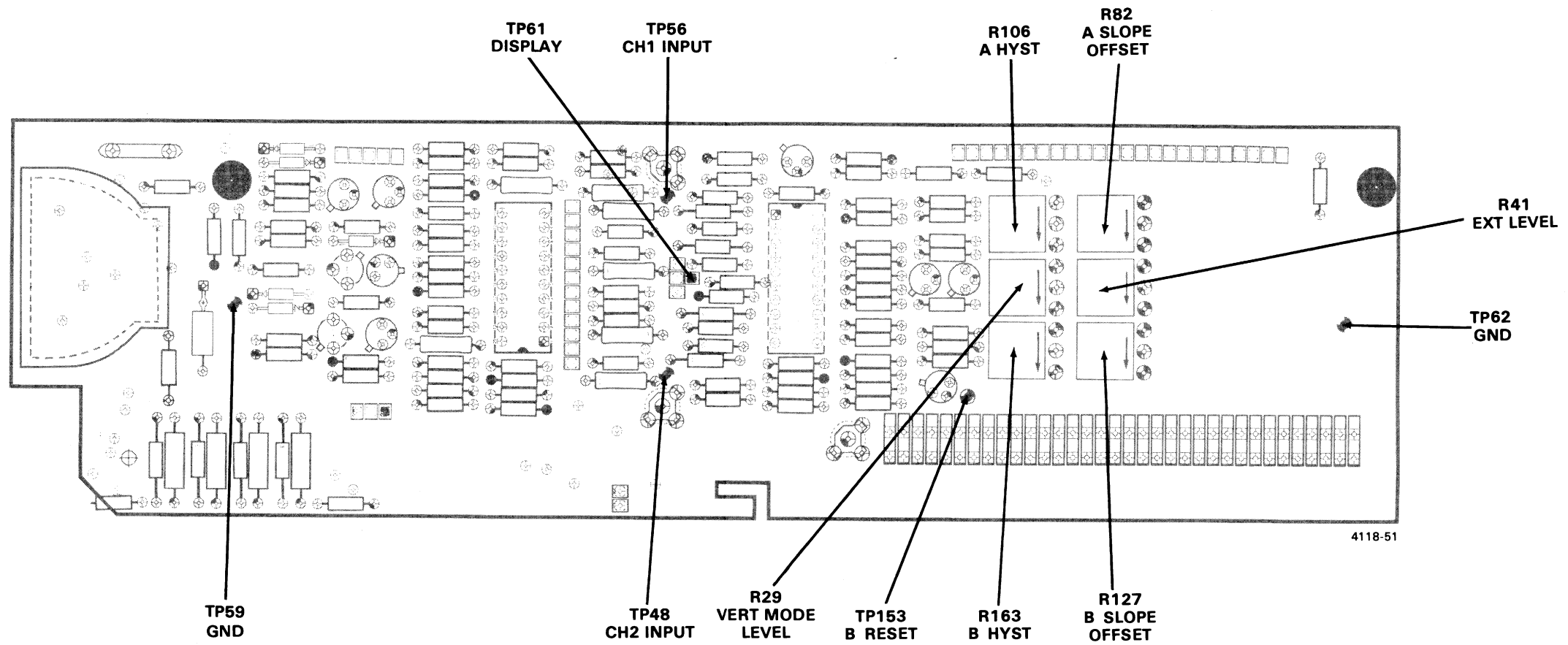

ADJUSTMENT LOCATIONS 2

A23—TRIGGER, ADJUSTMENT LOCATIONS

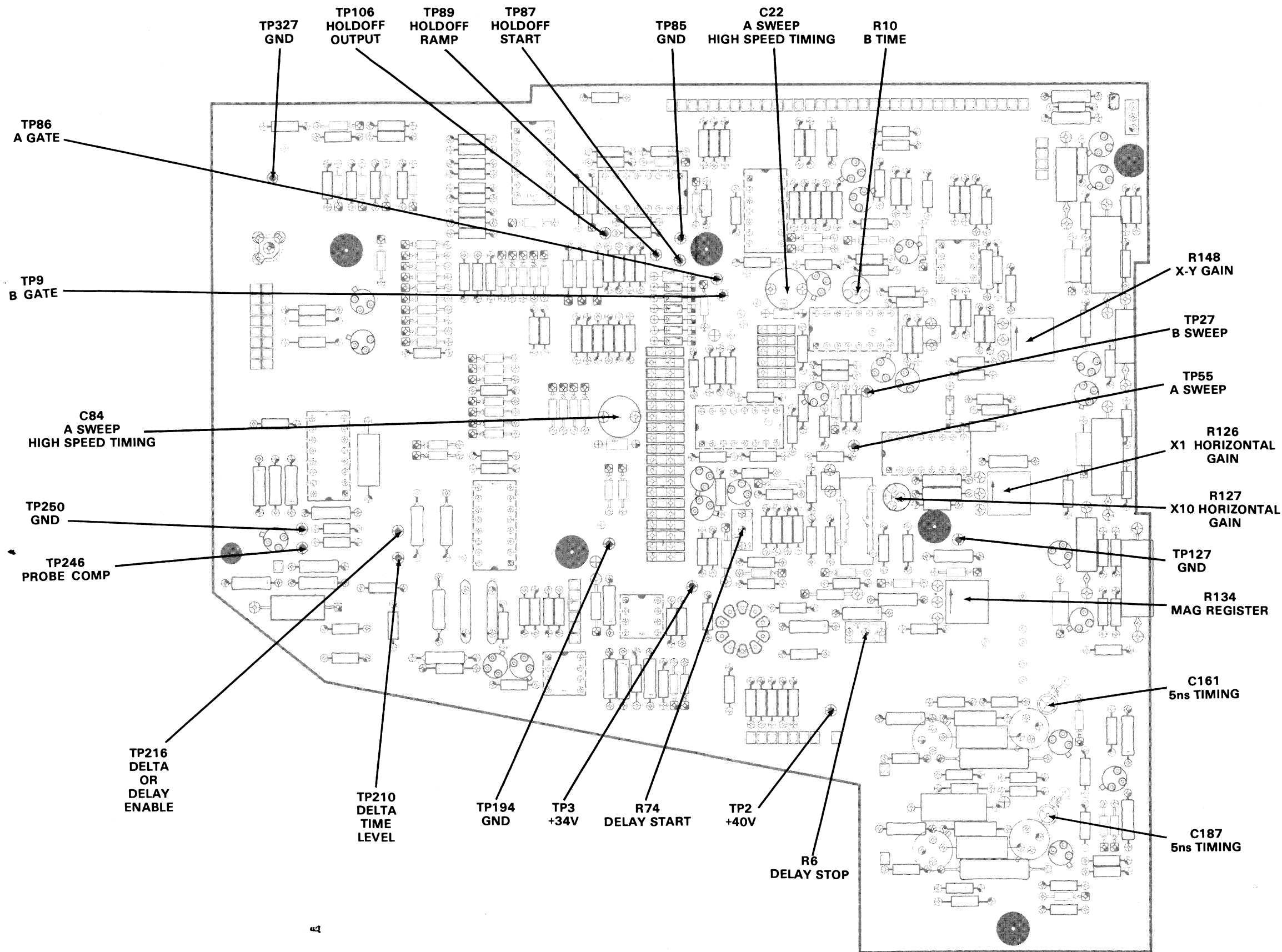

ADJUSTMENT LOCATIONS 3

4118-52

A24—SWEEP/HORIZONTAL AMPLIFIER, ADJUSTMENT LOCATIONS

@

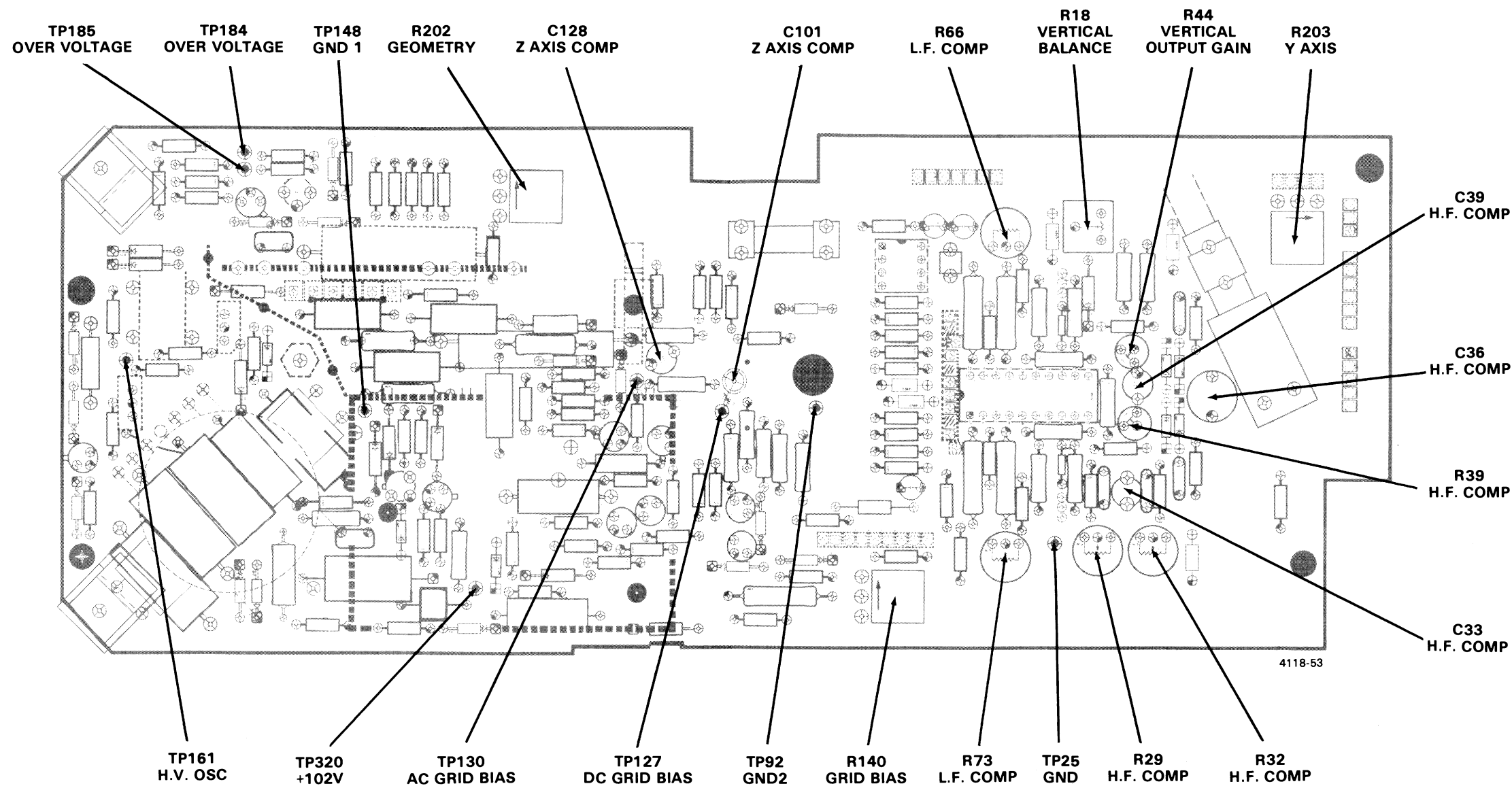

A15—VERTICAL OUTPUT/HIGH VOLTAGE POWER SUPPLY, ADJUSTMENT LOCATIONS

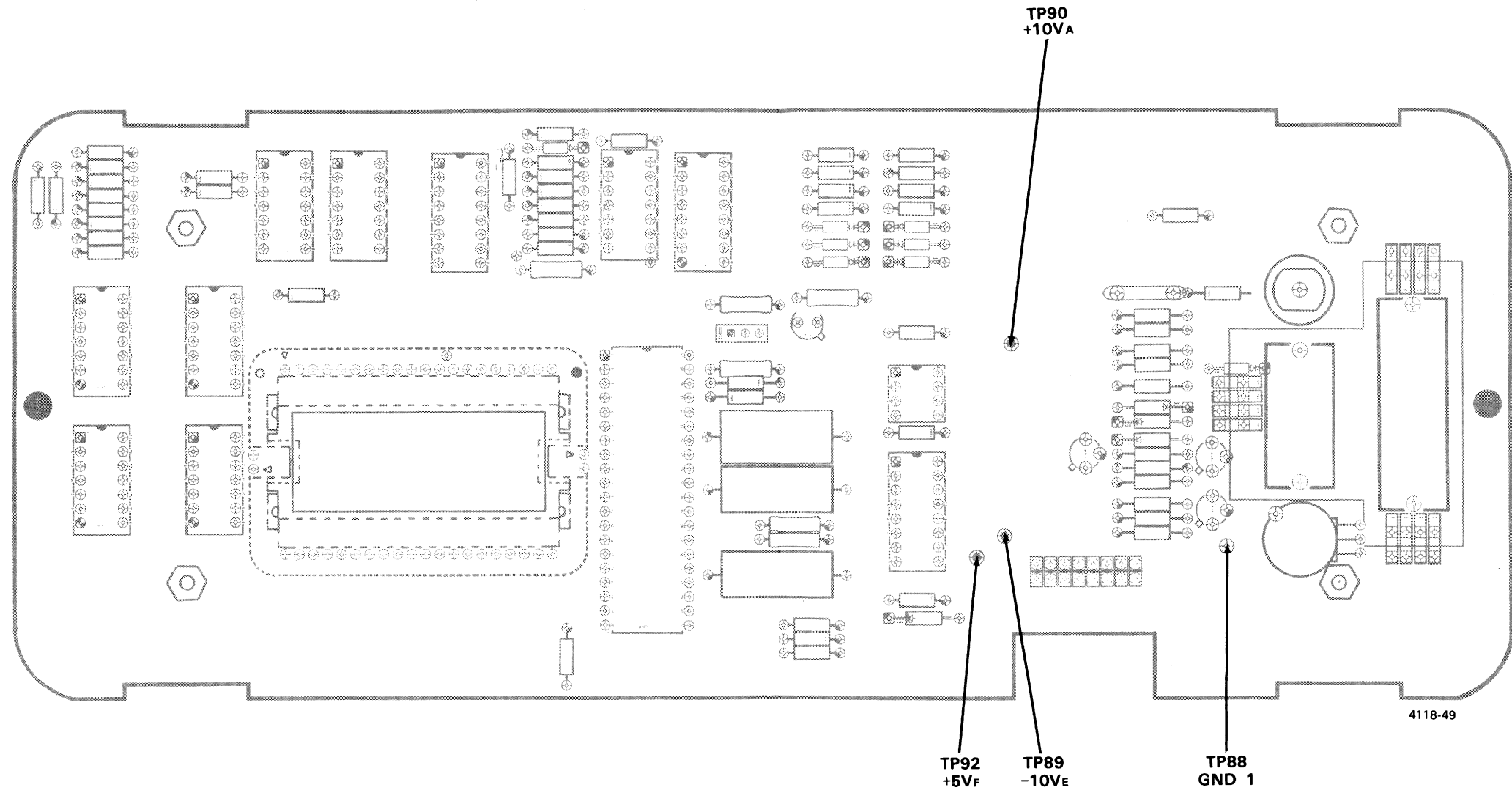

A30—DELTA TIME LOGIC, ADJUSTMENT LOCATIONS

A

@

#### GENERAL NOTES

- A. Always set POWER switch to OFF before swapping, removing, or replacing components, and before connecting or disconnecting leads or cables.
- B. When analyzing circuit malfunctions, consider sockets and cables as possible causes of failure.

**SPECIFIC NOTES**

- Set the instrument front-panel controls initially as follows:
 

TRIG SOURCE	VERT MODE
TRIG SLOPE	+
TRIG MODE	AUTO
VAR TIME	In detent
A AND B SEC/DIV	1ms
HORIZ MODE	A
CH 1 VOLTS/DIV	0.1V
CH 1 AC-GND-DC	DC
VERTICAL MODE	CH 1
VERTICAL POSITION	Midrange
HORIZONTAL POSITION	Midrange
X10 MAG	OFF
INTENSITY	Midrange
B DELAY TIME POSITION	Fully CCW

**GENERAL NOTES**

- Always set POWER switch to OFF before swapping, removing, or replacing components, and before connecting or disconnecting leads or cables.
- When analyzing circuit malfunctions, consider sockets and cables as possible causes of failure.
- Note that some troubleshooting-procedure boxes on each chart contain numbers in their bottom corners. These are the numbers of the applicable circuit diagram(s) and circuit board illustrations(s) (see figure). Numbers shown at the start of a troubleshooting path remain applicable to downstream procedure boxes in the path until the procedure specifies a different diagram and/or illustration.

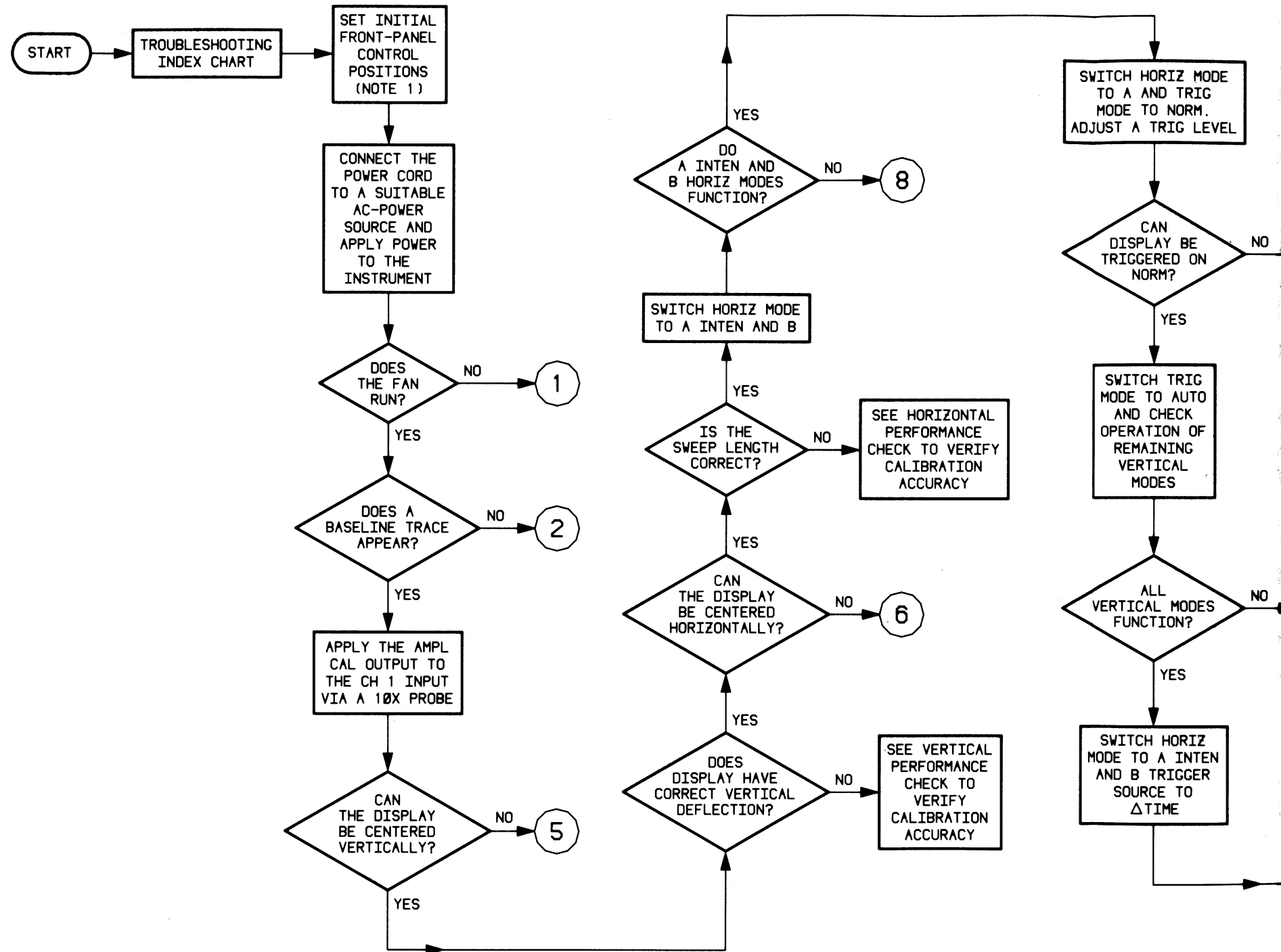
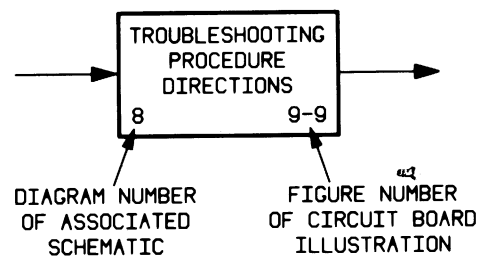



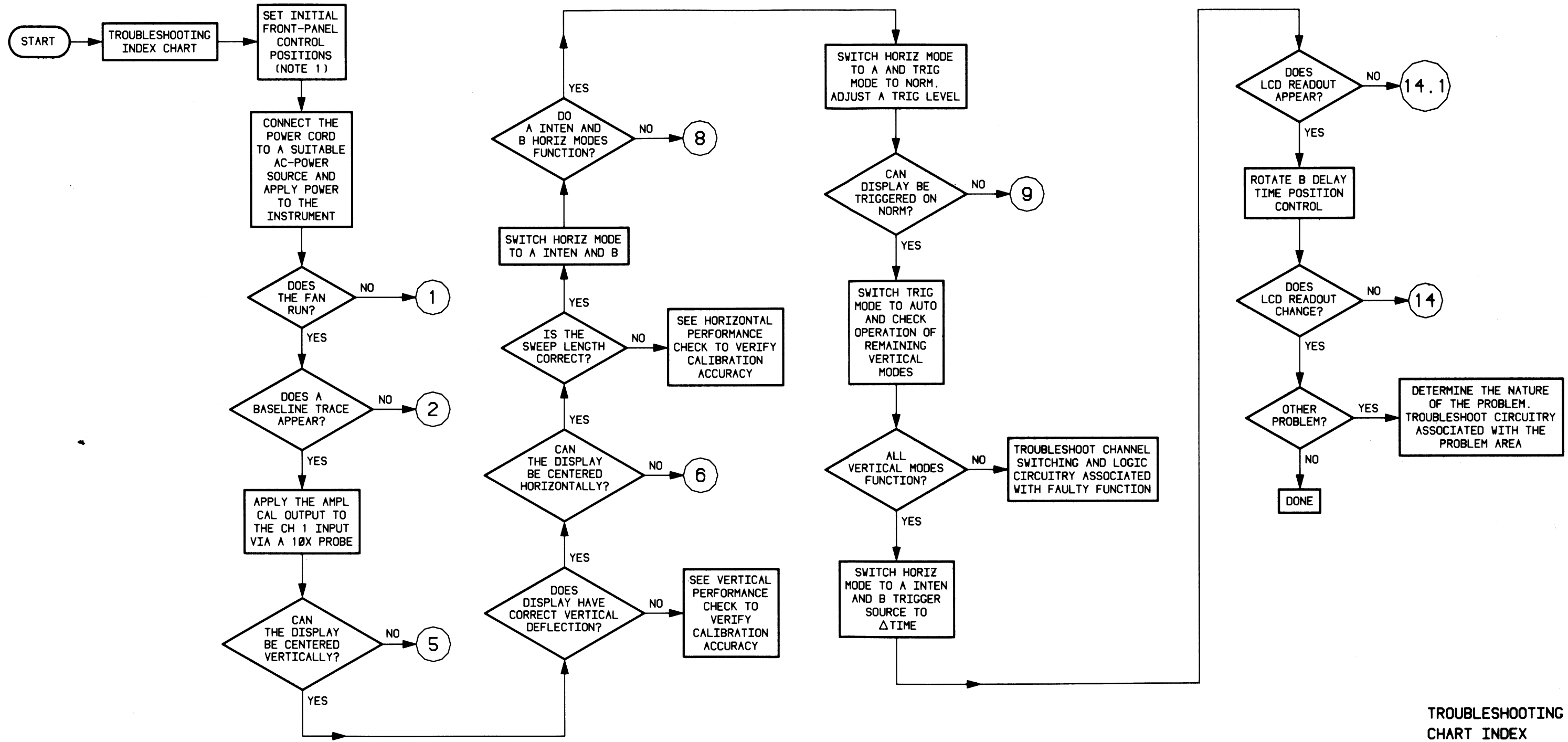

TROUBLESHOOTING CHART INDEX

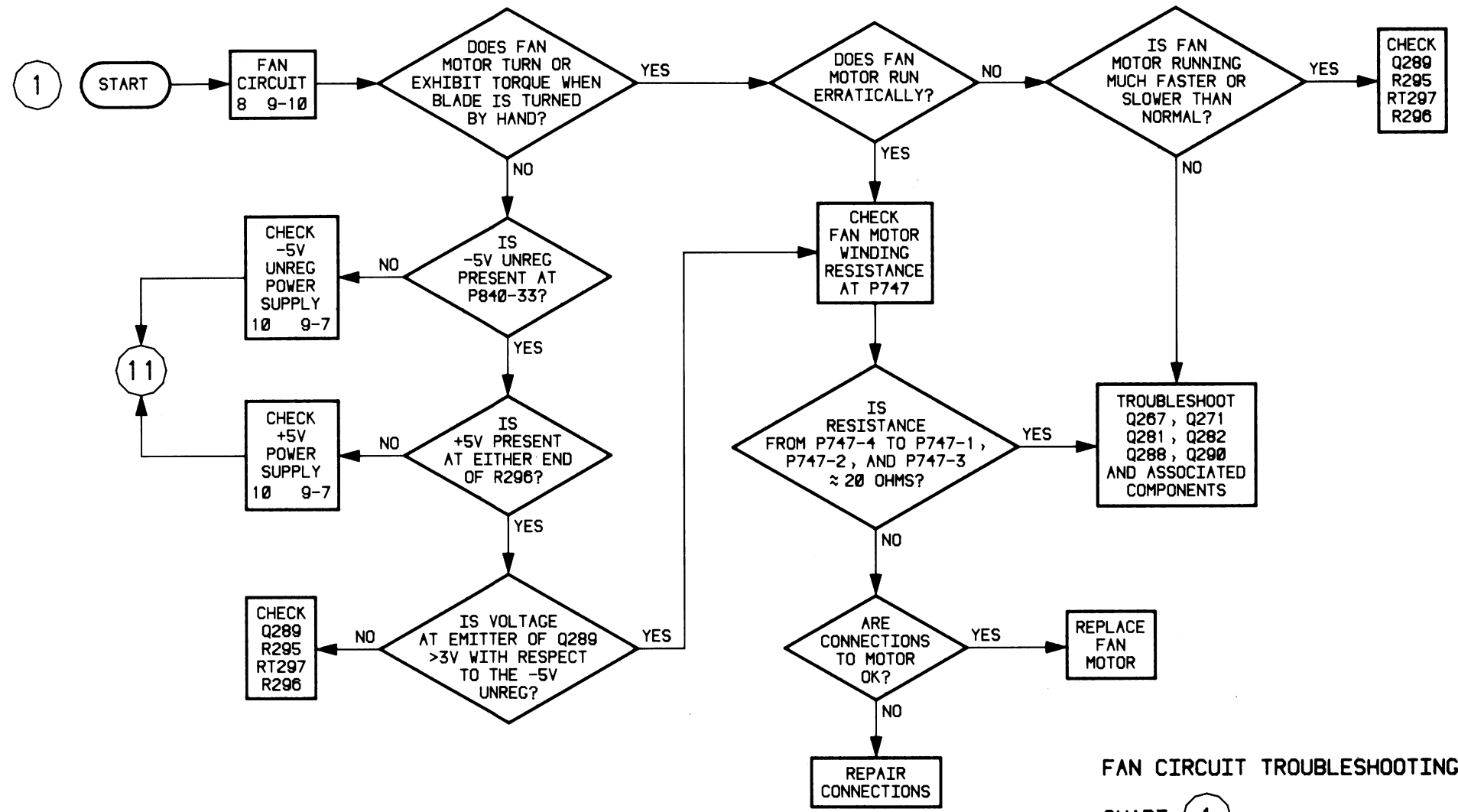

FAN CIRCUIT TROUBLESHOOTING CHART 1

FAN CIRCUIT TROUBLESHOOTING CHART 1

**SPECIFIC NOTES**

- Verify the power supplies at the following test points:

SUPPLY	TEST POINT	CIRCUIT BOARD AND FIGURE NO.
+40V	TP247	A10 (9-6)
+10V	TP252	A10 (9-6)
+5V	TP255	A10 (9-6)
-10V	TP265	A10 (9-6)
-5V	TP262	A10 (9-6)
+102V	TP320	A15 (9-7)

Power supply isolation procedure is described adjacent to the Power Distribution diagram in this manual.

- Set the instrument front-panel controls initially as follows:

TRIG SOURCE	VERT MODE
TRIG SLOPE	+
TRIG MODE	AUTO
VAR TIME	In detent
A AND B SEC/DIV	1ms
HORIZ MODE	A
CH 1 VOLTS/DIV	0.1V
CH 1 AC-GND-DC	DC
VERTICAL MODE	CH 1
VERTICAL POSITION	Midrange
HORIZONTAL POSITION	Midrange
X10 MAG	OFF
INTENSITY	Midrange
B DELAY TIME POSITION	Fully CCW

**GENERAL NOTES**

- Always set POWER switch to OFF before swapping, removing, or replacing components, and before connecting or disconnecting leads or cables.
- When analyzing circuit malfunctions, consider sockets and cables as possible causes of failure.

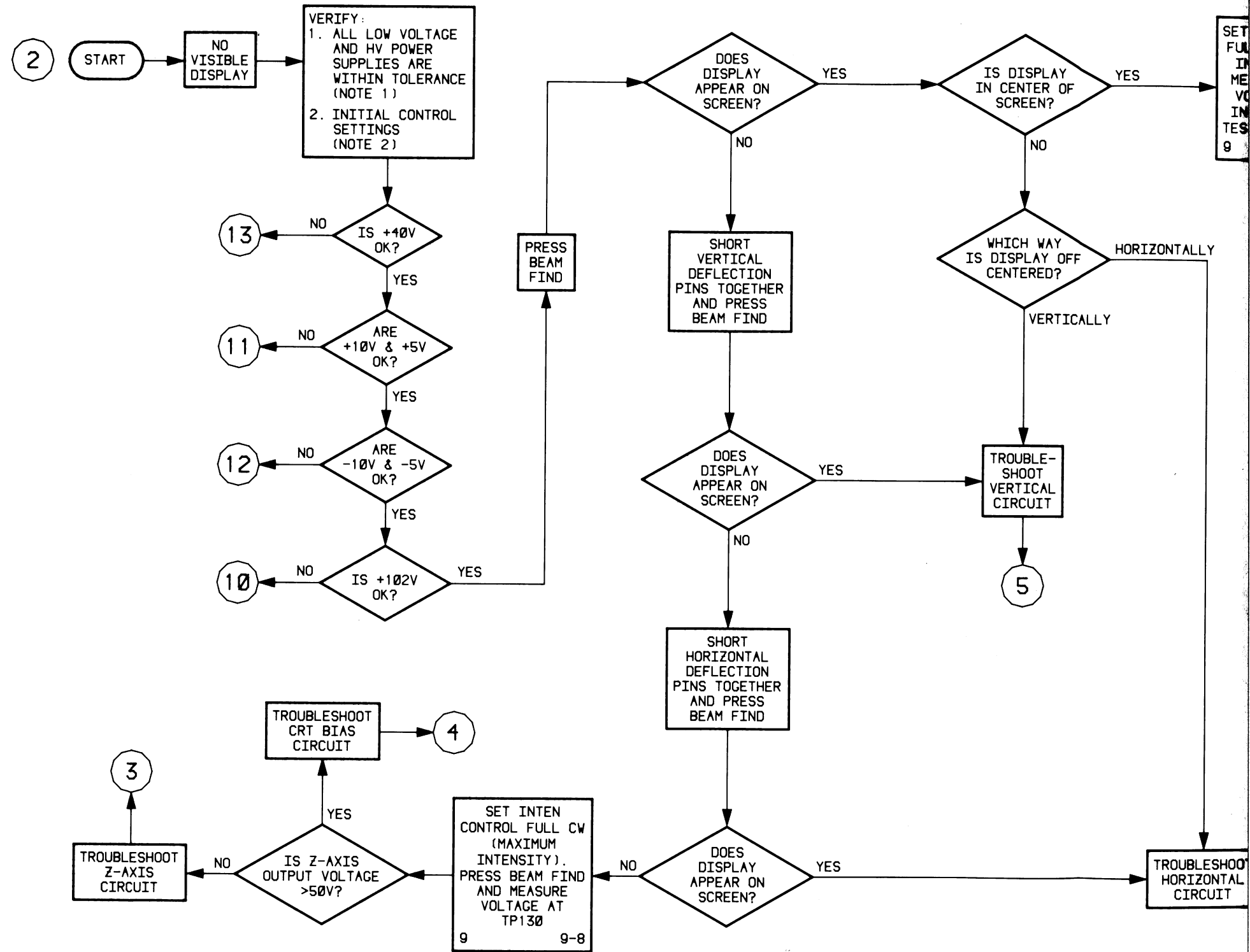

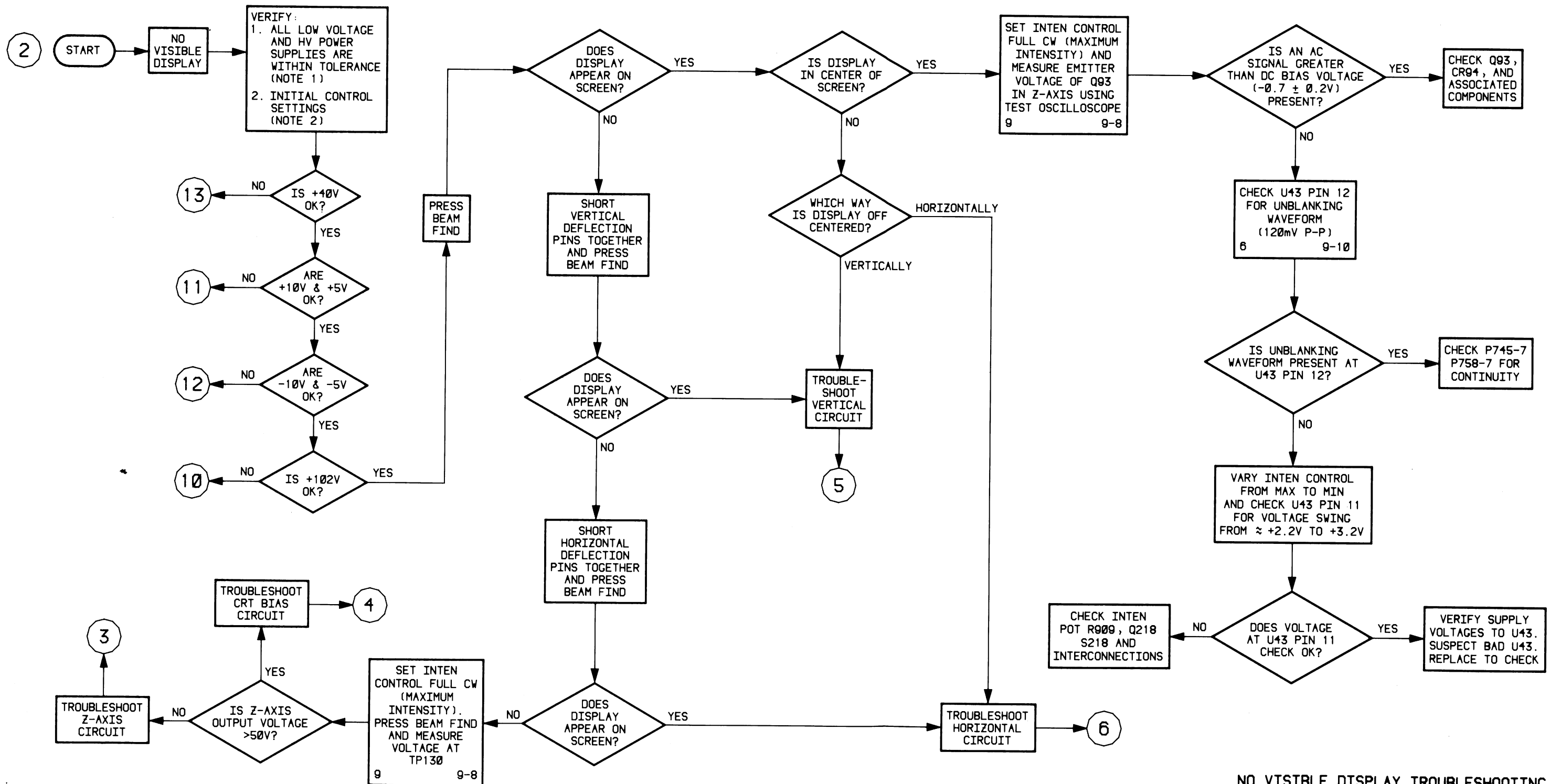

NO VISIBLE DISPLAY TROUBLESHOOTING CHART 2

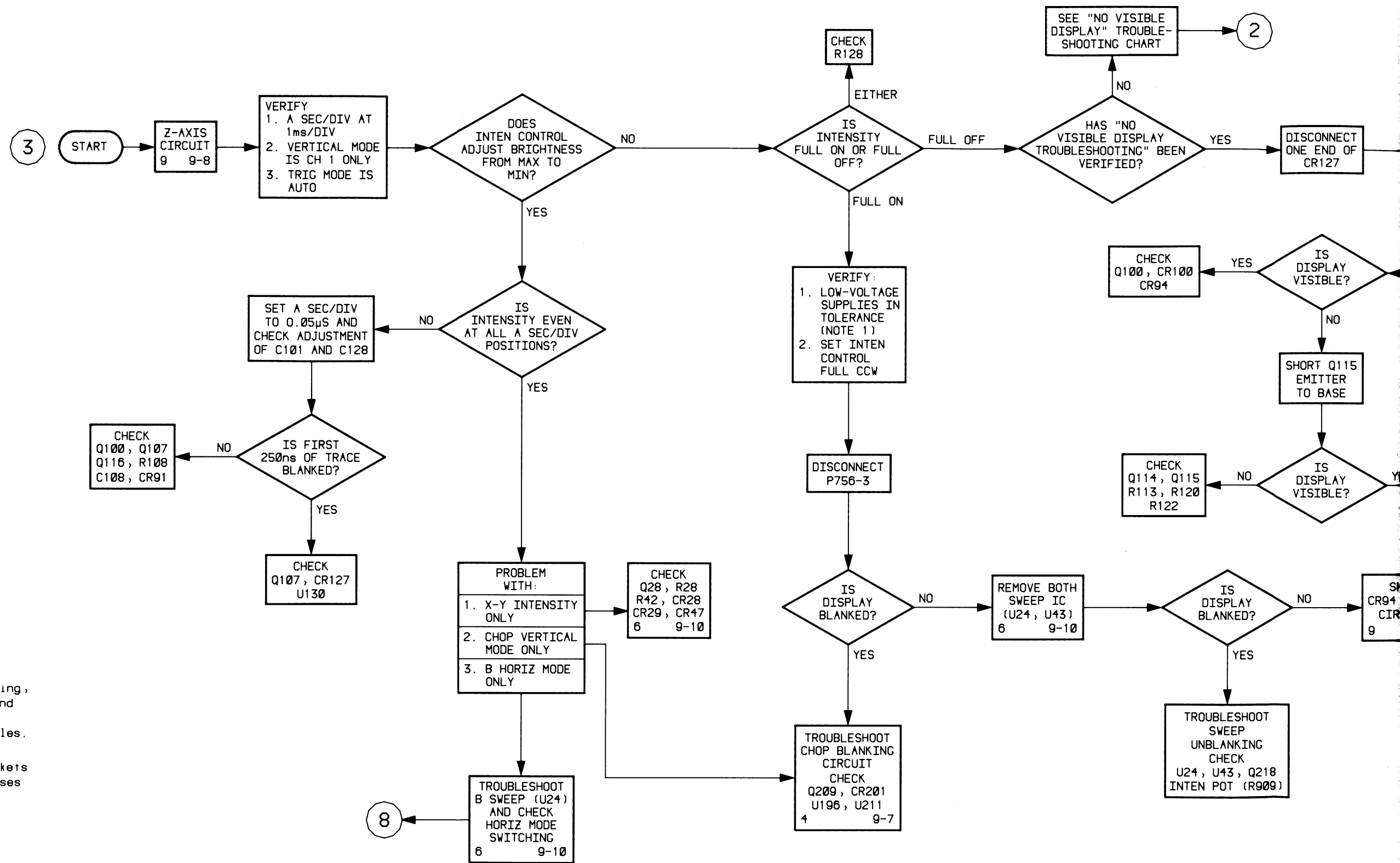

**GENERAL NOTES**

- A. Always set POWER switch to OFF before swapping, removing, or replacing components, and before connecting or disconnecting leads or cables.
- B. When analyzing circuit malfunctions, consider sockets and cables as possible causes of failure.

A

@

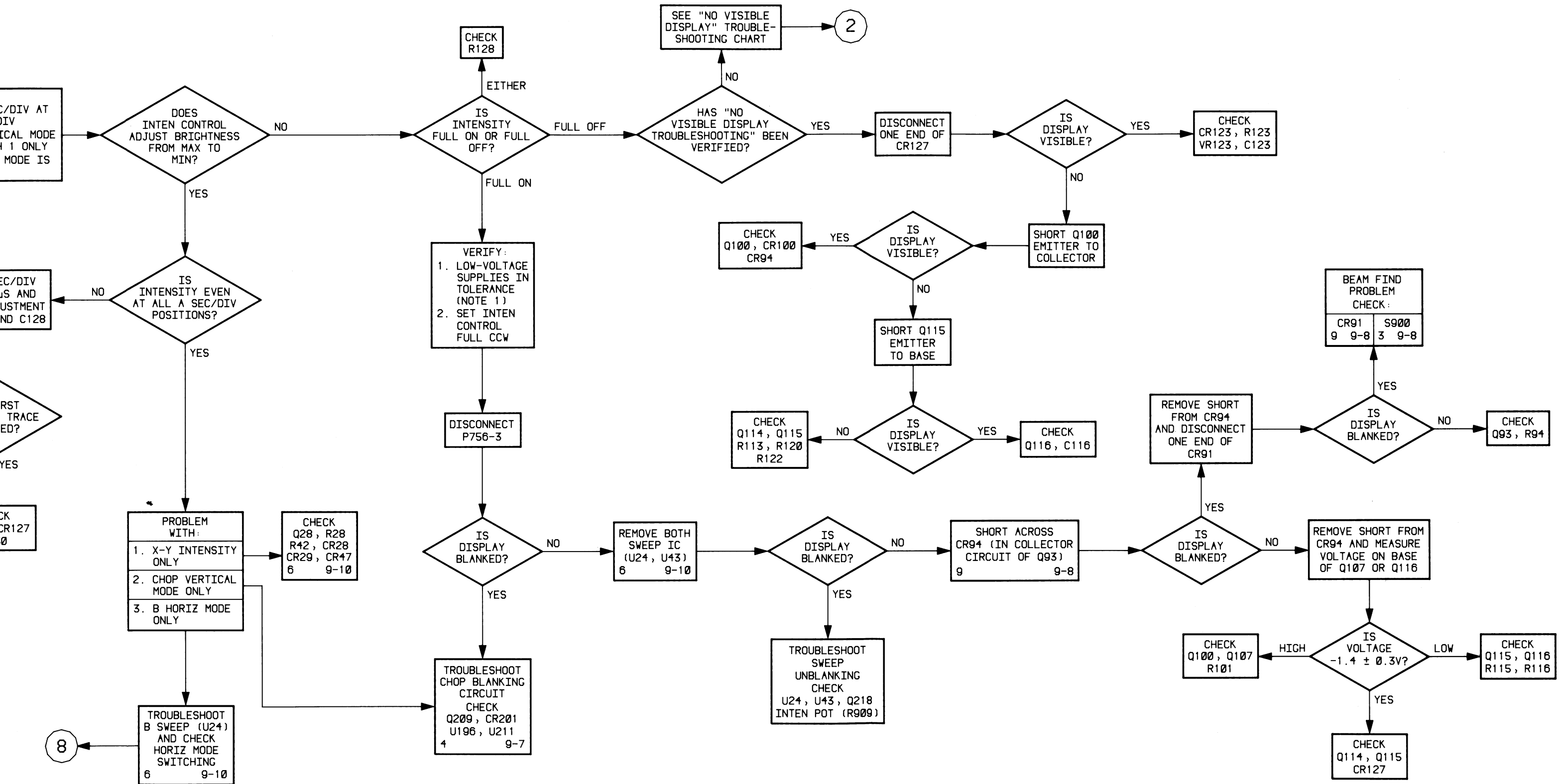

Z-AXIS TROUBLESHOOTING

CHART 3

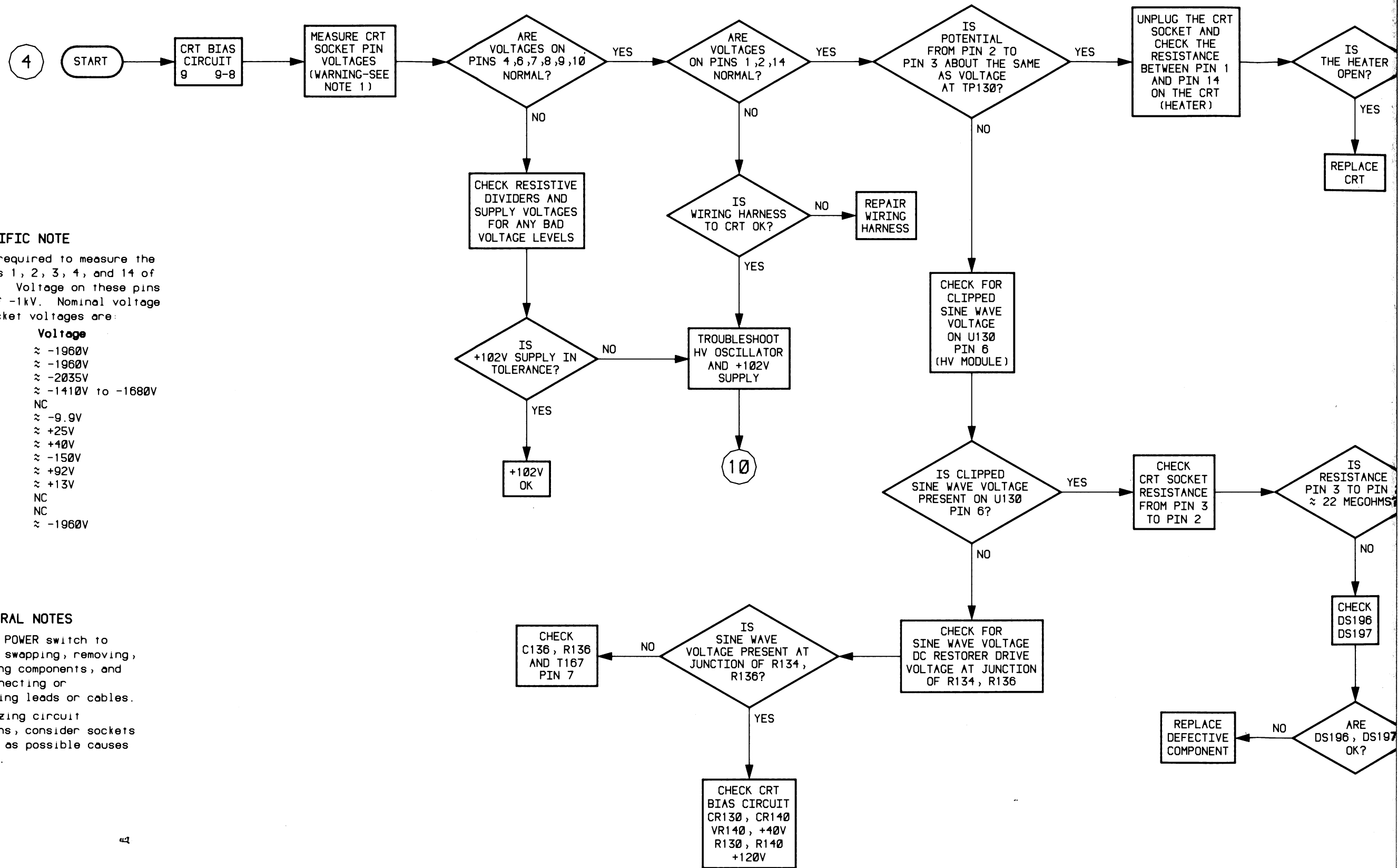

**SPECIFIC NOTE**

1. A HV probe is required to measure the voltage on pins 1, 2, 3, 4, and 14 of the crt socket. Voltage on these pins is in excess of -1kV. Nominal voltage for the crt socket voltages are:

Pin Nr.	Voltage
1	≈ -1960V
2	≈ -1960V
3	≈ -2035V
4	≈ -1410V to -1680V
5	NC
6	≈ -9.9V
7	≈ +25V
8	≈ +40V
9	≈ -150V
10	≈ +92V
11	≈ +13V
12	NC
13	NC
14	≈ -1960V

**GENERAL NOTES**

- A. Always set POWER switch to OFF before swapping, removing, or replacing components, and before connecting or disconnecting leads or cables.
- B. When analyzing circuit malfunctions, consider sockets and cables as possible causes of failure.

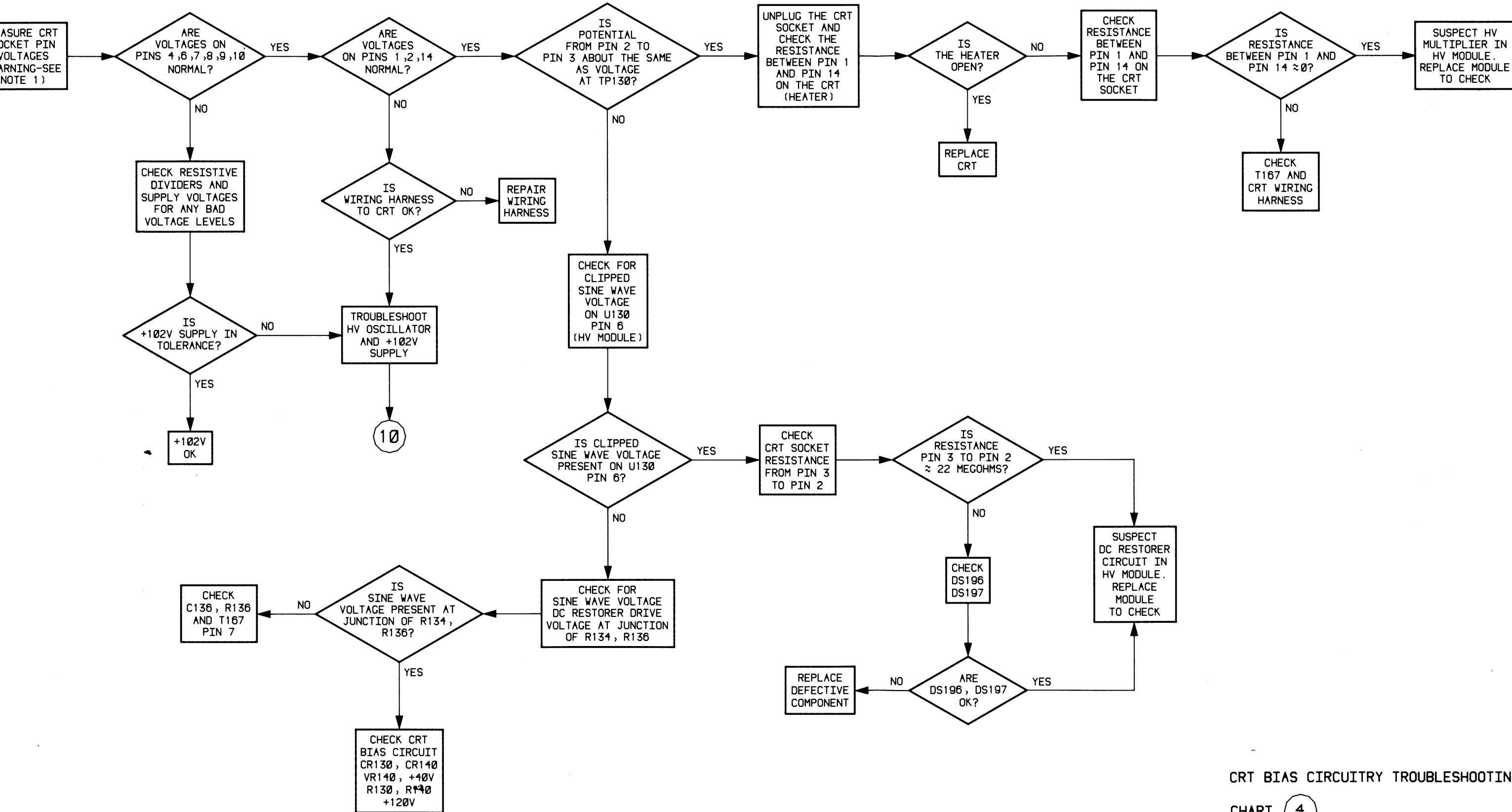

CRT BIAS CIRCUITRY TROUBLESHOOTING

CHART 4



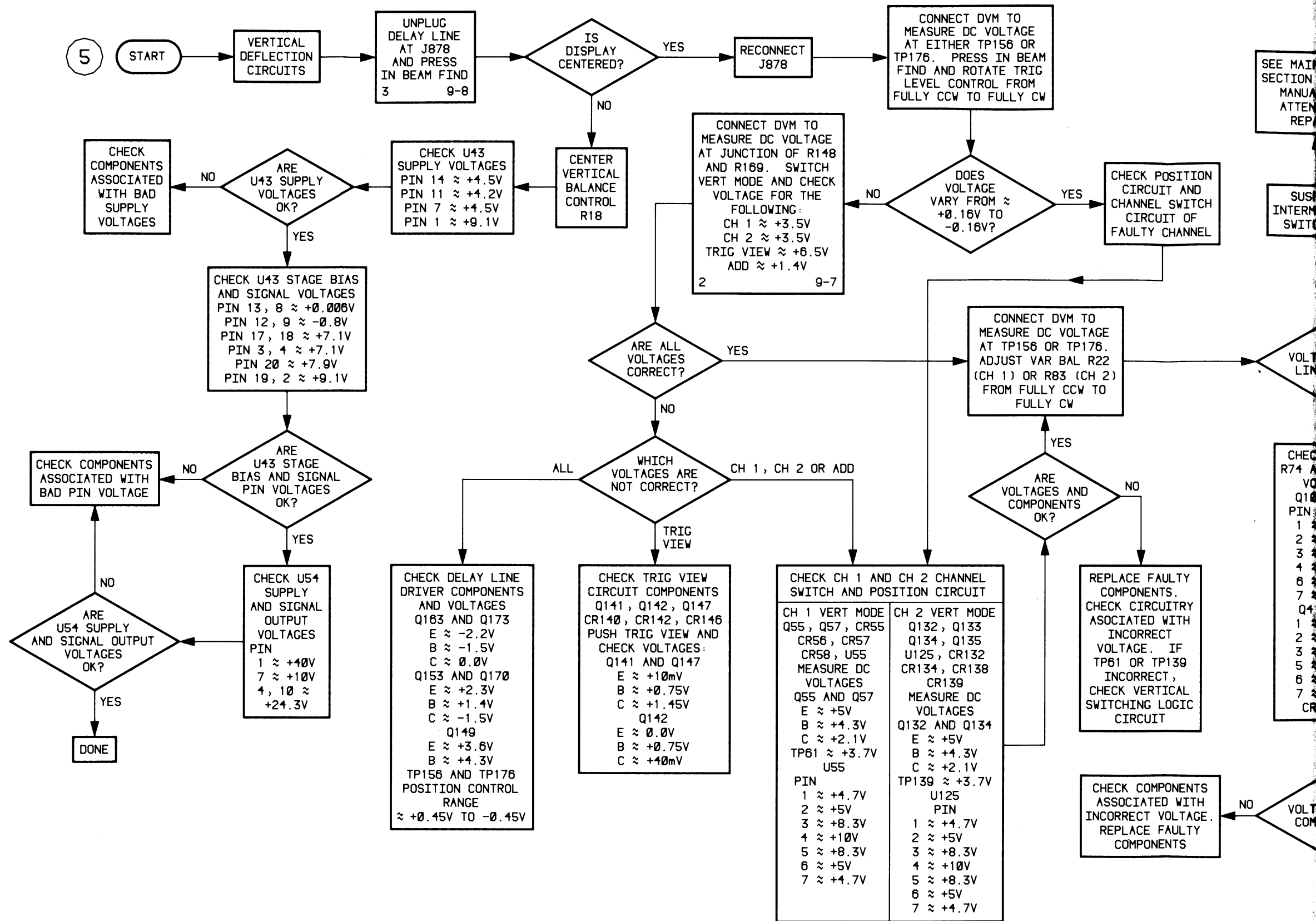

**GENERAL NOTES**

- A. Always set POWER switch to OFF before swapping, removing, or replacing components, and before connecting or disconnecting leads or cables.
- B. When analyzing circuit malfunctions, consider sockets and cables as possible causes of failure.

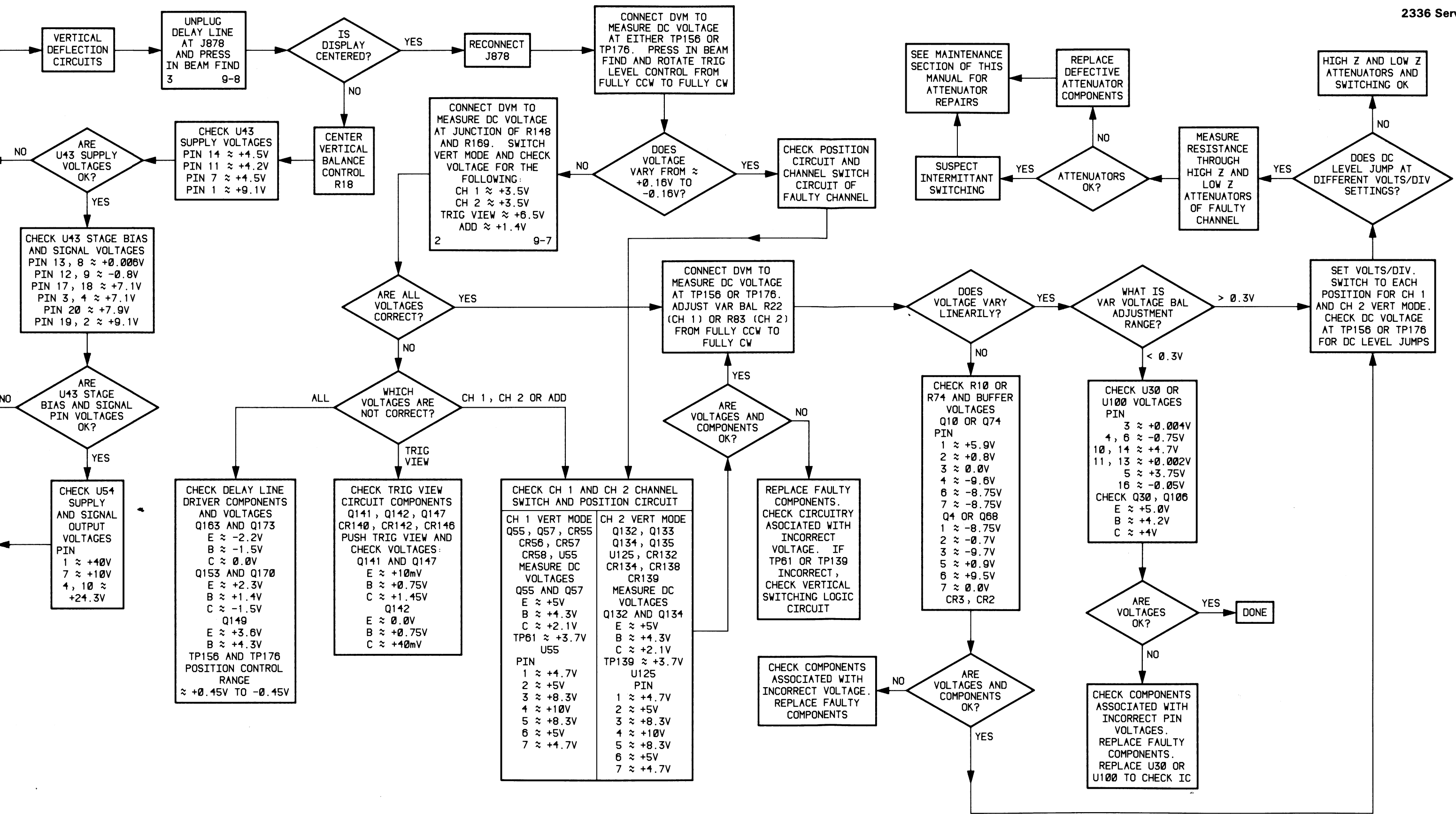

VERTICAL TROUBLESHOOTING

CHART 5

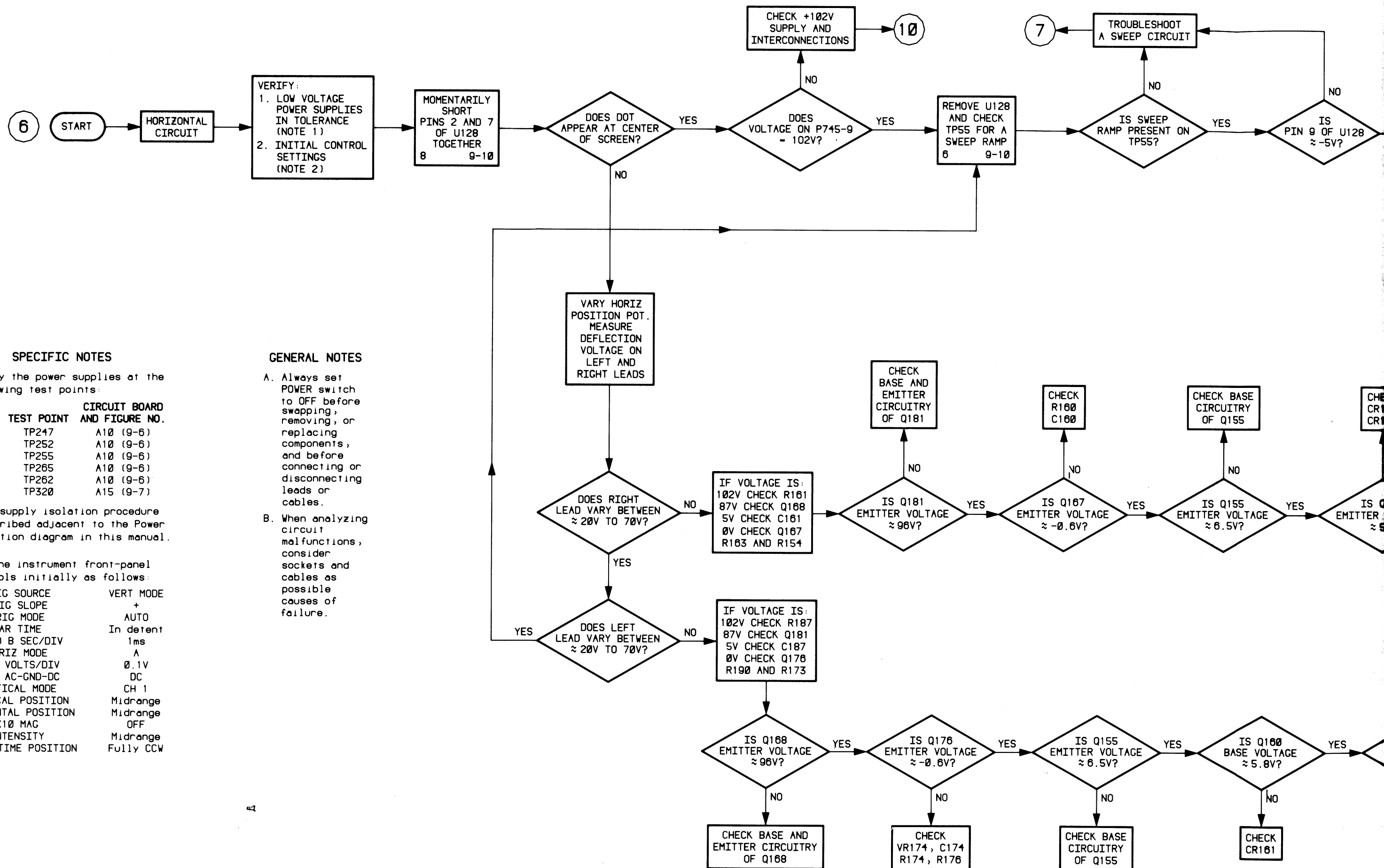

**SPECIFIC NOTES**

1. Verify the power supplies at the following test points:

SUPPLY	TEST POINT	CIRCUIT BOARD AND FIGURE NO.
+40V	TP247	A10 (9-6)
+10V	TP252	A10 (9-6)
+5V	TP255	A10 (9-6)
-10V	TP265	A10 (9-6)
-5V	TP262	A10 (9-6)
+102V*	TP320	A15 (9-7)

Power supply isolation procedure is described adjacent to the Power Distribution diagram in this manual.

2. Set the instrument front-panel controls initially as follows:

TRIG SOURCE	VERT MODE
TRIG SLOPE	+
TRIG MODE	AUTO
VAR TIME	In detent
A AND B SEC/DIV	1ms
HORIZ MODE	A
CH 1 VOLTS/DIV	0.1V
CH 1 AC-GND-DC	DC
VERTICAL MODE	CH 1
VERTICAL POSITION	Midrange
HORIZONTAL POSITION	Midrange
X10 MAG	OFF
INTENSITY	Midrange
B DELAY TIME POSITION	Fully CCW

**GENERAL NOTES**

A. Always set POWER switch to OFF before swapping, removing, or replacing components, and before connecting or disconnecting leads or cables.

B. When analyzing circuit malfunctions, consider sockets and cables as possible causes of failure.

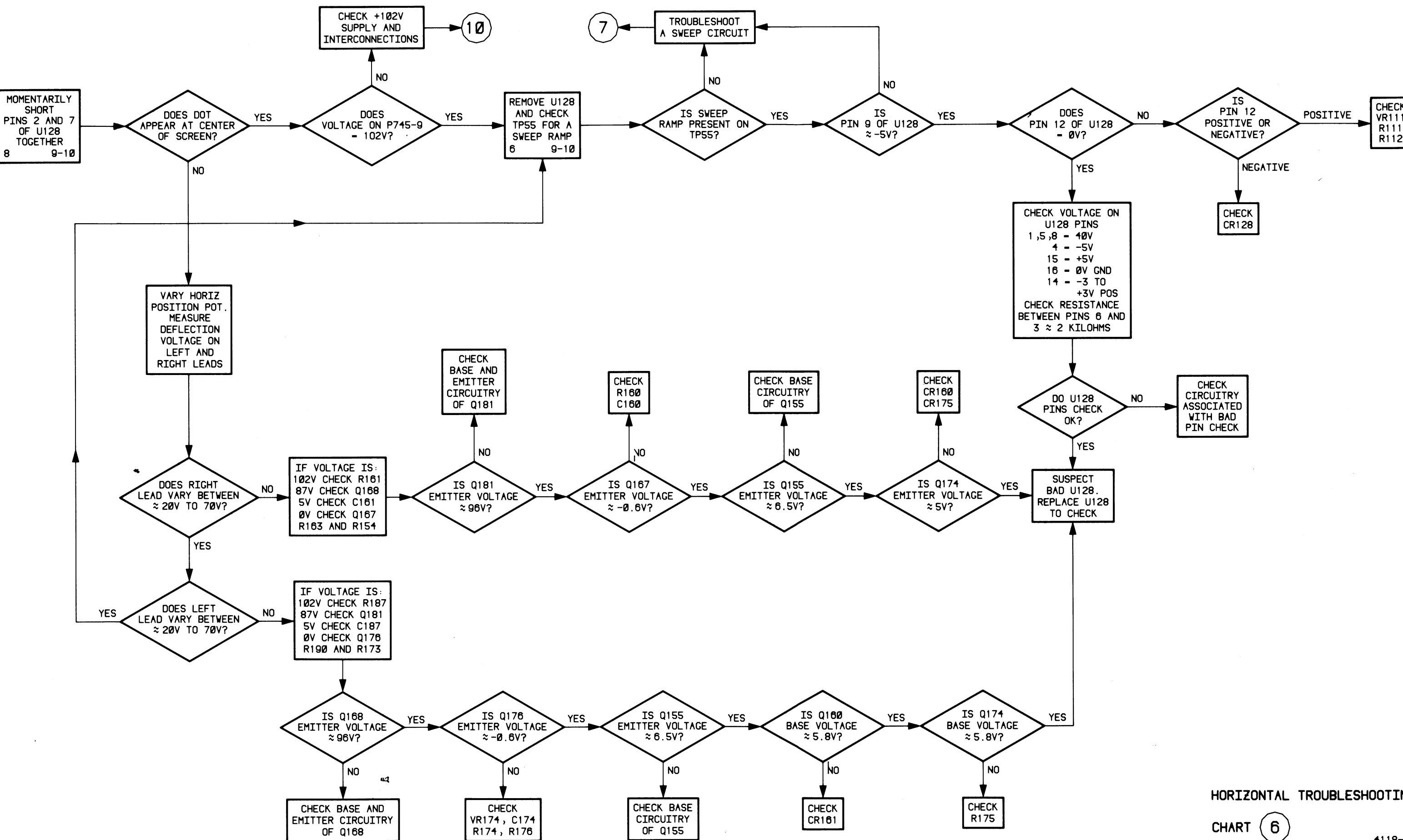

HORIZONTAL TROUBLESHOOTING

CHART 6

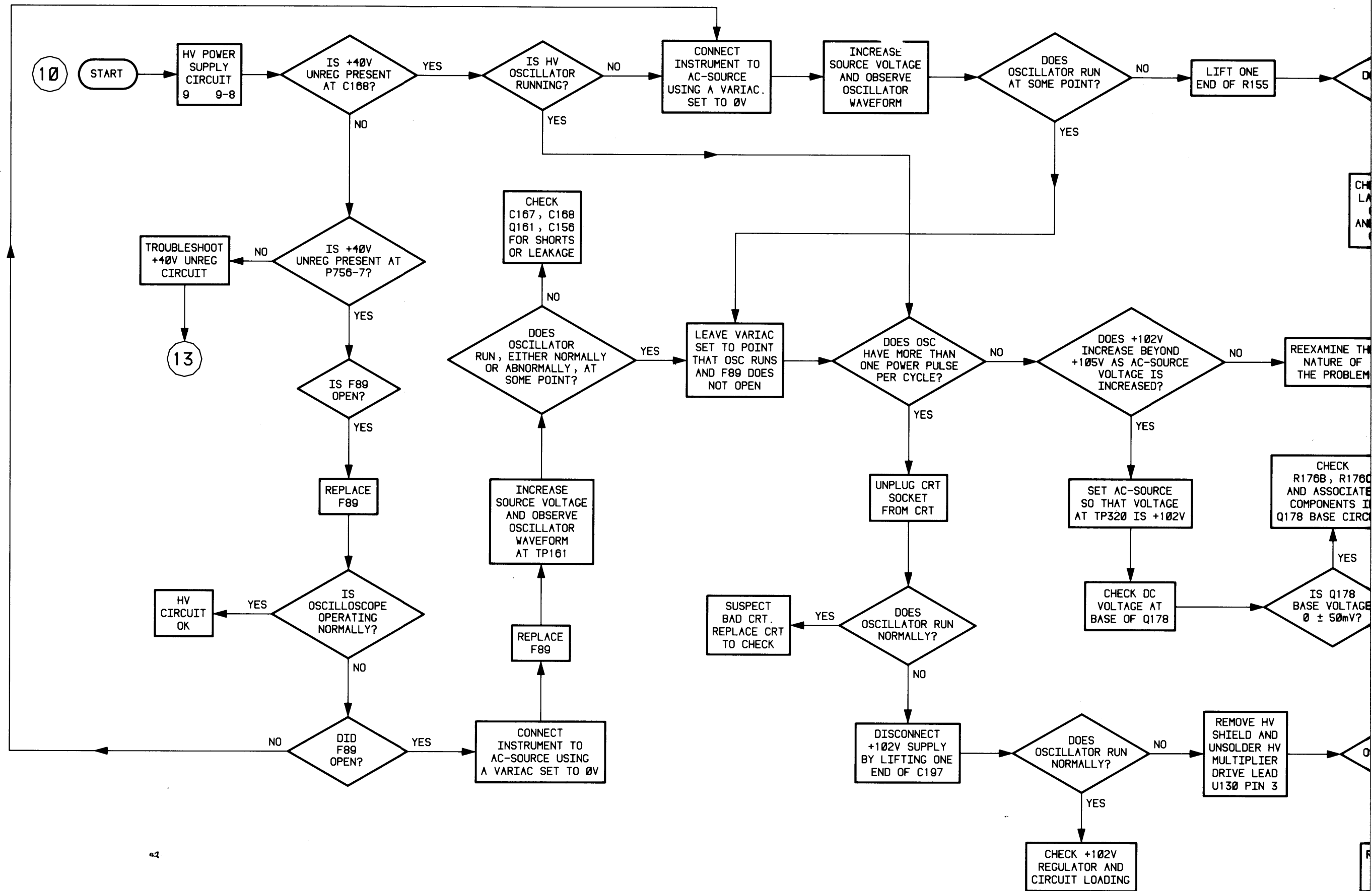

**GENERAL NOTES**

- A. Always set POWER switch to OFF before swapping, removing, or replacing components, and before connecting or disconnecting leads or cables.
- B. When analyzing circuit malfunctions, consider sockets and cables as possible causes of failure.

**SPECIFIC NOTES**

1. Set the instrument front-panel controls initially as follows:
- |                       |           |
|-----------------------|-----------|
| TRIG SOURCE           | VERT MODE |
| TRIG SLOPE            | +         |
| TRIG MODE             | AUTO      |
| VAR TIME              | In detent |
| A AND B SEC/DIV       | 1ms       |
| HORIZ MODE            | A         |
| CH 1 VOLTS/DIV        | 0.1V      |
| CH 1 AC-GND-DC        | DC        |
| VERTICAL MODE         | CH 1      |
| VERTICAL POSITION     | Midrange  |
| HORIZONTAL POSITION   | Midrange  |
| X10 MAG               | OFF       |
| INTENSITY             | Midrange  |
| B DELAY TIME POSITION | Fully CCW |

**GENERAL NOTES**

- A. Always set POWER switch to OFF before swapping, removing, or replacing components, and before connecting or disconnecting leads or cables.
- B. When analyzing circuit malfunctions, consider sockets and cables as possible causes of failure.

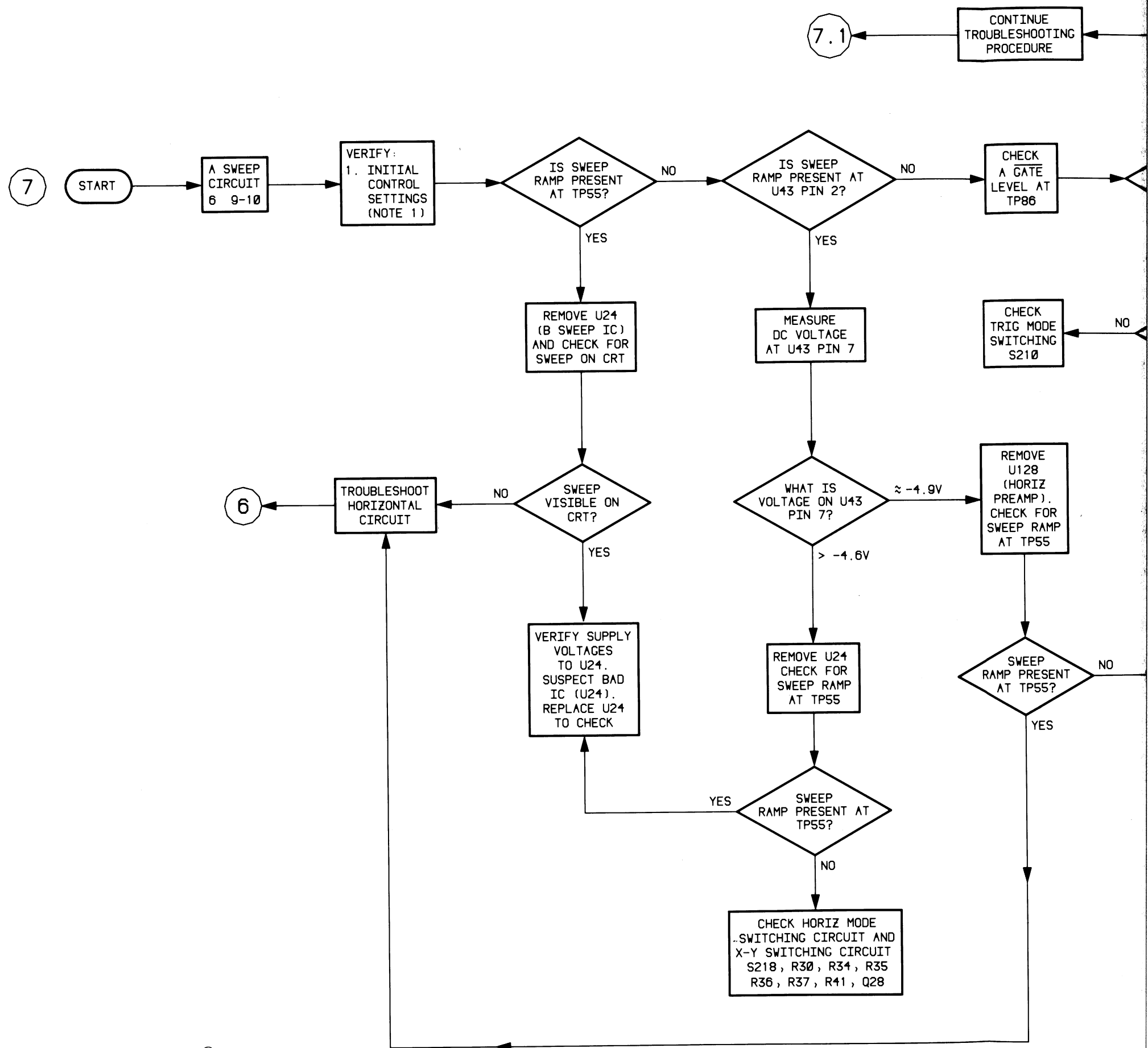

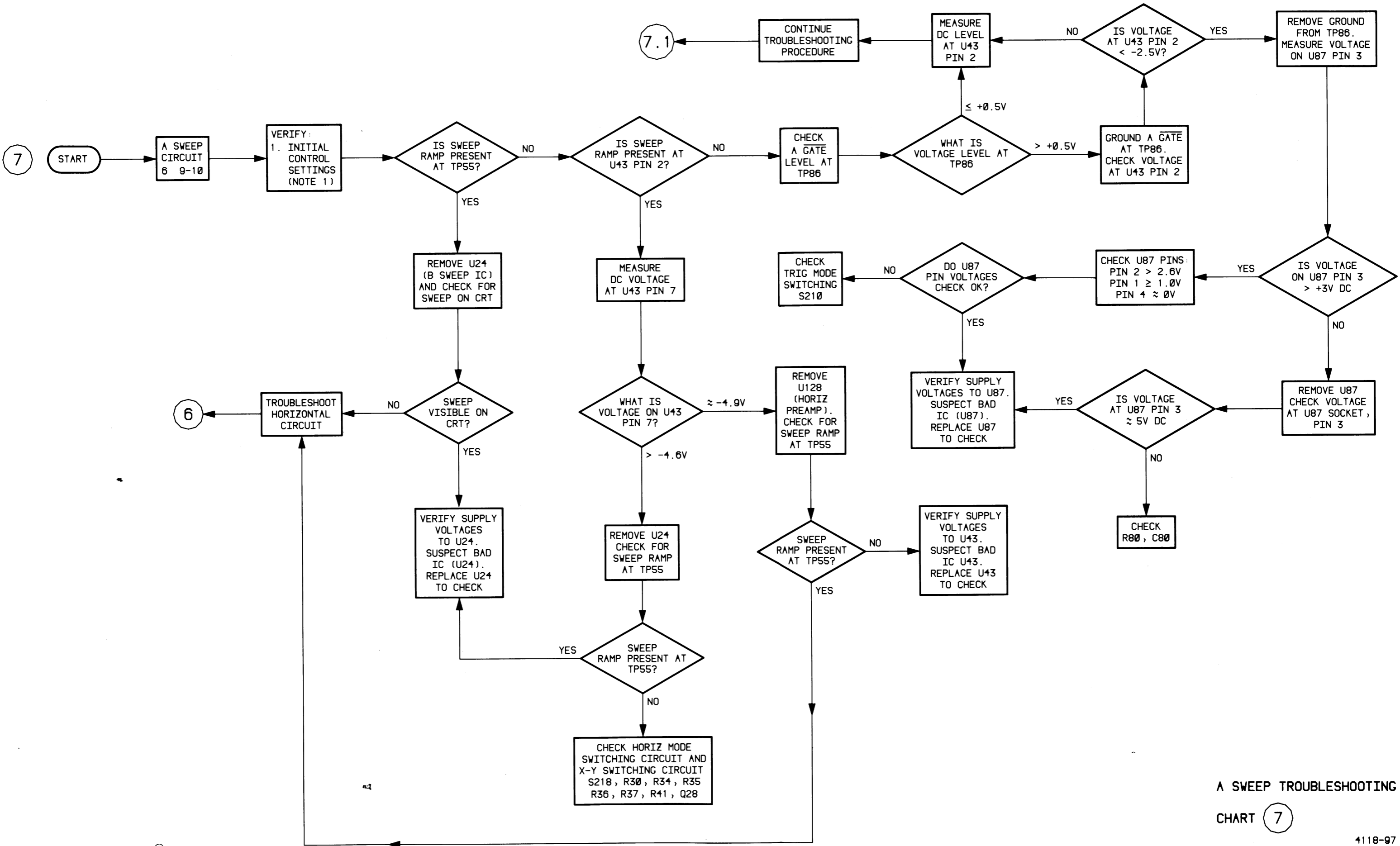

A SWEEP TROUBLESHOOTING CHART 7

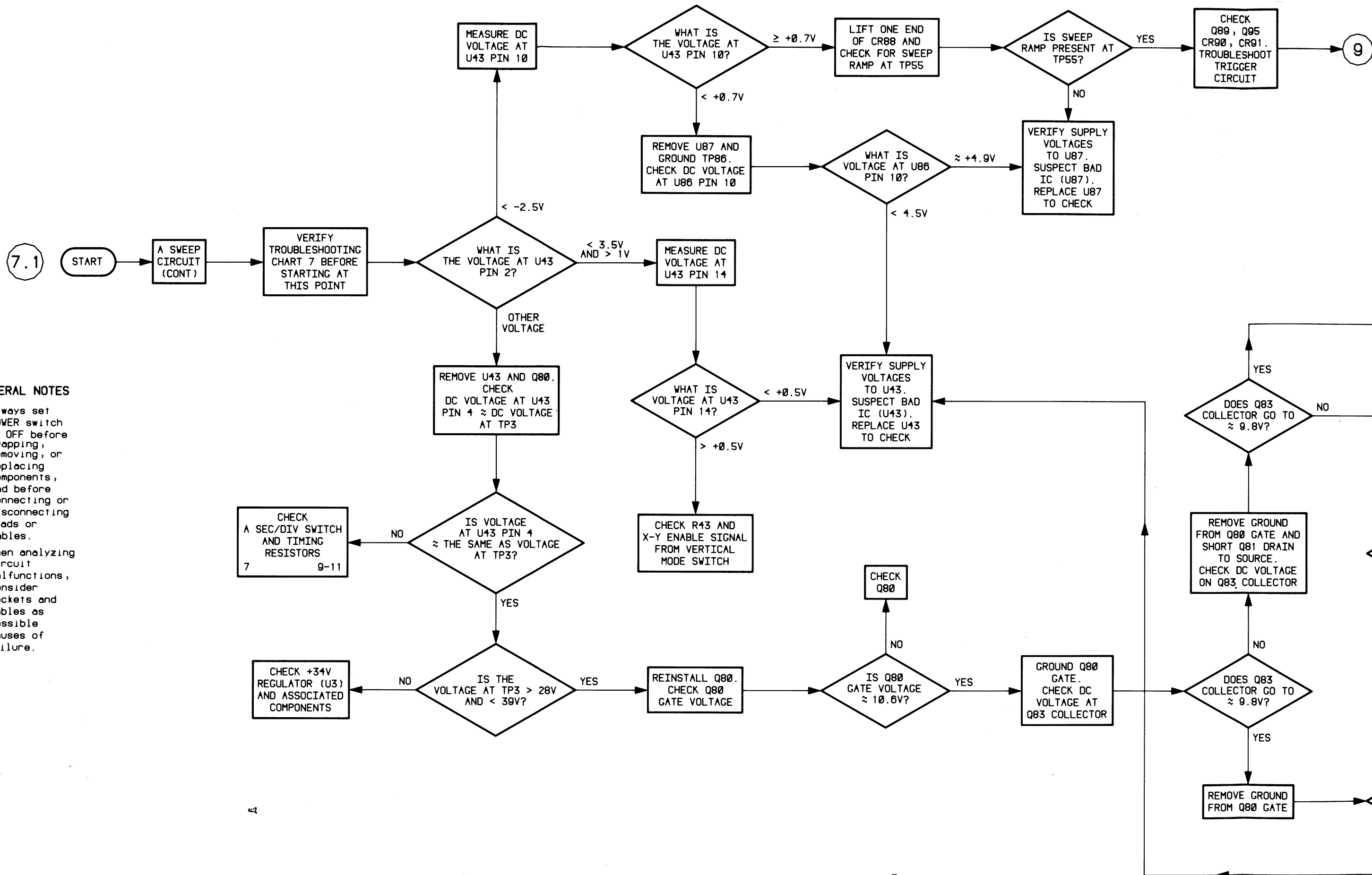

**GENERAL NOTES**

- A. Always set POWER switch to OFF before swapping, removing, or replacing components, and before connecting or disconnecting leads or cables.
- B. When analyzing circuit malfunctions, consider sockets and cables as possible causes of failure.



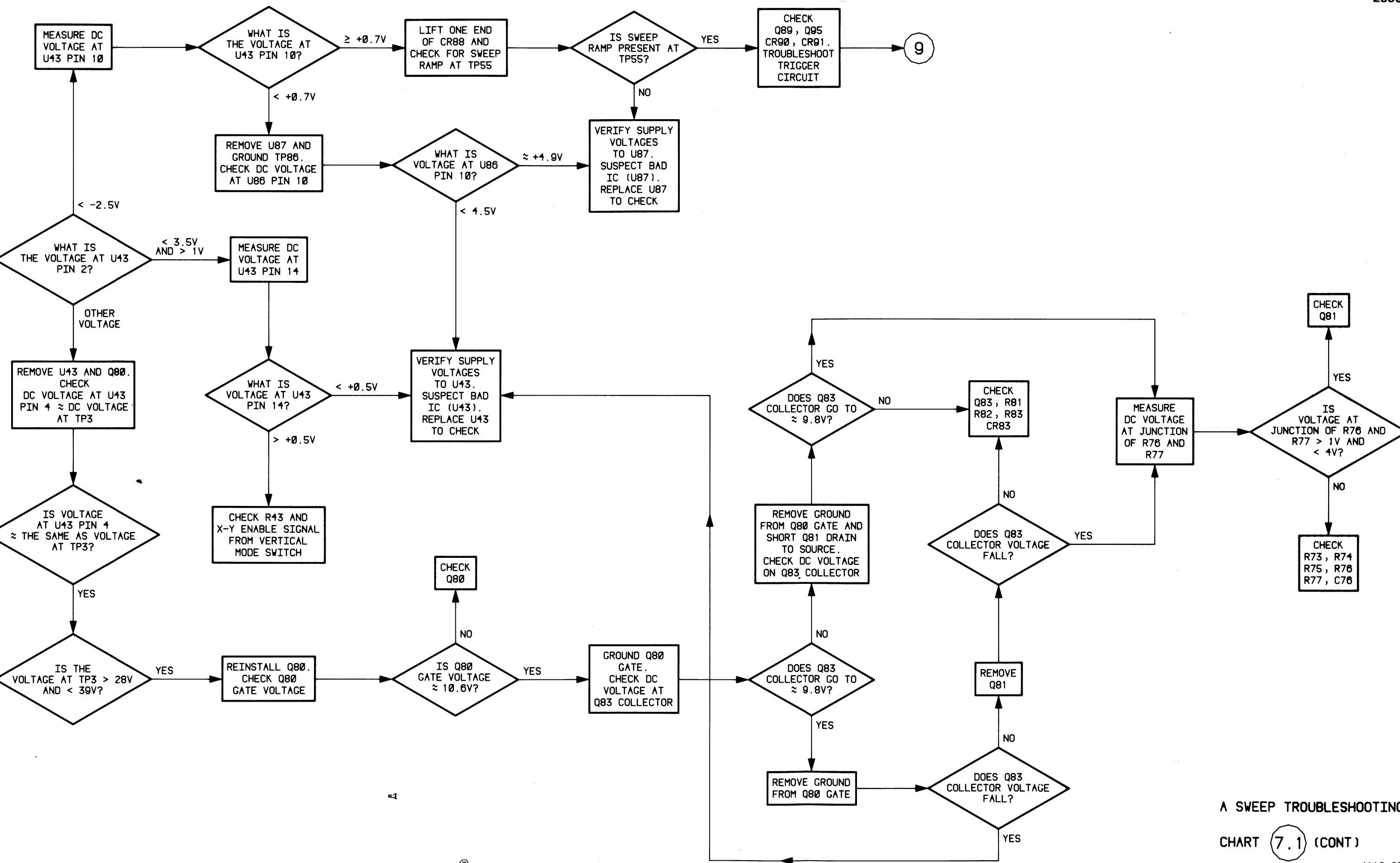

A SWEEP TROUBLESHOOTING CHART (7.1)

A SWEEP TROUBLESHOOTING CHART (7.1) (CONT)

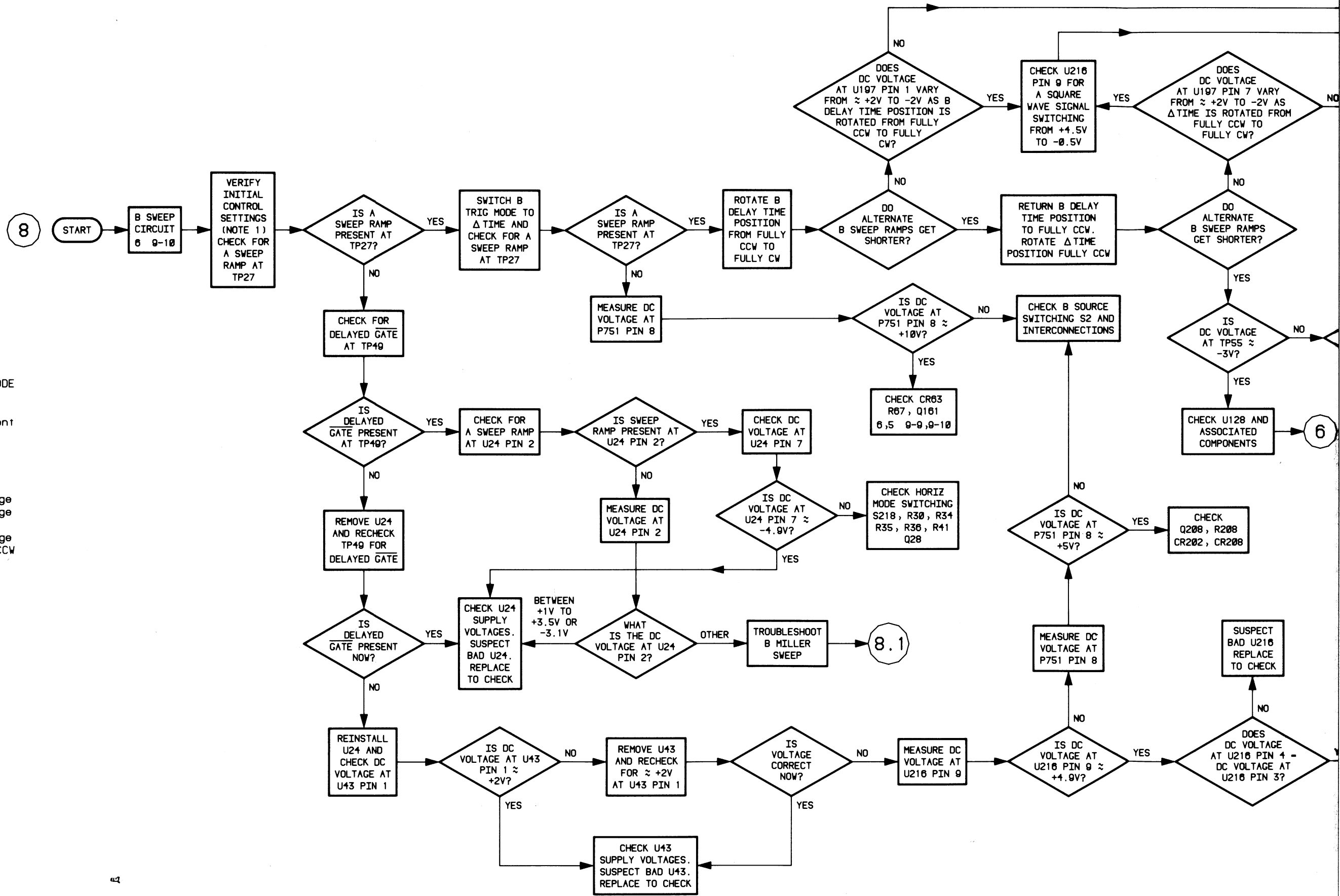

**SPECIFIC NOTES**

1. Set the instrument front-panel controls initially as follows:

TRIG SOURCE	VERT MODE
TRIG SLOPE	+
TRIG MODE	AUTO
VAR TIME	In detent
A AND B SEC/DIV	1ms
HORIZ MODE	A
CH 1 VOLTS/DIV	0.1V
CH 1 AC-GND-DC	DC
VERTICAL MODE	CH 1
VERTICAL POSITION	Midrange
HORIZONTAL POSITION	Midrange
X10 MAG	OFF
INTENSITY	Midrange
B DELAY TIME POSITION	Fully CCW

**GENERAL NOTES**

A. Always set POWER switch to OFF before swapping, removing, or replacing components, and before connecting or disconnecting leads or cables.

B. When analyzing circuit malfunctions, consider sockets and cables as possible causes of failure.



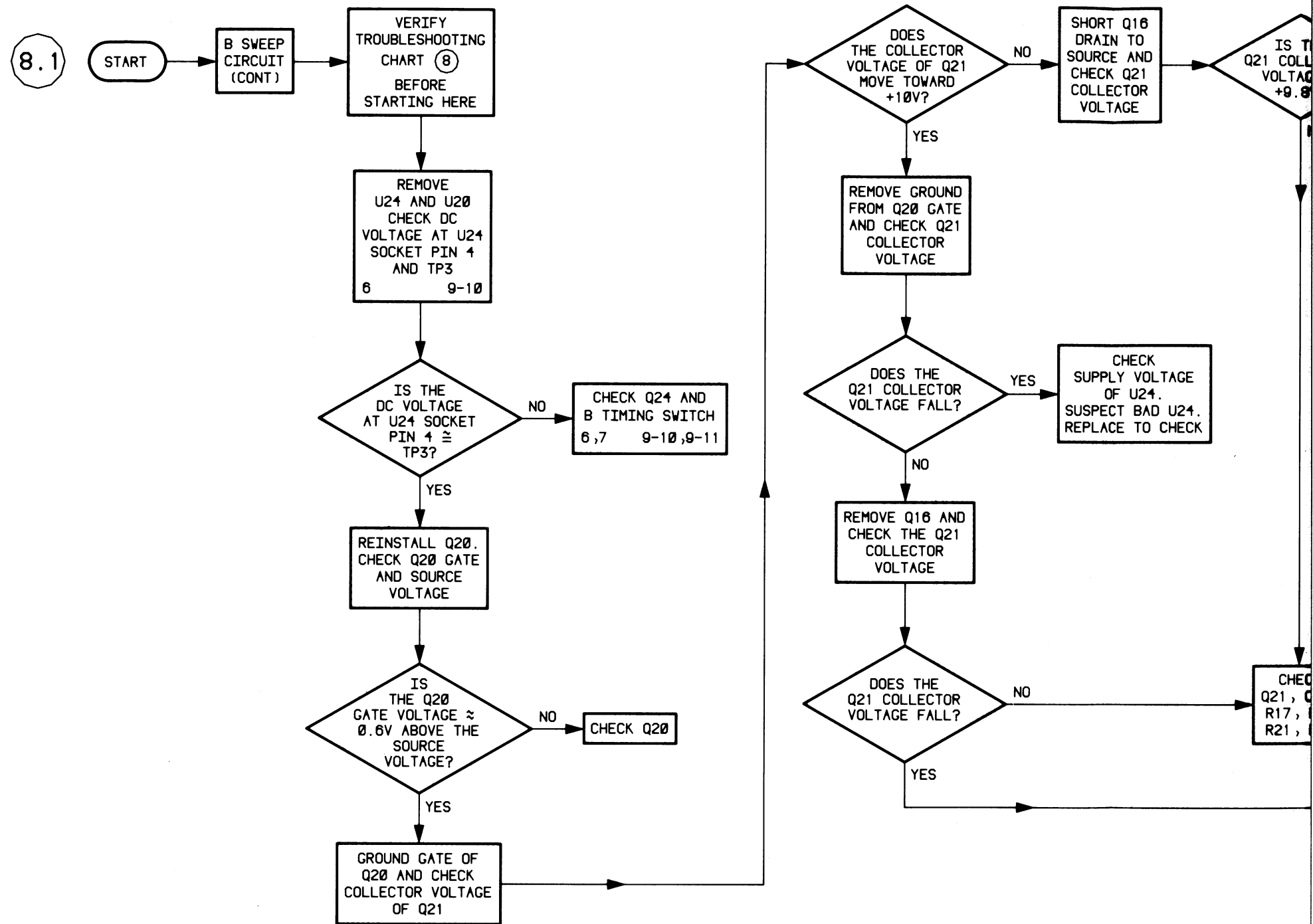

**GENERAL NOTES**

- A. Always set POWER switch to OFF before swapping, removing, or replacing components, and before connecting or disconnecting leads or cables.
- B. When analyzing circuit malfunctions, consider sockets and cables as possible causes of failure.

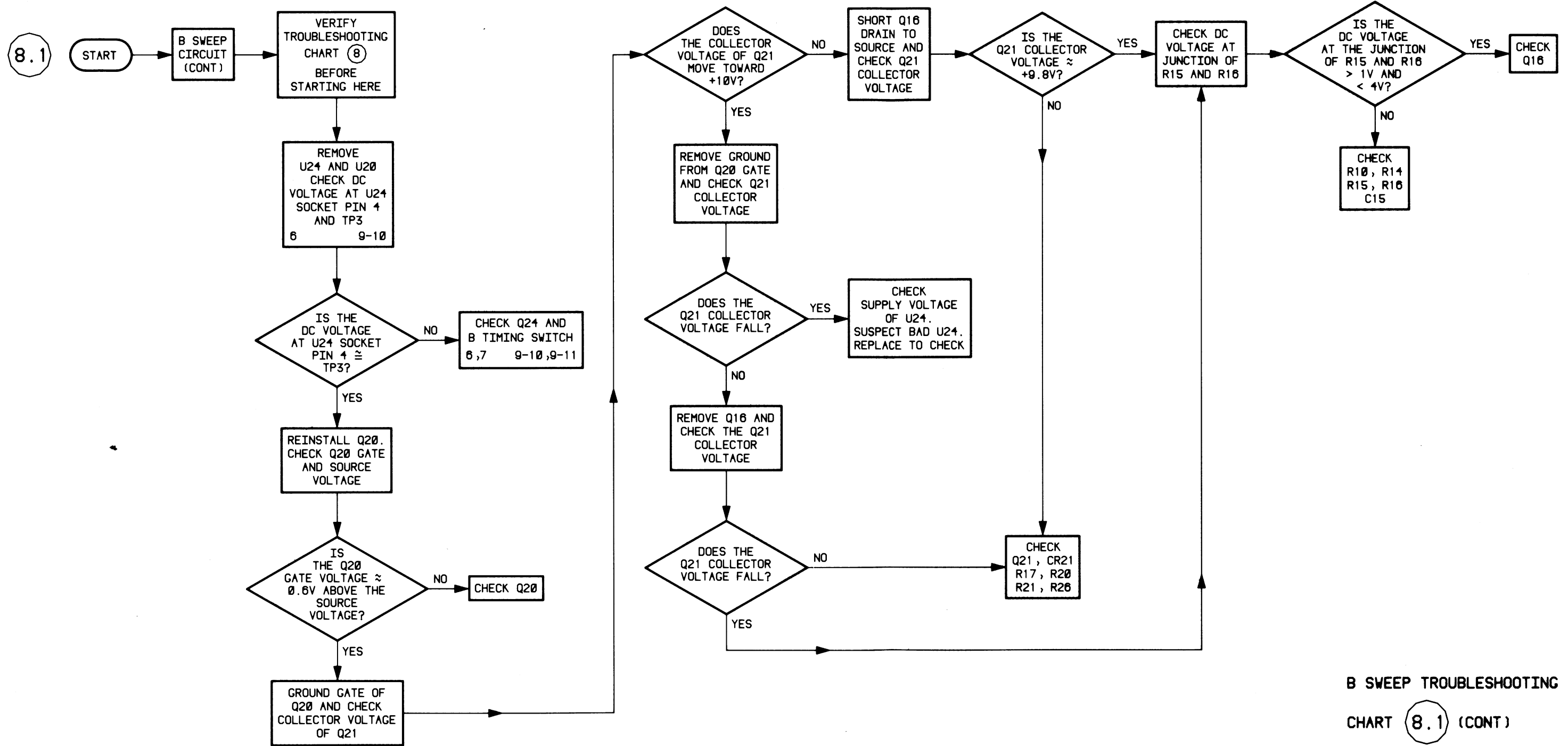

B SWEEP TROUBLESHOOTING CHART 8.1 (CONT)

9

START

TRIGGER CIRCUIT 5 9-9

VERIFY:  
1. LOW VOLTAGE POWER SUPPLIES WITHIN TOLERANCE (NOTE 1)  
2. INITIAL CONTROL SETTINGS (NOTE 2)

APPLY AMPL CAL SIGNAL TO CH 1 INPUT VIA 10X PROBE SET CH 1 AC-GND-DC TO AC

**SPECIFIC NOTES**

- Verify the power supplies at the following test points:

SUPPLY	TEST POINT	CIRCUIT BOARD AND FIGURE NO.
+40V	TP247	A10 (9-6)
+10V	TP252	A10 (9-6)
+5V	TP255	A10 (9-6)
-10V	TP265	A10 (9-6)
-5V	TP262	A10 (9-6)
+102V	TP320	A15 (9-7)

Power supply isolation procedure is described adjacent to the Power Distribution diagram in this manual.

- Set the instrument front-panel controls initially as follows:

TRIG SOURCE	VERT MODE
TRIG SLOPE	+
TRIG MODE	AUTO
VAR TIME	In detent
A AND B SEC/DIV	1ms
HORIZ MODE	A
CH 1 VOLTS/DIV	0.1V
CH 1 AC-GND-DC	DC
VERTICAL MODE	CH 1
VERTICAL POSITION	Midrange
HORIZONTAL POSITION	Midrange
X10 MAG	OFF
INTENSITY	Midrange
B DELAY TIME POSITION	Fully CCW

**GENERAL NOTES**

- Always set POWER switch to OFF before swapping, removing, or replacing components, and before connecting or disconnecting leads or cables.
- When analyzing circuit malfunctions, consider sockets and cables as possible causes of failure.

7

SEE A SWEEP TROUBLESHOOTING CHART

IS SWEEP PRESENT IN AUTO TRIGGER MODE?

VERIFY A SEC/DIV SET TO 1 ms/DIV

CHECK DC VOLTAGE AT J876 PIN 13

CHECK CR346 CR347 R347 C347

IS +10V PRESENT AT J876 PIN 13?

CHECK A SEC/DIV SWITCHING 7 9-11

CHECK FOR HOLDOFF RAMP ON TP89 6 9-9

IS HOLDOFF RAMP PRESENT ON TP89?

SUSPECT BAD U87. REPLACE U87 TO CHECK

IS A RESET GATE PRESENT AT TP106?

CHECK FOR A RESET GATE AT TP106

CHECK TRIGGER SIGNAL OUTPUT AT U30 PIN 16 2 9-7

IS TRIGGER SIGNAL PRESENT AT P732 PIN 2?

CHECK HF SOURCE AND COUPLING SWITCHING C63, R56A THROUGH 0

CHECK FOR A RESET GATE AT U81 PIN 17 5 9-9

CHECK Q104, R103 R104, R106 R107 5,6 9-9,9-10

IS A RESET GATE PRESENT AT U81 PIN 17?

CHECK DC VOLTAGE ON U81 PIN 4 - 0V TO 0.2V PIN 3, 7, 1, & 5 - -2V TO -3V

CHECK SOURCE AND COUPLING SWITCHING AND R56A THROUGH 0

DO U81 PIN VOLTAGES CHECK OK?

IS HF TRIGGER SIGNAL PRESENT AT U81 PIN 3?

CHECK FOR HF TRIGGER SIGNAL AT U81 PIN 3

CHECK FOR LF TRIGGER SIGNAL AT U81 PIN 19

IS LF TRIGGER SIGNAL PRESENT AT U81 PIN 14?

VARY LEVEL CONTROL CHECK FOR DC COUPLING AT U81 PIN 14

CHECK LF SOURCE AND COUPLING SWITCHING AND ASSOCIATED COMPONENTS

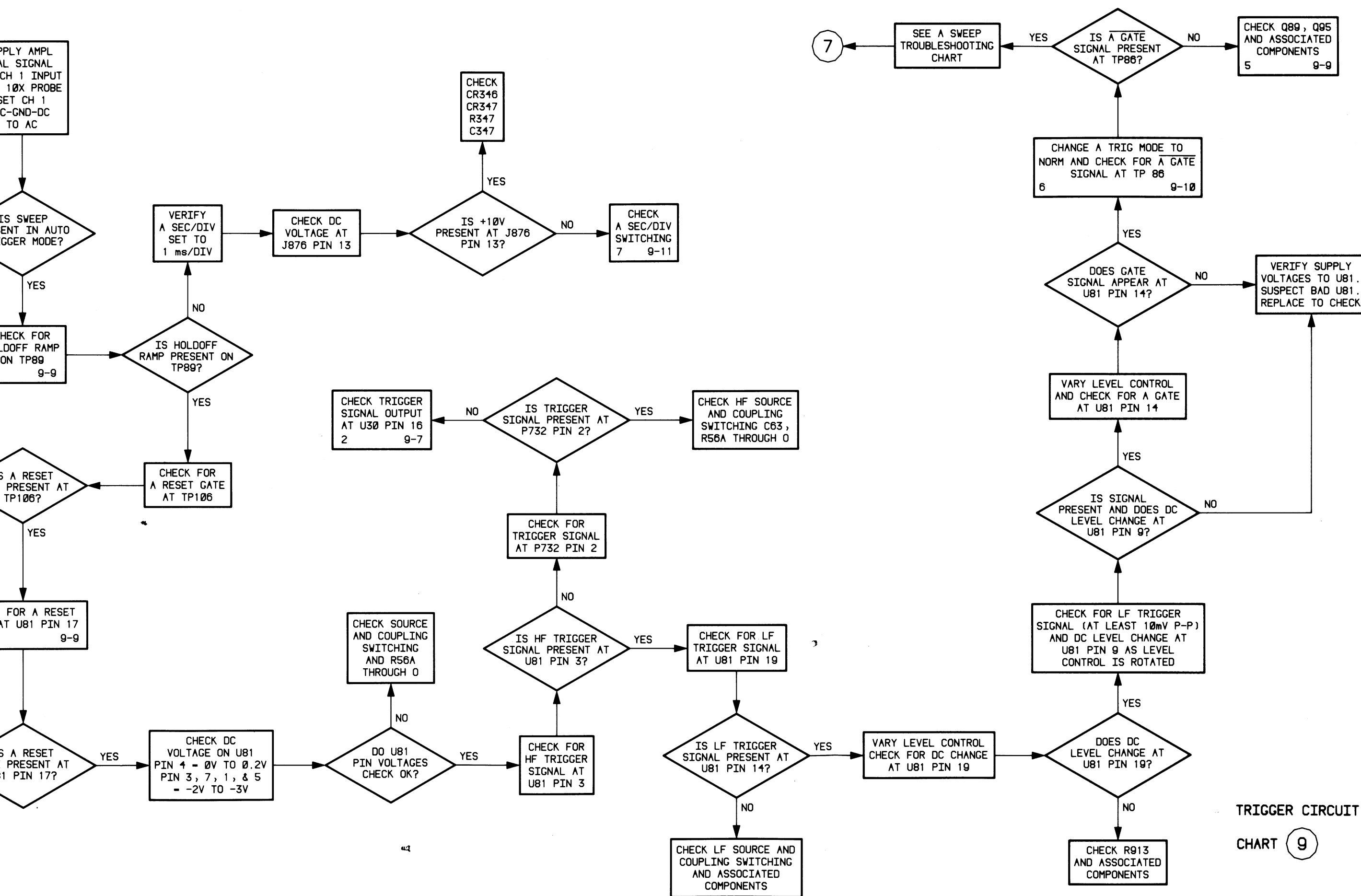

TRIGGER CIRCUIT TROUBLESHOOTING CHART 9

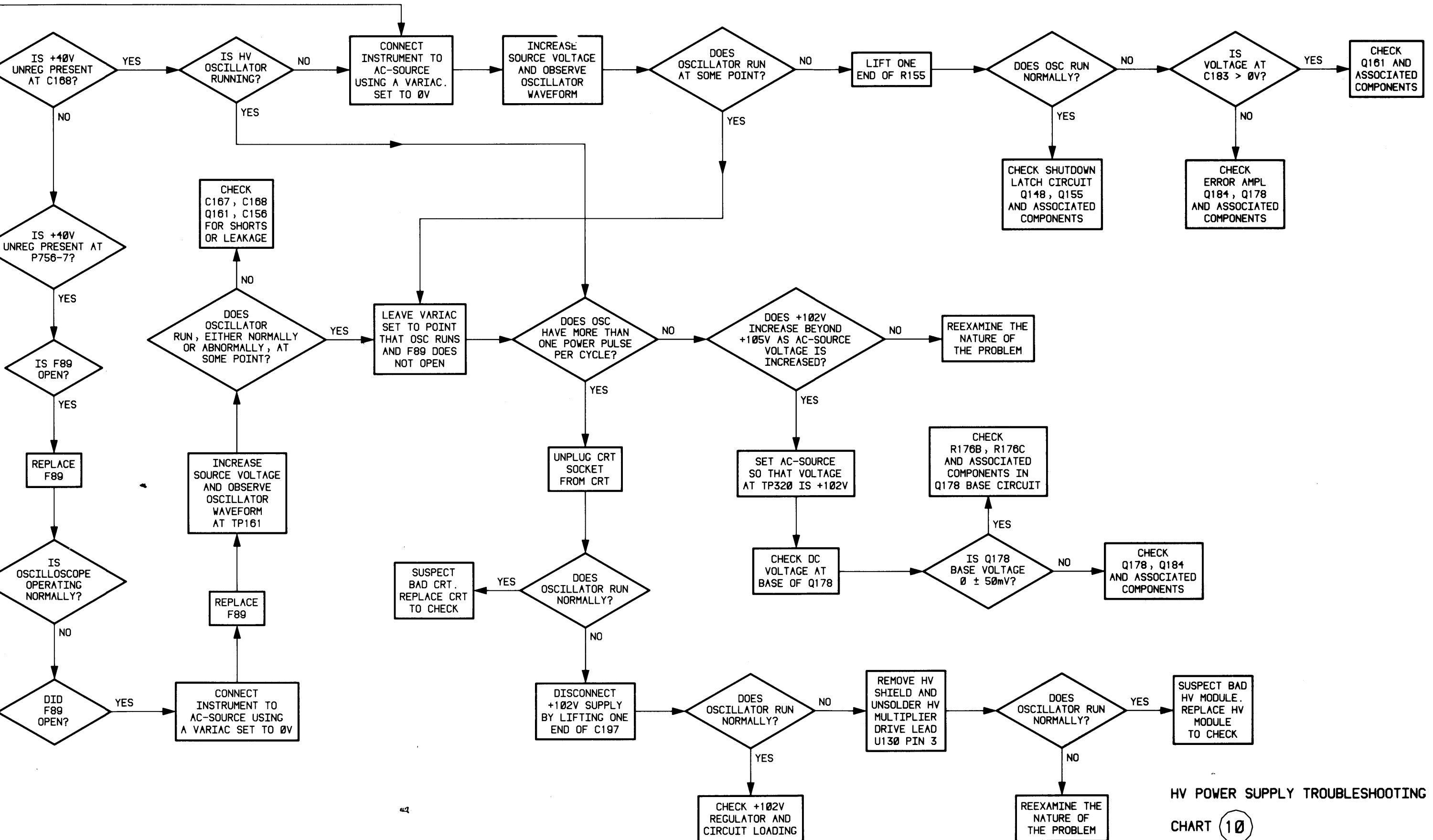

 HV POWER SUPPLY TROUBLESHOOTING  
 CHART 10

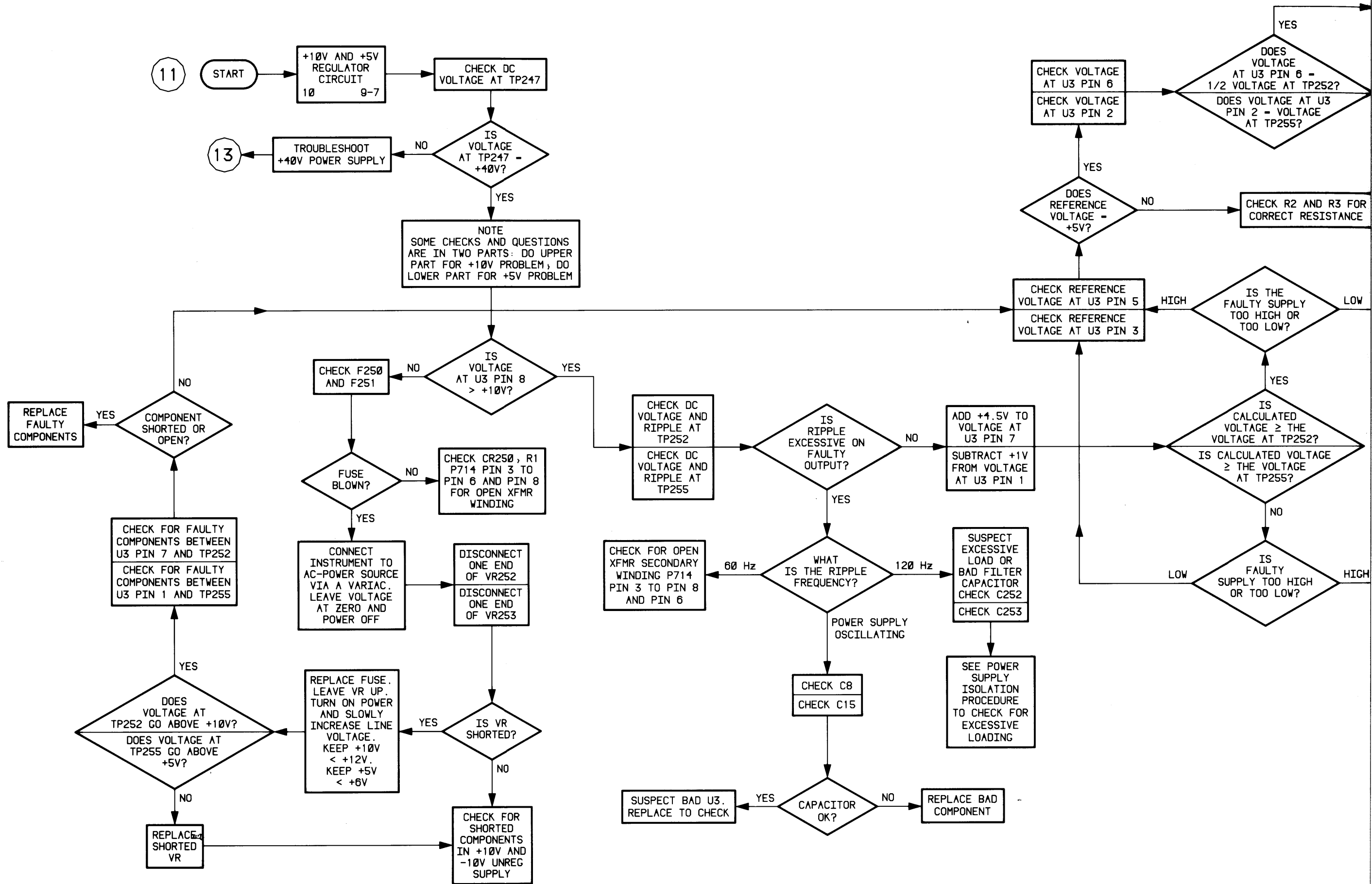

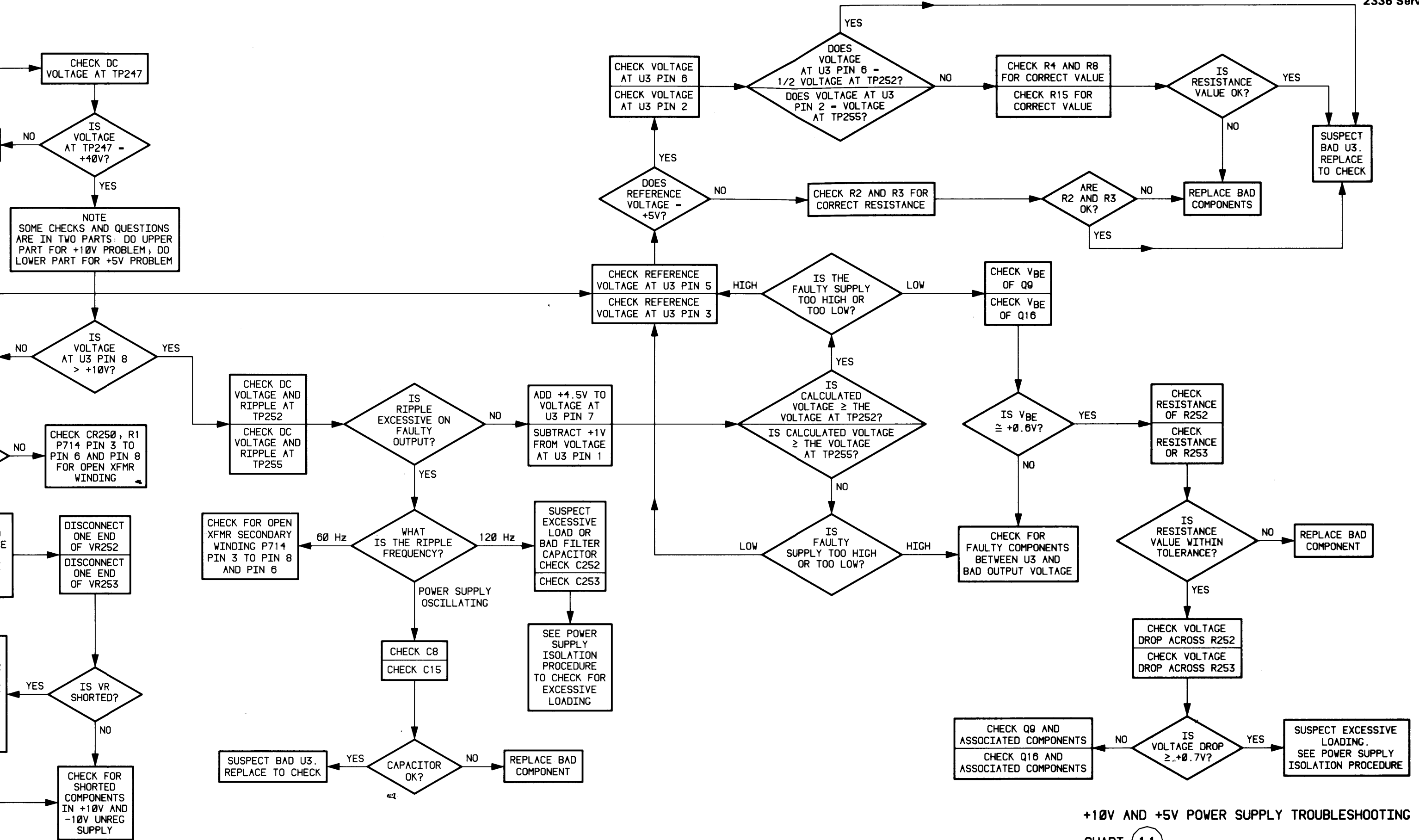

**GENERAL NOTES**

- A. Always set POWER switch to OFF before swapping, removing, or replacing components, and before connecting or disconnecting leads or cables.
- B. When analyzing circuit malfunctions, consider sockets and cables as possible causes of failure.
- C. The power supply isolation procedure is described adjacent to the Power Distribution diagram in this manual.



+10V AND +5V POWER SUPPLY TROUBLESHOOTING CHART (11)

+10V AND +5V POWER SUPPLY TROUBLESHOOTING CHART (11)

**GENERAL NOTES**

- A. Always set POWER switch to OFF before swapping, removing, or replacing components, and before connecting or disconnecting leads or cables.
- B. When analyzing circuit malfunctions, consider sockets and cables as possible causes of failure.

- C. The power supply isolation procedure is described adjacent to the Power Distribution diagram in this manual.

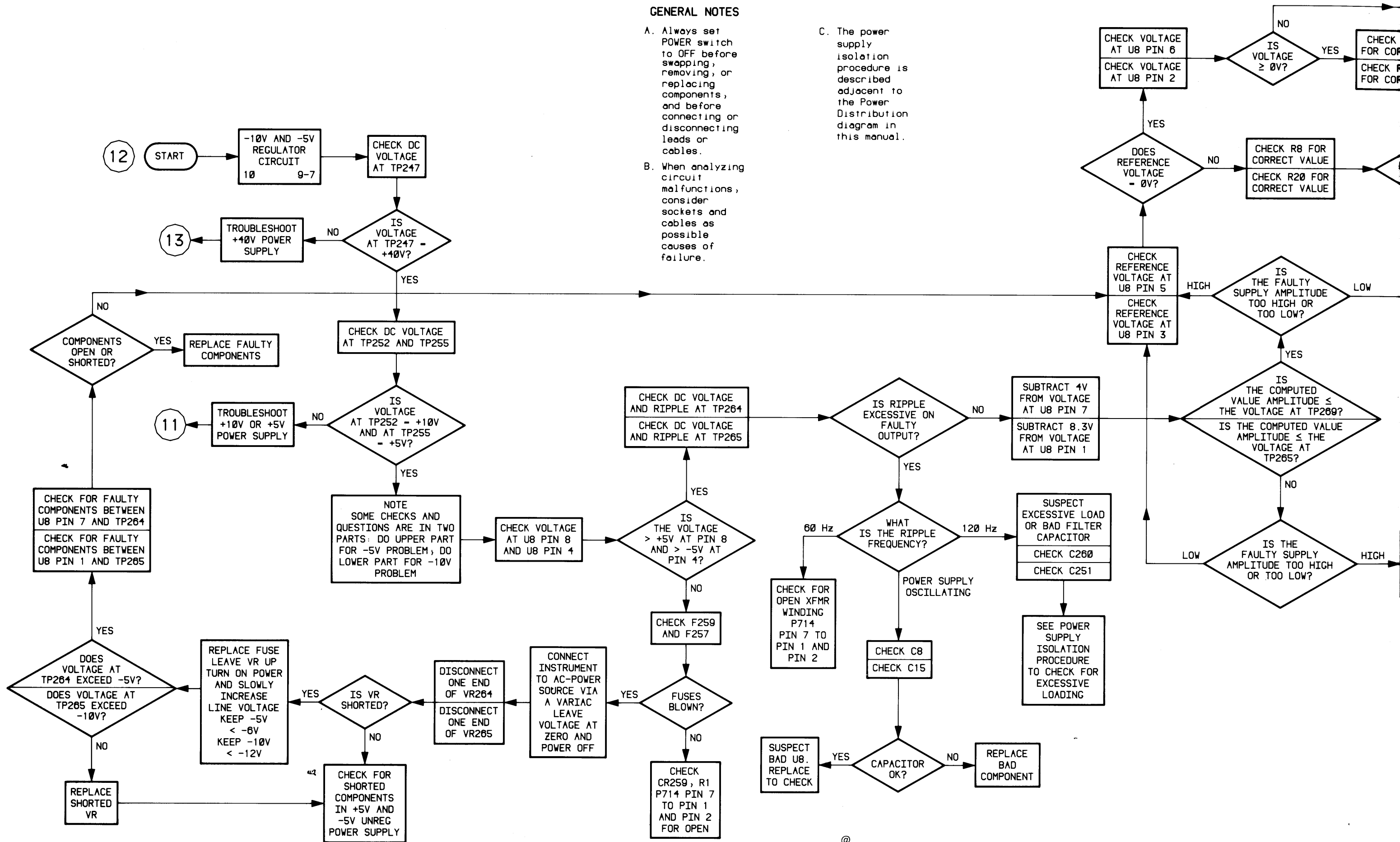

**GENERAL NOTES**

- A. Always set POWER switch to OFF before swapping, removing, or replacing components, and before connecting or disconnecting leads or cables.
- B. When analyzing circuit malfunctions, consider sockets and cables as possible causes of failure.

C. The power supply isolation procedure is described adjacent to the Power Distribution diagram in this manual.

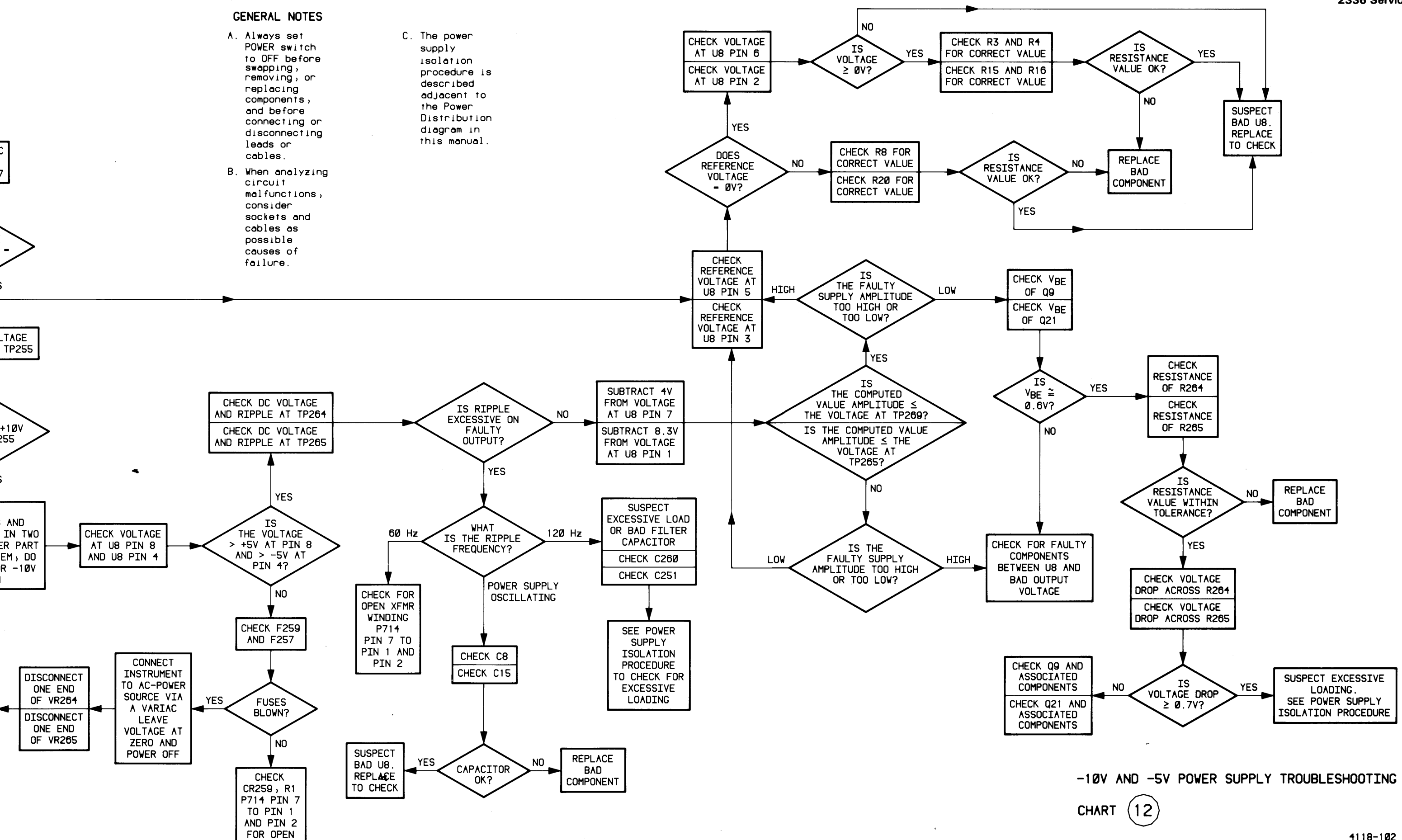

-10V AND -5V POWER SUPPLY TROUBLESHOOTING  
CHART 12

-10V AND -5V POWER SUPPLY TROUBLESHOOTING CHART 12

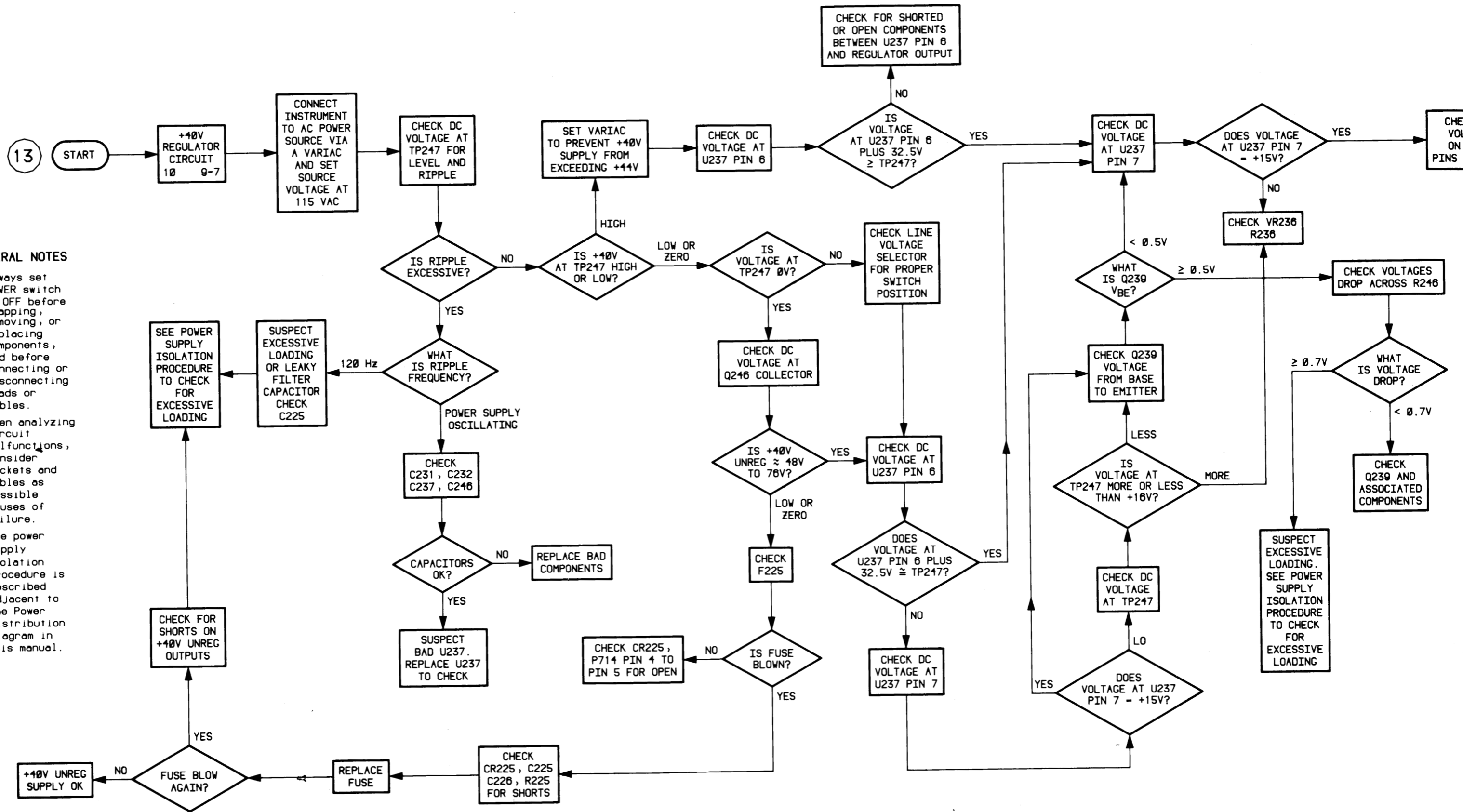

**GENERAL NOTES**

- A. Always set POWER switch to OFF before swapping, removing, or replacing components, and before connecting or disconnecting leads or cables.
- B. When analyzing circuit malfunctions, consider sockets and cables as possible causes of failure.
- C. The power supply isolation procedure is described adjacent to the Power Distribution diagram in this manual.

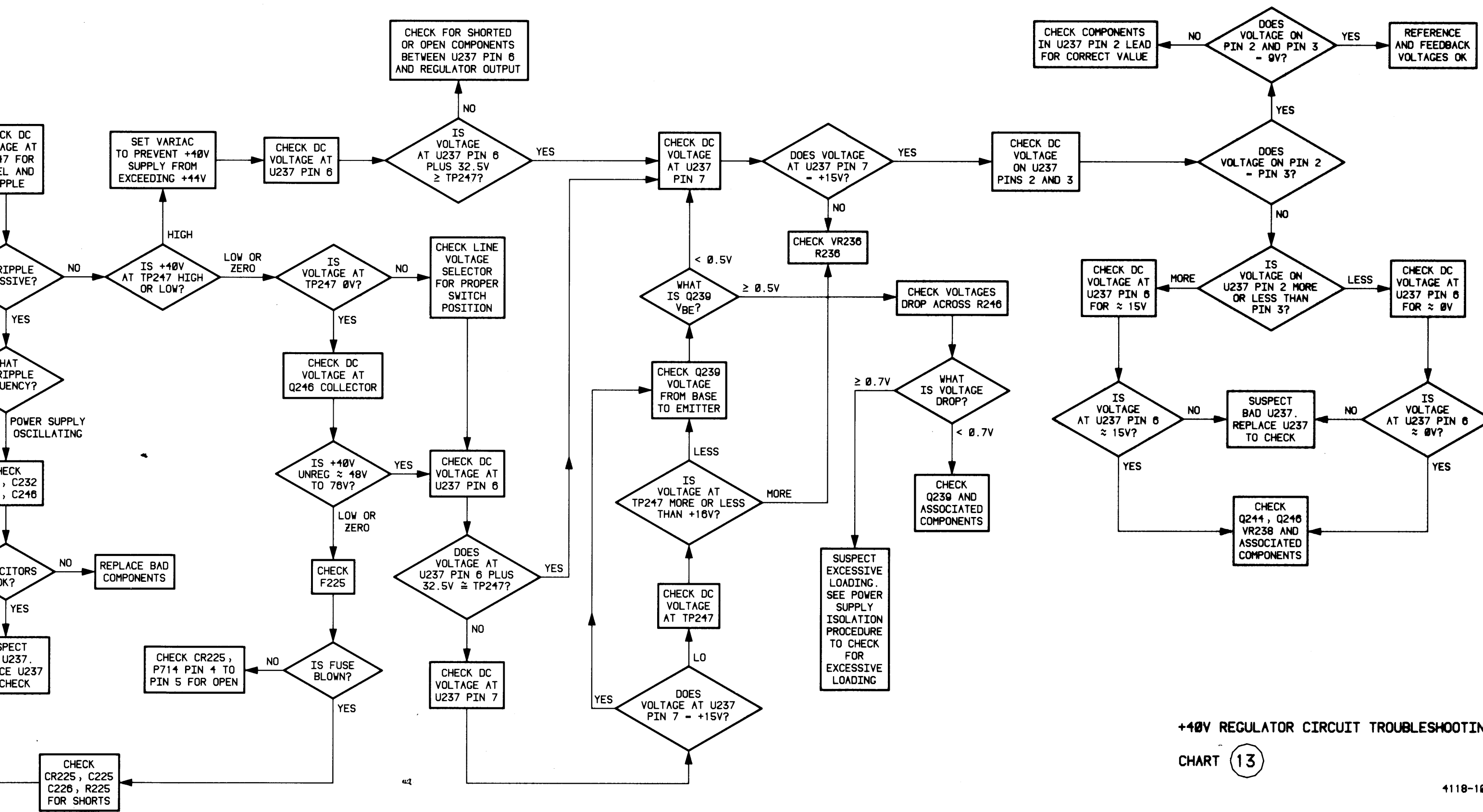

**+40V REGULATOR CIRCUIT TROUBLESHOOTING**  
**CHART 13**

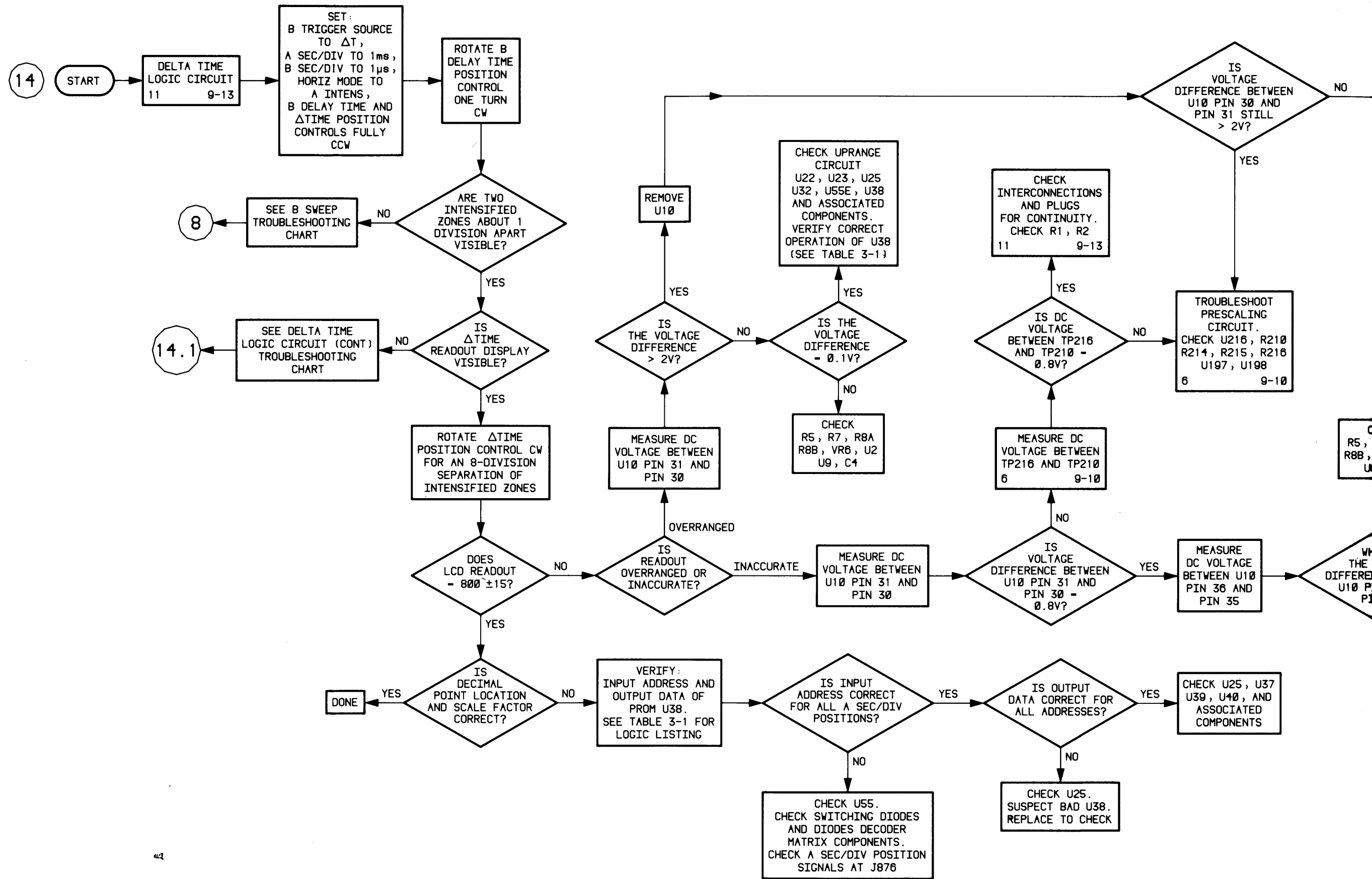

**GENERAL NOTES**

- A. Always set POWER switch to OFF before swapping, removing, or replacing components, and before connecting or disconnecting leads or cables.
- B. When analyzing circuit malfunctions, consider sockets and cables as possible causes of failure.

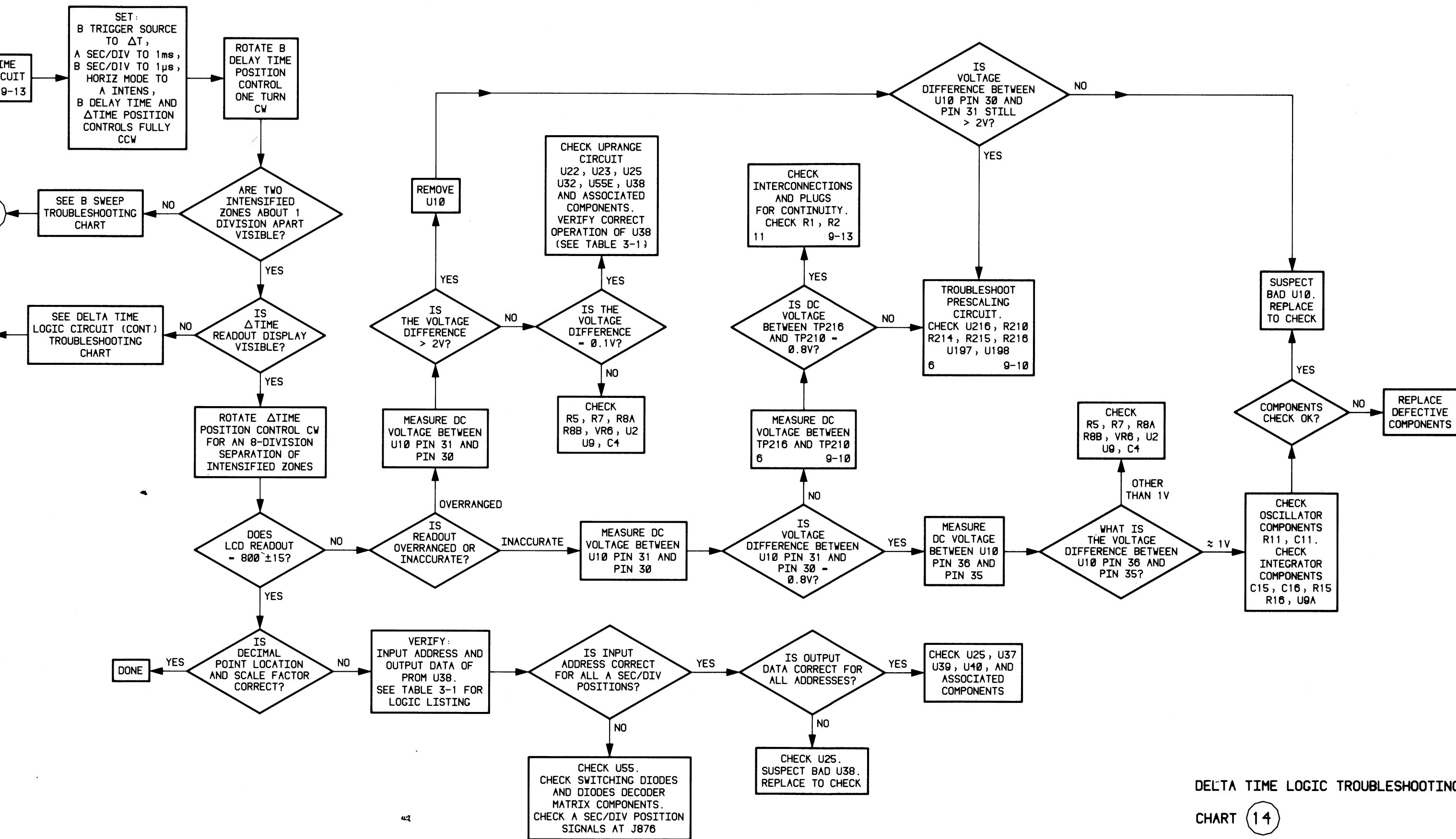

DELTA TIME LOGIC TROUBLESHOOTING CHART 14



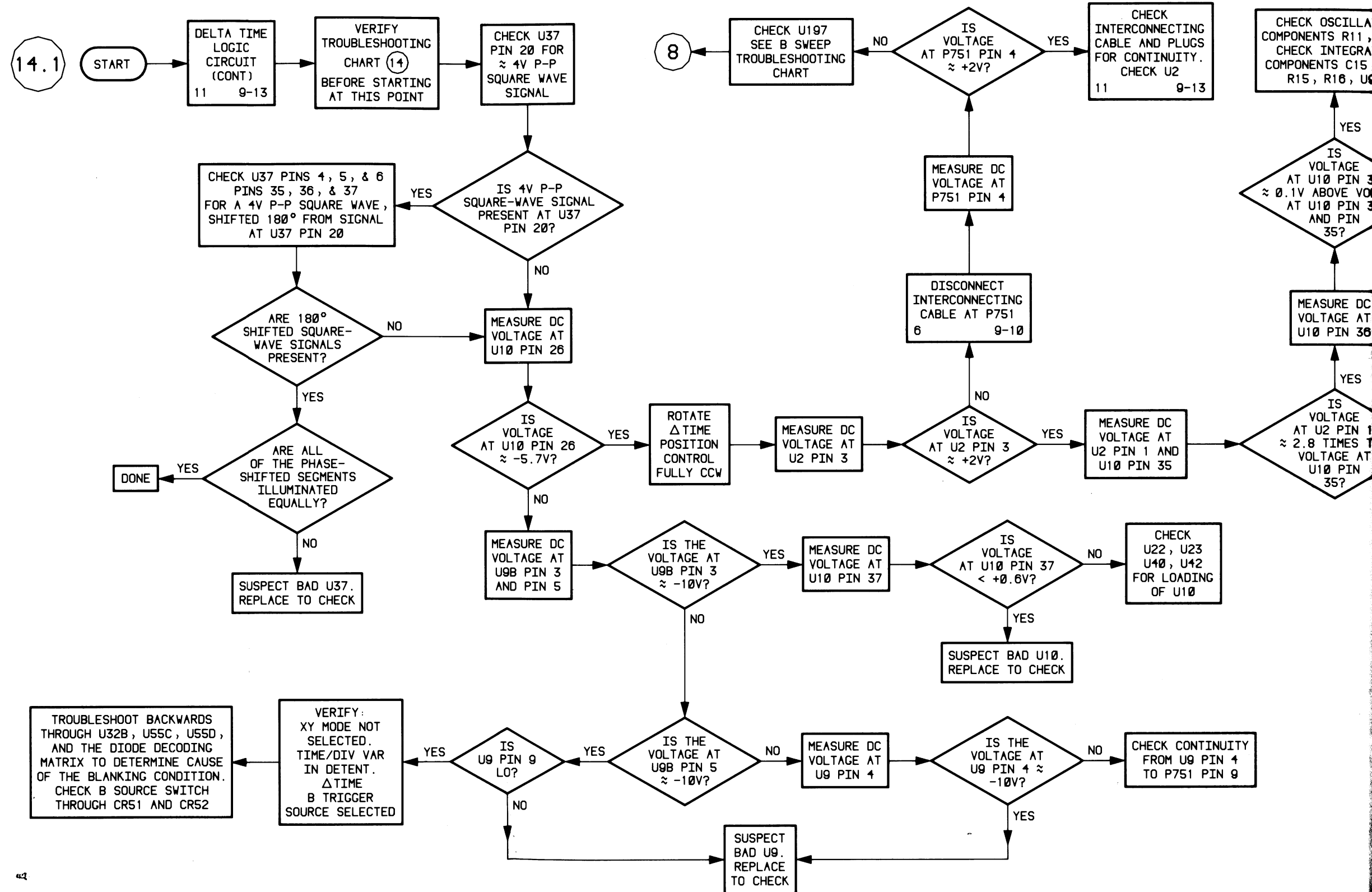

**GENERAL NOTES**

- A. Always set POWER switch to OFF before swapping, removing, or replacing components, and before connecting or disconnecting leads or cables.
- B. When analyzing circuit malfunctions, consider sockets and cables as possible causes of failure.

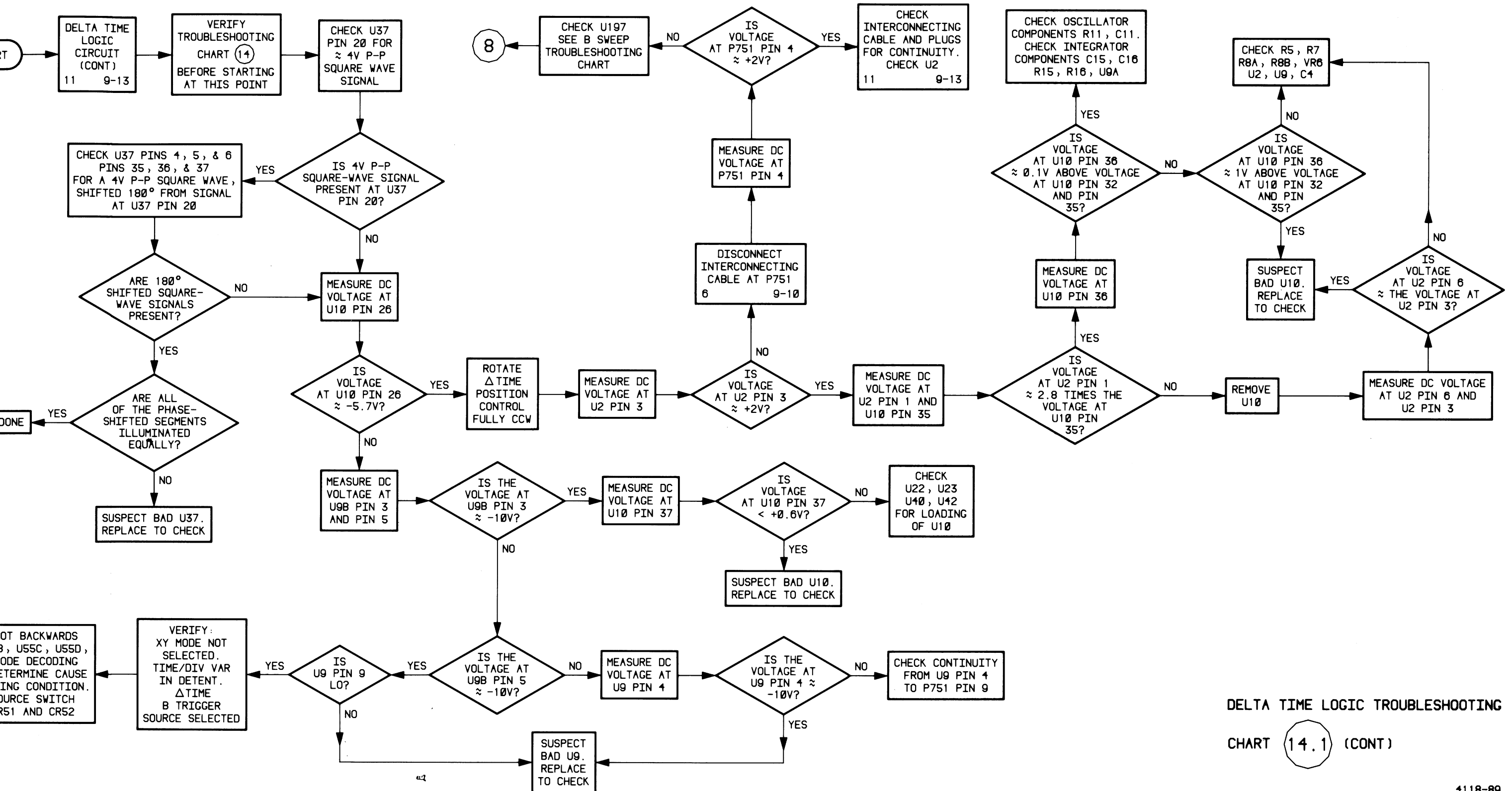

DELTA TIME LOGIC TROUBLESHOOTING

CHART (14.1) (CONT)

# REPLACEABLE MECHANICAL PARTS

## PARTS ORDERING INFORMATION

Replacement parts are available from or through your local Tektronix, Inc. Field Office or representative.

Changes to Tektronix instruments are sometimes made to accommodate improved components as they become available, and to give you the benefit of the latest circuit improvements developed in our engineering department. It is therefore important, when ordering parts, to include the following information in your order: Part number, instrument type or number, serial number, and modification number if applicable.

If a part you have ordered has been replaced with a new or improved part, your local Tektronix, Inc. Field Office or representative will contact you concerning any change in part number.

Change information, if any, is located at the rear of this manual.

## SPECIAL NOTES AND SYMBOLS

X000 Part first added at this serial number  
00X Part removed after this serial number

## FIGURE AND INDEX NUMBERS

Items in this section are referenced by figure and index numbers to the illustrations.

## INDENTATION SYSTEM

This mechanical parts list is indented to indicate item relationships. Following is an example of the indentation system used in the description column.

```

1 2 3 4 5           Name & Description
Assembly and/or Component
Attaching parts for Assembly and/or Component
    - - - * - - -
Detail Part of Assembly and/or Component
Attaching parts for Detail Part
    - - - * - - -
Parts of Detail Part
Attaching parts for Parts of Detail Part
    - - - * - - -
  
```

Attaching Parts always appear in the same indentation as the item it mounts, while the detail parts are indented to the right. Indented items are part of, and included with, the next higher indentation. The separation symbol - - - \* - - - indicates the end of attaching parts.

**Attaching parts must be purchased separately, unless otherwise specified.**

## ITEM NAME

In the Parts List, an Item Name is separated from the description by a colon (:). Because of space limitations, an Item Name may sometimes appear as incomplete. For further Item Name identification, the U.S. Federal Cataloging Handbook H6-1 can be utilized where possible.

## ABBREVIATIONS

"	INCH	ELCTRN	ELECTRON	IN	INCH	SE	SINGLE END
#	NUMBER SIZE	ELEC	ELECTRICAL	INCAND	INCANDESCENT	SECT	SECTION
ACTR	ACTUATOR	ELCTLT	ELECTROLYTIC	INSUL	INSULATOR	SEMICOND	SEMICONDUCTOR
ADPTR	ADAPTER	ELEM	ELEMENT	INTL	INTERNAL	SHLD	SHIELD
ALIGN	ALIGNMENT	EPL	ELECTRICAL PARTS LIST	LPHLDR	LAMPHOLDER	SHLDR	SHOULDERED
AL	ALUMINUM	EQPT	EQUIPMENT	MACH	MACHINE	SKT	SOCKET
ASSEM	ASSEMBLED	EXT	EXTERNAL	MECH	MECHANICAL	SL	SLIDE
ASSY	ASSEMBLY	FIL	FILLISTER HEAD	MTG	MOUNTING	SLFLKKG	SELF-LOCKING
ATTEN	ATTENUATOR	FLEX	FLEXIBLE	NIP	NIPPLE	SLVG	SLEEVING
AWG	AMERICAN WIRE GAGE	FLH	FLAT HEAD	NON WIRE	NOT WIRE WOUND	SPR	SPRING
BD	BOARD	FLTR	FILTER	OBD	ORDER BY DESCRIPTION	SO	SQUARE
BRKT	BRACKET	FR	FRAME or FRONT	OD	OUTSIDE DIAMETER	SST	STAINLESS STEEL
BRS	BRASS	FSTNR	FASTENER	OVH	OVAL HEAD	STL	STEEL
BRZ	BRONZE	FT	FOOT	PH BRZ	PHOSPHOR BRONZE	SW	SWITCH
BSHG	BUSHING	FXD	FIXED	PL	PLAIN or PLATE	T	TUBE
CAB	CABINET	GSKT	GASKET	PLSTC	PLASTIC	TERM	TERMINAL
CAP	CAPACITOR	HDL	HANDLE	PN	PART NUMBER	THD	THREAD
CER	CERAMIC	HEX	HEXAGON	PNH	PAN HEAD	THK	THICK
CHAS	CHASSIS	HEX HD	HEXAGONAL HEAD	PWR	POWER	TNSN	TENSION
CKT	CIRCUIT	HEX SOC	HEXAGONAL SOCKET	RCPT	RECEPTACLE	TPG	TAPPING
COMP	COMPOSITION	HLCPS	HELICAL COMPRESSION	RES	RESISTOR	TRH	TRUSS HEAD
CONN	CONNECTOR	HLEXT	HELICAL EXTENSION	RGD	RIGID	V	VOLTAGE
COV	COVER	HV	HIGH VOLTAGE	RLF	RELIEF	VAR	VARIABLE
CPLG	COUPLING	IC	INTEGRATED CIRCUIT	RTNR	RETAINER	W/	WITH
CRT	CATHODE RAY TUBE	ID	INSIDE DIAMETER	SCH	SOCKET HEAD	WSHR	WASHER
DEG	DEGREE	IDNT	IDENTIFICATION	SCOPE	OSCILLOSCOPE	XFMR	TRANSFORMER
DWR	DRAWER	IMPLR	IMPELLER	SCR	SCREW	XSTR	TRANSISTOR

CROSS INDEX—MFR. CODE NUMBER TO MANUFACTURER

Mfr. Code	Manufacturer	Address	City, State, Zip
S3629	PANEL COMPONENTS CORP.	2015 SECOND ST.	BERKELEY, CA 94170
000AQ	CONNOR SPRING & MFG. COMPANY	1426 SE 6TH	PORTLAND, OR 97214
000DW	CURRAN COIL SPRING, INC.	635 NW 16TH AVENUE	PORTLAND, OR 97210
000EO	ZEPHER ELECTRONIC SALES CORP.	647 INDUSTRY DRIVE	SEATTLE, WA 98188
000IE	UNITED SCREW PRODUCTS INC.	P.O. BOX 177	LAKE OSWEGO, ORE 97034
00779	AMP, INC.	P O BOX 3608	HARRISBURG, PA 17105
05006	TWENTIETH CENTURY PLASTICS, INC.	415 E WASHINGTON BLVD.	LOS ANGELES, CA 90015
09922	BURNDY CORPORATION	RICHARDS AVENUE	NORWALK, CT 06852
11897	PLASTIGLIDE MFG. CORPORATION	P O BOX 867, 1757 STANFORD ST.	SANTA MONICA, CA 90406
12327	FREEWAY CORPORATION	9301 ALLEN DRIVE	CLEVELAND, OH 44125
13511	AMPHENOL CARDRE DIV., BUNKER RAMO CORP.		LOS GATOS, CA 95030
16428	BELDEN CORP.	P. O. BOX 1331	RICHMOND, IN 47374
17217	GORE, W. L. AND ASSOCIATES, INC.	555 PAPER MILL RD.	NEWARK, DE 19711
18565	CHOMERICS INC.	77 DRAGON COURT	WOBURN, MA 01801
22526	BERG ELECTRONICS, INC.	YOUK EXPRESSWAY	NEW CUMBERLAND, PA 17070
23880	STANFORD APPLIED ENGINEERING, INC.	340 MARTIN AVE.	SANTA CLARA, CA 95050
24931	SPECIALITY CONNECTOR CO., INC.	2620 ENDRESS PLACE	GREENWOOD, IN 46142
27264	MOLEX PRODUCTS CO.	5224 KATRINE AVE.	DOWNERS GROVE, IL 60515
33096	COLORADO CRYSTAL CORPORATION	2303 W 8TH STREET	LOVELAND, CO 80537
59730	THOMAS AND BETTS COMPANY	36 BUTLER ST.	ELIZABETH, NJ 07207
70276	ALLEN MFG. CO.	P. O. DRAWER 570	HARTFORD, CT 06101
70485	ATLANTIC INDIA RUBBER WORKS, INC.	571 W. POLK ST.	CHICAGO, IL 60607
70903	BELDEN CORP.	2000 S BATAVIA AVENUE	GENEVA, IL 60134
71159	BRISTOL SOCKET SCREW, DIV. OF AMERICAN CHAIN AND CABLE CO., INC.	P O BOX 2244, 40 BRISTOL ST.	WATERBURY, CT 06720
71279	CAMBRIDGE THERMIONIC CORP.	445 CONCORD AVE.	CAMBRIDGE, MA 02138
71400	BUSSMAN MFG., DIVISION OF MCGRAW-EDISON CO.	2536 W. UNIVERSITY ST.	ST. LOUIS, MO 63107
71785	TRW, CINCH CONNECTORS	1501 MORSE AVENUE	ELK GROVE VILLAGE, IL 60007
73743	FISCHER SPECIAL MFG. CO.	446 MORGAN ST.	CINCINNATI, OH 45206
73803	TEXAS INSTRUMENTS, INC., METALLURGICAL MATERIALS DIV.	34 FOREST STREET	ATTLEBORO, MA 02703
74445	HOLO-KROME CO.	31 BROOK ST. WEST	HARTFORD, CT 06110
75037	MINNESOTA MINING & MFG CO. ELECTRO PRODUCTS DIV.	3M CENTER	ST. PAUL, MN 55101
75915	LITTELFUSE, INC.	800 E. NORTHWEST HWY	DES PLAINES, IL 60016
77250	PHEOLL MANUFACTURING CO., DIVISION OF ALLIED PRODUCTS CORP.	5700 W. ROOSEVELT RD.	CHICAGO, IL 60650
78189	ILLINOIS TOOL WORKS, INC. SHAKEPROOF DIVISION	ST. CHARLES ROAD	ELGIN, IL 60120
80009	TEKTRONIX, INC.	P O BOX 500	BEAVERTON, OR 97077
80033	PRESTOLE EVERLOCK, INC.	P. O. BOX 278, 1345 MIAMI ST.	TOLEDO, OH 43605
80126	PACIFIC ELECTRICORD CO.	747 W. REDONDO BEACH, P O BOX 10	GARDENA, CA 90247
83385	CENTRAL SCREW CO.	2530 CRESCENT DR.	BROADVIEW, IL 60153
84830	LEE SPRING COMPANY, INC.	30 MAIN STREET	BROOKLYN, NY 11201
86221	GROMAN CORP.	54530 COUNTRY RD. NO 17	ELKHART, IN 46514
86928	SEASTROM MFG. COMPANY, INC.	701 SONORA AVENUE	GLENDALE, CA 91201
88245	LITTON SYSTEMS, INC., USECO DIV.	13536 SATICOY ST.	VAN NUYS, CA 91409
93907	TEXTRON INC. CAMCAR DIV	600 18TH AVE	ROCKFORD, IL 61101

Replaceable Mechanical Parts—2336 Service

Fig. & Index No.	Tektronix Part No.	Serial/Model No. Eff	Dscont	Qty	1	2	3	4	5	Name & Description	Mfr Code	Mfr Part Number
1-1	348-0706-00			2						BUMPER, PLASTIC: FRONT COVER (ATTACHING PARTS)	80009	348-0706-00
-2	211-0244-00			2						SCR, ASSEM WSHR: 4-40 X 0.312 INCH, PNH STL - - - * - - -	78189	OBD
-3	105-0905-00			2						. STRIKE, CATCH: INSERT, ALUMINUM	80009	105-0905-00
-4	390-0841-01			1						COVER, PROT: FRONT (ATTACHING PARTS)	80009	390-0841-01
-5	211-0661-00			4						SCREW, MACHINE: 4-40 X 0.25 INCH, PNH, STL - - - * - - -	83385	OBD
-6	129-0895-00			4						SPACER, POST: 1.148 L, W/4-40 INT THD ONE END	80009	129-0895-00
-7	-----			1						. CKT BOARD ASSY: DELTA TIME LOGIC (SEE A30 REPL)		
-8	131-2093-00			2						. . SKT, PL-IN ELEK: MICROCKT, 20 CONT, LOW PF	23880	CSA-3200-208
-9	-----			1						. . DISPLAY, LIQUID CRYSTAL: (SEE U37 REPL)		
-10	136-0623-00			1						. . SOCKET, PLUG-IN: 40 DIP, LOW PROFILE	73803	CS9002-40
-11	214-0579-02			4						. . TERM, TEST POINT: BRASS	80009	214-0579-02
-12	136-0252-07			6						. . SOCKET, PIN CONN: W/O DIMPLE	22526	75060-012
-13	131-0608-00			16						. . TERMINAL, PIN: 0.365 L X 0.025 PH BRZ GOLD	22526	47357
-14	131-0955-00			1						. . CONN, RCPT, ELEC: BNC, FEMALE	13511	31-279
-15	129-0855-00			1						. . SPACER, POST: 0.675 L W/0.375 INT THD	80009	129-0855-00
-16	136-0499-04			3						. . CONNECTOR, RCPT, :4 CONTACT	00779	3-380949-4
-17	-----			1						. . RESISTOR, VARIABLE: (SEE R94 REPL)		
	213-0048-00			2						. . SETSCREW: 4-40 X 0.125 INCH, HEX SOC STL (ATTACHING PARTS)	74445	OBD
-18	210-0583-00			1						. . NUT, PLAIN, HEX. : 0.25-32 X 0.312 INCH, BRS	73743	2X20317-402
-19	210-0046-00			1						. . WASHER, LOCK: 0.261 ID, INTL, 0.018 THK, BRS - - - * - - -	78189	1214-05-00-0541C
-20	-----			1						. CKT BOARD ASSY: B TRIGGER SW (SEE A31 REPL)		
-21	131-1857-00			1						. . TERM. SET, PIN: 36/0.025 SQ PIN, ON 0.1 CTRS	22526	65500136
	175-3680-00			1						CA ASSY, SP, ELEC: 16, 28 AWG, 6.275 L, RIBBON (ATTACHING PARTS)	80009	175-3680-00
-22	210-0586-00			2						NUT, PL, ASSEM WA: 4-40 X 0.25, STL CD PL - - - * - - -	83385	OBD
-23	346-0174-00			1						. STRAP, RETAINING: BOOT, FRONT COVER (ATTACHING PARTS)	80009	346-0174-00
-24	211-0005-00			1						. SCREW, MACHINE: 4-40 X 0.125 INCH, PNH STL - - - * - - -	83385	OBD
-25	344-0333-00			1						. CLIP, GROUNDING: 0.125 ID X 0.0126	80009	344-0333-00
-26	131-2201-01			1						. CONN, PLUG, ELEC: 2 X 8, 01 SPACING	75037	3452-7000
-27	175-3361-00			FT						. CABLE, SP, ELEC: 16, 28 AWG, STRD	17217	GFS-909-050N16
-28	131-2569-00			1						. CONTACT, ELEC: GROUNDING STRAP (ATTACHING PARTS)	80009	131-2569-00
-29	210-0407-00			1						. NUT, PLAIN, HEX. : 6-32 X 0.25 INCH, BRS	73743	3038-0228-402
-30	210-0803-00			1						. WASHER, FLAT: 0.15 ID X 0.032 THK, STL CD PL - - - * - - -	12327	OBD
-31	337-2879-00			1						. SHIELD, ELEC: FLAT CABLE	80009	337-2879-00
-32	131-2201-01			1						. CONN, PLUG, ELEC: 2 X 8, 01 SPACING	75037	3452-7000
	131-2770-00			5						CONTACT, ELEC: GROUNDING	80009	131-2770-00
-33	333-2709-00			1						PANEL, FRONT: LID (ATTACHING PARTS)	80009	333-2709-00
-34	211-0007-00			6						SCREW, MACHINE: 4-40 X 0.188 INCH, PNH STL - - - * - - -	83385	OBD
-35	105-0870-00			1						LATCH, CABINET: TOP RIGHT (ATTACHING PARTS)	80009	105-0870-00
-36	211-0087-01			1						SCREW, MACHINE: 2-56 X 0.188, FLH 82 DEG, STL - - - * - - -	83385	OBD
-37	105-0871-00			1						LATCH, CABINET: TOP LEFT (ATTACHING PARTS)	80009	105-0871-00
-38	211-0087-01			1						SCREW, MACHINE: 2-56 X 0.188, FLH 82 DEG, STL - - - * - - -	83385	OBD
-39	214-3163-00			2						ACTUATOR, LATCH: CABINET TOP	80009	214-3163-00
-40	101-0057-00			1						TRIM, COVER: HINGE, ARS	80009	101-0057-00
-41	214-3071-00			1						PIN, HINGE: 9.45L X 0.0937 DIA, SST	80009	214-3071-00
-42	101-0056-00			1						TRIM, FRONT PNL: HINGE, ABS (ATTACHING PARTS)	80009	101-0056-00
-43	211-0097-00			6						SCREW, MACHINE: 4-40 X 0.312 INCH, PNH STL - - - * - - -	83385	OBD

**Replaceable Mechanical Parts—2336 Service**

Fig. & Index No.	Tektronix Part No.	Serial/Model No. Eff	Dscont	Qty	1 2 3 4 5	Name & Description	Mfr Code	Mfr Part Number
1-44	367-0296-01			1		HANDLE, CARRYING: W/GRIP AND INDEX (ATTACHING PARTS)	80009	367-0296-01
-45	212-0144-00			2		SCREW, TPG, TF: 8-16 X 0.562 L	93907	225-38131-012
	214-0536-01			1		SPRING, HLCPS: 0.342-0.826 OD X 0.531 L - - - * - - -	80009	214-0536-01
-46	334-4101-00			1		MARKER, IDENT:	80009	334-4101-00
-47	200-2654-00			2		COVER, LATCH: FOOT PAD (ATTACHING PARTS)	80009	200-2654-00
-48	211-0313-00			2		SCR, ASSEM WSHR: 4-40 X 0.5 PNH, STL CD PL - - - * - - -	78189	OBD
-49	386-4676-00			2		PLATE, REINF: LATCH	80009	386-4676-00
-50	105-0902-00			2		LATCH, COVER: FOOT	80009	105-0902-00
-51	214-1035-00			2		SPRING, HLCPS: 0.3 OD X 0.265 L	84830	LC-026D-4SS
-52	214-3251-00			2		SPRING, GROUND: (ATTACHING PARTS)	80009	214-3251-00
-53	211-0105-00			2		SCREW, MACHINE: 4-40 X 0.188, 100 DEG, FLH STL - - - * - - -	83385	OBD
-54	352-0630-00			2		HOLDER, LATCH:	80009	352-0630-00
-55	212-0008-00			4		SCREW, MACHINE: 8-32 X 0.500 INCH, PNH STL	83385	OBD
-56	348-0681-00			2		FOOT, SCOPE: REAR (ATTACHING PARTS)	80009	348-0681-00
-57	211-0578-00			4		SCREW, MACHINE: 6-32 X 0.438 INCH, PNH STL - - - * - - -	83385	OBD
-58	334-4151-00			1		MARKER, IDENT: MKD CAUTION, FUSE DATA	80009	334-4151-00
-59	334-4152-00			1		MARKER, IDENT: MKD CAUTION, LINE VOLTAGE SEL	80009	334-4152-00
-60	343-0896-00			1		CLAMP, CABLE: POWER, SST (ATTACHING PARTS)	80009	343-0896-00
-61	211-0510-00			1		SCREW, MACHINE: 6-32 X 0.375, PNH, STL, CD PL	83385	OBD
	166-0107-00			1		SPACER, SLEEVE: 0.18 ID X 0.219 L - - - * - - -	80009	166-0107-00
-62	348-0675-00			1		CABINET, REAR: (ATTACHING PARTS)	80009	348-0675-00
-63	211-0507-00			2		SCREW, MACHINE: 6-32 X 0.312 INCH, PNH STL - - - * - - -	83385	OBD
-64	437-0274-01			1		CABINET, SCOPE:	80009	437-0274-01

Fig. & Index No.	Tektronix Part No.	Serial/Model No. Eff Dscont	Qty	1	2	3	4	5	Name & Description	Mfr Code	Mfr Part Number
2-1	366-1059-00		1						PUSH BUTTON:GRAY	80009	366-1059-00
-2	366-1879-01		1						KNOB:GRAY 0.5 OD X 0.531 H PLASTIC	80009	366-1879-01
	213-0020-00		1						. SETSCREW:6-32 X 0.125 INCH,HEX.SOC STL	70276	OBD
-3	366-1866-01		5						KNOB:GY,VAR,0.127 ID X 0.5 OD X 0.54 H	80009	366-1866-01
-4	366-1031-02		2						KNOB:RED,VAR,0.127ID X 0.392 OD	80009	366-1031-02
	213-0246-00		2						. SETSCREW:5-40 X 0.093 ITL BK OXD,HEX SKT	71159	OBD
-5	366-1831-01		2						KNOB:W/SKIRT	80009	366-1831-01
-6	366-1857-00		1						KNOB:RED,VAR,0.083ID X 0.45 OD X0.389 H	80009	366-1857-00
	213-0048-00		1						. SETSCREW:4-40 X 0.125 INCH,HEX SOC STL	74445	OBD
-7	366-1881-00		1						KNOB:GRAY,TIME DIVISION	80009	366-1881-00
-8	214-3158-00		1						COLLET,SW SHAFT:0.125 ID X 0.34 L (ATTACHING PARTS)	0001E	OBD
-9	220-0572-00		1						NUT,PLAIN,HEX.:10-32 X 0.25 INCH,PL BRS	73743	OBD
-10	210-1035-00		1						WASHER,SPR TNSN:0.195 ID X 0.006 THK,STL * - - - -	80009	210-1035-00
-11	377-0524-01		1						INSERT,KNOB:0.38 ID X 0.645 L	80009	377-0524-01
-12	214-3159-00		1						COLLET,SW SHAFT:0.25 X 0.7 L (ATTACHING PARTS)	0001E	OBD
-13	210-0413-00		1						NUT,PLAIN,HEX.:0.375-32 X 0.50 INCH,STL * - - - -	73743	3145-402
-14	358-0647-00		1						BUSHING,SHAFT:0.25 ID	80009	358-0647-00
-15	366-1877-00		1						KNOB:0.248 ID X 0.392 OD	80009	366-1877-00
	213-0020-00		1						. SETSCREW:6-32 X 0.125 INCH,HEX.SOC STL	70276	OBD
-16	366-1880-00		1						KNOB:GRAY,TIME/DELTA TIME 0.252 ID X 0.4 OD	80009	366-1880-00
	213-0020-00		2						. SETSCREW:6-32 X 0.125 INCH,HEX.SOC STL	70276	OBD
-17	333-2744-00		1						PANEL,FRONT:	80009	333-2744-00
-18	337-2760-00		1						SHLD,IMPLOSION:	80009	337-2760-00
-19	343-0892-00		1						RETAINER,SHIELD:IMPLOSION	80009	343-0892-00
-20	101-0059-00		1						TRIM,FRONT PNL:SPACER,ABS,BLACK (ATTACHING PARTS)	80009	101-0059-00
-21	211-0101-00		4						SCREW,MACHINE:4-40 X 0.25,100 DEG,FLH STL * - - - -	83385	OBD
-22	348-0671-00		1						SHLD GSKT,ELEK:SOLID TYPE,26.0 L	80009	348-0671-00
-23	-----		1						RESISTOR,VAR:(SEE R942 REPL) (ATTACHING PARTS)		
-24	220-0510-00		1						NUT,PLAIN,HEX.:0.25-32 X 0.312 INCH	80009	220-0510-00
-25	210-0046-00		1						WASHER,LOCK:0.261 ID,INTL,0.018 THK,BRS	78189	1214-05-00-0541C
-26	358-0409-00		1						BSHG,MACH.THD:0.25-32 X 0.159 ID X 0.24 * - - - -	80009	358-0409-00
-27	-----		1						RESISTOR,VAR:(SEE R909 REPL)		
-28	129-0846-00		1						SPACER,POST:1.275 L W/0.25-32 EXT THD (ATTACHING PARTS)	80009	129-0846-00
-29	210-0562-00		1						NUT,PLAIN,HEX.:0.25-40 X 0.312 INCH,BBS * - - - -	73743	2X20224-402
-30	-----		1						RESISTOR,VAR:(SEE R945 REPL) (ATTACHING PARTS)		
-31	220-0510-00		1						NUT,PLAIN,HEX.:0.25-32 X 0.312 INCH	80009	220-0510-00
-32	210-0046-00		1						WASHER,LOCK:0.261 ID,INTL,0.018 THK,BRS	78189	1214-05-00-0541C
-33	358-0409-00		1						BSHG,MACH.THD:0.25-32 X 0.159 ID X 0.24 * - - - -	80009	358-0409-00
-34	200-2631-00		1						COVER,VAR RES:	80009	200-2631-00
-35	-----		1						RESISTOR,VAR:(SEE R940 REPL) (ATTACHING PARTS)		
-36	210-0562-00		1						NUT,PLAIN,HEX.:0.25-40 X 0.312 INCH,BBS * - - - -	73743	2X20224-402
-37	213-0878-00		4						SET SCREW:0.25-28 X 0.625 L STL CD PL	80009	213-0878-00
	426-1072-00		16						FRAME,PUSH BTN:PLASTIC	80009	426-1072-00
-38	-----		2						RESISTOR,VAR:(SEE R903,907 REPL) (ATTACHING PARTS)		
-39	210-0562-00		2						NUT,PLAIN,HEX.:0.25-40 X 0.312 INCH,BBS	73743	2X20224-402
-40	210-0223-01		2						TERMINAL,LUG:0.25 INCH DIA,SE,60 DEG BEND * - - - -	86928	OBD
-41	-----		1						RESISTOR,VAR:(SEE R935 A & B REPL) (ATTACHING PARTS)		
-42	210-0562-00		1						NUT,PLAIN,HEX.:0.25-40 X 0.312 INCH,BBS * - - - -	73743	2X20224-402

Replaceable Mechanical Parts—2336 Service

Fig. & Index No.	Tektronix Part No.	Serial/Model No. Eff Dscont	Qty	1 2 3 4 5	Name & Description	Mfr Code	Mfr Part Number
2-43	131-1315-01		2		CONN,RCPT,ELEC:BNC,FEMALE	24931	28JR 306-1
-44	131-0258-01		1		CONN,RCPT,ELEC:PROBE TIP	24931	OBD
-45	343-0961-00		1		RETAINER,SHIELD: (ATTACHING PARTS)	80009	343-0961-00
-46	211-0101-00		1		SCREW,MACHINE:4-40 X 0.25,100 DEG,FLH STL - - - * - - -	83385	OBD
-47	-----		1		RESISTOR,VAR:(SEE R913 REPL) (ATTACHING PARTS)		
-48	210-0562-00		1		NUT,PLAIN,HEX.:0.25-40 X 0.312 INCH,BBS - - - * - - -	73743	2X20224-402
-49	-----		1		RESISTOR,VAR:(SEE R918 A & B REPL) (ATTACHING PARTS)		
-50	220-0495-00		1		NUT,PLAIN,HEX.:0.375-32 X 0.438 INCH BRS - - - * - - -	73743	OBD
-51	131-0955-00		1		CONN,RCPT,ELEC:BNC,FEMALE	13511	31-279
-52	210-0255-00		1		TERMINAL,LUG:0.391" ID INT TOOTH	80009	210-0255-00
-53	386-4479-01		1		SUBPANEL,FRONT: (ATTACHING PARTS)	80009	386-4479-01
-54	211-0661-00		1		SCREW,MACHINE:4-40 X 0.25 INCH,PNH,STL	83385	OBD
-55	211-0101-00		2		SCREW,MACHINE:4-40 X 0.25,100 DEG,FLH STL	83385	OBD
-56	210-0586-00		1		NUT,PL,ASSEM WA:4-40 X 0.25,STL CD PL - - - * - - -	83385	OBD
-57	366-1767-00		1		PUSH BUTTON:BLACK,YELLOW INDICATOR	000E0	FA201
-58	384-1574-00		1		EXTENSION SHAFT:1.238 L X 0.13 OD	80009	384-1574-00
-59	-----		1		SWITCH,PUSH:(SEE S903 REPL) (ATTACHING PARTS)		
-60	211-0022-00		2		SCREW,MACHINE:2-56 X 0.188 INCH,PNH STL - - - * - - -	83385	OBD
-61	337-2796-00		1		SHIELD,ELEC:POWER SWITCH, TOP	80009	337-2796-00
-62	337-2797-00		1		SHIELD,ELEC:POWER SWITCH, BOTTOM (ATTACHING PARTS)	80009	337-2797-00
-63	211-0661-00		1		SCREW,MACHINE:4-40 X 0.25 INCH,PNH,STL - - - * - - -	83385	OBD
-64	344-0250-00		1		CLIP,ELECTRICAL:COMPONENT MOUNTING (ATTACHING PARTS)	80033	E50005-007
-65	211-0661-00		1		SCREW,MACHINE:4-40 X 0.25 INCH,PNH,STL - - - * - - -	83385	OBD
-66	441-1531-00		1		CHASSIS,SCOPE:LEFT	80009	441-1531-00
	-----		1		DELAY LINE,ELEC:(SEE DL900 REPL) (ATTACHING PARTS)		
-67	211-0313-00		1		SCR,ASSEM WSHR:4-40 X 0.5 PNH,STL CD PL - - - * - - -	78189	OBD
	-----		-		. DELAY LINE ASSY INCLUDES:		
-68	200-2507-00		1		. COVER,HOLDER:DELAY LINE	80009	200-2507-00
-69	346-0175-00		4		. STRAP,TIE DOWN:7.0 L,PLASTIC	59730	TYB-2315M
-70	175-1993-01		FT		. CABLE,SP,ELEC:2,27 AWG,SHIELDED	80009	175-1993-01
-71	131-2571-00		4		. CONTACT,ELEC:MALE,BRASS GOLD PLATE	71785	403-3099-126-410
-72	380-0634-00		2		. HOUSING,CONN:BOTTOM,DELAY LINE	80009	380-0634-00
-73	380-0628-00		2		. HOUSING,CONN:TOP,DELAY LINE	80009	380-0628-00
-74	352-0584-00		1		. HLDR,DELAY LINE:ABS	80009	352-0584-00
-75	337-2896-00		1		SHIELD,CRT:	80009	337-2896-00
-76	348-0705-00		1		SHLD GSKT,ELEK:MESH,CRT SHIELD	80009	348-0705-00
-77	210-0202-00	B010100	1	B010419	TERMINAL,LUG:0.146 ID,LOCKING,BRZ TINNED	78189	2104-06-00-2520N
	210-0201-00	B010420	1		TERMINAL,LUG:0.12 ID,LOCKING,BRZ TIN PL (ATTACHING PARTS)	86928	OBD
-78	211-0116-00		1		SCR,ASSEM WSHR:4-40 X 0.312 INCH,PNH BRS	83385	OBD
-79	210-0586-00		1		NUT,PL,ASSEM WA:4-40 X 0.25,STL CD PL - - - * - - -	83385	OBD
-80	337-2894-00		1		SHIELD,CRT:	80009	337-2894-00
-81	384-1570-00		1		SHAFT,DRIVE:VAR RES.,5.125 L X 0.123 OD	80009	384-1570-00
-82	-----		2		ATTENUATOR,VAR:(SEE S1,S2 REPL) (ATTACHING PARTS)		
-83	211-0661-00		1		SCREW,MACHINE:4-40 X 0.25 INCH,PNH,STL - - - * - - -	83385	OBD
-84	672-0919-00		1		CKT BOARD ASSY:TIMING SWITCH	80009	672-0919-00



Replaceable Mechanical Parts—2336 Service

Fig. & Index No.	Tektronix Part No.	Serial/Model No. Eff	Dscont	Qty	1	2	3	4	5	Name & Description	Mfr Code	Mfr Part Number
2-85	361-1042-00			1						SPACER,CKT BD:BRASS (ATTACHING PARTS)	80009	361-1042-00
-86	211-0661-00			1						SCREW,MACHINE:4-40 X 0.25 INCH,PNH,STL - - - * - - -	83385	OBD
-87	-----			1						FAN,TUBEAXIAL:(SEE B924 REPL) (ATTACHING PARTS)		
-88	211-0020-00			4						SCREW,MACHINE:4-40 X 1.125 INCH,PNH STL	83385	OBD
-89	210-0004-00			4						WASHER,LOCK:#4 INTL,0.015THK,STL CD PL - - - * - - -	78189	1204-00-00-0541C
-90	378-0164-00			1						SHROUD,FAN:	80009	378-0164-00
-91	361-1123-00			2						SPACER,FAN:	80009	361-1123-00
-92	441-1530-01			1						CHASSIS,SCOPE:RIGHT	80009	441-1530-01
-93	-----			1						TRANSFORMER:(SEE T900 REPL)		
-94	200-2645-00			1						COVER,LINE SEL:PLASTIC,BLACK	80009	200-2645-00
-95	352-0629-00			1						HOLDER,XFMR:	80009	352-0629-00
-96	407-2542-00			2						BRACKET,XFMR: (ATTACHING PARTS)	80009	407-2542-00
-97	211-0661-00			4						SCREW,MACHINE:4-40 X 0.25 INCH,PNH,STL - - - * - - -	83385	OBD
-98	210-0202-00			2						TERMINAL,LUG:0.146 ID,LOCKING,BRZ TINNED (ATTACHING PARTS)	78189	2104-06-00-2520N
-99	210-0457-00			2						NUT,PL,ASSEM WA:6-32 X 0.312 INCH,STL - - - * - - -	83385	OBD
-100	361-1042-00			2						SPACER,CKT BD:BRASS (ATTACHING PARTS)	80009	361-1042-00
-101	211-0661-00			2						SCREW,MACHINE:4-40 X 0.25 INCH,PNH,STL - - - * - - -	83385	OBD
-102	255-0334-00			FT						PLASTIC CHANNEL:12.75 X 0.175X 0.155,NYL	11897	122-37-2500
-103	131-0955-00			1						CONN,RCPT,ELEC:BNC,FEMALE	13511	31-279
-104	129-0855-00			1						SPACER,POST:0.675 L W/0.375 INT THD	80009	129-0855-00
	213-0048-00			2						SETScrew:4-40 X 0.125 INCH,HEX SOC STL	74445	OBD
-105	204-0833-00			1						BODY,FUSEHOLDER:3AG & 5 X 20MM FUSES	S3629	031.1653(MDLFEU)
-106	200-2264-00			1						CAP.,FUSEHOLDER:3AG FUSES (REPLACED BY 200-2265-00 FOR OPTION A1,A2 & A3)	S3629	FEK 031 1666
-107	337-2901-00			1						SHIELD,ELEC:LINE FILTER	80009	337-2901-00
-108	-----			1						FILTER,RFI:(SEE FL900 REPL) (ATTACHING PARTS)		
-109	211-0014-00			2						SCREW,MACHINE:4-40 X 0.50 INCH,PNH STL	83385	OBD
	166-0107-00			2						SPACER,SLEEVE:0.18 ID X 0.219 L - - - * - - -	80009	166-0107-00
-110	-----			1						SWITCH,SLIDE:(SEE S901 REPL) (ATTACHING PARTS)		
-111	211-0661-00			2						SCREW,MACHINE:4-40 X 0.25 INCH,PNH,STL - - - * - - -	83385	OBD
-112	355-0227-00			1						STUD,BDG POST:0.25-28 X 1.11,BRASS (ATTACHING PARTS)	80009	355-0227-00
-113	210-0455-00			1						NUT,PLAIN,HEX.:0.25-28 X 0.375 INCH,BRASS	73743	3089-402
-114	210-0046-00			1						WASHER,LOCK:0.261 ID,INTL,0.018 THK,BRS - - - * - - -	78189	1214-05-00-0541C
-115	200-0103-00			1						NUT,PLAIN,KNURL:0.25-28 X 0.375" OD,BRASS	80009	200-0103-00
-116	441-1529-00			1						CHASSIS,SCOPE:REAR (ATTACHING PARTS)	80009	441-1529-00
-117	211-0661-00			4						SCREW,MACHINE:4-40 X 0.25 INCH,PNH,STL - - - * - - -	83385	OBD

**Replaceable Mechanical Parts—2336 Service**

Fig. & Index No.	Tektronix Part No.	Serial/Model No. Eff Dscont	Qty	1	2	3	4	5	Name & Description	Mfr Code	Mfr Part Number
3-1	-----		1						CKT BOARD ASSY:SWEEP/HORIZ AMP(SEE A24 REPL) (ATTACHING PARTS)		
-2	211-0661-00		8						SCREW,MACHINE:4-40 X 0.25 INCH,PNH,STL - - - * - - -	83385	OBD
	-----		-						. CKT BOARD ASSY INCLUDES:		
-3	131-1003-00		1						. CONN,RCPT,ELEC:CKT BD MT,3 PRONG	80009	131-1003-00
-4	136-0252-07		13						. SOCKET,PIN CONN:W/O DIMPLE	22526	75060-012
-5	131-0608-00		35						. TERMINAL,PIN:0.365 L X 0.025 PH BRZ GOLD	22526	47357
-6	214-0579-02		19						. TERM,TEST POINT:BRASS	80009	214-0579-02
-7	136-0499-10		2						. CONNECTOR,RCPT,:10 CONTACT	00779	4-380949-0
-8	136-0499-06		1						. CONN,RCPT,ELEC:CIRCUIT BD,6 CONTACTS	00779	3-380949-6
-9	136-0260-02	B010100 B010512	4						. SKT,PL-IN ELEK:MICROCIRCUIT,16 DIP,LOW CLE	71785	133-51-92-008
	136-0260-02	B010513	2						. SKT,PL-IN ELEK:MICROCIRCUIT,16 DIP,LOW CLE	71785	133-51-92-008
-10	131-0787-00		34						. CONTACT,ELEC:0.64 INCH LONG	22526	47359
-11	-----		1						CKT BOARD ASSY:A & B TRIGGER(SEE A23 REPL) (ATTACHING PARTS)		
-12	211-0661-00		2						SCREW,MACHINE:4-40 X 0.25 INCH,PNH,STL	83385	OBD
	211-0101-00		2						SCREW,MACHINE:4-40 X 0.25,100 DEG,FLH STL - - - * - - -	83385	OBD
	-----		-						. CKT BOARD ASSY INCLUDES:		
-13	131-0787-00		24						. CONTACT,ELEC:0.64 INCH LONG	22526	47359
	136-0514-00	B010100 B010512X	1						. SKT,PL-IN ELEK:MICROCKT,8 DIP	73803	CS9002-8
-14	136-0499-14		1						. CONNECTOR,RCPT,:14 CONTACT	00779	4-380949-4
-15	136-0499-10		2						. CONNECTOR,RCPT,:10 CONTACT	00779	4-380949-0
-16	136-0252-07		9						. SOCKET,PIN CONN:W/O DIMPLE	22526	75060-012
-17	131-1003-00		3						. CONN,RCPT,ELEC:CKT BD MT,3 PRONG	80009	131-1003-00
-18	214-0579-02		6						. TERM,TEST POINT:BRASS	80009	214-0579-02
-19	131-0608-00		13						. TERMINAL,PIN:0.365 L X 0.025 PH BRZ GOLD	22526	47357
-20	136-0634-00		2						. SOCKET,PLUG-IN:20 LEAD DIP,CKT BD MTG	73803	CS9002-20
	-----		1						. SW LEVER ASSY:A SOURCE(SEE S67 REPL) (ATTACHING PARTS)		
-21	211-0246-00		1						. SCR,ASSEM WSHR:4-40 X 0.625 INCH,PNH,STL	78189	OBD
-22	210-0551-00		1						. NUT,PLAIN,HEX.:4-40 X 0.25 INCH,STL - - - * - - -	83385	OBD
	-----		-						. . SWITCH ASSY INCLUDES:		
-23	351-0448-01		1						. . GUIDE ,SWITCH:W/SPRING AND ROLLER	80009	351-0448-01
-24	214-1126-02		1						. . SPRING,FLAT:RED COLORED	80009	214-1126-02
-25	214-1127-00		1						. . ROLLER,DETENT:0.125 DIA X 0.125,SST	80009	214-1127-00
-26	214-3061-01		1						. . LEVER,SWITCH:6 POSN,14 DEG,A SOURCE	80009	214-3061-01
	-----		1						. SW LEVER ASSY:A COUPLING(SEE S22 REPL)		
-27	351-0448-01		1						. . GUIDE ,SWITCH:W/SPRING AND ROLLER	80009	351-0448-01
-28	214-1127-00		1						. . ROLLER,DETENT:0.125 DIA X 0.125,SST	80009	214-1127-00
-29	214-1126-02		1						. . SPRING,FLAT:RED COLORED	80009	214-1126-02
-30	214-3060-01		1						. . LEVER,SWITCH:4 POSN,14 DEG,A COUPLING	80009	214-3060-01
-31	-----		1						CKT BOARD ASSY:VERT OUT/HV PWR(SEE A15 REPL) (ATTACHING PARTS)		
-32	211-0661-00		4						SCREW,MACHINE:4-40 X 0.25 INCH,PNH,STL	83385	OBD
-33	211-0313-00		1						SCR,ASSEM WSHR:4-40 X 0.5 PNH,STL CD PL - - - * - - -	78189	OBD
	-----		-						. CKT BOARD ASSY INCLUDES:		
-34	343-0088-00		4						. CLAMP,LOOP:0.062 INCH DIA	80009	343-0088-00
-35	131-0589-00		12						. TERMINAL,PIN:0.46 L X 0.025 SQ	80009	131-0589-00
-36	131-1857-00		1						. TERM. SET,PIN:36/0.025 SQ PIN,ON 0.1 CTRS	22526	65500136
	131-0608-00		20						. TERMINAL,PIN:0.365 L X 0.025 PH BRZ GOLD	22526	47357
	131-0589-00		6						. TERMINAL,PIN:0.46 L X 0.025 SQ	80009	131-0589-00
-37	136-0388-00		2						. SOCKET,PIN TERM:U/W 0.04 DIA PIN	71279	450-3704-01-0300
-38	344-0286-00		1						. CLIP,ELECTRICAL:FOR 3AG FUSE,BRS	75915	102074
-39	344-0329-00		2						. CLIP,ELECTRICAL:FUSE,5 X 20MM	80009	344-0329-00
	131-0589-00		6						. TERMINAL,PIN:0.46 L X 0.025 SQ	80009	131-0589-00
-40	124-0092-00		1						. TERMINAL BOARD:3 NOTCH,CERAMIC,CLIP MTD	80009	124-0092-00
-41	361-0007-00		1						. SPACER,SLEEVE:0.250 INCH DIA,PLASTIC	80009	361-0007-00
-42	214-0579-02		7						. TERM,TEST POINT:BRASS	80009	214-0579-02
-43	337-2757-00		1						. SHIELD,ELEC:HIGH VOLTAGE	80009	337-2757-00
-44	348-0031-01		1						. GROMMET,PLASTIC:GRAY,ROUND,0.127 ID	80009	348-0031-01

Replaceable Mechanical Parts—2336 Service

Fig. & Index No.	Tektronix Part No.	Serial/Model No. Eff	Dscont	Qty	1	2	3	4	5	Name & Description	Mfr Code	Mfr Part Number
3-45	129-0425-00			1	.	.	.	.	.	SPACER, POST:0.90 L X 0.25HEX (ATTACHING PARTS)	80009	129-0425-00
-46	211-0661-00			1	.	.	.	.	.	SCREW, MACHINE:4-40 X 0.25 INCH, PNH, STL - - - * - - -	83385	OBD
-47	348-0171-00			1	.	.	.	.	.	GROMMET, PLASTIC:U-SHAPED	80009	348-0171-00
-48	337-2759-00			1	.	.	.	.	.	SHIELD, ELEC:HIGH VOLTAGE (ATTACHING PARTS)	80009	337-2759-00
-49	211-0038-00			1	.	.	.	.	.	SCREW, MACHINE:4-40 X 0.312, FLH, 100 DEG - - - * - - -	83385	OBD
	176-0122-02			1	.	.	.	.	.	WIRE, ELECTRICAL:22 AWG, BARE, 1.5 L	80009	176-0122-02
	198-4288-00			1	.	.	.	.	.	WIRE SET, ELEC:	80009	198-4288-00
-50	352-0202-00			1	.	.	.	.	.	HLDR, TERM CONN:6 WIRE BLACK	80009	352-0202-00
-51	136-0202-04			1	.	.	.	.	.	SKT, PL-IN ELEK:ELECTRON TUBE, 14 CONT	80009	136-0202-04
-52	200-0616-00			1	.	.	.	.	.	COVER, CRT SKT:1.78 DIA X 0.2 D, WHITE	80009	200-0616-00
-53	200-2632-00			1	.	.	.	.	.	COVER, CRT SKT:PLASTIC	80009	200-2632-00
-54	343-0970-00			1	.	.	.	.	.	CLAMP, SKT SHLD:PLASTIC	80009	343-0970-00
-55	337-2905-00			1	.	.	.	.	.	SHIELD, DLY LINE:2.1 X 1.85 X 0.29, PLASTIC	80009	337-2905-00
	672-0918-00			1	.	.	.	.	.	CKT BOARD ASSY:VERTICAL PREAMP	80009	672-0916-00
	-----			-	.	.	.	.	.	(119-1193-00 IS A SUB-PART OF THIS ASSEMBLY SEE FIGURE 4)		
-56	129-0413-01			4	.	.	.	.	.	SPACER, POST:0.538 L, W/4-40 TAP 1 END (ATTACHING PARTS)	80009	129-0413-01
-57	211-0661-00			4	.	.	.	.	.	SCREW, MACHINE:4-40 X 0.25 INCH, PNH, STL - - - * - - -	83385	OBD
	-----			-	.	.	.	.	.	CKT BOARD ASSY INCLUDES:		
-58	-----			1	.	.	.	.	.	CKT BD ASSY:VERT PREAMP/LV PWR(SEE A10 REPL)		
-59	131-1857-00			1	.	.	.	.	.	TERM. SET, PIN:36/0.025 SQ PIN, ON 0.1 CTRS	22526	65500136
-60	344-0331-00			1	.	.	.	.	.	CLIP, SPR, TNSN:TRANSISTOR RETAINING	80009	344-0331-00
-61	214-3070-00			1	.	.	.	.	.	HEAT SINK, XSTR: (ATTACHING PARTS)	80009	214-3070-00
-62	211-0661-00			2	.	.	.	.	.	SCREW, MACHINE:4-40 X 0.25 INCH, PNH, STL	83385	OBD
-63	211-0313-00			1	.	.	.	.	.	SCR, ASSEM WSHR:4-40 X 0.5 PNH, STL CD PL	78189	OBD
-64	210-0406-00			4	.	.	.	.	.	NUT, PLAIN, HEX.:4-40 X 0.188 INCH, BRS	73743	2X12161-402
-65	210-1122-00			4	.	.	.	.	.	WASHER, LOCK:0.12 ID, DISHED, 0.025 THK - - - * - - -	86928	OBD
-66	342-0533-00			1	.	.	.	.	.	INSULATOR, PLATE:HEAT SINK	18565	OBD
-67	-----			3	.	.	.	.	.	SWITCH, PUSH:(SEE S210 REPL)		
-68	361-1103-00			1	.	.	.	.	.	SPACER, SWITCH:0.4 THK	80009	361-1103-00
-69	-----			1	.	.	.	.	.	SWITCH, PUSH:(SEE S218 REPL)		
	361-1103-00			3	.	.	.	.	.	SPACER, SWITCH:0.4 THK	80009	361-1103-00
-70	-----			1	.	.	.	.	.	SWITCH, PUSH:(SEE S134 REPL)		
	361-1103-00			1	.	.	.	.	.	SPACER, SWITCH:0.4 THK	80009	361-1103-00
-71	-----			1	.	.	.	.	.	SWITCH, PUSH:(SEE S194 REPL)		
	361-1103-00			5	.	.	.	.	.	SPACER, SWITCH:0.4 THK	80009	361-1103-00
-72	-----			2	.	.	.	.	.	SWITCH, PUSH:(SEE S190, S219 REPL)		
-73	337-2766-00			1	.	.	.	.	.	SHIELD, ELEC:CKT BOARD, FRONT	80009	337-2766-00
-74	337-2765-00			1	.	.	.	.	.	SHIELD, ELEC:CKT BOARD, BACK	80009	337-2765-00
-75	131-0344-01			2	.	.	.	.	.	TERMINAL, STUD:0.569 L BIFURCATED, GOLD PL	88245	421837-2
-76	358-0241-00			2	.	.	.	.	.	INSULATOR, BSHG:0.05 ID X 0.125" OD, W/FLGE	88245	421565
-77	131-1003-00			2	.	.	.	.	.	CONN, RCPT, ELEC:CKT BD MT, 3 PRONG	80009	131-1003-00
-78	214-0579-02			14	.	.	.	.	.	TERM, TEST POINT:BRASS	80009	214-0579-02
-79	136-0252-07			74	.	.	.	.	.	SOCKET, PIN CONN:W/O DIMPLE	22526	75060-012
-80	344-0329-00			10	.	.	.	.	.	CLIP, ELECTRICAL:FUSE, 5 X 20MM	80009	344-0329-00
-81	131-0608-00			27	.	.	.	.	.	TERMINAL, PIN:0.365 L X 0.025 PH BRZ GOLD	22526	47357
-82	131-2484-00			1	.	.	.	.	.	TERM, SET, PIN:8 PIN, INSULATED	27264	09-61-1081
-83	-----			1	.	.	.	.	.	SWITCH, PUSH:(SEE S211 A & B REPL)		
-84	361-1104-00			4	.	.	.	.	.	SPACER, SWITCH:0.1, POLYAMIDE	80009	361-1104-00
-85	343-0951-00			5	.	.	.	.	.	RETAINER, CAP:0.039 MUSIC WIRE	80009	343-0951-00
-86	136-0499-14			1	.	.	.	.	.	CONNECTOR, RCPT, :14 CONTACT	00779	4-380949-4
-87	136-0499-10			1	.	.	.	.	.	CONNECTOR, RCPT, :10 CONTACT	00779	4-380949-0
-88	344-0286-00			1	.	.	.	.	.	CLIP, ELECTRICAL:FOR 3AG FUSE, BRS	75915	102074
-89	136-0388-00			2	.	.	.	.	.	SOCKET, PIN TERM:U/W 0.04 DIA PIN	71279	450-3704-01-0300
-90	-----			1	.	.	.	.	.	CKT BOARD ASSY:NEGATIVE REG(SEE A11 REPL)		
-91	131-0787-00			11	.	.	.	.	.	CONTACT, ELEC:0.64 INCH LONG	22526	47359
-92	-----			1	.	.	.	.	.	CKT BOARD ASSY:POSITIVE REG(SEE A12 REPL)		

**Replaceable Mechanical Parts—2336 Service**

Fig. & Index No.	Tektronix Part No.	Serial/Model No. Eff Dscont	Qty	1 2 3 4 5	Name & Description	Mfr Code	Mfr Part Number
3-93	131-0787-00		8		. . . CONTACT,ELEC:0.64 INCH LONG	22526	47359
-94	366-2013-00		16		PUSH,BUTTON:DIRTY GRAY,0.134 SQ X 0.480 H	80009	366-2013-00
-95	384-1136-00		2		EXTENSION SHAFT:0.95 INCH LONG	80009	384-1136-00
-96	384-1626-00		2		EXTENSION SHAFT:7.402 L X 0.187 SQ	80009	384-1626-00
-97	337-2784-00		1		SHIELD,ELEC:CKT BOARD (ATTACHING PARTS)	80009	337-2784-00
-98	211-0101-00		2		SCREW,MACHINE:4-40 X 0.25,100 DEG,FLH STL - - - * - - -	83385	OBD
-99	210-0202-00	B010100 B010419	1		TERMINAL,LUG:0.146 ID,LOCKING,BRZ TINNED	78189	2104-06-00-2520N
	210-0201-00	B010420	1		TERMINAL,LUG:0.12 ID,LOCKING,BRZ TIN PL (ATTACHING PARTS)	86928	OBD
-100	211-0661-00		1		SCREW,MACHINE:4-40 X 0.25 INCH,PNH,STL - - - * - - -	83385	OBD
-101	175-3586-00		1		CA ASSY,SP,ELEC:34,28 AWG,5.5 L	80009	175-3586-00
-102	175-3579-00		1		CA ASSY,SP,ELEC:8,26 AWG,11.0L,RIBBON	80009	175-3579-00
	348-0667-00		1		. GROMMET,PLASTIC:NATURAL,OBLONG	80009	348-0667-00
	352-0161-00		1		. HLD,TERM CONN:3 WIRE BLACK	80009	352-0161-00
	352-0163-00		1		. CONN BODY,PL,EL:5 WIRE BLACK	80009	352-0163-00
	352-0166-00		1		. CONN BODY,PL,EL:8 WIRE BLACK	80009	352-0166-00
-103	175-3580-00		1		CA ASSY,SP,ELEC:6,22 AWG,9.0 L,RIBBON	80009	175-3580-00
	352-0165-00		2		. CONN BODY,PL,EL:7 WIRE BLACK	80009	352-0165-00
-104	175-3581-00		1		CA ASSY,SP,ELEC:8,26 AWG,4.0 L,RIBBON	80009	175-3581-00
	352-0167-00		2		. HLD,TERM CONN:9 WIRE BLACK	80009	352-0167-00
-105	175-3584-00		1		CA ASSY,SP,ELEC:4,26 AWG,4.0 L,RIBBON	80009	175-3584-00
	352-0162-00		1		. HLD,TERM CONN:4 WIRE BLACK	80009	352-0162-00
-106	195-2013-00		1		LEAD,ELECTRICAL:26 AWG,5.0 L	80009	195-2013-00
	352-0171-00		1		. HLD,TERM CONN:1 WIRE BLACK	80009	352-0171-00
-107	175-3575-00		1		CA ASSY,SP,ELEC:3,22 AWG,3.0 L,RIBBON	80009	175-3575-00
	352-0163-00		1		. CONN BODY,PL,EL:5 WIRE BLACK	80009	352-0163-00
-108	175-3710-00		1		CA ASSY,SP,ELEC:3,26 AWG,4.5 L,RIBBON	80009	175-3710-00
	348-0002-00		1		. GROMMET,RUBBER:	70485	54G
	352-0161-00		1		. HLD,TERM CONN:3 WIRE BLACK	80009	352-0161-00
-109	175-3713-00		1		CA ASSY,SP,ELEC:6,26 AWG,3.0 L,RIBBON	80009	175-3713-00
	352-0164-00		1		. CONN BODY,PL,EL:6 WIRE BLACK	80009	352-0164-00
-110	175-3585-00		1		CA ASSY,SP,ELEC:4,18 AWG,21.0L	80009	175-3585-00
	210-0203-00	B010100 B010138	1		TERMINAL,LUG:SE #6	78189	2103-06-00-2520N
	210-0307-00	B010139	1		TERMINAL,LUG:RING,INS,16-14 AWG,#8	09922	BA14E-8
-111	176-0045-00		FT		BRAID,WIRE:# 24	70903	5112R424/36
	175-2640-00		2		CABLE ASSY,RF:50 OHM,COAX,8.0 L	80009	175-2640-00
	175-4150-00		1		CA ASSY,SP,ELEC:3,26 AWG,3.0 L,RIBBON	80009	175-4150-00
	175-5180-00		1		CA ASSY,SP,ELEC:6,26 AWG,8.0 L,RIBBON	80009	175-5180-00
	198-2915-00		1		WIRE SET,ELEC:	80009	198-2915-00
	175-3578-00		1		CA ASSY,SP,ELEC:3,22 AWG,3.0 L,RIBBON	80009	175-3578-00
	175-3709-00		2		CA ASSY,SP,ELEC:2,26 AWG,6.0 L,RIBBON	80009	175-3709-00

Replaceable Mechanical Parts—2336 Service

Fig. & Index No.	Tektronix Part No.	Serial/Model No. Eff	Dscont	Qty	1 2 3 4 5	Name & Description	Mfr Code	Mfr Part Number
4-1	-----			2		ATTENUATOR,VAR:(SEE A19 REPL)		
-1	384-1570-00			2		. SHAFT,DRIVE:VAR RES.,5.125 L X 0.123 OD	80009	384-1570-00
-2	214-3063-00			2		. LEVER,SWITCH:0.6 DIA AC/GND/DC	80009	214-3063-00
-3	-----			2		. SWITCH,CAM:(SEE A19S1,S2 REPL)		
-4	131-2661-00	B010100	B010319X	2		. . CONTACT,ELEC:GROUND (ATTACHING PARTS)	80009	131-2661-00
-5	211-0198-00	B010100	B010319X	2		. SCREW,MACHINE:4-40 X 0.438 PNH,STL,POZ	77250	OBD
-6	210-1002-00	B010100	B010319X	2		. WASHER,FLAT:0.125 ID X 0.25 INCH OD,BRS - - - * - - -	12327	OBD
	211-0121-00	XB010320		2		. SCR,ASSEM WSHR:4-40 X 0.438 INCH,PNH BRS	83385	OBD
-7	131-2472-01			2		. . CONTACT,ELEC:GROUND W/NUT BLOCK	80009	131-2472-01
-8	386-4358-01			2		. . PLATE,RETAINER:SIDE (ATTACHING PARTS)	80009	386-4358-01
-9	211-0207-00	B010100	B010512	2		. . SCR,ASSEM WSHR:4-40 X 0.312 DOUBLE SEMS	83385	OBD
	211-0207-00	B010513		1		. . SCR,ASSEM WSHR:4-40 X 0.312 DOUBLE SEMS	83385	OBD
	211-0121-00	XB010513		1		. . SCR,ASSEM WSHR:4-40 X 0.438 INCH,PNH BRS - - - * - - -	83385	OBD
-10	386-4357-01			2		. . PLATE,RETAINER:LOWER (ATTACHING PARTS)	80009	386-4357-01
-11	211-0121-00			4		. . SCR,ASSEM WSHR:4-40 X 0.438 INCH,PNH BRS - - - * - - -	83385	OBD
-12	-----			2		. . RESISTOR,NTWK:(SEE A19R20 REPL)		
-13	131-1758-09			2		. . CONT ASSY,ELEC:2 CONTACTS	80009	131-1758-09
-14	131-1758-10			2		. . CONT ASSY,ELEC:2 CONTACTS	80009	131-1758-10
-15	386-4356-01			2		. . PLATE,RETAINER:UPPER (ATTACHING PARTS)	80009	386-4356-01
-16	211-0121-00			6		. . SCR,ASSEM WSHR:4-40 X 0.438 INCH,PNH BRS - - - * - - -	83385	OBD
-17	-----			2		. . RESISTOR,NTWK:(SEE A19R30 REPL)		
-18	131-1758-08			2		. . CONT ASSY,ELEC:5 CONTACTS	80009	131-1758-08
-19	131-1758-07			2		. . CONT ASSY,ELEC:4 CONTACTS	80009	131-1758-07
-20	376-0051-00			2		. CPLG,SHAFT,FLEX:0.127 ID X 0.375 ID DELRIN	80009	376-0051-00
-21	407-2504-00			2		. BRACKET,CMPNT:VAR RESISTOR (ATTACHING PARTS)	80009	407-2504-00
-22	211-0101-00			2		. SCREW,MACHINE:4-40 X 0.25,100 DEG,FLH STL - - - * - - -	83385	OBD
-23	-----			2		. RESISTOR,VAR:(SEE A19R902,R906 REPL) (ATTACHING PARTS)		
-24	210-0583-00			2		. NUT,PLAIN,HEX.:0.25-32 X 0.312 INCH,BRS	73743	2X20317-402
-25	210-0046-00			2		. WASHER,LOCK:0.261 ID,INTL,0.018 THK,BRS - - - * - - -	78189	1214-05-00-0541C
-26	175-3850-00			2		. CA ASSY,SP,ELEC:2,26 AWG,3.0 L,RIBBON	80009	175-3850-00
	352-0169-01			2		. . HLDR TERM CONN:2 WIRE,BROWN	80009	352-0169-01

**Replaceable Mechanical Parts—2336 Service**

Fig. & Index No.	Tektronix Part No.	Serial/Model No. Eff Dscont	Qty	1 2 3 4 5	Name & Description	Mfr Code	Mfr Part Number
5-	672-0919-00		1		CKT BOARD ASSY:TIMING SWITCH	80009	672-0919-00
-1	401-0340-01		1		. BEARING,RTRY SW:FRONT,0.375 DIA (ATTACHING PARTS)	80009	401-0340-01
-2	213-0759-00		3		. SCR,TPG,THD FOR:2-28 X 0.437 INCH,PNH,STL - - - * - - -	93907	OBD
-3	214-1627-00		2		. LATCH,SLIDING:	80009	214-1627-00
-4	214-1126-01		2		. SPRING,FLAT:GREEN COLORED	80009	214-1126-01
-5	384-1573-01		1		. SHAFT,ROTARY SW:8.61 L X 0.125 OD	80009	384-1573-01
-6	384-1616-00		1		. EXTENSION SHAFT:9.375 L X 0.081 OD	80009	384-1616-00
-7	384-1572-01		1		. SHAFT,ROTARY SW:TIME DIV	80009	384-1572-01
-8	352-0457-28		1		. HOLDER,CONTACT:PANCAKE SW,2 CONT	80009	352-0457-28
-9	-----		1		. CKT BOARD ASSY:A TIMING SW(SEE A17 REPL)		
-10	131-0608-00		8		. . TERMINAL,PIN:0.365 L X 0.025 PH BRZ GOLD	22526	47357
-11	131-0787-00		20		. . CONTACT,ELEC:0.64 INCH LONG	22526	47359
-12	352-0457-26		1		. HOLDER,CONTACT:PANCAKE SW,4 CONT	80009	352-0457-26
-13	401-0345-01		1		. ROTOR,ELEC SW:PULL/TURN	80009	401-0345-01
-14	105-0694-01		1		. STOP RTRY SW:	80009	105-0694-01
-15	354-0550-00		1		. RING,RETAINING:EXTERNAL, FOR 0.44 OD	000AQ	OBD
-16	214-1352-00		1		. SPRING,HLCPS:0.2 OD X 0.5 L,CLOSED	000DW	OBD
-17	401-0406-00		1		. BEARING,RTRY SW:INTERMEDIATE	80009	401-0406-00
-18	214-1127-00		2		. ROLLER,DETENT:0.125 DIA X 0.125,SST	80009	214-1127-00
-19	214-1126-01		2		. SPRING,FLAT:GREEN COLORED	80009	214-1126-01
-20	214-3062-00		1		. DETENT,RTRY SW:24 POSITION	80009	214-3062-00
-21	352-0457-29		1		. HOLDER,CONTACT:PANCAKE SW,3 CONTACT	80009	352-0457-29
-22	-----		1		. CKT BOARD ASSY:B TIMING SW(SEE A16 REPL)		
-23	131-0787-00		6		. . CONTACT,ELEC:0.64 INCH LONG	22526	47359
-24	352-0457-27		1		. HOLDER,CONTACT:PANCAKE SW,1 CONTACT	80009	352-0457-27
-25	401-0341-02		1		. BEARING,RTRY SW:REAR,0.315 ID	80009	401-0341-02
-26	376-0039-00	B010100 B010512	1		. ADPT,SHAFT,CPLG:0.128 AND 0.082"DIA SHAFT	80009	376-0039-00
	376-0050-00	B010513	1		. CPLG,SHAFT,FLEX:FOR 0.081/0.125 INCH SHAFTS	80009	376-0050-00
-27	407-2102-00		1		. BRACKET,ELEC SW:TIMING (ATTACHING PARTS)	80009	407-2102-00
-28	213-0772-00		3		. SCREW,TPG,TF:2-56 X 0.5,PLASTITE,PNH,STL - - - * - - -	93907	OBD
-29	-----		1		. RESISTOR,VAR:(SEE R930 REPL)		

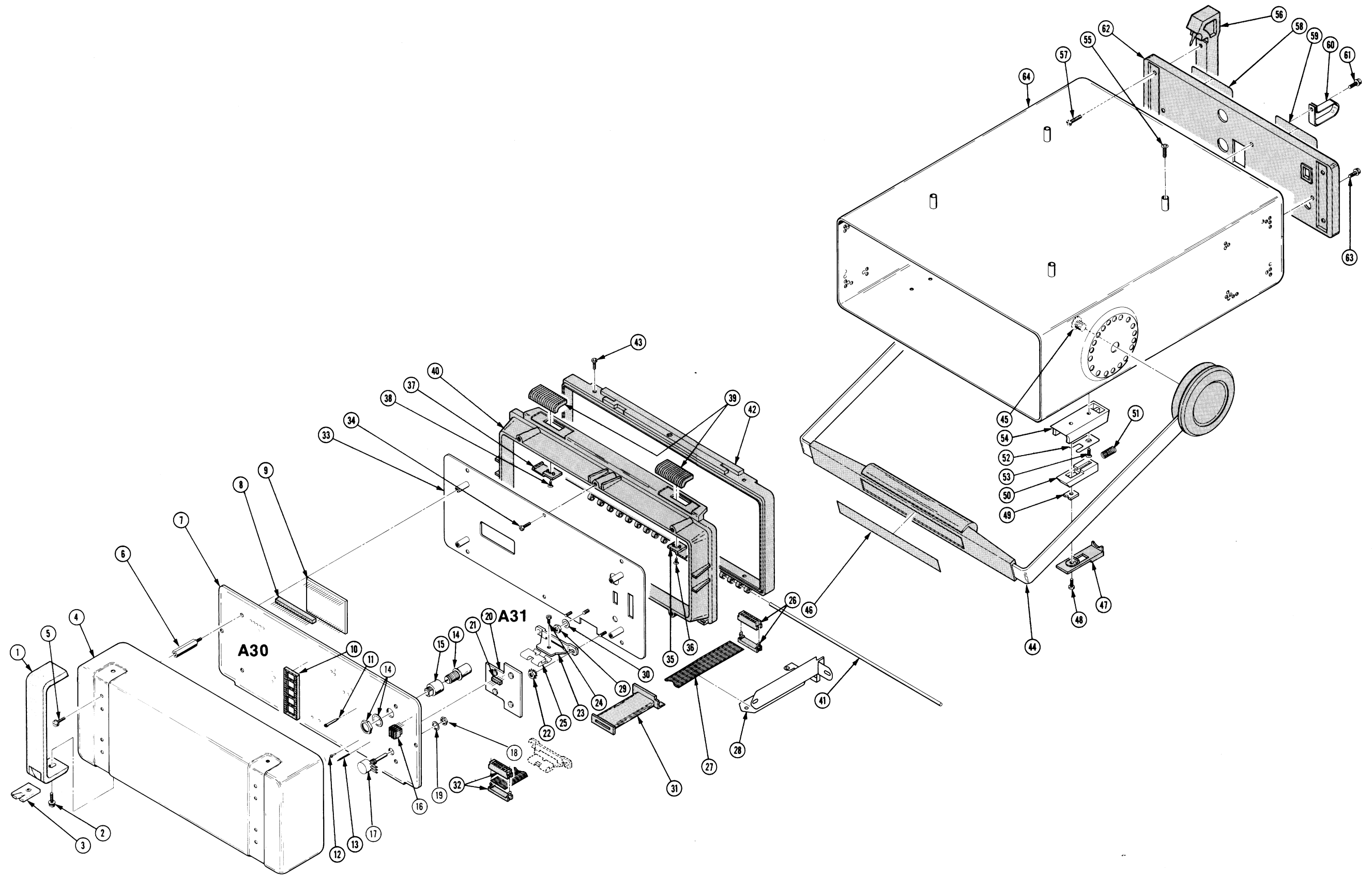

4

REV NOV 1981

2336 OSCILLOSCOPE

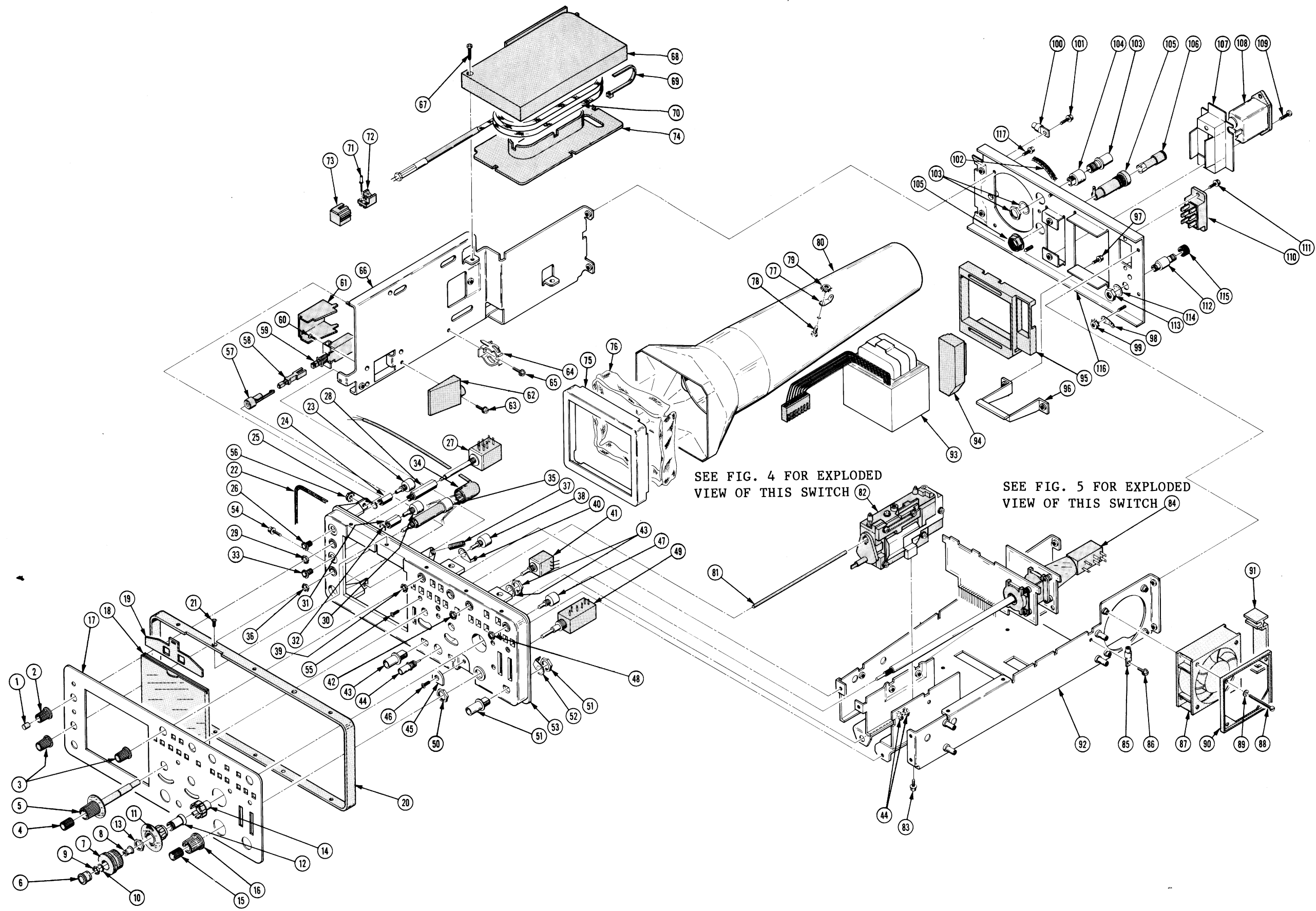



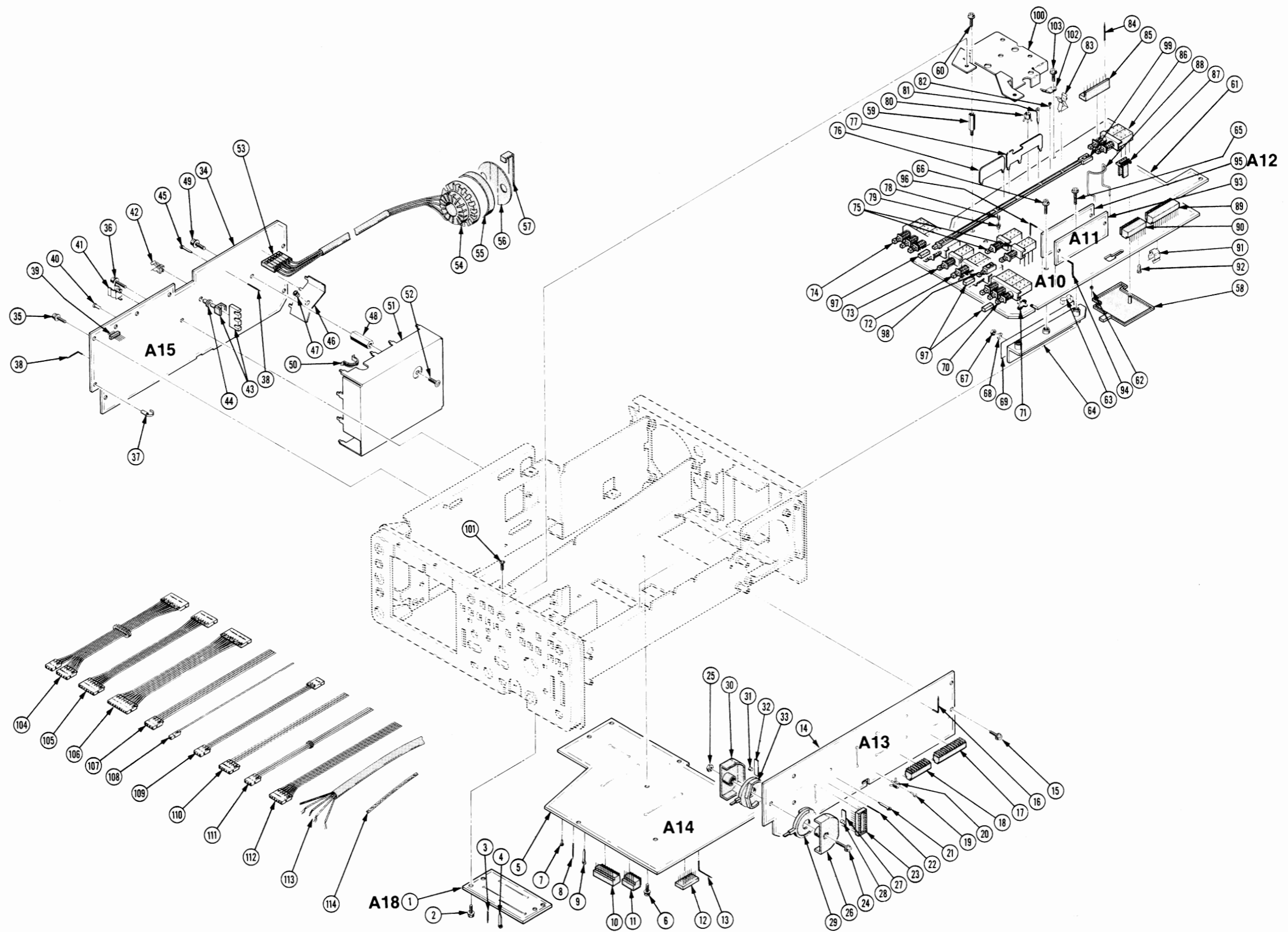

REV, JUL 1981

44

2335 OSCILLOSCOPE

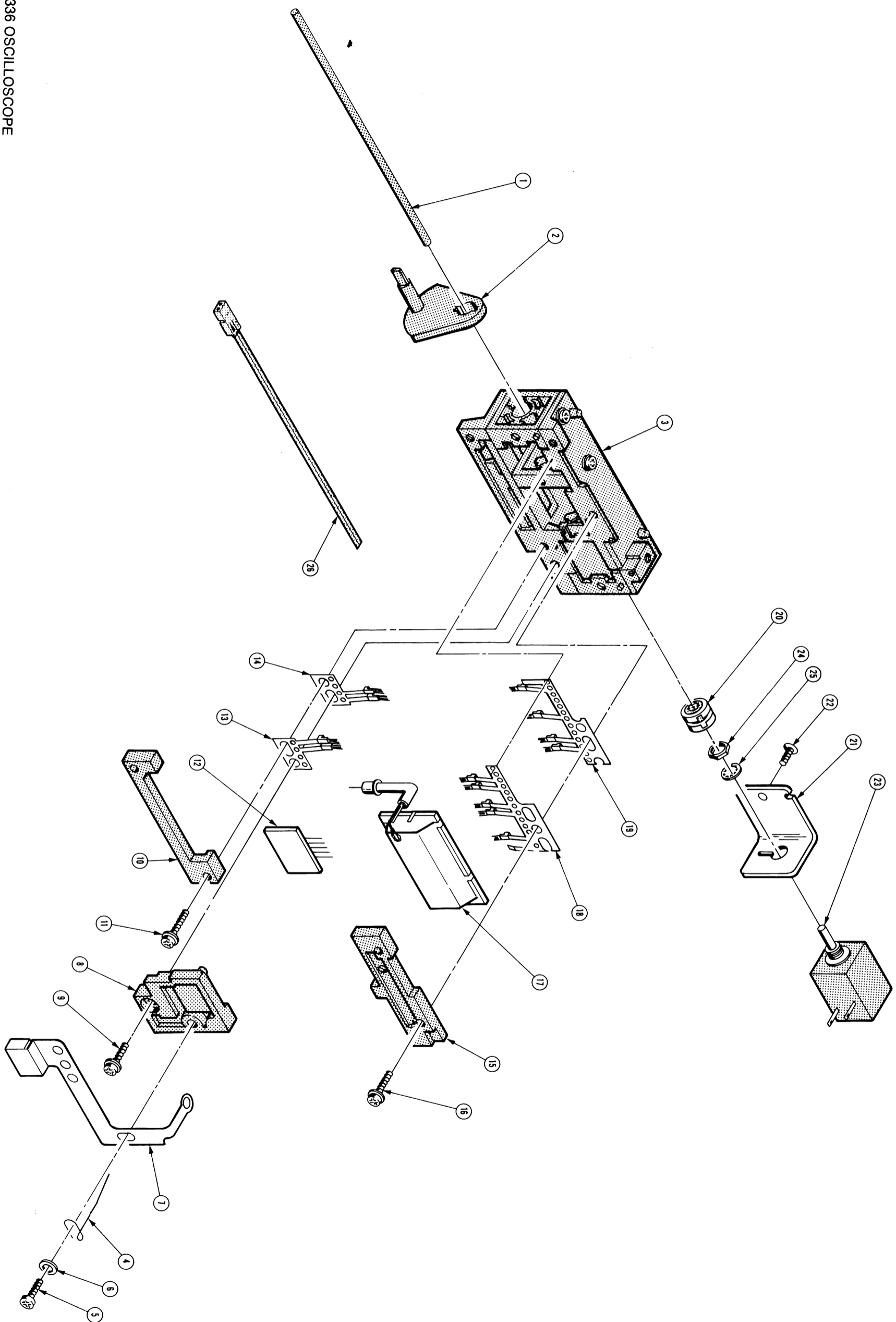

2336 OSCILLOSCOPE

4

©

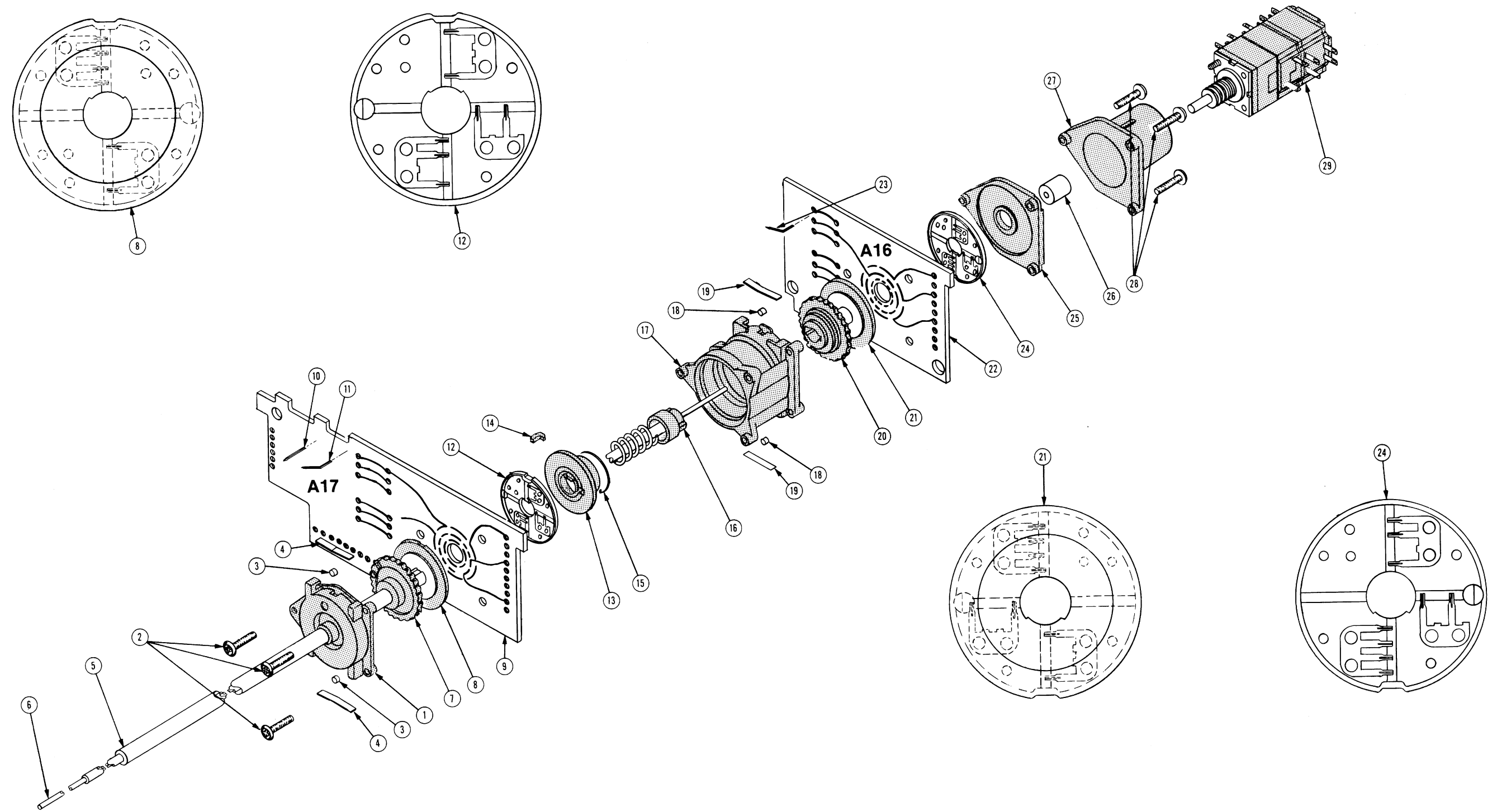

FIG. 5 TIMING SWITCH

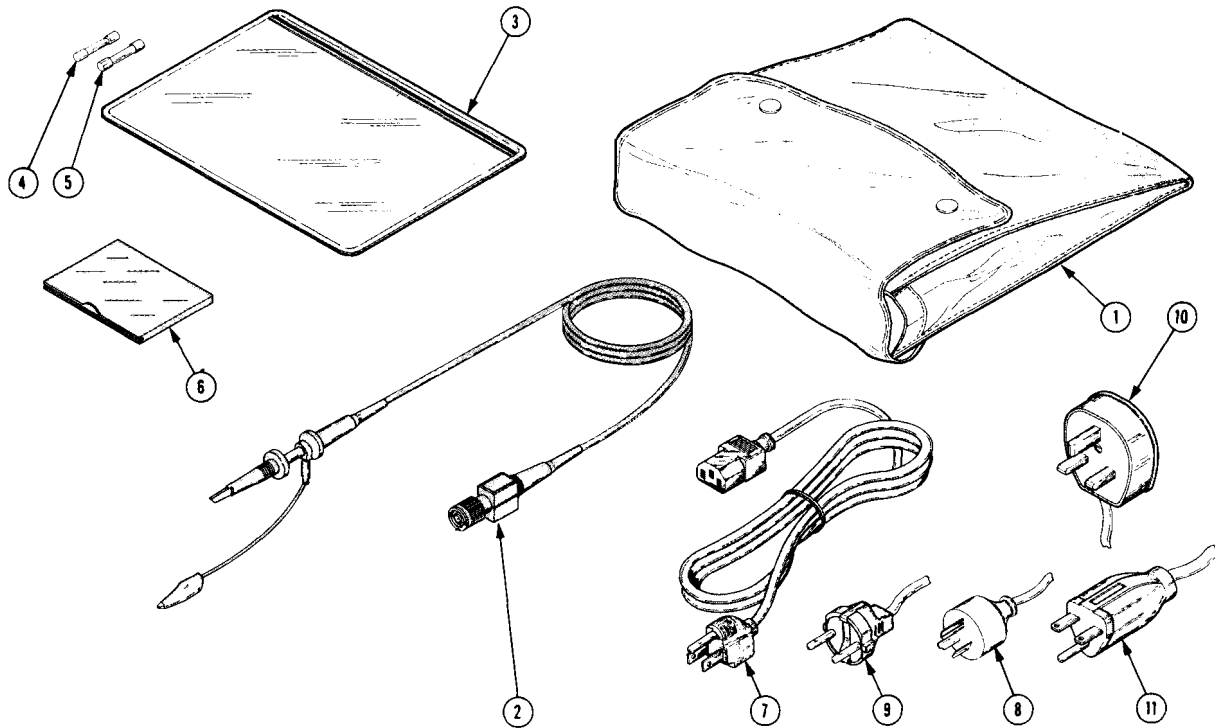

Fig. & Index No.	Tektronix Part No.	Serial/Model No. Eff Dscnt	Qty	1	2	3	4	5	Name & Description	Mfr Code	Mfr Part Number
STANDARD ACCESSORIES											
-1	016-0674-01		1						POUCH,ACCESSORY:	80009	016-0674-01
	016-0674-00		1						. POUCH,ACCESSORY:	80009	016-0674-00
	386-4615-00		1						. PLATE,REINF:	80009	386-4615-00
	212-0008-00		4						. SCREW,MACHINE:8-32 X 0.500,PNH	83385	OBD
	210-0967-00		4						. WASHER,SHLDR:0.156 ID X 0.094 D	86928	5607-82
	020-0646-00		1						. ACCESSORY PKG:	80009	020-0646-00
	006-0764-00		1						. BAG,PLASTIC:	80009	006-0764-00
-2	010-6108-03		2						. PROBE,VOLTAGE:P6108,10X,2 METER W/ACCESS	80009	010-6108-03
-3	016-0537-00		1						. POUCH,ACCESSORY:VINYL,W/ZIPPER	05006	OBD
-4	159-0022-00		2						. FUSE,CARTRIDGE:3AG,1A,250V,FAST-BLOW	71400	AGC 1
	-----		-						. (REPLACED BY 159-0181-00 FOR OPTIONS A1,		
	-----		-						. A2 & A3)		
-5	159-0025-00		1						. FUSE,CARTRIDGE:3AG,0.5A,250V,FAST-BLOW	71400	AGC 1/2
	-----		-						. (REPLACED BY 159-0182-00 FOR OPTIONS A1,		
	-----		-						. A2 & A3)		
	337-2760-00		1						. SHLD,IMPLOSION:	80009	337-2760-00
	-----		-						. (INSTALLED)		
-6	337-2781-00		1						. SHLD,IMPLOSION:3.085 X 3.71,NATURAL	80009	337-2781-00
	070-4117-00		1						MANUAL,TECH:OPERATORS	80009	070-4117-00
	070-4118-00		1						MANUAL,TECH:SERVICE	80009	070-4118-00
-7	161-0104-00		1						CABLE ASSY,PWR,:3 WIRE,98.0 LONG	80009	161-0104-00
-8	161-0104-05		1						CABLE ASSY,PWR:3,18 AWG,240V,98.0 L	86221	OBD
	-----		-						(OPTION A3 AUSTRALIAN)		
-9	161-0104-06		1						CABLE ASSY,PWR:3 X 0.75MM SQ,220V,98.0 L	80126	OBD
	-----		-						(OPTION A1 EUROPEAN)		
-10	161-0104-07		1						CABLE ASSY,PWR:3 X 0.75MM SQ,240V,98.0 L	80126	OBD
	-----		-						(OPTION A2 UNITED KINGDOM)		
	159-0172-00		1						. FUSE,CARTRIDGE:TYPE C,13 AMP	80009	159-0172-00
-11	161-0104-08		1						CABLE ASSY,PWR:3,18 AWG,240V,98.0 L	80126	OBD
	-----		-						(OPTION A4 NORTH AMERICAN)		

## **MANUAL CHANGE INFORMATION**

At Tektronix, we continually strive to keep up with latest electronic developments by adding circuit and component improvements to our instruments as soon as they are developed and tested.

Sometimes, due to printing and shipping requirements, we can't get these changes immediately into printed manuals. Hence, your manual may contain new change information on following pages.

A single change may affect several sections. Since the change information sheets are carried in the manual until all changes are permanently entered, some duplication may occur. If no such change pages appear following this page, your manual is correct as printed.

**DESCRIPTION**

TEXT CHANGES

Page 1-9 Table 1-1 Electrical Characteristics

INTERNAL POWER SUPPLIES

CHANGE:

Characteristics	Initial Setting
+102 V	± 2.5%

Page 5-5 INITIAL CONTROL SETTINGS

CHANGE: CRT

INTEN Minimum (Fully counterclockwise)

Page 5-6 Table 5-2 Main Power Supply Tolerances and p-p Ripple

CHANGE:

+102 V	TP 320	+99.4 to +104.6	± 2.5%	1 V
--------	--------	--------------------	--------	-----

REPLACEABLE ELECTRICAL PARTS LIST CHANGES

REF

ADD:

A11Q10 151-0188-03 TRANSISTOR:SILICON,PNP,SEL

A12CR16 152-0141-02 SEMICOND DEVICE:SILICON,30V,150MA

CHANGE:

CHASSIS PARTS

S901 260-1967-02 SWITCH,SLIDE:DPDT,5A/250V,10A/125 V, MKD

PC 94

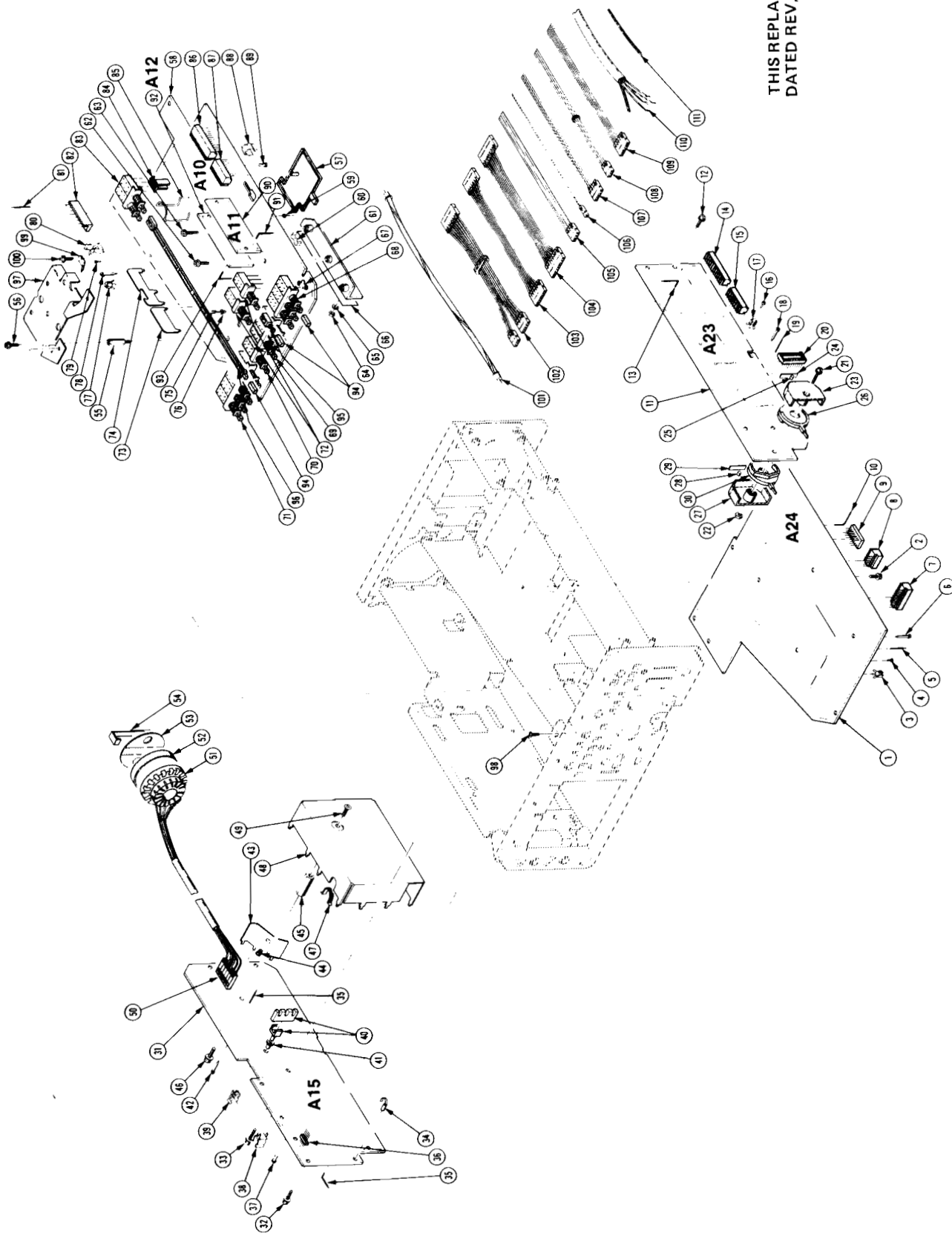

THIS REPLACES FIG. 3 CHASSIS  
DATED REV, JUL 1981

2336 OSCILLOSCOPE

C6/182

PAGE 1 OF 1

070-4118-00

**DESCRIPTION**

EFF ALL SN

TEXT CHANGES

Page 5-10 Step 4. Check AUTO Vertical Mode Operation

CHANGE section f to read....with a period of approximately 4 us....

DIAGRAM CHANGES

DIAGRAM 4 VERTICAL SWITCHING LOGIC & CHOP BLANKING

Connect both ends of R197 and C197 together at location 6D.

DIAGRAM 5 TRIGGER

INTERCHANGE: the + and - signs on S219 SLOPE button at location 1J  
(button out is + slope)

DIAGRAM 10 LOW VOLTAGE POWER SUPPLY

CHANGE: the value of F257 (location 7C) to 1.5A

REPLACEABLE ELECTRICAL PARTS LIST CHANGES

ADD: A30VR6 156-1490-00 MICROCKT, LINEAR: VOLTAGE REFERENCE, 1.2V



### DESCRIPTION

EFF SN: SEE BELOW

#### REPLACEABLE ELECTRICAL PARTS LIST

CHANGE:	SN	PN	DESCRIPTION	PC
A10C27	B010540	281-0772-00	CAP,FXD,CER DI: 4700PF,10%,100V	60
A10C88	B010540	281-0772-00	CAP,FXD,CER DI: 4700PF,10%,100V	60
A10Q246	B010655	151-0476-01	TRANSISTOR: SILICON,NPN	57
A10R46	B010575	317-0911-00	RES,FXD,CMPSN: 910 OHM,5%,0.125W	68
A10R47	B010575	311-0634-00	RES,VAR,NONWW: TRMR,500 OHM,0.5W	68
A10R48	B010575	317-0331-00	RES,FXD,CMPSN: 330 OHM,5%,0.125W	68
A10R114	B010575	311-0634-00	RES,VAR,NONWW: TRMR,500 OHM,0.5W	68
A10R115	B010575	317-0911-00	RES,FXD,CMPSN: 910 OHM,5%,0.125W	68
A10R118	B010575	317-0331-00	RES,FXD,CMPSN: 330 OHM,5%,0.125W	68
A23C4	B011100	281-0547-00	CAP,FXD,CER DI: 2.7PF,±0.25PF,500V	90
A23C8	B011100	281-0814-01	CAP,FXD,CER DI: 100PF,10%,500V	90
A23R11	B011100	317-0620-00	RES,FXD,CMPSN: 62 OHM,5%,0.125W	90
A30C15	B010655	285-1238-00	CAP,FXD,PLASTIC: 0.22UF,20%,100V	71
A30C16	B010655	285-1238-00	CAP,FXD,PLASTIC: 0.22UF,20%,100V	71
ADD:				
A10R45	B010575	317-0331-00	RES,FXD,CMPSN: 330 OHM,5%,0.125W	68
A10R116	B010575	317-0331-00	RES,FXD,CMPSN: 330 OHM,5%,0.125W	68
A30R9	B010655	317-0824-00	RES,FXD,CMPSN: 820K OHM,5%,0.125W	71
REMOVE:				
A10C231	B010540	281-0814-00	CAP,FXD,CER DI: 100PF,10%,500V	77

#### DIAGRAM CHANGES

DIAGRAM  CH 1 & CH 2 VERT PREAMPS & DELAY LINE DRIVER

##### CHANGE:

- C27 (location 3B) to a 4700PF capacitor.
- C88 (location 6B) to a 4700PF capacitor.
- R46 (location 3E) to a 910 Ω resistor.
- R47 (location 3E) to a 500 Ω variable resistor.
- R48 (location 3E) to a 330 Ω resistor.
- R114 (location 6E) to a 500 Ω variable resistor.
- R115 (location 7E) to a 910 Ω resistor.
- R118 (location 7E) to a 330 Ω resistor.

##### ADD:

- R45 (330 Ω) in parallel with RT46 (location 3E).
- R116 (330 Ω) in parallel with RT115 (location 6E).

DESCRIPTION

DIAGRAM CHANGES (cont)

DIAGRAM  $\diamond 5$  TRIGGER

CHANGE:

C4 (location 2B) to a 2.7PF capacitor.

C8 (location 2B) to a 100PF capacitor.

R11 (location 2B) to a 62  $\Omega$  resistor.

DIAGRAM  $\diamond 10$  LOW VOLTAGE POWER SUPPLY

REMOVE:

C231 (location 2G).

DIAGRAM  $\diamond 11$  DELTA TIME LOGIC

ADD:

R9 (820K  $\Omega$ ) in parallel with the 1K  $\Omega$  section of R8 (location 2C).