

Scan by Zenith

**TEK** SERVICE  
MANUAL

070-6741-00  
Product Group 46

**CFC250  
FREQUENCY  
COUNTER  
SERVICE**

**Tektronix**  
COMMITTED TO EXCELLENCE

Tillhör  
**TEKTRONIX AB**  
Service  
08/83 00 80



# CFC250 FREQUENCY COUNTER SERVICE

**WARNING**

THE FOLLOWING SERVICING INSTRUCTIONS ARE FOR USE BY QUALIFIED PERSONNEL ONLY. TO AVOID PERSONAL INJURY, DO NOT PERFORM ANY SERVICING OTHER THAN THAT CONTAINED IN OPERATING INSTRUCTIONS UNLESS YOU ARE QUALIFIED TO DO SO. REFER TO OPERATORS SAFETY SUMMARY AND SERVICE SAFETY SUMMARY PRIOR TO PERFORMING ANY SERVICE.

*Please Check for  
CHANGE INFORMATION  
at the Rear of This Manual*

Copyright © 1988 Tektronix, Inc. All rights reserved. Contents of this publication may not be reproduced in any form without the written permission of Tektronix, Inc.

Products of Tektronix, Inc. and its subsidiaries are covered by U.S. and foreign patents issued and pending.

TEKTRONIX, TEK, SCOPE-MOBILE, and  are registered trademarks of Tektronix, Inc.

Printed in U.S.A. Specification and price change privileges are reserved.

## INSTRUMENT SERIAL NUMBERS

Each instrument has a serial number on a panel insert, tag, or stamped on the chassis. The first two digits designate the country of manufacture. The last five digits of the serial number are unique to each instrument. The country of manufacture is identified as follows:

B000000 Tektronix, Inc., Beaverton, Oregon, U.S.A.

E200000 Tektronix United Kingdom, Ltd., London

G100000 Tektronix Guernsey, Ltd., Channel Islands

HK00000 Hong Kong

H700000 Tektronix Holland, NV, Heerenveen,  
The Netherlands

J300000 Sony/Tektronix, Japan

# TABLE OF CONTENTS

	Page		Page
LIST OF ILLUSTRATIONS .....	iii	<b>Section 4</b>	<b>PERFORMANCE CHECK PROCEDURE</b>
LIST OF TABLES .....	iii		INTRODUCTION .....
OPERATORS SAFETY SUMMARY .....	iv		4-1
SERVICING SAFETY SUMMARY .....	v		TEST EQUIPMENT NEEDED .....
			4-1
			PREPARATION .....
			4-2
			PROCEDURE .....
			4-2
<b>Section 1</b>	<b>GENERAL INFORMATION</b>	<b>Section 5</b>	<b>ADJUSTMENT PROCEDURE</b>
	INTRODUCTION .....		INTRODUCTION .....
	1-1		5-1
	SPECIFICATION .....		PREPARATION FOR ADJUSTMENT .....
	1-1		5-1
			PROCEDURE .....
			5-1
<b>Section 2</b>	<b>PREPARATION FOR USE</b>	<b>Section 6</b>	<b>MAINTENANCE</b>
	SAFETY .....		STATIC-SENSITIVE COMPONENTS .....
	2-1		6-1
	LINE VOLTAGE .....		PREVENTIVE MAINTENANCE ...
	2-1		6-2
	POWER CORD .....		INSPECTION AND CLEANING .....
	2-1		6-2
	FUSES .....		TROUBLESHOOTING .....
	2-2		6-4
	OPERATING INFORMATION .....		TROUBLESHOOTING AIDS ..
	2-2		6-4
			TROUBLESHOOTING TECHNIQUES .....
			6-4
			TROUBLESHOOTING TIPS ...
			6-8
<b>Section 3</b>	<b>THEORY OF OPERATION</b>		CORRECTIVE MAINTENANCE .....
	INTRODUCTION .....		6-11
	3-1		MAINTENANCE PRECAUTIONS .....
	DIGITAL LOGIC CONVENTIONS .....		6-11
	3-1		OBTAINING REPLACEMENT PARTS .....
	BLOCK DIAGRAM DESCRIPTION .....		6-11
	3-1		REPACKAGING FOR SHIPMENT .....
	DETAILED CIRCUIT DESCRIPTION .....		6-11
	3-1		

	Page		Page
MAINTENANCE AIDS .....	6-12	<b>Section 7</b>	<b>OPTIONS</b>
INTERCONNECTIONS .....	6-12		INTERNATIONAL POWER
TRANSISTORS AND			CORDS .....
INTEGRATED CIRCUITS ....	6-12		7-1
SOLDERING		<b>Section 8</b>	<b>REPLACEABLE PARTS</b>
TECHNIQUES .....	6-13	<b>Section 9</b>	<b>DIAGRAMS</b>
REMOVAL AND			<b>CHANGE INFORMATION</b>
REPLACEMENT			
INSTRUCTIONS .....	6-14		

# LIST OF ILLUSTRATIONS

Figure		Page
	The CFC250 Digital Multimeter .....	vi
2-1	Rear Panel .....	2-1
2-2	Optional power cords .....	2-2
3-1	Block Diagram .....	3-2
6-1	Digit Strobe Waveforms .....	6-9
9-1	Color codes for resistors.	
9-2	Semiconductor lead configurations.	
9-3	Main circuit board and adjustment locations.	
9-4	Display circuit board.	

# LIST OF TABLES

Table		Page
1-1	General Characteristics .....	1-2
1-2	Electrical Characteristics .....	1-3
4-1	Test Equipment Required .....	4-1
6-1	Relative Susceptibility to Static-Discharge Damage .....	6-1
6-2	External Inspection Checklist .....	6-3
6-3	Internal Inspection Checklist .....	6-3
6-4	Normal CFC250 Displays .....	6-8
6-5	Correct Waveforms at Input Circuit Test Points .....	6-10
6-6	Maintenance Aids .....	6-12

# OPERATORS SAFETY SUMMARY

The general safety information in this part of the summary is for both operating and servicing personnel. Specific warnings and cautions will be found throughout the manual where they apply and do not appear in this summary.

## Terms in This Manual

**CAUTION** statements identify conditions or practices that could result in damage to the equipment or other property.

**WARNING** statements identify conditions or practices that could result in personal injury or loss of life.

## Terms as Marked on Equipment

**CAUTION** indicates a personal injury hazard not immediately accessible as one reads the markings, or a hazard to property, including the equipment itself.

**DANGER** indicates a personal injury hazard immediately accessible as one reads the marking.

## Symbols in This Manual



This symbol indicates where applicable cautionary or other information is to be found. For maximum input voltage see Tables 1-1 and 1-2.

## Symbols as Marked on Equipment



**DANGER** – High voltage.



Protective ground (earth) terminal.



**ATTENTION** – Refer to manual.



Replace fuse as specified – Refer to manual.

## Power Source

This product is intended to operate from a power source that does not apply more than 250 volts rms between the supply conductors or between either supply conductor and ground. A protective ground connection, by way of the grounding conductor in the power cord, is essential for safe operation.

## Grounding the Product

This product is grounded through the grounding conductor of the power cord. To avoid electrical shock, plug the power cord into a properly wired receptacle before making any connections to the product input or output terminals. A protective ground connection, by way of the grounding conductor in the power cord, is essential for safe operation.

## Danger Arising From Loss of Ground

Upon loss of the protective-ground connection, all accessible conductive parts (including knobs and controls that may appear to be insulating) can render an electric shock.

## Use the Proper Power Cord

Use only the power cord and connector specified for your product.

Use only a power cord that is in good condition.

For detailed information on power cords and connectors, see Figure 2-2.

## Use the Proper Fuse

To avoid fire hazard, use only a fuse of the correct type, voltage rating, and current rating as specified in the parts list for your product.

## Do Not Operate in an Explosive Atmosphere

To avoid explosion, do not operate this instrument in an explosive atmosphere.

## Do Not Remove Covers or Panels

To avoid personal injury, do not remove the product covers or panels. Do not operate the instrument without the covers and panels properly installed.

# SERVICING SAFETY SUMMARY

*FOR QUALIFIED SERVICE PERSONNEL ONLY*

*Refer also to the preceding Operators Safety Summary*

## **Do Not Service Alone**

Do not perform internal service or adjustment of this product unless another person capable of rendering first aid and resuscitation is present.

## **Use Care When Servicing With Power On**

Dangerous voltages exist at several points in this product. To avoid personal injury, do not touch exposed connections or components while power is on.

Disconnect power before removing protective panels, soldering, or replacing components.

## **Power Source**

This product is intended to operate from a power source that does not apply more than 250 volts rms between the supply conductors or between either supply conductor and ground. A protective ground connection by way of the grounding connector in the power cord is essential for safe operation.



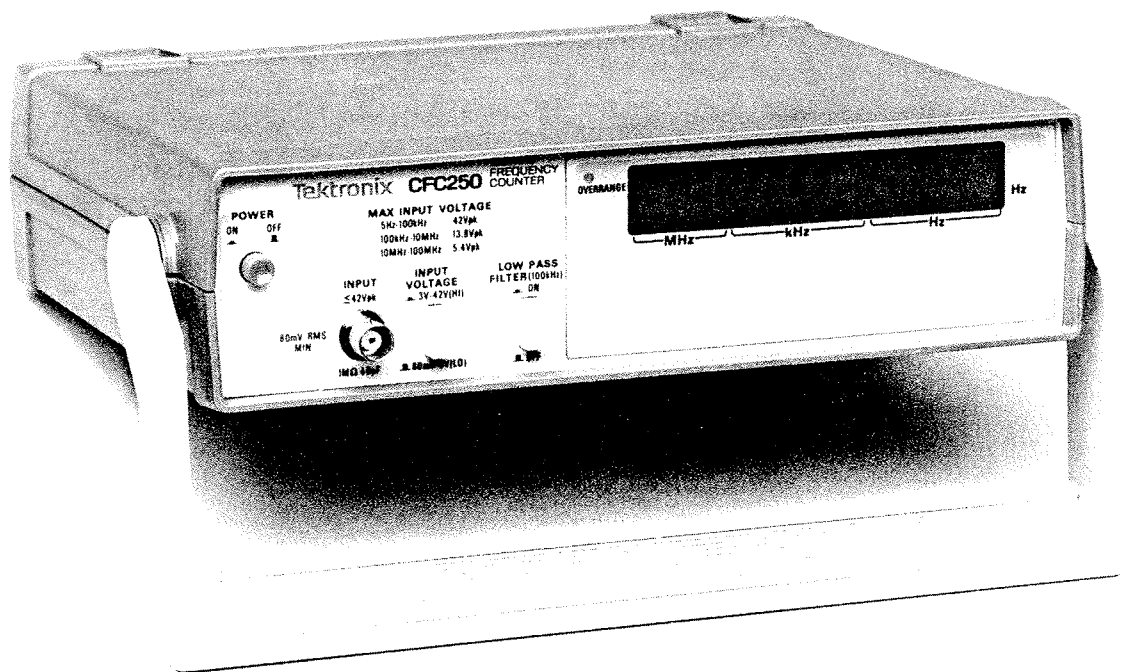

6741-02

The CFC250 Frequency Counter.

# GENERAL INFORMATION

## INTRODUCTION

The TEKTRONIX CFC250 100 MHz Frequency Counter counts the signal frequency of sine, square, and triangle waves from 5 Hz to 100 MHz at input levels from 80 mV to 42 V peak. The frequency count is shown on an eight-digit, LED (light-emitting diode) numerical display.

The CFC250 has a LOW PASS FILTER that can be switched on to prevent high-frequency interference on signals below 100 kHz. Other front-panel features include an OVERRANGE indicator, an automatic MHz decimal point, and an INPUT VOLTAGE pushbutton for switching input sensitivity.

The frequency counter has a locking, multiposition handle that folds under the instrument to allow stacking with other instruments of the same series.

Standard accessories provided with the CFC250 include a power cord and an Operator's manual. For part numbers and further information about standard and optional accessories, refer to Replaceable Parts (section 8) in this manual. For additional information, contact your Tektronix Sales Office or Distributor and the Tektronix products catalog.

## SPECIFICATION

General characteristics are given in Table 1-1. The electrical characteristics given in Table 1-2 are valid when the instrument has been adjusted at an ambient temperature between +21°C and +25°C, has had a warmup period of at least one hour, and is operating at an ambient temperature between +10°C and +40°C, with 75% maximum relative humidity.

**Table 1-1**  
**General Characteristics**

Characteristics	Performance Requirements
<b>OPERATIONAL</b>	
Display	Eight-digit, 0.43-inch, seven-segment LED readout.
Overflow Indicator	OVERRANGE LED.
Input Voltage (Attenuation)	Selectable; 80 mV-5 V or 3 V-42 V.
Time Base	Crystal-controlled oscillator.
Gate Time	1 second.
<b>PHYSICAL</b>	
Width	240 mm (9.4 in).
Height	64 mm (2.5 in).
Depth	190 mm (7.48 in).
Weight	1.9 kg (4.2 lb).
<b>ENVIRONMENTAL</b>	
Operating Temperature	+10°C to +40°C, ≤75% relative humidity.
Nonoperating Temperature	-10°C to +60°C, ≤80% relative humidity.

**Table 1-2**  
**Electrical Characteristics**

Characteristics	Performance Requirements
Line Voltage Range	90 to 110, 108 to 132, 198 to 242, and 216 to 250 Vac at 50–60 Hz.
Power Consumption	15 VA, 12 W maximum.
Frequency Range	5 Hz to 100 MHz, ac coupled.
Maximum Input Voltage	
5 Hz to 100 kHz	42 V peak.
100 kHz to 10 MHz	13.8 V peak.
10 MHz to 100 MHz	5.4 V peak.
Typical Sensitivity (minimum input voltage)	
5 Hz to 30 MHz	30 mV <sub>rms</sub> .
30 MHz to 70 MHz	50 mV <sub>rms</sub> .
70 MHz to 100 MHz	80 mV <sub>rms</sub> .
Accuracy	±1 count ± time base accuracy.
Time Base Accuracy	
Crystal Frequency	3.579545 MHz ±3 ppm.
Temperature Stability	±10 ppm, 0 to 50°C.
Aging Rate	±10 ppm per year.
Resolution	1 Hz.
Impedance	1.0 MΩ, paralleled by 40 pF.





# PREPARATION FOR USE

## SAFETY

This section of the manual tells how to proceed with the initial start-up of the instrument.

Refer to the Safety Summaries at the front of this manual for power source, grounding, and other safety considerations pertaining to the use of the instrument. Before connecting the CFC250 to a power source, read both this section and the Safety Summaries.

## LINE VOLTAGE



*This instrument may be damaged if operated with the LINE VOLTAGE SELECT switches set for the wrong line voltage.*

This product is intended to operate from a power source that does not supply more than 250 V<sub>rms</sub> between the

supply conductors or between either supply conductor and ground. Normal USA line voltage is 120 Vac. Before connecting the power cord to a power-input source, verify that the LINE VOLTAGE SELECT switches on the Rear Panel are set to the correct line voltage setting. Figure 2-1 shows the location of the LINE VOLTAGE SELECT switches.

## POWER CORD

A protective ground connection, the third wire in the power cord, is necessary for safe operation. To avoid electrical shock, plug the power cord into a properly wired receptacle before making any connections to the equipment input terminals. Do not remove the ground lug from the power cord for any reason. Use only the power cord and connector specified for this equipment.

Instruments are shipped with the required power cord as ordered by the customer (see Figure 2-2). Contact your Tektronix representative or Tektronix Field Office for additional power-cord information.

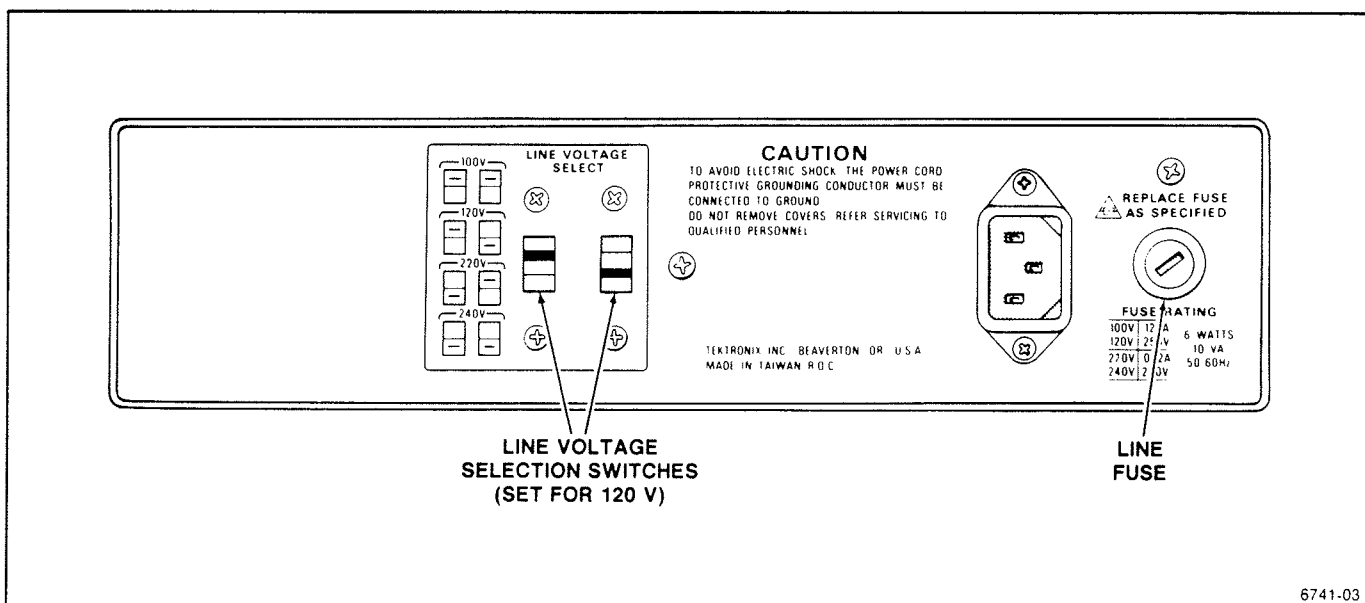

Figure 2-1. Rear Panel.

6741-03

## Preparation for Use – CFC250 Service





Plug Configuration	Option	Power Cord/ Plug Type	Line Voltage	Reference Standards <sup>b</sup>
	U.S. Std.	U.S. 120V	120V	ANSI C73.11 NEMA 5-15-P IEC 83 UL 198.6
	A1	EURO 220V	220V	CEE(7), II, IV, VII IEC 83 IEC 127
	A2	UK <sup>a</sup> 240V	240V	BS 1383 IEC 83 IEC 127
	A3	Australian 240V	240V	AS C112 IEC 127
	A4	North American 240V	240V	ANSI C73.20 NEMA 6-15-P IEC 83 UL 198.6
	A5	Switzerland 220V	220V	SEV IEC 127
<p><sup>a</sup> A 6A, type C fuse is also installed inside the plug of the Option A2 power cord.</p> <p><sup>b</sup> Reference Standards Abbreviations:</p> <p>ANSI – American National Standards Institute  AS – Standards Association of Australia  BS – British Standards Institution  CEE – International Commission on Rules for the Approval of Electrical Equipment  IEC – International Electrotechnical Commission  NEMA – National Electrical Manufacturer's Association  SEV – Schweizerischer Elektrotechnischer Verein  UL – Underwriters Laboratories Inc.</p>				

Figure 2-2. Optional power cords.

## FUSES

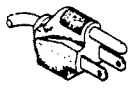
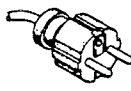

*The instrument may be damaged if operated with the wrong type and rating line fuse installed.*

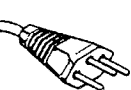
## WARNING

*Unplug the power cord and disconnect the signal input cable from any signal source before checking or changing the fuse.*

Verify the proper value of the fuse with the following procedure. Figure 2-1, Rear Panel, shows the location of the fuse:

1. Disconnect the power cord from the power-input source.
2. Press in the fuse-holder cap and release it with a slight counterclockwise rotation.
3. Pull the cap (with the attached fuse inside) out of the fuse holder.
4. Verify proper fuse value.
5. Install the proper fuse and reinstall the fuse-holder cap.

## OPERATING INFORMATION

Before connecting a signal to the INPUT, be sure to connect the counter to a properly grounded power outlet and check that the signal to be measured does not exceed the specified limits.

Refer to the Operator's manual for this instrument for instrument operation and measurement procedures.

# THEORY OF OPERATION

## INTRODUCTION

This section contains a general description of the CFC250 100 MHz Frequency Counter circuitry. General operation of the instrument is described in the Block Diagram Description. Each functional circuit is described in more detail in the Detailed Circuit Description.

The schematic diagram and the circuit board illustrations are located in the Diagrams section near the rear of this manual. To understand the circuit descriptions in this section, refer to both the Block Diagram, Figure 3-1 in this section, and to the schematic diagram.

## DIGITAL LOGIC CONVENTIONS

Functions and operation of digital logic circuits are represented by logic symbology and terminology. Most logic functions are described using the positive-logic convention. Positive logic is a system of notation whereby the more positive of two levels is the TRUE (or 1) state; the more negative level is the FALSE (or 0) state. In this manual, the TRUE state is referred to as HI, and the FALSE state as LO. The voltages that constitute a HI or a LO state vary between specific devices. For device characteristics, refer to the manufacturer's data book.

## BLOCK DIAGRAM DESCRIPTION

Signal input to the CFC250 is through a BNC connector on the front panel. When INPUT VOLTAGE switch S1 is set to the HI position, the input signal is connected through an Attenuator circuit to the Input Buffer. When S1 is in the LO position, the signal is applied directly to the Input Buffer. A pair of diodes in the Buffer circuit clamp high-amplitude signals. When LOW PASS FILTER switch S2 is set to the ON position, a Low Pass Filter circuit prevents high-frequency interference on signals below 100 kHz.

The signal goes from the Input Buffer to the Amplifier/Schmitt Trigger circuit, which squares the signal. The output of the Time Base, the Control Logic,

and the Schmitt Trigger are routed through the Digit Prescaler circuit to the Main Counter.

The Main Counter, integrated circuit U9, performs all frequency and totaling functions and drives the displays. The output of the Main Counter is connected to the display through the Digit Strobes Driver and the BCD Decoder/Segment Driver. Each digit is selected and turned on momentarily. At the same time, the proper seven-segment and decimal-point data for that digit is sent from the counter.

The BCD Decoder/Segment Driver circuit detects display leading-zeros and triggers the autorange circuitry. Leading zeros are eliminated, and the counted frequency is displayed on eight or less seven-segment LEDs.

The ac power input provides ac power to the transformer through POWER switch S3 and LINE VOLTAGE SELECT switches S4 and S5. Secondary voltages are applied to rectifier-filter circuits to generate two unregulated dc voltages. The unregulated voltages are applied to regulators U13 and U14 to generate two separate +5 V regulated dc supplies.

The CFC250 circuitry returns to chassis ground through the grounded outlet of the power receptacle; the outside of the front-panel BNC INPUT connector is connected through the instrument to the power-source ground.

## DETAILED CIRCUIT DESCRIPTION

### Input Circuits

Signals to be counted are connected via a grounded BNC connector (INPUT) on the front panel.

When INPUT VOLTAGE switch S1 is actuated (set to the HI position), the input signal is connected through an Attenuator circuit before going to the Input Buffer. When S1 is not actuated (LO setting) the signal goes directly to the Input Buffer.

**ATTENUATOR.** Voltage divider R1, R2 attenuates signals by a factor of 10.

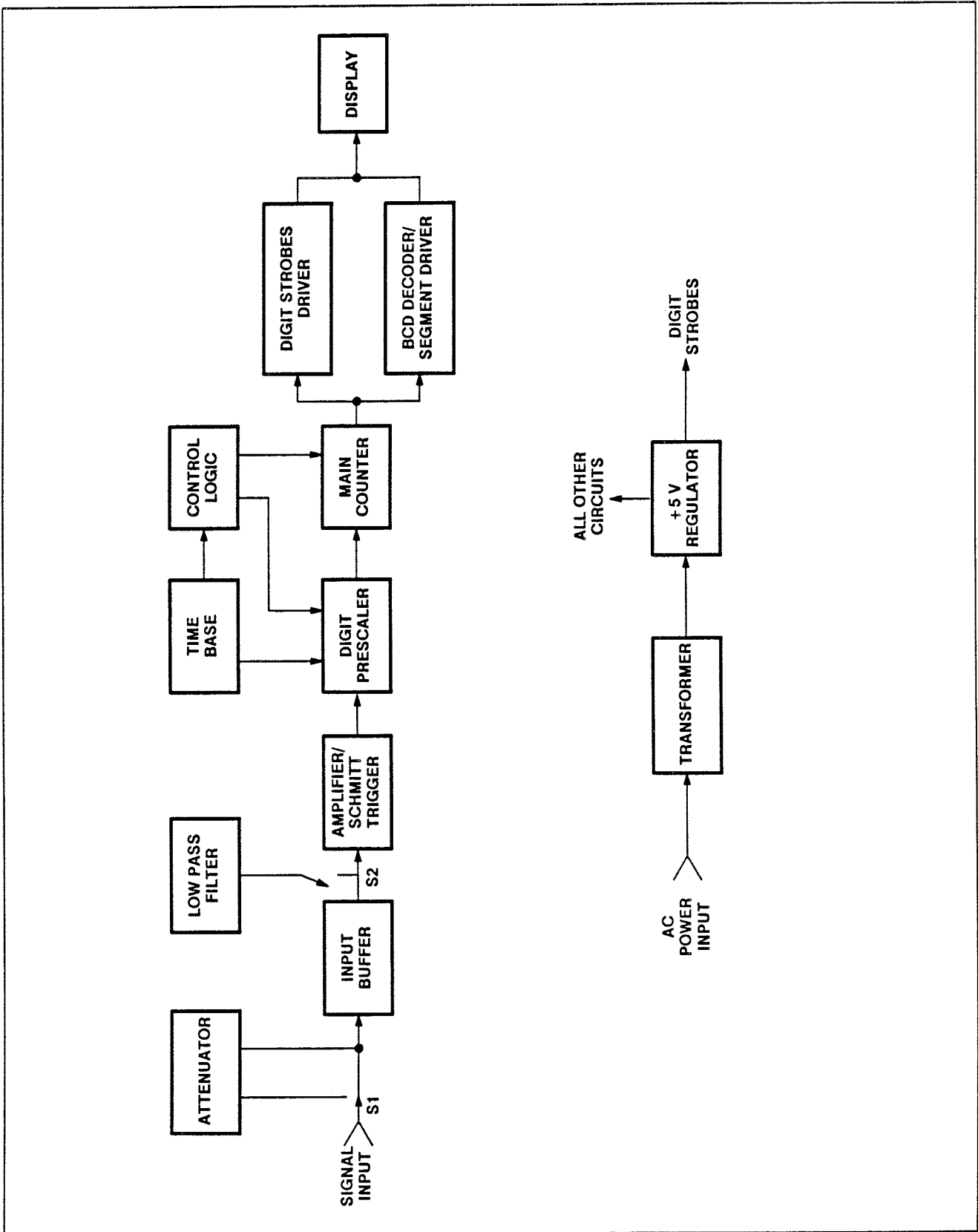

Figure 3-1. Block Diagram.

**INPUT BUFFER.** When S1 is in the LO position (not actuated) the entire signal is applied directly to the Input Buffer. The Input Buffer isolates the signal being tested from the circuitry in the frequency counter. The Input Buffer provides amplitude limiting through D5 and D6, a pair of diodes in the buffer circuit that clamp high-amplitude signals. FET Q1 and bipolar common emitter Q2 help generate constant amplitude signals in spite of input variations. The Input Buffer passes the prepared incoming signal to the Amplifier/Schmitt Trigger through LOW PASS FILTER S2. When S2 is actuated, the signal is shunted by the Low Pass Filter circuit. When S2 is OFF, all frequencies will pass directly to the Amplifier/Schmitt Trigger circuit.

**LOW PASS FILTER.** The Low Pass Filter removes the high-frequency components in a waveform (removes RF from a radio signal), so a lower frequency (modulation waveform) can be measured. It actually passes high frequencies to ground while it allows low frequencies to be picked up by the next stage. Only frequencies below 100 kHz pass to the next stage when S2 actuated.

**AMPLIFIER/SCHMITT TRIGGER.** The Amplifier/Schmitt Trigger circuit is a three-stage ECL amplifier that converts input signals into constant-amplitude, fast-rise, fast-fall pulses. Q3 and Q4 are connected as an ECL-to-TTL converter. The squared output signal from the Amplifier/Schmitt Trigger is routed to the Digit Prescaler.

### Time Base

The Time Base circuit generates an accurate reference signal to compare against incoming signals. It generates an exact gating pulse for the counter circuitry. The Time Base consists of two circuits: crystal-controlled oscillator U6 and circuitry, and divide-by-ten decade counter U7 and circuitry. U6 and circuitry form an accurate, stable, 60 Hz time base derived from XTAL, a 3.579545 MHz crystal. U7 divides 60 Hz to 6 Hz for Control Logic.

### Control Logic

Control Logic determines when the Digit Prescaler and the Main Counter count and reset.

Control Logic tells the Main Counter when to update its count and when to reset to zero. Reset prepares the counter to begin a new sample.

### Digit Prescaler

Digit Prescaler (U2, U4, and associated circuitry) accepts the Time Base signal and the incoming signal from the Schmitt Trigger and prepares them for various sections of the Main Counter. The Prescaler divides the input frequency into various signals needed by the Main Counter.

### Main Counter

The Main Counter performs all frequency-totaling functions when directed to do so by the Control Logic gates. It counts input frequency and multiplexes information for use by the decoder and driver circuits. Main Counter integrated circuit U9 has two sets of output lines. One set goes to the Digit Strobes Drivers. These drivers supply current to all the numbers in the display. The other output lines, a 4-bit binary set, are fed into the BCD Decoder/Segment Driver.

### Decoder and Driver Circuits

Each number in the display is made ready by the Digit Strobes Driver circuit, and each segment in the display is selected by the BCD Decoder/Segment Driver circuit. These two circuits together make the correct numbers turn on or they keep unwanted numbers and segments off.

**DIGIT STROBES DRIVER.** ICs U10 and U11 provide multiplexed signal information to the Display board.

**BCD DECODER/SEGMENT DRIVER.** BCD stands for Binary Coded Decimal. U12 is a BCD-to-seven-segment decoder that accepts binary information from the Main Counter and converts it to turn on the decimal equivalent LED segments of the display.

### Display

The Display Board contains eight LED displays. Each digit in the display has seven segments. These are separate LEDs that must be turned ON or OFF to form the appropriate number. When all of the segments are lighted, an "8" is displayed. The display indicates the frequency of the applied signal, with leading zeros blanked.

### Power Supply

The Power Supply provides the regulated low-voltage power required by the instrument circuitry.



## Theory of Operation—CFC250 Service

**AC POWER INPUT.** The ac power input provides ac power to the transformer through POWER switch S3 and LINE VOLTAGE SELECT switches S4–S5. Switches S4 and S5 are used to select the proper primary taps to compensate for varying power-line voltages. The primary side of the Power Supply contains the main power fuse FS3.

**TRANSFORMER.** The power transformer has a primary and two secondary windings. Secondary voltages are applied to rectifier-filter circuits to generate two unregulated dc voltages.

**+ 5 V REGULATOR.** Both secondary circuits are identical up to the IC regulators (U13 and U14). They are rectified by a set of diodes in a full-wave center-tapped configuration. Each output is filtered to remove ripple and then regulated to supply a stable + 5 V. Unregulated voltage is applied to three-terminal regulators U13 and U14 to generate two separate + 5 V dc supplies. The V1 output supplies U1, the op amp circuits, and all the transistor circuits. The V2 output supplies all other ICs and the Display board.

# PERFORMANCE CHECK PROCEDURE

## INTRODUCTION

This procedure checks the electrical characteristics listed in the Specification part of Section 1 of this manual. If the instrument fails to meet the requirements given in this performance check, the adjustment procedure in Section 5 should be done. This performance check may also be used as an acceptance test or as a troubleshooting aid.

You do not have to remove the instrument case to do this procedure. All checks can be made with controls and connectors accessible from the outside.

To ensure instrument accuracy, check its performance after every 2000 hours of operation, or once each year if

used infrequently. If these checks indicate a need for readjustment or repair, refer the instrument to a qualified service person.

## TEST EQUIPMENT NEEDED

The test equipment listed in Table 4-1 is a complete list of the equipment needed for this performance check and the adjustment procedure in Section 5. All test equipment is assumed to be operating within tolerance. Detailed operating instructions for test equipment are not given in this procedure. If operating information is needed, refer to the appropriate test equipment instruction manual.

**Table 4-1**  
**Test Equipment Required**

Item	Minimum Specification	Purpose
Oscilloscope with 10X Probes	Bandwidth: DC to 15 MHz. (Suitable equipment: TEKTRONIX 2225 50 MHz Oscilloscope or TEKTRONIX 2205 20 MHz Oscilloscope.)	Frequency check and Trigger Level adjustment.
Function Generator	Range: 10 Hz to 2 MHz. (Suitable equipment: TEKTRONIX CFG250 2 MHz Function Generator.)	Frequency check.
Signal Generator	Range: 250 kHz to 100 MHz. (Suitable equipment: TEKTRONIX SG 503 Signal Generator.)	Frequency check and Trigger Level adjustment.
Frequency Standard	Accuracy: $\geq 5$ parts in 10 million (0.5 ppm). <i>5 · 10<sup>-7</sup></i>	Time Base Accuracy check and Time Base adjustment.
Alignment Tool	Length: 1-in shaft. Bit size: 3/32 in. (Suitable equipment: Tektronix Part Number 003-0675-00.)	Trigger Level adjustment.
Coaxial Cable	50 Ω, BNC. (Suitable equipment: Tektronix Part Number 012-0057-01.)	Frequency check and Trigger Level adjustment.
Termination	50 Ω, BNC. (Suitable equipment: Tektronix Part Number 011-0049-01.)	Frequency check and Trigger Level adjustment.
10X Attenuator	50 Ω, BNC. (Suitable equipment: Tektronix Part Number 011-0059-02.)	Frequency check.

## Performance Check Procedure—CFC250 Service

**PREPARATION**

1. Ensure that all power switches are off.
2. Ensure that all test equipment and the CFC250 are suitably adapted to the line voltage to be applied.
3. Connect the equipment under test and the test equipment to a suitable line voltage source. Turn all equipment on and allow at least 20 minutes for the equipment to warm up and stabilize.
4. Set the CFC250 controls as follows during warm-up time:
 

INPUT VOLTAGE	80 mV–5V(LO) (button out)
LOW PASS FILTER	OFF (button out)
- g. Remove the coaxial cable from the function generator and connect the signal generator to the oscilloscope. Set the signal generator to 50 kHz. Set the signal generator for 0.24 V p-p output. Disconnect the oscilloscope and connect the generator to the CFC250.
- h. Set the signal generator to 100 MHz.
- i. CHECK—that the CFC250 will trigger on 0.24 V p-p at 99.5 MHz.
- j. Set the signal generator to 1 MHz.
- k. Press in the LOW PASS FILTER button on the CFC250.
- l. CHECK—that the CFC250 does not trigger.
- m. Set the LOW PASS FILTER button to OFF (button out) and set the INPUT VOLTAGE button to 3V–42V(HI) (button in).
- n. Remove the connection from the CFC250 and connect it to the oscilloscope. Remove the X10 attenuator and the 50  $\Omega$  termination.
- o. Adjust the signal generator output amplitude for 8.4 V p-p.
- p. Remove the connection from the oscilloscope and connect it to the CFC250.
- q. CHECK—that the CFC250 triggers on 1 MHz.
- r. Disconnect the test equipment.

**PROCEDURE**

1. **Frequency Range and Sensitivity Check**
  - a. Set the function generator to 1 kHz.
  - b. Connect a coaxial cable from the function generator output through a 10X attenuator and a 50- $\Omega$  termination to the input of the oscilloscope.
  - c. Adjust the function generator output amplitude for 0.24 V p-p sinewave.
  - d. Remove the connection from the oscilloscope and connect it to the CFC250.
  - e. Reduce the frequency from the function generator to 10 Hz.
  - f. CHECK—that the CFC250 triggers on 10 Hz.
2. **Check Time Base Accuracy**
  - a. Connect a 1 MHz or 10 MHz signal from the frequency standard to the counter input. Set input voltage to 80 mV.
  - b. CHECK—that the CFC250 reads 1 MHz (10 MHz)  $\pm 11$  counts ( $\pm 101$  counts).
  - c. Disconnect test equipment.

This completes the performance check.

# ADJUSTMENT PROCEDURE

## INTRODUCTION

There are two calibration adjustments—the Trigger Level adjustment and the Time Base adjustment. To ensure instrument accuracy, the Trigger Level adjustment should be done every 2000 hours of operation or at least once each year if used infrequently. Do not attempt to do the Time Base adjustment unless you have a standard frequency source with a known accuracy of at least five parts in ten million (0.5 ppm).

## PREPARATION FOR ADJUSTMENT

Make the adjustments in this procedure at an ambient temperature of +21°C to +25°C (+70°F to +77°F) and a relative humidity of 75% or less.

It is necessary to remove the top of the instrument cabinet to access the component side of the Main circuit board. Disconnect the power cord from the CFC250 and follow the cabinet removal instructions in the Maintenance section of this manual.

Test equipment needed for these adjustments is described in Table 4-1 at the beginning of the Performance Check Procedure. Refer to the appropriate test equipment instruction manuals for test equipment operating information.

Connect the test equipment and the CFC250 to a suitable ac-power source and allow a 20-minute warmup period before making the Trigger Level adjustment.

## PROCEDURE

### 1. Adjust Trigger Level (SVR1)

- a. Set the CFC250 front-panel pushbuttons as follows:

INPUT VOLTAGE	80mV-5V(LO) (button out)
LOW PASS FILTER	OFF (button out)

- b. Connect a 50-Ω terminated BNC cable from the signal generator to the vertical input of the oscilloscope.

- c. Set the oscilloscope to 50 mV per division.
- d. Set the signal generator to 50 kHz, 225 mV peak-to-peak output (4½ divisions at 50 mV per division).
- e. Disconnect the cable from the oscilloscope and connect it to the CFC250 INPUT connector.
- f. Set the signal generator to 99.5 MHz ±0.5 MHz.

## NOTE

*No further disassembly is required to adjust SVR1. It may be adjusted with an alignment tool through the rear hole in the metal shield covering the Amplifier/Schmitt Trigger circuitry. (See Main circuit board and adjustment locations, Figure 9-3, in the Diagrams section.)*

- g. ADJUST—SVR1 until the CFC250 readout agrees with the signal generator output reading. Turn SVR1 to the right until the frequency counter begins to misread the signal; then turn SVR1 to the left until the counter begins to misread. Center the SVR1 adjustment between the two points where the incorrect readouts begin (the midpoint of the input signal).
- h. Turn off the CFC250 and replace the top cover. Turn the CFC250 back on and allow a five-minute warmup period.
- i. RECHECK—the accuracy of the CFC250 readout. If necessary, repeat step g.
- j. Disconnect the test equipment.

### 2. Adjust Time Base (Trimmer TC1)

## NOTE

*Do not attempt to adjust the Time Base unless you have a standard frequency source having a known accuracy of at least five parts in ten million (0.5 ppm).*

## Adjustment Procedure—CFC250 Service

**NOTE**

*The CFC250 has an accuracy of three parts per million (3 ppm). This means an error of three cycles when reading a 1 MHz (seven digit) signal. Most signal sources are not stable enough nor accurate enough for this error to be meaningful.*

- a. Replace the top cover on the disassembled instrument. Ensure that the CFC250 INPUT VOLTAGE is set to LO (button out) and the LOW PASS FILTER is OFF (button out).
- b. Turn the CFC250 POWER ON and allow one hour for it to warm up.
- c. Apply a 10 MHz  $\pm 1$  Hz standard signal to the CFC250 INPUT connector.
- d. Remove the top of the cabinet from the CFC250.
- e. ADJUST—Trimmer (TC1) until the display reads 10.000000  $\pm 2$  (9.999998 to 10.000002).
- f. Replace the cabinet top and allow five minutes to restabilize.
- g. CHECK—the CFC250 display reads 10.000000  $\pm 2$  (9.999998 to 10.000002).
- h. READJUST—if necessary.
- i. Disconnect the test equipment.

This ends the Adjustment Procedure.



# MAINTENANCE

This section of the manual contains information on static-sensitive components, preventive maintenance, troubleshooting, and corrective maintenance.

## STATIC-SENSITIVE COMPONENTS

The following precautions apply when performing any maintenance involving internal access to the instrument.



*Static discharge can damage any semiconductor component in this instrument.*

This instrument contains electrical components that are susceptible to damage from static discharge. Table 6-1 lists the relative susceptibility of various classes of semiconductors. Static voltages of 1 kV to 30 kV are common in unprotected environments.

When performing maintenance, observe the following precautions to avoid component damage:

1. Minimize handling of static-sensitive components.
2. Transport and store static-sensitive components or assemblies in their original containers or on a metal rail. Label any package that contains static-sensitive components or assemblies.
3. Discharge the static voltage from your body by wearing a grounded antistatic wrist strap while handling these components. Servicing static-sensitive components or assemblies should be performed only at a static-free work station by qualified service personnel.
4. Keep anything capable of generating or holding a static charge off the work station surface.
5. Keep the component leads shorted together whenever possible.
6. Pick up components by their bodies, never by their leads.
7. Do not slide the components over any surface.
8. Avoid handling components in areas that have a floor or work-surface covering capable of generating a static charge.

9. Use a soldering iron that is connected to earth ground.

10. Use only approved antistatic, vacuum-type desoldering tools for component removal.

Table 6-1

Relative Susceptibility to Static-Discharge Damage

Semiconductor Classes	Relative Susceptibility Levels <sup>a</sup>
MOS or CMOS microcircuits or discretes, or linear microcircuits with MOS inputs (Most Sensitive)	1
ECL	2
Schottky signal diodes	3
Schottky TTL	4
High-frequency bipolar transistors	5
JFET	6
Linear microcircuits	7
Low-power Schottky TTL	8
TTL (Least Sensitive)	9

<sup>a</sup>Voltage equivalent for levels (voltage discharged from a 100-pF capacitor through a resistance of 100  $\Omega$ ):

1 = 100 to 500 V  
 2 = 200 to 500 V  
 3 = 250 V  
 4 = 500 V  
 5 = 400 to 600 V

6 = 600 to 800 V  
 7 = 400 to 1000 V (est)  
 8 = 900 V  
 9 = 1200 V

## PREVENTIVE MAINTENANCE

Preventive maintenance consists of cleaning, inspection, and checking instrument performance. Preventive maintenance done on a regular basis may prevent some instrument problems and improve reliability. The required frequency of regular maintenance depends on the environment in which the instrument is used. A good time to do preventive maintenance is just before instrument adjustment.

### INSPECTION AND CLEANING

Inspect and clean the CFC250 as often as operating conditions require. Dirt inside the instrument can cause overheating and component breakdown because dirt insulates and prevents heat dissipation. It also provides an electrical conduction path that could result in instrument failure, especially under high-humidity conditions.



*Do not use chemical cleaning agents which might damage the plastics used in this instrument. Use a nonresidue-type cleaner, preferably isopropyl alcohol or a solution of 1% mild detergent and 99% water. Before using any other type of cleaner, consult your Tektronix Service Center or representative.*

#### Exterior

**INSPECTION.** Inspect the external parts of the instrument for damage, wear, and missing parts; use Table 6-2 as a guide. Instruments that appear to have been dropped or abused should be checked for correct operation. Defects that could cause personal injury or could further damage the instrument should be repaired at once.



*Do not allow moisture to get inside the instrument during external cleaning. Use only enough liquid to dampen the cloth or applicator.*

**CLEANING.** Dust on the outside of the instrument can be removed with a soft cloth or small soft-bristle brush.

The brush is useful on and around controls and connectors. Remove remaining dirt with a soft cloth dampened in a mild detergent-and-water solution. Do not use abrasive cleaners.

#### Interior

#### WARNING

*To avoid electrical shock, disconnect the instrument from the ac power source before inspecting or cleaning the internal circuitry.*

To clean or inspect the inside of the instrument, first refer to the removal and replacement instructions in the Corrective Maintenance part of this section.

**INSPECTION.** Inspect the internal parts of the CFC250 for damage and wear, using Table 6-3 as a guide. Repair any problems immediately. The repair method for most visible defects is obvious, but take particular care if heat-damaged components are found. Since overheating usually indicates other trouble in the instrument, the cause of overheating must be found and corrected to prevent further damage.



*To prevent damage from electrical arcing, ensure that circuit boards and components are dry before applying power to the instrument.*

**CLEANING.** To clean the interior, blow off dust with dry, low-pressure air (approximately 9 psi). Remove any remaining dust with a soft brush or a cloth dampened with a solution of mild detergent and water. A cotton-tipped applicator is useful for cleaning in narrow spaces and on circuit boards.

#### Semiconductor Checks

Periodic checks of the transistors and other semiconductors in this instrument are not recommended. The best check of semiconductor performance is actual operation in the instrument.

**Table 6-2**  
**External Inspection Checklist**

<b>Item</b>	<b>Inspect For</b>	<b>Repair Action</b>
Front-panel buttons	Missing, damaged, or loose buttons.	Repair or replace missing or defective items.
Front-panel connectors	Broken shells, cracked insulation, and deformed contacts. Dirt in connectors.	Replace Front-Panel assembly or replace defective parts. Clean or wash out dirt.
Accessories	Missing items or parts of items, bent pins, broken or frayed cables, and damaged connectors.	Replace damaged or missing items, frayed cables, and defective parts.

**Table 6-3**  
**Internal Inspection Checklist**

<b>Item</b>	<b>Inspect For</b>	<b>Repair Action</b>
Circuit Boards	Loose, broken, or corroded solder connections. Burned circuit boards. Burned, broken, or cracked circuit-run plating.	Replace circuit board assembly or repair as follows: Clean solder corrosion with an eraser and flush with isopropyl alcohol. Resolder defective connections. Determine cause of burned items and repair. Repair defective circuit runs.
Resistors	Burned, cracked, broken, or blistered.	Replace circuit board assembly or repair as follows: Replace defective resistors. Check for cause of burned component and repair as necessary.
Solder Connections	Cold solder or rosin joints.	Resolder joint and clean with isopropyl alcohol.
Capacitors	Damaged or leaking cases. Corroded solder on leads or terminals.	Replace circuit board assembly or repair as follows: Replace defective capacitors. Clean solder connections and flush with isopropyl alcohol.
Semiconductors	Loosely inserted in sockets. Distorted pins.	Firmly seat loose semiconductors. Remove devices having distorted pins. Carefully straighten pins (as required to fit the socket), using long-nose pliers, and reinsert firmly. Ensure that straightening action does not crack the pins, causing them to break.
Wiring and Cables	Loose plugs or connectors. Burned, broken, or frayed wiring.	Firmly seat connectors. Repair or replace defective wires or cables or replace assembly.
Chassis	Dents, deformations, and damaged hardware.	Replace defective assembly or straighten, repair, or replace defective hardware.

## TROUBLESHOOTING

Preventive maintenance done on a regular basis should reveal most potential problems before an instrument fails. However, should troubleshooting be needed, the following information will help to locate the problem. Also, the Theory of Operation and the Diagrams sections of this manual may help with troubleshooting.

### TROUBLESHOOTING AIDS

#### Schematic Diagram

A schematic diagram is located on a tabbed foldout page in the Diagrams section. Portions of circuitry mounted on each circuit board are enclosed by heavy black lines. The assembly number and name(s) of the circuit(s) are shown near the top or the bottom edge of the diagram.

Functional blocks on the schematic diagram are outlined with a wide gray line. Components within the outlined area perform the function named by the block label. The Theory of Operation uses these functional block names when describing circuit operation.

Component numbers and electrical values of components in this instrument are shown on the schematic diagram. Refer to the first page of the Diagrams section for the reference designators and symbols used to identify components. Important voltages and waveforms are also shown on the diagram.

#### Circuit Board Illustrations

Circuit board illustrations in the Diagrams section show the physical location of each component.

#### Grid Coordinate System

The schematic diagram and circuit board illustrations have grid borders along their left and top edges. The grid coordinates for the components are given in an accompanying table.

#### Component Color Coding

An illustration at the beginning of the Diagrams section gives information about color codes and markings on resistors and capacitors.

**RESISTORS.** Resistors used in this instrument are carbon-film, composition, or precision metal-film types. They are usually color coded with the EIA color code; however, some metal-film type resistors may have the value printed on the body. The color code is interpreted starting with the stripe nearest to one end of the resistor. Composition resistors have four stripes; these represent two significant digits, a multiplier, and a tolerance value. Metal-film resistors have five stripes representing three significant digits, a multiplier, and a tolerance value.

**CAPACITORS.** Common disc capacitors and small electrolytics have capacitance values marked on the side of the capacitor body. White ceramic capacitors are color coded in picofarads, using a modified EIA code. Dipped tantalum capacitors are color coded in microfarads. The color dot indicates both the positive lead and the voltage rating. Since these capacitors are easily destroyed by reversed or excessive voltage, be careful to observe the polarity and voltage rating when replacing them.

**DIODES.** The cathode end of each glass-encased diode is indicated by either a stripe, a series of stripes, or a dot. The cathode and anode ends of a metal-encased diode may be identified by the diode symbol marked on its body.

#### Semiconductor Lead Configurations

The second figure in the Diagrams section shows some typical lead configurations for semiconductor devices that may be used in this instrument. If a semiconductor does not seem to match the configurations shown, consult a manufacturer's data sheet.

### TROUBLESHOOTING TECHNIQUES

When troubleshooting the CFC250, be sure to read the troubleshooting techniques given here before going on to CFC250 Troubleshooting Tips. The troubleshooting methods described in this procedure are general techniques that should be used together with the more specific CFC250 Troubleshooting Tips.

This procedure is arranged to check simple trouble possibilities before doing more extensive troubleshooting.

When a defective component is located, either replace the assembly containing the defective part or replace the component by using the appropriate replacement

procedure given in Corrective Maintenance. Replacement assemblies are available through Tektronix and are shown in an exploded-view drawing in Replaceable Parts (section 8) and are described in the parts list in that section.



*Before using any test equipment to make measurements on static-sensitive, current-sensitive, or voltage-sensitive components or assemblies, ensure that any voltage or current supplied by the test equipment does not exceed the limits of the component to be tested.*

### 1. Check Control Settings

Incorrect control settings can give a false indication of instrument malfunction. If there is any question about the correct function or operation of any control, refer to the CFC250 Operators Manual.

### 2. Check Associated Equipment

Before proceeding, ensure that any equipment used with the CFC250 is operating correctly. Verify that input signals are properly connected and that the interconnecting cables are not defective. Check that the ac-power-source voltage to all equipment is correct.

### 3. Visual Check

#### WARNING

*To avoid electrical shock, disconnect the instrument from the ac power source before inspecting the internal circuitry.*

Look for broken connections or wires, damaged components, semiconductors not firmly mounted, damaged circuit boards, or other clues to the cause of a malfunction.

### 4. Check Instrument Performance and Adjustment

Check the performance of either those circuits where you suspect trouble or the entire instrument. An apparent trouble may be the result of misadjustment. The

Performance Check is in Section 4 of this manual, and the Adjustment Procedure in Section 5.

### 5. Isolate Trouble to a Circuit

To isolate problems, use any symptoms noticed when checking the instrument's operation to help localize the trouble to a particular circuit. The CFC250 Troubleshooting Tips, following this procedure, may help in locating a problem.

### 6. Check Individual Components

#### WARNING

*To avoid electrical shock, always disconnect the instrument from the ac power source before removing or replacing components.*

The following procedures describe methods of checking individual components. Two-lead components that are soldered in place are most accurately checked by first disconnecting one end from the circuit board. This isolates the measurement from the effects of the surrounding circuitry. See Figure 9-1 for component value identification and Figure 9-2 for semiconductor lead configurations.



*When checking semiconductors, observe the static-sensitivity precautions given at the beginning of this section.*

**TRANSISTORS.** A good check of a transistor is actual performance under operating conditions. A transistor can most effectively be checked by substituting a known-good component. However, be sure that circuit conditions are not such that a replacement transistor will also be damaged. If substitute transistors are not available, use a dynamic-type transistor checker for testing. Static-type transistor checks are not recommended, since they do not check operation under simulated operating conditions.

When troubleshooting transistors in the circuit with a voltmeter, measure both the emitter-to-base and emitter-to-collector voltages to find out if they are consistent with normal circuit voltages. Voltages across a transistor may vary with the type of device and its circuit function.

## Maintenance — CFC250 Service

Some of these voltages are predictable. The emitter-to-base voltage for a conducting silicon transistor will normally range from 0.6 V to 0.8 V. The emitter-to-collector voltage for a saturated transistor is about 0.2 V. Because these values are small, the best way to check them is by connecting a sensitive voltmeter across the junction rather than comparing two voltages taken with respect to ground. If the former method is used, both leads of the voltmeter must be isolated from ground.

If voltage values measured are less than those just given, either the device is shorted or no current is flowing in the external circuit. If values exceed the emitter-to-base values given, either the junction is reverse biased or the device is defective. Voltages exceeding those given for typical emitter-to-collector values could indicate either a nonsaturated device operating normally or a defective (open-circuited) transistor. If the device is conducting, voltage will be developed across the resistors in series with it; if open, no voltage will be developed across the resistors unless current is being supplied by a parallel path.



*When checking emitter-to-base junctions, do not use an ohmmeter range that has a high internal current. High current may damage the transistor. Reverse biasing the emitter-to-base junction with a high current may degrade the current-transfer ratio (Beta) of the transistor.*

A transistor emitter-to-base junction also can be checked for an open or shorted condition by measuring the resistance between terminals with an ohmmeter set to a range having a low internal source current, such as the R X 1 k $\Omega$  range. The junction resistance should be very high in one direction and much lower when the meter leads are reversed.

When troubleshooting a field-effect transistor (FET), the voltage across its elements can be checked in the same manner as previously described for other transistors. However, remember that in the normal depletion mode of operation, the gate-to-source junction is reverse biased; in the enhanced mode, the junction is forward biased.

**INTEGRATED CIRCUITS.** An integrated circuit (IC) can be checked with a voltmeter, test oscilloscope, or by

direct substitution. A good understanding of circuit operation is essential when troubleshooting a circuit having IC components. Use care when checking voltages and waveforms around the IC so that adjacent leads are not shorted together. An IC test clip provides a convenient means of clipping a test probe to an IC.

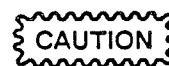

*When checking a diode, do not use an ohmmeter scale that has a high internal current. High current may damage a diode. Checks on diodes can be performed in much the same manner as those on transistor emitter-to-base junctions.*

**DIODES.** A diode can be checked for either an open or a shorted condition by measuring the resistance between terminals with an ohmmeter set to a range having a low internal source current, such as the R X 1 k $\Omega$  range. The diode resistance should be very high in one direction and much lower when the meter leads are reversed.

Silicon diodes should have 0.6 V to 0.8 V across their junctions when conducting; Schottky diodes about 0.2 V to 0.4 V. Higher readings indicate that they are either reverse biased or defective, depending on polarity.

**RESISTORS.** Check resistors with an ohmmeter. Refer to the Replaceable Parts list for the tolerances of resistors used in this instrument. A resistor normally does not require replacement unless its measured value varies widely from its specified value and tolerance.

**INDUCTORS.** Check for open inductors by checking continuity with an ohmmeter. Shorted or partially shorted inductors can usually be found by checking the waveform response when high-frequency signals are passed through the circuit.

**CAPACITORS.** A leaky or shorted capacitor can be detected by checking resistance with an ohmmeter set to one of the highest ranges. Do not exceed the voltage rating of the capacitor. The resistance reading should be high after the capacitor is charged to the output voltage of the ohmmeter. An open capacitor can be detected with a capacitance meter or by checking whether the capacitor passes ac signals.

## **7. Repair and Adjust the Circuit**

If any defective parts are located, follow the replacement procedures given under Corrective Maintenance in this section. After any electrical component has been replaced, the performance of that circuit and any other

closely related circuit should be checked. Since the power supplies affect all circuits, performance of the entire instrument should be checked if work has been done on the power supplies. Refer to the Performance Check Procedure and the Adjustment Procedure, sections 4 and 5 in this manual.

### CFC250 TROUBLESHOOTING TIPS

**NOTE**

Refer to the schematic diagram in section 9. Waveforms, voltages, component values, and test points for troubleshooting are shown on the schematic. Component values and resistor tolerances are given in the Replaceable Parts list. Also refer to Troubleshooting Techniques in this section for more detailed troubleshooting methods.

Set POWER ON and connect a 100 MHz, 80 mV rms signal source to the INPUT connector. Set the front panel pushbuttons as follows: INPUT VOLTAGE to 80 mV – 5V (button out) and LOW PASS FILTER to OFF (button out).

Input each signal frequency listed in Table 6-4 and check for a correct display. If the CFC250 does not show the normal display given in Table 6-4, troubleshoot as follows:

**Table 6-4**  
**Normal CFC250 Displays**

Signal Frequency	Normal Display
5 Hz to 999 Hz	5 to 999
1 kHz to 999 kHz	1000 to 999000
1 MHz to 99 MHz	1.000000 to 99.000000
101 MHz	01000000 with OVERRANGE LED flashing

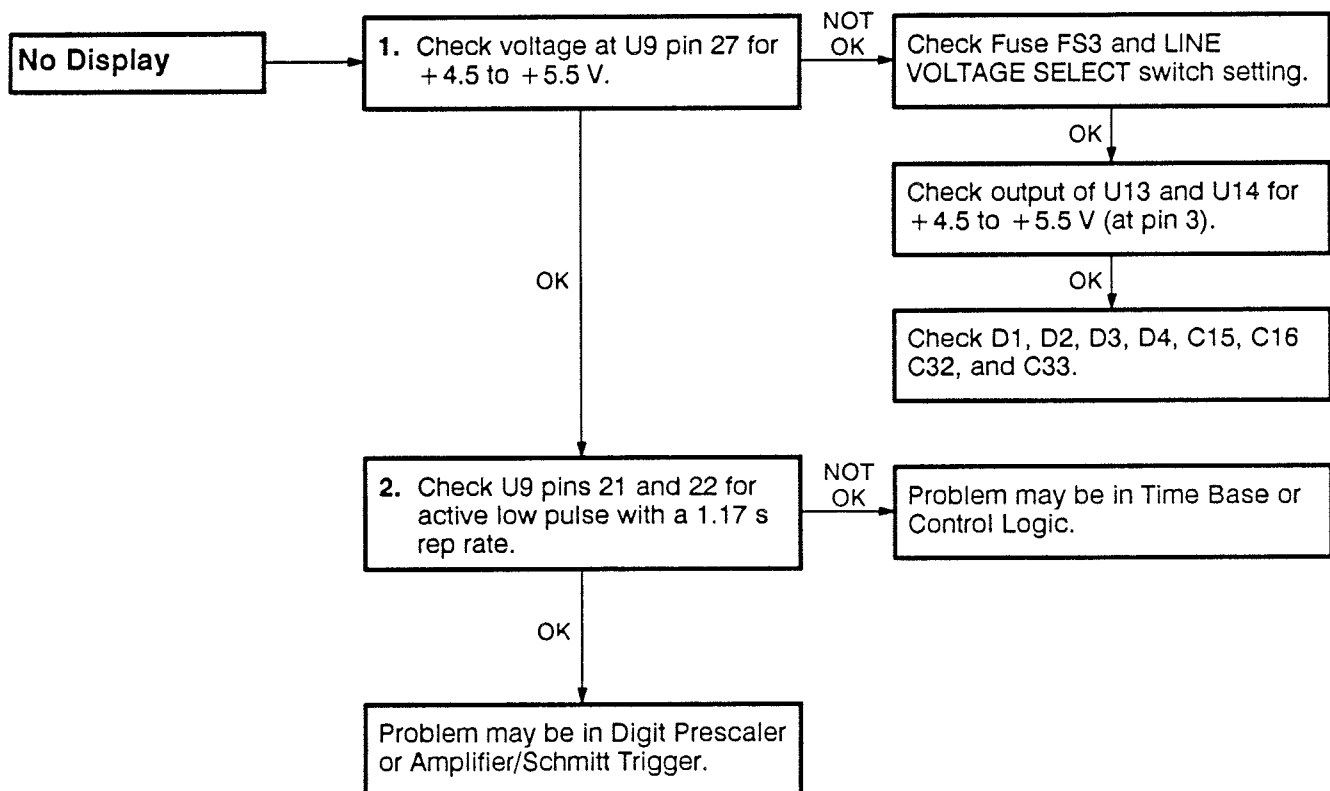



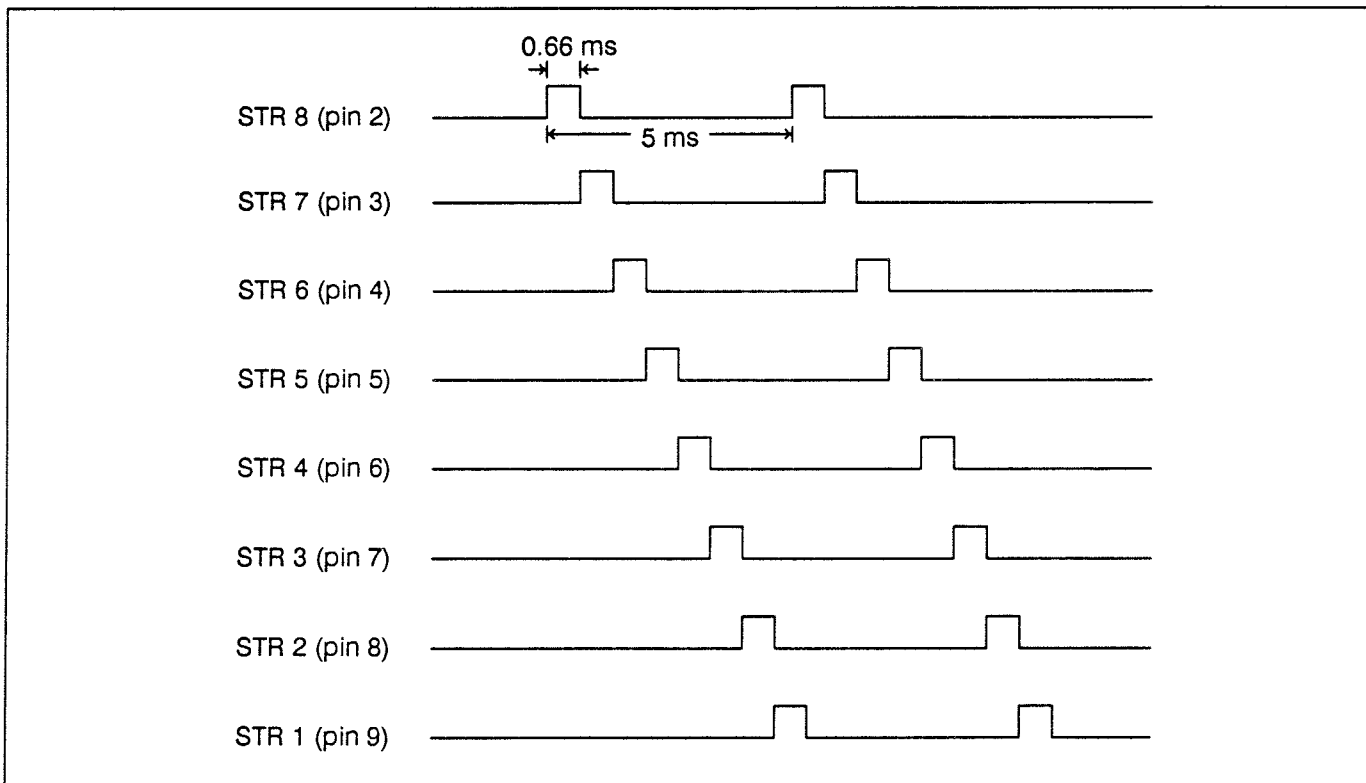
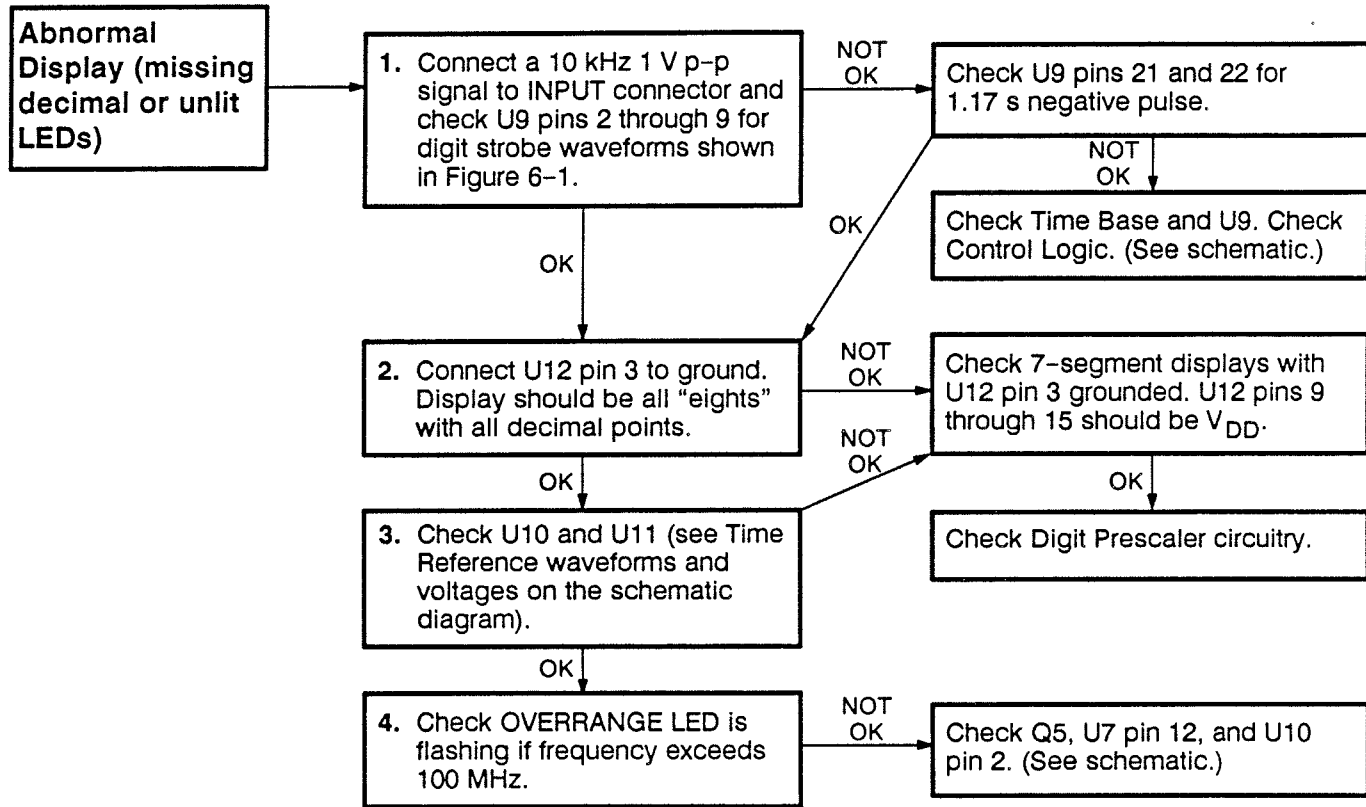
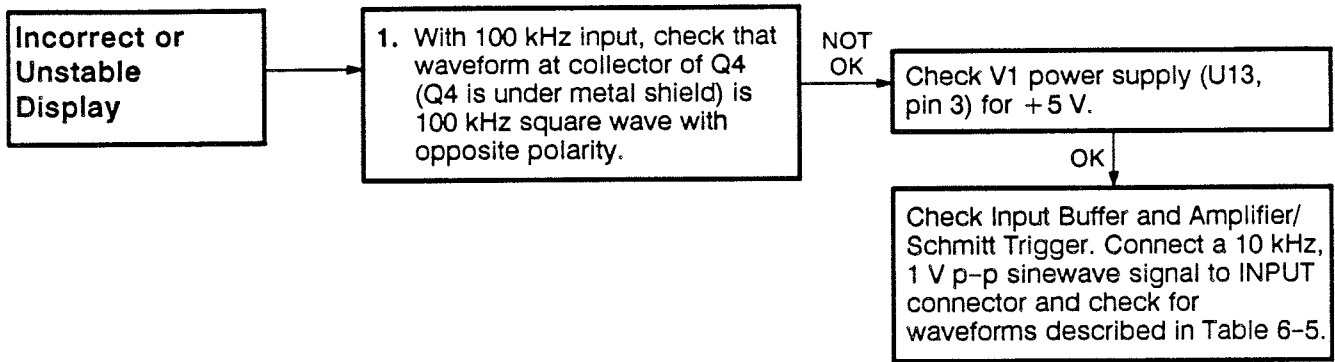

Figure 6-1. Digit Strobe Waveforms.



**Table 6-5**  
**Correct Waveforms at Input Circuit Test Points**

Test Point <sup>a</sup>	Waveform
Gate of Q1	≈ 0.7 V p-p, 10 kHz sinewave, 0 V dc level.
Gate of Q1 with INPUT VOLTAGE switch HI (button in)	0.1 V p-p, 10 kHz sinewave, 0 V dc level.
Emitter of Q2	0.5 V p-p, 10 kHz sinewave, 2.5 V dc offset.
U1 pin 10 (INPUT VOLTAGE switch LO)	0.5 V p-p, 10 kHz sinewave, 3.8 V dc offset.
U1, pins 5 and 6	0.9 V p-p, 10 kHz inverted rounded squarewave, 3.8 V dc offset.
U1, pins 4 and 7	0.9 V p-p, 10 kHz rounded squarewave, 3.8 V dc offset.
U1, pins 2, 13 and 15	Same as pins 4 and 7, with squarer corners.
U1, pin 14	Same as pins 2, 13, and 15, but inverted.

<sup>a</sup>All test points are located under metal shield (see Main board removal and replacement).

## CORRECTIVE MAINTENANCE

Replacement assemblies (i.e., Main Board, Front Panel, etc.) can be obtained from Tektronix. Many of the standard electrical components in this instrument can be obtained from your local electrical parts supplier. Corrective maintenance, therefore, consists of either complete assembly replacement or component replacement with locally obtained parts.

### MAINTENANCE PRECAUTIONS

To avoid personal injury or damage to equipment, observe the following precautions:

- Disconnect the instrument from the ac-power source before removing or installing components.
- Verify that any line-rectifier filter capacitors are discharged before doing any servicing.
- Use care not to interconnect instrument grounds which may be at different potentials (cross grounding).
- When soldering on circuit boards or small insulated wires, use only a 15-watt, pencil-type soldering iron.

### OBTAINING REPLACEMENT PARTS

Replacement assemblies for this instrument (Main Board, Front Panel, Rear Panel, Display Board, and Cabinet) can be obtained through your local Tektronix Field Office or representative. The CFC250 assemblies and their Tektronix part numbers are shown in the exploded-view drawing in section 8 of this manual.

The Replaceable Parts list in section 8 gives the Tektronix part number, name, and description of the CFC250 assemblies and also lists the electrical parts in each assembly. This generic list includes the value, rating, tolerance, and description of the parts in the various assemblies. This list of the electrical parts in each assembly may be useful if parts are obtained from your local supplier, as most CFC250 parts may be ordered from Tektronix at the assembly or kit level only.

### NOTE

*Physical size and shape of a component may affect instrument performance, particularly at high frequencies. Always use direct replacement components, unless you know that a substitute will not degrade performance.*

### Ordering Parts

When ordering parts from Tektronix, Inc., be sure to include the following information:

- Instrument type (include all modification and option numbers).
- Instrument serial number.
- A description of the part (if electrical, include its full circuit component number).
- Tektronix part number.

### REPACKAGING FOR SHIPMENT

Save the original carton and packing material for reuse if the instrument should have to be reshipped on a commercial transport carrier. If the original materials are unfit or not available, repackage the instrument as follows:

1. Use a corrugated cardboard shipping carton with a test strength of at least 200 pounds and with an inside dimension at least six inches greater than the instrument dimensions.
2. If the instrument is being shipped to a Tektronix Service Center, enclose the following: the owner's address, name and phone number of a contact person, type and serial number of the instrument, reason for returning, and a complete description of the service needed.
3. Completely wrap the instrument with polyethylene sheeting or equivalent to protect the outside finish and prevent entry of foreign material into the instrument.
4. Cushion the instrument on all sides, using three inches of padding material or urethane foam tightly packed between the carton and the instrument.

## Maintenance – CFC250 Service

5. Seal the shipping carton with an industrial stapler or strapping tape.
6. Mark the address of the Tektronix Service Center and also your own return address on the shipping carton.

### MAINTENANCE AIDS

The maintenance aids recommended in Table 6-6 include items that may be needed for instrument maintenance and repair. Equivalent products may be substituted if their characteristics are similar.

### INTERCONNECTIONS

Pin connectors used to connect the wires to the interconnect pins are factory assembled. They consist of machine-inserted pin connectors mounted in plastic

holders. If the connectors are faulty, the entire assembly should be replaced.

### TRANSISTORS AND INTEGRATED CIRCUITS

Transistors and integrated circuits should not be replaced unless they are actually defective. If one is removed from its socket or unsoldered from the circuit board during routine maintenance, return it to its original board location. Unnecessary replacement or transposing of semiconductor devices may affect the adjustment of the instrument. When a semiconductor is replaced, check the performance of any circuit that may be affected.

Any replacement component should be of the original type or a direct replacement. Bend component leads to fit their circuit board holes, and cut the leads to the same length as the original component. See Figure 9-2 in the Diagrams section for the semiconductor lead configurations.

Table 6-6  
Maintenance Aids

Description	Specification	Usage	Example
Soldering Iron	15 to 25 W.	General soldering and unsoldering.	Antex Precision Model C.
Phillips Screwdriver		Assembly and disassembly.	
Long-nose Pliers		Component removal and replacement.	Diamalloy Model LN55-3.
Diagonal Cutters		Component removal and replacement.	Diamalloy Model M554-3.
Vacuum Solder Extractor	No Static Charge Retention.	Unsoldering static sensitive devices and components on multi-layer boards.	Pace Model PC-10.
Contact Cleaner	No-Noise.®	Switch and pot cleaning.	Tektronix Part Number 006-0442-02.
IC-removal Tool		Removing DIP IC packages.	Augat T114-1.
Isopropyl Alcohol	Reagent grade.	Cleaning.	2-Isopropanol.



*After replacing a power transistor, check that the collector is not shorted to the chassis before applying power to the instrument.*

To remove socketed dual-in-line packaged (DIP) integrated circuits, pull slowly and evenly on both ends of the device. Avoid disengaging one end of the integrated circuit from the socket before the other, since this may damage the pins.

To remove a soldered DIP IC for replacement, clip all the leads of the device and remove the leads from the circuit board one at a time. If the device must be removed intact for possible reinstallation, do not heat adjacent conductors consecutively. Apply heat to pins at alternate sides and ends of the IC as solder is removed. Allow a moment for the circuit board to cool before proceeding to the next pin.

## SOLDERING TECHNIQUES

The reliability and accuracy of this instrument can be maintained only if proper soldering techniques are used to remove or replace parts. General soldering techniques that apply to maintenance of any precision electronic equipment should be used when working on this instrument.

### WARNING

*To avoid an electrical shock hazard, observe the following precautions before attempting any soldering: turn the instrument off, disconnect it from the ac power source, and wait at least three minutes for line-rectifier filter capacitors to discharge.*

Use rosin-core wire solder containing 63% tin and 37% lead. Contact your local Tektronix Field Office or representative to obtain the names of approved solder types.

When soldering on circuit boards or small insulated wires, use only a 15 to 25 watt, pencil-type soldering iron. A higher wattage soldering iron may cause etched circuit conductors to separate from the board base material and melt the insulation on small wires. Always keep the soldering iron tip properly tinned to ensure the

best heat transfer from the tip to the solder joint. Apply only enough solder to make a firm joint. After soldering, clean the area around the solder connection with an approved flux-removing solvent (such as isopropyl alcohol) and allow it to air dry.



*Only a maintenance person experienced in the use of vacuum-type desoldering equipment should attempt repair of any circuit board in this instrument. Many integrated circuits are static sensitive and may be damaged by solder extractors that generate static charges. Perform work involving static-sensitive devices only at a static-free work station while wearing a grounded antistatic wrist strap. Use only an antistatic vacuum-type solder extractor approved by a Tektronix Service Center.*



*Attempts to unsolder, remove, and resolder leads from the component side of a circuit board may cause damage to the reverse side of the circuit board. The following techniques should be used to replace a component on a circuit board:*

1. Touch the vacuum desoldering tool tip to the lead at the solder connection. Never place the tip directly on the board; doing so may damage the board.

### NOTE

*Some components are difficult to remove from the circuit board due to a bend placed in the component leads during machine insertion. To make removal of machine-inserted components easier, straighten the component leads on the reverse side of the circuit board.*

2. When removing a multipin component, especially an IC, do not heat adjacent pins consecutively. Apply heat to the pins at alternate sides and ends of the IC as solder is removed. Allow a moment for the circuit board to cool before proceeding to the next pin.



*Excessive heat can cause the etched circuit conductors to separate from the circuit board. Never allow the solder extractor tip to remain at one place on the board for more than three seconds. Solder wick, spring-actuated or squeeze-bulb solder suckers, and heat blocks (for desoldering multipin components) must not be used. Damage caused by poor soldering techniques can void the instrument warranty.*

3. Bend the leads of the replacement component to fit the holes in the circuit board. If the component is replaced while the board is installed in the instrument, cut the leads so they protrude only a small amount through the reverse side of the circuit board. Excess lead length may cause shorting to other conductive parts.
4. Insert the leads into the holes of the board so that the replacement component is positioned the same as the original component. Most components should be firmly seated against the circuit board.
5. Touch the soldering iron tip to the connection and apply enough solder to make a firm solder joint. Do not move the component while the solder hardens.
6. Cut off any excess lead protruding through the circuit board (if not clipped to the correct length in step 3).
7. Clean the area around the solder connection with an approved flux-removing solvent. Be careful not to remove any of the printed information from the circuit board.

## REMOVAL AND REPLACEMENT INSTRUCTIONS

### WARNING

*To avoid electrical shock, disconnect the instrument from the power input source before removing or replacing any component or assembly.*

The exploded-view drawings in the Replaceable Parts list may be helpful during removal and replacement of assemblies. Component locations are shown in the Diagrams section.

Read these instructions before attempting to remove or install any components.

### Cabinet

To remove the cabinet:

1. Unplug the power cord from its rear-panel connector.
2. Place the instrument upside down on a clean, flat surface.
3. Remove the four cabinet-securing screws from the bottom of the instrument. The two rear screws also hold the rear rubber pads (feet) in place. The front screws to be removed are separate from and to the outside of the front pads.
4. Carefully turn the instrument right side up, while holding together the top and bottom of the cabinet.
5. Remove the top half of the cabinet and the handle.

### WARNING

*Potentially dangerous voltages exist at several points throughout this instrument. If it is operated with the cabinet removed, do not touch exposed connections or components. Before replacing parts, disconnect the ac-power source from the instrument.*

### NOTE

*Removal of the top half of the cabinet and the handle will access the component side of the Main board and allow adjustment of TC1 (Trimmer) and SVR1 (see the Adjustment Procedure in section 5).*

*In addition, most of the checks described in the Troubleshooting part of this section can be done without further disassembly.*

To continue to remove the cabinet:

6. Remove the two screws securing the Main board to the cabinet bottom. One screw is near U2, and the other is near U7.
7. Lift the Main board along with the attached front and rear panels, away from the bottom of the cabinet.

To replace the cabinet, do the reverse of the preceding steps.

## Display Board

To remove the Display board:

1. Remove the cabinet.
2. Remove the two screws from the bottom of the Main board that secure the Display board support brackets to the Main board.
3. Remove the Display board solder connections from the bottom of the Main board.
4. Lift out the Display board along with its securing brackets.

To replace the Display board, do the reverse of the preceding steps.

## Main Board

To remove the Main board:

1. Remove the cabinet and the Display board.
2. Unplug the six-wire connector that connects the transformer to the Main board.
3. Unplug the ground connector from the Main board (between the power input and the transformer).
4. Unsolder the two wires (SIG and GND) attaching the front panel INPUT connector to the Main board. As these wires are part of the Main Board assembly, be sure to detach them from the INPUT connector and leave them attached to the Main Board.
5. The front and rear panels together with all the connecting wires can now be lifted away from the Main board.

### NOTE

*It is not necessary to remove the metal shield over the Input circuits in order to remove the Main board.*

*If you need to remove the metal shield to troubleshoot or replace components in the Input circuits:*

*Unsolder the three solder connections on the bottom of the Main board that hold the shield in place. Their location is designated by small squares on the top of the Main board at the edges of the shield.*

To replace the Main board, do the reverse of the preceding steps.

## Front Panel Assembly

To remove the Front Panel assembly:

1. Follow the removal steps for the Cabinet, Display board, and Main board.
2. Separate the Front Panel from the Rear Panel as follows:

Remove the two screws and washers securing the Power switch to the Front Panel and remove the screw and washer securing the green ground wire to the Front Panel.

### NOTE

*The Power switch and the ground wire detached in step 2 are part of the Rear Panel assembly.*

To replace the Front Panel assembly, do the reverse of the preceding steps.

## Rear Panel Assembly

To remove the Rear Panel assembly:

1. Follow the procedure given for Front Panel assembly removal and replacement. Note that the Power switch and ground wire are part of the Rear Panel assembly.

### NOTE

*When replacing assemblies in the instrument, be sure to use new wire ties to replace any clipped during disassembly.*





# OPTIONS

## INTERNATIONAL POWER CORDS

Instruments are shipped with the detachable power cord option ordered by the customer. Descriptive information about international power cord options is given in Section 2. The following list describes the power cords available for this instrument.

Standard	North American, 120 V
Option A1	Universal Euro, 220 V
Option A2	UK, 240 V
Option A3	Australian, 240 V
Option A4	North American, 240 V
Option A5	Switzerland, 220 V



# REPLACEABLE PARTS

## PARTS ORDERING INFORMATION

Replacement parts are available from or through your local Tektronix, Inc. Field Office or representative.

Changes to Tektronix instruments are sometimes made to accommodate improved components as they become available, and to give you the benefit of the latest circuit improvements developed in our engineering department. It is therefore important, when ordering parts, to include the following information in your order: Part number, instrument type or number, serial number, and modification number if applicable.

If a part you have ordered has been replaced with a new or improved part, your local Tektronix, Inc. Field Office or representative will contact you concerning any change in part number.

Change information, if any, is located at the rear of this manual.

## ITEM NAME

In the Parts List, an Item Name is separated from the description by a colon (:). Because of space limitations, an Item Name may sometimes appear as incomplete. For further Item Name identification, the U.S. Federal Cataloging Handbook H6-1 can be utilized where possible.

## FIGURE AND INDEX NUMBERS

Items in this section are referenced by figure and index numbers to the illustrations.

## INDENTATION SYSTEM

This mechanical parts list is indented to indicate item relationships. Following is an example of the indentation system used in the description column.

```

1 2 3 4 5           Name & Description
Assembly and/or Component
Attaching parts for Assembly and/or Component
    **** END ATTACHING PARTS ****
Detail Part of Assembly and/or Component
Attaching parts for Detail Part
    **** END ATTACHING PARTS ****
Parts of Detail Part
Attaching parts for Parts of Detail Part
    **** END ATTACHING PARTS ****
  
```

Attaching Parts always appear in the same indentation as the item it mounts, while the detail parts are indented to the right. Indented items are part of, and included with, the next higher indentation. The separation symbol - - - \* - - - indicates the end of attaching parts.

## ABBREVIATIONS

INCH	NUMBER SIZE	ELCTRN	ELECTRON	IN	INCH	SE	SINGLE END
ACTR	ACTUATOR	ELEC	ELECTRICAL	INCAND	INCANDESCENT	SECT	SECTION
ADPTR	ADAPTER	ELCTLT	ELECTROLYTIC	INSUL	INSULATOR	SEMICOND	SEMICONDUCTOR
ALIGN	ALIGNMENT	ELEM	ELEMENT	INTL	INTERNAL	SHLD	SHIELD
AL	ALUMINUM	EPL	ELECTRICAL PARTS LIST	LPHLDR	LAMPHOLDER	SHLDR	SHOULDERED
ASSEM	ASSEMBLED	EOPT	EQUIPMENT	MACH	MACHINE	SKT	SOCKET
ASSY	ASSEMBLY	EXT	EXTERNAL	MECH	MECHANICAL	SL	SLIDE
ATTEN	ATTENUATOR	FIL	FILLISTER HEAD	MTG	MOUNTING	SFLKKG	SELF-LOCKING
AWG	AMERICAN WIRE GAGE	FLEX	FLEXIBLE	NIP	NIPPLE	SLVG	SLEEVING
BD	BOARD	FLH	FLAT HEAD	NON WIRE	NOT WIRE WOUND	SPR	SPRING
BRKT	BRACKET	FLTR	FILTER	OB	ORDER BY DESCRIPTION	SO	SQUARE
BRS	BRASS	FR	FRAME or FRONT	OD	OUTSIDE DIAMETER	SST	STAINLESS STEEL
BRZ	BRONZE	FSTNR	FASTENER	OVH	OVAL HEAD	STL	STEEL
BSHG	BUSHING	FT	FOOT	PH BRZ	PHOSPHOR BRONZE	SW	SWITCH
CAB	CABINET	FXD	FIXED	PL	PLAIN or PLATE	T	TUBE
CAP	CAPACITOR	GSKT	GASKET	PLSTC	PLASTIC	TERM	TERMINAL
CER	CERAMIC	HDL	HANDLE	PN	PART NUMBER	THD	THREAD
CHAS	CHASSIS	HEX	HEXAGON	PNH	PAN HEAD	THK	THICK
CKT	CIRCUIT	HEX HD	HEXAGONAL HEAD	PWR	POWER	TNSN	TENSION
COMP	COMPOSITION	HEX SOC	HEXAGONAL SOCKET	RCPT	RECEPTACLE	TPG	TAPPING
CONN	CONNECTOR	HLCPS	HELICAL COMPRESSION	RES	RESISTOR	TRH	TRUSS HEAD
COV	COVER	HLEXT	HELICAL EXTENSION	RGD	RIGID	V	VOLTAGE
COPLG	COUPLING	HV	HIGH VOLTAGE	RLF	RELIEF	VAR	VARIABLE
CRT	CATHODE RAY TUBE	IC	INTEGRATED CIRCUIT	RTNR	RETAINER	W/	WITH
DEG	DEGREE	ID	INSIDE DIAMETER	SCH	SOCKET HEAD	WSHR	WASHER
DWR	DRAWER	IDNT	IDENTIFICATION	SCOPE	OSCILLOSCOPE	XFMR	TRANSFORMER
		IMPLR	IMPELLER	SCR	SCREW	XSTR	TRANSISTOR

Replaceable Parts - CFC250

## CROSS INDEX - MFR. CODE NUMBER TO MANUFACTURER

Mfr. Code	Manufacturer	Address	City, State, Zip Code
	ESCORT	2ND FLOOR NO.37 POA HSIN RD. SHIN TIEN	TAI PEI, TAIWAN
80009	TEKTRONIX INC	14150 SW KARL BRAUN DR PO BOX 500	BEAVERTON OR 97707-0001

Fig. & Index No.	Tektronix Part No.	Serial/Assembly No. Effective Dscont	Qty	12345 Name & Description	Mfr. Code	Mfr. Part No.
1-1	118-7923-00		1	CABINET ASSY: .CASE, TOP: (QTY. 1) .WITH SHIELDING FOIL ATTACHED (QTY. 1) .CASE, BOTTOM: (QTY. 1) .WITH SHIELDING FOIL ATTACHED (QTY. 1) .HANDLE: (QTY. 1) .FEET, FRONT (QTY. 2) .SCREW, PLASTIC (QTY. 2)	80009	118-7923-00 15-25585-6 11-25005-1 15-25585-6A 11-25005-1 15-25598-4 16-25593-5 15-25047-1



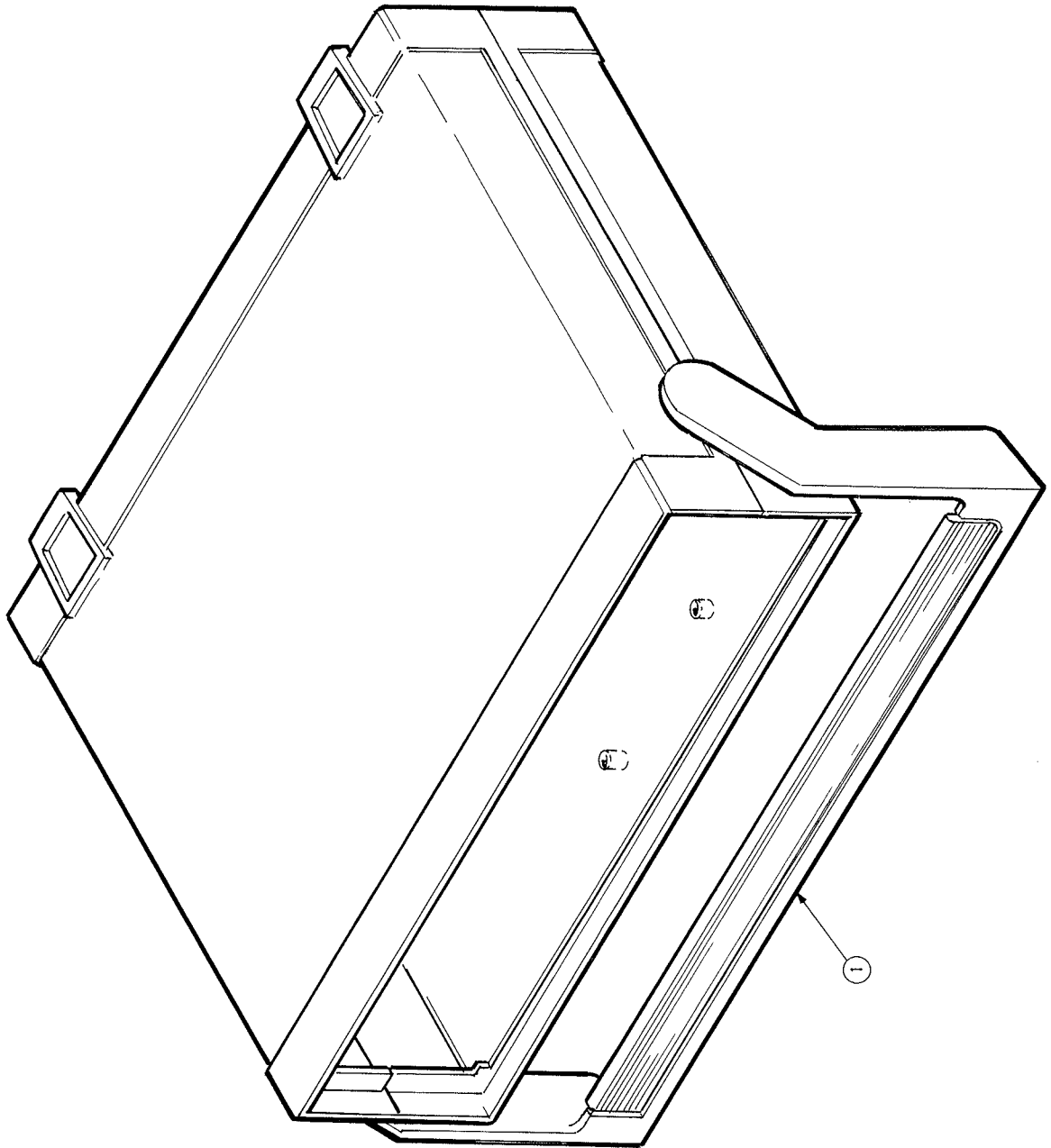
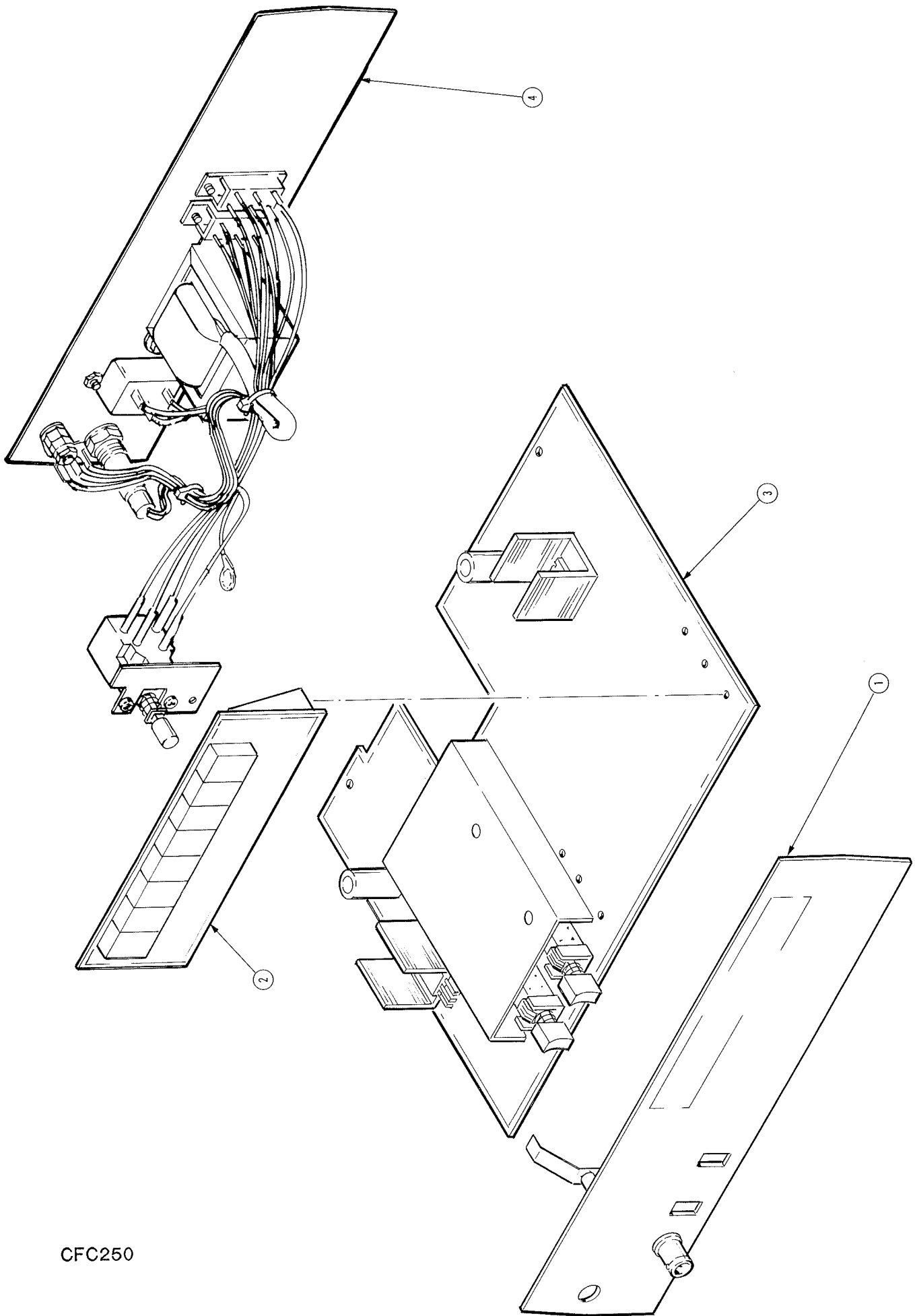

FIG. 2 ASSEMBLIES



CFC250



Fig. & Index No.	Tektronix Part No.	Serial/Assembly No.		Qty	12345	Name & Description	Mfr.	
		Effective	Dscont				Code	Mfr. Part No.
2-1	118-7924-00			1		FRONT PNL ASSY:	80009	118-7924-00
						.PANEL,FRONT: (QTY. 1)		1-25004-4
						.CFC250 OVERLAY: (QTY. 1)		24-25108-1
						.BNC: (QTY. 1)		30-25437-1
						.GROUND METAL		1-25056-1
-2	118-7927-00			1		CIRCUIT BD ASSY:DISPLAY	80009	118-7927-00
						.DISPLAY BOARD: (QTY. 1)		25-25749-1A
						.WAFER:20P,RTANG,UNLOCK (QTY. 1)		30-25626-3
						.RESISTOR:0 OHM,1/8W (J1 THRU J10)		33-000J8T-7
						.DIGIT LED:COMM CATH,ORANGE (DS1 THRU DS8)		57-25024-10
						.LED:ORANGE (D10)		64-25232-10
-3	118-7926-00			1		CIRCUIT BD ASSY:MAIN	80009	118-7926-00
						.MAIN BOARD: (QTY. 1)		25-25750-1B
						.CAPACITOR:47UF,+80/-20%,16V (C9,11,12,13,19,24,36,37,39)		31-476216-2
						.CAPACITOR:1000UF,+80/-20%,35V (C15,33)		31-108235-2
						.CAPACITOR:2PF,+/-0.25PF,50V (C2)		31-2R0Y50-3
						.CAPACITOR:33PF,5%,50V (C3)		31-12QJ50-3
						.CAPACITOR:120PF,10%,50V (C35)		31-121K50-3
						.CAPACITOR:470PF,10%,250V (C4,41)		31-471K250-3
						.CAPACITOR:4700PF,10%,50V (C21)		31-472K50-3
						.CAPACITOR:0.01UF,10%,50V (C6)		31-103K50-3
						.CAPACITOR:0.1UF,+80/-20%,50V (C5,7,8,10,14,17,18,20,22,23,25,26,30,31)		31-104Z50-3
						.CAPACITOR:0.047UF,10%,250V (C1)		31-473K250-4M
						.CAPACITOR:30PF,10%,50V (C28)		31-300K50-3N
						.CAPACITOR:330UF,+80/-20%,16V (C16,32)		31-337Z16-2
						.RESISTOR:1.1M,1%,1/8W (R1)		33-1104F8T-6DT
						.RESISTOR:0 OHM,1/8W (J1 THRU J20)		33-000J8T-7
						.RESISTOR:22 OHM,5%,1/8W (R28,29,45 THRU 51)		33-22QJ8T-7
						.RESISTOR:47 OHM,5%,1/8W (R16,52,53)		33-47QJ8T-7
						.RESISTOR:121K,1%,1/8W (R2)		33-1213F8T-6DT
						.RESISTOR:100 OHM,5%,1/8W (R17)		33-101J8T-7
						.RESISTOR:130 OHM,5%,1/8W (R25)		33-131J8T-7
						.RESISTOR:270 OHM,5%,1/8W (R15,26,27)		33-271J8T-7
						.RESISTOR:470 OHM,5%,1/8W (R6,7,19 THRU 24)		33-471J8T-7
						.RESISTOR:510 OHM,5%,1/8W (R4,5)		33-511J8T-7
						.RESISTOR:1K,5%,1/8W (R40)		33-102J8T-7
						.RESISTOR:2.2K,5%,1/8W (R12,13)		33-222J8T-7
						.RESISTOR:10K,5%,1/8W (R30 THRU 39,42)		33-103J8T-7
						.RESISTOR:27K,5%,1/8W (R3,43,44)		33-273J8T-7
						.RESISTOR:47K,5%,1/8W (R11)		33-473J8T-7
						.RESISTOR:22M,5%,1/8W (R41)		33-226J8T-7
						.RESISTOR:120 OHM,5%,1/8W (R9)		33-121J8T-7
						.SEMI-VR:10K,20% (SVR1)		34-1031-08E
						.TRIMMER:6-70PF,10% (TRIMER)		32-25401-1
						.DIODE:1N4148 (D5 THRU D8)		35-25111-1
						.DIODE:1N4002 (D1 THRU D4)		35-25112-2
						.TRANSISTOR:MPS3640 (Q2,3,4)		36-25352-1
						.TRANSISTOR:MPSA13 (Q5,6)		36-25288-1
						.FET:2N5486 (INTERSIL) (Q1)		37-25519-3
						.MICROCKT:MC10116P (MOTOROLA) (U1)		39-25572-1
						.MICROCKT:HD14017BP (HITACHI) (U7,8)		39-25196-1
						.MICROCKT:MM5369A/N (NS) (U6)		39-25568-1
						.MICROCKT:HD14011BP (HITACHI) (U5)		39-25126-1
						.MICROCKT:CD4511BE (RCA) (U12)		39-25569-1
						.MICROCKT:SN74LS90N (TI) (U4)		39-25571-2
						.MICROCKT:HD7402D (HITACHI) (U3)		39-25553-1
						.MICROCKT:SN74S196N (TI)		39-25578-1
						.MICROCKT:UA75492PC (FAIRCHILD) (U10,11)		39-25579-1
						.MICROCKT:LSI7031 (U9)		40-25420-1
						.MICROCKT:HA17805P (HITACHI) (U13,14)		41-25410-P5J
						.CRYSTAL:3.579545 MHZ (Y1)		58-25126-2
						.SWITCH:2P2G,LPF,ATT (S1,2)		80-25595-1
-4	118-7925-00			1		REAR PNL ASSY:	80009	118-7925-00
						.PANEL,REAR: (QTY. 1)		1-25055-1
						.FUSEHOLDER:CARRIER (QTY. 1)		62-25604-1
						.FUSEHOLDER:BASE (QTY. 1)		62-25604-3

## Replaceable Parts - CFC250

Fig. & Index No.	Tektronix Part No.	Serial/Assembly No. Effective Dscont	Qty	12345	Name & Description	Mfr. Code	Mfr. Part No.
2-					. FUSE:125MA, SLOW BLOW (FS3)		62-25596-2U
					. AC POWER JACK: (QTY. 1)		30-25625-1
					. TRANSFORMER: (T1)		63-1923-915
					. SWITCH, POWER: (S3)		80-25604-1
					.. HOLDER: (QTY. 1)		1-25057-1
					.. SCREWS: (QTY. 2)		4-11103-0602
					.. WASHERS: (QTY. 2)		6-12103-03
					. SAFETY GROUND CONNECTION:		
					.. LUG, FOUR LEG: (QTY. 1)		1-25071-1
					.. LUG, GROUND: (QTY. 1)		6-13103-02A
					.. SCREW, GROUND: (QTY. 1)		4-1113R5-1002
					.. NUT, GROUND: (QTY. 3)		5-1423R5-02
					.. WASHER, FLAT: GROUND (QTY. 1)		6-1113R5-02
					. SWITCH, VOLTAGE CONVERSION (S4,5)		80-25605-1

Fig. & Index No.	Tektronix Part No.	Serial/Assembly No. Effective Dscont	Qty	12345 Name & Description	Mfr. Code	Mfr. Part No.
ACCESSORIES						
	070-6741-00		1	MANUAL, TECH:SERVICE,CFC250	80009	070-6741-00
	070-6742-00		1	MANUAL, TECH:OPERATORS,CFC250	80009	070-6742-00
	161-0248-00		1	CABLE ASSY,PWR,:	80009	161-0248-00
	214-4204-00		1	HARDWARE KIT:CFC250	80009	214-4204-00



# DIAGRAMS AND CIRCUIT BOARD ILLUSTRATIONS

## Symbols

Graphic symbols and class designation letters are based on ANSI Standard Y32.2-1975.

Logic symbology is based on ANSI/IEEE 91-1984. Logic symbols depict the logic function performed and may differ from the manufacturer's data.

The overline on a signal name indicates that the signal performs its intended function when it is in the LO state.

Abbreviations are based on ANSI Y1.1-1972.

Other ANSI standards that are used in the preparation of diagrams by Tektronix, Inc., are:

Y14.15-1966 Drafting Practices.  
 Y14.2M-1979 Line Conventions and Lettering.  
 ANSI/IEEE 280-1985 Letter Symbols for Quantities Used in Electrical Science and Electrical Engineering.

American National Standards Institute  
 1430 Broadway  
 New York, New York 10018

## Component Values

Electrical components shown on the diagrams are in the following units unless noted otherwise:

Capacitors Values one or greater are in picofarads (pF).  
 Values less than one are in microfarads ( $\mu$ F).  
 Resistors Ohms ( $\Omega$ ).

———— The information and special symbols below may appear in this manual. ————

## Assembly Numbers and Grid Coordinates

Each assembly in the instrument is assigned an assembly number (e.g., A20). The assembly number appears on the circuit board outline on the diagram, in the title for the circuit board component location illustration, and in the lookup table for the schematic diagram and corresponding component locator illustration. The Replaceable Electrical Parts list is arranged by assemblies in numerical sequence; the components are listed by component number \*(see following illustration for constructing a component number).

The schematic diagram and circuit board component location illustration have grids. A lookup table with the grid coordinates is provided for ease of locating the component. Only the components illustrated on the facing diagram are listed in the lookup table. When more than one schematic diagram is used to illustrate the circuitry on a circuit board, the circuit board illustration may only appear opposite the first diagram on which it was illustrated; the lookup table will list the diagram number of other diagrams that the circuitry of the circuit board appears on.

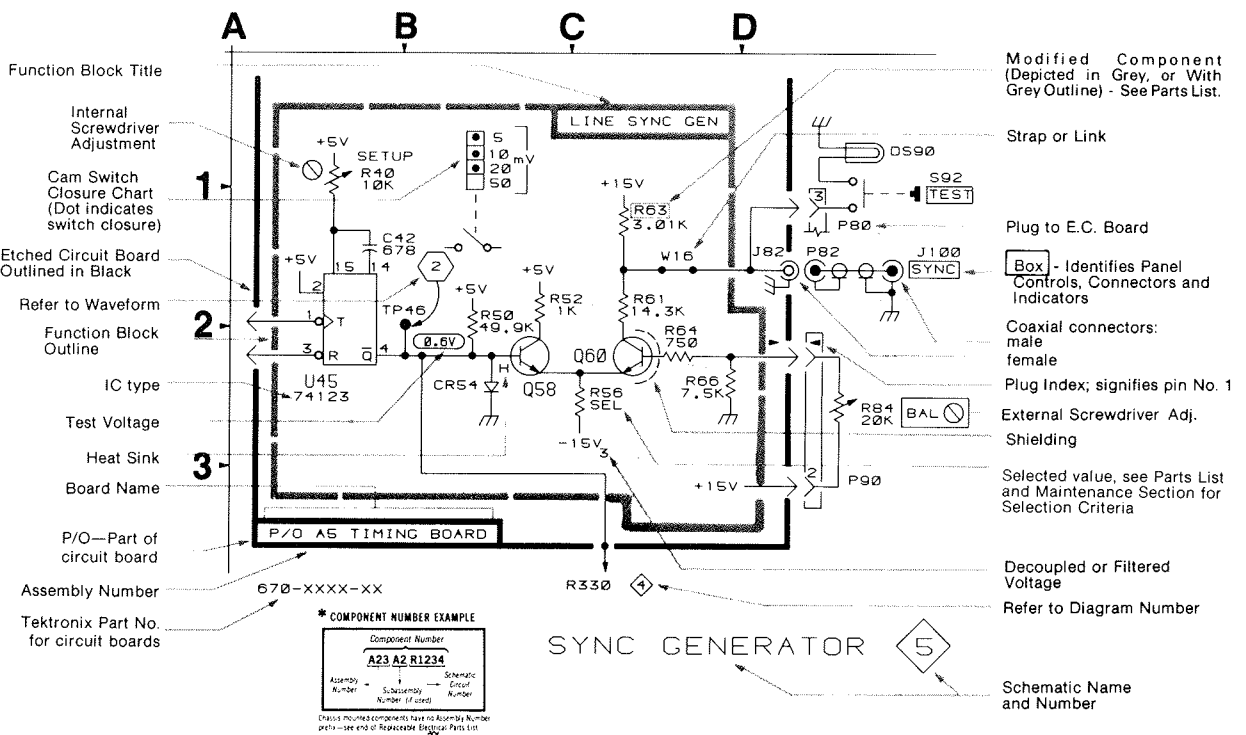

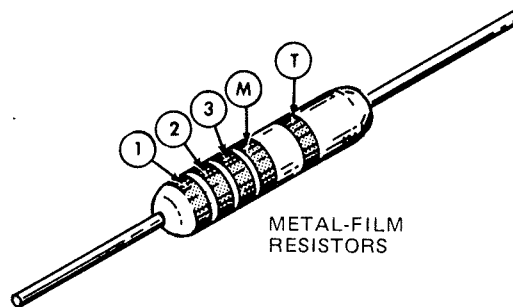
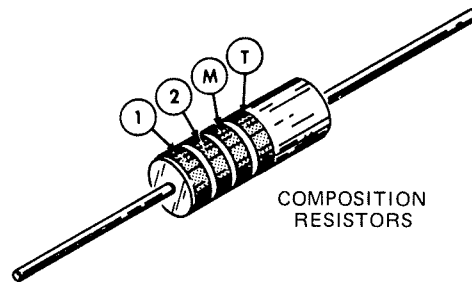

① ② and ③ — 1st, 2nd, and 3rd significant figures  
 (M) — multiplier      (T) — tolerance

COLOR	SIGNIFICANT FIGURES	RESISTORS	
		MULTIPLIER	TOLERANCE
BLACK	0	1	---
BROWN	1	10	±1%
RED	2	10 <sup>2</sup> or 100	±2%
ORANGE	3	10 <sup>3</sup> or 1 K	±3%
YELLOW	4	10 <sup>4</sup> or 10 K	±4%
GREEN	5	10 <sup>5</sup> or 100 K	±½%
BLUE	6	10 <sup>6</sup> or 1 M	±¼%
VIOLET	7	---	±1/10%
GRAY	8	---	---
WHITE	9	---	---
GOLD	—	10 <sup>-1</sup> or 0.1	±5%
SILVER	—	10 <sup>-2</sup> or 0.01	±10%
NONE	—	---	±20%

(1861-20A)6557-87

Figure 9-1. Color codes for resistors.

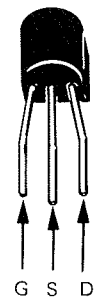
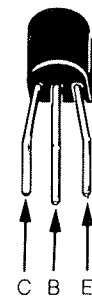
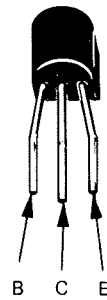
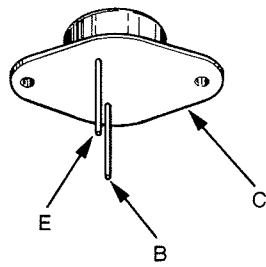
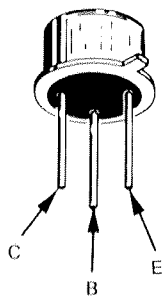

METAL CASE  
TRANSISTORS

PLASTIC CASE  
TRANSISTORS

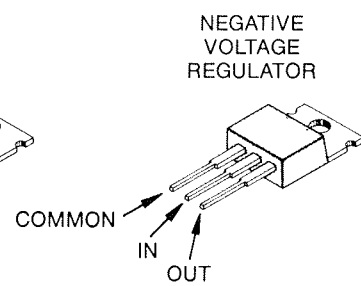
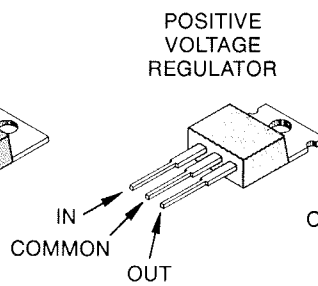
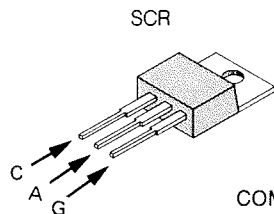
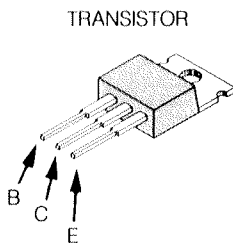

FLAT PACK

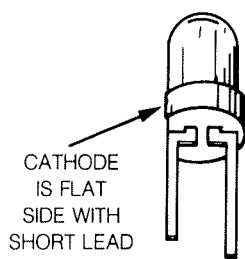

LED

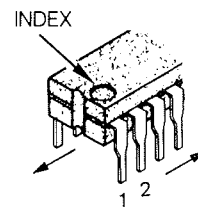

INTEGRATED CIRCUITS

LEAD CONFIGURATIONS AND CASE STYLES ARE TYPICAL, BUT MAY VARY DUE TO VENDOR CHANGES OR INSTRUMENT MODIFICATIONS.

Figure 9-2. Semiconductor lead configurations.





## CFC250 DIAGRAM

A1 MAIN BOARD											
CIRCUIT NUMBER	SCHEM LOCATION	BOARD LOCATION	CIRCUIT NUMBER	SCHEM LOCATION	BOARD LOCATION	CIRCUIT NUMBER	SCHEM LOCATION	BOARD LOCATION	CIRCUIT NUMBER	SCHEM LOCATION	BOARD LOCATION
C1	1B	5B	C5	6F	5B	R21	2E	4B	R50	3L	6G
C10	2C	4C	C6	3C	5C	R22	2E	4B	R51	3L	6G
C11	2D	5C	C7	3D	5C	R23	2G	3B	R52	1B	6B
C12	2C	5C	C8	2E	4D	R24	2F	4B	R53	3A	5C
C13	2C	4C	C9	2D	4D	R25	2F	3C	R6	2D	4B
C14	6E	3C				R26	3D	6D	R7	1E	4B
C15	6D	2A	D1	5D	2C	R27	3D	6D	R9	3C	5C
C16	6E	3B	D2	6D	2B	R28	4L	6E			
C17	6F	3B	D3	6D	2E	R29	4L	6E	SVR1	2C	4D
C18	7F	4D	D4	7D	3E	R3	3B	5B			
C19	7E	5D	D5	3B	5B	R30	4L	5D	U10	2L	6E
C2	2B	6C	D6	3B	5B	R31	4K	5E	U10B	4K	6E
C20	7F	4E	D7	3C	5C	R32	2H	4E	U11	1L	6F
C21	4J	4E	D8	3D	5C	R33	2J	4E	U12	3L	6H
C22	7F	3F				R34	2J	4E	U13	5E	5A
C23	7F	4F	Q1	3C	5B	R35	2J	4F	U14	6E	3F
C24	7E	4G	Q2	3C	5C	R36	3H	4F	U1A	2E	4C
C25	7F	4H	Q3	2F	3D	R37	3J	4F	U1B	1D	4C
C26	7F	3H	Q4	2F	4C	R38	3J	4F	U1C	1F	4C
C28	5B	2H	Q5	4L	5D	R39	3J	4F	U2	2H	3E
C29	6F	5D	Q6	4L	6D	R4	3B	5B	U3A	4F	3E
C3	2B	5C				R40	5C	2H	U3B	3F	3E
C30	7F	2G	R1	2B	6C	R41	4C	2H	U3C	3H	3E
C31	7F	3F	R11	1C	4D	R42	5G	5H	U3D	3J	3E
C32	7E	3F	R12	2D	4C	R43	4K	5G	U4	3H	3G
C33	7D	2F	R13	2D	4C	R44	3K	6H	U5B	4F	3G
C35	3C	5C	R15	2E	4C	R45	3L	6F	U5C	4F	3G
C36	6E	4B	R16	2F	3C	R46	4M	6F	U5D	3G	3G
C37	6F	3C	R17	2F	4C	R47	4M	6F	U6	4C	3G
C38	6E	5D	R19	2D	4B	R48	3L	6F	U7	4D	4H
C4	3B	5B	R2	2B	5C	R49	3L	6F	U8	3E	5H
C41	1D	4C	R20	2D	4B	R5	3C	5C	U9	1K	5E
OTHER PARTS											
CIRCUIT NUMBER	SCHEM LOCATION	BOARD LOCATION	CIRCUIT NUMBER	SCHEM LOCATION	BOARD LOCATION	CIRCUIT NUMBER	SCHEM LOCATION	BOARD LOCATION	CIRCUIT NUMBER	SCHEM LOCATION	BOARD LOCATION
FS3	6B	CHASSIS	S2	3D	CHASSIS	S3B	7B	CHASSIS	S5A	6B	CHASSIS
S1	1A	CHASSIS	S3	5B	CHASSIS	S4A	6C	CHASSIS	S5B	6B	CHASSIS
			S3A	6B	CHASSIS	S4B	7C	CHASSIS			

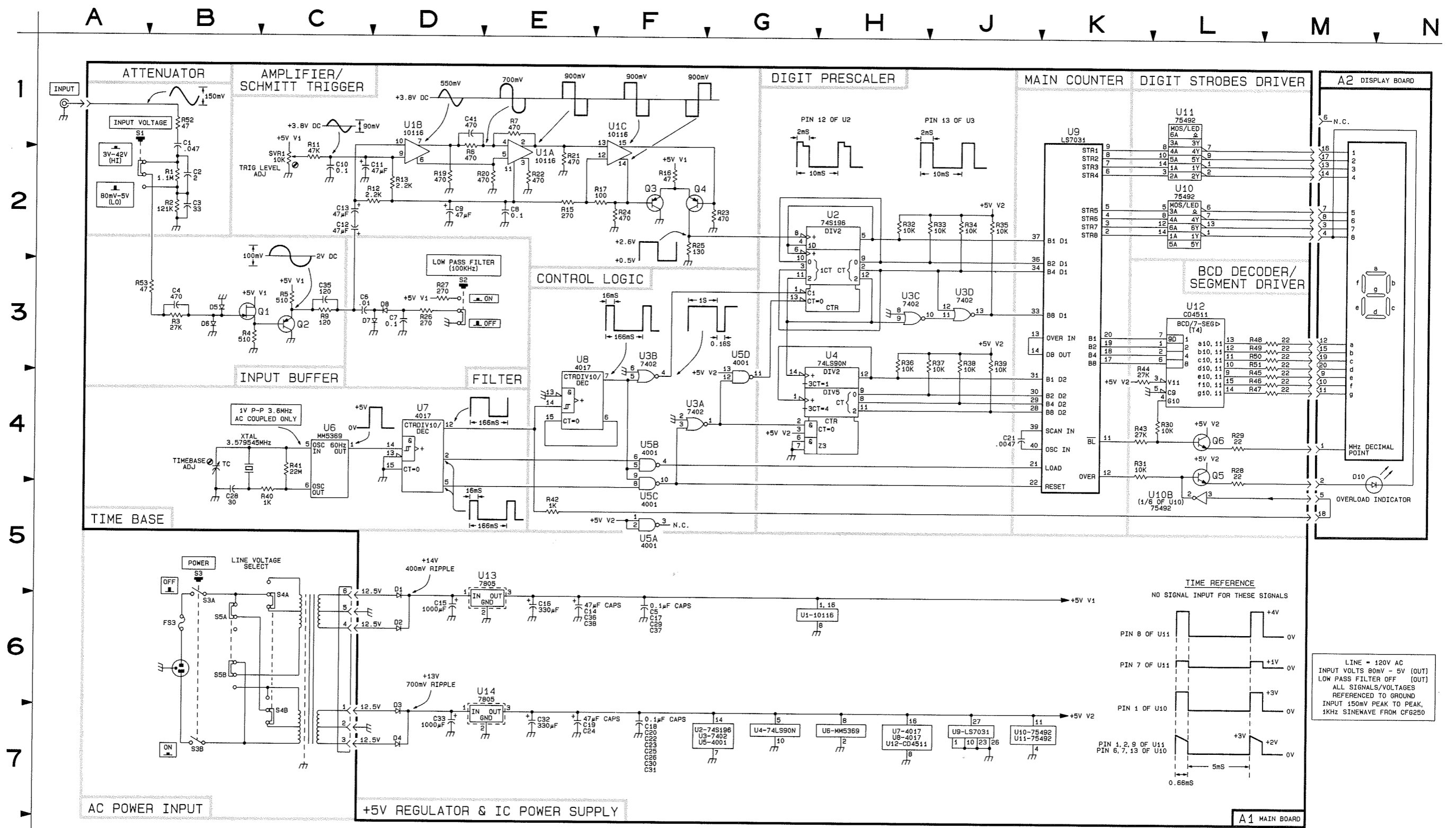

CFC250 100MHz FREQUENCY COUNTER