

# 11A71 Amplifier Service Reference

## WARNING

The following servicing instructions are for use by qualified personnel only. To avoid personal injury, do not perform any servicing unless you are qualified to do so. Refer to the Safety Summary prior to performing any service.

*Please check for CHANGE INFORMATION at the rear of this manual.*

## INSTRUMENT SERIAL NUMBERS

Each instrument has a serial number on a panel insert, tag, or stamped on the chassis. The first number or letter designates the country of manufacture. The last five digits of the serial number are assigned sequentially and are unique to each instrument. Those manufactured in the United States have six unique digits. The country of manufacture is identified as follows:

B000000	Tektronix, Inc. Beaverton, Oregon, USA
100000	Tektronix Guernsey, Ltd., Channel Islands
200000	Tektronix United Kingdom, Ltd., London
300000	Sony/Tektronix, Japan
700000	Tektronix Holland, NV, Heerenveen, The Netherlands

Copyright © Tektronix, Inc., 1987. All rights reserved. Tektronix products are covered by U.S. and foreign patents, issued and pending. TEKTRONIX, TEK, SCOPEMOBILE and  are registered trademarks.

Printed in U.S.A.

# Contents

---

List of Illustrations .....	iii
List of Tables .....	iv
Safety Summary .....	v

## Section 1—General Information

Introduction .....	1-1
Plug-in to Mainframe Compatibility .....	1-1
Initial Inspection .....	1-2
Installing and Removing the Plug-In .....	1-2
Instrument Options .....	1-3
Packaging for Shipment .....	1-3
Operating Environment .....	1-4
Operating Temperature .....	1-4

## Section 2—Checks and Adjustments

Using this Procedure .....	2-1
Menu Selections and Measurement Techniques .....	2-1
Plug-In Installation and Removal .....	2-2
Initialized Setting .....	2-2
Test Equipment .....	2-2
Procedure Parts .....	2-3
Part 1—Initial Setup .....	2-6
Part 2—Examine/Adjust Trigger Balance and Common Mode (A1R812, A1R813) .....	2-7
Part 3—Examine/Adjust Input Current and Impedance (A1R521, A1R511) .....	2-9
Part 4a—Examine/Adjust Low-Frequency Transient Response: Standard Procedure (A1R310, A1R311, A1R312, A1R410, A1R411, A1R510, A1C412) .....	2-11
Part 4b—Examine/Adjust Low-Frequency Transient Response: Alternative Procedure (A1R310, A1R311, A1R312, A1R410, A1R411, A1R510, A1C412) .....	2-14
Part 5—Check Bandwidth .....	2-16
Examine Mainframe Bandwidth .....	2-17
Check Plug-in Bandwidth .....	2-18
Part 6—Check Enhanced Accuracy .....	2-20
Part 7—Check DC Balance .....	2-22
Part 8a—Check $\Delta V$ DC Accuracy: 11401/11402 Mainframe Procedure .....	2-23
Characterize 11401/11402 Mainframe .....	2-24
Test Plug-in .....	2-25
Part 8b—Check $\Delta V$ DC Accuracy: 11301/11302 Mainframe Procedure .....	2-27
Characterize 11301/11302 Mainframe .....	2-28
Test Plug-in .....	2-29
Part 9—Check DC Offset Accuracy .....	2-31
Characterize 11401/11402 Mainframe .....	2-31
Characterize 11301/11302 Mainframe .....	2-32
Test Plug-in .....	2-33

### Section 3—Maintenance

Preventive Maintenance .....	3-1
Plug-In Shield Removal .....	3-1
Cleaning .....	3-1
Visual Inspection .....	3-2
Periodic Electrical Adjustment .....	3-2
Corrective Maintenance .....	3-3
Ordering Parts .....	3-3
Static-Sensitive Device Classification .....	3-3
Removing and Replacing FRU Modules .....	3-5
Semiconductor FRU Removal .....	3-7
Circuit Board and Attenuator FRU Removal .....	3-10
Programming the Unit Identification .....	3-15
Cables and Connectors .....	3-16
Troubleshooting .....	3-18
Diagnostic Troubleshooting .....	3-18
Diagnostics Overview .....	3-18
Kernel Tests .....	3-18
Self-Test/Extended Diagnostics .....	3-20
Using the Self-Tests/Extended Diagnostics .....	3-21
New Configuration Calibration .....	3-21
Restoring Calibration Data .....	3-21
Plug-In Memory Backup Power .....	3-22
Field Replaceable Unit (FRU) Guide .....	3-22
Abbreviations of FRU Names .....	3-22
Abbreviations of Component and Module Names .....	3-23
Error Index Codes .....	3-23
Fuse Troubleshooting .....	3-24

### Section 4—Theory of Operation

Block Diagram Description .....	4-1
Signal Flow .....	4-1
Main Board .....	4-1
Kernel Board to Main Board .....	4-1
Control Flow .....	4-3
Power .....	4-3

### Section 5—Replaceable Parts

#### Change Information

#### Related Documentation

The Replaceable Parts Section at the rear of this manual lists the Tektronix part numbers for all Standard Accessories provided with this product.

#### Manuals (Standard Accessories)

11A71 User's Reference Supplement  
 11A71 Incoming Inspection Procedure

# List of Illustrations

---

Figure 1-1	Installing a plug-in in a mainframe oscilloscope .....	1-3
Figure 2-1	A1 Main board Trigger Balance test point and adjustment locations .....	2-8
Figure 2-2	A1 Main board Input Current and Impedance adjustment locations .....	2-10
Figure 2-3	A1 Main board Low-Frequency Response adjustment locations .....	2-13
Figure 3-1	Field Replaceable Units (FRU) locator .....	3-6
Figure 3-2	Semiconductor indexing diagram .....	3-8
Figure 3-3	IC insertion-extraction tool .....	3-9
Figure 3-4	Location of screws and parts for removal of Attenuator .....	3-12
Figure 3-5	Location of a nut block securing the circuit board to the frame section .....	3-13
Figure 3-6	Locations of the nut blocks for removal of the A1 Main board .....	3-13
Figure 3-7	Indexing of multi-pin connectors .....	3-17
Figure 3-8	Sample LED fault code timing diagram .....	3-19
Figure 4-1	11A71 Amplifier .....	4-2

# List of Tables

---

Table 2-1	Test Equipment .....	2-4
Table 2-2	11A71 Bandwidth in the 11402 Mainframe .....	2-19
Table 2-3	11A71 Bandwidth in the 11401, 11301, and 11302 Mainframes .....	2-19
Table 2-4	11A71 DC Offset Accuracy .....	2-34
Table 3-1	Relative Susceptibility to Damage From Static Discharge .....	3-4

# Safety Summary

---

The general safety information in this part of the summary is for both operating and servicing personnel. Specific warnings and cautions will be found throughout the manual where they apply, but may not appear in this summary.

## Terms

### In This Manual

**CAUTION** statements identify conditions or practices that could result in damage to the equipment or other property.

**WARNING** statements identify conditions or practices that could result in personal injury or loss of life.

### As Marked on Equipment

**CAUTION** indicates personal injury hazard not immediately accessible as one reads the marking, or a hazard to property including the equipment itself.

**DANGER** indicates a personal injury hazard immediately accessible as one reads the marking.

## Symbols

### In This Manual



Static-Sensitive Devices.



This symbol indicates where applicable cautionary or other information is to be found.

### As Marked on Equipment



**DANGER** – High Voltage.



Protective ground (earth) terminal.



**ATTENTION** – refer to manual.

## Warnings

### **Power Source**

This product is intended to operate in a mainframe connected to a power source that will not apply more than 250 V rms between the supply conductors or between either supply conductor and ground. A protective ground connection, by way of the grounding conductor in the mainframe power cord, is essential for safe operation.

### **Grounding the Product**

This product is grounded through the grounding conductor of the mainframe power cord. To avoid electric shock, plug the mainframe power cord into a properly wired receptacle before connecting to the product input or output terminals. A protective-ground connection, by way of the grounding conductor in the mainframe power cord, is essential for safe operation.

### **Danger Arising from Loss of Ground**

Upon loss of the protective-ground connection, all accessible conductive parts (including knobs and controls that may appear to be insulating), can render an electric shock.

### **Do Not Operate in Explosive Atmospheres**

To avoid explosion, do not operate this product in an atmosphere of explosive gasses.

### **Do Not Service Alone**

Do not perform internal service or adjustment of this product unless another person capable of rendering first aid and resuscitation is present.

### **Use Care When Servicing with Power On**

Dangerous voltages exist at several points in this product. To avoid personal injury, do not touch exposed connections and components while power is on.

Disconnect power before removing protective panels, or replacing components.



# Section 1

## General Information

---

This section gives all the information needed to apply power to the 11A71 Amplifier. Information on installing and removing the plug-in, instrument options, packaging for shipment, as well as environmental conditions such as operating temperature is included here.

### Introduction

This manual is designed for use by qualified service personnel. It contains information necessary to check, troubleshoot, and maintain the 11A71 Amplifier. Troubleshooting is primarily based upon internal Diagnostics. These diagnostics identify suspect Field Replaceable Unit(s) (FRUs). Once the faulty FRU is identified, use the instructions provided in this manual to remove and replace it. Section 5, Replaceable Parts gives a complete list of the FRUs in this instrument.

The 11A71 plug-in is a single-channel, wide-bandwidth plug-in amplifier that plugs into any of the 11000-series plug-in mainframes. Commands from the mainframe control all the plug-in functions. The plug-in front panel has a momentary pushbutton and a back-lighted "display on" indicator. Other controls and status indicators are located on the mainframe.

The impedance of the input is 50  $\Omega$ . The plug-in provides display and trigger signals to the host mainframe.

The plug-in has a TEKPROBE® input connector. The TEKPROBE® input connector accepts a Level 1 or Level 2 TEKPROBE®, a probe with a BNC connector, or a BNC connector. The plug-in detects the probe-encoding information and uses this information to automatically achieve the desired settings.

### Plug-in to Mainframe Compatibility

The system bandwidth depends on the host mainframe. Details about bandwidth are included in Part 4, Specification, of the User's Reference Supplement, and in the Tektronix Corporate Catalog. Refer to the Tektronix Corporate Catalog for complete compatibility information.

# Initial Inspection

This instrument was inspected mechanically and electrically before shipment. Therefore, this instrument should not have any marks or scratches and should meet all electrical specifications.

Inspect the plug-in for possible physical damage incurred in transit. Use the Incoming Inspection Procedure shipped with the instrument to verify instrument performance. If you find damage or deficiency, contact your local Tektronix Field Office or representative.

## Installing and Removing the Plug-In

To install the plug-in in any 11000-series oscilloscope mainframe:

1. Set the mainframe ON/STANDBY switch to STANDBY to prevent damage to the instrument.



*If the green indicator light remains ON when the STANDBY position is selected, then the switch has been left internally disabled after the servicing of the Power Supply. To enable the ON/STANDBY switch, refer to the Maintenance section of the mainframe plug-in Service Manual.*

2. Align the grooves in the top and bottom of the plug-in with the guides in the mainframe plug-in compartment.
3. Insert the plug-in into the mainframe until its front panel is flush with the front panel of the mainframe.

To remove the plug-in from a mainframe.

1. Set the mainframe ON/STANDBY switch to STANDBY to prevent damage to the instrument.
2. Pull the release latch (refer to Fig. 1-1) to disengage the unit from the mainframe.
3. Pull the plug-in straight out of the plug-in compartment.

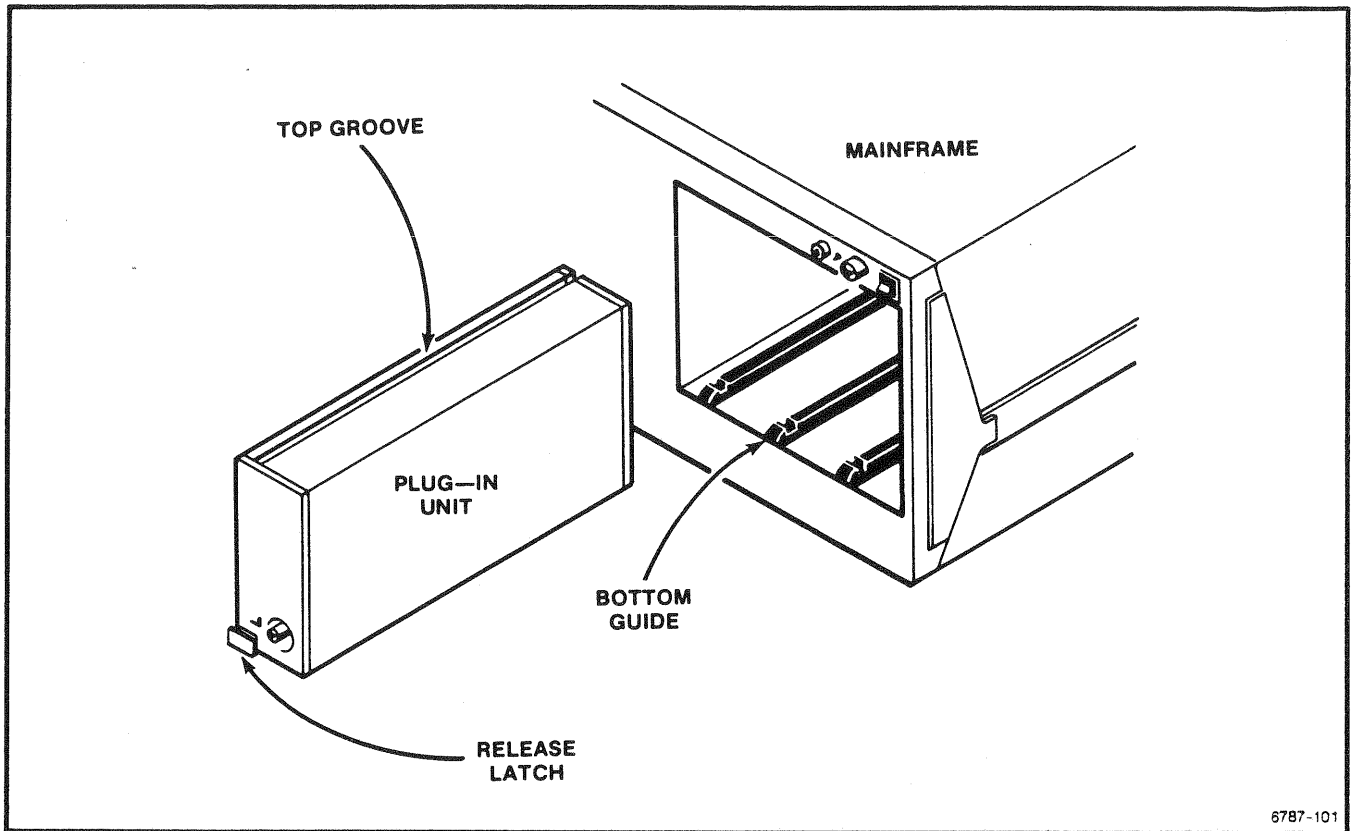

Figure 1-1. Installing a plug-in in a mainframe oscilloscope.

## Instrument Options

The customer can order Option 26, which includes one P6231 probe.

## Packaging for Shipment

If possible, save and reuse the original carton and packaging to package the instrument when shipping it by commercial transportation. Package and ship the plug-ins and mainframes separately.

Attach a tag to the plug-in if it is shipped to a Tektronix Service Center for service or repair. Include the following information on the tag:

- Name and address of the instrument owner
- Name of a person at your firm who can be contacted about the instrument
- Complete instrument type and serial number
- A description of the service required

Package the plug-in as follows, if the original package is not available or is not fit for use:

1. Obtain a corrugated cardboard carton with inside dimensions at least six inches (15 cm) greater than the instrument dimensions. Use a carton with a bursting test strength of at least 200 pounds per square inch.
2. Fully wrap the plug-in with anti-static sheeting, or its equivalent, to protect the finish.
3. Tightly pack dunnage or urethane foam between the carton and the instrument to cushion the plug-in on all sides. Allow three inches of packing on each side.
4. Seal the carton with shipping tape or with industrial staples.
5. Mark the address of the Tektronix Service Center and your return address on the carton in one or more prominent places.

## Operating Environment

The following environmental requirements are provided to ensure proper operation and long instrument life.

## Operating Temperature

Operate the plug-in where the ambient air temperature is between 0° and +50° C. Store the plug-in in ambient temperatures from -40° to +75° C. After storing the plug-in at temperatures outside the operating limits, allow the chassis to reach the safe operating temperature before applying power.

Enhanced system accuracy is available after a 20-minute warmup period. After entry into Enhanced Accuracy, the instrument reverts to non-enhanced accuracy if the internal mainframe temperature changes more than 5° C.

## Section 2

# Checks and Adjustments

---

This section contains procedures to check electrical specifications and to manually set all internal adjustments. This procedure provides a logical sequence of check and adjustment steps for either returning the instrument to specified operation following repair or for performing a part of a routine maintenance program. Consult the User's Reference manual for more information about advertised specifications and instrument operation. Consult the test equipment manuals for information concerning test equipment setup or interconnection. The Specifications or Measurement Limits are given at the beginning of each procedure.

### Using this Procedure

In these procedures, the following conventions are used:

- CAPITAL letters within the body of text identify front-panel controls, indicators, and connectors (for example, MEASURE) on the mainframe and plug-in.
- Bold letters identify menu labels and display messages.
- Initial Capital letters identify connectors, controls, and indicators (for example, Position) on associated test equipment. Initial Capital letters also identify adjustments inside the plug-in (for example Vert Pos).

A heading system is used to readily identify the steps that contain performance verification and/or adjustment instructions. For example, if **CHECK** is the first word in the title of a step, an electrical specification is checked. If **ADJUST** appears in the title, the step involves an electrical adjustment. If **EXAMINE** is the first word in the title, the step concerns measurement limits that indicate whether the instrument is operating properly; these limits are not to be interpreted as electrical specifications.

### Menu Selections and Measurement Techniques

Details on measurement techniques and instructions for making menu selections are generally not included in this procedure. Comprehensive descriptions of menus and instrument features are located in the User's Reference manual.

The mainframe tutorial manual is strongly recommended to familiarize the first-time user with the mainframe controls and features.

# Plug-In Installation and Removal



*To avoid instrument damage, set the mainframe ON/STANDBY switch to STANDBY before installing or removing the plug-ins.*

*Turning the instrument power off during probe calibration, self-calibration, Extended Diagnostics, or other intensive system activity may result in some internal data being corrupted. If corruption occurs, refer to Restoring Calibration Data in Section 3.*

## Initialized Setting

At the beginning of most steps, the user is instructed to **Initialize** the instrument as part of the setup. The **Initialize** feature, available through the **UTILITY** menu, presets all instrument controls and functions to known values. Initializing the instrument at the beginning of a step eliminates the possibility of settings from previous steps causing erroneous or confusing results. For more information on initialization, refer to the mainframe User's Reference manual.

## Test Equipment

Table 2-1 contains suggested test equipment used with the Checks and Adjustment Procedure. The procedures are based on the test equipment examples shown in the Setups, but other equipment with similar specifications may be substituted. However, using other equipment could alter the test results, the Setup information, or the related connectors and adapters required.

# Procedure Parts

The procedure is divided into the following parts which should be performed sequentially:

1. Initial Setup
2. Examine/Adjust Trigger Balance and Common Mode
3. Examine/Adjust Input Current and Impedance
4. Examine/Adjust Low-Frequency Transient Response
5. Check Bandwidth
6. Check Enhanced Accuracy
7. Check DC Balance
8. Check  $\Delta V$  DC Accuracy
9. Check DC Offset Accuracy

**TABLE 2-1  
Test Equipment**

<b>Description</b>	<b>Minimum Specification</b>	<b>Examples of Applicable Test Equipment</b>
11000-series plug-in mainframe.	Tektronix plug-in mainframe.	TEKTRONIX 11301 11302 11401 11402
Power Module	Tektronix four-compartment power module.	TEKTRONIX TM 504 Power Module.
Leveled Sine Wave Generator	250 MHz to 1000 MHz, Leveled variable amplitude, 50 kHz or 6 MHz reference.	TEKTRONIX SG 504 Leveled Sine Wave Generator with a TM 500-series Power Module.
Power Supply	Continuously variable from 0-40 V; current limit, adjustable from 0-400 mA.	TEKTRONIX PS 503A Dual Power Supply with a TM 500-series Power Module.
DC Voltage Calibrator	Output, 0-4 V.	Data Precision 8200.
Digital Multimeter (w/test leads)	Accuracy $\leq 0.01\%$ .	Fluke 8842A Digital Voltmeter.
Signal Standardizer	Tektronix Calibration Fixture with interface connector modified for 11000-series use.	TEKTRONIX 067-0587-02 Signal Standardizer.
Calibration Generator	Period, 0.1 ms, Amplitude, -60 V; Period, 10 ms; Amplitude, 1 V; Risetime, < 1 ns.	TEKTRONIX PG 506 Calibration Generator with a TM 500-series Power Module.
Calibration Fixture Flexible Extender		TEKTRONIX 067-1261-00 Flexible Extender Calibration Fixture.
Coaxial Cable	50 $\Omega$ , 18-inch, male BNC connectors.	Tektronix Part 012-0076-00.
Coaxial Cable (2 required)	50 $\Omega$ , 36-inch, male BNC connectors.	Tektronix Part 012-0482-00.
Adapter, BNC to Alligator Clips	BNC Female to Clip leads.	Tektronix Part 013-0076-00.
Attenuator, 10X	Impedance: 50 $\Omega$ , one male and one female BNC connector.	Tektronix Part 011-0059-02.



**TABLE 2-1 (cont)  
Test Equipment**

Description	Minimum Specification	Examples of Applicable Test Equipment
Adapter, BNC to Banana (2 required)	BNC Female to Dual Banana.	Tektronix Part 103-0090-00.
Connector, T	BNC, T: Two female and one male BNC connector.	Tektronix Part 103-0030-00.
Resistor	430 $\Omega$ ; Tolerance, 10%; Power rating, 1 W.	Tektronix Part 303-0431-00.
Alignment Tool (insulated slot)	Insulated slot.	Tektronix Part 003-0675-01.
Magnetic Screwdriver	Holder for Torx tips.	Tektronix Part 003-0293-00.
Torx Screwdriver Tips	#6 tip #7 tip #8 tip #10 tip #10 tip (narrow shank) #15 tip	Tektronix Part 003-1415-00. Tektronix Part 003-1293-00. Tektronix Part 003-0964-00. Tektronix Part 003-0814-00. Tektronix Part 003-0815-00. Tektronix Part 003-0966-00.
Integrated Circuit Extracting Tools	IC Insertion-Extraction Pliers 28-pin type.	General Tool P/N U505BG or equiv.
24-pin Socket		Tektronix Part 136-0751-00.
Needle-nose pliers		
Tweezers		
Static Control Mat		Tektronix Part 006-3414-00.
Wrist Strap		Tektronix Part 006-3415-00.

---

## Part 1 – Initial Setup

---

### Description

Perform the Checks and Adjustment procedure within the ambient temperature range of +18° and +28° C, to assure proper instrument operation.

**CAUTION**

*To avoid instrument damage, set the mainframe ON/STANDBY switch to STANDBY before installing or removing the plug-ins.*

*Turning the instrument power off during probe calibration, self-calibration, Extended Diagnostics, or other intensive system activity may result in some internal data being corrupted. If corruption occurs, refer to Restoring Calibration Data in Section 3.*

### Procedure

- a. Power on the following test equipment so that it is warmed up with the instrument to be tested:
  - Power Supply
  - Calibration Generator
  - Leveled Sine Wave Generator
  - Digital Multimeter
- b. With the ON/STANDBY switch set to STANDBY, connect the mainframe to a suitable power source.

## Part 2 – Examine/Adjust Trigger Balance and Common Mode (A1R812, A1R813)

### Description

The Trigger Amplifier is adjusted for balance when the Vertical Amplifier output is balanced. The Common (Com) Mode adjustment, R812 (if installed), does not need adjustment.

### Measurement Limits

Balance =  $0.0 \pm 25$  mV.

### Setup

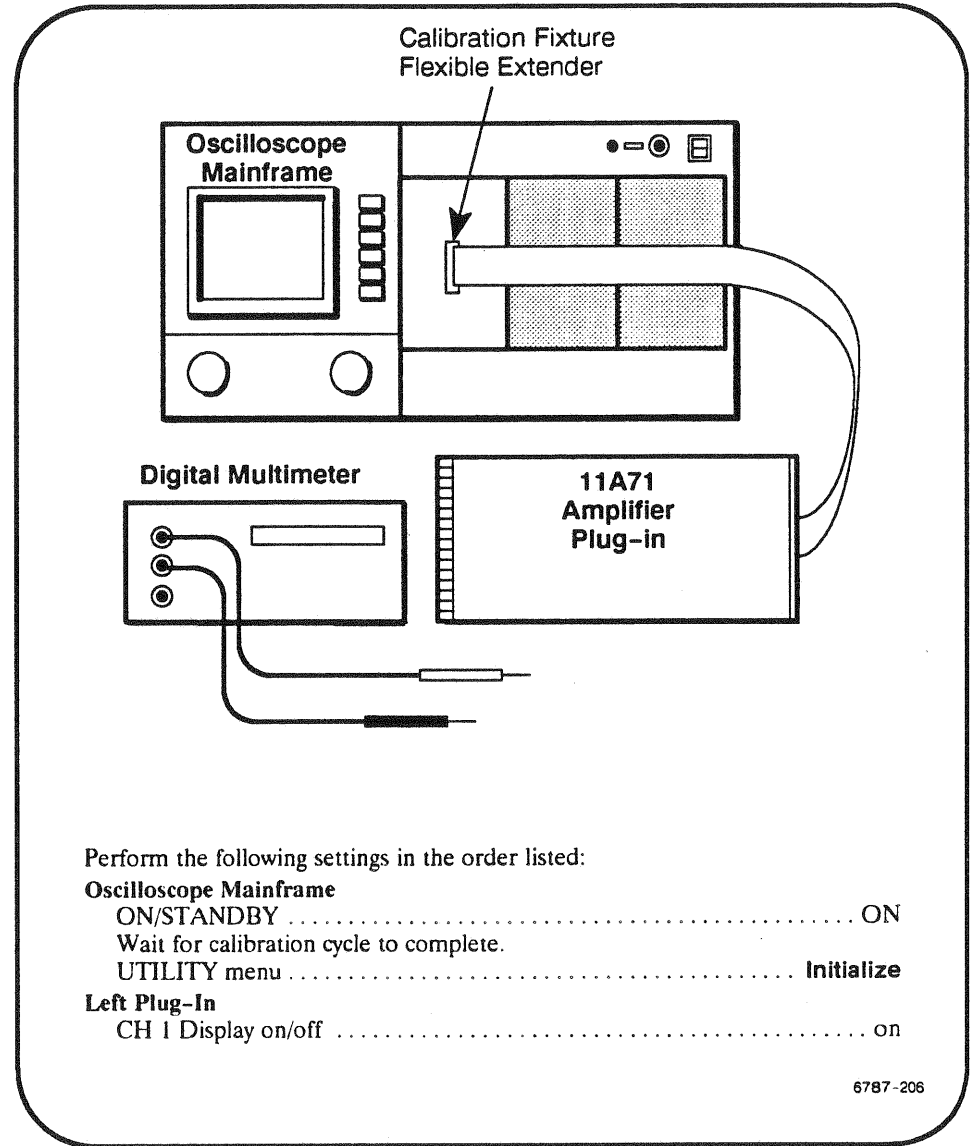

**Procedure**

- a. Connect the Digital Multimeter (DMM) leads to points K and M. Refer to Figure 2-1 for test point locations.
- b. Set the **Vert Offset: Fine**, for a Digital Multimeter readout of  $0\text{ mV} \pm 5\text{ mV}$ .
- c. Connect the Digital Multimeter leads to points D and E. Refer to Figure 2-1 for test point locations.
- d. **EXAMINE**—the Digital Multimeter for a reading of  $0\text{ mV}$ , within the limits of  $-20\text{ mV}$  and  $+20\text{ mV}$ .



**DO NOT** attempt to adjust the Trigger Balance (Bal) if it is within the stated limits. Proceed to step f.

- e. **ADJUST**—Trigger Balance adjustment, R813 on the A1 Main board, to  $0 \pm 20\text{ mV}$ . Refer to Figure 2-1 for adjustment locations.
- f. Set the ON/STANDBY switch to STANDBY. Remove the Flexible Extender from the mainframe and the plug-in.

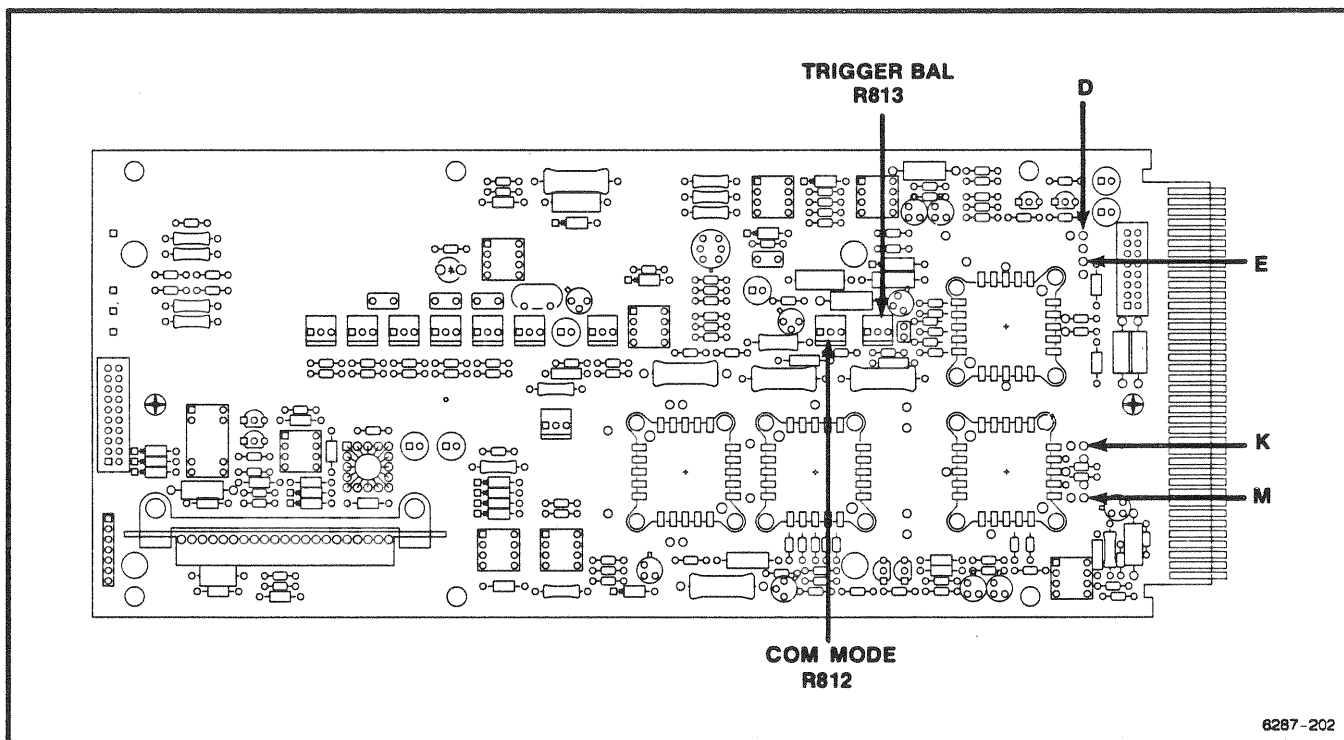

**Figure 2-1. A1 Main board Trigger Balance test point and adjustment locations.**

# Part 3 – Examine/Adjust Input Current and Impedance (A1R521, A1R511)

## Description

The Fast Protection circuit is adjusted for proper input impedance and minimum input current.

## Measurement Limits

Input Resistance =  $50 \pm 1 \Omega$ . Open circuit input voltage =  $0 \pm 2 \text{ mV}$ .

## Setup

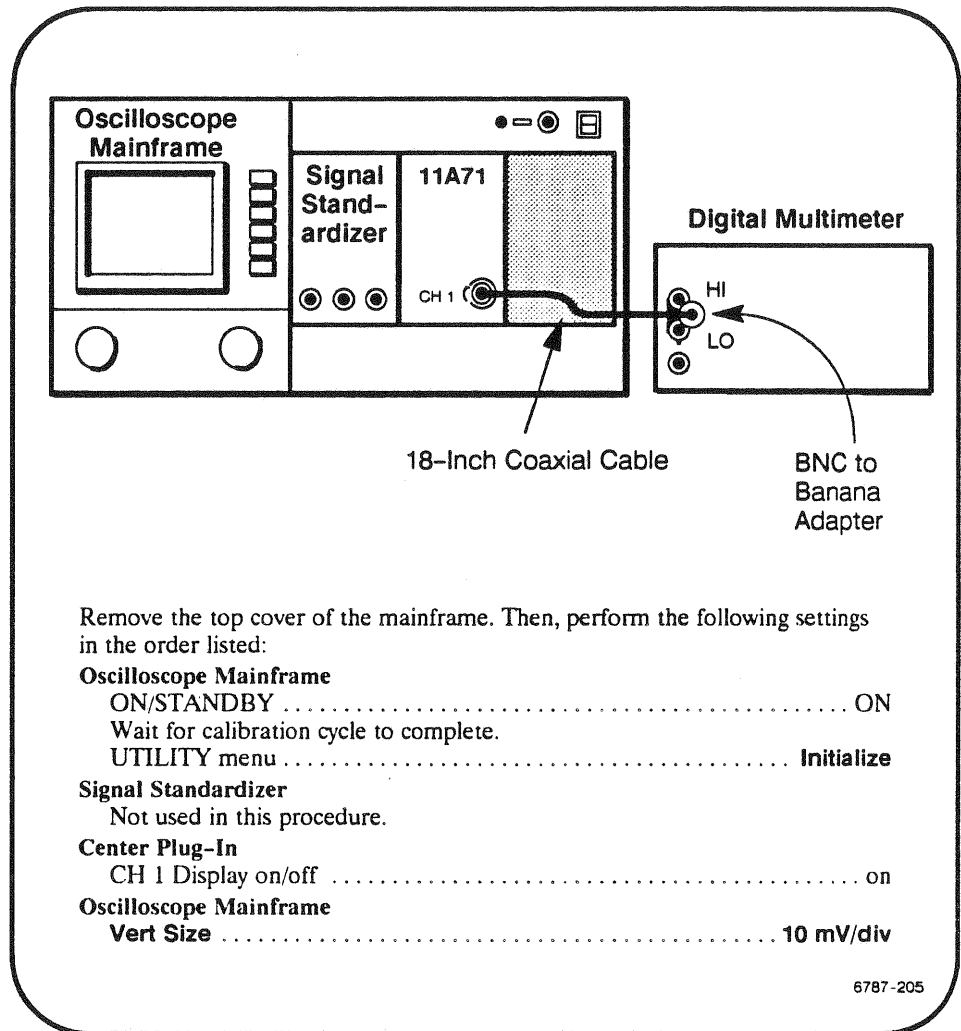

## Procedure

- a. Set the Digital Multimeter Range to 200 mV DC.
- b. **EXAMINE** – the Digital Multimeter for a reading of 0.0 mV, within the limits of  $\pm 2.0 \text{ mV}$ .



**DO NOT** attempt to adjust the Input I if it is within the stated limits. Proceed to step d.

- c. **ADJUST**—Input I adjustment, R521 on the A1 Main board, for 0.0 mV. Refer to Figure 2-2 for adjustment locations.
- d. Set the DMM to the 200  $\Omega$  range.
- e. Read the DMM.
- f. Reverse the BNC to banana connection on the DMM.
- g. Read the DMM.
- h. **EXAMINE** —the average DMM reading of steps e and g for a value of 50.0  $\Omega$ , within the limits of 49.0  $\Omega$  and 51.0  $\Omega$ .



DO NOT attempt to adjust the Z IN if it is within the stated limits. Proceed to step j.

- i. **ADJUST**—Z IN adjustment, R511 on the A1 Main board, for 50.0  $\Omega$ . Refer to Figure 2-2 for adjustment locations.
- j. The adjustments in step b and i are interactive (that is, adjusting one may affect the adjustment of the other); therefore repeat steps a through i until both EXAMINE steps yield readings within the stated limits.

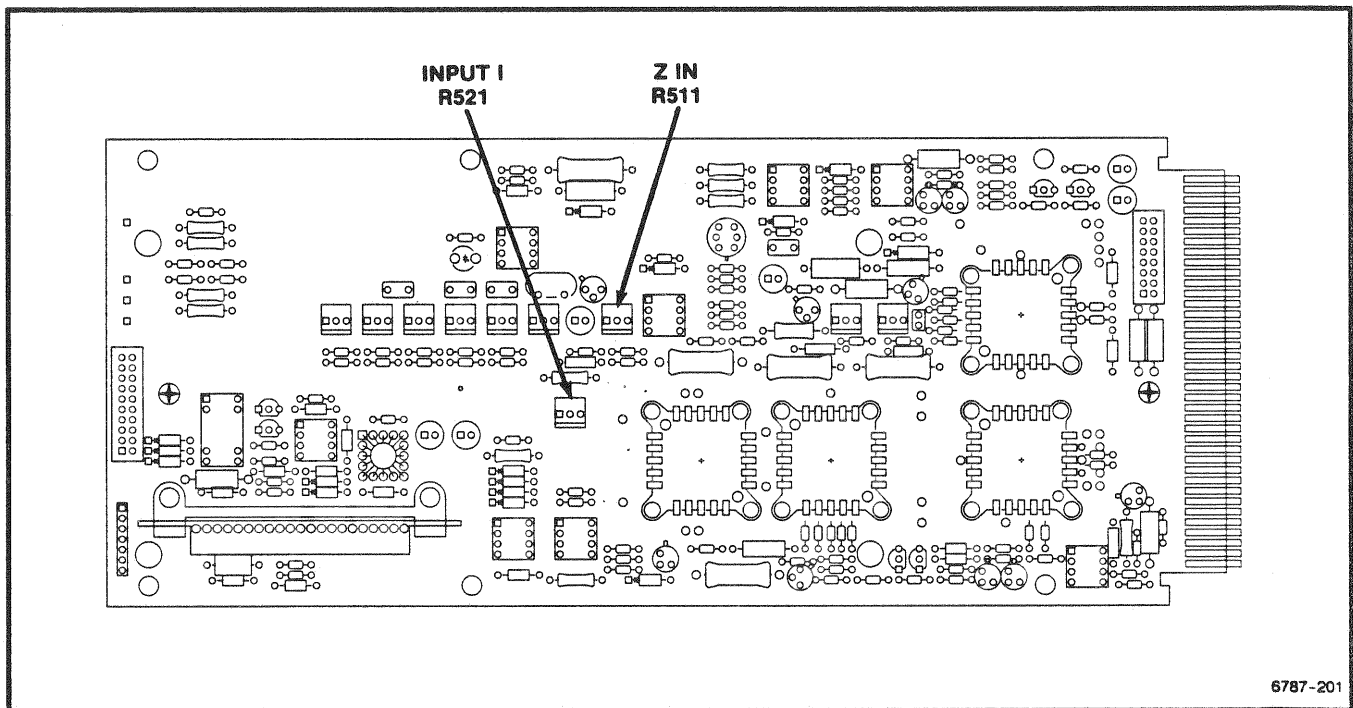

Figure 2-2. A1 Main board Input Current and Impedance adjustment locations.

# Part 4a – Examine/Adjust Low-Frequency Transient Response: Standard Procedure (A1R310, A1R311, A1R312, A1R410, A1R411, A1R510, A1C412)

**Description** Compensation networks are adjusted to optimize the transient response. The Standard Procedure requires the use of an 11401 or 11402 mainframe to assure that the plug-in performs properly in any mainframe. If neither an 11401 nor 11402 mainframe is available, then use the Alternative Procedure at the end of this part.

**Measurement Limits** Square wave aberrations within +1% and -0.5% peak.

**Setup**

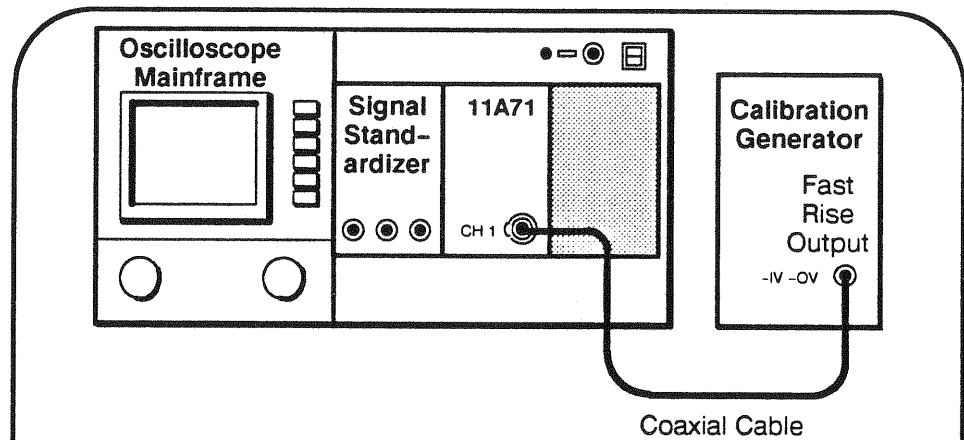

Remove the top cover of the mainframe. Then, **Initialize** the oscilloscope's settings, and perform the following settings in the order listed:

- Oscilloscope Mainframe**
- STORE/RECALL menu ..... Delete Waveform; All Waveforms
- WAVEFORM menu ..... L (left)
- Main Trigger Source Description ..... L (left)
- Main Size ..... 1 ms/div
- Main Pos ..... -1 ms
- Signal Standardizer**
- Test ..... Vert or Horiz + Step Resp
- Amplitude ..... 8 div
- Position ..... 1 div from top
- Rep Rate ..... 100 Hz
- Oscilloscope Mainframe**
- Store Waveform ..... Wfm 1
- Signal Standardizer**
- Rep Rate ..... 1 kHz
- Oscilloscope Mainframe**
- Main Size ..... 100  $\mu$ s/div
- Store Waveform ..... Wfm 1
- Signal Standardizer**
- Rep Rate ..... 10 kHz
- Oscilloscope Mainframe**
- Main Size ..... 10  $\mu$ s/div
- Store Waveform ..... Wfm 1
- Remove Wfm ..... L (left)
- Center Plug-in**
- CH 1 Display on/off ..... on

## Setup

<b>Oscilloscope Mainframe</b>	
Vert Size .....	100 mV/div
Vert Offset .....	-400 mV
<b>Calibration Generator</b>	
Function .....	Fast Rise
Period .....	10 ms
Pulse Amplitude .....	8 div
<b>Oscilloscope Mainframe</b>	
Main Size .....	1 ms/div
Recall Waveform .....	Stored 1

6787-204

## Procedure

- a. **EXAMINE** – the dim waveform (as compared to the bright waveform) for a flat top, within the limits of +1% peak and -0.5% peak.



DO NOT attempt to adjust the compensation if it is within the stated limits. Proceed to step c.

- b. **ADJUST** – compensation adjustments, R410 and R411 on the A1 Main board, for a flat top on the dim waveform as compared to the bright waveform. Refer to Figure 2-3 for adjustment locations.
- c. Set Calibration Generator Period to 1 ms.
- d. **Remove Wfm; Stored 1.**
- e. Set **Main Size** to 100  $\mu$ s/div.
- f. **Recall Waveform; Stored 2.**
- g. **EXAMINE** – the waveform for minimum long-term spiking and rolloff (flat top), within the limits of +1% peak and -0.5% peak.



DO NOT attempt to adjust the compensation if it is within the stated limits. Proceed to step i.

- h. **ADJUST** – compensation adjustment, R311 and R312 on the A1 Main board, for optimum square-wave flat top. Refer to Figure 2-3 for adjustment locations.
- i. Set Calibration Generator period to 0.1 ms.
- j. **Remove Wfm; Stored 2.**
- k. Set the **Main Size** to 10  $\mu$ s/div.
- l. **Recall Waveform; Stored 3.**



- m. **EXAMINE** – the waveform for minimum long-term spiking and rolloff (flat top), within 1% peak and -0.5% peak.



DO NOT attempt to adjust the compensation if it is within the stated limits. Proceed to step o.

- n. **ADJUST** – compensation adjustment, R310, R510, and C412 on the A1 Main board, for optimum square-wave flat top. Refer to Figure 2-3 for adjustment locations.
- o. Reinstall the top cover of the mainframe.

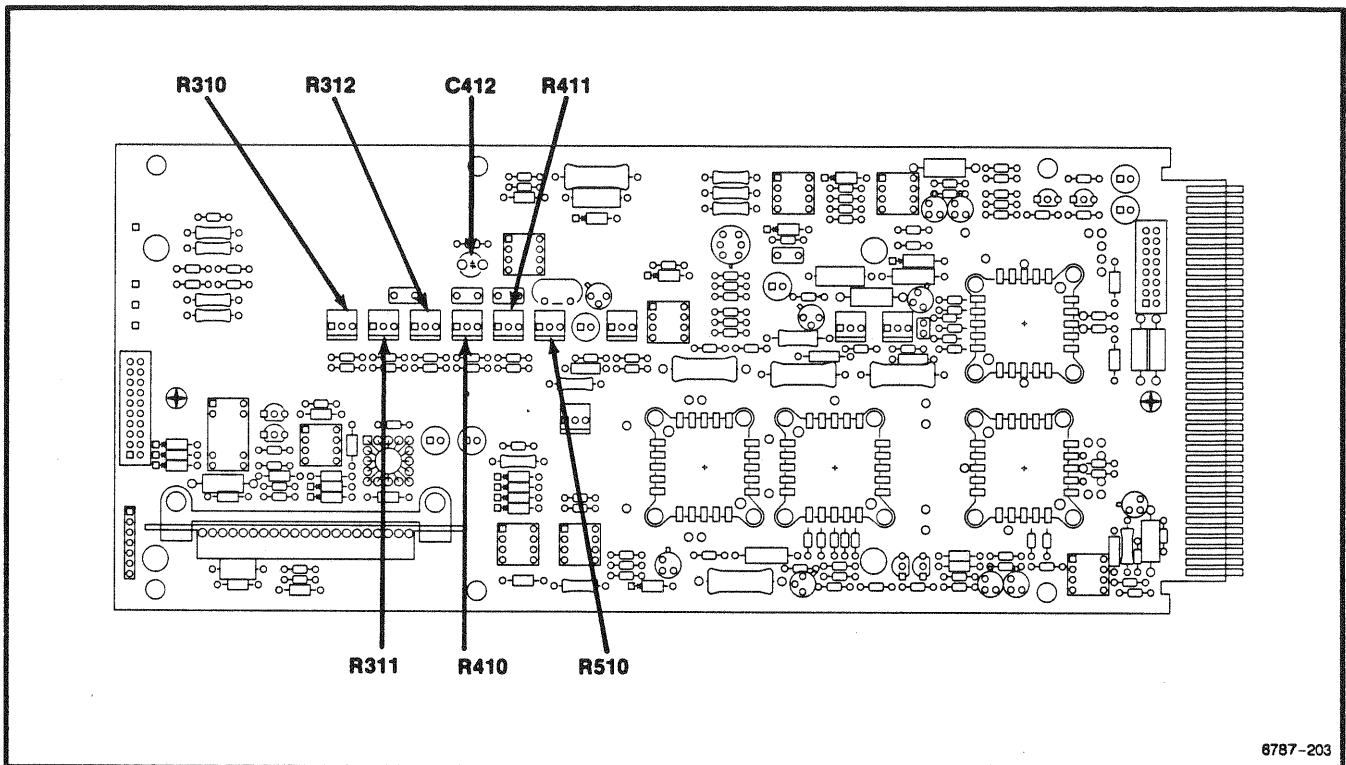

6787-203

Figure 2-3. A1 Main board Low-Frequency Response adjustment locations.

## Part 4b – Examine/Adjust Low-Frequency Transient Response: Alternative Procedure (A1R310, A1R311, A1R312, A1R410, A1R411, A1R510, A1C412)

### Description

Compensation networks are adjusted to optimize the transient response. This procedure is used when neither the 11401 nor the 11402 mainframe is available. Performance is assured only for the particular plug-in and mainframe combination examined and adjusted in this procedure.

### Measurement Limits

None.

### Setup

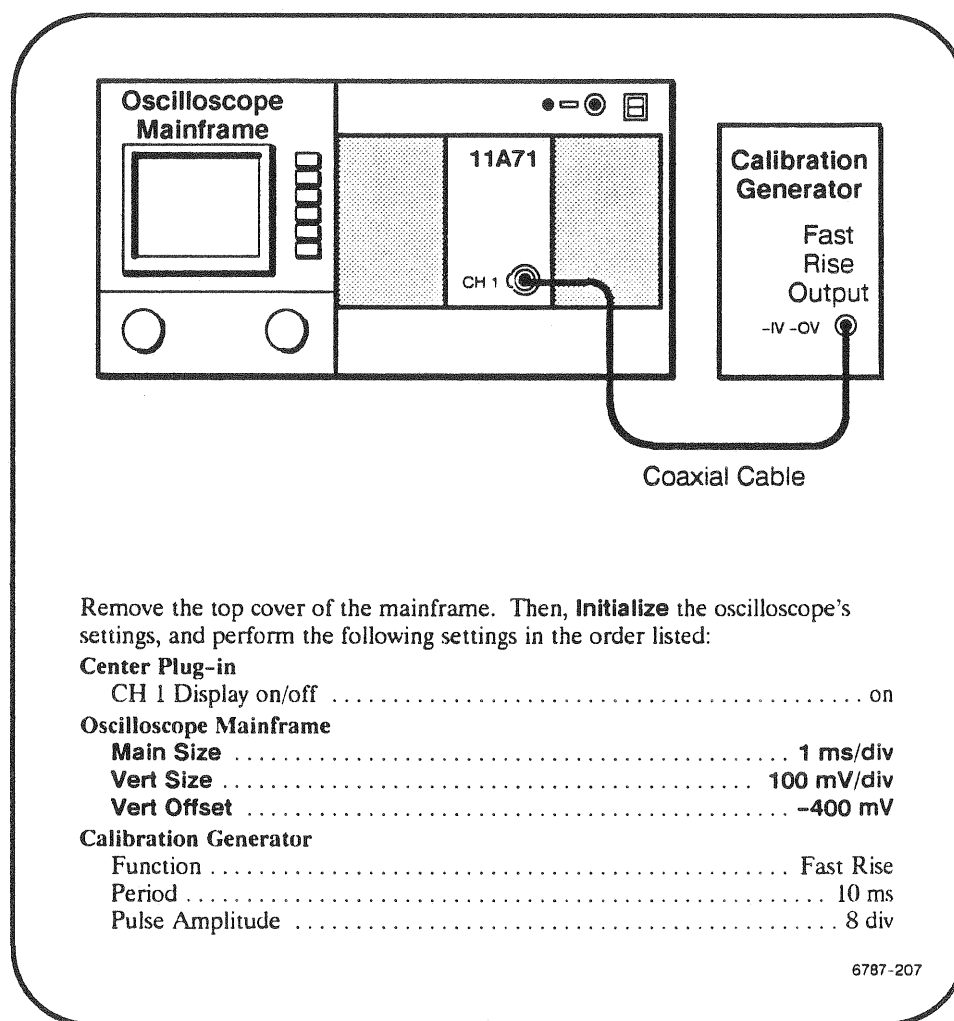

**Procedure**

- a. *EXAMINE*—the waveform for a flat top.



DO NOT attempt to adjust the compensation if the waveform already appears to be appropriate. Proceed to step c.

- b. *ADJUST*—compensation adjustments, R410 and R411 on the A1 Main board, for a flat top on the waveform. Refer to Figure 2-3 for adjustment locations.

- c. Set the Calibration Generator Period to 1 ms.

- d. Set **Main Size** to **100  $\mu\text{s}/\text{div}$** .

- e. *EXAMINE*—the waveform for minimum long-term spiking and rolloff (flat top).



DO NOT attempt to adjust the compensation if the waveform already appears to be appropriate. Proceed to step g.

- f. *ADJUST*—compensation adjustment, R311 and R312 on the A1 Main board, for optimum square-wave flat top. Refer to Figure 2-3 for adjustment locations.

- g. Set the Calibration Generator period to 0.1 ms.

- h. Set the **Main Size** to **10  $\mu\text{s}/\text{div}$** .

- i. *EXAMINE*—the waveform for minimum long-term spiking and rolloff (flat top).



DO NOT attempt to adjust the compensation if the waveform already appears to be appropriate. Proceed to Part 5—Check Bandwidth.

- j. *ADJUST*—compensation adjustment, R310, R510, and C412 on the A1 Main circuit board, for optimum square-wave flat top. Refer to Figure 2-3 for adjustment locations.

- k. Reinstall the top cover of the mainframe.

---

## Part 5 – Check Bandwidth

---

### Description

First, amplitude is measured at the specification frequencies using the Signal Standardizer, to characterize the mainframe.

Then, the displayed amplitude is checked at the specification frequencies to determine the plug-in's contribution to the bandwidth.

Specified performance of the plug-in in all mainframes is assured only if the plug-in is tested in an 11402 mainframe. If the plug-in is tested in a mainframe of lower bandwidth, then specified performance is assured only in mainframes of equal or lower bandwidth.

### Specifications

Refer to Tables 2-2 and 2-3 for the bandwidth specifications. Use either Table 2-2 or 2-3 depending on the type of mainframe you are using.

## Examine Mainframe Bandwidth

### Setup

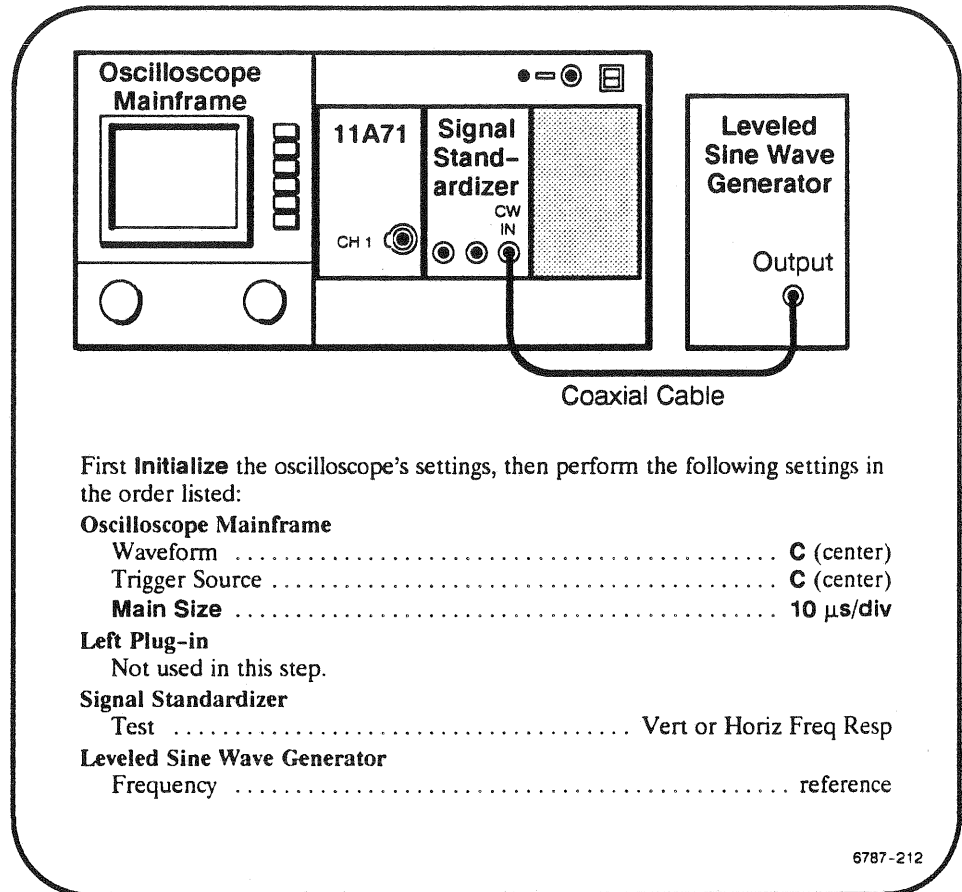

### Procedure

The reference frequency must be between 50 kHz and 6 MHz.

- Set the Leveled Sine Wave Generator output amplitude so that the Signal Standardizer CW Leveled light is on. **CHECK** that the light remains on throughout the following steps.
- Set the Signal Standardizer Position and Amplitude for a 6-division display amplitude, centered on the screen.
- Set the Leveled Sine Wave Generator frequency to each Test Frequency in column (1) of Table 2-2 or Table 2-3, and record the Displayed Amplitude in column (2) on a copy of Table 2-2 or Table 2-3. This data is used in the Check Plug-in Bandwidth procedure for calculating the plug-in bandwidth.
- Set the mainframe ON/STANDBY switch to STANDBY.
- Remove the Signal Standardizer from the Center plug-in compartment. Remove the 11A71 from the Left plug-in compartment and reinstall it in the Center plug-in compartment.

## Check Plug-in Bandwidth

### Setup

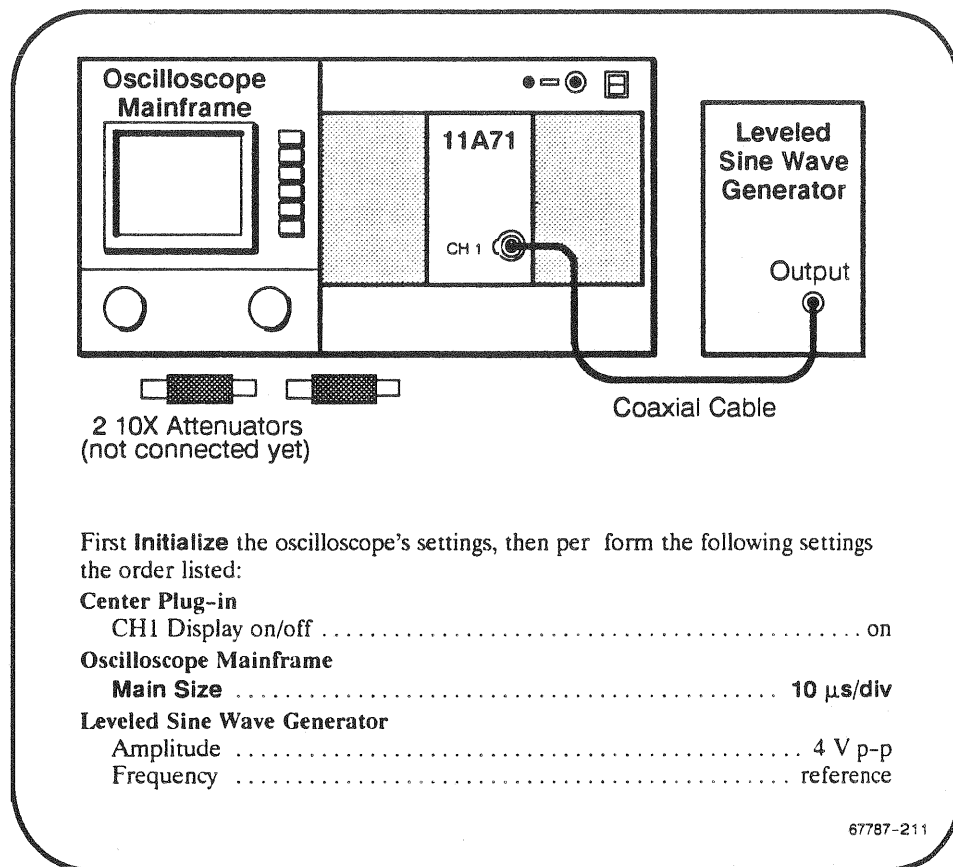

First **Initialize** the oscilloscope's settings, then perform the following settings in the order listed:

- Center Plug-in**
- CH1 Display on/off ..... on
- Oscilloscope Mainframe**
- Main Size** ..... 10  $\mu$ s/div
- Levelled Sine Wave Generator**
- Amplitude ..... 4 V p-p
- Frequency ..... reference

If the Levelled Sine Wave Generator has a remote leveling head, then you must connect it to the plug-in input connector without additional coaxial cables.

The reference frequency must be between 50 kHz and 6 MHz.

### Procedure

Perform this procedure for each Vertical Size listed in column (3) of Table 2-2 or Table 2-3.

If the Levelled Sine Wave Generator is not equipped with internal attenuators, then use 10X Attenuators at the plug-in input when setting amplitude.

To measure the amplitude, either count the divisions, use the  $\Delta V$  cursors, or use the peak-to-peak measurement function (for the 11401 or 11402 only).

- a. Set the Levelled Sine Wave Generator amplitude as shown in the Reference Amplitude column (4).
- b. Set the Levelled Sine Wave Generator frequency as shown in the Frequency column (1).

- c. Record the Displayed Amplitude in column (5).
- d. *CHECK*—that the plug-in amplitude, computed by dividing column (5) by column (2), is at least the value shown in column (6).
- e. Set the Leveled Sine Wave Generator to the reference frequency.

**TABLE 2-2**  
11A71 Bandwidth in the 11402 Mainframe

(1) Test Frequency MHz	(2) Mainframe with Standardizer	(4) Mainframe with Plug-in			(6) Plug-in only
	Displayed Amplitude: div	Vertical Size	Reference Amplitude: div	Displayed Amplitude: div	Calculated Amplitude: col (5) ÷ col (2)
1000	_____	1 V/div	4	_____	_____ ≥0.583
1000	_____	500 mV/div	6	_____	_____ ≥0.875
1000	_____	50 mV/div	6	_____	_____ ≥0.875
1000	_____	20 mV/div	6	_____	_____ ≥0.875
1000	_____	10 mV/div	6	_____	_____ ≥0.875
500	_____	10 mV/div	6	_____	_____ ≥0.920

**TABLE 2-3**  
11A71 Bandwidth in the 11401, 11301, and 11302 Mainframes

(1) Test Frequency MHz	(2) Mainframe with Standardizer	(4) Mainframe with Plug-in			(6) Plug-in only
	Displayed Amplitude: div	Vertical Size	Reference Amplitude: div	Displayed Amplitude: div	Calculated Amplitude: col (5) ÷ col (2)
500	_____	1 V/div	4	_____	_____ ≥0.613
500	_____	500 mV/div	6	_____	_____ ≥0.920
500	_____	50 mV/div	6	_____	_____ ≥0.920
500	_____	20 mV/div	6	_____	_____ ≥0.920
500	_____	10 mV/div	6	_____	_____ ≥0.920

## Part 6 – Check Enhanced Accuracy

### Description

When displayed, the Enhanced Accuracy symbol (EA) indicates that the instrument is at its highest accuracy state. The instrument saves the calibration time and the ambient temperature, since this data is used in maintaining the Enhanced Accuracy state.

For more information about the Enhanced Accuracy state, refer to Enhanced Measurement Accuracy Indicator in the mainframe User's Reference manual.

While Enhanced Accuracy is in effect, to verify the DC measurement accuracy of the plug-in and mainframe system, apply and monitor test voltages, and compare these test voltages with the measurements made on the screen.

### Specifications

When invoked, the self-calibration activity executes successfully.

### Setup

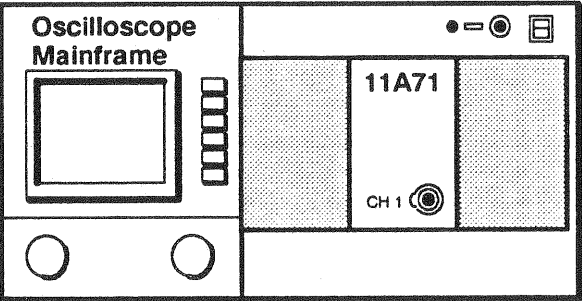

**Initialize** the oscilloscope's settings.  
**Center Plug-in**  
No setting changes.  
**Oscilloscope Mainframe**  
No setting changes.

6787-208



## Procedure

- a. Twenty minutes after power up, the instrument must recalibrate itself to achieve the Enhanced Accuracy state. Press the ENHANCED ACCURACY button. Another prompt then appears on the display. Press the ENHANCED ACCURACY button again. Self-calibration takes a couple of minutes.

### CAUTION

*Turning the instrument power off during self-calibration may result in losing some of the non-volatile RAM data. This could cause diagnostic errors at the next power-up and affect normal instrument operation in unpredictable ways. If this occurs, refer to Restoring Calibration Data in Section 3.*

- b. **CHECK**—for the message, “**Calibration in Progress**” or “**Enhanced Accuracy in Progress**”, indicating that the instrument began self-calibration.
- c. **CHECK**—for the message, “**Calibration completed and passed**” or “**Self calibration completed successfully**”, indicating successful self-calibration. The **EA** indicator appears on the display when calibration is finished.

## Part 7 – Check DC Balance

### Description

The position of the displayed trace with no input signal applied is examined.

The purpose of this procedure is to confirm that dc balance can be accomplished accurately. This procedure does not test for drift over time or temperature. Therefore, the specifications are more precise than the specifications in the User's Reference manual and this procedure must be performed immediately after Enhanced Accuracy calibration.

### Specifications

Balance within  $\pm 0.2$  division.

### Setup

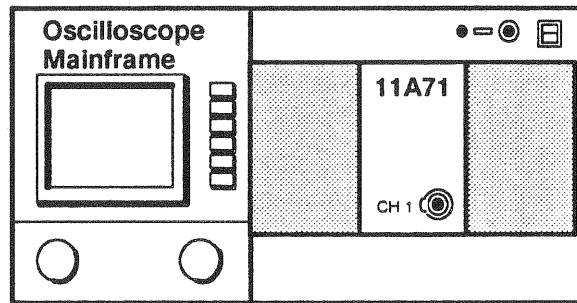

First **Initialize** the oscilloscope's settings, then perform the following settings in the order listed:

**Center Plug-in**

CH 1 Display on/off ..... on

**Oscilloscope Mainframe**

No setting changes.

6787-208

### Procedure

**CHECK**—that the displayed trace position is at the center graticule line, within  $\pm 0.2$  division, for each Vertical Size setting.

If you are using the 11301 or 11302 mainframe, then select **Vertical Cursors** to help measure the trace position.

If you are using the 11401 or 11402 mainframe, then set **Average N** to **ON** and use **Mean (whole zone)** in the MEASURE menu to help measure the trace position.

---

## Part 8a – Check $\Delta V$ DC Accuracy: 11401/11402 Mainframe Procedure

---

### Description

The system  $\Delta V$  DC Accuracy is checked using a precision Digital Multimeter and a Power Supply. The system must be in Enhanced Accuracy mode during this procedure.

The purpose of this procedure is to confirm that the plug-in can be accurately calibrated. This procedure does not test for mainframe calibration voltage reference accuracy or long term stability. Therefore, the mainframe is characterized and tests must be performed immediately after an Enhanced Accuracy calibration, and the plug-in specifications are more stringent than those in the User's Reference Manual.

### Specifications

$\Delta V$  DC Accuracy within  $\pm 0.8\%$ .

## Characterize 11401/11402 Mainframe

### Setup

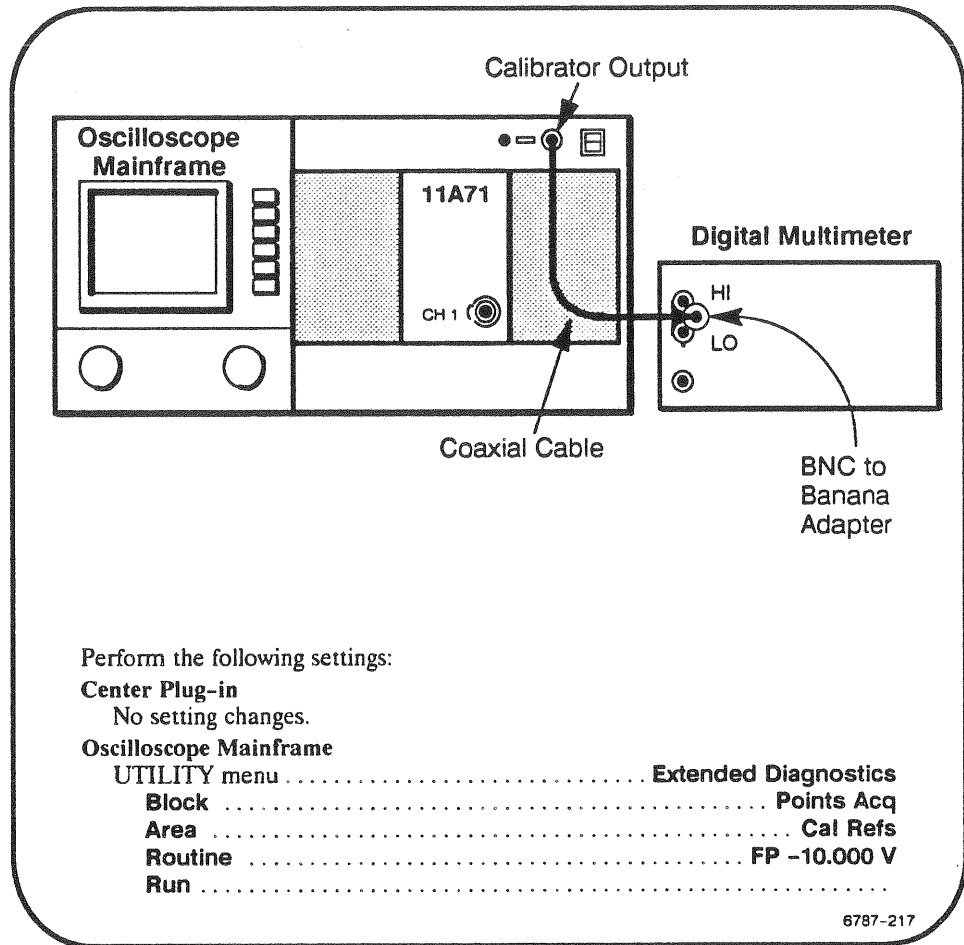

### Procedure

- a. Record the DMM absolute value.
- b. Press **Exit**.
- c. Press **FP + 9.9951 V**.
- d. Press **Run**.
- e. Record the DMM reading.
- f. Press **Exit**.
- g. Press **Exit Diagnostics**.
- h. Add the absolute value of the DMM readings obtained in steps a and e. Divide the result by 19.9951 V to obtain the mainframe's calibration voltage reference characterization factor (which is used in the Test Plug-in procedure).

# Test Plug-in Setup

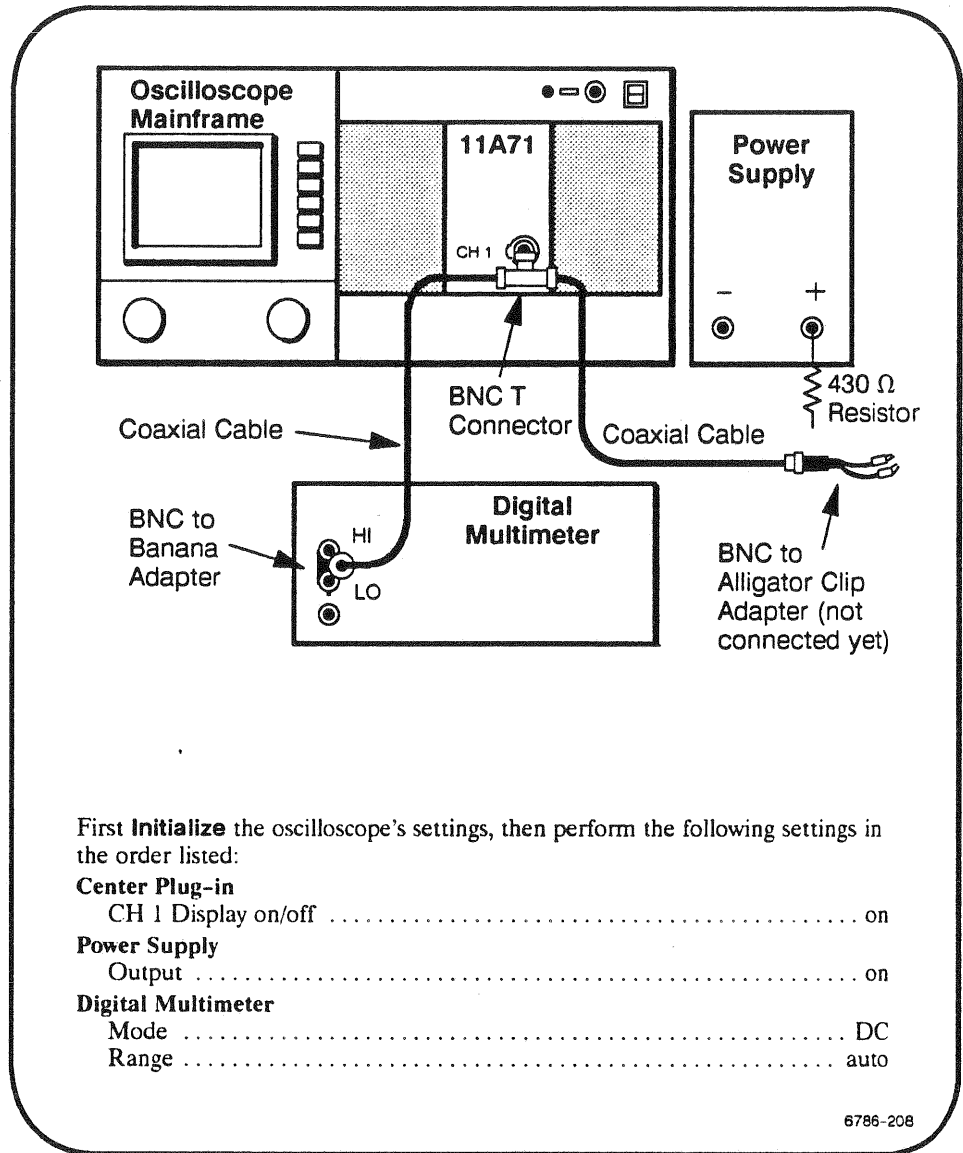

If the environment is electrically noisy, then connect a capacitor (at least 0.1  $\mu\text{F}$ ) across the input terminals of the DMM.

## Procedure

Press the Enhanced Accuracy button twice. Immediately after self-calibration has completed and passed, perform this procedure.

It is helpful if you use a pocket calculator to do the calculations required for evaluating the data in this part. If your Digital Multimeter is equipped with a comparison or relative reference feature, use this feature for the readings and calculations required in steps b and d.

When connecting the alligator clips, connect one clip to the Power Supply's negative terminal directly and the other clip to the 430  $\Omega$  resistor (not the Power Supply's positive terminal).

- a. Set **Average N** to **ON** select **Mean (whole zone)** in the MEASURE menu, and set **Compare** to **ON**.
- b. Connect the alligator clips to the Power Supply and set the voltage so that the trace is within  $\pm 0.2$  divisions of the first graticule line above the bottom of the screen. Read the Digital Multimeter and record the absolute value (that is, ignore the polarity).
- c. Select **Save Current Meas Value as References** in the Compare and Reference popup menu of the MEASURE menu.
- d. Connect the alligator clips to the Power Supply and set the voltage so that the trace is within  $\pm 0.2$  divisions of the first graticule line below the top of the screen. Read the Multimeter and add the absolute value (that is, ignore the polarity) to the reading obtained in step b.
- e. Read the  $\Delta$ Mean value in the MEASURE menu.
- f. Divide the sum obtained in step d by the  $\Delta$ Mean obtained in step e. Then, divide this result by the mainframe characterization factor (obtained in step h of the Characterize 11401/11402 Mainframe procedure.)
- g. **CHECK**—that the result obtained in step f is  $\geq 0.992$  but  $\leq 1.008$ .
- h. Repeat steps b through g for the vertical size settings listed below. When testing with small voltages, it may help to install attenuators in series between the BNC to alligator clip adapter and the coaxial cable so that you can set the voltages with better resolution. You can also use a DC Voltage Calibrator to achieve better resolution (when testing with small voltages).

1 V/div  
0.5 V/div  
0.2 V/div  
0.1 V/div  
50 mV/div  
49.8 mV/div  
23 mV/div  
20 mV/div  
10 mV/div

---

## Part 8b – Check $\Delta V$ DC Accuracy: 11301/11302 Mainframe Procedure

---

### Description

The system  $\Delta V$  DC Accuracy is checked using a precision Digital Multimeter and a Power Supply. The system must be in Enhanced Accuracy mode during this procedure.

The purpose of this procedure is to confirm that the plug-in can be accurately calibrated. This procedure does not test for mainframe calibration voltage reference accuracy or long term stability. Therefore, the mainframe is characterized and tests must be performed immediately after an Enhanced Accuracy calibration, and the plug-in specifications are more stringent than those in the User's Reference Manual.

### Specifications

$\Delta V$  DC Accuracy within  $\pm 1.5\%$ .

# Characterize 11301/11302 Mainframe

**NOTE**

*After entering Extended Test, verify that your mainframe's firmware is Version V2.4 or higher. If your mainframe's firmware version is lower than V2.4, then you cannot perform this procedure.*

**Setup**

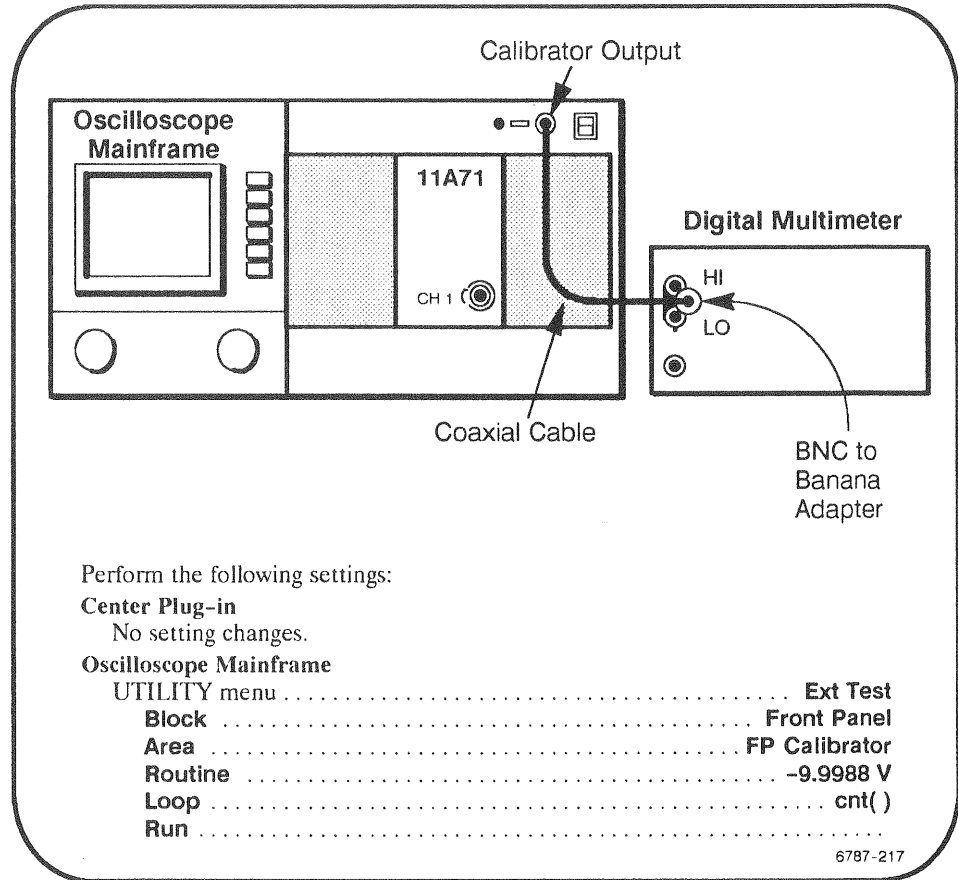

**Procedure**

- a. Record the DMM reading.
- b. Select **Exit**.
- c. Select **Routine** and select **+9.9939V**.
- d. Select **Run**.
- e. Record the DMM reading.
- f. Select **Exit**.
- g. Select **Exit Diagnostic**.
- h. Add the absolute values of the DMM readings obtained in steps a and e. Divide the result by 19.9927 to obtain the mainframe's calibration voltage reference characterization factor (which is used in the Test Plug-in procedure).



## Test Plug-in Setup

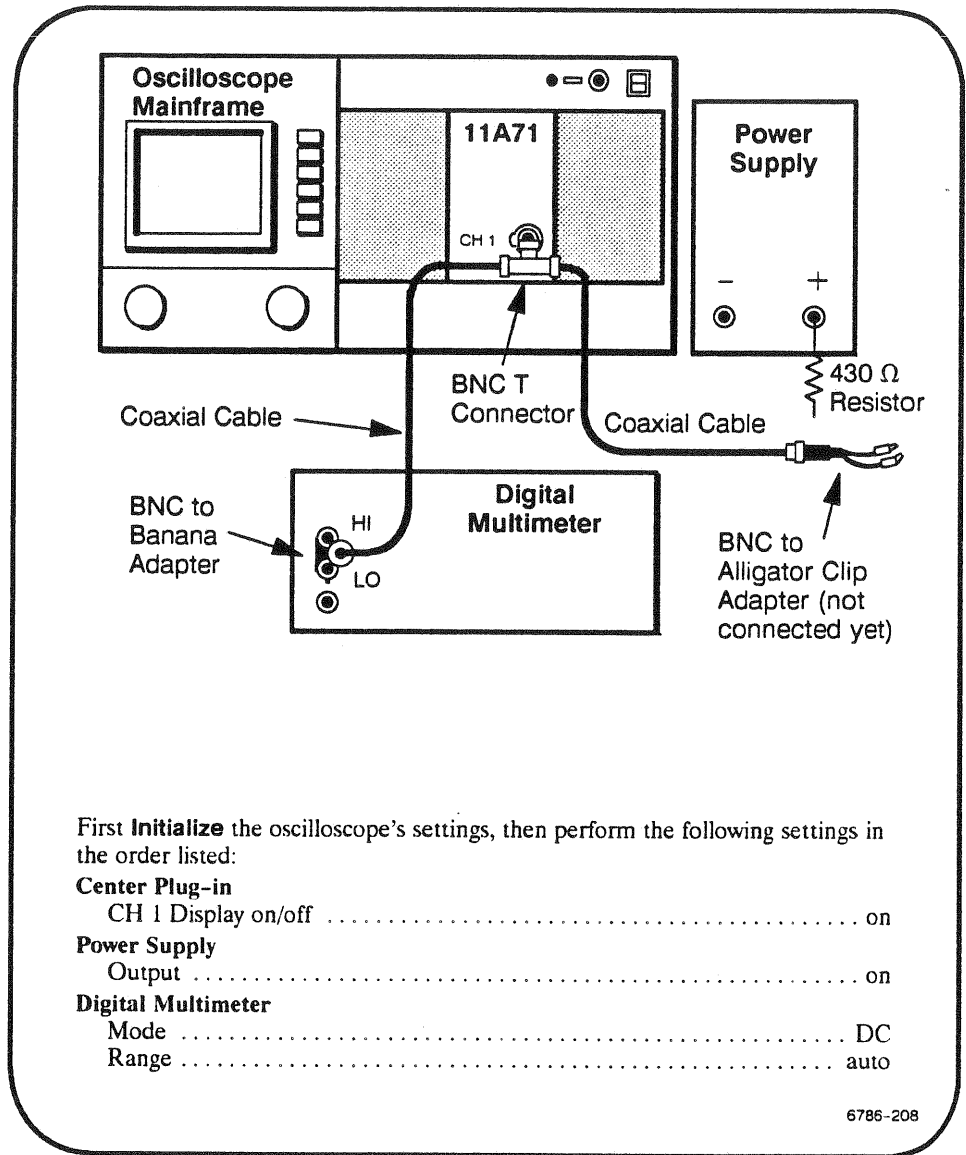

If the environment is electrically noisy, then connect a capacitor (at least 0.1  $\mu\text{F}$ ) across the input terminals of the DMM.

## Procedure

Press the Enhanced Accuracy button twice. Immediately after self-calibration has completed and passed, perform this procedure.

It is helpful if you use a pocket calculator to do the calculations required for evaluating the data in this part. If your Digital Multimeter is equipped with a comparison or relative reference feature, use this feature for the readings and calculations required in steps b and d.

When connecting the alligator clips, connect one clip to the Power Supply's negative terminal directly and the other clip to the 430  $\Omega$  resistor (not the Power Supply's positive terminal).

- a. Select **Vertical Cursors**.
- b. Connect the alligator clips to the Power Supply and set the voltage so that the trace is within  $\pm 0.2$  divisions of the first graticule line above the bottom of the screen. Read the Digital Multimeter and record the absolute value (that is, ignore the polarity).
- c. Set the Vert Ref cursor on the trace using the left function control knob with FINE resolution.
- d. Connect the alligator clips to the Power Supply and set the voltage so that the trace is within  $\pm 0.2$  divisions of the first graticule line below the top of the screen. Read the Multimeter and add the absolute value to the reading obtained in step b.
- e. Set the  $\Delta$ Vert cursor on the trace using the right function control knob with FINE resolution. Read the  $\Delta$ Vert readout.
- f. Divide the sum obtained in step d by the  $\Delta$ Vert readout obtained in step e. Then, divide this result by the mainframe characterization factor obtained in step h of the Characterize 11301/11302 Mainframe procedure.
- g. **CHECK**—that the result obtained in step f is  $\geq 0.985$  but  $\leq 1.015$ .
- h. Repeat steps b through g for the vertical size settings listed below. When testing with small voltages, it may help to install attenuators in series between the BNC to alligator clip adapter and the coaxial cable so that you can set the voltages with better resolution. You can also use a DC Voltage Calibrator to achieve better resolution (when testing with small voltages).

1 V/div  
0.5 V/div  
0.2 V/div  
0.1 V/div  
50 mV/div  
49.8 mV/div  
23 mV/div  
20 mV/div  
10 mV/div

# Part 9 – Check DC Offset Accuracy

## Description

The system DC Offset is checked using a precision Digital Multimeter and a Power Supply.

The purpose of this procedure is to confirm that the plug-in can be accurately calibrated. This procedure does not test for mainframe calibration voltage reference accuracy or long term stability. Therefore, the mainframe is characterized and tests must be performed immediately after an Enhanced Accuracy calibration, and the plug-in specifications are more stringent than those in the User's Reference Manual.

## Specifications

Refer to Table 2-4.

## Characterize 11401/11402 Mainframe

### Setup

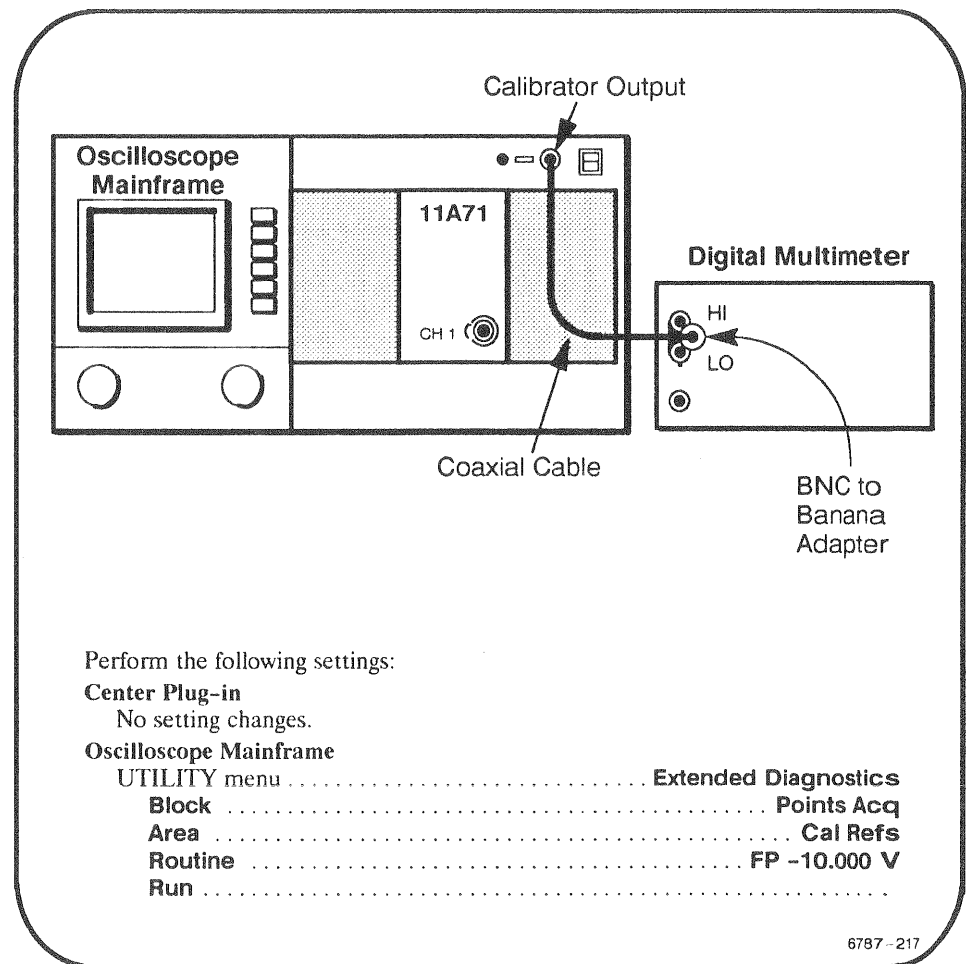

## Procedure

- a. Record the DMM absolute value.
- b. Press **Exit**.
- c. Press **FP + 9.9951 V**.

- d. Press **Run**.
- e. Record the DMM reading.
- f. Press **Exit**.
- g. Press **Exit Diagnostics**.
- h. Add the absolute value of the DMM readings obtained in steps a and e. Divide the result by 19.9951 V to obtain the mainframe's calibration voltage reference characterization factor (which is used in the Test Plug-in procedure).

## Characterize 11301/11302 Mainframe

### NOTE

*After entering Extended Test, verify that your mainframe's firmware is Version V2.4 or higher. If your mainframe's firmware version is lower than V2.4, then you cannot perform this procedure.*

### Setup

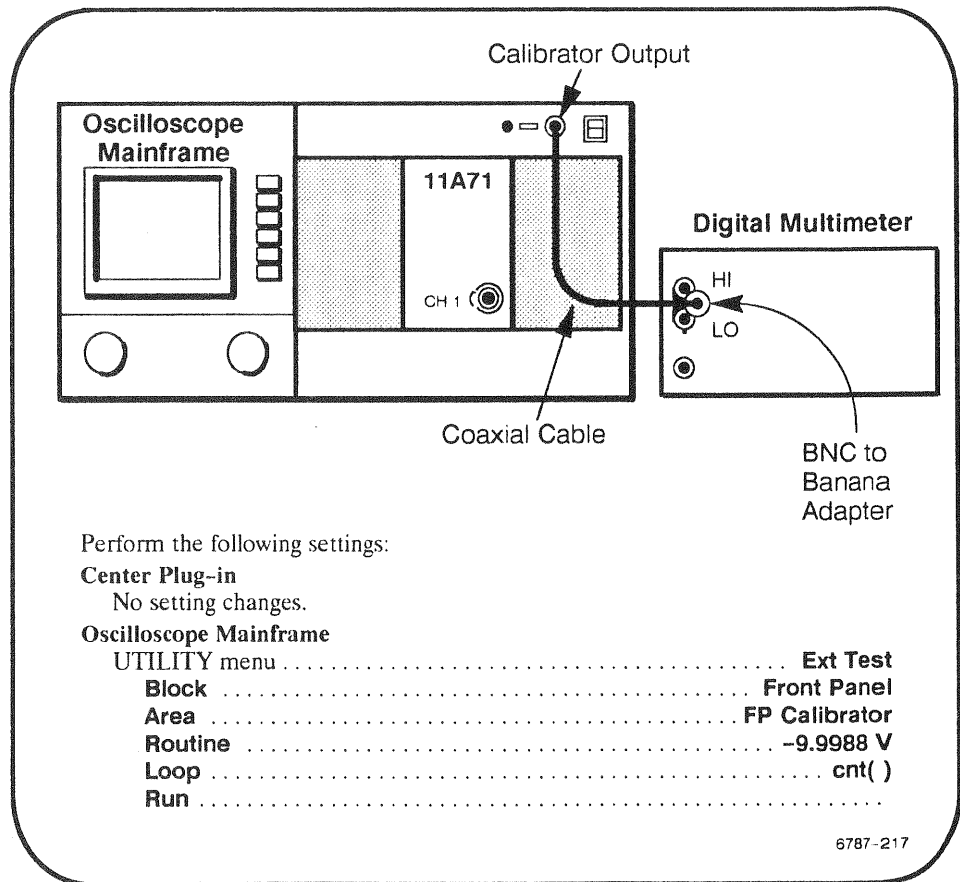

### Procedure

- a. Record the DMM reading.
- b. Select **Exit**.
- c. Select **Routine** and select **+9.9939V**.

- d. Select **Run**.
- e. Record the DMM reading.
- f. Select **Exit**.
- g. Select **Exit Diagnostic**.
- h. Add the absolute values of the DMM readings obtained in steps a and e. Divide the result by 19.9927 to obtain the mainframe's calibration voltage reference characterization factor (which is used in the Test Plug-in procedure).

## Test Plug-in

### Setup

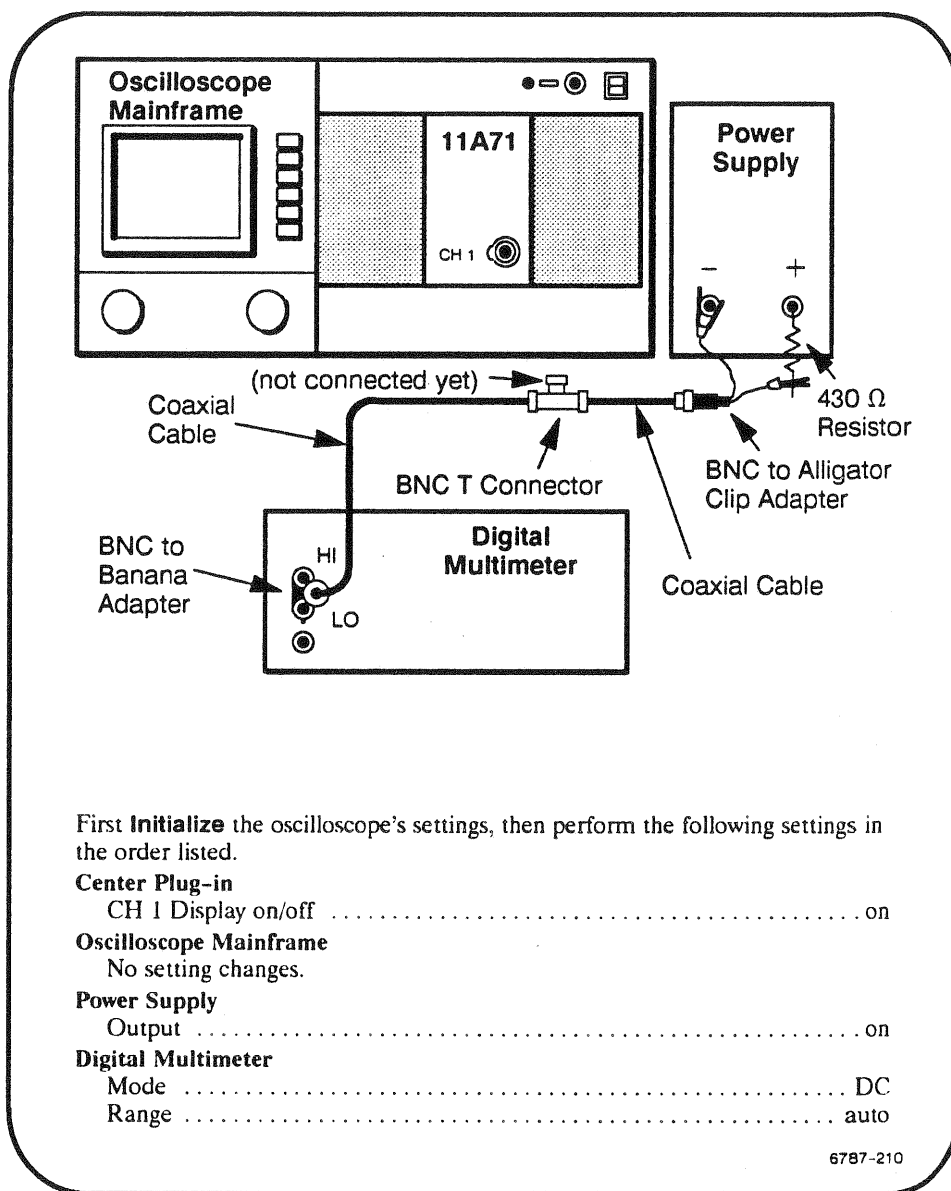

If the environment is electrically noisy, then connect a capacitor (at least 0.1  $\mu\text{F}$ ) across the input terminals of the DMM.

## Procedure

Press the Enhanced Accuracy button twice. Immediately after self-calibration has completed and passed, perform this procedure.

When connecting the alligator clips, connect one clip to the Power Supply's negative terminal directly and the other clip to the 430  $\Omega$  resistor (not the Power Supply's positive terminal).

- a. Note the position of the displayed trace (it should be near the center of the graticule).

If you are using the 11301 or 11302 mainframe, then use **Vertical Cursors** to help measure and set the trace position.

If you are using the 11401 or 11402 mainframe, then set **Average N** to **ON** and use **Mean (whole zone)** in the MEASURE menu to help measure and set the trace position.

- b. Connect the BNC T Connector to the CH 1 input connector, with the DMM connected.
- c. Set the **Vert Offset** to **4 V**. Set the Power Supply voltage so that the displayed trace returns to the position noted in step a. Divide the DMM reading by the mainframe characterization factor (obtained in the Characterize Mainframe procedure) and subtract the Vertical Offset.
- d. **CHECK**—that the result obtained in step c is less than the Error Limit shown in Table 2-4.
- e. Disconnect the BNC T connector at the CH 1 input connector and set **Vert Offset** to **0**.
- f. Repeat steps a through e for each Vertical Size and Offset shown in Table 2-4. When testing with small voltages, it may help to install attenuators in series between the BNC to alligator adapters and the coaxial cable so that you can set the voltages with better resolution. You can also use a DC Voltage Calibrator to achieve better resolution (when testing with small voltages).

TABLE 2-4  
11A71 DC Offset Accuracy

Vertical Size	Vertical Offset	Error Limit ( $\pm$ Volts)
1 V/div	4 V	26.0 mV
500 mV/div	4 V	21.0 mV
200 mV/div	2 V	10.0 mV
100 mV/div	1 V	5.0 mV
50 mV/div	500 mV	2.5 mV
20 mV/div	200 mV	1.0 mV
10 mV/div	100 mV	0.50 mV
10 mV/div	50 mV	0.30 mV

# Section 3

## Maintenance

---

This section contains information for performing preventive maintenance, corrective Field Replaceable Units (FRU) maintenance, testing, and diagnostics. All support-related items mentioned in this section are listed in Table 2-1.

---

### Preventive Maintenance

---

Preventive maintenance performed regularly can prevent or forestall plug-in breakdown and may improve plug-in reliability. The severity of the environment to which the plug-in is subjected determines the frequency of maintenance.

### Plug-In Shield Removal

The side shields, top and bottom frames, and front panel reduce radiation of electromagnetic interference (EMI) from the mainframe. The side shields are held in place by grooves in the frames.

To remove a shield, pry it out with your fingers, beginning at the rear of the appropriate side. To install a shield, position it over the frame grooves, then press down with your fingers until the shield snaps into place. Pressure must be applied along the full length of the frames to secure the shield.

The plug-in will not slide into the mainframe if the side shields are not fully seated in the frames.

### Cleaning

The plug-in should be cleaned as often as operating conditions require. Accumulation of dirt on components acts as an insulating blanket and prevents efficient heat dissipation, which can cause overheating and component breakdown. Dirt also provides an electrical conduction path that can result in plug-in failure.

The cabinet panels of the mainframe, in which the plug-in is installed, reduce the amount of dust reaching the interior of the plug-in. Keep the cabinet panels in place for safety and cooling.

**CAUTION**

*Avoid the use of chemical cleaning agents which might damage the materials used in this plug-in. Use only isopropyl alcohol or totally denatured ethyl alcohol. Before using any other type of cleaner, consult your Tektronix Service Center or representative.*

## Exterior

Loose dust accumulated on the outside of the plug-in can be removed with a soft cloth or small brush. The brush is particularly useful for dislodging dirt in and around the side-shield ventilation holes and front-panel switches. Remove the side shields before cleaning them.

## Interior

Cleaning the interior of the plug-in should seldom be necessary. The best way to clean the interior is to blow off the accumulated dust with dry, low-velocity air (such as from a vacuum cleaner). Remove any dirt that remains with a soft brush or a cloth dampened with a mild solution of detergent and water. A cotton-tipped swab is useful for cleaning in narrow spaces, or for cleaning more delicate circuit components.

**CAUTION**

*To prevent damage from electrical shorts, the circuit boards and components must be dry before applying power.*

## Visual Inspection

The plug-in should be inspected occasionally for loosely-seated or heat-damaged components. The corrective procedure for most visible defects is obvious. However, particular care must be taken if heat-damaged parts are found. Overheating usually indicates other problems with the plug-in. Therefore, correcting the cause of overheating is important to prevent reoccurrence of the damage.

## Periodic Electrical Adjustment

To ensure accurate measurements, check the electrical adjustment of this plug-in after each 2,000 hours of operation, or every 24 months if used infrequently. Instructions are given in Section 2, Checks and Adjustments.



---

## Corrective Maintenance

---

Corrective maintenance consists of FRU module replacement and plug-in repair. Special techniques required to replace FRU modules in the plug-in are given here.

## Ordering Parts

When ordering replacement parts from Tektronix, Inc., include the following information:

- Instrument type
- Instrument serial number
- A description of the part (if electrical, include circuit number)
- Tektronix part number

## Static-Sensitive Device Classification



*Static discharge can damage any semiconductor component in this plug-in.*

This plug-in contains electrical components that are susceptible to damage from static discharge. Table 3-1 gives relative susceptibility of various classes of semiconductors. Static voltages of 1 kV to 30 kV are common in unprotected environments.

Observe the following precautions to avoid damage:

1. Minimize handling of static-sensitive components.
2. Transport and store static-sensitive components or assemblies in their original containers either on a metal surface or conductive foam. Label any package that contains static-sensitive assemblies or components.
3. Discharge the static voltage from your body by wearing a wrist strap while handling these components. Servicing static-sensitive assemblies or components should be performed only at a static-free work station by qualified service personnel. We recommend use of the static control mat.
4. Allow nothing capable of generating or holding a static charge on your work station surface.
5. Keep the component leads shorted together whenever possible.

6. Pick up components by the body, never by the leads.
7. Do not slide the components over any surface.
8. Avoid handling components in areas that have a floor or work-surface covering capable of generating a static charge.

**TABLE 3-1**  
**Relative Susceptibility to Damage From Static Discharge**

Semiconductor Classes	Relative Susceptibility Levels <sup>1</sup>
MOS or CMOS microcircuits, and discrete or linear microcircuits with MOS inputs (most sensitive)	1
ECL	2
Schottky signal diodes	3
Schottky TTL	4
High-frequency bipolar transistors	5
JFETs	6
Linear microcircuits	7
Low-power Schottky TTL	8
TTL (least sensitive)	9

<sup>1</sup>Voltage equivalent for levels.

1 = 100 to 500 V

2 = 200 to 500 V

3 = 250 V

4 = 500 V

5 = 400 to 600 V

6 = 600 to 800 V

7 = 400 to 1000 V (est.)

8 = 900 V

9 = 1200 V

(Voltage discharged from a 100 pF capacitor through a resistance of 100 ohms.)

## Removing and Replacing FRU Modules

**CAUTION**

*To avoid instrument damage, set the mainframe ON/STANDBY switch to STANDBY and remove the plug-in from the mainframe before removing or replacing FRUs.*

To determine the location of a FRU, refer to Figure 3-1.

The side shields will have to be removed to gain access to the circuit boards and other FRUs. Refer to "Plug-In Shield Removal" which is located near the beginning of this section.

The exploded-view drawing associated with the Replaceable Parts list may be helpful in the disassembly procedures that follow. This drawing is located in Section 5, at the end of this manual.

**CAUTION**

*If the green indicator light remains lit when the STANDBY position is selected, then the switch has been left internally disabled after the servicing of the Power Supply. To enable the ON/STANDBY switch, refer to the Maintenance section of the mainframe Service Manual.*

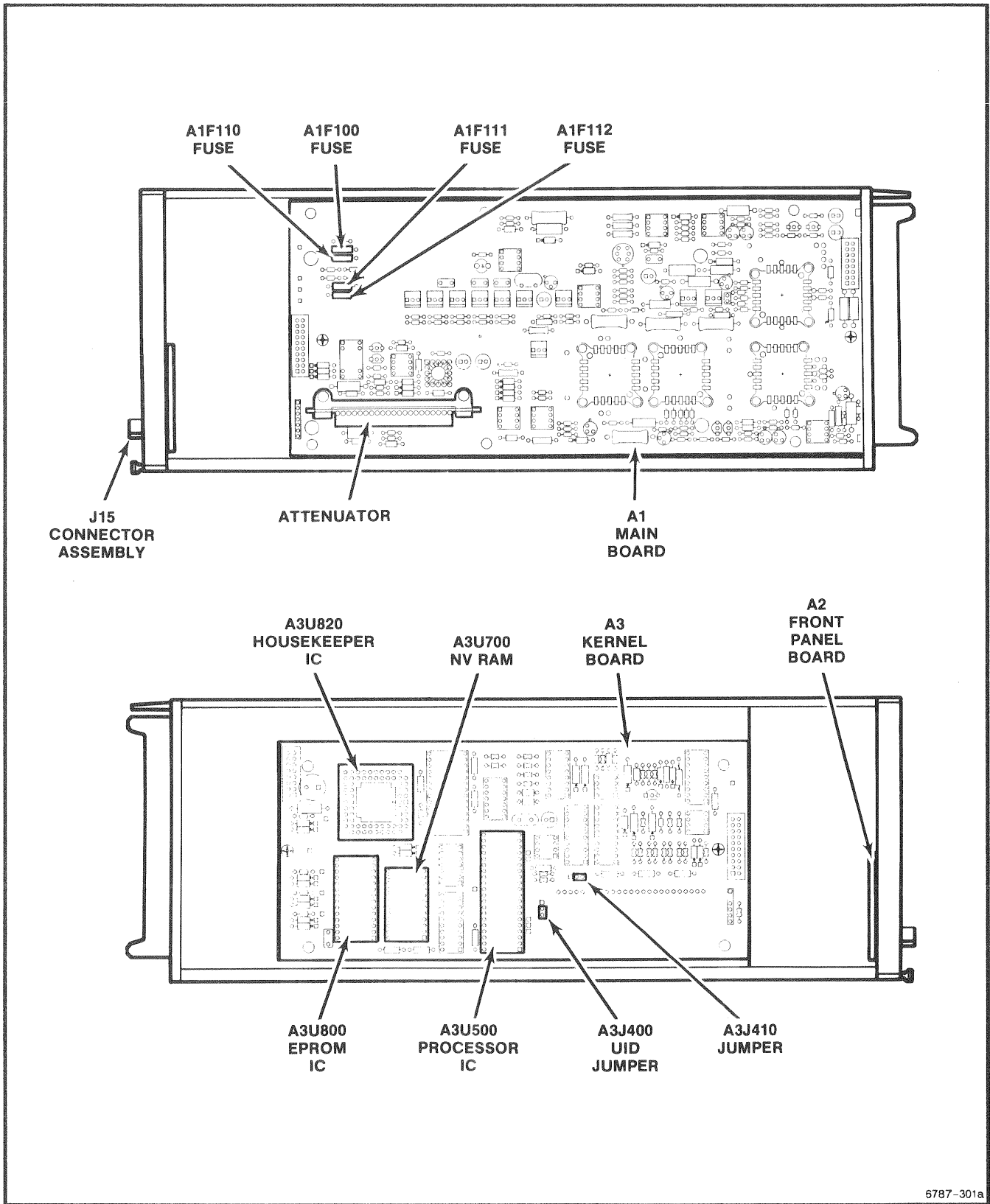

Figure 3-1. Field Replaceable Units (FRU) and jumper locator.

## Semiconductor FRU Removal

**CAUTION**

*Observe all the special precautions mentioned under Static-Sensitive Device Classification earlier in this section.*

## Housekeeper Integrated Circuit (IC)

The Housekeeper IC is indexed to its socket by a beveled corner. The other corners are notched to fit the edges of the socket. The beveled corner aligns with a spring (small metal tab) at one corner of the socket. Refer to Figure 3-2.

### How to Remove Housekeeper IC

1. Unfasten the retaining clip by moving it across the tabs. It may help to push down slightly on the cover.
2. Remove the cover slowly to prevent the IC from falling out. Observe the index of the IC before removing it.
3. Remove the IC with tweezers.

**CAUTION**

*Avoid touching the IC or the socket contacts with your fingers. Finger oils can lessen reliability.*

### How to Install Housekeeper IC

1. Using tweezers, place the beveled corner of the replacement IC against the index spring.

**CAUTION**

*Do not damage the spring with the beveled corner. Shorting of the two corner contacts could result.*

2. Arrange the other IC corners, with the tweezers, to fit evenly at the edges of the socket.
3. Set the cover flat on the IC with its end tabs properly aligned with the mating recesses in the socket. (The cover is not symmetrical.)

4. Push the cover down, keeping it flat on the IC, and slide into place. Hold the cover in place while moving the retaining clip over the tabs on the opposite end.

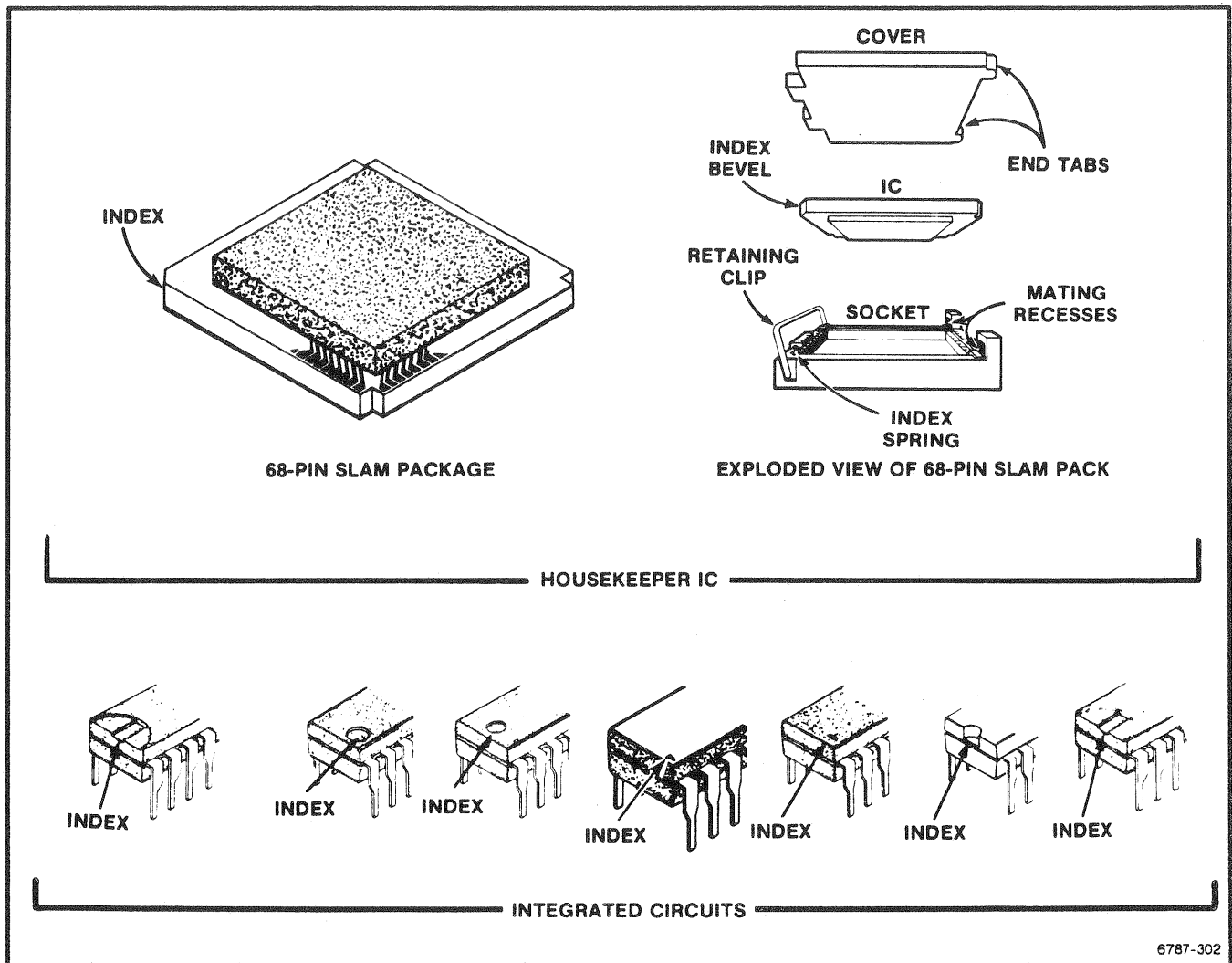

Figure 3-2. Semiconductor indexing diagram.

## Dual In-line Package Integrated Circuits (DIP ICs)

If the RAM IC is soldered into the board, then consult a Tektronix Service Center for recommended removal procedures. Do not solder in the replacement IC. Instead, install a 24-pin socket and plug the RAM IC into the socket.

### How to Remove a DIP IC

1. Use an insertion-extraction pliers (such as General Tool's Part Number U505-Series) to grasp the IC. (An illustration of these pliers is shown in Fig. 3-3.)
2. Position the pliers around the outside of the IC body. Squeeze the handles of the pliers and slowly pull the IC from its socket.

### CAUTION

*Avoid touching the IC pins or socket contacts with your fingers. Finger oils can lessen contact reliability.*

### How to Install a DIP IC:

1. Grasp the IC with the insertion-extraction pliers. Check that all the IC pins are straight and evenly spaced. Do not use the IC label as an index. Look for the index on the end of the IC body.
2. Align the index slot with that of the socket. (Refer to Fig. 3-2 for IC indexing information.)
3. Align the IC pins with their respective socket contacts. Slowly and evenly press the IC into its socket.

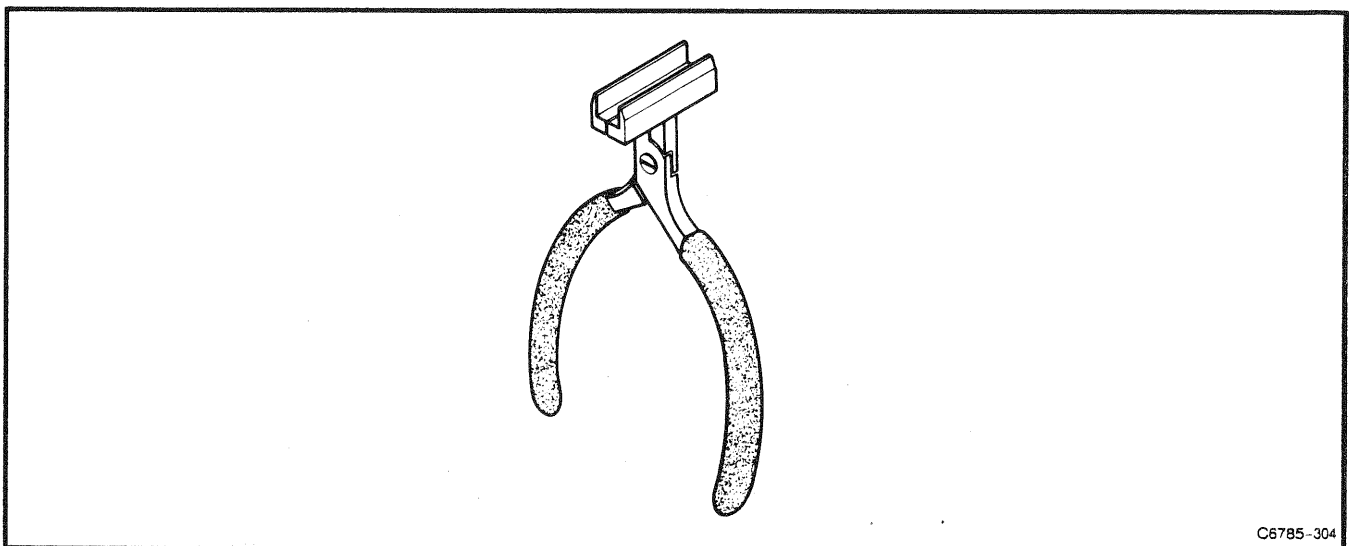

C6785-304

Figure 3-3. IC insertion-extraction tool.

## Circuit Board and Attenuator FRU Removal

### How to Remove the Front Panel

1. Unhook the return spring from the release bar, and set it aside.
2. Use a Torx T-8 screwdriver to remove the four screws that fasten the front subpanel to the top and bottom frames.
3. Pull the release bar as far out of the plug-in as it will come, and leave it in that position.
4. Insert a slender, sharp-pointed tool, such as a scribe, between the front panel and the subpanel at the notch around the release bar. Gently separate the front panel from the subpanel. Use care to prevent bending the front panel.

### How to Install the Front Panel

1. Check that the four screws that fasten the front subpanel to the top and bottom frames are removed.
2. Check that the release bar return spring is removed.
3. Set the plug-in on its side with the front panel facing you.
4. Pull the release bar as far out of the plug-in as it will come, and leave it in that position.
5. Position the front panel so that the notch in the bottom fits over the release bar rod, then carefully insert the four front-panel tabs into the slots in the front subpanel. (You may need to pull the top and bottom frames away from the subpanel to allow the front-panel tabs to fit between the casting and the frames.)
6. Gently snap the edges of the front panel into place around the input connector and the outer edges of the panel.
7. Use a Torx T-8 screwdriver to install the four screws that fasten the front subpanel to the top and bottom frames.
8. Install the release bar return spring. Orient the spring so that its loop fits over the frame hook correctly (flat against the frame section).

### How to Remove and Install an A2 Front Panel Board

1. Remove the front panel as outlined in "How to Remove the Front Panel."
2. Unplug the connector that provides electrical connection to the A3 Kernel board.
3. Use a Torx T-6 screwdriver to remove the screws that fasten the A2 Front Panel board to the front subpanel, and remove the A2 Front Panel board.
4. To replace an A2 Front Panel board, follow the preceding steps in reverse order.



### How to Remove and Install the A3 Kernel Board

1. Unplug the A2 Front Panel board connector from the A3 Kernel board.
2. Remove the two gray A1 Main board connectors from the A3 Kernel board.
3. Use a Torx T-10 screwdriver to remove the four screws that fasten the A3 Kernel board to the A1 Main board.
4. To install, follow the preceding steps in reverse order.

### How to Remove the Attenuator

1. Remove the A3 Kernel board.
2. Unplug the coaxial connectors from the input and output of the Attenuator.
3. Use a Torx T-10 screwdriver to remove the two screws that fasten the Attenuator to the A1 Main board (refer to Fig. 3-4).
4. Using care to keep it straight, unplug the Attenuator from the A1 Main board. Avoid disengaging one end of the Attenuator before disengaging the other end. Do not apply force to any subcomponents on the Attenuator.

### How to Install the Attenuator

1. Set the plug-in on its side with the pushbutton down.
2. Align the Attenuator pins with the connector on the A1 Main board, and align the Attenuator frame with the holes in the A1 Main board.
3. Plug the Attenuator into its connector on the A1 Main board. Do not apply force to any subcomponents on the Attenuator.
4. Use a Torx T-10 screwdriver to install the two screws that fasten the Attenuator to the A1 Main board.
5. Plug the coaxial connectors into the input and output of the Attenuator (refer to Fig. 3-4). Care is necessary when engaging these connectors. For best results, proceed as follows:
  - a. Check that the center conductor is straight. Straighten if necessary.
  - b. Plug the connector straight into the receptacle.
  - c. Look through the slot in the outer receptacle, and watch the center conductor enter its receptacle as you insert the connector.
6. Replace the A3 Kernel board.

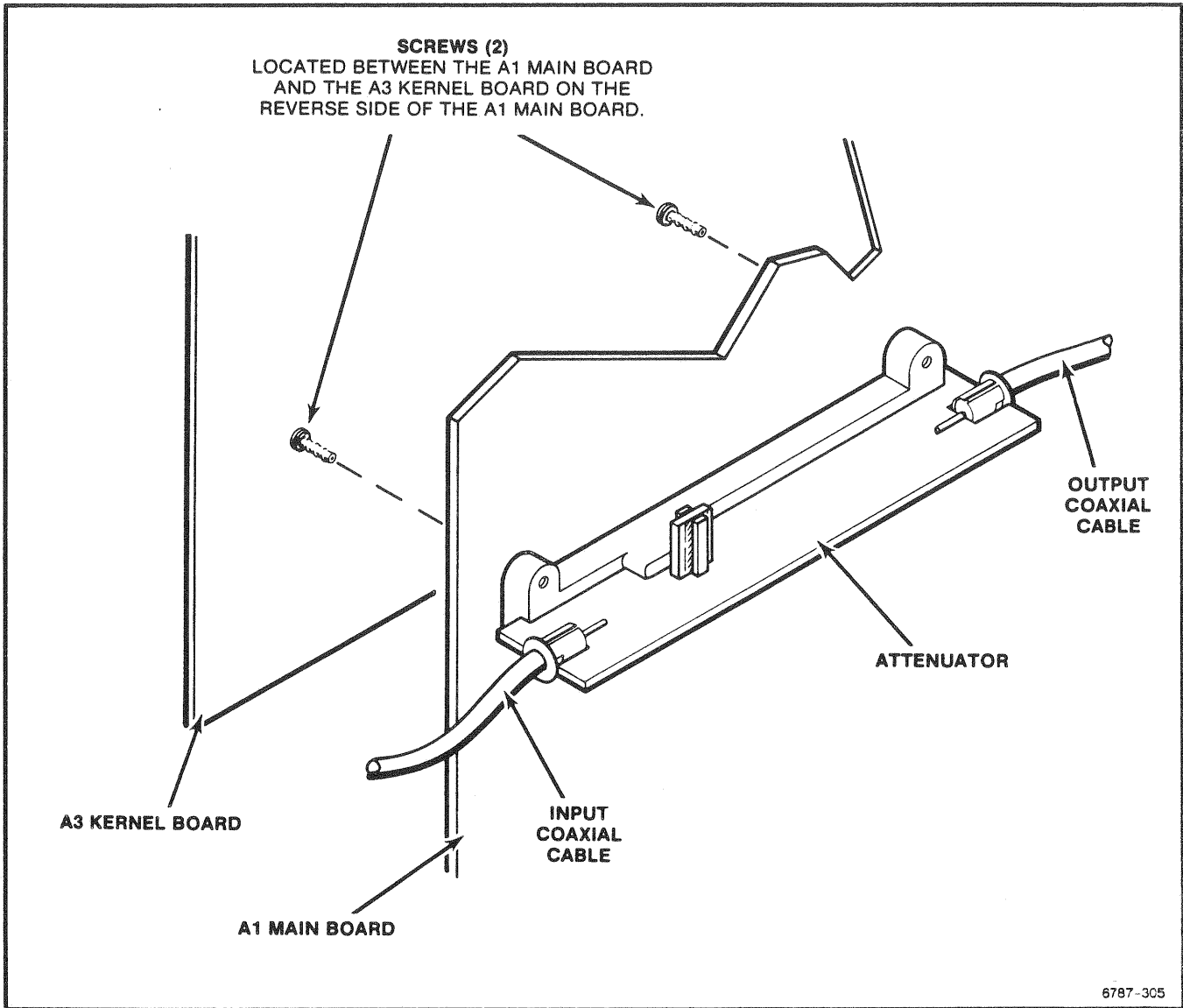

Figure 3-4. Location of screws and parts for removal of Attenuator.

### How to Remove the A1 Main Board

1. Remove the A3 Kernel board.
2. Unplug the coaxial connector from the input of the Attenuator.
3. Unplug the probe information connectors from the A1 Main board: place your index finger under the metal contacts and your thumb on top, and lift the seven metal contacts out of the plastic block on the A1 Main board.
4. Use a narrow-shank, Torx T-10 screwdriver to remove the six screws and nut blocks that secure the A1 Main board to the top and bottom frames. Figures 3-5 and 3-6 show nut blocks.
5. Use a Torx T-15 screwdriver to remove the four screws that fasten the plastic rear panel to the top and bottom frames.

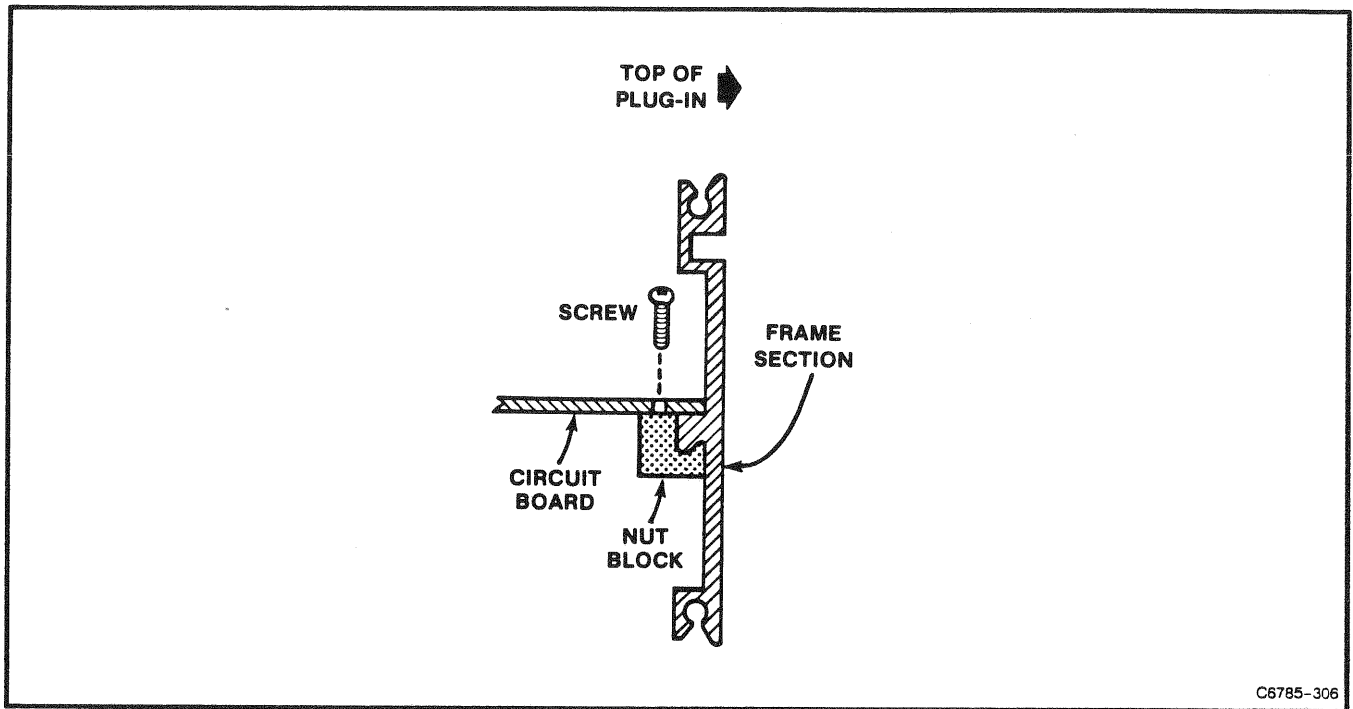

Figure 3-5. Location of a nut block securing the circuit board to the frame section.

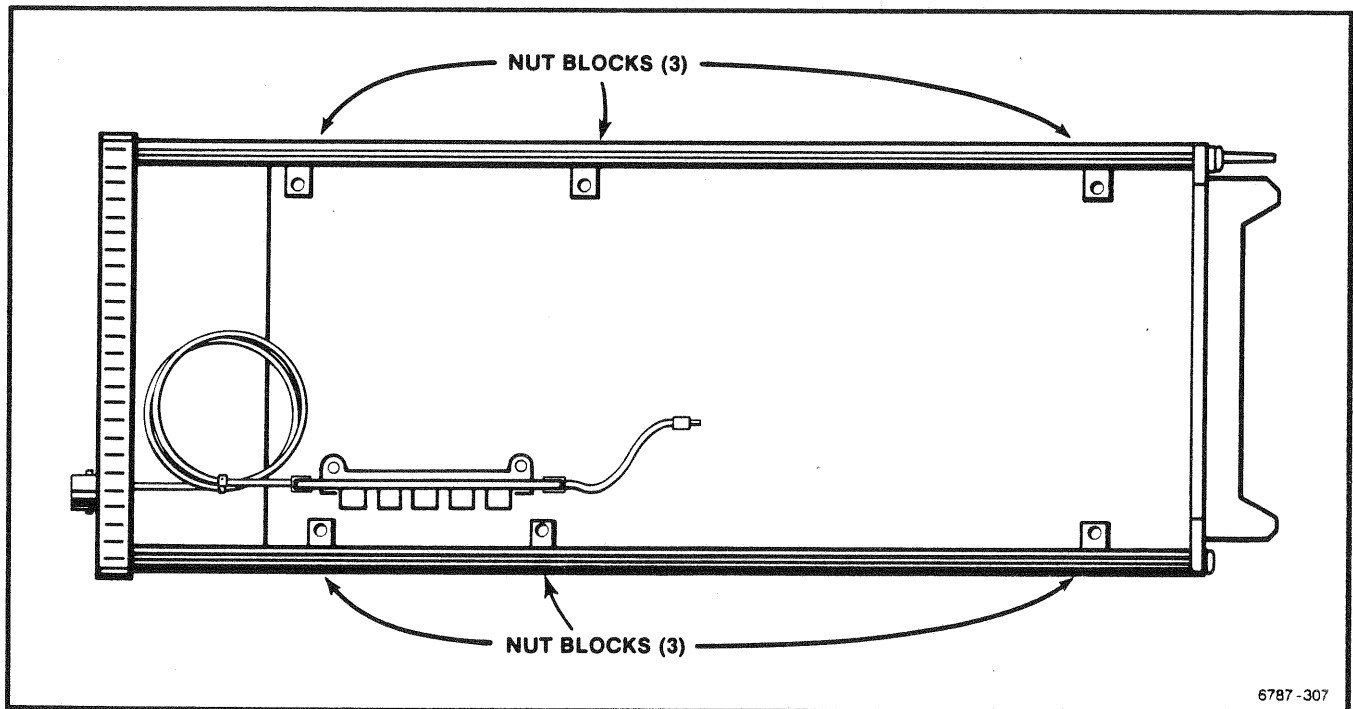

Figure 3-6. Locations of the nut blocks for removal of the A1 Main board.

6. Carefully withdraw the A1 Main board from between the frames.
7. Remove the rear panel from the A1 Main board.

### **How to Install the A1 Main Board**

1. Set the plug-in on its side with the pushbuttons up. Reinstall the rear panel on the A1 Main board.
2. Carefully insert the A1 Main board between the frames until the plastic rear panel contacts the top and bottom frames. The board fits on the top of the center ridges on the top and bottom frames.
3. Use a Torx T-15 screwdriver to install the four screws that fasten the rear panel to the top and bottom frames.
4. Use a Torx T-10 screwdriver to install the six screws and nut blocks that clamp the A1 Main board to the top and bottom frames.
5. Plug the probe information connector into its socket on the A1 Main board.
6. If you installed a new board without an attenuator, install one as outlined in "How to Install an Attenuator."
7. Install the A3 Kernel board.
8. If the A1 Main board has been replaced, then the Unit Identification (UID) number needs to be re-entered. Refer to the instructions in "Programming the Unit Identification", that follows.

## Programming the Unit Identification

The Unit Identification (UID) is identical to the plug-in's serial number and is stored in NV RAM. It is necessary to enter this number if the A1 Main board is replaced or if data in NV RAM becomes corrupted. If only confirmation of the UID is needed, then use the following procedure except skip step 4.

### How To Enter the UID

1. Connect the Terminal to the mainframe's RS-232-C port. (Refer to the mainframe User's Reference Manual for instructions on setting up the RS-232-C parameters.)
2. Locate the UID jumper A3J400 on the A3 Kernel board (as shown in Fig. 3-1). The jumper should be on pins 2 and 3 in its normal position. Remove the jumper and install it on pins 1 and 2.
3. Install the plug-in into any compartment. Turn the power on. Wait until the Diagnostics checks are completed.
4. At the Terminal, type the command:  

```
UID [Left|Center|Right]:“ < Serial Number > ”
```

  - Left|Center|Right refers to the name of the compartment.
5. At the Terminal, type the query:  

```
UID? [Left|Center|Right]
```

Observe that the correct UID is reported.
6. Move the ON/STANDBY switch to STANDBY.
7. Remove the plug-in.
8. Return the jumper A3J400 to its normal position on the A3 Kernel board.

## Cables and Connectors

### BNC Connectors

#### How to Remove a Connector Assembly

1. Remove the front panel as outlined in “How to Remove the Front Panel.”
2. Unplug the coaxial connector from the back of the connector assembly. Figure 3-1 shows the locations of the connectors.
3. Unplug the cable from the A2 Front Panel board at the connector on the A1 Main board.
4. Unplug the probe information connectors from the A1 Main board: place your index finger under the metal contacts and your thumb on top, and lift the seven metal contacts out of the receptacle on the A1 Main board. (The probe information cable is a flat, flexible, seven-conductor cable.)
5. Use a Torx T-6 screwdriver to remove the four screws that fasten the connector assembly to the front subpanel.
6. Remove the connector assembly from the plug-in.

#### How to Install a Connector Assembly

1. Set the gray connector alignment ring on the connector with its index on the inside of the connector assembly. The “inside” is the side where the flat cable enters the connector assembly.
2. Insert the connector and the connector alignment ring into the hole in the front subpanel. Check that the flat cable faces the inside of the plug-in and the index on the connector alignment ring fits into the notch in the front subpanel.
3. Use a Torx T-6 screwdriver to install the four screws that fasten the connector assembly to the front subpanel.
4. Plug the probe information connector into its receptacle on the A1 Main board.
5. Plug the coaxial connector from the attenuator into the connector assembly. For best results, proceed as follows:
  - a. Check that the center conductor is straight. Straighten if necessary.
  - b. Plug the connector straight into the receptacle.
6. Plug the A2 Front Panel board cable connector into the A1 Main Board.
7. Install the front panel as outlined in “How to Install the Front Panel.”

## Multi-Pin Connectors

Pin 1 on the black, multi-pin connector is designated by a triangle (or arrowhead) on its holder. A square pad on the circuit board denotes pin 1. When a connection is made to a circuit board, align the symbol on the multi-pin holder with this square pad.

The black, multi-pin connector is also keyed by a gap between the pin 1 and 3 positions in the holder. (A small plastic plug covers the pin 2 position on the end of the holder.) There is a corresponding gap between pins 1 and 3 on the circuit board, as shown in Figure 3-7.

Align the holder plug with the gap between the circuit board pins. The connector is then ready to be installed.

The gray connector has a contrasting-color line along one side of its ribbon cable. This colored line represents the location of pin 1 or the triangle index mark on the connector.

To remove this connector, grasp the ends of the connector and pull it straight out from the circuit board. To install this connector, align the connector's color line with the square-shaped, circuit board pad, which is pin 1. Push the connector on the pins.

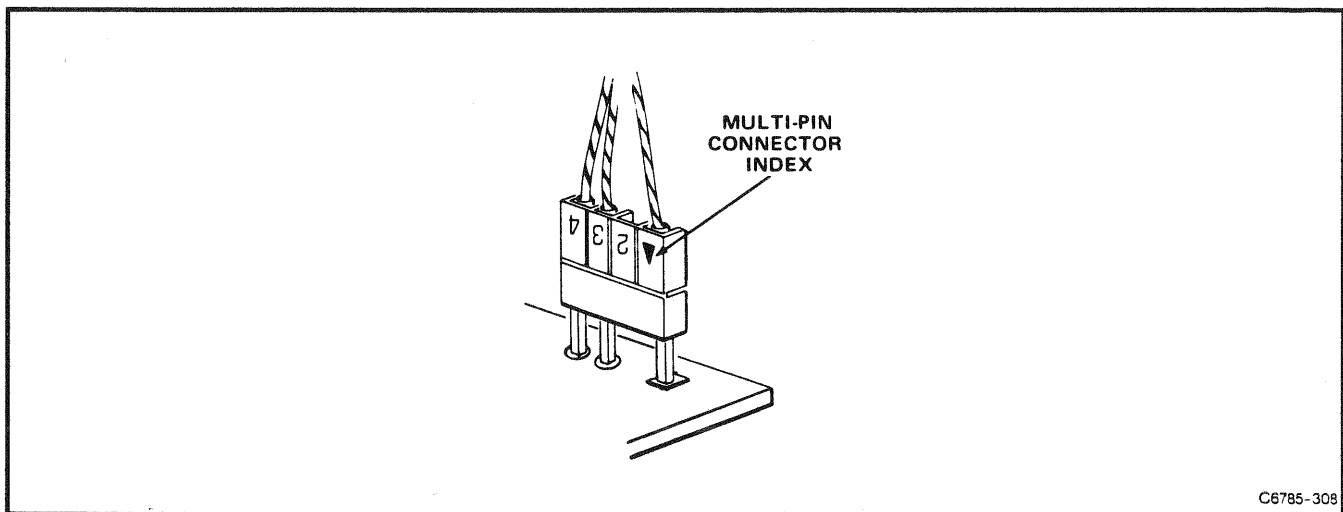

Figure 3-7. Indexing of multi-pin connectors.

C6785-308

---

# Troubleshooting

---

## Diagnostic Troubleshooting

This section provides the information necessary to troubleshoot a faulty instrument to the Field Replaceable Unit (FRU) level. FRUs are circuit boards, attenuator modules, and integrated circuits or hybrids that are replaceable without soldering. The primary means for troubleshooting is to use the error index code output from the Diagnostics or Self-Tests and cross-reference them to the suspect FRU(s) in the FRU Guide tables. After the faulty FRU is replaced, recalibration of the instrument is normally required.

## Diagnostics Overview

The processor runs a set of Kernel Tests prior to the Self-Tests. If this is successful, then the Self-Tests are run to verify the functionality of each of the subsystems. Any failure causes the instrument to enter Extended Diagnostics and to display the error index code(s) in a diagnostic menu. Extended Diagnostics tests are a superset of the Self-Tests.

The Kernel Tests, Self-Tests/Extended Diagnostics, and the Enhanced Accuracy mode produce and format error index codes differently, so these error index codes are covered separately.

Some of these tests that may indicate faulty FRU(s) are not run automatically during the Self-Tests (that is, some error codes are only generated by manually selecting tests).

The next two subsections provide a quick overview of Kernel Tests and Extended Diagnostics.

For an overview of the Enhanced Accuracy mode refer to Part 6—Check Enhanced Accuracy in Section 2, Checks and Adjustments.

### Kernel Tests

Each time the front-panel ON/STANDBY switch is set to ON, the mainframe and plug-ins perform Power-Up Diagnostics on their microprocessor subsystems and Self-Test Diagnostics on all of their major circuits.



#### CAUTION

*Turning the instrument power off during the execution of the Diagnostic tests may result in losing some or all of the non-volatile RAM data (such as stored settings, calibration constants, etc.). This could affect normal instrument operation in unpredictable ways. If this occurs, refer to Restoring Calibration Data later in this section.*

After the plug-in is powered-up and the MPU has reset, the plug-in begins a sequence of test routines to determine if its kernel systems are operating properly. If any of these tests fails, then it is unlikely that the plug-in can communicate failure information to the mainframe. The flashing of a fault code on the front panel CH 1 LED indicates a particular failure. This fault code indicates which Kernel Test is failing.



The following description explains how to read the fault code:

If the plug-in Kernel Tests detect a fault, then the CH 1 LED is flashed eight times to display a fault code. Each time the CH 1 LED turns on, count the occurrences. If the CH 1 LED is lit twice as long (that is, during one cycle, CH 1 is lit for twice the normal pulse width), then the test corresponding to the current count accumulated is the one which failed. Refer to the timing diagram in Figure 3-8 for an example LED fault code. The timing diagram illustrates a test number 2 failure.

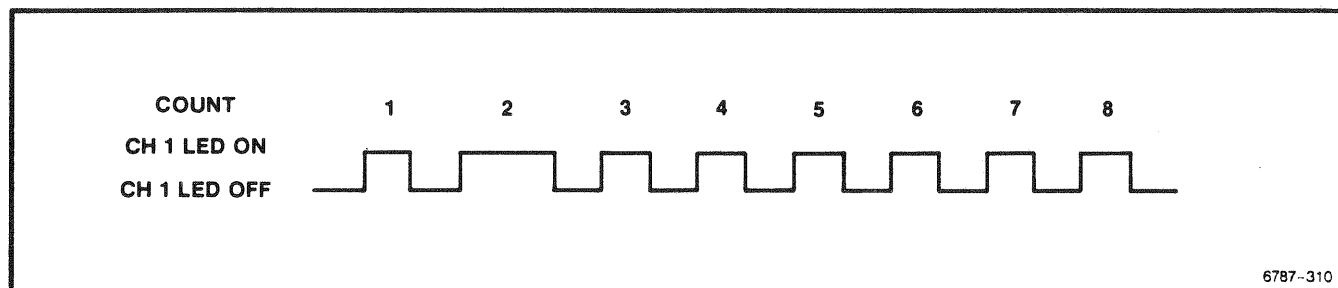

Figure 3-8. Sample LED fault code timing diagram.

The Kernel Tests are:

1. Non-volatile RAM Test
  2. Housekeeper IC Test
1. The Non-volatile RAM (NV RAM) Test verifies that the NV RAM is functioning properly. Since the NV RAM contains calibration information which must remain undamaged, this test does not alter critical data. If the testing algorithm detects a failure, then the plug-in reports a fault code of 1 and repeatedly loops the NV RAM Test. The instrument continues looping the NV RAM Test until the power is removed. Until the condition causing the NV RAM Test to fail is corrected, the mainframe does not recognize the plug-in.

The NV RAM Test could corrupt calibration data stored in the NV RAM if the power is cycled or removed during this test. If corruption occurs, then the Calconstant Checksum is corrupted as well. Furthermore, at the next power-up, the plug-in resets the cal constants to default ROM settings and reports a Plug-in Calconstant Checksum Error during mainframe-invoked, Power-up Diagnostics. After the mainframe/plug-in system is run through an Enhanced Accuracy cycle, the plug-in is once again properly calibrated.

2. The Housekeeper IC Test verifies the functionality of the Housekeeper IC. The Housekeeper IC performs many "housekeeping" chores of the Amplifier; including channel sequencing, refreshing the analog control voltage system, latching Amplifier step gain settings, and the communications with the mainframe. This test applies controlled stimulus to the Housekeeper IC to exercise this IC. This test also records the IC's reactions using an algorithm similar to the algorithm that signature analysis uses. If the resulting signature of the Housekeeper IC does not match a known good signature, then the test fails and reports a fault code of 2. Also, the test is executed repeatedly if it fails. The instrument continues looping the Housekeeper IC Test until power is removed. Until the condition causing the Housekeeper IC Test to fail is corrected, the mainframe does not recognize the plug-in.

After all power-on Kernel Tests have completed and successfully passed, the instrument initializes its settings and communicates with the mainframe.

## Self-Test/ Extended Diagnostics

First, the plug-in must successfully power-up, initialize its settings, and establish communication with the mainframe. Then, the mainframe requests that the plug-in execute its Self-Test routines (unless the mainframe's Self-Tests are disabled, in which case all the Self-Tests are ignored). Return to normal operation or entry into the New Configuration calibration, as discussed below, indicates successful completion of the Self-Test Diagnostics. Any failures cause the instrument to display the Extended Diagnostics menu. Record the displayed error codes for the failed circuit Block(s) and refer the instrument to a qualified service person. You may have to step through several pages of the menu display to find all the failure codes.

The format of the error index codes is based on the Extended Diagnostics menu structure. The Extended Diagnostics menus are in a three-level hierarchy with the Block menu at the highest level. Each plug-in is one Block. A Block is broken into a number of parts or circuit areas in the Area menu, the second level. Touching the Area label at the bottom of the menu displays the Area menu for the selected Block. Each circuit area has a Routine menu, the third level, associated with it that has one or more selectable routines. Routines are the smallest test units that are selectable and runnable. This Block, Area, and Routine menu hierarchy generates the error index codes.

Extended Diagnostics error index codes are five digit codes whose first character indicates the subsystem or plug-in unit tested. The last four digits are hexadecimal (hex) numbers that indicate the Block, Area, Routine and specific failure mode. For example, R1241 is decoded as follows:

R	Right Plug-in
1	Block name – plug-in
2	Area name – Group II
4	Routine name – Checksum Probe
1	Failure Identity – specific failure mode

The subsystem character of an error index code is one of the following, and indicates the compartment in which the plug-in is installed. In the tables in this section, only the four digit failure code is listed; the prefix L, C, or R is omitted.

L	-Left
C	-Center
R	-Right

Front-panel controls are active during the Self-Test sequence and any disturbance causes a test failure.

Self-Test Diagnostics test the following circuits:

- Attenuator relay driver
- Probe coding
- Calibration (cal) constant checksums
- Calibration (cal) constant values
- A/D and D/A converters
- Probe power fuses
- Input protection
- Signal path

## Using the Self-Tests/Extended Diagnostics

After all Extended Diagnostic/Self-Tests have run, any resultant error index codes appear on the display next to the associated circuit Block names in the Extended Diagnostics menu. Each circuit block that had a failure gives the first error encountered and the number of failures in the Block. Select the label of a failed Block, then select the Area label to get a more complete list of the error index codes in a Block. Selecting the Routine label shows the lowest level test routines in the selected Area. The currently selected Block, Area, and Routine are shown. Several operating mode selectors are available on the screen. When certain test routines are selected, some of these operating modes are unselectable.

Refer to the mainframe User's Reference manual for information on Extended Diagnostics or Extended Test menus and operation.

## New Configuration Calibration

When a plug-in is first installed in a mainframe or when one is moved to a different compartment in the mainframe, the instrument is in a new configuration mode. After the instrument runs the Power-Up Diagnostics, it recalibrates itself for the new configuration. During this calibration, the message **"Powerup new configuration partial calibration occurring"** appears. If the calibration is successful (as indicated by a message), the instrument enters the normal operating mode.

## Restoring Calibration Data

If the instrument power is turned off during probe calibration, self-calibration, Extended Diagnostics or other intense system activity, then some internal data may be corrupted. The display of the Extended Diagnostics menu when the power is turned on, indicates that this corruption has occurred.

If the Extended Diagnostics menu displays a Cksm Probe error (this error indicates that power was turned off during probe calibration), then using the following procedure usually restores normal operation.

1. Note from the Extended Diagnostics menu which plug-in is at fault.
2. Exit the Extended Diagnostics menu.
3. Remove and re-install the probes on the plug-in that is at fault.
4. Repeat the calibration of these probes.
5. Run the Self-Tests and confirm that the test pass.

If the Extended Diagnostics menu displays a Cksm Plug or any other new error, then using the following procedure usually restores normal operation.

1. Exit the Extended Diagnostics menu.
2. Wait for the self-calibration to complete and pass.
3. Run the Self-Tests and confirm that the tests pass.

Usually these procedures restore normal operation. If these procedures do not restore normal operation, then your mainframe or plug-in requires servicing.

## Plug-In Memory Backup Power

The non-volatile RAM (A3U700 NV RAM) within the plug-in allows retention of the data in memory when the plug-in is removed.

The NV RAM stores system-configuration data such as the plug-in, mainframe, and probe IDs as well as the calibration constants. The data that the NV RAM stores, enable the plug-in to resume Enhanced Accuracy performance from a powered-down condition, without performing a full calibration (Enhanced Accuracy) operation.

The rated lifetime of the NV RAMs integral power source is ten years. If, on system power-up, the plug-in habitually loses Enhanced Accuracy status without a system configuration change (that is, the plug-in remains plugged into the same slot in the same mainframe), then the NV RAM may require replacement.

## Field Replaceable Unit (FRU) Guide

This section correlates error index codes resulting from Diagnostic tests with the hybrid, integrated circuit (IC) module, or board FRU(s) suspected of causing each error. The FRU(s) in each category are listed in most-to-least probable cause order (assuming only one error is indicated). If any diagnostic errors occur, inspect the suspect FRU for loose connections and components. Repeat the Diagnostic test. If any diagnostic errors occur again, replace the suspect FRU(s) with a known good FRU(s). Verify that the new FRU is the correct replacement for the old FRU. If the old FRU contains firmware, then verify that the new firmware is either the same version as, or an updated version of, the old firmware version.

The error index codes are divided into three tables. A table of Kernel Test error codes, a table of Self-Test/Extended Diagnostic error indexes, and a table of Enhanced Accuracy error indexes.

## Abbreviations of FRU Names

All boards are listed here with the abbreviation used in the Suspect Board FRU(s) column of the Error Index Code tables that follow:

Abbreviation	Name	Designator
Main	Main Board	A1
Front	Front Panel Board	A2
Kernel	Kernel Board	A3

## Abbreviations of Component and Module Names

All active components and modules are listed here with the abbreviation used in the Suspect Module, Hybrid, or IC FRU(s) column of the Error Index Code tables that follow.

Abbreviation	Name	Designator
MPU	Processor	A3U500
EPROM	Firmware	A3U800
RAM	Memory	A3U700
HK	Housekeeper	A3U820
Att	Attenuator	
FUSE	Probe power fuses	A1F100, A1F110 A1F111, A1F112

## Error Index Codes

This table lists the error codes possible in the Kernel Tests.

Error Code	Suspect Module, Hybrid, or IC FRU(s)	Suspect Board FRU(s)
1	RAM	Kernel
2	HK, MPU	Kernel

This table lists the error messages possible in the Self-Tests and Extended Diagnostics.

Error Index	Suspect Module, Hybrid, or IC FRU(s)	Suspect Board FRU(s)
-1111		Kernel
-1121		Kernel
-1131 <sup>1</sup>	RAM	Kernel
-1141 <sup>1</sup>	RAM	Kernel
-1211		Kernel
-1221	FUSE	Kernel
-1231	HK	Main, Kernel
-1311	HK	Kernel
-1511		Main, Kernel
-1521	Att	Main

<sup>1</sup>These error indexes may also result from the corruption of the calibration data (refer to Restoring Calibration Data earlier in this section).

Interconnections are not listed but should be considered as possible problem sources.

This table lists the error indexes resulting from Enhanced Accuracy. Enhanced Accuracy is available after the system has a 20-minute warmup period.

Error Index	Suspect Hybrid or IC FRU(s)	Suspect Board FRU(s)
-1411	Att	
-1421	Att	
-1431		Main
-1441		Main
-1451		Main
-1461		Main
-1471		Main

## Fuse Troubleshooting

Failure code 1221 indicates that one or more probe power fuses are defective.

Refer to Figure 3-1 (FRU locator) for fuse locations.

To find a defective fuse, remove the plug-in from a mainframe, and use a Multi-meter to check for continuity across each fuse. Replace all defective fuses. Then, install the plug-in in the mainframe and verify that the diagnostic error does not re-appear.

The most likely cause of a blown fuse is a short circuit applied at the front-panel TEKPROBE® input connector. If a newly installed fuse blows with nothing connected at the TEKPROBE® input connector, then look for a short circuit on the A1 Main board or on the flexible circuit connecting the A1 Main board to the TEKPROBE® input connector.

## Jumpers

Two jumpers are installed in the instrument for normal operation. Refer to Figure 3-1, and verify that they are properly installed.

A3J400  
A3J410

# Section 4

## Theory of Operation

---

This section describes and illustrates (refer to Fig. 4-1) the plug-in block diagram; including signal flow and control flow. This section also discusses the power supplies for the plug-in.

---

### Block Diagram Description

---

#### Signal Flow

##### Main Board

The signal display begins with the application of a signal directly to the CH 1 input connector on the Main board (possibly with a probe) and proceeds as follows:

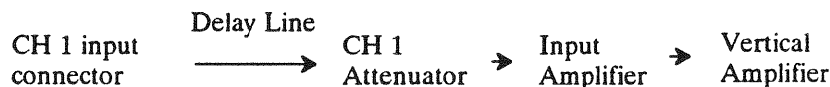

The input coupling mode is either AC, DC, or Off. In the AC and DC coupling modes, the input signal is coupled to the Attenuator. In the Off coupling mode, the signal path is open.

During self-calibration, the mainframe supplies the signal to the CH 1 input connector and the coupling mode is set to Off.

The CH 1 Attenuator contains resistive dividers, an ac coupling capacitor, and relays.

The Attenuator has 2X, 5X, and 10X attenuation sections, which are connected to produce 2X, 5X, 10X, 20X, 50X or 100X attenuation.

The Fast Protection circuit protects the Input Amplifier from fast-rise, high-amplitude input signals that could cause damage to the Input Amplifier.

##### Kernel Board to Main Board

The Kernel board contains a microprocessor (MPU) that communicates with the mainframe. The MPU constantly monitors the input Overload Sense and the Probe Data communication lines. The MPU operates through the internally stored program in its read only memory (ROM). The MPU stores the plug-in calibration (cal) constants in random access memory (RAM). A battery backs-up random access memory (RAM) memory, therefore, the internal calibration constants are not lost upon power-down. Also, when powering-down, the mainframe stores the oscilloscope's settings. When the system re-powers, the mainframe restores and transmits these settings to the plug-in.

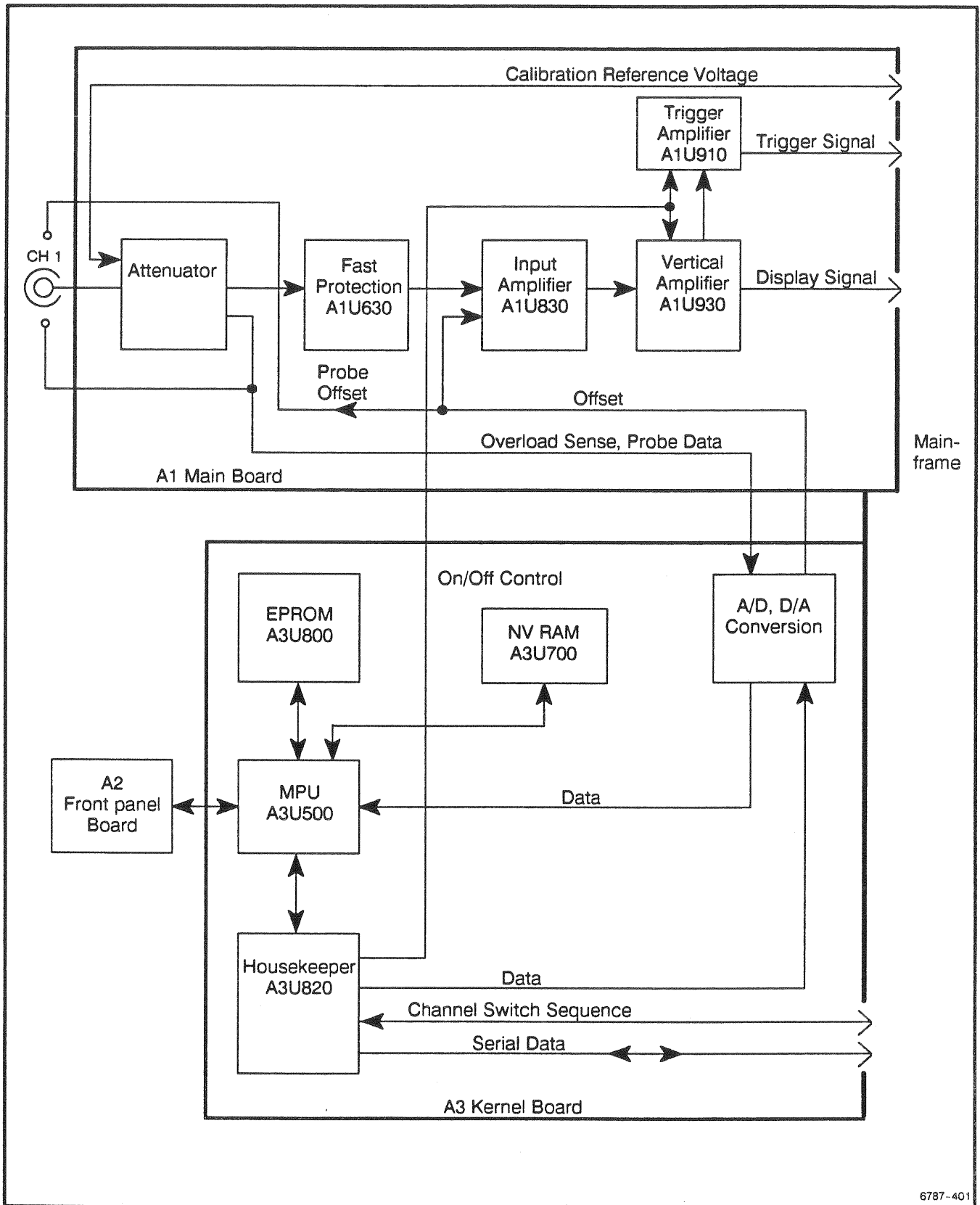

6787-401

Figure 4-1. 11A71 Amplifier.



The MPU communicates with the mainframe through a peripheral IC called the Housekeeper. The Housekeeper converts the 8-bit data bytes from the MPU into a serial data signal. This signal is sent to the mainframe. Conversely, the Housekeeper converts the serial data signal from the mainframe into 8-bit data bytes for the MPU to read. The MPU stores the channel switching sequence in the Housekeeper. The Housekeeper also updates the analog control voltages.

The MPU uses an analog-to-digital (A/D) converter to read the value of the Overload Sense and Probe Data lines. The A/D converter is also used in the Self-Tests.

The MPU reads the front-panel pushbuttons. The MPU tells the mainframe when a front-panel button is pushed. The mainframe then tells the plug-in what action to take (for example, display the channel and turn on the channel's respective front-panel LED).

## Control Flow

Under the control of the mainframe's channel switch sequencing signals, the Housekeeper sequentially turns the outputs on or off.

If the amplitude of the input signal is excessive, the Kernel board switches the coupling mode to Off.

On/Off signals from the Kernel board independently control both the Vertical and Trigger Amplifiers.

The Kernel board also provides dc balance, dc offset, and gain adjust signals to the Input Amplifier and controls the Attenuator.

## Power

The mainframe supplies all the power to the plug-in.



# REPLACEABLE PARTS

## PARTS ORDERING INFORMATION

Replacement parts are available from or through your local Tektronix, Inc. Field Office or representative.

Changes to Tektronix instruments are sometimes made to accommodate improved components as they become available, and to give you the benefit of the latest circuit improvements developed in our engineering department. It is therefore important, when ordering parts, to include the following information in your order: Part number, instrument type or number, serial number, and modification number if applicable.

If a part you have ordered has been replaced with a new or improved part, your local Tektronix, Inc. Field Office or representative will contact you concerning any change in part number.

Change information, if any, is located at the rear of this manual.

## ITEM NAME

In the Parts List, an Item Name is separated from the description by a colon (:). Because of space limitations, an Item Name may sometimes appear as incomplete. For further Item Name identification, the U.S. Federal Cataloging Handbook H6-1 can be utilized where possible.

## FIGURE AND INDEX NUMBERS

Items in this section are referenced by figure and index numbers to the illustrations.

## INDENTATION SYSTEM

This mechanical parts list is indented to indicate item relationships. Following is an example of the indentation system used in the description column.

1	2	3	4	5	Name & Description
					<i>Assembly and/or Component</i>
					<i>Attaching parts for Assembly and/or Component</i>
					**** END ATTACHING PARTS ****
					<i>Detail Part of Assembly and/or Component</i>
					<i>Attaching parts for Detail Part</i>
					**** END ATTACHING PARTS ****
					<i>Parts of Detail Part</i>
					<i>Attaching parts for Parts of Detail Part</i>
					**** END ATTACHING PARTS ****

Attaching Parts always appear in the same indentation as the item it mounts, while the detail parts are indented to the right. Indented items are part of, and included with, the next higher indentation. The separation symbol - - - \* - - - indicates the end of attaching parts.

## ABBREVIATIONS

..	INCH	ELECTRN	ELECTRON	IN	INCH	SE	SINGLE END
#	NUMBER SIZE	ELEC	ELECTRICAL	INCAND	INCANDESCENT	SECT	SECTION
ACTR	ACTUATOR	ELCTLT	ELECTROLYTIC	INSUL	INSULATOR	SEMICON	SEMICONDUCTOR
ADPTR	ADAPTER	ELEM	ELEMENT	INTL	INTERNAL	SHLD	SHIELD
ALIGN	ALIGNMENT	EPL	ELECTRICAL PARTS LIST	LPHLDR	LAMPHOLDER	SHLDR	SHOULDERED
AL	ALUMINUM	EQPT	EQUIPMENT	MACH	MACHINE	SKT	SOCKET
ASSEM	ASSEMBLED	EXT	EXTERNAL	MECH	MECHANICAL	SL	SLIDE
ASSY	ASSEMBLY	FIL	FILLISTER HEAD	MTG	MOUNTING	SLFLKG	SELF-LOCKING
ATTEN	ATTENUATOR	FLEX	FLEXIBLE	NIP	NIPPLE	SLVG	SLEEVING
AWG	AMERICAN WIRE GAGE	FLH	FLAT HEAD	NON WIRE	NOT WIRE WOUND	SPR	SPRING
BD	BOARD	FLTR	FILTER	OBD	ORDER BY DESCRIPTION	SQ	SQUARE
BRKT	BRACKET	FR	FRAME or FRONT	OD	OUTSIDE DIAMETER	SST	STAINLESS STEEL
BR	BRASS	FSTNR	FASTENER	OVH	OVAL HEAD	STL	STEEL
BRZ	BRONZE	FT	FOOT	PH BRZ	PHOSPHOR BRONZE	SW	SWITCH
BSHG	BUSHING	FXD	FIXED	PL	PLAIN or PLATE	T	TUBE
CAB	CABINET	GSKT	GASKET	PLSTC	PLASTIC	TERM	TERMINAL
CAP	CAPACITOR	HDL	HANDLE	PN	PART NUMBER	THD	THREAD
CER	CERAMIC	HEX	HEXAGON	PNH	PAN HEAD	THK	THICK
CHAS	CHASSIS	HEX HD	HEXAGONAL HEAD	PWR	POWER	TNSN	TENSION
CKT	CIRCUIT	HEX SOC	HEXAGONAL SOCKET	RCPT	RECEPTACLE	TPG	TAPPING
COMP	COMPOSITION	HLCPS	HELICAL COMPRESSION	RES	RESISTOR	TRH	TRUSS HEAD
CONN	CONNECTOR	HLEXT	HELICAL EXTENSION	RGD	RIGID	V	VOLTAGE
COV	COVER	HV	HIGH VOLTAGE	RLF	RELIEF	VAR	VARIABLE
CPLG	COUPLING	IC	INTEGRATED CIRCUIT	RTNR	RETAINER	W/	WITH
CRT	CATHODE RAY TUBE	ID	INSIDE DIAMETER	SCH	SOCKET HEAD	WSHR	WASHER
DEG	DEGREE	IDNT	IDENTIFICATION	SCH	OSCILLOSCOPE	XFMR	TRANSFORMER
DWR	DRAWER	IMPLR	IMPELLER	SCR	SCREW	XSTR	TRANSISTOR

## CROSS INDEX - MFR. CODE NUMBER TO MANUFACTURER

Mfr. Code	Manufacturer	Address	City, State, Zip Code
06383	PANDUIT CORP	17301 RIDGELAND	TINLEY PARK IL 60477
22599	AMERACE CORP ESNA DIV	15201 BURBANK BLVD SUITE C	VAN NUYS CA 91411-3532
34649	INTEL CORP	3065 BOWERS AVE	SANTA CLARA CA 95051
75915	LITTELFUSE INC	800 E NORTHWEST HWY	DES PLAINES IL 60016
80009	TEKTRONIX INC	4900 S W GRIFFITH DR P O BOX 500	BEAVERTON OR 97077
83385	MICRODOT MFG INC GREER-CENTRAL DIV	3221 W BIG BEAVER RD	TROY MI 48098
91260	CONNOR SPRING AND MFG CO	1729 JUNCTION AVE	SAN JOSE CA 95112
93907	TEXTRON INC CAMCAR DIV	600 18TH AVE	ROCKFORD IL 61101
TK1326	NORTHWEST FOURSLIDE INC	5858 WILLOW LANE	LAKE OSWEGO OR 97034
TK1831	PACIFIC HYBRID MICROELECTRONICS INC	7790 SW NIMBUS AVE BLDG 10	BEAVERTON OR 97005

Fig. & Index No.	Tektronix Part No.	Serial/Assembly No.		Qty	12345 Name & Description	Mfr.	
		Effective	Dscont			Code	Mfr. Part No.
1-1	366-0600-00			1	PUSH BUTTON:0.269 X 0.409,ABS	80009	366-0600-00
-2	366-1058-00			1	KNOB:GRAY,0.625 X 0.255 X 0.485 (ATTACHING PARTS)	80009	366-1058-00
-3	214-1095-00			1	PIN,SPRING:0.187 L X 0.094 OD,STL,CD PL (END ATTACHING PARTS)	22599	52-022-094-0187
-4	105-0076-04			1	RELEASE BAR,LCH:PLUG-IN UNIT	80009	105-0076-04
-5	214-1280-00			1	SPRING,HLCPS:0.14 OD X 1.126 L,TWIST LOOP	91260	ORDER BY DESCR
-6	214-1054-00			1	SPRING,FLAT:0.825 X 0.322,SST	TK1326	ORDER BY DESCR
-7	105-0075-00			1	BOLT,LATCH:	80009	105-0075-00
-8	333-3409-00			1	PANEL,FRONT: (ATTACHING PARTS)	80009	333-3409-00
-9	211-0392-00			4	SCREW,MACHINE:4-40 X 0.25,FLH,82 DEG,STL (END ATTACHING PARTS)	80009	211-0392-00
-10	348-0235-00			2	SHLD GSKT,ELEK:FINGER TYPE,4.734 L	80009	348-0235-00
-11	386-5219-00			1	SUBPANEL,FRONT:	80009	386-5219-00
-12	670-9336-00			1	CIRCUIT BD ASSY:FRONT PANEL (SEE A2) (ATTACHING PARTS)	80009	670-9336-00
-13	211-0398-00			2	SCREW,MACHINE:2-56 X 0.312,FLH,82 DEG,STL (END ATTACHING PARTS)	80009	211-0398-00
-14	174-0159-00			1	CA ASSY,SP,ELEC:6,26 AWG,3.0 L,RIBBON	80009	174-0159-00
-15	426-2061-00			1	FR SECT,PLUG-IN:LOWER,ALUMINUM	80009	426-2061-00
-16	334-3540-00			1	MARKER,IDENT:MARKED WARNING	80009	334-3540-00
-17	131-3589-00			1	CONN ASSY,ELEC:FRONT PNL (ATTACHING PARTS)	80009	131-3589-00
-18	211-0398-00			4	SCREW,MACHINE:2-56 X 0.312,FLH,82 DEG,STL (END ATTACHING PARTS)	80009	211-0398-00
-19	354-0654-00			1	RING,CONN ALIGN:BNC	80009	354-0654-00
-20	174-0205-00			1	CABLE ASSY,RF:50 OHM COAX,2.6 L	80009	174-0205-00
	174-0665-00			1	CABLE ASSY,RF:50 OHM COAX,13.3 L	80009	174-0665-00
	343-0549-00			1	STRAP,TIEDOWN,E:0.091 W X 4.0 L,ZYTEL	06383	PLT1M
-21	119-2397-00			1	ATTENUATOR:5 STAGE PROGRAMMABLE (ATTACHING PARTS)	TK1831	119-2397-00
-22	211-0409-00			2	SCR,ASSEM WSHR:4-40 X 0.312,PNH,STL (END ATTACHING PARTS)	93907	ORDER BY DESCR
-23	174-0559-00			1	CA ASSY,SP,ELEC:20,28 AWG,2.25 L,RIBBON	80009	174-0559-00
-24	426-2060-00			1	FR SECT,PLUG-IN:UPPER,ALUMINUM	80009	426-2060-00
-25	334-3438-00			1	MARKER,IDENT:MARKED TURN OFF POWER	80009	334-3438-00
-26	214-1061-00			1	CONTACT,ELEC:GROUNDING,CU BE	80009	214-1061-00
-27	337-1064-12			2	SHIELD,ELEC:SIDE FOR PLUG-IN UNIT	80009	337-1064-12
-28	220-0022-00			6	NUT BLK:0.4 X 0.25 X 0.33,4-40 THRU,NI SIL (ATTACHING PARTS)	80009	220-0022-00
-29	211-0409-00			6	SCR,ASSEM WSHR:4-40 X 0.312,PNH,STL (END ATTACHING PARTS)	93907	ORDER BY DESCR
-30	174-0560-00			1	CA ASSY,SP,ELEC:16,28 AWG,2.75 L,RIBBON	80009	174-0560-00
-31	670-9747-00			1	CIRCUIT BD ASSY:KERNEL (SEE A3) (ATTACHING PARTS)	80009	670-9747-00
-32	211-0409-00			4	SCR,ASSEM WSHR:4-40 X 0.312,PNH,STL (END ATTACHING PARTS) KERNAL BOARD ASSEMBLY INCLUDES:	93907	ORDER BY DESCR
-33	156-1684-01			1	.MICROCKT,DGTL:MICROCOMPUTER,8 BIT	34649	P8031AH
-34	156-2625-00			1	.MICROCKT,DGTL:NMOS,CUSTOM,SENECHAL	80009	156-2625-00
-35	160-4065-02			1	.MICROCKT,DGTL:HMOS,16385 X 8 EPROM,PRGM	80009	160-4065-02
-36	156-2671-00			1	.MICROCKT,DGTL:CMOS,2048 X 8 SRAM MDL W/ .INTEGRAL BATTERY DS1220,24	80009	156-2671-00
-37	670-9735-00	B010100	B010508	1	CIRCUIT BD ASSY:MAIN	80009	670-9735-00
	670-9735-01	B010509		1	CIRCUIT BD ASSY:MAIN (SEE A1)	80009	670-9735-01
-38	159-0253-00			2	.FUSE,CRTG:0.250A,125V,FAST,SUBMINIATURE	75915	251.250 T & R T1
-39	159-0235-00			2	.FUSE,WIRE LEAD:0.75A,125V,FAST	80009	159-0235-00
-40	386-5296-00			1	PANEL,REAR: (ATTACHING PARTS)	80009	386-5296-00
-41	213-0904-00			4	SCREW,TPG,TR:6-32 X 0.5,PNH,STL (END ATTACHING PARTS)	83385	ORDER BY DESCR

Fig. & Index No.	Tektronix Part No.	Serial/Assembly No. Effective    Dscnt	Qty	12345	Name & Description	Mfr. Code	Mfr. Part No.
1-					STANDARD ACCESSORIES		
	070-6288-00		1		MANUAL, TECH:USERS REFERENCE, 11A71	80009	070-6288-00
	070-6699-00		1		PROCEDURE: INCOMING INSPECTION, 11A71	80009	070-6699-00
					OPTIONAL ACCESSORIES		
	070-6787-00		1		MANUAL, TECH:SERVICE REF, 11A71	80009	070-6787-00

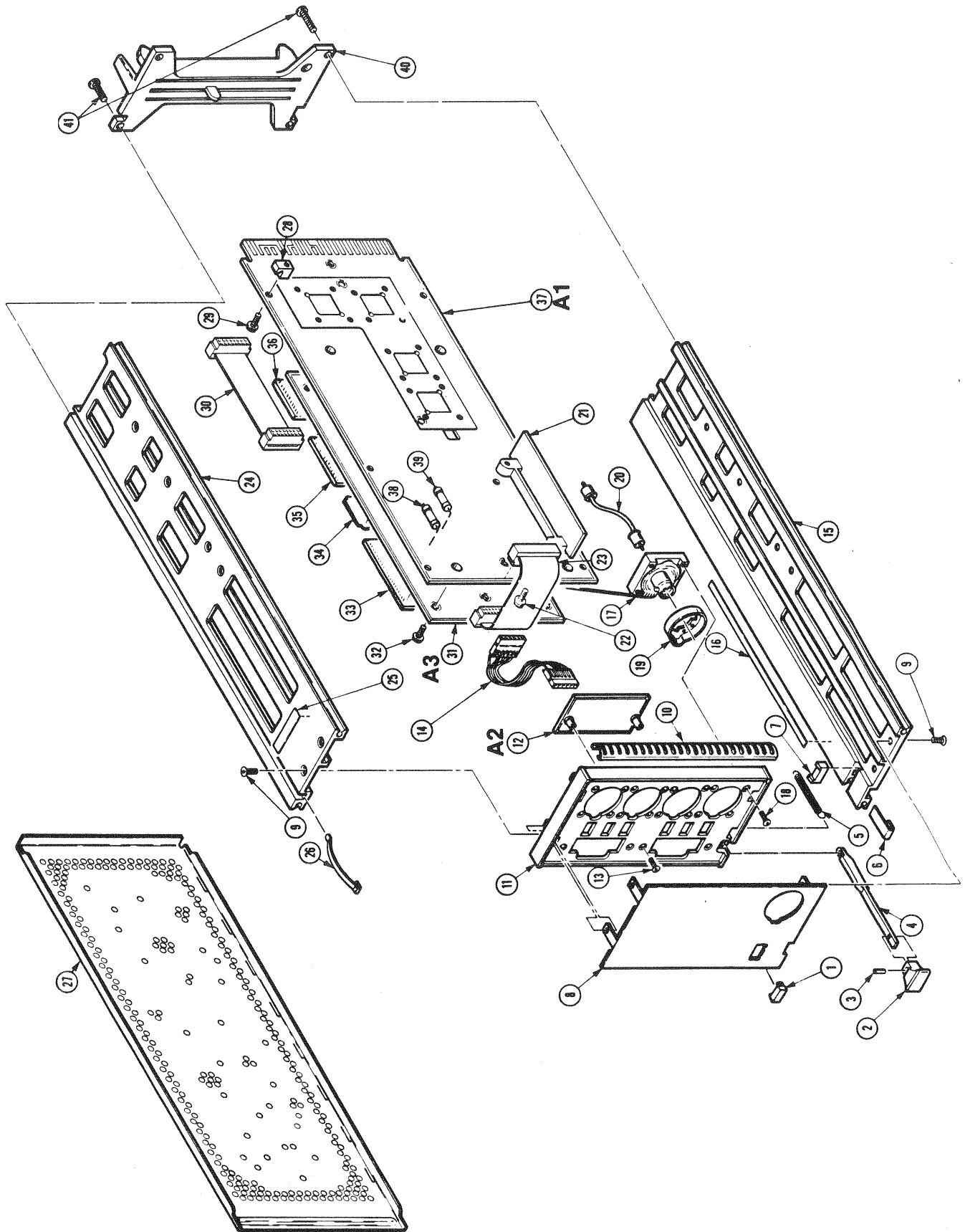

FIG.1 EXPLODED  
11A71





## **MANUAL CHANGE INFORMATION**

At Tektronix, we continually strive to keep up with latest electronic developments by adding circuit and component improvements to our instruments as soon as they are developed and tested.

Sometimes, due to printing and shipping requirements, we can't get these changes immediately into printed manuals. Hence, your manual may contain new change information on following pages.

A single change may affect several sections. Since the change information sheets are carried in the manual until all changes are permanently entered, some duplication may occur. If no such change pages appear following this page, your manual is correct as printed.



SEND TO: TEKTRONIX, INC.  
LAB INSTRUMENTS MARKETING SUPPORT  
P.O. BOX 500, DEL STA 39-327  
BEAVERTON, OREGON 97077

# 11000-SERIES OSCILLOSCOPE PROBLEM REPORT

**A INSTRUMENT CONFIGURATION:**

Instrument	Section	ROM (Version)	ID # (Serial Number)

Option Information

**B** COMPANY NAME: \_\_\_\_\_  
USER: \_\_\_\_\_  
ADDRESS: \_\_\_\_\_  
CITY: \_\_\_\_\_ STATE: \_\_\_\_\_ ZIP: \_\_\_\_\_  
PHONE: \_\_\_\_\_ EXTENSION: \_\_\_\_\_  
SUBMITTED BY: \_\_\_\_\_ DATE: \_\_\_\_\_

**REASON FOR REPORT**

- Hardware/Mechanical Problem
- Software/Firmware Problem
- Documentation Problem
- Suggested Enhancement **C**

**IS THE PROBLEM REPRODUCIBLE?**

- Yes
- No
- Intermittent

**D** SYSTEM DESCRIPTION: (Hardware, software, firmware and host related to the problem)

**E** DESCRIPTION OF PROBLEM:

LIST ENCLOSURES:



# Instructions For Completing The Problem Report

- I. Please type or print clearly. Use a separate Problem Report (PR) for each problem.
- II. SECTION A  
Fill in the instrument configuration table, including all plug-in units, modules, and probes installed in the oscilloscope. The information can be found in one of the menus under the UTILITY major menu.  
**Instrument:** Write the instrument name (e.g., 11301, 11401, 11A32, etc.).  
**Section (Microprocessor Subsystem):** If the instrument has more than one section write the section name. For plug-ins, write in which mainframe slot they are located (e.g., left, center, right).  
**ROM (Version):** Write the rom version number for each instrument and section. Instruments with more than one section will have more than one version number.  
**ID# (Serial Number):** Write the serial number for each instrument. At the factory the ID number is programmed to be the instrument's serial number. If this value has been changed, please write the serial number physically attached to the instrument (mainframes: front panel, plug-in units: top rail).
- III. SECTION B  
Use the complete company mailing address. Include the name and phone number of the person reporting the error. Also, be sure to fill in the name of the person submitting the PR.
- IV. SECTION C  
Check the reason for the report and whether the problem is reproducible. We cannot fix a problem when we cannot reproduce the problem condition.
- V. SECTION D  
Give a complete description of the system configuration on which the problem occurred. Include related peripherals, interfaces, options, special switch and/or strap settings and operating system.
- VI. SECTION E  
Describe the problem completely. Include any information which might help in evaluating the error with the PR. If you have determined a procedure to avoid the error condition, please include this procedure. If this problem prevents you from accomplishing any useful work with the product, please state this fact. Be sure to include with the PR any information (programs, listings, hard copies, etc.) which will help us duplicate your problem.
- VII. SECTION F  
This section is for use by Tektronix Lab Instruments Marketing Support personnel. **DO NOT WRITE IN THIS SPACE.**
- VIII. Mail **all** copies of the Problem Report to:  

TEKTRONIX, INC.  
LAB INSTRUMENTS MARKETING SUPPORT  
P.O. BOX 500, DEL STA 39-327  
BEAVERTON, OREGON 97077

---

INTERNAL USE ONLY  
(DO NOT WRITE BELOW THIS LINE)

---

F

	DATE RECEIVED .....
	IR # .....



# MANUAL CHANGE INFORMATION

Date: 2/22/88 Change Reference: M63731

Product: 11A71 AMPLIFIER

Manual Part No.: 070-6787-00

Product Group Code: 47

## DESCRIPTION

This change is effective at serial number B010509.

### REPLACEABLE PARTS LIST CHANGE

If the component listed for change cannot be found in the Replaceable Parts List section of your manual, check for related change information at the rear of the manual.

#### CHANGE TO:

Fig. & Index No.	Tektronix Part No.	Qty	12345	Name & Description
1-13	211-0413-00	2		SCREW,MACHINE:2-56 X 0.375,FLH,82 DEG,STL
1-18	211-0413-00	4		SCREW,MACHINE:2-56 X 0.375,FLH,82 DEG,STL





# MANUAL CHANGE INFORMATION

Date: 2/22/88 Change Reference: M64932

Product: 11A71 AMPLIFIER

Manual Part No.: 070-6787-00

Product Group Code: 47

## DESCRIPTION

This change is effective at serial number B010197.

### REPLACEABLE PARTS LIST CHANGE

If the component listed for change cannot be found in the Replaceable Parts List section of your manual, check for related change information at the rear of the manual.

#### CHANGE TO:

Fig. & Index No.	Tektronix Part No.	Qty	12345	Name & Description
1-35	160-4065-03	1		.MICROCKT,DGTL:H MOS,16385 X 8 EPROM,PRGM







# MANUAL CHANGE INFORMATION

Date: 2/22/88 Change Reference: M65596

Product: 11A71 Amplifier

Manual Part No.: 070-6787-00

Product Group Code: 47

## DESCRIPTION

This change is effective at serial number B010288.

### REPLACEABLE PARTS LIST CHANGE

If the component listed for change cannot be found in the Replaceable Parts List section of your manual, check for related change information at the rear of the manual.

#### CHANGE TO:

Fig. & Index No.	Tektronix Part No.	Qty	12345	Name & Description
1-35	160-4065-04	1		.MICROCKT,DGTL:HMOS,16385 X 8 EPROM,PRGM

