

**TECHNICAL MANUAL**  
**OPERATOR'S, ORGANIZATIONAL, DIRECT SUPPORT**  
**AND GENERAL SUPPORT MAINTENANCE MANUAL**  
**INCLUDING REPAIR PARTS AND SPECIAL TOOLS LISTS**  
**FOR**  
**RF PLUG-IN HP MODEL 86260A**

---

**HEADQUARTERS, DEPARTMENT OF THE ARMY**

**18 MARCH 1981**



**5**

**SAFETY STEPS TO FOLLOW IF SOMEONE IS THE VICTIM OF ELECTRICAL SHOCK**

**1**

**DO NOT TRY TO PULL OR GRAB THE INDIVIDUAL**

**2**

**IF POSSIBLE, TURN OFF THE ELECTRICAL POWER**

**3**

**IF YOU CANNOT TURN OFF THE ELECTRICAL POWER, PULL, PUSH OR LIFT THE PERSON TO SAFETY USING A DRY WOODEN POLE OR A DRY ROPE OR SOME OTHER INSULATING MATERIAL**

**4**

**SEND FOR HELP AS SOON AS POSSIBLE**

**5**

**AFTER THE INJURED PERSON IS FREE OF CONTACT WITH THE SOURCE OF ELECTRICAL SHOCK, MOVE THE PERSON A SHORT DISTANCE AWAY AND IMMEDIATELY START ARTIFICIAL RESUSCITATION**

**WARNING**

**Voltages are present in this instrument, when energized, which can cause death on contact.**

**With the ac power cable connected, the ac line voltage (115 or 230 Vac) is present at the terminals of the mainframe power line assembly FLI (mounted on rear panel) and at the mainframe POWER switch, whether the POWER switch is on or off. With top cover removed, these terminals are exposed and carry ac voltages capable of causing death.**

**Do not attempt internal service or adjustment unless another person, capable of rendering first aid and resuscitation, is present. Deenergize the instrument before making or removing internal connections.**

**Any interruption of the protective (grounding) conductor, inside or outside the instrument, or disconnection of the protective earth terminal is likely to make this instrument dangerous.**

**A/(B Blank)**

*This manual includes copyright material reproduced by permission of the Hewlett-Packard Company. All rights reserved.*

TECHNICAL MANUAL  
No. 11-6625-2917-14&P-14



HEADQUARTERS  
DEPARTMENT OF THE ARMY  
WASHINGTON, DC, 18 March 1981

**OPERATOR'S, ORGANIZATIONAL, DIRECT SUPPORT  
AND GENERAL SUPPORT MAINTENANCE MANUAL  
INCLUDING REPAIR PARTS AND SPECIAL TOOLS LISTS  
FOR  
RF PLUG-IN HP MODEL 86260A**

**REPORTING ERRORS AND RECOMMENDING IMPROVEMENTS**

You can help improve this manual. If you find any mistakes or if you know of a way to improve the procedures, please let us know. Mail your letter, DA Form 2028 (Recommended Changes to Publications and Blank Forms), direct to Commander, US Army Communications and Electronics Materiel Readiness Command, ATTN: DRSEL-ME-MQ, Fort Monmouth, NJ 07703.

In either case, a reply will be furnished direct to you.

**TABLE OF CONTENTS**

Section	Page
0. INTRODUCTION	
Scope .....	0-1
Indexes of Publications .....	0-1
Maintenance Forms, Records, and Reports .....	0-1
Reporting Equipment Improvement Recommendations (EIR).....	0-1
Administrative Storage .....	0-1
Destruction of Army Electronics Materiel .....	0-1

**I(ii blank)**

**CONTENTS**

Section	Page	Section	Page
I. GENERAL INFORMATION .....	1-1	4-3. Equipment Required.....	4-1
1-1. Introduction .....	1-1	4-5. Test Record .....	4-1
1-6. Specifications.....	1-1	4-7. Frequency Range and Accuracy .....	4-1
1-8. Safety Considerations.....	1-1	4-8. Frequency Stability .....	4-3
1-9. General.....	1-1	4-9. Residual FM in 10 KHz Bandwidth .....	4-4
1-11. Service.....	1-1	4-10. Power Level and Variation.....	4-6
1-16. Instruments Covered by Manual.....	1-2	4-11. Spurious Signals.....	4-10
1-21. Description .....	1-2	4-12. Residual AM .....	4-12
1-24. Options .....	1-3	4-13. Equivalent Source SWR .....	4-14
1-26. Option 001 .....	1-3	4-14. External FM .....	4-16
1-28. Option 004 .....	1-3	4-15. Internal and External AM .....	4-19
1-30. Option 001/004 .....	1-3	V. ADJUSTMENTS .....	5-1
1-32. Option 005 .....	1-3	5-1. Introduction.....	5-1
1-34. Option 006 .....	1-3	5-3. Equipment Required.....	5-1
1-36. Accessories Supplied.....	1-3	5-5. Factory Selected Components .....	5-1
1-38. Equipment Required But Not Supplied ..	1-3	5-7. Related Adjustment .....	5-2
1-40. Equipment Available .....	1-3	5-11. Adjustments Location .....	5-2
1-42. Deleted.....	1-3	5-13. Oscillator Bias Level .....	
1-44. Recommended Test Equipment .....	1-3	and Bias Limit Adjustment .....	5-2
II. INSTALLATION .....	2-1	5-14. Frequency Adjustment.....	5-5
2-1. Introduction .....	2-1	5-15. Leveling Amplifier Offset .....	
2-3. Initial Inspection .....	2-1	Adjustment .....	5-7
2-5. Preparation for use .....	2-1	.....	
2-6. Power Source .....	2-1	.....	
2-8. Interconnections .....	2-1	VI. REPLACEABLE PARTS .....	6-1
2-10. Mating Connectors .....	2-1	6-1. Introduction.....	6-1
2-12. Operating Environment.....	2-2	6-3. Abbreviations.....	6-1
2-16. Frequency Scale Installation.....	2-2	6-5. Replaceable Parts List.....	6-1
2-17. Swing-down Front Panel.....	2-2	6-7. Deleted.....	
2-18. Stationary Front Panel.....	2-2	.....	
2-19. Storage and Shipment .....	2-2	VII. MANUAL CHANGES.....	7-1
2-20. Environment .....	2-2	7-1. Introduction.....	7-1
2-22. Deleted .....		7-5. Manual Change Instructions.....	7-1
2-23. Deleted .....		VIII. SERVICE.....	8-1
2-24. Deleted .....		8-1. ....	8-1
III. OPERATION .....	3-1	8-3. ....	8-1
3-1. Introduction .....	3-1	8-5. ....	8-1
3-3. Panel Features.....	3-1	8-6. ....	8-1
3-6. Operator's Check.....	3-1	8-8. ....	8-1
3-8. Operating Instructions.....	3-1	8-15. ....	8-2
3-10. External Crystal Detector Leveling .....	3-1	8-19. ....	8-2
3-12. External Power Meter Leveling.....	3-1	8-21. ....	8-2
3-14. External AM .....	3-1	8-22. ....	8-2
3-16. External Fm .....	3-2	8-24. ....	8-2
3-18. Phase lock Operation .....	3-2	8-26. ....	8-2
3-20. Frequency Reference .....	3-2	8-28. ....	8-3
3-22. FM-Norm-PL Switch .....	3-2		
3-24. Operator's Maintenance.....	3-2		
IV. PERFORMANCE TESTS .....	4-1		
4-1. Introduction .....	4-1	IX. Option 001 Internal Leveling .....	9-1
		9-1. Introduction.....	9-1

**OPTIONS**

**CONTENTS (Cont'd)**

Section	Page	Section	Page
9-3.	Description.....	9-1	
9-5.	Manual Changes.....	9-1	
X.	Option 004 Rear Panel Output.....	10-1	
	.....		
10-1.	Introduction.....	10-1	
10-3.	Description.....	10-1	
10-5.	Option 004 Manual Changes.....	10-1	
XI.	Option 001/004 Internal Leveling and Rear Panel Output.....	11-1	
11-1.	Introduction.....	11-1	
11-3.	Description.....	11-1	
		11-5.	Manual Changes ..... 11-1
		XII.	Option 005 APC-7 RF Output Connector.....
			12-1/12-2
		12-1.	Introduction.....
			12-1/12-2
		12-3.	Description.....
			12-1/12-2
		12-5.	Manual Changes.....
			12-1/12-2
		XIII.	Option 006 High Power Output.....
			13-1/13-2
		13-1.	Introduction.....
			13-1/13-2
		13-3.	Description.....
			13-1/13-2
		13-5.	Manual Changes.....
			13-1/13-2

**APPENDIXES**

		Page
APPENDIX	A.	REFERENCES..... A-1
APPENDIX	B.	COMPONENTS OF END ITEM LIST (Not Applicable).....
APPENDIX	C.	ADDITIONAL AUTHORIZATION LIST (Not Applicable).....
APPENDIX	D.	MAINTENANCE ALLOCATION.....
Section	I	Introduction..... D-1
	II	Maintenance Allocation Chart for RF Plug-in HP Model 86260A..... D-3
	III	Tools and Test Equipment Requirements for RF Plug-in HP Model 86260A..... D-4
	IV	Remarks (Not Applicable).....
APPENDIX	E.	EXPENDABLE SUPPLIES AND MATERIALS (Not Applicable).....

ILLUSTRATIONS

Figure	Page	Figure	Page
1-1.	Model 86260A RF Plug-in and Accessories Supplied .....	1-0	
1-2.	Serial Number Plate .....	1-2	
1-3.	YIG Oscillator Warranty.....	1-4	
1-4.	Service Accessories for the 86260A .....	1-10	
3-1.	Front Panel Controls, Connectors and Indicator .....	3-3	
3-2.	Rear Panel Connectors and Controls.....	3-4	
3-3.	Operator's Check .....	3-5	
3-4.	Unleveled RF Power Output.....	3-7	
3-5.	Leveled RF Power Output .....	3-7	
3-6.	Oscillations with ALC Gain Too High .....	3-7	
3-7.	External Crystal Detector Leveling .....	3-8	
3-8.	Power Meter Leveling Operation.....	3-10	
4-1.	Frequency Range and Accuracy Test Setup .....	4-2	
4-2.	Frequency Stability Test Setup.....	4-3	
4-3.	Residual FM Test Setup.....	4-5	
4-4.	Residual FM Displayed on Spectrum Analyzer .....	4-6	
4-5.	Crystal Detector Leveling Test Setup .....	4-7	
4-6.	Power Meter Leveling Test Setup .....	4-9	
4-7.	Spurious Signal Test Setup.....	4-11	
4-8.	Residual AM Test Setup.....	4-13	
4-9.	Equivalent Source Match Test Setup .....	4-14	
4-10.	Typical Pattern of a Swept SWR Measurement .....	4-16	
4-11.	Graph to Convert Oscilloscope Trace to Source Match SWR .....	4-17	
4-12.	External Frequency Modulation Test Setup .....	4-18	
4-13.	Spectrum Analyzer Display of Frequency Deviation.....	4-19	
4-14.	Amplitude Modulation Test Setup .....	4-20	
5-1.	Oscillator Bias Adjustment Setup .....	5-2	
5-2.	Frequency Adjustment Setup.....	5-6	
5-3.	Leveling Amplifier Offset Adjustment Setup.....	5-7	
6-1.	RF Output Connector J2 Exploded View.....	6-9	
6-2.	Cabinet Parts .....	6-10	
7-1.	Partial Schematic of A2 ALC Assembly (CHANGE B).....	7-2	
8-1.	YIG Sphere in Non-Magnetic Field .....	8-1	
8-2.	YIG Sphere in Magnetic Field .....	8-1	
8-3.	Net Magnetization Vector.....	8-1	
8-4.	Magnetization Vector with RF Field Applied.....	8-1	
8-5.	Increased DC Magnetic Field.....	8-2	
8-6.	Coupling RF and DC Magnetic .....	8-2	
8-7.	UNLEVELED Lamp Removal and Replacement Procedure .....	8-4	
8-8.	General Information on Schematic Diagrams .....	8-5	
8-9.	Schematic Diagram Notes .....	8-6	
8-10.	Schematic Measurement Conditions ...	8-8	
8-11.	Troubleshooting Test Setup.....	8-9	
8-12.	Troubleshooting Block Diagram.....	8-11	
8-13.	A1 YIG Driver Assembly, Component Locations .....	8-13	
8-14.	A1 YIG Driver Assembly, Schematic .....	8-13	
8-15.	A1 ALC Assembly, Components Location .....	8-15	
8-16.	A2 ALC Assembly, Schematic .....	8-15	
8-17.	A3 FM Assembly, Components Location .....	8-17/8-18	
8-18.	A3 FM Assembly, Schematic .....	8-17/8-18	
8-19.	Adjustments and Test Points Location.....	8-19/8-20	

**ILLUSTRATIONS**

Figure	Page	Figure	Page		
8-20.	Major Assemblies Location, ..... Top View.....	8-19/8-20	10-1.	Front Panel Controls, Connector and Indicator (Option 004).....	10-2
8-21.	Major Assemblies Location, ..... Bottom View .....	8-19/8-20	10-2.	Rear Panel Connectors and Controls (Option 004).....	10-3
9-1.	Front panel Controls, Connectors ..... and Indicator (Option 001).....	9-2	10-3	AI YIG Driver Assembly, Schematic (Option 004) .....	10-4
9-2.	Internal Leveling Test Setup.....	9-3	10-4.	Location of Major Assemblies, Left Side View (Option 004) .....	10-4
9-3.	Internal Leveling Slope and..... Gain Adjustments Test Setup.....	9-5	11-1.	Front Panel Controls, Connector and Indicator (Option 001/004).....	11-2
9-4.	Partial Block Diagram (Option 001).....	9-9	11-2.	Partial Block Diagram (Option 001/004) .....	11-4
9-5.	AI YIG Driver Assembly,..... Schematic (Option 001).....	9-10	11-3.	AI YIG Driver Assembly, Schematic (Option 001/004) .....	11-4
9-6.	A2 ALC Assembly,..... Components Location .....	9-11	11-4.	A2 ALC Assembly, Schematic (Option 001/004) .....	11-5
9-7.	A2 ALC Assembly,..... Schematic (Option 001).....	9-11	11-5.	Location of Major Assemblies, Left Side View (Option 001/00) .....	11-5
9-8.	Location of Adjustments and..... Test Points(Option 001) .....	9-12	11-6.	Location of MAJOR Assemblies, Top View (Option 001/004) .....	11-6
9-9.	Location of Major Assemblies, ..... Left Side View (Option 001).....	9-12	11-7.	Location of Major Assemblies, Bottom View (Option 001/004) .....	11-6
9-10.	Location of Major Assemblies, Top View (Option 001).....	9-13/9-14	12-1.	APC-7 RF Output Connector, Exploded View (Option 005) .....	12-1/12-2
9-11	Location of major Assemblies, Bottom View (Option 001) .....	9-13/9-14			

**TABLES**

Table	Page	Table	Page
1-1.	Specifications for 86260A Installed in 8620A1-5....	5-3	5-7
1-2.	Supplemental Performance Characteristics..... for 86260A Installed in 8620A .....	6-1	6-2
1-3.	Recommended Test Equipment.....	1-8	6-4
2-1.	Model 86260A Mating Connectors .....	2-1	6-13
4-1.	Performance Test Record .....	4-23/4-24	7-1
5-1.	List of Adjustments .....	5-1	8-11
5-2.	Selection of AICR5 Breakdown Diode.....	5-3	9-7
			5-7
			6-2
			6-4
			6-13
			7-1
			8-11
			9-7

\* Part Number - National Stock  
Number Cross Reference Index.



## SECTION 0 INTRODUCTION

---

### 0-1. Scope

This manual describes the Hewlett-Packard Model 86260A RF Plug-in, which is identified throughout this manual as the Model 86260A RF Plug-in. This manual includes technical data, installation, operation and maintenance instructions. Section VI includes Table 6-3, a cross-reference between the Hewlett-Packard part numbers and the equivalent NATO/National Stock Number (NSN). Appendix A contains a list of technical manuals and other publications that pertain to the Model 86260A and to equipments that support it. Appendix D contains the Maintenance Allocation Chart (MAC) which defines the levels and scope of maintenance functions for the equipment in the Army system.

### 0-2. Indexes of Publications

*a. DA Pam 310-4.* Refer to the latest issue of DA Pam 310-4 to determine if there are any new editions, changes, or additional publications pertaining to the equipment.

*b. DA Pam 310-7.* Refer to DA Pam 310-7 to determine if there are any modification work orders (MWO's) pertaining to the equipment.

### 0-3. Maintenance Forms, Records, and Reports

*a. Reports of Maintenance and Unsatisfactory Equipment.* Department of the Army forms and procedures used for equipment maintenance will be those prescribed by TM 38-750, The Army Maintenance Management System.

*b. Report of Item and Packaging Discrepancies.* Fill out and forward SF Form 364 (Report of Discrepancy (ROD)) as prescribed in AR 735-11-2/DLAR 4140.55/-NAVMATINST 4355.73/AFR 400-54/MCO 4430.3E.

*c. Discrepancy in Shipment Report (DISREP) (SF 361).* Fill out and forward Discrepancy in Shipment Report (DISREP) (SF 361) as prescribed in AR 55-38/-

NAVSUPINST 4610.33B/AFR 75-18/MCO P4610.19C and DLAR 4500.15.

### 0-4. Reporting Equipment Improvement Recommendations (EIR)

If your Model 86260A needs improvement, let us know. Send us an EIR. You, the user, are the only one who can tell us what you don't like about your equipment. Let us know why you don't like the design. Tell us why a procedure is hard to perform. Put it on an SF 368 (Quality Deficiency Report). Mail it to Commander, US Army Communications and Electronics Materiel Readiness Command, ATTN: DRSEL-ME-MQ, Fort Monmouth, NJ 07703. We'll send you a reply.

### 0-5. Administrative Storage

The Model 86260A can be stored in stockrooms, warehouses, or other protected facilities. The equipment should be protected from excessive humidity, sand, dust and chemical contaminants. Before putting the Model 86260A into administrative storage, make the following preparations:

*a.* Complete the performance tests, adjustments, and services indicated in Sections IV, V, and VII, and assure that the unit is completely operable.

*b.* If the original packing material is not available, at least protect the unit with protective plastic or paper wrapping. Place the unit in a carton or box with makeshift protective packing material around it.

*c.* Store the equipment indoors, protected from elements. Maintain the equipment at moderate temperatures and humidity. (See para 2-19).

### 0-6. Destruction of Army Electronics Materiel

Destruction of Army electronics materiel to prevent enemy use shall be in accordance with TM 750-244-2.



HP 86260A RF Plug-in

Scale for 8620A  
86260-00008



Scale for 8620B  
86260-00009



NOTE: See ACCESSORIES SUPPLIED in Section 1 for part number information.

Figure 1-1. Model 86260A RF Plug-in and Accessories Supplied

## SECTION I GENERAL INFORMATION

### 1-1. INTRODUCTION

1-2. This operating and Service manual contains information required to install, operate, test, adjust, and service the Hewlett-Packard Model 86260A RF Plug-in. Figure 1-1 shows the instrument and accessories supplied. This section covers instrument identification, description, options, accessories, specifications, and other basic information.

1-3. This manual is divided into 13 sections which provide information as follows:

a. SECTION I, GENERAL INFORMATION, contains the instrument description and specifications as well as the accessory and recommended test equipment list.

b. SECTION II, INSTALLATION, contains information relative to receiving inspection, preparation for use, mounting, packing, and shipping.

c. SECTION III, OPERATION, contains operating instructions for the instrument.

d. SECTION IV, PERFORMANCE TESTS, contains information required to verify that instrument performance is in accordance with published specifications.

e. SECTION V, ADJUSTMENTS, contains information required to properly adjust and align the instrument after repair.

f. SECTION VI, REPLACEABLE PARTS, contains information required to order all parts and assemblies or effect exchange of assemblies.

g. SECTION VII, MANUAL CHANGES, normally contains backdating information to make this manual compatible with earlier equipment configurations.

h. SECTION VIII, SERVICE, contains descriptions of the circuits, schematic diagrams, parts location diagrams, and troubleshooting procedures to aid the user in maintaining the instrument.

i. SECTIONS IX through XIII, OPTIONS.

### 1-6. SPECIFICATIONS

1-7. Instrument specifications are listed in Table 1-1. These specifications are the performance standards or limits against which the instrument is tested. Table 1-2 lists supplemental characteristics. Supplemental characteristics are not specifications but are typical characteristics included as additional information for the user.

### 1-8. SAFETY CONSIDERATIONS

#### 1-9. General

1-10. This is an International Electrotechnical Commission Safety Class I instrument. This instrument has been designed and tested according to IEC Publication 348, "Safety Requirements for Electronic Measuring Apparatus," and has been supplied in safe condition.

#### 1-11. Service

1-12. Although the instrument has been designed in accordance with international safety standards, the information, cautions, and warnings in this manual must be followed to ensure safe operation and to keep the instrument safe. Service and adjustments should be performed only by qualified service personnel.

1-13. Adjustment or repair of the opened instrument with the ac power connected should be avoided as much as possible and, when inevitable, should be

## General Information

performed only by a skilled person who knows the hazard involved.

1-14. Capacitors inside the instrument may still be charged even though the instrument has been disconnected from its source of supply.

1-15. Whenever it is likely that the protection has been impaired, make the instrument inoperative and secure against it any unintended operation.

### WARNING

Any interruption of the protective (grounding) conductor, inside or outside the instrument, or disconnection of the protective earth terminal is likely to make this instrument dangerous. Intentional interruption of the earth ground is prohibited.

Servicing this instrument often requires that you work with the instrument's protective covers removed and with ac power connected. Be very careful; the energy at many points in the instrument may, if contacted, cause personal injury.

### CAUTION

BEFORE SWITCHING THIS INSTRUMENT ON, ensure that all devices connected to the instrument are connected to the protective earth ground.

## 1-16. INSTRUMENTS COVERED BY MANUAL

1-17. Attached to the instrument is a serial number plate (Figure 1-2). The serial number is in two parts. The first four digits and the letter are the serial number prefix; the last five digits are the suffix. The prefix is the same for all identical instruments; it changes only when a change is made to the instrument. The suffix, however, is assigned sequentially and is different for each instrument. The contents of this manual apply to instruments with the serial number prefix(ea) listed under SERIAL NUMBERS on the title page.

1-18. An instrument manufactured after the printing of this manual may have a serial number prefix that is not listed on the title page. This unlisted serial prefix indicates the instrument is different from those described in this manual. The manual for this newer instrument is accompanied by a Manual Changes supplement. This supplement contains "change information" that explains how to adapt the manual to the newer instrument.

Figure 1-2. Serial Number Plate

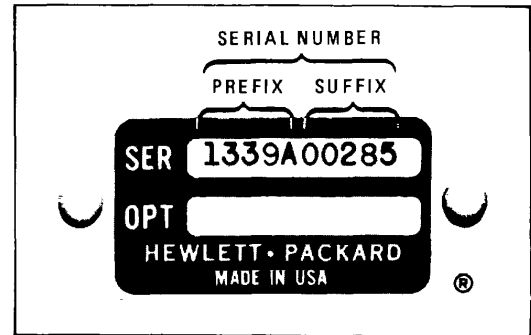

1-19. In addition to change information, the supplement may contain information for correcting errors in the manual.

## 1-21. DESCRIPTION

1-22. The HP Model 86260A RF Plug-in is designed as a plug-in for the Model 8620A or 8620B Sweep Oscillator mainframe. The instrument consists of a fundamental oscillator in the 12.4 to 18.0 GHz range and associated drive circuitry for tuning. The instrument may be remotely programmed through an 8620A rear panel connector.

1-23. The RF output of the instrument is controlled by the front panel POWER LEVEL control. Power can be leveled externally across the band using a conventional power sampling and feedback technique. The automatic level control (ALC) switch selects the mode of leveling either external (EXT), power meter (MTR), or (OFF). The front panel ALC EXT. INPUT and ALC GAIN are provided to use with an external leveling loop. When the UNLEVELED light is on it indicates that the RF power is not level across the band. BNC connectors on the rear panel allow for external FM signal inputs and a frequency reference voltage output.

Model 86260A

General Information

**1-24. OPTIONS**

1-25. Options for the Model 86260A RF Plug-in are as follows:

Option 001 - Internal Leveling

Option 004 - Rear Panel RF Output

Option 005 - APC-7 RF Output Connector

Option 006 - High Power Output

These options may be combined in any configuration.

**1-26. OPTION 001**

1-27. The 86260A Option 001 adds internal leveling capability to the standard 86260A. This is accomplished by adding a directional coupler and a crystal detector to sample the RF output. An Internal position is added to the front panel ALC switch. See SECTION IX for more information.

**1-28. OPTION 004**

1-29. The 86260A Option 004 provides rear panel RF output through a Type-N connector. See SECT I ON X for more information.

**1-30. OPTION 001/004**

1-31. The 86260A Option 001/004 provides internal leveling and rear panel RF output. See SECT. XI for more information.

**1-32. OPTION 005**

1-33. The 86260A Option 005 provides an APC-7 RF output connector in place of the standard Type-N connector. See SECTS XII for more information.

**1-34. OPTION 006**

1-35. The 86260A Option 006 provides a higher power output (+ 10 dBm) as compared to the standard

instrument (+7 dBm). This is accomplished by the use of a higher power YIG oscillator. SECT. XIII for more information.

**1-36. ACCESSORIES SUPPLIED**

1-37. Two 12.4 to 18.0 GHz scales are supplied for use with the HP 8620A or HP 8620B mainframe. The dial scale used with the HP 8620A mainframe has HP Part Number 86260-00008 and the one used with the HP 8620B mainframe has HP Part Number 86260- 00009. (See Figure 1-1).

**1-38. EQUIPMENT REQUIRED BUT NOT SUPPLIED**

1-39. To operate the instrument it must be plugged into a Model HP 8620A or HP 8620B Sweep Oscillator mainframe.

**1-40. EQUIPMENT AVAILABLE**

1-41. Service accessories containing a plug-in extender cable, service board, adjustment tool, and RF service cables may be obtained from Hewlett-Packard by ordering Service Accessories Part No. 08620- 60030. This is available for convenience in aligning and troubleshooting the mainframe and the RF plug-in. Service aids specifically for the plug-in are shown in Figure 1-4

**1-42. DELETED****1-44. RECOMMENDED TEST EQUIPMENT**

1-45. Equipment recommended to maintain the Model 86260A is listed in Table 1-3. Other equipment may be substituted if it meets or exceeds the critical specifications listed in the table.

See Section III of Appendix D, Maintenance Allocation Chart.

Table 1-1. Specifications for 86260A Installed in 8620A

**SPECIFICATIONS**

**FREQUENCY**

**Frequency Range:**

Calibrated: 12.4 to 18.0 GHz

**Frequency Accuracy:2**

(At 25 ° C; FM switch in PL or FM position)  
 CW Mode: 3 ±50 MHz  
 All Sweep Modes (Sweep Time >0.1 sec): +70 MHz

**Frequency Stability:**

Temperature: ±3.6 to 5.4 MHz/ ° C (300 ppm/ ° C)  
 10c Line Voltage Change: ±180 kHz  
 10 dB Power Level Change from specified maximum power: ±6 MHz

**Residual FM in 10 kHz Bandwidth:2**

(FM-NORM-PL switch in NORM position)  
 CW Mode: <25 kHz peak

**POWER OUTPUT1**

**Power Level:2**

(For calibrated frequency range, at 25 ° C)  
 Maximum Leveled Power: > +7 dBm (5 mW)

**Power Variation:**

Unleveled: < ±4.0 dB  
 Crystal Detector Leveled (External):4 < ±0.1 dB  
 Power Meter Leveled (External):5 < ±0.1 dB

**Spurious Signals:**

(Below fundamental at +7 dBm power output)  
 Harmonics: > 25 dB  
 Nonharmonics: >50 dB

**Residual AM:**

(AM noise in 100 kHz bandwidth below fundamental at maximum power output)  
 Residual AM: >50 dB

**Source SWR:**

Unleveled: < 2.0  
 Output Impedance of 86260A RF OUTPUT connector: 50 ohms nominal.

**MODULATION'**

**External FM:**

(FM-NORM-PL switch in FM position)  
 Sensitivity: = -20 MHz/V6  
 (FM-NORM-PL switch in PL position)  
 Sensitivity: = -6 MHz/V  
 Maximum Deviation for Modulation Frequencies:  
 DC to 200 Hz: ±75 MHz  
 200 Hz to 200 kHz: ±5 MHz

**Internal AM:**

(Below maximum leveled power)  
 1 kHz squarewave ON/OFF Ratio: > 25 dB

**External AM:2**

(At 3 dB below maximum power output)  
 Sensitivity to - 10V input: > 25 dB

- 1 All specifications are at 0 to 55 degrees C except where noted and at RF output jack. Allow 30 minutes warmup time.
- 2 See also the Supplemental Characteristics, Table 1-2.
- 3 Approach desired frequency from low-frequency end of band.
- 4 Excluding coupler and detector variation.
- 5 Use HP Model 431B, 431C, and 432A power meters Sweep durations > 10 seconds.
- 6 A positive input voltage decreases frequency.
- 7 It may be necessary to calibrate the 862650 in the °620 mainframe in which it will be used. Refer to the adjustment section, paragraph 5-14.

Table 1-2. Supplemental Performance Characteristics for 86260A Installed in 8620A (1 of 2)

**SUPPLEMENTAL PERFORMANCE CHARACTERISTICS**

**FREQUENCY**

**Frequency Range:**

Usable: 12.0 to 18.0 GHz

**Frequency Accuracy:**

(FM-NORM-PL switch in FM or NORM position)

**START-STOP END POINTS:**

Sweep Time 0.01 to 0.1 sec: <  $\pm 168$  MHz  
or <  $\pm 56$  MHz  $\pm 2\%$  of sweep width

**Marker:**

Sweep Time > 0.1 sec: <  $\pm 112$  MHz  
Sweep Time 0.01 to 0.1 sec: <  $\pm 168$  MHz  
or <  $\pm 56$  MHz  $\pm 2\%$  of sweep width

**AF CENTER FREQUENCY:**

MANUAL Sweep: < CW Frequency  $\pm 1$  MHz  
 $\pm 2\%$  of sweep width  
AUTO Sweep (Sweep Time 0.01 to 0.1 sec):  
< CW Frequency  $\pm 1$  MHz  $+4\%$  of sweep  
width

**A F Sweep Width:**

MANUAL Sweep: <  $+ 1$  MHz  $\pm 3\% - 10\%$  of  
sweep width.  
AUTO Sweep (Sweep time > 0.1 sec):  
<  $\pm 1$  MHz  $+ 1\% - 12\%$  of sweep width  
AUTO Sweep (Sweep time 0.01 to 0.1 sec):  
<  $\pm 1$  MHz  $+3\% - 17\%$  of sweep width

**CW VERNIER:**

CW Vernier Frequency: <  $\pm 2$  MHz  $+3\%$   
 $-10\%$  of scale setting

**CW REMOTE PROGRAMMING:**

CW Frequency: <  $\pm 25$  MHz

**Frequency Linearity:**

(Correlation between frequency and SWEEP  
OUT voltage)

Sweep Time 0.1 sec: >  $\pm 112$  MHz  
Sweep Time 0.01 to 0.1 sec: >  $\pm 168$  MHz or  
<  $\pm 56$  MHz  $\pm 2\%$  of sweep width

**Residual FM in 10 kHz BANDWIDTH:**

(FM-NORM-PL switch in FM position)  
MANUAL sweep mode: < 100 kHz

**Residual FM in 10 kHz Bandwidth:**

(FM-NORM-PL switch in NORM position)

All MANUAL or AUTO sweep modes: < 100  
kHz peak

**POWER OUTPUT**

**Power Level:**

Stability with temperature change: < -0.1  
dB/ C  
Dynamic range of 86260A POWER LEVEL con-  
trol (while maintaining 60-40 symmetry of  
internal 1 kHz square wave)

Leveled: > 20 dB  
Unleveled: > 30 dB

**Source SWR:**

**Unleveled:** < 2.0  
Output Impedance of 86260A RF OUTPUT con-  
nector: 50 ohms nominal

The values in this table are not specifications but are typical performance characteristics for information to the user.

Some YIG start-up problems may occur below 12.4 GHz.

Table 1-2. Supplemental Performance Characteristics for 86260A Installed ill 8620A (2 of 2)

**SUPPLEMENTAL PERFORMANCE CHARACTERISTICS1**

**MODULATION**

**GENERAL**

**External FM:**

(FM-NORM-PL switch in FM position)  
Sensitivity: -20 MHz/V  
Rate: DC to 2 MHz at ±2 MHz deviation

**Oscillator Type:** Fundamental

**Net Weight:** 7 lbs., 8 oz. (3,4 kg)

**Dimensions:** With 8620A/B overall:  
5-1/4 inches (133,4 mm) high, 11 1/2 inches  
(297,4 mm) deep, 16-3/4 inches (425,5 mm) wide

**Internal AM:**

(Below maximum leveled power)  
RF Blanking ON/OFF Ratio: > 25 dB

**Options:**

- Option 001: Internal Leveling
- Option 004: Rear Panel RF output
- Option 005. APC-7 RF Output connector
- Option 006: High power output

**External AM:**

Frequency Response: (50% modulation)  
(With RF signal down 6 dB from maximum  
power output)  
Unleveled: DC to 500 kHz  
Leveled: DC to 300 kHz

1 The values in this table are not specifications but are typical performance characteristics for information to the user.



Table 1-3. Recommended Test Equipment (1 of 2)

Instrument	Critical Specifications	Recommended Model	Use*
Sweep Oscillator	Only Substitute: 8620B	HP 8620A	P,A,T
Spectrum Analyzer	Frequency Range 12.4 to 40 GHz	HP 8555A/8552B/ 141T	P
Oscilloscope	Vertical bandwidth: 20 MHz minimum  Vertical Sensitivity: 5 mV/Div.  Horizontal Sweep Rate: 1 uS/ Div. maximum	HP 180A/1801A/ 1820A	P,A,T
Frequency) Counter	Range: 12.4 to 18.0 GHz	HP 5340A	P,A,T
Frequency Meter	Range: 12.4 to 18.0 GHz	HP P532A	T
Test Oscillator	Frequency: 10 Hz to 2 MHz  Output: 3.16V into 600 fl	HP 651B	P
DC Digital Voltmeter	Range: -50V to +50V  Accuracy: 0.05%	HP 3460B	P,A,T
Power Meter and Ther miitor Mount	Frequency: 12.4 to 18.0 GHz  Rage: + 10 dBm to -20 dBm	HP 432A/8478B	P,A,T
RMS Voltmeter	Scale: RMS volts  Accuracy: + 5%  Frequency Range: 10 Hz to 2 MHz	HP 3400A	P
Directional Coupler	Coupling: 20 dB  Frequency Range: 12.4 to 18.0 GHz	HP 779D	P,A,T
Crystal Detector	Frequency: 12.4 to 18.0 GHz  SWR: < 1.7 Connector: Type-N	HP 8470A, Option 012	P,A,T
DC Power Supply	Range: 0 to 10 Vdc  Current: 0. 1 Amp	HP 721A	P
Adjustable AC Line Transformer	Output: 100 to 150 Vac MT3A Power: 150 watts	General Radio	P

Table 1-3. Recommended Test Equipment (2 of 2)

Instrument	Critical Specifications	Recommended Model	Use*
Sweep Oscillator BNC Tee	Only Substitute: 8620B Connectors: BNC jack and plug	HP 8620A HP 1250-0781	P,A,T P
10-dB Attenuator	SWR: 1.3  Attenuation: 10 dB +0.5 dB	HP 8491B Option 010	P,A,T
RF Service Cable**	Impedance: 50 ohms  Connectors: SMA to SMA	HP 8120-1578	T
RF Connector Adapter**	SMA Jack to SMA Jack	HP 1250-1158	T
Extender Board	Connector (2 x 15)	HP 5060-0049	T
Wrench	5/16 in. Box End Open End	HP 08555-20097	T
Extender Cable**	Connectors (2 x 18)	HP 08620-60032	T
20 cm Air Lines (2)	APC-7 Connectors	HP 11567A	P
Adapter	APC-7 to N Male	HP 11525A	P

\* A = Adjustment; P = Performance Test; T = Troubleshooting

\*\* These parts are included in Service Kit 08620-60030

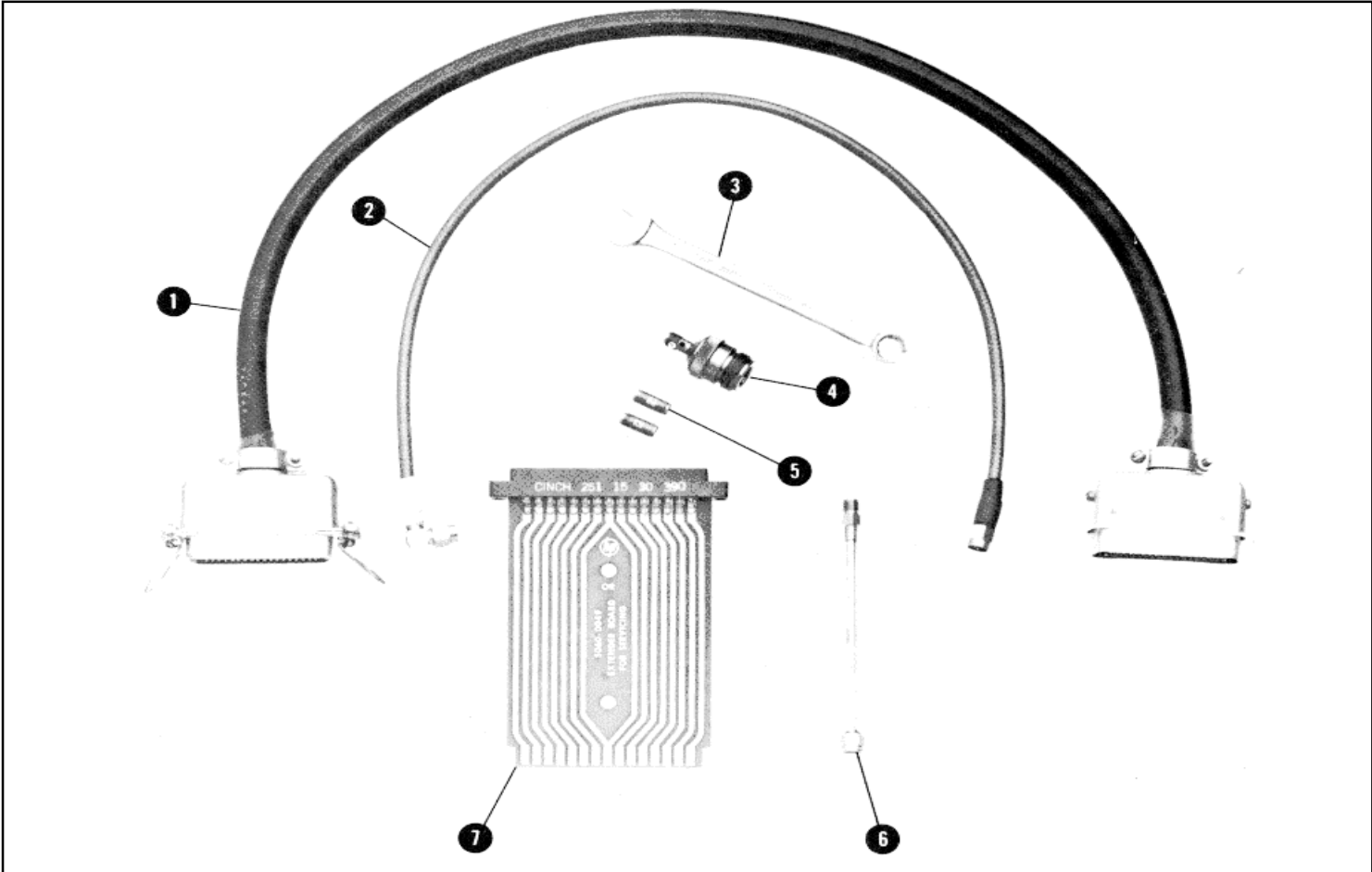

Index Number	Description	HP Part Number
1	Extender Cable*	08620-60032
2	RF service cable*	8120-1578
3	Wrench 5/16" slotted box end open end	08555-20097
4	Adapter type N to SMA	1250-1404
5	RF connector adapter (2) SMA jack to SMA jack*	1250-1158
6	Cable SMA connectors (PIN Modulator bypass)	86260-20009
7	15-contact extender board	5060-0049

\*Included in Service Kit HP Part Number 08620-60030

Figure 1-4. Service Accessories for the 86260A

**SECTION II  
INSTALLATION**

**2-1. INTRODUCTION**

2-2. This section provides installation instructions for the Model 86260A RF Plug-in and its accessories.

**2-3. INITIAL INSPECTION**

2-4. Inspect the shipping container for damage. If the shipping container or cushioning material is damaged it should be kept until the contents of the shipment have been checked for completeness and the instrument has been checked mechanically and electrically. The contents of the shipment should be shown in Figure 1-1, and procedures for checking electrical performance are given in Section IV.

**2-5. PREPARATION FOR USE**

**2-6. Power Source**

2-7. When the Model 86260A RF Plug-in is properly installed, it obtains all necessary power through the rear connector from the HP Model 8620A or 8620B Sweep Oscillator mainframe.

**2-8. Interconnections**

2-9. For the Model 86260A RF Plug-in to operate, it must be plugged into an 8620A or 8620B main- frame. Connection is made by pushing the RF Plug- in into the mainframe so that the plug-in interface connector P1 mates with the mainframe connector J6.

**2-10. Mating Connectors**

2-11. The mating connectors used in the HP Model 86260A RF Plug-in are shown in Table 2-1. This table identifies each connector and gives the HP Part Number and a part number of an alternate source.

*Table 2-1. Model 86260A Mating Connectors*

Connector	Industry Identification	HP Part Number	Alternate Source
RF OUTPUT J2	Type-N	86290-60005	
FM Input J4	BNC	1250-0118	Amphenol RF Div 31-221-1022
ALC EXT INPUT J3	BNC	1250-0118	Amphenol RP Div 31-211-1022
FREQ REF J5	BNC	1250-0118	Amphenol Rf Div 31-221-1022
Interface P2	Micro-Ribbon 36 Contact Rack and Panel Plug	1251-0483	Amphenol Corp. 57-10360-375

Installation

**2-12. Operating Environment**

2-13. The operating environment should be within the following limitations:

- Temperature.....0 to 55" C
- Humidity) .....95';c relative
- Altitude.....< 15,000 feet

**2-14. RF Unit Installation**

2-15. To install RF Plug-in into mainframe:

- a. Set Model 8620A/B mainframe line switch to off.
- b. Position drawer latch handle so rectangular cutout is exposed and slot is toward rear of unit.
- c. Slide unit into place toward of compartment.

**NOTE**

When sliding unit into place, the drawer latch handle slot will engage the locking pin and start to move down.

- d. Press latch handle downward while still pushing in on RF Plug-in, until drawer latch is closed or flush with front panel.

**2-16. Frequency Scale Installation**

**CAUTION**

To prevent damage to frequency pointers when bandswitch drum is rotated, make certain that frequency scale is firmly in place and flush with band drum edges.

**2-17. Swing-down Front Panel.** To frequency scale in a mainframe with a swing-down front panel, proceed as follows:

- a. Select correct scale. (See Figure 1-1.)
- b. Disengage mainframe front-panel latch handle and tilt front panel down.
- c. Depress BAND Lever until desired drum position is accessible from inside mainframe.

**NOTE**

If necessary to remove a frequency scale, exert a pressure OUTWARD, away from drum on right-hand edge of scale.

- d. Insert frequency scale so key (1/2-inch protrusion) fits into notch on left-hand side of drum. Then exert inward pressure on right-hand edge of frequency scale to snap it in place.

- e. Return front panel to upright position, and re-engage front-panel latch handle.

**2-18. Stationary Front Panel.** To install a frequency scale in a mainframe with a stationary front panel, proceed as follows:

- a. Select correct scale. (See Figure 1-1.)
- b. Turn off instrument and remove 8620A/B top cover.

**WARNING**

With the top cover removed, terminals are exposed that have AC voltages capable of causing death. Remove the AC line cord from the 8620A/B before continuing.

- c. Depress BAND lever until desired drum position is accessible from inside mainframe.

**NOTE**

If necessary to remove a frequency scale, exert a pressure OUTWARD, away from drum on right-hand edge of scale.

- d. Insert frequency scale so key (1/2-inch protrusion) fits into notch on left-hand side of drum. Then exert inward pressure on right-hand edge of frequency scale to snap it in place.

**2-19. STORAGE AND SHIPMENT**

**2-20. Environment**

2-21. The instrument may be stored or shipped in environments A within the following limits:

- Temperature.....-40 C to t75' C
- Humidity ..... Up to 95,%'
- Altitude ..... Up to 25,000 feet

The instrument should also be protected from temperature extremes which cause condensation within the instrument.

**SECTION III  
OPERATION****3-1. INTRODUCTION**

3-2. This section explains the function of controls and indicators and typical operating modes of the Model 86260A RF Plug-in.

**3-3. PANEL FEATURES**

3-4. Front and rear panel features are described in Figures 3-1 and 3-2. Description numbers match the numbers on the illustration.

3-5. The following information covers the basic purpose and function of the panel features.

a. When the UNLEVELED indicator is on, it indicates that the RF power is not level across the band. The light is also on when not in an RF leveling mode.

b. The POWER LEVEL control sets RF output level.

c. A BNC connector labeled EXT INPUT is used in the external leveling mode. It provides connection to the external leveling crystal detector or power meter Recorder Output.

d. The GAIN control is used when leveling externally to adjust ALC gain.

e. The ALC switch is used to select the mode of leveling; external leveling, power meter leveling or off when leveling of the RF is not required.

f. The RF output is a 50-ohm connector.

g. The rear panel FM connector allows for the input of modulation signals to frequency modulate the oscillator.

h. The FREQ REF connector provides a dc output voltage which is an analog of the frequency.

**3-6. OPERATOR'S CHECK**

3-7. Figure 3-3 is an operator's check procedure and is supplied to allow the operator to make a quick check of the main instrument functions prior to use. The operator's check assumes that the RF Plug-in is installed in an 8620A Sweep Oscillator mainframe. The test covers the RF Plug-in and mainframe,

therefore, if the correct indications are not obtained, trouble may be in either unit. If the RF Plug-in is suspected, use the performance test in Section IV to determine if the instrument is working correctly. Otherwise, follow the troubleshooting chart in Section VIII to isolate the problem.

**3-8. OPERATING INSTRUCTIONS**

3-9. Figures 3-3 through 3-8 give the general operating procedures for the RF Plug-in.

**3-10. External Crystal Detector Leveling**

3-11. External leveling using a directional coupler and crystal detector allows for leveled RF power near the point of measurement. This leveling system uses the coupler to sample the RF output signal and a crystal detector to produce a dc voltage proportional to RF signal level (Detector output between 25 mV and 250 mV). The detector dc output voltage is applied to amplifiers in the 86260A Leveling loop and a PIN modulator to control the RF output power level. A polarity switch on the A2 ALC Board Assembly selects either positive (+) or negative (-) inputs to match output polarity of the crystal detector. To operate in the external crystal detector leveling mode, use the test setup and procedures in Figure 3-7.

**3-12. External Power Meter Leveling**

3-13. Power leveling can be accomplished with a power meter connected to a directional coupler. The coupler samples the RF energy and applies it to the power meter. A dc voltage from a rear panel jack on the power meter is applied to the EXT INPUT connector on the 86260A front panel. The circuitry senses the changing dc level and causes the RF output to change, thus keeping the RF output at a constant level. A power-meter switch on the A2 ALC Board selects either 431 or 432.

**3-14. External AM**

3-15. At approximately 6 dB below maximum power out, the RF output (CW) signal can be amplitude modulated from 0 to 100% using an external modulating signal applied to the 8620A EXT

## Operation

AM connector. External amplitude modulation is possible in all operating modes. A negative 10 volts reduces the RF output power by at least 30 dB.

### 3-16. External FM

3-17. The RF output signal can be frequency modulated using an external modulating signal applied to the FM connector. The external FM function provides a means of obtaining an output frequency that varies under the control of an external modulation signal. A positive going voltage causes output frequency to decrease while a negative going voltage causes output frequency to increase.

### 3-18. Phase Lock Operation

3-19. The RF output (CW) signal may be phased- locked using an external phase-lock signal applied to the FM connector. The phase-lock function provides a means of obtaining a very stable CE frequency by transferring the frequency stability of the reference oscillator to the source. If the CW frequency starts to drift, the phase difference between the CW frequency and the reference frequency (reference oscillator) is detected, and a dc voltage is a correction signal which restores the CW frequency to its previous point. Stability of this CW frequency is determined by the stability of the reference oscillator.

### 3-20. Frequency Reference

3-21. A dc voltage which is an analog of frequency is available for referencing or phase-locking external equipment to the plug-in. The dc voltage is 12.0 to 18.0 V (1V/GHz) corresponding to the frequency range.

### 3-22. FM-NORM-PL Switch

3-23. The FM-NORM-PL Switch is located on the rear panel of the instrument. The switch is used in NORM Position for normal operation, in PL position for phase-locking, and in FM position for high modulation frequencies.

### 3-24. OPERATOR'S MAINTENANCE

3-25. There is no operator maintenance required on the 86260A RF Plug-in. If there is a loss of power to the Plug-in, it may be necessary to replace a defective fuse in the 8620A or 8620B mainframe. See mainframe Operating and Service Manual for fuse replacement.

3-26. Replacement of the UNLEVELED lamp is shown in section VIII as a maintenance procedure. (See Figure 8-7.)

## FRONT PANEL FEATURES

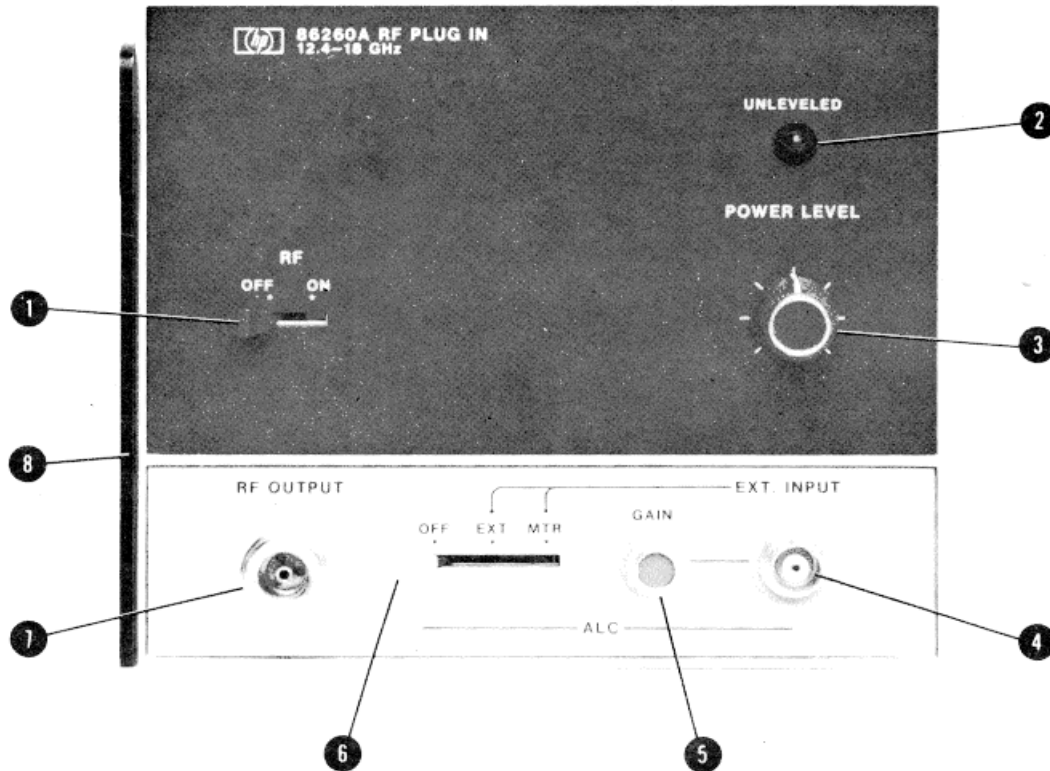

- 1 **RF ON-OFF switch S1.** Turn, RF power on and off. Resets oscillator bias voltage when turned to off then on.
- 2 **UNLEVELED light DS1.** Lights when not in automatic leveling mode or when in a leveling mode and RF output is not level across the band.
- 3 **POWER LEVEL control R1.** Adjusts RF power output.
- 4 **EXT INPUT connector J3.** Input for external leveling from crystal detector or power meter.
- 5 **GAIN control R2.** Adjusts output of ALC amplifier when using external leveling.
- 6 **ALC switch S2.** Selects MTR (power meter) or EXT (external) power leveling modes. In OFF position RF is not leveled.
- 7 **RF OUTPUT Connector J2.** Type-N 50 Ohm RF connector.
- 8 **Drawer Latching Handle.** Aids in installing and removing RF Plug-in. After installing, handle locks to hold RF Plug-in in place.

Figure 3-1. Front Panel Controls, Connectors and Indicator



REAR PANEL FEATURES

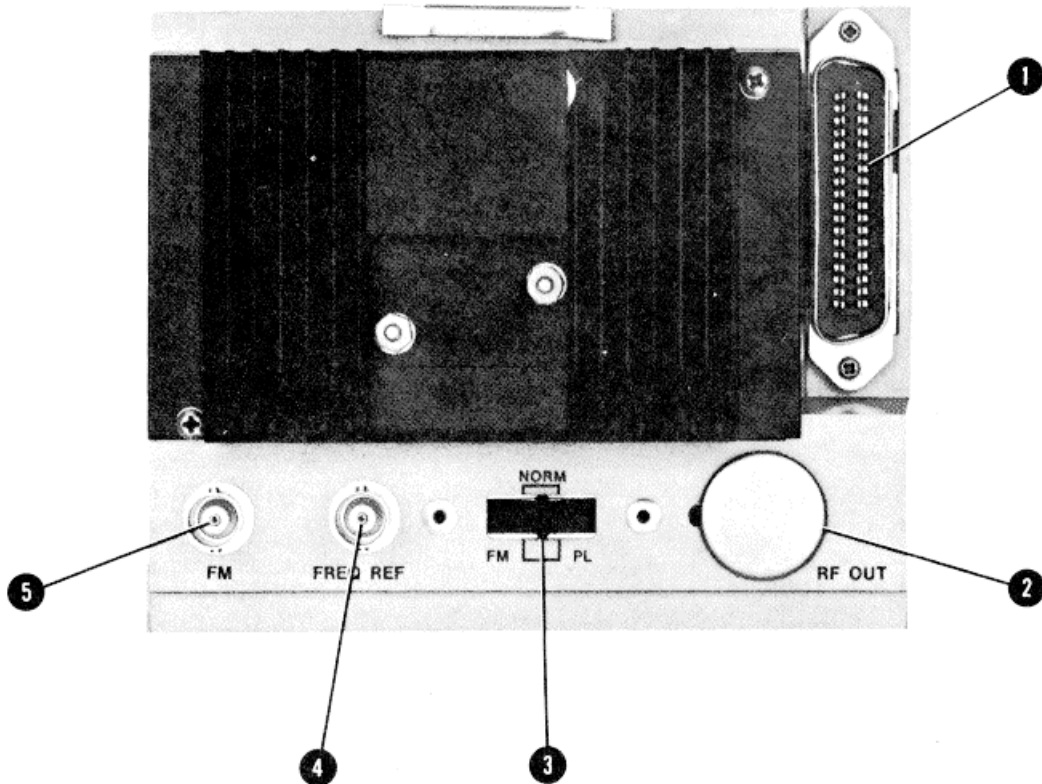

- 1 **Interface Connector P2.** Provides interconnection between 8620A/B mainframe and 86260A RF Plug-in.
- 2 **RF OUTPUT Connector J2.** Option 004 only Type-N 50 ohm RF connector.
- 3 **FM-NORM-PL switch S3.** Operates in conjunction with FM input connector. It switches components in oscillator drive circuits for optimum perfor-

- mance in normal sweep (NORM), frequency modulation (FM), or phase lock (PL) modes of operation.
- 4 **FREQ REF** connector J5. Provides 12.0 to 18.0 volt ramp signal from the Plug-in. The signal is used as a dc analog of frequency.
- 5 **FM Connector J4.** Input connector for frequency modulation signal or phase-locking error signal.

Figure 3-2. Rear Panel Connectors and Controls

Model 86260A

Operation

OPERATOR'S CHECK

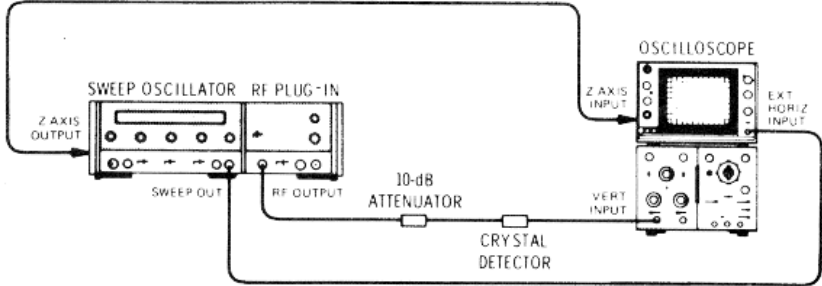
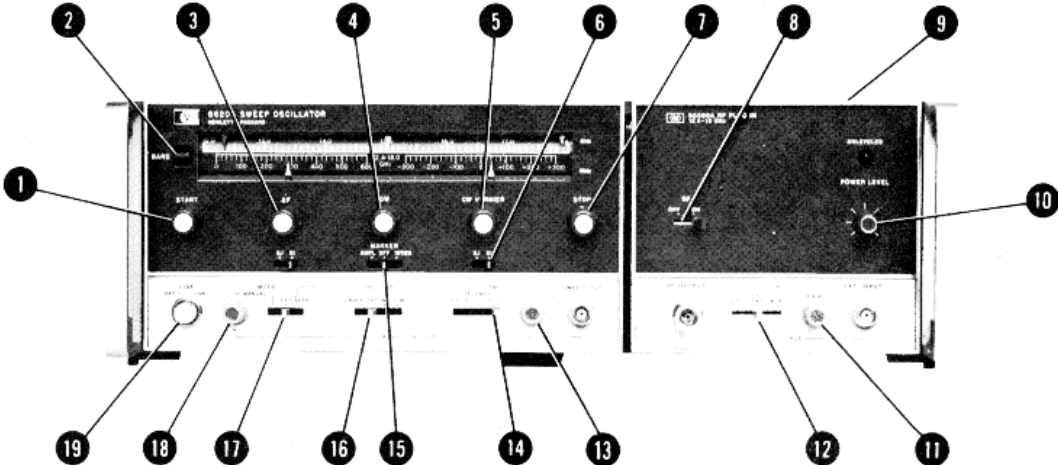

EQUIPMENT:

- Sweep Oscillator ..... HP 8620A
- RF Plug-in ..... HP 86260A
- Oscilloscope ..... HP 180A/1801A/1820A
- Crystal Detector ..... HP 8470A, Option 012
- 10-dB Attenuator..... HP 8491B, Option 010

Figure 3-3. Operator's Check (1 of 2)  
3-5

**OPERATOR'S CHECK**

PROCEDURE:

1. Set controls as follows:

8620A

BAND 2 ..... 12.4 to 18.0 GHz  
 START (green) 1 ..... Left-hand end frequency  
 STOP (red) 7 ..... Right-hand end frequency  
 CW (white) 4 ..... Center of scale  
 MARKER 15 ..... OFF  
 MODE 17 ..... AUTO  
 TRIGGER 16 ..... INT  
 MANUAL SWEEP control 18 ..... Fully counterclockwise  
 TIME-SECONDS 14 ..... 0.01  
 FO 3 ..... Fully counterclockwise  
 TIME SECONDS Vernier 13 ..... Fully clockwise  
 CW VERNIER 5 ..... Centered  
 1 KHZ SQ WV/OFF (Rear Panel) ..... OFF  
 RF BLANKING/OFF (Rear Panel) ..... RF BLANKING

86260A

RF 8 ..... ON  
 POWER LEVEL 10 ..... Fully clockwise  
 ALC 12 ..... OFF  
 ALC GAIN 11 ..... Fully clockwise  
 UNLEVELED Lamp ..... ON (when ALC switch is OFF)  
 FM-NORM-PL (Rear Panel) ..... NORM (Normal)

2. Press LINE pushbutton switch 19 to turn on instrument; LINE, START, and STOP pushbuttons should light.
3. Check that RF Plug-in is sweeping correctly. This is indicated by a continuous signal line on oscilloscope similar to Figure 3-4
4. Set 8620A MARKER switch 15 to INTEN position and marker should appear on oscilloscope trace as intensity spot. Set MARKER switch 15 to AMPL position and marker should appear on oscilloscope trace as a pip.

Figure 3-3. Operator's Check (2 of 2)

**OPERATOR'S CHECK**

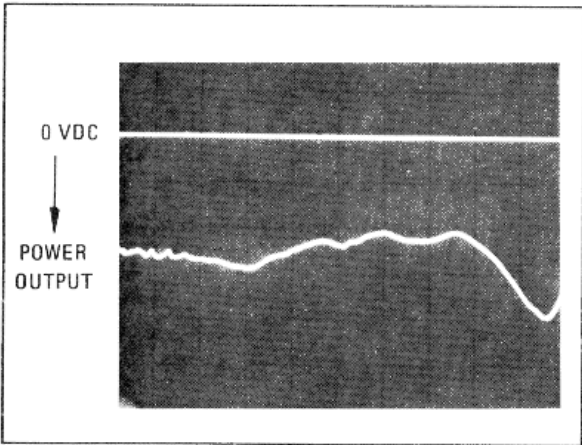

Figure 3-4. Unlevelled RF Power Output

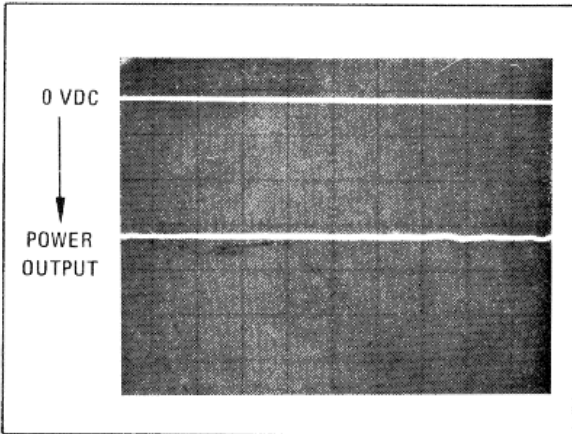

Figure 3-5. Levelled RF Power Output

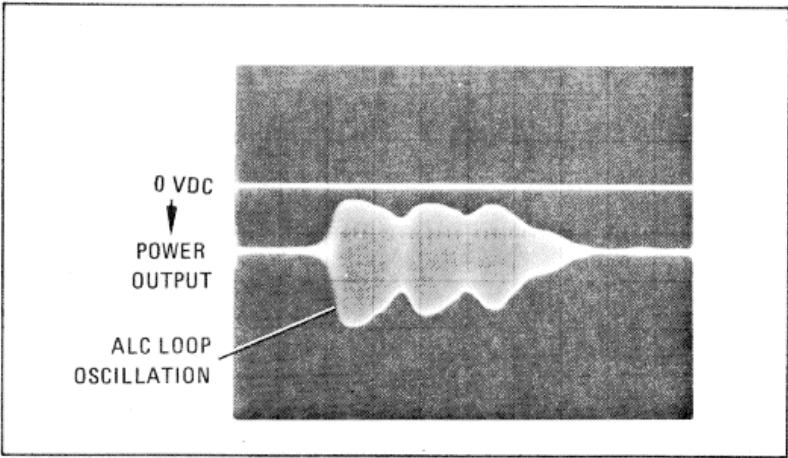
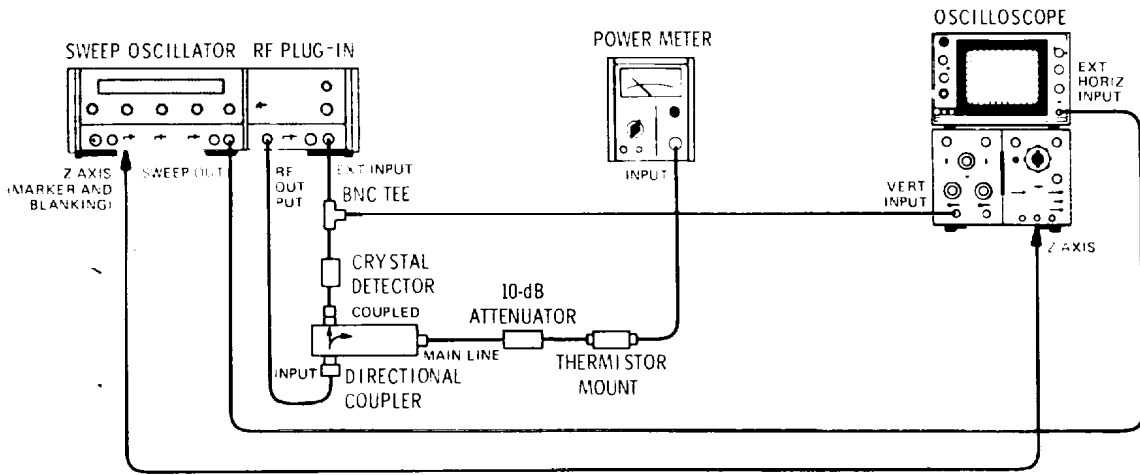

Figure 3-6. Oscillations with ALC Gain Too High

**CRYSTAL LEVELING**



**EQUIPMENT:**

Sweep Oscillator .....	HP 8620A
RF Plug-in .....	HP 86260A
Oscilloscope .....	HP 180A/1801A/1820A
Power Meter .....	HP 432A
Crystal Detector .....	HP 8470A, Option 012
10-dB Attenuator .....	HP 8491B, Option 010
Directional Coupler* .....	HP 779D
Thermistor Mount .....	HP 8478B

**NOTE\***

The HP 779D Directional Coupler is used for this procedure but the directivity at the upper frequencies (12.4 - 18 GHz) is reduced to about 15 dB.

**PROCEDURE: \***

1. Connect equipment as shown in test setup in Figure 3-7. The ALC Polarity switch is set for negative (-) output crystal detectors at the factory. If a positive (+) output detector is used, resetting of detector polarity switch is necessary.

Figure 3-7. External Crystal Detector Leveling (1 of 2)

**CRYSTAL LEVELING**

2. Set controls as follows:

8620A

- BAND 2 ..... 12.4 to 18.0 GHz
- START (green) 1 ..... 12.4 GHz
- STOP (red) 7 ..... 18.0 GHz
- MARKER 15 ..... OFF
- MODE 17 ..... AUTO
- TRIGGER 16 ..... INT
- TIME-SECONDS 14 ..... 0.1 -- 0.01
- TIME-SECONDS Vernier 13 ..... Fully clockwise
- 1 KHZ SQ WV/OFF (Rear Panel) ..... OFF
- RF BLANKING/OFF (Rear Panel) ..... RF BLANKING

86260A

- POWER LEVEL 10 ..... Fully clockwise
- ALC 12 ..... EXT
- ALC GAIN 11 ..... Fully clockwise

3. Press 8620A LINE pushbutton switch 19 to turn instrument on. The LINE switch 19 and START- STOP pushbuttons 1, 7 should be light, indicating START-STOP sweep mode is selected.

4. Adjust ALC GAIN 11 and POWER LEVEL 10 controls fully clockwise for maximum RF power and maximum external preamplifier gain. One of the conditions shown in Figure 3-4 through 3-6 should be displayed on oscilloscope. If trace is unlevelled, as shown in Figure 3-4, or just partially levelled and UNLEVELED light is on, turn POWER LEVEL 10 control counterclockwise to reduce power output until trace is level across band as shown in Figure 3-5. If external preamplifier gain is too high, oscillations may occur as shown in Figure 3-6. To remove oscillations, reduce external preamplifier gain by turning ALC GAIN 11 control counterclockwise.

*Figure 3-7. External Crystal Detector Leveling (2 of 2)*

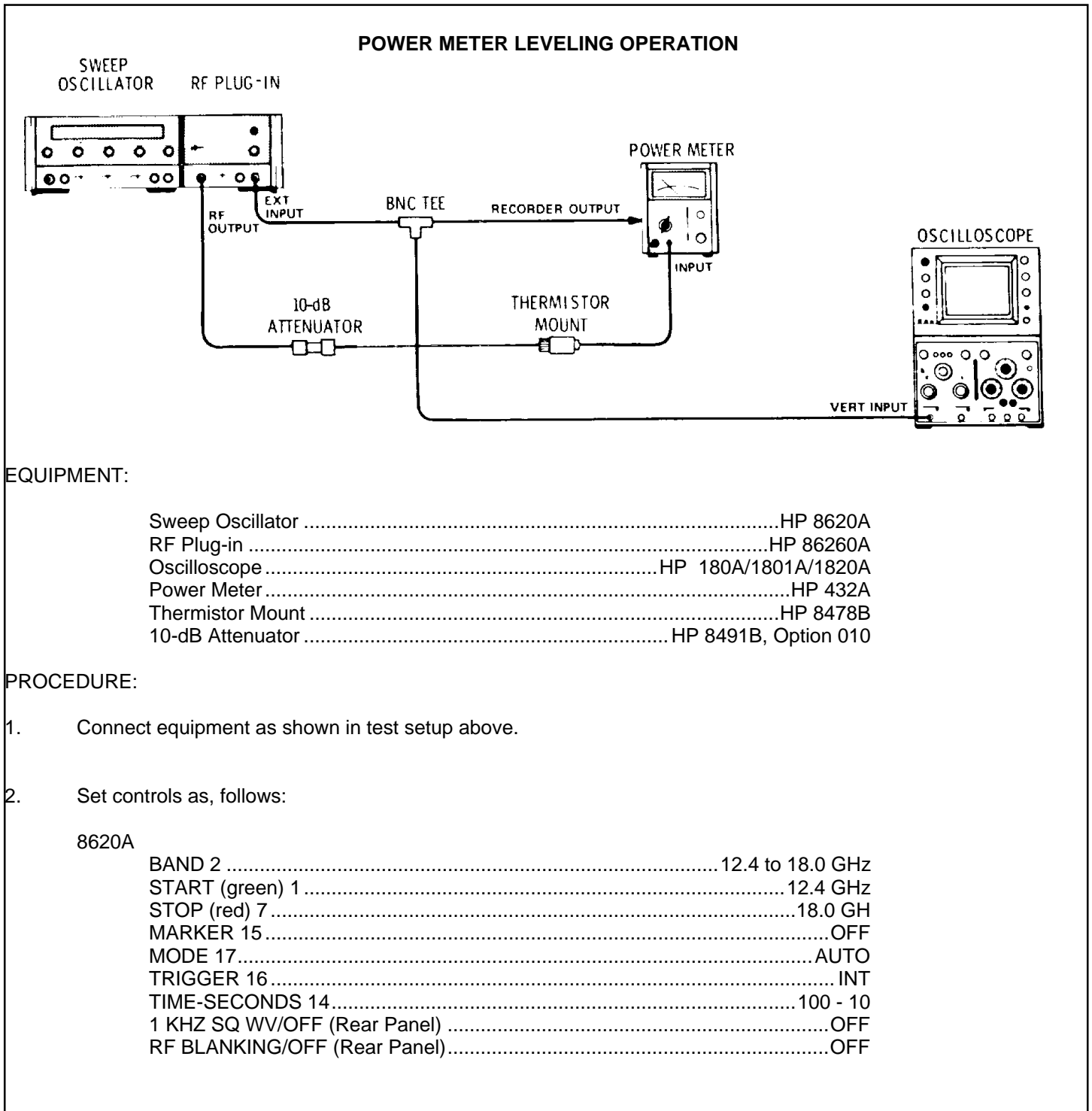

Figure 3-8. Power Meter Leveling Operation (1 of 2)

**POWER METER LEVELING OPERATION**

86260A

RF 8.....ON  
POWER LEVEL 10 ..... Fully clockwise  
ALC 12 .....ON  
ALC GAIN 11..... Fully clockwise

3. Press 8620A LINE pushbutton switch 19 to turn instrument on. The LINE switch 19 and START-STOP pushbuttons 1, 7 should light, indicating START-STOP sweep mode is selected.
4. Adjust power meter range to obtain upscale indication near top 1/3 of meter deflection range.
5. One of the conditions shown in Figure 3-4 through 3-6 should be displayed on oscilloscope. If trace is unlevelled as shown in Figure 3-4, turn POWER LEVEL control 10 counterclockwise to reduce power output until trace is level across band as shown in Figure 3-5. If loop gain is too high, oscillations may occur as shown in Figure 3-6. To remove oscillations, reduce gain by turn ALC GAIN control 11 counterclockwise.

*Figure 3-8. Power Meter Leveling Operation (2 of 2)*  
**3-11/3-12**



## SECTION IV PERFORMANCE TESTS

### 4-1. INTRODUCTION

4-2. The performance tests check that the instrument meets the specifications listed in Table 1-1. These tests may be used for incoming inspection, after repair of the instrument, after performing the alignment procedure, or for periodic evaluation. If only a simple check of the instrument operation is needed, the operator's check in Section III may be used. If a test measurement is slightly out of tolerance, go to Section V and perform the appropriate adjustment procedures. If a function fails to operate, go to Section VIII for troubleshooting information.

### 4-3. EQUIPMENT REQUIRED

4-4. A complete list of equipment required for the performance tests is given in Table 1-3. If the recommended equipment in the list is not available, a

substitute may be used if it meets or exceeds the critical specifications listed in the table.

### 4-5. TEST RECORD

4-6. Table 4-1 is a test record form that is provided to record results from the performance tests. The table is keyed to the paragraph numbers and test titles in the procedures.

#### NOTE

In the following procedure, an 8620A mainframe is specified. However, an 8620B may be used, but the control names will be different than those called out in the procedure. These procedures assume that the mainframe is fully calibrated to its specifications.

---

## PERFORMANCE TESTS

---

### 4-7. FREQUENCY RANGE AND ACCURACY

#### NOTE

Allow 30 minutes warmup time.

#### SPECIFICATION:

Frequency range: 12.4 to 18.0 GHz.

Frequency Accuracy (At 25 ° C; FM switch in PL or FM position.):  $\pm 50$  MHz CW mode. (Approach desired

Frequency from low-frequency end of band.)

$\pm 70$  MHz All Sweep Modes (Sweep Time > 0.1 sec.)

#### DESCRIPTION:

The CW mode is checked at three frequencies across the band to determine if the RF signal is within frequency tolerance. Start-Stop manual sweep is then selected and the frequency at each end-point is checked.

**PERFORMANCE TESTS**

**4-7. FREQUENCY RANGE AND ACCURACY (Cont'd)**

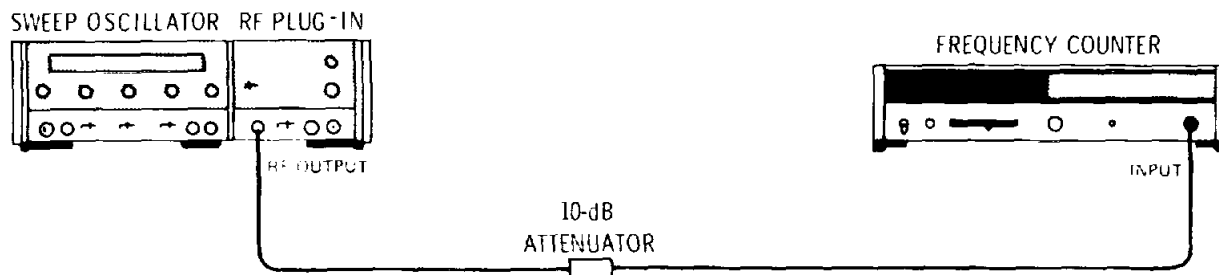

**Figure 4-1. NOTE**

It may be necessary to calibrate the 86260A in the 8620 mainframe in which it will be used. Refer to the adjustment section, paragraph 5-14.

**EQUIPMENT:**

Sweep Oscillator .....	HP 8620A
RF Plug-in .....	HP 86260A
Frequency Counter.....	HP 5340A
10-dB Attenuator .....	HP 8491B, Option 010

**PROCEDURE:**

a. Connect equipment as shown in Figure 4- 1. Connect frequency counter through a 10-dB attenuator to RF OUTPUT connector.

b. Set controls as follows:

**8620A**

BAND .....	12.4 to 18.0 GHz
START pointer.....	12.4 GHz
CW pointer .....	15.2 GHz
STOP pointer.....	18.0 GHz
MIODE.....	MANUAL
TRIGGER .....	INT
TIME .....	0.1 -- 0.01
1 KHZ SQ WV/OFF (Rear Panel) .....	OFF
RF BLANKING/OFF (Rear Panel).....	RF BLANKING

**86260A**

RF.....	ON
ALC .....	OFF
POWER LEVEL .....	Fully clockwise

c. Press 8620A LINE switch to ON position. Press 8620A CW pushbutton. Allow equipment to warm up for 30 minutes.

---

**PERFORMANCE TESTS**

---

**4-7. FREQUENCY RANGE AND ACCURACY (Cont'd)****NOTE**

Always approach frequency settings from low-frequency end.

- d. Adjust CW pointer to high-frequency end, then to low-frequency end; repeat several times. Set CW pointer to 12.4 GHz. Frequency counter should indicate 12.400 GHz  $\pm$  50 MHz.
  - e. Set 8620A CW pointer to 15.2 GHz. Frequency counter should indicate 15.200 GHz  $\pm$  50 MHz.
  - f. Set 8620A CW pointer to 18.0 GHz. Frequency counter should indicate 18.000 GHz  $\pm$  50 MHz.
  - g. Press 8620A START pushbutton. Set MANUAL control fully counterclockwise. Frequency counter should indicate 12.400 GHz  $\pm$  70 MHz.
  - h. Set MANUAL control fully clockwise. Frequency counter should indicate 18.000 GHz  $\pm$  70 MHz.
- 

**4-8. FREQUENCY STABILITY****SPECIFICATION:****Frequency Stability:**

With 10% change in line voltage:  $\pm$  180 kHz.

With 10 dB power level change from specified maximum power:  $\pm$  6 MHz,

**DESCRIPTION:**

Frequency is measured for change due to line voltage, and power level changes.

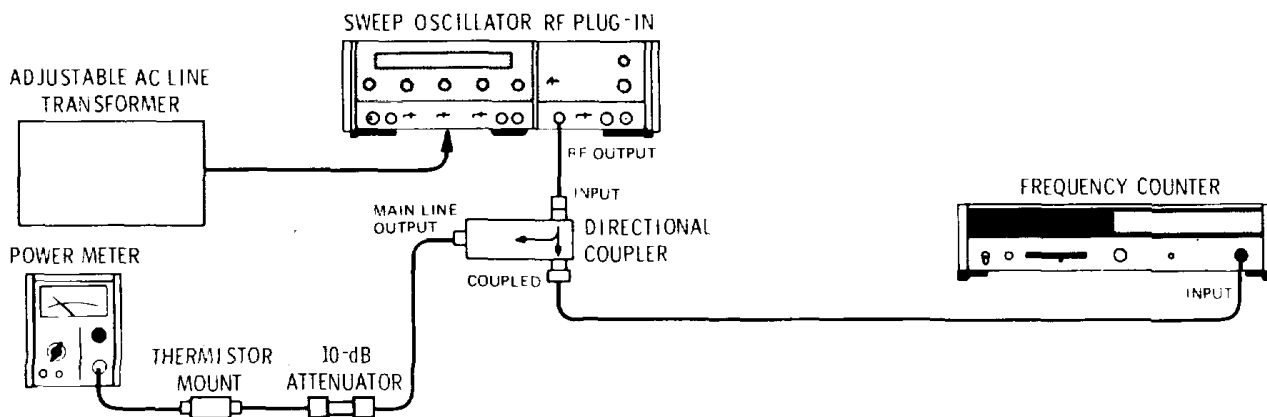

Figure 4-2. Frequency Stability Test Setup

---

**PERFORMANCE TESTS**

---

**4-8. FREQUENCY STABILITY (Cont'd)**

## EQUIPMENT:

Sweep Oscillator .....	HP 8620A
RF Plug-in .....	HP 86260A
Frequency Counter.....	HP 5340A
Power Meter.....	HP 432A
Thermistor Mount .....	HP 8478B
Directional Coupler.....	HP 779D
Adjustable AC Line Transformer .....	General Radio MT3A
10-dB Attenuator .....	HP 8491B, Option 010

*Frequency Change With Line Voltage Change*

- a. Record frequency indication on counter at 115 Vac.
- b. Set line voltage to 103 Vac with adjustable line transformer. The frequency change from that noted in Step a should be less than + 180 kHz.
- c. Set line voltage to 127 Vac with adjustable line transformer. The frequency change from that noted in Step a should be less than +180 kHz. Return line voltage to 115 Vac.

*Frequency Change With Line Voltage Change*

- d. Set POWER LEVEL to specified maximum power and note frequency indication on the counter. With POWER LEVEL control, decrease power by 10 dB as indicated on power meter. The frequency change should be less than +6 MHz.

---

**4-9. RESIDUAL FM IN 10 KHZ BANDWIDTH**

## SPECIFICATION:

Residual FM in CW mode measured in a 10 kHz bandwidth < 25 kHz peak (86260A FM-NORM-PL switch in NORM position).

## DESCRIPTION:

The sweep oscillator RF output signal is displayed on a Spectrum Analyzer. The residual FM is observed on a storage display by displaying five superimposed traces.

---

**PERFORMANCE TESTS**

**4-9. RESIDUAL FM IN 10 KHZ BANDWIDTH (Cont'd)**

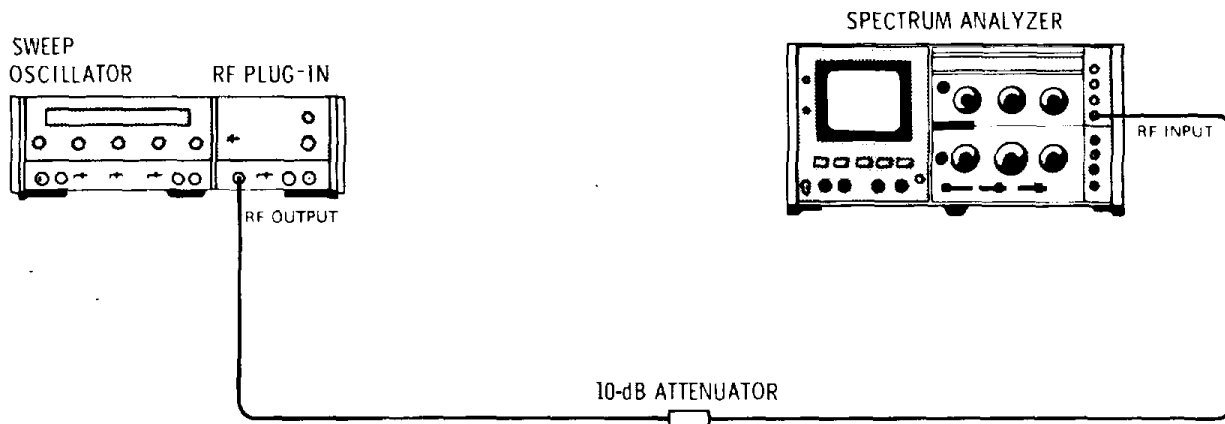

Figure 4-3. Residual FM Test Setup

**EQUIPMENT:**

Sweep Oscillator .....	HP 8620A
RF Plug-in .....	HP 86260A
10-dB Attenuator .....	HP 8491B, Option 010
Spectrum Analyzer .....	HP 8555A/8552B/141T

**PROCEDURE:**

a. Connect equipment as shown in Figure 4-3. Set controls as follows:

8620A

BAND .....	12.4 to 18.0 GHz
CW Pointer .....	15.2 GHz
1 KHz SQ WV/OFF (Rear Panel) .....	OFF
RF BLANKING/OFF (Rear Panel) .....	OFF

86260A

ALC .....	OFF
POWER LEVEL .....	Fully clockwise
FM-NORM-PL .....	NORM

b. Press 8620A LINE switch to ON. Press 8620A CW pushbutton.

c. Allow equipment to warm up for a minimum of 30 minutes.

d. Center RF output signal on spectrum analyzer. Verify that fundamental of the oscillator is displayed by signal identification procedure.

e. Set spectrum analyzer BANDWIDTH to 10 kHz and SCAN WIDTH PER DIVISION to 10 kHz while keeping signal centered on CRT display.

f. On spectrum analyzer, select 10 dB LOG display and adjust LINEAR SENSITIVITY vernier control for a full eight division display.

---

**PERFORMANCE TESTS**

---

**4-9. RESIDUAL FM IN 10 KHZ BANDWIDTH (Cont'd)**

- g. Set SCAN TIME PER DIVISION to 20 msec and set SCAN MODE to SINGLE sweep.
- h. Push SINGLE sweep pushbutton five times at approximately one second intervals and store resultant traces on CRT screen.
- i. The trace should be similar to Figure 4-4. The FM deviation measured across top of trace should be less than 50 kHz (5 divisions).

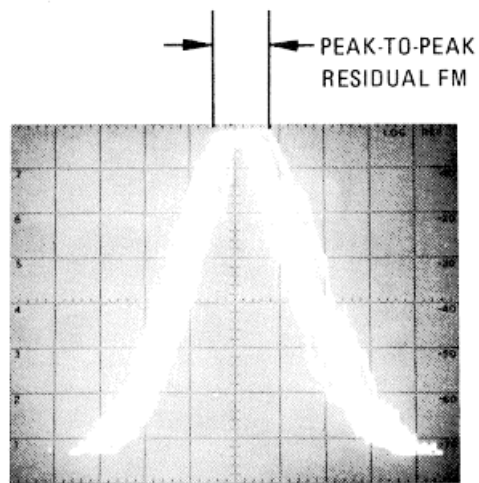

Figure 4-4. Residual FM Disposable on Spectrum Analyzer

**4-10. POWER LEVEL AND VARIATION**

## SPECIFICATION:

Maximum leveled power: 12.4 to 18.0 GHz > +7 dBm (5.0 mW).

*Power Variation At Maximum Leveled Power*

Externally leveled by crystal detector: <  $\pm 0.1$  dB<sup>1</sup>, excluding crystal detector and directional coupler frequency response.

Externally leveled by power meter: < +0.1 dB<sup>1</sup>, excluding thermistor mount frequency response. Sweep time at least 10 seconds. Works with HP 431B, 431C, and 432A Power Meters. Unleveled: <  $\pm 4$  dB<sup>1</sup>.

---

<sup>1</sup>Example-  $\pm 3$ -dB variation means 6-dB peak-to-peak total variation.

---

**PERFORMANCE TESTS**

**4-10. POWER LEVEL AND VARIATION (Cont'd)**

**DESCRIPTION:**

Maximum leveled power is checked with crystal detector leveling, and power meter leveling. The power output specification is stated for the output of the unit with no options installed. In each mode, the power variations are measured on the oscilloscope trace. The trace is calibrated by changing the RF output power by the amount of the specification as noted on the power meter and the corresponding change in trace on the oscilloscope.

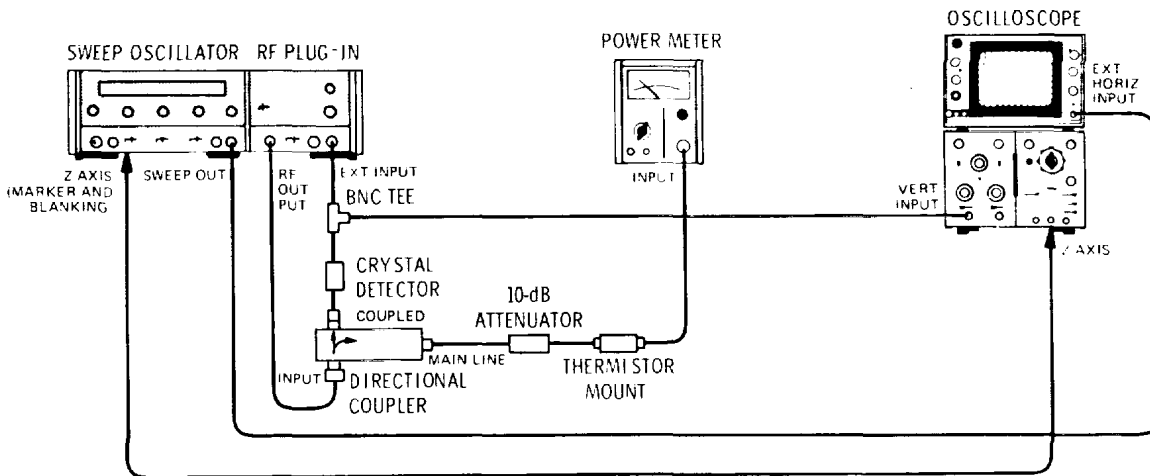

Figure 4-5. Crystal Detector Leveling Test Setup

**NOTE**

The following list includes equipment used in Figures 4-5 and 4-6 test setups.

**EQUIPMENT:**

Sweep Oscillator .....	HP 8620A
RF Plug-in .....	HP 86260A
Thermistor Mount .....	HP 8478B
Power Meter .....	HP 432A
Oscilloscope .....	HP 180A/1801A/1820A
Crystal Detector .....	HP 8470A, Option 012
Directional Coupler .....	HP 779D
10-dB Attenuator .....	HP 8491B, Option 010

---

**PERFORMANCE TESTS**

---

**4-10. POWER LEVEL AND VARIATION (Cont'd)***External Leveling With Crystal Detector*

a. Connect equipment as shown in Figure 4-5. Set detector polarity switch to either negative or positive to match crystal detector output. The polarity switch is located on top of the A2 ALC board just inside 86260A. To gain access to the switch, slide RF Plug-in out set switch then slide back in place.

b. Set controls as follows:

## 8620A

BAND .....	12.4 to 18.0 GHz
START pointer.....	12.4 GHz
CW pointer .....	15.2 GHz
STOP pointer.....	18.0 GHz
NIODE .....	AUTO
TRIGGER .....	INT
TIMIE-SECONDS.....	.01 -- 0.01
1 KHZ SQ WV/OFF (Rear Panel) .....	OFF
RF BLANKING/OFF (Rear Panel).....	OFF

## 86260A

RF.....	ON
ALC .....	EXT
POWER LEVEL .....	Fully clockwise
ALC GAIN.....	Fully clockwise

c. Press 8620A START pushbutton. Adjust ALC GAIN and POWER LEVEL controls for highest power meter indication with UNLEVELED light not lit. (If oscillations appear on trace, adjust ALC GAIN and POWER LEVEL controls counterclockwise as necessary to obtain a leveled trace.) The power meter should indicate > +7 dBm less the approximate 0.5 dB loss through the directional coupler.

d. Press 8620A CW pushbutton. Adjust oscilloscope trace to bottom of display and note trace position. Decrease output power indication by 0.2 dB by adjusting POWER LEVEL control. Note position of oscilloscope trace. (The area between the two positions noted represents leveling tolerance of 0.11 dB.)

e. Press 8620A START pushbutton. Adjust POWER LEVEL control fully clockwise, then counterclockwise until UNLEVELED lamp goes out at maximum leveled power.

f. Adjust position of oscilloscope trace vertically so that it is displayed between upper and lower specification limits noted in step d(. The highest and lowest portion of the sweep trace must be within 0.2-dB peak-to-peak limit noted.

*External Leveling With Power Meter*

g. Connect equipment as shown in Figure 4-6, with crystal detector connected at oscilloscope VERT INPUT.

---



PERFORMANCE TESTS

4-10. POWER LEVEL AND VARIATION (Cont'd)

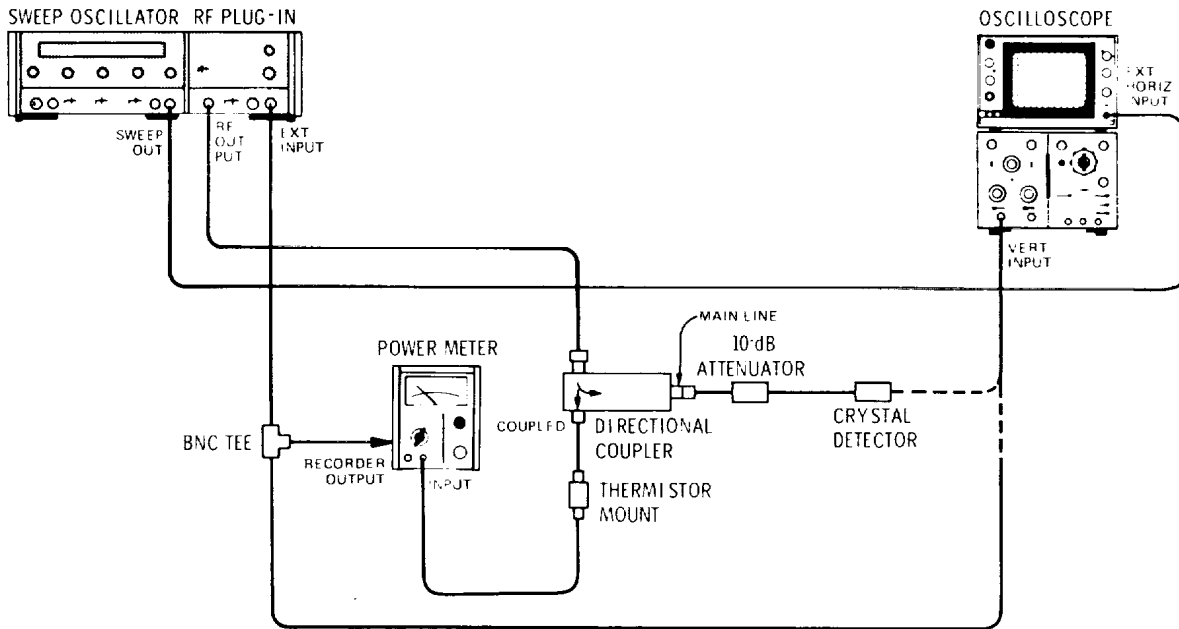

Figure 4-6. Power Meter Leveling Test Setup

h. Set controls as follows:

8620A

- BAND ..... 12.4 to 18.0 GH,
- START pointer..... 12.4 GHz
- CW pointer ..... 15.2 GH/
- STOP pointer..... 18.0 GH,
- MODE..... AUTO
- TRIGGER ..... INT
- TIME-SECONDS ..... 100 -- 10
- 1 KHZ SQ WV/OFF (Rear Panel) ..... OFF
- RF BLANKING/OFF(Rear Panel)..... OFF

86260A

- ALC ..... ON
- POWER LEVEL ..... Fully clockwise

**NOTE**

Power meter switch A2S2 must be set to 432 or 431 depending on power meter used. For power meter leveling, sweep rates slower than 10 sec per sweep must be used. The rate of leveling is dependent on the comparatively slow response of the thermistor mount to power level changes.

i. Press 8620A LINE switch to ON. Press 8620A START pushbutton. Set power meter range to obtain a meter indication in upper half of scale. Adjust 86260A POWER LEVEL to obtain flat RF power level across the band as indicated on power meter.

---

**PERFORMANCE TESTS**

---

**4-10. POWER LEVEL AND VARIATION (Cont'd)**

- j. Press 8620A CW pushbutton. Adjust oscilloscope trace to bottom of display and note trace position. Decrease output power indication by 0.2 dB by adjusting POWER LEVEL control. Note trace position. (The area between the two positions noted represents leveling tolerance of +0.1 dB.)
- k. Press 8620A START pushbutton. Adjust POWER LEVEL control fully clockwise, then counterclockwise until leveled RF condition is met.
- l. Set 8620A MODE switch to MANUAL. Adjust the MANUAL sweep control slowly through the sweep band and note maximum and minimum power meter indications. These should be within tolerance limits noted on oscilloscope display. (If necessary adjust trace position vertically to center it between upper and lower limits.)

*Unleveled Power*

- m. Turn A.L.C off.
- n. Adjust POWER LEVEL control for maximum power out. Adjust the MANUAL sweep control slowly through the band and note maximum and minimum power meter indications. The difference between maximum and minimum power should be  $\pm 8$  dB.

---

**4-11. SPURIOUS SIGNALS**

## SPECIFICATION:

Harmonic signals are down greater than 25 dB and non-harmonic spurious signals are down greater than 50 dB from the fundamental output level of +7 dBm.

## DESCRIPTION:

The output RF signal from the Sweep Oscillator is displayed in frequency domain by a Spectrum Analyzer to verify that the spurious signal output is down from the fundamental frequency output by the specified amount.

---

**PERFORMANCE TESTS**

**4-11. SPURIOUS SIGNALS (Cont'd)**

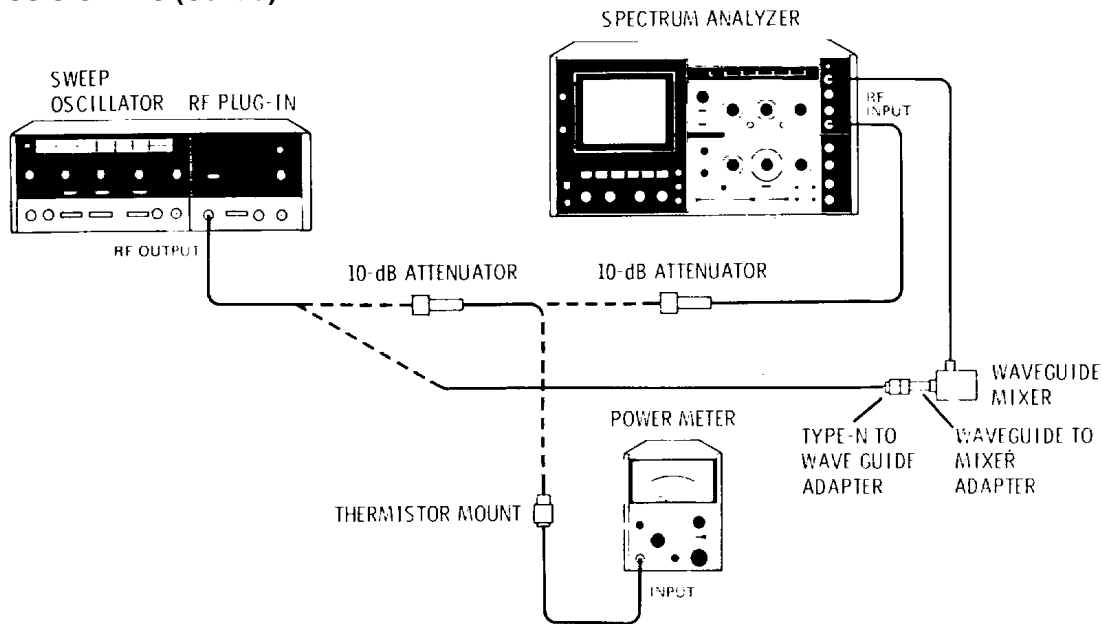

Figure 4-7. Spurious Signal Test Setup

**EQUIPMENT:**

Sweep Oscillator .....	HP 8620A
RF Section.....	HP 86260A
Spectrum Analyzer .....	HP 8555A/8552B/141T
Power Meter.....	HP 432A
Thermistor Mount .....	HP 8478B
10 dB Attenuator (2 each) .....	HP 8491A, Option 010
Waveguide Mixer .....	HP 11517A
Type-N to Waveguide Adapter.....	HP P281B, Option 013
Waveguide to Mixer Adapter.....	HP 11518A

**PROCEDURE:**

a. Connect equipment as shown in Figure 4-7 with power meter connected through a 10 dB attenuator to the 86260A RF OUTPUT connector.

b. Set controls as follows:

8620A/B

BAND .....	12.4 to 18.0 GHz
CW pointer .....	15.2 GHz
1 KHZ SQ WV/OFF (Rear Panel) .....	OFF
RF BLANKING/OFF (Rear Panel).....	RF BLANKING

86260A

RF.....	ON
ALC .....	OFF
POWER LEVEL .....	+ 7 dBm
FM-NORM-PL (Rear Panel).....	NORM

---

**PERFORMANCE TESTS**

---

**4-11. SPURIOUS SIGNALS (Cont'd)**

c. Set 8620A LINE switch to ON; press CW pushbutton. Connect Spectrum Analyzer input through two 10 dB attenuators to 86260A RF OUTPUT connector. (See Figure 4-7.)

**NOTE**

The spectrum analyzer originates some mixing harmonics that may appear on the display. If a signal is in question, increase the spectrum analyzer input attenuation by 10 dBm, note if signal decreases in amplitude by 10 dB, then return the attenuator to the original position. If the signal in question originates in the spectrum analyzer, the level will either change by greater or less than 10 dB or it may not change at all.

d. Adjust 8620A/B CAW control through the 12.4 to 18.0 GHz band and observe harmonics and spurious signals. Identify signal in question as harmonic or as non-harmonic and measure difference in dB between this signal level and the level of the fundamental frequency. To observe harmonics and spurious signals in the frequency range of 18 to 40 GHz, use HP 1517A External Mixer with the 8555A Spectrum Analyzer. (Refer to 8555A Operating and Service Manual.) Use signal substitution to determine signal levels when using the external mixer.

---

**4-12. RESIDUAL AM**

## SPECIFICATION:

AM noise in a 100 kHz bandwidth (below fundamental at maximum power):  
Residual AM > 50 dB below carrier.

## DESCRIPTION:

The carrier signal from the 86260A Plug-in is amplitude modulated with a squarewave from the 8620A. This modulated signal is used to establish reference on the Model 3400A RMS Voltmeter that is 9 dB below the actual carrier signal. The 9-dB reduction occurs because of the voltmeter response to a squarewave and the square-law response of the crystal detector. The modulation is then removed and the magnitude of the Residual AM component is measured with respect to the established reference.

---

**PERFORMANCE TESTS**

**4-12. RESIDUAL AM (Cont'd)**

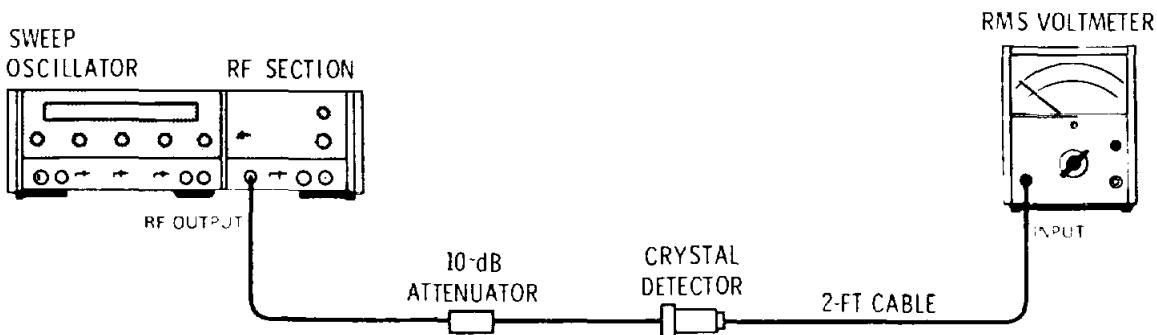

Figure 4-8. Residual AM Test Setup

**EQUIPMENT:**

Sweep Oscillator .....	HP 8620A
RF Plug-in .....	HP 86260A
10-dB Attenuator .....	HP 8491B, Option 010
RMS Voltmeter .....	HP 3400A
Crystal Detector .....	HP 8470A, Option 012
2-foot BNC Cable .....	HP 11086A

**PROCEDURE:**

a. Connect equipment as shown in Figure 4-8.

b. Set controls as follows:

8620A

BAND .....	12.4 to 18.0 GHz
CW pointer .....	15.2 GHz
1 KHZ SQ WV/OFF (Rear Panel) .....	1 KHZ SQ WV
RF BLANKING/OFF (Rear Panel) .....	RF BLANKING

86260A

POWER LEVEL .....	Fully clockwise
-------------------	-----------------

c. Set 8620A LINE switch to ON press CW pushbutton. Set RMS voltmeter to a range that gives an on-scale indication. Note meter indication.

d. Set 8620A rear-panel 1 KHZ SQ WV/OFF switch to OFF. Adjust RNIS voltmeter range switch to obtain an on-scale indication. The difference between this indication and the one noted in step c should be a minimum of 41 dB (see NOTE below).

## PERFORMANCE TESTS

## 4-12. RESIDUAL AM (Cont'd)

## NOTE

A 4 -dB decrease in the RMS voltmeter indication corresponds to a 50-dB reduction in signal level. A correction factor of 9 dB is added because of the RMS voltmeter response to a squarewave and the square-law response of the crystal detector.

## 4-13. EQUIVALENT SOURCE SWR

## SPECIFICATION:

SWR: <2.0

Impedance: 50 Ohms nominal

## DESCRIPTION:

The RF OUTPUT signal is measured using a directional coupler, crystal detector, and oscilloscope. This incident signal from the Plug-in contains (1) the initial signal from the oscillator, and (2) the reflected signal. The reflected signal is developed as follows. The original oscillator signal travels down the 20 cm air lines, sees the open end, and is reflected back to the source. If the reflected signal going into the RF OUTPUT connector sees a perfect 50-ohm source match, no signal is reflected back out of the source. However, the greater the mismatch, the greater the reflected signal. This reflected signal adds and subtracts in and out of phase with the incident oscillator signal, and is displayed on the oscilloscope.

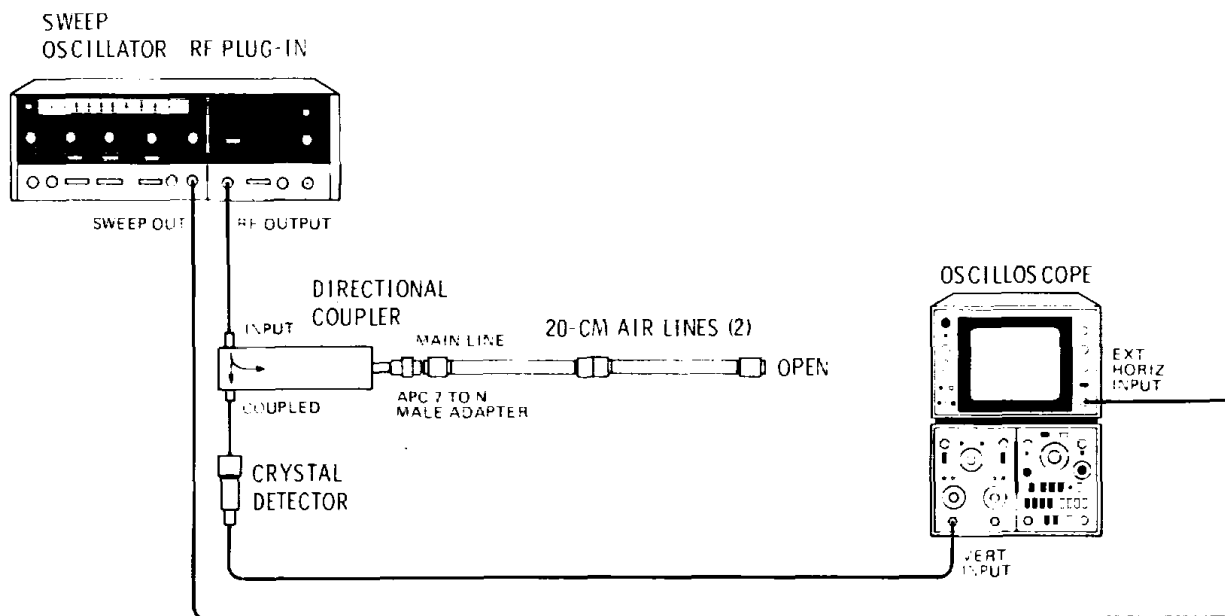

Figure 4-9. Equivalent Source Match Test Setup

**PERFORMANCE TESTS**

---

**4-13. EQUIVALENT SOURCE SWR (Cont'd)**

EQUIPMENT:

Sweep Oscillator .....	HP 8620A
RF Plug-In .....	HP 86260A
Oscilloscope .....	HP 180A/1801A/1820A
Crystal Detector.....	HP 423A
Directional Coupler.....	HP 779D
20-cm Air Lines (2).....	HP 11567A
APC-7 to N Male Adapter.....	HP 11525A

PROCEDURE:

a. Connect equipment as shown in Figure 4-9.

b. Set controls as follows:

8620A:

BAND .....	12.4 to 18.0 GHz
START (green) .....	12.4 GHz
STOP (red).....	18.0 GHz
MARKER .....	OFF
MODE.....	AUTO
TRIGGER .....	INT
TIME-SECONDS.....	0.1 -- 0.01
TIME-SECONDS Vernier .....	Fully Clockwise
1 KHZ SQ WV/OFF (Rear Panel) .....	OFF
RF BLANKING/OFF (Rear Panel).....	RF BANKING

86260A:

POWER LEVEL .....	Fully clockwise
-------------------	-----------------

c. Set 8620A LINE switch to ON; press START pushbutton.

d. Note maximum amplitude from zero Vdc on oscilloscope. If it is greater than -25 mV maximum peak trace to place the crystal detector in square-law output range.

e. Display swept power output trace on oscilloscope (Figure 4-10). Select several points on trace and calculate VMAX/VMIN.

f. Convert VMAX/VMIN ratio noted in step e into source match SWR, using Figure 4-11. The SWR value should be <2.0:1.

**PERFORMANCE TESTS**

**4-13. EQUIVALENT SOURCE SWR (Cont'd)**

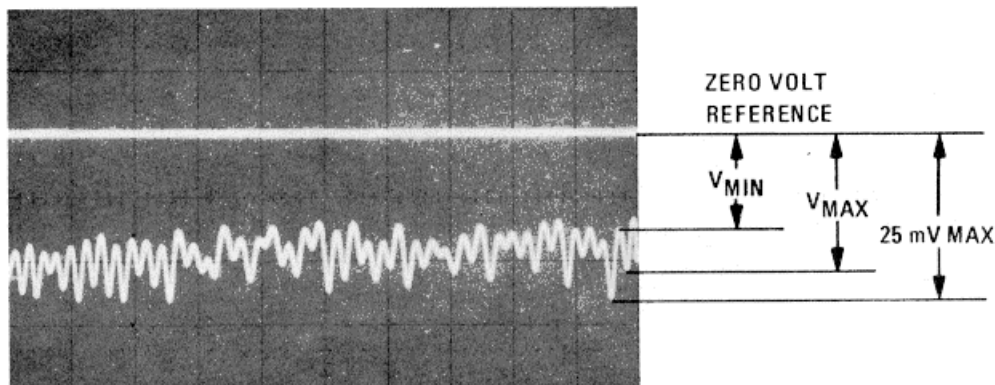

*Figure 4-10. Typical Pattern of a swept SWR Measurement*

**4-14. EXTERNAL FM**

**SPECIFIC:**

FM Mode (FM-NORM-PL switch in FM position):

Sensitivity ..... = -20 MHz/V  
 (FM switch in PL position)  
 Sensitivity ..... = -6 MHz/V

Maximum Deviation Modulation Frequencies:

DC to 200 Hz .....  $\pm 75$  MHz  
 DC to 200 kHz .....  $\pm 5$  MHz

**DESCRIPTION:**

The oscillator is modulated with an external signal source through the input range to 200 kHz. The resulting FM deviation is displayed on a spectrum analyzer CRT.



PERFORMANCE TESTS

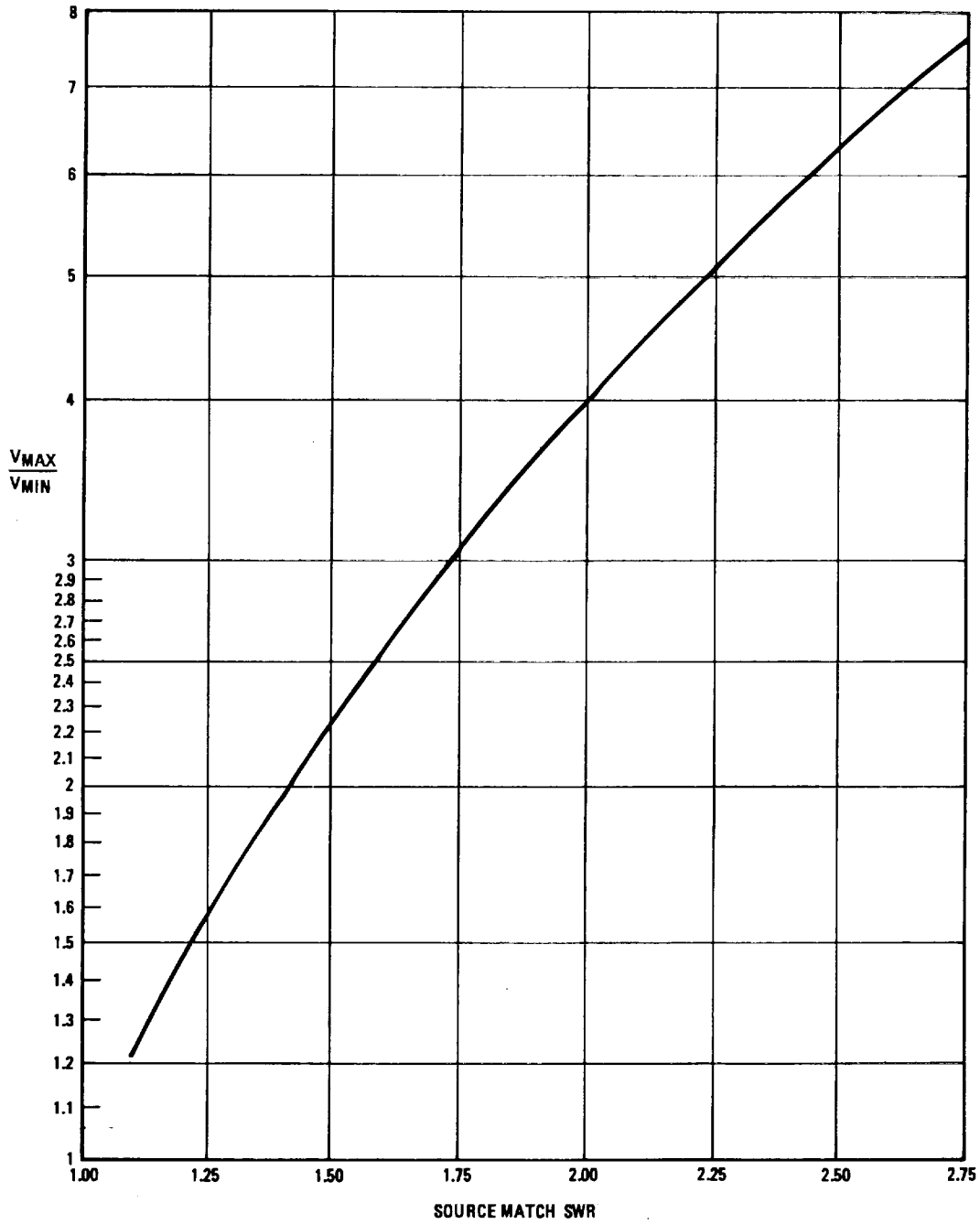

Figure 4-11. Graph to Convert Oscilloscope Trace to Source Match SWR

**PERFORMANCE TESTS**

**4-14. EXTERNAL FM (Cont'd)**

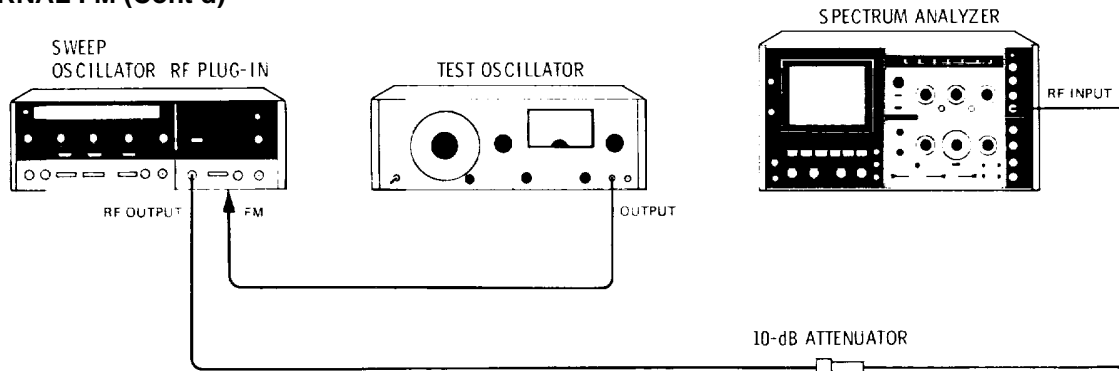

Figure 4-12. External Frequency Modulation Test Setup

**EQUIPMENT:**

Sweep Oscillator .....	HP 8620A
RF Plug-in .....	HP 86260A
Test Oscillator .....	HP 651B
Spectrum Analyzer .....	HP 8555A/8552B/141T
10-dB Attenuator .....	HP 8491B, Option 010

**PROCEDURE:**

a. Set controls as follows:

8620A

BAND .....	12.4 to 18.0 GHz
CW .....	15.2 GHz
1 KHZ SQ WV/OFF (Rear Panel) .....	OFF
RF BLANKING/OFF (Rear Panel) .....	OFF

86260A

RF .....	ON
ALC .....	OFF

651B

FREQUENCY .....	200 Hz
OUTPUT ATTENUATOR AND AMPLITUDE .....	Set for 2.0 divisions p-p (horizontal) display on CRT

- b. Connect spectrum analyzer input through 10-dB attenuator to the RF OUTPUT connector. (See Figure 4-12.) Press 8620A LINE switch to ON.
- c. Center fundamental signal on spectrum analyzer CRT display. Adjust test oscillator AMPLITUDE control clockwise until frequency deviation (displayed on spectrum analyzer CRT is  $\pm 75$  MHz). (See Figure 4-13).
- d. Set test oscillator frequency to 200 kHz and adjust its AMPLITUDE control clockwise until frequency deviation is  $\pm 5$  MHz.

---

**PERFORMANCE TESTS**

---

**4-14. EXTERNAL FM (Cont'd)**

Figure 4-13. Spectrum Analyzer Display of Frequency Deviation

---

**4-15. INTERNAL AND EXTERNAL AM**
**SPECIFICATION:****INTERNAL AM:**

1 kHz squarewave ON/OFF ratio: > 25 dB below maximum leveled power.

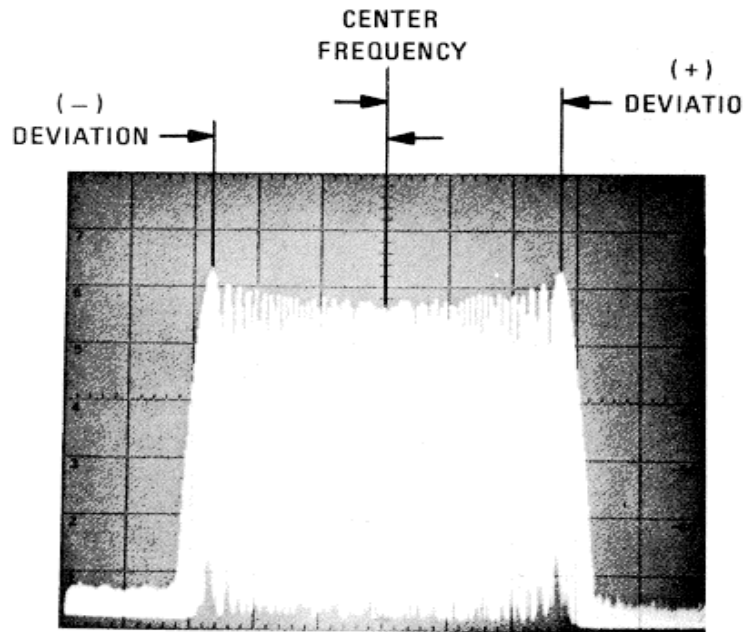
**EXTERNAL AM:**

Sensitivity: A -10 V input reduces the RF output signal 25 dB below maximum leveled power.

**DESCRIPTION:**

Attenuation is checked by applying - 10 Vdc and observing the corresponding decrease in RF power out (25 dB below maximum leveled power). ON/OFF ratio is checked by applying the internal 1 kHz squarewave and observing the display.

---

**PERFORMANCE TESTS**

**4-15. INTERNAL AND EXTERNAL AM (Cont'd)**

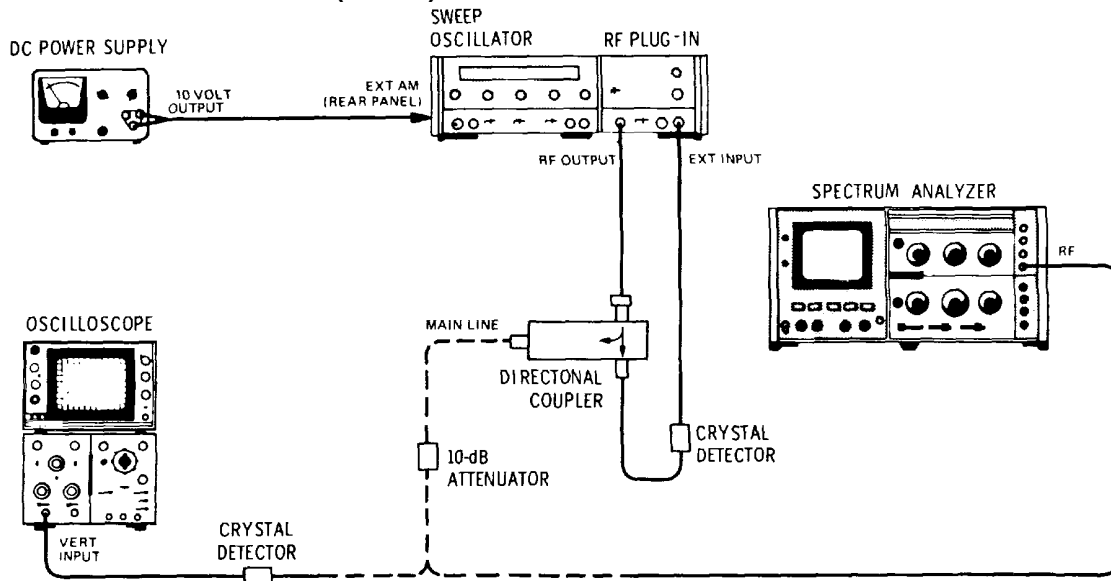

Figure 4-14. Amplitude Modulation Test Setup

**EQUIPMENT:**

Sweep Oscillator .....	HP 8620A
RF Plug-in .....	HP 86260A
DC Power Supply.....	HP 721A
Crystal Detector (2) .....	HP 8470A, Option 012
Spectrum Analyzer .....	HP 8555A/8552A/141T
Oscilloscope .....	HP 180A/1801A/1820A
Directional Coupler.....	HP 779D
10-dB Attenuator .....	HP 8491B, Option 010

**PROCEDURE:**

- a. Connect spectrum analyzer as shown in Figure 4-10.
- b. Set controls as follows:

8620A

BAND .....	12.4 to 18.0 GHz
CW pointer .....	15.2 GHz
START pointer.....	12.4 GHz
STOP pointer.....	18.0 GHz
MARKER .....	OFF
RF BLANKING/OFF (Rear Panel).....	RF BLANKING
1 KHZ SQ WV/OFF (Rear Panel) .....	OFF

86260A

POWER LEVEL .....	Maximum Leveled Power
ALC .....	EXT

**PERFORMANCE TESTS**

---

**4-15. INTERNAL AND EXTERNAL AM (Cont'd)**

- c. Press CW pushbutton.
- d. Set spectrum analyzer controls as follows:

8555A

Frequency BAND.....	10.29 to 18.0 GHz
BANDWIDTH .....	100 kHz
SCAN WIDTH .....	5 MHz/division
INPUT ATTENUATION .....	0 dB
TUNING STABILIZER .....	OFF
Signal Identifier.....	OFF

8552A

SCAN TIME .....	10 ms/division
LOG REF LEVEL .....	0 dBm
LOG/LINEAR.....	LOG
VIDEO FILTER.....	OFF
SCAN MODE.....	INT

*External AM Sensitivity Checks*

- e. Note signal level of fundamental frequency displayed on spectrum analyzer. This is the reference level for the test.
- f. Set the 8620A rear-panel 1 KHZ SQ WV/OFF switch to OFF Position. Adjust external power supply for - 10.0 Vdc output. The power output as observed on OFF spectrum analyzer should decrease by >25 dB below the reference.
- g. Disconnect external power supply from 8620A EXT AM connector.

*ON/OFF Ratio*

- h. Connect oscilloscope and crystal as shown in Figure 4-14.
- i. Set controls as follows:

8620A

SWEEP MODE .....	AUTO
SWEEP TIME.....	1 -- .01 SEC
SWEEP TIME Vernier .....	Fully clockwise
1 KHZ S WV/OFF (Rear Panel) .....	1 KHZ SQ WV
RF BLANKING/OFF (Rear Panel).....	RF BLANKING

86260A

POWER LEVEL .....	Maximum Levelled Power
ALC .....	EXT

---

**PERFORMANCE TESTS**

---

**4-15. INTERNAL AND EXTERNAL AM (Cont'd)**

- j. Press 8620A START pushbutton. Observe oscilloscope trace. The blanking line should be coincident with "OFF" portion of the RF signal. (This shows that the squarewave ON/OFF ratio and blanking ON/OFF ratio are the same.)
  - k. Disconnect crystal detector and oscilloscope, and connect spectrum analyzer. Set 8620A MODE switch to AUTO, set TRIGGER switch to EXT, and set RF BLANKING/OFF switch (rear panel) to OFF.
  - l. Set reference level of signal on spectrum analyzer. Set RF BLANKING/OFF to RF BLANKING. Power level difference should be >25 dB (ON/OFF ratio).
  - m. Adjust START control through frequency band and note minimum and maximum power points. Check ON/OFF ratio at these points by setting 8620A RF BLANKING/OFF switch to RF BLANKING and OFF Power level at all frequency points across band should have an RF ON/OFF ratio of >25 dB.
-

Table 4-1. Performance Test Record

Hewlett-Packard Model 86260A RF PLUG-IN		Tested By: _____		
Serial No. _____		Date: _____		
Para. No.	Test Description	Lower Limit	Measured Value	Upper Limit
4-7	<b>FREQUENCY RANGE AND ACCURACY</b> d. CW pointer to 12.4 GHz e. CW pointer to 15.2 GHz f. CW pointer to 18.0 GHz g. START-STOP, MANUAL control ccw h. START-STOP, MANUAL control cw	12.350 GHz 15.150 GHz 17.950 GHz 12.330 GHz 17.930 GHz	_____ _____ _____ _____ _____	12.450 GHz 15.250 GHz 18.050 GHz 12.470 GHz 18.070 GHz
4-8	<b>FREQUENCY STABILITY</b> b. Line Voltage at 103 c. Line Voltage at 127 VAC d. 10 dB Power Level Change		_____ _____	± 180 kHz change ± 180 kHz change ± 6 MHz change
4-9	<b>RESIDUAL FM IN 10 KHZ BANDWIDTH</b> i. Peak-to-peak Residual FM		_____	50 kHz
4-10	<b>POWER LEVEL AND VARIATION</b> c. Crystal leveled maximum output power f. Crystal detector leveling variation j. Power meter leveling variation n. Power variation unlevelled	+7 dBm	_____ _____ _____	0.2 dB p-p 8 dB p-p
4-11	<b>SPURIOUS SIGNALS</b> d. Below fundamental at +7 dBm power output Harmonic: Non-Harmonic:	> 50 dB > 25 dB	_____ _____	
4-12	<b>RESIDUAL AM</b> d. Below maximum output power	50 dB	_____	
4-13	<b>EQUIVALENT SOURCE SWR</b> f. SWR		_____	2.0:1
4-14	<b>EXTERNAL FM</b> c. Modulation frequency of 200 Hz d. Modulation frequency of 200 kHz	± 75 MHz ± 5 MHz	_____ _____	
4-15	<b>INTERNAL AND EXTERNAL AM</b> f. Attenuation with -10 Vdc input m. ON/OFF ratio with internal 1 kHz applied	25 dB 25 dB	_____ _____	

**SECTION V  
ADJUSTMENTS**

**5-1. INTRODUCTION**

5-2. This section provides adjustment procedures for the Model 86260A RF Plug-in. These procedures should not be performed as a routing maintenance procedure but should be used (1) after replacement of a part or component, (2) when performance tests show that the specifications of Table 1-1 cannot be met, or (3) when instructed to do so in troubleshooting tree in Section VIII. Before attempting any adjustment, allow 30 minutes warmup time for the instrument. A List of Adjustments by reference designation, schematic name, and function is given in Table 5-1 and the test setup for the adjustment procedure is shown in Figure 5-1.

**5-3. EQUIPMENT REQUIRED**

5-4. Table 1-3 lists the equipment required for the adjustment procedure. If the test equipment recommended is not available, other equipment may be used if its performance meets the "Critical Specifications" listed in the table.

**5-5. FACTORY SELECTED COMPONENTS**

5-6. Factory selected components can be recognized by an asterisk on the schematic diagram. The range of values and HP Part Numbers are listed in the Replaceable Parts List, Table 6-3. Refer to Table 5-3 for the selection of A ICR5 and paragraph 5-13 for the installation and adjustment procedure.

*Table 5-1. List of Adjustments*

Reference Designation	Schematic Name	Function
AIR34	BIAS LEVEL	Adjusts bias voltage applied to YIG tuned Oscillator
A1R43	BIAS LIMIT	Adjusts firing point of over-voltage protection for YIG tuned Oscillator
AIR3	LOW	Adjusts tuning voltage level for low frequency limit of band
A1R6	HI	Adjusts tuning voltage level for high frequency limit of band
A2R29	OFFSET	Adjusts bias level offset for leveling amplifier
R1	POWER LEVEL	Front panel control to adjust level of RF power output
R2	GAIN	Front panel adjustment for gain of ALC amplifier



**5-7. RELATED ADJUSTMENTS**

5-8. The bias voltage applied to the YIG tuned Oscillator A4 must be checked prior to making the frequency adjustments since there is interaction between these controls.

5-9. The BIAS LEVEL and BIAS LIMIT adjustments are not interacting controls but the adjustments must be done in the order indicated by the procedure. The BIAS LEVEL sets the oscillator bias voltage (VBIAS). VBIAS is a critical value which determines the optimum operation of the oscillator or the point at

which the oscillator operates with the best power distribution across the band and in the most stable mode. The BIAS LIMIT is an equipment protection control and adjusts the firing point at which the bias voltage is removed from the oscillator.

5-10. The oscillator bias voltage must be checked prior to setting the HI and LOW tuning voltage limits for the high and low frequency points.

**5-11. ADJUSTMENTS LOCATION**

5-12. For the location of the adjustments, refer to Figure 8-19

**ADJUSTMENTS**

---

**5-13. OSCILLATOR BIAS LEVEL AND BIAS LIMIT ADJUSTMENT**

REFERENCE:

Service Sheet i, YIG DRIVER ASSEMBLY

DESCRIPTION:

Sets bias voltage (V.BAS) for the YIG tuned oscillator A4 and firing point of protective circuit for the oscillator. The required VBIAS is stamped on the oscillator and the firing point is set 0.5 volts more negative than VBIAS.

**NOTE**

Before beginning these adjustments, note the oscillator VBIAS indicated on the oscillator nameplate.

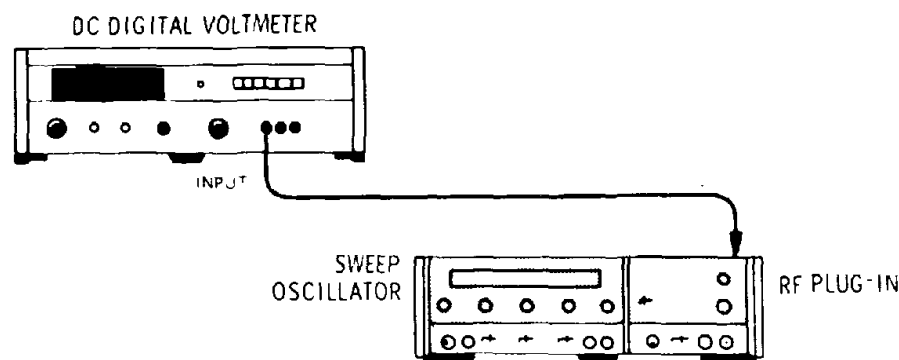

Figure 5-1. Oscillator Bias Adjustment Setup  
5-2

**ADJUSTMENTS**

**5-13. OSCILLATOR BIAS LEVEL AND BIAS LIMIT ADJUSTMENT (Cont'd)**

**EQUIPMENT:**

Sweep Oscillator .....	HP 8620A
RF Plug-in .....	HP 86260A
Digital Voltmeter .....	HP 3460B

**NOTE**

The following adjustments are factory adjustments for each oscillator. The adjustments are made only when (1) an oscillator is replaced, (2) the Regulated Bias Supply on A1 is repaired, or (3) the bias voltage is out of tolerance with that stamped on the oscillator.

- a. Turn off 8620A and remove mainframe top cover.

**WARNING**

With the top cover removed, terminals are exposed that have AC voltages capable of causing death.

- b. Determine correct zener diode, A1CR5.

**NOTE**

If an oscillator is replaced, it may be necessary to change A CR5 depending upon the new oscillator bias voltage.

1) Note VBIAS indicated on oscillator nameplate.

2) Refer to Table 5-2. See which Oscillator Bias Voltage Range the new oscillator is in and determine which zener diode to use.

*Table 5-2. Selection of A1CR5 Breakdown Diode*

<b>Oscillator Bias Voltage Range**</b>	<b>Selected Zener Diode Values for A1CR5*</b>
-- 6.70V to -- 7.15V	6. 19V
-- 7.15V to -- 7.77V	6.81V
-- 7.77V to -- 8.67V	7.50V
-- 8.67V to -- 9.55V	8.25V
-- 9.55V to -- 10.50V	9.09V
-- 10.50V and above	10.00V
<p>* Refer to Table 6-3 for A1CR5 HP part numbers.                      ** Select range that covers bias voltage required by oscillator A4.</p>	

**ADJUSTMENTS**

---

**5-13. OSCILLATOR BIAS LEVEL AND BIAS LIMIT ADJUSTMENT (Cont'd)**

**NOTE**

If the Bias Voltage of the new oscillator is in the same range as the Bias Voltage of the old oscillator, no replacement is necessary.

3) Replace AICR5 with correct zener diode if the new and old diodes are in different Bias Voltage Ranges.

4) Select zener diode that corresponds to the range of the new oscillator bias voltage.

Example: The old bias voltage was -9.50V and the new bias voltage is -7.5V. The old oscillator is in the range of -8.67 to -9.55V using an 8.25V zener diode. The new oscillator is in the range of -7.15V to -7.77V using a 6.81V zener diode. Replace the 8.25V diode with the 6.81V diode. (Refer to Table 6-2 for HP Part Number.)

5) Install new zener diode and continue VBIAS adjustment procedure.

**NOTE**

In the following procedure, an 8620A mainframe is used; however, an 8620B may be used, but the controls will be different that those called out in the procedure.

c. Set 8620A controls as follows:

RF.....ON  
ALC .....OFF

d. Disconnect P1 located by XA3. Temporarily remove A3 board for easy access to P1.

e. Remove fuse AIFI located under A1TP5.

f. Turn BIAS LEVEL, A1R34, fully counterclockwise and BIAS LIMIT, A1R43, fully clockwise.

**NOTE**

The BIAS LEVEL and BIAS LIMIT adjustments are 17-turn potentiometers.

g. Connect DVM to 86260A A1TP7 and ground lead to A1TP6.

**CAUTION**

The BIAS LEVEL and BIAS LIMIT controls must be adjusted in the exact order and to the exact voltage levels indicated in the procedure or damage to the YIG tuned oscillator may result.

h. Turn on 8620A.

i. Adjust BIAS LEVEL to VBIAS, noted on oscillator nameplate, plus --0.5V ±0.01V. Example: If the required bias voltage is --8.5V, then BIAS LEVEL is adjusted to --9.0V: --8.5V + (--0.5V)= --9V.

---

**ADJUSTMENTS**

---

**5-13. OSCILLATOR BIAS LEVEL AND BIAS LIMIT ADJUSTMENT (Cont'd)**

- j. Adjust BIAS LIMIT counterclockwise until bias voltage suddenly drops to less than 1 volt. This is the firing point of the oscillator protective circuit.

**NOTE**

$$\text{Firing-Point Voltage} = V_{\text{BIAS}} + (-0.5V \pm 0.01V)$$

- k. Move RF ON/OFF switch to OFF position.

**NOTE**

Once the protective circuits are tripped, the power supply must be shut down before the supply will reset. To RESET the bias voltage, turn the RF ON/OFF switch to OFF, then ON.

- l. Adjust BIAS LIMIT one turn clockwise, switch RF ON, and adjust BIAS LIMIT counterclockwise until firing point again occurs.
- m. Reset bias voltage and repeat step k to ensure that BIAS LIMIT adjustment is set to correct firing-point voltage.
- n. Adjust BIAS LEVEL counterclockwise 1/2 turn, and reset bias voltage.
- o. Adjust BIAS LEVEL to  $V_{\text{BIAS on RF heatsink nameplate}} + 0.01V$ .
- p. Turn off 8620A mainframe, reconnect P1, and insert A1F1.
- q. Turn on 8620A and check bias voltage to ensure that bias level is correct. Readjust if necessary.

---

**5-14. FREQUENCY ADJUSTMENT**

## REFERENCE:

Service Sheet I, YIG DRIVER ASSEMBLY.

## DESCRIPTION:

Adjusts for CW frequency accuracy to obtain correlation with tuning voltage from 8620A mainframe.

**NOTE**

Initial adjustments may be made in MANUAL mode, but final adjustments and measurements must be made in CW. Always approach frequency settings from low-frequency end.

**ADJUSTMENTS**

**5-14. FREQUENCY ADJUSTMENT (Cont'd)**

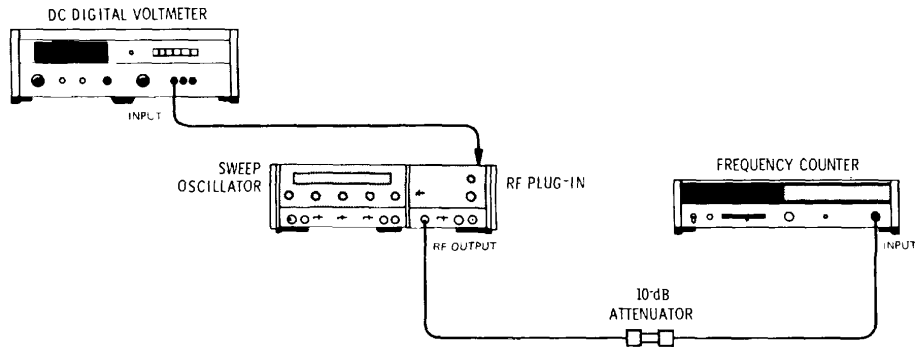

Figure 5-2. Frequency Adjustment Setup

**EQUIPMENT:**

Sweep Oscillator .....	HP 8620A
RF Plug-in .....	HP 86260A
Digital Voltmeter .....	HP 3460B
Frequency Counter.....	HP 5340A
10-dB Attenuator .....	HP 8491B, Option 010

**PROCEDURE:**

- a. Press 8620A START pushbutton to select START-STOP sweep mode. Turn MANUAL sweep control through its range several times.
- b. Set 8620A MANUAL control fully counterclockwise. Adjust LOW frequency limit A1R3 for frequency counter indication of 12.400 GHz  $\pm$  70 MHz.
- c. Set 8620A MANUAL control fully clockwise. Adjust HI frequency limit AIR6 for frequency counter indication of 18.000 GHz  $\pm$ 70 MHz.
- d. Press 8620A CW pushbutton. Set CW pointer so voltages at A1TP4 will correspond to DVM voltages listed in Table 5-3, If readout on frequency counter is out of tolerance, adjust A1R3 and A IR6 as necessary to obtain all points within tolerance.

**ADJUSTMENTS**

**5-14. FREQUENCY ADJUSTMENT (Cont'd)**

*Table 5-3. Frequency Tracking Adjustment*

Set CW for DVM Indication at 86260A- A1TP2 (Vdc)	Frequency Counter Indications (GHz)	Compromise Adjustment
0.667 ± 0.005	12.400 ± 0.025	} A1R3
2.500 ± 0.005	13.500 ± 0.025	
5.000 ± 0.005	15.000 ± 0.025	} A1R6
7.500 ± 0.005	16.500 ± 0.025	
10.000 ± 0.005	18.000 ± 0.025	

**5-15. LEVELING AMPLIFIER OFFSET ADJUSTMENT**

REFERENCE:

Service Sheet 2, ALC ASSEMBLY.

DESCRIPTION:

Adjust ALC Leveling Amplifier to provide a zero to -5 mV output.

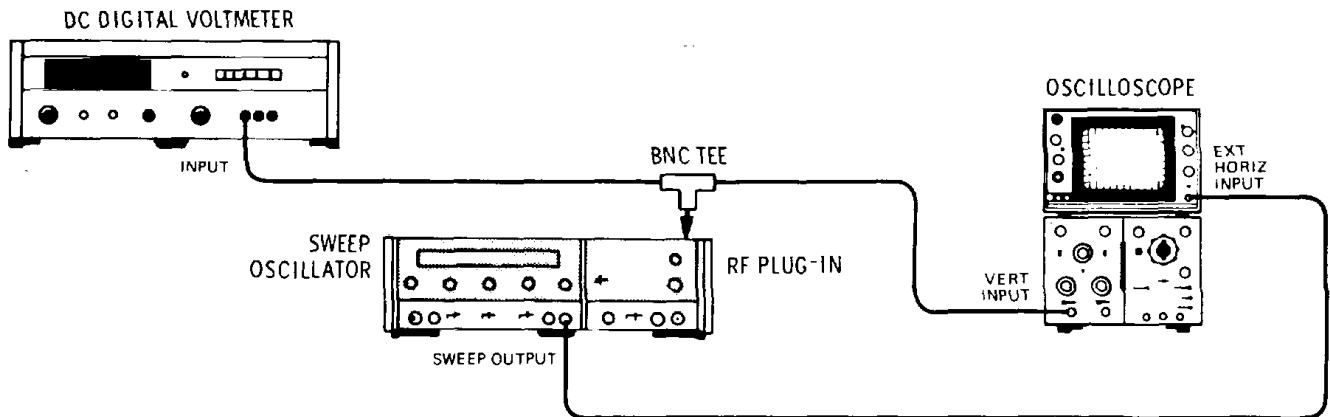

*Figure 5-3. Leveling Amplifier Offset Adjustment Setup*

EQUIPMENT:

- Sweep Oscillator ..... HP 8620A
- RF Plug-in ..... HP 86260A
- Digital Voltmeter ..... HP 3460B
- Oscilloscope ..... HP 180A/1801A/1820A

**ADJUSTMENTS**

---

**5-15. LEVELING AMPLIFIER OFFSET ADJUSTMENT (Cont'd)**

PROCEDURE:

a. Connect digital voltmeter to A2TP5.

b. Set 8620A controls as follows:

MODE..... AUTO  
 TIME-SECONDS..... 0.1 - 0.01  
 SWEEP TIME vernier..... Fully clockwise  
 RF BLANKING/OFF ..... RF BLANKING

c. Set 86260A controls as follows:

RF.....ON  
 ALC .....EXT  
 ALC GAIN..... Fully clockwise

d. Adjust POWER LEVEL fully clockwise and then rotate counterclockwise to point where UNLEVELED lamp just goes off.

e. Reduce ALC GAIN so blanking overshoot disappears. If no overshoot appears, leave GAIN at maximum.

f. Adjust polarity switch A2S1,  $-\pm$ , and power meter switch A2S2, 431/432, for a combination that develops highest positive voltage at A2TP5.

g. Adjust OFFSET A2R20 for a zero to -5 mV at A2TP5.

## SECTION VI REPLACEABLE PARTS

### 6-1. INTRODUCTION

6-2. This section contains information for ordering parts.

Table 6-1 lists abbreviations used in the parts list and throughout the manual. Table 6-2 lists all replaceable parts in reference designator order. Table 6-3 is the PART NUMBER - NATIONAL STOCK NUMBER CROSS REFERENCE INDEX.

### 6-3. ABBREVIATIONS

6-4. Table 6-1 gives a list of abbreviations used in the parts list, schematics, and throughout the manual. In some cases, two forms of the abbreviation are given; one is in capital letters, and one is partial or no capitals. This occurs because in the parts list, abbreviations are all capitals. However, in the schematics and other parts of the manual, other abbreviation forms are used with both lower case and upper case letters.

### 6-5. REPLACEABLE PARTS LIST

6-6. Table 6-2 is the list of replaceable parts and is organized as follows:

- a. Electrical assemblies and their components in alpha-numerical order by reference designation.
- b. Chassis-mounted parts in alpha-numeric order by reference designation.

- c. Miscellaneous parts.
- d. Illustrated parts breakdown, if appropriate.

The following information given for each part consists of the following:

- a. The Hewlett- Packard part number.
- b. The total quantity (QTY) in the instrument.
- c. The description of the part.
- d. The typical manufacturer of the part in a five-digit code.
- e. Manufacturer part number.

The total quantity for each part is given only once - at the first appearance of the part number in the list.

### 6-7. DELETED



Table 6-1. Reference Designations and Abbreviations (1 of 2)

**REFERENCE DESIGNATIONS**

A ..... assembly	E ..... miscellaneous electrical part	P ..... electrical connector (movable portion): plug	U ..... integrated circuit; microcircuit
AT ..... attenuator; isolator; termination	F ..... fuse	Q ..... transistor: SCR; triode thyristor	V ..... electron tube
B ..... fan; motor	FL ..... filter	R ..... resistor	VR ..... voltage regulator; breakdown diode
BT ..... battery	H ..... hardware	RT ..... thermistor	W ..... cable; transmission path; wire
C ..... capacitor	HY ..... circulator	S ..... switch	X ..... socket
CP ..... coupler	J ..... electrical connector (stationary portion); jack	T ..... transformer	Y ..... crystal unit (piezo-electric or quartz)
CR ..... diode; diode thyristor; varactor	K ..... relay	TB ..... terminal board	Z ..... tuned cavity tuned circuit
DC ..... directional coupler	L ..... coil; Inductor	TC ..... thermocouple	
DL ..... delay line	M ..... meter	TP ..... test point	
DS ..... annunciator; signaling device (audible or visual); lamp; LED	MP ..... miscellaneous mechanical part		

**ABBREVIATIONS**

A ..... ampere	COEF ..... coefficient	EDP ..... electronic data common	INT ..... internal
ac ..... alternating	current ..... COM	ELECT ..... electrolytic	kg ..... kilogram
ACCESS ..... accessory	COMP ..... composition	ENCAP ..... encapsulated	kHz ..... kilohertz
ADJ ..... adjustment	COMPL ..... complete	EXT ..... external	ic ..... kilohm
A/D ..... analog-to-digital	CONN ..... connector	F ..... farad	kV ..... kilovolt
AF ..... audio frequency	CP ..... cadmium plate	FET ..... field-effect transistor	lb ..... pound
AFC ..... automatic frequency control	CRT ..... cathode-ray tube	F/F ..... flip-flop	LC ..... inductance-capacitance
AGC ..... automatic gain control	CTL ..... complementary transistor logic	FH ..... flat head	LED ..... light-emitting
AL ..... aluminum	CW ..... continuous wave	FIL H ..... fillister head	LF ..... low frequency
ALC ..... automatic level control	cw ..... clockwise	FM ..... frequency modulation	LG ..... long
AM ..... amplitude modulation	cm ..... centimeter	front ..... panel	LH ..... left hand
AMPL ..... amplifier	digital-to-analog ..... FP	FREQ ..... frequency	LIM ..... limit
APC ..... automatic phase control	dB ..... decibel	FXD ..... fixed	LIN ..... linear taper (used in parts list)
ASSY ..... assembly	dBm ..... decibel referred to 1 mW	g ..... gram	lin ..... linear
AUX ..... auxiliary	dc ..... direct current	GE ..... germanium	LK WASH ..... lock washer
avg ..... average	deg ..... degree (temperature interval or difference)	GHz ..... gigahertz	LO ..... low; local oscillator
AWG ..... American wire gauge	degree (plane angle) ..... C	GL ..... glass	LOG ..... logarithmic taper (used in parts list)
BAL ..... balance	degree Celsius (centigrade) ..... HEX	GND ..... ground(ed)	log ..... logarithm(ic)
BCD ..... binary coded decimal	OF ..... degree Fahrenheit	H ..... henry	LPF ..... low pass filter
BD ..... board	K ..... degree Kelvin	h ..... hour	LV ..... low voltage meter (distance)
BE CU ..... beryllium copper	DEPC ..... deposited carbon	HET ..... heterodyne	mA ..... milliampere
BFO ..... beat frequency oscillator	DET ..... detector	hexagonal ..... m	MAX ..... maximum
BH ..... binder head	diam ..... diameter	HD ..... head	M ..... megohm
BKDN ..... breakdown	DIA ..... diameter (used in parts list)	HDW ..... hardware	MEG ..... meg (106) (used in parts list)
BP ..... bandpass	DIFF AMPL ..... differential amplifier	HF ..... high frequency	MET FLM ..... metal film
BPF ..... bandpass filter	div ..... division	HG ..... mercury	MET OX ..... metallic oxide
BRS ..... brass	DPDT ..... double-pole, double-throw	HI ..... high	MF ..... medium frequency; microfarad (used in parts list)
BWO ..... backward-wave oscillator	DR ..... drive	HP ..... Hewlett-Packard	MFR ..... manufacturer
DSB ..... DSB	double ..... sideband	HPF ..... high pass filter	mg ..... milligram
CAL ..... calibrate	DTL ..... diode counter-clockwise logic	HR ..... hour (used in parts list)	MHz ..... megahertz
ccw ..... counter-clockwise	DVM ..... digital voltmeter	HV ..... high voltage	mH ..... millihenry
CER ..... ceramic	ECL ..... emitter logic	Hz ..... Hertz	nhomho
CHAN ..... channel	EMF ..... electromotive force	integrated ..... circuit	min ..... minute (time)
cm ..... centimeter		ID ..... inside diameter	minute ..... (plane angle)
CMO ..... cabinet mount only		IF ..... intermediate frequency	MINAT ..... miniature
COAX ..... coaxial		IMP ..... impregnated	mm ..... millimeter
		in ..... inch	
		coupled ..... INCD incandescent	
		INCL ..... include(s)	
		INP ..... input	
		INS ..... insulation	

**NOTE**

All abbreviations in the parts list will be in upper-case.

Table 6-1. Reference Designations and Abbreviations (1 of 2)

MOD . . . . . modulator	OD . . . . . outside diameter	PWV . . . . . peak working voltage	TD . . . . . time delay
MOM . . . . . momentary	OH . . . . . oval head	RC . . . . . resistance-capacitance	TERM . . . . . terminal
MOS . . . . . metal-oxide semiconductor	OP AMPL . . . . . operational amplifier	RECT . . . . . rectifier	TFT . . . . . thin-film transistor
ms . . . . . millisecond	OPT . . . . . option	REF . . . . . reference	TGL . . . . . toggle
MTG . . . . . mounting	OSC . . . . . oscillator	REG . . . . . regulated	THD . . . . . thread
MTR . . . . . meter (indicating device)	OX . . . . . oxide	REPL . . . . . replaceable	THRU . . . . . through
mV . . . . . millivolt	oz . . . . . ounce	RF . . . . . radio frequency	TI . . . . . titanium
mVac . . . . . millivolt, ac	$\Omega$ . . . . . ohm	RFI . . . . . radio frequency interference	TOL . . . . . tolerance
mVdc . . . . . millivolt, dc	P . . . . . peak (used in parts list)	RH . . . . . round head; right hand	TRIM . . . . . trimmer
mVpk . . . . . millivolt, peak	PAM . . . . . pulse-amplitude modulation	RLC . . . . . resistance-inductance-capacitance	TSTR . . . . . transistor
mVp-p . . . . . millivolt, peak-to-peak	PC . . . . . printed circuit	RMO . . . . . rack mount only	TTL . . . . . transistor-transistor logic
mVrms . . . . . millivolt, rms	PCM . . . . . pulse-code modulation; pulse-count modulation	rms . . . . . root-mean-square	TV . . . . . television
mW . . . . . milliwatt	PDM . . . . . pulse-duration modulation	RND . . . . . round	TVI . . . . . television interference
MUX . . . . . multiplex	pF . . . . . picofarad	ROM . . . . . read-only memory	TWT . . . . . traveling wave tube
MY . . . . . mylar	PH BRZ . . . . . phosphor bronze	R&P . . . . . rack and panel	U . . . . . micro ( $10^6$ ) (used in parts list)
$\mu$ A . . . . . microampere	PHL . . . . . Phillips	RWV . . . . . reverse working voltage	UF . . . . . microfarad (used in parts list)
$\mu$ F . . . . . microfarad	PIN . . . . . positive-intrinsic-negative	S . . . . . scattering parameter	UHF . . . . . ultrahigh frequency
$\mu$ H . . . . . microhenry	PIV . . . . . peak inverse voltage	s . . . . . second (time)	UNREG . . . . . unregulated
$\mu$ mho . . . . . micromho	pk . . . . . peak	" . . . . . second (plane angle)	V . . . . . volt
$\mu$ s . . . . . microsecond	PL . . . . . phase lock	S-B . . . . . slow-blow (fuse) (used in parts list)	VA . . . . . voltampere
$\mu$ V . . . . . microvolt	PLO . . . . . phase lock oscillator	SCR . . . . . silicon controlled rectifier; screw	Vac . . . . . volts, ac
$\mu$ Vac . . . . . microvolt, ac	PM . . . . . phase modulation	SE . . . . . selenium	VAR . . . . . variable
$\mu$ Vdc . . . . . microvolt, dc	PNP . . . . . positive-negative-positive	SECT . . . . . sections	VCO . . . . . voltage-controlled oscillator
$\mu$ Vpk . . . . . microvolt, peak	P/O . . . . . part of	SHF . . . . . superhigh frequency	Vdc . . . . . volts, dc
$\mu$ Vp-p . . . . . microvolt, peak-to-peak	POLY . . . . . polystyrene	SI . . . . . silicon	VDCW . . . . . volts, dc, working (used in parts list)
$\mu$ Vrms . . . . . microvolt, rms	PORC . . . . . porcelain	SIL . . . . . silver	V(F) . . . . . volts, filtered
$\mu$ W . . . . . microwatt	POS . . . . . positive; position(s) (used in parts list)	SL . . . . . slide	VFO . . . . . variable-frequency oscillator
nA . . . . . nanoampere	POSN . . . . . position	SNR . . . . . signal-to-noise ratio	VHF . . . . . very-high frequency
NC . . . . . no connection	POT . . . . . potentiometer	SPDT . . . . . single-pole, double-throw	Vpk . . . . . volts, peak
N/C . . . . . normally closed	p-p . . . . . peak-to-peak	SPG . . . . . spring	Vp-p . . . . . volts, peak-to-peak
NE . . . . . neon	PP . . . . . peak-to-peak (used in parts list)	SR . . . . . split ring	Vrms . . . . . volts, rms
NEG . . . . . negative	PPM . . . . . pulse-position modulation	SPST . . . . . single-pole, single-throw	VTO . . . . . voltage-tuned oscillator
nF . . . . . nanofarad	PREAMPL . . . . . preamplifier	SSB . . . . . single sideband	VTVM . . . . . vacuum-tube voltmeter
NI PL . . . . . nickel plate	PRF . . . . . pulse-repetition frequency	SST . . . . . stainless steel	V(X) . . . . . volts, switched
N/O . . . . . normally open	PRR . . . . . pulse repetition rate	STL . . . . . steel	W . . . . . watt
NOM . . . . . nominal	ps . . . . . picosecond	SQ . . . . . square	W/ . . . . . with
NORM . . . . . normal	PT . . . . . point	SWR . . . . . standing-wave ratio	WIV . . . . . working inverse voltage
NPN . . . . . negative-positive-negative	PTM . . . . . pulse-time modulation	SYNC . . . . . synchronize	WW . . . . . wirewound
NPO . . . . . negative-positive zero (zero temperature coefficient)	PWM . . . . . pulse-width modulation	T . . . . . timed (slow-blow fuse)	W/O . . . . . without
NRFR . . . . . not recommended for field replacement		TA . . . . . tantalum	YIG . . . . . yttrium-iron-garnet
NSR . . . . . not separately replaceable		TC . . . . . temperature compensating	Z <sub>0</sub> . . . . . characteristic impedance
ns . . . . . nanosecond			
nW . . . . . nanowatt			
OBD . . . . . order by description			

NOTE

All abbreviations in the parts list will be in upper-case.

MULTIPLIERS

Abbreviation	Prefix	Multiple
T	tera	$10^{12}$
G	giga	$10^9$
M	mega	$10^6$
k	kilo	$10^3$
da	deka	10
d	deci	$10^{-1}$
c	centi	$10^{-2}$
m	milli	$10^{-3}$
$\mu$	micro	$10^{-6}$
n	nano	$10^{-9}$
p	pico	$10^{-12}$
f	femto	$10^{-15}$
a	atto	$10^{-18}$

TABLE 6-2. Replaceable Parts

Reference Designation	HP Part Number	Qty	Description	Mfr Code	Mfr Part Number
A1	86260-60035	1	BOARD ASSY: YIG DRIVER INCLUDES ALL A1CR5:: VALUES. SEE PARAGRAPH 5-13.	28480	86260-60034
A1C1	0160-3460	1	C: FXD CER 0.05 UF +80-20% 100DCW	56289	C023E401L503ZS22-CDM
A1C2	0160-0127	5	C:FXD CER 1.0 UF 20% 25VDCW	56289	5C13CS-CML
A1C3	0160-3450	1	C:FXD 5000 PF 10% 250VDCW	56289	C067B251H502KS25-CDH
A1C4	0180-0228	2	C:FXD ELECT 22 UF 10% 15VDCW	56289	150D226x9015B2-DYS
A1C5	0180-0228		C:FXD ELECT 22 UF 10% 15DCW	56289	150D226X90115B2-DYS
A1C6	0160-2199	3	C:FXD CER30 PF 5% 500VDCW	28480	0160-2199
A1C7	0160-2204		C:FXD CER 100 PF 5% 300 VDCW	28480	0160-2204
A1C8	0160-3459	2	C:FXD CER 0.02 UF 20% 100VDCW	56289	C023F101H203MS22CDH
A1C9	0160-2055		C:FXD CER 0.01 UF +80-20% 100VDCW	56289	C023F10F103ZS22-CDH
A1C10	0180-0374	3	C:FXD TANT 10 UF 10% 20VDCW	56289	150D106X9020B2-DYS
A1C11	0180-2486		C:FXD TANT 470 UF 20% 30VDCW	28480	0180-2486
A1C12	0180-2486		C:FXD TANT 470 UF 20% 30VDCW	28480	0180-2486
A1C13	0180-0094	1	C:FXD ELECT 100 UF +75-10% 25VDCW	56289	30D107G025DD2-DSM
A1C14	0180-1746	1	C:FXD ELECT 15 UF 10% 20VDCW	28480	0180-1746
A1CR1	1901-0025	5	DIODE: SILICON 100MA/1V	07263	FD 2387
A1CR2	1902-0041	1	DIODE: BREAKDOWN:5.11V 5%	04713	SZ10939-98
A1CR3	1902-3193	1	DIODE BREAKDOWN:9.09 5%	28480	1902-3149
A1CR4	1902-3193	1	DIODE BREAKDOWN:13.3V 5%	28480	1902-3193
A1CR5*	1902-0049	0	DIDODE:BREAKDOWN:6.19V 5%	047133	SZ10939-122
A1CR5*	1902-0064	0	DIDODE BREAKDOWN: 7.5V	28480	1902-0064
A1CR5*	1902-3149	0	DIODE BREAKDOWN: 9.09V 5%	28480	1902-3149
A1CR5*	1902-0025	0	DIODE, BREAKDOWN:10.0V 5% 400 MW	28480	1902-0025
A1CR5*	1902-3139	0	DIODE: BREAKDOWN:8.25V 5%	04173	SZ10939-158
A1CR5*	1902-0048	0	DIODE:BREAKDOWN:6-81V 5%	04713	SZ10939-134
A1CR6	1901-0743	2	DIODE:BREAKDOWN		
A1CR7	1902-3290	1	DIODE BREAKDOWN:SILICON 31.6V 5%	28480	1902-3290
A1F1	2110-0047	1	FUSE:CARTRIDGE 1A	71400	TYPE GMW-1
A1K1	0490-0885	1	RELAY:REED 24VDC	80131	RA30192241
A1MP1	0360-0065	2	TERMINAL:SOLDER STUD SWAGE TYPE	0000	OBD
A1MP2	0360-0065		TERMINAL:SOLDER STUD SWAGE TYPE	00000	OBD
A1MP3	1251-2313	2	CONNECTOR:SINGLE CONTACT	00779	3-332070-5
A1MP4	1251-2313		CONNECTOR:SINGLE CONTACT	00779	3-332070-5
A1MP5	1400-0774	2	CLAMP:CABLE 0.375" DIA	00000	OBD
A1MP6	1400-0774		CLAMP:CABLE 0.375" DIA	00000	OBD
A1MP7	4040-0749	2	EXTRACTOR:PC BOARD, BROWN	28480	4040-0749
A1MP8	4040-0749		EXTRACTOR:PC BOARD, BROWN	28480	4040-0749
A1Q1	1854*0404	1	TSTR:SI NPN	28480	1854-0404
A1Q2	1853-0038	2	TSTR:SI PNP	28480	1853-0038
A1Q3	1884-0073	1	THRISTOR:SCR	03877	SW4051
A1Q4	1853-0451	3	TSTR: PNP 2N3799	28480	1853-0451
A1Q5	1853-0451		TSTR: PNP 2N3799	28480	1853-0451
A1Q6	1853-0038		TSTR:SI PNP	28480	1853-0038
A1Q7	1854-0071	7	TSTR:SI NPN(SELECTED FROM 2N3704)	28480	1854-0071
A1R1	0757-0458	2	R:FXD MET FLM 51.1K OHM 1% 1/8W	28480	0757-0458
A1R2	0757-0460	3	R:FXD MET FLM 61.9K OHM 1% 1/8W	28480	0757-0460
A1R3	2100-3154	1	R:VAR CERMET 1000 OHM 10% TYPE P 3/4W	28480	2100-3154
A1R4	0757-0442	9	R:FXD MET FLM 10.0K OHM 1% 1/8W	28480	0757-0442
A1R5	0757-0442		R:FXD MET FLM 10.0K OHM 1% 1/8W	28480	0757-0442
A1R6	2100-3056	3	R:VAR CERMET 5K OHM 10% TYPE P 3/4W	28480	2100-3056
A1R7	0811-2902	1	R:FXD WW 3.4K OHM 1.0% 1/8W	28480	0811-2902
A1R8	0811-1195	1	R:FXD WW 2.15K OHM 1.0% 1/8W	28480	0811-1195
A1R9	0698-3454	6	R:FXD MET FLM 215K OHM 1% 1/8W	28480	0698-3454
A1R10	0757-0444	1	R:FXD MET FLM 12.1K OHM 1% 1/8W	28480	0757-0444
A1R11	0811-3146	1	R:FXD WW 7.50K OHM 1% 1/8W	28480	0811-3146
A1R12	08113209	1	R:FXD WW 6.670K OHM	28480	0811-3209
A1R13	0757-0401	3	R:FXD MET FLM 100 OHM 1% 1/8W	28480	0757-0401
A1R14	0764-0023	1	R:FXD MET FLM 910 OHM 5% 2W	28480	0764-0023
A1R15	0811-3213	1	R:FXD WW 3.16K OHM 1%	28480	0811-3213
A1R16	0757-0180	1	R:FXD MET FLM 31.6 OHM 1% 1/8W	28480	0757-0180
A1R17	0811-3207	2	R:FXD WW 2.5K OM	28480	0811-3207
A1R18	0757-0465	3	R:FXD MET FLM 100K OHM 1% 1/8W	28480	0757-0465
A1R19	0811-3208	1	R:FXD WW 2.083K OHM	28480	0811-3208
A1R20	0757-0280	13	R:FXD MET FLM 1K OM 1% 1/8W	28480	0757-0280
A1R21	0757-0288	1	R:FXD MET ELM 9.09K OHM 1 1/8W	28480	0757-0288
A1R22	0698-0083	2	R:FXD MET ELM 1.96K OHM 1 1/8W	28480	0698-0083
A1R23	0698-3102	1	R:FXD MET ELM 237 OHM 1% 1/2W	28480	0698-3102
A1R24	0698-3150	2	R:FXD MET FL4 2.37K OHM 11 1/8W	28480	0698-3150
A1R25	0811-3207		R:FXD WW 2.5K OHM	28480	0811-3207
A1R26	0811-1178	1	R:FXD WW 6.19K OHM 13 1/8W	28480	0811-1178
A1R27	0757-0346	2	R:FXO MET ELM 10 OHM 11 1/6W	28480	0757-0346
A1R28	0811-1553	1	R:FXD WW 0.68 OHM 53 2W	28480	0811-1553
A1R29	0757-0467	1	RPFXO MET ELM 121K OHM 1 1/8W	28480	0757-0467
A1R30	0683-2265	3	R:FXD COMPO 22 MEGOHM 5% 1/4W FACTORY SELECTED PART, SELECT QTY OF ONE.	01121	CB 2265

See introduction to this section for ordering information

TABLE 6-2. Replaceable Parts

Reference Designation	HP Part Number	Qty	Description	Mfr Code	Mfr Part Number
A1R31	0757-0440	1	R:FXD MET FLM 7.50K OHM 1%/8W	28480	0757-0440
A1R32	0757-0416	2	R:FXD MET FLM 511 OHM 1% 1/8W	28480	0757-0416
A1R33	0757-0279	3	R:FXD MET FLM 3.16K OHM 1%/8W	28480	0757-0279
A1R34	2100-3056		R:VAR CERMET 5K OHM 10% TYPE P 3/4W	28480	2100-3056
A1R35	0757-0290	1	R:FXD MET FLM 6.19K OHM 1% 1/8W	28480	0757-0290
A1R36	0757-0279		R:FXD MET FLM 3.16K OHM 1%/8W	28480	0757-0279
A1R37	0157-0441	1	R:FXD MET FLM 8.25K OHM 1%/8W	28480	0757-0441
A1R38	0757-0394	3	R:FXD MET FLM 51.1 OHM 1% 1/8W	28480	0157-0394
A1R39	0757-0397	1	R:FXD MET FLM 68.1 OHM 1% 1/8W	28480	0757-0397
A1R40	0698-3152	1	R:FXD MET FLM 3.48K OHM 1% 1/8W	28480	0698-3152
A1R41	0757-0416		R:FXD MET FLA 511 OHM 1% 1/8W	28480	0757-0416
A1R42	0698-3453	1	R:FXD MET FLM 196K OHM 1% 1/8W	28480	0698-3453
A1R43	2100-3056		R:VAR CERMET 5K OHM 10% TYPE P 3/4W	28480	2100-3056
A1R44	0757-0280		R:FXD MET FLM 1K OHM 1% 1/8W	28480	0757-0280
A1U1	1820-0223	3	INTEGRATED CIRCUIT:OPERATIONAL AMPLIFIER	28480	1820-0223
A1U2	1826-0013	1	IC:LINEAR	28480	1826-0013
A1U3	1820-0223		INTEGRATED CIRCUIT:OPERATIONAL AMPL.	28480	1820-0223
A2	86260-60011	1	BOARD ASSY:A L C	24480	86260-60011
A2C1	0140-0198	4	C:FXD MICA 200 PF 5% 300VDCW	72136	RDM15F201J3C
A2C2	0160-2255	2	C:FXD CER 8.2 PF 50VDCW	72982	301-00-COHO-829C
A2C3	0160-0174	2	C:FXD CER 0.47 UF ±80-20% 25VDCW	56289	5C11875-CML
A2C4	0140-0198		C:FXD MICA 200 PF 52 300VDCW	72136	RDM15F201J3C
A2C5	0160-2255		C:FXD CER 8.2 PF 50VDCW	72982	301-000-COHO-829C
A2C6	0180-1743	3	C:FXD ELECT 0.1 UF 105 35VDCW	56289	150D104X9035A2-DYS
A2C7	0160-0127		C:FXD CER 1.0 UF 205 25VDCW	56289	5C13CS-CML
A2C8	0160-0127		C:FXD CER 1.0 UF 20% 25VDCM	56289	5C13CS-CML
A2C9	0160-3459		C:FXD CER 0.02 UF 205 10VDCW	56289	C023F101H203MS22CDH
A2C10	0160-0174		C:FXD CER 0.47 UF ±80-202 25VDCW	56289	5C11B75-CML
A2C11	0160-2306	1	C:FXD MICA 27 PF 55 300VDCW	28480	0160-2306
A2C12	0180-1743		C:FXD ELECT 0.1 UF 105 35VDCW	56289	150D104X9035A2-DYS
A2C13	0160-0127		C:FXD CER 1.0 UF 202 25VDCW	56289	5C13CS-CML
A2C14	0160-0127		C:FXD CER 1.0 UF 205 25VDCW	56289	5C13CS-CML
A2C15	0160-3454	1	C:FXD CER 220 PF 10% 500VDCW	56289	C067F501F221KS22-CDH
A2C16	0180-1743		C:FXD ELECT 0.1 UF 105 35VDCW	56289	150D104X9035A2-DYS
A2C17	0180-0197	1	C:FXD ELECT 2.2 UF 10% 20VDCW	56289	150D225X9020A2-DYS
A2CR1	1901-0025		DIODE:SILICON 100MA/IV	07263	FD 2387
A2CR2	1901-0025		DIODE:SILICON 100MA/IV	07263	FD 2387
A2CR3	1901-0025		DIODE:SILICON 100MA/IV	07263	FD 2387
A2CR4	1901-0376	4	DIODE:SILICON 35V	28480	1901-0376
A2CR5	1901-0376		DIODE:SILICON 35V	28480	1901-0376
A2CR6	1901-0040	9	DIODE:SILICON 30MA 30WV	07263	FDG1088
A2CR7	1901-0535	5	DIODE:HYBRID HOT CARRIER	28480	1901-0535
A2CR8	1901-0535		DIODE:HYBRID HOT CARRIER	28480	1901-0535
A2CR9	1901-0535		DIODE:HYBRID HOT CARRIER	28480	1901-0535
A2CR10	1901-0040		DIODE:SILICON 30MA 30WV	07263	FDG1088
A2CR11	1901-0040		DIODE:SILICON 30MA 30WV	07263	FDG1088
A2CR12	1901-0040		DIODE:SILICON 30MA 30WV	07263	FDG1088
A2CR13	1901-0040		DIODE:SILICON 30MA 30WV	07263	FDG1088
A2CR14	1901-0040		DIODE:SILICON 30MA 30WV	07263	FDG1088
A2CR15	1901-0040		DIODE:SILICON 30MA 30WV	07263	FDG1088
A2CR16	1901-0535		DIODE:HYBRID HOT CARRIER	28480	1901-0535
A2CR17	1901-0376		DIODE:SILICON 35V	25480	1901-0376
A2CR18	1901-0376		DIODE:SILICON 35V	28480	1901-0376
A2CR19	1901-0535		DIODE:HYBRID HOT CARRIER	28480	1901-0535
A2CR20	1901-0040		DIODE:SILICON 30MA 30WV	07263	FDG1088
A2CR21	1910-0016	2	DIODE:GERMANIUM 100MA/0.85V 60PIV	93332	D2361
A2CR22	1910-0016		DIODE:GERMANIUM 100MA/0.85V 60PIV	93332	D2361
A2MP1	4040-0750	2	EXTRACTOR:PC BOARD, RED	28480	4040-0750
A2MP2	4040-0750		EXTRACTOR:PC BOAR., RED	28480	4040-0750
A2Q1	1855-0081	7	TSTR:SI FET	80131	2N5245
A2Q2	1854-0071		TSTR:SI NPN(SELECTED FROM 2N3704)	28480	1854-0071
A2Q3	1855-0081		TSTR:SI FET	80131	2N5245
A2Q4	1855-0081		TSTR:SI FET	80131	2N5245
A2Q5	1855-0081		TSTR:SI FET	80131	2N5245
A2Q6	1853-0020	2	TSTR:SI PNP(SELECTED FROM 2N3702)	28480	1853-0020
A2Q7	1855-0081		TSTR:SI FET	80131	2N5245
A2Q8	1853-0451		TSTR: PNP 2N3799	28480	1853-0451
A2Q9	1854-0053	2	TSTR:SI NPN	80131	2N2218
A2Q10	1853-0020		TSTR:SI PNP(SELECTED FROM 2N3702)	28480	1853-0020
A2Q11	1854-0071		TSTR:SI NPN(SELECTED FROM 2N3704)	28480	1854-0071
A2Q12	1852-0071		TSTR:SI NPN(SELECTED FROM 2N3704)	28480	1854-0071
A2Q13	1854-0071		TSTR:SI NPN(SELECTED FROM 2N3704)	28480	1854-0071
A2Q14	1855-0081		TSTR:SI FET	80131	215245
A2Q15	1855-0081		TSTR:SI FET	80131	2N5245
A2R1	0757-0442		R:FXD MET FLM 10.OK OHM 1% 1/8W	28480	0757-0442

See Introduction to this section for ordering information

TABLE 6-2. Replaceable Parts

Reference Designation	HP Part Number	Qty	Description	Mfr Code	Mfr Part Number
A2R2	0757-0438	5	R:FXD MET ELM 5.11K OHM 1% 1/8W	28480	0757-0438
A2R3	0698-3156	2	R:FXD MET ELM 14.7K OHM 1% 1/8W	28480	0698-3156
A2R4	0683-2265		R:FXD COMP 22 MEGOHM 5% 1/4W	01121	CB 2265
A2R5	0683-2265		R:FXD COMP 22 MEGOHM 5% 1/4W	01121	CB 2265
A2R6	0757-0442		R:FXD MET FLM 10.0K OHM 1% 1/8W	28480	0757-0442
A2R7	0757-0460		R:FXD MET FLM 61.9K OHM 1% 1/8W	28480	0757-0460
A2R8	0757-0438		R:FXD MET FLM 5.11K OHM 1% 1/8W	28480	0757-0438
A2R9	0757-3280		R:FXD MET FLM 1K OHM 1% 1/8W	28480	0757-0280
A2R10	0757-0442		R:FXD MET FLM 10.0K OHM 1% 1/8W	28480	0757-0442
A2R11	0698-3156		R:FXD MET ELM 14.7K OHM 1% 1/8W	28480	0698-3156
A2R12	0757-0280		R:FXD MET FLM 1K OHM 1% 1/8W	28480	0757-0280
A2R13	0757-0280		R:FXD MET FLM 1K OHM 1% 1/8W	28480	0757-0280
A2R14	0698-3450	3	R:FXD MET FLM 42.2K OHM 1% 1/8W	28480	0698-3450
A2R15	0757-0280		R:FXD MET FLM 1K OHM 1% 1/8W	28480	0757-0280
A2R16	0757-0280		R:FXD MET FLM 1K OHM 1% 1/8W	28480	0757-0280
A2R17	0757-0280		R:FXD MET FLM 1K OHM 1% 1/8W	28480	0757-0280
A2R18	0757-0401		R:FXD MET FLM 100 OHM 1% 1/8W	28480	0757-0401
A2R19	0698-3160	1	R:FXD MET FLA 31.6K OHM 1% 1/8W	28480	0698-3160
A2R20	2100-3162	1	R:VAR CERMET 200K OHM 10% TYPE P 3/4W	28480	2100-3162
A2R21	0698-3454		R:FXD MET FLM 215K OHM 1% 1/8W	28480	0698-3454
A2R22	0757-0442		R:FXD MET FLM 10.0K OHM 1% 1/8W	28480	0757-0442
A2R23	0757-0442		R:FXD MET FLM 10.0K OHM 1% 1/8W	28480	0757-0442
A2R24	0757-0279		R:FXD MET FLM 3.16K CHN 1% 1/8W	28480	0757-0279
A2R25	0757-0280		R:FXD MET FLM 1K OHM 1% 1/8W	28480	0757-0280
A2R26	0698-3150		R:FXD MET FLM 2.37K OHM 1% 1/8W	28480	0698-3150
A2R27	0698-3454		R:FXD MET FLM 215K OHM 1% 1/8W	28480	0698-3454
A2R28	0757-0458		R:FXD MET FLM 1 1k OHM 1% 1/8W	28480	0757-0458
A2R29	0698-0084	1	R:FXD MET FLM 2.15K OHM 1% 1/8W	28480	0698-0084
A2R30	0757-0442		R:FXD MET FLM 10.0K OHM 1% 1/8W	28480	0757-0442
A2R31	0698-3451	1	R:FXD MET FLM 133K OHM 1% 1/8W	28480	0698-3451
A2R32	0757-0442		R:FXD MET FLM 10.0K OHM 1% 1/8W	28480	0757-0442
A2R33	0683-3955	1	R:FXD COMP 3.9 MEGOHM 5% 1/4W	01121	C8 3955
A2R34	0757-0199	2	R:FXD MET FLM 21.5K OHM 1% 1/8W	28480	0757-0199
A2R35	0757-0438		R:FXD MET FLM 5.11K OHM 1% 1/8W	28480	0757-0438
A2R36	0757-0465		R:FXD MET FLM 100K OHM 1% 1/8W	28480	0757-0465
A2R37	0698-3157	1	R:FXD MET FLM 19.6K OHM 1% 1/8W	28480	0698-3157
A2R38	0698-3154	1	R:FXD MET FLM 4.22K OHM 1% 1/8W	28480	0698-3154
A2R39	0698-3454		R:FXD MET FLM 215K OHM 1% 1/8W	28480	0698-3454
A2R40	0698-3454		R:FXD MET ELM 215K OHM 1% 1/8W	28480	0698-3454
A2R41	0698-3454		R:FXD MET ELM 215K OHM 1% 1/8W	28480	0698-3454
A2R42	0757-0274	1	R:FXD MET FLM 1.21K OHM 1% 1/8W	28480	0757-0274
A2R43	0698-3450		R:FXD MET FLM 42.2K OHM 1% 1/8W	28480	0698-3450
A2R44	0757-0460		R:FXD MET FLM 61.9K OHM 1% 1/8W	28460	0757-0460
A2R45	0757-0465		R:FXD MET FLM 100K OHM 1% 1/8W	28480	0757-0465
A2R46	0757-0280		R:FXD MET FLM 1K OHM 1/8W	28480	0757-0280
A2R47	0757-0280		R:FXD MET FLM 1K OHM 1% 1/8W	28480	0757-0280
A2R48	0757-0438		R:FXD MET FLM 5.11K OHM 1% 1/8W	28480	0757-0438
A2R49	0698-3136	1	R:FXD MET ELM 17.8K OHM 1% 1/8W	28480	0698-3136
A2R50	0757-0438		R:FXD MET FLM 5.11K OHM 1% 1/8W	28480	0757-0438
A2R51	0757-0199		R:FXD MET FLM 21.8 OHM 1% 1/8W	28480	0757-0199
A2R52	0757-0405	1	R:FXD MET FLM 162 OHM 1% 1/8W	28480	0757-0405
A2R53	0698-3439	1	R:FXD MET FLM 178 OHM 1% 1/8W	28480	0698-3439
A2S1	3101-1274	2	SWITCH:SLIDE SPDT-DB	95146	MSS-22
A2S2	3101-1274	2	SWITCH:SLIDE SPDT-DB	95146	MSS-22
A2U1	1826-0081	2	IC:LINEAR OPERATIONAL AMPLIFIER	12040	LM318H
A2U2	1826-0081	1	IC:LINEAR OPERATIONAL AMPLIFIER	12040	LM318H
A2U3	1820-0223		INTEGRATED CIRCUIT:OPERATIONAL AMPL	28480	182-0223
A2U4	1820-0223		INTEGRATED CIRCUIT:OPERATIONAL AMPL	28480	182-0223
A3	86260-60012	1	BOARD ASSY:FM	28480	86260-60012
A3C1	0160-0970	1	C:FXD MY 0.47UF 10% 80VDCW	56289	192P4749R8-PTS
A3C2	0160-3536		C:FXD MICA 620 PF 5% 100VDCW	00853	RDM15F621J1C
A3C3	0180-0374		C:FXD TANT. 10 UF 10% 20VDCW	56289	150D106X9020B2-DYS
A3C4	0180-0374		C:FXD TANT. 10 UF 10% 20VDCW	56289	150D106X9020B2-DYS
A3C5	0160-1600	1	C:FXD MY 0.0082 UF 10% 200VDCW	56289	192P82292-PTS
A3C6	0160-2257		C:FXD CER 10 PF 5% 500VDCW	72982	301-000-COHO-100J
A3C7	0180-2208		C:FXD ELECT 220 UF 10% 10VDCW	56289	150D227X9010S2-DYS
A3C8	0160-3536	2	C:FXD MICA 620 PF 5% 100VDCW	00853	RDM15F621J1C
A3CR1	1901-0025		DIODE:SILICON 100MA/IV	07263	FD 2387
A3CR2	1901-0743		DIODE; PWR RECT IN4004 1A DO-41	04713	1901-0743
A3CR3	1901-0040		DIODE:SILICON 30MA 30VW	07263	FDG1088
3K1	0490-0884	1	RELAY:REED	28480	0490-0884
A3MP1	0360-1514	1	TERMINAL PIN:SOURCE	28480	0360-1514
A3MP2	1480-0073	2	PIN:DRIVE 0.250" LG	00000	OBD
A3MP3	1480-0073		PIN:DRIVE 0.250" LG	00000	OBD

See introduction to this section for ordering information

TABLE 6-2. Replaceable Parts

Reference Designation	HP Part Number	Qty	Description	Mfr Code	Mfr Part Number
A3MP4	4040-0751	2	EXTRACTOR:PC BOARD, ORANGE	28480	4040-0751
A3MP5	4040-0751		EXTRACTOR:PC BOARD ORANGE	28480	4040-0751
A3Q1	1854-0071		TSTR:SI NPN(SELECTED FROM 2N3704)	28480	1854-0071
A3Q2	1853-0034	1	TSTR:SI PNP(SELECTED FROM 2N3251)	28480	1853-0034
A3Q3	1854-0071		TSTR:SI NPN(SELECTED FROM 2N3704)	28480	1854-0071
A3Q4	1854-0053		TSTR:SI NPN	80131	2N2218
A3R1	0757-1094	1	R:FXD MET FLM 1.47K OHM 1% 1/8W	28450	0757-1094
A3R2	0757-0394		R:FXD MET FLM 51.1 OHM 1% 1/8W	28480	0757-0394
A3R3	0698-0083		R:FXD MET FLM 1.96K OHM 1% 1/8W	28480	0698-0083
A3R4	0757-0398	1	R:FXD MET FLM 75 OHM 1% 1/4W	28480	0757-0398
A3R5	0757-0420	1	R:FXD MET FLM 750 OHM 1% 1/8W	28480	0757-0420
A3R6	0757-0418	1	R:FXD MET FLM 619 OHM 1% 1/8W	28480	0757-0418
A3R7	0757-0462	1	R:FXD MET FLM 75.0K OHM 1% 1/8W	28480	0757-0462
A3R8	0757-0317	2	R:FXD MET FLM 1.33K OHM 1% 1/8W	28480	0757-0317
A3R9	0757-0317		R:FXD MET FLM 1.33K OHM 1% 1/8W	28480	0757-0317
A3R10	0683-1555	1	R:FXD COMP 1.5 MEGOHM 5% 1/4W	01121	CB 1555
A3R11	0757-0280		R:FXD MET FLM 1K OHM 1% 1/8W	284E0	0757-0280
A3112	0698-3159	1	R:FXD MET FLM 26.1K OHM 1% 1/8W	28480	0698-3159
A3R13	0698-0082	1	R:FXD MET FLM 464 OHM 1% 1/8W	28480	0698-0082
A3R14	0698-3450		R:FXD MET FLM 42.2K OHM 1% 1/8W	28480	0698-3450
A3R15	0157-0394		R:FXD MET FLM 51.1 OHM 1% 1/8W	28480	0757-0394
A3R16	0757-0280		R:FXD MET FLM 1K OHM 1% 1/8W	28480	0757-0280
A3R17	0757-0795	1	R:FXD MET FLM 75 OHM 1% 1/2W	28480	0757-0795
A3R18	0757-0401		R:FXD MET FLM 100 OHM 1% 1/8W	28480	0757-0401
A3R19	0757-0346		R:FXD MET FLM 10 OHM 1% 1/8W	28480	0757-0346
A3R20	0698-3429	1	R:FXD MET FLM 19.6 OHM 1% 1/8W	28480	0698-3429
A3U1	1820-0223		INTEGRATED CIRCUIT:OPERATIONAL AMPL.	28480	1820-0223
A4	86260-60032	1	YIG TUNED OSCILLATOR ASSY I INCLUDES SELECTED ZENER DIODE (A1CR5*). SEE PARAGRAPH 5-13.	28480	086260-60032
A5	0960-0322		ISOLATOR:PIN MODULATOR	28480	0960-0322
P1	1251-1037	1	CONNECTOR:MINAT MALE PLUG 7-CONTACT	81312	M7P
P1MP1	1251-1040	1	LOCK:SPRING, R & P CONNECTOR, HEX	81312	M7-LS
P1MP2	1251-1041	1	HOOD:INSULATING,R S P CONNECTOR	81312	M5-H16
P1MP3	1251-3172	1	CONNECTOR:SINGLE CONTACT	00779	2-331677-9
P2	1251-0483	1	CONNECTOR:R & P MALE 36 CONTACT PLUG	28480	1251-0483
DS1	1990-0325	1	DIODE:VISIBLE LIGHT EMITTER	28480	1990-0325
J1	1251-1036	1	CONNECTOR:7 CONTACT MINIATURE HEX	81312	M7S
J2	8690-60005	1	CONNECTOR. TYPE-N RF OUTPUT	28480	86290-60005
J3	1250-0118	1	CONNECTOR.BNC ALC EXT INPUT	24931	28JR 128-1
J4	1250-0083	2	CONNECTOR BNC FM	02660	31-221-1020
J5	1250-0083		CONNECTOR:BNC FREQ REF	02660	31-221-1020
C1 & Q2	1853-0252	2	TSTR:SI PNP	04713	SJ1798
R1	2100-2838		R:VAR COMP 20K OHM 10% LIN 0.5W POWER LEVEL	28480	2100-2838
R2	2100-2838	2	R:VAR COWP 20K OHM 10% LIN 0.5W ALC GAIN	28480	2100-2838
R3	0811-3145	1	R:FXD WW 20 OHM 1.0% 25W	28480	0811-3145
S1	3100-3086	1	SWITCH:LEVER (RF-ON-OFF)	28480	3100-3086
S2	3100-3085	1	SWITCH:LEVER (ALC)	28480	3100-3085
S3	3101-0106	1	SWITCH:SLIDE DP3T	82389	11D1031C
W1	856260-20005	1	CABLE ASSY:RF OUTPUT	28480	86260-20005
b3	86260-60005	1	CABLE ASSY,DRIVE-OSCILLATOR	28480	86260-60005
XA1	1251-0159	3	CONNECTOR:PC EDGE 2 X 15 CONTACT	71785	251-15-30-261
XA2	1251-0159		CONNECTOR:PC EDGE 2 X 15 CONTACT	71785	251-15-30-261
XA3	1251-0159		CONNECTOR:PC EDGE 2 X 15 CONTACT	71785	251-15-30-261
			MISCELLANEOUS		
	0370-1810	2	KNOB:LEVER SWITCH, OLIVE BLK RF OFF-ON	28480	0370-1810
	0590-0007	1	NUT:HEX 1/2-20 THREAD	73734	OBD
	0590-0075	2	NUT:CAPACITOR 4-40 THREAD	00000	OBD
	1200-0041	2	SOCKET:TRANSISTOR	71785	133-32-10-013
	1200-0043	2	INSULATOR:TSTR MOUNTING (TO-3)	71785	293011
	141-0069	1	BUSHING:POT. 1/4-32 EXTERNAL THREAD	00866	OBD
	5040-0345	2	INSULATOR:CONNECTOR	28480	5040-0345
	86260-00008	1	SCALE:FOR USE WITH 8620A MAINFRAME	28480	86260-0008
	86260-00009	1	SCALE:FOR USE WITH 8620B MAINFRAME	28480	86260-00009
	86260-60001	1	CABLE ASSY:MAIN	28480	86260-60001
	86260-60002	1	CABLE ASSY:SHIELD 2	28480	86260-60002

See introduction to this section for ordering information.

TABLE 6-2. Replaceable Parts

Reference Designation	HP Part Number	Qty	Description	Mfr Code	Mfr Part Number
<b>MISCELLANEOUS</b>					
	86260-20003	1	HEAT SINK:BIAS	28480	86260-00003
	0403-0153	2	GUIDE: PC BOARD, BROWN	28480	0403-0153
	0403-0154	2	GUIDE: PC BOARD, RED	28480	0403-0154
			GUIDE: PC BOARD, ORANGE	28480	0403-0155
			(BUSHING PANEL, OPTION 004)		
	86260-20008	1	PIN HINGE	28480	86260-20008
	1400-0825	1	4418 PANEL CLIP, MOLDED PLASTIC, BLK	28480	1400-0825)
	1460-1186	1	WIREFORM: SPRING DRAWER LATCH	28480	1460-1186
	86260-00006	2	BRACKET: HEAT SINK	28480	86260-00006
	6960-0016	2	PLUG: NYLON 0.125" DIA HOLE	00000	OBD
	86260-00010	2	BRACKET: ISOLATOR	28480	86260-00010
	6960-0046	1	PLUG-HOLE	00000	OBD
	86260-70004	1	HEAT SINK: OSCILLATOR	28480	86260-20004
	7123-2359	1	PLATE: SERIAL(SER CPT)	28480	7120-2359
	08612-00006	1	SPRING: GROUND	28480	08621-00006
	08621-20002	1	FRAME: DRAWER REAR	28480	08621-20002
	08620-20005	1			
	08640-60103	1	CONNECTOR ASSY: OUTPUT	28490	08640-60103
	86260-00001	1	PANEL: FRONT, UPPER	28430	86260-00001
	86260-00002	1	PANEL: FRONT, LOWER	28480	86260-00002
	86260-00004	1	FRAME: LEFT SIDE	28480	86260-00004
	86260-00005	1	DECK: MAIN	28480	86260-0 0005
	86260-00007	1	BRACKET: BOARD SUPPORT	28480	86260-00007
	86260-00011	1	SHIELD: TRANSISTOR	28480	86260-00011
	86260-00012	1	BRACE: DRAWER	28480	86260-00012

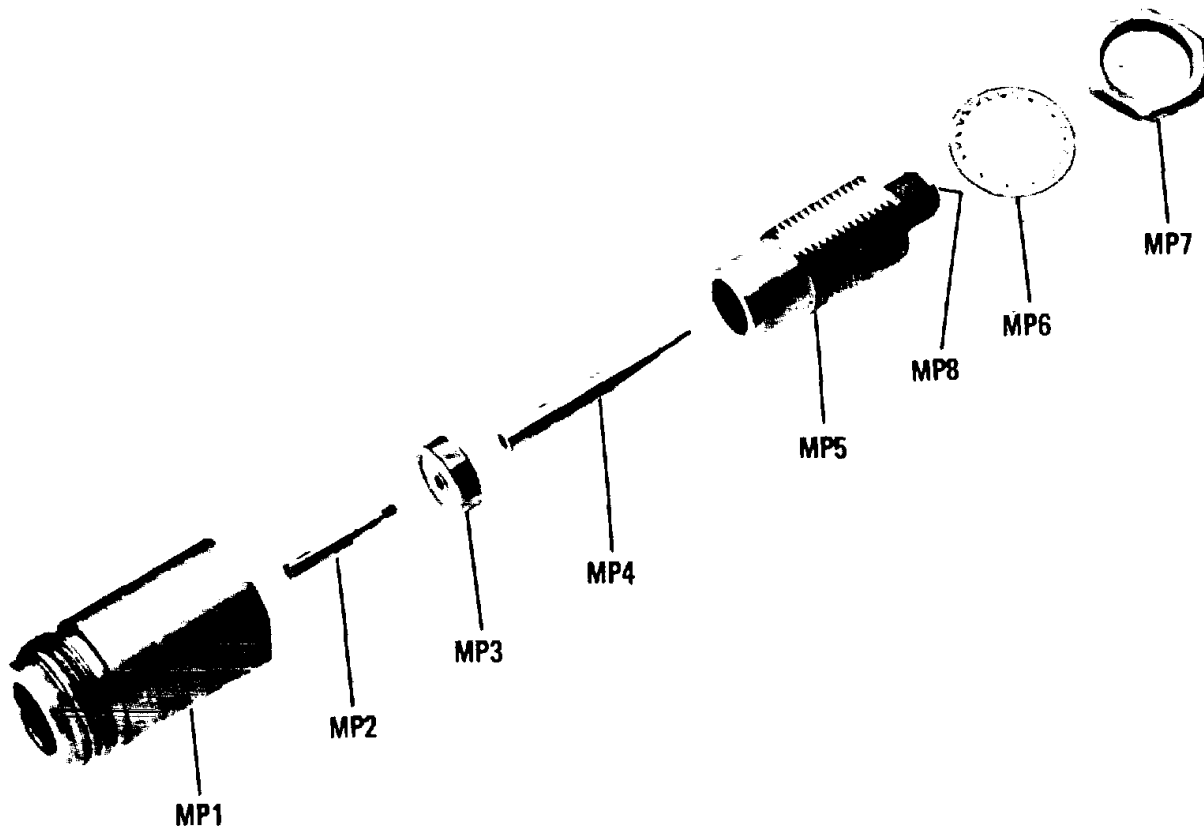

Reference Designation	HP Part Number	Qty	Description	Mfr Code	Mfr Part Number
J2MP1	1250-1577	1	Body: RF Connector (Type N)	28480	1250-1577
J2MP2	1250-0915	1	Contact: RF Connector (Type N)	02660	131-149
J2MP3	5040-0306	1	Insulator	28480	5040-0306
J2MP4	08555-20093	1	Center Conductor	28480	08555-20093
J2MP5	08555-20094	1	Body: Bulkhead	28480	08555-20094
J2MP6	2190-0104	1	Washer: Lock 0.439" ID	00000	OBD
J2MP7	2950-0132	1	Nut: Hex 7/16" OD - 28 Threads per inch	00000	OBD
J2MP8	08761-2027	1	Insulator	28480	08761-2027

Figure 6-1. RF Output Connector J2 Exploded View



Reference Designation	HP Part Number	Qty	Description	Mfr Code	Mfr Part Number
CABINET PARTS					
1	08621-20052	1	Screw: Latch	28480	08621-20052
2	08621-20051	1	Handle: Drawer Latch	28480	08621-20051
3	3050-0001	1	Washer: Latch Handle	28480	3050-0001
4	1460-1186	1	Spring: Latch	28480	1460-1186
5	86260-00004	1	Panel: Left Side	28480	86260-00004
6	2360-0115	2	Screw 6-32 .312"	28480	2360-0115
7	86260-00006	1	Bracket	28480	86260-00006
8	0590-0182	1	Heat Sink: Oscillator	28480	0590-0182
9	2360-0117	2	Screw 6-32. .375"Pan	28480	2360-0117
10	86260-20003	1	Heat Sink: Driver	28480	86260-20003
11	1200-0041	2	Socket: Transistor	28480	1200-0041
	1200-0043	2	Insulator: Transistor	28480	1200-0043
12	0590-0106	2	Nut: Plastic Hex 2-56 .141"	28480	0590-0106
13	08621-2002	1	Frame: Rear	28480	08621-20002
14	08621-00006	1	Spring: Ground	28480	08621-00006
15	1251-0483	1	Connector: 36 Pin Male Microribbon	71785	57-10310-375
16	0520-0131	2	Screw: Cap 1/4 x 20 1.5"	28480	0520-0131
17	86260-20003	1	Heat Sink: Bias 1		86260-20003
18	2200-0143	2	Screw 4-40 .375" Pan	28480	2200-0143
	2190-0019	2	Washer Lock .115" ID	28480	2190-0019
19	1250-0118	2	Connector: BNC Female Long	28480	1250-0118
	1250-0083	1	Connector: BNC Female Short	28480	1250-0083
20	2360-0182	4	Screw 6-32 .312" Flat	28480	2360-0182
21	2190-0016	2	Washer: Lock .377" ID	28189	1920-02
22	2950-0001	2	Nut: Hex 3/8-32 .094"	12697	20/4-13
23	2360-0182	2	Screw 6-32 .312" Flat	28480	2360-0182
24	86260-00012	1	Rail: Side	28480	86260-00012
25	86260-00005	1	Deck: Main	28480	86260-00005
26	2360-0205	2	Screw 6-32 .15" Pan	28480	2360-0205
	2190-0018	2	Washer Lock .141" ID	28480	2190-0018
27	2360-0117	2	Screw 6-32 .375" Pan	28480	2360-0117
28	86260-00007	1	Bracket: PC	28480	86260-00007
29	86260-00037	1	Panel: Sub	28480	86260-00037
30	0370-1101	1	Knob: Power Level Control	28480	0370-1101
31	86260-00002	1	Panel: Front Lower	28480	86260-00002
32	5040-0345	1	Insulator: Connector	28480	5040-0345
33	0370-1001	1	Knob: ALC Gain	28480	0370-1001
34	0370-0929	1	Knob: ALC Switch	28480	0370-0929
35	1400-0560	1	Clip: Mounting	28480	1400-0560
36	08690-60005	1	Connector: RF Type N	28480	08690-60005
37	0370-1810	1	Knob: RF ON-OFF	28480	0370-1810
38	86260-00001	1	Panel: Front Upper	28480	86260-00001

Figure 6-2 . Cabinets Parts (1 of 2)

Model 86260A

Replaceable Parts

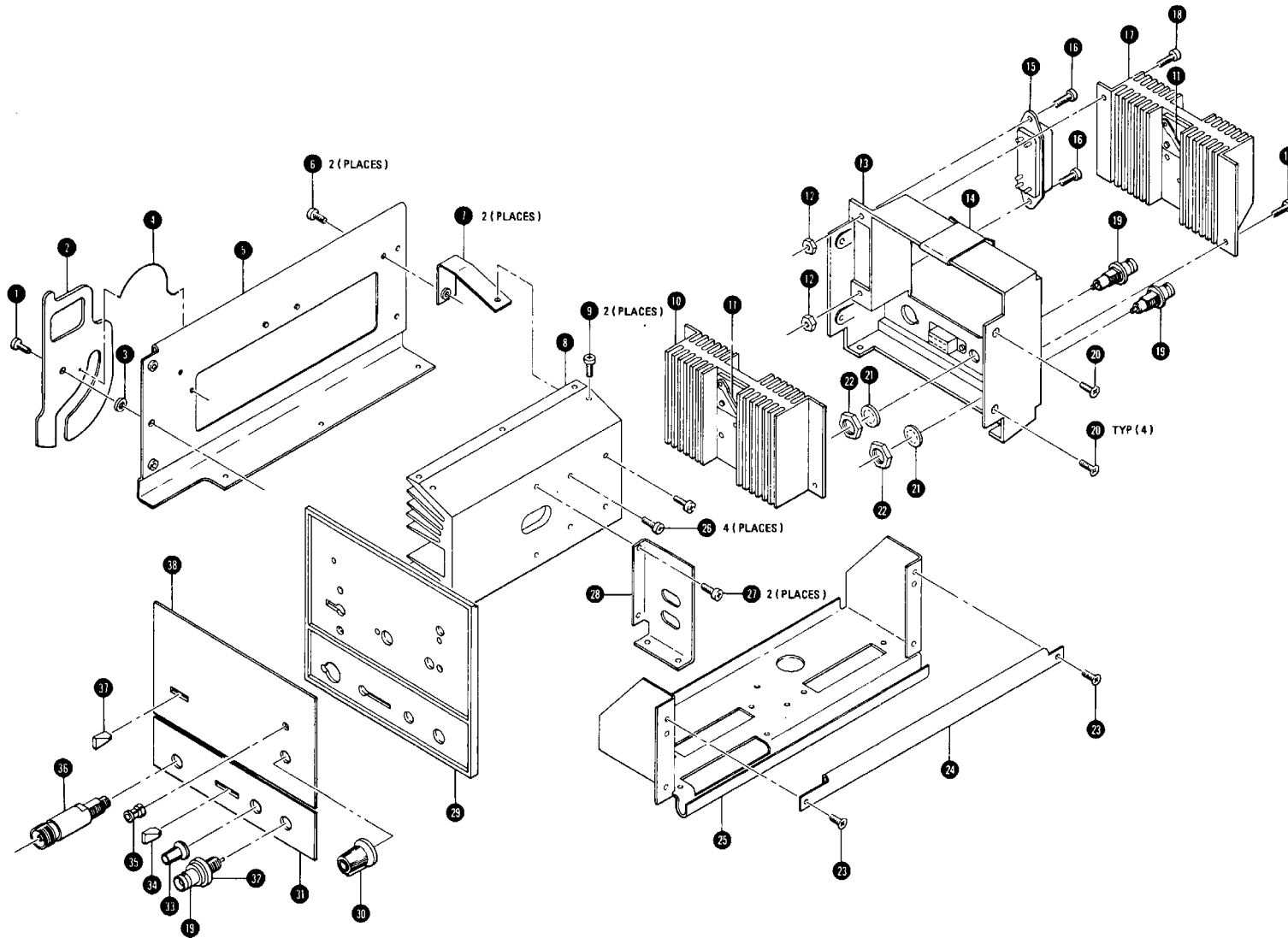

Figure 6-2. Cabinet Parts (2 of 2)  
6-11

**PART NUMBER - NATIONAL STOCK NUMBER  
CROSS REFERENCE INDEX**

<b>PART NUMBER</b>	<b>FSCM</b>	<b>NATIONAL STOCK NUMBER</b>	<b>PART NUMBER</b>	<b>FSCM</b>	<b>NATIONAL STOCK NUMBER</b>
CB1555	01121	5905-00-111-1684	0490-0884	28480	5945-00-175-4758
CB2265	01121	5905-00-402-4242	0683-2265	28480	5905-00-402-4242
C023F101H203MS22CDH	56289	5910-00-894-6728	0698-0082	28480	5905-00-974-6075
D2361	93332	5961-00-954-9182	0698-0083	28480	5905-00-407-0052
FDG1088	07263	5961-00-928-7939	0698-0084	28480	5905-00-974-6073
M7P	81312	5935-00-257-9879	0698-3102	28480	5905-00-007-3674
M7S	81312	5935-00-259-2039	0698-3136	28480	5905-00-891-4247
SJ1798	04713	5961-00-424-9411	0698-3150	28480	5905-00-481-1357
			0698-3152	28480	5905-00-420-7130
SZ10939-134	04713	5961-00-912-3099	0698-3154	28480	5905-00-891-4215
SZ10939-158	04713	5961-00-845-6458	0698-3156	28480	5905-00-974-6084
0140-0198	28480	5910-00-914-2605	0698-3157	28480	5905-00-433-6904
0160-0127	28480	5910-00-809-5484	0698-3159	28480	5905-00-407-0053
0160-0160	28480	5910-00-891-4207	0698-3160	28480	5905-00-974-6078
0160-0174	28480	5910-00-234-9817	0698-3429	28480	5905-00-407-0075
0160-2055	28480	5910-00-211-1611	0698-3439	28480	5905-00-407-0059
0160-2199	28480	5910-00-244-7164	0698-3450	28480	5905-00-826-3262
0160-2204	28480	5910-00-463-5949	0698-3451	28480	5905-00-405-3677
0160-2255	28480	5910-00-430-5934	0698-3453	28480	5905-00-078-1548
0160-2306	28480	5910-00-883-6281	0698-3454	28480	5905-00-974-6077
0160-3459	28480	5910-00-894-6728	0757-0180	28480	5905-00-972-4907
0160-3460	28480	5910-00-008-4458	0757-0199	28480	5905-00-981-7513
0180-0094	28480	5910-00-082-5119	0757-0274	28480	5905-00-858-9105
0180-0197	28480	5910-00-850-5355	0757-0279	28480	5905-00-221-8310
0180-0228	28480	5910-00-719-9907	0757-0280	28480	5905-00-853-8190
0180-0374	28480	5910-00-931-7050	0757-0288	28480	5905-00-193-4318
0180-1743	28480	5910-00-430-6017	0757-0290	28480	5905-00-858-8826
0180-1746	28480	5910-00-430-6036	0757-0317	28480	5905-00-244-7189
0180-2208	28480	5910-00-172-3140	0757-0346	28480	5905-00-998-1906
0360-1514	28480	5940-00-150-4513	0757-0394	28480	5905-00-412-4036

**PART NUMBER - NATIONAL STOCK NUMBER  
CROSS REFERENCE INDEX**

<b>PART NUMBER</b>	<b>FSCM</b>	<b>NATIONAL STOCK NUMBER</b>	<b>PART NUMBER</b>	<b>FSCM</b>	<b>NATIONAL STOCK NUMBER</b>
0757-0397	28480	5905-00-232-3125	1820-0223	28480	5962-00-614-5251
0757-0398	28480	5905-00-788-0291	1826-0013	28480	5962-00-247-9568
0757-0401	28480	5905-00-981-7529	1826-0081	28480	5962-01-021-5220
0757-0405	28480	5905-00-493-0738	1853-0020	28480	5961-00-904-2540
0757-0416	28480	5905-00-998-1795	1853-0034	28480	5961-00-987-4700
0757-0418	28480	5905-00-412-4037	1853-0038	28480	5961-00-111-0455
0757-0420	28480	5905-00-493-5404			
0757-0438	28480	5905-00-929-2529	1853-0252	28480	5961-00-424-9411
0757-0440	28480	5905-00-858-6795	1854-0071	28480	5961-00-137-4608
0757-0441	28480	5905-00-858-6799	1854-0404	28480	5961-00-408-9807
0757-0442	28480	5905-00-998-1792	1855-0081	28480	5961-00-350-8299
0757-0444	28480	5905-00-858-9132	1884-0073	28480	5961-00-654-3308
0757-0458	28480	5905-00-494-4628	1901-0025	28480	5961-00-978-7468
0757-0460	28480	5905-00-858-8959	1901-0040	28480	5961-00-965-5917
0757-0462	28480	5905-00-493-0783	1901-0376	28480	5961-00-790-7834
0757-0465	28480	5905-00-904-4412	1901-0535	28480	5961-00-790-7834
0757-0467	28480	5905-00-858-8868	1901-0743	18480	5961-00-496-7364
0757-0795	28480	5905-00-196-6747	1902-0025	28480	5961-00-914-3087
0757-1094	28480	5905-00-917-0580	1902-0041	28480	5961-00-858-7372
0764-0023	28480	5905-00-998-1799	1902-0048	28480	5961-00-912-3099
0811-1195	28480	5905-00-163-1325	1902-0049	28480	5961-00-911-9277
0811-1553	28480	5905-00-139-9567	1902-0064	28480	5961-00-904-0297
1200-0041	28480	5935-00-971-9712	1902-3139	28480	5961-00-494-4848
1200-0043	28480	5970-00-805-7166	1902-3149	28480	5961-00-252-1308
1250-0083	28480	5935-00-804-5144	1902-3193	28480	5961-00-247-8437
1250-0118	28480	5935-00-897-9351	1902-3290	28480	5961-00-225-9493
1251-0159	28480	5935-00-867-0119	1910-0016	28480	5961-00-954-9182
1251-1036	28480	5935-00-259-2039	1990-0325	28480	5961-00-622-0772
1251-2313	28480	5935-00-104-1184	2-331677-9	00779	5935-01-017-6539
133-32-10-013	71785	5935-00-885-8598	2N5245	80131	5961-00-350-8299

**PART NUMBER - NATIONAL STOCK NUMBER  
CROSS REFERENCE INDEX**

<b>PART NUMBER</b>	<b>FSCM</b>	<b>NATIONAL STOCK NUMBER</b>	<b>PART NUMBER</b>	<b>FSCM</b>	<b>NATIONAL STOCK NUMBER</b>
2100-2838	28480	5905-00-163-7035			
2100-3056	28480	5905-00-378-0987			
2100-3154	28480	5905-00-615-8111			
2360-0205	28480	5305-00-583-3935			
251-15-30-261	71785	5935-00-867-0119			
2950-0001	28480	5310-00-450-3324			
3-332070-5	00779	5935-00-104-1184			
31-221-1020	02660	5935-00-804-5144			
3101-1274	28480	5930-00-407-2017			
4040-0749	28480	6625-00-031-4796			
4040-0750	28480	5999-00-415-1213			
4040-0751	28480	5999-00-230-8835			
6960-0016	28480	5340-00-178-8004			
86290-60005	18480	5935-01-064-1602			

**NOTE**

**STOCK NUMBERS HAVE BEEN REQUESTED FOR THOSE ITEMS THAT DO NOT SHOW A STOCK NUMBER. WHEN ASSIGNED THEY WILL BE ADDED BY A CHANGE TO THIS MANUAL. UNTIL STOCK NUMBERS ARE ASSIGNED, THE ITEMS MAY BE REQUISITIONED BY MANUFACTURER AND PART NUMBER, DIRECT FROM: US ARMY COMMUNICATIONS AND ELECTRONICS MATERIEL READINESS COMMAND, ATTN: DRSEL-MM, FORT MONMOUTH, NJ 07703.**

6-15/6-16

**SECTION VII  
MANUAL CHANGES**

**7-1. INTRODUCTION**

7-2. This section contains information for adapting this manual to instruments for which the content does not apply directly.

7-3. To adapt this manual to your instrument, refer to Table 7-1 and make all of the manual changes listed opposite your instrument serial number. Perform these

changes in the sequence listed.

7-4. If your instrument serial number is not listed on the title page of this manual, or in the following tables, it may be documented in a yellow MANUAL CHANGES supplement. For additional important information about serial number coverage refer to INSTRUMENTS COVERED BY MANUAL in Section I.

*Table 7-1. Manual Changes by Serial Number*

**Serial Prefix or Number -Make Manual Changes**

1339A00356 thru 1339A00390	A
1339A00223 and 1339A00231 thru 1339A00355	A,B

**Serial Prefix or Number Make Manual Changes**

1217A00211 and 1217A00212, 1217A00217 thru 1217A00220 and 1217A00230	A,B,C
--	-------

**7-5. MANUAL CHANGE INSTRUCTIONS**

**CHANGE A**

Page 6-5, Table 6-3:

Change A1C7 to HP Part Number 0160-2257, C: FXD CER 10 PF 5% 500 WVDC, 28480, 0160-2257.

Page 8-1, Figure 8-13, SERVICE SHEET 1:

Change A1C7 to 10.

**CHANGE B**

Page 6-6, Table 6-3:

Add A2C6, HP Part Number 0180-1743, C: FXD ELECTROLYTIC 0.1 UF 10% 35VDCW

**CHANGE B (Cont'd)**

Page 8-15, Figure 8-15, SERVICE SHEET 2:  
Add A2C6 as shown in partial schematic, Figure 7-1.

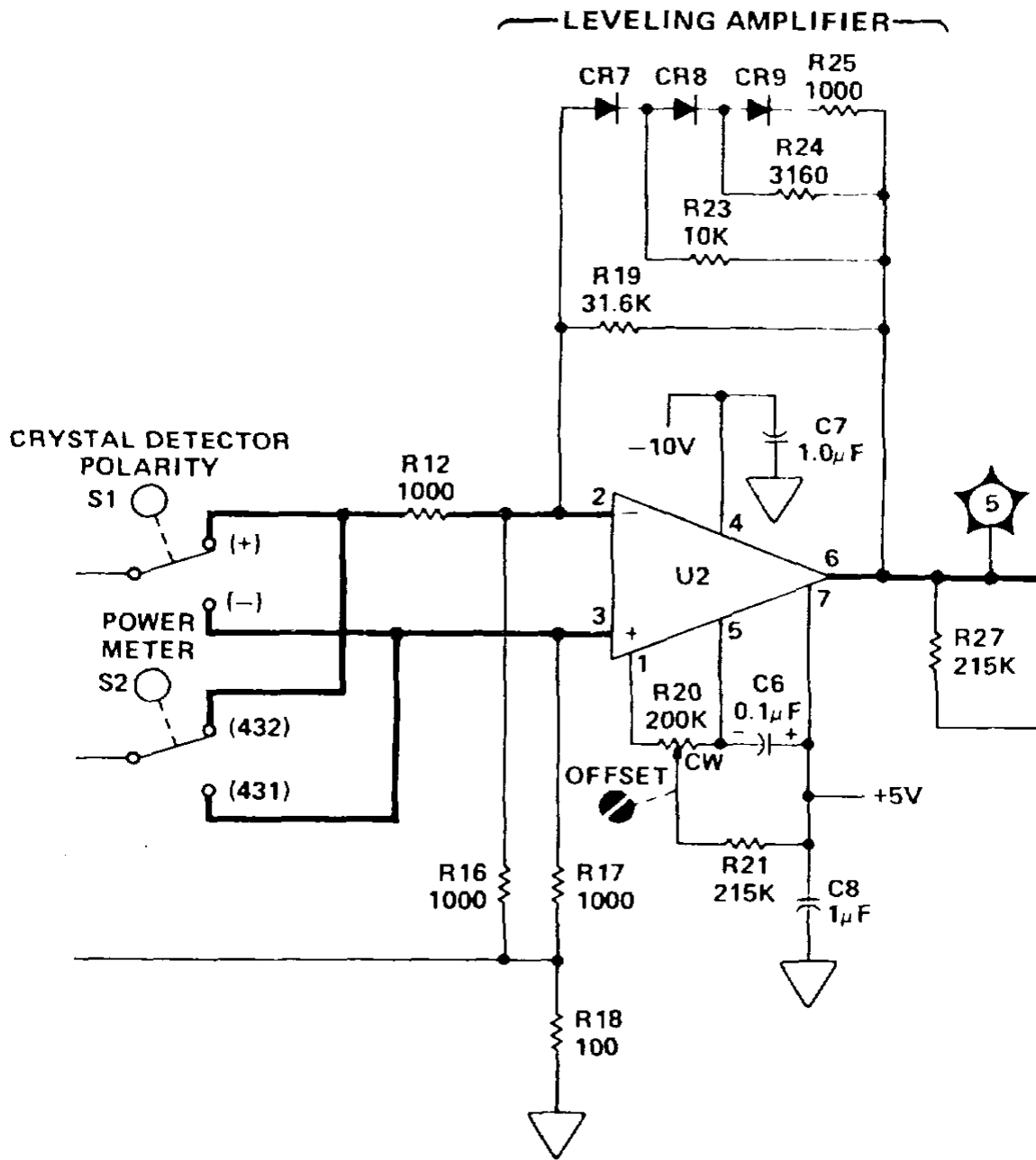

Figure 7-1. Partial Schematic of A2 ALC Assembly (CHANGE B)

**CHANGE C**

Page 6-5, Table 6-3:  
Change A1C6 to HP Part Number 0160-2257, C: FXD CER 10PF 5%  
500VDCW, 28480, 0160-2257.

Page 8-13, Figure 8-13, SERVICE SHEET 1:  
Change A1C6 to 10.

## MANUAL CHANGES

**MANUAL IDENTIFICATION**

**Model Number:** 86260A  
**Date Printed:** August 1975  
**Part Number:** 86260-90012

This supplement contains important information for correcting manual errors and for adapting the manual to instruments containing improvements made after the printing of the manual.

To use this supplement:

Make all ERRATA corrections

Make all appropriate serial number related changes indicated in the tables below.

Serial Prefix or Number	Make Manual Changes
1530A	1
1544A	1,2
1607A00496 thru 1607A025	1,2,3
1607A00526 thru 1607A prefix	1 thru 4
1633A	1 thru 5
1647A	1 thru 6
1705A	1 thru 7

Serial Prefix or Number	Make Manual Changes
1725A	1 thru 8
1843A	1 thru 9
1846A	1 thru 10

▶ NEW ITEM

The following Service Notes are available from your local HP Sales and Service Office.

SERVICE NOTE	SERIAL NUMBER	DESCRIPTION
86260A-1	1339A00385 AND BELOW	Modification Required for 8410B Compatibility

### ERRATA

▶ Page 1-5, Table 1-1, Frequency Accuracy:

Change the second line to read: CW Mode:3 ±50 MHZ7.

Page 1-5, Table 1-1, Frequency Stability:

Change third line to read: 10 dB Power Level Change from specified maximum power: ±6 MHz.

### NOTE

Manual change supplements are revised as often as necessary to keep manuals as current and accurate as possible. Hewlett-Packard recommends that you periodically request the latest edition of this supplement. Free copies are available from all HP offices. When requesting copies quote the manual identification information from your supplement, or the model number and print date from the title page of the manual.



**ERRATA (Cont'd)**

Page 1-5, Table 1-1, MODULATION:

Change sixth line under External FM to read: DC to 200 Hz:  $\pm 75$  MHz.

Change seventh line under External FM to read: 200 Hz to 200 kHz:  $\pm 5$  MHz

▸ Page 1-5, Table 1-1, footnotes:

Add: <sup>7</sup>It may be necessary to calibrate the 86260A in the 8620 mainframe in which it will be used. Refer to the adjustments section, paragraph 5-14.

Page 1-7, Table 1-2:

Change External AM specification to read: Unleveled: DC to 500 kHz, Leveled: DC to 300 kHz.

Page 4-2, Paragraph 4-7:

Add the following note before PROCEDURE:

**NOTE**

**It may be necessary to calibrate the 86260A in the 8620 mainframe in which it will be used.  
Refer to the adjustment section, paragraph 5-14.**

Page 4-3, Paragraph 4-8, SPECIFICATION:

Change second line of Frequency Stability to: With 10 dB power level change from specified maximum power:  $\pm 6$  MHz.

Page 4-4, Paragraph 4-8, steps b and c:

Change step d in second sentence to step a.

Page 4-4, Paragraph 4-8, step d:

Change first sentence to: Set POWER LEVEL to specified maximum power and note frequency indication on counter.

Page 6-1, Paragraph 6-2:

Delete second-sentence reference: "Table 6-1 is a list of exchange assemblies." Second sentence should read:

Table 6-1 lists abbreviations used in the parts list and throughout the manual.

Change beginning of third sentence to: Table 6-2 lists all replaceable .

Change beginning of last sentence to: Table 6-3 contains names and addresses .

Page 6-1, Paragraph 6-4:

Change Table 6-2 to Table 6-1.

Page 6-1, Paragraph 6-6:

Change Table 6-3 to Table 6-2.

▸ Page 6-4, Table 6-2:

Change A1Q4 and A1Q5 to HP and Mfr Part Number 1853-0451, TRANSISTOR PNP 2N3799.

Change A1CR6 to HP and Mfr Part Number 1901-0743, DIODE-PWR RECT 1N4004 400V 1A DO41.(RECOMMENDED REPLACEMENT)

▸ Page 6-5, Table 6-2:

Change A2Q8 to HP and Mfr Part Number 1853-0451, TRANSISTOR PNP 2N3799 (RECOMMENDED REPLACEMENT.)

▸ Page 6-6, Table 6-2:

Change A3CR2 to HP and Mfr Part Number 1901-0743, DIODE: PWR RECT 1N4004 400V 1A DO-41.

Page 6-7, Table 6-2:

Change J2 to HP and Mfr Part Number 86290-60005.

**ERRATA (Cont'd)**

Page 6-9, Figure 6-1:

Change J2MPI to HP and Mfr Part Number 1250-1577, Mfr Code 28480.

Page 6-10, Figure 6-2:

Change item 29 (PANEL. SUB) to HP and Mfr Part Number 86260-00037.

Page 8-13, Figure 8-14:

Change Q4 and Q5 to Part Number 1853-0451.

Add connection from junction of resistors R9 and R15 to UI pin 2.

▶ Page 8-15, Figure 8-16:

Change Q8 to Part Number 1853-0451.

Page 9-7, Table 9-1:

Change A2Q4 and A2Q5 to HP and Mfr Part Number 1853-0451, TRANSISTOR PNP 2N3799.

Page 9-8, Table 9-1:

Change A2R26 entry to 0757-0199, RESISTOR 21.5K 1% .125W F TC=0±-100, 42546, C4-1/8-TO-2152-F.

Page 9-11, Figure 9-7:

Change Q8 and Q17 HP Part Numbers to 1855-0081.

Add arrows pointing in on gates of all FETs.

Add switch contact detail and wiring diagram shown in Figure 2 of this Manual Changes.

Make corrections to A2 ALC Assembly schematic as shown in Figure 3 of this Manual Changes.

Add the words "NOTE 4" above S2 on schematic and add below note 3 the following:

4. INT is connected only for Option 001. There is no connection to 946 wire in Standard instrument.

Change Q4 and Q5 to Part Number 1853-0451.

Change reference designator of diode shown just below CR37 from CR28 to CR38.

**CHANGE 1**

Page 9-7, Table 9-1.

Add A2CR39 HP Part Number 1901-0033.

Page 9-11, Figure 9-7:

Add CR39 as shown in partial schematic Figure 9-7 (CHANGE 1).

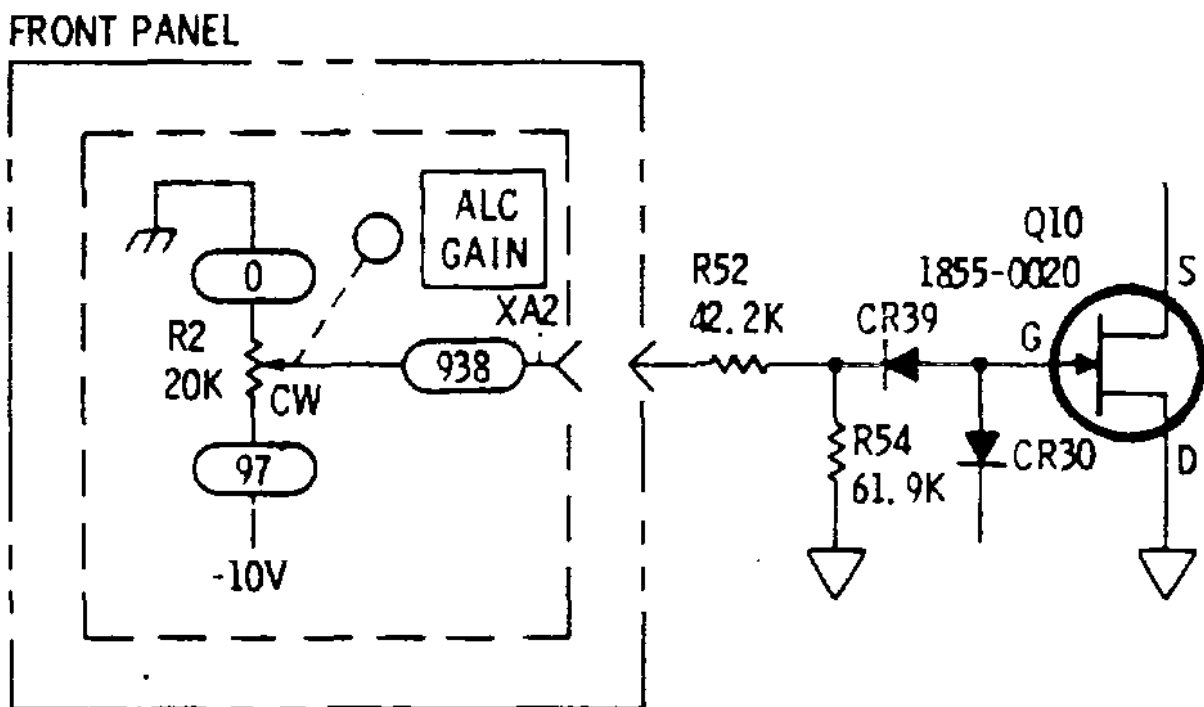

Figure 9-7 (CHANGE 1)

**CHANGE 2****NOTE**

This change deletes the standard A2 ALC Assembly, including the replaceable parts list, component locations, and schematic. The Option 001 A2 ALC Assembly schematic and parts list in Sect. TX will be used for both the standard 86260A and 86260A Option 001.

Page 6-5, Table 6-2:

Delete A2 ALC Assembly HP Part Number 86260-60011 and all A2 parts.

Add the NOTE: See the A2 Replaceable Parts in Table 9-1, Page 9-7 of Section IX

Page 6-7, Table 6-2:

Change S2 to HP Part Number 3100-2659 SWITCH: LEVER, ALC.

Change HP Part Number 86260-60001 to 86260-60026 CABLE ASSY: MAIN.

Change S1 HP Part Number to 3100-3085.

**CHANGE 2 (Cont'd)**

Page 8-11, Figure 8-12:

Replace A2 ALC Assembly with Figure 1 of this change sheet.

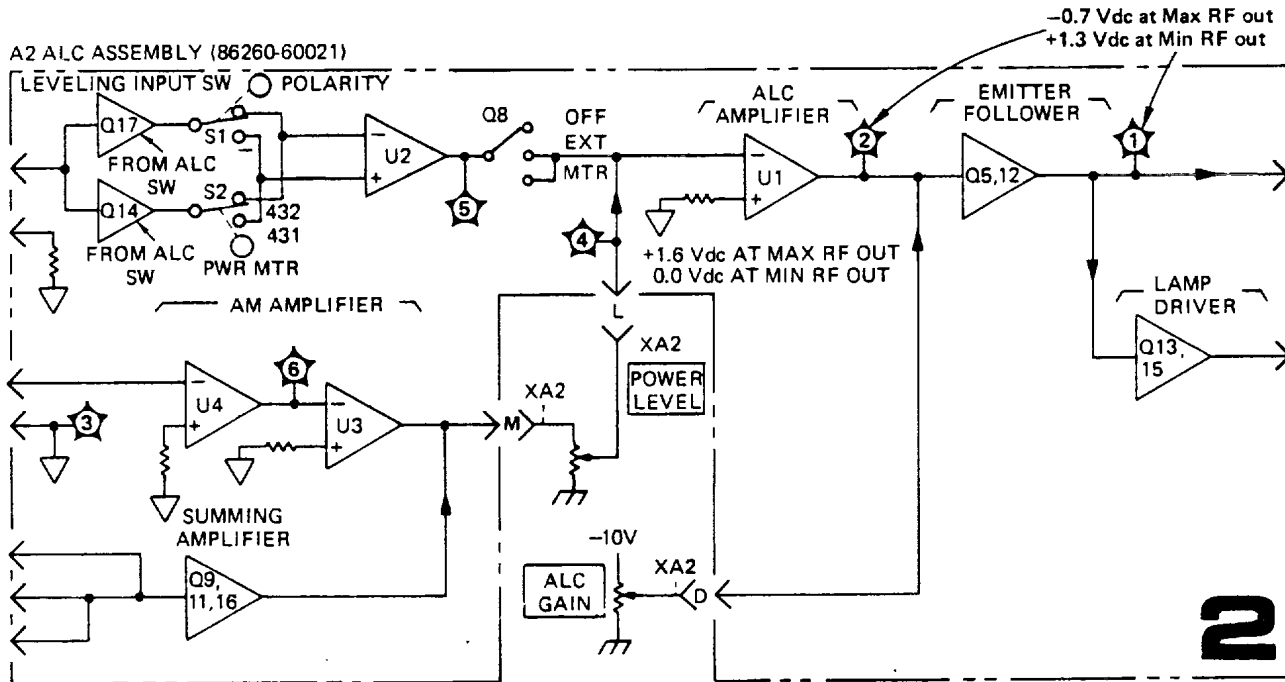

Figure 1. P/O Figure 8-12, Troubleshooting Block Diagram (Change 2)

Page 8-15, Figures 8-15 and 8-16:

Delete Figures 8-15 and 8-16.

Add the NOTE: See Figure 9-6, A2 ALC Assembly, Component Locations and Figure 9-7, A2 ALC Assembly, Schematic on page 9-11 of Section IX.

**NOTE**

**The A2 ALC Assembly, Circuit Description on page 814 applies to the A2 schematic on page 9-11. However, since Figure 9-7 has different reference designators, care must be taken when cross referencing. The Read Only Memory (ROM) Diode Decoder in Figure 9-7 is explained below.**

**Read Only Memory (ROM) Diode Decoder, Circuit Description**

The diode decoder circuit in the 86260A A2 ALC Assembly (Option 001) (Figure 9-7) is a means for selecting one of three leveling control functions: Meter, External, and Internal leveling. The OFF position disables all leveling so the UNLEVELED lamp DS1 remains ON. The following description details the operation of two circuits in the internal leveling circuitry: the Slope adjust A2R17 and Internal leveling switch A2Q7. The other circuits connected to the diode decoder operate similarly.

**CHANGE 2 (Cont'd)**

With INT mode selected,  $\pm 20V$  is applied to A2CR9 and A2CR15. This develops approximately  $\pm 19V$  at the cathodes. The +19V at CR15 cathode reverse biases A2CR4 and A2CR12. With CR4 OFF, the Slope control A2R17 is activated; and with CR12 OFF, the internal leveling switch A2Q7 is turned ON to close the ALC loop. When the ALC switch S2 is in either the OFF, EXT, or MTR positions, -10V forward biases A2CR4 and A2CR12 to disable both the Slope circuit and Q7 switch.

**Slope and Internal Gain Adjustments**

The Slope adjust A2R17 and INT Gain A2R58 operate only in INT mode. These controls are inoperative in the standard 86260A since the INT Mode is disconnected.

**CHANGE3**

Page 6-5, Table 6-2:

Change A1U2 HP Part Number to 1826-0261.

Page 8-13, Figure 8-14:

Change A1U2 Part Number to 1826-0261.

**NOTE**

**The 1826-0261 is a high reliability replacement for the 1826-0013.**

**CHANGE 4**

Page 1-0, Figure 1-1:

Delete scale for 8620B, 86260-00009. This scale is no longer supplied with the instrument.

Page 1-3, Paragraph 1-37:

Change to read: "One scale is supplied with the 86260A for use with the 8620A and 8620C mainframes. This scale has HP Part Number 86260-00008. (See Figure 1)."

Page 6-7, Table 6-2:

Delete 86260-00009 entry.

**CHANGE5**

Page 6-7, Table 6-2:

Change A3R17 to HP Part Number O757-1000, R:FXD FLM, 51.1 OHM 1% 1/2W.

Page 8-17/8-18, Figure 8-18, SERVICE SHEET 3:

Change A3R17 value to 51.1.

**CHANGES**

Page 9-9:

Change third line to read: "Add A7 HP Part Number 86290-60045, Detector, LBHCD, (Hot Carrier Diode)."

**NOTE**

**The 86290-60045 Hot Carrier Diode Detector is a recommended replacement for the 5060-0313 Crystal Detector.**

Page 9-11, Figure 9-7:

Change A7 Detector HP Part Number to 86290-60045.

**CHANGE 6 (Cont'd)**

Page 11-3:

Change second entry for Page 6-7, Table 6-2 to read: "Add A7 HP Part Number 86290-60045, Detector, LBHCD, (Hot Carrier Diode)."

**NOTE**

**The 86290-60045 Hot Carrier Diode Detector is a recommended replacement for the 5060-0313 Crystal Detector.**

Page 11-5. Figure 11-4:

Change A7 Detector HP Part Number to 86290-60045.

**CHANGE 7**

Front Cover:

Delete "OPTION 006".]

Title Page:

Delete "OPTION 006".]

Page iii, Contents, Section I, General Information:

Delete entry for Paragraph ' 1-34. Option 006".]

Page iv, Contents, Section XIII, Option 006 High Power Output:

Delete entry for Section XIII

Page 1-3, Paragraph 1-25:

Delete reference to Option 006.]

Page 1-3, Paragraph 1-34 and 1-35.

Delete paragraphs 1-34 and 1-35.

Page 1-5, Table 1-1, POWER OUTPUT

Change Power Level: Maximum Leveled Power: to  $>\pm 10$  dBm (10 mW).

Change Spurious Signals entry to read: "(Below fundamental at  $\pm 10$  dBm power output)"

Page 4-6, Paragraph 4-10, SPECIFICATION:

Change Maximum Leveled Power specification to  $>\pm 10$  dBm (10 mW)

Page 4-8, Paragraph 4-10, step c:

Change power meter indication in last line to  $\pm 10$  dBm.

Page 4-10, Paragraph 4-11, SPECIFICATION:

Change fundamental output level to  $\pm 10$  dBm.

Page 4-11, Paragraph 4-11, step b.

Change 86260A POWER LEVEL control setting to  $\pm 10$  dBm.

Page 9-1, Paragraph 9-6:

Change Maximum Leveled Power (Option 001) specification for entries on pages 1-5, 4-6, and 4-23 to  $\pm 9$  dBm .

Page 9-4, Paragraph 4-10, step q:

Change power meter indication in fourth line  $>\pm 9$  dBm.

Delete Fifth line.

Page 11-1, Paragraph 1-6:

Change Maximum Leveled Power (Option 001) specification for entries on pages 1-5, 4-6, and 4-23 to  $\pm 9$  dBm .

Page 13-1

Delete entire page.

**CHANGE 8**

Page 6-4, Table 6-2:

Change A1C14 HP Part Number to 0180-0553 and value to 22UF.

Page 8-13, Figure 8-14, SERVICE SHEET 1:

Change A1C14 value to 22UF.

**CHANGE9**

Page 6-7, Table 6-2:

Change A3R4 to HP and Mfr Part Number 0757-0278, R: FXD MET FLM 1.78K OHM 1% 1/8W.

Page 8-17, Figure 8-18:

Change value of A3R4 to 1780 ohms.

**CHANGE 10**

Page 6-6, Table 6-2:

Change A3C1 to HP and Mfr Part Number 0160-0303, C: FXD POLYE, 0.15 UF 200V, Mfr Code 28480.

Change A3C5 to HP and Mfr Part Number 0160-0154, C: FXD POLYE, 2200 PF 200V, Mfr Code 28480.

Page 6-7, Table 6-2:

Change A3R7 to HP and Mfr Part Number 0757-0464, R: FXD MET FLM 90.9K OHM 1% 1/8W.

Change A3R14 to HP and Mfr Part Number 0757-0458, R: FXD MET FLM 51.1K OHM 1% 1/8W.

Page 8-17, Figure 8-18.

Change value of A3C1 to 0.15 uF.

Change value of A3C5 to 2200 Pf.

Change value of A3R7 to 90.9K..

Change value of A3R14 to 51.1K.

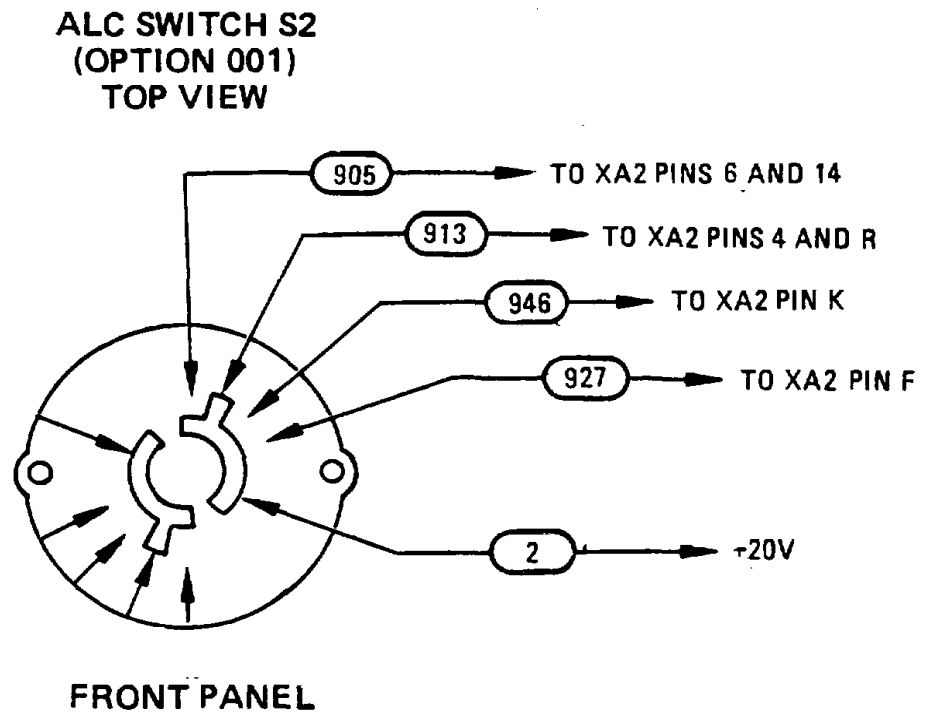
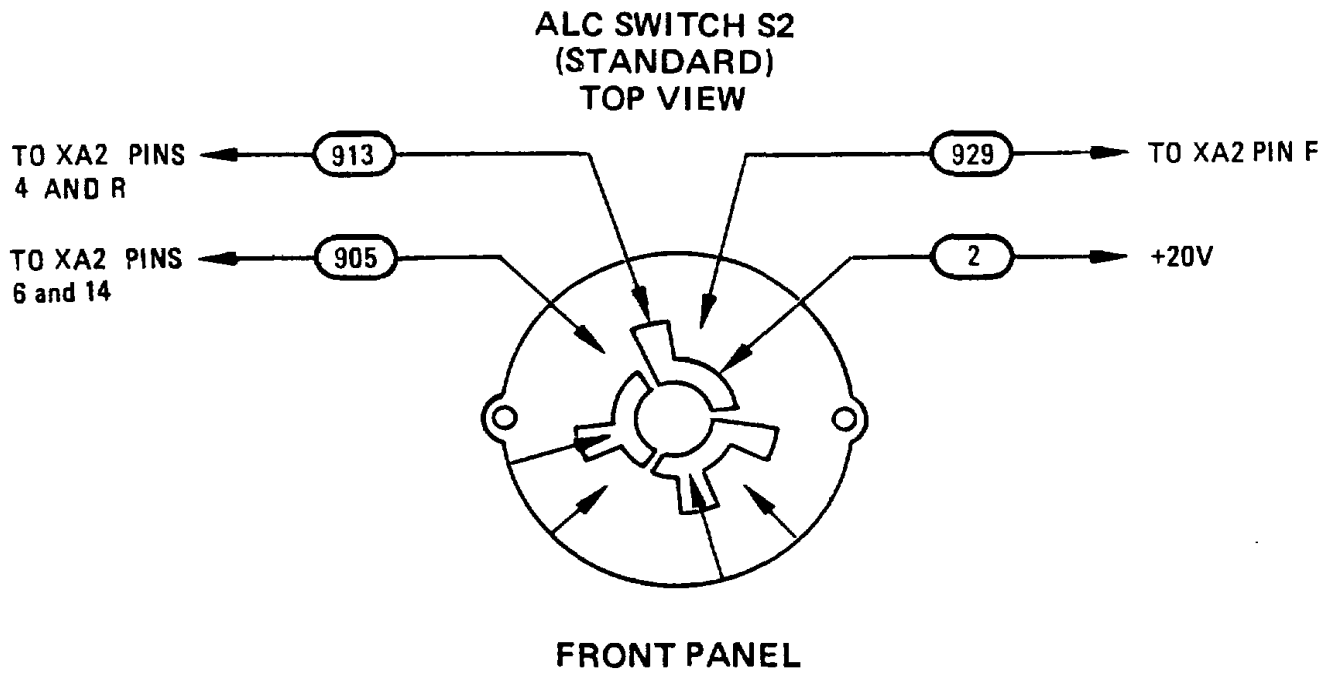

Figure 2. ALC Switch S2 Contact Detail and Wiring Diagram (Errata)



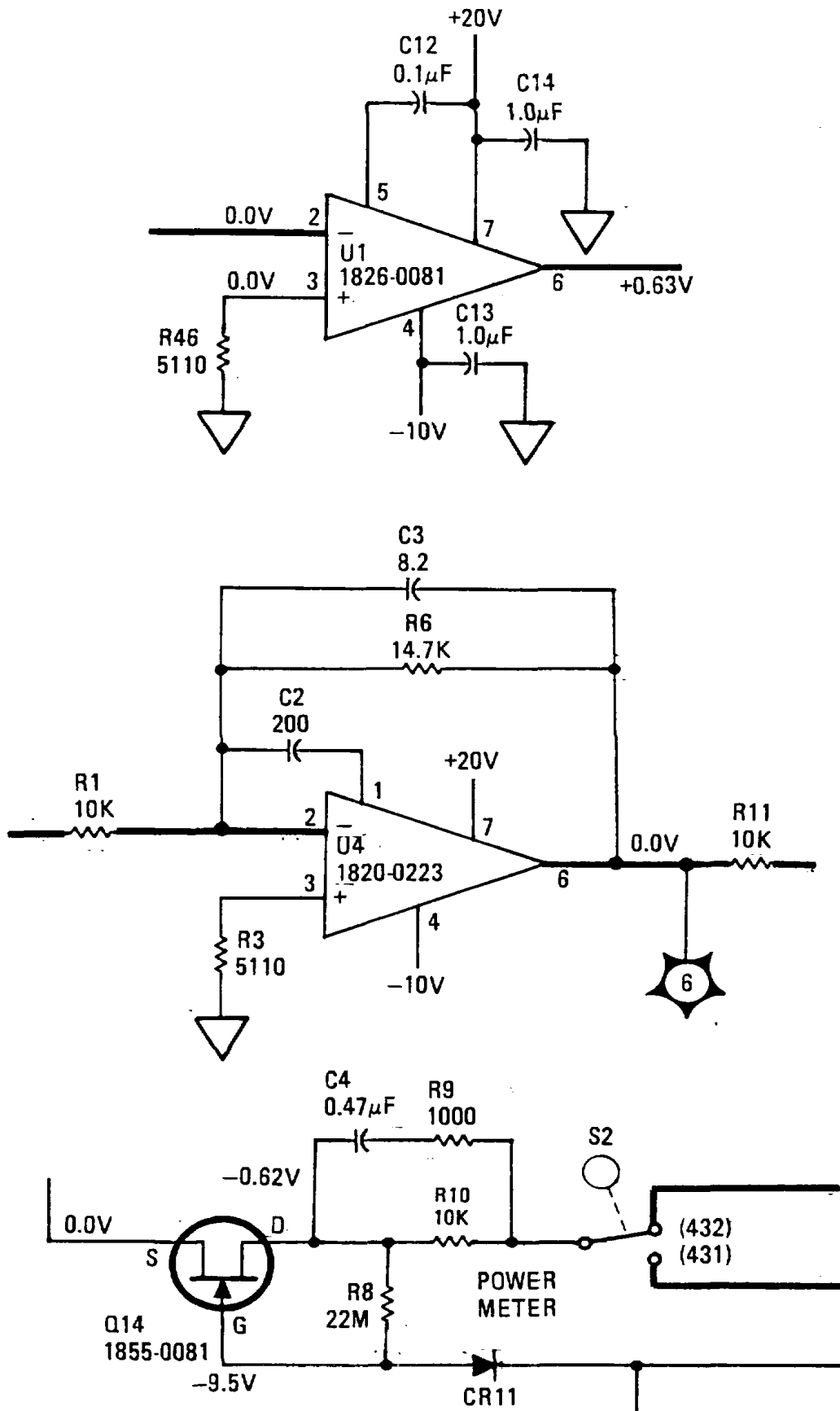

Figure 3. P/O Figure A-7. A2 ALC A.4assembly, Schematic (Errata)

**SECTION VIII  
SERVICE**

**8-1. INTRODUCTION**

8-2. This section provides instructions for troubleshooting and repairing the Model 86290ARF Plug-in. This information includes timing diagrams, troubleshooting block diagrams and a troubleshooting chart. Circuit descriptions and simplified block diagrams are included with the schematic diagrams of the assemblies. Exploded views and component location illustrations are contained in this section to add visual information for servicing and repairing. Figure 8-12 provides a block diagram and functional description of the 86290A. Schematic presentations, in this manual show electrical circuit operation and are not intended to serve as wiring diagrams.

**8-3. ASSEMBLY SERVICE SHEETS**

8-4. The schematics are arranged by service sheets. The service sheet numbers appear in the lower right-hand corner of the schematics (large number above assembly number). Included in the service sheet is the schematic as well as the accompanying circuit theory, component-parts location photo, simplified block diagrams, and schematic-level troubleshooting.

**8-5. PRINCIPLES OF OPERATION**

**8-6. Circuit Description**

8-7. Detailed circuit description for each individual schematic diagram is placed on the facing left-hand foldout page. This places material needed for printed-circuit-level diagnosis in one location and allows easy correlation between function and specific circuitry.

**8-8. YIG-Tuned Oscillator**

8-9. The YIG (yttrium-iron-garnet) oscillator is an electrically tunable resonant structure, made from a single yttrium-iron-garnet crystal and formed into a highly polished sphere. Because yttrium-iron-garnet is a ferrite (magnetic) material, it is made up of a high density of randomly oriented magnetic dipoles. Each dipole consists of a minute current loop formed by a spinning electron. Because of the random orientations, there is no net magnetic effect external to the YIG sphere (Figure 8-1).

8-10. When a dc magnetic field,  $H_0$ , is applied, the dipoles align themselves parallel to it (Figure 8-2). This produces a net magnetization vector,  $M_0$  (Figure 8-3).

8-11. To support oscillations, a second magnetic field produced by an RF signal is applied perpendicular to the net magnetization vector. This causes the net magnetization vector to precess, or rotate, about the axis that is parallel to  $H_0$ . See Figure 8-4.

8-12. The rate of precession, or rotation, is at the frequency of the RF field. The unique characteristic of the YIG sphere is that it has a natural, or inherent, ferrimagnetic resonant frequency determined by the magnetic field. The angle of precession will only be large at the resonant frequency. At all other excitation frequencies of resonance, this angle will be very small. That is, it will not support oscillations at other than its ferrimagnetic resonant frequency. See Figure 8-4.

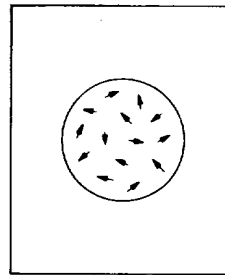

Figure 8-1. YIG Sphere in Non-Magnetic Field

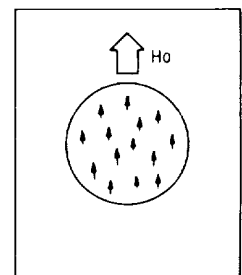

Figure 8-2. YIG Sphere in Magnetic Field

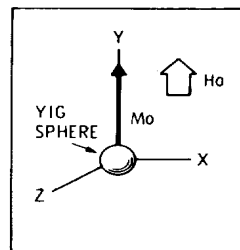

Figure 8-3. Net Magnetization Vector

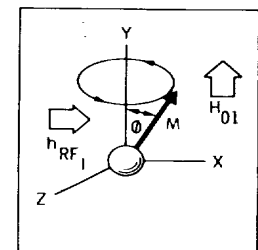

Figure 8-4. Magnetization Vector with RF Field Applied

8-13. A second unique characteristic of the YIG is that this natural resonant frequency is a linear function of the strength of the dc magnetic field,  $H_0$ . Thus, the resonant frequency of the YIG sphere is tunable by varying the dc current through the electromagnet that produces  $H_0$ . See Figure 8-5.

8-14. The small YIG sphere is positioned directly between the poles of an electromagnet. The current through the electromagnet is varied by the tuning voltage (or sweep ramp). The high frequency transistor oscillator is coupled to the YIG sphere by a single loop of flat wire. See Figure 8-6.

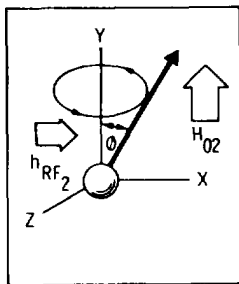

Figure 8-5. Increased DC Magnetic Field

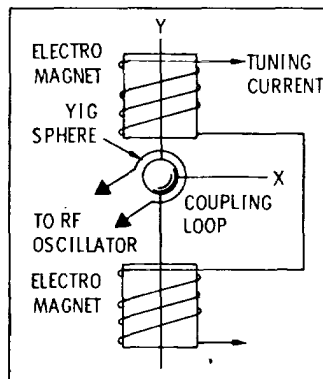

Figure 8-6. Coupling RF and DC Magnetic

## 8-15. TROUBLESHOOTING

### WARNING

With the ac power cable connected, the ac line voltage (115 or 230 Vac) is present at the terminals of the mainframe power line assembly FL I (mounted on rear panel) and at the mainframe POWER switch, whether the POWER switch is on or off. With the top cover removed, these terminals are exposed and carry ac voltages capable of causing death.

8-16. Troubleshooting is generally divided into two maintenance levels in this manual. The first level isolates a trouble to a circuit or assembly. This is done by using a troubleshooting flow diagram that provides a step-by-step procedure to isolate the cause of a malfunction and identify the defective assembly. Troubleshooting Hints, Table 8-1, provides typical instrument symptoms and assembly level cures.

8-17. The second maintenance level isolates the trouble to the component. Schematic diagrams and circuit descriptions for each assembly aid in troubleshooting to the component level. The schematic also contains waveforms and voltages for use during troubleshooting. Locations of service illustrations useful for troubleshooting are given in Table 8-1.

8-18. When troubleshooting a transistor stage, check for a forward bias condition of the base-emitter junction. If this condition exists, the next step is to remove the forward bias by shorting the base to the emitter and checking to see if the collector voltage rises to the approximate level of the supply. The next check that can be made, if it is known that the transistor is not operating in a saturated condition, is to check for a voltage drop between emitter and collector. Obviously these serve only as quick checks and will help in getting started with the problem. When an operational amplifier is suspected of being bad, and since the inputs should not draw current, a test can be made by inserting some resistance in series with the input, and checking for a voltage drop across the resistor. If there is a voltage drop, the operational amplifier should be replaced.

## 8-19. RECOMMENDED TEST EQUIPMENT

8-20. Test equipment and accessories required to maintain the Model 86260A are listed in Table 1-3. If the equipment listed is not available, equipment that meets the minimum specifications shown may be substituted.

## 8-21. REPAIR

### 8-22. Service Accessories

8-23. Service accessories, HP Part No. 08620-60030, is available as an aid in maintaining the Model 86260A and the 8620A mainframe. These accessories described in Paragraph 1-41 and shown in Figure 1-3.

### 8-24. Cleaning Switches

8-25. The cleaning agent to be used on the switches is isopropyl alcohol, HP Part No. 8600-0755. Spray the solvent into the switch and slide or rotate the switch back and forth. Repeat this procedure several times, continue to slide or rotate the switch back and forth until the solvent is evaporated.

### 8-26. YIG-Tuned Oscillator Installation

8-27. When installing a YIG-tuned oscillator there

must be a minimum amount of heat sink compound (HP Part Number 6040-0239) between mating surfaces of the oscillator and heat sink to ensure sufficient heat transfer.

**8-28. Unleveled Lamp**

The UNLEVELED lamp, DS1, is a light-emitting diode (LED). It may be checked as follows:

a. Connect a 178-ohm resistor between DS1 anode and + 5 Vdc.

b. Connect negative side of supply to DS 1 cathode. The LED should light.

**CAUTION**

**The LED current must be limited to less than 50 mA to prevent damage to the LED.**

Removal and installation procedure are described in Figure 8-7

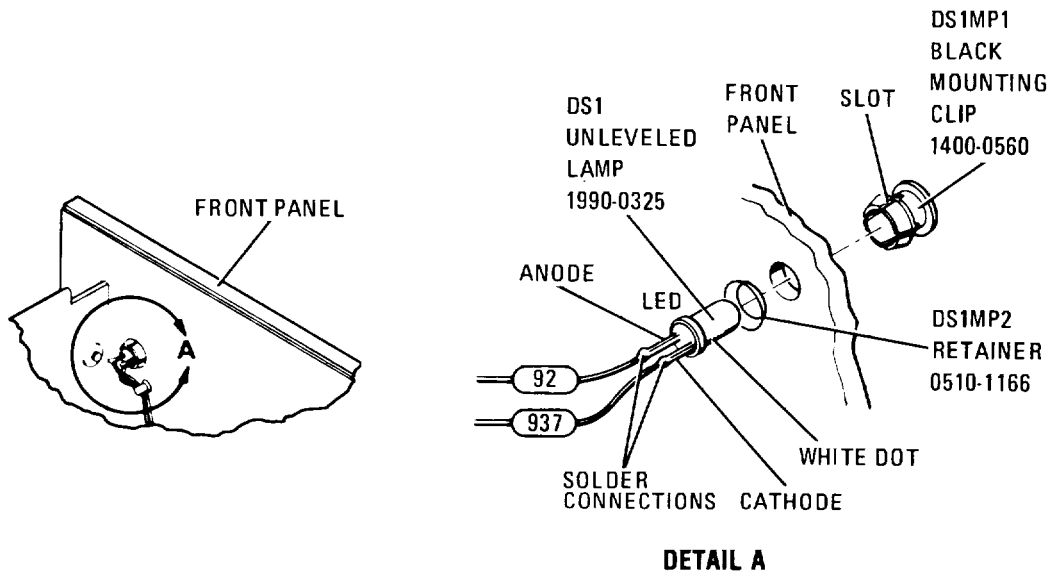

### 1. REMOVAL PROCEDURE:

- a. Remove RF Plug-in from mainframe.
- b. Remove retainer ring holding DS1 in mounting clip and slide over leads.
- c. Remove DS 1 from backside of front panel while pushing on DS1 at front side of front panel.

#### NOTE

To facilitate removal, pull DS1 leads with a pair of needlenose pliers.

- d. Unsolder anode and cathode leads.

### 2. INSTALLATION PROCEDURE:

- a. Ensure that retainer ring is over leads before soldering.
- b. Connect (solder) 92 white-red wire to anode (long lead) of DS 1, and ( 937 ) white-orange- violet wire to cathode (short lead) of DS 1.

#### NOTE

On some Light-Emitting Diodes (LED) the leads are the same strength and the cathode is designated by a white dot.

- c. Push DS1 into mounting clip until it snaps into place.
- d. Install retainer ring around mounting clip.

Figure 8-7. UNLEVELED Lamp Removal and Replacement Procedure

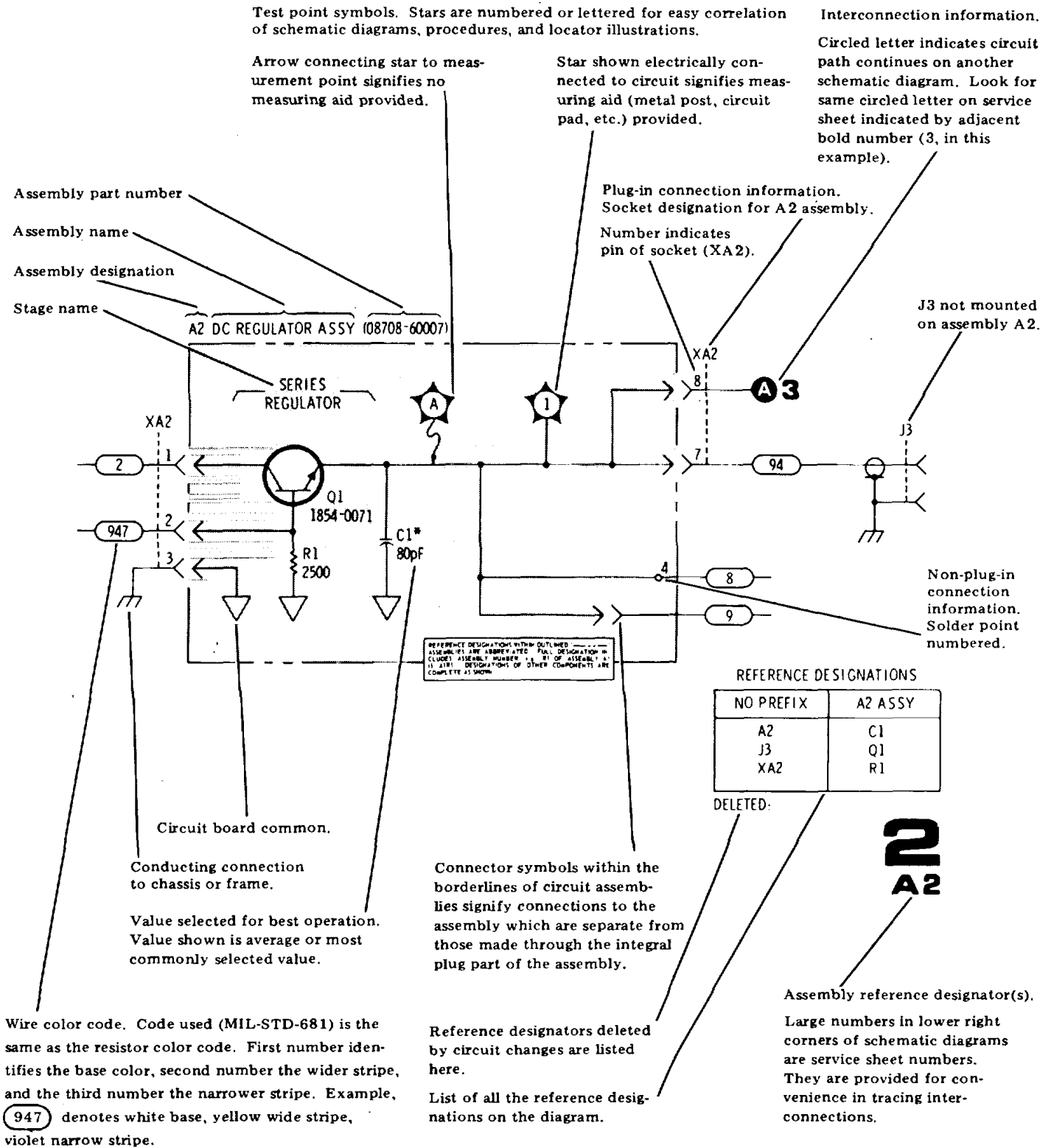

Figure 8-8. General Information on Schematic Diagrams

**SCHEMATIC DIAGRAM NOTES**

R, L, C	Resistance is in ohms, inductance is in microhenries, capacitance is in picofarads, unless otherwise noted.
P/O	Part of.
*	Asterisk denotes a factory-selected value. Value shown is typical.
○	Panel control.
◐	Screwdriver adjustment.
▭	Encloses front panel designation.
▭	Encloses rear panel designation.
-----	Circuit assembly borderline.
- - - - -	Other assembly borderline.
→	Heavy line with arrows indicates path and direction of main signal.
- - - - - →	Heavy dashed line with arrows indicates path and direction of main feedback.
	Wiper moves toward CW with clockwise rotation of control as viewed from shaft or knob.
▭	Encloses wire color code. Code used (MIL-STD-681) is the same as the resistor color code. First number identifies the base color, second number the wider stripe, and the third number identifies the narrower stripe; e.g. <u>947</u> denotes white base, yellow wide stripe, violet narrow stripe.
2A	Number = Service Sheet number for off-page connection. Letter = off-page connection.
	Light-emitting diode (LED).
	Breakdown diode.
	PIN diode.
	Field effect transistor (FET) with N-type base.

Figure 8-9. Schematic Diagram Notes (1 of 2)

**SCHEMATIC DIAGRAM NOTES (Cont'd)**



Field effect transistor (FET) with P-type base.

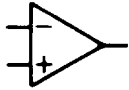

Operational amplifier (integrated circuit).



Test point location. Number denotes test point number.



Assembly ground.



Signal ground.



Chassis ground.



Earth ground.



Common connection on same page.

For symbols not shown, refer to USA Standard Y32.2 - 1967 "Graphic Symbols for Electrical and Electronic Diagrams."

Logic Symbols used conform to MIL-STD-806B (Military Standard 806B) "Graphic Symbols for Logic Diagrams."

Figure 8-9. Schematic Diagram Notes (2 of 2)



**SCHEMATIC MEASUREMENT CONDITIONS**

Voltages noted within circuits are measured with respect to chassis ground and have a  $\pm 10\%$  tolerance.

Conditions for waveforms and dc voltages on schematics are as follows:

- a. Waveforms taken in START-STOP sweep mode (START pushbutton pressed).
- b. DC Voltages measured in CW mode (CW pushbutton pressed). Other 8620A/86260A control setting the same as noted below.

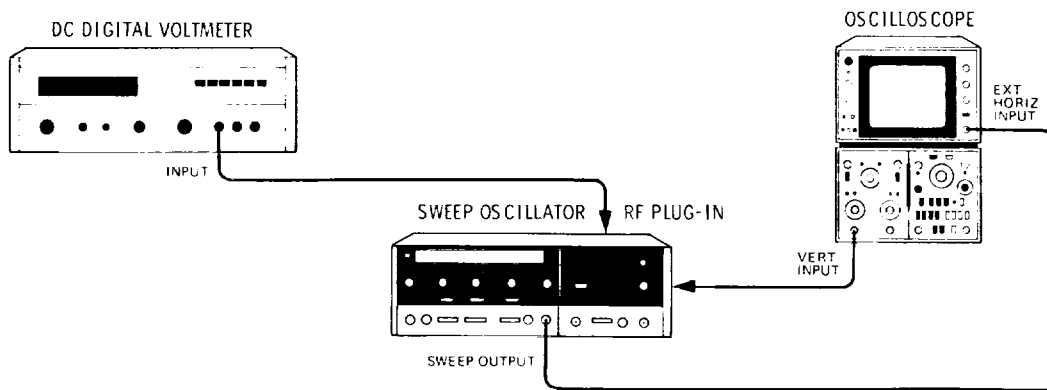

*Test Setup for Waveforms and Voltages Shown on Schematics*

**EQUIPMENT REQUIRED:**

Sweep Oscillator .....	HP 8620A
RF Plug-in .....	HP 86260A
Oscilloscope .....	HP 180A/1801A/1820A
DC Digital Voltmeter .....	HP 3460B

Set controls as follows:

8620A

START pointer .....	12.4 GHz
CW pointer .....	15.2 GHz
STOP pointer .....	18.0 GHz
MARKER .....	OFF
LINE .....	ON
MODE .....	AUTO
TRIGGER .....	INT
TIME-SECONDS .....	0.1 - 0.01
SWEEP TIME Vernier .....	Fully clockwise
1 KHz SQ WV/OFF (Rear Panel) .....	OFF
RF BLANKING/OFF (Rear Panel) .....	OFF

86260A

RF .....	ON
ALC .....	OFF
POWER LEVEL .....	Fully clockwise

*Figure 8-10. Schematic Measurement Conditions*

**TROUBLESHOOTING TEST SETUP**

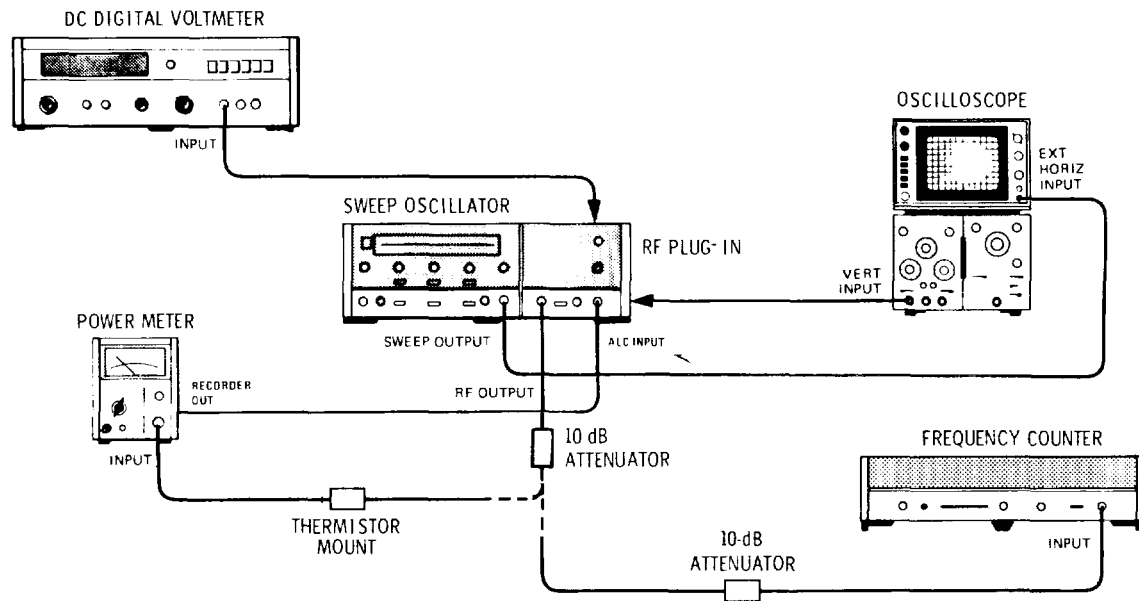

**EQUIPMENT REQUIRED:**

Sweep Oscillator .....	HP 8620A
RF Plug-in .....	HP 86260A
Power Meter .....	HP 432A
Thermistor Mount .....	HP 8478B
DC Digital Voltmeter .....	HP 3460B
Frequency Counter .....	HP 5340A
Oscilloscope .....	HP 180A/1801A/1820A
Directional Coupler .....	HP 779D
10-dB Attenuator (2 required) .....	HP 8491B, Option 010

Figure 8-11. Troubleshooting Test Setup

## FUNCTIONAL DESCRIPTION OF THE 86260A RF PLUG-IN

### GENERAL

The 86260A is an RF Plug-in utilizing a YIG-tuned oscillator controlled by the 86260A/B Sweep Oscillator mainframe. Combined they can provide a single frequency or swept RF signal with frequency modulation, amplitude modulation, and leveled output capability.

### TUNING

The mainframe generates a voltage (tuning) ramp corresponding to the start to stop swept frequency range or a constant DC level corresponding to a point on the ramp for a single frequency. The tuning voltage is applied to the AI YIG DRIVER Assembly where it is inverted and amplified to drive the main tuning coil of the YIG-tuned oscillator.

### FREQUENCY MODULATION

The external FM signal is processed in the A3 FM Assembly. High deviation FM, limited to low modulation frequencies, is accomplished by applying the signal to the A1 YIG Driver Assembly, and summing it with the tuning voltage to drive the main tuning coil of the YIG-tuned oscillator. Large deviations are possible due to the wide tuning range of the main tuning coil. The large inductance of the main tuning coil offers a high reactance at high frequencies, limiting the response of the main tuning coil to low frequencies. Low deviation FM, capable of high modulation frequencies, is achieved by driving the low-inductance FM coil. This coil has much less tuning control than the main tuning coil, but will respond to high modulation frequencies. The high-pass filter on FM Assembly A3 keeps high modulation frequencies limited to the FM coil.

### AMPLITUDE MODULATION

Amplitude modulation is accomplished by varying the insertion loss of A5 PIN Modulator which varies the amount of RF to the RF output connector. External AM signals are applied to the EXT AM Amplifier on the A2 ALC board and the internal AM signals (1 KHZ Square Wave, Markers, Blanking) are fed to the Summing Amplifier on the A2 ALC board. The outputs of the AM Amplifier, Reference Amplifier and the Summing Amplifier are summed and fed to the ALC Amplifier then to the Modulator Driver which provides the PIN Modulator bias voltage.

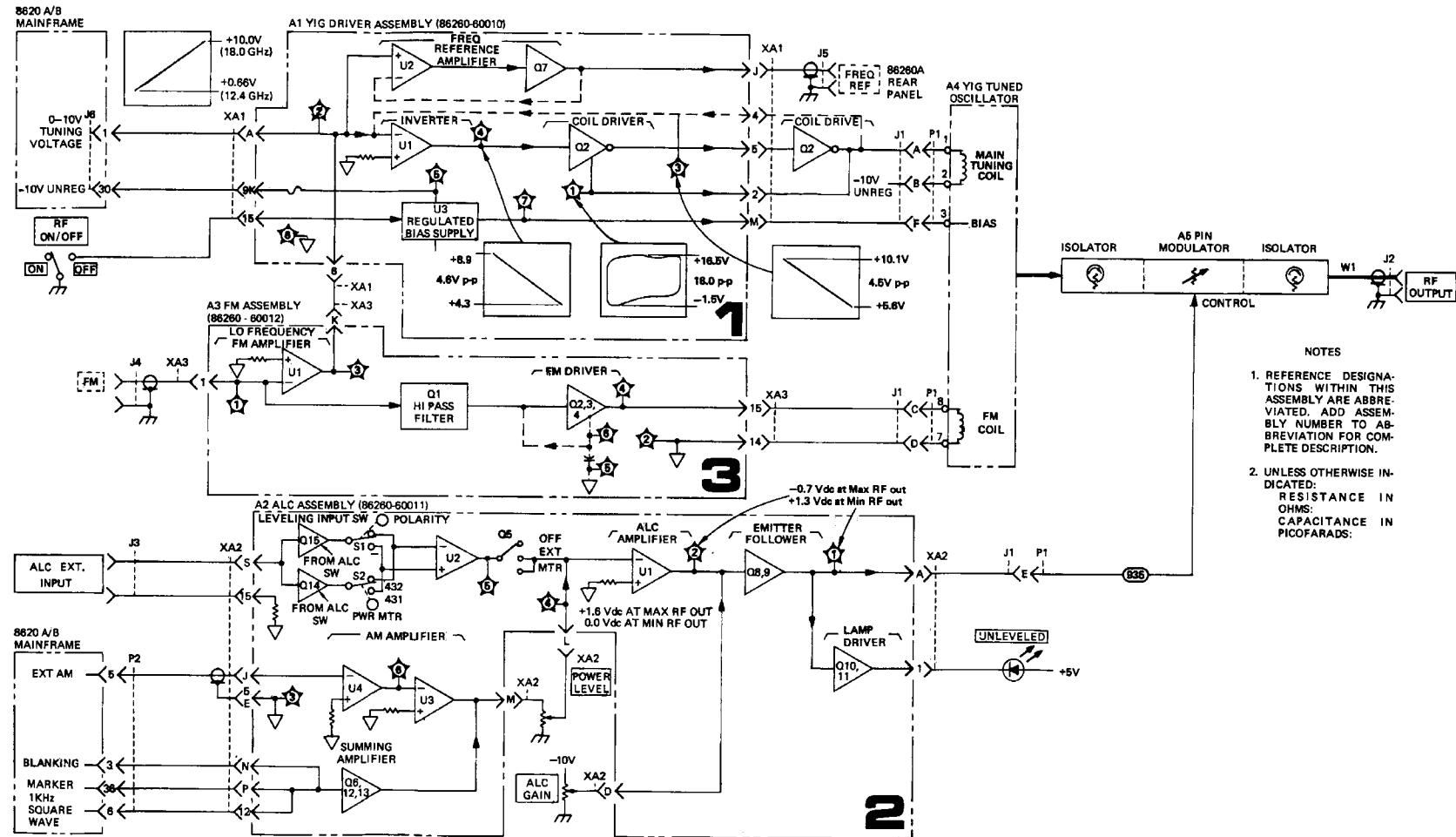

Figure 8-12. Troubleshooting Block Diagram

## SERVICE SHEET 2

### A2 ALC Assembly, Circuit Description

#### GENERAL

The A2 Automatic Leveling Control (ALC) Assembly contains circuitry to provide leveled RF output power. Leveling is accomplished by sampling the RF output power (with a crystal detector or a power meter) and supplying a proportional dc voltage to the ALC EXT INPUT connector. This ALC feedback voltage is amplified by PRE AMPLIFIER U2 and then applied to the ALC Amplifier where it is summed with the dc reference voltage established by the front panel POWER LEVEL setting. To compensate for different feedback levels, (crystal detector 25mV to 250mV, power meter 0 - 1.0V), front panel ALC GAIN control is provided. The Modulator Driver, (emitter-follower Q8 and Q9), provide the necessary current to drive the PIN Modulator. A front panel indicator, UNLEVELED Lamp DS 1, will light when the power level is set to high to maintain leveling. Lamp DS1 is driven by Lamp Driver circuitry Q10 and 11 which triggers from the PIN Modulator bias voltage. External AM signals are amplified by EXT AMPLIFIER U4 and summed with the dc reference voltage established by the REFERENCE AMPLIFIER U3.

#### EXTERNAL AM AMPLIFIER, REFERENCE AMPLIFIER, AND SUMMING AMPLIFIER

The External AM Amplifier, U4, is a fixed gain (- 1.47) amplifier for External AM signals. The Reference Amplifier, U3, provides additional fixed gain (- 1.47) and a fixed dc offset voltage (+2.4V) to the front panel POWER LEVEL control.

#### SUMMING AMPLIFIER

The Summing Amplifier, Q6, Q12, and Q13, sums the internal AM signals from the 8620A Sweep Oscillator (Blanking, Marker, 1 KHZ Square Wave) with the dc reference voltage established by the front panel POWER LEVEL control setting. Positive signals applied to the base of Q13 are inverted and applied to the front panel POWER LEVEL control.

In power MTR mode, Q12 is turned on and shunts the internal AM signal to ground. This is done to prevent power meter measurement error that would be caused by amplitude modulation.

#### EXT-MTR SWITCH

The EXT-MTR (external crystal detector-power meter) switch consists of two field-effect transistors (FET's), Q14 and Q15, used as switches between the ALC EXT INPUT connector and the ALC Preamplifier to select the leveling feedback source used. With the ALC switch in the EXT position, +20Vdc is applied to the gate of Q15, turning it on and providing a low resistance path for the EXT crystal feedback voltage to the ALC Preamplifier. When power MTR is selected, Q14 is turned on allowing the feedback voltage from the

power meter to be applied to the ALC Preamplifier. In this mode, R9, R10, and C3 are used to provide a good match to the power meter output.

#### ALC PREAMPLIFIER

The ALC Preamplifier, U2, utilizes hot-carrier diodes, CR7, CR8, and CR9, (0.3V junction drop), in a step-function feedback configuration to gain-shape the ALC signal. Op amp U2 operates in either an inverting or non-inverting mode, depending upon the setting of the Crystal Detector Polarity switch S1 and the Power Meter switch S2. These switches maintain a negative U2 output for either a positive or negative ALC feedback voltage. The gain is controlled by U2 output voltage. If the output voltage is less than -0.3 Vdc, the voltage gain is 63. When the output voltage is between -0.3Vdc and -0.6Vdc, hot-carrier diode CR7 conducts, placing R23 in parallel with feedback resistor R19, resulting in a gain of 15.2. If the output voltage exceeds -0.6Vdc, CR8 conducts, and if the voltage exceeds -0.9Vdc, CR9 conducts. This action will place resistors R24 and R25, respectively, in parallel with feedback resistor R 9. Stage gain with all diodes conducting is - 1.4.

#### ALC AMPLIFIER

The reference voltage, AM signals, and the preamplified feedback voltage are summed at the inverting input of the ALC Amplifier U 1. Clamp diodes CR16, CR17, and CR18 prevent U1 from saturating in the positive direction, and diode CR19 prevents saturation in the negative direction. Transistors Q1, Q2, and Q3 are turned on, respectively, with the front panel ALC switch in the OFF, EXT, and MTR positions to provide proper U1 gain-shaping for each input. With the ALC switch in the OFF position, the voltage at TP2 should be variable from -0.7Vdc to +1.3Vdc by rotating the front panel POWER LEVEL control from clockwise (maximum RF power output) to counterclockwise (minimum RF power output).

#### MODULATOR DRIVER

The Moduator Driver, Q8 and Q9, are emitter-followers that supply current to drive the PIN modulator. The complementary emitter-base junctions provide no dc offset voltage between TP1 and TP2. Transistor (FET) Q7 acts as a variable resistor to shunt a portion of Q8 base current to ground, controlling the gain of the ALC circuit. When the ALC GAIN control is set counterclockwise, FET Q7 is at a maximum conduction, and the ALC gain is minimum. With the ALC switch in the OFF position, -10Vdc is applied to CR15, turning it on and turning Q7 off. This will cause the front panel ALC GAIN control to be inoperative.

**A1 YIG Driver Assembly, Components Location**  
**←A1 YIG Driver Assembly, Schematic**  
**SERVICE SHEET 1**

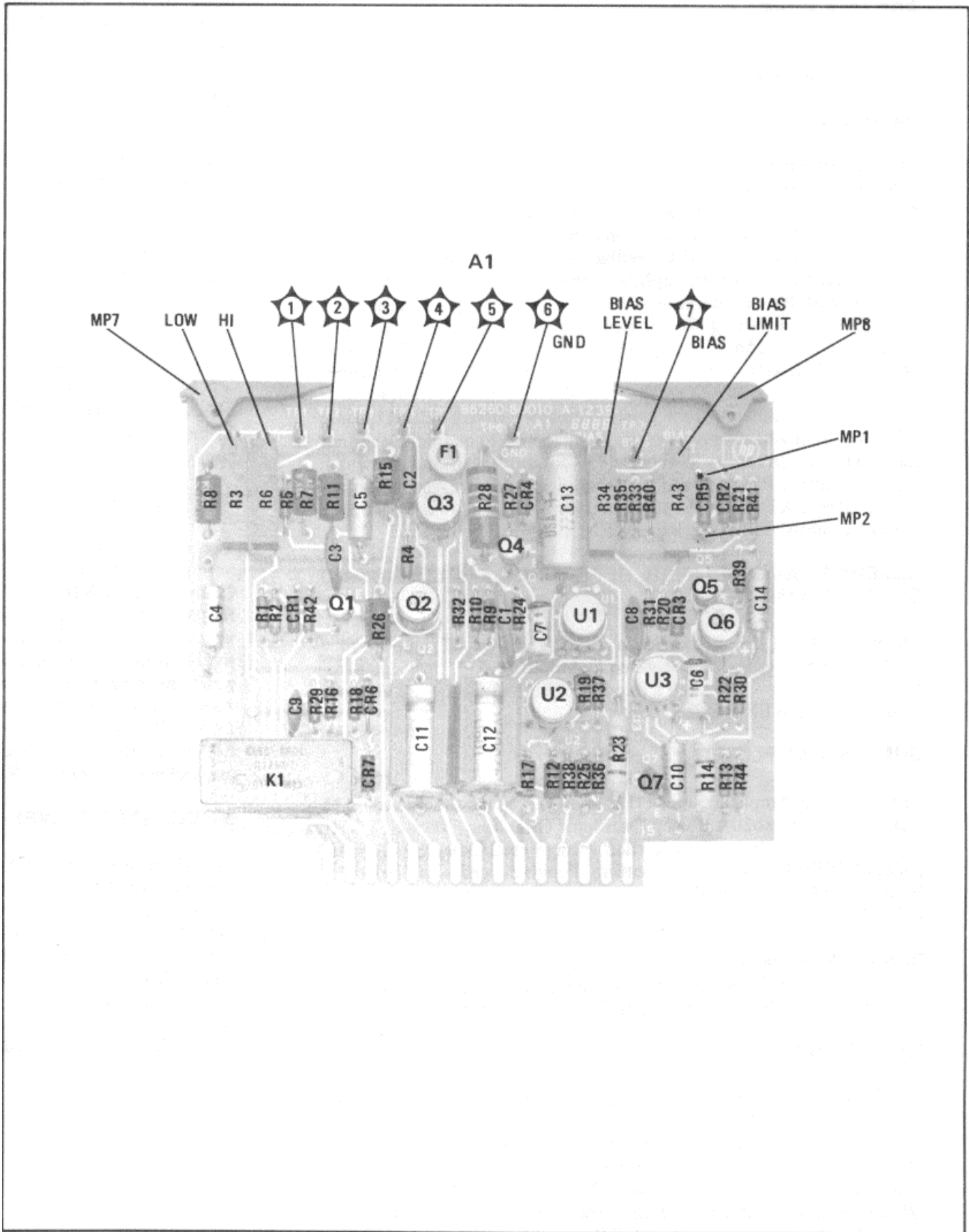

Figure 8-13. A-1 YIG Driver Assembly, Components Location

## Model 86260A

### CURRENT LIMITING

The current limiting circuit consists of A1Q4, A1R27, and A1R28, and will allow several hundred milliamps of current to flow with no reduction in output voltage. When excessive current is being drawn, the voltage drop across parallel resistors A1R27 and A1R28 forward biases A1Q4. The increased conduction of A14 shunts current from the base of A1Q1, thus allowing less current to A1Q6. With less base current to A1Q1, the conduction of A1Q1 decreases, making the output voltage decrease. Maximum current available from the supply is approximately 1.2 amperes with the voltage approaching zero volts depending upon load conditions (Voltage foldback).

### OVERVOLTAGE PROTECTION

To prevent damage to the YIG-tuned oscillator, the regulated bias supply has two methods of overvoltage protection. If the bias voltage exceeds 13.3V, A1CR4 draws excessive supply current activating the current limiting circuit to reduce the supply voltage and possibly blowing fuse F1. The second method operates as follows: The output bias voltage is held below a specific maximum voltage by breakdown diode A1CR5 (breakdown value depends upon bias voltage requirement of the oscillator). If the bias voltage increases beyond the specified level, A1CR5 will conduct, biasing on A1Q5 which will cause silicon control rectifier (SCR) A1Q3 to gate on and blow fuse F1.

### FREQUENCY REFERENCE AMPLIFIER

The frequency reference amplifier consists of A1U2, A1Q7, and associated components. The tuning voltage from the 8620A mainframe is applied to the non-inverting input of A1U2 at pin 3. The low output impedance of A1Q7 isolates the external equipment from the 8620A mainframe and oscillator circuits. The reference voltage

## Service

is applied to the rear panel FREQ REF connector J5. The output voltage is proportional to frequency; 1V/GHz.

### RELAY DRIVER

In CW or Manual sweep, relay driver A1Q1 energizes A1K1, placing a capacitance (A1C11/A1C12) across the YIG tuning coil to reduce residual FM.

### INVERTER

Integrated circuit A1U1 is an operational amplifier that amplifies and inverts the 0 to +10 volt tuning-voltage ramp developed in the 8620A mainframe and low frequency FM signals from the A3 FM assembly. From A1U1 the inverted ramp and the frequency modulation from the FM assembly A3 are applied to A1Q2.

HI FREQ A1R6 and LO FREQ 1/8 A1R3 adjustments at the input to A1U1 set the ramp limits. Capacitor A1C4, connected across the input to A1U1, filters the tuning voltage which reduces the residual FM in CW and Manual sweep operations.

### COIL DRIVER

The output of the inverter A1U1 is applied to a darlington pair amplifier comprising A1Q2 and chassis-mounted transistor Q2. Q2 is in series with the YIG tuning coil and controls the current through the coil. Any large negative-going spikes are shunted around the coil by coil protection circuit CR6/CR7.

### FUNCTIONAL DESCRIPTION

#### ← TROUBLESHOOTING HINTS

#### TROUBLESHOOTING BLOCK DIAGRAM

## **SERVICE SHEET 1**

### **A1 YIG Driver Assembly, Circuit Description**

#### **GENERAL**

The A1 YIG Driver Assembly contains a Regulated Bias Supply that provides constant-voltage current-limited bias for the A4 YIG-Tuned Oscillator. The supply consists of Control Amplifier U3, Driver Q6, Series Regulator (chassis-mounted) Q1, Current Limiting Q4, and Overvoltage Protection CR4, CR5, Q3, Q5, and F1. Typical oscillator bias requirements are -10V to -11 V with current between 300mA and 500mA. The A1 YIG Driver Assembly also contains Frequency Reference Amplifier U2 and Q7, Relay Driver1, Inverter U1, and Coil Drive Q2.

#### **CONTROL AMPLIFIER**

The purpose of Control Amplifier A1U3 is to maintain a constant bias voltage to the YIG-tuned oscillator. The amplifier controls the voltage drop across the chassis-mounted Series Regulator Q1 corresponding to instantaneous changes in the bias voltage. These changes in bias voltage produce a corresponding change in voltage at the inverting input, pin 2, of Control Amplifier A1U3. With the RF ON/OFF switch S1 set to ON, breakdown diode A1CR2 establishes a -5.11V reference at the non-inverting input, pin 3, of A1U3. The voltage at pin 2 is compared to the voltage at pin 3. If the voltage at pin 2 is less negative (more positive) than the voltage at pin 3, the negative output of the Control Amplifier increases the conduction of the driver A1Q6. The emitter-follower action of A1Q6 couples a negative voltage to the series regulator 1 causing the bias voltage to increase (go more negative). The bias voltage will increase by this action until the voltages at pins 2 and 3 are equal. If the voltage at pin 2 is more negative than the voltage at pin 3, the output of the Control Amplifier will approach zero volts, decreasing the conduction of both A6 and Q1. This action will cause the bias voltage to decrease until the voltages at pins 2 and 3 are equal.

#### **NOTE 1**

**Since there is no positive supply voltage to A1U3, the output is limited to a negative (or zero) voltage.**

#### **NOTE 2**

**Because of the fast equalizing action of Control Amplifier A1U3, it is not possible to measure the instantaneous voltage changes at pin 2. In normal operation, the voltage at pin 2 will be within a few millivolts of the voltage at pin 3**



**Service****Model 86260A**

The Lamp Driver consists of Q10 and 11 in common emitter configuration. With the ALC switch in the OFF position, --10 Vdc is applied to CR20, back biasing it and turning on Q10. The applies to +5 Vdc to base of Q11, turning it on and lighting UNLEVELED LAMP DS1. With the ALC switch in either the EXT or MTR position, the -10Vdc is removed and +20V is applied to CR20 turning it on. When the power level control is set to high to maintain leveling, the modulator drive (TP1) signal goes from a positive voltage to a -0.7V, turning on Q16. With Q16 turned on Q11 turns on and Unleveled Lamp DS1 is on. Capacitor C17 acts as a peak detector so that the lamp will light for small amounts of unleveled power.

Table 8-1. Troubleshooting Hints (1 of 2)

Symptom	Possible Cause	Check Point
No RF Power	<ol style="list-style-type: none"> <li>1. Incorrect YIG bias voltage. (Should be same as marked on YIG)</li> <li>2. Pin Modulator Biased On (Should be -0.4V with clockwise POWER LEVEL setting.)</li> <li>3. Defective Modulator</li> <li>4. Defective A4 YIG Oscillator Assy</li> <li>5. Defective A1 YIG Driver Assy</li> </ol>	<p>SS1, A4-3</p> <p>SS2, A5 - 935 wire</p> <p>SS2</p> <p>SS1</p> <p>SS1</p>
Low RF Power	<ol style="list-style-type: none"> <li>1. RF power measuring equipment no capable of measuring up to 18.0 GHz</li> <li>2. Incorrect Modulator Bias (Should be -0.4V with clockwise POWER LEVEL setting.)</li> </ol>	<p>SS2, A5 - 935 wire</p>
Frequency Accuracy out of Spec	<ol style="list-style-type: none"> <li>1. Misadjusted A1 YIG Driver Assembly</li> <li>2. Defective A1 YIG Driver Assy</li> <li>3. Defective A3 FM Assembly</li> </ol>	<p>SS1, Paragraph 4-7.</p> <p>SS1</p> <p>SS3</p>
Front Panel POWER LEVEL Control Inoperative	<ol style="list-style-type: none"> <li>1. Incorrect PIN Modulator Bias (Should be -0.4V with clockwise POWER LEVEL setting, +0.9V with counter-clockwise POWER LEVEL setting.)</li> <li>2. Incorrect voltage change from control (Should be +1.6V with clockwise POWER LEVEL setting; 0.0V with counter-clockwise POWER LEVEL setting.)</li> </ol>	<p>SS2, A5 - 935 wire</p> <p>SS2, A2TP4</p>
External ALC Inoperative	<ol style="list-style-type: none"> <li>1. A2S1 Crystal Detector Polarity switch not set to match feedback detector.</li> <li>2. DC feedback voltage not correct. (Should be -25 mV to 250 mV)</li> <li>3. Defective A2 ALC Assembly</li> </ol>	<p>SS2</p> <p>SS2</p>

Table 8-1. Troubleshooting Hints (2 of 2)

Symptom	Possible Cause	Check Point
Power Meter (MTR) Leveling Inoperative	<ol style="list-style-type: none"> <li>1. A2S2 Power Meter switch not set to match power meter.</li> <li>2. Incorrect Power meter RECORDER Output (Should be 1V Full scale)</li> <li>3. Defective A2 ALC Assembly</li> </ol>	<p>SS2</p> <p>SS2</p>
Residual FM (CW Mode)	<ol style="list-style-type: none"> <li>1. Rear panel FM-NORM-PL switch not in NORM position</li> <li>2. A1K1 CW Filter relay not engaged. (Defective A1 YIG Driver Assy)</li> <li>3. Noisy A1 YIG Driver Assembly (DEFECTIVE A1 YIG Driver Assy)</li> </ol>	<p>86260A Rear Panel</p> <p>SS1</p> <p>SS1</p>
Excessive Frequency Drift <b>NOTE</b> Frequency stability should be measured after minimum 30-minute warm-up period at the same frequency with RF power ON.	<ol style="list-style-type: none"> <li>1. Defective A1 YIG Driver Assembly</li> <li>2. Defective Reference Resistor R3 (chassis mounted)</li> <li>3. Defective A4 YIG Oscillator Assembly</li> </ol>	<p>SS1</p> <p>SS1</p> <p>SS1</p>
Low RF Power and/or CW Frequency changes after cycling RF ON/OFF SWITCH.	<ol style="list-style-type: none"> <li>1. CW frequency set below 12.4 GHz</li> <li>2. Defective A1 YIG Oscillator</li> </ol>	<p>8620A</p> <p>SS1</p>

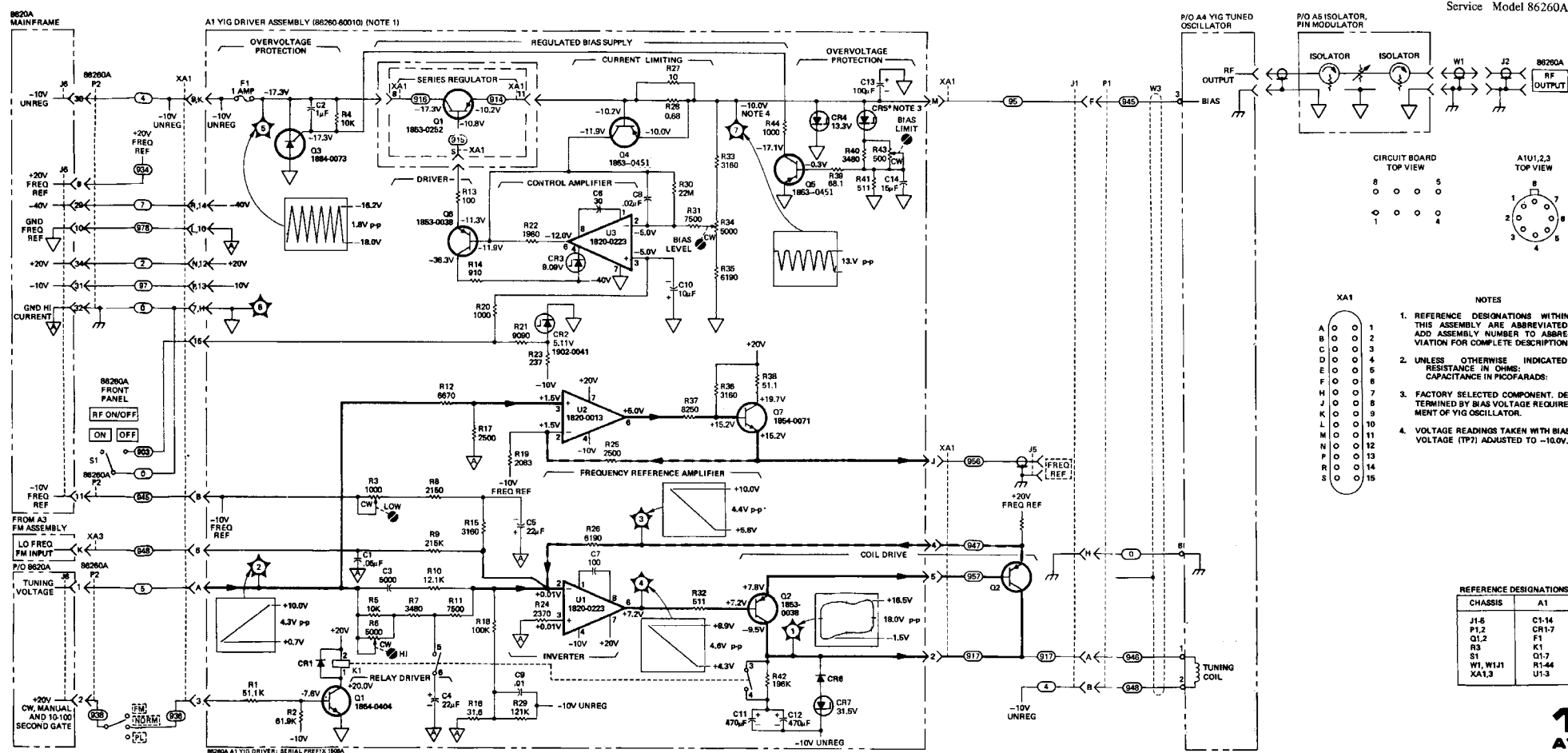

Figure 8-14. A1 YIG Driver Assembly, Schematic

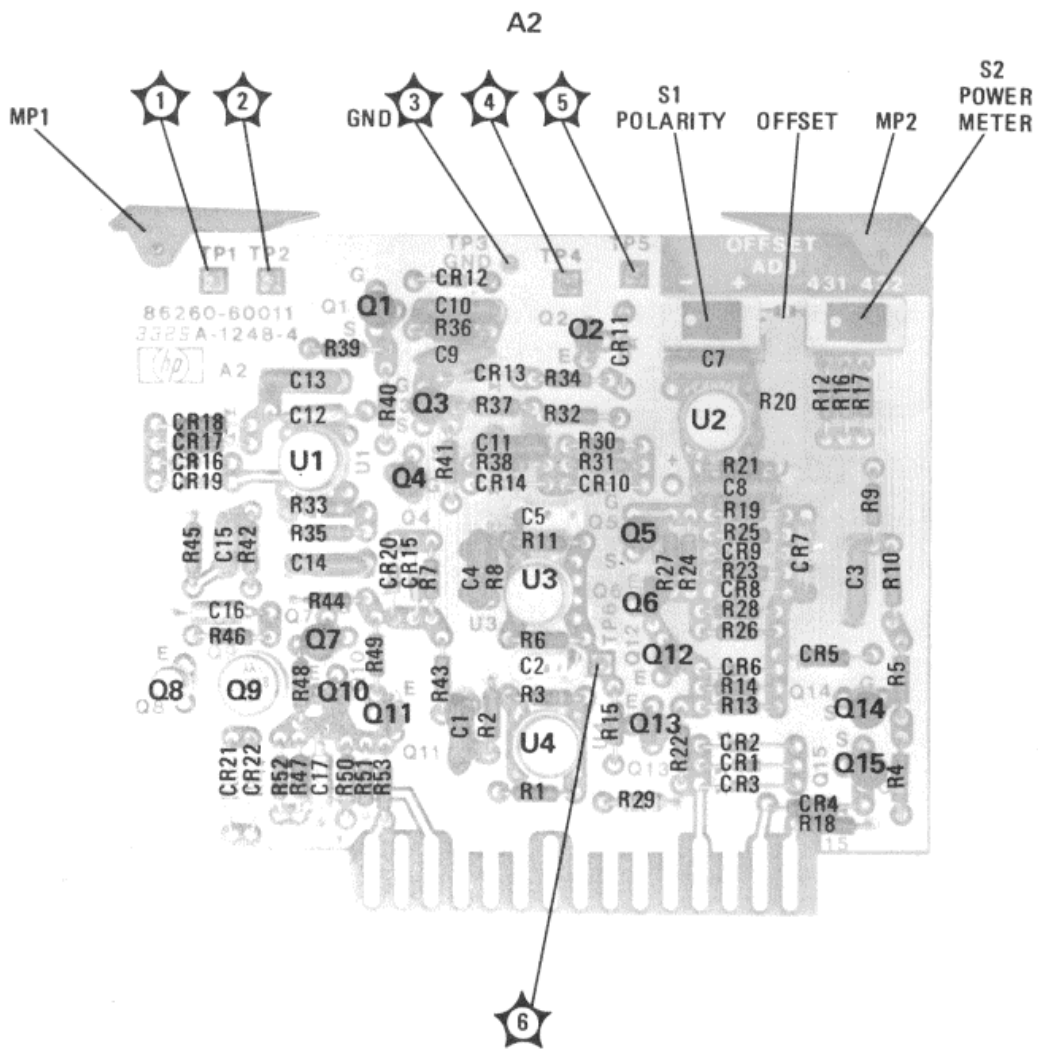

Figure 8-15. A2 ALC Assembly, Components Location 8-14

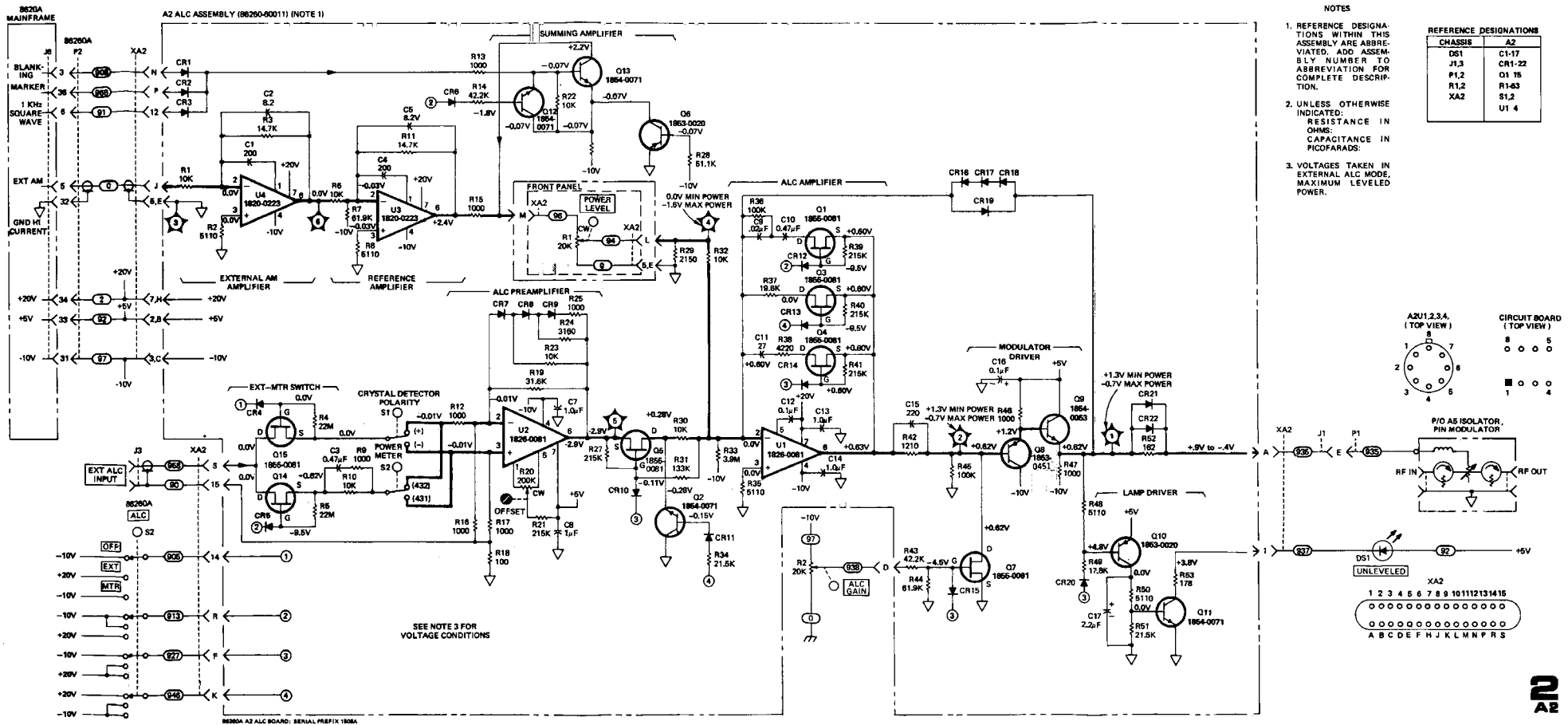

Figure 8-16. A2 ALC Assembly, Component Locations

**SERVICE SHEET 3****A3 FM Assembly, Circuit Description****GENERAL**

The A3 FM Assembly contains FM Driver and Lo Freq FM Amplifier circuitry that provide frequency modulated RF output for the 86260A. The FM Driver consists of Q 1, 2, Q3, and Q4 and the Lo Freq Amplifier consists of U1. External FM signals are applied to the A3 FM Assembly through rear panel BNC connector J4. FM sensitivity is selected by the 86260A rear panel FM-NORM-PL switch: - 20 MHz/V in the FM or NORM positions and-6 MHz/V in the PL position. The A3 FM Assembly also contains a Hi Pass Filter.

**HI PASS FILTER**

Hi Pass Filter consisting of C1, C2, R4 and R5, prevent signals below 200 Hz from reaching the FM Driver circuitry. These low frequency signals are passed to the Lo FM Freq Amplifier.

**FM DRIVER**

The three-transistor FM Driver circuit provides sufficient gain to drive the FM coil of the YIG Oscillator. The sensitivity of the FM coil is 100 kHz/mA.

**LO FREQ FM AMPLIFIER**

The Lo Freq FM Amplifier is a single op amp, U 1, in a fixed gain configuration that provides signal inversion and less than unity gain.

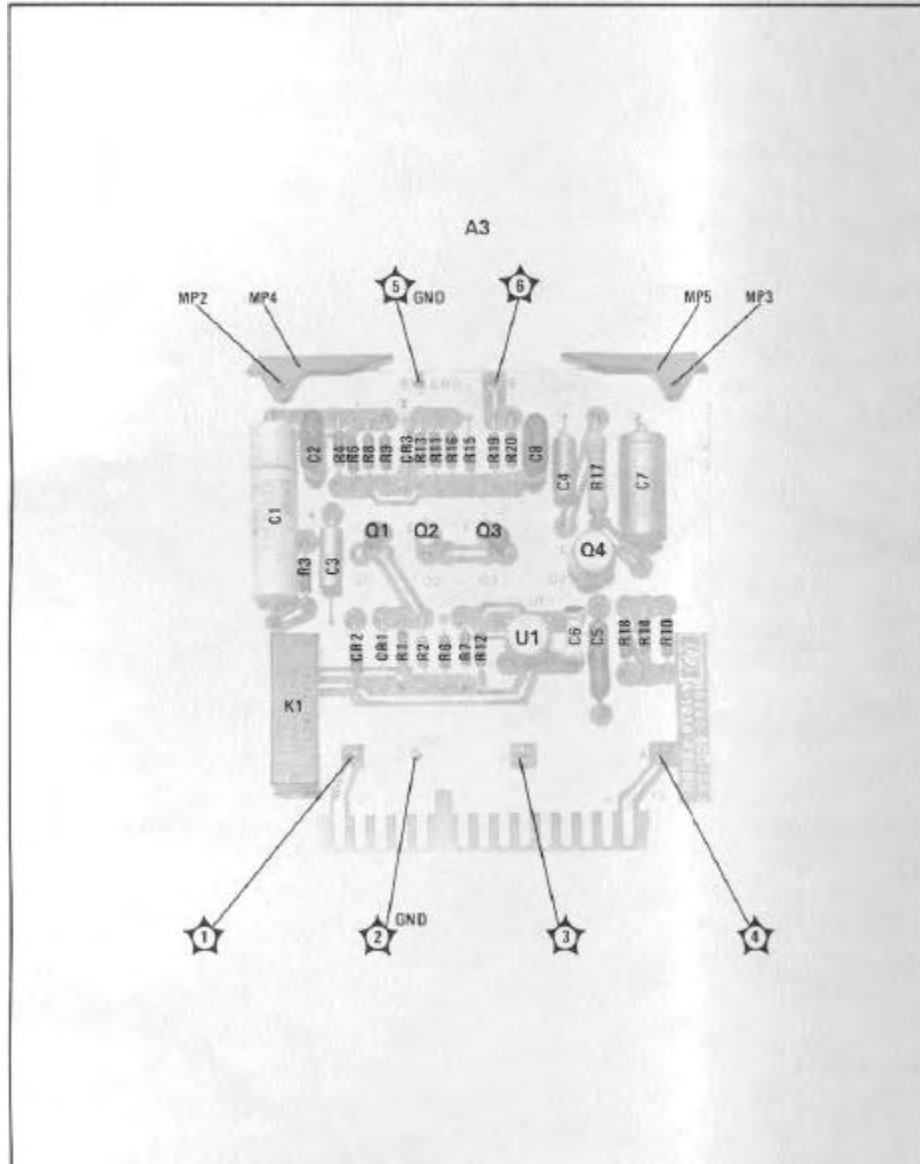

Figure 8-17. A3 FM Assembly, Components Location

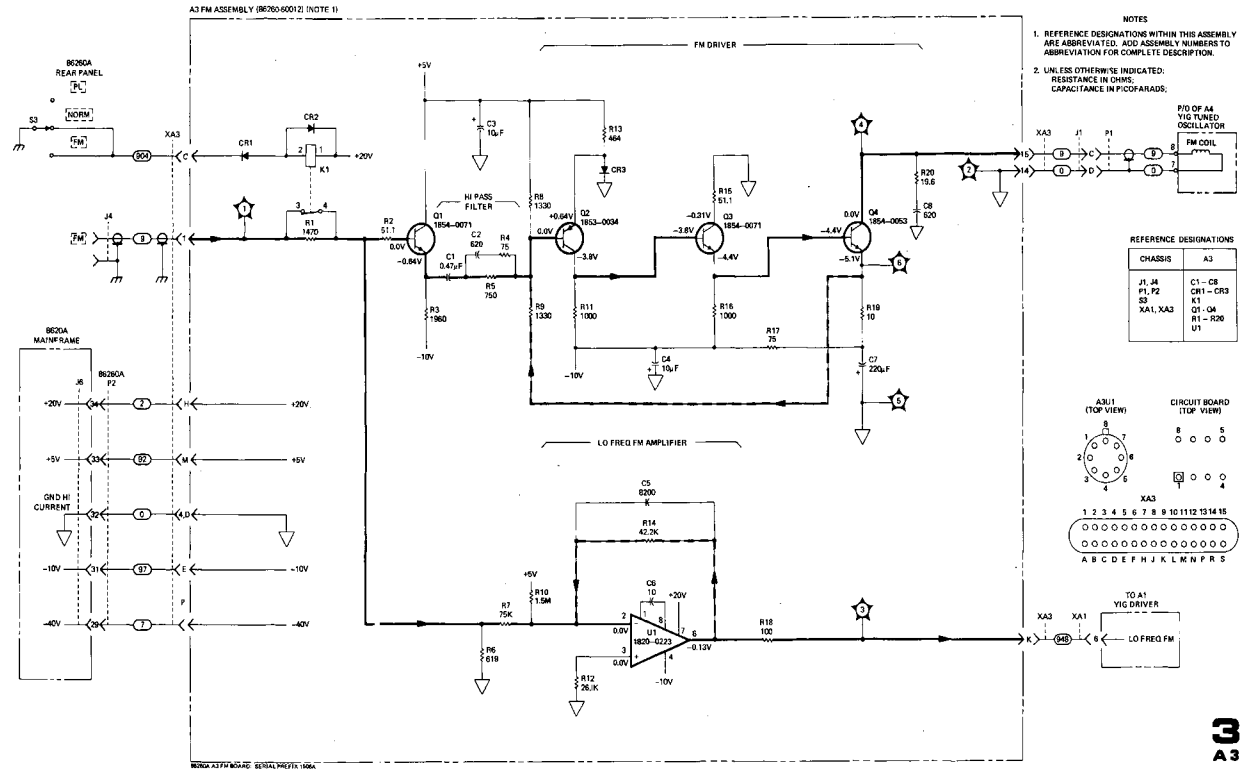

Figure 8-18. A3 FM Assembly, Schematic

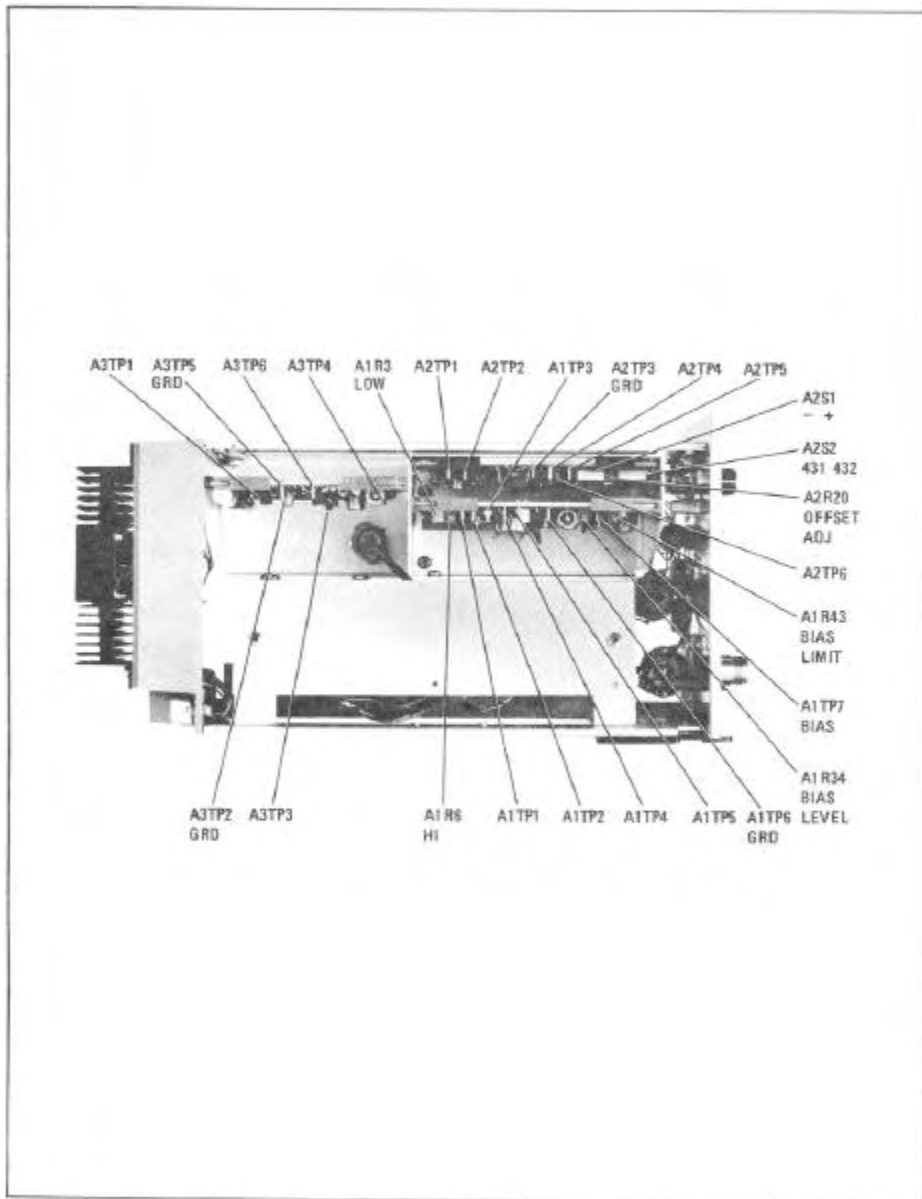

Figure 8-19. Adjustments and Test Points Location

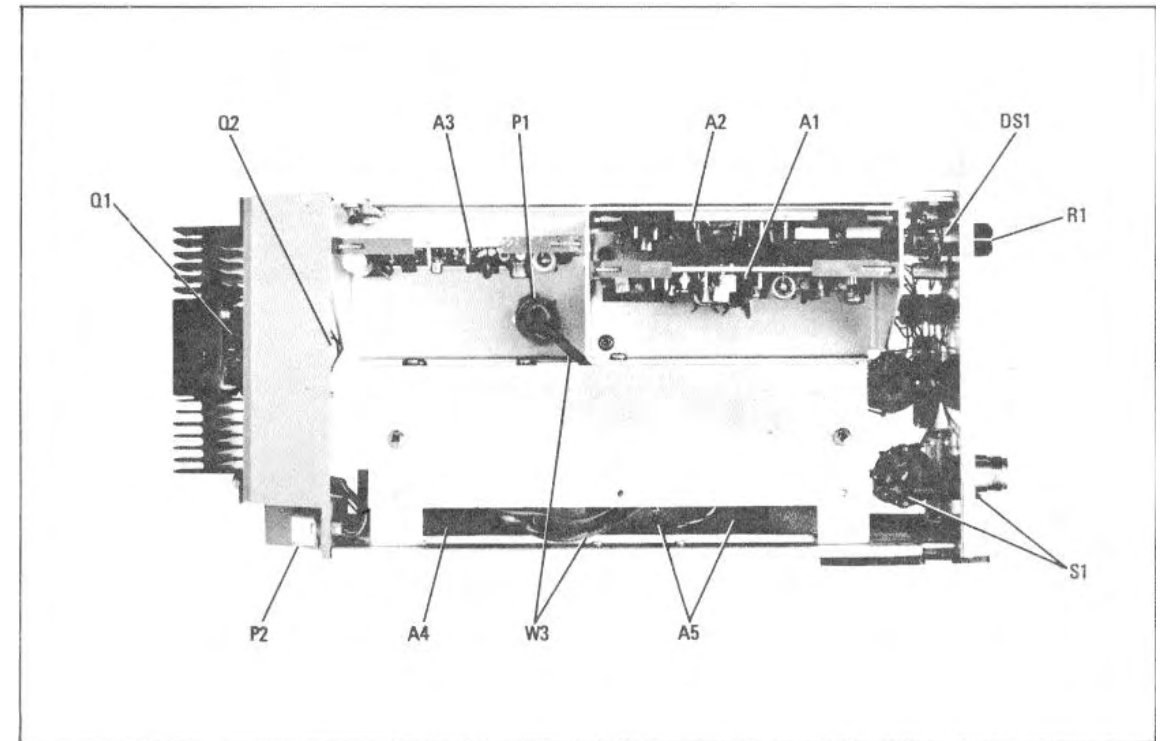

Figure 8-20.. Major Assemblies Location, Top View

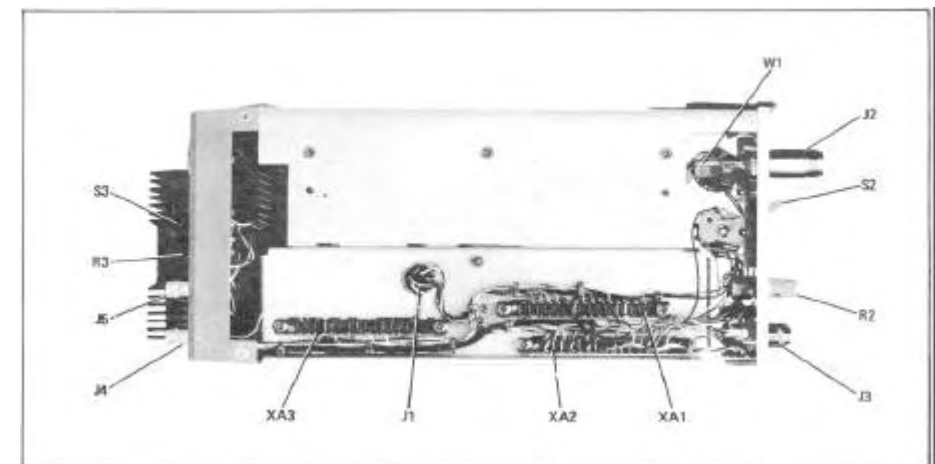

Figure 8-21. Major Assemblies Location, Bottom View



## SECTION IX

## OPTIONS

## OPTION 001 INTERNAL LEVELING

**9-1. INTRODUCTION**

9-2. This section describes the differences in the Model 86260A RF Plug-in with Option 001 installed. The components and assemblies used with the Option 001 are contained in this section. In addition, it describes the manual changes necessary to document the addition of Option 001. The Option 001 is compatible with all 86260A options.

**9-3. DESCRIPTION**

9-4. The HP Model 86260A Option 001 incorporates a detector and directional coupler to provide internal leveling capability. A four-position ALC Switch S2 is mounted on a new lower front panel.

**9-5. MANUAL CHANGES**

9-6. The following changes are required to modify and expand the Model 86260A Operating and Service Manual to include the HP Model 86260A Option 001.

Page 1-5, Table 1-1, Power Level and Power Variation:

- Change Power Level to: Maximum Leveled Power (Option 001) > +6.0 dBm (4 mW).
- Add under Power Variation the following specification: Internally Leveled: <  $\pm 0.7$  dB.

Page 3-3, Figure 3-1:

- Replace Figure 3-1 with Figure 9-1.

Page 4-6, Paragraph 4-10:

- Change SPECIFICATION to: Maximum Leveled Power (Option 001): > +6.0 dBm (4 mW).
- Add Power Variation at Maximum Leveled Power: Internally Leveled (Option 001): <  $\pm 0.7$  dB.

Page 4-10, Paragraph 4-10:

- Add after step n the Performance Test for Internal Leveling(86260A Option 001), steps o through t, in this Section

Page 4-23, Table 4-1, Paragraph 4-10:

- Add the following after step n:
 

q. Internally leveled maximum output power	Lower Limit: +6 dBm
t. Internally leveled variation	Upper Limit: 1.4 dB p-p

Page 5-1, Table 5-1:

- Add the following:
  - A2R17 SLOPE Adjusts for minimum leveled power variation.
  - A2R58 GAIN Sets gain of ALC loop in internal mode.

Page 5-8:

- Add Paragraph 5-16, Internal Leveling Slope and Gain Adjustments (Option 001) in this Section.

## FRONT PANEL FEATURES

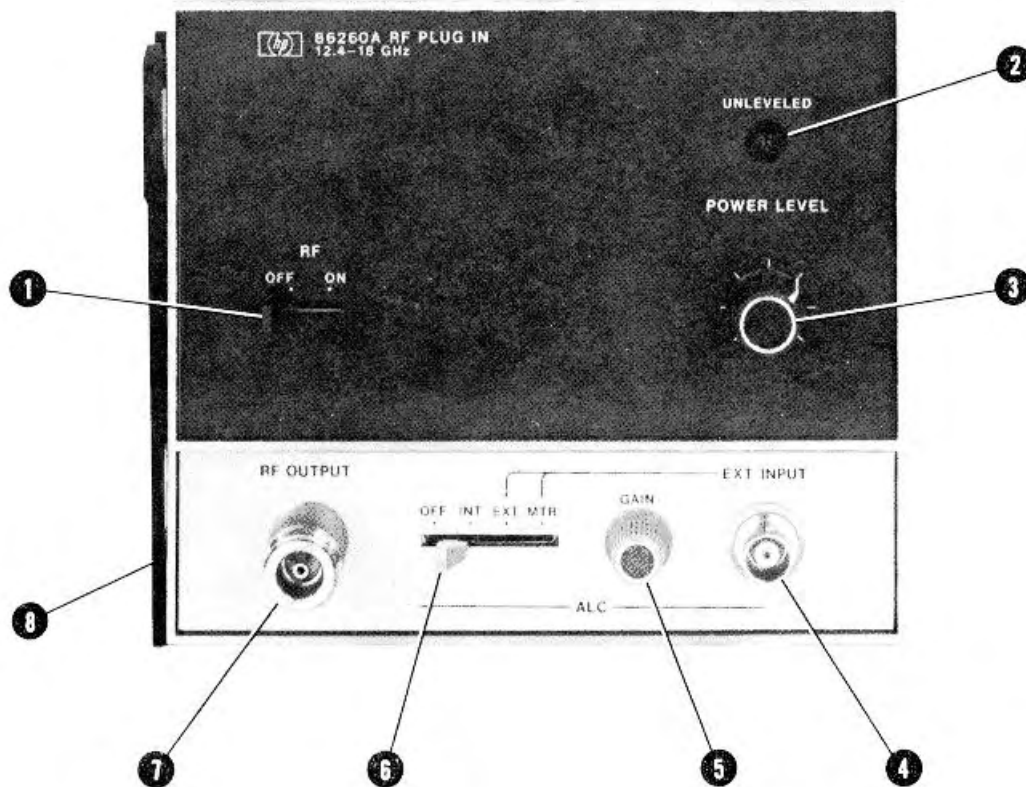

- (1) **ON-OFF switch S1.** Turns RF power on and off. Resets oscillator bias voltage when turned to off then on again.
- (2) **light DS1.** Lights when not in an automatic leveling mode or when in a leveling mode and RF output is not level across the band.
- (3) **LEVEL control R1.** Adjusts RF power out-put.
- (4) **EXT INPUT connector J3.** Input for external leveling from crystal detector or power meter.
- (5) **GAIN control R2.** Adjusts output of ALC amplifier when using external leveling.

- (6) **switch S2.** Selects INT (internal), EXT (external), or MTR (power meter) power leveling modes. In OFF position, RF is not leveled.
- (7) **OUTPUT J2.** Type-N 50 Ohm RF output connector.

**NOTE**

When Option 005 is installed, the output connector is an APC-7.  
When Option 004 is installed, the RF OUTPUT connector is on the rear panel.

- (8) **Latching Handle.** Aids in installing and removing RF Plug-in. After installing, handle locks to hold RF Plug-in in place.

Figure 9-1. Front Panel Controls, Connectors and Indicator (Option 001)

PERFORMANCE TESTS

4-10. POWER LEVEL AND VARIATION

Internal Leveling (86260A Option 001 only):

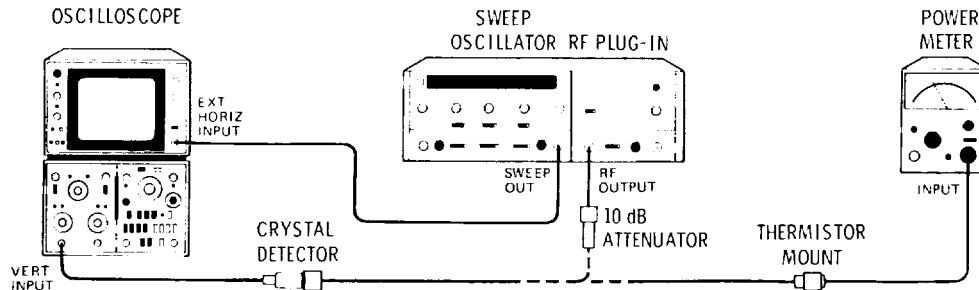

Figure 9-2. Internal Leveling Test Setup

EQUIPMENT:

Sweep Oscillator .....	HP 8620A
RF Plug-in .....	HP 86260A, Option 001
10-dB Attenuator .....	HP 8491B, Option 010
Crystal Detector .....	HP 8470A, Option 012
Oscilloscope .....	HP 180A/1801A/1820A
15-Contact Extender Board .....	HP 5060-0049
Extender Cable .....	HP 08620-60032

PROCEDURE:

o. Connect equipment as shown in Figure 9-2.

p. Set controls as follows:

8620A

BAND .....	12.4 to 18.0 GHz
START pointer .....	12.4 GHz
CW pointer .....	15.2 GHz
STOP pointer .....	18.0 GHz
MARKER .....	OFF
MODE .....	AUTO
TRIGGER .....	INT
TIME-SECONDS .....	10.1 to 0.01
1 kHz SQ WV/OFF (Rear Panel) .....	OFF
RF BLANKING/OFF (Rear Panel) .....	OFF

86260A

ALC .....	INT
-----------	-----

---

**PERFORMANCE TESTS**

---

**4-10. POWER LEVEL AND VARIATION (Cont'd)**

- q. 8620A LINE switch to ON. Press 8620A START pushbutton. Adjust POWER LEVEL control fully clockwise, then counterclockwise until UNLEVELED lamp goes out. The power meter should indicate  $>+6.0$  dBm, . minus any additional loss due to other equipment used. (With Option 006 installed, power meter should indicate  $>+9$  dBm.)
- r. 8620A CW pushbutton. Adjust oscilloscope trace to bottom of display and note trace position. Decrease output power indication on power meter by 1. dB by adjusting POWER LEVEL control and note position of oscilloscope trace. (The area between two positions noted represents leveling tolerance of +0.7 dB.)
- s. 8620A rear panel RF Blanking/OFF switch to RF Blanking. Press 8620A START pushbutton. Adjust POWER LEVEL control fully clockwise, then counterclockwise until UNLEVELED lamp goes out for maximum leveled power.
- t. position of oscilloscope trace vertically so it is displayed between the upper and lower specification limits noted in Step r. The highest and lowest portion of the sweep trace must be within the 1.4 dB peak-to-peak limit noted.

---

**ADJUSTMENTS**

---

**5-16. INTERNAL LEVELING SLOPE AND GAIN ADJUSTMENTS (OPTION 001)**

## REFERENCE:

Service Sheet 2, ALC ASSEMBLY.

## DESCRIPTION:

Adjust SLOPE control A2R17 to provide minimum leveled power variation. Adjust GAIN control A2R58 for sufficient ALC gain without oscillation.

---

ADJUSTMENTS

5-16. INTERNAL LEVELING SLOPE AND GAIN ADJUSTMENTS (Option 000) (Cont'd)

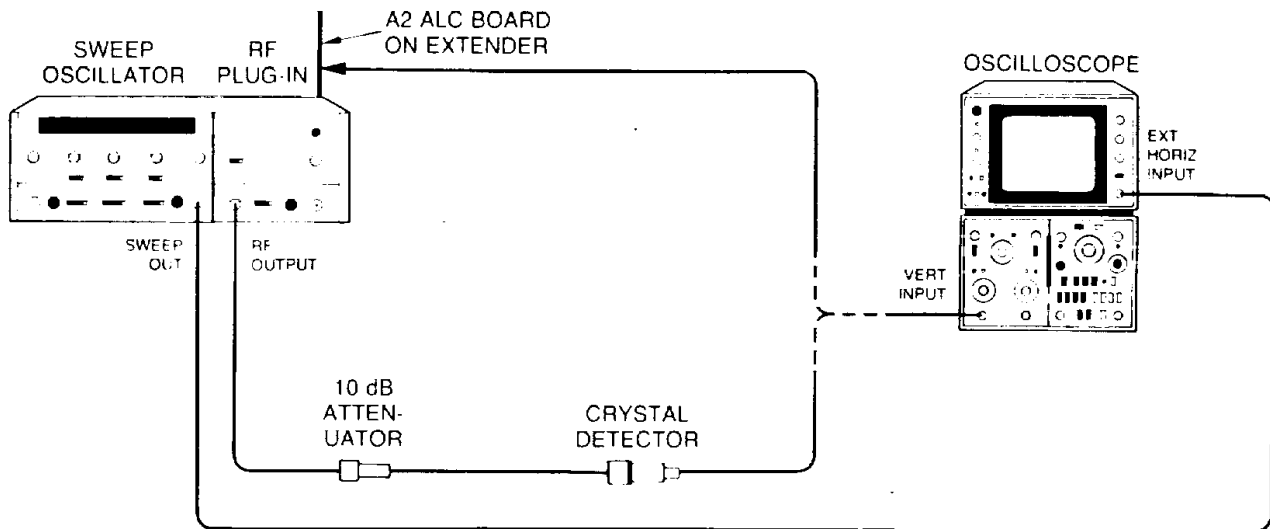

Figure 9-3. Internal Leveling Slope and Gain Adjustments Test Setup

EQUIPMENT:

Sweep Oscillator .....	HP 8620A
RF Plug-in .....	HP 86260A, Option 001
10-dB Attenuator .....	HP 8491B, Option 010
Crystal Detector .....	HP 8470A, Option 012
Oscilloscope .....	HP 180A/1801A/1820A
15-Contact Extender Board .....	HP 5060-0049
Extender Cable .....	HP 08620-60032

PROCEDURE:

*Slope Control Adjustment*

- a. RF Plug-in from mainframe and install extender cable. Remove A2 ALC board and install 15-contact extender board. (See Figure 1-2.)
- b. equipment as shown in Figure 9-3 with 0-dB attenuator and crystal detector connected directly to RF OUTPUT.
- c. controls as follows:

8620A

MODE .....	AUTO
TIME-SECONDS .....	.1 to .01
TIME-SECONDS vernier .....	Fully clockwise
RF BLANKING/OFF .....	RF BLANKING
1 kHz S WV/OFF .....	1 KHz SQ WV

PERFORMANCE TESTS

5-16. INTERNAL LEVELING SLOPE AND GAIN ADJUSTMENTS (Option 001) (Cont'd)

86260A

RF .....	ON
ALC .....	INT
ALC GAIN .....	Fully clockwise

- d. Press 8620A LINE pushbutton.
- e. Set oscilloscope for external sweep and apply sweep signal from 8620A.
- f. Observe RF signal and adjust SLOPE control A2R17 for optimum level RF output at 12.4 GHz.

*Internal Leveling Gain Adjustment*

- g. 0.2 VOLTS/DIV sensitivity on oscilloscope.
- h. Connect oscilloscope to A2TP5.
- i. GAIN potentiometer A2R58 fully clockwise. Oscillations should appear on trace. (See Figure 3-6.)
- j. GAIN counterclockwise until oscillations just disappear.
- k. Rotate POWER LEVEL control through its full range. As the POWER LEVEL control is rotated, oscillations may occur.
- l. oscillations occur, continue to adjust GAIN counterclockwise to just remove all oscillations over entire range of POWER LEVEL control.

Page 6-5, Table 6-2:

Change A2 to HP Part Number 86260-60021.

Change A2 Replaceable Parts List to read as Table 9- 1.

Table 9-1. Replaceable Parts

Reference Designation	HP Part Number	Qty	Description	Mfr Code	Mfr Part Number
A2	86260-60021	1	ALC ASSEMBLY	28480	86260-60021
A2C1	0160-3451	1	CAPACITOR-FXD .01UF +80-20% 100WVDC CER	28480	0160-3451
A2C2	0143-0198	2	CAPACITOR-FXD 200PF +/-5% 300WVDC MICA	72136	DM15F201J0300WVICP
A2C3	0160-2255	2	CAPACITOR-FXD 8.2PF +/-25PF 500WVDC CER	28480	0160-2255
A2C4	0160-0174	2	CAPACITOR-FXD .47UF +80-20% 25WVDC CER	28480	0160-0174
A2C5	0140-0198		CAPACITOR-FXD 200PF +/-5% 300WVDC MICA	72136	DM15F201J0300WVICP
A2C6	0160-2255		CAPACITOR-FXD 8.2PF +/-25PF 500WVDC CER	28480	0160-2255
A2C7	0160-0127	4	CAPACITOR-FXD 1UF +/-20% 25WVDC CER	28480	0160-0127
A2C8	0160-0127		CAPACITOR-FXD 1UF 1 =20% 25WVDC CER	28480	0160-0127
A2C9	0160-3452	1	CAPACITOP-FXD.02UF +/-20% 100WVDC CER	28480	0160-3452
A2C10	0160-2306	1	CAPACITOR-FXD 27PF +/-27PF 300WVDC MICA	28480	0160-2306
A2C11	0160-0174		CAPACITOR-FXD .47UF +/-80-20% 25WVDC CER	28480	0160-0174
A2C12	0180-1743	2	CAPACITOR-FXD; .1UF +/-10% 35VDC TA=SOLID	56289	150D104X9035A2
A2C13	0160-0127		CAPACITOR-FXD; 1UF +/-10% 25WVDC TA=SOLID	28480	0160-0127
A2C14	0160-0127		CAPACITOR-FXD 1UF +/-20% 25WVDC CER	28480	0160-0127
A2C15	0160-3446	1	CAPACITOR-FXD 220PF +/-10% 1000WVDC CER	28480	0160-3446
A2C16	0180-1743		CAPACITOR-FXD; .1UF +/-10% 35VDC TA-SOLID	56289	150D104X9035A2
A2C17	0180-0197	1	CAPACITOR-FXD; 2.2UF +/-10% 20VDC TA	56289	150D225X9020A2
A2CR1	1901-0033	20	DIODE-GEN PRP 180V 200NA DO-7	28480	190140013
A2CR2	1901-0033		DIODE-GEN PRP 180V 200NA DO-7	26480	1901-0033
A2CR3	1901-0033		DIODE-GEN PRP 180V 200NA DO-7	28480	1901-0033
A2CR4	1901-0033		DIODE-GEN PRP 180V 200NA DO-7	29480	1901-0033
A2CR5	1901-0033		DIODE-GEN PRP 180V 200NA DO-7	28480	1901-0033
A2CR6	1901-3765		DIODE-GEN PRP 35V 50NA DO-7	28480	1901-0376
A2CR7	1901-0033		DIODE-GEN PRP 180V 200NA DO-7	28480	1901-0033
A2CR8	1901-0033		DIODE-GEN PRP 180V 200NA DO-7	28480	1901-0533
A2CR9	1901-0033		DIODE-GEN PRP 180V 200NA DO-7	28480	1901-0033
A2CR10	1901-0033		DIODE-GEN PRP 180V 200NA DO-7	28480	1901-0033
A2CR11	1901-0376	5	DIODE-GEN PRP 35V 50NA 00-7	28480	1901-0376
A2CR12	1901-0376		DIODE-GEN PEP 35V 50NA 00-7	28480	1901-0376
A2CR13	1901-0033		DIODE-GEN PRP 180V 200NA DO-7	28480	1901-0033
A2CR14	1901-0033		DIODE-GEN PRP 180V 200NA DO-7	28480	1901-0033
A2CR15	1901-0033		DIODE-GEN PRP 180V 200NA DO-7	28480	1901-0033
A2CR16	1901-0033		DIODE-GEN PRP 180V 200NA DO-7	28480	1901-0033
A2CR17	1901-0033		DIODE-GEN PRP 180V 200NA DO-7	28480	1901-0033
A2CR18	1901-0040	6	DIODE-SWITCHING 30V 50NA 2NS DO-35	28480	1901-0040
A2CR19	1901-0535	5	DIODE-SCHOTTKY	28480	1901-0535
A2CR20	1901-0033		DIODE-GEN PRP 180V 200NA DO-7	28480	1901-0033
A2CP21	1901-0535		DIODE-SCHOTTKY	29480	1901-0535
A2CR22	1901-0033		DIODE-GEN PRP 180V 200NA DO-7	28480	1901-0033
A2CR23	1901-0535		DIODE-SCHOTTKY	28480	1901-0535
A2CR24	1901-0033		DIODE-GEN PRP 180V 200NA DO-7	28480	1901-0033
A2CR25	1901-0040		DIODE-SWITCHING 30V 50NA 2NS DO-35	28480	1901-0040
A2CR26	1901-0040		DIODE-SWITCHING 30V 50NA 2NS DO-35	28480	1901-0040
A2CR27	1901-0040		DIODE-SWITCHING 30V 50NA 2NS DO-35	28480	1901-0040
A2CR28	1901-0040		DIODE-SWITCHING 30V 50NA 2NS DO-35	28480	1901-0040
A2CR29	1901-0040		DIODE-SWITCHING 30V 50NA 2NS DO-35	28480	1901-0340
A2CR30	1901-0033		DIODE-GEN PRP 180V 200NA DO-7	28480	1901-0033
A2CR31	1901-0033		DIODE-GEN PRP 180V 200NA DO-7	28480	1901-0033
A2CR32	1961-0535		DIODE-SCHOTTKY	28480	1901-0535
A2CR33	1901-0376		DIODE-GEN PRP 35V 50NA DO -7	28480	1901-0376
A2CR34	1901-0535		DIODE-SCHOTTKY	28480	1901-0535
A2CR35	1901-0376		DIODE-GEN PRP 35V 50NA DO-7	28480	1901-0376
A2CR36	1901-0033		DIODE-GEN PRP 180V 200NA DO-7	28480	1901-0033
A2CR37	1910-0018	2	DIODE-GE 60V 60NA 1US DO-7	28480	1910-0316
A2CR38	1910-0016		DIODE-GE 60V 60NA 1US DO-7	28480	1910-0016
A2MP1	4040-0750	2	EXTRACTOR-PC BD RED POLYC .062-BD-THKNS	28480	4040-0750
A2MP2	4040-0750		EXTRACTOR-PC BD RED POLYC .062-BD-THKNS	28480	4040-0750
A2Q1	1855-0081	7	TRANSISTOR J-FET 2N5245 N-CHAN D-MODE S1	01295	2N5245
A2Q2	1854-0071	4	TRANSISTOP NPN SI PD:300MW FT=200MHZ	28480	1854-0071
A2Q3	1855-0081		TRANSISTOR J-FET 2N5245 N-CHAN D-MODE S1	01295	2N5245
A2Q4	1853-0451	2	TRANSISTOR PNP 2N3799	28480	1853-0451
A2Q5	1853-0451		TRANSISTOR PNP 2N3799	28480	1853-0451
A2Q6	1855-0081		TRANSISTOR J-FET 2N5245 N-CHAN D-MODE S1	01295	2N5245
A2Q7	1855-0081		TRANSISTOR J-FET 2N5245 N-CHAN D-MODE S1	01295	2N5245
A2Q8	1855-0081		TRANSISTOR J-FET 2N5245 N-CHAN D-MODE S1	01295	2N5245
A2Q9	1853-0020	2	TRANSISTOR PNP SI PD=300MW FT=150MHZ	28480	1853-0020
A2Q10	1855-0020	1	TRANSISTOR J-FET N-CHAN D-MODE TO-18 S1	28480	1855-0020
A2Q11	1854-0071		TRANSISTOR NPN SI PD=300MW FT=200MHZ	28480	1854-0071
A2Q12	1854-0039	1	TRANSISTOR NPN 2N3053 SI TO-5 PD=1W	04713	2N3053
A2Q13	1853-0020		TRANSISTOR PNP SI PD=300MW FT=150MHZ	28480	1853-0020
A2Q14	1855-0081		TRANSISTOR J-FET 2N5245 N-CHAN D-MODE S1	01295	2N5245
A2Q15	1854-0071		TRANSISTOF NPN SI PD=300MW FT=200MHZ	28480	1854-0071

Table 9-1. Replaceable Parts

Reference Designation	HP Part Number	Qty	Description	Mfr Code	Mfr Part Number
A2Q16	1854-0071		TRANSISTOR NPN SI PD=300MW FT=200MHZ	28480	1854-0071
A2Q17	1855-0081		TRANSISTOR J-FET 2N5245 N-CHAN D-MODE SI	01295	2N5245
A2R1	0757-0442	7	RESISTOR 10K 1% .125W F TC=0±100	24546	C4-1/8-TO-1002-F
A2R2	0757-0465	3	RESISTOR 100K 1% .125W F TC=0±100	24546	C4-1/8-TO-1003-F
A2R3	0757-0438	8	RESISTOR 5.11K 1% .125W F TC=0±100	24506	C4-1/8-TO-5111-F
A2R4	0698-3160	4	RESISTOR 31.6K 1% .125W F TC=0±100	16299	C4-1/8-TO-3162-F
A2R5	0698-3160		RESISTOR 31.6K 1% .125W F TC=0±100	16299	C4-1/8-TO-3162-F
A2R6	0698-3156	2	RESISTOR 14.7K 1% .125W F TC=0±100	16299	C4-1/8-TO-1472-F
A2R7	0683-2265	3	RESISTOR 22M 5% .25W FC TC=900/+1200	01121	CB2265
A2R8	0683-2265	5	RESISTOR 22M 5% .25W FC TC=900/+1200	01121	CB2265
A2R9	0757-0290	8	RESISTOR 1K 1% .125W F TC=0±100	24546	C4-1/8-TO-1001-F
A2R10	0757-0442		RESISTOR 10K 1% .125W F TC=0±100	24546	C4-1/8-TO-1002-F
A2R11	0757-0442		RESISTOR 10K 1% .125W F TC=0±100	24546	C4-1/8-TO-1002-F
A2R12	0757-0438		RESISTOR 5.11K 1% .125W F TC=0±100	24546	C4-1/8-TO-5111-F
A2R13	0757-0460	2	RESISTOR 61.9K 1% .125W F TC=0±100	24546	C4-1/8-TO-6192-F
A2R14	0757-0438		RESISTOR 5.11K 1% .125W F TC=0±100	24546	C4-1/8-TO-5111-F
A2R15	0698-3160		RESISTOR 31.6K 1% .125W F TC=0±100	16299	C4-1/8-TO-3162-F
A2R16	0757-0442		RESISTOR 10K 1% .125W F TC=0±100	24546	C4-1/8-TO-1002-F
A2R17	2103-2517	1	RESISTOR-TRMR 50K 10% C SIDE-ADJ I-TURN	30983	ET50X503
A2R18	0683-2265		RESISTOR 22M 5% .25W FC TC=900/+1200	01121	CB2265
A2R19	0698-3156		RESISTOR 14.7K 1% .125W F TC=0±100	16299	C4-1/8-TO-1472-F
A2R20	0757-0438		RESISTOR 5.11K 1% .125W F TC=0±100	24546	C4-1/8-TO-5111-F
A2R21	0757-0280		RESISTOR 1K 1% .125W F TC=0±100	24546	C4-1/8-TO-1001-F
A2R22	0757-0280		RESISTOR 1K 1% .125W F TC=0±100	24546	C4-1/8-TO-1001-F
A2R23	0757-0280		RESISTOR 1K 1% .125W F TC=0±100	24546	C4-1/8-TO-1001-F
A2R24	0757-0401	1	RESISTOR 100 1% .125W F TC=0±100	24546	C4-1/8-TO-101-F
A2R25	0757-0280		RESISTOR 1K 1% .125W F TC=0±100	24546	C4-1/8-TO-1001-F
A2R26	0757-0199	2	RESISTOR 21.5K 1% .125W F TC=0±100	42546	C4-1/8-TO-2152-F
A2R27	0757-0280		RESISTOR 1K 1% .125W F TC=0±100	24546	C4-1/8-TO-1001-F
A2R28	0757-0438		RESISTOR 5.11K 1% .125W F TC=0±100	24546	C4-1/8-TO-5111-F
A2R29	2100-3162	1	RESISTOR-TRMR 200K 10% C SIDE-ADJ	32991	3006P-I-204
A2R30	0698-3160		RESISTOR 31.6K 1% .125W F TC=0±100	16299	C4-1/8-TO-3162-F
A2R31	0757-0442		RESISTOR 10K 1% .125W F TC=0±100	24546	C4-1/8-TO-1002-F
A2R32	0698-3454	5	RESISTOR 215K 1% .125W F TC=0±100	16299	C4-1/8-TO-2153-F
A2R36	0695-3454		RESISTOR 10K 1% .125W F TC=0±100	16299	C4-1/8-TO-2153-F
A2R37	0757-0442		RESISTOR 215K 1% .125W F TC=0±100	24546	C4-1/8-TO-1002-F
A2R38	0698-3150	1	RESISTOR 2.37K 1% .125W F TC=0±100	16299	C4-1/8-TO-2371-F
A2R39	0757-0458	1	RESISTOR 51.1K 1% .125W F TC=0±100	24546	C4-1/8-TO-5112-F
A2R40	0757-0442		RESISTOR 10K 1% .125W F TC=0±100	24546	C4-1/8-TO-1002-F
A2R41	0698-3451	1	RESISTOR 133K 1% .125W F TC=0±100	16299	C4-1/8-TO-1333-F
A2R42	0683-3955	1	RESISTOR 3.9M 5% .125W F TC=900±1100	01121	CB3955
A2R43	0757-0199	2	RESISTOR 21.5K 1% .125W F TC=0±100	24546	C4-1/8-TO-2152-F
A2R44	0757-0440	1	RESISTOR 7.5K 1% .125W F TC=0±100	24546	C4-1/8-TO-7501-F
A2R45	0757-0465		RESISTOR 100K 1% .125W F TC=0±100	24546	C4-1/8-TO-1003-F
A2R46	0757-0438		RESISTOR 5.1K 1% .125W F TC=0±100	24546	C4-1/8-TO-5111-F
A2R47	0698-3157	1	RESISTOR 19.6K 1% .125W F TC=0±100	16299	C4-1/8-TO-1962-F
A2R48	0698-3154	1	RESISTOR 4.22K 1% .125W F TC=0±100	16299	C4-1/8-TO-4221-F
A2R49	0698-3454		RESISTOR 215K 1% .125W F TC=0±100	16299	C4-1/8-TO-2153-F
A2R50	0698-3454		RESISTOR 215K 1% .125W F TC=0±100	16299	C4-1/8-TO-2153-F
A2R51	0698-3454		RESISTOR 215K 1% .125W F TC=0±100	16299	C4-1/8-TO-2153-F
A2R52	0698-3450		RESISTOR 42.2K 1% .125W F TC=0±100	16299	14-1/8-TO-4222-F
A2R53	0757-0274	1	RESISTOR 1.21K 1% .125W F TC=0±100	24546	C4-1/8-TO-1213-F
A2R54	0757-0460		RESISTOR 61.9K 1% .125W F TC=0±100	24546	C4-1/8-TO-6192-F
A2R55	0757-0465		RESISTOR 100K 1% .125W F TC=0±100	24546	C4-1/8-TO-1003-F
A2R56	0757-0424	1	RESISTOR 1.1K 1% .125W F TC=0±100	24546	C4-1/8-TO-1101-F
A2R57	0757-0280		RESISTOR 1K 1% .125W F TC=0±100	24546	C4-1/8-TO-1001-F
A2R58	2100-2497	1	RESISTOR-TRMR 2K 10% C TOP-ADJ I-TURN	19701	ET50W202
A2R59	0757-0280		RESISTOR 1K 1% .125W F TC=0±100	24546	C4-1/8-TO-1001-F
A2R60	0757-0438		RESISTOR 5.11K 1% .125W F TC=0±100	24546	C4-1/8-TO-5111-F
A2R61	0698-3136	1	RESISTOR 17.8K 1% .125W F TC=0±100	16299	C4-1/8-TO-1782-F
A2R62	0757-0438		RESISTOR 5.11K 1% .125W F TC=0±100	24546	C4-1/8-TO-5111-F
A2R63	0757-0199		RESISTOR 21.5K 1% .125W F TC=0±100	24546	C4-1/8-TO-2152-F
A2R64	0757-0405	1	RESISTOR 162 1% .125W F TC=0±100	24546	C4-1/8-TO-162R-F
A2R65	0698-3439	1	RESISTOR 178 1% .125W F TC=0±100	16299	C4-1/8-TO-178R-F
A2S1	3101-1274	2	SWITCH-SL SPDT-NS SUBMIN 2A 120VAC	10389	23-021-008
A2S2	3101-1274		SWITCH-SL SPDT-NS SUBMIN 2A 120VAC	10389	23-021-008
A2U1	1826-0081	2	IC LM318H AMPL	27014	LM318H
A2U2	1826-0081		IC LM318H AMPL	27014	LM318H
A2U3	1826-0223	2	IC LINEAR	28480	1826-0223
A2U4	1826-0223		IC LINENR	28480	1826-0223



Page 6-7, Table 6-2:

- Add A6 HP Part Number 0955-0061 Coupler: Directional.
- Add A7 HP Part Number 5060-0313 Detector: Crystal.
- Change S2 to HP Part Number 3100-2094 Switch: Lever, ALC (Option 001).
- Delete W1.
- Add W4 HP Part Number 86260-20014 Cable Assy: RF Output (Option 001).
- Add W5 HP Part Number 86260-20015 Cable Assy: Modulator/Directional Coupler (Option 001).
- Add W6 HP Part Number 86260-60028 Cable Assy: Detector Output, Blue (Option 001).
- Change HP Part Number 86260-60001 to HP Part Number 86260-60026 Cable Assy: Main (Option 001).

Page 6-8, Table 6-2:

- Change HP Part Number 86260-00002 to HP Part Number 86260-00017 Panel: Front, Lower (Option 001).

Page 8-11, Figure 8-12; and Page 8-14, Figure 8-14:

- Add the Partial Block Diagram (Option 001) in Figure 9-4.

Page 8-17, Figure 8-15:

- Add Figure 9-5.

Page 8-19, Figure 8-17:

- Add Figure 9-6.
- Replace Figure 8-8 with Figure 9-7.

Page 8-19:

- Replace Figure 8-19 with Figure 9-8.
- Add Figure 9-9.
- Replace Figure 8-20 with Figure 9-10.
- Replace Figure 8-21 with Figure 9-11.

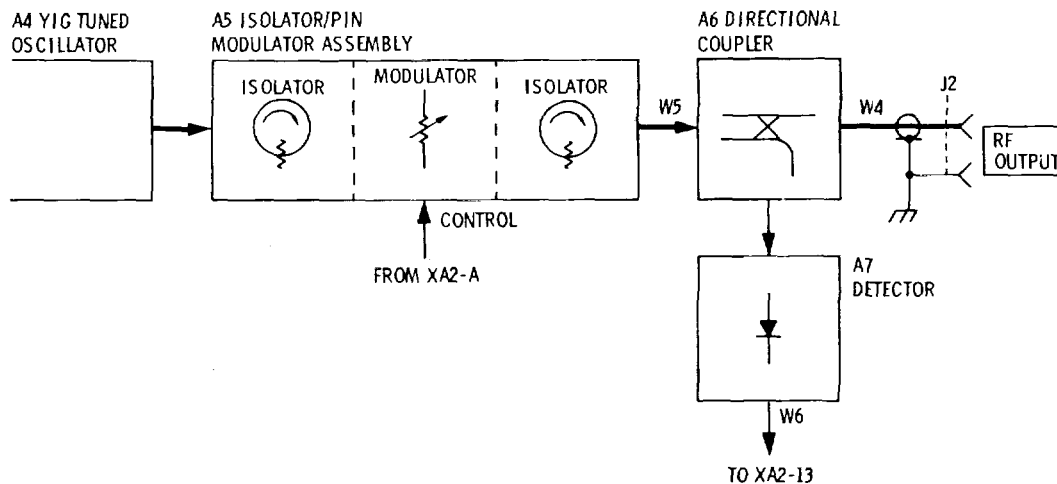

Figure 9-4. Partial Block Diagram (Option 001)

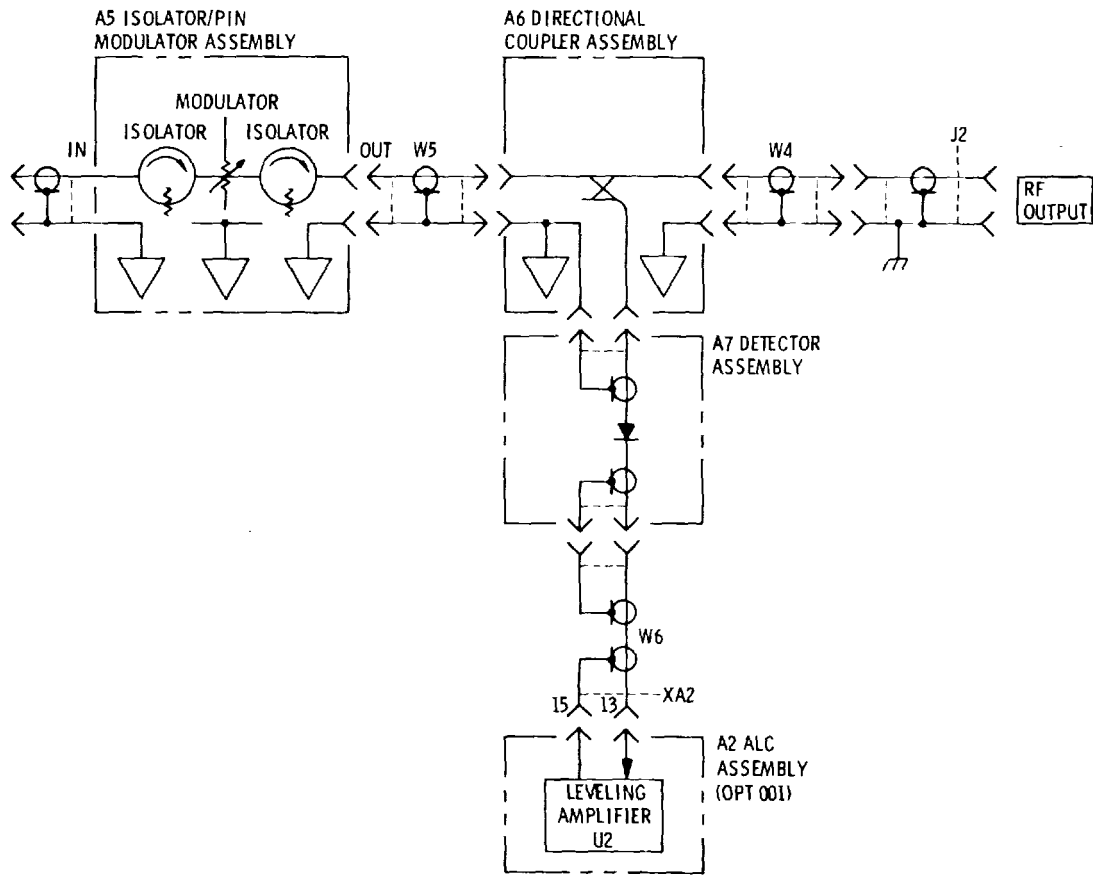

Figure 9-5. A1 YIG Driver Assembly, Schematic (Option 001)

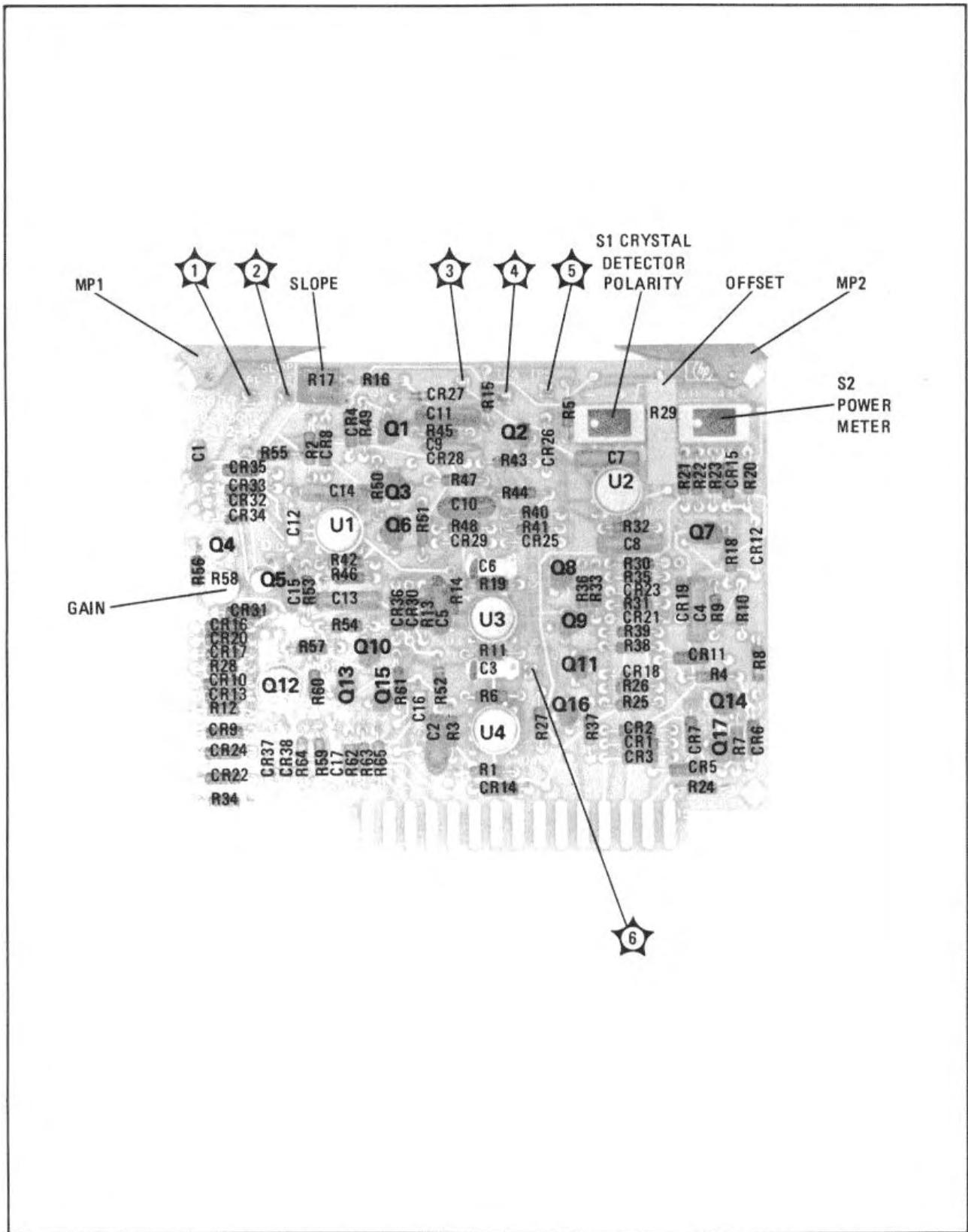

Figure 9-6. A2 ALC Assembly, Components Location

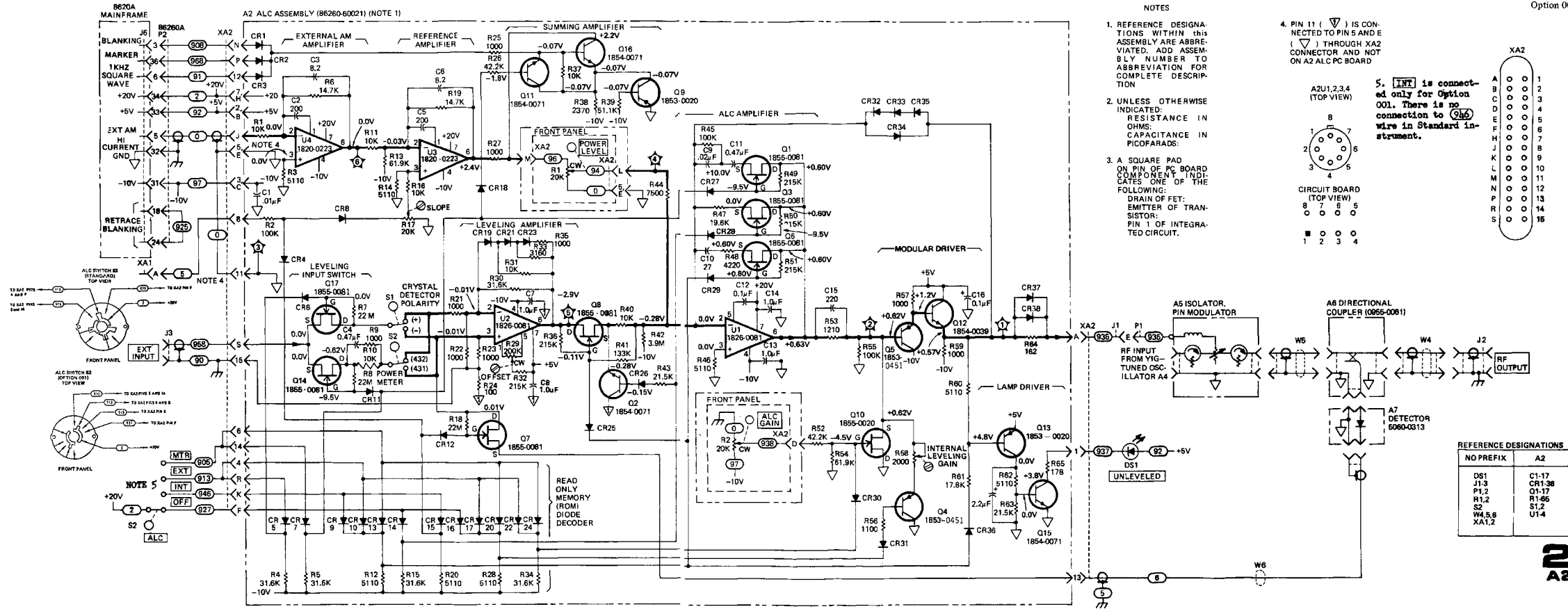

Figure 9-7. A2 ALC Assembly, Schematic

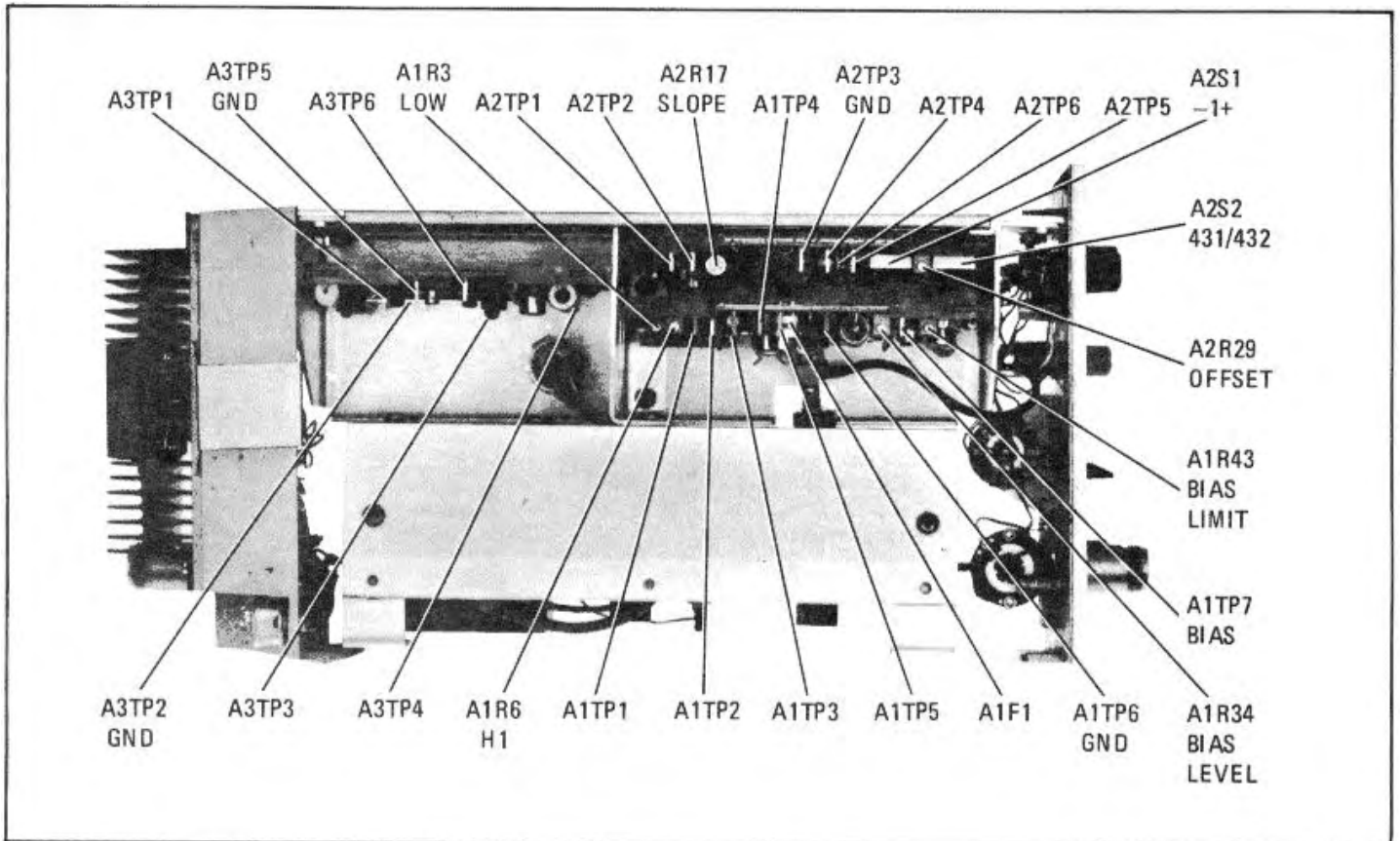

Figure 9-8. Location of Adjustments and Test Points (Top View) (Option 001)

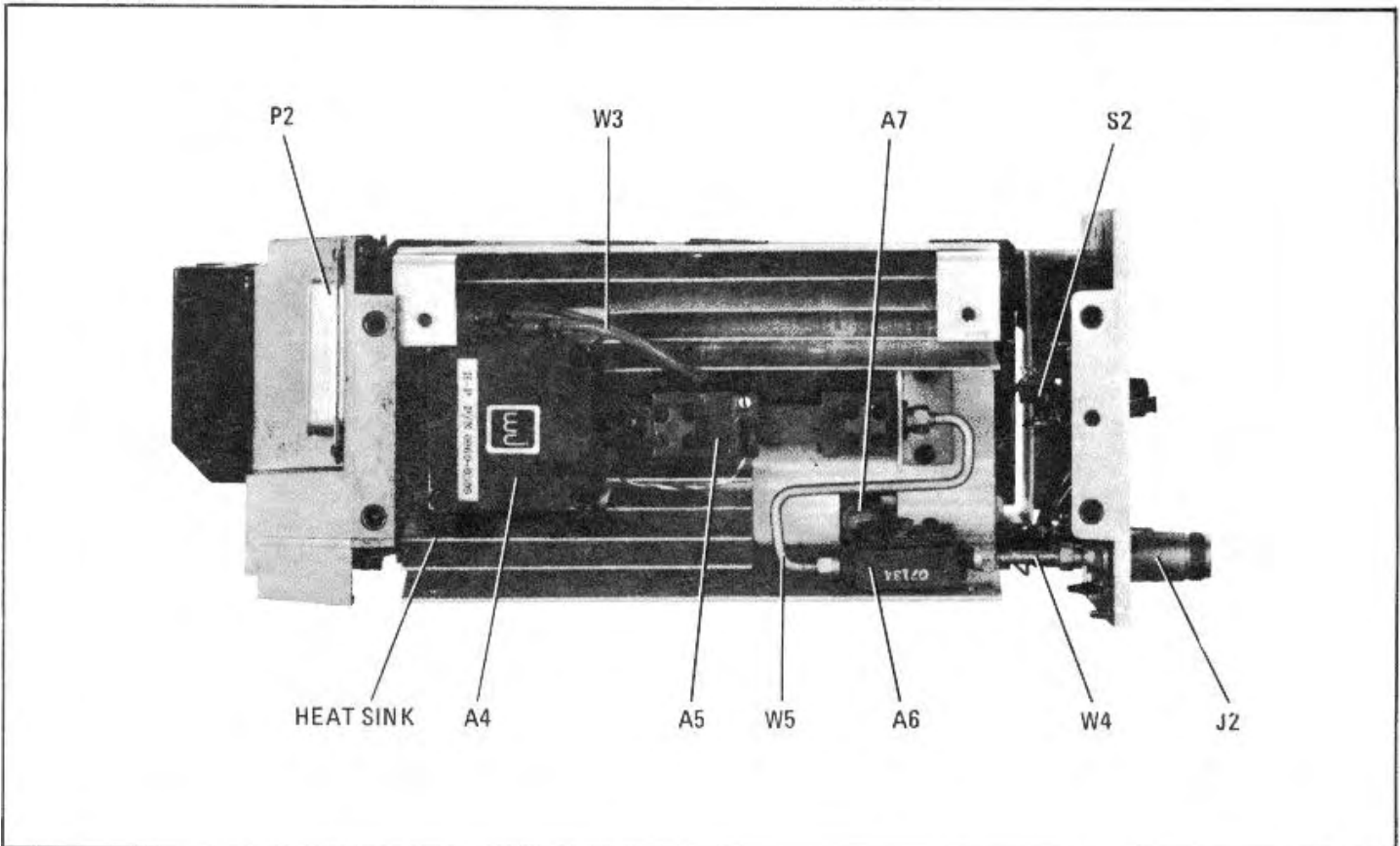

Figure 9-9. Location of Major Assemblies, Left Side view (Option 001)

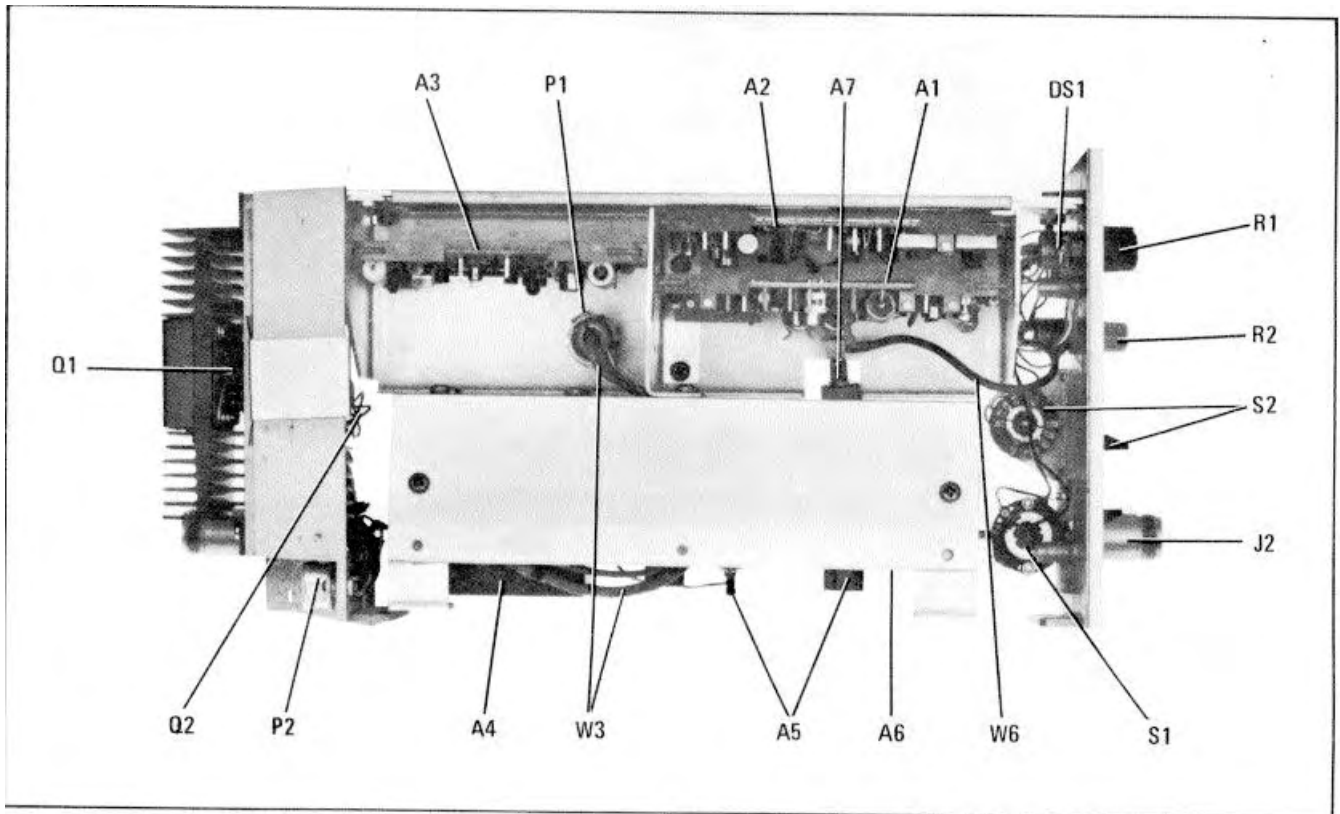

Figure 9-10. Location of Major Assemblies, Top View (Option 001)

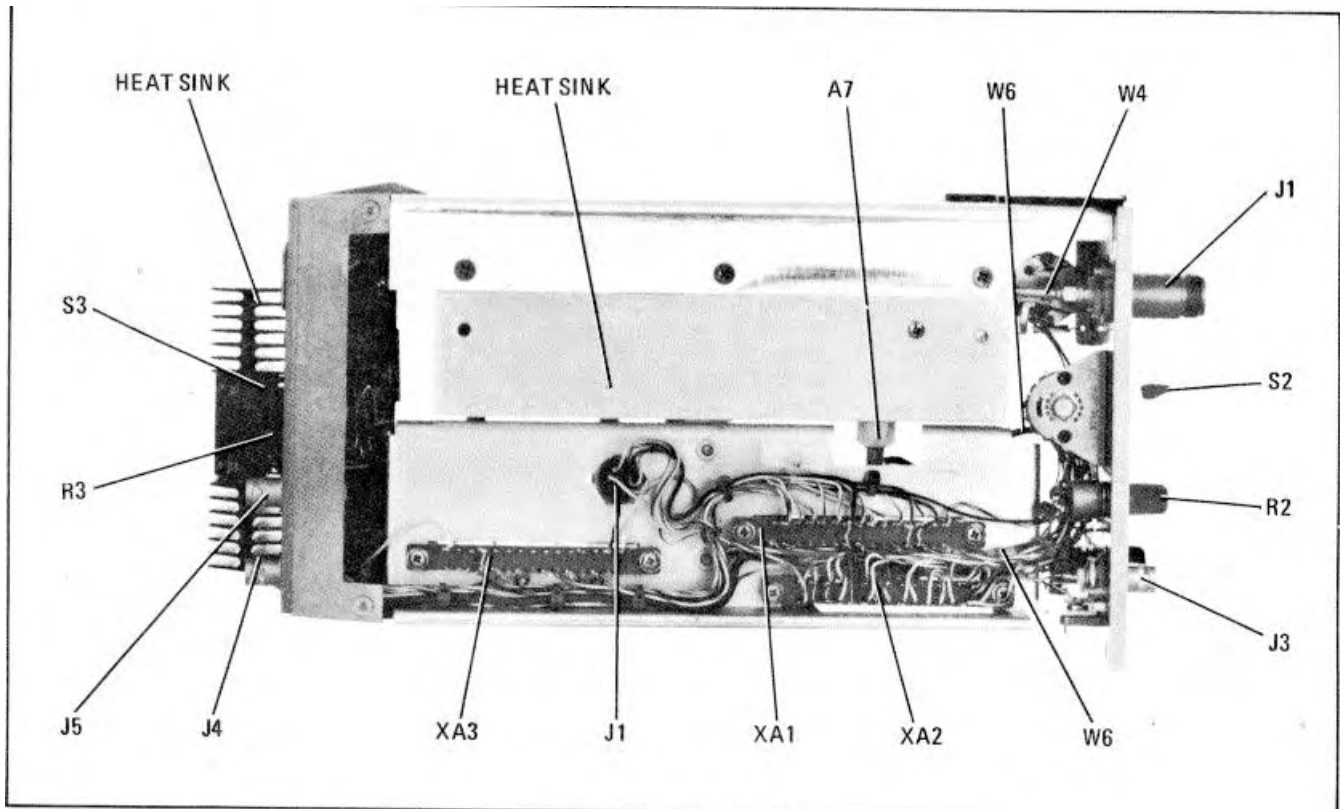

Figure 9-11. Location of Major Assemblies, Bottom View (Option 001)

## SECTION X

## OPTION 004 REAR PANEL OUTPUT

**10-1. INTRODUCTION**

10-2. The components used in the HP Model 86260A Option 004 are listed in the standard 86260A Operating and Service Manual. This supplement provides illustrations and additional information pertinent to the Option 004.

**10-3. DESCRIPTION**

10-4. The Model 86260A Option 004 provides the RF Output connector mounted on the rear panel (Type-N for all instruments except Option 001/004). The differences in the front and rear panels, with Option 004 installed, are shown in Figures 10-1 and 10-2.

**10-5. OPTION 004 MANUAL CHANGES**

10-6. The following changes and additions provide information to show the differences in the RF Plug-in with Option 004 installed.

Page 3-3, Figure 3-1:

Replace Figure 3-1 with Figure 10-1.

Delete description for item (7) and add NOTE 1 as follows: With Option 004 installed, the RF OUTPUT connector J6 is on the rear panel.

Page 3-4, Figure 3-2:

Replace Figure 3-2 with Figure 10-2.

Sections III, IV, and V:

Change all connections to the front panel RF OUTPUT connector in test setups to the-rear panel RF OUT connector.

Page 6-7, Table 6-2:

Delete W1.

Page 6-8, Table 6-2:

Delete HP Part Number 86260-00002 Panel: Front, Lower.

Page 8-11, Figure 8-12 and Page 8-14, Figure 8-14:

Change W1 to W2 and W1J1 to J6.

Change RF OUTPUT to RF OUT.

Page 8-17, Figure 8-16:

Add Figure 10-3 to Figure 8-16.

Page 8-17:

Add Figure 10-4

### FRONT PANEL FEATURES

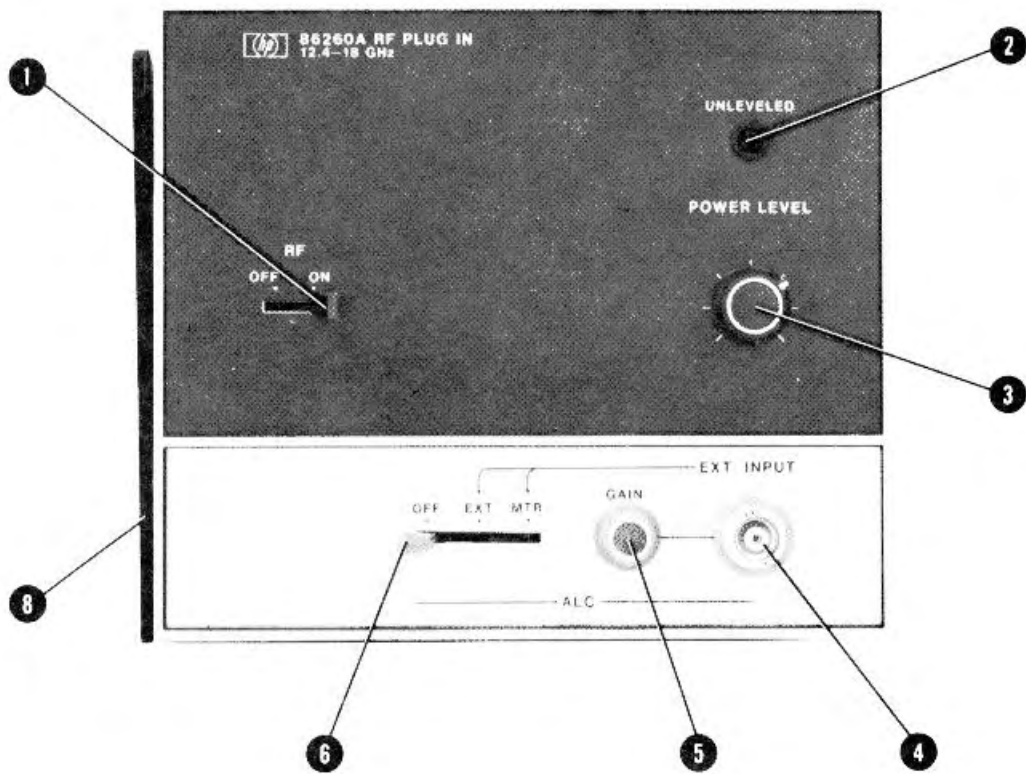

Figure 10-1. Front Panel Controls, Connector and Indicator (Option 004)



### REAR PANEL FEATURES

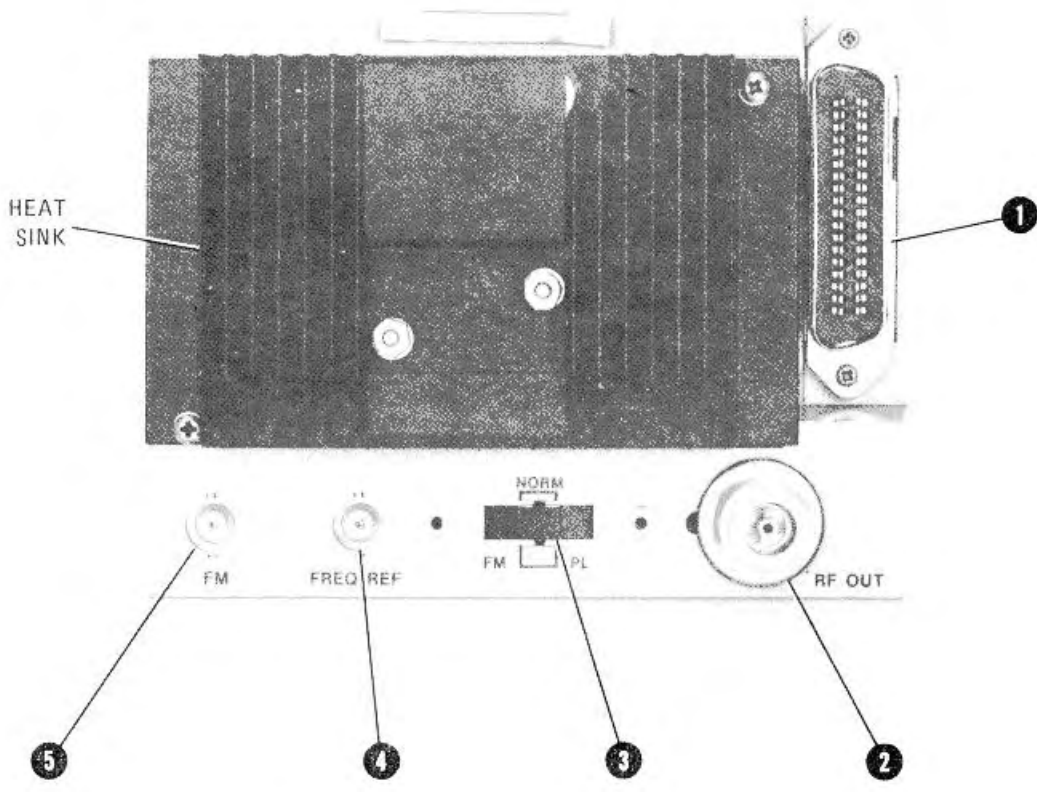

Figure 10-2. Rear Panel Connectors and Controls (Option 004)

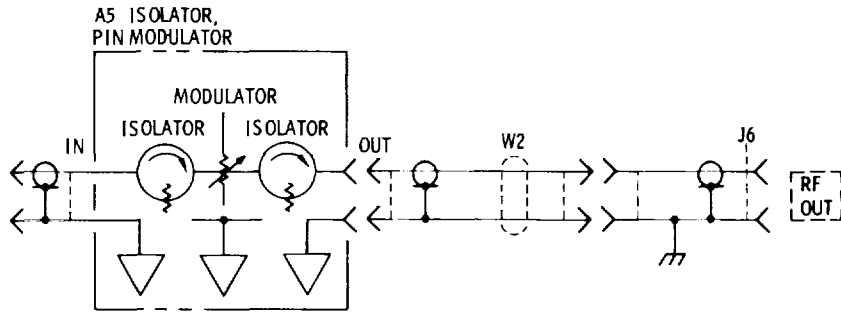

Figure 10-3. A1 YIG Driver Assembly, Schematic (Option 004)

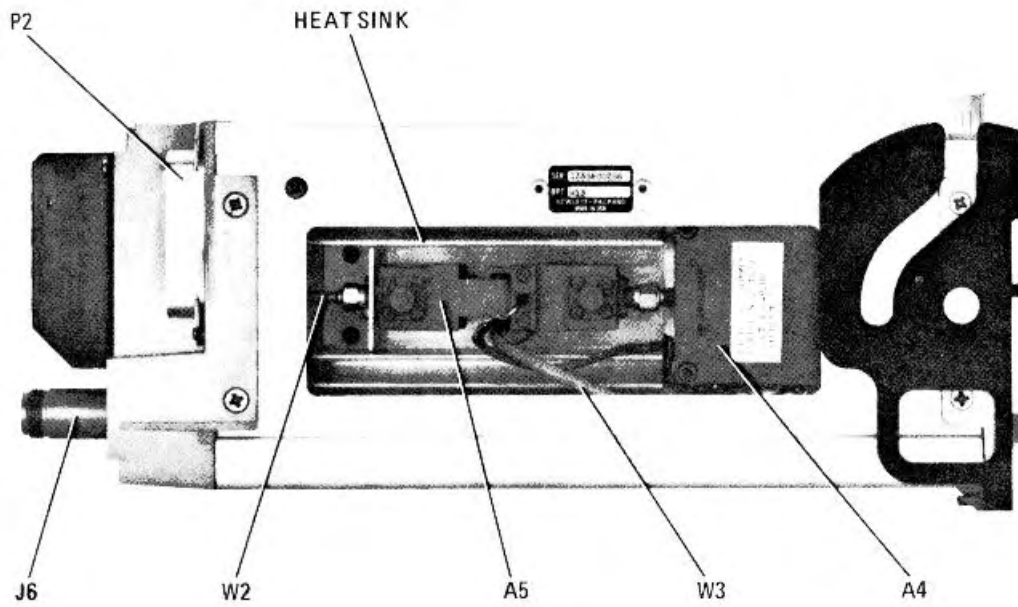

Figure 10-4. Location of Major Assemblies, Left Side View (Option 004)

## SECTION XI

## OPTION 001/004 INTERNAL LEVELING AND REAR PANEL OUTPUT

**11-1. INTRODUCTION**

11-2. This section describes the differences in the Model 86260A RF Plug-in with Option 001/004 installed. The components and assemblies used with the Option 001/004 are contained in this section. In addition, it describes the manual changes necessary to document the addition of Option 001/004. The Option 001/004 is compatible with the 86260A Option 005 and Option 006.

**11-3. DESCRIPTION**

11-4. The HP Model 86260A Option 001/004 incorporates a detector and directional coupler to provide internal leveling capability. The output of the directional coupler is routed to the RF OUT rear panel connector J6. A four-position ALC switch S2 is mounted on a new lower front panel.

**11-5. MANUAL CHANGES**

11-6. The following changes are required to modify and expand the Model 86260A Operating and Service Manual to include the HP Model 86260A Option 001/004.

Page 1-5, Table 1-1, Power Level and Power Variation:

- Change Power Level to: Maximum Leveled Power (Option 001)  $>+6.0$  dBm (4 mW).
- Add under Power Variation the following specification: Internally Leveled:  $< \pm 0.7$  dB.

Page 3-3, Figure 3-1:

- Replace Figure 3-1 with Figure 11- 1.

Page 3-4, Figure 3-2:

- Replace Figure 3-2 with Figure 10-2.

Sections III, IV, and V:

- Change all connections to the front panel RF OUTPUT connector in test setups to the rear panel RF OUT connector.

Page 4-6, Paragraph 4-10:

- Change SPECIFICATION to: Maximum Leveled Power (Option 001):  $> +6.0$  dBm (4 mW).
- Add Power Variation at Maximum Leveled Power: Internally Leveled (Option 001):  $< \pm 0.7$  dB.

Page 4-10, Paragraph 4-10:

- Add after step n the Performance Test for Internal Leveling (86260A Option 001), steps o through t, in Section IX

Page 4-23, Table 4-1, Paragraph 4-10:

- Add the following after step n:
 

q. Internally leveled maximum output power	Lower Limit: +6 dBm.
t. Internally leveled variation	Upper Limit: 1.4 dB p-p

## FRONT PANEL FEATURES

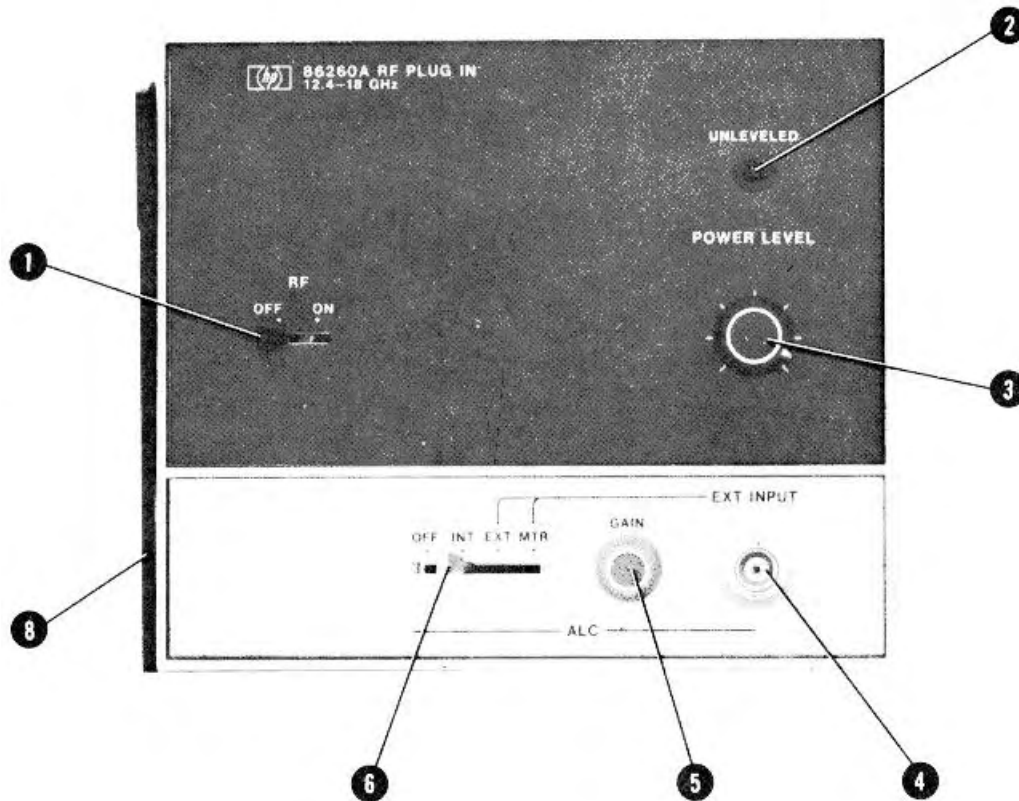

- (1) **RF ON-OFF switch S1.** Turns RF power on and off. Resets oscillator bias voltage when turned to off then on again.
- (2) **UNLEVELED light DS1.** Lights when not in an automatic leveling mode or when in a leveling mode and RF output is not level across the band.
- (3) **POWER LEVEL control R1.** Adjusts RF power output.
- (4) **ALC EXT INPUT connector J3.** Input for external leveling from crystal detector or power meter.

- (5) **ALC GAIN control R2.** Adjusts output of ALC amplifier when using external leveling.
- (6) **ALC switch S2.** Selects INT (internal), EXT (external), or MTR (power meter) power leveling modes. In OFF position, RF is not leveled.

**NOTE**

**With Option 004 installed, the RF OUTPUT connector is on the rear panel.**

- (7) **Drawer Latching Handle.** Aids in installing and removing RF Plug-in. After installing, handle locks to hold RF Plug-in in place.

Figure 11-1. Front Panel Controls, Connector and Indicator (Option 001/004)

Page 5-1, Table 5-1:

Add the following:

A2R17	SLOPE	Adjusts for minimum leveled power variation.
A2R58	GAIN	Sets gain of ALC loop in internal mode.

Page 5-8: Add Paragraph 5-16, Internal Leveling Slope and Gain Adjustments (Option 001) in Section IX,

Page 6-5, Table 6-2:

Change A2 to HP Part Number 86260-60021.

Change A2 Replaceable Parts List as in Section IX,

Page 6-7, Table 6-2:

Add A6 HP Part Number 0955-0061 Coupler: Directional.

Add A7 HP Part Number 5060-0313 Detector: Crystal.

Change S2 to HP Part Number 3100-2094 Switch: Lever, ALC (Option 001).

Delete W1.

Add W5 HP Part Number 86260-20015 Cable Assy: RF Output (Option 001)

Add W7 HP Part Number 86260-20016 Cable Assy: Modulator/Directional Coupler (Option 001/004).

Add W8 HP Part Number 86260-60027 Cable Assy: Detector Output Blue (Option 001/004)

Change HP Part Number 86260-60001 to HP Part Number 86260-60026 Cable Assy: Main (Option 001).

Page 6-8, Table 6-2:

Change HP Part Number 86260-00002 to HP Part Number 86260-00019, Panel: Front, Lower (Option 001/004).

Page 8-11, Figure 8-12; and page 8-14, Figure 8-14:

Add the Partial Block Diagram (Option 001/004) in Figure 11-2.

Page 8-12, Figure 8-16:

Add Figure 11-3.

Page 8-19, Figure 8-17:

Add Figure 9-6.

Add Figure 11-4 to Figure 9-7.

Replace Figure 8-8 with Figure 9-7.

Page 8-19:

Replace Figure 8-10 with Figure 9-8.

Add Figure 11-5.

Replace Figure 8-11 with Figure 11-6.

Replace Figure 8-12 with Figure 11-7.

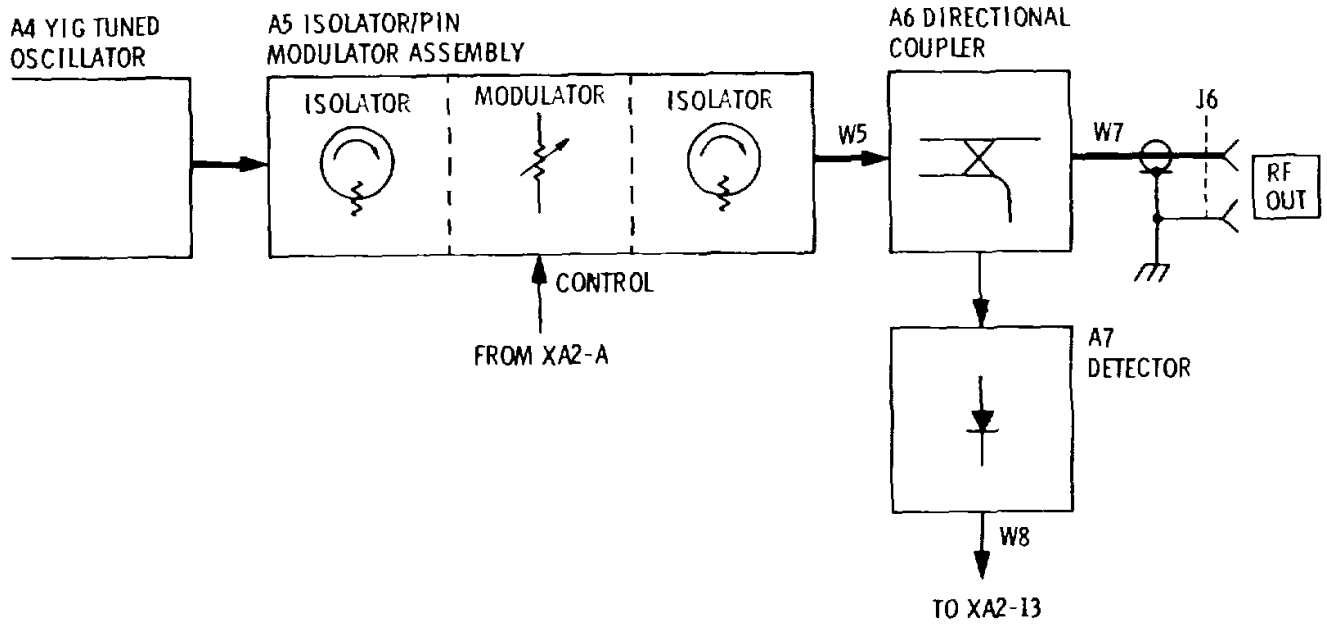

Figure 11-2. Partial Block Diagram (Option 001/004)

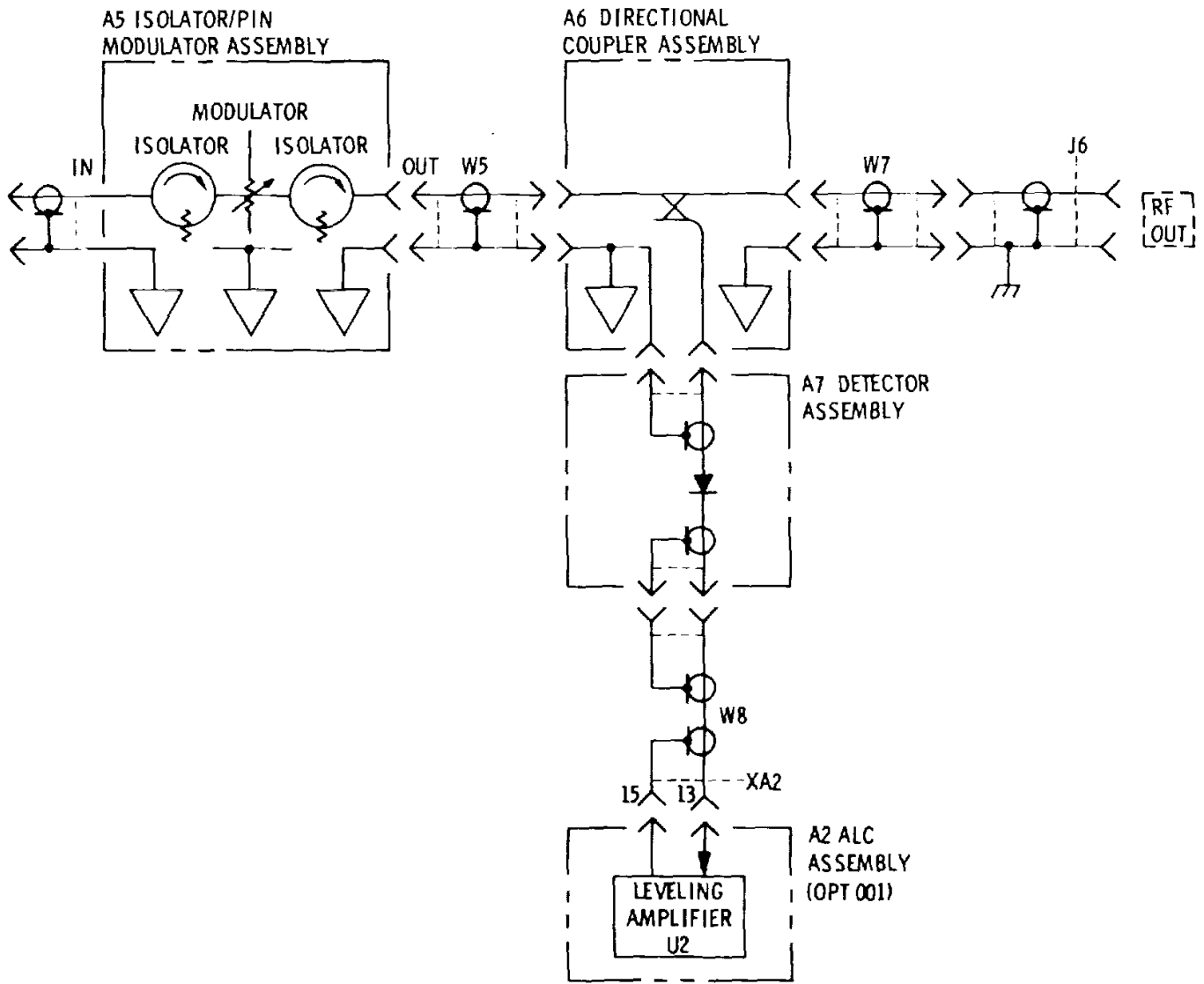

Figure 11-3. A1 YIG Driver Assembly, Schematic (Option 001/004)

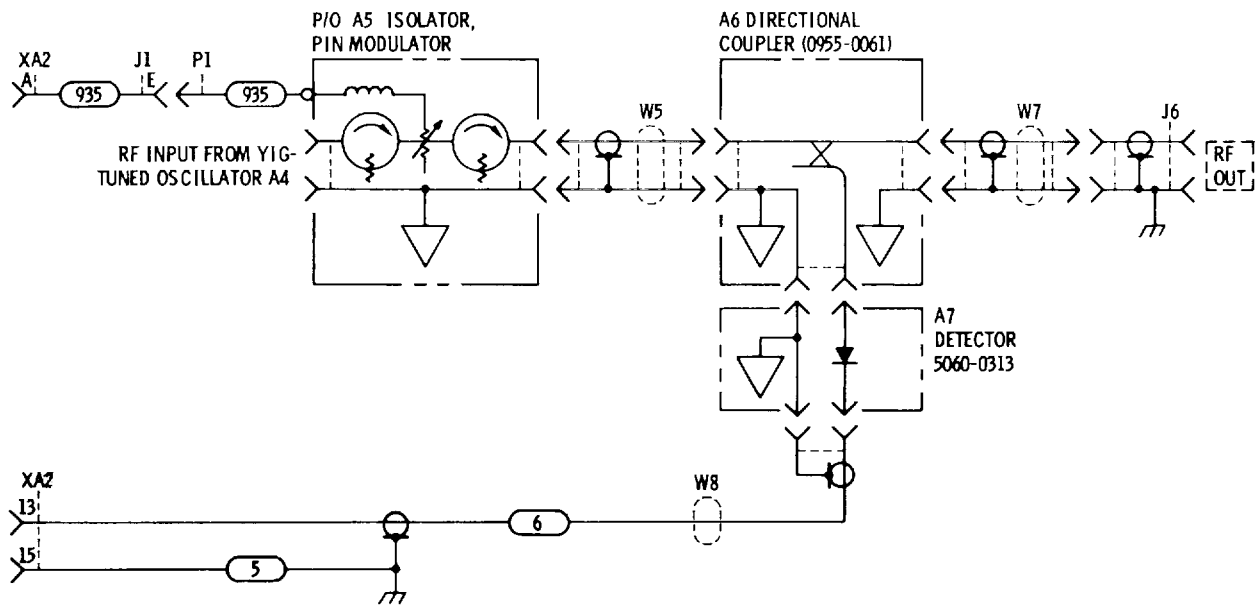

Figure 11-4. A2 ALC Assembly, Schematic (Option 001/004)

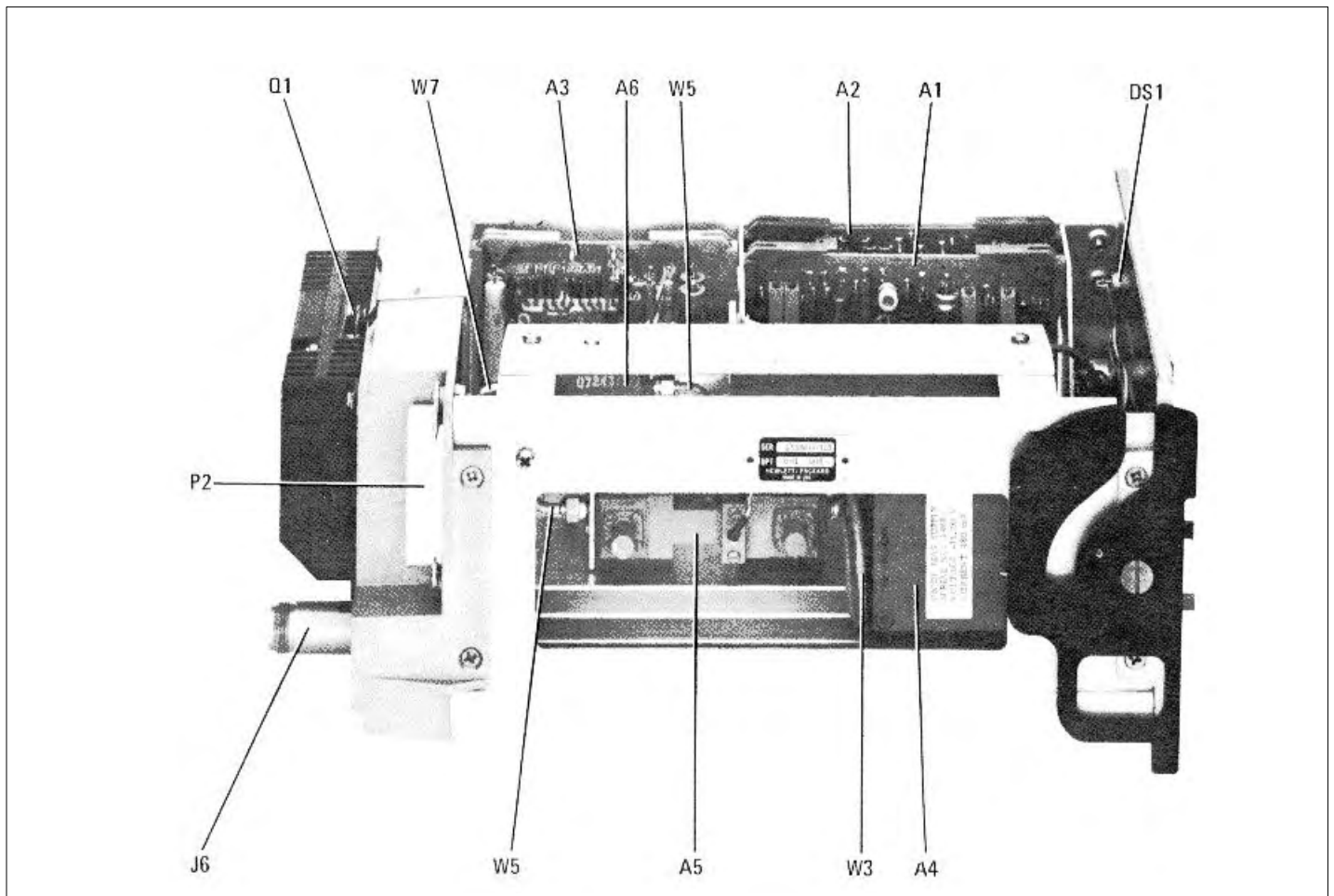

Figure 11-5. Location of Major Assemblies, Left Side View (Option 001/004)



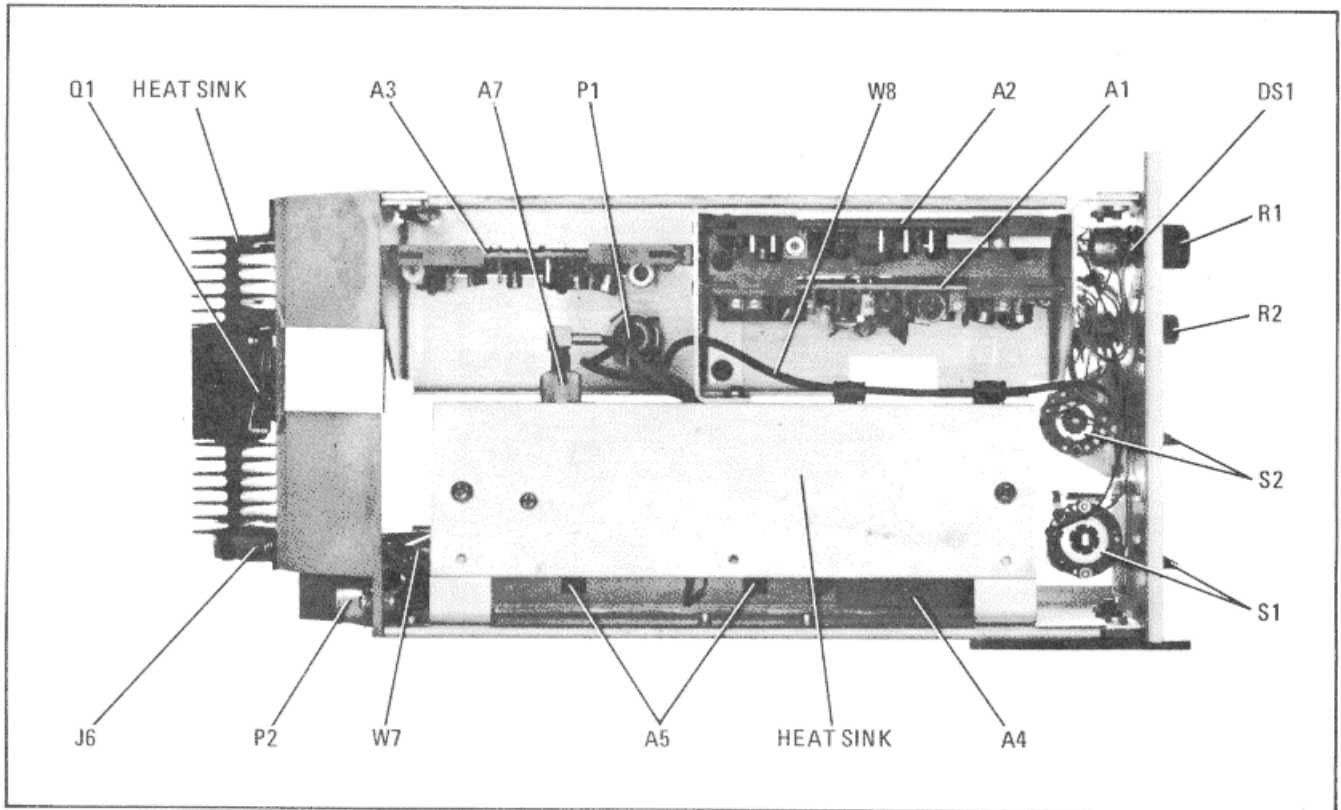

Figure 11-6. Location of Major Assemblies, Top View (Option 001/004)

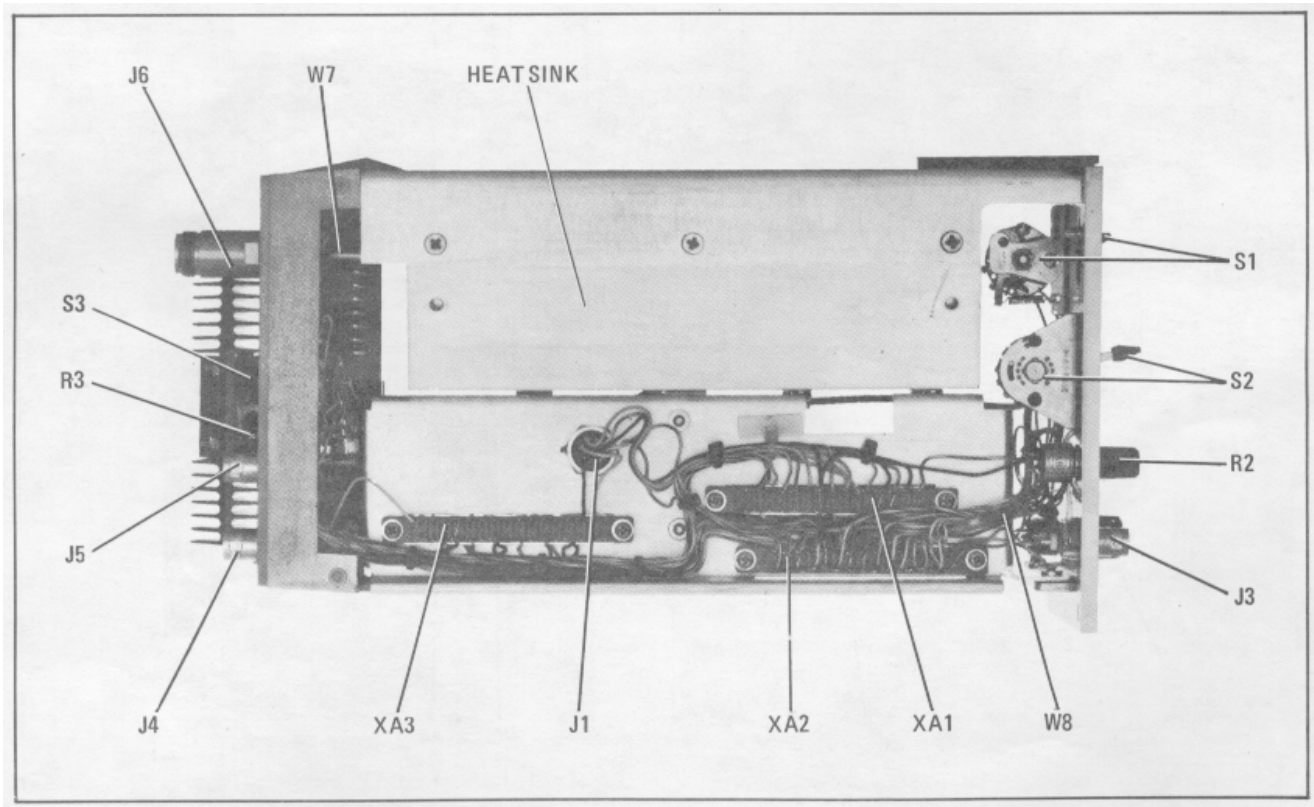

Figure 11-7. Location of Major Assemblies, Bottom View (Option 001/004)

## SECTION XII

## OPTION 005 APC-7 RF OUTPUT CONNECTOR

## 12-1. INTRODUCTION

12-2. The components used in the HP Model 86260A Option 005 are listed in the standard 86260A Operating and Service Manual. This section provides an illustration and additional information pertinent to the Option 005.

## 12-3. DESCRIPTION

12-4. The Model 86260A Option 005 provides an APC-7 Output connector. This is accomplished by replacing the type-N contact and body with the APC-7 contact and body shown in Figure 12-1. The Option 005 is compatible with all 86260A options.

## 12-5. MANUAL CHANGES

12-6. The following changes and additions provide information to show the differences in the RF Plug-in with Option 005 installed.

Page 6-7, Table 6-2:

Add J2 HP Part Number 86260-60007 Connector Assy: APC-7 (Option 005).

Add J6 HP Part Number 86260-60007 Connector Assy: APC-7 (Option 004/005 and Option 001/004/005).

Page 6-9, Figure 6-1:

Replace J2MP1 and J2MP2 on the illustration with Figure 12-1.

Change J2MP1 to HP Part Number 1250-0909 Body: RF Connector APC-7 (Option 005).

Change J2 MP2 to HP Part Number 1250-0816 Contact: RF Connector APC-7 (Option 005).

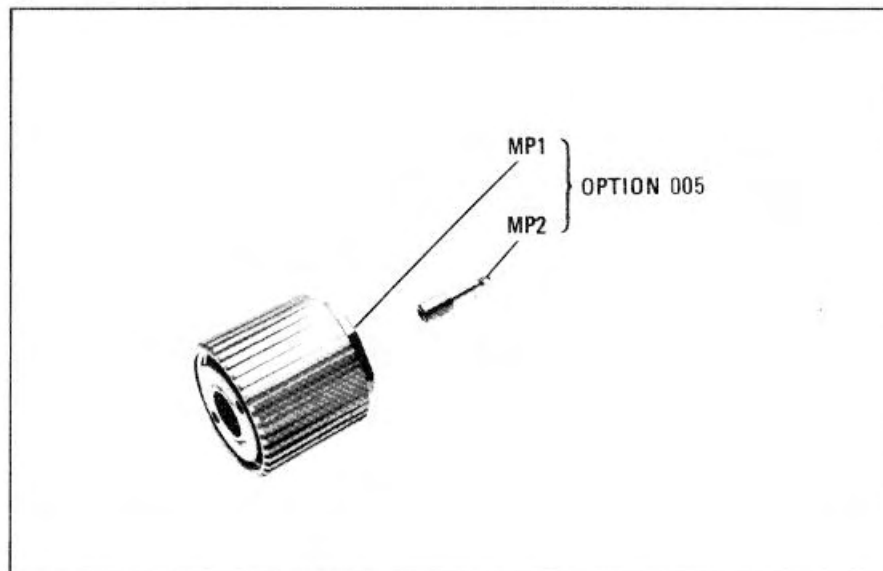

Figure 12-1. APC-7 RF Output Connector, Exploded View (Option 005)

## SECTION XIII

## OPTION 006 HIGH POWER OUTPUT

**13-1. INTRODUCTION**

13-2. This supplement describes the differences in the Model 86260A RF Plug-in with Option 006 installed. In addition, it describes the manual changes necessary to document the addition of Option 006.

**13-3. DESCRIPTION**

13-4. The Model 86260A Option 006 incorporates a YIG-Tuned Oscillator (YTO) that is capable of a higher output power. Using this YTO increases the 86260A output power to + 10 dBm.

**13-5. MANUAL CHANGES**

13-6. The following changes and additions provide information to show the differences in the RF Plug-in with Option 006 installed.

Page 1-5, Table 1-1, POWER OUTPUT:

Change Power Level to: Maximum Leveled Power (Option 006): +s10 dBm (10 mW).

Page 4-6, Paragraph 4-10:

Change SPECIFICATION to: Maximum Leveled Power (Option 006):  
12.4 to 18.0 GHz => + 10 dBm (10 mW).

Page 4-8, Paragraph 4-10, Step c:

Change the last sentence of step c to read: For Option 006, power meter should indicate > + 10 dBm.

Page 4-23, Table 4-1, Paragraph 4-10:

Change step c to read: dc. Crystal leveled maximum output power, (Option 006),  
Lower Limit + 10 dBm.

Page 6-7, Table 6-2:

Change A4 to HP Part Number 86260-60033 YIG TUNED OSCILLATOR ASSY (Option 006)

**APPENDIX A  
REFERENCES**

---

DA Pam 310-4	Index of Technical Publications: Technical Manuals, Technical Bulletins, Supply Manuals (Types 7, 8, and 9), Supply Bulletins, and Lubrication Orders.
DA Pam 310-7	US Army Equipment Index of Modification Work Orders.
TM 38-750	The Army Maintenance Management System (TAMMS).
TM 750-244-2	Procedures for Destruction of Electronics Materiel to Prevent Enemy Use (Electronics Command).

**A-1/(A-2 Blank)**

## APPENDIX D MAINTENANCE ALLOCATION

### Section I. INTRODUCTION

#### D-1. General

This appendix provides a summary of the maintenance operations for the Hewlett-Packard Model 86260A RF Plug-in. It authorizes categories of maintenance for specific maintenance functions on repairable items and components and the tools and equipment required to perform each function. This appendix may be used as an aid in planning maintenance operations.

#### D-2. Maintenance Function

Maintenance functions will be limited to and defined as follows:

a. *Inspect.* To determine the serviceability of an item by comparing its physical, mechanical, and/or electrical characteristics with established standards through examination.

b. *Test.* To verify serviceability and to detect incipient failure by measuring the mechanical or electrical characteristics of an item and comparing those characteristics with prescribed standards.

c. *Service.* Operations required periodically to keep an item in proper operating condition, i.e., to clean (decontaminate), to preserve, to drain, to paint, or to replenish fuel, lubricants, hydraulic fluids, or compressed air supplies.

d. *Adjust.* To maintain, within prescribed limits, by bringing into proper or exact position, or by setting the operating characteristics to the specified parameters.

e. *Align.* To adjust specified variable elements of an item to bring about optimum or desired performance.

f. *Calibrate.* To determine and cause corrections to be made or to be adjusted on instruments or test measuring and diagnostic equipments used in precision measurement. Consists of comparisons of two instruments, one of which is a certified standard of known accuracy, to detect and adjust any discrepancy in the accuracy of the instrument being compared.

g. *Install.* The act of emplacing, seating, or fixing into position an item, part, module (component or assembly) in a manner to allow the proper functioning of the equipment or system.

h. *Replace.* The act of substituting a serviceable like type part, subassembly, or module (component or assembly) for an unserviceable counterpart.

i. *Repair.* The application of maintenance services (inspect, test, service, adjust, align, calibrate, replace) or other maintenance actions (welding, grinding, riveting, straightening, facing, remachining, or resurfacing) to restore serviceability to an item by correcting specific damage, fault, malfunction, or failure in a part, subassembly, module (component or assembly), end item, or system.

j. *Overhaul.* That maintenance effort (service/action) necessary to restore an item to a completely serviceable/operational condition as

prescribed by maintenance standards (i.e., DMWR) in appropriate technical publications. Overhaul is normally the highest degree of maintenance performed by the Army. Overhaul does not normally return an item to like new condition.

k. *Rebuild.* Consists of those services/actions necessary for the restoration of unserviceable equipment to a like new condition in accordance with original manufacturing standards. Rebuild is the highest degree of materiel maintenance applied to Army equipment. The rebuild operation includes the act of returning to zero those age measurements (hours, miles, etc.) considered in classifying Army equipments/components.

#### D-3. Column Entries

a. *Column 1, Group Number.* Column 1 lists group numbers, the purpose of which is to identify components, assemblies, subassemblies, and modules with the next higher assembly.

b. *Column 2, Component/Assembly.* Column 2 contains the noun names of components, assemblies, subassemblies, and modules for which maintenance is authorized.

c. *Column 3, Maintenance Functions.* Column 3 lists the functions to be performed on the item listed in column 2. When items are listed without maintenance functions, it is solely for purpose of having the group numbers in the MAC and RPSTL coincide.

d. *Column 4, Maintenance Category.* Column 4 specifies, by the listing of a "work time" figure in the appropriate subcolumn(s), the lowest level of maintenance authorized to perform the function listed in column 3. This figure represents the active time required to perform that maintenance function at the indicated category of maintenance. If the number or complexity of the tasks within the listed maintenance function vary at different maintenance categories, appropriate "work time" figures will be shown for each category. The number of taskhours specified by the "work time" figure represents the average time required to restore an item (assembly, subassembly, component, module, end item or system) to a serviceable condition under typical field operating conditions. This time includes preparation time, troubleshooting time, and quality assurance/quality control time in addition to the time required to perform the specific tasks identified for the maintenance functions authorized in the maintenance allocation chart. Subcolumns of column 4 are as follows:

C-Operator/Crew

O-Organizational

F-Direct Support  
H-General Support  
D-Depot

e. *Column 5, Tools and Equipment.* Column 5 specifies by code those common tool sets (not individual tools) and special tools, test, and support equipment required to perform the designated function.

f. *Column 6, Remarks.* Not applicable.

**D-4. Tool and Test Equipment Requirements (Sect III)**

a. *Tool or Test Equipment Reference Code.* The numbers in this column coincide with the numbers used in the tools and equipment column of the MAC. The numbers indicate the applicable tool or test equipment for the maintenance functions.

b. *Maintenance Category.* The codes in this column indicate the maintenance category allocated the tool or test equipment.

c. *Nomenclature.* This column lists the noun name and nomenclature of the tools and test equipment required to perform the maintenance functions.

d. *National/NATO Stock Number.* This column lists the National/NATO stock number of the specific tool or test equipment.

e. *Tool Number.* This column lists the manufacturer's part number of the tool followed by the Federal Supply Code for manufacturers (5-digit) in parentheses.

**D-5. Remarks (Sec IV)**

Not applicable.

**(Next printed page is D-3)**

SECTION II. MAINTENANCE ALLOCATION CHART FOR HP-86260A

(1) GROUP NUMBER	(2) COMPONENT ASSEMBLY	(3) MAINTENANCE FUNCTION	(4) MAINTENANCE CATEGORY					(5) TOOLS AND EQUIPMENT	(6) REMARKS
			C	O	F	H	D		
00	**RF PLUG-IN 86260A	INSPECT TEST REPLACE REPAIR OVERHAUL		.3		1.0 1.5	2.0 3.0	15, 16 1-14 14-16 14-16 1-15	
0001	*YIG DRIVER ASSEMBLY (A1)	INSPECT TEST REPLACE REPAIR OVERHAUL		.1		.5 .2	.7 1.5	15, 16 1-14 14-16 14-16 1-15	
0002	ALC ASSEMBLY (A2)	INSPECT TEST REPLACE REPAIR OVERHAUL		.1		.3 .2	.7 1.5	15 1-14 14-16 14-16 1-15	
0003	FM ASSEMBLY (A3)	INSPECT TEST REPLACE REPAIR OVERHAUL		.1		.2 .3	.6 1.5	15 1-14 14-16 4-16 1-15	
**THE RF PLUG-IN MUST BE TESTED WITHIN THE 3629A *YIG (YTTRIUM IRON GARNET)									

**SECTION III: TOOL AND TEST EQUIPMENT REQUIREMENTS FOR HP-86260A**

TOOL OR TEST MAINTENANCE		NOMENCLATURE	NATIONAL/NATO STOCK NUMBER	TOOL NUMBER
EQUIPMENT REF CODE	CATEGORY			
1	HD	SWEEP OSCILLATOR SG-1121(V)1/U	6625-00-007-6661	
2	HD	SPECTRUM ANALYZER MAINFRAME 141T IP-1216(P)/GR	6625-00-424-4370	
3	HD	SPECTRUM ANALYZER PLUG-IN HP-3555A PL-1400/U	6625-00-422-4314	
4	HD	SPECTRUM ANALYZER PLUG-IN HP-8552B PL-1383/U	6625-00-431-9339	
5	H	OSCILLOSCOPE - TEK 5440	6625-01-034-3269	
6	HD	FREQUENCY COUNTER HP534A	6625-00-531-4752	
7	HD	TEST OSCILLATOR HP-652A	6625-00-054-3483	
8	HD	DC DIGITAL VOLTMETER HP-3490A/W	6625-01-010-9255	
9	HD	POWER METER AND THERMISTOR MOUNT HP-432A HP H75-478A AN/USM-260	6625-00-006-7638	
10	HD	TRUE RMS VOLTMETER JF-8922 A/AA		
11	HD	DC VOLTAGE SOURCE JF-332	6625-00-481-8901	
12	HD	10DB ATTENUATOR HP 350D AN/USM-30	4921-00-916-2920	
13	HD	ADJUSTABLE AC LINE TRANSFORMER CM 16	5950-00-235-2036	
14	D	RF PLUG-IN HP-86260A		
15	HD	TOOL KIT 105/U		
16	0	COMMON TOOLS NECESSARY TO THE PERFORMANCE OF THE MAINTENANCE FUNCTION ARE AVAILABLE TO MAINTENANCE PERSONNEL, FOR THE MAINTENANCE CATEGORY LISTED.		



By Order of the Secretary of the Army:

E. C. MEYER  
*General, United States Army*  
*Chief of Staff*

Official:

J. C. PENNINGTON  
*Major General, United States Army*  
*The Adjutant General*

Distribution:

*Active Army:*

TSG (1)  
USAARENBD (1)  
USAINSCOM (2)  
TRADOC (2)  
DARCOM (1)  
TECOM (2)  
OS Maj Comd (2)  
USACC (2)  
HISA (Ft Monrnoth) (21)  
Armies (1)  
USASIGS (10)  
Svc Colleges (1)  
Ft Richardson (CERCOM Ofc) (1)  
Ft Carson (5)  
Ft Gillem (10)  
NG: None  
USAR: None  
For explanation of abbreviations used see AR 310-50.

WSMR (1)  
USAERDAA (1)  
USAERDAW (1)  
Army Dep (1) except  
SAAD (30)  
TOAD (14)  
SHAD (2)  
USA Dep (1)  
Sig Sec USA Dep (1)  
Units org under fol TOE:  
29-207 (2)  
29-610 (2)  
29-134 (1)  
29-136 (1)

RECOMMENDED CHANGES TO EQUIPMENT TECHNICAL PUBLICATIONS



THEN... JOT DOWN THE DOPE ABOUT IT ON THIS FORM, CAREFULLY TEAR IT OUT, FOLD IT AND DROP IT IN THE MAIL!

SOMETHING WRONG WITH THIS PUBLICATION?

FROM: (PRINT YOUR UNIT'S COMPLETE ADDRESS)

DATE SENT

PUBLICATION NUMBER

PUBLICATION DATE

PUBLICATION TITLE

BE EXACT... PIN-POINT WHERE IT IS

PAGE NO.

PARA-GRAPH

FIGURE NO.

TABLE NO.

IN THIS SPACE TELL WHAT IS WRONG AND WHAT SHOULD BE DONE ABOUT IT:

TEAR ALONG PERFORATED LINE

PRINTED NAME, GRADE OR TITLE, AND TELEPHONE NUMBER

SIGN HERE:

DA FORM 2028-2  
1 JUL 79

PREVIOUS EDITIONS  
• ARE OBSOLETE.

P.S.—IF YOUR OUTFIT WANTS TO KNOW ABOUT YOUR RECOMMENDATION MAKE A CARBON COPY OF THIS AND GIVE IT TO YOUR HEADQUARTERS.

DEPARTMENT OF THE ARMY  
US ARMY AG PUBLICATIONS CENTER  
1655 WOODSON ROAD  
ST. LOUIS, MISSOURI 63114  
OFFICIAL BUSINESS  
PENALTY FOR PRIVATE USE \$300

POSTAGE AND FEES PAID  
DEPARTMENT OF THE ARMY  
DOD 314

**PIN: 048006-000**

# **K4XL's** **BAMA**

This manual is provided **FREE OF CHARGE** from the "BoatAnchor Manual Archive" as a service to the Boatanchor community.

It was uploaded by someone who wanted to help you repair and maintain your equipment.

If you paid anyone other than BAMA for this manual, you paid someone who is making a profit from the free labor of others without asking their permission.

You may pass on copies of this manual to anyone who needs it. But do it without charge.

Thousands of files are available without charge from BAMA. Visit us at <http://bama.sbc.edu>